

RADIO CONTROLLED MODELS

FOR AMATEURS

No. 133



by

J. M. KERNEY

5/-

BERNARDS PUBLISHERS LTD

RADIO CONTROLLED MODELS

FOR
AMATEURS

by

J. M. KERNEY



BERNARDS (PUBLISHERS) LTD.
THE GRAMPIANS
WESTERN GATE
LONDON, W.6

First Published June 1955

Reprinted October 1955

Reprinted November 1956

Reprinted June 1957

*The Publishers are indebted to
Messrs. Henry J. Nicholls, Ltd.
who kindly provided the photograph
which shows their AERONCA SEDAN.*

*Printed by V. Cooper & Partners, Ltd., Flitcroft Street, London, W.C.2
for Bernards (Publishers) Ltd., The Grampians, Western Gate, London, W.6*

CONTENTS

	Page
Preface	iii
CHAPTER ONE	
The Alternative Methods	1
CHAPTER TWO	
Receivers for Sequence Control	3
Relay Adjustment	5
Hard Valve Receivers	5
CHAPTER THREE	
Transmitters for Sequence Control	12
Simple Self-Excited Transmitter	14
Crystal Controlled Transmitter	17
CHAPTER FOUR	
Sequence Systems applied to Aircraft	20
The Rudder	20
Throttle Adjustment	23
Elevator Control	25
The "Rudevator"	36
CHAPTER FIVE	
Sequence Systems for Boats	40
Automatic Pulser Unit	44
CHAPTER SIX	
Audio Tone Control	48
Transmitters for Audio-Frequency Control	57
CHAPTER SEVEN	
Proportionate Control	61
Mark-space System	61
Audio Frequency Deviation	66

Preface

From time to time the general public see radio controlled models being displayed at Exhibitions, and perhaps they pause for a few minutes to watch the model being "put through its paces" by a white coated individual who manipulates the controls at a distance.

Whether young or old, the spectators walk away with the impression that they have just seen something rather uncanny; something akin to a conjuring show.

Only the select few, who are radio enthusiasts or model makers, fully appreciate the time, trouble, and loving care which have gone into the model. They watch in silence, and vague thoughts pass through their minds as to whether they could ever manage to undertake a similar project. They have read small pamphlets on Model Control, and have been rather intrigued by some of the ideas they saw, but the information was "sketchy" and incomplete. The radio circuits given were either too simple, or at the other extreme, frighteningly complex. The result was inevitable, the booklet was put away, and more practical matters were attended to in the Home Workshop.

This book is presented by Bernards without apology; we know that it's not the first book on the subject—on the contrary, we are publishing this book with a feeling of pride, because it's the first book which gives ALL the details in a clear, readable manner.

The Author has taken great trouble to present a highly complex subject in a simple fashion. He starts with elementary circuits and discusses their disadvantages, and whether these troubles can be overcome. Before the reader realises it, he is understanding a crystal controlled transmitter and a sensitive multi-stage receiver. Sequence control, Escapements, Servo-mechanisms, and a few simple controls are then explained; which in themselves are sufficient to satisfy the less ambitious constructor.

We next learn that Sequence Control has its limitations, and read on to find that Proportionate Control and 5-channel systems are really not so difficult to understand after all! The Author kindles one's enthusiasm until the construction of a radio controlled model becomes a "must" in the Home Workshop. Adjustment, alignment, and all the difficulties which can, and will arise, are treated with clarity, and an infectious confidence.

Bernards KNOW that this is the book for which you have been waiting.

J.K.M.

CHAPTER ONE

The Alternative Methods

To control models, whether aircraft, boats, or any kind of vehicle, it is necessary to operate elevators, rudders, steering wheels, engine speed, etc., as the case may be. Since this cannot be done by hand, a small motor of some kind is used for the purpose, called a "servo-motor," which actuates the control to be operated. This servo motor is started or stopped through the agency of the radio link between the receiver, which is aboard the model, and the transmitter, which is under the direct control of the operator. The radio link acts as if it were an electrical circuit linking the transmitter with the model. Thus, closing a switch at the transmitting end causes an electrically operated switch (a relay) aboard the model to be likewise closed, so operating the servo motor.

The first part of the problem is to devise a suitable radio system achieving this result. For this purpose, a receiver is designed which, instead of operating a loud-speaker or head-phones as is usual, closes a relay when it receives a radio signal of the correct frequency radiated by the transmitter. The relay opens again when the signal is no longer received. Having done this, we can switch on and off a circuit in the model. This, however, is not sufficient for controlling the model, and the next problem is to provide for the operation of several controls at will, since in most cases more than one control is required to obtain the desired behaviour.

There are a variety of ways of obtaining this result, some involving more complexity than others. For instance, we can imagine several circuits, instead of one, linking the transmitter with the receiver in the model, each operating a particular control. Alternatively, the technique developed for automatic telephones can be applied, whereby a code of pulses is sent over the single circuit, which is imagined as linking the transmitter with the model, to be deciphered in the latter as a result of which the correct control is operated.

In general, the first system, requiring a multi-channel radio link, involves rather more complication as far as the radio circuits are concerned, than the second system. The latter is much

simpler in this respect, but depends for control selection on a mechanical device which operates on a sequence basis. For this reason it is frequently referred to as sequence control.

Sequence control has the great advantage that it requires only a simple transmitter and receiver, and, provided the number of controls to be operated is limited to a few essential ones, it is lighter than any other system. For this reason, it is very popular, as it can be adapted for aircraft control, where considerations of weight are vital. It can also be incorporated in boats of quite small dimensions. With the general trend in recent years towards miniaturisation of radio components, and the availability on the market of parts for radio control, it is now possible to provide radio control in models of much smaller dimensions than would have been possible a few years ago. Another reason for the popularity of sequence control is the relatively simple radio equipment required which can be tackled by people who are skilled enough to make the relatively delicate mechanical parts required, but whose knowledge of radio is elementary.

The disadvantages of sequence control are first, the time lag, small but appreciable, between the initiation of the control at the transmitting end, and its execution in the model, second, the necessity for the transmitter control not to lose step with the sequence of controls in the model, and third, the degree of application of the controls, which is fixed. For instance, the rudder is turned to the right fully or not at all. There is no gradual movement or intermediate position possible without introducing additional complications. Sequence control can be obtained by the use of either a light rubber-powered escapement system, or by a step relay which makes successive contacts each time it receives a pulse through the receiver relay circuit. The rubber-powered escapement is very light, as all the energy for operating it is stored in the twisted rubber cord, being merely released in successive steps by a comparatively small magnet requiring very little current. It passes through several positions in sequence and has enough power stored for directly actuating a control, thus acting as a servo-motor. The rubber

cord is wound before the model is released, and will have sufficient energy stored to operate the controls until the model is returned to its base (theoretically at least!). This system provides the maximum amount of control for a given weight.

The electro-magnetically operated sequence switch is a much heavier contrivance, and uses more current for its operation, since all the power to operate it has to be supplied from the circuit. It usually switches in sequence various circuits each controlling a servo-mechanism. The number of such circuits is by no means restricted and a variety of controls can be obtained. Switches such as "uniselectors," as used in automatic telephone exchanges, are quite suitable, although rather heavy. They are provided with a device that automatically resets them to a suitable starting position, or "neutral," when the control required is completed and a "resetting pulse" sent. Because of the weight of the equipment required, this particular system is not used on model aircraft, but is quite suitable for boats or vehicles.*

Multi-channel control, so called because it requires a multi-circuit radio link, offers many interesting possibilities to the experimentally minded. It requires more complication in both the transmitter and the receiver, and also requires more equipment depending on the number of channels to be provided. There are many forms of multi-channel control, the more elaborate of which are quite beyond the means of the ordinary amateur. For all practical purposes, the simplest form of multi-channel operation is provided by audio tone modulation, and this is the type which will be considered here as being most suitable for model control work. The carrier wave, which is radiated by the transmitter, is modulated by an audio signal which can have one of several possible frequencies, each of which operates its own relay in the receiver. This result is obtained by providing a special circuit in the receiver which routes the various audio frequencies into their own appropriate channels. We thus have in effect a radio link which provides several independent circuits between the transmitter and the receiver instead of just one. The receiver relays then operate the servo-motors for each control, the number of which will depend on the number of audio channels.

The audio filter, which separates out the various audio frequencies in the receiver, is the heart of the multiple-channel audio system. The two types which will be considered are the tuned reed filter and the tuned choke filter. The former consists of steel strips each having a resonant fre-

quency slightly different from the other, which are placed across the pole pieces of an electro-magnet which is inserted in the output circuit of the receiver. A particular reed will vibrate with much greater amplitude when an audio signal of its own frequency is received, and it will operate a relay when this amplitude is sufficient for it to touch a fixed contact placed close to it.

Instead of reeds, tuned chokes may be used. The chokes are iron cored coils which, with a suitable capacitor, form a circuit electrically tuned to the appropriate audio frequency. Such a circuit will only respond to the particular audio signal which has a frequency corresponding to its own, when it will then operate a relay through a suitable valve circuit.

Proportionate control, which is the nearest approach towards ideal radio control, provides for the proportional movement of the rudder, steering wheels or other control surfaces, in accordance with the movement of the control column or steering wheel at the transmitting end. The radio link, in this case, can be considered as acting as the shaft linking the steering wheel with the steering mechanism, the latter being aboard the model.

As in the case of multi-channel control, there are various methods of achieving proportionate control, but only the simpler ones, within the means of the amateur, will be considered here. Perhaps the simplest is that which depends on the switching on and off of the carrier at a suitable rate, "on" corresponding to, say, right rudder, and "off" to left rudder. By having the carrier on and off for equal lengths of time, this being done sufficiently rapidly, the rudder will be unable to follow the rapid changes and will take a mean position, which in this case will be central. By varying the ratio of "on" to "off" of the carrier, the mean position of the rudder can be made to vary from central to right or to left, through intermediate positions, depending on whether the "on"-"off" ratio, (also called the "mark-space" ratio) is greater or less than unity. This system only requires a very simple radio link, the complication being in the relay arrangement to provide auxiliary controls. A second method, which requires more elaborate radio circuits, although by no means beyond the capabilities of the amateur, consists in sending a carrier modulated by an audio tone, the frequency of which determines the rudder (or other steering equipment) position. Varying this frequency within certain limits causes the rudder to move correspondingly about a mean central position.

It is possible to modulate the carrier with a

*"Lodex" Rotary Solenoids are somewhat lighter than "Uniselectors," and offer possibilities for experimentation.—Editor.

second audio tone of a different frequency which can provide proportionate control of, for instance, the elevators in an aircraft independently of the rudder, thereby providing a high degree of control over the model while in flight.

Regarding the models which can be controlled by radio, boats and aircraft have always been very popular, perhaps because, being more or less inaccessible when in operation, remote control offers a particular fascination. The main requirement is that the model should be large enough to be able to carry the weight of the equipment required. Aircraft, which impose severe limita-

tions in this respect, require the lightest possible equipment, so that the constructor has to be both ingenious and skilful to obtain successful results. Some years ago, the practice was to build large aircraft, capable of carrying several pounds of control equipment. With the modern trend towards miniaturisation, much smaller models are now the order of the day.

Radio control, however, need not be confined to boats and aircraft, and it is possible to incorporate it in such models as tanks, cars, railways and the like. Sailing yachts can also be interesting subjects for experimentation.

CHAPTER TWO

Receivers for Sequence Control.

Sequence control, as we have seen in the last chapter, only requires a radio link which closes or opens a circuit in the model when a switch is operated at the transmitter. The purpose of the receiver is therefore to operate a relay which will close or open, depending on whether a radio

signal is sent or not by the transmitter. The simplest type of receiver is shown in fig. 1. It is a self-quenched detector, the quench frequency being generated by the action of the grid leak which uses a high resistance. This circuit is so arranged that oscillations at the tuning frequency

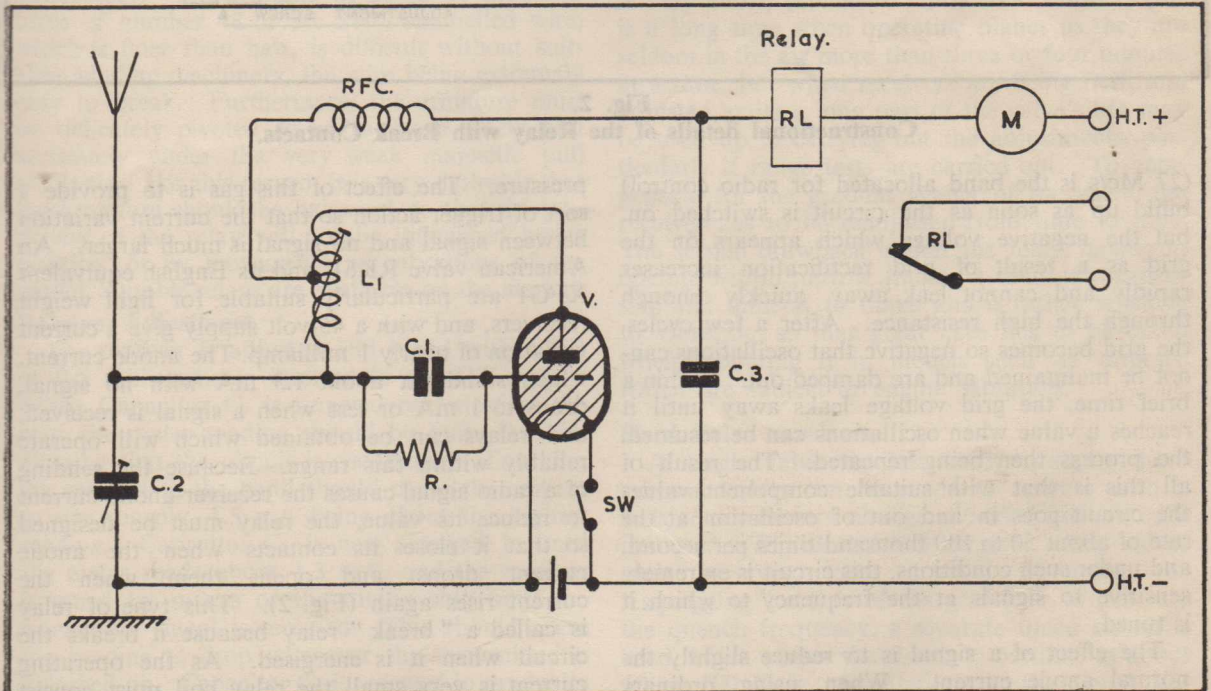

Fig. 1.

Receiver using a Gas-filled Valve.

- L1—15 turns 22 S.W.G. on a 3/8th in. dia. former fitted with a tuning slug.
- C1—100pf mica.
- C2—3-30pf. (Beehive) Concentric Trimmer.
- C3—0.002μf.

- R—1 MΩ
- RFC—100 turns 38 S.W.G. on a 1/2 in. dia. former.
- Relay—8,000Ω coil with break contacts.
- V—RK61 or XFG1.
- M—0.5mA Milliammeter.

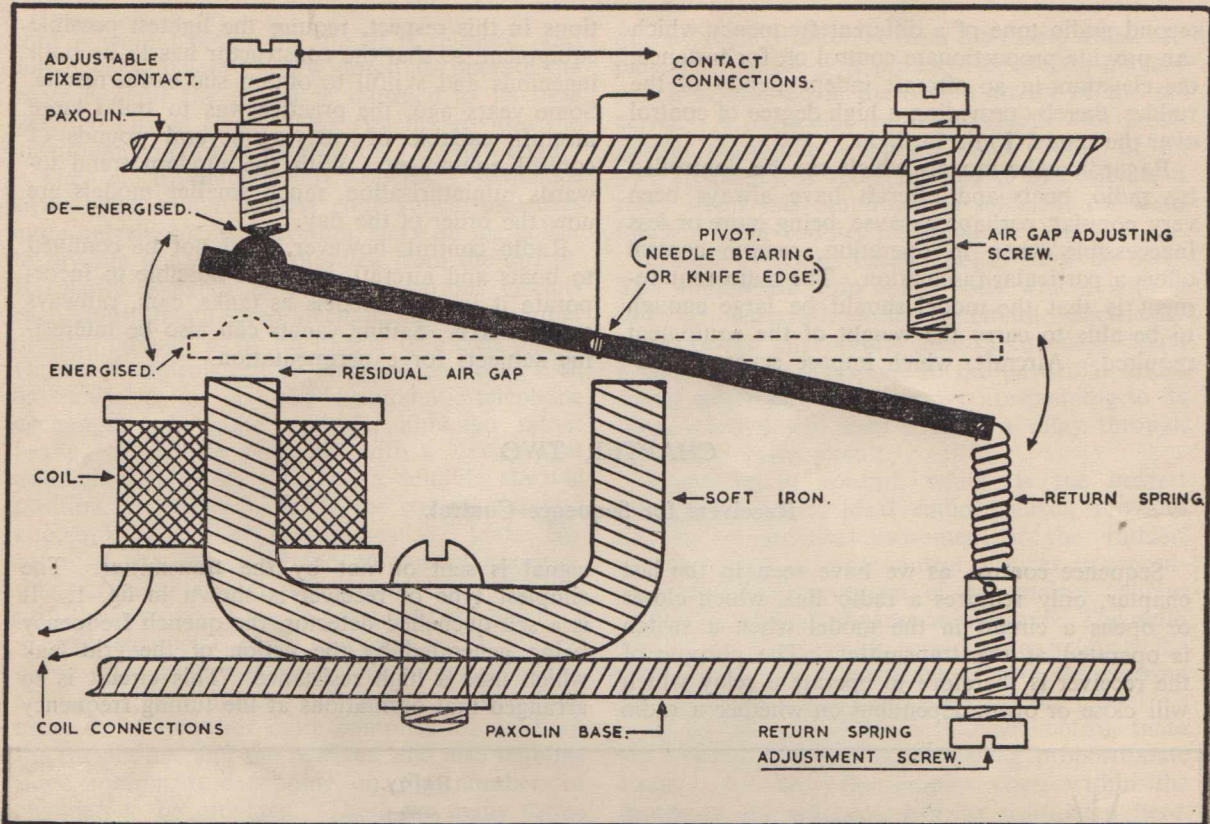

Fig. 2.
Constructional details of the Relay with Break Contacts.

(27 Mc/s is the band allocated for radio control) build up as soon as the circuit is switched on, but the negative voltage which appears on the grid as a result of grid rectification increases rapidly and cannot leak away quickly enough through the high resistance. After a few cycles, the grid becomes so negative that oscillations cannot be maintained and are damped out. Within a brief time, the grid voltage leaks away until it reaches a value when oscillations can be resumed, the process then being repeated. The result of all this is that with suitable component values the circuit goes in and out of oscillation at the rate of about 50 to 100 thousand times per second, and under such conditions, this circuit is extremely sensitive to signals at the frequency to which it is tuned.

The effect of a signal is to reduce slightly the normal anode current. When using ordinary valves with a hard vacuum, this current variation is very small, of the order of one-tenth of a milliamp or less, and is too small to operate a relay. Special valves, however, have been developed which, instead of being completely evacuated, are filled with an inert gas at low

pressure. The effect of this gas is to provide a sort of trigger action so that the current variation between signal and no signal is much larger. An American valve RK61, and its English equivalent XFG1 are particularly suitable for light weight receivers, and with a 45-volt supply give a current variation of nearly 1 milliamp. The anode current, which stands at about 1.5 mA with no signal, drops to 1 mA or less when a signal is received, and relays can be obtained which will operate reliably within this range. Because the sending of a radio signal causes the receiver anode current to reduce its value, the relay must be designed so that it closes its contacts when the anode current drops, and opens them when the current rises again (Fig. 2). This type of relay is called a "break" relay because it breaks the circuit when it is energised. As the operating current is very small the relay coil must consist of many turns of very fine wire.

This type of receiver is particularly suitable for use in small model planes because it can be made to weigh under two ounces complete with relay, but without batteries. Filament consumption is 50mA at 1.5 volts and a very small dry cell

can be used weighing about one ounce. Two 22½-volt batteries, each weighing just over one ounce can be connected in series to provide the high tension supply. Thus the complete receiver with its power supply will weigh about five ounces, to which must be added about 3 ounces for the escapement control and associated batteries. Any plane which can carry eight ounces pay-load can therefore be fitted with a radio which will operate a single control, usually the rudder.

The receiver circuit diagram is shown in fig. 1. L1, the tuning coil is wound with 22 SWG enamel wire on a former provided with a tuning slug. About fifteen turns are required on a ⅜" former, or twenty-five on a ½" former. Position the tap about midway along the coil. The base on which the receiver is mounted can be cut from a paxolin strip or any similar insulating material. Valves should be mounted flat, and secured by rubber bands which are passed through holes in the base on either side of them, and secured by means of a clip made from a small piece of wire. Connecting leads are wired directly into the circuit.

Note that the relay has a resistance of about 8000 ohms, and requires considerable skill to make satisfactory. The winding of 20 to 30 thousand turns of number 48 or 50. SWG enamelled wire, which is finer than hair, is difficult without suitable winding machinery, the wire being extremely easy to break. Furthermore, the armature must be delicately pivoted so as to move freely and accurately under the very weak magnetic pull available. For this reason, it is very desirable that the armature should be balanced, so that the sensitivity of the relay will not be influenced by its position, or by movements, or vibrations of the model. Suitable relays are available on the market.

Receiver Adjustment.

The receiver is adjusted and tuned with a 0.2 or 0.5 milliammeter inserted in the HT supply. When Capacitor C₁ is screwed out most of the way, the meter reading should be quite low, indicating that the circuit is oscillating. Touching the aerial with the hand should cause the current to rise sharply, 1.5 mA being about the highest reading. Capacitor C₁ is now screwed in until the meter reads about 1.3 mA, and the receiver is tuned by means of the tuning slug until the transmitter signal is received. This should cause the reading to drop whenever the transmitter is switched on. Capacitor C₂ is screwed in gradually until the current variation is greatest, but as this detunes the circuit it may be necessary to readjust the tuning coil.

Relay Adjustment.

Once the receiver is operating properly, the relay can then be adjusted to operate within the

available current change. For maximum overall sensitivity, the relay armature should drop out at a value of current very little less than the pull-in value. By increasing the air gap and weakening the spring, the pull-in and drop-out values can be brought closer to one another, but this makes the relay more delicate in operation and more sensitive to vibration. Also, sparking of the contacts might cause the latter to stick, because the weak magnetic pull due to the large air-gap might be insufficient to overcome the slight welding effect of the spark. To prevent this possibility, a compromise is reached by reducing the air gap, increasing the spring tension and reducing the travel of the armature. If the armature travel be made small, then the pull-in and drop-out values will come nearer to one another. A limit is reached in practice because of play in the bearings. For a very small travel, the armature bearings must be very accurate. If the relay can be made to pull in at 1.3 mA and drop out at 1.1 mA, quite-satisfactory range will be obtained with a low power transmitter.

This type of receiver is very simple and light, but it suffers from two disadvantages. The first is that the life of the soft valves which it uses is very short, (about 10 hours useful life). This is a long time when operating planes as they are seldom in the air more than three or four minutes at a time, but when receivers are being built and adjusted, quite a long part of the valve's life may be used up in carrying out the adjustments, particularly if range tests are carried out. To compensate for the gradual ageing of the valve, the receiver has to be readjusted from time to time. The second drawback is that the relay, having to operate within narrow limits, is relatively expensive and difficult to make and is rather sensitive to vibration, so that great care has to be taken when mounting it in models such as aircraft, which are subject to engine vibration.

Hard Valve Receivers

A single valve receiver using ordinary hard vacuum valves can be made to operate with a satisfactory current change provided quench coils are used. Fig. 3 shows a receiver using valves such as type 1S4. Instead of using the "squegging" action of the grid leak to generate the quench frequency, a separate tuned circuit is used, which causes the circuit to oscillate at about 50 to 100 Kc/s. Oscillations at the signal frequency (27 Mc/s) can only take place during the positive part of the quench cycle and under such conditions, the circuit will be extremely sensitive. The anode current variation available is practically the same as for the previous receiver for the same HT voltage, and is considerably greater if

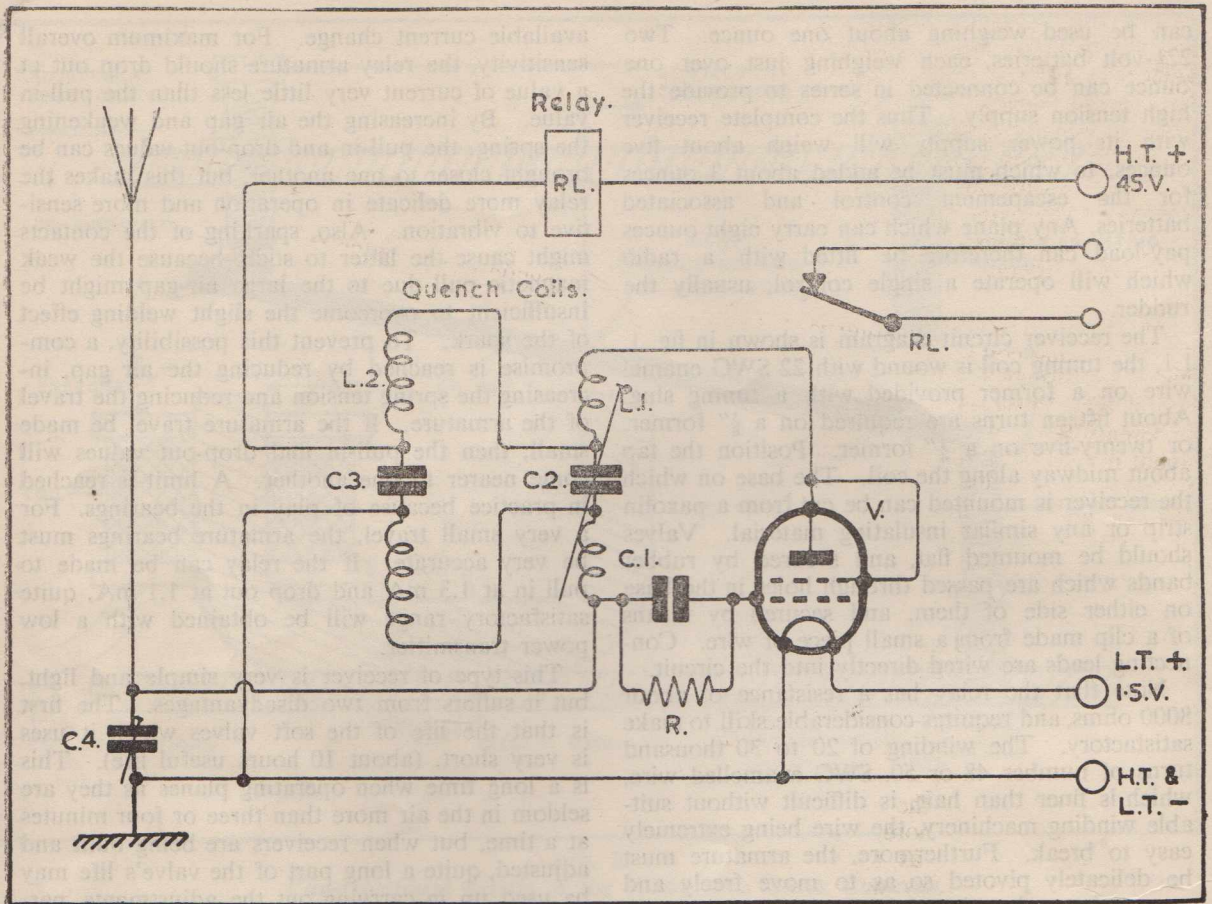

Fig. 3.
Hard Valve Receiver.

L1—15 turns 22 S.W.G. on a $\frac{3}{8}$ th in. dia. former fitted with a tuning slug. Winding is in two sections of $7\frac{1}{2}$ turns each.
L2—Two Coils. 600 turns each, of 38 S.W.G. on a $\frac{1}{2}$ in. dia. former; winding to be $\frac{3}{16}$ th in. wide.
C1—100pf mica.

C2—250pf mica.
C3—0.002 μ f.
C4—3-30pf (Beehive) Concentric Trimmer.
R—1 M Ω .
Relay—8,000 Ω with break contacts.
V—1S4, 3S4, DL92 or equivalent.

higher anode voltages are used. The quench coils consist of 600 turns each of 38 SWG wire wound on formers $\frac{1}{2}$ " in diameter and $\frac{3}{16}$ " wide. In spite of the extra complication and weight of the quench coil, and also of the increased filament consumption of suitable valves, necessitating heavier LT batteries, this type of receiver is becoming increasingly popular, mainly because of the long life of the valves. More rugged relays are possible since voltages in excess of 90 volts can be used safely, giving increased current variation. This arrangement is suitable for boats but in the case of planes, 45 volts or $67\frac{1}{2}$ volts are not usually exceeded so as to keep down the weight of the HT batteries. The same relay as previously described can be used. However, the vibration drawback still exists. The adjustment

is similar to that of the previous receiver. Once the quench coils have been wound and connected as shown, the circuit should oscillate at the quench frequency, even when the detector is not allowed to oscillate at the signal frequency. Connect a pair of headphones in the anode circuit, and the characteristic hissing sound of the self-quenched detector will be heard when the circuit is operating properly. If not, and if touching the aerial causes fluctuations of a 0.5 mA meter, thereby indicating that the detector is oscillating at the signal frequency, a check should be made to verify that the quench coils have been connected correctly, and the connections changed should it be found necessary.

The receivers described use grid leak detection, which means that the application of the signal

causes the standing detector anode current to fall to a lower value. The relay has to be designed so that the armature closes the contacts when dropping out, and opens them when it is pulled in, which is the condition existing with no signal. Failure of either the HT or the LT supply, or failure of the valve filament would cause the relay armature to drop out, so closing the contacts and applying a control. In the case of self-neutralizing escapements in model planes, this is pretty certain to lead to dire results! Admittedly, careful construction and attention to soldered joints would tend to minimise this possibility. However, it would be an advantage to have a receiver designed to cause the relay armature to close with signal, as this would eliminate the possibility of a control being applied as a result of failure of the receiver power supplies. Also, there is less chance of the relay contacts chattering as the result of vibrations, when the latter are applied by direct magnetic pull rather than by the armature spring.

Stages of amplification can be added to the detector circuit, so that the output valve may be made to give a current rise with signal of sufficient variation to operate a simple relay. But if the signal is to remain on for an appreciable time to hold the control, such as would be required when operating a self-neutralizing escapement, a direct-coupled amplifier would be required. Direct-coupled amplifiers create difficulties with power supplies and are tricky to operate and keep in adjustment, so they are best avoided. If, however, the transmitter signal is modulated by an audio frequency, a conventional audio amplifier can then be used on the receiver. Such a receiver, using two to three valves, can be made to operate a relatively insensitive relay, as the current change available in the output stage may be 5 to 6 mA, or more. Also the relay can be made to close with application of signal, so that the relay armature closes the contacts when it is pulled in, and opens them when it drops out. However, it requires extra complication at the transmitting end as an audio oscillator and modulator has to be fitted to the transmitter. Since it is possible to make a two-valve receiver giving the same results for relay operation without the need for audio modulation, we will not go into the details of an audio receiver at this stage.

A considerable improvement in the performance of a super-regenerative receiver can be made by using a separate valve for detection purposes. The first valve, by its super-regenerating action, provides enormous gain. It is used in this case as an R.F. amplifier and the detection is carried out by small germanium rectifiers, the output of which is fed to the second valve for amplification.

Two circuits are shown. The first circuit, Fig. 4, uses two 3S4 valves, the first valve being a self-quenched detector using quench coils. The R.F. present in the tuning coil L, is tapped off at the grid end through capacitor C₅, and the quench frequency component is shorted out through the radio frequency choke RFC, which however has a high impedance to the signal frequency. The latter is rectified through the voltage doubler rectifying network formed by G₁, G₂, R₂ and C₇. The grid bias applied to the grid of V₂ is adjusted for cut-off, so that no anode current flows. The voltage developed across C₇ as a result of the signal, will make the grid of V₂ more positive if the germanium diodes are connected as shown, and the resulting anode current will close the relay. With a 45-volt supply the current rise available is of the order of 4 to 5 milliamps, and a 9000 ohm relay will work without any difficulty or critical adjustment. The relay must be so arranged that its contacts close when the armature is pulled in, which is the reverse arrangement to the relays used previously.

This type of receiver is well suited to model boats, as it is comparatively simple to build, and can operate a home-made relay without much trouble, Fig. 5. Certain varieties of audio transformer can be converted for the purpose quite easily; particularly if the laminations are shaped like the letter E, which should be re-arranged so that they all face in the same direction. An armature made from suitable soft iron or transformer laminations, is then mounted close to the pole faces formed by the rearranged transformer laminations. The armature should be supported on pivots at one end, and spring-loaded against a back-stop by means of a coil spring fitted behind the pivot. A contact made from a piece of silver wire is then rivetted at the other end of the armature, the fixed contact being made from a screw, at the tip of which a small piece of silver wire is soldered. The primary winding of the transformer is used as the operating coil, and there may be an advantage in connecting the secondary winding in series with it to increase the sensitivity. If a decrease in the magnetic pull is observed, reverse the polarity of one winding.

Good results can be obtained in this manner even when the armature is unbalanced, since the current flowing through the relay coil is ample. The air-gap and armature travel are made quite small, (consistent with the accuracy of the bearings) and the spring tension is adjusted until the relay operates within the desired range.

These relays are comparatively heavy and are hardly suitable for the smaller model planes on that account. Lighter relays can be built using

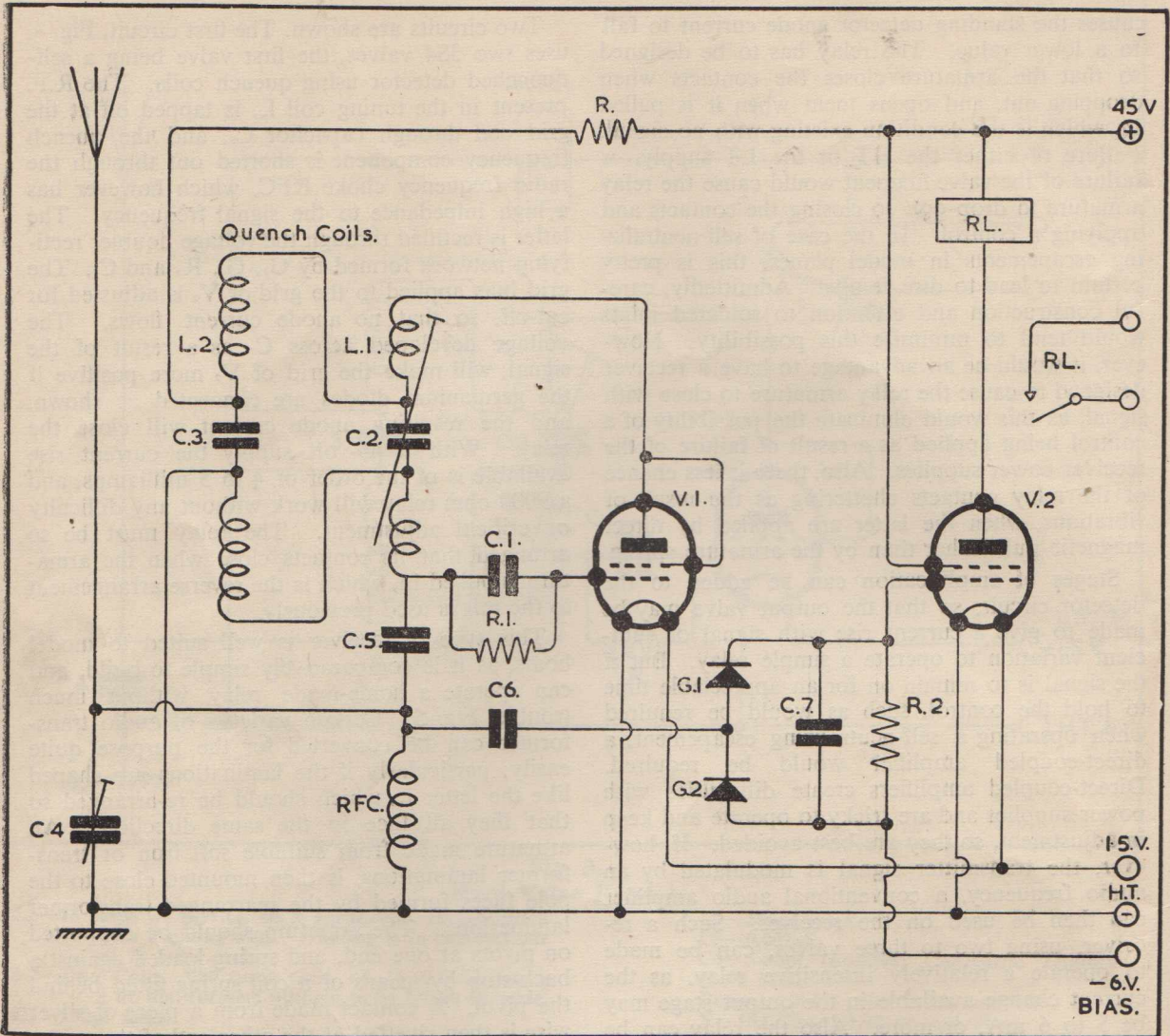

Fig. 4.

Two Valve Receiver.

L1, L2, C1, C2, C3, C4 as in Fig. 3.
 C5, C6—100pf mica.
 C7—0.002 μ f.
 R—1k Ω .
 R1—1M Ω .

R2—220k Ω .

RFC—100 turns. 38 S.W.G. on a $\frac{1}{4}$ in. dia. former.

G1, G2—Germanium diodes.

V1, V2—3S4, DL92, N17, IP10, or equivalent.

Relay—2,000 Ω with make contacts.

coils "borrowed" from high impedance headphones. Two coils of 2,000 ohms each should be connected in series, and will give adequate sensitivity. The coils should be slipped over laminations which have been bent like the letter U and wedged in position. Armature layout can be made similar to the previous relay.

The receiver just described gives positive relay operation with very quick response, and also has the advantage that no modulation is required, so that the transmitter can be made light, simple and

easy to adjust. If used in a model aircraft with self neutralizing escapement, loss of control due to flying out of range or failure of the transmitter, will cause the aircraft to fly or glide in a straight line. A similar result will be obtained if the receiver fails due to the HT or LT supply leads breaking, the batteries running low, or the valve filaments breaking. The exception is the grid connection of V₂ which, if broken, will cause the relay to close and turn the rudder permanently to either right or left.

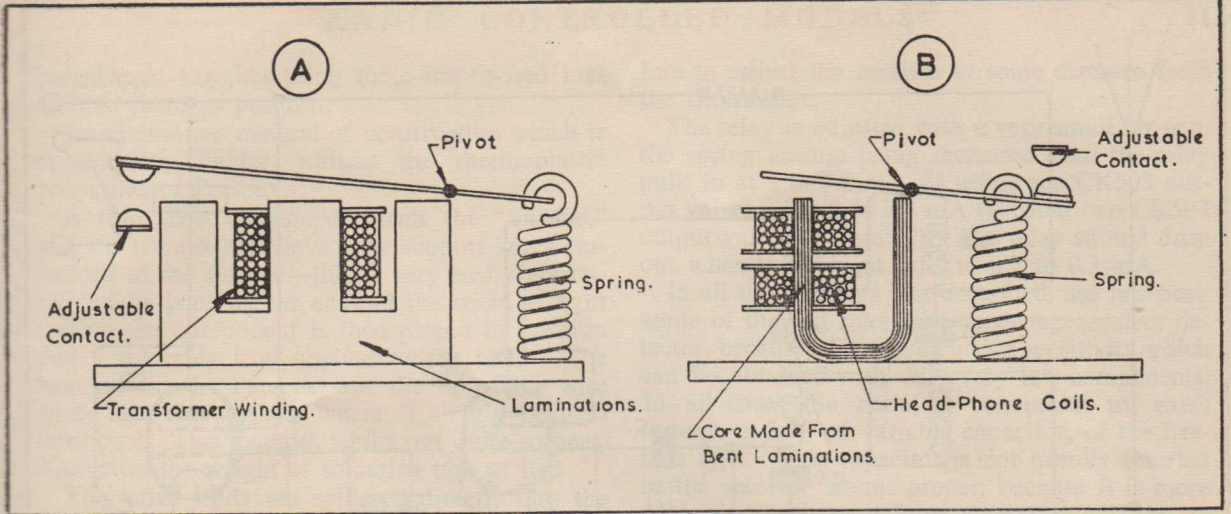

Fig. 5.

A.—Details of the Make-type Relay using transformer core and laminations.

B.—Lightweight Relay using head-phone coils.

A miniaturised version of this receiver is shown in Fig. 6 which uses sub-miniature valves and components of the hearing-aid type. The valves used are American type CK503, the nearest British equivalent being the Hivac XY14B. The circuit is identical to that already described, but for the addition of a second voltage doubler network in the anode circuit of V_2 . This gives improved sensitivity to compensate for the lower gain of the sub-miniature valves. As before, the signal frequency is tapped off one end of the tuning coil through C_5 and the quench frequency removed through RFC. We are now left with the signal frequency, modulated at the quench frequency. By using suitable time constants for the voltage doubler formed by G_1 , G_2 , R_1 and C_1 , the voltage appearing across C_7 after rectification will consist of positive pulses at the quench frequency, whose amplitude will vary with the signal strength. That is, with no signal, these pulses will be very small, but with signal, they will be quite large. After amplification through V_2 , these pulses will be fed to the second voltage doubler through the impedance-capacity coupling formed by the relay winding and C_8 . The time constant of R_2 , C_8 , is such that a steady voltage will appear across C_8 proportional to the signal amplitude. By connecting the germanium diodes as shown, this voltage will make the grid of V_2 more positive so that there will be a resulting steady increase in anode current, which will cause the relay to pull in and close its contacts. In practice, the sensitivity of this circuit is such that even with a weak signal, the voltage appearing across C_8 will be sufficient to completely neutralize the grid bias. Under

such conditions, with 45 volt HT supply, the CK503 output valve will pass about 1.5mA and a sensitive relay will close quite strongly. It is possible to make the current rise 0—3 mA instead of 0—1.5 mA by connecting a second CK503 in parallel with the first (by connecting the anodes, the grids and the filament terminals together respectively). The extra weight is insignificant and there is no extra complication in the circuit (but extra cash is required!).

Under such conditions the total consumption is 100 mA for the LT supply, while the HT would vary from 0.5 to 3.5 mA (depending on whether a signal is received or not) at 45 volts. Using miniature components throughout, the complete receiver weighs less than three ounces, permitting at the same time the use of a relatively insensitive relay with a coil resistance of between 2,000 and 4,000 ohms. Each CK503 valve takes only 33 mA at 1.5 volts for the filament supply, so that a quite small dry cell will be satisfactory, while the HT drain is small enough for the miniature deaf-aid type 22½ volt batteries, two of which are required in series. In contrast with the single valve receivers, the HT drain is small with no signal and increases with signal, so that the batteries are called upon to do most of their work only while the controls are being applied.

In comparison with the single hard valve receiver using a 3S4, this receiver is approximately the same weight and bulk, and has the same LT consumption. It uses the same HT batteries, although it is somewhat heavier on the latter when two CK503's are used in parallel. The relay is not so delicate and is much less sensitive to vibra-

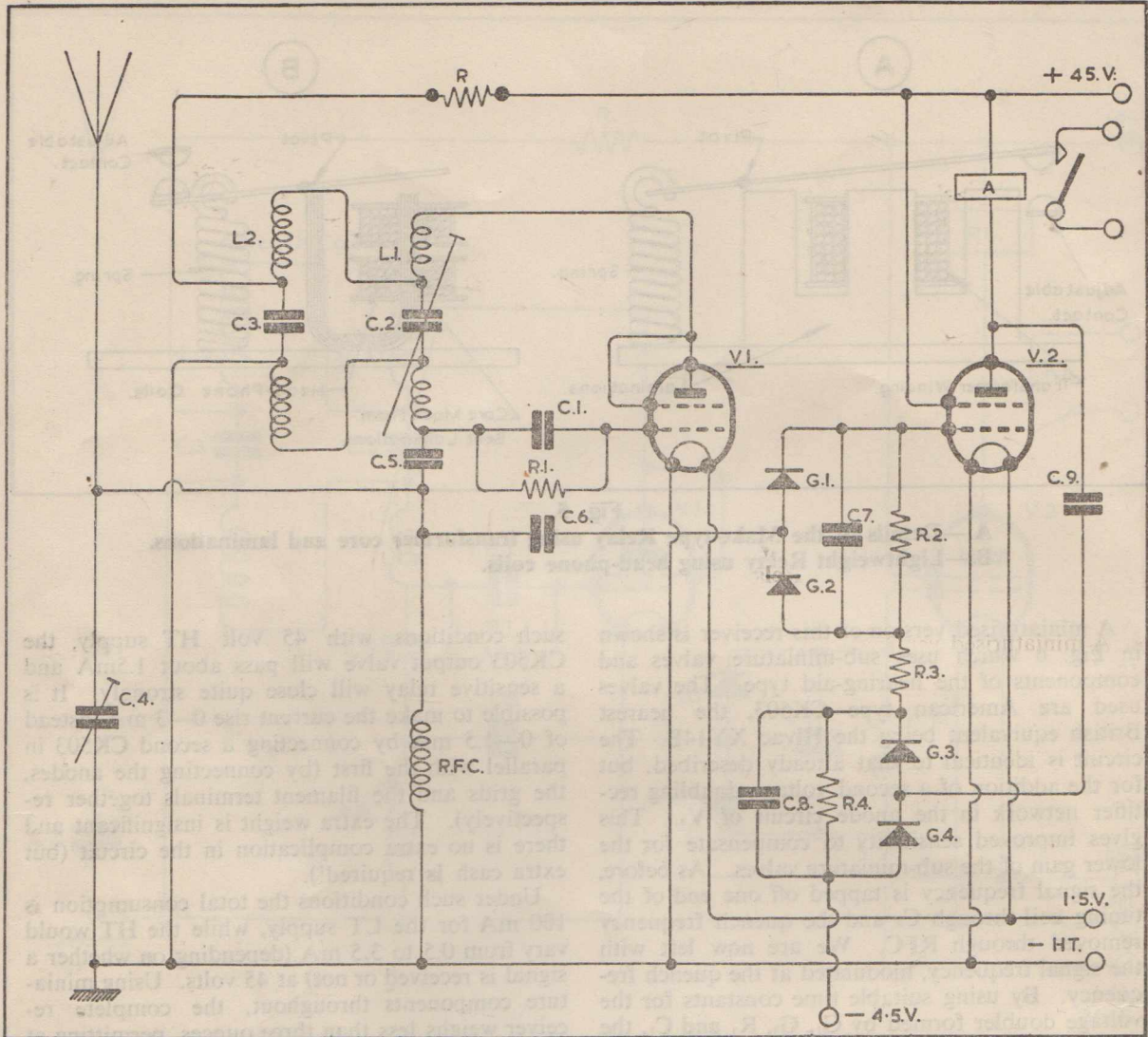

Fig. 6.
Receiver for Sub-miniature Valves.

All components are the same as Fig. 4, except the following:

C7—100pf. mica.
C8—0.002 μ f.
C9—0.02 μ f.
R3—50k Ω .

R4—220k Ω .

G3, G4—Germanium Diodes.

V1, V2—CK 503, XY14B (Hivac) or equivalent.

A—Relay 4,000 Ω coil with make contacts.

tion, and the receiver itself is more sensitive to the signal and less critical to adjust. The range is in excess of two miles even when using a low power transmitter using only 1½ watts input on the last stage. This receiver is therefore well suited for remote controlled aircraft of even quite small dimensions. The range of two miles is more than adequate as the model would by then be out of sight.

The receiver is built on a rectangular piece of paxolin or other insulating material. The tuning coil and quench coils are made exactly as

described for the single hard valve receiver. The choke is wound with 40 SWG wire on a ¼" polystyrene coil former from which the tuning slug has been removed. Mounting lugs are fitted along both edges of the base, in suitable positions, for mounting the capacitors, resistors and rectifiers of the voltage doublers. These are made by drilling 1/32" holes near the edge of the base and passing through them a short length of tinned wire about 22 SWG which is secured by twisting both ends together, the latter being bent to stand vertically upwards. The component leads can then

be soldered together using these improvised lugs to hold them in position.

An alternative method of construction which is considerably lighter, utilizes the thermoplastic properties of Perspex.

A thin sheet of Perspex forms the "chassis," and the components have their support wires embedded in the surface—this is very easily accomplished by bending the ends of the wires at right angles; the component is then placed in position and a soldering iron applied to the bend. The heat softens the Perspex, and the tip of the wire sinks into the surface, where it should be held until cool. This method, whilst not quite so neat, eliminates the weight of soldering tags or lugs.

The valve leads are soldered directly into the circuit. In order to avoid short circuits and accidental contacts, such leads should be covered with small plastic sleeves. Suitable sleeves can be obtained from single core bell wire. It will be found that lengths of plastic insulation can be cut and pulled off the latter, and that with a little care they can be slipped over the valve leads. The valves themselves are laid on their sides and secured to the base by means of small rubber bands passing through small holes in the base on each side of the valves and secured underneath.

By inserting a pair of headphones in the detector circuit, the correct operation of the latter can be checked. This is easily done by connecting the headphone leads to each side of resistor R. A loud hissing sound should be audible, which should disappear when the aerial lead is touched with the hand. If no hissing sound is heard, screw out the loading capacitor C_4 . If the quench coils have been wound and connected as indicated in Fig. 3 for the single valve receiver, there should be no difficulty in getting the detector valve to oscillate at the quench frequency. If not, it may be necessary to reverse the connections to one of the coils.

With the detector working correctly it will be found that the anode current of V_2 is operating the relay. A 0—5 mA meter should be inserted in the anode circuit of V_2 and capacitor C_4 screwed in gradually until the meter reading is practically zero. This, however, will detune the circuit, and the tuning coil slug should be readjusted until the receiver is tuned to the signal frequency. C_4 will again require readjustment, and the two operations should be carried out in association until the meter gives the maximum reading with signal, and zero reading with no signal. The grid bias should be such that V_2 is cut off when the detector is not oscillating.

Because the output valve is saturated, the tuning curve is almost flat and it is desirable there-

fore to adjust the receiver at some distance from the transmitter.

The relay is adjusted with a very small air-gap, the spring tension being increased until the relay pulls in at 1 to 1.2 mA (if using one CK503 output valve) or at 2 to 2.4 mA (if using two CK503 output valves in parallel). The relay should drop out when the current falls to 0.2 to 0.3 mA.

In all the receivers just described, use has been made of the self quenched super-regenerative detector, because of the tremendous sensitivity which can be obtained with only very few components. In all cases the aerial is connected to earth through a 3-30 pf variable capacitor, of the beehive type. This capacitor is not usually inserted in the receiver circuit proper, because it is more convenient to have it in an accessible position on the model as it requires to be adjusted frequently. The purpose of this capacitor is to load the detector to the point where it is barely oscillating and no more, as this is the condition when maximum sensitivity is obtained. In single valve receivers, this condition is reached when the meter inserted in the anode circuit shows only the barest perceptible increase in current when the detector oscillations are stopped by touching the aerial. In the case of multi-valve receivers, provision can be made to insert a meter in the detector anode circuit for this purpose, but this causes complications as a meter will also be required in the output valve circuit to check that the grid bias is correct. With a little practice, adjustments can be carried out with the latter meter alone but care must be taken to check the operation of the receiver at a distance from the transmitter. The reason is that if a meter is not used in the detector anode circuit, it may not be possible to check whether the detector is oscillating at all, since even when it is barely oscillating there will be no anode current flowing in the output valve. Should the detector not be oscillating, the output stage will still operate the relay while the receiver is in close proximity to the transmitter but will cease doing so when the receiver is removed some distance away. Hence the necessity for this check.

The aerial wire should not be made too long, because when it nears resonance the resultant load on the detector may prevent it oscillating. This is not a serious problem since the difficulty with most models is to find sufficient room for a long enough aerial. The usual method in the case of boats is to use the masts as supports, whilst in model aeroplanes the aerial can be stretched between the top of the fuselage (above or just behind the wings) and the top of the tail assembly. Another method is to fit the aerial wire inside the wings, but this becomes rather unsatisfactory if the wings are detachable. In the case

of land vehicles, a small vertical rod can be used if the model is not long enough to accommodate an aerial in any other fashion.

Another point to watch is that the HT and LT batteries should be placed close to the receiver and connected to it with short leads. The use of long leads may introduce parasitic resonance and the resultant loading on the detector may affect its operation, or even prevent it from oscillating entirely.

The receiver should be mounted in the model with sponge rubber to insulate it from vibration. This is particularly necessary if a small petrol or

diesel engine is used for propelling the model. If trouble is experienced because of chattering relay contacts, this may be cured by suspending the receiver from elastic bands passing through holes at the corners of the receiver base, and secured in a frame made of balsa wood. The receiver should be placed in the model in such a way as to make adjustments easy, particularly those of the tuning coil and the relay. The leads to the receiver should be left slack to prevent vibrations being transmitted. Stranded flexible wires should be used, both for flexibility and in order to reduce the risk of fracture.

CHAPTER THREE

Transmitters for Sequence Control

Transmitters for radio control are in no way different from those commonly used for amateur radio work but the requirements they have to meet are not quite the same. The radio control frequencies are in the 27 Mc/s band, so the transmitter must be designed to operate at this frequency. Another requirement is that the input into the stage feeding the aerial should not exceed five watts. Also, for practical reasons, the transmitter should be portable.

In the earlier days of radio-control, it was usual to make transmitters with adequate power output using indirectly heated valves primarily designed for mains operation and requiring high values of HT, usually about 250 to 300 volts. Such valves were heavy on both LT and HT supplies and had to be fed from storage batteries. These were usually car batteries, which provided the filament supply, and also the high tension through motor-generators or vibrators. The tendency is now to take advantage of the low-consumption valves designed for operation from dry cells, and to make hand-portable transmitters which are complete self-contained units. Many of the types of receivers now made will give adequate range without having to resort to the maximum permitted power.

A simple transmitter for sequence control can easily be made, for use with either single valve receivers or two valve receivers not requiring audio modulation. The circuit of a push-pull transmitter is illustrated in Fig. 7. The circuit used is known as a tuned-anode tuned-grid oscilla-

tor, which, being self-excited, depends on the settings of the capacitors for operation at the correct frequency. In order to be within the law, it will be necessary to ensure that the transmitter is operating within the 27 Mc/s band allocated to radio control, and some means of checking frequency is therefore required.

The safest way is to purchase a quartz crystal designed for radio control work. Such crystals, when inserted in an oscillator circuit, will control its frequency within very fine limits, the particular frequency being that for which the crystal has been cut. Crystals intended for radio control are usually cut for frequencies of about 9 Mc/s or just under 7 Mc/s.

If we now make a transmitter whose frequency is determined by the third harmonic of the crystal-controlled oscillator using the 9 Mc/s crystal, or the fourth harmonic of the oscillator using the 7 Mc/s crystal, we can be certain the transmitter frequency will be within the band, once the initial adjustment has been correctly made.

The simple transmitter illustrated in Fig. 7 does not require a crystal for its operation, but it will need to be calibrated each time it is taken out for use. Unless the operator knows a radio amateur who can provide him with the necessary calibration reference, the most satisfactory way is to build a crystal controlled oscillator which he can use for calibrating the transmitter. If, on the other hand, the crystal controlled oscillator is incorporated in the transmitter, the latter will not require calibration.

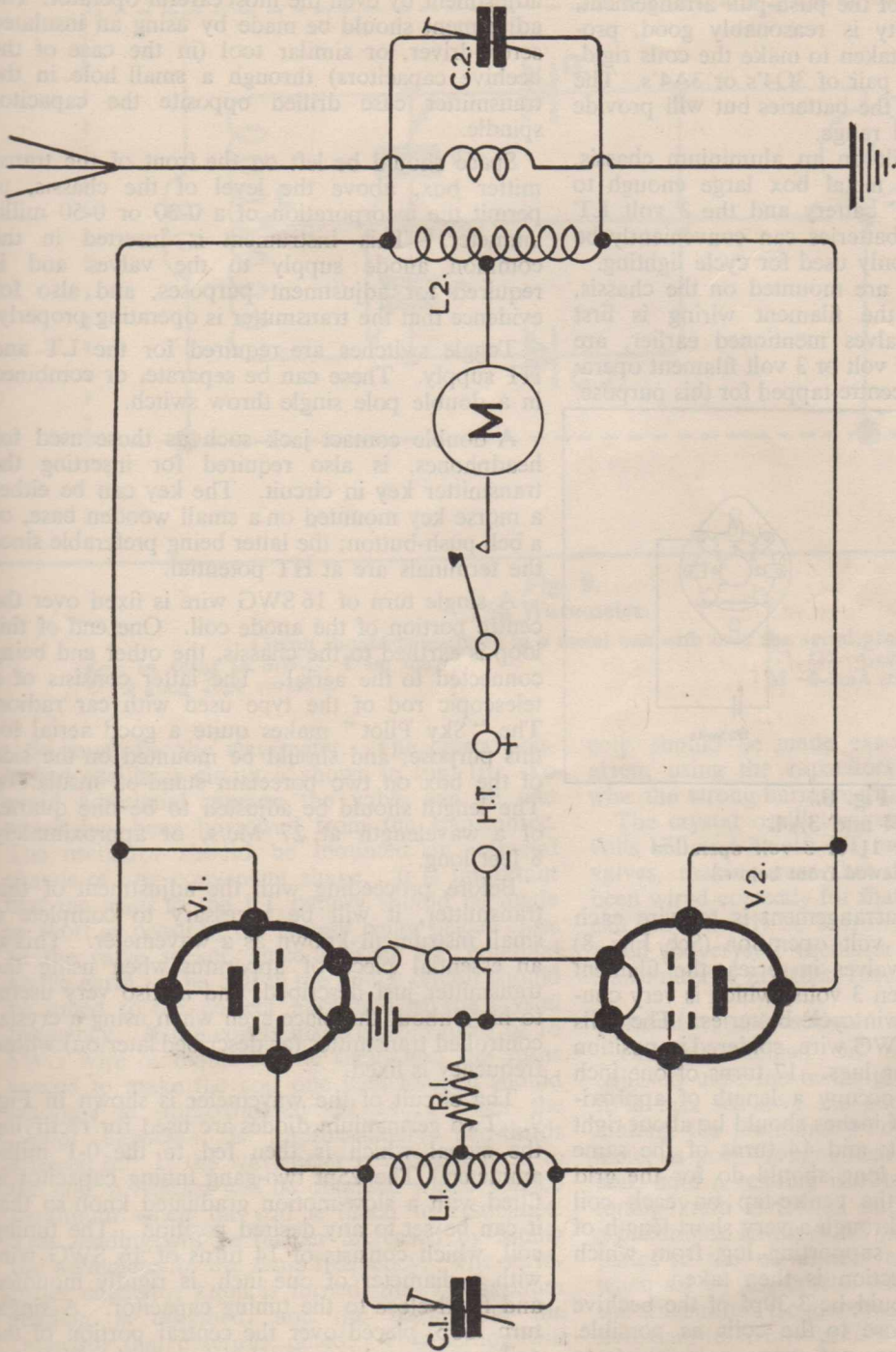

Fig. 7.
Simple Transmitter Circuit.

L1—14 turns 16 S.W.G. on a 1 in. dia. former.
L2—17 turns 16 S.W.G. on a 1 in. dia. former.
C1, C2—3-30pf (Beehive) Concentric Trimmer.

R1—15k Ω .
M—0-30 or 0-50mA meter.
V1, V2—3Q4, DL95, N18, 3A4, DL93, or equivalent.

Simple Self-Excited Transmitter

Two valves are used in the push-pull arrangement as shown on Fig. 7 feeding directly into the aerial. Because of the push-pull arrangement, the frequency stability is reasonably good, provided care has been taken to make the coils rigid. Suitable valves are a pair of 3Q4's or 3A4's. The latter are heavier on the batteries but will provide increased output and range.

This circuit is built on an aluminium chassis, designed to fit in a metal box large enough to take the 90 volt HT battery and the 3 volt LT batteries. The LT batteries can conveniently be the twin type commonly used for cycle lighting.

The valve holders are mounted on the chassis, side by side, and the filament wiring is first soldered in. The valves mentioned earlier, are suitable for either 1.5 volt or 3 volt filament operation, the latter being centre-tapped for this purpose.

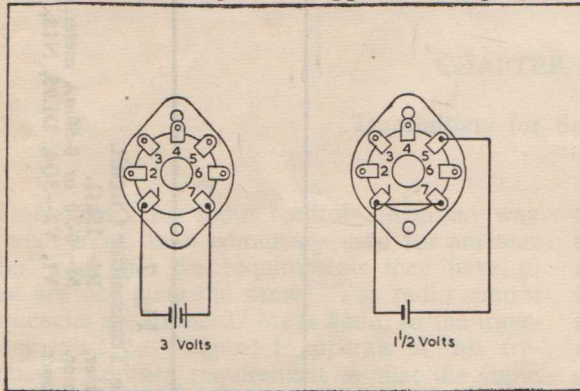

Fig. 8.
3Q4 and 3A4.
Connections for 1½ or 3 volt operation
(Valves viewed from below.)

A very satisfactory arrangement is to wire each valve-holder for 1.5 volt operation (See Fig. 8) and to connect the valves in series, the filament supply required is then 3 volts, which is very convenient when using twin cycle batteries. The coils are formed with 16 SWG wire, soldered in position on insulated mounting lugs. 17 turns of one inch diameter, spaced to occupy a length of approximately one and a half inches should be about right for the anode circuit; and 14 turns of the same wire about one inch long should do for the grid coil. For rigidity, the centre-tap on each coil should be soldered, through a very short length of stiff wire to another supporting lug, from which the centre-tap connection is then taken.

The capacitors should be 3-30pf of the beehive type, soldered as close to the coils as possible. These capacitors are not very convenient to adjust, but such adjustments should not be required frequently. If preferred, small 3-30pf capacitors for panel mounting can be used instead, but the

spindles should not be brought outside the transmitter box. This is said with good reason, because projecting spindles are very easily knocked out of adjustment by even the most careful operator. The adjustment should be made by using an insulated screw-driver, or similar tool (in the case of the beehive capacitors) through a small hole in the transmitter case drilled opposite the capacitor spindle.

Space should be left on the front of the transmitter box, above the level of the chassis, to permit the incorporation of a 0-30 or 0-50 milliammeter. This instrument is inserted in the common anode supply to the valves and is required for adjustment purposes, and also for evidence that the transmitter is operating properly.

Toggle switches are required for the LT and HT supply. These can be separate, or combined in a double pole single throw switch.

A double contact jack such as those used for headphones, is also required for inserting the transmitter key in circuit. The key can be either a morse key mounted on a small wooden base, or a bell push-button; the latter being preferable since the terminals are at HT potential.

A single turn of 16 SWG wire is fixed over the centre portion of the anode coil. One end of this loop is earthed to the chassis, the other end being connected to the aerial. The latter consists of a telescopic rod of the type used with car radios. The "Sky Pilot" makes quite a good aerial for this purpose, and should be mounted on the side of the box on two porcelain stand-off insulators. The length should be adjusted to be one quarter of a wavelength at 27 Mc/s, or approximately 8 feet long.

Before proceeding with the adjustment of this transmitter, it will be necessary to complete a small instrument known as a wavemeter. This is an essential piece of apparatus when using the transmitter just described, and is also very useful to have about the place even when using a crystal controlled transmitter (as described later on) whose frequency is fixed.

The circuit of the wavemeter is shown in Fig. 9. Two germanium diodes are used for rectifying the signal which is then fed to the 0-1 milliammeter. The 25pf two-gang tuning capacitor is fitted with a slow-motion graduated knob so that it can be set to any desired position. The tuning coil, which consists of 14 turns of 16 SWG wire with a diameter of one inch, is rigidly mounted and fixed close to the tuning capacitor. A single turn loop, placed over the central portion of the coil is connected to a small pick-up rod, which acts as a miniature aerial. The entire wiring should be enclosed in an aluminium box, with only the pick-up rod protruding.

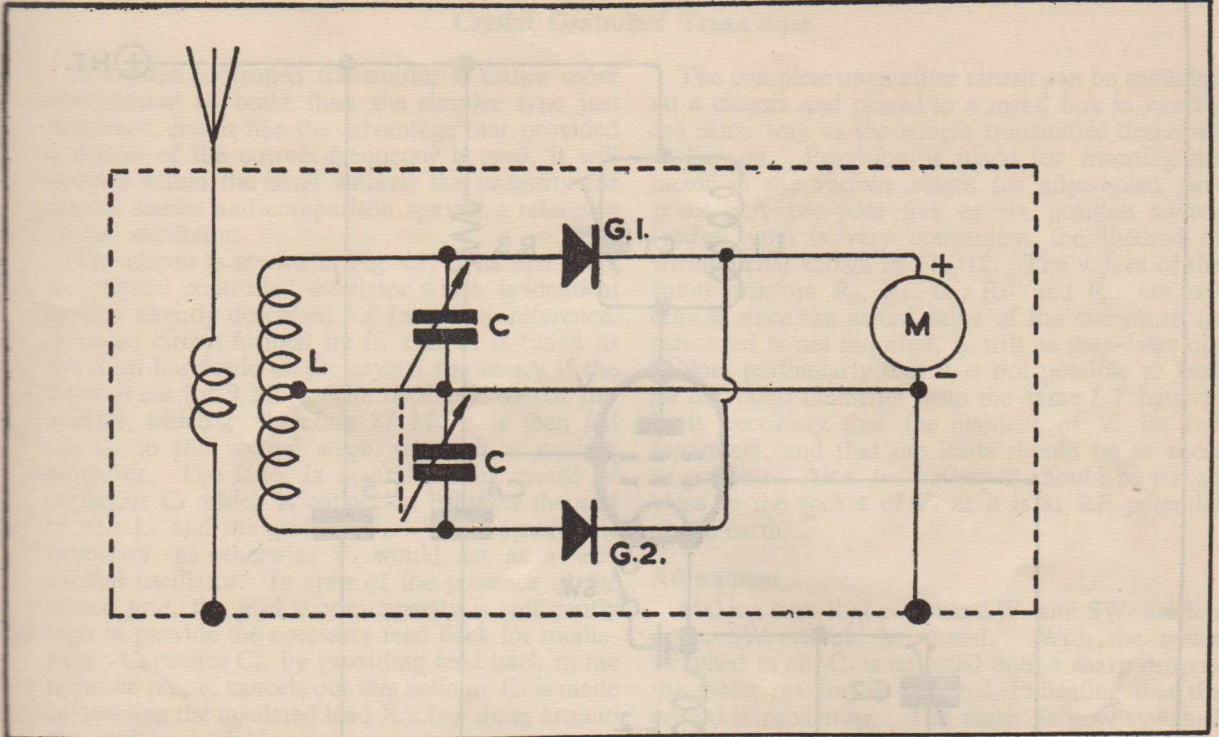

Fig. 9.
The Wavemeter.

Circuit should be enclosed in a metal box with only the aerial protruding.
 L— 14 turns 16 S.W.G. 1 in. dia. G1, G2—Germanium Diodes.
 C—2 gang 25pf variable. M—0-1mA meter.

So much for the wavemeter. The crystal-controlled oscillator circuit is shown in Fig. 10. To avoid additional expense the valve can be one which has been borrowed from the transmitter. The oscillator should be mounted on a metal chassis of any convenient shape. It is important that the leads to the LT battery should be made as short as possible, the battery being placed close to the valve socket, since it is at RF potential above earth. The coil in the anode circuit should be tuned to the correct harmonic of the crystal frequency. If the coil is made from 5 turns of 16 SWG wire of diameter one inch, and the turns spaced to make the coil one inch long, it should resonate at approximately 27 Mc/s when the 3-30pf capacitor is approximately two-thirds screwed in. If the wavemeter is brought close to the coil, a reading will be obtained which will be maximum when the coil is tuned to resonance. This reading will be further increased by tuning the wavemeter to the same frequency. The wavemeter capacitor knob is turned until a maximum reading is obtained, and the setting on the capacitor dial carefully noted. This setting will correspond to three times the frequency marked on the 9 Mc/s crystal, or four times that marked on the 7 Mc/s crystal. It is important that the

coils should be made exactly to the dimensions given, using the capacitors mentioned, as otherwise the wrong harmonic may be picked up.

The crystal oscillator can be supplied with 90 volts HT and 3 volts LT, when using 3Q4 or 3A4 valves, making sure that the valve holders have been wired correctly for that voltage. The batteries can conveniently be borrowed from the transmitter when the crystal oscillator is being used, as the transmitter is not then required.

Transmitter Adjustment

Having switched on the transmitter, C₁ is adjusted until the meter gives the lowest reading. It is best to have the aerial disconnected when making the preliminary adjustments. The wavemeter is now brought near the transmitter anode coil, until a reading is obtained. The wavemeter tuning knob is turned until this reading reaches a maximum. If this takes place when the capacitor plates of the wavemeter are more engaged than when set by the crystal oscillator frequency, then the transmitter frequency is too low and it will be necessary to screw out C₁ a turn or so. (Conversely, if the capacitor plates of the wavemeter are less engaged than when set to the crystal oscillator frequency, C₁ should be screwed in a turn or so).

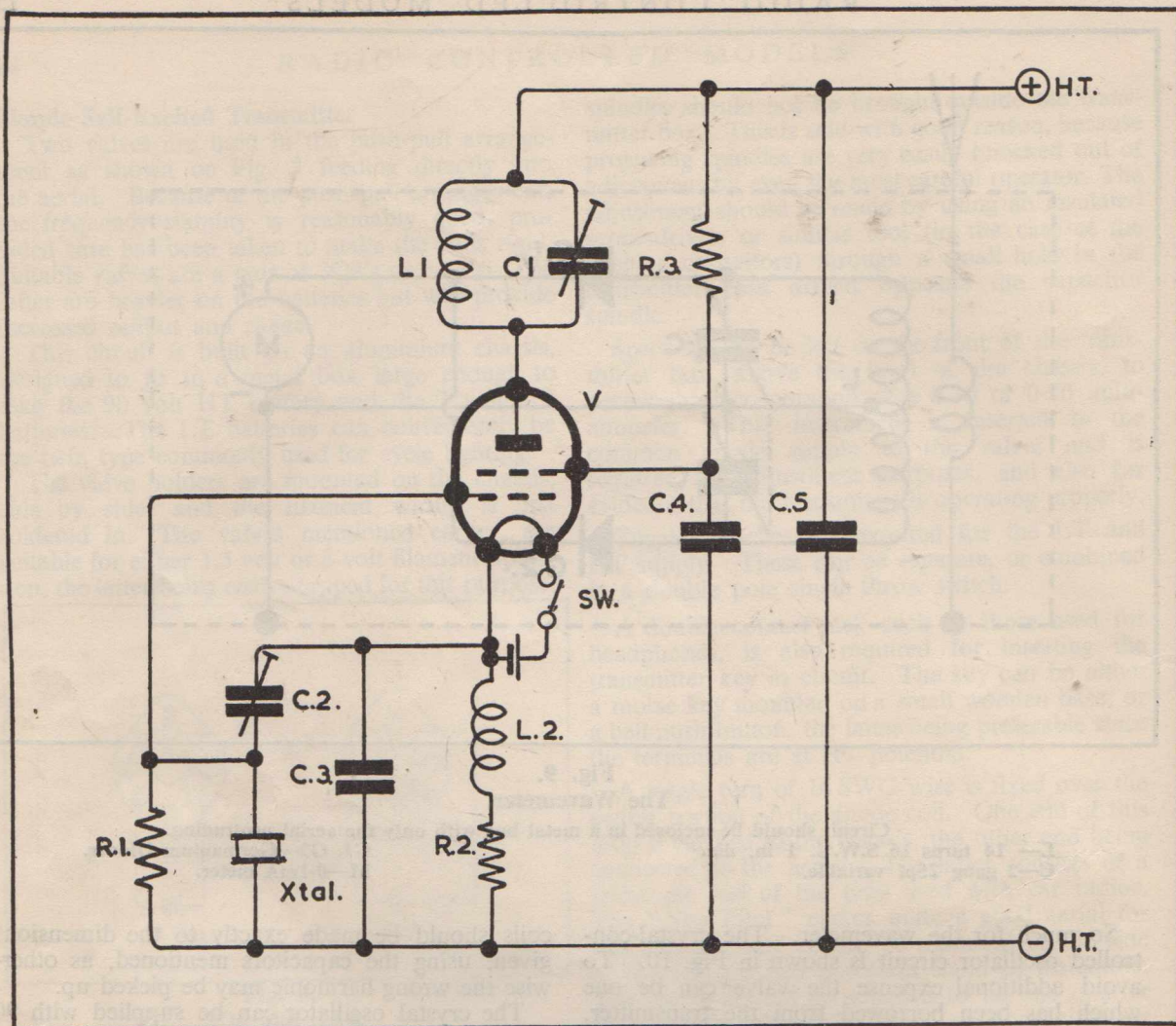

Fig. 10.

Crystal Oscillator.

C1, C2—3-30pf Concentric Trimmers. R1 20k Ω L1 5 turns 16 S.W.G. 1 in. dia.
 C3—100pf mica. R2 250 Ω L2 R.F. Choke. 100 turns 30 S.W.G.
 C4, C5—0.001 μ f. R3 50k Ω on a $\frac{1}{4}$ in. dia. former.

V-3Q4, 3A4 or equivalent.

This will have resulted in an increase in the transmitter meter reading and C₁ should now be adjusted until this is a minimum again. The wavemeter is now adjusted for maximum reading and the dial setting noted again.

This process is repeated until the dial setting on the wavemeter is the same as that obtained from the crystal-controlled oscillator.

The aerial is now connected up. In all probability this will have affected the frequency of the transmitter, which must be readjusted again to the correct reading. The effect of the aerial will be to load the transmitter and there will be a rise in the meter reading. By varying the coupling between the aerial and the transmitter coil, the

meter reading can be adjusted to a suitable value. If the coupling is increased beyond a certain point, the transmitter will cease to oscillate, and the anode current will rise to a very high value. This condition must not be allowed to persist or the valves will be damaged. When the transmitter has been properly loaded, the frequency is then checked again, against the crystal oscillator frequency. This particular operation should be carried out each time the transmitter is put into operation.

The wavemeter will retain its calibration over a reasonably long period if it has been sturdily constructed, but it should be checked regularly against the crystal oscillator.

Crystal Controlled Transmitter

A crystal controlled transmitter is rather more complicated to build than the simpler type just described, but it has the advantage that provided a crystal of the correct frequency is used, it will operate within the band without the necessity for careful checks and comparison against a reference crystal oscillator.

The circuit is shown in Fig. 11. The first stage is a crystal controlled oscillator which is identical to that already described for frequency reference. A tuned circuit formed by L_1 and C_1 is tuned to the third harmonic of the crystal frequency if the latter is cut for 9 Mc/s. The oscillator output frequency, which is therefore 27 Mc/s, is then fed via C_2 to the second stage, which is a straight amplifier. The latter is neutralized by means of capacitor C_3 which is connected between the end of coil L_2 and the grid of V_2 . This capacitor is necessary, as otherwise V_2 would act as a self-excited oscillator. In spite of the presence of the screen grid, the grid-anode capacity is sufficiently high to provide the necessary feed back for oscillation. Capacitor C_3 , by providing feed back in the opposite phase, cancels out this action. C_3 is made by twisting the insulated lead X a few times around the grid lead of V_2 .

Note that the final stage is almost identical to the push-pull transmitter described earlier on. The difference being that the valves are connected as pentodes, which are prevented from behaving as self-excited oscillators by the addition of neutralizing capacitors C_{12} and C_{13} . This circuit depends entirely on the drive provided by the previous stage for its operation, and its frequency is controlled solely by the signal from the crystal oscillator.

The complete transmitter circuit can be mounted on a chassis and placed in a metal box in exactly the same way as the simple transmitter described earlier on. Provision is made for inserting the meter in the various stages for adjustment purposes. A two-pole five or six position switch (wafer type) is very convenient, the method of wiring being shown in Fig. 12. The values of the shunt resistors R_7 , R_8 , R_9 , R_{10} and R_{11} are not critical since the actual value of the current to be measured is not required, as will be seen later on.

Note particularly that it is not possible to feed all the valve filaments from the same LT battery. It is necessary that the filament of V_1 be fed separately, and that the leads should be as short as possible. Also, the battery B should be placed close to the socket of V_1 , as it is at RF potential above earth.

Adjustment

Making sure that switches SW_1 and SW_2 are left open, SW_1 should be closed. With the meter switched to ab, C_1 is adjusted until a sharp drop in the meter reading is obtained, indicating that the crystal is oscillating. The meter is now switched to position cd, and the remaining valve filaments switched on. C_1 is rotated until a reading is obtained on the meter. The wavemeter is now brought close to L_1 , to check that the circuit is tuned to 27 Mc/s. When this is done, C_1 is carefully adjusted until the meter gives a maximum reading. C_1 is now rotated until a dip is observed in the meter reading. C_1 is adjusted, by winding turns on and off the grid lead, until no dip can be detected when C_1 is rotated. Switch SW_2 can now be closed and M switched to position

T S L

T S L RESISTORS have been specially designed for circuit applications such as Radio Control. They can be specified with confidence in any circuit where extremely small physical size, indifference to vibration and conservative power-rating are of paramount importance.

Available in all preferred values and ratings, with tolerances of 10%, 5% 2% and 1%, these resistors can be obtained from any good Radio Supply House.

In case of difficulty apply direct to:—

TECHNICAL SUPPLIERS LTD.,
HUDSON HOUSE,
63, GOLDHAWK ROAD,
LONDON, W.12

ASK FOR T S L BY NAME

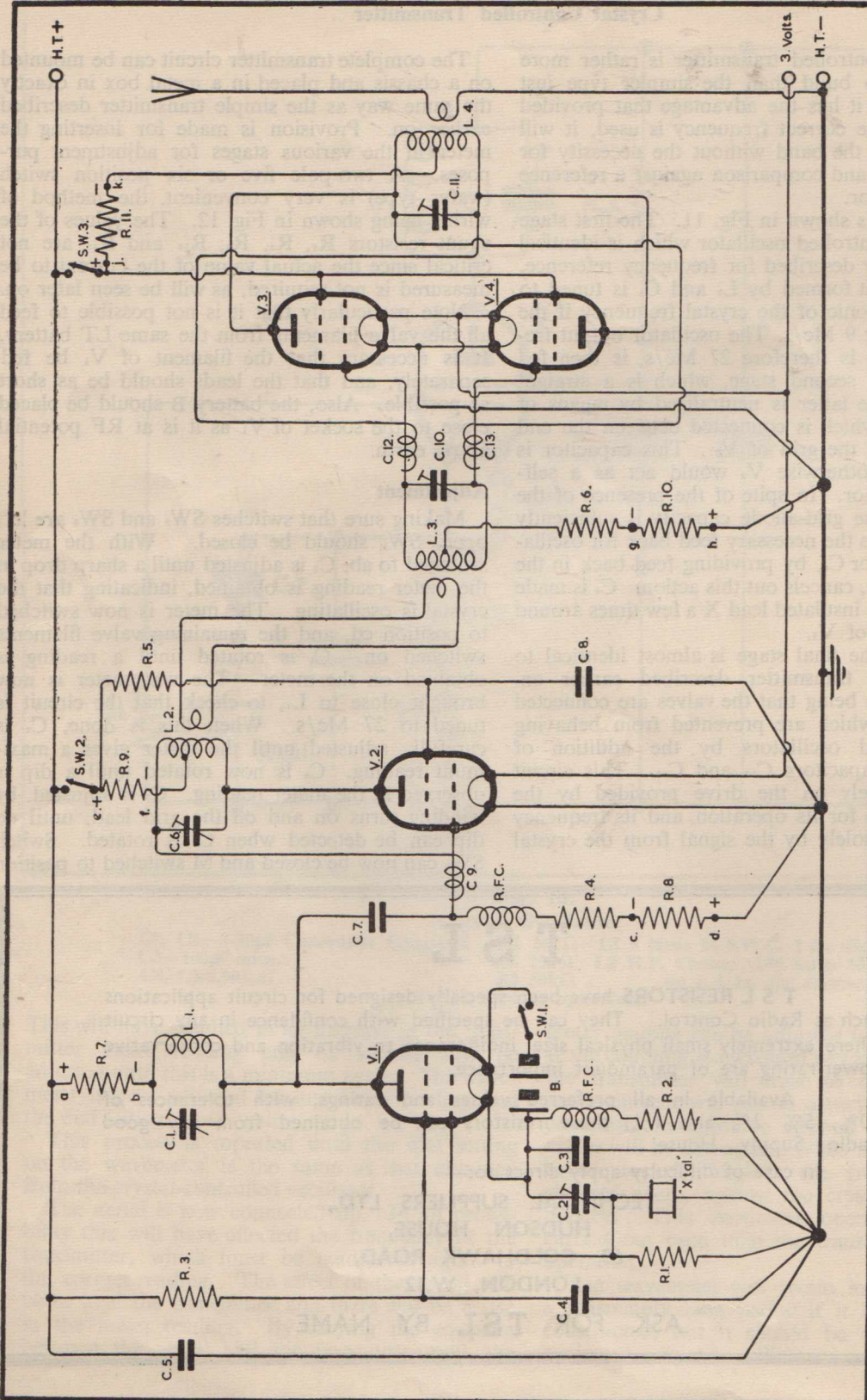

Fig. 11.
Crystal Controlled Transmitter.

R.4, R5—50kΩ.
R6—22kΩ.
R7, R8, R9, R10, R11—50Ω.
L1—5 turns 16 S.W.G. 1 in. dia.
L2—6 turns 16 S.W.G. 1 in. dia.

Fig. 10.
C6, C10, C11—3-30pf variable.
C7—100pf mica.
C8—0.001μf.
C9, C12, C13—Twisted insulated wire (See Text).

L3—14 turns 16 S.W.G. 1 in. dia.
L4—16 turns 16 S.W.G. 1 in. dia.
RFC—100 turns 30 S.W.G. on a 1/4 in. dia. former.
V1, V2, V3, V4—3Q4, DL95, N18 or equivalent.

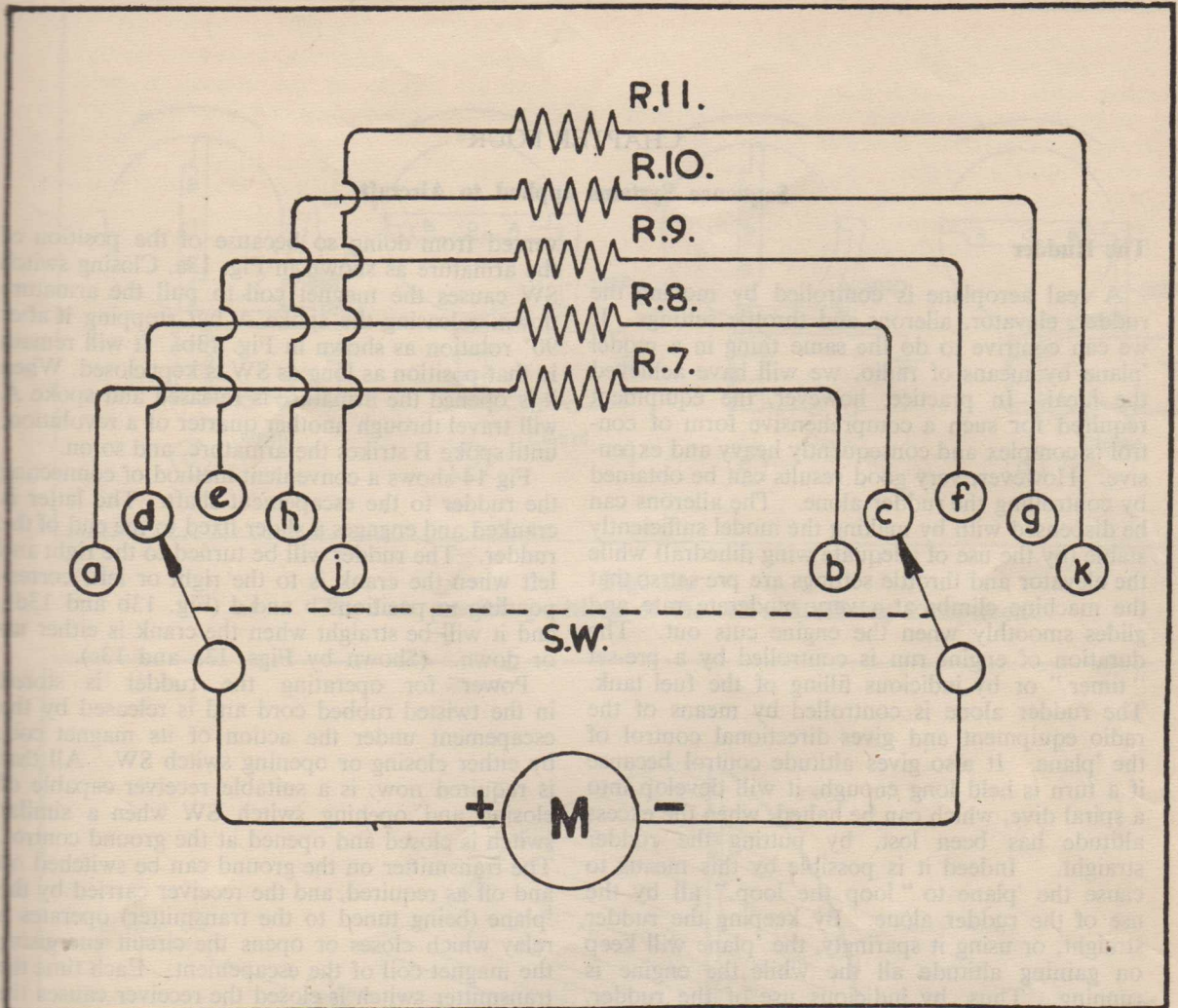

Fig. 12.

Selector switch enables the meter to read the voltage drop across five resistors in quick succession.
 SW—Double pole 5-position switch. R7, R8, R9, R10, R11—See Fig. 11. M—0-30mA Meter.

ef. C₁ is then rotated until a dip is obtained in the meter reading, and adjusted for minimum reading. Switching now the meter to the position gh, C₁ is adjusted until the grid current gives a maximum reading. C₁₁ is then rotated until a dip in the meter reading is observed. C₁₂ and C₁₃ are adjusted by adding a turn or two of the insulated wire over the grid leads, keeping them as nearly equal as possible. C₁₁ is again rotated, and if the dip is still present, although reduced, the process is repeated until no dip can be obtained. When this is done, switch SW₁ is closed, and the meter transferred to position jk. C₁₁ is now adjusted for minimum reading. The aerial loop is now coupled to L₁, as a result of which the meter reading will increase. The aerial loading should then be adjusted for optimum reading on the

meter, bearing in mind that the valve rating should not be exceeded. The transmitter is now ready for operation.

A crystal controlled transmitter is much more stable in operation than the simple 2 valve transmitter and will remain fixed on the correct frequency. It requires rather heavier batteries because of the greater number of valves. For this reason, 3Q4's should be used rather than 3A4's. A standard 90 volt battery will give reasonably long life, and two cycle twin batteries can be used for the LT, all the valves having their heaters connected for 3 volt operation for convenience.

The transmitters described so far are suitable for use with single valve receivers, and the two-valve receivers described in Chapter 2 not requiring audio modulation.

CHAPTER FOUR

Sequence Systems applied to Aircraft

The Rudder

A real aeroplane is controlled by moving the rudder, elevator, ailerons and throttle settings. If we can contrive to do the same thing in a model 'plane by means of radio, we will have achieved the ideal. In practice, however, the equipment required for such a comprehensive form of control is complex and consequently heavy and expensive. However, very good results can be obtained by controlling the rudder alone. The ailerons can be dispensed with by making the model sufficiently stable (by the use of adequate wing dihedral) while the elevator and throttle settings are pre-set so that the machine climbs at a very moderate rate and glides smoothly when the engine cuts out. The duration of engine run is controlled by a pre-set "timer" or by judicious filling of the fuel tank. The rudder alone is controlled by means of the radio equipment and gives directional control of the 'plane. It also gives altitude control because if a turn is held long enough, it will develop into a spiral dive, which can be halted, when the excess altitude has been lost, by putting the rudder straight. Indeed it is possible by this means to cause the 'plane to "loop the loop," all by the use of the rudder alone. By keeping the rudder straight, or using it sparingly, the 'plane will keep on gaining altitude all the while the engine is running. Thus, by judicious use of the rudder, altitude as well as directional control can be obtained.

The equipment required for control of the rudder only is simple and light, and this type of control is very popular because of the necessity of keeping the weight of the equipment as low as possible in a 'plane of reasonably small dimensions. The heart of the system is the rubber-powered escapement. In the self-neutralising type, which is the one usually chosen for use in aircraft, there are four possible positions, which occur in sequence, and which are made to correspond with the following rudder positions:—

1. Right.
2. Straight.
3. Left.
4. Straight.

By continuing the sequence, position 5 corresponds with position 1, position 6 with position 2, and so on.

An escapement is illustrated in Fig. 13. The spokes tend to rotate in the direction of the arrow under the influence of a rubber cord, but are pre-

vented from doing so because of the position of the armature as shown in Fig. 13a. Closing switch SW causes the magnet coil to pull the armature down, releasing the spoke A but stopping it after 90° rotation as shown in Fig. 13b. It will remain in that position as long as SW is kept closed. When it is opened the armature is released and spoke A will travel through another quarter of a revolution until spoke B strikes the armature, and so on.

Fig 14 shows a convenient method of connecting the rudder to the escapement shaft. The latter is cranked and engages a slider fixed to the end of the rudder. The rudder will be turned to the right and left when the crank is to the right or left, corresponding to positions b and d (Fig. 13b and 13d), and it will be straight when the crank is either up or down. (Shown by Figs. 13a and 13c).

Power for operating the rudder is stored in the twisted rubbed cord and is released by the escapement under the action of its magnet coil, by either closing or opening switch SW. All that is required now, is a suitable receiver capable of closing and opening switch SW when a similar switch is closed and opened at the ground control. The transmitter on the ground can be switched on and off as required, and the receiver carried by the 'plane (being tuned to the transmitter) operates a relay which closes or opens the circuit energising the magnet coil of the escapement. Each time the transmitter switch is closed the receiver causes the relay to close the escapement circuit, and the latter takes the position in Fig. 13b or 13d (rudder right or left) (depending on its previous position). When the transmitter switch is opened, the receiver relay opens the escapement circuit, and the latter takes the position of Fig. 13a or 13c (rudder straight).

This type of escapement has the advantage that the control (right or left rudder) is applied only while the transmitter is radiating. When the latter is switched off, the rudder always returns to the straight position. This is important in an aircraft, as failure of the radio link, due to a fault in either the transmitter or the receiver, or to the aircraft flying out of range, causes the rudder to return to the straight position. The aircraft will then fly or glide evenly and has a good chance of landing without damage. If, however, the rudder were to remain permanently in either the right or left position, then the turn would develop into a spiral dive with disastrous consequences, particularly if the engine were still running.

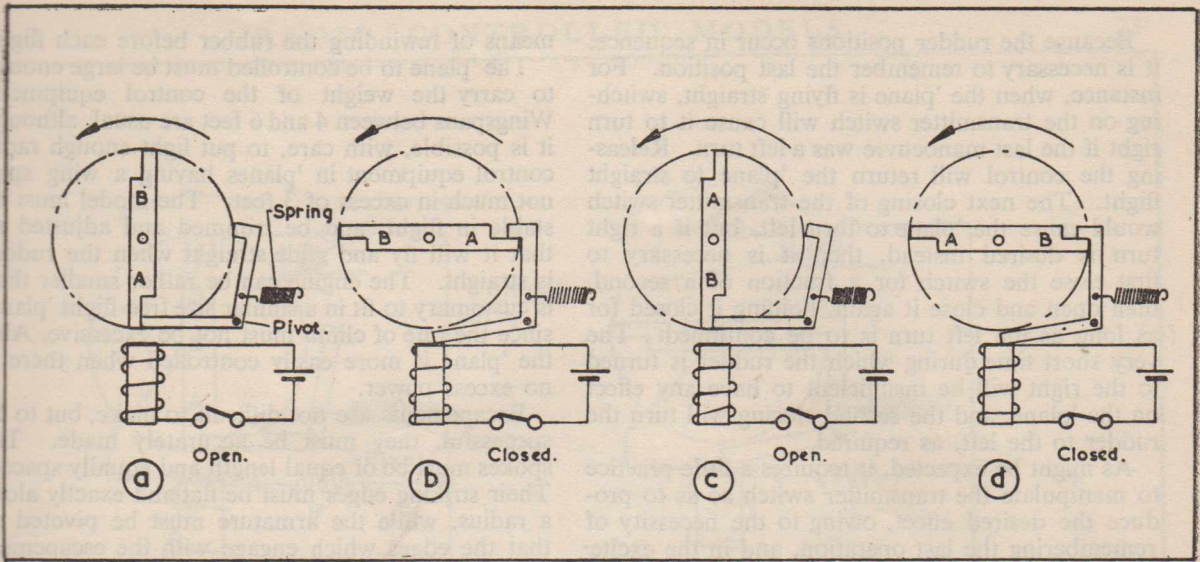

Fig. 13.
The four possible positions of the self-neutralizing Escapement.

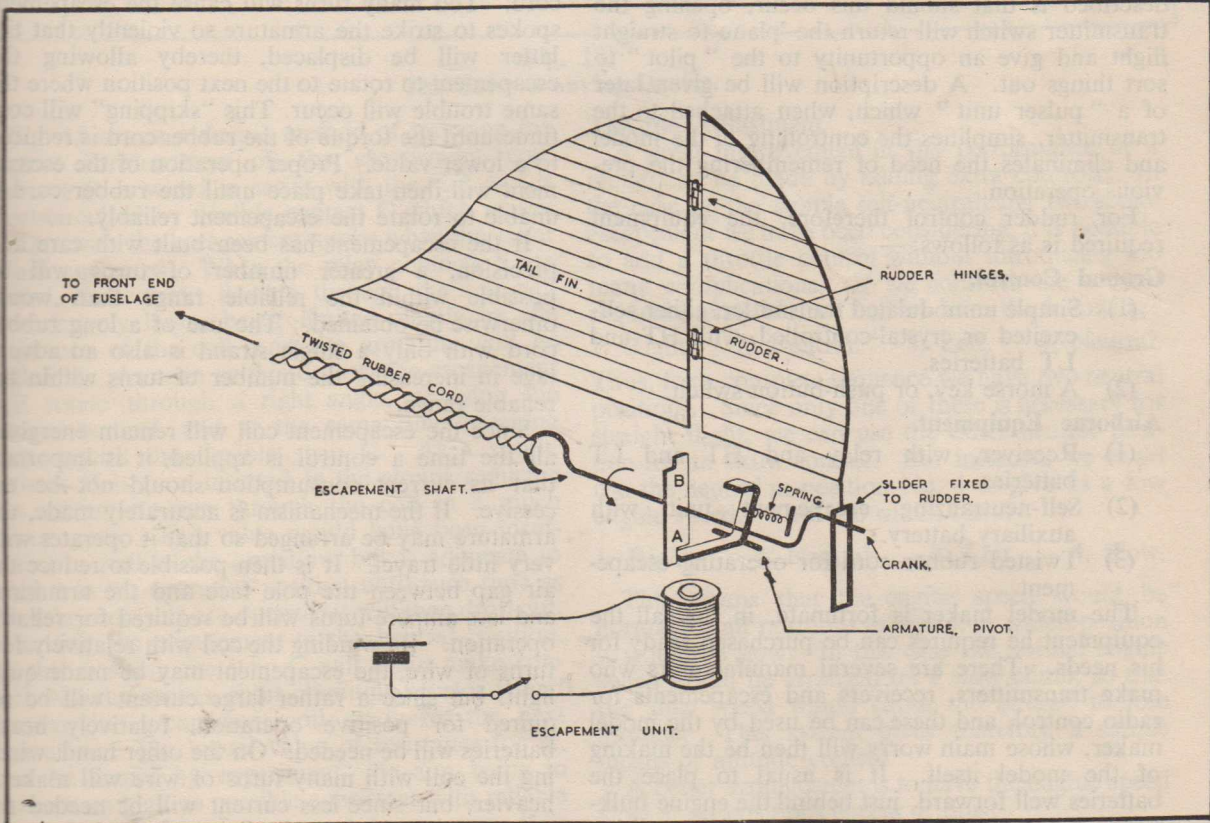

Fig. 14.
Details of the Rudder Control.

Because the rudder positions occur in sequence, it is necessary to remember the last position. For instance, when the 'plane is flying straight, switching on the transmitter switch will cause it to turn right if the last manoeuvre was a left turn. Releasing the control will return the 'plane to straight flight. The next closing of the transmitter switch would cause the 'plane to turn left, but if a right turn is desired instead, then it is necessary to first close the switch for a fraction of a second, then open and close it again, holding it closed for as long as the left turn is to be continued. The very short time during which the rudder is turned to the right will be insufficient to have any effect on the 'plane, and the second closing will turn the rudder to the left, as required.

As might be expected, it requires a little practice to manipulate the transmitter switch so as to produce the desired effect, owing to the necessity of remembering the last operation, and in the excitement of flying the 'plane, one is apt to become confused, with the result that the 'plane may do exactly the opposite of what was expected of it! The advantage of the self-neutralizing escapement just described is that should this occur, opening the transmitter switch will return the 'plane to straight flight and give an opportunity to the "pilot" to sort things out. A description will be given later of a "pulser unit" which, when attached to the transmitter, simplifies the controlling of the model and eliminates the need of remembering the previous operation.

For rudder control therefore, the equipment required is as follows:—

Ground Control.

- (1) Simple unmodulated transmitter, either self-excited or crystal-controlled, with HT and LT batteries.
- (2) A Morse key, or push-button switch.

Airborne Equipment.

- (1) Receiver, with relay and HT and LT batteries.
- (2) Self-neutralizing escapement unit with auxiliary battery.
- (3) Twisted rubber cord for operating escapement.

The model maker is fortunate, in that all the equipment he requires can be purchased ready for his needs. There are several manufacturers who make transmitters, receivers and escapements for radio control, and these can be used by the model maker, whose main worry will then be the making of the model itself. It is usual to place the batteries well forward, just behind the engine bulkhead, with the receiver in any convenient position in the fuselage. The escapement is placed close to the tail assembly, its shaft being extended so that the cranked portion projects behind the rudder fin. This cranked portion provides a convenient

means of rewinding the rubber before each flight.

The 'plane to be controlled must be large enough to carry the weight of the control equipment. Wingspans between 4 and 6 feet are usual, although it is possible, with care, to put light enough radio control equipment in 'planes having a wing span not much in excess of 3 feet. The model must be stable in flight, and be trimmed and adjusted so that it will fly and glide straight when the rudder is straight. The engine can be rather smaller than is customary to fit in a similar size free-flight 'plane, since the rate of climb must not be excessive. Also the 'plane is more easily controlled when there is no excess power.

Escapements are not difficult to make, but to be successful, they must be accurately made. The spokes must be of equal length and equally spaced. Their striking edges must be flat and exactly along a radius, while the armature must be pivoted so that the edges which engage with the escapement spokes move exactly at right angles to the latter.

The number of operations which the escapement will give on one winding will depend on the number of turns which were given to the twisted rubber cord. Too many turns will cause the escapement spokes to strike the armature so violently that the latter will be displaced, thereby allowing the escapement to rotate to the next position where the same trouble will occur. This "skipping" will continue until the torque of the rubber cord is reduced to a lower value. Proper operation of the escapement will then take place until the rubber cord is unable to rotate the escapement reliably.

If the escapement has been built with care and precision, a greater number of turns will be possible within the reliable range than would otherwise be obtained. The use of a long rubber cord with only a single strand is also an advantage in increasing the number of turns within the reliable range.

Since the escapement coil will remain energised all the time a control is applied, it is important that its current consumption should not be excessive. If the mechanism is accurately made, the armature may be arranged so that it operates with very little travel. It is then possible to reduce the air gap between the pole face and the armature, and less ampere-turns will be required for reliable operation. By winding the coil with relatively few turns of wire, the escapement may be made quite light, but since a rather large current will be required for positive operation, relatively heavy batteries will be needed. On the other hand, winding the coil with many turns of wire will make it heavier, but since less current will be needed for the same magnetic pull, lighter batteries can be used. Since weight is vitally important, the solution which gives the lightest combination consistent with reliable operation is the one which must be strived for.

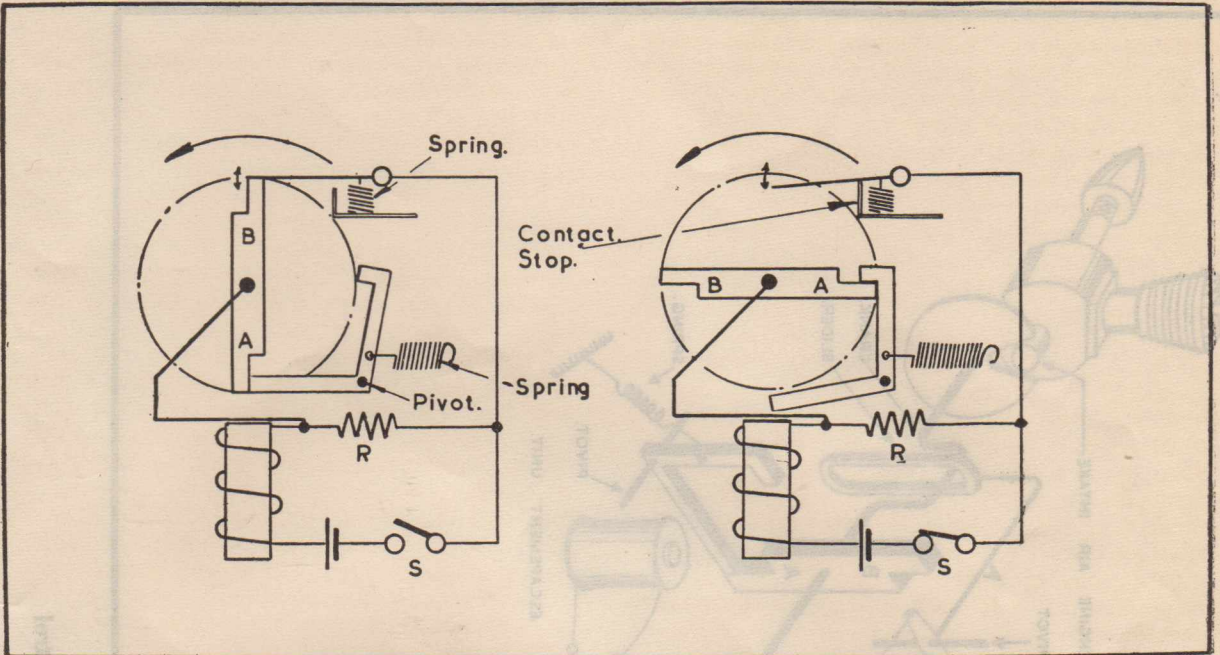

Fig. 15.
The Current Saving Device.

Fig. 15 shows a simple method of reducing the current consumption of the escapement coil. Resistor R is wired in series with the coil, but is short-circuited by flexible contact C which makes contact with the escapement spoke when the latter is not energised. When the relay contacts S are closed, the current flowing through the coil will be relatively large, being limited mainly by the resistance of the coil, and the armature will be pulled in. As soon as this occurs, the escapement will rotate through a right angle, applying the desired control, and at the same time breaking contact with the flexible strip C. As a result, resistor R is now inserted in the circuit reducing the current flowing through the coil to a much lower value. This value would have been insufficient to pull in the armature, but is adequate to hold it in the operative position until such time as the relay contacts are opened; it will then drop out, returning the escapement to the neutral position. In this position the strip C will again make contact with the spokes, short circuiting resistor R and leaving the escapement coil ready for the next operation. The actual value of resistance for R, can be found by experiment, the aim being to make it as high as possible consistent with reliable operation of the escapement. In practice, it is possible to reduce in this manner the coil consumption to one quarter or one fifth of its normal value, provided (a) that the armature has been adjusted so that the residual air-gap is very small and (b) that the armature spring tension has been carefully adjusted.

Throttle Adjustment

A great improvement in the performance of a model can be made by adding extra controls. In the case of the simple self-neutralizing two-spoke escapement we have been considering, it is possible to add a throttle control without introducing too many complications. If we consider the control sequence available, we find we have the following :

- 1. Right. 2. Neutral. 3. Left. 4. Neutral.
- Thus, for a complete sequence we have two neutral positions. Since only one of these is necessary for straight flight, we can use the other neutral position for an extra control. For instance, we could use the neutral in position No. 4 to give us a low engine speed. Thus we would have:

- 1. Right. 2. Neutral. 3. Left. 4. Slow.

This means that the engine speed would be normal for all positions except 4, in which position it would be slow. In this case the normal engine speed would be arranged for a slow climb, so that the slow speed would cause the aircraft to lose altitude. This system gives therefore a simple means of altitude control.

A better arrangement is to have the engine speed slow at all positions except 4, thus:

- 1. Right slow. 3. Left slow.
- 2. Neutral slow. 4. Neutral fast.

In this case, the engine is adjusted for maximum revs. in No. 4 position, and for sufficient revs. to maintain level flight in the other three positions.

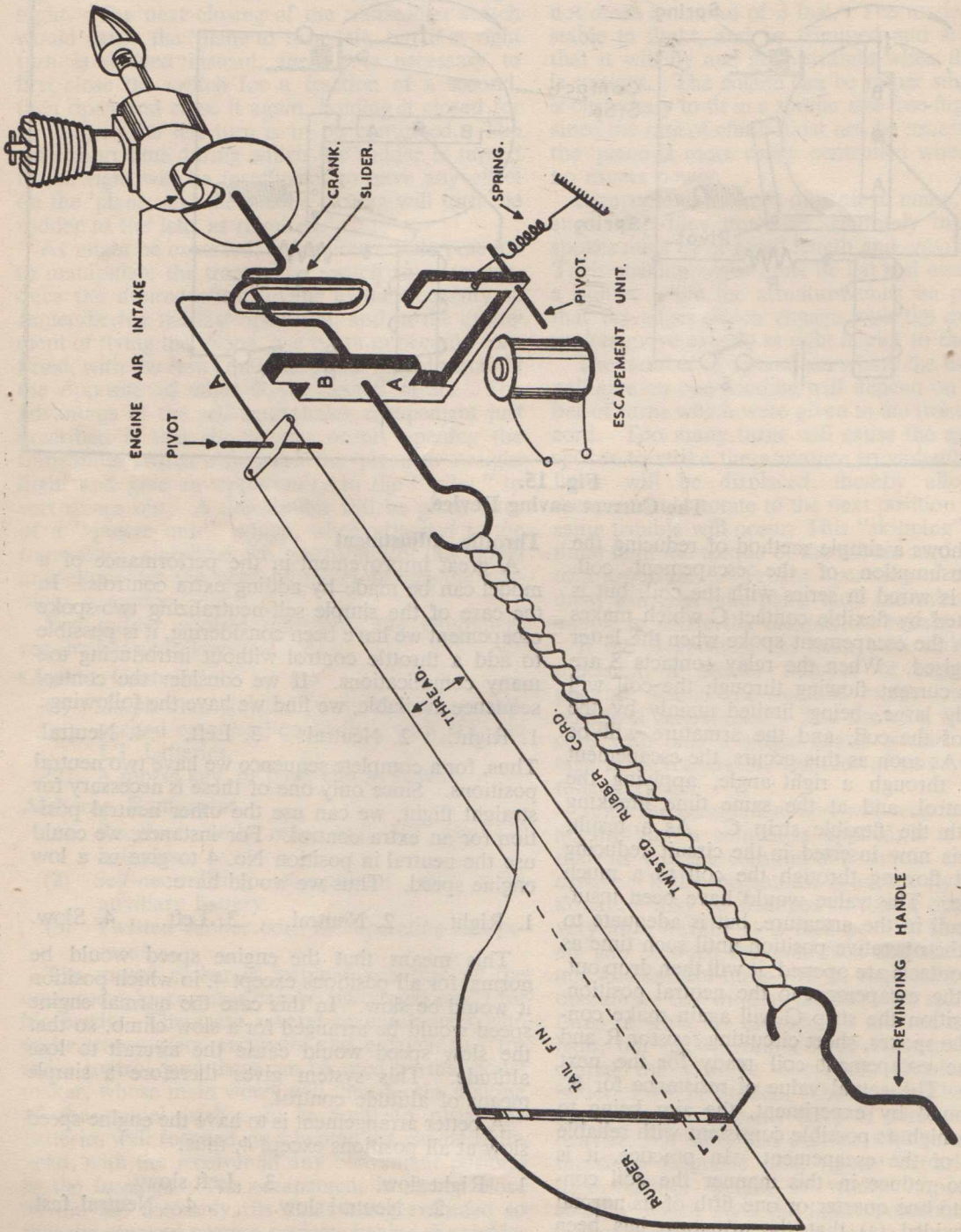

Fig. 16.
Combined Rudder and Throttle Control

The technique is then to use position No. 4 when the 'plane is launched so as to climb as quickly as possible to a safe altitude, when the escapement is then transferred to the neutral in No. 2 position. The engine slows down so that the 'plane ceases to climb and remains in approximately level flight. Turns are more controllable with the engine at reduced speed. The 'plane can be made to lose altitude by means of a prolonged turn, and the No. 4 position used in order to climb.

The same receiver and escapement unit are used as before, but instead of placing the latter near the tail assembly, it is fixed immediately behind the engine bulkhead, the other end of the rubber cord being fixed at the tail end of the fuselage, with a winding handle arranged to protrude slightly behind the tail fin for rewinding purposes. The escapement shaft is cranked as shown in Fig. 16 and because of this arrangement it is necessary to use either threads, or a light rod, for transferring the escapement movement through lever A, to the rudder. The end of the escapement shaft is continued through the bulkhead and carries a disc in which a circular hole or a notch is cut out. This disc is adjusted so as to nearly close off the engine air intake in all but one of the escapement positions. This arrangement suits best engines having disc valves with air intake at the back, and works well with diesel engines. Engines having the air intake at the front can be adapted by providing a piece of plastic tubing to bring the opening of the air intake to a convenient position.

The engine is adjusted so that the maximum revs. are obtained when the opening in the disc is opposite the air intake. In the other positions, the disc will cover the air intake opening, the clearance being adjusted so that the engine revs. are reduced to the point when altitude is just maintained. The disc is fixed on the escapement shaft so that the air intake is left clear in one neutral position and is covered in all other positions.

Elevator Control.

Self-neutralizing equipment can be made to operate the rudder mechanism with little trouble. If it is required to control also the elevators, perhaps the most obvious solution is to provide a second self-neutralizing escapement, operated through a second receiver operating on a separate wavelength. This is a rather expensive solution, however, and is not very practical because the simpler types of receivers which are most suitable for radio-control have very poor selectivity. In fact, they tune so broadly that there is really no room in the radio-control band to accommodate two receivers which will not react on one another. Broad tuning is an advantage in a way, since it is therefore not in the least critical, and the receiver will remain tuned to simple transmitters which may not have good frequency stability.

It is necessary to resort to some form of escapement which will provide both rudder and elevator control, from the one receiver. Direct actuation of the control surfaces by the escapement mechanism is not so easy when more than one control surface is to be operated, and one solution is to fit contacts on the escapement shaft which, according to the position of the latter, will close the circuit of small electric motors which operate the control surfaces. Very light motors can easily be obtained, such as the "electrotor," which weighs just under one ounce. Spring contact assemblies such as are fitted to P.O. type relays can be used for operation by means of cams on the escapement shaft. These cams have configurations to operate the contacts in accordance with the escapement position. The electric motors (one for the rudder and one for the elevators) are fitted with a suitable reduction gearing to operate the control crank lever and limit switches, (the latter for preventing overshoot of the controls). The circuit diagram is shown in Fig. 17. Two batteries are used, one for each direction of rotation of the motors, since this simplifies the contact arrangements for reversing. Each battery is in circuit only half the time the motors are running, so they need not be heavier, for the same life, than a single battery which would require more complicated contact arrangements.

In order to work both rudder and elevators, an escapement is required giving four control positions and four neutrals (instead of two control positions and two neutrals). The escapement wheel as shown on Fig. 18 has four spokes instead of two, the armature being modified so that the escapement wheel travels through 45° each time the armature moves. The positions are then as follows:—

Sequence:	1	2	3	4
Coil Circuit:	on	off	on	off
Control:	Right	Neutral	Up	Neutral
Sequence:	5	6	7	8
Coil Circuit:	on	off	on	off
Control:	Left	Neutral	Down	Neutral

The escapement is self-neutralizing and the control is held on as long as the escapement coil remains energised. De-energising the coil causes the escapement wheel to move to the next neutral position in which case no contact is made by the cams. A current saving device, as previously described can also be incorporated.

Since there are four neutral positions for each complete revolution of the escapement wheel, three can be made available for additional controls. For instance, one neutral position can be made to increase engine speed by fitting the escapement unit near the nose of the plane so that a throttle disc as previously described, can be fitted close to the engine air intake. The disc should have an opening provided, which uncovers the air intake during

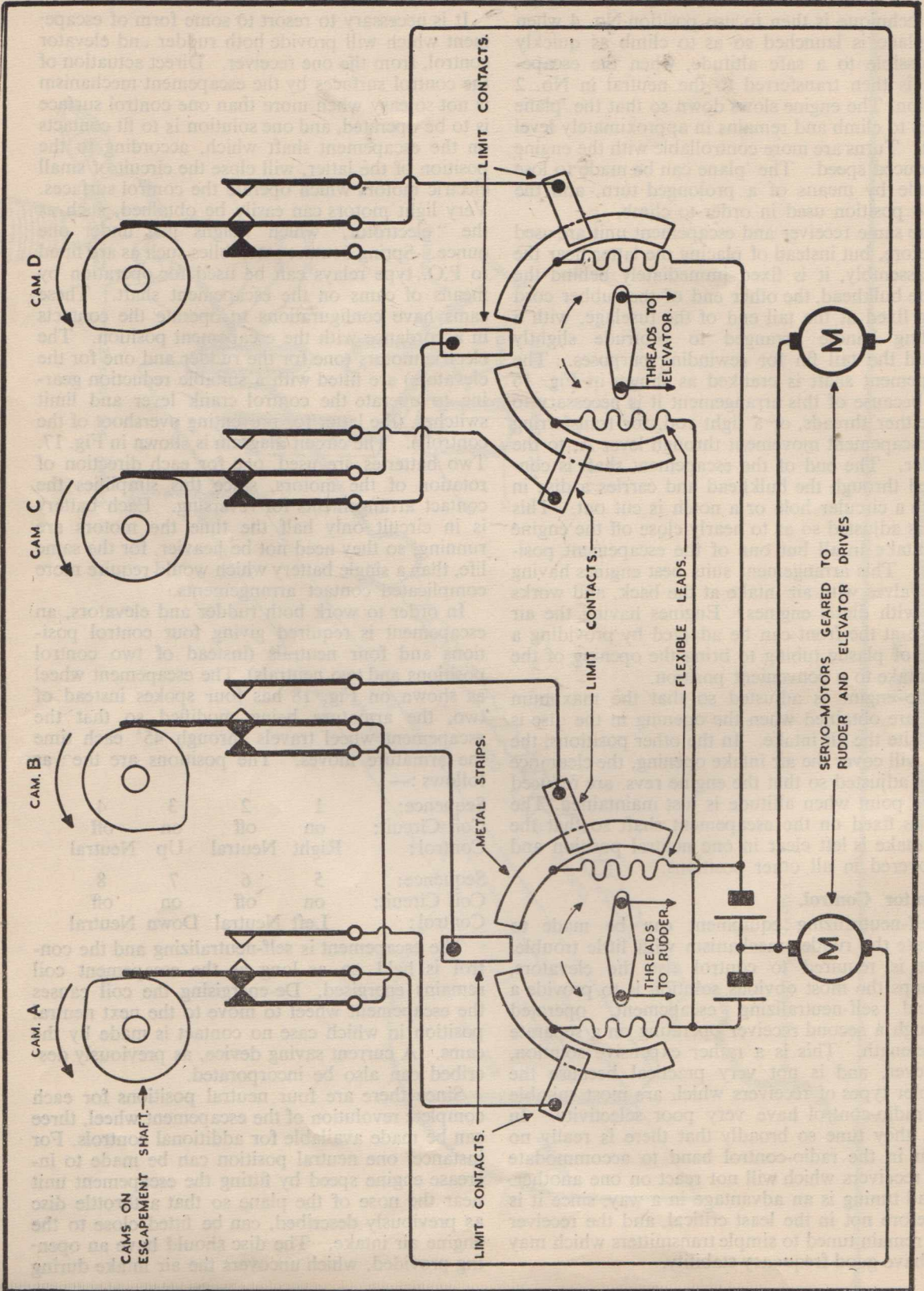

Fig. 17. Circuit Diagram for the operation of both Rudder and Elevators.

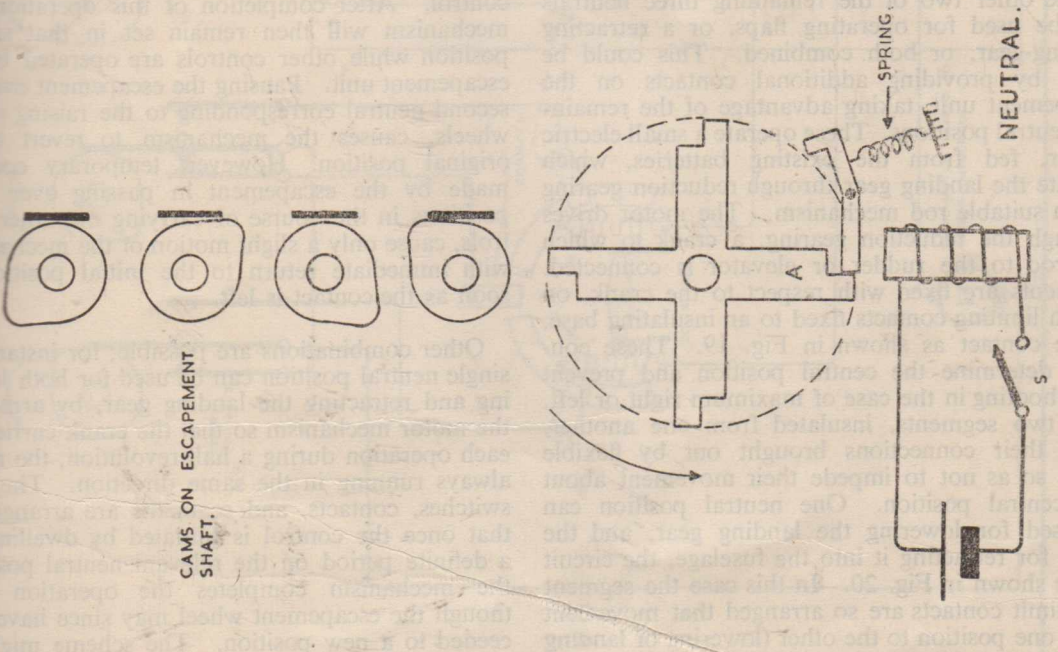
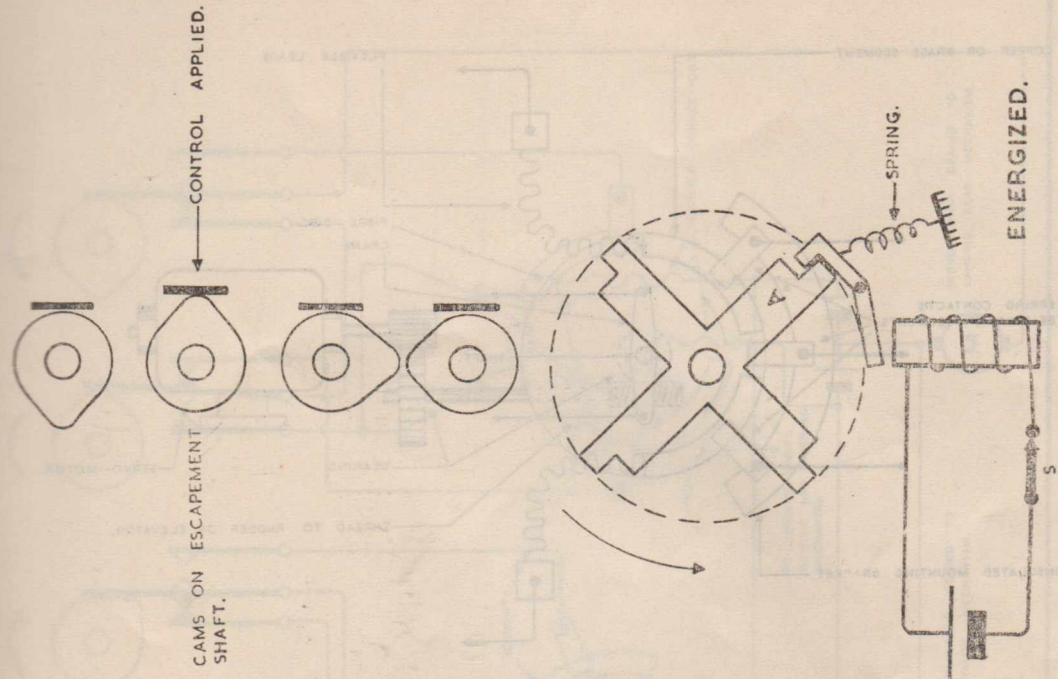

Fig. 18. Four-spoke Escapement showing cam positions.

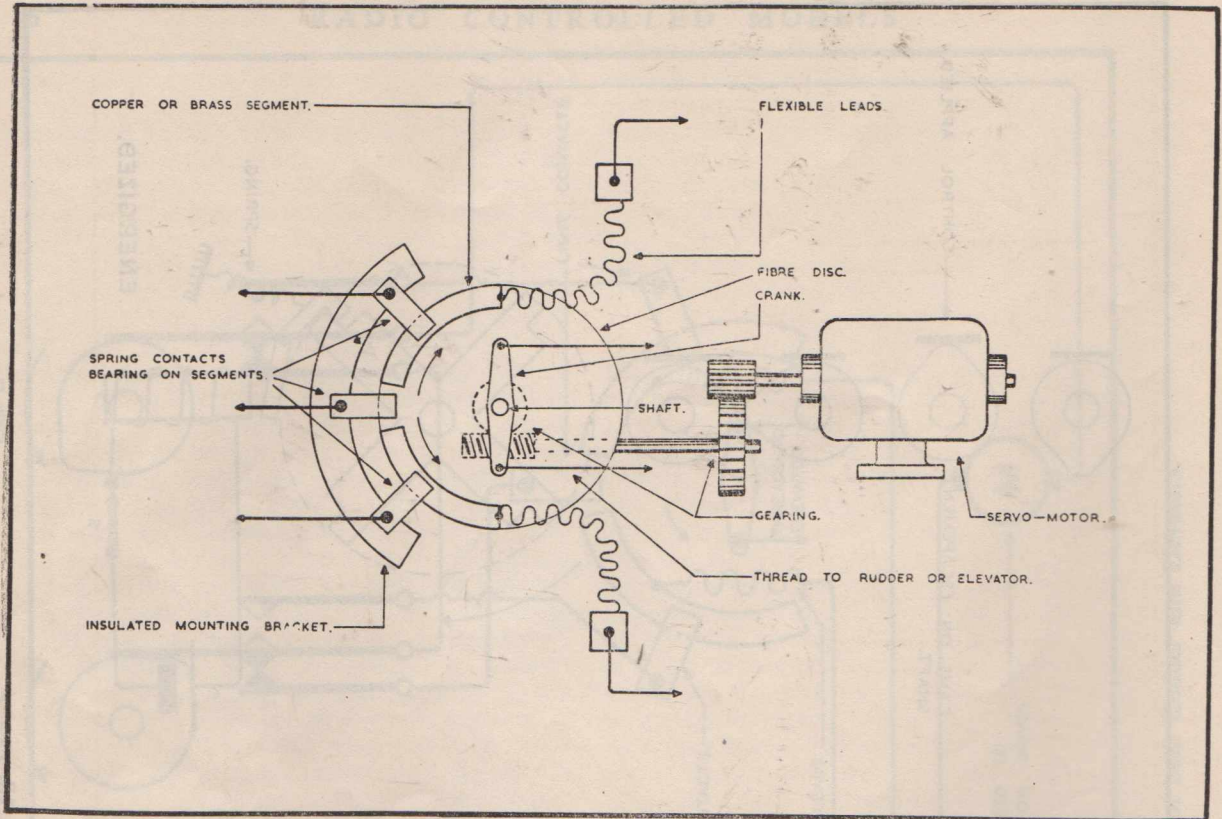

Fig. 19.
Servo-Mechanism with Limit contacts.

one eighth of a revolution of the escapement wheel.

The other two of the remaining three neutrals can be used for operating flaps, or a retracting landing-gear, or both combined. This could be done by providing additional contacts on the escapement unit, taking advantage of the remaining neutral positions. These operate a small electric motor, fed from the existing batteries, which actuate the landing gear through reduction gearing and a suitable rod mechanism. The motor drives through the reduction gearing, a crank to which the rod to the rudder or elevator is connected. Segments are fixed with respect to the crank, on which limiting contacts fixed to an insulating base, make contact as shown in Fig. 19. These contacts determine the central position and prevent overshooting in the case of maximum right or left. The two segments, insulated from one another, have their connections brought out by flexible wires so as not to impede their movement about the central position. One neutral position can be used for lowering the landing gear, and the other for retracting it into the fuselage, the circuit being shown in Fig. 20. In this case the segment and limit contacts are so arranged that movement from one position to the other (lowering of landing wheels for instance) takes place when the escape-

ment is paused on the neutral corresponding to this control. After completion of this operation, the mechanism will then remain set in that second position while other controls are operated by the escapement unit. Pausing the escapement over the second neutral corresponding to the raising of the wheels, causes the mechanism to revert to its original position. However, temporary contacts made by the escapement in passing over these positions in the course of carrying out other controls, cause only a slight motion of the mechanism, with immediate return to the initial position as soon as the contact is left.

Other combinations are possible; for instance, a single neutral position can be used for both lowering and retracting the landing gear, by arranging the motor mechanism so that the crank carries out each operation during a half-revolution, the motor always running in the same direction. The limit switches, contacts, and segments are arranged so that once the control is initiated by dwelling for a definite period on the relevant neutral position, the mechanism completes the operation even though the escapement wheel may since have proceeded to a new position. The scheme might be as follows:—

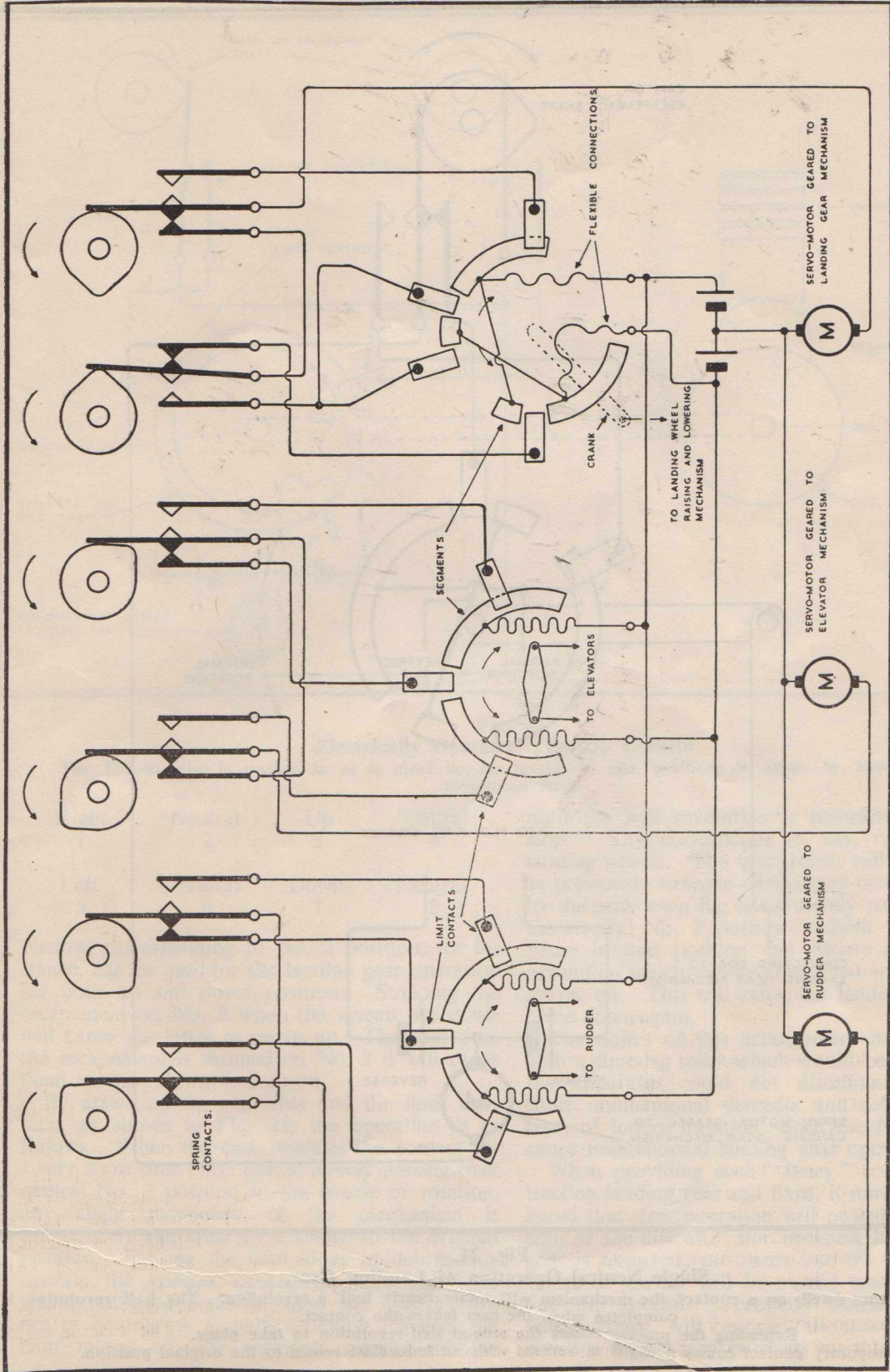

Fig. 20.

Circuit Diagram for Rudder, Elevators, and double neutral operation of Landing Gear.

The cams which are mounted on the escapement shaft are shown in the neutral, corresponding to landing wheels lowered. Temporary Contacts caused by the cam passing through a given position will cause slight motion of the mechanism concerned, with immediate return to the central position. The rudder and elevator controls only operate when a cam dwells on a contact, and they return to neutral immediately the contact is broken. The landing wheels remain down until returned by the action of the other cam.

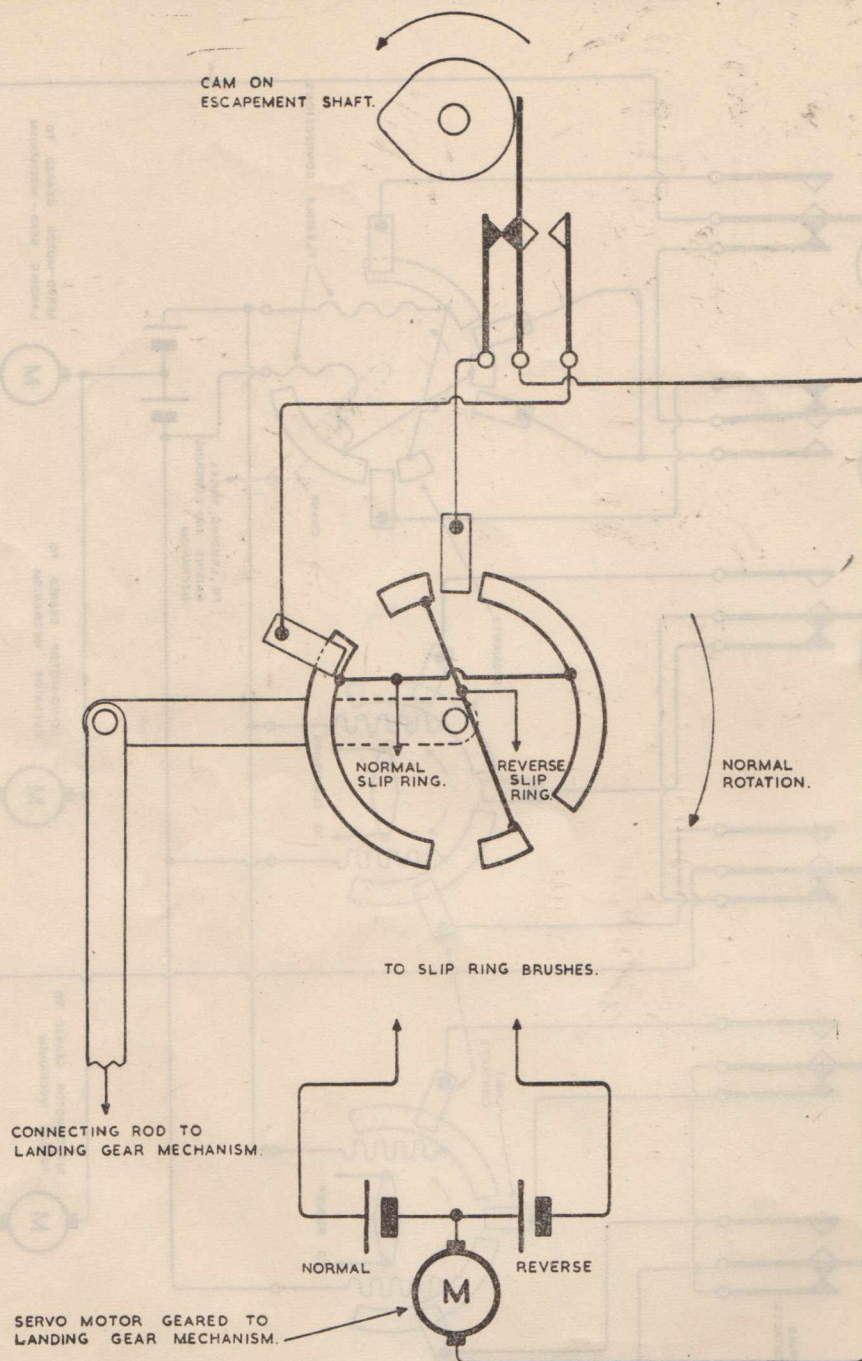

Fig. 21.

Single Neutral Operation of Landing Gear.

If the cam dwells on a contact, the mechanism will rotate nearly half a revolution. The half revolution is completed when the cam leaves the contact.

Repeating the process causes the second half-revolution to take place.

Temporary contact causes a slight movement with an immediate return to the original position.

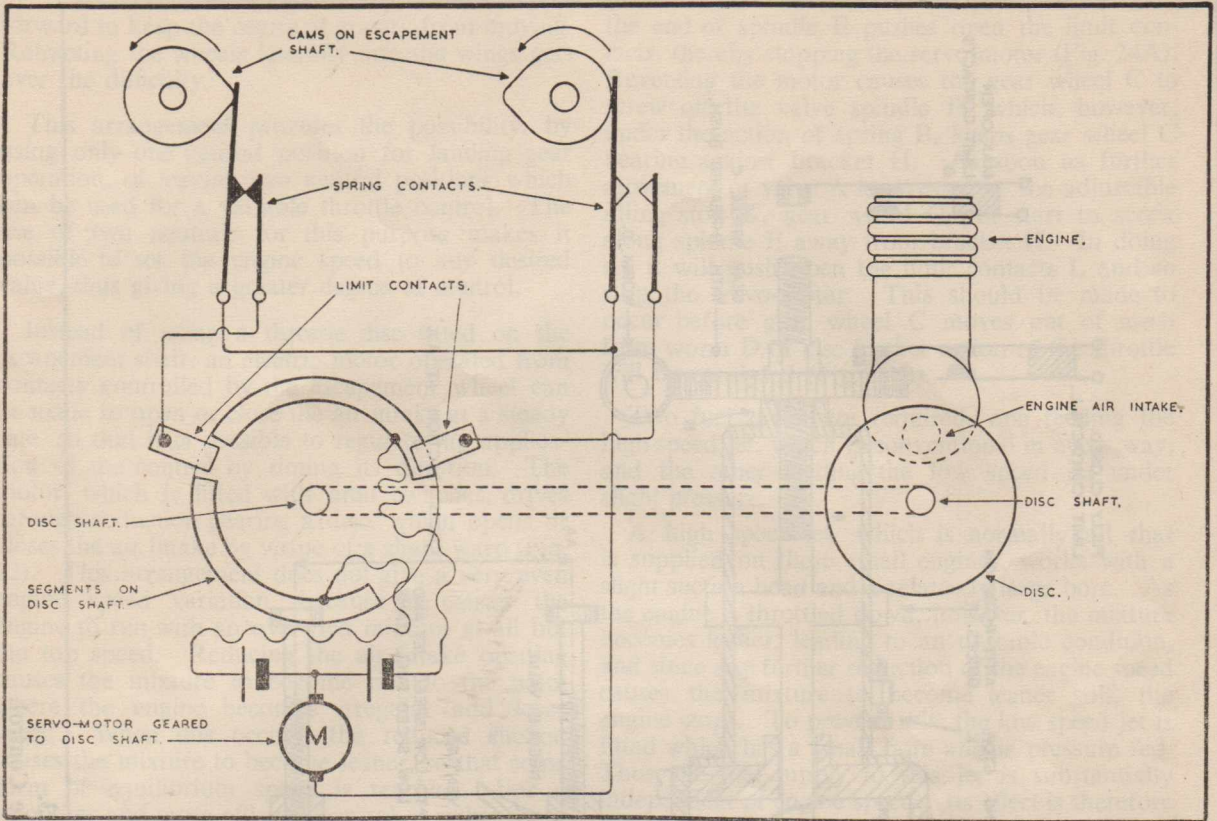

Fig. 22.
Electrically Operated Throttle Control

The Throttle disc is warped so as to close the air intake in one position; it opens to maximum half a revolution later.

Right	Neutral	Up	Neutral
1	2	3	4
Left	Neutral	Down	Neutral
5	6	7	8

Neutral corresponding to No. 2 position, for instance, can be used for the landing gear operation for both up and down positions. Stopping the escapement on No. 2 when the wheels are down will cause the latter to move up. The next time the escapement is stopped on No. 2 it will cause them to move down, and so on.

By arranging the segments and the limit contacts as shown in Fig. 21, the operation is as follows. When the cam operates the contact for a very short time only, due to merely passing over neutral No. 2 position in the course of rotation, any slight movement of the mechanism is immediately cancelled by a return to the original position. Pausing the cam so as to deliberately operate the contact causes the mechanism to rotate until the segments (and the crank) have nearly completed a half-revolution. When the cam moves on, the segments resume rotation

until the half revolution is completed and then stop. This corresponds to, say, retracting the landing wheels. The mechanism will now behave as previously towards momentary contacts caused by the cam when the latter merely passes through the neutral No. 2 position without pausing. A pause in that position will initiate another half revolution which will be completed when the cam moves on. This will cause the landing wheels to come down again.

The object of this arrangement is to dispense with a time-lag relay which would be necessary if the apparatus could not discriminate between short unintentional contacts and deliberate contacts of longer duration, since the former might cause unintentional landing gear operation.

When providing such "fancy" controls as retracting landing gear and flaps, it must be remembered that their operation will probably upset the trim of the aircraft. For instance, if the landing gear is retracted rear-wards into the fuselage, the centre of gravity will be moved towards the tail and the aircraft, if properly trimmed with the wheels down, will become tail heavy when they are up, unless compensating weights are moved

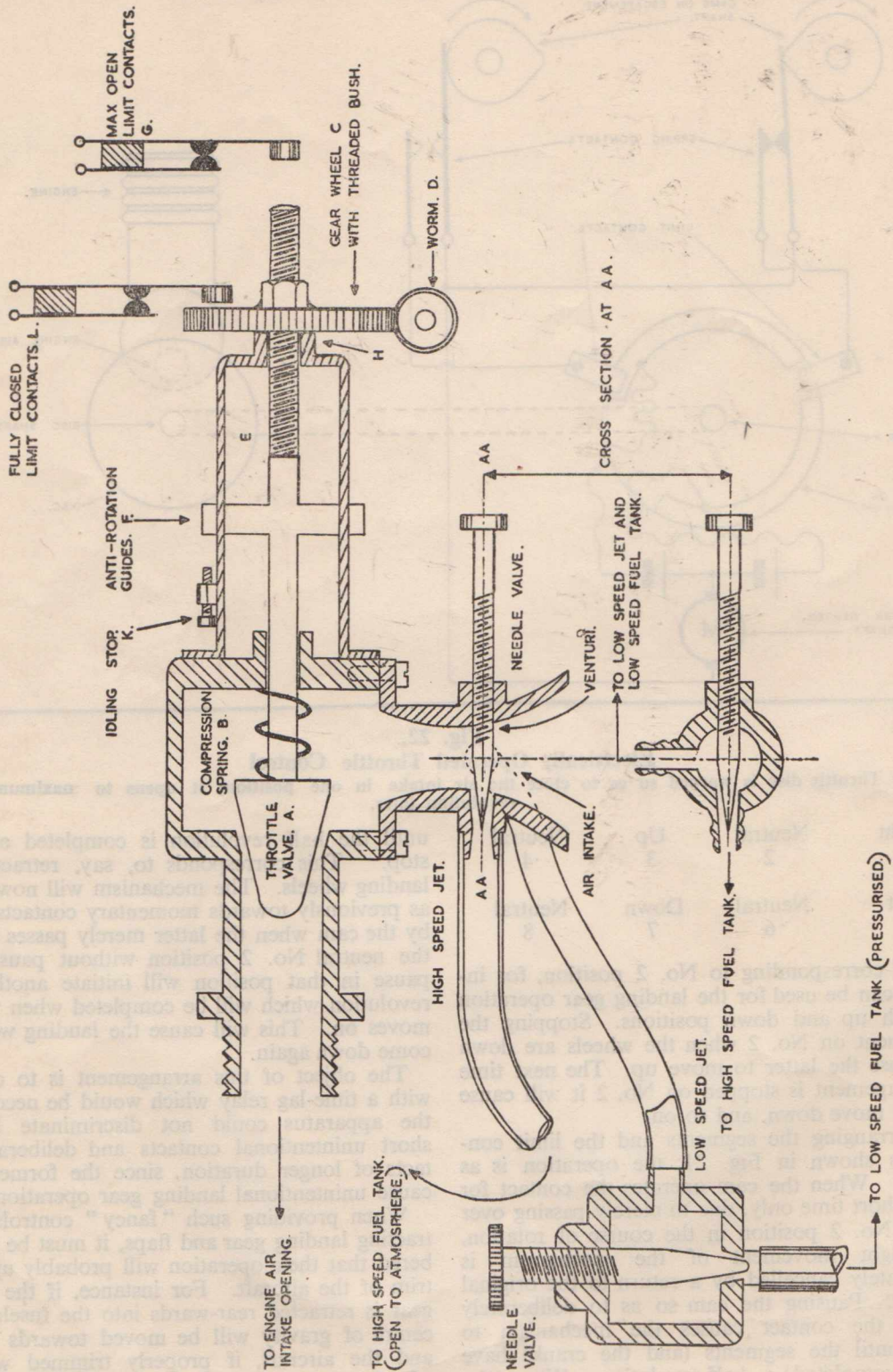

Fig. 23.
Two-jet Throttle Control.

forward to keep the centre of gravity from moving. Retracting the wheels laterally into the wings gets over the difficulty.

This arrangement provides the possibility, by using only one neutral position for landing gear operation, of leaving two neutral positions which can be used for a variable throttle control. The use of two neutrals for this purpose makes it possible to set the engine speed to any desired value, thus giving a greater degree of control.

Instead of using a throttle disc fitted on the escapement shaft, an electric motor operated from contacts controlled by the escapement wheel can be made to open or close the air intake at a steady rate, so that it is possible to regulate the application of the control by timing its duration. The motor, which is fitted with limit switches, drives through reduction gearing a disc, which opens or closes the air intake by virtue of a slight warp (Fig. 22). This arrangement does not give a very even engine speed variation, because it causes the engine to run with an over-rich mixture at all but the top speed. Reducing the air intake opening causes the mixture to become rich to the point where the engine becomes irregular and loses speed. When this occurs, the reduced suction causes the mixture to become leaner, so that some form of equilibrium speed is reached. For a smoother and more efficient control, a rather more elaborate arrangement is required. The following has been found quite successful:—

The existing air intake and jet is removed from the engine. Engines such as the E.D. 3-46 Mark IV with detachable air intakes are most suitable for this operation.

A throttle valve and new air intake arrangement are then made from a piece of aluminium bar, as shown by Fig 23, a lathe being required for this work. The air intake with venturi is made as nearly as possible like the existing one. The throttle valve is made as accurately as possible so that in its fully closed position it completely seals off the air intake (it is surprising on how little air an engine can run!).

The shape of valve A is such that a large motion is required to make a small variation in the size of opening. This arrangement prevents the setting from being too critical. The valve is held closed by compression spring B, and is opened against the spring by the screwing action, on the threaded valve spindle E, of gear wheel C. The gear wheel is driven by the worm D, the latter being on the shaft of a reduction gear connected to the servo-motor. The valve spindle E is prevented from rotating by the guides F. Before valve A is fully opened (spring B being then almost compressed),

the end of spindle E pushes open the limit contacts, thereby stopping the servo-motor (Fig. 24A). Reversing the motor causes the gear wheel C to screw off the valve spindle E, which, however, under the action of spring B, keeps gear wheel C bearing against bracket H. As soon as further movement of valve A is arrested by the adjustable idling stop K, gear wheel C will start to screw along spindle E away from bracket H. In doing so, it will push open the limit contacts L and so stop the servo-motor. This should be made to occur before gear wheel C moves out of mesh from worm D or else further action of the throttle will be paralysed (Fig. 24B).

Two fuel tanks are required, one feeding the high speed jet, which is conventional in every way, and the other feeding the low speed jet under slight pressure.

A high speed jet, which is normally all that is supplied on these small engines, works with a slight suction head and a relatively large bore. As the engine is throttled down, however, the mixture becomes leaner, leading to an unstable condition, and since any further reduction of the engine speed causes the mixture to become leaner still, the engine stops. To prevent this, the low speed jet is fitted which has a small bore and is pressure fed. Thus the fuel supply to this jet is substantially independent of engine speed. Its effect is therefore to make the mixture richer as the engine speed falls, thereby compensating for the effect of the high speed jet. The engine is adjusted so that, with the slow speed jet closed, it runs normally at high speed with the correct setting of the high speed jet. The slow speed jet is now opened slightly and the engine throttled back. The jet is adjusted until the engine is idling correctly. Smooth speed variation over practically the whole range from maximum revs. down to about 1,500 r.p.m. can now be obtained.

The tank feeding the low speed jet is pressurized by means of a rubber balloon connected to the air space of the tank, as shown by Fig. 25. The balloon is inflated by means of a cycle pump connected to a tyre valve fitted to the air connection between the tank and the balloon. The balloon is sufficiently inflated, so that when the tank is empty there is still enough air to distend the rubber sides of the balloon. The latter keeps the air pressure in the tank constant right up to the moment when the tank is empty. This is due to the interesting fact that as a balloon is deflated, its air pressure remains constant, and even tends to rise slightly until the rubber is no longer distended.

Note, the tank for the high speed jet is left open to the atmosphere and is not pressurized. It is possible to feed both jets from the pressurized tank only, but a small chamber with a float-

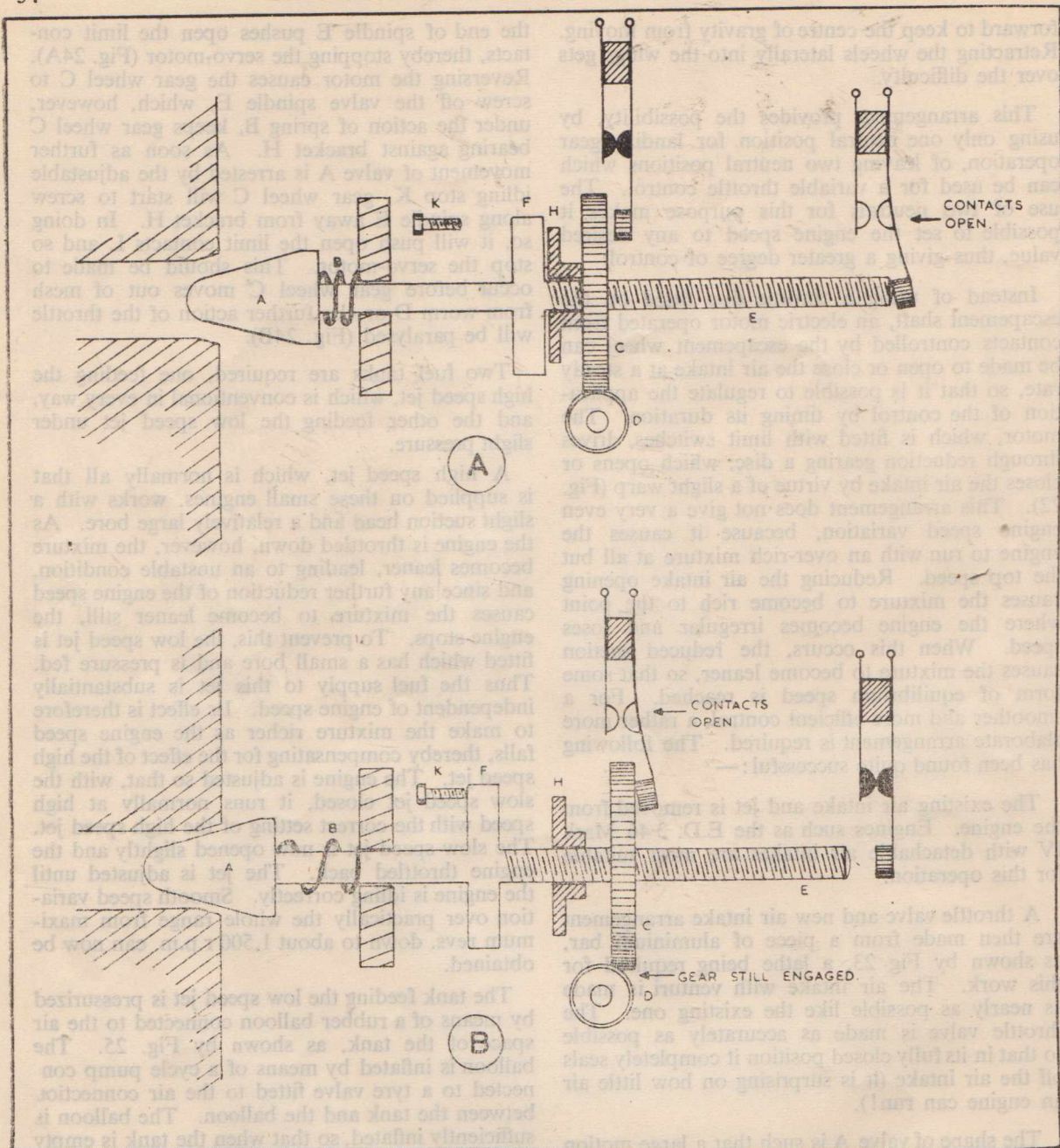

Fig. 24.

A.—Throttle fully open, having operated the limit contacts.

B.—Throttle fully closed.

The gear having moved to the right operates the second set of limit contacts.

operated valve would then be required to provide the feed to the high speed jet at atmospheric pressure, and this complication is hardly justified.

To avoid flooding of the engine should the latter stall with the idling jet turned on, it should be mounted so that the air intake is facing downwards. The fuel, which is supplied under pressure, will

then drip clear of the engine when the latter is not running.

This form of throttle control gives a wide range of engine speeds, and it is possible not only to control the altitude and the rate of climb, but also to make quite satisfactory landings with power on.

As must be expected, the weight of all the equip-

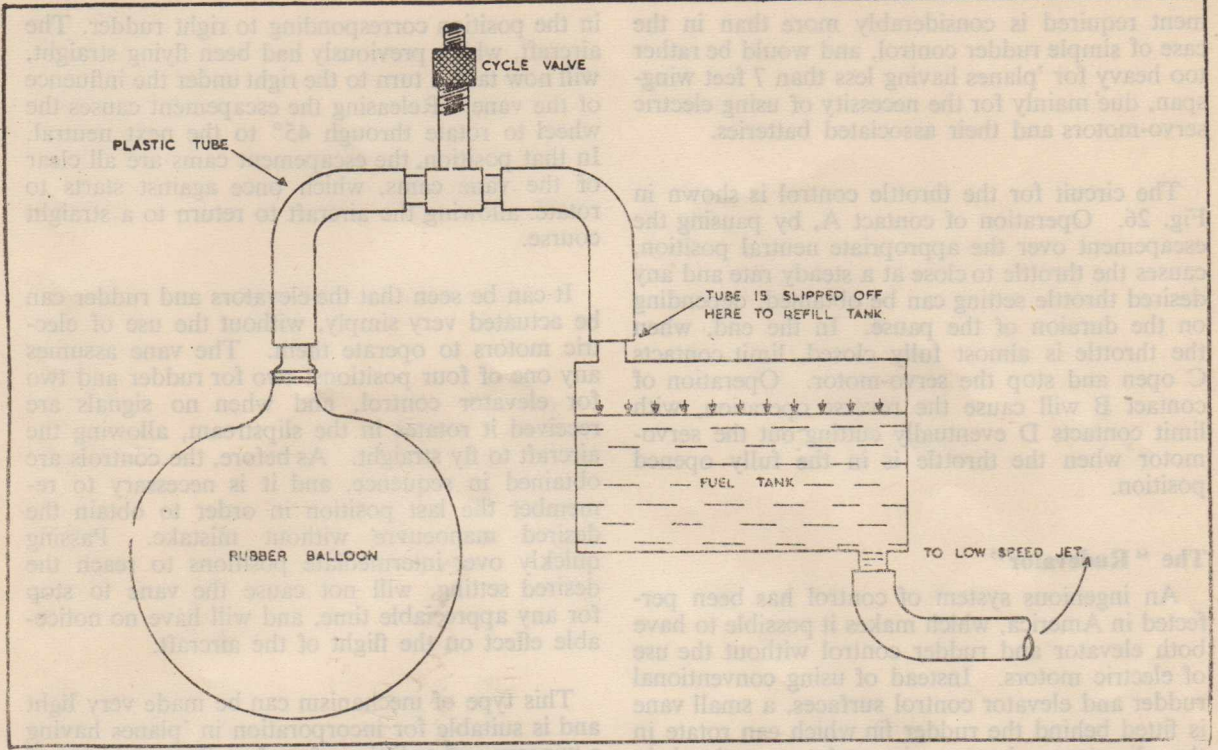

Fig. 25.
Pressurized Fuel Tank, for the Low Speed Jet.

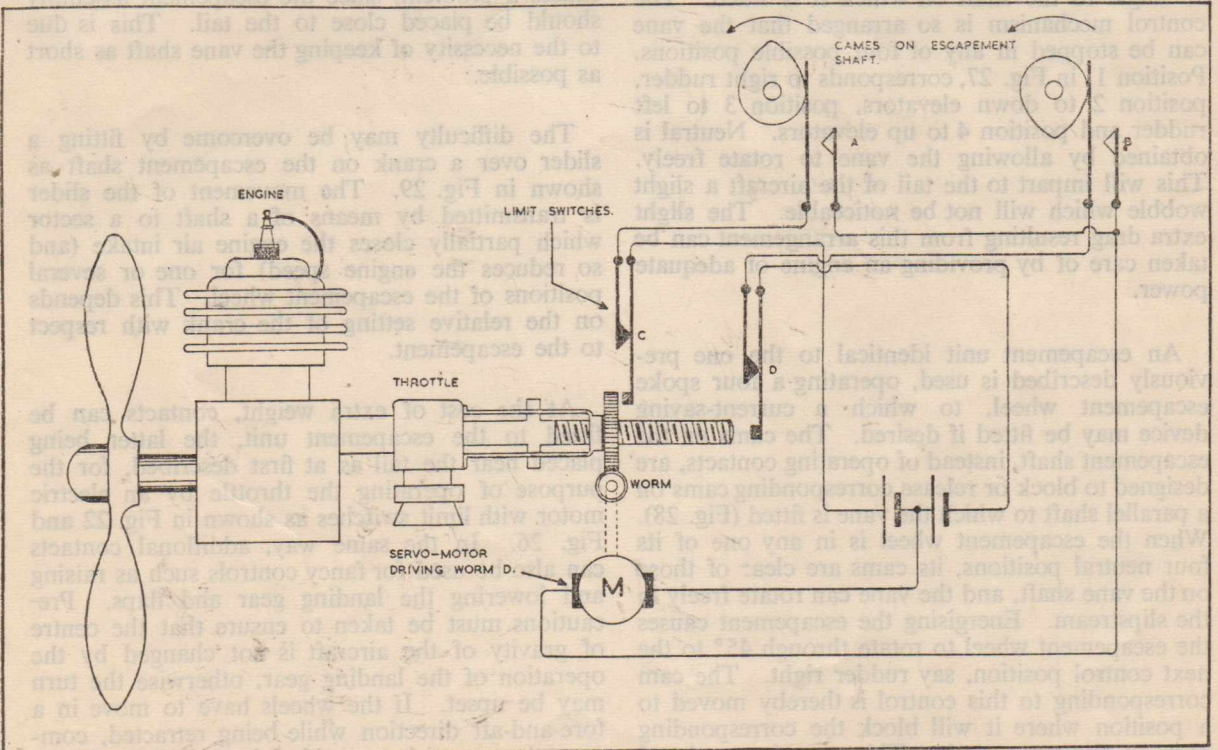

Fig. 26.
The Electrical Circuit for operating the Throttle Control.

ment required is considerably more than in the case of simple rudder control, and would be rather too heavy for 'planes having less than 7 feet wingspan, due mainly for the necessity of using electric servo-motors and their associated batteries.

The circuit for the throttle control is shown in Fig. 26. Operation of contact A, by pausing the escapement over the appropriate neutral position, causes the throttle to close at a steady rate and any desired throttle setting can be obtained, depending on the duration of the pause. In the end, when the throttle is almost fully closed, limit contacts C open and stop the servo-motor. Operation of contact B will cause the reverse operation, with limit contacts D eventually cutting out the servo-motor when the throttle is in the fully opened position.

The "Rudevator"

An ingenious system of control has been perfected in America, which makes it possible to have both elevator and rudder control without the use of electric motors. Instead of using conventional rudder and elevator control surfaces, a small vane is fitted behind the rudder fin which can rotate in the slip-stream because its ends are twisted in propeller-like fashion. The vane itself is bent at an angle to the shaft on which it is fitted. The control mechanism is so arranged that the vane can be stopped in any of four possible positions. Position 1, in Fig. 27, corresponds to right rudder, position 2 to down elevators, position 3 to left rudder and position 4 to up elevators. Neutral is obtained by allowing the vane to rotate freely. This will impart to the tail of the aircraft a slight wobble which will not be noticeable. The slight extra drag resulting from this arrangement can be taken care of by providing an engine of adequate power.

An escapement unit identical to the one previously described is used, operating a four spoke escapement wheel, to which a current-saving device may be fitted if desired. The cams on the escapement shaft, instead of operating contacts, are designed to block or release corresponding cams on a parallel shaft to which the vane is fitted (Fig. 28). When the escapement wheel is in any one of its four neutral positions, its cams are clear of those on the vane shaft, and the vane can rotate freely in the slipstream. Energising the escapement causes the escapement wheel to rotate through 45° to the next control position, say rudder right. The cam corresponding to this control is thereby moved to a position where it will block the corresponding cam on the vane shaft. This cam is so placed with respect to the vane, that the latter is stopped

in the position corresponding to right rudder. The aircraft, which previously had been flying straight, will now take a turn to the right under the influence of the vane. Releasing the escapement causes the wheel to rotate through 45° to the next neutral. In that position, the escapement cams are all clear of the vane cams, which once again starts to rotate, allowing the aircraft to return to a straight course.

It can be seen that the elevators and rudder can be actuated very simply, without the use of electric motors to operate them. The vane assumes any one of four positions; two for rudder and two for elevator control, and when no signals are received it rotates in the slipstream, allowing the aircraft to fly straight. As before, the controls are obtained in sequence, and it is necessary to remember the last position in order to obtain the desired manoeuvre without mistake. Passing quickly over intermediate positions to reach the desired setting, will not cause the vane to stop for any appreciable time, and will have no noticeable effect on the flight of the aircraft.

This type of mechanism can be made very light and is suitable for incorporation in 'planes having a wingspan of as little as four feet. The provision of simple throttle control by means of a disc valve causes a problem, since the escapement assembly should be placed close to the tail. This is due to the necessity of keeping the vane shaft as short as possible.

The difficulty may be overcome by fitting a slider over a crank on the escapement shaft as shown in Fig. 29. The movement of the slider is transmitted by means of a shaft to a sector which partially closes the engine air intake (and so reduces the engine speed) for one or several positions of the escapement wheel. This depends on the relative setting of the crank with respect to the escapement.

At the cost of extra weight, contacts can be fitted to the escapement unit, the latter being placed near the tail as at first described, for the purpose of operating the throttle by an electric motor with limit switches as shown in Fig. 22 and Fig. 26. In the same way, additional contacts can also be used for fancy controls such as raising and lowering the landing gear and flaps. Precautions must be taken to ensure that the centre of gravity of the aircraft is not changed by the operation of the landing gear, otherwise the turn may be upset. If the wheels have to move in a fore-and-aft direction while being retracted, compensation must be provided by moving suitable counter-weights during the process.

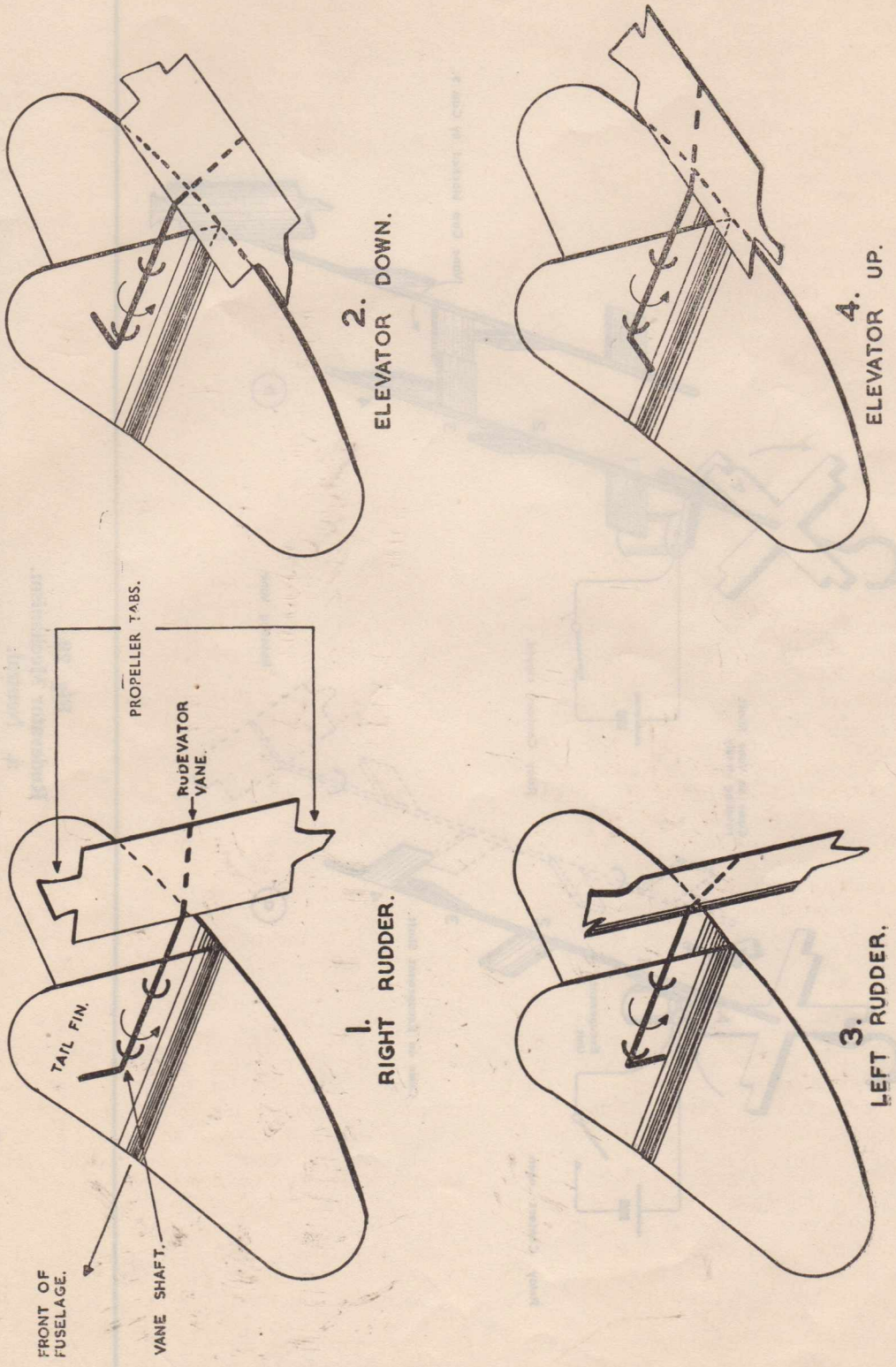

Fig. 27. Rudder Control, showing the four possible positions of the vane. In straight flight the vane rotates freely.

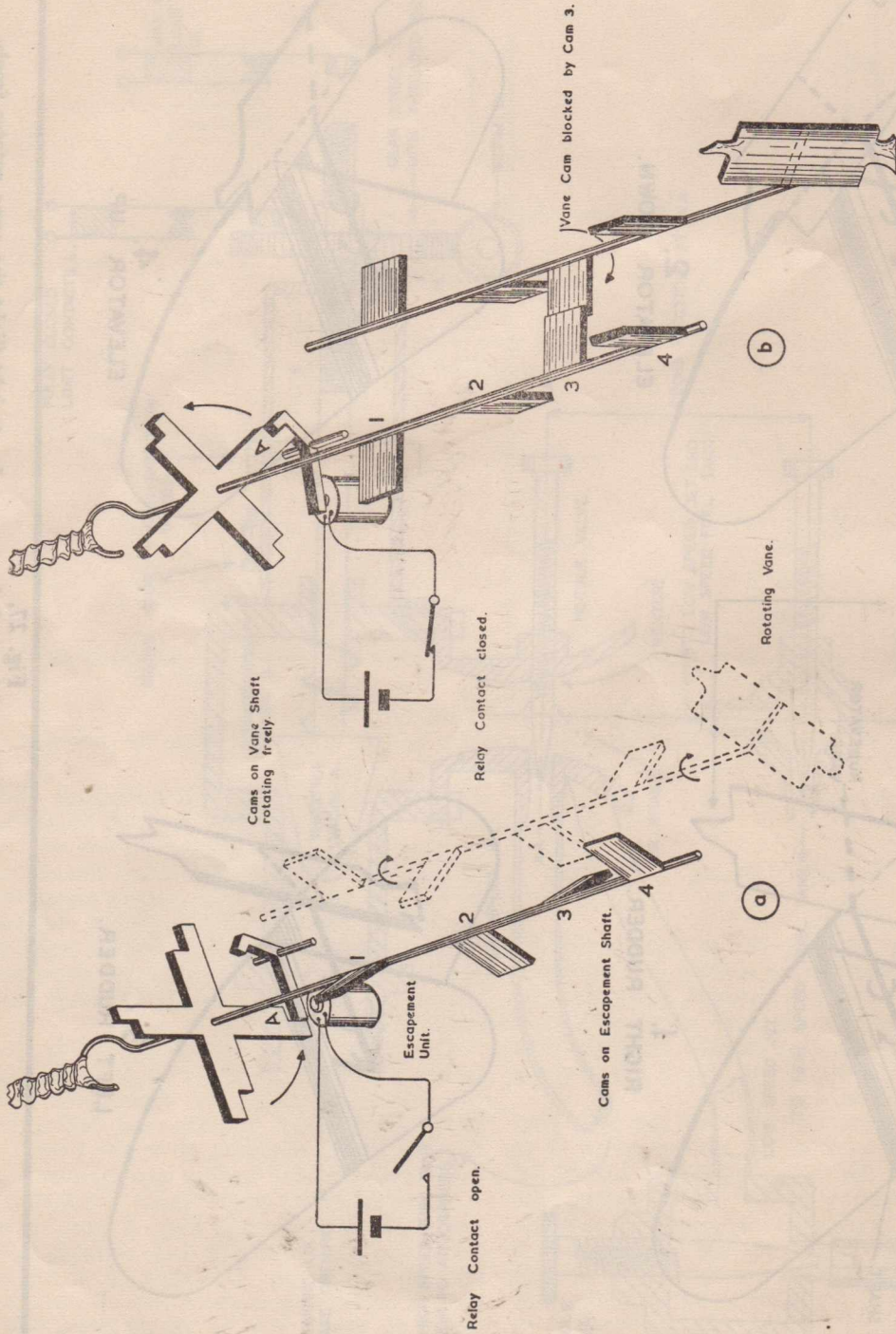

Fig. 28.
Rudevator Mechanism.
 a. Neutral.
 b. Right Rudder.

Escapement cams are clear of vane cams, which rotate freely under the propeller action of the vane.

Escapement movement brings Cam 3 into the path of the corresponding vane cam, stopping the vane in the appropriate position.

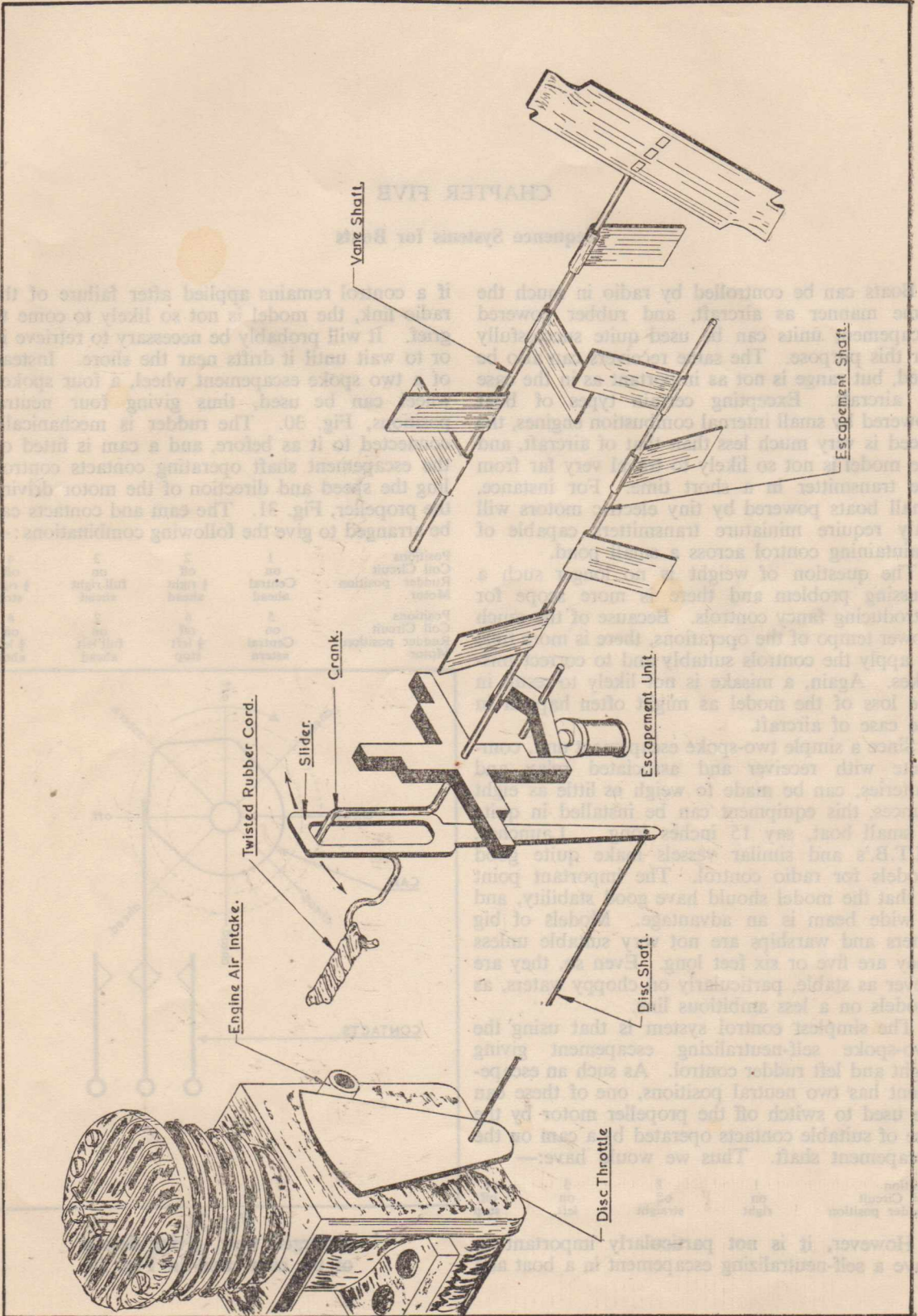

Fig. 29.
Rudevator with two-speed Throttle Control.

CHAPTER FIVE

Sequence Systems for Boats

Boats can be controlled by radio in much the same manner as aircraft, and rubber powered escapement units can be used quite successfully for this purpose. The same receivers can also be used, but range is not as important as in the case of aircraft. Excepting certain types of boat powered by small internal combustion engines, the speed is very much less than that of aircraft, and the model is not so likely to travel very far from the transmitter in a short time. For instance, small boats powered by tiny electric motors will only require miniature transmitters capable of maintaining control across a small pond.

The question of weight is no longer such a pressing problem and there is more scope for introducing fancy controls. Because of the much slower tempo of the operations, there is more time to apply the controls suitably and to correct mistakes. Again, a misake is not likely to result in the loss of the model as might often happen in the case of aircraft.

Since a simple two-spoke escapement unit, complete with receiver and associated relay and batteries, can be made to weigh as little as eight ounces, this equipment can be installed in quite a small boat, say 15 inches long. Launches, M.T.B.'s and similar vessels make quite good models for radio control. The important point is that the model should have good stability, and a wide beam is an advantage. Models of big liners and warships are not very suitable unless they are five or six feet long. Even so, they are never as stable, particularly on choppy waters, as models on a less ambitious line.

The simplest control system is that using the two-spoke self-neutralizing escapement giving right and left rudder control. As such an escapement has two neutral positions, one of these can be used to switch off the propeller motor by the use of suitable contacts operated by a cam on the escapement shaft. Thus we would have:—

Position	1	2	3	4
Coil Circuit	on	off	on	off
Rudder position	right	straight	left	stop

However, it is not particularly important to have a self-neutralizing escapement in a boat and

if a control remains applied after failure of the radio link, the model is not so likely to come to grief. It will probably be necessary to retrieve it, or to wait until it drifts near the shore. Instead of a two spoke escapement wheel, a four spoked wheel can be used, thus giving four neutral positions, Fig. 30. The rudder is mechanically connected to it as before, and a cam is fitted on the escapement shaft operating contacts controlling the speed and direction of the motor driving the propeller, Fig. 31. The cam and contacts can be arranged to give the following combinations:—

Positions	1	2	3	4
Coil Circuit	on	off	on	off
Rudder position	Central ahead	$\frac{1}{2}$ right ahead	full right ahead	$\frac{1}{2}$ right stop
Positions	5	6	7	8
Coil Circuit	on	off	on	off
Rudder position	Central astern	$\frac{1}{2}$ left stop	full left ahead	$\frac{1}{2}$ left ahead

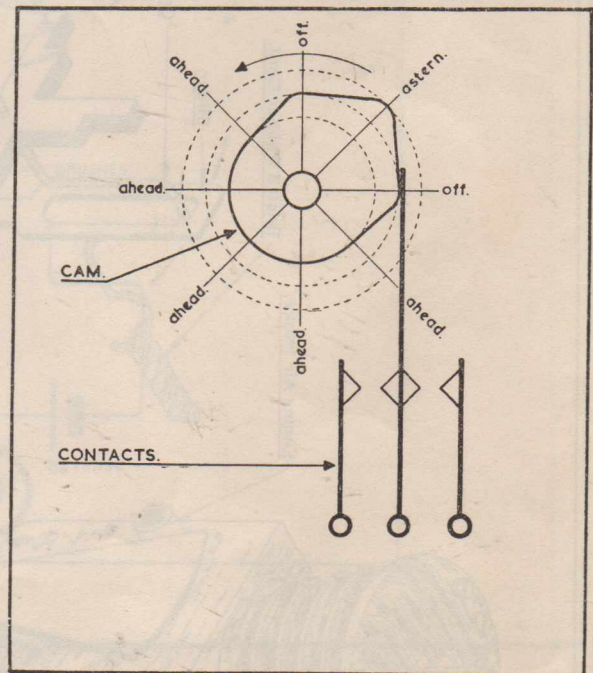

Fig. 31.
Enlarged view, giving details
of the cam used in Fig. 30.

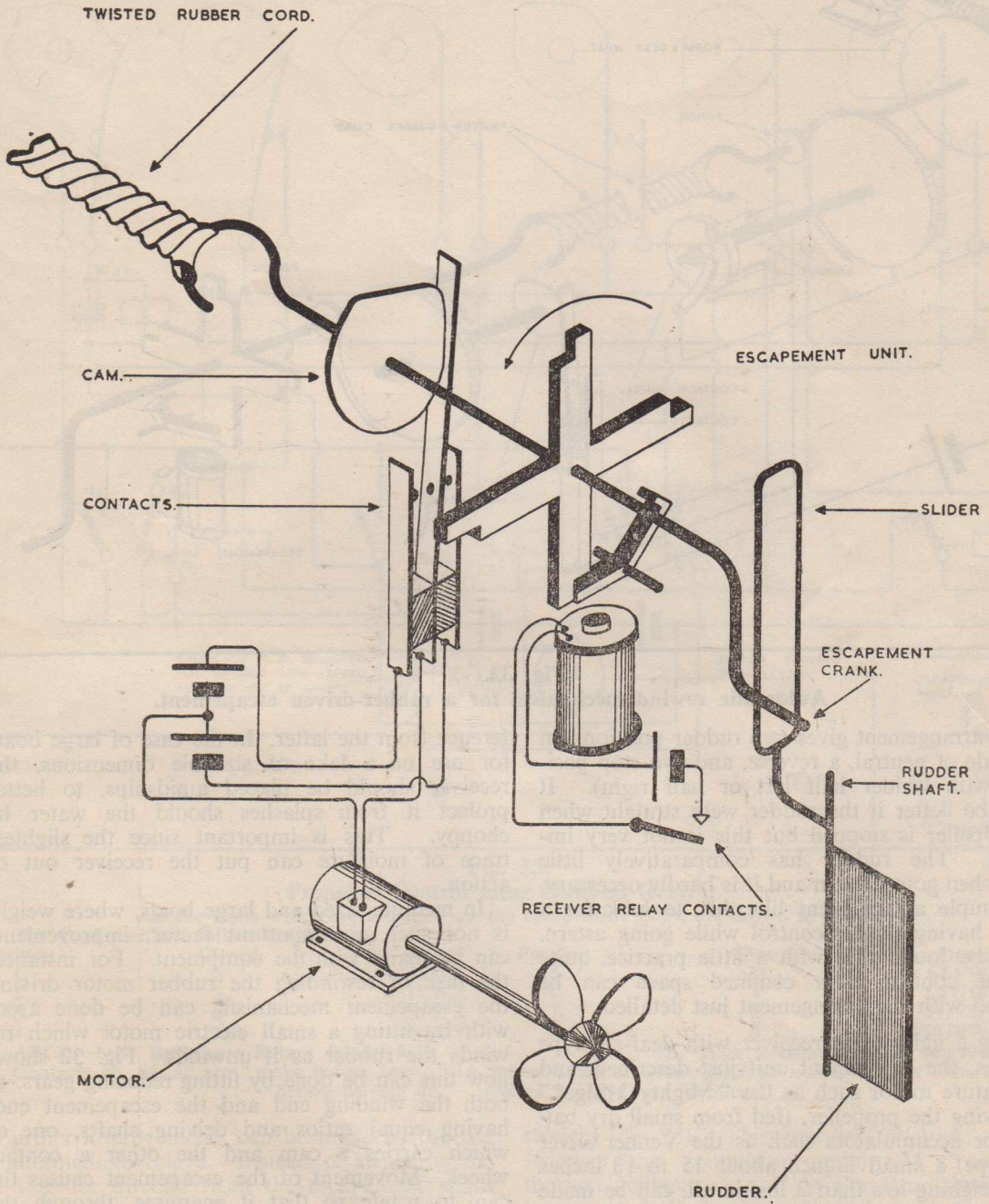

Fig. 30.
Rudder and Propeller Control for a Boat.

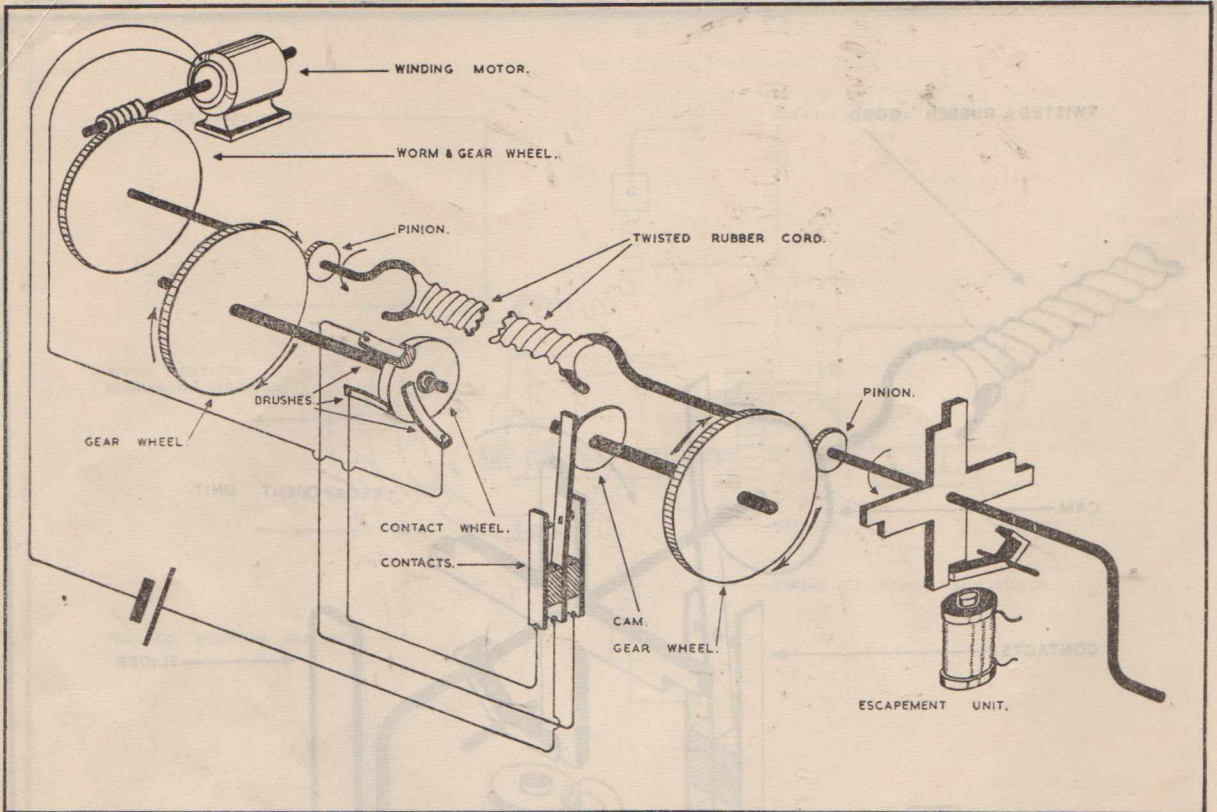

Fig. 32.

Automatic rewind mechanism for a rubber-driven escapement.

This arrangement gives two rudder positions on each side of neutral, a reverse, and two stop positions (with rudder half left or half right). It would be better if the rudder were straight when the propeller is stopped but this is not very important. The rudder has comparatively little effect when going astern and it is hardly necessary, in a simple arrangement like this, to look for a system having rudder control while going astern. It will be found that with a little practice, quite accurate control in a confined space can be obtained with the arrangement just detailed.

Using a lightweight receiver with deaf-aid type batteries, the escapement unit just described, and a miniature motor such as the "Mighty Midget" for driving the propeller, (fed from small dry batteries or accumulators such as the Venner silver zinc type) a small launch about 15 to 18 inches long weighing less than 2 lbs. in all, can be made and operated in confined spaces. Even a bath tub would do for the purpose!

Similar equipment can be used in bigger boats without alteration, except that a larger motor and heavier batteries would be required for propulsion. It is desirable to keep the receiver as far as possible from the motor to reduce radio inter-

ference from the latter. In the case of large boats for use on a lake of sizeable dimensions, the receiver should be placed amidships, to better protect it from splashes should the water be choppy. This is important since the slightest trace of moisture can put the receiver out of action.

In medium sized and large boats, where weight is not such an important factor, improvements can be made with the equipment. For instance, the task of rewinding the rubber motor driving the escapement mechanism, can be done away with by fitting a small electric motor which rewinds the rubber as it unwinds. Fig. 32 shows how this can be done by fitting reducing gears, at both the winding end and the escapement end, having equal ratios and driving shafts, one of which carries a cam and the other a contact wheel. Movement of the escapement causes the cam to rotate so that it energises, through the contacts, one of the brushes fitted to the contact wheel and so operates the winding motor. As the latter starts to wind, the contact wheel will rotate until contact with the energised brush is broken, thus stopping the motor. Further movement of the cam energises the second brush, causing the contact wheel to complete the revolution.

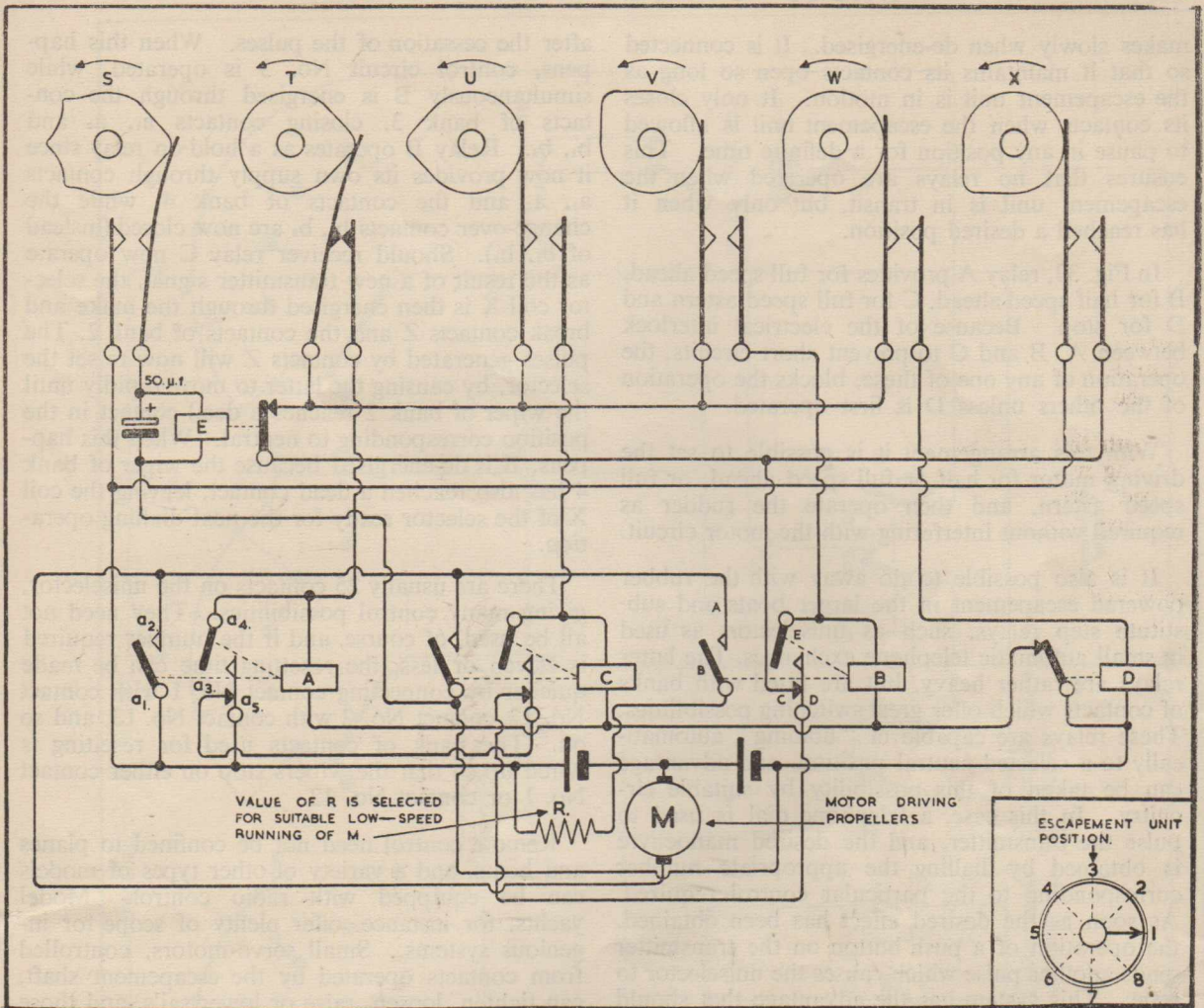

Fig. 33.

Propeller Control using Hold-on Relays.

All the cams which are mounted on the escapement shaft, are shown in position 1.

The Cam positions follow the sequence:—

Position	Closed	Open	Position	Closed	Open
1.	T	SUVWX	5.	U	STVWX
2.	S	TUVWX	6.	V	STUVWX
3.	S	TUVWX	7.	S	TUVWX
4.	WX	STUV	8.	S	TUVWX

ABCD—Low Resistance Relays (about 8Ω)

E—High Resistance Relay (4,000Ω)

Contacts a3, a4, a5 are "make before break," i.e. when Relay A is energised a5 makes contact with a4 before leaving a3. Relays B and C are identical.

Further improvements can be made by the use of intermediate relays. Instead of switching the main motor directly from the escapement shaft, the latter can be made to operate "hold-on" relays which switch the motor ahead or astern. A time-lag relay is also used, so that the hold-on relays are only pulled in or released when the escapement wheel dwells in the appropriate positions, but not when it merely passes over them.

The relays are connected so that the motor is switched for forward movement of the boat when the escapement unit is in position 1 (rudder

straight Fig. 33). This energises relay A, which switches the propulsion motor M "ahead" through contacts a₁, a₂. At the same time contacts a₄, a₅ hold the relay closed by completing an alternative circuit, even when the escapement unit moves on to other positions. Because contacts a₄, a₅ are now open, none of the other relays can be operated, except D in position 4, which, by breaking the return circuit of the hold-on relays A, B or C, causes the latter to drop out, and Motor M to stop.

Relay E breaks quickly on being energised, but

makes slowly when de-energised. It is connected so that it maintains its contacts open so long as the escapement unit is in motion. It only closes its contacts when the escapement unit is allowed to pause in any position for a definite time. This ensures that no relays are operated when the escapement unit is in transit, but only when it has reached a desired position.

In Fig. 33, relay A provides for full speed ahead, B for half speed ahead, C for full speed astern and D for stop. Because of the electrical interlock between A, B and C to prevent short circuits, the operation of any one of these, blocks the operation of the others unless D is first operated.

With this arrangement it is possible to set the driving motor for half or full speed ahead, or full speed astern, and then operate the rudder as required without interfering with the motor circuit.

It is also possible to do away with the rubber powered escapement in the larger boats and substitute step relays, such as uniselectors as used in small automatic telephone exchanges. The latter relays are rather heavy, but are fitted with banks of contacts which offer great switching possibilities. These relays are capable of "homing" automatically to a selected neutral position, and advantage can be taken of this possibility by suitable circuitry. In this case, a telephone dial is used to pulse the transmitter, and the desired manoeuvre is obtained by dialling the appropriate number corresponding to the particular control required. As soon as the desired effect has been obtained, the operation of a push button on the transmitter sends another pulse which causes the uniselector to reset. This system has the advantage that should an error occur when dialling for a particular control, it will not affect the selection of the correct position immediately afterwards.

A four-bank uniselector is used as shown in Fig. 34, in conjunction with a slow-release relay A and a change-over relay B. As before, the function of the slow-release relay A is to prevent any switching of the intermediate circuits while the selector is operating, only the circuit over which it finally stops being operated. Bank 1 selects the controls to be operated, banks 2, 3 and 4 being required to operate the auxiliary circuits needed for resetting the selector. The operation is as follows:—

Dialling, say, number 3 on the telephone dial at the transmitting end causes the transmitter to send three pulses. The receiver relay C closes its contacts 3 times, energising coil X of the selector and causing the latter to move three steps to contact 3. While the pulses are being sent, the contacts C₁, C₂ of A are held open, and close only after an interval of about 1/2 to 1/5th of a second

after the cessation of the pulses. When this happens, control circuit No. 3 is operated, while simultaneously B is energised through the contacts of bank 3, closing contacts a₁, a₂ and b₁, b₂. Relay B operates as a hold-on relay since it now provides its own supply through contacts a₁, a₂ and the contacts of bank 4, while the change-over contacts b₁, b₂ are now closed (instead of b₁, b₂). Should receiver relay C now operate as the result of a new transmitter signal, the selector coil X is then energised through the make and break contacts Z and the contacts of bank 2. The pulses generated by contacts Z will now re-set the selector, by causing the latter to move rapidly until the wiper of bank 2 reaches a dead contact in the position corresponding to neutral. When this happens, B is de-energised because the wiper of bank 4 has also reached a dead contact, leaving the coil X of the selector ready for the next dialling operation.

There are usually 25 contacts on the uniselector, giving many control possibilities. They need not all be used, of course, and if the number required is eleven or less, the resetting time can be made quicker by connecting contact No. 1 with contact No. 12, contact No. 2 with contact No. 13, and so on. The bank of contacts used for resetting is wired up so that the wipers stop on either contact No. 1 or contact No. 12.

Remote control need not be confined to planes and boats, and a variety of other types of models can be equipped with radio control. Model yachts, for instance, offer plenty of scope for ingenious systems. Small servo-motors, controlled from contacts operated by the escapement shaft, can tighten, loosen, raise or lower sails, and those particularly interested in yachting technique will get considerable satisfaction in operating this form of control.

Cars may be operated in a very similar manner to boats. The rudder is replaced by the steering mechanism for the front wheels. However, because the energy required to operate the front wheels is usually greater than that required for operating the rudder, a small servo-motor may be more satisfactory than direct-actuation by a rubber powered escapement.

Automatic Pulsar Unit

In its most usual form, sequence control involves the sending of an appropriate number of short pulses for control selection, followed by a long pulse, for control application. The number of short pulses to be sent for selection of a particular control, depends on the previous setting. All this has to be done by hand switching of the transmitter. Apart from the liability of making mistakes, this arrangement requires a lot of

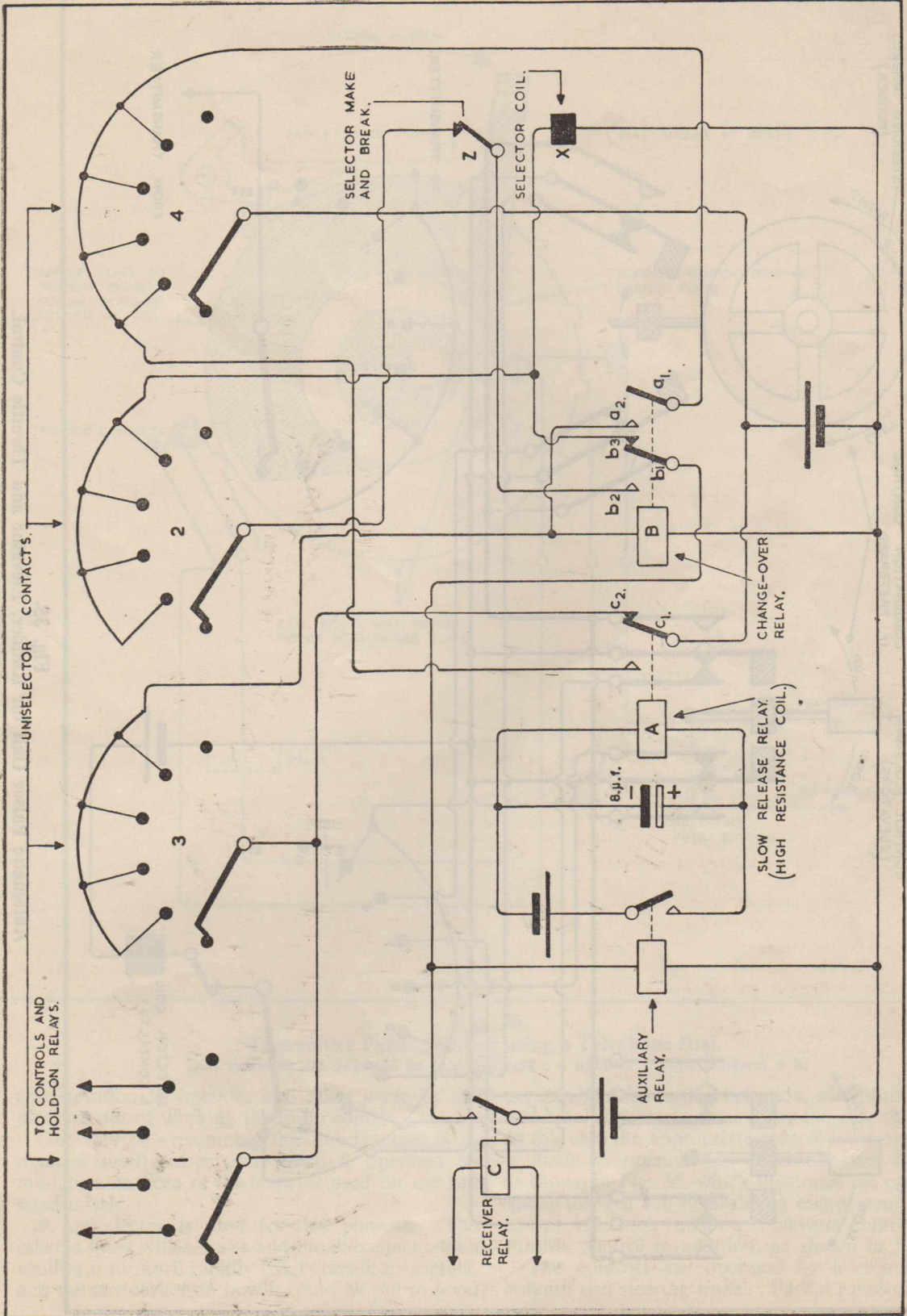

Fig. 34.
Control Selection with Automatic Resetting

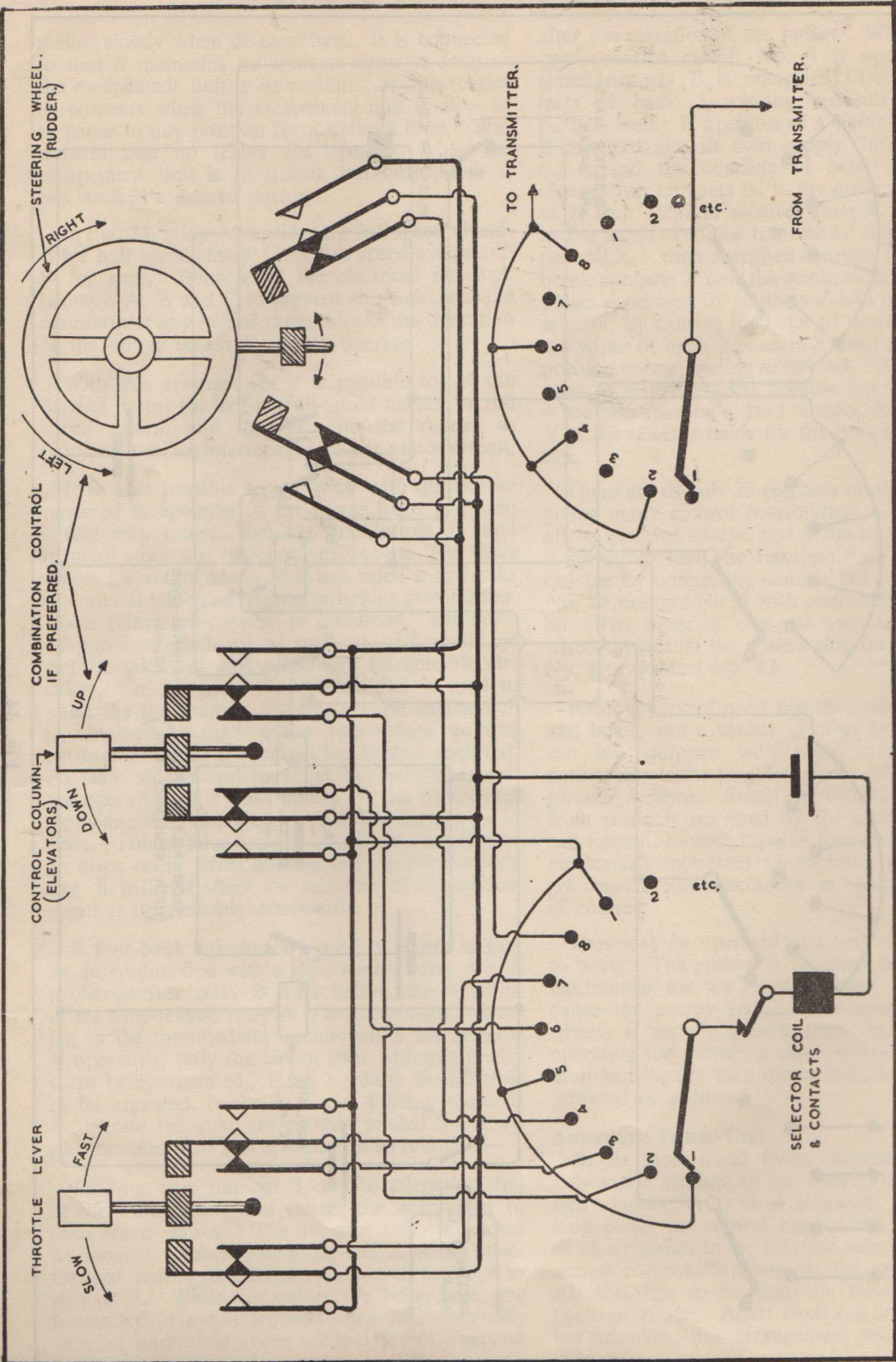

Fig. 35.
Automatic Pulsar Unit for Rudder, Elevator and Throttle Control.
Sequence.

- 1. Neutral
- 2. Up
- 3. Fast (Neutral)
- 4. Left
- 5. Neutral
- 6. Down
- 7. Slow (Neutral)
- 8. Right

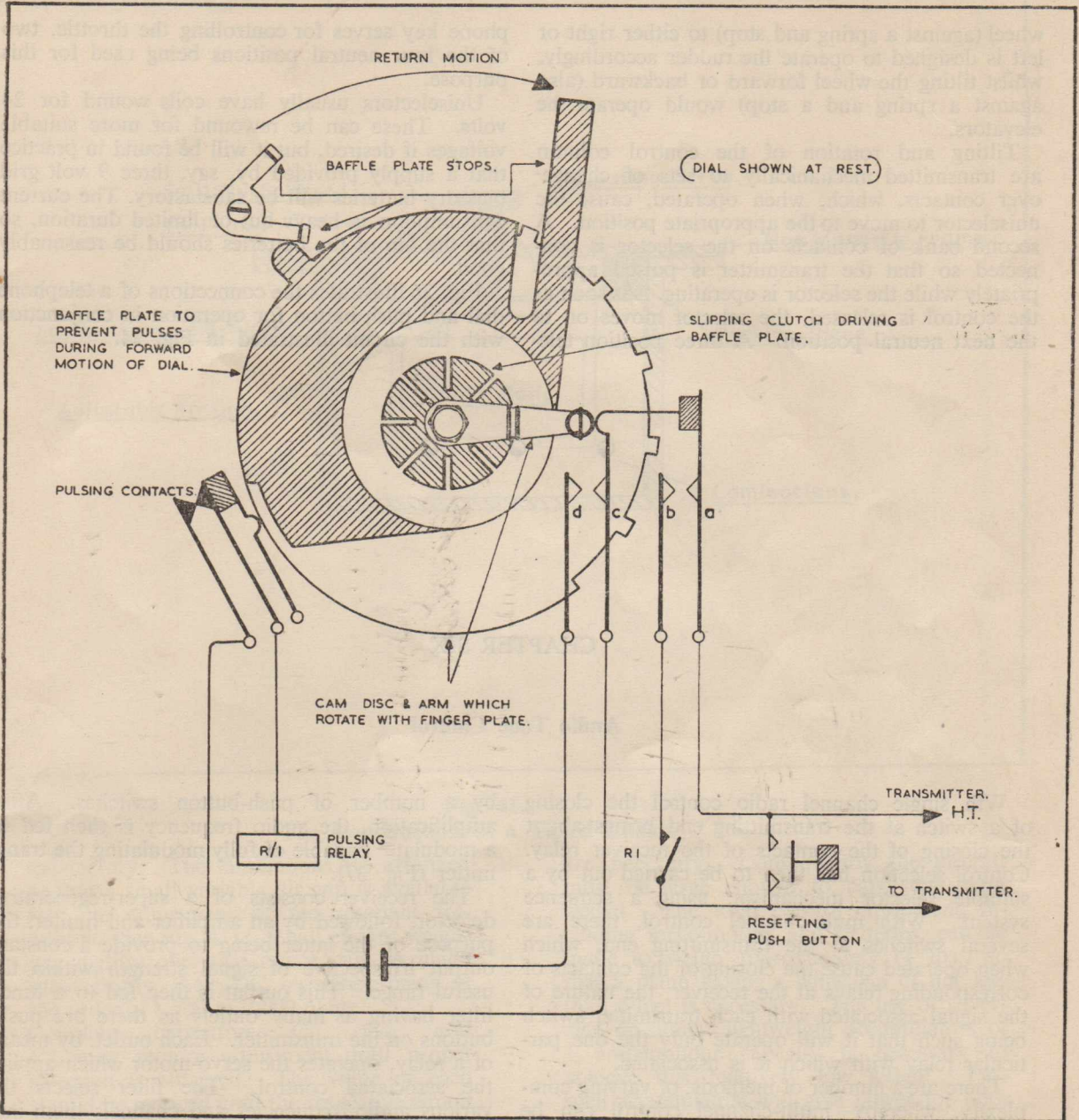

Fig. 36.
Transmitter Pulsing Circuit using a Telephone Dial.
 Dial contacts are adjusted so that contacts c d operate before contacts a b.

concentration to operate, and takes some of the pleasure out of working the radio control.

One way of overcoming this disadvantage is to make a small pulser unit, which is operated by miniature replicas of the controls used on the full sized article.

A uniselector is used for this purpose. The relay is fitted with a make-and-break contact which enables it to move rapidly from contact to contact, and we saw earlier on how it could be put to good

use in a boat for control selection, using this make-and-break feature to reset it for the next operation. In this case the appropriate control lever or wheel, is made to operate sets of change-over contacts as shown in Fig. 35, which illustrates the case of a 'plane using a self-neutralizing escapement. This can provide both rudder and elevator control, with throttle control in addition, as shown in Fig. 29.

The controls are operated by a combination column and steering wheel. Partial rotation of the

wheel (against a spring and stop) to either right or left is designed to operate the rudder accordingly, whilst tilting the wheel forward or backward (also against a spring and a stop) would operate the elevators.

Tilting and rotation of the control column are transmitted mechanically to sets of change-over contacts, which, when operated, cause the unselector to move to the appropriate position. A second bank of contacts on the selector is connected so that the transmitter is pulsed appropriately while the selector is operating. As soon as the control is released, the selector moves on to the next neutral position. A three position tele-

phone key serves for controlling the throttle, two of the four neutral positions being used for this purpose.

Uniselectors usually have coils wound for 24 volts. These can be rewound for more suitable voltages if desired, but it will be found in practice that a supply provided by, say, three 9 volt grid bias dry batteries will be satisfactory. The current consumption is heavy but of limited duration, so that the life of the batteries should be reasonably good.

Fig. 36 illustrates the connections of a telephone dial and push button for operation in conjunction with the circuit illustrated in Fig. 34.

CHAPTER SIX

Audio Tone Control

With single channel radio control the closing of a switch at the transmitting end brings about the closing of the contacts of the receiver relay. Control selection has then to be carried out by a suitable selector mechanism, using a sequence system. With multi-channel control, there are several switches at the transmitting end, which when operated cause the closing of the contacts of corresponding relays at the receiver, the nature of the signal associated with each transmitter switch being such that it will operate only the one particular relay with which it is associated.

There are a number of methods, of varying complexity, whereby multi-channel control can be achieved. For model control, where the equipment must be kept as light and simple as possible, audio modulation is the most practical solution. Super-regenerative receivers, which have the advantage of combining simplicity with sensitivity, will handle audio frequencies up to 2,000 or 3,000 c/s without difficulty but trouble may be experienced at higher frequencies due to interaction with the quench frequency. However, quite a few channels can be accommodated in the lower audio-frequency range.

The transmitter is provided with an audio oscillator, the frequency of which can be selected

by a number of push-button switches. After amplification, the audio frequency is then fed to a modulator capable of fully modulating the transmitter (Fig. 37).

The receiver consists of a super-regenerative detector, followed by an amplifier and limiter, the purpose of the latter being to provide a constant output irrespective of signal strength within the useful range. This output is then fed to a tuned filter having as many outlets as there are push-buttons on the transmitter. Each outlet, by means of a relay, operates the servo-motor which applies the associated control. The filter selects the various audio frequencies and channels them into their appropriate circuits. It may consist of a series of tuned chokes, each choke being tuned to a particular audio frequency, which it allows to pass on for further amplification so that it can operate a relay, while it remains unresponsive to all other frequencies.

Instead of tuned chokes, the filter may consist of tuned reeds, fitted with contacts, each tuned to a particular audio frequency which causes it to vibrate and make intermittent contact with a fixed contact, thus causing a relay to close. A particular reed will not vibrate with an amplitude sufficient for it to touch the fixed contact at any

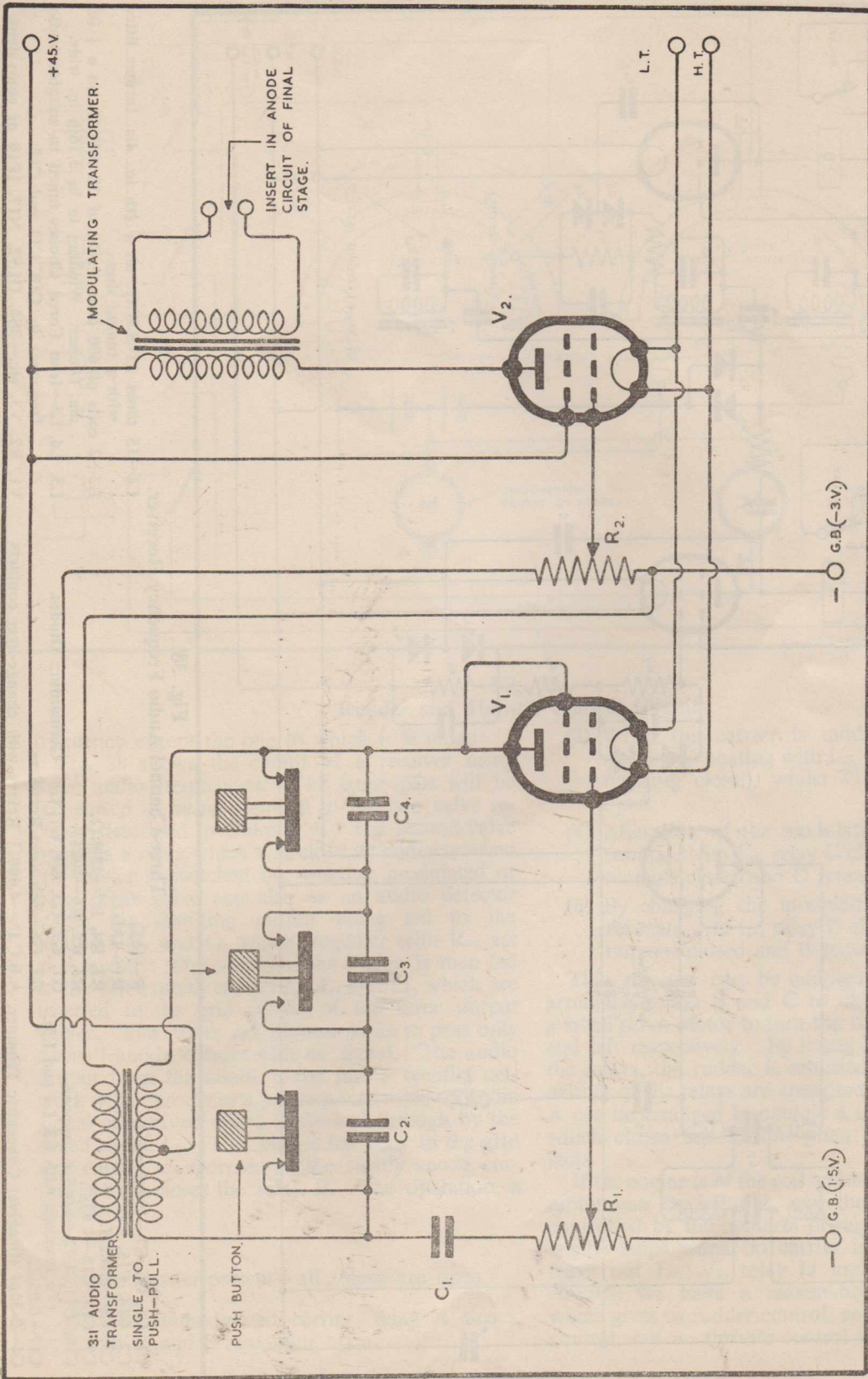

Fig. 37. Audio Oscillator and Modulator, suitable for use with Transmitter shown by Fig. 11. The circuit will oscillate only when one or other push-button is pressed.
 R1—100k Ω Potentiometer, adjusted to the lowest setting which will give stable oscillations.
 R2—500k Ω Potentiometer.

Fig. 11. The circuit will oscillate only when one or other push-button is pressed.
 R1—100k Ω Potentiometer, adjusted to the lowest setting which will give stable oscillations.
 R2—500k Ω Potentiometer.

C1—0.1 μ f Paper.
 C2, C3, C4—Selected to give the desired audio frequencies.
 V1, V2—3S4, DL92, N17, 1P10 or equivalent.

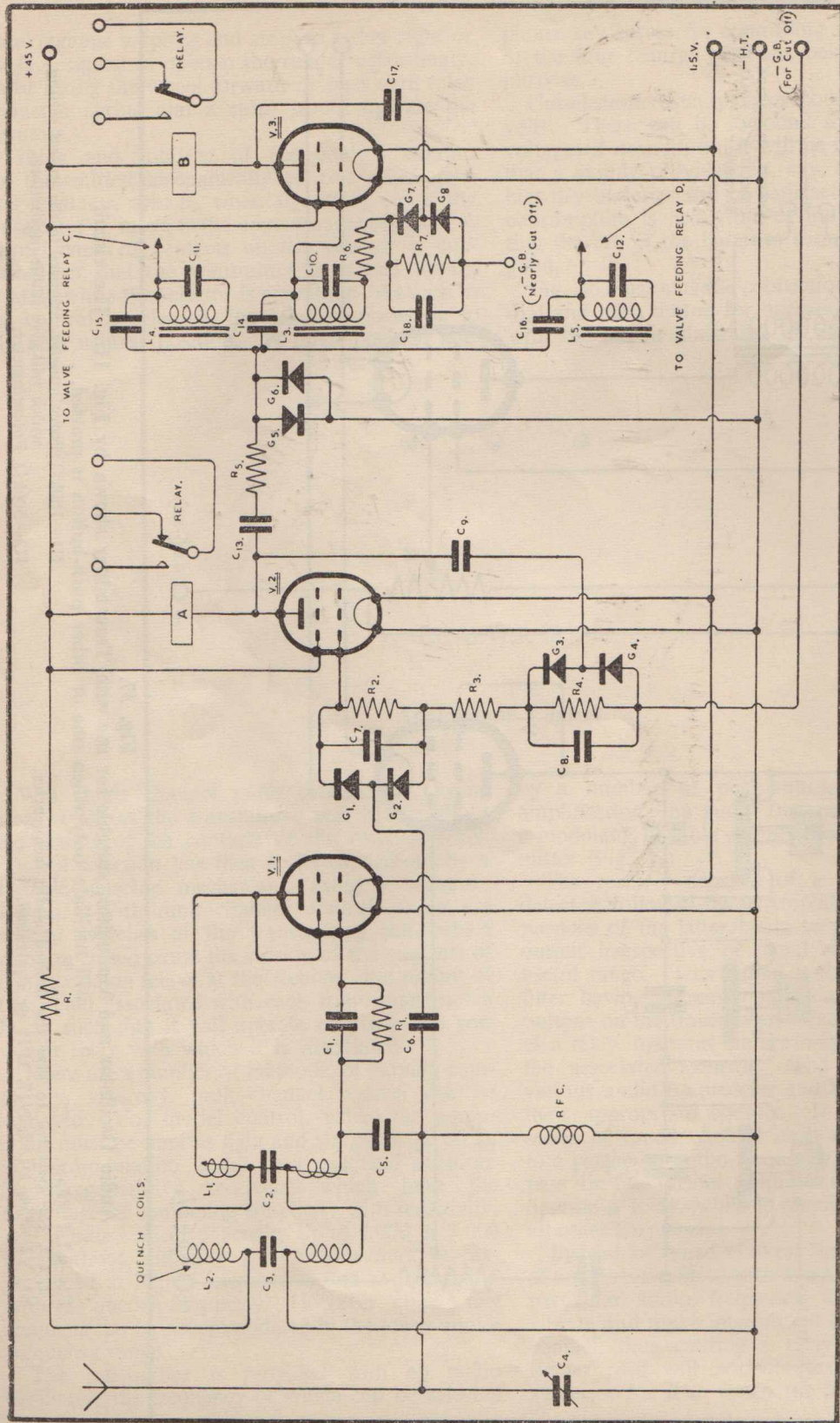

Fig. 38.

Three-Channel Audio Frequency Receiver.

- C1, C5, C6, C7—100pf mica.
- C2, C14, C15, C16—250pf mica.
- C3, C8—0.002 μ f.
- C9, C13, C18—0.02 μ f.
- C10, C11, C12—0.005 μ f. approx.
(To resonate with L3, L4 and L5).
- C17—0.05 μ f.
- C4—3-30pf (Beehive) Concentric Trimmer.
- A, B, C, D.—4,000 Ω Relays with change-over contacts.
- R—1k Ω .
- R1—1M Ω .
- R2, R4, R7—220k Ω .
- R3, R5, R6—50k Ω .
- G1, G2, G3, G4, G7, G8—Germanium Diodes.
- G5, G6—Selenium Rectifiers.
- V1, V2, V3.—6X4, DL92, NI7, 1P10 or equivalent.
- L1—15 turns 22 S.W.G. on a $\frac{3}{8}$ th in. dia. former fitted with a tuning slug.
- L2—2 coils of 600 turns each, of 38 S.W.G. on a $\frac{1}{2}$ in. dia. former. Winding to be $\frac{3}{16}$ th in. wide.
- L3, L4, L5—Iron Cored Chokes tuned to suitable audio frequency by C10, C11 and C12.

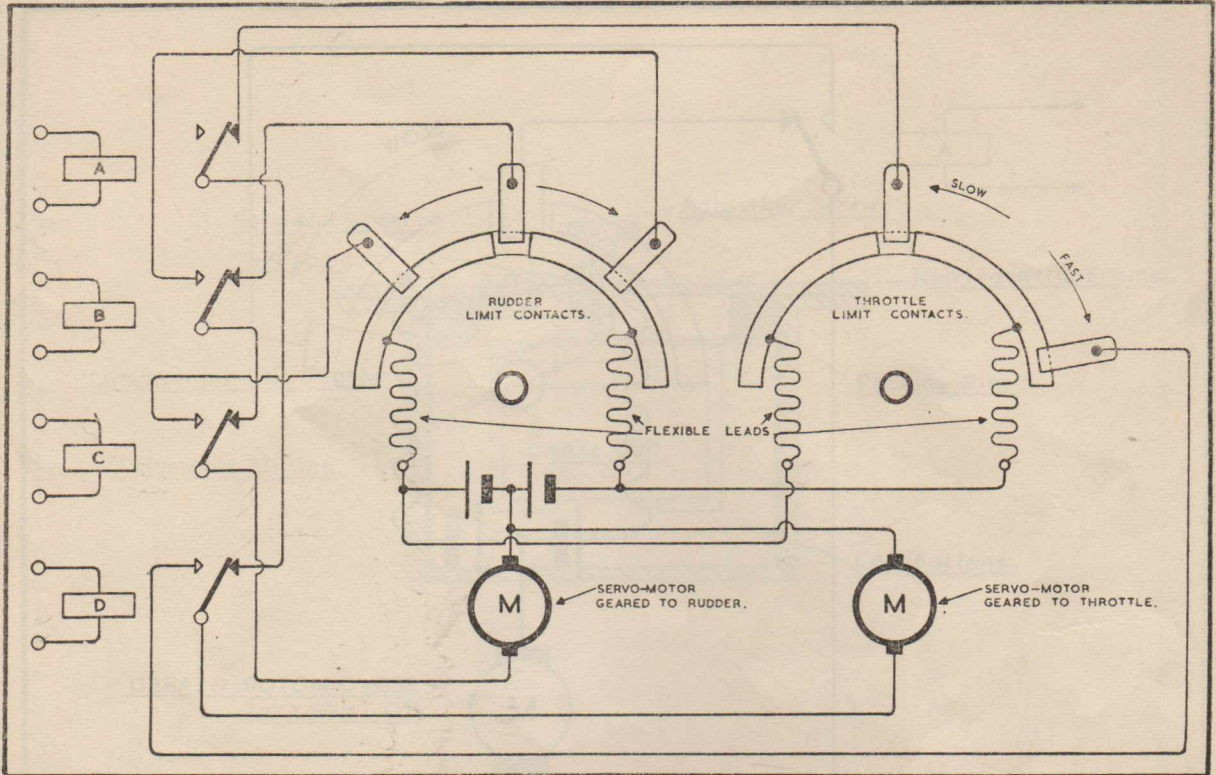

Fig. 39.
Rudder and Throttle Control Circuit.

frequency except the one to which it is tuned.

Fig. 38 shows the circuit of a receiver using three audio frequencies. The front part will be recognised as being identical to the two valve receiver described in Chapter 1. The second valve operates a relay which will close its contacts when the carrier is switched on, whether modulated or not. This valve acts also as an audio detector stage, the resulting output being fed to the rectifiers G_3 and G_4 which, together with R_3 , act as a limiter. The output of the limiter is then fed to the three tuned chokes L_3 , L_4 and L_5 , which are inserted in the grid circuit of the three output valves. The valves are biased so as to pass only a small anode current with no signal. The audio output from the anode is fed into a rectifier network which produces a positive bias when an audio signal is received which is allowed through by the tuned choke L_3 . This bias is fed back to the grid and causes an increase in the steady anode current which closes the relay B. The operation is as follows:

- (1) No carrier present—all relays are open.
- (2) With unmodulated carrier, relay A closes, B, C, and D remaining open.

- (3) When the carrier is modulated at a frequency resonating with L_3 , relay B closes, A remains closed, whilst C and D remain open.
- (4) Alteration of the modulating frequency to resonate with L_4 , relay C closes, B opens, A remains closed and D remains open.
- (5) By changing the modulating frequency to resonate with L_5 , relay D closes, C opens, A remains closed and B remains open.

This receiver can be adapted for aircraft by arranging relays B and C to close the circuit of a small servo-motor to turn the rudder to the right and left respectively. By fitting back contacts on the relays, the rudder is returned to neutral when neither of the relays are energised. (Fig. 39). Relay A can be arranged to operate a small servo-motor which closes the throttle when it opens its contacts.

If the engine is of the coil ignition type, the servo-motor can be left out, and the ignition directly controlled by the contacts of relay A, so that the engine stops when no carrier is present. If we leave out L_3 , V_3 , relay D and their associated circuits, we have a reasonably simple receiver which gives us rudder control, and an engine safety control, but no throttle control as such. (Fig. 40).

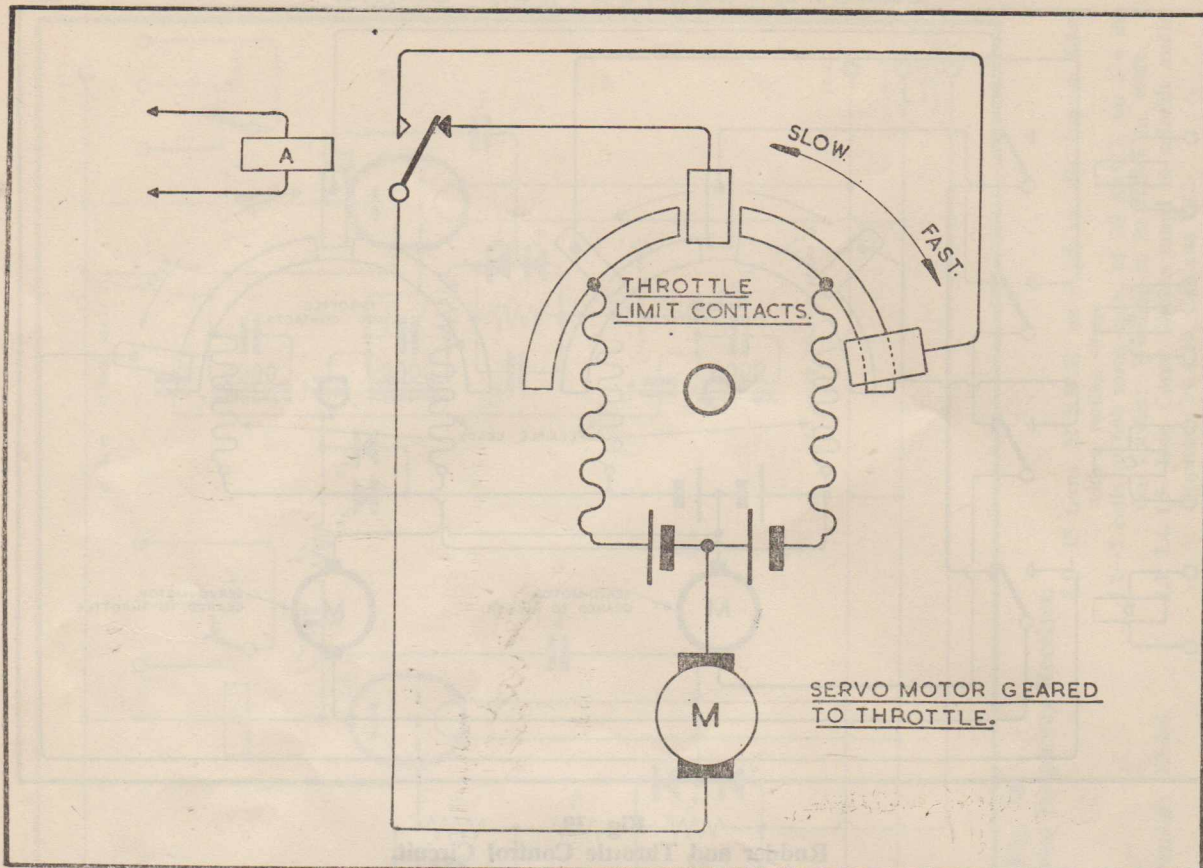

Fig. 40.

Modification of Fig. 39. Relay D being omitted, with ON-OFF Safety Throttle Control.

The engine can only run so long as the carrier is on, and the rudder remains straight so long as no modulation is present. By sending the appropriate audio frequency, the rudder can be made to turn right or left at will without having to observe any sequence, and removal of such audio frequency causes the rudder to return to neutral. The engine can be stopped by switching off the carrier, and finally, the aircraft cannot fly very far should it go out of range, or should the transmitter fail, because the engine would then stop and the rudder return to neutral, causing the aircraft to go into a straight glide to the ground.

At the cost of incorporating L_s , V_s , relay D and associated circuits, a throttle control can be provided. In this case, the throttle can be controlled by means of a servo-mechanism and a double jet carburettor arrangement, exactly as described in Chapter 3, giving a full range of speeds from maximum down to idling. Relay D causes the throttle to open, and relay A causes it to close. The engine speed is increased by sending the audio frequency corresponding to relay D, until the desired speed is obtained. The speed setting will then remain

unchanged unless relay D is operated again, causing a further increase of engine speed, until the servo-motor limit switch stops further movement of the throttle, which by then would be fully opened. To decrease the engine speed, the carrier is switched off, causing relay A to drop out and close its contacts. This operates the servo-motor causing the throttle to start closing. When the desired speed setting is reached, the carrier is switched on again, arresting any further closing of the throttle. If the carrier is switched off long enough, or permanently, the throttle will close until the limit switch operates, by which time the engine, if correctly adjusted, will be idling. Under such condition the aircraft will be rapidly losing altitude, in a power glide, and can be landed with power on. It could, in fact, be made to take off again by once more sending the carrier modulated by the audio frequency corresponding to relay D.

The points about the receiver just described are:

- (1) The tuned chokes must be carefully selected or made, so as to have a good sharp response. Small filter chokes out of war surplus audio filter units have been found

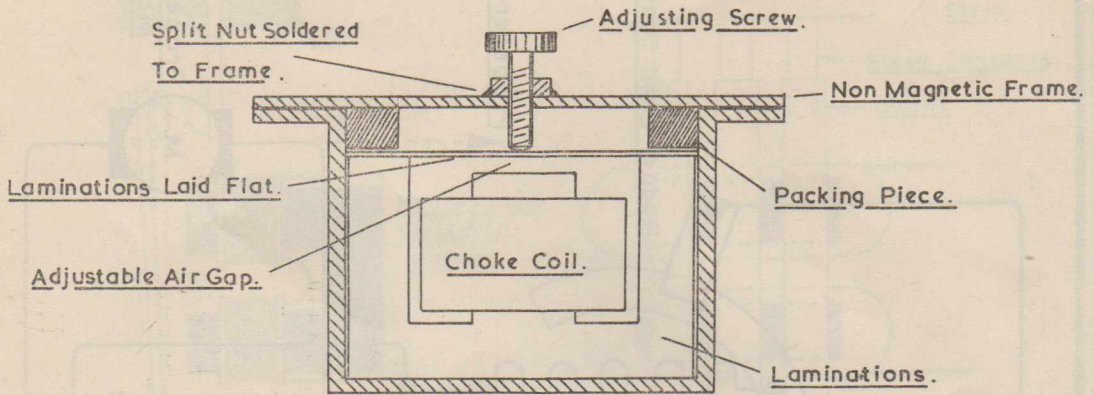

Fig. 41.
The Construction of a Tuned Choke.

satisfactory. The laminations are arranged so that a small variable air gap is available for fine adjustment of the resonant frequency. (See Fig. 41). Small chokes weighing slightly over one ounce can be made satisfactorily, their DC resistance being of the order of 1,500 to 2,000 ohms.

- (2) Coupling capacitors C_{14} , C_{15} , and C_{16} may require adjustment until proper selection is obtained. The value of each should be reduced until the respective circuit ceases to respond to any but the correct audio frequency.
- (3) The tuned chokes should be adjusted so that their resonant frequencies are as close together as is possible, whilst still maintaining good separation. With suitable chokes and loose coupling (through capacitors C_{14} , C_{15} and C_{16}) it should be possible to have good separation with not more than a tone or two between the audio channels.
- (4) This receiver is appreciably heavier than single-channel receivers used in conjunction with an escapement mechanism. Both the HT and LT are heavier and larger batteries

are necessary. Consequently the aircraft must be large enough to carry the extra weight. The total control equipment, including servo-motors and batteries, can be made to weigh approximately $1\frac{1}{2}$ lbs., so that a plane having a wingspan of not less than 6 feet is necessary. The use of silver-zinc or similar lightweight accumulators of 1 ampere-hour capacity is necessary to achieve this relatively low weight. Two such accumulators will give power for both the five valve receiver low tension supply, and the servo motors for the best part of two hours on one charge, their total weight being only two ounces. "Mighty Midget" motors are used for the servos as they work very satisfactorily on $1\frac{1}{2}$ volts. A saving in the weight can also be made by using deaf-aid type valves and components. In that case the relays will, of course, require to operate with a smaller current change.

The addition of more audio frequency channels will give extra controls. For instance, by providing two extra channels on the receiver just described, elevator control can be provided. The extra

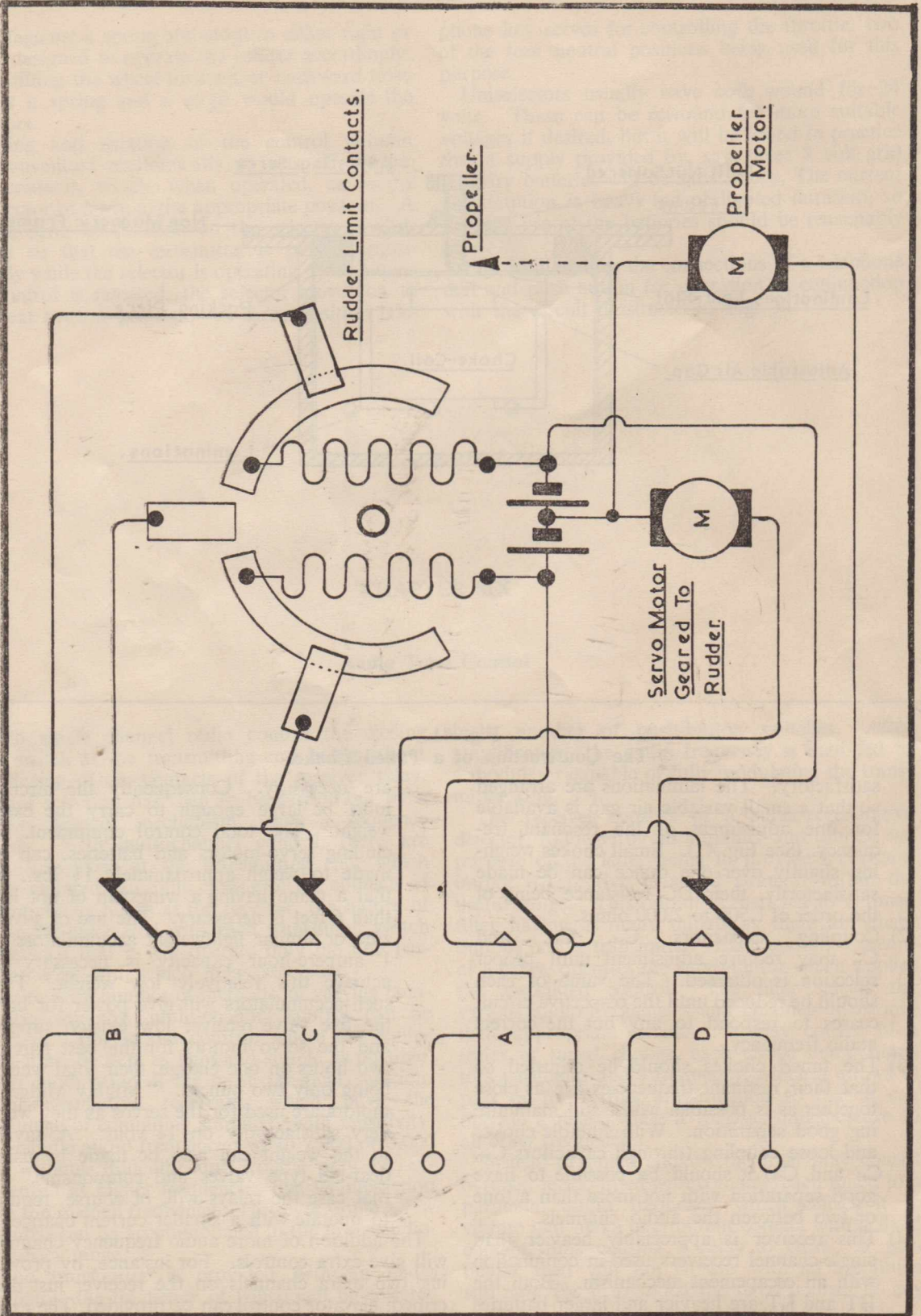

Fig. 42.
Rudder and Propeller Control.

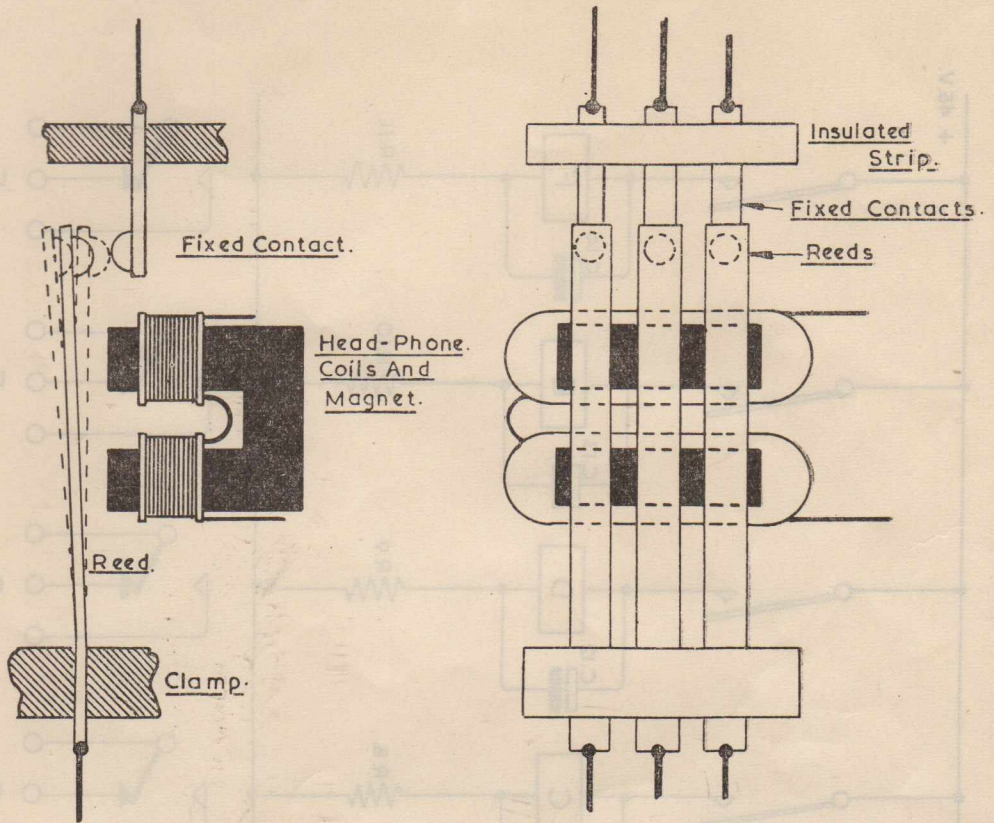

Fig. 43.

Details of a 3-Channel Reed Selector.

equipment required per channel consists of a tuned choke, valve, relay and associated circuits, exactly as in the case of the channels already illustrated.

For controlling a boat, the same receiver with 3 audio channels can be used as shown in Fig. 42, the controls being operated as follows:

Relay A is arranged to switch the propeller motor in the forward position.

Relays B and C control the rudder servo-motor to turn the rudder to the right and to the left respectively.

Relay D switches the propeller motor in reverse.

When the carrier is unmodulated, the propeller motor is switched in the forward position, and the boat moves forward in a straight line.

Modulating the carrier with audio frequencies operating either relay B or relay C will cause the boat to turn either right or left, the propeller motor being still switched in the forward position.

Modulation of the carrier by a frequency corresponding to relay D will reverse the propulsion motor and the boat will go astern with the rudder

straight. Switching off the carrier stops the boat.

With this arrangement, there will be no control of the rudder when going astern, but in practice this is not a serious drawback and does not prevent manoeuvres in a confined space.

Instead of using tuned chokes, tuned reeds can be used, and as no valves are required for each audio channel, an appreciable saving in weight can be obtained, particularly if many channels are required, because of the lower drain on the filament and HT batteries.

The output of the limiter stage is fed to the reed selector, which consists of a coil having a suitable impedance to match the output valve. A number of reeds are placed across the magnetic circuit in the manner shown by Fig. 43, each reed having a slightly different resonant frequency from the next one. The tip of each reed is silvered and opposite it is placed a fixed contact fitted on a spring, having a natural frequency much higher than that of the reed. Only that reed having a resonant frequency corresponding to the audio fre-

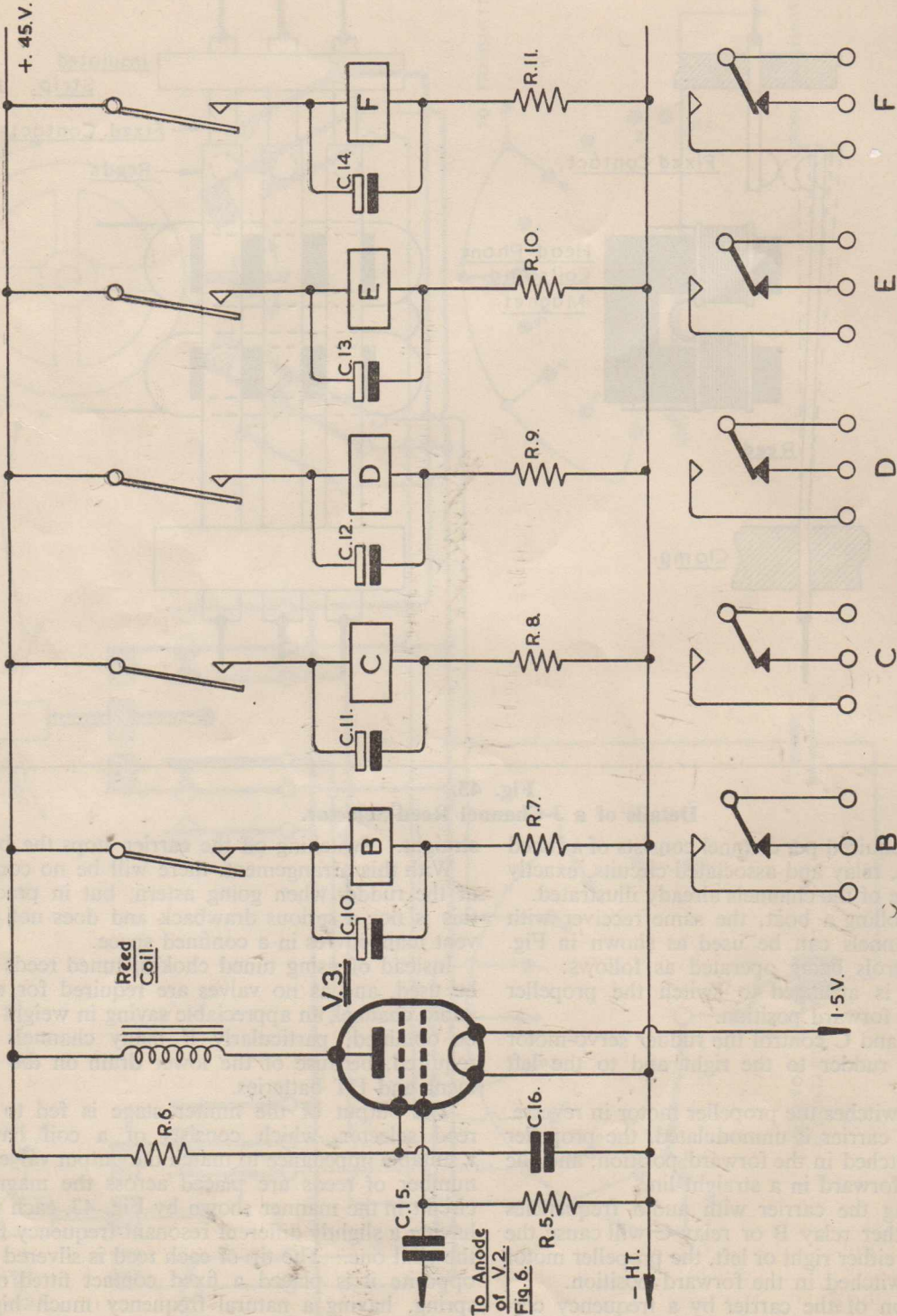

Fig. 44.

The electrical circuit for a 5-channel Reed Selector, to be used with the Receiver shown in Fig. 6.

- R.5, R.6—1M Ω .
- R.7, R.8, R.9, R.10, R.11—50 Ω .
- B C D E and F—4,900 Ω Relays.
- V.3—3S4, DL92 or equivalent.
- (One half of filament is not used.)
- C.10, C.11, C.12, C.13, C.14—8 μ f Electrolytic.
- C.15—0.05 μ f.
- C.16—0.1 μ f.

quency fed to the selector, will vibrate with sufficient amplitude to touch the fixed contact. In the circuit shown in Fig. 44, capacitor C_{10} , which is normally discharged, will be charged as soon as the reed touches the fixed contact during each oscillation. The capacitor then discharges more slowly into the relay, operating the latter. This arrangement is necessary, since the small current which can pass through the reed each time the latter is contacted, would be insufficient to work the relay satisfactorily.

The layout of the complete receiver is therefore as follows:—

The front end is as before, consisting of two valves, the second one operating relay A which pulls in when an unmodulated carrier is received.

It is followed by a limiter valve which has its screen operated at a low voltage. The output is fed to the reed selector, a five reed selector being a very practical proposition. Each reed controls a relay, through the smoothing circuit just described, the relay then operating the appropriate servo-motor.

The application of this system to aircraft control follows closely the arrangement described in the case of tuned chokes. Relays B and C are connected to the rudder. Relays E and F are used for elevator up and down, relay D increases the engine speed, and relay A, which is operated by the carrier (whether modulated or not), is used for decreasing the engine speed.

For controlling both rudder and elevators, the reed system is perhaps the best one, because it makes possible a lighter receiver than can be made using tuned chokes.

In the case of a boat, three reeds only are necessary, since no elevator is used. The two extra reeds, however, can be used with good effect for additional controls such as switching lights, blowing the siren, etc.

The points concerning the receiver using the reed selector are:—

- (1) The reeds must be made of steel, since they must consist of magnetic material. Their natural frequency should be around 200 to 400 c/s, and to obtain this very thin steel strips should be used, about .002 ins. thick. Cutting and adjustment are very delicate, and skill is required to make a successful selector.
- (2) Reeds have a very sharp resonant response. This means that a comparatively large number can be used with frequencies spaced quite close to one another. It also means that very good frequency stability is required if the audio oscillator is to remain in tune with the selected reed. For this reason, there is an advantage in keeping the reed frequencies as close together as possible, in which case drift of the audio oscillator will cause a different reed to respond almost as soon as the reed to which it was originally tuned ceases to function correctly. This helps in taking suitable corrective measures. Without this indication, some trouble may be experienced in finding whether the oscillator has drifted above or below the frequency of the reed which has ceased to respond.

Transmitters for Audio Frequency Control

The crystal controlled transmitter described in Chapter 2 is quite suitable for audio modulation. An audio oscillator can be tuned to various audio frequencies, but the method of tuning will vary according to the type of receiver to be operated. Push buttons may be used which insert various values of capacitor, thereby changing the frequency of audio oscillation. Each push button therefore operates a separate control on the model. Better still, joy sticks, throttle levers, steering wheels, etc., can be used to operate contacts, instead of the push buttons mentioned, providing much more realism and effectiveness.

Audio output from the oscillator is amplified and fed to the modulator. Modulation is applied to the final stage of the transmitter. Potentiometer R_2 in Fig. 45 controls the depth of modulation and should be set so that 100% modulation is not exceeded. This can be checked on a

cathode ray oscilloscope, which will at the same time show if the audio waveshape is reasonably free from harmonics. If an oscilloscope is not available, overmodulation can be detected by checking if the meter reading of the final stage shows a change when the audio oscillator is switched on. The audio modulation control should be adjusted somewhat below the point where this current change is first noted.

It is, of course, evident that if only one audio frequency oscillator is used, the various audio frequencies corresponding to each control can only be generated and transmitted one at a time. Thus while the receiver can receive and separate the various audio frequencies according to their pitch, it has only to deal with one at a time. There is no reason, however, why two or more audio frequencies could not be sent at the same time, causing the simultaneous operation of the corres-

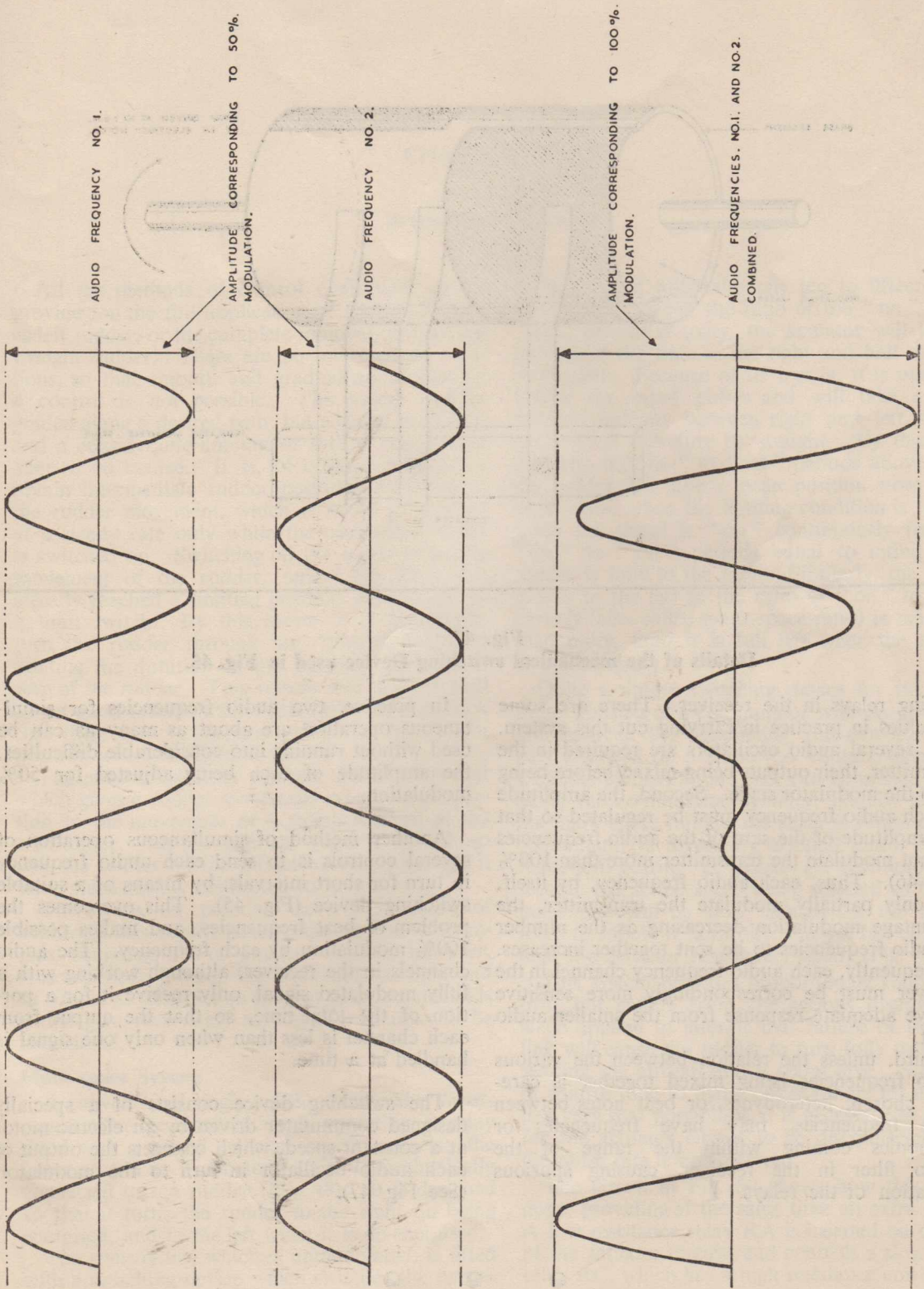

Fig. 46. Simultaneous Transmission of Two Audio Frequencies.

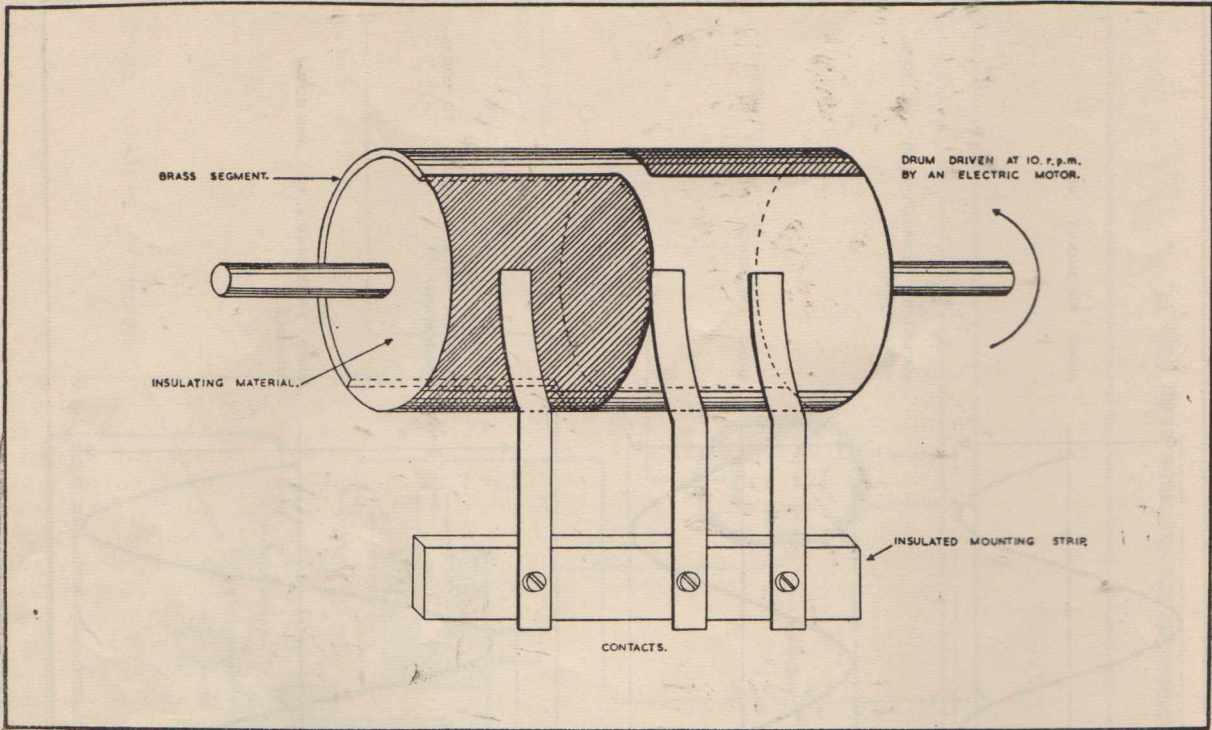

Fig. 47.
Details of the mechanical switching Device used in Fig. 45.

ponding relays in the receiver. There are some difficulties in practice in carrying out this system. First, several audio oscillators are required in the transmitter, their outputs being mixed before being fed to the modulator stage. Second, the amplitude of each audio frequency must be regulated so that the amplitude of the sum of the audio frequencies will not modulate the transmitter more than 100% (Fig. 46). Thus, each audio frequency, by itself, will only partially modulate the transmitter, the percentage modulation decreasing as the number of audio frequencies to be sent together increases. Consequently, each audio frequency channel in the receiver must be correspondingly more sensitive to give adequate response from the smaller audio input.

Third, unless the relation between the various audio frequencies being mixed together is carefully chosen, heterodynes, or beat notes between these frequencies, may have frequencies or harmonics coming within the range of the audio filter in the receiver, causing spurious operation of the relays.

In practice, two audio frequencies for simultaneous operation are about as many as can be used without running into considerable difficulties, the amplitude of each being adjusted for 50% modulation.

Another method of simultaneous operation of several controls is to send each audio frequency in turn for short intervals, by means of a suitable switching device (Fig. 45). This overcomes the problem of beat frequencies, and makes possible 100% modulation by each frequency. The audio channels in the receiver, although working with a fully modulated signal, only receive it for a portion of the total time, so that the output from each channel is less than when only one signal is handled at a time.

The switching device consists of a specially designed commutator driven by an electric motor at a constant speed, which connects the output of each audio oscillator in turn to the modulator. (See Fig. 47).

CHAPTER SEVEN

Proportionate Control

All the methods of control dealt with so far provide for the full application of a control, such as left rudder, or the complete removal of it, giving straight rudder. There are no intermediate positions, so that smooth and gradual application of a control is not possible. The model can be guided along a desired path, but without precision, and a considerable amount of skill is required to keep it on course. It is, of course, possible to obtain intermediate rudder positions by initiating the rudder movement, which is made to proceed at a steady rate only while the transmitter signal is switched on. Switching off the signal stops the movement of the rudder, unless the latter has already reached a limiting position determined by a limit switch. By this means it is possible to turn the rudder through any desired angle by relating the duration of the signal to the rate of turn of the rudder. This system also requires skill to get good results, and suffers from the drawback that there is no automatic return to the straight position when no signal is sent.

The most satisfactory method of control is that which gives a rudder movement exactly in proportion to the movement of a steering wheel at the transmitter. As the steering wheel is moved, so will the rudder on the model move, as though it were mechanically connected to it.

There are, in practice, several methods of achieving this result, some requiring rather complex equipment. For amateur models, however, it is necessary to keep the equipment as light and as simple as possible, so the less complex methods which give reasonably satisfactory results will be considered.

Mark-space System

A conventional single valve, or two valve super-regenerative receiver is used, operating a relay fitted with a set of "change-over" contacts; the latter control an "actuator" which is mechanically connected to the rudder (Fig. 48). It is designed so that it turns the rudder to the right on being energised, and to the left when it is de-energised.

The transmitter, which is unmodulated, is fitted with a switching device which switches the carrier

on and off at approximately ten to fifteen times per second. When the ratio of the "on" to the "off" periods is unity, the actuator will tend to move half the time to the right and half the time to the left. Because of its inertia, it is unable to follow the rapid pulses and will take a mean position halfway between right and left, so the rudder will therefore be straight. By increasing the ratio of "on" to "off" periods above unity, the rudder will take a mean position more to the right, until, when the limiting condition is reached when the signal is "on" continuously (ratio of "on" to "off" periods equal to infinity), the rudder is fully to the right. Similarly, the rudder moves to the left as the ratio of "on" to "off" periods (also called mark-space ratio) is made less than unity, until it is full left when the ratio is zero (no signal).

Quite a simple switching device for the transmitter consists of a commutator with the boundary line between the conducting and non-conducting part arranged on a slope. A contact, carried on a handle pivoted at one end, can be moved axially along the commutator cylinder, thereby selecting the mark-space ratio as the latter is rotating. The commutator is driven by a small motor through reduction gearing at about 10 revolutions per second, the actual speed being selected so that the pulse rate will be slow enough for the receiver relay to follow it faithfully, but yet fast enough to hold the actuator reasonably steady (Fig. 49).

This system provides proportionate rudder control, but suffers from the serious disadvantage, when applied to aircraft that failure of the radio link will cause the rudder to turn fully to the left, sending the aircraft into a spiral dive. Since loss of control (due to flying out of range, for instance) is a very real possibility, it is necessary to arrange for the actuator circuit to be disconnected when the pulse rate is not received.

The circuit in Fig. 50 shows how this can be done, providing at the same time an extra control. A low resistance relay RA is inserted on one side of the actuator circuit, and controls a slow release relay RC, which has a high resistance coil shunted

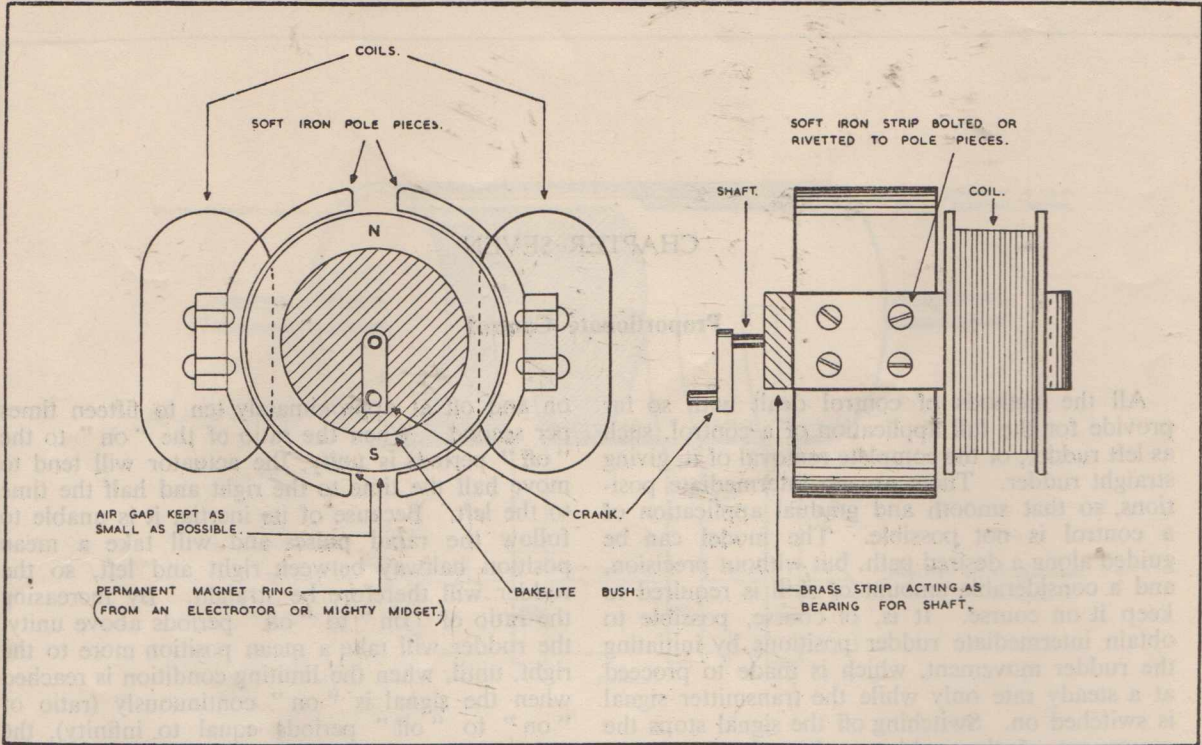

Fig. 48.
The Actuator—(Front and side views).

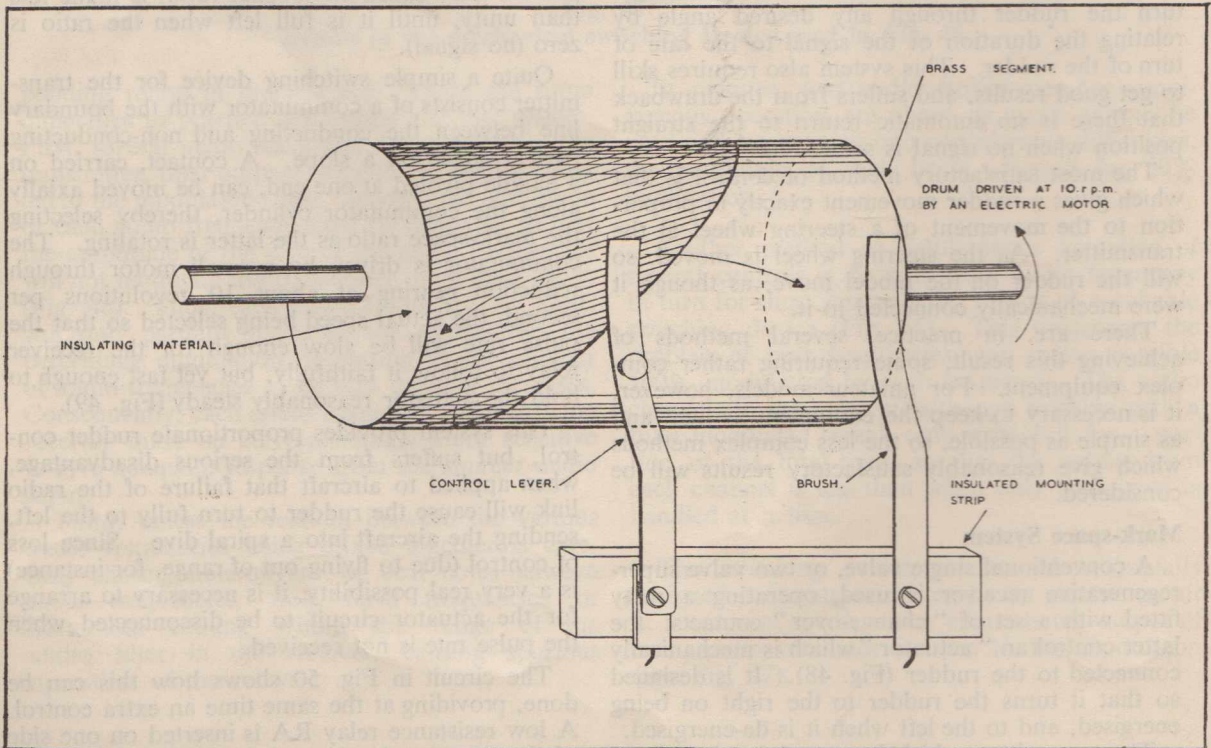

Fig. 49.
Details of the Mark-Space Pulse Generator.

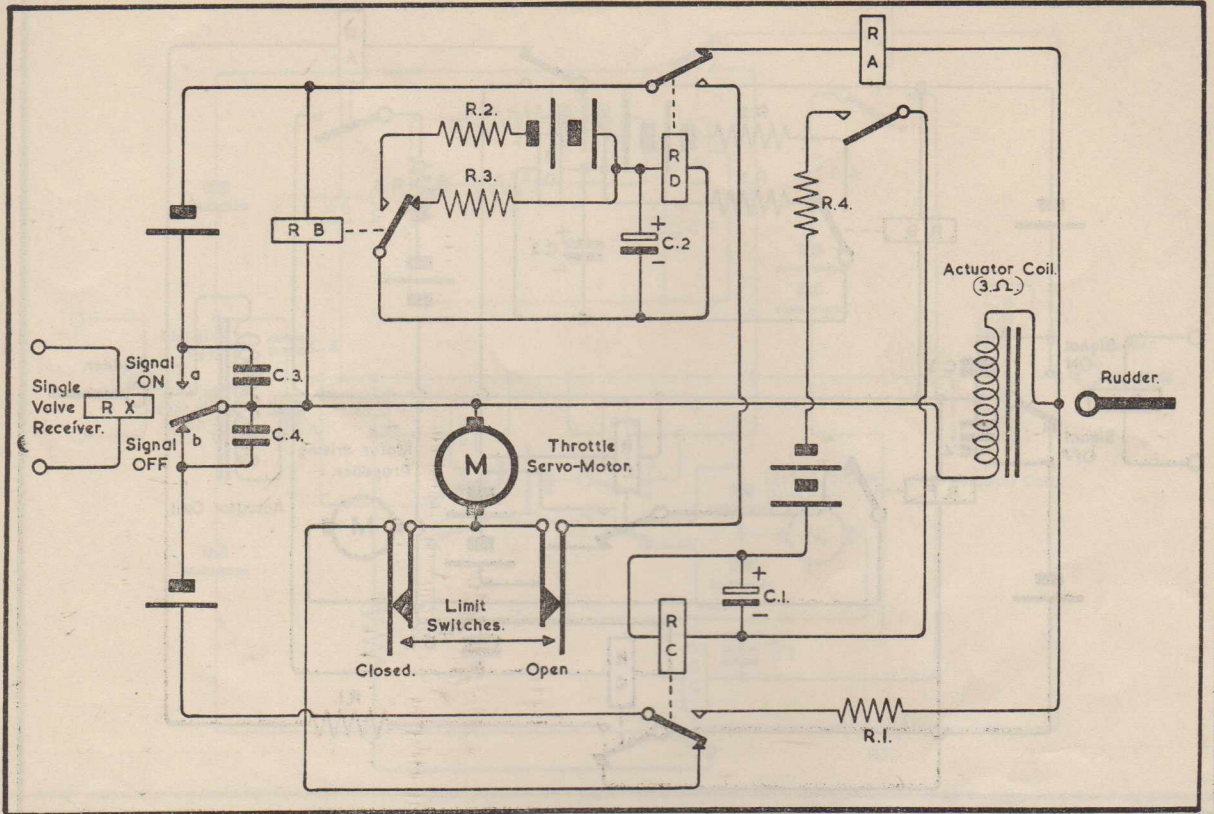

Fig. 50.

Pulse Rate Control of Rudder and Throttle, a circuit suitable for the two-jet carburettor shown in Figs. 23 and 24.

RX—Receiver Relay (Reverse the connections to a and b if a two valve receiver is used).

RA—Make Relay, 3Ω.

RB—Change-over Relay 8-10Ω.

RC—Quick Make, Slow Release Relay with change-over contacts. 4,000Ω coil.

RD—Slow Make, Quick Release Relay with change-over contacts. 4,000Ω coil.

R1—3Ω.

R2—500 to 1,000Ω (Actual value by experiment).

R3, R4—50Ω.

C1, C2—50μf Low Voltage electrolytic.

C3, C4—0.01μf.

by a large value electrolytic capacitor C₁. A medium resistance relay RB closes the circuit of a slow-make relay RD. Resistance R₁ is made equal to the resistance of relay RA to balance the actuator. The operation is as follows:—When the mark-space pulse rate frequency (about 10 per second) is sent, receiver relay RX switches over and back in accordance with the mark-space ratio. Relay RA closes its contacts intermittently; and relay RC, because of the storage action of the capacitor, remains pulled in all the while, completing the other half of the actuator circuit. If the mark-space ratio is unity, the actuator will now be in the straight position, whilst varying the mark-space ratio will alter the actuator setting. Should the transmitter signal be switched off, relay RX will remain in the "off" position and relay RC will drop out, so that the actuator will be dis-

connected on both sides, and will remain in the straight position.

Relay RC, by completing another circuit, can now be made to operate another control, for instance the throttle servo-motor M.

The contacts of relay RB will cause relay RD to be normally released when no signal is received (Relay RX in "off" position). Energising RB causes RD to be pulled in after a definite time lag, due to the large capacity of C₂, which has to be charged through resistor R₂ until the voltage across its terminals has risen sufficiently to operate RD. Release of RB causes C₂ to be rapidly discharged through R₃ which limits the discharge current to a safe value to prevent burning of the contacts of RB. It can be seen that RD will not close if RB is only pulsed for short periods, but will close when RB remains pulled in.

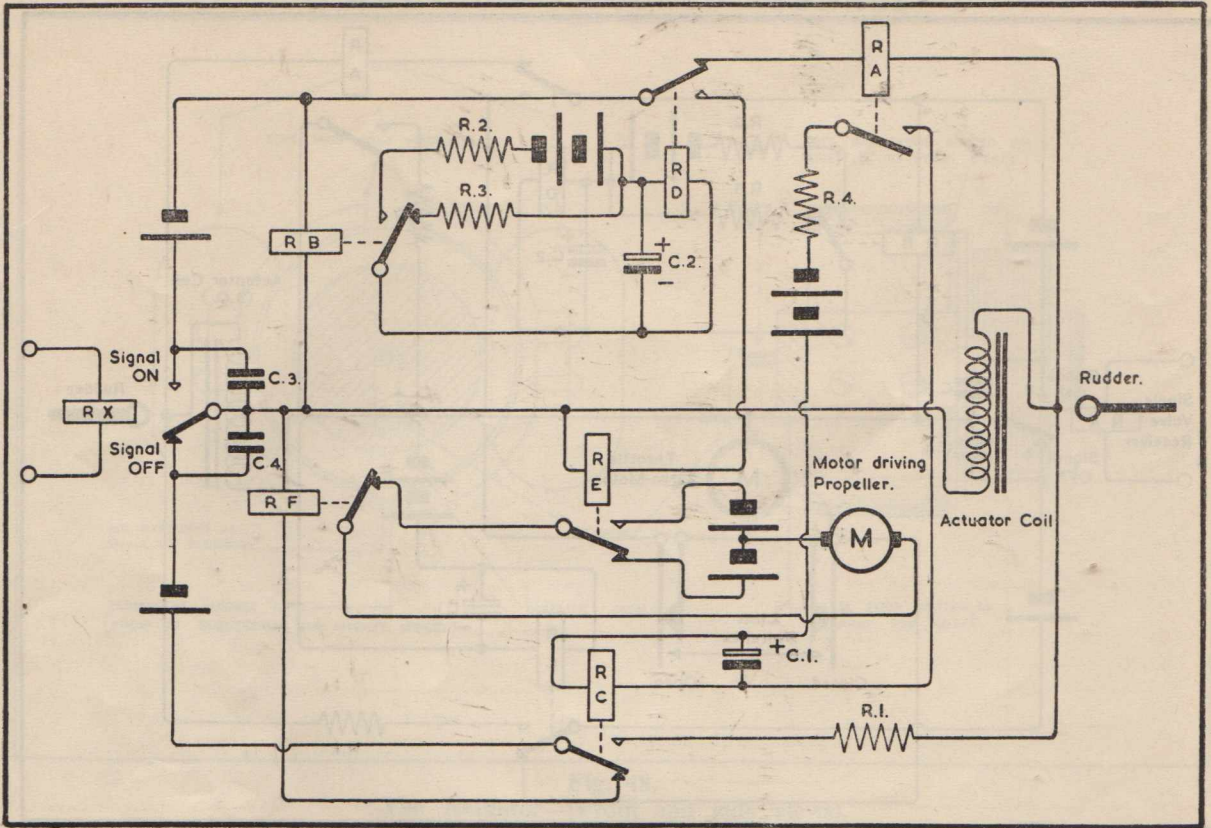

Fig. 51.

Pulse Control of Rudder and Propeller.

Circuit values as for Fig. 50. RE and RF Medium Resistance Relays similar to R.B.

We therefore have the position that sending a pulsed signal will maintain the throttle motor disconnected, while varying the mark-space ratio will control the position of the actuator.

Holding the signal on, will cause motor M to open the throttle, while the actuator will return to the central position after a brief kick to the right. Switching off the signal will cause motor M to close the throttle, while the actuator will again return to the central position after a brief kick to the left. In order to prevent inadvertent operation of the auxiliary controls, it is necessary to ensure that the extreme right and left positions of the rudder, or other control operated by the actuator, are reached before the mark-space ratio has reached the limiting conditions of infinity or zero, as it is under such conditions, when the pulsing has become non-existent, that relay RD or RC are operated. For aircraft operation the actuator operates the rudder, and relays RC and RD control the reversible throttle servo-motor. The latter is arranged so that the engine is throttled down when the signal is removed, and speeded up when the signal is held on. This system has, therefore, the advantage of having both propor-

tional rudder control and adjustable throttle control, while incorporating at the same time safety features such as the return of the rudder to the straight position and throttling down of the engine when no signal is received.

For boat control, the circuit in Fig. 51 is adapted so that RC operates a relay which opens the circuit of the propulsion motor, while RD closes it for reverse. With no signal, RC is released and the propulsion motor circuit is open, so that the boat is stationary. Sending a pulsed signal causes RC to pull in, and the propulsion motor is now switched for forward operation, the rudder being controlled by the mark-space ratio. Holding the signal on causes RD to close and switch the propulsion motor in reverse. The rudder will be in the straight position, but as it has little action when the boat is moving astern, this is of small moment. It is possible, if desired, to provide the reversing relay with a hold-on contact, so that when operated it remains set until released by switching the carrier off. Reverse operation can then be obtained whilst retaining rudder control. (Fig. 52).

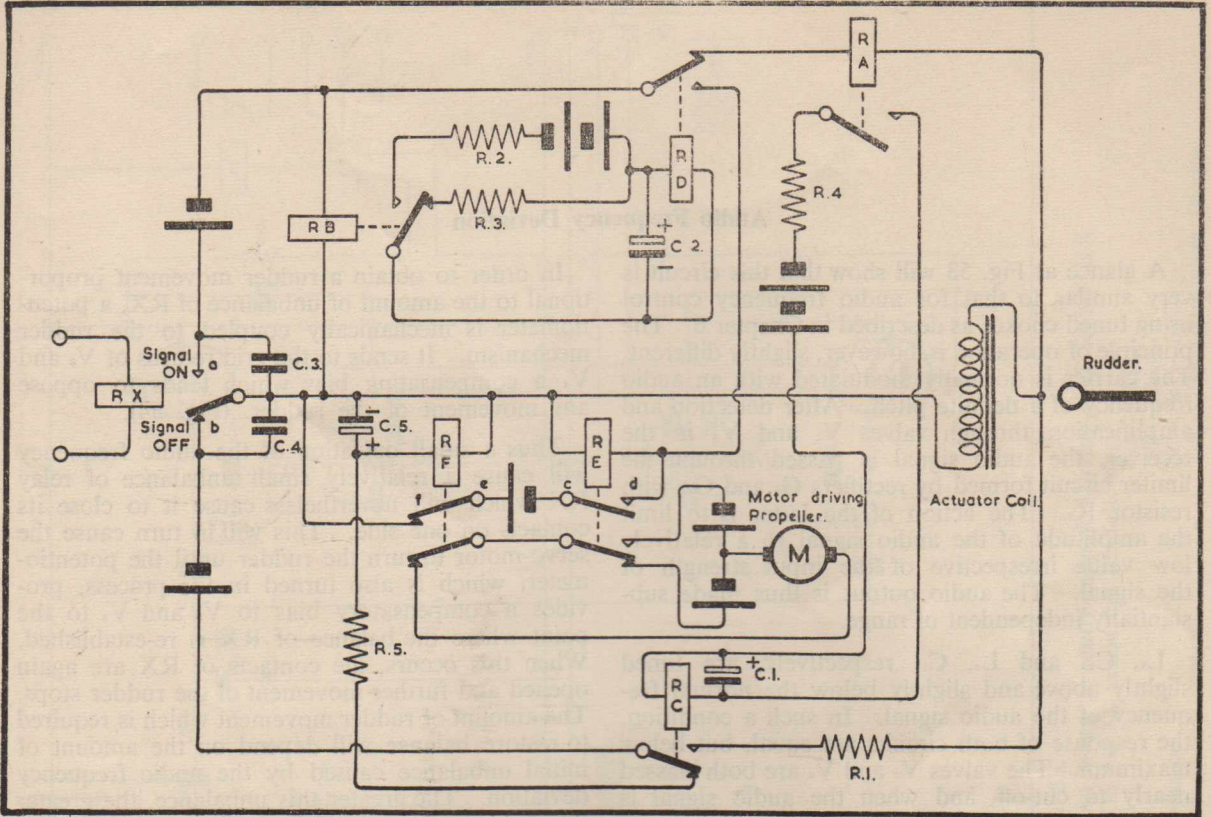

Fig. 52.
Pulse Rate Control of Rudder and Propeller with Hold-on Relay.
 Circuit values as for Fig. 50.

RF—Slow Make Relay (Medium Resistance).
RE—Hold-on Relay.

R5—Value about $\frac{1}{3}$ rd to $\frac{1}{2}$ that of **RF**
C5—50 μ f Low-Voltage Electrolytic.

When the signal is pulsed, both RE and RF are released, so switching the motor ahead, the rudder being controlled by the pulse mark-space ratio. If the signal is now held on for a second or more, RD closes the circuit of RE, which, when pulled in, provides its own supply through contacts cd and ef, since RF is also released. The motor is now switched astern. Pulsing the signal once more will cause RD to drop out and RC to pull in. The first few pulses will pass through RF before RC has time to pull in, but because of R₅ and C₅, RF will not have time to break the contacts ef before it is disconnected by RC, thus RE will remain pulled in, holding the motor in the astern position. The rudder is at the same time controlled by the pulse mark-space ratio. Suppressing the signal causes RF to be energised, breaking contacts ef, and RE is therefore disconnected and drops out, leaving the position as it was originally.

values of these capacitors must be chosen, so that the time lag action is about $\frac{1}{2}$ second. RC acts as a quick-close slow-release relay, and RD as a slow-close quick-release relay. R₅ must be high enough to provide the necessary time lag, but not too high to prevent enough voltage from appearing across RD when C₅ is fully charged.

The points about this system of control are:
 In addition to the receiver relay, RC and RD must be high resistance relays capable of closing with little more than 1 mA. C₁ and C₂ are low voltage large value electrolytic capacitors. The

The actuator should have a resistance of about 6 ohms for a 3 volt battery, or 3 ohms for a 1½ volt battery. By using split batteries as shown, no centre-tap is required. It can be made by converting a small motor such as an "electrotor" or a "mighty midget" for the purpose. If the model is large and requires appreciable power for operating the rudder, a servo-system as described a little later on can be used, although this involves rather more weight and complication. Since most of the relays are being pulsed continuously, contact life is likely to be short unless precautions are taken for spark suppression. The small capacitors C₃ and C₄ are fitted for spark suppression at the contacts of RX. R₂ and R₃ will reduce sparking at RB, while R₄ will do likewise for RA.

Audio Frequency Deviation

A glance at Fig. 53 will show that this circuit is very similar to that for audio frequency control using tuned chokes as described in Chapter 6. The principle of operation is, however, slightly different. The carrier is normally modulated with an audio frequency of a definite pitch. After detection and amplification through valves V_1 and V_2 in the receiver, the audio signal is passed through the limiter circuit formed by rectifiers G_1 and G_2 , with resistor R_1 . The action of the latter is to limit the amplitude of the audio signal to a relatively low value irrespective of the input strength of the signal. The audio output is thus made substantially independent of range.

L_3, C_{10} and L_4, C_{11} respectively, are tuned slightly above and slightly below the normal frequency of the audio signal. In such a condition, the response of both circuits are equal, but below maximum. The valves V_3 and V_4 are both biased nearly to cut-off, and when the audio signal is received, their mean anode currents will increase by a certain amount, because of the action of the rectifying circuits G_1, G_2, G_3 , and G_4 , which provide a positive voltage to the grids in proportion to the audio signal amplitude. Since the responses of L_3, C_{10} , and L_4, C_{11} are equal, the anode currents will rise an equal amount, and the moving coil relay RX will remain balanced, the moving contact remaining in the middle position. RY , however, which carries the sum of the anode currents, will close its contacts.

If the frequency of the audio signal is now increased, the response of L_3, C_{10} will increase while that of L_4, C_{11} will simultaneously decrease. The mean anode current of V_3 will consequently rise to a higher value, while that of V_4 will fall to a correspondingly lower value. Relay RX will be unbalanced and will make contact on one side. It will similarly make contact on the other side should the frequency of the audio signal be decreased, so that the reverse process takes place. Relay RY will maintain its contacts closed all the while, since the sum of the anode currents will remain nearly constant. It will drop out only if the audio signal is removed, because both anode currents will then decrease to a low value. The operating power of relay RX is very small and is insufficient for direct actuation of the rudder, so this is carried out by a small servo-motor controlled by the contacts of RX .

In order to obtain a rudder movement proportional to the amount of unbalance of RX , a potentiometer is mechanically coupled to the rudder mechanism. It sends to the grid returns of V_3 and V_4 a compensating bias which tends to oppose any movement of the rudder. (Fig. 54).

Thus a small deviation of the audio frequency will cause a relatively small unbalance of relay RX which will nevertheless cause it to close its contacts on one side. This will in turn cause the servo-motor to turn the rudder until the potentiometer, which is also turned in the process, provides a compensatory bias to V_3 and V_4 to the point where the balance of RX is re-established. When this occurs, the contacts of RX are again opened and further movement of the rudder stops. The amount of rudder movement which is required to restore balance will depend on the amount of initial unbalance caused by the audio frequency deviation. The greater this unbalance, the greater the rudder movement. Reversing the audio frequency deviation will also cause reversal of the rudder movement. Removing the audio signal when the rudder is not central will leave relay RX unbalanced because the compensating bias controlled by the potentiometer will only be equal at valves V_3 and V_4 when the rudder is central. Hence Relay RX will cause the rudder to move until it is central, while RY will at the same time open its contacts, as already indicated.

Proportional movement of the rudder on either side of the central position is therefore obtained by varying the frequency of the audio modulating signal about a mean frequency corresponding to the central position. Unfortunately, due to small time lags in the audio rectifying networks G_3 and G_4 , and to the inertia of the rudder servo-motor mechanism, the rudder turns through a small but definite angle after the servo-motor is switched off, and a phenomenon known as "hunting" may occur. This overshoot of the rudder after balance of relay RX has been achieved causes unbalance of the latter in the reverse direction, and the rudder moves back in an attempt to restore the balance. It may overshoot again in the other direction, and a series of oscillations of the rudder may take place before it eventually settles down to the correct position. In severe cases this "hunting" may continue indefinitely.

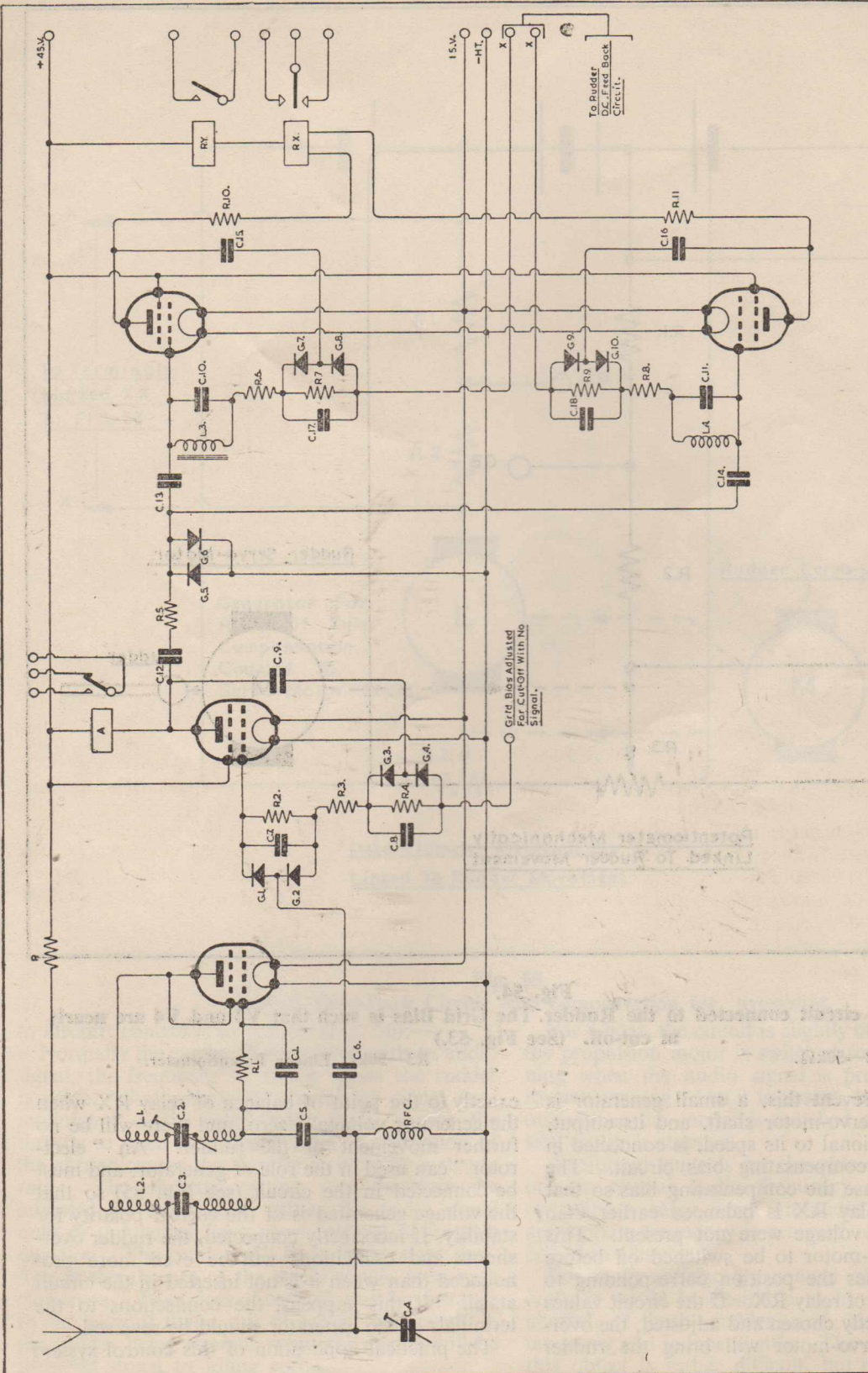

Fig. 53.
Audio Frequency Receiver for Proportionate Control using a centre-tapped Moving-Coil Relay RX.
 The components are the same as those in Fig 38, except for the following:

- RX—4,000 Ω Relay with Make contacts.
- RY—Moving Coil Relay with Change-over contacts.
- C12—0.02 μ f.
- C13, C14—250pf.
- C15, C16—0.05 μ f.
- C17, C18—0.02 μ f.
- R8—50k Ω .
- R9—220k Ω .
- R10, R11—5k Ω .
- G9, G10—Germanium Diodes.

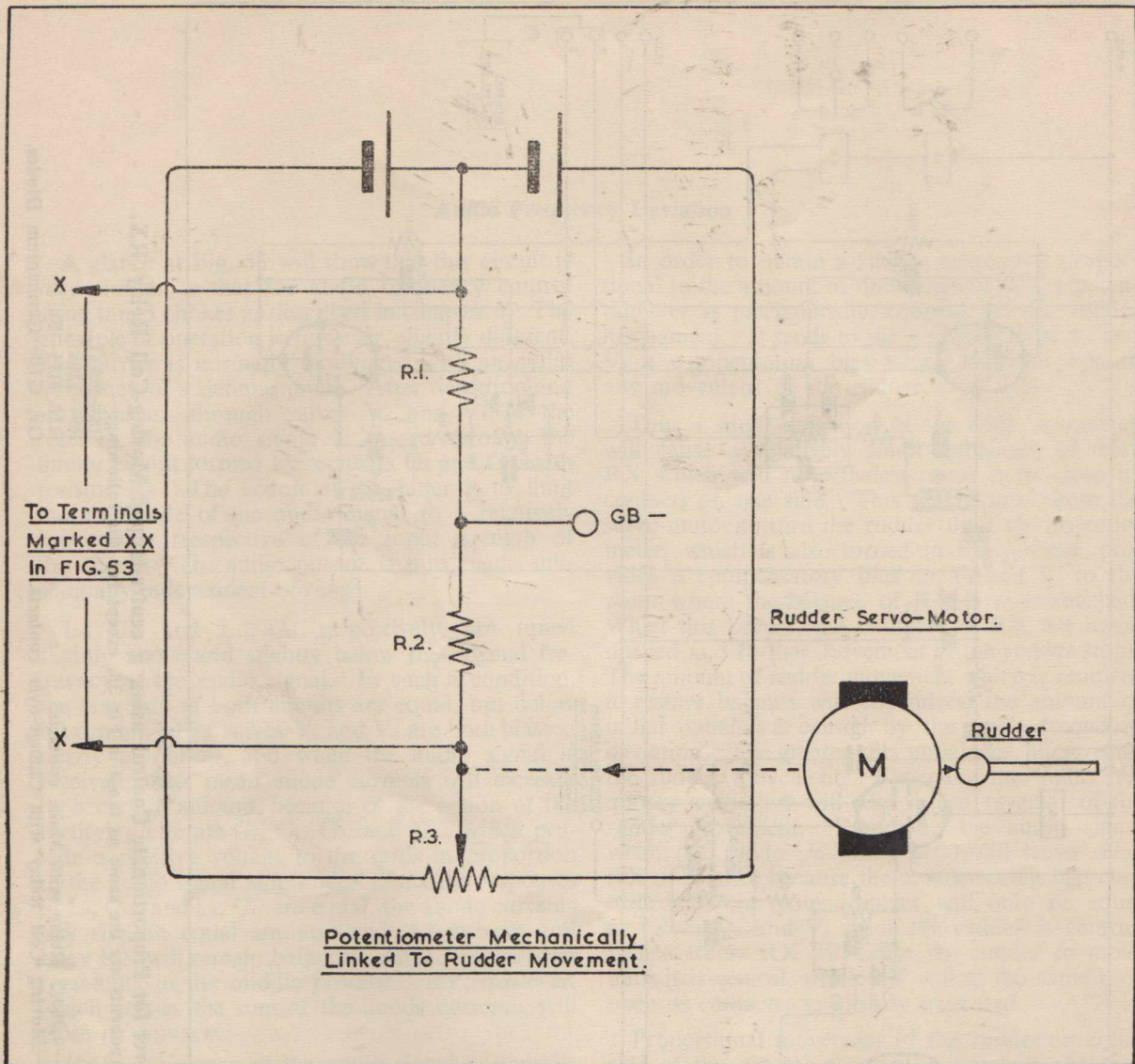

Fig. 54.

DC—Feed-back circuit connected to the Rudder. The Grid Bias is such that V3 and V4 are nearly at cut-off. (See Fig. 53.)

R1, R2—50k Ω .

R3—50k Ω Linear Potentiometer.

In order to prevent this, a small generator is coupled to the servo-motor shaft, and its output, which is proportional to its speed, is connected in series with the compensating bias circuit. The effect is to increase the compensating bias so that the circuit of relay RX is balanced earlier than if the generator voltage were not present. This causes the servo-motor to be switched off before the rudder reaches the position corresponding to the final balance of relay RX. If the circuit values have been correctly chosen and adjusted, the overshoot of the servo-motor will bring the rudder

exactly to the point of balance of relay RX when the generator voltage is zero, and there will be no further movement of the rudder. An "electrotor" can be used in the role of generator, and must be connected in the circuit (see Fig. 55) so that the voltage generated is of the correct polarity for stability. If incorrectly connected, the rudder overshoots and oscillations will be even more pronounced than when it is not inserted in the circuit at all. If this happens, the connections to the terminals of the generator should be reversed.

The practical application of this control system

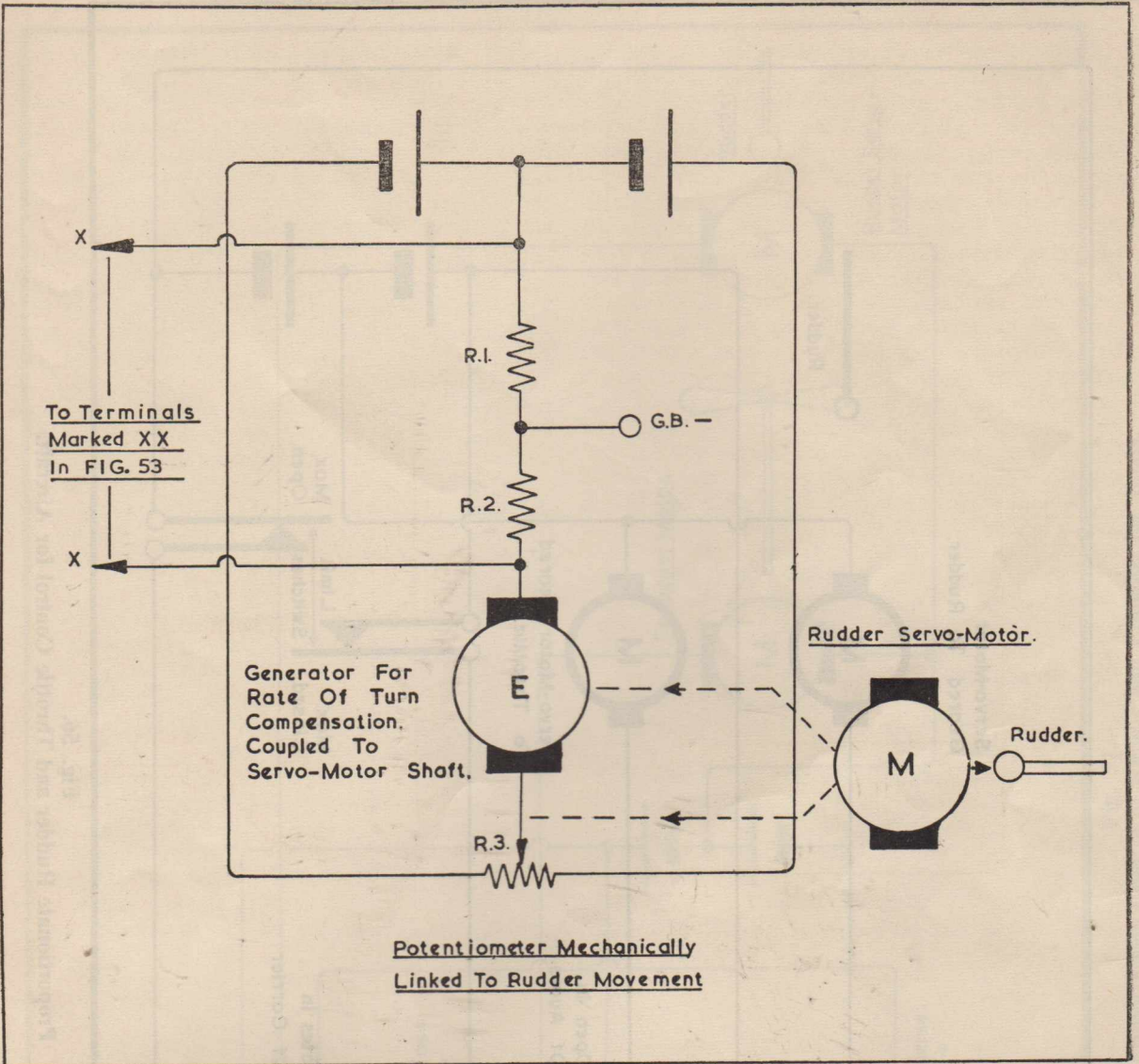

Fig. 55.

Rudder Feed-Back Circuit with compensation for overshoot.

to aircraft control is as follows (Fig. 56):—

Normally the carrier is modulated with an audio signal, the frequency of which varies the rudder position. Suppression of the audio signal (unmodulated carrier only being sent), causes the throttle to open at a steady rate. Suppression of the carrier causes the throttle to close at a steady rate. The throttle setting can therefore be adjusted by suppressing either the audio signal only or the carrier for a short interval of suitable duration. The rudder will be in the straight position in the absence of the audio signal, even with carrier on. Thus, loss of control, due for instance to the aircraft flying out of range, will result in the rudder being straight, while the engine will be throttled down to idling speed.

For a boat, the circuit is slightly modified so that the propulsion motor is switched for forward running when the audio signal is present, and for reverse running when it is absent, but with carrier on. When the carrier is switched off, the propulsion motor is stopped.

Additional controls can be obtained by adding one or several audio frequency channels each operating a relay when an audio signal of the appropriate frequency is received, exactly as described in Chapter 6.

For really satisfactory control of a model aircraft, it would be desirable to have proportional control of both rudder and elevators simultaneously and independently. The achievement of this object is rather difficult, but not impossible.

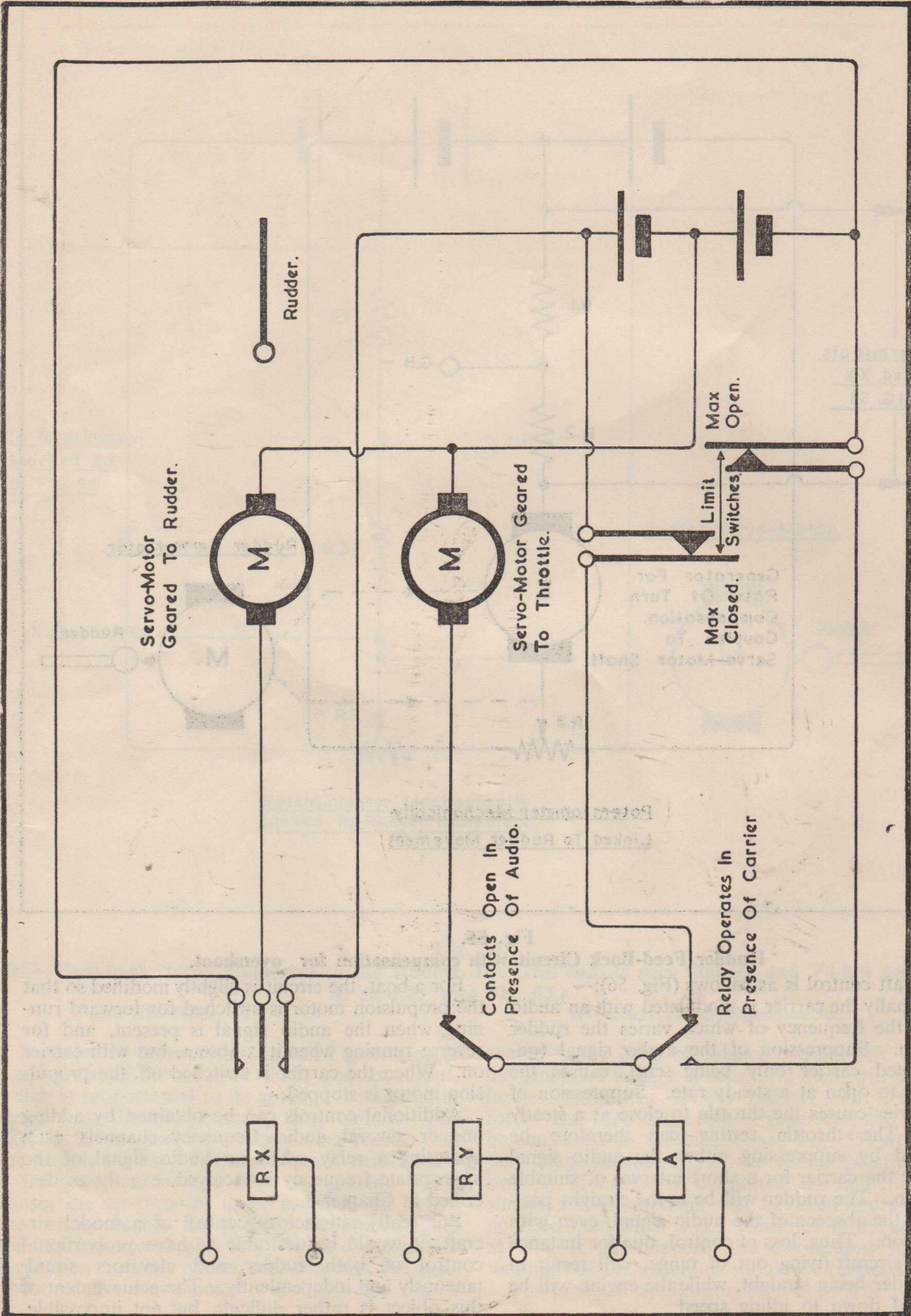

Fig. 56. Proportionate Rudder and Throttle Control for Aircraft.

In the circuit shown in Fig. 58, L_3 , C_{10} and L_4 , C_{11} respectively, are tuned slightly above and below the frequency of audio signal No. 1 which controls the rudder. L_5 , C_{23} and L_6 , C_{24} are tuned slightly above and below the frequency of audio signal No. 2 which controls the elevators.

By ensuring that the frequencies of audio signals Nos. 1 and 2 are suitably separated, it is possible to operate the two controls simultaneously, by mixing both audio signals and modulating the carrier with the resultant. Because each audio signal must not modulate the carrier by more than 50%, to avoid over-modulation when both signals are present, the sensitivity of each receiver audio channel is only half what it would be with 100% modulation, and the balanced relays must be made more sensitive to compensate for the reduced output. Also the audio limiter circuit does not work well when the two audio signals are mixed and it is necessary to omit it, taking care that the coupling to the audio channel inputs is loose enough to ensure that adequate selection is maintained. Even so, a certain amount of inter-action between channels will take place at close ranges when the signal strength is high. Added to this, there is the difficulty of preventing objectionable heterodynes, and as both audio signals are varied over a range of frequencies, this is by no means a simple problem.

Most of these difficulties can be overcome by resorting to the dodge of sending each audio signal in turn over the carrier in quick succession by means of a switching device as shown in Fig. 47. Since only one audio frequency is sent at a time, it can be made to modulate the carrier 100%, and there will be no heterodynes. Also, the audio

limiter at the receiver can be retained, so that the audio input to the various audio channels will remain constant for a wide range of signal strengths as received by the aerial. However, since the audio signal for each channel is on for only half the total time, the audio sensitivity of the channels will be no greater than when the two audio signals are sent mixed.

The balanced relay can be a miniature moving coil relay, some types of which can be obtained with a split or centre-tapped winding for push pull connection. A moving coil meter has been used successfully, the pointer having been shortened and fitted with silver contacts. As the coil in this case is not centre-tapped, it is connected in a bridge circuit and must operate intermediate relays since the moving contact is connected to one side of the coil. The contact pressure is very light and the relay must be mounted on rubber to protect it from vibrations. Special precautions must be taken to suppress sparking at the contacts, or the latter may stick.

The transmitting equipment required is in every way similar to that used for audio-frequency control, using the oscillator and modulator illustrated in Fig. 37.

The only difference is that capacitors C_2 , C_3 , and C_4 are replaced by a 3-gang 500pf variable capacitor, with all three sections paralleled. The controls then consist of a steering wheel coupled to the capacitor, a toggle on-off switch replacing the push-button switches illustrated, which, by short-circuiting the variable condenser suppresses the audio frequency, and a similar switch controlling the HT supply to the transmitter.

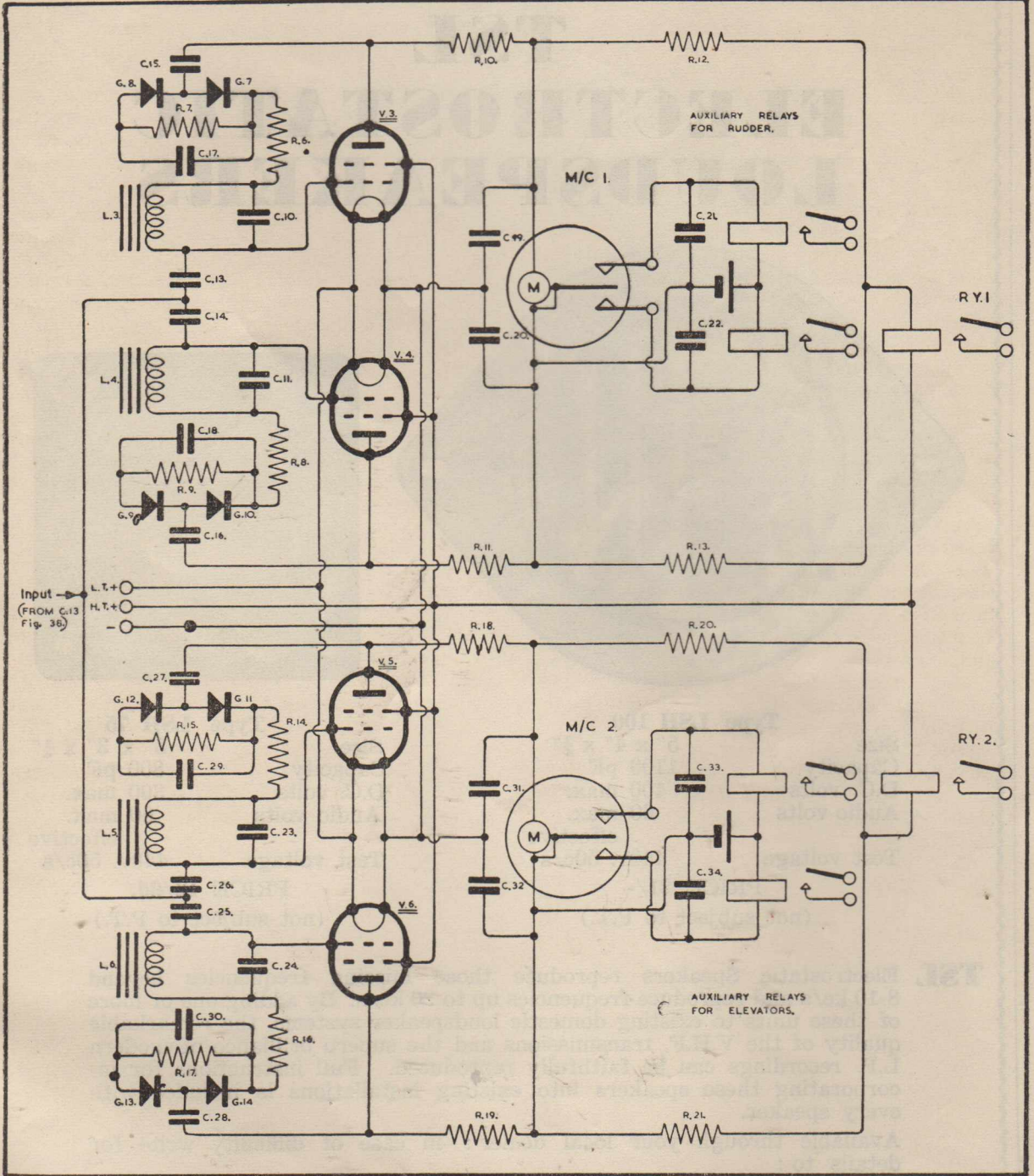

Fig. 58.

Two Channel Audio Frequency Receiver for Proportionate control, using Moving Coil Meters instead of Relay RX.

Components as for Fig. 53, with the following additions.

V3, V4, V5, V6—3S4 or equivalent.

C13, C14, C25, C26—250pf.

C15, C16, C27, C28—0.05μf.

C17, C18, C29, C30—0.02μf.

C19, C20, C31, C32—0.1μf.

C21, C22, C33, C34—0.01μf.

R6, R8, R14, R16—50kΩ.

R7, R9, R15, R17—220kΩ.

R10, R11, R12, R13, R18, R19, R20, R21—5kΩ.

RY1, RY2—4,000Ω Relays with Make Contacts.

M/C1, M/C2—Converted Moving coil meters. (See Text.)

G7 to G14—Germanium Diodes.

TSL ELECTROSTATIC LOUDSPEAKERS

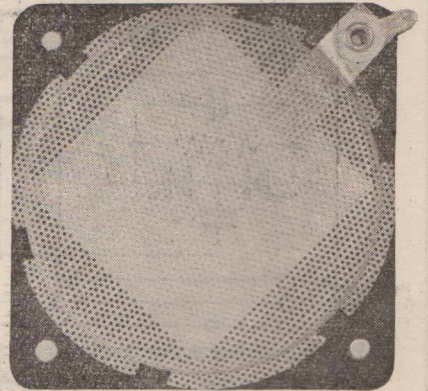
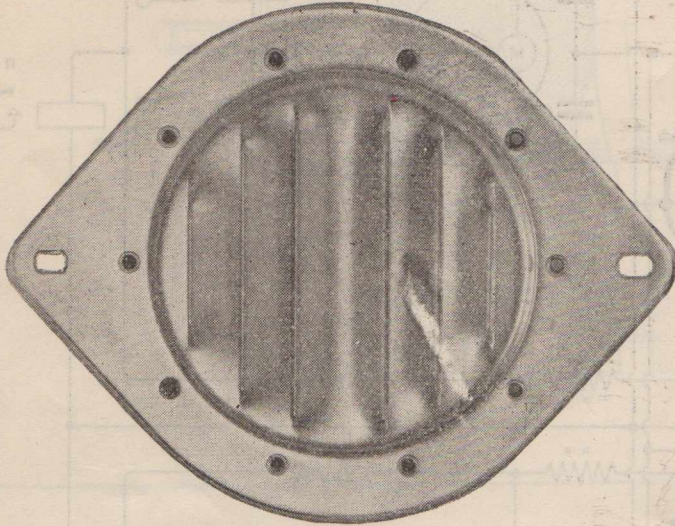

Type LSH 100	
Size	5" x 4" x $\frac{3}{4}$ "
Capacity	1100 pF
D.C. volts	400 max.
Audio volts	60 max. effective
Test voltage	440v. 50c/s

PRICE 21/-
(not subject to P.T.)

Type LSH 75	
Size	3" x 3" x $\frac{1}{4}$ "
Capacity	800 pF
D.C. volts	300 max.
Audio volts	60 max. effective
Test voltage	440v. 50c/s

PRICE 12/6d.
(not subject to P.T.)

TSL Electrostatic Speakers reproduce those missing frequencies beyond 8-10 kc/s and reproduce frequencies up to 20 kc/s. By adding one or more of these units to existing domestic loudspeaker systems, the remarkable quality of the V.H.F. transmissions and the superb brilliance of modern L.P. recordings can be faithfully reproduced. Full instructions for incorporating these speakers into existing installations is included with every speaker.

Available through your local dealer: in case of difficulty write for details to:

TECHNICAL SUPPLIERS LTD.

**HUDSON HOUSE
63 GOLDHAWK ROAD
LONDON, W.12**

BERNARDS RADIO BOOKS

No.		
35.	Dictionary of Mathematical Data	2/-
61.	Amateur Transmitter's Construction Manual	2/6
64.	Sound Equipment Manual	2/6
65.	Radio Designs Manual	2/6
66.	Communications Receivers' Manual	2/6
68.	Frequency Modulation Receivers' Manual	2/6
69.	Radio Inductance Manual	2/6
70.	Loudspeaker Manual	2/6
73.	Radio Test Equipment Manual	2/6
78.	Radio and Television Laboratory Manual	2/6
81.	Using Ex-Service Apparatus	2/6
83.	Radio Instruments and their Construction	2/6
86.	Midget Radio Construction	3/6
96.	Crystal Set Construction	1/-
97.	Practical Radio for Beginners, Book 1	3/-
99.	One Valve Receivers	1/6
100.	A Comprehensive Radio Valve Guide, Book 1	5/-
101.	Two Valve Receivers	1/6
102.	40 Circuits Using Germanium Diodes	3/-
103.	"Radiofolder" A. The Master Colour Code Index for Radio and Television	1/6
104.	Three Valve Receivers	1/6
106.	Radio Circuits Handbook No. 4	2/6
107.	Four Valve Circuits	1/6
108.	Five Valve Circuits	2/6
110.	The Emperor: A Radio-gram for Home Constructor	3/6
112.	"Radiochart" Electronic Multimeter Construction	2/6
115.	Constructors' Handbook of Germanium Circuits	2/6
120.	Radio and Television Pocket Book	2/6
121.	A Comprehensive Radio Valve Guide, Book 2	5/-
122.	Wide Angle Conversion: For Home Constructed Televisors; Constructional Envelope	3/6
123.	"Radiofolder" F. The Beginners' Push-Pull Amplifier	1/6
124.	"At a Glance" Valve and Valve Equivalents for Radio and Television	5/-
125.	Listeners' Guide to Radio and Television Stations of the World	2/6
126.	The Boys' Book of Crystal Sets	2/6
127.	Wireless Amplifier Manual No. 3	3/6
128.	Practical Transistors and Transistor Circuits	3/6
129.	Universal Gram-Motor Speed Indicator	1/-
130.	Practical F.M. Circuits for the Home Constructor	5/-
131.	"Radiochart" Guide to Modern Valve Bases	2/6
132.	Reactance—Frequency Chart for Designers and Constructors	1/6
133.	Radio Controlled Models for Amateurs	5/-
134.	F.M. Tuner Construction	2/6
135.	All Dry Battery Portable Construction	2/6
137.	An A.M.-F.M. De-Luxe Receiver	3/6
138.	How to make T.V. and F.M. Aerials Bands 1, 2 and 3	2/6
139.	Practical Radio for Beginners, Book 2	3/6
140.	Television Servicing for Beginners, Book 1	4/6
141.	Radio Servicing for Amateurs	3/6
142.	Modern Television Circuits and Fault Finding Guide	4/6
143.	A Comprehensive Valve Guide, Book 3	5/-
144.	The New "At a Glance" Valve and Television Tube Equivalents	5/-
	Servicing the Modern Radio Receiver	1/6
	A Magnetic Tape Recorder	3/6
	The Electronic Photographic Speedlamp: How to Make it and how to Use it	3/6