

# How to Build Your Own Solid State Oscilloscope

F.G. RAYER, T.Eng. (CEI), Assoc. IERE

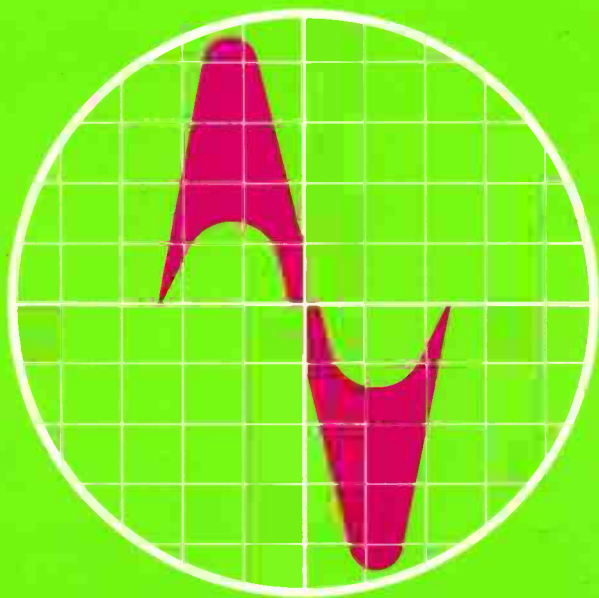



**HOW TO BUILD  
YOUR OWN  
SOLID STATE OSCILLOSCOPE**

by  
**F.G. RAYER, T.Eng. (CEI), Assoc. IERE**

**BERNARD BABANI (publishing) LTD  
THE GRAMPIANS  
SHEPHERDS BUSH ROAD  
LONDON W6 7NF  
ENGLAND**

Although every care is taken with the preparation of this book, the publishers or author will not be responsible in any way for any errors that might occur.

©1979 BERNARD BABANI (publishing) LTD

First Published – June 1979

Reprinted – June 1983

### WARNING NOTE

This oscilloscope is mains operated and it is advised that the mains plug should be pulled from its supply socket, before making any adjustments to circuits or doing any mechanical work. All mains operated and high voltage equipment has a shock hazard, if treated carelessly.

#### British Library Cataloguing in Publication Data

Rayer, Francis George

How to build your own solid state oscilloscope.

– Bernard & Babani Press radio and electronics book; 57).

1. Cathode ray oscilloscope – Amateurs' manuals

I. Title

621. 3815'48 TK9965

ISBN 0 900162 79 1

Printed and bound in Great Britain  
by Mayhew McCrimmon Printers Ltd

# CONTENTS

	Page
General Notes . . . . .	5
Block Diagram . . . . .	6
Order of Construction . . . . .	8
Front . . . . .	9
Finish . . . . .	10
Back and Chassis . . . . .	11
Cover . . . . .	12
Panel Controls . . . . .	12
Points on layout . . . . .	13
Top of chassis . . . . .	13
Under chassis . . . . .	16
Wiring runs . . . . .	18
Mains supply . . . . .	20
Low voltage supply circuit . . . . .	20
Tagboards . . . . .	22
Component values and ratings . . . . .	24
High voltage supplies . . . . .	25
Rectifier board . . . . .	27
Chassis layout . . . . .	28
HT Shocks . . . . .	28
Colour coding . . . . .	30
CRT Heater . . . . .	31
Voltage adjustment . . . . .	31
CRT mounting . . . . .	34
Pin connections . . . . .	36
The CRT and its supplies . . . . .	36
CRT alternatives . . . . .	40
3BP1 fitting . . . . .	42
Timebase circuit . . . . .	44
X amplifier output stage . . . . .	47
Timebase amplifier assembly . . . . .	49
The Y amplifier . . . . .	52
Y amplifier board . . . . .	55
Adjustments . . . . .	57
Y amplifier response . . . . .	59
Synchronisation . . . . .	61
Sync board . . . . .	63

Flyback suppression . . . . .	66
Flyback suppression board . . . . .	69
Alternative X input . . . . .	71
Reference voltage . . . . .	73
Calibrated attenuator . . . . .	74
Z axis . . . . .	75
Direct Y input . . . . .	76
Alternative semiconductors . . . . .	79
Test notes . . . . .	80
External synchronisation . . . . .	80
General use . . . . .	81
AC wave . . . . .	83
RMS value . . . . .	84
Generator . . . . .	84
Harmonics . . . . .	87
Lissajous figures . . . . .	88
Sine wave oscillator . . . . .	91
Special Notes for USA Readers . . . . .	94

## General notes

An oscilloscope is, in itself, quite a complicated instrument. However, it can be divided into various sections, and this is done here. These can be constructed and tested individually. The following is a brief outline of the more important sections making up the complete scope.

*Chassis and panel* work should come first, but the case can be left until last.

*Low voltage supply.* This provides current for the low level stages of the horizontal and vertical amplifiers, and for the timebase. A separate transformer is used.

*High voltage supply.* This supplies the output stages of the horizontal and vertical amplifiers, and also the various voltages required by the tube. A second transformer is employed, as individual transformers are more readily available than a single component having both low and high voltage windings.

*The timebase and X-amplifier* supplies the plates on the tube which cause the trace to move horizontally. For many purposes, the tube is scanned horizontally by this means, with a frequency of scanning, or spot velocity, to suit the tests being made.

*The Y-amplifier* receives the input to be displayed, and raises this to a sufficiently high level to deflect the spot vertically. The combination of both vertical and horizontal movement produces the cathode ray tube trace.

When deciding on the tube to use, several factors apply. Large tubes require a higher operating voltage, and also a more powerful scanning circuit, and the power supplies have to be arranged to suit. The size of tube chosen for this instrument allows a very useful display, while its power supply and scanning needs are met without any particular difficulty.

## Block diagram

Figure 1. will help to make the working of the oscilloscope clear. It is built round the cathode ray tube. This tube has a heated cathode, which emits a stream of electrons. These are accelerated and brought into focus so that a bright spot is obtained where the electrons strike the fluorescent coating on the face of the tube.

The beam is made to move across the tube face by magnetic deflecting coils, or internal electrostatic deflection plates. (The latter method is used here, as is general with oscilloscopes.) The plates used to deflect the beam vertically are Y-Y in Figure 1, while horizontal deflection is obtained by changing the potential on the X plates.

A regular sweep voltage is generally applied to the X plates. The spot traces a line across the screen from left to right, then flies back to the left to repeat the trace. Simultaneously a signal to be examined is amplified and taken to the Y plates. The beam is thus made to move up and down, in its transit across the screen, so producing the display. By examining this, various facts or information can be obtained.

Sometimes a cathode ray tube or scope may be employed for other purposes, such as finding modulation depth, or the relationship between two inputs of different frequency, or for voltage measurement.

It is possible to apply vertical and horizontal deflection voltages to one Y plate and one X plate only. This tends to result in a loss of linearity, so the present instrument uses push-pull outputs to both Y and both X plates.

A combination of switched and fully variable controls allows the sweep frequency to be adjusted between wide limits, as this is an essential requirement except for some particular uses. Similarly, other controls allow adjustment of focus, brightness, and vertical deflection of the spot.



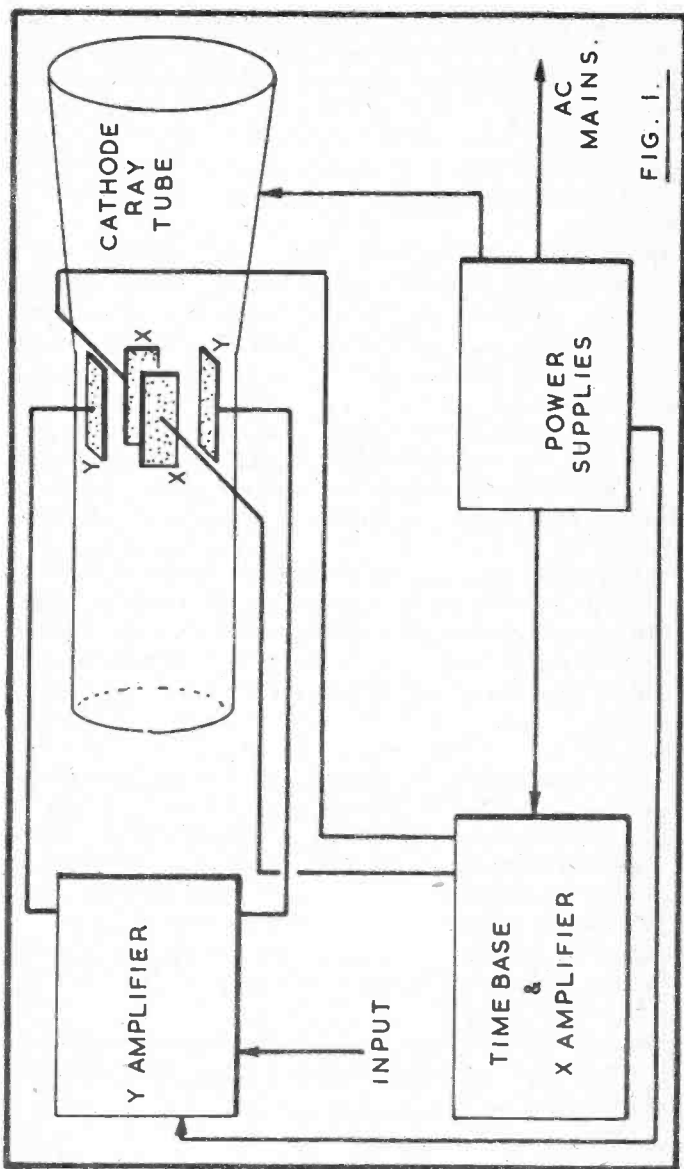

FIG. 1.

Further details of the actual use of an oscilloscope such as that described here appear later. These would, of course, also be applicable to the use of a ready-made instrument of similar type.

### **Order of construction**

It is necessary to prepare the back, chassis and panel first. Small holes for leads or fixing screws can be made from time to time, as necessary, but the large holes for capacitors, panel controls, CRT and input socket must be made first, before mounting any components.

The back ought not to be omitted, as when it is fixed in place the open, box-shaped assembly can be placed in any convenient position without damage to components, and can be turned over to reach connecting points under the chassis.

At an early stage it is necessary to make the cathode ray tube fittings described, and to check that the CRT will fit correctly. The tube is then removed, and need not be fitted until the supplies for it are available, so that its operation can be checked. At this time the X shift and Y shift controls can also be tested.

Afterwards, building the timebase and X amplifier board and connecting this will allow horizontal scanning of the tube. At the low scanning speeds operation of the coarse and fine controls can be seen, but at higher speeds only a horizontal line will be apparent. The X gain will enable this to be reduced to a central spot, or expanded to beyond the screen diameter. (Do not let the beam remain for any length of time at any position, to avoid ion burns.)

Addition of the Y amplifier allows the scope to be used in the normal way. Further points can be dealt with in the order described.

## Front

This is 7 x 9 in and is marked out as in Figure 2. Some of the panel holes will be optional, as described later. It is usually easy to obtain aluminium or suitable alloy panels and other components of this kind ready cut to size, though it is a relatively easy matter to cut these from a larger sheet.

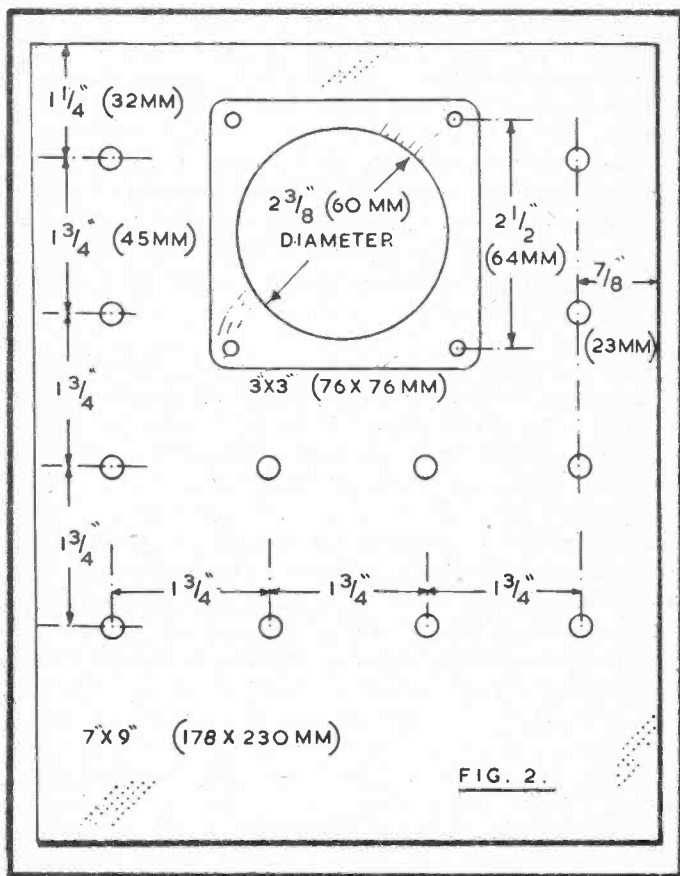

FIG. 2.

Holes for potentiometers are  $\frac{3}{8}$  in (10 mm) in diameter. These are most readily made by drilling the required smaller holes for a  $\frac{3}{8}$  in chassis punch — the type which cuts the hole with a few blows from a hammer will fit a  $\frac{1}{8}$  in hole. Screw-up types need somewhat larger holes. It is also possible to drill pilot holes, following with a  $\frac{3}{8}$  in drill, or to enlarge small holes with a reamer or similar means, according to what is available.

The larger hole can be made with an adjustable tank cutter fitted in a hand brace. The panel should rest against a board for support. An alternative is to draw the circle with a steel point, and drill a ring of small holes closely together just inside this. If necessary, metal between the holes can be cut with a mouse-tail or key hole (*rat-tail*) file, until the centre piece can be removed. The aperture can then be enlarged carefully with a half-round file, to reach the line. This work will be eased if the panel can be clamped vertically between two boards in a vice.

Side pieces 9 x 1 in (230 x 26 mm) and with top and bottom flanges are bolted to the panel. These strengthen it, and allow the cover to be fixed later. Two such parts can be made by cutting a single 9 x 2 in “universal chassis” member, and two similar parts are needed for the back.

A piece of thin Perspex or similar transparent material is cut 3 x 3 in (76 x 76 mm) and drilled near the corners to allow it to be bolted to the panel. (These bolts will also be used for the tube support.) A grid of vertical and horizontal lines spaced at 5 mm intervals can be scratched on the Perspex with a sharply pointed tool.

## Finish

A more professional appearance will be obtained if the panel and cover, at least, are painted. Silver is suggested, but other paints intended for metal could be used.

For the painting to be successful, brush and paint should be clean and the surfaces should be free of grease. As a smooth surface is not easy to obtain, a crackle finish is generally adopted. Special paints which take on a stippled or hammered finish as they dry are available. A somewhat similar result is obtained with an ordinary quick-drying paint by stippling with the brush. To do this, paint the surface in the usual way, then when it has begun to dry, dab it all over with the brush (not adding any more paint) with a vertical action, avoiding regular lines. This results in the paint hardening with a hammered finish without brush-marks of the usual type, or slight scratches on the metal being apparent.

Painting can be left until other work is finished. Afterwards replace the control knobs, Perspex square and bolts, and stick on labels to identify the controls.

### **Back and chassis**

The back is also 7 x 9 in (178 x 230 mm) with side flanges provided as described for the front.

The chassis is 12 x 7 in (305 x 178 mm) or 14 x 7 in (356 x 178 mm) for the 3BP1 tube and is fitted at a height of 3½ in (90 mm). So that under-chassis components may be reached easily, side flanges on the chassis should not be more than about 1 in or 25 mm deep. The four vertical pieces described can be arranged to fit outside the chassis, so that bolts may be run through to secure the parts together. Four bracing strips about 3 in (76 mm) long are bolt to the chassis and vertical members so that the whole assembly is rigid. Countersunk headed bolts must be used so that the cover can fit correctly,

The chassis, with front and back in place, will form a strong unit which can be turned over or on its side, as wiring proceeds. Small holes can be drilled in the chassis, as needed, for leads or bolts.

## Cover

The casing consists of a bottom 12 x 7 in (or 14 x 7 in), and a cover 12 x 7 x 9 in (or 14 x 7 x 9 in) for top and sides. The bottom plate can be secured with self-tapping screws or bolts and nuts. A few  $\frac{3}{8}$  in or 10mm diameter holes can be punched in it for ventilation, and four rubber feet should be screwed in place near the corners.

A piece of thin sheet metal 12 x 25 in is bent to form the cover. To do this, it is necessary to grip the metal firmly at the bending line, by means of strong boards in a vice. A right-angled bend is then made by forcing over the metal with a board held in the hands. Care is needed to obtain a sharp bend, and a few taps with a mallet on the board may be necessary.

Expanded and perforated metal will bend much more readily, and is suitable. It would also be possible to make the cover in three pieces — two 12 x 9 in (305 x 230 mm) for the sides, and a top 12 x 7 in (305 x 178 mm).

When work is otherwise finished, the bottom and cover can be screwed on, taking care that self-tapping screws for the latter do not foul any internal connections or parts.

In view of the mains (*line voltage*) and other high voltages present, the cover ought not to be omitted. It also provides protection and some measure of screening for internal items.

## Panel controls

Knobs already numbered on the skirt can be used with the potentiometers, or pointed type knobs with scales glued to the panel. Transfers for such purposes can be obtained,

The function of each control should also be indicated, with transfers, stick-on lettering, or similar means.

## Case, chassis, etc.

Panel 7 x 9 in (178 x 230 mm)

Back 7 x 9 in (178 x 230 mm)

Chassis 12 x 7 in (305 x 178 mm)

Four 9 x 1 x 1/2 in flanged angled girders, made from two  
9 x 2 in (230 x 51 mm) "universal chassis" members

Perspex (*Plexiglass*) 3 x 3 in (76 x 76 mm)

Four strips 3 x 1/2 in (76 x 13 mm)

Cover 12 x 25 in; or 2 off 12 x 9 in (305 x 230 mm) for sides  
and 12 x 7 in (305 x 178 mm) for top.

Bottom 12 x 7 in (305 x 178 mm)

Four rubber feet.

## Points on layout

Exact dimensions or the critical location of some items, such as tagboards, will be unlikely to have any effect on the appearance or functioning of the scope. However, reference to the points mentioned here should prove helpful when fixing the various items, and will allow any difficulty in fitting later items to be avoided.

## Top of chassis

The actual chassis is 12 x 7 in. Boards and other items here are located as in Figure 3. Parts to mount the CRT, as described later, should be prepared, and temporarily fitted with the tube in position. After checking that all will be in order, remove the tube.

Several metal can type capacitors are used, and the positions of these can be located approximately as shown. Holes for these must clear the capacitor positive tags adequately. If suitable screw-up chassis punches are not available, prepare these holes before doing any other assembly work, using an adjustable tank cutter, or by drilling a ring of small holes so that the piece can be removed, afterwards finishing the hole.

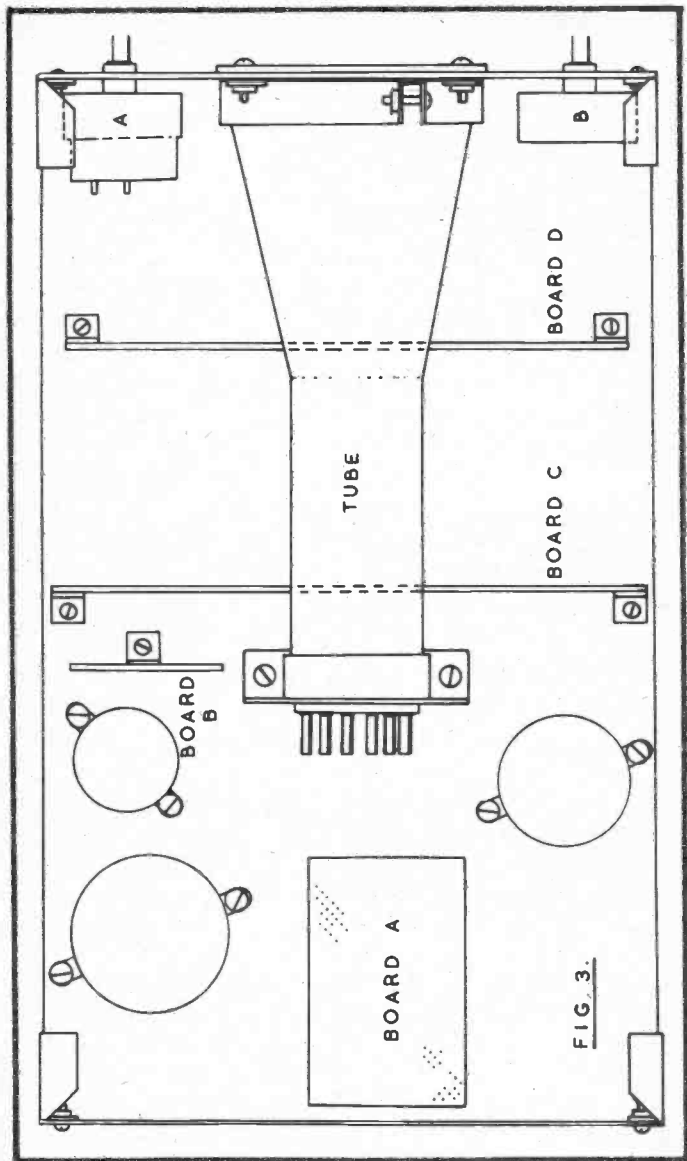

FIG. 3.



with a half-round file. There is sufficient space to allow capacitors of other types to be used, supported by tag strips. Reference to the power supply circuits will show that some capacitors will have positive connected to chassis, and this should not be overlooked if the above and below chassis layouts described are changed.

The small board A carries the low voltage and high voltage rectifiers. It is convenient to place the high voltage rectifiers at the back of this board. Wiring is shown elsewhere. This board is supported by bolts forming the chassis return, with spacers or extra nuts to bring it clear of the metal chassis.

The small board B is mounted vertically on a bracket near the CRT. It carries the fixed resistors forming the potential divider for the tube.

Board C is that for the timebase and X amplifier, and it is mounted by brackets which also provide connecting points for the chassis returns from the board circuits. Board D is similarly arranged, and is for the Y amplifier. Check that the tube will clear these boards, with a little to spare.

Potentiometer A is for brilliance, with its tags so connected that the brightness of the trace increases with clockwise rotation. This control incorporates the main on-off switch.

Potentiometer B is for X shift. Connect its tags so that rotation in a clockwise direction moves the spot to the right. Also wire the Y shift control so that movement of the spot up or down follows rotation.

The circuit boards are wired before mounting them on the chassis. When they are in place, most components are reasonably accessible, except those immediately under the cathode ray tube.

## Under chassis

Positions for the larger components can be seen from Figure 4. The mains transformers mount near the back. No mains hum on the CRT was observed with the transformers situated as shown. If necessary, this can be checked when the tube supplies have been provided, so that a spot is available on the screen. It does not seem likely that the spot will wobble at mains frequency due to the magnetic field of transformers of other type. If this should happen, one or both transformers may be rotated, to remove any difficulty of this nature. If changes to layout are made to employ an existing case or chassis, the transformers should be as far as possible from the CRT, and especially that part of the tube where the beam is subject to focus and deflection. In these circumstances, a mumetal screen was not found to be necessary for the CRT. But if such a screen is available it should be retained.

The position of wiring from the transformers up through the chassis to the rectifier board, then to the smoothing capacitors, will present no difficulty.

Board E carries the low voltage zener diode and associated items, and mounts on a bracket. It is a little clear of the capacitor fitted above the chassis at this point.

A bracket, cut from scrap metal, supports the X and Y potentiometers in the position shown. There is a reasonable amount of clear space here.

The tagstrips F and G support some of the capacitors, as shown in the wiring diagram for this section. Elsewhere, small tagstrips are used for other supporting or connecting points. That is, to anchor the mains (AC) cord near the low voltage transformer, and to provide support and take-off junctions for positive and negative power supply circuits.

The input socket and attenuator are adjacent on the panel. No AC wiring need be carried along this part of the chassis. Pick-up from nearby alternating current or other circuits, external

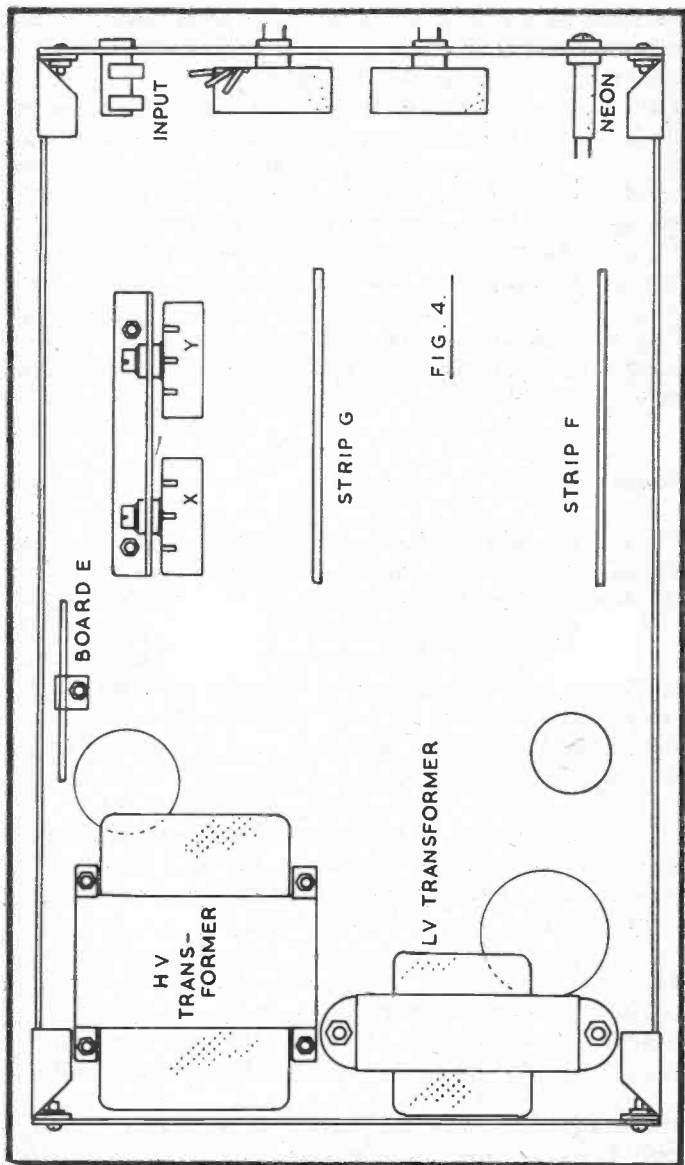

FIG. 4.

to the scope, can cause movement of the trace. These effects were not observed with power cords and other possible sources of interference at a reasonable distance, with the instrument cover off. With the cover on, there is less likelihood of trouble from this source. The screening afforded by a cover of the kind described is helpful, but cannot completely avoid interference from external sources. As example, hum could easily appear on the trace if the scope were placed on top of an AC power supply unit, or is immediately adjacent to other AC equipment.

In some places it will be found convenient to arrange mounting positions or brackets so that a bolt through the chassis can secure items both above and below.

### **Wiring runs**

The need for safety has been pointed out, especially in relation to mains (*power supply*) circuits at the transformer primaries, on-off switch, neon indicator, and mains cord anchor points. High positive and negative voltages are also present in the EHT circuit and its associated components. Care must be exercised so that the tags of panel controls or similar items are not touched when handling the scope during construction, unless the mains plug has been withdrawn, and capacitors are discharged.

HT circuits are wired with adequately insulated leads, and these can often run along the chassis, passing neatly from point to point. Similar considerations apply to the connections from transformer to HT rectifiers.

Elsewhere in the scope, low voltage supply circuits are not going to present a shock hazard, but are best run in a similar manner, against the chassis. Connections between smoothing capacitors, and to the boards, can all be arranged in this way.

It will not be overlooked that high voltages are present at the cathode ray tube base, although these leads are not very likely

to be touched unintentionally.

Other wiring, to boards and elsewhere, will carry scanning or other voltages. These need to be situated to avoid unnecessary coupling causing feedback or pick-up of AC, exactly as with an audio amplifier or similar piece of equipment.

In the case of the Y amplifier, the input socket, potentiometer, and base circuit of the first amplifier are kept clear of other leads. This is readily arranged as the potentiometer is close to the input socket, and a lead can run across under the chassis, to pass through a hole to the Y board. The board itself is clear of other items, and output connects to the Y plates run back to the tube base without any need for proximity to input circuits or other items.

If wished, low capacitance screened (*shielded*) cable can be used for the connections which have to run from the board. Form a pigtail about  $\frac{1}{2}$  in long at each end, by twisting together the strands of the outer conductor, and solder this to an adjacent chassis tag, or extend it with a wire connection to a nearby ground. Such screening is only applicable to circuits carrying signal or scanning voltages, and can prevent stray unwanted coupling into nearby circuits or components.

Hum accompanying the display can be shown as a wavering of the trace. But as the transformers and associated circuits are well away behind the tube, any trouble of this kind is more probably introduced by the external Y input lead. Possible causes include the presence of a small AC voltage between the grounds of the scope and equipment being tested, or pick up of AC by the scope input lead, this being unnecessarily close AC power supply or other leads, or the field of a power transformer which is rather near the scope. These possible causes can be identified by disconnecting the input lead at the scope, by checking between grounds with an AC voltmeter set to a sensitive or low voltage range, or by including external isolating capacitors in the input lead circuits, or moving or rotating adjacent equipment or situating it farther away. If these actions clear or substantially modify hum on the trace, then it

is apparent that the fault is not in the instrument itself.

With the timebase and X amplifier similar considerations apply. The layout lends itself to avoiding any unnecessary trouble here. Connections to the coarse and fine timebase controls run directly forward to these components, while the X output coupling capacitors lie near the base of the CRT. Connections to the X gain potentiometer are screened (*shielded*) as described, as these have to run under the Y board. Even here, screening is not strictly necessary, if the leads are run on the chassis.

It is helpful to use some colour coded leads. This makes them much easier to identify, when proceeding with further constructional work. It is also very helpful when wires run under other components or cannot be easily seen for part of their length.

### **Mains (AC power) supply**

For safety, the metalwork is earthed (*grounded*). Current is drawn from a 3-pin plug, fitted with a 3A fuse. A 3-core flexible cord is used, with blue for neutral, brown for live, and green-yellow for earth.

The cord passes through a grommet in the back, under the chassis at the left. Here, it is anchored at a 3-way tagstrip, with earth (*ground*) soldered to the chassis mounting tag. From this strip, leads run to the primaries of the transformers (neutral) and to the mains on-off switch. The panel neon indicator 240V (*or 115 volts in USA*) type with integral series resistor) is connected to one transformer primary circuit.

### **Low voltage supply circuit**

This provides current for the Y amplifier, timebase and X amplifier low power stages. Current is derived from a 20V transformer, Figure 5. Four silicon rectifiers give a supply

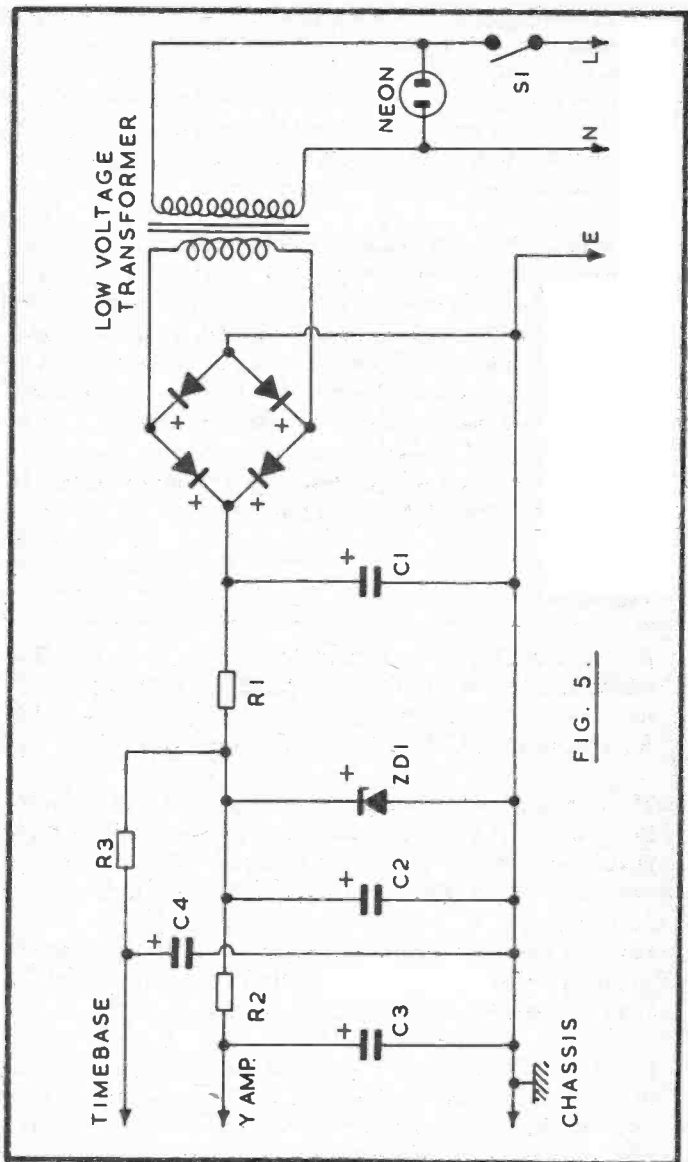

FIG. 5

of approximately 26V, which is smoothed by C1. R1 drops approximately 8V at 40mA, and a regulated 18V supply is obtained across ZD1.

Further smoothing by C2, C3 and C4, with resistors R2 and R3, provides individual outputs to operate the timebase, and low level stages of the X and Y amplifiers.

If required, R1 could be modified in value to suit a different transformer secondary voltage. For a higher voltage, R1 would be increased in value so that ZD1 is not over-run. With a 1 watt 18V Zener diode, current through the diode should not exceed 50mA. The voltage rating of C1 might need increasing. A transformer with a lower voltage output is not recommended, as stabilisation becomes less reliable.

With an open circuit test (no load applied) approximately 18V will be found across C2, C3 and C4.

## Tagboards

A small tagboard mounts the four rectifiers, Figure 6. The band indicates the positive end. Negative is connected to a soldering tag secured by one of the chassis mounting bolts. A lead runs from positive to the capacitor board.

The tagboard for the capacitors, resistors, and ZD1 is shown in Figure 7. It mounts vertically on the underside of the chassis, by means of a bracket bolted to it. This also provides the chassis return or negative line connecting point.

Later, as required, leads are brought from the timebase and amplifier circuits, and soldered to the tags which support C3 and C4, as shown.

It was found convenient to fix the rectifier board on top of the chassis, centrally at the back, and the capacitor board underneath, near the high voltage transformer (E, Figure 4). That is, on the right of the chassis, with the assembly upside



down and viewing it from the front. Both transformers are underneath, at the back, as far from the tube as possible.

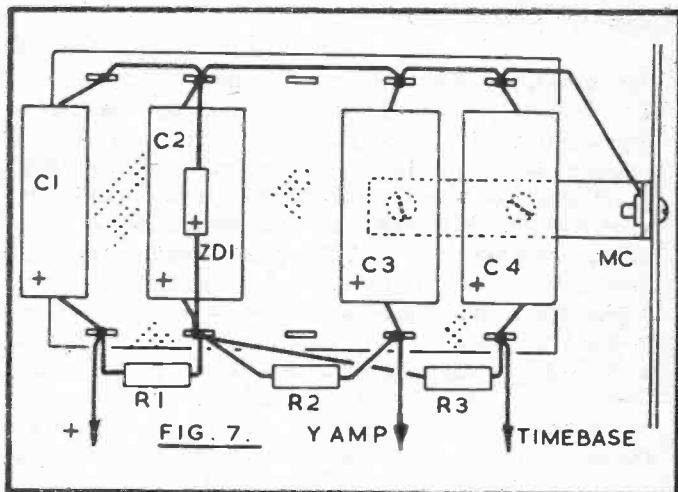
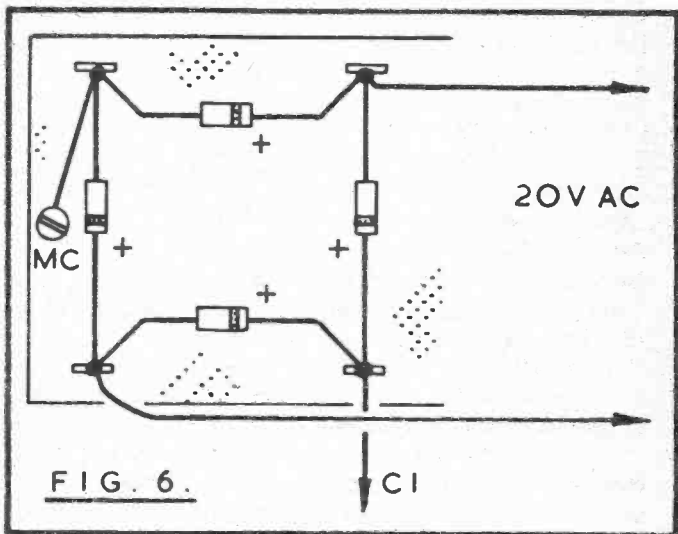

## Low voltage supply component list

20V 0.5A transformer

4 x 1N4001 silicon diodes

R1 220 ohm  $\frac{1}{2}$ W

R2 390 ohm  $\frac{1}{2}$ W

R3 1.2k  $\frac{1}{2}$ W

C1 220  $\mu$ F 30V

C2 470  $\mu$ F 20V

C3 1000  $\mu$ F 20V

C4 1000  $\mu$ F 20V

ZD1 18V 1W

Tagboards (terminal strips) and bracket, etc.

240V (115V in USA) neon indicator, 3-core flex, tagstrip (terminal strip) and plug.

## Component values and ratings

With reference to the component lists for the various sections which make up the completed instrument, essential points are mentioned from time to time. It will be understood that there is considerable latitude in the ratings of some components.

An example of this is given in the maximum voltage rating of the capacitors in the high voltage supply circuits. A voltage of 350 was found across some circuits, so capacitors of 350V rating could be used. But in some circumstances, the voltage could be a little higher, so that such capacitors would be operating outside their rating. It is quite possible that, even in these circumstances, 350V components would prove to be satisfactory. However, it is better that the capacitors are of higher rating, rather than lower. Here, 375V capacitors could be listed, but these seem less easily obtainable than somewhat higher voltage ratings. Since space is available to accommodate capacitors of any reasonable size, there is no reason to use capacitors of near minimum rating. Such items can rather be chosen according to availability, provided the ratings are not lower than the potentials which will be present. A similar

point applies to the 18V supplies, where 20V, 25V, or even high rating components which are easily obtainable would be fitted.

In some parts of the higher voltage circuit, the voltage is reduced, so that 350V capacitors would in all cases be suitable. But for convenience or the use of twin and similar capacitors the rating may well be higher.

Values such as 200  $\mu\text{F}$ , 220  $\mu\text{F}$  and 250  $\mu\text{F}$ , or 47  $\mu\text{F}$  and 50  $\mu\text{F}$ , or similar close figures, can be regarded as interchangeable. This also applies to coupling capacitors such as 0.47  $\mu\text{F}$  or 0.5  $\mu\text{F}$ . It will be clear from details provided when values should be as given.

Where necessary, suitable voltage ratings for small value capacitors are given. In most circuit positions the voltages are small so that ratings of 20V or 25V could be used, though components of this type will often be rated at 150V or more. So provided the rating is adequate, it can generally be ignored, and no necessity at all arises for obtaining components of some particular voltage rating here.

### **High voltage supplies**

High voltages are required for the output stages of the X and Y amplifiers, and for the cathode ray tube. These are obtained from a 250-0-250V transformer.

Figure 8 is the circuit of the high voltage supplies, providing up to 350V for the X and Y amplifiers, and 700V for the CRT.

The transformer centre tap is grounded to the chassis. The silicon rectifiers give full-wave rectification, and approximately 350V will be obtained across the reservoir capacitor C3. The peak voltage is approximately 1.4 times the transformer secondary voltage rating, so 375V or 400V capacitors are required. The rectifiers need a peak inverse voltage rating of twice this, but 1 kV and similar silicon diodes are readily available.

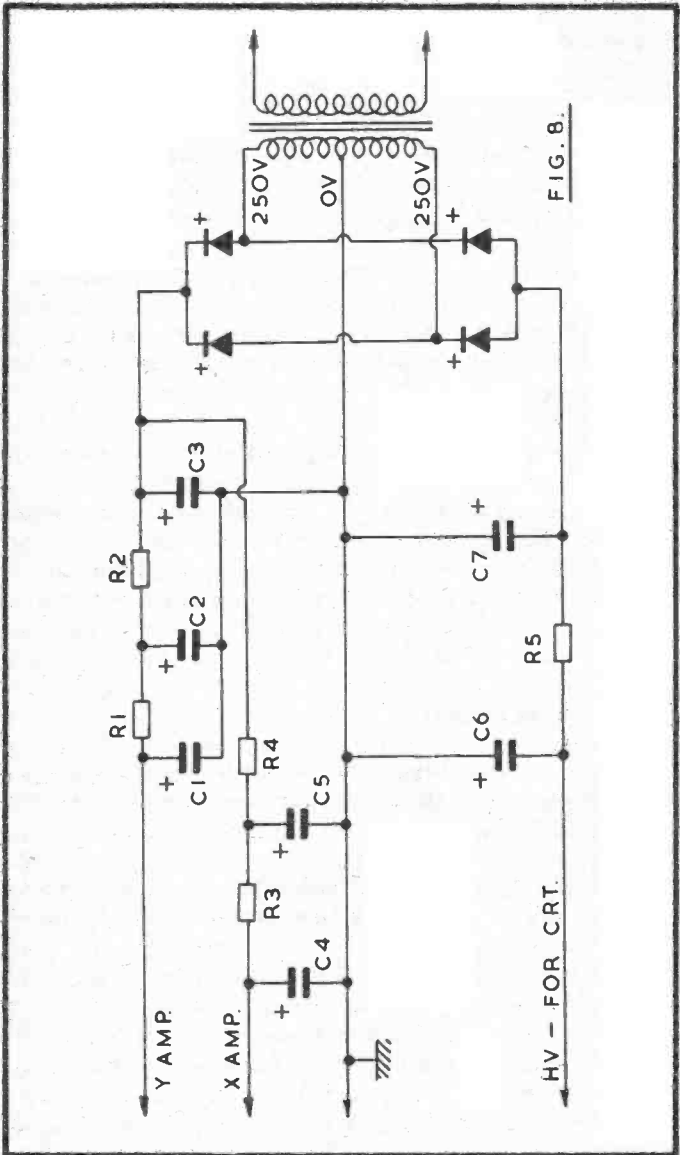

FIG. 8.

R1, R2, C1 and C2 furnish additional smoothing for this supply. The positive line from C1 runs to the push-pull output stage of the Y amplifier, and to the CRT circuits.

R3, R4, C4 and C5 provide a separate supply, and this is used for the X amplifier output stage.

The remaining rectifiers provide a supply which is negative with respect to the chassis. Smoothing is by C6, C7 and R5. This circuit is connected to the grid and cathode of the CRT, the brilliance control being incorporated between cathode and grid. The current drawn here is small, being that of the CRT itself, and a potential divider network incorporating focus and other controls.

There is some latitude in capacitor values, though variation should tend towards larger capacitances, rather than smaller, with a maximum however of 100  $\mu\text{F}$  for C3 and C7.

Multiple capacitors with negative metal cans are often found in radio or amplifier circuits and chassis mounting vertical types are ideal for C1, C2, C3, C4 and C5. With C6 and C7, positive will be connected to the chassis. Capacitors with metal cans common to negative must be adequately insulated from the chassis. But as these components need not be of such a large value, it is convenient to use wire-ended capacitors so that they can be mounted on tag strips under the chassis.

### **Rectifier board**

The four rectifiers are mounted on a small stag board, as in Figure 9. From here, leads run to the 250V taps on the transformer. Connections are also taken to C3 and C7.

This board is the second half of that which carries the four low-voltage rectifiers. The transformer centre tap is grounded to the chassis at one of the bolts holding it in place. The transformer primary is in parallel with the low voltage transformer primary.

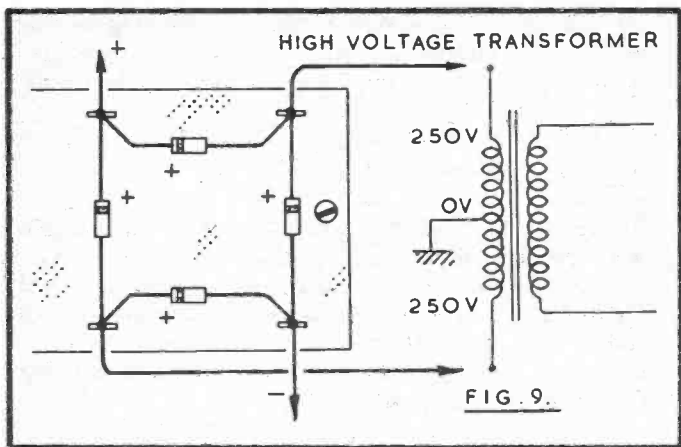

### Chassis layout

Figure 10 shows the placement of the transformers, capacitors and other items. C1 and C2 are in a double can, C3 is a single can, and C4 and C5 a double can. These are all mounted vertically by means of clips which grip the metal cans forming the negative common return. If the capacitors have isolated cans, there will be a negative tag for each, and these are wired to the chassis at a convenient near point.

C6 and C7 are mounted by means of their wire ends. Should these have bare metal cans be sure they do not touch the chassis or each other. Capacitors with card or other insulated sleeves are preferable for this position.

### HT shocks

When first testing the high voltage power supply, approximately 350V positive and 350V negative will be found at the positive and negative lines, with respect to chassis, as described.

FIG. 10.

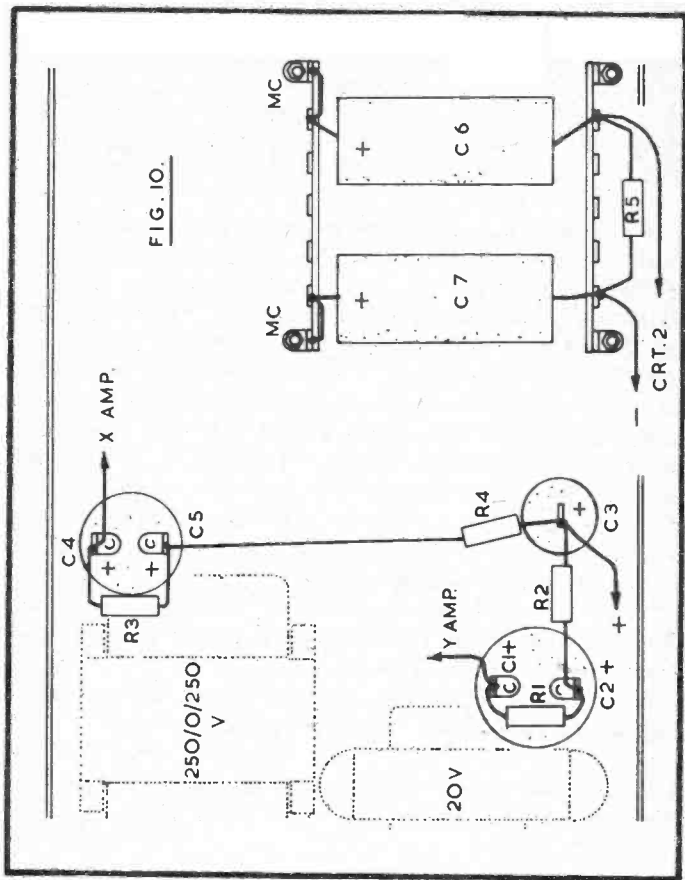

These voltages could of course be responsible for shocks, if any live part is touched. This might be from carelessly picking up the chassis and touching C2 or C4 connections, or the cans of C6 and C7, if the latter are not insulated.

As with all mains operated equipment, it is advised that the mains plug should be pulled from its supply socket, before making any adjustments to circuits or doing any mechanical work. All mains operated and high voltage equipment has a

shock hazard, if treated carelessly. The maximum voltages relative to chassis with this circuit are much lower than with many scopes, and only similar to those in many valve amplifiers. Despite this, care must be taken at all times, and particularly when checking voltages with the equipment switched on.

If a high resistance voltmeter is clipped from chassis to positive or negative lines, it will be seen that considerable voltage continues to be present for some little time after switching off and disconnecting the power. These voltages are from the charged capacitors, and can also be a shock hazard. Any chance of shocks from this reason can be avoided in several ways. One is to avoid touching circuits too soon after switching off, and to make a quick test with a voltmeter before doing so. Another is to have a shorting lead, consisting of a flexible wire with clip to attach to the chassis, and to discharge the capacitors with this. It is also possible to connect bleeder resistors, each 100k 2W, across C3 and C7, so that power leaks away more rapidly.

With no current drawn from the power supplies, voltages may remain present for a surprisingly long time. A check of this ought to be made with a voltmeter, when first testing the supply, and the point must be kept in mind.

Unplugging the equipment will avoid any chance of mains shocks by touching mains connection anchor points, on-off switch tags, etc.

### **Colour coding**

It will be found well worth while to have wires of several different colours to identify connections which run through the equipment. Red and black for positive and negative will be obvious. In some places leads run under other components, or can be taped together, and colour coding is then very useful. Green, blue, grey, yellow, white, and other colours will serve to identify leads running from panel controls to



other items, and will avoid any need for laborious tracing of wiring.

Also use connecting wire with adequate insulation, especially for the high voltage circuits. In general, all power-supply circuit wiring can run neatly against the chassis.

### **CRT heater**

The VCR139A tube has a 4V heater, so can be operated from a 4V winding on the transformer. Many transformers have at least one 0-4-6.3V, or 0-4-5V winding, and heater current is drawn from 0V and 4V taps.

Should only a 5V supply be available on the transformer, a 1 ohm 1 watt resistor must be included in series with the heater circuit. For a 6.3V winding, the resistor needs to be 2.3 ohm, rated at 1A, or 2.5W. A resistor may if necessary be made from resistance wire, starting with more than required, and gradually reducing this until the heater settles at 4V when at full temperature.

To avoid a large heater-cathode potential, the heater winding is left floating at the transformer, and 1 and 3 (cathode and heater) are connected together at the CRT base.

### **Voltage adjustment**

Some mains transformers have a single primary voltage with no taps for adjustment. Where the transformer has input taps for 230V, 240V and 250V, or some similar range of adjustment, employ the nearest to the actual mains supply voltage. This is often about 240V. With changes to the primary taps, a corresponding difference will arise with the secondary. Thus, if the secondary is providing 250V each side the centre tap, with the primary correctly run from a 240V mains supply, the secondary output would be approximately 260-0-260V if the 0-230V primary taps were used, or 240-0-240V if the

0–250V primary taps were adopted.

Where the transformer is for a single rated input – probably 240V – no such adjustment is possible. In addition, the actual measured secondary voltage may vary significantly from one transformer to another. This depends to some extent on the manufacturer's allowance for the transformer to maintain its rated output voltage with full load.

A combination of these factors can produce a significant change in the actual HT line voltage obtained. The MJE340 transistors are rated at 300V maximum collector voltage. Adequate scanning was found to be obtained with a 250V supply for these stages. It is thus worth while checking the HT potentials which will be present, and if necessary to arrange resistor values so that the actual working voltages for these stages will not be over 300V at the most. When the transistors are conducting, a voltage drop arises in their collector load resistors. But when bias conditions cut off collector current, collector voltage rises. It was noticed that with a line supply of a little over 300V, failure of the high voltage transistors could and did occur. This is shown as a sudden loss of scanning power and an abrupt change to a distorted waveform. The need to test and replace a transistor from this cause will be avoided by checking and adjusting the high voltage line potential.

With the transformer actually used, a supply of a little over 250V for the Y amplifier output stage was obtained by fitting 10k at the R2 position, and using a 45k bleeder in parallel with C2. (47k would be suitable.) It is an easy matter to check the HT voltages by clipping a high resistance meter from chassis to HT line, and then to modify R2 to bring this to about 250/260V with the oscilloscope working.

It will be seen that any reduction in the Y amplifier voltage produces a corresponding reduction in the CRT supply. This was not found to produce any difference which could be observed. Should the maximum possible EHT voltage be required for the CRT, then its supply can be taken from C2

positive, and R1 can be modified to change the Y amplifier line voltage. An alternative is to fit a bleeder resistor drawing a few milliampères across C1. This will increase the voltage drop in R1, and thus reduce the voltage of the supply to the Y amplifier.

Similar considerations apply to the high voltage supply for the X amplifier. Here, the voltage may be reduced by increasing the value of R3 or R4, or by connecting a bleeder in parallel with either C5 or C4.

In the worst conditions encountered when testing a power supply of this kind, a 250-0-250V transformer delivered nearly 265-0-265V when providing the required power, so that after rectification the HV supply was about 370V. With a small "replacement" transformer the secondary provided just under 240-0-240V. After rectification, only about 330V was provided.

It is thus apparent that a check ought to be made on the HT supplies actually produced, with the equipment working, so that any modification can be made to safeguard the push-pull output stages. A somewhat low voltage to these stages will result in loss of scan, but a high voltage, exceeding the transistor rating, can produce immediate failure of these devices.

Lack of scanning power on the vertical or Y axis will be shown by peaks flattening off at the top and bottom of the screen. Any lack of power in the horizontal or X direction will mean that the trace cannot be expanded sufficiently. This is not very likely, as scanning power was found easily to exceed the screen diameter.

#### High voltage supplies component list

R1 10k 1W  
R2 10k 1W  
R3 10k 1W

R4 10k 1W  
R5 100k 1W  
C1 200  $\mu$ F 450V  
C2 200  $\mu$ F 450V  
C3 50  $\mu$ F 450V  
C4 200  $\mu$ F 450V  
C5 200  $\mu$ F 450V  
C6 32  $\mu$ F 450V  
C7 50  $\mu$ F 450V

4 x BYX94 silicon rectifiers

Transformer: 250-0-250V 60mA, 6.3V 1A, or 4V 1A, secondaries.

### CRT mounting

The way in which the tube is mounted will be clear from Figure 11. A bracket  $2\frac{1}{2}$  in wide and  $4\frac{1}{2}$  in high (64 x 115 mm) is made by bending a flange on a piece of aluminium  $2\frac{1}{2}$  x 5 in. Cut a 2 in diameter hole to match the height of the panel opening.

Two clamps are made from thin sheeting. That for the front of the tube is about  $2\frac{7}{8}$  in diameter, while the back clamp is about 2 in in diameter. Four projections are cut for the front clamp, and are bent at right angles. Drill the holes in these somewhat larger than required, to assist matching up with the four holes in the panel. Washers may be put under the nuts. A 6ba bolt, with nut, passes through the ends of the clamp, which are also bent at right angles. Careful tightening of this bolt allows the front of the tube to be held.

The back clamp is similar, but has only two projections, drilled to fit against the vertical bracket.

The metal clamps must not be tightened against the glass of the tube, and a thin strip of soft rubber or other suitable packing is situated between the tube and clamps.

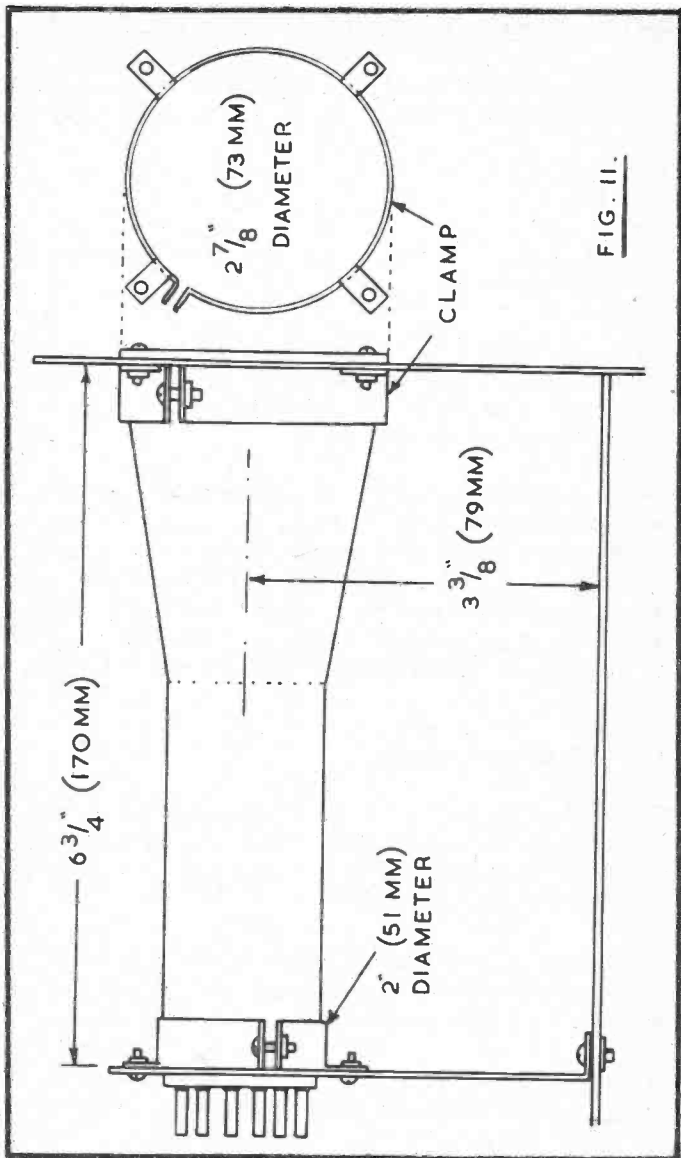

FIG. II.

## Pin connections

The 139A or CV1588 tube has a B12B base. Counting pins in a clockwise direction from the key-way, connections are:

1	cathode	7	Y2
2	grid	8	X2
3 & 4	heater	9	Anode 3
5	Anode 2	10	X1
6	not used	11	Y1

Fit the tube so that its key-way is at the top. When a display is obtained from the timebase and X amplifier, the tube can be rotated slightly, as necessary to obtain a horizontal trace, and the clamps can be re-tightened.

It was not found necessary to fit a screen round the tube, and this is optional. It would be of mumetal or other high-permeability magnetic alloy, and its purpose is to avoid any deflection of the beam by stray magnetic fields, either from the transformers, or external sources. Occasionally surplus tubes with screens are seen, and the screen can then be retained. It generally extends round the narrower part of the tube.

## The CRT and its supplies

Figure 12 shows the tube and the way in which voltages are applied to the various electrodes. Adjustment of these voltages by the potentiometers allows brilliance, focus, and other features to be controlled during use.

A supply of approximately 700V is available from the HT positive to HT negative lines indicated. R1, R2, R3, VR2, VR1 and R4 form a potential divider across the supply.

The control grid 2 is fully negative, and the grid-cathode voltage depends upon the total resistance of R4 and the part of VR1 in circuit here. With a substantial part of VR1 in circuit, the grid is very negative relative to the cathode 2, so

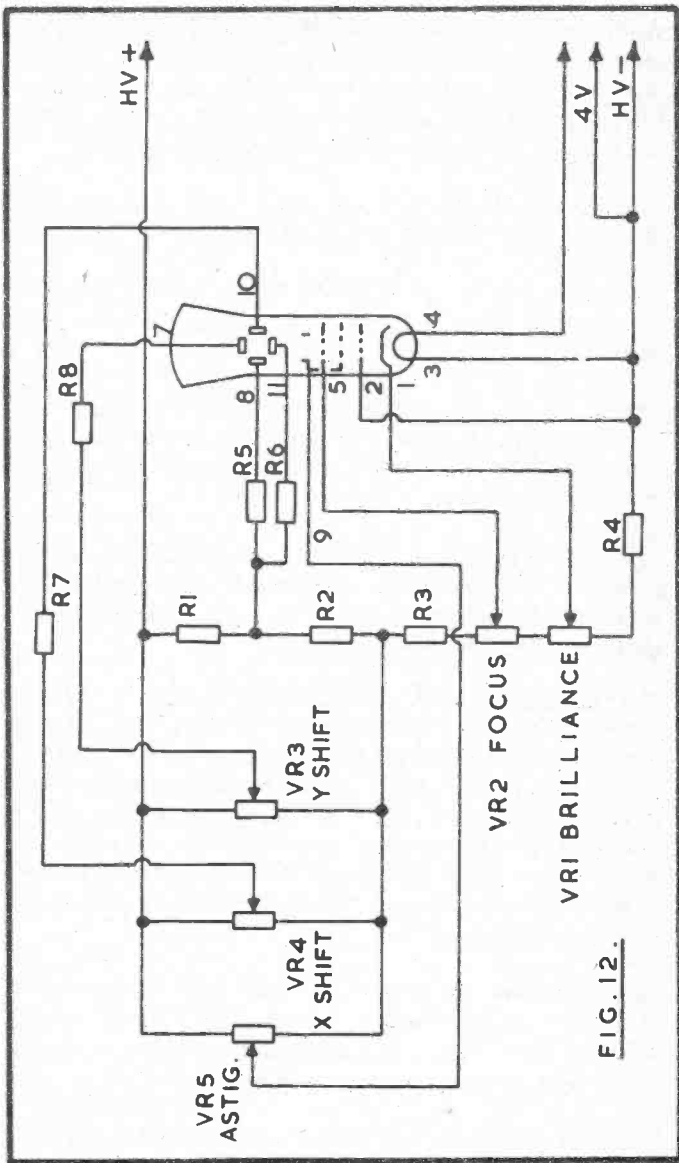

that beam current is negligible. With adjustment of VR1 to reduce the grid-cathode voltage, beam current increases, and thus the brilliance of the spot on the tube face. Maximum brilliance is obtained with VR1 wiper at R4, and depends on the value of R4, which sets the minimum bias condition.

Controls should never be left so that a bright spot remains in one position on the tube face, or a permanent burn can arise.

If no motion of the spot is available when testing the supply circuits, it should be reduced to minimum brilliance by means of VR1.

VR2 allows the voltage at the second anode 5 to be adjusted, and this controls the size of the spot, so is termed the focus. The astigmatism control, VR5, also has some effect on the size and shape of the spot.

In use, VR5 may often be left set, and VR2 is adjusted to produce a small spot, whose brightness is controlled by VR1. Brilliance generally has to be increased when the spot is moving rapidly over the tube face.

The potentials on the X plates 8 and 10 allow the spot to be moved horizontally. Plate 8 receives its supply from R5 and the fixed potential divider R1 and R2. Plate 10 receives potential via R7 from the X shift or horizontal shift potentiometer VR4. With VR4 at its central position, the potential of 8 is the same as that at 10, so the beam strikes the middle of the tube face. When VR4 is rotated, the potential at 10 can be raised or lowered, and so the beams can be moved across the face of the tube.

In the same way, the vertical deflection plate 11 has a fixed potential from R6, while the potential of Y plate 7 can be varied by VR3. VR3 is thus the vertical shift control, and by it the beam can be moved up or down.

When the scope is in use, the output of the X amplifier is superimposed on the static potential of plates 8 and 10, so



that the beam sweeps across the tube. Similarly, the Y amplifier provides a voltage to displace the beam vertically.

With the circuit wired as in Figure 12 the various controls should operate in the way explained. The spot can be kept moving by means of VR3 and VR4, while checking that brilliance, focus and other points are in order. An ion burn will only arise after some time, with some brilliance, but it is of course worth while taking care to avoid this, even though it has negligible effect on the actual utility of the scope.

It is convenient to use the top left-hand position for the X shift potentiometer VR4, with the Y shift VR3 below this, and VR5 under VR3.

The top right-hand control is for brilliance, VR1, and this potentiometer incorporates the main on-off switch. Wire VR1 so that brilliance is at a minimum when switching on, and further rotation of the control (after the tube has heated) is then necessary to obtain suitable brightness. VR2 is below VR1.

It is convenient to fit resistors R1 to R8 to a tagboard mounted on the vertical bracket described, adjacent to the tube base. Leads can then run away to the potentiometers.

### **CRT and its supplies component list**

R1	470k
R2	470k
R3	470k
R4	10k
R5	470k
R6	470k
R7	470k
R8	470k (resistors ¼W 5%)
VR1	100k linear
VR2	500k linear
VR3	500k linear

VR4 500k linear

VR5 500k linear

CRT: see text.

Mounting bracket etc. as described.

## CRT alternatives

The most expensive single item in building an oscilloscope is likely to be the cathode ray tube, though these are occasionally found as used and surplus at very low cost. It is not feasible to list all the alternative tubes which might be employed in the scope described here, but there are several points which have to be kept in view if an alternative is to be fitted successfully.

With the EHT circuit used, a maximum of about 700V will be available. This is satisfactory for the VCR139A or CV1588. Tubes which are intended for a higher EHT voltage will often give adequate brilliance with a somewhat lower voltage. When the EHT voltage is reduced, the scanning sensitivity of the tube is *increased*. With some tubes reducing the EHT voltage may cause difficulty in focus, so that a sharply defined trace cannot be obtained.

In the case of the VCR139A, the scanning sensitivity is 0.2 mm per volt, on both the X and Y axis. This is a fairly average figure, other tubes having somewhat similar deflection sensitivity. The circuit provides sufficient output to drive the trace beyond the tube diameter.

Smaller tubes, such as the 1¼ in and 1½ in types, can also present an adequate display. Some are slightly less sensitive, but where this is so compensation arises because the trace is shorter. In general, a 1½ in to 3 in tube is suggested as being most suitable.

With larger diameter tubes, increased scanning power will be needed if the trace is to be expanded to the full diameter, unless the scanning sensitivity is larger. For this reason, adequate results may not be obtained with a much larger

tube, even if the EHT circuit is adjusted to supply the increased voltage.

With a few exceptions (such as the 3AP1, 2.5V) the heaters will be for 4V or 6.3V operation. This will make necessary a 4V or 6.3V winding on the mains transformer, as explained, and should present no difficulty.

A medium persistence tube is recommended. The display is normally green, but blue and other colours may be encountered.

Beam current or brilliance depends on the negative bias on the control grid. Negative bias is increased by raising the value of the resistance between grid and cathode. This is made up by fixed and variable components in series. Adjustment over a wide range is easily provided. The fixed resistor sets a minimum bias still present when the variable control is adjusted for maximum brilliance. When the EHT voltage is lower than normal, the bias can also be reduced in proportion.

In some cases it may be necessary to experiment with the focus voltage range of adjustment, when using an alternative tube. If focus is improving with the focus potentiometer at the limit of its travel in one direction, an additional resistor can be incorporated in the circuit at the other side of the potentiometer.

Bases and dimensions of the various tubes varies, so the base and chassis layout have to be modified to suit.

A most easily used alternative to the 139A is the 3BP1. This is more expensive than the surplus 139A or CV1588, but costs less than the new 139A. The details given compare the 139A and 3BP1 characteristics.

	Dia.	H.	A1	A2	A3	Grid	mm/v
<b>VCR139A</b>	2½ in 64 mm	4V	—	155V	800V	-10V	X 0.2 Y 0.2
<b>3BP1</b>	3 in 76 mm	6.3V	—	350V	1500V	-50V	X 0.15 Y 0.2

Both have a green medium persistence display. Connections for the 3BP1 are as follows:

1&14 heater	7	Y1
2 cathode	8	Y2
3 grid	9	Anode 1
4 internal connection	10	X2
5 Anode 2 (focus)	11	X1
6 not used	12&13	not used.

It is as well to obtain the tube base from the CRT supplier at the same time as the tube. With some surplus and older type tubes, bases are not readily available. It is then necessary to push individual sockets directly on to the pins, or to make small clips, cased in sleeving, for these. 3BP1 holders are readily available.

### 3BP1 fitting

As the 3BP1 cathode ray tube is easily obtainable, and is frequently used in oscilloscopes of this and similar type, some individual details for employing it are given here.

At the panel, the metal clamp described can be about ¾ in (82 mm) in diameter. This will allow a thin layer of resilient packing round the tube between glass and metal. At the base end, the clamp can be 2½ in (64 mm) in diameter, this also allowing for packing. The Clamping screws shown are only tightened sufficiently to hold the tube, and undue pressure is not necessary. The base end can be supported by the holder provided this is fixed to give a correctly horizontal trace.

The distance from the panel to the base bracket has to be increased to approximately 9 in (230 mm). It is possible to accommodate this tube with a chassis of the dimensions given. But as the tube is longer than the VCR139A construction is simplified by extending the length of the chassis by 2 in (51 mm). There is then no loss of space behind the tube, and its base does not project over the rectifiers.

When arranging the mechanical fixing and assembly, prior to any wiring, a check should be made that the X and Y tagboards will fit under the tube readily. The tube is slightly larger in diameter than the VCR139A. A clear space of at least 2¼ in (58 mm) is wise when using tagboards 2 in (51 mm) high.

No particular difficulty should arise when using the 3BP1, but all mechanical fitting details must be adjusted to suit. There is a reasonable amount of free space to allow this.

The electrical characteristics of the 3BP1 are such that no changes to the circuit need be made except to provide 6.3V for the tube heater. This will be directly from a 6.3V 1A or similar winding on the transformer. Current required is 0.6A.

The 3BP1 will require a B14A 14-socket base, which can generally be obtained from the tube supplier. Where this has lugs with fixing holes, it can be bolted to the vertical bracket to support the rear of the tube, thus avoiding the need to make a clamp here.

Heater connections are now 1 and 14 (instead of 3 and 4). Cathode is 2 (instead of 1) and grid is 3 (instead of 2). Connections to 5 and 9 remain unchanged.

When connecting the deflection plates, note that the X plates are now 10 and 11 (instead of 8 and 10) and the Y plates are 7 and 8 (instead of 7 and 11).

Bias is normally a little higher for the 3BP1, but this is easily within the range of the brightness control potentiometer. The

figure is also reduced because of the change in EHT, which could be up to 1500V for this tube. Satisfactory brightness and focus are obtained within the supply of about 700V. Deflection sensitivity on the X axis is a little better than with the VCR139A, and the reduced EHT voltage raises sensitivity. It was thus found that the 3BP1 could be used instead of the VCR139A with a minimum of changes.

It is not proposed to give full details for the use of other tubes, in view of the large number of types which may be encountered, and reference should be made to the important points regarding the characteristics of any alternatives which might be adopted.

### Timebase circuit

The timebase produces a saw-tooth wave, which when amplified sweeps the trace horizontally across the CRT face. It is necessary to be able to cover a considerable range of frequencies, and this is generally arranged by having a multi-way switch to select various capacitors, for coarse adjustment, with a potentiometer for fine, variable control of frequency.

Figure 13 is the circuit of the timebase and first amplifier. This derives current from the low voltage supply for TR2 and TR3. TR1 is operated from the regulated supply obtained from ZD1. R1 is a series dropper, and C1 is in parallel with the Zener diode, current for base 2 of TR1 being from R2.

TR1 is a unijunction transistor in which current is not normally flowing. S1 selects one of the timebase capacitors TC1, 2, etc., which will be discharged. Current through TR2 charges the capacitor, so that its voltage rises until the emitter potential of TR1 is high enough for TR1 to conduct. This almost instantaneously discharges the capacitor, which begins to charge again through TR2, the process being repeated. A sawtooth wave is thus available at the emitter E of TR1.

With large value capacitors at TC1, 2, etc., the charging time

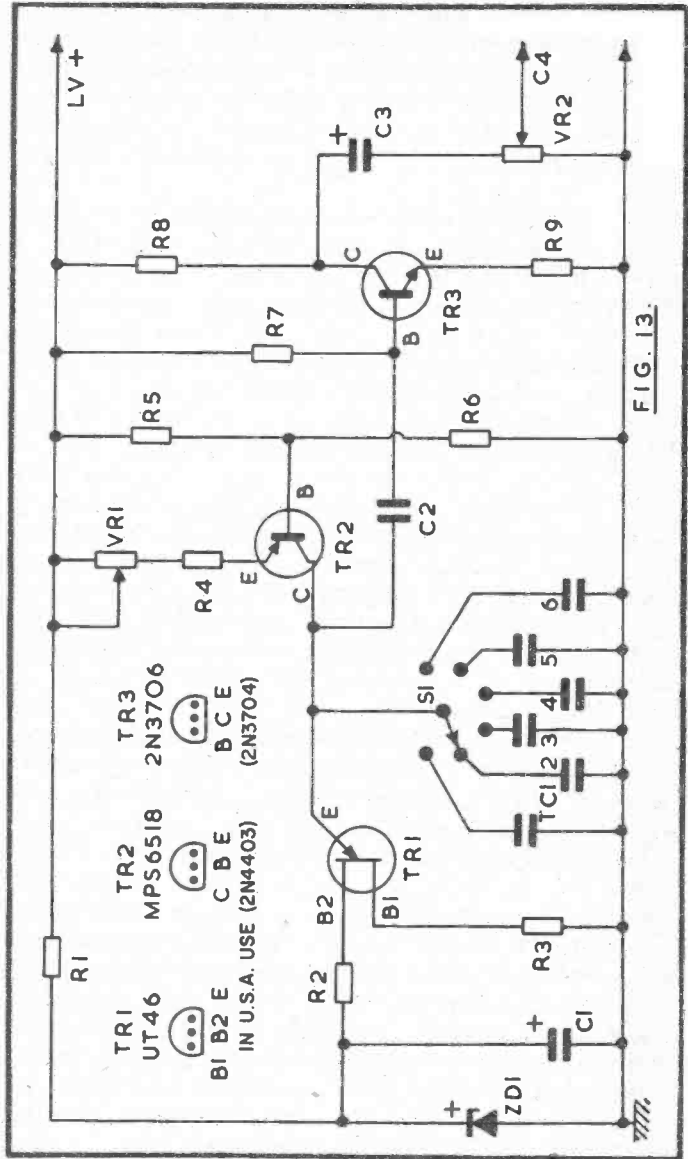

FIG. 13.

is longer than with smaller values. So the rotary switch S1 allows coarse selection of frequency. Limits are set by the response of the whole X amplifier. The lower useful limit is about 15 Hertz, and at the other end of the range the high frequency response of the amplifier begins to fall away. The six overlapping ranges cover approximately 15 Hz to 20 kHz.

The frequency with which a capacitor selected by S1 can charge depends largely on the value of resistance in TR2 emitter circuit, so is controlled by VR1. This is the fully variable fine frequency control.

TR2 derives base current from the divider R5 and R6, and stabilises current flow into the selected capacitor. This results in a more linear sawtooth than is obtained if VR1 with R4 are connected to charge the capacitor directly.

The timebase voltage at the emitter of TR1 is taken via the coupling capacitor C2 to the first timebase amplifier, TR3. This receives base current from R7, and the collector output is developed across R8. Coupling is by C3, and the potentiometer VR2 allows any required timebase oscillator voltage to be taken to the capacitor C4, which drives the push-pull output stage.

VR2 is the X amplification control. That is, it allows adjustment of the extent to which the trace moves horizontally across the tube face. Gain is sufficient to allow the trace to be expanded so that it exceeds the CRT screen diameter. This is often of advantage when examining a display.

Exact frequency calibration for S1 or VR1 is not usual on a general purpose scope. This would require precision values and means of trimming and is not justified. When the instrument is in use, S1 and VR1 are set to produce the required display, as explained in the section on oscilloscope operation. Where it is necessary to find some definite frequency ratio between horizontal and vertical movements of the trace, deflection on the horizontal axis will be obtained from 50 Hz mains, or some other known frequency standard.



By choosing suitable values for TC1, 2, etc., and VR1, overlap can be provided at the extreme ends of the ranges obtained by VR1, so that capacitors need not be of close tolerance.

### **X amplifier output stage**

The push-pull output stage uses two high voltage transistors, Figure 14, and is operated from the high voltage line. Its purpose is to provide enough voltage swing on the X plates to sweep the beam fully across the tube face. This is accomplished by driving one X plate positive, while the other X plate is driven negative. There is sufficient drive to expand the trace considerably beyond the screen diameter.

Base drive for TR4 is from the X gain or expansion control VR2, and coupling capacitor C4. Base current is from R10. The plate driving voltage is developed across R12, and taken to the X plate 10 by means of the DC isolating capacitor C7.

When TR4 collector and emitter current is maximum, the largest voltage drop arises across R13. The base of TR5 is grounded by C5 at operating frequency. Therefore phase reversal arises and the output to X plate 8 from C6 swings in the opposite direction to that taken to X plate 10. This allows good linearity to be obtained — the sweep velocity across the face of the tube is uniform, instead of changing in speed through its travel.

VR3 is a pre-set control, and adjusts base bias conditions of TR5 so that output from C6 can be arranged to match that from C7. Initially disconnect one lead of C6. Adjust VR2 so that a trace of convenient length is obtained on the screen (say 1 in). Disconnect one lead of C7, reconnect C6, and with VR2 untouched adjust VR3 so that the trace is of the same length as before. This is done with the trace near the middle of the screen, and when both C6 and C7 are connected the length of the trace should expand considerably. Later, final adjustment of VR3 can be with an accurate sine wave display. The setting of VR3 is fairly critical, though not exceptionally



so. Wrong adjustment of VR3 is shown by the trace accelerating or slowing in its motion horizontally across the tube.

### Timebase-amplifier assembly

Except for the potentiometers, and S1 with capacitors, the components for the timebase and its output stage are assembled on a single tagboard, Figure 15. This is approximately  $6\frac{3}{4} \times 2$  in (170 x 51 mm), and will be mounted vertically by means of two brackets.

The negative line may be completed first. This has sleeving and is clear of the other tags. Both ends of the negative line are soldered to tags which will be bolted to the chassis when the board is fixed in position.

Components are placed approximately as shown, though R1, C1, and some other items away from the board in Figure 15 to clarify wiring will lie over the board and tags. In general, no insulated sleeving will be necessary on the wire ends of resistors and capacitors. All bare connections must of course be arranged so that no short circuits can arise.

The transistor leads can be identified from Figures 13 and 14. These are left about  $\frac{1}{2}$  in long. Do not bend the wires immediately at the body of the transistors. All the transistors stand above the tags to which they are connected, but are shown flat with the board so that wiring may be more easily seen in Figure 15.

C6 and C7 are on the reverse side of the board, immediately behind TR5 and TR4.

Provide insulated leads for external connections. These are to the 18V supply, and high voltage positive supply. Also to VR1, and to VR2, which is returned to the chassis. In the same way, leads run to VR3, which is also returned to the chassis. Connections from C6 and C7 to 8 and 10 on the CRT complete wiring.

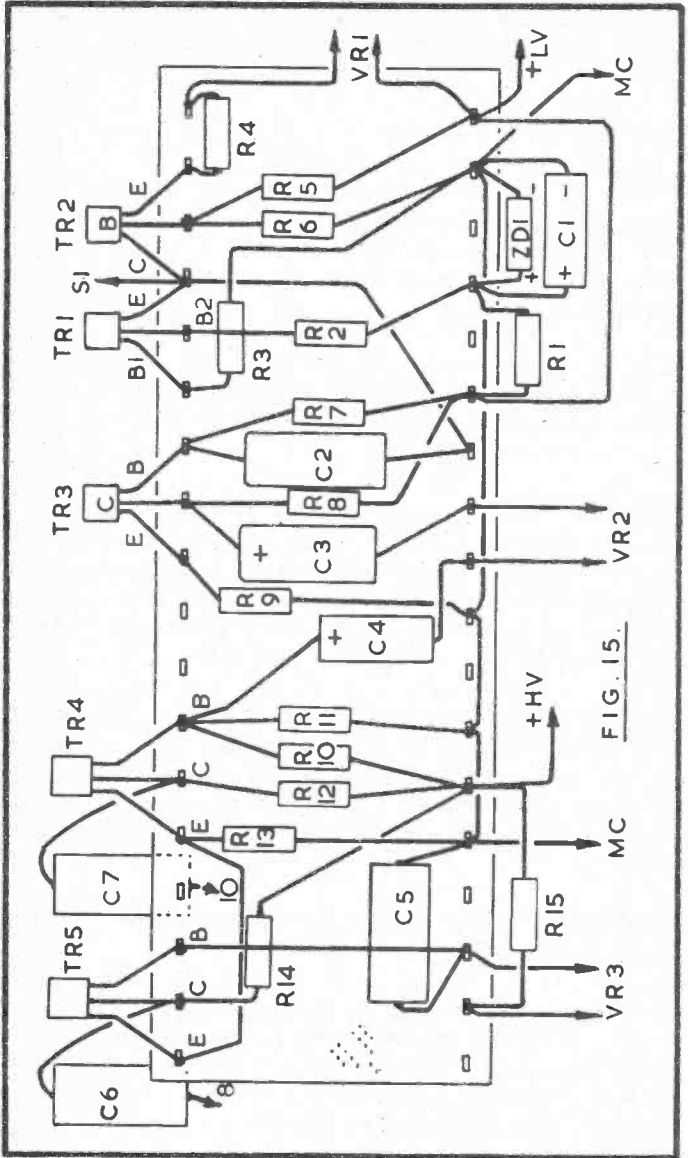

FIG. 15.

The board is situated vertically about 5½ in (140 mm) from the panel, below the tube but on top of the chassis. S1, VR2 and VR1 are on the panel, in line, occupying the holes below the screen. VR3 is fixed to a bracket under the chassis. It may have a control knob and be set with the cover off, or may have a slotted spindle, which lines up with a small hole in the cover side. It should not have a projecting control knob, as this might be moved, so that adjustment is upset unnecessarily.

Because of the high resistances present, voltage readings will depend very much on the meter. With a high resistance instrument, TR4 and TR5 collectors will be about 300V, with bases about 0.7V and emitters about 0.2V positive with respect to the chassis. Operation is checked if necessary by disconnecting C6 and C7 in turn, a similar but reduced scan being obtained. Should no scan be seen, the first test would be to assure that TR1 is oscillating, and this can be made with headphones having an isolating capacitor in one lead, or with an audio test probe. A strong audio tone should be found at TR1 emitter, C2, and TR3 collector, up to C4.

#### Timebase component list

R1	680 ohm
R2	560 ohm
R3	47 ohm
R4	8.2 k
R5	8.2 k
R6	68 k
R7	8.2 megohm
R8	12 k
R9	5.6 k (resistors 5% ¼W)
VR1	50 k potentiometer, wire wound linear
VR2	100 k log potentiometer
C1	220 μF 16V
C2	0.1 μF
C3	125 μF 25V
C4	125 μF 25V

TC1 0.5  $\mu$ F  
TC2 68 nF  
TC3 20 nF  
TC4 5 nF  
TC5 1200 pF  
TC6 680 pF  
ZD1 12V/1W Zener Diode  
TR1 UT46  
TR2 MPS6518 (2N4403)  
TR3 2N3706 (2N3704)  
S1 6-way rotary switch  
Board 6 $\frac{3}{4}$  x 2 in (170 x 51 mm)

#### *Output stage*

R10 3.3 megohm  
R11 18 k  
R12 47 k  
R13 150 ohm  
R14 47 k  
R15 3.3 megohm (resistors 5%  $\frac{1}{4}$ W)  
VR3 20 k linear potentiometer  
C5 1  $\mu$ F 12V  
C6 0.47  $\mu$ F 500V  
C7 0.47  $\mu$ F 500V  
TR4 MJE340 (2N6177)  
TR5 MJE340 (2N6177)

### **The Y amplifier**

The input to the scope is taken to the Y amplifier, and is raised in strength so as to deflect the trace in a vertical direction. The Y amplifier circuit is shown in Figure 16.

Signal input is to the attenuator VR1. The purpose of this control is to reduce the height of the trace so that it does not pass beyond the limits of the tube face. Maximum sensitivity is 50 mV per centimetre. Coupling is by capacitor C1, to the base of the first amplifier TR2.

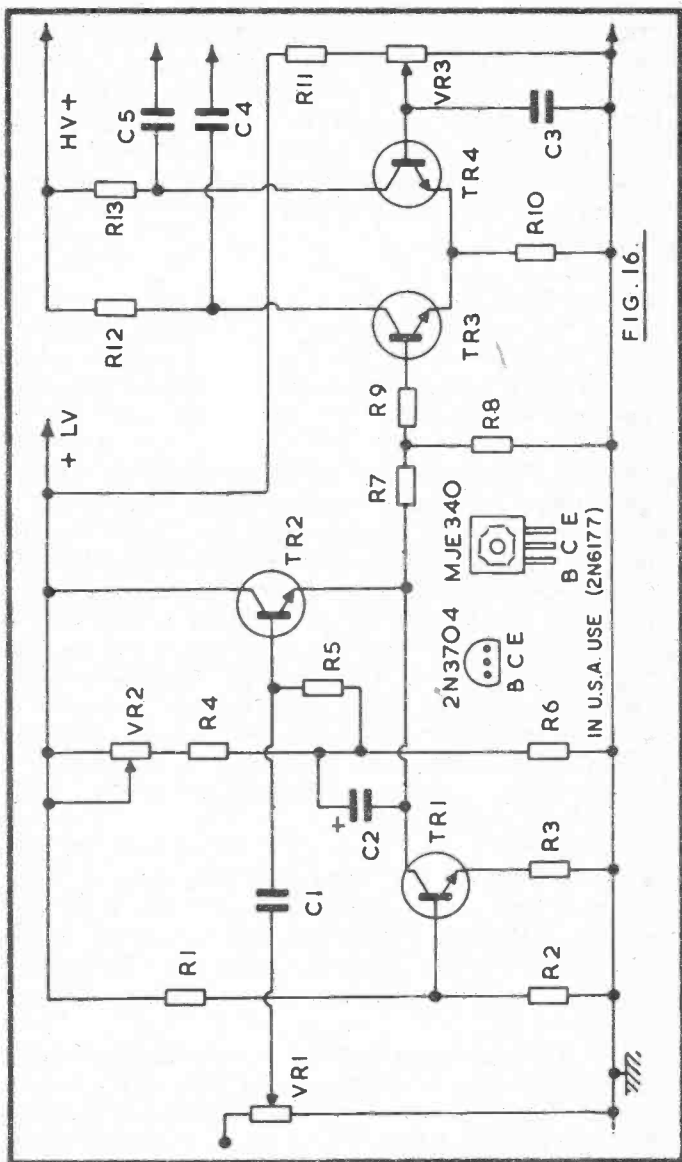

FIG. 16.

TR1 helps compensate for drift in TR2. The amplified signal is taken from TR2 emitter to the collector line of TR1 which is negative of the capacitor C2. The base supply resistor of TR2 goes to the junction of R4 and R6, and the signal voltage here is of the same phase as that at the base. The effect of this is to make R5 appear to be an extremely large value, so that the base input circuit of TR2 is effectively of high impedance.

TR1 and TR2, and the resistor network including R7 and R8, set the base bias conditions for TR3. The pre-set potentiometer VR2 allows compensation for spreads in transistors and resistor values, so that these stages can be adjusted for proper working conditions.

TR3 and TR4 form the push-pull output pair stage. C3 holds TR4 base grounded for signal voltages. When TR3 is driven into conduction its collector swings negative, and its emitter positive. TR4 receives a fixed DC bias from VR3. TR4 emitter is carried positive with TR3 emitter. As TR4 base is fixed, the base is now less positive relative to the emitter, so that TR4 collector current falls. When TR3 emitter moves negative with falling collector current in TR3, TR4 base is more positive relative to its emitter, and TR4 collector current increases. Drive for the Y plates is thus obtained in push-pull from C4 and C5. One plate sweeps positive as the other sweeps negative, this being reversed when the trace is being moved in the other direction.

VR3 allows the linearity of the push-pull amplifier to be adjusted. This will be apparent as an evening out of the trace above and below the centre line. Severely wrong adjustment of VR3 will produce a trace which is very pointed at the top or the bottom, when a sine wave is fed into the amplifier.

Severe misadjustment of VR2 will make the amplifier insensitive to weak signals, and will result in a distorted waveform being displayed. The best adjustments are those which produce a symmetrical display from a sine wave input, with VR1 turned back to reduce input. With an unnecessarily high



input, adjustment of VR2 may produce a non-linear characteristic through TR2, which might be offset to some extent by wrong adjustment of VR3. Initial adjustment is therefore made with an input only sufficiently great to give a vertical deflection of 1 cm to 2 cm or so. Adjustment is seen to be in order when this can be expanded to fill the screen, by means of VR1, without distortion appearing in the waveform.

### **Y amplifier board**

This is approximately  $6\frac{1}{2} \times 2$  in (165 x 51 mm), Figure 17. Resistor and capacitor leads are shaped and cut to allow these components to be fitted approximately as shown. Wires are positioned so that insulated sleeving is not generally required.

VR2 is a pre-set potentiometer, situated so that it can be adjusted from the side of the scope. It can be supported by short, stout wires from the adjacent tags.

Transistor leads are identified from Figure 16. Bend these a little away from the transistor body, using flat nosed pliers or tweezers. All joints must be sound but should not be cooked or heated for an unnecessarily long time as this may be harmful to the components.

The board mounts vertically about 3 in (76 mm) from the panel, on top of the chassis. Two brackets are made from 18 swg or similar scrap aluminium for this purpose. The lower row of tags and connections to them must be a little clear of the chassis. When the board is fitted in place solder the MC leads to tags bolted to the chassis.

Leads run to the 18V and high voltage points provided. VR1 is fitted below the timebase switch, and the input socket is immediately to the left of VR1. A jack socket or coaxial socket can be used. In each case the outer or sleeve is grounded to the panel.

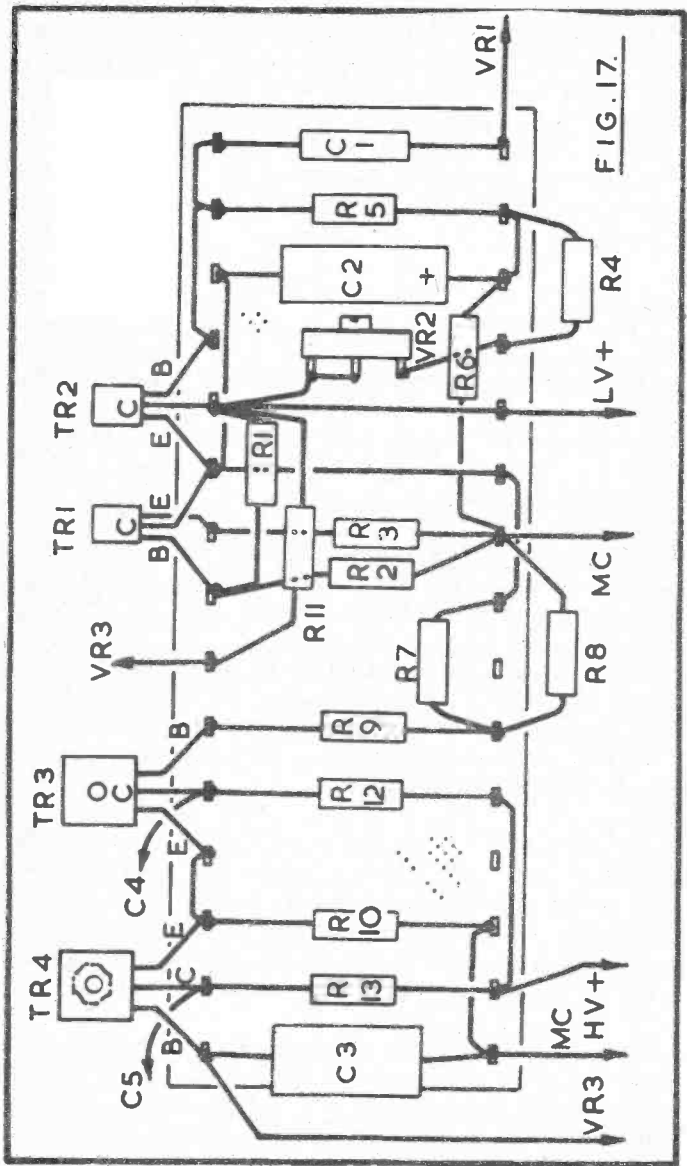

FIG. 17.

VR3 allows adjustment of bias conditions for TR4, and it is fixed to a bracket beside the similar control provided for the X amplifier. It is fitted with a control knob which can be set with the scope cover removed, or has a slotted spindle, to adjust through a small hole in the cover, as with the X amplifier.

C4 and C5 fit behind the board, in a similar manner to the two X plate capacitors on the board described earlier.

The transistors are shown away from the board in Figure 17 for clarity. They are actually over the board tags, this being necessary to clear the CRT when the board is in position.

### Adjustments

An initial setting for VR3 can be found by means of a high resistance meter, set for 500V or a similar range. Clip negative to chassis. Begin with the wiper of VR3 near the chassis end of the element. Take the meter positive prod to the collector tag of TR3, and note the reading, then transfer the prod to the collector of TR4. Adjust VR3 until these readings are similar. It will be necessary to check the setting of VR3 later, with a sine wave displayed, and after adjustment of VR2.

When a sine wave is presented on the screen, this should have equal excursions above and below the centre line, as shown later. A correctly balanced output is then being obtained from TR3/4. If the output is badly unbalanced, either the top or bottom peaks of the wave will be sharp and extended, while the opposite peaks will be flattened and nearer the centre line. Careful rotation of VR3 one way or the other, as observed to be necessary, will correct this, until both halves of the sine wave resemble each other, one half rising above the centre line, and the other falling below it.

VR2 sets the DC operating conditions in the earlier part of the circuit. Begin with the whole of VR2 in circuit. With a sine wave displayed on the screen, reduce this by means of VR1

until it is only a few millimetres high. Rotate VR2 slowly, from the position described, for best symmetry and height of the display.

If TR2 base is too negative (most of VR2 element in circuit) the trace is likely to be thick and flattened at the bottom, and the sensitivity of the amplifier is reduced. The correct adjustment is that which gives maximum sensitivity, while not losing the symmetrical display of the sine wave on the screen. Methods of obtaining a sine wave input are described later.

As mentioned earlier, wrong adjustment of VR2, causing distortion of the sine wave, can be offset by wrong adjustment of VR3. To avoid unnecessary trouble from this, first adjust collector voltages of TR3 and TR4, as explained, then set VR2 for good display of a weak sine wave input. A check is then necessary on the setting of VR3, as bias conditions for TR3 are modified by adjustments to VR2, because of the direct coupling.

There should not be any particular difficulty in making these adjustments satisfactorily when the scope is completed and a trace is available for observation.

### **Y amplifier component list**

R1	8.2 k
R2	1 k
R3	100 ohm
R4	2.2 k
R5	47 k
R6	2.2 k
R7	8.2 k
R8	2.2 k
R9	2.2 k
R10	150 ohm
R11	10 k
R12	100 k
R13	100 k (resistors $\frac{1}{4}$ W 5%)

VR1 2 megohm log  
VR2 5 k pre-set  
VR3 1500 ohm linear  
TR1 2N3704  
TR2 2N3704  
TR3 MJE340 (2N6177)  
TR4 MJE340 (2N6177)  
C1 0.47  $\mu$ F 150V  
C2 100  $\mu$ F 12V  
C3 1  $\mu$ F 12V  
C4 0.47  $\mu$ F 500V  
C5 0.47  $\mu$ F 500V  
Board 6½ x 2 in (165 x 51 mm)

### Y amplifier response

As shown in Figure 16 the Y amplifier has capacitor coupling at the input attenuator to TR2, and from the push-pull output stage to the vertical plates. Capacitor coupling is found in various commercially made scopes, and its use conveys both advantages and disadvantages.

The advantages arise from the direct current isolation which the capacitors provide. C1 thus isolates the base of TR2 from any DC potential which might be present across VR1, and also from changes in base bias conditions which could be caused by moving the slider of VR1, which needs to be grounded at its lower end of the element.

DC isolation by means of the coupling capacitors C4 and C5 means that the Y plates can be fed from the potential dividers which are present, and that changes to the collector voltages of the push-pull output transistors do not result in a permanent shift of the trace vertically. It is thus easier to set up the scope in the way described.

A disadvantage of capacitor coupling is that the low frequency response of the Y amplifier falls away, and it cannot be used at DC. The low frequency response is improved by using

coupling capacitors of larger value, but a practical limit to the gain in this direction is soon reached. For this reason direct coupling is often seen in Y amplifiers.

The elimination of the capacitors C4 and C5 is not very difficult but makes necessary more care in setting up and adjusting this part of the circuit. When the capacitors are removed and a direct connection exists between the transistor collectors and the Y plates, then collectors and plates will be at the same DC potential. It is then necessary to balance the collector voltages more correctly, or the trace will be permanently shifted up or down, and the vertical shift control may not be able to compensate for this.

With the capacitor coupling shown, sufficient compensation is available by means of VR3 to take care of transistor spread and any other tolerances. With C4 and C5 removed, this may no longer prove to be so.

Adjustment to VR3 will modify the collector current and thus the collector voltage, but the setting of VR3 which gives a central trace may not prove to be that which results in symmetrical amplification. It is then necessary to modify the values of R12 and R13, or one of these resistors, so that the trace is central when operating conditions, set by VR2 and VR3, are correct.

Some possible difficulty here can be avoided by using the capacitor coupling initially. When correct adjustment is present, the capacitors can be removed. If the trace is then seen to be displaced, either of the collector resistors can be changed to 82 k, or 68 k, as found necessary to move the trace so that the Y axis control will allow it to be centred easily.

With these two capacitors eliminated, the frequency characteristic of the output stage extends to DC. However, the whole Y amplifier cannot deal with DC (or very low frequencies) due to the presence of C1.

If C1 is removed, the base of TR2 is carried negative at the maximum attenuation setting of VR1, and as a result of the direct connection from VR1 to TR2 base, some vertical shift of the trace arises for various settings of the attenuator. This effect can be minimised by placing a resistor between VR1 slider and TR2 base. Very high values will reduce sensitivity. A 270 k resistor will allow the trace to remain central except for the extreme setting of VR1.

With all oscilloscopes there has to be a compromise between linearity of the Y amplifier over a wide range, and circuit complication. At high frequencies, the stray capacitances in wiring, and step or variable attenuators, play an increasing part in reducing the gain. Compensation can be made by circuits with inductances which help to boost amplification at higher frequencies. For the direct display of radio-frequency signals, such as may be needed for transmitter modulation depth testing, it is often preferred to take the RF signal directly to the scope plates. Even in these circumstances, the height of the display falls, as frequency is increased, due to the capacitance of the tube deflection plates, and between tube base sockets.

Points of this kind are dealt with later, in some particular applications of the CRT.

## **Synchronisation**

When examining a waveform on the screen, the fine frequency control of the timebase is adjusted to produce a display which is as free of movement as possible. The display may be a single wave, or may include several waves of the Y input signal, depending on the frequency of scan obtained from the timebase.

With careful adjustment of the fine frequency control, the wave (or train of waves) can be kept almost motionless. When the fine frequency control setting varies slightly above or below that which is required, the display will drift slowly one

way or the other across the screen. Quite often this is not too important. But many scopes have a synchronising circuit which can be brought into use, or which is permanently in operation.

Synchronisation is achieved by arranging that the Y input signal helps trigger the timebase. Thus, if the positive peak of the Y input can trigger the timebase, the latter will always commence its scan at this instant. As a result, the display will remain in the same position on the screen.

With many circuits, the scanning frequency is closely adjusted by means of the fine frequency control, and the synchronisation is then brought into action.

Synchronising will not be obtained if the timebase is set far away from the desired frequency; nor can synchronisation be achieved with very weak signals, unless further gain is available for the sync circuit. With the synchronisation provided here, good results are obtained with signals of reasonable level.

As in some circumstances synchronisation is not required, a variable sync control is fitted. With this at minimum, no synchronising pulses are available for the timebase.

With the unijunction transistor, the emitter triggering voltage falls as the potential at base 2 is reduced. The B2 supply is derived from a stabilised point. Triggering therefore normally arises at the same emitter voltage, and the rise time here depends on the settings of the coarse and fine timebase controls, as explained.

When the sync circuit is operating, a negative pulse, derived from the Y input, is taken to the B2 circuit. This depression of the B2 potential results in the UJT being triggered, if the emitter voltage is approaching the value at which this normally occurs. The Y input is thus able to synchronise the timebase, provided the latter is set sufficiently close to the correct frequency. The result is, that the display — which may be one or more waves, as wanted — will stay motionless on the



screen, each wavetrain repeating the position of that displayed earlier.

The sync circuit is shown in Figure 18. The Y signal is taken from the junction of the two resistors present in the base circuit of the Y output amplifier TR3. VR1 allows synchronisation to be adjusted from zero to the fullest level available. This panel control is below that for X gain.

TR1 is the first amplifier, and couples to TR2 by C2. When TR2 base is driven so that TR2 conducts, a voltage drop arises in R4, applying a pulse to B2 of the UJT through C3. This advances the UJT firing time to agree with the signal from the Y amplifier. This pulse cannot trigger the UJT until the emitter capacitor potential is near that required, so it cannot operate on the early waves of a series being displayed.

Since repeated pulses applied to B2 very slightly affect the operation of this stage, VR1 is adjusted so that pulses are not at a higher level than required to maintain synchronisation. This, in turn, will depend on the amplitude of the Y signal, and the accuracy with which the timebase fine control has been set. In use, the fine control is rotated until little movement arises, and the sync level is then turned up until the display stabilises.

### **Sync board**

The synchronisation circuit is assembled on a small board, Figure 19, which is afterwards fitted to the underside of the chassis by means of a bracket. This also provides the negative return or ground connection.

Current is drawn from the timebase 18V supply at the smoothing capacitor. The only other external connections are those to the panel control VR1, and base 2.

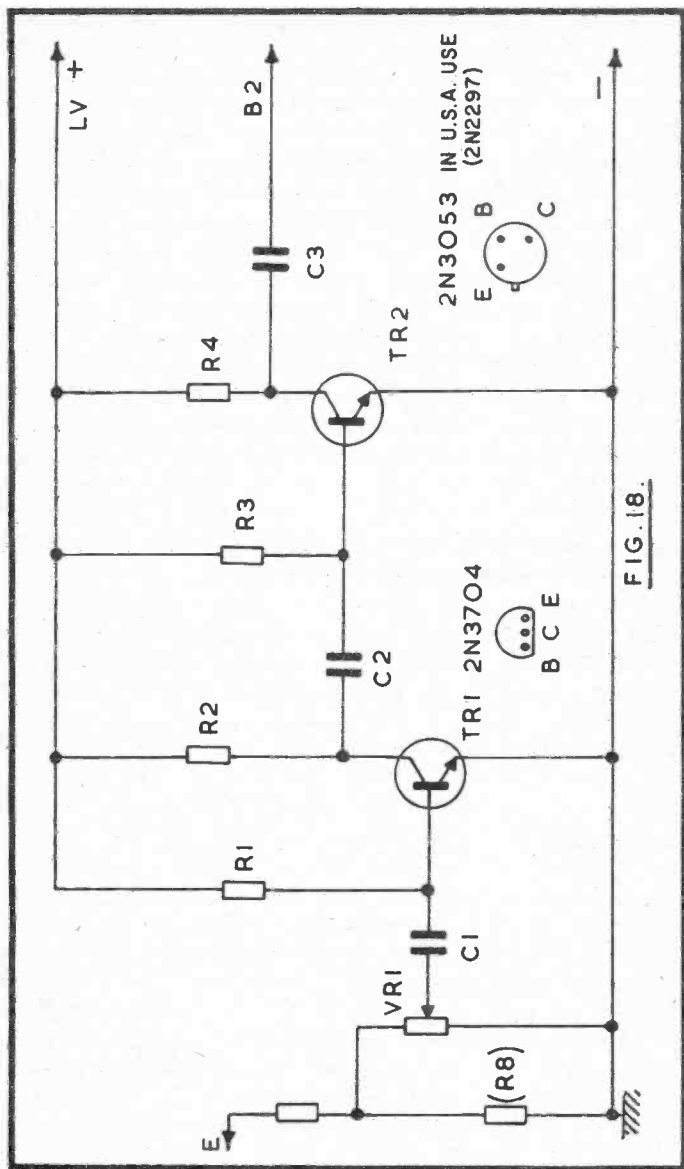
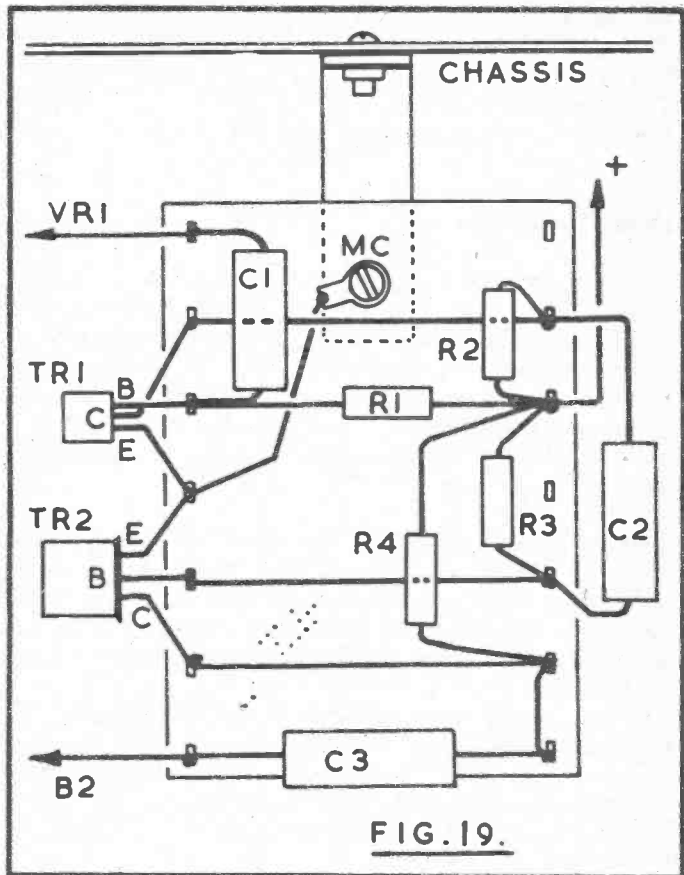

FIG. 18.



**FIG. 19.**

**Sync circuit component list**

- R1 1.5 megohm
- R2 22 k
- R3 68 k
- R4 1.5 k (resistors ¼W 5%)
- VR1 100 k linear potentiometer
- C1 22 nF

C2 0.1  $\mu$ F  
C3 0.22  $\mu$ F  
TR1 2N3704  
TR2 2N3053 (2N2297)  
Board about 3½ x 2 in (90 x 51 mm)

### Flyback suppression

The voltage generated by the timebase should resemble a saw-tooth as closely as possible. It should rise smoothly from zero to some particular positive voltage, then having reached this return instantaneously to zero. The CRT scan would travel at uniform rate across the screen from left to right, then would return from the right side of the screen back to the left instantly. This would be repeated at whatever frequency is required.

With the actual timebase generator, a graph showing the rise and fall of voltage would not be ideal, and the drop from maximum voltage to minimum is not absolutely instantaneous. The cathode ray can thus have the opportunity to produce a trace which is not part of the required scan.

It will be found that this flyback trace is often of no great importance, and with some adjustments it is impossible to find it. It is more likely to be evident at the higher scanning speeds, and when the brilliance is turned well up. With lesser brilliance, and slower scanning speeds, it can be totally insignificant.

Most (though not all) oscilloscopes have a flyback suppression circuit, which blanks out the beam during flyback. It does this by applying cut-off bias to the CRT grid during flyback.

Figure 20 shows the circuit used, employing two transistors and operated from the 18V X-amplifier supply, and high voltage positive supply lines.

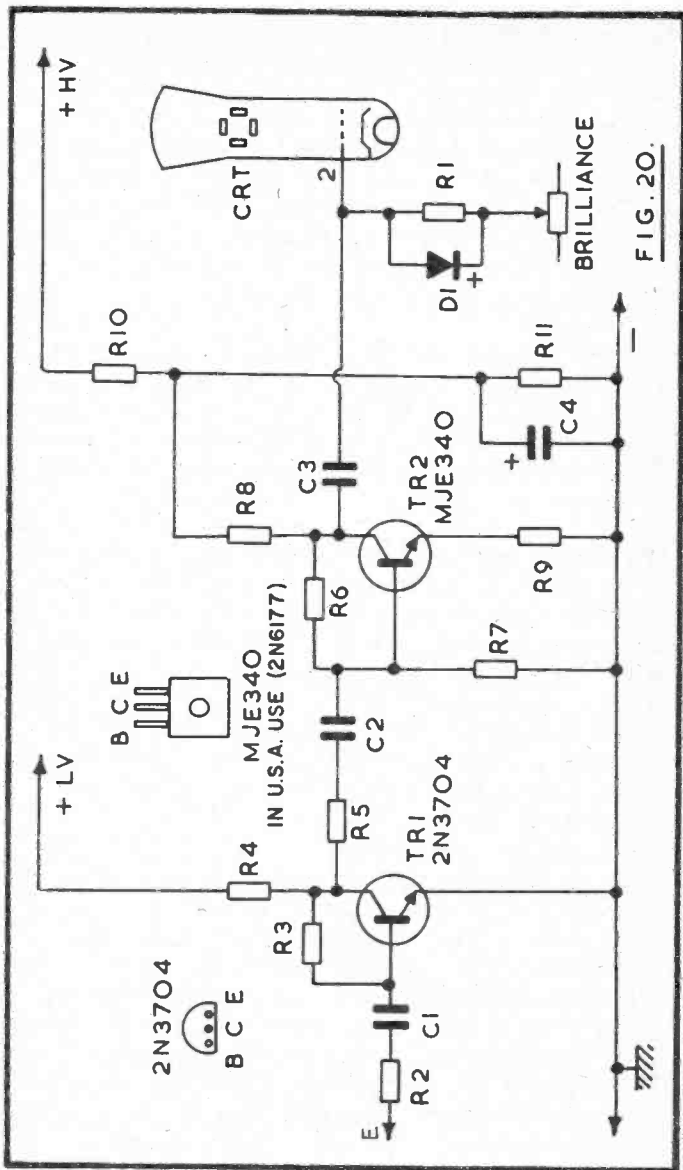

FIG. 20.

Modifications to the CRT grid circuit are first required. The connection from grid to the brilliance potentiometer is interrupted, and R1 and D1 are added. Provision for these components will be found on the flyback suppression board. The resistor allows the grid to be pulsed negative, during flyback, so that cut-off bias blanks out the trace. The diode prevents the grid being driven positive during the normal scan, as this would reduce bias and increase the brilliance. The presence of these two items, R1 and D1, otherwise have no influence on the working of the CRT.

The flyback suppressor circuit employs two transistors, the second operating at high voltage. TR1 is a capacitor coupled amplifier, driving TR2. The latter has its own supply, derived from a potential divider from the high voltage positive line. About 160V to 170V should be found across the 16  $\mu$ F capacitor C4.

TR1 is driven from the timebase in such a way that its base is moved negative during the flyback interval. TR1 collector current thus falls, voltage lost in the collector load resistor falls, and so collector potential moves positive. A similar phase reversal is obtained in TR2. Its base is driven positive, so the collector moves negative. The capacitor couples this negative pulse to the CRT grid, giving sufficient negative bias to cut off the beam. When TR1 base moves positive during the normal scan, TR2 base will be moving positive, so beam current and the trace are restored.

The circuit is not too critical, though the capacitor values in particular influence its working. Large values result in the CRT grid being driven so negative that it cannot recover quickly enough and some of the wanted trace will be lost. It is thus better to keep the capacitor values down to those which are seen to blank out unwanted flyback traces. Blanking bias conditions are also those which suit a sensitive CRT of the type described. However, it is easy to modify the strength of the pulse by changing the relative values of the two 12 k resistors R10 and R11, if necessary, so as to obtain a different collector circuit supply voltage for TR2. A higher potential

than about 250V is not recommended, and the supply of about 160V, as indicated, should easily be sufficient.

### Flyback suppression board

This is shown in Figure 21 and it is approximately  $3\frac{1}{2} \times 2$  in (90 x 51 mm). Two metal brackets are bent from scrap, and bolted as indicated, to form the earth return and to allow the

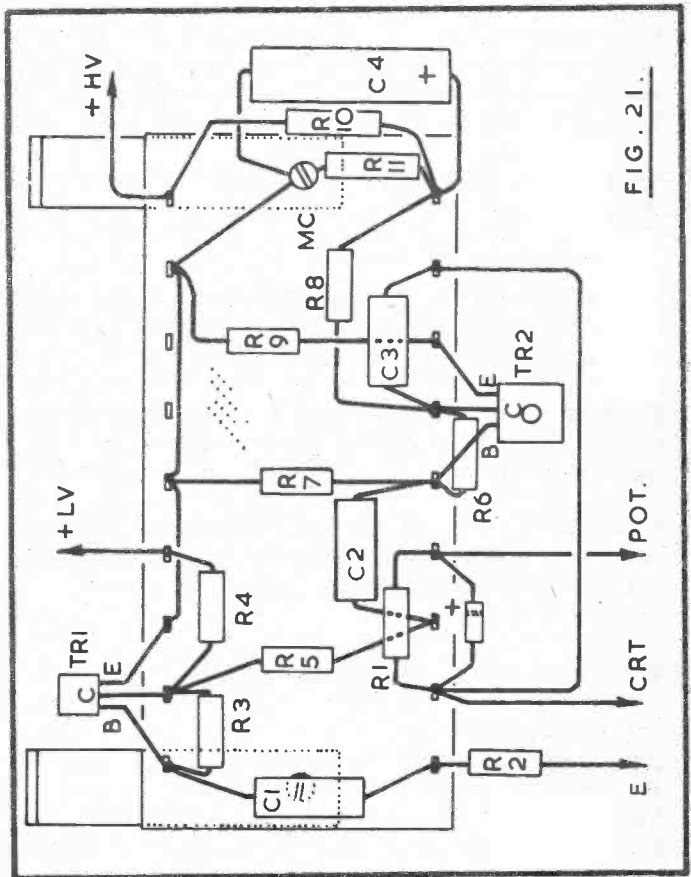

FIG. 21.

finished board to be attached to the rear of the scope, so that it is near the CRT base. Nuts or spacers are needed between the board and brackets, so that no danger of shorting TR1 base or the high voltage line can arise.

TR1, TR2 and the large capacitor are shown displaced off the board, to clarify wiring. Connections for TR1 and TR2 can be found from Figure 20 and note particularly that TR2 is shown with the same side upwards as on the board itself.

Connecting points for the high voltage supply and low voltage supply will be found at the reservoir capacitor (high voltage rectifiers positive) and positive line of the X amplifier board respectively. Negative is obtained via the chassis as described.

The brightness control wiper is now wired to D1 positive and the CRT grid, pin 2, to diode negative. R1 is also situated on the board.

Connect R2 from the board tag shown, to the emitter of the UJT on the X board. A simple way of modifying the degree of blanking is to change the value of this resistor.

The input circuit to TR1 in particular must be clear of leads carrying AC, or hum pick-up may be amplified by both stages, and manifest itself as changes in trace brightness.

With about 160V to 165V across C4, collector voltage of TR2, as shown by a high resistance instrument, is about 110V. The emitter reading is approximately 0.1V.

### **Flyback suppression circuit component list**

R1	1.5 megohm
R2	1 megohm
R3	470 k
R4	10 k
R5	2.7 k
R6	2.2 megohm



R7 18 k  
R8 100 k  
R9 220 ohm  
R10 12 k 2 W  
R11 12 k 2 W (resistors  $\frac{1}{4}$ W 5% except where indicated)  
C1 820 pF  
C2 0.1  $\mu$ F  
C3 10 nF 750 V  
C4 16  $\mu$ F 250 V  
TR1 2N3704  
TR2 MJE340 (2N6177)  
D1 1N914  
Board about  $3\frac{1}{2} \times 2$  in (90 x 51 mm)

### Alternative X input

The purpose of the timebase and X amplifier is to sweep the beam at uniform speed across the screen, then return it as rapidly as possible to the left, to commence the trace again, this being repeated. A sawtooth wave is used for this — the beam moves across the screen as the potential rises along the sloping face of the wave, then returns on the vertical or fly-back part of the wave.

For some purposes this type of operation is not wanted. Instead, it may be necessary to apply a sine wave to the X plates, as for example when comparing two frequencies. (This is described in the section on Lissajous figures, where two sinusoidal voltages are displayed in frequency relationship.)

A socket for an alternative X input is best placed in circuit before the first X amplifier stage. This is done by interrupting the circuit from the UJT emitter to the coupling capacitor (Figure 13) and completing this through a jack socket fitted to the panel, Figure 22. When the plug is inserted, A breaks contact with B, so that the timebase oscillator no longer drives the amplifier. The new input is from jackplug outer sleeve at C, to tip B, and thus to C2 and the amplifier.

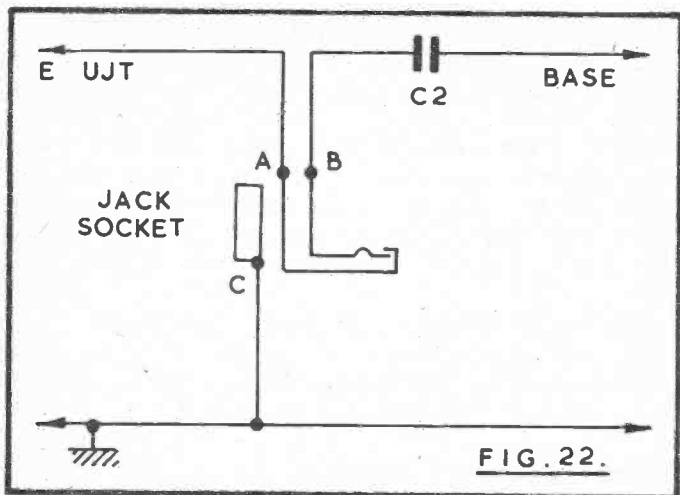

**FIG. 22.**

Deflection along the horizontal axis is now obtained from the input provided at the socket. In the case of a sinusoidal input, the spot will be swept backwards and forwards as the wave rises from zero to maximum in one direction, then falls through zero to its maximum in the other direction.

By this means it is possible to show the numerical relationship between two frequencies. One input is taken to the Y amplifier socket, and the other to the X input socket now available. The height and width of the display are adjusted by means of the Y and X gain controls.

As example, with inputs in a 2:1 relationship, a figure like that shown later is produced. Drift in either frequency will cause the figure to roll and change shape. For a 3:1 or higher ratio between the two frequencies, the figure will have more loops. When the ratio has risen to 10:1 or so, it becomes rather difficult to count the loops, and therefore to determine the frequency ratio. The Y input may be that of the higher frequency; or this input may be lower than the X input frequency. The displays which are obtained are covered in more detail later (see Lissajous Figures, in the section on scope operation).

The appearance of a figure such as that shown will give a good idea of the accuracy or otherwise of the adjustment of the output stages of the X and Y amplifiers. One input may be from a fixed frequency sine wave generator (Figure 28) and the other input is from a generator of adjustable frequency. The figure should appear symmetrical, both in the size of the loops above and below the cross-over point, and in the shape of each part of the loops. A little care in setting frequency will be necessary to obtain a stable figure. Variations in height or width will of course change the shape, but the outline should remain symmetrical, as also shown.

### Reference voltage

Vertical deflection will depend on the gain of the Y amplifier and setting of the attenuator. To obtain a reference point against which an unknown voltage can be found, many scopes have a reference voltage output socket.

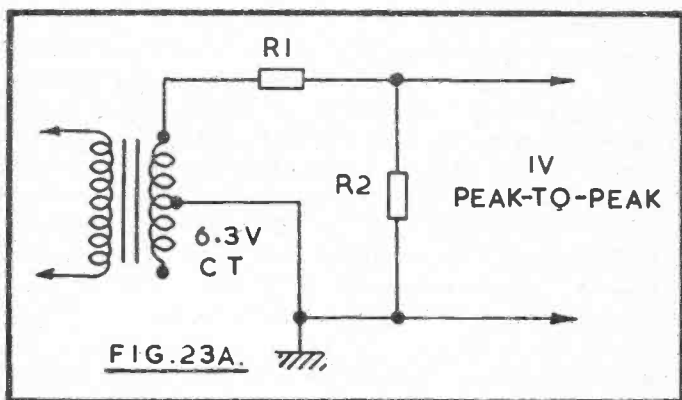

Figure 23A shows how to obtain a reference of 1V peak-to-peak from the 3.15V RMS obtained from one half of a 6.3V centre-tapped winding on the transformer. (The winding supplying the CRT heater cannot be used.) The peak swing is 0.5V each side zero, or chassis line. The resistors may be

soldered directly to the socket, with the lower value returned to chassis, and a lead from the second resistor to the heater winding. R1 is 490 ohm and R2 is 62 ohm.

For calibration, the reference voltage socket is connected to the Y input, and gain is adjusted for a suitable scale, such as 1 cm/V. That is, each 1 cm of vertical height of the scan indicates 1V peak-to-peak. If a graticule has been fitted, the length of the vertical scan can be taken from this. Otherwise a measure will have to be used.

Accuracy depends on the transformer secondary voltage, and resistor tolerances, as well as on the precision with which the scan is measured. But even a cursory test of this kind can show up a bad error in an expected peak-to-peak voltage. The Y amplifier should have the same gain on the reference and test frequencies, as otherwise the height would be incorrect.

### **Calibrated attenuator**

In order to extend the range of voltages which can be measured, a calibrated attenuator consisting of fixed resistors can be provided between the circuit tested, and the scope. Figure 23B allows measurement of the original voltage (1x), and 10 times (10x) and 100 times (100x) thus. The total network value is 3,666 k, and the 100x point allows the scope to be operated from a 36 k point, with 366 k for the 10x input to the Y amplifier. Thus if calibration is made at 1 volt peak-to-peak at 1x, transferring the scope to 10x or 100x will give 10V peak-to-peak and 100V peak-to-peak ranges.

With a network of this kind, stray capacitances influence the readings at high frequencies, but can be ignored at low frequencies. Compensation for this may be arranged by frequency-sensitive components, usually capacitors. These need individual adjustment, which is not easy unless a known input voltage can be provided over a range of frequencies. The values are small, and would also depend on the layout and type of resistors, and stray capacitance in the switch or

sockets used for range selection.

As with the reference voltage source, resistor values should be selected with an accurate meter, or precision resistors should be used. A reasonable level of accuracy should be obtained. R1 is 3.3 megohm, R2 is 330 k, and R3 is 36 k.

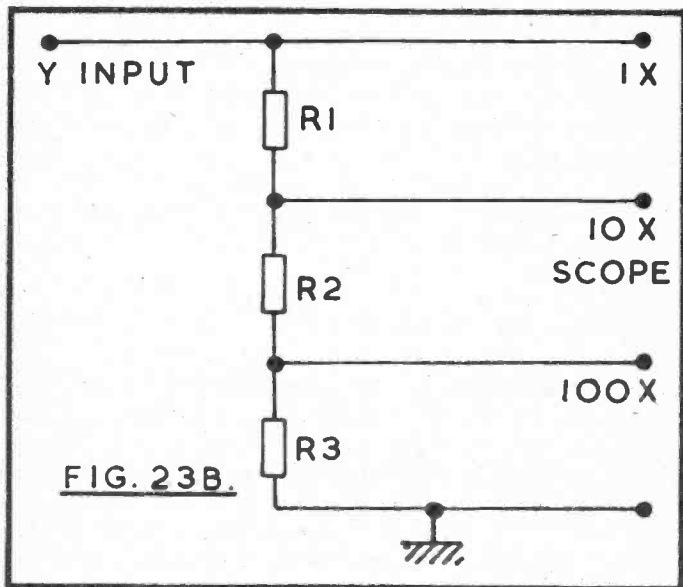

### Z axis

Horizontal scanning of the CRT is on the X axis, and vertical scanning on the Y axis. In a few applications modulation of the intensity of the beam can be employed, and this is termed the Z axis.

With many instruments, no Z axis input is provided. On others, it may be present as an auxiliary socket. A Z axis input is most conveniently taken to the CRT control grid. An isolating capacitor, with a voltage rating adequate for any

purpose likely to be encountered and for the grid potential, is connected between the socket and the grid. A 22 nF 2kV capacitor will normally be suitable. In order that signals can modulate the grid, a resistor is placed in series with the circuit from brightness potentiometer to grid. Here, 100k can be used.

A minimum input of several volts will be needed to produce changes in the trace brightness, this depending on the tube bias characteristics, as well as the degree of intensity modulation wanted. One display of this type is the brightness modulation of a circular display obtained by X and Y inputs of the same frequency, having a phase difference of either 90 degrees or 270 degrees.

Coupling or other circuits may have to be set up, as with direct Y plate inputs.

### **Direct Y input**

Some oscilloscopes have sockets allowing a direct input to the Y plates of the CRT. Such an input can only be used when the voltage swing is sufficient to give adequate vertical deflection, but has the advantage that frequency is not limited by the performance of the Y amplifier.

Sockets may allow direct connection to the plates; or DC isolating capacitors may be included inside the instrument. If any tests are to be made in which the upper frequency limit is set by stray capacitances in wiring, tube base, and tube, then connections must be short and clear of earthed metal, and may run to sockets at the back of the case. The coupling capacitors, one from each Y plate, can be 10 nF. An adequate voltage rating is required, at least 1 kV being preferable. Sockets bridged for normal working will allow the existing capacitors from the Y amplifier to be disconnected.

One purpose for which a direct Y input may be used is the examination of the output of amateur or other transmitters,

so that modulation may be checked. This allows tests to be made at high frequencies with which the scope could not otherwise deal.

One means of coupling the radio frequency output of the transmitter to the Y plates is shown in Figure 24. at A. L1 receives RF energy from the transmitter output. It may be in series with a dummy load (resistor of suitable value and adequate power rating) if tests are made without radiating. Only two or three turns of well insulated wire will generally be required. It is of advantage to be able to modify the degree of coupling easily, to alter the height of the display.

L2, with VC1 in parallel, is resonant at the operating frequency. A single section capacitor may be used at VC1 provided there is no unnecessarily large capacitance from rotor to ground.

With all but low power care should be taken when first coupling L1 and tuning L2 to resonance, as considerable RF voltage can be developed. The voltage need only be sufficient to give a satisfactory height of trace.

Figure 24 also shows outlines obtained for various modulation conditions of an AM transmitter. At B is the unmodulated carrier wave, obtained when no audio signal is present. With a sine wave as input to the transmitter, modulation may be shown by the outline C. (The frequency difference between RF and AF is so large the diagram is only representative.) Modulation is much under 100 per cent. At D, modulation is so heavy the carrier is interrupted, while E is 100 per cent modulation.

The modulation percentage is:

$$\frac{\text{Max} - \text{Min}}{\text{Max} + \text{Min}} \times 100$$

Measurements are taken as at C.

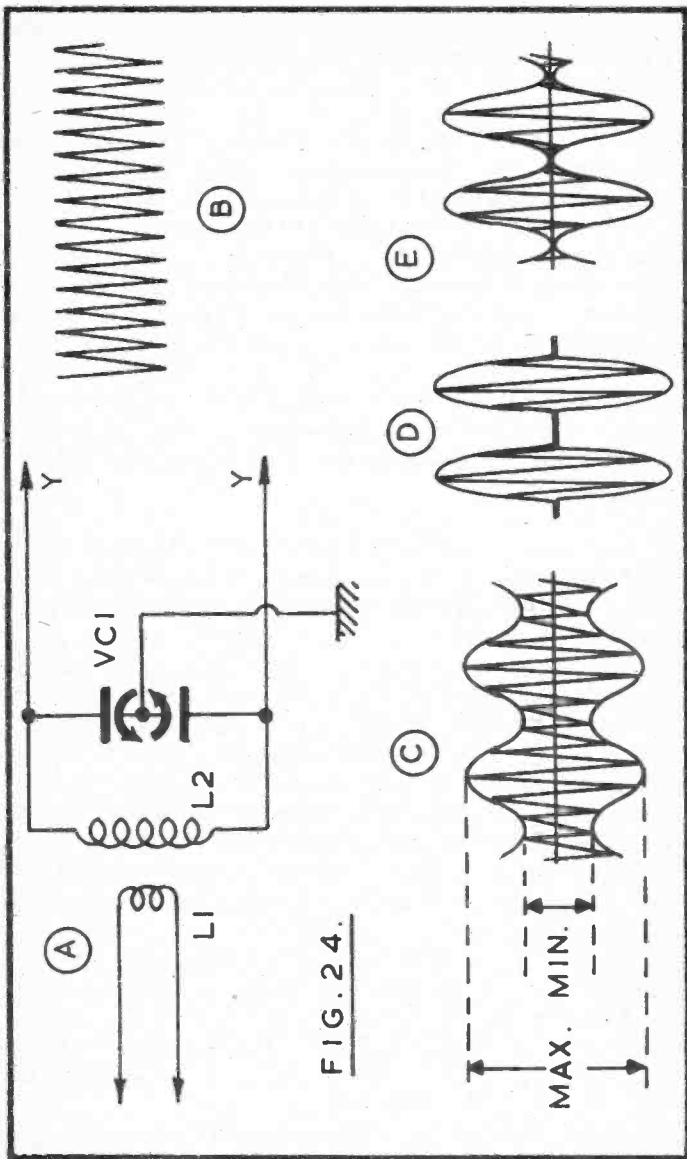

FIG. 24.



Numerous other tests of modulation for AM or SSB, such as those producing trapezoidal and two-tone patterns, can be made in accordance with the test arrangements generally used.

### Alternative semiconductors

Various alternative transistors have been found to give a satisfactory performance, but it is not practical to list all these, especially as the types shown are readily obtainable.

In the power supply circuits, numerous semiconductor rectifiers could no doubt be fitted as alternatives. The peak inverse voltage rating of rectifiers needs to be at least about three times that of the RMS rating of the secondary of the transformer. (Capacitors charge to about  $1.4 \times$  RMS voltage, and the rectifier is subjected to twice this voltage at the opposite peak.) Rectifier current ratings can be 1A, which is easily more than necessary, but readily available.

With the low level stages, various general purpose transistors may be used, though in some cases component values might need modification. It should not be overlooked that transistors of a given type may vary considerably in gain, and sometimes in other important characteristics. As example, the 2N3704 has an hFE (gain) range of 90–330, the actual figure of an individual sample not being specified. Inexpensive surplus may be found to have a lower gain than the minimum given.

For both X and Y amplifier output stages, high voltage transistors must be fitted. The MJE340 (2N6177) has an hFE of 30–240, and those at the lower end of this range naturally give a reduced performance. Substitution of these by alternatives should only be considered after examining all the characteristics. Some of the scanning transistors available for higher voltages have a much lower gain, and so would require additional drive.

It would probably be in order to use alternative unijunction transistors of similar type.

A brief outline of tests which can be made to check the working of various circuits is given below, and this should enable the source of any fault to be located.

### Test notes

Details of the operation of each section have been given, but some further tests which might be carried out if necessary are suggested.

The various supply voltages – for X and Y circuits, CRT heater, and positive and negative EHT – are readily checked with a meter. They can also be followed to the various points on the boards. Lack of voltage might arise from an omitted connection or short to chassis. The latter will overheat or damage rectifiers or transformer, if arising at these components.

A high resistance meter can be used to check collector and emitter voltages, if necessary. If there is no voltage drop in resistors in these positions, check that connections are complete, or assure the transistor is not defective.

Any investigation need only take in that part of a circuit which is not operating, or giving unsatisfactory results. Thus, if an input of adequate level allows sufficient vertical deflection, then the Y amplifier must be operating. Similarly, the timebase and X amplifier are operating if a horizontal trace is obtainable.

### External synchronisation

Provision for synchronisation of the timebase by an external signal can be made by switching the sync amplifier input from the Y amplifier to a panel socket. An input to this socket will

then give synchronisation, the timebase frequency being adjusted as for internal synchronisation.

Such an input may occasionally find uses, as when the Y amplifier is not employed and Y input is directly to the Y plates, or for other purposes.

In a similar way, the timebase frequency is sometimes made available for external use, by supplying a panel socket through an isolating capacitor from the X amplifier.

### General use

A screened lead is made up with a plug to match the scope input, using a metre or so of low capacitance coaxial cable. At the free end, crocodile clips are attached to both inner and outer conductors. These clips can be attached to circuits being tested.

It is convenient to have a second similar lead with plug. The end of this lead had a flexible connection soldered to the outer brading, several inches long, and fitted with a clip. The inner conductor is taken to a well insulated test prod. This can be the type which opens with pressure to grip leads or small components. It will be useful for inaccessible circuit points.

The earth line of the scope is connected to the earth line of the equipment to be tested, by means of the outer brading of the test lead described. These circuits (ground line or chassis) must be at the same potential. This will normally be so with mains equipment which incorporates a transformer and has a grounded chassis.

*Equipment which derives internal voltages directly from the mains will have a live chassis.* No direct connection should be made to this. No tests should be made on any such equipment unless the danger of shocks and way of avoiding these are fully understood.

Care is taken not to attach the prod to high voltage high tension or other circuits where the potential may cause damage or danger. The same forethought should be used as when employing a multi-range test meter or other equipment.

For AC or AF tests a capacitor to provide isolation is generally placed in the coaxial lead inner circuit. It can be 47 nF and may be fitted inside the instrument at the input socket. An alternative socket or switch to eliminate it will be necessary for DC tests.

Possible shock hazards are greater where high voltages are present, as in mains operation valve equipment. It must be remembered that capacitors may store a high voltage charge, even though the equipment has been switched off or disconnected from the mains.

With mains operated equipment having low voltage internal circuits, do not overlook that mains input, mains switching, and-transformer primary circuits may be alive and dangerous.

With an input to the scope, the attenuator is adjusted from zero until a display of suitable height is obtained. Coarse and fine timebase controls are set to obtain a suitable trace. A portion of the display can be expanded to occupy the screen by increasing the X gain.

Focus and brightness are set to produce a sharp and easily-seen trace. The scope is best located so that strong light does not fall directly on the screen. It is possible to construct a hood or light shield to fit over the top and sides of the screen. This can project about 2 in or 50 mm at the top, sloping away to an inch or so at the bottom, and can be held with the four bolts already present.

Remember not to leave the beam resting at one spot on the tube face for any length of time, especially if bright and in sharp focus.

With no signal input, the trace will move in a line horizontally

across the CRT, unless the X gain is set to zero.

The oscilloscope is an instrument which gives a visual display of changes in voltage. These changes may arise over a period of time which allows their actual observation; or they may be repeated in such a way that their observation becomes possible. For some tests the oscilloscope can be used alone, while for others auxiliary equipment would be needed.

The scope may display current in terms of voltage, show the relationship between two frequencies, allow modulation depth to be checked, reveal distortion in amplifier or other circuits, or perform other functions, according to the way it is connected and used.

### AC wave

A in Figure 26 shows one cycle of a sine wave. This is what could be seen on the CRT screen if the time taken for the beam to traverse were equal to the periodicity of the wave. With a 50 cycle per second or 50 Hertz wave, this time would be  $1/50$ th second.

During this interval the wave has risen from zero to its maximum positive value, descended from here through zero to reach its maximum negative value, and returned to zero.

If a circle is drawn on graph paper and a sine wave produced from it, zero is at 0 degrees, the positive peak at 90 degrees, zero at 180 degrees, negative peak at 270 degrees, and zero at 360 degrees. Similarly, the positive peak is reached in one-quarter of a cycle, while at one-half cycle this has descended to zero, and so on.

Often the traverse of the beam will take longer than one cycle and then several waves will be observed on the screen, in a way similar to that shown for B.

The sine wave has several features which have a particular relationship to each other.

## RMS value

The root mean square or RMS value is that shown by an alternating current meter or indicated by the usual multi-range testmeter. It is 0.707 times the peak voltage of the sine wave (or 0.3535 times the peak-to-peak voltage).

The peak voltage is that reached at the maximum positive and maximum negative excursions in A, Figure 26. For mains transformers and numerous circuits where alternating current is used, the voltage quoted is the RMS value. Where the RMS voltage is known, the peak value can be found by multiplying this by 1.414. Thus if an AC supply were 200V, the peak voltage would be 282.8V.

Generally, the relationship between peak and RMS values is the only one encountered in most work. An *instantaneous value* is one reached at any particular instant to be considered. An *average value* is 0.9 times the RMS value.

These relationships hold good only for a sine wave. As example, the wave at D in Figure 26 has pointed, narrow peaks, so the peak values are greater while the actual power is reduced.

Waveforms displayed by the scope may be of any shape, and observing the shape, or changes to it, gives information about the equipment being tested.

A test to show the generation of distortion in an amplifier or audio circuit can be made with a sine wave input.

## Generator

The audio generator, amplifier, and scope are connected as in Figure 25. Naturally the test might be of only one or two stages of the amplifier if there is any reason for investigating these alone.

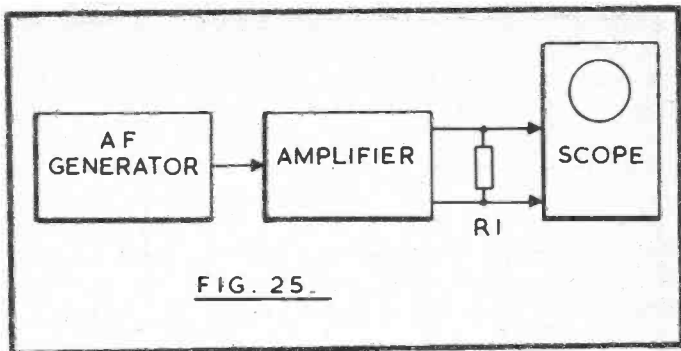

R1 in Figure 25 represents the usual output load of the amplifier. This must always be present, and be of the correct value. Its power handling capacity will depend on the power level up to which tests are made.

For such tests, a variable frequency audio signal generator giving a sine wave output is required. If this output is observed it will resemble the wave A in Figure 26. It is of advantage if the generator maintains the same level of output over its frequency range.

The simple type of multivibrator or audio oscillator often used for trouble-shooting in audio equipment is not suitable.

Assuming that A in Figure 26 is the generator output, the waveform will be the same when passed through the amplifier, if no distortion is introduced. If amplifier gain is reached, or output from the generator is raised, the wave grows in height.

At E, flattening of one peak shows that the amplifier is no longer able to deal with the signal level present. At F, both peaks are flattened. This could arise from a limitation in the power handling capacity of the output stage.

Only one wave is shown, but usually two or more will occupy the tube screen, as described.

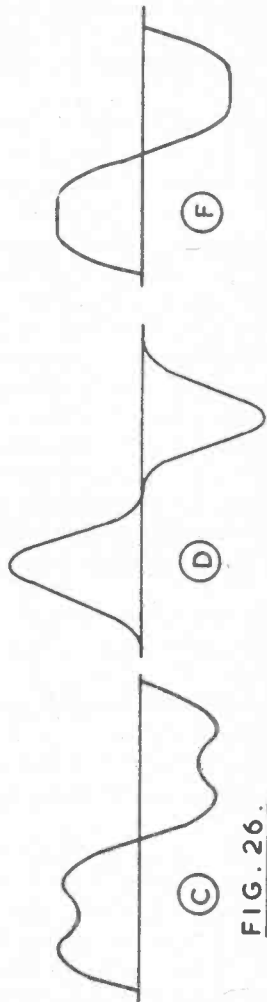
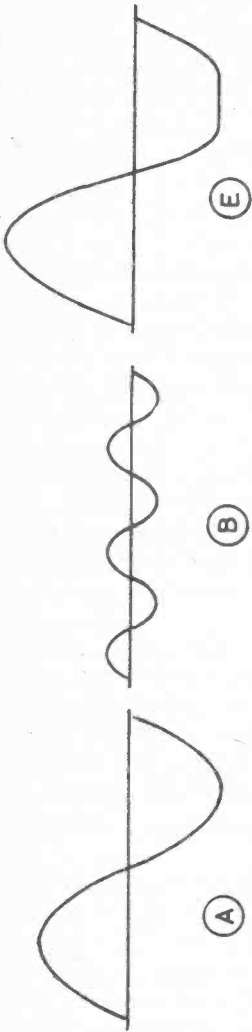

FIG. 26.



The flattening at E has arisen at only one peak. This could be caused by one transistor or valve in a push-pull output stage being inadequate, or being inoperative if the flattening is very severe. It could also be caused by faulty operation of a Class A stage, due to incorrect bias conditions, defective transistor or valve, or any fault which prevents the full audio signal swing in either direction.

With any audio equipment overloading and distortion will set in eventually if the signal input is raised sufficiently, producing effects like F. So amplifier input and output must be kept to those levels normal for sine wave running of the equipment.

### Harmonics

The waveform obtained when various harmonics are present will depend on the order of the harmonic, its relative strength and its phase relationship to the fundamental. The general way in which this is so will also be clear from Figure 26.

The fundamental sine wave has positive and negative peaks and resembles A. A second harmonic of this frequency is one of twice the frequency. So the harmonic will rise to a peak, pass through zero to the opposite peak, and return to zero during the same time interval as the fundamental takes for half a cycle. If a negative peak of the harmonic coincides with the negative peak of the fundamental at A, it will assist this, producing a longer peak. The next negative peak of the harmonic will coincide with the positive peak at A, so results in flattening.

The phase relationship between fundamental and harmonic might be different, so that the addition or subtraction of the harmonic is displaced.

If the harmonic energy is small compared with the original frequency, the change in waveform will be correspondingly slight. It is relatively easy to recognise waveforms such as these when displayed by the scope.

In the case of the third harmonic, there will be three harmonic waves for each single wave of the fundamental. B shows this. The harmonic power may thus give extended peaks and distortions D, or with a different phase relationship may produce distortion similar to C.

When an amplifier is being checked with a sine wave input, care must be taken, as mentioned, to avoid overloading.

Voice or music inputs have transient, peaky waveforms and the actual power is substantially less than for a continuous sine wave of equivalent peak. Repetitive peaks may also be of short overall duration. So equipment may not be able to deal with a sine wave input which gives a continuous power output from the amplifier equalling the transient peak output. This means that a continuous sine wave output should not be used for any length of time, unless it is known that the power falls within the continuous sine wave output rating of the equipment.

### Lissajous figures

These allow an unknown frequency to be found. The accuracy is similar to that of the source against which the unknown frequency is to be compared. The source will usually be a calibrated audio signal generator covering frequencies akin to those of the unknown frequency.

The scope timebase is not in use. One input is taken to the alternative X input socket, and the other input to the Y socket. The relative strength of each signal can be adjusted to give a suitable display.

With two sinusoidal inputs applied in this way, a particular pattern is obtained when the inputs bear a suitable frequency relationship to each other.

With a 2:1 relationship, the figure resembles A in Figure 27. "H" is an imagined horizontal line, touched by one loop.

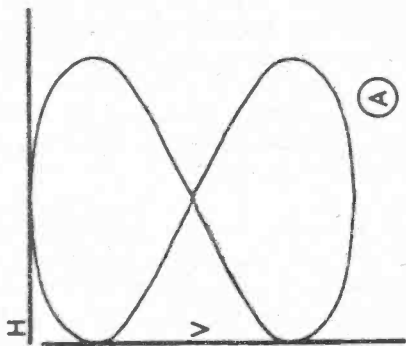

(A)

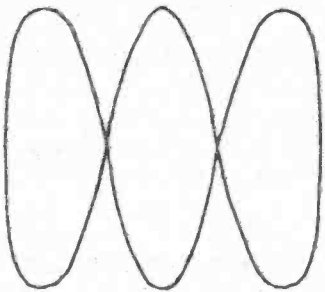

(B)

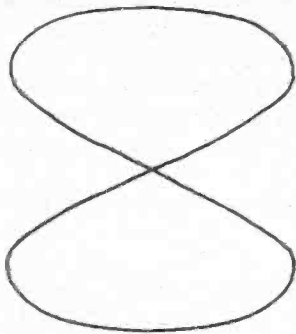

(C)

FIG. 27.

“V” is a vertical imagine line, touched by two loops. For a 3:1 relationship, the figure resembles B. At C is another 2:1 relationship but with the frequency inputs reversed. The known frequency is taken to the X amplifier, and the unknown to the Y input, to avoid confusion such as might arise between A and C.

An unknown frequency can be found from the following:—

$$\text{Unknown frequency} = \frac{\text{Horizontal loops} \times \text{known frequency}}{\text{Vertical loops}}$$

The horizontal loops are counted as touching the imagined line H, and the vertical loops as touching line V.

As example consider figure A, with 3000 Hertz or 3 kHz input.

$$\text{Unknown frequency} = \frac{1 \times 3000}{2} = 1500 \text{ Hz}$$

As the frequency difference is increased, more and more loops will appear. The limit is determined by the number of loops which can be counted by observing the screen. When a fairly large number (say 10) has been reached, it is necessary to change the known reference input frequency, to obtain a figure with fewer loops.

It is of advantage to have the figure very slowly rolling or rotating as in some circumstances this allows more accurate counting of the loops.

Frequencies need not bear a 1:2, 1:3, or similar relationship with unity, but may be in a 2:3, 3:4, 3:5, or any other relationship. A more complex grid then appears on the screen, with two or more loops touching the horizontal line at A, and two or more touching the vertical line (a 1:1 ratio is shown by a circle, not several vertical and horizontal loops). It is thus

possible to find a number of unknown frequencies, from a known single frequency.

Where the frequency relationship is of too high a ratio, or obscure, a mesh pattern, or moving pattern with no clear ratio apparent, will be produced.

### **Sine wave oscillator**

References have been made to the use of a sine wave as an aid to some adjustments. Such a wave is of the shape illustrated in Figure 26 at A and is free from harmonics and distortion. So when it is fed into the oscilloscope input, distortion on the CRT screen will, if present, be caused by incorrect operating conditions or adjustments in the oscilloscope circuits.

Signal generators with a sine wave output, and adjustable over a wide, calibrated frequency range, will of course be ideal for setting up the oscilloscope. They will also allow calibration of the timebase ranges.

Unfortunately many popular general purpose signal generators only have an audio output which is intended for circuit testing, and the waveform will usually carry many frequency components, and will not appear as a sine wave when taken to an oscilloscope. This is very much the case with the inexpensive multivibrator generator, and also many other circuits which are able to provide a single audio output tone. The wave provided will be distorted, may not extend equally above and below the centre line, and its display may be of little help when adjusting the scope for correct working.

In view of this, it can be worth while assembling an audio oscillator which will produce a sine wave. This need only be available at one frequency. Various circuits may be employed for this purpose, and that shown in Figure 28 uses no close tolerance components or items difficult to obtain, especially as there is no need for any particular frequency. It gives an excellent sine wave, producing a display as shown in Figure 26A,



The components for this or other suitable oscillators can be assembled on a small insulated board. A box to take the board and a 9V battery will afford protection. An output attenuator potentiometer is optional. It would not be required for setting up the scope, as the height of display can be adjusted by means of the scope attenuator. It can, however, be useful in some circumstances, as when the audio signal is used to test sections of an amplifier and the full output would cause overloading.

With the component values indicated, oscillation will be at about 3.5 kHz. Other frequencies would be entirely suitable for the adjustments which have been mentioned. The transistors may be OC70, or OC71.

The sine wave oscillator is simply connected to the scope input with a screened lead, and the attenuator is rotated from minimum until a trace of suitable height is observed on the screen. Final adjustments to the Y amplifier are made with a display of full height. VR1 allows adjustment for the best waveform. For other frequencies only C1, C2, R1 and R2 need be modified, as noted in Figure 28.

## SPECIAL NOTES FOR USA READERS

There are slight differences in language, terminology and component numbering and coding between the UK and USA. The following notes may be of help to the US reader.

### Terminology

<i>English</i>	<i>USA</i>
Earthed	Grounded
Fixing screws	Mounting screws
Centre	Center
Mains	AC supply voltage
Tagboards	Terminal boards
Tags	Terminals/lugs
Screened	Shielded
Smoothing	Filtering
HT (high tension)	High voltage
240 Volts AC	120 Volts AC in USA
Fitting	Installing

### Transistors

<i>Book used</i>	<i>US equivalent (JEDEC)</i>
BC108	2N929
BC109	2N930
BC184K	2N5827
BC184L	2N5210
MJE340	2N6177
MPS6518	2N4403
OC70	2N406
OC71	2N406
UT46	UJT
2N3053	2N2297
2N3704	2N3704
2N3706	2N3704
2N3707	2N5210



Please note overleaf is a list of other titles that are available in our range of Radio and Electronics Books.

These should be available from most good Booksellers, Radio Component Dealers and Mail Order Companies.

However, should you experience difficulty in obtaining any title in your area, then please write directly to the publishers enclosing payment to cover the cost of the book plus adequate postage.

If you would like a copy of our latest catalogue of Radio & Electronics Books then please send a Stamped Addressed Envelope to:

**BERNARD BABANI (publishing) LTD**  
The Grampians  
Shepherds Bush Road  
London W6 7NF  
England

205	First Book of Hi-Fi Loudspeaker Enclosures	95p
221	28 Tested Transistor Projects	1.25p
222	Solid State Short Wave Receivers for Beginners	1.25p
223	50 Projects Using IC CA3130	1.25p
224	50 CMOS IC Projects	1.35p
226	A Practical Introduction to Digital IC's	1.75p
226	How to Build Advanced Short Wave Receivers	1.95p
227	Beginners Guide to Building Electronic Projects	1.95p
228	Essential Theory for the Electronics Hobbyist	1.95p
RCC	Resistor Colour Code Disc	20p
BP1	First Book of Transistor Equivalents and Substitutes	£5.00p
BP6	Engineers and Machinists Reference Tables	75p
BP7	Radio and Electronic Colour Codes and Data Chart	40p
BP14	Second Book of Transistor Equivalents and Substitutes	1.75p
BP24	52 Projects Using IC741	1.25p
BP27	Chart of Radio Electronic Semiconductor and Logic Symbols	50p
BP32	How to Build Your Own Metal and Treasure Locators	1.95p
BP33	Electronic Calculator Users Handbook	1.50p
BP34	Practical Repair and Renovation of Colour TVs	1.25p
BP36	50 Circuits Using Germanium, Silicon and Zener Diodes	1.50p
BP37	50 Projects Using Relays, SCR's and TRIACs	£9.5p
BP39	50 (FET) Field Effect Transistor Projects	1.75p
BP40	Digital IC Equivalents and Pin Connections	3.50p
BP41	Linear IC Equivalents and Pin Connections	3.50p
BP42	50 Simple L.E.D. Circuits	£5.0p
BP43	How to Make Walkie-Talkies	£9.5p
BP44	IC555 Projects	1.95p
BP45	Projects In Opto-Electronics	1.95p
BP47	Mobile Discotheque Handbook	1.35p
BP48	Electronic Projects for Beginners	4.95p
BP49	Popular Electronic Projects	1.95p
BP50	IC LM3900 Projects	1.35p
BP51	Electronic Music and Creative Tape Recording	1.95p
BP52	Long Distance Television Reception (TV-DX) for the Enthusiast	£9.5p
BP53	Practical Electronic Calculations and Formulae	2.95p
BP55	Radio Stations Guide	1.75p
BP56	Electronic Security Devices	1.95p
BP57	How to Build Your Own Solid State Oscilloscope	1.95p
BP58	50 Circuits Using 7400 Series IC's	1.75p
BP59	Second Book of CMOS IC Projects	1.50p
BP60	Practical Construction of Pre-amps, Tone Controls, Filters & Attn	1.45p
BP61	Beginners Guide to Digital Techniques	95p
BP62	Elements of Electronics - Book 1	2.25p
BP63	Elements of Electronics - Book 2	2.25p
BP64	Elements of Electronics - Book 3	2.25p
BP65	Single IC Projects	1.50p
BP66	Beginners Guide to Microprocessors and Computing	1.75p
BP67	Counter, Driver and Numeral Display Projects	1.75p
BP68	Choosing and Using Your Hi-Fi	£6.5p
BP69	Electronic Games	1.75p
BP70	Transistor Radio Fault-Finding Chart	50p
BP71	Electronic Household Projects	1.75p
BP72	A Microprocessor Primer	1.75p
BP73	Remote Control Projects	1.95p
BP74	Electronic Music Projects	£7.5p
BP75	Electronic Test Equipment Construction	1.75p
BP76	Power Supply Projects	1.75p
BP77	Elements of Electronics - Book 4	2.95p
BP78	Practical Computer Experiments	1.75p
BP79	Radio Control for Beginners	1.75p
BP80	Popular Electronic Circuits - Book 1	1.95p
BP81	Electronic Synthesiser Projects	4.75p
BP82	Electronic Projects Using Solar-Cells	1.95p
BP83	VMS Projects	1.95p
BP84	Digital IC Projects	1.95p
BP85	International Transistor Equivalents Guide	2.95p
BP86	An Introduction to Basic Programming Techniques	1.95p
BP37	Simple L.E.D. Circuits - Book 2	1.35p
BP88	How to Use Op Amps	2.25p
BP89	Elements of Electronics - Book 5	2.95p
BP90	Audio Projects	£9.5p
BP91	An Introduction to Radio DX-ing	1.95p
BP92	Electronics Simplified - Crystal Set Construction	4.75p
BP93	Electronic Timer Projects	1.95p
BP94	Electronic Projects for Cars and Boats	1.95p
BP95	Model Railway Projects	1.95p
BP96	C 8 Projects	1.95p
BP97	IC Projects for Beginners	1.95p
BP98	Popular Electronic Circuits - Book 2	2.25p
BP99	Mini-Matrix Board Projects	1.95p
BP100	An Introduction to Video	4.95p
BP101	How to Identify Unmarked IC's	65p
BP102	The 6809 Companion	1.95p
BP103	Multi-Circuit Board Projects	1.95p
BP104	Electronic Science Projects	2.25p
BP105	Aerial Projects	1.95p
BP106	Modern Op-Amp Projects	£9.5p
BP107	30 Solderless Breadboard Projects - Book 1	1.95p
BP108	International Diode Equivalents Guide	2.25p
BP109	The Art of Programming the 1K ZX81	1.95p
BP110	How to Get Your Electronic Projects Working	1.95p
BP111	Elements of Electronics - Book 6	3.50p
BP112	A Z 80 Workshop Manual	2.75p
BP113	30 Solderless Breadboard Projects - Book 2	2.25p
BP114	The Art of Programming the 16K ZX81	2.50p
BP115	The Pre-Computer Book	1.95p
BP116	Electronic Toys Games and Puzzles	2.25p
BP117	Practical Electronic Building Blocks - Book 1	2.25p
BP118	Practical Electronic Building Blocks - Book 2	2.25p
BP119	The Art of Programming the ZX Spectrum	2.95p
BP120	Audio Amplifier Fault-Finding Chart	65p
BP121	How to Design and Make Your Own PCBs	2.25p
BP122	Audio Amplifier Construction	2.25p
BP123	A Practical Introduction to Microprocessors	2.25p
BP124	How to Design Electronic Projects	2.25p



# **BERNARD BABANI BP57**

## **How to Build Your Own Solid State Oscilloscope**

■ The cathode-ray oscilloscope is probably one of the most useful and versatile test instruments available to the engineer and hobbyist, as in many cases it can give visual insight into what is happening electrically in a circuit.

■ Although the oscilloscope is, in itself, a fairly complex instrument, it can however be divided into various sub-sections which may be individually constructed and tested, then finally assembled together to complete the instrument.

■ This approach is adopted by the author, who gives clear and concise practical instructions and it is hoped that even the inexperienced hobbyist can construct a fairly sophisticated instrument with the minimum of difficulty and expense.

■ Also covered are some basic uses of the oscilloscope as well as the construction of a Sine Wave Oscillator.

ISBN 0 900162 79 1



BERNARD BABANI (publishing) LTD