

**CONSTRUCTORS
HANDBOOK
OF
GERMANIUM
CIRCUITS**

by

SYLVANIA ELECTRIC PRODUCTS INC.

CRYSTAL RADIO

ELECTROPLATER

ELECTRONIC
DOOR LOCK

RADIO CONTROL
FOR MODELS

RADIO CONTROLLED
RELAY

DRY BATTERY
CHARGER

GARAGE DOOR
OPENER

ETC.

43 Illustrations

**BERNARDS (PUBLISHERS) LTD.
LONDON**

TWO SHILLINGS AND SIXPENCE NET

9.49

**CONSTRUCTORS
HANDBOOK
OF
GERMANIUM
CIRCUITS**

by

SYLVANIA ELECTRIC PRODUCTS INC.

**BERNARDS (PUBLISHERS) LTD.
LONDON**

FIRST PRINTED IN ENGLAND

December 1951

Printed for Bernard (Publishers) Ltd., The Grampians, Western Gate, W.6.
by the Reynard Press Ltd., Flitcroft Street, London, W.C.2.

FOREWORD

QUITE a few thousand words have been written in the last few years on applications of the versatile germanium diode. Most of this literature has been prepared for the benefit of readers who work with radio communications. We feel, therefore, that the radio amateur, experimenter, engineer, and service technician have been well supplied with information.

This booklet has been prepared expressly for another type of reader — the electrician, electrical experimenter, electronic hobbyist, and model maker. It has not been an easy task to develop circuits and gadgets of particular interest to the experimenter in these categories. However, we have selected from a growing mass of practical developments those devices which we believe will be of real service to a long neglected group of electrical men. Radio technicians will, of course, also find interest in the circuits and data contained in this booklet.

The great value of the Germanium Diode lies in the fact that it requires no power supply for its operation. It therefore can be used in systems in which standby power and frequent replacements of components are undesirable. Furthermore, the crystal diode is small in size and is simple in nature.

SYLVANIA ELECTRIC PRODUCTS INC.

ELECTRONICS DIVISION

1740 BROADWAY



NEW YORK 19, N. Y.

The information in this book is furnished without assuming any obligations

FOREWORD TO BRITISH EDITION

Following the unprecedented success of "40 Circuits using the Germanium Crystal." Messrs. Bernards (Publishers) Ltd., are encouraged to present a further manual dealing with the application of the germanium diode to the public. As before, permission to publish is due to the courtesy of Sylvania Electric Products Inc.

Interest in this manual is not confined to the radio amateur, it has appeal to the electrical experimenter and model maker.

As might be expected from a book of American origin, there are a number of components specified in the various designs which the British constructor might experience difficulty in obtaining and it is with this point in mind that the publishers invited some of the leading manufacturers of relays and germanium crystals to co-operate in producing an equivalent list of those components. Messrs. Sangamo Weston point out that where the contacts of their relays are subjected to an inductive load, a spark quench circuit is essential.

This may consist of a capacitor and resistor in series across the contacts, for guidance a list of suitable values is given for use when a P.O.-type 3000 relay is used as the inductive load.

RELAY RESISTANCE		SPARK QUENCH	
<i>ohms</i>	<i>mfd.</i>	<i>ohms</i>	
500	2	2,000	
1,000	2	2,500	
2,000	2	3,500	
5,000	2	5,000	
10,000	2	7,000	

With other relays the values should be adjusted so that no sparking is visible when the contacts are viewed under an eyeglass, in subdued light. Where it is necessary for relays to operate at 50 micro-amps., the adjustment must be made at the works and not by the constructor.

In a number of circuits it is suggested that a surplus type 3000 relay should be used when modified. The modification is simple, and consists of easing the tension springs and closing the contacts so that the relay will operate on a lower current than originally intended. There is also a set screw at one end which may be adjusted to limit the movement of the contacts.

It is pointed out that the circuits were originally designed for 100-120-volt operation whereas in Great Britain the majority of supply mains deliver 200-250 volts. Figs. 11, 32, 34, 37, are examples of this and of course provision must be made so that the voltage applied does not exceed 120 volts. This may be done either by transformer or dropper resistor. In other cases unless otherwise specified on the diagrams supply voltages of 200-250 volts are quite in order. In conclusion, the publishers wish to express their thanks to:

Sylvania Electric Products Inc., Emporium, Pennsylvania, U.S.A.
 The Westinghouse Co., York Way, London, N.
 Londex Ltd., 207 Anerley Road, London, S.E.20.
 Sangamo Weston Ltd., Enfield, Middlesex.
 B.T.H. Ltd., Rugby, England.

BERNARDS (PUBLISHERS) LTD.

LIST OF ILLUSTRATIONS

	PAGE
Figure 1. External View of Interval Timer.....	1
Figure 2. Timer Circuit	2
Figure 3. Internal View of Timer.....	2
Figure 4. Circuit of Simple DC Polarity Checker.....	3
Figure 5. External View of Polarity Reversal Alarm.....	3
Figure 6. Circuit of Polarity Reversal Alarm.....	4
Figure 7. Inside View of Polarity Reversal Alarm.....	4
Figure 8. Circuit of Relay Inductive-Kick Quencher.....	5
Figure 9. Spark Quencher Circuits.....	6
Figure 10. Replacing Tubes with Crystals (Socket Diagrams).....	7
Figure 11. Charger for Small Dry Batteries.....	8
Figure 12. Low-Current Relay Circuit.....	9
Figure 13. Door-Chime "Pepper" Circuit.....	10
Figure 14. External View of the Photoelectric Relay.....	11
Figure 15. Inside the Photoelectric Relay.....	11
Figure 16. Circuit of the Crystal-Powered Photoelectric Relay.....	11
Figure 17. Germanium Diode as Self-Generating Photocell.....	12
Figure 18. Overall View, Crystal Radio.....	13
Figure 19. Side View of the Crystal Radio.....	13
Figure 20. Circuit of the Crystal Radio.....	13
Figure 21. Overall View of the Electronic Metronome.....	14
Figure 22. Top View of the Metronome.....	14
Figure 23. Circuit of the Metronome.....	15
Figure 24. Under-Chassis View of the Metronome.....	15
Figure 25. Front View of the Radio-Controlled Relay.....	16
Figure 26. Inside View of the Radio-Controlled Relay.....	17
Figure 27. Circuit of the Radio-Controlled Relay.....	17
Figure 28. Circuit for Control of Heavy-Duty Devices with the Radio Relay.....	18
Figure 29. External View of the Wired-Radio-Control Transmitter.....	19
Figure 30. Under-Chassis View of Wired Radio Transmitter.....	19
Figure 31. Wired-Radio-Control Receiver	20
Figure 32. Circuits of the Wired-Radio-Control Equipment.....	21
Figure 33. Radio-Control Receiver for Model Trains.....	22
Figure 34. Details of Radio-Control Unit for Model Trains.....	23
Figure 35. Pocket-Type 60-cycle Stroboscope.....	24
Figure 36. Exploded View of the Stroboscope.....	25
Figure 37. Details of the Stroboscope.....	25
Figure 38. Light-Duty Electroplating Circuit.....	26
Figure 39. Low-Current Power Supplies.....	27
Figure 40. Radio Garage Door Opening Receiver.....	28
Figure 41. AC Ammeter-Wattmeter for Appliance Testing.....	29
Figure 42. DC-to-AC Converter	31
Figure 43. Electronic Door Lock.....	31

SUITABLE BRITISH RELAYS & CRYSTALS

- Figure 2. Relay: ex-Govt. type 3000 (modified).
Crystal: WG5B Westinghouse or CG6M B.T.H.
- Figure 4. Crystal: 80v. WG7A }
100v. WG7C } Westinghouse or CG6M B.T.H.
- Figure 6. Crystal: WB4B Westinghouse or CG6M B.T.H.
- Article 4. Crystal: WG7C Westinghouse.
- Figures 8-9. Crystal: WG7C Westinghouse or CG6M B.T.H.
- Figure 10. Crystal: WG6A Westinghouse or {CG5M } B.T.H.
CG6M }
- Figure 11. Crystal: "B" batteries WG7C }
"A" batteries WG4B } Westinghouse.
100-120v. only.
- Figure 12. Relay: Replace Sigma by Londex SSR or ex-Govt. type
3000 (modified) and mains type for Londex type
ML/AC or LQA.
Crystal: WG5B Westinghouse or CG6M B.T.H.
- Figure 13. Crystal: WG5B (for 24v. supplies use WG7C) Westinghouse
or CG6M B.T.H.
- Figure 16. Relay: Londex SSR or ex-Govt. 3000 (modified).
Crystal: WG5A Westinghouse or CG6M B.T.H.
- Figure 17. Crystal: CG1C } B.T.H.
CG4C }
- Figure 20. Crystal: WG4G Westinghouse or CG5M B.T.H.
- Figure 23. Relay: Londex SSR or ex-Govt. 3000 (modified).
Crystal: WG5B Westinghouse or CG6M B.T.H.
- Figure 27. Relay: Sangamo Weston S124.
Crystal: WG5B Westinghouse or CG5M B.T.H.
- Figure 28. Relay: Londex ML/AC or LQA.
- Figure 32. Relay: Sangamo Weston S115 and Londex ML/AC or
LQA.
Crystal: WG5B Westinghouse or CG6M B.T.H.
- Figure 34. Relay: Londex SSR or ex-Govt. 3000 (modified).
Crystal: WG5B Westinghouse of CG5M B.T.H.
- Figure 37. Crystal: WG7C Westinghouse 100-120v. only.
- Figure 38. Crystal: WG4B Westinghouse or CG6M B.T.H.
- Figure 39. Crystal: A: WG5B Westinghouse.
B: WG7C Westinghouse.
C: —
- Figure 40. Crystal: WG4B Westinghouse or CG5M B.T.H.
- Figure 41. Crystal: WG4B Westinghouse or CG6M B.T.H.
- Figure 42. Crystal: WG4B Westinghouse or CG6M B.T.H.
- Figure 43. Crystal: WG4B Westinghouse or CG5M B.T.H.
Relays: Sangamo Weston S115 and Londex ML.

TABLE OF CONTENTS

	PAGE
1. INTERVAL TIMER.....	1
2. SIMPLE DC POLARITY CHECKER.....	3
3. POLARITY REVERSAL ALARM.....	3
4. ADAPTING DC VOLTMETER FOR AC MEASUREMENTS	5
5. INDUCTIVE-KICK QUENCHER FOR DC RELAYS.....	5
6. SPARK QUENCHERS.....	6
7. REPLACING TUBES WITH GERMANIUM DIODES.....	7
8. CHARGER FOR SMALL DRY BATTERIES.....	8
9. LOW-CURRENT RELAY CIRCUIT.....	9
10. DOOR-CHIME "PEPPER".....	10
11. CRYSTAL-POWERED PHOTOELECTRIC RELAY.....	10
12. USE OF GERMANIUM DIODE AS PHOTOCCELL.....	12
13. SIMPLE CRYSTAL RADIO.....	12
14. ELECTRONIC METRONOME	14
15. RADIO-CONTROLLED RELAY	16
16. WIRED-RADIO-CONTROL RELAY SYSTEM.....	18
17. RADIO CONTROL SYSTEM FOR MODEL TRAINS.....	22
18. POCKET-TYPE 60-CYCLE STROBOSCOPE.....	24
19. LIGHT-DUTY ELECTROPLATER	26
20. LOW-CURRENT CRYSTAL POWER SUPPLIES.....	26
21. RADIO-OPERATED GARAGE DOOR OPENER.....	27
22. AMMETER-WATTMETER FOR ELECTRICAL APPLIANCE TESTING	29
23. DC-AC CONVERTER	30
24. ELECTRONIC DOOR LOCK.....	31
GERMANIUM DIODE INSTALLATION HINTS.....	32

1. INTERVAL TIMER

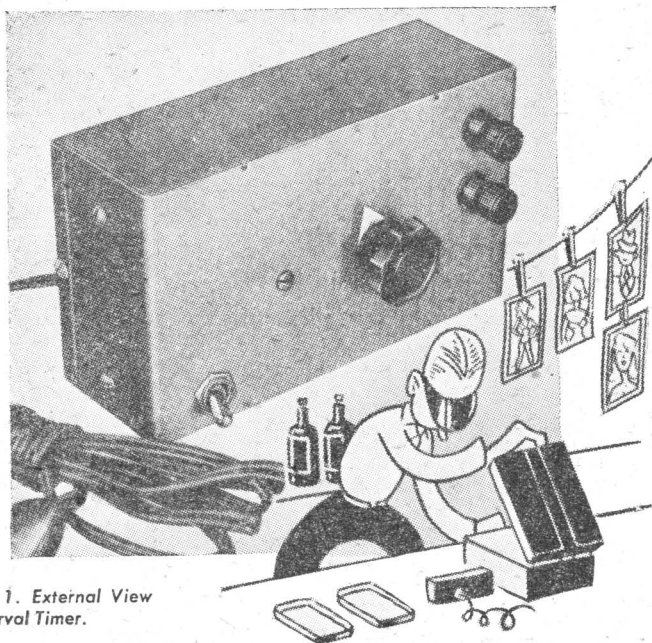

Figure 1. External View of Interval Timer.

FIGURES 1, 2, and 3 show an interval timer which may be used to control directly electrical devices of various kinds. An important application of this device is controlling the lamp in a photographic printing box or enlarger.

In this circuit (See Figure 2), direct current supplied by a 1N56 Germanium Diode energized by the 6.3-volt winding of a small filament transformer is used to charge a 1000-microfarad electrolytic capacitor. The capacitor is charged by throwing the single-pole double-throw spring-return switch, S, momentarily to its left-hand position. When the switch then is released, it returns to its normal right-hand position and the capacitor charge causes a current to flow through the coil of the sensitive relay. The relay accordingly closes and connects the two output terminals of the timer to the 115-volt ac line. The relay will remain closed

until the capacitor has discharged to a value below that required to energize the relay coil fully.

The time interval during which the relay remains closed is governed by the setting of the 50,000-ohm wirewound volume-control-type rheostat. The 50,000-ohm rheostat with the 1000 μ f. capacitor will give time intervals between 1 and 15 seconds. Longer time intervals may be obtained by using a larger capacitor, for example 2000 to 4000 microfarads.

The output terminals are connected directly to a 115-volt device, such as a lamp, which is to be controlled. If the full line voltage is not desired for the timed power, the relay contacts should be connected directly to the two output terminals with no connection back to the power line.

The sensitive dc relay specified in Figure 2 is a Sigma Type 4F. This unit,

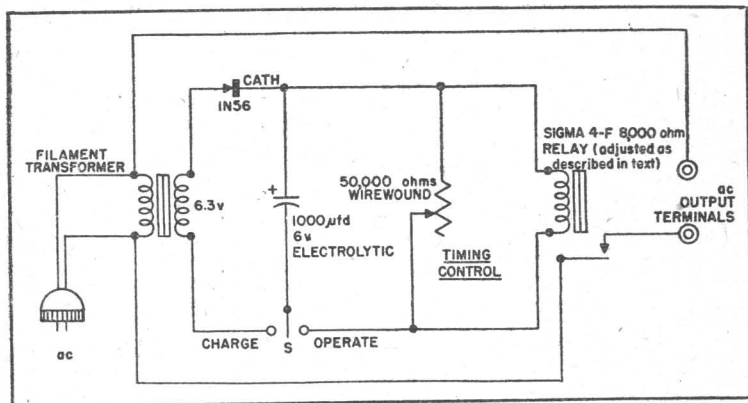

Figure 2. Timer Circuit

which may be obtained from electronic parts distributors and in some cases in the surplus market, has a coil resistance of 8000 ohms and is rated at 2 milliamperes. The reader must perform a simple operation to increase the sensitivity of the relay. This is done by rotating the single pivot-screw of the relay slightly in a clockwise direction. This loosens the armature spring and makes possible operation of the relay at currents as low as $\frac{1}{2}$ milliamperes. The spring tension must not be reduced too much or the relay will be sluggish in dropping out when current is removed.

Switch S should be a spring-return type. The normal resting position of the switch connects the capacitor to the relay circuit, as shown in Figure 2. Some readers will find it more desirable to

use, instead of a switch, a single-pole double-throw pushbutton.

Use of the timer is simple: Throw switch S to its CHARGE position (the switch need not be held in this position longer than 1 or 2 seconds), then allow the switch to return to its OPERATE position. The relay immediately will be picked up and will remain closed for a time interval determined by the setting of the rheostat. The controlled device, connected to the two output terminals of the timer, accordingly will operate during this interval. A scale, reading directly in seconds, may be drawn and installed under the pointer knob of the rheostat. This scale may be calibrated by means of a stop watch or the second hand of an ordinary watch or clock.

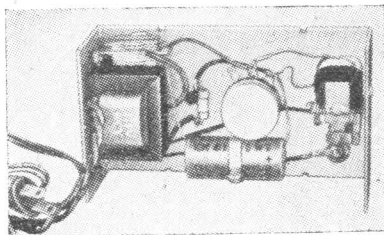

Figure 3.
Internal View of Timer.

2. SIMPLE DC POLARITY CHECKER

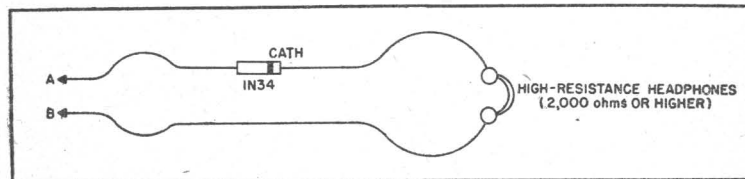

Figure 4. Circuit of Simple DC Polarity Checker.

A CRYSTAL diode and headphones may be used to check dc polarity when no other means is available. The simple arrangement for making this test is shown in Figure 4. Headphones must be the wirewound, not crystal type. The crystal diode must be connected with the polarity shown in the diagram; that is, with the crystal anode terminal "leading." When point A is touched to the positive terminal of the voltage source and point B to the negative terminal, a

loud click will be heard in the headphones. When A is negative and B positive, little or no click at all is heard. This action is due to the fact that the crystal offers high resistance (no click) to one polarity, and low resistance (loud click) to the opposite polarity.

If 2000-ohm (or higher resistance) headphones are used, dc voltages as high as 80 may be checked with a 1N34 without damaging the crystal. The 1N58 will handle 100 volts.

3. POLARITY REVERSAL ALARM

IN many dc applications, such as battery charging circuits, electroplaters, etc. where an output voltmeter either is not used or cannot easily be seen by a distant operator, the correct polarity of the line must be maintained. Trouble is caused by any accidental reversal of polarity, however it may occur. Hence, any reversal must be signalled immediately to the operator.

Figure 6 shows the circuit of a simple polarity reversal alarm. A small, Sylvania S48 2-volt pilot lamp is connected in series with a crystal diode and resistor across the line to be monitored. The cathode terminal of the crystal normally is connected to the positive side of the line. The crystal connected in this manner offers high resistance and the lamp cannot light. If the polarity of the line is reversed, the crystal cathode then is connected to the *negative* side of the line, and the crystal presents a low resistance to the line voltage. The larger current then flowing through the crystal circuit lights the lamp. A visual alarm which may be seen at some distance is provided.

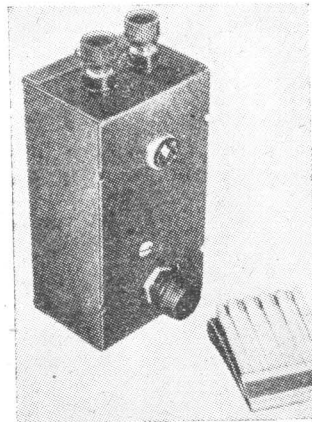

Figure 5. External View
of Polarity Reversal Alarm.

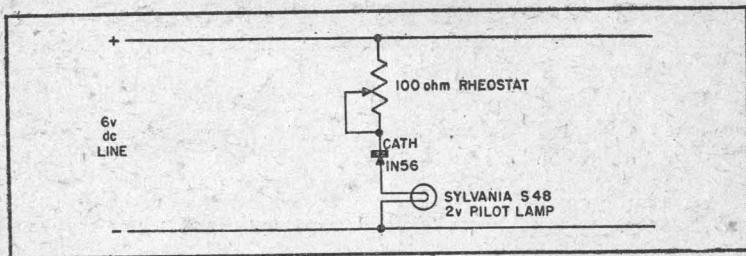

Figure 6. Circuit of Polarity Reversal Alarm.



The circuit as shown in Figure 6 is entirely satisfactory for short-time indications, since the resistor limits the crystal current to 60 milliamperes. If there is likelihood that the lamp might burn for some time before attracting the operator's attention, two crystal diodes should be connected in parallel to handle the current. If line voltages higher than 6 volts are employed, the resistance of the rheostat must be increased to a value which will limit current through the crystal and lamp to 60 milliamperes. The exact value of this resistance will have to be determined experimentally for the particular line voltage used.

To set the circuit of Figure 6 initially, make the upper side of the line negative and adjust the rheostat until the lamp burns. A dc milliammeter may be connected temporarily in series with the crystal and lamp to check the current. In normal operation, keep the upper side of the line positive.

External and internal views of the polarity reversal alarm are shown by

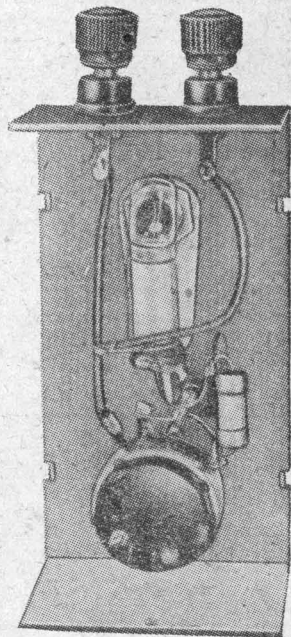

Figure 7. Inside View of Polarity Reversal Alarm.

Figures 5 and 7, respectively. As shown in these photographs, the instrument is built in a 4" x 2" x 1½" radio utility box which may be hung or mounted near the line to be monitored.

4. ADAPTING DC VOLTMETER FOR AC MEASUREMENTS

A dc voltmeter having a resistance of at least 1000 ohms per volt may be converted for emergency measurements of ac voltage by connecting a crystal diode temporarily in series with one of the indicating meter terminals at the meter. Connect the cathode terminal of the crystal to the positive terminal of the meter. A 1N34 will be satisfactory for short tests at all voltages. However, when long, continuous tests are to be made at

voltages of 100 and higher, Types 1N38, 1N39, 1N55, and 1N58 provide additional crystal safety.

The meter will not be highly accurate, especially on ranges up to 10 volts, unless a special calibration is made. For emergency use, however, when comparative values will suffice, the ac voltage may be read on the regular dc scales of the meter.

5. INDUCTIVE-KICK QUENCHER FOR DC RELAYS

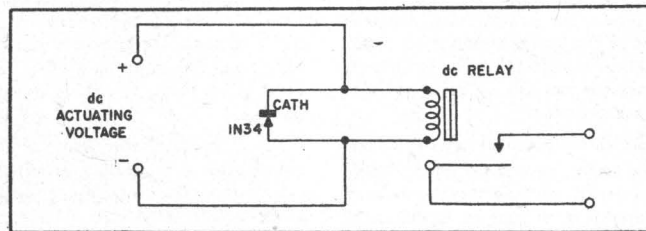

Figure 8. Circuit of Relay Inductive-Kick Quencher.

THE field coil of a small dc relay generates considerable inductive kick, by counter emf action, when the operating voltage is switched on and off. This kick produces sparking and pitting of the contacts of the actuating switch (or auxiliary relay) and can set up radio and television interference.

The inductive kick can be quenched effectively by means of a Germanium Diode connected in parallel with the relay coil, as shown in Figure 8. Note that the crystal cathode is connected to the positive terminal of the coil. Connected in this manner, the crystal appears as a

high resistance to the operating voltage and draws only a tiny current. However, the objectionable back-voltage produced by the coil is of the opposite polarity, and to this voltage the crystal is a virtual short circuit. The crystal draws a heavy current while the back-voltage is present and absorbs the effect of this voltage.

A Type 1N34 Germanium Diode will be satisfactory in most applications of this type. In obstinate cases, the 1N56 will prove superior because of its higher conductivity. Two or more diodes connected in parallel also will increase the quenching action.

6. SPARK QUENCHERS

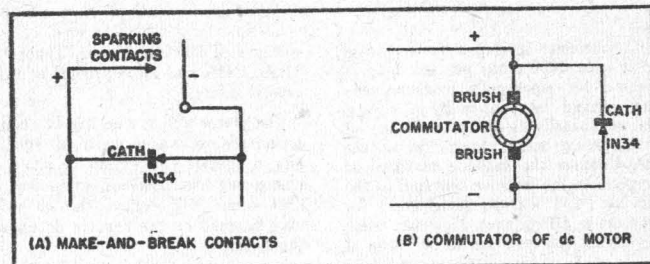

Figure 9. Spark Quencher Circuits.

FIGURE 9 shows how crystal diodes may be connected across sparking contacts and across the brushes of a small dc motor to suppress sparking. Such sparking leads to damage of the contacts or commutator and sets up radio and television interference.

Note that the crystal cathode is connected to the *positive* contact or brush. When connected in this manner, the crystal appears as a high resistance to the dc supply voltage and therefore draws only a few microamperes of current from the source. The sparking, however, is produced by a back-voltage which has a polarity opposite to that of the supply voltage. The positive of the back-voltage is applied to the crystal anode. To this polarity, the crystal appears as a low resistance, very nearly a short circuit, which nullifies effects of the back-voltage. This accounts for the suppression of sparking.

In obstinate cases, use the 1N56 crystal diode which offers lower resistance than the 1N34 to the back-voltage. In

some applications, it may be necessary to connect two or more crystal diodes in parallel to handle the current. A good test is to check the heating of the diode after 5 minutes of operation. If a single diode is hot to the touch, use several in parallel.

For the most effective action in eliminating radio and television interference, mount the crystals as close as possible to the contacts or brushes.

The scheme shown in Figure 9(A) is especially effective for thermostats, dc switches, and low-voltage contactors. The circuit of Figure 9(B) is intended for small battery-operated motors, such as those employed in models, gaming machines, and similar devices. This method of spark quenching often is superior to the better-known use of capacitors in parallel with firing contacts. But it is not applicable to auto radio vibrators or electric razors where the back-voltage may run into a thousand volts or higher. The maximum reverse voltage peak which a 1N34 can tolerate is 75 volts; and for a 1N56 is 50 volts.

7. REPLACING TUBES WITH GERMANIUM DIODES

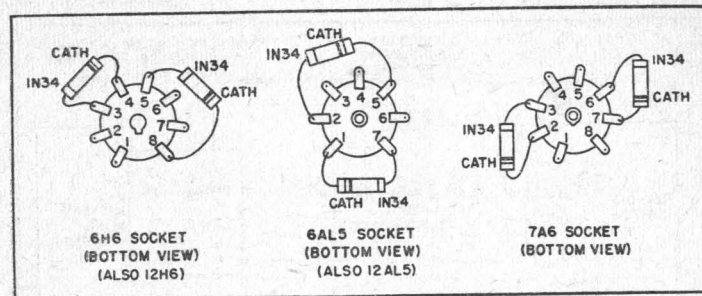

Figure 10. Replacing Tubes with Crystals (Socket Diagrams).

GERMANIUM Diodes may be used as diode and duo-diode detectors in original installations or as replacement of diode and duo-diode type vacuum tubes in home-made radio receivers, AM and FM tuners, and TV sets. This change is often desirable since the Germanium Diode has no filament and, therefore, requires no heating current. The Germanium Diode will also eliminate any hum produced by the tube it replaces, will generate no heat, and, in many instances, will afford better reception. Tubes which may be replaced successfully are types 6AL5, 6H6, 6H6G, 7A6, 12AL5, and 12H6.

The substitution of Germanium Diodes for a tube involves only a simple soldering operation in many cases. There are instances, however, where a circuit change may be necessary to obtain the best performance from the diode. In the

event that the substituted Germanium Diode results in a markedly lower signal level, the value of load resistor or resistors should be checked. Germanium Diodes work most efficiently into loads of 50,000 to 100,000 ohms rather than the 250,000 ohms or so commonly used with vacuum tube diodes.

Two Germanium Diodes will be needed for each tube replacement. Simply turn the receiver-chassis upside down, remove the diode-type tube from its socket, and solder the pigtail leads of the 1N34's to the proper socket contact lugs, as shown in Figure 10. Do not disturb any of the wiring to the socket. It will not be necessary to disconnect the filament wires from the socket, since no current is drawn through these leads when the tube is removed from the socket.

In ac-dc sets and others in which the tube filaments are connected in series, a special wirewound resistor must be connected between the filament lugs of the socket when the tube is replaced with crystals. The following table shows the correct value of resistor to use, and the socket terminals between which it must be connected.

TUBE REPLACED	WIRED WOUND SUBSTITUTION RESISTOR	SOCKET TERMINALS FOR RESISTOR CONNECTION
6AL5	21 ohms, 5 watts	3 and 4
6H6, 6H6G	21 ohms, 5 watts	2 and 7
7A6	42 ohms, 2 watts	1 and 8
12AL5	84 ohms, 2 watts	3 and 4
12H6	84 ohms, 2 watts	2 and 7



8. CHARGER FOR SMALL DRY BATTERIES

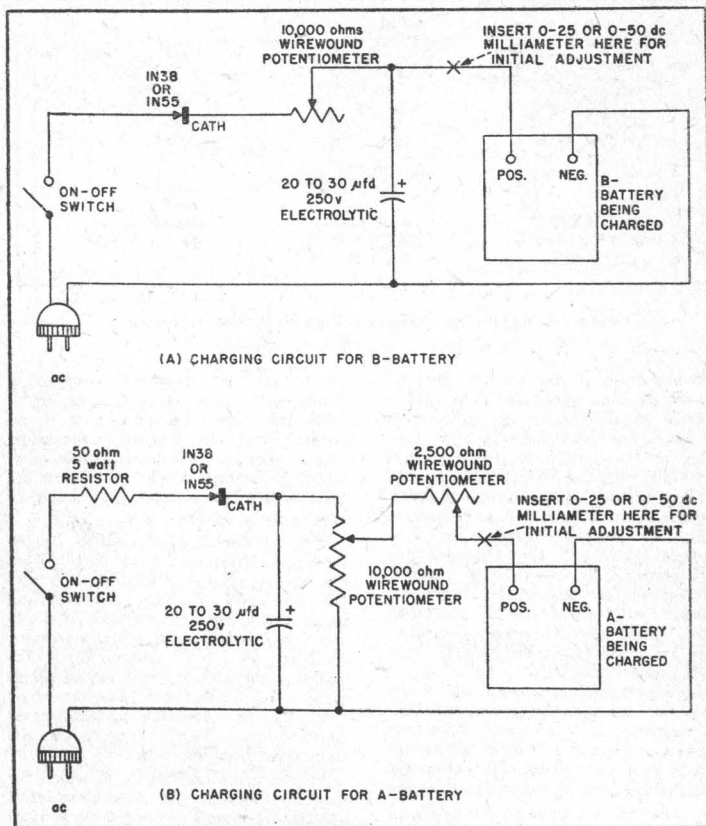

Figure 11. Charger for Small Dry Batteries.

SMALL dry "A" and "B" batteries, such as those used in hearing aids and portable radios, which have lost their pep can be rejuvenated sufficiently for at least one more service period by passing a small direct current through them.

A very compact charger can be made to operate from the ac power line by using a 1N38 or 1N55 crystal diode to convert the ac to dc. Figure 11 shows circuits for rejuvenating "A" and "B"

batteries. A combination of the two circuits might be employed to charge both batteries simultaneously. $1\frac{1}{2}$ volt "A" batteries, and "B" batteries from $22\frac{1}{2}$ to $67\frac{1}{2}$ volts can be accommodated with the circuits shown.

To adjust the circuit initially, insert temporarily a 0-25 or 0-50 dc milliammeter at the point marked "X" in the circuit diagram, and adjust the potentiometer for a current of 5 to 10 milliam-

peres through the battery. In the "A" battery charging circuit, both potentiometers must be adjusted.

The amount of time required to rejuvenate the battery will depend upon how much energy the battery has lost. Do not attempt to charge a battery which

is completely burnt out, or one which is leaking chemical. Some small batteries which are just under par can be rejuvenated within a few minutes. Others require an overnight charge. Discontinue the charging process when the battery becomes warm to the touch.

9. LOW-CURRENT RELAY CIRCUIT

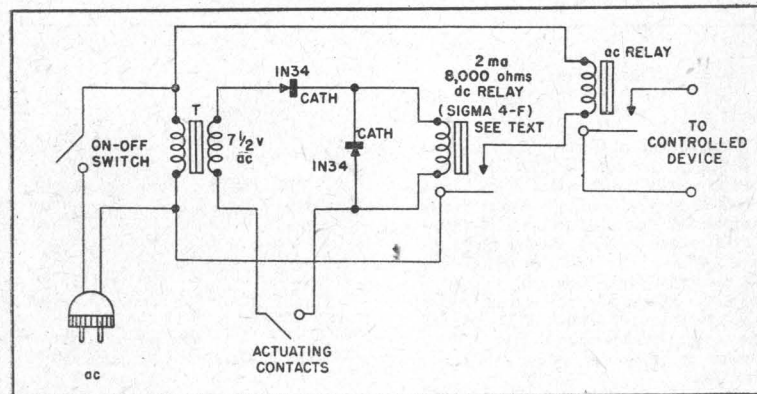

Figure 12. Low-Current Relay Circuit.

THE circuit shown in Figure 12 will be useful in applications where a pair of make-and-break contacts can carry only a tiny amount of current, must not spark, and yet must switch on and off a high-current device such as a motor. An important requirement for contacts of this type is in explosive atmospheres where sparking would be a hazard. Another application is the case of featherweight contacts which must be closed with tiny amounts of force.

The sensitive relay in this circuit is a Sigma Type 4F, rated at 2 milliamperes dc, which is available from electronic parts distributors or the surplus market. This relay must be adjusted to close on approximately $\frac{1}{2}$ milliamperes by turning its single pivot-screw slightly in a clock-

wise direction to loosen the armature spring.

One 1N34 Germanium Diode rectifies ac supplied by the $7\frac{1}{2}$ -volt secondary winding of a filament transformer, "T." The dc supplied by this crystal operates the relay when the light-duty actuating contacts are closed. The second 1N34 is connected in parallel with the relay coil "backward" with respect to the applied dc. This crystal absorbs the back voltage generated by the relay coil when the actuating contacts are opened.

The sensitive relay operates a heavier-duty 115-volt ac relay which in turn operates the controlled device. The relay equipment may be located at some distance from the actuating contacts.

10. DOOR-CHIME "PEPPER"

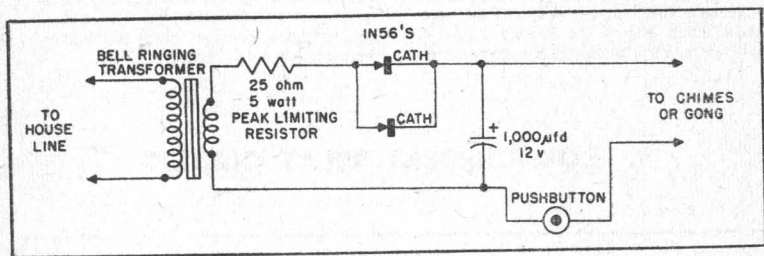
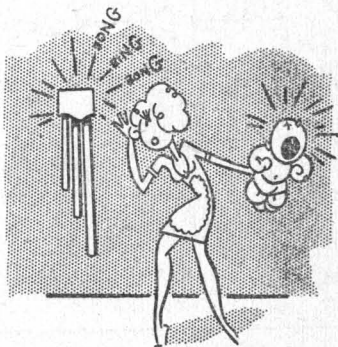

Figure 13. Door-Chime "Pepper" Circuit

THE circuit of Figure 13 is used to "pep up" door chimes or single-stroke signal gongs which have grown weak in service. The two crystal diodes in parallel supply dc to the 1000-microfarad capacitor which charges up to the peak value of the unloaded transformer secondary voltage. This full voltage is applied momentarily to the chime when the pushbutton is depressed. The capacitor charges quickly when the button is released or when the chime mechanism releases.

This circuit is intended only for solenoid type alarms which do not have a motor-driven or buzzing mechanism. The chime or gong must be capable of operating from a single pulse of applied voltage. The scheme is not recommended for use with vibrating type doorbells.

Transformers of the 12 or 16 volt type require one crystal or two in parallel as shown for quick condenser recovery after



the pushbutton is released. Transformers of 24 volts or more require two crystals in series or four in series-parallel for rapid operation. The crystals, being small in size, may be installed within the chime housing, or may be located close to the transformer.

11. CRYSTAL-POWERED PHOTOELECTRIC RELAY

THE self-generating selenium photocell is especially attractive to electrical experimenters and builders of electronic equipment, since it is rugged, has long life, and requires no tubes for its operation. However, the low dc output of this type of electric eye formerly has made necessary the use of expensive high-sensitivity microampere-type relays in order to secure photoelectric control of devices.

If a small dc bias is applied to this type of cell, the photoconductive property of the selenium may be used, and the cell will operate a more rugged, less expensive relay. Since the current drain is low, the dc bias may be supplied by a Germanium Diode rectifier operated from the 6.3-volt winding of a small filament transformer.

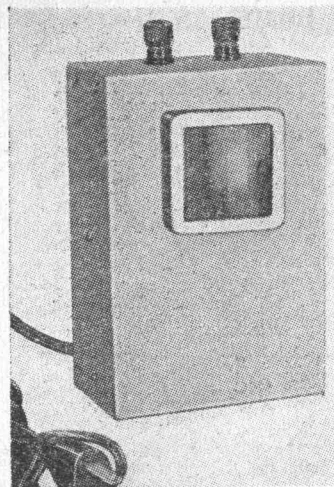

Figure 14. External View of the Photoelectric Relay.

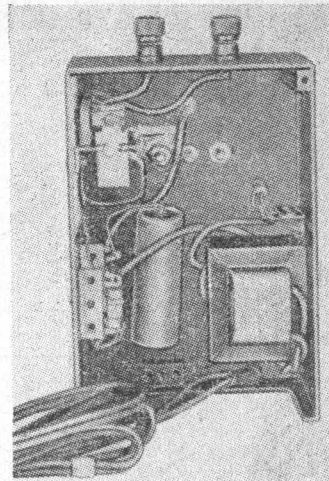

Figure 15. Inside the Photoelectric Relay.

Figure 16 shows the circuit of a crystal-powered photocell relay utilizing this operating principle. The dc relay is a 2-milliampere Sigma Type 4F. The reader must adjust the relay (in the manner described in Article 9) so that it will operate on approximately 1/2 milliamperes.

The photographs, Figures 14 and 15, show how the electric eye unit is built. A small aluminum box is used to house

the unit shown here, but the reader may use any other type of enclosure desired.

This photoelectric relay is adaptable to a variety of applications: such as intrusion alarms, object counters, light-operated switches, headlight-operated garage-door opener, interrupted light-beam door opener, machine safety control, etc. Its action is reliable and positive. Not having high-gain amplifier tubes in the circuit, the device is free from false operation due to extraneous signals.

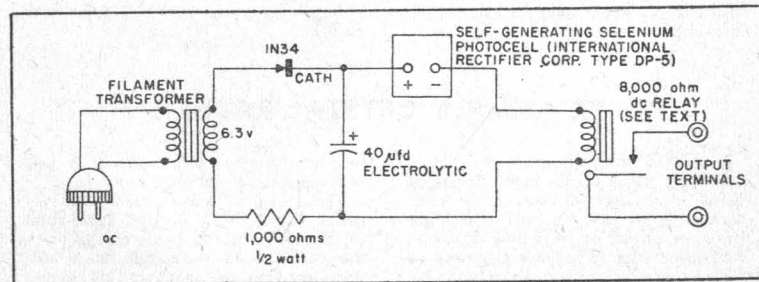

Figure 16. Circuit of the Crystal-Powered Photoelectric Relay.

12. USE OF GERMANIUM DIODE AS PHOTOCELL

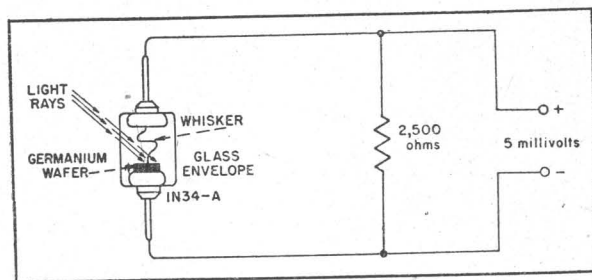

Figure 17 Germanium Diode as Self-Generating Photocell

THE new sealed-in-glass IN34A Germanium Diode may be employed as a self-generating photocell by illuminating the germanium wafer, through the glass envelope, at the point where the whisker makes contact. Due to the low sensitivity of this device when used as a photocell, an intense artificial light source, or direct sunlight, must be employed unless a suitable high-gain amplifier is also used.

Figure 17 shows the scheme. The light rays must be directed through the glass envelope in such a manner as to illuminate the face of the germanium wafer. A 2500-ohm $\frac{1}{2}$ watt carbon resistor is employed as the load resistance. The output voltage is positive at the whisker terminal and negative at the germanium terminal. Any external device connected to the output terminals, to utilize the light-generated voltage, must have high resistance (preferably several times the value of the 2500-ohm load resistance).

The diode delivers approximately 5 millivolts dc across the 2500-ohm load resistor when illuminated by a 200-watt incandescent lamp placed nearby. This voltage may be applied directly to the grid of the input tube in a high-gain photoelectric amplifier. A 2000-ohm Weston Model 705 sensitive meter-type dc relay (selected to operate at any value between 1 and 5 millivolts) can be operated directly by the IN34A when this relay is substituted for the resistor shown in Figure 17.

Although the sealed-in-glass type Germanium Diode is relatively insensitive when compared with conventional self-generating photocells, it will be of interest where high light intensities are available (as through concentration of a light beam through lens systems) and where its very small size offers appeal. Voltage output will vary with individual diodes.

13. SIMPLE CRYSTAL RADIO

A CRYSTAL set is the simplest radio receiver which can be built. Having no tubes, it requires no batteries or other form of local power supply, and it delivers speech and music reproduction with amazing clarity. When operated with an outside antenna and a good ground connection, the crystal radio will give reliable headphone operation on all local

broadcast stations and occasionally will pick up a distant station, as well.

Figures 18, 19, and 20 show constructional details of a simple, small-sized crystal radio in which all of the parts are mounted on the frame of a 365-microfarad tuning capacitor. This simple, space-saving assembly can be mounted inside a small box (approximately 4" x

4" x 4" in size) and a tuning dial attached to the protruding shaft of the tuning capacitor. The simple circuit schematic is given in Figure 20.

The IN34 crystal diode is mounted in small fuse clips which in turn are attached to a 1-inch-square Lucite plate bolted to the tuning capacitor frame (See Figure 18). The pigtail leads are cut from the IN34, since they are not needed in the fuse-clip type mounting. The coil is a manufactured "antenna coil"—Millen Type 20-A—which comes equipped with a slip-over primary winding. The two upper wire leads seen in the photographs are connected to antenna and ground; the two lower ones to the

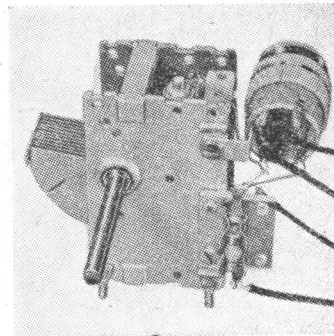

Figure 18. Overall View, Crystal Radio.

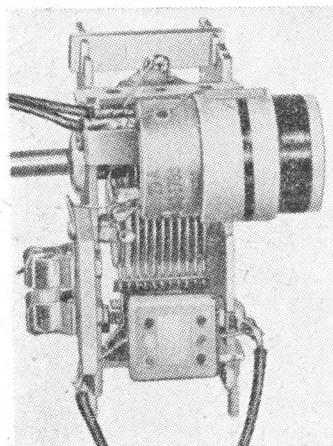

Figure 19. Side View of the Crystal Radio.

headphones. The mica bypass capacitor is mounted, by means of its pigtail leads, between the tuning capacitor frame and the cathode lug of the crystal holder. This method of mounting may be seen in Figure 19.

This miniature crystal set covers the entire standard broadcast band. Headphones connected to it should have a resistance rating of at least 2000 ohms. Do not use crystal type headphones. When loudspeaker operation is desired, the output leads may be connected directly to an audio amplifier with a 500,000-ohm $\frac{1}{2}$ -watt carbon resistor connected between the latter's input terminals.

The miniature crystal radio described in this article is the basis of the radio-operated alarm described in Article 15.

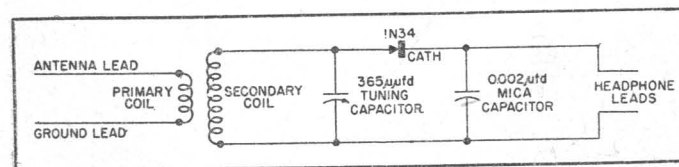

Figure 20. Circuit of the Crystal Radio.

14. ELECTRONIC METRONOME

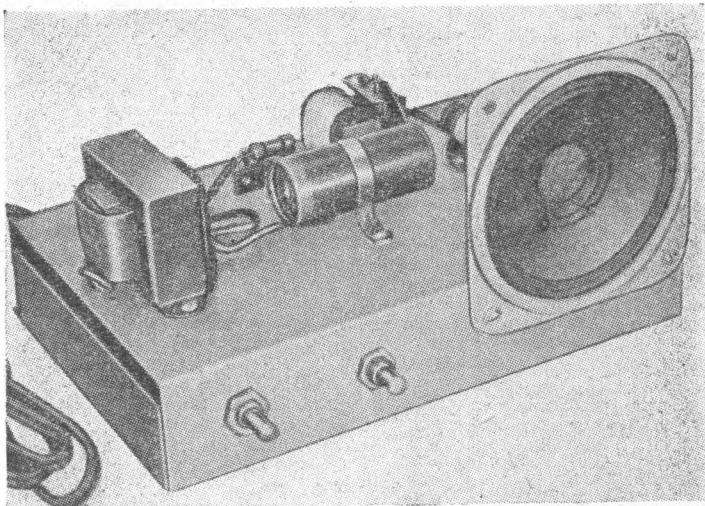

Figure 21. Overall View of the Electronic Metronome.

FIGURES 22, 23, and 24 show an electronic metronome which can be set to give beats or clicks at any rate between several beats per second to 1 in several minutes. This device can be used to replace the old clockwork-type metronome and is handy for setting rhythm in music and dancing practice and in timing operations of many sorts. In the photographs, the metronome chassis is shown removed from the small table-radio-type wooden cabinet in which it is housed.

The circuit schematic of the metronome is shown in Figure 23. The low current required for operation of the unit is supplied by a 1N34 Germanium Diode powered by the 6.3-volt secondary winding of a small filament transformer. The "beating" mechanism is a sensitive dc relay. This is an inexpensive Sigma 4-F 8000-ohm unit which must be adjusted by the reader, as described in Article 9, to operate on $\frac{1}{2}$ milliamperes. Beats are delivered by a $3\frac{1}{2}$ inch-diameter PM dynamic speaker. There are only two adjustable components—the *timing*

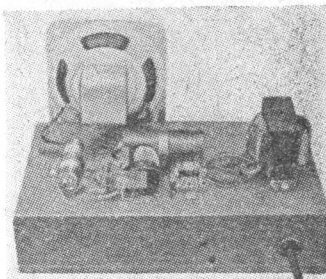

Figure 22. Top View of the Metronome.

control (a 5000-ohm wirewound rheostat) whose setting determines the beat speed, and the *volume control* (a 10,000-ohm wirewound rheostat). The ON-OFF switch is mounted on, and controlled by the timing-control rheostat.

The circuit operates in the following manner: When the relay is in its "resting" position, its armature rests against the lower contact (See Figure 23). The circuit from the crystal power supply to the relay circuit is completed through

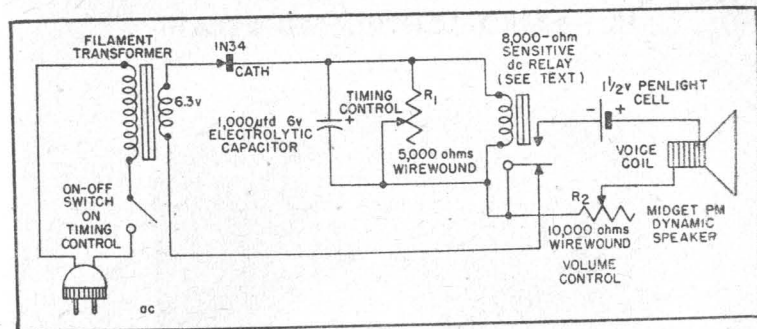

Figure 23. Circuit of the Metronome.

this lower contact. The 1000-microfarad electrolytic capacitor is charged by rectified current flowing from the 1N34 crystal diode. When the capacitor becomes charged, its voltage is applied to the relay coil and the relay accordingly picks up its armature. The armature then makes contact with the upper contact of the relay, closing the circuit from the $1\frac{1}{2}$ -volt cell through the volume control and the voice coil of the speaker. A pop or click is delivered by the speaker each time the relay is picked up. The relay will remain closed until the capacitor charge is dissipated entirely in the relay coil. When the capacitor becomes discharged, there will be no more current in the relay coil and the armature will drop, again making contact with the bottom contact of the relay. The capaci-

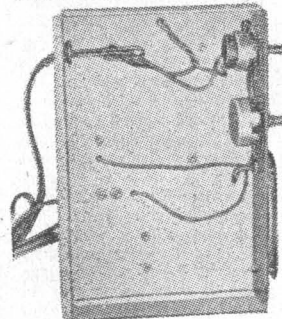

Figure 24. Under-Chassis View of the Metronome.



tor then will recharge and the cycle of events will be repeated.

The length of time taken for the capacitor to charge and discharge (and therefore the number of beats obtained in a given time interval) depends upon the setting of the time-control rheostat connected in parallel with the relay coil.

The 10,000-ohm rheostat gives good control of the volume. At maximum volume, the small speaker will deliver a loud "pop" which competes effectively with piano music.

15. RADIO-CONTROLLED RELAY

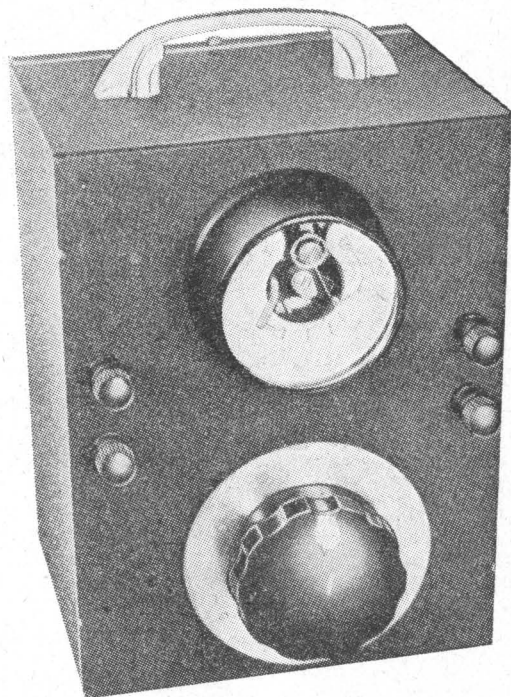

Figure 25. Front View of the Radio-Controlled Relay.

FIGURE 27 gives the circuit schematic of a simple radio-controlled relay designed to operate from the carrier wave of any local broadcast station between 500 and 1600 kc. The receiver used in this device is the simple crystal set described in Article 13. However operation is not restricted to the broadcast band. The reader may wind a coil for any other station frequency according to directions given in the amateur radio handbooks.

This relay device, when connected to an outside antenna and a good ground, and tuned to the desired station frequency, closes a local circuit when the station transmitter is switched-on. There is a number of uses to which such a gad-

get can be put. For example, an *electronic alarm clock* can be devised by having the relay operate a buzzer or bell when a dependable early-morning station goes on the air. Also, the device may be used to turn-on a radio receiver at the time that a desired station starts broadcasting. A particular feature of the crystal-type radio-controlled relay is its ability to operate and standby without any power consumption from local sources. There are no tubes to deteriorate from constant operation during idle periods.

The sensitive dc relay operated by the crystal detector in this device is a Weston Sensitrol meter-type unit for 50 micro-ampere operation. The contacts of this



relay can be moved closer together to obtain operation, when desired, on currents as low as 15 microamperes. This relay is presently obtainable in the surplus market. After the Sensitrol relay once has operated, it will remain closed until its magnetic contacts are separated by turning the re-set knob at the rear of the instrument case. (One type of Sensitrol relay may be obtained with the re-set shaft extending more conveniently through the front glass). If the reader prefers that the relay contacts release automatically when the controlling radio carrier is interrupted, a Weston Model 813 non-magnetic relay may be used.

Figures 25 and 26 show constructional details of the radio-controlled relay unit. In Figure 25, the antenna and ground binding post terminals are on the left-hand side of the front panel, and the output binding posts on the right. A 3-inch dial allows station settings to be logged. In Figure 26, the crystal tuning unit (also described in Article 13) is seen bolted directly to the bottom of the

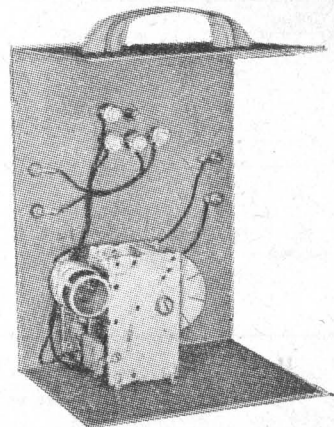

Figure 26. Inside View of the Radio-Controlled Relay.

metal case by means of the mounting screws of the tuning capacitor.

The Sensitrol relay will operate directly any device which does not require more than 5 watts at 120 volts. For control of heavier-duty devices, the radio-controlled relay must operate a second relay with heavier contacts which, in turn, controls the heavy-duty device. Figure 28 shows how a 115-volt ac relay may be operated as the auxiliary unit. The coil of the latter relay must not require more than 50 milliamperes. This second relay may be mounted inside the cabinet of the radio-controlled unit. If the Model 813 non-magnetic relay is employed in

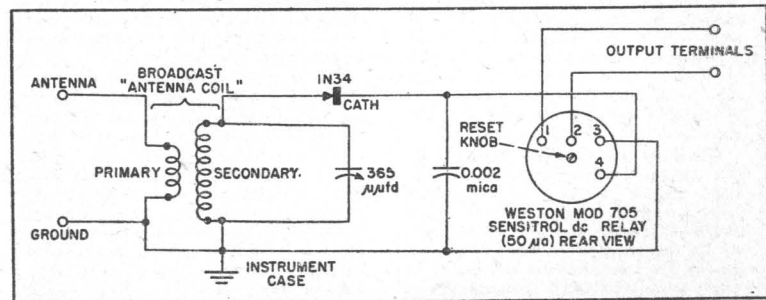

Figure 27. Circuit of the Radio-Controlled Relay

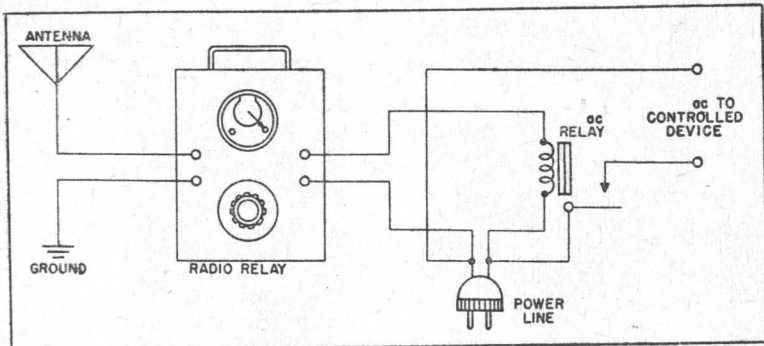

Figure 28. Circuit for Control of Heavy-Duty Devices with the Radio Relay.

the radio-controlled circuit, the auxiliary relay must not draw more than 30 milliamperes at 6 volts, and should be a dc type (not connected to the power line as shown in Figure 28), since this is the maximum current which can be handled

by the contacts of the Model 813. The auxiliary relay then may be a Weston Model 712 (6 vdc) or any similar type with a 30-ma. coil and heavy-duty contacts.

16. WIRED-RADIO-CONTROL RELAY SYSTEM

OFTEN, it is desirable to switch-on an electrical device located in the same building but at some distance from the control point, without running special wires for the purpose. Use of an "on-the-air" radio system is ruled out because in most cases the transmitter power must be so high that a radio station license and operator license will be required.

Wired radio is entirely satisfactory for this purpose. In this system, the controlling system is generated by a miniature, low-powered, low-frequency transmitter and is piped over the regular power line. At the remote point, a simple, low-frequency receiver picks up the signal by direct connection to the power line and uses it to operate a relay. By using a

crystal detector in the receiver, tubes are eliminated and no power is taken by the receiver. This results in maximum economy of operation both during operation and during standby periods.

The components of a simple, effective wired-radio-control system are shown in the accompanying illustrations. Figures 29 and 30 show the tiny transmitter, Figure 31 the receiver relay unit, and Figure 32 the circuit schematics of the two units. No antennas nor interconnecting wires are needed. The receiver is plugged into the power line at one location, and the transmitter at another. When the control switch in the transmitter is closed, the receiver relays also close. When operation is desired at different locations, it

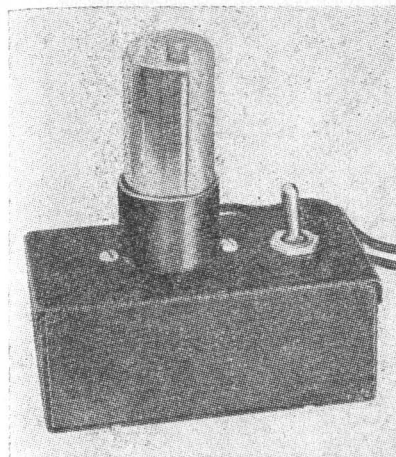
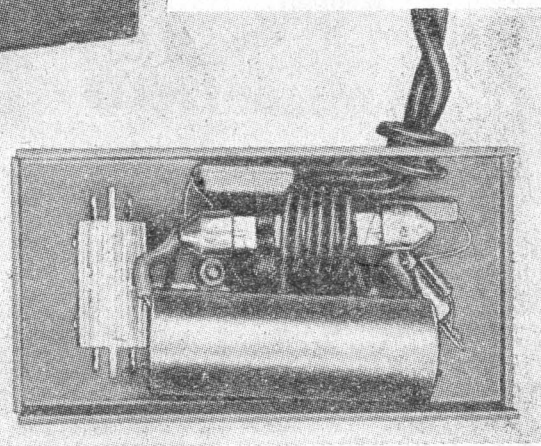

Figure 29. External View of the Wired-Radio-Control Transmitter.

Figure 30. Under-Chassis View of Wired Radio Transmitter.



is necessary merely to plug in transmitter and receiver at the desired points. Both transmitter and receiver operate on a frequency of approximately 100 kc. The radio signal is confined very well to the power line with the result that only a negligible amount of radio interference can be created.

The transmitter (See Figure 32-B) employs a 117-volt tube in a series-type Hartley oscillator circuit. The high-voltage-heater tube eliminates a number of circuit components and keeps the transmitter small in size. The oscillator coil, L_2 , is a $2\frac{1}{2}$ millihenry, a 4-pi-type radio-frequency choke. The reader must make a tap between the 1st and the 2nd pi's

from the lower end of the choke by carefully scraping the insulation from the wire connecting these two pi's and soldering a thin wire lead to the scraped portion. The pickup coil, L_1 , is made by winding 6 turns of No. 18 insulated solid hookup wire tightly around the outside of the rf choke. This pickup coil is seen plainly in Figure 30. If desired, a single-pole, single-throw pushbutton may be substituted for the single-pole control switch shown in Figure 32(B). Energy is coupled out of the transmitter and sent through the power line by means of the pickup coil, L_1 . The bottom end of this coil is connected directly to one side of the power line, the top end is capaci-

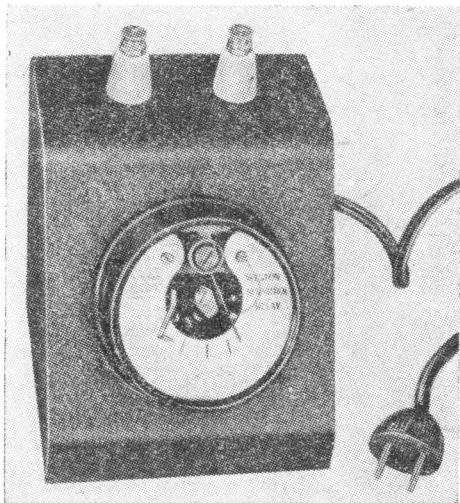

Figure 31 Wired-Radio-Control Receiver.

tance-coupled to the other side of the line through the 0.1-microfarad capacitor which prevents the pickup coil from short-circuiting the line. The transmitter is built in a small, metal radio utility box 4" long, 1½" wide, and 1½" high. Figures 29 and 30 show constructional details.

The control signal from the transmitter is picked up from the power line by the receiver. One side of the receiver circuit is connected directly to the power line; the other side is capacitance-coupled to the other side of the line through a 0.006-microfarad capacitor (See Figure 32-A) which prevents the receiver from short-circuiting the line. The receiver tuning coil, like the transmitter coil, is a 2½ millihenry, 4-pi-type rf choke. The 1N56 high-conduction crystal diode supplies high dc output for all normal strengths of control signal.

The dc output of the 1N56 is applied to a Weston Model 705 Sensitrol relay operated at 50 microamperes dc. This relay is presently available in surplus stocks. Since the contacts of the Sensitrol relay will handle only 50 ma. at 120 v, an auxiliary 115-volt ac relay (with 50-

ma. coil) having heavy-duty contacts is provided to switch power to the controlled device.

The Sensitrol relay contacts are magnetic and remain closed, once the relay has operated, until they are reopened by turning a re-set knob at the rear of the case. The Sensitrol relay may be obtained also with the re-set shaft extending through the front glass of the instrument). This feature may be objectionable, especially in applications requiring that the relay release automatically when the control signal is switched-off. For automatic release, a non-magnetic meter-type relay, such as the Weston Model 813, is recommended. However, the contacts of the Model 813 can handle only 30 milliamperes at 6 volts dc. For this reason, the auxiliary relay cannot be the 115-volt ac type shown in Figure 32(A), but must be one with a 6-volt dc coil (e.g., Weston Model 712). The contacts of the latter can, of course, switch the 115-volt power as shown in Figure 32(A). The 6-volt dc power for the auxiliary relay may be obtained with a 6.3-volt filament transformer and 1N56 crystal diode.

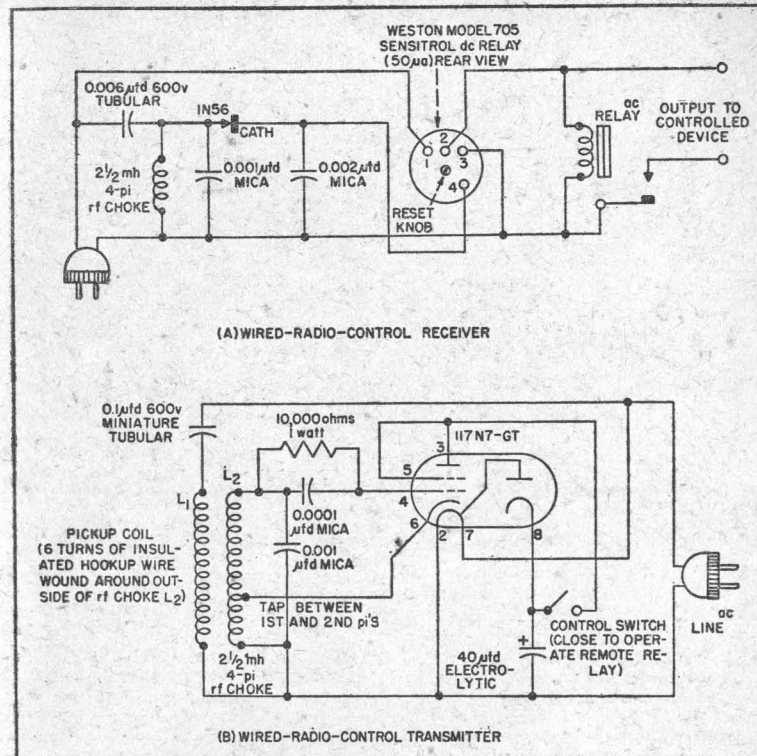

Figure 32. Circuits of the Wired-Radio-Control Equipment.

The entire receiver is built into a sloping-front metal meter case of the so-called "3-inch" size. Figure 31 shows the completed receiver.

Some of the possible applications of the wired-radio-control relay are (1) switching-on of remotely-located motors, fans, circuit breakers, door locks, and

similar equipment, (2) operation of door- or window-operated burglar alarms in installations such as separated buildings where the running of interconnecting wires is undesirable; (3) switching-on of remote radio receivers or transmitters; (4) operating remote lights; (5) operating remote garage door openers; etc.

parts are mounted on a $3\frac{1}{2}$ " x 2" plate of $\frac{3}{16}$ "-thick polystyrene or other insulating material, as shown in Figure 33. If more compact construction is desired, the parts can be grouped more closely around the relay.

This radio relay system operates at approximately 100 kc and creates only negligible interference with a radio in the same room. The signal strength is adequate for positive control even when the tracks are shunted by the locomotive motor and headlight lamp. The receiver relay operates whenever the transmitter control switch is closed, and releases when the switch is opened.

Several separate receivers may be employed to perform various operations, provided each is tuned to a separate frequency and the transmitter likewise is made tunable to each of these frequencies. Tuning in the transmitter may be accomplished by switching-in a separate mica capacitor for each new frequency in place of the 0.001-microfarad unit shown in parallel with the rf choke. Each separate receiver then must have the same value of capacitance connected across its choke coil. The receivers will operate separately, provided the control frequencies are spaced as far apart as practicable.

18. POCKET-TYPE 60-CYCLE STROBOSCOPE

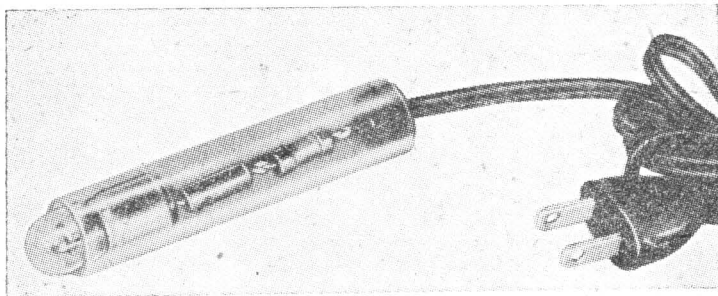

Figure 35. Pocket-Type 60-cycle Stroboscope.

FIGURES 35, 36, and 37 show details of a simple 60-cycle stroboscope which is small enough to be carried in the pocket. This little instrument produces a surprising amount of light, even in a lighted room, and can be held like a pencil between the fingers while directing its flashes on a near-by moving object.

A Model NE-48 $\frac{1}{4}$ -watt neon lamp is used as the flasher. The crystal diode rectifies the line voltage and causes the lamp to flash on and off once during each cycle. The flashes may be used to examine objects which are rotating or

vibrating at the rate of 60 times per second or some exact multiple of this rate. For example, a shaft turning at the rate of 3600 revolutions per minute will appear to stand still when illuminated by flashes from the pocket stroboscope. One important application of this simple stroboscope is examination of watch movements and electric clock motors.

Figure 37 shows the circuit and constructional details of the stroboscope. A 1N55 crystal diode is used in this application, since the high reverse voltage rating of the 1N55 enables it to with-

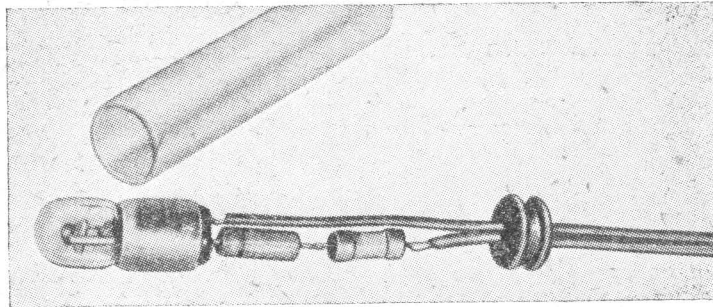

Figure 36. Exploded View of the Stroboscope.

stand safely the peak inverse voltage of the power line. The neon lamp, 1N55 diode, and 30,000 ohm resistor are wired in series with the power cord, and the entire assembly is slipped into a $3\frac{1}{2}$ "-long polystyrene tube. This tube has an outside diameter of $\frac{3}{4}$ inch and inside diameter of $\frac{5}{8}$ inch. It is obtainable in

various lengths, as coil form tubing, at radio supply stores. The neon lamp fits into one end of the tube snugly after the bayonet tips of the lamp base are filed down. The other end of the tube is closed by a standard rubber grommet through which the power cord passes.

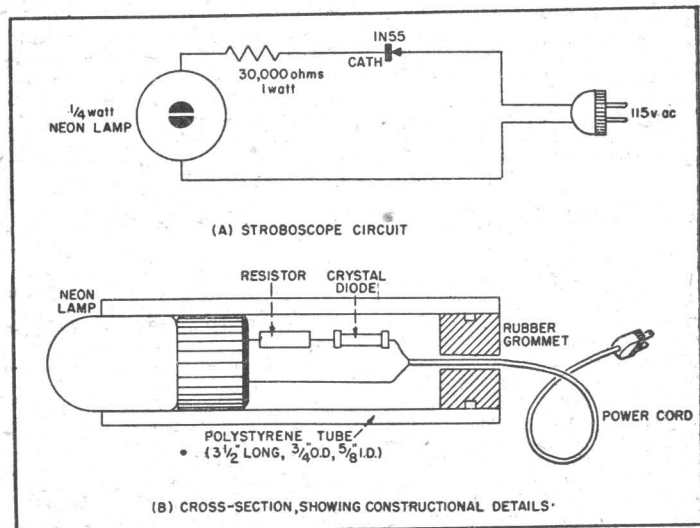

Figure 37. Details of the Stroboscope.

19. LIGHT-DUTY ELECTROPLATER

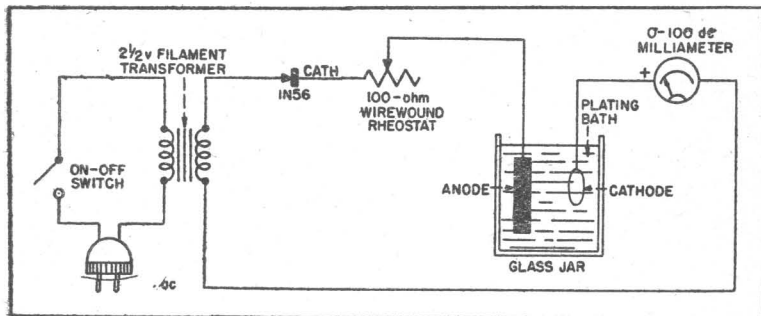

Figure 38. Light-Duty Electroplating Circuit.

EXPERIMENTERS occasionally plate small objects, such as switch contacts, brushes, relay contacts, small articles of jewelry, metallic curios, etc. The amount of direct current required to do a job of this kind is small. However the use of batteries for the purpose is not always desirable.

Figure 38 shows the circuit of a light-duty electroplating setup in which direct current is supplied by a 2½-volt filament transformer and IN56 crystal diode. A 100-ohm wire-wound rheostat is employed for adjusting and holding the plating current to a predetermined value. The current level is read with the dc milli-

ammeter shown in the circuit. For silver plating, which is most common with experimenters, the current is held to 50 milliamperes per square inch of surface being plated.

The IN56 will deliver a maximum current of 60 milliamperes dc without damage to the crystal when the current is drawn continuously as in electroplating. If higher current levels are desired, connect two IN56's in parallel. For small jobs, such as this plating setup is intended to accommodate, the plating fluid may be contained in a water glass, mayonnaise jar, or even a test tube.

20. LOW-CURRENT CRYSTAL POWER SUPPLIES

WHEN power supplies are called upon to deliver only small current values (not in excess of 50 milliamperes dc), real savings in space can be obtained by using crystal diodes as rectifiers. Figure 39 shows several circuits for low-current power supplies. These units may be employed for operating dc relays from ac, supplying fixed bias voltage for amplifiers, microphone voltage for simple "house-line" telephones, and similar uses.

Figure 39(A) shows a half-wave power supply. The IN34 may be used in this circuit to supply output currents not exceeding 50 milliamperes; the IN56 up to 60 ma. The secondary of the step-down

transformer should deliver not more than 20 volts rms and the resistance of the output circuit (resistance of the dc device to be operated plus any additional series resistance required) must be adjusted for an output current not in excess of the average anode current (maximum) rating of the crystal diode type used.

Figure 39(B) shows a full-wave circuit. Here; each half of the center-tapped secondary winding of the step-down transformer must deliver not more than 20 volts rms. The resistance of the output circuit (resistance of the dc device to be operated plus any additional series resistance required) must be adjusted for

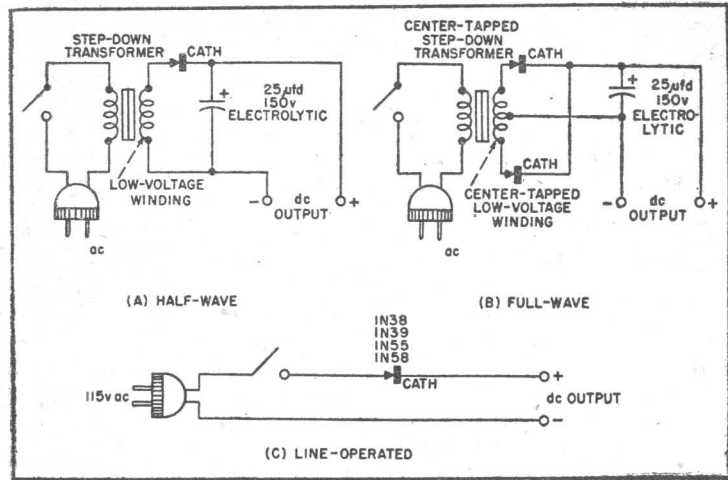

Figure 39. Low-Current Power Supplies.

an output current not in excess of twice the average anode current (maximum) rating of the crystal diode type used.

Figure 39(C) shows a half-wave circuit which may be operated directly from the power line for 100-volt, low-current output. This circuit is recommended only for applications in which a filter capacitor is not required. Here, the resistance of the output circuit (resistance of the

device to be operated plus any additional series resistance required) must be adjusted carefully for an output current not in excess of the average anode current (maximum) rating of the crystal diode type employed. Only types IN38, IN39, IN55, and IN58 are recommended for this application, since these types are able to withstand the peak inverse voltage of the power line.

21. RADIO-OPERATED GARAGE DOOR OPENER

THE radio ham who has a transmitter in his car can use his sending set to open his garage door by radio control. We do not recommend this scheme for use by unlicensed experimenters, since at least 10 to 20 watts transmitter power is required, and this amount of power fed into the automobile antenna meets the requirements of a radio station.

Figure 40 gives the circuit schematic of the receiving apparatus installed in

the garage. The front-end of the receiver employs a crystal detector, therefore no power is drawn by the equipment when it is idle. This is an essential feature, since there are no tubes to be kept burning when the equipment is not in use.

Coil L_1 has been selected for 6-meter operation. However, if the car transmitter operates on some other frequency, L_1 may be changed to tune to the used frequency. The receiver circuit gives positive opera-

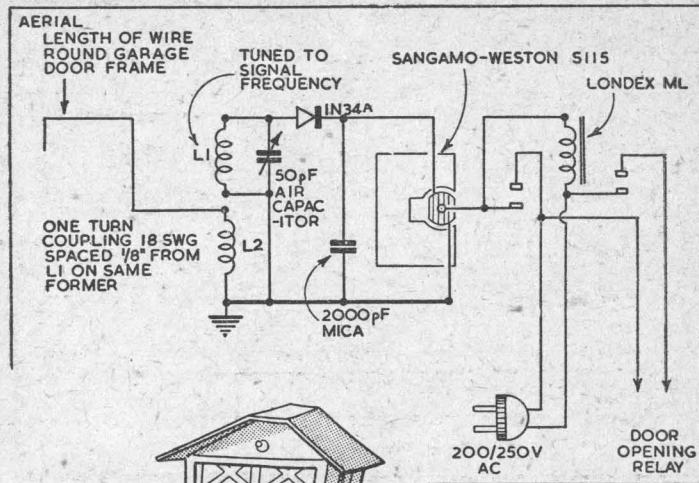

Figure 40. Radio Garage Door Opening Receiver.

tion at distances up to 15 feet between the car and the garage-door antenna, which is ample for all practical purposes. At the same time, the receiver is not sensitive enough to be operated erroneously by signals from local stations.

To adjust the receiver initially, turn on the transmitter and rotate the 50 μ fd. tuning capacitor in the receiver to the point where the relays operate. Tune-in

the signal "on the nose." The receiver tunes rather broadly, so that the transmitter frequency can deviate appreciably without control action being lost. To operate the system, it is necessary only to drive up near the garage door, switch-on the transmitter, and hold the control signal until the relay-controlled motor system has completed the job of opening the door.

Two crystal diodes are employed in the receiver-relay unit. One of these is the 1N34-A radio detector. The other, a 1N56 high-conduction diode, supplies 6 volts dc for operation of the Model 712 relay.



The information in this book is furnished without assuming any obligations.

22. AMMETER-WATTMETER FOR ELECTRICAL APPLIANCE TESTING

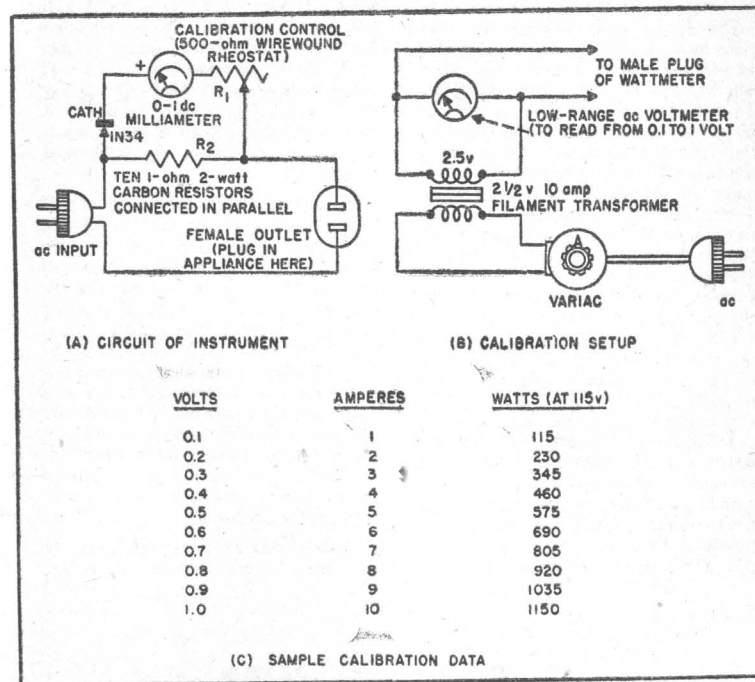

Figure 41. AC Ammeter-Wattmeter for Appliance Testing.

ELECTRICAL repairmen will find the crystal meter circuit shown in Figure 41(A) useful for checking the amperes and watts drawn by electrical appliances such as motors, heaters, lamps, irons, etc. This instrument is as easy to use as a voltmeter.

The circuit consists of a simple ac voltmeter (Germanium Diode in series with a 0-1 dc milliammeter) connected in parallel with a 0.1-ohm resistor. The latter is made up of ten 2-watt carbon 1-ohm resistors connected in parallel with each other. All current drawn by the

appliance under test must pass through the 0.1-ohm resistor. This current sets up a voltage drop across the resistor and this voltage deflects the meter. The meter reading is interpreted in terms of amperes or watts. By using a low value of series resistance, such as 0.1 ohm, the voltage drop is not high enough to reduce detrimentally the appliance voltage.

Use of the instrument is simple: The male plug is inserted into a power-line receptacle, the appliance is plugged into the female outlet of the instrument, and the amperes or watts read by referring

the millimeter reading to calibration data. For maximum convenience, the ampere and watt points, obtained in the initial calibration of the instrument, may be lettered-in on the millimeter scale.

The reader must calibrate his own instrument, since there is considerable variation in individual crystal diode characteristics at the low voltage employed. To make the calibration, set up the test circuit shown in Figure 41(B) and take the following steps: (1) Temporarily short-circuit the terminals of the female outlet in the instrument. (2) Set the Variac dial to zero, and set the calibration control rheostat R_1 to its maximum-resistance position. (3) Connect the calibration circuit to the wattmeter and advance the Variac dial carefully until the calibrating ac voltmeter reads exactly 1 volt. (4) Adjust rheostat R_1 to bring the milliammeter reading exactly to 1 milliamper (full scale). Do not disturb the setting of this rheostat at any future time unless a recalibration is being made. (5) Reduce the Variac until the ac voltmeter reads 0.9 volt. Record the milliammeter reading at this point as corresponding to 9 amperes, or inscribe 9 on the meter scale directly above the pointer position. (6) Reduce the Variac to obtain a voltmeter reading of 0.8 v and

23. DC-AC CONVERTER

FIGURE 42 shows the circuit of a single-crystal converter which may be used to change small dc voltages into small ac voltages and to step the resultant ac voltages up to higher values for easy measurement or for use in operating sensitive ac relays.

Two small $2\frac{1}{2}$ -volt filament transformers are used in conjunction with a 1N34 crystal diode. The $2\frac{1}{2}$ -volt winding of transformer T_1 is connected to the crystal diode which rectifies the ac voltage and passes positive pulses through the $2\frac{1}{2}$ -volt winding of transformer T_2 . The small dc voltage is applied to the dc input terminals in the polarity shown in the diagram. This dc voltage accordingly is added to the rectified positive pulses.

record this value (or mark it on the meter scale) as 8 amperes. (7) Repeat the procedure at each lower 0.1-volt step, as listed in the Table in Figure 41(C) until all values down to 0.1 volt have been covered. The corresponding ampere values are shown in the second column in the Table. The meter now is calibrated to read amperes between 1 and 10. Values between zero and 1 may be estimated. Remove the short-circuit from the female outlet, and disconnect the calibrating apparatus.

Corresponding wattage values at 115 volts are given in the third column of the Table. These values have been obtained by multiplying the number of amperes by 115 volts, and may be lettered-in on the meter scale. If a graph is drawn, instead, intermediate values, such as 500 watts, 1000 watts, etc., may be determined. The wattage values given in the Table or obtained by means of a graph will not be correct unless the voltage measured at the appliance is 115 v. For any other voltage value, determine wattage by multiplying the appliance voltage by the number of amperes indicated by the instrument.

The complete appliance tester may be built into a "3-inch" size metal meter box.

The positive pulses are stepped up through transformer T_2 across whose secondary an ac voltage appears which is proportional to the primary pulses plus or minus the applied dc. A high-resistance ac voltmeter or high-resistance ac relay may be connected to the ac output terminals.

To set the circuit, connect the dc source to the dc input terminals but do not switch-on the dc voltage. Connect the ac voltmeter to the ac output terminals and plug the converter into the power line. There will be a steady deflection of the meter which must be balanced out by means of a $1\frac{1}{2}$ -volt dry cell and 10,000-ohm rheostat connected to the meter movement. The positive terminal

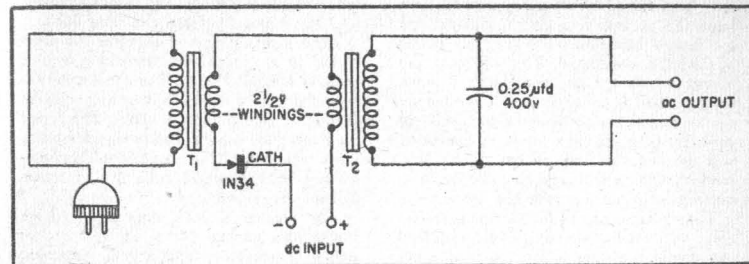

Figure 42. DC-to-AC Converter.

of this balancing circuit must be connected to the negative terminal of the meter. To balance, adjust the rheostat to bring the meter pointer down to zero. Now, switch-on the dc voltage and note the meter reading. The step-up ratio of transformer T_2 is better than 40 to 1. A dc input voltage of 10 millivolts thus will appear as approximately 0.4 volt at

the ac output terminals.

Response of the circuit is not linear, so an individual calibration is necessary when high accuracy is desired. This calibration may best be carried out by applying a series of known small voltage values to the dc input terminals and logging the readings of the ac voltmeter.

24. ELECTRONIC DOOR LOCK

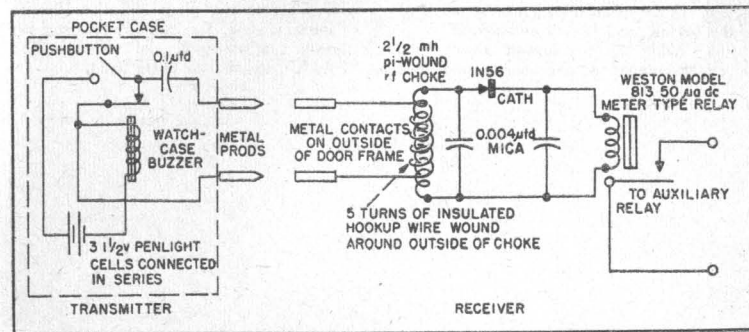

Figure 43. Electronic Door Lock.

FIGURE 43 shows the circuits of transmitter and receiver employed in a simple radio-controlled door lock. The transmitter employs the damped wave set up by the sparking contacts of a small watch-case type buzzer and can be made small enough (about the size of a hearing aid) to be carried in an ordinary

suit coat pocket.

The receiver is a 50-kc crystal diode circuit which consumes no power during idle periods and needs no attendance. Two metal plugs or nails connected to the input coil of the receiver pass through the door frame and are accessible from the exterior.

In use, the two metal prods extending from the pocket transmitter are touched to the two door plugs and the transmitter pushbutton depressed. This operates the buzzer which transmits a damped wave through to the receiver and operates its relays and the electric door lock. Clever prowlers who see the system in operation will assume that the pocket device is a battery, but will learn that dc from a battery will not operate the system.

The contacts of the 50-microampere dc relay will not handle the current required to operate the door lock. A second relay accordingly must be employed. The sen-

sitive relay operates the second relay, and the latter operates the door lock.

Both transmitter and receiver are very broad in response and therefore do not require critical tuning. For the same reason, there will be no difficulties due to frequency drift. Neither transmitter nor receiver uses tubes, hence maintenance problems, aside from occasional replacement of the penlight cells in the transmitter, are eliminated.

The electronic lock may be used on house and garage doors, as well as the doors of secret compartments, cabinets, storerooms, and other private chambers.

GERMANIUM DIODE INSTALLATION HINTS

1. Use the type of diode specified in the circuit diagrams. These types have been selected carefully to withstand circuit voltages and other operating conditions.

2. When soldering the diode into the circuit, hold the pigtail leads with a pair of long-nose pliers. This will prevent heat from the soldering iron from entering and possibly damaging the crystal unit.

3. In all installations, use as much of the pigtail lead length as possible.

4. While the Germanium Diode is a rugged component, the user is cautioned

against deliberately dropping the diode to the floor, tapping on it, or otherwise handling it in a rough manner so as to expose it unnecessarily to mechanical shock.

5. Mount the crystal diode so that it is reasonably free from severe mechanical vibration.

6. Keep the crystal diode as far as possible from heated objects.

7. Observe the diode polarity shown in the diagrams. The cathode terminal is plainly marked with the abbreviation "CATH" and with a wide band.

BERNARDS RADIO BOOKS

No. 53	RADIO CONSTRUCTORS' MANUAL	3/-
56	RADIO AERIAL HANDBOOK	2/6
57	ULTRA-SHORTWAVE HANDBOOK	2/6
58	RADIO HINTS MANUAL	2/6
60	RADIO REPAIRS MANUAL	2/6
61	AMATEUR TRANSMITTERS' CONSTRUCTION MANUAL ...	2/6
62	CAR AND PORTABLE RADIO CONSTRUCTORS' MANUAL ...	2/6
63	RADIO CALCULATIONS MANUAL	3/6
64	SOUND EQUIPMENT MANUAL	2/6
65	RADIO DESIGNS MANUAL	2/6
66	COMMUNICATIONS RECEIVERS' MANUAL	2/6
68	FREQUENCY MODULATION RECEIVERS' MANUAL	2/6
69	RADIO INDUCTANCE MANUAL	2/6
70	LOUDSPEAKER MANUAL	2/6
71	MODERN BATTERY RECEIVERS' MANUAL	2/6
73	RADIO TEST EQUIPMENT MANUAL	2/6
76	RADIO ANTI-INTERFERENCE MANUAL	2/6
77	WALKIE-TALKIE CONSTRUCTION MANUAL	2/6
78	RADIO AND TELEVISION LABORATORY MANUAL	2/6
80	TELEVISION SERVICING MANUAL	4/6
81	USING EX-SERVICE RADIO APPARATUS	2/6
82	AC/DC RECEIVER CONSTRUCTION MANUAL	2/6
83	RADIO INSTRUMENTS AND THEIR CONSTRUCTION	2/6
84	INTERNATIONAL WORLD RADIO STATION LIST	1/6
85	MINIATURE RADIO EQUIPMENT CONSTRUCTION MANUAL ...	3/6
86	MIDGET RADIO CONSTRUCTION	3/6
90	WIRELESS AMPLIFIER MANUAL No. 2	3/-
92	INTRODUCTION TO HAM RADIO	3/6
93	POWER PACK MANUAL	4/6
94	PRACTICAL CIRCUITS MANUAL	3/6
95	RADIO DATA BOOK	1/6
96	CRYSTAL SET CONSTRUCTION	1/-
97	PRACTICAL RADIO FOR BEGINNERS, BOOK I	3/-
98	MODERN VALVE COMPARISON MANUAL	3/-
99	ONE VALVE RECEIVERS	1/6
100	A COMPREHENSIVE RADIO VALVE GUIDE	5/-
101	TWO VALVE RECEIVERS	1/6
	THE ELECTRONIC PHOTOGRAPHIC SPEEDLAMP: HOW TO MAKE IT AND HOW TO USE IT	3/6
	ENGINEERS' REFERENCE TABLES	1/6
	A MAGNETIC TAPE RECORDER: PRINCIPLES, DESIGN AND CONSTRUCTION	3/6
	"TECHNI-GEN" CONSTRUCTORS' ENVELOPES, Nos. 1, 2, 4, 5, 6 & 7. 1. A 3-valve plus rectifier AC/DC Receiver (200-577 M. only). 2. An "Economy" 4-valve plus rectifier AC/DC Super-het. (200- 577 M. only). 4. An AC/DC "Quality" Receiver (medium and long waves). 5. A 20-watt "Quality" Amplifier. 6. A portable AC/DC P.A. Amplifier. 7. A de-luxe Tuning Unit for the 20-watt "Quality" amplifier.	2/- each
	HAM NOTES SERIES	1/-
	1. Comprehensive Crystal Calibrator. 2. The "R-9er." 3. Single Sideband Reception. 4. Low Power Transmitter.	each