



75p

**FIRST BOOK OF
PRACTICAL
ELECTRONIC
PROJECTS**

BY

B. B. BABANI

Historie v/d Ra

BABANI PRESS

No. 23

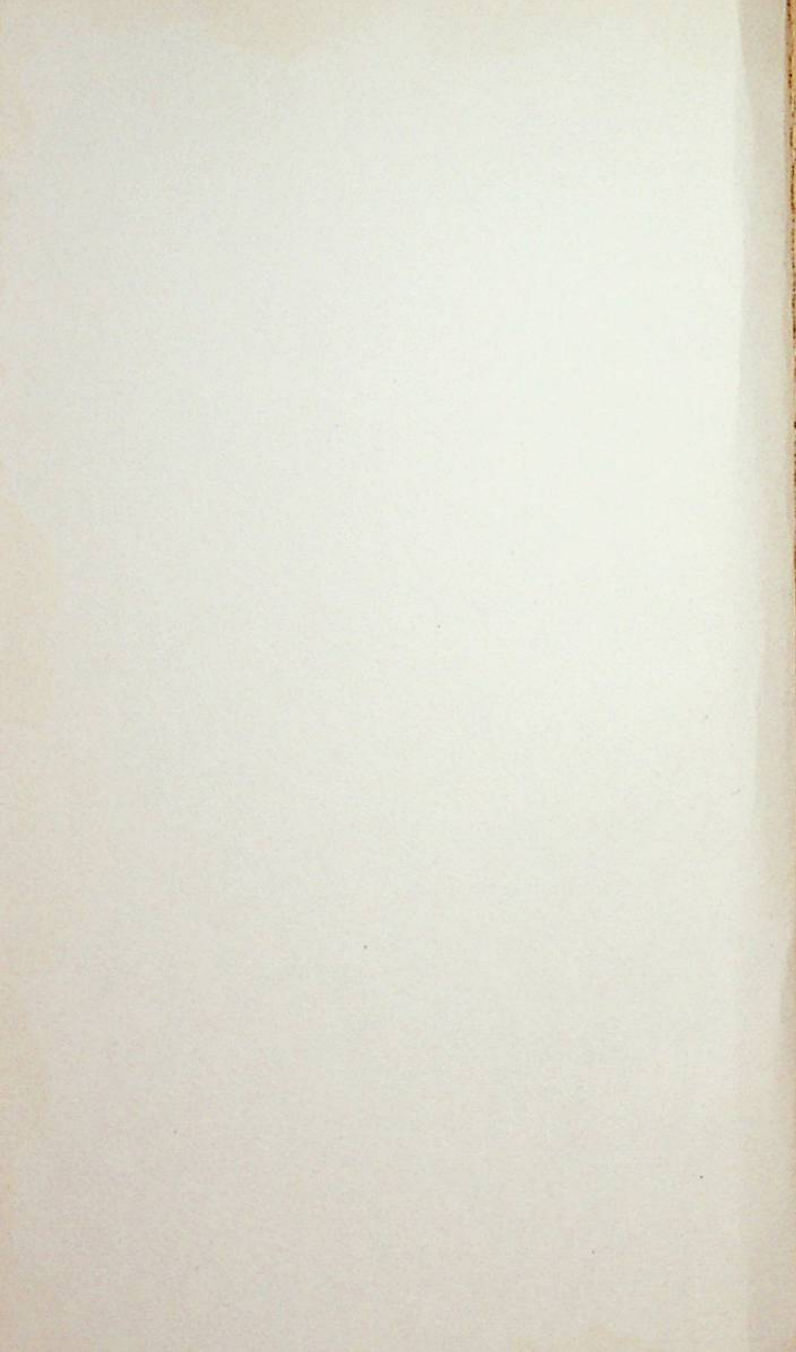

FIRST BOOK OF **BIBLIOTHEEK**
N.V.H.R.

**PRACTICAL
ELECTRONIC
PROJECTS**

BY

B. B. BABANI

BABANI PRESS

The Publishing Division of
Babani Trading and Finance Co Limited
The Gramplains
Shepherds Bush Road
London W6 7NF

Although every care is taken with the preparation of this book the publishers will not be responsible for any errors that might occur.

© 1975 by Bernard B. Babani

I.S.B.N. 0 85934 022 8

First Published February 1975

Reprinted October 1976

Made and printed in Great Britain by
C. Nicholls & Company Ltd. Manchester

CONTENTS

Improved Burglar Alarm	5
Electronics in Tomorrow's Cars	6
Code Practice Oscillator	13
Transistor Tester	14
Build Our Superfet Receiver	15
RIAA Preamplifier for Magnetic Cartridges	22
Intercom	30
Third Hand	30
A Solid State Audio Distortion Factor Meter	32
For Beginners A Simple TRF Receiver	56
Loudness Control	65
Sweet & Low Varilight Moodlighting	66
Low Cost 21 Watt Amplifier for Guitars	70
24 Hour Universal Clock	79
Lets Make a "DIN" about Audio Connectors	87
Simple Tester for Digital ICs	90
Audio Oscillator uses Two ICs	94
Is it a PNP or NPN transistor?	94
Transistorised Metronome with Variable Speed	96
12 Volt to 6 Volt DC Converter	96

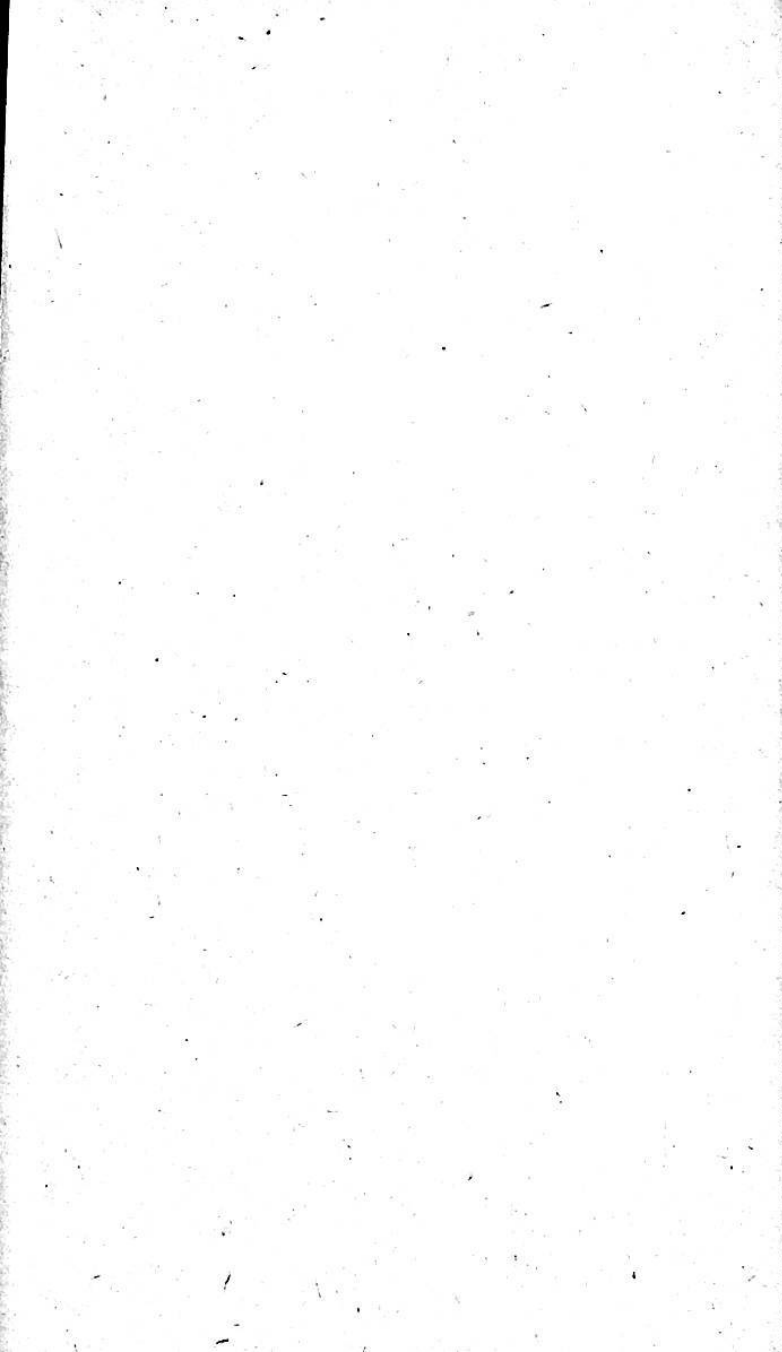

IMPROVED BURGLAR ALARM

THOSE READERS INTERESTED IN BURGLAR ALARMS MAY CARE TO ADD THIS CIRCUIT SUGGESTION TO THEIR FILES. IT IS AIMED AT GETTING THE ULTIMATE LIFE FROM THE SYSTEM'S BATTERIES

With this configuration the non-operate current is the I_{cbo} (collector current when emitter current is zero) of T1, normally 10-20 μ A. Operation of the circuit depends on the I_{ceo} (collector current when base current is zero) which flows when the base circuit is opened by any of the door or window contacts. This provides forward bias for T2, in place of the forward bias provided by the 5.6K resistor in the original circuit.

Note that only a germanium type transistor can be used for T1, as the bias current required to turn on T2 will normally be higher than that which can be provided by a silicon type.

Using this circuit, the batteries should now have a service life which really is equal to the shelf life. Admittedly, the improvement may be somewhat academic and the circuit was originally designed more as an exercise than anything else. However, the basic idea may appeal to some readers.

It has been reported that with particular specimens of T1 (2N649, AC127 etc). I_{ceo} is of such a value that under low ambient temperature conditions (i.e. during the winter months) it drops to a point where it will not provide sufficient forward bias to allow T2 to pull in the relay. In such cases the following modification is suggested. A small amount of forward bias is provided for T1 by connecting a 1M resistor from collector to base. A protection against thermal runaway is then provided by connecting a 470 ohm resistor in series with the lead from T1 emitter to T2 base.

2N629-AC127. RS276-2006. 2N2430. 2SD96-105.

BC107-108-109. RS276-2009/2031. 2N2921-3568. 2SC458.

2N649.AC127.etc

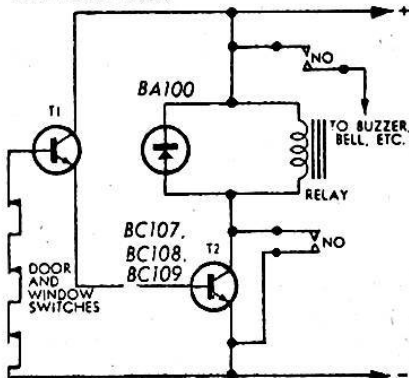

ELECTRONICS IN TOMORROW'S CARS

Electronics and its associated technologies seem to have permeated almost every field of human society. Communications, health, industry and even governments, seem to be dependent on electronic assistance.

However, the automobile industry seems, at first sight, to be lagging behind this general trend. The average car, or lorry, displays little electronic gadgetry. Its vital guidance, braking, and lighting systems are still comparatively primitive in design and function. Whilst it is true that some cars now feature an electronic ignition system, these are still very much a minority.

A look "behind the scenes" at electronic research and development reveals a very different picture. Spurred on by public demand for increased vehicle performance, and governmental demand for improved safety standards, manufacturers and researchers are combining to make rapid strides in the application of electronics to road transport. There will almost certainly be major developments in automotive design in the near future, and electronics will be a key factor in this development.

The idea of an electronic (or transistorised) auto ignition system is by no means a new one. It has been more than fifteen years since automotive engineers in the United States first recognised that the archaic electro/mechanical ignition system, whereby tungsten contacts were called upon to handle extremely high currents, had reached the limit of its development. The answer to a better system lay in finding a device that would remove the high current load from the points, and handle the load itself, without self destruction.

From the beginning, the development of electronic ignition systems has tended to follow diverse paths. Some manufacturers (chiefly American) concentrated on eliminating the contact points altogether, replacing them with a variety of systems ranging from Motorola's which supplied magnetic trigger impulses to an amplifier-driven circuit, to Motion Incorporated's which used a cold-cathode gas diode in conjunction with a cold-cathode thyatron.

The cheaper, mass-produced systems opted for the retention of the contact points, relegating them to a switching function where they no longer carried high currents. Two types of electronic ignition systems have become dominant in recent years: transistor assisted ignition, and capacitor discharge ignition. Whilst the latter is preferred, it is also more complicated, and it was long felt that cost would rule it out for mass production. However, improved production techniques and cheaper component costs have enabled capacitor discharge systems to compete favourably with conventional ignition systems.

Indeed one British company, Future Telematics, is now offering a capacitor discharge ignition system for less

than £12. The system is suitable for most family cars, and requires no special modifications to the ignition coil, or associated components. Offering increased fuel economy, longer spark plug life, better engine performance, and lower exhaust emissions, electronic ignition is undoubtedly a major advance in automotive technology. By 1980, most (if not all) cars will be fitted with such systems as standard equipment, and the complex electro/mechanical system, which has held sway for over 60 years, will finally be declared obsolete.

It is widely accepted amongst drivers, research engineers and safety officers that one of the major causes of automobile accidents is wheel lock, and subsequent loss of control of the vehicle, caused by "panic braking". Safety organisation advocate "cadence braking" in acute situations; that is, a constant jabbing of the brake pedal instead of continuous application of pressure. However, few drivers stay calm enough to carry out this procedure in an emergency.

The answer to this problem lies in the development of an automatic braking system designed to release brake pressure when wheel lock appears imminent. However, the cumbersome size and high cost of early designs frustrated attempts to produce these systems commercially, although Dunlop have, for some years marketed their "Maxaret" system on four wheel drive Jensen cars. In 1970 Mullard Ltd announced a new anti-lock system claimed to be the first over economically acceptable system for use in all types of motor vehicles.

As with most new automotive control systems, the Mullard system is a fusion of electronic and mechanical components. Diagnosing the condition of a road wheel is best done by electronic means whilst releasing and re-applying the brake is clearly a mechanical function.

Mullard originally researched the electronic problem with a view to adapting one of the existing anti-lock mechanisms. However, it was soon decided that none of the current systems offered sufficient potential for long term development. As a result, Mullard developed a new type of brake pressure modulating mechanism to be used as a test bed for electronic sensing circuits.

Basically, the system consists of a control circuit which monitors the wheel speed by means of a toothed ring mounted on the wheel hub. A magnetic pick-up, positioned near the ring, supplies a train of pulses to the control circuit. The pulse frequency is proportionate to the wheel speed and thus contains all the information necessary for the circuit to deduce the acceleration, or deceleration, of the wheel.

Unfortunately, the pulse train from the magnetic pick-up contains a considerable amount of noise due to vibrations within the wheel. Instead of designing a more complex pick-up unit, Mullard designed a noise rejection circuit, which emphasises the required signal and eliminates most

of the noise. As quantity production versions are to be made in integrated circuit or thin film form, this circuit should have little effect on the overall cost of the unit.

Whilst the control circuits can determine the onset of a dangerous wheel condition, they cannot modulate the brake pressure. A mechanical actuator was needed and Mullard decided to tackle this problem in a novel way.

Realising that previous systems had floundered on the size/cost factors inherent in the use of electric motors, large solenoids, or vacuum servo units, it was decided to take energy from the wheel itself.

When the electronic control circuit senses an impending wheel lock condition, it energises a hydraulic solenoid valve which relieves the brake pressure and, at the same time, applies a piston to an eccentric wheel hub. This piston then pumps the brake fluid, diverted to it by the solenoid valve, back into the brake line. If, however, the wheel approaches a lock condition, the pumping action of the piston ceases until sufficient brake pressure is relieved by the solenoid valve to enable the wheel to rotate. Each wheel is controlled independently, thus ensuring the shortest possible stopping distance and maximum steering ability during emergency braking procedures.

The result of Mullard's development work is a compact system in which the brake, anti-lock mechanism, and electronic sensing circuit form a single unit which is mounted on the road wheel. Several motor manufacturers are now studying the Mullard anti-lock system, together with other anti-lock designs. Although it is felt that there may be customer resistance to the added cost of a safety accessory, it can only be a matter of time before electronically controlled anti-lock brakes are the rule rather than the exception.

Another safety application for automotive electronics is in electronic seat belt circuits. Although it has been shown that seat belts can significantly reduce the risk of accident injuries they have provoked staunch resistance from the motoring public, despite legislation which makes the fitting of seat belts compulsory.

Legislation to enforce the wearing of seat belts is now in force in parts of the United States, France, and Australia. However, successive governments in Britain, and elsewhere in Europe, have been hesitant in adopting legislation along these lines. The alternative seems to be "compulsion without the law" - that is, a seat belt that either immobilises the vehicle until the belt is fitted, or one that is deployed automatically.

It is probable that the latter system will ultimately prevail. In the meantime, however, active development of "foolproof" electronic seat belt systems is continuing. In Britain, both British Leyland and Ford, who are working with Mullard, have made significant progress in this field

British Leyland's system uses two sensing switches operating in conjunction with a logic circuit. One of the switches is mounted in the seat cushion (to detect the presence of the occupant), whilst the other is situated in the belt buckle. The two sensors are linked to the logic circuit, which records the order in which the switches were activated.

If the occupant fails to activate one of the sensing switches, or if the switching sequence is wrong, the engine's starter is automatically disconnected. Certain safeguards are, of course, incorporated in the system. Once the engine is started, the seat sensor is de-activated so that the occupant may adjust his seating position. In addition, the engine starter is operable, without interference from the circuit, for a period of three minutes after the engine has been turned off.

The Ford/Mullard system takes anti-cheat precautions one step further by using ultrasonics to ensure that the seat belt is not only worn, but is worn in the correct position. In addition to seat and buckle sensors, this system consists of an ultrasonic transmitter which is mounted in the seat belt, and a detector which is mounted in the windscreen pillar. The ignition sequence is completed by fitting the seat belt and adjusting it to its correct position so that the signal from the transmitter is directed towards the detector. If the sequence is not completed, the driver is warned by an alarm (both audible and visible) mounted on the dashboard. Should the belt be disconnected whilst the vehicle is moving the engine will operate for a pre-determined safety period.

It has been estimated that ignition-wired seat belts would achieve an effective usage rate of 95%, and add approximately £25 to the cost of a new vehicle. However many critics claim that the systems are too complicated and that they are prone to tampering.

Thus far, we have had a brief look at three new electronic developments in the automotive field, all of which are likely to become commonplace in the near future. Now we will examine some of the more radical motoring innovations that are planned for future vehicles.

Motor vehicle developments and improvements are rarely prompted by government pressure. Public clamour for greater comfort and convenience, together with the racing fraternity's search for increased performance and increasing competition between the various companies have been the major causative factors in motor vehicle improvements. Government legislation has resulted in very few improvements to motor vehicles.

However, as the motoring world roles towards the year 2,000, this situation will inevitably change. Most European governments realise that their traffic density is likely to double within the next twenty years, the United States is already faced with enormous traffic problems and even Canada and Australia will eventually reach their respective traffic density limits.

It seems certain that in the years to come most governments will, through technology, demand greater control over the uses a vehicle is put to, and will exercise greater control over the vehicle whilst it is being used. Some research agencies, such as Britain's Transport and Road Research Laboratory, are already formulating schemes designed to provide external electronic control of motor vehicles.

Within the foreseeable future, the UK public will be protected from drunken drivers by a new electronic system called BLAST (British Leyland Alcohol Screening Tester). The unit, which is connected between the ignition switch and the starter circuit, consists of a central console on which is mounted a keyboard and a small display screen. Behind the display screen are nine lamps in a 3 x 3 matrix arrangement. When the ignition switch is activated, four of these lamps are illuminated, one after the other. A random sequence selector ensures that the numbers and the pattern will be totally unpredictable.

The test consists of selecting and pressing the correct key on the matching keyboard before each lamp is extinguished. If the driver is successful, a green light is displayed, and ignition is available. However, if the driver fails to execute the procedure, a red light flashes and the starter system remains deactivated.

In a series of tests at Birmingham University, subjects from 22 to 62 were tested on BLAST when sober and again after an intake of alcohol. Results showed that BLAST was 90 per cent effective in screening out subjects whose blood alcohol level was above the legal limit. Further tests are scheduled following circuit improvements. However, it seems likely that, in the not too distant future, potential drunken drivers will be saved from prosecution (or worse) by their inability to push the right button at the right time.

The development of large scale integrated circuits is leading the way towards radical improvements in vehicle instrumentation and telemetry. For example, Smiths Industries of Great Britain have designed a 'one-wire' system for automobile electrics in which all wiring is replaced by a ring main system consisting of a power lead and control wire passing around the perimeter of the vehicle. A control unit on the dashboard is connected to the same ring.

A remote switch on the dashboard panel control alters a particular code in the main sequence which is transmitted down the main control wire every millisecond. The appropriate accessory electronic module detects the code and stores the information. When the correct code is received four times (this takes about four milliseconds), the accessory is operated. If the accessory fails to operate, a 'fail' signal is returned to the control module.

One feature of this system is its ability to accept analog signals. For example, a tachometer sensor connected to the main ring near the motor has its own particular

code location. This is detected at the control unit, decoded, and displayed on the instrument in the conventional manner. Further locations can be made available for temperature, fuel, and pressure gauges, etc. It is estimated that the size of the circuit modules will be approximately 1 square inch.

Such integrated circuits offer advantages in terms of both cost and performance. These advantages include: less wiring required, the system is self checking, loom fixture costs reduced, and panel switches are only required to pass small currents. The above system should be commercially available in about five years.

Those who argue vehemently against the introduction of external vehicle control on the grounds of "personal freedom" are, to some extent, betrayed by the very high accident rate on multi-lane roads during periods of fog snow or other abnormal weather conditions. Such incidents (especially multi-vehicle pile-ups) indicate two possible conclusions: either the driver was unaware of the abnormal conditions in time to moderate his driving, or he was aware but lacked either the discipline or the ability to change his driving. On the assumption that the driver wasn't made sufficiently aware of the hostile conditions a new system called RITA (Road Information Transmitted Aurally) has been developed.

Basically the system consists of a speech recorder and transmitter housed in a road-side cubicle. The appropriate message for any given situation is selected, and the signal transmitted by modulating a very low frequency carrier which is fed into a wire loop buried along the edge of the road way. The continuously radiated signal is picked up by an aerial coil mounted on the vehicle, rectified and amplified to reproduce the spoken message to the driver via a loudspeaker. The use of a carrier frequency enables different languages to be transmitted on different channels.

As the information given is not obscured by other traffic or weather conditions, and since the driver is less heavily loaded aurally than visually, research engineers believe that RITA will prove to be a valuable aid in reducing the motorway accident rate. If not, then total automation is only a short step away.

One factor is common to all remote control systems presently under development - their high cost. Preliminary estimates indicate an outlay of around £75 per vehicle and £3,000 per lane kilometre. However, it is probable that these estimates are far too conservative.

Most systems envisage a road located guidance circuit and a vehicle borne electro/mechanical system to convert signal commands into action. A cable buried beneath the road surface will, when energised with an alternating voltage, become a guidewire. Two sensors on the front of the vehicle detect the magnetic field produced by the AC current flowing in the guidewire, the difference in signal levels detected by the two sensors representing how far the centre of the vehicle is from the guidewire.

In practice the signal voltages induced in the two sensing coils are amplified, rectified and then subtracted to produce a DC voltage which is proportional to the vehicle tracking error. The DC signal is applied to a comparator whose other input is derived from the vehicle's steering wheel position. A voltage is thus produced which is a measure of the error between the desired position of the steering wheel to centre the vehicle over the guidewire and the actual steering wheel position. The error voltage is used to drive an electric motor which controls the steering.

Vehicle speed and braking facilities are controlled in much the same manner. A speed command from the road cable in the form of a voltage is compared with a voltage proportional to the actual vehicle speed, thus producing an error voltage. This error voltage is fed via a signal conditioning circuit to a controller. Depending upon the sign and amplitude of the error voltage, signals varying in mark-space ratio are fed to either the throttle or brake actuators, increasing or decreasing the vehicle's speed as required.

A problem of vital importance in such automated systems is that of maintaining a safe distance between vehicles, and experimentation is continuing in an attempt to determine the best method of achieving the correct spacing. One system, known as the "travelling bucket" system, utilises a travelling wave train in the track, with vehicles swept along it like surf boards. The major disadvantage of this system is that if one vehicle breaks down, following vehicles will be swept onto it. Safety overrides are possible, but these considerably increase the cost of such systems.

Given such drawbacks, most researchers lean towards the "follow the leader" system in which lasers, radar, or ultrasonic devices are used to measure the range and speed of the vehicle ahead and adjust the speed of the following vehicle accordingly.

Through its application to the automobile, electronics has brought the motorist improvements in economy, performance, convenience, and safety. Ironically, there are now indications that electronic techniques will be instrumental in removing the motorist's most prized possession - the freedom to control his own vehicle. The completely "electronic car" of science fiction may not be all that far away. However, it may turn out to be more of a nightmare than a blessing.

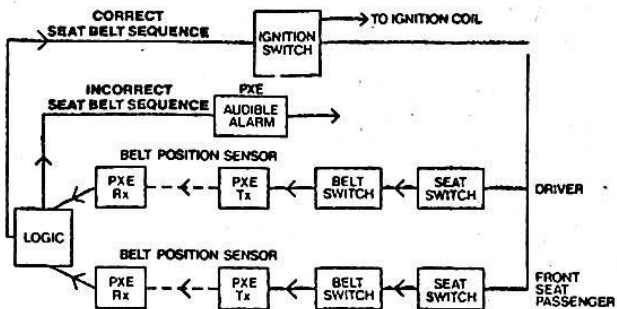

Shown at the top of the page are the receiver and transmitter modules of the Ford / Mullard ultrasonic seat belt system. A transmitter unit fitted to a seat belt is shown at centre, whilst directly above is a block diagram of the Ford / Mullard seat belt circuitry.

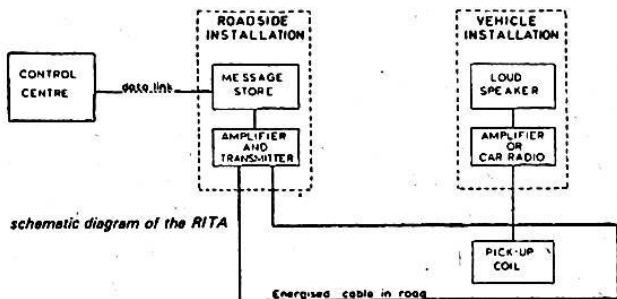

schematic diagram of the RITA

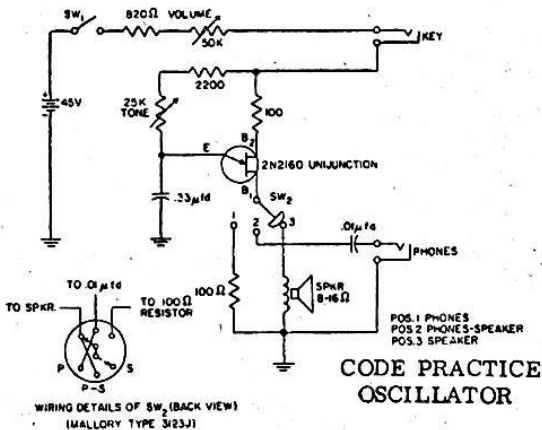

CODE PRACTICE
OSCILLATOR

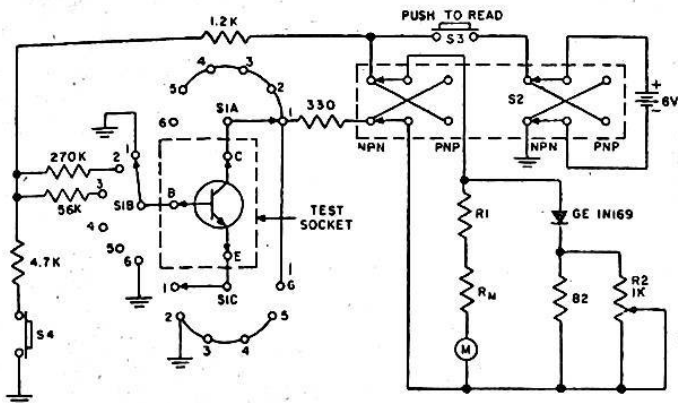

PARTS

S1-3 POLE 6 POSITION NON-SHORTING SELECTOR SWITCH

S2-4 POLE 2 POSITION SWITCH

S3-S4 NORMALLY OPEN PUSH SWITCHES

M-100 μ A FULL SCALE METER

R_M-METER'S INTERNAL RESISTANCE

TO TEST	WHEN	ADJUST SELECTOR SWITCH S1 TO POSITION	RESULT	
I _{CO}	V _{CB} = 6V	1	READ METER DIRECT	
I _C	I _B = 20 μ A	2	READ METER DIRECT	
I _C	I _B = 100 μ A	3	READ METER DIRECT	
I _{C10}	V _{CE} = 6V	4	READ METER DIRECT	
I _{CE5}	V _{CE} = 6V	5	READ METER DIRECT	
I _{EO}	V _{EO} = 6V	6	READ METER DIRECT	
h _{FE}	I _B = 20 μ A	2	CALCULATE: $h_{FE} = \frac{I_C}{I_B} = \frac{\text{METER READING}}{20\mu A}$	
h _{FE}	I _B = 100 μ A	3	CALCULATE: $h_{FE} = \frac{I_C}{I_B} = \frac{\text{METER READING}}{100\mu A}$	
h _{FE}	I _B = 20 μ A	2	CALCULATE: $h_{FE} = \frac{I_{C1} - I_{C2}}{4 \times 10^{-6}}$	WHERE: I _{C1} = METER READING I _{C2} = METER READING WITH S ₄ CLOSED
h _{FE}	I _B = 100 μ A	3	CALCULATE: $h_{FE} = \frac{I_{C1} - I_{C2}}{20 \times 10^{-6}}$	
6V. BATTERY	—	4	WITH 150 Ω RESISTOR CONNECTED TO C-E OF TEST SOCKET, FULL-SCALE METER DEFLECTION WILL RESULT WHEN S3 IS PRESSED.	

TRANSISTOR TESTER

BUILD OUR SUPERFET

WOULD YOU LIKE A PORTABLE, LOCAL BROADCAST STATION RECEIVER THAT IS SIMPLE TO BUILD, AND WON'T COST YOU THE EARTH? TRY OUR SUPERFET - YOU WON'T BE DISAPPOINTED!

The Superfet is a two stage regenerative receiver, with FET front end and a bipolar transistor audio amplifier.

This amplifier uses a valve-type speaker transformer to match into modern 8 ohm dynamic head phones. While a crystal earpiece could be used, the performance obtainable is nowhere near as good as that from low impedance "hi-fi" types.

The Superfet is built into a small plastic case, measuring approximately 160 x 90 x 70 mm.

Instead of a long-wire aerial and an earth, the Superfet uses a loopstick (ferrite rod) aerial. This enables it to be used anywhere - nothing is more annoying than having a set tied to an aerial and earth unless there is a good reason for doing so.

In parallel with the loopstick is a tuning capacitor. A standard 10-415pF single section type is used. To keep the cost down, you may be able to salvage one from an old set. However, it is likely that it will be physically larger than ours (though it would have the same capacitance) and a double gang. If so, the layout we have used will probably have to be changed. Also, check that the plates do not touch anywhere over the travel - you can do this with an ohmmeter.

Immediately following the tuned circuit (formed by the loopstick and capacitor) comes a device which may be new to many readers - a FET (type MPF 102). FET is an abbreviation for Field Effect Transistor.

FETs are three element devices - they have a gate, a source and a drain; equivalent to the valve grid, cathode and anode, respectively. However, they have one rather different characteristic - most junction FETs are not polarised. In other words, the drain can be used as the source and vice versa. This is fortunate if you happen to make a mistake wiring them up - providing the gate is connected correctly, the other two connections can be interchanged!

The FET is the nearest thing to a solid state equivalent of a valve so far developed, and has many similar characteristics. In fact, some FETs have been produced which are plug-in replacements for certain types of valve. As with most solid state devices, they are much more efficient than valves, requiring no heater current.

As the term "field effect" implies, the FET controls the current through its drain and source by an electric field or, in simpler terms, by means of the voltage applied between its control electrode - the grid - and its cathode.

And it is unlike the bipolar transistor, which controls the current through the collector and emitter by means of a (smaller) current through its control electrode - the base - and its emitter.

Also, like a valve, and unlike a transistor, the FET does not need a forward bias in order to conduct. If a valve is operated without bias it will allow a quite substantial current to flow unless this is lim-

ited by the external circuit. In some cases the current could be high enough to damage it. In any case, it is normally necessary to provide a reverse bias, both to keep the current flow within acceptable limits and to set the "working point" of the grid on the correct part of the characteristic curve.

Similarly, a FET operated without bias will allow a substantial and possibly destructive current to flow, unless this is limited by the external circuit. And it is necessary to provide a reverse bias to control this current and also set the "working point".

The transistor, on the other hand, will not pass any significant current in the absence of bias. It is necessary to provide a forward bias, first to establish a flow of current, and then to set the "working point".

Since the FET, like the valve, requires only voltage on its control electrode, and passes negligible current through it, it has a similar high input resistance. The bipolar transistor, on the other hand, passes significant current through its control electrode and has a low input resistance.

Regardless of these differences, all three devices have some characteristics in common. All have a current value beyond which it is either impossible or unsafe to go. All have "cut-off" condition where current ceases to flow or is reduced to a minimum value. And in using all three as an amplifier, it is normal to set the control electrode "working point" so that the standing current is approximately midway between these two extremes.

You may have noticed that there are no bias components in the gate circuit - where with a transistor there would be at least one, and possibly two resistors. In this case the bias is generated in the source circuit by the 10k resistor and the 1uF capacitor - a system virtually identical with one commonly used for valves. Current through the source resistor generates a voltage across this resistor, positive at the source end. Since the gate is connected to the other end of this resistor (via the tuning coil) the gate is negative with respect to the source by the voltage developed across the resistor.

In the drain circuit there is a 1k pot. This pot controls the "regeneration" of the set. "Regeneration" is another name for positive feedback, where part of the output is fed back to the input in phase. The feedback path is from the 1k pot, through the smaller winding and back through the tuned winding. Actually the small winding on the loopstick is known as the feedback winding. The 1k pot controls the amount of signal which feedback winding receives. If the pot is very close to the top of the travel, very little of the signal flows through the winding - but if the pot is near the bottom of the travel, a lot of the signal finds it easier to travel through the feedback winding than through the 1k resistance of the pot.

The pot also doubles as the on/off switch, and for this reason you should specify a switch pot when buying the parts. This saves the added expense of a completely separate switch - although there is nothing to stop this arrangement if it is desired.

A 4.7k resistor from the positive supply to the top of the pot is the load resistor for the FET. The audio signal is developed across this load.

From the top of the pot is a .01uF bypass capacitor. Its purpose is to

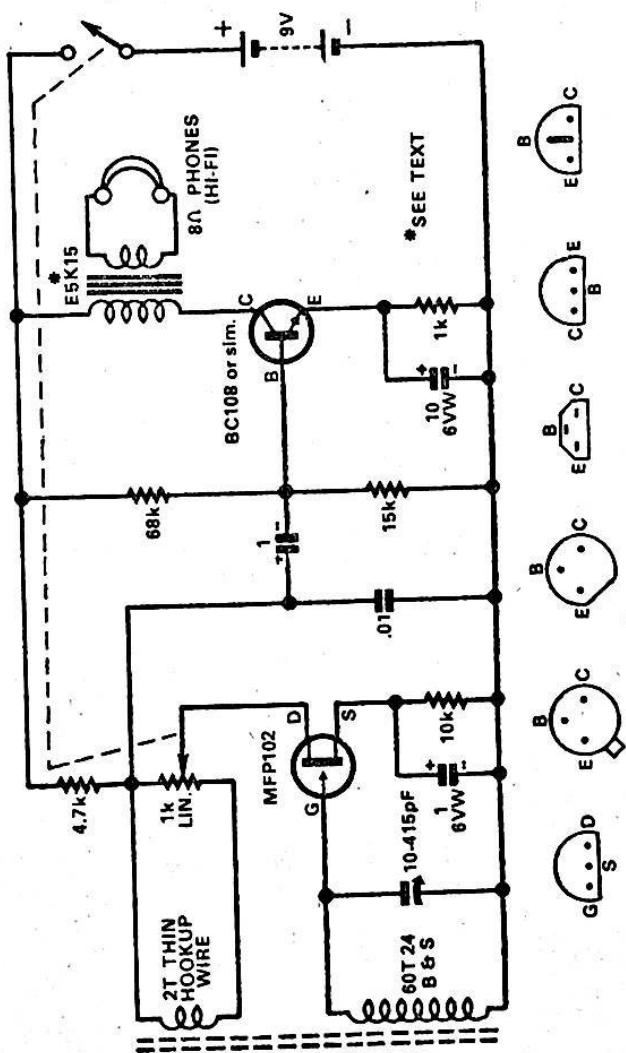

The essential simplicity of the Superfet is demonstrated by the circuit diagram. Each of the component functions is explained in the text. Take care with transistor lead configurations.

provide a path for RF signals to return to the tuned circuit via the negative rail, rather than via the audio circuit. If RF does manage to find its way into the audio section, it makes the whole circuit likely to burst into violent oscillation. It may also reduce the overall performance of the set, because the RF stages do not have a proper return path.

A 1uF capacitor couples the audio information developed across the 4.7k load resistor to the audio amplifier. The audio is amplified to a level which permits good, loud signals in the headphones.

We can already hear the question in many reader's minds; "Where is the detector?" What, you hadn't missed it? Well, look back over the circuit again. Can you see it?

We must admit that it is not immediately obvious. Detection takes place in the FET, due to the amount of bias used. We have deliberately biased it onto the curved portion of its characteristic and it is this curvature which causes one half of the signal to be amplified more than the other. The system is analogous to the old valve type "anode bend detector" so perhaps it should be called a "drain bend detector".

So that's the circuit - nothing to it, is there? Not really, but when you build this little set, don't be surprised at the performance. It quite belies its simplicity.

Construction of the Superfet may begin with the construction of the loopstick (tuned winding only). Ferrite rod is sold in 200mm lengths - and as we need only 100mm, it must be divided. Do not throw away the excess - it will come in handy in the future. Cut the ferrite as you would cut glass. File a nick right around the ferrite, then tap it on the edge of a desk, etc. Take care not to drop it, as ferrite is brittle and will break easily.

So not attempt to cut ferrite rod with a saw. If you do, it will almost certainly shatter, rendering it useless.

Wind a layer of insulation tape over the ferrite to protect the wire, then anchor the wire about 2cm from one end (leave about 10cm wire over) and wind on 60 turns, tightly and close together. Anchor the winding with insulation tape. No taps are required.

Once again, leave 10cm of wire for connection, then cover the winding with a layer of insulation tape for protection. Two small brackets are used to mount the ferrite rod - details of which are given. These screw to the rear of the case - but leave this for the moment.

Next the tagboard can be wired according to the circuit and layout. Note that two of the components are underneath the board - a capacitor and a resistor - this allows a much neater and logical layout than would otherwise have been possible. Try to stick to our layout - it is one which is likely to give the least trouble. Regenerative circuits can give trouble if the layout is poor.

We presume most readers will be using the speaker transformer and low impedance headphone system. High impedance headphones are not only hard to buy, but are now quite expensive - more so than a set of low impedance hifi headphones which you will also be able to use with your stereo amplifier.

If this is not the case, and you already have a set of high impedance 'phones which you wish to use, simply ignore the transformer and connect the earphones where the primary of the transformer would be (this can also be done via a plug and socket on the front panel).

If you use a transformer, it can be the first component placed in the box. It is placed against one side of the box, hanging from the top. Our holes were drilled 23mm from the outside edge, and were 52mm apart. All holes in the plastic case are countersunk from the outside, to enable countersunk head $\frac{1}{8}$ " whit. screws to be used. These look much neater than the usual round head screws - and also make sure that the set will not scratch any surface on which it is put. If countersunk head screws are hard to come by, try at least to use four on the underside for the above reason.

The tagstrip is mounted alongside the transformer, our mounting hole being 65mm from the edge. The 9 lug tagstrip fits well into the space. The wires from the tagstrip are left disconnected for the moment. The battery occupies the opposite corner to the transformer - again hanging from the "roof". A simple battery bracket made from tinplate or thin aluminium holds the battery, the bracket being secured with one screw and nut.

The brackets for the ferrite rod are screwed to the back of the case, so the ferrite rod occupies the space behind the transformer and the tuning capacitor, which is the last item fitted. The ferrite rod is held on the bracket by two grommets which are slid onto either end of the rod. The photograph shows this more clearly. The length between mounting brackets need not be exact, as the grommets can be moved to fit.

Now the tuning capacitor can be fitted. It is mounted on the bottom of the case by four screws, each fitted with 3 nuts - one to hold the screw in place, one to act as a spacer, and another to hold the capacitor in position. The capacitor is mounted so the shaft is on the horizontal centre line of the case, approximately 40mm from the right inside edge.

With the capacitor mounted, all leads can now be cut to their correct length and connected. First, connect the leads from the tagboard to the capacitor, then the flying leads from the tuned winding to the same points. The battery, transformer, potentiometer and output socket can also be connected at this time.

Make sure you get the leads to the potentiometer correct. If an error is made, the tuned winding will, at some point, be adversely affected by a short across the feedback winding. This alters the "Q" (quality) of the coil, and results in a very poor performance.

The wiring of the headphone socket also warrants a special mention. It is important that the socket be wired so that both phones receive signal. To do this (and also to present the correct impedance to the output transformer) we wire the phones in series. Simply use the socket tags which connect to the tip and ring of the plug. Ignore the tag which connects to the main body of the plug.

So far, we have not mentioned the feedback winding. This is deliberately left until last in order to get it right. Once you are sure all wiring is correct, plug in your earphones and turn on.

You should hear noise in the headphones - and if you are in a strong signal area, you may be able to pick up some broadcast stations. If so, you are almost finished. If not, re-check your wiring and battery.

If you are not in a strong signal area, it might be wise to place the set near an aerial lead for the final adjustment - there should be no need to connect the aerial to the set.

Tune slowly over the band until you can hear a station. It may take a while to find one with the set in this state, but persevere. When you have found one, be careful to move the tuning capacitor.

Solder a short length (say 20cm) of thin insulated hookup wire to one of the two outside pot terminals. Take the other end and pass it twice around the tuned winding on the ferrite rod - no more. Pull it reasonably tight, and anchor it in place with a length of insulation tape. Cut it to the required length and solder it to the other outside lug on the pot. This is the regeneration winding.

Here it may be appropriate to make a few comments about the behaviour of regenerative circuits. As regeneration is increased, the stage first goes into oscillation at a radio frequency determined mainly by the tuned circuit. Since it is RF oscillation, it is not audible, but you may hear a faint rushing noise. Alternatively, if you tune across a station you will hear a whistle.

More precisely, this is a high pitched audio note, dropping sharply to zero, then increasing again as the station is tuned out. The midpoint - or where there is no audio note - is called the zero beat.

If the regeneration is advanced still further the system may suddenly emit a harsh raspberry-like note, regardless of whether a station is tuned in or not. This is caused by the system choking up, going out of oscillation, then coming back in again, at an audio rate. It is this audio rate which produces the note. The condition is called squegging.

When you turn the set back on after fitting the regeneration winding you should hear one or other of the following results: (1) The station may be louder, and perhaps distorted, or with a whistle superimposed on it, or the set may be squegging. (2) The original station may be weaker.

If condition (2) is experienced, reverse the connections to the feed-winding. This should produce conditions described in (1). If you now find that the pot control works in reverse (anti-clockwise to increase regeneration) transfer the lead from the tag strip to the outer pot lug to the other outer lug. Leave the centre lug connection as it is.

If you find it impossible to get any joy out of the set either way, try another turn on the feedback winding (but only try this if you can't get results any other way - too much feedback may cause havoc). You may also try moving the feedback winding up and down the ferrite rod to change the coupling. Over the tuned winding gives the strongest coupling.

With the electrical side of the Superfet completed, all that remains is the front panel, plus a few pointers on how to use it. The front panel must be made from metal, and preferably earthed (to the negative supply). As aluminium is probably the easiest to get and work with, this is a logical choice. Ours was of 22g aluminium.

The panel should be exactly 85 x 158mm. The corners are rounded to fit the case. If the aluminium is cut this size, there is a pretty fair chance that it will be such a good fit that no screws will be needed to hold it in place - this was the case with ours. If necessary, however, four dimples are provided in the plastic case (one per corner) to be drilled out to suit self tapping screws (say number 4's).

The position of the hand span dial is more or less fixed by the position of the tuning capacitor. This should be on the centreline, but if it is not, it can be adjusted up or down by means of the spacing nuts.

To even things up, the regeneration control is placed on the centre line, equidistant in from the opposite side as the tuning capacitor knob.

On the inside of your front panel, mark a centre line. By careful measuring, determine the distance from the inside edge of the box to the centre of the pot shaft, and mark a point on the centre line. Mark a point the same distance in the opposite side. After re-checking, drill these holes to $\frac{1}{8}$ ". While the shaft of the tuning capacitor is only $\frac{1}{4}$ ", drilling a bigger hole means you have some margin for error - and in nine cases out of ten, there will be some error.

A standard pot requires a $\frac{1}{8}$ " hole for mounting. The headphone socket also requires a $\frac{1}{8}$ " hole, and this is located in the bottom left hand corner. It is located as close as possible to the corner - our hole being drilled 17mm in from each edge.

De-burr all holes with a larger drill, and try the lid out for size. If everything fits, you can take the lid off and mark it as you desire. We used "Letraset" for all marking (name stations and functions) after we dressed the surface by rubbing it with a wire brush. After lettering, a fine coat of clear enamel was applied to protect the surface.

Now for the driving instructions - not that you need a driver's licence (but you do need a broadcast listener's licence!) - but a regenerative set may be a little tricky while you are getting used to it. The easiest way to tune a set of this type is to "tune the whistles". Turn up the regeneration control until the set begins to squegg, then back it off until this ceases. Then tune a station by listening for the whistle and adjusting for zero beat. After adjusting for zero beat, back the regeneration control off slightly until the station becomes clear and no beat note can occur.

You will note that a different amount of regeneration is required for the top end of the band than for the bottom end - this is quite normal. It is quite possible for the set to go into regeneration without you even realising it. In fact, the only way you can tell is if the whistles are heard each side of the station. But for the most part, maximum volume is obtained with the set just on the verge of breaking into oscillation.

We hope you are as happy as we are with the performance of this little set. Considering the number of parts involved, it can truly be called a "gutless wonder" but the performance leaves nothing to be desired.

PARTS LIST

SEMICONDUCTORS:

1 MPF102 FET RS276-2035/6. 2N3819-5486
1 BC108.RS 2/6-2009

RESISTORS: $\frac{1}{4}$ W5 or 10%

1 1k
1 4.7k
1 10k
1 15k
1 68k
1 1k linear switchpot

CAPACITORS:

- 2 1uF 6VW electrolytic
- 1 10uF 6VW electrolytic
- 1 .01 low voltage ceramic
- 1 10-415pF single section tuning capacitor

MISC:

- 1 plastic instrument case (Japel approx 160x90x70mm)
- 1 aluminium front panel to suit
- 1 100mm length of 1/4in ferrite rod
- 1 speaker transformer 5k to 15 ohms
- 1 stereo headphone socket
- 1 9-lug section of tagstrip
- 2 rubber grommets
- 24B&S or SWG enamelled copper wire or Thin hookup wire
- 9V battery
- Scrap aluminium for brackets
- "Letraset" for marking front panel if required
- Countersunk head 1/4in Whit. screws and nuts to suit

RIAA PREAMPLIFIER, FOR MAGNETIC CARTRIDGES

As a "spin-off" from the Cassette Playback Preamplifier, we present this high performance RIAA preamplifier for magnetic cartridges. It has high overload margin, very low distortion and low noise.

As mentioned above, the preamplifier presented here was developed as a "spin-off" from the Cassette Playback Preamplifier.

Before describing the operation and construction of the preamplifier, let us compare its performance to an earlier design. First, the new preamplifier has more gain. At 1kHz, it delivers 110mV for an input of 1mV and as a bonus, its gain can be adjusted higher or lower to suit the application. At a gain of 110, maximum input signal at 1kHz is 80mV and has a similar order of overload margin over the whole frequency range. If the gain is reduced, the overload margin will be correspondingly improved, although it should be more than adequate as it stands.

With respect to noise, the new preamplifier has more gain and so could be expected to have more noise output. However comparative listening tests between the old and new preamps suggest that the differences are marginal. Measuring the noise with the input loaded by a typical magnetic cartridge and referring it to an input signal of 10mV gives a signal-to-noise ratio of 75dB. The old design is 3dB better in this respect.

Note that we have taken the measurement with the input loaded by a typical magnetic cartridge, instead of with the input open-circuit. The latter test gives more conservative results but is unrealistic - not too many people listen to their amplifiers with no source connected.

The signal-to-noise figures are unweighted, i.e. filters have not been used to exclude frequencies outside the audible spectrum. Weighting would undeniably give a better result. In a practical situation, the noise level of the preamplifier will depend very much on the internal shielding of the cartridge and the incidence of hum fields from transformers and mains wiring on the input leads

The other major feature of the preamplifier is its low harmonic distortion. We found it difficult to measure the distortion, as it was clearly less than the residual distortion of the measuring equipment. Hence, we rate the preamplifier at less than 0.1pc THD for frequencies from 30Hz to 20kHz and output voltages up to 3V RMS.

Whatever the distortion content contributed by the preamplifier, it is negligible compared to the distortion generated by the magnetic cartridge so that further improvements in this respect seem like "gilding the lily". The important thing is that the preamplifier cannot be overloaded by any currently available cartridge, whereas the preamplifier in many commercial amplifiers does suffer from this fault.

Apart from performance comparisons, the new circuit has three advantages over the earlier design. First, it does not require transistors selected for beta such as BC109C or BC109B. Second, the gain can be adjusted. Third, cartridges with other than the usual impedance characteristic will not suffer a degradation in bass response due to the rather unusual feedback configuration of the earlier circuit.

Referring now to the circuit, readers will note that it is basically similar to the Cassette Playback Preamplifier. The major difference

SPECIFICATIONS

Frequency response: Within 1dB of RIAA characteristic from 30Hz to 20kHz.

Sensitivity: 2mV for 220mV output at 1kHz and input overload capability of 80mV at same frequency.
Nominal input impedance 50k.

Noise: Residual noise output with a typical cartridge connected is less than 0.2mV. When referred to an input voltage of 10mV, the unweighted signal-to-noise ratio 75dB.

Distortion: Less than 0.1pc THD for frequencies over the range from 30Hz to 20kHz at output voltages up to 3V RMS; at voltages up to 9V RMS, less than 0.2pc.

is that the feedback components have been changed to suit the signal characteristics of magnetic cartridges.

Basically, the circuit uses a differential amplifier comprising two low-noise silicon NPN transistors driving an operational amplifier integrated circuit. Thus the low-noise transistors determine the noise performance of the circuit rather than the characteristics of the IC.

To ensure lowest possible noise from the differential amplifier transistors, they are run at a low collector current of about 22uA each. The balanced output signals from the collectors of the differential pair are fed to the inputs of the operational amplifier and negative feedback around the circuit is applied to the base of one discrete transistor from the output of the op amp. RIAA characteristics are determined by the 47k and 560k resistors in combination with the .0015uF and .0056uF capacitors, and the ratio of the impedance of this circuit to the ratio of the impedance of this circuit to the 560 ohm resistor determines the overall gain of the preamplifier

Bass roll-off at frequencies below 30Hz is accomplished by the 10uF capacitor in series with the 560 ohm resistor. The capacitor also ensures 100pc DC feedback so that the DC voltage at the output is as close as possible to that of the input transistor's base, ie, approximately zero. This means that the maximum output voltage swing is available without any adjustment being necessary.

Gain of the preamplifier may be varied by adjusting the 560 ohm resistor. To increase the gain, reduce the value of the resistor and vice versa. For example, to obtain a gain of approximately 75 times, the resistor should be increased to 820 ohms. We do point out, however, that we have not made tests on the preamplifier at gain levels differing greatly from that of the specified circuit. A general caution would be not to vary the preamplifier components unless the constructor knows what is is about!

At high frequencies, input impedance of the circuit is around 50k, in spite of the fact that the bias resistor feeding the first transistor is 100k. At lower frequencies, the input impedance does increase slightly but this is not important.

A series network consisting of a 1k resistor and .001uF capacitor ensures stability of the preamplifier at high frequencies. At the same time the 15k resistor connected from the output of the op amp to the positive 15V rail averts another nasty problem, that of cross-over distortion. It may seem something of a paradox that cross-over distortion could occur in a preamplifier circuit but the fact is that the uA741 op amp has a class-B output stage. Hence the 15k resistor to provide a current of 1 milliamp into the output, and provide class-A operation for output signals up to about 2V peak-peak. For larger signals, any cross-over distortion is likely to be negligible.

Input coupling capacitors should be 1uF tantalum types or, if size is not a problem, metallised polyester could be used. Since the two other signal capacitors in the circuit, 10uF and 4.7uF, have very little DC voltage applied to them, they ideally should be tantalum types also, although modern aluminium electrolytic capacitors are very much less prone to depolarisation and attendant loss of capacitance than earlier types.

Supply rails are plus and minus 15V which enables the maximum output voltage of the preamplifier to be just over 9V RMS. It is this which gives the high input signal overload capability, despite the high gain.

A pair of .047uF ceramic capacitors are connected between the positive and negative rails to the common rail to bypass any RF signals and "hash" that might be picked up by the supply cables. They also prevent any instability of the preamplifier which might occur due to the inductance of long supply leads.

The balanced 15V supply lines are derived from the mains via a transformer with a secondary winding of 15VAC. This should have a current capability of 50mA or more. Alternatively, if the amplifier with which the preamplifier is to be used has balanced supply lines, it may be possible to derive the necessary voltages from the amplifier. Current consumption of the preamplifier is light, at about 5mA for the two channels.

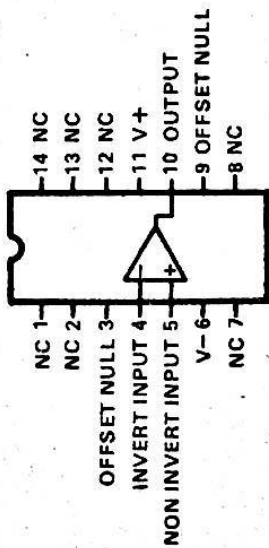

14 LEAD DIP

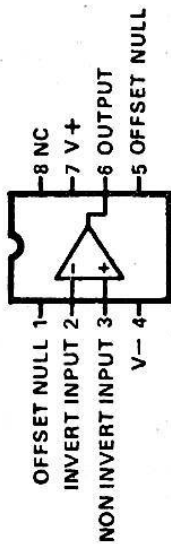

MINIDIP

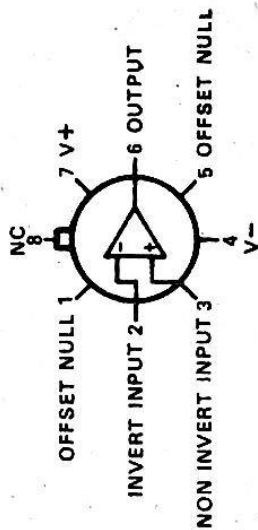

8 LEAD METAL CAN

NOTE PIN 4 CONNECTED TO CASE

CONNECTION DIAGRAMS
(TOP VIEW)

Three packages of the 741 op amp IC. All are compatible with the printed board.

Two half-wave rectifiers are connected to the 15V transformer winding to provide plus and minus 21 volts, approximately. Filtering is provided by two 470uF/35VW electrolytic capacitors. We do not recommend 25VW capacitors for this application. The 35VW units provide slightly better filtering and have greater voltage rating margin.

Regulation and further filtering is provided by two zener diodes fed by 470 ohm resistors. The zener diodes are 1.5W units, which provide better filtering and spike suppression than the smaller 400mW types. At a pinch, though, the 400mW units could be used without any circuit modification. Further filtering is provided by 220uF/16VW capacitors shunting each zener diode. These capacitors also remove any noise produced by the zener diodes themselves.

The rather complex supply is necessary to ensure that no residual hum or noise superimposed on the mains supply, such as "spikes" or switching tones, does not appear in the preamplifier output.

As noted above, the noise performance of the preamplifier depends substantially on the shielding of the cartridge and the incidence of hum fields on the input leads. For this to be true, the preamplifier itself must be well shielded otherwise it will contribute hum also. The best and easiest way to accomplish this is to mount the preamplifier in a standard diecast box. The one we used measures 120 x 95 x 55mm.

A printed board, measuring 86 x 76mm, accommodates the preamplifier components. The board is an easy fit in the diecast box just mentioned.

Hole spacing on the board suits $\frac{1}{4}$ W or $\frac{1}{2}$ W resistors, with $\frac{1}{4}$ W types giving the neatest result. Low noise resistors should be used, such as carbon film or metal film. Ordinary carbon composition resistors should be used if the constructor does not care about noise - in which case he should not build the unit in the first place. While the board has been designed to suit printed circuit mounting capacitors, pigtail types may be used if they are mounted vertically.

We recommend the use of sockets for the integrated circuits. They eliminate the possibility of damage to the IC while soldering, and obviate the necessity to de-solder if the IC fails.

Since pins 1,2,7,8,12,13 and 14 are unused in the 14-lead package of the uA741, the copper pattern on the board is also compatible with the 8-lead Minidip package or the 8-lead metal can package. With the 8-lead Minidip package for example, the IC may be pushed straight into the socket with pin 1 of the IC connecting into pin 3 of the socket. Similarly, the leads of the 8-lead metal can type may be bent to suit the socket. This means that hopefully there should be no supply problems with the uA741.

Two links of insulated copper wire are soldered on the copper side of the board to connect the supply rails from one side of the board to connect the supply rails from one side of the board to the other. See the wiring diagram. Note that there is only one pair of .047uF ceramic bypass capacitors on the board. These capacitors should preferably not be polystyrene or polyester types as these can have

appreciable inductance, as far as radio frequencies are concerned. Ceramic capacitors are better as RF bypass capacitors.

A 5-pin DIN socket is used for input connection and a 3-pin DIN socket for the output connection. A 4-pin polarised socket is used to connect the three supply leads. The shield connection of the input socket (pin 2) is bypassed with a 100pF ceramic capacitor to the "earthy" terminal on the same socket. At the output socket, the "earthy" connection is connected to pin 2 (the shield connection), so that the case is connected to the common line. Note that at no point in the circuit is there a connection back to the mains earth. This connection is made automatically when the preamplifier is connected to an amplifier.

Mount the board so that it is spaced away from the bottom of case by a clearance of about 10mm with the aid of screws and nuts and spacers.

Note that input cables to the preamplifier from the cartridge should be kept as short as possible. This is to keep hum induction at a minimum, and also to keep cable capacitance to a minimum so that high frequency attenuation is minimised.

PARTS LIST

- 1 diecast box, 120 x 95 x 55mm
- 1 printed board, 73p11, 86 x 76mm
- 1 4-pin polarised socket
- 1 5-pin DIN socket
- 1 3-pin DIN socket
- 2 14-lead IC sockets
- 1 power transformer with 15V winding

SEMICONDUCTORS

- 4 x BC109, BC149, BC209, RS276-2009, silicon NPN low noise transistors
- 2 x uA741 or RS276-038 operational amplifier
- 2 x EM401, BY126/100 RS276-1139 silicon diodes
- 2 x BZX70/C15 zener diodes (15V, 1.5W)

RESISTORS

- ($\frac{1}{4}$ W or $\frac{1}{2}$ W, 5pc tolerance)
- 2 x 560k, 2 x 330k, 2 x 100k, 4 x 56k, 2 x 47k, 2 x 15k, 2 x 1k, 2 x 560 ohms, 2 x 470 ohms.

CAPACITORS

- 2 x 470uF/35VW electrolytic
- 2 x 220uF/16VW electrolytic
- 2 x 100uF/3VW electrolytic (preferably tantalum)
- 2 x 4.7uF/6VW electrolytic (preferably tantalum)
- 2 x 1uF/25VW polyester or tantalum electrolytic
- 2 x .047uF/25VW ceramic
- 2 x .0056uF/100VW polyester or polystyrene
- 2 x .0015uF/100VW polyester or polystyrene
- 2 x .001uF/100VW polyester or polystyrene
- 1 x 100pF/63VW ceramic

MISCELLANEOUS

Shielded cable, hook-up wire, screws, nuts, Veroboard for power supply, solder.

INTERCOM

"The speakers are both normally connected to the output of the amplifier. When either "press-to-talk" switch is operated, the speaker in that unit is connected to the input of the amplifier, allowing the caller to be heard from the other unit.

"When the switch on one unit is operated to the 'monitor' position, the speaker in that unit is connected, via the 'press-to-talk' switch in the other unit, to the input of the amplifier. Operating the 'press-to-talk' switch in the second unit, changes the position of the speakers in the circuit, allowing one to speak back to the first unit.

"Due to the number of switch contacts involved, I had to use PMG type key-switches and I was fortunate enough to obtain a pair from one of the disposals houses, with four change-over sets in one direction and two in the other direction.

"The switches I bought were of the non-locking variety but a bit of 'fiddling' made them lock on one side. This side was arranged for the 'monitor' position.

"The whole system was made to operate in the balanced type of circuit. In other words, both legs were switched. To avoid coupling from input to output, all the wiring was left un-earthed. This meant that the feedback had to be omitted but the gain was not excessive and the whole system remained perfectly stable."

EDITORIAL NOTE: It appears that this switching method could be adopted by others who wish to have the monitoring facility at both ends of the system. It is obvious, however, that this "extra", as it were, is available if we are prepared to cope with the attendant problems.

Provided an eight-way cable, and the key switches are no obstacle, the modification may be achieved quite readily. A point worth noting is the fact that we were not able to fit a PMG type switch in the original, as it interfered with the battery space.

In the circuit submitted, there is no provision for battery switching. Due to the possibility that such a versatile unit may be in use almost continuously, this facility may not be considered necessary. However, it is felt that a simple switch could be provided by the constructor, even if it is only used to switch off at night or other prolonged periods when the unit is not required.

A reader reminds us that, in these days of miniature equipment, the most handy tools are not necessarily traditional pliers, etc., but tweezers, clamps and other items found in a doctor's surgery. Nor is there anything quite equal to a dental mirror when it comes to seeing behind inaccessible components!

THIRD HAND

I have noticed a lot of suggestions for various kinds of "third hand" to hold small components while soldering etc.

A common idea is to mount an alligator clip on a block of wood. I tried this but it was not entirely suitable in my case. As an alternative I mounted the alligator clip on a rubber suction cup. With this I can hold the work on the bench, or on a wall, without it slipping about.

TRANSISTOR AMPLIFIER

OUT

IN

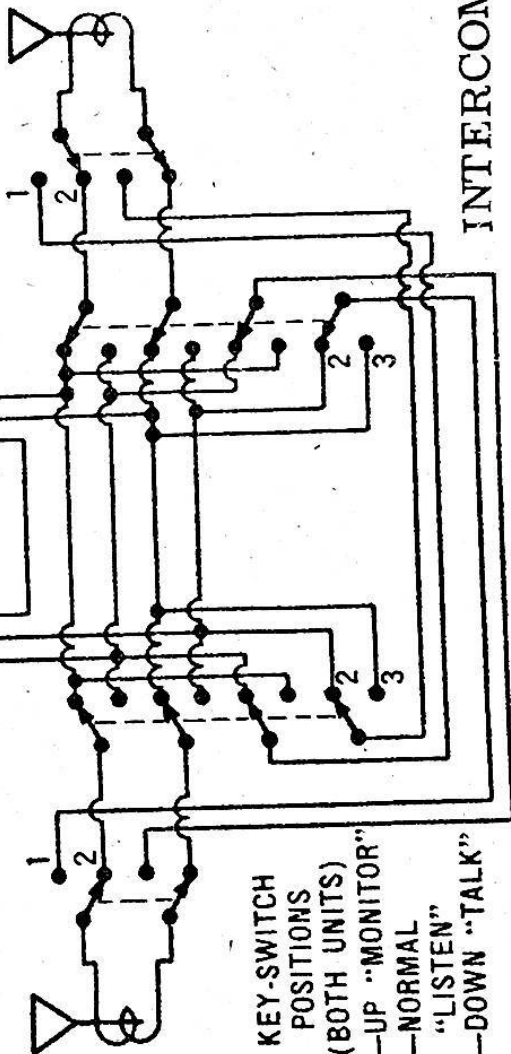

KEY-SWITCH
POSITIONS
(BOTH UNITS)
1—UP "MONITOR"
2—NORMAL
"LISTEN"
3—DOWN "TALK"

INTERCOM

A SOLID STATE AUDIO DISTORTION FACTOR METER

THIS DESCRIBES A RELIABLE AUDIO DISTORTION FACTOR METER FOR HOME CONSTRUCTION. THE METER CIRCUITRY IS FULLY SOLID STATE, AND WILL MEASURE DOWN TO 0.1pc DF ON SIGNALS BETWEEN 200mv AND 75V OVER THE FREQUENCY RANGE FROM 20Hz to 20kHz. AT THE SAME TIME, IT IS EASILY SET UP AND CALIBRATED USING SIMPLE EQUIPMENT.

For anyone seriously concerned with experiment, design or servicing on high quality audio equipment, a reliable method of measuring the distortion it introduces into a pure signal is almost indispensable. Such measurements are not especially difficult although rather time-consuming. The necessary instruments are fairly complex and, in their commercial form, quite expensive. For those who do not have the research and development budget of a sizable company to draw upon, this cost factor can be a problem.

The design to be described here was worked out with this factor well in mind. It should enable the experienced constructor to build for himself a reliable and flexible Distortion Factor Meter at a fraction of the cost of a commercial instrument. There is nothing very difficult about its construction or the components used, but it must be said that careful workmanship and accurate components are essential and the project cannot be recommended to an inexperienced constructor. Practical points to be watched will be highlighted as the description proceeds and if these are observed no difficulties need be feared.

The term distortion factor now commonly quoted for high-fidelity amplifiers defines the additions made by the imperfect equipment to a single pure sine-wave input signal. These additions include hum and noise as well as harmonic distortion, and their combined RMS voltage is expressed as a percentage of the total output voltage at the fundamental signal frequency; this percentage is the Distortion Factor which is to be measured. Note carefully that this is a voltage ratio, not a power ratio which would give a much more flattering figure.

What we have to do, then, is firstly to measure the total output voltage of the amplifier under test at the output level and frequency which interests us. This output will consist of three components: the amplified signal at the fundamental (input) frequency, the sum of the harmonics generated in the amplifier, and any hum and noise introduced by the amplifier. These can be called respectively, V (for the fundamental), D (for harmonic distortion) and N (for noise and hum). This combined output voltage is noted.

Next, we must eliminate the fundamental voltage V , by a suitable filter and then measure the combined voltage of the remaining factors D and N . This much smaller voltage is then compared with the voltage previously measured and is expressed as a percentage of it; this is the Distortion Factor. In the instrument to be described this comparison is done by a calibrated potential divider and the Distortion Factor is read directly from its scale.

From the foregoing, it is clear that the filter referred to, commonly called a "Notch Filter," must be capable of eliminating the fundamental frequency while leaving all other frequencies unaffected, before the distortion content alone can be measured; i.e., it must be sharply tuned. Several types of filter can be used, but for simple handling

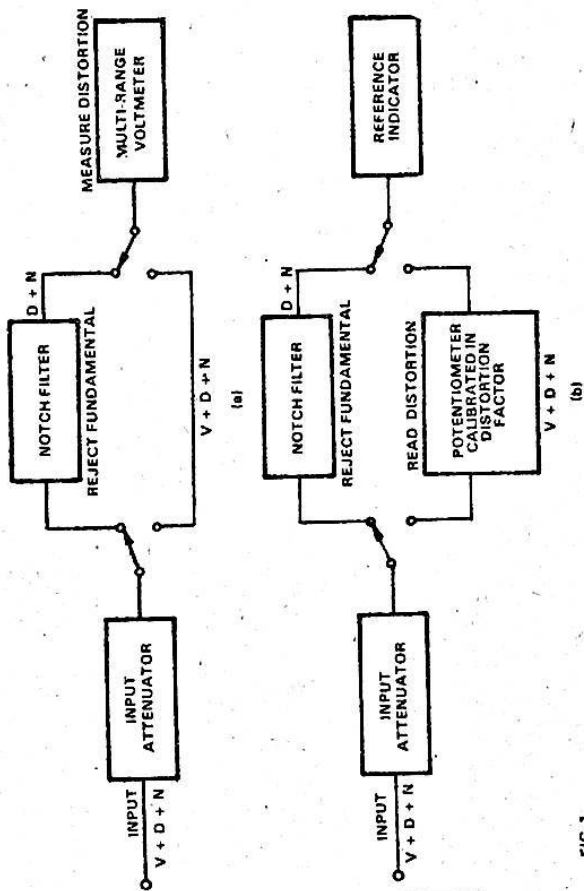

FIG. 1

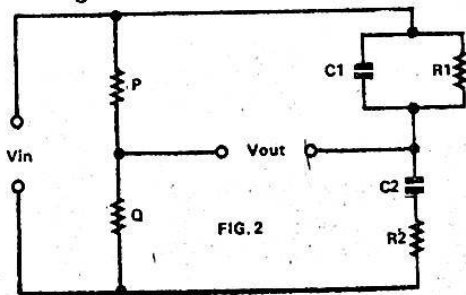

FIG. 2

and easy availability of cheap components the Wien Bridge filter seems most suitable and has been used here. The filter must, of course, be tunable over the full range of fundamental frequencies to be examined.

The bridge is adjusted until it is balanced at the signal frequency, which is thus suppressed. However, it is then considerably unbalanced for the harmonic frequencies and these appear at the output with virtually no attenuation.

Two principal methods are available for measuring Distortion Factor and they are shown in Fig 1, A and B. Each has some advantages and certain drawbacks.

In 1A, the signal to be investigated is fed through a variable attenuator to a ganged "function switch" S1 and S2 which connects the attenuator output either directly to a multi-range AC voltmeter (for measurement of signal plus distortion) or else through the "notch filter" to the voltmeter (for measurement of distortion only). The attenuator setting must remain unchanged for both measurements; therefore the voltmeter has to be a sensitive instrument (actually a millivoltmeter) with multiple ranges and a scale accurately calibrated over all its ranges. It must also have a frequency response which is flat over the full range of fundamentals plus their harmonics, up to at least the fifth - in practice, from 20Hz to around 100Hz. Such a voltmeter is an expensive thing to buy and almost beyond the scope of an experimenter to construct and calibrate; therefore this scheme was thought unsuitable for the present project.

The second method, Fig 1B, requires only a single-range AC millivoltmeter which does not have to be calibrated, as it is used only to give a single reference voltage reading. However, it still must be sensitive and have the necessary flat frequency response covering all of the harmonic range. If it can also give a true RMS indication rather than an average one this is an advantage, though not essential.

As before, the distorted signal is fed through a variable attenuator to the "function switch." However, from this point it goes to the voltmeter either through the "notch filter," which thus shows distortion and noise only, or else through a calibrated potential divider which passes both fundamental and distortion. In this method, distortion is first read by switching in the filter, balancing it to suppress the fundamental, and finally adjusting the input attenuator until the remaining distortion voltage produces a certain reference reading on the meter, indicated by a mark on the scale. The filter is then switched out and replaced by the calibrated potentiometer which passes both fundamental and distortion; this potentiometer is then set to produce the same reference reading on the meter. At this point the potentiometer output voltage has the same value as that of the distortion and noise in the signal, so that the potentiometer can be calibrated directly in percentage Distortion Factor.

This method has the advantage that the meter scale needs no calibration beyond the provision of the reference mark, and the meter accuracy is therefore unimportant. The accuracy of the calibrated potentiometer is merely a matter of using close-tolerance resistors, plus the making of a linear scale to suit a normal wire-wound potentiometer, and this is easily within the home constructor's ability. The method also has the advantage that since the meter is always used at high sensi-

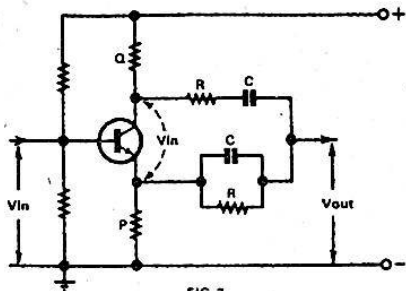

FIG. 3

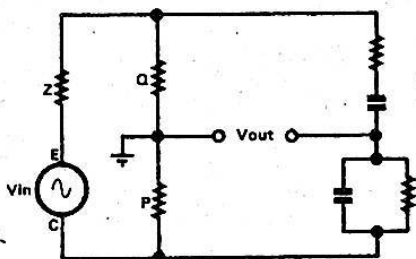

FIG. 4

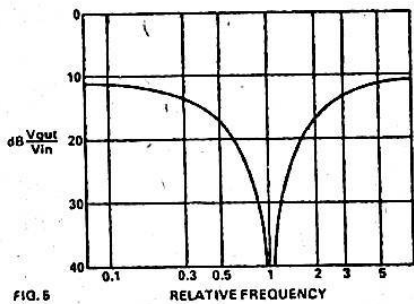

FIG. 5

tivity, the notch filter and its amplifier are always working at a very low signal level and are therefore less likely to introduce distortions of their own. (It must be realised that in any scheme of this kind the meter cannot distinguish between distortion in the input signal and distortion produced in circuits before the Wien Bridge, so the latter must be made negligible).

The drawback to this second scheme is that the very low signal level and high meter sensitivity required makes the whole circuit more liable to induced and self-generated noise - eg. transistor noise. However, careful choice of components and adequate shielding have overcome this difficulty. The reason for the high meter sensitivity will appear when we come to the details of the performance specification.

We have seen that when the fundamental frequency has been suppressed the output of the equipment under test is a mixture of distortion and noise. If we now switch off the source of the test signal at the input to the equipment, leaving everything otherwise unchanged, the remaining noise showing on the meter is the noise generated by the equipment under test. This noise, in the case of a mains-operated device, will probably have two components:

(a) mains hum, chiefly at twice the frequency of the mains, or 100Hz in this country, but quite possibly at harmonic frequencies also. In some localities the mains supply has been found to have a strong fifth harmonic which is not easily eliminated.

(b) so-called "white noise" or hiss, whose strength will depend somewhat on the bandwidth passed by the equipment - in general, the wider the bandwidth the greater the measured noise. However, the noise actually audible will not necessarily increase to the same extent, because the response of the human ear peaks at around 5kHz and decreases so rapidly above 10kHz that increased noise above this frequency goes largely unnoticed by most people. To take account of this, professional distortion and noise meters often include a "Weighting Filter" which can be switched in to give a weighted noise measurement corresponding to one of two international standards representing broadcast and line telephone conditions respectively. This added complication was not thought worthwhile for the present simplified design.

Another form of noise which may appear under these conditions is parasitic oscillation, either continuous or intermittent, the continuous type often being masked by the test signal but showing up when it is switched off. The distortion factor meter can be very useful in tracing and curing such troubles.

Let us now consider the performance specification for a practical meter:

SENSITIVITY. We first consider what signal voltages we are likely to meet. At the low end the most likely item to need testing will be an audio-frequency preamplifier and the lowest output voltage commonly met with will be around 200 millivolts. This, then, can be our lower design limit, though in practice this instrument can be used down to around 150 millivolts. We next decide on the lowest distortion percentage we expect to measure accurately, and in the present design 0.1pc was chosen. Now 0.1pc of 200 millivolts is 200 microvolts and this input must give the standard meter deflection, chosen in this case to be 70pc of the full scale reading. This, then, becomes the

sensitivity required of our meter and it will be working at this sensitivity at all times. To combine this performance with a bandwidth extending to 100kHz and using a small inexpensive meter movement presented some problems, now overcome, especially from transistor noise.

At the upper end of the signal scale amplifiers with an output of at least 100 watts may have to be tested, so the range of the input attenuator will have to be considerable. The present design will handle inputs up to 75 volts, equivalent to an amplifier output of 700 watts into 8 ohms, which should take care of any likely situation.

FREQUENCY RANGE. This was chosen at 20Hz to 20kHz, covering the whole useful range normally claimed for audio equipment. It is covered in three switched overlapping ranges.

DISTORTION RANGE. The basic range is from 0 to 0.5pc with switched multipliers giving X10 and X100 times.

HARMONIC RANGE. It was decided to include harmonics up to the fifth in all measurements; thus the meter circuit must have a flat response to 100kHz (fifth harmonic of 20kHz). The need for this might be questioned since even the second harmonic of 20kHz is quite inaudible. However, there is some evidence suggesting that when two or more frequencies are being amplified together their higher harmonics, though themselves inaudible, may beat together to produce audible distortion products of an especially offensive kind. Furthermore, one wished to provide for tests on audio-frequency oscillators where the extended harmonic range would be needed.

INPUT RESISTANCE. For a general-purpose instrument which may be used on equipment, such as pre-amplifiers, with a wide range of output impedances, it is best to give the meter an input resistance high enough to impose negligible load on any likely signal source. A value of 250k was chosen, being about the highest figure that can be used without difficulties due to high value, non-standard resistors in the attenuator and possibly, excessive residual noise.

The complete circuit diagram of the final instrument is shown as Fig 6. The instrument comprises four distinct and separate sections and these are now described in detail.

The Input Circuit. Four pi-section pads connected in series, together with a continuously-variable potentiometer comprise the input attenuator. Each pad gives 12dB loss, with an image impedance of 500k. As the attenuator is image-matched the input impedance is 250k for all positions of the switch S1, which provides the coarse control. The 500k carbon potentiometer RV1 provides the fine continuous control.

It is evident that when the circuit is switched from "Reject Fundamental" to "Read Distortion" the load on the input attenuator will vary considerably unless it is isolated. For this purpose a buffer stage (Tr1) is provided. This stage is critical, in that any noise generated there will appear in the measured distortion. After tests of several types of bipolar transistors, the Texas Instruments type 2N5245 field-effect transistor was found to give good results as a source follower in this circuit. The collector circuit is heavily decoupled for stability.

The Notch Filter (Wien Bridge). Fig 2 shows the elements of a Wien Bridge in basic form. If C1 and C2 are made equal, (denoted by "C") and R1 and R2 also equal (denoted by "R"), the conditions for balance (in this application, maximum fundamental suppression) are:-

$$(a) \frac{P}{Q} = \frac{1}{2}$$

$$(b) 2 FCR = 1$$

Thus the bridge will balance at frequency 2 F when

$$Q = 2P$$

$$2 F = \frac{1}{CR}$$

(C in farads, R in ohms, or C in microfarads, R in megohms.)

A bipolar transistor amplifier can be added to give the practical circuit in Fig 4. This arrangement gives input and output connections balanced with respect to ground and assists a sharp null.

For a true measurement of DF it is necessary that only the fundamental frequency is suppressed, and that all the harmonics from the second upwards shall reach the output of the notch filter unchanged. This implies quite sharp tuning. The frequency characteristic of the basic Wien Bridge is shown in Fig 5 and it is plain that the response to the harmonics is far from equal, there being a substantial difference in response between, say, the second and fifth harmonics; in fact the second harmonic is nearly 5dB down. This, if not corrected would give an apparent DF substantially better than the true figure.

This is remedied by including the bridge circuit within the loop of a negative-feed-back amplifier. By this means the overall response to harmonics can be made level to within 1dB, and with an insertion loss for all harmonics of less than 1dB. (See Fig 6 for circuit).

There are two important factors to be watched in the design of the feedback amplifier, apart from its possible introduction of noise and distortion of its own making. Firstly, the amount of feedback must be sufficient to achieve the desired flat harmonic response, but no more; excessive feedback sharpens the tuning to an uncomfortable degree, making the instrument difficult to handle and increasing the chances of instability and distortion of the fundamental, due to the large signal offered to the transistors at the null point where the feedback loop is effectively broken. The feedback required is X10 or a little more (20 to 21.5dB).

Secondly, the gain of the complete notch filter circuit with its feedback applied (ie. the closed-loop gain) must be closely unity, otherwise the harmonic voltage offered to the meter in the "Reject Fundamental" position will not be comparable to that coming from the calibrated potentiometer in the "Read Distortion" position, the potential divider having no associated amplifier.

These two factors, therefore, require that the overall open-loop gain (with feedback temporarily removed) shall be X10, and that this gain shall then be reduced to unity by adding closely-controlled negative feed-back, which will then be effective for all frequencies except the fundamental. These points seldom seem to be clearly brought out in such published discussions as the writer has seen.

The Wien Bridge can take either of two forms, namely, with fixed capacitors and ganged variable resistors for tuning, or with fixed resistors and ganged variable capacitor tuning. The first method offers the advantage of relatively low-resistance circuits which minimise noise and hum troubles and this method was originally used here, with a pair of ganged 10k wire-wound potentiometers for tuning in conjunction with pairs of precision fixed capacitors. However, prolonged experiment failed entirely to make this arrangement workable. Both tracking and resolution of these ganged pots proved inadequate for the precise setting needed for a true null and it proved impossible to get reliable and repeatable settings; handling was also intolerably critical. The method was finally abandoned and the alternative adopted, using a two-gang variable capacitor taken from a broadcast receiver and fitted with a reduction drive, and this solved the problem. It does, however, require good metallic shielding both between sections of the instrument and also overall by means of the cabinet, otherwise noise pickup from the mains or adjacent apparatus can be troublesome. It also requires non-standard fixed resistors of high ohmic value and very close tolerance, but these can be assembled from standard preferred values connected in series, as follows:-

For 16.8 megohms, use 10 megohms and 6.8 megohms in series.

For 1.68 megohms, use 1 megohm and 680k in series.

For 168k use 150k and 18k in series.

These values do not have to be exactly correct; the vital thing is that they shall be matched in similar pairs to within 1 per cent, one for each side of the bridge. A good Wheatstone bridge will do the matching, the lower of each pair being brought to within tolerance of its companion by the addition of a further series resistor of suitable lower value. Failing a bridge, if a DC supply of at least 250 volts - say from a valve broadcast receiver - is available together with a good 50 microamp meter having a knife-edge pointer, the resistors can be matched individually by the arrangement shown in Fig 7.

Starting from zero volts, increase the potentiometer setting gradually until some arbitrary scale division is reached, as near to full-scale as possible, and use this point as a reference mark for the selection of another resistor giving the same reading. With care a 1pc difference can be seen clearly, but the work must be done at a time when the mains voltage is steady (perhaps late evening). The potentiometer must be a linear wire-wound type of good quality and it may be advisable to alter the shape of the rotating contact to get as near to a single-turn resolution as possible. Failing these methods the resistors will have to be ordered as high-stability types of \pm 1pc tolerance, but closer tolerances do make a perfect null easier to obtain.

The emitter and collector resistors of the bridge amplifier Tr3 (1k and 1.9k respectively) must also be within 1pc tolerance. Theoretically the collector resistor should be 2k exactly, but in practice other tolerances in the range resistors and ganged capacitor make it necessary to provide a very finely-adjustable control over the exact value of this resistor. This is done by the 500ohm variable resistor.

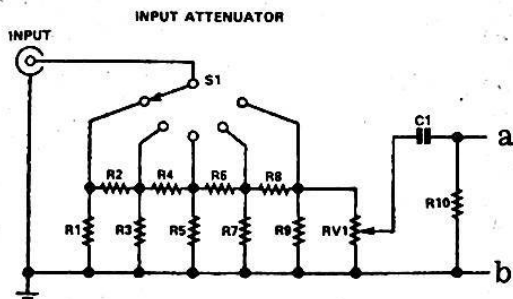

VOLTAGE ANALYSIS

	EMITTER (SOURCE)	COLLECTOR (DRAIN)
Tr 1	(2V)	(17V)
Tr 2	0.4V	3.5V
Tr 3	2.4V	5.8V
Tr 4	(5V)	(14V)
Tr 5	13.5V	18V
Tr 6	0.075V	4.4V
Tr 7	0V	2.35V
Tr 8	0.015V	1.2V
Tr 9	0.6V	5.0V

TOTAL CURRENT DRAIN

9 Volt Battery 1.2 mA.

18 Volt Battery 5.6 mA.

All voltages measured with 50 k/volt meter, with respect to chassis.

CALIBRATED POTENTIAL DIVIDER

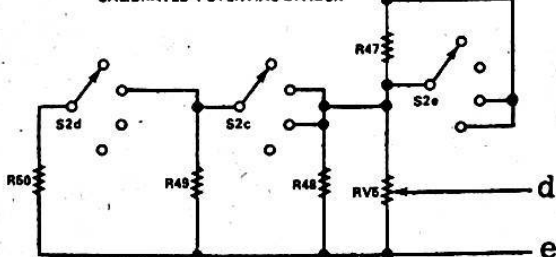

Connects with drawing on Page 41

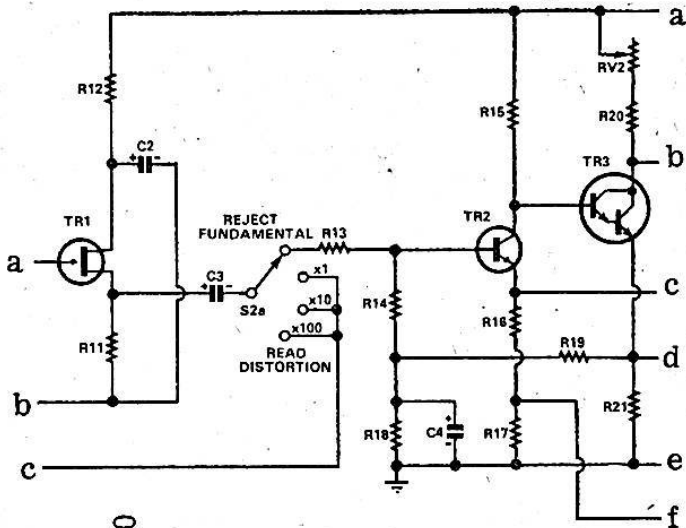

Connects with drawing on Page 40

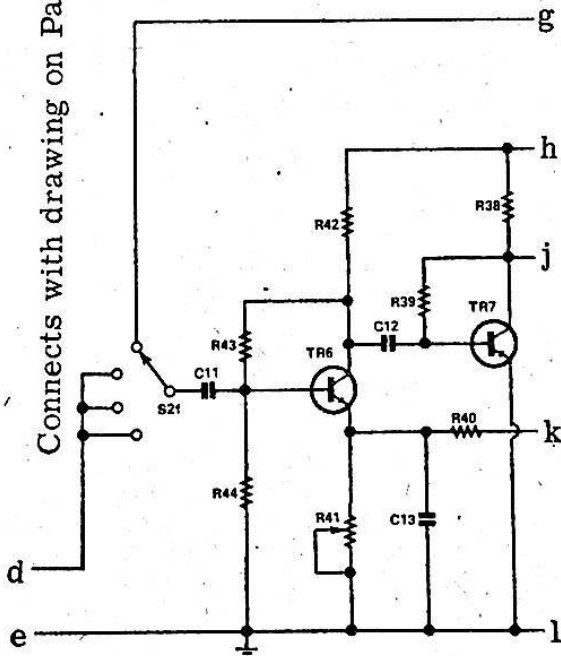

Connects with drawing on Page 42

FIG. 6

Connects with drawing on Page 41

NOTCH FILTER

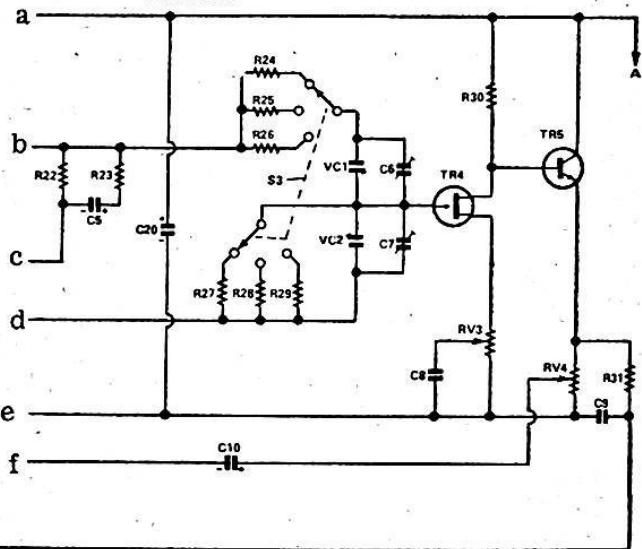

OUTPUT METER

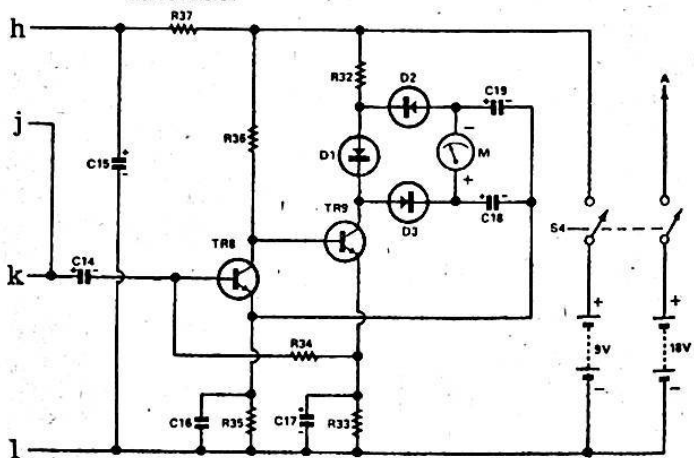

RV2 in series, is a 10-turn helical potentiometer mounted on the front panel and used as the fine control in the "Reject Fundamental" procedure. Note especially that a normal single-turn potentiometer is useless in this position as it cannot be set accurately enough. An accurate 1.9k resistor can generally be selected from a collection of 1.8k 10pc tolerance samples.

The circuit of the notch filter as shown in Fig 6 is a modified and simplified version of one described by J. Linsley Hood (Wireless World, July 1972). Tr2 is a preamplifier feed Tr3 and the bridge network. It is selected especially for its low-noise performance and for the same reason is operated at a very low collector current of 10 to 15 microamps. Many low-noise and high-gain types were tested here but it was not found possible to improve on the 2N930 finally specified. In addition to its good performance and modest price, this type seems inherently more stable, when used at very small collector currents, than some later types which show marked drift with time, regardless of temperature.

Tr3 is a Darlington type made by Motorola and chosen for its very low noise factor of 2dB at 1kHz with a high gain. Its characteristics enable a close approach to the theoretically ideal working conditions for the Wien bridge.

DC and AC negative feedback is applied from Tr3 collector to Tr2 emitter, and DC feedback from Tr3 emitter to Tr2 base to stabilise the working point. The combination gives a very low noise and distortion.

Since the base of Tr4 has no return to earth other than the bridge range resistors (16.8 megohms on the low range) and the signal path through the bridge is of high impedance, bipolar transistors which have comparatively low input impedance are hardly suitable for Tr4. A field-effect transistor, which draws virtually no gate current and needs no gate bias resistors, is a much better proposition and the 2N5245 was found satisfactory. The source resistor which furnishes gate bias in this circuit consists of a small "trim-pot" RV3 of 100k with a bypass capacitor of 0.1uF connected to its slider. This trim-pot is mounted in an accessible position for screwdriver adjustment and it controls the open-loop gain of the whole amplifier, gain increasing as the slider approaches the source terminal of Tr4.

Tr5, another 2N930, is an emitter-follower serving the dual purpose of a buffer between the notch filter and meter sections, and also as a means of setting the overall negative feedback of the system and thus adjusting the gain to unity, as previously outlined. The emitter resistor is RV4, another accessible trim-pot of 4.7k whose slider is returned through a 47uF tantalum capacitor to the emitter circuit of Tr2. With the slider at the earthy end, the feedback is zero and the open-loop gain can then be set to the required 10-12 times by adjustment of RV3, after which the slider of RV4 is advanced towards the emitter until the gain falls to unity. These adjustments are permanent. A suppressor resistor of 820 ohms (R31) takes the output of the filter to the meter section and serves, together with a 560pF capacitor, to suppress any tendency to high-frequency instability.

The filter and the attenuator buffer stage share a common 18 volt battery supply. This battery cannot, however, be used for the meter section also without instability, therefore the meter section has its own 9 volt battery.

The ganged capacitor in the bridge circuit is of 400 to 450pF per section; the exact value is not critical but the frequency coverage will vary accordingly. It should be of the best mechanical construction and electrical matching available. The writer used one of Philips origin with one-piece extruded frame and soldered brass vanes, taken from a broadcast receiver of the 1950's - a very accurate job. If no trimmer capacitors are provided suitable ones of 25 to 30 pF must be added. The concentric air trimmer is effective and has the necessary long-term stability. The trimmers are used to give the final close adjustment of the bridge null at the highest frequency (gang capacitor near minimum) after RV2 has been adjusted as closely as possible, and thereafter are not touched. RV2 is used over the rest of the range and is most effective at the lower frequencies.

The gang capacitor requires an insulated low-capacitance mounting of very rigid construction to allow exact setting, and as its frame is connected directly to the gate of Tr4 is prone to pick-up of hum, noise and feedback and needs some shielding, but need not be completely enclosed. For the same reason it needs to be set back from the metal front panel far enough to keep its spindle entirely inside the case, coupling to the external control being through an insulating universal coupling and a short length of $\frac{1}{2}$ in insulating rod. A slow motion dial, or control with a reduction of at least 5 to 1 - more for preference - is essential and it should be chosen carefully for absence of backlash.

The Calibrated Potentiometer. Essentially this is an accurate potential divider having three ranges, with an input resistance of 24k on all ranges. When the Function Switch S2 is set to the X1 position the output is 0.5pc of the input, while in the X10 position the ratio is 5pc, and in the X100 position it is 50pc. The fine calibrated control is provided by RV5, a 25k linear wire-wound potentiometer which should be of good quality and fairly large - say 2in diameter or more. It carries the scale from which Distortion Factor is read, calibrated from 0 to 0.5pc. As the required value for this control is $12k \pm 1pc$ it is shunted by a fixed resistor of nominal 22k, chosen from a number of samples to give the parallel resistance and tolerance required for the combination. The rest of the fixed resistors should also be of 1pc tolerance.

If the potentiometer has a metal cover this must be earthed to the panel. All wiring to this control must be well screened and earthed.

The Function Switch S2 is a six-pole four-position rotary switch of the usual type, with three decks each carrying two poles. A two-deck switch would be crowded, with more risk of unwanted capacitive coupling between circuits. S2D and S2F (see Fig 6) are on the deck nearest the front panel, S2C and S2E are on the next deck and S2A and S2B on the outermost one. This brings A, C and D in a vertical line, likewise B, E and F. The associated fixed resistors are mounted directly on the switch contacts. The non-standard-values are obtained by using two standard-value 1pc tolerance units in series, eg. 1k and 80 ohms for 1.08K, 100 and 33 for 133 ohms and so on. This has the incidental advantage that the overall tolerance of the combination may be closer than that of the individual resistors, since limit tolerance in the same direction on both components is unlikely.

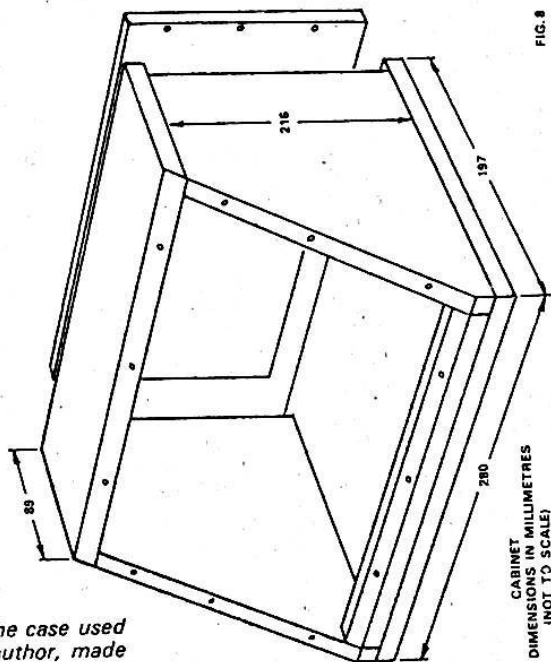
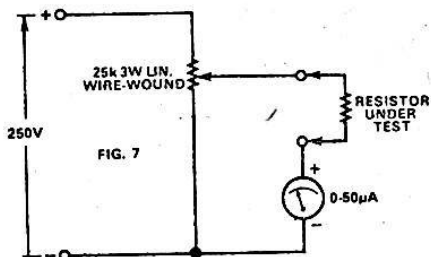

CABINET
DIMENSIONS IN MILLIMETRES
(NOT TO SCALE)

Fig 8: The case used by the author, made from 1/2-inch particle board. It should be lined with aluminium cooking foil, zinc flashing or copper foil to shield the wiring from external fields.

It has been suggested that the switching could be simplified by the use of a four-pole switch with modified circuit. I have not tried this, but it may well be satisfactory. To reduce the risk of signal feed-through due to stray capacitance, S2A and S2D should be on separate wafers and on opposite sides of the switch centerline. The wafers should be well spaced.

The distortion scale for the variable potentiometer can be made with the aid of a small circular celluloid protractor, as sold cheaply by stationers for school use. It is only necessary to devise a temporary mounting, either directly on the spindle and rotating with it or else stationary with a temporary pointer running over its scale; it must, however, be truly concentric with the spindle. Most such protractors have cross-lines to indicate true centre. With an ohm-meter connected successively between each end and the slider, determine the exact point on the protractor at which the resistance reading departs from zero (not necessarily the end-stop points) at each end. Read off the number of degrees between these points, divide by five to get the degrees separating the five cardinal points of the proposed scale, i.e., 0.5%, 0.4%, etc., down to zero and then further sub-divide these divisions as finely as desired. The writer used ten main divisions only, intermediate readings being easily estimated by eye. Once determined, these same divisions can be laid out with the same protractor on a suitable piece of card or plastic to form the scale of the instrument.

The Meter Circuit. This is a four-stage negative feedback amplifier driving a 0-100 microamp meter through a somewhat unusual silicon rectifier bridge. Its function is to compare the outputs of the calibrated potential divider (total signal) and of the notch filter (distortion and noise only) when brought to a standard reference reading. Therefore it is an indicator only, but as previously mentioned its essential requirements include a response flat within 1dB from 20 Hz to 100kHz, a sensitivity of at least 200 microvolts for 70pc of full-scale reading, and a high input resistance. This sensitivity requires good screening and full precautions against instability, since the scope for in-phase feedback and consequent oscillation is considerable. In final form it has proved quite stable and reliable and could well form the basis for a separate multi-range micro/millivolt meter with complete scale calibration for general use. The input impedance is around 100k and the meter shows no measurable noise.

Overall negative feedback from output to input proved difficult to stabilise, so multiple feedback paths were adopted, all DC coupled except that through the output meter. It also proved necessary to split the amplifier into two physical sections screened from each other by flat screening plates, and to decouple the first two stages from the battery supply by a 1k resistor and 220uF capacitor.

Input is through a non-polarised electrolytic capacitor of 4uF, or else two 10uF normal tantalum units connected back to back. Minimal leakage current is vital here. Tr6 is operated at very low collector current to minimise noise and has some DC feedback from collector to base. Its emitter bias resistor consists of a 220 ohm trim-pot connected as a variable resistor and it serves to set the ultimate sensitivity of the whole meter circuit. It will normally be at the full resistance setting, but it can be used for close adjustment of gain by those who have a metered audio source and a temporary input pad to give a calculated 200 microvolts of signal. Stable and almost

noise-free sensitivities down to 50 microvolts have been achieved experimentally but are not needed here.

DC feedback is applied between Tr7 collector and base and also from collector to Tr6 emitter. These two stages, together with the decoupling components, are assembled on their own small Verobaord panel and mounted on, and closely spaced from a flat earthed shielding plate of larger size. The other side of this plate carries the rest of the circuit upon another Verobaord panel, consisting of a further two-stage feedback amplifier using Tr8 and Tr9 in a circuit designed for high input and low output resistances. All transistors are of the high-gain type BC109C or equivalent.

The rectifier and meter circuit, through which negative feedback is taken over two stages, first came to the writer's notice in an Application Note published by Ferranti Ltd. Unlike some rectifier-meter circuits it is linear over about three-quarters of its scale and is claimed to give virtually true RMS readings over this range. Its properties, including frequency response, can depend somewhat upon the amount of feedback used; in this case the complete circuit has flat response from 20Hz to beyond 200kHz but by reducing gain somewhat it could easily be made flat to 1MHz and beyond.

The meter is a 0-100 microamp type whose resistance is not very important and it can be of any desired size or style. The diodes are all silicon types; the series units are 1N914 and the shunt unit (in series with Tr9 collector) is a 1S44. The two isolating capacitors are 22uF tantalum units for the sake of low leakage and other sizes down to 15uF could be used without much effect if more convenient. The relative polarities of diodes, capacitors and meter are shown on the circuit, "C" denoting cathode, and should be carefully noted for an error here can make the meter inoperative. This circuit has its own 9-volt battery supply with 220uF bypass capacitor and separate On-Off switch. The reference mark on the meter scale, indicated by a red line, was made at 70 microamps to give some scope for overswing during tuning.

CONSTRUCTION: This can take many forms to suit the constructor's ideas or available components, and no detailed plans are offered. A shielded case is required, either of metal (preferably not steel) or else of wood with internal metal shielding. The prototype used a case made up from $\frac{1}{2}$ " pineboard lined with aluminium cooking foil stuck on with adhesive; this unexpectedly proved effective. Zinc "flashing" or copper foil would be better and allow the seams to be soldered - very desirable. Fig 8 shows this box with rough dimensions, but these will vary with the components used.

The front panel of 18 gauge aluminium, is faced with 1/16th" white plastic sheeting of the same size. It carries the complete assembly apart from batteries, which must be housed inside the case to avoid noise pickup and should be insulated from the metal lining by waxed cardboard or other means to prevent noise due to leakage from battery to its outer case, which is not unknown.

A suggested control layout, used in the prototype, is shown in Fig 9. This lends itself fairly well to the necessary shielding behind the panel between sections and components which is, in principle, like

Fig 10. Signal input is through a standard Phono socket and plug. The meter used has a round barrel and a face about two inches square. It was found necessary to provide a tight-fitting cylindrical shield 2" high around the barrel of the meter behind the panel and earthed to it, to eliminate feedback. It was made of Zinc flashing strip (not steel or tinplate) which is available from most builder's hardware stores. The seam was soldered and twisted meter leads taken in through a hole drilled in the wall of the shield on the side of the shield remote from the rest of the circuit. These leads are "hot" and it may be well to use screened wire.

A 20 gauge hard aluminium dividing plate roughly 3in high by 9½in long runs horizontally across the rear of the front panel about 4in from the top edge and is mounted on a piece of ½in hard aluminium angle bolted to the panel. Holes are drilled in this plate where necessary to pass connections. It also carries an insulating panel of ½in sheet bakelite attached by further pieces of angle to the front panel and to the dividing plate; this panel carries the ganged capacitor and must be dimensioned to suit the capacitor used. Its mountings must be rigid and substantial, or there will be unwanted backlash in the capacitor drive which will be most frustrating.

The buffer amplifier for the input attenuator is assembled on a Veroboard panel about 1½in square, which is mounted on the dividing plate close to the attenuator controls. If much work on high-powered amplifiers is expected it would be worth while to enclose this and the coarse and fine attenuators and the input socket in a separate shield box bolted to the front panel for protection against the amplifier's stray signal field, which may penetrate the case and be picked up directly by the buffer stage.

The ganged capacitor will need some shielding from all other sections, but shape and size will depend on the component used. In the prototype a shield 2½in wide rising vertically from the front panel between the gang mounting and the input attenuator and then bent horizontally over the gang for 2in and clearing it by ½in was found sufficient.

The input attenuator switch S1 is a rotary single-deck switch of one-pole eleven-way type but with its rotation limited to five positions. The associated fixed resistors are then mounted either across the switch from side to side for the shunt elements, or between adjacent live contacts for the series making the whole assembly self-supporting. The 4.7µF coupling capacitor C3 should be a tantalum type, for low leakage. Earth the metal cover of the Fine Control potentiometer with a separate connection.

The notch filter was assembled on a 5in x 2in piece of 0.1in matrix board and mounted by bolts and nuts on the dividing plate parallel to it and alongside the ganged capacitor and Range Switch for short connections. It should be spaced ½in or less from the dividing plate for good shielding and if contact is feared a sheet of thin culluloid can be used between them. The input connection is at the end nearest the Function switch and output at the other. These connections, to S2A and S2F respectively, are made with 3mm shielded and PVC covered cable, with their shield coverings connected together at the switch ends and thence by a common insulated wire to the main earth point at the input socket. All circuit sections are, in fact, provided each with its own insulated earth wire and all are grounded only at the

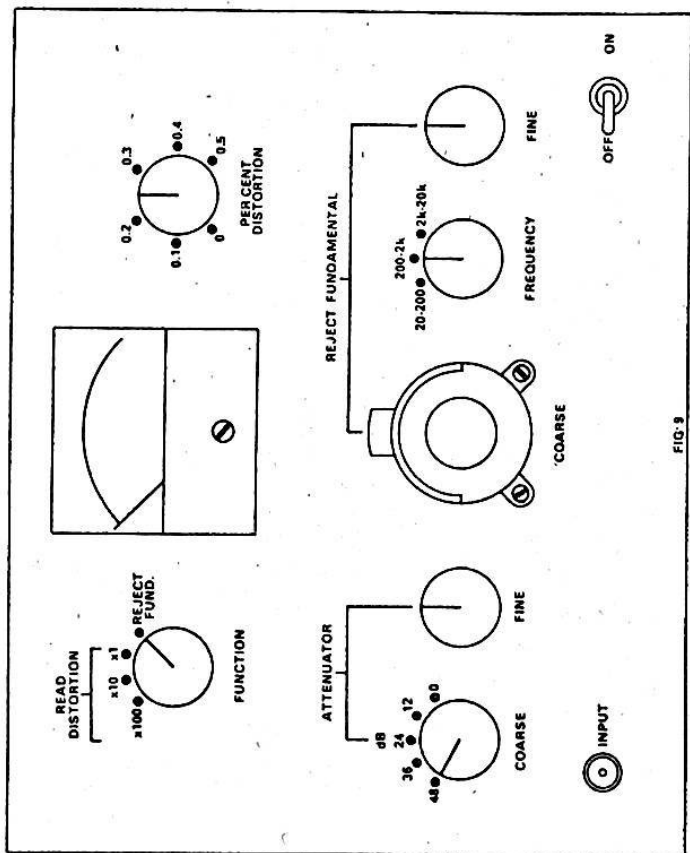

FIG. 9

Fig 9: The author's suggested layout for the front panel of the distortion meter. The meter movement is a small 100uA imported type.

input socket.

The Range Switch is another single-deck type, of two-pole three-way construction. The writer replaced the normal wafer assembly screws with two 1/2 in lengths of threaded rod with nuts, and on the ends of these a two-way-tag-strip was mounted with more nuts, to provide the two common terminations for the six range resistors, thus making another complete sub-assembly mounted to the panel by a single nut. Tinned-copper twisted loops are used on the matrix board for the emitter and collector connections of Tr3 and the gate connection of Tr4 and short stiff connections go from these to the frame of the capacitor and to the common resistor terminations. The trimmer capacitors C6 and C7 must be freely accessible for initial balancing, also potentiometers RV3 and RV4 for screwdriver adjustment. A twisted pair of leads must be brought out from the matrix board for connection to the ten-turn potentiometer RV2 which is connected as a variable resistor. If a "Helipot" is used connect to its two rearmost tags, ignoring the third one.

The "ON-OFF" switch has to a double-pole type to control the two separate batteries.

Coming now to the other side of the dividing plate, the two halves of the meter circuit are, as previously said, assembled on individual small Verobaards mounted on on each side of a shielding plate measuring 5 1/2 in x 2 1/2 in. This is mounted by long machine screws and nuts to the dividing plate with the input section next to it, with about 1/2 in between the plates for good shielding. A further shield plate measuring about 3 in x 2 1/2 in is then fitted over the output section of the circuit by long screws to the first-mentioned shield and separated from it by 5/8ths in., thus sandwiching the complete meter circuit. The arrangement is roughly shown in Fig 11. Input to section 1 and output from section 2 are arranged to be at the ends nearest the Function Switch and panel meter respectively, and the connections between sections at the other end, giving the shortest exposed wiring. Use 3mm shielded cable for the connection from S2F to meter circuit input, with braiding earthed.

Twin shielded and PVC-covered cable forms the three connections between the calibrated potentiometer RV5 and S2E, S2F and earth. As before, the earthy connection to the screening braid is insulated and carried right back to the main ground point at the input socket. The earth returns of R49 and R50 are also part of this system. R48 of 22k nominal resistance is mounted directly on the potentiometer tags. Don't omit to ground any metal cover on this potentiometer to its earthy terminal.

SETTING UP. This process requires an audio oscillator of reasonable waveform with an output controllable from 200 millivolts or more to zero, and also an oscilloscope or, failing that, a sensitive electronic voltmeter capable for reading down to 100 millivolts or less, with a high input resistance and a flat response over the audio range. The oscilloscope is preferable, especially if it has a "X10" facility switch on its vertical attenuator and an accurate graticule. Proceed as follows:

With an instrument temporarily in its shielded case to cut out noise pick-up, set the filter Coarse control (ganged capacitor) and Fine control (RV2) to around mid-range, the Frequency range switch to the 2-20kHz range, and the Function Switch to "Reject Fundamental". The sliders of RV3 and RV4 should be at their earth ends. Set the input attenuator controls Coarse and Fine, to 48dB and zero respectively (fully anticlockwise.)

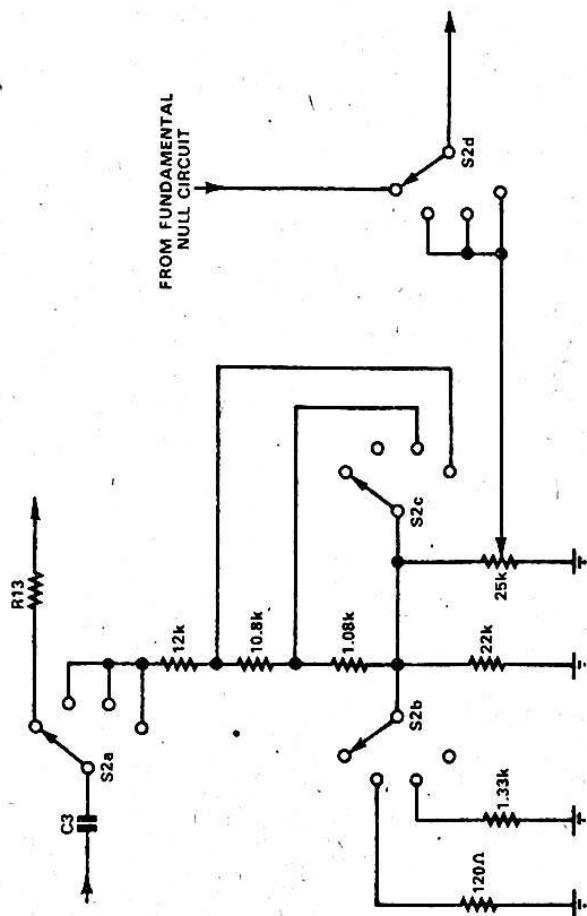

A suggested modification to the circuit which simplifies the function switch wiring and saves one section. The author has not tried it, however.

Switch on. The meter pointer will flick hard over several times during a period of five to ten seconds as the various large electrolytic capacitors gradually charge up to their terminal voltages and pass through some unstable regions on the way, but thereafter the needle should settle to a steady reading which should be fairly low if the testing area is reasonably free from electrical interference. An earth connection can be tried, but if it increases the meter reading discard it.

If all is well so far, remove the cabinet and proceed to the final adjustments. Set the controls as follows:-

1. Frequency range switch on 2 to 20kHz.
2. Filter Coarse control (capacitor) at 80 degrees, i.e., around 2.5kHz.
3. Set input attenuator controls to zero attenuation, i.e., fully clockwise.
4. Connect audio oscillator to Input socket by plug and a shielded cable long enough to allow about two feet separation between the instruments.
5. Set oscillator to around 500Hz - not critical - and its output control to give around 200 millivolts.
6. Switch on both instruments. The meter will go far beyond full-scale reading during this process, but no harm will result.
7. Switch on oscilloscope and connect its vertical input to the input of the notch filter (the corresponding lug on the Function Switch S2A is convenient). With the 'scope attenuator Switch on "X1" adjust its fine attenuator control and, if necessary, the oscillator output control to give a steady trace of convenient height - say 3 or 4 divisions on the graticule. Note this height.
8. Transfer the 'scope output to the output of the notch filter (again a convenient point is the Function Switch, lug S2F) and set the 'scope attenuator switch to "X10".
9. Adjust RV3 to give the original height of trace, thus giving the filter a gain of 10 times.
10. Re-set 'scope switch to "X1". Now adjust RV4 until the trace again returns to the original height; i.e., feedback has reduced the gain to unity which will now be the condition for all harmonic frequencies, but not for the fundamental ones which are being suppressed by the filter.
11. Return the 'scope to the filter input and compare to ensure that the signal amplitudes at input and output of the filter are now identical.

This completes the sensitivity/selectivity adjustments. The bridge capacities must now be balanced, and as this requires, full sensitivity and an accurate null it is best if the trimmer capacitors C6 and C7 are accessible with the instrument in its case but with back removed. In a "noisy" location it may be necessary to switch off all mains-operated equipment in the vicinity, including lighting if this is of the fluorescent type. Proceed thus:

1. Set C6 and C7 to about half their range.
2. Set the input Coarse attenuator to 48dB and the Fine attenuator fully anti-clockwise. Set the Function Switch to "Reject Fundamental," the Frequency range switch to 200-2kHz and the ganged capacitor to 15 degrees.
3. Switch on, allow a couple of minutes to settle down, and note the meter reading which should be quite low, around 5 microamps. This is the internal (transistor) noise of the

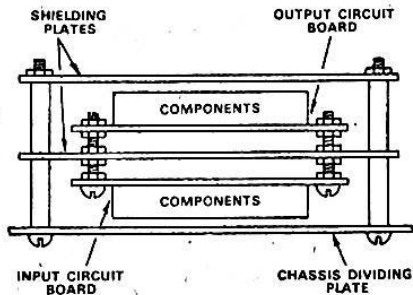
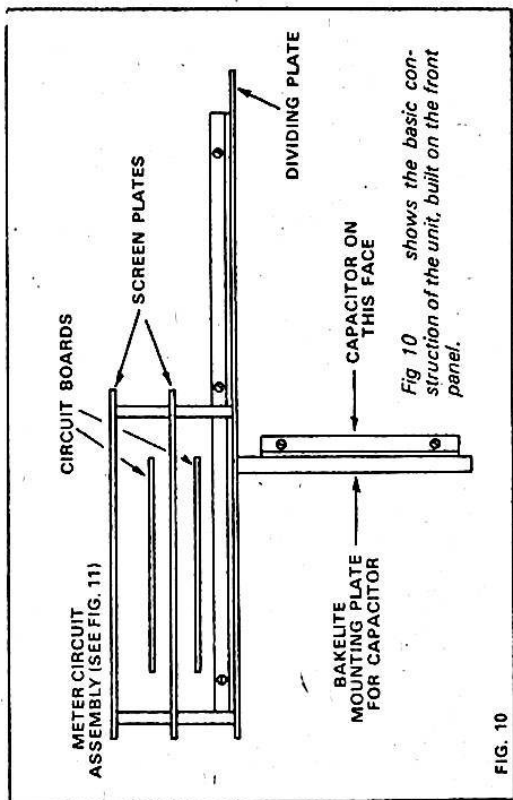

Fig 11 shows the meter amplifier assembly.

instrument and is normal. (The batteries should be in their final position inside the case for this operation.)

4. If all is well, set the audio oscillator frequency to 2kHz and output to 200 millivolts roughly, and switch on. Advance the input attenuator controls until a reading of half-scale or more is seen on the meter. Now tune the variable capacitor VC1/VC2 until a pronounced dip occurs, indicating an approach to balance at that frequency. Increase the attenuator setting to restore balance control RV2, when a further dip will probably be seen.

Next set VC1/VC2 to around 10 degrees on its dial, i.e., with plates almost unmeshed, and re-tune the oscillator until the dip is again seen. From this point on continue to adjust both Coarse and Fine balance controls together (they will interact a little) while gradually increasing input until the best null is seen. It will be found very sharp and a steady hand on the controls is needed. The Coarse input control will now probably be at 0dB and the Fine control fairly well advanced.

Now the final adjustment can be made by altering one of the trimmer capacitors C6 or C7 while rocking the ganged capacitor around the null point with, if necessary, a touch on the Fine balance until the best possible null is obtained. This completes the process, and assuming a 200 millivolt input signal of about 0.1pc distortion and with zero attenuation, a meter reading somewhere in the upper half of the scale should be seen, representing the total distortion in that signal; a less pure input will give a higher reading and require some attenuation.

Set the attenuator to bring the meter to the reference mark. Now move the Function Switch to "Read Distortion" without touching attenuator or oscillator. Adjust the calibrated potentiometer RV5 to again give the reference reading on the meter, and read the distortion percentage from the scale of RV5.

A signal having more than 0.5pc distortion will require the Function Switch to be moved to the "X10" or even the "X100" setting. In each case the distortion reading on the scale is to be multiplied by that factor.

USE: High sensitivity requires that measurement of an unknown signal must be approached from the position of maximum input attenuation gradually increasing the input until the first meter reading is seen. At this point a rough null should be sought on the Coarse control (capacitor). The input is then slowly increased while following up the null, which gets progressively sharper, on both Coarse and Fine controls until no further improvement can be obtained. In the course of such a measurement the meter pointer will frequently go "off scale" but no damage should result and the author's instrument has never given trouble. The working conditions of the associated transistors virtually preclude a damaging current flow. However, if the constructor wishes to minimise this effect, it can be improved though not eliminated by connecting an OA90 diode directly across the meter terminals with its cathode to the negative terminal. The meter reactions are then more gentle, but the sensitivity is reduced by some 20pc and linearity is spoiled. The decision rests with the user, but the writer feels it is hardly worthwhile.

The only other points to watch are concerned with noise and stray signal pick-up. A shielded input cable should always be used, allowing two feet or more between the case of high-powered amplifiers. Watch also for stray AC fields from transformers and especially from filter chokes, also for radiation from TV sets and from Oscilloscope timebases. In some locations radiated interference from the electric wiring can enter via the input, it is useful to have a dummy input plug which is short-circuited; if noise persists with this plugged in, it is either internally generated or is getting past the case shielding. An earth connection may be found beneficial, or even essential when using an oscilloscope together with the DV Meter, but do not assume it to be so without trying it - the meter itself will quickly tell you.

With shorted input and a reasonably "quiet" location the self-generated noise is not likely to exceed the equivalent of 0.01pc distortion. For the purist, it seems reasonable, to add this amount to the indicated figure to arrive at the true value, but this is perhaps to split hairs in the case of a simplified instrument of this nature. In the prototype the noise approximates to 0.008pc distortion.

It is advisable to replace batteries before their voltage falls 20pc, and even new batteries must be watched for noisiness which is far from uncommon in the small units sold for transistor radio sets. If the meter needle begins to show erratic fluctuations even with the input socket shorted, suspect a noisy battery. And beware of buying stale batteries, which can be useless for this instrument even though showing normal voltage. It is best to buy only from sources which have a large and rapid turnover of stock.

An approximate voltage analysis is given to help in trouble-shooting.

DISTORTION METER PARTS LIST

S1 1-pole 5-way switch.
 S2 6-pole 4-way switch.
 S3 2-pole 3-way switch.
 S4 Double-pole On-Off switch.
 M DC microammeter, 0-100 microamps.
 1 Slow-motion dial, 5 to 1 reduction or greater.
 1 9V battery.
 1 18V battery
 Shielded case, knobs, phono socket and plug, bolts and nuts, etc.

Semiconductors

TR1 2N5245 SK3116.	TR6-7-8-9 RS 276-2009 BC109C
TR2 RS276-2013 2N930	D1 1S44
TR3 MPSA14 2N5526	D2, D3, 1N914
TR4 2N5245 SK3116	
TR5 2N930 RS 276-2013	

Resistors

R1 320k 1pc	R13 24k	R20 1.9k 1pc	R30 47k
R2,4,6,8,932k 1pc	R14 47k	R21 1k 1pc	R31 820 ohms
R3,5,7 418k 1pc	R15 470k	R22 120k	R32 8.2k
R9 835k 1pc	R16 3.3k	R23 39k	R33 1.5k
R10 270k	R17 100ohms	R24, 27 16.8 M 1pc	R34 12k
R11 8.2k	R18 15k	R25, 28 1.68 M 1pc	R35 39 ohms
R12 2.7k	R19 22k	R26,29 168k 1pc	R36 22k

R37 1k	R44 470k
R38 22k	R45 12k 1pc
R39 1.5M	R46 10.8k 1pc
R40 10k	R47 1.08k 1pc
R41 220 ohms (see text).	R48 22k approx. (see text).
R42 47k	R49 1.33k 1pc
R43 2.2M	R50 133 ohms 1pc

RV1 500k linear Pot
 RV2 500 ohm 10-turn helical Pot. (Beckman "Helipot" type 7266.)
 RV3 100k trimpot.
 RV4 4.7k Trimpot
 RV5 25k linear wire-wound Pot.

Capacitors

C1 0.22 uF
 C2 220 uF, 20V Wkg.
 C3 4.7 uF 16V Wkg, tantalum.
 C4 220 uF 10V Wkg
 C5 22 uF 20V Wkg
 C6, 7 3/30 pF trimmer
 C8 0.1uF
 C9 560 pF
 C10 47 uF 16V Wkg. tantalum.
 C11 4uF Bi-polar electrolytic.
 C12 1uF polyester.
 C13 2000 pF
 C14 22uF 16V Wkg. tantalum.
 C15, 17, 250 uF 10V Wkg.
 C16 0.01 uF ceramic.
 C18, 19 22 uF 10V Wkg. tantalum
 VC1, VC2, 10/400pF ganged air variable, or nearest.
 C20 220 uF 20V Wkg.

FOR BEGINNERS: A SIMPLE TRF RECEIVER.

One of the most frequent requests we get is for information on simple am radio receivers and tuners for the broadcast band. These never seem to fall in popularity, particularly among the younger readers. It is an up-to-date TRF set using a new "receiver-on-a-chip" circuit, and you can build it up in either of two versions.

This receiver must surely be one of the simplest projects that we have published to date, despite the fact that it uses ten "transistors." The secret of its simplicity lies in the use of a new integrated circuit, the ZN414, which is virtually a complete TRF receiver in itself. However, before we begin to describe the constructional details of our receiver, it may be as well to examine a few historical facts regarding TRF receivers in general.

Radio receivers employing the superheterodyne principle have dominated the radio industry for the past 30 years. Prior to the superhet achieving complete acceptance, several other types of receiver designs enjoyed varying degrees of popularity, the main alternatives being the tuned radio frequency (TRF), the reflex and the super-regenerative designs.

Reflex receivers were capable, with careful use, of extremely good results. However, they were quite difficult to build and stabilise. As with any high gain device where feedback is encouraged, instability often resulted, making the receiver unpredictable in use. The super-regenerative receiver was even harder to build and operate correctly, the basic design radiating interference over a wide area if misused.

The TRF receiver was the design which enjoyed almost absolute exclusivity in the early days of broadcasting. It was reasonably sensitive, and was selective enough to separate the few stations then operating. In addition, it possessed four other advantages:

1. it was simple to build and operate;
2. it was economical;
3. no interference was generated in use- and
4. it was capable of excellent sound quality.

As the number of AM broadcasting stations increased, both the reflex receiver and the TRF became less popular. Furthermore, the technology existing at the time prevented improvements to these receivers beyond a certain point. The superhet, whilst not possessing many of the advantages of the other types of receiver, was the only design capable of resolving the mass of new stations which appeared during the 1930's.

Many changes have occurred in the last twenty years which have altered some of the design criteria for AM receiver designs. The function of AM broadcasting has altered quite markedly, the majority of people today using an AM receiver solely to listen to four or five major broadcasts. The average listener has no interest in listening to distant stations or foreign broadcasts.

These facts coupled with the advent of a new integrated circuit manufacturing process known as "Collector Diffusion Isolation," led engineers at Ferranti to re-think the design requirements for an AM receiver, and to examine the TRF receiver in more detail. The result was the ZN414, a complete TRF radio tuner in a 3-pin transistor package, the chip occupying less than one thousandth of a square inch. This IC forms the heart of our simple receiver.

Basically, the device is a ten transistor TRF tuner giving an audio output suitable for driving any reasonably sensitive amplifier. To obtain the high selectivity needed in a TRF design, an extremely high input impedance is provided. The radio frequency (RF) signal is amplified successively, using four stages of high stability. These are essential to ensure constant, reliable operation over a wide range of operating conditions. The amplified RF signal is then detected and used to derive automatic gain control action (AGC). Finally, the audio component of the detected waveform is fed through a low pass filter to drive an external amplifier or crystal earpiece.

If one elects to use the popular low impedance (hi-fi type) headphones, this requires that an impedance matching device be used between the tuner and the headphones. Our solution was to use a speaker transformer which has a primary impedance of 5,000 ohms, a secondary impedance of 15 ohms. Any similar speaker transformer would be suitable. While a crystal type earpiece could be used, the performance is nowhere near as good as that from the low impedance "hi-fi" types.

Instead of a long wire aerial and an earth, this receiver uses a ferrite rod aerial, enabling the set to be used anywhere. Nothing is more annoying than having a set tied to an aerial and earth, unless there is a good reason for doing so. In parallel with the ferrite aerial is a tuning capacitor. A standard 10-415pF single section type may be used. The alternative version of the set uses a miniature plastic dielectric capacitor.

The 1k resistor placed in series between the positive supply rail of the 1.5V battery and the output of the ZN414 is used to derive AGC action. It is not enough to wind a high "Q" aerial coil and expect optimum performance automatically. If the AGC action is incorrectly set, stations will either occupy an inordinately large bandwidth, or will not be received without undue noise. In addition, the audio output may well reduce with increasing signal strength due to the RF gain of the ZN414 being too high. This causes clipping of the modulation waveform, resulting in reduced output and high distortion.

In practice, we found that the receiver works well with the AGC resistor fixed at 1k. However, individual readers may have to alter this value should the above symptoms be experienced.

One of the characteristics of the TRF circuit is that, even with a high "Q" tuning mechanism, a very strong station will swamp the circuit. This condition will result in poor selectivity and possible high distortion levels. Rotation of the receiver to find a null is the most effective way to solve this problem. Alternatively, the supply voltage may be reduced.

To keep the construction of this receiver as simple as possible, keeping in mind our objective for a simple beginner's project, we initially elected to use the bread-board design approach. The major components, with the exception of the headphone socket and the on/off switch, were mounted on a piece of 5/8ths thick particle board, the dimensions of which are 16 x 10.5cm. A front panel was fashioned from a piece of scrap aluminium, and this accommodates the on/off switch and the headphone socket, together with the dial and station identifications.

Construction of the receiver may begin with the construction of the Ferrite aerial coil. Ferrite rod is sold in 200mm lengths - and as we need only 100mm, it must be divided. The rod is cut in a similar manner to glass: file a nick right around the circumference, then snap it carefully by hand. Take care not to drop it, as ferrite is brittle and will break easily.

the complete circuit diagram for our simple TRF receiver.

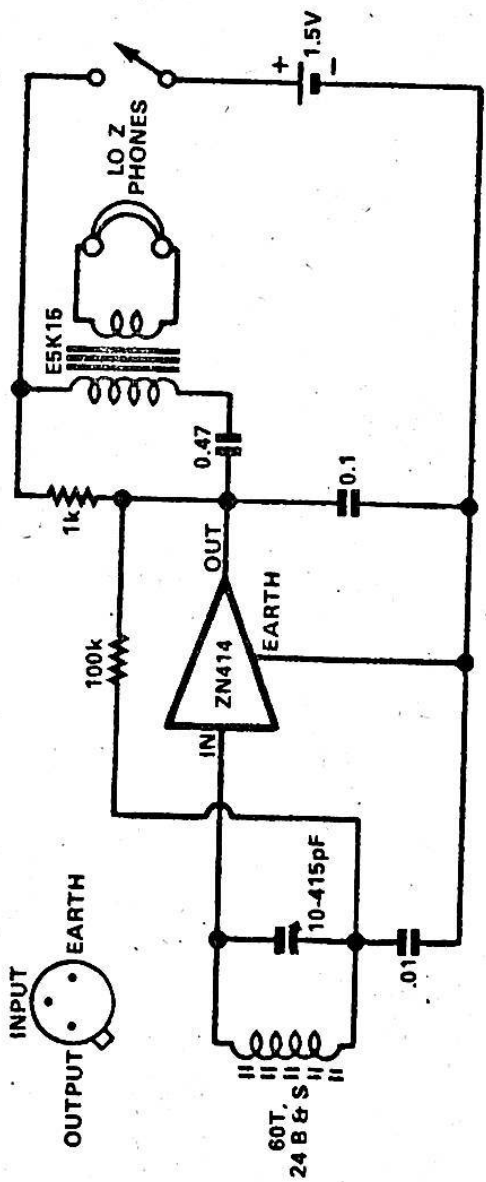

Wind a layer of insulation tape over the ferrite to protect the enamelled wire, then anchor the wire (24 SWG) about 2 cm from one end (leave about 10cm wire over) and close wind 60 turns onto the rod, making sure that the turns are tight. Anchor the winding with insulation tape, again leaving about 10 cm of wire for connection to the tuning gang. No taps are required on the coil.

The tuning capacitor is the first major item to be fitted on the board. It is mounted so that the centre of the shaft is approximately 4.5cm from the right hand edge of the board. To keep costs down, you may be able to salvage a tuning gang from an old discarded radio. However, it is probable that it will be physically larger than the gang we have used (though it will probably still have the same capacitance), and will almost certainly be a double gang type. If so, the layout that we have used will have to be modified somewhat to ensure that all components will fit on the board.

If you do salvage a gang from an old set, make sure that the plates of the gang do not touch anywhere over its travel. This is best done using an ohmmeter. The fact that the gang is a double section type is of no consequence (except in terms of size and physical layout) - simply ignore one section, unless you aim to try listening on frequencies down past the low end of the broadcast band.

The battery holder and transformer can now be mounted. Note that other transformers may be more bulky than the transformer we have used, in which case the transformer will have to be mounted slightly to the left of its present position. Make sure that you leave sufficient space between the transformer and the front of the board (at least 3.5cm) to enable the tagstrip to be mounted.

The next logical step is to wire the tagstrip according to the layout. This accommodates all the minor components, including the ZN414 integrated circuit. The tagstrip is then simply screwed to the board immediately behind the front panel and adjacent to the tuning capacitor.

Because some readers may experience difficulties in obtaining conventional double-sided resistor tagboard, we used a relatively new product - etched copper laminate tagboard. This is similar to conventional tagboard, but has etched copper pads instead of the usual rivetted tags. All holes and dimensions of the printed board version are exactly the same as with conventional tagboard. Either type of tagboard can be used in the construction of this receiver.

Two small brackets are used to mount the ferrite rod. These were bent up out of a piece of scrap 22g aluminium. They are screwed to the back of the board immediately behind the battery holder and the transformer. The rod is held in the brackets by two rubber grommets which are slid onto either end of the rod. The distance between the

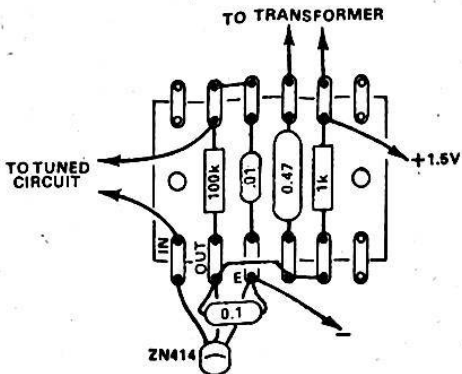

The wiring diagram for the tagboard. Be careful to ensure correct connections for the ZN414.

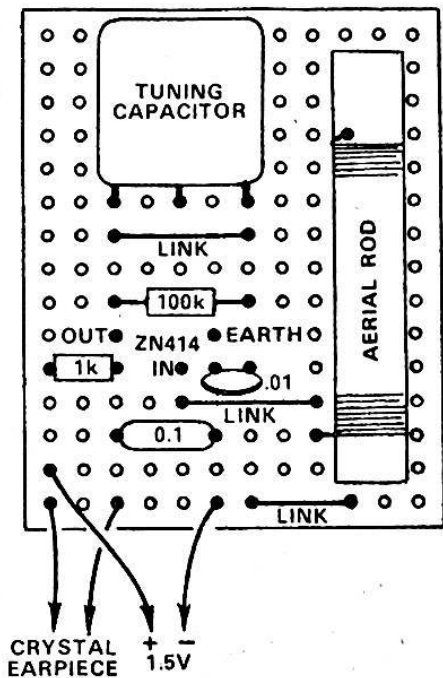

mounting brackets should be approximately 9cm. However, this is not critical as the grommets can be moved along the rod until they fit.

Having mounted all the major items, including the tagboard, all leads can now be cut to their correct length and connected. First, connect the leads from the tagboard to the tuning capacitor, then the flying leads from the tuned winding to the same points. The battery, on/off switch, transformer, and headphone socket can also be connected at this time. Make sure that the leads to the on/off switch are left long enough to enable these latter two items to be mounted on the front panel.

The wiring of the headphone socket warrants special mention where hi-fi stereo phones are to be used. It is important that the socket be wired so that both phones of the stereo headset receive the signal. To do this (and also to present the maximum impedance to the output transformer), the phones are wired in series. Simply use the socket tags which connect to the tip and ring of the plug, and ignore the tag which connects to the main body of the plug.

With the wiring side of our simple TRF receiver now completed, all that remains is the front panel. The panel used on the prototype was fashioned out of a piece of 22g aluminium, the dimensions being 16 x 9.5cm. Three holes need to be drilled in this front panel - one for the tuning capacitor shaft, a second for the on/off switch, and the third for the headphone socket. The holes for the tuning capacitor shaft and the headphone socket were drilled to 3/8th inch, whilst a 1/4in hole is used for the on/off switch. All holes should be de-burred with a large drill.

We used "Letraset" for all front panel marking and labelling, after which a fine coat of clear enamel was applied to protect the surface. If desired, the front panel can be dressed with a wire brush before labelling. A simple plastic "handspan" dial was fitted to the tuning capacitor shaft.

Having completed our breadboard version of the TRF receiver, we began to examine the possibility of miniaturising the design layout. One obvious solution to the problem of miniaturisation is the elimination of the bulky transformer, by using a high impedance crystal earpiece together with the use of a miniature tuning capacitor and a more compact loopstick. The use of a 1.3V mercury cell in place of the standard 1.5V penlight battery would also make for a more compact design, although at an increase in cost.

We built up a second version of the set on a piece of Veroboard with the objective of miniaturising the design as much as possible whilst retaining a neat and easy-to-follow layout. The basic circuit for the miniature version is exactly the same as for the breadboard version, except that the transformer and its associated 0.47uF coupling capacitor are eliminated; the output to the crystal earphone is simply taken across the 1k AGC resistor.

The aerial coil used in the miniature version also differs slightly from that used in the original breadboard design. It consists of 85 turns of 32SWG enamelled wire, the ends being soldered directly to the board. A small strip of insulation tape is used to further secure the aerial rod on the board.

We managed to fit all components, excepting the battery, the earpiece and the on/off switch (if required), onto a piece of Veroboard measuring just 6 x 5cm. No doubt a more compact arrangement could be achieved by standing resistors on end, etc. However, this is left to the individual constructor, as are the cabinet mounting and battery connection details.

Naturally, there is no need to adhere to the physical layouts we have used. However, if you do decide to alter the layout, certain design precautions should be followed to ensure stable, consistent operation. The most important of these are as follows:

1. the output decoupling capacitor should be soldered as near as possible to the output and earth leads of the ZN414;
2. all leads should be kept as short as possible especially those in close proximity to the ZN414; and
3. the "earth" side of the tuning capacitor should be connected to the junction of the 0.01uF capacitor and the 100k resistor.

Whether you decide to follow one of the layouts we have used or decide to design your own layout, little difficulty should be experienced in setting this simple little receiver into operation. We suggest that the beginner start with the breadboard version and progress to the miniature version. In fact it would be a real challenge to see just how small you can make this receiver.

You don't have to use it purely as a simple receiver, either. It would be just fine as a tuner for tape recorders, PA systems, and any other similar applications. With good sensitivity and fairly wide bandwidth, it can give remarkably high quality reception when used within a reasonable distance from the stations.

Incidentally, there's no reason why you shouldn't adapt the design to tune to other frequencies, as the ZN414 is designed to operate normally over the range 150kHz to 3MHz, which extends both well below and well above the broadcast band. You may even be able to push individual devices further still. There's plenty of room for experiment.

All you will need to do to modify the design for different frequency ranges is to change the tuned circuit - the aerial coil and the tuning capacitor. In most cases, the simplest approach will be to simply wind new coils for the aerial rod. To go down below the low frequency end of the broadcast band, wind on more turns than the figures we gave earlier. This will take you down to the "long waves" area of the spectrum.

On the other hand if you wind the coil with fewer turns than we have suggested, this will move your tuning range up above the broadcast band, into the "shorter waves" region. With little experimenting, you should be able to listen in to radio amateurs on the 1800kHz or "160 metre" amateur band, and perhaps also to ship-to-shore and other marine band services in the region above 2MHz.

Adapting the design to receive on different frequencies is far easier than with either a superhet or a regenerative set, as there is only one simple tuned circuit to modify.

List of component parts.

Breadboard version

Semiconductors:

1 ZN414 IC (Ferranti)

Resistors: $\frac{1}{2}$ W or $\frac{1}{4}$ W 5%

1 1k

1 100k

Capacitors:

1 0.01 μ F polyester or ceramic

1 0.1 μ F polyester

1 0.47 μ F polyester

1 10-415pF single section tuning gang

Miscellaneous:

1 piece of breadboard (16 x 10.5cm)

1 aluminium front panel (16 x 9.5cm)

1 10cm length of 3/8th inch ferrite rod.

1 speaker transformer 5k to 15 ohms, Eagle or Tandy RS273-1380.

1 stereo headphone socket

1 on/off switch

1 6-lug section of tagstrip (see text)

2 rubber grommets

24 SWG enamelled copper wire

Thin hookup wire

1.5V battery

"Letraset" for marking front panel

1 handspan plastic dial

Screws, solder, scrap aluminium for brackets, etc.

Veroboard Version

1 kit or parts comprising ZN414 IC, length of ferrite rod, 32SWG enamelled wire, miniature tuning gang, 1 x 1k $\frac{1}{2}$ W resistor, 1 x 100k $\frac{1}{2}$ W resistor, 1 x 0.01 μ F capacitor, 1 x 0.1 μ F capacitor.

1 miniature crystal earpiece (plus socket if required)

1 1.5V battery

1 piece Veroboard 0.2in pitch, 6 x 5 cm

1 on/off switch. Thin hookup wire.

LOUDNESS CONTROL

After building a stereo amplifier without a loudness control, I decided to design one and incorporate it in the new system. The circuit was designed primarily for use in a system where cheaper speakers are in use, to compensate for the poorer bass and treble response of these speakers. However, it was found that it gave a pleasant sound in a better system where the user wants to boost the bass.

The mid-frequencies gain has been reduced by 16dB, otherwise overloading of the power amplifier or speakers could occur when the loudness control is switched in. The circuit should theoretically be driven from a low impedance source but it was found to operate satisfactorily from a source impedance of 25k ohms. If the output of the loudness control is fed into a low impedance, C9 may have to be increased in value. If the treble boost is not required, C1, C2 and C3 may be omitted. The Loudness control operates at a level of 250 to 500mV.

Bass boost is achieved by the low-pass filters R3 R2 C4 R5 R4 C5 R7 R6 C6 and by high frequency negative feedback via R8 C8. The treble boost is achieved by the high-pass filters R1 C1, R3 C2 and R5 C3.

Loudness Control

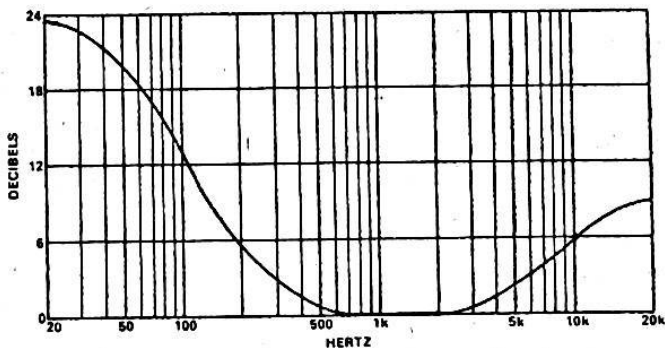
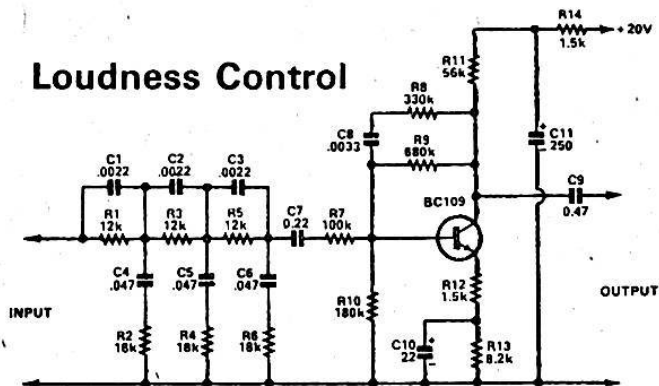

SWEET AND LOW

MOODLIGHTING WITH A VARILIGHT

Do you still turn on the lights in your dining room, living room or any other room with a simple on/off switch? You cannot vary the brilliance? Now's the time to get with it and build the Varilight Mk 2.

Back in the days of gaslight, people could vary the brightness of their lights at will. Now, in more modern times, it is only recently that we have been able to do the same with electric light. After all, why should you always use the lights at the same brilliance. Bright lights are fine if you're having a bath, cooking or reading or performing any other activity where the keenest of vision is an advantage.

But there are many times where the maximum brilliance of the lights is not required: such as at parties, dining, watching television, listening to music, etc. There are in fact any number of domestic light dimming applications, both for wall-mounted dimmers and for dimmers incorporated into table lamps.

Varilight Mk 1 was our first wall-mounting light dimmer. Since then light dimmers have become an accepted appliance in the modern home and there are now several different brands and models available from electrical retailers.

Typical brand name light dimmers often suffer from two problems. The first is a high level of interference to radio reception, which can be very severe in outer metropolitan and rural areas. The second is known as "snap-on" whereby the dimmer control has to be turned through 30 to 40% of its rotation before the lamp begins to glow. At this initial setting the lamp will be quite bright. The light can be reduced by rotating the control in the opposite direction but at the lower setting a momentary drop in mains voltage may extinguish the lamp.

Our new Varilight Mk 2 has considerably reduced RF interference and "snap-on" effects compared with most brand-name dimmers, and it is more flexible in its application. In addition, it actually has less components than its predecessor.

A typical light dimmer circuit uses a phase-controlled Triac fired by symmetrical breakdown device such as a neon lamp, diac or silicon bilateral switch. All of these trigger devices are characterised by a very high impedance in both directions until the voltage across them exceeds a certain value. When this happens the device "breaks over" and becomes a negative resistance.

For a neon lamp, the breakdown voltage is typically in the region of 60 to 80 volts; for a diac, 25 to 40 volts; for an SBS, 6 to 10 volts. The diac is the most commonly used Triac triggering device.

A feature of our new Varilight dimmer is a new type of breakover device, the asymmetrical AC trigger, made

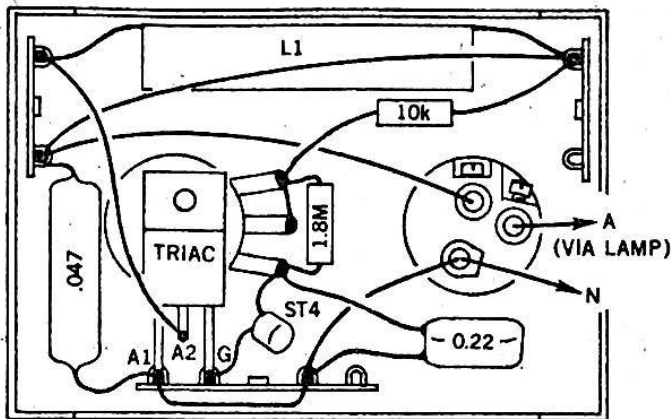

At top is the rear view of the dimmer assembled on a Clipsal switchplate. Below is the corresponding wiring diagram. Check your wiring against the circuit.

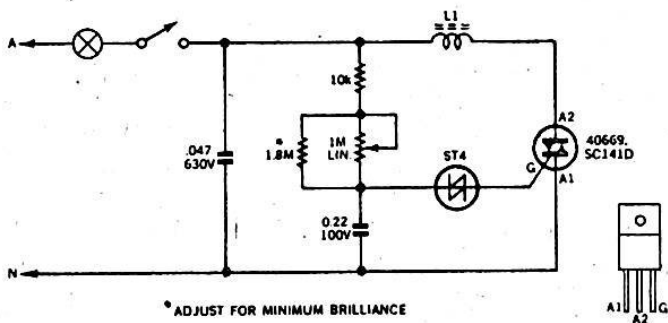

ADJUST FOR MINIMUM BRILLIANCE

L1 = 22 B&S EN CU WIRE CLOSEWOUND ON
2" LENGTH OF 3/8" DIA. FERRITE ROD

VARILIGHT MK. 2

Use of an ST4 allows simple circuit. Interference suppression is included.

by General Electric and designated ST4. It is available in a two-lead TO-98 plastic encapsulation.

This device greatly reduces the snap-on effects that are present in light dimmers using symmetrical trigger devices and single time-constant RC circuits. To explain how it does this let us first look at how "snap-on" occurs in a single RC time-constant Triac/diac circuit, as shown in Fig. 1.

Fig. 2 shows two voltage curves, superimposed but not drawn to scale. The large sine waveform represents the 240V mains supply. The smaller wave form shows the voltage across the capacitor in Fig1.

Initially, consider the variable resistor set at maximum so that the diac is not firing. In this case, the capacitor voltage is a sine waveform lagging the major waveform. If the variable resistor is reduced in value we will eventually reach the point where the diac fires for the first time, at the end of an AC half-cycle.

Immediately the diac fires the capacitor voltage is reduced from $+V_{bo}$ by perhaps 8 volts. This means that when the next half cycle begins, the capacitor will charge to $-V_{bo}$ sooner than if the diac had not fired. So, the second and succeeding diac trigger points will be sooner than desired.

Thus, the initial level of brilliance obtained when rotating the dimmer control up from zero tends to be relatively high instead of a very low level. Once the diac has begun firing the brilliance can be reduced by winding back the control. But if the mains voltage drops momentarily due to an additional load, the lamp will be extinguished. Inconvenient, to say the least!

This "snap-on" effect can be reduced by adding three components to give a second RC time-constant to the circuit. However the second capacitor is usually a good deal more bulky than the first, due to its higher voltage rating.

Much the same improvement can be had, without extra components, by using the asymmetrical device, ST4. Typically, this has a breakover voltage, V_{s1} , in one direction of 16 volts and V_{s2} , in the other direction of 8 volts. Additionally, its forward voltage (after breakdown) in the V_{s1} direction is about 8 volts while that in the V_{s2} direction is about 1.5 volts. These latter voltages are referred to as V_{f1} and V_{f2} .

Now consider the circuit in Fig. 1 again but using the ST4 instead of a Diac. Now, when the variable resistor is reduced to the point where the ST4 initially fires, the "breakover" is from V_{s2} (the lower breakover voltage) to V_{f2} , as shown at the first trigger point in Fig. 3. But now, instead of charging an equal amount in the opposite direction in the next half-cycle, the capacitor must charge to a higher voltage, V_{s1} , before the ST4 will fire. This means that the firing point in

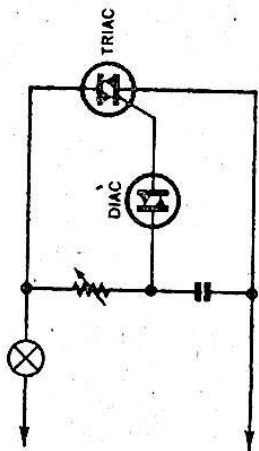

FIG. 1

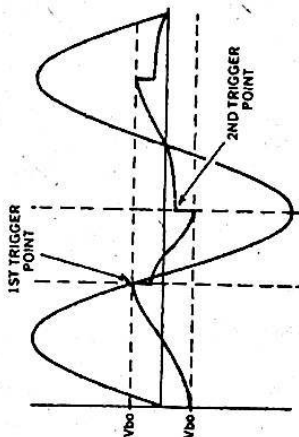

FIG. 2

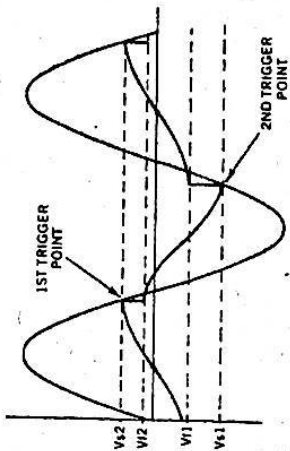

FIG. 3

At right is the basic Triac light dimmer circuit and below it, the initial trigger waveforms. Above are the trigger waveforms for the ST4-plus-Triac circuit.

the first two half-cycles is roughly the same. (The ST4 will always fire initially at the lower breakover voltage.)

On the second firing of ST4, the capacitor voltage is discharged to V_{f1} instead of $-V_{f2}$ so that when it is charged to V_{s2} it undergoes the same voltage change as it did in the preceding half-cycle. This means that the firing point in the third half-cycle is the same as it was in the first half-cycle. This train of events is continuously repeated with the capacitor diac voltages alternately shifting to maintain the same firing point in each half cycle. Thus, "snap-on" is greatly reduced.

The astute reader will no doubt comment: Aha! surely the fact that the ST4 has an asymmetrical breakover voltage will mean that the Triac will deliver uneven amounts of power to the lamp during each half-cycle and this will cause visible flicker! And he is right. There is noticeable flicker at lower settings with lower power lamps, but it is not nearly as pronounced as when half-wave rectified AC is applied to an incandescent lamp. At high power levels, the ST4 still fires unevenly but the effect is so small that it is undetectable.

Refer now to the complete circuit diagram. The 1M potentiometer connected as a variable resistor and the 0.22 μ F capacitor form the basic RC time-constant circuit. The 1.8M resistor in parallel with the potentiometer sets the minimum brilliance of the lamp(s) when the dimmer control is fully anticlockwise. It eliminates the "dead band" of rotation before the lamp initially lights, and ensures that when the dimmer is switched on there is always some light in the room.

The 10k resistor in series with the potentiometer protects the potentiometer track from excessive dissipation when it is set for high levels of brilliance. It also provides current limiting for the ST4 under the same conditions.

L1 and the 0.047 μ F capacitor remain to be discussed. These form a simple low-pass LC filter which prevents the switching transients of the Triac being radiated by the mains supply leads. As such, it considerably reduces the amount of RF interference produced. Similar RF interference suppression components should really be considered mandatory in all phase-controlled Triac circuits.

LOW COST AMPLIFIER FOR ELECTRIC GUITARS

A compact unit with 21 watts continuous output capability, very suitable for either practice work or for use in small halls. The circuitry is fully solid state, using a modern power IC, and veroboards are used to simplify assembly.

Specifications

Power: 21 watts continuous into an 8-ohm load; 13 watts continuous into a 16 ohm load.

Distortion: Less than 0.3% at 21 watts into 8 ohms at 1kHz; at lower power within range 100Hz to 10kHz typically less than 0.2%.

Frequency response at 1 watt: +2dB from 20Hz to 20kHz.

Tone control: \pm 18dB at 10Hz; \pm 17dB at 50Hz.

Sensitivity: 20mV (LOW) or 110mV (HIGH) for 21 watts into 8 ohm loads.

Signal-to-noise ratio: Better than 56dB for both inputs.

Guitar amplifiers range in power from very compact "practice" units incorporating a small loudspeaker with only a few watts drive, up to very large models with price tags in the four-figure range and ratings of several hundred watts. In between these extremes there is a vast area of confusion where the would-be guitarist often tends to muddle along with an amplifier which does not really suit his purpose.

Most guitarists appear to need only a compact amplifier for playing and practising at home and ideally, it will have an extra reserve of power to be used at parties and dances in small halls. To this end, they do not need an amplifier with a hundred watts output, although it is surprising just how many think they do. An amplifier with 10 to 20 watts will be more than adequate for many situations.

Our experience with the Playmaster 102 and 103 guitar amplifiers supports these conclusions. The Playmaster 102 was a valve amplifier with an output of 12 watts yet it was very popular. The Playmaster 103 had an extra reverb channel of similar power output. We believe the guitarist of today has not changed greatly from his counterpart of ten years ago in the uses he can find for a modest system.

We had these thoughts in mind when we developed the 20W PA amplifier.

Continuous power output is 21 watts into 8 ohms and 13 watts into a 16 ohm load. Harmonic distortion at 1kHz for 21 watts is less than 0.3%, while at lower powers it is typically less than 0.1%. For those guitarists who like to parry with figures, its "music power" is of the order of 30 watts into 8 ohms, depending on which method is used to measure it. Similarly, the "peak music power" can be quoted, if you so wish, as 6 watts. These figures are quoted, not because they have any special meaning but so that guitarists can relate them to other amplifiers.

Since the amplifier is intended for use at practice sessions, a headphone socket has been fitted on the rear panel. This is suitable for conventional stereo headphones of high or low impedance and enables the guitarist to play without disturbing anyone.

Lest we are swamped with correspondence asking how to fit headphone sockets to existing units, we warn readers that many guitar amplifiers are just not quiet enough to enable headphones to be successfully used. The unit presented there had no problems in this respect - it is very quiet, at all gain settings.

As with the PA amplifier referred to above, the heart of the unit is the 20 watt thick film hybrid IC, type TA 20B, (STC.) Some readers will perhaps remark that we could have used the higher powered unit, TA25B. There are two reasons why we did not.

First we believe the slightly increased power capability does not justify the extra cost. It would not be audible, anyway. Second, the power transformer used, a reasonably economical "off the shelf" unit, will not deliver the extra power. If we had specified a transformer with ratings to suit the TA 25B, its cost could be as much as 50% more. As it is, the transformer specified is ideally suited to the TA 20B.

Two jack sockets are provided to accept inputs from guitars. Sensitivities are 20mV and 110mV respectively for full power. The less sensitive input can be used for bass guitar or guitars which have more than usual signal output. Use of the less sensitive input prevents overloading of the preamplifier stage. Input impedance is approximately 100k for the LOW input and 47k for the HIGH input (less sensitive).

Tone controls for a guitar amplifier usually provide more bass and treble boost and cut than is normal with "high fidelity" amplifiers. This is to allow the guitarist more flexibility in setting the tone of his instrument. Accordingly, the tone controls on this unit provide $\pm 17\text{dB}$ at 50Hz and $\pm 18\text{dB}$ at 10kHz.

Frequency response for both inputs is $\pm 2\text{dB}$ from 20Hz to 20kHz, with the tone controls set for a flat response. Signal to noise ratio for both inputs is better than 56dB with respect to 20 watts. This measurement is taken, with the inputs unloaded, ie, open-circuit, and the figure is unweighted which means that it refers to wideband noise.

A problem which often plagues the users of guitar amplifiers is RF breakthrough from mobile radios in taxis, radar broadcast and shortwave stations. We have taken extensive precautions to avoid the problem. The amplifier is also relatively insensitive to mains-borne interference such as commutator hash from food mixers and other universal motors, clicks and pops from switched inductive loads such as refrigerators and fluorescent lamps.

Although perhaps desirable, electronic short-circuit protection has not been provided. The amplifier will withstand short-circuits of a brief duration without damage - the fuse is blown. However prolonged overloads, such as using the amplifier with a loudspeaker of too low an impedance will cause permanent damage. Do not use loudspeakers of less than 8 ohms impedance, therefore.

Let us now discuss the internal circuitry of the TA 20B integrated circuit. This is based on the conventional "quasi-complementary" class B configuration but it has several interesting features.

First of these is the differential amplifier stage consisting of Tr1 and Tr2. Besides contributing to high "open-loop" gain (ie., gain without negative feedback applied) it increases the ripple rejection of the amplifier. This is just another way of saying it reduces the hum in the output. A resistor from the output to the base of the Tr2 provides 100% DC feedback to ensure stability of the "half-supply" voltage at the output. This ensures symmetrical clipping of the output signal at the onset of overload, regardless of supply variations.

This last feature is very important since it means that the amplifier develops maximum power without distortion. (If the DC voltage at the output of this type of amplifier is not set correctly to suit the supply voltage, the output signal cannot make the maximum symmetrical "swing" and consequently the power available before overload is reduced.)

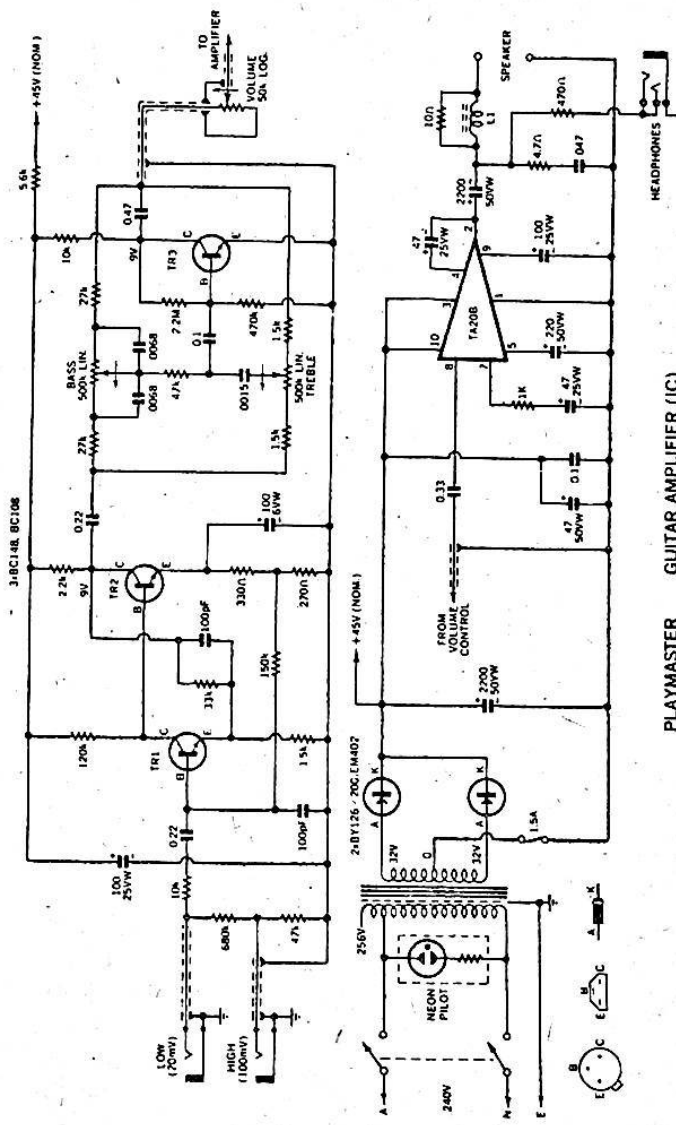

PLAYMASTER GUITAR AMPLIFIER (IC)

Tr3 provides further voltage amplification and acts as the class-A driver stage for the output driver transistors Tr6 and Tr7. Phase-splitting for the NPN output transistors takes place in the driver transistors.

A diode in series with the emitter of Tr7 improves the symmetry of the quasi-complementary output stage and greatly reduces the harmonic distortion at low power levels.

As with all class-B amplifiers intended for high quality sound reproduction, the output stage transistors are slightly forward biased. The small current resulting is called the quiescent or "no-signal" current and it provides a smooth transition between the conduction of one of the output transistors to the "cut-off" of the other. The quiescent current in this amplifier is set by the voltage drop across the Darlington transistor consisting of Tr4 and Tr5.

Normally, the quiescent current should be about 30mA, and certainly no more than 50mA.

Boot strapping (ie., positive feedback) is applied from the output to the input of Tr6 via a 47uF/25VW capacitor. This ensures that the full voltage swing is available at the output and enables more linear operation of the class-A driver stage, Tr3.

Voltage gain of the amplifier is set by the ratio of the internal resistor from pin 2 to the base of Tr2 to the 1k external resistor at pin 7. The low frequency cut-off characteristic is determined by the time constant of the 1k resistor and its associated 47uF capacitor.

As it stands, typical voltage gain of the amplifier is 30 times, for all load impedances. Input impedance is approximately 20k.

All the amplifier external components, apart from the 2200uF output coupling capacitor are mounted on a printed board measuring 3½ x 4 inches. Besides the components already mentioned there are two supply decoupling capacitors, 47uF and 220uF and an RF supply bypass capacitor, 0.1uF. The latter capacitor is mounted on the underside of the board directly between pins 1 and 3 of the TA 20B.

The rest of the components on the board are the 0.33uF input coupling capacitor, the 470 ohm resistor feeding the headphone socket, a Zobel stabilising network consisting of a 4.7 ohm resistor and .047uF capacitor in series, and also an RF choke L1 in parallel with a 10 ohm resistor.

These last four components ensure that the amplifier is stable with reactive loads, both inductive and capacitive. Thus the amplifier is completely stable, with an capacitance up to 1uF shunting the load.

Driving the power amplifier is a three-transistor circuit which provides the necessary signal amplification and the variable tone control facility.

Two NPN transistors make up the direct coupled preamplifier circuit which has a voltage gain of approximately 22 times. This is set by the ratio of the 33k resistor to the 1.5k resistor. Bias for the input transistor is derived from the junction of the 330 and 270 resistors. Notice that there are two DC feedback networks in the circuit, one the bias network and the other the 33k resistor to the emitter of the input transistor. These networks interact so that if one is changed so must the other.

A 100pF capacitor shunting the 33k resistor increases the negative feedback at high frequencies and thus rolls off the response above the audible range to assure low RF sensitivity.

In addition to rolling off the response at high frequencies, there is an RF attenuation network in the input circuit consisting of a series 10k capacitor and shunt 100pF capacitor. This prevents strong RF signals entering the base of the input transistor which can "detect" them due to the basic non-linearities of its junctions. If the signal is detected it becomes audible. (This is why an amplifier can sometimes reproduce taxi conversations.)

Following the preamplifier stage is the active tone control stage using a single NPN transistor. This stage has a gain of 1 at mid-frequencies, with tone controls set for flat response.

All the preamplifier and tone control circuitry, with the exception of the potentiometers, is mounted on a printed board measuring $4\frac{1}{2} \times 2\frac{1}{2}$ inches.

The power supply for the amplifier is simplicity itself. The power transformer has two 32 volt windings which are connected in series to give 64 volts centre-tapped. A full-wave rectifier consisting of two 200 PIV/1 amp silicon diodes supplies the filter/reservoir capacitor.

A 1.5amp fuse connected in series with the centre-tap connection provides protection for the amplifier and power supply components against short circuit loads and over loading.

Construction: The amplifier is assembled in a chassis with overall dimensions of $10\frac{1}{2} \times 3\frac{1}{2} \times 8\frac{1}{2}$ inches (257 x 83 x 213mm)

First component to be mounted is the power transformer. After this, the 2200uF can-type capacitors, fuseholder and sockets on the rear panel can be installed. Cut the potentiometer shafts to length (about $\frac{1}{2}$ inch) and mount them together with the input sockets and power switch.

Note that the front panel components will have to be removed when the escutcheon panel is mounted. This should be left until the amplifier is complete and tested to avoid marks and scratches. For the same reason, the neon pilot lamp is left until last.

The power amplifier board can now be assembled. All the passive components with the exception of the 0.1uF capacitor should be installed first. The RF choke L1 consists of 20 turns of 22 SWG enamelled copper wire on a 1 inch long section of $\frac{1}{2}$ inch diameter ferrite rod. Remember that if a ferrite rod has to be cut to length, it may be done by filing a nick around the circumference at the required point and snapping as if it were glass.

The integrated circuit pins are soldered direct to the edge of the printed board. The ten pins are bent up at right-angles at the point where they taper suddenly. The board assembly can then be installed. It is supported by two screws and nuts so that it has $\frac{1}{2}$ inch clearance from the chassis. The integrated circuit is secured to the rear of the chassis by two screws.

If the screws are over-tightened, the chassis rear will become warped, and if this occurs it will not make good thermal contact with the metal backing of the integrated circuit. To avoid this, an L-shaped reinforcing piece should be secured to the rear of

the chassis with the same screws that hold the IC in place. Silicone jelly should be lightly smeared over the back of the IC to improve thermal contact.

Assembly of the preamplifier control board is straightforward. Note that the shield for the HIGH input cable is not connected to the board but is connected at the socket end.

Note also that the amplifier circuitry is earthed only at the LOW input socket. Additional earth points anywhere else on the chassis will cause high hum levels and perhaps instability. The power amplifier circuit is earthed via the volume control and associated shielded cables.

Both sides of the mains are switched using a DPST switch. The transformer primary leads are terminated directly to the switch, as are the leads for the neon pilot. The switch used in the prototype was actually a DPDT type with one half unused.

The mains cord should be passed through a grommetted hole in the rear of the chassis and anchored by a clamp. This can be secured by one of the screws which hold the 8-lug tagstrip. The active leads should be taken to a terminal block, thence to the off-on switch.

Having assembled the amplifier, the unit can be switched on, with the supply lead to the amplifier disconnected. If the DC voltage across the 2200uF capacitor is more than 50 volts, the 256 volt tap in the transformer should be used instead of the 240V connection.

When this is done the supply may be connected to the amplifier. Current drain with no signal should be between 20 and 50 milliamps. If it is substantially more than this, the unit is probably oscillating supersonically. Switch off and check that your wiring is exactly the same as in the wiring diagram.

The voltage across the 2200uF output coupling capacitor should be within 1 volt of half the supply voltage, ie., if the supply is 48V the voltage across the capacitor should be between 23 and 25 volts.

Note that the 2200uF capacitor has a 50V rating. Capacitors with lower voltage ratings should not be substituted as they do not have sufficient AC current rating.

The pilot light is a neon assembly containing a limiting resistor, and is connected directly across the mains. The leads to it should be twisted and arranged as shown in the photograph and wiring diagram. In addition, a tinplate shield is arranged over the pilot assembly to stop hum radiation.

With the amplifier complete all that remains is to connect it to a suitable loudspeaker system. Many readers will have 8 to 12 inch loudspeakers which can be pressed into service but they should be installed in an effective cabinet.

Parts list.

- 1 chassis, 10½ x 8½ x 3½ inches, with cover.
- 1 reinforcing angle piece (see text)
- 1 neon pilot shield (see diagram)
- 1 power transformer, 64V centre tapped, at 2A AC.
- 2 microphone jack sockets, 100mm non-shorting type

- 1 stereo headphone socket
- 1 2-pin loudspeaker socket
- 1 fuseholder and 1.5 amp fuse
- 3 knobs
- 1 front panel
- 1 neon pilot lamp assembly (with limiting resistor)
- 1 miniature 240VAC DPST switch
- 1 8-lug tagstrip
- 1 mains cord clamp
- 4 rubber feet

Semiconductors:

- 2 EM402 RS 276-1102 RS 276-1137 or BY126/200 silicon diodes
- 3 BC 108, BC 148, 2N3565 or RS 276-2009 silicon NPN transistors.
- 1 Ta 20B power amplifier IC (STC)

Capacitors:

- 2 x 2200uF/50VW electrolytic
- 1 x 220uF/50VW electrolytic
- 1 x 100uF/25VW electrolytic
- 1 x 47uF/50VW electrolytic
- 2 x 47uF/25VW electrolytic
- 1 x 100uF/6VW electrolytic
- 1 x 0.47/100VW metallised polyester
- 1 x 0.33uF/100VW metallised polyester
- 2 x 0.22uF/100VW metallised polyester
- 1 x 0.1uF/100VW polyester
- 1 x 0.047uF/ polyester
- 2 x .0068uF/100VW polyester or polystyrene
- 1 x .0015uF/100VW polyester or polystyrene
- 2 x 100pF polystyrene or ceramic

Resistors:

- (all 10% tolerance, $\frac{1}{2}$ watt)
- 1 x 2.2M, 1 x 68k, 1 x 470k, 1 x 150k, 1 x 120k, 1 x 47k, 1 x 33k,
 - 2 x 27k, 2 x 10k, 1 x 5.6k.
 - 1 x 270 ohms, 1 x 10 ohms, 1 x 4.7 ohms.
 - 1 x 22k, 3 x 1.5k, 1 x 1k, 1 x 470 ohms, 1 x 330 ohms
 - 2 x 500k (lin) potentiometers
 - 1 x 50k (log) potentiometer

Miscellaneous:

Mains cord and plug, shielded cable, hook-up wire, ferrite rod, screws, nuts, lockwashers, solder.

Note: resistor wattage ratings and capacitor voltage ratings are those used for our prototype. Components with higher ratings may generally be used, providing they are physically compatible. Components with lower ratings may also be used in some cases, providing the ratings are not exceeded.

TWENTY-FOUR HOUR UNIVERSAL CLOCK

Here is a truly universal clock. Suitable for use anywhere in the world, it indicates local time, GMT, and the time in major world centres. The scales will also make a handy calculator to convert local time to GMT, to other world centres, or vice versa.

To most people, no matter what their occupation or hobby, the question of time at remote parts of the world is sooner or later raised. The question may be the result of watching a telecast of an overseas event, listening to a short-wave radio programme, or merely wondering what time one should telephone a person overseas. And short-wave listeners and amateur radio operators have a special interest in time at different parts of the world.

As far as the latter are concerned Greenwich Mean Time (GMT) presents the best solution to the problem. This is a universal time system based on the 0° meridian passing through Greenwich (London). It is used by virtually all international broadcasting systems, commercial communication channels, or amateurs wishing to make schedules on an international basis. The advantage of GMT is that it is recognised world wide and therefore avoids the need to make individual time calculations for individual countries. It also avoids the complications created by various "daylight saving", "summertime" or even "double summertime" systems employed in some localities.

Greenwich Mean Time is presented as a 24-hour cycle, rather than the more common 12-hour cycle used by conventional clocks. The 24-hour system expresses the time as four figures, two for the hours and two for the minutes. The cycle commences at midnight, which is designated as either 0000 or 2400. One hour after midnight is 0100 (spoken as "oh one hundred hours"). One hour thirty minutes after midnight is 0130 ("oh one thirty hours") and so on to 2359 ("twenty-three fifty-nine") at one minute to midnight the following day.

The 24-hour clock need not be confined to GMT. It is often used to express local time, for example by the armed services, and by amateur organisations when designating times for contests, important schedules, and so on.

Since a clock such as this does not appear to be available on the market (if it is it is certainly a well-kept secret) the problem is how to convert a standard clock to read on a 24-hour basis. This article discusses the means by which this can be done and presents a dial scale which can be used on the clock or separately as a hand-operated international time converter.

Having discussed the need for a GMT clock the first question is how to convert a standard electric clock movement so that the "hour" hand makes one sweep every 24 hours. One obvious way would be to modify the gearing. This may be easy enough for the hobbyist who possesses

the necessary equipment, but most people do not have the metal-working facilities.

The next approach would be to drive the clock with a 25Hz supply which could be synchronised with the 50Hz mains supply to take advantage of mains frequency standard. This would mean that all the clock hands would move at half speed. This could cause confusion as far as the minute and second hands are concerned and these might best be left off. If the clock was calibrated with 15-minute graduations this should be acceptable, as the time span of most short-wave programmes is in multiples of fifteen minutes and they usually begin on the hour or half-hour. If one really wanted to know the exact number of minutes past the hour one could always refer to a normal clock or wrist watch.

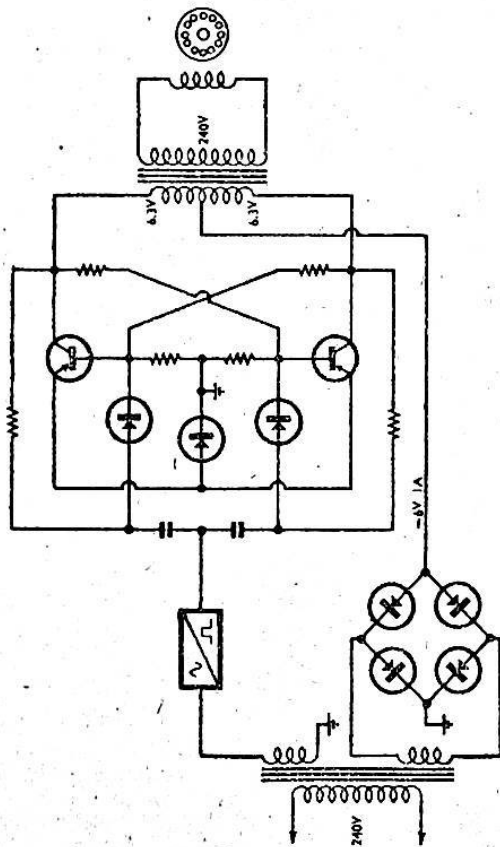

One of the transistor configurations with which we experimented. Although it could be made to work, the need for additional components for protective functions made it less economical than the valve approach.

There are several approaches to obtaining a 25Hz supply at sufficient voltage to drive a normal electric clock movement. One approach which we tried was to use two transistors in a "gated R-S flip-flop" to drive a centre-tapped heater transformer in a "push-pull" mode.

Theoretically, the flip-flop would provide an exact 25Hz, synchronised with the mains and the heater transformer would have an output of approximately 240 volts from the appropriate winding. However, the combination of a transformer resonance at around 50Hz and the presence of switching "spikes" forced the flip-flop to function as a free-running multivibrator with an output of about 48Hz.

The spikes could be eliminated by the use of diodes in appropriate sections of the circuit or rendered harmless by the use of transistors with higher voltage ratings. We could see, however, that by the time we had the flip-flop running reliably, and provided the necessary low voltage power supply and "shaping" for the 50Hz trigger pulses, that this was not the most economical approach. The two transistors (AC128s) were running close to their ratings and the provision of pulse "shaping" would require an additional transistor or perhaps an IC. For similar reasons, we decided against a transistor multivibrator synchronised with the mains. The basic circuit shown here indicates the number and type of components likely to be needed.

The other approach was to use a 6WG8 connected as a multivibrator. This appealed as being more economical and, in addition, most of the components could be found in the spare parts "hoard" of most hobbyists.

Referring to the circuit it will be seen that the triode and pentode sections of the 6GW8 are cross-coupled to form a conventional multivibrator. The pentode section itself is triode connected (screen to plate) and has as its AC load the clock motor. The DC circuit is provided by an iron-cored choke. This choke must present a very high impedance at 25Hz, relative to the motor's impedance, otherwise there will be considerable losses in the choke. For this reason an ordinary filter choke may not have sufficient inductance.

We used the primary winding of an old audio output transformer. Any audio output transformer would do provided it had a fairly large core to avoid saturation. A typical medium-sized transformer would have a primary inductance of around 30 henries and a DC resistance of about 500 ohms. The secondary winding is left unconnected.

The multivibrator is arranged to have a "free-running" frequency close to, but below, 25Hz. It can then be synchronised with the mains supply. The components having the main effect on the frequency are the 0.1uF capacitor from the pentode plate to the grid of the triode (via a 220K resistor) and the associated 100K resistor and 500K potentiometer. The mark/space ratio of the rectangular platform is determined mainly by the 0.47uF capacitor from the plate of the triode to the grid of the pentode and its associated 1M resistor. Synchronising is discussed in greater detail later in the article.

The power transformer may be any full wave rectifier type with a secondary voltage ranging from 225-0-225 volts at 285-0-285 at a nominal 40mA. If a valve rectifier was used the latter secondary voltage would be the minimum. We used silicon diodes with an inverse voltage rating of 800 volts. The actual DC supply may be from 320 to 400 volts. The DC current drawn by the prototype was around 50mA. A 6.3V winding is needed to operate the 6GW8 heater.

This heater also provides the synchronising voltage to lock the 25Hz multivibrator action to the 50Hz mains. One side of the winding connects to chassis in the usual way, while a pair of 470 ohm resistors are connected across the winding forming a voltage divider. From the centre of this divider, voltage is applied to the grid of triode via the 500K pot and the 100K and 220 K resistors.

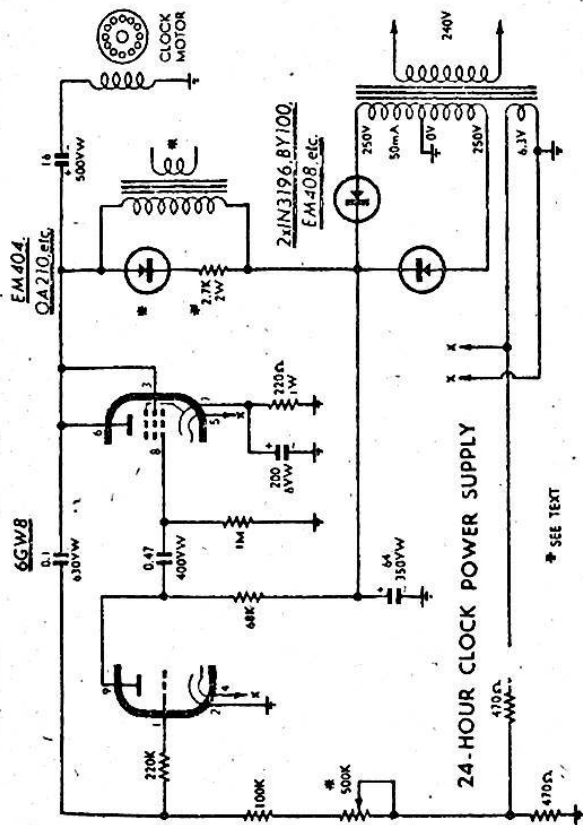

The practical circuit we finally evolved. The values and layout are not particularly critical, and most of the components will probably be found in the junk box.

The purpose of the 220K resistor in the grid circuit of the triode is to limit the grid current when the grid swings positive. Without this precaution two undesirable effects can occur: due to the large voltage swing at the pentode plate the triode may draw sufficient current to exceed its ratings and damage itself and, equally important, the pentode plate circuit will be heavily loaded, or damped, and the circuit will not function efficiently.

At this stage readers may think that this is a very straightforward arrangement—virtually foolproof. However, there is still a problem. When the pentode switches out of conduction the collapsing magnetic flux in the choke induces a very large voltage spike at the pentode plate. The amplitude of the "spike" was over 3,000 volts, with a 320 volt supply. (It can be said that: $V=L (di/dt)$ is true here!) While this is a tribute to the "Q" of the choke, the valve and valve socket found the strain too much and had to be consigned to the rubbish bin.

The spike can be very effectively eliminated by connecting a power diode from the pentode plate to the supply, in series with a suitable resistor, as shown in circuit diagram. In normal operation the diode will be reverse biased by the voltage across the choke. The appearance of positive (with respect to the supply) voltage spikes at the plate will cause the diode to conduct and thus "chop" the spike.

The degree to which the positive swing of the waveform is chopped can be controlled by the value of the resistor in series with the diode. If there is no series resistor the upward voltage swing will be clipped at just a little over the supply voltage. This would mean that we were not taking advantage of the inductive load's ability to give an output waveform with a peak-to-peak value in excess of the nominal supply voltage. The series resistor we used (2.7K) results in the symmetrical waveform shown in the photograph, with a peak-to-peak value of about 500 volts.

We advise that readers use a ceramic valve socket, as the voltage at the plate of the pentode will have a peak voltage of about 540 volts above chassis potential, or any socket pins connected to chassis.

The layout of the components on a chassis is non-critical and for this reason we have not assembled the prototype power supply in "photogenic" form. After all, there are only two transformers, a valve and few other components—what could be simpler?

Having constructed the multivibrator, the next step is to obtain "free-running" operation at a frequency close to, and below 25Hz. The 500K potentiometer in the grid circuit of the triode is used to set the free-running frequency. This is done with the potentiometer connected directly to earth instead of via the resistive divider across the heater winding. For those readers without an oscilloscope or other means of measuring frequency, the best method of checking the operating frequency would be to connect a standard electric clock to the supply and see how much it loses over a set period. For example, if it was operating at 24Hz the minute hand would sweep through only 14.4 minutes in a half-hour period.

The 500K potentiometer should be set so that the operating frequency is between about 22 and 24Hz. It is then connected to earth via the divider across the heater winding. The prototype was very easy to synchronise—in fact it would synchronise at 25Hz on the 100Hz ripple on the Ht rail. If the amplitude of 50Hz signal fed into the grid of the triode is too high the multivibrator may be "forced" into operation at 50Hz.

For those readers with access to an oscilloscope, the photographs of the waveforms will indicate what can be expected. The first shows the 25Hz output compared with the 50Hz taken from the heater winding. The second photograph is a lissajous figure obtained with a 50Hz sine wave applied to the horizontal plates and the output applied, via a resistive divider, to the vertical plates. To obtain this waveform, we also connected a 0.022 μ F capacitor across the output to partially smooth the waveform so that the lissajous figure would be continuous (otherwise the fast rise-time of the rectangular waveform would not be visible). If the power supply is correctly synchronised at 25Hz the lissajous figure will be rock-steady, with perhaps a little jitter due to ripple on the HT rail.

Not all the electric clocks we tried would operate at 25Hz even though they functioned quite reliably down to about 120 volts at 50Hz. These particular clocks are of the slow RPM self-starting type which rely on the inertia of the rotor for their operation. This problem can be solved in some cases by increasing the mass of the rotor. Indeed, one clock could be made to run quite reliably by temporarily glueing a 20c piece to the unenclosed rotor.

The clock used for most of our experiments and the one we assembled with the finished dial was a Telechron movement. These were available in large quantities from disposals sources a few years ago. These were originally fitted to clock radios and have shafts for setting the alarm and radio turnoff time. They will be readily recognised from the photograph.

The final step in this project is to make a suitable dial. We have reproduced the dial used on the prototype. The outer section has 15-minute graduations and the hours are listed from 0100 to 2400 as shown. The centre section is intended to be pasted to an aluminium disc of the same size which, in turn, is to be fastened to the hour hand. We remarked previously that the minute and sweep second hand would best be removed to avoid confusion, but some readers may prefer to retain the second hand as an indicator that the clock is operating.

The centre section carries the following information: Meridian markings from 0° to 180°, east and west, in 15° steps, together with principal countries and localities corresponding to the time of these meridians; the International Date Line; and an "hour hand" arrow which can be pasted on to the disc to correspond with the local time in the constructor's area.

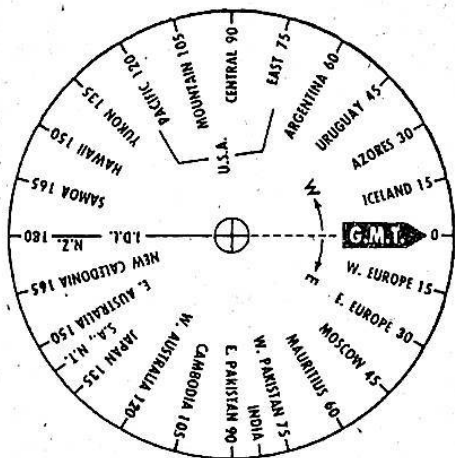

The dial scales for our universal clock.

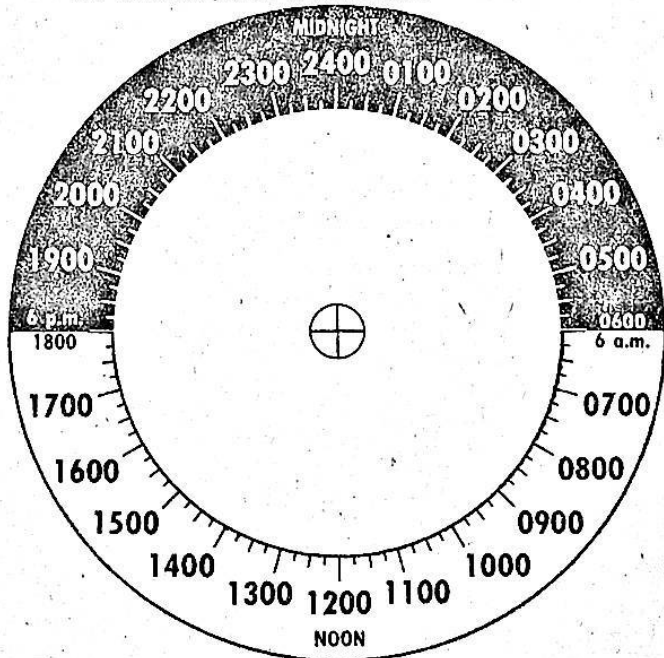

When used to make a complete clock dial these scales indicate local time, GMT, and the time in a number of main localities around the world. In this latter regard, the usefulness of the dial is increased by the list of additional localities alphabetically arranged, and coded to correspond to the meridian number on the inner scale

As intimated earlier, the scales can also be used to make a simple hand calculator, and we seriously suggest that, whether you make the complete clock or not, the hand calculator will prove invaluable. It enables one to start with GMT—as might be taken from a short-wave schedule—and quickly determine the corresponding local time. Conversely, one may start with a local time—such as the times one can most conveniently listen on short-wave—and convert it to GMT.

In the same way any time other than GMT can be compared with local time in either direction, i.e., starting with either local time or the time in the other locality. What is more, the system can be set up to serve any time zone in the world, by simply mounting the "hour hand" in the correct position. Truly a versatile arrangement, and its usefulness in addition to the clock will be obvious.

Using the scale may seem straightforward enough, but a few simple rules must be followed to take care of date as well as time differences. To compare the time and date between two localities, note the time at one (say local) then move around the circumference of the inner disc to the other locality, using the shortest path which does not cross the International Date Line. If "midnight" is passed on the way, then there will obviously be a change of date; to "yesterday" if moving anti-clockwise, to "tomorrow" if moving clockwise.

One point to be considered is the type of adhesive used to fasten the printed scales to their final support, whether it be cardboard when making a hand calculator or metal when making a clock scale. The main problem, in addition to that of good adhesion, is to find something that will not wrinkle the relatively light photographic paper.

Most water-based or water-soluble pastes or glues suffer from this disadvantage, and should be tried on a scrap of the photographic paper before risking the whole piece. Best results seem to be obtained with various forms of rubber solution designed for photographic use. These are available from most photographic stores.

The behaviour of this substance is something like contact cement, a coat is applied to each piece to be joined, allowed to dry, then the two pieces brought into contact. However, it does not have the same "sudden death" characteristic as contact adhesive, whereby any initial contact is virtually permanent, with no room for mistakes. On the other hand, its adhesive qualities are not so good, though probably good enough when working with card supports.

According to our art department better adhesion is obtained if, after the first coats have dried, a second coat is applied to one surface (preferably the thicker material) immediately before joining. This also makes exact positioning a little easier.

Really good results are obtained with contact adhesive, but this calls for care when joining. Do not try to match pre-cut pieces; join the pieces first and trim the combination afterwards. When joining, bow the print so that the centre makes first contact. Then carefully smooth the print outward from the centre to each corner. An extra pair of hands makes the job a good deal easier.

Finally, if gluing the whole print on to card in one operation, do not include the hour hand. This does not require the extra thickness.

LET'S MAKE A "DIN" ABOUT AUDIO CONNECTORS

For as long as I can remember, the matter of connectors and connections provided one of the frustrations of the audio scene. The industry has been able to overcome all manner of problems in the design and marketing of equipment but we've never quite been able to rationalise the secondary problem of interconnecting that equipment.

As I said, I've been aware of the problem for a long time, but, left to my own devices, I might not have got around to making an issue of it. But it is obvious that others have strong feelings about the subject and what follows is, as much as anything, an amalgam of what has been put forward by readers and other members of the staff.

When I first entered the industry, it relied primarily on valve sockets and matching plugs for input and output connections. And what an array there was. We had 4-pin, 5-pin, 6-pin, two sizes of 7-pin and later the Americal octal. I leave it to you to work out how many possible ways there were of using those 6 sockets and 37 pins.

It's not stretching the point too far to suggest that no two companies and no two enthusiasts ever used them in quite the same way.

Then came World War II and the disposals era which fed into the situation a whole new array of connectors in addition to the valve socket variety. A fair proportion of these had been intended primarily for RF cables, but they were so plentiful and accessible that they ended up in audio service at both the commercial and enthusiast levels.

But, as ever, confusion arose from their very variety. Anyone involved with a range of audio devices tended to accumulate a festoon of cables intended variously to connect this to that, or to convert from this plug to that socket. They served their purpose for a while, then took their place on a hook on the wall, gathering dust and growing stiff with age—against the possibility that they might be needed later.

Nor am I dramatising the situation. It's only a few weeks ago that I consigned just such a cable festoon to the local tip, along with a lot of other useless junk.

In the face of such a situation, and of such sentiments, one might be expected to look with relief at the modern DIN-audio plug as the way out of such difficulties; as the answer to the audioman's prayer.

But is it?

To be sure, when the DIN plug first appeared on the audio scene, many of us were not impressed. We had seen too many connectors appear and disappear to be convinced that the DIN plug would provide the exception to the rule. And, anyway, the pins seemed to be altogether too frail and too close together!

Since then, the DIN plug has won wide acceptance and this is a strong point in its favour. But has it really solved the confusion about connections? I doubt it.

In some ways, it has merely created a more orderly disarray!

To start with, it's wrong to talk about "the DIN plug" as a single item.

Without venturing beyond the commonplace, the familiar DIN audio shell may house 3 pins or 5 pins, or 5 pins in a different configuration. The old feeling of frustration returns when you look more closely at a DIN socket, only to discover that it differs from the plugs and cables you have on hand.

And, even if the two match physically, there is no guarantee that the same pattern of connections will have been used. All too frequently, one finds input and output connections interchanged.

Carelessness? Maybe, or maybe not!

Without having studied the origin of the aforementioned DIN connectors and the wiring conventions, it would appear that they have been heavily biased towards: (a) the basic role of interconnecting an amplifier and tape recorder, and (b) the idea of a straight-through cord, pin 1 to pin 1, pin 2 to pin 2 and so on.

To meet this concept, the basic connection pattern for plugs and sockets emerges, as in Fig 1. The vital point is that the pattern for amplifiers is a mirror image of that for tape recorders. It has to be, if the output of one is to connect straight through to the input of the other.

Unfortunately the deliberate mirror image variation, plus the usual uncertainty about top or bottom view, provides generous scope for confusion. Official standards information is notable for its absence from audio literature and a person originating a piece of equipment is as likely as not to refer to a piece of overseas equipment or a circuit to jog his memory.

Unless he is aware of the distinction between an amplifier and a tape recorder there is an even chance that he will come up with the wrong answer.

It would be possible to write off all such confusion as the natural and only-to-be-expected result of a non-thorough approach. But, even if one tries to dig a bit deeper, the picture still remains pretty murky. Let me quote from an explanation, taken originally from a European source:

"When a connector performs an output function, eg when mounted on a tuner, preamp mixer, etc; it uses pins 2, 3 and 5 (stereo) or 2 and 3 (mono). When the connector performs an input function, as when on a main amplifier, it uses pins 1, 2 and 4 (stereo) and 1 and 2 (mono)."

How do you interpret this? Is the plug on the end of a cord from a microphone, or a radio tuner, to be regarded as performing "an output function" from the source, or "an input function" to the device?

It may seem obvious to the writer or supporter of the scheme, but it certainly isn't obvious to the reader.

And how do you classify the connectors in Fig 1, which combine both functions? Is a tape recorder so obviously a "an output device" and an amplifier "an input device"?

As I write this, I am looking at a recent amplifier circuit from the Philips organisation in which a microphone socket is wired with input to pins 1 and 4—which is at variance with the simplistic diagram of Fig 1. Yet the tuner input goes to a similar socket, to pins 3 and 5.

Undoubtedly, there would be some "logical" justification for this but it would probably be logic of the roundabout variety. And I would expect that a little more digging would turn up other seeming contradictions.

Verification of the difficulties comes from an item by Harry Leeming in "Hi-Fi News and Record Review" (December 1971). It reads:

DIN CONNECTIONS

Unfortunately many manufacturers seem unable to read, and to prove this at first showed complete disregard for the "DIN" standards when fitting Continental-type sockets to their equipment. The message now seems to have got around and hence most modern equipment will be found to be wired to the following standards:—

AMPLIFIER	TAPE RECORDER
LH input pin 3	LH input pin 1
RH input pin 5	RH input pin 4
LH output pin 1	LH output pin 3
RH output pin 4	RH output pin 5

Note that these connections make it necessary to use a straight-through

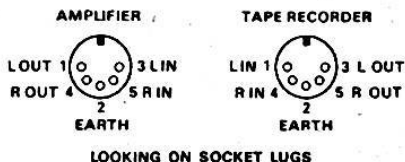

lead (ie pin 1 wired to pin 1) to interchange signals between a correctly wired amplifier and tape recorder. Connecting two tape recorders to each other involves the use of a lead in which the connections are crossed over, so that, for instance, Pin 1 on one plug is wired to Pin 3 on the other.

Harry Leeming disposes of the matter in quite summary fashion—including what seems to lie at the heart of the whole problem.

Was there ever any real objection to effecting a cross-over in connecting cables, so that pins 1 and 4 normally connected to pins 3 and 5, and vice versa?

In this way, pins 3 and 5, for example, could always be for signal input at the point of access to any device, while pins 1 and 4 could always be signal output at the point of egress.

It would certainly minimise confusion, and I can't see any great penalty from having to wire cables in accordance with such a practice.

After all, catalogues show literally dozens of prefabricated cables from various sources, with DIN plugs of one kind or another on one end or both ends, clips, pins-jacks, phone jacks, shielded, in-built resistive pads and so on.

He has disc equipment, tape equipment, a couple of sound film projectors, an amateur transmitting station and a reasonable array of test gear, all wired with 5-pin DIN plugs and sockets.

And they're all wired in the same way, with one pair of pins always used for input and the other pair for output. Maybe it's not "standard" but I'm willing to bet that his equipment can be interchanged more readily and with fewer cables and adaptors than would be necessary otherwise.

What have we overlooked? What is the real justification for the present DIN convention? Is it the result of a careful bit of original planning, or is it a hotchpotch, stemming from the concept of straight through cables and an effort to preserve some sort of compatibility between the 3-pin and 5-pin connectors?

Another reference from "Hi-Fi News and Record Review" would seemingly lend weight to this observation: "The connections are simply reversed in order to provide a means of connecting items of equipment with a straightforward lead whose plugs are joined on a pin-to-pin basis."

Again: "Since they started life as 3-pin devices, their numbering sequence has pins 4 and 5 added as an afterthought."

SIMPLE TESTER FOR DIGITAL ICs

A small unit which combines a power supply, an IC socket with LED indicators to indicate logic levels at the device pins, and a simple test signal generator. Low in cost and easily built, it makes an ideal test jig for the experimenter working with digital ICs.

The simple digital IC tester shown has been of great assistance to the author in designing and debugging digital projects using TTL devices. It can be used to familiarise yourself with the functions of a new

device, to test a used device suspected of being faulty, to check the operation of circuits built up around single ICs (such as different types of clock oscillator), and to connect a "forgotten" IC temporarily into a larger circuit. It will also serve as a small logic trainer, to help in teaching yourself the concepts of digital circuit operation.

Although the tester itself has only one IC socket, its power supply is capable of supplying current to quite a number of devices, so that it can be used to check more elaborate setups if required. The power supply output is made available via a small jack socket for this purpose.

Interconnections between the IC under test, the power supply and the test signal generator section are made by means of standard banana plugs and sockets. I have made up a set of ten leads, which seem to be quite sufficient for most purposes. Eight of the leads are single wires with a plug at each end, from 6 to 9 inches long; the other two leads are of the double type, with a common banana plug in the centre joined to two others via leads again 6-9in long.

The power supply uses a three-terminal 5V regulator IC made by National Semiconductor, the LM309K, which is capable of providing output currents in excess of 1A. It is short-circuit proof, and if adequately heatsunk can operate from input voltages anywhere from 7V to 37V. I have used a transformer with a 25V centre-tapped secondary, and two 1A silicon diodes in a standard full-wave rectifier feeding into a 220uF/18VW reservoir electro. This has proved to be quite adequate.

The IC holder is a standard 16-pin dual in line socket, many of which are available. It should be of the type capable of being bolted to the front panel of the box used, and preferably one which allows an IC to be inserted and removed easily without damage to the pins.

Each of the pins of the socket is connected to a banana socket and also to an LED for monitoring the logic level. The LEDs have the usual current limiting resistors fitted in series, and in order to reduce loading of the IC terminals, all of the LEDs are switched on and off rapidly with a short duty cycle, rather than operated continuously. Visually this actually improves the subjective brightness, while the current consumption and loading are very much reduced.

In the prototype unit pictures I used Monsanto MV50 LEDs, which are one of the cheapest devices available. However they are very small, which makes mounting something of a problem, and they are also rather fragile. Since making the first unit I have used the NSL5023 and the NSL100 devices from NS Electronics, which are easier to handle; they also have mounting clips which are free on request.

The oscillator which pulses the LEDs via the AC128 current gating transistor is a simple circuit using half of a low-cost quad two-input gate such as the 7400. It is frequency adjustable, which allows the duty cycle to be adjusted for optimum subjective brightness from the LEDs. Although I have not actually fitted it to the prototype unit, the circuit shows a switch (S2) fitted in series with the AC128 to allow the LEDs to be turned off altogether. This is worthwhile, as the LEDs can tend to degrade the performance of some ICs at high speeds.

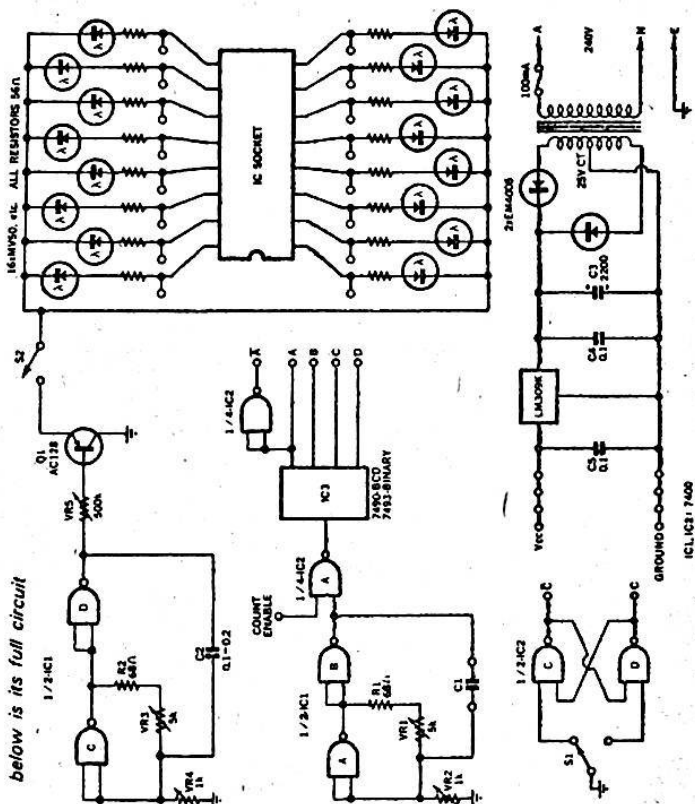

below is its full circuit

The circuitry which produces the test signals is very simple, yet it seems to be quite adequate. There is a simple pushbutton pulser, using a miniature pushbutton switch with an RS flip-flop made from two 2-input gates for bounce suppression. The gates are provided by half of another 7400 or similar. The other test signals are provided by an oscillator like that used for the LED pulsing, together with a divider to produce submultiples of the oscillator frequency. The divider may be either a 7490 for BCD division, or a 7493 or similar for straight binary; the idea is to produce signals which may be used to test decoders and similar devices.

A choice of oscillator capacitors is provided, to allow the rate to be adjusted from less than one hertz to about 15MHz. I used banana sockets for the range selection, but a switch would be somewhat neater and perhaps more convenient. A gate is connected between the oscillator and the divider IC to allow gating the outputs if required; if the

second input of the gate is connected to ground, the oscillator output will be prevented from reaching the divider. Conversely, leaving it open or connecting it to the positive rail will allow the divider to operate.

Note that for added flexibility I have made both outputs of the push-button flip-flop available via banana sockets, so that both "normally high" and "normally low" outputs may be used. Similarly the divider IC has a complementary output available from the first divider stage, and this too is made available.

The prototype unit was built in a small diecast aluminium box, which was then painted. The LM309K should be mounted on a reasonably good heat-sink, and this may well be the case if this is of metal. Note that the 0.1 μ F parasitic stopper capacitors should be wired directly between the input and output pins of the device and earth, respectively.

The layout of the unit is probably not very critical, and may be varied to suit your requirements and taste. I designed a small printed board to take most of the wiring and the ICs, but you could easily wire them up on a length of miniature resistor panel or a piece of Veroboard.

When the wiring is completed, turn VR1, VR3 and VR5 to maximum resistance and make sure S2 is in the off position. Turn the power on, and check that the regulator output is 5V. If it is not, you may have the rectifier output connected to the LM309K with the wrong polarity, so switch off immediately and check. If any of the other ICs gets hot, switch off and make sure that you haven't connected it into circuit the wrong way around.

Adjust VR4 until the LED pulsing oscillator is working, as monitored using a CRO or a high impedance earphone. Now switch on S2 and connect a lead between one of the test IC banana sockets and a Vcc supply socket (+5V). Then reduce the value of VR5 until the LED connected to the test socket pin glows, checking that the pulsing oscillator is still working. Now switch off S2, and connect a milliammeter across it, adjusting VR3 and VR5 for minimum current. This should be around 20mA or less. Finally remove the meter, switch S2 back on and try each of the LEDs in turn to check that they glow equally.

The test signal oscillator is adjusted in much the same way. VR1 is the main frequency range control, while VR2 is used to adjust the oscillator's operation so that its range of reliable oscillation is spread over the full rotation of VR1.

Use of the tester is fairly self-evident. As you use it, you will no doubt think of ways in which its usefulness may be extended by modifications and additions. You could increase its speed capability by using 74H or 74S series devices (and a suitable layout), or even perhaps ECL devices if these are your interest. You could even experiment with automating the testing of large numbers of similar ICs, using gates controlled by a program of binary numbers stored in a 64-bit semiconductor memory such as the National Semiconductor 7489.

In short, the basic tester unit shown is really only the starting point. The rest is up to the ingenuity and imagination of the reader.

Editor's Note: There are a variety of other devices available which could also be used in our contributor's circuit. Equivalents for the 7400 are the 9002, FJH131 and FLH101, while suitable LEDs would be the FLV101, FLV110, SL103, 5082-4403, OLD415 or OLD419. The Fairchild 7805 three-terminal regulator could also be used in place of the LM309K if desired.

AUDIO OSCILLATOR USES TWO ICs

Here is a circuit for a useful audio test oscillator which incorporates two IC operational amplifiers. The frequency coverage is from 30Hz to 30KHz, in three ranges. Sine wave and variable mark-space square wave outputs with variable output level, are available.

IC1 and its associated components go to make up a conventional Wien bridge oscillator, with amplitude stabilisation provided by a thermistor. An IRC logarithmic curve 'E' dual potentiometer helps to linearise the frequency calibration of the dial. An output of 1V RMS is obtained for loads of 300 ohms or more, with low distortion.

IC2 is the sine/square converter and which is a high gain "open loop" voltage comparator. The output switches very rapidly from positive to negative, depending on the comparison between the reference voltage selected by the markspace potentiometer and the instantaneous value of sine wave input. The converter produces a square wave output of 5V peak-to-peak for a load of 10K or more. Useful square waves of reduced amplitude are obtained for loads down to a few ohms.

Since the power requirements are low, a dual 9V battery was chosen, which makes the test oscillator very compact and portable. In the square wave mode the current drain is about 5mA from each 9V source. For the sine wave mode s2 switches IC2 out of circuit and the current drain is about 2mA. The double pole ON/OFF switch S3 can be incorporated in VR1.

IS IT A PNP OR NPN TRANSISTOR?

How readily can you recognise the "polarity" of a transistor symbol? Take a quick look at the nearest symbol and ask yourself whether it is PNP or NPN. If you can't make an immediate decision, the following hints may help. One is from a reader, the others from our own staff.

(1) Remember that the arrow points in the direction of conventional current flow, ie, from positive to negative. Thus the arrow is always pointing towards the negative terminal. The same rule applies for diodes.

(2) The middle letter of the normal three letter designation indicates the polarity of the collector supply. Thus, a PNP transistor has a Negative collector supply and an NPN type a Positive collector supply.

(3) This is our reader contribution. He suggests that the combination PNP could stand for "Point into Plate", the "point" being the arrow on the emitter symbol and the "plate" being the base symbol. Obviously, the opposite arrow arrangement then indicates the opposite letter combination, NPN.

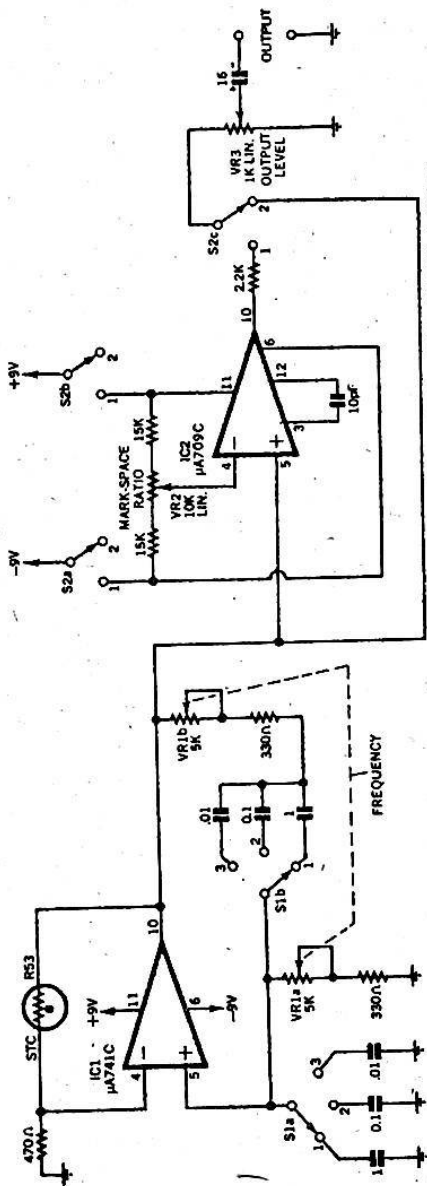

uA741C=RS276-007/010/1741
 uA709C=RS276-017

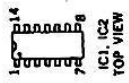

- S1 : 1 : 30 - 300Hz
 2 : 300 - 3000Hz
 3 : 3000 - 30000Hz
- S2 : 1 : SQUARE WAVE
 2 : SINE WAVE

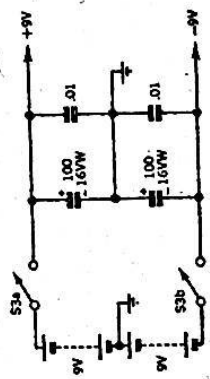

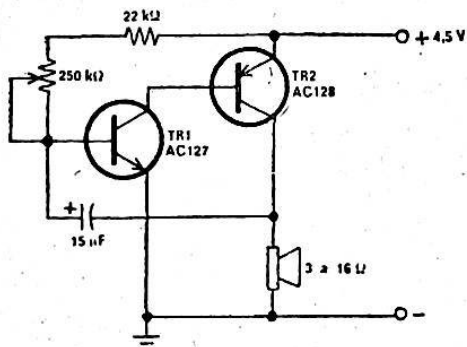

Transistorised Metronome with Variable Speed

AC127=RS276-2001. AC176-179. 2N2430

AC128=RS276-2005. AC117-124-153.

2N2431-4106

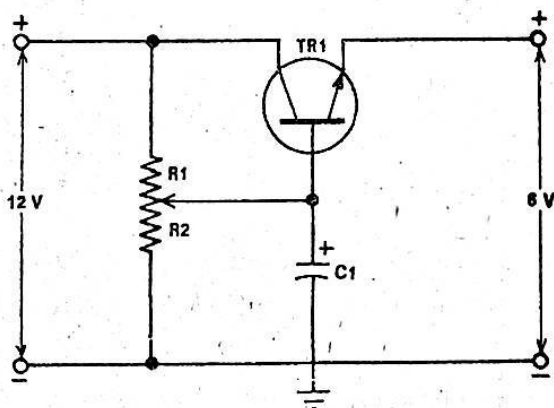

12V to 6V DC Converter

TR1 = BD109. RS276-2017. BDY34-39.

2N3054

R1/R2 = 100 ohms 15 Watt Variable

C1 = 200μF 16 Volt Working

BIBLIOTHEEK
N.V.H.R.

BERNARDS & BABANI PRESS RADIO AND ELECTRONICS BOOKS

BP1	First Book of Transistor Equivalents and Substitutes	40p
BP2	Handbook of Radio, TV and Ind. & Transmitting Tube & Valve Equiv.	60p
BP3	Handbook of Tested Transistor Circuits	40p
BP4	World's Short, Med. & LW FM & TV Broadcasting Stations Listing	60p
BP5	Handbook of Simple Transistor Circuits	35p
BP6	Engineers and Machinists Reference Tables	30p
BP7	Radio and Electronic Colour Codes and Data Chart	15p
BP8	Sound and Loudspeaker Manual	50p
BP9	38 Practical Tested Diode Circuits for the Home Constructor	35p
BP10	Modern Crystal and Transistor Set Circuits for Beginners	35p
BP11	Practical Transistor Novelty Circuits	40p
BP12	Hi-Fi, P.A., Guitar & Discotheque Amplifier Handbook	75p
BP13	Electronic Novelties for the Motorist	50p
BP14	Second Book of Transistor Equivalents	95p
BP15	Constructors Manual of Electronic Circuits for the Home	50p
BP16	Handbook of Electronic Circuits for the Amateur Photographer	60p
BP17	Radio Receiver Construction Handbook using IC's and Transistors	60p
BP18	Boys and Beginners Book of Practical Radio and Electronics	60p
BP22	79 Electronic Novelty Circuits	75p
BP23	First Book of Practical Electronic Projects	75p
BP24	52 Projects using IC741 (or Equivalents)	75p
BP25	How to Build Your Own Electronic and Quartz Controlled Watches & Clocks	85p
BP26	Radio Antenna Handbook for Long Distance Reception & Transmission	85p
BP27	Giant Chart of Radio Electronic Semiconductor & Logic Symbols	60p
BP28	Resistor Selection Handbook (International Edition)	60p
BP29	Major Solid State Audio Hi-Fi Construction Projects	85p
BP30	Two Transistor Electronic Projects	85p
BP31	Practical Electrical Re-wiring & Repairs	85p
BP32	How to Build Your Own Metal and Treasure Locators	85p
BP33	Electronic Calculator Users Handbook	95p
BP34	Practical Repair & Renovation of Colour TV's	95p
BP35	Handbook of IC Audio Preamplifier & Power Amplifier Constuction	95p
100	A Comprehensive Radio Valve Guide - Book 1	40p
121	A Comprehensive Radio Valve Guide - Book 2	40p
126	Boys Book of Crystal Sets	25p
129	Universal Gram-Motor Speed Indicator (Combined 50 & 60 ea model)	10p
138	How to Make Aerials for TV (Band 1-2-3)	25p
143	A Comprehensive Radio Valve Guide - Book 3	40p
150	Practical Radio Inside Out	40p
157	A Comprehensive Radio Valve Guide - Book 4	40p
160	Coil Design and Construction Manual	50p
161	Radio TV and Electronics Data Book	60p
170	Transistor Circuits for Radio Controlled Models	40p
177	Modern Transistor Circuits for Beginners	40p
178	A Comprehensive Radio Valve Guide - Book 5	40p
183	How to Receive Foreign TV Programmes on your Set by Simple Mods.	35p
196	AF-RF Reactance - Frequency Chart for Constructors	15p
200	Handbook of Practical Electronic Musical Novelties	50p
201	Practical Transistorised Novelties for Hi-Fi Enthusiasts	35p
202	Handbook of Integrated Circuits (IC's) Equivalents and Substitutes	75p
203	IC's and Transistor Gadgets Construction Handbook	60p
204	Second Book of Hi-Fi Loudspeaker Enclosures	60p
205	First Book of Hi-Fi Loudspeaker Enclosures	60p
206	Practical Transistor Circuits for Modern Test Equipment	60p
207	Practical Electronic Science Projects	60p
208	Practical Stereo and Quadrophony Handbook	60p
209	Modern Tape Recording Handbook	60p
210	The Complete Car Radio Manual	75p
211	First Book of Diode Characteristics Equivalents and Substitutes	75p
213	Electronic Circuits for Model Railways	75p
214	Audio Enthusiasts Handbook	75p
215	Shortwave Circuits and Gear for Experimenters and Radio Hobbies	85p
216	Electronic Gadgets and Games	60p
217	Solid State Power Supply Handbook	60p
218	Build Your Own Electronic Experimenters Laboratory	60p
219	Solid State Novelty Projects	60p
220	Build Your Own Solid State Hi-Fi and Audio Accessories	60p
221	28 Tested Transistor Circuits	60p
222	Solid State Short Wave Receivers for Beginners	60p
RCC	Resistor Colour Code Disc Calculator	60p

Bibliotheek Ned. Ver. v

The Gramplains, Shepherds Bush Road, London W6 7NF England
Telephone: 01-603 2581/7296