

Amateur

RADIO

For all two-way radio enthusiasts

Beginners' workshop –
a simple project to build

**FREE
READERS'
ADS**



**On test:
Trio TS811E**

QUESTIONS & ANSWERS

R WITHERS COMMUNICATIONS



**584 HAGLEY ROAD WEST, OLDBURY, WARLEY
B68 0BS (QUINTON, BIRMINGHAM) WEST MIDS.
Tel: 021-421 8201/2 (24 HR ANSWERPHONE)**



RWC SPECIAL OFFERS



**PLEASE ASK ABOUT THE RWC CREDITCARD
AVAILABLE NOW VIA LOMBARD TRICITY**

**M5
JUNCT
3**

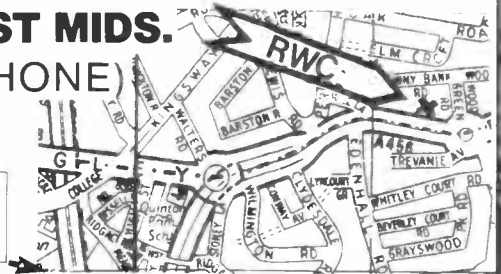

R.W.C.'S BARGAIN WINDOWS – ONCE ONLY OFFERS

<p>2 Mtr</p>	<p>YAESU FT290R £349 With free variable power supply, worth over £40.00. While stocks last. Charger & Ni-Cads £19.98 WHILE STOCKS LAST</p>	<p>TURN THAT BEAM KOPEK ROTATORS 50KG LOAD-ING FULL 1 YEAR WARRANTY OUTSTANDING VALUE £38.50</p>	<p>GOOD QUALITY FIELD-STRENGTH VSWR METERS IN-LINE DESIGN WORK VERY WELL ON 2 METRES £9.50 inc post ONLY 50 AT THIS PRICE</p>	<p>VARIABLE BENCH POWER SUPPLIES 0 to 15 Volts, 3 Ampere, IC Protected Normally over £40.00. RWS SPECIAL AT £19.50 (= £2.50 P&P). 60 Only, UNREPEATABLE OFFER, GET YOURS QUICK...</p>
<p>NEW RANGE OF LINEAR AMPLIFIERS FROM RAYCOM LTD SEND SAE FOR FULL DETAILS</p>	<p>10 METRE KIT LCL 2740 & DNT 40FM COMP 2 CRYSTALS 1 CRYSTAL FILTER 2 CAPACITORS & FULL INSTRUCTIONS RWC BEST SELLER, STILL ONLY £12.95 plus £1.00 p&p</p>	<p>'R.W.C. Special' Revco RS 2000 Ext Coverage 60-179 & 380-520MHz AM-FM THIS PRICE INCLUDES *70 MEMORIES *AC-DC SUPPLY *AUTO SEARCH *LOCK PRIORITY *Plus usual functions £259.00</p>	<p>3 ONLY</p>	<p>5% OVER 5/8 2 METRE COLINEAR BASE ANTENNA, TERRIFIC VALUE, ONLY £35.98, INCLUDING 5 STAR CARRIAGE TO YOUR DOOR.</p> <p>THE AMAZING NEW ARM MULTI-P6+ VHF-UHF MOBILE ANTENNA, THE MOST VERSATILE ANTENNA EVER MADE. ONLY £34.50 + £2.50 P&P. Colinear element £4.75</p>
<p>10 METRES FM QUALITY LOWE TX40G *SUPER SENSITIVE RECEIVER *4 WATTS OUTPUT *4KHz DEVIATION FM *REPEATER OFFSET INCLUDED ONLY 50 JOIN IN THE GROWING ACTION ON AVAILABLE TEN-FM. ONLY £52.00 + £2.50 P&P</p>		<p>RAYCOM SUPER MODIFICATION FOR YAESU FT757GX HF MOBILE FIT THIS MOD YOURSELF, AND HEAR THE DIFFERENCE. ELIMINATES VCO GLITCH, IMPROVING VFO TUNING, AND AS AN ADDED BONUS, INCREASES TUNING SPEED TO 50KHz per DIAL REVOLUTION, SELECTABLE ON 500KHz STEP SWITCH. £29.50, post Free, FOR TESTED COMPLETE PCB AND FULL INSTRUCTIONS. SEE AD IN JUNE AMATEUR RADIO.</p>	<p>WANTED FT225R/D, IC202E/S, FRG-7, IC2E, TR2300 BEST PRICES PAID - WORKING OR NOT</p>	
<p>BREM BRS 35 HEAVY DUTY 10 AMP POWER SUPPLY ELECTRONIC PROTECTION, & CURRENT LIMITING BARGAIN PRICE £49.50 FEW LEFT... HURRY!!!</p>	<p>AKD WAVE METER, A MUST FOR ALL VHF STATIONS £24.95 inc p THE BEST</p>	<p>SPECIAL '8 C SIZE NI-CADS 1800mAh £18.50</p>	<p>RWC'S HB9CV 2 Mtrs £6.99. 70Cms £5.99 post & pck £1.00.</p>	<p>POWER MODULES FOR FDK YAESU ICOM TRIO ETC. EG 25W 2 MTR WRITE FOR FULL LIST, FROM £35.00</p> <p>FULL RANGE OF TONNA AND JAYBEAM ANTENNAS ALWAYS IN STOCK.</p>
<p>6 METRES BARGAIN 5 ONLY TONNA 5 ELEMENT YAGI SUPER SPECIAL £25.00</p>	<p>8 ONLY HOXIN DC GROUND 1/2 WAVE MOBILE ANT INC PL259 + CO-AX £9.50 TO CLEAR</p>	<p>NEW LINE 10 METRE DIPOLE (RIGID) TELESCOPIC QUALITY CONSTRUCTION £9.50</p>	<p>HIGH QUALITY RUGGED GUTTER MOUNTS USEABLE ON ALL SORTS OF ANTENNAS ONLY £4.98 £1.00 P&P</p>	<p>STOP PRESS LOW PASS TVI FILTER BY TELCO LIST £39.95 12 ONLY £12.50 MADE IN USA</p> <p>G5RV HF MULTI-BAND DIPOLE ANTENNA FULL SIZE £14.95 1/2 SIZE £12.95 POST & PACKING FREE!</p>
<p>TRAVELLING JIM 2M + 70CMS INC LEAD 2M £7.95 + PL259 70CM £6.95</p>	<p>R.W.C. BARGAIN PACK BNC KIT SILVER + NICKEL PLATED ELBOWS WORTH £10 PLUGS ETC ONLY £6.99</p>	<p>USA MADE PUSH ON PL259 LAST 300 TO CLEAR FOR UR67 UR43 99p FOR THREE!</p>	<p>ALWAYS A LARGE RANGE OF SECONDHAND EQUIPMENT IN STOCK SEND LARGE SAE FOR LATEST LIST</p>	<p>HF AERIAL TRAPS G8KW-W3DZZ TYPE HIGH QUALITY 71MHZ £8.95 PAIR POST FREE</p> <p>CCTV LENS 39MM JAP 'C' TYPE FIXING 16mm FOCAL LENGTH £7.50 £1.00 P&P</p>
<p>YAESU FT102 AM FILTERS XF 8.2 GA £19.50</p>	<p>RF TRANSISTORS OVER 20,000W IN STOCK FOR ALL HF/VHF/UHF RADIOS EG. 2SC 1947 £7.50 2SC 2290 @ £24.00</p>	<p>VERY HEAVY CHROME PLATE MORSE KEY BLOCK SUIT HK705 ETC. WITH FREE 1/4" JACK + LEAD £6.95</p>	<p>MINI HEADPHONES 3.5MM + 1/4" JACKS MONO SUPER STEREO QUALITY LIGHTWEIGHT DESIGN £3.95 INC P&P</p>	<p>KENWOOD TRIO MC-355 NOISE CANCELLING DYNAMIC MIKE SUPER QUALITY LAST FIVE £12.50</p> <p>HEAVY DUTY MAGNETIC MOUNT S0239 MOUNT 3M COAX + PL259 SPECIAL PRICE £8.95</p>

All offers subject to availability on a first come first served basis. Prices subject to change without notice, all correct at time of going to press, E&OE. **TERMS:** No COD. Barclaycard and Access accepted. Post free over £50, under £50 add £2.50 post and handling, unless stated. Please send SAE with all enquiries and for latest secondhand list.

Amateur RADIO

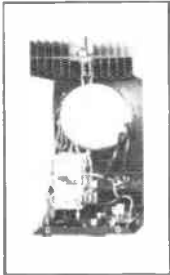

Editor:

Jim Chalmers

Editorial Assistant:

Anita Ley

Advertisement

Manager:

Margaret Hall

Subscriptions:

01-684 3157

Accounts:

Clare Brinkman

Publisher:

Peter Williams

General Manager:

Alan Golbourn

On sale:

Fourth

Thursday of the month

preceding cover date

Next issue: Cover date

June 1985 on sale

23 May 1985

Published by: Amateur

Radio Magazines,

Sovereign House,

Brentwood, Essex CM14

4SE, England

(0277) 219876

Printed: In England

ISSN: 0264-2557

News Trade Sales by:

Argus Press Sales &

Distribution Ltd, 12-18

Paul Street, London

EC2A 4JS.

01-247 8233

Front cover: Trio TS811E

reviewed this month (p23)

Photo by Jay Moss-Powell G6XIB

and Pete Galvin

Whilst every care is taken

when accepting

advertisements we cannot

accept responsibility for

unsatisfactory transactions.

We will, however, thoroughly

investigate any complaints.

The views expressed by

contributors are not

necessarily those of the

publishers.

Every care is also taken to

ensure that the contents of

Amateur Radio are accurate,

we assume no responsibility

for any effect from errors or

omissions.

7 Letters

Your opinions on topics of interest

8 Straight and Level

All the latest news, comment and developments on the amateur radio scene

12 DX Diary

Don Field G3XTT with this month's DX news

14 The Three Peaks

Three climbers, three mountains, one radio and 30 hours: a recipe for disaster

19 Beginners' workshop

Veroboard construction explained by Rev George Dobbs G3RJV

23 Angus McKenzie tests

This month G3OSS reviews the Trio TS811E multimode, the new BNOS 2m solid-state linear and 12/25A 13.8Vdc power supply

30 Aerials and propagation

Bill Sparks G8FBX closes the series with a closer look at some of the theory involved

34 SWL

Trevor Morgan GW4OXB comments on the multiband version of the 'Dipole of Delight'

36 On the Beam

Glen Ross G8MWR with all the latest news from VHF, UHF and Microwaves

39 CB Conversions

This month the EPROM is explained

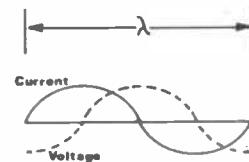
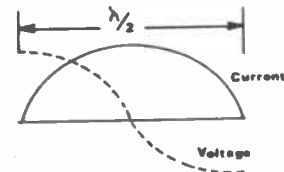

44 Back to Basics

How do these signals propagate through the atmosphere?

47 Coming next month

What's in store for you

48 Questions and answers

Multiple choice questions to test you on your knowledge of the RAE syllabus

51 Secondhand

Hugh Allison G3XSE tackles drift problems in early valve equipment

53 Free Classified Ads

The market for buying and selling.

SERVICES

52 Subscription order form

55 Free Classified Ad form

57 Radio and Electronics World
subscription order form

58 Advertisers index

58 Advertising rates and information

© Copyright 1985
Amateur Radio Magazines

PHONE
0474 813225
3 LINES

P.M. COMPONENTS LTD
DEPT REW SELECTRON HOUSE, WROTHAM ROAD
MEOPHAM GREEN, MEOPHAM, KENT DA13 0QY

TELEX
966371
PM COMP

VISA

A SELECTION FROM OUR
STOCK OF BRANDED VALVES

AT14	11.90	EB41	3.85	EL91	6.70	M8099	5.00	OV002-6	9.00	1X2B	1.45	6A16	2.60	6F23	0.60	12AU6	1.95	19.80	1.95
A288	11.90	EB42	0.85	EL95	0.70	M8100	5.00	OV003-10MUL	19.80	12Z	0.85	6A17	2.00	6F24	2.60	12AV6	1.25	92AG	1.95
A2134	14.95	EB43	1.95	EL133	12.15	M8106	7.00	OV003-10MUL	2.00	2C21	0.90	6A18	2.00	6F25	2.00	12AV6	1.25	92AG	1.95
A2293	6.30	EB44	1.95	EL183E	3.50	M8107	7.00	OV003-20A	0.90	2C9A	2.30	6A19	2.00	6F26	1.80	12AX7	0.65	92AG	1.95
A2599	37.90	EB45	0.90	EL360	6.75	M8112	5.00	OV003-20B	1.00	2C9B	35.50	6A20	2.00	6F27	1.80	12AX7	0.65	150B2	6.95
A3000	11.50	EB46	0.90	EL504	1.40	M8116	5.00	OV006-40A	32.00	2C9C	25.50	6A21	2.00	6F28	1.80	12AX7A	1.95	150C2	2.15
A3001	11.50	EB47	0.90	EL515	0.95	M8119	5.00	OV007-27.80	27.80	2C9D	25.50	6A22	2.00	6F29	1.80	12A7A	3.90	150C4	2.15
A3002	11.50	EB48	0.90	EL516	0.95	M8120	5.00	OV007-27.80	27.80	2C9E	25.50	6A23	2.00	6F30	1.80	12B4A	3.90	150C4	2.15
A3003	11.50	EB49	0.90	EL517	0.95	M8121	5.00	OV007-27.80	27.80	2C9F	25.50	6A24	2.00	6F31	1.80	12B4B	3.90	150C4	2.15
A3004	11.50	EB50	0.90	EL518	0.95	M8122	5.00	OV007-27.80	27.80	2C9G	25.50	6A25	2.00	6F32	1.80	12B4C	3.90	150C4	2.15
A3005	11.50	EB51	0.90	EL519	0.95	M8123	5.00	OV007-27.80	27.80	2C9H	25.50	6A26	2.00	6F33	1.80	12B4D	3.90	150C4	2.15
A3006	11.50	EB52	0.90	EL520	0.95	M8124	5.00	OV007-27.80	27.80	2C9I	25.50	6A27	2.00	6F34	1.80	12B4E	3.90	150C4	2.15
A3007	11.50	EB53	0.90	EL521	0.95	M8125	5.00	OV007-27.80	27.80	2C9J	25.50	6A28	2.00	6F35	1.80	12B4F	3.90	150C4	2.15
A3008	11.50	EB54	0.90	EL522	0.95	M8126	5.00	OV007-27.80	27.80	2C9K	25.50	6A29	2.00	6F36	1.80	12B4G	3.90	150C4	2.15
A3009	11.50	EB55	0.90	EL523	0.95	M8127	5.00	OV007-27.80	27.80	2C9L	25.50	6A30	2.00	6F37	1.80	12B4H	3.90	150C4	2.15
A3010	11.50	EB56	0.90	EL524	0.95	M8128	5.00	OV007-27.80	27.80	2C9M	25.50	6A31	2.00	6F38	1.80	12B4I	3.90	150C4	2.15
A3011	11.50	EB57	0.90	EL525	0.95	M8129	5.00	OV007-27.80	27.80	2C9N	25.50	6A32	2.00	6F39	1.80	12B4J	3.90	150C4	2.15
A3012	11.50	EB58	0.90	EL526	0.95	M8130	5.00	OV007-27.80	27.80	2C9O	25.50	6A33	2.00	6F40	1.80	12B4K	3.90	150C4	2.15
A3013	11.50	EB59	0.90	EL527	0.95	M8131	5.00	OV007-27.80	27.80	2C9P	25.50	6A34	2.00	6F41	1.80	12B4L	3.90	150C4	2.15
A3014	11.50	EB60	0.90	EL528	0.95	M8132	5.00	OV007-27.80	27.80	2C9Q	25.50	6A35	2.00	6F42	1.80	12B4M	3.90	150C4	2.15
A3015	11.50	EB61	0.90	EL529	0.95	M8133	5.00	OV007-27.80	27.80	2C9R	25.50	6A36	2.00	6F43	1.80	12B4N	3.90	150C4	2.15
A3016	11.50	EB62	0.90	EL530	0.95	M8134	5.00	OV007-27.80	27.80	2C9S	25.50	6A37	2.00	6F44	1.80	12B4O	3.90	150C4	2.15
A3017	11.50	EB63	0.90	EL531	0.95	M8135	5.00	OV007-27.80	27.80	2C9T	25.50	6A38	2.00	6F45	1.80	12B4P	3.90	150C4	2.15
A3018	11.50	EB64	0.90	EL532	0.95	M8136	5.00	OV007-27.80	27.80	2C9U	25.50	6A39	2.00	6F46	1.80	12B4Q	3.90	150C4	2.15
A3019	11.50	EB65	0.90	EL533	0.95	M8137	5.00	OV007-27.80	27.80	2C9V	25.50	6A40	2.00	6F47	1.80	12B4R	3.90	150C4	2.15
A3020	11.50	EB66	0.90	EL534	0.95	M8138	5.00	OV007-27.80	27.80	2C9W	25.50	6A41	2.00	6F48	1.80	12B4S	3.90	150C4	2.15
A3021	11.50	EB67	0.90	EL535	0.95	M8139	5.00	OV007-27.80	27.80	2C9X	25.50	6A42	2.00	6F49	1.80	12B4T	3.90	150C4	2.15
A3022	11.50	EB68	0.90	EL536	0.95	M8140	5.00	OV007-27.80	27.80	2C9Y	25.50	6A43	2.00	6F50	1.80	12B4U	3.90	150C4	2.15
A3023	11.50	EB69	0.90	EL537	0.95	M8141	5.00	OV007-27.80	27.80	2C9Z	25.50	6A44	2.00	6F51	1.80	12B4V	3.90	150C4	2.15
A3024	11.50	EB70	0.90	EL538	0.95	M8142	5.00	OV007-27.80	27.80	2CA0	25.50	6A45	2.00	6F52	1.80	12B4W	3.90	150C4	2.15
A3025	11.50	EB71	0.90	EL539	0.95	M8143	5.00	OV007-27.80	27.80	2CA1	25.50	6A46	2.00	6F53	1.80	12B4X	3.90	150C4	2.15
A3026	11.50	EB72	0.90	EL540	0.95	M8144	5.00	OV007-27.80	27.80	2CA2	25.50	6A47	2.00	6F54	1.80	12B4Y	3.90	150C4	2.15
A3027	11.50	EB73	0.90	EL541	0.95	M8145	5.00	OV007-27.80	27.80	2CA3	25.50	6A48	2.00	6F55	1.80	12B4Z	3.90	150C4	2.15
A3028	11.50	EB74	0.90	EL542	0.95	M8146	5.00	OV007-27.80	27.80	2CA4	25.50	6A49	2.00	6F56	1.80	12B5A	3.90	150C4	2.15
A3029	11.50	EB75	0.90	EL543	0.95	M8147	5.00	OV007-27.80	27.80	2CA5	25.50	6A50	2.00	6F57	1.80	12B5B	3.90	150C4	2.15
A3030	11.50	EB76	0.90	EL544	0.95	M8148	5.00	OV007-27.80	27.80	2CA6	25.50	6A51	2.00	6F58	1.80	12B5C	3.90	150C4	2.15
A3031	11.50	EB77	0.90	EL545	0.95	M8149	5.00	OV007-27.80	27.80	2CA7	25.50	6A52	2.00	6F59	1.80	12B5D	3.90	150C4	2.15
A3032	11.50	EB78	0.90	EL546	0.95	M8150	5.00	OV007-27.80	27.80	2CA8	25.50	6A53	2.00	6F60	1.80	12B5E	3.90	150C4	2.15
A3033	11.50	EB79	0.90	EL547	0.95	M8151	5.00	OV007-27.80	27.80	2CA9	25.50	6A54	2.00	6F61	1.80	12B5F	3.90	150C4	2.15
A3034	11.50	EB80	0.90	EL548	0.95	M8152	5.00	OV007-27.80	27.80	2CA0	25.50	6A55	2.00	6F62	1.80	12B5G	3.90	150C4	2.15
A3035	11.50	EB81	0.90	EL549	0.95	M8153	5.00	OV007-27.80	27.80	2CA1	25.50	6A56	2.00	6F63	1.80	12B5H	3.90	150C4	2.15
A3036	11.50	EB82	0.90	EL550	0.95	M8154	5.00	OV007-27.80	27.80	2CA2	25.50	6A57	2.00	6F64	1.80	12B5I	3.90	150C4	2.15
A3037	11.50	EB83	0.90	EL551	0.95	M8155	5.00	OV007-27.80	27.80	2CA3	25.50	6A58	2.00	6F65	1.80	12B5J	3.90	150C4	2.15
A3038	11.50	EB84	0.90	EL552	0.95	M8156	5.00	OV007-27.80	27.80	2CA4	25.50	6A59	2.00	6F66	1.80	12B5K	3.90	150C4	2.15
A3039	11.50	EB85	0.90	EL553	0.95	M8157	5.00	OV007-27.80	27.80	2CA5	25.50	6A60	2.00	6F67	1.80	12B5L	3.90	150C4	2.15
A3040	11.50	EB86	0.90	EL554	0.95	M8158	5.00	OV007-27.80	27.80	2CA6	25.50	6A61	2.00	6F68	1.80	12B5M	3.90	150C4	2.15
A3041	11.50	EB87	0.90	EL555	0.95	M8159	5.00	OV007-27.80	27.80	2CA7	25.50	6A62	2.00	6F69	1.80	12B5N	3.90	150C4	2.15
A3042	11.50	EB88	0.90	EL556	0.95	M8160	5.00	OV007-27.80	27.80	2CA8	25.50	6A63	2.00	6F70	1.80	12B5O	3.90	150C4	2.15
A3043	11.50	EB89	0.90	EL557	0.95	M8161	5.00	OV007-27.80	27.80	2CA9	25.50	6A64	2.00	6F71	1.80	12B5P	3.90	150C4	2.15
A3044	11.50	EB90	0.90	EL558	0.95	M8162	5.00	OV007-27.80	27.80	2CA0	25.50	6A65	2.00	6F72	1.80	12B5Q	3.90	150C4	2.15
A3045	11.50	EB91	0.90	EL559	0.95	M8163	5.00	OV007-27.80	27.80	2CA1	25.50	6A66	2.00	6F73	1.80	12B5R	3.90	150C4	2.15
A3046	11.50	EB92	0.90	EL560	0.95	M8164	5.00	OV007-27.80	27.80	2CA2	25.50	6A67	2.00	6F74	1.80	12B5S	3.90	150C4	2.15
A3047	11.50	EB93	0.90	EL561	0.95	M8165	5.00	OV007-27.80	27.80	2CA3	25.50	6A68	2.00	6F75	1.80	12B5T	3.90	150C4	2.15
A3048	11.50	EB94	0.90	EL562	0.95	M8166	5.00	OV007-27.80	27.80	2CA4	25.50	6A69	2.00	6F76	1.80	12B5U	3.90	150C4	2.15
A3049	11.50	EB95	0.90	EL563	0.95	M8167	5.00	OV007-27.80	27.80	2CA5	25.50	6A70	2.00	6F77	1.80	12B5V	3.90	150C4	2.15
A3050	11.50	EB96	0.90	EL564	0.95	M8168	5.00	OV007-27.80	27.80	2CA6	25.50	6A71	2.00	6F78	1.80	12B5W	3.90	150C4	2.15
A3051	11.50	EB97	0.90	EL565	0.95	M8169	5.00	OV007-27.80	27.80	2CA7	25.50	6A72	2.00	6F79	1.80	12B5X	3.90	150C4	2.15
A3052	11.50	EB98	0.90	EL566	0.95	M8170	5.00	OV007-27.80	27.80	2CA8	25.50	6A73	2.00	6F80	1.80	12B5Y	3.90	150C4	2.15
A3053	11.50	EB99	0.90	EL567	0.95	M8171	5.00	OV007-27.80	27.80	2CA9	25.50	6A74	2.00	6F81	1.80	12B6A	3.90	150C4	2.15
A3054	11.50	EB00	0.90	EL568	0.95	M8172	5.00	OV007-27.80	27.80	2CA0	25.50	6A75	2.00	6F82	1.80	12B6B	3.90	150C4	2.15
A3055	11.50	EB01	0.90	EL569	0.95	M8173	5.00	OV007-27.80	27.80	2CA1	25.50	6A76	2.00	6F83	1.80	12B6C	3.90	150C4	2.15
A3056	11.50	EB02	0.90	EL570	0.95	M8174													

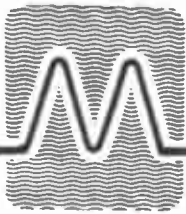

MICROWAVE MODULES LTD

Microwave Modules Ltd. Is a full time professional organisation, established over **16 years** ago in **1969**, and currently employs over **30 full time**, on site staff based in our two modern, purpose built factories. In addition, a similar number of 'Outworkers' are involved in assembly and mechanical operations

OUR EXTENSIVE RANGE . . .

Our product range now exceeds **50 individual items** in total and is the widest range available from any one manufacturing company. Our technical resources have enabled us to not only become **the largest and most successful** designer and manufacturer of R F Products, such as **Linear Amplifiers** and transverters, but also designers and manufacturers of **Innovative** microprocessor and digital products such as **The MorseTalker**, MMSI, and the RTTY to TV decoder. MM2001

ALL BRITISH . . .

Every product in our range is designed and manufactured in the UK by our own employees, and wherever possible British Components are utilised.

GUARANTEED . . .

All Microwave Modules Products are **Fully Guaranteed for 12 months**. This includes all semi-conductors and **PA Transistors**. We have built our reputation around our customer service and back-up and it is second to one.

OUR RANGE OF LINEAR AMPLIFIERS . . .



MML144/30-LS



MML144/50-S



MML144/100-LS



MML144/200-S

PRODUCT	INPUT POWER	OUTPUT POWER	MODES OF OPERATION	Pre Amplifier		POWER REQUIREMENTS	RF * VOX	PRICE INC VAT
				GAIN	NF			
MML144/30-LS	1 or 3W	30W	SSB.	12dB	<1.5dB	13.8V @ 4A	✓	£82.90 (p&p £3.50)
MML144/50-S	10W	50W	FM.			13.8V @ 6A	✓	£92.00 (p&p £3.50)
MML144/100-S	10W	100W	AM.			13.8V @ 12A	✓	£149.95 (p&p £4.00)
MML144/100-HS	25W	100W	CW.			13.8V @ 12A	✓	£149.95 (p&p £4.00)
MML144/100-LS	1 or 3W	100W				13.8V @ 14A	✓	£169.95 (p&p £4.00)
MML144/200-S	3, 10 or 25W	200W				13.8V @ 30A	✓	£299.00 (p&p £5.25)



MML432/30-L

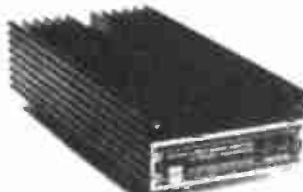

MML432/50

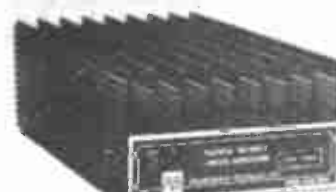

MML432/100

PRODUCT	INPUT POWER	OUTPUT POWER	MODES OF OPERATION	PRE AMPLIFIER		POWER REQUIREMENTS	RF * VOX	PRICE inc VAT
				GAIN	NF			
MML432/30-L	1 or 3W	30W	SSB.	12dB	2dB	13.8V @ 6A	✓	£145.00 (p&p £4.00)
MML432/50	10W	50W	FM, ATV.	12dB	2dB	13.8V @ 8A	✓	£129.95 (p&p £4.00)
MML432/100	10W	100W	CW.	—	—	13.8V @ 20A	✓	£299.00 (p&p £5.25)

*THE RF VOX CAN BE OVERRIDDEN AND HARDWIRED

CONNECTORS . . .

144MHz Products — Our standard connector on these products is SO239. We use a high quality PTFE socket of superior quality, but we are able to supply the choice of BNC or 'N' type at no extra charge. Please specify.

432 MHz Products — The MML 432/30-L's fitted with BNC connectors, 'N' type available, please specify. The MML432/50 and MML432/100 both have BNC input sockets and 'N' type output sockets. If this is not to your preference please specify when ordering.

DATA SHEETS . . .

A full printed data sheet is available on each product, and is free on request.

CATALOGUE . . .

A copy of our latest catalogue can be obtained free of charge on request.

AVAILABILITY . . .

Our products are normally available from stock, either direct from ourselves or any of our 75 UK outlets.



VISA

WELCOME

MICROWAVE MODULES (AR)

BROOKFIELD DRIVE, AINTREE, LIVERPOOL L9 7AN, ENGLAND
Telephone: 051-523 4011. Telex. 628608 MICRO G
CALLERS AE WELCOME, PLEASE TELEPHONE FIRST

HOURS:
MONDAY-FRIDAY
9-12.30, 1-5.00
E & O.E.

L·E·T·T·E·R·S

ODD BALL

As a reader of *Amateur Radio* I thought I would put a few words together which may be of interest.

I have been an SWL and a constructor since 1932 and have progressed through a range of receivers such as the John Scott Taggart series Telson 3 and the Cosser Melody Maker.

My first set was a Burndept bright emitter type which after a few hours of listening would require you to change the accumulator as the filaments would slowly sink in the west, but it was great fun.

I am still a 100% valve man, thus the heading 'Odd Ball' which I am considered locally.

I can't seem to take to the Lego-type building; sticking bits into little holes holds nothing for me, but everyone to his own.

The rigs I'm using at the moment are a 10 valve Super, 6 valve TRF (all EF50) and a 4

valve direct converter. I don't think the black box boys hear any more DX, but I fight a lot harder.

The QTH at this end is a hill farm (1100 asl) so aerials are also a big interest to me.

Keep up the good work on the mag.
G Waddington, West Yorks

BLASTING CWS

I have followed your magazine since October '83, and as a beginner found it most helpful. Now however I have passed the RAE and I'm struggling with the dreaded Morse.

I should like to ask through these pages for our enthusiastic Morse men to stay off the slow Morse transmission frequencies - in particular the 3.550MHz locking sessions at 1800 and 1830.

At my QTH I receive the locking signals weekly and get annoyed and frustrated at

other CWS blasting over and around 3.550MHz whilst I am struggling to sort out the dots from the dashes.

So, CWS, please don't transmit on slow Morse sessions and confuse us hardworking beginners.
R Burnet, Southampton

HAD ENOUGH

As an ex-candidate of the RAE, having failed part two of the examination twice, I would like to add my support to the novice licence lobby. I do not mean this to be a cry of 'sour grapes' but I do feel that some of the RAE courses should be looked at.

My first course was six months of one night per week evening classes and even then we did not have time to cover the full syllabus.

Upon passing part one and failing part two I enrolled with another evening class for a 'crash course' hoping that this would do the trick. This

consisted of only 10 two hourly evening classes.

On entering the exam again I found it as a previous correspondent described it: 'like studying German and being examined in Swahili!'

I personally only wanted to be a clean operator and fail to see how the way the holes in a semi-conductor move (which was one of the exam questions) would influence that.

Although not claiming to be a genius, I have never had this problem with an exam before; having taken many exams for a technical career in the RAF and since in Curry Street. I feel however that I will have to be content with remaining an SWL, which I've been through thick and thin for twenty years or so.

Please don't say 3rd time lucky - I've had enough, I've really tried and I've had the RAE up to here!

L G Slater, Moseley

WPO COMMUNICATIONS

20 FARNHAM AVENUE, HASSOCKS G3WPO
WEST SUSSEX BN6 8NS MAIL ORDER ONLY

24hr
ANSAPHONE

07918 6149



DSB/CW

DSB80

2w+

Our most popular kit ever. Simple 80m (also 160m version) Tx/Rx with superbly sensitive receiver. VFO. Basic pcb kit (only needs psu/mic/key & speaker) ONLY £39.95. Case (punched but plain finish)/hardware £25.95 and digital display option @ £29.50. All above for £85.00 inc 12v operation.



only
£39.95
Basic Kit

UNIVERSAL MORSE MEMORY

Our unique design which works with Hand keys! 10-120 sec message length at any input/output speed. Memory back-up, sidetone, battery or external supply. SPECIAL MS VERSION now available with 1-15 sec message length.



£52.45
READY
BUILT

See previous ads for more details

NEW

micron

Now our best selling kit!



OUR LATEST TRANSCEIVER KIT, sets new standards in QRP performance - LOOK AT THESE FEATURES - a 6 band CW only 8/10W output rig covering the 80, 40, 30, 20, 15 & 10m bands (bottom 200KHz of each). 0.25uV sensitivity receiver, featuring AGC, with S Meter. Stable 2 speed VFO with IRT (Spot facility), 1W AF output to speaker, and 3 position LC filter + switchable attenuator. Silent solid state Rx/Tx switching with fast semi break-in and shaped keying. Sidetone facility. Fully variable RF power output from OW to full power metering. Needs +12v/14v supply.

PLUS CUSTOM punched & painted aluminium case/hard-ware and speaker with unique facility for optional INTERNAL ATU (Transmatch type) & SWR metering. DIGITAL READOUT option. The MICRON uses a compact single pcb design with easy step-by-step assembly instructions and drawings designed for the relative newcomer - minimal test equipment needed! Mostly prewound coils and transformers.

PRICES: Basic pcb kit inc VFO capacitor/drive/ enclosure, for 2 bands (state which) £99.45 - extra bands £11.75 each. Full pcb kit for 6 bands Tx/Rx £145. Case £46.20. COMPLETE KIT WITH CASE/6 BANDS £182.50. Optional extras - Digital readout (LCD) kit £38.50, and ATU Kit (for internal mounting) with SWR/Power metering at £37.00. COMPLETE KIT/CASE WITH DISPLAY AND ATU - £241.00.

Please phone or write for full brochure on the MICRON or place your order now!

PROFESSIONALLY CONDITIONED AUDIO WITH A PARAMETRIC EQUALISER THE ULTIMATE PUNCH!

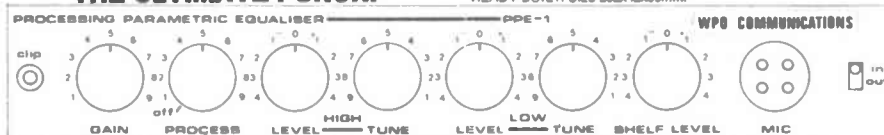

NOT TO BE CONFUSED WITH STANDARD AUDIO PROCESSORS! FULLY TUNABLE High AND Low frequency plus 12dB BOOST/CUT controls & SHELVEING provides distortionless tailoring of YOUR voice, microphone and rig. Hi-Lo Z i/p with VOGAD. Variable gain and switchable internal PROCESSOR. PLUS, it has an INTERNAL 2W AF Amp plus speaker/rec input for correcting and modifying your Rx audio if you prefer. +12v supply needed. BYPASS switch. State 4 or 8 pin i/p socket. Complete with case. PRICE: £53.45 in KIT form or £72.45 READY BUILT. Size 252x42x90mm.

ALPHA - SINGLE BAND SSB/CW 50W TRANSCEIVER KIT

160M
or
20M



NEW LOW PRICE - £179.95 complete! To quote a customer 'Very pleased with the kit, and you must be congratulated on the standard of the design, which is excellent'. 90dB + Dynamic range, PLL VFO. Digital display, Blanker, IF Gain, Custom Finished Case with mobile bracket etc etc. Join the ALPHA builders! Comprehensive instructions & drawings.

VFO & OTHER KITS

MINISYNTH - As used in the DSB2. 1 band simple PLL VFO - versions for most bands and i.f.'s. and for 160-10m (28-26.6). Full kit with tuning cap ONLY £29.70. VHF MINISYNTH our 2 Meter version with continuous coverage of 144-146MHz. Direct output on 2m and options for up to 3 other bands ie 135-137 for Rx + 2 repeater shifts. Full kit with air tuning cap £38.50. Again, very stable - drives SBL1. CATALOGUE 50p in stamps please. Allow 7-28 days for delivery. EXPORT - Europe use UK prices. Rest of World UK + 5%. See us at the NEC - STAND B9.

STRAIGHT & LEVEL

All the latest news, comment and developments on the amateur radio scene

SPRING CATALOGUE

Packed with over 4,000 different components plus associated new products for the electronics hobbyist and sporting a lively new format, Cirkit's spring components catalogue is to be published on 11 April.

It will be available from leading newsagents throughout the country at the cover price of £1.15.

Products introduced for the first time in the catalogue include the BBC Model B microcomputer as well as a range of computer add-ons such as disc drives, expansion boards, speech synthesizers, disc interfaces and the new widely acclaimed AMX Mouse, which performs such useful functions as computer aided design and word processing with fingertip control.

Additional product introductions are calculators from Texas Instruments,

Cooper Tools' Weller W12D soldering iron, plus new tools, kits and modules. Among the innovative new kits is a heart rate monitor which will enable hobbyists to test their own fitness. The assembled unit provides audio/visual and analogue output which facilitates connection to a chart recorder, oscilloscope or personal computer.

Also new from Cirkit is a weather satellite receiver kit, which will allow hobbyists to follow weather patterns such as cloud cover and wind direction.

The assembled kit will receive 137MHz satellite transmissions and display them on a home computer by linking up with a simple aerial, interface and the use of appropriate software.

For further information contact: Cirkit Holdings plc, Park Lane, Broxbourne, Herts EN10 7NQ. Tel: (0992) 444111.

SCREENED LOOP

A number of refinements and improvements for the final engineered model of the screened loop antenna for 80m, included in the April issue of *Amateur Radio*, have been suggested by the author, Richard Marris. Any reader wishing to build such a loop could bear these in mind.

1 To improve screening and neatness the variable capacitor, VC, would be installed in a small metal box. The outer conductors of the two ends of the loop would be bonded on to the box at points of entry. The outer conductor of the coaxial feeder to the Rx would also be bonded to the box.

2 A circular loop construction would be adopted if possible. The proposal in mind is to incorporate the loop coaxial cable around the inner tube of an ordinary plastic hula-hoop. These appear to come in sizes between 24

inches and 36 inches in diameter. A 36 inch diameter hula-hoop would give an overall diameter of 9.4 feet.

3 A coaxial cable would be used which had a capacity not exceeding 20pF per foot between the inner and outer conductor. With this in mind, it was noted that RG/U62 has a capacity of 20.5pF and RG/U93 has a capacity of 13.5pF.

4 A simple rotation turntable base would be used.

5 The diagram shows a possible illustration of the final engineered loop.

6 In conclusion it should be mentioned that the screened loop has a very low impedance, and considerable work could be done to improve the impedance match between it and the coaxial feeder to the Rx. This would no doubt improve the results obtained.

DE-SOLDERING TOOLS

The Oryx range of soldering equipment, manufactured by Greenwood Electronics of Reading, has been updated by the redesign of four de-soldering tools, together with the addition of a special anti-static version of the Oryx SR3A de-soldering pump.

These redesigned tools, the SR Series, remove all unwanted solder from printed circuit and other soldered joints and their unique design prevents molten solder from making contact with the actuator spring, a feature which provides for virtually maintenance free operation.

The SR3A has been developed to cater for most electronics applications. It has a safety guard and action is triggered by simple push-button operation.

Nozzles are 16mm long and measure 2mm diameter at the

tip and are supplied in packs of three.

A similar model, the SR3A micro, has a 21mm nozzle

measuring 1.7mm diameter at the tip.

The SR3A/ASN, a new anti-static de-solder pump which

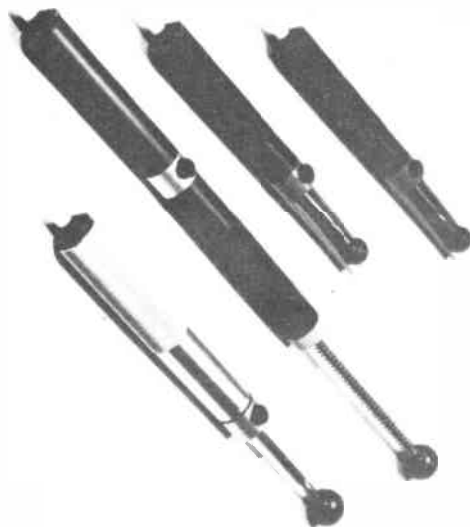

was designed specifically for British Telecom, is also available as a normal commercial unit. It is similar to the SR3A but incorporates a special anti-static nozzle and carries BT approval.

The SR2 incorporates a non-recoil spring and double action chamber which allows the plunger to remain stationary after push-button release.

The range is completed by the SR3A/S, on which the guard has been omitted because the piston throw is less than 50mm.

This arrangement offers the advantage of easier spring loading and, because of the short piston throw, minimises the risk of injury to the operator.

Information from: Greenwood Electronics Ltd, Portman Road, Reading, Berks RG3 1NE. Tel: (0734) 595844.

His weekdays are rewarding. His weekends even more so.

Working in telecommunications requires a great deal of skill and training and involves a lot of commitment.

Yet at the weekends some communications experts take on another equally demanding role. As Officers in the Territorial Army.

The training and selection processes are tough, but if you make the grade you'll have the satisfaction of applying your skills in a totally different field. As an Officer in the Royal Signals.

It's a serious undertaking.

The TA accounts for a third of the Army's strength, and in the event of war you would be commanding your men under battle

conditions alongside Regular Army units.

There's more than one way to earn a commission. Some people are selected to come in as potential Officers whilst others start as soldiers.

Your commitment will be at least 6 weekends and 2 weeks camp per year, plus some weekday evenings.

You'll be well paid for your time of course. But we think you'll find the real rewards lie in the camaraderie, team-work and sense of achievement that the TA experience gives you.

Officer
The Territorials 



Find out more: If you are between 18 and 28 years of age and think you have the abilities we're looking for, complete the coupon and post it to Major Nigel Ley, (Dept. ARG), Duke of York's H.Q., Centre Block, Chelsea, SW3 4SG or contact your nearest TAVR Association. (We're in the phone book under 'Army').

Name _____
Address _____
Town _____ County _____ Age _____
Educational Qualifications _____

GB3GD

GB3GD, the Isle of Man repeater, was recently reduced in power on the instructions of the Repeater Management Group who have responsibility for the co-ordination of the repeater networks.

The power reduction was necessary because the new repeater had caused severe interference to users of the co-channel Stoke-on-Trent repeater, 140 miles away.

The interference was the direct result of the IOM Repeater Group erecting an aerial (a 3dB 'white-stick' colinear) totally unsuited to the job of covering a small island from a site 2000ft above sea level.

The use of the aerial was directly contrary to: the assurances on coverage made to the Repeater Management Group when arguing against the RSGB's initial decision to reject the proposal on the grounds that it would not fit in with the rest of the network; the specific advice on suitable and unsuitable aerials given to the group by the RMG on a number of occasions; the

repeater group's formal application to the RSGB which states that a dipole would be used; the repeater group's Site Clearance Form on which the DTI based their acceptance of the licence application. This, too, referred to a dipole.

The RMG are continuing to advise on suitable aerials which are expected to give better coverage of the island than the colinear did, but without the unnecessary interference to the rest of the network.

It has been the declared intention of the IOMRG, and is RMG policy, that GB3GD's primary purpose is to improve the extremely difficult VHF communication on the island itself, rather than to facilitate inter-G/GW/GM/GI/EI working on FM.

YAESU FRG9600

The FRG9600 is an all mode scanning receiver that provides features never offered before, covering 60 through 905MHz continuously, with one-hundred keypad-programmable memory channels.

In addition to FM wide (for FM and TV broadcasts), FM narrow (for two-way police, military, business and amateur communications) and AM wide and narrow (for aeronautical and amateur communications), the FRG9600 also provides SSB reception up to 460MHz, allowing monitoring of amateur and military CW and SSB, and the new ACSB mode now used by the military and experimentally as the mode of the future for VHF.

A front panel tuning knob is provided to simplify tuning of SSB and narrowband AM. Seven tuning/scanning rates between 100Hz and 100KHz assure fast and efficient scanning while still permitting easy tuning of narrowband signals.

The scanning system allows either full or limited (keypad programmed) band scanning as well as memory channel scanning, with auto-resume. In addition to carrier sensing scan stop, audio scan stop sensing is also selectable to avoid stopping on inactive 'carrier-only' channels.

Signal strength is indicated by a two-colour graphic S-

meter on the display. A 24-hour clock/timer is included, along with a recorder output, for automatic power on/off switching and recording.

Additional jacks provide cpu band selection outputs, multiplexed (FM wide) output, AF and RF mute and other control signals for maximum expansion potential with future options or for those who wish to provide their own add-on hardware for special applications.

The Yaesu CAT System provides a direct control link to the cpu in the FRG9600, allowing operators with personal computers to add virtually unlimited customised control functions in software. The FRG9600 requires 12V dc, which may be provided using the optional PA-4B/C ac adapter from the ac line.

An optional video IF unit is available for reception of TV pictures (NTSC format) on a video monitor.

For further information contact: South Midlands Communications Ltd, SM House, Rumbridge Street, Totton, Southampton SO4 4DP. Tel: (0703) 867333.

CLUB NEWS

BARTG 'Datanet'

The British Amateur Radio Teleprinter Group (BARTG) has announced the inauguration of a Sunday morning SSB phone net on 80m called 'Datanet'. The net starts at 1000GMT on a nominal frequency of 3.660MHz, and is intended to be an informal meeting point on the air for all people interested in any aspect of data communications, including RTTY, AMTOR and Packet Radio.

Where possible BARTG committee members will participate in the net so that ordinary members will have the opportunity to discuss group affairs and get up-to-date information on BARTG matters.

The net is open to all licensed amateurs with an interest in data communications. Simply call 'CQ Datanet' on 3.660MHz SSB and join in. Listener reports and comments are also welcome and may be sent to: BARTG Chairman, Stuart Dodson G3PPD, 63 Malvern Avenue, South Harrow, Middlesex HA2 9EU.

Also on Sundays, BARTG

transmits an RTTY news bulletin on 80m, 20m and 2m at various times throughout the day. As well as containing news of interest to BARTG members, the transmissions also provide an opportunity to set up receiving equipment.

Full details of these transmissions are listed in DATA-COM, the group's magazine. Information on this and other BARTG services is contained in two leaflets entitled BARTG in the Eighties and BARTG and Data Communications. Free copies of these leaflets may be obtained from: John Beedie GW6MOK, PO Box 3, Llan-deilo, Dyfed, Wales. Tel: (0558) 822286.

Hazelrigg ARC

The Hazelrigg Amateur Radio Club has been in existence for about two years and organises a variety of activities for its members. These include RAE classes taken by Mike Scott G8BGU and a club station (G4YPT) which operates most club evenings.

Meetings are held every Monday except holidays at 7.15pm in the Community Centre, Hazelrigg village.

New members and visitors are always welcome as are visitors to the area.

For further information contact: G W Robinson G1HDV (Secretary), 43 Bingfield Gardens, Fenham, Newcastle NE5 2RX.

RS of Harrow

The Radio Society of Harrow meets each Friday night from 8.15pm at The Harrow Arts Centre, High Road, Harrow Weald. On alternate Fridays they hold an activity night where members are encouraged to use the club station; CW practice is also available.

The society's magazine, QZZ, is packed full of club news and contributions from a selection of sane and not so sane members, Grubby Gremlin, Uncle Oscar and Karismatic Katy Kathode being a sample of the regular contributors.

In addition to the crazy gang it was noted with interest that HM King Hussein of Jordan JY1 is an honorary member of the club.

For further details contact: Dave Atkins G8XBZ (Publicity Officer), 25 Maxwell Close,

Rickmansworth, Herts. Tel: Rickmansworth 779942.

Royal Navy ARS

The Royal Navy Amateur Radio Society celebrates its 25th anniversary during 1985 and to mark the year it is holding a mobile rally on 16 June.

The rally is to be held at the HMS Mercury, Leydene, Nr Petersfield, Hants, from 10.00am to 17.30pm. Full family entertainment will be available including steam trains, radio controlled boats and racing cars, archery etc, as well as the usual radio amateur stands. Talk-in will be available on 2m and 70cm and the entrance fee is 90p with children accompanying adults going free.

For further information contact: Tom Biddlecombe G3WAO, 3 Humber Close, Stubbington, Fareham, Hants (not QTHr).

East Suffolk Wireless Revival

This popular annual mobile rally for radio amateurs is being held on Sunday 26 May 1985, at the usual venue of the Civil Service Sportsground, Straight Road, Bucklesham,

Ipswich, Suffolk.

With the usual attractions such as traders, flea market, car boot sale, aerial testing range and vintage radio display, plus non-radio stalls, children's play area and model aircraft flying display, this rally provides a happy day out for the whole family.

Newly completed road-works make for easier access from all areas and improved accommodation, catering and car parking help to make this a most enjoyable rally.

Further details are available from: *Jack Tootill G4IFF, 76 Fircroft Road, Ipswich.*

Glasgow exhibition

After hosting the two largest and most successful amateur radio shows ever staged north of the border, the West of Scotland Amateur Radio Society is this year organising The Glasgow Amateur Radio Exhibition, which it plans to make an annual event each spring.

Already trade exhibitors have booked more space than was taken up at last year's record-breaking show.

The exhibition is to be held on Saturday 11 May, from 11.00am to 5.00pm, at the Cardonald College, which

has proved to be an ideal setting from everyone's point of view in the past.

The college is close to the M8, which avoids congested city traffic and provides easy access from all over Scotland and the south, and it has extensive car parks, halls, lecture theatres and catering facilities.

The past two autumn conventions have been held at this venue and the response from exhibitors and amateurs from all over Scotland, the north of England and as far afield as Northern Ireland has been terrific.

In addition to the trade stands, this year's exhibition will feature a large information and bookstall from the RSGB and exhibits on special-interest aspects of the hobby such as amateur TV, data and satellite communication.

There will also be a large bring-and-buy sale and in the course of the day a series of lectures on developments in amateur radio will be given.

Further information is available from: *Ian McGarvie GM4JDU, 3 Kelso Avenue, Paisley PA2 9JE. Tel: (050 581) 2708.*

SARUG

The Sinclair Amateur Radio User Group has over 300 members in more than 25 countries, of which 80% have amateur licences.

The group issues five newsletters a year, the contents of which are aimed at giving ideas, hints and news as well as complete software material to the members of the group.

The newsletters also include reviews on a range of software (on some of which they have obtained reasonable discounts on prices for their members) and construction projects.

The group offers unparalleled opportunities for worldwide exchange of news, views and ideas due to its extensive membership.

For further information write enclosing an SAE to: *Paul Newman G4INP, SARUG, 3 Red House Lane, Leiston, Suffolk IP16 4JZ.*

Golden Jubilee Award

To celebrate its Golden Jubilee in 1985 the Ipswich Radio Club, in association with the Ipswich Borough Council and Arrow Electronics, will present a special award certificate signed by the President of the club and the Mayor of Ipswich for contacts made during 1985 with Ipswich club members and stations in the county of Suffolk.

SWLs may also apply for the award by supplying a similar list of QSOs heard between the appropriate G stations and others in their own country.

Rules and further information are available from: *Jack Tootill G4IFF, 76 Fircroft Road, Ipswich IP1 6PX.*

Kidderminster and District ARS

The Kidderminster and District Amateur Radio Society (G6GXP, G6KRC) holds its meetings fortnightly on Tuesdays at the Aggborough Community Centre, Hoo Road, Kidderminster at 8.00pm.

On the alternate Tuesdays that meetings are not held the society operates a 2m net on S23 at 2000GMT, with an 80m CW net running simultaneously.

After some time the society has re-established its radio link with its twin town society in Husum, Germany, and skeds have been arranged for the near future.

All visitors with an interest in amateur radio are welcome to any of the meetings.

For further information contact: *Tony Hartland G8WOX, Secretary, 22 Glan-*

ville Crescent, Offmore Farm, Kidderminster, Worcs DY10 3QS.

Morse tests

The Swindon and District ARC has managed to arrange for Morse tests to be held at the Swindon Rally on Sunday 12 May.

At last year's rally the pass rate was 85% and it is hoped that a similar result will be obtained this year. With luck Morse tests will become a regular feature at future rallies, but this does of course rely on the support of amateurs.

The tests can be booked by sending the normal application form and fee of £15.00 payable to British Telecom International to: *K A Saunders G8SFM, 'Tamarisk', Tisbury Lane, Leighterton, Glos GL8 8UP.*

40th anniversary

Radio amateurs in Guernsey will be celebrating the 40th Anniversary of the Liberation of the Channel Islands from German occupying forces by operating a special event station from the 9-11 May 1985.

During the course of World War II, the Channel Islands of Guernsey, Jersey, Alderney, Sark and Herm were the only part of Britain to be occupied by enemy forces. On Sunday 30 June 1940, German troops landed in Guernsey to begin what turned out to be a five year occupation. The first few years were little different for Islanders than for people in other parts of occupied Europe but as the war in Europe drew to its close, critical shortages of food, medical supplies and other

essential provisions meant enormous hardship for those Islanders who had chosen not to evacuate.

For this reason, the Liberation of the Islands by allied forces on 9 May 1945 is still a major day of celebration.

This year, the anniversary of the liberation will be marked with even greater prominence than before. Islanders are planning a week of events which will include a carnival, exhibitions, parades and flying displays.

There will also be a special event amateur radio station operating from the ancient fortification of Castle Cornet. This historic building dominates the entrance to St Peter Port harbour where first the German troops landed and then later the liberators.

The station will be operated

Plymouth mobile rally

The Plymouth annual mobile rally is being held on 26 May at the Devonport Secondary School, Park Avenue, Devonport, Plymouth and begins at 10.00am.

A variety of attractions will be available including a secondhand stall, a licensed bar and other refreshments. Talk-in will be provided on S22 and RB2 by G3PRC.

The club meets on alternate Mondays from 7.00pm at the Plymouth Albion Rugby ground club.

There is no admission fee and lectures on all aspects of amateur radio are held at every meeting. Everyone interested in the subject is welcome.

For further information on the club or the rally contact: *R B Weston (Hon Secretary), PO Box 46, Plymouth.*

by a team of local amateurs working in shifts and operation, under the callsign GV4LIB, will be from midnight to midnight on Liberation day itself, Thursday 9 May, and between 1000-1700 hours on the 10th and 11th. Operation will be on both 2 metres and HF.

Exact bands for the latter will depend on conditions prevailing on the day but there are hopes to operate most bands including 160, 80, 40, 20 and 10 metres.

All contacts made with the special event station will be acknowledged by a special QSL card with information and souvenir pack.

For further information contact: *Peter Rouse (Publicity Officer), 5/7 Park St, St Peter Port, Guernsey, C.I. Tel: (0481) 23451/25893.*

DX DIARY

News for HF operators compiled by Don Field G3XTT

Band conditions in March were, on the whole, worse than in February, although there were some interesting stations to be worked. In particular, Desecheo Island was activated under the calls NR5M/KP5 and K5LZO/KP5. QSL to K5LZO, Charles Coleman II, 36530 FM 1774, Magnolia, TX 77355, USA. This one was worked in the UK on 5 bands, 160-15, as was Walter DJ6QT, who appeared for a couple of weeks as 5V8WS. QSL to his home address.

J28EI was very active from Djibouti and may still be there when you read this. Finally, the itinerant ZL1AMO appeared from Tonga as A35EA with good signals into Europe on 20 and 40. One French station even reports a contact with him on 80.

What's on in May?

All this, of course, is history. Hopefully you were able to put them in the log. But what will May bring? Firstly, of particular interest is the fact that the GB prefix for special event calls will be replaced by GV during 5-12 May to commemorate the 40th anniversary of VE day. The RSGB HQ station will be active on 8 May as GV2HQ.

DL7FT will be active from May 12-24 as DL7FT/SV9 from the island of Crete. Crete used to be a fairly hard one to work but with the advent of cheap package tours is now one of the most frequent destinations for amateurs wanting to combine a holiday with a DXpedition.

Apart from the above, the calendar for May is looking remarkably blank. Certainly

the general downward trend in conditions is enough to dissuade any serious DXpeditioner from setting forth during May to August when conditions in any year are at their worst. Look out, though, for casual DXpeditions from holiday destinations.

Islands on the air

Apropos such expeditions, many are to islands in the Mediterranean or the Caribbean. While not all these islands are DXCC countries in their own right, many count towards the Islands on the Air (IOTA) awards programme. This programme, which I have

mentioned briefly on previous occasions, was established many years ago by Geoff Watts, a British SWL, and has achieved great prestige around the world.

One of its great merits is that it is an evolving programme, in other words new islands are added to the list when they are activated for the first time, so you can never sit back having worked them all.

In March Geoff reluctantly gave up running IOTA, due mainly to the demands of looking after his wife who is confined to a wheelchair. The programme has now been

taken on by the RSGB under the custodianship of Roger Balister G3KMA, who will handle future claims and updates.

Roger is one of the country's most enthusiastic and persistent DX chasers and can be expected to apply the same qualities to running IOTA. He will be using the RSGB's *DX News Sheet* as the principal organ for IOTA news, and I will pass on any interesting snippets in this column.

Suffice it to say for now that, with new countries getting harder to work under the prevailing sunspot situation,

10m BEACON FREQUENCIES

28175	VE3TEN	Ottawa	28252.5	VE7TEN	Vancouver
28200	DL0IGI	W Germany	28255	LU1UG	Argentina
28202.5	9J2B	Zambia	28257.5	DK0TE	W Germany
28202.5	ZS5VHF	Natal, RSA	28260	VK5WI	S Australia
28205	DL0IGI	W Germany	28261	VK2RSY	NSW
28207.5	W4ESY/N4RD	Florida	28262.5	VK2WI	NSW
28209	WA1IOB/B	Mass	28265	PY2EXD	Sao Paulo
28210	3B8MS	Mauritius	28265	VE3TEN	Ottawa
28212.5	ZD9GI	Gough Is	28270	ZS6PW	RSA
28215	GB3SX	Sussex	28271	VK4RTL	Queensland
28217.5	VE2TEN	Quebec	28272.5	TU2ABJ	Ivory Coast
28220	5B4CY	Cyprus	28272.5	9L1FTN	Sierra Leone
28225	HG2BHA	Hungary	28277.5	DF0AAB	W Germany
28225	EA6AU	Balearic Is	28280	YV5AYV	Caracas
28225	VE8AA	Yukon	28284	VP8ADE	Adelaide Is (Antarctic)
28230	ZL2MHF	N Zealand	28286	KA1YE/B	Connecticut
28235	VP9BA	Bermuda	28287	W8OMV/B	N Carolina
28237.5	LA5TEN	Oslo	28288	W2NZH/B	New Jersey
28240	OA4CK	Lima	28290	VS6TEN	Hong Kong
28240	PY1CK	Rio	28295	VU2BCN	New Delhi
28242	KA9NFE/B	Illinois	28296	W3VD/B	Maryland
28242.5	ZS1CTB	RSA	28297.5	ZS1STB	RSA
28242.5	LU4FM	Argentina	28299	PY2AMI	Sao Paulo
28245	A92C	Bahrain	28315	ZS6DN	RSA
28247.5	EA2HB/EA2OIZ	Spain	28335	VK5AWI	S Australia
28249	Z21ANB	Zimbabwe	28888	W6IRT/B	California
28250	PA0GG	Netherlands	28890	WD9GOE/B	USA
28251	ON5AV	Belgium	28992	DL0NF	W Germany

island-chasing might prove an interesting and challenging diversion. A directory of islands is available from Roger for £1.

Contests

Although DXpeditions may be few and far between during May, there are one or two interesting contests to get your teeth into. The Russian CQ-M contest starts at 2100 GMT on Saturday 11 May and runs for 24 hours. This is one of the best opportunities each year to work Mongolia (JT, zone 23). Indeed last time I took part in the contest I worked three JT stations on 20 metres in about 10 minutes and, what's more, got QSL cards from 2 of them.

The other major contest is the CQ WPX (Worked Prefixes) CW event which runs for the whole of the last weekend (25/26 May). A good opportunity to work some more prefixes for the *Amateur Radio* magazine award. The contest exchange consists of RST plus serial number, and logs go to *CQ Magazine* in the USA. I have copies of the log and cover sheets if needed (SAE please).

HF beacons

VHF operators will be familiar with the extensive network of beacons which exist throughout Europe and are an invaluable guide to prevailing propagation. It is not always realised that similar networks of beacons exist on the HF bands. At a time of falling sunspot numbers (such as now!) they are extremely useful in indicating which bands and paths are open at any given time.

Best known are the 10 metre beacons, a list of which appears in the table. Although these are usually installed and funded by local groups or societies, it is clear that considerable international co-operation is required to ensure that no two beacons share the same frequency. The IARU 10 metre beacon co-ordinator is G3DME.

On 20 metres the Northern California DX Foundation sponsors a worldwide chain of beacons which operates on 14100KHz. A list of these beacons appears in the table. Each beacon transmits in sequence for 1 minute in every ten minutes, thus 4U1UN transmits on the hour,

NCDXF 20m BEACONS		
Time	Call sign	Location
xx:00	4U1UN/B	New York, NY
xx:01	K6OBO/B	Stanford, CA
xx:02	KH60/B	Honolulu, HI
xx:03	JA2IGY	Tokyo
xx:04	4X4TU/B	Tel Aviv
xx:05	OH2B	Espoo
xx:06	CT3B	Madeira
xx:07	ZS6DN/B	Transvaal
xx:08	HK4LR/B	Colombia

and at 10, 20, 30 etc minutes past the hour.

The message sequence is as follows (note the progressive reduction in power levels): (100W) 'QST de (call sign) beacon', (100W) nine second dash, (10W) nine second dash, (1W) nine second dash, (0.1W) nine second dash, (100W) 'SK (call sign)'. The beacon antennae are single element quad loops and the station at each beacon consists of a modified TS130 transceiver.

Reception reports on these 14100KHz beacons can be sent to the Northern California DX Foundation, PO Box 2368, Stanford, CA 94305, USA and will be acknowledged with a QSL card. If you want to support the project, donations can be sent to the same address.

Turning now to the other bands, VE3DPB is the call sign of a 100mW beacon operating on 7033KHz. Reception reports can be sent to George Collins VE3FXT. George is particularly keen that amateurs (whether licensed or SWL) should experiment with very narrow bandwidth receivers, to determine just what the limits are on the reception of this beacon.

Top Band DX enthusiasts are particularly anxious to determine the nature of propagation at any given time, but there are no licensed amateur beacons to help them. In consequence they must turn to some commercial beacons which share the band. The most useful are:

- 1805KHz OA36 Peru
- 1830KHz DHJ W Germany
- 1831KHz OSN Belgium
- 1837KHz ZA01 Albania
- 1837KHz OY12 Faeroes
- 1865.5KHz MPG UK

Currently there are no beacons that I know of on 15 or 80 metres or on the WARC bands, but I will be surprised if we don't see beacons

appearing on some or all of these bands over the next few years, as the need for a reliable indicator of propagation increases.

The beacons are, of course, a valuable aid to scientific investigation of propagation, a subject which is still a long way from being fully understood. In fact, like astronomy, this is an area in which the amateur can continue to do valuable work because amateurs represent a more numerous and widespread body than do the professionals and they can collect large amounts of data.

Amateur radio in the year 2000

In the February column I invited readers to describe how they thought HF amateur radio would look in the year 2000. John Herries of Witney in Oxfordshire took me up on the challenge. John is licensed as WA1QXX and may well have a UK call by the time this appears in print. He feels that the current modes (CW, RTTY, SSB and SSTV) will still be very much in vogue and that technical advances will have served to improve the effectiveness of these modes through better filters, etc.

He also raises the point that we may see better control of QRM from domestic and industrial sources, thus making operating a more pleasurable activity. We can only hope he is right. John also makes the plea for a continuing interest in home construction and keeping things simple so that in an emergency amateurs can still get on the air and put out some sort of signal.

Certainly, from my own point of view, it has been interesting to see the enthusiasm for the G-QRP Club lectures at successive Birmingham conventions; a reaction no doubt to the complexities of the modern Japanese boxes.

Talking about conventions, do earmark Sunday 29 September for a day out near Oxford. The event is the RSGB's HF Convention which, this year, will be held separately from the Birmingham event. The programme has yet to be finalised, but it should be an enjoyable occasion for all with an interest in HF operating and construction. More details nearer the time.

Operation Raleigh

This is something else I mentioned in the February column. Unfortunately the itinerary has been modified to cut out the South Atlantic islands for 'security reasons'. The expedition organisers are however keen to recruit qualified radio officers to join the expedition ship for various legs of the voyage over the next 3 years or so.

Those selected will be expected to find their own air fare to and from the ship, together with £10 per day for board. There will be little opportunity to go ashore for amateur radio operation, but the expedition call sign GB0SWR/MM will be available for use. If you want more information contact the RSGB.

Dipole of Delight

The four band (40-10) version of this aerial, patented and sold by GM3HAT, turned up in the post the other day from Trevor Morgan who had been reviewing it for the SWL column in this mag. I look forward to trying it out and giving my assessment in a future column.

To give a broader view, I would be interested in hearing from any readers who have used this antenna. Let me know how easy it was to install, how well you find it works, your views on the quality of construction, etc, by 27 May if possible please.

Sign off

There we have it for another month. I hope the column has been of interest but if you feel there are yawning gaps in my coverage of HF please let me know. Meanwhile, keep monitoring the bands and those new ones will find their way into your log quicker than you would believe. 73 de Don Field, 105 Shiplake Bottom, Peppard Common, Henley, Oxon RG9 5HJ.

This mad-cap idea all started the other side of last summer. I was spending an averagely hectic evening at Tony's (G8YFA) trying to sort out one of his construction projects, which I should say proved to be very successful. It was as I was leaving and ploughing through all the pleasantries that one normally goes through at such a time that a quick little remark got thrown in;

'Oh, by the way Dave, how would you like to walk up the 'Three Peaks'?

'Yes I would like to', I replied, not knowing what those five little words would actually mean.

'Okay I'll find out some more details and let you know'.

A couple of days later Tony phoned me to say that I should go and meet somebody called Graham Crabtree to find out some further details about the walk. This was subsequently arranged and so I went with Tony to see Graham in his office.

Graham had tried to organise this walk previously but had to cancel it when he broke his leg in a training exercise. He was now trying to plan the walk again and needed a new team member.

Accident

A couple of years ago Graham was climbing White Rock in Devon when he had a slight accident – he fell! Unfortunately he was 150 feet up the rock face at the time and spent many months in hospital having his body repaired. Injuries included some to his chest, a broken tibia and fibula, head injuries and internal injuries. Well, if you fall that far what else do you expect?

For those of you who are climbers and are wondering why he wasn't saved by the safety line, the answer is quite simple – he didn't have one! He was climbing as he did in the army, without ropes and without chalk; he didn't even have sensible footwear. Graham has since made a very good recovery (and hasn't been put off climbing) and wanted to prove to himself that he was fit by attempting this walk (he is however very modest about it).

Also at that meeting was John Gladstone, another of the original team. John works with Action Sports just outside

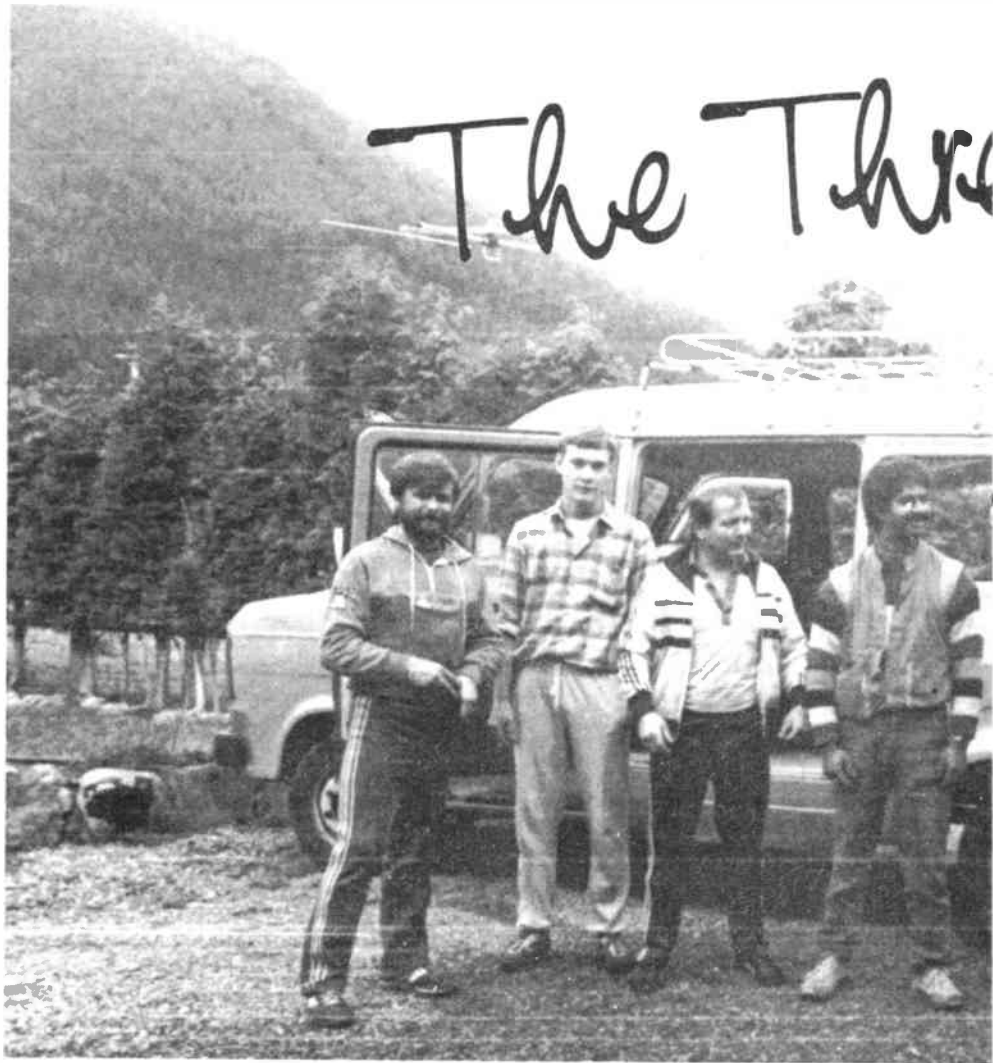

The descent of Snowdon

Cannock and so was also experienced. My own qualifications include a Gold Duke of Edinburgh Award and Outward Bound Award as well as a few lesser known awards. As a team we were therefore not newcomers to mountaineering.

I did however possess one qualification which the others did not: the City & Guilds certificate for the Radio Amateurs Examination, which allows me to include the initials G6UDM after my name.

Therefore, as part of my contribution I decided that I would take with me some method of radio communication, making amateur radio a point of interest on the walk. The whole event was to be used to raise money for charity – the All Saints Play Association, which provides outdoor pursuits facilities for underprivileged youths in the city of Wolverhampton.

After much cajoling I was able to borrow an FT290R with fully charged nicads and a six element beam, which was not collapsible. It was proposed that Graham and myself would spend a day in Wales to climb Snowdon, firstly to see how we managed with the beam and to pace ourselves against each other to see if we walked at approximately the same speed.

At around this time I had what is called a technical hitch, a real problem to walkers. I had to have an operation on

one of my toes and needed a walking stick to walk with. This however did not stop us from doing the walk. I may have been a bit sore but as long as I could walk I was determined to finish the event.

Our training walk was accomplished despite one or two slight problems, the main one being that the beam wouldn't collapse and I couldn't get it into the boot! After much adjustment to the car, which involved taking out the back seat, I was able to push some of the elements through the bulkhead (through existing holes). I don't wish to linger on the practice run but we learnt two things: 1) that a different aerial would be needed and 2) that it was possible to get signals at least into the Midlands.

The latter was proved by the contact that I had with Eddie G4KWR in 'Pye Green, Cannock. I was only using 500mW from the FT290R and using its in-built whip (without an extension). This contact was held right up to our stroll over Crib-Goch. Eventually however I had to end the contact when we came across a couple of youths who had got themselves into trouble by attempting a climb that they weren't able to cope with (Crib-Goch has a two foot knife edge on its peak).

The actual walk was planned for the first weekend in September but unfortunately I had already planned to be in EA-land at that time. Therefore the walk was postponed until the weekend of 22

Three Peaks



Cancelled bid to climb peaks is on again

An expedition to climb Britain's three highest peaks in just 30 hours — cancelled when its leader broke his leg — is on again for September. The "three peaks" climb, which should have taken place at Easter, is now to go ahead on September 20.

It was cancelled when team leader, 33-year-old Graham Crabtree, broke his leg and injured his knee in a fall while climbing.

Now Graham, of Bristol Street, Penn Fields, Wolverhampton, is fully recovered and has started training again. Graham and two other climbers are tackling the climb of Snowdon, Ben Nevis and Scafell Pike in the Lake District, to raise money for two projects.

One is a venture club, to be set up by Wolverhampton's All Saints Play Association, to provide climbing training for youngsters by qualified instructors.

The other is Project 84, an overland trip to India by members of Steelhouse Lane Youth Project in Wolverhampton.

Graham was nearly killed in a mountaineering fall five years ago, which left him with permanent leg injuries.

"It was a shame the climb had to be cancelled at Easter — but it had an unexpected benefit," Graham said.

"While I was in hospital with a broken leg they operated on one of my old injuries. I am much fitter."

Graham will be accompanied on the climb by 19-year-old John Gladstone, and a new team member, Derek Rickwood, who is also a member of Wolverhampton Amateur Radio Club.

Derek will be transmitting the progress of the expedition from each peak so that radio club members and other radio hams can keep up to date with news of the climb.

September. In the meantime I needed to establish contact with the amateur radio press. This was no problem but I also needed to obtain a portable beam and I didn't have that much time to race around the country to find one. I therefore made a trip to Dewsbury Electronics where Tony Dewsbury gave me the assurance that he could obtain the beam for me within the week. Sure enough that was what he did and at a competitive price, thus allowing me time to plan out the other necessary arrangements.

One holiday in Ibiza later (not paid for out of the sponsor money!) and I was ready for the trip. Last minute checks were made and I set off to meet the rest of the team (in the Dartmouth Arms!). Apart from Graham, John and myself there was Tim, Tony (the mini-bus driver), Jo and Rab (chief cooks and bottle washers). Not too long later we set off to the cottage, known as 'The Hovel' for obvious reasons, where we would spend the night.

Ascent of Snowdon

We began the ascent of Snowdon at 7am, and as you can imagine it was in darkness. Not being easily put off out came the torches, under the beam of the mini-bus headlights, and off we set. It was from this point onwards that we realised that we hadn't found an adequate method of strapping that beam on to

our backs! Very quickly the sun came up and the torches were put away for a rainy day (which wouldn't be long in coming).

An upsetting thing at this point was to see how many other people were on the ascent of Snowdon, especially since we thought that we would have the 'lump' to ourselves. The walk to the top was fairly uneventful (with the exception of Graham's stomach rejecting the sausage and bacon that had been rammed down it at half past some ridiculous hour that morning!) and so we made it to the cafe, which was shut, and started putting up the aerial. At this time there was low cloud at about 3,200 feet which created a

problem as we were at 3,560 feet and therefore couldn't see anything around us apart from the cloud!

Despite this the aerial was erected very quickly, SWR was fine and so the unmistakable call went out with great expectation:

'CQ CQ, CQ CQ, this is GW6UDM/P at the summit of Snowdon calling CQ and standing by for any calls'.

There was then a pause that seemed to last forever, presumably while everybody dived for the microphone because it was then chaotic. Following this came contacts with the following stations: G6HCV, G1BGZ, GW4DTQ, G1FEA, G4WAS, G6YZL, G4ORX, GW1GZX, G4GZK, G8YFA, G4SEU, G3JJR, GW6UDG/A and G6HYZ. Unfortunately I wasn't able to have any contacts with stations in Scotland or Ireland, whether due to conditions or lack of activity I don't know. I hadn't however got time to hang on for them and so after a period of about half an hour it was time to go QRT and start the descent.

A tale of adventure
by David Rickwood
G6UDM, GW6UDM/P,
GM6UDM/P.

THE THREE PEAKS

The descent of Snowdon can only be described as *rapid*. Graham and Tim had set off in advance of John and myself to ease the strain on Graham's leg. This meant it was up to John and myself to put the beam away and yomp down the mountain. I'm just glad that I didn't have a full pack on me as well! It wasn't long however before we caught up with the rest of the team and re-formed before returning to the mini-bus.

Well that was the first peak finished and none of us were feeling too bad. Diving into the cafe for a twice normal size mug of tea seemed to be just the answer to revive us fully. Strange though, I don't normally like tea, but when you have just spent hours on a mountain in those conditions you don't refuse anything wet, hot and refreshing!

Tony Reins, our high speed (but not that high speed!) mini-bus driver and ground team leader, rounded us up to dive into the back of the bus for our trip to the Lake District. The problem with a trip like this is how quickly you can get very tired. To this end Tony, Jo, and Rab had laid boards across the back seats of the mini-bus and then placed our sleeping bags across the top of them. This provided an excellent facility for us to get some sleep. To go without sleep would be slightly stupid as you need to be fully aware anytime you are on a mountain (this will become particularly apparent a little later on).

We set off from the bottom of Snowdon (having refreshed ourselves) very nearly on schedule, although probably a little late having spent too long drinking a pint of tea. The journey to the Lakes took longer than expected, partly due to an error on our part in calculating times and partly to the traffic conditions (surprise, surprise) on the motorway. Also, the people who had organised the timetable had forgotten to involve the mini-bus driver (fatal mistake) and no time had been allocated to stopping for refreshment and for him to rest his legs.

High speed

All was well until we decided that we needed to make up time. That was alright; I don't object to travelling quickly and it was reasonably smooth on the main roads, but for anybody who is familiar with the Wrynose pass, we travelled down it at between 40 and 50 miles an hour, *never* less. For those of you who have not had the pleasure of travelling down that scenic pass I should just like to state that it has gradients which even the Highways Department haven't bothered to work out, but have just put up 'Drive Slowly' signs. Occasionally we were travelling on two wheels and that is no exaggeration. It was an experience that I don't want to go through again – particularly as I'd only brought one spare set of undies with me!

Having survived that journey we reached the start of the most exciting mountain of the three! We set out at 4.30pm (sorry to those people who were listening for me at this time). For some



Alternative method of getting up Ben Nevis!

reason, which none of our party could understand, it took between twenty minutes and half an hour from the mini-bus stopping to us setting off up the mountain. Maybe it was to recover from Tony pretending that he was on a motorbike and not driving over a hundredweight of mini-bus.

It was 7.00pm before we made it to the top of Scafel Pyke, slightly behind schedule (2.5 hours to be precise – sorry to those amateurs who waited for me to appear at the time that I stated and several hours longer, and no doubt turned the rig off three minutes before the time that I made it to the top). Then, in true style and not to be beaten, John and myself braved taking off the thermal gloves and began to attack the wing nuts needed to erect the beam.

By the time the beam was ready for erection Graham and Tim had caught us up, having come up to the summit by a slightly different route, so we were all ready for the big moment on the second 'big hill'. I was just about to connect the FT290 when it happened! 'What was that?' I asked the others.

'What was what?' they replied.

'I thought that I saw something over there!' I said pointing over towards one of the next peaks.

'We can't see anything. You must be seeing things'. I wish I had! Here we were on Scafel Pyke, the highest mountain in England, holding on to the mast; 3 metres of metal. Have you guessed what it was that I saw? No? Well I'll tell you then – *lightning*. All of a sudden there were cries of 'Get that bl*@@@%dy thing down quick and let's get out of here!'

Needless to say the aerial came down a lot quicker than it went up, despite half of the team now throwing mountain leadership out of the window and racing off to the 'lowlands' ahead with cries of; 'We'll check that it's not like this further down'.

However our problems were not yet at an end. Let me try to put you into the picture:

Do you remember what time I said it was? Answer – 7.00pm.

Where did I say we were? Answer – 3,210ft up the highest mountain in England.

What were the weather conditions like? Answer – thunder and lightning.

What was morale like? Answer – now starting to ebb.

Now, most of us in similar conditions would just run for the shelter of our own homes and offices or at least seek shelter around us. However, no matter how much we would have liked to have done just that there was the slight oversight on our part to bring our brollies. There was only one thing for us to do – put on our waterproofs and head for the lowlands as quickly as we could.

The descent

The descent of the mountain was also quite entertaining due to a factor that I haven't mentioned but which the more perceptive of you will have realised; when there was no lightning it was *pitch black*, night time had fallen and there was not a council street lamp for miles around.

It was either time for some very quick lessons in astronomy or prayer, remembering that the three shepherds of years gone by followed a star to find their destination. There was however a subtle problem in that method; there were no stars, they were all covered by the thunder clouds that were precipitating heavily upon us.

Our method of getting off that mountain was quite simple – to walk off. We were no longer on Snowdon where we could get a train down, even if it did run at that time of night. Fortunately we had brought sufficient survival gear (well almost) and had got three torches between us (yes, I know that there were four of us) and so on that basis we began our descent.

Everything was fine for the first hour, apart from taking a wrong turn which put us on a very narrow ledge with a few hundred feet drop to one side, but we soon got ourselves back onto the right path. By 9.00pm yet another problem was

THE THREE PEAKS



The team at the summit of Ben Nevis

encountered; we hadn't used Duracell, and so one by one all the torches started to fade out and die on us. You really need to have been there to understand the problem this left us with. However, we did have one torch that survived this ordeal, which is perhaps as well else we would have had to spend the night on the mountain. That torch was our lifeline and all four of us were trying to use its light.

It was then that the 13 element tonna in its very unsuitable case started to take its toll on us, for although we could manage it in the daylight the darkness brought its own problems. Most of our time was spent 1) ensuring that we put our feet in the right places and 2) in scouring the mountainside looking for piles of rocks.

To some this may seem like a very silly thing to do under the circumstances. To others it will seem like the most obvious. These piles of rocks are called cairns and are sometimes pyramids, but more likely piles of rocks marking the major paths at frequent (or less frequent) intervals. This often meant three of us staying still while the other person went ahead to search for the rocks.

This method was however short-lived as very soon the remaining torch died. Under normal circumstances in this situation it would be usual to 'bivouac' on the mountain (ie, crawl into a plastic bag under a rock that was not likely to move!). However, this would mean that the expedition would fail and so we took another decision which is not to be recommended and that was to carry on using instinct, mountain experience, and what little knowledge we had of the mountain to find our way off. The adrenalin certainly started to flow that night as we were surrounded by running water, small streams and wet rock. The ground support team having knowledge of our likely moves had had the sense to leave the mini-bus headlights on and as we got closer to the pick-up point we were able to see them and our hope was renewed!

We got to the mini-bus to be greeted with sighs of relief, for by now it was

midnight and we were two and a half hours overdue. In the meantime our ground support team (sounds professional doesn't it) had called for the assistance of the local mountain rescue team. They hadn't set off into the hills for us but they were on standby until 1 o'clock when they would review the situation. They therefore needed to be informed of our return and having worked with mountain rescue teams I can appreciate the concern they had for us and I thank them and apologise for getting them out of bed.

While Tony sorted that out Rab and Jo made saucepans of hot sweet tea for us to put back some of the energy that we had lost that evening. After consuming that the only thing left for us to do was to remove our boots! That was no mean feat (excuse the pun) for any of us, either the owner of the feet who had to unmesh his skin from his socks or for the people around us who had to put up with the smell! Anyway, not to linger on this point we hit the sleeping bags while Tony began the long drive to bonny Scotland.

We arrived at Fort William, the nearest town to Ben Nevis, at 6.00am on the Sunday morning feeling pretty exhausted. But perhaps not as exhausted as Tony Reins must have felt after driving 500 miles. That aside and throwing away our feelings of collapsing into our sleeping bags and recovering from the previous days activities we got ourselves settled, picked up the rig, survival kit, sandwiches and beam and began the ascent of 'The Ben'. It was this ascent which really showed me how tired I was. This became obvious by the number of times I had to stop to take a rest. Due to this factor climbing Ben Nevis seemed to be a really hard slog and my morale wasn't helped any by the rest of the members in the team apparently sprinting up the mountain even though, in true mountain leadership style (unlike on Scafel), they did hang on for the slowest and encourage him (ie me).

Although by now we were very tired, climbing Ben Nevis was very refreshing

for us. It was our last mountain and it gave us a sense of success and a desire to continue no matter what. The weather was fairly good to us for our finale and as usual for a Sunday morning we met up with all the locals going for their Sunday morning stroll.

On the way up we were only passed by somebody on a trials bike who comes up every Sunday morning before his breakfast! Ben Nevis is quite flat at the top and this makes it seem longer to reach the summit than it actually does. When we reached the top there was a foot of snow and a temperature of -9 degrees. Consequently, it again meant that I wasn't able to stay up there for very long and by the time I had finished a contact with a station at the Mull of Kintyre I had had enough. It was too cold to stay and so mission accomplished we began the descent and thankfully, due to the licensing laws being different in Scotland than they are down here in England, as soon as we reached 'base camp' we ensured that our bodies were warmed as much as possible.

Conclusions

In trying to bring some conclusions together for this event it is necessary to remember our original intentions. The original purpose was to raise £1,000 towards sending a group of unemployed youths on an educational exchange to the Indian Punjab, which we accomplished. We raised that money by walking up the three highest mountains in Wales, England, and Scotland within a time limit of 30 hours. All of this was accomplished and therefore our target had been reached.

However, there was another issue to go alongside this target and that was to take along a radio and talk to amateurs in each country, from each of the Three Peaks. This, as I am sure you are now aware, did not really get anywhere near being accomplished due to the inclement weather and bad planning on the team's behalf. However, I am grateful for those amateurs who listened out for me and I apologise for the errors that were made on our part.

I do however intend to do the event again, this time with the primary objective being communication with other amateurs and to that end I will endeavour to spend a day on each peak. Obviously next time I will be doing it in the summer, when the weather should be a lot better (well it couldn't be any worse could it?).

Acknowledgements

My thanks go to Tony Dewsbury of Dewsbury Electronics for obtaining that dreaded beam for me at such short notice, to G3JJR and G3UBX for loaning equipment, to Action Sports and Tony Reins for providing our mini-bus transport (and for bringing Jo!) and thanks to you for listening out for me. Oh yes, and lastly (most definitely lastly) to Tony G8YFA for having the idea in the first place; maybe next time he'd like to come along as well?

WOOD & DOUGLAS

★ NEW CATALOGUE
★ NEW PRODUCTS
★ NEW PRICES

For those of you who missed the NEC here are details of a few of the new products that we introduced.

70FM3B - The popular 70FM3 500 mW to 3 Watt 70cms power amplifier has been updated to have rf switched automatic PIN changeover. The board fits a standard miniature diecast box and is sufficiently compact to allow direct connection to your handheld's aerial socket. The module has facilities for line powering and has our standard 'straight through' mode with power supply disconnected.

AF1 - A small audio amplifier board consuming very low quiescent current. The unit is intended to complement the CWF1 CW filter where it would act as an audio buffer. The board also boasts an externally activated mute circuit.

144 LIN30 - The popular 144 LIN25B linear has been updated to yield in excess of 30W for 3W drive at 145 MHZ.

★ ★ ★

Details of these and other new products are included in our 1985 catalogue. This will be posted to you on receipt of an A5 stamped self-addressed envelope. Kits are usually available by return of post but please allow 28 days for any unforeseen shortages. Please include £1.00 to cover order handling and postage.

Our products are kits or assembled kits consisting of circuit board and all components to mount on the board. We do not include external hardware such as boxes, connectors etc.

If your purchase does not work when assembled then apart from being surprised we will offer to service the module for a small charge depending on the complexity of the project. So please remember...

ANYONE CAN SELL A KIT... REPUTATION SELLS OURS

**UNIT 13, YOUNGS INDUSTRIAL ESTATE
ALDERMASTON, READING RG7 4PQ**

TEL: (073 56) 71444 TX: 848702

RITTY and CW TRANSCEIVE with NO TERMINAL UNIT

This fantastic program interfaces direct with your rig, slashing the cost of previous systems. Split screen, type ahead, auto CR/LF, accurately preset baud rates and shifts (normal or reverse), QSO review, tracks and sends any CW speed up to 250wpm. Tape and kit for the very simple interface, including PCB and User Port connector, for only £20. Ready-made interfaces available. For CBM64, BBC-B, VBIC20 (+ at least 8k). CW-only version for SPECTRUM (no interface needed, max speed 150wpm) £10.

And for CBM64, VIC20, BBC-B, SPECTRUM, ZX81-16k

Morse Tutor Britain's best. Learn fast in easy stages from absolute beginner to over 40wpm. Join the hundreds who have succeeded with this program. Tape and full learning guide £6.

RAE Maths All the practice and testing you need. Tape and comprehensive reference sheet detailing all you need to know £8. VC20 needs expansion (any). Don't let maths make you fail. PASS with this program.

Superb locator, logbook and contest log programs also available.

All programs are very easy to use and come with full instructions.

Prices include p&p 1st Class by return. Add £1 per tape if outside UK or Ireland

technical software (AR)

From, Upper Llandwrog, Caernarfon, Gwynedd LL54 7RF. Tel: 0286 881886

SANDPIPER COMMUNICATIONS AERIALS (STAINLESS STEEL ELEMENTS)

	PRICE	P&P
145mhz/2mtr	£20.00	3.00
2 x 3/8 Collinear	£20.00	4.00
3 x 3/8 Collinear	£20.00	4.00
6 El Yagi	£20.00	4.00
10 El Yagi	£20.00	4.00
12 El Yagi	£28.00	4.00
6 El Yagi Crossed	£23.00	4.00
10 El Yagi Crossed	£28.00	4.00

	PRICE	P&P
435mhz/70cm	£25.00	2.00
4+ F/glass Collinear	£18.00	4.00
17 Element	£35.00	4.00
Double Delta	£35.00	4.00
8 Turn Helical	£35.00	4.00

	PRICE	P&P
1296/23cm & 934/33cm	£25.00	2.00
Mobile Collinear	£39.95	2.00
Base Collinear	£33.00	4.00
20 Turn Helical	£45.00	5.00
Para Delta	£95.00	9.00
6ft 6in Parabolic Dish	£95.00	9.00

DIY Versions

Available in most models Also 4mtr & 6mtr PMR Weather Satellite/s 70cm TV, 24cm TV and all one/off frequencies.

Power Splitters

2 mtr
70cm
23/32cm

2 way & 4 way
Lots more available.

FIBRE GLASS MASTS/TUBES
3/8in to 1 1/2in e.g. 1/2in dia = £5 per mtr.

**SAE FOR FULL LISTS
40 Trehafod Rd, Trehafod,
Pontypridd, Mid Glam.**

Tel: Porth 685515 Aberdare 870425
Delivery Cash/P.O. Return Cheque 7 Days

LOOK! BARGAINS GALORE OLD STOCK & END OF LINE ITEMS MUST BE CLEARED

YAESU		PRICE	P&P
FRV 7700	VHF converter type "A"	65.00	2.50
YC 500E	Bench counter with oven	195.00	3.00
YP 150Z	Dummy load w/meter with fan	69.00	3.00
FTU 107R	Transverter frame FT1/107	29.50	3.50
SC1	Push button console/PSU - 480/780R	69.00	3.00
NC11C	Charger FT 290R	5.95	1.00
YO 901P	Multi scope FT902 S/S	295.00	5.00
HALF WAVE	Telescopic ant. for FT208R	6.95	1.00
FT ONE AM	Filter 6KHZ	13.95	0.75
FT ONE FM	Unit	34.95	1.50
FT 1012D	AM Unit	9.95	1.00
FT 902 + FT	ONE DC lead + ADPT. each	6.00	1.00
VALVES 572B		29.95	2.50
VALVES 614B		6.95	1.50
NICADS 1.2V	1.2V 2AH FT 290R etc.	each 1.75	0.25

ICOM		PRICE	P&P
ICHM8	Keyboard mic with touch tone	14.90	1.50
ICHCM11E	Scan mic	14.95	1.50
ICFL34	10.75 A filter (IC720A)	19.95	1.00
ICCP1	Mobile charger lead IC2E/4E	2.95	1.00
ICLC3	Leather case IC2E/4E	2.90	1.00

ACCESSORIES

	PRICE	P&P
Van Gorden HIQ-1 Balun transformer	6.95	0.90
Van Gorden trap formers for home base antennas pair	4.95	0.50
SMC PSU 4-5 amps	11.95	3.00
Dummy load VHF/UHF 150W	24.95	1.00
Datong direction finder complete	129.95	3.50
Dipole centre piece c/w fittings + PL259 etc.	8.00	1.00
Antex soldering irons c/w stand etc	8.00	1.00
Antex spare bits small, med, large each	0.90	FWA

QUALITY SWR/PWR MTRS OSKAR BLOCK

	PRICE	P&P
SWR 200 3.5 - 150 MHZ 2KW	42.80	2.00
SWR 145 144 - 145 MHZ thru line type 250W	34.95	2.00
427 H 1+8 - 150 MHZ auto SWR/peak power	62.95	2.50
Toyo YM 11E 3.5 - 150 MHZ 200W	17.95	2.00
SST T-1 random wire antenna tuner	15.95	1.50



A well known + trusted Japanese name this 2 mtr. Hand held similar to IC2E comes complete with flexible Ant, charger, earphones, and carrying strap.

KENPRO	PRICE	P&P
KT 200EE	145.00	3.75
Soft case	4.90	F.W.A
Speaker Mic	14.95	F.W.A
Mobile Ch/Lead	7.95	F.W.A
Spare Batt/Pack	17.95	F.W.A

AZTEC UHF/VHF ANTENNAS

	PRICE	P&P
HB9CV	2 Ele Yagi complete 2mtr	4.50 1.50
AZ2CL	2x5/8 co/linear 2mtrs kit complete	11.00 2.50
AZ2FD	Slim Jim kit complete	3.50 1.00
AZ2FD	Slim Jim assembled	5.00 1.00
AZ2Y5	3 Ele Yagi 2 mtr kit complete	5.50 2.50
AZ2Y5	5 Ele Yagi complete	9.50 2.50
AZ2Y8	8 Ele Yagi 2mtr kit complete	5.00 3.50
AZ2Y8	8 Ele Yagi 2mtr complete	14.00 3.50
AZ2Y10	10 Ele Yagi 2mtr kit complete	14.00 4.00
AZ2Y10	10 Ele Yagi 2mtr complete	18.00 4.00
AZ2Q6	6 Ele quad 2mtr kit complete	12.95 5.00
AZ2Q10	10 Ele quad 2mtr kit complete	17.95 6.00
AZ70Y10	10 Ele Yagi 70cm complete	9.50 2.50
AZ70Y17	17 Ele Yagi 70cm complete	13.50 2.75
AZPM	11'6" portable mast C/W guys fittings etc.	5.00 3.00
AZPM	17'6" portable mast c/w guys fittings etc.	12.50 4.00
AZPM	23' 3" portable mast c/w guys fittings etc.	17.50 5.00
URG67	good quality coax 20mtr coil	10.00 2.50
14 SWG	hard drawn copper wire 30mtr coil	5.50 2.50
Pan Spyder	for h/brew HF triband quads 8 pole	9.95 3.00
Pan Spyder	4 pole for additional elements	5.00 2.00

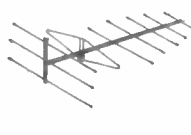

6 ELE DI - YAGI
FEATURES LARGE REFLECTOR FOR
BETTER F/BACK RATIO QUAD TYPE
DRIVEN ELE FOR IMPROVED F/GAIN
EG. 11.5 DB

LIST PRICE BRAND NEW BUT
S/SOILED £17.00 P&P £4.50

DRAE MORSE TUTOR
LEARNING MORSE? HERE'S THE ANSWER
FEATURES INCLUDING



- Built in power supply
- Group of 5 random letters
- Continuous Morse
- Built in practice oscillator
- Single letters with repeat
- Variable Speed + space

REBORN MORSE EQUIPMENT	PRICE	P&P
HK808	Straight key marble base	29.95 2.00
MK705	Squeeze paddle marble base	17.95 2.00
MK703	Squeeze paddle shop/soiled	12.95 2.00
BK100	Mechanical bug	17.95 2.00

ANTENNAS MOBILE HF/VHF	PRICE	P&P
Oscar 10SE	10 mtrs fold over	10.95 1.50
Oscar 15SE	15 mtrs fold over	11.95 1.50
Oscar 20SE	20 mtrs fold over	12.95 1.50
Oscar 78F	2 mtrs 7/8 fold over	10.95 1.50

SUN ANTENNAS SIMILAR TO OSCAR	PRICE	P&P
KG309 SE2	5/8 2 mtr	10.95 1.50
KG208 SE2	2 mtrs 7/8 fold over	11.95 1.50
KG5	2 mtr Co/lin	9.95 1.50
J BEAM	2 mtr Co/lin	7.95 1.50

G whip flexi ten 2mtr through HF to 80mtrs all in one package including (WARC) complete with very heavy duty sprung mount and bumper strap **50.00**

BASE ANTENNA HF/VHF	PRICE	P&P
J BEAM	4 Ell Quad	£24.95 3.50
J BEAM	BM 28/70 multi beam 70cm	17.95 2.75
J BEAM	VR3 10-15-20 mtr vertical	38.95 2.75
HYGAIN	12 AVQS 10-15-20 mtr vertical	44.95 2.75
OSCAR	3 x 5/8 CO/LIN 2 mtr S/S	29.95 3.50
SUN	LM 144 2 mtr/Dual Bander	11.95 2.00
SUN	LM 72 - Ditto	11.50 2.00

INSTANT CREDIT FOR ALL LICENCED AMATEURS
VIEWFLINT LIMITED
GRAIG-Y-MASTER, PENYCAEWAU, NR USK, GWENT, S WALES
TEL 02915-552

BEGINNERS'

WORKSHOP

A series for the would-be constructor

PART THREE: VEROBOARD CONSTRUCTION

Rev George Dobbs G3RJV

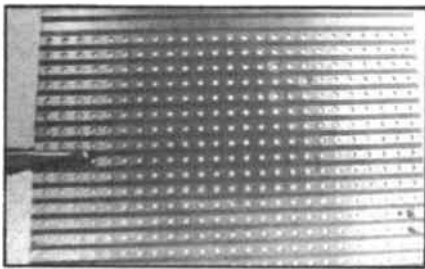

In the days of yore, when radio equipment glowed inside and had lethal voltages, construction was largely a matter of hanging the components between fixed points in the chassis. Valves had bases so transformers, capacitors, inductors and all manner of components were fixed to the chassis and had sturdy solder tags from which the circuitry could be suspended.

In these more genteel days of solid-state circuitry the constructor has to rely upon the base-board mounting method to secure the components and solder up the circuit. The commonest method is the printed circuit board but many constructors do not want to go to the trouble of etching a printed circuit board for a small project or a one off circuit board.

Veroboard

There are several methods of constructing a circuit without the use of etched boards but for many years one of the most popular has been the use of Veroboard.

Veroboard was originally produced, and is still used, for prototyping work in the commercial electronics industry. It is an insulated board which has a matrix of holes to accept component leads. Usually these holes are spaced at 0.1 inch, the lead spacing on integrated circuit pins, although 0.15 inch spaced Veroboard has been available.

On one side of the board strips of copper join adjacent rows of holes. Thus the underside of the board and components leads are pushed through the top side of the board and can be soldered onto the copper strips.

Building a project on Veroboard is a matter of working out the layout to fit the lines of copper strips. These can be broken or linked to enable the board to make circuit connections other than in a straight line. This may sound complex but one look at a piece of Veroboard will quickly show how it is made up and the possibilities for its use. Veroboard is very popular amongst amateur constructors for building even the most complex projects. Such seasoned Veroboard constructors seem to develop the ability to think their circuits into lines of copper strips. I am not very keen on Veroboard construction but thousands are avid fans of the stuff.

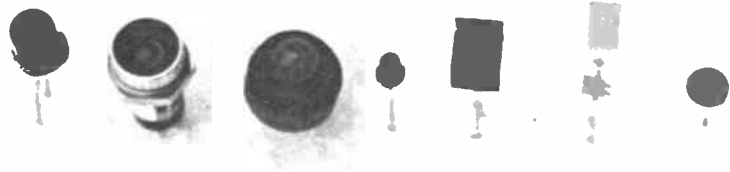

Types of LED

There are difficulties which arise from the very nature of the board. The most obvious is making careless solder joints, which not only solder the components into place, but also bridge adjacent tracks. Many constructors have had the frustration of a 'mysterious fault' on a Veroboard project which has proved to be a solder bridge between tracks.

Another problem can be the size of the holes in the board. Obviously the manufacturers drill the holes to fit most component lead sizes. It would be frustrating if all the holes were small and required frequent drilling out of holes to get a component lead to fit onto the board. The result is that the holes are really too large for many modern wire ended components. This results in a sloppy fit which can prompt a poor solder joint.

The best technique to overcome this problem is to bend the lead a little. Push the wire into the hole, bend it over so it firmly touches one side of the hole then jam the tip of the soldering iron between the wire and the hole in the copper strip. As with all good solder joints the heat of the lead and copper should be used to melt the solder rather than the soldering iron tip. Like a lot of soldering, it's a three handed job.

Convenient

Having said all this, Veroboard is popular, convenient and ideal for wiring up tidy little circuit boards, especially if ICs (integrated circuits) are being used. I have my doubts about its use at particular radio frequencies but do know several constructors who have used it up to VHF frequencies with success. The problem can arise from capacitive coupling between adjacent strips of copper.

The best method for radio frequencies is to make breaks in the strips that are unwanted and to solder the unwanted sections together and join them to ground as an 'earth mat' around the circuit.

Most Veroboard circuits require both breaks and links in the copper strips to obtain the required circuit connections under the board. The links are easy, just a matter of joining copper strips with a link wire. The link can be added under the board, but the most common practice is to run link wires across the top side of the Veroboard. The breaks in the copper strip have to be made with a sharp pointed tool.

The copper strips are very thin so removal of copper around a hole is very easy. A special cutting tool called a 'spot cutter' can be bought for the purpose, but using the end of a small twist drill usually works just as well. The diameter of the twist drill should be slightly greater than the width of the copper strips.

The point of the drill, which is held in the hand, is pushed firmly onto a hole and several twists of the drill will carve away enough copper to form a break in the strip. Care must be taken not to damage or break the adjacent strips when making the hole in the required strip.

After a little experience the use of links and breaks can convert the Veroboard into a neat series of underside connections to suit any circuit.

The wonderful LED

Unless a modern piece of electronic equipment flashes, lights and dances like Blackpool illuminations it will not sell. Or at least, judging from what the manufacturers do with their equipment

these days, that would appear to be the case. Their chief aid to providing these optical delights is the *light emitting diode* (or LED).

I can recall, not so long ago, when LEDs were quite expensive and adding one or more to a project was a bit of a luxury. Now they are so cheap that even the meanest constructor can pepper his front panel with them, if that is his weakness. They are cheap to buy, easy to use and can enhance the look of a finished piece of equipment.

The LED simply relies on the fact that some types of crystal emit light when a voltage is put across a thin section of that crystal. I'm told that a Mr Round, an American electrical engineer, first recorded the effect in 1907. He had noticed that if he connected a voltage across a piece of Silicon Carbide a dull yellowish light was produced. But it was many years before the LED, as we know it, was finally developed.

The sophisticated will tell you that it is all due to the fact that a forward biased PN junction emits light when excited electrons return to the rest state. For me it's enough to know that putting a voltage across some bits of crystal makes them glow.

The LED is a source of cold light and has a very long life. It would probably take a 100 years before the light output ceased from an average LED; I wish I could say that for the light bulbs I get from my supermarket.

Depending upon the type of crystal and method of construction various colours of light are emitted by the LED. Red LEDs were the first to be developed, followed by green and orange. There are other colours including infra red and blue, but these are less common and more expensive.

The fact that the plastic coating of the LED is coloured is not the main reason for the colour of light emission, the tinting of the plastic is merely an aiding filter. Some red and green LEDs can be bought in clear plastic moulding, they look as if they might be white light sources but emit the colour given by the crystal. The plastic housings can be shaped to give a particular style of lighting; round, square, wedge and so on.

The circuit symbol for the LED is shown in *Figure 1*. It is the diode symbol with one or more arrows coming away from the diode to indicate that light is being emitted. The drawing also shows the connections for a typical LED. The *anode* (connected to the positive side of the supply) is usually the longest of the two leads, the shorter lead being the *cathode* (connected to the negative side of the supply).

Many LED housings have a flattened side and this indicates the cathode (negative) lead. Most common LEDs will have one or both of these methods of lead identification. Connect an LED the wrong way round and it will not light. LED segments have been used, and still are, in the make up of seven segment numerical displays but these days they

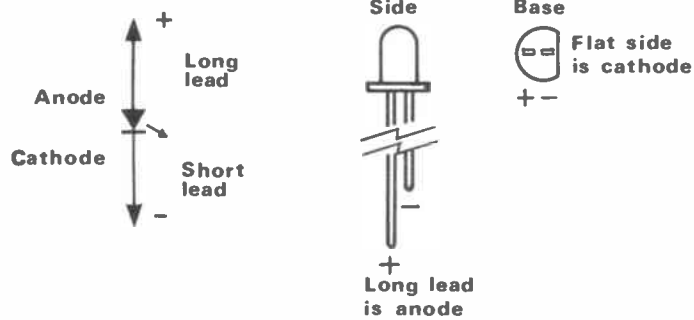

Fig 1 Showing LED diagram and connection

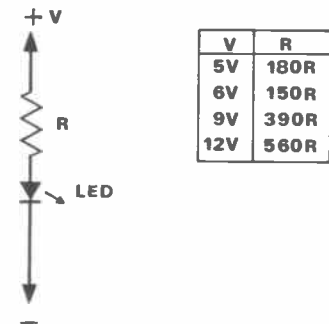

Fig 2 Showing the circuit for a simple LED indicator. This is just the LED connected to a series limiting resistor.

are often replaced by the less current hungry liquid crystal (LCD) displays.

Basic LED

The basic LED is a single colour on-off device used for indicating the presence of a voltage. They are always used in conjunction with a series current limiting resistor. The voltage drop across an illuminated LED is a nominal 1.6 volts dc for a red LED and 2 volts for a green LED. The series resistor can be chosen so that the LED can indicate a voltage above the voltage for illumination.

The circuit for a simple LED indicator is shown in *Figure 2*. This is just the LED with the series limiting resistor. Although the forward voltage of the LED should be that stated above and will vary from one colour type to another, for practical purposes the range 1.6 to 2.3 volts is a suitable operating area for all common LEDs.

The forward dc current of a typical LED ought not to exceed 50mA, and it is usual to operate them at around 20mA. The LED is designed as a soft light source; increasing the current will make it brighter but will reduce the life of the device. LEDs can be bright, rather than soft, I have driven some so hard that they have given a small light beam, but they don't like it and do not last long.

The required resistance for the series resistor R can be worked out from the formula:

$$R = \frac{\text{supply voltage}}{20\text{mA}} - 35$$

The 35 knocked off at the end is roughly the LED resistance at 20mA. To save a lot of time a chart of suitable series resistances for common voltages is shown in *Figure 2*.

With this basic information it is possible to add LEDs to home constructed projects as indicators. The LED is simply wired, with an appropriate series resistor, across the circuit requiring an on/off state indication. LEDs can be front panel mounted using small plastic housings sold to fit the size of the LED in use.

The cheapest housings are called LED clips but a metal chrome bezel provides a much smarter finish at a smarter price. One easy, but not cheap, way of having an attractive LED indicator is to use a panel mounting LED. These are LEDs built into a chrome or plastic bezel. Very pleasing to the eye, but they do cost about four times as much as a basic LED.

Constructors with an eye for economy can mount LEDs on a front panel without any form of housing. With a little care a hole can be made in a front panel just large enough for a cheap LED to be a snug push fit.

The mysterious SS17

So now we know something about construction using Veroboard and how to use LEDs as a simple on/off state indicator. This project combines the two and might even be useful. Some time ago I bought a motor caravan in lovely condition with lots of expensive extras lovingly added by the previous owner.

To protect the van and its contents he had fitted a sophisticated and expensive looking burglar alarm. Sadly there is no outward sign that the alarm is fitted and Mr Thief might do a reasonable amount of damage trying to enter the van before the welter of noise sends him on his way.

Burglar alarms in houses usually have those brightly painted little boxes on the

wall to deter the would-be burglar. So what could be added to the van to announce the presence of an alarm?

The SS17 was my answer to the problem. It's really nothing but a nice technical looking box with a flashing light that I put above the dashboard where it can be easily seen from the outside of the vehicle. Why the 'SS17'? Well, I had to put some external markings on the box to make it look commercial and convincing and these letters seemed plentiful on the Letraset sheet I used for the markings.

Other odds and ends were also added to the box such as a G-QRP Club plastic logo and a 'serial number' which happened to be on the bottom of the sheet of rub-down lettering I was using.

The circuit of the contents of the box is shown in *Figure 3*. It is one integrated circuit (IC), the 3909. The 3909 is an IC designed to flash an LED at a frequency that can be externally set and uses the minimum of current to produce the flashes.

The LED is connected across pins 6 and 8 of the IC and the capacitor, C, sets the frequency of the flashing. The value for C used here gives a flash of the LED at intervals of just over a second. The current consumption is very low; using a C cell type battery this little box should flash about once a second for over a year.

The circuit is built on a small offcut of Veroboard. All that is required is a piece with 49 holes; 7 holes by 7 holes. The layout for the board is shown in *Figure 4* and the link wires are shown on the board. These are short pieces of 26 swg tinned copper wire across the top of the Veroboard which can be obtained by stripping the covering off a length of single core PVC covered hook up wire. If no single core wire is available some short lengths of fuse wire would do the job.

The breaks in the copper tracks are indicated by crosses on the diagram. Identify the holes where the breaks are to occur, turn the board over to the copper side and remove the copper around that hole with a spot face cutter or a small twist drill.

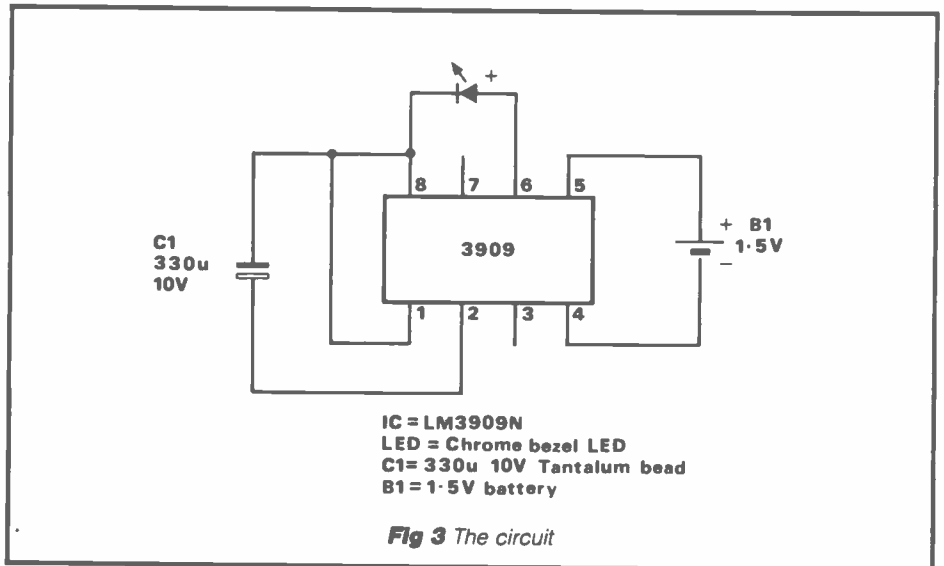

Fig 3 The circuit

Do not damage the adjacent tracks and inspect the break after it has been cut. Sometimes shavings of copper from the cut can form a bridge between tracks, so it is not a bad idea to clear the channel between the tracks by running a knife along the gap.

Link wires

Solder the link wires first. Make a compact but clean joint by pushing the point of the soldering iron bit firmly into the edge of the hole and trapping the wire. Melt the solder on the junction of the track hole and wire, on the other side of the wire from the soldering iron bit. This means that the joint will melt the solder rather than the iron tip. This ensures that the joint is hot enough for the solder to flow freely and form a good joint. Allow just enough solder to flow to make a good joint.

Inspect the joint after soldering is completed. The solder should have cleanly flowed around the junction of the wire and the hole, and no solder ought to be in the track between the soldered track and the next track. If a solder bridge has been formed by excessive use of solder the excess solder can usually be removed from the channel by

drawing the point of the soldering iron bit quickly along the channel. Take this sort of care with all the solder joints.

The next component to mount is the capacitor. This is a tantalum bead capacitor and must be put into the board the correct way round as it is a polarised component. The diagram is marked with a + and a - to show the positive and negative lead positions and these will be marked on the capacitor. Note that there is a break in the track between the two leads of the capacitor and avoid getting stray solder into this break.

Tantalum bead capacitors are more expensive than the more usual electrolytic capacitors. This type of capacitor is used here because they are physically much smaller and this is quite a compact layout. The supply leads are soldered onto the board at the places marked on the layout drawing. It is worth colour coding these leads to avoid later mistakes when joining the wires to the battery.

I used a holder for a single C cell which just fits into the box. If a larger box is used a D cell would give a longer flash life for the unit.

IC - handle with care!

The next component to be added to the board is the IC and considerable care must be taken when soldering it into place. First of all double check that it is placed in the board the right way round; pins 1 and 8, marked by the little bevel cut into one end of the IC casing, go towards the inside of the board.

The IC pins may be quite a slack fit in the holes so the soldering iron must be firmly jammed into the edge of the hole, pushing the pins against the opposite side of the hole, when the solder joint is made. Avoid making a long winded job of the soldering as ICs tend not to like too much heat for too long.

The wary new constructor could solder an 8 pin IC holder onto the board and then push the IC into the holder. This can prevent soldering accidents and also give a second chance at having the IC the correct way around in the circuit board.

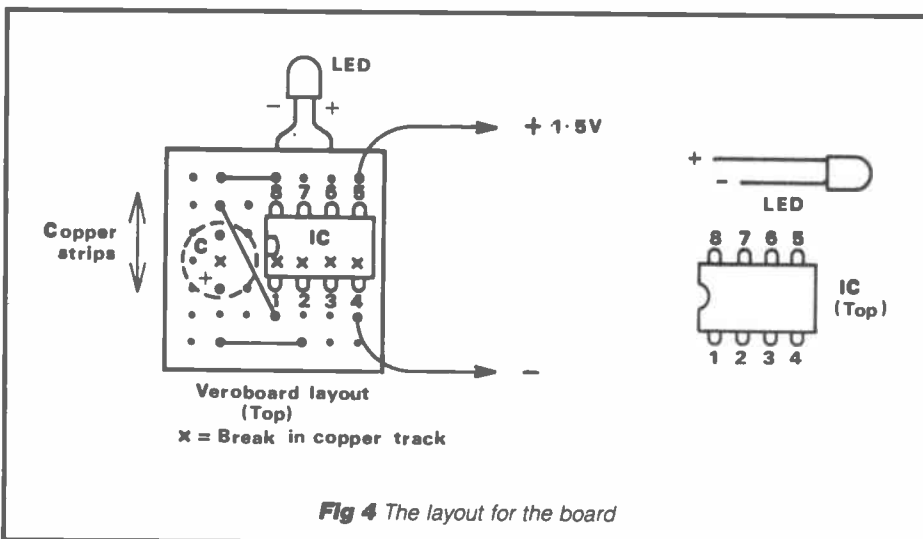

BEGINNERS' WORKSHOP



The LED is added last of all because it is mounted on the board in a somewhat unusual way. The LED used in the prototype is a chrome bezel LED, which is the type that comes complete with a metal housing which screws on the front panel.

A plain LED could be used but that would be difficult in this case as the LED leads are used to hold the board in place. Other constructors might like to use a larger box, in which case the LED could be mounted on the front panel with extra leads between it and the board.

The LED in my version is not soldered into holes in the Veroboard but soldered into place along two tracks of the copper on the underside of the board. This can be a slightly tricky operation and requires a steady hand or component



holding jig when the solder joint is made.

First of all the LED is put into place on the front panel and the screw fixing is tightened for a firm fit. The leads are opened to align with the tracks onto which they are to be soldered. The ends of the leads to be soldered must be parallel to ensure they do not bridge between tracks.

Tin the leads well and carefully align the board so that the end of the leads run along a little of the tracks to which they are to be soldered. Carefully check that the LED is the right way round. Pushing the leads securely against one of the tracks, make a quick but good solder joint. Repeat the operation for the other lead.

These solder joints should be strong because not only do they have to be

electrically sound but they have to take the weight, albeit small, of the board. The board should now be in place in the box and all that remains is to wire up the supply leads to the battery holder.

The box

The box used for the prototype is a box made by Vero. It is an ABS plastic box of the type Verobox 106, but any similar small box would serve the purpose and constructors may like to choose the cheapest plastic, or metal, box that they can find.

The markings on the boxes, as mentioned above, are purely random and really designed to give it credibility. The markings are in rub-down lettering which is sprayed to make them scratchproof.

A special clear varnish spray can be bought to protect rub-down lettering but I used a quick spray of PCB lacquer (RS aerosol printed circuit board lacquer) because I happen to have it in the stocks in my workshop. I also sprayed some of it inside the box (cover the battery connection plates first) anticipating dampness when the board is in use.

Not perhaps the most obvious electronic project for the radio amateur, but quite a useful and simple little device. Perhaps the constructor might like to make a LED flasher for some other application....amuse the children?

NEW NAVY SPECIAL BASE STATION COMPACT DIPOLE FOR 10, 15, 20 & 40m.

New Bands Available Shortly.

- ★ Each unit matched for 50 ohm feed impedance
- ★ Fits directly to 1 1/4" diameter mast
- ★ Ideal for limited space operation - maximum overall length 3m.
- ★ May be used without ATU.
- ★ Multi-band arrays require only one feeder.

Price per band: £29.99
inc post & packing
Please specify band(s) required.

**GLENSTAR ELECTRICAL MOTOR
DISTRIBUTORS LTD**
Newton Road, Henley-on-Thames,
Oxon RG9 1HQ.
Henley (0491) 576591



CENTRE ELECTRONICS SPECIALISTS IN THE SALE AND SERVICING OF VALVE TYPE RADIO EQUIPMENT

OFFER Brand new Eddystone Model 1590 (all solid state) general coverage receiver complete with full workshop manual one years works guarantee £790.00.

OTHER RECEIVERS FOR SALE include the following RACAL RA17 @ £175, RA17/L @ £195, RA17/E @ £250, EDDYSTONE MODELS 830/9 @ £155, 730/6 @ £145, 770U @ £115. Also a selection of Vintage Communication Receivers HRO's, AR88's, S27, 358X, S504 etc; LISTS OF OTHER RECEIVERS AND ITEMS ETC: AVAILABLE

ADMIRALTY B40 Single Side Band Adaptor Units £50 each including connector leads.

Large stocks of assorted vintage components (1920's - 80's) to clear Callers only

SPECIAL OFFER TWIN CORE COAX CABLE (100ohms) uses include Data Transfer, Inter connecting word processors, micro computers etc 12p per metre or £10 per 100 metre roll. (Free sample on request)

ALL PRICES INCLUDE PACKAGING AND DELIVERY

SPECIAL DOOR TO DOOR

CENTRE ELECTRONICS

345 STOCKFIELD ROAD, YARDLEY, BIRMINGHAM, W MIDLANDS

B25 8JP

SHOP OPENING HOURS 10 - 5.30PM THURSDAYS, FRIDAYS,

SATURDAYS ONLY. TELEPHONE ENQUIRIES 0676 32560

ANYTIME

DELIVERY SERVICE

AMATEUR ELECTRONICS UK

G6XBH

R.A.S. (Nottingham)

G6UUS



Radio Amateur Supplies

Tel: 0602 280267

Visit your Local Emporium

Large Selection of New/Used Equipment on Show

AGENTS FOR:

F.D.K.
AZDEN
ICOM
YAesu
PORTOP ATV

ACCESSORIES:

Wet Range
Microwave Modules
Adonis Mics
Mutek Pre-Amps
Barenco Mast Supports
DRAE PSU and
Wave Meters

AERIAL: Tonna, Halbar, New Diamond Range of Mobile Whips

PLUS OWN

'Special' Q.R.P. GW5 HF5 Band Beams
JUST GIVE US A RING

Monday: CLOSED Tuesday - Saturday: 10.00am to 5.00pm

3 Farndon Green, Wollaton Park, Nottingham, Off Ring Road
Between A52 (Derby Road) & A609 (Ilkeston Road)

ANGUS MCKENZIE

TESTS

TRIO TS811E 70cm MULTIMODE



The TS811E is Trio's latest addition to a long established range of multimode VHF and UHF rigs which began around ten years ago with the TS700, and more recently included the 770 and 780 models which are dual banders.

The 811 is almost identical to its 144MHz counterpart, the TS711, and covers the entire 70cm band from 430 to 440MHz incorporating FM, upper and lower sideband, CW and an automode which automatically selects the appropriate mode for the part of the band you are on. Trio however have a strange idea about some sections, for CW is selected from 430 to 432.15MHz, USB from 432.15 to 432.5, FM from 432.5 to 435, LSB from 435 to 438 and, finally, 438 to 440MHz is FM again.

A unique mechanism allows one to select continuous rotation or click steps on all modes by pressing the appropriate button. On CW and SSB the steps are 10 and 100Hz, but with the click position on these become 1KHz and 5KHz. On FM however the click steps are 5 and 12.5KHz, a step size button selecting the appropriate alternative.

All the mode buttons, when depressed, cause an appropriate CW letter to pip out of the speaker. Other buttons select scan, memory write, reverse repeater or lock, alert circuit for channel one from memory and memory channel select. Smaller buttons select code, digital code squelch on/off, code alert on/off and digital code search status, 1750Hz auto toneburst on/off, repeater offset on/off and \pm (cycling between these), continuous or stepped rotation, step size, memory to VFO, VFO to memory (ie memory write), memory zero special access which can be a priority channel, VFO A or B, VFO split for Tx/Rx, VFO A=B, MHz up/down, RIT on/off and RIT clear to zero.

On the bottom right hand corner, which is so easy for a blind person to find, is a speech frequency readout enable button, the actual speech synthesiser, type VS1, costing £28.88 including VAT, being an optional extra. This also indicates the repeater shift status.

Almost all the push-buttons activate a

bleeper when touched, but particularly useful for the blind operator is that when rotating the main tuning knob in the memory mode it not only goes round in click steps but, when it reaches memory 1, a pip indicates this allowing one to count steps to engage any of the 40 memories.

Lock push-buttons select processor on/off, meter ALC/RF out on Tx and accessory 2 socket pin 1/2 short or open. The latter can be used to switch on or off any accessory masthead pre-amp for example, which would have to be RF sensed. The RIT control tunes ± 9.9 KHz. Centrally mounted rotary pots control RF/AF gains, squelch (all modes) and IF shift, and RF output power (working on all modes)/mic gain (unfortunately this works on SSB only).

Frequency display

The digital frequency display reads in 100Hz increments, or 1KHz if wider steps are selected. This display also shows the logic state including VFO and memory details, tone on/off, repeater shift, split VFO on/off, alert operation, RIT status, Tx/Rx, reverse or lock, channel busy, step size and indicators for the digital squelch operation.

Each mode button has a light behind it which comes on when the mode is selected. The mic socket is a standard 8 pin Trio type, and by its side is a headphone quarter-inch jack. The S-meter is scaled up to '9+60dB'.

The loudspeaker is mounted in the top panel and thus throws audio out without being muffled. The rig is metal encased with a heavy duty carrying handle on the right side cheek and miniature feet on the left one, whilst underneath are four larger feet, a pull forward bail stand being provided under the front to lift it up about an inch.

On the back panel are many accessory

sockets including 3.5mm jacks for external speaker and Morse key, a 2.5mm jack for external PTT input, an accessory 1 socket (which is normally blanked off) for a computer interface, accessory 2 providing pins for shorting through an external voltage when the front panel button is pushed, audio output at fixed level, ground, mic mute enable, audio input and external PTT in. No external ALC input is provided, nor is any short on Tx, open on Rx relay, but Lowe Electronics can provide an optional mod kit with instructions if this is required.

The mains socket is a standard IEC with voltage selection, but in addition there is a 13V jumper socket which can also be used to accommodate an optional 13V dc power lead type PG2J, costing around £4.69 including VAT. (Surely the importers could throw this in with every set, for as a matter of principle quite a few amateurs who have bought this rig have been heard moaning about this on the air!).

Across the centre of the back panel is a reasonably substantial heatsink with built in auto fan. The antenna socket is most appropriately an N type, which is so much better than an SO239 on this band.

Auto callsign

Trio's new digitally coded squelch facility is incorporated into this rig which allows (when enabled and suitably programmed) another amateur who has a rig incorporating the same system to identify your call sign on an optional display the moment you go to Tx. The DCS display unit type CD10 is an optional extra costing £115.76 including VAT. This system also allows stations with the system to call one another and automatically open up the receiver, normal stations not opening the squelch.

You can enter your call sign into the system, which comes out as ASCII data,

G3OSS TESTS

but you can also add up to ten other amateur's codes, any of which when received can open up the rig.

Searching between the stored frequencies in memories 39 and 40 can be enabled, as can searching frequencies outside those in 39/40. Memory scanning is provided either for all modes or selected ones. In memories 36 to 38 you can enter non standard Tx/Rx shifts which can be quite useful for special purposes. The memories can store frequency, mode, dial status (continuous or click steps), repeater shift and tone burst on/off, and this is one of the few rigs to include the toneburst in store.

Programming to DCS is fairly simple and you can commence by pressing code squelch followed by code alert. Most of the operation buttons then become 0 to 9, letters and numbers being represented by a series of ASCII characters, the sequence being described in the manual. Trio's manual shows an improvement over earlier ones but is still not quite comprehensive enough, board layouts being omitted for example.

Subjective tests and ergonomics

From an ergonomic point of view this is easily the best rig that I have used on 70cm, for its operation is simplicity itself once you have got used to it. For a blind operator it will be an absolute boon, for Trio have thought of everything to assist a blind person. The unique clutch type tuning mechanism which gives steps for continuous tuning is fabulous and I am delighted to see 12.5KHz steps incorporated for FM. A pip tone sounds if you have selected the auto mode and go over a mode change frequency, and it is useful to be reminded that you are either going into the CW section or into the satellite portion for example.

The passband tuning helped CW reception but it is a pity that there is no CW optional filter. Squelch worked on all modes and the very comprehensive memory facilities will be found extremely useful. You can set into memory zero (called COM) a priority channel such as a Raynet one and this can be immediately accessed on pressing the COM button. Memory to VFO is splendid for you can put various calling channels in different memories, go to them and immediately transfer to VFO to go up and down from a calling frequency. I regret the absence of an ALC input but this should not be too much of a problem if any linear amplifier is properly set up.

The input sensitivity seemed quite good, although both SSB and FM were considerably improved when I switched in a masthead pre-amp. It is a pity that Trio did not add a button which put 12V on the inner of the antenna socket to fire up mastheads in the conventional way on many European designs; Icom provide this useful facility.

Despite my receiving some extremely strong signals on the band I did not notice as much spreading as I sometimes do, proving that a good intercept point can be important. Signals on the band

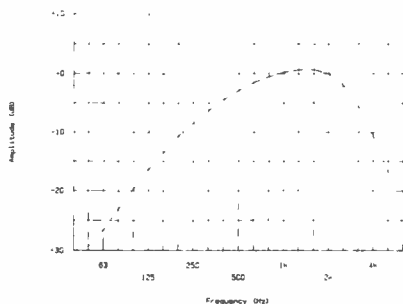

FM received audio response

also sounded very clean, and strong CW off channel did not seem to create puffing noises, which usually is an indication of a noisy local oscillator. Thus, it was clear that the 811 was better than many of its competitors.

Selectivity on SSB and FM seemed very good and audio distortion seemed good, well up to Trio's usual high standard. Transmitted quality was well liked but a slight hum was reported, both on FM and SSB, when the unit was worked off mains, and it is clear that this hum is getting into the mic amp from the power supply. Its level is not particularly high, but when a station is receiving a strong transmission from an 811 AGC will, of course, bring up the background noise and hence the hum, thus exaggerating its presence.

The rig runs quite warm but the cooling fan is quieter than usual. A processor can be switched in on Tx which, of course, assists readability if you are weak. The digitally coded squelch and coding signal causes a bleep tone containing ASCII characters to be transmitted at the beginning and at the end of a transmission. Although few people have, as yet, purchased the callsign display unit, I have a feeling that once the system is established, and particularly when groups of amateurs within an area all have rigs with the facility, the callsign display system will become quite popular.

It is comparatively easy to program the required data into the microprocessor. It can be switched on and off and one or two locals found it a little tiresome and asked me to turn it off as it was redundant, which may be a fairly important reaction. I must admit to disliking a K or bleep tone at the end of some peoples' overs, but on the other hand such a bleep is actually extremely useful on DX contacts in order to hear more positively that an over has ended, particularly on SSB. It is perhaps a pity that DCS only works on FM. Audio quality was excellent on all modes.

Laboratory tests

SSB and FM sensitivities were reasonably good but could have been perhaps 2dB better. However, since most serious users of the band will be using a masthead pre-amp this will not be of any concern, and what is important is the rig's excellent RFIM performance which results in a very high intercept point for a UHF rig.

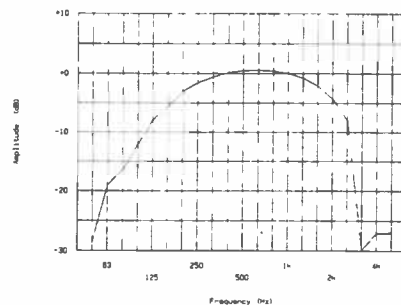

SSB received audio response

We had a long look at the reciprocal mixing performance using a muTek crystal controlled high power signal source and I must commend Trio for the remarkable way that the RM performance was so good near the carrier, in fact better than many rigs on HF. The ratio did not improve much well away from the carrier but the measurement was fully satisfactory in the context of UHF anyway.

Intercept point

The intercept point, of course, deteriorated when we measured it with two carriers within, or nearly within, the passband of the first IF roofing filter. However, the deterioration was nowhere near so marked well within the passband as it is on many other rigs. In fact, it is actually better within this passband than many 70cm walkie-talkies when the latter are tested with wide spacing, which always gives the best figures.

The selectivity was good on SSB and excellent on FM. The S-meter only displayed an 18dB range between S1 and S9 which is not really enough, and readings above S9 indicated an average of 20dB increments for around 14dB RF level increases. On FM S-meter readings were similar although 5dB more sensitive. Above S9, though, readings were very optimistic. Product detector and discriminator distortions measured reasonably well and the rig gave more than the usual power into 8 ohms, 4 ohms showing a useful additional available power. Whilst the capture ratio measured well, the quieting performance on a weak signal showed a dramatic improvement over the sinad sensitivity, so I would conclude that distortion on very weak signals was slightly high.

Frequency accuracy on FM was excellent and on SSB the received frequency was only 240Hz high, which is amazing on a UHF rig. CW is received with an offset of 800Hz. The AGC plot shows the recovery time to be reasonably slow and about ideal for average circumstances. The AGC threshold is at just below 1μV, but I would have preferred it to be at a slightly lower level as band noise is so low. Limiting came in on FM at around 3dB below the 12dB sinad sensitivity point, which is about right.

The transmitter had excellent frequency stability and transmitted frequency accuracy was very good (the repeater shift was also extremely accurate). The FM repeater toneburst was

G3OSS TESTS

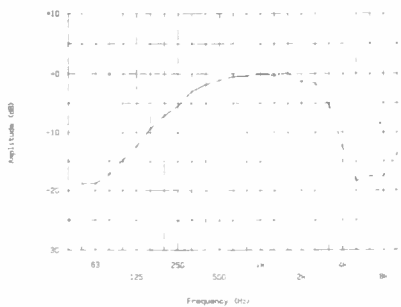

FM transmitted response (750µS de-emphasis). Below limiting

exactly on the right frequency and it also had just about the right deviation. Typical speech deviation was well optimised and when I provoked it to be as high as possible by the usual yelling noises there was no sign of any real over-deviation.

The transmitted response on FM measured below limiting and showed a reasonable LF cut, whilst the HF roll-off was reasonably steep above 2.8KHz bearing in mind that the plot was taken with 750µS de-emphasis. Slight noise problems arose in taking the plot, showing the presence of some background noise on the transmission, and this could have been a lot better if the mic gain control gave adjustment on FM, for as it is the mic amp works almost flat out on this mode.

We took a most interesting plot of the response from audio in to SSB carrier set at the maximum output power being set at just 2.5W to keep well below any ALC threshold. The plot represents a scan of the RF output from -5 to +5KHz and thus also shows sideband rejection and the carrier breakthrough ref 2.5W. The maximum alternate sideband breakthrough was at the very low level of -47dB at 200Hz, so this parameter is excellent. Carrier breakthrough was at -55dB which is superb and represents 65dB below full output.

The passband response, although showing no ripple, is slightly narrow, but you can see that it falls fairly rapidly on the two skirts. It will be seen that the response is 70dB down at 4KHz which is very good again for a UHF rig. Noise can be seen to be slightly high on the LSB side of the plot.

As a few amateurs who had purchased this rig had commented on the transmitted hum problem, we took two plots of a 1KHz tone being transmitted on SSB. The first plot shows the sideband and carrier rejections together with the AM ripple

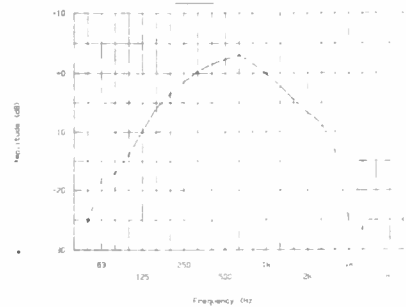

FM transmitted response (750µS de-emphasis). Well into limiting

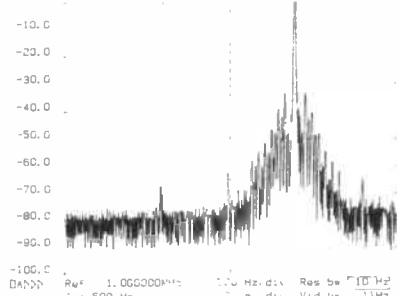

1KHz mod USB at 20W, showing carrier, LSB, USB and hum ripple

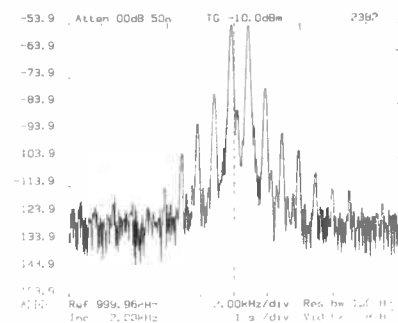

Two tone plot at 10W PEP

peaks on the down slope of the 1KHz tone. In the other plot we expanded the trace to 50Hz per division with 3Hz resolution bandwidth, from which you can see that the higher ripple components are fairly marked and disappear when the rig is run off dc.

Transmitted RF harmonics were immeasurable for they were at least 65dB below full carrier level. The rig had been set up to give just under 25W output on FM and CW, whilst SSB reached 27W PEP output. Power was adjustable from 1.7W up to full power on all modes which will be very useful if you want to drive a linear at the right level.

Two tone intermodulation plots were taken at three levels. At the lowest, 10W PEP, intermodulation levels measured

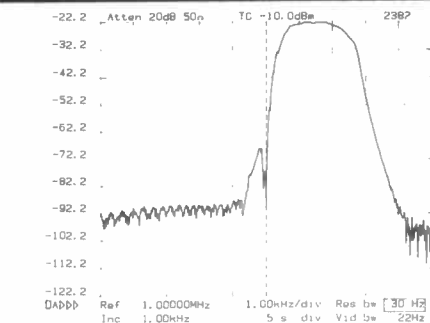

AF/RF transmitted response with output set at 2.5 watts (below ALC threshold)

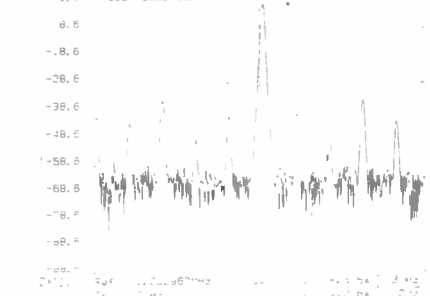

Zoom of 1KHz mod USB at 50Hz per division, showing PSU ripple

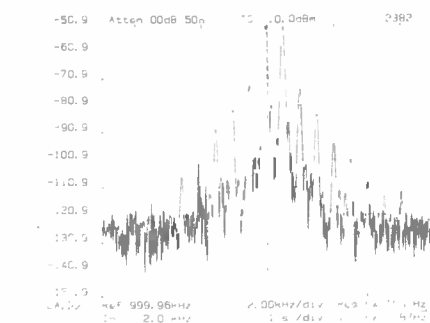

Two tone plot at 20W PEP

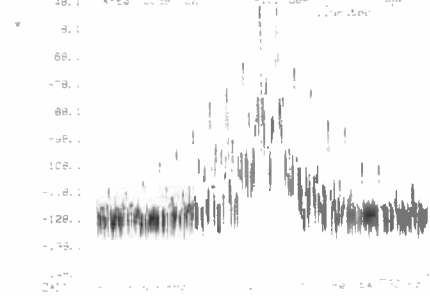

Two tone plot at 27W PEP

fairly well with high order products falling quite rapidly, showing that the spreading performance would be very good at this level. At 20W you can see that the performance is slightly inferior but, again, quite reasonable as far as spreading is concerned. At maximum power, well into ALC, the performance is acceptable although third order products are just a little high. The higher orders did fall down reasonably but, of course, spreading will be slightly worse than with lower powers.

It should be remembered that a two tone test is somewhat violent and tends to show the worst position, and spreading performance in practice will normally be somewhat better. In listening to 811

AGC action

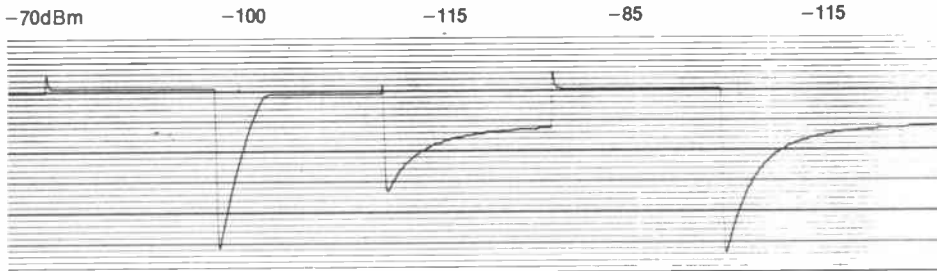

transmissions I felt the spreading performance in practice was good so the rig should not introduce problems on the band if it is properly driven.

Conclusions

Imported rigs from Japan are now becoming rather expensive, and one must be fair and compare prices in relation to the facilities offered and, indeed, with inflation. Ironically, considering inflation, rigs are cheaper now than they were many years ago, especially if you take into account many of the outstanding performance and ergonomic features. I like this rig very much indeed, even ignoring the amazing facilities offered for the white stick operator, and I strongly recommend it, although it has to be said that Trio ought to improve the hum/ripple problem when it is worked from ac mains.

I have a feeling that we will hear a lot of these rigs on the band soon and that a few bank managers will begin to twitter! I strongly recommend the use of a masthead pre-amp with it which would then allow it to become a really hot receiving system. The basic price is £965 including VAT. The call sign display type CD10 costs £115.76 and the usual microphone and other accessories are available, some of which have been detailed above.

Thanks to Lowe Electronics for supplying the review sample at quite short notice and to my colleague, Jonathan Honeyball, for his patience when taking all the many measurements with me.

The 2m version of this rig, the TS711E, is almost identical, covering 144 to 146MHz. Instead of the accessory pin shorting switch, though, it has a 20dB Rx attenuator. It is also a highly recommendable rig which performs well.

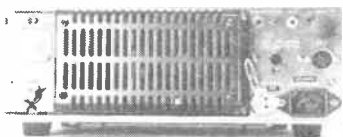

TRIO TS811E LABORATORY RESULTS

Receiver Results		
Sensitivity (SSB)		
RF level required to give 12dB sinad product	-124.5dBm	
Sensitivity (FM)		
RF level required to give 12dB sinad product of 1KHz mod/3KHz dev		
432.025MHz	-122dBm	
433.400MHz	-122dBm	
435.975MHz	-122dBm	
439.975MHz	-121.5dBm	
Selectivity (SSB)		
3dB bandwidth	2.3KHz	
6dB bandwidth	2.5KHz	
40dB bandwidth	3.6KHz	
60dB bandwidth	4.5KHz	
70dB bandwidth	6.7KHz	
80dB bandwidth	9.8KHz	
Selectivity (FM)		
±25KHz	65.0/65.5dB	
±50KHz	66/66dB	
Reciprocal mixing (SSB)		
Level of off channel carrier required to degrade sinad by 3dB ref noise floor		
+50KHz spacing	90dB	
+20KHz spacing	90dB	
+10KHz spacing	89dB	
+5KHz spacing	81dB	
S-meter		
RF level required to give the following S-meter readings		
	FM	SSB
S1	-115dBm	-110dBm
S3	-106.5dBm	-106.5dBm
S5	-103dBm	-103dBm
S7	-100.5dBm	-96.5dBm
S9	-98dBm	-92dBm
S9+20	-94dBm	-78dBm
S9+40	-90.5dBm	-64dBm
S9+60	-86dBm	-52dBm
Capture ratio (FM)		4.3dB
Product detector distortion (SSB)		2.2%
Distortion (FM)		
at 3KHz deviation		2.1%
at 1KHz deviation		0.5%
Maximum audio output power at 10% THD		2.8W into 8 ohms
RFIM (SSB)		
Off channel carriers producing 12dB sinad product on channel		
+100/+200KHz spacing gives calculated intercept point of		-4.5dBm
+20/+40KHz spacing gives calculated intercept point of		-17.5dBm
+10/+20KHz spacing gives calculated intercept point of		-26dBm
+5/+10KHz spacing gives calculated intercept point of		-26dBm
SSB received accuracy		+240Hz
CW received accuracy		+200Hz
FM 3dB limiting point		-125dBm
Transmitter Results		
Power output (FM)		1.66W to 24.1W
Power output (CW)		1.6W to 24W
Transmitted harmonics and spurs		all below -65dB ref full power on CW
FM transmitted accuracy		450Hz low
CW transmitted accuracy		260Hz low
FM repeater shift accuracy		500Hz low
FM repeater tone frequency		1750Hz within 1Hz
FM repeater tone deviation		4.75KHz
FM typical speech deviation		4.3KHz
FM provoked deviation		5KHz

NEW BNOS LPM144-3-180 TWO METRE SOLID-STATE LINEAR

I have tried a good few 2m solid-state linears in my time and, although the Mirage low gain model offering around 160W output received a good review in this magazine two years ago, I have not yet come across a high gain model that was worth considering before I discovered this one.

180W output

The BNOS LPM144-3-180 2m solid-state linear covers the band 144 to 146MHz and is specified to require up to 3W input drive to achieve the rated output of 180W. Front panel switches are provided for switching the Tx section to enable or straight through mode, and to put in the RF pre-amp when receiving.

A third switch varies the RF sensing

hold time to almost instantaneous for FM and around 0.5S for SSB and CW. However, the SSB hold time is on the short side and is fixed by a resistor and capacitor, and I would have preferred to have seen a user preset giving a range up to around 1.5S. The front panel has three LEDs for status indications and a row of seven LEDs to give output power indication, an eighth one indicating the presence of RF shut-down if the linear is overdriven in any way.

Input and output sockets on the back are SO239s, a 3.5mm jack being fitted for external PTT. This is fairly high impedance so the earthing current on transmit is quite low, allowing it to be interconnected with many PTT inputs as well as outputs on transceivers. The 13V

power leads are good beefy ones, around 1.8m long, the positive one including an appropriate fuse.

The bottom cover can be unscrewed to reveal the circuitry, which includes four presets for adjusting driver and PA bias separately, RF shut-down sensitivity and the power indicator calibration, although unfortunately these are not labelled. The internal wiring and layout is very good and the entire presentation better than much of the competition. The top of the linear is entirely covered by an enormous heatsink.

The transmitter section employs a Motorola MRF224 as a driver and a single Thompson-CSF SD1441 NPN device as the PA. The manufacturers have incorporated an integrated circuit bias source, which clearly assists the linear to give a far better performance than usual. Various switching functions are operated with solid-state circuitry.

The received pre-amp uses a BF981 transistor designed to give just enough gain to overcome the input noise figure of a moderately deaf rig without degrading the system RFIM performance too much.

Subjective tests

After considerable discussion I thought that it would be fair to carry out the subjective trials using a very popular drive source, the Yaesu FT290. On checking the latter, we found that its output intermodulation performance was so chronically bad that we had to spend quite a considerable time in the lab carefully setting it up with a two-tone audio input source and with its output monitored by a Marconi 2382 spectrum analyser.

Before we started, the third order products were, somewhat alarmingly, as high as -13dB, the output PEP having been set by the factory at 3.8W - surely far too high? We very carefully adjusted the input matching to the PA device, and all the output matching components from it, eventually achieving around 2.5W PEP into ALC with third order products amazingly low at around -30dB, probably rather better than the majority of 290s that so frequently seem to lurk on the band.

We then interconnected the output to the BNOS and obtained subjective reports from two London amateurs well known for giving very accurate estimations of transmission quality. They both

commented that the transmissions were very good indeed and that spreading was minimal.

One station commented that he noted a plop every now and then which must have been due to the RF sensing dropping out occasionally when I lost breath. One of the stations was receiving me very strongly indeed (around 5/9 +30dB) and stated that the sound was right down to the noise blanker by ± 5 kHz. When I turned my beam slightly off him to reduce the signal by around 10dB he found the width to be ± 2.5 kHz, which is surely very encouraging. It is quite clear that when this linear is correctly used it can achieve some excellent results.

The RF pre-amplifier worked well and no problems were introduced. We had no troubles with the linear in the tests, apart from the fact that the RF sensing circuits were a little too insensitive with about 250mW being required to open up the rig to transmit. In my opinion, the circuit should have been perhaps 6dB more sensitive to avoid it dropping out if you get back from the microphone on SSB if you are not using the PTT facility. This facility however should be easy to interface and could be used with many PTT inputs which short on Tx but may have a small voltage present on Rx such as the FT290.

This linear should give excellent service if properly used and you should do very well with it in a mobile

installation. I must emphasise though that it is essential to keep the input peak drive power well below the maximum rated input in order to avoid spreading and upsetting everybody.

Laboratory tests

For the lab tests we used a Trio TS711 with its power backed off very carefully for it to give a maximum of 3W PEP output, the mic gain also being adjusted to optimise the input level taken from a Bruel and Kjaer two-tone source.

We checked two-tone intermodulation products of both the drive source and from the output of the linear. At 3W PEP input we noted just over 200W output, the third order products being just a little high at -19dB, better however than some of the competition. When input drive was reduced to around 1.5W the output at 140W PEP was far cleaner, the third order products being particularly reasonable for a solid-state PA at around -31dB with higher orders falling off reasonably but not as steeply as they would with a very good valve PA. At 50W PEP output the third order products were slightly higher but still acceptable. Note the three two-tone IM plots which make an interesting comparison.

Input SWR

The input SWR, taken with a single input carrier of 1.5W, measured quite well at 1.5:1 and this should not be a strain for any reasonable rig. Maximum



Two tone 0.75W PEP drive, 50W PEP out

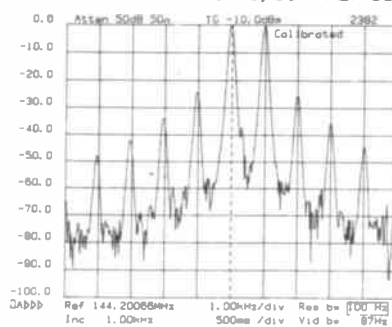

Two tone 1.5W PEP drive, 140W PEP out

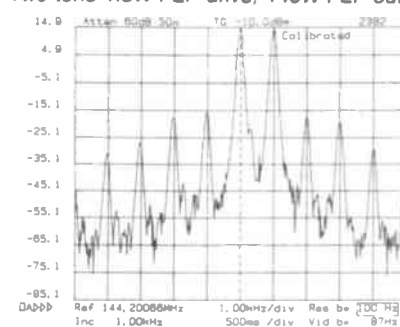

Two tone 3W PEP drive, 210W PEP out

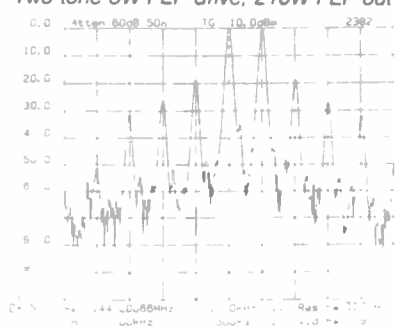

G3OSS TESTS

dc current drawn at full power was around 19A, the power source used being a BNOS type of 12/25A supply.

The RF pre-amp section had an input noise figure of around 2dB, but this was not measured really accurately at the time and from the tests that we did do any error would be in a pessimistic direction. The overall gain averaged 12.75dB across the band and the gain versus frequency plot shows the overall bandwidth, out of band signals being attenuated moderately well – although I would have preferred the bandwidth to have been Pnarrower. The RF intercept point was at -3dBm which is quite reasonable,

although some competition is a little bit better than this (but quite a lot is worse!).

Conclusions

This linear has got some excellent facilities, and I particularly liked the row of LED power indicators which can warn you if you are driving it over the top (please don't!). The design seems excellent and it is a lot cleaner than many other solid-state designs, some of which seem to be almost in class C when overdriven!

I most strongly recommend this model, which I feel is very good value for money, but make sure that your main transceiver

is very clean before you start amplifying it up. The average FT290 will not be good enough for it unless it is very carefully aligned first. However, this is the sort of driver that will be used.

The linear will work very satisfactorily on FM, but you will have to watch the input drive level and take account of your co-ax cable loss to avoid exceeding the licence regulations! A most worthwhile product from BNOS.

Many thanks to BNOS for loaning the review sample and to my colleagues Jonathan (G1LMS) and Nigel (G1LSA) for helping with all the measurements. The retail price is £235.75 including VAT.

BNOS 12/25A 13.8Vdc POWER SUPPLY

BNOS submitted this power supply for review together with their 2m linear, also reviewed this month. They also loaned me a massive fan-cooled resistor load box with various jumpers, allowing one to take many different current levels for measurement purposes.

The PSU uses a conventional circuit with around 25V raw HT developed from the mains transformer secondary, which after smoothing feeds four 3055 NPN transistors which are the main regulators. Each of these feeds through to the output via 0.1 ohm power resistors. The outputs are on two very large screw terminals above which is an ammeter with FSD at 30A.

On the back of the unit are two large heatsinks with the four power transistors in between them. The mains lead is a heavy duty three core. On the top is a carrying handle. The front panel also includes a mains fuse (5A) and a main on/off switch. Two LEDs indicate output power on and emergency shutdown.

The output regulation is of a feedback type with an integrated circuit driving a TIP120, which controls the bases of the four regulator transistors. Presets are included for setting the output voltage anywhere between 11 and 16V dc, for current trip normally set at around 27A.

Many protection circuits are incorporated including overvoltage, switch on anti-surge (allowing the dc output voltage to come up evenly), short circuit protection and protection against back EMF when used with inductive loads.

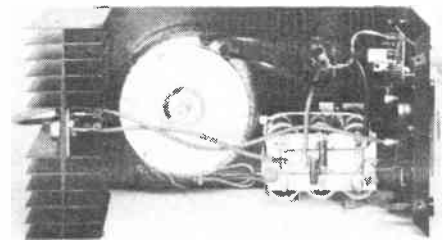

Across the output terminals is a parallel network of several capacitors from 1000 μ F down to 68nF for RF suppression, together with a fixed 1000 ohm internal load, protective diodes type 1N5401 (3A, 50V) and a thyristor type THY1 (25A) device for crowbar protection.

Laboratory tests

We used the power supply for driving very many rigs including HF transceivers, VHF linears, multimode rigs and many other gadgets. At no time did we have any problem whatsoever and no ripple problems were ever noted. For the basic lab tests we bridged the output terminals to a Hewlett-Packard 3478A six digit multimeter and also to a Bruel and Kjaer 2010 superheterodyne wave analyzer/RMS voltmeter.

The loads were connected through a Levell current shunt with a fluke millivolt meter across it, effectively to read current very accurately. Various resistor combinations were plugged in to give the varying currents and measurements were taken of current, dc voltage, ac ripple (RMS) and 50Hz, 100Hz and 150Hz ripple components.

The table below shows that the performance was outstanding for a

shack power supply, the ripple RMS level, measured from 2Hz to 200KHz, never exceeding 550 μ V. The 50Hz component hardly changed at all when changing the load from 12 to 26A, but note that the 150Hz ripple increases slowly with load, although the level can be ignored for all amateur radio purposes.

We were astonished to see that the output voltage remained stable at 14V dc within a maximum of 10mV, which is really excellent. The PSU could give 25A continuous but only gave 26A for a minute or so before it shut down. It will give bursts of more than 26A for a few seconds, but is specified to give no more than 30A even for a second or so. The internal ammeter was very accurate, the indication being within 0.5A when giving high current.

Conclusions

Judging by the results that we got in our lab, BNOS have justly acquired a very good reputation in the last year or so for their power supplies. My sole point of criticism is that unlike the Daiwa supplies there are only two output terminals, and it would have been very handy to have had two or three pairs of small banana socket terminals in parallel for feeding other bits of gear. Perhaps they might also have included a very low value capacitor such as 470pF across the output for even further improved UHF breakthrough suppression.

I most strongly recommend this unit which should be very reliable, costing £138 including VAT. Many thanks to John and Nigel (G1LMS and G1LSA) for their help in taking measurements, and to BNOS for supplying the review sample.

BNOS PSU TYPE 12/25A LABORATORY TESTS

Current	Voltage	RMS ripple	50Hz comp	100Hz comp	150Hz comp
6A	14V	0.38mV			
12A	14V	0.42mV	0.18mV	0.12mV	0.18mV
20A	14V	0.5mV	0.18mV	0.16mV	0.2mV
23A	14V	0.52mV	0.17mV	0.17mV	0.21mV
26A	14V	0.55mV	0.17mV	0.19mV	0.25mV

KAGA 12" MONITORS

B/W or anti glare green screen 18MHz video band width composite video input. New uncased need 12V 1.3A supply callers only 45

ELMASET INSTRUMENT CASE

300x133x217mm deep £10.00 ea (£11.50)

REGULATORS

LM317T Plastic TO220 variable £1.00
LM317 Metal £2.20
7812 Metal 12v 1A £1.00
7805/12/15/24 plastic 50p
7905/12/15/24 plastic 50p
CA3085 T099 Variable regulator £1.00

EPROMS/MEMORIES

27128-300nS £12.00
2764 INTEL/FUJITSU 300ns £5
2716, 2708, 1702 EX EQUIPMENT £2
2732 EX EQPT £2.50
2114 EX EQPT 60p 4116 EX EQPT 70p
4164-200nS new £3.80
MC6810P £1.00

POWER TRANSISTORS

TIP141, 142, 147 £1 ea, TIP112, 125, 42B 2/£1.00
TIP35B £1.30 TIP35C £1.50
SE9302 100V 10A DARL SIM TIP121 2/£1.00
2N3055 Ex eqpt tested 4/£1.00
Plastic 3055 or 2955 equiv 50p 100/£30.00
2N3773 NPN 25A 160V £1.80 10/£16.00

DISPLAYS

Futaba 4 digit clock, fluorescent display 5-LT 16 £1.50
Futaba 8 digit calculator, fluorescent display 9CT-01-3L £1.80
LCD Clock display 0.7" digits £3.00
Large LCD Clock display 1" digits £3.00
7 seg 0.3" display comm cathode 2/£1.00

QUARTZ HALOGEN LAMPS

A1216 24v 150w £2.25
H1 12v 55w (car spot) £1.25

MISCELLANEOUS

NEW BRITISH TELECOM PLUG+LEAD £1.50
1.25" Panel Fuseholders 5/£1.00
5.25" floppy discs Verbatim DSDD 10/£20 (£1)
MAINS ROCKER SWITCHES 6A SPST 5/£1
4700µF 63v ITT 10A RIPPLE £1
STAINLESS STEEL HINGES 14.5" BY 1" OPEN £1.00 each 10/£7.00

MAINS TRANSIENT SUPPRESSORS 245v 3/£1.00
TOK KEY SWITCH 2 POLE 3 KEYS - ideal for car/home alarms £3 £100+ £2.00
12v 1.2w small wire ended lamps fit AUDI/VW TR7 VOLVO SAAB 10/£1.00
Heat shrink sleeving pack £1.00
PTFE sleeving pack asstd colours £1.00
250 mixed res diodes, zeners £1.00
Mixed electrolytic caps 100/£2.00
Stereo cassette deck £5.00 (£1.50)
Stereo cass R/P head £2.50
Mono head £1, Erase head 50p
Thermal cut-outs 50, 77, 85, 120°C 80p
Thermal fuse 121°C 240v 15A 5/£1.00
Vero pins fit 0.1" Vero 200/£1.00
Double sided PCB pins 200/£1.00
TO220 Micas + bushes 10/50p 100/£2.00
TO3 Micas + bushes 20/£1
RELAYS 240v AC coil PCB mounting 2 pole changeover £1 3 pole c/o £1.00
Fig. 8 mains cassette leads 3/£1.00
KYNAR wire wrapping wire 2oz reel £1.00
PTFE min. screened cable 10m/£1.00
TOKIN MAINS RFI FILTER 250v 15A £3.00
IEC CHASSIS PLUG/RFI FILTER 10A £3.00
Epoxy potting compound 500g £2.00
Mercury tilt switch small £1.00

Min. rotary sw. 4p c/o 1/8" shaft 2/£1.00
Thorn 9000 TV audio o/p stage 2/£1.00
10m7 CERAMIC FILTER 50p 100/£20.00
6m or 9m CERAMIC FILTER 50p 100/£25.00
240v AC FAN 4.6" SQUARE NEW £5.50 (£1.60)
240/115v AC FAN 4.6" SQ. NEW £7.00 (£1.60)
KLIPPON terminal block EKS 12/4 12-way 20A term block 3/£1.00
BELLING-LEE 12-way block L1469 4/£1.00
POTENTIOMETERS short spindle 2k5 10k 2m5 Lin 5/£1
500k tin 500k log long spindle 4/£1
40KHZ ULTRASONIC TRANSDUCERS EX-EQPT. NO DATA PAIR/£1.00
STICK-ON CABINET FEET 30/£1.00
T03 TRANSISTOR COVERS 10/£1.00
TRANSISTOR MOUNTING PADS T05/T018 £3/1K DIL REED RELAY 2 POLE N/O CONTACTS £1.00

RECTIFIERS

120v 35A stud 50p
12FR400 12A 400v small stud 4/£1.50
BY127 1200V 1.2A 10/£1.00
BY254 800v 3A 8/£1.00
BY255 1300v 3A 6/£1.00
1A 800v bridge rectifier 4/£1.00
6A 100v bridge 50p
10A 600v bridge £1.50
15A 100v bridge £1.50
25A 200v bridge £2.00 ea 10/£18.00
25A 400v bridge £2.50 10/£22.00

SCRs

MCR72-6 400v £1 BTX95 800V 15A £1.50
35A 800v stud £2.00
70A 500v large stud £3.00
MCR106 equiv. 4A 400v 40p
2N5061 800mA 60V T092 4/£1.00
TICV106D .8A 400v T092 3/£1 100/£15.00
MEU21 Prog. unijunction 3/£1.00

TRIACS

TXAL225 8A 400V 5mA gate 2/£1.00 100/£35.00
TXAL228 8A 400v isol. tab 2/£1.00 100/£37.00
25A 400v ex eqpt. tested £1.50

CONNECTORS (EX EQPT. price per pair)

'D' 9-way £1; 15-way £1.50; 25-way £2.00
37-way £2; 50-way £3.50; covers 50p ea
NEW 25-way PCB SKT. STRAIGHT £1.00
D9 PCB PLUG 90 deg £1.50
0.1" double sided edge connector, 32-way ideal ZX81/SPECTRUM £1.50
0.1" d/sided pcb plug 24+25-way £1.50
2 pole sub min. connectors ideal radio control RS 466/472/488/343 5 pairs £2.00

IDC CONNECTORS

25 WAY 'D' PLG or SKT 37 'D' PLUG ea £2.00
20-WAY SOCKET (BBC USER PORT) £1.00
26-WAY SOCKET (BBC PRINTER) £1.50
34-WAY SOCKET (BBC DISC DRIVE) £2.00
40-WAY SOCKET £2.00

MADE UP DISC DRIVE CABLES

34 IDC TO 34 WAY CARD EDGE SINGLE DRIVE £6 DOUBLE DRIVE £8

WIRE WOUND RESISTORS

W21 or sim 2.5W 10 OF ONE VALUE FOR £1.00
1R0 2R0 2R7 3R9 5R0 10R 12R 15R 18R 20R 27R 33R 36R 47R 120R 180R 200R 330R 390R 470R 560R 680R 820R 910R 1K 1K1 1K2 1K3 1K5 1K8 2K4 2K7 3K3 10K

W22 or sim 6 watt 7 OF ONE VALUE for £1.00
1R5 9R1 10R 12R 20R 33R 51R 56R 62R 120R 180 270R 390R 560R 620R 1K 1K2 2K2 3K3 3K9 10K

W23 or sim 9 watt 6 OF ONE VALUE for £1.00

R22 1R0 3R0 6R8 56R 62R 100R 220R 270R 390R 680R 1K 1K8 10K

W24/ sim. 12 watt 4 OF ONE VALUE for £1.00
R50 2R0 10R 18R 47R 68R 75R 82R 150R 180R 200R 270R 400R 620R 820R 1K

PHOTO DEVICES

Slotted opto-switch OPCOA OPB815 £1.30
2N5777 50p 100/£26.00
TIL81 T018 Photo transistor £1.00
TIL38 Infra red LED 2/50p 100/£16.00
OPI2252 Opto isolator 80p
Photo diode 50p 6/£2.00
MEL12 (Photo darlington base n/c) 50p
RPY58A LDR 50p ORP12 LDR 85p
LEDs RED 3mm or 5mm 12/£1 100/£6.00
GREEN or YELLOW 3 or 5mm 10/£1 100/£6.50
FLASHING RED 5mm 50p 100/£30.00

DIODES

1N4148 100/£1.50
1S3740 Germanium 100/£2.00
1N4004 or SD4 1A 300v 100/£3.00
1N5401 3A 100V 10/£1.00
BA157 1A 400V Fast recovery 100/£2.50
BA159 1A 1000V Fast recovery 100/£3.50

MULTI TURN PRESETS

10R 20R 100R 200R 500R 40p
2K 5K 22K 50K 100K 200K

IC SOCKETS

8-pin 12/£1; 14-pin 10/£1.00; 18/20-pin 7/£1; 100/£12; 1k/£50; 22/28-pin 25p; 24-pin 25p; 100/£20; 1k/£100; 40-pin 30p; 16-pin 12/£1; 100/£5

TRIMMER CAPACITORS small

GREY 1.5-6.4pF GREEN 2-22pF 5 for 50p
GREY larger type 2-25pF 5 for 50p

SOLID STATE RELAYS NEW 10A 250v AC

Zero voltage switching £2.50
Control voltage 8-28v DC £2.50
VARIAC 0 to 130v 6A new uncased £6.00 (£2)

POLYESTER/POLYCARB CAPS

10n/15n/22n/33/47n/68n 10mm rad 100/£3.00
100N 250V radial 10mm 100/£3 1000/£25.00
1u5 P/carb 15mm rad 100/£7.00 (£1)
2u2 160v rad 22mm 100/£10.00 (£1.50)
470n 250v AC X rated rad 4/£1.00
33n/47n 250v AC X rated rad 15mm 10/£1.00
10n 250v AC X rated rad 10mm 10/£1.00
100n 600V SPRAGUE axial 10/£1 100/£6.00

BEAD THERMISTORS

GLASS BEAD NTC Res @ 20°C 80p
250R 1K2 50K 220K 1M4
R53 THERMISTOR £2.00

BEAD TANTALUM CAPS

6u8 25V 47u 3V 68u 6V 12/£1 100/£6.00
2u2 20V 8/£1 100/£8.00

MONOLOTHIC CERAMIC CAPS

100N 50v 100/£6 10N 50V 100/£3.00
470N 50v 100/£7 1uF 50V 100/£8.00
10N 50v dil package 0.3" rad. £4/100 £30/1k

STEPPER MOTOR 4 PHASE 2 9v WINDINGS

£3.50 10/£30.00

KEYTRONICS

332 LEY STREET, ILFORD, ESSEX

Shop open Mon-Sat 10am-2pm

TELEPHONE: 01-553 1863

MIN ORDER £2.50 OFFICIAL ORDERS WELCOME
UNIVERSITIES COLLEGES SCHOOLS GOVT DEPARTMENTS
P&P AS SHOWN IN BRACKETS (HEAVY ITEMS)
65p OTHERWISE (LIGHT ITEMS)

ADD 15% VAT TO TOTAL

ELECTRONIC COMPONENTS BOUGHT FOR CASH



AERIALS AND PROPAGATION

BILL SPARKS G8FBX

APPENDIX

A closer look at some of the theory dealt with in the course of this series

1) The formation of the standing wave on the half wave aerial

In considering the voltage and current distribution on the standard half wave aerial we may assume that the aerial is divided into small sections, each being represented by a small value of inductance as shown in *Figure A1*. It will be appreciated that the greater the number of sections considered, the greater the degree of accuracy. For simplicity, however, only eight sections are shown. The capacity values shown indicate the relative capacity of the distributed capacity between half sections of the aerial. Since the points nearer to the extreme ends of the aerial have lower

values of capacity per unit of length, it follows that the related capacity values will decrease from CA-CD.

Suppose that an RF current is fed into the aerial, this current will then have a varying RMS value at different points on the conductor. As can be seen from the diagram the currents related to the respective capacitors are individually fed to the aerial but all combine to a maximum at the centre of the aerial since any charge which passes from one end of the system to the other must pass through the centre.

By adding the vectorial values of the RMS voltage values these values will increase away from the centre of the aerial towards the ends since the value at the centre is zero and at the ends a maximum. Since one half of the aerial is positively charged when the other half is negatively charged the voltage curve is shown as passing through zero at the aerial centre.

The diagram also indicates the variation in impedance as the feed point moves either side of centre.

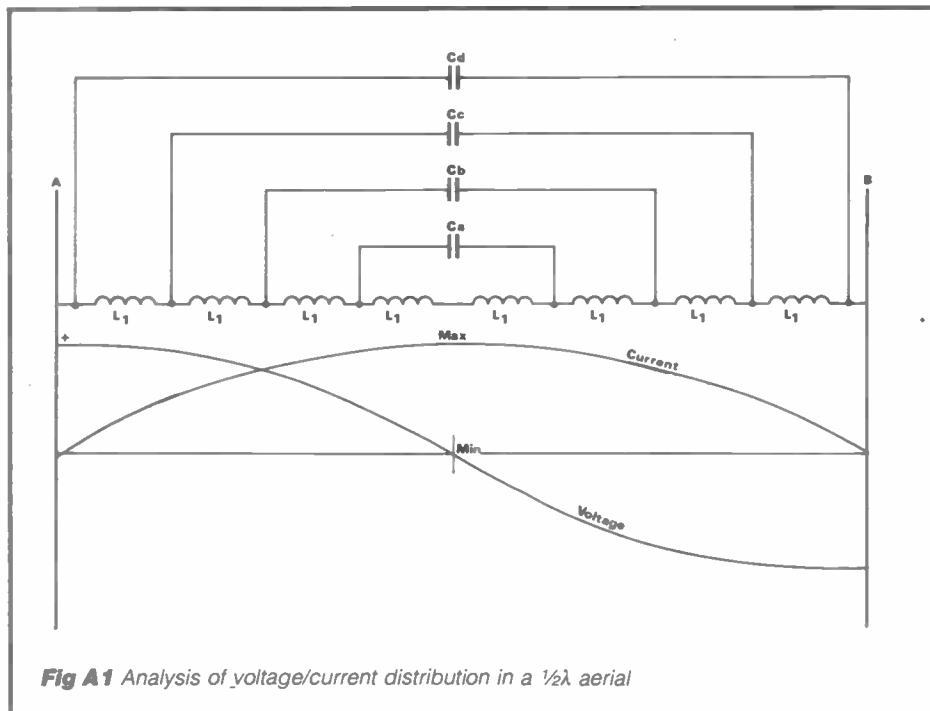

Fig A1 Analysis of voltage/current distribution in a $\frac{1}{2}\lambda$ aerial

2) VHF ducting

Figure 4, Part 2 (November 1984) showed the rate of change in water content in the lower atmosphere at normal conditions indicated a linear regression, with altitude. To permit return of VHF waves to earth some form of bending is required and this condition is brought about when a state of super refraction is created. Super refraction occurs when:

- a temperature inversion which is in excess of 2.8°C per 100ft increase in altitude occurs or,
- the rate of decrease in water content of the atmosphere exceeds 0.5g of water per kg of air during a 100ft alteration in altitude. In the figure shown, which is a measurement taken in the USA in July, the rate of change was in excess of 4.0g for a 350ft change, ie over twice the required limit. The MB indicated an instability in the radio due to extremely low frequency operation.

The effect of the inversions is to cause excess water vapour to be released at odd altitudes, thus creating an area of varying refractive index. Under super refraction conditions the refraction is often sufficient to create the required degree of refraction to cause the wave to return to earth, or be directed to a remote point where a subsequent change will cause a slow return to earth.

3) Aerial height at VHF

From *Figure A2* the calculation involved in determining the optical horizon is as follows:

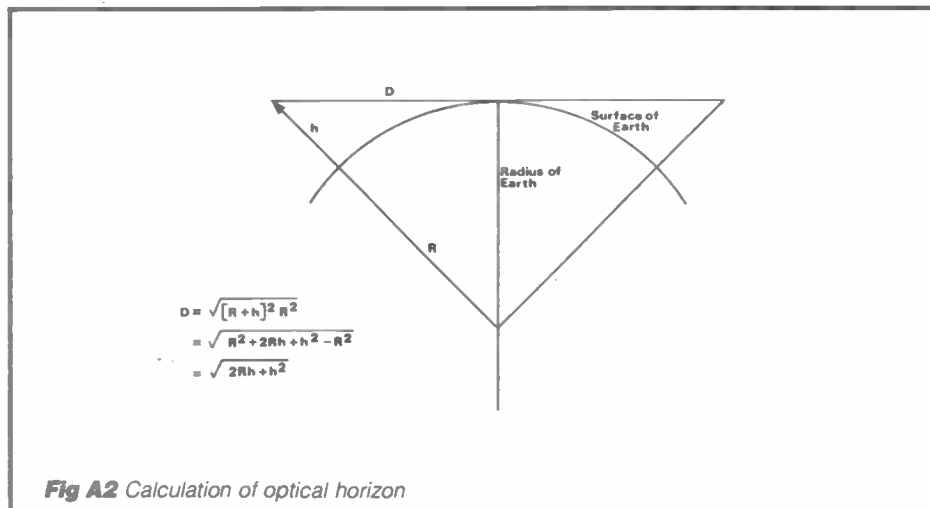

Fig A2 Calculation of optical horizon

AERIALS & PROPAGATION

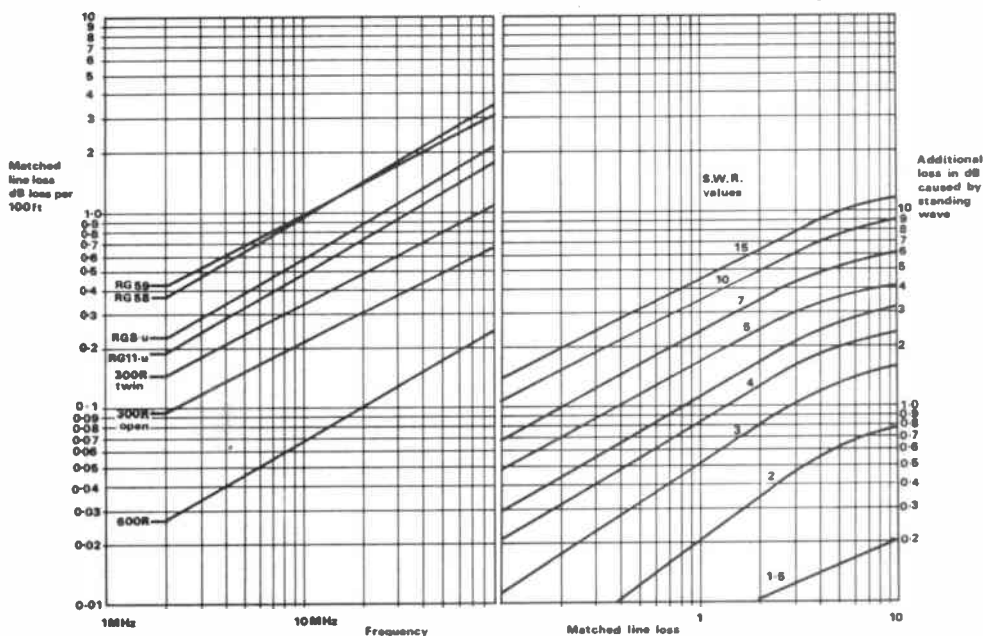

Fig A3 Losses due to feed lines

$$D = \sqrt{2Rh + h^2}$$

This applies to a perfectly smooth surface and ignores tropospheric features. For the UK suitable values are R = 209000000ft or 6370000 metres, so a very

close approximation would be D (miles) = 1.5h(ft). This holds good to about 3500ft altitude and is correct to ± 500 ft in D.

Simple manipulation indicates a required height above sea level for any one situation $h = \frac{2}{3}D^2$ for a required value of D or in metres:

$$\frac{D^2}{12.7\text{Km}}$$

Reference to the previous section will show that the normal condition chart will cause some bending of the wave front; the degree actually experienced will be determined by the measured values of pressure, temperature and humidity. Under normal conditions the effect will be to increase the optical horizon previously calculated by some 15-20% as a radio horizon.

4) Line losses

To determine the power losses due to feed line attenuation it is necessary to combine the attenuation due to the feeder at the specific frequency in question with the losses due to the SWR at the same point. Reference to *Figure A4* will show relative power losses against standing wave ratio over a limited range, as an example to illustrate the correct use of the charts shown in *Figure A3*. Let's assume a 150ft length of RG8/u co-ax at 21.0MHz with an indicated SWR of 1.5. The chart shows that at 21MHz RG8/u has a matched loss of 0.85dB/100ft or 1.28dB for 150ft. When we examine the matched line loss chart for the 1.5 SWR curve, the additional loss due to SWR is less than 0.1dB, so is of no consequence. Suppose the SWR went to 3.0, then the losses would be increased by 0.65dB giving a total loss of over 1.93dB.

The significance of these details is brought to importance when considering the effects at VHF.

A 1dB loss means that 80% of the power is transmitted, a 2dB loss that 65% is forwarded and a 3dB loss indicates a 50% power reduction.

VSWR	Reflected power %	dB return loss	Power transmitted %	Transmission loss dB
1.1		26		
1.15		20		
1.2		19	99	0.05
	1	18		
1.3		17		
	2	16	98	0.1
		15		
1.4		14.5	97	
	3	14		
1.5		13.5	96	
	4	13		0.2
		12.5	95	
1.6		12		
	5	11.5	94	
	6	11		
1.7		10.5	93	0.3
	7	10		
1.8		10	92	
	8			
	9	10	91	0.4
1.9			90	
	10			

Fig A4 Showing relative power losses against standing wave ratio

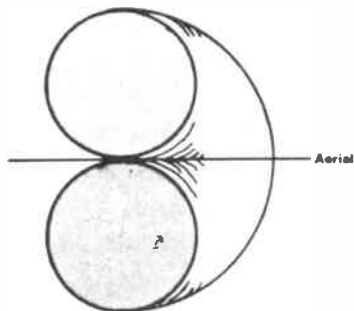

Fig A5/1 Section through solid polar diagram

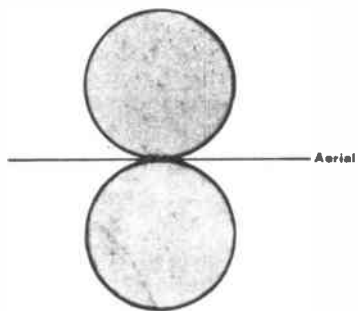

Fig A5/2 Typical single plane presentation fed with balanced feeder

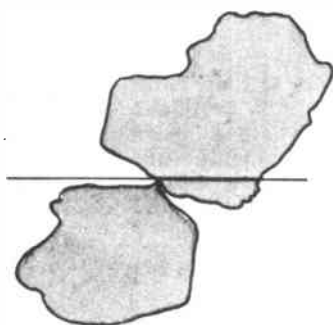

Fig A5/3 As A5/2 only fed direct with co-ax feeder. Nb: distorted pattern

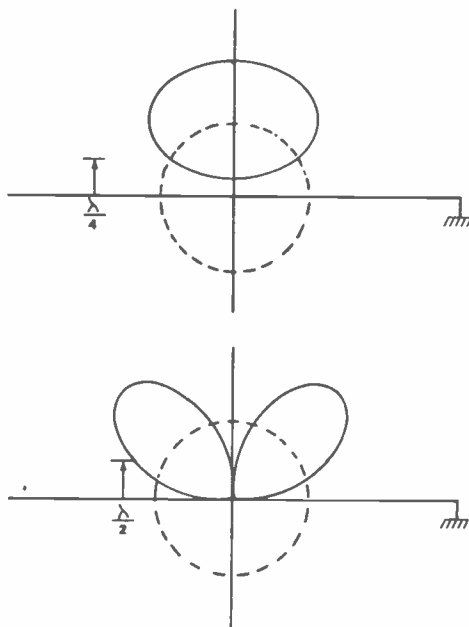

Fig A5/4 Effect of height above ground aerial

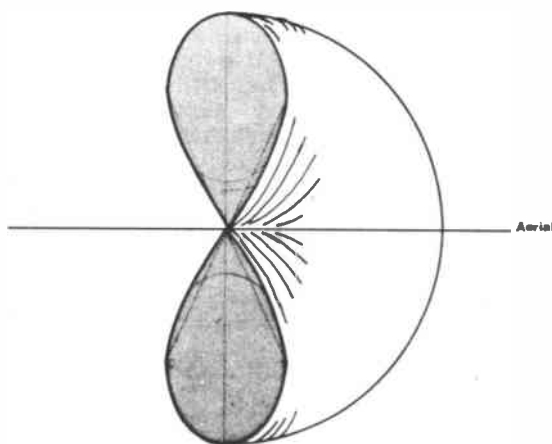

Fig A5/6 Section through solid polar diagram of $2 \times \frac{1}{2}\lambda$ in phase colinear

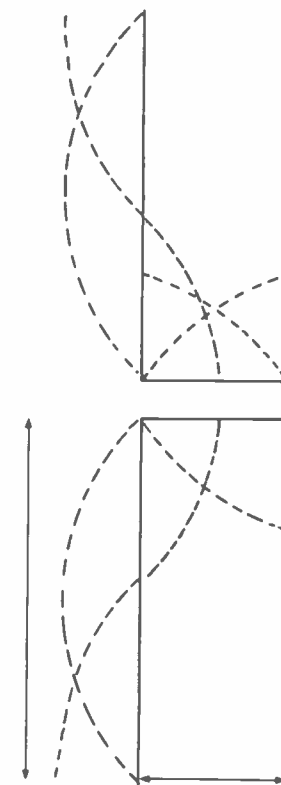

Fig A5/5 Voltage and current distribution in $2 \times \frac{1}{2}\lambda$ colinear

5) Radiation patterns

Simple radiation patterns (theoretical) are shown in the group of diagrams in Figure A5. Attention is drawn to the one showing the effect of feeding a dipole aerial with co-ax feeder. The degree of imbalance created in the aerial gives a very much distorted radiation pattern. To achieve the more satisfactory doughnut pattern it is necessary to transfer the feed from an unbalanced to a balanced form.

This transformation is achieved in many ways, the most common being to use a *balun* or balanced to unbalanced line transformer. The technique is for the incoming signal to be used to excite what is virtually the primary of an RF transformer with one end at low impedance to earth. The secondary of the transformer is left floating so that each end is at equal

potential to earth, thus ensuring a balanced feed to the load.

Obviously, since the device is a transformer, any step up or down ratio can be achieved and one very useful application is in the feeding of yagi aerials where the centre impedance of the radiator is affected by the number of parasitic elements. The use of a balun ensures an accurate match to the feedline and also gives a much more even radiated pattern.

6) Figure A5 shows the distribution of RF from various forms of aerial array. A5/1 shows the classical arrangement for a $\frac{1}{2}$ dipole in free space and A5/2 shows the single plane presentation. This only applies when the aerial is fed with a balanced feed and is in free space. Feeding with an unbalanced line, such as coaxial cable, will result in a field pattern

similar to A5/3. A5/4 shows the effect on the radiated wave of aerial height. Obviously, the $\frac{1}{4}$ wave height will only result in sky-waving whereas the $\frac{1}{2}$ height gives a decided radiation at reasonably low angles suitable for DX. A5/5 shows the way in which folding the centre section back in a collinear permits the current and voltage waves to be in phase. This results in a 'flattening' of the doughnut pattern with increased concentration at right angles to the aerial as shown in A5/6.

A5/7 shows the effect of feeding an aerial consisting of $3 \times \frac{1}{2}$ lengths. The relevant low angle of radiation in four directions gives a very useful cheap DX aerial. A5/8 illustrates the simpler methods of feeding aerials which are whole numbers of $\frac{1}{4}$ wavelengths in length. The Hertzian aerial is high

AERIALS & PROPAGATION

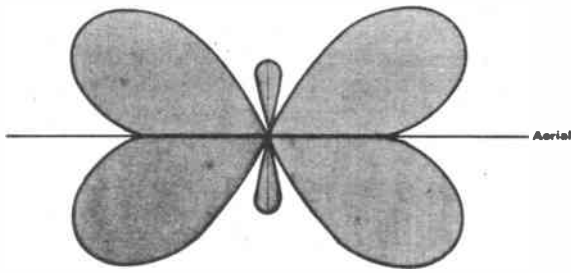

Fig A57 Section through solid polar diagram of $\frac{3}{2}\lambda$ horizontal balanced fed aerial

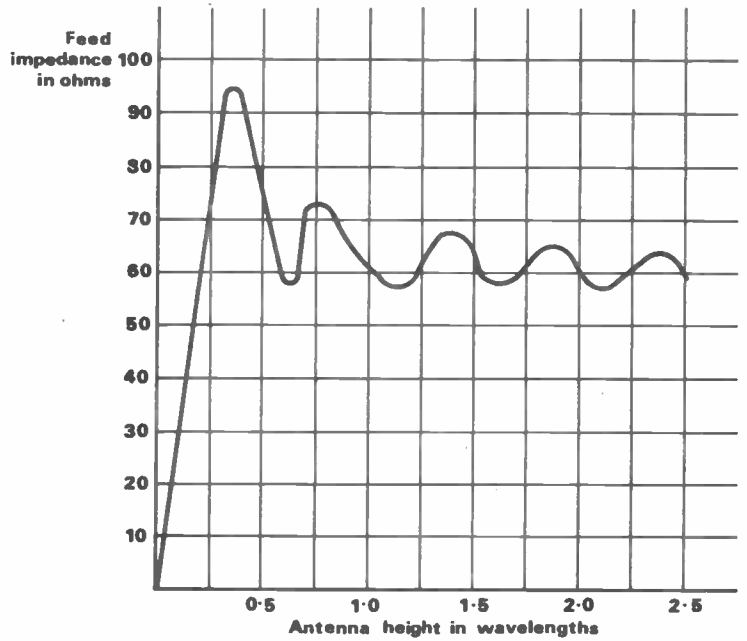

Fig A59 Showing effect of antenna height on centre fed impedance of $\frac{1}{2}\lambda$ dipole

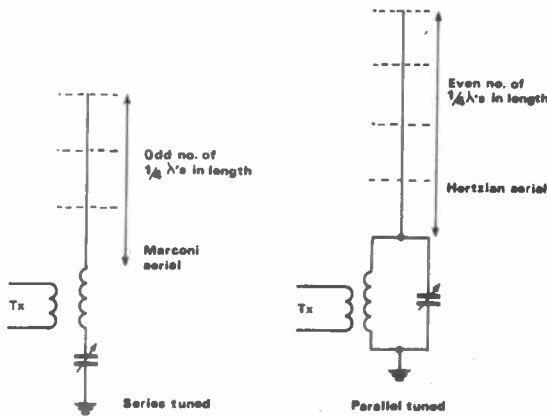

Fig A5/8

impedance and is known as a voltage fed system, whereas the Marconi aerial is current or low impedance fed.

A5/9 indicates the effect of aerial height on the feed impedance at the centre of a half wave dipole. It will be noted that at each successive $\frac{1}{2}$ wave point the feed impedance passes through the optimum value and at this point the load is purely resistive. At other points a certain amount of reactance is present.

Figure A6 shows the result of feeding varied lengths of co-ax at impedances different to the characteristic impedance. In the case of odd $\frac{1}{4}$ wavelength sections the impedance seen at the output end will be different to that of the input unless the line is fed at its own impedance. The discussion on SWR illustrates the reason for this but it is sufficient to say that in any odd $\frac{1}{4}$ wave section the input will be opposite to the output, whereas in a half wave or any even number of $\frac{1}{4}$ wave sections, the output will be the same as the input, irrespective of line impedance. This is a favoured RAE question and a simple memory jog is to remember *odd, opposite, even, exactly same*.

The study of aerials is the most fascinating aspect of amateur radio and the writer hopes that these notes will enable more operators to enjoy this facet of the hobby.

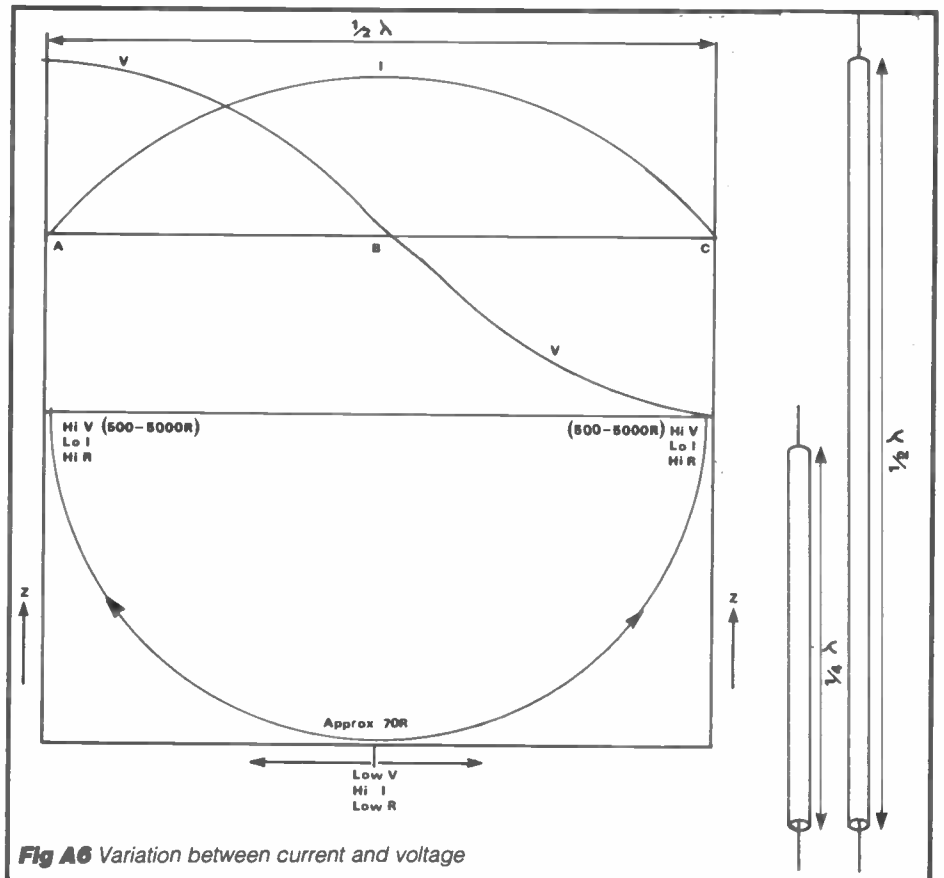

Fig A6 Variation between current and voltage

SHORT WAVE LISTENER

TREVOR MORGAN GW40XB

Well, what a month for the postman! The *Prefix Award* scheme really took off this month and we are receiving claims from all over the place and many more enquiries, for which I hope last month's details came in useful.

One new question arose regarding the totalling of scores. It's quite simple, you claim for the 'bronze' award with 250 prefixes, submit another 250 to gain the 'silver' and a further 500 for the 'gold' award.

Claims

Now for the claims. Well the first claim by Don GM3JDR, up in Caithness, for 250 CW contacts was quickly followed by the first claim from a short wave listener. Alan Mather of Cadishead sent in photostats of his logsheets with some of the choice bits of DX marked off. Some nice catches in LS2, A71, W3/VP2, ZP5 amongst the list.

Scotland came to the fore again with Stuart Wilson in Fife sending in his list, all heard with his Sommerkamp FRDX500 and a couple of long wires.

Not to be outdone by the northerners, Dave Prizeman sent in his offering received using the Realistic DX300 and a 'Dipole of Delight' backed up with a G5RV. Choice catches included some specials like SW2RE (Thessalonika), SKOTM (the Stockholm Technical Museum) and VQ9DG on Chagos Island. Dave is now using a Commodore 64 for RTTY/CW at his London QTH.

I think the above claims show that you don't necessarily need super receivers or fancy aerials to hear the DX.

Indoor aerial

Getting away from the *Prefix Awards*, a very nice letter arrived from a new listener in the London area. The letter told me that he is now retired and living in a maisonette, a situation which must interest many retired folk in similar situations as the question of aerials is an important one.

One of the old tricks I used

to get up to while living in a council flat in the old days was to use ex-telephone type wire passed around the picture rail, and I wonder how many of you remember the 'Joystick' indoor antenna. That firm also marketed an 'artificial earth' which consisted of a plastic tube wound with enamelled wire, tapped at intervals, fed via a switch to a length of wire which was laid under your carpet round the edge of the room.

If you have a window-sill or balcony handy, a multiband 'mobile whip' could be the answer. Listeners can be quite inventive chaps and there are no rules as to what can be wired up. Failing a direct earth connection a water pipe is the next best bet, but lots of plumbers are using plastic nowadays.

Now for some more snippets from the mailbox this month. Firstly a request from Geoff Curtis, BRS 20104, for any ex-aircrew wireless operators interested in dropping him a line to do so at 45 Holyrood Avenue, South Harrow, Middlesex. Geoff was with the RAF Signals Aircrew until 1946.

Geoff also brings up the point of set listening periods. In case you haven't heard of these, they are an idea thought up by another journal some time ago and were very popular. The idea is for us to set a certain period in which listeners concentrate on a set band at a set time to get an idea on what can be heard in different areas under different operating conditions.

'New' bands

This links up nicely with another current interest in promoting the new amateur bands. The new bands on 10, 18 and 24MHz seem to be under-used at the present time and it has been suggested that a concerted effort should be made to use these bands more. After all, there are plenty of complaints about lack of space on the heavily occupied regular bands so why are the new ones so lacking in support?

So, during the month of July 1985 let's see just how much these bands are used and I'll give a prize to the sender of the best list sent in. How's that for an offer you can't refuse? Entries to me please at 1 Jersey Street, Hafod, Swansea SA1 2HF.

A very nice letter from Mike Ribton in Gillingham mentions, amongst other items, the question of an index of short wave listeners. Well, Mike, the idea of an information exchange bureau was suggested a few months ago and I have already started compiling a list of those interested. However, I think Mike is probably suggesting a short wave listeners version of the RSGB callbook. It's a nice idea and if I get enough response I will attempt to get something organised. It's up to the listeners...interested? Then let me know!

Now to an interesting piece from John Griffiths in Holyhead, Gwynedd, also on the information bureau. Thanks for your kind comments, John!

Contact

Although very busy, being an able seaman in the Merchant Navy, John manages to keep his ear in with temporary 'lash ups' whenever he can using the Yaesu FRG7700 and an AOR 2001 scanner with the AD370 doing the signal catching. Being interested in broadcast and amateur bands, John would like to correspond with like-minded folk who enjoy a lively correspondence! Home QTH is 3 Morawelon Road, Holyhead LL65 2ED.

I've been a G5RV user (some would say a bit of a bore sometimes - but then we've all got our little quirks!) for some years now and I have found it the sort of aerial that, apart from being blooming cheap, seems to work in all sorts of funny positions. For listening on the bands, especially eighty, I think it must be the most used aerial in the UK.

However, in common with trap dipoles, windoms, 'cut to

length' dipoles and hundreds of other tried and tested aerials, an aerial tuning unit is essential for really getting the best out of the aerial, whether listening or transmitting.

Multiband DD

Well, as promised, I have been trying out the multiband version of the 'Dipole of Delight' by Maurice Hatley, GM3HAT. Unfortunately, the time I had off work coincided with the time that the weather decided to do its worst and there was no way I was going to drop my mast in 80kph winds and below freezing temperatures!

The only place left to hook up the aerial, which measures some 69 feet overall, was between the chimney stack (which is beginning to look like a spider's nightmare) and a linepost at the other end of the garden which, due to the lie of the garden, left a mean height at the dipole centre of about 14 feet...not a lot!

The dipole itself consists of a centre plate about 6 inches square from which the two 'arms' of the dipole emerge at the top outer corners and the SO239 socket is fitted at the bottom edge.

Using the standard UR67 50 ohm coaxial cable, feeder was taken, as instructed, down to ground level, along the ground to the house and up the wall where it passed into my temporary 'winter quarters' in the back bedroom.

As the old G5RV was still up on the mast some 40 feet above ground, it had the advantage of height over the dipole.

Both feeders were attached to a two-way switch with the G5RV going through the omni-match and the dipole going direct. My SW200 meter was put in circuit to keep a check on the readings.

The DD is meant to operate on 7, 14, 21 and 28MHz and the chart shows the sort of readings I obtained on a cold dry day (my soil is very well drained). The worst SWR was only 1.7-1 and even this was at

the upper band edge, which was very pleasing as it makes the antenna a winner for contest operating where you have to quickly move from one end of a band to the other. On HF, of course, this means very little power loss, especially when using solid-state rigs that cut the power as SWR rises.

This also applies for the occasional QRP operator and I was pleased to have made a two-way QRP contact with I7CCF using 4 watts for a 569

report, despite some terrible 'noises off'.

For the listener, this means that four band operation is possible without a tuner, and much quicker prefix or DX hunting as you have no tune ups to make every few KHz. So how did it compare with the G5RV? . . .OK, I suppose I asked for that one!

To be perfectly honest, checking readings between the two aerials on both 'beacon' signals and QSOs, I found very little difference

and a reading of, say, S8 on the G5RV was the same on the DD.

However, taking the difference between the heights of the two into consideration, I must confess that the DD was remarkably good on reception and, going by the reports I received, on transmission too.

On transmission, I made A-B comparisons and from another QRP station in Italy I got reports of 569 on 4 watts, 579 on 10 watts and 599 using

full chat on the linear. Listening around found K8 at S7-8, a couple of PYs at S6 and S8 and an HK at S7, all on 21MHz.

I don't get a lot of local QRM but the DD did seem a bit quieter on forty and there were not so many pops and squeaks on twenty. Fifteen was a bit dead anyway at the time I was on.

Hately do claim that the DD, due to the grounding of the screen of the co-ax by taking it straight to earth level from the dipole centre, does tend to eliminate a certain amount of QRM.

I found that lifting the co-ax about three feet off ground level resulted in the SWR readings going up quite a bit. . . typically from 1.2-1 to 1.5 or even 2-1. Also, on a particularly rainy day (it was chucking it down!) the SWR also rose by about the same amount.

In testing this aerial, in far from ideal conditions, I used my own set-up with no devices added so the comments made are as I found the aerial in everyday use. I dare say that added height would make a difference to the results but I think that, all said, it performed extremely well.

It's not cheap at £58.00 but against the cost it must be realised that an ATU is not required and for contest operators, or those needing an aerial to get on the bands quickly in difficult conditions without an ATU, I recommend it wholeheartedly.

For the technically minded the Smith Charts are reproduced here together with the circuits and, I dare say, we shall be hearing more about this antenna from one of the technical lads. My thanks to Maurice Hately for the loan of the aerial.

It's your column

Well, that's it for another month. Keep the letters and award claims coming in and I look forward to hearing from anyone regarding the subjects raised and, indeed, on any other matter. It's your column, lads, so let's hear from you!

I enjoy reading your letters and helping out where I can. If you want a direct reply *please* send a stamp for the return postage.

Have a good month's listening - especially on the new bands!

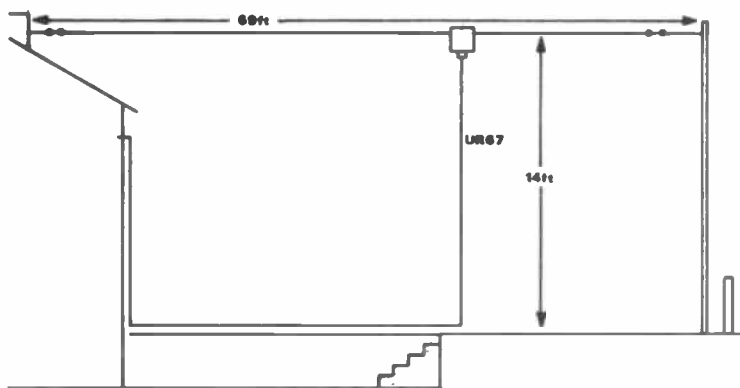

The Dipole of Delight

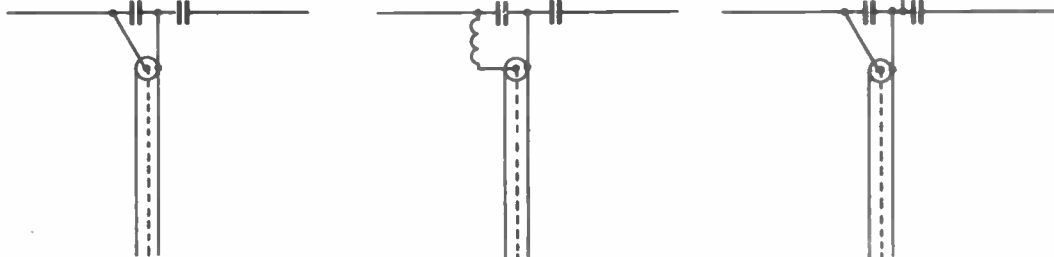

Input impedance with 15m of feeder, at 8m above ground

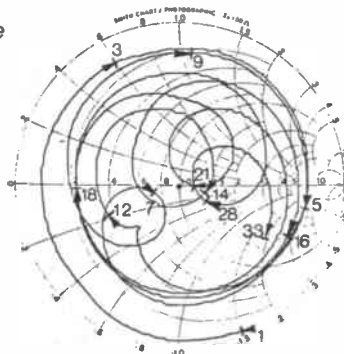

Input impedance of antenna alone (feeder counteracted to zero length)

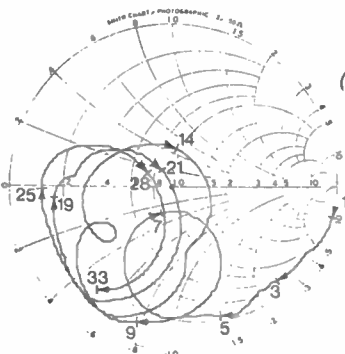

Standing wave ratios using the 'Dipole of Delight' antenna fed with UR67 co-ax (readings via Kenwood SW200 meter)

7.005	1.6	14.025	1.2	21.025	1.3	28.025	1.4
7.025	1.4	14.100	1.1	21.100	1.2	28.100	1.35
7.050	1.7	14.200	1.2	21.200	1.05	28.200	1.25
		14.300	1.4	21.300	1.1	28.300	1.25
						28.400	1.45

Attempts to use the DD on other bands resulted in readings of 5-1 on 3.5 and 10.1MHz. Readings on 28.5 upwards were in excess of 1.5 and up to 3-1 at 29.5MHz. Readings were taken while running 200W PEP or 100W CW using a Trio TS130/TL120.

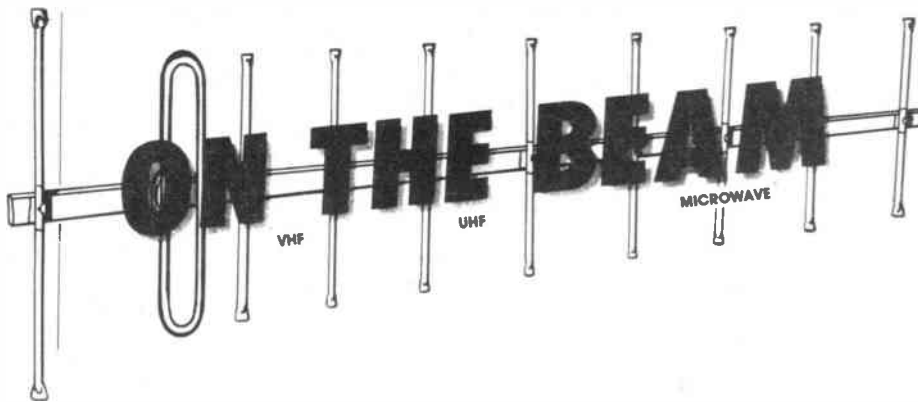

News and comment from Glen Ross G8MWR

B Morse

As this is being written the news is that the RSGB have issued something like 6,000 letters of variation to enable class B Morse operation. It remains to be seen just how many people who have the opportunity to use Morse will actually take advantage of it. One thing is certain and that is that if we are not careful the original enthusiasm is likely to run away with us.

During mid-March several stations, mainly in the Midlands area, have been heard using Morse on two metres even though the permission did not come into effect until 1 April. With so many people wanting to make use of the facility, most of them on 145MHz, it is clear that unless we indulge in some heavy self-policing the result is likely to be rather chaotic to say the least.

The idea of keeping operation out of the normal CW section of the bands seems like a good idea, but encouraging people to use a modulated tone transmission on FM, so taking up a complete simplex frequency, does not seem very bright.

Surely it would be much better to encourage operators to use true CW operating but to keep it in the all-mode section of the band. You would still have the problem that very few rigs, if any, are fitted with narrow CW filters and so transmission would still take up around 2.5KHz instead of the required 100 cycles or so, but this would be a vast improvement over the use of FM.

As the tuning on most rigs when used on CW runs at around the 100Hz mark, it would also mean that several stations would be able to operate in the space taken up by one FM transmission and so take a lot of pressure off the available FM spots.

There can be no doubt from the number of letters issued that this was certainly a popular requirement; all that is left now is to use it sensibly and in such a way as to cause the minimum amount of QRM so that we may be fairly sure that it will be written into the licence on a permanent basis. The RSGB have done a great job and if this does not convince

you that they deserve your support, I wonder what will?

Novice licensing

There is still a lot of pressure for a novice allocation and this is something which should be of great concern to the metrewave operator as, at the end of the day, they will probably arrive on one of our allocations. It seems that this is a subject that is going to be with us for years and the chances are that it is unlikely to be resolved, or at least not on the basis that most people who are calling for it would want.

A lot is heard and written about the desirability of a novice licence to encourage people into the hobby and to raise the standard of amateur radio operating.

No doubt this is what some people want, but it must be obvious to most people that what a lot of them are looking for is easy access to the HF bands without the usual Morse test.

If one looks at the correspondence in the various magazines, the call is always for 100 watts on 14MHz or some similar arrangement. When the option of say 10 watts on 433MHz has been mooted the acceptance of this idea has been noticeably absent. Surely if the real requirement was for a 'training ground' for would-be amateurs then the frequency it was available on would not be of any consequence. You can practice your technique just as easily on 70cm as on twenty metres. No, the real truth is that it is easy access to the HF bands that is required, and nothing else will be acceptable.

Now, if we think about this it is obviously not in the best interest of amateur radio. I do not think that most people want a whole load of people on the bands who have come in via the 'easy option' route. Surely in the past the standards of the hobby, whatever that may mean, have been maintained due to the fact that there was no easy way in and we all had to serve our apprenticeship as an SWL and then take the RAE (and until fairly recently the Morse test) before we could get our licence.

Incentive licence

The one possible way around this problem is to institute a system of incentive licensing. This would not only provide a lower grade of licence but also an advanced class and this might be more acceptable to the majority of operators.

Just how it would be implemented is a matter for discussion but, without too much doubt, the VHF bands are where these people are likely to end up and we have more than our fair share of problems already. A major consideration would be where to locate a sub-band for them? One look at last month's run-down on the two metre band will show the difficulty that we face. Perhaps 70cm would be a better place? Let's look and see.

Band plan

Well there is certainly more space available than there is on two metres. The band is in fact five times as wide, covering 430 to 440MHz, and there is the added advantage that there are a lot less people around, although as the word spreads that the band opens up more often than two metres does and that the distances covered are very much the same, its popularity is growing.

One of the greatest advantages is that because the physical size of an aerial is around one third of the size of a comparable two metre array, neighbour acceptance is a lot more likely. We start our survey at the LF end between 430 and 432MHz and the news that this part of the allocation is not available to you if you live within 100Km of Charing Cross! This is one of the few frequency bands which is still available on a geographical basis.

The area from 432 to 432.150MHz is the CW segment and the sub-band to 432.025 is reserved for moonbounce activity. Going on up to 432.500 is the SSB section with most activity centred around the calling frequency at 432.200MHz. Above the SSB segment and extending up to 432.800 is the all-mode part of the band which also contains three spot frequencies. These are the calling frequencies for RTTY at 432.6, for data at 432.675 and FAX at 432.70MHz. From 432.8 to 433 is the beacon band and our comments regarding the same area on two metres apply with equal force here.

Repeaters

There are 15 repeater channels on 70 and the output frequencies are between 433 and 433.40MHz. Having said that, it is not uncommon to hear people working simplex on spots that are not allocated to nearby repeaters. Extending above the repeater inputs are the simplex channels, up to 433.6 officially, but they tend to extend through the 'no man's land' right up to 434.6MHz where we meet up with the repeater inputs. Unlike two metres the repeater inputs are higher in frequency than the outputs.

Satellite and TV

There is a bit of a mixture here. The fast-scan TV allocation is from 435 to 440MHz but this includes the amateur satellite service between 435 and

ON THE BEAM

438MHz. The general idea is that TV operators will choose their spots so as to cause the least amount of annoyance to the satellite boys. In practice it seems to work well and most people co-exist with few problems.

So there you have it, ten megahertz of wide open space to play with and gear which is, in some cases, cheaper than the equivalent two metre stuff. A band that deserves some very serious consideration.

Contests

The RSGB have, at last, announced the dates for the microwave cumulative contests: 12 May, 16 June, 14 July, 11 August and 15 September. Somehow they have managed to organise these so that the four dates clash with no less than five major rallies. Surely someone at RSGB could have had a look at the event calendar which they recommend so highly to other people who are organising events?

Contests on 24GHz are run on 12 May, 16 June and 15 September; 3.4GHz on 16 June and 5.7GHz on 11 August. The weekend of 4/5 May is taken up by the mammoth 432 to 24GHz event and the 18/19 May is the 144MHz contest. Looking forward into June we have the 1296 Trophy on the 8th and the 432MHz Trophy the following day. An event of particular interest is the Sheffield Microwave

Workshop on 25 May: this gives you an opportunity to get your hands on some very expensive test equipment and also lets you meet people who have the same interests as you do. Full details of this one can be obtained from G8AGN who is QTHr.

50MHz

We commented recently that the Norwegians were going to issue some permits for 'out of hours' use of the 50MHz band. A complete listing will not be given here but they include some well known call signs, probably the best known being LA8AK. TV hours in Norway are somewhat different to ours and the stations may operate only between 2200 and 0730.

News comes from Norway of the first G-LA meteor scatter contact. This took place between G4IJE and LA8AK on 4 February. LA8AK was running 25 watts to a four element TV aerial and had only received his permit on the 1st.

Satellites

The saga of the Russian RS series continues with the news that there are battery problems on both RS5 and 7 but that RS8 is still operating well and will continue in the normal transponder mode. The units vary as to the days on which they are available, the schedule being Monday and Friday - RS5, Tuesday

and Saturday - RS7 and Thursday and Sunday - RS8. Updates on this can be obtained from the bulletin board on RS7.

The new Russian units RS9 and 10 are likely to be placed in polar orbit at a height of around 2000Km, but there is no date available yet for the launch of these. Oscar-10 continues to operate well and does not suffer as much from the 'alligator' brigade as it did at one time. If you want to make the most of the DX available on this bird you really need an aerial that you can tilt upwards, because at the moment it is spending a lot of time at an elevation around 50 degrees.

Odds and ends

I am pleased to report that we have had the first three entries for our new awards, all for the two metre bronze certificate, and I hope to give some details next month.

Don't forget the starting level is reasonable, so why not give it a try?

Heard on the local repeater: 'Is my signal any better now that I have switched the pre-amp in?'. I've said it before; who needs a novice licence?

I look forward to hearing from you with any comments you may have on the metre scene. I rarely mention individuals in the column but most of the content is based on comments I receive. The address is 81 Ringwood Highway, Coventry.

YOUR RADIO AMATEURS EXAM SUCCESS

Study at home - pass first time with

RRC's Complete Home Tuition Service

- Self-contained courses, regularly updated for The City & Guilds Radio Amateurs Exam ● Fully inclusive fees ● No costly, time consuming text books to buy
- Everything you need in booklet lecture form
- Regular tests ensure you are fully prepared ● Enrol at any time ● Timetable to suit you ● Continued tuition at no extra cost if you don't pass first time

FREE RADIO AMATEURS PROSPECTUS BY RETURN

Write or phone today for full details, and a FREE copy of our prospectus, without obligation to:



THE RAPID RESULTS COLLEGE

Dept JS6, Tuition House, London SW19 4DS

Tel: 01-947 7272 (9am-5pm) -

or use our 24-hour Recordacall Service: 01-946 1102 quoting Dept JS6

Name _____
(BLOCK CAPITALS PLEASE)

Address _____

Postcode _____



THE RAPID RESULTS COLLEGE

FORTY OF THE BEST



- 1 H100 50 ohm Low Loss COAX 80p per M 50m less 10% 100m less 20% (post 5p p/m)
 - 2 POFES RG213U 10.3mm low loss Coax N/C PVC 60p per m (p 6p p/m)
 - 3 PERMANIOD or BICC UR67 10.3mm Low Loss 50 ohm 60p per m (p 6p/m)
 - 4 UR43 50 ohm solid conductor 5mm COAX 23p per m (p 3p pm)
 - 5 UR76 50 ohm stranded conductor Coax 23p per m (p 3p pm)
 - 6 POFES RG58C/U (UR76) with NC PVC 23p per m (p 3p pm)
 - 7 Mini Coax RG174/U 50 ohm 25p per m (p 1p pm)
 - 9 UR70 6mm Coax 23p per m (p 3p pm)
 - 10 UR57 10.5mm low loss 75 ohm COAX 60p per m (p 6p pm)
 - 11 75 ohm Double Screened 8mm 75 ohm Coax 25p per m (p 4p pm)
 - 12 Low Loss UHF TV Coax 75 ohm 20p per m (p 3p pm)
 - 13 75 ohm Twin Feeder 18p per m (p 2p pm)
 - 14 Standard 300 ohm Twin Feeder 12p p m (p 2p pm)
 - 15 BOFA GMP6 Slotted 300 ohm Feeder 20p per m (p 3p pm)
 - 16 Strong PVC covered Aerial Wire 6p per m (p 2 1/2p pm)
 - 17 14 SWG Copper HD Aerial Wire 20p per m (p 2 1/2p pm)
 - 18 500m Mixed equipment Wire on Reels £5 post £1.40
 - 19 GREENPAR 50 ohm N PLUGS for H100/UR67/213 £2.40 each
 - 20 Greenpar 50 ohm N line Sockets H100/UR67/213 £2.20 each
 - 21 Greenpar 50 ohm N Chassis Sockets £1.80 each
 - 22 Greenpar 50 ohm N Plugs for UR43/76 £2.40 each
 - 23 Greenpar PL259s Silver/PTFE for H100/67/213 £1.15 each
 - 24 Self Amalgamating Tape large roll £3.50
 - 25 Egg Insulators glazed ceramic 1 1/4" long 50p each
 - 26 Egg Insulators large polyprop 2 1/4" long 65p each
 - 27 Standard chrome plated PL259s UR67/H100 50p each
 - 28 As above but for UR43/76 45p each
 - 29 2 x SO239 Coupler two sockets back to back 70p each
 - 30 As above but Plugs (PL259) back to back 70p each
 - 31 SO239 Chassis Sockets either square or round 50p each
 - 32 In line lightning arrestors SO239/PL259 £1.20 each
 - 33 50 ohm 30 watt Carbon Dummy Load fitted PL259 £4 (normally £6)
 - 34 REVCO/SBE External Quality Speakers £7.95 (post £1)
 - 35 REVCO Professional Solder Suckers £7 (post 50p)
 - 36 DRAE WAVEMETER to UHF £27 (post free)
 - 37 DRAE 3 Way AERIAL SWITCHES to 500 mhz £15 (post free)
 - 38 COSSOR Mid Band Transistor Radio Telephones with data £15 (post £3)
 - 39 Ditto but 20 watt output version 703 £18 less speaker
 - 40 90,000 MFD Computer capacitors 40v @ £2 P&P £1
- Postage is 40p per order on items not otherwise quoted. Vat included in all prices 10% discount off 5 or more Greenpar items

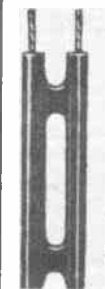

**W H WESTLAKE, Dept REW, CLAWTON, HOLSWORTHY
DEVON (0409) 253758**

MARCO TRADING



LINEAR I.C.'s	
CA3011	1.80
CA3012	1.75
CA3014	2.38
CA3018	1.10
CA3020	2.10
CA3028A	1.30
CA3035	2.55
CA3080E	1.80
CA3085	1.20
CA3086	0.68
CA3090AQ	5.00
CA3130E	1.40
CA3140E	0.60
HA1336W	3.15
LM324N	0.55
LM339	0.65
LM348	0.90
LM380	1.65
LM381N	1.45
LM382N	1.45
LM386	0.99
LM387	1.45
LM389N	1.20
LM3914N	2.55
LM3915N	2.50
MI 232B	2.10
555	0.35
C-mos555	0.88
741	0.25
SAS560S	1.85
SAS570S	1.85
SL901B	5.20
SL917B	6.25
TA7205AP	1.50
TA7222P	2.12
TDA1004	2.90
TLO72	98p
TLO81	68p
TLO84	1.28

C MOS	
4000	0.24
4001	0.24
4002	0.25
4007	0.25
4011	0.24
4012	0.24
4013	0.26
4014	0.26
4015	0.26
4016	0.40
4017	0.60
4018	0.60
4020	0.85
4021	0.58
4022	0.96
4023	0.35
4024	0.60
4025	0.24
4026	0.45
4027	0.45
4028	0.45
4029	0.75
4030	0.35
4031	1.30
4033	1.25
4034	1.45
4035	0.70
4036A	2.75
4038	0.75
4039A	2.80
4040	0.60
4042	0.40
4043	0.42
4044	0.40
4046	0.60
4050	0.30
4051	0.38
4052	0.60
4053	0.90

TELECOM EQUIP	
BT Plug & 3M lead	1.25
BT Master Socket	2.85
BT Sec Skt	1.95
BT 4-core cable 1M	0.15
BT approved 100M	12.00

RESISTOR KITS	
1/4W pack 10 each value E12 - 10R-1M	ONLY 4.80
1/4W pack 5 each value E12 10R-1M	ONLY 2.75
1/2W pack 10 each value E12 2R2-2M2	ONLY 5.25
1/2W pack 5 each value E12 2R2-2M2	ONLY 3.50
50V Ceramic Kits - 5 each value 125 per kit	£3.50
Zenner pack 400 M/W - see value	£58
Zenners	£3.50 per kit

MIN. D CONNECTORS	
9 way	15 way
15 way	25 way
25 way	37 way
Solder Lug	52p
Right Angle	89p
SOCKET	
Solder Lug	79p
Right Angle	£1.18
COVERS	
8 pin	0.08
14 pin	0.10
16 pin	0.11
22 pin	0.21
28 pin	0.30
40 pin	0.34

ROCKER SWITCH	
(white rocker)	
3A 250V	
DPOT	
85p ea	
10 for	
£5.00	

SERVICE AIDS ALL SERVISOL PRODUCTS	
Switch Cleaner	0.98
Circuit Freezer	1.14
Foam Cleanser	0.98
Aero Klene Silicone Grease (Aerosol)	1.22
Antistatic Spray	0.98
Plastic Seal	1.08
Excel Polish	0.92
Fire Extinguisher 640g	2.90
Video Head Cleaner	
Solda Mop (Std)	0.74
Solda Mop (L/Gauge)	0.74
Additional p&p on above 30p	

SOLDERING AIDS	
Antex 15W Iron	8.00
Antex 18W Iron	5.00
Antex 25W Iron	5.20
Antex elements	2.00
Antex bits	0.95
Antex stands	1.90
Desolder Tool	4.80
Spare nozzles	0.48
25W Kit-Iron with 13A plug and stand	ONLY £7.20
18W Kit with 13A plug	7.10

ROTARY POTS	
0.25W Carbon Log & Lin 1K-2M2	each
2	0.32
10	3.00
Any 100	28.00

74LS	
LS00	28p
LS01	28p
LS02	28p
LS03	32p
LS08	28p
LS09	28p
LS10	28p
LS11	28p
LS12	25p
LS13	33p
LS14	58p
LS15	25p
LS20	28p
LS21	28p
LS22	28p
LS30	30p
LS32	28p
LS37	23p
LS74	38p
Pkt of 100 pins	0.30
Spotface cutter	1.48
Pin insert tool	1.80
Vero wiring pen & spool	4.50
DIP board	3.85
Vero Strip	1.25

IC SOCKETS	
8 pin	0.08
14 pin	0.10
16 pin	0.11
22 pin	0.21
28 pin	0.30
40 pin	0.34

BRIDGES	
1 1/2A 50V	0.27
100V	0.28
200V	0.32
400V	0.40
600V	0.50
800V	0.58
2A 100V	0.52
200V	0.55
400V	0.61
600V	0.67
800V	0.70
6A 100V	0.66
200V	0.68
400V	0.74
600V	0.80
800V	0.86
10A 50V	2.20
100V	2.24
200V	2.38
400V	2.60
600V	3.60
25A 50V	2.05
100V	2.25
200V	2.40
400V	3.20
600V	3.95

VOLTAGE REGULATORS	
78L05/12/15	0.30
7505/12/15	0.55
7905/12/15	0.68
LM317K	3.50

PLASTIC BOXES	
3x2x1"	0.38
3x2 1/2x2"	0.65
4x3 1/2"	0.70
4 1/2x4 1/2"	0.83
6x4x2 1/2"	1.18
8 1/2x5x3 1/4"	2.18
Colour Black, all boxes with lids and screws	

TRANSFORMERS
British made

Primary	Secondary	Current	1+	10+	100+
240v:	4.5-0-4.5v	400mA	50p	45p	35p
240v:	6-0-6v	100mA	58p	52p	43p
240v:	6-0-6v	500mA	85p	80p	48p

VEROBOARD	
2 3/4 x 3 3/4	0.85
2 3/4 x 5	1.00
2 3/4 x 7	3.07
3 3/4 x 7	1.05
3 3/4 x 5	1.15
3 3/4 x 17	4.10
4 3/4 x 17 3/4	4.95
Pkt of 100 pins	0.30
Spotface cutter	1.48
Pin insert tool	1.80
Vero wiring pen & spool	4.50
DIP board	3.85
Vero Strip	1.25

IC SOCKETS	
8 pin	0.08
14 pin	0.10
16 pin	0.11
22 pin	0.21
28 pin	0.30
40 pin	0.34

PLUGS & SOCKETS	
Metal Co-ax Plug	EACH 0.15
Plastic Co-ax Plug	0.14
Single Junction Socket	0.80
Plastic Phone	0.15
FM Plugs	0.20
4P L259	0.38
Reducer	0.15
1/4in Plastic-Mono Plug	0.15
1/4in Metal Mono Plug	0.30
2.5mm Plug Metal	0.15
3.5 Plug Metal	0.15
2.5mm Chassis Socket	0.10
3.5mm Chassis Socket	0.10
2pin 1/4in Mono Chassis Socket	0.14
4pin 1/4in Mono Chassis Socket	0.20
6pin 1/4in Mono Chassis Socket	0.30
4mm Banana Plug-Ror B	0.15
4mm Banana Socket-Ror B	0.15
PP3 Battery Connectors	0.08
PP3 Battery Connectors	0.15

EUROPEAN ADAPTORS	
DC Voltage	Current
4.5V	200mA
6V	200mA
6V	400mA

POWER LEADS 4Way Spider Plug	
65p	

These very high quality British made two pin European adaptors are ideal for driving radios, cassette recorders, TV games, calculators etc. The adaptors fit in the UK shaver socket.

TRANSISTORS	
AC127	0.30
AC128	0.30
AC128K	0.34
AC132	0.55
AC141	0.26
AC141K	0.40
AC142	0.26
AC142K	0.48
AC151	0.48
AC152	0.45
AC178	0.28
AC178K	0.48
AC187	0.42
AC187K	0.48
AC198	0.44
AC198K	0.60
ACY40	0.88
AD142	1.10
AD143	1.10
AD149	0.95
AD181	0.92
AD182	0.92
AD181/182	0.98
AF106	0.48
AF114	2.10
AF115	2.10
AF116	2.10
AF117	2.10
AF118	0.85
AF121	0.82
AF124	0.48
AF125	0.48
AF126	0.48
AF127	0.48
AF139	0.66
AF178	0.66
AF299	0.98
AF299S	0.78
AL100	2.90
AL102	8.00
AL113	2.20
ASY90	1.78
AU110	1.40
AU102	4.32
BA102	0.34
BA103	0.37
BA121	0.40
BA129	0.38
BA148	0.18
BA154	0.08
BA155	0.10
BA156	0.08
BA157	0.28
BA184	0.14
BB104B	0.52
BB105B	0.30
BB105G	0.48
BB110B	0.48

DIODES	
BC107	0.10
BC108	0.12
BC109	0.10
BC128	0.12
BC134	0.12
BC135	0.12
BC136	0.12
BC137	0.12
BC138	0.12
BC139	0.12
BC141	0.12
BC142	0.12
BC143	0.12
BC144	0.12
BC147	0.12
BC148	0.12
BC149	0.12
BC158	0.12
BC159	0.12
BC160	0.12
BC161	0.12
BC168	0.12
BC169	0.12
BC170	0.12
BC171	0.12
BC172	0.12
BC173	0.12
BC177	0.12
BC178A	0.22
BC182	0.08
BC183	0.08
BC184	0.08
BC185	0.08
BC186	0.08
BC187	0.08
BC188	0.08
BC189	0.08
BC190	0.08
BC191	0.08
BC192	0.08
BC193	0.08
BC194	0.08
BC195	0.08
BC196	0.08
BC197	0.08
BC198	0.08
BC199	0.08
BC200	0.08
BC201	0.08
BC202	0.08
BC203	0.08
BC204	0.08
BC205	0.08
BC206	0.08
BC207	0.08
BC208	0.08
BC209	0.08
BC210	0.08
BC211	0.08
BC212	0.08
BC213	0.08
BC214	0.08
BC215	0.08
BC216	0.08
BC217	0.08
BC218	0.08
BC219	0.08
BC220	0.08
BC221	0.08
BC222	0.08
BC223	0.08
BC224	0.08
BC225	0.08
BC226	0.08
BC227	0.08
BC228	0.08
BC229	0.08
BC230	0.08
BC231	0.08
BC232	0.08
BC233	0.08
BC234	0.08
BC235	0.08
BC236	0.08
BC237	0.08
BC238	0.08
BC239	0.08
BC240	0.08
BC241	0.08
BC242	0.08
BC243	0.08
BC244	0.08
BC245	0.08
BC246	0.08
BC247	0.08
BC248	0.08
BC249	0.08
BC250	0.08
BC251	0.08
BC252	0.08
BC253	0.08
BC254	0.08
BC255	0.08
BC256	0.08
BC257	0.08
BC258	0.08
BC259	0.08
BC260	0.08
BC261	0.08
BC262	0.08
BC263	0.08
BC264	0.08
BC265	0.08
BC266	0.08
BC267	0.08
BC268	0.08
BC269	0.08
BC270	0.08
BC271	0.08
BC272	0.08
BC273	0.08
BC274	0.08
BC275	0.08
BC276	0.08
BC277	0.08
BC278	0.08
BC279	0.08
BC280	0.08
BC281	0.08
BC282	0.08
BC283	0.08
BC284	0.0

THE 11m CB TO 10m AMATEUR BAND CONVERSION GUIDE

PART SIX
The EPROM used to store the program codes, and the design of the memory board PCB

ROGER ALBAN GW3SPA

BSc. C ENG, MIEE

The EPROM

Having arrived this far, it is now necessary to investigate using a memory device to store all the program codes that will be required. I have chosen to use an EPROM because it is relatively easy to input the program codes. This can be done either by using a home computer such as the Sinclair ZX81 with an attached home built EPROM blower (1) or by building an inexpensive hardware orientated manual programmer and inputting eight bits at a time using a series of switches connected to a power supply.

This is the easier way for anybody who does not wish to become involved with home computers, but I can add from experience that it does take a long time and a lot of patience to 'blow' the EPROM.

Intel 2716

I have chosen to use the Intel 2716 EPROM because it only requires a single 5V power supply, as opposed to other EPROMs which require a combination of mixed voltages to operate. To extract data from the EPROM it is necessary to ensure that pins 18 and 20 are earthed and that pin 21 and pin 24 are at logic level '1' + 5 volts (see Figure 1b). Now, by selecting logic levels on the address lines A0 to A10 a unique address containing eight bits of data will appear continuously on the data pins O0 to O7, as long as the logic levels remain on the address pins.

Programming the EPROM

To program the EPROM it is necessary to remove the EPROM from your special PCB and insert it into a home-made programming circuit. It is necessary to ensure that pin 21 is kept at a potential of 25V and pin 24 at +5V. The data to be entered into the EPROM should appear as logic levels on the data outputs. The data is only entered into the memory when pin 18 is pulsed to logic level '1'.

The data will be entered into a location in memory determined by the logic levels on the address inputs.

The manufacturer insists that the 2716 must not be programmed with a dc signal applied to the PD/PGM input, pin 18. It is recommended that a 50ms pulse should be used to program the 2716. One can verify that the data has been programmed correctly by earthing pins 18 and 20 and the programmed data should now appear as logic levels on the data output pins. If you make a mistake and require to change a '0' to a '1', the only way to achieve this is to erase the total memory and start again.

Program erasing

The EPROM can be erased by exposing the window to ultraviolet light. There are a number of cheap EPROM erasers on the market, or alternatively it is quite easy to construct a simple light box

containing an ultraviolet lamp. After erasing the EPROM it is advisable to check the various addresses to ensure that data on all the address locations is at logic level '1'. This is the normal erased state of the EPROM. Programming changes the logic '1' to '0' in the appropriate address locations. One will now appreciate how easy it is to program and use the 2716 EPROM.

The memory board

In designing a general purpose PCB containing the Motorola MC145151 PLL chip, it is worth noting that to obtain the range of divide-by-N ratios from channel 1 through to channel 40 requires more than eight program lines of the MC145151 to be altered. Therefore, it is necessary to use two EPROMs to program the PLL chip. If two EPROMs are used it is also possible to connect RA0, RA1 and RA2 to the data lines of one of the EPROMs.

Fig 1 The Intel 2716

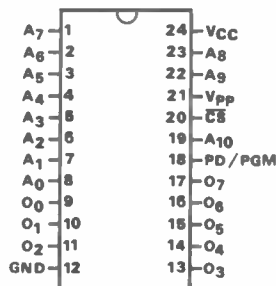

Fig 1a Pin connections

Fig 1c

PIN NAMES	
A0-A10	ADDRESSES
PD/PGM	POWER DOWN/PROGRAM
CS	CHIP SELECT
O0-O7	OUTPUTS

MODE SELECTION						
MODE	PN18	PD/PGM (18)	CS (20)	V ₂₁ (21)	V ₂₄ (24)	OUTPUTS (0-11, 13-17)
Read		V _L	V _L	+5	+5	Drive
Deselect		Don't Care	V _H	+5	+5	High Z
Power down		V _H	Don't Care	+5	+5	High Z
Program		Pulsed V _L to V _H	V _H	+25	+5	Dr
Program verify		V _L	V _L	+25	+5	Drive
Program inhibit		V _L	V _H	+25	+5	High Z

Fig 1b

Fig 1d Block diagram

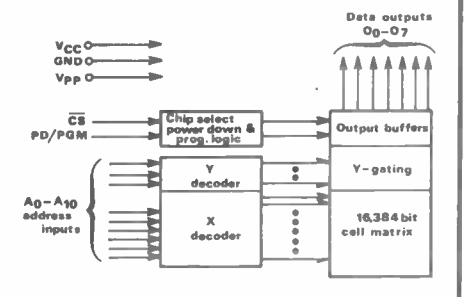

CONVERSIONS

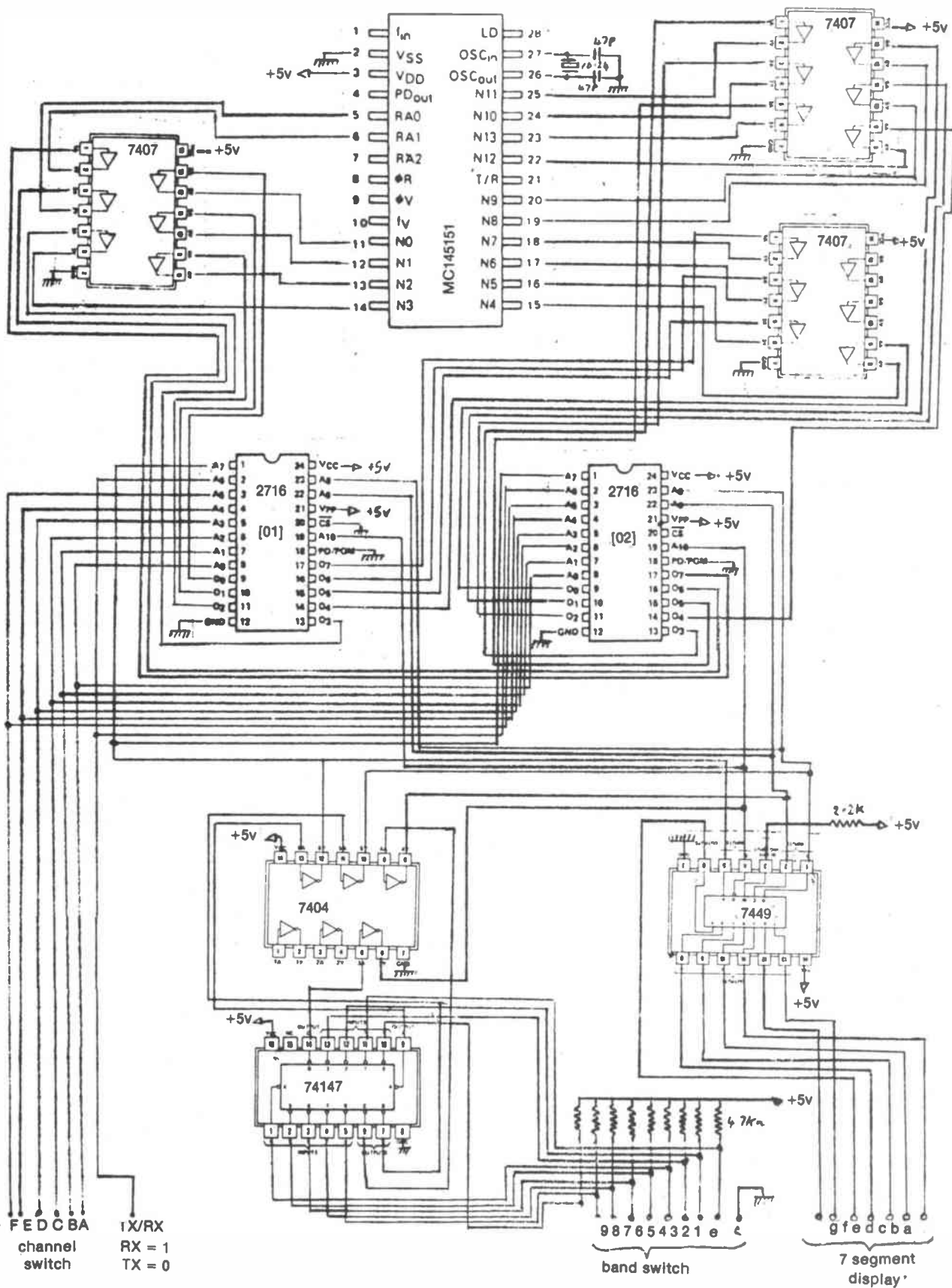

Fig 2 Prototype memory board

CONVERSIONS

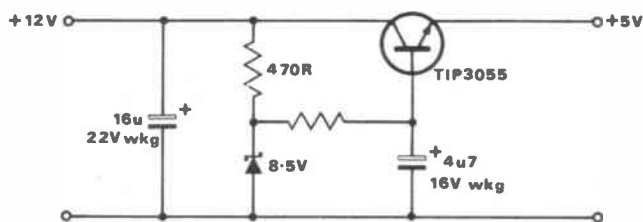

Fig 3 Simple 5V voltage regulator

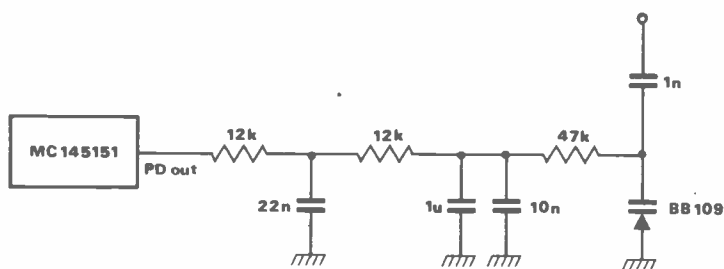

Fig 4a Low pass filter using PD OUT phase detector output

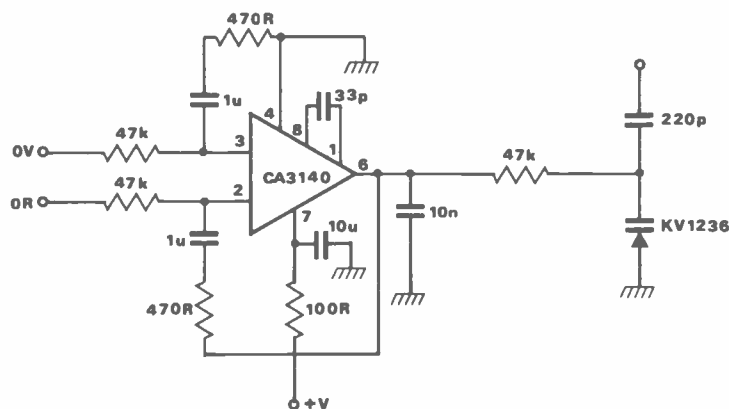

Fig 4 Active low pass filter using 0V and 0R phase detector outputs

Figure 2 shows the circuit of the prototype memory PCB which has the capability of selecting ten bands each comprising 40 channels.

The two EPROMs will contain different information and have been identified by marking each memory clearly with the symbols Ø1 and Ø2 to ensure that you do not mix up the two memory chips. The address lines are connected in parallel. The inputs from the channel switch have been taken from the old pin connections for the LC7137, which has now been removed, and from the circuit board and the logic outputs of the channel switch address A₀ through to A₅. A₆ is connected to the transmit/receive line which can be taken from pin 20 of the old PLL chip socket.

To obtain the selection of the ten bands an additional ten-way switch has been added to the front panel. This was

achieved by removing the mic socket, which was located on the front panel and moving it to the side panel of the rig, thus making room for the band switch.

Conversion to BCD

The decimal code produced by the band switch is converted to BCD logic by the 74147 chip, which is a 10 line decimal to 4 line BCD priority encoder. However, the BCD code is inverted and is therefore passed through a 7404 chip, which is a HEX inverter, to obtain the correct BCD code.

A sample of the code is fed to a 7449 chip which converts the BCD to drive a seven segment miniature display which has been added to the left of the original two seven segment displays and show the channel number.

At a glance it is now easy to determine not only the channel you have selected,

but also which band the rig is working on. The decimal dot on the miniature seven segment display can be driven by the lock detector of the MC145151 to indicate the status of the loop. The band switch BCD code is connected to the memory address lines A₈, A₉ and A₁₀, completing the address structure for the memory.

Each memory output is dedicated via a 7407 buffer to a function on the MC145151 PLL chip. The memory outputs of Ø1 provide logic voltages for driving P₀ through to P₇, memory Ø2 is used for driving P₈ through to P₁₃ and memory output O₆ and O₇ drive RA0 and RA1. RA2 has been left open circuit permanently at logic level '1'. The 7407 buffers were included in the prototype as a precaution and have been left in the final design.

The 74 series of logic devices used may be exchanged for CMOS devices if power supply consumption is important. Also, for ease of displaying the circuit diagram, power supply decoupling capacitors have not been shown. The +5V power supply used to drive the memory board was obtained from a voltage regulator built into the rig using the side panel of the rig as a heatsink.

Figure 3 shows the simple voltage regulator that was built to supply the memory board. Room within the rig was found for the PCB by removing the speaker and hinging the board for servicing above the original PCB within the rig.

Low pass filter

If you do decide to use this memory board and want to extend the operating range of your rig you will have to pay attention to the low pass filter fitted between the phase detector on the MC145151 and the capacitance diode in the VCO. First of all connect the capacitance diode to the centre of a potentiometer connected across the 5V supply. Adjust the value of the trimming and padding capacitors to track the VCO across the required operating frequency.

Having satisfied yourself that the VCO will operate over the intended frequency range, reconnect the PLL chip and select two programming codes at either end of the required operating frequency range. Connect an oscilloscope probe to pin 4 of the MC145151 and observe the response of the dc levels when switching between the two program codes. You may find it necessary to make changes to the values of resistance and capacitance comprising the low pass filter.

Figure 4 shows some designs tried by the author to varying degrees of success, but should provide some ideas on the eventual design.

Next month

Next month we look at how FM modulation can be added to an American AM rig.

Reference

1. EPROM blower. Dec/Jan '83 issue of *Sinclair Projects* (p34).



4,000

WORLD-WIDE USERS

Isn't it time
you switched
to Icom?

New!
IC-3200E



A new exciting set is the ICOM IC-3200E FM Dual-band transceiver (144-430/440 MHz). This is the smallest transceiver available.

The IC-3200E employs a function key for low-priority operations to simplify the front panel. LCD display is easy to read in bright places, showing frequency, VFO A/B, memory channel duplex mode and S/R/F meter information.

Other features include a 10 channel memory able to store operating frequencies. Simplex or Duplex A memory lock-out function allows the memory scan to skip programmed channels when not required. The IC-3200E has a built-in duplexer and can operate on one antenna for both VHF and UHF. Options include: IC-PS45 DC, power supply, HS-15 mobile mic, SM6 and SM8 desk mics, SP-10 external speaker and UT-23 speech synthesizer. A great future is predicted for the IC-3200E.

IC-290D/290E



290D is the state of the art 2 meter mobile, it has 5 memories and VFO's to store your favourite repeaters and a priority channel to check your most important frequency automatically. Programmable offsets are included for odd repeater splits, tuning is 5KHz or 1KHz.

The squelch on SSB silently scans for signals, while 2 VFO's with equalising capability mark your signal frequency with the touch of a button. Other features include: RIT, 1 KHz or 100Hz tuning CW sidetone, AGC slow or fast in SSB and CW, Noise blanker to suppress pulse type noises on SSB/CW.

You can scan the whole band between VFO's/scan memories and VFO's. Adjustable scan rate 144 to 146 MHz, remote tuning with optional IC-HM1 microphone. Digital frequency display, Hi Low power switch. Optional Nicad battery system allows retention of memory.

Soon to be announced!

IC-735 New Compact HF and R7000 VHF/UHF Receiver.



BACK TO BASICS

So far in this series we have dealt with both the generation of a radio signal and its reception. Now comes the part of the course that shows us just how these radio signals travel or *propagate* through the atmosphere and how they are transmitted and received using an antenna.

Propagation of radio waves

Here is an example of a typical RAE question on propagation. For radio contacts on the 14MHz band between the British Isles and the United States of America, what type of propagation is used? Is it a) direct wave, b) ground wave, c) ionospheric, or d) tropospheric.

Some of you will already know the answer, which is c) ionospheric, but do you really understand what this means and why at different frequencies the mode of propagation may well be different, such as for frequencies above 50MHz where for contacts over long distances the major mode of propagation would be refraction of the radio waves by the troposphere? What are the ionosphere and the troposphere? Let's have a look.

When the output of a transmitter is fed into an antenna system the alternating radio frequency currents in the antenna create electromagnetic waves which radiate out into the atmosphere and can be likened to the way in which waves on a pond travel away from the point at which a stone has been dropped into the water. It is these electromagnetic waves that propagate through the atmosphere in a number of ways which we shall look at in a second.

Because it is alternating the transmitted signal has two fields. One is the *electric field* (E), created by the changing voltage, and the other is the *magnetic field* (H), created by current changes. These two fields always remain at right-angles to each other and to the direction of propagation as the electromagnetic wave travels along. Remember this as it constitutes another typical question. *Field strength* is the term associated with the electric field and is measured by the change of potential per unit distance.

Another term you will come across is *polarised*. Electromagnetic waves are said to be polarised parallel to the electric lines of force, so that normally a vertical antenna produces vertically-polarised waves and a horizontal antenna produces horizontally-polarised waves. Ideally, both the transmitting and the receiving antennae should be to the same polarisation to receive the signal at its strongest, although the polarisation of the wave itself may often be modified, particularly at VHF and higher, by such things as abnormal weather conditions.

From your physics lessons at school, you will remember that radio waves make

Give me a D; give me an E;
give me an F1; give me an F2;
what does it spell (DEFF)? Bill Mantovani
G4ZVB reckons that it spells
PROPAGATION

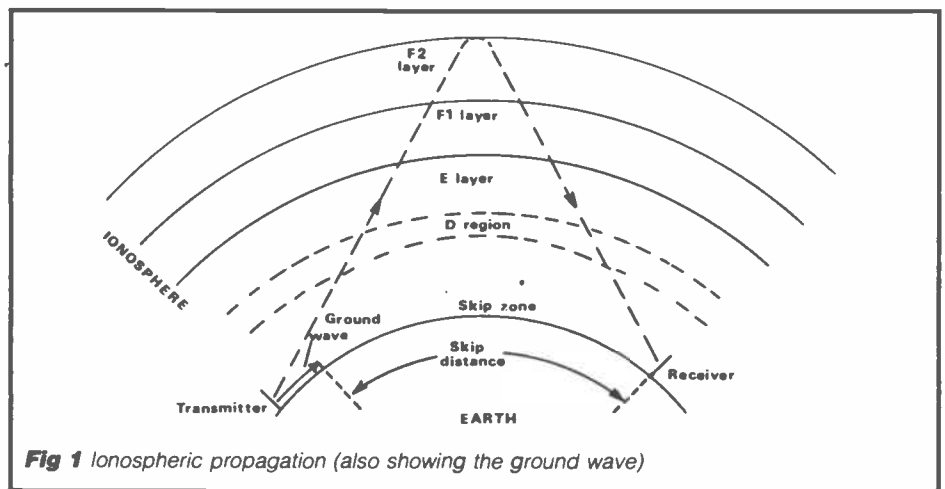

Fig 1 Ionospheric propagation (also showing the ground wave)

up a fair sized chunk of the electromagnetic spectrum and are said to travel at the same speed as light, which in free space is approximated to 300,000,000 metres per second or 186,000 miles per second. The relationship between the velocity, wavelength and frequency of an electromagnetic wave is expressed by the following formula: wavelength (metres) = 300/frequency (MHz).

Modes of propagation

For the RAE, we will look at three main modes of radio wave propagation. They are as follows:

Ground-wave propagation: This is where, as the term implies, the radiated wave travels along near to the ground following the curvature of the earth. The ground itself actually absorbs some of the energy from the wave, causing it to bend with the curve of the Earth's surface but also serving to attenuate it somewhat. At frequencies above about 2MHz this attenuation becomes ever greater so that at 20MHz, say, the ground wave may only be extending out for a couple of miles. Below 2MHz though it is a different story as the ground wave becomes the major mode of propagation, with attenuation being so small at very low frequencies that reliable communication becomes possible worldwide at all times. Atmospheric conditions do not have as great an effect on the ground wave as they do on the other modes of propagation.

Ionospheric propagation: This is where the radio waves are bent (or refracted) back to earth by the layers of ionised gases in the upper atmosphere. This is demonstrated by *Figure 1*, which also shows the ground wave and the various layers that constitute the ionosphere.

The layers that affect our radio waves are the E layer at about 120Km above sea level, the F1 layer at about 200Km asl and the F2 layer at a height of between 300 to 400Km asl. There is also a D region at about 80Km asl whose major significance to us is that in abnormal circumstances it will absorb our HF signals. We shall study this layer first and see how it can disrupt communication on the HF spectrum.

Normally, radio waves pass through the D region on their way up into the ionosphere before being refracted by one of the layers back towards earth. The level of ionisation of the gases within the D region is such that these waves usually pass through without any problem. A sudden burst of intense ultra-violet or X-radiation from the sun however, such as is given off at the time of a solar flare, can change all of that. The radiation causes the gases to become ionised to the point where the D region now absorbs the radio waves, stopping them from reaching the E and F layers. The result of this is that communications over all or part of the HF bands fade out for anything from a few minutes to over an hour. This phenomenon is known as SID (*sudden*

BACK TO BASICS

ionospheric disturbance) whilst the result is called *Dellinger fade-out*.

A couple of days after a SID has occurred there may be another period of fade-out, this time caused by an *ionospheric storm* which can last for anything up to several days. These storms are more frequent at times of high sunspot activity but their effect is more significant when the sunspot activity is at a minimum.

Because the degree of ionisation of the gases in the E and F layers is also affected by the activity that takes place at the sun, the characteristics of these layers are always changing. Also, there are a couple more things that affect ionospheric propagation. For instance at night and during the winter months the F1 and F2 layers combine into one single layer at a height of about 250Km, whilst the degree of sunspot activity (which varies in accordance with an 11-year cycle) is another factor.

Thus, the degree of ionisation of our upper atmosphere varies not only according to the time of day or season but also according to what stage we are at along the sunspot cycle. Those of you who listen on the air will well know that we are currently near low point in the cycle and that, on the whole, the higher HF bands such as 21MHz and 28MHz are silent for much of the time whilst 14MHz 'closes down' in the evening, although things are beginning to improve. The last sunspot maxima was in December 1980, so we can expect the next one to occur in 1991-2. Hopefully you will all be licensed by then so start building your two-element quads for 10 metres now because when it opens up this band will really bring in the DX!

Anyway, back to the ionosphere. The layer we are most interested in is the F2 layer because this is the one furthest from the earth and which normally has the highest degree of ionisation to reflect back the HF frequencies which have found their way through the lower layers, a higher frequency requiring higher ionisation to cause it to reflect back to earth. There is a limit to the highest frequency radio wave that the ionosphere will reflect, depending upon all the factors just mentioned. This is known as the *maximum usable frequency* (MUF) and any radio waves above this simply pass straight through the F2 layer and head out into space.

If the radio signal is directed vertically at the ionosphere instead of horizontally out over the horizon, it is possible to measure the highest frequency that each different layer will reflect. This is called the *critical frequency* and is used to forecast MUF. The critical frequency is lower than the MUF.

What about the E layer? Well, during the summer months areas of extremely high ionisation often occur in this layer which will reflect far higher frequencies than normal, possibly even as high as 150MHz. Obviously, this phenomenon is of great interest to VHF operators as it allows them to communicate over longer distances than is normally possible. It is

called *sporadic-E* and may last for only 30 minutes or even several days. Sporadic-E propagation can often be detected on 28MHz, when stations who are about 1,000 miles or so away start coming in at exceptionally strong signal strengths.

If the ground wave of an HF signal only travels a short distance and the wave reflected off the ionosphere travels a long distance, it is obvious that there exists in the region between the transmitter and the point at which the reflected wave returns to earth an area where no signal is received. This is called the *dead zone* or *skip zone* (shown in Figure 1) and the *skip distance*, as it is called, begins where the ground wave ends.

By simple maths you can see that the greatest distance that can be covered by one single reflection from the F2 layer is about 2,500 miles (4,000Km), so for worldwide communication it is obvious that several reflections between the F2 layer and the ground are required.

A final note about the different types of fading. Fading (Q-code - QSB) is a common occurrence on the HF bands. This is because the conditions in the ionosphere are constantly changing and also because the signal may arrive at the receiving antenna by two totally different paths. One could have been reflected only once whilst the other may have come the long way round the world and needed far more reflections, though in this particular case the interference caused by the much weaker signal would probably be small.

If the signals both travelled in the same direction though and one took one reflection and the other two, then the signal would fade to a minimum when the two *sky waves* (or more) arrived at the antenna out of phase. Some distortion may also be evident because of the time delay between the two different paths. Ionospheric propagation is the mode normally used for the frequency range 1MHz to 30MHz.

Tropospheric propagation: Over about 50MHz the mode of propagation for long distance contacts is known as tropospheric. This is where the radio waves are refracted around the curvature of the earth by the characteristics of the lower atmosphere, or *troposphere*. The refraction is caused by the changes in the troposphere's dielectric constant due to varying combinations of humidity, temperature and pressure, which also affect our weather. Thus, by studying the weather conditions it is possible to forecast when there will be good tropospheric propagation.



Fig 2 Standing waves on a resonant antenna of $\lambda/2$ and λ .

There are a number of other modes of propagation associated with very high frequencies for achieving communication over longer distances than normal. These include the use of the ionised particles that exist in the trails of meteor showers, the auroral zones which appear at the poles and scatter from areas within the troposphere itself (known as *troposcatter*). Even 'bouncing' signals off the moon has now become a (specialist) part of amateur communication.

Antennae

We have just seen how radio waves can be made to travel great distances round the world using the natural elements that surround this planet, but to take full advantage of these modes of propagation we must ensure that we are using the correct antenna at both the transmitter and receiver points. In this context, correct means an antenna that is correctly matched to the transmitter so that all of the power generated by the transmitter's output stage can be usefully radiated out into the atmosphere, or an antenna which is so polarised as to make the best use of, say, ionospheric propagation by radiating the signal out at a very low angle to the earth's surface.

Consider a piece of wire cut to exactly one wavelength long (1λ). The current and voltage variations on this wire will be as shown in Figure 2 and this is known as a *second-harmonic* or *full-wave* antenna. If the wire was cut to be exactly half of this length, ie, only one half of a wavelength long ($\lambda/2$), the voltage and current variations on this antenna would be different (again, see Figure 2). The two antennae however are both said to be *resonant* and the variations shown are known as *standing waves*. Please note that when an antenna is said to be half or a full wavelength long the wavelength referred to is that which corresponds with the frequency at which we wish to radiate. Thus for 7MHz operation a half wave antenna would be about 20 metres long and a full wave antenna 40 metres long.

As the ratio of voltage and current varies along the length of the wire, at any particular point it may be inductive, capacitive or resistive. We refer to this term as the antenna *impedance* and it can be seen from Figure 2 that a full wave antenna will show a very high impedance and voltage at its centre whilst the centre point of the half wave antenna will have a low impedance and low voltage, the current now being high and the high voltage points appearing at the antenna

ends. The latter situation is the one we are looking for as the output impedance of our transmitter PA stage is also low. We can therefore achieve a good match between antenna and transmitter (and have maximum power transfer) if we use a half wave antenna and feed the signal into it at its centre.

The output impedance of most transmitters is between 50 and 100 ohms and as the impedance at the centre of a half wave antenna is in the region of 75 ohms, 50 or 75 ohm cable can be used to couple the two together and the system is said to be matched. More on this in a moment.

We have seen that wavelength (in metres) = $300/\text{frequency (MHz)}$, so the length of a half wave antenna will be $150/\text{frequency (MHz)}$ metres. In practice, the actual length required will be about 5 per cent less than this because the above formula refers to a radio wave in free space, not travelling through the atmosphere.

Other factors also have an influencing effect, like the diameter of the wire used (though this is not all that great at HF frequencies) and the presence of nearby objects to the antenna such as trees, buildings and even the insulators or guy wires holding the antenna up. A *correction factor* of 0.95 can thus be applied to our previous formula to give a more practical wavelength formula of $\text{wavelength} = 143/\text{frequency (MHz)}$ metres.

Antenna radiation patterns

Take a half wave antenna and imagine that it is suspended at least one full wavelength above a perfect earth, parallel to the ground and far enough away from any object that may have an influence on it. The radiation from this theoretical antenna would be concentrated at right angles to its length and the pattern, which would encircle the wire like an imaginary 'doughnut', is shown in *Figure 3a*.

The area of maximum radiation is known as a *lobe* and as the length of the antenna is increased in odd or even multiples of half a wavelength the effect is to produce more of these lobes and the radiation now begins to concentrate towards the ends of the antenna. *Figure 3b* shows the pattern for a full wave antenna whilst *Figure 3c* gives the pattern for an antenna where nearly all of the radiation has been concentrated in one direction, such as is the case with a *beam* or *Yagi* antenna which uses a reflecting and a directing element to modify the radiation pattern to our advantage.

If the antenna were turned by 90 degrees into a vertical position radiation would be in all directions and the angle at which the signal left the antenna with respect to the earth's surface would be quite low if the antenna length were, say, three or four wavelengths. As pointed out when we looked at propagation, good long distance communication calls for a low angle of radiation and this angle can be further reduced by increasing the

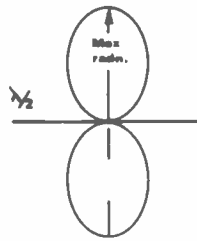

Fig 3a Radiation pattern for a half-wave antenna

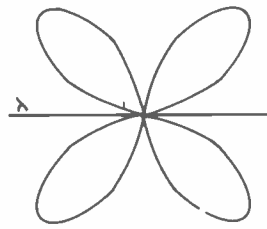

Fig 3b Radiation pattern for a full-wave antenna

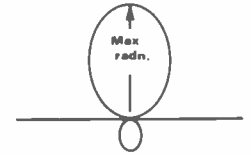

Fig 3c Radiation pattern for a directional antenna

height of the antenna from the ground.

The simple half wave antenna is called a *dipole* but there are in fact many other types of antenna used by amateurs which offer an advantage over the dipole, provided they are correctly fed and matched. A directional beam for instance has a higher *forward gain* than the dipole and a better *front-to-back ratio*; that is, signals coming in from the back of the beam are attenuated, so reducing sources of possible interference to the reception.

Transmission lines.

We have already briefly looked at how the transmitter and antenna are connected together using a transmission line (in our example, coaxial cable). Quite often the antenna may be situated a good distance from the transmitter so that a long transmission line or *feeder* is required, and it is therefore important that this feeder be of low-loss quality. It would be of little use to us if most of the signal from the output of the transmitter were attenuated on its way to the antenna.

The feeder may be *balanced* or *unbalanced*. In the first type both wires of the transmission line have an equal potential to ground (neither is earthed), whereas with unbalanced line one side is normally earthed. As stated, a transmission line has a characteristic impedance which is dependent upon various factors such as the spacing between the two wires, the diameter of the wire used and, in the case of coaxial cable, the internal diameter of the outer screen.

Twin-feeder, as balanced line is often called, can be purchased in impedances of 75 ohms or 300 ohms, though it can also be easily made as required by spacing apart two lengths of suitable wire with low-loss spacers. Whilst balanced line is easy to make and is very efficient it does have the disadvantage that its characteristics can be affected by the elements (ie rain, snow etc), sharp bends in the line or by being run close to other objects, such as near a tree or close to a building, resulting in, amongst other things, possible TVI. With thought it is possible to avoid many of these snags and balanced line is widely used.

The transmission line you will probably be more familiar with though is co-ax cable which is unbalanced, as is the output circuit of most transmitters. For this reason, and because co-ax cable can be bent round corners easily and run

close to other objects without fear of affecting the line, co-ax is often preferred to two-wire open feeder. There are a number of different types of co-ax cable on the market in impedances of 50 ohms and 75 ohms. An electromagnetic wave travels slower down a transmission line than it does through free space and the ratio between these two velocities is known as the *velocity factor*. For 300 ohm twin-feeder this is about 0.85 whilst for most solid polythene co-ax cables the velocity factor is a much lower 0.66.

Co-ax cable has another use other than being a transmission line. It has been proven that a length of co-ax line which is cut to a quarter of a wavelength long at the operating frequency and which is left open-circuit at one end presents an effective short-circuit at the other end. This only happens at the frequency for which it is cut, thus a *coaxial stub* makes an excellent attenuator when connected in parallel with the transmitter antenna transmission line. In this way it is possible to reduce any spurious radiation being generated by the transmitter and which coincide with, say, the frequency of a local TV channel, hence avoiding possible TVI problems.

If a transmitter whose output impedance is 50 ohms is connected by a transmission line whose characteristic impedance is 50 ohms to a feed point on the antenna which is also 50 ohms the system is said to be perfectly matched and maximum power transfer will result between the output of the transmitter and the antenna, where it can all be radiated.

In practice this is not always possible and certainly the feed point impedance of the antenna alone may often vary widely from the expected figure. The proximity of the antenna to its surrounding objects and its height above ground are two possible causes whilst another is that the antenna will have been cut for a particular frequency at one end of an amateur band, so that when you tune away to another part of the band the antenna is no longer the correct length for the new frequency that you have moved to. The latter brings us back to the term *bandwidth*. Certain types of antenna exhibit a wider bandwidth than others and thus allow more of the band to be covered before they go 'out of tune'.

When all of the impedances in the transmitter/antenna system are correctly matched all is well, but when the antenna does not present the correct

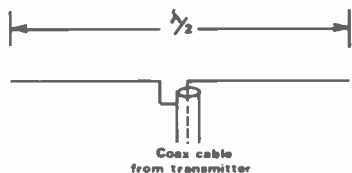

Fig 4 The half-wave dipole

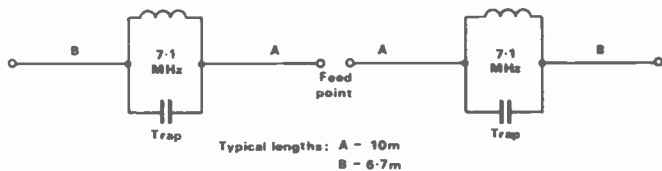

Fig 5 The trap dipole

impedance for the system then a mismatch exists. Some of the power that is delivered to the antenna by the transmission line is reflected from this mismatch and opposes the power that is being delivered by the transmitter.

There are two sets of standing waves on the feeder now, those going forward from the transmitter to the load and those reflected back from the load because of the mismatch. RF currents and voltages are now no longer constant but vary along the length of the line and this variation is expressed by the *standing wave ratio* or SWR. This is measured using an SWR meter (called a

reflectometer) and the perfect match would be when the SWR reading is 1.0:1.

In practice the perfect match is impossible to achieve, although the SWR meter does enable you to get pretty close. The current commercial solid-state transmitters usually have inbuilt protection against high SWR, reducing the drive to the PA stage so that the transmitter will no longer generate much power.

Valve PA stages are far more tolerant and will stand an SWR of up to 3:1, though this is not advised. Also a high power output in conjunction with a high SWR may cause flashover in the feeder

or any in-line filters or tuning unit. A greater loss can result in the feeder (depending on its quality) if a high SWR is present, a factor that becomes more significant as frequency increases.

A point to note is that the SWR will be constant along the whole length of the feeder. It is usually more convenient to measure the SWR at the transmitter than at the antenna.

In order to ensure that the antenna always presents a satisfactory match to the transmitter an *antenna tuning unit* (ATU) is used. Note that although the term tuning is used the purpose of the ATU is to match the transmitter output to the impedance seen when looking into the feeder, so that the PA stage can be persuaded to deliver full output.

Like the SWR meter, the ATU is also normally connected to the transmission line at the transmitter end, though with certain systems where it only needs to be adjusted the once it can also be sited at the antenna or at a point along the transmission line, for whatever reason.

Next month we will look at practical antennae, such as the two given in *Figures 4 and 5*, and at transmitter interference.

Acknowledgements and references
City and Guilds of London Institute.
Radio Amateurs' Examination Manual - G L Benbow G3HB (RSGB).

NEXT MONTH

Amateur RADIO

all the regulars. . .

DX Diary
On the Beam
Back to Basics
SWL
Straight and Level
Your letters and features covering the whole of Amateur Radio

■ CQ CONTEST

Kevin Fox takes the lid off the contest scene and suggests a survival kit for would-be operators

■ ANGUS MCKENZIE TESTS

Next month G3OSS reviews the Yaesu FT2700RH 2m/70cm dual-band FM mobile and the muTek SLNA144S 2m pre-amp

DON'T MISS THE JUNE ISSUE

On sale 23 May

QUESTIONS & ANSWERS

RAE PRACTICE DEvised BY R.E.G. PETRI G8CCJ

Fig 1

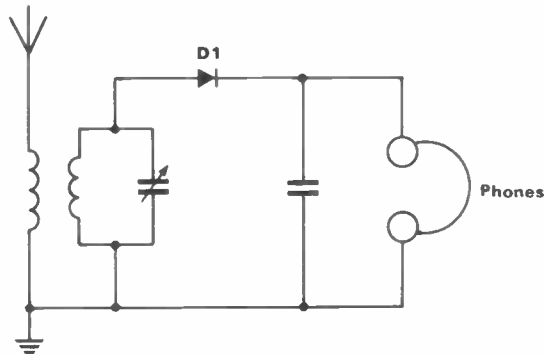

- Figure 1 shows the circuit diagram of a typical 'crystal set' type receiver. It has the disadvantage of:
 - requiring a high stability oscillator
 - poor selectivity and is insensitive
 - D1 having a high unstable gain
 - suitable diodes being unavailable since WWII
- An early generation of receivers sometimes employed a regenerative detector. What is the name by which this type of receiver is generally known?
 - superheterodyne
 - radiodyne
 - tuned radio frequency (TRF)
 - tuned superdyne (TSD)
- Reception of CW signals on the TRF receiver is by:
 - adjusting the antenna coupling
 - removing the supply voltage from the detector stage
 - using headphones of very high impedance
 - means of a regenerative detector stage
- Which of the list below describe some of the disadvantages of the TRF receiver?
 - low current and very high battery voltage is required
 - very high current and high battery voltage required
 - not suitable for CW reception and very short antennae required
 - poor selectivity and possibility of RF instability
- When a weak signal is being received, the poor selectivity of the TRF receiver will make it prone to:
 - being swamped by strong signals in adjacent channels
 - severe IF rejection
 - severe audio negative feedback
 - AGC voltage fluctuations
- The receiver developed to overcome most of the problems associated with the early TRF type receivers is known as the:
 - synchrodyne
 - selectodyne
 - superheterodyne
 - supersynchrodyne
- What feature has the receiver selected in your answer to Q6 that the early TRF receivers did not?
 - an audio amplifier
 - a fixed frequency IF amplifier
 - a self oscillating detector
 - a radio frequency amplifier
- Referring to Figure 2, which one of the features listed below is desirable in the design of an RF amplifier stage?
 - low noise
 - high noise
 - high gain, about 1000dB
 - high thermal noise

Fig 2

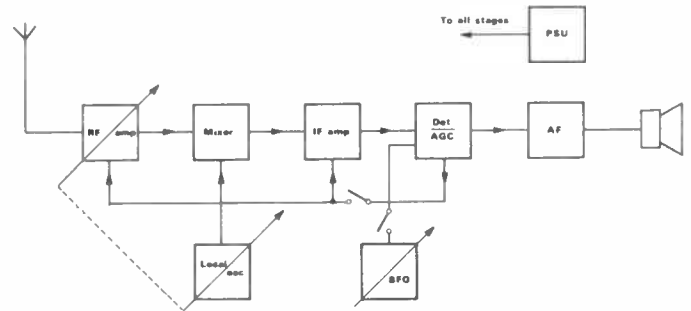

- The RF stage of a superheterodyne receiver, apart from preventing local oscillator radiation from the antenna, also:
 - reduces image, or second channel interference
 - increases second channel interference
 - improves BFO injection
 - prevents co-channel interference
- Which pair of the following are types of oscillator suitable for tuning an HF bands receiver?
 - Helmholtz/Kaiser
 - Gallium/Selenium
 - Colpitts/Hartley
 - Rhombic/Colpitts
- In order to give greater flexibility, accuracy of tuning and frequency stability the local oscillator of a modern communication receiver usually takes the form of a:
 - cavity resonator
 - heterodyne resonator
 - frequency synthesiser
 - strip-line oscillator
- Certain stages of a communication receiver have a marked effect on the overall signal to noise (S/N) ratio. These stages are most likely to be the:
 - power supply and audio amplifier
 - audio amplifier and loudspeaker
 - IF amplifier and carrier insertion oscillator
 - RF amplifier and mixer stage
- The RF amplifier stage of a communication receiver must provide low noise amplification. The lower the noise contribution of this stage the better will be the:
 - signal to noise (S/N) ratio and sensitivity
 - ripple rejection and selectivity
 - cross mode rejection and selectivity
 - selectivity and second channel rejection
- A receiver's variable frequency oscillator (VFO) is tuned by a variable capacitor of the metal vane type. What device, with its associated circuitry, might be used to replace it and save space?
 - a 100K Ω resistor
 - a leaky electrolytic capacitor
 - a 50mH RF choke
 - a variable capacitance diode
- The mixer, or frequency changer stage of a communication receiver, normally needs to be preceded by:
 - a low sensitivity diode
 - a very non-linear resistor
 - a low noise RF amplifier
 - an oscillating RF stage
- Referring to Figure 2, there is always a fixed frequency difference between the required received signal and the local oscillator. This frequency difference is called the:

QUESTIONS & ANSWERS

- a) image frequency
- b) local oscillator frequency
- c) intermediate frequency
- d) adjacent channel

17. The frequency stability of a communication receiver is dependent upon the:

- a) Q factor of the IF amplifier tuned circuits
- b) frequency stability of the local oscillator
- c) frequency stability of the sending transmitter
- d) self capacitance of the receive antenna

18. The power supply voltage to a receiver's local oscillator should:

- a) be able to supply a heavy current
- b) be able to supply a high voltage
- c) be suitably stabilised
- d) have a high source impedance

19. The tuning components, L and C, of a receiver's local oscillator have not been securely mounted and are of poor quality. What is the most likely effect on the receiver?

- a) unpredictable tuning point
- b) oscillator re-radiation
- c) microphony and poor frequency stability
- d) both a) and c) above

Fig 3

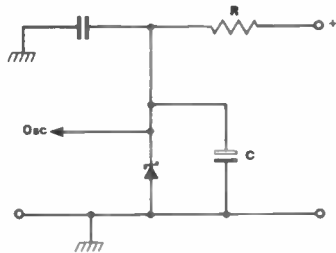

20. Part of the circuit diagram of a typical communication receiver is shown in Figure 3. What is it?

- a) a varicap modulator
- b) a varicap demodulator
- c) a zener diode voltage regulator
- d) a speech clipping circuit

21. Having decided what the circuit of Figure 3 is for, what would be the effect on the receiver if resistor R became disconnected?

- a) the local oscillator would stop oscillating and the receiver wouldn't work
- b) nothing noticeable
- c) the diode would burn out
- d) capacitor C would burn out

Fig 4

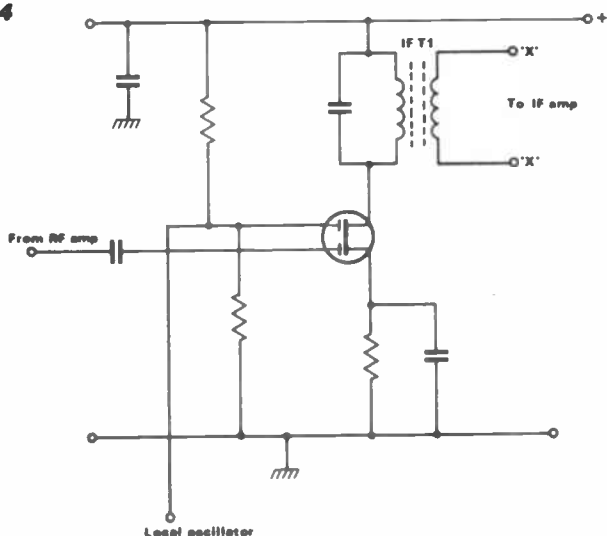

22. The circuit shown in Figure 4 is that of a typical:

- (a) AGC control amplifier
- (b) dual gate MosFET mixer stage
- (c) automatic frequency control (AFC) stage
- (d) antenna impedance matching stage

23. Referring to Figure 4, the drain current of the MosFET will be influenced by:

- (a) the RF input signal and the local oscillator signal
- (b) the RF input signal only
- (c) the local oscillator signal only
- (d) the gain of the detector stage

24. There are many frequencies present at the output of the mixer stage shown in Figure 4. Which frequency is the most important at points 'X' on the diagram?

- (a) the intermediate frequency
- (b) the image frequency
- (c) the oscillator frequency
- (d) the co-channel frequency

Fig 5

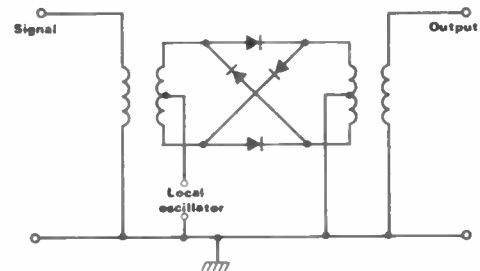

25. Figure 5 shows a type of mixer circuit employed in some receivers. What type is it?

- (a) FET ring mixer
- (b) double balanced mixer
- (c) quad switched mixer
- (d) quad diode mixer

26. When the circuit of Figure 5 is correctly balanced there is:

- (a) only the oscillator signal present at the output
- (b) only the received frequency present at the output
- (c) no output at all
- (d) no local oscillator signal present at the output

27. Which stage of a receiver provides most of the gain, selectivity and adjacent channel rejection?

- (a) the IF amplifier
- (b) the preselector stage
- (c) the rejector circuit
- (d) the RF amplifier

Fig 6

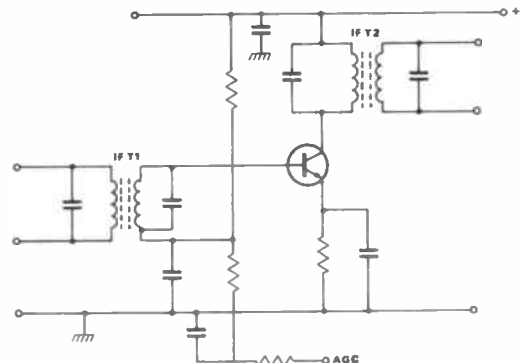

28. Figure 6 shows the circuit of a typical IF amplifier stage. What determines the selectivity?

- (a) the transistor gain
- (b) the mixer noise level
- (c) the AGC voltage
- (d) the design and adjustment of the tuned circuits, IFT1 and IFT2

QUESTIONS & ANSWERS

Fig 7

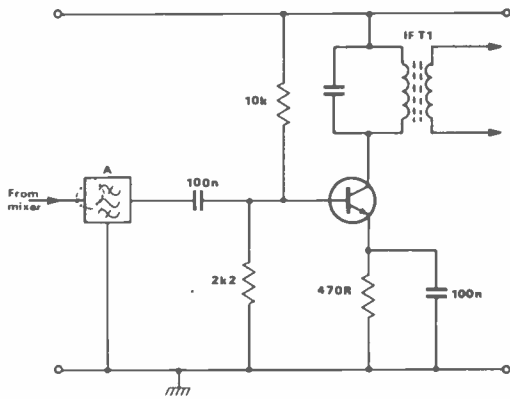

29. Figure 7 shows the first stage of a typical IF amplifier. This circuit differs from that of Figure 6 in that it gains its selectivity from the component labelled 'A'. Name the component and state one of its characteristics:
- High Pass Filter (HPF)/it introduces negative feedback
 - Band Pass Filter (BPF), crystal or ceramic/it introduces insertion loss
 - Band Stop Filter (BSF)/it introduces insertion loss
 - Low Pass Filter (LPF)/it introduces distortion
30. A communication receiver employs the IF amplifier and filter shown in Figure 7. The receiver is tuned to a frequency of 3.5MHz, image or second channel interference occurs from an unwanted signal on a frequency of 4.440MHz. What is the centre frequency of the filter (box 'A')?
- 455KHz
 - 470KHz
 - 440KHz
 - 10.7MHz
31. How can image or second channel interference be reduced?
- the frequency difference between the wanted signal and the local oscillator can be reduced
 - the difference between the signal and the interference can be reduced
 - the RF bandwidth can be increased and the intermediate frequency reduced
 - the RF amplifier bandwidth can be reduced and the intermediate frequency increased
32. What is the purpose of the amplitude limiter in the IF amplifier of an FM receiver?
- to remove amplitude variations etc from the frequency modulated signal
 - to enable the demodulator to demodulate AM signals
 - to restrict amplitude modulation to 30%
 - to regenerate the original AM envelope
33. The correct demodulation of an amateur SSB signal requires that:
- the AGC is delayed by 75mS
 - the AGC is delayed by 2 volts
 - the IF bandwidth is greater than 6KHz
 - the receiver's carrier insertion oscillator is at the correct frequency

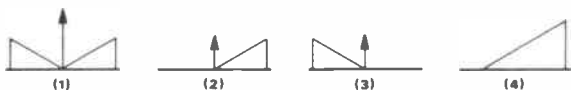

34. Which one of the above frequency spectrum diagrams is representative of an amateur J3E upper sideband transmission?
- 1
 - 2
 - 3
 - 4

35. From the four emission classes, represented above by their frequency spectrum diagram, which one could be demodulated by a receiver using a simple envelope detector, and what is the class of emission?
- 1 - A3E
 - 2 - R3E
 - 3 - R3E
 - 4 - J3E

And now a word
from our sponsor...

This set of questions has been prepared to follow Bill Mantovani's article on receivers, which was published in the February issue of this magazine.

Receivers, in common with every other syllabus subject of the RAE, have complete books devoted to them. It is not possible in a few pages, or with a few questions, to do anything but highlight the essential features or characteristics of them.

It is essential to know how the superheterodyne receiver works and the advantages and disadvantages of low and high intermediate frequencies. Adjacent channel and image channel interference, their causes and cures (or avoidance) must be understood.

It will also be necessary to understand how a receiver detects or demodulates the four main types of transmission that it is likely to receive, CW, AM, FM and SSB.

The RAE student will find that a copy of the City & Guilds syllabus will prove useful, particularly when the appropriate part of the syllabus is read in conjunction with the subject being studied.

Finally, in March's article on semiconductors there were typing errors which made the answers to Q2 and Q18 incorrect.

Please make a note of the changes on your copy: Q2 a) and b), the word 'deflection' should read 'depletion'. Q18 c), delete the word 'without' and insert 'whilst'.

Now let's plug the book . . .

For more question and answer practice Ray Petri's book 'The Radio Amateurs' Q & A reference manual' is available from:
W P Publications,
11 Wayville Road,
Dartford, Kent DA1 1RL.
Price £5.95 & £1.00 P&P.

The book contains 20 sections of multiple choice questions and answers which follows the RAE syllabus in roughly the same order that any recognised RAE course would progress, making it an ideal source of course homework.

The book is also available from your local emporium.

Now if you haven't cheated already,
turn the mag upside down
and see how you did . . .

ANSWERS

1 - b; 2 - c; 3 - d; 4 - d; 5 - a; 6 - c; 7 - b; 8 - a; 9 - a; 10 - c; 11 - c; 12 - d; 13 - a; 14 - d; 15 - c; 16 - c; 17 - b; 18 - c; 19 - d; 20 - c; 21 - a; 22 - b; 23 - a; 24 - a; 25 - b; 26 - d; 27 - a; 28 - d; 29 - b; 30 - b; 31 - d; 32 - a; 33 - d; 34 - d; 35 - a.

Drift

A few months ago I wrote about the early Trio TS510 and its slight tendency to drift. Dozens of letters have indicated that this is a common problem on lots of valve rigs, so I have decided to dedicate this page to its cure.

The problem with drift in early valve equipments is normally due to heat, and after an hour or two the rigs normally settle down and are quite stable. This is fine for contest operating, or for when you know you have an hour in the shack coming up after lunch, but isn't too handy when you suddenly fancy a quick half hour on the spur of the moment.

As I said in the previous article, the drift is 'only' about 10KHz in the first hour, but consider a rig with a 300Hz CW filter. If you were to listen to one stable CW station for an hour you would have to re-tune the rig at least 32 times! Conversely, if you turned the rig on from cold and successfully called someone on, sked, after an hour's chat you could be transmitting 10KHz up the band.

Golden rules

Before tackling a rig with drift problems there are three golden rules to follow. The first rule is to note the rate of drift on one band then *check it on another band*. I recommend checking the drift over the first hour on one band one day, then checking it on the other band the next day. The reasoning is simple, although the drift is probably due to the VFO, it could well be a 'rubbery' crystal.

Since nearly all valve rigs used the classic crystal controlled pre-mix system, then a VFO covering a fixed span (normally 5 to 5.5MHz) and a dodgy pre-mix crystal will be bad news. It's unlikely, but not impossible, that the two different band crystals will suffer the same degree of excessive shift with respect to temperature. Note that I have specifically mentioned the rate of drift.

Since some 'classic' rigs have their IF within the operating frequency range of the rig, you may find, say, a positive drift on 160, 80 and 40, and a negative drift of the same rate on 20, 15 and 10. This is due to subtractive or additive mixing, depending on band. It is only the drift, in KHz, over the hour, that interests us.

Golden rule 2

Owners of KW2000s take particular notice. I have spent hours sorting out drift problems on a rig, got it stable, returned it to its owner and then had it come back a few months later only to find that it was just the VFO valve inter-electrode capacitances going hay-wire. From golden rule 1, above, you should have determined the rate of drift over the first hour, so fit another VFO valve.

You might be lucky and find another valve of the same type within the rig, so simply swap it over. Watch out for oddball side effects though, like increased residual carrier. We are only checking for rate of drift, so after the test swap them back. Dodgy valves are not uncommon on any rig, but 2000s seem particularly prone. If the drift stops, buy a new valve!

SECONDHAND EQUIPMENT GUIDE

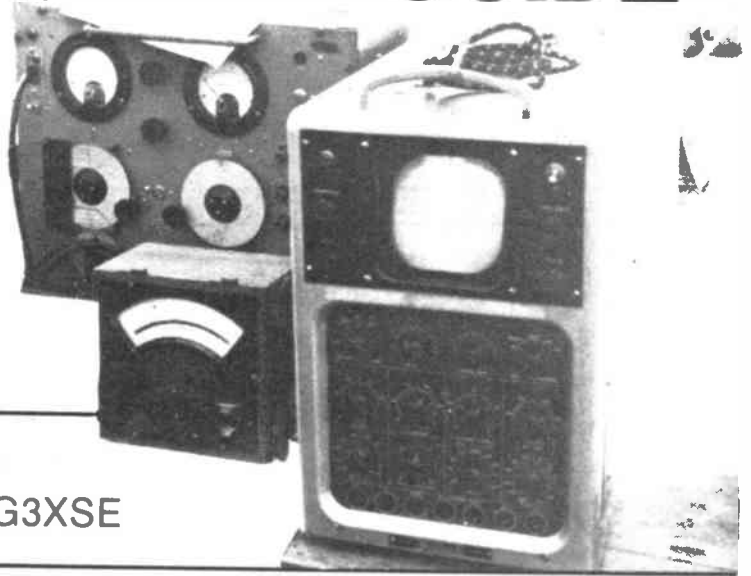

by Hugh
Allison G3XSE

Golden rule 3

So the drift isn't the mixing crystals and it isn't the VFO valve, so off with the covers and on to rule 3. Draw yourself a picture of the VFO compartment and take extreme care to note the positions of all the variable components – inductor cores and trimmer capacitor slots. I normally measure the length of inductor cores sticking up, if they are of that type, or depth down the core if of that design.

Trimmer capacitor slots are not only carefully drawn out, in addition I normally make a light, small pencil mark on the trimmer and another on the chassis to show its exact position. The reasoning behind the above is simple; if you start playing around with the VFO and make things worse, at least you can reset it and undo any damage you might have caused!

The mathematics

As I said above, the drift after switch-on is typically 10KHz over the first hour. Given that most VFOs tune 5 to 5.5MHz and have, say, a 100pF variable capacitor to tune them, then a few moments thought will determine that the drift is equivalent to a change of 500KHz (the VFO range) divided by 100 (the capacitance change), or 5KHz per pF. For our 10KHz we have twice this, so we are looking for an equivalent change of only 2pF – frighteningly small really!

The cure

The recommended way of curing the drift is to unsolder a fixed capacitor in the oscillator frequency determining part of the circuit and fit in another with a temperature characteristic that will trim out the equivalent capacitance worked out as above, with due allowance for the

coefficient of the removed capacitor.

In theory this sounds simple. In practice it's not too easy. For a start, fixed capacitors are only manufactured in fixed temperature coefficients, you will be lucky to find one exactly as required. Sod's law also determines that you cannot get the value you want with the required coefficient.

A mix of fixed capacitors of various coefficients may well effect a cure. The good news is that most rigs have a trimmer across the variable, and this trimmer will often have a fairly large maximum capacitance, say 50pF. If your luck is really in then this capacitor may be well emeshed, ie a high capacitance. There is thus a large scope to try various capacitors whilst re-tuning the frequency to that indicated on the dial by use of the trimmer alone.

Remember that the trimmer will have a temperature coefficient of its own. Be careful to check the VFO accuracy at each end of the travel, especially if forced to tweak any inductance. Since the L/C ratio will have been disturbed, the tuning rate and/or tuning linearity may well be ruined.

The good news

All of the above may seem quite daunting, especially to the newcomer who is disappointed with his drifting first rig. However, help is at hand in the shape of a little known device called a temperature compensating trimmer. Various trade names are given to these, such as Thermotrimmer and Tempatrimmer. Although not easily available new, since the days of valve oscillators have passed, they are often available dirt cheap on the surplus market.

I keep my eyes open for these at rallies

FREE CLASSIFIED ADS

FREE CLASSIFIED ADS CAN WORK FOR YOU

We are pleased to be able to offer you the opportunity to sell your unwanted equipment advertise your 'wants'.

Simply complete the order form at the end of these ads, feel free to use an extra sheet of paper if there is not enough space. We will accept ads not on our order form.

Send to: **Amateur Radio Classified Ads**, Sovereign House, Brentwood, Essex CM14 4SE.

DEADLINE AND CONDITIONS

Advertisements will be published in the first available issue on a first come first served basis. We reserve the right to edit or exclude any ad. Trade advertisements are not accepted.

FOR SALE

■ Trio R1000 general coverage receiver, £160, bargain. Tel: (091) 2673507, Newcastle-on-Tyne.

■ Realistic DX 150A 4 band Rx £25. Cossor dual beam CRO £25. US 453B Rx 190-550KHz unused £20. CR100 Rx new w/change cord need £25. 10p coin operated electric meter variable tariff £10. Arena F211 FM tuner stereo, 5 tunable push buttons, good order £20. Large high power horn loud speaker £25. All plus carriage. Leon Charlish, 7 Cranbourne Ave, Windsor. Tel: Windsor 64761.

■ Transformer 240V 20 watt to 12V 0.6A £8. Galvanoter, very old, offers. Perfect order 19 set. Tel: (0283) 221870.

■ Yaesu FRG7700, FRT7700, long wire, log book, various RSGB books and wall charts. All in excellent condition £300. John Massey. Tel: (0482) 868085 after 7pm.

■ Heathkit SB301 receiver 10-80m with matching speaker. Property of SK amateur, with assembly manual, possibly assist with transport £55. G3VYP, QTHR near Ludlow. Tel: (056 885) 296.

■ Eprom programmer, acorn atom computer, high resolution black and white monitor, tape recorder, books and software. Complete system in working order only £99. C J W, 4, Mill Close, Ackworth Pontefract Yorkshire, WF7 7PU. Tel: (0977) 611395. Buyer collect.

■ BBC and Electron tape back-up program. Make back-up copies of virtually all your tape software. Lock and unlock programs. Send £3.75 for your copy by return post to C J W, 4 Mill Close, Ackworth, Pontefract, Yorkshire WF7 7PU, stating which machine you have.

■ Tandy CB handheld, 40 channels, 4 watts, £65. Two metre scanning receiver, 8 channel RO-7 all REP eaters fitted, crystal controlled, plus rechargeable battery £45. Sony ICF2001 portable communications RCVR 0.5-30MHz 88-108MHz VHF FM £100. Scanning receiver 76-87MHz and 156-168MHz £80. CB pre-amp £10. Bremi power supply, 3 amp, £12.50. New walkmate personal stereo radio with headphones £12.50. Mike De Wynter, 2 Woodside, Wimbledon, London SW19. Tel: (946) 2967, ask for Jane.

■ BBC model B, software, speech synth, cassette and few extras. £700 worth of equipment all less than 4 months old. Would exchange for HF transceiver such as FT7B. Better class radios with cash adjustment. Radio must be digital display. Tel: Jon: (051 638) 3401 after 6pm.

■ Belcom LS102L boxed, as new, AM, FM, USB, LSB, CW, 26.27, 28 and 29MHz, hardly used £240 ono. Borland, 'Beechwood', Kinfauns, Perth. Tel: Perth 32719.

■ WS18, any condition. If complete with or without accessories. G4ULB, Alan Watkins, 9A High St, Langley, Warley, West Midlands, B69 4SN. Tel: (021) 552 1838 day.

■ One Revcone Discone aerial from 100 to 470MHz. Model no DC1/WB. Tel: Clochen 378.

■ Cybernet 934 or Reftec 934MHz with conversion in good condition, for quality Minolta SLR camera. SRT101B F1.7 and ERC. Also sun zoom lens 35mm to 70mm, various filters also automatic exten tubes and Tamron 28mm wide angle, Cobra auto flash gun. M G Gibbons, 2 Marton St, Hartlepool, Cleveland, TS248PW.

■ Microwave 24GHz directional coupler and detector with crystal £28, variable attenuator £35. Microwave 10GHz 75mW klystron with micrometer tuning and waveguide mount £18, 25mW klystron £4, professional micrometer wavemeter £78, variable attenuator and detector with crystal £48. QV0310 £3. 4 rev/min mains reversible motor (suit small beam) £8. Lamp with 2 matched photocells assembly £2. Mann G4FFO. Tel: (0223) 860150.

■ Sommerkamp FT250, good condition. Manual, spare valves, one owner from new, no mods, any trial, buyer collect, £250. Bill Ball. Tel: Penketh 2381

evenings.

■ Kenwood R1000 communication receiver, general coverage. £240 ono. Tel: (065261) 213 (any time).

■ TS700G FM, SSB, CW, AM 2m, variable power output 5mW to 10 watt. Ideal for correct drive to QRO linear. Fitted pre-amp, original packing, both manuals, mike, 22 fixed channels all stalled, £270. Buyer collects. Good general coverage Rx required. G4DBI QTHR. Tel: (068 45) 68627 after 5pm weekdays, weekends.

■ Exchange DX160 HF receiver in good condition and Skidmaster SK42000 base mike plus cash adjustment for Sony ICF2001 or Lafayette HF receiver HA600A. Write or call after 5.30pm please. Philip Howlett, 41 Preston Rd, Taddington, Nr Dunstable, Beds LU15 6EG.

■ FLDX500 270W, FRDX500 fitted FM, £230 ono prefer exchange QRP Tx/Rx buyer collects. BR32755 2/1, 1 Dunphail Road, Glasgow G34/BX.

■ Sanyo XL400S 8mm sound camera and Sanyo SHV2000 portable 8mm sound projector with built in screen. £250 or exchange for HF linear 70cms base station or WHY. G4NJP, QTHR. Tel: (0262) 673635.

■ 2m colinear, 13ft, clamps, 8m RG58, £45. Resistors, capacitors, potentiometers, ICs incl TTL, transistors, diodes, bargain pack, 50p - £2.50, new transformers, TV set-side 2-output amplifier, Belling, £8. Valves, Apple keyboard £5, Apple Doscard £4, Firmware cards £4, Teletext and general odds/ends, very cheap. Geoff, tel: Hastings 442308, evenings, weekends.

■ Yaesu FRG7700 ant, FRT7700 ATU mint condition ten months old very little used, £255 or exchange for Yaesu 707 or similar mobile Tx/Rx. With cash adjustment either way. Also have x2 SMC Yaesu comul radio 10 channel can be retuned for 2 meter. Mr R Hankinson, 7A The Broadway, Greenford, Middlesex. Tel: 01-575 1167.

■ Yaesu FT209RH (5 watt), 2m, as new - 3 months old, complete with nicads and charger, £220 ono. Reason for sale - upgrading of equipment, purchaser will collect or extra for carriage. Tel: Blackpool 592248

■ Yaesu FT102 HF mode transceiver with matching FC102 ATU brand new never been used cost over £1000. Best offer. Will take trails bike in part exchange, Montesa Yamaha, must be very good condition. Kevin Preston. Tel: (0274) 721467 day, (0274) 42790 night.

■ Icom SP3 speaker £30. Icom RC11 remote control for R71 receiver £35. AT1000 antenna tuner £27. All boxed, as new. K Ferry, Tel: 01-570 5603.

■ Yaesu FT290R, nicads, charger, case, CW foot switch, stand, boxed mint condition, any trial/demo, £220. Heatherlite mobile boom microphone. Up/down buttons, wired 290R little used, as new condition, £16. Martin G4VZD. Tel: (0532) 585806.

■ FTDX560, fan, speaker, spare valves, dummy load, sure desk mike, 160m, 30m, £230. FT207R, nicad battery pack, charger, £100. Leson TW232 desk mike, £16. Tel: Tisted 306. Ask for Darren (after 6pm).

■ Kenwood R600 cost £263 vgc accept £210. No 19 set Tx Rx, all valves, no power pack offers. R1155 Rx part converted, no power pack, offers. Realistic 50 channel scanner aircraft 2 metres direct input, programmable costs £279, accept £165. 68-88.000, 108-174000, 410-512000, 12V or mains PRO2002 model Rx 9R-59DE. Trio 550-30000 with manual, offers £65.00. Tel: 01-864 2652, evenings.

■ Shack clearance. Pye Communications receiver PCR2 + internal PSU £40. No 31 manpack 40-48MHz £30. Also two Pye Westminsters, high band, need slight attention, £15 pair. Consider swap for 2 metre rig. Andrew Durrant, Wray Castle, Ambleside, Cumbria.

■ BC342/N Rx 1.5MHz-18MHz, as new, first class performance, inc PSU & S-meter £40 ovno. BC221

wavemeter as new, £20 ovno. Signal Gen, 100KHz to 30MHz good, £20 ovno. Philips 1500 VCR plus 12 cassettes £10. Or swap. Eric Parkes, Silkstone View, Plaits Common, Barnsley, Yorks.

■ Kenwood TS530S VFO240, SP230, MC50, all in new and unmarked condition, £650. Stuart G4OOK Tel: 0642 211685.

■ Armoured co-ax low loss double shielded approx 110 yds £100. Tel: (0248) 351894.

■ AR88, S-meter, original speaker, manual, spare valves £35. ASR33, manuals, stand £40. HF5 ar.tenna £35. G4LLQ. Tel: (0608) 811102 (Oxon).

■ Elmo 8mm projector plus 5 movie cameras, screen table, tripod, slide projector, splicer kit, one reel to reel tape, mike, pwr supply, 1 1/2 in reels, lasts 33 mins. Exchange for any CB SSB or receiver, or sell £120 ovno. Ian Underwood, 12 Forge Lane, Gillingham, Kent ME7 1WG.

■ FT290R in v good condition, no mods. Includes a 25 watt linear, £200. Also Drake TR4CW, spare set of PA valves, needs some attention £180. Matthew (G4XWV). Tel: (042058) 532.

■ TS780 2m/70cm multimode, as new £700. FRDX400 HF/2m/4m Rx realigned £100. Zetagi 2m linear 100W £45. 17 element 2m tonna (2 months old) £25. 11 Element 2m cushcraft £20. muTek SNLA144S, 2m preamp £25. Going QRT. G8YTF, not QTHR. Tel: (0706) 350650.

■ FRG7 Rx. Excellent condition £100. R Richards, 37 Queen Elizabeth Way, Woking, Surrey GU229AG. Tel: Woking 69169.

■ CP5 five band trap vertical with radial kit, was £130 when new, only 7 months old £70, Frank. Tel: (061 626) 0677.

■ FT707 HF transceiver £375. IC2E portable 2m with charger accessories £135. Drae 13.8V 24A PSU £90. SEM transmatch with Ezitune £70. Bencher iambic paddle key £25. Yaesu HF antenna filter £12. Welz coaxial switch £14. 100W dummy load £10. 80-10m trapped unipole antenna £10. All ono and in perfect condition. Tel: (07356) 2594 after 6.30pm.

■ Trio 130S excellent condition, CW filter, new bands. Reason for sale - want top band. Less than two years old. £395. John G4TGK. Tel: New Romney 62295.

■ Icom 730 HF transceiver dual VFO + memories, built in pre-amp and processor, VOX facility, new bands with Icom IC-HM10 scanning microphone very good condition £450 ono offer. G4VYX QTHR. Tel: (0670) 851528.

■ Realistic DX300 general coverage receiver 150Hz to 30MHz AM, USB, LSB, digital readout, ex cond, SWL contest award winner, £90. Tel: Eve or weekend 01-311 1544.

■ Major M588 (modified) 26.515MHz-28.045MHz. Working order. Suitable for ham conversion, £60. Tom Valentine, 38 Grampian View, Montrose Angus. Tel: (0674) 76503.

■ Heil EQ300 micro-phone equaliser. Give your station increased talk power, wired by Ammcom to suit Yaesu 8 pin but easily changed to suit your own rig. Mike gain plus 20dB boost or cut at 490Hz and 2400Hz, can be used with any type of mic and will run into audio processor £35 ono, or swap for HF wave-meter. Tel: 01-247 6097 (day).

■ SB102 TX/Rx SSB/CW inc p/supply spkr, mike, handbooks etc, sell £210 ono AR88LF good working order and clean condx, sell £55. Howard 450, a rare pre-war Rx, USA by Howard Hughes Corp 1937, a collectors item £100 ono, working ok. BC906 freq meter needs tube +45V dc £10. Tel: (0908) 314095.

■ Linear amp 3-30MHz, solid state, CP163X 200W PEP. Cobra 148GTL DX, little used. Linear is 13.8V dc mobile, also SWR power meter, low pass filter, 3 element mini loaded beam (£190) or P/X for 2 metre multi mode FT209R or similar Tx, cash adjustment if necessary. Mr Ray, 40 Little Harlescott Lane, Harlescott Grange, Shrewsbury, Salop SY1 3PY.

■ For sale FT75 ac dc power packs, twelve crystals

FREE CLASSIFIED ADS

used but good, £90. Tiger Z match, plus Tiger SWR meter £45. MM frequencies meter plus probe hardly used £55. TCS 12 transistor plus home made power pack, complete but not tested lately, offers. Large quantity various magazines, mainly SW magazines covering 20 year period, give away before destruction. Tel: 01-437 7186, 1430 to 1630 only, weekdays.

■ IC271E unused going HF £575, also matching ICP515, together £675, cost new £820, or would take in part exchange FT290R or either TR9130, older IC251E, FT77 or WHY, or would swap for FT757GX. Also for sale FDK700AX Mars model £140, postage extra, other rigs considered. Mr Waters, 42 Tregundy Road, Perranporth, Cornwall TR6 OEF.

■ One HF mobile aerial model number MMANT 20/15/10 metre helical with automatic band selection by Lowe Electronics, £25.50 with no base for car mounting. One Codar mains preselector £10. Tel: Clochen 378.

■ Minolta SLR camera SRT101B F1.7 with ERC, sun zoom, macro lens, 35-70mm. Also 28mm Tamron wide angle lens, also auto extension tubes, various filters and Cobra automatic flash gun. I am tired of carrying it around hence price of £200 the lot, or exchange for converted 40CH Reftec or Cybernet rig. M Gibbons, 2 Marton St, Hartlepool, Cleveland, TS24 8PW.

■ CB Barracuda HB940 Cybernet chassis also SWR meter and 4in ext speaker £25. Tel: (0727) 36057. Buyer must collect.

■ Rxs Nems Clarke 1302 VHF/UHF, 55-900MHz, R390/URR £185. Eddystone 888A £65. Eddystone 640 £55. Tuning units, TN28, APR1, TN16, APR4 £15 each. TA33JR antenna £45. R Davey, 53 Stalham Road, Hoveton, Norwich, Norfolk. Tel: Wroxham 3153.

■ Newdos 80 V20 for TRS80 model 1, includes manual and articles. £50 (£120 new). Oric-1 481C computer plus some software £50. Various programs on tape and disk for TRS80 model 1. Send SAE for lists. Also large quantity of books for TRS80. TRS80 model 4P portable and DMP110 printer, Scripsit, Visicalc, Newdos 80 V20 plus other programs: £1,000 or offers. Mr Berks, 43 Milford Court, Gale Moor Avenue, Averstoke, Hants PO12 2TN. Tel: Gosport 520204.

■ HRO with PSU and six coil packs covering 0.9 to 30MHz. BC221 HET freq meter, also Radio and TV Servicing vols 1 to 5 and six more volumes 1955 to 1963. Radio and TV Engineers Handbook, Radio and Electronics Constructor 1976 to 1979, all in good condition. Offers to Sam Tel: Preston 27191.

■ Crusader X communication radio 12 bands, long, medium, 4 short, 5 VHF, UHF band, digital BFO, squelch, mains battery, portable de luxe, £100 as new. Eddystone marine receiver model 1004, 7 range plus pretuned channel 150-535KHz, 1.6-30MHz £75. Weale, 1 Candy Croft, Bookham, Surrey KT23 4BZ. Tel: Bookham 56741.

■ Aerial rotor. Fuba stereo 8 aerial. Plemi UHF TV aerial, 91 element. Ant-ference Band I/III aerial. All little used £60.00. Buyer collects. Also Fairmate A532320 mobile scanning receiver 110MHz to 161.995MHz and 296MHz to 367.9875MHz, £60.00. K L Jenkins, Old Fire Station, Pill, Avon BS20 0DH. Tel: (027581) 4858 office hours (Bristol area).

■ Five TVs, various. Eight record players, tape recorders, radiogram, music centre, several meters, burglar alarm and keyswitch, old vernier potentiometer. Various working orders, several kilos electro junk. Lot £60 ono. Must, repeat must, sell. Swap for scope? unused components? Good Combo amp? Someone make an offer! Would be a shame to dump everything but time is running short. Junction 35 M1, then second right. S Harper, 8 Birchtree Road, Thorpe Hesley, Rotherham, South Yorks S61 2TH.

■ AR22R rotor, new £35. FT101 series workshop manual £20. Datong Morse tutor £25. FRG7700M £225. Triband 10/15/20 trapped vertical dipole £15. SX200N scanner £210. Polaroid 350 £50. Sentinel HF pre-amp £5. Minox B £50. Audio/visual IFR training course, approved fan, projector, manuals, records £95. SM-D100 stereo mic £15. Record-a-call remote 80A telephone answering machine £100. Philips ultrasonic burglar alarm £10. Copley-Max, 'Upper Durford', Durford Wood, Petersfield, Hants GU31 5AN. Tel: (0730) 892143.

■ Collins R278 UHF Rx, 1800 channel 225.0 to 399.9MHz. Good condition, motor tuned, xtal

controlled oscs mains input. With manual, working F/B, 19in rack cabinet heavy unit £85. Tel: Leeds 677101.

■ Tektronix scope 502, good condition, complete with manual £50. Surplus TV panels to clear, most makes and types available, going very cheap, also transporter valves, tubes etc. Mr A Boyskill, 129 Lyminster Road, Sheffield. Tel: (0742) 311191 after 6pm.

■ Major M588 multimode CB rig, AM, FM, USB, LSB works very well. Very good condition, needs only new crystals to enable use on ten metre band, £75. Tel: Milborne Port 250 526.

■ 123 spy set, perfect order with xtals, reformer handbook, clandestine aerial and headphones. All complete in original transit case. £95 carriage paid. Roberts. Tel: Hereford (0432) 267876.

■ Marconi Atlanta gen coverage, HRO, Marconi, Mercury, new, secondhand valves, CRTs. Jones plugs, sockets. WS46 for spares, offers or exchanges for WW2 gear. Mr D J Skilton, 40 Mid-Street South, Nutfield, Redhill, Surrey. Tel: Nutfield Ridge 2888.

■ Trio R2000 communications receiver with VC10 VHF converter 118 to 174MHz, very good condition, £430 ono. J A Jones. Tel: (0405) 61872.

■ Pye audio oscillator, 20Hz to 20KHz old but working, Solartron oscillator 25Hz to 500KHz (large), (untested), Marconi electronic voltmeter TF2604 (untested), model 26 valve voltmeter old wooden case type (working), AVO allwave oscillator 95KHz to 80MHz (untested), Taylor model 45C valve tester and CRT box (untested), Greysaw CR bridge CR50 (untested), Vidor 351 battery valve portable radio (working), 5 off PY500A valves, 6 off PL519 valves, offers. SAE to N Covington, 25 Ridge Road, Letchworth, Herts SG6 1PW (no callers). Tel: Letchworth 79681 (evenings).

■ 400 off 1000µF/50 volt tag end caps, 400 off FM aerial matching baluns (suit hi-fi etc), 75ohms to 300ohms with 6 inches co-ax and plug! 5 packets each of 10,000 6BA zinc plated plain washers, valves, UABC60/50p each, UCC85/50p each, UCH81/50p each, UL84/60p each, EF92/50p each, ECH81/50p each, ECH84/50p each, EF41/£2 each, ECC83/50p each, 2 off KT88 gold lion £18 each, 2 off KT66 USA £7 each, ZM1172 offers, B7G skirted 15p each, B9A skirted 20p each, UX5 ex-equip (suit 807) 25p each, post please estimate. SAE to N Covington, 25 Ridge Road, Letchworth, Herts SG6 1PW. Tel: 79681 (evenings).

■ T199/4A software. Morse programs, random groups, plus plain language £5.00. QRA and Maidenhead Locator programs £5.00. 'Word Writer' word processor, extended basic £5. Daiwa 70cm masthead pre-amp, boxed unused £20.00. Philips 1500 video recorder, working, good video heads, 3 tapes, ideal for ATV £25. 13.8V power supply to match linear 2 £10. D G Hewitt, 311 London Road, Headington, Oxford OX3 9EJ. Tel: (0865) 67165.

■ Trio 2200G 2 metre, FM handy portable, fitted S19-23 R3-7 and Raynet. Complete with nicads, charger ER case shoulder strap and manual. Good condition £75. S Tubb, 11 St Andrews Road, Bexhill on Sea TN40 2BQ. Tel: Bexhill 215619.

■ £110 will buy you: Kenpro KR400RC rotor with cable and upper bracket, Jaybeam 10XY/2m two metre, ten element crossed beam, SA450 two way aerial switch, support pole and other bits and pieces. All in very good condition. Neil Billingham, 49 Lancaster Close, Gt Eccleston, Nr Preston, Lancs. Tel: (0995) 70927.

■ Icom R71E 4 months old, absolutely mint cond. Still under guarantee £550. Dressler ARA30 active antenna cost £86.00, never yet used, £70.00, first to see will buy. Save 21%. Tel: (01) 272 2465, any evening.

■ Sony ICF2001 general coverage receiver AM/SSB/CW with FM broadcast, PLL synthesizer, six memory, scanning etc. All complete with original packing and mains PSU little used. £90 ono. Everington, 73 Prospect Crescent, Whitton, Middx TW2 7DZ. Tel: (01) 894 7051.

■ Shack clearance, packs of assorted parts, large and small. Super selection contains at least 1 meter, 2 relays, 1 motor, 1 transformer, 250 new nuts, bolts, washers, 200 new solder tags plus resistors, capacitors, transistors, ICs etc. Guaranteed min weight 2Kg. Send £4.90 plus £2.10 postage to K Bailey, 40 Seymour Close, Selly Park, Birmingham B29 7JD.

■ Icom ICR70 HF Rx mint and boxed with Yaesu FRT7700 tuner, £450, no offers. Tel: (0883) 43534.

■ Oscilloscopes: Telequipment D61a dual beam, probes etc, excellent condition £150. Cossor CDU130 portable batt/mains scope, new 4Ah nicads, service manual, probes, adaptors, leads. Vgc £140. Technicolor micro video, portable player/recorder, model 312E, mains adaptor/charger/RF unit. All leads, camera-cables, strap manuals £250. Pioneer SR202W reverb pre-amp, as new, offers? Matthey video low-pass filters 1MHz and 2MHz, brand new, boxed £40 each. RCA monochrome CCTV camera with 8.5mm f1.5 and 25mm f1.9 lenses, incl mains cables and long video cable, good condition £50 ono. 3 RCA TC1020X CCTV cameras with 16mm f1.6 lenses, brand-new, unused for project, in original boxes, £150 each. Box of 10 KCA60 U-matic tapes-never used £70. This is a clearout of all my surplus equipment. I could arrange carriage at cost. Telephone after 6pm: Paul (0224) 895395.

■ Cossor scope mod 1071K double beam £30. Eddystone HF940 com/Rx set £95. Buyer collects. Also brand new comps. SAE list. All items fully working. Also DP7-5 scope CRT £5+ post. 2m Tx/Rx Storno 50 watts base station £49. X'tal ch, buyer collects. Tel: (0440) 705216 Bede.

■ Standard C58 soft case nicads charger, boxed, manuals etc. CMB8 mobile bracket for above £210 ono. Icom IC2AT US version IC2E, base charger, 2 spare nicad packs. Spk-mic, leather case, boxed, manuals etc, £170 ono. Trio 9R59DS SW Rx, good cond, £50 ono. MM 2m converter to suit Trio, £10 ono. Deliver locally or carriage at cost. Phone after 6pm. D Bosworth G4NAC, 105 Kingsley ave, Kettering NN16 9ES. Tel: (0536) 523979.

■ Standard C146A handheld 2m R3, 6, 7, S20, 21 inc nicad charger etc, £60. Eagle AA2 stereo audio amp £20. G3PTU QTHR. Tel: (0484) 606506.

WANTED

■ Early FT101 up to FT101E considered. Also require FT290R or mobile 2m multimode. Must be in very good condition. Good price paid. David. Tel: (04024) 57722.

■ Anything for ZX81/16K inc software but especially to copy CW from receiver. Any converters. Also cheap rotor and 2m beam or a colinear. Also valves for AR88D. Any mods for AR88D, especially how to fit S-meter, even an external one. Does anyone have a genuine AR88D S-meter? Could help with delivery. WHY. Eric Parkes, 1 Silkstone View, Platts Common, Barnsley, Yorks.

■ B44 MKII army transmitter/receiver information required, circuit data or conversion data to 70MHz, can you help? HS Yorke, 9 Broomlea, Kelso TD5 7RB. GM31KD. Tel: Kelso 23386.

■ R1000. G4LLQ. Tel: (0608) 811102 (Oxon).

■ Yaesu FT902DM must be in absolutely mint condition, good cash price paid. G3BRD. Tel: (0323) 897313.

■ HAC triple 'T' transistor receiver or kit. Tel: 01-451 3093.

■ FRG7700 as new (or similar). Gloucester area. Tel: (0452) 423908.

■ Labgear LG300 circuit diagram and any other info for this transmitter. All costs met and £4 offered. Peter Gordon, Dormer House, Walpole Drive, Ramsey, Isle of Man. Tel: (0624) 812528.

■ General coverage receiver, prefer digital and 144MHz equip hand held or base. Offered LAR HF omnimatch all band incl WARC rated 250W plus triple meter unit SWR output, modulation rated 500W. Panasonic stereo cassette recorder vgc. £25. John Randall, G3OAZ, 243 Paddock Road, Basingstoke, Hants. Tel: (0256) 465126.

■ Belcom LS102L, Trio 820 Rx Racal freq counter, exchanges cash etc. Tel: (0908) 314095.

■ Ten-Tec 263 VFO. Trowell Hamlyn. Saxon Ave. Minster, Sheerness, Kent ME12 2RP. Tel: (0795) 873100.

■ TR100 receiver, one owner, mint condition model only. Please contact: Razavi, Top-flat, 16 Buxton Road, Brighton, Sussex.

■ FT707, also good communication set or 1355 ex WD. Tel: (0283) 221870.

■ FT290 in exchange for FRG7 with inst book. Plus sound cine camera and sound cine projector, cash value of which exceeds £275. Roy Johns, 20 Grangefield Avenue, Rossington, South Yorkshire, DN11 0LS.

Amateur RADIO SMALL ADS

DW ELECTRONICS G3 XCF

Amateur Radio Supplies
71 Victoria Rd, Widnes
Tel: 051-420 2559
Open Mon-Sat 9.30-6 (closed 1.00pm Thurs)
We supply Yaesu, ICOM, Tonna, Jaybeam,
Microwave Modules, Datongs etc

MORSE TUTOR

£4.00 on cassette. £8.50 on microdrive for Sinclair Spectrum. 4 to 19 words per minute, variable spacing, variable groups of random letters, numbers or mixed; Random sentences, own message, single characters and variable pitch. Feedback on screen, printer, or speech (Currah Microspeech 48K only) and repeat facility, 16K and 48K versions on one cassette 48K only on microdrive.

WD SOFTWARE

Hilltop, St. Mary, Jersey, C. Islands
Telephone (0534) 81392

R J PRODUCTS

9 Somers Rd, Welham Green,
Hatfield, Herts AL9 7PR
07072 69334

VIDEO RECORDER THEFT!!!

VALUGUARD

Although designed to protect Video Recorders, the VALUGUARD can protect any valuable, ie computer, TV, Ham Radios etc. **£27.50**

CAR THEFT!!!

IMOBILIZER

(Neg chassis Petrol engines only). This unit connects into the ignition system of a vehicle and will only allow it to start after a 'Personal' trigger has been operated. It also resets itself automatically after the ignition has been turned off for 20 seconds. **£15.20**

TRADE ENQUIRIES WELCOME
ALL PRICES INCLUDE P&P
SAE FOR DETAILS
PROPS RT + VEL WAGSTAFFE

USED EQUIPMENT CENTRE

★ Buying/Selling? ★
RCQ Electronics for the Best Deal. Tel:
Hornchurch 55733 or send SAE for current list,
RCQ Electronics,
65 Cecll Avenue, Hornchurch, Essex

NEXT ISSUE OF

Amateur RADIO

ON SALE
Thursday 23rd May

ALPHA KEYS

Precision engineered keys for the connoisseur. Twin or single paddle keys individually made to be one of the smoothest and lightest movements ever. For the fast operator.

CAVITY WAVEMETER

One wavemeter to cover 144MHz to over 2500MHz. Can measure RF as low as 50 Milliwatts with suitable meter. Also now short version to cover 430MHz to over 2500MHz.

10GHz WAVEMETER KIT

A pre machined cavity to make a 10GHz wavemeter using your micrometer. Can be fixed direct to your wave guide.

COAXIAL RELAY KITS

The cavity block is pre machined to take your BNC or N type sockets.

Send large SAE for full information to:

PAUL SERGENT G4ONF
6 GURNEY CLOSE
COSTESSEY
NORWICH NR5 5HB
Tel: (0603) 747782

Amateur RADIO

This method of advertising is available in multiples of a single column centimetres — (minimum 2cms). Copy can be changed every month.

RATES

per single column centimetre:
1 insertion £7.00, 3 — £6.60, 6 — £6.30, 12 — £5.60.

SMALL ADS

AMATEUR RADIO SMALL AD ORDER FORM

TO: Amateur Radio · Sovereign House
Brentwood · Essex CM14 4SE · England · (0277) 219876

PLEASE RESERVE.....centimetres by.....columns

FOR A PERIOD OF 1 issue..... 3 issues..... 6 issues..... 12 issues.....

COPY enclosed..... to follow.....

PAYMENT ENCLOSED:..... £ —

Cheques should be made payable to
Amateur Radio. Overseas payments by
International Money Order

CHARGE TO MY ACCOUNT.....

COMPANY

ADDRESS

SIGNATURE TELEPHONE.....

C P I

VALUABLE SPACE FOR SALE!

Telephone the advertising department on: 0277 219876 for details

USED AMATEUR EQUIPMENT ? I BUY, SELL & EXCHANGE!
My low overheads mean the best Possible Deal for YOU!

Whether Buying or selling Phone Dave on HORNCHURCH (040 24) 57722 ANYTIME, or send SAE for latest list to:

G4TNY ELECTRONICS
132 Albany Road, Hornchurch, Essex. RM12 4AQ.
New Equipment Supplied at Competitive Prices!
Marine Radio also Bought and Sold.

AKD Armstrong
Kirkwood
Developments
10, Willow Green, Grahame Park Estate, London, NW9
Tel: 01-205 4704

VHF/UHF ABSORPTION WAVEMETER
Covers 120-450 MHz. Extremely sensitive Low-profile. Requires PP3 battery £24.95



HIGH PERFORMANCE RF FILTERS
SLIMLINE, ATTRACTIVE APPEARANCE
Used by British Telecom, Thorn-EMI, ITT, Telefusion, Granada etc.

Standard range terminated in Belling Lee plug/socket (75ohms) - others to order

Model TNF2 Tuned Notch Filters (Braid & Inner) for 2, 10, 15, 20 Metres & CB (state which) £7.50
The TNF2 range have a very low insertion loss and very high rejection over the band for which they are supplied. They are the best possible answer for aerial borne interference from a single known frequency or frequency band.

Model RBF1-70cms Notch Filter (inner only) £7.75
Model BB1 Braid Breaker £3.95
Also available, 3 High Pass models and a "Radar Blip" filter for VCRs. Please send A4 or C4 stamped addressed envelope for filters data sheet and price list.

All items are manufactured by AKD in UK and carry a two year guarantee plus 14 day money back promise (no reason required).

Items usually despatched within two days from receipt of order. Prices include VAT, postage & packing.
(Prop.) J.W. ARMSTRONG
ALSO AVAILABLE FROM MOST LEADING AMATEUR RADIO DEALERS

XXX ADULT VIDEO CLUB
For the genuine adult films. Available only from ourselves. Ring
0924-471811 (24hrs)
For the intimate details or write
ADULT VIDEO CLUB
P.O. Box 12, Batley, W. Yorks.

QSL Cards
Printed on white or colour gloss cards, printed to your own design.
Please send SAE for sample to:
Caswell Press
21 Homethorpe Ave, Redhill, Surrey
Tel: (Redhill) 71023

★ SERVICE MANUALS ★
from just £1 POST FREE.
For ALL electronic equipment. Any age, make, model. Amateur Radio, Test Equipment, Televisions, Colour & Mono, Vintage Wireless, Audio, Music Centres, Video etc. Thousands stocked.
see enquiries and quote BY RETURN.
MAURITRON TECHNICAL SERVICES
Dept. AR, 8 Cherry Tree Road,
Chinnor, Oxon, OX9 4QY.

G4BMK RADIO SOFTWARE
DRAGON/TRS80C - RTTY+ASCII CW AMTOR
Return old RTTY program with £5 for upgrade to mk3 RTTY+ASCII
Return RTTY/CW cart. with £25 for the addition of AMTOR s/w
CBM64 - RTTY - tape £11 disk £14
CBM64 - CW Tx/Rx tape £10 disk £12
VIC20 - RTTY - tape £10
ATOM - RTTY - Utility ROM £16
All are split-screen type-ahead.
State callsign (if any). SAE for details
GROSVENOR SOFTWARE (AR)
2 Grosvenor Road, Seaford, Sussex BN25 2BS
TEL: (0323) 893378

THE PERFECT COMPLEMENT TO AMATEUR RADIO

Packed with construction projects and the latest technology plus pages of readers' classified ads



- Take out a POST-FREE (UK) sub while offer lasts
- Delivery to your door by publication date each month
 - Inflation proof - price guaranteed for 12 months

On sale NOW at your newsagent and at equipment dealers

RADIO & ELECTRONICS WORLD SUBSCRIPTION ORDER FORM

To: Subscription Department • Radio & Electronics World • 513 London Road • Thornton Heath • Surrey • CR4 6AR. Tel: 01-684 3157

PLEASE SUPPLY: (tick box) for 12 issues, all rates include P & P

Inland	World-Surface	Europe-Air	World-Air
£11.80.....	£13.10.....	£19.20.....	£25.90.....

NAME.....
ADDRESS.....
.....
.....Postcode.....

PAYMENT ENCLOSED: £ —

CREDIT CARD PAYMENT VISA 

Signature

Cheques should be made payable to Radio & Electronics World. Overseas payment by International Money Order, or credit card.

ADVERTISERS INDEX

Arrow Electronics.....59	Microwave Modules 6
Centre Electronics.....22	Rapid Results..... 37
PM Components4,5	RAS (Nottingham)..... 22
WPO Communications7	
Dewsbury Electronics60	Sandpiper Communications..... 18
Edwardschild.....59	ITA Specialist Officers 9
Glenstar22	Technical Software 18
Hately Antennas.....59	Thanet Electronics 42,43
Keytronics.....29	Viewflint..... 18
Marco Trading38	W H Westlake 37
	R Withers 2
	Wood & Douglas 18

Amateur RADIO

ADVERTISING RATES & INFORMATION

ABC membership approved pending first audit Jan-Dec 1985

DISPLAY AD RATES		series rates for consecutive insertions			
depth mm x width mm	ad space	1 issue	3 issues	6 issues	12 issues
61 x 90	1/8 page	£66.00	£62.00	£59.00	£53.00
126 x 90 or 61 x 186	1/4 page	£115.00	£110.00	£105.00	£92.00
126 x 186 or 263 x 90	1/2 page	£225.00	£210.00	£200.00	£180.00
263 x 186	1 page	£430.00	£405.00	£385.00	£345.00
263 x 394	double page	£830.00	£780.00	£740.00	£660.00

COLOUR AD RATES		colour rates exclude cost of separations	series rates for consecutive insertions		
depth mm x width mm	ad space	1 issue	3 issues	6 issues	12 issues
126 x 186 or 263 x 90	1/2 page	£305.00	£290.00	£275.00	£245.00
263 x 186	1 page	£590.00	£550.00	£530.00	£470.00
263 x 394	double page	£1,130.00	£1,070.00	£1,010.00	£900.00

SPECIAL POSITIONS	Covers: Bleed Facing Matter:	Outside back cover 20% extra, inside covers 10% extra 10% extra [Bleed area = 307 x 220] 15% extra
-------------------	------------------------------------	--

DEADLINES		*Dates effected by public holidays			
issue	colour & mono proof ad	mono no proof & small ad	mono artwork	on sale thurs	
Jun 85	25 Apr 85	1 May 85	3 May 85	23 May 85	
Jul 85	30 May 85	5 Jun 85	7 Jun 85	27 Jun 85	
Aug 85	27 Jun 85	3 Jul 85	5 Jul 85	25 Jul 85	
Sep 85	25 Jul 85	31 Jul 85	2 Aug 85	22 Aug 85	

CONDITIONS & INFORMATION			
<p>SERIES RATES Series rates also apply when larger or additional space to that initially booked is taken. An ad of at least the minimum space must appear in consecutive issues to qualify for series rates. Previous copy will automatically be repeated if no further copy is received. A 'hold ad' is acceptable for maintaining your series rate contract. This will automatically be inserted if no further copy is received. Display Ad and Small Ad series rate contracts are not interchangeable.</p>	<p>If series rate contract is cancelled, the advertiser will be liable to pay the unearned series discount already taken. COPY Except for County Guides copy may be changed monthly. No additional charges for typesetting or illustrations (except for colour separations). For illustrations just send photograph or artwork. Colour Ad rates do not include the cost of separations.</p>	<p>Printed — web-offset. PAYMENT All single insertion ads are accepted on a pre-payment basis only, unless an account is held. Accounts will be opened for series rate advertisers subject to satisfactory credit references. Accounts are strictly net and must be settled by the publication date. Overseas payments by International Money Order or credit card. FOR FURTHER INFORMATION CONTACT Amateur Radio, Sovereign House, Brentwood, Essex CM14 4SE (0277) 219875</p>	<p>Commission to approved advertising agencies is 10%. CONDITIONS 10% discount if advertising in both Amateur Radio and Radio & Electronics World. A voucher copy will be sent to Display and Colour advertisers only. Ads accepted subject to our standard conditions available on request.</p>

YOUR ONE SOURCE FOR RADIO

ARROW

ELECTRONICS LIMITED

5 The Street, Hatfield Peverel, Essex
Tel: Chelmsford (0245) 381626/381673
Telex: 995801 (Ref A5)

FOR IMMEDIATE DESPATCH
phone with your Access, Eurocard,
Mastercharge or Visa number to

0245 (Chelmsford) 381673 or 381626.
Telex 995801 (ref: A5)

OVER 500 LINES AT UNBEATABLE PRICES

IT WILL PAY YOU TO PAY US A VISIT!

THE NAME YOU CAN TRUST FOR PRICE & AFTER SALES SERVICE

INTEREST FREE FINANCE

Yes, you really can spread the cost of your new rig over 6, 9 or 12 months and ARROW pays the interest charges for you

Three schemes: 22% deposit, balance over 6 monthly payments
1/3rd deposit, balance over 9 monthly payments
50% deposit, balance over 12 monthly payments

And remember, you pay no more than the normal RR price!!
Just call us and we will send agreement for your new gear same day!!!



One of the country's largest Yaesu stockists you can see all the new models at ARROW plus get the very best deals—take advantage of our Interest Free Credit or call us for a really keen price—Nobody does it better!!!

DAIWA produce a marvellous range of PSUs—see the variable volt PS300 or the Cross needle SWR bridges. New 2M RTU/SWR meter. And some of the best HF tuning units around.

"Bencher" Paddles stocked and "Vibroplex" Hi-Mound see and try a key or paddle at the ARROW shops. BNOS make some of the finest British made PSUs we have seen and the Linears are superb with 5 year warranty

APPROVED TRIO DEALER

YES! it's true ARROW became fully franchised dealers for TRIO in December and are now fully stocked with all the latest models



AR2001 Receiver 25/500MHz



Rotators stocked include the new Daiwa multi-torque with up to 4 motors possible.

Also the full Daiwa range at competitive prices. Kenpro from KR2000RC to KR250 inc KR500 Elevation type

AUTHORISED ICOM DEALER



IC751, IC745, R71, R70, IC271E, IC471E, IC2E, IC4E, IC02E, IC04E, all stocked with accessory ranges—Call us for price

Send us an SAE for details of the new TET beams with 40 metre band 11 & the minibeams with the same gain as fullsize



WELZ full range stocked

Come and see the new Trix-tower at Chelmsford, 30 or 40ft folds down really low, tilt or wall mounted. Keen prices

Our normal despatch is *one or two days* (as thousands of satisfied customers will tell you). Subject to manufacturers supplies being available. CARRIAGE FREE on all orders of £300 value and over (UK Mainland only)

Access and Barclaycard accepted. Save time—phone over your order with your Access or Barclaycard number. Express delivery can be arranged on all items for a total charge of £7.50. Please phone for details. This offer applies to UK Mainland only.

N.B. The F.O.C. carriage offer does *not* apply when Express Delivery is requested.



ORDER BY POST

All mail orders to ARROW ELECTRONICS LTD
5 The Street, Hatfield Peverel, Chelmsford, Essex

Hatfield Peverel showrooms which are just off the A12 trunk road, are open 9-5pm Mon, Tues, Weds, Fri, Sat. Closed all day Thursdays. Approach by road via M25 & A12. By rail to BR Hatfield Peverel (3 mins from shop). We will taxi you back to rail station with heavy equipment. Buses from Chelmsford and Colchester pass the door. Free parking in our own car park. Local repeater GB3DA R5.

Scottish customers welcome at ARROW ELECTRONICS (SCOTLAND) 51 Hyndland Street, Partick, Glasgow. Tel: 041 339 6445 ask for Bill GM0ARO. Parking free outside the shop, which is near the Clyde Tunnel and Kelvin Museum. Open six days (closed Sunday) 9-5.30

At ARROW ELECTRONICS (MIDLANDS) Tel: 0858 62827 you will find Alan G4TZY who will be pleased to assist you. Alan lives at 33 Fairway, Market Harborough, Leics, but please telephone first.

We stock: Trio, Yaesu, Musen, Icom, Sommerkamp, Standard, Mutek, Datong, Tonna Antennas, Daiwa, Kenpro, Adonis, Sagant, TET Antenna Systems, G-Whip, Tono, Tasco Telereaders, Ainco, Bencher, Tokyo Hi-Power, Revtec scanners, Vibroplex, R5GB Books and many other titles especially RTTY and intercept frequency books, G4MH Beams, Oscar Antennas, Welz, AOR, Microwave Modules, BNOS Power Units and Linears, Swedish Keys, Hi-Mound keys and paddles. Signal Communication Airband receivers, ICS, Trio Test Instruments, RKD filters, Wire, Cable, Coax, Insulators, Trix-tower masts, Spares and tubes galore

COMPARE THE REST — THEN COME TO THE BEST



HATELY ANTENNA TECHNOLOGY (GM3HAT)
1 Kenfield Place, Aberdeen AB1 7UW, Scotland, UK

DIPOLE OF DELIGHT

Our Antennae are efficient, quiet, and broadband. On the bands they cover they do not require an ATU. That is why so many purchasers have bought second, third, even fourth antennae, following impressive results with their first one.

The Dipole of Delight is our trade name for the CAPACITOR DIPOLE detailed at the IEE Conference on HF Communication Systems and Techniques in our paper 'Multiband Dipole and Ground Plane Antennas' late February 1985. The centre cut of each dipole is centre-tapped by capacitors which give correct BALUN behaviour from coax to dipole and also allow the several dipoles within the group to develop individual band resonance and radiation.

All antennae will radiate 1kW pep. Four page leaflet, send SAE or two IRC's.

MULTIBANDERS	DD USA 7/21 21m (69ft)	£28.00	Homologized prices for UK and DX
	DD 10/18/24 15m (50ft)	£56.00	
	DD 14/21/28L 10.7m (36ft)	£46.50	
	DD 7/14/21/28L 21m (69ft)	£58.00	
MONOBANDERS	DDM 10 length 15m (50ft)	£23.50	UK inc VAT
	DDM 14 10.7m (36ft)	£15.50	First Cl Mail
	DDM 21 7m (24ft)	£11.50	DX inc Air Mail
	DDM 28 5.8m (19ft)	£11.50	

Price does not include recommended 5mm 50ohm coax (available for UK antenna purchasers at 35p per metre, parcel post paid. PL259 inc reducer £1.20). Antennae are mostly ex-stock
One month money back guarantee. Payment by personal cheque in any currency (where national law permits).

Proprietor: Maurice C Hately, M SC, MIEE, Chartered Electrical Engineer (GM3HAT)

Amateur Radio smart blue binders, each holding up to 12 issues keeping them in prime condition.

BINDERS!

Only **£4.25** inc p&p

Overseas readers please add 30p
Please allow 14 days for delivery

Send your orders to:

Edwardschild Ltd, 28 Shenfield Cres.
Brentwood, Essex CM15 8BN

DEWSBURY



ELECTRONICS

APPROVED
TRIO
DEALER

APPROVED
TRIO
DEALER



THE NEW ELECTRONIC KEYS STAR – MASTERKEY

The STAR-MASTERKEY has been designed with both the established CW operator and the newcomer in mind.

Featuring full IAMBIC keying, together with the facility for SEMI-AUTOMATIC keying, the STAR MASTERKEY has DASH/DOT memories, SPEED ranges from 1-55 WPM, and the facility to allow the user to select either POSITIVE OR NEGATIVE keying, thus suiting both the latest transistorised transmitters and the valved transceivers.

The built in SIDETONE OSCILLATOR and LOUDSPEAKER offer the facility of monitoring the generated morse code. For practice purposes a HEADPHONE socket has been provided on the rear panel.

Power may be derived from a user supplied 9 volt battery (internally mounted) or from a 6-15 volt DC external power supply, making the KEYS ideal for shack or field day and portable use.

The STAR-MASTERKEY is attractively packaged in a custom designed black vinyl covered steel enclosure with screen printed, anodised aluminium front panel.

The STAR-MASTERKEY has been BRITISH built in response to the soaring cost of imported equipment, and is fully guaranteed for a period of five years.

The STAR-MASTERKEY is available, complete with DC power lead and all necessary plugs from DEWSBURY ELECTRONICS and other discerning dealers for only £49.95 including VAT.

Available by mail order Post and Packing £3.00.

Suitable mains power supply £10.00 P&P £1.50 Paddles available for the above from £15.00.

Dewsbury Electronics offer a full range of **Trio Equipment** always in stock

We are also stockists of DAIWA – MET ANTENNAS – MUTEK – WOOD & DOUGLAS – TASCOS TELEREADERS – MICROWAVE MODULES – IC's AMTOR – AEA PRODUCTS – DRAE

Dewsbury Electronics, 176 Lower High Street, Stourbridge, West Midlands

Telephone: Stourbridge (0384) 390063/371228

Telex: 337675 TELPES G

VISA

Instant finance available subject to status. Written details on request.

