

MR F W PREZIOSI
8 EASTGATE CRES
SCARBOROUGH ONT

EPM
CRC
QEL
1211C

ELECTRONICS AND COMMUNICATIONS

An Operational View Of Equipment Reliability
by R. Drenick

A Heat Dissipating Shield For Electron Tubes
by Allan Q. Mowatt

The Skill Of Functional Management
by C. R. Miner

A Packaged Nuclear Training Laboratory
by O. Kenton Neville, Ph.D.

APRIL 1958



AN AGE PUBLICATION
TORONTO, CANADA

AROUND THE WORLD

again and again!

A fair idea of the extent to which Stackpole fixed composition resistors are used may be gained from this illustration.

Laid end to end, the total number of these tiny components produced to date by Stackpole would extend many times around the world.

Such acceptance is a tribute, both to the high quality of the resistors and to the dependable, personalized service, that Stackpole puts behind each resistor order.

CANADIAN STACKPOLE LTD.

550 Evans Ave., Etobicoke
Toronto 14, Ontario

Type CM-1/32
($\frac{1}{2}$ watt)

Made in Canada . . . By
Canadians . . . In this modern
21,000 square-foot building.



Type CM-2
(2 watts)

Type CM-1
(1 watt)



STACKPOLE RESISTORS

FIXED COMPOSITION

Available for your convenience through leading parts distributors.

MAGNETRONS

FROM CANADIAN MARCONI

Vital electronic components now produced in this country

A million dollar production plant, complete with micro-wave tube development laboratories, now assures Canada of a domestic supply of magnetrons for vital defence and navigation equipment.

These same laboratories are being staffed and equipped to deal with advanced work on magnetrons and other micro-wave devices. We would welcome the opportunity to help you with any of your micro-wave tube problems.



Canadian Marconi's new Electronic Tube plant in the town of Mount Royal, Quebec.

Electronic Tube and Components Division

CANADIAN **Marconi** COMPANY

830 Bayview Avenue, Toronto, Ontario

BRANCHES: Vancouver • Winnipeg • Montreal • Halifax • St John's, Nfld.

NEW OHMITE®

"TAN-O-MITE®" TANTALUM CAPACITORS

HIGH STABILITY
FOR -55°C to + 85°C OPERATION
HIGH CAPACITANCE
SUBMINIATURE SIZES
LONG SHELF LIFE

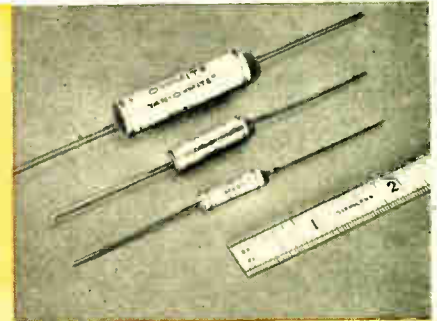
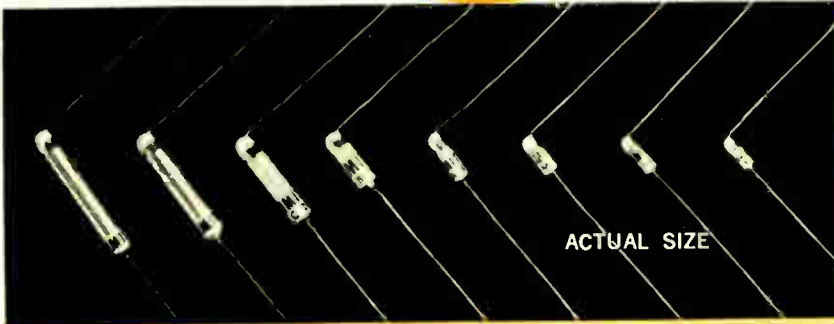

SERIES TW WIRE-TYPE TANTALUM CAPACITORS

These new subminiature, wire-type units feature greater capacitance per unit volume, lower leakage current and power factor, and small capacitance drop at extremely low temperatures as compared to other types of electrolytics. Ultrasmall for low-voltage DC transistorized electronic equipment, these new tantalum capacitors have *high stability, high capacitance, long shelf life, and excellent performance* under temperature extremes of -55°C to + 85°C. Available in eight subminiature sizes; 0.1 to 80 mfd. over-all capacitance range.

SIZE	UNINSULATED		INSULATED	
	D (Inches)	L (Inches)	D	L
*T	.075 (3/16)	.156 (5/32)	.082	.203
*S	.075 (3/16)	.187 (3/8)	.082	.234
*M	.095 (3/32)	.172 (11/64)	.100	.218
*A	.095 (3/32)	.250 (1/4)	.100	.312
*B	.125 (1/8)	.312 (5/16)	.134	.375
C	.125 (1/8)	.500 (1/2)	.134	.562
D	.125 (1/8)	.625 (5/8)	.134	.687
E	.125 (1/8)	.750 (3/4)	.134	.812

Smallest size is .075 (3/16) x .156 (5/32) inches; the largest is .125 (1/8) x .750 (3/4) inches. Five stock sizes (*) are available in a wide range of capacitances and voltages. Units insulated with a tough Mylar® plastic sleeve can be furnished. Write on company letterhead for Bulletin 148B.

SERIES TF FOIL-TYPE

These capacitors are tantalum foil, electrolytic units designed for low voltage AC and DC applications where small size, top performance, and stability of electrical characteristics are required. Units feature unusually long shelf and operating life.

CASE SIZE	D*	L*
J	3/16"	1 1/16"
K	9/32"	7/8"
L	3/8"	1 7/16"

*Add 1/8" to L and 1/16" to D when insulating sleeve is used.

Three sizes now available; .25 to 140 mfd. over-all capacitance range. Standard tolerance is ±20%. Working voltage up to 150 volts. Polar and nonpolar units are available. Bulletin 152. Design and construction meet military specification MIL-C-3965, paragraph 3.3.

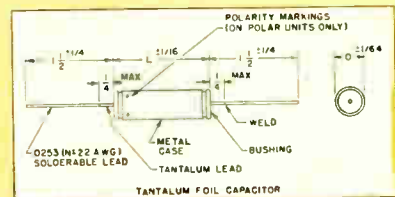
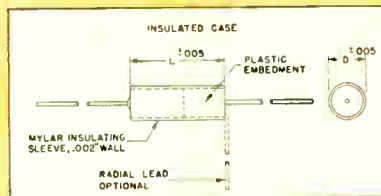
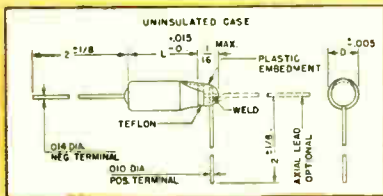

OHMITE®

QUALITY Components

RESISTORS • RELAYS • TAP SWITCHES
RHEOSTATS • TANTALUM CAPACITORS
VARIABLE TRANSFORMERS

OHMITE MANUFACTURING COMPANY
3689 Howard Street, Skokie, Illinois

A. C. Simmonds & Sons, Ltd.
100 Merton St., Toronto, Ont.
C. M. Robinson Co.
1550 Erin St., Winnipeg 3, Man.

For further data on advertised products use page 65.

Electronics And Communications

VOLUME 6

APRIL, 1958

NUMBER 4

FEATURES

An Operational View Of Equipment Reliability	18
by R. Drenick	
A Heat Dissipating Shield For Electron Tubes	22
By Allan Q. Mowatt	
Ultrasonic Thickness Testing In Practice	24
The Skill Of Functional Management	25
by C. R. Miner	
A Packaged Nuclear Training Laboratory	28
by O. Kenton Neville, Ph.D.	
Diversity Radar	30
Portable X-Ray Units In Industry	33

DEPARTMENTS

Editorial	9
RETMA Report	11
CRTPB Newsletter	12
Editor's Page	15
Book Review	34
Business Briefs And Trends	35
New Products	41
News Report	46

President, Norman G. McHardy; Vice-President, Secretary-Treasurer, L. R. Kingsland; Editor, Thomas W. Lazenby; Consulting Technical Editor, Leslie Hill, Ph.D. Eng.; Editorial Assistant, D. K. Trowell; Advertising Manager, H. E. Dallyn; Assistant Advertising Manager, Arthur Dixon; Production Manager, Nevill A. Campling; Business Manager, Clifford A. Sparks; Circulation Manager, Paul A. Irwin; Art Editor, Wm. McReynolds; Photo Editor, Guido Milanesio. United Kingdom and European Representative, Norman F. Keenan, 47 Manchester Street, London W. 1, England. West Coast Representative, Dillenbeck-Galavan, Inc., 266 South Alexandria Ave., Los Angeles 4, Calif.

PUBLISHED BY AGE PUBLICATIONS LIMITED

Founded in 1923 by Norton W. Kingsland

Publishers of Heating, Plumbing and Air Conditioning AGE • Restaurants and Institutions
Automatic Heating • Wine, Beer and Spirits in Canada • Industrial Aeronautics

TORONTO, ONT., CANADA: 31-35 Willcocks Street, Tel. WALnut 2-3115. MONTREAL, QUE., CANADA: Keith Edgar,
116 Rue de Flandre, Montreal 23 (Preville), Quebec, Telephone: OR. 1-2020.

SUBSCRIPTION RATES: Canada, U.S.A. and British Possessions - \$5.00 per year • Foreign - \$10.00 per year.

Contents copyright by Age Publications Limited. No part of this periodical may be reproduced without the consent of the publisher.

Authorized as second class mail. Post Office Department, Ottawa.



Member Canadian Circulations



Audit Board, Inc.

PRINTED IN CANADA
60

where modern styling is required...

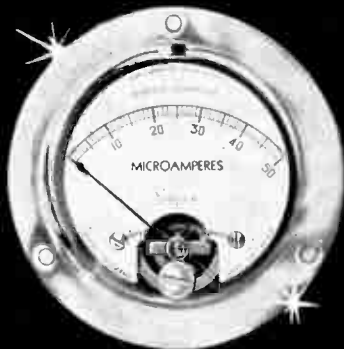

Simpson Model #1421
Transparent Case



Simpson Model #1502
Edgewise

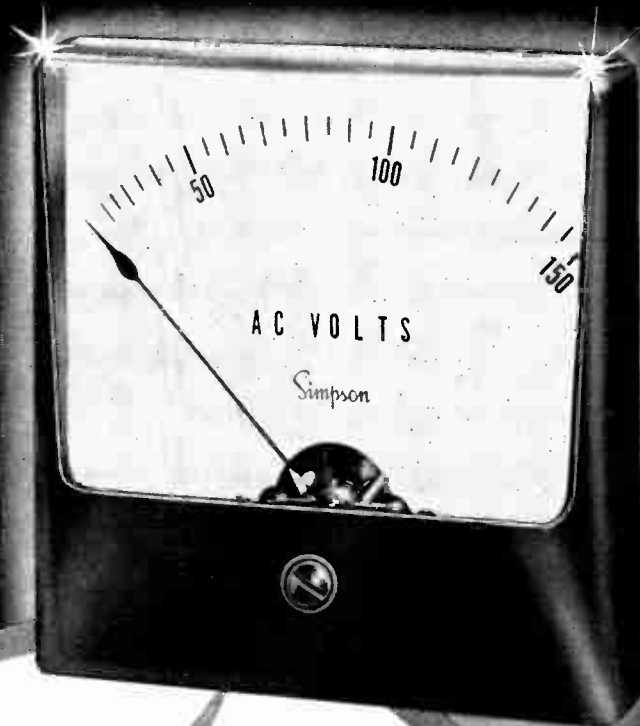

Simpson
Model #1327
Wide-Vue

NEW Simpson PANEL INSTRUMENTS

These NEW Simpson Panel Instruments are not only functional, but sleek and clean of line for ultramodern panel styling. Conservative, traditional case designs still have their place, but with Simpson instruments you have complete freedom of choice.

Circuits too can go modern and Bach-Simpson facilities are completely flexible in all phases of movement design to meet the most exacting or advanced requirements. Never discard any equipment design requiring unusual instrumentation without first consulting us.

IN U.S.A.: SIMPSON ELECTRIC COMPANY,
5200 W. KINZIE STREET, CHICAGO 44, ILLINOIS

Bach-Simpson
LIMITED

1255 Brydges St.

London, Ontario

H-6948

For further data on advertised products use page 65.

Taking the "MISS" out of MISSILES



ACTUAL SIZE OF THE NEW *Bendix* "PYGMY" Connectors

Bendix has developed a "Pygmy" line of miniature electrical connectors that do the work of standard AN connectors one-third the standard weight and size. These mighty midgets combine the outstanding qualities that have made Bendix connectors a by-word in advanced electronic equipment—ruggedness, reliability, serviceability. Bendix "Pygmy" connectors—like all Bendix connectors—are also outstandingly resistant to vibration, moisture and corrosion.

For the vital job of forming safe, reliable electrical connections in today's advance design missiles you cannot do better than specify "Bendix". And if your problem is also one of miniaturization—Bendix "Pygmy" connectors are the best possible answer available today.



AVIATION  ELECTRIC
LIMITED

HALIFAX • MONTREAL • OTTAWA • TORONTO
CALGARY • VANCOUVER

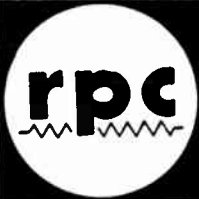

RESISTORS

PRECISION WIRE WOUND • HIGH VOLTAGE • HIGH MEGOHM • HIGH FREQUENCY

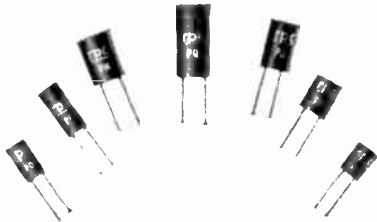

Printed Circuit Precision Resistors

To meet the requirements for printed circuitry, RPC has developed Type P Encapsulated Wire Wound Precision Resistors. Miniature, single ended units designed for easy rapid mounting on printed circuit panels with no support other than the wire leads. Many newly developed techniques are employed in the manufacture of Type P Resistors. These units can be operated in ambient temperatures up to 125°C. and will withstand all applicable tests of MIL-R-93A, Amdt. 3. Available in 6 sizes, rated from 1/10 watt to .4 watt. 1/4" diameter by 5/16" long to 3/8" diameter by 3/4" long. Resistance values to 3 megohms. Tolerances from 1% to 0.05%.

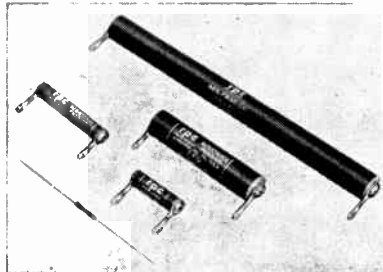

High Frequency Resistors

Used where requirements call for very low inductance and skin effect in circuits involving pulses and steep wave fronts. Depending on size and resistance value, these resistors are usable at frequencies to over 400 mc. Resistance values range from 20 ohms to 100 megohms with tolerance of 20% to 5%. 2 types available.

TYPE F resistors (shown) in 8 sizes from 9/16" long x 0.10" diameter to 6 1/2" long x 9/16" diameter, with lugs or wire leads. Power ratings 1/4 to 10 watts.

TYPE G resistors (not shown), in 6 sizes up to 18 1/2" long. Power ratings 10 to 100 watts.

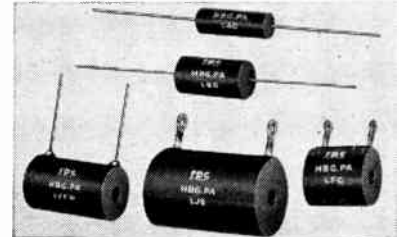

Encapsulated Precision Wire Wound Resistors

RPC Type L Encapsulated Resistors will withstand temperature and humidity cycling, salt water immersion and extremes of altitude, humidity, corrosion and shock without electrical or mechanical deterioration. Type L resistors are available in many sizes and styles ranging from sub-miniature to standard with lug terminals, axial or radial wire leads. Available for operation at 105° C. or 125° C. ambient temperatures. These resistors will meet all applicable requirements of MIL-R-93A, Amdt. 3. Type L can be furnished with all resistance alloys and resistance tolerances from 1% to .02%.



High Voltage Resistors

Type B Resistors are stable compact units for use up to 40 KV. These resistors are used for VT voltmeter multipliers, high resistance voltage dividers, bleeders, high resistance standards and in radiation equipment. They can be furnished in resistance to 100,000 megohms. Available as tapped resistors and matched pairs. Sizes range from a 1 watt resistor 1 inch long x 3/8 inch diameter rated at 3500 volts, to a 10 watt resistor 6 1/2 inches long x 3/8 inch diameter rated at 40 KV. Low temperature and voltage coefficients. Standard resistance tolerance 15%. Tolerances of 10%, 5% and 3% available. Tolerance of 2% available in matched pairs.



High Megohm Resistors

Type H Resistors are used in electrometer circuits, radiation equipment and as high resistance standards. Resistance available to 100 million megohms. (10¹⁴ ohms). For utmost stability under adverse conditions Type HSD and HSK Hermetically Sealed are recommended. Eight sizes from 1/8 inch to 3 inches long are available. Voltage rating to 15,000 volts. Low temperature and voltage coefficients. Standard resistance tolerance 10%. Tolerance of 5% and 3% available. Also matched pairs 2% tolerance.

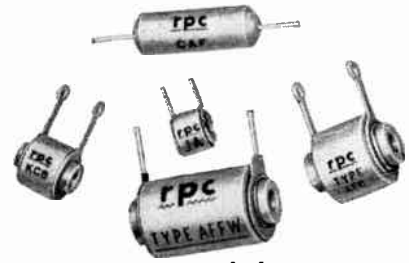

Unsealed Precision Wire Wound Resistors

Unsealed precision resistors are wound on steatite forms and are used for all general requirements. They can be furnished with all resistance alloys in tolerances from 1% to .02%. These resistors will meet the requirements of MIL-R-93A, Amdt. 2, characteristic B. Special winding techniques, impregnation and thermal aging result in resistors of exceptional stability. They are available in a wide variety of sizes, styles and terminal types. Matched resistors, networks and special assemblies can be supplied.

"DISTRIBUTED IN CANADA BY"

CANADIAN
CURTISS-WRIGHT
LIMITED

1980 SHERBROOKE ST. W. • MONTREAL, P.Q.



Electronics And Communications

Volume 6

April, 1958

Number 4

American Domination?

"Canada's engineering profession, heavily infiltrated by foreign specialists, is facing complete domination by the United States as technical personnel flee the recession in their own country for employment in Canadian subsidiaries of U.S. firms . . ."

The above is reported in the first of a series of articles dealing with the Canadian engineering profession and published in a Toronto newspaper.

The position of the engineer in Canada becomes more and more difficult to understand. Not too long ago there appeared to be a crucial shortage of engineers in this country. Now, we understand from leading authorities on the subject, there never was a shortage. Shortage or

surplus, however, it is hard to believe that the Canadian scene is becoming dominated by American personnel if figures recently released by the Association of Professional Engineers of Ontario are any guide to the situation.

In a report prepared by the executive director of this organization it was pointed out that of 563 applications for registration dealt with by the Executive Council on January 31, 35.1 per cent were of Canadian origin and training; 39.9 per cent of Commonwealth origin and training; 2.9 per cent U.S.; and 22.1 per cent European.

While these figures do indicate a trend to the domination of the Canadian profession by foreign born engineers, it is certainly not an American domination.

Five Years Of Publication

With this issue **ELECTRONICS AND COMMUNICATIONS** marks its fifth year of publication.

Five years ago Canadian industry was already conscious of its growing power and world stature. Familiar methods were being transformed by science into shining instruments of a new progress, to be expressed in new technological terms. Electronics was evoking visions of fresh industrial peaks to be scaled, new heights of enterprise to be achieved.

Looking back, one recalls the electronics industry of those days lacked cohesion. The very speed of its growth made it difficult for manufacturers to realize the magnitude of what was happening, the extent and revolutionary nature of the industrial changes taking place.

There had been no "Who's Who" of the electronics industry. Manufacturers knew little or nothing of other manufacturers in the same line of electronic endeavor. Scores of new factories and workshops ministering to the complicated needs of hitherto undreamed of markets were springing up across Canada, reaching out to embrace new types of industry with new applications. But there was no market place, no assured way by which suppliers could tell prospective buyers what they had to offer. There was no established means of communication between manufacturers, no interchange of news about developments and new products, no information center.

In those days a publisher of trade journals, not being immersed in the daily details of industrial operation, but keenly aware of the significance of what was taking place, had the advantage of being able to detect the need of a medium through which the various sectors of the electronics industry could become closely integrated.

It was then, five years ago, that we published the first issue of **ELECTRONICS AND COMMUNICATIONS** as Canada's pioneer publication in this field. It brought an immediate response from readers.

From the first, **ELECTRONICS AND COMMUNICATIONS** sought to exercise a unifying influence, to facilitate communication, to gather and disseminate the information so urgently needed. New ideas, applications, products and uses were, in fact, the main ingredients of the editorial fare we served to readers athirst for the information that filled our pages.

To say that we were right in the course we charted in

those earlier days is not to say that we have ever been fully satisfied with our efforts. All progress is made through trial and error. We have learned—and are still learning — by experience. But our editorial compass showed that we were headed in the right direction. Our readership was assured; its interest and loyalty have grown with the service we have been able to render the electronics industry. The industry, itself, has provided a wealth of information for us to draw upon. And from far and wide, advertisers have rallied to us, swiftly and in growing numbers.

Today, the electronics industry is far more closely integrated. By the very nature of its operations it may never, perhaps, be as compact in its administration and organization as other large industries, or as easily identifiable. But the electronics supplier is no longer frustrated in his search for his own proper market. Information is no longer dammed up at its source for lack of open channels of communication from one manufacturer to another.

In such developments as these, **ELECTRONICS AND COMMUNICATIONS** may modestly but justifiably claim to have played a not insignificant part. In our pages the advertiser has found the open channels he sought, carrying his message directly to the people he wanted to reach.

As Canada's pioneer publication in the electronics field, we are proud to serve this great industry. We have watched its development and recorded its many triumphs. Within the past five years the Institute of Radio Engineers has recognized Canadian achievement by electing its first Canadian president, Dr. J. T. Henderson, of the National Research Council. The same years have witnessed the opening of the first Canadian I.R.E. Convention and Exposition — an event of historic importance — in the publicizing of which **ELECTRONICS AND COMMUNICATIONS** was happy to co-operate.

For five years it has been our privilege to record in the pages of this journal the growth, development and success of the electronics industry in Canada. We have grown with the industry, and we gratefully acknowledge that our growth would never have been possible but for the friendly co-operation of the entire electronics industry. May it long continue!

All new oscilloscope

\$435⁰⁰

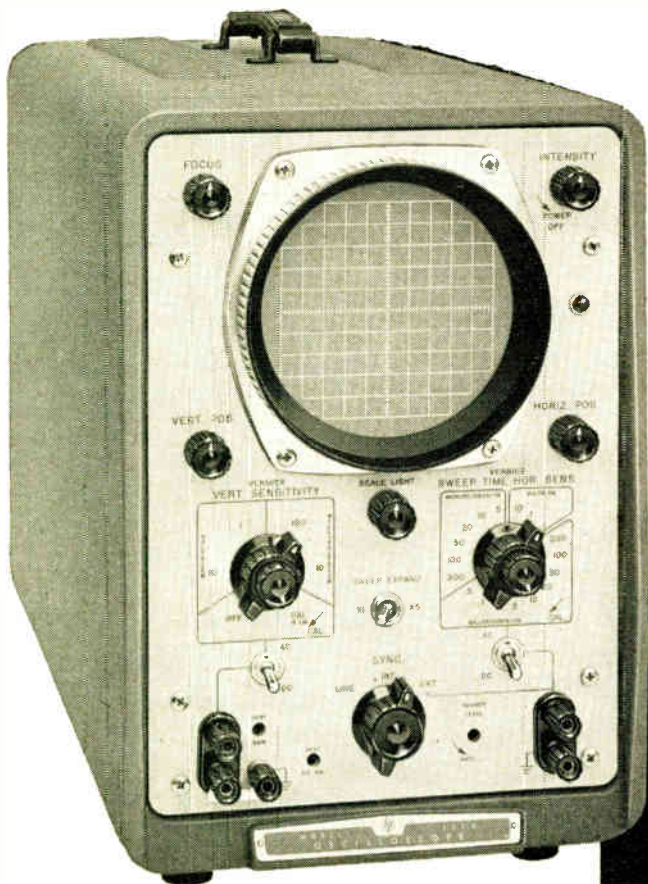

DC to 200 KC coverage; automatic triggering, minimum controls

Sweep speed range 1 μ sec/cm to 0.5 sec/cm; x 5 sweep expansion all ranges; vernier

15 calibrated sweeps, 1-2-5 sequence

Automatic synchronizing on any internal or external voltage; also line voltage

High sensitivity, calibrated vertical amplifier

All power supplies regulated for maximum stability

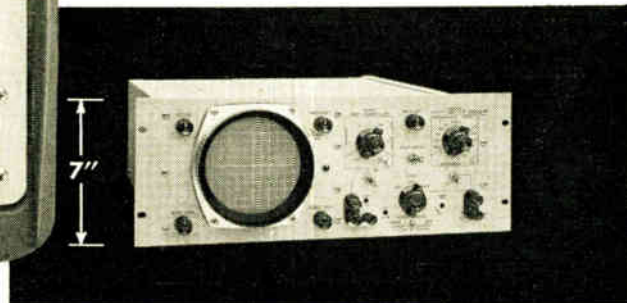

New *-hp-* 120A and *-hp-* 120AR (rack mount) oscilloscopes. Note space-saving 7" height of 120AR.

These totally new *-hp-* oscilloscopes are engineered to perform most oscilloscope measurements more quickly, simply, dependably. Automatic triggering means no adjustment over entire range. Yet automatic trigger and base line can be cut out for bright, steady photography trace.

Sweep speeds vary from slow for mechanical or medical work to high for rapid transients. High sensitivity permits working direct from transducers in many cases. Vertical and horizontal amplifiers have identical band width for phase measurements. Voltage regulation on all power supplies insures steady, drift-free traces.

These new instruments combine calibrated precision for lab work with brute ruggedness for the production line; the rack-mounted 120AR is ideal for fixed installations and test consoles.

Call your *-hp-* representative for full information and demonstration, or write direct. *Fast delivery!*

4621

Represented in Canada by

ATLAS INSTRUMENT CORPORATION, LTD.

50 Wingold Ave., Toronto 10, Ontario • 105-525 Seymour St., Vancouver, B.C. • 72 Princess St., Winnipeg, Manitoba

***-hp-* provides industry's newest, most complete oscilloscope line**

For further data on advertised products use page 65.

RETMA Report



By Basil Jackson, A.R.Ae.S., Tech. M.C.A.I.

29th Annual Meeting

Plans are practically completed for the 29th annual meeting of RETMA scheduled for Thursday and Friday, June 19 and 20, at Bigwin Inn, Lake-Of-Bays, Ontario.

Meetings of the Components, Receiver and Electronics Divisions are scheduled, together with meetings of committees, including meetings of the Components Engineering Committee, Receiver Engineering Committee, Microwave Engineering Committee, Mobile Equipment Engineering Committee and others.

Election of directors to the new Board will also take place at the 29th annual meeting. Further details of the event will be announced in this column.

Recent Board And Division Meetings

On April 14 the RETMA Board of Directors met in Toronto. Under discussion were the reports of the three divisions together with reports from committees which report to the Board including the Government Liaison Committee, Government Acts and Regulations Committee, Industrial Relations Committee, Tariff Advisory Committee Report, and the Publicity and Public Relations Committee. The budget for the fiscal year 1958-1959 was also reported on by the Budget Committee and later accepted by the Board of Directors. The Director of Engineering reported to the Board on activities of the engineering committees and Canada's position in world radio frequencies allocations.

The Components Division met on April 16, in Toronto. Reports of the various committees were presented and discussed in detail, including a report from the Components Engineering Committee.

The Electronics Division met on April 15 and discussed engineering and commercial reports together with a report by the Director of Engineering and the Government Relations Representative.

Service Committee Activities

At a recent meeting of the Service Committee E. Reale, president of R.E.T.A. (Radio Electronics Technicians Association of Canada), the past president J. Forde, and honorary director A. L. Vincent, were present to outline the present status and aims of the re-organized R.E.T.A. One of the most important objectives was the certification of radio and television service technicians, to protect the public interest.

Recent Engineering Committee Meetings

The Components Engineering Committee met in Toronto on April 9. The Sub-Committee chairmen reported, and business referring to technical matters of components was discussed, including standard proposals and standards for the industry.

The Receiver Engineering Committee met on April 16, at Toronto. Chairmen-Observers on the various EIA (U.S.) engineering committees presented reports of the activities of these committees, while the adoption of standard proposals and standards was discussed in addition to other items of business relating to the technical aspects of radio and television receivers.

The Transformer Engineering Sub-Committee of the Components Engineering Committee met in Toronto on March 27 to discuss the disposition of the proposed RETMA engineering specification on audio output transformers for radio and television receivers. A progress report on the testing of magnetic steels was also presented and discussed.

Newsletter

Canadian Radio Technical Planning Board

WHO'S WHO IN THE PLANNING BOARD No. 3 — The American Radio Relay League

The American Radio Relay League is a national non-profit association of radio amateurs in the United States, its possessions, and Canada. Founded in 1914 at Hartford, Conn., by the inventor and scientist Hiram Percy Maxim, its aims are the promotion of amateur radio communication and experimentation, the relaying of messages, the advancement of the radio art and of the public welfare, representation of the amateur in legislative matters, and the maintenance of fraternalism and a high standard of conduct.

The League is governed by a Board of sixteen directors, representing fifteen geographical areas in the United States and one in Canada. Each director is elected for a two-year term. The Canadian director for the past 28 years is Alex Reid of St. Lambert, Que., who is the dean of the League's Board, and the main representative of the League on the CRTPB.

Canadian Radio Stations Permitted To Increase Power Output

Lifting of power ceilings on many Canadian radio broadcasting stations was announced recently by the Department of Transport. The reason given for the move is that due to the rapid growth of Canadian metropolitan areas, existing power ceilings were no longer adequate to provide the proper service in many places.

Under the North American broadcasting agreement, which governs the assignment of radio broadcasting station channels, regional stations are restricted to a maximum power of five kilowatts and local stations to 250 watts.

However, Canada reserved the right to make use of powers in excess of these limits under certain conditions.

The Department of Transport is now prepared to accept applications for increasing the power of these radio stations, it was stated. Permission to increase power must be justified by service area requirements and full protection accorded to other stations on the same and adjacent channels, it was emphasized.

News From The FCC

The Federal Communications Commission of the United States has announced an amendment of the tables governing the U.S.A.-Canadian border frequency allocations. These changes concern the southern areas of Alberta, Manitoba, Ontario and Quebec. Details are not available at time of going to press.

The FCC has amended the Aviation Services rules to allow continued use of 420 to 460 mc. band for aircraft altimeter operations until 15 February 1963.

Executive Committee Meets

The CRTPB executive committee met in Toronto on March 21 and April 25. The Fixed Land and Maritime Mobile Committee met on April 2 and again on April 14.

New FCC Commissioner

John Storrs Cross, the new FCC commissioner, who replaces Richard A. Mack, is an electrical engineer. The new commissioner was recommended for the position by President Eisenhower, and he is a graduate of Alabama Polytechnic Institute.

In 1935 he was chief of all electrical and radio design with the United States Department of Interior, was a naval

captain from 1942 to 1946, and was with the Telecommunications Division of the State Department from 1946 until the present time. He has been connected at first hand with international agreements on radio frequency allocations and has been in contact with the Federal Communications Commission regularly.

Canadian Railroads Radio Frequency Assignment Plan

A brief prepared by the Railroad, Highway and Transit Utilities Committee of the CRTPB, under the chairmanship of C. J. Bridgland, for submission to the DOT, has been sent to all contributing sponsors for approval. The brief is entitled "Canadian Railroads Radio Frequency Assignment Plan for 30 kc. Narrow-Band Assignments". It deals with the general requirements, effective date of changeover, existing and planned railroad systems, the applications for railroad radio, frequency allocations plan, and radio frequency assignment areas shown in map form.

The plan has been co-ordinated with the Radio Committee of the American Association of Railroads.

Contributing sponsors are to vote on this proposed frequency allocation plan by May 8.

Recommendations On DOT Specifications 106, 107, 108, and 109

The CRTPB has passed to the Department of Transport the results of the ballot taken by contributing sponsors of the Planning Board regarding DOT Specifications 106, 107, 108 and 109 dealing with land mobile equipment. A majority of contributing sponsors favored the adoption of the specifications; one dissenting opinion was registered and one qualified assent was received.

DOT Specification 112 entitled "Maritime Mobile Radio Telephone Equipment Operating In The 1.6 mc. to 10.0 mc. Band for Non-Compulsorily Fitted Ships Only" was sent to all contributing sponsors early in April for official approval and comment. Prepared by the CRTPB Fixed Land and Maritime Mobile Committee, the final draft has been reviewed and approved by the Executive Committee.

CRTPB Participation In CCIR And ITU Conferences

The Department of Transport has asked the CRTPB for its co-operation in providing items for the agenda of the Canadian delegation to attend the CCIR (Consultative Committees on International Radio) and ITU (International Telecommunications Union) conferences to be held soon. The CCIR conference is scheduled for 1959 in San Francisco, while the ITU conference will take place at Geneva in 1960.

The DOT would like CRTPB representation on the Canadian delegation. The DOT would possibly help share the expense and would provide a secretariat. All contributing sponsors have been notified of this request and a special meeting of the Planning Board may be held to co-ordinate the various views and suggestions put forward.

Radio Frequency Spectrum Management

A few copies are still available of the paper entitled "A Canadian Point of View on Radio Frequency Spectrum Management" by C. M. Brant, Chief of Technical Co-ordination, Department of Transport.

Applications for copies should be addressed to the Canadian Radio Technical Planning Board, 200 St. Clair Avenue West, Toronto 7, Ontario.

Canadian Radio Technical Planning Board
200 St. Clair Avenue West, Toronto 7, Ontario

F. H. R. POUNSETT, President; C. J. BRIDGLAND, Vice-President; R. A. HACKBUSCH, General Co-ordinator;
R. C. POULTER, Director of Public Relations; F. W. RADCLIFFE, Secretary-Treasurer

VIBRATION

PROBLEMS?

CALL OUT CANNON PLUGS

Improvements are constantly being made in Cannon connectors to give you maximum reliability in circuitry under constantly increasing highly critical vibration conditions. New lines... improvements on the MS-E design... include the EX, the CT, the EA, and the EB Series.

You'll find Cannon vibration and moisture-proof resilient-insert lines extensive and complete, in hundreds of carefully designed layouts. Interfacial sealing. Improved grommets and grommet followers. Styles with extra strong coupling nuts. Telescoping rubber bushings. Strong clamps. Means for safety wiring. Grounding lugs. Every facility to give solutions to vibration, moisture condensation, flashover, and corona problems.

Vibration-proof Series include MS-E, CA-F, EA, EB, EX, and CT. Write TODAY for full information.



MS-E (Series CT)
Socket Assembly
Ask for
MS-E Catalog



CA 3100 F
Wall Mounting Receptacle
Ask for
AN/MS Catalog



MS-E (Series ME)
63 Inserts Available
Ask for
MS-E Catalog



EX 06
Plug Assembly
Ask for
EX Catalog



Write for 44-page,
2-color Plug Guide,
Bulletin CPG-3

CANNON ELECTRIC (CANADA) LIMITED, 160 Bartley Drive, Toronto 16. Montreal Office: Montreal Airport, Dorval, P.Q. Ottawa Representative: M. J. Howard & Co., 1206 Bank Street. Factories also in Los Angeles, Salem, London, Melbourne. Licences in Paris, Tokyo.

5801

H. J. Benschel

Congratulations to

READER'S DIGEST

A coupon is a tough test — not only for an advertisement, but for a magazine that carries it. Last February the "Live Better Electrically" program offered an idea book to readers of Reader's Digest.

"In just 5 weeks the coupon produced more than 65,000 enquiries" excerpt from Reader's Digest advertisement in a recent issue of News Week.

We think Reader's Digest had some justification to brag a little about such coupon returns. We congratulate this highly respected, widely read periodical . . . 65,000 enquiries represent a return of around 5.65 for every 1,000 of their total 11,500,000 circulation.

But now it is our turn to brag ! In the December issue of **ELECTRONICS AND COMMUNICATIONS** the Philco Corporation Limited of Canada, ran $\frac{2}{3}$ of a page of advertising — with no free offer — and without a coupon. Result — **ELECTRONICS AND COMMUNICATIONS** received in 3 weeks, from its readership 127 enquiries, representing 12.7 for every 1,000 of its 10,000 circulation. $3\frac{1}{4}$ times as many replies per 1,000 circulation.

But that is only part of the story. In addition, the Philco Corporation itself received numerous enquiries direct and has already made sales to important buyers as a result of this advertising.

So we think that **ELECTRONICS AND COMMUNICATIONS** also has some reason to brag a little about coupon returns from advertising appearing in it and it presents the above advertising experience as an indication of its reader interest among its responsive audience of engineers and others who specify or buy in the Canadian market.

ELECTRONICS and COMMUNICATIONS

31 WILLCOCKS ST.

—

TORONTO 5, ONT.

the editor's page

*A commentary on affairs
pertinent to the electronics
and communications industries.*

Making Information Available

THE need for more efficient dissemination of the world's technical literature has long been recognized and the recent advances of Russian technology have sparked the action of Western authorities in the matter of investigating the methods used by the Russians in the handling and distribution of foreign technical literature and in the establishment of an organization which may more efficiently process the technical literature of other countries and place it in the hands of our engineers and scientists with the least possible delay.

The importance which the Russian government places on the interpretation and distribution of foreign scientific information is emphatically revealed in the Industrial Bulletin of Arthur D. Little Incorporated, Research Consultants, which has the following to say on the subject:

"Scientists in the United States may soon become more familiar with Russian and other foreign technical developments. Government and private agencies are planning combined agencies to abstract and index technical information — paralleling the operations of the All Union Institute of Scientific and Technical Information, one of the world's largest technical information services.

The All Union Institute is operated jointly by the USSR Academy of Sciences and the State Committee for New Technology. This committee is essentially a planning body which studies technological development throughout the world and recommends the areas of the Soviet economy in which modern technological resources should be concentrated. The USSR Academy of Sciences — directly subordinate to the Council of Ministers and almost equivalent to any of the 56 Ministries that control Soviet economic and cultural life — is the largest single and most important research institution in the Soviet Union. With an annual budget that amounts to about 10% of total annual Soviet expenditures for scientific research, the Academy supervises the activities of more than 35,000 research personnel in 136 major research institutes. Administratively, there are eight primary divisions, each with its own overall plan; the various programs are directed by the few hundred men who are either full or corresponding members of the Academy.

The All Union Institute of Scientific and Technical Information was created in 1952. It employs about 2000 permanent staff members and uses another 20,000 scientists and engineers as part-time translators and abstractors. Among its services the Institute publishes, in 13 journals, 475,000 abstracts a year. These abstracts come from new books, patents and dissertations, but primarily from articles appearing in the 1800 scientific journals published annually in Russia as well as from articles appearing in over 12,000 journals originating in 85 countries.

To counteract the length of time necessary for abstracting, the Institute publishes a series of 30 "Express Information" bulletins, covering such subjects as general technology, the petroleum industry, radio engineering, agricultural machinery, mining, metallurgy and metal working. This service enables the full or partial translations of some of the most pertinent papers on foreign technical developments in each field to reach key Soviet industries and scientists within two or three weeks after

their receipt, and often as early as three months after the original publication of an article. Closely related to this effort at greater speed is the Academy's research on electronic translation of English, Japanese, French, Chinese, and German scientific papers.

In addition to the abstracts and translations, the Institute also publishes technical foreign language dictionaries and reviews summarizing progress in specialized fields. Microfilm or photocopies of an original article and complete translations of any scientific paper in any language are supplied by the Institute on request, at a price equivalent to that in the United States for similar services.

Intensified services of this nature would obviously be advantageous to the United States. For example, the radio frequencies to be used in the Soviet satellites appeared in the June and July issues of *Radio*, a Soviet magazine for radio amateurs, but the English translation was published too late to be of any use. To avoid such lapses in the future, the National Science Foundation, Stanford Research Institute, and the Council for Documentation Research at Western Reserve University, among others, have urged a centralized information service in the United States. The Commerce Department's Office of Technical Services is working with the National Science Foundation to this end; fourteen abstracting agencies have set up the National Federation of Science Abstracting and Indexing Services; and Congress has passed enabling legislation for a central clearing house. These are all important steps toward keeping the growing literature of science accessible."

Forgive Our Fallibility

It is now nearly six months since *Electronics and Communications* published its 1958 Directory and Buyers' Guide and we like to think that by now the pages of the more than ten thousand copies of this issue that were mailed out to our readers are thumb-marked and well worn with good useful service. And now that the merry month of May is approaching we here in the editorial office are preparing to roll out the directory production machinery and get started on the compilation of our 1959 Directory and Buyers' Guide.

Having to start the compilation of a directory so far in advance of its publication will, we believe, give some idea of the magnitude of this task, a task with an infinite amount of detail that has to pass through checkers' hands, compilers, type-setters, proof-readers and make-up editors.

With so many hands involved and with the similarity of firm names included in our listings, the similarity of names of components and equipment, mistakes are bound to creep into our effort and although we have been mildly and good naturedly chastised by some of our friends in the industry for some of our errors we have managed to control the blush on our cheeks by making *rest* equipment read *test* equipment, *geranium* growing equipment read *germanium* growing equipment, by changing *magets* into *magnets* and by making *Peters* Instrument read *Meter* Instrument.

There were others of course that got away on us and for these we can only ask the indulgence of the firms concerned to forgive our fallibility.

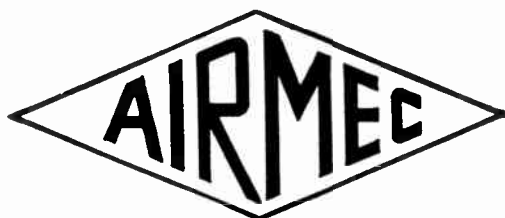

ELECTRONIC INSTRUMENTS

PORTABLE TEST OSCILLATORS

- Hermetically sealed
- Extremely Robust
- Ideal for field use in any climate, as well as in lab and workshop
- Hinged chassis design for ease of service

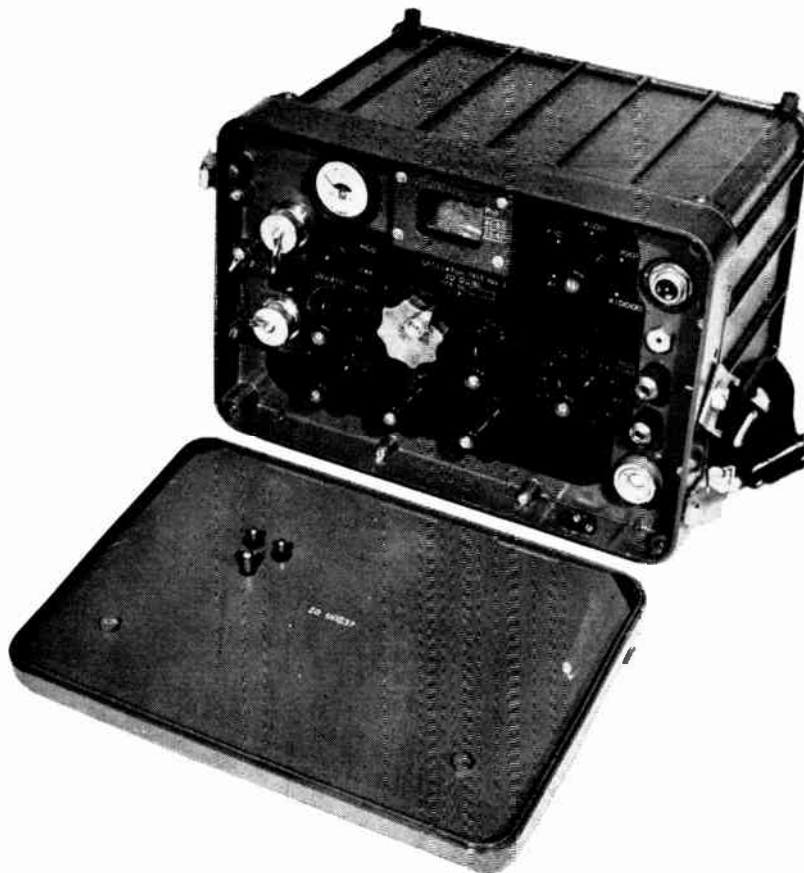

Specifications...

Oscillator No. 2 (Type 872)

	No. 1 (Type 871)	No. 2 (Type 872) as illustrated
CARRIER FREQUENCY	85 Kc/s to 32 Mc/s (seven ranges)	20 to 80 Mc/s (two ranges)
MODULATION	AM & FM	AM & FM
MODULATION OUTPUT	A signal greater than 5 V R.M.S. into 600 ohms	
OUTPUT LEVEL	1 mV to 100 mV into 75 ohms or .1 mV to 10 mV into 7.5 ohms	
DIMENSIONS	12" x 8½" x 10½"	
WEIGHT	Approximately 30 lbs.	
POWER SUPPLY	110 V A.C. and/or 12 V D.C.	

Airmec Electronic Equipment Includes:

Time and Frequency Meters
Frequency Standards
Ionisation Testers
Temperature and Level Control Equipment

Oscillators
Signal Generators
Electronic Counters

Electronic Batch Counters
Electronic Tachometers
Photo-cell Controls
Radio and TV Servicing Equipment

SEND FOR YOUR
COPY OF CATALOG



**RADIO COMMUNICATIONS
EQUIPMENT & ENGINEERING LTD.**
475 METROPOLITAN BLVD., MONTREAL 32

*slide it on
and crimp!*

*a fully-insulated
one-piece tap
connector
for shielded
and
coaxial cable*

UNI-RING

UNI-RING offers a tremendous saving in installation time over any previous method of tapping or terminating shielded or coaxial cable. As the inner ring slides under the shielded braid, the tap wire is held between the braid and the outer ring. Single or multiple taps, from either the front or back of the connector, can be accommodated . . . A single crimp, using the same basic HYTOOLS used for installing HYRINGS, completes the uniform, secure, and insulated assembly.

The protecting nylon insulation extends beyond both ends of the UNI-RING, eliminating metal-to-metal contact and preventing harmful wire-chafing in tight locations. The UNI-RING is color-coded to indicate conductor sizes.

UNI-RING's one-piece design insures electrical integrity, prevents heating, and eliminates noises caused by isolated metal parts.

BURNDY CANADA LTD

1530 BIRCHMOUNT ROAD, METROPOLITAN TORONTO
SCARBORO, ONTARIO

Offices in:
MONTREAL, WINNIPEG,
CALGARY, VANCOUVER

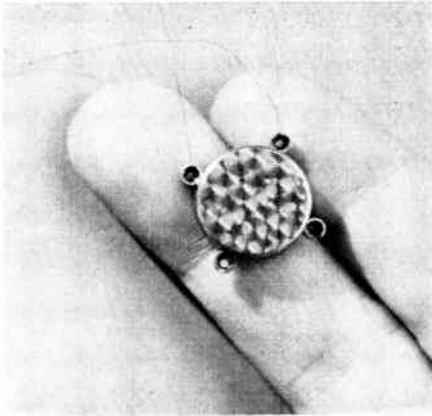

Typical of the thousands of components in use today is the atomic-powered battery shown at the left, a product of the Elgin National Watch Company and the Walter Kidde Nuclear Laboratories. It is on such components that engineers and scientists continue to labor in search of better reliability and better means of measuring reliability. The following article shows examples of how reliability may be measured mathematically.

An Operational View Of Equipment Reliability

By R. Drenick

*Bell Telephone Laboratories **

SOME OF THE recent discussions on the subject of reliability have been pervaded by the uneasy feeling that, while a lot could be said about the subject, no one was altogether certain of just what the subject was. In fact, there was some rather strong indication that not all concerned were talking about the same subject.

The term reliability, it is true, is quite universally used to describe the extent to which a type of equipment is likely to retain desirable performance characteristics. The inconsistency of usage arises when some more

quantitative definitions are proposed. There is certainly no harm in having as many definitions of reliability as there are discussants of the subject, provided only that each one of them understands what the other means by his "reliability", and perhaps also why he considers it most appropriate. They can then compare notes in a logical fashion on what their problems have in common and what conclusions and solutions derived

*This paper is based on work done by the author when employed by the Radio Corporation of America.

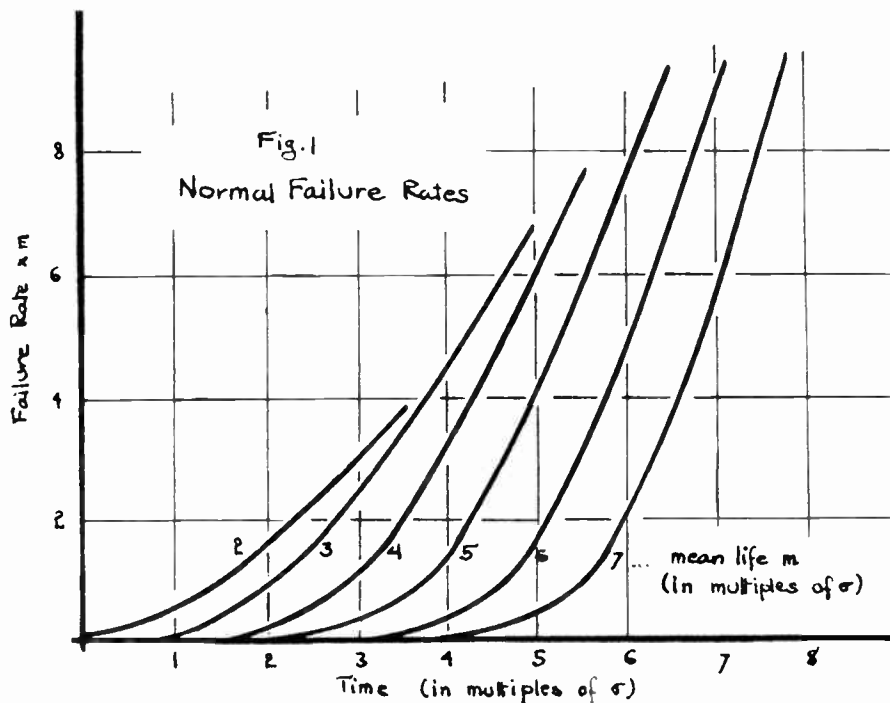

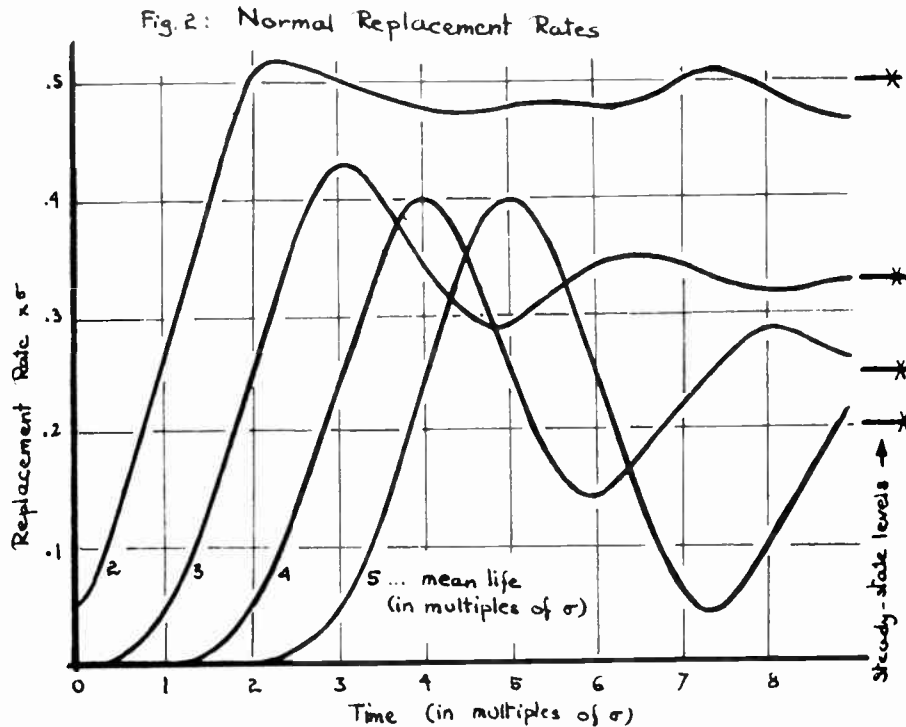

by one can be used also by the other.

It is this general topic with which this article is concerned. It develops first a common ground for such discussions by suggesting a fairly general concept of reliability and by exhibiting, through a few examples, that under certain circumstances one reliability definition is in fact more appropriate than most others. Later, an attempt is made to show that care should be taken in drawing conclusions concerning reliability improvements: Procedures, such as preventive maintenance or duplication of equipment, may be highly economical in some operations and yet quite unattractive in others.

The discussion in this article will utilize examples throughout to make its points. This has the disadvantage of making the argument seem spotty and limited. Unfortunately, it takes considerable attention to detail to treat the subject reasonably completely, more detail in any case than seemed appropriate here.

What Is Equipment Reliability?

The impression that the term "reliability of equipment" means different things to different people is readily confirmed by a review of the literature on the subject.

The general practice is, of course, to have reliability be represented by a number which is the larger, the lower the incidence of failure. High favorites for this number are the survival probability of the device (over some given period of time), or its mean life. The opposite is also encountered. That is to say, the number used for this purpose decreases with the incidence of failure (such as the maintenance ratio or the replacement rate), in which case the number is understood to represent unreliability. Whenever necessary, reliability is converted into unreliability (or conversely), sometimes by subtracting it from unity, sometimes by taking the reciprocal, whatever seems most appropriate.

There is a way of putting these practices on a somewhat firmer common footing. "Reliability", broadly speaking, is a term used to describe the quality of operation of a type of equipment in regard to deterioration and failure. What is needed, therefore, is a quantitative measure for this, taking due account of the fact that deterioration and failure are random phenomena. The situation is strongly remindful of the type with which statisticians have been dealing for some time and for which they have found a very satisfying and flexible method of

attack: When they need to measure the desirability or undesirability of the outcome of some uncertain event or series of events, they assign a numerical gain or loss to it, and use the mean value of this gain or loss as the required measure.

The same idea can be applied here. To each failure, or series of failures, in a given type of equipment there is assigned a certain gain (or loss) and reliability is defined as the mean gain (or loss) which the operator of this equipment derives from it.

This may seem a very artificial and clumsy concept, and quite possibly it is. In order to assess its usefulness, it should be tested from three points of view:

- (1) Is there an easy and natural way of fixing gains and losses in practice?
- (2) Under circumstances under which one expects the conventional definitions of reliability to apply, does the one proposed here reduce to these?
- (3) Does the present concept shed any new light, or allow any new conclusions, which could not have been easily derived without it?

The discussion which follows is intended to suggest an answer to these questions. After some preliminaries in the next section, a series of typical situations are reviewed which show how gains and losses can be chosen, and that in fact the reliability concepts are obtained which one would intuitively associate with those situations.

Preliminaries

Before the main topic of this article is dealt with, a few preliminaries may be useful to establish rapport on the terminology and notation to be used below. The general pattern of failure of a component will be called its "failure law", following what seems rather common practice. Mathematically, a failure law can be characterized in a number of equivalent ways. Most frequently encountered is a characterization in terms of the probability of survival for a period of time t , which shall be denoted here with $F(t)$. The failure rate $g(t)$, or the hazard, of a component is also used, though perhaps not as frequently. It is related to the survival probability by the formula

$$g(t) = -\frac{d}{dt} \log F(t).$$

The failure laws which are much used in practice are

the exponential and the normal. The first of these is characterized by

$$F_s(t) = \exp\left(-\frac{t}{m}\right), \quad g(t) = \frac{1}{m}$$

where m is the mean life of the component. The failure rate is seen to be a constant, namely, the reciprocal of the mean life. An interesting fact is that the age of a component obeying the exponential law has no bearing on the likelihood of failure.

The normal law has the well-known shape which need not be reproduced here. Less well known may be the corresponding failure rate which is shown in Fig. 1, for several values of m/δ . The normal failure rate invariably rises to infinity as the age t of the equipment increases, a fact which it shares with probably the failure rates of all physical equipment.

Special Cases

In this section, a review will be made of three examples which, it is hoped, will illustrate the idea of defining "reliability" as a mean operational gain or loss. The first of these is a situation in which a conventional reliability concept, namely, the survival probability, has been patently appropriate. The point here will be to show, for one, that the definition of reliability suggested here confirms the survival probability as the most appropriate, and that the choice of gain or loss to be associated with the operation is a rather natural and straightforward one. The second example leads to a measure of reliability, namely, the replacement rate which is not overly common but which has some interesting properties. The last example deals with a simple situation which has not been as generally studied but which may suggest the usefulness of the reliability concept developed here.

Each example will be given a name, hopefully a reasonably descriptive one, which is intended to characterize but not to limit it. The mathematical detail and its derivation will be omitted in all cases and only results will be mentioned.

Example 1: Guided Missile

This example is chosen as the first because it is conceptually the simplest. A guided missile, and for that matter every component of one, is a piece of equipment which is considered a total loss after the first failure in flight. No repairs are possible then.

It has been customary to think of the survival probability $F_s(T)$ for the time of flight T of the missile as the appropriate measure of reliability.

To apply the present concept, a unit gain is assigned to each successful flight, and a zero gain to each unsuccessful one. The mean gain R which is in this case derived, that is the reliability as defined here, is found to be

$$R = F_s(T),$$

that is, again the survival probability.

Example 2: Replaceable Component

This example will differ from the previous one in that the device whose reliability is to be investigated is assumed indefinitely replaceable (like, say, a radio tube but unlike the preceding example in which no repair or replacement is contemplated). It will further be assumed that the device is replaced or completely repaired immediately after each failure.

Intuitively, such a component will be considered the less reliable the more often (per unit time) replacements are expected to be necessary. In this example, unlike in its predecessor, therefore, the unreliability is to be characterized, as opposed to the reliability. This can be achieved by assigning a unit loss or, which is the same thing, a gain of minus unity to each replacement and by then calculating the mean loss (or gain) per unit time.

What is obtained by this calculation is a quantity which has been used in practice and which has come to be called the replacement rate. Contrary perhaps to intuition, it is not a very simple quantity: Its derivation from, say, the survival probability of the part can be

a fairly tedious affair, and requires the solution of an integral equation, called very appropriately the "renewal equation". This equation has apparently received relatively little attention in recent work on reliability but it has been much studied by actuaries (1) and some of their results may be of interest here.

The replacement rate usually starts out with an oscillation which can be quite pronounced, like some of the ones derived from the normal law, shown in Fig. 2. Invariably, however, the oscillations die down after several mean lives. The resulting plateau is called the "steady-state" of the replacement rate and its level is the reciprocal of the mean life ($1/m$). There is only one failure law for which the replacement rate does not oscillate at all but is constant throughout, and that, as may be expected, is the exponential failure law.

Example 3: Automobile Battery

The manufacturers of automobile batteries are in the habit of "guaranteeing" a certain life T for their product. By that they mean that if the battery fails at some earlier time t they will prorate the original purchase price and make a corresponding allowance for the unexpired life towards the purchase of a new battery made by the same manufacturer. That is to say, they will charge for the new battery instead of the list price C a prorated price

$$C - \frac{T-t}{T} C = \frac{t}{T} C.$$

This is, therefore, the gain which a manufacturer derives from a battery replacing another one which has failed at the time t , prior to the guaranteed life.

The reliability of battery, from the manufacturer's point of view, is his average income, that is, the gain per car and per month, say, from his battery sales. If he calculates this he finds

$$R = \frac{m}{T} C + C \left[F_s(T) + \int_T^{\infty} \frac{t}{T} dF_s(t) \right].$$

This equation may not be very instructive as it stands but it can be analyzed fairly easily. It develops that the maximum income (per car and per month) which the manufacturer can possibly hope for, and hence the maximum rate of expenditure which the buying public must fear, is C/T ; however, he can achieve this only by the miraculous feat of building batteries which last for exactly the warranty period and fail immediately thereafter. It is unlikely that he can achieve this but he can seek to approximate it and, according to rumors, this is exactly what battery manufacturers strive to do.

Preventive Maintenance

The examples which have been discussed above are descriptive: They attach a numerical value to what might be called "reliability" of a device. This value, it is hoped, coincides more or less with what seems intuitively the appropriate one. However, none of the examples suggests what could be done about reliability if its value turns out lower than desirable. It will be the purpose of this section, and of the next one, to illustrate how the reliability concept introduced here can be used to study possible improvements. This section in particular will be concerned with the idea of preventive maintenance.

The general problem of when to attempt preventive maintenance, and of how to design an optimal one for a given operation, is by all indications a difficult one. In certain special cases, however, solutions can be obtained. One such case will now be discussed, as an illustration of the whole concept.

Consider a device such as the radio tube mentioned earlier (example 2 in the preceding section) which can be thought of as being replaceable an unlimited number of times. However, instead of using it until it fails, as was assumed in that example, a preventive replacement at a suitably chosen age T is to be considered. The economics of the situation is this: The price of the tube is C , and that must be paid in any case whether the replacement is

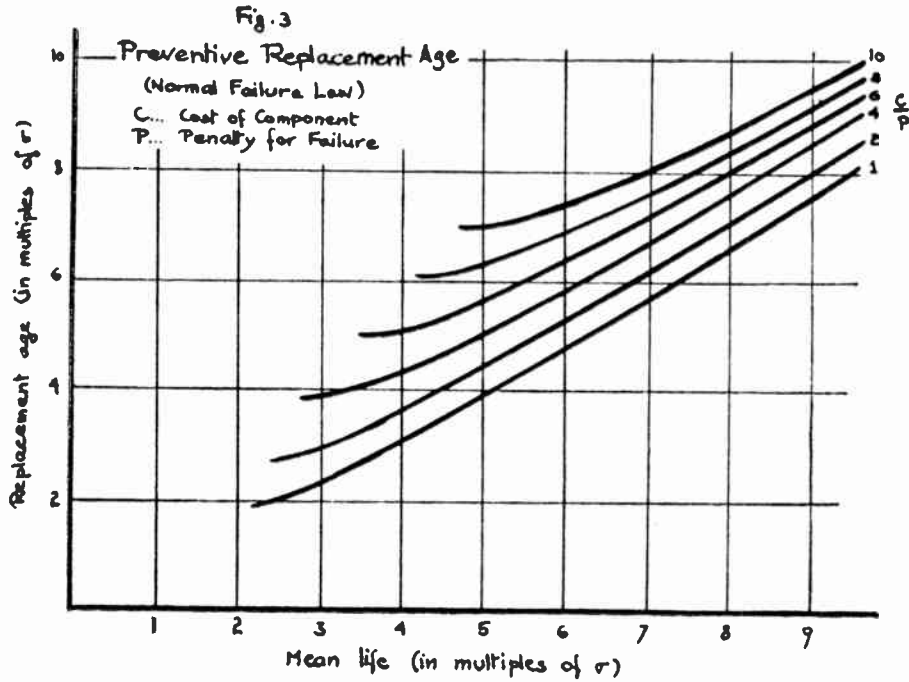

preventive or a repair. In the latter case, however, an additional service charge P is expected. The replacement age T is to be so chosen that the mean rate of expenditure (the unreliability in this case) is as low as possible.

Example 2 has yielded a result which applies here: If no preventive maintenance is carried out, the mean rate of expenditure will be equal to the mean number of failures per unit time (which is 1/m, in the steady state), multiplied with the cost of each failure (which is C+P). That is to say, the reliability in this case is

$$R = (C+P)/m$$

A study of the question of preventive maintenance yields the following facts. There are certain circumstances under which preventive maintenance is definitely uneconomical, in the sense that it can only increase expenditures. This is the case where the failure rate is either constant (which implies the exponential law), or uniformly decreasing. In the opposite case, preventive maintenance may, but need not, be profitable. If it is, and if T is chosen in an optimal fashion, the expenditures can be reduced from the value of R shown above, to

$$R' = P g(T)$$

In the case of the normal failure law, the optimal replacement age can be read from Fig. 3. It is assumed that one knows (or can make a good guess of) the mean life m and the δ of the distribution, and that the cost C and service charge P can be determined. The chart is then entered with the appropriate ratios and the correct replacement age, in multiples of δ , is immediately evident. The cost of the operation then follows from the failure rate chart in Fig. 1.

Take, for instance, a component which costs \$20. It obeys the normal law with a mean life of 2 years, and a δ of 3 months. The service charge for the repair of a failure is \$10. In this case, $m/\delta = 8$, $C/P = 2$, and the chart of Fig. 3 yields $T/\delta = 7$. This is to say, the device should be preventively replaced at the age of 21 months. The mean rate of expenditures (the "reliability" in this case) would be \$1.25 per month without preventive maintenance, and 96c per month with it. This is a saving of nearly 25 per cent.

Fig. 3 exhibits a phenomenon which may be worth pointing out: The curves are missing in the left upper region, that is, for small values of m/δ and for large values of C/P . This is no accidental omission. The empty area indicates that no preventive maintenance should be done in that region.

The duplication of components is a measure which, like preventive maintenance, can be adopted to improve the reliability of a device. The point will be to show by a brief example that the reliability concept introduced here can be used to evaluate the extent of such an improvement.

Consider again the situation treated in example 2, that is, a replaceable component such as a radio tube. To be specific, imagine this tube to be part of a broadcast transmitter. In such an installation, a duplicate transmitter is usually provided which is put on the air when the original one fails, to gain time for its repair. The question is, how much of an improvement in reliability is derived from that?

In example 2, a unit loss was charged for each failure and the replacement rate was obtained as the appropriate measure of reliability. In the present example, a unit loss will be charged only in case both transmitters fail, that is, when the duplicate went out, before the original could be repaired. To simplify things, we will assume the exponential law not only for the failures of the tube but also for the repair times.

With this assumption, the steady-state loss rate (that is, the mean number of double failures per unit time) is found to be

$$R = \frac{1}{m} \cdot \frac{1}{2 + \frac{m}{m_R}}$$

Here, m_R is the mean repair time. The factor $1/(2 + \frac{m}{m_R})$

is the improvement factor. It is the greater, the greater m is relative to m_R . Thus, if the mean life is ten times greater than the mean repair time, the reliability is improved by a factor of 12. It can be seen from this that a substantial gain is possible in this type of operation from use of duplicate equipment.

The operation described in this example is very favorably influenced by equipment duplication. Caution is indicated, however. The gain need not be as great in all cases and in some operations the question of whether it is, or is not, economical to duplicate is not clear cut. A careful analysis of what improvement can be expected will usually be very much in order.

Reference:

- (1) A. J. Lotka, A contribution to the theory of self-renewing aggregates, with special reference to industrial replacement, Ann. Math. Stat.; Vol. 10 (1939), p. 1.

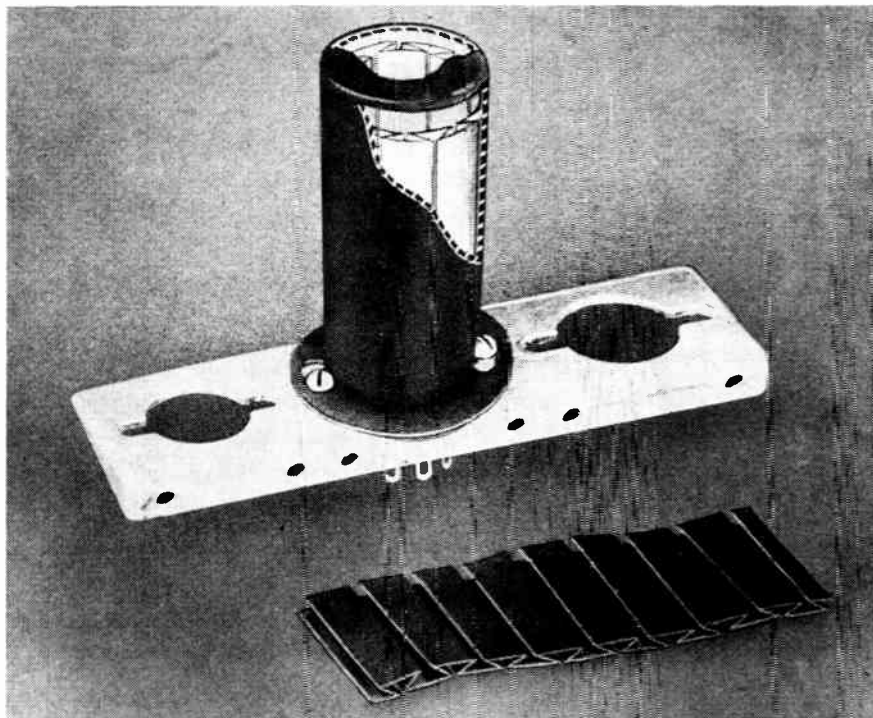

● Cutaway photograph showing the arrangement of the Atlas full contact insert.

A Heat Dissipating Shield For Electron Tubes

By Allan Q. Mowatt

Atlas E-E Corporation, Woburn, Mass.

IT IS GENERALLY acknowledged that temperature is one of the most significant factors affecting tube life. A great amount of work has been done in investigating the effect of temperature on tube life by the U.S. Navy Electronics Laboratory at San Diego. The results of their work have been made public through the Reliability Design handbook. It was the Navy Electronics Laboratory that gave wide publicity to the damage that was being caused by the use of JAN TS Shields in equipment for the Armed Services. These TS Shields set up a thermal barrier between the tube and the shield creating a dead air space. This barrier increased the envelope temperature of the tube well above the danger point resulting in a high failure rate. Tube life was shortened because of excessive heat.

Realization of the thermal inadequacy of the JAN S-28 Shield led to the development of the "type B" improved shield described in military specification MIL-S-9372. In October, 1956 the Navy Electronics Laboratory issued a supplement to their Reliability Design handbook describing a corrugated insert which had been designed by engineers at the laboratory for use in TS Shields. This liner carried the heat from the tube envelope down through

the base into the chassis which operated as a heat sink. This served to reduce bulb temperatures by 50°C or more. Reports were received of spectacular results in prolonging tube life through the use of the insert or heat dissipating shields. The insert had another advantage in that it was readily adaptable to existing equipment. Reductions obtained in maximum bulb temperature through the use of these two methods are shown in Figure I. The Type B Shield shows an improvement of approximately 10° cooling below the modified S-28 Shield with corrugated N.E.L. liner. However this shield was not suitable for retrofit because of the different shield base required. In the type B Shield the heat is taken from the surface of the tube by means of a "finger type" liner which conducts the heat to the shield can, thence to a base and into the chassis. The "finger type" liner provides symmetrical rows, horizontally and vertically, of contact areas which contact between 35 and 40 per cent of the major diameter tube envelope area. The corrugated square-wave type of insert developed at the Navy Electronic Laboratory increases the contact area to about 50 per cent of the tube envelope surface. Engineers of the Atlas E-E Corporation have carried this a step further

and developed a full-contact insert which increases the contact area to between 95 and 98 per cent of the major diameter tube envelope surface. This reduces the thermal barrier by a considerable amount at this point. Figure II shows the cross-section of the N.E.L. type insert compared to the Atlas full-contact insert.

Figure III shows the main thermal barriers which exist in attempting to cool electron tubes by use of heat dissipating tube shields. The Number 1 barrier is that between the glass envelope itself and the outside metal of the shield can. The Number 2 barrier is between the shield can and the shield base, and the Number 3 barrier is between and shield base and the chassis. The new full-contact insert described above virtually eliminates thermal barrier Number 1. Thermal barrier Number 3 can be kept to a minimum by (1) making the shield base with as flat a surface area as possible and (2) making the contact area of the base as large as possible without causing interference. The Type B Shield base is an example of a base which minimizes thermal barrier Number 3.

Thermal barrier Number 2 between the shield can and the shield base became another focal point of attention for N.E.L. engineers. First, some experiments were performed to determine whether the shield can would give better thermal conductivity with or without openings in the side. It was found that a solid can or "no-window" can gave increasingly better cooling as ambient temperature increased. Next a "no-window" can using corrugated liner and the Type B Shield base was tested under the same conditions as for Figure I. The results of this test are shown in Figure IV on the curve marked NW-Corrugated liner. Bulb temperature was reduced 30°C below the Type B Shield and approximately 40° below the blackened (modified) TS Shield with corrugated insert. N.E.L. then attempted to eliminate thermal barrier Number 2 completely by soldering the shield base to the shield can. The performance of this unit with a corrugated liner is shown on Figure IV in the bottom curve marked "Special". The Tube envelope temperature was reduced 50° below that obtained with Type B Shield. These facts were presented to the Reliability Conference at Syracuse, New York on June 11, 1957.

Atlas engineers learned of the above test results by the N.E.L. and simultaneously carried on development work on the design of a one-piece shield can and base which would eliminate the thermal barrier Number 2. Elimination of this barrier would result in the greatest increase in tube cooling as evidenced by N.E.L. tests. The photograph shows this new one-piece shield locked

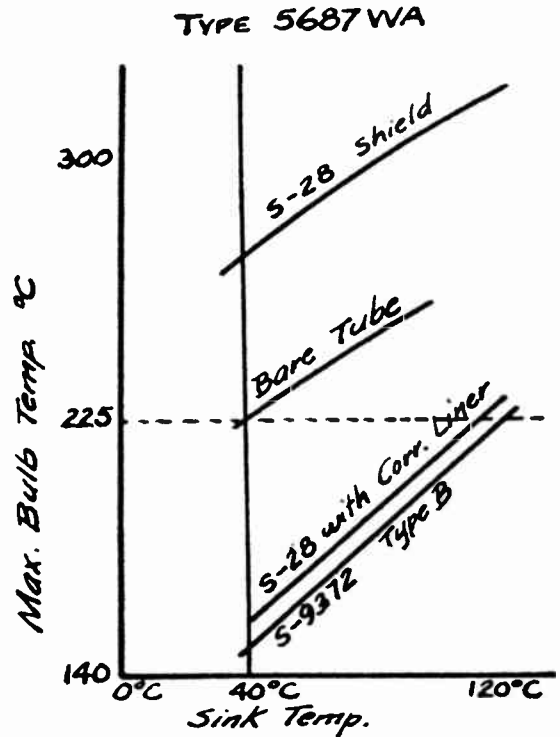

● Fig. I. Tube temperature curves.

in position on the chassis. Doubleheaded screws are used to hold the tube socket in place under the chassis. The new one-piece shield twist-locks in place on these two screws. This unique and simple device for holding the one-piece shield in place makes possible its use on existing equipment simply by replacing the two screws which hold the tube socket in place under the chassis with the special doubleheaded screws.

The application engineer who uses this new one-piece shield can expect to achieve maximum bulb temperatures 10°C to 20°C lower than the curve marked special in Figure IV. This difference is made possible by the reduction in thermal resistance at point number one, since the one-piece tube shield incorporates the full-contact insert.

The following special features are incorporated in the design: (1) The shield itself is made of .010" aluminum to provide the lightest possible weight for air-

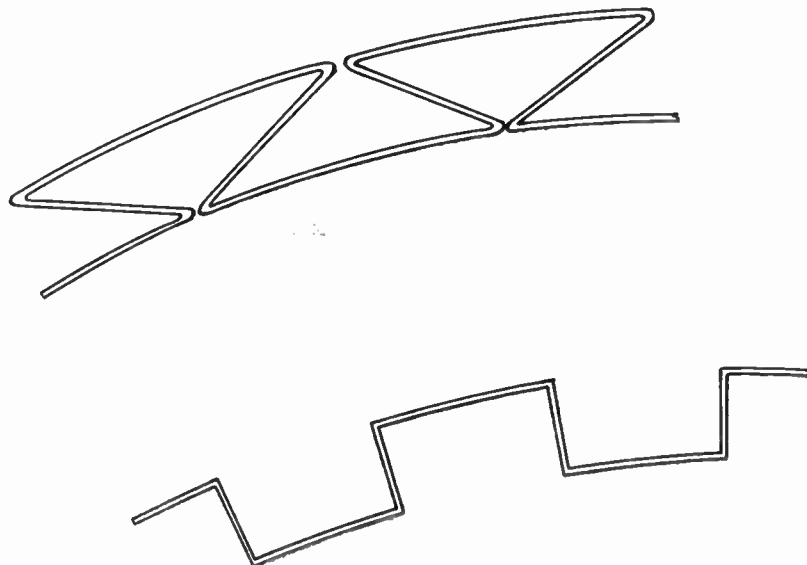

● Fig. II. Comparison insert cross-sections. Top is the Atlas full contact insert for electron tube shields. (Patent pending). Bottom — N.E.L. corrugated insert.

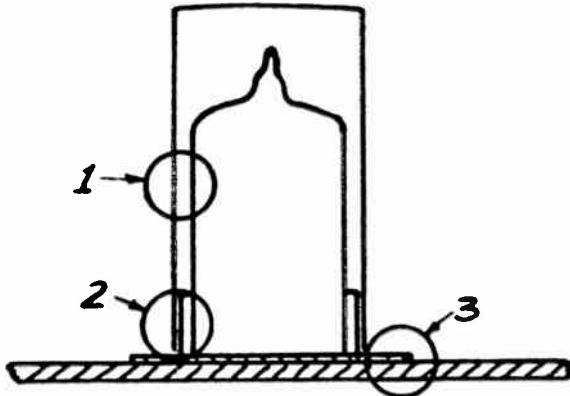

• Fig. III. Thermal barriers in tube cooling.

borne equipment and at the same time the best possible thermal conductivity. (2) The full-contact insert is of black cadmium plated beryllium copper .0015 inches thick. It provides a soft cushion for the electron tube in application involving vibration and shock. (3) The shield base surface has been ground to give maximum flatness for best contact to the chassis. (4) The inner surface of the tube shield is blackened to prevent reflection of radiant energy back into the tube structure.

In presenting this new design for increasing the effectiveness of tube cooling, however, Atlas engineers strongly discourage the operating of tubes at maximum electrical input in elevated environments to take advantage of the superior cooling now made available. As plate temperatures are raised because of increased dissipation or environments, envelope temperature may no longer serve as an accurate index of tube operating conditions.

TYPE 5687WA

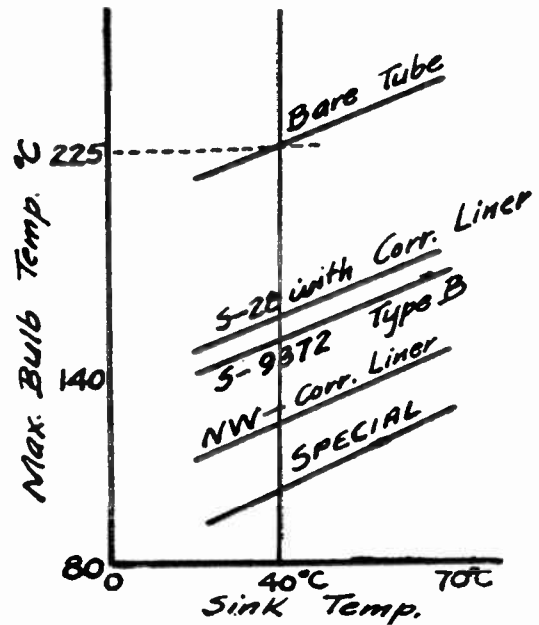

• Fig. IV. Tube temperature curves.

The new heat dissipating tube shields should be used to lower envelope temperatures to the lowest practical figure resulting from conservative tube operation. Thus greater reliability of electronic equipment will be obtained through prolonging tube life.

Ultrasonic Thickness Testing In Practice

IN chemical and other plant that suffer from the effects of corrosion and/or erosion it is essential to be able to carry out check tests for thickness reduction at regular intervals during the life of the plant. The normal method of checking this corrosion is to shut down the plant, clean it out and mechanically measure the areas of known or suspected weakness. This is both costly and time consuming. The modern method is to use ultrasonics for thickness testing and an auxiliary equipment for this purpose has been designed by Kelvin Hughes, for use in connection with the Supersonic Flaw Detector. This equipment is known as the Depth Gage. By its use it is possible to measure accurately the thickness of any material capable of transmitting supersonic oscillations. An important feature of this method of measurement is that access to one side only is necessary. The gage consists of a transmitting and receiving crystal separated by a column of liquid. The distance between the crystal can be varied by operating a control and can be read off on a scale. Probes are applied to the material and a range and frequency chosen to give a clear signal on the screen as far away from the transmission mark as possible. The gage is then plugged into the flaw detector and adjusted until the start of the bottom echo obtained from the gage coincides with the start of the signal obtained from the material under test. Using probes on mild steel the thickness is then read off direct from the scale of the gage.

An example of where this exact technique is used regularly as part of routine inspection is at the Crittall factories, the largest manufacturers of Hot Dip Galvanized metal window frames.

The completed steel frames are dipped into a hot

spelter bath to effect final galvanizing.

The spelter baths are approximately 5' x 10' and 9' deep, built of 2" mild steel with a brick flue surround. The furnace is oil fired.

Over a period the hot spelter affects the bath plate. Consequently the liquid is pumped out of one bath into another and the empty bath is examined with particular regard to the thickness of the bath plate. Before the introduction of the Flaw Detector to this type of testing, the complete brickwork of the bath was dismantled and the thickness of the bath plate examined and tested physically. Thin spots thus detected were welded over and the bath rebuilt. The procedure was obviously a lengthy operation.

Nowadays the use of ultrasonic thickness testers reduces the measuring procedure to about a day or a day and a half.

At regular intervals the bath is taken out of service, emptied and cooled. The lining is marked off by vertical chalk marks into sections. The engineer then takes the Flaw Detector into the tank and tests the thickness of the bath plate at various points within the marked out sections.

The results are entered on a chart and the complete results are plotted and compared with previous figures.

Sectors showing reduced thickness are given closer examination with the Flaw Detector. Thin places are then welded up to the required thickness and the tank is again ready for use.

The introduction of this instrument will be welcomed in many industries where similar problems such as those so successfully overcome by Messrs. Crittall's exist.



● The engineer manager must master the skill of translation of the technical into easily understood meaningful language.

The Skill Of Functional Management

By C. R. Miner *

**Engineering Management Must Skilfully Blend The Knowledge
Of Its Profession With Non-Engineering Groups In Order
To Achieve Maximum Efficiency In Manufacturing Operations.**

THE engineering graduate comes to industry having learned the fundamental principles of his profession. More often than not he has had little experience in the application of his theoretical knowledge. Industry generally recognizes this and is, therefore, tolerant of the time needed for the graduate to bridge the gap between theory and practice and become a qualified, useful engineer. There is, unfortunately, very little written in this area of practical application and the graduate grows into an engineer only through actual practice and experience. It is in the practice of his profession that the electronic engineer experiences such gremlins of the science as cathode migration, grid emission, parasites, barkhausen oscillation, sleeping sickness, etc. The mechanical engineer, similarly, encounters the failures due to crystallization of metals in vibration and all of the difficulties in practice of molding, casting, drawing, forming, and finishing of materials. The theoretical training of the engineer, if

thoroughly understood, will carry him through such difficulties and continued practical application and experience will culminate in true professional skill.

It is useful to look upon management in much the same way. In recent years, management has come to be recognized as a science which can be taught and learned. Many excellent books are available for the student of management and many business corporations offer training courses to qualified employees on the subject of professional management. It is likely therefore that you either have been or will be exposed to some of the new teachings on modern management. There is diversity of opinion as to whether or not management should be regarded as a true profession. For our purposes of study, however, it is

*Manager, Monochrome TV Product Engineering, Television Receiver Department, General Electric Company, Electronics Park, Syracuse, New York.

helpful to treat it as one. A profession has been described as having the following attributes:

1. A specialized body of knowledge.
2. Special skill in the application of that knowledge.
3. A code of ethics.

For our immediate purpose we shall assume that the theoretical knowledge has been mastered and we are concerned with the skill of application. It is here where success depends so heavily on practical understanding. If more is not done to cover this area, two results may be feared: One is that young students of management will emerge with idealized and unrealistic notions of the general applicability of the new philosophies and will fail in the attempt for pure lack of skill. Perhaps the worst example of this kind of manager product is the one who becomes a walking fountain of strange and lofty phrases which to him seem to cover every situation but which to his subordinates breed nothing but disgust and the comment: "So help us, our boy has read a book." Second, is the probability that older experienced managers will reject many valuable principles because they do not seem to fit their experience and appear unworkable.

This article is pointed to the problem of the young student of management who either has been or will be exposed to heavy doses of modern management theories and is likely to become bewildered for lack of better linkage with life's realities. We shall dwell in the area of functional management, i.e., engineering, where most of our interests lie, rather than in the broader aspects of general management.

The writings on professional management have labeled the unprofessional type manager as the "intuitive" manager. Doubtless this is as good a term as could be used to make apparent that he lacked professional training for the job. It would be most regrettable, however, if we allowed ourselves to conclude from this that there is something bad with intuition, per se. Webster says that intuition is: "The power of knowing, without recourse to reasoning; innate or instinctive knowledge: familiarly, a quick or ready apprehension." Certainly, we can agree that quick and ready apprehension is a necessary and desirable virtue.

True skill is the result of long practice. Practice effects a transfer of mental control from the conscious to the subconscious mind. The perfect example of this is in learning to play a musical instrument or to drive an automobile. When a full measure of skill is attained, then we witness subconscious control, or what is here called intuitive action. In other words, the higher the skill, the more intuitive the action. Since we obviously want skilled management, we should not condemn, universally, intuitive action.

It seems worthwhile to point out that the real short-coming of the so-called "intuitive" manager is his heavy dependance on intuition in all situations, both new and old, simple and complex, without a conscious understanding of the basic principles involved. He is unable to determine when his intuition should not be trusted. For the lack of theoretical knowledge he relies wholly upon intuition and therefore occasionally, unconsciously, violates fundamental principles, just as he frequently unconsciously applies them. He also is handicapped in his inability to explain to subordinates the reasons for his decisions and therefore comes to be regarded as arbitrary.

Henry Van Dyke has said: "There is no conflict between the Old and the New; the conflict is between the False and the True." How often we have seen the student of modern management so carried away by the "New" that he failed to recognize the "True." The new teachings speak of persuasion replacing command and of motivation by objectives rather than by drives, as examples. The underlying logic of these teachings has always been true, being derived from basic human nature which is timeless. A very large measure of human understanding and common sense is required of the management student if he is to understand fully and put into proper perspective the writings on modern management.

When he moves into a position where he is required

to practice good management, he encounters countless situations and problems not specifically covered by "the book." Of necessity, the theoretical treatment of management is full of generalized principles which are of value only as a guide to solution of specific problems, and the manner in which every day problems arise frequently is such as to camouflage the basic principles involved. Real managerial skill can exist only if the manager readily recognizes the basic truths involved when there is no "sheet music" to read, and he has to "play by ear." It is not enough to acquire knowledge. There must be understanding of the knowledge, coupled with ultimate skill in its application.

Perspective

Certainly, one of the first requirements of the engineering manager is that he have the right perspective. By this is meant that he understand completely and broadly the role that his function should play and what it must contribute to the business enterprise. A complete understanding of engineering's role must of necessity accept some slight subordination of certain ideals of the engineering profession in deference to the goals of the business. This is not to say, however, that these ideals should be forsaken but it is necessary that there be proper balance between them and overall demands of the business.

One way to look at this, for example, is in the exercise of engineering's ideal to serve society. Surely, this is a rewarding and valuable tenet of the profession and its pursuit does much to maintain high standards of professional performance and integrity. From the purely professional viewpoint, for instance, the corporation is regarded by the engineer simply as an instrument through which he serves society. When this concept is followed to the exclusion of other necessities of the business, such as the minimizing of costs, control of investment, timeliness of product introduction, or emphasis on sales features and styling, the business is bound to suffer and the engineer may lose his chosen "instrument" entirely. After all, the business in its own way also serves society and neither the business nor the engineer can be completely successful alone.

The proper perspective, then, must be understood and maintained by the engineering manager to enable the business to succeed. Doubtless, you know of examples of business mediocrity due to one function or another having dominated the business to an extreme. Franksteins are as likely to emerge from Marketing, Manufacturing or Accounting as from Engineering, and the functional manager will be most successful who skilfully integrates his function effectively into the whole overall effort.

External Relationships

The functional manager, it seems, has a particularly exacting problem in his relationships upward and sideways in the business organization. To a very large degree his effectiveness in the business is determined by his skill in handling these outward relationships. Internally, the engineering manager must maintain a highly aggressive, achievement-minded climate among his engineers in order to serve efficiently and professionally the ends of his function. If he has been successful in creating this climate, each of his professionals has a more or less built-in sense of urgency and dedication to achieve. This is a priceless possession to any functional manager who is so blessed.

Unfortunately, however, there are countless obstacles to the preservation of this happy state which originate in the external relationship area. There is almost always, for instance, a language barrier to complete mutual understanding between the engineering function and others, particularly with Marketing. To most marketing managers, the engineer is obscured by a gobbledy-gook of technical language and is frequently regarded as unapproachable on equal terms. Top management may also share this feeling of distance from the engineer if it is not itself of engineering origin. The engineering manager, therefore, must master the skill of translation of the technical into easily understood meaningful language.

Another aspect of importance in this area of outward relationships is in the evolution and scheduling of the product. Classically, in a competitive product business, the time left for design is the time between the formulation of what the product shall be and the time when tools and material must be procured to start manufacturing on a date desired by Marketing. The former is always too late and the latter is always too early. The difference, or time for design, is too little or even in some cases negative. It does no real good to bemoan this unfortunate situation and the alert engineering manager will skillfully anticipate and avoid this "little end of the stick." If he does not, the opportunity for engineering contribution is lost and the morale of his engineers will be dulled if not destroyed. He may accomplish it by use of several devices. First, he can alert Marketing and top Management to the consequences of late decisions, keeping before them at all times the schedule required of them in order not to sacrifice the design time. Secondly, he can gain extra time for engineering by working closely with procurement so that needlessly early releases are avoided and the procurement cycle shortened as much as possible. Thirdly, the engineering manager should be sufficiently attuned to commercial requirements and viewpoints that he can at all times keep his engineers productively engaged in product development which anticipates market requirements. It frequently happens, when this is done, that a very successful product results which never would have occurred had the engineering manager passively waited for commercial decision.

It is exceedingly demoralizing to an engineering group for its sense of direction to become confused. The engineering manager must use every legitimate avenue open to him to prevent outside influences from obstructing or confusing the creative course of his group. The real danger in this lies, of course, in the tendency toward an isolated existence wherein engineering carries on for its own sake rather than serving the needs of the business. It behooves the engineering manager to see to it that his internal programs are adequately coupled with objectives and philosophies of the business, even when the orderly functioning of the organization designed to provide this guidance breaks down. How skilfully the functional manager does this determines to a very large degree the effectiveness of his group's contribution as well as its being a measure of his own promotability.

Internal Relationships

The text books on management and supervision cover quite adequately the mechanics of organization, delegation, measuring, etc. There are a few aspects, however, which are especially important in the skill of successful management downward. The first of these has to do with organization and assignment. The theoretical approach is to break down the overall task into easily handled components and then to set about the filling of jobs thus created with the proper kinds of people. Invariably, however, the situation is such that this approach, if blindly pursued, would not guarantee achievement. In fact, it can guarantee failure. Very seldom is it possible to set up immediately the ideal organization and to guarantee achievement with the available assortment of talents. The manager must first be achievement-minded in his approach to the organization structure. The way in which he breaks down the whole task must be such that the combination of talents and skills in all of his men gets the greatest utilization and will guarantee maximum overall achievement. To this extent his organization must be tailored to fit the men he has. If this organization is short of the ideal, he should have a parallel program in place to secure the proper combination of abilities to fit the right organization in the future.

So far as possible every assignment should be a package in itself. This is not always possible, of course, but the men who are called upon to play a contributing role should at least, in future assignments, be given a well defined piece of the project to call their own. One must keep foremost in his mind that the man's inner urge to achieve and be recognized must be served. There is a

middle-ground in this area of assignment between a completely subordinated service function on the one hand and an over-exalted desk-admiral job on the other. The group will be stronger and happier if assignments are avoided which approach either extreme.

A most important consideration, particularly in this matter of internal relationships, is the basic character of the man who is manager. Surely, integrity is a necessary prerequisite of the manager, but it should be emphasized that he can never be completely successful without a special sincerity in his relationships downward. It frequently happens that the functional manager must decide between two courses of action, one of which would serve his personal ambition at the expense of his men, and another which might damage his personal prestige but serves the interest and loyalty of the group. The latter is a bitter pill to swallow particularly for the young and ambitious, but it must be swallowed.

As their representative to top management, the group will not tolerate his selling them short, and the functional manager should prize highly the respect of his men. There must always be quick and willing response to the manager's leadership. One of the surest ways to destroy the willingness of response is any semblance of insincerity on the part of the manager in the interest of personal ambition.

One of the most important jobs of the functional manager is that of the teacher. Because of his knowledge and experience, he can supply foresight to the execution of the task which frequently no other member of the group can provide. His approach, however, must be on the basis of explaining and emphasizing the pitfalls of the situation so as to equip the engineer with the understanding required to "go it alone." Only in rare instances is it wise for the manager to think out and plan the design by himself. This procedure may achieve immediate temporary results, but it does not educate the group to think and plan for itself. The functional manager should work toward his own expendability through teaching. It is only in this way that his group can become strong and progressive and that his own strengths can achieve maximum effectiveness.

This is a difficult lesson for many engineering managers to learn. Frequently, the manager, having been a successful engineer in his own right, cannot effect the change from designing to teaching and managing without great personal frustration. This transition must be accomplished, however, even at the expense, temporarily, of efficiency, or excellence of design. He must regard the product as the fruit of the efforts of the group and the group as the fruit of his own efforts. The real test of the effectiveness of the manager's skill lies in how well the group has learned to carry on without him.

It is hoped that this article may contribute to a better understanding of functional management. It is to be expected that viewpoints will differ, as well they should, on the question of just what is functional management, e.g. skill, science, profession, practice or just another way of making a living. By looking at it as a profession and drawing parallels with the engineering profession, it is believed that one can reach a new plateau of understanding, which in turn aids in the development of skill which is an absolute necessity for success in any endeavor. Just as the engineering student, after having mastered the basic principles, grows into a truly professional engineer by development in practice of understanding and skill, so must the student of management acquire basic knowledge, understand its practical application and achieve high skill in its use before he qualifies as a truly professional manager.

REFERENCES:

- "The Practice of Management", Peter F. Drucker.
- "Dynamic Administration"; The Collected Papers of Mary Parker Follett.
- "Individual Behavior", Snugg and Combs.
- "How To Talk With People", Irving R. Lee.
- "Bedrock Foundations For Manager Development", H. H. Race
- "The Professional Attitude in Engineering and Management", H. H. Race.
- "Professional Management in General Electric".



● The above photograph shows a packaged nuclear training laboratory delivered complete with a curricula of training experiments and the necessary electronic equipment to conduct the experiments.

A Packaged Nuclear Training Laboratory

By O. Kenton Neville, Ph.D.*

MODERN commercial reactors may be divided into three main classes: power reactors, research reactors, and training reactors; and the three types differ a great deal according to their purpose. Power reactors are designed to provide a maximum amount of heat at the highest possible temperature and to operate at the highest possible efficiency in terms of fuel burn-up. Research reactors are designed to run as cool as possible with the goal of providing the highest possible number of neutrons per unit time. Most of the research and development in the last ten years has been on these two types.

There is, however, a growing need for the third type, the training reactor, if we are to educate new generations of scientists and engineers to carry forward the design of the first two types. It is obvious that one does not teach young mechanical engineers to design better automobiles by providing them with a new \$10,000 Cadillac to drive around the block, with the admonition that they must not tinker around with the motor or they might ruin it.

It is equally obvious that one does not best train young nuclear scientists and engineers by providing them with a power or research reactor costing hundreds of thousands of dollars upwards to play around with.

You can set the student down at the control console and let him start the reactor up and stop it and learn in general how it performs, but you are not thereby educating a designer; you are educating a "button pusher." Even button-pushing has to be done with some caution with such reactors lest the device get out of hand and end up as a pool of molten metal.

In our consideration of the design of training tools for the student scientist, certain criteria became obvious:

1. The device must be inherently safe such that no possible arrangement or error could lead to a reactor run-away. If this criterion is met, there is no requirement for U.S. Atomic Energy Commission Reactor Safeguards Approval and the red tape associated with it. (This conceivably may also apply insofar as Canadian authorities are concerned).[‡]
2. The student must be able to "get inside it," to disassemble and rearrange it and to become intimately acquainted with its work.
3. The device must not be too complicated, nor must the fundamentals be obscured by frills or gadgetry.
4. The device must be relatively inexpensive such that schools may obtain them without making an unreasonably large financial commitment.

When all of these criteria were considered and their effects maximized we were led, naturally, to the type of device we are now providing. This, we feel to be the ideal training reactor for nuclear scientists and engineers on a broad educational scale.

The new Model 9000 student training reactor is in essence, a stainless steel tank 4 feet in diameter and 5 feet high in which are inserted a grid of vertical tubes arranged in a symmetrical pattern. There are 260 vertical tubes standing in this tank. Each of these tubes contains five slugs of natural uranium metal of the type used in the Savannah River reactor. These are reject slugs which are unsuitable for use in production reactors but are

* Nuclear Chicago Corporation.

excellent for our purposes. In the whole assembly, then, there are 1300 slugs, the total weight of uranium being about 5500 pounds.

The volume in between the tubes is filled with tap water and this becomes the moderator. In the center of the assembly a neutron source made of a mixture of plutonium and beryllium is inserted. The neutrons from this source are moderated by the water, and taken up by the uranium to cause fission. The fission process in this assembly results in a multiplication of the neutron flux by about a factor of seven.

Such an assembly of uranium, water, and a neutron source is inherently a subcritical reactor, and cannot be arranged in any possible way such that it will become critical. It is sometimes called a zero power reactor. The fundamental characteristics, such as the neutron multiplication and distribution, are nearly identical in nature with those in a full scale power or research reactor. The student may therefore become intimately acquainted with the fundamentals of reactor theory and design and may see for himself the effect on the important characteristics of a change in the basic uranium configuration, amount of moderator, etc.

If we are to provide for the broad education of students in nuclear technology it is apparent that we must also provide for broad training of the university staffs who are best equipped by nature to provide the training. It is not enough simply to design a device like this and to assume that its use will be quickly picked up by university staff members. The setting up of proper course-work, the design of suitable student experiments and the assembling of the proper associated instruments is a laborious and time-consuming job. It is obvious therefore that if one group can do this, once and for all, sufficiently well that almost any university staff can quickly take over, this broad scale training can begin sooner and proceed faster. With this object in view there has been assembled with the student training reactor a group of radiation-measurement instruments which it is felt are ideal for student use and student training. There has also been developed a set of some 30 experiments which it is believed are equally ideal for basic student training. By use of the experiments, the instrumentation and the subcritical assembly, almost any college or university in the country can take part in nuclear training without unusual specific training of their technical academic staff. The present training package can be easily learned and utilized by any technically competent university staff member, whether he is a physicist, a chemist, a mechanical engineer, an electrical engineer, etc.

It is expected of course that once the training package is in the hands of universities many new types of experiments and procedures will be devised which are different and in many cases superior to those provided by ourselves. Indeed, it is hoped that this is the case, for all we hope to accomplish is the triggering of the learning cycle by making it easy to get started without tremendous losses in time and effort by the university staff members.

There is a widespread feeling that the field of atomic energy and other new fields of science are treated as too mysterious and too awe-inspiring. There is no sound reason why nuclear engineering should not be integrated in the university course work as simply another phase of modern engineering. Undoubtedly the best way to encourage young scientists and engineers to enter these new fields is to permit them to "rub shoulders" with nuclear devices as a normal part of their university training. If this can happen on a broad scale it is reasonable to assume that the student will find these new fields so fascinating that there will be no problem in supplying a sufficient number of trained scientists in the future. Since the fundamentals of nuclear technology, when stripped of the mystery and of the engineering details, are relatively simple, there is no reason why such instructions should not occur in junior colleges and indeed in many high schools, and we may all look forward to the day when this becomes the case.

† Editor.



● The above photograph shows an instructor loading the subcritical reactor with neutron source which is generally placed in the center of the uranium lattice. Source can be easily moved to bottom of reactor for special experiments. When installed in the reactor, the source presents no radiation hazard since it is shielded by both water and the uranium slugs.



● Strip Foil Analyzer is used to plot induced radioactivity of foils placed in reactor. Strip foils activated in reactor are drawn automatically past Geiger counter in analyzer. Recording shows exponential decrease in activity along radius of uranium lattice.

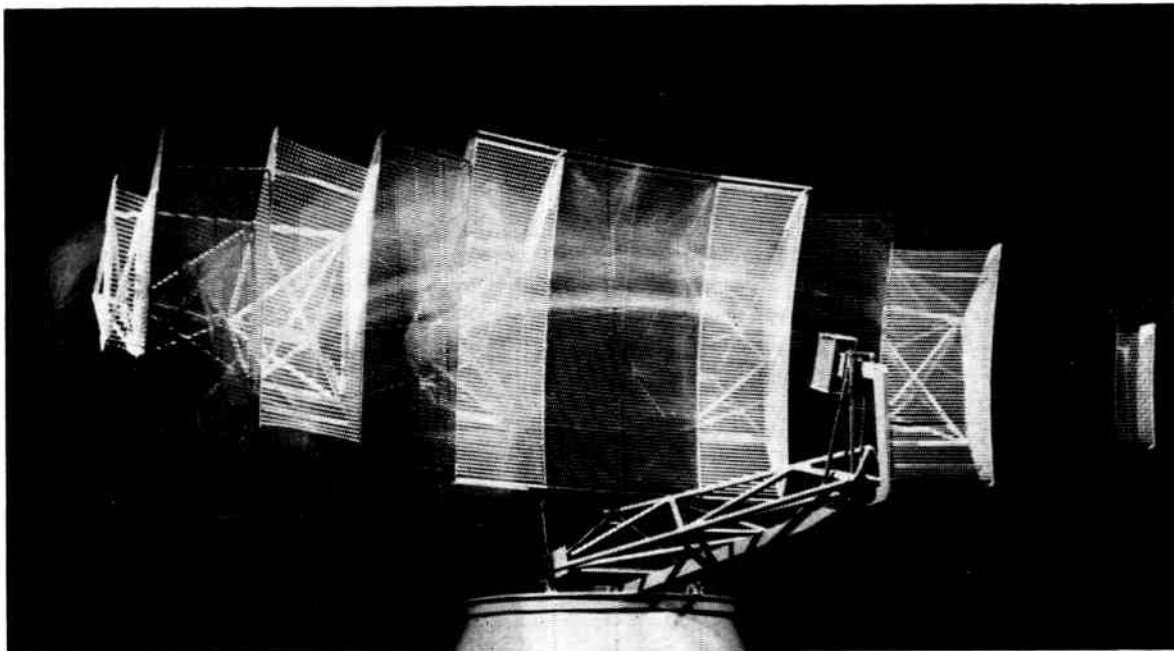

● The single antenna used for three radar installations in the Intec Diversity Radar system.

**In This Age Of Supersonic Flight And Guided Missiles
Air Safety And The Protection Of Frontiers Largely
Depend On The Efficiency Of Radar Warning Networks.
The Following Article Describes A System Whereby
The Quality Of Radar Displays Is Increased And The
Radar "Watch" Made More Effective.**

Diversity Radar

WITH ANTENNAS rotating 24 hours a day, each radar transmits several hundred pulses every second and catches the echoes reflected from any object moving in the space being explored. In the darkness of the operations room, the dimly illuminated display screens are being continually swept by the luminous pointer of the radar trace.

Moving echoes must be recognized and located so that they may be followed and identified as soon as they appear on these screens.

This task is much easier when the screen indications are clear and free of spurious signals, fixed echoes or possible jamming, which all interfere with observation.

To this end, manufacturers have endeavored to develop devices to improve the quality and sharpness of the displays, thus providing a more effective "radar" watch.

As a further improvement to these early warning networks, various radar retransmission systems have been developed which make the location of the operations rooms independent of the radar stations.

Some aspects of these problems as encountered in the operation of a radar system will be examined in turn.

Improvement to the Display

A "raw" radar display is subject to various permanent or temporary phenomena which reduce the sharpness of the echoes being followed. These are fixed echoes seen as bright blotches more or less concentrated in a zone around the radar station and spurious signals, such as background noise (usually non-recurrent), which appear as a spotted background considerably lowering the contrast of the echoes. A display can also be subject to further interference when two neighboring stations clash.

The CSF Group has studied these problems and has found certain solutions which merit attention:

Improvement of signal-to-noise ratio by operating in frequency diversity or by means of devices which correlate the useful signals.

Suppression of fixed echoes (or signals from targets having a definite radial velocity) by means of eliminators using memory tubes.

Elimination of spurious signals by an equipment designed to deal with the random nature of background noise.

Frequency-Diversity Radar

Transmission engineers have long been aware of the principle of diversity operation of radio equipment and of its practical applications to long-distance links. Equipment can be operated in either "space" or "frequency" diversity; in the former case, several receiving antennas are used on the same frequency; in the latter, transmission and reception are carried out simultaneously on several frequencies using a common antenna. The two systems can of course be combined.

In either system the best signal available at any given instant is selected from two or three received signals by automatic change-over switches.

Theoretically the same principle can be applied to radar, but space diversity is found difficult in practice because of the necessity of maintaining synchronism of operation and especially of antenna rotation. Frequency diversity can be more conveniently applied to radar.

Two or three transmitter-receivers operating on different frequencies use a common antenna, possibly with a relative time delay of a few microseconds; a special hyper-frequency switch is then needed to feed the transmitter pulses to the common antenna, and the echo pulses to the appropriate receiver; the pass band of this antenna must also provide the same radiation characteristics for the two or three operating frequencies.

On reception, the signals reaching the two or three receivers must be re-synchronized by compensation of the relative delay introduced at the transmitter.

It only remains to make the best possible use of the video signals thus synchronized.

It would be possible to select the best signal at any given instant and to use that signal alone, but in fact this method would not take advantage of the increased mean power available from several transmitters, or of the increased range provided as compared with a single transmitter of similar characteristics.

A more complex utilization of the video signals is advantageous.

Considering for instance the case of three transmitter-receivers supplying video signals a, b, and c, the following alternatives are possible.

Addition of $a + b + c$.

Addition of the video signals in pairs and multiplication of the partial sums, so as to obtain a signal of the form $(a + b)(b + c)(c + a)$.

Obtaining the partial products and adding them together to obtain a signal of the form $(ab + bc + ca)$.

The first solution is naturally the simplest. It is also the solution which gives the most marked improvement in the signal-to-noise ratio, since the echoes appear at the same instant on all three video stages, while noise peaks which are erratic and independent are only occasionally superimposed. This system has an obvious disadvantage: the video sum is subject to interference occurring on any one of its three video stages.

In this respect the second and third solutions are more satisfactory; it will be appreciated that if one of the three video stages is subject to interference, video "a" for instance, multiplication will remove that interference, in the absence of signals on video stages "b" and "c". The simultaneous use of two or more frequencies is then an excellent anti-interference arrangement effective both against jamming and against interference originating from the transmissions of neighboring stations.

In any case, with any or all of these methods, a notable improvement in coverage is secured.

For the 90% detection curves, range is increased by 30 or 35% compared to the range of a single station having the same characteristics, and there is a marked increase in the detection percentage at equal range; in fact, apart from a weak zone at the edges of the reception lobe, the detection "blanks" completely disappear. In addition, fluctuations due to variations in the echo surface areas of a target are practically eliminated. It can be said then that a station equipped with three transmitters of power P, diversity coupled, is, from the point of view of an assured 90% detection coverage, equivalent to a single radar transmitter of power 3 P.

It must also be emphasized that almost 100% reliability of operation is secured with a twin transmitter-receiver installation, and, of course, with three transmitter-receivers, since such an installation continues to function with one unit out of action for purposes of maintenance or repair.

It would therefore always be advantageous to apply the diversity principle to any installation duplicated for reasons of reliability.

Tests were carried out by the French Air Force over long periods on an experimental station in order to evaluate the advantages of the method.

This was the first diversity-radar station in the world,

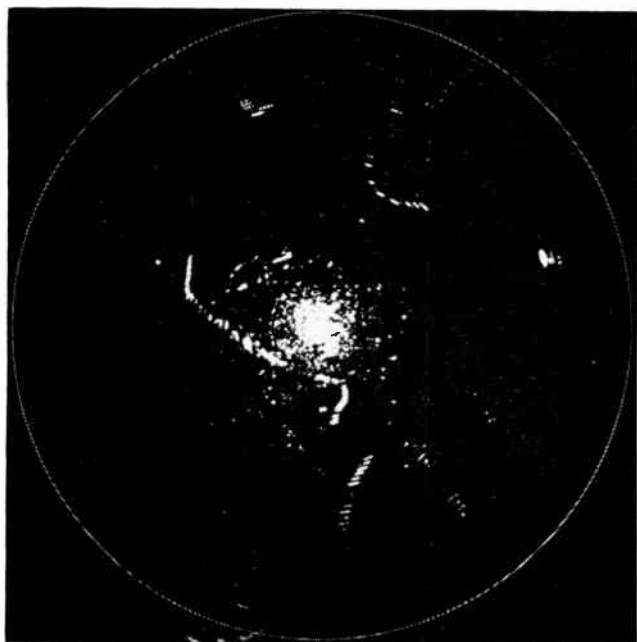

● The Intec Diversity Radar with Moving Target Indicator (MTI) eliminates fixed echoes and gives a clearer image.



● The Diversity Radar scope picture without Moving Target Indicator equipment.

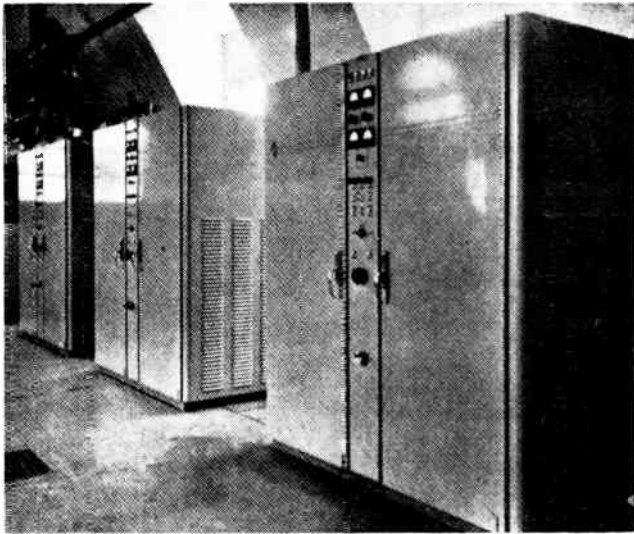

● Three transmitter-receivers operating on frequency-diversity. Above them is the hyper-frequency switch whose function it is to mix the transmitted signals in a single waveguide and to separate and direct the received signals toward the three receivers.

and the results secured favorably impressed specialists from many countries.

Suppression of Fixed Echoes

Another improvement in a radar display is the elimination of echoes from fixed obstacles such as hills, overhead lines, etc. which confuse the PPI display and always impair watch-keeping.

The methods used are well known; they are abundantly described in the technical literature and have been divided in two main groups: "coherent" systems, in which the

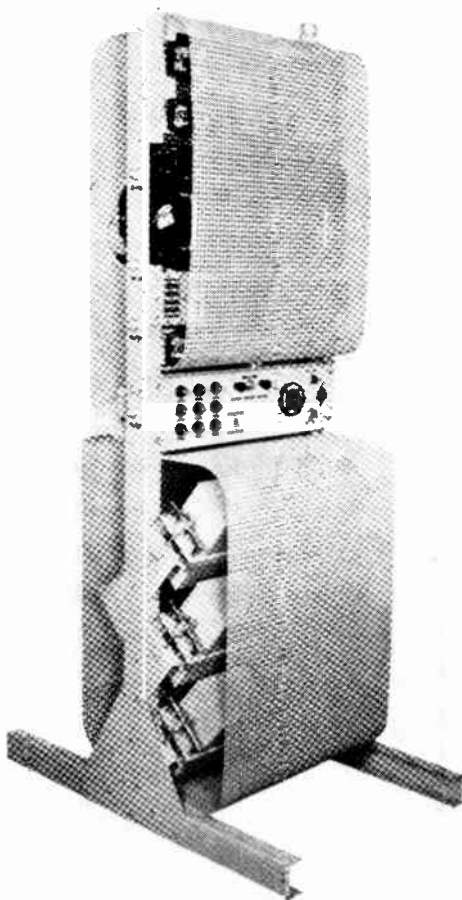

● Interference suppressor unit built by CSFR.

IF signals are made to beat with a reference oscillation initiated at each transmitter pulse and having a certain phase difference with respect to the local oscillator, and "self-coherent" systems in which use is made of the beats between the superimposed fixed and moving echoes.

In either case a memory element is necessary in order to compare the amplitudes of the beat signals from one pulse to the next.

The "coherent" equipment built by CSFR consists of a memory tube which replaces the more conventional delay line elements.

The advantages of this method, used by the French Air Force over a long period of experimental trials, can be summarized as follows:

Simplicity of adjustments — those of the cathode ray tubes.

Stability of adjustments — no frequent touching up.

Possibility of varying the radar repetition frequency, the tube's memory being available at any time and at any desired rate.

This device is designed for adaptation to transmitter-receivers equipped with a stabilized local oscillator, with the possibility of adjusting it to the various intermediate frequencies of the radars. In the case of installations not thus equipped, an additional unit containing a stabilized oscillator can be substituted for the radar's local oscillator.

Also, CSFR has developed an experimental "Self Coherent" device which is at present undergoing systematic trials.

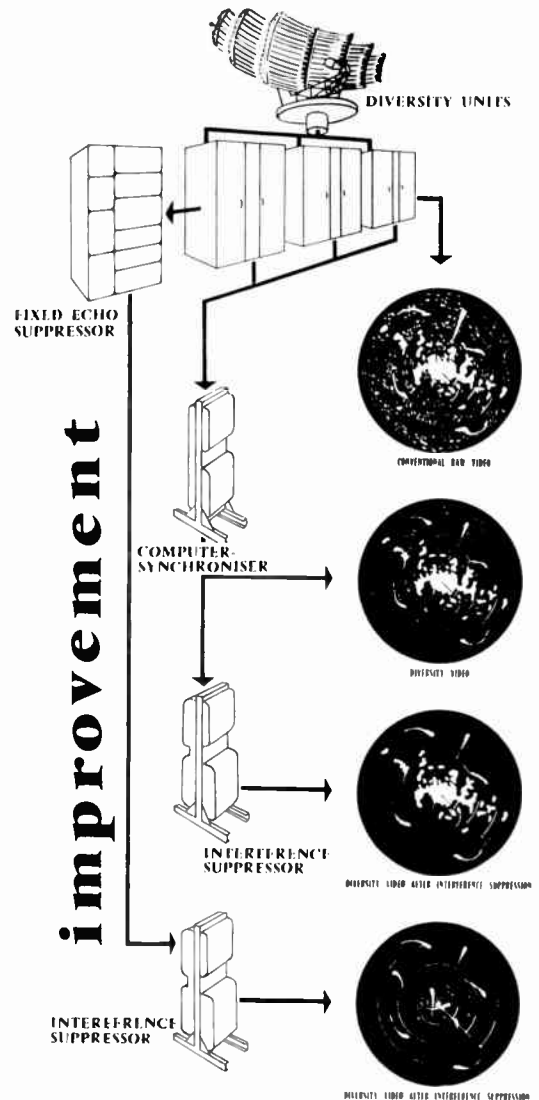

● A diagrammatic arrangement showing the improvement of video signals achieved with the Diversity Radar system.

Coincidence Selector

On the principle that noise is of a random nature while echoes appear over several consecutive radar cycles and at a practically constant distance (the distance changes from one rotation of the antenna to the next, but only slightly during the sweep of the beam over the target), it was theoretically possible to boost echoes with respect to noise.

As for the elimination of fixed echoes, a memory element is necessary to compare the video signals obtained during successive repetition cycles of the radar.

The memory element is a special tube of the "barrier-grid storage" type, having sufficient definition to allow the whole of the discrimination of the radar to be retained.

Known as "Coincidence Selector" or "Interference Suppressor", the device can be incorporated in any type of radar so long as its circuits and memory unit are suited to the characteristics of the main equipment. It ensures the elimination of all non-recurrent signals, as

well as of recurrent signals with a repetition frequency different from that of the unit.

There are two industrial versions, one in sealed "containers", designed for mobile stations, the other rack-mounted for installation under cover.

It is difficult to quote a performance figure for interference suppressors; although they do not enhance the sensitivity of the radar, they considerably improve the signal-to-noise ratio by the practically complete cancellation of noise as soon as the echo exceeds noise level.

In practice, improvement in the video signals on the PPI displays results from a picture of high contrast on a completely dark background; watch is thus considerably eased. In addition, screen remanence is generally sufficient to ensure that the 4 or 5 preceding echoes produce a visible trace permitting evaluation of the course, and even of the approximate speed, of the aircraft.

Adjust for elimination of strong interference, the device permits easy following of a situation which would otherwise be cluttered with interference.

Portable X-Ray Units In Industry

THE OX-175 is a versatile, portable industrial x-ray unit capable of producing a 360-degree radiation sweep, enabling radiographers to attain high inspection efficiency at greatly reduced cost.

Many products can be set up in a circle around the "business head" of the unit for multiple x-raying with a single exposure. This can reduce radiographic operation time in some industries as much as 97 per cent! If desired, the unit can also operate as a conventional type with a limited angle cone of radiation.

The unit can be placed inside a pipe or pressure vessel to take "inside out" x-ray views. The advantage of this technique is that it confines the radiation within an enclosed area and thus increases protection to personnel against radiation exposure. Furthermore, this technique permits making a complete circumferential weld radiograph with a single exposure.

The unit consists of a tank to house the x-ray tube, control, energizing transformers, and interconnecting cables. The tube head weighs less than 185 pounds, has a diameter of only 10½ inches and a length of only 42 inches. The small control measures only 18 by 18 by 14 inches, and weighs 145 pounds.

The OX-175 can be mounted and used in field, shop and laboratory in many different ways. For example — on a mobile truck with elevating tube stand, rotating tube stand or tube carrier; on a bridge crane; installed inside a radiographic cabinet; on a mobile base; or, on a fixed mounting with an elevating tube stand.

The entire unit can be easily transported to any location desired. It can be operated at x-ray tube voltages from 45,000 to 175,000 and contains many features for the operator's convenience, plus automatic safeguards against improper operation.



● The OX-175 with control on back of truck. Head is being inserted in pressure vessel preparatory to taking radiography in the field.

Book Review

Books Of Special Interest To Engineers And Others Engaged In The Electronics Industry.

Fundamentals Of Electron Devices by Karl R. Spangenberg, Professor of Electrical Engineering, Stanford University.

In this book the author presents a unified fundamental treatment of electron devices including vacuum tubes and transistors, with emphasis on their similar features, rather than their differences, through the common denominator of semiconductor theory.

The book stresses the internal physics of the devices and discusses the role physics plays in determining the external characteristics.

A new approach is represented in the detailed treatment of energy levels in semiconductors and the influence of these on junction effects, emission, and photo-effects. There is an unusual emphasis on the analogous features of vacuum tubes and transistors. Recent advances include the latest forms of transistors and photoconductive and photovoltaic cells. The numerous problems contained in the text are intended to be suggestive rather than exhaustive.

Fundamentals Of Electron Devices is published by McGraw-Hill Company of Canada Limited, 253 Spadina Rd., Toronto 4, Ont., contains 505 pages, hard cover bound, price \$12.00.

Basic Electric Circuit Theory by Walter W. Lewis with the assistance of Clarence F. Goodheart, Professor Emeritus and Chairman respectively of the Department of Electrical Engineering, Union College.

This book has been divided into two parts. Part I consists of nine chapters that cover the basic principles necessary for the solution of circuits. Part II consists of seven chapters that bring out important secondary principles and applications. This division of material lends itself to the use of Part I for a one-semester or two-quarter-term course. Part II could follow if the course covers two semesters or the equivalent.

All important concepts have been worked out from fundamentals, and each new concept is illustrated by an example. Numerous pertinent problems are also given at the end of each chapter.

Great care has been taken to make the text both explicit and clear, and interesting mathematical developments have not been pursued beyond the point necessary for a clear treatment of the subject.

Unique in this book are a chapter on the solution of transients by Laplace Transforms and a chapter on Hyperbolic and Exponential Functions.

Basic Electric Circuit Theory is published by The Ronald Press Company, 15 East 26th Street, New York 10, N.Y., contains 650 pages, hard cover bound, price \$9.00.

Closed-Circuit And Industrial Television by Edward M. Noll.

The purpose of this book is to present information about closed-circuit television systems available and to suggest some of the ways in which such systems can serve modern needs.

The first chapter describes operations and services that are already being performed by closed-circuit systems and provides many practical examples. The remainder of the book stresses the technical phases — systems, types of cameras and viewers, circuits and techniques, installation and service. The final chapter presents sufficient construction details for the technician to construct a small inexpensive television camera. In this way he can gain experience and become familiar with the pickup techniques.

The book can be used as a text in technical institutes and in adult education for courses covering the principles of TV transmission.

Closed-Circuit And Industrial Television is published by Brett-Macmillan Ltd., 25 Hollinger Road, Toronto 16, Ontario, contains 230 pages, paper bound, price \$4.95.

Logical Design of Digital Computers by Montgomery Phister, Jr., Director of Engineering, Thompson-Ramo-Wooldrige Products, Inc., Los Angeles, California.

Using synchronous circuit components almost entirely, this book describes and interprets the methods and techniques of various men in the field, and applies them to a wide variety of problems in the logical design of digital computers. The book provides the reader with the information, tools, and procedures needed to carry out the complete logical design of a general or special-purpose computer.

Of particular value are the detailed discussions of: the Veitch Diagram method of simplification of Boolean equations; the "difference-equation" approach to memory elements; the Huffman-Moore model of digital systems; the complete solutions to flip-flop input equations; and a mathematical introduction to Boolean algebra.

Many simple, yet pertinent examples of how to use these techniques enable the reader to apply them readily to other computing configurations.

Logical Design of Digital Computers is published by John Wiley & Sons, Inc., 440 Fourth Avenue, New York 16, N.Y., contains 408 pages, hard cover bound, price \$10.50.

Abstracts of Literature on Semiconducting and Luminescent Materials and Their Applications - Volume III - 1955 Issue, compiled by Battelle Memorial Institute and sponsored by the Electrochemical Society, Inc.

To those who have not previously obtained volumes of the Electrochemical Society Semiconductor Abstracts, these volumes are provided to assist those persons concerned with the broad growing field of industrial and scientific endeavor. With these organized abstracts, workers in the field have an even chance of keeping up with the contributions from the many branches of science which are encompassed by activities in this field.

This most recent compilation of abstracts has been prepared jointly by members of the Solid State Devices Division and the Physical Chemistry Division of Battelle Memorial Institute.

Abstracts of Literature on Semiconducting and Luminescent Materials and Their Applications - Volume III - 1955 Issue is published by John Wiley & Sons, Inc., 440 Fourth Avenue, New York 16, contains 322 pages, hard cover bound, price \$10.00.

Network Synthesis - Volume I by David F. Tuttle, Jr., Professor of Electrical Engineering at Stanford University.

This initial volume in a two-volume work presents the principles of synthesis of electric networks in which steady-state behavior as a function of frequency is all-important. Volume I covers networks with two terminals (Volume II will treat those networks with four terminals).

The author gathers together the important advances in network synthesis of the last twenty years and adds this to the classical material. The result is a coherent, intelligible treatment of what network synthesis can accomplish. Nearly all subjects discussed are supported by demonstrations or proofs.

To give the reader a full knowledge of modern synthesis, the book is organized on three steps of procedure: (1) obtain a working knowledge of the properties of networks; (2) investigate ways of approximating behavior which may be desired, but which the results of step 1 indicate is not realizable; (3) carry out the actual synthesis (realization) of networks to achieve such attainable ends.

Network Synthesis - Volume I is published by John Wiley & Sons, Inc., 440 Fourth Avenue, New York 16, N.Y., contains 1175 pages, hard cover bound, price \$23.50.

Electronics And Electron Devices by Arthur Lemuel Albert, Professor of Communication Engineering, Oregon State College.

This book is the third edition of *Fundamental Electronics and Vacuum Tubes*, the title having been modified in accordance with present usages. This edition has been rewritten almost entirely, and much of the descriptive material of the earlier editions has been eliminated to provide space for new material. The objectives remain as for preceding editions: to provide a textbook for junior and senior college and university courses on basic electronics and electron devices; a book that is well balanced between theory and illustrative applications; and a book that is suited to the needs of students interested in the power field, as well as those who are looking forward to careers in communication and control.

An important feature of this book is the chapter on Magnetic Amplifiers. Although these amplifiers are not electronic in the usual sense, magnetic devices are important in control and often supplement, and sometimes supplant, electron devices. Because basic training in magnetic amplifiers so often is overlooked, the chapter was included.

In addition to the changes mentioned, this book differs from its predecessor by including a chapter on Wave-Shaping and Control Circuits, covering differentiating, integrating, limiting, clipping, multivibrator, and similar circuits.

Electronics And Electron Devices is published by Brett-Macmillan Ltd., 25 Hollinger Road, Toronto 16, Ontario, contains 582 pages, hard cover bound, price \$8.00.

A number of paper-bound books, published by John F. Rider Publisher, Inc., which may be of special interest to readers of *Electronics and Communications* magazine are as follows:

Receiving Tube Substitution Guidebook — Third Supplement by H. A. Middleton — 72 pages — price \$1.35.

How to Read Schematic Diagrams by David Mark — 160 pages — price \$3.50.

Heat (One of the Basic Science Series) by Dr. Alexander Efron — 112 pages — price \$1.50.

Sound (Another in the Basic Science Series) by Dr. Alexander Efron — 80 pages — price \$1.25.

L-C Oscillators (Electronic Technology Series) by Dr. Alexander Schure — 72 pages — price \$1.25.

Antennas (Electronic Technology Series) by Dr. Alexander Schure — 88 pages — price \$1.50.

Resonant Circuits (Electronic Technology Series) by Dr. Alexander Schure — 72 pages — price \$1.25.

Wave Propagation (Electronic Technology Series) by Dr. Alexander Schure — 64 pages — price \$1.25.

Energy — a modernized reprint of a book originally written by the world renowned English physicist, Sir Oliver Lodge. Contains 64 pages — price \$1.25.

TV Picture-Tube Chassis Guide by the Rider Laboratory Staff — 72 pages — price \$1.35.

Stereophonic Sound by Norman H. Crowhurst — 128 pages — price \$2.25.

Getting Started In Amateur Radio by Julius Berens, W2PIK — 144 pages — price \$2.40.

How To Install & Service Intercommunication Systems by Jack Darr — 152 pages — price \$3.00.

Repairing Television Receivers by Cyrus Glickstein — 212 pages — price \$4.40.

All the above mentioned paper-bound books are published by John F. Rider Publisher, Inc., 116 West 14th Street, New York 11, N.Y.

business briefs and trends

★ In twenty years the electronics industry in Canada has mushroomed from a \$20 million a year business to a volume of \$500 million annually. Of this amount \$184 million worth of television receivers were produced in 1957. Radio sets accounted for \$55 million of income. \$124 million could be attributed specifically to defense equipment; and an estimated \$100 million for replacement parts, tubes and service.

* * *

★ Plans are being made for the armies of the United States and Canada jointly to conduct tests during next winter of two missile systems at Fort Churchill, Manitoba. These tests will determine the effects of excessively low temperature on the component parts of these weapons systems.

* * *

★ It is estimated that one hundred years hence there will be three times as many people in the world as there are at present. With such a population increase, annual world energy demand is expected to grow between 10 and 100 times. With the further prediction that fossil fuel production (i.e. coal, oil, gas) in the United States will fall short of demand within ten to thirty years, ways and means of developing new sources and methods of creating electrical energy will have to be devised.

* * *

★ Professional engineers registered in Ontario now number 16,450, according to figures announced at the annual meeting of the Association of Professional Engineers of Ontario. This represents an increase of 1,352 as of a year ago. C. T. Carson, the new president of A.P.E.O. predicted that the engineering profession in Canada was on the threshold of a new era in which professional recognition and professional status would be universally achieved.

* * *

★ Plans for the North Atlantic ionospheric forward scatter system, as proposed by the International Civil Aviation Organization, may be abandoned in favor of a transatlantic cable network. In view of the higher-than-estimated cost to Canada of the proposed scatter system, this country is considering the practicability of a cable between Iceland, Greenland and Canada.

* * *

★ In the five-year period, 1951-1956, some 3,000 engineers left Canada for the United States. This figure represents approximately one-third of the engineering graduates of that period. In addition, another 800 scientists have emigrated from Canada.

* * *

★ Defense Minister George Pearkes, addressing the Royal Canadian Flying Clubs Association, said recently that weapons must be maintained in Canada to enable this country to destroy an enemy threat. The implication was that in time there would be missile-equipped defense bases across the Dominion to augment the present defense system.

* * *

★ During 1957 sales of Japanese products of precision manufacture were boosted in Canada. These products included cameras and photographic accessories, radios and radio apparatus, electrical precision instruments and tools of various kinds.

* * *

★ The first All-Canadian Conference on Electronic Computing and Data Processing will be held at the University of Toronto on June 9 and 10, 1958. Its objective is to inform Canadians of what is being accomplished in Canada with computers as applied to business, industry and government. Sponsors of the event are the University of Toronto and a group of companies and organizations who are using, or shortly propose to use, computing devices.

* * *

★ Canadian Admiral Corporation reports that its 1957 radio sales were up substantially over 1956, whereas radio sales for the industry were about the same. Stuart D. Brownlee, executive vice-president of the company, also reports that his firm took a greater proportion of the television sales market than it has enjoyed since the early years of television.

business briefs and trends

★ The Tube Section of the Canadian General Electric Company Ltd. is proposing, as a part of its planned program to establish a Canadian facility to cater to the rapidly growing Canadian market for semi-conductor products, to manufacture in Canada low-current rectifier cells from both germanium and silicon crystals.

* * *

★ The B.C. Telephone Company and its associated companies now have nearly 8,000 employees — twice the number employed ten years ago. This company contends that the more automatic telephones there are, the greater is the need for operator assistance, and, as the number of telephones increases, more "Information" and long distance operators are essential.

* * *

★ Based on a RETMA estimate, 2¾ million television sets were owned by Canadians at the end of 1957. Prospects for replacement sales could be regarded as those owners whose sets have been in constant use for more than three years; in other words, 35 per cent of the sets in use this year.

* * *

★ In an address delivered in Hamilton before the Ontario Association of Appliance Dealers, F. W. Radcliffe, secretary-treasurer of RETMA, expressed his belief that a re-birth of salesmanship was required in the radio and television industry. The cardinal points he stressed were: Know more about the product you are selling. Show the customer how to operate it. Ask the prospect to buy your product. Develop a greater pride in your profession.

* * *

★ Subliminal advertising, a new technique of persuasive public appeal by invisible messages flashed on TV screens, which has been experimented with in the United States, has been proclaimed a complete failure in Canada when it was recently subjected to a full-scale test on the TV network of the CBC. Use of such a technique has been banned in Canada by the board of governors of the CBC.

* * *

★ The B.C. Telephone Company forecasts that 1958 may be the greatest year in its history. The expansion and improvement program for this year will involve an expenditure of \$50 million. Telephones will increase by more than 40,000 to bring the total number in the system to nearly half a million by the end of 1958.

* * *

★ The Dominion Bureau of Statistics reports that Canadians purchased fewer television sets in 1957, but bought more radios and record players. Sales of TV sets dropped nearly 25 per cent over the previous year's business, while purchases of radios rose from 709,416 to 721,674 units, and of record players from 205,127 to 243,153.

* * *

★ F. W. Beatty, provincial surveyor-general, speaking at the annual meeting of the Association of Ontario Land Surveyors in Toronto, commented that a project to make a \$2¼ million mapping survey of the province — originally estimated to take 18 years to complete — is receiving impetus through the use of electronic equipment in the process of ground measurement. More than half of the project has been completed after a period of only eight years.

* * *

★ The first flight simulator of its kind in Canada is being installed at the Vancouver International Airport. Canadian Aviation Electronics of Montreal has been occupied for twelve months in building the Super DC-6B electronic pilot trainer for Canadian Pacific Airlines. It is claimed that with the use of the new simulator the cost of pilot training will be reduced by fifty per cent.

* only a
LENKURT assembly
 includes this
 important
 engineering tool!

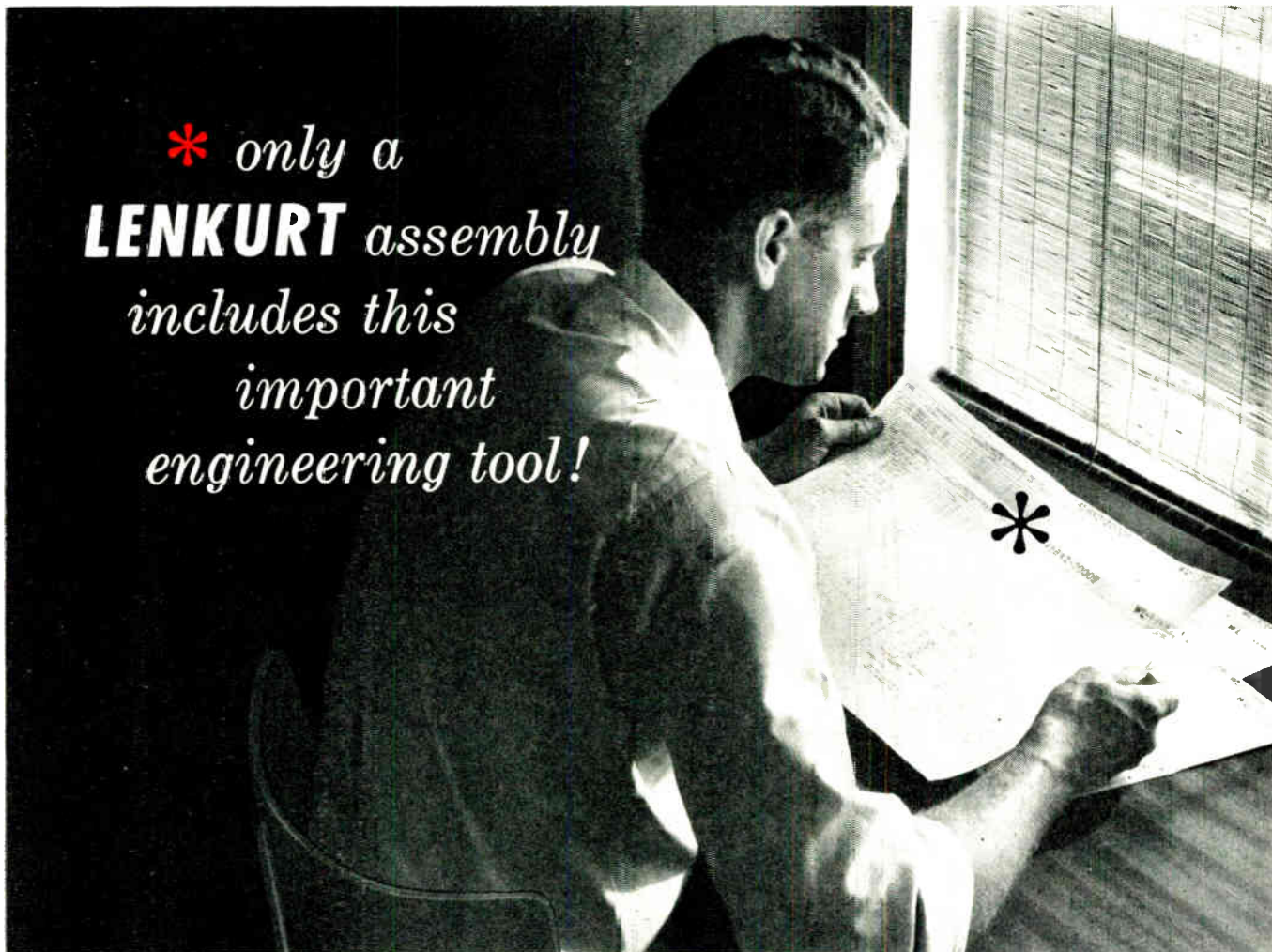

When you install Lenkurt multi-channel communications systems, you not only receive the ultimate in performance, and quality—you also receive a **W.L.*** that provides you with full mechanical and electrical details—right at your fingertips.

This exclusive Lenkurt **W.L.*** sets out all equipment used, the arrangement, and is the key to the technical information and drawings that are also supplied.

Use your Lenkurt **W.L.*!** Check it against your order. Note carefully the options indicated. Make it your installation guide and keep it for future reference when adding to the system. Remember—Lenkurt supplies *complete* technical information with every shipment.

*Address your enquiries about Lenkurt equipment and literature to
 AUTOMATIC ELECTRIC SALES (CANADA) LIMITED,
 185 Barkley Drive, Toronto 16, Ontario. Branches in Montreal, Ottawa,
 Brockville, Hamilton, Winnipeg, Regina, Edmonton, Vancouver.*

* Wiring List

5766

AUTOMATIC  **ELECTRIC**

ORIGINATORS OF THE DIAL TELEPHONE



to please the ladies..

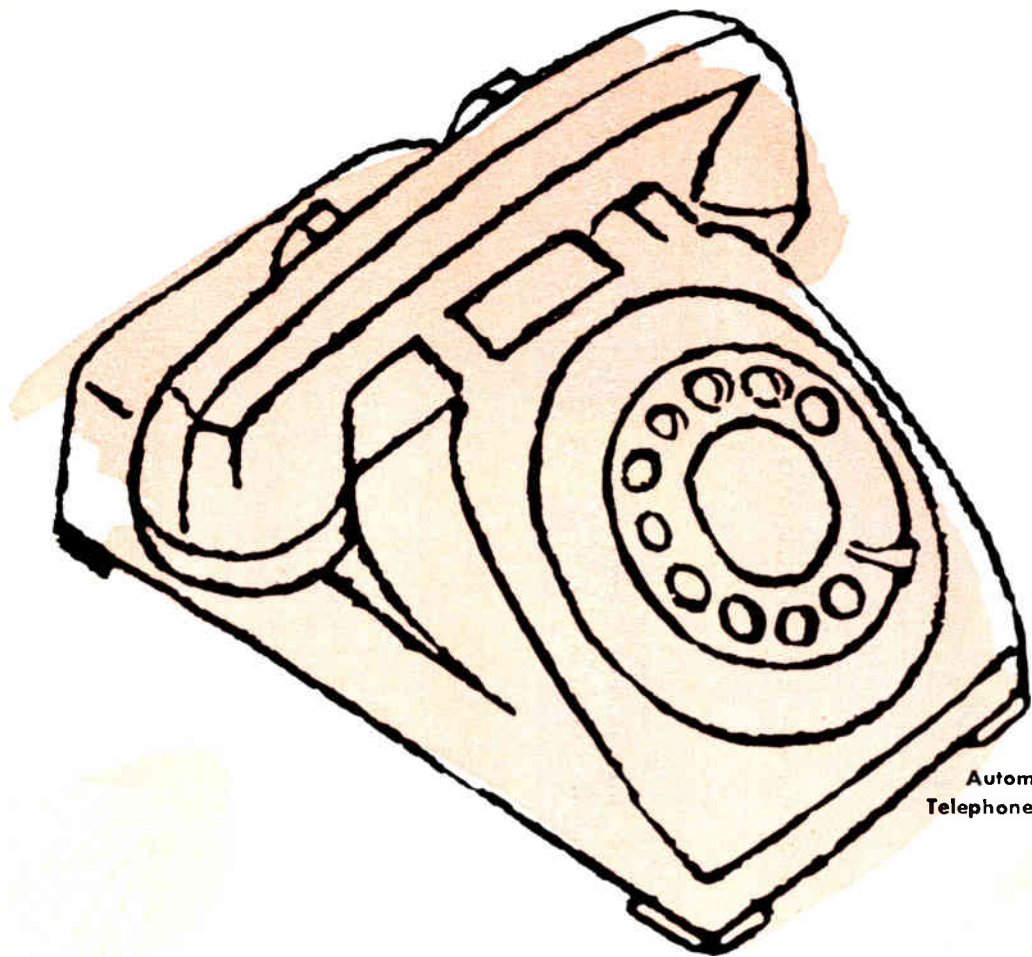

Automatic's famous Type 8 Telephone in new Camellia Pir

.. 3 new colours!

CAMELLIA PINK . . FORGET-ME-NOT BLUE . . GARDENIA WHITE

Automatic's Type 80 Telephones have a fresh new appeal for women: three soft, delicate, petal hues—each a feminine favorite. Your customers will be delighted with these Type 80's in Forget-Me-Not Blue, Camellia Pink, and Gardenia White. More important, these colours will sell 'extra' telephones, for bedrooms, for kitchens, for any room in the house!

Here's your opportunity to stimulate *second* telephone sales, and build good will as well. To assure an ample supply of these new colours from our initial production, address: *Automatic Electric Sales (Canada) Limited, 185 Bartley Drive, Toronto 16, Ontario. Branches in Montreal, Ottawa, Brockville, Hamilton, Winnipeg, Regina, Edmonton, Vancouver.*



FREE SALES AID!

To help you promote the Type 80 in colours for women, we've prepared a small envelope stuffer. It shows all the new colours, and lists the regular colours available. You'll want a supply for bill inserts, mailings, counter distribution, etc. Write and let us know how many you'll need.

5826

AUTOMATIC  ELECTRIC

ORIGINATORS OF THE DIAL TELEPHONE





HARDWARE WITHOUT HARDSHIP

FROM AUTOMATIC ELECTRIC

When you want telephone hardware fast—whether it's made by Slater, C.L.M., or any other manufacturer—just call us. We offer quick delivery on *all* items.

Avoid hardware hardship, order all your needs from one complete source of supply—Automatic Electric. Automatic Electric Sales (Canada) Limited, 185 Bartley Drive, Toronto 16, Ontario. Branches in Montreal, Ottawa, Brockville, Hamilton, Winnipeg, Regina, Edmonton and Vancouver.

AUTOMATIC ELECTRIC
SALES (CANADA) LIMITED

For further data on advertised products use page 65.

New Products

New Product specifications published in *Electronics and Communications* have been briefed for your convenience. If you require further information on any of the items published you may readily obtain such by using our Readers' Service, Page 65. Just mark the products you are interested in on the coupon on Page 65 and the information will be in your hands within a few days.

Fast Digital Recorder

Item 1913

The Hewlett-Packard Model 560A Digital Recorder prints 11 column digital information at rates to five prints per second. Although primarily designed to make a permanent record of electronic counter read-outs, the manufacturer states that the 560A can be used with two or more counters simultaneously, digital voltmeters, time recorders, flowmetering equipment and systems, such as telemetering installations and engine test stands.

In addition to the printed tape record, the Model 560A provides an analog current or voltage output to drive a galvanometer or potentiometer strip chart recorder or to provide a servo control.

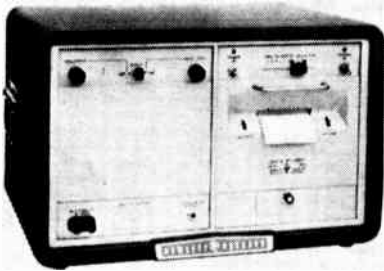

For further information contact Canadian Factory Representatives: Atlas Radio Corporation Ltd., 50 Wingold Avenue, Toronto, Ontario.

Printed Circuit Laminates

Item 1914

International Resistance Company Limited announce a new line of two Printed Circuit Laminates with improved environmental and electrical characteristics.

Fluoropoly-P employs a new base of punchable grade XXXP Phenolic with a film of fluoro carbon between the baseboard and the copper surfaces.

Fluoropoly-E is similar to Fluoropoly-P with the added advantage of having the highest available grade of epoxy fibre glass board as the base material.

Both of these laminates possess the physical characteristics of their base materials. When etched, the fluoro carbon surface is exposed which provides highest surface resistivity and arc resistances. Since fluoro carbon has substantially zero water absorption characteristics and low moisture vapor transmission, the broad surfaces of the base material are sealed. This measurably reduces moisture absorption and improves environmental performance.

For further information write to: International Resistance Co. Ltd., 349 Carlaw Ave., Toronto, Ontario.

Shaped Beam Tube

Item 1915

A new electronic tube which will simultaneously display radar or TV images with identifying letters, numerals and symbols superimposed has been developed by the Stromberg-Carlson Division of General Dynamics Corporation for use in controlling air traffic.

The tube, called the CHARACTRON Shaped Beam Tube, Type C19Q, is designed to aid in solving the increasingly complex problem of routing ever heavier air traffic in and out of the nation's air terminals.

Because of its ability to show both aircraft and identifying symbols simultaneously,

the tube will be vital in air traffic control operations, the company states, in emphasizing the tube is the ideal link between complex electronic systems and human controllers.

The new tube is an adaptation of the CHARACTRON Shaped Beam Tube now in production by Stromberg-Carlson. This latter tube is a basic element of the SAGE system of air defense and has numerous other uses in the electronic display and data processing fields.

The C19Q tube uses the same signals as any other cathode ray tube in providing live radar displays, but in addition it uses the infinitesimal fraction of a second between radar pulses to form character displays as in the conventional CHARACTRON Shaped Beam Tube. Thus, on the C19Q tube the air traffic controller will see the radar "blip" of a plane and, alongside it, a series of numbers, letters and symbols denoting its identity, type, destination, position and the like.

Random characters can be displayed on the tube at 50,000 characters per second. The tubes can be used in a series of consoles which would display different geographic areas and operate independently of each other. This would provide virtually unlimited flexibility in the air traffic control operation.

For further particulars write Stromberg-Carlson Co., Division of General Dynamics Corporation, 100 Carlson Road, Rochester 3, N.Y.

Split-Bolt Connectors

Item 1916

A completely new line of cold-forged Split-Bolt Connectors that meet ESCI standards for strength and performance, is being introduced by the A. B. Chance Company of Canada Ltd.

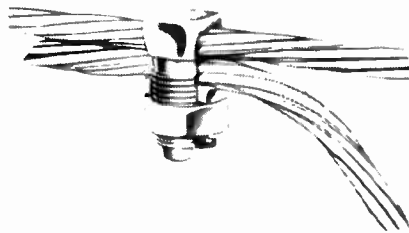

The new connectors are manufactured in all the more popular sizes for use on No. 10 solid through 1/0 stranded copper. Chance Split-Bolt Connectors are made of commercially pure copper and, thus, have the same electrical characteristics as the copper conductors they connect.

Designed for tight connections under all temperatures and conductor-load variations, these 99% copper clamps contract and expand with the copper conductor to maintain a continuous tight connection and prevent cold flow and nicking of the conductor.

A. B. Chance Company of Canada Ltd., 1206 Kingston Road, Toronto, Ontario.

Solenoid For Rotary Or Linear Action

Item 1917

Developed primarily for the home appliance trade, the "Rotosol" rotary solenoid employs a magnetic circuit that is highly

efficient and permits operation under over wide fluctuations in voltage. The permissible angle of rotation at which work can be performed is up to 70 deg. The torque produced by the electromagnetic circuit increases as the angle of rotation diminishes.

The Rotosol features rugged construction with sturdy mounting frames supporting the drive shaft in oil impregnated bronze bearings. The drive shaft extensions from either side or both sides are supplied according to customer specifications. Connection to the load can also be made directly to the rotor for special applications and further reduction in machine parts.

Magnet coils are wound on molded phenolic bobbins, varnish impregnated and baked. The magnet coil is serviced without disassembly. A thermal device is built into the coil to prevent damage to surroundings by smoke and fire in case of overload.

This solenoid is claimed to be 25 per cent more efficient than plunger type relays due to the action of the rotor being hinged with a ground shaft and operated in permanent lubricated bearings. This not only increases the efficiency, because the air gap is never opened on the one pole, but reduces the friction that is present in a plunger solenoid by the rotor section sliding in a tract from open to a closed position. A device can be connected to the shaft on either side of the solenoid to give rotary action either in a cw or ccw rotation, or can be connected to the rotor and give linear action.

Manufactured and sold in Canada by Alliance Motors, Schell Avenue, Toronto 10, Ontario.

General Purpose Midget Relay

Item 1918

The series GP was designed to fill the need for a small, general purpose, dependable control relay that would rest solidly and firmly in a printed circuit board. Sturdy 1/8 by 1/32 solid lugs inserted into printed circuit board give relay considerable rigidity which makes it an ideal relay for a multitude of printed circuit applications. Coils are available in all standard AC and DC voltages to 115 volts.

The same frame and printed circuit feature is available in the series PC as a sensitive plate circuit relay. Sensitivity is about 130 mW per pole, pre-set at factory and coils are available in 2,500, 5,000 and 10,000 ohms.

Both relays use selected silicon steel or magnetic iron. Contacts are self-wiping 1/4" fine silver rated 5 amperes for series GP and 2 amperes for series PC, non inductive. Board is NEMA grade LE and all insulation is tested at 500 V.A.C. minimum. Dimensions are 1" wide, 1 1/4" long and 1 1/4" high.

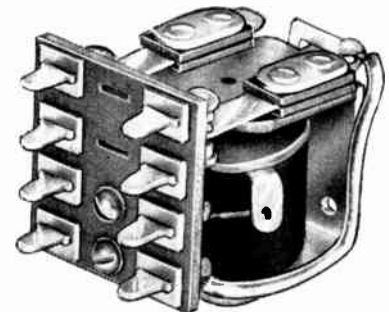

For additional information contact: Hillburn Electronic Products Co., 55 Nassau Avenue, Brooklyn 22, N.Y., U.S.A.

New Products

No. 118A Protector

Item 1919

When poles are jointly used for telephone lines and power lines or the two services are on separate poles, but are close together, there is the possibility of accidental contact between them. If the open wire telephone lines are exposed to power wires at a voltage to ground below 3KV, the protection provided by conventional station protectors is usually sufficient. When power supply conductors operate at higher voltages, auxiliary protectors offer additional protection to the telephone plant.

For some years, the Northern Electric's No. 99A Protector has been used to provide protection for telephone open-wire plant in case of contacts with power wires operating at over 2900 volts to ground. However, the trend towards increased loads on power distribution circuits has resulted in the use of circuit reclosers and fuses in the power circuit which exceed the time-current characteristics of the No. 99A Protector. Development work on a new protector has resulted in the No. 118A Protector.

Rated at 2000 volts the No. 118A Protector will effectively de-energize line wires subjected to contacts by power wires operating at voltages of 2000 volts to ground or more. This new protector has a time-current characteristic considerably better than that of the No. 99A Protector and in general, has higher current carrying capability than the commonly used line wires.

For further information on this product, write Communications Equipment Division, Northern Electric Company Limited, P.O. Box 6124, Montreal, Que.

Industrial Electronic Timers

Item 1920

Measurement Engineering Limited has introduced a series of industrial electronic timers in the MELTROL line.

Four models are available. Model ET-1 covers the range from 1 to 300 seconds. Model ET-2, designed for spot welding applications, covers 0.05 to 2 seconds. Model ET-3 is a repeat cycle timer — one range being 0.1 to 60 seconds and the other 0.3 to 180 seconds. Model ET-4 is a general purpose short cycle timer with two ranges 0.04 to 4 seconds and 0.04 to 16 seconds.

The units are housed in NEMA-1 steel cases, 8" x 5 3/4" x 5 1/4" with standard conduit knock-outs.

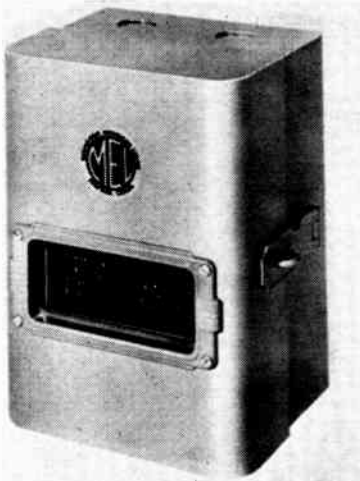

The controls may be located remotely. The self contained relays are rated at 10 amperes (non inductive) at 115 volts.

An isolation transformer is included so that the timers may be operated from 115 volt or 230 volt power at 60 cycles.

Further information from Measurement Engineering Limited, Arnprior, Ontario.

Series "LT" Plug And Cable Jack

Item 1921

Amphenol Canada Limited announce the availability of No. 82-160 plug and No. 82-161 cable jack designed for use with Teflon taped RG-117/U cable, Amphenol numbers 421-103 & 421-121. These units are designed to meet low VSWR requirements and increase electrical performance. They mate with other LT connectors and a mounting flange can be added to 82-161 to convert it to a panel jack.

Both the plug and jack have an impedance of 50 ohms, a 5000 V peak voltage rating, a silicone rubber gasket and are silverplated. They offer simplified and reliable cable assembly through the use of improved cable clamping device.

For further information write to: Amphenol Canada Ltd., 300 Campbell Ave., Toronto, Ontario.

Micro Miniature Relay

Item 1922

A new micro miniature relay of ruggedized construction providing high resistance to shock, vibration and temperature, required in missiles and missile guidance systems, is announced by Magnecraft Electric Company.

Frame and header assembly of rugged, bridge-type construction affords tremendous resistance to distortion from shock, vibration and temperature. A balanced armature minimizes the effect of gravity, shock and vibration on operating reliability. Oversize

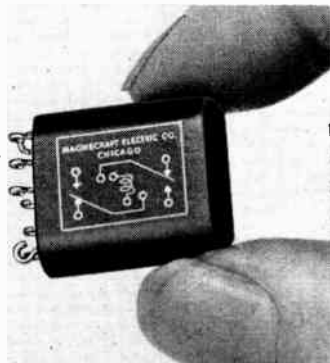

instrument-type bearings at both ends minimize hinge friction for increased sensitivity and greater contact pressure with increased operating reliability and extended service life. High temperature insulation incorporates the latest and best developments in high heat resisting materials. Hermetically sealed and filled with inert gas for maximum protection against severe ambient conditions.

Contacts DPDT, 100,000 operations minimum at 2 amperes, 28 VDC or 115 VAC, non-inductive load. Available for low level and dry current switching. Operating voltages, up to 110 VDC. Resistance range, 22 to 5,000 ohms and up. Power requirement, 500 milliwatts, DC. Insulation to ground, 500 VAC R.M.S. minimum. Insulation resistance, 100 megohms minimum at 500 VDC, 25° C. Vibration, 10-55 cps at 10 G, acceleration; 55-500 ops at 20 G. Shock, 40 G, for 11 milliseconds. Weight, .35 to .55 ounce. Dimensions .797 x .675 x .359 (maximum).

Further information on this product may be obtained from Magnecraft Electric Company, 3354 RC West Grand Ave., Chicago 51, Ill., U.S.A.

Transistor Frequency Changer

Item 1923

The design engineer faced with increasingly strict vibration, temperature, size and frequency tolerances will welcome a recent addition to Varo's line of precision transistorized power supplies for missile, aircraft, and ground applications. The completely transistorized Frequency Changer, shown in the attached photograph, will convert an input of 400 cps $\pm 5\%$ to 400 cps $\pm 0.1\%$ at 60 va, unity power factor load while operating under extreme environmental condi-

tions such as temperatures of -50°C to $+71^{\circ}\text{C}$ and vibration of 5 G's at 70-2000 cps.

The model 2261 transistorized, tuning fork controlled Frequency Changer, designed to Mil-E-5400, is composed of three small assemblies with a total weight of only 5 1/2 pounds. The design of the Frequency Changer in three sections allows unusual versatility. For example, if only a single phase output is required, the phase splitting network will be deleted; if a DC input of 28 volts is available, the power supply section will be eliminated; if a 28 volt DC input is available and a single phase output is specified, only the basic 60 va single phase inverter section, weighing 2 1/2 pounds will be supplied.

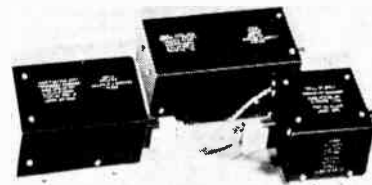

The three sections of the Transistor Frequency Changer operate as follows:

1. Power Supply Section — transformer rectifier produces 28 VDC from the AC input.
2. Single Phase Inverter Section — Frequency — synchronized by Varo tuning fork oscillator. Regulation — achieved by comparing sample of output with stable DC reference voltage, the resulting error signal is used to control amplitude of diode modulator. Low Distortion And Output Impedance — achieved by Class B power amplifiers employing voltage feedback.
3. Phase Splitting Network — balanced three phase power developed by capacitor-reactor circuit from single phase inverter output.

Complete specifications and the theory of operation of the Frequency Changer are obtainable from the manufacturer, Varo Mfg. Co., Inc., 2201 Walnut St., Garland, Texas, U.S.A.

1 Kw VHF Transmitter

Item 1924

Pye Canada Limited has announced a medium power transmitter designed primarily for airport ground-to-air operations and also for teleprinter and VHF point-to-point links. It is basically a two-unit transmitter; the RF and modulator sections are combined into a composite equipment for R/T service.

The frequency range from 118 to 136 mc. is continuously covered. The drive unit consists of a crystal oscillator followed by three harmonic generator stages, providing a total frequency multiplication of twelve times the crystal frequency. These stages are followed by two push-pull stages which drive the amplifier. A feature of the transmitter is the ease and rapidity with which it is possible to set it up on any frequency in the range. All coupling circuits up to carrier frequency are fully screened and double tuned.

The transmitter may be remotely controlled and is fully protected against damage due to overloads or maladjustments. All tubes are accessible from the front of the unit; doors are provided at the rear to facilitate inspection and maintenance. The safety of operating personnel is ensured by interlocking gate switches which remove all dangerous voltages when the doors are opened or the detachable panels are removed.

All tubes and components have been chosen and rated to achieve a high standard of reliability and as a result, the transmitter may be operated unattended in tropical climates. Forced-air cooled tetrodes are used in the RF output stage and radiation-cooled triodes are used in the modulator.

Further enquiries to: Pye Canada Limited, 82 Northline Road, Toronto 16, Ontario.

New Products

Heat Resistant Electrical Laminate

Item 1925

Phenolite G-7-830, manufactured by National Vulcanized Fibre Co., Wilmington, Del., is a glass-base, silicone resin laminate specially developed for high temperature electrical applications. It has a heat resistance rating of 500° F, short time, and 400° F, continuous — 66 per cent and 60 per cent higher, respectively, than similar values for conventional paper-base laminates. Dielectric strength perpendicular to laminations is 400 volts/mil, short time, for $\frac{1}{16}$ in. thicknesses and 350 volts/mil, short time, for $\frac{1}{8}$ in. thickness.

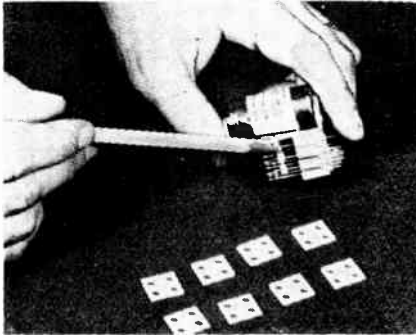

The improved heat resistance and good dielectric strength of the spacers permits relay operation at proportionately higher temperatures. Hermetic sealing of the relay is facilitated by the extremely low volatility of the Phenolite G-7-830 spacers, since higher vacuums and temperatures can be applied without danger of gassing.

The ability of the spacers to safely withstand higher temperatures makes possible a 30 to 50 per cent increase in coil ampere turns, which provides greater sensitivity than conventional relays. However, even with this substantial increase of built-in power, these units still fall into the miniature relay class.

In addition to increasing the power and operating temperature range of these miniature relays, the use of Phenolite G-7-830 has improved production methods. Its good punching qualities have resulted in faster production of spacers, with cleaner holes and less rejects.

Additional information on the properties and application of Phenolite G-7-830 is available from National Vulcanized Fibre Co., 1057 Beech Street, Wilmington 99, Delaware, U.S.A.

Taped Teflon Dielectric Cables

Item 1926

Amphenol Canada Ltd., announce the availability of new Taped Teflon Dielectric Cables electrically equivalent to RG-117/U. These cables provide greatly improved flexibility by a combination of multistranded center conductor and Teflon Taped Dielectric. Dimensional stability when subjected to temperature extremes is provided by the Teflon Taped Dielectric and the high power handling capabilities are as great as 6 times that of comparable Polyethylene Cables.

These new cables are satisfactory for any cable assembly applications requiring high power handling capabilities, a high degree of flexibility, good dimensional stability, and low VSWR characteristics. Type 421-121 provides, in addition, a high temperature jacket for operation at elevated ambient temperatures.

Temperature range is from -55° to +200°C, impedance is 50 ohms and the dielectric strength is 10,000 volts RMS.

For further information with regard to these new cables write to: Amphenol Canada Ltd., 300 Campbell Ave., Toronto 9, Ontario, Canada.

High Performance Composition Resistors

Item 1927

Coldite 70+ a new series of fixed composition resistors developed by the Stackpole Carbon Company, pace the trend toward higher operating temperatures and critical environments — even for low cost components.

Characteristics of the new Stackpole Resistors far exceed stringent MIL-R-11B (Amendment 1) requirements and offer particularly outstanding performance in such essential characteristics as load life and moisture resistance.

Made by a cold-mold process that assures an unusually high degree of production uniformity, Stackpole Coldite 70+ Resistors are available in MIL-R-11B Styles RC-20 ($\frac{1}{2}$ -watt), RC-32 (short 1-watt), and RC-42 (2 watts). Resistance tolerances of 5%, 10%, and 20% can be furnished in all EIA preferred resistance values.

Complete performance specifications on new Stackpole Coldite 70+ Resistors are available upon request to the Electronic Components Division, Stackpole Carbon Company, St. Marys, Pa.

Time Delay Relay

Item 1928

A high reliability, miniaturized time delay relay has been added to the growing Tynmag line of magnetic amplifier components produced by Torwico Electronics, Inc., 1090 Morris Avenue, Union, New Jersey.

The new relay provides precise time delays without the use of thermal or motor elements by incorporating a highly sensitive magnetic amplifier with a ruggedized relay. Time delays up to 30 seconds or greater can be provided depending on actuation voltage. Normal sensitivity is 10 Milliwatts D.C. The device can be provided with an instant resetting feature.



An exceptional feature of this relay is the complete absence of contact "chatter" at pick-up and drop-out points. This allows the unit to operate with high reliability in a 40 G shock, 20 G vibration environment.

Excitation required for the relay unit is 115 volts RMS, 400 CPS, with other ratings available. Power consumption is a few milliwatts. Contacts are rated at 2 amps resistive and in configurations up to DPDT.

The relay unit is packaged in a hermetically sealed seamless drawn case $1\frac{1}{8}$ " x $1\frac{1}{8}$ " x $2\frac{1}{4}$ " high with silicone rubber compression type terminals. Operating temperature range is -55°C to +100°C.

For further information write Torwico Electronics, Inc., 1090 Morris Avenue, Union, New Jersey, U.S.A.

Complete Line Of Transducers

Item 1929

CONTROL, a division of Magnetics, Inc. of Butler, Pa., has recently introduced the industry's first standard line of transducers. CONTROL transducers are used for the measurement of large amounts of direct current without electrical connection to the systems in which they are used.

The line consists of nine units, six for 120-volt and three for 240-volt, ranging in capacity from 200 to 10,000 amperes. Accuracy of current measurement is to within 1%, even with up to ± 10 per cent voltage variation. Meter ratio reduction extends from 2 amperes in the largest size to 50 milli-amperes in the smallest.

In addition to measurement of line current, CONTROL transducers also can be used for overload relaying, recording, and providing a feedback signal or reference to a magnetic amplifier. They can be used also with other transducers in a summation system.

Essentially, the transducer is a series magnetic amplifier or saturable reactor. The line carrying the current to be measured is passed through the center of the reactor so that, while not directly connected to the circuit, electrically, the transducer output is linearly proportional to the inducing current.

Transducers have been used successfully in those many applications requiring large amounts of direct current. Hence they are widely used in the electro-chemical industry on plating lines. Their high level of signal power can operate relatively high overload relays, as well as supply control power to a magnetic amplifier regulator.

Orthogonal high permeability magnetic cores are used in CONTROL transducers because their extremely low magnetizing requirements permit accuracy to be maintained within a range of 5% to 100% of rated bus currents. Even at 150% of rated current (nominal line voltage, low burden), output will deviate no more than 3% (from 150%) of rated output.

Full information regarding these standard lines of transducers may be obtained by writing CONTROL, Butler, Pennsylvania, U.S.A.

Load Isolator

Item 1930

Rantec Corporation of Calabasas, California, has announced the addition of a new product to its ferrite line, the BX 812 I Load Isolator. The isolator utilizes the principle of resonant absorption of microwave energy.

The unit is constructed with RG-52/U waveguide and covers the entire useful X-band frequency range from 8.2 to 12.4 mc. This broad-band coverage is made possible through the employment of special design techniques.

The unit is 3.5" long, light-weight, rugged, and has a typical isolation of 20 db with an insertion loss of 1.0 db.

Rantec Corporation, P.O. Box 18, Calabasas, California, U.S.A.

Communications Transmitter Receiver

Item 1931

The Hamlyn HTR 10 high frequency communications transmitter receiver is a product of Hamlyn Electronics Corporation, Hicksville, L.I., N.Y. It is a 10 channel 50 watt crystal controlled transmitter receiver, which is remote controlled by a miniaturized control panel.

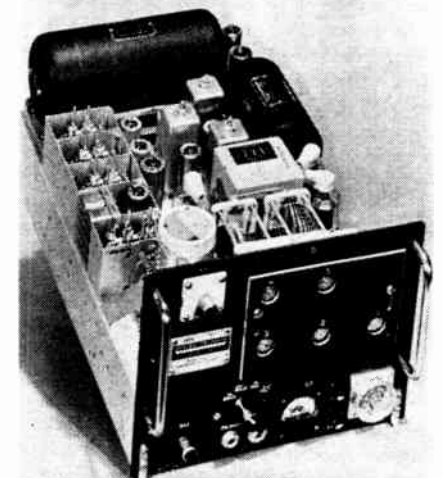

For further information write Aviation Electric Limited, P.O. Box 6102, Montreal, P.Q., who market and service this equipment in Canada.

New Products

Two Channel Direct Writing Oscillograph

Item 1932

A new, two channel, high performance, low cost, direct writing oscillograph, the Offner Type 542 Dynograph, has been produced by Offner Electronics Inc., of Chicago, Ill.

According to the manufacturer, this new unit was specifically designed and developed to make it a practical routine test instrument for every laboratory work bench. Combining exceptionally compact instrument, with low cost and high performance, the Type 542 Dynograph can be used in many applications for which direct recorders were previously unavailable. This includes vibration and transient recording beyond the range of the usual direct recorder, geophysical recording, and in biological work, direct recording of action potentials and electromyograms.

The new unit features two millisecond deflection time and a sensitivity of 5 mv/cm made possible by combining the high torque, low inertia Dynograph writing unit with a new transistorized amplifier.

This at the same time makes possible an ultra-compact unit of high stability barely larger than the pen units alone of previous models. Literature on this unit is available from the manufacturer, Offner Electronics Inc., 5320 N. Kedzie Avenue, Chicago, Ill., U.S.A.

Single-Scale Megohmmeter

Item 1933

Many production and laboratory tests can be made faster and more accurately with the new Model 510 Megohmmeter. It measures six decades of resistance on a single six-inch mirror scale and has 5 to 10 times faster response than conventional ohmmeters. Typical uses are: rapid checking of insulation resistance of motor windings, capacitors, transformers, cables and many appliances; and measurements of surface and volume resistivity in insulating compounds. With its 5, 50 and 500 volt test potentials, the instrument provides a selection of safe voltages for measuring all test samples and for checking voltage coefficients.



Features of the Model 510 include elimination of range-switching, a linear scale with no compression at the high end, negligible drift, simple operating controls, and a guarded, completely shielded input.

Details about the Model 510 Megohmmeter are available in Keithley Engineering Notes, Vol. 5, No. 4. Write to Keithley Instruments, Inc., 12415 Euclid Avenue, Cleveland 6, Ohio, U.S.A.

Transistorized Computer Power Supplies

Item 1934

Multi-output transistorized computer power supplies for Airborne applications, portable instruments, and line-operated equipment are now available from the UAC Electronics Division of Universal Transistor Products Corp., 143 East 49th Street, New York 17, New York.

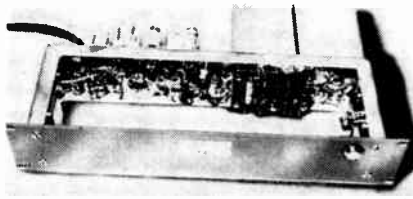

Three different types are being manufactured to operate from either (1) 115v60cps input (for Line Operation) . . . from (2) 115v400cps input (for Airborne applications) . . . or from (3) 24 VDC input (for Portable instruments).

A typical line operated model produces seven outputs ranging from + 30 VDC @ 2 Amps to - 30 VDC @ 5 Amps. This unit fits a standard 19" x 8 3/4" x 13" relay rack, and weighs 22 lbs.

UAC transistorized computer power supplies have low output impedance, from DC to 100 Kc. Standard regulation is 1%; units operate efficiently from -55°C to 55°C.

Regulation on custom units is available to 0.1%, and units can be made to operate up to 85°C.

UAC Electronics Division of Universal Transistor Products Corp., 143 East 49th St., New York 17, N.Y., U.S.A.

Carbon Resistor Color Coder

Item 1935

A useful carbon resistor color coder has been made available by the General Cement Mfg. Co., Rockford, Illinois. The handy gadget will allow anyone to read carbon resistor color codes immediately. It works on the slide rule principle where you merely set the indicators on the slide face opposite the colors in their order. Then you read the value of the resistor through associated windows in the centre of the card. It is said to be so simple that even the most unenlightened student of electricity can read color code.

Russell D. Gawne, general sales manager of the General Cement Mfg. Co., says that the new card has all the advantages of being easy to read and compact in size while still providing all the information needed when working with carbon resistors. The back side of the coder has scales for RETMA 10% standard values and a chart for the Ohm's Law formulae. In addition there is the formula for computing parallel resistance. The G.C. color coder measures 3" x 3 1/4" and is sturdily constructed. Colors are printed on a white background for easy identification and the printed portion is extremely easy to read.

The G.C. Carbon Resistor Color Coder (Catalog No. 5230) is available from parts jobbers. Additional information may be obtained from General Cement Mfg. Co., (a division of Textron Inc.) 400 South Wyman Street, Rockford, Illinois, or Charles W. Pointon Limited, 6 Alcina Avenue, Toronto 10, Ontario.

Tape Wound Core Calculator

Item 1936

Magnetics, Inc. has developed a tape wound core slide rule which provides a rapid means of solving the equations relating voltage to flux, current to magnetizing force, and wire to space factor.

The calculator, and its accompanying instruction book, have been designed to enable engineers working with tape wound cores to calculate rapidly a variety of problems. As examples, they permit quick design of cores to support a given frequency, voltage and current capacity, or the calculation of the number of turns

required to re-set the core to a specific magnetizing force.

The instruction book also details the tape wound cores produced by Magnetics, Inc. to meet the AIEE-proposed standard sizes, as well as other sizes which the company offers as standard. All Magnetics, Inc. tape wound cores carry the company's "Performance Guarantee".

A second table in the instruction book details characteristics of wire sizes to be used in design calculations.

Copies of the calculator and instruction book may be obtained by writing Magnetics, Inc., Butler, Pennsylvania.

Marine Radar Set

Item 1937

Aviation Electric Limited, an affiliate of the Bendix Aviation Corporation, markets in Canada the line of Bendix Marine communications equipment and navigational aids. As well as numerous different types of marine transmitters and receivers an interesting piece of equipment is the MR3 Marine Radar Set.

This radar set is designed particularly for the medium sized boat owner in mind. It has a maximum range of 20 miles and a minimum range of 1 mile, which makes it useful for manoeuvring in crowded harbors. An interesting feature of this set



is that all the RF and IF circuitry as well as the magnetron, klystron and wave guide filters are mounted in a weather sealed compartment forming a base for the rotating antenna assembly. This obviates the necessity for running a wave guide from the console up to the antenna. The only connection between the antenna assembly and the control console is a flexible control cable carrying power supplies and a small co-axial cable connecting video signals to the picture tube providing the P.P.I. display.

Aviation Electric Limited, P.O. Box 6102, Montreal, P.Q.

UHF Blade Antenna

Item 1938

The Dorne & Margolin Type DM-C7 antenna is designed to operate in the 225-400 mc band for use with communication and data link equipment. This antenna is a high-strength swept-back aluminum blade, with a height of 7 3/4 inches from the aircraft skin, designed for use at speeds well into the supersonic region. The maximum thickness of the antenna is substantially less than 10% of the average chord length. The DM-C7 can be supplied as a replacement for the AT-256 and, with the use of a special mounting adapter, this antenna can also be supplied as a replacement for the AT-141.

The antenna has been designed to meet the environmental requirements of MIL-T-5422C and Paragraph 4.12 of MIL-E-5272A. Load tests indicate that the antenna can withstand more than eight pounds per square inch lateral static load. The weight is approximately 20 ounces and the VSWR is less than 2.5:1.0 over the 225-400 mc band. For further information write to Dorne & Margolin, Inc., 30 Sylvester St., Westbury, L.I., N.Y., U.S.A.

New Products

Side Mount Gain Antenna

Item 1939

Andrew Corporation, manufacturers of antenna systems, has developed a new 25-50 MC gain antenna for two-way radio communications that is a real space saver, permitting maximum utilization of tower area. The side mounting feature of the Andrew Type 262 antenna presents the advantage of having a firmly supported unit mounted directly to structural members of communication towers, allowing the top of the tower to be used for microwave or other antenna equipment.



The basic unit of this antenna is a center-fed, half-wave folded dipole. Two of these units, spaced one wavelength apart, comprise the standard Andrew Type 262 antenna. The rigid 3-point mounting arrangement reduces the fluctuation of antenna impedance to a minimum under varying windloadings.

Andrew Type 262 has an average gain of 2.5 db over a dipole, and a coverage pattern that is omnidirectional on conventional communication towers. Larger towers may require additional bays to compensate for pattern distortion. Increased omnidirectional gain, or greater gain in a given direction, can also be obtained by using an additional number of half-wave units of the basic antenna. The harness design of the antenna permits these additional units to be incorporated with no appreciable effect on the low VSWR of the standard antenna.

Andrew recommends the use of Type HO Heliax, a $\frac{7}{8}$ " flexible air dielectric cable for use with this antenna. In a typical run of 100 feet, an average increase in systems efficiency of 17 per cent over RG-8 U is realized, with similar ease of installation.

Information on this new antenna system may be procured by writing Andrew Antenna Corporation, Ltd., 606 Beech St., Whitby, Ontario, Canada.

Ring Balance Electronic Recorder

Item 1940

A new electronic recorder that can receive and record output from as many as four remote ring balance meter-operated slide wires is being marketed by Hagan Corporation (Canada) Ltd., Toronto, Ont.

The instrument can be used to record any quantity measured by a Hagan Ring Balance Meter, including fluid density, liquid level in open or closed vessels, boiler drum water levels, and temperature and pressure compensated fluid flow readings.

Heart of the Ring Balance Electronic Recorder is a newly designed electronic

receiver, a compact unit housing an amplifier, input box, servomotor and slide wire. As many as four receivers can be installed in a single recorder. Various accessory combinations, including a pneumatic transmitter for control system signals, slide wire output for logging systems, alarm contacts and computing devices, can be used with the receiver.

Available as an AC bridge, DC potentiometer or DC voltmeter, the receiver converts incoming electrical signals into corresponding pen positions for the recorder and indicator. This same motion drives the integrator. Each input box contains appropriate components for individual measurements. The box receives the incoming signal, then converts it to a specific drive signal which is relayed to the AC amplifier.

The amplifier drives a reversible motor (shaded pole type) and feedback potentiometer to the precise output shaft position for circuit balance. The motor also drives the recording pen arm linkage, thus securing a pen position exactly proportional to the input quantity. The same amplifier is used for all applications, but the input box varies, depending on application and range desired. Overall accuracy is within .5 per cent of full scale.

Design features include plug-in type input box and amplifier, a printed circuit board and transistor chopper for DC applications. Where distances do not exceed 2,000 feet or 20 ohms total line resistance, the receiver can be furnished with an AC servo operated bridge. For greater distances, a DC potentiometer is used.

For literature, write Hagan Corporation (Canada) Ltd., 185 Eileen Street, Toronto, Ontario.

A Versatile New Instrument

Item 1941

The Model 1051 C-R-A-M Unit is a versatile new instrument combining four separate test functions in one unit for laboratory, communications or production line use.

This unit is designed for use as: (1) a secondary frequency standard of 0.0005 per cent accuracy, (2) for the reception of standard time and frequency broadcasts from WWV, (3) as a moderate gain audio amplifier for general use, and (4) as a mixer to compare two external signals to each other or to compare one external signal to one of the harmonics or sub-harmonics of its 10 MC crystal oscillator.

Calibrator: Radiates harmonics of 10 MC to over 500 MC., harmonics of 1 MC to over 500 MC., harmonics of 100 KC to over 250 MC., and harmonics of 10 KC to over 100 MC to an accuracy of ± 0.0005 per cent at ordinary room temperatures without reference to WWV. Rear panel jacks provide 0.5 volts sine wave from each locked oscillator at 50, 100 and 200 KC and 1, 2 and 10 MC. Waveform of the 10 KC output is square.



Receiver: Receives standard time and frequency broadcasts from WWV on 5 MC with a sensitivity of 5 μ v. The standard frequency broadcasts are used to adjust the oven-controlled 10 MC crystal in the unit to exact frequency, or to standardize an external oscillator connected to one of the input jacks.

Amplifier: Increases the strength of the audio output for operation of the self-contained speaker or phones. The amplifier, with a gain to several hundred times and a frequency response to 5 KC, may be picked up on panel jacks for external use.

Mixer: Enables comparing two external signals up to 1000 MC, or comparing one such signal to harmonics of one of the internal oscillators. An audio difference frequency may be amplified and fed to built-in speaker or to external phone jack. A radio difference frequency may be picked up for external use through a panel jack.

The Model 1051 C-R-A-M Unit has a self-contained, regulated power supply. Overall size of cabinet is 11 $\frac{1}{4}$ " high x 21 $\frac{1}{2}$ " wide x 14 $\frac{1}{8}$ " deep. Weight of unit is 49 lbs. Chassis is mounted on standard 8 $\frac{3}{4}$ " x 19" relay rack panel and may be removed from cabinet for relay rack mounting. Depth of chassis behind panel is 11". Chassis, less cabinet, weighs approximately 25 lbs.

For further information and descriptive literature, please write to Radio Frequency Laboratories, Inc., Powerville Rd., Boonton, New Jersey, U.S.A.

Test Set For Checking High Speed Polar Relays

Item 1942

The Sigma Model 4501 Relay Test Set permits five separate testing and adjustment measurements to be made on high speed polar relays of the type commonly used in pulse equipment, such as computers and teletypewriters. Typical relays in this group include Sigma Series 72 and 7, Western Electric 215 and 255, Western Union 202 and 203, and the foreign-made Carpenter and Siemens & Halske.

The new Test Set is useful in relay preventive maintenance inspection, adjustment of types with replaceable or adjustable parts, and in incoming inspection of new relays. The five operations it performs are (1) measurement of trip or operate currents manually (2) automatic indication of trip currents, for making adjustments (3) measurement of contact bias and (4) percent-break, under various operating

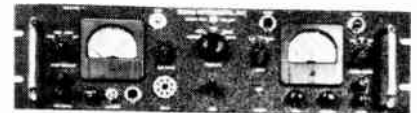

conditions, and (5) application of 500 volt RMS AC hipot between coils and frame. All tests except hipot may be made on either or both coils of dual coil relays. Hipot is applied to both coils simultaneously. Terminals are also provided for connecting an external drive directly on coils, and for connecting an oscilloscope for observing contact performance during bias and break tests.

Other features of the 4501 Test Set include standard relay rack or separate case mounting; regulated DC power supply; all controls, indicators and terminals on front panel; limitation of exposed voltages to safe values; accessible construction for easy servicing. Bulletin available on request from Sigma Instruments, Inc., 47 Pearl St., So. Braintree 85, Mass., U.S.A.

Ultrasonic Transducer

Item 1943

A new ultrasonic transducer, Model UT-2-42, for ultrasonic cleaning, degreasing, and processing is announced by Vibro Ceramics Division, Gulton Industries, Inc.

Using Glennite piezoelectric ceramics, the ultrasonic transducer is designed for modular assembly to cover large areas with nonfocusing and uniform sound field. It has a high conversion efficiency and a frequency for many types of processing.

Hermetically sealed in stainless steel housing, the Model UT-2-42 is completely immersible in organic solvents, aqueous solutions of normal detergents, mild alkalis or acids.

For further information, write Gulton Industries, Inc., 212 Durham Ave., Metuchen, N.J., U.S.A.

News Report

A monthly roundup of news and personnel changes in the Canadian electronics industry.

Technical Papers For IRE Canadian Convention

The Technical Program Committee is asking for papers to be submitted for the technical sessions of this year's IRE Canadian Convention, which will be held in Toronto's Exhibition Park, October 8, 9 and 10.

It is pointed out that papers may be submitted on any topic likely to be of interest to IRE members, but that it is not necessary for the author to be a member of the Institute of Radio Engineers.

Authors should take special note of the following instructions. They should submit, in duplicate, (a) a 500 word summary of their paper, from which the committee can judge the suitability of the paper for the technical program; and (b) a 100 word abstract of their paper, suitable for insertion in the Technical Program pamphlet, if the paper is accepted.

Summaries and abstracts should be sent to — Mr. A. P. H. Barclay, IRE Canadian Convention, 1819 Yonge Street, Toronto 7, Ontario.

The deadline for receiving the above information is May 31, 1958.

British Instrument Makers Visit Canada

A small group of directors of prominent British producers of scientific instruments and equipment visited Toronto on March 17 and 18 with a view to exploring the opportunities for interesting the Canadian market in buying such products from the United Kingdom.

The visitors were all members of the Scientific Instrument Manufacturers Association and constituted a trade mission following up the Canadian trade mission to Britain of several months ago. This was the first of a probable series of influential British groups likely to visit Canada during the year in quest of trade.

The British Trade Center, managed by The Canadian Association of

British Manufacturers and Agencies, arranged a program which enabled the British trade team to meet with leading technical representatives in various Canadian industries and with editors of selected technical publications interested in scientific instruments and laboratory equipment.

Spokesman for the group was L. A. Woodhead, director of Cossor Instruments, Ltd., who made it clear that British instrument manufacturers have no desire to injure Canadian production of scientific instruments, but since, he said, 90 per cent of Canada's needs for scientific instruments is imported, the British industry would like to have a larger share in that trade.



● Members of the Scientific Instrument Manufacturers Association of Great Britain, comprising the first British trade team to visit Canada following the Canadian Trade Mission to Great Britain, are pictured above. Front row, left to right: W. H. Storey, Unicam Instruments; L. A. Woodhead, Cossor Instruments Limited; Stan Rybb, Dawe Instruments, Ottawa, Canada (secretary of the delegation). Back row, left to right: D. A. Pitman, Electronic Instruments Limited; Dr. V. A. Sheridan, British Physical Laboratories.

CANADIAN SIMULATION COUNCIL



● Members of the Canadian Simulation Council met recently at Canadian Westinghouse Electronics Division, Hamilton. Pictured here in the company's computation laboratory are: (left to right) W. S. Kozak, Canadian Westinghouse; S. Kwitckowsky, Avro, Toronto; G. Gbinsky, ElectroData, Ottawa; F. W. Pruden, National Research Council, chairman of the society.

Edmonton Office Opened By S. & T. Sales Ltd.

According to a recent announcement by Louis H. Potvin, managing director of S. & T. Sales Ltd. of Vancouver, British Columbia, the company have recently opened a sales office at 6303 Capilano Crescent, Edmonton, Alberta.

The establishment of an Edmonton Sales Office was considered by the company to be of prime importance to them in their expansion program, because it will now be possible to provide more efficient and "on the spot" sales service for their many customers throughout Alberta, Saskatchewan, Manitoba and Western Ontario.

Mr. Ed. Benekritis, who is manager of the new division, was previously service manager at the S. & T. Sales' head office in Vancouver for a number of years, and has a solid technical background of over 20 years in the electronics business.

S. & T. Sales Ltd. are exclusive distributors for Spilsbury & Tindall radio communications and radar equipment. Their Eastern Sales Division is at 620 Golden Avenue, Ottawa 3, Ontario.

Larger Quarters For E. S. Gould Sales

The E. S. Gould Sales Company, manufacturers' agents in Montreal, announces its recent removal to larger offices with an increased staff.

The address is now Suite 315, 353 St. Nicholas Street, Montreal 1, Que. The telephone number is AV. 8-5716.

ADCOLA

CANADA LIMITED
REGD. TRADE MARK

MAKERS OF HIGH QUALITY SOLDERING INSTRUMENTS, HAND PYROMETERS, ETC.

Soldering Instruments Available With 1/8", 3/16" and 1/4" Tips

All Voltages Supplied

List No. 64
1/4" Detach Bit

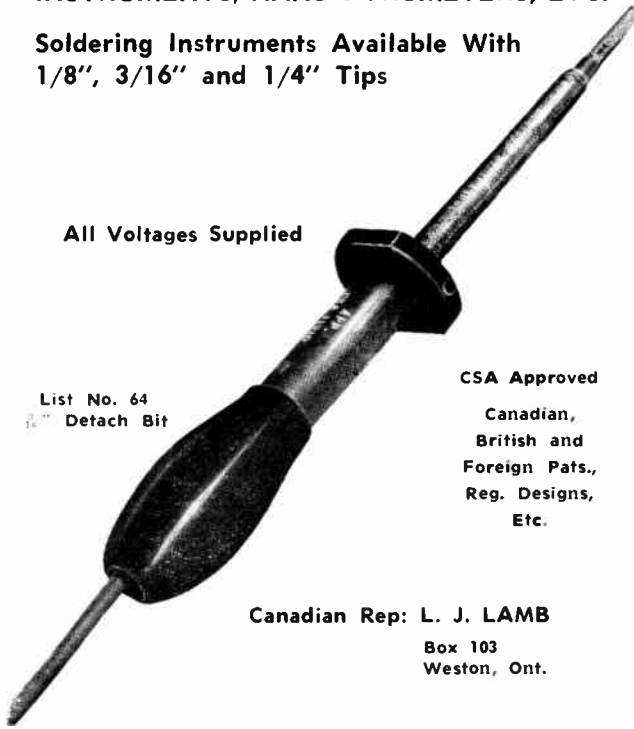

CSA Approved
Canadian,
British and
Foreign Pats.,
Reg. Designs,
Etc.

Canadian Rep: L. J. LAMB
Box 103
Weston, Ont.

Space-Saving Subminax Connectors by



FEATURES

- Smallest ever offered for RF applications — saves half the space.
- Weight-saving design.
- Available in screw-on and push-on types.
- 50 and 75 ohm impedance, featuring full size electrical characteristics.
- Gold finishing offers excellent corrosion resistance and like-new shelf life.
- Proven reliability and efficiency.

For more information write to Dept. 5 for catalog D-3



CANADA LIMITED
300 CAMPBELL AVE.
TORONTO - ONTARIO

FOR **SAFE** SHIPMENT OF DELICATE EQUIPMENT



TRANSIT CASE — TYPE TC-4

- Dural Body
- Weather-Proof
- Dust-Tight
- Foam Padding
- No fatigue or low-temperature problems
- Made to order for sure fit

WRITE FOR FREE CATALOG



PYLON ELECTRONIC DEVELOPMENT company, Ltd.

Communications Systems and Equipment
161 CLEMENT ST., VILLE LA SALLE, MONTREAL 32, QUE.

World's First Battery Operated Pocket Tape Recorder

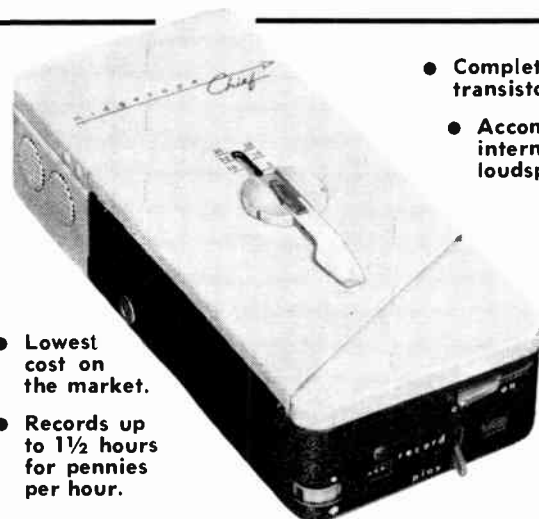

- Completely transistorized.
- Accommodates internal loudspeaker.

- Lowest cost on the market.
- Records up to 1 1/2 hours for pennies per hour.

Midgetape is pocket size. It has a variety of devices for confidential recordings. Power converters for non-battery use in car, office or home. One battery with visual life indicator. Ideal for engineers, lawyers, insurance investigators, doctors, public relations and salesmen, as well as for inventory taking.

INSTANTANEOUS RECORDING SERVICE

40 - 42 LOMBARD STREET - TORONTO 1, ONTARIO
TELEPHONE EMPIRE 3-5767

NEW QUARTERS FOR R. H. NICHOLS LTD.



● R. H. Nichols Ltd. new building at 4544 Dufferin Street (at Finch Avenue) Toronto. Expanded facilities promise greater efficiency and improved service. The new building puts head office, manufacturing and service divisions under one roof. New mailing address is P.O. Box 500, Downsview.

For direct measurement of

F. M. DEVIATION

from 4 to 540 Mc/s

MEASURED TO WITHIN 3%



Marconi
Carrier
Deviation
Meter
TF 791C

The Marconi direct-reading Carrier Deviation Meter, TF 791C, is designed for use with all types of systems from narrow-band mobile communications to hi-fidelity broadcasting. High measurement accuracy is assured by a built-in crystal-controlled deviation standard. The Meter covers the carrier frequency range of 4 to 540 Mc/s, has a modulation frequency range extending from 50 c/s to 35 kc/s, and deviation is measured on any one of the four direct reading ranges of 5, 25, 75 and 125 kc/s full-scale. There is an independently-buffered l.f. output for aural or visual monitoring of the demodulated signal.

Carrier Frequency range: 4 to 540 Mc/s
in 7 bands.

Frequency Deviation Range: 0 to ± 5
kc/s, 0 to ± 25 kc/s, 0 to ± 75 kc/s
and 0 to ± 125 kc/s.

Frequency Deviation Accuracy: For modulation frequencies between 50 c/s and 25 kc/s, $\pm 3\%$ of full scale. For modulation frequencies between 25 and 35 Kc/s, $\pm 3\%$ of full scale $\pm 3\%$ of the reading.

For further details, write to: CANADIAN MARCONI COMPANY, Instrument Dept.,
6035 Cote de Liesse Road, Montreal, Que.

Marconi



CANADA'S LARGEST
ELECTRONIC SPECIALISTS

Canadians Present Papers IRE National Convention

A total of 850 exhibits spread over four floors of the New York Coliseum constituted the exhibition portion of the 1958 IRE National Convention which was held in New York from March 24 to 27. Regarded as the largest technical gathering in the world it is estimated that more than 55,000 engineers and business executives of the electronics industry attended the affair to examine the latest products of the electronics business or to hear some of the 275 technical papers that were delivered at the 55 technical sessions of the Convention.

Papers presented by Canadians and the subjects dealt with that were presented at the Convention were as follows:

New Transpositions in Power Transformer Windings, R. G. deBuda, Canadian General Electric Co., Ltd., 830 Lansdowne Ave., Toronto 4, Ont., Canada.

Direct Despatch Service, A. J. Dinnin, Bell Tel. Co. of Canada, 1050 Beaver Hall Hill, Montreal, P.Q., Canada. The Canadian Automation System of Postal Operations, M. Levy, Canada Post Office Dept., Ottawa, Ontario, Canada.

Organization of the Electronic Computer for the Canadian Electronic Mail Sorting System, A. Barszczewski, Canada Post Office Dept., Ottawa, Ontario, Canada.

Coding and Error Checking in the Canadian System, M. Levy and V. Czorny, Canada Post Office Dept., Ottawa, Ontario, Canada.

The Canadian Automation System of Postal Operations, H. Jensen and K. H. Ulliyatt, Canada Post Office Dept., Ottawa, Ontario, Canada.

Limitations of the Output Pulse Shape of High Power Pulse Transformers, R. G. deBuda and J. Vilcans, Canadian General Electric Co., Ltd., 830 Lansdowne Ave., Toronto 4, Ont., Canada.

Company Name Change

In order to avoid confliction with companies bearing similar titles, Electronic Enterprises Reg'd., formerly of 551 Oakwood Avenue, Toronto 10, Ontario, and now located at 1514 Eglinton Avenue West, Toronto 10, have changed their name to Conway Electronic Enterprises Reg'd.

They continue to act as exclusive Canadian distributors for The Universal Transistor Products Corporation and The Universal Atomics Corporation of the United States, and are pleased to announce their appointment as exclusive Ontario distributors for the Advance Company of England.

Advance instruments cover a wide field and include crystal calibrators, radio frequency generators, VHF and UHF signal generators, magnetizers, and audio frequency generators.

Got a tube problem

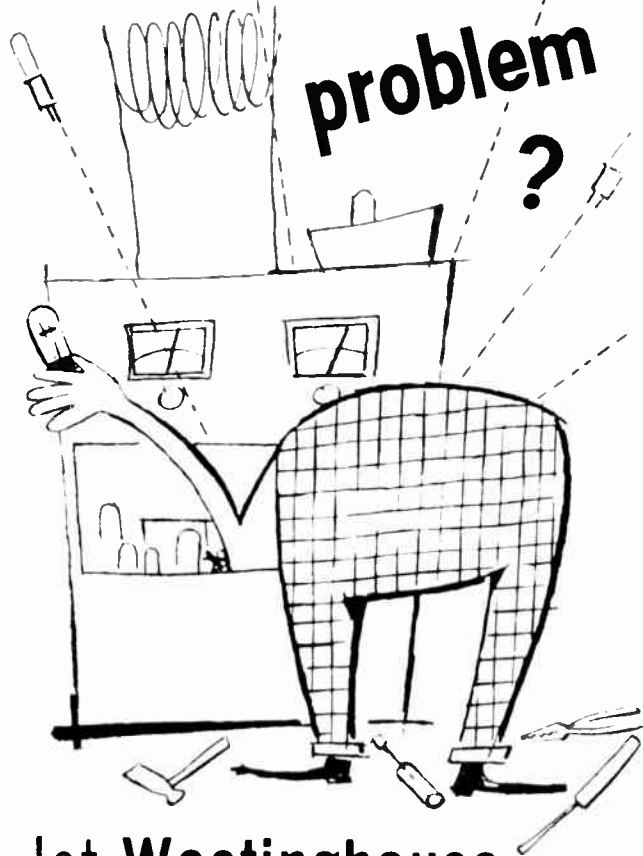

Let Westinghouse application engineers help you pick the right tube for the job!

As a designer or manufacturer of Electronic equipment, you've got enough to worry about without keeping the functions of hundreds of different tube types in your head. That's a job for Westinghouse. With Canada's most modern Electronic Tube engineering and manufacturing facilities at its disposal, Westinghouse can offer you on-the-spot service to help you solve any problem you may have concerning the function or application of Electronic Tubes. Write to Canadian Westinghouse Company Ltd., Electronic Tube Division, Hamilton, Ont.

YOU CAN BE SURE ... IF IT'S

Westinghouse

Watch the new "Westinghouse Studio One in Hollywood" Mondays 10 p.m. TV

ELECTRONICS & COMMUNICATIONS, APRIL, 1958

Get a GOOD Charger!

CHARGING VOLTAGE AUTOMATICALLY REGULATED

The proper charging rate at 2.15 volts per cell provided at all times prolongs battery life. Increased voltage settings for older batteries by simple adjustment.

Equalizing Charges Without Violent Changes In Charging Rate

To equalize cell voltages, a "Hi/Lo" switch in "Hi" position increases to correct over-voltage value by a gradual process, returning slowly to regular floating voltage upon switching to "Lo" position.

Protection From Line and Load Irregularities

Thermostat control automatically reduces charging rate if overheating occurs. Circuit breakers provide overload protection on both AC and DC lines. Inherent characteristics of selenium rectifiers ensure that the battery cannot discharge through the charger in the event of AC power failure.

Benefit by Nichols' Engineering Service

There is a Nichols Rectifier Unit for practically every purpose. Consult with us, or write for information to Dept. EC-4.

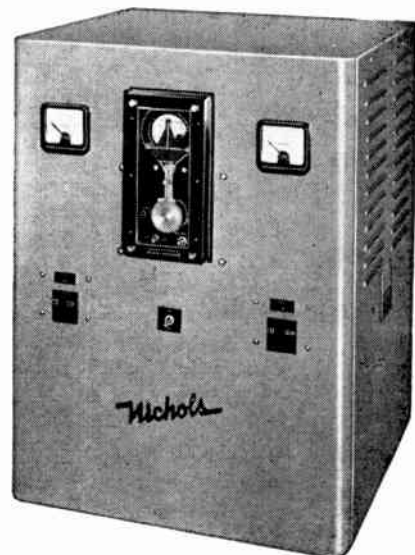
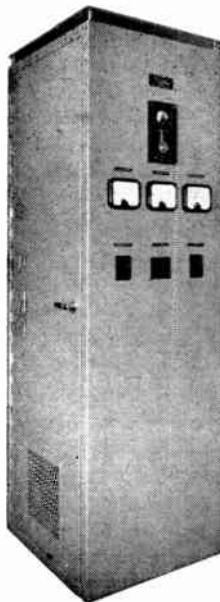

R.H. **Nichols** LIMITED
2781 DUFFERIN STREET • TORONTO

For further data on advertised products use page 65.

Before you buy
any capacitor
checker see
and try the

ALL-NEW MODEL 97 AEROVOX LC-CHECKER



\$89.95

The all-new Model 97 LC-Checker represents the ultimate in r-f circuit and component testing. In a single instrument it covers the widest range of checking functions. It's the only instrument that will test for capacitance without disconnecting capacitors from the circuit. Incorporates latest printed-circuit techniques.

THE ALL-NEW MODEL 97 LC-CHECKER CAN DO ALL THESE JOBS . . .

- 1—Measure capacitance and relative "Q" of capacitors.
- 2—Measure capacitor insulation resistance.
- 3—Align r-f and i-f circuits.
- 4—Check super-het oscillator tracking with set "hot-or-cold."
- 5—Align i-f channels in FM receivers and independent alignment of i-f transformers.
- 6—Determine resonant absorption points.
- 7—Locate resonant points in unused portions of coil assemblies in multi-range oscillators.
- 8—Align video and sound i-f systems in TV sets.
- 9—Precise alignment of 4.5 mc intercarrier sound i-f channels.
- 10—Determine natural resonant points of r-f chokes.
- 11—Determine natural period of antennas and transmission lines.
- 12—Measure fundamental crystal frequencies and operation at harmonic levels.
- 13—Measure transmitter buffer, amplifier and tank circuits for parasitic current loops with power off.
- 14—Measure correct wave-trap and filter tuning.
- 15—With a standard plug-in crystal, can be used as an accurate signal generator for signal substitution and precise signal sources.

Write for descriptive literature

**AEROVOX
CANADA LIMITED
HAMILTON, CANADA**

WESTERN SALES
Chas. L. Thompson, Vancouver, B.C.
IN U.S.A.
Aerovox Corporation, New Bedford, Mass.

5801

News Report

C.E.W.A. Annual Western Meeting And Convention

The annual meeting of the Western Division of the Canadian Electronic Wholesalers' Association will be held in the Royal Alexandra Hotel, Winnipeg, Manitoba, on Monday, May 12th, under the chairmanship of W. H. Cowley, chairman of the Western Division. Following the meeting the delegates will leave for Toronto to attend the Association's national convention at Niagara Falls.

The annual meeting of the Eastern Division of the Canadian Electronic Wholesalers' Association will be held in the Sheraton-Brock Hotel, Niagara Falls, Ontario, on Wednesday, May 14th, under the chairmanship of I. Morris, of Montreal, chairman of the Eastern Division.

Following the Eastern Division annual meeting, the convention and annual meeting of the national Canadian Electronic Wholesalers' Association will be held in the Sheraton Brock Hotel at Niagara Falls. It will run through Wednesday afternoon to Friday morning, May 14th-16th. Chairman will be M. L. Poole, of Poole Electronics Limited, Windsor and London, who is president of the national association.

Mr. DeMambro will deliver the keynote address at the convention dinner.

Third Generation Joins Sales Rep Organization

Charles William (Bill) Pointon has joined the firm of Charles W. Pointon Limited, 6 Alcina Avenue, Toronto 10, Ontario.

This third generation member of the wellknown sales representative organization joins his grandfather, Charles W. Pointon, who founded the business in the early 1930's, and his father, Charles G. (Jerry) Pointon, who is currently chairman of the Canadian Sales Representatives.



C. W. Pointon

"Bill" Pointon studied at the Radio College and then went to work on his own account with a large parts distributor firm to learn something about the parts business from the jobber's viewpoint. At the present time he is assisting the Pointon organization in stock control and sales, and it is planned that he will gradually spend some time with each of the Pointon organization's principals at their factories to further gain firsthand knowledge on the products represented.

SPECIALISTS IN MICROWAVE ANTENNAS and Antenna Systems

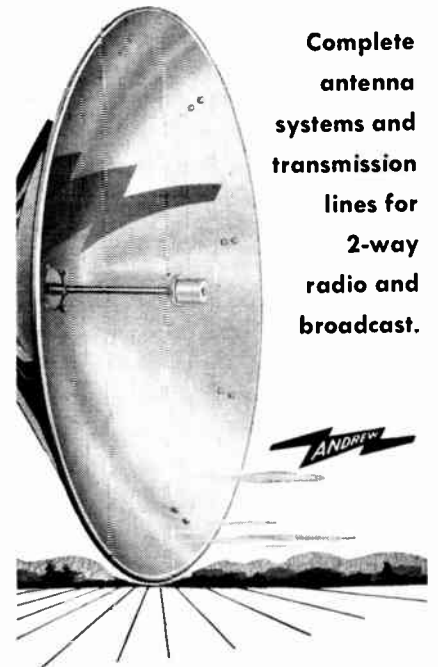

Complete antenna systems and transmission lines for 2-way radio and broadcast.

Accurate, reliable antenna performance is vital to every microwave system. Andrew engineers are specialists in the design and manufacture of parabolic antennas for microwave . . . experienced in planning complete systems for commercial and military use.

Andrew produces over 30 standard models of parabolic antennas. Special models or adaptations made to order.

Let us help you plan your new antenna system or improve your present one. Our engineers will make a complete study of your requirements and submit recommendations.

Andrew
ANTENNA
CORPORATION LTD.
WHITBY, ONTARIO

ANTENNAS • ANTENNA SYSTEMS • TRANSMISSION LINES



MANUFACTURED IN CANADA

STANWYCK

Coils for every
application in the
R.F. Spectrum

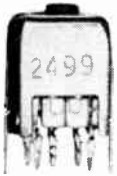

Transistor I.F.
and Osc. Units

R.F.
Inductors



Adjustable
R.F. Inductor
for B.C., H.F.
and VHF
Service

Encapsulated
Inductors



Shielded
Variable
Inductors



Special
Transmitting
Inductor

Also complete line of
Radio and TV Coils

Stanwyck Coil Products

Limited
HAWKESBURY, ONTARIO

Telephones

Toronto
PL. 7-3253

Hawkesbury
ME. 26651

News Report

Toronto Section, IRE Holds March Meeting

A meeting of the Toronto Section of The Institute of Radio Engineers was held on March 31 at which the speaker was C. A. Norris, B.A.Sc., P.Eng., Coordinator of Sales, Univac Computer Division, Remington Rand Ltd.

The subject of Mr. Norris' talk was "An Introduction To Electronic Computers." His presentation provided a broad scale coverage of electronic computing equipment, including basic components of the system, an appraisal of input media functional operation of the main computer, advantages to be gained in high speed data processing systems and management considerations involved in applying such systems.

Dr. E. A. Racicot, technical counselor of Remington Rand Ltd., was on hand to answer technical questions during the discussion period.

Sales And Service Rep For Aviation Electric

A. Lavendel, Director of the Overhaul Division at Aviation Electric Limited has announced the appointment of Naylor C. Sargent as a Sales and Service Representative for the Overhaul Division.



N. C. Sargent

Mr. Sargent has had many years of experience in the Aviation Industry and, in particular, in work associated with the overhaul of aircraft instruments, accessories and components. He started his career at Canadair Limited in 1951 and held the position of Inspector of Planning when, in 1954 he joined Aviation Electric Limited in the capacity of Technical Assistant (Overhaul Division).

A. C. Wickman Represents Daytronic Corporation

A new line of products is being introduced to the Canadian market by A. C. Wickman Limited, 1425 Queensway, Toronto, Ontario. The Company has been appointed representatives of Daytronic Corporation, Dayton, Ohio.

Principal items distributed will be motion transducers, force transducers, controllers, transducer amplifiers, which are especially applicable to users of instrumentation, manufacturers and users of process control equipment, automatic inspection systems and automatic weighing systems.

Announcing! exclusive distribution of CLOUGH- BREngle

Precision
Laboratory and
Maintenance
Instruments for the
Radio and Allied
Communication
Fields
by

HACKBUSCH ELECTRONICS

LIMITED

23 PRIMROSE AVENUE
TORONTO - ONTARIO

MORE ACTIVE! EFFECTIVE!



**THE BEST FOR TV-RADIO WORK . . .
EVERYTHING ELECTRICAL**—Kester "Resin-Five"
Core Solder is better and faster than any solder ever
developed. It has an activated flux-core that does a perfect job on
all metals including zinc and nickel-plate. The flux residue
is absolutely non-corrosive and non-conductive.

Available in all practical Tin-Lead
Alloys; 40/60, 50/50 and 60/40 in
diameters of $\frac{3}{32}$ ", $\frac{1}{16}$ ", $\frac{3}{64}$ ", $\frac{1}{32}$ " and
others.



Printed Circuit Soldering
On Copper-etched boards
use 60% Tin - 40% Lead
Alloy . . . for those that
are Silver-surfaced use
3% Silver-61½% Tin-
35½% Lead

KESTER SOLDER COMPANY
OF CANADA, LTD., Dept. U Brantford, Canada

Aladdin[®] ELECTRONICS MICRO-MINIATURE COMPONENTS

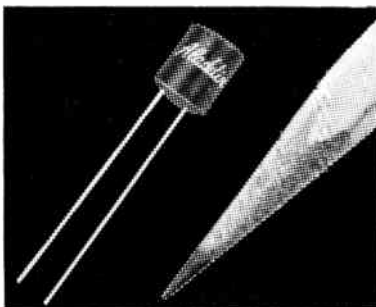

INDUCTORS

Standard increments of inductance up to ONE HENRY . . . Operating temperatures up to 125° C.
Size:285" dia.
.300 to .350" long
Weight:73 gram

Write for Bulletin 54.

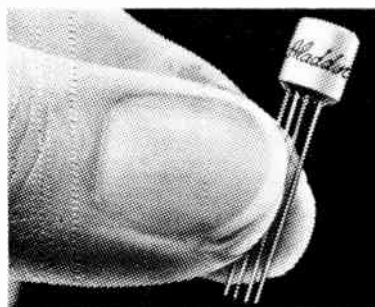

PULSE TRANSFORMERS

Described in a new supplement to the Aladdin Pulse Transformer Encyclopedia.

189 standard catalog units, ideal for transistor circuit applications.

Write for the complete encyclopedia (Bulletin 55).

For Immediate Deliveries contact your nearest Distributor
or Canadian Representative:

LAKE ENGINEERING CO. LTD.

767 Warden Avenue, Scarborough, Ontario, Canada.

Telephone PL 7-3253

For further data on advertised products use page 65.

World Radio History

News Report

Canadian Outlet Sought By Glaser-Steers Corp.

It has been reported that the firm of Glaser-Steers Corporation, of Belleville, New Jersey, has been visiting Canada with a view to arranging for an outlet through which to supply the Canadian market with the company's Hi-Fi record changers.

Although official announcement has not yet been made, it is known that Essex Electronics of Canada Ltd. at Trenton, Ontario, has been approached by a representative from Glaser-Steers Corporation to explore the possibility of his firm's products being manufactured and assembled at the Trenton plant of Essex Electronics. Such an arrangement, if consummated, would materially increase the scope of operations at the Essex plant with a resultant increase in the labor force employed.

Canadian Sales Rep For Tri-Point Plastics

Wm. T. Barron of Toronto, Canada, has been appointed sales representative by Tri-Point Plastics, Inc., Albertson, N.Y. His territory for Tri-Point includes all of Canada, with the exception of British Columbia.

William "Bill" Barron, an independent sales representative for the past 15 years, will promote Tri-Point products in the Canadian radio, television, electronic and electrical industries from his main office in New Toronto. Prior to establishing his own business, Bill Barron was formerly chief engineer and vice-president of such companies as Canadian Westinghouse, Philco Corp. of Canada and Radio Speakers Ltd.

AEROVOX APPOINTMENT



W. J. McINTYRE

• J. Cartwright, Sales Manager of Aerovox Canada Limited, announces the appointment of W. J. McIntyre as sales representative for Quebec and Maritimes.

News Report

Canadian Hunting Research Helps Develop Canada

An intensive research program by the Hunting Group of Canadian companies has helped to establish Canadian leadership in aerial survey equipment and techniques. Further discovery and better utilization of the world's dwindling natural resources have been promoted as a result of this work.

Various types of survey equipment designed, developed and produced by Hunting have been successfully used in Canada and have been exported for use around the world.

While the Canadian Hunting group have had to spend large sums of money in developing various types of equipment, it is considered money well spent, although most of the cost on certain developments has not yet been recovered.

Outstanding among the Hunting equipment are such instruments as the electromagnetometer which, after being fitted to aircraft and helicopters, has been responsible for the location of no less than eight major ore bodies in Canada alone. Patents for the invention have been made in 55 countries. It has been successfully used under licence in Europe, Africa, Australia, and the United States.

Another instrument which has proved to be very successful is the airborne profile recorder, a device which was originally conceived in the National Research Council, but which was developed to practical use by Hunting engineers and technicians. Orders for this particular equipment are coming from the United States, the United Kingdom and from other parts of the world.

Final Link In "Telex" Service Marked By Ceremony

The completion of the final link in a coast-to-coast trans-Canada "Telex" service, the world's newest form of business communication, was recently observed in a ceremony at St. John's, Newfoundland, when the mayor of that city and the mayor of Victoria, B.C., sent the first messages from coast to coast to officially inaugurate the trans-Canada Telex service.

Telex, a unique and revolutionary means of communication, provides instant, permanent, printed conversations between business firms across Canada and around the world.

Telex is operated across Canada by Canadian National Telegraphs and by Canadian Pacific Telegraphs. Participating in the overseas operation are two of the world's largest communications firms, Canadian Overseas Telecommunications Corporation and Commercial Cables Limited.

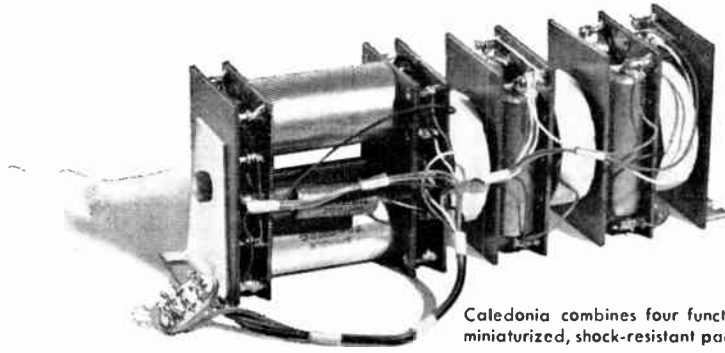

Caledonia combines four functions in miniaturized, shock-resistant package.

Electronics today is partly packaging

PROBLEM: Design a small (50 cubic in.) and light (3¾ lbs.) unit that contains:

1. a positive d.c. pulse selector
2. a negative d.c. pulse selector
3. a high level 60 cps band pass filter
4. a 400 cps detector circuit (all with tight tolerances, naturally).

Design it to operate within the usual military environmental conditions, including high vibration and shock.

SOLUTION: We assembled the components shishkabob style. Then mounted the

shishkabob in a metal case filled with an epoxy foam compound to hold the parts in a firm cushion.

TIME ELAPSED: From original assignment, through design to volume production—two months.

If such quick, dependable assistance in design and production can make your work more effective, we'll be glad to hear from you. We offer experience, good production facilities, and a recognized quality record.

CALEDONIA

ELECTRONICS AND TRANSFORMER CORPORATION

Dept. EC-4, Caledonia, N.Y. • In Canada: Hackbusch Electronics, Ltd., 23 Primrose Ave., Toronto 4, Ont.

RELIABLE, LIGHTWEIGHT, PORTABLE POWER

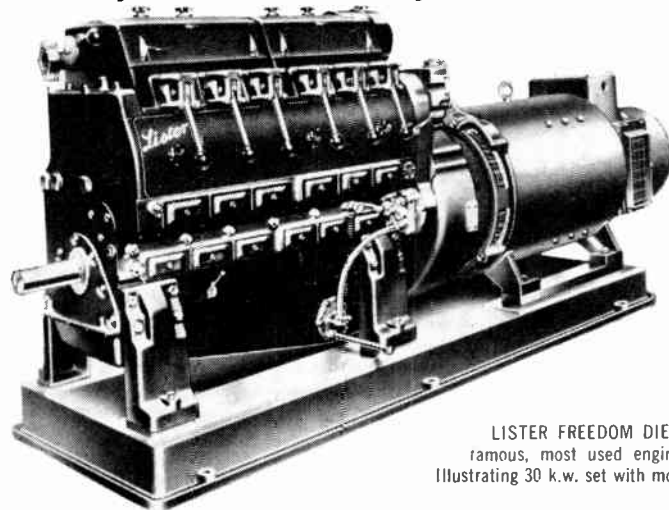

LISTER FREEDOM DIESELS—the most famous, most used engines in industry. Illustrating 30 k.w. set with model FR6 Engine.

Built in a tradition of reliability, Lister-Blackstone engines incorporate the very latest improvements in Diesel design. The full line includes engines from 3½ to 1300 h.p. and there are models for every purpose. Ease of maintenance and economical operation are assured when you specify Lister-Blackstone. Service and spare parts are available from coast to coast.

Write us for the name of your nearest Distributor.

CANADIAN LISTER-BLACKSTONE LIMITED

1921 EGLINTON AVE. E., TORONTO 13 • 3135 WEST BROADWAY, VANCOUVER
25 ST. JAMES ST., VILLE ST. PIERRE, MONTREAL

In the U.S. — Lister-Blackstone Inc., 42-32, 21st St., Long Island City 1, N.Y.

DISTRIBUTORS: B.C. Equipment Co. Ltd., 551 Howe Street, Vancouver; Bruce Robinson Electric (Edm.) Ltd., 10056-109th Street, Edmonton; Medlard Machinery Limited, 576 Wall Street, Winnipeg; Russel-Hipwell Engines Ltd., Owen Sound; Consolidated Engines & Machinery Co. Ltd., 5645 Pare Street, Town of Mount Royal, P.Q.; Russell-Hipwell Engines Ltd., 1298 Barrington Street, Halifax; Clayton Construction Co. Ltd., P.O. Box 118, Muir Bldg., St. John's, Nfld.



YOUR MOVE NEXT

WE HAVE SYNCHROS AND SERVOMOTORS READY FOR IMMEDIATE DELIVERY

Call Muirheads for an answer to your synchro delivery problems. It's more than likely we have what you want in stock, or, if not, we can give a realistic answer.

The list of synchros in production is extensive and new types are being added all the time. Sizes include 08, 10, 11, 15, 18 and 23; types: Control Transmitters, Control Transformers, Control Differential Transmitters, Resolvers, Torque Receivers, Torque Transmitters, Torque Differential Transmitters and Receivers, Linear Variometers, Servomotors, Motor Tachometers and Tachometer Generators.

It's your move next, let us quote for your needs
Data and prices on request

MUIRHEAD

PRECISION ELECTRICAL INSTRUMENTS

MUIRHEAD INSTRUMENTS LIMITED

STRATFORD · ONTARIO · CANADA



3717 & 3718

318/3Ca

News Report

Toronto Sales Office For Computing Devices

Opening of a branch sales office in Toronto for Computing Devices of Canada Limited of Ottawa, Ontario, was recently announced by W. S. Kendall, CDC Marketing Director.

Manager of the new office, at 164 Eglinton Avenue East, will be R. G. Powers. Mr. Powers has represented CDC in the Toronto area for the past two years.

A Bendix G-15D digital computer has been installed in the office, primarily for sales demonstration purposes.



● View of the Bendix G-15D digital computer in CDC's Toronto office. Shown in the picture is Mr. George Kirkpatrick a member of CDC's Toronto staff.

Assisting Mr. Powers will be George Kirkpatrick and Ed Cheng.

Starting on April 1, a series of courses on programming of digital computers, presented by CDC staff members, has been arranged to emphasize simplified programming methods which an engineer can use to program typical engineering problems.

F-R Machine Works Represented By Radionics Limited

Radionics Limited, of 8230 Mayrand Street, Montreal 9, P.Q., recently announced its appointment as Canadian representative for F-R Machine Works, Inc. of Woodside, N.Y.

The F-R line of microwave test equipment covers the entire microwave frequency spectrum. Products include broadband spectrum analyzers, signal sources, ratiometers, microwave power supplies, modulators, attenuators, terminations, mounts, tuners, frequency meters and transmission line components.

For further data on advertised products use page 65.

"better to hear you with"

In the rural areas of Canada, T.M.C. Magneto Telephone Equipment has been keeping open vital communications for almost a decade. Suppliers to many of the world's major telephone users for over forty years, T. M. C. equipment has the features for which you are seeking. Rugged construction, stylish appearance, easy maintenance, highly competitive initial cost. Telephone EM. 6-5314 or call at our showroom to discuss your problems with our engineers.

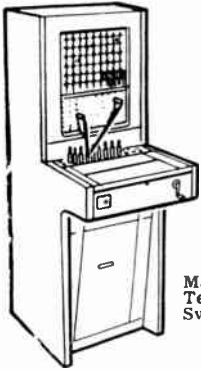

Magneto Telephone Switchboards

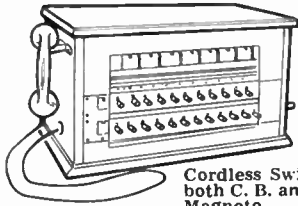

Cordless Switchboards both C. B. and Magneto

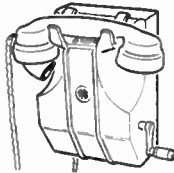

Magneto Wall Telephone



MAGNETO TELEPHONES

TELEPHONE MANUFACTURING CO. LTD.
Saxony Building, 26 Duncan Street, Toronto

Write For Technical Details
To Department EC

COMPACT, LOW COST POWER for Hundreds of Uses



"VOLTABLOC" BUTTON CELLS

NICKEL-CADMIUM • SINTERED • Hermetically Sealed • RECHARGEABLE

2 TYPES
VO-.250 VO-.500
CAPACITY
(2 hour rate)
250 mah 500 mah
DIAMETER
1.375" 1.375"
THICKNESS
.1875" .3125"
WEIGHT
(ounce)
.5 .75
VOLTAGE
1.2 V per cell

Button cells are the latest addition to Saft's extensive line of "Voltabloc" hermetically sealed, nickel cadmium sintered-plate batteries. Smaller than a silver dollar, these miniature batteries offer unlimited possibilities in electronic and electrical applications.

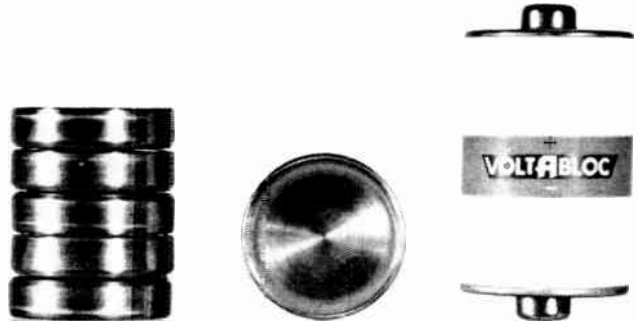

WARD LEONARD OF CANADA LIMITED

1070 BIRCHMOUNT ROAD TORONTO 16



CANADIAN FACTORY AND HEAD OFFICE

Resistors • Rheostats • Relays • Motor Controls • Dimmers • Switchboards • SAFT Batteries • Barkelew Switches • Kenco Pumps 5806

Looking for a "POT"?

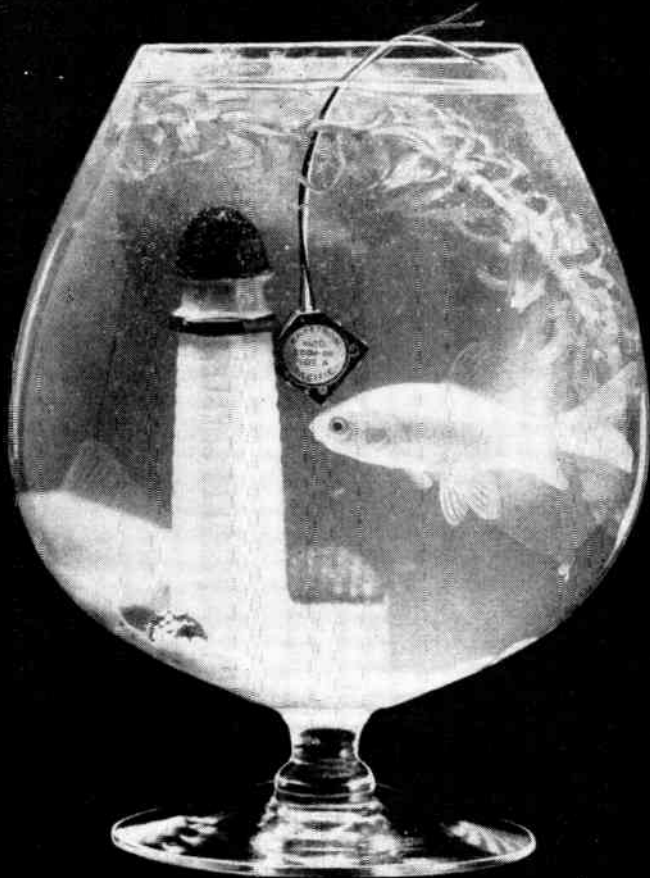

Even under these conditions . . .

We'll admit a gold fish bowl is a peculiar place to use a precision-built, wire-wound, sub-miniature potentiometer . . . but, "even under these conditions," the **NEW HUMIDITY PROOF Series 300H** Trimming Potentiometer will operate with complete reliability.

NOW, the **NEW Series 300H** offers complete protection against humidity and moisture without sacrificing the other environmental and performance specifications which have made the Daystrom Series 300 accepted as **THE** outstanding Trimming Potentiometer.

- Finer Resolution
- Higher Power Rating
- Better Stacking (20 units in less than one cubic inch)
- Greater Reliability under the most adverse environment

Write **TODAY** for complete details on this and other precision potentiometers from **DAYSTROM POTENTIOMETER DIVISION!**

Openings exist for highly qualified engineers.

ACTUAL
SIZE

DAYSTROM LIMITED

840 Caledonia Road, Toronto, Ontario
5430 Ferrier Street, Montreal, Quebec,
a subsidiary of Daystrom Incorporated

5802

For further data on advertised products use page 65.

World Radio History

News Report

Pointon Represents Celestion Loudspeakers

Charles W. Pointon Limited, 6 Aleina Avenue, Toronto 10, Ontario, recently announced their appointment as exclusive Canadian sales agents for Rola Celestion Limited, Thames Ditton, Surrey, England, manufacturers of loudspeakers for all purposes.

The speakers handled by the Pointon organization in Canada will be marketed under the trade style "Celestion."

Further information is available by writing to the Pointon organization.

Daly-Arrow Limited Has Change Of Name

Daly Capacitors is the new name for the company previously known as Daly-Arrow Limited. Their capital stock has been increased to \$80,000 with the change of name.

Besides their own production of electrolytic capacitors for radio and television, Daly Capacitors also handles the products of Daly (Condensers) Limited in Ealing, London, England, who manufacture a wide range of electrolytics, including photo-flash, industrial and motor start capacitors.

In charge of the Canadian operations is Frank S. Dunkl, who has been with the company since 1952. The offices of Daly Capacitors are at 140 Kendal Avenue, Toronto 4, Ontario.

SALES REP.



A. GRIFFITHS

• Associated Electronic Components of 37 Roselawn Ave., Toronto, takes pleasure in announcing the appointment of Mr. Al Griffiths as Industrial Sales Representative. Mr. Griffiths was previously associated with the wholesale electronics industry.



FASHIONS CHANGE IN **STEEL** TOO

For almost half a century transmission towers have cable-crossed city and pasture alike to feed us electric power. Now inventive genius has added the fashionable and highly practical television and micro-wave relay tower to our horizon.

Central has fabricated and erected many towers in Canada similar to this one of several built for Eastern Telephone and Telegraph. Have Central Bridge quote on your next structural steel job.

CENTRAL BRIDGE *Company Limited*
Toronto, Ontario

*For your structural steel requirements
call Central soon.*

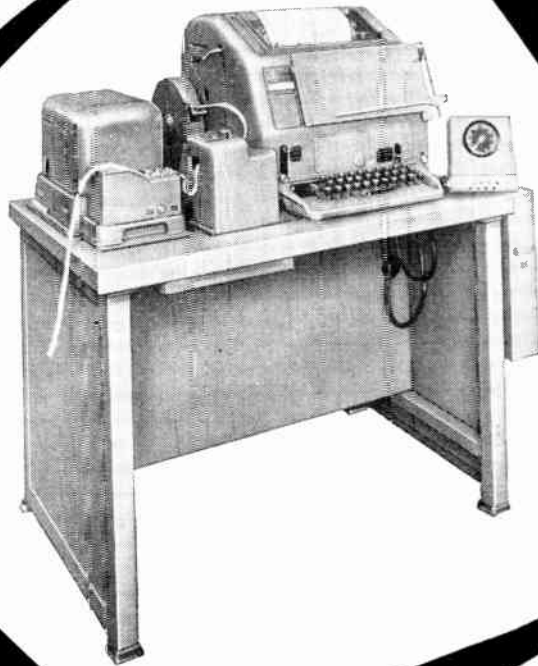

IDP*

IDP is based on the modern mechanical languages that are common to or compatible with various business machinery. The punch tape shown here is such a common language — it can actuate many different types of business machines.

*Integrated Data Processing is a method of mechanizing business paperwork so that a single typing can be used over and over again. The resultant labor savings can be substantial. In addition, "paperwork lag" is cut down and accuracy is improved, since the reproduced data will always be identical.

Consult Bell Telephone communication specialists on how data processing can be integrated between offices, factories and warehouses. Bell Teletype equipment is a dependable communication component of IDP systems — maintenance service is as close as your local telephone office.

For the booklet "Bell Teletype's Place In Your IDP Program", write or phone (collect) to:

MONTREAL

1060 University St. — Tel.: UN 6-3911
— Ext. 2981

TORONTO

393 University Ave. — Tel.: EM 8-3911
— Ext. 2155



THE BELL TELEPHONE COMPANY OF CANADA

News Report

H. K. Porter Co. (Canada) Acquires Site In Acton

A 67-acre site is being prepared in Acton, Ontario, for the construction of an 80,000 square foot building to house the Disston Division of H. K. Porter Company (Canada) Limited and provide factory area for other products of the company.

Federal Wire and Cable Division, acquired in 1957, manufactures a complete line of electrical conductors including many types of cable and wire. Under a recent agreement with Enfield Cables Company, Limited, London, England, the new Division also markets a complete line of high voltage power cables under the name Federal-Enfield.

It is proposed to make the Acton plant, when completed, serve as head office for H. K. Porter Company (Canada) Limited.

C.C.P.E. Appoints General Secretary

Leopold Maurice Nadeau, P.Eng., of Montreal, has been appointed general secretary of the 32,000 - member Canadian Council of Professional Engineers, according to a recent announcement by C. N. Murray, P.Eng., of Sydney, N.S., Council president.

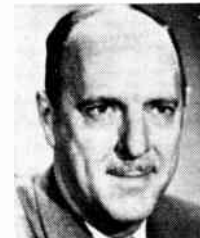

L. M. Nadeau

Mr. Nadeau will make his headquarters in Ottawa. In his new capacity, he will co-ordinate the activities of the engineering licensing bodies of which there are 11 — one in each province and one in the Yukon. At present he is preparing for the Council's annual meeting, which is to be held in Vancouver in May.

The Canadian Council of Professional Engineers (C.C.P.E.) is the national body for all provincial engineering associations.

Annual Meeting Of C.E.W.A. - May 14-16

The annual meeting and convention of the Canadian Electronic Wholesalers' Association (National) will be held in the Sheraton-Brock Hotel, Niagara Falls, Ontario, from May 14 to 16, 1958. These dates were selected to permit those attending the convention to proceed to Chicago the same weekend for the Electronic Parts Distributors' Show which commences on May 19 for a period of three days.

John T. Rochford, secretary of C.E.W.A., will be pleased to answer any enquiries regarding these events. His address — 25 Taylor Drive, Toronto 6, Ontario, OXFord 1-5304.

Please Bear With Us —

you who have requested the addition of your name to our regular mailing list by returning a green card.

Your growing interest in **ELECTRONICS & COMMUNICATIONS**, as shown by the many requests received lately, has exceeded our capacity to handle in time for the next issue.

Please be assured that, if you qualify, you will be receiving your first personally addressed copy as soon as possible.

WHAT DO YOU WANT in a MERCURY SWITCH?

**GORDOS
MERCURY
SWITCHES ARE . . .**

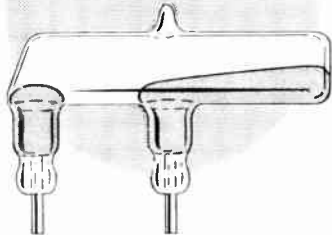

- VERSATILE** — can do switching jobs from milliamps to 45 amperes
— operate within a normal temperature range of -35° F. to 150° F.
— are hermetically sealed
- RELIABLE** — positive, trouble-free action, no moving parts to wear out, **ONLY THE MERCURY MOVES**
- ECONOMICAL** — are low cost, have long life, require small space
- DURABLE** — aged in the factory
— triple distilled vacuum distilled mercury used
— have true-sealed atmosphere of hydrogen insuring cool operation and extended life.

Write to Dept. 7 for Mercury Switch catalog

J.R. LONGSTAFFE CO. LTD.
300 CAMPBELL AVENUE
TORONTO ONTARIO

New HI-SPEED MUTUAL CONDUCTANCE TUBE TESTER



STARK Model 8-77
Portable — Only 16 lbs.

Exclusive: NEW METHOD OF CALIBRATION

Voltages are precision calibrated, thus assuring the testing of tubes with professional accuracy, with the time-proven Stark-Hickok method of Dynamic Mutual Conductance — in line with the approved Canadian Armed Forces accepted methods.

Exclusive: NEW SOCKET DESIGN

Supplied with snap-in master socket panel, easily and quickly removed to expose new type 11-pin socket that saves time in replacing worn out sockets, and will take other adaptors for checking foreign and older, seldom used, types.

Exclusive: NEW HIGH SPEED EXTRA SENSITIVE SHORT TEST

(12 times more sensitive)

Five neon lights automatically indicate shorts or leakage between elements and identify which are shorted.

Exclusive: NEW GRID CURRENT (GAS) TEST

The gas content (grid current) is measured very accurately in terms of microamps.

NEW FILAMENT CONTINUITY TEST — As soon as the tube is plugged into test socket, depressing of Filament Continuity button, immediately determines if filament "open" or not.

RESERVE CATHODE CAPACITY TEST — Reserve capacity of tube under test can be determined to weed-out tubes which could cause trouble in the near future.

FILAMENT VOLTAGES — In 18 steps from 0.6 to 117 volts.

SCALE READING IN MICROMHOS — Read directly on the 3-range micromho scales (0 to 3,000, 6,000, 15,000)

Write for full particulars



STARK ELECTRONIC INSTRUMENTS LTD.
Factories and Sales Office: Ajax, Ont.
Foreign Division: 276 West 43rd Street
New York 36, N.Y., U.S.A.

S581



*When the tension's terrific and a life hangs
on the balance, Beckman Frequency Meters read*

right at a glance

BECKMAN FREQUENCY METERS read right on the button: on the run, on the fly, at an angle, at a distance. It's the expanded scale that does it.

HOW? The jammed-up, useless divisions at the end of the scale are ruthlessly pruned.

WHAT'S LEFT? The vital part of the scale, fanned out for highest possible readability, resolution and accuracy.

JUST HOW ACCURATE? $\pm 0.5\%$ at 400 cps,
 $\pm 0.75\%$ at scale extremities.

APPLICATIONS? For panel mounting on the ground, in the air, and test equipment anywhere. Wherever accurate and readable monitoring of frequency is a must.

OTHER FEATURES? Beckman Frequency Meters are small. Meter, transformer and expansion network are entirely self-contained in a ruggedized case.

MORE? Lots! Presented in detail in data file 44E.

Beckman Helipot Corporation

Newport Beach, California
a division of
Beckman Instruments, Inc.
Canadian Factory:
No. 3 Six Points Rd., Toronto 18, Ont.
Sales Representative:
R.O.R. Associates, Ltd.
1470 Don Mills Road, Don Mills, Ont.

News Report

New Aluminum Processing Plant For Canada

Agreement has been reached to form a new company to manufacture aluminum wire and cable in Canada. The company, to be known as Phillips CBA Conductors Ltd., is a joint enterprise of Phillips Electrical Company Limited, (wire and cable manufacturers) and Canadian British Aluminum Company Limited, who have a large refinery at Baie Comeau, Quebec. This combines an assured source of raw materials with an established manufacturing and marketing organization.

With location planned for Brockville, the new venture will have access to both railways, the Seaway, and the main highway to the major markets of Canada. This arrangement will provide excellent distribution facilities as well as being adjacent to the Phillips company for administration and operational purposes.

When incorporated, Phillips CBA Conductors Ltd. will be managed by Phillips Electrical Co. under a management contract, and the Phillips organization will act as a marketing agency for the company's products. It is planned to manufacture aluminum rod, wire and cable, including ACSR for power transmission.

Due to the recent expansion in electrical facilities, aluminum conductors are in increasing demand, particularly for high voltage power transmission lines where they are used exclusively. At the same time, within the Electrical Industry there is a growing interest in the use of aluminum for other types of conductors.

This marketing situation, coupled with the facilities and resources of the two parent companies, indicates a promising future for Phillips CBA Conductors Ltd.

Toronto Section, IRE Holds Annual Meeting

On Monday, April 21, the Toronto Section of the Institute of Radio Engineers held the Annual Meeting for the 1957-1958 season at Hart House, University of Toronto.

A panel discussion on the grading and registration of qualified technicians was conducted by the Association of Professional Engineers. The panel members included R. C. Poulter, as Moderator of the group; E. L. Palin, Ryerson Institute; W. Currie, Dominion Electrohome; T. Millen, Philco Corporation; and B. Goodings of the Association of Professional Engineers.

Announcement was made that the following had been elected by acclamation as the officers of the Toronto Section for 1958-59: Chairman, H. Shoemaker; Vice-chairman, R. Turner; Secretary-treasurer, K. MacKenzie.

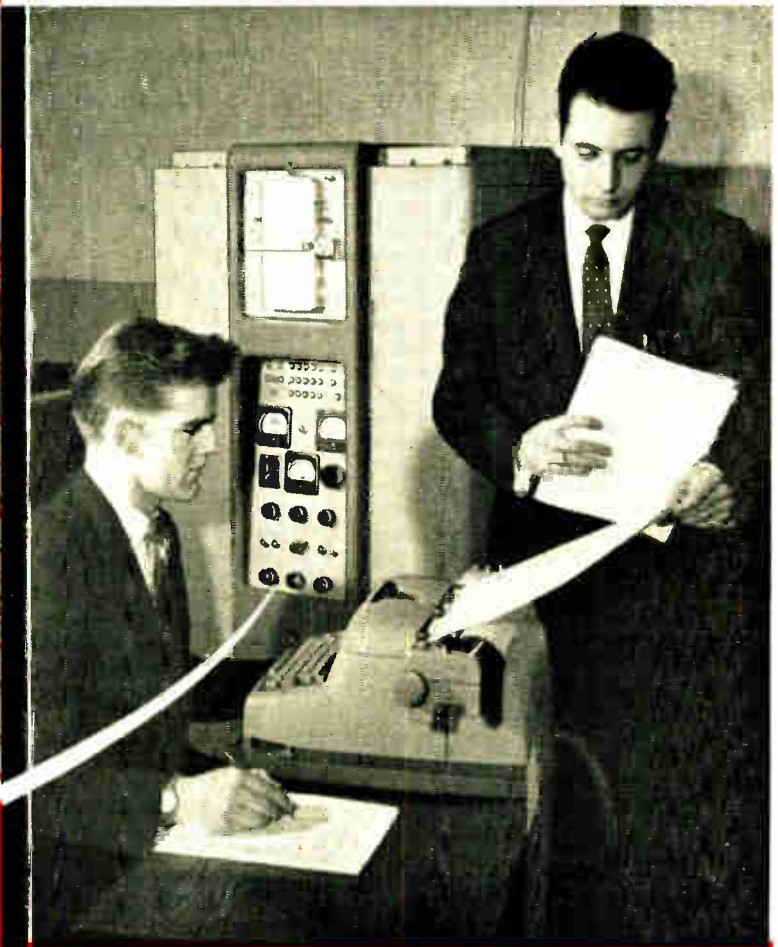

**LOWER
COSTS**

in highway design

That was the objective of Western Computing Co. Ltd. when they chose the Bendix G15D Computer to free the engineers of their group from the tedium of routine earthwork and bridge design computation.

They achieved their objective — and more — because savings extend far beyond design computation. For instance: greater precision in computation, a more realistic safety factor and the ability to explore additional alternatives enable this leading civil engineering design and survey group to produce even better and more economical final designs.

Time savings of 30 to 1 in earthwork computations and even greater savings in stress calculations for bridges have enabled the Bendix G15D Computer to more than double the engineering productivity of Western Computing Co. Ltd.

Versatile G15D digital computers are in everyday use for such things as photogrammetric data reduction; highway pay quantity calculations; traffic studies; pipeline, hydraulic and structural design calculations; and many other applications.

REDUCE COSTS - SAVE TIME - INCREASE EFFICIENCY WITH THE BENDIX G 15 D

COMPUTING DEVICES OF CANADA LIMITED
P. O. BOX 508 • OTTAWA • CANADA

5803



SYNTRON

Vacuum Process

SELENIUM RECTIFIERS

for all your d-c needs

... the widest range of cell sizes in the industry

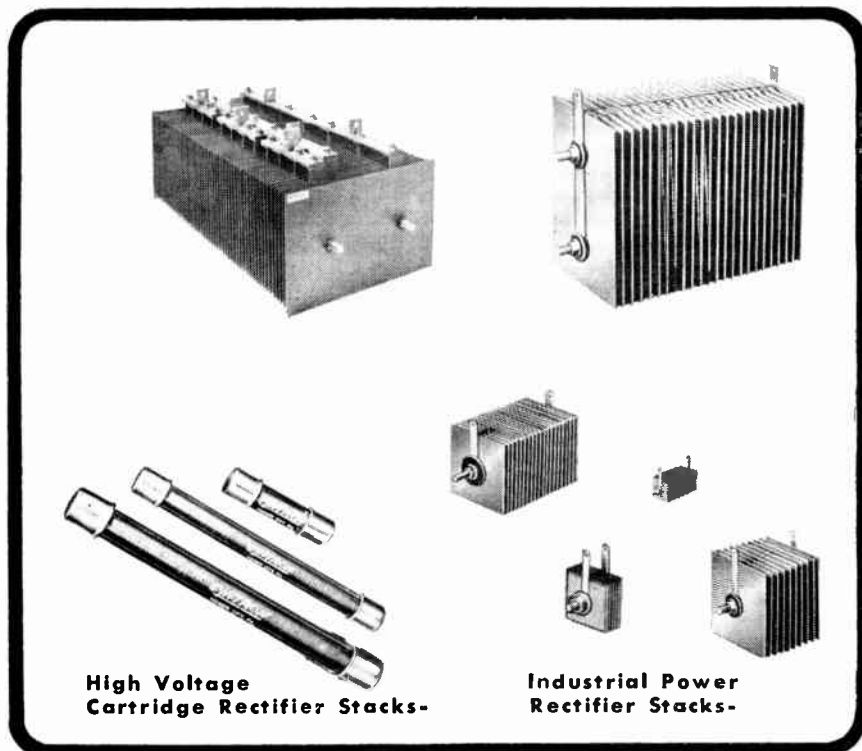

High Voltage
Cartridge Rectifier Stacks-

Industrial Power
Rectifier Stacks-

SYNTRON SELENIUM RECTIFIERS FEATURE:

- High short circuit surge-current ability to 300 times normal rating
- Withstand high transient conditions without damage
- Cell voltage ratings from 15 to 45 volt RMS means fewer cells per stack
- Protection available for all atmospheric conditions alkaline or acid
- Constructed to withstand high amplitude vibrations

LONGER LIFE TEST PROVES LOWEST AGING, HIGHEST OUTPUT RESULTS IN LONGER LIFE FOR SYNTRON RECTIFIERS.

SYNTRON Selenium Rectifiers consistently out-perform and out-last similarly rated rectifiers. Adequate, long lasting circuit control of SYNTRON Selenium Rectifiers is accomplished in the design stages, not by replacement.

SYNTRON Selenium Rectifiers are noted for these exceptional characteristics—lowest voltage drop, lowest leakage current, lowest temperature rise, longest life, greater uniformity from cell to cell and greatest voltage ratings.

E.558

Other SYNTRON Products of Proven Dependable Quality

- SELENIUM RECTIFIER UNITS
- ELECTRIC HEATING PANELS
- SINUATED WIRE
- ELECTRIC HEATING ELEMENTS
- PARTS FEEDERS

Write for complete information on all SYNTRON Products

SYNTRON (CANADA) LIMITED

12 MAIN STREET EAST • Dept. K • STONEY CREEK, ONTARIO

News Report

Simulator Trains Personnel For Radiation Detection

Reports from Canadian Admiral Corporation, Ltd., 501 Lakeshore Road, Port Credit, Ontario, indicate that the parent company's government laboratories division in Chicago has developed a radiac simulator which can be safely used to train military personnel in detecting atomic radiation. This device, which was developed under the sponsorship of the Department of the Army Participation Group of the U.S. Naval Training Device Center at Port Washington, N.Y., makes harmless radio waves behave like radiation in a nuclear fall-out area. Trainees learning to explore radiation fields carry the instrument which can be energized by harmless radio signals from a nearby special transmitter, thus learning their hazardous trade without personal exposure to deadly radiation rays.

The instrument carried in actual field work looks and behaves in a fall-out area exactly as the radiac simulator did.

Technically speaking, the Admiral Corporation has designed a simulator that essentially duplicates with radio signals the performance of an ionization chamber instrument in a nuclear fall-out region.

ELECTED PRESIDENT



F. E. PETERS

● F. E. Peters has been elected president of Dominion Sound Equipments Ltd., succeeding D. M. Farish, who is retiring.

Mr. Peters has been general manager of the company since 1937, a director since 1939 and a vice-president since 1947.

The Philips 5861 EC55 Disc Seal Triode has been developed for application in receivers and small transmitters working at 1000 to 3000 Mc/s. This Special Quality* tube has many advantages due to its rugged planar-electrode construction. It is recommended as a high-frequency amplifier and local oscillator in receivers and as a pulse modulator in transmitters. As an oscillator in a coaxial line circuit, this tube gives an output power of 2.8 W at 1000 Mc/s and 0.5 W at 3000 Mc/s with a d.c. anode input of 10 W.

**Rogers Special Quality tubes are finding more and more applications in all types of professional equipment. The greater reliability and lower maintenance cost of the apparatus in which they are used more than compensates for the higher initial cost.*

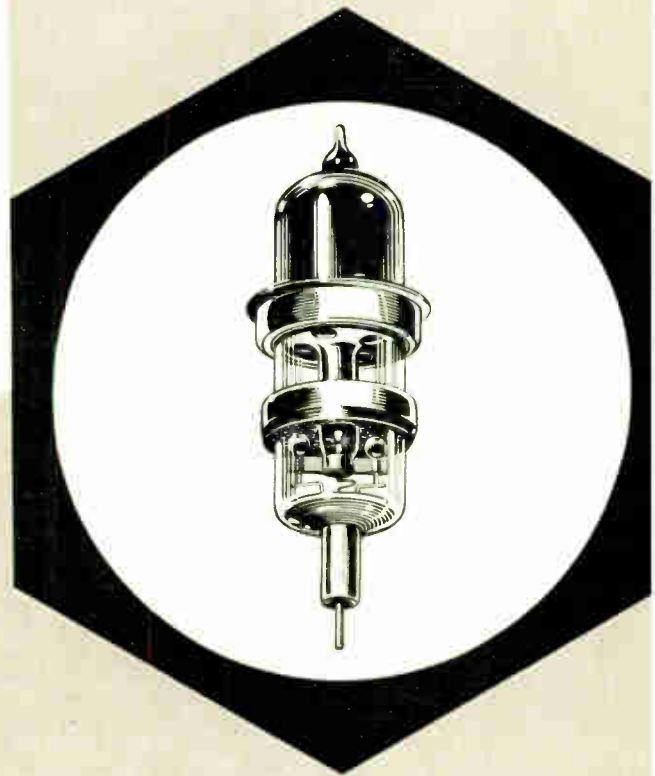

ROGERS

electronic tubes & components

A DIVISION OF PHILIPS ELECTRONICS INDUSTRIES LTD.
116 VANDERHOOF AVENUE, TORONTO, ONTARIO / BRANCHES: MONTREAL, WINNIPEG, VANCOUVER

★ Rogers Electronic Tubes are sold through Canada's Independent Electronic Parts Distributors

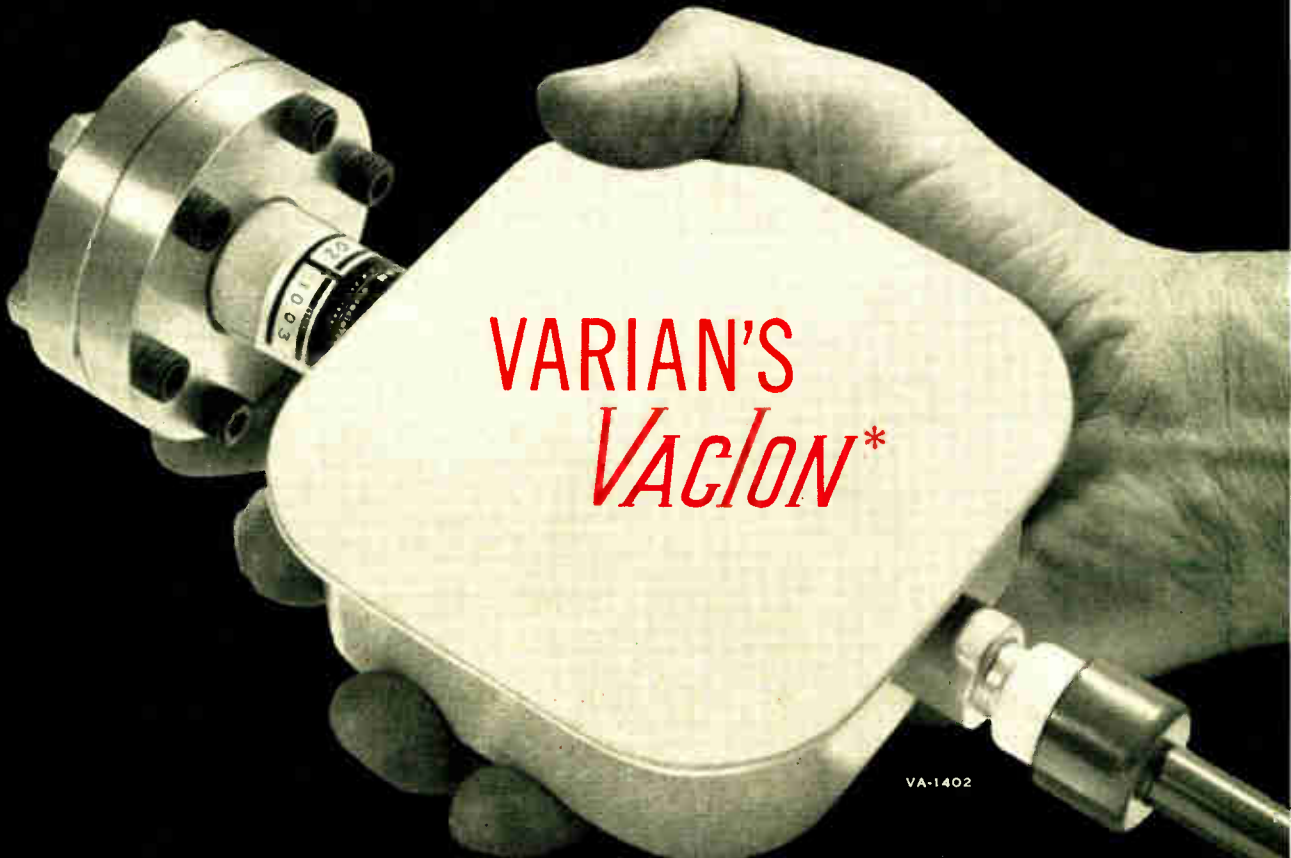

VARIAN'S
*VACLON**

VA-1402

A
COMPLETELY NEW HIGH VACUUM PUMP

*TRADE MARK

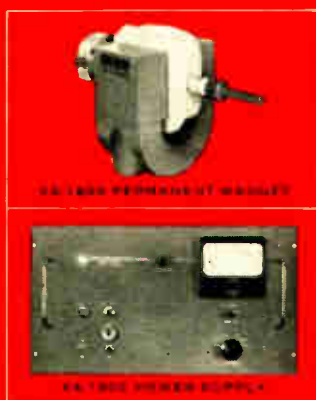

Used where clean high vacuums are required... processing vacuum tubes... evacuating accelerator sections and ionization chambers laboratory and industrial applications

SIMPLICITY ITSELF—

The Varian high vacuum pump operates entirely electronically — no moving parts.

NO OIL VAPORS—

Cold traps or vapor traps are not necessary.

ULTRA HIGH VACUUM—

Creates vacuum in excess of 1×10^{-7} mm of Hg, one trillionth of an atmosphere. This small compact unit has a pumping speed of 10 liters/second at 10^{-7} mm of Hg.

LOW POWER CONSUMPTION—

At 10^{-7} mm Hg power consumption is only 0.25 watts. No continuously running three-pump is required.

MEASURES ITS OWN VACUUM—

The current indication on the power supply meter provides a practical measurement of pressure.

SIMPLE INSTALLATION—

Complete unit consists of the VACLON Pump shown above, a permanent magnet, and a power supply.

ONLY FROM VARIAN—

The VACLON high vacuum pump has no equal for simplicity, cleanliness, and maintenance. Get the complete story in the VACLON High Vacuum Pump Engineering Bulletin — write for your copy today.

THE
MARK OF
LEADERSHIP



VARIAN associates

OF CANADA, LTD. • GEORGETOWN, ONTARIO

DIETZONS, TRAVELING WAVE TUBES, BACKWARD WAVE OSCILLATORS, LINEAR ACCELERATORS, MICROWAVE SYSTEM COMPONENTS, R. F. SPECTROMETERS, MAGNETS, MAGNETOMETERS, STACIS, POWER AMPLIFIERS, GRAPHIC RECORDERS, RESEARCH AND DEVELOPMENT SERVICES

For further data on advertised products use page 65.

INDEX TO ADVERTISERS

Page number is on the right. Key number for use with READER SERVICE CARDS is on the left.

Key No.		Page No.
1.	Adcola Products Ltd.	47
2.	Aerovox (Canada) Ltd.	50
3.	Alliance Motors	72
4.	Andrew Antenna Corp. Ltd.	50
5.	Automatic Electric Sales (Canada) Ltd.	37
6.	Automatic Electric Sales (Canada) Ltd.	38-39
7.	Automatic Electric Sales (Canada) Ltd.	40
8.	Aviation Electric Ltd.	7
9.	Bach-Simpson Ltd.	6
10.	Bell Telephone Co. of Canada, The	58
11.	Burndy Canada Ltd.	17
12.	Caledonia Electronics & Transformers Corp.	53
13.	Canadian Curtiss-Wright Ltd.	8
14.	Canadian Lister-Blackstone Ltd.	53
15.	Canadian Marconi Co.	3
16.	Canadian Marconi Co.	48
17.	Canadian Stackpole Ltd.	2
18.	Canadian Westinghouse Co. Ltd.	47
19.	Cannon Electric (Canada) Ltd.	13
20.	Central Bridge Co. Ltd.	74
21.	Centralab Canada Ltd.	57
22.	Computing Devices of Canada Ltd.	61
23.	Crane Packing Co. Ltd.	69
24.	Curry Bulmer Ltd.	72
25.	Daven Co., The	68
26.	Daystrom Ltd.	56
27.	Eitel-McCullough Inc.	67
28.	General Radio Co.	75
29.	Hackbusch Electronics Ltd.	51
30.	Helipot Corp.	60
31.	Helipot Corp.	75
32.	Hewlett-Packard Co.	10
33.	Instantaneous Recording Service	47
34.	Kester Solder Co. of Canada Ltd.	52
35.	Lake Engineering Co. Ltd.	68
36.	Lake Engineering Co. Ltd.	52
37.	Longstaffe Co. Ltd., J. R.	47
38.	Longstaffe Co. Ltd., J. R.	59
39.	Longstaffe Co. Ltd., J. R.	68
40.	Longstaffe Co. Ltd., J. R.	72
41.	Measurements Corp.	71
42.	Moloney Electric Co. of Canada Ltd.	68

(Continued overleaf)

Please ADD my name to the mailing list for **ELECTRONICS & COMMUNICATIONS** (no obligation).

My Name
(Please print)
Mail copies to my home, or business address as noted below.

Street
City Prov.

If you have recently **CHANGED** your address for receiving copies of **E & C** please note former address here:

Company Nature of Business

Signature Position
4-58 (For card to be valid it must be completed in full, including signature)

PLEASE SEND FURTHER INFORMATION ON THE FOLLOWING NEW PRODUCT ITEMS AS NUMBERED BELOW — USE PRODUCT ITEM NUMBERS

- | | | | | | | | | | |
|-------------------------------|-------------------------------|-------------------------------|-------------------------------|-------------------------------|-------------------------------|-------------------------------|-------------------------------|-------------------------------|-------------------------------|
| <input type="checkbox"/> 1913 | <input type="checkbox"/> 1914 | <input type="checkbox"/> 1915 | <input type="checkbox"/> 1916 | <input type="checkbox"/> 1917 | <input type="checkbox"/> 1918 | <input type="checkbox"/> 1919 | <input type="checkbox"/> 1920 | <input type="checkbox"/> 1921 | <input type="checkbox"/> 1922 |
| <input type="checkbox"/> 1923 | <input type="checkbox"/> 1924 | <input type="checkbox"/> 1925 | <input type="checkbox"/> 1926 | <input type="checkbox"/> 1927 | <input type="checkbox"/> 1928 | <input type="checkbox"/> 1929 | <input type="checkbox"/> 1930 | <input type="checkbox"/> 1931 | <input type="checkbox"/> 1932 |
| <input type="checkbox"/> 1933 | <input type="checkbox"/> 1934 | <input type="checkbox"/> 1935 | <input type="checkbox"/> 1936 | <input type="checkbox"/> 1937 | <input type="checkbox"/> 1938 | <input type="checkbox"/> 1939 | <input type="checkbox"/> 1940 | <input type="checkbox"/> 1941 | <input type="checkbox"/> 1942 |
| <input type="checkbox"/> 1943 | | | | | | | | | |

PLEASE SEND FURTHER INFORMATION ON THE FOLLOWING ADVERTISEMENTS AS NUMBERED BELOW — USE KEY NUMBER

- | | | | | | | | | | | | |
|-----------------------------|-----------------------------|-----------------------------|-----------------------------|-----------------------------|-----------------------------|-----------------------------|-----------------------------|-----------------------------|-----------------------------|-----------------------------|-----------------------------|
| <input type="checkbox"/> 1 | <input type="checkbox"/> 2 | <input type="checkbox"/> 3 | <input type="checkbox"/> 4 | <input type="checkbox"/> 5 | <input type="checkbox"/> 6 | <input type="checkbox"/> 7 | <input type="checkbox"/> 8 | <input type="checkbox"/> 9 | <input type="checkbox"/> 10 | <input type="checkbox"/> 11 | <input type="checkbox"/> 12 |
| <input type="checkbox"/> 13 | <input type="checkbox"/> 14 | <input type="checkbox"/> 15 | <input type="checkbox"/> 16 | <input type="checkbox"/> 17 | <input type="checkbox"/> 18 | <input type="checkbox"/> 19 | <input type="checkbox"/> 20 | <input type="checkbox"/> 21 | <input type="checkbox"/> 22 | <input type="checkbox"/> 23 | <input type="checkbox"/> 24 |
| <input type="checkbox"/> 25 | <input type="checkbox"/> 26 | <input type="checkbox"/> 27 | <input type="checkbox"/> 28 | <input type="checkbox"/> 29 | <input type="checkbox"/> 30 | <input type="checkbox"/> 31 | <input type="checkbox"/> 32 | <input type="checkbox"/> 33 | <input type="checkbox"/> 34 | <input type="checkbox"/> 35 | <input type="checkbox"/> 36 |
| <input type="checkbox"/> 37 | <input type="checkbox"/> 38 | <input type="checkbox"/> 39 | <input type="checkbox"/> 40 | <input type="checkbox"/> 41 | <input type="checkbox"/> 42 | <input type="checkbox"/> 43 | <input type="checkbox"/> 44 | <input type="checkbox"/> 45 | <input type="checkbox"/> 46 | <input type="checkbox"/> 47 | <input type="checkbox"/> 48 |
| <input type="checkbox"/> 49 | <input type="checkbox"/> 50 | <input type="checkbox"/> 51 | <input type="checkbox"/> 52 | <input type="checkbox"/> 53 | <input type="checkbox"/> 54 | <input type="checkbox"/> 55 | <input type="checkbox"/> 56 | <input type="checkbox"/> 57 | <input type="checkbox"/> 58 | <input type="checkbox"/> 59 | <input type="checkbox"/> 60 |

Name Position

Company Nature of Business

Company Address City Prov.
4-58

PLEASE SEND FURTHER INFORMATION ON THE FOLLOWING NEW PRODUCT ITEMS AS NUMBERED BELOW — USE PRODUCT ITEM NUMBERS

- | | | | | | | | | | |
|-------------------------------|-------------------------------|-------------------------------|-------------------------------|-------------------------------|-------------------------------|-------------------------------|-------------------------------|-------------------------------|-------------------------------|
| <input type="checkbox"/> 1913 | <input type="checkbox"/> 1914 | <input type="checkbox"/> 1915 | <input type="checkbox"/> 1916 | <input type="checkbox"/> 1917 | <input type="checkbox"/> 1918 | <input type="checkbox"/> 1919 | <input type="checkbox"/> 1920 | <input type="checkbox"/> 1921 | <input type="checkbox"/> 1922 |
| <input type="checkbox"/> 1923 | <input type="checkbox"/> 1924 | <input type="checkbox"/> 1925 | <input type="checkbox"/> 1926 | <input type="checkbox"/> 1927 | <input type="checkbox"/> 1928 | <input type="checkbox"/> 1929 | <input type="checkbox"/> 1930 | <input type="checkbox"/> 1931 | <input type="checkbox"/> 1932 |
| <input type="checkbox"/> 1933 | <input type="checkbox"/> 1934 | <input type="checkbox"/> 1935 | <input type="checkbox"/> 1936 | <input type="checkbox"/> 1937 | <input type="checkbox"/> 1938 | <input type="checkbox"/> 1939 | <input type="checkbox"/> 1940 | <input type="checkbox"/> 1941 | <input type="checkbox"/> 1942 |
| <input type="checkbox"/> 1943 | | | | | | | | | |

PLEASE SEND FURTHER INFORMATION ON THE FOLLOWING ADVERTISEMENTS AS NUMBERED BELOW — USE KEY NUMBER

- | | | | | | | | | | | | |
|-----------------------------|-----------------------------|-----------------------------|-----------------------------|-----------------------------|-----------------------------|-----------------------------|-----------------------------|-----------------------------|-----------------------------|-----------------------------|-----------------------------|
| <input type="checkbox"/> 1 | <input type="checkbox"/> 2 | <input type="checkbox"/> 3 | <input type="checkbox"/> 4 | <input type="checkbox"/> 5 | <input type="checkbox"/> 6 | <input type="checkbox"/> 7 | <input type="checkbox"/> 8 | <input type="checkbox"/> 9 | <input type="checkbox"/> 10 | <input type="checkbox"/> 11 | <input type="checkbox"/> 12 |
| <input type="checkbox"/> 13 | <input type="checkbox"/> 14 | <input type="checkbox"/> 15 | <input type="checkbox"/> 16 | <input type="checkbox"/> 17 | <input type="checkbox"/> 18 | <input type="checkbox"/> 19 | <input type="checkbox"/> 20 | <input type="checkbox"/> 21 | <input type="checkbox"/> 22 | <input type="checkbox"/> 23 | <input type="checkbox"/> 24 |
| <input type="checkbox"/> 25 | <input type="checkbox"/> 26 | <input type="checkbox"/> 27 | <input type="checkbox"/> 28 | <input type="checkbox"/> 29 | <input type="checkbox"/> 30 | <input type="checkbox"/> 31 | <input type="checkbox"/> 32 | <input type="checkbox"/> 33 | <input type="checkbox"/> 34 | <input type="checkbox"/> 35 | <input type="checkbox"/> 36 |
| <input type="checkbox"/> 37 | <input type="checkbox"/> 38 | <input type="checkbox"/> 39 | <input type="checkbox"/> 40 | <input type="checkbox"/> 41 | <input type="checkbox"/> 42 | <input type="checkbox"/> 43 | <input type="checkbox"/> 44 | <input type="checkbox"/> 45 | <input type="checkbox"/> 46 | <input type="checkbox"/> 47 | <input type="checkbox"/> 48 |
| <input type="checkbox"/> 49 | <input type="checkbox"/> 50 | <input type="checkbox"/> 51 | <input type="checkbox"/> 52 | <input type="checkbox"/> 53 | <input type="checkbox"/> 54 | <input type="checkbox"/> 55 | <input type="checkbox"/> 56 | <input type="checkbox"/> 57 | <input type="checkbox"/> 58 | <input type="checkbox"/> 59 | <input type="checkbox"/> 60 |

Name Position

Company Nature of Business

Street City Prov.
4-58

BUSINESS REPLY CARD
No Postage Stamp Necessary if Mailed in Canada

5c POSTAGE WILL BE PAID BY

ELECTRONICS AND COMMUNICATIONS

31 - 35 Willcocks Street

Toronto 5, Ontario



BUSINESS REPLY CARD
No Postage Stamp Necessary if Mailed in Canada

5c POSTAGE WILL BE PAID BY

ELECTRONICS AND COMMUNICATIONS

31 - 35 Willcocks Street

Toronto 5, Ontario



BUSINESS REPLY CARD
No Postage Stamp Necessary if Mailed in Canada

5c POSTAGE WILL BE PAID BY

ELECTRONICS AND COMMUNICATIONS

31 - 35 Willcocks Street

Toronto 5, Ontario



INDEX TO ADVERTISERS

(Continued)

Key No.	Advertiser	Page No.
43.	Muirhead & Co. Ltd.	54
44.	Nichols Ltd., R. H.	49
45.	Ohmite Manufacturing Co.	4
47.	Porter Co. (Canada) Ltd., H. K.	73
48.	Prodelin Inc.	70
49.	Pylon Electronic Development Co. Ltd.	47
50.	Radio Communications Equipment & Engineering Ltd.	16
51.	Rogers Majestic Electronics Ltd.	63
52.	Stanwyck Coil Products Ltd.	51
53.	Stark Electronic Instruments Ltd.	59
54.	Syntron (Canada) Ltd.	62
55.	Telephone Mfg. Co. Ltd.	55
56.	Varian Associates of Canada Ltd.	64
57.	Ward Leonard of Canada Ltd.	55
58.	Welwyn Canada Ltd.	71

ACTIVE CIRCULATION

It costs us a lot of active dollars annually to keep our circulation lists up-to-date and it's important enough to us that we have them audited every year by CCAB (Canadian Circulations Audit Board Inc.)

Advertisers trust CCAB audited figures so we get more advertisers and YOU get the high standard of editorial you have always wanted to read.

ELECTRONICS and COMMUNICATIONS

is a



audited publication

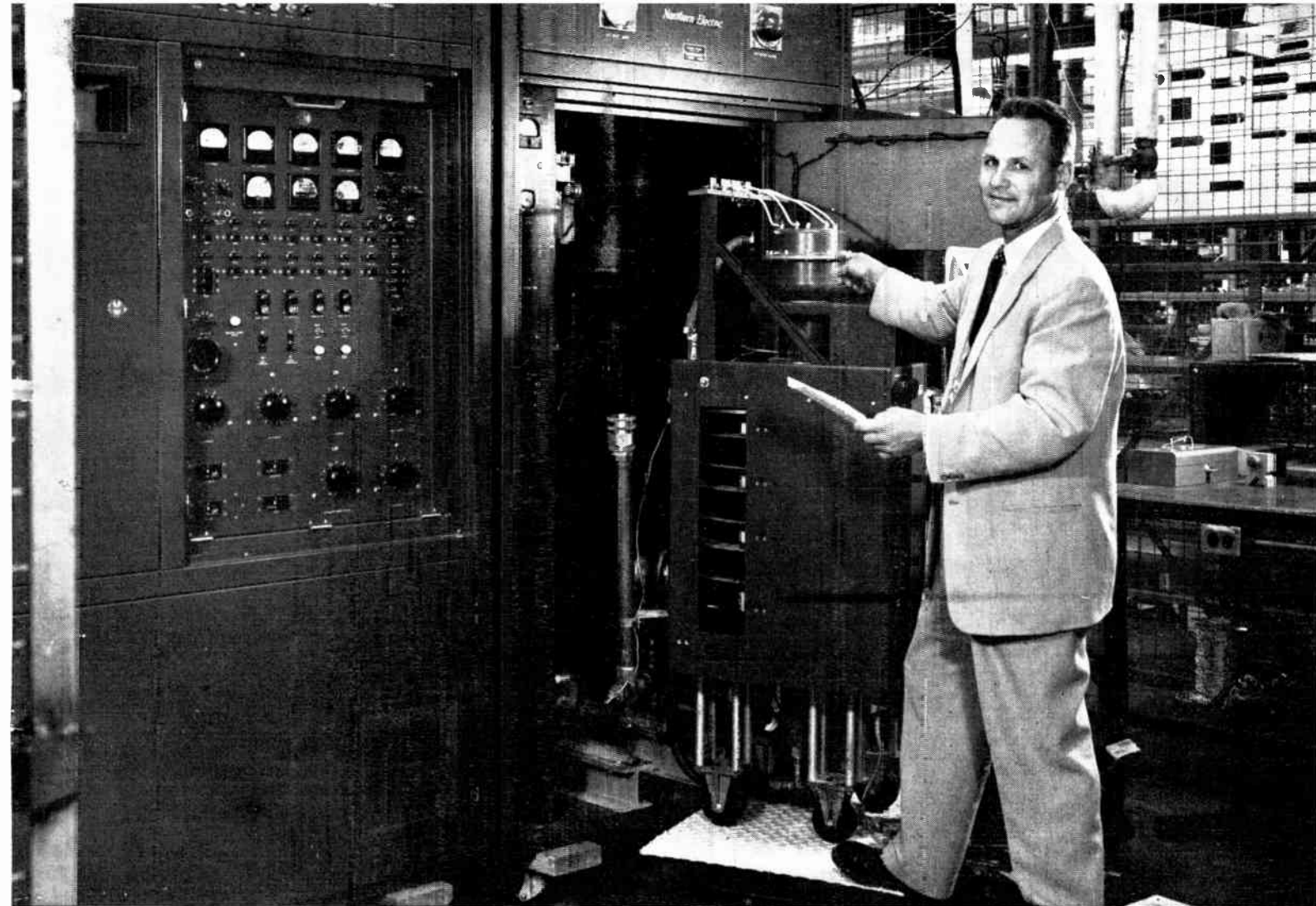

Final amplifier of Northern Electric Company, Type R20004A Telorizon transmitter showing Eimac high power klystron installed.

Northern Electric Uses Eimac Klystrons In their new **"TELORIZON"** COMMERCIAL TROPOSCATTER EQUIPMENT

Northern Electric Company, Ltd., has announced new 2 kw and 10 kw "Telorizon" tropospheric scatter equipment for commercial application. This equipment was evolved from Northern Electric Company's military scatter transmitters developed and manufactured under licence from Radio Engineering Laboratories which are now "on-the-air" over 2,500 miles of rugged Canadian terrain. A typical span is in excess of 200 miles with 18 voice channels and more than

99% reliability. Shorter spans having capacities up to 132 voice channels are also in use.

When developing "Telorizon" equipment for commercial use, Northern Electric Company engineers again selected Eimac klystrons as final amplifier power tubes just as they did for their military equipment. So today, *all* Northern Electric Tropospheric communication transmitters use Eimac klystrons.



Eimac First for high power amplifier klystrons

EITEL-McCULLOUGH INC.

SAN BRUNO

The World's Largest Manufacturer of Transmitting Tubes

CALIFORNIA

5710

Canadian Representative: R. D. B. SHEPPARD, 2036 Prince Charles Road, Ottawa 3, Canada

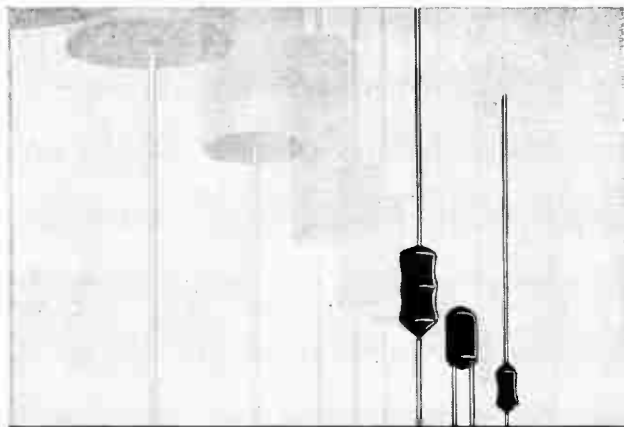

The INCREDIBLE SHRINKING RESISTOR

Daven has always been the leader in the miniaturization of precision wire wound resistors. Now, due to further advances in resistor manufacture, Daven is able to offer higher resistance values in smaller sizes than ever before.

For guided missiles, airborne radar, telemetering, and for any application where extremely small size and dependability are of prime importance, specify Daven miniature wire wounds.



THE **DAVEN** CO.
LIVINGSTON, NEW JERSEY

WORLD'S LARGEST MANUFACTURER OF ATTENUATORS
In Canada: ADAMS ENGINEERING LTD., Montreal and Toronto

the NEW High Brightness Neon Glow Lamp NE-51H

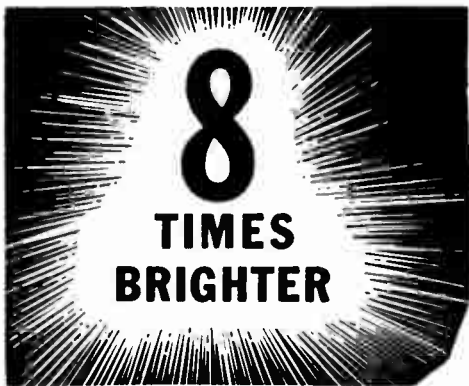

This lamp may be operated at about 3 times the level of current that may be applied to the standard lamp, and it will produce 8 times as much light — with long life!

For prompt delivery on this and other Neon Glow Lamps contact us.

Lake Engineering Co. Ltd.

767 WARDEN AVE SCARBOROUGH, ONT.
PLYMOUTH 7-3253

MOLONEY

Specialists in transformers

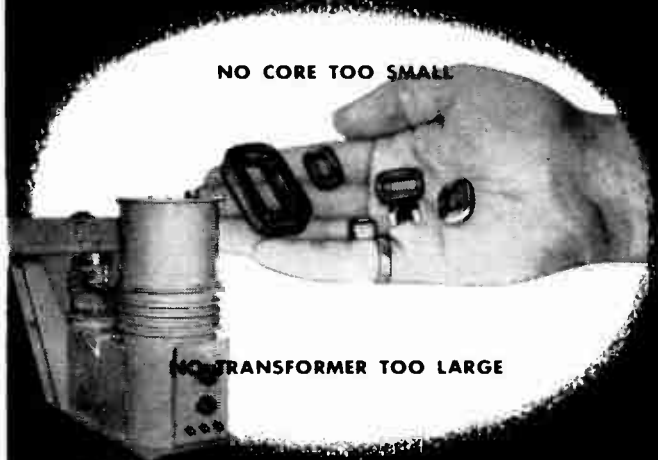

For larger and higher voltage electronic components, consult MOLONEY

MOLONEY
ELECTRIC COMPANY OF CANADA LIMITED
FACTORY & HEAD OFFICE 213-219 STERLING RD., TORONTO
REGIONAL OFFICES: MONTREAL, CALGARY

Sales agents across Canada

5804

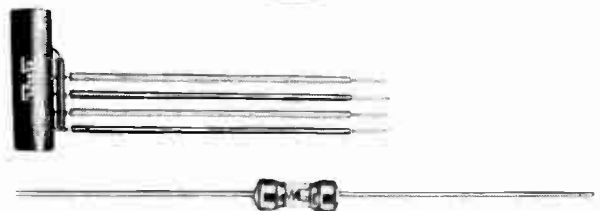

WHAT DO YOU WANT IN SELENIUM RECTIFIERS AND DIODES?

Variety?	Miniature Size?	Highest Grade?
Dependability?	Uniformity?	Moisture-Proof?
Life-Long Performance?	No Noise?	

With IRC Microstak standard and hermetically-sealed units you have all of these and more.

For complete characteristics and sizes available write to Dept. 8 for Bulletin SR-1A

INTERNATIONAL RESISTANCE CO. LTD.

349 CARLAW AVE. TORONTO 8, ONT.

Radiovision Sales Ltd.
325 Tenth Ave. West
Calgary, Alta.

SALES OFFICES:
492 Somerset St. West
Ottawa
Ont.

1500 St. Catherine St. West
Montreal
Que.

News Report

CGE Radio Transmitter Destined For Venezuela

A 50 KW AM radio broadcast transmitter, designed and manufactured at Canadian General Electric Company's Royce plant in Toronto, Ontario, has been sold to Radio Caracas, the government-owned radio station in Venezuela. The new transmitter is scheduled to arrive in Caracas next May. Tests will be conducted during June and the transmitter is due to go into operation in July.

CGE officials claim this 50 KW AM radio broadcast transmitter to be one of the most significant developments in the broadcast industry since the early days of radio. A team of engineers was appointed to design a transmitter utilizing the most modern components. As a result, the new transmitter is almost one-half the size of former 50 KW power equipment. While the standard transmitter is some 28 feet long, the new one is only 13½ feet long.

By using germanium rectifiers, tube requirements have been reduced from the 40 or 50 in present-day transmitters to only 16 in the new one. Weight of the final amplifier tube has been reduced from 225 pounds to 20 pounds.

Because of its simplicity, the transmitter requires much less technical skill for its operation and maintenance.

CALDWELL APPOINTMENT



R. L. HARWOOD

• The appointment of R. L. "Bob" Harwood, as Sales Representative at the Montreal office of S. W. Caldwell Ltd. has been announced. Born and educated in Montreal, Mr. Harwood has had extensive sales experience in TV film and allied fields. As assistant to "Bud" DeBow, manager of Caldwell's Montreal office, Mr. Harwood will handle sales-service activities for TV films, radio transcriptions and audio-visual equipment. Mr. Harwood spent a week in Toronto recently to familiarize himself with the various Caldwell divisions.

TEFLON*

PARTS OR MATERIALS
FOR UHF APPLICATION?

FOR MINIATURE AND
SUB-MINIATURE COMPONENTS?

YOU CAN GET JUST WHAT YOU WANT

from

JOHN CRANE

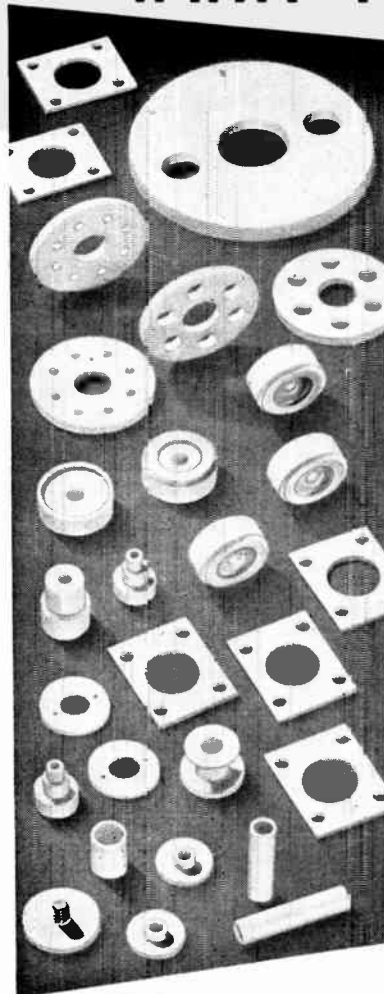

FOR: insulators of all types, sleeves or inserts, capacitor seals, feed through insulators, bushings, slot liners, coaxial spacers, layer insulation or any other parts or forms subject to high charge, extended frequency range, mechanical and thermal shock, extreme temperatures and climatic conditions.

You can order in any quantity and be sure of true Teflon performance, because "John Crane" gives you these *plus* factors: complete uniformity throughout, high density control, freedom from flaws and rigid adherence to your specifications.

"John Crane's" complete fabrication facilities assure you prompt delivery on *exactly* what you want. If you have an entirely new requirement, no standard design or procedure—"John Crane's" laboratory facilities, know how, research and engineering experience go to work on *your particular need*.

Now is a good time to put "John Crane" to test. Contact Crane Packing Company today.

* **TEFLON** DuPont trademark

Dielectric Strength: 480 v/mil.
Dielectric Constant (60 to 10⁸ cycles): 2.0
Power Factor (60 to 10⁸ cycles): <0.0005
Volume Resistivity: 10¹⁵ ohm-cm
Surface Resistivity: 3.6x10⁶ megohms
Surface Arc-Resistance: does not track
Temperature Range: -450° to +500°F.
Chemical Resistance: completely inert
Moisture Absorption: zero

Crane Packing Co.,
Ltd., 627 Parkdale
Ave. N., Hamilton,
Ontario.



JOHN CRANE

CRANE PACKING COMPANY

38 YEARS
INDUSTRIAL PROGRESS

OFFICES IN ALL PRINCIPAL CITIES

NEW All-American!

Spir-O-line®

SEMI-FLEXIBLE ALUMINUM TRANSMISSION LINE

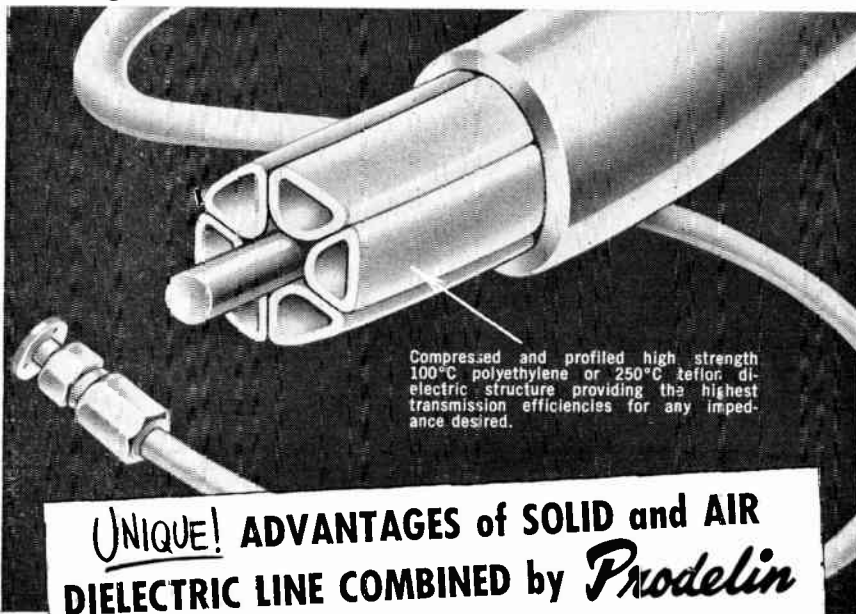

Compressed and profiled high strength 100°C polyethylene or 250°C teflon dielectric structure providing the highest transmission efficiencies for any impedance desired.

UNIQUE! ADVANTAGES of SOLID and AIR DIELECTRIC LINE COMBINED by Prodelin
in revolutionary All-Aluminum Cable and Connector

Spir-O-line® — Prodelin's latest contribution to air-dielectric transmission — combines the low loss of air dielectric with the high power of solid dielectric lines by using dielectric tubes compressed and profiled into a symmetrical supporting structure. *Spir-O-line* is available in continuous lengths up to 1000' with reliably low VSWR and 50, 70, 75 ohm, and other impedances; the 50 ohm line usable up to these cut-off frequencies: $\frac{3}{8}$ " - 15.0 Kmc; $\frac{1}{2}$ " - 10.0 Kmc; $\frac{7}{8}$ " - 5.0 Kmc; $1\frac{1}{8}$ " - 2.8 Kmc; $3\frac{1}{8}$ " - 1.5 Kmc. The normally non-corroding aluminum-alloy outer conductor is available with a non-contaminating polyethylene jacket for caustic environments.

FEATURES

- No special techniques or tools required to make up cable-connector assembly
- No metallic welds or dielectric splices are used regardless of cable length
- Continuous high-conductivity aluminum sheath assures maximum pressure tightness and weather protection
- Uniform straight lay tubular support throughout keeps inner conductor smoothly centered on bends
- Pressure-tight and high tensile cable-connector assembly can be made with only hand-tightening
- Dielectric structure makes continuous and intimate line contact with both conductors without spiraling — yielding best broadband performance, highest power handling capacity, lowest attenuations, and VSWR smoothness
- Both cable and connector available for -90° C to +250° C operation
- Terminates in standard EIA (RETMA) dimensions



PLUS

Spir-O-line Connector

Amazing Prodelin development! Adequately pressure-tight for lab use when hand-tightened... ready for field service when wrench-tightened. Specifically designed for use with soft aluminum tubing to provide highest tensile strengths without tube distortion. No special techniques, bulky fixtures, or non-standard tools required. May be used again and again without redressing tubing or replacing connector parts! Saves time and money! RETMA dimensioned.

Specify Spir-O-line HI-TEMP with Teflon for 250°C operation



Reconsider your cable requirements now and ask how Spir-O-line can provide new life with added economies in your service! WRITE FOR TECHNICAL BULLETIN TODAY

Dept. EC, 307 Bergen Ave., Kearny, N.J.

*PATENTS PENDING

News Report

Kearfott Representation In Canada

Canadian Applied Research Limited, of 1500 O'Connor Drive, Toronto, announces that it has completed arrangements to act as exclusive Canadian distributor for Kearfott products. Kearfott Co. Inc., of Little Falls, New Jersey, is one of the largest designers and manufacturers of technical components and systems in the United States. The arrangement is a result of the announcement made last September linking General Precision Equipment Corporation and A. V. Roe Canada Limited, the respective parent companies of Kearfott and Applied Research.

Under the new agreement Applied Research plans to continue the present excellent customer relations built up in Canada by Kearfott, while expanding and improving the service on their products for the rapidly growing Canadian electronics, instrumentation and aviation industries.

B.C. Telephone Co. Elects

Successor To Retiring President

Gordon Farrell, president of the British Columbia Telephone Company for 30 years, retired from that post on March 13, 1958. His successor is Cyrus H. McLean, former official and currently a director of the company, who has held telephone executive positions on this continent and in



C. H. McLEAN

other parts of the world.

The change in the presidency took place at the meeting of directors following the annual meeting of the company.

Mr. Farrell was named chairman of the board, succeeding Frank S. Spring, who continues as a director.

Mr. McLean, in addition to becoming president of the B.C. Telephone Company also replaces Mr. Farrell as president of the North-west Telephone Company, an associate of the previously mentioned company.

When the North-west Telephone Company was created to establish a radiotelephone system on the coast because the B.C. Telephone Company did not at that time have the authority to do so, Mr. McLean was named radio engineer of the new company as well as continuing in his post with the B.C. Telephone Company which he had joined in 1916. He pioneered commercial radiotelephone service on the B.C. coast for ships and land points, this being the first application of radio for telephone use on the continent.

News Report

Age Publications To Occupy New Premises

To meet the needs of much expanded operations during the past five years—AGE PUBLICATIONS LIMITED, publishers of Industrial and Technical publications, 31 Willcocks Street, are moving to new larger plant and offices on Alliance Avenue, South of Eglinton Avenue West and East off Jane Street. The new offices and plant with floor space of around 30,000 feet and with new equipment and presses, will be ready for occupancy, it is expected, around the first of July this year.

Westinghouse President Honored By Brooklyn Polytechnic Institute

George L. Wilcox, president of Canadian Westinghouse Company, Limited, Hamilton, Ontario has been elected to the Board of Trustees of the Polytechnic Institute of Brooklyn, according to a recent announcement by Preston R. Bassett, chairman.

Mr. Wilcox received the degree of bachelor of electrical engineering from the Polytechnic in 1939 after studying for eight years in the Insti-

tute's evening session. During this period he worked for the New York Edison Company as wireman, installer, electrical mechanic and engineer.

He joined Westinghouse Electric and Manufacturing Company in 1942 and held various positions in sales, plant management and foreign operations. In 1955 he was named president of Canadian Westinghouse Company Limited.

Mr. Wilcox is governor of McMaster University, Hamilton, Ontario; a director of the Toronto-Dominion Bank, Toronto; and a director of the Polytechnic Research and Development Company.

Canadian-Made Equipment Selected By U.S.A.F.

Airborne mapping equipment, designed and built in Canada, has been chosen to assist a new program of the U.S. Air Force in bringing the world's geography up to date.

This news came recently with the announcement by Canadian Applied Research Limited, O'Connor Drive, Toronto, that its MK5 Airborne Profile Recorder had been installed in specially designed Lockheed prop-jet aircraft for a giant U.S. Air Force mapping project.

The Airborne Profile Recorder, designed and built in Canada by CARL,

is an improved precision radar designed for air survey work and measures and records the rise and fall of land the aircraft is flying over. It is capable of measuring topography from 1,000 to 35,000 feet with a high degree of accuracy. It provides two records simultaneously on a paper chart recorder. One record gives the height of the terrain beneath the aircraft in reference to sea level. The other gives the distance between the aircraft and the ground.

Tax-Saving By Hugh B. Savage, C.A.

"Tax-Saving", 2nd Edition, just published, provides a hundred or more tax saving slants accumulated from scores of tax men. Any one of these approaches may pay off a hundredfold and more.

This 2nd edition has been greatly expanded and thoroughly revised and, in common with the too few published authorities, will reward without fail the most or the least experienced tax man; lawyer, accountant, business executive and bookkeeper. Order enough copies of Tax-Saving, 2nd Edition to equip each member of your staff concerned with taxes. Single copies \$4.00; 10 copy lots \$3.50 each; 20 copy lots \$3.00 each. Write Kingsland Publications, P.O. Box 337, Station L, Montreal 6, P.Q.

MEASUREMENTS' UHF

STANDARD SIGNAL GENERATOR
400 Mc to 1000 Mc



MODEL 84-TVR

FEATURES

- Accurately calibrated mutual inductance type attenuator
- 0.1 microvolt to 0.5 volt output
- Negligible stray field and leakage
- Low residual AM and FM

WRITE FOR BULLETIN

Laboratory Standards



MEASUREMENTS
A McGraw-Edison Division
BOONTON, NEW JERSEY

Canadian Representative:
H. Roy Gray Ltd., 46 Danforth Rd., Toronto

WELWYN

*Hermetically Sealed
Deposited Carbon Resistors*

WELWYN
CANADA
S12 1%
WELWYN

High stability resistors sealed into glazed and vitrified ceramic shells for complete protection against ambient humidity changes. Silicone oil filled. Acts as efficient convective medium for improved heat dissipation. Also serves as infallible quality control for detecting seal leakage defects.

Each resistor is subjected to sustained pre-load test at 1½ times rated wattage. Insures against catastrophic failures under normal operating conditions.

Designed to meet military specifications.
MIL-R-10509 (current issue)

for complete data, write to:

WELWYN CANADA LTD.

1255 BRYDGES ST.

LONDON, ONT.



Tele-Radio Systems Appointed As Canadian Rep

The Budelman Radio Corporation of Stamford, Connecticut, has recently announced the appointment of Tele-Radio Systems Ltd. as its exclusive representative for Canada.

Budelman telephone line carrier and point-to-point 450 and 960 mc. radio links are well-known to Canadian customers, and several new products are scheduled for introduction to the Canadian market in the near future.

Ivor H. Nixon, president of Tele-Radio Systems Limited, has announced the incorporation of his company and the opening of new offices at 3534

Dundas Street West, Toronto 9, Ont.

Sales manager of the new company is John A. Fellows, formerly manager of the telephone equipment division of Pye Canada Limited. Mr. Fellows will be responsible for liaison with the independent telephone companies, a market with which he is thoroughly familiar.

Donald G. Fink Elected 1958 President For American I.R.E.

Succeeding Dr. John T. Henderson as president of the Institute of Radio Engineers for the year 1958 is Donald G. Fink, who is director of research for the Philco Corporation.

Airtron

SPECIAL BROAD BAND FERRITE ISOLATORS FOR TEST EQUIPMENT APPLICATIONS

FEATURES



- extremely broad band characteristics permit operation over entire frequency range of waveguide
- high degree of isolation
- extends life of R.F. source
- enables optimum stability of test equipment and measurements during test
- magnets carefully stabilized and potted with epoxy resin for maximum resistance to thermal or magnetic shock
- simple inline construction
- extremely long life
- unit may be pressurized
- size .360 x .220 (O.D.) to 3.00 x 1.50 (O.D.)

For more information write to
Dept. 6 for bulletin 3590

Airtron CANADA LIMITED
300 CAMPBELL AVE., TORONTO

DIRECTORY CORRECTION

On page 98 of the 1958 Directory and Buyers' Guide of Electronics and Communications, an error occurred in the recording of the proper title of Texas Instruments Incorporated under the section "American Electronics Manufacturers And Suppliers". The name was inadvertently shown as Texas Instronics Inc., whereas it should have read:

Texas Instruments Incorporated, 6000 Lemmon Ave., Dallas 9, Texas. Represented by: Earl F. Johnson, Texas Instruments Incorporated, Semiconductor-Components Division, 53 Queen St., Ottawa 7, Ontario.

The correction of this company's name also extends to the listings under the caption of "Buyers' Guide of Electronic Equipment and Components", pages 34 to 68 inclusive of the Directory Issue.

HEADQUARTERS FOR

**JOHNSON MOTORS
PETERBOROUGH BOATS
MARINE HARDWARE
BOATING ACCESSORIES
WATER SPORTS EQUIPMENT**

CURREY BULMER Ltd.

2919 BATHURST ST., TORONTO

OPEN EVENINGS

GOOD PARKING



SMALL MOTORS? That's a job for

ALLIANCE

They specialize in small motors of all types . . . and in special applications and variations. Alliance Motors are also Canadian engineering representatives for Howard Industries Inc. of Racine, Wis., leading manufacturers of small motors.

Bring your small motor problems and requirements to

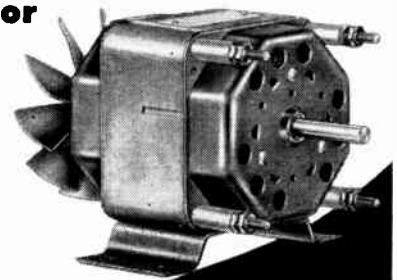

ALLIANCE MOTORS • SCHELL AVE • TORONTO (10) ONT. RE 6124

For further data on advertised products use page 65.

TEFLON* INSULATED

FEDERAL'S NEW HIGH TEMPERATURE HOOK-UP WIRE

CONSTRUCTION—

Federal's Teflon insulated hook-up wire has a silver coated copper conductor, insulated with an extruded wall of Teflon tetrafluoroethylene resin having an extremely uniform diameter. Where necessary, an overall Teflon enamelled glass braid and/or shield may be supplied.

Teflon insulated hook-up wire meets the requirements of military specifications MIL-W-16878 for types E and EE, rated at 600 and 1000 volts respectively, and MIL-W-7139 for type RM, rated at 600 volts. Supplied in 10 standard solid colours and up to 3 spiral stripes for circuit identification.



HEAT RESISTANCE—Teflon is suitable for continuous service at temperatures from 90° to 250°C. A hot soldering iron in contact with Teflon insulation will not damage it—particularly important where space is limited. As well as withstanding high ambient temperatures, Teflon also permits higher operating temperatures, making possible reduced conductor size with a saving in space and weight.

ELECTRICAL PROPERTIES—Teflon's low power factor, low dielectric constant, high volume and surface resistivity and good dielectric strength are all constant over a wide range of frequencies and temperatures.

CHEMICAL INERTNESS—Wherever there is danger of exposure to solvents or chemicals Teflon in many instances affords the only complete protection. Of all the chemicals encountered in commercial practice, only molten alkali metals and fluorine at elevated temperatures and pressures show any sign of attack on Teflon.

LOW COEFFICIENT OF FRICTION—Teflon has an exceptionally slippery surface—ideal when passing leads through sleeves or similar confined spaces.

Federal's Teflon insulated wire opens the door to new and improved design. Let us know *your* requirements now.

* DuPont registered Trade-Mark

5827

GUELPH, ONTARIO • St. John's Nfld. • Truro • Montreal • Toronto • Winnipeg • Regina • Saskatoon • Calgary • Edmonton • Vancouver

H. K. PORTER COMPANY (CANADA) LTD.

FEDERAL WIRE AND CABLE DIVISION

Divisions of H. K. Porter Company, Inc.: Connors Steel, Delta-Star Electric, Disston, Forge and Fittings, Leschen Wire Rope, Quaker Rubber, Refractories, Riverside-Alloy Metal, Vulcan-Kidd Steel. In Canada: H. K. Porter Company (Canada) Ltd., Disston, Federal Wire and Cable.

Ultra-Miniature Low Cost Capacitors for Transistor Circuits

Centralab[®]

ULTRA-KAP*

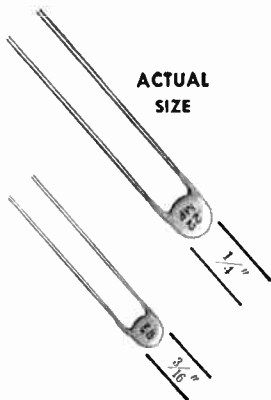
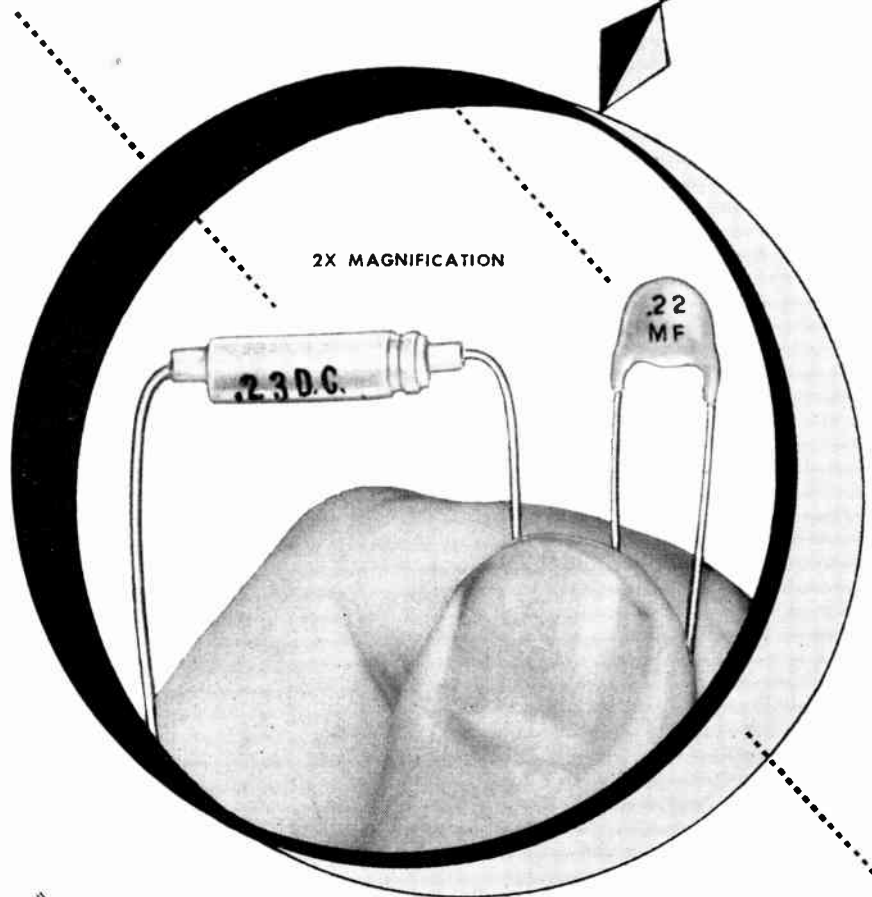

... with performance characteristics that equal or exceed much larger or more costly components. Excellent temperature stability: plus or minus 25% from 10° to 85° C. Extremely low power factor. Working voltage, 3 VDC. GMV tolerances. Maximum thickness, 0.156".

TYPICAL SIZES

.10 mfd	$\frac{3}{16}$ " diameter
.22 mfd	$\frac{1}{4}$ " diameter
.47 mfd	$\frac{3}{8}$ " diameter
1.0 mfd	$\frac{9}{16}$ " diameter
2.2 mfd	$\frac{3}{4}$ " diameter

For detailed information write for Engineering Bulletin EP-87 or contact your local Centralab sales representative.

D-5812



Centralab Canada Ltd. 804 MT. PLEASANT ROAD
TORONTO 12, ONTARIO
Affiliated: CENTRALAB • MILWAUKEE 1, WISCONSIN
VARIABLE RESISTORS • SWITCHES • PACKAGED ELECTRONIC CIRCUITS
CERAMIC CAPACITORS • ENGINEERED CERAMICS • SEMI-CONDUCTOR PRODUCTS

TECHNICAL PERSONNEL AVAILABLE

MANAGER. P.Eng., age 39. Bus. Adm. Graduate. Available for responsible position in general management or marketing. Background: Communications, Automotive Batteries, Electrical Appliances, Industrial Electronics. Experience: Production Engineer, Product Sales Manager, Administrative Assistant, Marketing Manager, Commercial Research Manager-Market Research and Industrial Development. Reply to Box 518, Electronics and Communications.

ELECTRONIC ENGINEER: age 40, sixteen years of experience in development of transmitters, pulse circuitry, installations, several years in supervisory and administrative position in charge of technical, product design and production units. Estimates, schedules, budgets, hiring and customer liaison experience. Salary \$9000 to \$10,000. Reply to Box 519, Electronics and Communications.

ELECTRONIC TECHNICIAN — age 26. Received from the Ryerson Institute of Technology an Electronic Engineering Technicians diploma on completion of three-year course. Has had experience in field of Geophysics in Edmonton, Alberta, where duties involved the completion of Gamma-Ray and Neutron Logs on semi-completed oil wells. Also worked with Toronto firm in field of Aeronautics, servicing and testing the Altitude Controller and the Airspeed Compensator for the Auto-Pilot system of the CF-100 fighter aircraft. Reply to Box 520, Electronics and Communications.

ELECTRONIC ENGINEER — member IRE, versed in radar, radio and telephone communications, systems facilities, in development, installation and maintenance, sales, supervisory-managerial phases. Especially strong in field or application work. Security clearance up to secret. Desires responsible, challenging position with progressive firm. Reply to Box 521, Electronics and Communications.

INDUSTRIAL EDITOR and WRITER: age 43, ten years as editor of production management and chemical magazines, plus a year and a half as advertising manager of electrical manufacturer. Personal interest tends toward public and industrial relations, B.A. (mainly in science), (R.C.A.F. as navigator). Reply to Box 522, Electronics and Communications.

ADVERTISING AND SALES Promotion Manager, age 25; experience in industrial and consumer advertising, marketing, sales promotion and merchandising. Capable of handling entire department. Experience extends to radio and TV, also conventions, sales meetings, public relations, catalogue preparation and agency liaison. Familiar with Communications, Telephone, Television, Scientific Instruments and Domestic Products. Ryerson graduate. Reply to Box 523, Electronics and Communications.

For further data on advertised products use page 65.

A pot you can bet on

When you're playing with a hot system and the stakes are high . . . raise!

Raise as high as 150° C . . . and HELIPOT® series 5000 precision potentiometers will still operate continuously with 1 watt dissipation.

Although it's only 1/2 inch in diameter and weighs but 0.3 ounce, on this pot you can bet the limit. You'll hold the winning hand with these five high cards off the top of the Helipot deck:

- stainless steel construction
- excellent linearity ($\pm 0.25\%$ best practical, $\pm 0.5\%$ standard)
- 500 to 100,000 ohms standard resistance range
- one-piece housing
- all-metal card for uniform heat dissipation

When the chips are down, these three standard models will strengthen your hand: the bushing-mount precision 5001, the servo-mount precision 5002, the trimming-type 5016.

There's a house full of specs the series 5000 meets or beats: JAN-R-19(7), MIL-E-5272A, NAS-710, MIL-R-12934A, MIL-E-5400, MIL-R-19518, MIL Std 202.

The straight inside story on the new series 5000 is available in data file 12E.

*Helipot Corporation, Newport Beach, California
a division of Beckman Instruments, Inc.
Engineering representatives in principal cities
Canadian Factory: No. 3 Six Points Road, Toronto 18, Ontario
Sales Representative: R-O-R Associates, Ltd.
1470 Don Mills Road, Don Mills, Ontario*



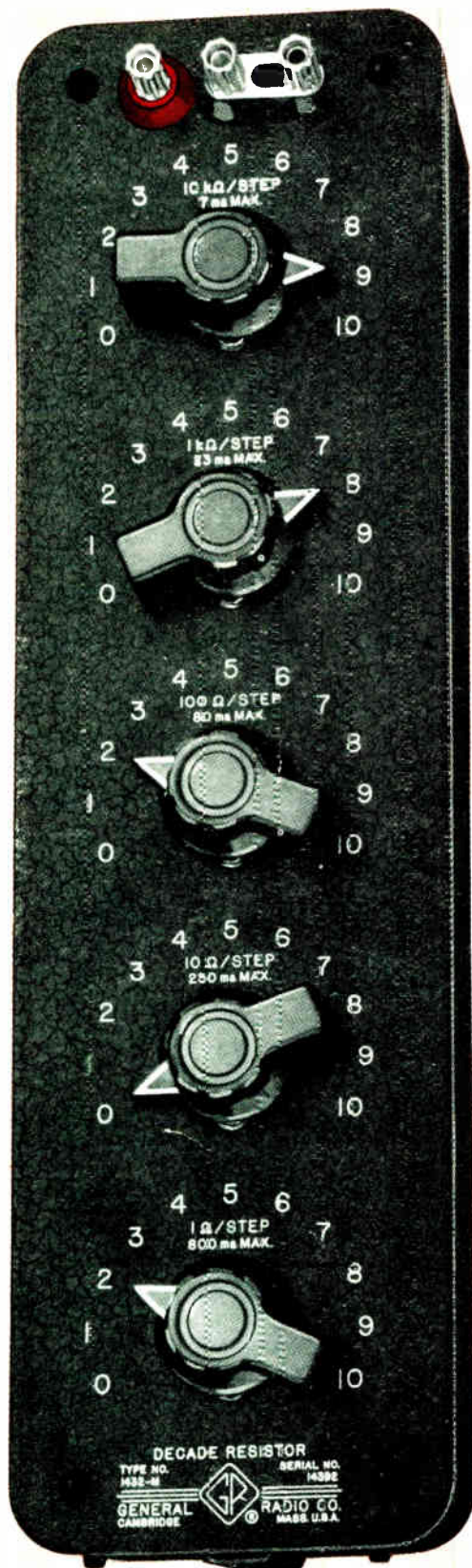

Type 1432

Decade Resistors

are available in ten different models: 111Ω total, to 11,111Ω total, in 0.1Ω steps; 11,100Ω total, to 1,111,100Ω total, in either 1Ω or 10Ω steps; and 1,111,000Ω total, in either 100Ω or 1000Ω steps. Accuracy is ±0.05% for most units. Resistance elements are individually adjusted to specified values so that resistance increments are always correct. Residual reactances are small due to the use of flat resistance forms and unifilar or Ayrton-Perry windings. Excellent stability is provided by the use of accurately alloyed resistance wire, careful production methods, continuous quality control, and preaging at elevated temperatures for all units. They can be used at frequencies as high as several hundred kc. Prices, \$68 to \$143.



Type 510

Decade-Resistance UNITS



used in Type 1432 Decade-Resistance Boxes, can also serve as inexpensive standards for many measurements. These units are ideal for assembly into equipment where decade-resistance switching is required. Eight different decade units from 0.1Ω total, to 1 MΩ total, are available. An additional model has 100,000Ω maximum in seven steps: 0.1; 1; 10; 100; 1000; 10,000; and 100,000Ω. Prices range from \$14 to \$35. Write for complete information.

For power-level, gain, or loss measurements — Type 1450 Decade Attenuator, a 600Ω T-section attenuator.



Type 1450-TA 110 db, total, in 1 db steps..... \$240
Type 1450-TB 111 db, total, in 0.1 db steps..... \$340

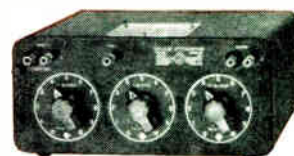

Type 670-F Compensated Decade Resistor is a constant inductance decade resistor for a-c measurements where non-reactive increments of resistance are required. 0 to 111 ohms, total, in 0.1-ohm steps. Price: \$100.

For the determination of voltage ratios by comparison or null methods — Type 1454-A Decade Voltage Divider. Price: \$145.



Ratios from 0.0001 to unity in 0.0001 steps

• Accuracy: ±(0.1% + 0.000001)

GENERAL RADIO Company

Cambridge, Massachusetts, U.S.A.

Canadian Office: 99 Floral Parkway, Toronto 15, Ontario

Arthur Kingsnorth

Richard J. Provan

Telephone: CHerry 6-2171

Repair Service:
Bayly Engineering, Ltd.,
Ajax, Ontario



All G-R Products
are now covered by a

2-Year Warranty

