

ETI for Electronics & Computing Enthusiasts

ZX Interface Board

Electronics Today

\$2.25
MM70924

INTERNATIONAL

April 1983

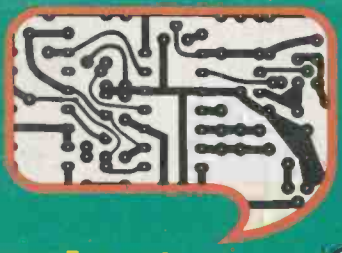

Spy Satellites

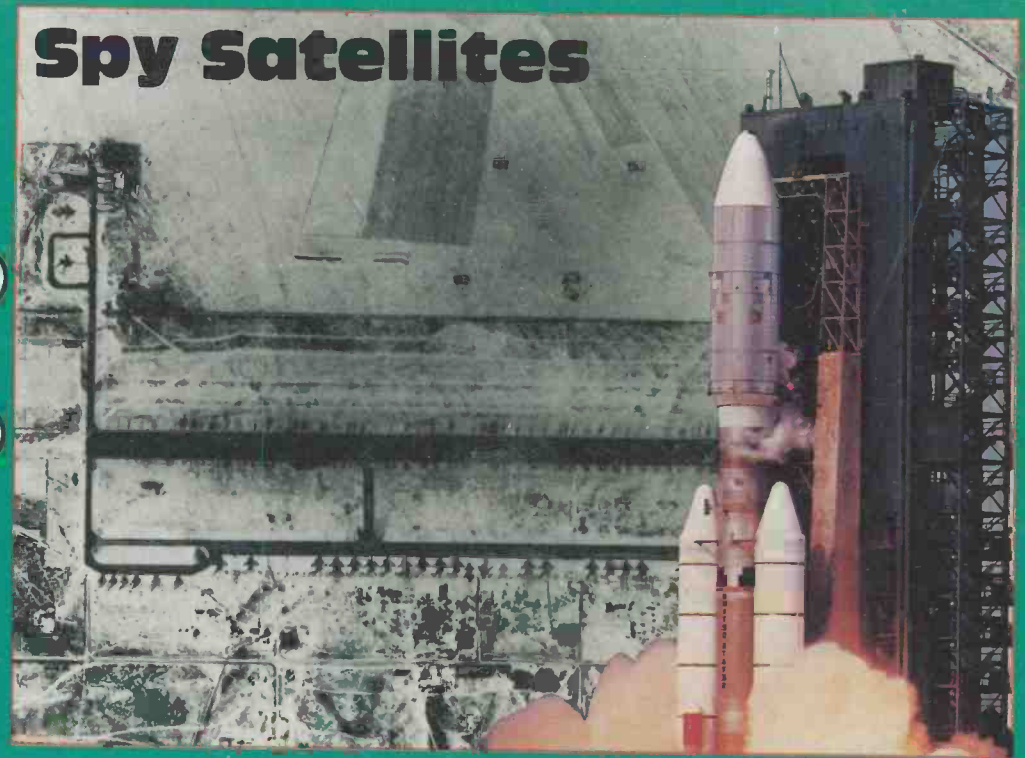

Project: 1 = 5 

Loudspeaker Protector
Safeguard your Series 5000 

Inertial Navigation
Flying blind

Project Fault Finding
Squash those bugs

Equalisers
A graphic explanation

Digital Counters & Timers
Splitting seconds



North Star Advantage Review



Exceltronix

Exceltronix Computer Division
computers at unbeatable prices!
921-1067 921-4013



Apple™ Computer

Apple II™ Plus with 48K RAM
SPECIAL \$1545

Apple disk drive with controller
\$795

Apple drive without controller
\$700

We provide our own 120 day warranty

EPROM PROGRAMMER FOR APPLE™ Special \$99. — A&T

120 day warranty Normal price \$150.
 Plugs into the Apple, and is capable of programming or copying EPROMS. (Can take any slice of memory, and copy it into EPROM).

Has on board DC to DC inverter to generate 25 volts, and also comes with a ZIF socket. Programs: 2716, 2732, 2732A and 2764. Disk with software & documentation included.

Multiflex Disk Drives for your Apple™

or Franklin™ fully compatible with Apple computer and software.

This attractively packaged disk drive, ready to plug in an Apple disk drive controller card, or equivalent controller is now available at a sale price, which you can not afford to miss.

Drive (no controller) **\$349**

Drive with controller, (Shamrock™) which can handle up to 2 drives **\$429**

Drive with controller, (Rana™) which can handle up to 4 drives.
\$489 90 DAY WARRANTY

16K RAM CARD FOR APPLE™

16K RAM card made by Multiflex Inc. for your Apple allows you to expand your 48K Apple to 64K, assembled & tested with 120 day warranty (good stock)

\$75 Normal Price \$99



SPECIAL DISKETTES

WABASH 5 1/4" Single Sided Double Density **\$33.95** box of 10

VERBATIM Single Sided Double Density **\$48.95** box of 10

DISK LIBRARY CASES \$3.95 ea

Also Available: Maxell and CDC

Monitors

Zenith Monitors complete with housing and power supply ready-to-use with any composite video signal 12" green phosphorus screen switch selectable for 40 or 80 characters. 90 day warranty; quantity discounts available.



Special \$159

80x24 VIDEO BOARD FOR APPLE

Made by Multiflex Tech, this video board is based on 6845 CRT controller, and switches automatically between 80x24 and 40x24, composite video out. Designed to work with CP/M™, PASCAL™, DOS™ (good stock) 120 day warranty. A&T. **Special \$99**

AMDEK 13" COLOUR MONITOR Special \$499

AMDEK 310 — A AMBER MONITOR \$249
 90 day warranty

OSBORNE COMPUTER

New model on sale now **\$2289**

\$2395 With 12" Zenith green screen + adapter (This month only)

MULTIFLEX SUPER PACKAGE

See Catalogue **Price Kit \$1195**
A&T \$1389

NEW MULTIFLEX PORTABLE PACKAGED SYSTEM

Expected release Mar. 15, 1983. **\$1895**

2 SA200 drives, 9" monitor, power supply, keyboard, 64K RAM (provision up to 256K RAM also capable to expand up to 4 8" DD DD drives, also includes CP/M & BASIC. Orders taken now.

6502 BOARD CASES

New professional looking aluminum case for the 6502 board, at unbeatable **\$48.95**

Also Multiflex keyboard A&T which fits into case, ready to plug into 6502 **\$99**

Combination case & keyboard A&T (while they last — limited stock only!!! Hurry. **\$139**

Also if you buy 3 boards at once • 16K RAM • 80x24 Card • EPROM prog. • Special \$269/3.

PRINTERS

EPSON

MX80 type III \$759
 MX80FT type III \$869
 MX82 type III \$825
 MX82FT type III \$959
 MX100 type III (limited special) \$995

Note: All type III printers include graphics. All printers come with 90 day warranty.

GEMINI 10

\$619

GEMINI 15

\$799

SERIAL CARD

\$119

Special Hameg Scopes HM203-2 \$629 While quantities last.

MAIL ORDERS

Send a certified cheque or money order (do not send cash). Minimum order is \$10 plus \$3 for shipping. Ontario residents must add 7% provincial sales tax. Visa, Mastercard and American Express accepted: send card No., signature, expiry date and name of bank.



PRICE POLICY

Remember that at Exceltronix, all prices are negotiable for quantity purchases. If you cannot afford large quantities on your own, how about starting a Co-op.



319 COLLEGE STREET, TORONTO, ONTARIO, CANADA. M5T 1S2 (416) 921-5295
 ALL PRICES ARE IN CANADIAN FUNDS, 9% FEDERAL SALES TAX INCLUDED

Circle No. 7 on Reader Service Card.

You can't beat the best!

Exceltronix

Components & Computing Inc.

Don't hesitate to contact us on our price hotline 921-4114 for the most competitive prices in Canada!

Multiflex Keyboard (55 Key)

With connector wired in for external keypad. This keyboard uses 2716 to store the ASCII characters, therefore can be customised to suit your needs (all drawings and codes supplied).

Unbeatable **\$99**

Great for 6502 boards assembled & tested (even has auto repeat)

Optional case \$29

MULTIFLEX STATIC 64K RAM BOARD 5100 BUS

(with provision for battery back up)

Special: (using 6116 150 ns RAMS)

16K version = \$289 A&T = \$350

32K version = \$349 A&T = \$395

64K version = \$485 A&T = \$519



DISK DRIVES This Month Only!

SA400L **\$259**
(5 1/4" SS Shugart)

SA200 **\$257**
(5 1/4" Slimline SS Shugart)

SA801 **\$595**
(8" SS Shugart)

SA851 **\$849**
(8" DS Shugart)



CONTROL DATA

CDC 9409 **\$399**
(5 1/4" DS DD)

CDC 9406 **\$589**
(8" DS DD)

MEMORY SPECIALS

4164 - 150 ns (1x64k single (+ 5V) supply) **8.95**

4116 - 150 ns (1x16k) — 1.95

4116 - 200 ns (1x16k) — 1.75

2114L - 200 ns (1kx4 static) — 1.89

6116 - 150 ns (2kx8 static RAM) — 8.95

(Pin compatible with 2716 uses negligible amount of power)

2016 - 150 ns (2kx8 static) — 8.75



2102L - 200 ns (1kx1 static) — 1.95

5101 - CMOS RAM — 3.85

2708 - (1kx8) EPROM — 5.75

2716 - (2kx8 EPROM single + 5V) — 4.89

2732 - (4kx8 EPROM single + 5V) — 8.69

2532 - (4kx8 EPROM single 5V) — 8.95

2764 - (8kx8) EPROM single 5V) — 13.95

For quantity discounts contact us for best pricing.

Note: (a) we have good stock of the above memory chips.
(b) Prices in red are this months specials only - don't miss it.

New Improved Multiflex

Great for beginners or pros

\$349 A&T \$395

Comes with a motherboard and a S100 CPU card. Standard features:

Motherboard

Includes 32 keypad with 16 HEX and 16 control keys; HEX display; Cassette interface; EPROM Programmer for 2708, 2716, 2732, 2532, 2764, 27128; Wire-Wrap area (space for about fifty 14-pin chips); Parallel Port (8255); S100 Connector (with space for three more).

CPU card includes

Z80A CPU, 2732 (EPROM with our monitor), 6116 (2K x 8 RAM) and all the circuitry. The CPU card has provision (but kit does not include the parts for) 64K of RAM, 4 sockets for EPROM/RAM (2732, 2764, 6116, 8255), parallel port and 8253 timer. Also piggyback board is available for this CPU with 2 serial ports, real time clock and much more.



PRICE POLICY
Remember that at Exceltronix, all prices are negotiable for quantity purchases. If you cannot afford large quantities on your own, how about starting a Co-op.

MAIL ORDERS

Send a certified cheque or money order (do not send cash). Minimum order is \$10 plus \$3 for shipping. Ontario residents must add 7% provincial sales tax. Visa, Mastercard and American Express accepted: send card No., signature, expiry date and name of bank.

921-2571



INTELLIGENT TERMINAL (with 4 page memory)

This multiflex intelligent terminal comes with a keyboard, and 8k of RAM. 80x24 character composite video display and RS232 output (uses 6845 CRT controller and Z-80A CPU) has many attributes, works at 75 to 9600 baud rate). This product is one of our best sellers and you can't afford not to have it at our low price.

Terminal kit with 8k RAM **\$259**

Assembled & tested (No cases & supply) **\$289**

Options are as follows:

Case - 39.00, Power supply - 45.00, TV option - 29.00

THIS MONTH SPECIAL

Complete terminal with power supply & case assembled & tested **\$350**

With every terminal you buy you get 10% discount on a Zenith 12" green screen monitor.

U OF T 6809 BOARD

(Used in courses at U of T)

Requires any RS232 terminal (Multiflex terminal works great with it). Includes 6809 CPU, 2(6522) parallel ports, 2(6551, serial ports) 48K of dynamic RAM, 4k of monitor and 8k of assembler. **This month only save \$160.00**

6809 Kit with assembler & editor & full documentation only **\$375.00**

Multiflex Modem Kit 300 and 800 works great
(See catalogue page 30) **\$149**

MULTIFLEX LOGIC STATE ANALYSER (see pg. 24 catalog)

This instrument is a must for debugging complicated digital & microprocessor circuitry.

Special Kit (with case) **\$289**

-16 channel inputs (low loading) A & T — **\$349**

-1k of storage memory

MULTIFLEX S100 FLOPPY CONTROLLER

Features 1) S100 Compatible. 2) DMA. 3) Based on 1793 — capable of handling up to four 8 inch of 5 1/4 inch drives in double sided double density or SS, SD.

Special kit **\$295**

with DMA

A&T **\$375**



S100 VIDEO BOARD BY MULTIFLEX

Based on 8275 CRT controller and Z80A CPU processor, and 8K of RAM, you get a 80x24 composite video, output with features comparable, if not better, to a board twice more expensive. **Special Kit \$289 A&T \$349**

319 COLLEGE STREET, TORONTO, ONTARIO, CANADA, M5T 1S2 (416) 921-5295
ALL PRICES ARE IN CANADIAN FUNDS, 9% FEDERAL SALES TAX INCLUDED

Circle No. 7 on Reader Service Card.

SURPLUSTRONICS

we will not be undersold

We accept Visa, Mastercard and American Express

We buy, trade and sell

ABS 6502 CASES SPECIAL \$79



Made to fit power supply, P.C. board and keyboard perfectly.

POWER SUPPLY



\$109
5V 5A, +12V 2 UP TO 3A PEAK,
-5V 1/2 A, -12V 1/2 A

SUPER SALE!

SUPER SALE!

SUPER SALE!

SUPER SALE!

SUPER SALE!

SUPER SALE!

PARTS ON SALE

2114 (200ns)	\$1.95
4116 (150ns)	\$1.70
Special: 24 of above	\$39.00
2716	\$4.95
Special: 6 of above	\$25.95
2732	\$8.95
Special 3 of above	\$21.95
6502	\$6.89
All sockets. Super quality	1c per pin
(Quantity discounts available)	

VIDEO CARD 80x24 BARE BOARD = \$17.95

Assembled & tested ready for use (Auto switching between 80x24 and 40x24) Fully compatible with CPM, Wordstar, Pascal, DOS 3.3. **\$89**
—Note again that to build this card it will probably cost you more than to buy it assembled & tested.

Floppy cont bd. which has provision for 2716 EPROMS (350ns) **\$17.95**

DISK DRIVES SALE (This month only) \$249

New Shugart SA400L Disk Drives

Disk Drives (all drives are brand new and fully pre-tested). 5 1/4" Single side single or double density. Ideal for modifying (for your 6502 board)

DRIVE CASE \$14.95

PRINTERS (ADDITIONAL 4K OPTIONAL) 2.7K BUFFER OVER 25% LESS THAN THE BEST SELLING COMPETITOR.

• Standard and Italic character sets • Proportional character set available • Two graphics modes - 480 Dot Pitch - 960 Dot Pitch • Optional serial interface • Bidirectional printing • Subscript and superscript • Double strike • Emphasized print • Double width • Underline • Compressed characters • 10, 12, 17 CPI — Software selectable.

GEMINI 10 \$595.00 GEMINI 15 \$769.00 SERIAL CARD \$109.00

ASCII KEYBOARD

Fits aluminum case perfectly, ready to plug into 6502 board. Assembled & tested with ALC documentation **\$99**

(Keyboard uses EPROM, which makes it very flexible. Combination at special Aluminum case & Keyboard. **\$139**

ASCII KEYBOARDS

This keyboard is ready to plug into your 6502 board and fit your case perfect. **\$89**

16K RAM CARD



For your 6502 board allowing you to expand your 48K system to 64K fully assembled and tested ready to plug in **ONLY \$69**

BARE BOARD \$16.95

NOTE: We believe that to buy the parts for your bare 16K board may end up costing you more, than to buy the finished product. (also no debugging headaches.)

VIDEO MONITORS (80x24) 12" Brand new, ready to plug in \$119

APPLE™ COMPATIBLE DISK DRIVES Attractively packaged, and ready to plug in — **SA400L \$345** (extremely reliable) **Slimline SA200 \$355** **Shamrock Controller \$89**

SAVE SAVE SAVE SAVE

(on peripheral boards)

(APPROX.)

\$300

THIS SUPER 6502 BOARD has on board provision for: 64K RAM (using 8-4164). 80x24 Video, floppy controller (using 2716), five slots for additional boards.

ORDER A COMPLETE PACKAGE NOW, PAY ONLY \$649

New case with keyboard including numeric keypad \$249

Powerful Power Supply

5V 5A, +12V 2 UP TO 3A PEAK, **\$115**
-5V 1/2 A, -12V 1/2 A

New Super 6502 PC board (blank) \$57

Parts for above board including all options (note eproms are included but are blank) **\$255**

BUY COMPLETE PACKAGE FOR \$649 and get a **FREE Z80 blank PC Board**

NOTE: This board in all honesty far exceeds our expectations, and demand for this product is simply spectacular! ALSO this board fits the old cheap cases and keyboards.





ETI Electronics Today

INTERNATIONAL

Features

13 Inertial Navigation
Neither sleet nor snow nor rain shall keep a gyro from its appointed rounds.

27 All Things Being Equal
How tone circuits take the lumps and holes out of listening, and the pitfalls thereof.

30 Digital Counters and Timers
They'll measure a 50 MHz signal even better than your dad's old railroad watch.

35 Spy Satellites
Keeping an eye on the neighbours, and then some.

41 Northstar Advantage Review
Between a rock and a hard disc? Here's an extra-fast computer.

60 Fault Finding for Beginners
Lesson One: criticise your friend's tie.

65 Into Digital IC's Part 8
Ian Sinclair examines registers: cash, hot-air, and shift.

Projects

19 Multipurpose PC Board
Make one PC and assemble five projects, or the other way around if you like drilling.

46 ZX Interface Board
Teach your ZX-81 to operate the doorbell and other hi-tech things.

56 Loudspeaker Protector
Shuts off the speaker on overloads; nothing it can do about Barry Manilow.

Our cover
Spy satellite technology has proven conclusively that a Ruskie walking along a muddy road does indeed leave footprints. Photo courtesy of the CIA, Washington. See page 35. We took advantage of the availability of the Northstar Advantage and the review begins on page 41. Photo courtesy of TRW.



ADVERTISERS' INDEX

- Active Component Sales Corp 75
- Arkon Electronics 39
- Audiovision 12
- BCS Electronics Centre Section
- Catalogue 43
- Blenkhorn & Sawle Limited 75
- Brunelle Instruments Inc. 43
- B.T.W. Enterprizes 69,70
- Classified 73
- Daetron 43
- Dufex Electronic Inc. 75
- Electronic Packaging Systems 2,3
- Exceltronix 70
- General Electronics 77,79,80
- Gladstone Electronics 70
- Kitstronic International Ltd. 43
- McBride Loudspeaker Source Inc. 33
- McGraw-Hill 44
- Metermaster 48
- Micro Computech Electronics Ltd 8,9
- Orion Electronic Supplies 7
- Parts Galore 75
- Protec 12
- H. Rogers Electronic Instruments 73
- Shamrock Computer Inc 71
- Smith Corona 4
- Surplustronics 34
- Timex, Sinclair User

NEWSSTAND DISTRIBUTION:
Master Media, Oakville, Ontario

SUBSCRIPTIONS
\$18.95 (one year), \$33.95 (two years). For US add \$3/yr., other countries add \$5/yr. Please specify if subscription is new or a renewal.

BINDERS
Binders made especially for ETI are available for \$8.00 including postage and handling. Ontario residents please add provincial sales tax.

BACK ISSUES AND PHOTOCOPIES
Previous issues of ETI Canada are available direct from our offices for \$3.00 each; please specify by month, not by feature you require. See order card for issues available.

We can supply photocopies of any article published in ETI Canada; the charge is \$2.00 per article, regardless of length. Please specify both issue and article.

COMPONENT NOTATION AND UNITS
We normally specify components using an international standard. Many readers will be unfamiliar with this but it's simple, less likely to lead to error and will be widely used everywhere sooner or later. ETI has opted for sooner!

Firstly decimal points are dropped and substituted with the multiplier: thus 4.7uF is written 4u7. Capacitors also use the multiplier nano (one nanofarad is 1000pF). Thus 0.1uF is 100nF, 5600pF is 5n6. Other examples are 5.6pF = 5p6 and 0.5pF = 0p5.

Resistors are treated similarly: 1.8Mohms is 1M8, 56kohms is the same, 4.7kohms is 4k7, 100ohms is 100R and 5.6ohms is 5R6.

PCB SUPPLIERS
ETI magazine does NOT supply PCBs or kits but we do issue manufacturing permits for companies to manufacture boards and kits to our designs. Contact the following companies when ordering boards.

Please note we do not keep track of what is available from who so please don't contact us for information on PCBs and kits. Similarly do not ask PCB suppliers for help with projects.

K.S.K. Associates, P.O. Box 266, Milton, Ont.
L9T 4N9
B—C—D Electronics, P.O. Box 6326F, Hamilton, Ont., L9C 6L9.
Wentworth Electronics, R.R.No. 7, Waterdown, Ont., L0R 2H0.
Danocinths Inc., P.O. Box 261, Westland MI 48185, USA.
Arkon Electronics Ltd., 409 Queen Street W., Toronto, Ont., M5V 2A5.
Beyer & Martin Electronic Ltd., 2 Jodi Ave., Unit C, Downsview, Ontario M3N 1H1.
Spectrum Electronics, Box 4166, Stn 'D', Hamilton, Ontario L8V 4L5.
Dacor Limited, P.O. Box 683, Station Q, Toronto, M4T 2N5.

POSTAL INFORMATION
Second Class Mail Registration No.3955. Mailing address for subscription orders, undeliverable copies and change of address notice is: Electronics Today International, Unit 6, 25 Overlea Blvd., Toronto, Ontario, M4H 1B1.

Columns, News and Information

News 6	Computing Today 58
Next Month 23	Order Form 63
ETI Specials 24	Subscriptions 64
ETI Bookshelf 52	Fun of Electronics 68
	Classifieds 69
	Tech Tips 72

News

New Power Megaphones

A new series of compact, dependable power megaphones now is available for tour guides, public speakers, construction supervisors and others who must project important messages clearly over large distances, indoors or outdoors. The popular-priced Bogen Megaphones offer a choice of 5, 12 or 16 watts of power and convenient features.

The hand-held public address systems feature solid-state amplifier circuitry, efficient horns and balanced design for prolonged use without fatigue. Both the 12- and 16-watt megaphones also have a built-in, attention-getting electronic siren.

Bogen is represented in Canada by Atlas Electronics Limited, 50 Wingold Avenue, Toronto, Ontario, with branch offices in Montreal, Ottawa, Winnipeg, and Vancouver.



Self-Instruction Programming

Ron Finnigan, of Creative Programming, announced today the availability in Canada of a series of self-instruction manuals for use with virtually every type of popular home computer. The seven volume series has been developed and tested for over two years on hundreds of primary through adult learners. Since this type of instruction is largely unavailable in public and private schools, CREATIVE offers an excellent opportunity for the home computer owner to achieve computer competency on their own. The series is available for the TRS-80 in a Primary Version (for students not yet reading at fourth grade level), a Regular Version (designed for those students who have attained at least a fourth grade level reading), and an Adult Version (aimed at those who wish to progress more rapidly and do not feel the need for as many examples). The Primary Version and Regular Versions are also available for the APPLE and Commodore PET computers. The Regular Versions only are available for the TI-99/4A and the ATARI home computers. Only volumes 1 and 2 are available from the Regular Version for the Commodore VIC-20. The manuals will sell in Canada for \$17.95 each or \$115.50 for the entire 7 volume series. For more information, inquiries may be mailed to: Creative Programming, P.O. Box 34, Station "A", Toronto, Ontario M5W 1A2.

Low-Cost Compact Bridge

Three compact full-wave bridge-rectifier assemblies, in two physical configurations, occupy less than 0.11 cubic inches, allowing placement on printed-circuit boards along with other logic and analog circuits. Designated the 2KBP, KBPC1 and KBPC6 Series by International Rectifier, the single-phase bridges have 2A, 3A and 6A output current ratings with maximum voltage ratings from 50V to 1000V. At IR dealers.

Module Pushbutton Switch

C&K Components, Inc. announces the availability of a mechanical pushbutton switch module, the MP01. This versatile, long-life switch is suitable for data entry or function control in individual or multiple keyboard arrays. Six field replaceable cap styles, with or without L.E.D.'s, are available in 8 colors to complement panel design. Caps and L.E.D.'s may also be ordered separately. Dip-pattern compatibility ensures ease of installation.

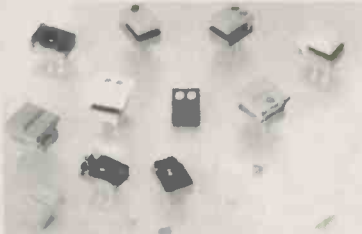

Switching function is SPDT momentary with epoxy sealed terminals to with-stand wave soldering temperatures, and has electrical life of 1,000,000 actuations at full load.

Contact Avotronics Ltd., 230 Don Parker Rd., Unit 2, Markham, Ont. L3R 2P7 (416) 475-2024.

VIC-20 Software

United Microware Industries, which has built its reputation with video games for the VIC-20, has introduced eight new business and

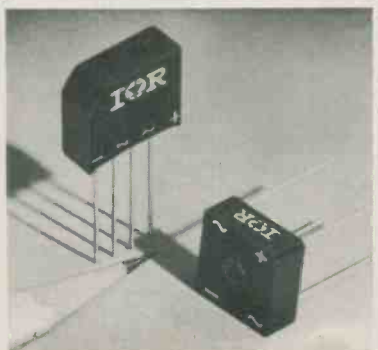

home-management software packages for that popular computer. Included are a powerful word processor, FORTH-20, a communications program, a calculator program, a printer and graphics program, checkbook and record-keeping systems. UMI President Russ Bedord said "As important as games are to us, there's more to life than recreation." There you have it. Warm up that VIC-20 and contact UMI dealers.

Shugart Announces New 3.5" Disk Drives

Shugart Associates, inventor of the Minifloppy™ disk drive in 1976, has introduced a new generation of rotating storage devices with the announcement of a 3.5-inch "microfloppy" disk drive.

Standing just 1.60 inches high and occupying about one-fourth the volume of a standard Minifloppy, the single-sided SA300 is well-suited for desktop and portable computer applications where high capacity in a small, low-cost package is required.

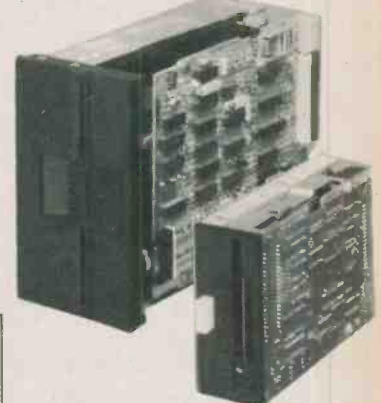

Designed to operate with the 3.5-inch cartridge media format proposed by the microfloppy standards committee, formed in May 1982 by 19 leading disk drive and media manufacturers, the SA300 provides 500 kilobytes of unfur-matted capacity, 135 tracks-per-inch (TPI) density and six-millisecond track-to-track access time. Contact Shugart in Markham, Ontario, at (416) 475-2655.

Continued on page 11

ETI Magazine is Published by:

Electronics Today International
Editorial and Advertising Offices
Unit 6, 25 Overlea Boulevard,
Toronto, Ontario, M4H 1B1
Telephone (416) 423-3262

Publisher

and Editor: Halvor W. Moorshead
Assistant Editor: Steve Rimmer
Editorial Assistant: Bill Marwick
Production Manager: Ann Rodrigues
Production: Cindy Baker
Liz Longwill

Subscription Department: Bebe Lall
Diane Neill

Accounts Department: Pirjo Dunphy
Advertising Manager: Senga Harrison

Advertising Representatives: Omar Vogt
Rick May

Advertising Services: Carolyn Wyatt

COPYRIGHT

All material is subject to worldwide copyright protection. All PCB patterns are copyright and no company can sell boards to our design without our permission.

LIABILITY

While every effort has been made to ensure that all construction projects referred to in this magazine will operate as indicated efficiently and properly and that all necessary components are available, no responsibility whatsoever is accepted in respect of the failure for any reason at all of the project to operate efficiently or at all whether due to any fault in the design or otherwise and no responsibility is accepted for the failure to obtain component parts in respect of any such project. Further no responsibility is accepted in respect of any injury or damage caused by any fault in design of any such project as aforesaid.

EDITORIAL QUERIES

Written queries can only be answered when accompanied by a self-addressed, stamped envelope. These must relate to recent articles and not involve the staff in any research. Mark such letters ETI-Query. We cannot answer telephone queries.

6502 Mother Board (Bare) with Z-80, 80 Column, 16K, Disc Ctrl.

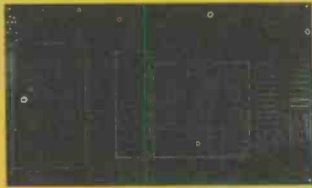

Due to the advent of improved 6502 boards with peripherals laid out on the board we have decided to include the above 4 peripheral cards with our proven Parts Galore 6502 board. You will now retain full access to all 8 slots plus have all the features that the newer boards provide. All boards are G-10 epoxy with full screening and plate through. Whats more these boards are a known and proven commodity with full compatibility with all Apple™ products and other types of 80 column cards and software.

6502 Board + 4 Peripherals \$57.95

PARTS KITS

For those in need we have these parts kits.

- (a) Tin IC sockets, 8,14,16,20,24,40 \$13.00
- (b) Gold IC Sockets 8,14,16,20,24,40 \$26.00
- (c) 1/2-1/2 IC Sockets, gold, 40,24 rest tin \$18.00
- (d) Edge connectors, set of 8 \$25.00
- (e) Resistors, all the 1/4 W resistors \$1.00
- (f) SIP resistors, 3-0.1w 1Kx9 \$2.00
- (g) Capacitors all the .1 + others \$7.00
- (h) Transistors & diodes \$2.00
- (i) Crystal, trimcaps, trimpot, RCA jack audio jacks, header pins, coll \$6.00
- (j) All TTL parts \$34.95
- (k) All linear parts \$4.00
- (l) 6502 CPU \$7.00
- (m) RAMS 24 4116's \$36.00
- (n) 2716's 6 pcs \$27.00
- (o) 2716 character gen programmed \$8.00
- (p) 2732's 3 pcs \$25.00
- (q) Complete kit, no IC's \$57.00
- (r) Complete kit, all IC's \$160.00
- (s) Complete kit, all IC's, gold \$170.00
- (t) Wired and tested motherboard with all parts, including blank 2732's \$395.00
- (u) Wired motherboard, with all IC's packed separately ready to stuff \$300.00
- (v) Wired motherboard, no IC's \$189.95

NEW. A high quality channel 11 interference free modulator with computer/TV switch and connector to fit inside case and plug right onto video peripheral pins. Made just for the 6502 board.
New Modulator \$22.00

ASCII Keyboards



Some of you will get your PC boards running with surplus keyboards but some will not and if you want the 'original' look try one of these two keyboards. Both are ASCII and can implement all the 'original' keyboard functions.

- (a) Light brown, suitable for our beige enclosure. With header cable \$99.00
- With numeric pad \$109.00
- (b) Light grey, suitable for our Ivory enclosure. With header cable \$99.00
- With numeric pad \$109.00

SMALL PARTS

16 Pin header \$2.00	14.318Mhz xtal \$3.00
50PI trimcap \$0.75	17.430Mhz xtal \$5.00
250-ohm trimpot \$0.50	27Uu coil \$0.75
RCA Jack \$0.75	Audio jack \$0.75
Header pins (10) \$0.35	Header (5 pin) \$0.50
1K by 8 SIP \$0.75	Power, male \$0.75
1K by 9 SIP \$0.75	Power, female \$0.75
1K by 7 SIP \$0.75	Speaker, 3", 8ohm \$1.50
10K by 9 SIP \$0.75	Ribbon cable 8' \$3.00

DISC DRIVES



(a) Siemens full height 5 1/4" drive, fully enclosed with cable ready to plug in to your Apple™ or similar computer. Fully software compatible, Apple is now using Siemens drives instead of Shugart for that good old German precision. 6 month warranty.

- \$349.00
- with controller \$438.00
- (b) SA-200 style 1/2" height low profile 5 1/4" disc drive fully enclosed with cable ready to plug in, etc. 6 month warranty. Saves a lot of space \$369.00
- with controller \$458.00
- (c) Bare SA400L DISK DRIVE all set for you to modify with an analog board to make into your own system \$249.00
- Analog card, bare \$12.00
- Analog card, stuffed \$35.00
- Case for SA400L \$16.00
- Cable for SA400L \$9.00
- (d) Bare SA390L DISK DRIVE. Mechanism only, no PCB on back a lot easier to modify. Comes with speed controller on board. \$219.00
- Analog Card bare \$20.00
- Analog Card Stuffed \$70.00

PERIPHERAL BOARDS



A variety of printed circuit boards that allow you to add various capabilities to your 6502 board. All the bare boards are \$10.00 each, alone or in quantity. The wired and tested peripheral boards vary in price with their capability.

- (a) Z-80 A very popular board that allows for the use of CPM™ and Z-80 programs on the 6502 PCB. Wired and tested \$89.00
- (b) 80 Character. Another popular board that displays 80 characters of text on a normal screen. Wired and tested \$89.00
- (c) 16K, or language, allows an extra 16K of memory to be used and avoids the need for a ROM card on disc based systems, one of the most popular. Wired and tested \$85.00
- (d) Floppy disc controller. A must if you want a disc drive. You must buy a DOS to run with the card. Wired & tested \$88.00
- (e) ROM card, when populated with a few 2716's can hold another language. Does not come with a language. Useful until you get a disc. Wired & tested \$59.00
- (f) RS-232 Another very useful card that lets you communicate with printers ect using serial data flow. Has RS-232 serial capability. Wired & tested \$86.00
- (g) Printer card allows you to talk to parallel printers, such as the very popular EPSON. Wired & tested \$86.00
- (h) Prototype. A card that does nothing but lets you wire wrap any kind of circuit you can imagine. All holes no annoying power buses to eat up all the space. Bare Board only \$10.00

REMEMBER ANY BARE BOARD IS ONLY \$10.00

ABS CASES

New ABS case with numeric pad cutout to the right of regular keyboard

\$99.00



For those who wish to copy the 'original' as closely as possible we have the following enclosures, both fit the PCB's, power supplies, and keyboards exactly.

- (a) Beige case, ABS, all hardware, close colour match to the real thing
- (b) Ivory case, ABS, all hardware, to many a nicer colour for the home

Regular ABS Case \$79.00

GREAT DEAL



Want a great deal? Want a winner? Well here's one for you. We made a big buy on the power supplies (Black Beauty), ABS cases, ASCII keyboards and the famous Parts Galore 6502 bare board and we now offer this special deal. All four of the above for only \$299.00

Includes Z-80, 80 col, 16K, Disc PCB's.
Great Deal with numeric pad includes numeric pad keyboard and numeric ABS case with Z-80, 80 col, 16K and disc for only \$319.00

MONITORS

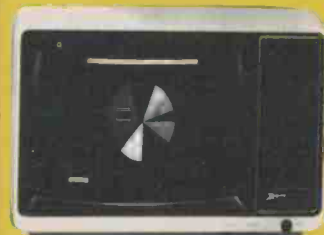

- (a) Zenith 12" green phosphor, with 40/80 column switch, ideal for the Apple™ or similar video output systems \$159.00
- (b) Electrohome, a true 12" green phosphor professional monitor in a shielded metal enclosure for RFI rejection. Made in Canada \$165.00
- Same with 9" CRT \$139.00
- (c) Electrohome RGB colour monitor, 13" screen an excellent monitor for showing what an Apple™ can do in Hi-Res mode. \$459.00
- (d) Electrohome RGB signal extractor card. Needed to drive any RGB colour monitor from an Apple™. Plugs into any slot takes little current, and works very well \$169.00

Prices

Prices are rapidly changing in the 6502 PCB game. If by chance we are higher in price than someone else (due to magazine lead times, etc) we will equalize our price to theirs. Just tell us as you order what page in ETI they advertise on or where their store is and you get the break.

AMAZING QUALITY AT LOW COST

At last, a high quality, 3 1/2 digit, LCD, DMM with all the features of the higher priced American brands at an affordable price. Check these specs.

- Voltage, DC
- 0.2, 2.0, 20.0, 200.0, 1000.0
- Voltage, AC
- 0.2, 2.0, 20.0, 200.0, 750.0
- Current, DC
- 200ua, 2ma, 20ma, 200ma, 2000ma, 10A
- Current AC
- 200ua, 2ma, 20ma, 200ma, 2000ma, 10A
- RESISTANCE
- 200, 2K, 20K, 200K, 2000K, 20M Ohms
- ACCURACY 0.25% ± 1 DIGIT

LARGE LCD DISPLAY
LOW BATTERY READOUT

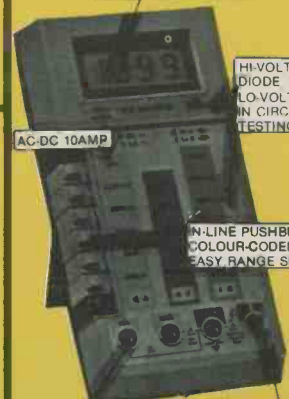

HI-VOLTAGE FOR DIODE TESTING,
LO-VOLTAGE FOR IN-CIRCUIT TESTING

IN-LINE PUSHBUTTONS
COLOUR-CODED FOR EASY RANGE SELECTION

RECESSED INPUT JACKS

OVERLOAD PROTECTION ON ALL RANGES

\$99.00

EXTRA FEATURES

- Diode test circuit • Lo voltage ohms, 0.5v • Lo battery indicator • Auto-Zero • Auto polarity • Overload protection, all ranges • ABS case (will not crack) • One hand push buttons.

SWITCHING POWER SUPPLY



We only stock one power supply, the best and highest power of all. We found out that almost everyone wanted high power and not the weak effort that the original company puts out. So we found the one that had the best construction internally as well as the best output. Our "Black Beauty" puts out 5 amps at 5V, 2 1/2 amps at 12V and 1/2 an amp at -5 and -12. We went one step further and obtained Ontario Hydro inspection for them so that you know they are OK. "BLACK BEAUTY POWER SUPPLY" \$115.00

PROJECT BOARD

Have you ever tried to get an economical protoboard and had a shock? Well look at this, a good quality protoboard at a 30-40% saving. The KH-408 has 1560 holes on a std 0.1" grid for IC's and a sturdy plastic base with two binding posts for power, an excellent buy for the student.

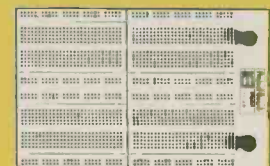

- KH-408 (as pictured) \$38.00
- KH-204 1/2 the size of KH-408 \$20.00

PARTS ELECTRONIC COMPUTER GALORE

316 COLLEGE ST., TORONTO. M5T 1S3 (416) 925-8291

Min Order \$15.00 Visa, MC, American Express,
All Ont. Residents add 7% Sales Tax. Add 5% delivery charge; we ship Canpar or Canada Post, or Purolator

Circle No. 15 on Reader Service Card.

Sinclair ZX81 Computer Etc . . .

Assembled \$99.95

ZX81

The ZX81's advanced capability. The ZX81 uses the same fast microprocessor (Z80A), but incorporates a new, more powerful 8K BASIC ROM — the "trained intelligence" of the computer. This chip works in decimals, handles logs and trig, allows you to plot graphs, and builds up animated displays. And the ZX81 incorporates other operation refinements — the facility to load and save named programs on cassette, or to select a program off a cassette through the keyboard.

New, improved specification. "Unique 'one-touch' key word entry: eliminates a great deal of tiresome typing. Key words (PRINT, LIST, RUN, etc.) have their own single-key entry. "Unique syntax-check and report codes identify programming errors immediately. "Full range of mathematical and scientific functions accurate

(to eight decimal places. "Graph-drawing and animated-display facilities. "Multi-dimensional string and numeric arrays. "Up to 26 FOR/NEXT loops. "Randomize, function. "Programmable in machine code. "Cassette LOAD and SAVE with named programs. "1K-byte RAM expandable to 16K. "Full editing facilities. "Able to drive the new Sinclair ZX Printer (to be available shortly).

If you own a ZX80. . . The new 8K BASIC ROM as used in the ZX81 is available as a drop-in replacement chip. (Complete with new keyboard template and operating manual). With the exception of animated graphics, all the advanced features of the ZX81 are now available on your ZX80 — including the ability to drive the Sinclair ZX Printer.

16K Memory Expansion Kit (No P.C. Board) \$49.00



\$159.00

Sinclair's new 8K Extended Basic offers features found only on computers costing three or four times as much. "Continuous display, including moving graphics. "Multi-dimensional string and numerical arrays. "Math and scientific functions accurate to 8 decimals. "Unique one touch entry of "key words" (i.e. basic and system commands). "Automatic syntax error detection. "Randomize function. "Built-in interface for ZX Printer. "Connects to standard TV and cassette recorder. "164 page manual included. "Power supply (9V at 650 ma) optional for \$14.95. "1K of memory is included.

Designed exclusively for use with the ZX81 (and ZX80 with 8K basic ROM), the printer offers full alphanumeric and highly sophisticated graphics. COPY command prints out exactly what is on screen. At last you can have a hard copy of your program listing and results. Printing speed is 50 characters per second, with 32 characters per line and 9 lines per vertical inch. Connects to rear of ZX81 — using a stackable connector so you can use a RAM pack as well. A 65 ft paper roll, instructions included. Requires 9 volts, 1.2 amp power supply (option extra).

Machine Language Software
ZXAS Machine Code Assembler. A full specification Z80 assembler. Standard mnemonics are written directly into your BASIC program \$19.00
ZXDB Disassembler/Debugger. Perfect complement to ZXAS, also provides single step, string search, block transfer, hex loader. \$19.00

Etc . . .

Software

GAMES (Arcade, Adventure, Strategy)

- KRAKIT - Win \$20,000 \$24.95
- 1K GAMES PACK - 11 games for 1K ZX81 13.95
- GOBBLEMAN - Famous arcade game. 19.95
- ZX GALAXIA - SYNC said this ZX81 version was the best 19.95
- ZOMBIES/SWORD OF PEACE two exciting games 19.95
- GUNFIGHTER/3D TIC TAC TOE/LIFE - 3 For 1 15.95
- RUN THE COUNTRY - What would you do if you were in power? 19.95
- MOVIE & SUPERHERO HANGMAN - Guess the names before the hangman comes 13.95
- PLANET OF FEAR - Find your kidnapped spaceship 19.95
- INCA CURSE - Get the gold out of Inca Temple 19.95
- ALIEN SPACESHIP - Free your ship from an Alien Cruiser 19.95
- AROUND EUROPE IN 80 HOURS - a race against time! 15.95
- INHERITANCE - Inherit your Great Uncle's estate 15.95
- POP STAR - Enter the exciting music business 13.95
- BLACKJACK - Up to 5 players against a computerized dealer 13.95
- SLOTS - Beat the one-armed bandits 13.95
- ZX SCRAMBLE - Fast moving space scenario 19.95
- GALAXY INVADERS - Repel fleets of hostile invaders 19.95
- THE KEYS TO GONDROUN - a magical kingdom awaits 19.95
- MARINE RESCUE - rescue divers from a sunken sub 13.95
- ESPIONAGE ISLAND - survive on a secret island 19.95
- INVASION FORCE - The ultimate space game! 19.95
- BATTLESHIP - The classic confrontation of strategy. 13.95

- CONCENTRATION, WORD CHALLENGE, NUMBER CHALLENGE 19.95
- SHELL GAME, NUMBER MAZE - challenging puzzles 13.95
- TRADER - fully animated game 24.95
- SUBSPACE STRIKER - a new dimension in space warfare. 19.95
- STARQUEST - discover a New Earth among disaster 19.95
- ZOR - medieval jousting by two robots 19.95
- ENCOUNTER - a UFO sighting turns into a nightmare 19.95
- 3D MONSTER MAZE - great graphics; highly rated 19.95
- CATACOMBS - unlimited number of game levels 19.95
- BACKGAMMON 19.95
- FLIGHT SIMULATION - 19.95

CHESS GAMES

- 1K CHESS (ZX81) 13.95
- ZK CHESS (TS1000) 19.95
- ZK CHESS I (Master-16K) 19.95
- ZK CHESS II (Enhanced - 16K) 29.95

PROGRAMMERS AIDS & LANGUAGES

- ZX ASSEMBLER - Two pass assembler for MC programs 19.00
- ZK BUG - MC monitor and disassembler for debugging 19.00
- TOOLKIT - 9 new BASIC commands for the ZX81 19.95
- ZK FORTH - 56 pg manual enhances this language 39.95
- Z-AID 1.0 - A must for MC programmers 19.95
- FASTLOAD - LOAD programs up to 6 times faster 24.95
- *TM

HOUSEHOLD/BUSINESS MANAGEMENT

- BUSINESS PACK #1 - Cash, Break-even and Depreciation Programs & Int Rate Return 39.95
- BUSINESS PACK #2 - Project Scheduler, Proj Proposal 19.95
- PERSONAL FINANCIAL PLANNING PACK - 2 tapes & manual 39.95
- PERSONAL STOCK MARKET PLANNING - 2 tapes & book 29.95
- PROPERTY MANAGER - a must for landlords 39.95
- INVENTORY CONTROL & STOCK ANALYSIS - for businesses 24.95
- VUCALC - Financial Spreadsheet 29.95
- VUFILE - Information Retrieval System 29.95

EDUCATION & FAMILY ENTERTAINMENT

- SIGNALS & CODES - learn Morse Code 19.95
- BIORHYTHMS - Track your up & down cycles 15.95
- FLASHCARD - Memory Aid and testing device 15.95
- SOLAR SYSTEM FILE - a databank of solar system 15.95
- PROGRAM OF DAYS - Irlivia and famous birthdays 15.95
- WEIGHT CONTROL DIET PROGRAM - A weight loss program includes booklet 39.95
- *MATHEMATICS - GRADE ONE 29.95
- MATHEMATICS - GRADE TWO 29.95
- MATHEMATICS - GRADE THREE 29.95
- MATHEMATICS - GRADE FOUR 29.95
- MATHEMATICS - GRADE FIVE 29.95
- MATHEMATICS - GRADE SIX 29.95

* All Mathematics series includes two tapes, holder & workbook.

ADDITIONAL SOFTWARE FOR SINCLAIR AVAILABLE.

Books

- COMPLETE ZX81 BASIC COURSE - inc. 2 tapes 39.95
- NOT ONLY 30 PROGRAMS: 1K 16.95
- MACHINE LANGUAGE MADE SIMPLE 19.95
- ZX81 ROM DISASSEMBLY PART A & PART B 24.95
- UNDERSTANDING ZX81 ROM 19.95
- T/S 1000: PROGRAMS, GAMES and GRAPHICS 16.95
- LEARNING T/S BASIC 23.95
- THE BASIC HANDBOOK 29.95
- 48 EXPLODING GAMES 16.95
- COMPUTER FOR KITS SINCLAIR EDITION 8.95
- MASTERING MACHINE CODE ON YOUR ZX81 24.95
- T/S 1000 USERS GUIDE (Vol 1) 16.95
- EXPLORERS GUIDE TO THE ZX81 16.95
- ZX81 POCKET BOOK 15.95
- GETAWAY GUIDE 16.95
- GETTING ACQUAINTED WITH YOUR ZX81 16.95

Hardware

- ZX81 Ass. 99.95
- ZX Print 159.00
- 64K - RAM (Memotech) 249.95
- 32K RAM (Memotech) 179.00
- 16K RAM (Memotech) 89.00
- 16K RAM (Sinclair) 99.00
- 16K RAM (Kit no PC board) 49.00
- Power Supply (650 M.A.) 14.95
- Power Supply (1 AMP) 19.95
- Keyboard (uncased) - 47 Keys, Assembled no soldering req. 119.95
- Metal Case for above 29.95
- ZX99 Automatic tape control 219.95

* Interface for any serial printer & 4 cassette recorders; includes plugs, cords and a detailed manual.

Memopak . . .

MEMOPAK 32K \$179.00 and 16K \$89.00 MEMORY EXTENSIONS

These two packs extend and complete the Memotech RAM range (for the time being!) A notable feature of the 32K pack is that it will run in tandem with the Sinclair 16K memory extension to give 48K RAM total.

MEMOPAK HIGH RES GRAPHICS PACK

HRG Main Features — • Fully programmable Hi-Res (192 x 248 pixels) • Video page is both memory and bit mapped and can be located anywhere in RAM • Number of Video pages is limited only by RAM size (each takes about 6.5K RAM) • Instant inverse video on/off gives flashing characters • Video pages can be superimposed • Video page access is similar to basic plot/unplot commands • Contains 2K EPROM monitor with full range of graphics subroutines controlled by machine code or USR function **\$199.95**

MEMOPAK CENTRONICS TYPE PARALLEL PRINTER INTERFACE

Main Features — • Interfaces ZX81 and parallel printers of the Centronics type • Enables use of a range of dot matrix and daisy wheel printers with ZX81 • Compatible with ZX81 Basic, prints from LLIST, LPRINT and COPY • Contains firmware to convert ZX81 characters to ASCII code • Gives lower-case characters from ZX81 inverse character set **\$159.95**

POWER SUPPLY 500ma \$14.95
 POWER SUPPLY 1A \$19.95 (FOR PRINTER)

Orion Electronic Supplies Inc.
 40 Lancaster Street West
 Kitchener, Ontario N2H 4S9
 (519) 576-9902

Master Charge & Visa, COD, Cheque, Money Orders accepted. COD's, shipping & insurance extra. Write for our FREE FLYER.

Prices subject to change without notice.

EXPANDER \$1775.00

Disc Controller Card up to four Double sided, Double Density Disc Drive \$475.00

SPECIFICATIONS

PHYSICAL

- Dimensions: 17 1/2" Wide, 4 1/2" High, 16 3/4" Deep.
- Shipping Weight: 32lbs.

DISPLAY CHARACTERISTICS

- Black and white mode 24 x 80 character display.
- 128 character upper/lower case including control keys.
- Option: expandable to 256 characters.
- Black/white graphics resolution 160 horizontal x 72 vertical.
- Color graphics resolution 80 x 72.
- 64 colors, each with 4 intensities for a total of 256 colors.
- Simultaneous use of all colors
- 40 characters x 24 lines in color mode
- Video output standard NTSC television compatible.

INTERFACE

- RS-232 Serial Interface
- Centronic-style parallel Interface for I/O.

KEYBOARD

- 80-key layout.
- 62-key typewriter style
- 18-key numeric calculator-style keypad.
- Auto repeat
- User-selectable for 4 function keys.
- 4 cursor keys

GENERAL OPERATING FEATURES

- Z80 A (3.58 MHz) CPU
- 64K RAM memory.

- S-100 bus (IEEE-696)
- 4 slots for expansion
- Real-time clock programmable for 64 msec. to 4 mil. sec.
- Interrupt driven keyboard, real-time clock, serial port and cassette interfaces.
- 5 additional prioritized Interrupts available
- Addressable up to 16 mBytes using bank switching.

SOFTWARE

- CP/M compatible
- 4K ROM Monitor with commands for loading and saving on cassette to and from memory and for program execution.
- Runs on any Z80-based CP/M compatible applications software.

A PROFESSIONAL COMPUTER

for the price of a personal computer

At last, a professional computer that doesn't cost more than a personal computer. It's called the Expander, and it's easy for beginners to understand, yet capable of the most complex tasks for your business needs. As a business computer, the Expander can also be used as a word processor, can display graphics in 256 colors, and handle numerous program languages. The Expander accommodates many existing peripherals, making it the most flexible professional computer on the market today . . . and all for the price of a personal computer. The Expander may well be exactly what you are looking for in a computer, but, until now, you haven't been able to find.

EXPANDER CAN BE USED FOR WORD PROCESSING
The Expander also works as a word processor, with a high quality typewriter-style keyboard. Any experienced typist will feel comfortable with the Expander. It's as simple as working with an ordinary typewriter! There are several different word processing programs available for use with the Expander.

EXPANDER DISPLAYS GRAPHICS IN 256 COLORS
The Expander can display your graphics in any or all of 256 colors, all selectable in either BASIC or the system monitor, making it easy for a programmer who wants graphics in many colors. S-100 boards are also available to plug into your Expander for very high-resolution graphic needs.

EXPANDER HELPS YOU TAKE CARE OF BUSINESS
The Expander can help you with all your business needs: Speed up customer service. Avoid hiring extra clerical help. Set up close inventory controls. Produce accurate, timely and complete management reports. Make billing easier. Monitor receivables and payables. Tap underdeveloped profit centers. Free staff from routine tasks for more important jobs. The Expander can help you make dramatic improvements in all these areas!

EXPANDER COMPATIBLE WITH MANY PERIPHERALS
The Expander is a S-100 (IEEE-696) compatible computer, and gives you the widest choice of boards and peripherals available. As a result, the Expander can be used for many applications not previously considered for small computers. For example, controlling very large inventories, communicating intensively with other computers, and monitoring a sophisticated burglar alarm or heating/air conditioning system in several different locations.

EXPANDER CAN USE MANY LANGUAGES
The Expander can use many different program languages: BASIC, PASCAL, FORTRAN, COBOL, APL, ALGOL, C, MACRO and many more that run under CP/M format. If you use a special program language, the Expander is likely to fit your needs.

EXPANDER IS EASY TO UNDERSTAND
The Expander has been designed for easy use, because a computer is only as useful as your ability to understand it. The Expander is very easy to understand, with an easy-to-read instruction book. You will start learning how to program in BASIC within 10 minutes. Try it for yourself. You'll be surprised!

EXPANDER DOESN'T NEED A TERMINAL
The Expander, unlike other more expensive professional computers, doesn't need a separate terminal. This gives you important advantages: faster operation, less cost, and less space.

EXPANDER AND ALL THIS
High quality typewriter-style keyboard. Built-in separate calculator keypad. 2 user-programmable function keys w/4 functions. 4 cursor control keys. Screen format: 24 Characters/line-24 lines. Characters in both upper and lower case. 4K ROM operating system. 64K RAM memory. Parallel printer interface (Industry standard). S-100 Bus (IEEE-696) w/4 slots. CP/M compatibility. Z80 A processor (3.58 MHz). Real-time clock. RS-232 Serial interface. Cassette tape Interface. Video output & color graphics in 256 colors. Complex-tone generator w/internal speaker. Expandable to 512K of memory!

Includes 64K of RAM

WOWIE! LOOK AT THIS!

6502 BOARDS & ACCESSORIES



Electrohome Monitors & Accessories

EDM926/B&W	\$159.50
9" Black & White monitor	
EDM926/P31	\$169.50
9" P31 Green Monitor	
EDM1226/B&W	\$179.50
12" Black & White Monitor	
EDM1226/P31	\$189.50
12" P31 Green Monitor	
ECM1302-1	\$499.50
13" Color RGB Monitor	
ECM1302-2	\$850.50
13" Color RGB Monitor Hi Rez.	
I-1302	\$ 69.50
NTSC Interface for ECM1302 for Apple II Computers	
MP-1302-APL	\$249.50
RGB Card for Apple II or Franklin 100	

ABB-2	\$59.95
Has on-board provision for 64K RAM 80x24 Video, Floppy Controller and 6 slots.	
2114L-3 Low power RAM	\$2.25
AMB-1	\$399.50
Mother Board, APPLE II Compatible, Assembled & Tested c/w Basic ROMS, 48K RAM, Made in Japan	
ABB-1	\$ 55.00
APPLE II Compatible, Motherboard (no components)	
6502 Board Kit	\$275.00
Includes all parts	
PDA-232C	\$169.00
Serial interface RS232C Card for APPLE II c/w Cable & Manual, Three Operating Modes: I/O, Terminal, Remote	
AEB-1	\$169.00
EPROM Burner Card	
AIC-1	\$139.00
Integer Card	
AEC-1	\$169.00
80 Column Card	
AZC-1	\$149.00
Z80A (CPM) Card	
APC-1	\$149.00
Parallel Printer Card	
ASC-1	\$179.00
Serial Printer Card	
ALC-1	\$119.00
16K RAM (Language) Card	

AGC-1	\$219.00
Graphics Parallel Printer Card	
AKB-1	\$119.95
Keyboard; replacement for APPLE II	
AC-1	\$99.95
Beige APPLE II Case (No keyboard)	
KBC-1	\$ 29.00
Plastic 2-tone Beige & Brown Case for Apple-type keyboard	
APS-1	\$ 99.00
Switching Power Supply for APPLE II; +5V @ 5 amps, +12V @ 1 amp, -5V @ 1 amp, -12V @ 1 amp	
APS-2	\$119.95
Switching Power Supply for APPLE II; +5V @ 3 amps, +12V @ 2 amps, -5V @ 1/2 amp, -12V @ 1/2 amp; c/w on-off switch & connecting wires	
AAA-2 (Siemens)	\$450.95
Disc Drive, 5 1/4", APPLE II Compatible, Excluding Controller Card	
ADC-1	\$109.95
Disc Drive Controller Card for two drives; Apple II Compatible	
AXT	\$ 5.50
14.31818 MHz Crystal for APPLE II; HC-18/U package	

APPLE II is a registered trade mark of Apple Computer Inc.

ORION
Electronic Supplies Inc.

ELECTRONIC DISTRIBUTOR
INDUSTRIAL - EDUCATIONAL - COMMERCIAL - HOBBYIST

Circle No. 6 on Reader Service Card.

COMPUTER ROOM ORION ELECTRONICS COMPUTER ROOM ORION ELECTRONICS COMPUTER ROOM

A brand-new Special Publication from

Electronics Today

INTERNATIONAL

**Personal
Computer
Guide**

**Special
Publication** **\$3.95**
MAY 1983

From Electronics Today Magazine **Spring 1983**



Fifteen in-depth Computer Reviews

ZX81 Update • Selecting a Printer
Modems • Hex Notation
Bulletin Boards • CP/M for Apple II



A bumper issue containing reprints of the Computer Reviews from recent ETI issues plus several features such as choosing a printer, the best from our Computing Today column, and software information.

Our last special publication, Circuits File, was extremely successful; we have even more confidence in Personal Computing Guide.

\$3.95

cover price

Available end of March from your newsstand, component and computer store or by mail from ETI, #6, 25 Overlea Blvd., Toronto, Ont. M4H 1B1. Please add \$1.00 for postage and handling. Cover date Spring 1983

Compact Digital Multimeter

New from Hickok is the Model LX-306 digital multimeter, named the "Pied Piper" and featuring the same VARI-PITCH[®] audible tone as previously introduced in Hickok's Model MX-333, yet more compact and economical.

The LX-306 has 3½ digit capability and is accurate to within 0.25%. Includes full AC/DC voltage ranges up to 1000 VDC, 750 VAC (usable to 5 kHz), 10 Amp AC/DC current ranges, resistance ranges from 200 ohms to 20M ohms, diode test function, 10M ohms input impedance and VARI-PITCH[®].



The Canadian price is \$189.00. Contact Rogers Electronics, P.O. Box 310, Ajax, Ont. (416) 683-4211.

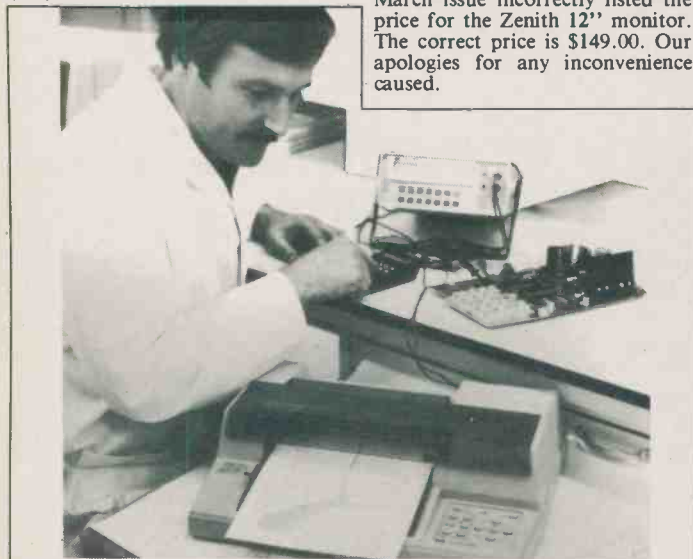

Plotter Module for HP-41

A low-priced system for generating graphics and bar code with the HP-41 handheld computers is now available from Hewlett-Packard. With the introduction of the plotter module, HP-41 owners can link their handheld computers to the HP 7470 color graphics plotter and plot charts, graphs and bar code. The HP-41 handheld com-

Batteries Eliminate Topping-Up

Standby batteries which are the first sealed cells available with this capacity, need no topping-up and are a third of the size and half the weight of conventional batteries have been developed by a British firm.

The gases which are normally evolved in the float/recharge operation recombine to form water so that no topping-up is required. This also allows the battery to be sealed for life, which is expected to be about 10 years. In a six-month shelf life, a battery will lose 50% of its charge and a freshening charge should be given with a constant potential charger.

Currently available are two 2V batteries, with capacities of 60 Ah and 150 Ah, and a 6 V monobloc type with a 55 Ah capacity. A 300 Ah capacity type will be available shortly.

Canadian Agent: Chloride Canada Limited, 7480 Bath Road, Mississauga, Ontario L4T 1L2. (416) 677-8627.



Correction

The advertisement for Artech Peripherals Unlimited in our March issue incorrectly listed the price for the Zenith 12" monitor. The correct price is \$149.00. Our apologies for any inconvenience caused.

Also...

RCA plans to introduce an advanced "CED" VideoDisc Player late in the second half of 1983 with interactive random capability.

The new player will have the ability to search out specific segments of video information contained in the two-hour "CED" disc, thus clearly showing the potential of the "CED" system in applications other than consumer entertainment.

Webster Instruments, 1134 Aerowood Dr., Mississauga L4W 1Y5, have introduced a sine wave oscillator from Krohn-Hite which has only .001% distortion. It also features pushbutton frequency selection from 1 Hz to 110 KHz in .1 Hz steps. Also announced: the K-H Model 6900 distortion analyser which has completely automatic nulling and level setting.

Department of Industry and Regional Expansion reported more than \$2-billion in trade deficits for computers and office equipment. This may be why it's shortened to DIRE. The high level of imports is said to be due to a rapid growth in demand for office automation equipment, much of which is supplied from the U.S. Observers predict the situation will worsen to \$5-billion by 1986.

The Foreign Investment and Review agency has allowed Arrow Electronics of Connecticut to acquire control of the business carried on by Cescio Electronics of Montreal.

The electronic keyboard and video display screen is fast replacing the traditional "plugs-in-hole" operator system of the past. TOPS, short for Traffic Operator Position System, computerizes many telephone operator functions, including the manual timing, ticketing and much of the supervising of phone calls.

Designed by Bell-Northern Research and manufactured by Northern Telecom, TOPS gives the operator more complete knowledge of all the details of each call. Depending on the type of call, the video screen can show the number being called, the credit card or billing number, the applicable billing rate, the routing of the call, the number of the hotel room or extension. If this is necessary for accurate billing, along with other information.

The Department of Industry Trade and Commerce reports that the electronics industry in Canada spent \$42 million on integrated circuits for the year ending in June 1982. This contrasts with \$15 million spent on discrete semiconductors. Figures for vacuum tubes were not available, though.

The Canadian Radio Relay League estimated in their December newsletter that there are about 22,000 amateur radio operators in Canada.

Research and Development spending in Canada this year is estimated at 1.2 per cent of Gross National Product and while this is still well below the proportion allocated by other countries in this field, it is the highest level in Canada in a decade. The federal government has a goal of 1.5 per cent by 1985. In a brief report November 29, Statistics Canada said that a number of other indicators show that Canada does not seem to be as active as other countries in the science and technology fields. For example, only 7 per cent of the patent applications filed in Canada are for inventions by Canadians.

RCA's Burt L. Prosser, of Canadian Sales Operations, who predicts a record-breaking year in 1983, says that "In spite of the recession, VCR sales more than doubled in 1982 throughout the industry, with an estimated 220,000-240,000 units sold in '82, compared to 100,000 in '81. Video disc player sales came on strong in the fourth quarter and video disc sales sky-rocketed, with an estimated quarter million discs sold in Canada last year. And 1982 was also a very good year for video camera sales."

The industry's fastest RAM has been introduced by Motorola. It's the new bipolar 64-bit ECL RAM (MC10H145) with an address access time of 3 ns (typ) and 6 ns (max). The MC10H145 is organized as a 16x4 memory array and is a member of the MECL 10KH family.

These very high speeds were achieved through new circuit designs as well as advanced processing techniques.

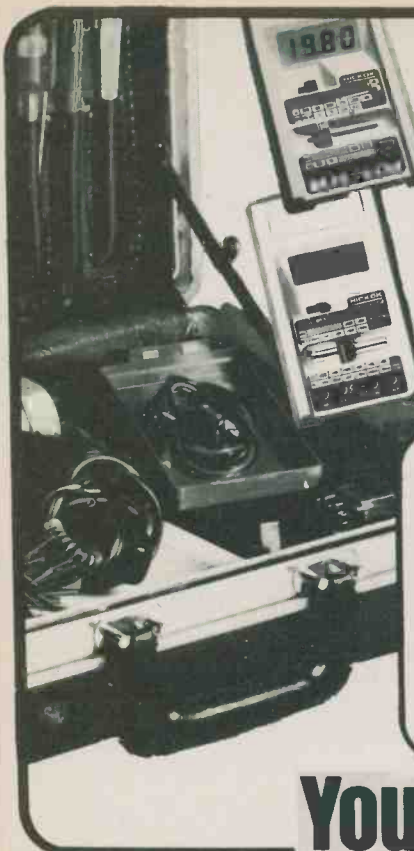

LX304 digital multimeter with automatic decimal point, built in low battery indicator and transistor testing capability. **\$138.00**

LX303 digital multimeter with easy-to-read LCD display. Only **\$110.00**

Model 216 Transistor Tester with fast, automatic switching for instant good-bad analysis of NPN's, PNP's, FET's, diodes and SCR's in or out of circuit. **\$172.00**

Model 240 Video Generator with 10 step gray scale staircase for VTR, CCTV monitor and TV applications. **\$230.00**

HICKOK
the value innovator

ROGERS electronic instruments Ltd.
P.O. Box 310, 595 Mackenzie Ave. Units 1&2
Ajax, Ontario L1S 3C5. Tel. (416) 683-4211
Duty and FST included. ChargeX (Visa) accepted.
Ontario residents add 7% sales tax. Shipping extra.

FOR THOSE ON THE GO FROM... HICKOK
the value innovator

ROGERS electronic instruments Ltd.

Your Toolbox Test Bench

Circle No. 4 on Reader Service Card.

<p>AUDIOVISION</p> <p>EASTERN CANADA: 578 MARLEE AVE., TORONTO, ONT. M6B 3J5 TEL: (416) 781-3263</p> <p>MAIL ORDER: SEND A CERTIFIED CHEQUE OR MONEY ORDER PLUS \$5.00 FOR SHIPPING & HANDLING. ONTARIO RESIDENTS ADD 7% SALES TAX. PERSONAL CHEQUE, VISA AND MASTER CARDS ONLY ACCEPTED ON ORDERS SENT TO OUR TORONTO STORE.</p>		<p>WESTERN CANADA: P.O. BOX AMF23581, VANCOUVER, B.C. TEL: (604) 271-7539</p>																											
<p>6502 COMPUTER</p> <p>PARTS, KITS AND ACCESSORIES. ONE STOP SOURCE.</p>		<p>PLASTIC CASE</p> <p>\$78.00</p>																											
<p>6502 MOTHER BOARD (BARE)</p> <ul style="list-style-type: none"> • HIGH QUALITY MADE • PRINTED PARTS LOCATION • ON-BOARD PROTOTYPE • COLOUR & CRYSTAL TRIM V.C • ONE OF THE BEST BOARDS IN THE MARKET <p>\$55.00</p>		<p>DISK DRIVE</p> <p>COMPLETE & READY TO PLUG INTO CONTROLLER CARD AND USE WITH YOUR COMPUTER.</p> <p>SLIMLINE DRIVE \$325.00</p> <p>FULL HEIGHT DRIVE \$369.00</p>																											
<p>KEYBOARD</p> <ul style="list-style-type: none"> • HIGH QUALITY MADE • BROWN COLOR KEYS. • UPPER & LOWER CASE • SUITABLE FOR OUR ABS OR ALUMINUM CASE <p>\$128.00</p>		<p>JOY STICK</p> <p>\$30.00</p> <p>COMPLETE WITH 4 PRESS SWITCHES AND CONNECTION CABLE</p>																											
<p>SWITCHING POWER SUPPLY</p> <p>CAPABLE TO RUN TWO DISK DRIVES AND SEVERAL PERIPHERALS.</p> <p>+5V 3A, +12V 2.5A -5V 0.3A, -12V 0.3A</p> <p>\$105.00</p>		<p>MODULATOR</p> <p>WITH SWITCH AND CABLE \$25.00</p>																											
<p>LOW COST LINEAR POWER SUPPLY</p> <p>-5V 1/2A, 5V 6A -12V 1/2A, 12V 1.5A (Up to 2.5A)</p> <p>KIT \$29.50</p> <p>POWER TRANSFORMER \$15.00</p>		<p>REPAIR SERVICE</p> <p>WE REPAIR 6502 COMPUTER BOARDS AT REASONABLE CHARGES.</p>																											
<p>12" ZENITH MONITOR</p> <ul style="list-style-type: none"> • GREEN PHOSPHOROUS SCREEN • COMPLETE w/HOUSING & POWER SUPPLY. • READY TO USE WITH YOUR COMPUTER. • SELECTABLE SWITCH FOR 40 OR 80 CHARACTERS. <p>\$135.00</p>		<p>PERIPHERAL CARDS</p> <table border="0"> <tr> <td></td> <td>A. & T.</td> </tr> <tr> <td>1. Integer basic card (5 ROM)</td> <td>\$70.00</td> </tr> <tr> <td>2. FOTH-79 card</td> <td>70.00</td> </tr> <tr> <td>3. Language card</td> <td>72.00</td> </tr> <tr> <td>4. 16K RAM card</td> <td>68.50</td> </tr> <tr> <td>5. Z80 soft card (Z80A 4MHz)</td> <td>85.00</td> </tr> <tr> <td>6. 80 Column card</td> <td>88.50</td> </tr> <tr> <td>7. Disk interface card</td> <td>85.00</td> </tr> <tr> <td>8. Epson printer interface card (with cable)</td> <td>95.00</td> </tr> <tr> <td>9. RS-232C serial card (with cable & connector)</td> <td>95.00</td> </tr> <tr> <td>10. EP-ROM writer card (2708-2764)</td> <td>98.50</td> </tr> <tr> <td>11. Communication card</td> <td>99.00</td> </tr> <tr> <td>12. Parallel card</td> <td>65.00</td> </tr> </table>			A. & T.	1. Integer basic card (5 ROM)	\$70.00	2. FOTH-79 card	70.00	3. Language card	72.00	4. 16K RAM card	68.50	5. Z80 soft card (Z80A 4MHz)	85.00	6. 80 Column card	88.50	7. Disk interface card	85.00	8. Epson printer interface card (with cable)	95.00	9. RS-232C serial card (with cable & connector)	95.00	10. EP-ROM writer card (2708-2764)	98.50	11. Communication card	99.00	12. Parallel card	65.00
	A. & T.																												
1. Integer basic card (5 ROM)	\$70.00																												
2. FOTH-79 card	70.00																												
3. Language card	72.00																												
4. 16K RAM card	68.50																												
5. Z80 soft card (Z80A 4MHz)	85.00																												
6. 80 Column card	88.50																												
7. Disk interface card	85.00																												
8. Epson printer interface card (with cable)	95.00																												
9. RS-232C serial card (with cable & connector)	95.00																												
10. EP-ROM writer card (2708-2764)	98.50																												
11. Communication card	99.00																												
12. Parallel card	65.00																												
<p>PACKAGE DEAL</p> <p>PACKAGE 101: \$120.00 All IC's, RAMS, 6502 CPU and blank 2716's.</p> <p>PACKAGE 102: \$26.00 All resistors, capacitors, diode, TRS, crystal, coil and jacks.</p> <p>PACKAGE 103: \$40.00 All IC sockets and 50-pin edge connectors.</p> <p>PACKAGE 104: \$7.00 Speaker, keyboard cable w/Header, stand off.</p> <p>Assembled mother board without IC's \$160.00</p> <p>A. & T. Mother Board with all parts and blank EPROMs. \$325</p> <p>COMPLETE 6502 KIT: \$545.00</p> <p>THIS MONTH ONLY</p> <p>Kit includes mother board, plastic case, keyboard, switching power supply, Package 101, 102, 103 and 104.</p>																													

Inertial Navigation Systems

It took the human race over 900 years to progress from the primitive lodestone compass to a self-contained navigation system dubbed INS — the inertial navigation system. Here's a rundown on how it works.

THE EARTH's rotation was discovered by Heraclides of Pontus in the 4th Century BC. During the next century, Erathosthenes of Cyrene calculated the circumference of the Earth to be approximately 38,500 km (24,000 miles), a figure undisputed for another 20 centuries.

Early writings suggest that the first lodestone compass was discovered by the Arabs or Chinese around 100 BC. The first reference to its use by Europeans is dated 1178. Also, the astrolabe was discovered about this period, the predecessor of the sextant, which was used to measure the angular elevation of stars and planets with respect to the horizon. This information was used in conjunction with elementary astronomical tables and time to plot a rudimentary navigational fix. Using this type of instrument, Columbus sailed to the New World.

The following inventions, together with Newton's Laws of gravitation, and Faraday's rules of electricity and magnetism, made INS a reality:

- an accurate marine chronometer (1766)
- the Foucault pendulum (1800)
- the marine gyro compass (1909).

The basics of INS

A basic inertial navigation system comprises the following subsystems:

- gyros
- accelerometers
- a computer.

A gyro is a device which, when spinning, points to a fixed position in space. To move the gyro from this position, pressure must be applied to the mounting frame (gimbals). If the

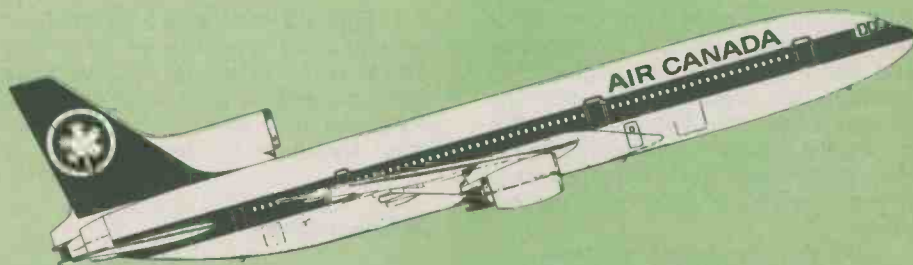

Motion detection systems of incredible accuracy are used to display the position of aircraft, submarines, ships and missiles. The units compute the craft's speed by measuring acceleration, and its course by gyroscopic detection of deviation from a straight line. The instruments used are sensitive enough to be seriously affected by a speck of dust.

gyro is moved up or down, it moves to the left or right. This action is called 'precession'.

An INS employs two gyro subsystems, one fitted in each horizontal plane or axis (X and Y). However, gyros are themselves subject to natural precession (errors) caused by the rotation of the earth (coriolis error) and the movement of the vehicle in which the gyro is fitted (attitude error). These errors are corrected by a servo or follow-up loop.

An accelerometer is an instrument which measures lateral movement and converts it to an electrical signal. To reduce errors in the accelerometers they are usually mounted to the gyro assembly. The electrical outputs from the instruments are converted to a suitable form and applied to the associated computer. Usually three accelerometers are fitted in a system, one in each axis (X, Y and Z).

The computer associated with an INS provides the following functions:

- coriolis correction
- latitude information
- attitude correction
- longitude information
- altitude or depth information
- distance travelled
- vehicle speed
- true or magnetic course data
- Earth's radius.

However, other systems are used in conjunction with INS to provide all the stated functions.

The computer runs an operational program automatically at a system switch-on, or manually via the associated control unit. The program employs algorithms to solve various forms of mathematical equations, using detected variable and fixed quantities generated within the system or externally. These include distance travelled, vehicle acceleration, and the Earth's radius and rotational rate.

Although a self-contained system, its accuracy deteriorates with running time. This requires some form of external positional updating every 24 hours. Radio navigation aids are normally used for this purpose. These include Omega, Decca, LORAN and distance measuring equipment (DME).

A basic inertial navigation system is shown in Figure 1 and operates as follows.

The accelerometer output (1) is integrated to a velocity function (2). A second integral produces distance travelled (3). This is added to initial position (4) and updates the present latitude (7). Present latitude is processed to provide Earth-rate torque (8). The velocity function (5) is processed to give transport torque rate (6). This and Earth-rate torque are added to generate gyro correction (9).

Inertial Systems

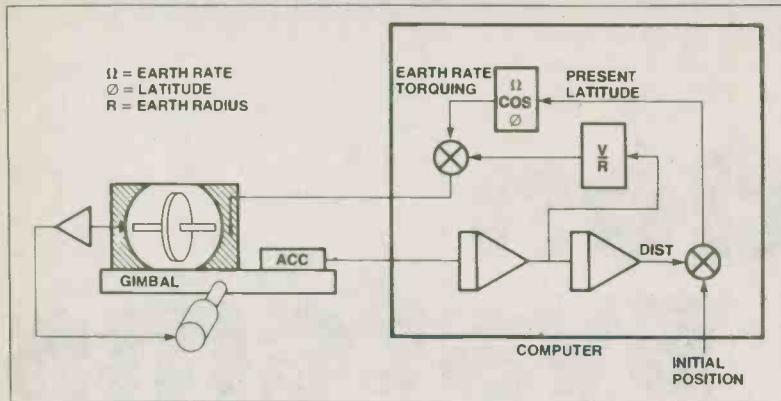

Fig. 1 Basic INS diagram.

This quantity causes the gyro rotor (10) to tilt with respect to the case and generate an output signal (11), which in turn is amplified to drive the gimbal motor (12). The gimbal motor moves the gimbal (13) in proportion to the Earth-rate and transport-rate terms, providing platform corrections.

Inertial navigation systems are fitted to military and commercial aircraft, surface ships of all types, submarines, hovercraft and space vehicles. To cater for this variety of system applications, the basic differences between types are as follows:

- a shipborne system requires precision gyro assemblies but less accurate accelerometers.
- an airborne system requires precision gyros and accelerometers.
- a missile-installed system requires less accurate gyros but precision accelerometers.

System description

An inertial navigation system can be divided into the following sections for the purposes of description:

- simplified INS operation
- accelerometers
- gyros
- types of gyro
- platform stabilisation
- platform corrections
- system alignment
- system computer.

Simplified INS operation

The objective of all forms of navigation is to guide a vehicle from one point to another, relative to a reference system. Figure 2 shows a grid reference system upon which the course of an aircraft has been placed, and provides vector representation of the movement of the X and Y-axis accelerometers.

Figure 3 illustrates a simple form of computer capable of resolving equations relating to vehicle displacement. Figure 4 presents a graphical indication of acceleration input and displacement output.

Accelerometers

A basic accelerometer, shown in Figure 5, comprises a precision-machine slug, or 'proof mass', which slides in a frictionless tube when lateral movement is detected. The slug is retained in the 'null' or zero position by springs. The magnitude of slug movement is a measure of acceleration, which is converted to an electrical signal by a 'pickoff unit'.

An alternative type of accelerometer, which operates on the pendulum principle, is detailed in Figure 6. This device provides displacement data in angular rather than linear form.

The relative movement of the mass in most accelerometers is restrained and therefore small, so small that it can only be detected by electrical measurement (via the pickoff). The pickoffs comprise a pair of primary coils, mounted to the instrument case. A secondary coil attached to the mass, sits between the primary coils in the null position.

An excitation supply, applied to the primary and secondary coils, is arranged to provide zero output at the null. Under acceleration, the secondary coil moves towards one or the other primary coils and changes the phase and voltage output. The phase relationship between primary and secondary coils determines the sense of the acceleration (plus or minus) while the amplitude is proportional to acceleration magnitude.

In a typical application, the accelerometer output is amplified and used to drive a phase sensitive demodulator. The dc output signal is used to reset the mass to null, while

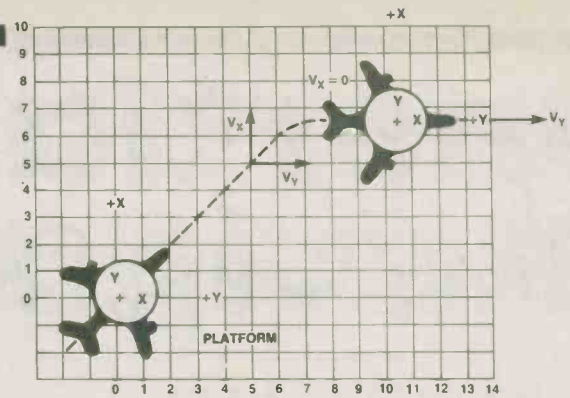

Fig. 2 Two-axis navigation grid.

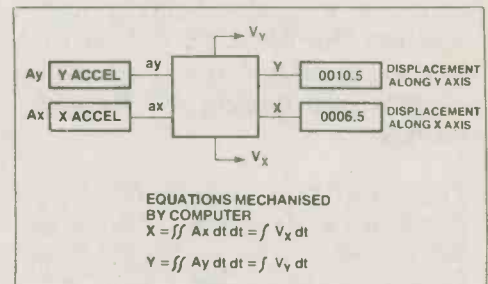

Fig. 3 Simple INS computer.

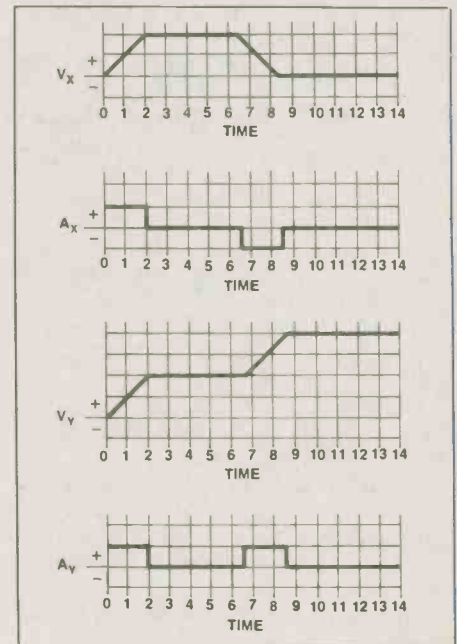

Fig. 4 Acceleration input and displacement output.

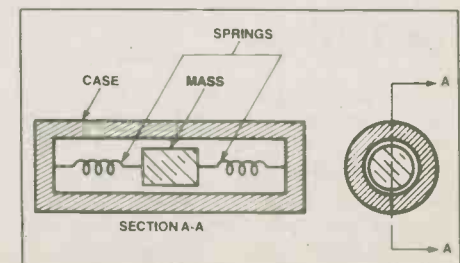

Fig. 5 General arrangement of a slug-type accelerometer.

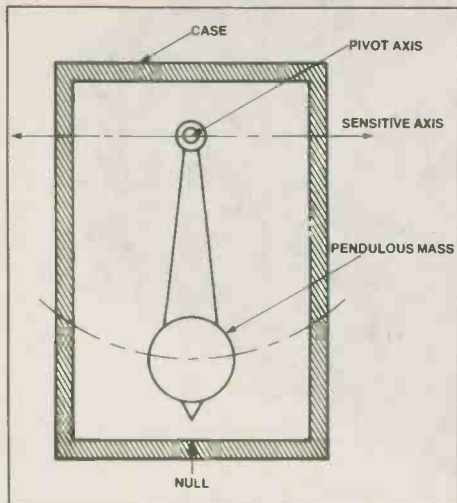

Fig. 6 General details of a pendulum-type accelerometer.

generating a sense and magnitude input signal to the system computer.

This action is called torque rebalancing, which instead of measuring mass displacement, measures the current required to return the mass to the null position. A torque rebalancing arrangement is shown in Figure 7.

Both types of accelerometer exhibit natural oscillatory characteristics, which are neutralised by immersion in damping fluid, carefully matched to the density of the mass to achieve neutral buoyancy. Other mechanical components reduce vibration and component instability to provide accuracies down to $10^{-6}g$.

The latest types of accelerometer employ ceramic discs and capacitive pickoffs incorporated in a bridge circuit to detect acceleration displacement, the amount of electrical imbalance indicating the magnitude of the sensed acceleration. This signal is then used to operate a coil, called a force motor, or 'torquer', provides a computer input in a similar manner to the inductive type of accelerometer. However, the capacitive device uses fewer components and is much smaller.

Gyros

In 1750, a Swiss mathematician called Euler studied the behaviour of spinning rotors and documented his findings. A century later, a Frenchman, Foucault, constructed a device to demonstrate the Earth's rotation. He called it a gyroscope, from two Greek words — gyros (to

turn) and skopios (to see or view). A German, Dr. Kaempfe, produced the first marine gyro compass, followed three years later by Elmer Sperry, who set the standard for gyro compass design until the introduction of INS in the 1950s. A modern gyro contains the following items:

- wheel assembly
- gyro motor
- spin bearings
- float elements
- signal pickoffs
- torque elements
- lead-in wires
- magnetic shields
- case.

The majority of the angular momentum of a spinning gyro is provided by the wheel assembly, which is a compromise of design factors. These include weight, rotation speed, diameter and construction material. Gyro wheels are usually manufactured of beryllium, to take advantage of its mechanical stability. However, titanium and stainless steel are used for some applications.

A gyro wheel is driven by a polyphase synchronous hysteresis motor, which is excited by a high frequency supply in order to achieve the required operating speed. The relative inefficiency of the motor is overcome by saturating the rotor to produce a virtual permanent magnet motor. However, the hysteresis motor has the ability to maintain, at synchronous speed, any load that it can accelerate from a dead stop.

The spin bearings are either long-life conventional ball bearing assemblies or gas-lubricated bearings. The latter eliminate metal-to-metal contact between surfaces once the device is operating. To achieve

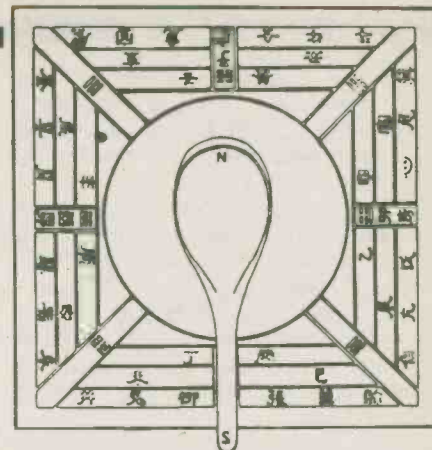

Primitive Chinese compass consisting of a magnetic spoon resting on a polished copper plate.

this state, the bearings run in a bath of gaseous lubricant, usually helium or hydrogen. This reduces wear to nil while the gyro is rotating, and provides an unlimited life expectancy, determined by the number of system stop-start cycles.

The gyro float elements provide support for the spin bearings, gyro wheel, torque elements, and pickoffs, as well as forming a sealed enclosure around the rotating components. Floatation comprises suspension of the gyro sensing elements in liquid, in a similar manner to the slug of an accelerometer. However, gimbaled (two-axis stabilised) rotor assemblies do not require floatation and are called 'dry gyros'.

The signal pickoff units monitor the angular displacement of the rotating components with respect to the gyro case and produce an electrical output proportional to this displacement. The pickoff elements are either inductive or capacitive devices which are highly sensitive electrical transducers, excited by an

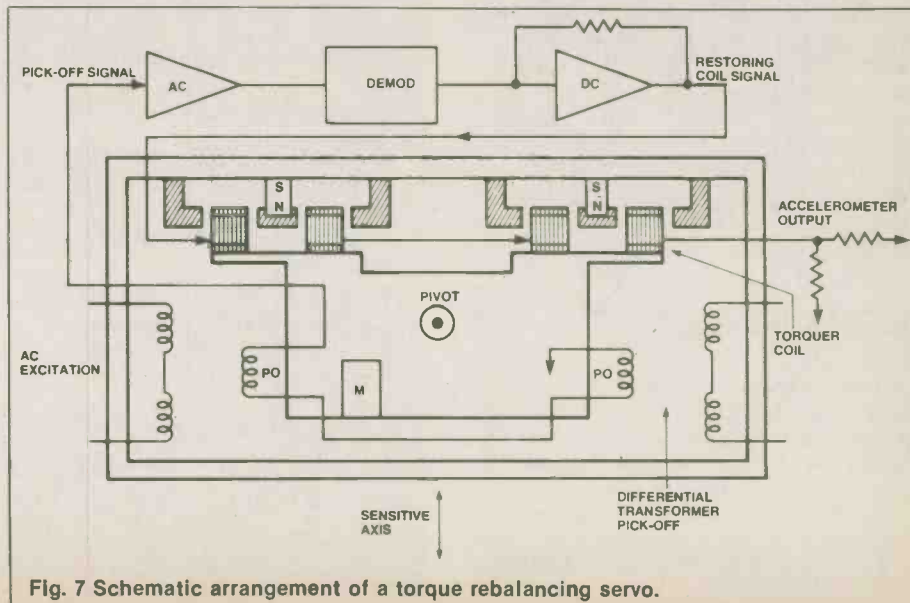

Fig. 7 Schematic arrangement of a torque rebalancing servo.

Inertial Systems

ac supply. Their characteristics ensure that they produce negligible heat and are capable of resolving the smallest increments of motion inherent in a gyro system.

The torque elements, which reposition the gyro assembly, are either synchro devices or dc force motors. These elements are manufactured to precision tolerances as they are required to produce high, variable precession velocities associated with components of Earth-rate varying with latitude.

The lead-in wires or ribbons connect the ac supply to the gyro motor, provide a signal path for the pickoffs, and apply input signals to the torquing elements. Mechanical errors produced by the lead-in wires are reduced by design.

Magnetic shields, which are made of steel alloys, are placed around the gyro assembly to reduce the effects of stray magnetic fields. These fields could produce unwanted torque on the moving parts.

The case provides a protective, gastight enclosure for the gyro assembly, and acts as a frame for the moving parts. The inside of the case is fitted with sensors which indicate the presence of moisture, high temperatures and excessive pressure.

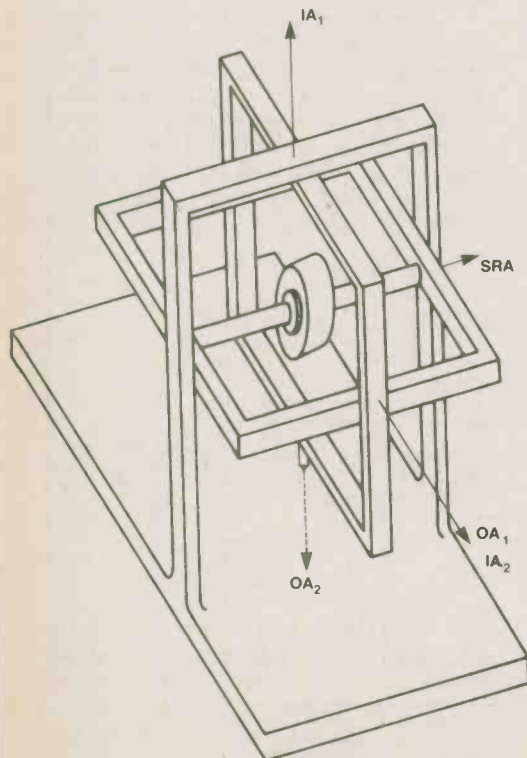
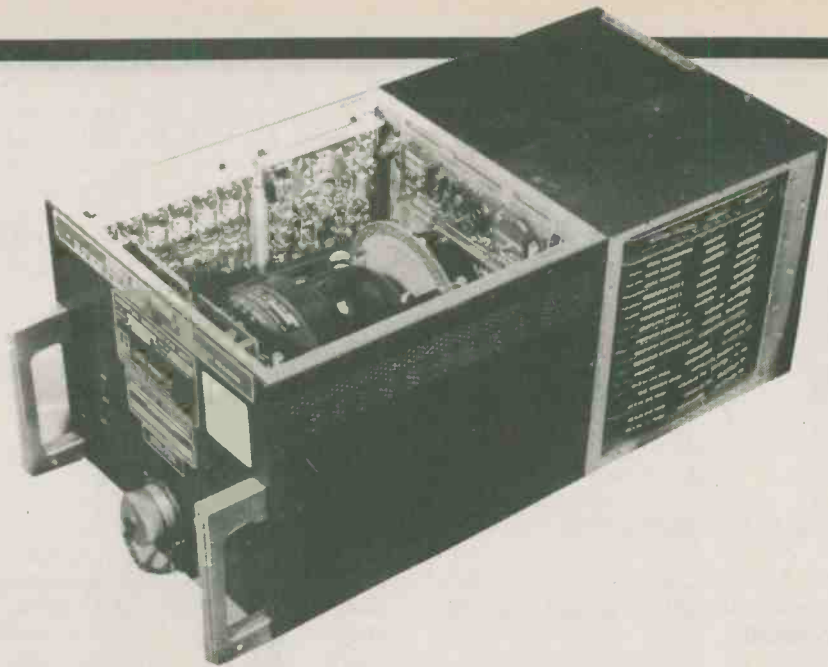

Fig. 8 A gimbaled two-degrees-of-freedom (TDF) gyro.



A gimbal system, from Litton. This unit contains a cantilevered gimbal set comprising two non-floated, two-axis, precession-tuned rotor gyroscopes and three flexure-supported, non-floated, torque-to-balance accelerometers.

Types of Gyro

There are two main types of gyro used for INS applications, the single-degree-of-freedom (SDF) type and the two-degree-of-freedom (TDF) type. The TDF gyro can be either a floatation or a gimballed device; Figure 8 shows the latter.

The gimballed TDF gyro can accept two different input torques, 90° apart. The input axis for one torque (IA₁) is also the output for one pickoff (OA₂); the converse (IA₂ and OA₁) is also true. Therefore two TDF gyros provide four sensing axes, three (X, Y, and Z) of which can be controlled by two gyros. The redundant axis is caged or pegged in a closed loop servo condition.

By driving the rotor at the natural frequency of the support gimbals (tuned rotor) a rugged, unfloated gyro system is produced which has the following advantages over other gyro systems:

- reduction in components by 40%
- simplification of test and calibration procedures
- reduced manufacturing and repair costs
- improvement in reliability and mechanical performance
- increased system accuracy
- considerable reduction in size and weight.

An operational gyro of the tuned rotor type is shown in Figure 9. The rotor, which consists of a ring magnet encased in a soft iron return path fitted with a circumferential slot, is driven by a 400 Hz supply. The torquer (torque elements) comprises four coils,

wound on a cylindrical former attached to the case. The coils in turn fit into a slot in the inertial ring where they can influence its magnetic field. The pickoffs are also magnetic devices consisting of differential transformers, which are influenced by the flux in the inertial ring. This method of pickoff can detect angular displacements in the order of 0.1 seconds of arc. To reduce non-magnetic, unwanted torques, the gyro operates in a low pressure hydrogen atmosphere.

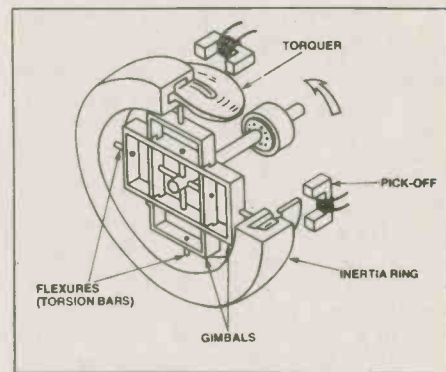

Fig. 9 A 'tuned rotor' operational gyro.

Platform Stabilisation

The gyros, accelerometers and associated equipment are known as the 'inertial platform' or 'platform' to distinguish them from the electronic, electrical and fixed components which form the rest of an INS installation.

The rotating gyro assembly possesses angular stability; the ac-

celerometers do not, and therefore must be stabilised. This is achieved by mounting the gyros and accelerometers to a common platform. As the gyro case is attached to the same assembly as the accelerometers, their angular movement reflects the displacement between the gyro case and the rotor. These changes in movement are detected and held to a tolerable level, which in turn stabilises the platform. The application of this technique is detailed in Figure 10; however, the circuit shown is for one axis (X) only.

As the signal detected by the pickoff varies, the demodulator provides a drive signal of the opposite polarity to the platform drive motor, which adjusts the platform attitude accordingly. Over-correction is prevented by secondary servo loops.

Stabilisation in three axes (X, Y and Z) requires two gyros and three accelerometers, one in each axis. However, the Z-axis is generally used to generate platform correction terms and in airborne systems to provide altitude information, whereas the X and Y axes are used to generate navigational information.

Platform corrections

When used for terrestrial navigation, an INS is subject to two major forms of error, Coriolis error and centripetal error. Coriolis error is due to the rotation of the Earth, which acts upon the gyros, and centripetal error is brought about when the platform moves over the surface of the Earth between poles.

Compensation for Coriolis error is achieved by the application of the Earth's rotation rate (approximately 15 degrees of arc per hour at the equator) to the platform. However, the rate varies with respect to latitude angle and is produced from a resolution of vector, as shown in Figure 11. These vectors are calculated from the following equation:

$$\begin{aligned} \text{Horizontal vector} &= \Omega \cos \phi \\ \text{Vertical vector} &= \Omega \sin \phi \end{aligned}$$

where Ω is full Earth rate (15 degrees) and ϕ is latitude angle.

Centripetal correction is only applied to the horizontal (X and Y) axes of the platform, as the vertical (Z) axis is insensitive to centripetal accelerations.

If the platform is held tangential to the curvature of the Earth, moves at a constant velocity, shares the Earth's centre of gravity, and moves over a great circle path (one whose

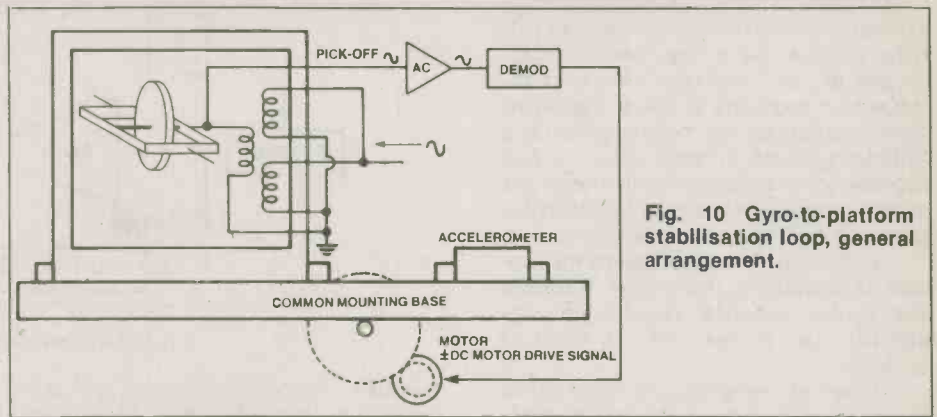

Fig. 10 Gyro-to-platform stabilisation loop, general arrangement.

axis passes through the centre of the earth), then the X and Y axes will sense the path of travel as a straight line and not require centripetal correction. However, any other path requires correction, which takes the form of a constant southward acceleration applied to the X and Y axis accelerometers. This correction is required, as the system, which is north-seeking, possesses an inherent northward drift when moving. The net result of the drift and correction is a zero velocity component applied to the accelerometers. The correction is generated within the system computer.

corrected for ground velocity over a curved surface given by the following equation:

$$\text{radial acceleration} = \frac{\text{velocity}^2 \times \text{gravity}}{\text{Earth's radius}}$$

The necessary functions are generated within the system computer.

System alignment

The operation of an inertial navigation system uses the mathematical integration of acceleration to obtain velocity and positional information.

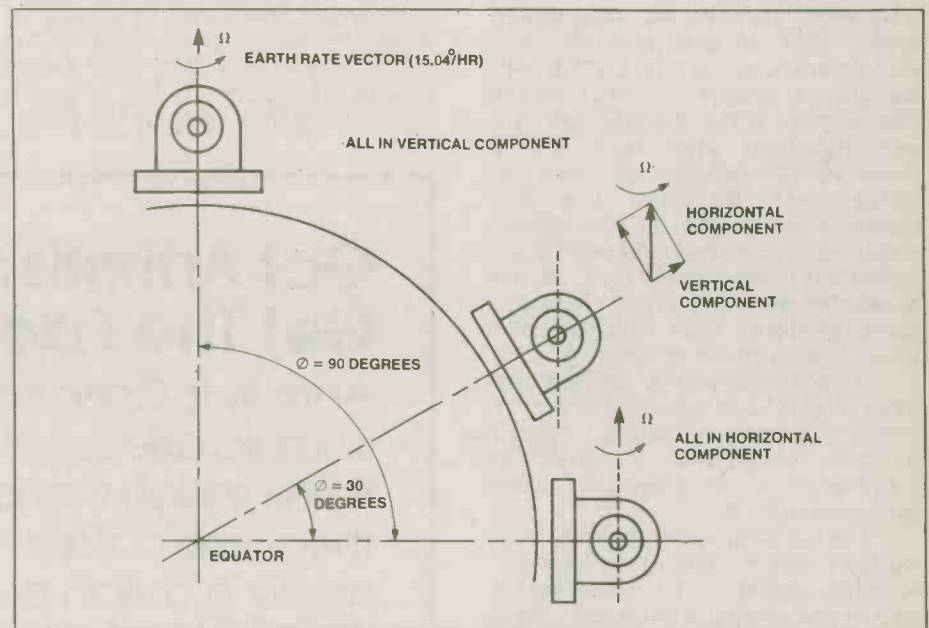

Fig. 11 Resolution of vectors in Coriolis correction.

A servo system in conjunction with the system computer simulates the effect of the platform sharing the Earth's centre of gravity. This is called the Schuler pendulum effect, after the scientist who demonstrated the effect of Earth rotation.

To allow for radial accelerations in the Z-axis, the accelerometer is

To implement any integration process, an accurate initial reference must be established, in this case velocity and position. The establishment of these references is called system alignment.

The alignment procedures entail the matching of platform and computer axes to external or internal

Inertial Systems

known references. External references can be terrestrial, celestial or inertial. Terrestrial reference systems employ surveyed lines, benchmarks, plumb-bobs and bubble gauges. These devices can provide level accuracies in the order of ten seconds of arc and heading accuracies to three minutes of arc.

Celestial reference systems obtain information from star trackers and radio sextants. Accuracies are similar to those for terrestrial devices.

Inertial references comprise some form of portable inertial platform. However, accuracies are only as good as the last equipment calibration, which could have been months previous to their use.

An external reference system uses some form of interface unit to connect to the INS under test. These interfaces take the form of optical couplers, synchro devices, electrical transducers, digital-to-analogue or analogue-to-digital converters, or some form of logic conversion circuit.

Internal or self-alignment systems use the sensors on the platform to sense the physical deviation from a fixed position to align the platform using its servo systems.

To determine the orientation of a three-axis, right-angled co-ordinate system (INS), at least two reference vectors are required. The Earth's spin and gravitational vectors are used for this purpose when implementing a self-alignment procedure. Using these vectors reduces computer requirements because the accelerometer outputs do not require resolution into gravity and vehicle acceleration components. Also, as the accelerometers and gyros share the same platform, their relative positions do not require computing.

A self-alignment is divided into three inter-related modes. The first is coarse alignment, or caging, followed by fine alignment, or levelling, culminating in an operation called gyro-compassing.

Coarse alignment involves slaving the gyro gimbals to their own servo output signals, or to some external source possessing a particular orientation with respect to the vehicle in which the platform is fitted. The caging sequence is automatically implemented by a timing circuit and lasts for about 30 seconds after system switch-on.

Fine alignment, together with gyro-compassing circuit configuration, is shown in Figure 12. The top feedback loop identifies levelling. This involves setting the pendulums of each accelerometer to the null

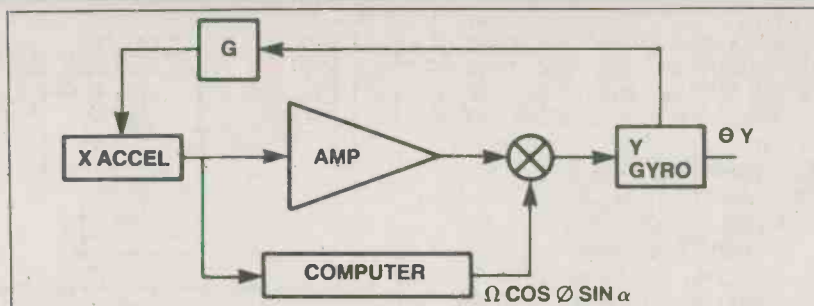

Fig. 12 System alignment servo loops.

position, each pendulum at 90° with respect to the other two. This is implemented by connecting the X-axis accelerometer output, via a function generator (G), to the Y-axis gyro and vice-versa. When the errors between the X and Y axes are zero, the Z or gravity axis is automatically in alignment. This provides one of the unknown vectors; gyro-compassing provides the other.

The bottom feedback loop in Figure 12 identifies the gyro-compassing circuit configuration. If left uncorrected, the platform Y-axis gyro would tilt under the influence of the Earth's spin vector. The angle of tilt is called the 'wander angle' or alpha (α). The system computer produces a set of acceleration corrections to the Y-axis gyro for a range of values for alpha, using a modification of the coriolis correction information detailed in Figure 11. The acceleration correction is given by the follow-

ing equation:

$$\text{acceleration correction} = \cos \theta \sin \alpha$$

When the output of the X-axis accelerometer is zero, the platform has been aligned in the present position and no further system alignment is required. The Y-axis gyro and X-axis accelerometer are then connected in their normal operational configurations (X-axis accelerometer with X-axis gyro).

System computer

The system computer consists of a standard type of digital computer using microprocessor chips for control and computation purposes. The majority of program and mathematical information is held in EPROM memories. Access to the computer control circuits is via an operator-orientated keyboard. A set of digital readout units provides navigational and other data.

ETI

Got Arthritis? Get The Facts!

Arthritis is Canada's number one chronic disease. It affects more than three million Canadians. 30,000 of them are children under 15 and nearly a million are between 30 and 45. Get the facts about arthritis! Contact the office of The Arthritis Society nearest you.



THE ARTHRITIS SOCIETY

Multipurpose PCB



HEAT LIGHT CONTROLLER

In the dark or frozen out? Don't be with the ETI switching unit, designed for porch lights or thermostatic control. Design by Andy Elam. Development by Dave Bradshaw.

ONE OF the main uses of electronics is in control systems. The design we describe here can be used either to control a porch light, so that it comes on when it gets dark, or to act as a thermostat. It's possible to adapt this circuit to other uses as well, provided you have a transducer that varies its resistance with the controlled parameter. So, for example, you could use the same circuit with a level sensor and a relay-controlled valve to keep the water level constant in a storage tank.

If the circuit is used as a thermostat, the transducer should be a thermistor with a negative temperature coefficient and a range of operation covering the temperature you want to control. The values chosen for the circuit should work with most thermistors, but if you have problems you can alter the value of R2 to compensate — it should be within a factor of three or so of the thermistor resistance at control temperature.

How heavy a load can be switched depends on the relay contacts; if you don't use a relay that's up to the job it won't last very long. It is particularly important to use a suitable relay if you want to control a line-powered appliance. And take great care to ensure that the electronics is well separated from the line. Using a more meaty transistor for Q1 (and adjusting R5 and R6 for a correspondingly higher base current) will make it possible to drive a fairly hefty relay, though it must have a 12 V coil.

Construction

Assembly of the components on to the PCB should be straightforward

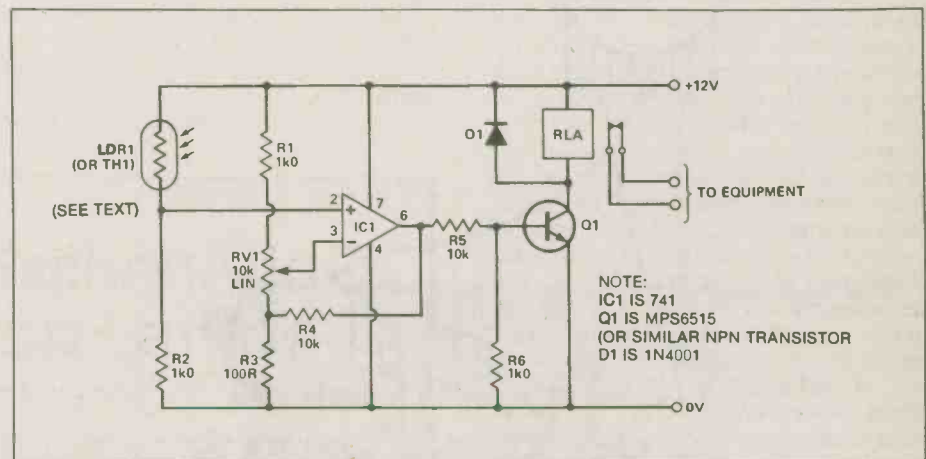
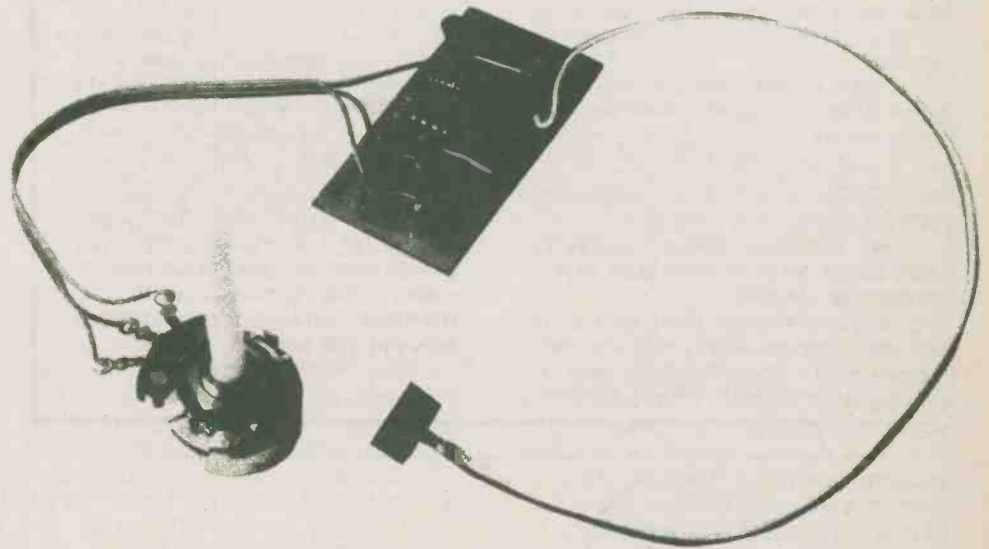

Fig. 1 Circuit diagram of porch light controller or thermostat.

provided the overlay shown is carefully followed. We suggest using Vero pins for the wiring connections and these should be attached first. Next solder in the resistors, then all the other components. Be sure to get the connections of D1 the correct way around and note that the connections of Q1 will vary depending on what type of transistor you use — it may be necessary to bend the leads to get the transistor to fit if you don't use the one we specify.

Once you've built the circuit, you

can check it's working correctly by connecting the power and adjusting RV1. If it is working, the relay will switch on and off as you move the wiper of RV1 from one end of the track to the other.

Next install the transducer in position, and then set RV1 so that the relay energises at the desired light level or temperature. However, the LDR shouldn't be illuminated by the porch light it's controlling, or you'll get oscillation which isn't the effect we're looking for!

Multipurpose PCB

HOW IT WORKS

The only difference between the circuit used as a porch light controller and as a thermostat is the transducer used — the operation of the circuit in sensing the change of resistance of the LDR or thermistor is identical. For the LDR, the resistance increases as the light falling on the sensitive surface lessens. If you use a thermistor with a negative temperature coefficient, as we suggest for the thermostat, then its resistance increases as the temperature falls. So in both cases, the circuit should turn on the relay as the resistance of the transducer increases.

The transducer chosen is used with a 1k0 resistor to create a potential divider at the inverting (-) input of the op-amp, so that the potential seen at the input is dependent on either the light or the temperature. There is another potential divider supplying the non-inverting (+) input, but in this case the input voltage is determined solely by the position of the potentiometer slider (neglecting supply variations).

Differential op-amps have the property of amplifying the voltage difference between the inverting and non-inverting inputs. Without negative feedback, the inter-

nal DC gain of 100 dB (x100,000) is obtained. This means that whenever the inverting input voltage is greater than the non-inverting input voltage, the output of the op-amp goes to its minimum — a volt or two above 0V. If the non-inverting input voltage exceeds the inverting input voltage, the output rises to nearly +12V.

The effect of R3 and R4 is to introduce very limited positive feedback, and so hysteresis (not to be confused with hysteria, which is an effect widely found amongst ETI editorial staff). The op-amp with switch on at one light level (or temperature) and go off at a slightly higher one. This is to provide clean switching, with no flickering on and off of the controlled light or heater.

Q1 is driven via R5 and R6, and in turn drives the relay. R5 is necessary to limit the base current of the transistor; R6 prevents the minimum (off) output of the op-amp from turning Q1 on. D1 protects Q1 against any back-EMF generated by the relay coil.

Transposing the transducer (LDR1 or TH1) with R2 will have the effect of reversing the switching action of the circuit, i.e. the light will go off as daylight fades.

PARTS LIST

Resistors (all ¼ W, 5%)

R1,2,6	1k0
R3	100R
R4,5	10k

Potentiometer

RV1	10k linear
-----	------------

Semiconductors

IC1	741
Q1	MPS6515 (or any other general purpose NPN transistor)
D1	1N4001

Miscellaneous

LDR1	ORP12 or Radio Shack 276-116 or thermistor — see text
TH1	12V relay, minimum coil resistance 100R; see text

PCB

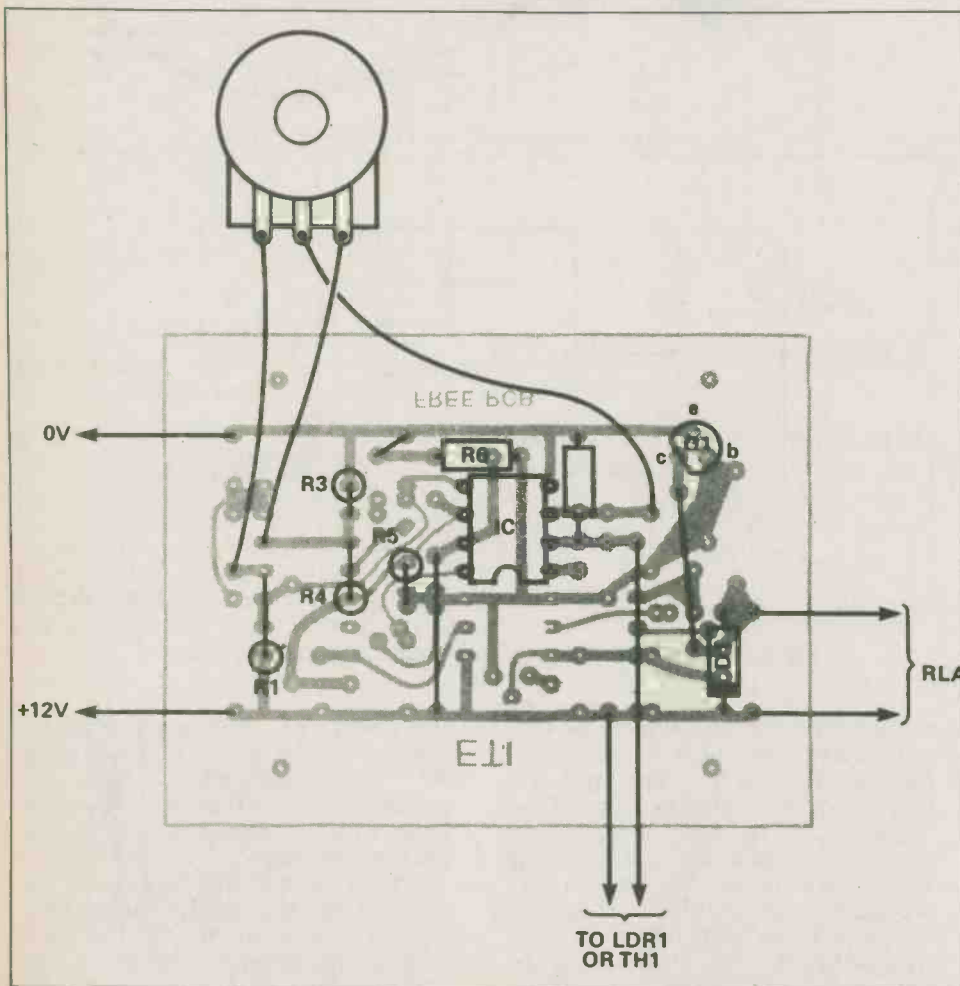

Fig. 2 Component overlay. Note that LDR1 (or TH1), RV1 and RLA are mounted off the board.

IF STRIP TESTER

You're listening to The News when the radio goes dead; if you're one of the few people in the country who wouldn't regard this as a blessing, here's a simple little circuit to help you to find the fault. Design and development by Andy Elam.

THE IF strip tester is a very useful and simple-to-build piece of test equipment. The purpose of it is to inject a signal onto an AM radio's IF strip and determine where a fault might be — the test waveform used is a 455 kHz signal modulated by 1.5 kHz. The probe should be first connected to the radio's ground rail with the croc-clip; the point of the probe should be touched onto various points along the IF strip while the radio is switched on. If the section works the radio will demodulate the signal and give a 1.5 kHz tone through the loudspeaker. When no signal is output the fault must lie after that point in the circuit.

Construction

A suitable probe can be constructed from an old ball-point pen case with a piece of 50R co-ax cable. The refill should be removed from the pen,

along with the end-cap. Strip 9" from the end of the cable and insert this into the pen, forcing the sleeve of the cable into the end of the pen. This may be glued (if necessary) with an epoxy adhesive. Then strip the shield of the cable back to the top of the pen, tin the end and insulate it with a piece of plastic sleeving. The end should be soldered to an insulated croc-clip. The inner core should be cut back to about 1 cm and stripped to the end of the pen. The tip may now be tinned and gently filed away to form a point. Strip the other end, tin the cable and solder it to the board when this is completed.

The board should be constructed as shown in the component overlay. Once complete, the output may be tested with a scope. The faster frequency seen should have a period of approximately 2.2µs. If this is less than 2.1 µs or greater than 2.3 µs a 1kΩ variable resistor may be connected in place of R3. Once the correct frequency is obtained, the potentiometer should be removed and measured on a multimeter. The closest preferred value should then be used to replace R3.

PARTS LIST

Resistors (all ¼ W, 5%)

R1	68k
R2	27k
R3	220R
R4	6k8

Capacitors

C1,2,3	100n ceramic
C4	150p ceramic

Semiconductors

IC1	NE556
-----	-------

Miscellaneous

PCB; test probe (ball point pen, 1m solid inner core 50R coax cable).

HOW IT WORKS

The circuit uses a dual 555-type timer chip, the NE556, and it's very similar in action to the doorbell circuit. The first section, built around IC1a, is a 1.5 kHz square wave generator. This is set by the time constant of R1, R2 and C1. Pin 5 is the output, which is sent to the reset pin of the next astable. This section generates a rectangular (not quite square) signal, at around 455 kHz modulated by the 1.5 kHz square wave from IC1a.

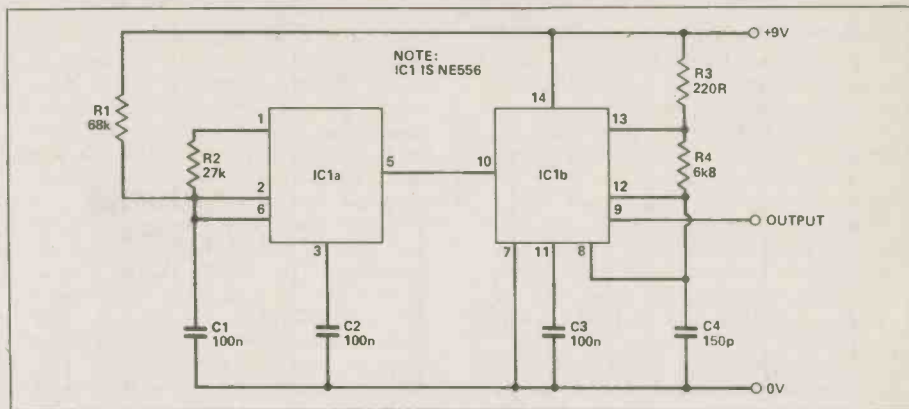

Fig. 1 Circuit diagram of the 1F strip tester.

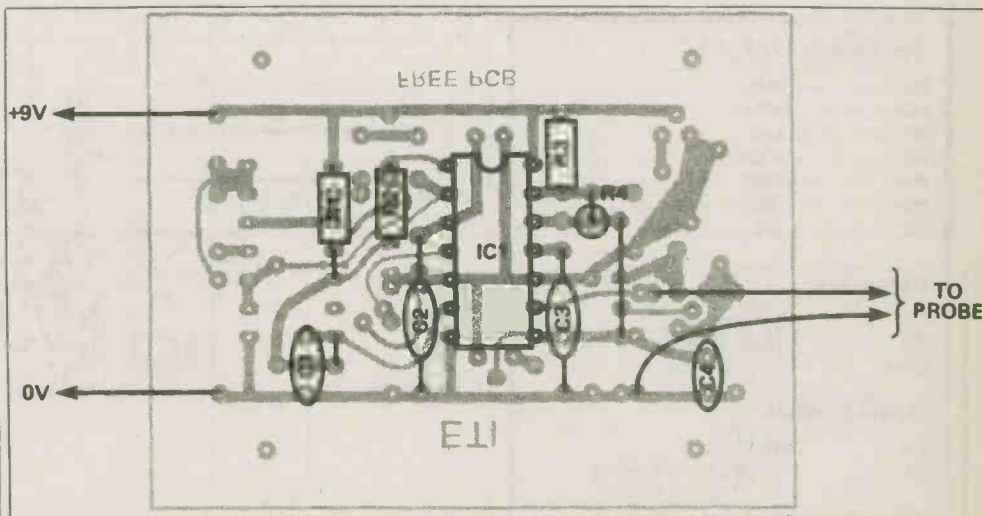

Fig. 2 Component overlay.

ELECTRONIC DOORBELL

If he'd had this project instead of the bells, Quasimodo wouldn't have gone deaf; let your visitors announce themselves with a gentle warbling. Design and development by Andy Elam.

This circuit is a simple but useful device which may be used for many applications as well as the intended doorbell. No problems should be encountered with the construction of this project if the overlay diagrams are closely followed. The push-button may be a standard bell-push. However, if you use an illuminated bell-push, you'll have to use a line-powered supply and reduce the value of R3 to around a few tens of ohms — you'll have to experiment to get a suitable value, because it will depend on the bulb in the bell-push. Should you want to change either of the frequencies the CR networks may be ad-

justed to suit. The frequency of oscillation of IC1a is given by:

$$\frac{1.44}{(R1 + 2R2) \times C1}$$

(R1 and R2 in ohms; C1 is farads).

Other variations may also be obtained with some ingenuity — try varying the signal fed to the second astable as well as the two repeat and tone frequencies.

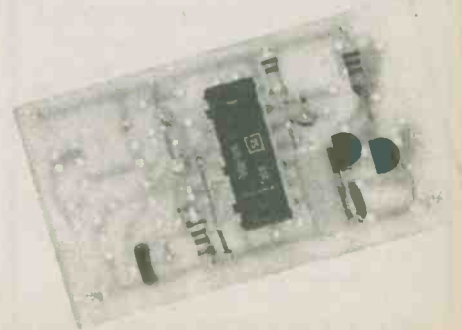

Multipurpose PCB

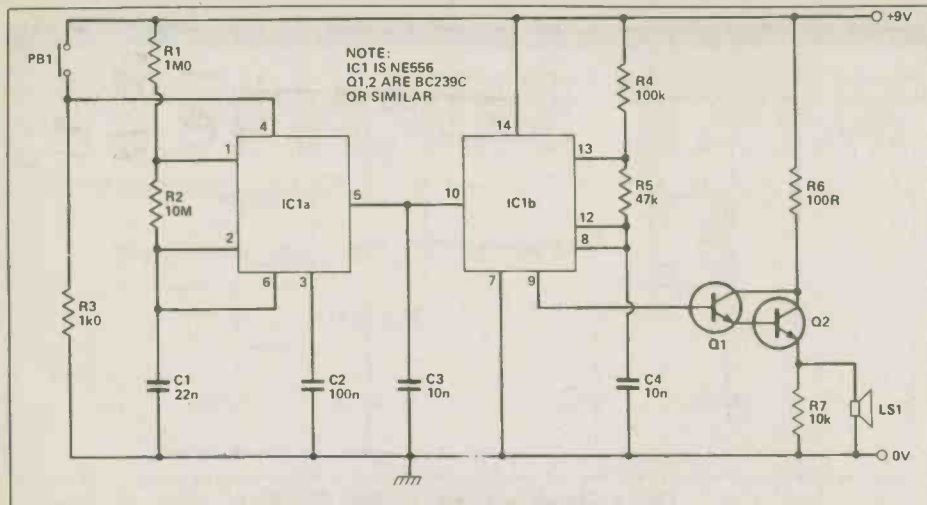

Fig. 1 Circuit diagram of doorbell.

PARTS LIST

Resistors (all 1/4 W, 5%)

R1	1M0
R2	10M
R3	1k0
R4	100k
R5	47k
R6	100R
R7	10k

Capacitors

C1	22n ceramic
C2	100n ceramic
C3,4	10n ceramic

Semiconductors

IC1	NE555
Q1,2	MPS6515 or similar

Miscellaneous

LS1	8R miniature loudspeaker
PB1	push-to-make switch
PCB	

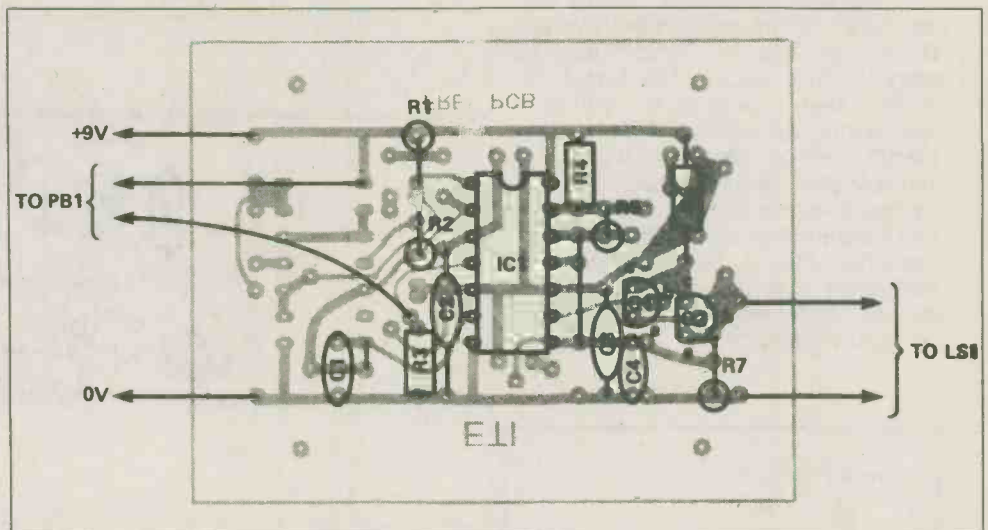

Fig. 2 Component overlay.

HOW IT WORKS

The circuit functions in a similar way to the IF strip tester. A 555 is used to provide two 555-type timers, connected here as astable multivibrators with unequal on and off periods. The first of these provides the lower, modulating frequency which gives the repeat rate. The second astable gives the higher frequency, ie the tone. Thus when the push-button is pressed the tone is generated and modulated on and off at the repeating frequency.

Until PB1 is pushed to make, the reset input of IC1a is held low by R3; this ensures that the output of IC1a (pin 5) is held low, so that the reset input (pin 10) and hence the output (pin 9) of IC1b are also held low. When PB1 makes, IC1a oscillates at a frequency determined by R1, R2, and C1 — with the values shown this is about 3 Hz. IC1b will oscillate at a frequency determined by R4, R5 and C4 (about 750 Hz) only while its reset input is high, hence producing the modulated tone.

The Darlington pair, Q1 and Q2, are used to provide sufficient current to drive LS1.

TOUCH SWITCH

Get a touching feeling with our CMOS touch switch. Design and development by Andy Elam.

THIS CIRCUIT uses CMOS technology to provide a time delay switch, suitable for use in situations where you don't want to leave a light on all night. This is very useful for those of us fortunate (?) enough to be blessed with kids. The circuit can control line-powered lighting with a suitable relay.

A time latch switch is built around a micropower CMOS IC. In the quiescent state, this IC will consume less than one microamp from the supply. The IC employed is a quad two-input NAND gate, the 4011.

Construction

This is very straightforward; the touch pads may be any type of metal connections which will not corrode or oxidise, mounted on a good insulator such as a plastic sheet. Two screw heads could be used. If the time cons-

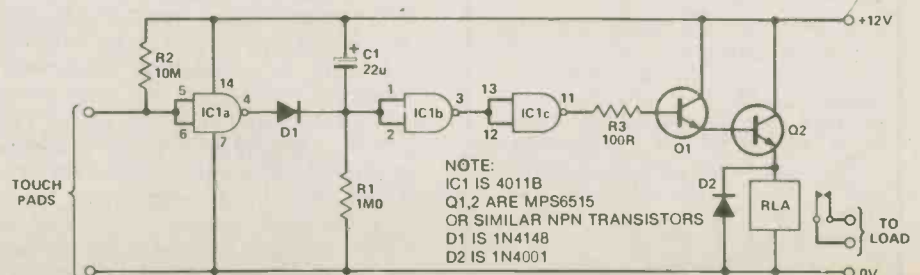
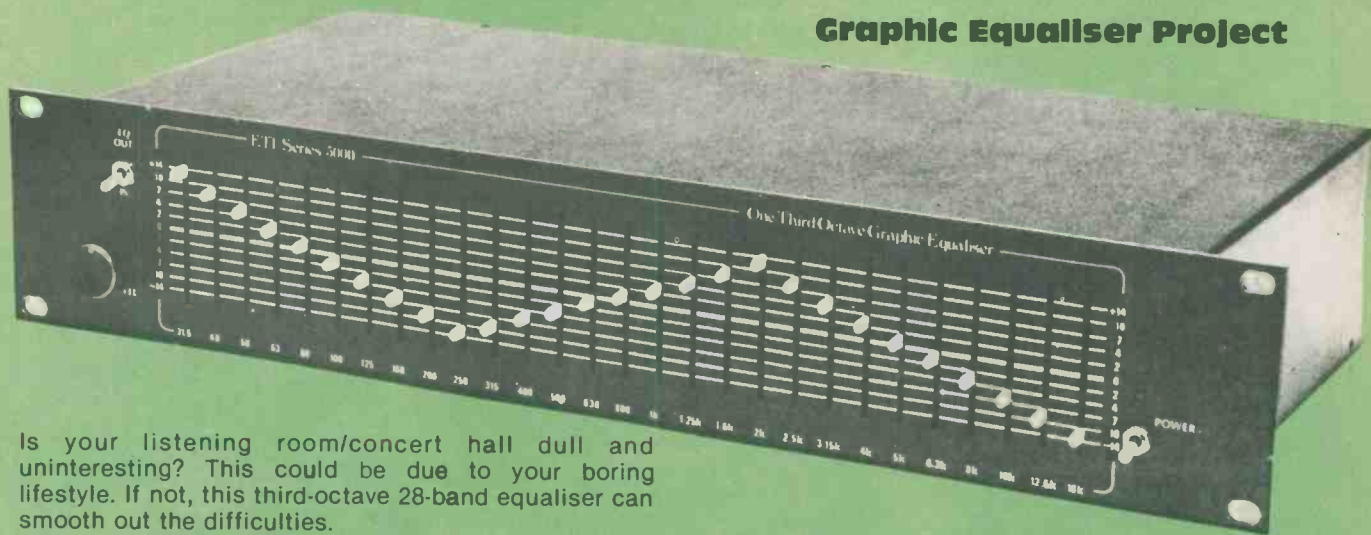

Fig. 1 Circuit diagram of touch switch.



next month

Graphic Equaliser Project



Is your listening room/concert hall dull and uninteresting? This could be due to your boring lifestyle. If not, this third-octave 28-band equaliser can smooth out the difficulties.

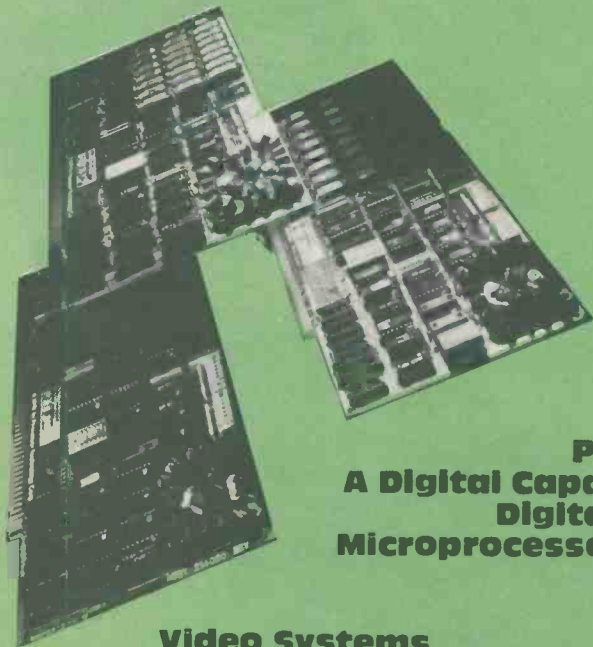

The State of the Electronics Industry in Canada

Is Canada a thriving producer of electronic products, or are we just a branch-plant warehouse? Is enough government money allocated to the industry, and is it being used wisely? Does the government do anything wisely?

PLUS!
A Digital Capacitance Meter!!!
Digital Dice!!!
Microprocessor Support Chips!

Video Systems

We examine the plumbing and wiring of video tape recorders and discs, giving you an idea of how the signals are stored, and no idea at all why most programs are so silly.

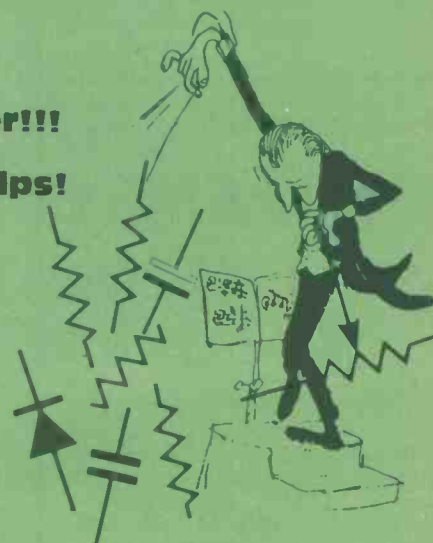

Electromusic Techniques

The first of a three-part series which looks at electronic music synthesis techniques, and includes practical circuits.

ETI Special Publications

If you enjoy ETI, why not try some of our highly successful special publications.



•Projects Book No. 2
100 pages
\$3.95
Contains 25 of the best projects from recent issues including the High Performance Series 4000 Amplifier (including Preamps and Power Supply), Rumble Filter, Dynamic Noise Filter, Logic Probe, Cable Tester, Function Generator, Rain Alarm, Digital Tacho, Two Octave Organ, Light Chaser, Shutter Speed Timer, Ni-Cad Charger and more. First published January 1981.



•Circuits File
100 pages
\$3.95
A 100-page special crammed with electronic circuits, 90% of them never before published in Canada.
The publication is divided in three sections: short-form projects; designer-circuits which are normally self standing designs but with no building details, Tech-Tips which are circuit ideas. About 125 circuits in all.



•Hobby Projects
100 pages
\$3.95
First published Summer 1980. Contains 25 straight-forward projects, most of which have never appeared in the magazine. Including: Stereo Amp, Audio Mixer, Scratch and Rumble Filter, Constant Volume Amp, Graphic Equaliser, Envelope Volume Amp, White Noise Equaliser, Generator, Ohmmeter, Intercom, Drill Linear Scale, Electronic Organ, Parking Meter Timer, Dice, Siren, Simple Switch, Electronic Simple Receivers.



•More Circuits
108 pages
\$4.50
Over 150 circuits plus articles on Circuit Construction, Test Gear, a project on a Digital Panel Meter. Design notes on Speaker Crossovers, TTL pin-outs, Design notes on Crystal Oscillators.

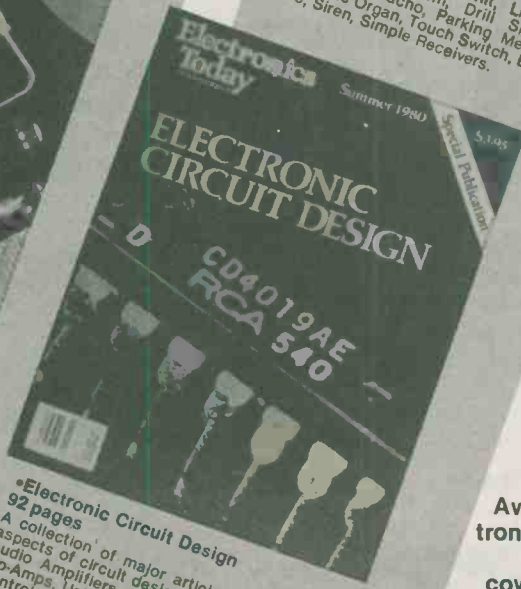

•Electronic Circuit Design
92 pages
\$3.95
A collection of major articles on various aspects of circuit design including CMOS, Audio Amplifiers, Power Supplies, SCR's, Op-Amps, Using the 3080 and Temperature Control. A large number of useful circuits are given but the emphasis is on guidance and how to design for yourself.

Available from your local electronic parts store or direct from ETI please add 45c each to cover postage. Send money to: Electronics Today Magazine, Unit 6, 25 Overlea Blvd., Toronto, Ont., M4H 1B1

Multipurpose PCB

Continued from page 22

HOW IT WORKS

When the circuit is waiting for a touch the input to the first gate, IC1a, is pulled high via the 10M resistor. So the output of IC1a is low, the input to the Darlington pair is low and the transistors do not conduct or draw any significant current.

When the contacts are bridged by the relatively low resistance of the skin, the input of IC1a is pulled low, and this leads to all the other gates switching their states. Thus, the negative plate of C1 rises to around +12V. After skin contact is removed, the first gate will resume its quiescent state, with input high and output low. R1 gradually recharges C1, so that the negative

plate voltage drops (the input impedance of IC1b can be neglected because it's very high). With a 22uF and 1MΩ resistor combination approximately 8 seconds elapses before the input to IC1b goes low enough for the Darlington pair to be turned off via IC1c.

This means that the relay coil will be energised for about the duration of the RC time-constant. The relay isn't necessary if a 1V4 voltage drop from the supply is tolerable for a circuit. However, the current available is limited by the two transistors' capability.

tion some beginners may feel, has become a basic building block in electronics. The system takes the audio signal from a radio cassette player or other piece of audio equipment and lights up the corresponding light emitting diodes depending on the frequency components of the signal; using opto-coupled triacs, line-powered lighting can be controlled — more on this later.

The circuit should be constructed as shown in the overlay diagram with all the external connections made carefully. The input signal may be taken directly from the loudspeaker terminals of a radio or cassette player, or the output for an earpiece may be used providing the loudspeaker is not switched off. In use, RV1 can be adjusted to get most pleasing effect, with the lights flashing in time to the sound source.

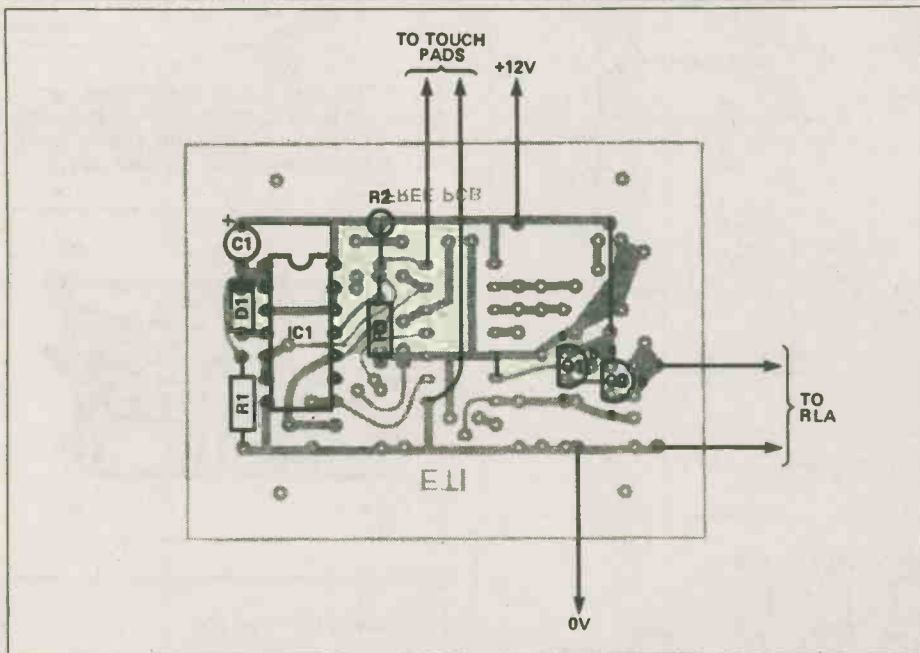

Fig. 2 Component overlay.



HOW IT WORKS

Three types of filter must be used, one which passes low frequencies, one which passes the mid-band frequencies, and one which passes high frequencies. Thus, low-pass, band-pass and high-pass filters are needed.

The first element in the circuit is a level control and amplifier. The gain of the amplifier can be increased by increasing the value of R2, in order to provide sufficient signal to drive the filters. The circuit also provides a buffer between the sign-providing circuit and the filters.

IC1b provides the high-pass section, IC1c the band-pass and finally IC1d the low-pass. The high and low pass sections are actually passive filters, buffered by IC1b and IC1d respectively; the band-pass filter around IC1c is the only true active filter. When a signal has enough low frequency elements the low-pass filter permits its output to saturate and this switches the LED on. Similarly, with mid and high frequency elements, the mid and high LEDs come on.

Substituting the LED with the control inputs of an opto-isolated triac (see Fig. 2) and reducing R13, 14 and 15 to 820R will enable you to control line-powered lights.

In Fig. 2 the circuit for one control channel only is shown: the other two will be identical. Note that all the circuit to the right of the optoisolator is at line potential: use extreme caution when connecting to the line and ensure that all components are enclosed within a grounded metal container or plastic box. If the common terminal of the line unit isn't grounded already, then you should connect it to ground as shown.

PARTS LIST

Resistors (all 1/4 W, 5%)

R1	1M0
R2	10M
R3	100R

Capacitors

C1	22u 16V tantalum
----	------------------

Semiconductors

IC1	DC4011B
-----	---------

Q1,2	MPS6515 (or similar)
D1	1N4148
D2	1N4001

Miscellaneous

RLA	12V relay, coil resistance greater than 185R
PCB	

tant is too short a larger capacitor may be used, or a smaller capacitor to get a shorter time constant. The board is small enough to stick to the relay with some double-sided sticky pads if required.

SOUND TO LIGHT UNIT

Feel like flashing? Don't get arrested — build this sound-to-light unit instead! Design and development by Andy Elam.

THIS MINIATURE sound-to-light circuit uses an electronic element, the active filter, that, despite the trepida-

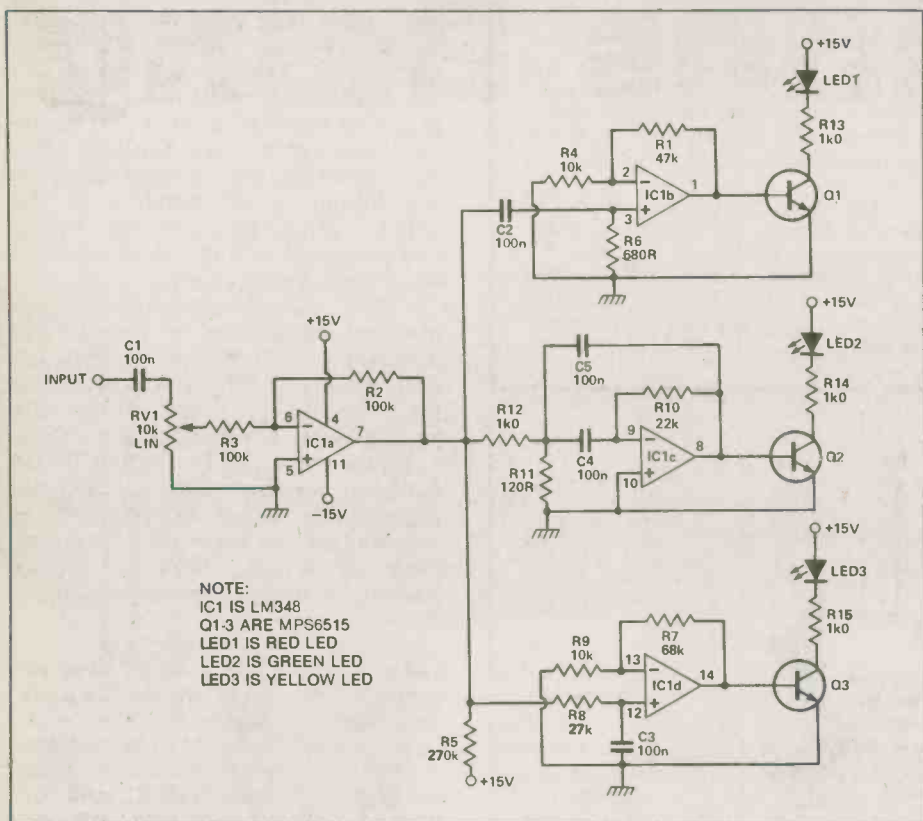

Fig. 1 Basic circuit diagram.

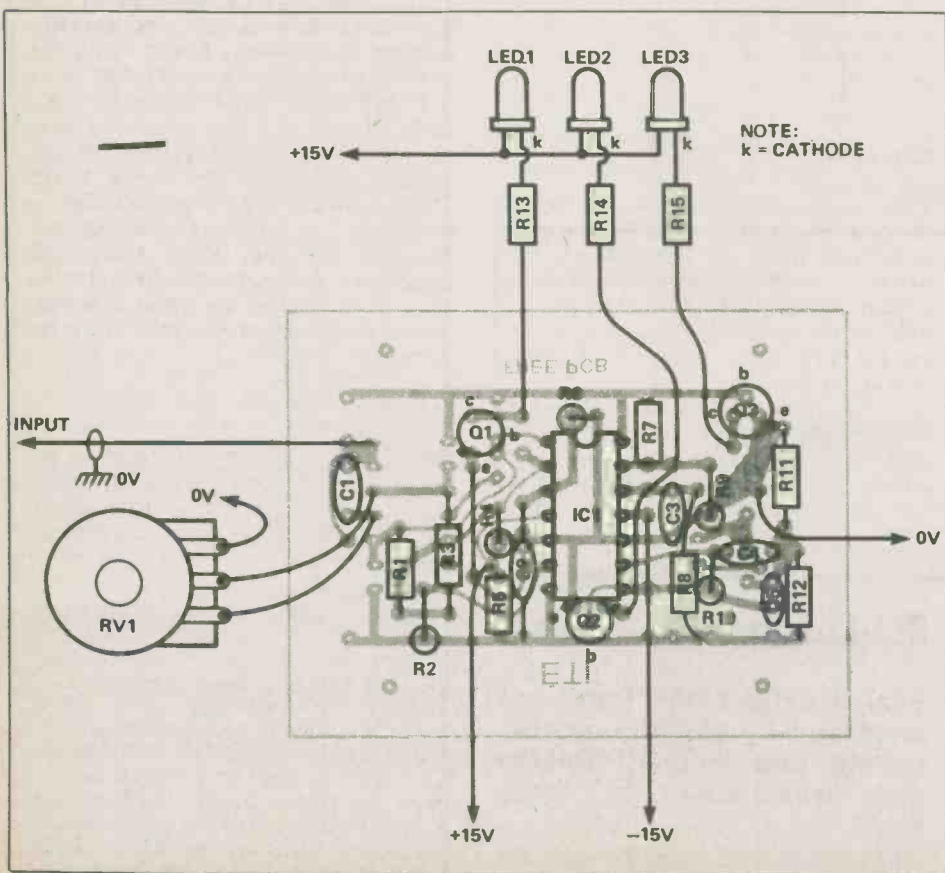

Fig. 3 Component overlay.

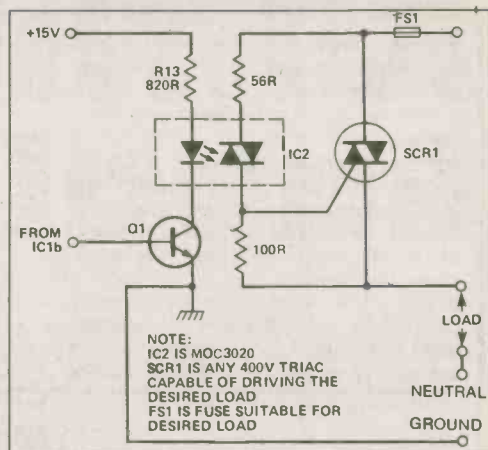
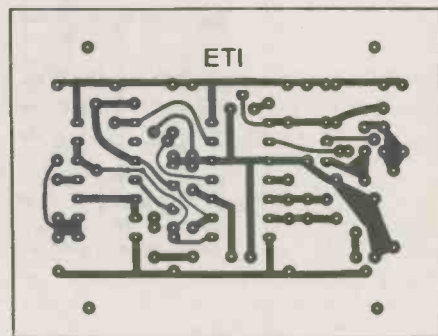

Fig. 2 Circuit to drive line-operated lights. Note: IC2 is MOC 3020, SCR1 is any 400V triac capable of driving the desired load, FS1 is fuse suitable for desired load.



PARTS LIST

Resistors (all 1/4 W, 5%)

R1	47k
R2,3	100k
R4,9	10k
R5	270k
R6	680R
R7	68k
R8	27k
R10	22k
R11	120R
R12,13,14,15	1k0

Potentiometers

RV1	10k linear
-----	------------

Capacitors

C1-5	100n ceramic
------	--------------

Semiconductors

IC1	LM348
LED1	any red LED
LED2	any green LED
LED3	any yellow LED

Miscellaneous

PCB	
-----	--

All Things Being Equal

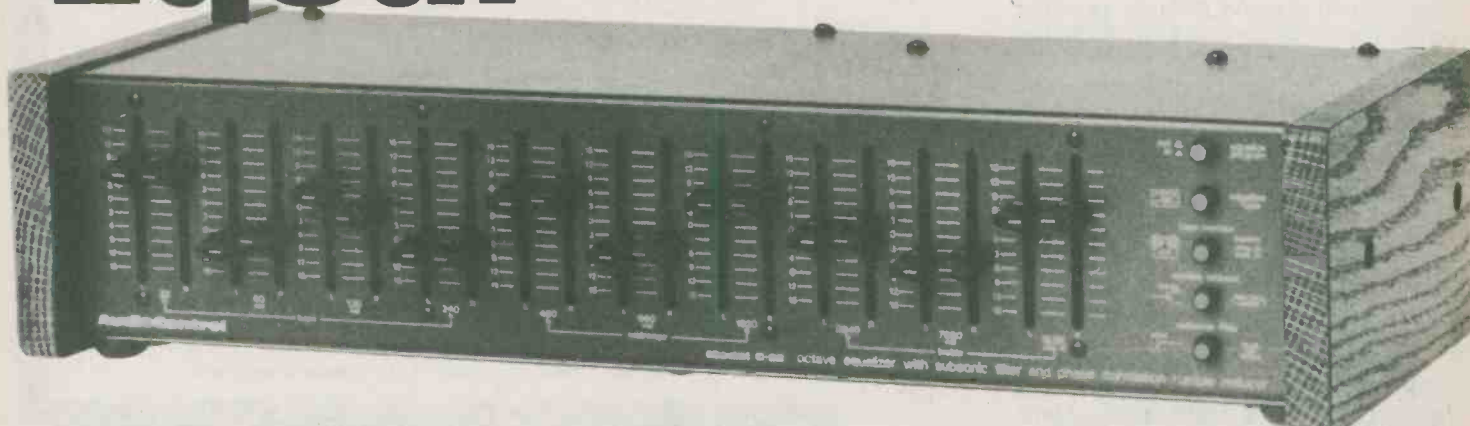

Equalisation, in audio, is the fine art of adjusting frequency response curves.

MEN AND WOMEN are said to be created equal — but they don't stay that way. Some become short and fat, others grow thin and tall; in other words, some become more equal than others. The same is true with audio signals. Sure, they start off OK, but as soon as a musician pushes sound out of his instrument and sends it hurtling towards a microphone, little gremlins start chewing at it. Considering it's tortuous path through the air, the bewildering maze of wires, the transistors, the loudspeakers and, finally, the air in the listening room, it's miraculous the sound emerges even vaguely resembling the original. Then, of course, there is man — ever ready to show mother nature the error of her ways, tinkering with the signal so it conforms to his own concept of perfection.

Sound was never meant to be recorded, so we have no choice but to adapt our equipment to suit the nature of sound; the laws of physics won't change for our convenience, except possibly when proving Murphy's Law! So, let's deal with the three most popular questions concerning equalisation (and most other subjects, for that matter) — what, why and how. What do we equalise, why is it necessary and how can it all be achieved?

Circuits

Volumes have been written on the individual circuits for equalisation and, doubtless, more will be written in the future — so we won't get too involved in complicated circuitry. However, a brief examination of a few simple circuits will be useful for understanding how equalisers are used.

The circuit of Figure 1 shows a simple high-pass filter with a 6 dB/octave slope and its frequency and phase response curves. These show how the output level changes with fre-

quency and the associated phase difference — how much the output wave 'lags' behind or 'leads' the input — at those frequencies. Note that the formula $0.16/RC$ is another form of the reactance formula $1/6.28RC$, and the other values are simply one-tenth and ten times. Figure 2 shows the low-pass counterpart and in Figures 3 and 4 the circuits are modified to provide high and low boost respectively. Notice that the low boost circuit is derived from the low-pass filter, while the high boost comes from the high-pass circuit. It is also clear that low-pass and high-cut characteristics are, strictly speaking, the same thing. This has led to the mistaken belief — even today — that bass boost and treble cut are the same thing. All equalisers attenuate all frequencies equally, except in the relatively narrow region in which boost or cut is required.

Locating It

The location of an equaliser in an audio system usually means resolving several conflicting factors, determined by the type of boost/cut circuit, average signal level and frequency

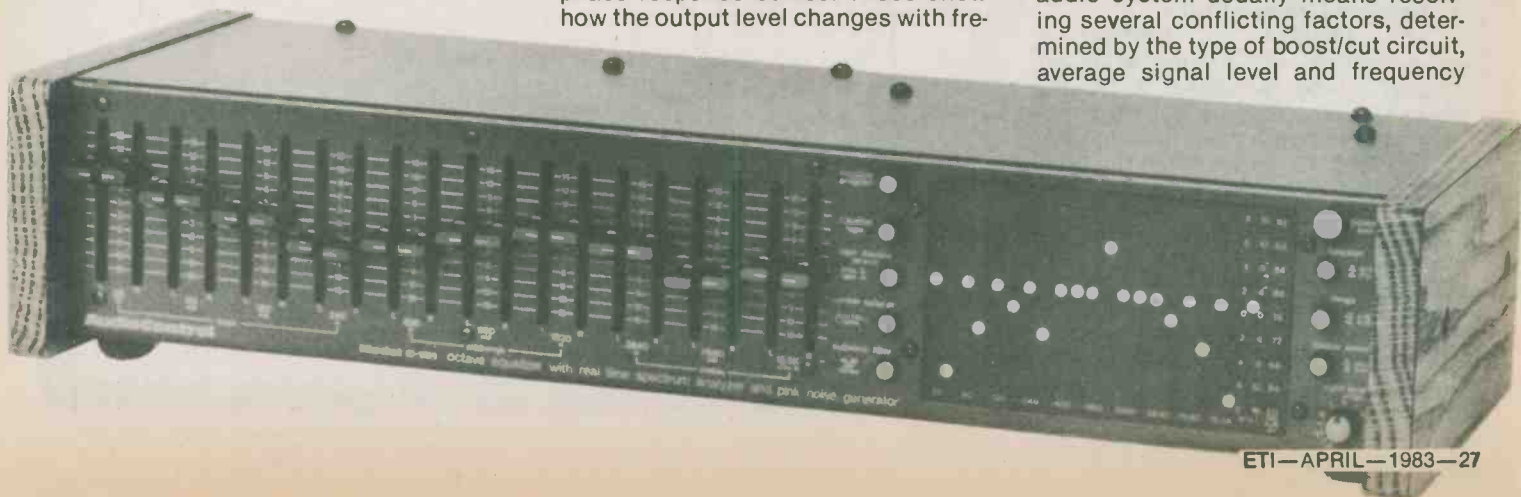

All Things Being Equal

bandwidth over which the device operates.

Since bass boost has the effect of reducing mid and high frequency levels, it is generally desirable to have most of the amplifier gain before the equaliser, in order to decrease noise components along with the treble signal. However, 'hum' components would then be boosted with the bass. Conversely, high frequency boost should be inserted early enough (before the main amplifier) to raise signals above the noise of following stages.

Where signal levels are unusually high, as in the case of a loud noise picked up by a sensitive microphone, say, our greatest concern is to avoid overloading the amplifier and causing distortion, particularly at high frequencies — applying boost here only makes matters worse!

Most amplifiers provide a recording output/playback input and this is generally the most satisfactory point for 'patching in' an equaliser. Alternatively, many combination preamp/power amplifiers allow access to the preamp output and the power amp input and this is also a suitable location for an equaliser. In general, the equaliser should be used after some preamplification but before the main amplifier stages. If your amplifier does not allow either of these options, there is really no solution but to buy more suitable equipment! Putting the equaliser before a preamplifier is simply hopeless.

Colour It Flat

Equalisation can be divided into two basic types, on the basis of purpose: corrective — a means of flattening out any 'peaks' and 'troughs' in the frequency response, and adaptive — the response is made to deliberately deviate from flat to improve some tonal quality or emphasise a particular band of frequencies. You can look at these types as 'what you take out' (the nasties) and 'what you add' to the signal, respectively.

An example of corrective equalisation is encountered in magnetic tape recording. A typical playback response (without equalisation) would show a curve which rises at the rate 6 dB/octave when the tape is recorded with constant flux in the gap on the tapehead — the result of constant current through the coils in the head. However, because of the tape and head characteristics, the response will level off as frequency rises. This 6 dB/octave slope can be corrected (and is) by a low frequency boost circuit in the playback system. As we continue up the frequency

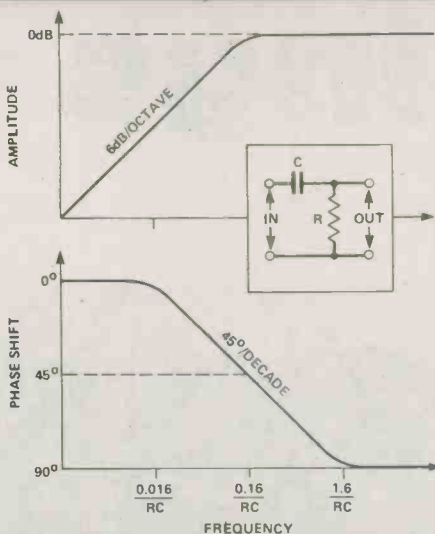

Fig. 1 Top, a simple high-pass filter section; an octave is just a 2:1 frequency ratio, eg 500 — 1000 Hz, 2 kHz — 4 kHz etc. Bottom, the phase shift from input to output.

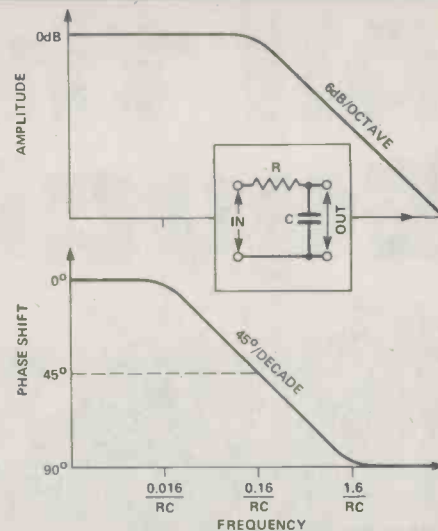

Fig. 2 Top, a simple low-pass filter. Bottom, the phase response, plotted against frequency, expressed in terms of the time constant of the RC network.

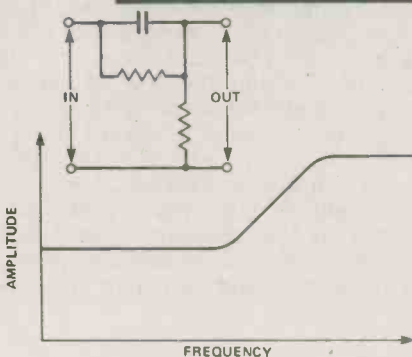

Fig. 3 (above). A treble boost circuit, derived from the simple high-pass filter.

Fig. 4 (above right). A bass boost circuit.

Fig. 5 (right). Equalisation used in tape recording and playback, to correct for the tape and head characteristics.

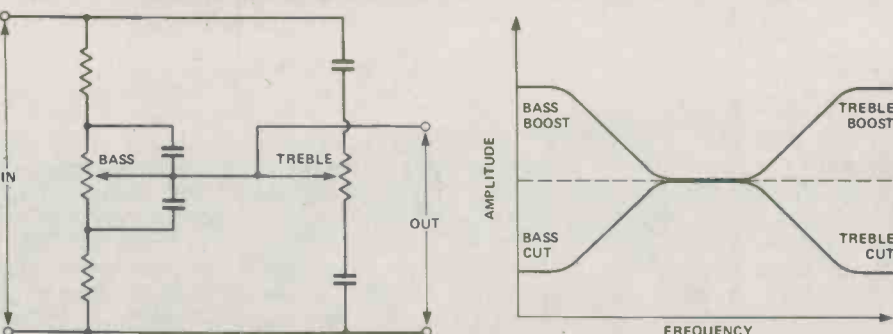
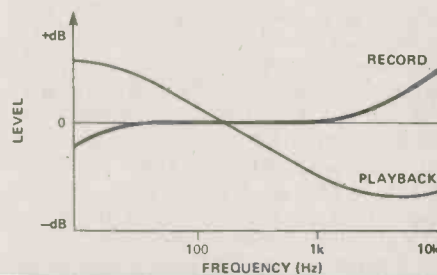

Fig. 6 Left, a typical combined bass and treble tone control circuit. Right, the response range available from this circuit.

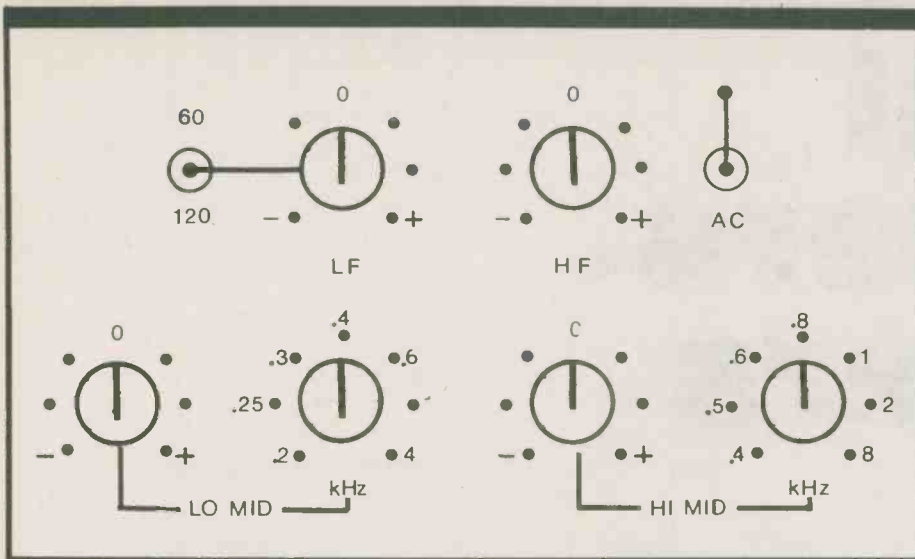

Fig. 7 An equalizer similar to the parametric type. It includes a two-frequency bass, treble, and two mid-range controls with adjustable frequencies.

range past this leveling-off region, the curve starts to fall off — this means that inherent tape noise will eventually swamp the signal, so that we cannot restore it in the playback equaliser but must do so during recording. However, increasing the treble signal level during recording risks overloading the tape, possibly requiring a reduction of the overall recording level, thereby causing a deterioration in the signal-to-noise ratio. On the other hand a certain amount of noise and unwanted material also appears as part of the output signal and boosting the treble response during playback just increases the noise. Therefore, as is so often the case, the end result is a compromise or, with luck, a fine balance between the various conflicting requirements.

Use With Discretion

Adaptive, or 'discretionary' equalisation is used either because we don't think the sound we're getting is correct, or we just don't like it and want to make improvements add special effects. It's something like the photographer who uses a skylight filter to obtain a more 'realistic' colour balance — or a red filter to simulate a Martian landscape. Since recordings are made by humans much of the time — monitoring the signal through loudspeakers with their own peculiarities and in rooms with particular acoustical properties — it's not surprising that average listeners are in disagreement (over the sound) from time to time. 'Live' sound is just as contentious. Perhaps one listener feels that the lead guitarist needed that extra 3 kHz

boost to add some 'bite' to his performance; another may complain about the missing bass — although any boost may have resulted in a slightly blurred, 'boomy' sound because of the reverberant property of the hall. In either case an equaliser would be necessary to provide the appropriate compensation. It may be sufficient to use a simple tone control arrangement like those of Figures 3 and 4

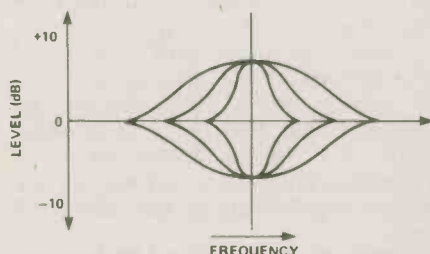

Fig. 8 (above). The response range of a single-stage parametric equaliser, showing variations in bandwidth and boost/cut. The centre-frequency (the position on the frequency axis) is also variable.

but, at best, these are a rather crude and clumsy form of equalisation. An alternative approach is to use a graphic equaliser, so called because it normally includes slider controls which provide a graphic or 'pictorial' representation of the response — assuming you had something flat to start with. This device gives you several sliders to control the response of a set of frequency bands and it may divide the spectrum into as few as five broad bands or up to thirty narrow bands. These provide precise control, but you can only adjust the response until it 'sounds' right — much like a tone control.

A similar device is the parametric equaliser, so-called because it varies the parameters or factors which define a response, eg centre frequency, bandwidth and the degree of boost or attenuation. In general this means fewer bands (ie, centre frequencies) than with the

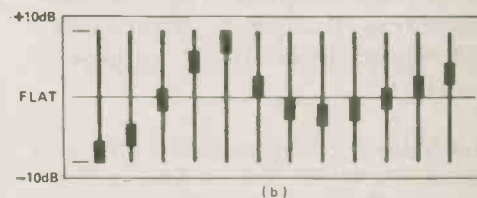
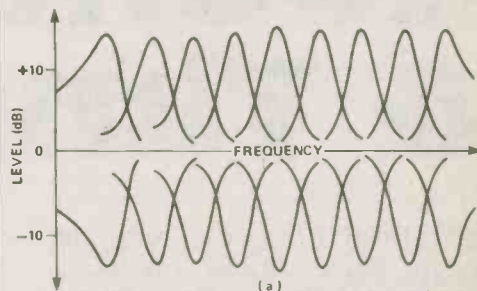

Fig. 9 The individual filter response curves of a multi-range graphic equaliser; setting the sliders of a graphic EQ; the resultant response curve.

graphic type, but a greater flexibility for those that are processed. In some parametric equalisers there is a facility for operating on the same band twice, or on two very closely spaced bands. This allows you to combine the two responses and end up with a unique response curve. Such versatility doesn't come cheap, so these units are mainly found in professional circles.

The graphic equaliser is probably more familiar since it's been around much longer and is widely available. Several units have been featured as constructional projects; ETI plans one for May '83. Graphic equalisers are especially useful in compensating for irregularities in room acoustics or speaker systems. Indeed, one application, for professionals, is in setting up studio and live-music speaker systems. This is done by feeding the speakers with pink noise — noise with a frequency spectrum that gradually decreases in energy as the frequency increases — and the response measured by a specially calibrated instrument (an

Digital Counters & Timers

Several ETI projects, recently, have used digital measurement techniques. This article explains the basic principles of digital timers and frequency meters.

MEASURING frequency and time intervals to a known accuracy is often important in many areas of electronics: in communications, broadcasting and audio applications, in digital work and particularly in computer applications — from micros to mainframes. Digital frequency meters (DFMs), or counter/timers as they are also called, have become such an essential item of test equipment that many manufacturers are offering a range of instruments ranging in price from a \$200 instrument covering the range 20 Hz to 200 MHz to many thousands of dollars for a microprocessor-controlled instrument capable of measuring frequencies well into the gigahertz region and time intervals in the picosecond range.

Frequency and time interval measurement is an area where digital techniques come into their own. The object is to accurately quantify a measurement. Prior to the development of digital instrumentation to do this job, analogue techniques were used — often ingenious and highly refined, but laborious. Heterodyne frequency meters were used widely. These consisted of a stable, accurately calibrated, variable oscillator (VFO) driving one input of a wideband mixer, the unknown frequency being applied to the other input. The output of the mixer was monitored on headphones or an audio amplifier while tuning the VFO. As the unknown frequency was approached an audible 'beat note' would be heard, decreasing in pitch as the VFO was tuned closer to the frequency being measured. At 'zero beat' you could then read off the

unknown frequency from the instrument's calibrated dial. The method will no doubt be familiar to many of our older readers. It was laborious, especially when you didn't even know the 'ballpark' of the unknown frequency, and to get a measurement accuracy better than several hundred Hertz (... maybe that's cycles/second!) was tantamount to magic: Top frequency was about 20 MHz.

These days pocket DFMs can measure frequency to within ± 50 Hz or better, up to 200 MHz! That's at least a factor of ten better all round than the old method. And readout is obtained in a few seconds or less.

Time interval measurement was, and still is, very much left to that old work-horse — the oscilloscope. But, a scope has its limitations and quantifying a time measurement to the accuracies required these days is best done with a digital counter.

Frequency Measurement

The block diagram of a basic digital frequency meter is shown in the accompanying illustration. The input signal first encounters a 'trigger' or 'squaring stage' which ensures that the measurement always commences on the same part of the input

waveform. The output of the trigger then enters a gate. The gate is 'opened' for a period and allows a number of input cycles through to the counter. The period for which the gate remains open is determined by the output from a divider/scaler driven by a very stable, accurate clock oscillator. A number of outputs from the divider/scaler may be selected to vary the period the gate is open. Usually, a number of decade steps are provided.

The output of the gate drives a counter which provides a binary coded decimal. (BCD) output for the display. A 'hold' or 'latch' stage is generally added so a steady group of numerals is displayed.

The timing diagram below the block diagram illustrates the sequence of events. The input signal, often sinusoidal, is shaped by the trigger stage into a train of rectangular pulses. The gate allows a number of pulses through to the counter, in this case three, during the period it is 'open'. The circuit selects only the positive-going pulses in this example, though negative-going pulses from the trigger stage could equally well be used.

If, say, a gate period of one millisecond (1 mS) were selected the counter would display '3000'. In other words, the input frequency would be 3 kHz.

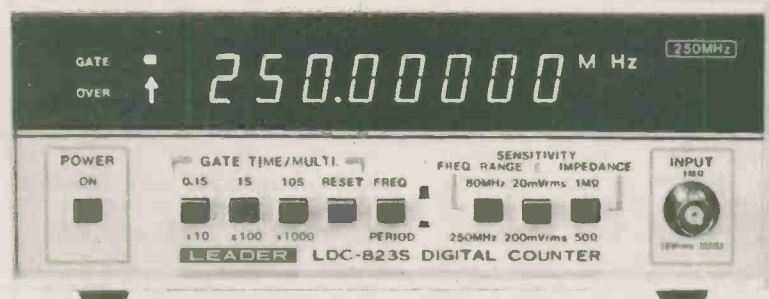

Practical instruments will have selectable gate periods ranging from one microsecond (1 μ S) to as much as 10 seconds. The display may have five digits, though eight digit displays are more common.

Many modern digital frequency meters incorporate a high speed divider immediately following the gate, the output of this divider being used to derive the first and second digits of the display. To extend the range of the instrument, a 'prescaler' may be included. This is a high speed divider providing a fixed division ratio of ten. Its output may drive either the trigger stage or the gate directly.

Period Measurement

Measuring the period between 'events' is done by re-arranging things a little. The gate, counter and display are used as before but the gate is turned 'on' and 'off' by the input events and the clock signal is passed through to the counter. As the clock is a highly stable, accurate oscillator, the period between input events can be measured with great precision. The accompanying block diagram shows the general arrangement of the instrument for period measurement.

Separate input signals in the arrangement shown are used to trigger the gate on and off. However, a single repetitive input signal may be used to trigger the gate with a slightly different circuit arrangement. The timing diagram with the period counter block diagram shows the sequence of events. If the clock was running at 1 kHz, for example, the time interval between pulses would be one millisecond. As 17 pulses passed through the gate in the example, the period between the A input event and the B input event was 17 mS and the display would read, say, 17,000 (resolution of one microsecond).

Pulse widths can be measured with a period counter, too. In this instance, the gate is triggered on the positive-going and negative-going edges of the input pulse. However, some difficulties arise. If the input pulse had a perfectly 'square' shape, the on and off gating points would always give an accurate result because the triggering transitions would occur precisely on the rise and fall of the pulse. Trigger level would not affect the interval measured. Real-life pulses however, are seldom perfect, the edges having definite rise and fall times. In this case, the trigger level becomes critical in determining the width of a pulse. The diagram

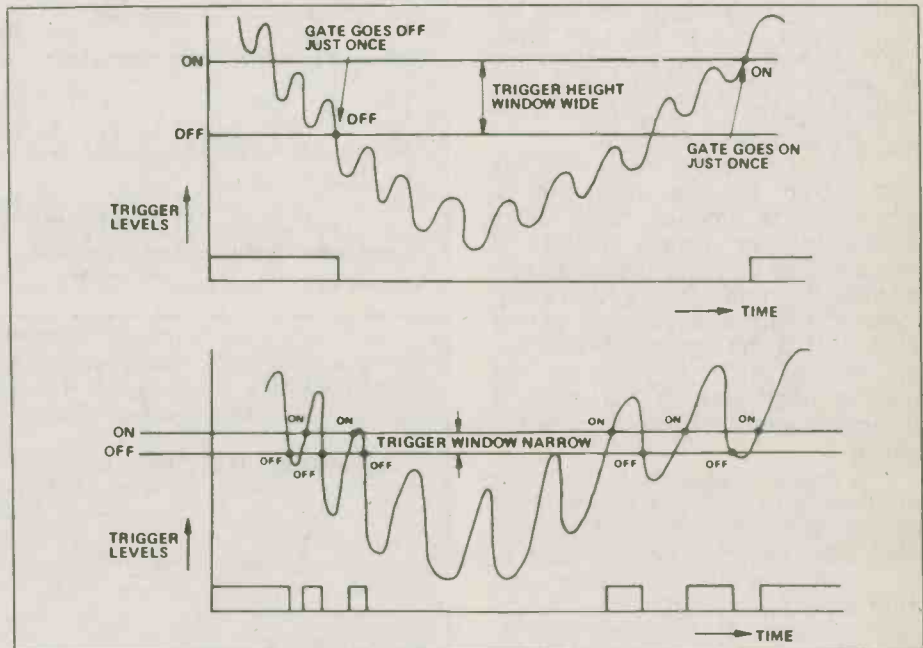
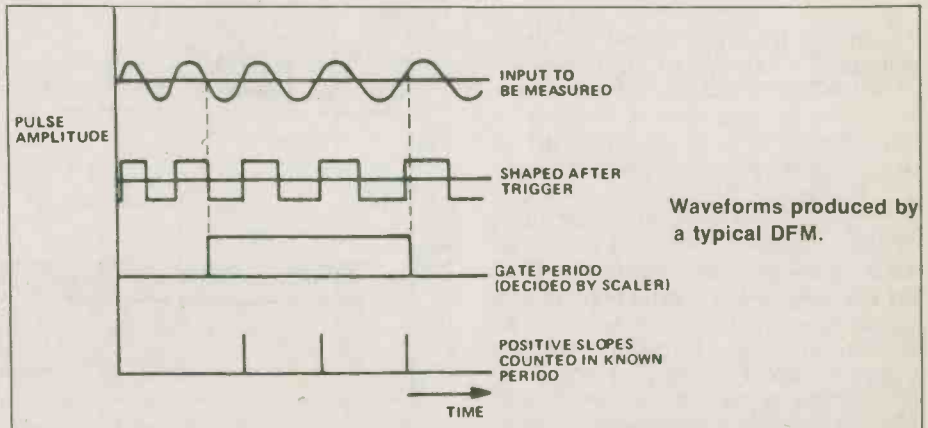
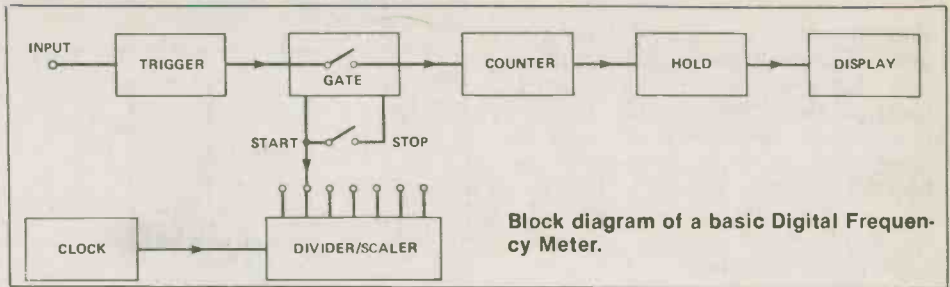

The Trigger Window diagram. Setting the Window too low (below) will cause inaccurate measurements.

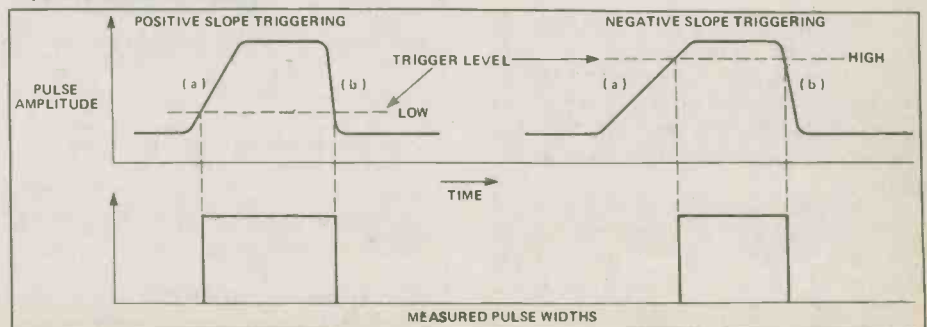

When measuring pulse widths, the accuracy will depend on whether positive or negative slope triggering is selected, and on the trigger level setting.

Digital Counters

here shows why and how it is overcome. Counters are usually provided with a 'slope selection' control which determines whether the trigger operates on the positive or negative slope — (a), or (b) respectively in the diagram.

Noise Error Reduction

The above descriptions give the basic operating modes of the various counter/timer/frequency-meter combinations. In practice, a number of refinements may be incorporated to obtain better performance.

Noise can be reduced by incorporating a fixed amount of backlash in the trigger circuit; this produces what is called the 'trigger window'. On the way up the trigger level is at a higher level than on the way down, as shown in the Trigger Window Diagram here. Provided the noise added to the signal has an amplitude smaller than the window width, the counter will only trigger once on the way up and once on the way down. This method works well for high-frequency measurements where the noise is usually a small percent of the signal-plus-noise amplitude.

Low frequency measurements can often involve interference sources that produce rapid spike transients. One simple method of reducing this is to use filters. Advanced designs contain filter systems that reject all frequencies higher than that being tested, the appropriate filter being automatically selected by the counter itself after it has made a determination of the frequency of the signal.

A recent approach to the noise problem is to set up a time-window (as opposed to the trigger height window) that, once the counter gate is on, inhibits the off-state chance until after a time just shorter than the expected interval. This is known as trigger masking. It is very useful in eliminating contact-bounce retriggers.

Before using a counter/timer on an unknown waveform, it is good practice wherever feasible to look at the wave-shape on an oscilloscope in order to decide the best strategy for trigger-level and height-window width settings.

As the readout is in digital form it is necessary to hold the display at the determined value for a period long enough to allow the value to be read. Some units incorporate a control that gives the operator a choice of hold time.

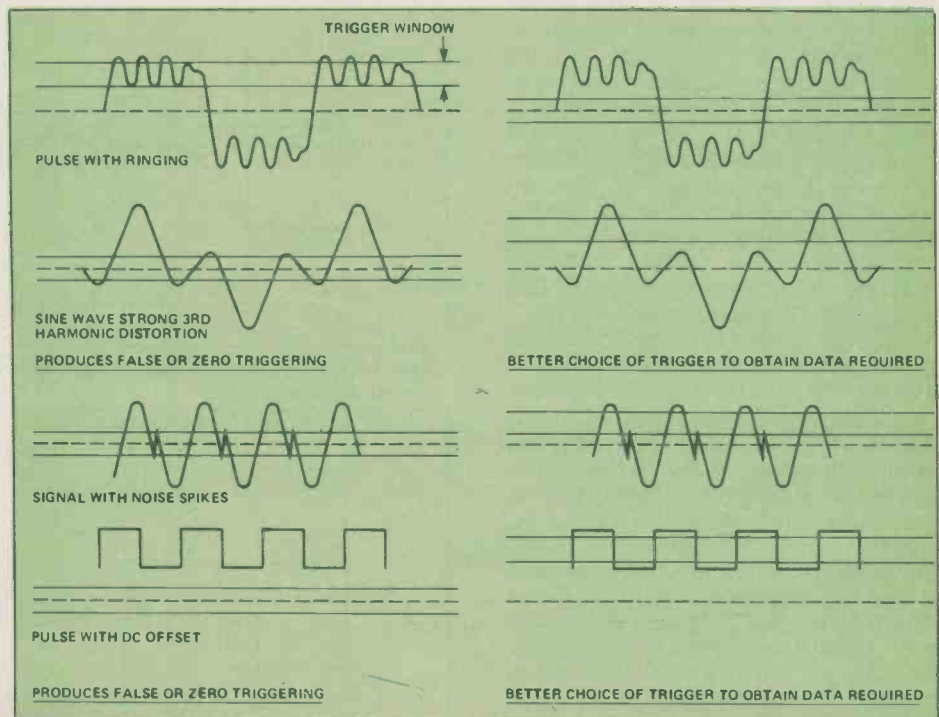
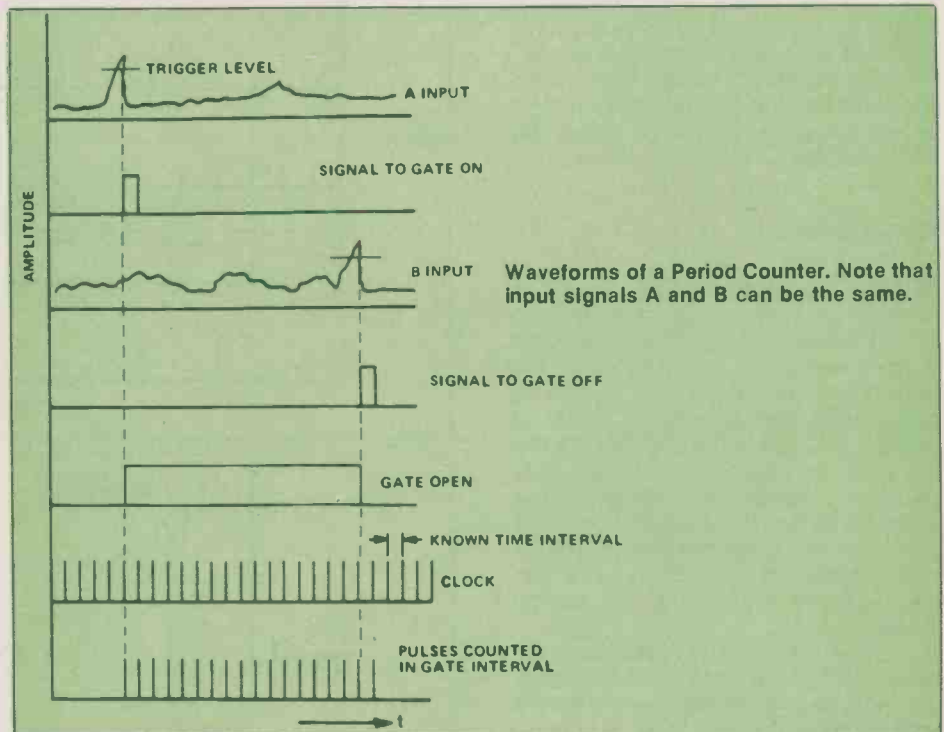
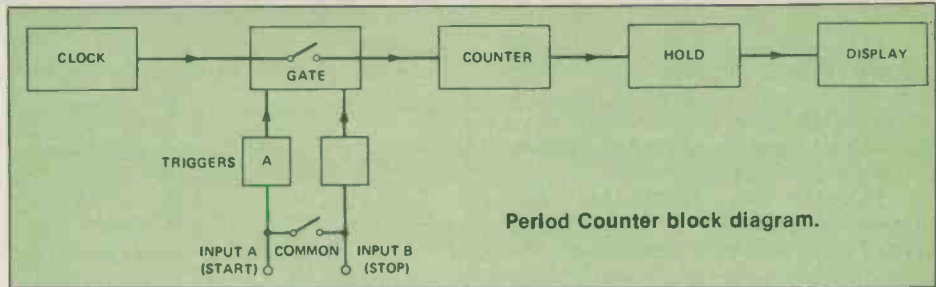

Continued on page 78

Now NRI takes you inside the new TRS-80 Model III microcomputer to train you at home as the new breed of computer specialist!

NRI teams up with Radio Shack advanced technology to teach you how to use, program and service state-of-the-art microcomputers...

It's no longer enough to be just a programmer or a technician. With microcomputers moving into the fabric of our lives (over 250,000 of the TRS-80™ alone have been sold), interdisciplinary skills are demanded. And NRI can prepare you with the first course of its kind, covering the complete world of the microcomputer.

Learn At Home in Your Spare Time

With NRI training, the programmer gains practical knowledge of hardware, enabling him to design simpler,

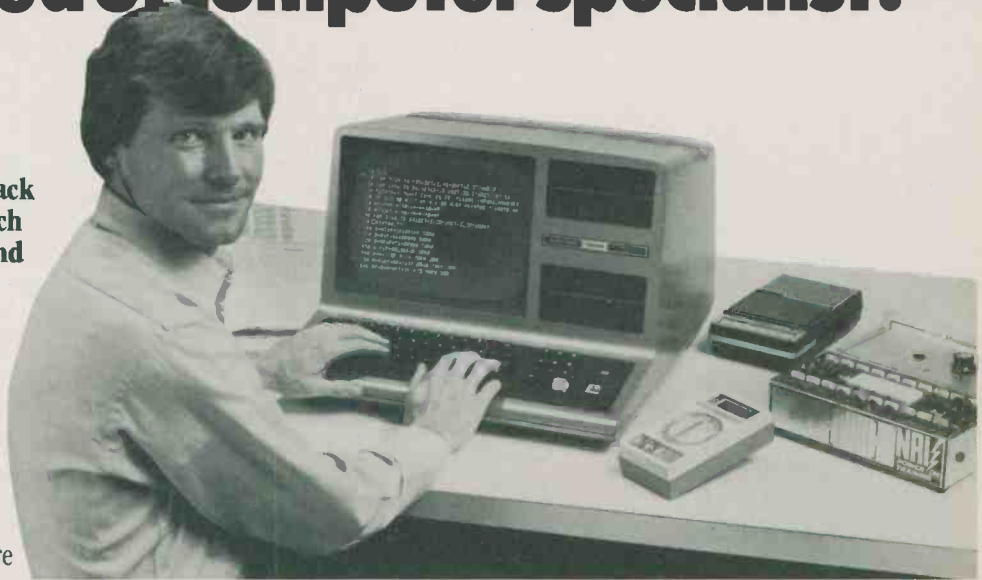

more effective programs. And, with advanced programming skills, the technician can test and debug systems quickly and easily.

Only NRI gives you both kinds of training with the convenience of home study. No classroom pressures, no night school, no gasoline wasted. You learn at your convenience, at your own pace. Yet you're always backed by the NRI staff and your instructor, answering questions, giving you guidance, and available for special help if you need it.

You Get Your Own Computer to Learn On and Keep

NRI training is hands-on training, with practical experiments and demonstrations as the very foundation of your knowledge. You don't just program your computer, you go inside it... watch how circuits interact... interface with other systems... gain a real insight into its nature.

You also work with an advanced liquid crystal display hand-held multimeter and the NRI Discovery Lab, performing over 60 separate experiments. You learn troubleshooting procedures

and gain greater understanding of the information. Both microcomputer and equipment come as part of your training for you to use and keep.

Rush Card for Free Catalog

Get all the details on this exciting course in NRI's free, 100-page catalog. It shows all equipment, lesson outlines, and facts on other electronics courses such as Complete Communications with CB, TV/Audio and Video, Digital Electronics, and more. Keep up with the latest technology as you learn on the latest model of the world's most popular computer. If card has been used, write to:

NRI NRI Schools
McGraw-Hill Continuing
Education Center
330 Progress Avenue
Scarborough, Ontario M1P 2Z5
or telephone 416-293-1911

We'll give you tomorrow.



Training includes new TRS-80 Model III microcomputer, 6-function LCD Beckman multimeter, and the NRI Discovery Lab with hundreds of tests and experiments.

(TRS-80 is a trademark of the Radio Shack division of Tandy Corp.)

Use the POWER within your reach!

timex sinclair user

A new and unique magazine for the world's most popular personal computer



12 issues only \$29.95
Save \$6.00!
Plus receive free software cassette!

Now that you've got a TIMEX SINCLAIR computer make sure you get the new magazine that helps you to get the most out of it... TIMEX SINCLAIR USER! And take advantage of our special bonus of a free software cassette (\$15.00 retail value) with each subscription.

TIMEX SINCLAIR USER is published monthly. It keeps you totally up-to-date. It helps you make full use of the power of your computer.



TS1000
ZX81

TIMEX SINCLAIR 1000: the price and technology breakthrough that finally made computers affordable.

TIMEX SINCLAIR USER: the magazine that helps you use the power of this revolutionary computer.

*U.S. dollars

TIMEX SINCLAIR USER covers the full spectrum of user interests. Education. Business applications. Home management. Games and family entertainment. And TIMEX SINCLAIR USER does it in an easy-to-understand style that's authoritative yet friendly.

Each issue is packed with articles and information that help owners make use of the power of their computer. News about software releases. Reviews. Hardware developments. Reader question and answer column. Eight pages of program listings in every issue. New and unique user applications. How to program. Interviews. Special money saving offers to readers.

In fact, all the latest ideas and information to ensure that new owners and expert users never tire of their computer.

FREE BONUS WITH YOUR SUBSCRIPTION



"Packrabbit"
Retail value
\$15.00

A good reason to order now! Receive a software program cassette of an exciting, new arcade game! "Packrabbit" is a regular \$15.00 retail value. Free with subscriptions for a limited time only.



For any age
or experience

Remember: the TS1000 was designed precisely for you. Whatever your age and experience in computers, TIMEX SINCLAIR USER can help you use the power of your computer.

SUBSCRIBE NOW and take advantage of our special offer. Only*\$29.95 for 12 monthly issues postage paid. This represents a \$6.00 saving over regular newstand prices. And remember, you receive a FREE BONUS with every subscription, a "Packrabbit" software cassette (\$15.00 retail value).

To order call

(513) 729-4300

Ask for Operator 243.

These numbers are for orders only. Have your VISA, Mastercard card ready.

Mail to TIMEX SINCLAIR USER, 49 La Salle Avenue, Buffalo, New York, 14217

Name _____

Address _____

City _____ State _____ Zip _____

() Check () Money order. Or charge to

() Visa () Mastercard

Number _____

Expiry _____

Signature _____



() Yes, I want to subscribe to TIMEX SINCLAIR USER at the special rate of \$29.95 for 12 issues delivered to my door. In addition I understand I will receive the FREE software cassette with my first issue.

ET4

Spy Satellites

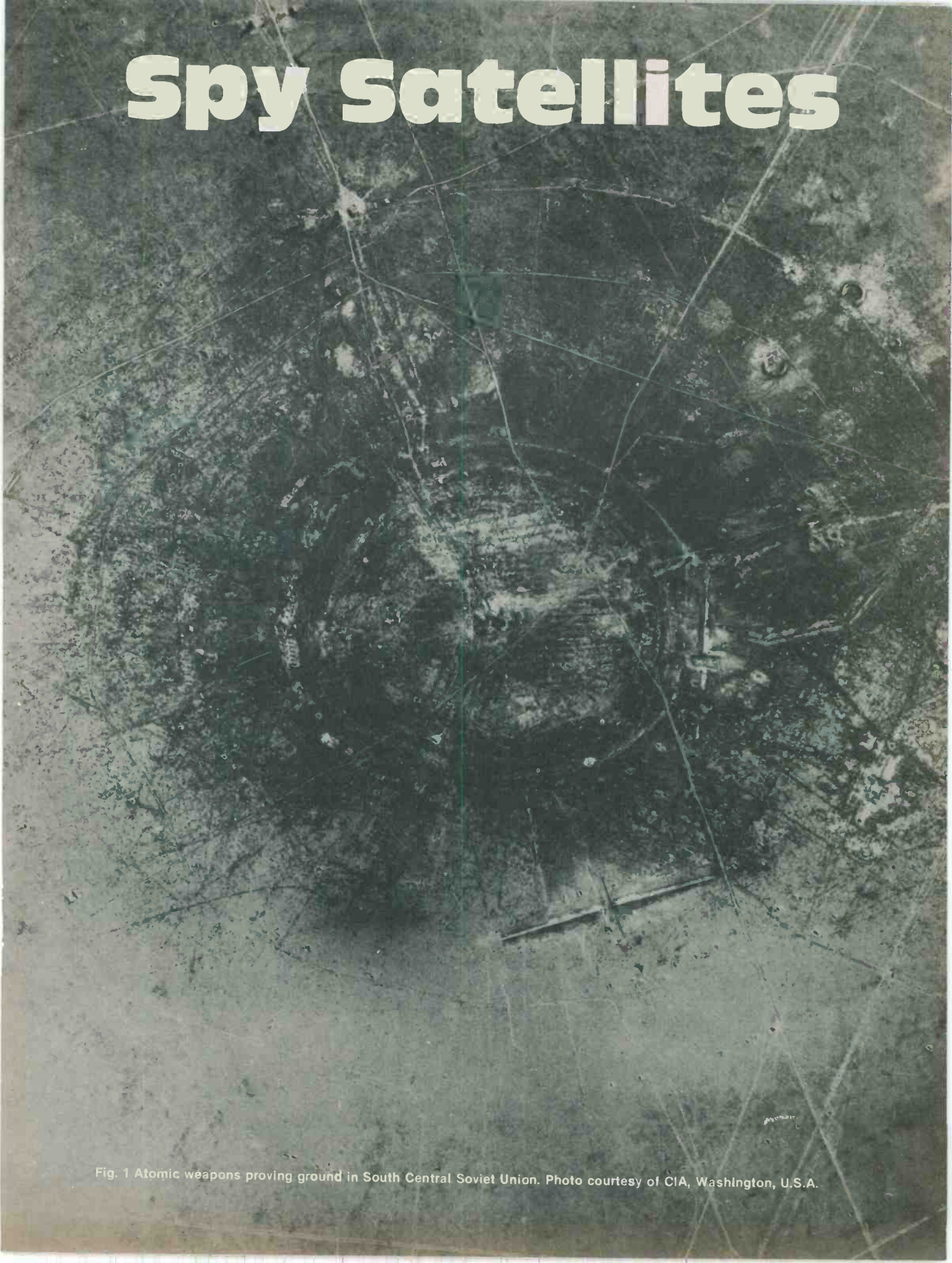

Fig. 1 Atomic weapons proving ground in South Central Soviet Union. Photo courtesy of CIA, Washington, U.S.A.

Spy Satellites

Over the last thirty years, developments in rockets, radar and photography have embroiled the United States and the Soviet Union in a quiet struggle for military surveillance domination. Roger Allan follows America's course.

BY 1952, US military intelligence analysts were becoming increasingly concerned about the build up in Soviet military capabilities. Most of the several hundred German workers who had been involved in the V-2 project and then shipped to the Soviet Union at the conclusion of World War II had been repatriated, bringing with them tales of atomic programs and missiles. The truth contained in their debriefing reports was brought home dramatically in 1953 when the Soviet Union detonated its first hydrogen bomb, only nine months after the US had succeeded in doing so. It was obvious that the US had to determine how far Soviet capabilities had grown, and this meant surveillance of the Soviet heartland.

The first step in the surveillance program consisted of the establishment of a radar facility at Samsun in Turkey, which gave adequate coverage of the Soviet missile tests at Kapustin Yar, some 1550 km to the northeast. However, it was apparent that the missiles' impacts, occurring some 1500 km away in the Kyzyl Kum desert, were not covered by the radar station. Further, due to the range of these missiles, they could only be IRBMs, not the longer ranged ICBMs which posed the most immediate threat to US security. It was obvious that the ICBM tests were conducted deeper inside Soviet territory, beyond the monitoring range of the Samsun facility. To penetrate that deeply into the Soviet Union, (if only to find where the tests were taking place), the U-2 high flying aircraft was developed. The U-2 commenced reconnaissance flights in June, 1956, and was rewarded in April of 1957 with the discovery of the cosmodrome at Tyuratam where the ICBM tests were conducted. As more and more of the Soviet Union had to be studied, the U-2 flights became longer and longer so one way flights from Peshawar in Pakistan to Bodo in Norway were introduced. It was on the first of these flights that an inherent problem in aircraft photographic surveillance became apparent: a U-2, piloted by Gary Powers, was shot down by a

surface-to-air missile. In the international shouting match that followed, U-2 flights over the Soviet Union were cancelled.

Satellite Development

Fortunately, some thought had been directed at alternate methods of surveillance. As far back as 1951 the RAND Corporation had submitted a technical report entitled "The Utility of a Satellite Vehicle for Reconnaissance." By 1956 this study had progressed to the point that a contract for a strategic satellite system, known as Project WS-117L, had been awarded to Lockheed (later Lockheed Missiles and Space Systems) to be based on the as then undeveloped vehicle, the Agena rocket/satellite.

Lockheed's proposal was relatively simple: a second stage would be placed on top of an ICBM first stage. As the payload and the second stage were not to be separated in orbit, the command circuitry for the second stage could be used to control the payload, cutting overall weight. Instrumentation would be carried in the payload area, and recovery of the surveillance intelligence payload would be achieved by physical recovery of the nose cone. C-130 transports, trailing trapeze-like devices, would snatch the parachute containing the instrumentation in mid-air, primarily over the sea in a region south of Hawaii. Once snatched, the payload would be hauled onboard the aircraft for further processing and analysis in Washington.

As for surveillance equipment, TV was rejected for not having sufficient clarity. Instead, a conventional camera was used to photograph the scene, the film developed onboard, and then, at the conclusion of the mission, the nose cone would separate and re-enter the atmosphere.

So concerned was the Department of Defense over the lack of surveillance capabilities that, largely in response to the launching of Sputnik, Lockheed's budget was quadrupled in November, 1957. In 1958 the DoD announced that the program WS-117L would consist of three parts: **Discoverer** which would be used as a test bed for developing systems and concepts; **Sentry** (later re-named **Samos**) which would be the operational reconnaissance system; and **Midas** (not covered in this article) which would be an early warning system to detect missiles and warn of an attack. Samos and Midas were each to consist of 8 to 12 satellites in polar orbit, with an expected operational capability by the mid-1960's.

Toward the end of 1958 the first Agena was delivered to the USAF. It weighed 3,850 kg on the ground and 770 kg in orbit and measured 1.52 metres in diameter and 5.94 metres long. The instruments were located in the conical nose section which measured 84 cm by 69 cm and weighed 135 kg. Stabilization was by two sets of cold gas reaction jets, and the system's rocket engine, a Bell Hustler, produced 6,800 kg of thrust.

Blast Off Discoverer

All launches of Discoverer were from the Vandenberg Air Force Base using a Thor rocket as the first stage. The choice of Vandenberg was the result of range safety considerations: as the satellites were to be placed in polar orbit they would have to be fired in a northward direction. To do so from Cape Canaveral would result in the rockets passing over populated areas. It was safer to launch from Vandenberg.

The first launch took place on February 28, 1959 and the last on February 27, 1962. Unravelling the history of Discoverer rapidly

Programme	Discoverer	Area Survey	Close Look	Big Bird	Ferret (large)	Ferret (sub-satellite)	KH-11
1959	8						
1960	11	1					
1961	17	4					
1962	2	18	6		3		
1963		17	4		2	3	
1964		14	10		3	2	
1965		14	9		1	3	
1966		9	15		2	3	
1967		9	10		1	3	
1968		8	8		2	5	
1969		6	6		1	4	
1970		4	5		1	3	
1971		3	4	1	1	1	
1972		2	5	3	1	3	
1973			3	3		1	
1974			4	2		2	
1975			2	2		1	
1976			2	2		1	
1977			3	2		1	
1978			2	2		3	
1980			2	2		4	
1981			2	2		?	1
1982			?	?		?	?
TOTAL	38	109	104	21	17	43+	1+

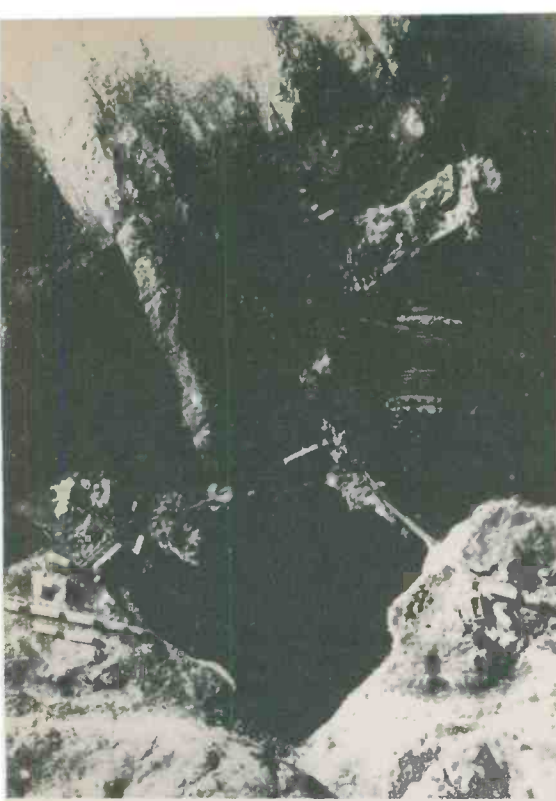

Fig. 2 Soviet attack submarine base in Northern fleet area. Photo courtesy of CIA, Washington, U.S.A.

degenerates into a seemingly endless litany of mechanical and human successes and failures including guidance errors. In brief, the program involved 38 launches, of which 26 reached orbit carrying 23 payloads. Of the payloads, 8 were recovered in mid-air and 4 from the sea; essentially, 12 successes out of 28 tries. While superficially this program appears to have been unsuccessful, it must be borne in mind that space flight was still in its infancy. Discoverer racked up a goodly score of successes: it was the first polar orbiting satellite, the first satellite to be stabilized in space on all three axes, the first to be maneuvered in space, the first capsule to be recovered from orbit, the first aerial recovery of a space capsule by the air-snatch technique and, not surprisingly, the first satellite to photograph Soviet military installations. Regrettably, however, for the purposes of this article, only four photographs taken by US military satellites have been released. There is no indication of what system they were taken by or when, and their clarity has been deliberately reduced for security reasons, so there is no way of determining what Discoverer photographed.

This photographic surveillance method tended to give high resolution of ground objects and showed good detail but the weight penalty of carrying a re-entry capsule was high

and meant that only a small quantity of film could be carried. Radio transmission, while not giving as high resolution, could, by means of a radio ground link, result in many more photographs per orbit which could then be analysed within hours of being taken. Radio photographic methods were concurrently used alongside optical photographic, or 'hard film', techniques. Due to the two types of photography, film recovery vehicles were referred to as "close look satellites", while radio transmission satellites were referred to as "area survey satellites". These area and close look satellites were used conjointly in the early 1960's to provide the answers to the three main problems facing American intelligence: the provision for targeting data for US missiles; the determination of the number of missiles the Soviets had, necessitating an area survey of suspected missile sites (missile sites tend to be large); and the obtaining of a detailed look at the main Soviet ICBM, the SS-6, which would tell the US how quickly an attack could be launched and how vulnerable America would be to a first strike.

Samos Program

The area survey satellites were predicated on a radio transmission system developed by Kodak (the camera) and CBS Laboratories (the film scanner), which would find later use in the Lunar Orbiter series of spacecraft in 1966 and 1967. Originally known as Sentry, the program name was changed in 1963 to Samos (for Satellite and Missile Observation System). The first of these Code Named E-5 satellites was launched in October 1960 with propulsion provided by an Atlas-Agena A. Because most of the Atlas rockets coming off the assembly line were earmarked for ICBM deployment, the Samos program got off to a slow start, and was also hampered by the inevitable launch failures and mechanical breakdowns. However, once it was determined to use Thor rockets rather than Atlas rockets and the mechanical bugs were ironed out, the program rapidly became a success and was only curtailed in 1972 by the introduction of the Big Bird satellites, which are detailed later. Of five launches using an Atlas-Agena A or B, three failed to orbit, while of twenty-six Thor-Agena D's only three failed to orbit. Later, utilizing the TAT-Agena D (for Thrust Augmented Thor-

Agena D), of forty nine launches there were only seven vehicles which failed to orbit and, when the Long Tank Thrust Augmented Thor-Agena D (or LTTAT-Agena D) was used, there was only one failure in thirty launches. The evolution from Atlas-Agenas to LTTAT-Agenas was primarily because of improvements in photographic capability resulting in lower payload weight, for while the Atlas-Agena could loft some 1,860 kg into orbit, the Thor-Agena could manage only 1,000 kg, the TAT-Agena only some 1,500 and the LTTAT-Agena some 2,000kg. All the satellites were placed in the same sort of polar orbit, having a perigee of roughly 180 km and an apogee of some 300-400 kg, with a period of about 94 minutes. In thirteen years some 109 launches had been made, with 98 managing to get the payloads into orbit, a 90% success rate.

Look Closely

Close look satellites were first launched in March of 1962 using an Atlas-Agena B combination rocket, a camera developed by Eastman Kodak and a recovery vehicle by General Electric. The satellite weighed about 2,000 kg, about twice the weight of the Discoverer satellites. The Agena-B satellites followed the design of the Discoverer series in that its retro-rocket was attached to the capsule so that its firing, which occurred after separation of the capsule from the main spacecraft, would not alter the orbit of the main vehicle, (which would remain in space until it decayed from atmospheric drag.) By 1963, after six successful launches, the satellite vehicle was changed to the Agena D which had a new type of retro-fire. The engine of the Agena D was restartable and was used to carry out retro-fire, which gave a significant weight saving over the earlier configuration. It also meant that when the engine was fired to initiate re-entry, the main spacecraft was also decelerated and so the orbital lifetime of the Agena was equal to that of the recoverable capsule.

In 1966, a third generation of close look satellites was introduced, using the new Titan 3B-Agena D launcher. They weighed about 3,000 kg in orbit, and the extra capacity was used to carry more film and consumables, along with a new multi-spectral camera built by the Itek Corporation, detailed later. The orbit used by these third generation satellites is slightly different from that of the

Spy Satellites

older types with a perigee of close to 135 km and an apogee in the region of 400 km. Atmospheric drag at altitudes like 135 km is quite marked, and the satellites had to fire their Agena engines often to stay in orbit. Despite this, their orbital lifetimes have increased over the years from 3 days to about 10 days. Close look satellites are still operational with about 102 having been successfully launched since the program's inception in 1962, representing about a 92% success rate.

The Fourth Generation

In the early seventies, the fourth generation satellites were developed, combining both area and close look surveillance functions. Technically called Program 467, the Big Bird satellites, as they are customarily known, were built by Lockheed and based yet again on the Agena. They are the largest military satellites developed by the United States, weighing 13,000 kg and measuring 15 m long and 3 m in diameter. They carried two imaging systems, one a giant high resolution camera developed by the Perkin Elmer Corporation for close look photography and the other an Eastman Kodak area survey camera with a new film scanner. It has also been suggested that they may have carried side looking radar which produces far better resolution than conventional radar but uses the same frequencies and thus has the same cloud penetrating capability. Six recoverable capsules were carried on board, and at regular intervals they were loaded with exposed film and returned to earth, while the radio transmissions were handled by a 6 m unfurlable antenna.

The first launch was in 1971 placing the Big Bird in an orbit with a perigee of 184 km and an apogee of 300 km which is typical of the area survey type missions. Its orbital inclination (96°) was chosen so that it covered the same area each day at the same local time — its precession was synchronized with the apparent yearly motion of the sun. This meant that lighting conditions at the target areas would be the same every time the satellite passed overhead, which would make picking out changes to the scene that much easier. Their orbital lives were approximately five months, with the program petering out in the early 1980's when the KH-11 program came on stream.

The subsatellites carried by the Big Birds were for ferret type missions, which might loosely be con-

sidered the ears of the satellite reconnaissance program. The subsatellites picked up the radio and radar transmissions from the areas being studied for later replay back to ground stations for analysis. In this way it was possible to locate Soviet aircraft and missile defence radars, deduce a good deal about their characteristics and performance, and eavesdrop on military and governmental communications, including submarine-to-shore links. It has even been suggested that telephone conversations could be monitored. Such knowledge gave a great insight into the offensive and defensive threats posed by the opposition, and to his strategy and future plans. There were two types of ferrets, a larger one requiring its own booster, and a smaller one which could be launched as a sub-satellite along with another. It has been suggested that the two types of craft performed complementary roles, with the small ones carrying out search and find missions using low sensitivity equipment, and the

Very little is known about the KH-11 satellite, which since its first launch in 1981 has replaced the Big Birds. It was launched atop a Titan III C into an orbit that operates at altitudes from 186 to 273 miles at an inclination of 97 degrees.

Eye In The Sky

All the information that reaches a satellite from the earth comes in the form of electromagnetic radiation. Although the atmosphere may appear transparent to the human eye, it is in fact opaque to most wavelengths, with only two 'windows' through which radiation can pass freely. One 'window' covers wavelengths in the range from 0.3 microns up to about 10 microns, which includes some near ultra-violet, visible light, near infra-red and some far infra-red; and the other range from 3 cm to 3 m which includes radio and radar in the US military bands A through I. Any satellite that is to observe events on

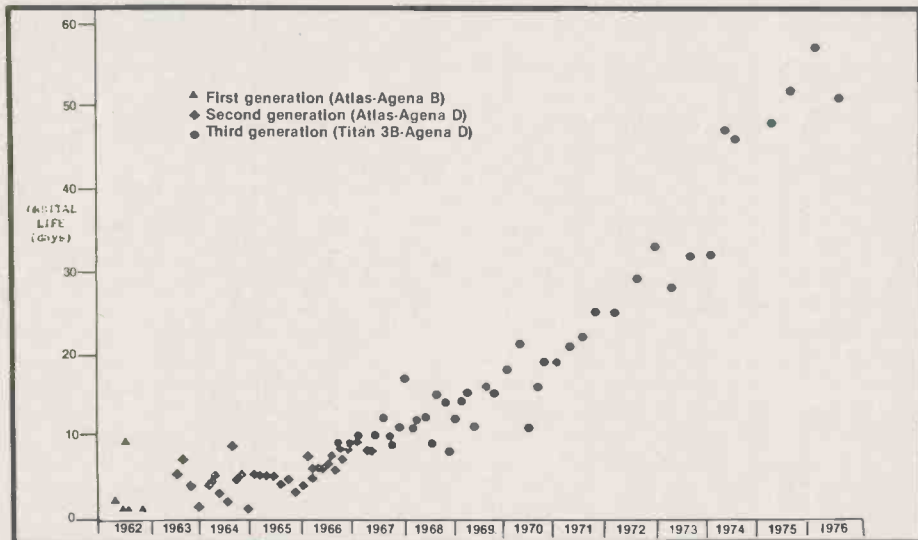

Orbital lives of the close - look satellite

larger ones carrying out detailed examinations of selected targets using high sensitivity equipment.

Ferrets were first launched in 1962 and tailed off in the early 70's when their functions were transferred to the subsatellites carried by Big Bird. It appears that the close look ferrets and the area survey ferrets functions were combined into a single vehicle, much like Big Bird combining the function of close look and area survey photography. Between 1962 and 1971 there were some 17 large ferrets launched, with no reported launch failures; and between 1963 and 1975 there were some 42 ferret subsatellites launched, also with no reported failures.

earth must use sensors which operate at these wavelengths.

Cameras operating in the visible portion of the spectrum were the first type of sensor to be used for reconnaissance, and they are still the most common today, not including the KH-11. The reasons are that camera design and technology are well understood. The limiting resolution for such a system consists of the interaction of the limiting resolution of the camera and the limiting resolution of the atmosphere, customarily considered to be 10 cm independent of satellite design or altitude.

The scale number is the parameter determined by the ratio of a satellite's altitude and the camera's

resolution. With a focal length of 15.24 cm and an altitude of 436 km, the S 190 A Multispectral Photographic Camera used on Skylab missions had a round resolution of 24 m, giving a scale number of 2,860,000. The Big Bird's have been reported to carry a camera with a focal length of "more than eight feet," say 2.5 m. At an altitude of 160 km, a typical perigee height, this results in a scale number of 64,000. Assuming its level of technology is similar to Skylab's, this would result in a resolution of about 55 cm.

The dimensions quoted for the smallest objects that can be resolved generally refer to objects whose length and width are of the same order. It is well known, however, that an object which is several orders of magnitude longer than it is wide can be resolved when its width is well below the limiting resolution. An example is a photograph taken from a Viking rocket with a computed resolution of 150 m, and yet it is possible to pick out a railway line, which would be no more than one twentieth of this wide, even allowing for cuttings and embankments. Using the figures derived for Big Bird, it is therefore possible that objects as small as two or three centimetres can be resolved. Reports from the early seventies that the buttons on a man's shirt could be resolved should be rejected as fantasy.

The main concern of satellite reconnaissance is to maximize the amount of information that can be extracted from the data returned, and one aid to this is infra-red photography. The main advantage that infra-red has over visible light imagery is that surfaces which may be indistinguishable in visible light imagery, such as a patch of grass or a camouflaged missile silo cover, look quite different in infra-red because of the different reflection characteristics. Unfortunately, the resolution obtainable with infra-red is not nearly as good as visible light photography — Skylab's S 190 A camera's infra-red resolution was 68 m compared to 24 m in the visible band — so simultaneous photography in both regions of the spectrum came into use, taking advantage of the good features of each while minimizing the effects of the bad ones. This led to multi-spectral photography, where images are made in several portions of the visible and infra-red spectrum simultaneously. By careful choice of the film/filter combinations, each image can show different features of the target and comparisons between the images

can yield still more to the skilled photo-interpreter.

Passive and Active

Sensors which use the long wavelength atmospheric 'window' can be divided into two types, passive and active. Passive sensors do not emit radio or radar signals, they simply listen to whatever they can pick up, record it and then when they are over home territory re-transmit it to a receiving station for processing and

analysis on the ground. This type of sensor has been in use on the ferret satellites since 1962, but like everything else to do with this program, their performance is shrouded in secrecy.

Active sensors are those which transmit their own signals and use reflections to determine the presence of other objects. For reconnaissance and surveillance purposes these are mostly confined to radars operating at the middle of the wavelength range, in what used to be called the

CANADA'S LARGEST SOFTWARE SUPPLIER!

arkon
electronics ltd

409 Queen St West
Toronto, Ont. M5V 2A5
593-6502/03/04 — Computer Dept
593-9653/54/55 — Electronic Dept

WATCH FOR THIS
AD SPECIAL
EVERY MONTH &
GET READY TO
WIN!!

THIS MONTH'S TOP 10 GAMES



#1. Aztec Adventure	Datamost	54.95
2. Chop Lifter	Broderbund	47.95
#3. Miner 2049'er	MicroLab	49.95
#4. A.E.	Broderbund	41.95
5. Crisis Mountain	Synergistic	47.95
#6. Repton	Sirius	52.95
7. Frogger	On-Line	47.95
8. Wizardry	Sir-Tech	68.95
9. Serpentine	Broderbund	47.95
10. Wavy Navv	Sirius	45.95



#1. Miner 2049'er	Big Five	Rom - 69.96
2. Canyon Climber	Datasoft	Tape - 41.95 Disk - 41.95
3. Choplifter	Broderbund	Disk - 47.95
4. Penetrator	Aventure Int.	Tape - 41.95 Disk - 41.95
5. Froggie	On-Line	Tape - 47.95 Disk - 47.95
6. Baja Buggies	Gamestar	Tape - 39.95 Disk - 39.95
#7. Wizard of War	Roklan	Tape - 50.95 Rom - 58.95
8. Shamus	Synapse	Tape - 44.95 Disk - 44.95
9. Protector II	Synapse	Tape - 44.95 Disk - 44.95
10. Pinball	Sublogic	Disk - 38.95

These lists are comprised of unit sales as well as advanced orders to date

TRS-80

#1. Outhouse	Softsector	Tape - 20.95 Disk - 25.95
#2. Weerd	Big Five	Tape - 27.95 Disk - 27.95
3. Sea Dragon	Adventure Int.	Tape - 34.95 Disk - 34.95
4. Penetrator	Melbourne	Tape - 32.95 Disk - 32.95
5. Panik	Fantastic	Tape - 23.95 Disk - 29.95
6. Caterpillar	Softsector	Tape - 20.95 Disk - 25.95
#7. Frogger	Cornsoft	Tape - 20.95 Disk - 25.95
8. Flight Simulator	Sublogic	Tape - 32.95 Disk - 42.95
9. Steller Escort	Big Five	Tape - 21.95 Disk - 27.95
10. Laser Defence	Med Systems	Tape - 25.95 Disk - 32.95

(Specify Model I or III when ordering)

VIC-20

1. Grid Runner	Hes	59.96	Rom
2. Choplifter	Creative	59.95	Rom
#3. Crossfire	On-Line	47.95	Tape
4. Martain Raiders	Broderbund	27.95	Tape
5. Agressor	Hes	54.95	Rom
6. Spiders Of Mars	U.M.I.	68.95	Rom
7. River Rescue	Thorn Emi	52.95	Rom
8. Deadly Duck	Sirius	52.95	Rom
9. Skibbereen	U.M.I.	54.95	Rom
#10. Swarm!	Tronix	38.95	Tape

INDICATES BEST PERFORMANCE

Recent Expansions allow us to offer over 1,000,000 bytes of different software.

- EDUCATIONAL
- BUSINESS
- UTILITIES
- GAMES
- LANGUAGES

Other software available for
Apple IIe/III, IBM P.C., CP/M 8",
Commodore 64 &
the TRS-80 Colour.

SEND FOR OUR NEW 83 CATALOGUE
\$1.00 PLUS .60¢ POSTAGE
IT'S FULL OF HARDWARE
SOFTWARE BOOKS
& MORE

HERE'S HOW TO ORDER

Send Certified cheque, money order, Visa, Master Card, American Express number. Include expiry date and signature. (We also accept government purchase orders.) Add \$1.50 shipping & handling. Ontario residents add 7% sales tax. Phone orders accepted or pick it up now!! All products and more on display.

Address:
ARKON ELECTRONICS
I.M.S.W. COMPUTER STORES INC.)
409 Queen St. West, Toronto,
Ontario M5V 2A5
(416) 593-6502/03/04



Circle No. 16 on Reader Service Card.

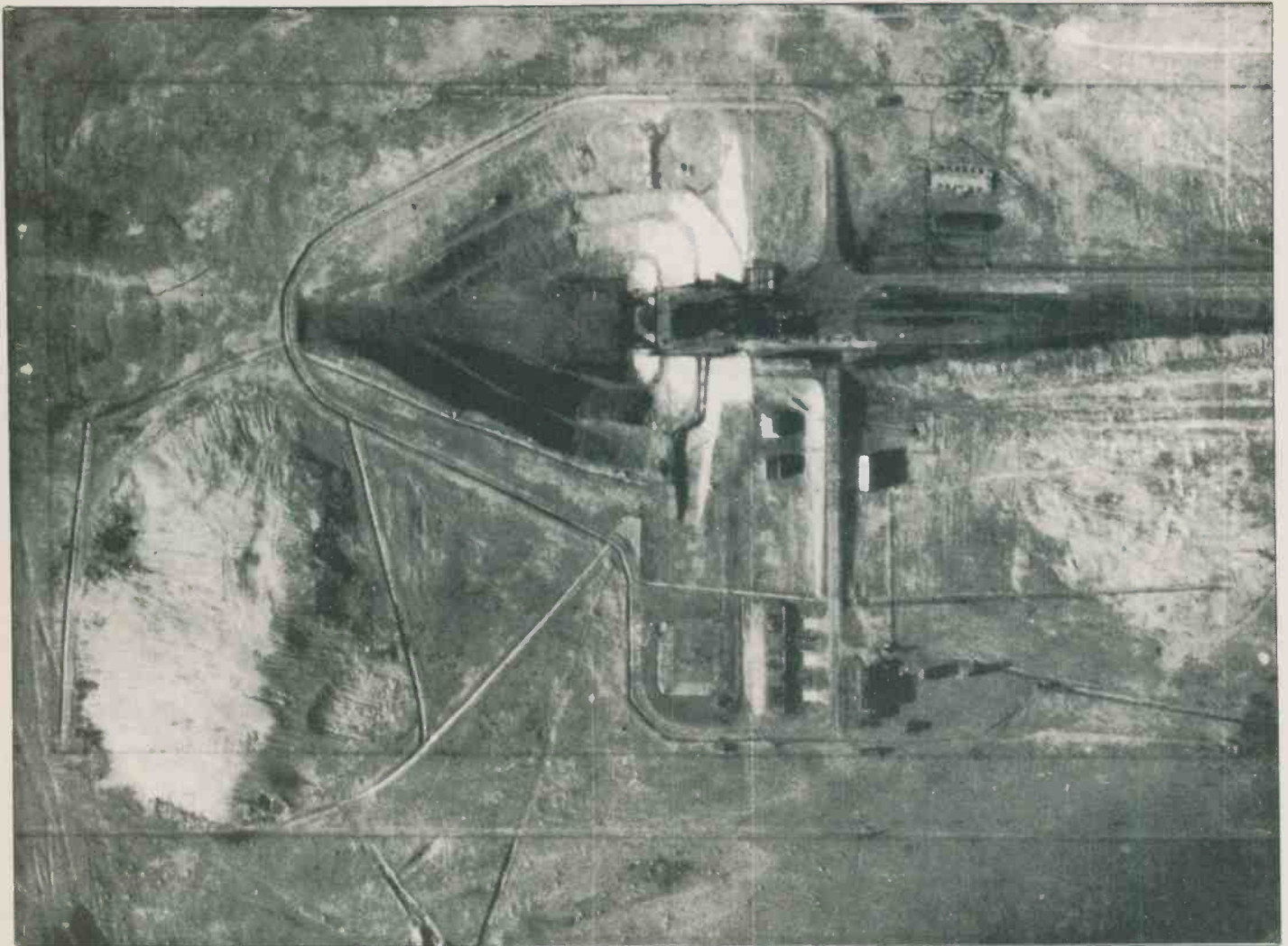

Fig. 3 Soviet space launch vehicle platform in South-central USSR. Photo courtesy of CAI, Washington, U.S.A.

L-band but which is now referred to as the D-band by the US military agencies (15 cm to 30 cm, 1 GHz to 2 GHz). Radars such as these have one great advantage: their performance is unaffected by weather conditions. However, they do have one great disadvantage: to give anything like reasonable resolution requires very large antennae, on the order of 29 m. This problem is overcome by the use of synthetic aperture side looking radar. For this the vehicle transmits radar impulses in a narrow fan at right angles to the direction of flight. As the radar beam sweeps through the fan, the reflected signal is converted into a fine light beam which is scanned across a photographic film. The forward motion of the vehicle, and thus the radar fan, is translated into a motion on the photographic film, so that successive scans build up a picture in much the same way as a television image is built up from a set of lines. The vehicle's forward motion makes the antenna 'appear'

much larger to objects on the ground and as the resolution of a radar is proportional to its antenna size, a dramatic improvement in performance over conventional radars can be realized.

A more recent development, used in the KH-11 satellites, is a sensor called a mosaic focal plane array. A mosaic array is a two-dimensional array of batch processed detectors mounted integrally with charge coupled devices on a single chip, with as many as several thousand on one chip. By integrating the charge coupled devices, which amplify and process the detector signals on the same chip as the detectors, much of the weight can be reduced. Operating on a 'staring' mode with each detector observing the same region continuously, the signal processing logic programmed into the chip responds to changes in illumination levels.

This last process, the main one used by the KH-11, has produced the only public argument concerning

satellite reconnaissance and surveillance. Essentially, the Big Bird program, with its optical photographic capabilities, still produces the best resolutions obtainable, but they are being phased out, with only four currently in storage for use in a national emergency. Partisans of the KH-11 program say that while their satellite does not produce the same high resolution, it produces more photographs and by transmitting the data via data link satellites directly to Washington, the surveillance results can be produced in real time. Partisans of the Big Birds say that while that is true enough, it is still useful to have photographs with resolutions of a few centimetres even if one has to wait for the capsule to return to earth to be processed.

In summary, the 333+ known military reconnaissance satellites launched by the United States represent some 43% of all satellites launched by that country at a cost of some 12 billion dollars. **ETI**

BCS
ELECTRONICS
LIMITED

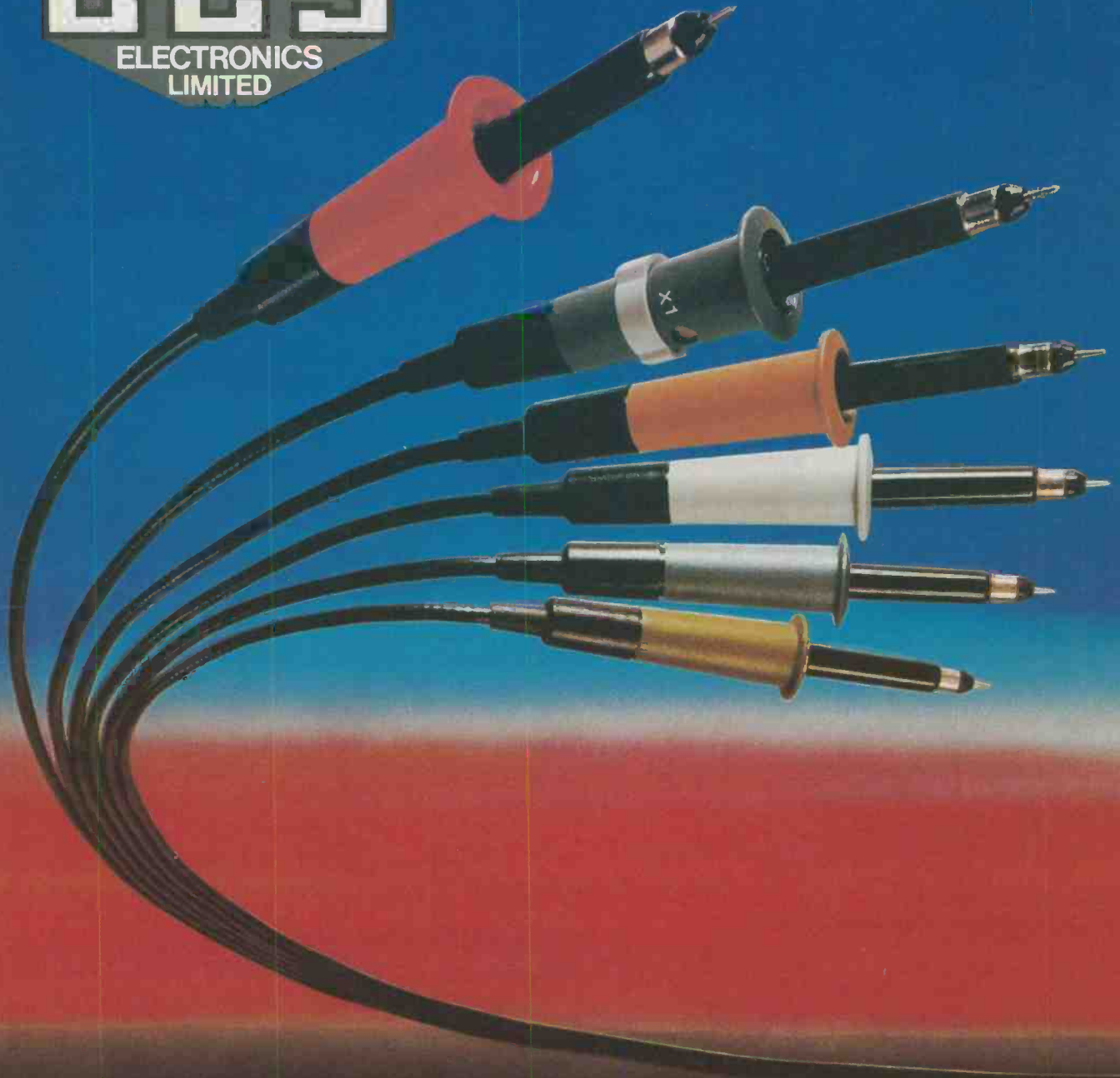

Instruments for Industry and Service

980 Alness St. Downsview, Ontario M3J 2S2 (416) 661-5585.

Specification

Vertical Deflection (Y)

Bandwidth: DC to 10MHz (-3dB),
DC to 15MHz (-6dB)

Risetime: approx. 35ns.
Overshoot: maximum 1%

Deflection coefficients: 12 calibrated steps,
5mV/cm to 20V/cm in 1-2-5 sequence,
with variable control 1:2.5 uncal. to 2mV/cm.
Accuracy in calibrated position: $\pm 3\%$.

Input impedance: 1M Ω || 28pF.
Input connection: BNC connector.
Input coupling: AC-DC-GND.
Input voltage: max. 500V (DC + peak AC).

Timebase

Time coefficients: 18 calibrated steps,
0.5 μ s/cm to 0.2s/cm in 1-2-5 sequence,
with variable control 1:2.5 uncal. to 0.2 μ s/cm.
Accuracy in calibrated position: $\pm 5\%$.
Normal length of sweep line: approx. 7cm.

Trigger System

Mode: Automatic or Normal (with level adj.).
Slope: positive or negative.
Source: internal or external (BNC connector).
Coupling: AC, TV (frame) low-pass filter.
Threshold: internal 3mm, external 0.4V.
Bandwidth: 2Hz to 30MHz.

Horizontal Deflection (X)

Bandwidth: 2Hz to 850kHz (-3dB).
Risetime: approx. 412ns.
Deflection coefficient: approx. 0.65V/cm.
Input: BNC connector (on front panel).
X-Y phase shift: $< 3^\circ$ up to 70kHz.

Component Tester

Test voltage: max. 7.5Vrms (open circuit).
Test current: max. 23mA rms (shorted).
Test frequency: 50-60Hz (line frequency).
Test connection: 2 banana jacks 4mm dia.
One test lead is grounded (Safety Earth).

General Information

Cathode-ray tube: DG10-119 (P1 phosphor),
rectangular screen, internal graticule 6x7cm.
Accelerating potential: 1800V.
Trace rotation: adjustable on front panel.
Calibrator: square-wave generator ≈ 1 kHz
for probe compensation and sensitivity check;
output (on front panel): 0.2V $\pm 1\%$.
Electronic regulation for all important
supply voltages including the high voltage.
Protective system: Safety Class I (IEC 348).
Line voltages: 110, 125, 220, 240V AC.
Permissible line fluctuation: $\pm 10\%$.
Line frequency range: 50 to 60Hz.
Power consumption: approx. 21 Watts.
Weight: approx. 3.7kg.
Cabinet (mm): **W** 212, **H** 114, **D** 280.
Color: techno-brown.

Subject to change.

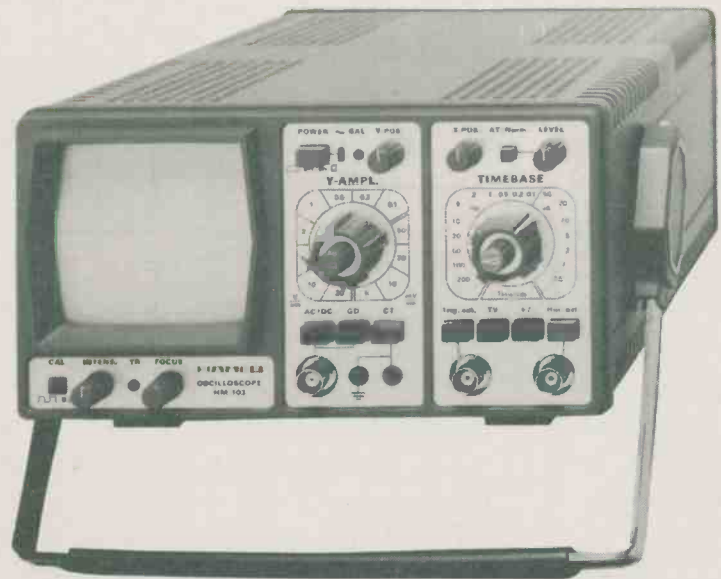

- **Y:** DC-10MHz, max. 2mV/cm
- **X:** 0.2 μ s/cm to 0.2s/cm
- **Triggering up to 30MHz**
- **Component Tester**

This small **Trigger Oscilloscope** with 6x7cm screen has been specifically designed for field service personnel and advanced amateurs. The vertical input sensitivity can be increased to **2mV/cm at full bandwidth** using the variable control. Even a very small signal — beginning at 3mm display height — **triggers** the sweep generator easily up to **at least 30MHz**. A TV low-pass filter facilitates the display of video signals at frame frequency. For the purpose of **checking semiconductors** and other components, even in circuit, a **Component Tester** is incorporated. Pressing a single button is sufficient to switch from oscilloscope to test operation and v.v.

The bright and sharp **CRT with internal graticule** enables **parallax-free viewing**, which is very important for certain maintenance and monitoring tasks. Compact design, low weight, rugged construction, easy operation, and reliable performance make the **HM 103** an indispensable asset for workshop and field service.

LIST \$550.00

Accessories optional

Attenuator probes 1X, 10X, 100X; demodulating probe;
various test cables; 50 Ω BNC feed-through termination;
BNC-banana adapter; carrying case; etc.

Specification

Vertical Deflection (Y)

Bandwidth of both channels:
DC to 80MHz (-3dB), DC to 100MHz (-6dB)
Risettime: ≈ 4.4 ns. Overshoot: max. 1%
Deflection coefficients: 12 calibr. steps,
5mV/div to 20V/div in 1-2-5 sequence,
with variable control 1.25 uncalibr. to **2mV/div**.
Accuracy in calibrated position $\pm 3\%$
Input impedance: 1M Ω || 28pF
Input coupling: DC-AC-GND
Input voltage: max. 500V (DC + peak AC).
Polarity: normal or inverted on Channel I only
Y-Over-scanning indication: with 2 LEDs
Delay line: to view leading trigger edge.
Operating Modes
Channel I, Channel II, Channel I and Ch. II
alternate or chopped (chop frequency ≈ 1 MHz),
sum or difference: Channel II \pm Channel I.

Timebase

Time coefficients: 23 calibrated steps,
50ns/div to 1s/div in 1-2-5 sequence,
with variable control uncal. 2.5:1 to 2.5s/div,
with 10x magnification ($\pm 5\%$) to **5ns/div**.
Accuracy in calibrated position $\pm 3\%$
Hold-off time: variable control approx. 10:1
Ramp output: approx. 5V (positive-going).
Trigger System
Modes: Automatic or Normal (with level adj.)
Trigger action indication: with LED
Single sweep: Single-Reset buttons with LED.
Slope: positive or negative-going edge
Source: Ch. I, II, alternate Ch. I/II, line, ext
Coupling: DC-AC-HF-LF (TV frame).
Threshold: internal 0.5div, external 0.5V.
Bandwidth: DC to at least 100MHz.

Sweep Delay

Time range: 7 decade steps, 100ns to 0.1s,
with variable fine control approx. 10:1 to 1s.
Modes: Search, Delay. With LED indicator.
2nd Triggering "after delay":
with variable level control, pos. or neg. slope,
int. or ext., disconnectable to "free run".

Horizontal Deflection (X)

Bandwidth: DC to 4MHz (-3dB).
Input: via Channel II (see Y deflection spec.).
X-Y phase shift: $< 3^\circ$ up to 100kHz.

Storage Operation

Operation modes: fast charge transfer, half tone.
Store modes: Write, Fast, Multi (integrating),
Auto Store, Variable Persistence, Save, Erase.
Writing speed: 1cm/ μ s-100cm/ μ s (dark background),
100cm/ μ s-1000cm/ μ s (some background illum.).
(Request our special data sheet.)

General Information

Cathode-ray tube: E 725 (P31 phosphor),
internal graticule 8x10 divisions (1 div = 9mm)
Total acceleration voltage: 8.5kV
Z-Modulation input: positive TTL level
Trace rotation: adjustable on front panel
Calibrator: sq-wv gen. ≈ 1 kHz, outp. 0.2V $\pm 1\%$
Regulated DC power supplies: all operating
voltages including the high voltage.
Protective system: Safety Class I (IEC 348).
Line voltages: 110, 125, 220, 240V AC
Permissible line fluctuation: $\pm 10\%$.
Line frequency range: 50 to 60Hz.
Power consumption: 56W (approx.).
Weight: approx. 10kg. Color: techno-brown
Cabinet (mm): W 212, H 237, D 460

Subject to change



■ Y: DC-80MHz, max. 2mV/div ■ X: 5ns/div to 2.5s/div

■ Analog Storage

■ After-Delay Triggering

To repeat the display of an electrical process, the **HM 808** is equipped with an **electronically regulated storage system**. With the storage part switched off, the unit works like a normal oscilloscope, and its technical specification corresponds largely to those of the HM705. On changing from normal mode to write mode, any previously stored signal will be erased automatically. Using the **variable persistence mode**, very slow moving signals can be displayed without flicker.

The writing speed is adjustable within a wide range in two modes: **half tone storage** and **charge transfer**. So it is possible to store periodic signals just as non-repetitive actions up to the **bandwidth of the vertical amplifier**. The maximum view time depends on the selected writing speed. When the unit is switched on, special circuitry prevents the unintentional erasure of signals already stored. In case of power failure or if the HM808 is turned off, any stored image will be retained for several days. The **Auto Store** feature permits **automatic storing of unpredictable single events** over a longer period of time for monitoring purposes.

LIST \$6915.00

Accessories optional

Attenuator probes 1X, 10X, 100X; demodulating probe;
various test cables; 50 Ω BNC feed-through termination;
viewing hood; BNC-banana adapter; 4-Channel Amplifier;
Component Tester; etc.

Specification

Vertical Deflection (Y)

Bandwidth of both channels

DC to 20MHz (-3dB), DC to 28MHz (-6dB)

Risetime: ≈ 17.5 ns. Overshoot: max. 1%

Deflection coefficients: 12 calibr. steps, 5mV/cm to 20V/cm in 1-2-5 sequence, with variable control 1:2.5 uncal. to **2mV/cm**

Accuracy in calibrated position: $\pm 3\%$

Input impedance: 1M Ω || 28pF

Input coupling: DC-AC-GND

Input voltage: max. 500V (DC+peak AC)

Polarity: normal or inverted on Channel I only

Y-Output from Ch. I or Ch. II: approx. 90mV/cm

Y-Overscan indication: with 2 LEDs

Operating modes

Channel I, Channel II, Channel I and II alternate or chopped (chop frequency ≈ 1 MHz), sum or difference Channel II \pm Channel I

Timebase

Time coefficients: 21 calibrated steps,

0.5 μ s/cm to 2s/cm in 1-2-5 sequence, with variable control 1:2.5 uncal. to 200ns/cm, with 10x magnification ($\pm 5\%$) to **20ns/cm**

Accuracy in calibrated position: $\pm 3\%$

Hold-off time: variable control 10:1

Ramp output: approx. 5V (on rear panel)

Trigger System

Modes: Automatic (peak-to-peak value) or Normal Triggering. LED indication for trig. action

Single sweep: Single-Reset buttons with LED.

Slope: positive or negative.

Sources: Ch. I, Ch. II, alternate Ch. I/II, line, ext.

Coupling: DC-AC-HF-LF (TV frame)

Threshold: internal 5mm, external 0.3V

Bandwidth: DC to 50MHz

Sweep Delay

Time range: 7 decade steps, 100ns to 0.1s, with variable fine control, approx. 10:1 to 1s

Modes: Search, Delay. With LED indication

Horizontal Deflection (X)

Bandwidth: DC to 1.8MHz (-3dB)

Input: via Channel II (see Y deflection spec.)

X-Y phase shift: $< 3^\circ$ up to 120kHz

Component Tester

Test voltage: max. 8.5V rms (open circuit)

Test current: max. 24mA rms (shorted)

Test frequency: 50 or 60Hz (line frequency)

One test lead is grounded (Safety Earth)

General Information

Cathode-ray tube: D14-360 P43/93 (med.), P7/93 optional (long decay characteristic), rectangular screen, internal graticule **8x10cm**

Accelerating potential: 2000V

Z-Modulation input: positive TTL level

Trace rotation: adjustable on front panel

Graticule illumination: three-position switch

Calibrator: square-wave generator ≈ 1 kHz for probe compensation. Output 0.2V $\pm 1\%$

Regulated DC power supplies: all operating voltages including the high voltage

Protective system: Safety Class I (IEC 348)

Line voltages: 110, 125, 220, 240V AC

Permissible line fluctuation: $\pm 10\%$

Line frequency range: 50 to 60Hz

Power consumption: 38 Watts (approx.)

Weight: 7.5kg (approx.). Color: techno-brown

Cabinet (mm): W 285, H 145, D 380

Subject to change

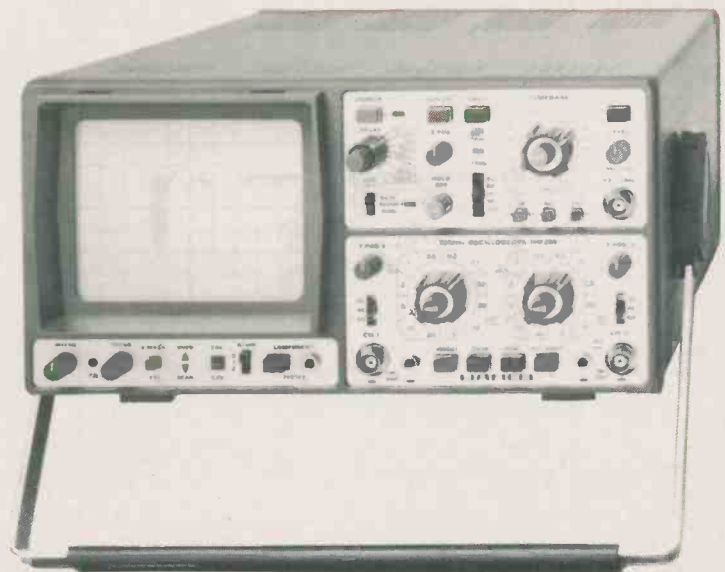

■ Y: DC-20MHz, max. 2mV/cm ■ X: 20ns/cm to 2s/cm

■ Triggering: DC to 50MHz ■ Component Tester

The high performance standards HAMEG Oscilloscopes have achieved today is best demonstrated by the new HM204. Uncommon in this price range are mainly the **high resolution** up to **20ns/cm** and the **Sweep Delay**. Similar to scopes with a second timebase, even smallest details can be expanded.

The multitude of trigger facilities including variable hold-off time, as well as the **peak-value triggering up to 50MHz** indicate what the HM204 has to offer.

For checking individual components or quick tests "in-circuit", this oscilloscope also features a **Component Tester**, which is operated by pressing only one button. Despite the multitude of operating modes, the front panel layout is very clear and logical. The operating comfort is increased by various LEDs indicating overscan, triggering, delay mode and single sweep. Rectangular CRT with **illuminated internal graticule** and **trace rotation** are standard. The application of the HM204 covers **practically all areas of electronics**.

LIST \$1120.00

Accessories optional

Attenuator probes 1X, 10X, 100X; demodulating probe; various test cables; 50 Ω BNC feed-through termination; BNC-banana adapter; 4-Channel Amplifier; viewing hood.

Specification

Vertical Deflection (Y)

Bandwidth of both channels:

DC to 70MHz (-3dB), DC to 100MHz (-6dB).

Risetime: \approx 5ns. Overshoot: max. 1%.

Deflection coefficients: 12 calibr. steps, 5mV/cm to 20V/cm in 1-2-5 sequence, with variable control 1:2.5 uncal. to **2mV/cm**. Accuracy in calibrated position: \pm 3%.

Input impedance: 1 M Ω || 28 pF.

Input coupling: DC-AC-GND.

Input voltage: max. 500V (DC + peak AC).

Polarity: normal or inverted on Channel I only.

Y-Overscanning indication: with 2 LEDs.

Delay line: to view leading trigger edge.

Operating Modes

Channel I, Channel II, Channel I and Ch. II alternate or chopped (chop freq. \approx 1 MHz), sum or difference: Channel II \pm Channel I.

Timebase

Time coefficients: 23 calibrated steps, 50ns/cm to 1s/cm in 1-2-5 sequence, with variable control uncal. 2.5:1 to 2.5s/cm, with 10x magnification (\pm 5%) to **5ns/cm**. Accuracy in calibrated position: \pm 3%.

Hold-off time: variable control approx. 10:1.

Ramp output: approx. 5V (positive-going).

Trigger System

Modes: Automatic (peak-to-peak) or Normal Triggering. LED indication for trig. action.

Single sweep: Single-Reset buttons with LED.

Slope: positive or negative-going edge.

Sources: Ch. I, Ch. II, alternate Ch. I/II, line, ext.

Coupling: DC-AC-HF-LF (TV frame).

Threshold: internal 5mm, external 0.5V.

Bandwidth: DC to at least 100MHz.

Sweep Delay

Time range: 7 decade steps, 100ns to 0.1s, with variable fine control, approx. 10:1 to 1s. Modes: Search, Delay. With LED indication.

2nd Triggering "after delay":

with variable level control, pos. or neg. slope, int. or ext., disconnectible to "free run"

Horizontal Deflection (X)

Bandwidth: DC to 4MHz (-3dB).

Input: via Channel II (see Y deflection spec.).

X-Y phase shift: $<$ 3° up to 100kHz.

General Information

Cathode-ray tube: D 14-654 P31 (med.), P7 optional (long decay characteristic), rectangular screen with internal graticule 8x10 divisions (1 div = 9.7 mm).

Total acceleration voltage: 14kV

Z-Modulation input: positive TTL level.

Trace rotation: adjustable on front panel.

Graticule illumination: three-position switch.

Calibrator: square-wave generator \approx 1kHz for probe compensation. Output 0.2V \pm 1%.

Regulated DC power supplies: all operating voltages including the high voltage.

Protective system: Safety Class I (IEC 348)

Line voltages: 110, 125, 220, 240V AC

Permissible line fluctuation: \pm 10%.

Line frequency range: 50 to 60Hz.

Power Consumption: approx. 43 Watts

Weight: approx. 8.5kg. Color: techno-brown

Cabinet (mm): W212, H237, D380.

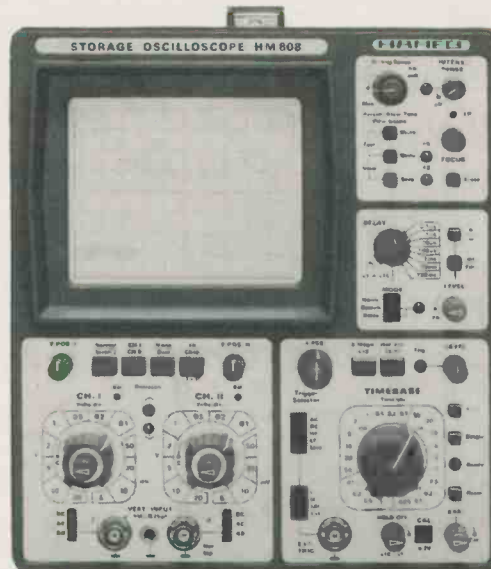

- Y: DC-70MHz, max. 2mV/cm
- X: 5ns/cm to 2.5s/cm
- Triggering DC to 100MHz
- Delayed Sweep Mode

The General-Purpose Oscilloscope **HM 705** with its **multitude of operating modes and trigger facilities** is designed for both laboratory and field service. The maximum Y sensitivity of **2mV/cm at full bandwidth** shows the outstanding performance of both vertical amplifiers. The HM705 triggers even complex signals **beyond 100MHz**. Two **non-synchronous signals**, or a composite signal with a non-synchronous component, and also **aperiodic events** can likewise be triggered. Single-shot operation is also possible. The wide sweep range from **5ns/cm** (including **10x magnification**) to 2.5s/cm gives an excellent resolution. Additionally, it is possible to expand short signal periods by factor of 1000 using the sweep delay. Several LEDs facilitate easy handling and help prevent incorrect setting. The **14kV CRT** with rectangular screen and illuminated internal graticule ensures an **extremely bright and well-defined display**.

These features and others make the **HM 705** an instrument of great flexibility in all fields of **Communications, Consumer and Industrial Electronics**.

LIST \$1750.00

Accessories optional

Attenuator probes 1X, 10X, 100X; demodulating probe; various test cables; 50 Ω BNC feed-through termination; viewing hood; BNC-banana adapter; 4-Channel Amplifier; Component Tester; carrying case; etc.

Subject to change.

Specification

Vertical Deflection (Y)

Bandwidth of both channels

DC to 20MHz (-3dB), DC to 28MHz (-6dB)

Risetime: ≈ 17.5 ns. Overshoot: max. 1%

Deflection coefficients: 12 calibr. steps, 5mV/cm to 20V/cm in 1-2-5 sequence, with variable control uncal. 1:2.5 to **2mV/cm**.

Accuracy in calibrated position: $\pm 3\%$.

Input impedance: 1M Ω || 28pF.

Input coupling: DC-AC-GND.

Input voltage: max. 500V (DC + peak AC).

Operating modes

Channel I, Channel II, Channel I and II alternate or chopped (chop freq. ≈ 1 MHz), sum or difference Ch. II \pm Ch. I (with Invert button for Channel II).

Timebase

Time coefficients: 18 calibrated steps, 0.5 μ s/cm to 0.2s/cm in 1-2-5 sequence, with variable control uncal. 1:2.5 to 0.2 μ s/cm, with 5x magnification uncal. to 40ns/cm. Accuracy in calibrated position: $\pm 3\%$.

Trigger System

Modes: Auto or Normal (with level adj.).

Slope: positive or negative.

Sources: Ch. I, Ch. II, line, external.

Coupling: DC-AC-HF-LF (TV frame).

Threshold: internal 5mm, external 0.6V.

Bandwidth: DC up to 40MHz.

Horizontal Deflection (X)

Bandwidth: DC to 2.5MHz (-3dB).

Input: via Channel II (see Y deflection spec.).

X-Y phase shift: $< 3^\circ$ up to 300kHz.

Component Tester

Test voltage: max. 8.5Vrms (open circuit).

Test current: max. 24mA rms (shorted).

Test frequency: 50-60Hz (line frequency).

Test connection: 2 banana jacks 4mm dia.

One test lead is grounded (Safety Earth).

General Information

Cathode-ray tube: D14-360 P43/93 (med.), P7/93 optional (long decay characteristic), rectangular screen, internal graticule **8x10cm**. Accelerating potential: 2000V.

Trace rotation: adjustable on front panel.

Calibrator: square-wave generator ≈ 1 kHz for probe compensation. Output 0.2V $\pm 1\%$.

Regulated DC power supplies: all operating voltages including the high voltage.

Protective system: Safety Class I (IEC 348).

Line voltages: 110, 125, 220, 240V AC.

Permissible line fluctuation: $\pm 10\%$.

Line frequency range: 50 to 60Hz.

Power consumption: 36 Watts (approx.).

Weight: 7kg (approx.). Color: techno-brown.

Cabinet (mm): **W** 285, **H** 145, **D** 380.



■ **Y:** DC-20MHz, max. 2mV/cm ■ **X:** 40ns/cm to 0.2s/cm

■ **Triggering:** DC to 40MHz ■ **Component Tester**

The already well-known good **price/performance ratio** of the **HM203-4** was again improved. Both vertical amplifiers now have **variable controls** and an input sensitivity of **max. 2mV/cm** at full bandwidth. New is also that the sum and difference of two signals can be displayed. The trigger facilities were also extended. Besides Line- and TV-triggering, **HF-** and **DC-triggering** are now possible, as well. At 5mm display height the HM203 will trigger up to **at least 40MHz**. The CRT's internal graticule permits **parallax-free viewing** from different angles. Particularly for maintenance purposes, the HM203-4 also has a built-in **Component Tester** for quick **tests of semiconductors** and other components, single or in-circuit.

The HM203 has been designed for **general purpose applications in industry and service**. The multitude of operating modes, concise layout of the front panels, and ease of operation recommend it also for the **training of engineers and technicians**.

LIST \$835.00

Accessories optional

Attenuator probes 1X, 10X, 100X; demodulating probe; various test cables; 50 Ω BNC feed-through termination; BNC-banana adapter; 4-Channel Amplifier; viewing hood.

Subject to change.

Specification

Amplitude Calibrator Output

Waveform: Square-Wave.
 Polarity: positive going.
 Frequencies: 0.5-1-5 kHz.
 Accuracy (by quartz): 0.005%.
Risetime: <150ns.
 Amplitude Range: 16 mV-40V.
 Output Attenuator with 11 steps
 for 2-5-10-20-50mV/div.
 and 0.1-0.2-0.5-1-2-5V/div.
 Display Height: 4 divisions
 (via preattenuator 2:1).
Voltage Accuracy: 0.5%
 (terminated into 2M Ω).
 Output Resistance Source:
 approx. 600 Ω .

Fast Rise Output

Waveform: Square-Wave.
 Polarity: positive going.
 Frequencies:
 5-10-50-100-500-1000 Hz,
 5-10-50-100-500-1000 kHz.
 Accuracy (by quartz): 0.005%.
Risetime: <5ns.
 Amplitude Range: 0-250mV.
 Output Attenuator with 5 steps
 for 2-5-10-20-50mVpp.
 Voltage Accuracy: 5%
 (terminated into 50 Ω).
 Display Height: approx. 5 div.

Time Marker Output

Waveform: Needle Pulse.
 Polarity: positive going.
 Frequency Range: 2Hz-10 MHz.
 Time Range: 0.5s/div. - 100ns/div.
 Time Range Switch with 21 steps
 in a 1-2-5 sequence.
Accuracy (by quartz): 0.005%.
 Output Voltage: approx. 0.3Vpp
 (terminated into 50 Ω).



- Calibrator 0 - 40 V
- Square pulse edge < 5 ns
- Marker 0.5 s - 0.1 μ s/div.
- Quartz controlled freq.

The HZ62 is a calibration generator for checking and adjusting the **attenuator performance, transient response, and time accuracy** of the sweep for all types of commercial oscilloscopes. Normally, several instruments are required for these tasks. With omission of all unnecessary controls, three such instruments are combined in the HZ62. The **crystal-controlled frequency** accuracy and the **fast risetime** of the basic generator also allow measurements on very high-grade laboratory oscilloscopes. In addition, it is usable as a normal **Square-Wave Generator**. The controls and connectors are clearly arranged and so easy to see that the use of the calibrator poses no problems and involves **no time-consuming instruction**.

Acquiring an HZ62 is very advantageous for checking many oscilloscopes and for the oscilloscope service. The HZ44 Carrying Case is available if frequent transportation is necessary.

LIST \$755.00



LIST \$95.00

HZ65 Component Tester

Works with any oscilloscope featuring X-Y operation. An indispensable aid when repairing electronic equipment as it displays the current-voltage characteristics of any component on the screen. Components can also be tested "in-circuit", with clear go / no go indication within seconds. For low power transistors two sockets are provided with switchable connections, facilitating tests of each junction. Test currents of approx. 3.7mA_{rms}, 37mA_{rms}, and 320mA_{rms} can be selected with slide switch. Supplied with pair of test leads, two coax-cables for scope, power cord. Safety Class II.

CONNECTORS

GENERAL SPECIFICATION

Coline's Connectors conform to their relevant MIL, IEC and DEC standards.

Coline has registered approval to Ministry of Defence standard 05-24.

COLINE PART NO. LEGEND

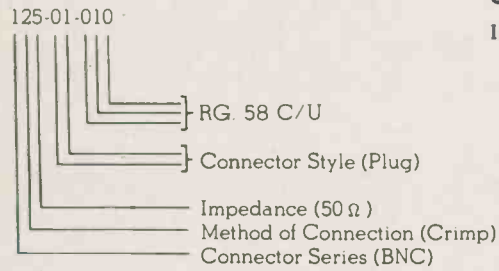

MATERIAL SPECIFICATION

Surface Finish – Centre Contacts and Ferrules
Bright Silver Plate

Other Parts Bright Nickel Plate

Bodies Brass (with the exception of 236-31-000 which is Alluminium Alloy)

Contacts Berillium Copper or Brass

Gaskets Silicone Rubber

Insulation P.T.F.E. (with the exception of 236-31-000 which is a Thermosetting Plastic)

SERIES N PANEL SOCKET
50Ω Part No. 335-31-000

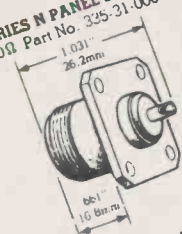

SERIES UHF BULKHEAD SOCKET
Part No. 230-28-000



SERIES N JACK
50Ω Part No. 315-04-010



SERIES BNC PLUG
50Ω Part No. 115-01-010



SERIES UHF PLUG
Part No. 210-01-001

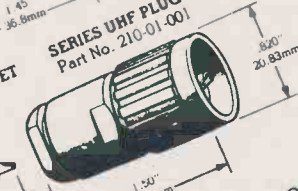

SERIES BNC STRAIGHT ADAPTOR
50Ω Part No. 105-13-000

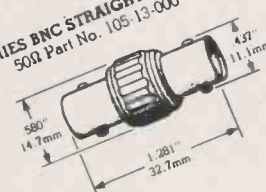

SERIES BNC PANEL SOCKET

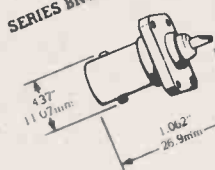

SERIES BNC RESISTOR PLUG
50Ω Part No. 105-12-000
75Ω Part No. 107-12-000

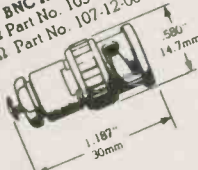

SERIES BNC JACK
50Ω Part No. 115-04-010

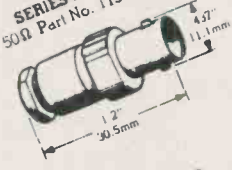

SERIES UHF PANEL SOCKET
Part No. 236-31-000

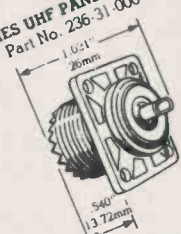

SERIES BNC PLUG
75Ω Part No. 117-01-025

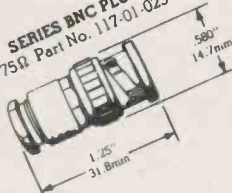

SERIES BNC ELBOW PLUG
75Ω Part No. 117-05-012

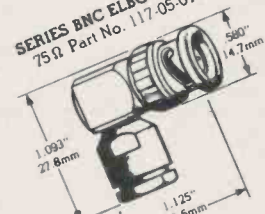

SERIES BNC PLUG
50Ω Part No. 125-01-010
75Ω Part No. 127-01-025

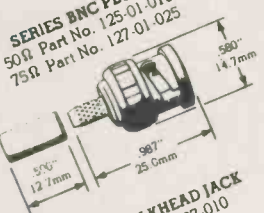

SERIES BNC ELBOW PLUG
50Ω Part No. 115-05-010

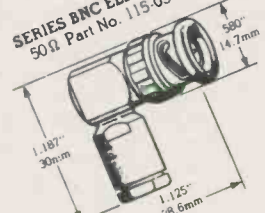

SERIES BNC T ADAPTOR
50Ω Part No. 105-03-000
75Ω Part No. 107-03-000

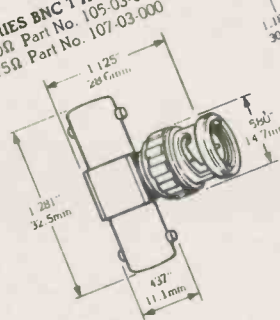

SERIES BNC STRAIGHT ADAPTOR
50Ω Part No. 105-14-000

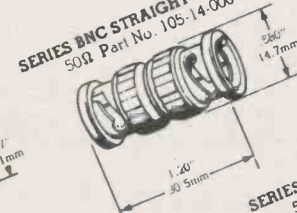

SERIES BNC BULKHEAD SOCKET
50Ω Part No. 135-22-000

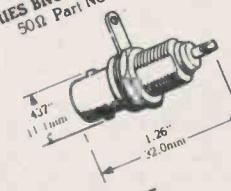

SERIES BNC BULKHEAD JACK
50Ω Part No. 115-07-010

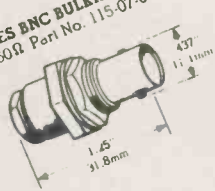

SERIES BNC PANEL JACK
50Ω Part No. 115-38-010

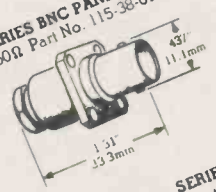

SERIES BNC BULKHEAD SOCKET
50Ω Part No. 135-20-000

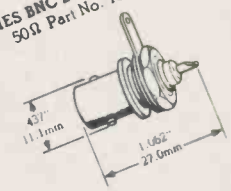

SERIES N PLUG
50Ω Part No. 315-01-010

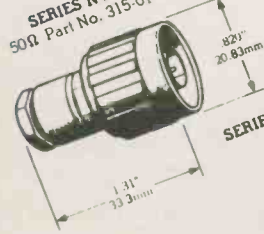

SERIES BNC BULKHEAD SOCKET
75Ω Part No. 137-20-000

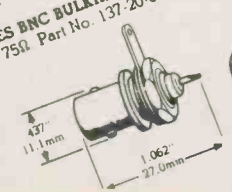

SERIES N PLUG
50Ω Part No. 315-01-001

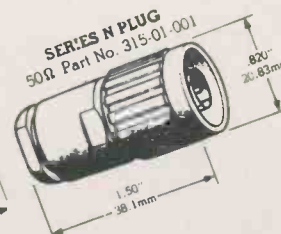

SERIES N JACK
50Ω Part No. 315-04-001

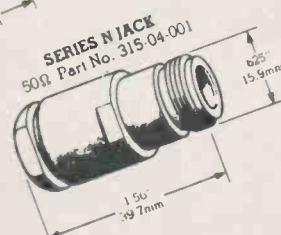

SERIES UHF PLUG
Part No. 210-01-010

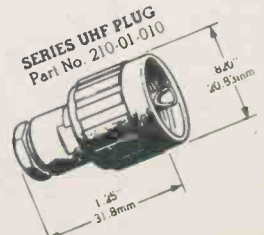

BCS

CONNECTORS PRICE LIST

US MIL #	COLINE CODE #	TYPE	DESCRIPTION	IMP	1-9
UG-274A/U	105-03-000	BNC	T ADAPTOR	50	7.22
	105-12-000	BNC	RES PLUG LESS CHAIN	50	5.81
UG-914/U	105-13-000	BNC	ADAPTOR OBL. FEMALE	50	4.83
UG-491B/U	105-14-000	BNC	ADAPTOR OBL. MALE	50	4.70
	107-03-000	BNC	T ADAPTOR	75	7.22
	107-12-000	BNC	RES PLUG LESS CHAIN	75	5.51
UG-88E/U	115-01-010	BNC	PLUG	50	3.29
	115-01-012	BNC	PLUG	50	3.84
UG-89C/U	115-04-010	BNC	JACK	50	3.84
UG-913/U	115-05-010	BNC	ELBOW PLUG	50	6.87
UG-909B/U	115-07-010	BNC	BULKHEAD JACK	50	5.17
UG-291B/U	115-38-010	BNC	PANEL JACK	50	4.01
	117-01-025	BNC	PLUG	75	3.59
	117-04-025	BNC		75	4.14
	117-05-012	BNC	ELBOW PLUG	75	7.00
	117-07-025	BNC	BULKHEAD JACK	50	5.17
UG-1785/U	125-01-010	BNC	CRIMP PLUG	50	2.73
UG-1789/U	127-01-025	BNC	CRIMP PLUG	75	2.73
UG-1094/U	135-20-000	BNC	BULKHEAD SOCKET	50	1.92
UG-1094A/U	135-22-000	BNC	BULKHEAD SOCKET	50	3.16
UG-290A/U	135-32-000	BNC	PANEL SOCKET	50	2.73
	135-33-000	BNC	PANEL SOCKET	50	2.73
	135-34-000	BNC	PANEL SOCKET	50	2.73
	137-20-000	BNC	BULKHEAD SOCKET	75	2.39
	135-73-000	BNC	PANEL SOCKET	50	4.78
	210-01-010	UHF	PLUG	50	5.29
	210-01-001	UHF	PLUG	50	6.62
UG-223/U	230-28-000	UHF	BULKHEAD SOCKET	50	3.07
SO239	236-31-000	UHF	PANEL SOCKET	50	1.71
UG-1185A/U	315-01-001	-N-	PLUG	50	5.29
UG-1186A/U	315-04-001	-N-	JACK	50	4.40
UG-536B/U	315-01-010	-N-	PLUG	50	4.74
	315-04-010	-N-	JACK	50	4.48
UG-58/U	335-31-000	-N-	PANEL SOCKET	50	4.53
	120082/3/4/5	BNC	ATTEN.3/6/10/20 DB	50	28.86
	161-61-540	***	SCREENING BOX	***	15.80
	105-52-000	BNC	TERMINATOR 20Hz	50	12.38
	805-53-000	BNC	SHUNT TERMINATOR	50	26.77

BNC ATTENUATORS

LIST \$28.86



Part No. 120085

A range of 50 ohm attenuators with BNC mating faces, available in values of 3dB, 10dB and 20dB.

3dB Part No. 120082
6dB Part No. 120083
10dB Part No. 120084
20dB Part No. 120085

Specification

Impedance: 50 ohm
Frequency Range: D.C. to 1GHz
Accuracy: ± 0.2 dB
Maximum Power: 1 Watt Average

BNC SHUNT

LIST \$26.77



Part No. 805-53-00

A range of 50 ohm through termination useful for correctly terminating a transmission system when testing with a high impedance measuring instrument such as an oscilloscope.

Specification

Resistance Tolerance: $\pm 1\%$
Frequency Range: D.C. to 1GHz
Maximum Power: 2 Watts Average

Modular Oscilloscope Probes

A comprehensive range of high quality probes and accessories to assist in making a wide variety of oscilloscope measurements. The modular types feature pencil slim heads, detachable earth leads, wide bandwidths, excellent pulse response and field replaceable parts.

A catalogue listing our range of test leads, probes and accessories for analogue and digital measuring instruments is also available on request.

M15X10HF Modular X10 High Frequency Probe



Specification

Attenuation Ratio	10:1
Bandwidth	DC - 300 MHz
Rise Time	1.2 nS
Input Capacitance	Nominal 16 p.F.
Compensating Range	10-60 p.F.
Input Resistance	10 M Ω When used with oscilloscopes which have 1 M Ω Input. (Probe resistance 9 M Ω \pm 1%)
Maximum Input Voltage	600 Volts DC Including peak AC, derating with frequency
Working Temperature Range	-25 to +70°C
Cable Length	1.5 Metres

Also available with cable lengths of 2 & 3 metres, details on request.

M12X1, Modular X1 Probe

Specification

Attenuation Ratio	1:1
Bandwidth	DC - 30 MHz
Rise Time	11 nS
Input Capacitance	45 p.F. + Oscilloscope Input Capacitance
Input Resistance	1 M Ω (Oscilloscope Input resistance)
Maximum Input Voltage	600 Volts DC Including peak AC
Working Temperature Range	-25 to +70°C
Cable Length	1.2 Metres

Also available with cable lengths of 2 & 3 metres, details on request.



See page 14 for prices

M12X10 Modular X10 Probe

Specification

Attenuation Ratio	10:1
Bandwidth	DC - 250 MHz
Rise Time	1.4 nS
Input Capacitance	Nominal 16 p.F.
Compensating Range	10-60 p.F.
Input Resistance	10 M Ω When used with oscilloscopes which have 1 M Ω Input. (Probe resistance 9 M Ω $\pm 1\%$)
Maximum Input Voltage	600 Volts DC Including peak AC. derating with frequency
Working Temperature Range	-25 to +70°C
Cable Length	1.2 Metres

Also available with cable lengths of 2 & 3 metres, details on request.



M12SW Modular Switch Selectable X1/X10 Probe

Specification

$\times 10$ POSITION	
Attenuation Ratio	10:1
Bandwidth	DC - 250 MHz
Rise Time	1.4 nS
Input Capacitance	Nominal 18 p.F.
Compensating Range	10-60 p.F.
Input Resistance	10 M Ω When used with oscilloscopes which have 1 M Ω Input. (Probe resistance 9 M Ω $\pm 1\%$)
$\times 1$ POSITION	
Attenuation Ratio	1:1
Bandwidth	DC-10 MHz
Rise Time	35 nS
Input Capacitance	40 p.F. + Oscilloscope Input Capacitance
Input Resistance	1 M Ω (Oscilloscope Input)
Maximum Input Voltage	600 Volts DC Including peak AC. derating with frequency
Working Temperature Range	-25 to +70°C
Cable Length	1.2 Metres

Also available with cable lengths of 2 & 3 metres, details on request.



M12DM Modular RF Detector Probe

Specification

Bandwidth	100 KHz to 500 MHz ± 1 dB 100 KHz to 750 MHz ± 3 dB
Input Capacitance	Approx. 5 p.F.
Maximum AC Input Voltage	50 Volts RMS
DC Isolation Voltage	200 Volts DC Including peak AC
Diode Turn On Voltage	250 mV
Working Temperature Range	-25 to +70°C
Cable Length	1.2 Metres

Also available with 4 mm plugs (type M12DM4) and cable lengths of 2 & 3 metres, details on request.



M15X100 Modular X100 Probe

Specification

Attenuation Ratio	100:1
Bandwidth	DC - 250 MHz
Rise Time	1.4 nS
Input Capacitance	Nominal 6.5 p.F.
Compensating Range	15-50 p.F.
Input Resistance	100 M Ω When used with oscilloscopes which have 1 M Ω Input. (Probe resistance 99 M Ω $\pm 1\%$)
Maximum Input Voltage	1200 Volts DC Including peak AC, derating with frequency.
Working Temperature Range	-25 to +70°C
Cable Length	1.5 Metres

Also available with cable lengths of 2 & 3 metres, details on request.



See page 14 for prices

Fixed Lead Oscilloscope Probes

1P20 X1 Oscilloscope Probe

Specification

Attenuation Ratio	1:1
Bandwidth	DC - 20 MHz
Rise Time	17 nS
Input Capacitance	55 p.F. + Oscilloscope Input Capacitance
Input Resistance	1 M Ω (Oscilloscope Input Resistance)
Maximum Input Voltage	600 Volts DC Including peak AC
Working Temperature Range	-25 to +70°C
Cable Length	1.5 Metres

Also available with cable lengths of 2 & 3 metres, details on request.

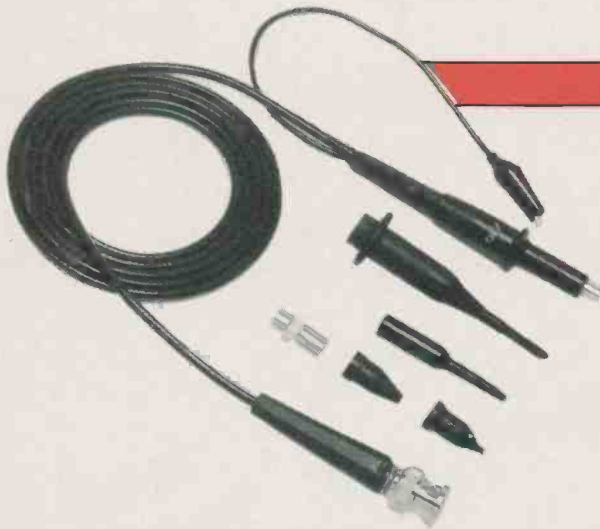

P100 X10 Oscilloscope Probe

Specification

Attenuation Ratio	10:1
Bandwidth	DC - 100 MHz
Rise Time	3.5 nS
Input Capacitance	Nominal 15 p.F.
Compensating Range	10-60 p.F.
Input Resistance	10 M Ω When used with oscilloscopes which have 1 M Ω Input. (Probe resistance 9 M Ω \pm 1%)

Maximum Input Voltage	600 Volts DC Including peak AC, derating with frequency
Working Temperature Range	-25 to +70°C
Cable Length	1.5 Metres

Also available with cable lengths of 2 & 3 metres, details on request.

SP100 Switch Selectable X1/X10 Probe

Specification

$\times 10$ POSITION

Attenuation Ratio	10:1
Bandwidth	DC - 100 MHz
Rise Time	3.5 nS
Input Capacitance	Nominal 16 p.F.
Compensating Range	10-60 p.F.
Input Resistance	10 M Ω When used with oscilloscopes which have 1 M Ω Input. (Probe resistance 9 M Ω \pm 1%)

REF POSITION

Probe tip grounded via 9 M Ω resistor, oscilloscope input grounded

$\times 1$ POSITION

Attenuation Ratio	1:1
Bandwidth	DC - 10 MHz
Rise Time	35 nS
Input Capacitance	55 p.F. + Oscilloscope Input Capacitance
Input Resistance	1 M Ω (Oscilloscope Input)
Maximum Input Voltage	600 Volts DC Including peak AC, derating with frequency
Working Temperature Range	-25 to +70°C
Cable Length	1.5 Metres

Also available with cable lengths of 2 & 3 metres, details on request.

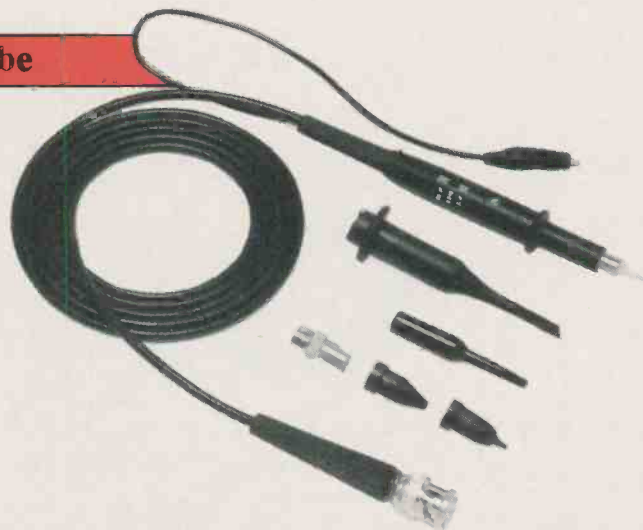

See page 14 for prices

BNC Patchcords 50 ohm

Interfaces available: BNC, N and UHF complete with moulded on cable reliefs, using RG58 C/U cable.

Preferred types

Interfaces	Length	Coline Code No.
BNC Plug to plug	1 metre	126023
BNC plug to plug	1.5 metres	126024
BNC plug to plug	2 metres	126050

Other lengths to customer specifications.
Standard finish of connectors: bright nickel plate.

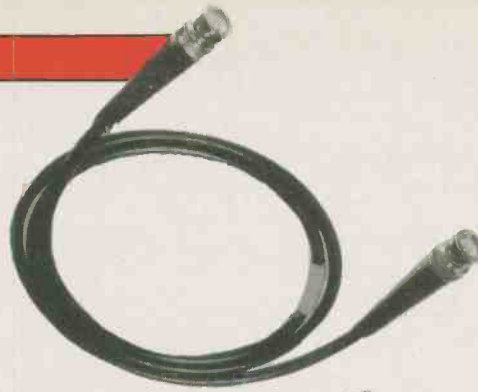

BNC Flying leads 50 ohm

Interfaces available: BNC, N and UHF complete with moulded on cable reliefs, using RG58 C/U cable, together with shielded plugs and crocodile clips.

Preferred types

Interfaces	Length	Coline Code No.
BNC plug to 4 mm plugs	1 metre	126074
BNC plug to 4 mm plugs	1.5 metres	126059
BNC plug to 4 mm plugs	2 metres	126060
BNC plug to 2 Croc Clips	1.5 metres	126083

Other lengths and combinations available to customer specifications.
Standard finish of connectors: bright nickel plate.



BNC SHUNT

Part No. 805-53-000



A 50 Ω through termination useful for correctly terminating a transmission system when testing with a high impedance measuring instrument such as an oscilloscope.

Specification

Resistance Tolerance	$\pm 1\%$
Frequency Range	DC - 1 GHz
Maximum Power	2 Watts Average (1 kW Peak)

BNC Switched Attenuator

Part No. 129000



A switched attenuator enabling attenuation ratios to be selected in 1 dB steps from 0 dB to 31 dB.

Specification

Attenuation	0-31 dB in 1 dB steps
Impedance	50 Ω
Frequency Range	DC - 1 GHz
Maximum Power	1 Watt Average (1 kW peak)
VSWR	Less than 1.5:1

BNC Attenuators



A range of 50 Ω attenuators with BNC mating faces, available in values of 3 dB, 6 dB, 10 dB and 20 dB.

3 dB Part No.	120082
6 dB Part No.	120083
10 dB Part No.	120084
20 dB Part No.	120085

Specification

Impedance	50 Ω
Frequency Range	DC - 1 GHz
Accuracy	± 0.2 dB
Maximum Power	1 Watt Average (1 kW Peak)
VSWR	Less than 1.2:1 at 1 GHz

BNC TERMINATION

A small 50 or 75 ohm termination with low VSWR up to 2GHz.

Specification

Resistance Tolerance:	$\pm 1\%$
Frequency Range:	D.C. to 2GHz
Maximum Power:	1 Watt Average (1k W Peak)
VSWR:	Less than 1.2: 1 at 2GHz



Part No. 105-52-000
75 ohm PT # 107-52-000

See page 14 for prices

PROBE COMPARISON CHART TEKTRONIX - PHILIPS - COLINE

Tektronix No.	Coline No.	Remarks
P6101	M12X1	Coline type has slightly higher input capacitance-45 p.F., and does not have grounding button.
P6108	M12X10	Coline type has wider bandwidth but higher input capacitance-15 pF and does not have grounding button.
P6105	M12X10AP	As type M12X10 but fitted with readout BNC Barrel.
P6106/P6053B	M15X10HFAF	Coline type has higher input capacitance 15 pF but no trace identity button. Includes readout BNC Barrel.
P603B	M12SW	Coline type does not have readout facility or trace identity button and has higher input capacitance-16 pF, but has wider bandwidth-250 MHz.
P6009	M15X100	Coline type does not have special readout barrel and has a higher input capacitance-6 pF but has much wider bandwidth-250 MHz and higher input resistance-100 M Ohms, (Important for CMOS and ECL measurements). Working Voltage is lower-1200 V DC Max. Inc. Pead AC.
Philips No.		
PM8921	1P20	Coline type has fixed earth lead but wider bandwidth-20MHz.
PM8923	M12SW	Coline type is modular, has wider bandwidth, lower input capacitance but does not have zero line position.
PM8927	M12X10	Coline type has wider bandwidth, wider compensation range but slightly higher input capacitance-15pF and no zero button.
PM8927L	M20X10	Coline type is 2m long, otherwise as M12X10.
PM8935	M15X10HF	Coline type has wider compensation range but slightly higher input capacitance and zero button.
PM8935L	M20X10HF	Coline type is 2m long, otherwise as type M15X0HF.
PM8932	M15X100	Coline type has wider bandwidth and higher input resistance but higher input capacitance -6 pF and max working voltage of 1200 V DC.

COLINE PROBES-CABLES & ACCESSORIES PRICES

COLINE CODE #	TYPE OR DESCRIPTION	LIST
M12X1	PROBE MODULAR X1	42.26
M12X10	PROBE MODULAR X10	50.01
M15X100	PROBE MODULAR X100	56.76
M15X10HF	PROBE MODULAR X10 (300 MHz)	80.37
M12SW	PROBE MODULAR SWITCHABLE (X1 & X10)	56.76
M12DM	PROBE MODULAR DETECTOR	53.39
1P20	PROBE FIXED LEAD X1	31.47
P100	PROBE FIXED LEAD X10	39.90
SP100	PROBE FIXED LEAD SWITCHABLE (X1-REF-X10)	50.01
HV40BNC	PROBE HIGH VOLTAGE (40 Kv @ 800 Hz)	61.64
LG3	PROBE LOGIC ANALYZER X10	36.52
121589	REPLACEMENT TIPS FOR ABOVE PROBES	2.20
2P150	PROBE FIXED (X10) 2 METRES ▶ 150 MHz	46.64
2P250	PROBE FIXED (X10) 2 METRES ▶ 250 MHz	76.99
2SP100	PROBE SWITCHABLE (X1-REF-X10) 2 METRE	56.76
LCP100	PROBE FIXED (X100) 100 MHz	60.13
2LCP100	PROBE FIXED (X100) 100 MHz 2 METRES	103.97
SF150	PROBE SWITCHABLE (X1-X10) SLIM BODY	54.06
2SF150	PROBE SWITCHABLE (X1-X10) SLIM BODY 2MTR	57.43
DP750	PROBE DETECTOR (METER LEADS) 750 MHz	46.64
120079	SPRUNG HOOK FITS SP100/P100 ETC	4.86
120326	SPRUNG HOOK FITS MODULAR/TEK/SF150	4.86
121089	WIRE WRAP ADAPTER FOR SP100	3.26
TLS2000	TEST LEAD KIT WITH ACCESSORIES	21.65
126023	PATCHCORD 50 OHM - BNC/BNC - 1 METRE	8.46
126024	PATCHCORD 50 OHM - BNC/BNC - 1.5 METRE	8.86
126050	PATCHCORD 50 OHM - BNC/BNC - 2 METRE	9.26
126074	PATCHCORD 50 OHM - BNC/PLUGS - 1 METRE	10.46
126059	PATCHCORD 50 OHM - BNC/PLUGS - 1.5 METRE	10.86
126060	PATCHCORD 50 OHM - BNC/PLUGS - 2 METRE	11.26
126083	PATCHCORD 50 OHM - BNC/CROC - 1.5 METRE	9.26

PRICING AND ORDERING

All prices in this catalogue are List. Your dealer's prices may differ from the quoted amounts. If you order directly from BCS then send Certified Cheque or Money Order. Minimum order for post or C.O.D. is \$25.00. All shipments are F.O.B. Downsview. Orders shipped within Ontario must include 7% Provincial Sales Tax. We accept VISA. Send card number, signature, expiry date along with name of bank.

Prices subject to change.

BECKMAN

DIGITAL MULTIMETERS

- Model 3000
 • 0.25% Vdc accuracy
 • Full six-function

\$190

- Model 3010
 • Insta-ohms® continuity indicator
 • 0.25% Vdc accuracy
 • 10 Amp ac,dc current

\$212.55

- Model 3010UL
 • Insta-ohms® continuity indicator
 • UL listed
 • 0.25% Vdc accuracy

- HD-100 SERIES
 • Drop-proof
 • Contamination-proof
 • Shockproof

- Model 3020B
 • Audible and visual continuity indicator
 • 0.1% Vdc accuracy

\$271

- Model RMS 3030
 • True RMS measurement
 • 0.1% Vdc accuracy

\$315

- Model 3050
 • 0.1% Vdc accuracy
 • 10 Amp ac/dc current
 • Audible and visual continuity indicator
 • .01Ω resolution on 20Ω range

\$326

- Model 3060
 Same features as 3050 plus:
 • True RMS measurement
 • Direct temperature measurement

\$424

The special features of Beckman's nine models satisfy the needs of all applications from laboratory use to adverse industrial environments. All Beckman models are easy to use and reliable because of the single rotary switch and a custom CMOS LSI chip which eliminates most discrete components found in other DMMs. One-hundred percent burn-in and complete computer testing insure consistent reliability.

COMMON FEATURES FOR ALL MODELS

- 2,000 hour battery life with standard 9V battery
- 2 amps ac/dc current ranges
- 22MΩ Vdc input impedance
- Superior RF shielding
- Separate "high power" diode test function
- Auto-polarity, auto-zero, auto-decimal
- 100% factory checkout
- Large LCD display

DESCRIPTION WITH ADDITIONAL FEATURES

Model 3000: 3½-digit multimeter; 0.25% Vdc accuracy
Model 3010: 3½-digit multimeter; 0.25% Vdc accuracy, 10 amps ac and dc ranges, Visual Continuity Indicator
Model 3010UL: 3½-digit multimeter; 0.25% Vdc accuracy, 10 amps ac and dc ranges, Visual Continuity Indicator, Underwriters Laboratories® listed
Model 3020: 3½-digit multimeter; 0.1% Vdc accuracy, 10 amps ac and dc ranges, Visual Continuity Indicator
Model 3020B: 3½-digit multimeter; 0.1% Vdc accuracy, 10 amps ac and dc ranges, Audible/Visual Continuity Indicator
Model RMS 3030: 3½-digit multimeter; True RMS, 0.1% Vdc accuracy, 10 amps ac and dc ranges, Visual Continuity Indicator
Model 3050: Bench/Portable 3½-digit multimeter; 0.1% Vdc accuracy, 10 amps ac and dc ranges, Audible/Visual Continuity Indicator, 0.20 ohms, 4 year battery life
Model RMS 3060: Bench/Portable 3½-digit multimeter; True RMS, 0.1% Vdc accuracy, Temperature Measuring Capability, 10 amps ac and dc ranges, Audible/Visual Continuity Indicator, 0.20 ohms, 4 year battery life
HD-100: Heavy Duty 3½-digit Industrial multimeter; 0.25% Vdc accuracy, contamination-proof, drop-proof, high overload protection, Visual Continuity Indicator
HD-110: Heavy Duty 3½-digit Industrial multimeter; 0.25% Vdc accuracy, 10 amps ac and dc ranges, contamination-proof, drop-proof, high overload protection, Visual Continuity Indicator.

BECKMAN ACCESSORIES

MODEL	DESCRIPTION	LIST	MODEL	DESCRIPTION	LIST
VC-201	Black Vinyl Carrying Case (1&2)	16.90	TL-242	Spare Test Leads (1)	9.81
DC-205	Deluxe Carrying Case (1)	56.14	DL-243	Deluxe Test Lead Kit (2&3)	19.62
DC-206	Deluxe Bench Meter Carrying Case (3)	59.95	TL-245	Spare Test Leads (2&3)	11.99
HV-211	High Voltage Probe-50KV DC Maximum (1,2&3)	82.30	TP-254	Thermocouple Temperature Probe K-type nickel chromium/nickel aluminum (4)	71.94
RF-221	RF Probe - 2KHZ-200MHZ (1,2&3)	68.13	TP-255	K-type Thermocouple, four foot leads (4)	16.90
CT-231	AC Current Transformer - 10-150 Amps (1,2&3)	108.46	TC-253	Temperature/Voltage Converter, C or F (1&2)	93.74
CT-232	AC Current Transformer - 10-1000 Amps (1,2&3)	256.15	FP-260	Multimeter Fuses, 2A/600V, packet of 4 (1&2)	3.65
DL-241	Deluxe Test Lead Kit (1)	19.62			

NOTES:

- 1 Compatible with Models 3000, 3010, 3020, 3020B, RMS3030.
 2 Compatible with Models HD100, HD110.

- 3 Compatible with Models 3050, RMS3060 bench/portable meters.
 4 Compatible with Model RMS3060 bench/portable meter.

FREQUENCY COUNTERS to 1.3 GHz

Optoelectronics inc



MODEL 7010-S
10 Hz to 600 MHz

\$338.00



MODEL 7010-S/1 GHz
10 Hz to 1 GHz

\$499.00



MODEL 8013-S
10 Hz to 1.3 GHz

\$739.00



MODEL 8010-S
10 Hz to 600 MHz

\$499.00



MODEL 8010-S/1 GHz
10 Hz to 1 GHz

\$667.00

Quality instruments at reasonable prices, featuring 8½ digit display, state-of-the-art circuitry, super sensitivity, battery portable operation, vinyl covered aluminum cases, choice of TCXO and proportional oven time bases, 1 MegOhm and 50 Ohm inputs, NBS traceable calibration, and more. Choose the model and options that fit your exact application. Our rugged, compact instruments won't break your budget either. Starting at less than \$350 our price, quality, and performance package can't be beat! Private labeling available. Call or write the factory for additional information.

- ALL ALUMINUM CASES WITH MACHINE SCREWS
- 100% PARTS & LABOR GUARANTEE FOR FULL YEAR

- 115 VAC, 12 VDC OR BATTERY OPERATION
- CERTIFIED NBS TRACEABLE CALIBRATION

- COMPACT SIZES: 8010-S/8013-S 3" H x 7½" W x 6½" D
- 7010-S 1¾" H x 4¼" W x 5¼" D

MODEL	RANGE (FROM 10 Hz)	TIME BASE		AVERAGE SENSITIVITY		GATE TIMES	MAX RESOLUTION			SENSITIVITY CONTROL	EXT CLOCK INPUT/ OUTPUT	METAL CASE
		FREQ	STABILITY-DESIGN	BELOW 500 MHz	ABOVE 500 MHz		12 MHz	60 MHz	MAX FREQ			
7010-S	600 MHz *1 GHz	10 MHz	±1 PPM-TCXO *±0.1 PPM-OCXO	10 mV -27 DBM	20 mV -21 DBM	(3) .1, 1, 10 SEC	1 Hz	1 Hz	10 Hz	Yes	No	Yes
8010-S	600 MHz *1 GHz	10 MHz	±1 PPM-TCXO *±0.05 PPM-OCXO	10 mV -27 DBM	20 mV -21 DBM	(4) .01, .1, 1, 10 SEC	1 Hz	1 Hz	10 Hz	Yes	Yes	Yes
8013-S	1.3 GHz	10 MHz	±1 PPM-TCXO *±0.05 PPM-OCXO	10 mV -27 DBM	20 mV -21 DBM	(4) .01, .1, 1, 10 SEC	1 Hz	1 Hz	10 Hz	Yes	Yes	Yes

*AVAILABLE OPTION



980 Alness St.,
Unit 7,
Downsview, Ontario
Canada 416-661-5585
M3J 2S2

Northstar Advantage Review

WELL WELL well, another computer to check out. My office is beginning to look like fun time at the transistor plant, lads. Just park it over there on top of the PDP 5 and we'll get to it in due course. Let me guess, runs CP/M, two disks, communications facilities, greatest thing since the last greatest thing and ... oh, wait, it draws pictures!

Pictures? And what's that plastic thing where the drive's supposed to be? Hard disk, what ... I like hard disks. I wonder if they'd notice if it wasn't there when we returned the system. Okay, you guys can split now. I want to play.

The Northstar Advantage is the latest thing in computers to be plomped on my work table. It's big, brown and only moderately funny looking. However, beneath that amusing exterior lies real silicon ... and fiberglass ... and other suchlike stuff. And it's all arranged very cleverly.

The Northstar combines a number of very handy aspects in its design. It is, first off, a one piece deal, with no wires or other sundry appendages to plug, unplug or rip out of their sockets. It comes with two five and a quarter inch disks or one disk and a five megabyte hard disk drive. It has a green screen capable of reproducing bit mapped graphics and a choice of operating systems.

What wonders will they spring on us next?

In Graphic Detail

The Northstar can be had with one or both of two disk operating systems, these being the justly renowned CP/M and the justly unheard of GDOS, a rumour in its own time. The CP/M is a little unusual in that while it takes a floppy disk to get it up and running, it lives on the hard disk. The software on the start up floppy is predominately to initialize things and warm up the hard disk in an orderly fashion.



The CP/M has two logical drives on the hard disk, these being A: and L:. I have no idea why they picked L instead of B ... it takes a bit of getting used to. Being hard disk based it is unspeakably fast. There is no disk clanking or other sonic phenomena to indicate the passing of time, and very little passing to indicate. The word "WAIT" flashes on the Wordstar screen so fast as to be all but invisible, programs load like lightning and so on. All told, the hard disk is fun.

The manual that comes with the system to explain the CP/M consists of the usual Digital Research books plus an additional bit that handles the eccentricities of the machine. This extra book is no mean volume, being both very thick and very detailed. It basically handles all the neat stuff on the computer, primarily the high resolution graphics. Let us, thus, consider the bits, brethren (and sistren, I suppose).

CP/M does not actually provide any routines for accessing a bit mapped graphics driver. This isn't to say it can't be done; it just can't be done in the same simple way one uses the BDOS calls to print characters, get input and so on. In other words, there is no way to make the graphics drivers logical devices.

The Northstar can do a lot of things that a basic CP/M system isn't required to do. Primarily, this involves its being able to draw high resolution pictures in a matrix of 640 x 192 pixels, and meddle with the characters on this screen. Spin-offs of this capability include niceties like smooth scrolling; you can move the characters around in increments of one dot, rather than one line.

In order to do all this there are a number of programs included with the Northstar to drive the fancy functions of the screen. These little fellows, technically called "device drivers", tickle the screen hardware through the Z-80 ports where it lives and get it to do the appropriate dances.

What is probably most admirable about the Northstar's "graphics subsystem" device driver is that it is documented in splendid detail in the book. Thus, you can figure it out, mess around with it and ultimately incorporate it into your own programs knowing exactly what it is likely to do.

The graphics system can draw rectangles, polygons, ellipses and lines, clear the screen, plot characters for mixed text and graphics, all as per control bytes handed to it from whatever is calling

Northstar Advantage Review

it. If you are using a higher level language it should be possible to call this routine and access the graphics functions without excessive groping in the dark. The graphics drivers are only loaded into RAM when you want them, meaning that they don't tie up any additional space when you have no use for freaky visuals. All told, it's highly civilized.

The book comes complete with a number of sample Z-80 machine code programs that use the graphics routines to draw various figures on the screen illustrating the syntax and other floundering required to make them work.

Using these device drivers and their associated software is by no means as simple as drawing pictures from BASIC... they are decidedly the province of the advanced programmer. However, what you wind up with are machine code results; the programs you'll get together are fast and professional. As I alluded to a while back, if you were to come up with MBASIC or something similar, and felt so moved you could probably incorporate these routines into BASIC programs through calls. However, it still won't be as much fun as a proper graphics BASIC.

Go GBASIC (Rah Rah Rah!!!)

As I mentioned at the beginning, there is a second disk operating system which is, as is most often the case with these things, special and unique to the Northstar. Called GDOS... they're all called something DOS... it has its own set of weirdnesses and peculiarities. Most of them remain a mystery to me to this day as I didn't get a GDOS manual for the system and had to puzzle through the syntax of it by inference and meditation. The incense grew a bit thick after a while; GDOS is strange. Not necessarily bad, you understand... just strange.

The fellow who delivered the Northstar and set it up began with, "Like usual, to get into BASIC you'd type GO GBASIC..." and I began to suspect something was going to be amiss.

The command for running some machine language program from GDOS is, in fact, GO. There were many that wouldn't run, given this prodding, and I never did figure out how to wake a number of them up. However, I will allow that it's probably fairly sensible once you know the incantations. The BASIC's the interesting bit.

The BASIC is not a Microsoft creation. In fact, it is almost as if someone had carefully sat down and tried to see just how many of the words could be changed without making up a whole new language. While the structure of the BASIC isn't necessarily bad, it is unspeakably infuriating if you are used to a Microsoft dialect. If you're new to programming this last can be disregarded; I think one could get used to this set of peculiarities as easily as any other.

First off, there are sixteen versions of GBASIC. These are split between versions for hard and floppy disks. Then there are ones with and without graphics. You can have arithmetic in eight, ten, twelve or fourteen digit precision, and so forth. This is a bit confusing at first. I only did extensive playing with the GBASIC proper, which occupies a bit over sixteen K of RAM and has eight digit precision.

The BASIC, as I suggested earlier, uses a lot of really interesting language to communicate with the outside world, and expects some in return. This extends to common commands. For example, there are the disk operations. To see what's on the disk you type CAT, as opposed to FILES. This provides a single column directory (which is a bit inconvenient), including several meaningful-looking numbers for each file entry which are never adequately explained. To save something on the disk you type SAVE... uh, except if you haven't saved it before, in which case it's NSAVE. Now, if you have saved it before but it's gotten bigger since the last time type DESTROY and the file name to wipe out the existing file and then NSAVE it again. There is also SCRATCH, which is analogous to NEW. CHAIN and a filename is like RUN and a filename in Microsoft. The actual Microsoft CHAIN function, which passes variables between two

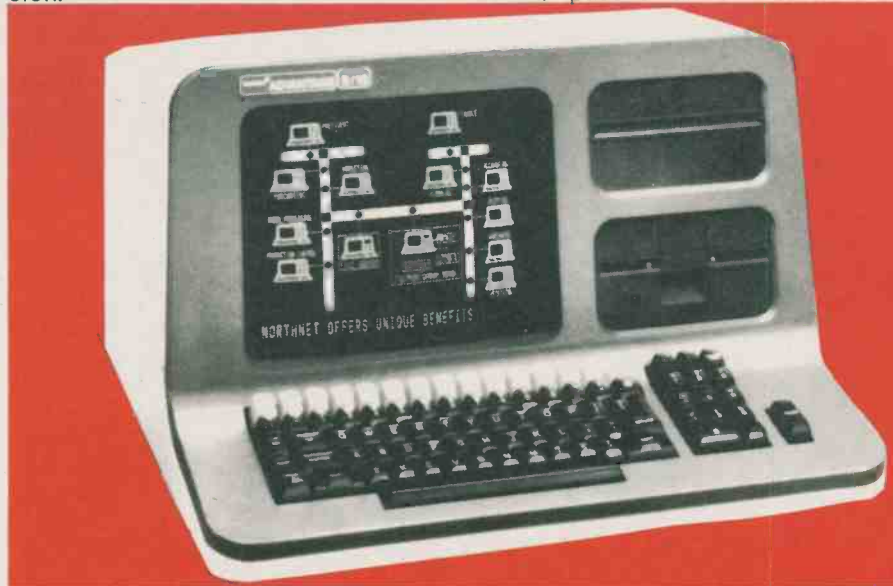

All GBASIC commands must be entered in upper case. If you use lower case letters the machine freaks and throws an error message. Secondly, the system doesn't accept tokens at all. You can't even use a question mark for PRINT. This is a heavy grouch. This also brings us to a third hassle; there ain't no line editor to speak of.

Well, no, actually, I think that there is supposed to be some way to edit your program, short of retyping in the offending lines, but I never did get it to work. The manual is a bit vague in this area, rambling on about pointers and the like for a page before giving up... which is what I did after a bit of fighting. Yes, I'm a coward... but the thing was making my program look like a dog's breakfast.

programs, doesn't appear to be available.

The BASIC does have a number of redeeming qualities. First off, it's fairly fast. Its disk file handling routines for doing disk accesses from inside a program are bizarre but easy to use and reliable. Best of all, the graphics section of the BASIC is highly profound, with commands to do lines, points, arcs, circles, *pie slices*, *chord slices*... and all manner of highly neat things. The graphics commands do not allow the random mixing of text and graphics; you have to define part of the screen as a text window. However, this can be any bit of the screen you feel like having it be, so quite a lot can be done with the works.

There was no music synthesizer.

Continued on page 45

**EXPAND YOUR
WORLDLY
KNOWLEDGE ...**

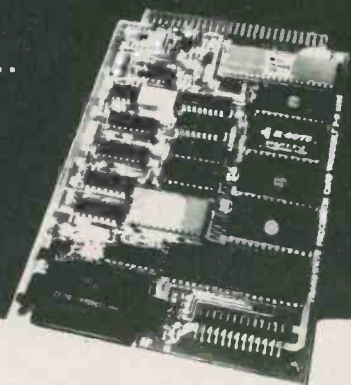

with the
"TINY BASIC"
perspective on
process control

TRANSOUAVE'S Tiny BASIC Microcomputer K-8073

eliminates machine language programming and drastically reduces program development time with an on-chip Tiny BASIC Microinterpreter. It also provides unsurpassed power and versatility for Data Measurement Control and New Product Development.

— SOME SPECIAL FEATURES —

- Cassette Tape I/O * RS -232 * STD BUS * Real Time CLOCK * PPI 24 Bi - Dir. I/O
- *8K EPROM Programmer * Operates on 5V * 2K ROM Firmware *
- * 4.5" x 6.5" Board * 1K RAM Exp. to 26K.

To order your K-8073 or for further information, write or call:

CONTROL SYSTEMS

Division of Blenkhorn & Sawle Ltd., 100 Grantham Ave., P.O. Box 3010
St. Catharines, Ontario L2R 7B9. (416) 684-9251 Watts 1-800-263-7242/3

Circle No. 13 on Reader Service Card.

**Quality Boards & Kits
All Apple™ Compatible**

	PCB	Kit	A & T
Disk Controller Card	18.00	75.00	99.00
80 Column Card	18.00	125.00	N/A
Printer Card	18.00	70.00	120.00
EPROM Programmer Card	18.00	115.00	149.00
(This Card can program 2708, 2716, 2732, 2764)			
RAM Card	18.00	62.00	75.00
Universal Card	20.00		
Z-80 Card	18.00	79.00	120.00
AP-2 Board (6502J)	55.00	299.00	
(All Kits sold with parts list & layout)			
ASCII Keyboard			125.00
Switching Power Supply (Powerful replacement)			
5V(6A), 12V(3A), - 5V(½A), - 12V(½A)			125.00
5V(3A), 12V(2A), - 5V(½A), - 12V(½A)			99.00
ABS Case			95.00
Joystick			30.00
TV/Game Switch Box			2.25
UHF Modulator (Interface circuit required)			9.95
3" Speaker (With mating connector)			2.00

Terms: Send Check or Money order (Allow 2 weeks for personal check), No COD., Quebec Res. add 9% sales tax. Min. order 10.00, Do not send cash.

Freight: 10-49	\$2.00	250-499	\$ 9.00
50-99	\$4.00	500-999	\$11.00
100-249	\$8.00	1000-up	Call

We service and troubleshoot 6502 boards as well as other peripherals. Please contact us for further information.

D **DULEX** *electronique inc.*
electronic inc.

13092 RUE MONK ST., PIERREFONDS, QUÉ., CANADA
H8Z 1V2 TEL.: 514-620-0079

Circle No. 1 on Reader Service Card.

**Now...
all your
speaker needs
from a single
source**

Only McBride, Canada's largest distributor of quality loudspeakers can offer such a broad range of speaker sizes and electrical characteristics. Accessories such as ceiling grills and boxes, crossover networks etc. are also available.

Call or write for your nearest dealer:



LOUDSPEAKER SOURCE INC.

440 Phillip Street; Waterloo, Ontario N2L 5R9 (519) 884-3500

Canadian Distributors for:

- **MARSLAND BRAND**
Hi-Fi and replacement,
commercial sound
- **PHILIPS**
Quality domes, mids, woofers
- **QUAM**
Small run specialists
- **MOTOROLA**
Peizo ceramics
- **ARGOS**
Sound columns, baffles

Circle No. 10 on Reader Service Card.



**B.T.W. Enterprizes
COMPUTER HOBBYIST**

2114 LC-5 150ns	\$1.75
4116 150ns ceramic	\$2.50
4164 150ns	\$8.50
6116 150ns	\$8.50
2708 450ns	\$5.20
2716 450ns	\$4.46
2732 450ns	\$8.25
2732A 350ns	\$9.00
2532 450ns	\$8.50
2764 250ns	\$13.95
6520	\$5.10
8080A	\$6.80
8085A	\$7.50
TMS9927	\$15.00
MM76EL	\$31.00
WD8250	\$14.10
TBP24S41	\$4.50
82S181	\$9.10
D2118-4	\$5.50
D5244	\$4.95
2016 150ns	\$9.00
8035	\$6.90

Mail orders: Please send certified cheque or money order. Ont. residents add 7% P.S.T. Minimum order \$10.00, plus \$3.00 for shipping.

**2914 Sheppard Avenue East,
Suite 203-A, Scarborough,
Ontario M1T 3J4 (416) 499-7221**

Circle No. 3 on Reader Service Card.

OSCILLOSCOPES!

The Best Buys Available

watch for our "NEW" 100 MHz feature packed Scope ... SOON!

Model 65310

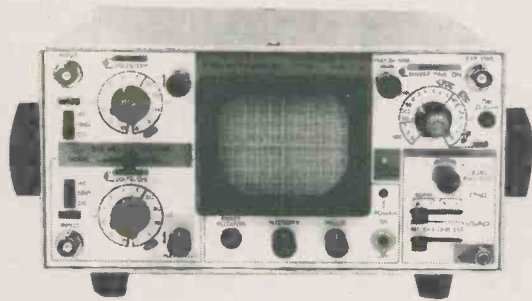

Dual Trace Portable Scope

- 15 MHz (-3dB) Bandwidth
- X5 Sweep Magnifier
- Battery, 12 VDC & AC Operation
- 2 mV Vertical Sensitivity
- Trace Rotator

\$795.00

Probes and F.S.T. included

Model 65601

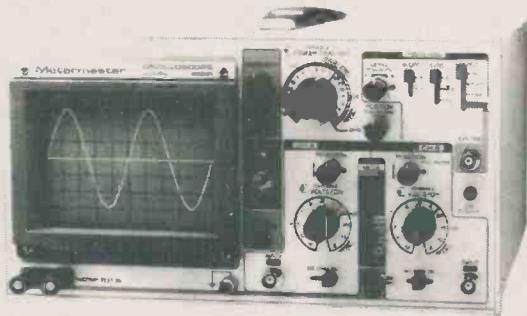

Dual Trace Bench/Portable Scope

- Featuring At No Extra Cost The Component Tester'
- 20 MHz (-3dB) Bandwidth
- 6" CRT Display
- Fully Automatic Triggering
- Trace Rotator
- 2 mV Vertical Sensitivity
- HF Rejection

\$795.00

Probes and F.S.T. included

Model 65625

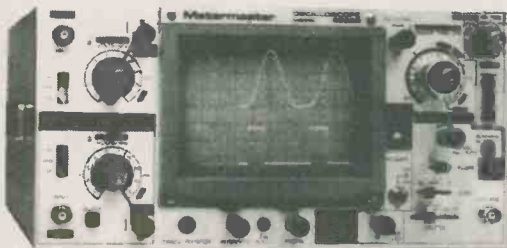

Dual Trace Bench/Portable Scope

- 45 MHz (-3dB) Bandwidth
- Delayed Sweep (selectable)
- Single Sweep (selectable)
- Extremely Bright 5" CRT
- Illuminated Internal Graticule
- Optimal Sensitivity of 1 mV
- X-Y or X-Y-Z Operation
- 120 VAC Line Operation

\$1385.00

Probes and F.S.T. included

Model 65635

NEW!

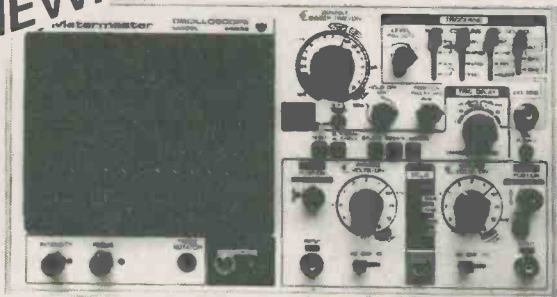

Dual Trace Bench/Portable Scope

- 35 MHz (-3dB) Bandwidth
- Delayed Sweep (selectable)
- Single Sweep (selectable)
- 6" CRT Display
- Optimal Sensitivity of 1 mV
- X-Y or X-Y-Z Operation
- 120 VAC Line Operation
- X5 Sweep Magnifier

\$995.00

Probes and F.S.T. included

Metermaster
R. H. NICHOLS



5% Discount for Cash,
Certified Check, or Money Order

All prices F.O.B.
Downsview, Ontario
subject to change with-
out notice, P.S.T. extra
where applicable.

Head Office: 214 Dolomite Drive, Downsview, Ontario M3J 2P8

Circle no. 11 on Reader Service Card.

TORONTO (416) 661-3190 MONTREAL (514) 337-0425 EDMONTON (403) 432-7746 OTTAWA (613) 238-7007

Northstar Advantage Review

Continued from page 42

Rats.

The BASIC manual was pretty good in most places. It is a three ring binder deal, so it lies flat. It lacks example programs in many areas where they'd be nice, but there is enough information to puzzle through the better part of the language if you have some knowledge of the rudiments of BASIC. It appears to have been done on a word processor; one can only hope that it was running on a Northstar at the time.

I wasn't really taken with the BASIC. It works well enough, but it seems to be different from the usual syntax of the tongue for no really profound reason. It is very picky over syntax and yet does not provide a convenient way to repair bugs. However, if you want to play with the pictures, it's a far sight easier than tromping through the machine code workings in CP/M.

Other Things

There are a number of other bits about the Northstar that seem passingly interesting, although limited time has not permitted all of them to be properly scrutinized. The hard disk comes loaded with all manner of useful utilities. You can change all of its parameters ... our version no longer signs on with "NORTHSTAR HARD DISK SYSTEM", but, rather, with "Electric Wombats Rule The Skies". More seriously, the whole system can be configured to suit your needs, including the disk allocation, types and number of the drives used, the logical device allocations and so on.

The hard disk for GDOS is a little hard to get used to. It talks a lot about "projects" and other key words not commonly found in common digital speakings. However, once you get over this all the parts make sense and run like the wind.

There were a few functions which simply didn't want to work. We could not, for example, duplicate floppy disks using the hard disk based utility provided. Again, the missing manuals might have cleared this up.

The Northstar has a single serial port. I couldn't find any meaningful documentation for it and there wasn't any communications software, so I have no idea whether its karma is particularly splendid.

My Computer Understand Me

The Northstar is really a very nice computer. Its combination of high



The Advantage features superb high resolution graphics on a crisp green screen, making it ideal for situations requiring both visual presentations and a tube that doesn't try one's orbs by the end of the day.

resolution graphics but no colour is a bit unusual, but in fact has several advantages for someone who only wants to mess with graphics occasionally. For one thing, it's cheaper than a machine with a colour tube. Secondly, the screen definition is much higher, making the thing easier to look at for long periods of time.

Mechanically the Northstar is first rate. The fan is quiet, the hard disk all but silent and the keyboard is of the highest quality. There are fifteen programmable function keys and a numeric keypad.

We actually put our evaluation sample machine to a rather nastier than usual test. We took it to a computer show programmed to be an interactive terminal display. It got prodded and stared at for three days, twelve hours a day without even a hiccup. The fan kept it quite cool ... there was no unpleasant scorching PCB smell emanating from it even at the end of a full day's computing, and smoke was never caught wafting out of the internals. The disk drive, which was being accessed quite a lot during this ordeal, never freaked at all.

One last weirdness is that the Northstar uses hard sectored diskettes. This will prove to be a moderate hassle, methinks, as the usual soft sectored deals are frequently the only kind available at the corner computer shop and donut casino. The all-holy cheap diskettes are usually not made in these oblique formats at all.

The Northstar Advantage certainly ranks up there with systems I would not weep over if someone accosted me on the street and forced one into my hands. Unlikely, this, I know. In fact, I'd even accept two. It's a good system for anyone with serious inclinations ... programming and the like ... who wants to have a dabble now and then in messing up the screen with artsiness. It's certainly a good solid choice for a business system; its hard disk option is a wonderful thing if you foresee numerous disk accesses in relatively little time. It'd make a great bulletin board system.

And, listen, Billy, the cat stopped complaining about the no-name cat food ever since we got one and dropped it on her.

ETI

ZX Interface Board



This month we present a practical circuit, an Input/Output interface board which can be built to work with either the ZX81 or the Spectrum.

I/O INTERFACES for the ZX81 are best designed to look like normal memory ('Memory Mapped I/O'). For the Spectrum, soon to be available, it makes more sense to use the Z80's I/O address space ('I/O Mapped'). We have therefore designed the PCB so that the circuit can be constructed as either a Memory Mapped or an I/O mapped interface.

Whichever version is built, it will give you eight separate TTL level outputs, which can be controlled by the ZX, to drive LEDs, relays or whatever you will. There are also eight TTL inputs to the board, and the ZX can examine the states of signals applied to these inputs.

The ZX81 version of the board is designed to work with the basic (1K RAM) ZX81, and also with the ZX printer and the Sinclair 16K RAM pack. It should also be compatible with most ZX81 add-ons offered by other firms except for those which use memory addresses in the range 8192 to 16383.

The Spectrum version will also work with the ZX printer and — as far as we can tell from the limited information available at this time — will be compatible with future Sinclair add-ons such as the Microdrive and RS232 interface.

Circuit Description

The circuit for both versions of the board are shown in Figure 1. In the ZX81 (Memory Mapped) version, IC4 and IC3c, IC3d monitor the states of the ZX address lines A13, A14, A15, and also the ZX MREQ line. When A13 is high (logic '1'), and A14, A15 and MREQ are all low, then the output, pin 11, of IC3d will go low. This will happen whenever the ZX81 accesses any memory address in the range 8192 to 16383. At the same time, the ZX81



ROMCS line is pulled high through D1, to disable the unwanted 'echo' of the ZX81 8K ROM which would otherwise appear at these addresses.

For the Spectrum (I/O Mapped) version, IC4, D1 and R1 are not fitted, and IC3d is connected so that its output, pin 11, goes low when address line A5 and the Spectrum IORQ lines are both low.

In either case, pin 11 of IC3d going low enables IC3a and IC3b so that during a ZX 'write' operation, when WR goes low, the output, pin 6, of IC3b goes low. Similarly, during a ZX 'read', the output of IC3a pin 3, will go low.

Both versions of the board do respond to a wide range of ZX addresses rather than to a single address. This has been done for simplicity, since to reduce the number of addresses that the board would respond to would mean adding more gates to monitor the states of more of the ZX's address lines. In both cases, the address decoding provided is adequate to allow the I/O board to work properly both with the

computer and with Sinclair add-ons.

The eight board outputs are via PL1 and PL2 from the outputs of the 8-bit latch, IC1. The eight inputs to IC1 are connected to the ZX data bus lines D0-D7, so that when IC3b pin 6 pulses low the data present on D0-D7 is clocked into the latches. It will be held there until another ZX 'write' operation, to a suitable memory or I/O address, updates it.

IC2 contains 8 'tri-state' buffers. The inputs to these buffers are connected to the I/O board input points on PL3 and PL4. The output of each buffer is connected to one of the ZX data bus lines, but normally has no effect because the IC2 outputs are held open-circuit by a 'high' input to pins 1 and 19. When, however, the ZX does a 'read' operation from a suitable memory or I/O address, so that pin 3 of IC3a goes low, the output circuits of the buffers are enabled, transferring the information present at IC2 inputs to the ZX data bus lines.

Construction

Refer to the component overlay, Figure 2. Begin by adding wire links in

Continued on page 49

Reboot Your Brain

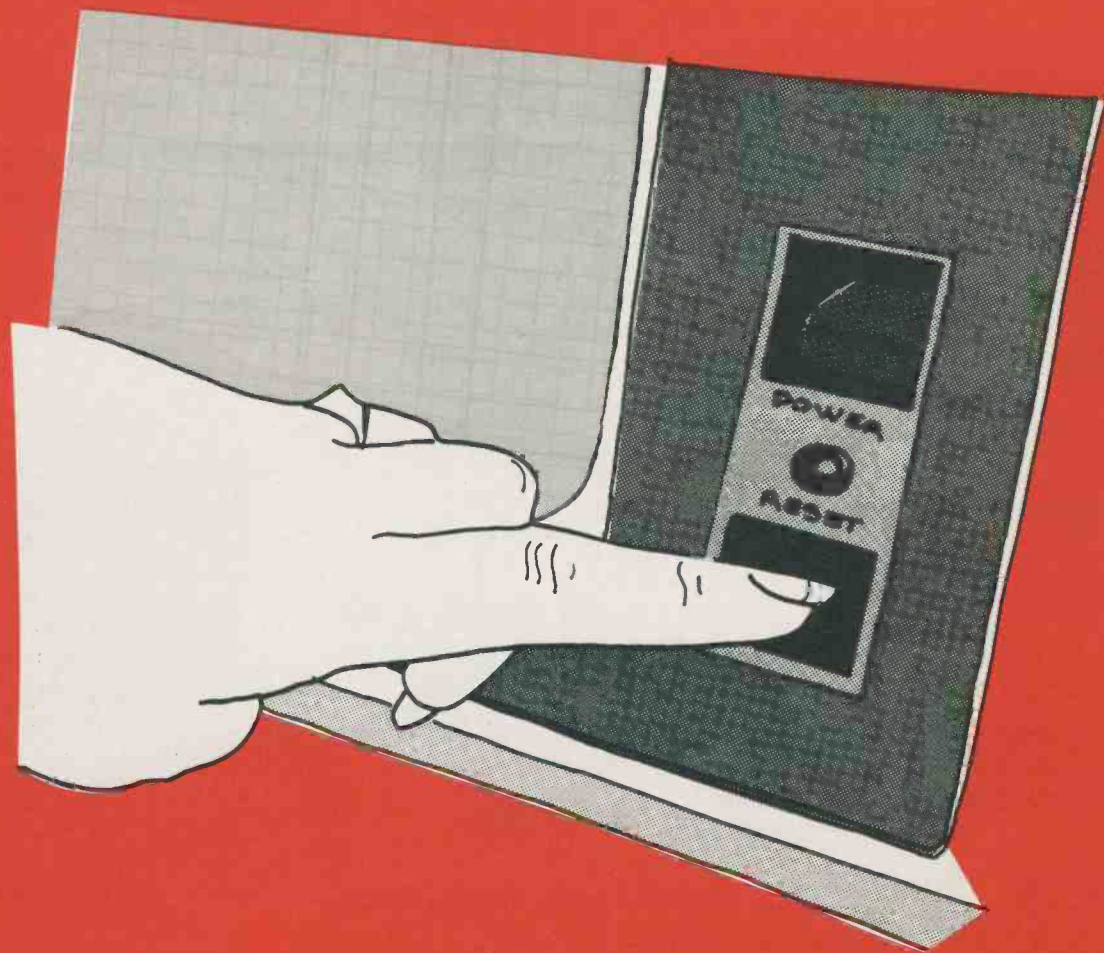

The first issue of Computing Now! is on sale even as you read this. Clear all the dusty arrays out of your Crania/RAM. Set your creative pointers to zero. Run a quick Cooks test of your grey cells and then load up a whole mental buffer of up to the minute mind-ware. Computing Now! features articles for beginners through to digital wizards who count change in hexadecimal and everyone in between on a vast range of topics . . . all designed to enhance your system with extra ROMs for the processor *in front of* the screen.

Dare you miss it?

Included in first issue: 50 systems surveyed
• Introduction to Wordstar • The true capacities of systems • What is CPM? • Apple Pirate Update • VisiCalc • ZX81 Large Keyboard • Survey of meaty printers • And a lot more.



MICRO COMPUTECH ELECTRONICS LTD.



SUPER 800

64K RAM * upper and lower case with upper case with upper case locking key * 4x5 numeric key pad with editing keys auto repeat * 10 function keys * high wattage power supply * fully APPLE™ hardware and software compatible * 120 day warranty

\$1199



\$42/10

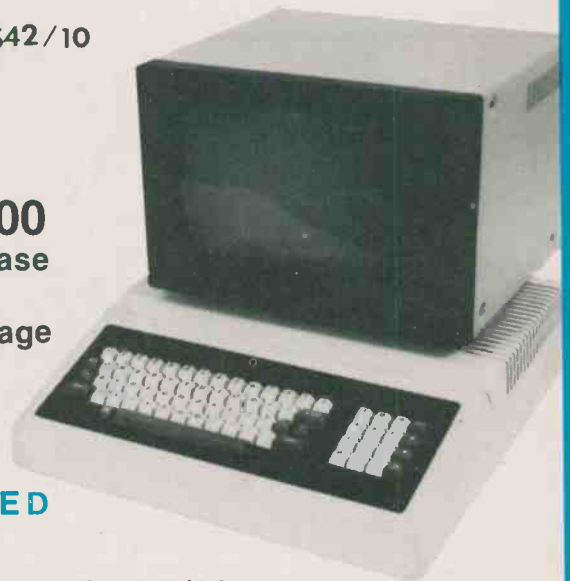

SUPER 400

48K RAM upper and lower case with upper case locking key numeric key pad * auto repeat * high wattage power supply fully APPLE™ hardware and software compatible 120 day warranty

\$995

\$425

DEALER INQUIRIES INVITED ATI FDD-810 series



The "FDD-810 minifloppy disk drive is a high performance and economical mini type disk drive which is specially designed for APPLE II™ personal computer.

SLIM TYPE DISK DRIVE IS 1/2 THE HEIGHT OF CONVENTIONAL MINIFLOPPY DISK DRIVES.

HALF TRACKING ABILITY ● AUTO EJECT ● FULLY COMPATIBLE WITH APPLE II™ ● FAST DATA ACCESS (12 msec. between tracks) ● SOFTWARE TRANSPARENT ● HIGHER PRECISION POSITIONING THAN CONVENTIONAL DRIVES ● USES STANDARD 5 1/4 DISKETTE. ● HIGH-RELIABILITY, LOW NOISE

DC MOTORS PROVIDE AN MTBF OF OVER 8 000 HOURS, BACKED BY A 120 DAY PARTS AND LABOUR WARRANTY.

We carry a full range of APPLE II™ compatible products: bare boards part kits, as well as fully assembled and tested boards.

80x24 VIDEO CARD \$129/Z80 CARD \$119/LANGUAGE CARD \$69/DISK CONTROLLER CARD \$99

EPSON CONTROLLER CARD \$119/EPROM WRITER CARD \$139

HIGH WATTAGE POWER SUPPLY WITH BUILT IN LINE FILTER \$115 / KEYBOARD & PAD \$118 / NEW ABS 6502 CASE \$118
R.F MODULATOR \$21 SUPER QUALITY R.F MODULATOR WITH AUDIO \$29/ JOY STICK \$21/ RS 232 COMMUNICATION BOARD
most of above available in KIT form, call for best price.

We carry new 6502 BOARD has on board provision for 64K RAM, 80x24 Video, Disk Drive Controller and 6 slots for some of the above boards.

6502 KIT \$279 ELECTROHOME MONITOR 12" P31 GREEN MONITOR \$159

EPSON PRINTER MX80FT type III call for best price

APPLE II™ IS A TRADE MARK OF APPLE COMPUTERS INC.

MAIL ORDERS

Send a certified cheque or money order (do not send cash).

Minimum order is \$10. ADD 5% for shipping cost.

ANY EXCESS WILL BE CREDITED. Ontario residents add 7% provincial sales tax.
VISA and MASTERCARD accepted. Send card No. signature expiry date and name of bank.



535 QUEEN ST. W., TORONTO, ONTARIO, CANADA, M5V-2B4
(416)864-0332 ALL PRICES ARE IN CANADIAN FUNDS, 9% FEDERAL SALES TAX INCLUDED (416)864-0397

Continued from page 46

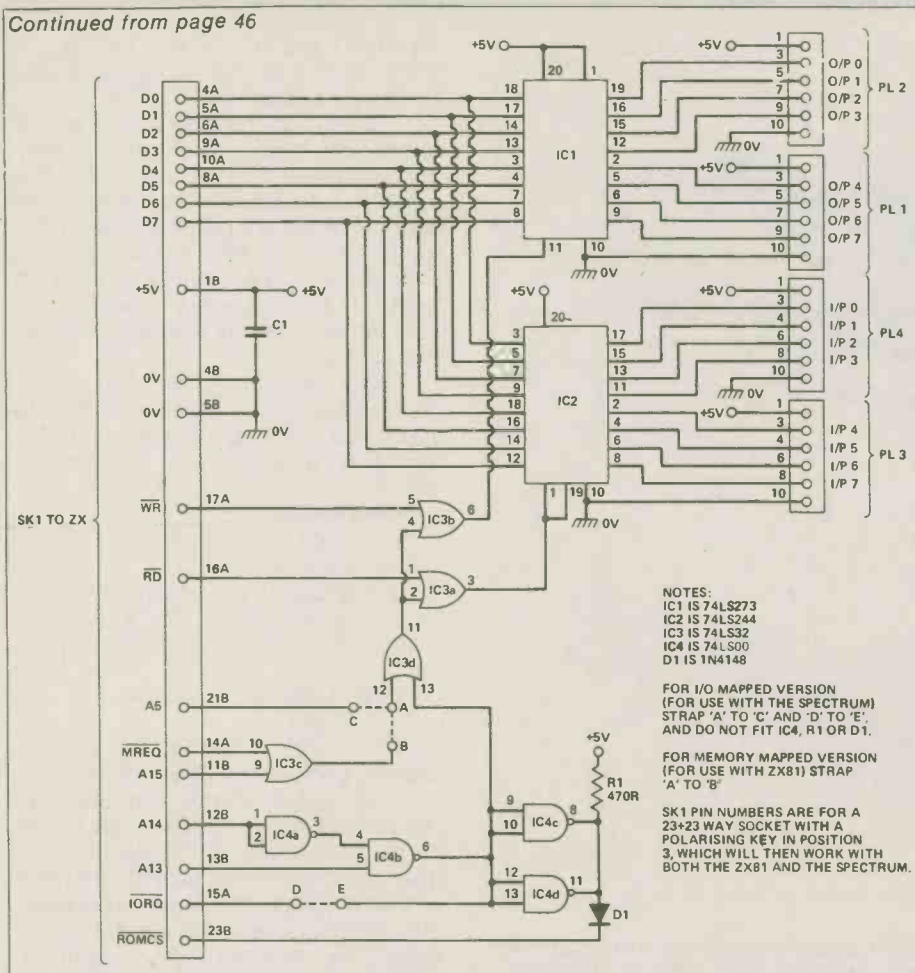

Fig. 1 The circuit diagram shows both versions; note the links required to fit the board for one or the other.

the positions shown. You should end up with 15 links (including the strap a-b) for the memory mapped version, or 16 (including straps a-c and d-e) for the I/O mapped board. Insulating sleeves should be fitted over the wire for the longer links, which might otherwise be liable to bend and touch each other.

Newcomers to the art of electronic circuit building may be interested to learn an old trick for making neat sleeved-wire links. It involves taking a piece of solid cored (not stranded) plastic insulated tinned copper wire about 18" (457.2 mm) long and carefully — without nicking the conductor — stripping a short length of insulation from each end. You then grip one bare end firmly in a vice or a pair of pliers. Then, holding the other bare end with the pliers, pull firmly until the wire suddenly stretches. Stretching the wire this way straightens it, and removes most of its 'spring'. It also breaks the wire free from the inside of the insulation and reduces its diameter slightly, so that what was insulation now becomes the correct sized sleeving.

Next, solder in D1 and R1 — but only if you are making the ZX81 (Memory Mapped) version of the board. Note that D1 must be fitted the right way round, with the broad coloured band away from the edge of the board. Now fit and solder the IC sockets and then C1. The pins of the IC sockets are fairly close together, so make sure that you don't leave any unwanted solder 'bridges' between adjacent pins.

The four Input/Output connectors, PL1-4, can now be soldered in, but before doing so pull out the metal pins from the positions for which there is no corresponding hole in the PCB. The plastic moulding and the long ends of the plug pins should be on the component side of the board, the short ends of the pins should go through the board to be soldered on the track side.

The 23 + 23 way ZX socket can now be fitted so that the body of the connector is on the component side of the board, as close to the board as it will go. Tack-solder a couple of the corner pins first, then make sure that the socket is exactly perpendicular to the board before proceeding. For mechanical soundness, each pin of the socket should be soldered to its PCB pad, even though there may be no track going to that pad. Make sure that no solder bridges are formed between adjacent pads or tracks.

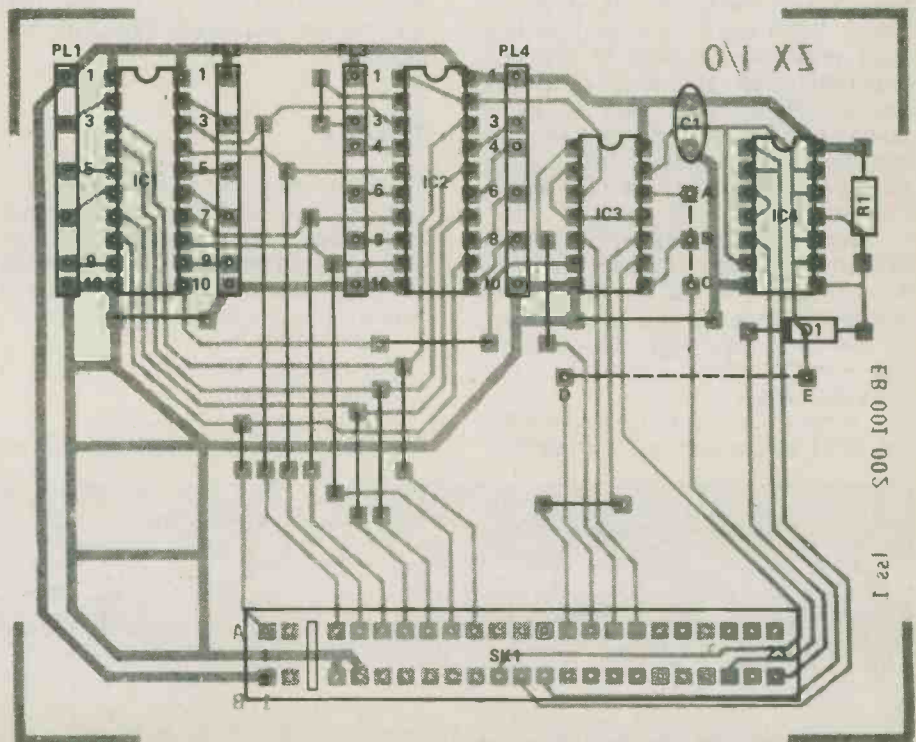
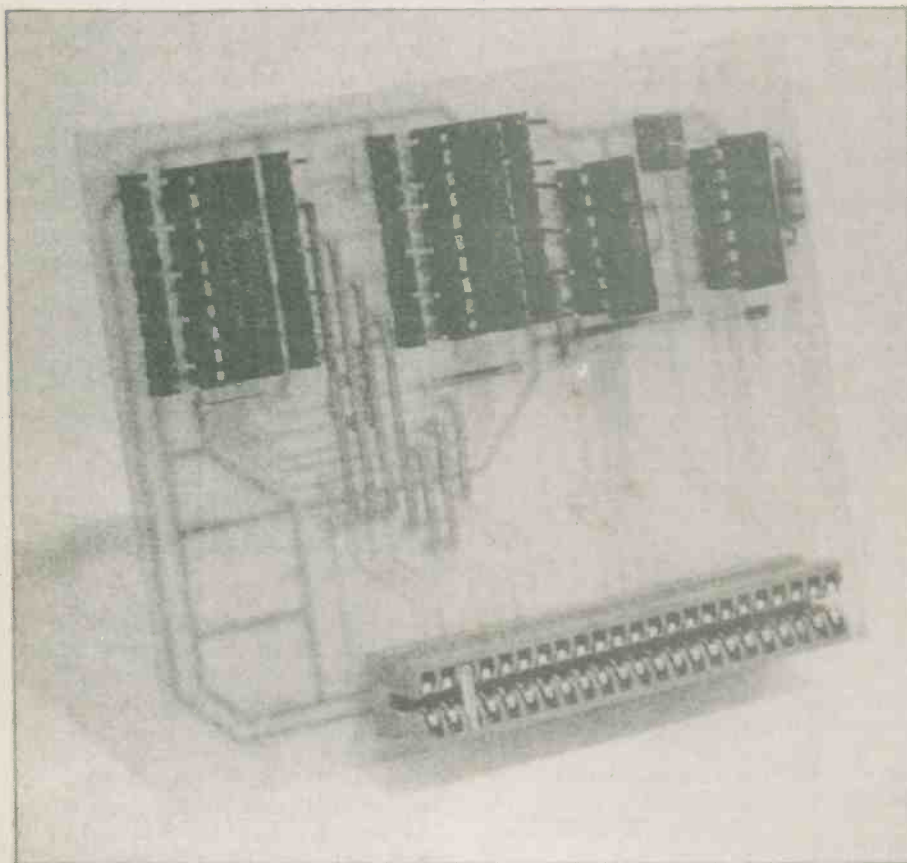

Fig. 2 The component overlay diagram.



If you want to use other add-ons such as the ZX81 16K RAM pack, then a 23 + 23 way double-sided PCB plug must be fitted, projecting at right-angles from the track side of the I/O board. Each connection pad on this plug must be soldered to the corresponding 'tail' of the 23 + 23 way socket. Again, take care to avoid solder bridges, and make sure that the plug is positioned so that it is exactly perpendicular to the PCB and in line with the 23 + 23 socket.

Note that although the Spectrum actually has a 28 + 28 way plug, the wanted connections lie within the scope of a 23 + 23 way ZX81 connector and — if the polarising key is fitted — in the correct positions to suit both machines.

Finally ICs 1, 2 and 3 (and IC4 for the ZX81 version) may be fitted into

their sockets, making sure that they are oriented with the semi-circular depressions in the IC mouldings pointing towards the top edge of the board as shown in Figure 2, and that all pins are properly engaged in their sockets.

Testing It

The first, and most important, test is to plug the board onto your computer and check that the computer itself still operates properly! If all is OK, we can test the input side of the board by first keying one of the instructions:

```
PRINT PEEK 8192
(for the ZX81 version);
PRINT IN 65503
(for the Spectrum board).
```

The correct answer is 255 (not 42!), as

all eight inputs to IC2 are, for the moment, open circuit and therefore look to the I/O board as logic '1's.

Repeating the instruction with a temporary connection with a temporary connection between 0V (PL3 pin 10) is a suitable point to make connection to the 0V rail) and one of the inputs (PL3 or PL4 pin 3,4,6 or 8) should give the results shown in Table 1. Only one input should be connected to 0V at any one time for this test.

Now for the output. Connect a DC voltmeter, switched to its 5 or 10 volt range, between 0V and o/p 0 (PL2 pin 3). Now key in one of these instructions;

```
POKE 8192,0
(for the ZX81 version);
OUT 65503,0
(for the Spectrum version).
```

This should result in a voltage reading of between 0V and 0V4. Then input:

```
POKE 8192,1 or
OUT 65503,1
```

which should make the voltage change to between 2V5 and 5V.

The other seven outputs can then be tested, in turn. For each one, POKE 8192,0 or OUT 65503,0 should give less than 0V4, while POKE 8192,n or OUT 65503,n should give between 2V5 and 5V, where n is a number corresponding to a particular output, as shown in Table 2.

Programming

Considering the output half first, we have eight separate TTL level outputs which can each be set to give a logic '1' or '0' level by a program command which loads a suitable value into the 8-bit latch, IC1. The value will affect all eight lines simultaneously so, if we want to change just one output, we must remember to load a value which — as well as affecting the output we want to change — will also preserve the previous states of the other seven outputs.

This value can be calculated by considering the eight output lines as

TABLE 1

254 IF I/P 0 (PL4 PIN3) IS CONNECTED TO 0V					
253	..	1	..	4	..
251	..	2	..	6	..
247	..	3	..	8	..
239	..	4	(PL3 PIN3)
223	..	5	..	4	..
191	..	6	..	6	..
127	..	7	..	8	..

Testing the inputs to the board; the result is '255' if all inputs are logic 1.

TABLE 2

n	=	1 FOR O/P 0 (PL2 PIN3)
2	..	1 .. 5
4	..	2 .. 7
8	..	3 .. 9
16	..	4 (PL1 PIN3)
32	..	5 .. 5
64	..	6 .. 7
128	..	7 .. 9

Testing the outputs; each will go high (between 2V5 and 5V) when the corresponding value of 'n' is POKed or OUTput to the latch.

TABLE 3

O/P SET TO '1'	DECIMAL VALUE
0	1
1	2
2	4
3	8
4	16
5	32
6	64
7	128

Each output is set by loading a decimal value, as shown above.

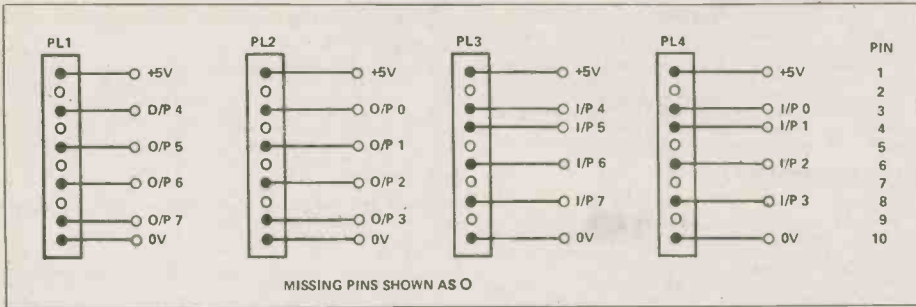

Fig. 3 The I/O connectors. PL1 and 2 carry the output lines; PL3 and 4 carry the inputs.

individual bits on an 8-bit byte, o/p 0 being the least significant bit and o/p 7 the most significant, and converting the result to decimal. To do this, add together the values from Table 3 corresponding to the wanted '1' level outputs. For example, if we wanted to set outputs 2 and 5 to '1', and the other 6 lines to '0', the value to be loaded into the latch would be 00100100 binary, or $4 + 32 = 36$ decimal, and the correct BASIC instruction would be;

```
POKE 8192,36
(for the ZX81) or
OUT 65503,36
(for the Spectrum).
```

If we wanted to then change output 2 to a '0' without affecting the other lines, then the appropriate instruction would be: POKE 8192,32 or OUT 65503,32.

Alternatively, we could let the computer do the hard work by inserting the following lines near the beginning of our program:

```
LET OP0 = 1
LET OP1 = 2
LET OP2 = 4
LET OP3 = 8
LET OP4 = 16
LET OP5 = 32
LET OP6 = 64
LET OP7 = 128
```

Then, to set, o/p s 1, 5 and 7 to '1', use the program line:

```
POKE 8192, (OP1 + OP5 + OP7)
```

or

```
OUT 65503, (OP1 + OP5 + OP7)
```

Spectrum programs could use the BIN function, which takes an 8-bit

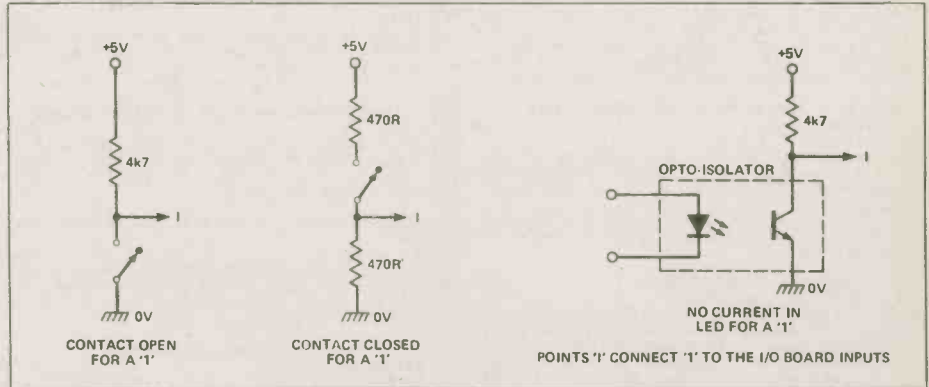

Fig. 4 Inputs to the I/O board; points '1' connect to the board inputs.

binary number expressed as a string of '1's and '0's and converts it to the decimal equivalent. For example:

```
OUT 65503,BIN 10100010
```

Now for Input. The combined states of the 8 inputs applied to the I/O board are read by the ZX as a single decimal number in the range 0 to 255. For example, if a '1' were applied to inputs 0 and 7, and '0' to the other six inputs, then the variable X would be given the value 129 by a ZX BASIC instruction of the form:

```
LET X = PEEK 8192
(for the ZX81) or
LET X = IN 65503
(for the Spectrum).
```

The following routine can then be used to sort out the states of the eight individual inputs;

```
DIM I(8)
FOR J = 1 TO 8
LET I(J) = X - 2 * INT (X/2)
```

```
LET X = INT (X/2)
NEXT J
```

This routine will give each of the eight array elements I(1) to I(8) the value '1' or '0', depending on the logic level applied to the individual I/O board inputs.

Using It

The whole point of an I/O board is that it will be connected to other equipment, and to this end the board

described here has four 10-way plugs (PL1-4) fitted to it. As shown in Figure 3, PL1 and PL2 each carry four of the output lines, as well as 0V and +5V rails. PL3 and PL4 each have four of the input lines, and also the 0V and +5V connections. Leads can be soldered to the pins of the plugs or — more professionally — the mating

PARTS LIST

Resistor (all 1/4 watt, 5%)

R1 470R

Capacitors

C1 100n polycarbonate

Semiconductors

IC1 74LS273 TTL octal D type flip-flop
 IC2 74LS244 TTL octal tri-state buffer
 IC3 74LS32 TTL quad 2-input OR
 IC4 74LS00 TTL quad 2-input NAND

Miscellaneous

20-pin DIL socket (2); 14-pin DIL socket (2); 23 + 23 way ZX edge connector socket, polarising key in position 3; 23 + 23 way ZX connector, matching socket; 10-pin 0.1" PCB plug (4); 10-2 way 0.1" socket housing (4); crimp terminal for socket housing (24); PCB, wire, solder, etc.

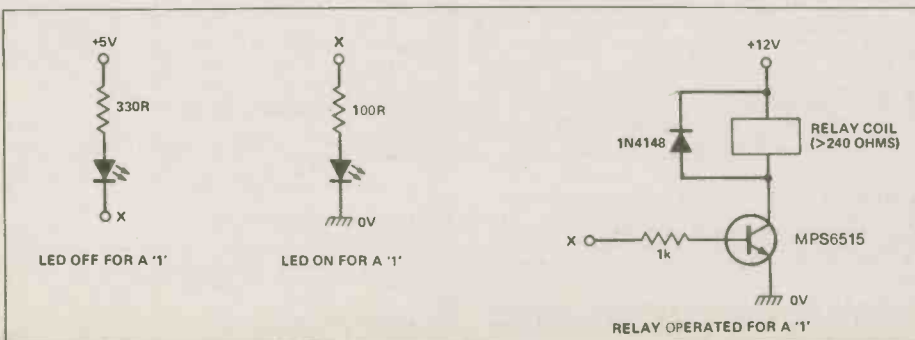

Fig. 5 Outputs from the I/O board; points 'X' connect to the output pins.

COMPUTERS (HARDWARE)

THE ESSENTIAL COMPUTER DICTIONARY AND SPELLER AB011 \$10.45

A must for anyone just starting out in the field of computing, be they a businessman, hobbyist or budding computerist. The book presents and defines over 15,000 computer terms and acronyms and makes for great browsing.

A BEGINNER'S GUIDE TO COMPUTERS AND MICROPROCESSORS — WITH PROJECTS. TAB No. 1015 \$13.45

Here's a plain English introduction to the world of microcomputers — it's capabilities, parts and functions — and how you can use one. Numerous projects demonstrate operating principles and lead to the construction of an actual working computer capable of performing many useful functions.

BP66: BEGINNERS GUIDE TO MICROPROCESSORS AND COMPUTING E.F. SCOTT, M.Sc., C.Eng. \$7.55

As indicated by the title, this book is intended as an introduction to the basic theory and concepts of binary arithmetic, microprocessor operation and machine language programming.

There are occasions in the text where some background information might be helpful and a Glossary is included at the end of the book.

BP72: A MICROPROCESSOR PRIMER \$7.70 E.A. PARR, B.Sc., C.Eng., M.I.E.E.

A newcomer to electronics tends to be overwhelmed when first confronted with articles or books on microprocessors. In an attempt to give a painless approach to computing, this small book will start by designing a simple computer and because of its simplicity and logical structure, the language is hopefully easy to learn and understand. In this way, such ideas as Relative Addressing, Index Registers etc. will be developed and it is hoped that these will be seen as logical progressions rather than arbitrary things to be accepted but not understood.

BEGINNERS GUIDE TO MICROPROCESSORS TAB No. 995 \$10.45

If you aren't sure exactly what a microprocessor is, then this is the book for you. The book takes the beginner from the basic theories and history of these essential devices, right up to some real world hardware applications.

HOW TO BUILD YOUR OWN WORKING MICROCOMPUTER TAB No. 1200 \$16.45

An excellent reference or how-to manual on building your own microcomputer. All aspects of hardware and software are developed as well as many practical circuits.

BP78: PRACTICAL COMPUTER EXPERIMENTS \$7.30 E.A. PARR, B.Sc., C.Eng., M.I.E.E.

Curiously most published material on the microprocessor tends to be of two sorts, the first treats the microprocessor as a black box and deals at length with programming and using the "beast". The second type of book deals with the social impact. None of these books deal with the background to the chip, and this is a shame as the basic ideas are both interesting and simple.

This book aims to fill in the background to the microprocessor by constructing typical computer circuits in discrete logic and it is hoped that this will form a useful introduction to devices such as adders, memories, etc. as well as a general source book of logic circuits.

HANDBOOK OF MICROPROCESSOR APPLICATIONS TAB No. 1203 \$14.45

Highly recommended reading for those who are interested in microprocessors as a means of accomplishing a specific task. The author discusses two individual microprocessors, the 1802 and the 6800, and how they can be put to use in real world applications.

MICROPROCESSOR/MICROPROGRAMMING HANDBOOK TAB No. 785 \$14.45

A comprehensive guide to microprocessor hardware and programming. Techniques discussed include subroutines, handling interrupts and program loops.

BP102: THE 6809 COMPANION \$8.10 M. JAMES

The 6809 microprocessor's history, architecture, addressing modes and the instruction set (fully commented) are covered. In addition there are chapters on converting programs from the 6800, programming style, interrupt handling and about the 6809 hardware and software available.

AN INTRODUCTION TO MICROPROCESSORS EXPERIMENTS IN DIGITAL TECHNOLOGY HB07: \$15.85 SMITH

A "learn by doing" guide to the use of integrated circuits provides a foundation for the underlying hardware actions of programming statements. Emphasis is placed on how digital circuitry compares with analog circuitry. Begins with the simplest gates and timers, then introduces the fundamental parts of ICs, detailing the benefits and pitfalls of major IC families, and continues with coverage of the ultimate in integrated complexity — the microprocessor.

DESIGNING MICROCOMPUTER SYSTEMS HB18: \$15.85 POOCH AND CHATTERGY

This book provides both hobbyists and electronic engineers with the background information necessary to build microcomputer systems. It discusses the hardware aspects of microcomputer systems. Timing devices are provided to explain sequences of operations in detail. Then, the book goes on to describe three of the most popular microcomputer families: the Intel 8080, Zilog Z-80, and Motorola 6800. Also covered are designs of interfaces for peripheral devices, and information on building microcomputer systems from kits.

S-100 BUS HANDBOOK HB19: \$22.75 BURSKY

Here is a comprehensive book that exclusively discusses S-100 bus computer systems and how they are organized. The book covers computer fundamentals, basic electronics, and the parts of the computer. Individual chapters discuss the CPU, memory, input/output, bulk-memory devices, and specialized peripheral controllers. It explains all the operating details of commonly available S-100 systems. Schematic drawings.

BASIC MICROPROCESSORS AND THE 6800 HB06: \$21.45

Provides two books in one: a basic guide to microprocessors for the beginner, and a complete description of the M6800 system for the engineer.

Each chapter is followed by a problem section.

DIGITAL INTERFACING WITH AN ANALOG WORLD TAB No. 1070 \$14.45

You've bought a computer, but now you can't make it do anything useful. This book will tell you how to convert real world quantities such as temperature, pressure, force and so on into binary representation.

MICROPROCESSOR INTERFACING HANDBOOK: A/D & D/A TAB No. 1271 \$14.45

A useful handbook for computerists interested in using their machines in linear applications. Topics discussed include voltage references, op-amps for data conversion, analogue switching and multiplexing and more.

COMPUTER TECHNICIAN'S HANDBOOK TAB No. 554 \$17.45

Whether you're looking for a career, or you are a service technician, computer repair is an opportunity you should be looking at. The author covers all aspects of digital and computer electronics as well as the mathematical and logical concepts involved.

HOW TO TROUBLESHOOT AND REPAIR MICROCOMPUTERS AB013 \$13.45

Learn how to find the cause of a problem or malfunction in the central or peripheral unit of any microcomputer and then repair it. The tips and techniques in this guide can be applied to any equipment that uses the microprocessor as the primary control element.

TROUBLESHOOTING MICROPROCESSORS AND DIGITAL LOGIC TAB No. 1183 \$13.45

The influence of digital techniques on commercial and home equipment is enormous and increasing yearly. This book discusses digital theory and looks at how to service Video Cassette Recorders, microprocessors and more.

HOW TO DEBUG YOUR PERSONAL COMPUTER AB012 \$13.45

When you feel like reaching for a sledge hammer to reduce your computer to fiberglass and epoxy dust, don't. Reach for this book instead and learn all about program bug tracking, recognition and elimination techniques.

COMPUTERS (SOFTWARE)

BP109: THE ART OF PROGRAMMING THE 1K ZX81 \$8.10 M. JAMES and S.M. GEE

This book shows you how to use the features of the ZX81 in programs that fit into the 1K machine and are still fun to use. Chapter Two explains the random number generator and uses it to simulate coin tossing and dice throwing and to play pool. Chapter Three shows the patterns you can display using the ZX81's graphics. Its animated graphics capabilities, explored in Chapter Four, have lots of potential for use in games of skill, such as Lunar Lander and Cannon-ball which are given as complete programs. Chapter Five explains PEEK and POKE and uses them to display large characters. The ZX81's timer is explained in Chapter Six and used for a digital clock, a chess clock and a reaction time game. Chapter Seven is about handling character strings and includes three more ready-to-run programs — Hangman, Coded Messages and a number guessing game. In Chapter Eight there are extra programming hints to help you get even more out of your 1K ZX81.

BEGINNER'S GUIDE TO COMPUTER PROGRAMMING TAB No. 574 \$16.45

Computer programming is an increasingly attractive field to the individual, however many people seem to overlook it as a career. The material in this book has been developed in a logical sequence, from the basic steps to machine language.

HOW TO PROFIT FROM YOUR PERSONAL COMPUTER: PROFESSIONAL, BUSINESS, AND HOME APPLICATIONS LEWIS HB01 \$17.00

Describes the uses of personal computers in common business applications, such as accounting, managing inventory, sorting mailing lists, and many others. The discussion in-

cludes terms, notations, and techniques commonly used by programmers. A full glossary of terms.

PROGRAMS FOR BEGINNERS ON THE TRS-80 BLECHMAN HB02 \$13.05

A valuable book of practical and interesting programs for home use that can be understood and used immediately by the beginner in personal computer programming. You'll learn step-by-step how 21 sample TRS-80 programs work. Program techniques are described line-by-line within the programs, and a unique MartriDex™ matrix index will enable you to locate other programs using the same BASIC commands and statements.

THE JOY OF MINIS AND MICROS: DATA PROCESSING WITH SMALL COMPUTERS STEIN AND SHAPIRO HB03 \$15.85

A collection of pieces covering technical and management aspects of the use of small computers for business or science. It emphasizes the use of common sense and good systems design for every computer project. Because a strong technical background is not necessary, the book is easy to read and understand. Considerable material is devoted to the question of what size computer should be used for a particular job, and how to choose the right machine for you.

USING MICROCOMPUTERS IN BUSINESS VEIT HB04 \$14.45

An essential background briefing for any purchaser of microcomputer systems or software. In a fast-moving style, without the usual buzz words and technical jargon, Veit answers the most often asked questions.

BASIC FROM THE GROUND UP SIMON HB15 \$17.00

Here's a BASIC text for high school students and hobbyists that explores computers and the BASIC language in a simple direct way, without relying on a heavy mathematical background on the reader's part. All the features of BASIC are included as well as some of the inside workings of a computer. The book covers one version of each of the BASIC statements and points out some of the variations, leaving readers well prepared to write programs in any version they encounter. A selection of exercises and six worked out problems round out the reader's experience. A glossary and a summary of BASIC statements are included at the end of the book for quick reference.

BASIC COMPUTER PROGRAMS FOR BUSINESS: STERNBERG (Vol. 1) HB13 \$15.85

A must for small businesses utilizing micros as well as for entrepreneurs, volume provides a wealth of practical business applications. Each program is documented with a description of its functions and operation, a listing in BASIC, a symbol table, sample data, and one or more samples.

BP86: AN INTRODUCTION TO BASIC PROGRAMMING TECHNIQUES S. DALY \$8.25

This book is based on the author's own experience in learning BASIC and in helping others, mostly beginners, to program and understand the language. Also included are a program library containing various programs, that the author has actually written and run. These are for biorhythms, plotting a graph of Y against X, standard deviation, regression, generating a musical note sequence and a card game. The book is complemented by a number of appendices which include test questions and answers on each chapter and a glossary.

THE BASIC COOKBOOK. TAB No. 1055 \$9.45

BASIC is a surprisingly powerful language if you understand it completely. This book, picks up where most manufacturers' documentation gives up. With it, any computer owner can develop programs to make the most out of his or her machine.

PET BASIC — TRAINING YOUR PET COMPUTER AB014 \$17.45

Officially approved by Commodore, this is the ideal reference book for long time PET owners or novices. In an easy to read and humorous style, this book describes techniques and experiments, all designed to provide a strong understanding of this versatile machine.

PROGRAMMING IN BASIC FOR PERSONAL COMPUTERS AB015 \$13.45

This book emphasizes the sort of analytical thinking that lets you use a specific tool — the BASIC language — to transform your own ideas into workable programs. The text is designed to help you to intelligently analyse and design a wide diversity of useful and interesting programs.

COMPUTER PROGRAMS IN BASIC AB001 \$15.45

A catalogue of over 1,600 fully indexed BASIC computer programs with applications in Business, Math, Games and more. This book lists available software, what it does, where to get it, and how to adapt it to your machine.

PET GAMES AND RECREATION AB002 \$17.45

A variety of interesting games designed to amuse and educate. Games include such names as Capture, Tic Tac Toe, Watchperson, Motie, Sinners, Martian Hunt and more.

BRAIN TICKLERS AB005 \$9.00

If the usual games such as Bug Stomp and Invaders From the Time Warp are starting to pale, then this is the book for you. The authors have put together dozens of stimulating puzzles to show you just how challenging computing can be.

PASCAL
TAB No.1205 \$16.45
 Aimed specifically at TRS-80 users, this book discusses how to load, use and write PASCAL programs. Graphic techniques are discussed and numerous programs are presented.

PASCAL PROGRAMMING FOR THE APPLE
AB008 \$17.45
 A great book to upgrade your programming skills to the UCSD Pascal as implemented on the Apple II. Statements and techniques are discussed and there are many practical and ready to run programs.

APPLE MACHINE LANGUAGE PROGRAMMING
AB009 \$20.45
 The best way to learn machine language programming the Apple II in no time at all. The book combines colour, graphics, and sound generation together with clear cut demonstrations to help the user learn quickly and effectively.

Z80 USERS MANUAL
AB010 \$21.45
 The Z80 MPU can be found in many machines and is generally acknowledged to be one of the most powerful 8 bit chips around. This book provides an excellent 'right hand' for anyone involved in the application of this popular processor.

HOW TO PROGRAM YOUR PROGRAMMABLE CALCULATOR
AB006 \$12.45
 Calculator programming, by its very nature, often is an obstacle to effective use. This book endeavours to show how to use a programmable calculator to its full capabilities. The TI 57 and the HP 33E calculators are discussed although the principles extend to similar models.

Z-80 AND 8080 ASSEMBLY LANGUAGE PROGRAMMING
SPRACKLEN
HB05 \$14.25
 Provides just about everything the applications programmer needs to know for Z-80 and 8080 processors. Programming techniques are presented along with the instructions. Exercises and answers included with each chapter.

BASIC COMPUTER PROGRAMS IN SCIENCE AND ENGINEERING
GILDER
HB08 \$15.85
 Save time and money with this collection of 114 ready-to-run BASIC programs for the hobbyist and engineer. There are programs to do such statistical operations as means, standard deviation averages, curve-fitting, and interpolation. There are programs that design antennas, filters, attenuators, matching networks, plotting, and histogram programs.

GAME PLAYING WITH COMPUTERS SECOND EDITION
SPENCER
HB11 \$31.25
 Now you can sharpen programming skills through a relaxed approach. Completely devoted to computerized game playing, this volume presents over 70 games, puzzles, and mathematical recreations for a digital computer. It's fully illustrated and includes more than 25 game-playing programs in FORTRAN or BASIC complete with descriptions, flowcharts, and output.

MICROCOMPUTERS AND THE 3 R'S
DOERR
HB09 \$14.25
 This book educates educators on the various ways computers, especially microcomputers, can be used in the classroom. It describes microcomputers, how to organize a computer-based program, the five instructional application types (with examples from subjects such as the hard sciences, life sciences, English, history, and government) and resources listings of today's products. The book includes preprogrammed examples to start up a microcomputer program; while chapters on resources and products direct the reader to useful additional information. All programs are written in the BASIC language.

GAME PLAYING WITH BASIC
SPENCER
HB10 \$15.25
 The writing is nontechnical, allowing almost anyone to understand computerized game playing. The book includes the rules of each game, how each game works, illustrative flowcharts, diagrams, and the output produced by each program. The last chapter contains 26 games for reader solution.

SARGON: A COMPUTER CHESS PROGRAM
SPRACKLEN
HB12 \$25.00
 "I must rate this chess program an excellent buy for anyone who loves the game." Kilobaud.
 Here is the computer chess program that won first place in the first chess tournament at the 1978 West Coast Computer Faire. It is written in Z-80 assembly language, using the TDL macro assembler. It comes complete with block diagram and sample printouts.

A CONSUMER'S GUIDE TO PERSONAL COMPUTING AND MICROCOMPUTERS, SECOND EDITION
FREIBERGER AND CHEW
HB14 \$14.45
 The first edition was chosen by Library Journal as one of the 100 outstanding sci-tech books of 1978. Now, there's an updated second edition!
 Besides offering an introduction to the principles of microcomputers that assumes no previous knowledge on the reader's part, this second edition updates prices, the latest developments in microcomputer technology, and a review of over 100 microcomputer products from over 60 manufacturers.

THE BASIC CONVERSIONS HANDBOOK FOR APPLE, TRS-80, AND PET USERS
BRAIN BANK
HB17 \$11.75

Convert a BASIC program for the TRS-80, Apple II, or PET to the form of BASIC used by any other one of those machines. This is a complete guide to converting Apple II and PET programs to TRS-80, TRS-80 and PET programs to Apple II, TRS-80 and Apple II programs to PET. Equivalent commands are listed for TRS-80 BASIC (Model I, Level II), Applesoft BASIC and PET BASIC, as well as variations for the TRS-80 Model III and Apple Integer BASIC.

SPEAKING PASCAL
BOWEN
HB16 \$17.25
 An excellent introduction to programming in the Pascal language. Written in clear, concise, non-mathematical language, the text requires no technical background or previous programming experience on the reader's behalf. Top-down structured analysis and key examples illustrate each new idea and the reader is encouraged to construct programs in an organized manner.

BP33: ELECTRONIC CALCULATOR USERS HANDBOOK
M.H. BABANI, B.Sc.(Eng.) \$4.25
 An invaluable book for all calculator users whatever their age or occupation, or whether they have the simplest or most sophisticated of calculators. Presents formulae, data, methods of calculation, conversion factors, etc., with the calculator user especially in mind; often illustrated with simple examples. Includes the way to calculate using only a simple four function calculator: Trigonometric Functions (Sin, Cos, Tan); Hyperbolic Functions (Sinh, Cosh, Tanh) Logarithms, Square Roots and Powers.

THE MOST POPULAR SUBROUTINES IN BASIC
TAB No.1050 \$10.45
 An understandable guide to BASIC subroutines which enables the reader to avoid tedium, economise on computer time and makes programs run faster. It is a practical rather than a theoretical manual.

PROJECTS

BP48: ELECTRONIC PROJECTS FOR BEGINNERS
F.G. RAYER, T.Eng.(CEI), Assoc.IERE \$5.90
 Another book written by the very experienced author — Mr. F.G. Rayer — and in it the newcomer to electronics, will find a wide range of easily made projects. Also, there are a considerable number of actual component and wiring layouts, to aid the beginner.

Furthermore, a number of projects have been arranged so that they can be constructed without any need for soldering and, thus, avoid the need for a soldering iron.

Also, many of the later projects can be built along the lines as those in the 'No Soldering' section so this may considerably increase the scope of projects which the newcomer can build and use.

221: 28 TESTED TRANSISTOR PROJECTS
R.TORRENS \$5.50
 Mr. Richard Torrens is a well experienced electronics development engineer and has designed, developed, built and tested the many useful and interesting circuits included in this book. The projects themselves can be split down into simpler building blocks, which are shown separated by boxes in the circuits for ease of description, and also to enable any reader who wishes to combine boxes from different projects to realise ideas of his own.

BP49: POPULAR ELECTRONIC PROJECTS
R.A. PENFOLD \$6.25
 Includes a collection of the most popular types of circuits and projects which, we feel sure, will provide a number of designs to interest most electronics constructors. The projects selected cover a very wide range and are divided into four basic types: Radio Projects, Audio Projects, Household Projects and Test Equipment.

EXPERIMENTER'S GUIDE TO SOLID STATE ELECTRONIC PROJECTS
AB007 \$10.45
 An ideal sourcebook of Solid State circuits and techniques with many practical circuits. Also included are many useful types of experimenter gear.

BP71: ELECTRONIC HOUSEHOLD PROJECTS
R. A. PENFOLD \$7.70
 Some of the most useful and popular electronic construction projects are those that can be used in or around the home. The circuits range from such things as '2 Tone Door Buzzer', Intercom, through Smoke or Gas Detectors to Baby and Freezer Alarms.

BP94: ELECTRONIC PROJECTS FOR CARS AND BOATS
R.A. PENFOLD \$8.10
 Projects, fifteen in all, which use a 12V supply are the basis of this book. Included are projects on Wipers, Wiper Control, Courtesy Light Delay, Battery Monitor, Cassette Power Supply, Lights Timer, Vehicle Immobiliser, Gas and Smoke Alarm, Depth Warning and Shaver Inverter.

BP69: ELECTRONIC GAMES
R.A. PENFOLD \$7.55
 In this book Mr. R. A. Penfold has designed and developed a number of interesting electronic game projects using modern integrated circuits. The text is divided into two sections, the first dealing with simple games and the latter dealing with more complex circuits.

BP95: MODEL RAILWAY PROJECTS
R.A. PENFOLD \$8.10
 Electronic projects for model railways are fairly recent and have made possible an amazing degree of realism. The projects covered include controllers, signals and sound effects: striboard layouts are provided for each project.

BP93: ELECTRONIC TIMER PROJECTS
F.G. RAYER \$8.10
 Wiperscreen wiper delay, darkroom timer and metronome projects are included. Some of the more complex circuits are made up from simpler sub-circuits which are dealt with individually.

110 OP-AMP PROJECTS
MARSTON
HB24 \$11.75
 This handbook outlines the characteristics of the op-amp and present 110 highly useful projects—ranging from simple amplifiers to sophisticated instrumentation circuits.

110 IC TIMER PROJECTS
GILDER
HB25 \$10.25
 This sourcebook maps out applications for the 555 timer IC. It covers the operation of the IC itself to aid you in learning how to design your own circuits with the IC. There are application chapters for timer-based instruments, automotive applications, alarm and control circuits, and power supply and converter applications.

110 THYRISTOR PROJECTS USING SCRs AND TRIACS
MARSTON
HB22 \$10.05
 A grab bag of challenging and useful semiconductor projects for the hobbyist experimenter, and student. The projects range from simple burglar, fire, and water level alarms to sophisticated power control devices for electric tools and trains. Integrated circuits are incorporated wherever their use reduces project costs.

110 CMOS DIGITAL IC PROJECTS
MARSTON
HB23 \$11.75
 Outlines the operating characteristics of CMOS digital ICs and then presents and discusses 110 CMOS digital IC circuits ranging from inverter gate and logic circuits to electronic alarm circuits. Ideal for amateurs, students and professional engineers.

BP76: POWER SUPPLY PROJECTS
R.A. PENFOLD \$7.30
 Line power supplies are an essential part of many electronics projects. The purpose of this book is to give a number of power supply designs, including simple unregulated types, fixed voltage regulated types, and variable voltage stabilised designs, the latter being primarily intended for use as bench supplies for the electronics workshop. The designs provided are all low voltage types for semiconductor circuits.

There are other types of power supply and a number of these are dealt with in the final chapter, including a cassette power supply, Ni-Cad battery charger, voltage step up circuit and a simple inverter.

BP84: DIGITAL IC PROJECTS
F.G. RAYER, T.Eng.(CEI), Assoc.IERE \$8.10
 This book contains both simple and more advanced projects and it is hoped that these will be found of help to the reader developing a knowledge of the workings of digital circuits. To help the newcomer to the hobby the author has included a number of board layouts and wiring diagrams. Also the more ambitious projects can be built and tested section by section and this should help avoid or correct faults that could otherwise be troublesome. An ideal book for both beginner and more advanced enthusiast alike.

BP67: COUNTER DRIVER AND NUMERAL DISPLAY PROJECTS
F.G. RAYER, T.Eng.(CEI), Assoc. IERE \$7.55
 Numeral indicating devices have come very much to the forefront in recent years and will, undoubtedly, find increasing applications in all sorts of equipment. With present day integrated circuits, it is easy to count, divide and display numerically the electrical pulses obtained from a great range of driver circuits.

In this book many applications and projects using various types of numeral displays, popular counter and driver IC's etc. are considered.

BP73: REMOTE CONTROL PROJECTS
OWEN BISHOP \$8.60
 This book is aimed primarily at the electronics enthusiast who wishes to experiment with remote control. Full explanations have been given so that the reader can fully understand how the circuits work and can more easily see how to modify them for other purposes, depending on personal requirements. Not only are radio control systems considered but also infra-red, visible light and ultrasonic systems as are the use of Logic ICs and Pulse position modulation etc.

BP99: MINI — MATRIX BOARD PROJECTS
R.A. PENFOLD \$8.10
 Twenty useful projects which can all be built on a 24 x 10 hole matrix board with copper strips. Includes Doorbuzzer, Low-voltage Alarm, AM Radio, Signal Generator, Projector Timer, Guitar Headphone Amp, Transistor Checker and more.

BP103: MULTI-CIRCUIT BOARD PROJECTS
R.A. PENFOLD \$8.10
 This book allows the reader to build 21 fairly simple electronic projects, all of which may be constructed on the same printed circuit board. Wherever possible, the same components have been used in each design so that with a relatively small number of components and hence low cost, it is possible to make any one of the projects or by re-using the components and P.C.B. all of the projects.

BP107: 30 SOLDERLESS BREADBOARD PROJECTS — BOOK 1
R.A. PENFOLD \$9.35
 A "Solderless Breadboard" is simply a special board on which electronic circuits can be built and tested. The components used are just plugged in and unplugged as desired. The 30 projects featured in this book have been specially designed to be built on a "Veribloc" breadboard. Wherever possible the components used are common to several projects, hence with only a modest number of reasonably inexpensive components it is possible to build, in turn, every project shown.

BP110: HOW TO GET YOUR ELECTRONIC PROJECTS WORKING

R.A. PENFOLD \$8.10
We have all built circuits from magazines and books only to find that they did not work correctly, or at all, when first switched on. The aim of this book is to help the reader overcome just these problems by indicating how and where to start looking for many of the common faults that can occur when building up projects.

CIRCUITS

BP80: POPULAR ELECTRONIC CIRCUITS — BOOK 1

R.A. PENFOLD \$8.25
Another book by the very popular author, Mr. R.A. Penfold, who has designed and developed a large number of various circuits. These are grouped under the following general headings: Audio Circuits, Radio Circuits, Test Gear Circuits, Music Project Circuits, Household Project Circuits and Miscellaneous Circuits.

BP98: POPULAR ELECTRONIC CIRCUITS, BOOK 2 \$9.35
R.A. PENFOLD
70 plus circuits based on modern components aimed at those with some experience.

The GIANT HANDBOOK OF ELECTRONIC CIRCUITS \$24.45
TAB No.1300
About as thick as the Webster's dictionary, and having many more circuit diagrams, this book is ideal for any experimenter who wants to keep amused for several centuries. If there isn't a circuit for it in here, you should have no difficulty convincing yourself you don't really want to build it.

BP39: 50 (FET) FIELD EFFECT TRANSISTOR PROJECTS \$5.50
F.G. RAYER, T.Eng.(CEI), Assoc.IERE
Field effect transistors (FETs), find application in a wide variety of circuits. The projects described here include radio frequency amplifiers and converters, test equipment and receiver aids, tuners, receivers, mixers and tone controls, as well as various miscellaneous devices which are useful in the home.

This book contains something of particular interest for every class of enthusiast — short wave listener, radio amateur, experimenter or audio devotee.

BP87: SIMPLE L.E.D. CIRCUITS \$5.90
R.N. SOAR
Since it first appeared in 1977, Mr. R.N. Soar's book has proved very popular. The author has developed a further range of circuits and these are included in Book 2. Projects include a Transistor Tester, Various Voltage Regulators, Testers and so on.

BP42: 50 SIMPLE L.E.D. CIRCUITS \$3.55
R.N. SOAR
The author of this book, Mr. R.N. Soar, has compiled 50 interesting and useful circuits and applications, covering many different branches of electronics, using one of the most inexpensive and freely available components — the Light Emitting Diode (L.E.D.). A useful book for the library of both beginner and more advanced enthusiast alike.

BP82: ELECTRONIC PROJECTS USING SOLAR CELLS \$8.10
OWEN BISHOP
The book contains simple circuits, almost all of which operate at low voltage and low currents, making them suitable for being powered by a small array of silicon cells. The projects cover a wide range from a bicycle speedometer to a novelty 'Duck Shoot'; a number of power supply circuits are included.

BP37: 50 PROJECTS USING RELAYS, SCR'S & TRIACS \$5.50
F.G. RAYER, T.Eng.(CEI), Assoc.IERE
Relays, silicon controlled rectifiers (SCR's) and bi-directional triodes (TRIACS) have a wide range of applications in electronics today. This book gives tried and practical working circuits which should present the minimum of difficulty for the enthusiast to construct. In most of the circuits there is a wide latitude in component values and types, allowing easy modification of circuits or ready adaptation of them to individual needs.

BP44: IC 555 PROJECTS \$7.55
E.A. PARR, B.Sc., C.Eng., M.I.E.E.
Every so often a device appears that is so useful that one wonders how life went on before without it. The 555 timer is such a device. Included in this book are Basic and General Circuits, Motor Car and Model Railway Circuits, Alarms and Noise Makers as well as a section on the 556, 558 and 559 timers.

BP24: 50 PROJECTS USING IC741 \$4.25
RUDI & UWE REDMER
This book, originally published in Germany by TOPP, has achieved phenomenal sales on the Continent and Babani decided, in view of the fact that the integrated circuit used in this book is inexpensive to buy, to make this unique book available to the English speaking reader. Translated from the original German with copious notes, data and circuitry, a "must" for everyone whatever their interest in electronics.

BP83: VMOS PROJECTS \$8.20
R.A. PENFOLD
Although modern bipolar power transistors give excellent results in a wide range of applications, they are not without their drawbacks or limitations. This book will primarily be concerned with VMOS power FETs although power MOSFETs will be dealt with in the chapter on audio circuits. A number of varied and interesting projects are covered under the main headings of: Audio Circuits, Sound Generator Circuits, DC Control Circuits and Signal Control Circuits.

BP65: SINGLE IC PROJECTS \$6.55
R.A. PENFOLD
There is now a vast range of ICs available to the amateur market, the majority of which are not necessarily designed for use in a single application and can offer unlimited possibilities. All the projects contained in this book are simple to construct and are based on a single IC. A few projects employ one or two transistors in addition to an IC but in most cases the IC is the only active device used.

BP97: IC PROJECTS FOR BEGINNERS \$8.10
F.G. RAYER
Covers power supplies, radio, audio, oscillators, timers and switches. Aimed at the less experienced reader, the components used are popular and inexpensive.

BP88: HOW TO USE OP AMPS \$9.35
E.A. PARR
A designer's guide covering several op amps, serving as a source book of circuits and a reference book for design calculations. The approach has been made as non-mathematical as possible.

IC ARRAY COOKBOOK \$14.25
JUNG HB26
A practical handbook aimed at solving electronic circuit application problems by using IC arrays. An IC array, unlike specific-purpose ICs, is made up of uncommitted IC active devices, such as transistors, resistors, etc. This book covers the basic types of such ICs and illustrates with examples how to design with them. Circuit examples are included, as well as general design information useful in applying arrays.

BP50: IC LM3900 PROJECTS \$5.90
H.KYBETT, B.Sc., C.Eng.
The purpose of this book is to introduce the LM3900 to the Technician, Experimenter and the Hobbyist. It provides the groundwork for both simple and more advanced uses, and is more than just a collection of simple circuits or projects.

Simple basic working circuits are used to introduce this IC. The LM3900 can do much more than is shown here, this is just an introduction. Imagination is the only limitation with this useful and versatile device. But first the reader must know the basics and that is what this book is all about.

223: 50 PROJECTS USING IC CA3130 \$5.50
R.A. PENFOLD
In this book, the author has designed and developed a number of interesting and useful projects which are divided into five general categories: I — Audio Projects II — R.F. Projects III — Test Equipment IV — Household Projects V — Miscellaneous Projects.

224: 50 CMOS IC PROJECTS \$4.25
R.A. PENFOLD
CMOS IC's are probably the most versatile range of digital devices for use by the amateur enthusiast. They are suitable for an extraordinary wide range of applications and are also some of the most inexpensive and easily available types of IC.

Mr. R.A. Penfold has designed and developed a number of interesting and useful projects which are divided into four general categories: I — Multivibrators II — Amplifiers and Oscillators III — Trigger Devices IV — Special Devices.

THE ACTIVE FILTER HANDBOOK \$11.45
TAB No.1133
Whatever your field — computing, communications, audio, electronic music or whatever — you will find this book the ideal reference for active filter design.

The book introduces filters and their uses. The basic math is discussed so that the reader can tell where all design equations come from. The book also presents many practical circuits including a graphic equalizer, computer tape interface and more.

DIGITAL IC'S — HOW THEY WORK AND HOW TO USE THEM \$11.45
AB004
An excellent primer on the fundamentals of digital electronics. This book discusses the nature of gates and related concepts and also deals with the problems inherent to practical digital circuits.

MASTER HANDBOOK OF 1001 PRACTICAL CIRCUITS \$20.45
TAB No.800
MASTER HANDBOOK OF 1001 MORE PRACTICAL CIRCUITS \$19.45
TAB No.804
Here are transistor and IC circuits for just about any application you might have. An ideal source book for the engineer, technician or hobbyist. Circuits are classified according to function, and all sections appear in alphabetical order.

THE MASTER IC COOKBOOK \$16.45
TAB No.1199
If you've ever tried to find specs for a so called 'standard' chip, then you'll appreciate this book. C.L. Hallmark has compiled specs and pinout for most types of ICs that you'd ever want to use.

ELECTRONIC DESIGN WITH OFF THE SHELF INTEGRATED CIRCUITS

AB016 \$13.45
This practical handbook enables you to take advantage of the vast range of applications made possible by integrated circuits. The book tells how, in step by step fashion, to select components and how to combine them into functional electronic systems. If you want to stop being a "cookbook hobbyist", then this is the book for you.

AUDIO

BP90: AUDIO PROJECTS \$8.10
F.G. RAYER
Covers in detail the construction of a wide range of audio projects. The text has been divided into preamplifiers and mixers, power amplifiers, tone controls and matching and miscellaneous projects.

HOW TO DESIGN, BUILD AND TEST A SPEAKER SYSTEM \$4.45
KER
OUT OF PRINT
This book contains a variety of speakers as well as instructions on how to design your own.

205: FIRST BOOK OF HI-FI LOUDSPEAKER ENCLOSURES \$3.55
B.B. BABANI
This book gives data for building most types of loudspeaker enclosure. Includes corner reflex, bass reflex, exponential horn, folded horn, tuned port, klipschorn labyrinth, tuned column, loaded port and multi speaker panoramic. Many clear diagrams for every construction showing the dimensions necessary.

BP35: HANDBOOK OF IC AUDIO PRE-AMPLIFIER AND POWER AMPLIFIER CONSTRUCTION \$5.90
F.G. RAYER, T.Eng.(CEI), Assoc.IERE
OUT OF PRINT
This book includes practical circuits for pre-amp, tone controls, PA, amplifier, etc. Includes practical construction details for IC and Hybrid IC and Transistor circuits from about 250mW to 100W output. Out of stock until December 1982.

BP47: MOBILE DISCOTHEQUE HANDBOOK \$5.90
COLIN CARSON
The vast majority of people who start up "Mobile Discos" know very little about their equipment or even what to buy. Many people have wasted a "small fortune" on poor, unnecessary or badly matched apparatus. The aim of this book is to give you enough information to enable you to have a better understanding of many aspects of "disco" gear.

HOW TO BUILD A SMALL BUDGET RECORDING STUDIO FROM SCRATCH \$16.45
TAB No.1166
The author, F. Alton Everest, has gotten studios together several times, and presents twelve complete, tested designs for a wide variety of applications. If all you own is a mono cassette recorder, you don't need this book. If you don't want your new four track to wind up sounding like one, though, you shouldn't be without it.

BP51: ELECTRONIC MUSIC AND CREATIVE TAPE RECORDING \$5.50
M.K. BERRY
Electronic music is the new music of the Twentieth Century. It plays a large part in "pop" and "rock" music and, in fact, there is scarcely a group without some sort of synthesiser or other effects generator.

This book sets out to show how electronic music can be made at home with the simplest and most inexpensive of equipment. It then describes how the sounds are generated and how these may be recorded to build up the final composition.

BP74: ELECTRONIC MUSIC PROJECTS \$7.70
R.A. PENFOLD
Although one of the more recent branches of amateur electronics, electronic music has now become extremely popular and there are many projects which fall into this category. The purpose of this book is to provide the constructor with a number of practical circuits for the less complex items of electronic music equipment, including such things as a Fuzz Box, Waa-Waa Pedal, Sustain Unit, Reverberation and Phaser-Units, Tremolo Generator etc.

BP01: ELECTRONIC SYNTHESISER PROJECTS \$7.30
M.K. BERRY
One of the most fascinating and rewarding applications of electronics is in electronic music and there is hardly a group today without some sort of synthesiser or effects generator. Although an electronic synthesiser is quite a complex piece of electronic equipment, it can be broken down into much simpler units which may be built individually and these can then be used or assembled together to make a complete instrument.

ELECTRONIC MUSIC SYNTHESIZERS \$10.45
TAB No.1167
If you're fascinated by the potential of electronics in the field of music, then this is the book for you. Included is data on synthesizers in general as well as particular models. There is also a chapter on the various accessories that are available.

TEST EQUIPMENT

BP75: ELECTRONIC TEST EQUIPMENT CONSTRUCTION \$7.30

F.G. RAYER, T.Eng. (CEI), Assoc. IERE
This book covers in detail the construction of a wide range of test equipment for both the Electronics Hobbyists and Radio Amateur. Included are projects ranging from an FET Amplified Voltmeter and Resistance Bridge to a Field Strength Indicator and Heterodyne Frequency Meter. Not only can the home constructor enjoy building the equipment but the finished projects can also be usefully utilised in the furtherance of his hobby.

99 TEST EQUIPMENT PROJECTS YOU CAN BUILD TAB No.805 \$14.45

An excellent source book for the hobbyist who wants to build up his work bench inexpensively. Projects range from a simple signal tracer to a 50MHz frequency counter. There are circuits to measure just about any electrical quantity: voltage, current, capacitance, impedance and more. The variety is endless and includes just about anything you could wish for!

HOW TO GET THE MOST OUT OF LOW COST TEST EQUIPMENT AB017 \$9.45

Whether you want to get your vintage 1960 'TestRite's signal generator working, or you've got something to measure with nothing to measure it with, this is the book for you. The author discusses how to maximize the usefulness of cheap test gear, how to upgrade old equipment, and effective test set ups.

THE POWER SUPPLY HANDBOOK TAB No.806 \$16.45

A complete one stop reference for hobbyists and engineers. Contains high and low voltage power supplies of every conceivable type as well mobile and portable units.

BP70: TRANSISTOR RADIO FAULT-FINDING CHART \$2.40

CHAS. E. MILLER
Across the top of the chart will be found four rectangles containing brief descriptions of various faults; vis: — sound weak but undistorted; set dead; sound low or distorted and background noises. One then selects the most appropriate of these and following the arrows, carries out the suggested checks in sequence until the fault is cleared.

ELECTRONIC TROUBLESHOOTING HANDBOOK AB019 \$12.45

This workbook guide can show you how to pinpoint circuit troubles in minutes; how to test anything electronic, and how to get the most out of low cost test equipment. You can use any and all of the time-saving shortcuts to rapidly locate and repair all types of electronic equipment malfunctions.

COMPLETE GUIDE TO READING SCHEMATIC DIAGRAMS AB018 \$10.45

A complete guide on how to read and understand schematic diagrams. The book teaches how to recognize basic circuits and identify component functions. Useful for technicians and hobbyists who want to avoid a lot of headscratching.

RADIO AND COMMUNICATIONS

BP79: RADIO CONTROL FOR BEGINNERS \$7.30

F.G. RAYER, T.Eng.(CEI),Assoc.IERE
The aim of this book is to act as an introduction to Radio Control for beginners to the hobby. The book will commence by dealing with the conditions that are allowable for such things as frequency and power of transmission. This is followed by a "block" explanation of how control-device and transmitter operate and receiver and actuator(s) produce motion in a model.

Details are then given of actual solid state transmitting equipment which the reader can build. Plain and loaded aerials are then discussed and so is the field-strength meter to help with proper setting up.

The radio receiving equipment is then dealt with which includes a simple receiver and also a crystal controlled superhet. The book ends with the electro-mechanical means of obtaining movement of the controls of the model.

BP96: CB PROJECTS \$8.10

R.A. PENFOLD
Projects include speech processor, aerial booster, cordless mike, aerial and harmonic filters, field strength meter, power supply, CB receiver and more.

222: SOLID STATE SHORT WAVE RECEIVERS FOR BEGINNERS \$5.20

R.A. PENFOLD
In this book, R.A. Penfold has designed and developed several modern solid state short wave receiver circuits that will give a fairly high level of performance, despite the fact that they use only relatively few and inexpensive components.

BP91: AN INTRODUCTION TO RADIO DXing \$8.10

This book is divided into two main sections one to amateur band reception, the other to broadcast bands. Advice is given to suitable equipment and techniques. A number of related constructional projects are described.

BP105: AERIAL PROJECTS \$8.10

R.A. PENFOLD
The subject of aerials is vast but in this book the author has considered practical designs including active, loop and ferrite aerials, which give good performances and are reasonably simple and inexpensive to build. The complex theory and math of aerial design are avoided.

BP46: RADIO CIRCUITS USING IC's \$5.90

J.B. DANCE, M.Sc.
This book describes integrated circuits and how they can be employed in receivers for the reception of either amplitude or frequency modulated signals. The chapter on amplitude modulated (a.m.) receivers will be of most interest to those who wish to receive distant stations at only moderate audio quality, while the chapter on frequency modulation (f.m.) receivers will appeal to those who desire high fidelity reception.

BP92: ELECTRONICS SIMPLIFIED—CRYSTAL SET CONSTRUCTION \$7.30

F.A. WILSON
Aimed at those who want to get into construction without much theoretical study. Homewound coils are used and all projects are very inexpensive to build.

REFERENCE

THE BEGINNER'S HANDBOOK OF ELECTRONICS AB003 \$10.45

An excellent textbook for those interested in the fundamentals of Electronics. This book covers all major aspects of power supplies, amplifiers, oscillators, radio, television and more.

ELEMENTS OF ELECTRONICS — AN ON-GOING SERIES F.A. WILSON, C.G.I.A., C.Eng.

BP62: BOOK 1. The Simple Electronic Circuit and Components \$8.95

BP63: BOOK 2. Alternating Current Theory \$8.95

BP64: BOOK 3. Semiconductor Technology \$8.95

BP77: BOOK 4. Microprocessing Systems And Circuits \$12.30

BP89: BOOK 5. Communication \$12.30

The aim of this series of books can be stated quite simply — it is to provide an inexpensive introduction to modern electronics so that the reader will start on the right road by thoroughly understanding the fundamental principles involved.

Although written especially for readers with no more than ordinary arithmetical skills, the use of mathematics is not avoided, and all the mathematics required is taught as the reader progresses.

Each book is a complete treatise of a particular branch of the subject and, therefore, can be used on its own with one proviso, that the later books do not duplicate material from their predecessors, thus a working knowledge of the subjects covered by the earlier books is assumed.

BOOK 1: This book contains all the fundamental theory necessary to lead to a full understanding of the simple electronic circuit and its main components.

BOOK 2: This book continues with alternating current theory without which there can be no comprehension of speech, music, radio, television or even the electricity utilities.

BOOK 3: Follows on semiconductor technology, leading up to transistors and integrated circuits.

BOOK 4: A complete description of the internal workings of microprocessor.

BOOK 5: A book covering the whole communication scene.

BP85: INTERNATIONAL TRANSISTOR EQUIVALENTS GUIDE \$12.25

ADRIAN MICHAELS
This book will help the reader to find possible substitutes for a popular user-orientated selection of modern transistors. Also shown are the material type, polarity, manufacturer selection of modern transistors. Also shown are the material type, polarity, manufacturer and use. The Equivalents are sub-divided into European, American and Japanese. The products of over 100 manufacturers are included. An essential addition to the library of all those interested in electronics, be they technicians, designers, engineers or hobbyists. Fantastic value for the amount of information it contains.

BP108: INTERNATIONAL DIODE EQUIVALENTS GUIDE \$8.35

ADRIAN MICHAELS
This book is designed to help the user in finding possible substitutes for a large user orientated selection of the many different types of semiconductor diodes that are available today. Besides simple rectifier diodes also included are Zener diodes, LEDs, Diacs, Triacs, Thyristors, Photo diodes and Display diodes.

BP1: FIRST BOOK OF TRANSISTOR EQUIVALENTS AND SUBSTITUTES \$2.80

B.B. BABANI
This guide covers many thousands of transistors showing possible alternatives and equivalents. Covers transistors made in Great Britain, USA, Japan, Germany, France, Europe, Hong Kong, and includes types produced by more than 120 different manufacturers.

BP14: SECOND BOOK OF TRANSISTOR EQUIVALENTS AND SUBSTITUTES \$4.80

B.B. BABANI
The "First Book of Transistor Equivalents" has had to be reprinted 15 times. The "Second Book" produced in the same style as the first book, in no way duplicates any of the data presented in it. The "Second Book" contains only additional material and the two books complement each other and make available some of the most complete and extensive information in this field. The interchangeability data covers semiconductor manufacturers in Great Britain, USA, Germany, France, Poland, Italy, East Germany, Belgium, Austria, Netherlands and many other countries.

TOWER'S INTERNATIONAL OP-AMP LINEAR IC SELECTOR TAB No.3216 \$13.45

This book contains a wealth of useful data on over 5,000 Op-amps and linear ICs — both pinouts and essential characteristics. A comprehensive series of appendices contain information on specs, manufacturers, case outlines and so on.

CMOS DATA BOOK TAB No.984 \$14.45

There are several books around with this title, but most are just collections of manufacturers' data sheets. This one, by Bill Hunter, explains all the intricacies of this useful family of logic devices — the missing link in getting your own designs working properly. Highly recommended to anyone working with digital circuits.

MISCELLANEOUS

BP68: CHOOSING AND USING YOUR HI-FI \$7.25

MAURICE L. JAY
The main aim of this book is to provide the reader with the fundamental information necessary to enable him to make a satisfactory choice from the extensive range of hi-fi equipment now on the market.

Help is given to the reader in understanding the equipment he is interested in buying and the author also gives his own opinion of the minimum standards and specifications one should look for. The book also offers helpful advice on how to use your hi-fi properly so as to realise its potential. A Glossary of terms is also included.

BP101: HOW TO IDENTIFY UNMARKED IC'S \$2.70

K.H. RECORR
Originally published as a feature in 'Radio Electronics', this chart shows how to record the particular signature of an unmarked IC using a test meter, this information can then be used with manufacturer's data to establish the application.

SIMPLIFIED TRANSISTOR THEORY TRAINING SYSTEMS, INC. AND LEVINE \$10.25

HB20
This book is designed to provide an understanding of the physical theory and operation of transistors and transistors and transistors. It is a previous knowledge of basic electronics is assumed.

Presented in a series of brief, easy-to-read chapters, or frames — over 400 in all. A concluding section provides both a concise review and a complete reference source for future use.

AUDIO AND VIDEO INTERFERENCE CURES \$9.05

KAHANER
HB21
A practical work about interference causes and cures that affect TV, radio, hi-fi, CB, and other devices. Provides all the information needed to stop interference. Schematic wiring diagrams of filters for all types of receivers and transmitters are included. Also, it supplies simple filter diagrams to eliminate radio and TV interference caused by noisy home appliances, neon lights, motors, etc.

BASIC TELEPHONE SWITCHING SYSTEMS \$15.25

TALLEY
HB27
The Revised Second Edition of this book, for trainee and engineer alike, includes updated statistical data on telephone stations, and new and improved signaling methods and switching techniques. It also includes E & M signaling interface for electronic central offices and automatic number identification methods used in step-by-step, panel and crossbar central offices.

INTERRELATED INTEGRATED ELECTRONICS CIRCUITS FOR THE RADIO AMATEUR, TECHNICIAN, HOBBYIST AND CB'ER \$11.35

MEDELSON
HB29
This book provides a variety of appealing projects that can be constructed by anyone from the hobbyist to the engineer. Construction details, layouts, and photographs are provided to simplify duplication. While most of the circuits are shown on printed circuit boards, every one can be duplicated on handwired, perforated boards. Each project is related to another project so that several may be combined into a single package. The projects, divided into five major groups, include CMOS audio modules, passive devices to help in benchwork, test instruments, and games.

BASIC CARRIER TELEPHONY, THIRD EDITION \$14.45

TALLEY
HB28
A basic course in the principles and applications of carrier telephony and its place in the overall communications picture. It is abundantly illustrated, with questions and problems throughout, and requires a minimum of mathematics.

ROBOTICS

THE COMPLETE HANDBOOK OF ROBOTICS TAB No.1071 \$13.45

All the information you need to build a walking, talking mechanical friend appears in this book. Your robot can take many forms and various options — light, sound, and proximity sensors — are covered in depth.

HOW TO BUILD YOUR OWN SELF PROGRAMMING ROBOT \$13.45

TAB No.1241
A practical guide on how to build a robot capable of learning how to adapt to a changing environment. The creature developed in the book, Rodney, is fully self programming, can develop theories to deal with situations and apply those theories in future circumstances.

BUILD YOUR OWN WORKING ROBOT \$11.45

TAB No.841
Contains complete plans — mechanical, schematics, logic diagrams and wiring diagrams — for building Buster. Buster is a sophisticated experiment in cybernetics you can build in stages. There are two phases involved: first Buster is leashed, dependent on his creator for guidance; the second phase makes Buster more independent and able to get out of tough situations.

Loudspeaker Protector



This unit affords both dc and over-power protection of loudspeakers or loudspeaker systems rated at up to 1500 watts! The unit requires no power supply and has no discernible audible effect on sound quality, making it suitable for both hi-fi and sound reinforcement applications.

YOU'VE JUST unpacked and connected that shiny new 400 watt amplifier you've always wanted, and you lower the tonearm expectantly. There's a short detonation, and smoke gently and silently curls from the speaker grille cloth. Nobody had pointed out to you that those bargain basement speakers could only handle 15 watts.

Never, you say? You always check such things? Murphy's Law lies in wait: power amps fail occasionally, and a shorted output transistor can connect the power supply directly to the speaker coil, applying a steady 30 to 50 volts DC, usually enough to char the coil or rip the mountings apart.

A solution to this is the ETI Signal Powered Loudspeaker Protector. It is applicable to almost all speakers, and can fit inside the cabinet itself. Since the unit is powered by the audio signal, there are no batteries to fuss with, and unlike a fuse, it automatically resets when the overload is removed. It can also tell the difference between applied DC and low-frequency signals, and can be adjusted to cut out at a desired signal level without tripping on loud but harmless transients.

The self-powering feature is not only convenient, but adds no audible distortion to the signal, even with low-wattage amplifiers having rather high output impedances.

This is done in this case by placing a fullwave rectifier across the speaker lines and charging a 1000uF capacitor through a 47 ohm resistor. The worst possible load presented to the speaker line is therefore 47 ohms

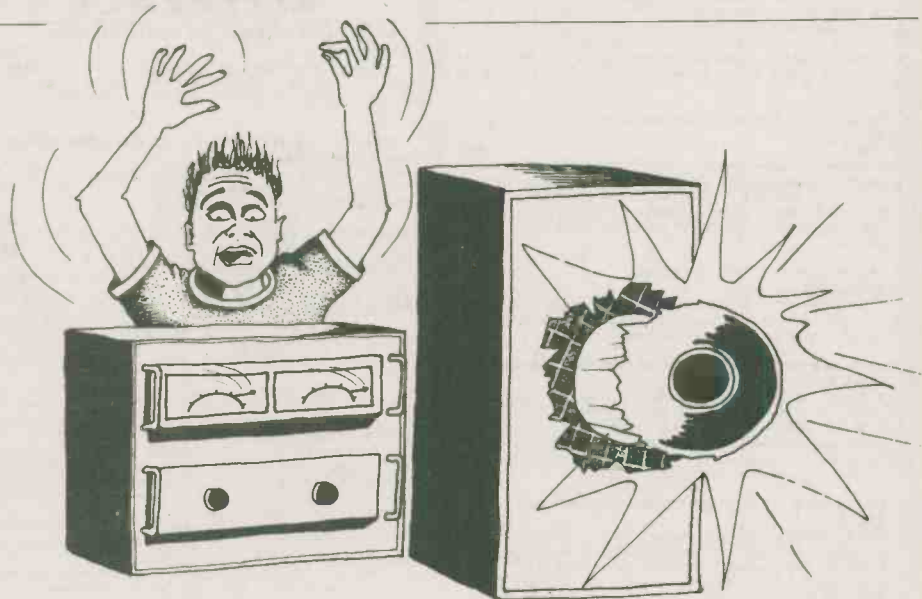

and this is only while charging the capacitor and for signal voltages in excess of 12 V. This ensures that the unit has no discernible effect on audio quality but makes possible a truly 'set-and-forget' loudspeaker protector that can be mounted inside the loudspeaker enclosure if desired.

The protector tests for both dc and over-power, which can be adjusted by a preset on the board to suit a particular loudspeaker or application. The circuit also uses a new filter design with an almost 'brick wall' response enabling it to be connected to very high power amps. This is discussed in more detail in the 'How it Works' section.

The maximum power that can be applied to the unit is determined by the type of regulator transistor (Q1) used. We have specified a TIP31C for this device which has a 100V collector-to-emitter breakdown voltage. Since the emitter is at 12V, the maximum voltage that can be applied to the unit is 112V. This is equivalent to an amp capable of supplying approximately 784 watts into an 8 ohm load or 1568 watts into a 4 ohm load. If the amplifier to be used is capable of powers greater than these the regulator transistor should be substituted for a device with a higher V_{ce0} rating. The relay pulls around 40 mA when operated, so

power dissipation in the regulator transistor will be around 4 watts when dropping 100 volts. Although this is not a particularly high dissipation it is high enough to lie outside the Safe Operating Area rating of many high voltage transistors, so be careful when choosing an alternate regulator transistor.

Construction

Construction is straightforward since all of the components are mounted on the pc board. The usual precautions should be taken to ensure that all polarised components have been mounted with the correct orientation. The IC used is a CMOS type and is therefore static sensitive. Solder this last and preferably using an grounded soldering iron. It is a wise precaution to discharge yourself before handling the device by first touching an grounded metal appliance.

It is a wise precaution to space the 2.5W resistor, R2, off the pc board slightly. In the case of a high powered loudspeaker going faulty with dc this component will get quite hot and spacing improves ventilation around the component and prevents the possibility of charring the pc board. If you can't obtain a 2.5 watt type (e.g. Philips PR52), then a 5W type may be substituted.

Before mounting the unit check operation by connecting around 20V dc across the speaker input terminals on the pc board. The relay should cut in after about one tenth of a second. If the protector passes this test connect the speaker wiring. If the preset is turned fully down (turn it counter-clockwise when viewing the board with the components on top and the relay to the right) the relay will cut in when the power exceeds around 20 watts for an extended period. The protector allows transients to the full supply rail to pass but will prevent a continuous 20W from being applied to the loudspeaker. To increase this, turn the preset clockwise until the desired response is achieved.

HOW IT WORKS

The signal from the power amp is rectified by the fullwave rectifier formed by D1-D4. The output of this is fed through a 12V regulator circuit formed by Q1 and its associated resistors and zener diode, and charges the electrolytic capacitor, C1. The output of the rectifier is also fed to the input of the dc sense and over-power detection circuitry.

IC1 gates a and c form the dc filter. Resistors R4 and R6 form a Schmitt trigger with a small deadband. When the signal goes above the trigger voltage the output of the trigger swings hard to the positive supply rail of the IC, charging C2 through the 220k resistor, R8. Resistors R10 and R11 with gate c form a second Schmitt trigger monitoring the voltage across C2. If the voltage across C2 reaches the trigger voltage of this second Schmitt, gates d, e and f are activated, pulling in the relay contacts and disconnecting the loudspeaker. It takes about 100 ms to charge C2 through R8, and on normal audio content the out-

put of gate 'a' will be driven low before this occurs, discharging C2 rapidly through D6. Only signals which do not have a zero crossing for longer than 100 ms will trigger the protector.

The over-power protector consists simply of a voltage divider feeding a third Schmitt trigger. Whenever the signal voltage exceeds the trigger voltage the output of gate 'b' is driven high and C3 starts to charge. If this condition persists for long enough the output gates are turned on and the relay pulls in. Note that both the dc and over-power sense circuits charge C3 when activated. The circuits are decoupled from this capacitor by diodes so that, once charged, C3 can only be discharged by the parallel resistor R12 (the effect of the input impedance of the gates is negligible). Since it takes about one second to discharge this capacitor, the relay will hold in for this time. The protector therefore reconnects the loudspeaker approximately one second after the fault condition has been removed.

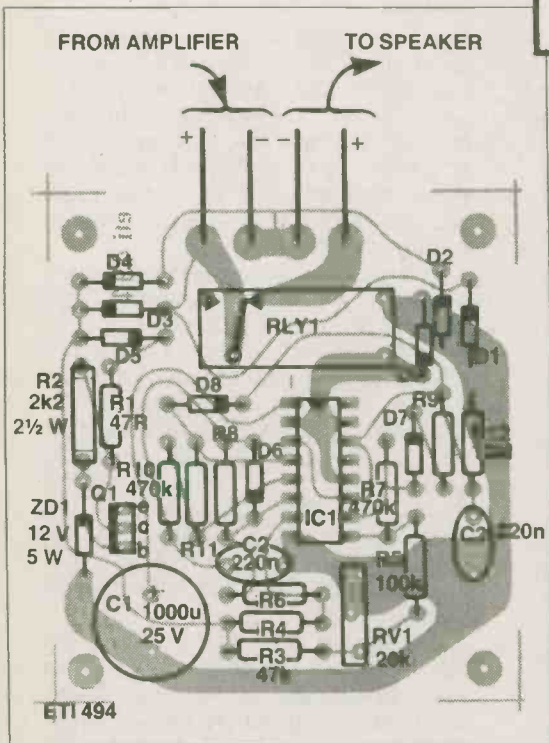

ETI 494

eti 494

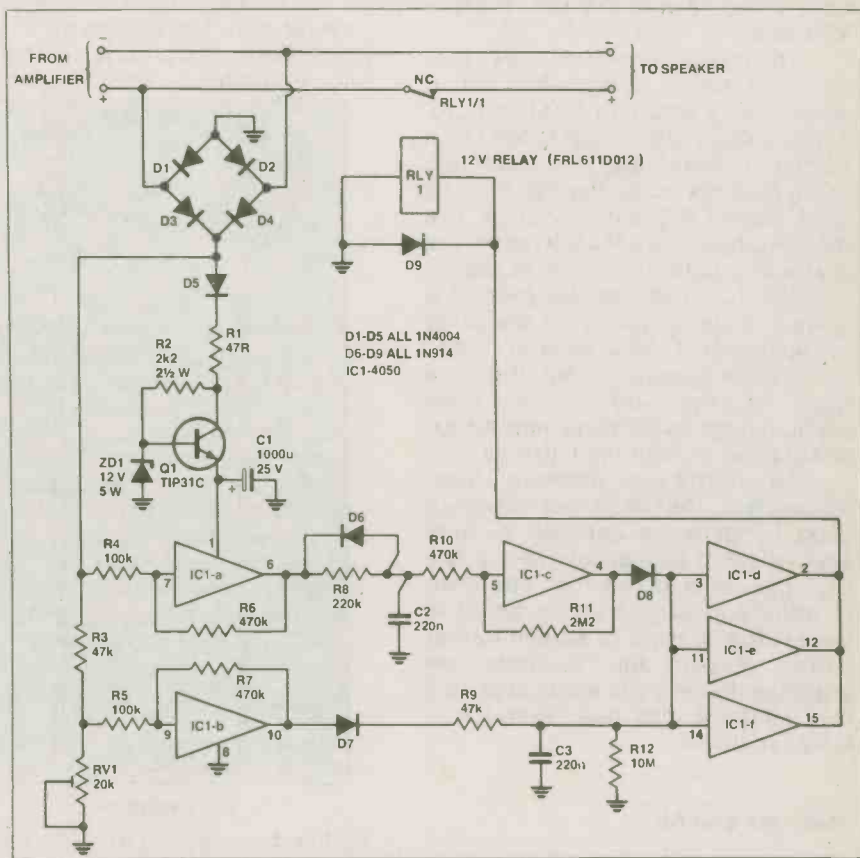
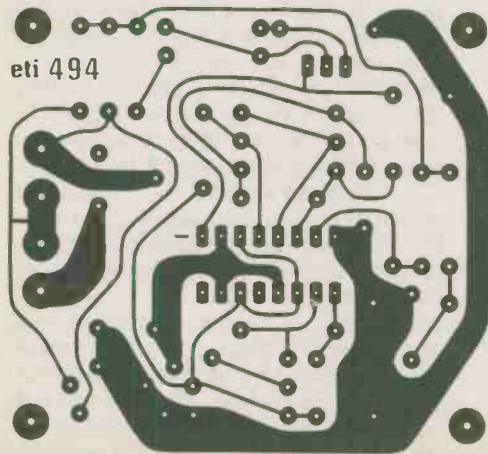

PARTS LIST

Resistors (all 1/2 W, 5% unless noted)

R1	47R
R2	2k2, 2 1/2 W
R3,9	47k
R4,5	100k
R6,7,10	470k
R8	220k
R11	2M2
R12	10M
RV1	20k min. trimpot

Capacitors

C1	1000u/25V electro
C2,3	220n

Semiconductors

D1-5	1N4004, EM404
D6-9	1N914, 1N4148
IC1	4050 hex buffer
Q1	TIP31C
ZD1	12V, 5W zener

Miscellaneous

pc board; RL1 — Fujitsu FRL611D012, 12 volt SPDT 10A contacts or Guardian 1345-IC-12D or similar relay (pc mount type).

ETI

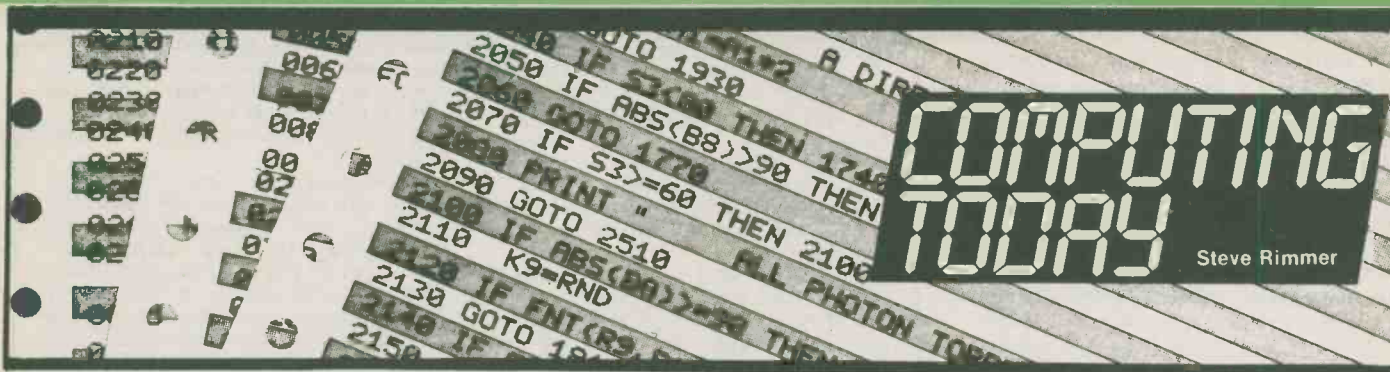

THE MOTOROLA 6845 CRT controller has been turning up a lot of late. We used it in our intelligent terminal project, the Apple II 80 column board has one, and even such lofty machinery as the IBM PC incorporates this beauty. It's profoundly versatile and powerful. This month we're going to have a look at what this little brute is all about.

The basic function of a CRT controller is pretty straight-forward. It scrutinizes a chunk of RAM and produces a video signal that looks like a screen of characters, the characters being determined by the bytes in the RAM. Some CRT controller chips, like the 6847, have the dot patterns for the characters built into them. However, in order to allow the designer of a system more flexibility in choosing the characters to be displayed... and to allow the designer of the chip more room to play with... the more sophisticated controllers use an external ROM to hold the patterns.

As hardware hackers have discovered, the 6845 represents a good compromise between a fairly sophisticated display interface and a CRT controller board that stretches to infinity. It can be programmed to have virtually any size screen format within reason and versions are available that will clip along at up to 2 megaHertz. It also has several auxiliary functions.

Registers and All

The 6845 is a forty pin LSI chip. It can provide alpha-numeric displays of a number of sorts or full bit mapped graphics if it has enough RAM to draw on. It can be programmed to scroll by line, page, or just on a character-by-character basis. It can handle the memory refresh for its associated memory, allowing up to 16K of RAM for doing high resolution plotting. Even the cursor is fully programmable; you can choose what it will look like, whether or not it will flash and how fast, and so on. The chip can also handle full colour.

The processor that's driving the CRTC has to control it through its internal registers. In essence, bytes loaded into memory locations in the chip make it do its stuff. These registers are loaded via the data bus of the CRTC. The data bus input is usually in a coma and unreceptive until the R/\bar{W} is pulled low, at which time the CRTC is ready to accept data input. When it's high it can be read only. Furthermore, the CS line must

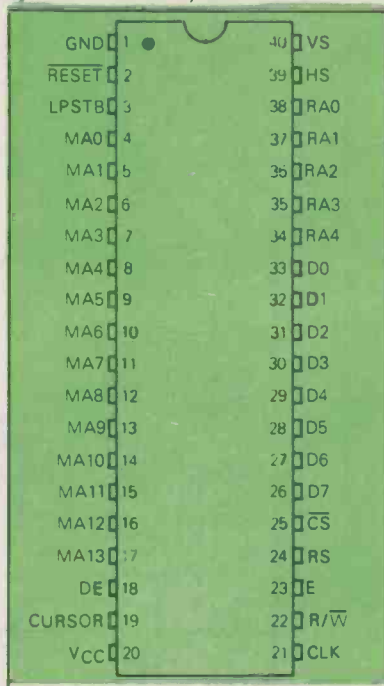

Pin assignments

be low for anything at all to happen, otherwise the data bus tri-states into oblivion and won't do anything at all, allowing other operations to be happening on the data bus that don't concern the CRTC.

There is also the \bar{RS} line which decides which register is being written. If it's low the data will be going to the address register. If it's high it selects a data register as specified by the address register. Tricky, huh?

There are a number of other bus structures oozing their way out of the chip. MA0 - MA13 are the memory refresh lines. If the CRTC has its own

block of dynamic RAM to use as a screen it will refresh this without the need for special circuitry. There are also five lines, RA0 - RA4 that output the count of an internal generator to address a character generator EPROM.

One of the most interesting, and most often unused pins of the 6845 is the LPSTB, the light pen strobe. If it goes high the internal light pen register latches the current refresh address... a bit funky, this, but when these registers are thereafter read, you will have the location of the pen on the screen.

One of the interesting points about the CRTC and its rather large address bus is that it does not have to drive a standard monitor. You are not limited to 525 lines of video information. A 16K character store can be organized as a few very large pages if you can come up with a dense enough monitor to permit displaying them. Alternately, you can use the hardware scrolling features of the chip to allow you to scroll the text window of a standard sized page over a large buffer.

Now for the tricky bits. The parameters of the chip are, as we've seen, controlled by registers. There are, in fact, nineteen of these, one address register and eighteen others for data. We've talked about how to access these little trolls using the chip control lines. Here's what they do. The examples given are for a hypothetical screen size of twenty four lines of eighty characters each, this being the configuration the chip most frequently discovers itself in.

The scan registers... there are ten of them... define the nature of the scan lines on the CRT. R0 sets the horizontal frequency. It is figured as being the time for the displayed characters plus the non-displayed characters minus one. A sample value is 65H. R1 is the number of characters per line. In this case it would be 50H (which is 80 decimal). R2 is the sync delay for the scanning pulses. This model would use 56H. R3 is the width for the synch pulses. The

Fault Finding For Beginners

Fault-finding, on a newly completed project or even on commercial equipment, is easy — once you know the rules!

FAULT-FINDING on a project can be a time-consuming job. Even experienced electronics engineers will sometimes spend hours looking for a reason why a particular circuit doesn't work - so what chance has the hobbyist got of quickly locating faults? Occasionally, a fault will be obvious, but more often than not it will remain hidden away, after many hours of hard slog to detect and then repair it.

Prevention Is Better Than Cure

There are many categories of possible faults, but the more usual ones occur because of a mistake. For instance, it's all too easy to misread the resistor colour code and put an incorrect value into the circuit. Of course, in some cases a small change may not make any difference, but in other circuits resistances can be critical — and you may find that a project simply doesn't work at all just because you've inserted a 100k resistor instead of a 120k. The moral of the story is to make sure you know the colour code.

Similarly, an incorrect capacitor value may prevent a circuit from operating according to plan while polarised components ie, transistors, integrated circuits, diodes and certain capacitors, have to be inserted the right way round, for obvious reasons.

Another builder-originated source of faults is to do with soldering. A single dry-joint can affect performance and may prevent the circuit from working at all. Soldering technique improves with practice, so fewer and fewer soldering problems should arise the more projects you make. But dry-soldered joints aren't the only type of fault which can be caused by slap-happy soldering; in its hot state solder is, of course, molten, and unless care is taken it can form con-

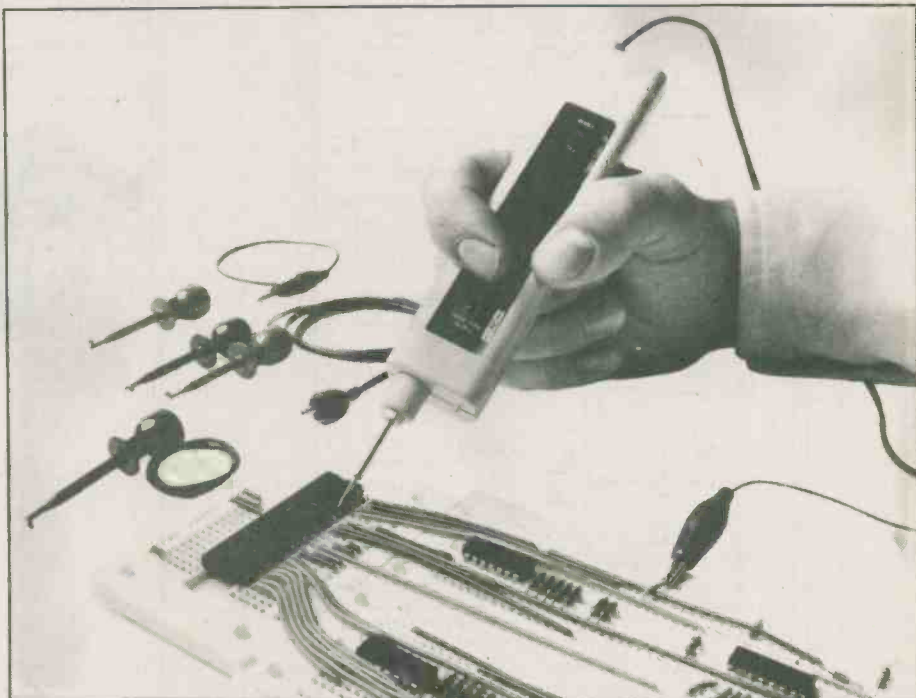

Projects that don't work the first time don't have to be a total mystery; the faults can be traced using a systematic approach. Usually the circuit can be up and running in no time, especially if you know where to look.

ducting bridges to copper tracks close by the soldering joint. Even a microscopically thin solder bridge can form a short circuit and prevent your project from working.

Occasionally, too, a circuit will malfunction due to a faulty component, but it is the exception to the rule.

Most suppliers thoroughly screen the components they sell and it is unlikely that a component will be faulty at the time of purchase. It can happen however, that a component may be damaged by mis-handling — some components are quite 'fragile'. Always take particular care with CMOS ICs, which can be easily destroyed by static discharge. Never touch the pins, and always solder the supply pins to connect the protection before moving onto the input/output connections.

Begin At The Beginning

OK, you've taken all the right precautions, worked carefully and finally

completed the project. Now the magic moment — power on! WAIT! There's something you should do first; check everything once more. Many faults can actually be detected before you switch on, and that's the best time to find them. A smoking resistor may precisely pin-point a fault — but it could also destroy many valuable components in the process. Far better to check first.

- Look at the components; are they all in the right places, according to the component overlay diagram? Are all the polarised components inserted the right way round?

- Look underneath the PCB or Veroboard, on the copper side; check carefully for solder bridges or stray bits of wire, component leads not trimmed etc. Particularly check around the power supply connections; if something is going to 'blow', it will probably be caused by an incorrect connection to the power rails. Solder bridges can be very fine and difficult to detect, so if your project is using expensive components, the time spent going over the board (with

a jeweller's eyeglass, if possible) is time well spent.

● Finally, check for dry joints. All soldering connections should be clean and bright. A dull, mottled joint is probably a dud, though they aren't always that obvious.

Once these pre-switch-on observations have been completed, it's time to apply the volts. But remember, those first few seconds, just after you hit the switch, can tell you a lot about the nature of a fault. For example, if the project is an amplifier, say, you might get a high pitched whine for a very few seconds, after which the project just lies there like a stale loaf in a baker's shop... or it may be some other strange, unexpected results. The point is that those first few moments just may be the only clue you have!

Crash, Bang, Wallop

There, you've done it, now. Switched on the power, only to find... well, something other than what you expected. But wait a minute. What did you expect? Very few circuits will actually do anything, at first, since there are usually a series of adjustments, setting-up operations and so on to be completed before a project will 'work'. Never mind... just for the moment, you are simply looking to see that nothing disastrous is happening. If it's a common or garden variety mutant-blaster (originally from the planet Zorg), then why is R23 glowing red hot?

If R23 is glowing, then switch off immediately. It takes only fractions of a second to 'cook' an expensive component so, at the first sign of a serious fault, the sooner you switch off the better.

At this stage you should be using your eyes, ears and nose (an overheated resistor has a very distinctive smell which you will probably come to recognise!) but not your fingers, please. It's a good idea to take notes, too, because it's all too easy to forget something which may provide the vital clue to the location of the fault.

What happens next depends on the results after power-on. If the project immediately began to smoke, then something is obviously very wrong. On the other hand, perhaps it just lays there, harmlessly. A third possibility is that everything looks alright but, after performing all the adjustments and so on, it still lies there, uselessly.

The Golden Rules

Assuming, for the moment, that something is drastically wrong, it's time to follow the First Rule of Fault-Finding, which is this: "Look For The Simplest Faults First". If the circuit was overheating, check the board again, looking for incorrect resistor values, short circuits, incorrect supply connections etc. Here's where those first observations will pay off; if R23 was smoking then it's safe to assume that the fault lies in that area of the circuit.

Check the supply voltages; it's surprising how often a 'brand new battery' will turn out to be an old, overused one that should have been thrown out but somehow got mixed up with a new one! If the circuit is mains-powered, disconnect the DC supply to the circuit and check the off-load voltage. If the positive supply is fused, have you remembered to put a fuse in? (don't laugh, it could happen to you!).

After checking and re-checking all the obvious things, without finding a clue to the fault, it is time to consider the Second Law: "When In Doubt, Read The Manual" (or the Circuit Description/How It Works or whatever). Read all about it and try to understand, firstly, the result you should be getting and secondly, the result you are getting. You should assume, at this stage, that the fault is caused by an error on your part. Yes, of course you're perfect (aren't we all?) but it is nevertheless true that 99% of faults are caused by an error in construction, so don't immediately write off to the editor, or complain to the component supplier.

Even if you suspect that your problem is caused by that stray 1%, don't just give up. Study the circuit closely, comparing it with the component overlay and all the other information printed in the magazine. Errors in published projects are usually very obvious, once you know where and how to look. With stripboard construction, for example, a common

problem is the omission of one or two track breaks — cuts in the copper strips — so if you suspect this, check the component layout against the circuit, making sure that there are no components connected on the board which are not connected in the circuit. Ask yourself, for example, should the collector of that transistor really be connected to the 0V rail? This procedure will often produce results with projects on PCB, too.

Look for circuit blocks which are repeated, eg, op-amp units, and try to 'spot the difference'. The more work you can put in at this stage, the sooner your project will be alive and well — and the more you will learn about electronics, too. Also, a single dead component is a lot easier to replace than an entire circuit board!

Blocks And Chains

Now, we're just about out of rules. The remaining one is best expressed as "Divide And Conquer". It works like this.

Most circuits consist of a number of circuit elements — amplifiers, oscillators, filters and so on — linked in chains, or connected together in some other, more complicated fashion.

The block diagram, Figure 1, shows an example of circuit elements.

The principle of the last rule is simply to isolate sections of the circuit until the fault has been pinned down to a single block. The exact method used depends on the type of circuit; with straight-chain circuits, such as an audio amplifier or an AM radio receiver, the recommended approach is to start in the middle. If the circuit is working correctly at that point proceed towards the output end, until you locate the stage where the signal is lost. If there is no signal present at the mid-point, then the fault obviously (well, probably) lies towards the 'input' end of the chain, so work back in that direction.

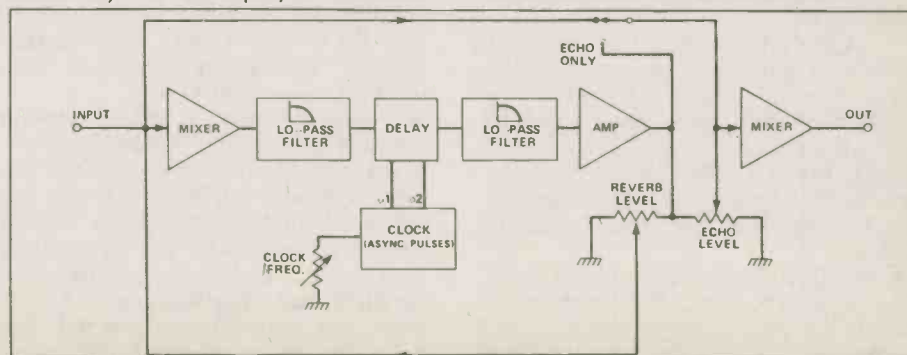

Fig. 1 Block diagram of an echo-reverb line showing a chain of circuit elements.

Fault Finding

Above all, fault-finding at this level requires a calm, logical common-sense approach. If you know how the circuit works and what it is supposed to be doing, you stand a good chance of being able to figure out the block in which the fault lies. The diagrams of Figures 2 and 3 show the block diagram of a typical, small transistor radio, together with a section of a fault-finding chart. The chart illustrates the advantages of a logical approach; simply by asking the right questions, the correct answer becomes obvious and the location of the fault can be found.

What Next?

Once you've decided in which block the fault lies, look at the circuitry of the block itself and once again apply the Golden Rules. Carefully check the PCB area and each component for physical defects. You know the fault is there, somewhere — it's just a matter of finding it! Perhaps the body of a resistor is cracked, or one of the IC's pins has been bent underneath. Try tapping components very lightly with the insulated end of a small screwdriver; this trick will often turn up a bad solder joint or duff component. If overheating seems to be the problem use an aerosol freezing spray to cool down the suspect component; if the fault suddenly vanishes, you've at least isolated the component. Now you only have to find out why it's overheating! These two 'tricks of the trade' are the most effective methods for locating intermittent faults — those which come and go!

Tools of the Trade

Fault finding without instruments is impossible. If you've come this far without even a multimeter then you're some undiscovered genius who should be writing this, rather than reading it!

A multimeter is simply the most common and most useful tool of the electronics trade. Already, a multimeter will have been used to isolate the fault to a particular circuit block, but it's when you're locating the faulty component that a meter is really essential for the following tests:

- Measure the supply voltages on all ICs; be sure to use probes with sharp points for this, to avoid bridging two adjacent pins. You should know the voltages (or range of voltages —

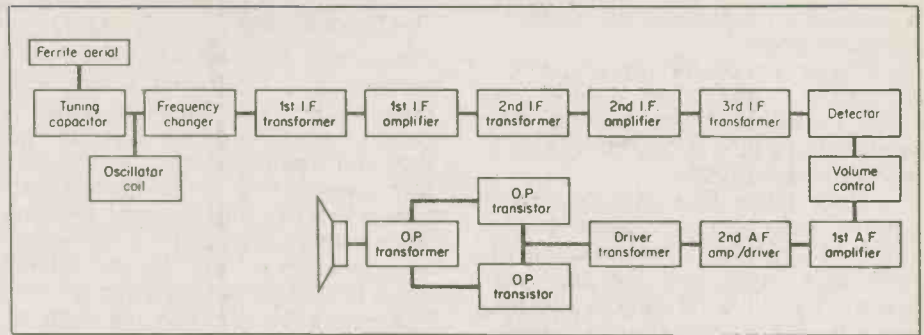

Fig. 2 A typical small transistor radio.

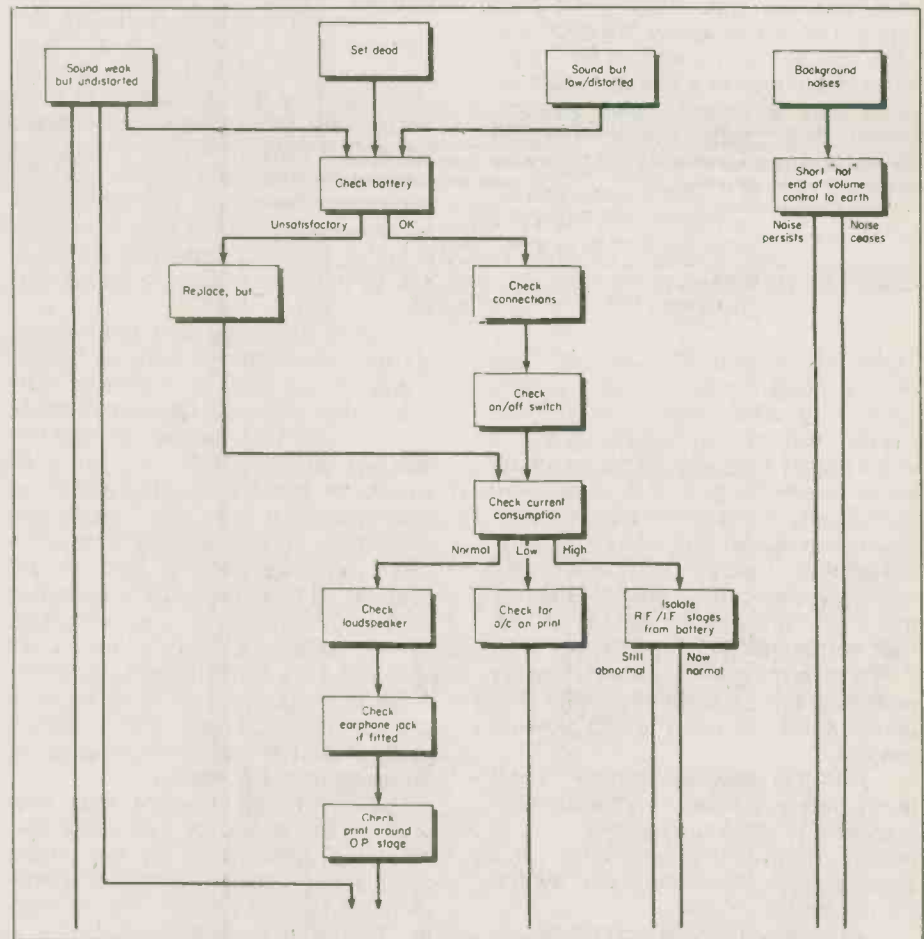

Fig. 3 Flow-chart for fault-finding on a transistor radio of the type illustrated in Figure 2.

they're rarely exactly as marked on the circuit) to expect, and where to find them. If you find an incorrect reading, track along the copper, looking for breaks, shorts etc.

- Measure the voltages around suspect transistors; although the actual readings will depend on the circuit configuration, in general the collector of an NPN transistor that is normally conducting will be positive with respect to the emitter (negative for PNP), but the voltage will be somewhat less than the positive rail. The base should be at least 0V6 more positive than the emitter (0V6

negative, for PNP). If the transistor is normally cut off, the base voltage will be less than 0V6 above the emitter, or even negative (for NPN), while the collector will be at the positive supply voltage, give or take a volt or so.

- Measuring in-circuit resistance, eg, when checking for a high resistance dry joint, it can be quite frustrating because the components in the circuit will obviously affect the reading; the only certain way to measure resistance in-circuit is to isolate, by lifting components or (in extreme cases only) cutting the circuit tracks. These measures may also

Continued on page 76

A world free from early heart attack
and stroke

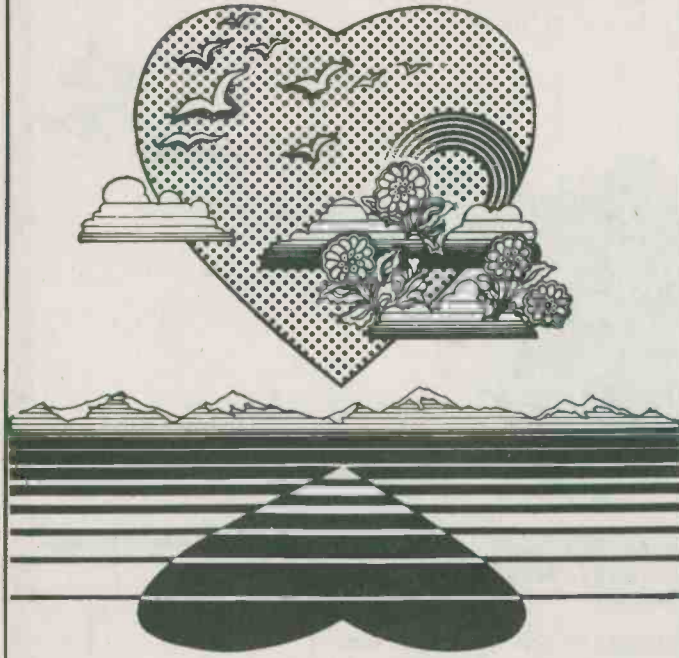

That's what we're all about.

Ask your Heart Association  Give Heart Fund

**For the man who has
everything else...**



ETI Binders keep your issues in perfect shape. \$8.00 inc postage (Ontario residents add 7% PST). Send to: ETI Binders, Unit 6, 25 Overlea Blvd, Toronto, Ont. M4H 1B1.

ETI, always crammed with features, has brought to you in the past:

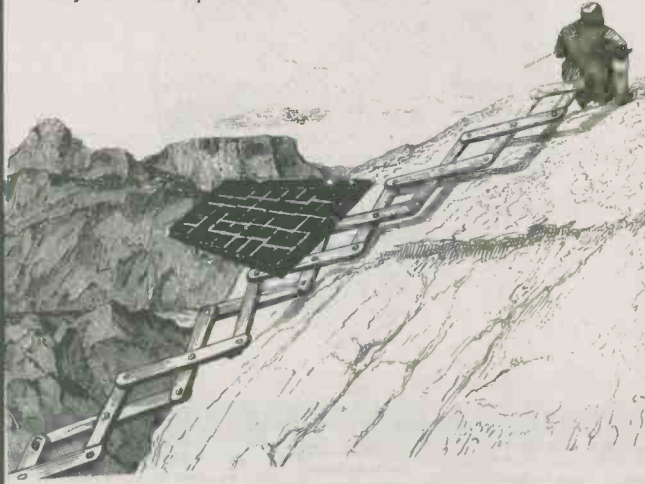

PROJECTS, such as the Solar Powered Mountain Climber Rescuer.

BIOGRAPHIES, such as Electronics Pioneer Rufus Jones, who invented insulation.

COMPUTER REVIEWS, such as this latest 32 bit offering from Silicon Valley.

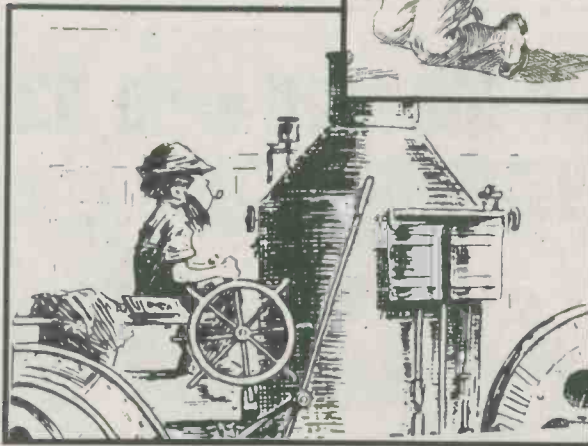

and whole bunches more, all of which is available to you by sending only \$18.95 for one year, or \$33.95 for two years, to:

ETI Subscriptions
25 Overlea Blvd., Unit 6
Toronto, Ont. M4H 1B1

and your monthly copies will be arriving through the latest technology of Canada Post.



Into Digital Electronics Part 8

This month, Ian Sinclair turns the LS76 into various counting circuits, and introduces the shift register, a basic circuit for dividing and storing.

THE FOUR stage binary counter goes through its count from binary 0000 to binary 1111 (decimal 15) before going back to 0000 again. Suppose we wanted to count to nine and then reset back to zero? Nine in binary is 1001 (eight plus one), so we need four binary digits (or bits) to count to nine. Four bits means four flip-flops, so we can't economise in flip-flops just by counting to a smaller number. In addition, because a four-stage counter, left to itself, will count up to 1111, we need some method of stopping the action when the count gets too high.

Figure 1 shows how this can be done. The Q outputs of flip-flops are used to operate a gate, in this case a NAND gate whose output is connected to the reset line. The two Q outputs which are used are Q_3 and Q_2 , so that the NAND gate is activated when the outputs are $Q_3=1$, $Q_2=0$, $Q_1=0$, $Q_0=0$. This is 1010 in binary, which is decimal ten.

What happens? Well, the counter works quite normally, starting from 0000 and counting up to 1001 (decimal nine). At no point in the count do we ever have Q_3 and Q_2 both at 1, so the NAND gate always has 1 at its output. That in turn keeps the RESET inputs high, so there is no reset. At the instant when the Q_3 and Q_2 outputs go high together, though, the output of the NAND gate goes low, and operates the reset. This makes all the outputs zero, and the gate output goes high again, letting the count continue again from 0000. This is a method which is used in some simple counters, but it has two disadvantages:

- 1) if you have a latching circuit at the counter outputs, the value 1010 (decimal 10) will be latched in, even though it existed for only a fraction of a microsecond
- 2) using the reset input for this purpose makes it more difficult to use it for manual (switch) resetting — you

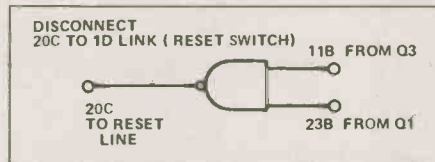

Fig. 1 Automatic resetting on a count of ten. This lets us use binary counters for counting denary scale (BCD, which is binary coded decimal).

have to use a NOR gate or a NAND gate, as shown in Fig. 2

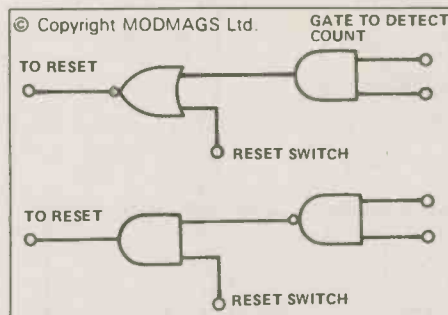

Fig. 2 Alternative resetting systems which permit both automatic (at the count of ten) and manual resetting.

A four-bit binary set of outputs which goes only to 1001 (nine) before resetting is called a BCD count — the letters mean binary-coded decimal. BCD counters are used whenever a decimal number has to be displayed — which means practically every counter which uses a display. Later on we'll look at how these BCD counts are converted and displayed as decimal numbers.

Meantime, we have a four-stage

counter on the board, and there are still a lot of things we can do with four J — K flip-flops. Figure 3 shows just one of them. We've removed the BCD gate wiring, so that the counter is back to a normal four-stage counter again, but there's another alternative to each flip-flop except the first (F/F0). This time, instead of connecting Q_0 to Ck1, Q_1 to Ck2, Q_2 to Ck3, we've used the Q outputs to connect to the clock input. The LEDs are still connected to the Q outputs, but the clock inputs for F/F1, F/F2 and F/F3 are connected to the Q outputs of the previous flip-flops. What does this do? Try it!

Set switch 3 low and 4 high. This sets each flip-flop, so that the LEDs should read 1111. Make sure SW1 is down, so that the flip-flops are not being clocked, and slide SW3 high, isolating the R — S inputs. Now watch the LEDs very carefully, and flick SW1 up to start counting. What happens? Right — it's counting backwards, starting at 1111 and going to 1110, 1101 and so on up to 0000. After 0000, the next step is back to 1111 again, just the reverse of the four-stage counter.

Very interesting, but what's the advantage? There's one peculiar advantage of down-counting compared with up-counting — the end of the count is always 0000. We could arrange to gate the input to the counter so that the counter always stopped at 0000. It's easy enough, a four-input OR gate will do the trick and we don't need to try it out. We can now use this as a counter for any number up to 15! How? Just by using switches to set

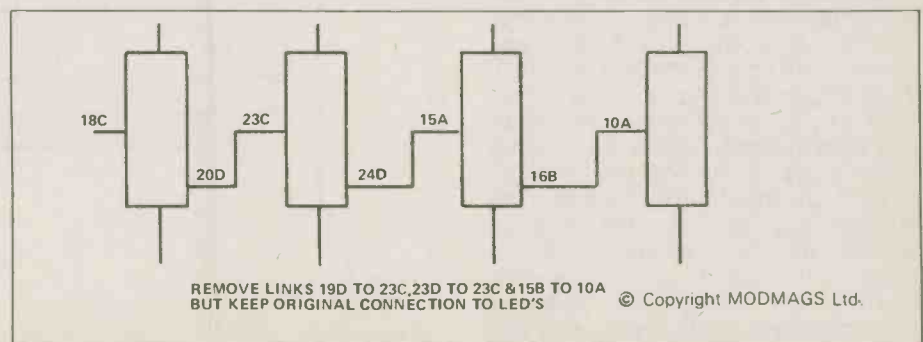

Fig. 3 Modifications to the flip-flop connections so that it can act as a down-counter.

Into Digital

each flip-flop. Take a look at the circuit in Fig. 4 which is not intended for construction, because we're not using any 4-input gates. The switches 1 to 4 control each input separately, and can be set so that any binary number from 0001 to 1111 can be 'loaded-in' to the flip-flops. Switch SW5 (another reason for not trying it out!) then acts as a load/run switch — in the load position, it allows switches 1 to 4 to set the flip-flops. In the run position it releases the R and S lines so that the counter can operate. The counter will now count down starting at whatever value it was set to and ending at 0000, when the gate switches the input pulses off. It's very useful if you want to count a different number every now and again. If you used an up-counter, you would have to redesign the gating system each time you wanted to change the count number, which is a lot less convenient.

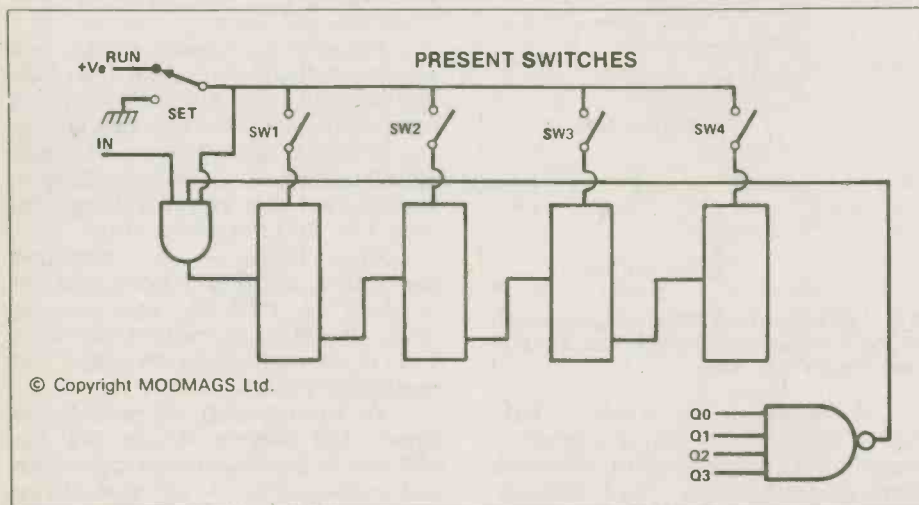

Fig. 4 How a down-counter can be preset.

Counting ripples

Up and down counters, incidentally, are called ripple counters. The reason for the name is that a change 'ripples' through all the counter stages. For example, when a ripple counter has reached a count of 0111, the next pulse in will change the last digit to 0. This in turn will send a pulse to the next 1 to zero. The same happens at the third flip-flop, and a pulse from that one makes the final change from 0 to 1 at the fourth flip-flop. The change has 'rippled' from one to another, and there will be a small but significant delay between one step and the next. This causes trouble in high-speed counters when gates are used to detect numbers, because by the time the last digit has changed, the first might have counted-on

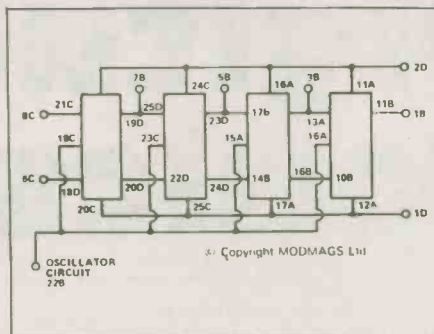

Fig. 5 Action of a shift-register.

several digits more! This is overcome by using synchronous counters, which apply the same input pulse to all the clock inputs, and use the J and K inputs to control the action. We're only going to look at the simpler types of synchronous counters here, because the more complicated types are available in IC form anyway.

Shift 'em

To start with, take a look at the circuit in Fig. 5. It uses four stages of J — K flip-flops with switches 1 and 2 feeding the J — K inputs of F/FA and switches 3 and 4 used for setting/resetting just as before. The new step is that each Q output is connected to the next J input, and each Q output is connected to the next K input. This is a circuit called a shift register, and the LEDs on each of the Q output will show us what happens in the circuit. Start by resetting (SW3 and 4 both down). Set SW1 high (J = 1) and SW2 low (K = 0). Now watch your LEDs, and set SW3 up so as to release the flip-flops. Whenever LED1 lights, put SW1 low (J = 0) and keep watching as the clock ticks on. Interesting? OK, try again, but this time keep SW1 set high after you release the flip-flops by setting SW3 high. Just for an encore, you can try the effect of starting from scratch with J = 1 and K = 1.

What's happening is the action called right shift. At each clock pulse, a bit at the Q output of a flip-flop is 'shifted' to the Q output of the next flip-flop to the right. It's not really shifted, what is happening is that the bit at the Q output sets up the J input of the next flip-flop so as to cause that flip-flop to go to the same output on the next clock pulse. For example, imagine F/FA with Q = 1, Q = 0. That sets up the J and K inputs of F/FB, with JB = 1, KB = 0. When the next clock pulse comes along, JA = 1, KB = 0 will cause QB to go to logic 1, the same bit as was on QA. Now think of the other possible action. If QA = 0, then QA = 1 and JB = 0, KB = 1. With

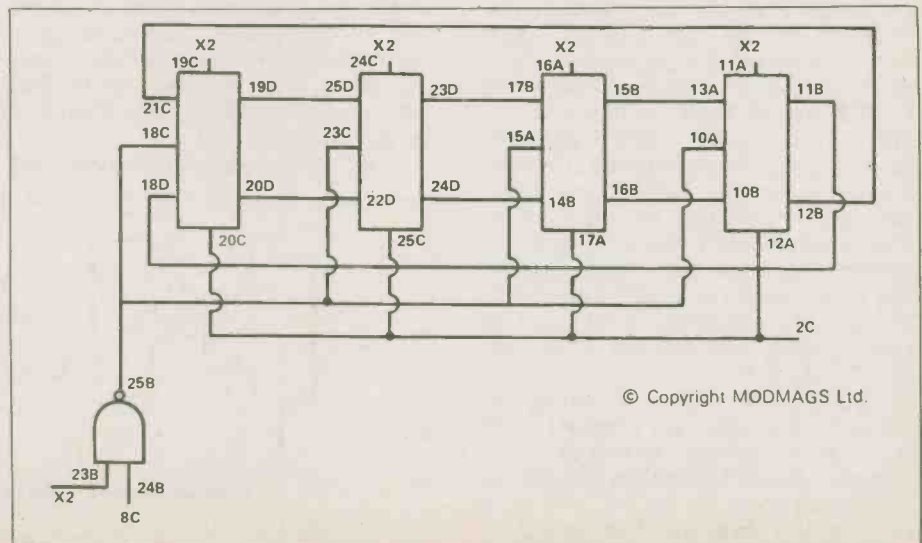

Fig. 6 Simple ring-counter circuit.

these voltages on the J, K inputs, QB will go to logic 0 at the next clock pulse.

What happens at the input depends on how the J and K inputs of F/F1 were set, and the exercises we tried used different types of inputs. For example, with $J_A = 1$, $K_A = 1$, the first flip-flop will toggle, and this will cause a pattern of 1s and 0s to shift through all the other stages. This is a nice way of creating a chain of changing lights, incidentally.

Reversing the direction of the shift isn't quite so easy, because we have to connect the Q output of each flip-flop to the J input of the previous flip-flop and the Q output of each flip-flop to the K input of the previous flip-flop. A few IC shift registers (notably the 74194) will shift in either direction, making use of the voltage on a 'SHIFT' pin to control the shift direction. These ICs use gating, with each Q output taken to a gate system which will connect it either to the next flip-flop or to the previous one.

Now the straightforward shift register in Fig. 5 is quite useful, but we can generate even more interesting effects by connecting the outputs of such a register back to the inputs. Connect up the circuit which is shown in Fig. 6. This one uses SW1 to gate the clock pulses into the register, and SW2 to set the output of F/FA. Switch SW3 is used to reset all the flip-flops in the register. The clock generator and gate are the same circuit as we've used before. Start with SW1 down, so that clock pulses are gated out. Put SW2 up, and SW3 down. This resets flip-flops B, C, and D, and putting SW2 down will now set F/FA. Now put switches SW2 and 3 up to isolate the set and reset lines. Note, incidentally, that we have not connected the set terminal of flip-flops B, C, or D.

The register should now show a 1 at QA and 0 at all the other outputs. Start the clock pulses by switching

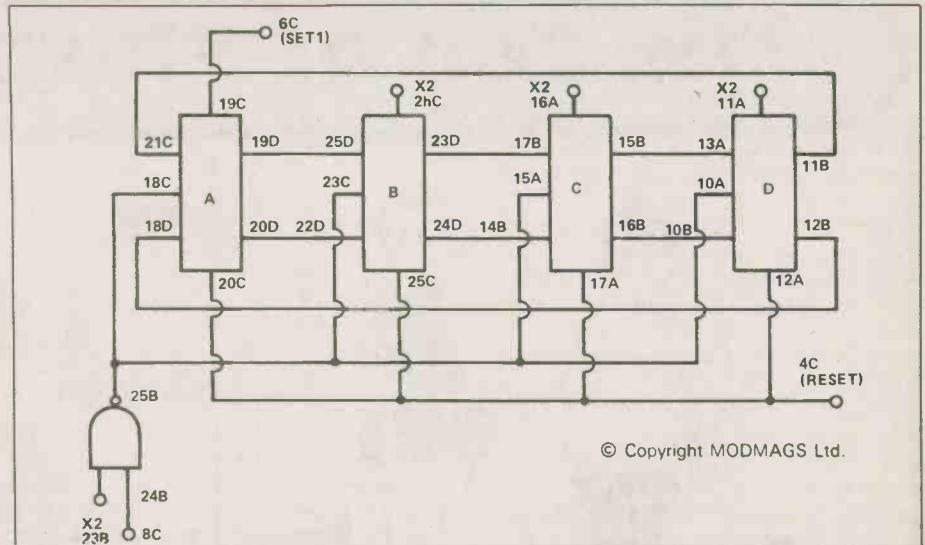

Fig. 7 'Twisted ring' or Johnson counter circuit.

SW1 up, and watch what happens to the LEDs. A circuit like this is called a ring counter because the connections between flip-flops form a complete ring. A 1 at any output will be shifted to the next flip-flop at each clock pulse. There's even a special name for this operation: it's called a right rotation, and it's one of the actions which every microprocessor must carry out.

A ring counter is very useful if you want to display counted numbers simply. For example, if the LEDs are labelled 1, 2, 3, 4 . . . and so on, then the number of pulses which have been inputted will be shown by the number on the LED which is lit. This is a very simple way of making a decimal number counter without having to use a seven-segment display. If you need a large display, then each Q output can drive an emitter-follower which in turn drives a power transistor connected in a lamp driver circuit. If you're a really determined lamp flasher, you could even use thyristors or triacs — but make sure that the high-voltage circuits are completely isolated from the low-voltages of the digital circuits.

There's a rather nifty variation on the ring counter in Fig. 6 which is shown in Fig. 7. This is a 'twisted-ring' counter, and the main change is that the connections between QD, QD, KA and JA have been crossed over. Try this one out, starting with all the flip-flops reset, and fill in the state table for each pulse. You can use SW1 to stop and start the clock pulses, and SW4 to reset the circuit — SW2 and SW3 are not used this time.

A simple ring counter will count to a number equal to the number of flip-flops — in our example, four. A twisted-ring counter will count to a greater number, equal to twice the number of flip-flops (eight in our example), but the outputs have to be decoded — you can't just use one LED to represent one digit. The twisted-ring counter is sometimes known as the Johnson counter. Next month, we take a more extended look at the versatile shift register.

Corrections to Parts List

(ETI Oct. 82 page 70) The D-type flip-flop shown in the list in this first part of the series should be 74LS74, not 74LS75 as shown.

Also a 1u0, 10V capacitor should be added to the list.

ETI

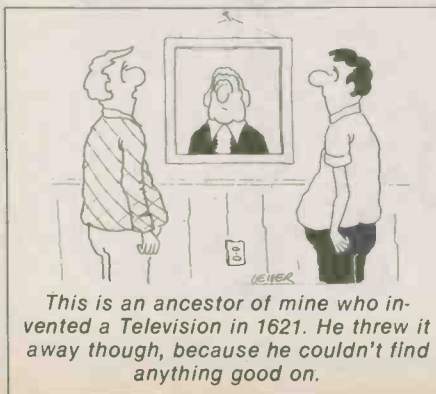

The Fun of Electronics



Gee Herb, you're the only guy I know who'd buy an AC adapter for a walkman.

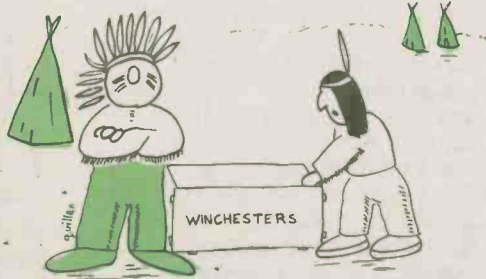

These are not rifles chief, they're disc drives.



No, no. I want a half-watt resistor, not a half-wit resistor.

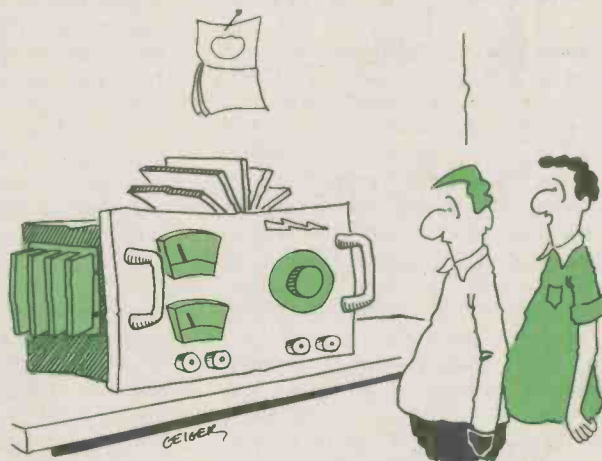

My new power supply. Hard to believe it only delivers 5 volts @ 3 millamps.



The Pay-TV companies have developed a very sophisticated scrambling system — the picture comes in clearly, but the playboy bunnies appear fully clothed.



"Gee ... It's just like the commercial says! The tape will break glass!"

CLASSIFIED ADVERTISING

ETI's classified advertising section allows you to reach about 30,000 Canadian readers nation-wide for \$1.00 per word. For as little as \$20 per insertion (there's a 20 word minimum) you can promote your business from coast-to-coast.

WHAT DO YOU DO?

Send us your typewritten or clearly printed words, your permanent address and telephone number and your money (no cash please). Make your

cheque or money order payable to 'ETI Magazine'. We're at Unit 6, 25 Overlea Blvd., Toronto, Ontario, M4H 1B1.

WHAT DO WE DO?

We typeset your words (and put the first word and your company name in BOLD capital letters). If we get your message by the 14th of the month, it will appear in ETI 1½ months later. For example if we receive it by October 14th you (and thousands more) will see it in the December issue.

BINDECHEX - 16 bit slide converter for computer math. \$3/assembly \$5/deluxe model \$15. - Load level "peak" meter for Sinclair/Timex computers \$15. **ROIS R. HARDER**, 995 Shakespeare Ave., North Vancouver, B.C. V7K 1E7. (604) 980-4167.

FREE LIST. 2716 - \$4.00, 2532 - \$5.00, 2764 - \$10.00, 4116 (200 NS) \$1.00, (150 NS) \$1.50, 2114 - \$1.50. **M.O. ENTERPRISES**, P.O. Box 2066E, Bramalea, Ontario. L6T 3S3.

ATARI® memory boards. Lifetime guarantee. Gold-plated contacts. 32K: Board only - \$29.95, kit - \$99.95, assembled - \$104.95; 16K: Board only - \$24.95, kit - \$54.95, assembled - \$64.95. 48K: Board only \$39.95, kit - \$139.95, assembled - \$149.95. Send cheque or money order to: **BONTEK**, 37 Dunsany Cres., Weston, Ont. M9R 3W7. Dealer inquiries invited. Add \$2.00 shipping (insured), Ontario residents add 7% sales tax. Phone (416) 245-9758.

APPLE II™ compatible motherboards - wave-soldered, completely assembled including all devices and connectors \$275.00 plus \$5.00 shipping. Ontario residents add 7% P.S.T. Peripheral boards available. 32¢ stamp brings further info. **K.S.K. ASSOCIATES**, P.O. Box 266, Milton, Ontario L9T 4N9.

HYDROGEN GAS GENERATOR plans and starter kit, \$12. **PRAIRIE POWER RESEARCH AND DEVELOPMENT**, P.O. Box 8291, Edmonton, Alberta. T6H 0L0.

CORONET ELECTRONICS, 649A Notre Dame W., Montreal, Que. H3C 1H8, Catalogue IC's, Semi's, Parts, send \$1.00 to cover postage. Monthly specials at crazy prices.

ROBOTICS Stepping Motor controller suitable for use with personal computers (requires T.T.L. pulses), instructions included \$49.95; P.S.T. extra. **MARTONIX**, 602-3311 Bathurst St., Toronto, Ontario M6A 2B5.

OSCILLOSCOPE - Dual trace, 15 MHz, solid state, triggered. Model WO-555 from VIZ. Hardly used, like new. \$900.00. **CALL (416) 745-5035** (Weston).

ALARMS. Commercial security equipment used by professional installers now available to you. Best quality only at low prices. Ask catalog #25. **POLYGRAFF**, P.O. Box 276, Sherbrooke, Que. J1H 5J1.

1000 liters of hydrogen for \$1! Make with ordinary household supplies! \$9.95 **NATIONAL ENERGY**, Dept. VG34 R.R. #1, Brooklin, Ont. L0B 1C0.

CONTRACT Bridge software for popular home computers. (Timex, Sinclair, Commodore, Texas, Shack). Details free. **ALLAN MICROCOMPUTING**, Box 313, Azilda, Ont. P0M 1B0.

APPLE™ compatible disk drives. Our tested, plug-in board, converts your Shugart SA400L with no modifications to drive. Including cable \$69.95. Assembled drive with case \$369.95. Now available: Serial cards with manual \$145.00. Send cheque or money order, Ontario tax 7%. 120 day warranty. Drive shipped freight collect. **OCTAL ROBOT SYSTEMS**, 29 Edgemount Drive, Brampton, Ontario, L6V 1K9, (416) 922-0169.

APPLE™ fully compatible computer boards. Mother board — \$60.00. Peripheral boards — Z80, 80 column, disk controller, 16K — \$20.00 each. All boards of high quality glass — solder — masked, silk-screened. Parts kits also available to allow you to build a fully Apple compatible and supported computer at a fraction of the original's price. Special prices for quantity and school buyers. Listed prices include shipping. B.C. residents add 6% P.S.T. Stamp brings further details. **K-K ENTERPRISES**, P.O. Box 65368, Station F, Vancouver, B.C. V5N 5P3.

WANTED: Used LCR IMPEDENCE BRIDGE or INDUCTANCE METER, specify manufacturer, model, range(s) of instrument, price. Write: **IMPEDENCE BRIDGE**, 1265 Sixth Line, Apt. 704, Oakville, Ontario. L6H 1X2. 416-842-0469, 682-3966.

ATARI COLECOVISION and **INTELLIVISION** Start your own repair business. Send \$5.00 for information to **SILVER GLO ELECTRONICS LTD.**, 12418-66 St., Edmonton, Alberta T5B 1K4.

TEST-EQUIPMENT. High quality reconditioned Tektronix, HP, etc. Warranty. Calibrated to original specifications. Free illustrated catalogue. **ALDONICS**, Box 2980, Ottawa "D", K1P 5W9.

RAECOM ELECTRONICS, 262 Evans St., Duncan, B.C., V9L 1P8., surplus!, parts, tx. tubes, power supplies, transistors, test equipment, ham gear. Send S.A.S.E. and \$1.00 for our new flyer.

HIGH QUALITY Printed Circuit Boards available for all E.T.I. projects since 1977. Only 30¢ per square inch plus postage. Enclose this advertisement for 10% OFF. Custom P.C.B.'s available from your schematic or artwork. Write to: **WENTWORTH ELECTRONICS**, Dept D-3, R.R. #1, Waterdown, Ontario, L0R 2H0.

ZX81 Motherboard. Accepts two Vector or Radio Shack type multi-purpose plugboards, plus all Sinclair accessories. Build your own hardware. Assembled circuit board and connectors \$29.95 also ZX81 Video Amp, drives composite type monitors. \$9.95 **JDC**, 5-14 Sentinel Rd., Downsview, Ont. M3M 2Y5.

J&J ELECTRONICS Ltd., P.O. Box 1437E, Winnipeg, Manitoba R3C 2Z4. Surplus and Semiconductor Specialists. Do you get our bargain flyer? Send \$1.00 to receive the current literature and specials and to be placed on the mailing list for future publications.

PROJECT BOARDS. Apple, TRS80 Color, ZX-81 and VIC20 - \$16.00. Four slot mother board for the ZX-81 \$60.00. Top quality with gold contacts. Send check or M.O., add 7% P.S.T. **IAE**, Box 743, Kitchener, N2G 4B6.

AIM 65, used, with card cage mother video and prototype boards. \$400. Call **NORMAND** (416) 667-4795, 665-9420.

WSI RADIO — SWL Radios — Ham radios 18 Sheldon Avenue North, Kitchener, Ontario N2H 3M2. Tel. (519) 579-0536. Write for 1983 catalogue, \$2.00 (VE3EHC).

DIGITAL project mini-book for multi-purpose voltmeter and drilled, etched P.C. board, U.S. \$8.50 pp. Canadian International Postal moneyorder, please. Kits and other projects available. **DIGITAL WORLD**, P.O. Box 5508, Augusta, GA 30906 USA.

OSCILLOSCOPE, Tektronix 455, 50 MHz, dual-channel with delayed sweep; two x10 3-metre probes. Excellent condition. Asking \$1,800. **BILL**, 823-4540.

FREE, 1983 **HOBBILT** Component Catalogue and Spring Sale Flyer! Super prices on quality IC's, Semiconductors, Testers and much more! Student discounts! Just send your name and address to **HOBBILT ELECTRONICS**, 7303A Dumesnil, St. Leonard, Que. H1S 3A7.

COMMODORE 64 owners. We offer a fine selection of programs. Send for free catalogue. **SANDISON SOFTWARE**, Box 1403, Chatham, Ontario, N7M 5W8.

REPAIR 6502 boards, \$38.00 plus parts. Also service other home/business computers, peripherals. Low prices on ribbons, paper. Memorex 5¼" diskettes from \$30.95. Cassette tapes, C-10 \$9.50/10, C-20 \$11.95/10, boxes \$2.95/10. Min order \$10.00, Postage and PST extra. **MICROCOMPUTER TECHNICAL SERVICES**, Box 381, Station J, Toronto, Ontario (416) 463-9045.

SINCLAIR ZX81 Newsletter: software, listings, hardware and more. Send \$1.00 M.O. for sample to: **ZX-PROGRAMMING**, Dept., 23605, 28 Reims Street, Touraine, Quebec J8T 1J8.

DESIGN and manufacturing PCB's. PROMS programmed. Custom industrial controllers designed. **PERPETUAL MOTIONS ENTERPRISES**, 2643 Kennedy Road, Agincourt, Ontario M1T 3H5. (416) 293-4864.

ZX81 peripherals. 16K nude RAM board \$54.95. Programmable sound board \$54.95. Motherboard with power supply, 2 connectors, room for more \$89.95. Multichannel output-board with relays \$59.95. Cheque or money order. Free brochure. **RX MICRO-ENGINEERING**, Box 2277, 100 Mile House, B.C. V0K 2E0.

VERBATIM, 5¼", SSDD, Plastic case \$44; DSDD: \$54. Ribbons, Epson M80: \$16; Verbatim head cleaning kit: \$16, IBM keyboard extension cable: \$26. Ontario +7%. **COM-PACC**, 620 Auburn Cr., Burlington, Ont. L7L 5B2.

APPLE™ & 6502 computer compatible hardware & peripheral equipment - disk drives, modulators, boards, keyboards, power supplies, professional housings with remote keyboard, monitors, temperature control attachments . . . Ready to go systems from \$599.50 - Mil Speck 6502 motherboard \$39.95 -complete **SUPER-SHUGART PACKAGE** SA400L disk drive with controller \$449.50, for a limited time **ONLY \$399.50. BUY DIRECT** at **FACTORY PRICES** -write **DACOR LIMITED, COMPUTER DIVISION, P.O. Box 683, Station Q, Toronto, Canada, M4T 2N5.**

UNBELIEVABLE Buys on Prime LED's, IC's, Semi's, Resistors, Capacitors, Switches Surplus Equipment and S-100 Boards. Send stamp for latest flyer. **ELECTRONICS**, Box 68, Whitecourt, Alberta, T0E 2L0.



AP II 6502 PROJECT

- * **ABS LOOK-A-LIKE CASE** \$99.95
 - * **GOLD SWITCHING POWER SUPPLY** \$115.00
(+ 5V - 5 AMPS, + 12V - 2.5 AMPS, - 5V - ½ AMP, - 12V - ½ AMP.)
 - * **BEAUTIFUL MATCHING ASCII KEYBOARD** \$109.95
 - * **6502 PROJECT BOARD** \$59.95
 - * **DISC DRIVE, SLIMLINE w/CONTROLLER CARD** special \$399.95
- SPECIAL PACKAGE OFFER:**
Includes Keyboard, Power Supply, Case and Motherboard \$349.95

- * **ALL SMALL PARTS**, IC's Capacitors, Crystal, Trim Caps, Resistors, Sockets, Choke, etc. **LOW PRICES**
- * **Peripheral board kits**
Z80, Floppy Disc, 80 character, 16K expansion and more coming **LOW PRICES**
- * **In case your project has problems we have a repair service** **LOW PRICES**

Mall orders accepted, send certified cheque or M/O. Add 5% for shipping. Ontario residents add 7% P.S.T. Visa accepted; send card No. signature, expiry date and name of bank.



general electronics

5511 YONGE ST., WILLOWDALE, ONT., M2N 5S3 221-6174

SABTRONICS • HAMEG SCOPES
PARTS, KITS • SURPLUS



NEW EXPANDED STORE OPENING MAY 1st.

Write/telephone for new free catalogue.

Circle No. 5 on Reader Service Card.



1. a) Computer Keyboard (Apple compatible) Upper & lower case switch - Exclusive in Canada \$129.00
b) ASC II Keyboard grey or brown colour \$99.00
2. A.B.S. Case (Apple look-a-like) \$79.00
3. Color R.F. Modulator with switch & 10 ft. cable \$29.95
4. Joystick (high quality ribbon cable) \$34.95
5. Games Paddle \$39.95
6. GOLD Switching Power Supply (+ 5V, 5 AMP, + 12V, 2.5 AMPS, - 5V, ½ AMP, - 12V - ½ AMP). Heavyduty. \$115.00
Run 2 drives and lots of peripherals.

Upper and lower case switch

7. a) **MITAC DISK DRIVE** with interface card (much quieter than the Shugart Drives) 120 days warranty \$469.00

Extended 1 year warranty available

b) **SUPER 5 Slim Disk Drive** with controller card (made in Japan) \$499.00
6 month warranty

6502 PROJECT PARTS

- A. ALL TTL. LINEAR PARTS \$38.95
- B. RAM 24, 4116's \$42.00
- C. 6502 CPU \$7.00
- D. 6052A CPU \$7.80
- E. 2716's 7 pcs \$31.50
- F. TIN IC SOCKETS, 8,14,16, 20,24,40 \$14.00
- G. All Capacitors, Transistors, Crystal Trimcaps, Trimpot, R.C.A. Jack, Audio Jacks, Coil \$21.00
- H. Edge Connectors, set of 8 \$25.00
- I. 6502 Mother Board (Japan) \$57.00

SPECIALIST IN JAPANESE "IC" COMPONENTS

MEMORY SPECIAL

- 4164 15nS \$8.75
- 4116 250nS \$1.70
- 2114L 300nS \$1.69
- 2764 450nS \$9.50
- 2732 4Kx8 \$8.59
- 2716 450nS \$4.88

We have good stock of memory chips and TTL, CMOS, LINEAR and CPU.

PHONE FOR DETAILS

Service Centre and Retail Outlet, 4051 Sheppard Avenue East (at Kennedy), Agincourt, Ontario M1S 1S8 (416) 298-3280

Kitstronic

INTERNATIONAL LTD.

Box 577, Stn. J. Toronto, Ontario.
M4K 4Z2

Mall Orders: Send a certified cheque or money order plus \$4.00 for shipping and handling. For Special Delivery, please add \$1.00 extra. Ontario residents add 7% P.S.T. Visa & Mastercard accepted. **HOTLINE: (416) 292-8872**

Circle No. 8 on Reader Service Card.

Smith-Corona introduces the first printer with real character at the unreal price of \$1095.*



Now available with French capability.

The Smith-Corona Daisy Wheel Printer

Until now, if you wanted to include a reasonably-priced printer as part of your computer or word processing system, you had to use a dot matrix printer. Daisy wheel printers were just too expensive.

Not anymore. Now Smith-Corona* offers a daisy wheel printer at such an incredibly low price, you can't afford *not* to include it. That means that even the smallest installation or business can now have letter quality printing capabilities at every work station.

The Smith-Corona printer operates with micro-processor-controlled daisy wheel technology, and is available with industry standard serial or parallel data interfaces.

Best of all, it produces results identical to those of our very finest office typewriters – printing with real character. So it can be used to create letters or documents that have to look perfect. As well as financial statements, inventory reports, direct mail campaigns – anything that requires quality printing.

And it's easy to use – just turn on the power, load the paper and away it goes. (It works equally beautifully with letterhead bond or fanfold paper.) There are drop-in ribbon

cassettes and a choice of easy-to-change, snap-on daisy print wheels for a variety of fonts.

So why not get your hands on a real bargain: letter-perfect printing at an amazingly low price. Because, thanks to Smith-Corona, a printer with real character is no longer expensive.

Ask for it by name. **Smith-Corona**

DIVISION OF **SCM** (CANADA) LIMITED

*suggested retail price

Please send me more information on the Smith-Corona daisy wheel printer.
 Name _____
 Title _____
 Company Name _____
 Business Address _____
 City _____ Prov. _____ Postal Code _____
 Type of Business _____

Mail coupon or call:
 Education Director,
 Smith-Corona
 29 Gervais Drive, Don Mills, Ontario M3C 1Z1
 (416) 449-0164

ETI

Circle No. 27 on Reader Service Card.

TECH TIPS

Tamper-proof Burglar Alarm

Iain S. Campbell

Recently I have started to install a burglar alarm in my home and, while planning the installation, I realised that I would require some form of tamper-proof or 'self-activating' bell. In other words, I required the bell to ring if the wires leading to it were cut or short-circuited. I consequently designed the following circuit.

The circuit is a window comparator and works as follows. R4, R5 and R6 are voltage dividers with one-third of the supply voltage across each. R3 is chosen so that $R1 \gg R3 \gg \frac{1}{2}R1$, noting that $R1 = R2$ (in practice, for R3 I used the next lowest standard value from R1, R2). Both non-inverting inputs of the comparators are thus kept lower than their respective inverting inputs.

If R2 is open-circuited, ie the leads to it are cut, the non-inverting input of IC1 is pulled high, thus taking the output high. If R2 is short-circuited the voltage across the non-inverting input of IC2 and ground is between one-half supply voltage and just over one-third of the supply (depending on the value of R3), thus taking the output of IC2 high. The two outputs may now be ORed using any general purpose diodes and the output used to drive a suitable load, in my case a TIP122 Darlington transistor and a 1½ amp bell.

I would recommend other users to put a monostable between the diodes and the load as well as employing a battery back-up, although these were not necessary in my case. A five minute monostable should be sufficient to keep the neighbours happy if the alarm is activated or tampered with. When installing this circuit, R2 should be situated inside the burglar alarm control unit across the existing relay contacts or an opto-coupler. When the alarm is activated, R2 is shorted. Tampering with the interconnecting cable can be detected and the bell enclosure may be protected with the appropriate normally-open or normally-closed microswitches.

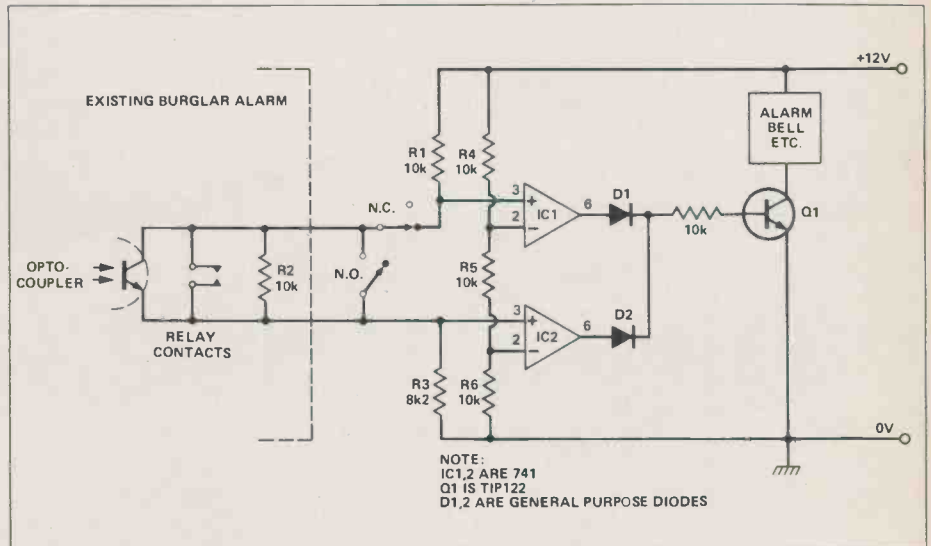

Low Resolution A-to-D Converter

Paul Hill

A simple, low-resolution analogue-to-digital converter (three-bit output) can be built using the LED bargraph driver IC, the LM3914. This ADC can be used in applications where more usual (and more expensive) eight-bit or

greater ADCs would give unnecessary accuracy.

The bargraph IC converts the input voltage into a low signal on one of the 10 outputs, depending on its amplitude. The diodes code the outputs to binary-coded decimal, IC2 providing the ADC with TTL outputs.

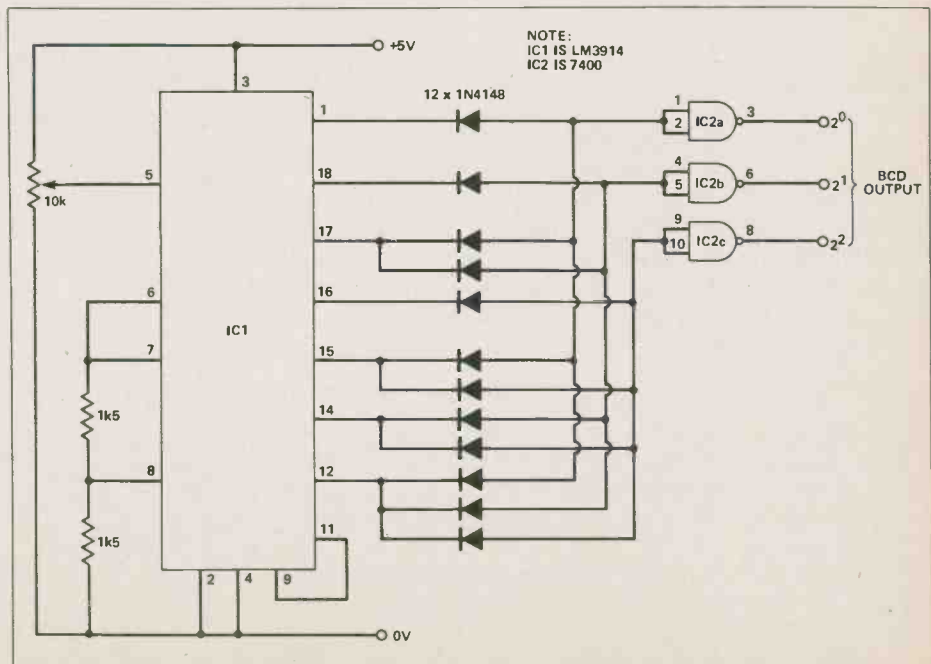

APPLE™ USERS!

- Fully software compatible with Apple™ software
- Half tracking capability (40/80 tracks)
- Auto DOS 3.2/3.3 select controller
- High quality mechanism (MTBF 8000 POH)
- Assembled and Serviced in Toronto.
- 90 day warranty
- Drive/controller package

Only **\$495.00**

LOOKING FOR A GOOD DRIVE SYSTEM FOR YOUR MICRO?

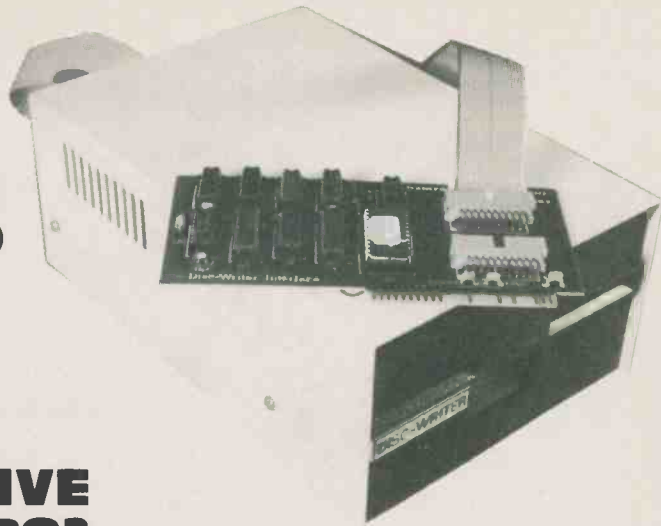

shamrock computer inc.

DEALER ENQUIRIES INVITED

TORONTO (416) 474-0113
OTTAWA (613) 828-1715

Circle No. 23 on Reader Service Card.

WHY SPEND A FORTUNE ON A DIGITAL CAPACITANCE METER?

As a matter of fact you don't have to pay \$250 to \$700 and up, anymore, for a Digital Capacitance Meter that is both dependable and rugged, with good accuracy.

The Model MC100 is manufactured by DAETRON and is sold directly to you, eliminating costly mark ups by the middle man and distributors.

Check these features:

- Portable (only 4 3/4" x 2 1/2" x 1 1/2")
- Extensive range - 50 pF to 9,999 uF
- Completely assembled (no kit to assemble)
- Basic accuracy 2% (± one count) on pF and nF ranges, 5% (± one count) on uF range
- Decimal points light up when battery is low or when capacitor is over range.
- Uses special circuitry to save on batteries (batteries not included)
- 90 Day parts and labour warranty

The meter is also well suited for the hobbyist, technician or engineer who wants to quickly sort and check out many different type capacitors, especially those that have lost their markings.



DAETRON

935 THE QUEENSWAY, BOX 641
TORONTO, ONTARIO M8Z 5Y9
(416) 499-7221

DEALER ENQUIRIES INVITED



\$89.95

PLEASE SEND ME

____ (QUANTITY) MC 100(s) @ \$89.95 \$ _____
ONTARIO RESIDENTS ADD 7% PST \$ _____
SHIPPING AND HANDLING @ \$1.00 per Instrument \$ _____

TOTAL \$ _____

I ENCLOSE CHEQUE MONEY ORDER BILL MY VISA
 VISA CARD NO _____ EXPIRY DATE _____

SIGNATURE _____

Immediate shipping on orders with Certified cheque, money order or Visa.
Personal cheques, please allow 2 to 3 weeks for clearance.

NAME _____

ADDRESS _____

CITY _____ PROV. _____ POSTAL CODE _____

ETI 0483.

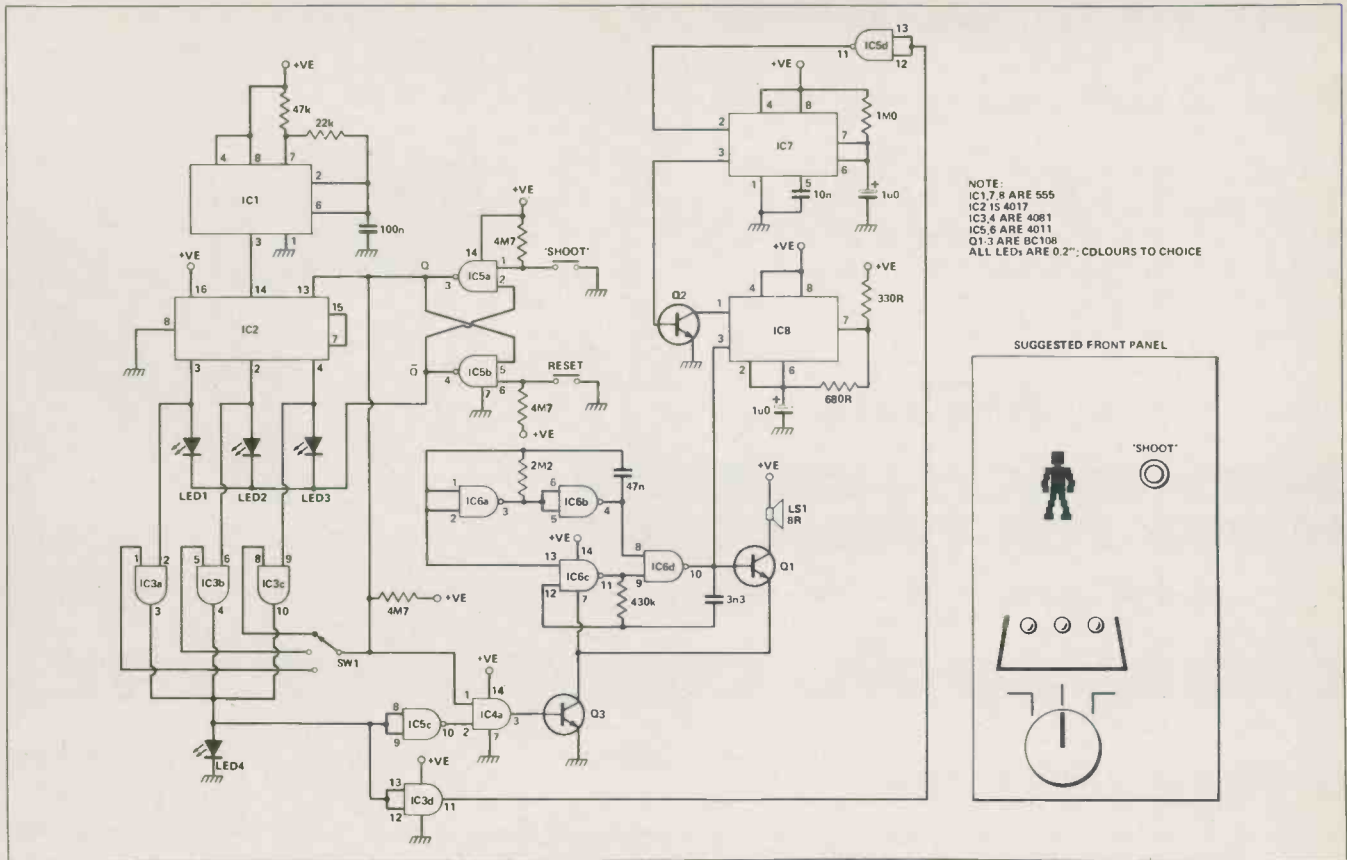

Penalty Kicks
G. Durant and D. Hall

We designed this following hand held game to be simple for construction, cheap and most of all fun for the operator. The idea of the game is to put yourself in the position of the goal keeper and to guess which way the striker is going to kick the ball, by turning the rotary switch to the marked positions. The shoot button is then pressed; a noise will indicate whether the operator has guessed right.

IC1, a 555, is wired up as a astable multivibrator running at about 100 Hz feeding the clock input of the 4017. If the 'shoot' button is not operated, the Q output of the latch formed by IC5a,b is low, allowing the 4017 to count. Three LEDs are driven by the 4017; in the reset state these are blanked by the latch.

Switch SW1 is turned into the position the 'goalie' thinks the ball will come towards the goal. The 'shoot' button is pressed. IC2 stops counting and one of the LEDs lights.

If you guessed correctly the 'saved' LED is lit via IC3a,b or c and a 1 kHz sound generator built around IC8 is sounded for just over a second, being controlled by IC7, a one-shot monostable.

If you 'let the ball into the goal' a buzzer is triggered, formed by IC6.

ETI Classified's Work!

One of the best ways to judge if other advertisers are getting good results from a publication is to see if the space booked is stable, going down or increasing.

Classified ads in ETI have increased 88% in the last seven months. In addition ETI circulation is still increasing giving better and better value.

Reach 30,000 Canadian readers for as little as \$20.



DIV.: BRUNELLE INSTRUMENTS INC.
826 BELVEDERE ST., SHERBROOKE, QUEBEC J1H 4B8
1-819-569-1335 TELEX 05-836266

MODEL'S 4040 & 4050

DIGITAL MULTI-METERS

Amazing quality at low cost!

\$99.00

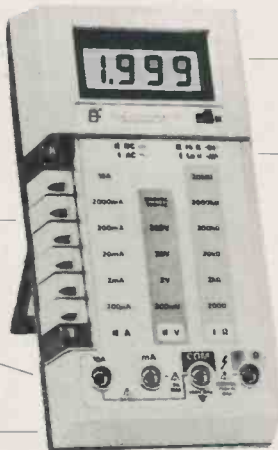

3-DIGIT LCD DISPLAY
WITH AUTO ZERO
AUTO POLARITY LOW BAT

HI VOLT FOR
DIODE TEST
LO VOLT FOR
IN-CIRCUIT RESISTANCE
MEASUREMENTS

IN LINE PUSH-BUTTONS
ARE EASY TO USE
COLOR CODED BUTTONS-
FUNCTION PANEL ALLOW
SPEEDY RANGE SELECTION

DC, AC 10 AMP
MEASUREMENT

RECESSED INPUT JACKS
AVOID SHOCK HAZARD

OVERLOAD
PROTECTION ON ALL RANGES

Mail Orders accepted: Send certified cheque or money order.
Quebec residents add 9% P.S.T. add \$3.00 for shipping.

Circle No. 9 on Reader Service Card.

QUALITY
SERVICE
AVAILABILITY



ACTIVE, YOUR
NUMBER ONE
CHOICE

Active Components

Active Components
Your one stop source for the
widest variety of factory
fresh electronic components

Extensive Product Offering

Semiconductors, Integrated Circuits, Micro-
computer Boards, Microprocessor and
Support Circuits, Transistors, Diodes,
Capacitors, Resistors, Optoelectronics,
Potentiometers, Relays, Multimeters,
Switches, Knobs, Connectors, Sockets, P.C.
Boards, Enclosures, Data and Reference
Books, Soldering Aids, AND MUCH MORE

Superior Service

Greater choice. Easier, faster ordering and more
reliable deliveries. Active's all NEW comprehensive
Fall/Winter catalogue is now available — FREE OF
CHARGE. Circle No. 2 on free information card
or write to: 5651 Ferrier Street, Montreal, Quebec
H4P 1N1, or call: (514) 731-7441

TELEX: 05-823554

TWX: 610-421-3251

Circle No. 2 on Reader Service Card.

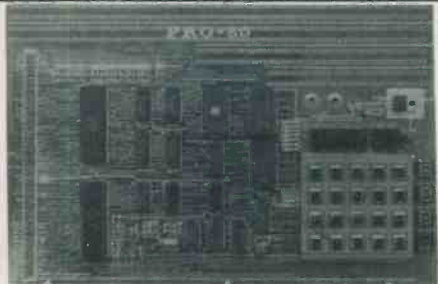

A COMPLETE Z-80 BASED MICROCOMPUTER KIT: ONLY \$169.00

IT INCLUDES: • 2 parallel I/O ports • 1K byte RAM, socket for a second K • 1K powerful monitor • Another Kbyte EPROM available to the user • S-100 bus • Wire wrap area • Hex keyboard • Hex digit display • Voltage regulator • Audio cassette interface. A detailed assembly and test manual (English or French) is also included.

PRO-VIDEO KIT \$249.00

Now ask for our new PRO-VIDEO expansion card that includes • Video controller for standard colour and B/W TV • 1K, 2K, and 4K EPROM programmer • 8K byte editor assembler, and up to 22K byte static RAM. Prepaid orders can be mailed to:

PROTEC 725 Decarie Blvd., Suite 202
St-Laurent, Montreal, Quebec.
H4L 3L4 (514) 744-3363.

Or to our authorized distributor:
General Electronics, 5511 Yonge St., Willowdale, Ont, (416) 221-6177

Cheque, money order, visa accepted, Please print your name, visa number, expiration date and signature.

Circle No. 17 on Reader Service Card.

VERO

For the Professional Amateur

Vero can offer a complete package to help you build your product to a truly professional standard. Full range of veroboards, accessories and housings. For your free catalogue circle no. 14 on Reader Service Card.

ELECTRONIC PACKAGING SYSTEMS LIMITED
Retail Department
P.O. Box 481, Kingston, Ontario K7L 4W5
Telephone: (613) 384-1142
Dealers reply on letterhead.

Circle No. 14 on Reader Service Card.

ZX Interface

Continued from page 51

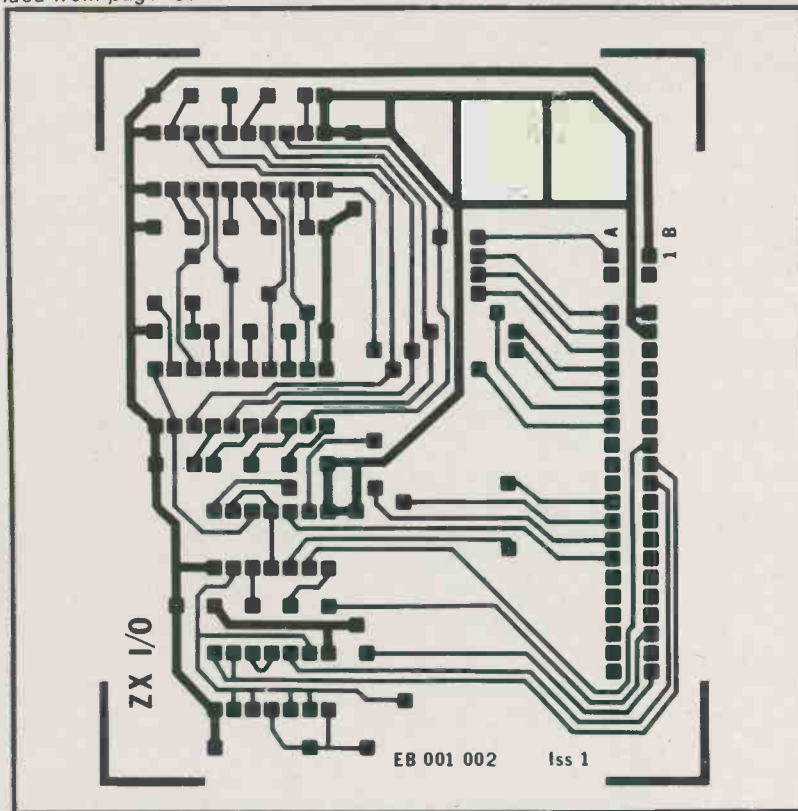

the foilside pattern for the ZX PCB.

sockets shown in the components list can be used; note that these consist of a shell moulding with separately supplied contacts.

The I/O board inputs can, of course, be connected directly to TTL or 5V CMOS outputs, and switch or relay contacts can be easily interfaced as shown in Figure 4, which also shows how a LED-phototransistor opto-isolator could be used to sense signals that it may not be possible to connect to the computer's 0V rail.

LEDs or low power relays can be driven from the board's output lines, as shown in Figure 5. In all cases, the total amount of current drawn from the +5V rail on pin 1 of PL1-4 should be not more than about 50 mA, as it is being provided by the regulator in the ZX, which runs hot enough anyway!

Note also that any large or inductive loads such as motors or relay coils should have interference suppressors fitted to cut down the risk of noise pulses upsetting the computer. For this reason it is advisable to isolate any large loads with a relay or opto-isolator, so that high voltage or heavy current circuits are completely separate from the computer. This will also reduce the chance of high voltages getting accidentally connected to your valuable ZX!

ETI

Fault Finding

Continued from page 62

be necessary if you suspect that a faulty component or group of components are responsible for an incorrect voltage reading (Divide And Conquer, remember?). Some meters have a special range for measuring in-circuit resistance, and this facility is very useful for taking resistance readings around transistors or diodes.

Scope For Improvement

For most hobbyists, owning test equipment other than a multimeter is something of a luxury. However, there are several other items which can be built cheaply; an audio signal generator is quite adequate for work on audio circuits. A simple audio amplifier with a high impedance, AC-coupled input (to isolate DC levels in the circuit under test) or even a high impedance earphone, is invaluable for tracing the signal path through an amplifier. An audio/RF signal injector/tracer is slightly more versatile, as it can be used on AM radio circuits as well.

This list could go on indefinitely, because the more complicated circuits require more specialised test equipment. In general, though, there is one item which, though expensive,

is useful for almost all fault-finding and totally essential for work on some kinds of circuits, and that is an oscilloscope. If you are going to be 'into electronics', either as a long-term hobbyist or as a semiprofessional, say, then a scope is a very worthwhile investment.

Extracting The Digit

A scope is usually necessary for fault-finding on digital circuits, where correct operation depends not on voltage levels but on the presence (or absence) of a fixed-level pulse which is too fast to register on a multimeter. The only way pulses can be observed is either on a scope, or by using a special logic probe. It is also important to understand the logic of the circuit, from the truth tables of simple AND, OR, NOR and NAND gates through flip flops, registers and so on, to the logical combination of the elements used in the circuits. The timing diagrams, tracing the effect on the circuit of a sequence of inputs, are an important fault-finding tool for this type of circuit!

The Final Secret

To conclude, I will now reveal the most important secret of fault-



A scope is a technician's best friend! A small model, such as the one shown, will more than repay the investment if you are working on a good number of projects, while for professional (or even semi-professional) work, a scope is essential.

finding: experience. There is no substitute, so when your project just lies there limply, don't get frustrated and annoyed, or throw it against the wall! Roll up your sleeves and get on with it. Sooner or later the circuit will burst into life, and you will discover that you've learned a lot about electronics, in the process.

Happy Hunting!

Our thanks to Bernard Babani (publishing) Ltd. for permission to reproduce the diagrams of Figures 2 and 3 from their "Transistor Radio Fault-Finding Chart" by Chas E. Miller; publication number BP70, price \$2.40 from ETI.

ETI

thandar measures up to your expectations

Performance, Reliability & Value

Counters

TF 200



- ▶ Bench/Portable
- ▶ Frequency range 10Hz — 200MHz
- ▶ Sensitivity 10mV rms
- ▶ Battery life 200 hrs. (included)
- ▶ Timebase accuracy 0.3ppm
- ▶ 8 digit Liquid Crystal Display

\$485.00

PFM 200A Led Hand-Held	\$195.00
TF 040 40MHz Freq. Meter	\$385.00
TP 600 600MHz Pre-Scaler	\$121.00
TP 1000 1GHz Pre-Scaler	\$225.00

Multimeters

TM 451

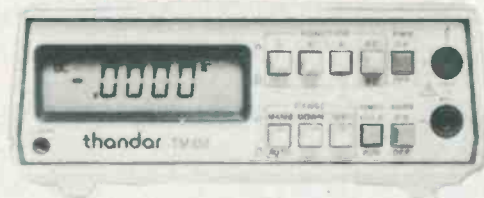

- ▶ Bench/Portable
- ▶ 4½ digit 0.4" LCD
- ▶ 0.03% basic accuracy
- ▶ Full auto-ranging or manual
- ▶ Audible continuity test
- ▶ Complete with battery and test leads

\$495.00

TM 351 LCD 3½ digit DMM	\$309.50
TM 353 LCD 3½ digit DMM	\$264.00
TM 354 LCD 3½ digit Hand-Held	\$121.00

Single Trace Bench/Portable Oscilloscope SC110 A



- ▶ 10MHz (± 3 dB) Bandwidth
- ▶ Bright 2" CRT Display
- ▶ 10mV/div Vertical Sensitivity
- ▶ Economy mode
- ▶ Disposable Rechargeable Battery, 4V-10VDC & AC operation
- ▶ X-Y operation
- ▶ External triggering
- ▶ Trace Rotation
- ▶ Calibration Output

\$480.00

Generators

TG 100

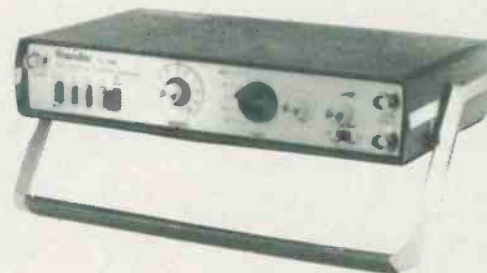

- ▶ 1Hz to 100kHz Function Generator
- ▶ Sine, square triangle waveforms
- ▶ Variable 600 ohm output
- ▶ TTL output
- ▶ External sweep mode

\$281.00

TG 102 Function Generator	\$511.00
TG 105 Pulse Generator	\$275.00

One year guarantee
Full range of accessories available

Circle No. 22 on Reader Service Card.

Write on letterhead for FREE colour catalogue
DEALER ENQUIRIES INVITED

ALSO: LOGIC ANALYZERS, THERMOMETERS

Order direct from:

(416) 636-9404

GLADSTONE ELECTRONICS

1736 Avenue Rd., Toronto, Ont. M5M 3Y7 (416) 787-1448

Digital Counters

Continued from page 32

How To Choose

First, look in your piggy bank! Prices for a straight digital frequency meter start at around \$150. Instruments range right up to several thousand dollars, which is beyond most hobbyists!

Next step is to look at your applications. But, keep in mind future applications and get something a little better — if your budget will stretch that far. The number of digits in the display will certainly be a deciding factor, depending on your applications. The majority of instruments

available have either six- or eight-digit displays. Next consideration is the number of ranges offered (gate time selection). Resolution is important and is related to the display; an eight-digit instrument has a better resolution than a six-digit instrument, naturally enough.

The clock oscillator stability determines the inherent accuracy of the instrument and it is instructive to compare the specifications of different makes and models when considering this parameter. Generally, a temperature range over which the accuracy is maintained will be quoted

along with this specification. Accuracy will be quoted in parts-per-million (ppm) or parts in 10^n . A reasonable figure for accuracy, for most hobbyist applications, would be one ppm (one in 10^6) over a temperature range of 15°C to 50°C.

Whether you get a battery operated or a mains/battery operated instrument will depend largely on your applications.

Refinements like filters, trigger window control, gate time delays, frequency ratio, totalizing etc depend entirely on your application — and your budget! **ETI**

PLEASE MENTION ETI WHEN REPLYING TO ADVERTISEMENTS.

All Things Being Equal

Continued from page 29

Audio Spectrum Analyser). The equaliser is then inserted in the chain, before the power amplifier, and adjusted until the desired response (usually flat) is achieved.

A serious drawback, often overlooked, is that non-professionals sometimes buy such units in order to try to correct faults in a system which has been badly put together in the first place. One enthusiast who built a kit and used it in a set-up of budget equipment succeeded only in burning out his system! So, before you make a hasty purchase of a new equaliser to 'sort out' your system, just think: can things be improved merely by upgrading things be improved merely by upgrading part or all of the system for the same price? To make this point clearer, consider the situation with a pair of hi-fi speakers; take a look at Figure 10, which shows the impedance and frequency response curves for a typical small speaker. Although the manufacture may boast a response down to 30 Hz, at the frequency it's actually down by a good 20 dB and the impedance is equal to the voice coil resistance — 6 ohms. Now, to flatten that response would require a power increase of about 100. If the amplifier is supplying 10 watts at midfrequencies, it would need to supply 1000 watts at the lower end of the audio spectrum — the resultant explosion might be worth watching! Naturally the same point is true if you are making a recording or trying to give your bass player some extra 'oomph'.

Something else worth considering is that if you are using your equaliser to correct the sound

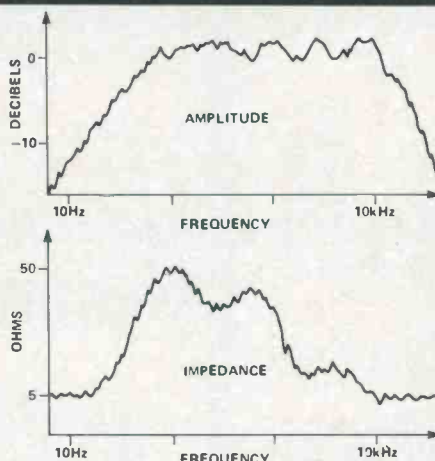

Fig. 10 The amplitude (top) and impedance variations frequency of a typical low-priced, small speaker system.

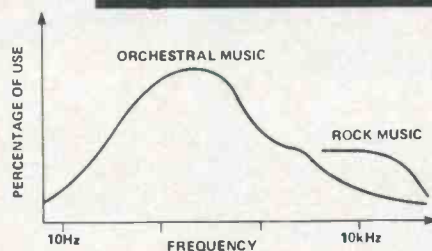

Fig. 11 The energy distribution in orchestral music, compared with the energy in rock music.

because of equipment design, then you cannot use it for specifically improving certain areas at the same time. In other words you are limited by the amount of boost/cut available and whether the rest of your gear can cope. Another factor is the energy distribution of the music that is being

amplified or recorded. The curves in Figure 8 show the energy distribution of orchestral music and of rock music. The peak energy of orchestral music is in the mid-frequencies, dropping off fairly rapidly above about 500 Hz, whereas the energy in rock music (particularly electronic and synthesizer music) continues, at a high level, up to 20 kHz. Excessive treble boost, then, is likely to over-drive the high frequency speakers (tweeters) with the result that they may begin to smoke, if not burn!

Then, if you are making a recording, there's the high frequency boost that is always used in record mode — that uses up part of the 'headroom', too; any excessive boost in this case will cause high frequency distortion due to overloading the tape. The problem of equalisation is always the same — a compromise between boosting the signal (but not hum and noise) without causing distortion.

Is It Equal?

At this point the reader might well wonder why he should bother with equalisers. In some instances they can do more harm than good, but his is largely the result of using them as a substitute for good design. If the performance you want requires the use of a large super-speaker, get one — not a super-compact \$10.00 special — it won't do the job. Do pay attention to the room acoustics, proper speaker design and placement. Then select an equaliser if you really need one. You will then be in a position to use it to make fine adjustments to the sound in the best possible way. **ETI**

The \$99.95 Computer!

A personal computer that grows with you.



ZX81 Assembled

\$99.95

Now includes Heavy-duty AC Adaptor

Sinclair ZX81. . . .World's most popular personal computer. . . .more than 500,000 sold. . . .owned by 20% of ETI's readers!

Uses standard TV & cassette.

Your ZX81 connects directly to colour or black & white television for a 32 character x 24 line display. You can store programs on a standard cassette recorder. All the connecting cables you require for TV and cassette are provided.

Sinclair 16K RAM PACK \$59.95

Provides massive add-on memory in a compact plug-in module via an edge connector. Can be used for program storage or as database. Yet it costs as little as half the price of competitive memory.

Sinclair ZX Printer . . . 149.95

Designed exclusively for use with the ZX81 (and ZX80 with 8K basic ROM), the printer offers full alphanumerics and highly sophisticated graphics. COPY command prints out exactly what is on screen. At last you can have a hard copy of your program listing and results. Printing speed is 50 characters per second, with 32 characters per line and 9 lines per vertical inch. Connects to rear of ZX81 — using a stackable connector so you can use a RAM pack as well. A 65 ft paper roll, instructions included.

Free catalogue with your purchase of a ZX81 Computer.

Lower price: higher capability.

Sinclair's new ZX81 personal computer is a tremendous advance over the highly successful ZX80. It offers far more computer capability, yet Gladstone Electronics is able to offer the ZX81 at less than half the ZX80 price!

How is it possible? Quite simply, by design. The ZX81 uses only 4 chips (as opposed to 21 in the original ZX80). The secret lies in the totally new Master chip. Designed by and custom-manufactured for Sinclair, this unique chip replaces 18 chips from the ZX80.

The ZX81's advanced capability.

The ZX81 uses the same fast microprocessor (Z80A), but incorporates a new, more powerful 8K BASIC ROM — the "trained intelligence" of the computer. This chip works in decimals, handles logs and trig, allows you to plot graphs, and builds up animated displays. And the ZX81 incorporates other operation refinements — the facility to load and save named programs on cassette, or to select a program off a cassette through the keyboard.

Features.

- * Unique 'one-touch' key word entry: the ZX81 eliminates a great deal of tiresome typing. Key words (PRINT, LIST, RUN, etc.) have their own single-key entry.
- * Unique syntax-check and report codes identify programming errors immediately.
- * Full range of mathematical and scientific functions accurate to eight decimal places.
- * Graph-drawing and animated-display facilities.
- * Multi-dimensional string and numeric arrays.
- * Up to 26 FOR/NEXT loops.
- * Randomize function.
- * Programmable in machine code.
- * Cassette LOAD and SAVE with named programs.
- * 1K-byte RAM (expandable)
- * Full editing facilities.

ZX81 Professional Keyboard and Case

A full-sized professional keyboard for the ZX81. Features 47 keys and a full-sized space bar. Connects to the ZX81 with no soldering required, via a plug-in flexible connector. You can purchase the keyboard only, or the optional metal case that holds both keyboard and ZX81. Expansion devices (i.e. RAM packs, etc) connect to the ZX81 edge-connector which extends from the rear of the cabinet.

A professional keyboard makes program entry easier and less error-prone.

Keyboard K70 \$119.95
Metal case for keyboard and ZX81 E70 \$29.95



NEW 32K RAM MEMOTECH

*May be used with Sinclair 16K RAM to give a total system memory of 48K RAM! Unit simply plugs into back of ZX81 and existing 16K RAM "piggy backs" on. May also be used instead of 16K. Greatly extends the capacity of the ZX81 to store masses of data and longer programmes.

Memotech Memopak 32K \$179.95
64K RAM.

The maximum the ZX81 can address. With 64K your ZX81 is transformed into an extremely powerful computer for business, leisure, and educational use, at a fraction of the cost of comparable systems.

Memotech Memopak 64K A64 \$259.95
High Resolution Graphics. Memopak HRG A70 \$199.95
● Centronics/Parallel Printer Interface. Memopak I/F A71 \$159.95 ● Printer Cable for above A72 \$35.00

GLADSTONE ELECTRONICS

Phone orders only 1-800-263-3640
in Ontario (416) 787-1448

Telephone (416) 787-1448. Use VISA, Mastercard, AMEX to order.

Circle No. 12 on Reader Service Card.

1736 Avenue Rd.,
Toronto, Ont., M5M 3Y7