

NEW COLUMN FOR TEACHERS — THIS ISSUE

\$1⁵⁰

electronics today

AUGUST 1979

GG70409

Projects:

- Audio Power Meter
- Don't Wet Your Plants! Let ETI —
- Home For Your Projects: Boxes And Cases
- Smoke Detectors

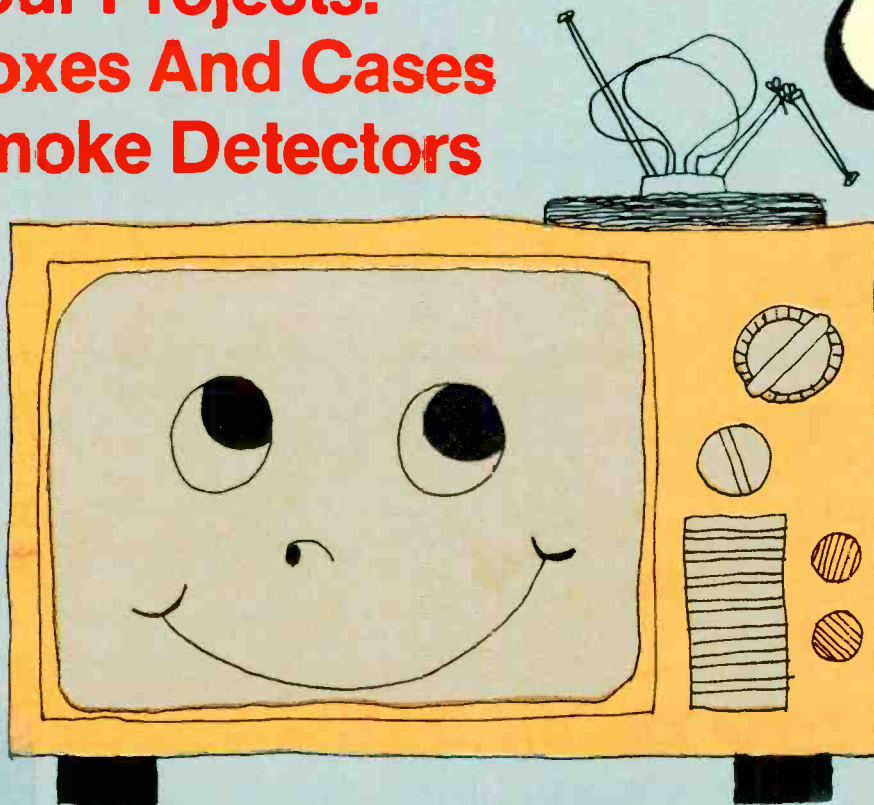
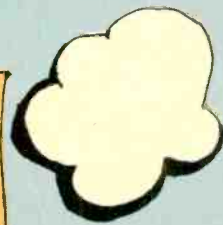
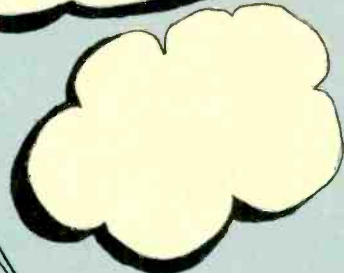
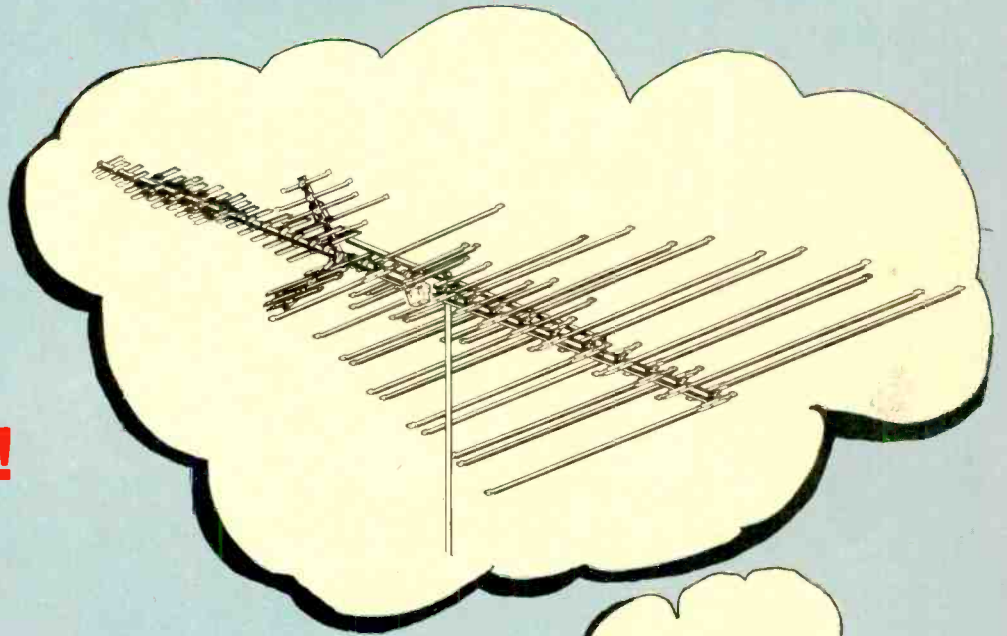

**TV Antennas:
Why, What
and How**

Sprague gives you MORE with LESS



YOU DON'T HAVE TO BUY A STACK TO STOCK UP.

Six Extended-Range Twist-Lok® Capacitors will give you all you need to replace O.E.M. twist-mounting electrolytics in as many as 100 different ratings. Sometimes more. Just how many depends on which six Type TVLU capacitors you pick up. Or maybe you'll want a full dozen to cut down on phone and road time between you and your distributor.

These capacitors come in 299 different capacitance, voltage and case-size combinations for replacing over 2,000 existing can-type capacitors in entertainment and commercial applications requiring twist-prong mounting, wire-wrap terminals, or circuit board snap-in mounting.

Order Extended-Range Twist-Lok® Capacitors from your Sprague Distributor.

For the name of the Sprague distributor nearest you, write or call:

TRANS CANADA ELECTRONICS LTD.

1900A Eglinton Ave. East
Scarborough, Ont. M1L 2L9
Tel. (416) 757-4171

P.O. Box 117, Dollard Des
Ormeaux, Que. H9G 2H5
Tel. (514) 747-4266

SMITH-PATTERSON & ASSOCIATES

1120 Hamilton St.
Vancouver, B.C. R3E 2T1
Tel. (604) 681-0743

489 Kensington St.
Winnipeg, Manitoba R3J 1J8
Tel. (204) 885-1376

YOUR NUMBER 1 SOURCE FOR ELECTRONIC COMPONENTS

SPRAGUE®

THE MARK OF RELIABILITY

Acting Editor
GRAHAM WIDEMAN BAsc
Editorial Assistant
JOHN VAN LIERDE

ADVERTISING
Advertising Manager
MARK CZERWINSKI BAsc
Advertising Services
SHARON WILSON
Advertising Representatives
JIM O'BRIEN
Eastern Canada JEAN SEGUIN &
ASSOCIATES INC. 601 Cote Vertu,
St. Laurent, Quebec H4L 1X8.
Telephone (514) 748-6561.

Subscription Department
BEBE LALL
Accounts Department
SENGA HARRISON
Layout and Assembly
SARAH-JANE NEWMAN
Contributing Editors
WALLACE PARSONS (Audio)
BILL JOHNSON (Amateur Radio)
JOHN GARNER (ShortWave Listening)
DICK CARTWRIGHT (Servicing)

EDITORIAL AND ADVERTISING
OFFICES
Unit 6, 25 Overlea Boulevard,
Toronto, Ontario, M4H 1B1
Telephone (416) 423-3262
Published by Electronics Today
International (Canada) Ltd.
Printed by Livingstone Printing Ltd
Delta Web Graphics
News Stand Distribution
Gordon & Gotch, Toronto.
COPYRIGHT

All material is subject to worldwide
copyright protection. All reasonable
care is taken to ensure the accuracy
of the information.

All ETI PCB Patterns are copyright .
No company may sell boards to our
designs without our permission.

INTERNATIONAL EDITIONS
Electronics Today International, 25-27
Oxford St., London W1R 1RF U.K.
Editor Ron Harris
Electronics Today International
Ryrie House, 15 Boundary St.,
Rushcutters Bay, Sydney, Australia.
Managing Editor Collyn Rivers.
Acting Editor Roger Harrison
Elrad
Kommanditgesellschaft, Bissendorfer
Strasse 8, 3000 Hannover 61 Germany
Editor Udo Wittig

Postal Information
Second Class Mail registration number
3955. Return postage guaranteed. Post
office returns to Unit 6, 25 Overlea
Bld, Toronto, Ontario. M4H 1B1

electronics today

international

INCORPORATING ELECTRONIC WORKSHOP

PROJECTS

AUDIO POWER METER	14
<i>Find out how much sound is really going to your speakers.</i>	
SHOOTOUT	28
<i>Kill kill kill . . . without getting hurt.</i>	
ETI-WET	30
<i>Now you only have to talk to your plants.</i>	

FEATURES

TEACHERS' TOPICS	13
<i>New column for teachers . . . and students starts this month.</i>	
SURVEY OF BOXES AND CASES	21
<i>A look inside what to put around the outside.</i>	
SMOKE DETECTORS: CHOOSING AND USING	33
<i>Don't get caught in a fire: protect yourself with one of these.</i>	
TELEVISION ANTENNAS	37
<i>. . . are still very popular, and with good reason.</i>	
WHAT'S ON	44
<i>Our new column for videophiles, a look at satellites.</i>	
REED SWITCHES	49
<i>A continuing look at these useful devices.</i>	
INTERSIL COUNTER BOARD KIT	52
<i>Neat chip plus neat board plus neat parts = neat kit.</i>	
MAGNETIC FIELD AUDIO AMP	54
<i>Will it revolutionise audio?</i>	
INDUSTRIAL ELECTRONICS	61
<i>What it is, and how to learn about it.</i>	
SURVEY ANNOUNCEMENTS	64

NEWS & COLUMNS

NEWS DIGEST	4
AUDIO TODAY	9
<i>Who hears what with which ears.</i>	
QRM	56
<i>Packets on packets.</i>	
SERVICE NEWS	59
<i>Lots of news from here and there.</i>	
MORE ON PROPAGATION	65
<i>How those long distance signals get about.</i>	
TECH TIPS	68
<i>Ideas for experimenters</i>	
FUN OF ELECTRONICS	70
<i>Ho ho ho, ha ha ha . . .</i>	

INFO & MISCELLANEOUS

ETI Panel Transfers	20	Free Library Subscriptions	60
Tower's I. T. S.	27	Upcoming in ETI... ..	64
ETI Binders	32	Classified Ads	71
Electronics Paperbacks	48	Project File	72
ETI Canadian Projects Book	51	ETI More Circuits	73
ETI Circuits No. 1	51	Reader Service Info	74
ETI Marketplace	57	Advertisers' Index	74
Subscriptions	60		

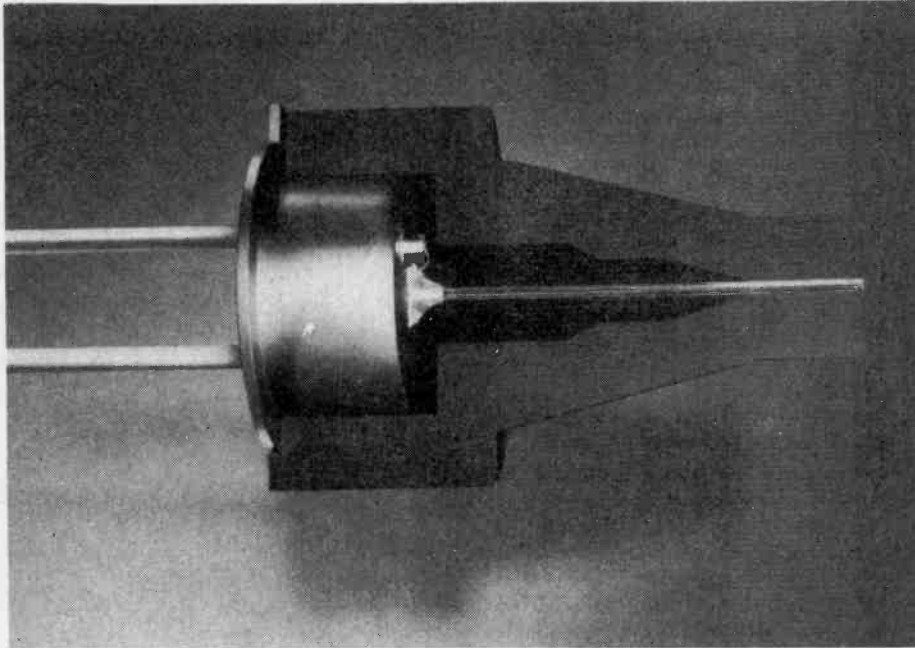

Cut-away view of Motorola's new package for fiber-optics applications shows fiber strand bonded to the semiconductor die, for maximum light transfer. Other end of fiber is accurately centered within the "nosecone" of the encapsulating ferrule.

New Ferruled Plastic Fiber-Optic Semi-Conductors Introduced By Motorola

Earlier this year, Motorola and AMP, Inc. jointly announced the culmination of a coordinated development effort which yielded a new concept in fiber-optics packaging. This state-of-the-art concept consists of a series of optical emitters and detectors that are mechanically so well matched that they hurdle the three main impediments to increased fiber optics use. The three improved fiber optics applications characteristics resulting from this development effort are:

1. Greatly improved light-transfer efficiency between active device and the fiber — through intimate bonding of the fiber to the light emitting or detecting surface of the semiconductor chip.
2. Rugged semiconductor package which protects the internal light pipe and is well suited for high-volume manufacturing to reduce ultimate cost.
3. Simple, highly efficient interconnection of device package and cable connectors due to a unique interactive design.

Now, Motorola has formally introduced its new family of ferruled plastic fiber-optic semiconductor

components, and has announced its introductory pricing and off-the-shelf delivery. Included in the introduction are one solid state light source and four detectors, dubbed the "Straight Shooters"®.

To achieve optimum performance, emitters and detectors are spectrally matched for maximum responsivity.

The new interconnection method furnishes coupling efficiency of active devices to optical fibers equal to pigtail devices and with the added advantages of lower cost and improved handling. Measured performance includes speeds up to 20 megabytes per second and systems of five kilometers in length can be achieved.

Expose Yourself

News digest is a regular feature of ETI Magazine. Manufacturers, dealers, clubs and government agencies are invited to submit news releases for possible inclusion. Submissions, or questions about material, should be sent to: News Digest, c/o ETI Magazine Unit 6, 25 Overlea Blvd., Toronto, Ontario, M4H 1B1.

Audio products news will be directed to Audio Today's product department, and similarly Shortwave news will appear in Shortwave World. Sorry, submissions cannot be returned.

Pack Up Your Kit . . .

Twelve years ago when R-A-E Industrial Electronics Ltd. was struggling to establish itself in Burnaby, B.C., high school shop teachers in the area repeatedly asked the company to provide them with do-it-yourself electronic kits to enable students to learn the practical application of the theory they were given in class.

The company didn't relish the proposition. While the kits would be expensive to design and develop they would have to be priced to fit students' limited pocketbooks, returns on investment would be slow to materialize and a fledgling firm can ill afford a long wait, and production of the kits would require diverting staff from the company's main work which is wholesale distribution of electronic components to industry.

Still, a company owes something to the community that supports it, and the location of this particular company made that obligation hard to ignore. Next door was the British Columbia Institute of Technology with many students who would benefit from working with the kits.

The company took the plunge and now, putting the finishing touches on its twenty-first "Raekit," General Manager Albert Harskamp happily observes that good deeds are also good business. Annual sales of the educational kits have reached the six figure mark.

The road to success was not without bumps, however. A year ago R-A-E Industrial Electronics nearly went out of the kit business. At the time it had only 12 kits and additions seemed unlikely because the program was complicated and used up too much manpower. It was saved by a Design Canada program which was announced about that time by the Department of Industry, Trade and Commerce.

The Design Canada scheme was implemented to stimulate industrial design and new product development, and to provide young Canadians with opportunities to gain practical experience in the fields of design, development and marketing of new or improved products in order to build up a national capability in these areas for the future. The scheme's objectives were, in fact, similar to those of the company's kit program, and it solved the manpower problem by paying 75 per

cent of the salary for a full-time trainee or intern designer. No longer would experienced staff have to interrupt their regular work to design kits. For that job the company, one of 770 firms that subscribed to the Design Canada scheme, hired a 22-year-old student who, within a few months, designed nine new kits which is almost as many as the company had produced in the previous 10 years.

The potential market value of the new kits is an estimated \$500,000 but says Mr. Harskamp, their real value lies in another direction.

"This student is a genius. He started coming into our store to buy complex parts to make his own products when he wasn't tall enough to see over the counter, and working on these kits has really whetted his appetite for design. Maybe that's the best return of all on this investment."

Battery Holder

Most small enclosures on the market today make no provision for battery housing and dismantling a complete instrument in order to replace an exhausted battery is both tedious and time consuming.

Electronic Packaging Systems now make available an injection moulded battery housing allowing access for battery replacement from outside the instrument.

The cover, with a flip-over type hinge moulded as part of the housing opens easily for battery changing and snaps closed securely.

Supplied as a kit, the battery holder comes complete with battery connector and lead under order code 75-2859C.

Write to Electronic Packaging Systems, P.O. Box 481, Kingston, Ontario K7L 4W5.

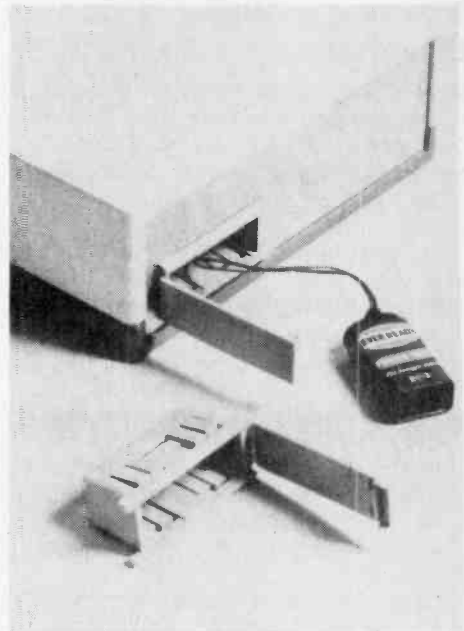

Electrohome color TV for 1979/80 features the latest in technological advancements and consumer benefits. Pricing for Electrohome's 20 inch color TV line, complete with 3-year warranty, begins at \$639.95.

Each highlights a new AM/FM 8 track and cassette record/play chassis in elegant new cabinets.

The company's microwave oven line now includes 4 models. The top-of-the-line unit has 'soft touch' controls, time and temperature readout and is programmable.

Electrohome also announced that it had become the exclusive Canadian distributor for Atari Inc. and its sophisticated, programmable color video games. The basic 'games' control console, plus cartridges with 5 to 50 games on each, provides an almost limitless selection of games to be played on a color TV unit. New cartridges which include Video Chess and Backgammon are slated for fall introduction.

Cats, Cats, Cats

Winegard new catalog, no. 179, features their most complete line of products to date. The catalog features a broad line of antennas, cable, splitters, amplifiers, converters and much more. A definite must for CATV, MATV and home installations. Get it from Omnitronix Ltd, 2056 South Service Road, Trans Canada Hwy., Dorval, P.Q. H9P 2N4. You can speed delivery by telling them ETI sent you.

More Cats

The Watt shop announces its new 1979 catalog featuring a broad range of ICs, transistors and other components at low prices. Get it from The Watt Shop, Box 434, Oshawa, Ontario L1H 7L5.

1979 ECG Semiconductor Master Replacement Guide

The most comprehensive guide in the industry with 352 information packed pages. Completely revised and updated, the '79 edition features:

- Almost 600 new products — 84 Transistors (RF types, FET's etc.); 70 Optoelectronic Devices, LED Indicators and Displays.
- Plus, thousands of new cross references.

Suggested price is \$2.95, but you can get yours free by mentioning ETI when you write GTE Sylvania Canada Ltd., 8750 Cote de Liesse Road, Montreal, Quebec H4T 1H3.

Canadian Distributors

Weber Electronics Inc. sales representatives for AP Products appoints two master distributors for their product line. Cam Gard Supply Ltd. have been franchised for Western Canada and Semad Electronics Ltd. have received a franchise for Southern Ontario.

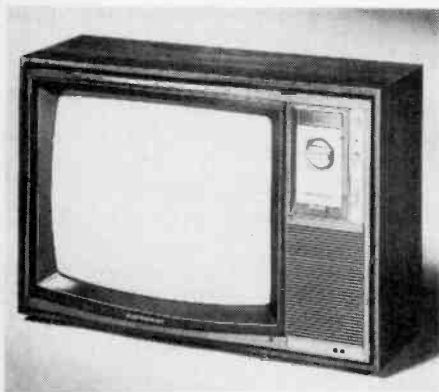

Electrohome Previews Broad New Range of Electronic Products for 1979-80

Electrohome Limited previewed today a broad new range of electronic products for Canadian markets in 1979-80.

Shown was a 25-model line of color TV featuring the latest in electronic technology. Automatic controls, electronic tuning, advanced V.I.R. circuitry for broadcast perfect color and built-in full cable capability are features found in many of the new models. Screen sizes are 14, 20 and 26 inches.

Four small screen black and white television units were previewed. One was multi-made B&W combination unit which includes 3-inch TV, tape, 40 channel C.B. receiver, AM/FM stereo and public service band ratio.

Six new stereo consoles were shown.

Ampex To Begin Manufacturing VHS Videocassettes

Ampex Corporation today announced it has received a license from Victor Company of Japan (JVC) to manufacture and market videocassettes in the highly popular VHS® format.

"As with the Beta-format® product we now offer, demand for VHS videocassettes from both consumers and industrial users is running ahead of supplies," said George J. Ziadeh, vice-president — general manager of Ampex's magnetic tape division. Ziadeh also said that precision magnetic tape production lines at the company's Alabama manufacturing facility have reached an advance pre-production stage in anticipation of the JVC license.

Ziadeh said it is Ampex's intention to become a major supplier of all popular videocassette formats.

Ampex's licensing agreement with JVC covers the manufacture and marketing of Ampex-branded VHS-format videocassettes in all play lengths. Ampex will utilize its own technology to manufacture the cassette shell to JVC specifications and will use its own tape in the cassette.

Dial Philips

The Code-A-Phone Deluxe Electronic Dialer from Philips Electronics Ltd. now offers automatic hands-free dialing by storing 32 of one's most frequently-called numbers for immediate access.

Priced at \$399.95 (or less) and available from Philips' Telephone Answering Department, the Electronic Dialer connects to any phone. Because of its adjustable dialing mode, it can save dialing time especially on rotary dial phones. It also has a built-in one-way speaker which allows line monitoring.

All 32 numbers can be easily assigned. A battery powered back-up system also is available with the Electronic Dialer.

A sharp, visual display unit gives instant verification of the number being dialed. And, the LED continuous display digital clock is perfect for information at a glance.

For more information write Philips Electronics Ltd Telephone Answering Department, 601 Milner Ave., Scarborough, Ont. M1B 1M8.

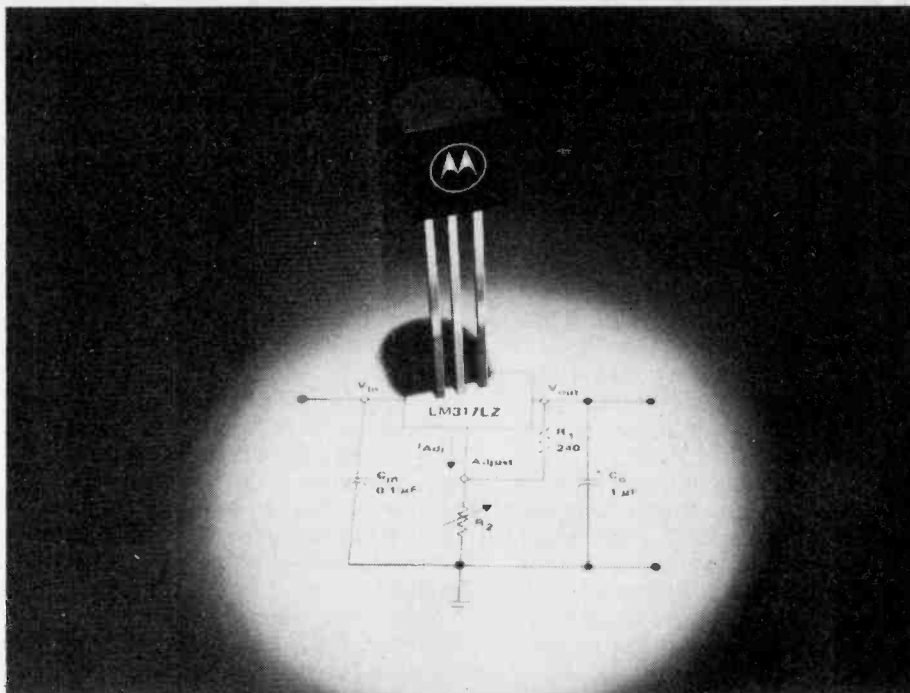

Motorola offers industry's first 100 mA Adjustable Positive Voltage Regulator. Shown here is the TO92 plastic device, LM317LZ, with temperature range of 0 to +125°C. Other devices in the series are in the TO-39 metal can.

100 mA Adjustable Positive Voltage Regulator

Motorola has introduced the industry's first 100 mA, adjustable positive voltage regulator. The new three-terminal device is capable of supplying in excess of 100 mA over an output voltage range of 1.2 V to 37 V.

Designated the LM117L/LM217L/LM317L, these voltage regulators offer unusual ease-of-use features, and require just two external resistors to set the output voltage. In addition, they employ internal current limiting,

thermal shutdown and safe area compensation, making them essentially blow-out proof.

A principle advantage of the LM117L is that it eliminates the stocking of many fixed-voltage regulators. Other features of the LM117L series include:

- Internal thermal overload protection
- Internal short-circuit current limiting.
- Output transistor safe-area compensation.
- Floating operation for high-voltage applications.

Typical prices start at 49¢ (US, 100 lots). Delivery is from OEM and authorized Motorola distributor warehouse stock.



ACA's Toronto Phone

Due to typesetting error, Allan Crawford gave the wrong Phone number for their Toronto office in ETI June and More Circuits. The correct number is 416-678-1500.

New Sales Rep

Jerome and Francis Co., head office in North Vancouver, British Columbia, have been appointed exclusive Canadian representative for Dage Scientific Instruments of California.

Dage Scientific Instruments make complete line of instruments which are provided in kit or fully assembled; noteworthy is their Digital Autorange Capacitance Meter and 1KHz function generator.

For more information, please contact, John Joyce at Jerome & Francis Co. P.O. Box 86549, North Vancouver, British Columbia, Canada V7L 4L1

Introducing the TROUBLESHOOTER

3½ digit

DMM

\$179*

* Suggested Canadian price. Duty and federal sales tax included. Subject to change without notice. Fluke DMM's are represented in Canada exclusively by Allan Crawford Associated Ltd., and are stocked and sold by authorized distributors coast-to-coast. Individual distributors may sell at other than the suggested price.



We call our new 8022A hand-held digital multi-meter the "Troubleshooter" because it provides all the measurement functions you normally need: high ohms, low ohms, AC voltage, DC voltage, AC current, and DC current.

And it's packed in a small, light-weight impact-resistant plastic case with circuitry designed to withstand both physical shock and electrical overloads.

Even the razor sharp 3½ digit LCD readout is made to handle the extremes of humidity, temperature and vibration.

For extra convenience and safety the probes feature Fluke's exclusive finger guards and shrouded connections, discouraging accidental contact with circuit voltages.

And it's so handy to pick one up. The 8022A is in stock right now at Fluke distributors across Canada.

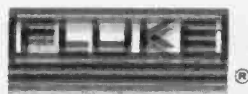

Buy **FLUKE** from

BRITISH COLUMBIA

Vancouver: ACA Electronic Centres
Allan Crawford Associates Ltd. 604/294-1326
Victoria: Queale Electronics Ltd. 604/388-6111
Nanaimo: Queale Electronics Ltd. 604/753-1124
Vernon: Interior Electronics Ltd. 604/545-2394
Kelowna: Interior Electronics Ltd. 604/860-0585

ALBERTA

Calgary: ACA Electronic Centres
Allan Crawford Associates Ltd. 403/230-1341
Edmonton: Cardinal Industrial Electronics Ltd. 403/455-4122

SASKATCHEWAN

Cardinal Industrial Electronics Ltd. 403/455-4122

MANITOBA

Winnipeg: WES Ltd. 204/632-1260

ONTARIO

Toronto: ACA Electronic Centres
Allan Crawford Associates Ltd. 416/678-1500
Ottawa: Allan Crawford Associates Ltd. 613/829-9651
Sudbury: Sonic-Northern Ltd. 705/674-5691
Timmins: Sonic-Northern Ltd. 705/264-1228

QUEBEC

Montreal: ACA Electronic Centres
Allan Crawford Associates Ltd. 514/670-1212

NOVA SCOTIA

Halifax/
Dartmouth: Allan Crawford Associates Ltd. 902/469-7865

Voltage/Frequency Converters

Teledyne Semiconductor has recently introduced two additional voltage-to-frequency, frequency-to-voltage converters. Designated the 9401 and 9402, these two devices have the same pinout as the popular 9400 which was introduced two years ago.

The Teledyne Semiconductor 9401 and 9402 combine bipolar and CMOS technology on a single chip, interface with all logic families, and are available in a 14pin plastic or ceramic dip.

The devices operate from 10Hz to 100 KHz in V/F applications. Both pulse and square wave outputs are provided and they operate on single or dual power supplies, while drawing only 1.6mA.

In the F/V mode, the 9401 and 9402 operate from DC to 100KHz, with maximum non-linearity guaranteed to 0.02% and 0.25% respectively.

For further information contact Michael Paiva, Product Marketing Manager 1300 Terra Bella Avenue Mountain View, CA 94043.

Active Components To Open Store In Western Canada On July 16, 1979

Active Component Sales Corp. (a division of Future Electronics Inc.) will open their newest stocking facility on July 16, 1979 in Vancouver, British Columbia; to be located at: 3070 Kingsway, Vancouver, British Columbia V5R 5J7 Tel: (604) 438 3321.

Ham News

Ham Traders announces their new 1979-80 Amateur Radio Products catalog. Brand names listed include Kenwood, Drake, Ten Tec, Dentron, Atlas, Swan, and more. New products include Kenwood's new TS-120V HF transceiver and an antenna tuner from MFJ.

Furthermore, inside there's a 12 page Cushcraft antenna catalog (catalog A9). Ham Traders, 45 Brisbane Rd., Downsview, Ontario M3J 2K1.

Calendar Dates

September 11 and 12, 1979: The Government Computer Conference. The Chateau Laurier Hotel, Ottawa, Canada. The theme of the conference is "Policies, problems and the promise of Canada's information age". Some of the session topic areas that will be discussed are:

- Canada, competition and a changing order: The need for a national information policy.
- Planning for the 80's — the people factor.
- The automated future: conversing with your computer.
- Communications coming of age in the brave new world.

October 17 and 18, 1979: The Western Computer Conference. The Calgary Convention Centre, Calgary, Alberta. Some of the session topic areas that will be discussed are:

- Distributed data processing in the natural resources industries.
 - Growth of the OEM market in Canada's Western provinces.
 - Transborder data flows, national and international: north/south vs east/west communications links.
 - Use of graphics in seismographic and geophysical modelling.
- Contact Janet Glover, Conference Coordinator, Whitsted Publishing Limited, 2 Bloor Street West, Suite 2504, Toronto, Ontario. M4W 3E2 (416) 967-6200 or toll free across Canada at 1-800-268-7108.

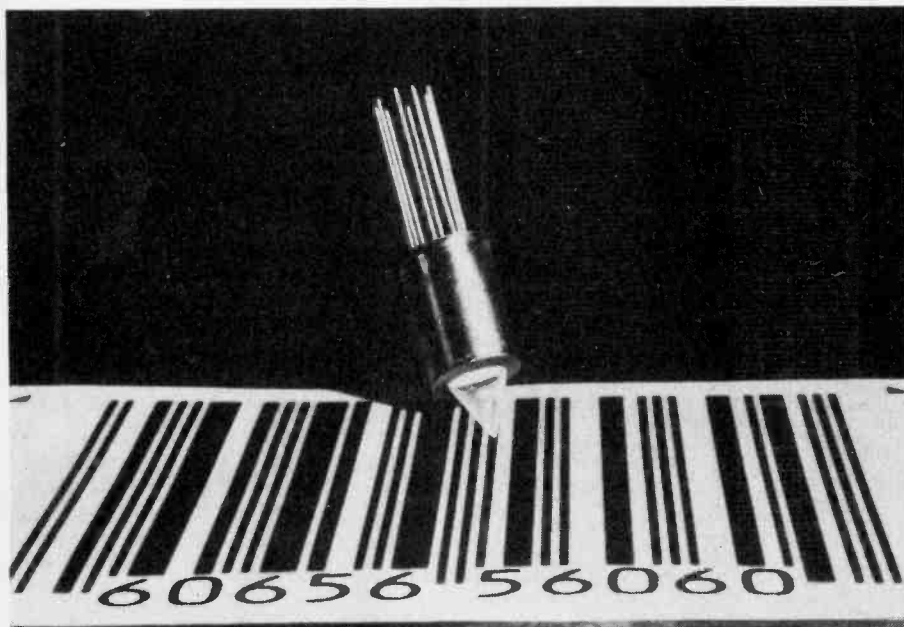

The Hewlett-Packard HEDS-1000. A new high resolution, high speed reflective sensor using a LED emitter, photo IC detector and precision optics. (but what do those bars say, anyway?)

BarSensor

A new high resolution, high speed reflective sensor using a light emitting diode emitter, photo IC detector and precision optics, was introduced today by Hewlett-Packard Company.

The HEDS-1000, the only such device on the market designed to scan color bar codes, will find application in optical inspection, facsimile sensing, pattern recognition, edge sensing and tachometry. Printers, plotters and copiers could use the edge sensing capabilities of the product.

The HEDS-1000 operates from a single 3.5V to 20V power supply. It has a bipolar photo IC detector which allows simplified interface electronics. Exposed surfaces are metal and glass for durability and easy cleaning.

HEDS-1000's performance is based on a new approach to LED reflective sensing. One half of a bifurcated

precision plastic lens projects the light from a 0.17 mm diameter, 700 nm LED onto the sensing plane. The other identical half focuses reflected light onto an integrated silicon photo detector. An on-board transistor in the detector provides added gain. Each lens half has a numerical aperture of 0.3 for maximum light gathering power, and spherical aberrations are eliminated through the use of aspheric lens surfaces. The HEDS-1000 has a resolution of 0.17 mm. Depth of field is +0.5 mm.

The new HEDS-1000 reflective sensor module is priced at \$23.99 Cdn in quantities of 100. Delivery is immediate from Hewlett-Packard franchised component distributors.

Write to HP's Inquiries Manager Hewlett-Packard (Canada) Limited, 6877 Goreway Drive, Mississauga, Ontario. L4V 1M8.



Audio Today

Developments in audio reviewed by Wally Parsons

I FIND MYSELF frequently visiting shopping plazas these days, often for no reason than to buy a newspaper. This isn't a matter of choice, actually; it's just that I live outside of Toronto but have to come into town frequently, so I drive a great deal of the time. But this part of the world is ruled by political lackeys of the trendy leftist zealots, whose philosophy is based on the Gospel according to Ralph Nader, and who have decreed that we "rich folk who drive are a menace to the world, and have conceived the diabolical plot of trying to ground us by arranging traffic mazes and parking restrictions, so we are forced to the shopping plazas just in order to park.

Almost every plaza has at least one stereo and/or TV-Stereo shop; consequently, I spend a great deal of time browsing through them. I'm the guy who goes around turning off loudness controls and setting tone controls to their flat positions.

EQUAL LOUDNESS

It really is quite remarkable how few people understand the proper function of a Loudness control, including salesmen. What is even more surprising is the large number of manufacturers who either do not understand its function, or cynically design equipment in such a way to encourage its misuse.

Most receivers/pre-amps/integrated amplifiers of up to the medium-high quality, and even a few alleged "state of the art" units have a switch of some sort labelled "Loudness In-Out" or similar identification. Activating it switches in a circuit which adds bass boost, and sometimes a little treble boost, which increases, usually, as the volume control setting is lowered. If you ask a salesman what it does he will most likely

explain that it restores bass response which is lost at low levels, and if you probe more deeply, such as asking about different programme sources, live vs. playback levels, etc., you'll probably get either evasion, gobbledegook, or he may even walk away. If you examine what it *really* does you'll find that it's handy for making junky speaker sound good in the dealer's show-room, degrading good speakers if they happen to be of lower sensitivity than the junky stuff, and is useful as a sales aid to show that you need about ten times as much power as you really do.

Which is most unfortunate, as the loudness control is potentially such a

useful device that it is almost a necessity for anyone who uses his system at anything other than live performance level.

FLETCHER, MUNSEN, AND ALL THAT

The earliest and best-known scientific investigation into the frequency response characteristics of the human hearing system was conducted by Fletcher and Munsen many decades ago, and although the specific data have been disputed over the years, the general form has not, and is shown in Fig. 1, the "Fletcher-

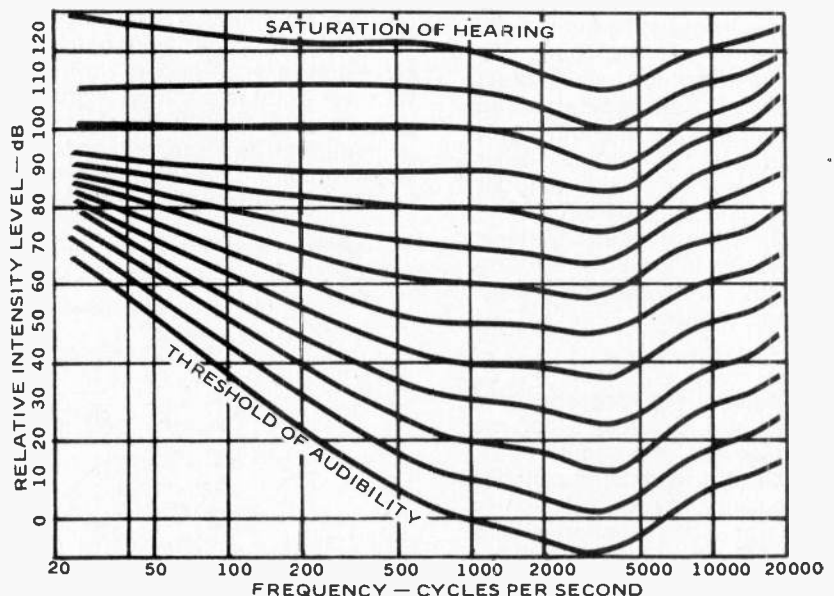

Fig. 1. Graph shows how well the ear hears across the sound spectrum. Note that on this plot the better the ear hears, the lower the line.

Munsen Equal Loudness Contours". If each curve is labelled such that each is 10 dB above the other, and the lowest one labelled as "0 dB", you'll notice that each curve corresponds to the horizontal grid labelled on the left, at 1000 Hz. Each of these curves represents auditory perception of level in Phons. Notice that although the threshold of hearing at 1000 Hz is 0 dB and is perceived as 0 Phons, at 40 Hz the hearing threshold, or 0 Phons, requires a level of 58 dB. Put another way, if a tone of 1000 Hz is perceived as being at a level of 0 Phons, a tone of 40 Hz which is perceived as being of equal loudness, that is, 0 Phons, is actually 58 dB louder. Similarly, 1000 Hz may be perceived as having a level of 80 Phons, at a level of 80 dB, but for 40 Hz to be perceived as being equally loud, that is, 80 Phons it must have an actual level of 90 dB, or 10 dB louder. Thus, two things are immediately apparent: perception of equal loudness is frequency dependent, with response dropping with frequency, and the shape of the curve describing equal loudness, is also level dependent, becoming more acute as level goes down. Notice too, that above 1000 Hz although the response curve assumes a complex shape, they are all substantially the same.

MUSICIANS' RESPONSE

When listening to live music we are not consciously aware of this phenomenon; in quiet passages bass instruments sound just as well balanced in comparison with the others as they do at high levels. This is natural, of course. After all, musicians are subject to the Fletcher-Munsen effect just as are other mortals and automatically balance the output of their instruments to that of other musicians. However, an outdoor concert is a different matter. As we move away from the orchestra, the level reduces due to distance, but there is no compensation. Consequently, bass output tends to drop off.

VS. USERS' RESPONSE

If we attempt to reproduce a performance at a level lower than the original, the effect, one should think, would be the same as adding distance between oneself and the musicians. In part this is true. The reduction in bass occurs in a similar way, but if the performance took place in a hall or studio, the reproduction would also contain ambience information and the acoustic environment's tonal colouration which the ear uses as cues

to the environment. It simply does not sound realistic to perceive the acoustic characteristics of an enclosed space and a direct to reflected sound ratio which suggests a specific distance, and yet hear the level and spectral balance associated with an outdoor performance heard at a greater distance. It really isn't practical at present, to alter the reproduced acoustics to the extent that they can be removed at the reproduction end, even if we wanted to hear an outdoor performance. But it is practical to restore the spectral balance appropriate to the transmitted sound field, although the reduced level will still constitute an anomaly in terms of dynamics.

CURVE INTERPRETATION

Most popular treatment of loudness compensation leave the impression that all you have to do is insert equalization which conforms to the shape of the Fletcher-Munsen curves at different settings. Nothing could be further from the truth; in any case, there is nothing simple about achieving such response curves.

Consider a situation in which sound level is 80 Phons. If we wished to lower that level to 60 Phons, it would require that response at 40 Hz be reduced by only 8 dB, the difference between equal loudness for the 80 Phon curve and that for 60 Phons and a slope of about 3 dB/Octave starting just below 200 Hz. If the music level itself drops to 60 dB it will still be reproduced 20 dB down, or at 40 dB. The required correction curve now will be the difference between 60 dB and 40 dB, which means reducing 40 Hz response by only about 8 dB, but the turnover point has shifted slightly to a little above 200 Hz. Obviously, tracking is imperfect, but the balance is still pretty good. Purist arguments carried to their logical extremes would suggest

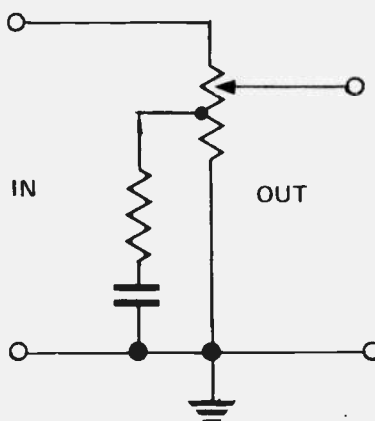

Fig. 2. Simple loudness compensation.

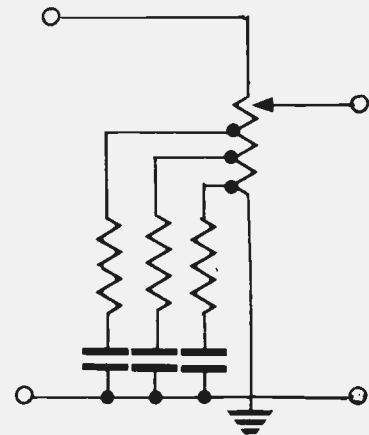

Fig. 3. Multiple taps for more range.

that pretty good is not good enough, but they conveniently forget that a true purist wouldn't lower the volume in the first place.

A more serious problem occurs with respect to setting a reference curve. As we saw in the previous paragraph, the response required is the difference between the original level and the new level. At a level of 100 dB the perception curve is flat, suggesting that perhaps this should be the reference, and if we lower level from say 80 Phons to 60 phons, the curve to use would be the one shown for 80 phons, since it is 20 phons below a reference of 100 phons. This approach is often used, but it completely misses the point. This approach imposes a constantly increasing slope as level goes down, yet we have seen that the slope changes required are not that great unless we are starting from a very high level.

In actual practice we might be inclined to reduce the level of a symphony orchestra much more than a small jazz group, in comparison with performance level, although both might reproduce at the same level. But recording engineers use the recording level technically suitable to the recording medium. Thus, a symphony orchestra might record at a lower level than a string quartette, yet the relative playback levels would be just the opposite.

It follows, then, that if the flat response condition on a loudness control corresponded to live performance level on one particular recording, the level would be either too high or too low for another. It also follows that a single control incorporating level and loudness compensation is totally useless. If means are provided for switching compensation out of the circuit, it might as well not even be there. In other words, you might as well leave it out permanently.

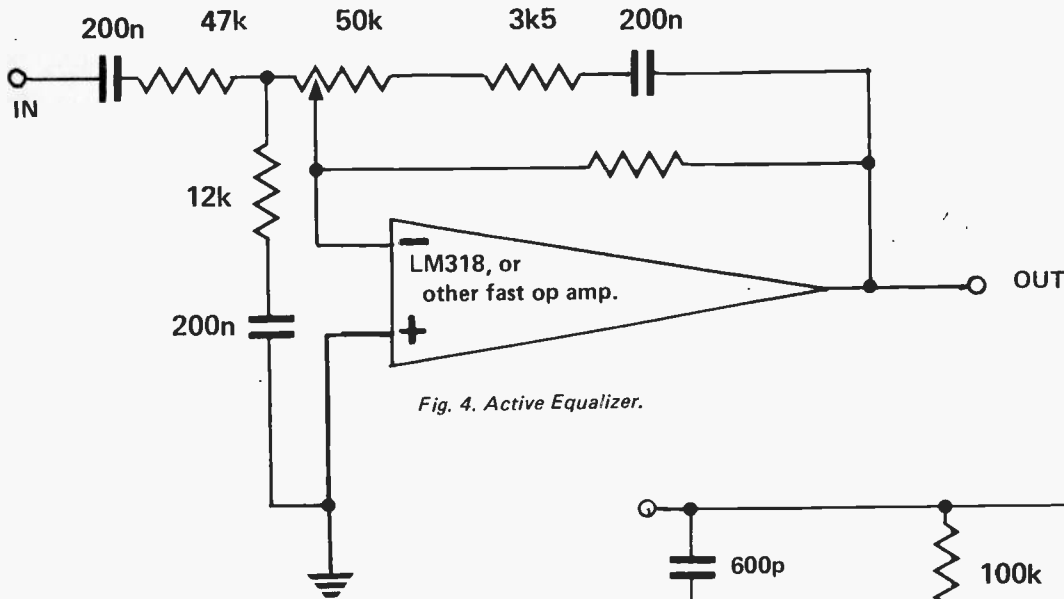

Fig. 4. Active Equalizer.

DUAL CONTROLS

It can be categorically stated that any loudness compensation requires a minimum of two controls. One of them will adjust level with flat response at all settings. The other will either introduce loudness compensation in conjunction with level change, with the maximum setting flat — it may or may not go to a zero level position — or it will produce no change in level but will introduce progressively greater equalization. The latter course offers the potential for greater precision, while the former is more convenient to use and has the advantage of providing automatic, correct compensation as level is changed. The only problem is getting the live performance calibration level set. This is done with the loudness set at maximum, and requires that you be familiar with live sounds enough to know whether your levels are correct or not. This is something only experience can provide.

CIRCUITS

Fig 2 shows the most common method. It works, but does not provide for change in turn-over when set below the tap. Fig. 3 is better because the multiple taps ensures that the turn-over of the network below the tap will progressively change. It also allows compensation at extreme attenuation rates because the slope can exceed the 6 dB/Octave limit of a single RC network. Neither provides a true 3 dB/Octave slope as is required at small attenuations, but more complex networks are possible in each tap to allow a closer approximation.

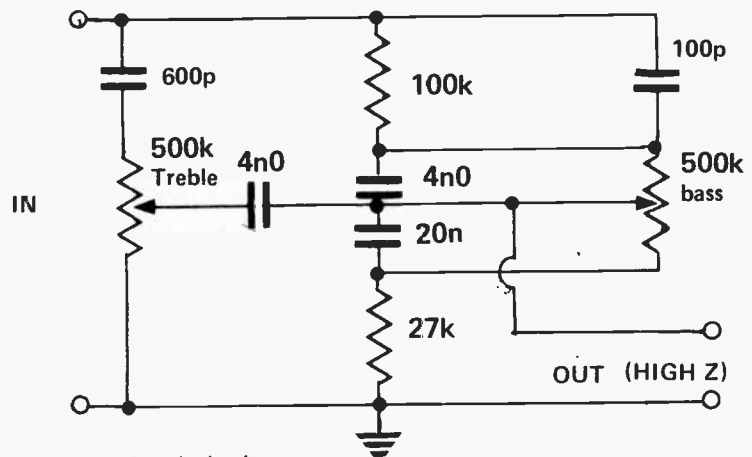

Fig. 5. Quad's circuit.

By inserting a network in the ground leg of the potentiometer in Figs. 2 and 3, slope can be increased, and the control does not go to zero. It is also more suited to extreme attenuations.

The final circuit is something of a teaser, and is shown in Fig. 4. It was developed by Arthur Newcomb, Jr., and Richard Young of the Langley Research Centre, NASA and appeared in the Journal of the Audio Engineering Society for January/February, 1976. An

active equalizer, it varies the ratio of input signal to feedback with most of the equalization in the feedback network.

But the simplest approach is to get a Quad preamp. I find its tone control slopes among the most useful for a wide variety of needs, including loudness correction. The circuit is shown in Fig. 5.

Of course, if you sound-proof the room, you wouldn't need loudness compensation.

Jensen Triaxial® 3-Way Speakers

Quite simply, the most advanced car stereo speaker ever.

For the best sound ever in your car. The first car stereo speaker with a woofer, a tweeter and a midrange.

Identical in principle to the best home stereo speakers. Jensen's midrange picks up a whole range of tones lost to any other car speaker.

Write today for Free catalogues and the name of your nearest Jensen Dealer —



len finkler limited

25 Toro Road, Downsview, Ontario M3J 2A6
Telephone (416) 630-9103 Telex 065-24010

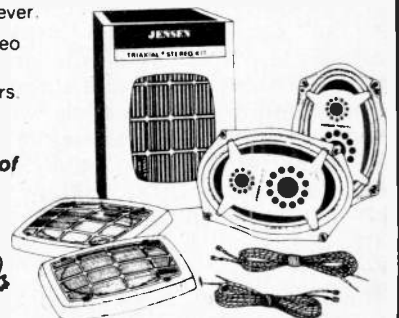

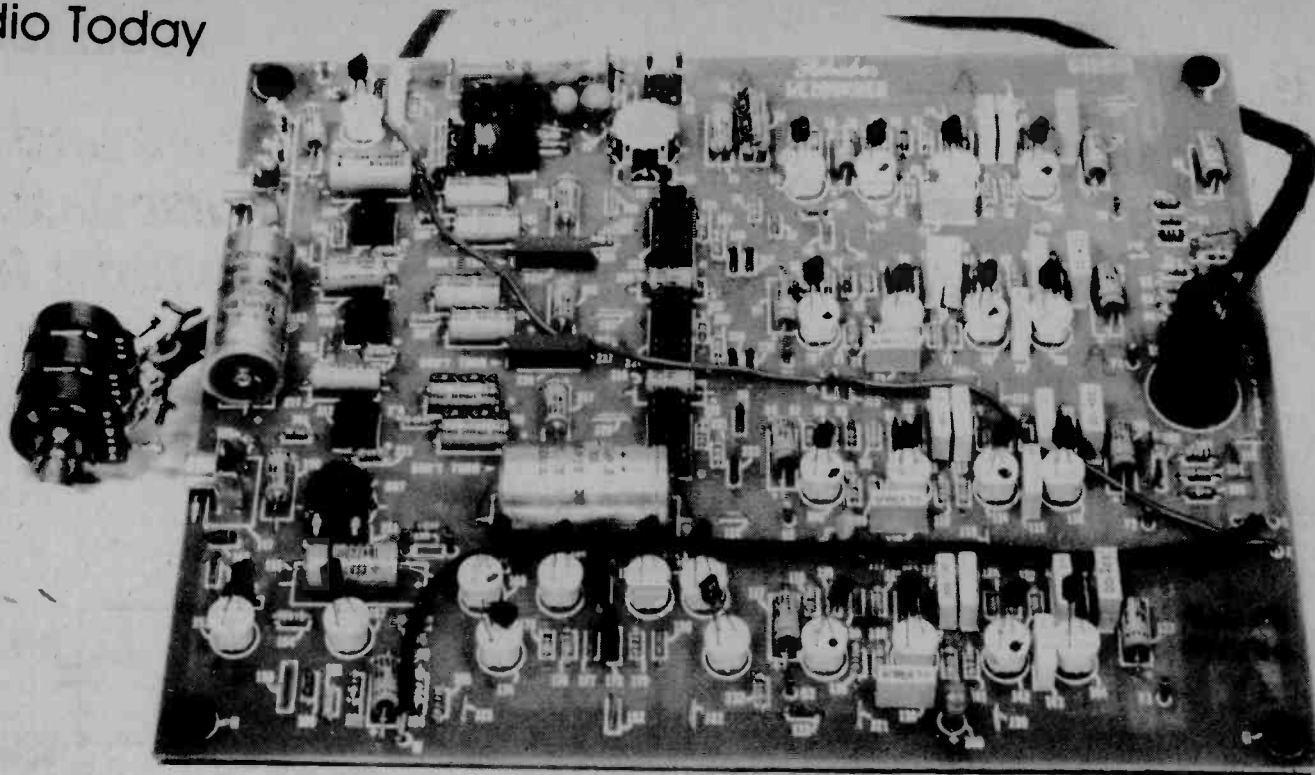

Schober's Rezoander adds reverberation.

Audio Today Products

Audio developments reviewed by ETI's Contributing Audio Editor Wally Parsons.

Two items this month are specifically aimed at electronic organ enthusiasts. Both are from the Schober Organ Corp., both are intended to replace mechanical devices, and although specifically intended for use in their own instruments should be adaptable to those of other manufacturers as well as reproduction systems.

First, the REZOUNDER, is a reverberation circuit intended to replace a tape reverb system used since the early sixties. Operation is said to be by means of three Bucket Brigade Devices of 4096 stages each. Delays of 0.1 second each, cascaded, and the final device output fed back to the input, allow for delay time adjustable from zero to six seconds in stepless increments. Also available is a multichannel adapter which distributes reverberation to all channels while preserving each channel's integrity.

Available in *kit* form, the RZ-4 Rezoander sells for US \$332.00 and the TRZ-2 Multichannel adapter is \$20.00.

ROTATONE

The second item, more suitable for use in organs than for reproducers is the ROTATONE, intended to replace

rotating speakers, such as the Leslie. It adds vibrato and tremolo, either at about a 6 Hz modulation rate, or switchable to a slower, more subtle rate. It can also be turned off. An "inertia" circuit allows for gradual speed-up and slow-down of the

modulation rate, but it is defeatable.

Also in kit form, the Rotatone sells for US \$87.50.

Write to The Schober Organ Corp., 63 West 61st St. New York NY 10023, or phone (212) 586-7552, and ask for Richard Dorf.

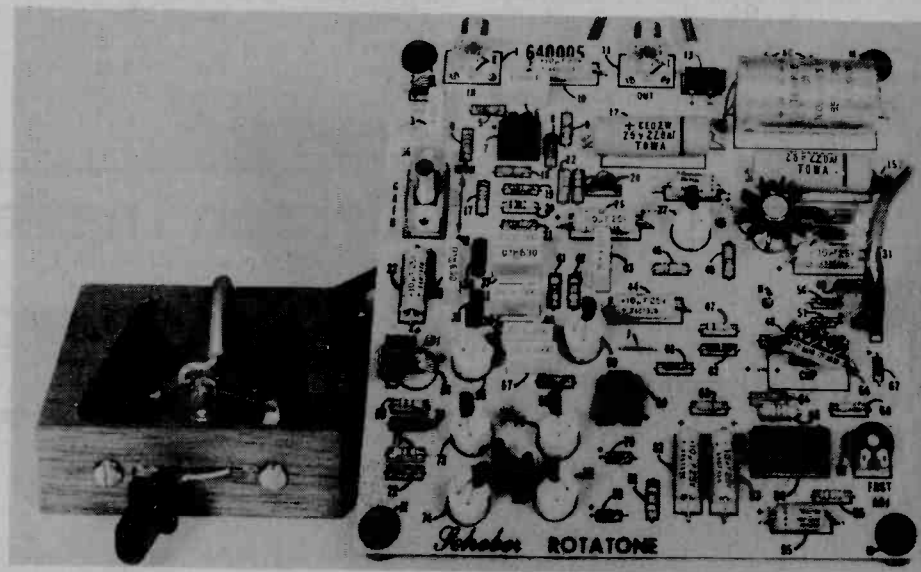

The Schober Rotatone simulates rotating speakers.

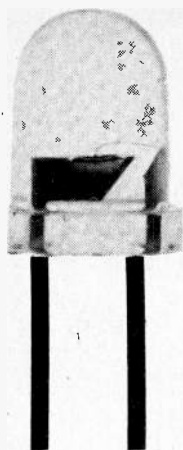

New column for teachers and students: a forum for discussion on curriculum and concepts from high school to university.

"ELECTRONICS IS FASCINATING." If you are reading this magazine, you are fairly likely to agree. But there's no doubt that it's difficult to convince others, or even get other people to understand your feelings for the subject area.

Yet learning about electronics is a little like learning a foreign language. At first it's incomprehensible, a mass of seemingly complicated words and concepts. After a while things become clearer and clearer until you can actually understand whole sentences and conversations, perhaps put together a few yourself.

Now having mastered the basics you can through usage build up to a very workable level of knowledge.

The big difference between learning a language, and electronics, is that if you don't learn anything about the language that's OK so long as you stay away from the country which uses that language. Electronics however is here and today, and taking an ever increasing part in our lives. To choose to avoid even a very basic understanding of electronics, is to be in the dark, and perhaps to some extent be in fear of this major factor in today's society. (Some such fears which spring to mind are those surrounding computers, and those relating to one's colour TV breaking down!)

So, it's important to know about electronics. That's what this column is about, making learning electronics easy, whether in the formal school atmosphere, or independently.

To this end we are providing this forum for discussing electronics education, and we invite letters from individuals (teachers or students), and groups, making or asking for suggestions in the following areas:

Philosophy of Electronics Education: What should be taught? Where should electronics education start? — personal views or conference consensus welcomed. If you're a student you're welcome to ask — "why did I have to learn

about...." or say "I'm glad I learned in this order...".

How to Teach Concepts:

Got any neat ways of getting across a certain concept? Brilliantly enlightening experiments? Or perhaps that's exactly what you lack — write to Teachers' Topics and we'll present your letter for discussion.

Teaching/Learning Materials:

Have you found any particularly useful books, or other aids? Or perhaps would like to comment on how poorly a certain concept is covered in all the texts you've seen, maybe someone will be able to suggest a better book, or write a better book for that matter!

Other Topics — You decide.

Write to Teachers' Topics, Electronics Today Magazine, Unit 6, 25 Overlea Blvd., Toronto, Ontario, M4H 1B1.

All letters we publish will receive a free subscription (or extension) to ETI for the school library or department of your choice.

Dear Sir:

I have been a reader of your magazine for the past four years and have found it invaluable in my teaching of electronics. The projects you have chosen and displayed have caught many a student's eye and thus they have pursued construction of same. I must also add that these projects the students have chosen to build from you magazine have been highly successful.

There are at times however the odd discrepancies which students in their zest for completion fail to see. This is of course where my job as an instructor becomes at some times difficult for I am called on to trouble shoot problems.

This trouble shooting could probably be aided with a few typical operating voltages and current draws related on the schematic diagram.

Another thing which I might comment on is that if the parts layout

diagram was placed beside the foil diagram it would aid students in mounting projects. If the student folds the page so as the parts diagram lays over the foil diagram, he or she has a visual picture of both sides of the board.

The system developed for identifying parts lists in your magazine is terrific, however a note somewhere within the magazine describing your system would be very helpful. The reason I mention this is: that students who have never been exposed to 2M2, tend to loose interest because of not recognizing the designation, in what was initially a highly interesting project. Remember for some people this may be the first issue they have ever looked at.

I hope the people of E.T.I. will continue to set the pace for highly stimulating and interesting projects and that I or other teachers will again be allowed to express some of our wishes, problems, or solutions.

Bob Harbottle

Electronics Instructor

We hope we'll get more comments from teachers such as you, both regarding the magazine and concerns of teachers and students. (Please note that component value notation is detailed every month in Project File.)

Calendar Date

The 1979 Frontiers In Education Conference will be held in Niagara Falls, Ontario Canada at the Sheraton-Brock Hotel on October 15, 16 and 17, 1979. The conference is sponsored by the Education Group of the Institute of Electrical and Electronics Engineers (IEEE) and the Education Research and Methods Division of the American Society of Electrical Engineering (ASEE). The purpose of the conference is to bring together persons concerned with education in schools, colleges, universities, and in industry and government to discuss new developments and new directions in engineering and other post-secondary technical education.

Audio Power Meter

This design multiplies voltage and current to come up with the correct value of power, using an analogue multiplier IC.

POWER IS PROBABLY the least understood and most misrepresented quantity in the electrical measurement system. This is especially so in the area of audio amplifier and speaker specifications when terms like peak, peak to peak, music and RMS are related to power.

Power is simply the rate at which energy is being used. It is expressed in watts and the value may vary from femtowatts (10^{-15} W), as in the input power of a FET, to thousands of megawatts in the power generation field. The term thousand megawatts is generally used in preference to the more correct term, gigawatts.

Power can be calculated simply by multiplying voltage and current:

$$P = EI$$

In a dc circuit where both voltage and current remain constant no problem arises. However in an ac or a dc circuit where the voltage is not constant with time, this formula only holds for instantaneous power as the power varies with time. Power as we usually use the term is the time average of this. If the load is resistive, i.e. contains no inductance or capacitance, and we can measure the RMS value of the voltage, we can still use this simple formula. However measuring the RMS voltage is not easy as most voltmeters measure the peak or average rectified voltage with a suitable scaling factor built in to give a correct result when measuring a sine wave signal.

If the load is reactive the current and voltage will no longer be in phase, i.e. the peaks do not occur at the same point in time. The difference can be expressed either by the phase angle in degrees or by the cosine of this angle (known as the power factor). The current waveform can either be ahead of the voltage (leading) or behind it (lagging). Capacitive circuits give rise to a leading power factor while inductive circuits lag.

If working with a sine wave, and if the power factor is known, the formula for power can be expressed as:

$$P = EI \cos \phi$$

where ϕ is the phase angle. In a dc circuit $\cos \phi$ is unity so the formula holds for this case as well. An example is a 40 W fluorescent light which takes 860 mA from the 120V AC. At first sight, this implies a power consumption of over 100 W, until it is realised that its power factor is about 0.45 lagging. The formula above, using $\cos \phi = 0.45$, thus gives a power consumption of only 46.4 W. (The additional 6 odd watts is dissipated in the ballast). The product of voltage and current is known as the VA rating and is used when calculating the currents in a circuit. If a capacitor is connected across a sine wave ac circuit the current taken can be calculated by dividing the voltage by the reactance of the capacitor. While this circuit draws current, it has a power factor of very near zero (90° phase lead) and therefore takes no power! By adding the correct

amount of capacitance to an inductive circuit (i.e. the fluorescent light) the power factor can be altered, reducing the current drawn (but not the power).

Confused yet?

Getting back to audio amplifiers and their ratings, the problem lies in the complex nature of the music waveform and how to specify the amplifier's rating. As the waveform is far from a constant sine wave with the peak power being anything up to 20 times the average, numerous methods such as peak power, peak to peak power, music power, etc. evolved. However, for a long time there was no set standard, and one amplifier advertised with a 50 W (music) rating was in fact a 5 W stereo amplifier. The situation got so out of hand that the US Government brought down legislation on how amplifiers were to be tested. This is with a continuous sine wave signal with level set so that the distortion is at a specified level and power calculated from the RMS output voltage: hence the term RMS power. Note however that the term RMS refers to the method of measurement, i.e. the use of RMS voltage, and it is not the RMS value of the power waveform. It is, in fact, the average of the power waveform.

Speakers are just as confusing. They are normally specified not in terms of the power they can dissipate, but the maximum power of amplifier they are suitable for. This is due to the fact that music is never (well, rarely) a

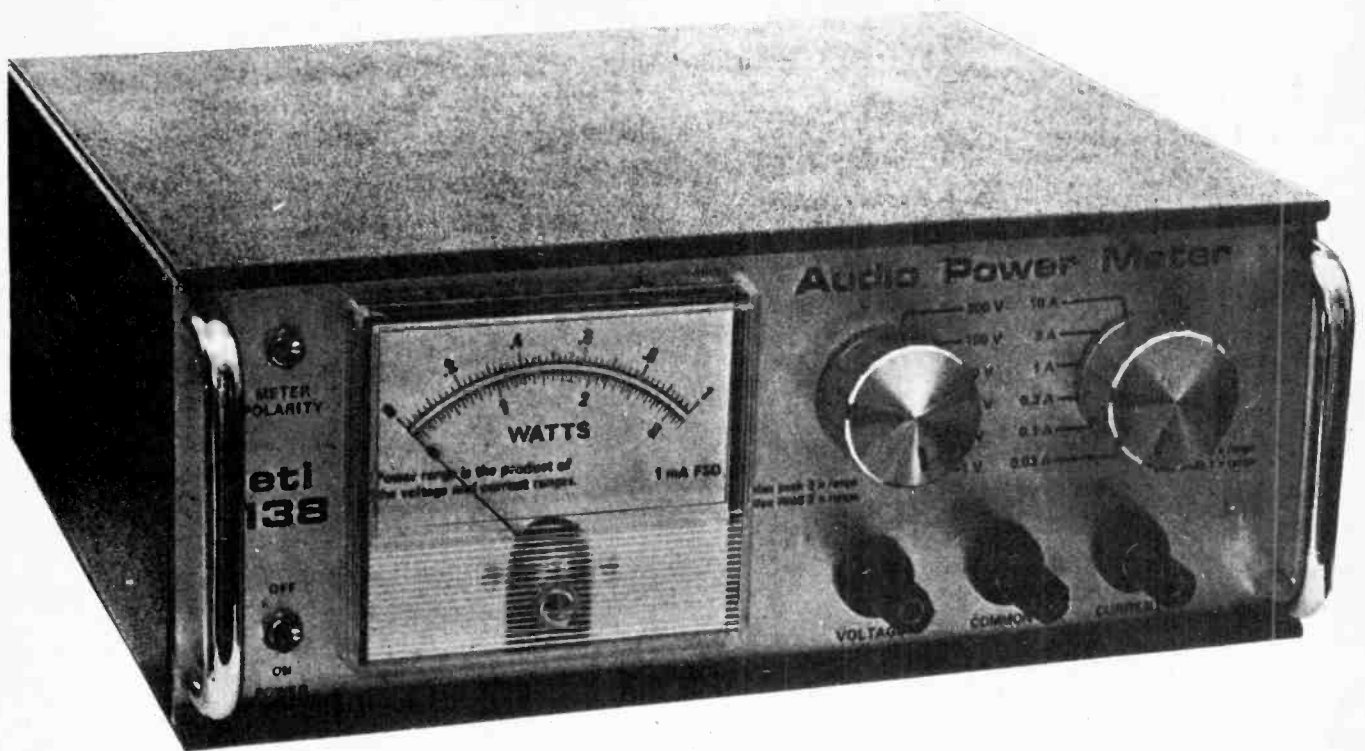

SPECIFICATIONS

Power range	30mW – 3000W FSD in eleven ranges
Input impedance	
1V	47k
3V–300V	100k
10A	0.1 ohm
3A	0.32 ohm
1A	1 ohm
0.3A	3.2 ohm
0.1A	10 ohms
0.03A	32 ohms
Overload capability	
Voltage ranges	RMS – 200% peak – 300%
Current ranges	RMS – 100% peak – 300%
Accuracy	< 5%
Frequency range	dc to 100kHz

continuous sine wave and the average power in the speaker may be only 10% of the RMS rating of the amplifier, even with the amplifier clipping.

To measure the power actually being delivered to the speaker under music conditions, a wattmeter must be used.

DESIGN FEATURES

To multiply current and voltage together we had the choice of analogue or digital techniques. Unfortunately while digital is the 'in' thing, offering versatility and accuracy, it is not fast enough to calculate the instantaneous power on high frequencies. We therefore chose the analogue method.

Looking around for ICs, the only ones with reasonable price and availability were the MC1494, 1495 and 1496. The 1496 (or 796) is the cheapest and most readily available, but has the disadvantage of not being able to multiply dc signals or ac signals with a dc offset. The 1494 and 1495 are about the same price, and of the two, the 1494 was more linear and easier to use.

We chose not to use any input buffer on the voltage input but had to pay the penalty of having a lower input impedance than normal with voltmeters.

ETI Project

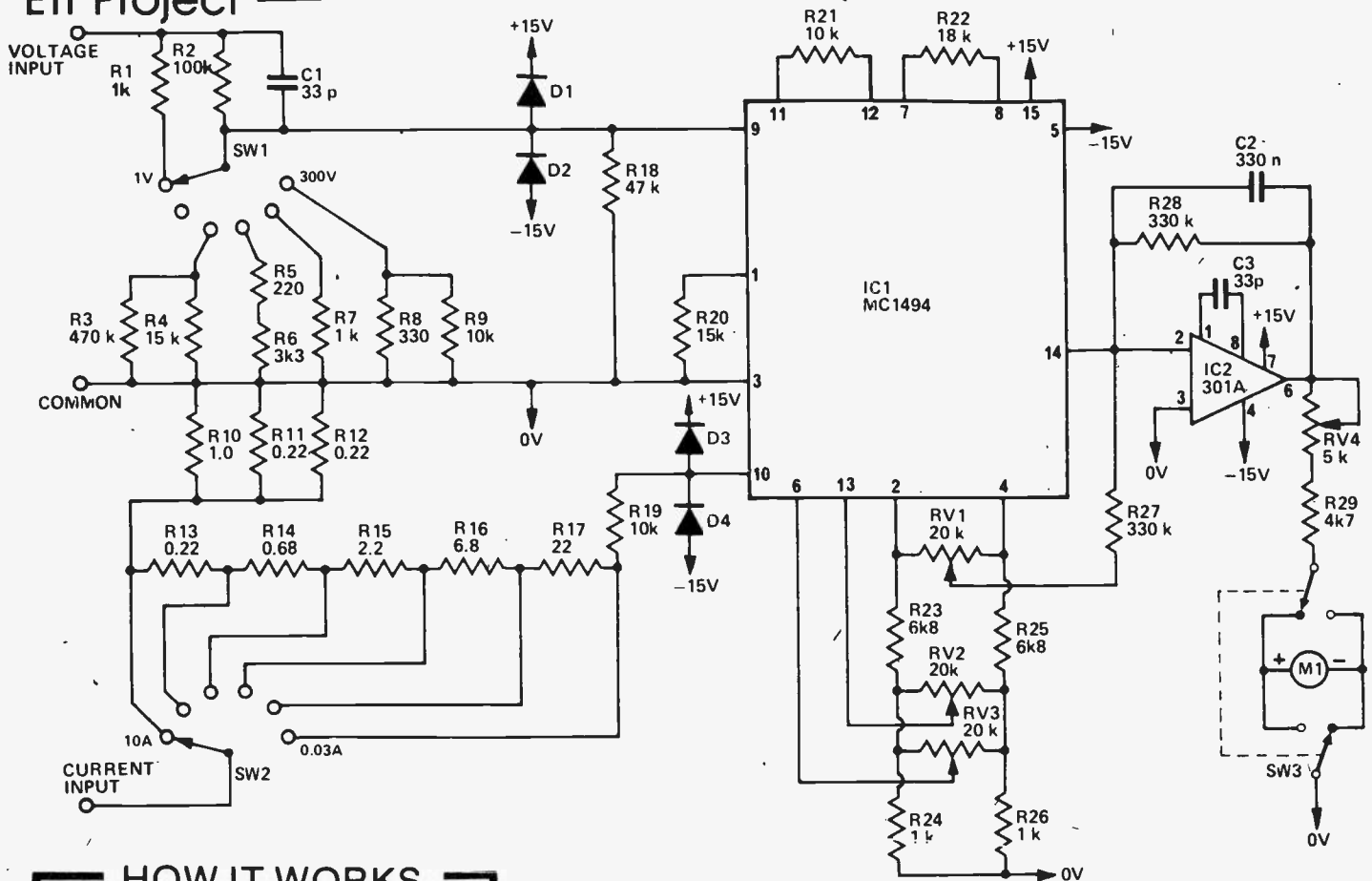

HOW IT WORKS

Power is the product of current and voltage. This holds irrespective of the nature of the load, provided you are talking about instantaneous power. By multiplying current and voltage together and then taking the average of these instantaneous values we find the true power. Again this works irrespective of the load.

In this circuit the multiplying is done by IC1 (MC1494), the output of which is a current proportional to the product of the inputs. For more detailed notes on this IC, see the separate section. The current output of this IC is converted to a voltage by IC2 with C2 providing the averaging. The meter is then simply wired across the output of this IC with a meter reversing switch provided. This reversing switch is needed not to measure negative power, but to correct for reversed readings due to differing external connections.

The power supply is a full wave bridge with a centre tap giving about ± 20 V dc which is then regulated to the ± 15 V required by IC1.

Adjustments for zeroing the voltage and current inputs are provided by RV2 and RV3 while RV1 compensates for offsets in the output. These are supplied by a stable ± 4 V reference in IC1. Range switching is done by SW1 and SW2. Protection against overvoluting the IC is provided by D1 - D4.

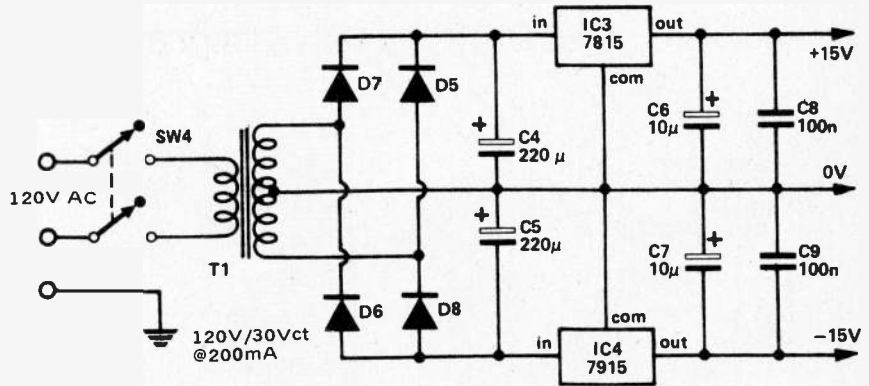

Fig. 1 The circuit diagram of the audio power meter.

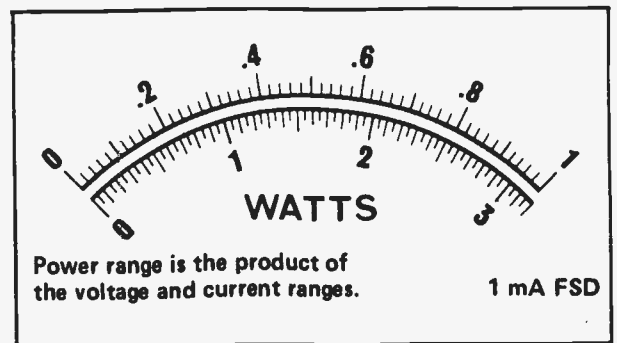

Fig. 2 Sample meter scale.

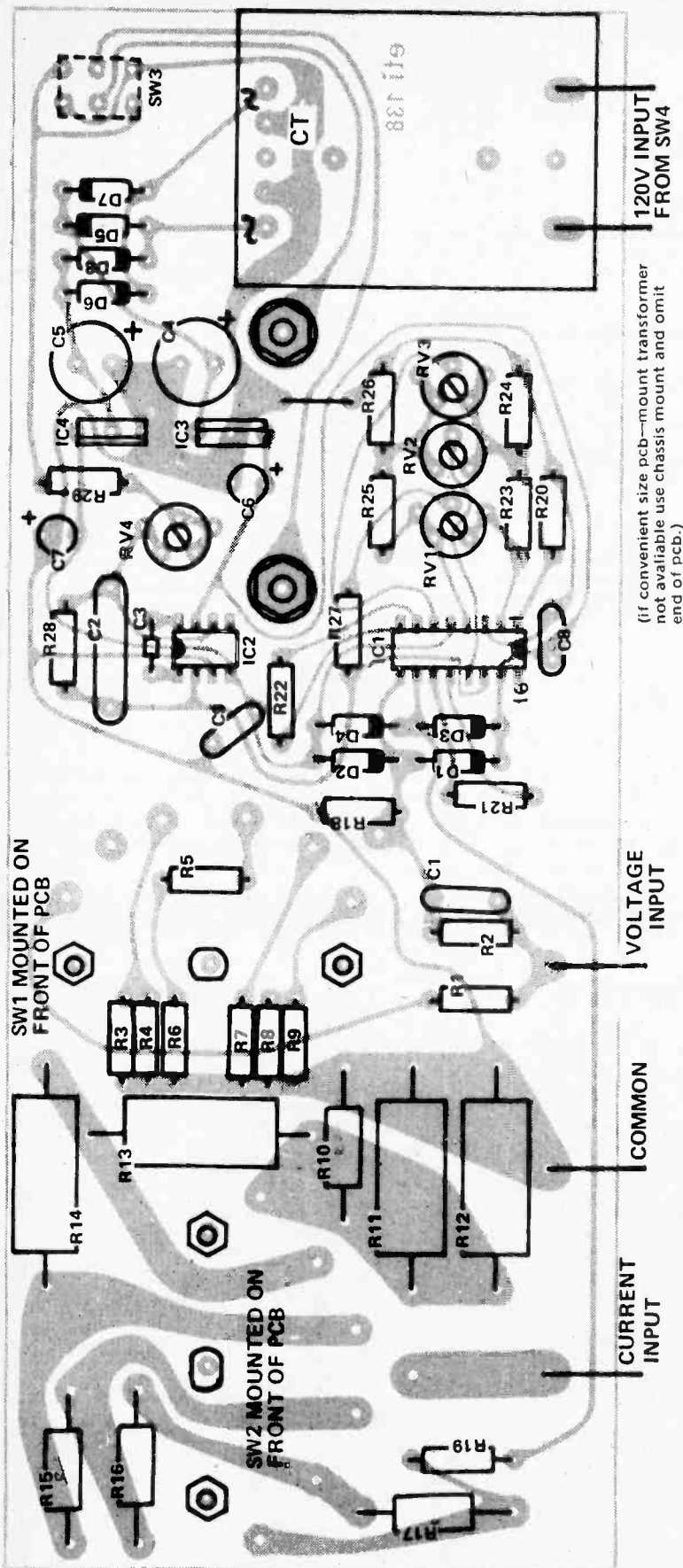

Fig. 3 The component overlay of the power meter.

PARTS LIST

RESISTORS all 1/4% 5W unless stated

R1	1k
R2	100k
R3	470k
R4	15k
R5	220R
R6	3k3
R7	1k
R8	330R
R9	10k
R10	1 ohm 1W
R11-R13	0.22 ohm 5W
R14	0.68 ohm 5W
R15	2.2 ohms 1W
R16	6.8 ohms 1W
R17	22R
R18	47k
R19	10k
R20	15k
R21	10k
R22	18k
R23	6k8
R24	1k
R25	6k8
R26	1k
R27, 28	330k
R29	4k7

POTENTIOMETERS

RV1-RV3	20k trim
RV4	5k trim

CAPACITORS

C1	33p 500V ceramic
C2	330n polyester
C3	33p ceramic
C4, 5	220µ 35V electrolytic
C6, 7	10µ 25V electrolytic
C8, 9	100n polyester

SEMICONDUCTORS

IC1	MC1494
IC2	301A
IC3	7815
IC4	7915
D1-D4	1N914
D5-D8	1N4004

MISCELLANEOUS

- PC board ETI 138
- SW1, 2 two pole 6 position 10A rotary switches
- SW3. 4 two pole toggle switches
- Transformer 30Vct .2A
- Meter 1mA FSD
- Three binding posts
- Instrument case 255 x 100 x 205mm
- Power cord and clamp
- Two knobs
- Front panel

PCB for this project is available from:
 B & R Electronics, P. O. Box 6326F
 Hamilton Ontario L9C 6L9, and
 Spectrum Electronics, 38 Audubon St. S
 Hamilton Ontario L8J 1J7.

ETI Project

USING THE POWER METER

To use the meter we must measure both voltage and current. There must be a common point for these measurements. The current connection can be in either of two ways as shown in the drawings below. One measures the power out of the supply and the second the power into the load. The difference? The current shunt in the wattmeter drops one volt when working at the full range value and this may or may not affect the reading. At 10 A this accounts for 10 W which, if the power being measured is only 100 W, is a 10% error — although if the measured power is 2400 W the error is only 0.4%.

The range of the meter is the product of the individual ranges, i.e. on 30 V and 1 A the fsd is 30 W, while 30 V and 3 A gives 100 W fsd. To help give a reading reasonably high on the scale, the voltage range can be overvolted by a factor of 2. Due to power dissipation problems this should not be attempted on the current ranges. The peak voltage or current can be as high as three times the range value.

CONSTRUCTION

We mounted all the components associated with the meter and the switches on a single pc board and if the same or similar case is to be used this is recommended.

Except for the meter and the switches the components are mounted on the 'normal' side of the pc board. These should be mounted first with the only critical part of the assembly in the area of the range switches. Here the high powered resistors should be spaced at least 5 mm from the pc board as they run hot at maximum current. Also the leads of all the resistors in this area should be cut off close to the pc board after soldering. This is to give adequate clearance to the rotary switches. We used two self tapping screws into the plastic of the transformer case to help fix it onto the board. We have made allowance for either the cermet (VTP) or the normal carbon trim potentiometer.

Particular care must be taken in selecting SW1 and SW2. These should be capable of handling at least 10A at 240V since they can be called upon to handle large power levels. A less substantial switch could become intermittent and cause dangerous transients. Make sure also that the switches are connected with heavy (no.16) wire to prevent power loss.

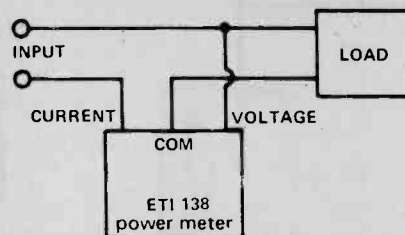

Fig. 4 This connection measures the power into the load.

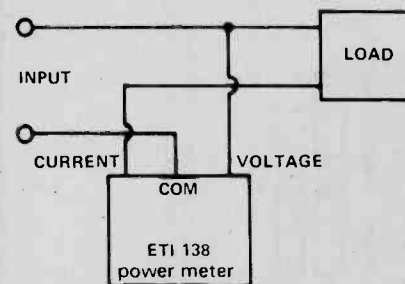
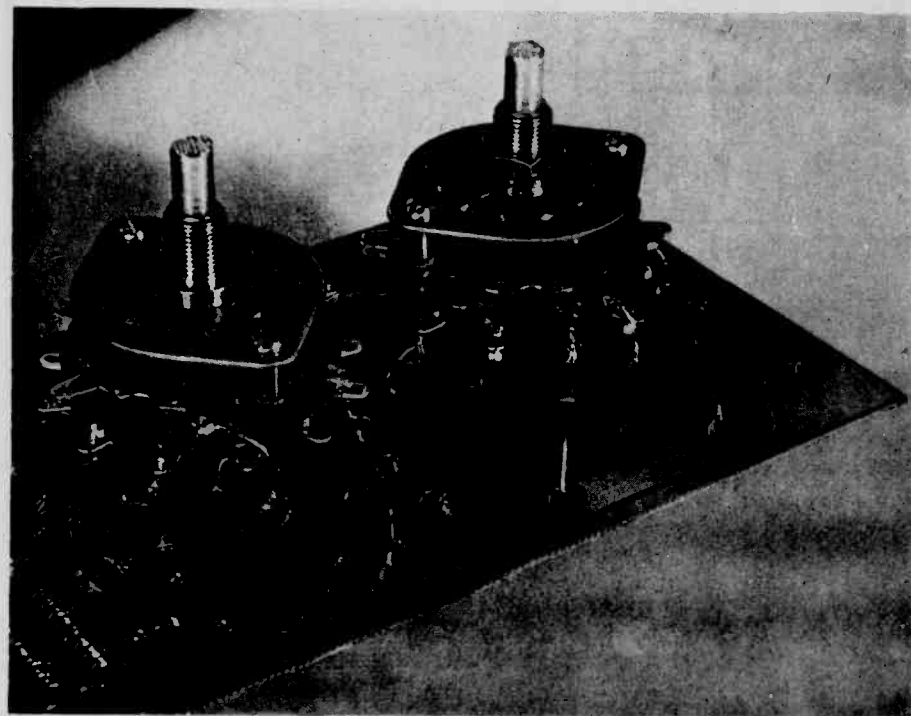

Fig. 5 This connection measures the power out of the supply.

If you mount the switches on the pc board as we did, be sure to use some means of support other than the switch leads. Vibrations and shocks could tear the foils from the board.



Mount the meter onto the front panel along with the two toggle switches and the binding posts. Remove the nuts from the voltage switch, leaving one on the current switch and then mount the pc board onto the meter. Run the nut on the current switch up to the back of the front panel and then fit the second nut on the the front side.

The toggle switches can now be wired along with the power wiring, fitting the knobs ready for calibration.

CALIBRATION

Four adjustments are required, which are performed as follows:

Select the 1 V and 0.03 A ranges and switch on. If the meter reads in reverse, toggle SW3. Don't worry about the reading unless it is off scale. If it is, adjust RV1 to bring it back towards zero. Now apply a voltage of about 1 V dc to the voltage input and note the meter deflection. Adjust RV2* until there is no deflection when this voltage is applied. Now apply the voltage to the current input (it will take about 30 mA) and adjust RV3 until there is no deflection. Recheck the voltage input and readjust if necessary.

Now with no voltage applied adjust RV1 to give zero output. Apply exactly 1 V to both current and voltage inputs and adjust RV4 to make the meter read FSD.

This is all the calibration that should be necessary.

ABOUT 1494

The 1494 is a variable transconductance multiplier with a bidirectional current source output. What this means is that it looks at the voltage on the two inputs and gives an output current proportional to the product of the two. Typical applications include: multiply, divide, square, square root, phase detection, frequency doubling, balanced modulation/demodulation and electronic gain control. An internal circuit diagram is given below for those interested.

VALUES AND LIMITATIONS

- 1 For best temperature coefficient R_1 (pin 1 to 0V) should be 16k (we used 15k as it is easier to obtain). This sets the value of all the current sources inside the IC ($I_1 = 8/R_1$)
- 2 The value of R_x (pin 11 to pin 12) should be $\geq 3x$ peak input voltage (X) expressed in k ohms.
- 3 The value of R_y (pin 7 to pin 8) should be $\geq 6x$ peak input voltage (Y) expressed in k ohms
- 4 Choose the scaling factor required ie $V_{out} = K \cdot V_x \cdot V_y$
- 5 Load resistance (pin 14 to 0V) can be calculated by $R_L = (K \cdot R_x \cdot R_y \cdot I_1) / 2$
- 6 If R_L is connected between pin 14 and 0V without an inverting amp. the frequency response is limited by the output capacitance of 10pF.
- 7 For best temperature coefficient the load between pins 2 and 4 should be 8.6k.

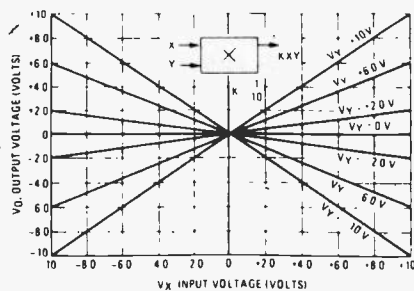

Fig. 6 Transfer characteristics of the IC.

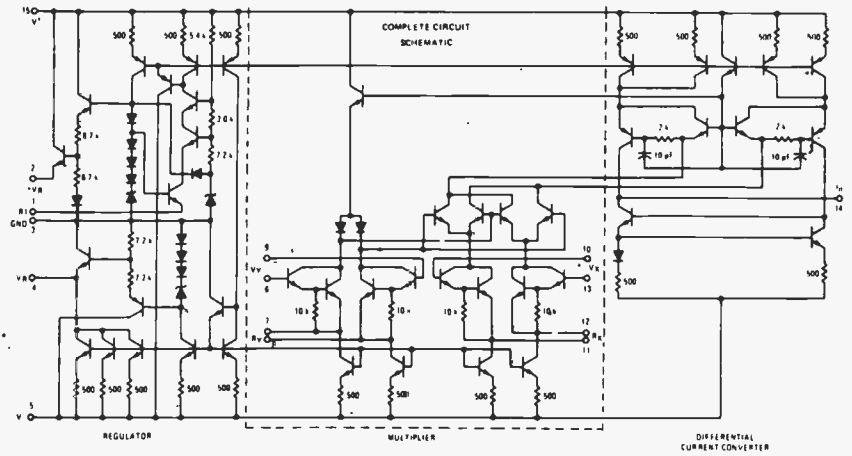

Fig. 8 The internal circuit diagram of the IC.

Fig. 9 Typical connection of a low frequency multiplier. For a squaring circuit simply parallel the two inputs. In this case pin 6 can be connected to 0V and P1 deleted.

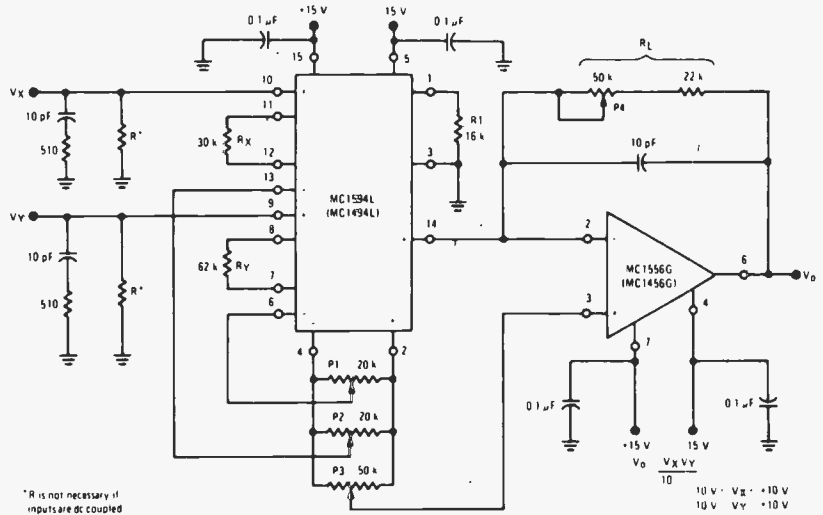

Fig. 10 Typical connection of a divide circuit. For the square root joins pin 9 and 10. Like the squaring circuits pin 6 can be connected to 0V and P1 deleted.

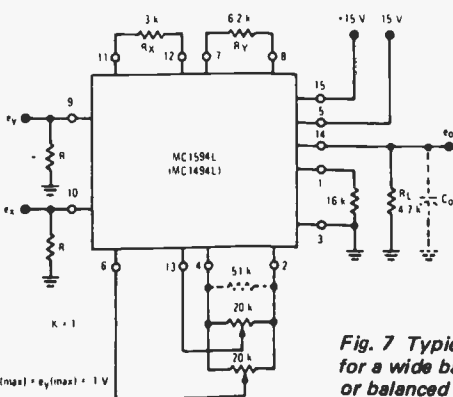
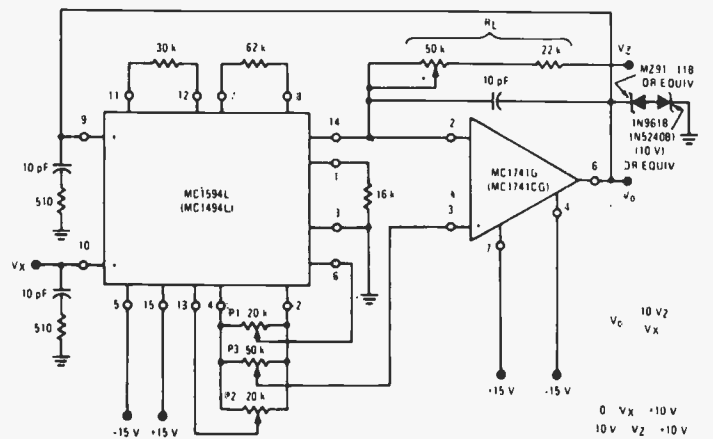
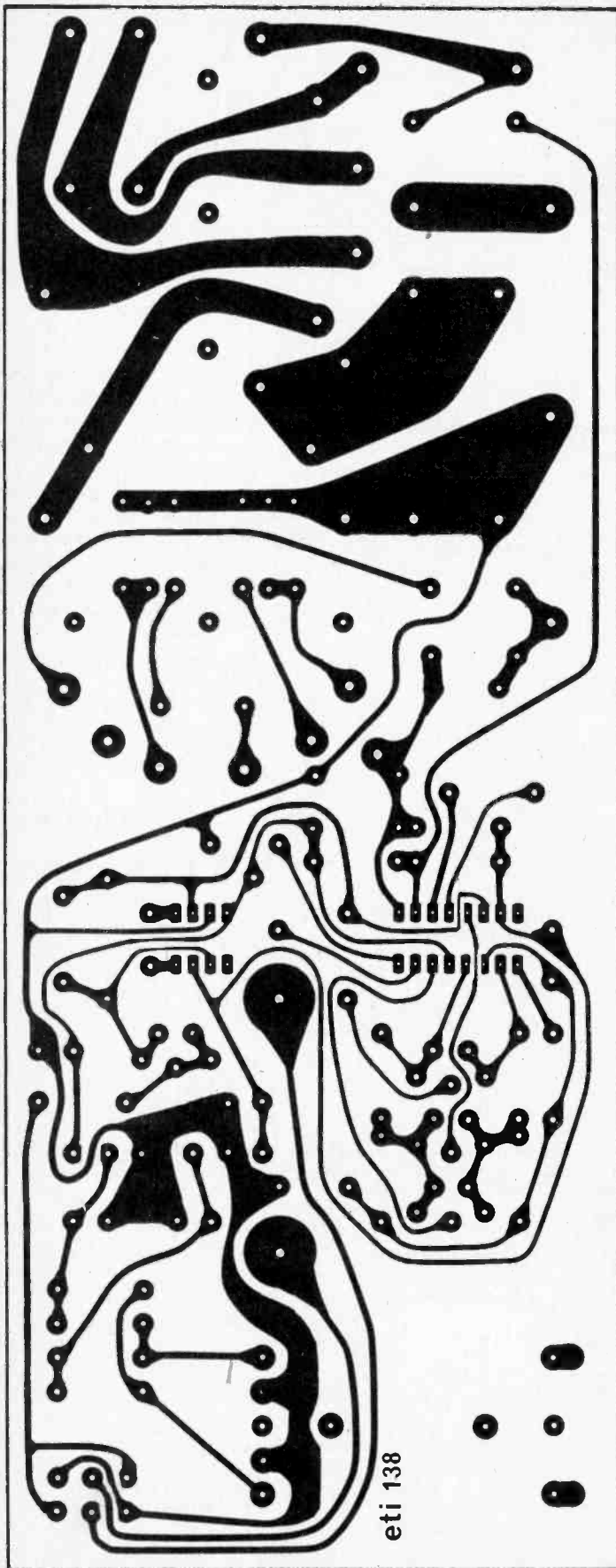

Fig. 7 Typical connections for a wide band multiplier or balanced modulator.



eti 138



MODEL SP100
UNIVERSAL OSCILLOSCOPE PROBE KIT



SP100

Switchable X1 & X10 Attenuation Factor

APPLICATION

A switchable X1 and X10 attenuation factor allows the Model SP100 Universal Oscilloscope Probe Kit to satisfy a wide variety of user applications. In addition, a "ground reference" switch position enables the oscilloscope input to be grounded at the probe tip. This feature facilitates ground reference location on the CRT display. It also serves as a positive means of trace identification. Standard accessories are included within each probe kit to further enhance its versatility. These include an I.C. tip, insulating tip, BNC adaptor, sprung hook and trimmer tool. Specifications are excellent.

Rugged, yet flexible, construction further adds to the usefulness of each SP100. This is achieved through a break resistant (undulated wire) center conductor, effective strain relief at connector and probe head fittings, and a "BNC pin diameter" tip.

OTHER KEY FEATURES

- 100 MHz Bandwidth
- Ground Reference Can Be Activated At Probe Tip
- Break Resistant Center Conductor
- Wide Compensation Range
- Slender, Flexible Cable
- 1.5 Meter Length
- Sharp, Heavy Duty Tip (BNC Pin Diameter)
- Fits All Oscilloscopes

SPECIAL INTRODUCTORY OFFER

SP100 DUAL SWITCHABLE X1-X10 REG. \$46.08 **\$35.00 EA.**

WE ALSO CARRY A COMPLETE LINE OF
HAMEG OSCILLOSCOPES AND COLINE PROBES.

BCS ELECTRONICS LTD.

980 Ainess St. Unit 35, Downsview, Ontario M3J 2S2, Tel: (416) 661-5586.

eti PANEL TRANSFERS

A really high quality system for finishing off your projects. The sheets include a mass of lettering and control scales for both rotary and linear pots.

The lettering is transferred simply by laying on to the panel and rubbing down — it's strong and permanent.

The markings are on two sheets (a full-sized one cut in half for easy postage) and contain sufficient lettering for dozens of projects.

Send \$3.50 (including postage) to ETI PANEL TRANSFERS. Unit Six, 25 Overlea Blvd., Toronto, Ontario, M4H 1B1. Ontario Residents add PST.

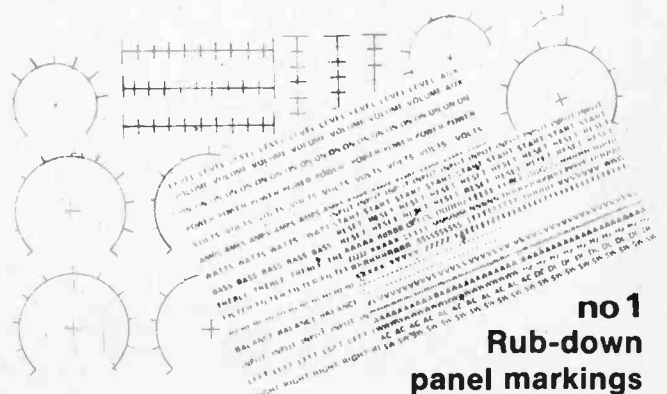

no 1
Rub-down
panel markings

Survey: Boxes and Cases

It's three in the morning and you've just got your ETI Wet working, now what are you going to put it in? John Van Lierde surveys cases available in Canada...

THE REALIZATION of a project has different forms for different people. Some experimenters are merely content to breadboard their designs and leave it at that. Others never get past the pc-board-with-four-feet stage.

The impact of any project you undertake depends heavily on its final appearance. Your girlfriend will probably be more impressed by an electronic egg-timer in simulated woodgrain case with handles than your Z80 microcomputer with 169k RAM mounted on a single sided pc board with its 1350 jumper wires.

All this comes down to the subject of this month's survey, small equipment enclosures.

There is a wide variety of enclosures available in Canada to the experimenter and the engineer. They range from simple miniboxes to expandable rack and console systems. In between, there are equipment cases, shadow cabinets, miniature consoles, shielded enclosures and so on. Many of the items here are used in industrial and commercial applications. All are used in various prototyping applications.

Prices for these items can be quite high (like \$230 for the biggest Zero Centurion Elite Carrying Case), but remember that these boxes are engineer-

ed, and are usually part of an integrated system of hardware. A brief study of Hammond's Pac Tec or Zero's 6 Way VIP enclosures will bear this out.

For space reasons, this survey is limited to small enclosures. However it should be noted that Hammond*, Zero, Amco, and Scientific Atlanta all manufacture equipment rack systems with a broad range of accessories such as blowers, power panels, drawers, etc. These are very expensive systems, costing well into the thousands. Definitely not for that egg timer.

Some products, such as Hammond's, are widely distributed and we couldn't list all their retailers. If there aren't any dealers in your area, check out Camgard, Electrosonic, or Cesco-Electronics.

In any case (no pun intended), you will have to write for catalogs, information, and possible distributors in your area. Tell them ETI sent you.

PRICES

To simplify matters, we have established the following criteria for pricing. Low applies to items below \$15.00. These are generally the plain unadorned miniboxes that we've all come to know and love. There is however some fancy

* Chroma Racks, see News Digest, July 1979 ETI.

stuff here, check out, for instance, Radio Shack or Jana. Medium applies to equipment over \$15.00, but under \$100.00. This applies to virtually all the manufacturers we surveyed. High applies to anything over \$100.00. For the most part, items such as these are beyond the scope of this article. However, for microcomputers, instruments and so on, these enclosures are unparalleled for their versatility, ruggedness and appearance.

ADDRESSES

- GC ELECTRONICS
write to:
• Canadian Astatics Ltd.
1820 Ellesmere Road
Scarborough, Ontario M1H 2V5
• Electrotec Marketers
1624 Third Ave.
Vancouver, B.C.
SCIENTIFIC-ATLANTA
write to:
• Scientific-Atlanta (Canada), Ltd.
1640 Bonhill Rd.
Unit 6
Mississauga, Ontario L5T 1C8
VERO & OKW
write to:
• Electronic Packaging Systems Ltd.
P.O. Box 481
Kingston, Ontario K7L 4W5
AMCO
write to:
• R N Longman Sales Inc.
1715 Meyerside Drive
Unit 1
Mississauga, Ontario L5T 1C5
JANA ELECTRONICS LTD.
available from Camgard distributors or
write to:
• Jana Electronics Ltd.
1777 Ellice Ave.
Winnipeg, Manitoba R3H 0W5
ZERO CORPORATION
write to:
• Active Component Sales Corp.
(head office)
5651 Ferrier Street
Montreal, Quebec H4P 2K5
• 4800 Dufferin Street
Downview, Ontario M3H 5S8
• Baxter Centre
1050 Baxter Road
Ottawa, Ontario K2C 3P2
• 3070 Kingsway
Vancouver, B.C. V5R 5J7
HAMMOND MFG.
check your area or write to:
• Hammond Mfg.
394 Edinburgh Rd.
Guelph, Ontario N1H 1E5
or
• Electro Sonic Inc.
Willowdale, Ontario M2H 3B3
• Cam Gard Supply Ltd.
Winnipeg, Manitoba
• Cesco Electronic Ltd.
Montreal, Quebec H4P 1W1
VECTOR ELECTRONICS CO.
write to:
• Electro Sonic Inc.
• Cesco Electronics Ltd.
• R-A-E Industrial Electronics Ltd.
1629 Main Street
Vancouver, B.C. V6A 2W5

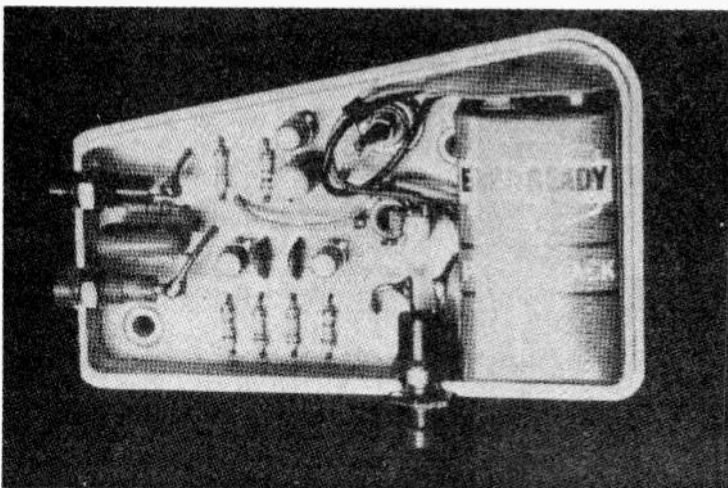

Nifty signal tracer mounted in Vero Hand-held style case.

Survey: Boxes and Cases

Hammond Mfg.

Perhaps the sole Canadian manufacturer of enclosures, Hammond offers a broad line of enclosures to the experimenter and engineer. Of particular note are their new Pac Tec, 1456 and SCED series of Desktop Consoles.

Pac Tec has one of the more elegant styles of instrument cases we've seen. Fabricated from moulded ABS plastic, the cases come in a variety of colours. Features include, multiple height and card mounting grooves and bosses. Some models also have six position tilt stands/handles. Sizes available are from 8 x 9 x 2" H at \$28.50.

The SCED series of consoles are designed to harmonize with any setting. They feature solid oiled walnut end pieces and textured paint finishes. The utility of these units is enhanced with a line of accessories including Chromafilter® display filters, custom punched (for keyboards) sloping panels and hinged covers with holding struts 15° and 30° slopes in sizes from 10 x 10 x 4.4" H at \$44.00.

The 1458 series of instrument cases is an example of an integrated system of

cabinet components. This series offers over 300 colour/size combinations from a selection of 21 components. Sizes from 7 x 7 x 3" H at \$14.10.

Hammond also has a large selection aluminum chassis and boxes. Check their catalog # 9C-5 for full details.

Hammond has a large number of retail outlets across Canada, which makes their products more available than most.

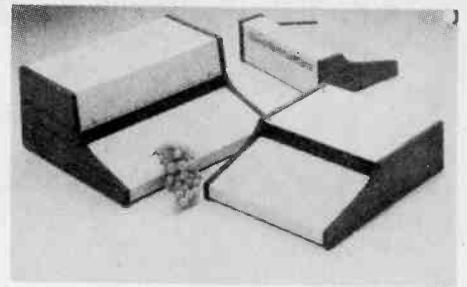

SCED Series consoles.

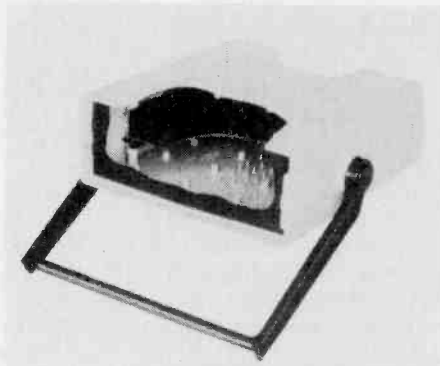

Pac Tec.

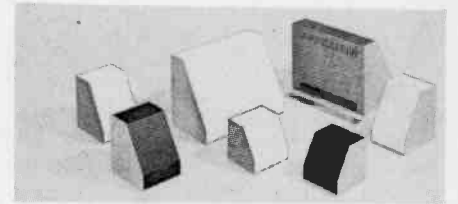

LOW SILHOUETTE CABINETS
1000 SERIES

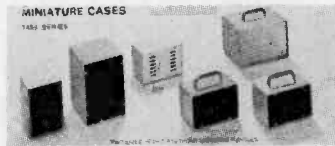

MINIATURE CASES
1000 SERIES



SLOPING FRONT UTILITY CASES
1000 SERIES

Zero Corporation

Zero specializes in deep-drawn aluminum technology. Advantages of this include rugged two piece construction, hermetic sealing is more easily accomplished, and pleasing contours.

The basic box resembles a tiny bath tub with lid. These come in round and rectangular configurations in a wide variety of sizes. Sizes start at 2 x 3 x 2" H at \$4.50.

Other deep drawn product include Centurion Elite Carrying cases, which are essentially light weight aluminum suitcases. Sizes from 9 x 12 x 5" H.

Zero VIP 6-Way Enclosures are another example of multifunction enclosures. Several units can be joined together to form larger enclosures. Accessories include side handle, rack mounting handles and tilt stands. Similar, and somewhat less expensive products are Zero's Compact enclosures.

Zero products price in the medium to high range. Future Electronics imports and distributes them through Active Components sales with four locations in Vancouver, Toronto, Ottawa and Montreal (head office).

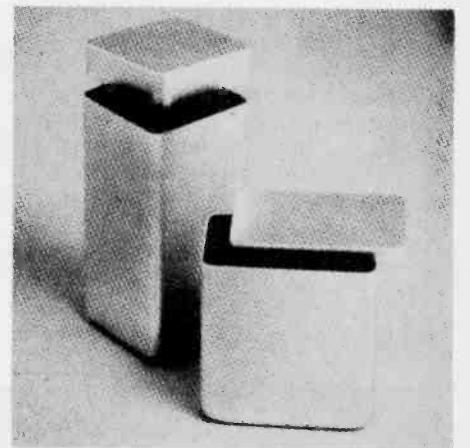
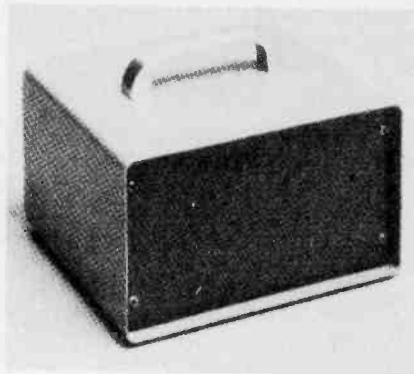

A few of Zero's products. Top left, 400 Series instrument cases. Above, deep drawn aluminum boxes with lids. Left, Compact 1 Cases.

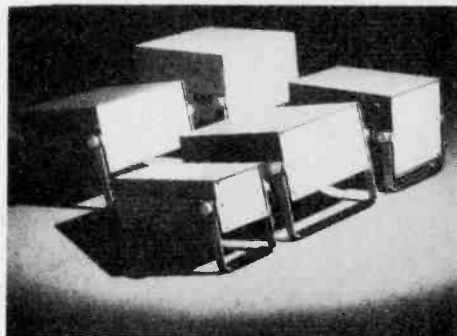

AM/FM FREQUENCY DISPLAY & CLOCK

Up-date your HI-FI set up with this frequency and time display that can be an add-on accessory or built into a modified AM/FM set.

Receiver or tuner requirements:

All Solid State
10.7 MHz FM IF
455 KHz AM IF

Assembled

\$75⁰⁰

Plus Tax

Add \$2.50 shipping & handling

**Limited
Quantities**

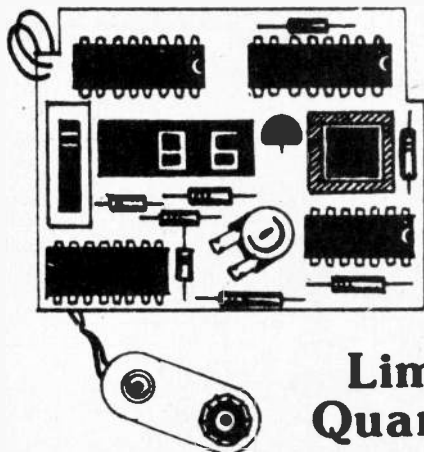
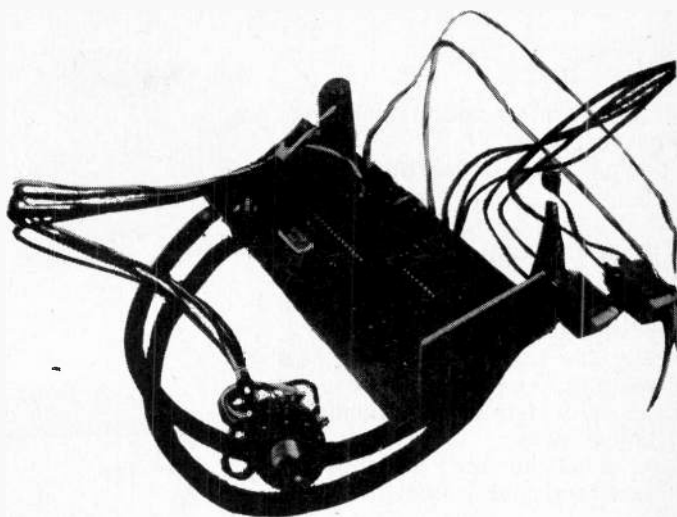

**Limited
Quantities**

DIGITAL TIMER COUNTER

- 2 Digit LED Display
- CMOS Circuitry
- 9V Battery Operation

We have come up with a stop watch modification allowing the counter to count in seconds.

\$3⁰⁰

Plus Tax

3 Digit LED Display, add 50¢

Add \$1.00 Shipping & Handling

SEMICONDUCTORS

2N3050.....	50¢	CD4001.....	15¢
2N3054.....	35¢	CD4007.....	15¢
1TIS131.....	25¢	CD4015.....	15¢
MC1001.....	50¢	MC1458.....	50¢
74141.....	50¢	LM308.....	50¢
7493.....	50¢	TIL080.....	50¢
74LS93.....	50¢	LM747.....	50¢
74121.....	50¢	C103-SCR.....	30¢
74161.....	50¢		

Limited Quantities

DURACELL MERCURY BATTERY

Model RM12

1.4 Volts

50¢ each

WE HAVE ETI PROJECT BOARDS

Send today for your free price list!

We Buy & Sell Anything

- Electronic Components
- Measuring Instruments
- Tooling
- Electric Supplies

ACTIVE SURPLUS ANNEX

345 Queen Street West
Toronto, Ontario

(416) 368-7936

Radio Shack

Radio Shack offers a good selection of low cost cabinets.

For digital projects their display case offer fair value. Supplied with red tinted filter, its size is approximately 2 x 4 x 4½". Price including mounting bracket is \$5.69.

Radio Shack also has several attractive cabinets at a low price, typically \$14 to \$20. These cabinets feature either carrying handles or tiltbails and are fabricated of aluminum and laminal steel.

Also available are a range of miniboxes and chassis from 3 x 2 x 2" H at \$2.

Radio Shack has over 640 stores and dealers across Canada. This, coupled with their low/medium prices makes their products more accessible than most.

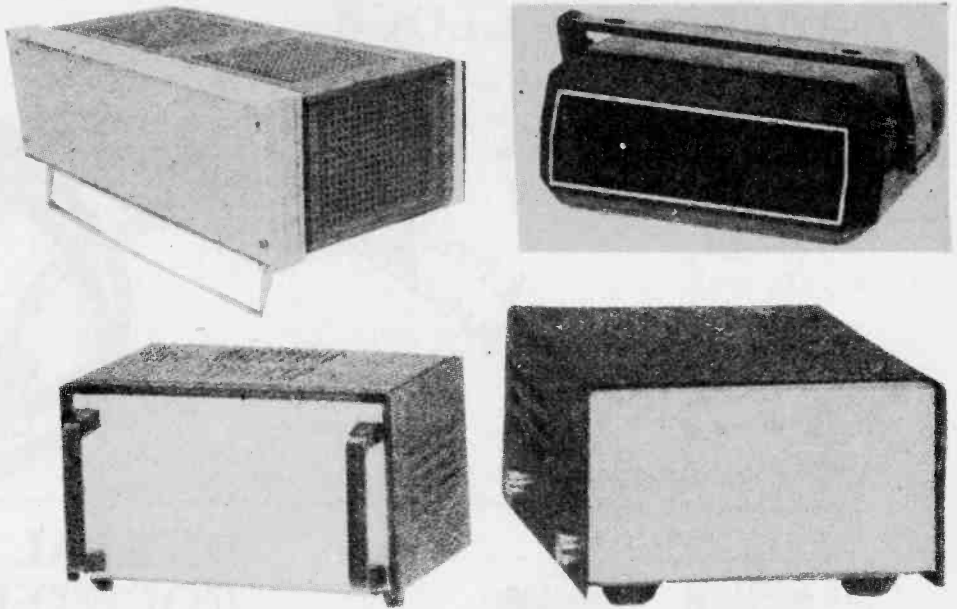

Radio Shack offers a broad range of cases and cabinets at low prices.

Odenwalder Kunststoffwerk

OKW (I'm not writing it out in full again) manufactures a broad range of high impact polystyrene cases. A lot of their products exhibit thoughtful design with such refinements as moulded battery cases, clear plastic lids and conveniently placed bosses and cutouts for mounting speakers and pc boards.

Product names include Standard Box, Tall Standard Box, Standard Box with Handle, Sloping Front Box, Ventilated... you get the idea.

OKW products are distributed by Electronic Packaging Systems Ltd. You'll find that prices are in the low-medium range.

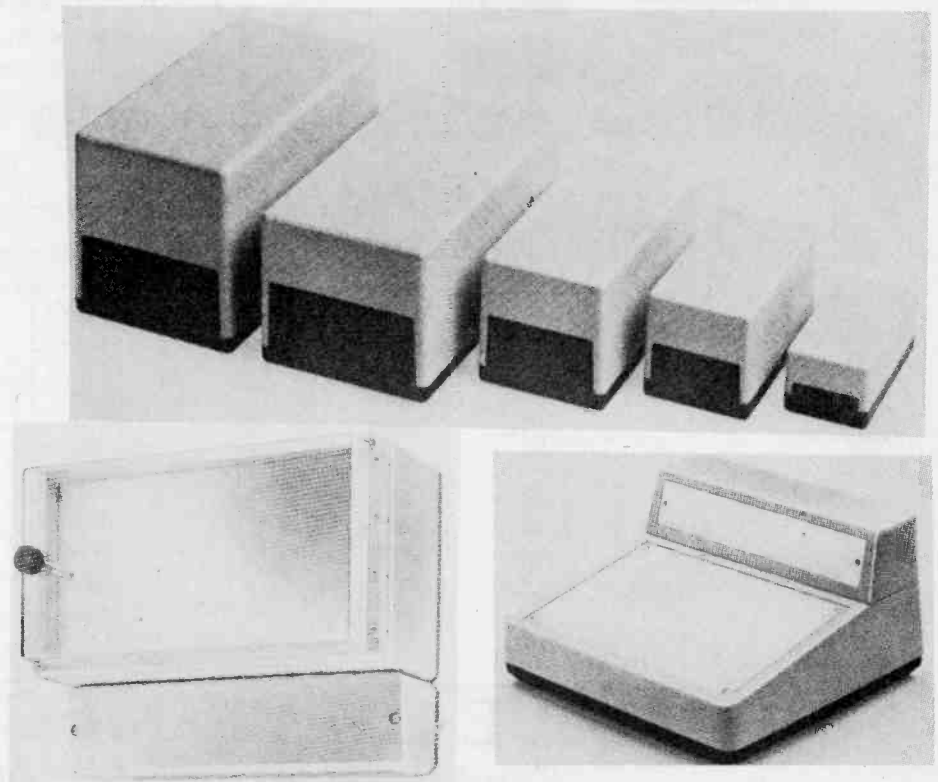

Top, one of many types of Standard Boxes. Far right, console with aluminum panel. Left, Wall mounted box, note enclosure for connectors at bottom.

Jana Industrial Electronics

If you need an inexpensive case, check out Jana's selection. They have three bakelite boxes to choose from, the smallest (5 x 2.5 x 1½" H) starting at \$4.75.

Also available is a handy two piece

box. Fabricated from steel, it is formed with two flanges to allow mounting on any flat surface.

Jana also has two shadow cabinets. One is 4 x 2.5 x 2.5" H at \$2.75, the other 8½ x 5½ x 2" H at \$7.55. Jana products are available from Camgard Supply Ltd. and some Jana dealers.

See Jana's ad, page 69.

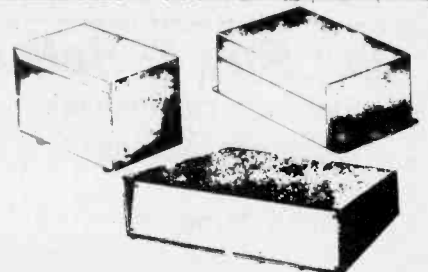

GC Electronics

GC Electronics manufactures a wide range of simple boxes. First there are two styles of plastic boxes. One is fabricated of phenolic with recessed lid. There are four sizes available from 3.75 x 2.5 x 1.3" H. Another variety is made from high impact styrene and comes with aluminum lid.

GC also offer 10 sizes of snap lock aluminum boxes, starting from 2 x 1.3 x 1.2" H.

GC Electronics products are imported by Canadian Astatics and Electrotek Marketers.

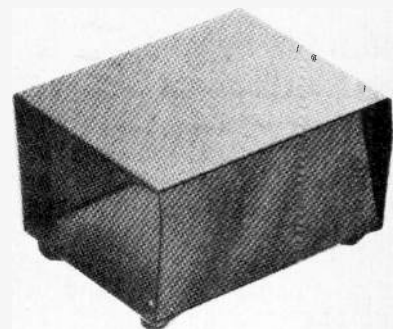
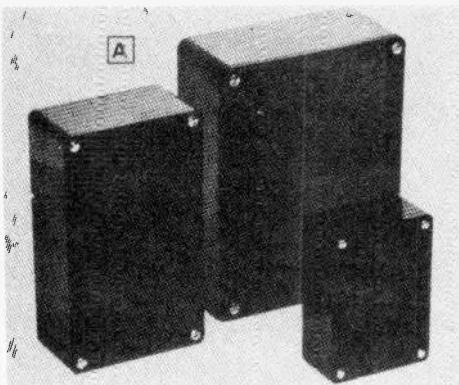

Vector Electronics

Vector is another manufacturer of integrated cabinets. They offer three different lines; Vector Cono-Cases, Vector-pak series VP and VS.

Vector-pak is constructed of aluminum alloy extrusions and plates. Options include card mounts that allow pc boards to be inserted from any side. Also available are pc standoffs (hinged, no less), plexiglass covers and a choice of 11 colours.

Cono-Cases offer two piece construction at a lower cost. Accessories include ribbon cable assemblies and hinged board standoffs.

These cabinets list in the high range. Vector products are available from RAE Industrial Electronics, Cesco Electronics, and Electrosonic. Cases and accessories available only on order.

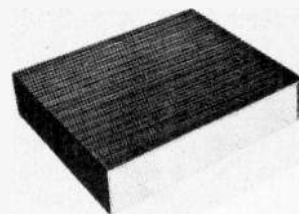
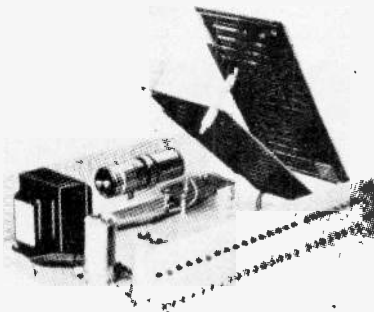
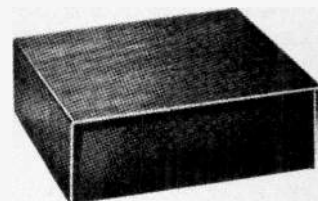
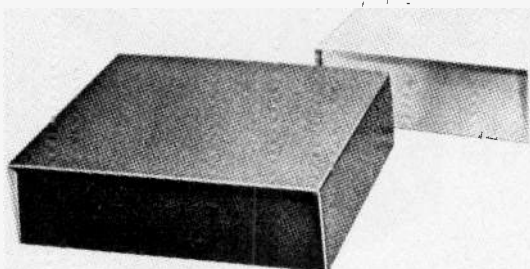

Top, Vector's Series VP instrument cabinets. Bottom, Cono Cases.

Amco Polydimensional Case

One the more expensive products we've reviewed, Amco Polydimensional cases offer extreme versatility to the designer. The fundamental case has a base of 19 x 18 3/4" D, with a choice of heights from 3 to 14". In addition the cases can be combined to produce consoles of literally any shape and size. Angular configurations are possible also. Handles extend the full length of the cabinet allowing easy carrying no matter where the center of gravity is.

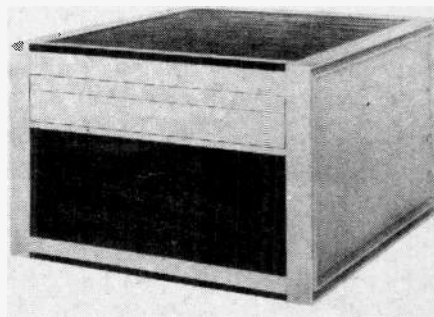
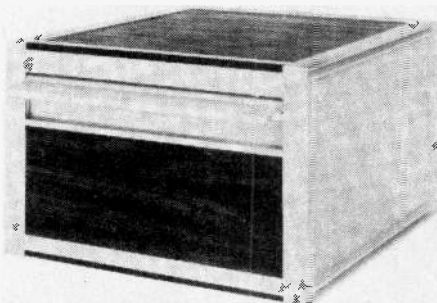

Panelling comes in walnut, black and white vinyl. Anodized Aluminum Trim in gold clear or black. Price for a basic 5" high case is \$122 US. Contact RN Longman Sales.

Survey: Boxes and Cases

Top right, Vero Flip Top Instrument Cases. Top left, Verobox aluminum enclosures. Bottom right, how Verobox works.

Vero Electronics Ltd.

Vero Electronics has a huge array of boxes available in Canada. Most cases are of moulded ABS construction with aluminum front panels. Products in this category include small (hand held) instrument cases with hinged lids, Vero-case consoles, and hand held control box.

Also available is a product called Verobox. These enclosures are constructed of interlocking extruded aluminum sections. Any size/shape combination is available up to 4 x 8 x 8" H.

Vero also offers instrument cases designated as D Series Slimline cases. Construction is of steel and aluminum and accessories include front handles, panels, tilt feet and so on.

Sizes start at 11 x 8.5 x 4.3" H.

Vero products are distributed by Electronic Packaging Systems Ltd. Other products include wire wrapping tools and accessories, printed circuit soldering systems and various types of connectors.

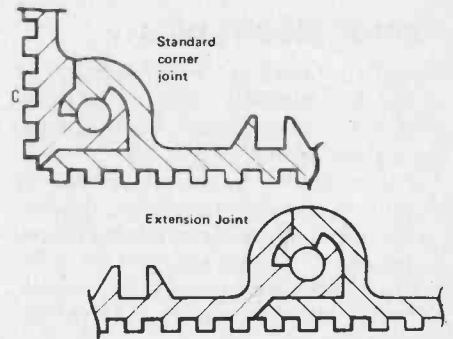
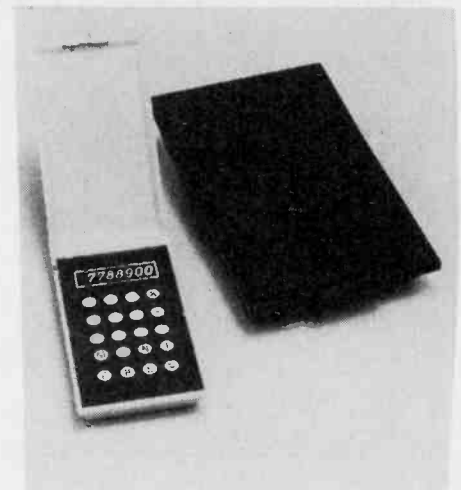
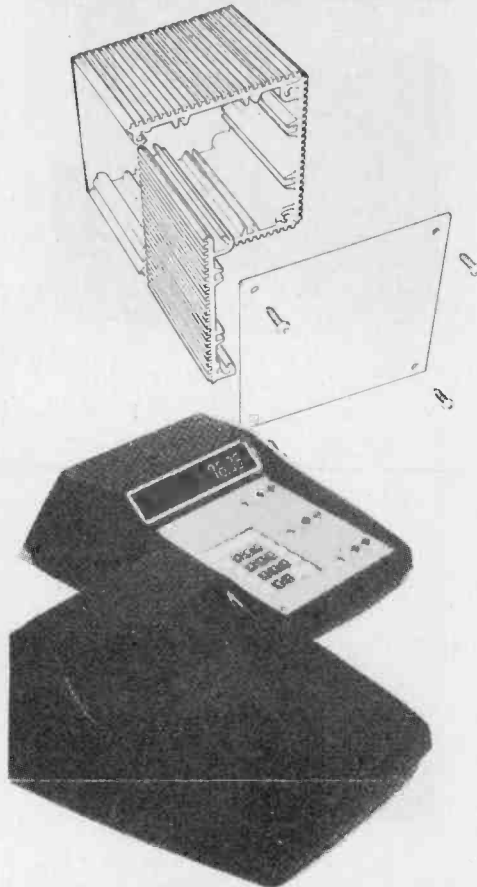

Right, Vero console, a wider model is available.

Scientific-Atlanta

Scientific-Atlanta offers a clean functional line of Optima cabinets. The various lines are called Optima Pak, Optima 17, Optima Accent, Optima (do you see a pattern?) Small Cases and so on. Features available include wood sides, handles sloped fronts, tilt stands, perforated panels and more. Sizes start typically at 5 x 11 x 3" H and go up to sizes that can accommodate 19" racks.

Prices for these units sit in the medium to high category. A 5 x 10 x 3" H high Optima Small case lists for \$45 US.

Scientific-Atlanta also manufactures instrument racks and desks in an attractive range of styles. Write to Scientific-Atlanta (Canada) Ltd.

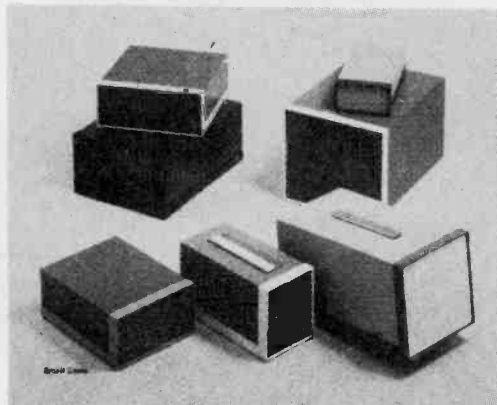
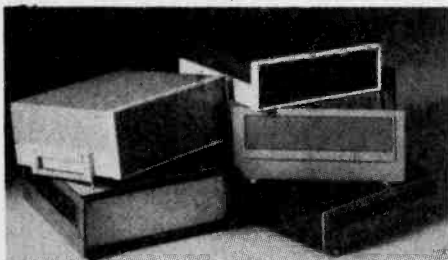
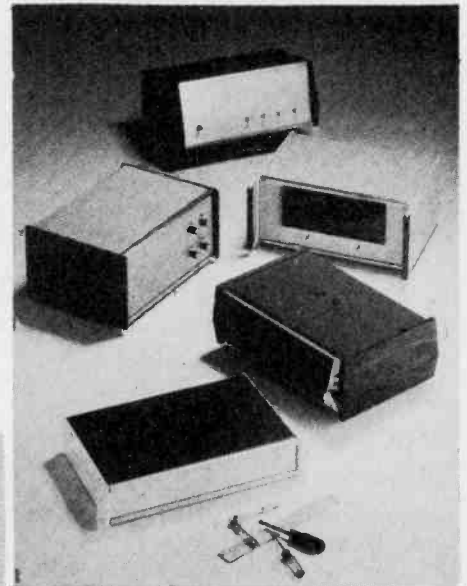
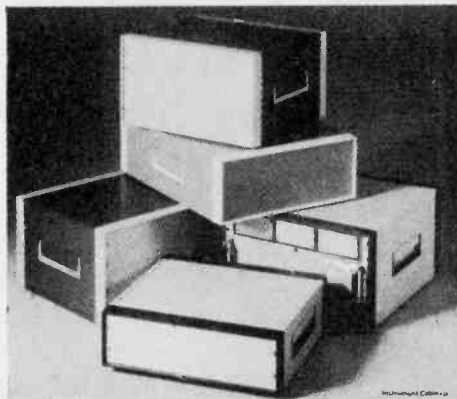

Far left, Optima 17. Left, Optima Small Cases. Top left Optima Instrument Cabinets. Above, Accent Cases.

New Sinclair DM235 digital multimeter.



Reg. \$159.95

\$149⁹⁵

SPECIAL LIMITED TIME OFFER AT THE DISTRIBUTORS LISTED BELOW.

3½ digits . . . 6 functions . . . fully portable!

Sinclair DM235 offers the most important features in a bench-top meter in a rugged yet lightweight instrument for true portability! High basic accuracy (0.5% 2VDC range), high resolution (8mm LEDs), high input impedance (10 megohm) means superior performance at a price lower than any competitive makes. Special offer valid till August 31/79 at participating distributors. See it today!

Six Functions, 26 ranges
 DC Volts 1mV to 1000V
 AC Volts 1mV to 750V
 DC Current 1uA to 1A
 AC Current 1uA to 1A
 Resistance 1 to 20M
 Diode test 0.1uA to 1mA

SINCLAIR DMM's AVAILABLE IN: MONTREAL - Addison TV, Microtron, Visiontronique. TORONTO - A-1 Electronics, Arkon, Dominion Radio, Duncan Instr., General Electronics, Gladstone Electronics, MISSISSAUGA - Atwater. LONDON - Provincial Electronics. OTTAWA - Kris Electronics, Wack'd Radio. WATERLOO - Waterloo Electronics. KITCHENER - Orion Electronics. HAMILTON - Canadian Admiral. GUELPH - Neutron Electronics.

Dealer/distributor enquiries welcome. AUDIEX ELECTRONICS, 1736 Avenue Rd., Toronto (416) 787-7367.

INTRODUCING COMPUCOLOR II

The CompuColor II is a disk based microcomputer system for business and personal use.



- 13" COLOR MONITOR
- 17K R.O.M.
- 8K R.A.M. (16 & 32 AVAILABLE)
- COLOUR GRAPHICS
- BASIC
- FULL SIZE KEYBOARD
- FLOPPY DISK
- RS232 INTERFACE
- MUCH, MUCH MORE

JUST \$2250.00

MAIL ORDERS: Ont. Residents add 7% Prov. Tax, F.O.B. Toronto. Please specify shipping method desired.

COME IN AND SEE US
 FULL SERVICE DEPARTMENT
 COMPLETE SELECTION OF BUSINESS SYSTEMS AND SOFTWARE IN STOCK.

OPEN Thus. & Fri. Til 9:00 p.m.

HOUSE OF COMPUTERS INC.

368 EGLINTON AVE. W., TORONTO, ONT. M5N 1A2
 (416) 482-4336 (AT AVENUE RD.)

THE KING

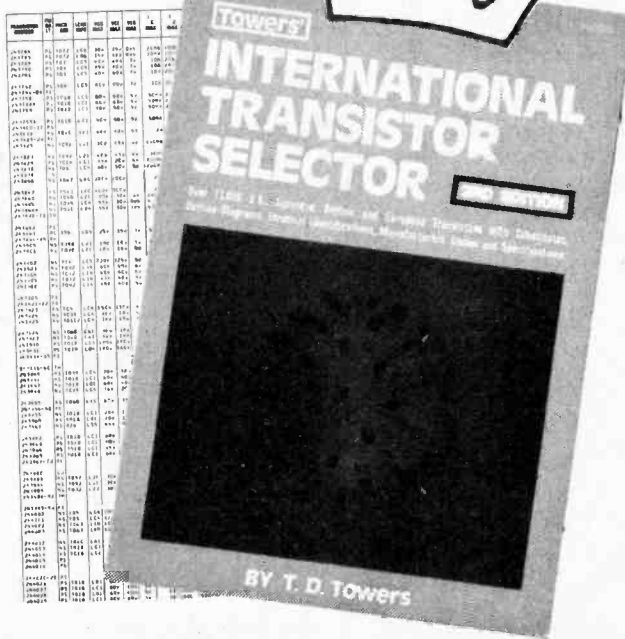
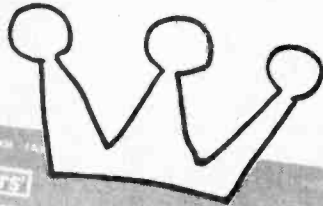

TOWER'S INTERNATIONAL TRANSISTOR GUIDE is now available from ETI. We are proud to be able to bring you this "bible" of transistor data. It contains data on over 13000 transistor types, 2Ns, 2SCs, European and "replacement" types. Information includes polarity, material, package and lead info, maximum ratings for VCB, VCE, VEB, IC, TJ, P, minimum FT, HFE, typical use, manufacturer and suggested equivalents.

To order use the card in this issue, or mail the coupon below to: TOWER'S, Electronics Today Magazine, Unit 6, 25 Overlea Blvd, Toronto, Ontario, M4H 1B1.

OK ETI - I don't want to be in the dark about transistor specs any longer - send me THE KING. Here's my \$8.95 plus .45 for postage and handling. (That's \$9.40 if your calculator battery is flat, or 2 for \$18.80)

NAME _____

ADDRESS _____

Cheque enclosed. DO NOT send cash.

Bill Mastercharge. A/C No. _____

Bill Chargex. Expiry Date _____

Signature _____

Electronic Shoot out

Jana presents a means of settling your arguments the electronic way.

IN THE DAYS OF THE OLD WEST you took your life in your hands just walking down the street. Men (and women, they were all tough) lived on the knife-edge of death. Bar room brawls ended up with shoot outs and when the smoke had cleared, someone lay dead in the streets.

This, however, is not true of the times we live in now. Modern discos are much to loud for brawls, and modern gun control laws severely restrict the fatality of such occurrences.

You can, if you wish, relive (at least vicariously) these exciting times in your own living room with our electronic shoot out game.

DRAW!

The game consists of three LEDs. Two at each end represent the gunners while a center one (green) signals when to 'fire'. When the center LED lights, both

players fire by pressing their respective buttons. The LED of the winning 'gunman' lights up. There is one wrinkle added to keep everything honest and above board. If either gunman fires before the green LED lights, the green LED will flash on and off signifying that there's foul play afoot. The game can be reset by switching it off and then on again.

CONSTRUCTION HINTS

Layout is not critical, if you wish you can use perforated board or Veroboard. We have included a pc pattern for your convenience.

Mount the LEDs on the board in such a fashion that the green LED is between the two red ones. Alternatively you can mount the LEDs elsewhere and connect them with lengths of wire. The pushbutton switches should be mounted sufficiently far apart to prevent players from interfering with each other.

When you have finished wiring the whole thing together, make sure that wiring is correct before applying power. In particular verify the orientation of the ICs and transistors.

When you are sure that all is well, connect the battery and go nuts.

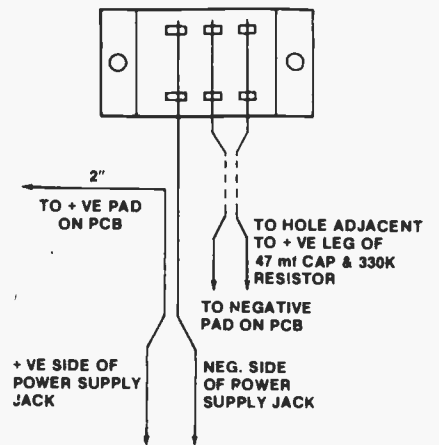

Detail for wiring SW1. Light hook-up wire is satisfactory.

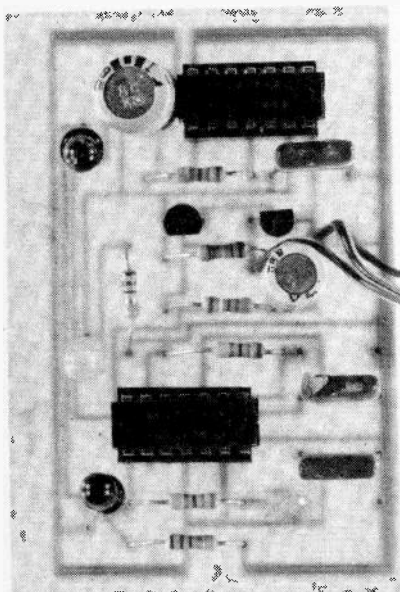

Electronic Shoot Out. Note that most parts can be mounted on the pc board.

Complete kits are available from Jana, see ad on page 69 for details.

PARTS LIST

RESISTORS

R1,2,5	680R 1/4W
R3,4	330R 1/4W
R6	330k 1/4W
R7	39k 1/4W

CAPACITORS

C1,2,3	22n 50V mylar
C4	100u 16V electrolytic
C5	47u 16V electrolytic

SEMICONDUCTORS

Q1	2N3702
Q2	2N3707
IC1,2	7400
LED1,2	red LED
LED3	green LED

SWITCHES

SWL,SWR	SPST pushbutton
SW1	SPDT slide switch

MISCELLANEOUS

6V battery or similar power source
pc board
case, solder, wire, hardware, patience, etc.

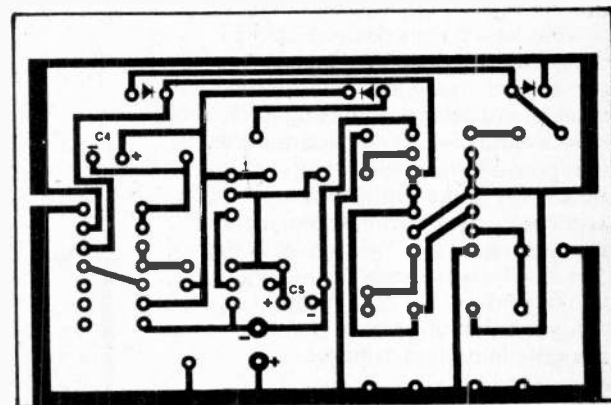
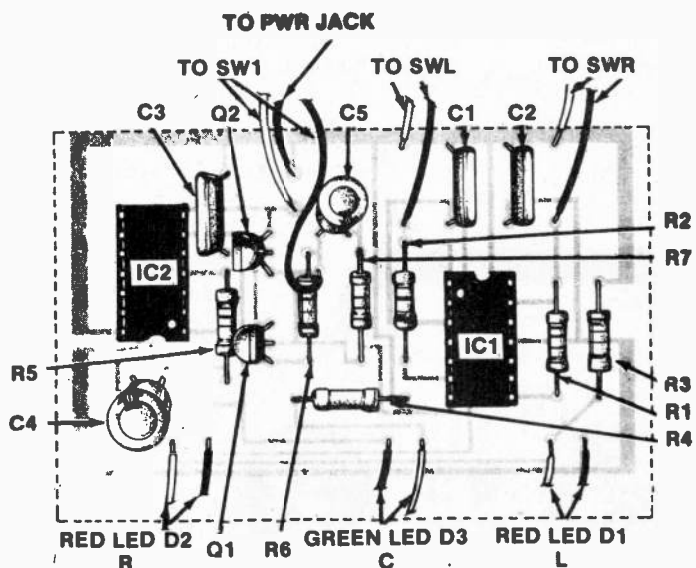
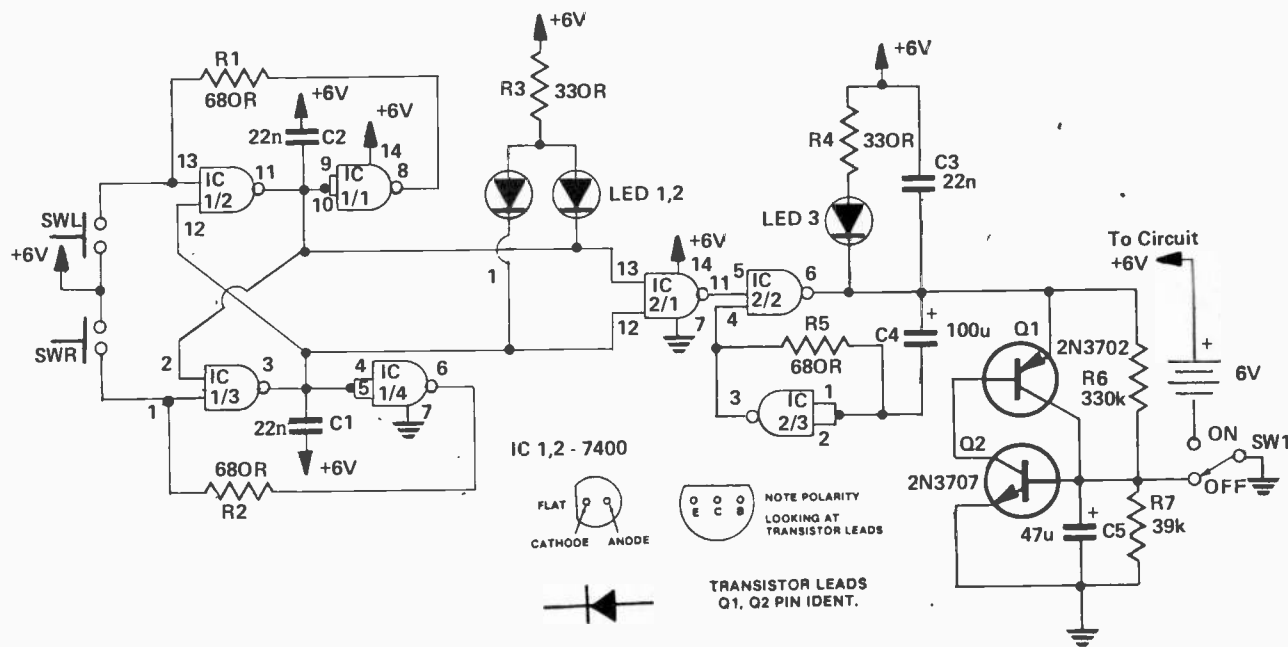

Layout of components on pc board. Use this in conjunction with the photo on the left.

Full size pc template.

HOW IT WORKS

The circuit may be broken down into four main blocks. These are: IC1/1,2 and IC1/3,4 each forming a "bistable multivibrator"; IC2/2,3 forming an oscillator of about 2 Hz, and finally a timing circuit composed of Q1 and Q2 with associated components.

(First it is important to remember that the TTL NAND gates in this circuit work as follows: both inputs high means output low, otherwise output is high.)

A bistable multivibrator is a circuit which is stable in two states, that is to say its output can either be high or low and will change only in response to a particular change at the input. In our case pins 11 and 3 of IC1 are the outputs, and pins 13 and 1 the inputs of the multivibrators.

Initially when switching on the circuit it would not be known which state the

multivibrator would start up in. Thus C1 and C2 are incorporated to initially force the outputs high. This of course means that the two red LEDs are off.

Meanwhile, at the other end of the circuit, C5 is slowly charging up due to the small current through R6. When the voltage on the base of Q2 is sufficient, about .6V, Q2 switches on which switches Q1 on which switches Q2 on more (in other words you can be sure that the pair is on) and draws current through the green LED3, telling the players to fire.

Supposing player L activates his push-button first (SWL). Then IC1 pin 11 goes low, lighting his LED to indicate that he won. In addition, the low output on pin 11 is connected to the input of the other player's multivibrator, and disables it from changing output state, hence the slower player's LED cannot go on.

To reset the game SW1 is switched off, discharging C5, and also C1 and 2.

The only remaining circumstance to account for is the guy who fires before the green light. If this happens IC2/1 output (pin 11) will go high, allowing the oscillator IC2/2,3 to operate, which flashes the green LED on and off repeatedly.

But doesn't this conflict with the operation of Q1 and Q2? No. If the green LED is flashing, the fluctuating voltage at the "top" of R6 means that C5 doesn't charge up any more. If on the other hand the time has properly run out and the green LED is continuously illuminated, then it doesn't matter what IC2 pin 6 does, since TTL outputs, when high, are capable of supplying very little current, so that Q1 and Q2 will draw enough current to light the LED and "pull down" the output IC2 pin 6.

ETI Wet

Plant Waterer

If your plants suffer from a drink problem let our ETI WET look after them when you are away, ensuring that they get their daily dose of life giving liquid.

WATER, WATER, EVERYWHERE and not a drop to drink runs an old poem, well plants need to quench their thirst as well as humans — and during holiday time most are left to wilt. In the interests of flower power we decided to produce a unit that would refresh the plants that owners could not reach, hence the ETI WET.

The unit consists of a sensor, timer and electric water pump. The sensor is embedded in the soil and when dry the electronics operate the water pump for a preset time — thus infusing the plant with thirst quenching water. When the plant has drunk its fill and the sensor is dry again the cycle repeats. In this way you can soak up the sun in the knowledge that your prize plant is getting its fair share at home.

CONSTRUCTION AND CALIBRATION

The electronics are mounted on the PCB, using a socket for the IC. We used a plastic card filing box for the case and a 5 litre container to hold the water supply. Make sure you drill an extra small hole in the cap of the water container — so that air can replace water when the pump operates.

We used a small 6V pump (see buy lines) but other pumps can be used. For example a pet shop can probably supply small pumps (used in fish tanks) and pumps are available from most car accessory shops (used for windshield washer). If the pump you use needs 12V the battery will need changing — the electronics will work at this higher voltage.

The moisture control and water

flow control need careful setting — to ensure that the plant gets enough water, but not too much. When first switched on the ETI WET will pump water for the time set by the water flow control — use this water to wet

the soil around the plant, with the probe in position.

With a properly watered plant, adjust the moisture control until the ETI WET feeds more water — then reduce the setting. ▶



Head on view of the completed prototype, the LED can be left out if you want extended battery life.

PARTS LIST

R1, 3	100k
R2	4M7
R4	47k
R5	22k
R6	470R
POTENTIOMETERS	
RV1	500k linear
RV2	100k linear
CAPACITORS	
C1, 2	100n polycarbonate
C3	100u 10V tantalum
C4	2200u 16V electrolytic
SEMICONDUCTORS	
IC1	D4011
Q1	2N3905
Q2	TIP31
D1	1N914
D2	LED

MISCELLANEOUS
Toggle switch 6v lantern battery Box to suit,
PCB, water pump, tubing, water container,
etc.

PCB for this project is available from:
B & R Electronics, P. O. Box 6326F
Hamilton Ontario L9C 6L9, and
Spectrum Electronics, 38 Audubon St. S
Hamilton Ontario L8J 1J7.

Below is an internal shot of our prototype, notice how we used screws to give extra 'bite' to the epoxy holding the tube connections on the front panel. On the left is the overlay for the PCB.

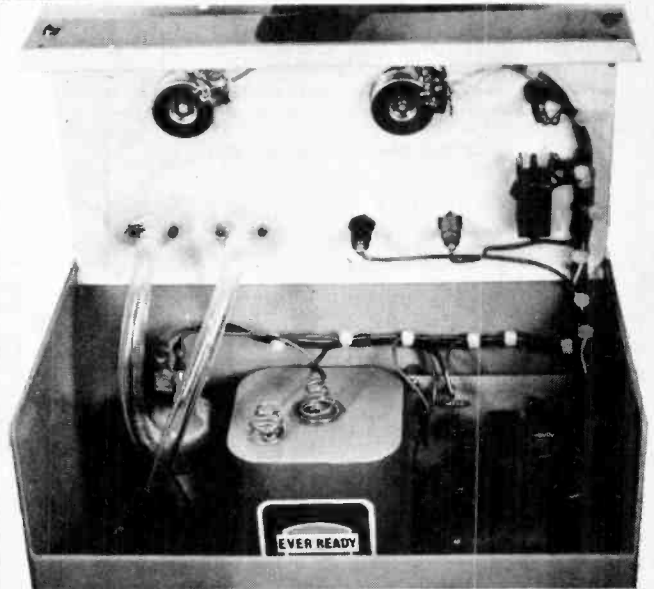
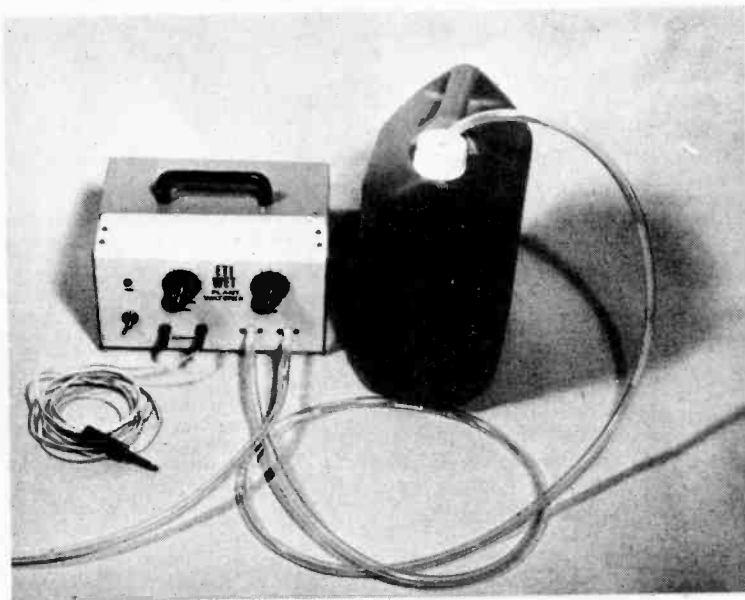
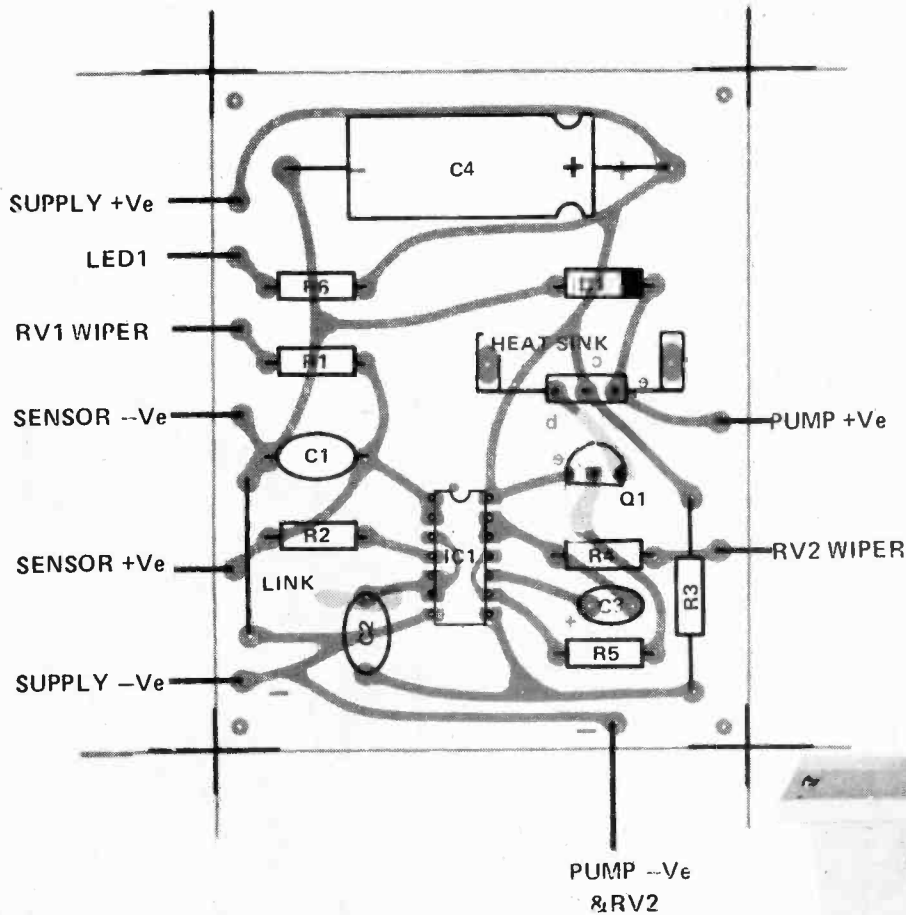

On the left is the complete system, the probe used was made from a jack plug. Above left is the PCB shown full size (70mm by 90mm).

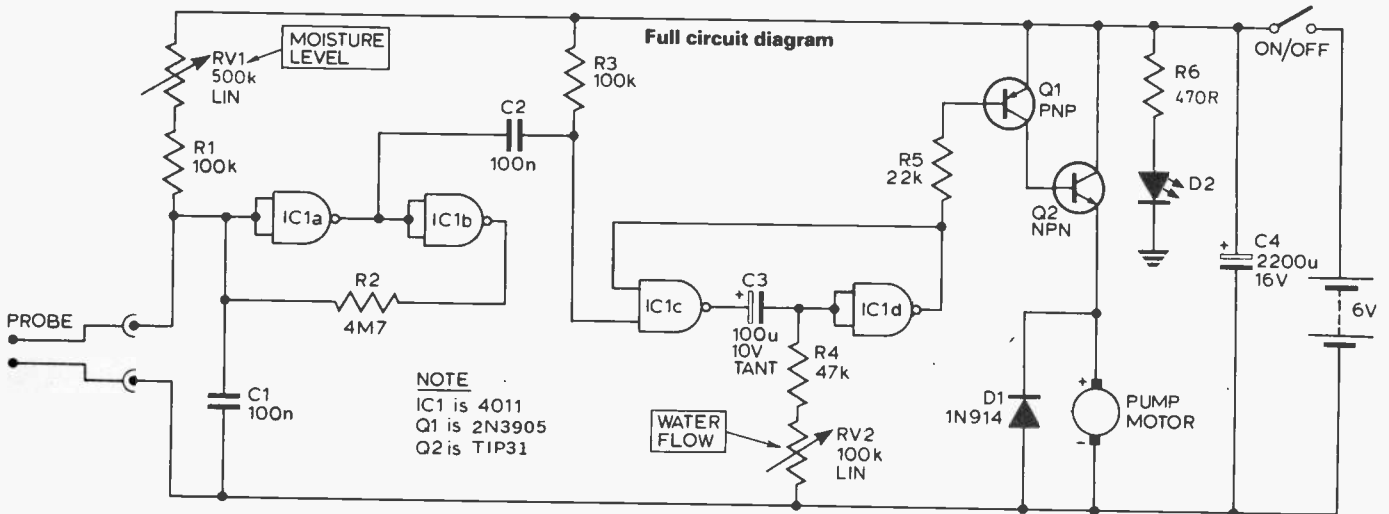

HOW IT WORKS

The circuit is composed of three main sections: Level sensitive Schmitt trigger, variable time monostable and output driver. The level sensitive Schmitt is formed from IC1a and IC1b with the probe and R1, RV1 forming a potential divider on its input. When the resistance across the probe increases beyond a set value (ie the soil dries), the Schmitt is triggered. C2 feeds a negative going pulse to the monostable when the Schmitt triggers and R2 acts as feedback, to ensure a fast switching action.

The monostable (IC1c and IC1d) time period is determined by the values of C3 and R4, RV2. When triggered by the Schmitt the monostable turns on Q1, Q2 which drive the water pump. The monostable will only trigger with negative going input pulses, and therefore unless the probe has been shorted

(by water) the Schmitt cannot retrigger the monostable. This acts as a fail safe to prevent the plant from drowning!

Thus the "water flow" and "moisture level" controls must be adjusted to provide at least enough moisture to pull the input of IC1a low. This is of course a compromise. We decided on this method over simply controlling the pump from the moisture "resistance" signal directly, since in the latter system a broken wire, or accidentally removed sensor would ask the pump for infinite quantities of water, and drench not just the plant, but the carpet also.

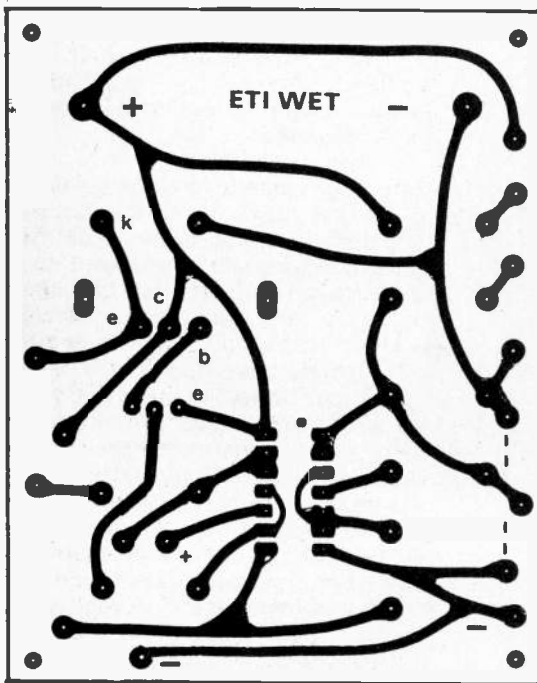

BINDERS

In response to many request from our readers we have arranged for binders to be made so that you can keep ETI's first volumes together and protected from damage. The binders are covered in attractive leather-look black plastic and are designed to hold twelve issues. The ETI design is printed in gold letters on the spine.

The binders cost \$6.00 each, which includes postage and packaging. Do not send cash - you can pay by cheque, MasterCard, or Chargex. Credit card orders must include your account number, the expiry date, and your signature. In all cases allow six weeks for delivery. Send your order to ETI Binders, Unit 6, 25 Overlea bld., Toronto, Ontario M4H 1B1. Don't forget to include your name and address. Ontario residents add 7% PST



Smoke Detectors

Choosing & Using

Too often we are unaware of the dangers that surround us everyday. That's why we have insurance. Jim Essex describes one form.



From Honeywell, one of the myriad of smoke detectors on the market today. New technology and low prices make these an absolute necessity in the home.

(All figures in this article courtesy of Honeywell)

LIFE AND PROPERTY loss from fires is not new, what is news is that you now have an inexpensive and reliable way to combat fire loss. Gone are the days when little red boxes marked "break glass — pull hook", were our only defense. Now, households can have full protection for a minimum of cost — thanks to electronics. The little red boxes will, of course, remain in public buildings and to those who can afford them. But you and I will be equally safe with the new, compact units now available everywhere — and at minimum cost. All it takes is the desire to be protected.

A town near where I live, New Hamburg, recently launched a public awareness campaign of the value of detectors. Assisted by the local fire-fighters organization, they went door-to-door proclaiming the fact fires affect all of us and that no one is safe. Emphasis to their argument came at the height of the campaign when a nearby farm house burned to the ground with not only loss of life, but important historical documents which can't be reclaimed — family records dating back 100 years. At about the same time in another village, Drayton, five children lost their lives and the fire inspector said they might have been saved "had they had a smoke detector". Happily, still another fire in nearby Waterloo saw students saved from burning to death,

after which the fire marshal proclaimed that what saved them was a smoke detector. And with the U.S., leading all the major industrial nations in the deaths per million, it's now nearly a matter of life-or-death to have one. Canada, just so you don't lapse into a false sense of security, runs a close second; and who's to say you won't be next?

So what makes the new breed of alarms so desirable? Can anyone buy them? And what are the best?

STAGES OF A FIRE

First, fires have four different stages in their life cycle which makes them amenable to detection.

First stage:

involves invisible particles or combustion and can last minutes or days;

Second stage:

visible smoke is produced, along with toxic gases. This stage may last for minutes or hours.

Third stage:

is the flame stage. This takes merely minutes or seconds and becomes a major threat.

Fourth stage:

is the "high heat" stage involving visible flame and high heat and becomes extremely dangerous in seconds; (here, it is often too late to do anything about it).

The role of the alarm is to sound before this happens.

HOW THEY WORK

We'll concentrate on the two most popular (and proven) smoke and fire detectors, the Ionization and Photo-Cell types. Both actuate audible alarms of about 85 decibels, more than enough to scare the life out of you:

Ionization type: these respond to traces of *invisible* products of combustion emitted in the *first stages of fire* — the incipient stage — where there is yet NO visible smoke or fire. They will respond to the other three stages as well. They literally "smell" smoke.

Photoelectric type: these respond to *visible* smoke of the smouldering type where there are still no flames or significant heat. They, however, must "see" the smoke to work.

While both units will successfully detect fire, the ionization device is capable of giving earlier warning in a broader range of fires.

There is, of course, a third, the thermal detector, which reacts to heat only and is therefore limited in its use, because it reacts only at the last stages of combustion. It is a property protector only, and not a life-saver and has only limited commercial use.

PHOTOELECTRIC

The photoelectric detector as the name implies uses a principle called "light scattering" to actuate the alarm (Fig. 1). A beam of light from a bulb or light-emitting diode (LED) is sent

across a light-tight chamber to a light trap on the other side. A photocell looks at the side of the beam; it senses no light as long as the air inside the chamber is clean. If smoke enters the chamber, light from the beam is reflected in all directions. (The light-scattering effect is similar to that seen when a flashlight is beamed across a dark room; particles in the air make the beam visible.) When the reflected light reaches the photocell, the resulting change in photocell resistance initiates the alarm. This is why clean lenses are necessary parts of the successful operation of the photocell type of detector.

IONIZATION

The ionization detector on the other hand, (Fig. 2) relies on the fact that ionized air will conduct a small electric current. A harmless amount of radioactive material ionizes the air inside a sensing chamber. When a voltage is applied across the ends of the chamber, a small electric current is carried by the ionized air. When smoke particles enter the chamber, some of the ions attach to the smoke particles instead of the air molecules. The ionized smoke particle is much larger than an air molecule, and it moves much slower toward the end of the chamber. Smoke in the chamber thus decreases the flow of ions, and the current drops. An electronic circuit detects this drop in the current and initiates the alarm. (see Fig. 3 for block diagram).

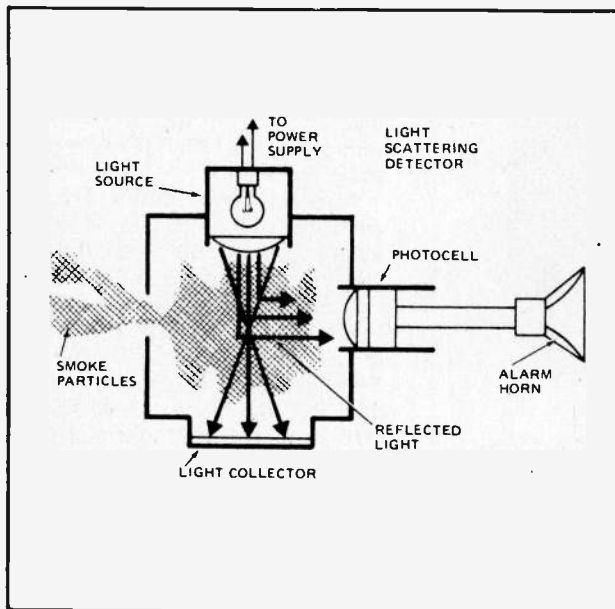

Fig. 1 'Photocell' detector. Smoke particles enter chamber and scatter light beam. Scattered light impinges on photocell and sets off alarm.

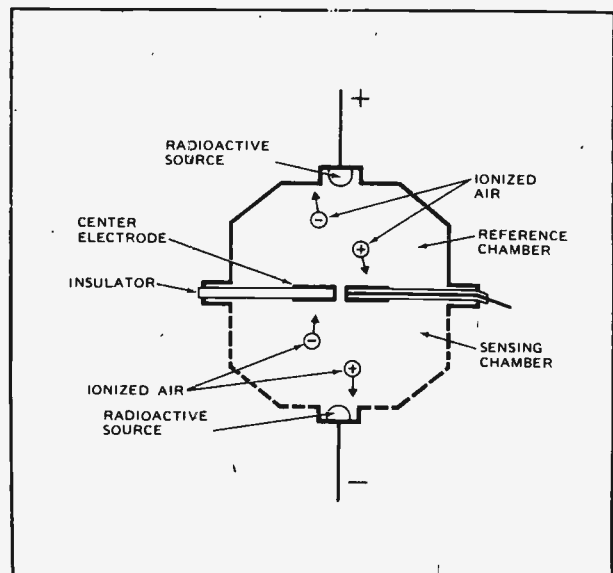

Fig. 2 'Ionization' detector. Smoke particles cause a drop in current between electrodes.

Smoke Detectors Choosing & Using

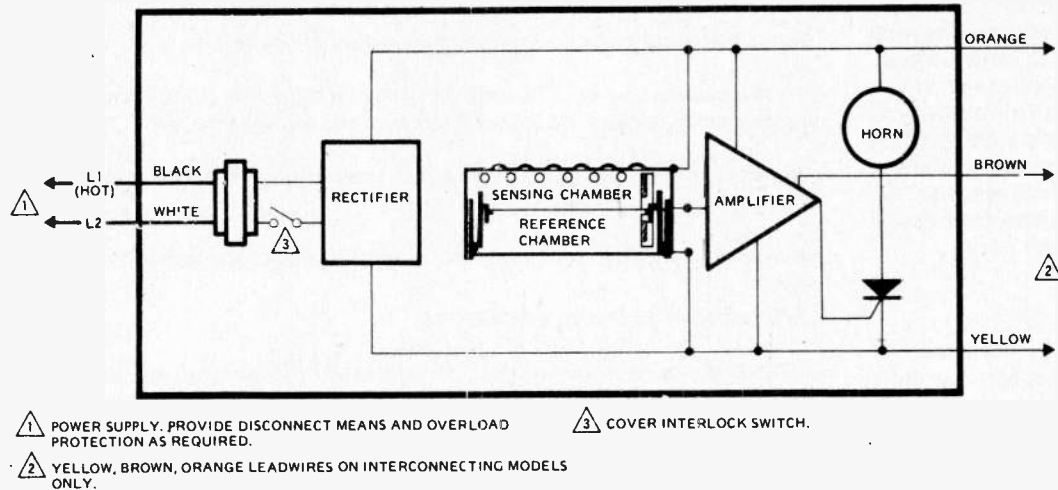

Fig. 3 Block diagram of a typical smoke detector. Low level signal from detector is applied to a switching amplifier and amplified to a level that can trigger the SCR. A large number of the models available are battery powered.

Because this chamber has a "radioactive" source, some have expressed concern over having it in a house. However, fire and medical authorities agree minute quantities of radiation emitted from an ionization detector constitute no health hazard. The source is securely sealed in a tamperproof enclosure. Compared with a 4-hour jet flight at 30,000 feet, where the body is subject to an average dose of 2.4 micro-rems (units of radiation), an average annual dose, equivalent to 0.02 micro-rems, is emitted by a smoke detector typically mounted in a hall-way ceiling 10 feet from sleeping accommodation. According to Honeywell, this dose is in fact, many times less than a normal person receives annually from such commonly occurring radiation sources as colour TV and that from a radium self-luminous watch you wear on your wrist!

COMPARISON

Although a recent study by the CAC (Canadian Consumers Association) said that "no single smoke detector was adequate", the answer is obvious, buy one of each type, as indicated. Or, where one is more sensitive to a particular circumstance over another, place the one more appropriate to that situation. For example, when used to detect a smouldering wood-fire, the CAC tests indicated the photoelectric

device was best. But where a combustible fuel fire was concerned, the ionization detector reacted faster, as it also did when a test was tried using burning paper. In this case the photoelectric model ignored the paper fire completely. As the Honeywell people found, ionization detectors were simply more sensitive to a much wider range of fires than the photoelectric.

But, as reported by R.G. Bright, of the National Bureau of Standards, "The smoke from a typical dwelling fire will be composed of a wide range of particle sizes. A portion of these particles will be in the ion chamber detector range and a portion in the photoelectric detector range... hence, given the present state of knowledge, either detector can suffice for residential, early-warning fire detection purposes".*

*Fire Journal, Vol. 68, p.73

WHEN BUYING...

On purchasing, the first rule-of-thumb should be to buy only from a reputable manufacturer who has demonstrated field experience. The technology is being constantly updated with components being miniaturized and made increasingly more reliable, so we have reaped the rewards of 17 years of improvements since they first appeared as a serious contender in fighting fires.

As for costs, no one should pay over \$40.00 for one; the firemen in New Hamburg sold theirs for \$20.00 — installed. However, don't buy on price, alone... the market is full of units for \$13.00 or less, which unfortunately lack sensitivity. Buy a name brand, and, preferably, from a reputable outlet.

Ensure that the unit you buy has a ULC stamp of approval symbol (Underwriters' Laboratories of Canada) on it. This means they've been checked for fire, shock, and for performance. Reliable devices are sold at major chain stores, hardware and building supply stores and electrical outlets. Store personnel should be expected to know something about the detector they're selling, and demonstrate the product.

There is no need to worry about the battery wearing out, for those that are battery operated. In an ionization model, the life of an average 9-volt alkaline battery is about 13 months (assuming the battery is tested before use). Most units sound a buzzer when a battery needs replacing. It's advisable to look for a device which has a test button. This allows the customer to test it whenever he questions its sensitivity.

There are two other things you should know about smoke detectors. The first is the capability to hook up several units in parallel Under

Smoke Detectors Choosing & Using

this arrangement, if any of the detectors senses smoke, it sets off all the alarms, thus alerting you to the danger wherever you happen to be. To this end a typical detector may have several wires to be connected to other units.

Most detectors these days also have a sensitivity adjustment. This allows you to cook or smoke in the vicinity while not triggering the alarm, but the alarm will sound for higher smoke levels. This is, of course, a compromise, but a useful one if you must smoke or cook.

FINALLY

Families should establish carefully planned escape routes and alternate routes, keeping in mind that open door and windows help the fire spread.

Regular inspection and maintenance of your detector is vital. An annual vacuuming is all that may be necessary with the ionization detector. The photo-electric type must be cleaned regularly, since dust may make it inoperative.

LOCATE the detector;

Whenever possible, on the ceiling close to the centre of the room — particles of combustion tend to rise to the ceiling, then flow out and down the walls.

On the wall, for convenience, or if you have radiant ceiling heating.

If wall mounting is selected, mount the detector no closer than 6 inches and no further than 12 inches from the ceiling, and at least 2 feet from any corner of the room.

On sloped ceiling, place the detector 3 feet (measured horizontally) from a vertical line to the ceiling peak.

In mobile homes, wall mounting is recommended. (check local codes for additional requirements.)

AVOID THE FOLLOWING LOCATIONS;

KITCHENS — burned food or toast, or broiling and frying might cause unnecessary alarms. Use a heat detector here.

GARAGE — the particles of combustion in the automobile exhaust may cause unnecessary alarms. Use a heat detector if desired.

DIRECTLY IN FRONT OF AIR REGISTERS AND LIGHTS — abnormal airflow may blow particles of combustion away from the detector and delay an alarm.

IN DEAD AIRSPACE — smoke tends to bypass corners, closets, and the far end of closed hallways.

INSIDE AIR DUCTS — high velocity airflow may cause nuisance alarms.

ATTIC MOUNTING — extreme temperatures may cause nuisance alarms or damage the device.

Fig.4 Proper installation of a smoke detector requires careful thought. These diagrams show suggested locations.

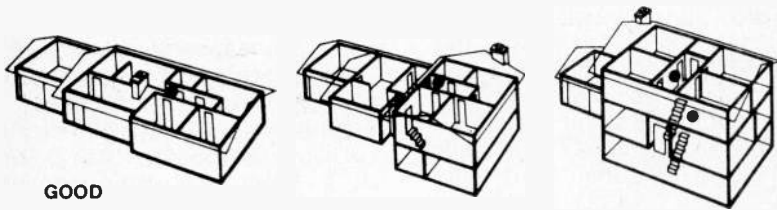

GOOD

GOOD: Install a Smoke & Fire Detector in the hallway leading to the bedrooms (typical installation for mobile homes and apartments) and at the top of each stairway in a multi-level home.

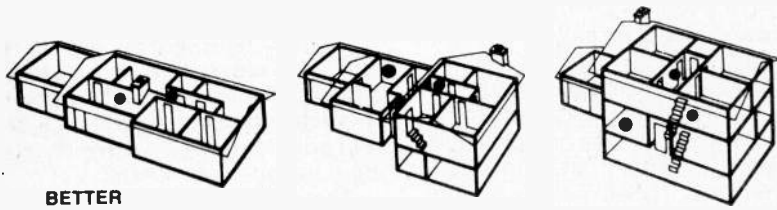

BETTER

BETTER: Add additional Smoke & Fire Detectors to the living room and the top of each stairway leading to occupied areas. Stairways act as vertical shafts for smoke and toxic gases.

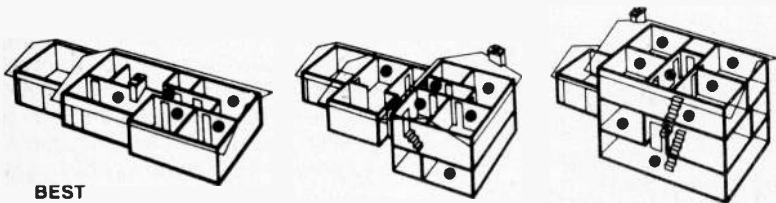

BEST

BEST: Add detectors to living room, family room, basement or work shop, utility and furnace room, and in each smoker's bedroom.

TV Antennas

Are television antennas on their way out? Has cable replaced the outdoor structure as the major source of television reception? Not too likely! David Van Ihinger of Town and Country television in Toronto reports.

IN MANY AREAS, viewers are switching from cable to antennas — at an accelerating rate. Why?

Cable suffers from two inherent faults. First, having channels crowded shoulder to shoulder was not intended in the original concept of television broadcasting. Channel authorizing went to non-adjacent channels to prevent adjacent-channel interference. Keep in mind that there are spaces between channels 4 & 5, 6 & 7 and 13 & 14. In order for the cable companies to pipe all the channels, plus their own feature channels into the 30 or so spaces allocated to them, they have had to cram the stations together. For the television receiver to separate them calls for some pretty fine engineering and design. Many sets, including most of the older varieties, cannot separate the channels satisfactorily, and cross-modulation, or background flutter contaminate the viewing as a result.

The second problem with cable is money. It costs, and costs, and costs... The money you pay for cable, if put into an antenna, could buy as many as three new colour television set in the next 20 years, and the antenna as well! Let's be fair. There are many areas in which cable is welcome and necessary. Many apartment owners find the cost of their own MATV system beyond their budget, and tenants, in those situations, would enjoy improved reception by subscribing to cable. Likewise, reception in some areas can be seriously impaired or impossible, say in valleys, locations shadowed or ghosted up by high-rise construction. Other areas are just too far away from the stations to get them satisfactorily, with standard equipment. Proximity to high voltage electrical transmission towers & lines may wipe out TV reception, particularly when damp. Go cable. However, there are countless areas where *better* reception can be

had with a proper antenna than with cable.

This article will give an outline on the selection of antennas and their supporting equipment and installation methods to help the reader to decide whether an antenna would be his better choice over cable, and if so, whether to try to install it himself or leave it to a professional.

FROM THE TOP ...

Let us start by choosing the head or heads. Are there more than one channel? Are they in the same direction? Are they local, distant, both? UHF? VHF?

How about your location, are you in a valley or surrounded by highrise? Are you close to hydro lines and towers? Is there a busy airport nearby? Or are you on the highest point of land for miles, with a clear unobstructed view of the horizon in all directions? Lucky you.

Do you own or rent? How long are you intending to stay where you are? If you intend to move, would you want to take your antenna with you to your new location? In other words, how permanent an installation do you want? Keep in mind that new channels may be added in your area at a later date. What you choose now may not do later.

The simplest way to choose an antenna for your area is to look at what's already up. To see how well it performs, visit its owner, very few will turn you away when you tell them what you want, because of pride of ownership, look at their reception and ask questions. Find the names of the local installers. Confide in these people, tell them what you expect in the way of reception, and how much you expect to spend. Even though you may not buy from them, the advice they give you will be most valuable. Before buying a head, no matter from whom, go back to the installer and ask his opinion on your

choice. He might save you from duplicating his own past mistakes.

In any case, you'll probably be faced with the following decisions:

(1) Choose a head that will do the job. Will one be enough? (2) Decide whether it should rotate. (3) Consider sources of interference. (4) Project how long you want it to last.

WHY THEY LOOK LIKE THAT

A couple of notes about antennas regarding why they look like they do. A single "rod" in a TV antenna is called an "element". The length of the element is inversely proportioned to the frequency it is intended to respond to. The frequencies of interest in this case are: Ch 2 to 6: 54 to 88 MHz; Ch 7 to 13: 174 to 216 MHz; Ch 14 to 83: 470 to 890 MHz; (as reported in QRM May 79, however, it looks as though we will lose the UHF band above Ch 60 at 752 MHz). This explains why antennas for VHF (Ch 2 to 13) have bigger elements than those for UHF antennas.

The number of elements on the antenna are for two purposes, to make the antenna respond to a wide (r) range of frequencies, and to make the antenna more "directive", which goes along with making it pick up a bigger signal. Thus more elements means more sensitivity.

We have indicated now that there are directional characteristics to be considered in the purchase of antenna heads. Some so-called all channel heads receive the desired channel from many different directions, making it impossible to predict their performance. Some heads work backwards or sideways better than straight ahead, on some channels. Many manufacturers supply "polar" charts for their product. Provided that the antenna head is situated in a similar environment to that which it occupied during the mapping tests, its results can

TV Antennas

be predicted, (but this is a huge task for one who would only wish to install one antenna!).

BACK TO BASICS

The simplest antenna is the so-called rabbit ear, for VHF and bowtie or loop for UHF. Being designed for indoors, they both suffer from limited range, poor directivity (ghost rejection) and human interference. The latter is the effect on the picture when someone moves in the room, being part of the antenna system, because of its proximity, the human body influences the reception pattern. This is why built-in antennas have so far been the least acceptable.

SINGLE CHANNEL

Single channel antennas are available in two to ten element designs, and are generally chosen on the basis of distance and directivity, the more elements, the better. (Fig 1) They are most popular for MATV systems, where rotators would be impractical. However, in areas with very limited reception possibilities, these are the most economical.

MULTI CHANNEL VHF

A variety of heads are available which are directive and cover all VHF channels, (Fig 2)

However, these must be contrasted with multi-channel antennas which can often be obtained from manufacturers who design them for individual areas. For example in Toronto, a special channel 2, 4, 7 head is designed to pick up those three channels from Buffalo to the south, Hamilton 11 appr 45 degrees and 5 & 9 more or less 90 degrees (Fig 3). This is a great head for non-rotating use, and is often used below a rotor for the second and third set. It is rather obvious, referring to our previous statement, that for a single head installation this type of antenna would be preferable to an all-channel directional head installed without a rotor. Although the all-channel head were designed for the extra channels, 5, 9 and 11, since the head pointed south towards Buffalo, those channels would suffer in many areas, depending on their relative directions.

UHF ANTENNAS

For UHF there are 3 basic types: multi-element (Fig 4.), bow-tie & reflector (Fig 5) and combinations of both. The most powerful for all-channel use are the parabolic reflector types (Fig 6), however they have their problems. The reception angles can be so narrow that slight twisting of their support structure

can cause serious flutter in high winds. Good design in the structure will offset this, however. Multiple bow-ties on common screen-type reflectors (Fig 7) are great ghost melters.

OVER SPEC?

At this time, let us consider the problem of over-specifying, in the choice of an antenna. As has been suggested above, perhaps the strongest is not the best. The bigger heads require bigger structures and heavier machinery to rotate them. A good designer stays within reasonable limits, and his skill is readily visible.

Most antenna installers have settled upon two or three favourite heads which they have found by experience to satisfy their local requirements. These heads are sometimes specially-designed for their particular area, by manufacturers who are ever-conscious of their market. This would suggest, and indeed indicate, that catalogue purchasing may not be the best route to follow. But it does remain as a last resort.

UHF-VHF COMBOS

UHF and VHF heads can be installed individually, with the separate lead-in wires run to the appropriate terminals on the television. Alternatively, they can be joined with a UV joiner and brought down on a single lead and split at the set through a UV separator. (Fig. 8.)

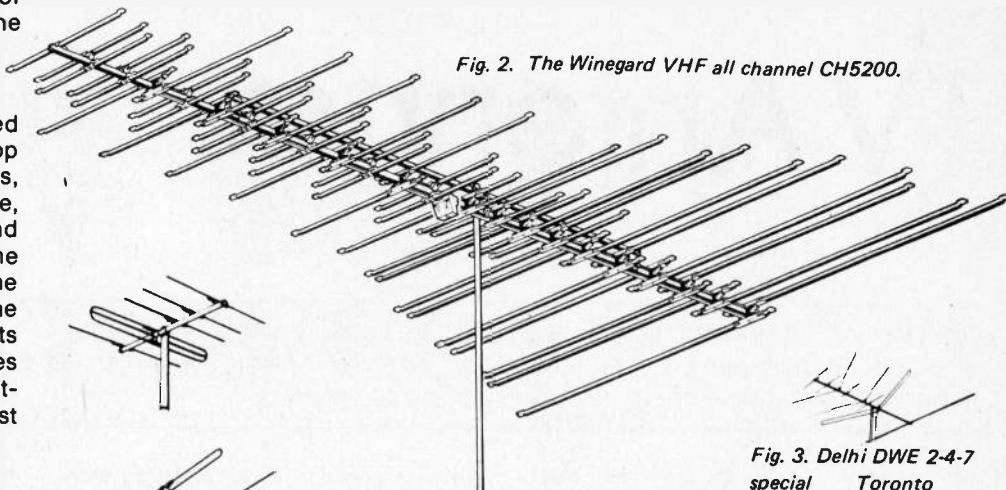

Fig. 2. The Winegard VHF all channel CH5200.

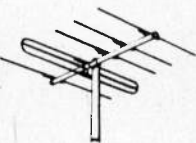

Fig. 1. Three Delhi single channel antennas.



Fig. 3. Delhi DWE 2-4-7 special Toronto antenna.



Fig. 4. Delhi FA1445 multi-element UHF model.

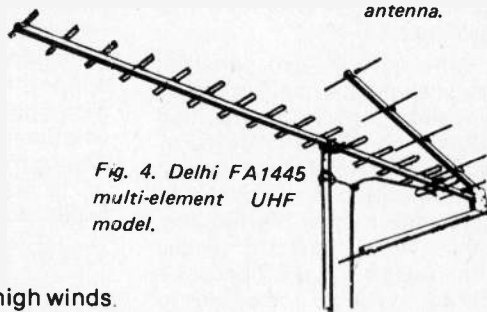

Fig. 5. UHF bow-tie and reflector.



Fig. 6. UHF antenna with parabolic reflector.

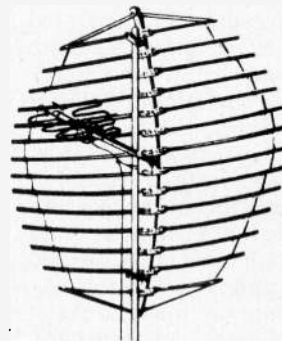

Fig. 7. Multi-bow-tie with flat reflector.



Fig. 8. Channel Master separators.

SYLVANIA INDOOR TV ANTENNAS



TA188



VP500

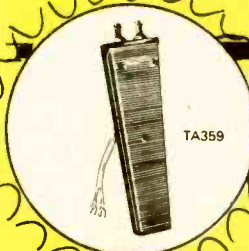

TA359



TA705



VP100

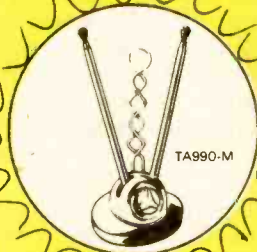

TA990-M

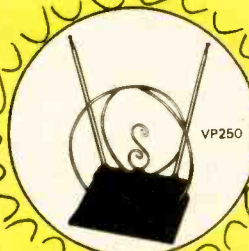

VP250

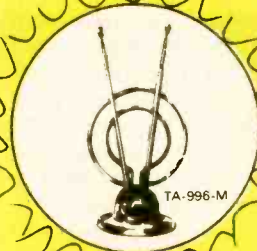

TA-996-M



VP350



VP200



Improve Reception!

A selection of models to satisfy every taste and meet your every price and quality need.

FEATURES INCLUDE:

- Phased diamond loop clear up ghosts, snow and smears.
- Multi position tuning control locks in brighter pictures.
- Extra long rods capture more signal.
- Lustrous all brass elements.
- Elegantly sculptured tilt-proof pedestal stand.

See your nearest SYLVANIA Distributor today, to meet all your indoor antenna requirements.

GTE Sylvania Canada Ltée
8750 Côte de Liesse Road
Montreal, Que. H4T 1H3
(514) 735-4201

SYLVANIA

Electronic Components
and Systems

GTE

ALL CHANNEL HEADS

Although there are feelings pro and con, there is no question that the most convenient head is one that combines UHF and VHF. (Fig. 9) Since the advent of UHF, the manufacturers of antennas have concentrated a tremendous amount of energy into the design of all-channel heads. It would be safe to assume that their performance was of the highest level. Here, again, proof is available in the already-installed product: Feel confident that no one will pay top dollar to an installer for an inferior job. Where reception has no ghost problems and distance to the transmitters is less than fringe (horizon) medium-sized all channel heads usually suffice. Prices range from \$50 to \$100. Look for sturdy design in both the elements and their plastic supports. Good design calls for light weight combined with strength. Where ghosting, even in local reception areas, or snow (indicating weak signals) exist, larger more complex antennas are required. Although some papers rate antennas under headings such as suburban, fringe, ultra fringe etc., their ghost-clearing characteristics and actual channel-by-channel qualities may differ from manufacturer to manufacturer.

This particularly refers to directional and band-pass qualities. Each channel requires at least 6 megahertz bandwidth to pass all the picture, colour and audio information correctly. Failure of the antenna to respond evenly to the whole band for a particular channel could impair the quality of the television picture and/or sound, on that channel. It can be understood, then, that certain antennas work better one place than another. There is no doubt, though that in many areas, rotors are needed to pinpoint the reception from the various stations ranged around the compass.

TURNING IT

Rotors come in about four levels of quality. The cheapest do not necessarily have less power or weight capacity than their bigger brothers. Usually their differences are in the ease of operation. The simplest may or may not have an indicator for direction. The more expensive models are automatic, the lesser of them stopping every 5 degrees or so, the better infinitely adjustable.

Some manufacturers supply a heavy-duty version of the same product which is recommended for their very largest heads, or where more than one item has to be rotated such as TV and CB. The most important precaution to watch

when installing a rotor is to know in advance the direction in which it is now pointing so you know where to route the lead-in from the head above. You must allow enough slack for the turning pipe, and take steps to prevent the lead-in from snagging on projections. Double rotating is possible with some rotors.

SUPPORTING THE ANTENNA:

THE WHOLE STORY

There are three categories of antenna supports: pipes, towers and brackets.

PIPES

Pipe is available in 1¼ and 1½ inch and 16 gauge steel, hot-dipped galvanized, in 10 and 20 ft. lengths. For all but the lightest heads, 1½ is preferred.

In the early days, shell-type joiners were popular. Other methods of joining pipes included sleeving together 1¼ and 1½ pipes about a foot holding them from slipping by either drilling a couple of holes and installing nuts & bolts, or driving cement nails right through, with or without drilling pilot holes, and, as was sometimes done by the more adventuresome installers, driving a cement nail or two into the gap. Today's pipe is available swaged at one end to permit easy assembly without extra hardware. It is most satisfactory, and saves a lot of time. Most suppliers prefer 10 ft sections, which simplify storage and handling.

Aluminum and iron pipes are not particularly recommended as they do not have the "memory" that steel has. I know this will bring arguments, so let's call it a personal preference.

All installations require pipes of some sort, so now we will discuss methods of holding them up.

For simplest method I know, which works well for small heads for local reception, short pipes can be drilled

with a couple of holes near one end and nailed with spikes, or screwed with lag bolts into the edge of a structure, such as the end board of the roof, etc. Possibilities for this method are endless. Keep the pipe short to reduce the wind leverage. Larger loads call for increasing the spacing between holes, and adding more nails or screws.

In some areas, where they are plentiful & cheap, telephone poles are used, the short pipe fastened near the top so that it extends above the wood. Servicing is simplified by keeping the pipe short and providing climber-spikes up the pole.

TREES AND THINGS

Short pipes have been installed in trees. The author once installed a huge ten-element channel 3 yagi in Dorset, Ont., on top of a pine tree. First the tree was chopped where the trunk was 4" diameter. Without disturbing the branches, a five foot pipe was nailed through 3 holes approx. 10" apart leaving over 3 ft of pipe extending above the new tree level. Reception from Barrie, over 60 miles distant, was excellent. Unfortunately, as learned some years later, the tree died. Cause, unknown, although lightning was suspect. More about grounding later. For now, we will look at brackets.

Tripods are popular in some regions, as are wall mounts and chimney mounts. (Figs 10 & 11) The latter suffer from a few problems, such as corrosion from the flue gasses, conductive deposits of carbon which deduct from the signals, (more so when damp) and questionable life-span considering that their only support is by straps not much different from those of mast stand-off insulators, but which are subjected to many times the stress. However, pipe lengths of 10 or more feet can be accommodated. The author installed one 25 years ago on the chimney of an apartment building whose roof was

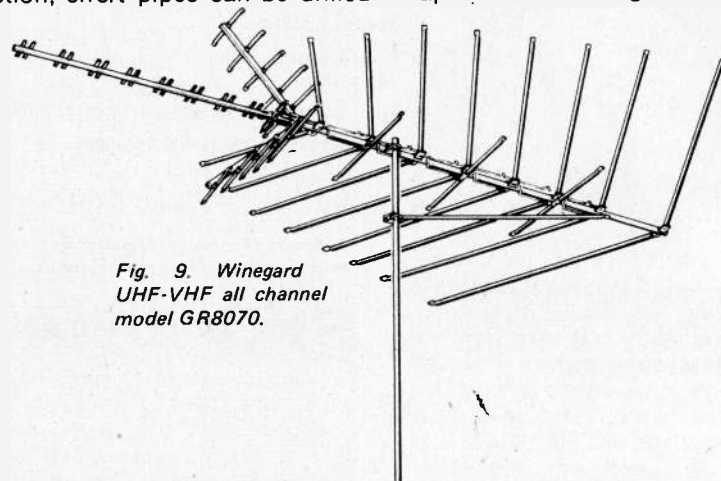
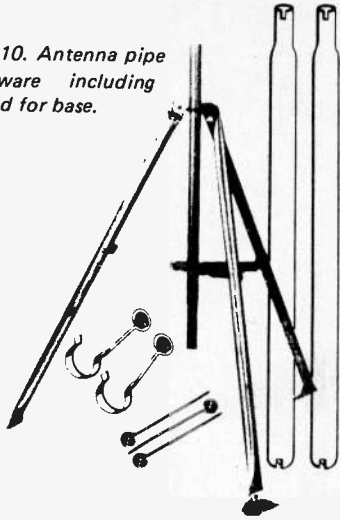

Fig. 9. Winegard UHF-VHF all channel model GR8070.

Fig. 10. Antenna pipe hardware including tripod for base.



already overcrowded, the chimney being the only available space left. (Anybody remember those days?) Two twenty foot pipes, one 1½" and one 1¼" were put one inside the other for extra circumference, and sturdy enough to stand the load. Four straps were used, and it was still standing last time I looked, not too long ago.

However, more than ten years is unusual, not only for chimney mounts but guyed pipes, as well which I will now describe.

GUYED AND WHY

For receiving distant channels, two factors figure prominently in the antenna design & installation. Firstly, the gain of the antenna head must be high to capture enough signal to overcome the inherent noise in the tuner. The snow you see on a TV screen when there is no antenna connected is produced by the RF amplifiers operating at full gain. As the signal input to the tuner is increased, the snow disappears, usually between 100-200 microvolts. According to some sources, a stable, (but snowy) picture can be obtained with as little as 5 microvolts, on some of the newer sets with F.E.T. transistor input. Comfortable viewing, sitting close to a large screen TV, is not likely at this level however, so we will aim for the snow-free threshold as a minimum antenna requirement.

The other factor is ambient noise from local sources such as housewiring which causes unsightly bars and patterns over the pictures, and, in severe cases, jitters and rolling. Since we know that most signals passing through the air are clear so far as static is concerned, except during severe thunderstorms and the like, all we have to do is to keep out the local interference. When signals from the

desired stations have to compete with the static radiating from the housewiring, one obvious solution is to place the antenna head as far away as possible from the noise source. Housewiring goes all over the structure including the attic, so if we go up, we can beat the problem. Antenna heights 20 feet or more above the rooftop seem to hit the correct compromise where basic signal strengths exceed the 100-200 microvolt point.

Guyed pipes 20 and more feet high used to be a common sight in some areas, silhouetting the skyline as far as the eye could see. Up they went, 20, 30, 40 or even 50 feet straight up from the rooftops, reaching frantically for the feeble electromagnetic waves passing barely within their reach. Although they have been replaced in many places by other methods, guyed poles are by no means discontinued. They do offer a low-cost answer to the reception problem. At today's price for cable, or all channel rotors and towers and all that, the simple antenna may be all a person can afford. How then, do we install one? Basically, a guyed-pole installation consists of a galvanized pipe held up by guy wires of galvanized stranded steel (clothesline) wire and fastened to hooks screwed through the roofing and (hopefully) into the rafters, or, more recently, to so-called under-eave guy straps. (Fig. 12)

Whether or not to use turnbuckles (Fig. 13) comes down to personal preference. An installer with normal physical strength should have no problem pulling the wires tightly enough without them. Back to hooks. The ideal installation calls for one per wire. Here again, compromise comes with experience.

WHAT TO DO WITH THE WIRES

Guy wires are attached to the mast by various methods. The earliest was called a guy ring (Fig. 14) held from slipping down the mast by a nut and bolt inserted in a previously-drilled hole. Guys were customarily placed every ten feet up. As the guy ring presented a sharp edge where the wire went through the hole, it fell into disfavour, and the wire was simply wrapped around the pipe, and the bolt, sometimes, reducing sharp angles. This also reduced the tendency for the guy wires to twirl themselves around the pipe during erection ending up off-centre to the pull. (You oldtimers will recall what I mean!) Cement nails were again substituted for nuts & bolts, and finally, all of those were eliminated when it was discovered that the strap standoff insulators were just as

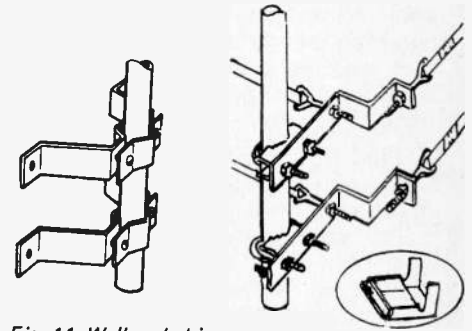

Fig. 11. Wall and chimney strap mounts.



Fig. 12. Hook and strap.



Fig. 13. Turnbuckle.



Fig. 14. Guy wire ring.

effective for supporting guy wires. Their life-span challenged that of the guy wire, so another labour and parts item was removed from the antenna cost.

Guy wires, no less than three per level, should be arranged at equal angles around the pipe — 120 degrees for 3 way and 90 degrees for 4 way. The angle between the guy and the pipe should not be less than 15 degrees. More is better, naturally, as wind stress is mostly horizontal.

Further, avoid even spacing between levels, to prevent harmonic vibration from wiping out the pipe during heavy storm gusts.

GETTING IT STRAIGHT

When installing, sight the pipe at right angles to the pull and tighten the bottom set first. Sight up the pipe to set the top guys, lower levels first, one level at a time. Guy wires should be wrapped twice around the hooks before starting the back wrap. You only need to put a couple of turns on the back wrap to hold each wire secure while adjusting the plumb of the pole. When you are satisfied, that all guys are correctly tightened, finish the back wraps, using a good 10 inches of wire, cutting off the excess.

Base supports for pipes range from swivel mounts to saddle bases. The latter require no fasteners through the roof, and, as their name implies, are mounted on the peaks of roofs (Fig. 15)

TOWERS

Pipe & guy wire installations have been widely superceded by tower structures, of which there are two major types; self-supporting (Fig. 16) and non-self supporting. Self supporting towers are especially designed for the purpose, and instructions for their installation are supplied by their manufacturers. One such firm is Delhi Metal Products. Their kits are available in most parts outlets.

Non self-supporting towers come in various forms, and each has its own advantage. Most popular is the tower installed in the ground and fastened to the edge of the building structure. For fringe reception, the 20 ft clearance above the roof can be achieved quite easily, and installation is rather simple. No cement is required (as a matter of fact, many towers which had been set in cement, split at their bases when water from condensation froze inside the pipes).

INSTALLATION

To install a tower of this type we first choose a location where the heads will be clear of trees, away from dirty chimney exhaust, esthetically related to windows and doors, etc., and, if it is practical, than close to the television set as possible if for noother reason to save money on wire. Towers do look better behind rather than in front of a house, or even at a side, but keep in mind that unless your neighbour gives you clearance in writing, someday you may be called to task for encoaching on his or his successor's airspace.

Remove any flagstones or flimsy concrete sidewalks to make room for a hole dug below frost line. If a tower has to go on a flat surface, such as a concrete base or a sub-level roof, use a tower base, (Fig. 16) and in the case of a roof installation, add a plank of treated wood approximately 5 ft long 2 x 12, laid so as to spread the weight of the tower over three or more rafters.

On all such installations, when all the work has been completed, seal the roof with mastic plastic to prevent leaks. We are not as worried about water getting into house as we are about avoiding rot at the point of support!

Assemble the tower, stand it up, and set it in the hole (or on the plate). If space does not permit assembly in one piece, then assemble enough to reach to roof, stand it up and drive it down into the hole. Go up to the roof and install the

bracket. This is the crucial poing of this installation. Several types of brackets are available on the market, the most versatile being the x bracket. The author prefers to attach right through the roof into the rafters where they cross the plate, (Fig. 17) as experience has shown that lags & shields in brick, for one, tend to come loose. The outside rafter, rafter ends and fascia boards do not rate for maximum support either. Four to eight properly-installed spiral spikes placed so that the stresses are shear (at right angles to the length of the spikes) will hold the tower firmly. Brackets should be horizontal, if possible when attached over to the tower. It is up to the individual installer to choose the procedure at this time. Some prefer to assemble the whole antenna, rotor and any other equipment on the tower while it is hanging over the roof just before raising it up and putting it into the hole. This permits them to do all the work while standing on a relatively flat surface, and with practice, they never need to go up the tower. The opposite to this, is to build the tower a section at a time, going straight up. As mentioned before, space might dictate this procedure.

A ladder can be used as a gin-pole, tying it to the already-installed tower, projecting about six feet above the top piece, throwing a rope over the top rung and using this as a crane to lift and hold the next section of tower while it is set in place as shown in Fig. 18. Seasoned installers just stand on the top rung of the last-installed section and lift the next section into place, by skillful balancing and juggling. In a commercial operation it could mean the difference between a man installing four towers a day or six. After the top section has been installed on the tower, the pipe can be inserted, if it has not already been done, and the head(s) and rotor (if any) can go on. Donot leave too much pipe. Assembly and installation of heads and rotors is adequately outlined in the manufacturer's enclosed instructions, so now for some special suggestions.

GROUNDING

All antenna structures must be grounded. Favourite is #8 aluminum wire attached to the antenna pipe or tower leg with an approved grounding clamp, and the same at the other end at a ground pipe or a ground stake driven into damp ground.

Towers buried into the ground are automatically grounded, however those set in concrete may not be, as concrete is not a good electrical

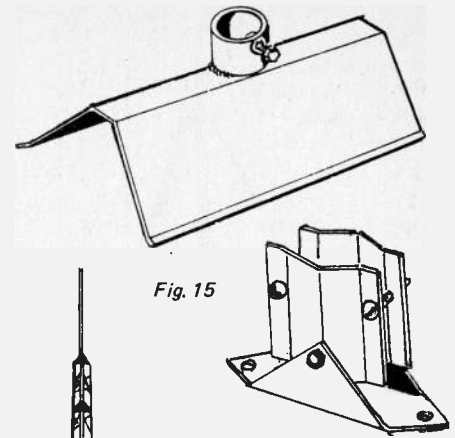

Fig. 15

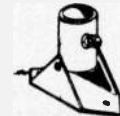

Fig. 15. Saddle and tilt mounts.

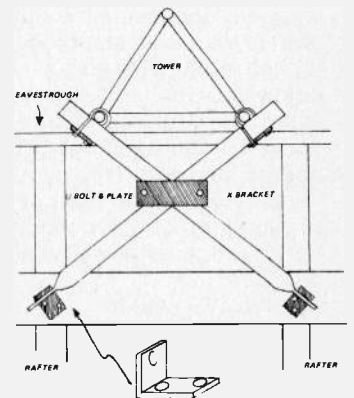

Fig. 17. Author's recommended method of holding tower up with house.

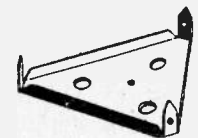
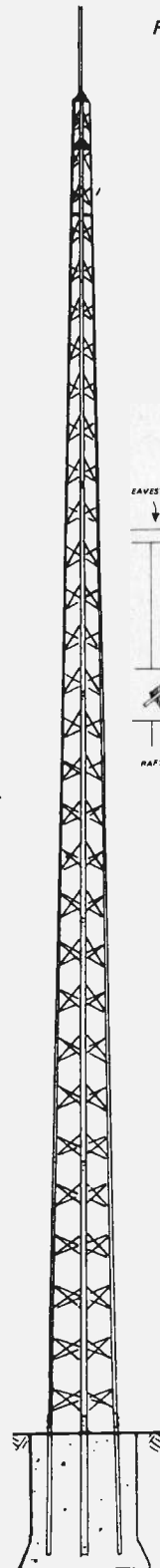

Fig. 16. A self supporting tower (Delhi in this case) and a base for non-self supporting towers.



conductor. Lightning arrestors may be used. Follow manufacturer's instructions.

LEAD IN WIRING

Lead in wires range from flat wire, Foam, air-core and shielded 300 ohm, to standard and foam co-axial 75 ohm. Coaxial and shielded wires are preferred where noise and ghosts are to be avoided. They cost more, and in the case of 75 ohm lead, transformers must be installed to match the 300 ohm antenna and in many cases, the set, to the wire's impedance. An advantage of shielded wire is that it can be routed right against metal, through conduit, cold-air pipes, and in the case of co-axial, cable-type hardware has been highly developed to make installation easier and more permanent. Open wires, on the other hand, carry electromagnetic waves (signal) outside the actual wire, and cannot be dressed too closely to any other wires or metal. Stand-off insulators are needed to route the wire down pipes, towers and even away from wooden walls which could get wet and absorb signal. Life expectancy of 300 ohm flat and air core is rather short, about the same as its strap standoffs.

Co-axial and 300 ohm shielded wire can be taped to the pipe and tower; about every 5 ft will do. Rotor wires are available also in flat or round. The flat wire suffers from the same problems, in many cases, as the 300 ohm flat, as the plastic insulation seems to deteriorate rapidly. When installing any wiring on an antenna, allow a bit of slack at the ends where they are connected up to the heads or rotors, to take the weight off the connections. Make sure that standoff insulators, when used, are well secured, and after installing the wire in the slot, close the ring with a pair of slip-joint pliers to hold the wire firmly.

Twisting 300 ohm flat lead helps to cancel out interference, so allow for about one turn per foot for this. Finally, give a little tap on the underside of the standoff insulator while you tug down on the lead-in wire to snug it up.

DON'T GET "DRIP AROUND THE LEAD-IN"!

Just before the wiring enters the house, form a drip loop of about six inches, to avoid embarrassing water stains inside the house. If you are using air-core, cut a small hole at the bottom of the drip loop to let out condensation that somehow forms in the wire.

Leave about 5 ft extra at the TV set to allow the set to be moved out for housecleaning. Do not hang up or roll unshielded wiring as standing waves

will be set up in the downlead and spoil reception.

MULTIPLE TV

So far we have dealt with antennas for one television. If more than one is to be used on an antenna, "splitters" can be used, or better, separate heads for each set. Some installers feed the top head to the most important TV, and split one or more simpler heads to serve the less-important. Co-axial switches and knife switches simplify the problem when sets are not used simultaneously. With them there is no reduction in signal strength such as with splitters. There is also a variety of antenna amplifiers available, which strengthens the signal at the antenna, to better enable it to survive the trip to your set, or multiple

sets. However, these are a whole separate topic and won't be covered here. Note: When buying co-axial equipment, be sure it is rated for 900 megahertz where UHF is desired. Cable company equipment is rated only to 300 MHz and can kill UHF.

CONCLUSION

From the comments in this article you will probably conclude that the best all-round antenna would be mounted on a tower, using a good-quality all-channel head, an automatic rotor and co-axial downlead. So would I.

FOR MORE INFORMATION (including catalogues and local distributor addresses) check your yellow pages, or write to:

Channel Master, 21 First Avenue, St Thomas, Ontario N5P 3X1.

Delhi Metal Products Limited, 65 Waverly St., Delhi, Ontario N4B 1E8.

GTE Sylvania Canada Ltee, 8750 Cote de Liesse Road, Montreal, Quebec, H4T 1H3

Winegard Company:

Omnitronix Ltd, 2056 South Service Road, Trans Canada Highway, Dorval, Quebec H9P 2N4.

Zenith Radio Corporation, 1020 Islington Ave., Toronto, Ontario, M8Z 5X5.

Fig. 18. Tricky method of using ladder to hoist mast sections.

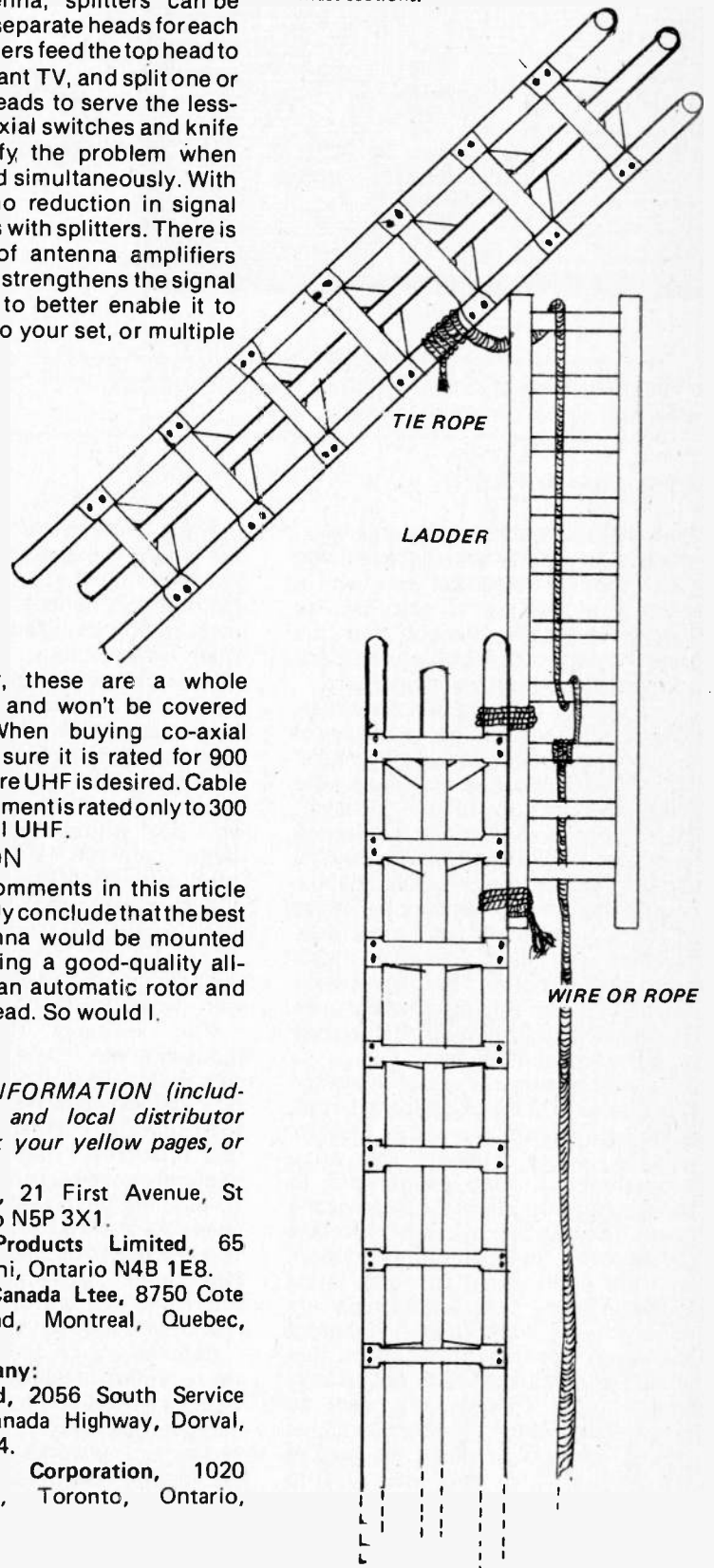

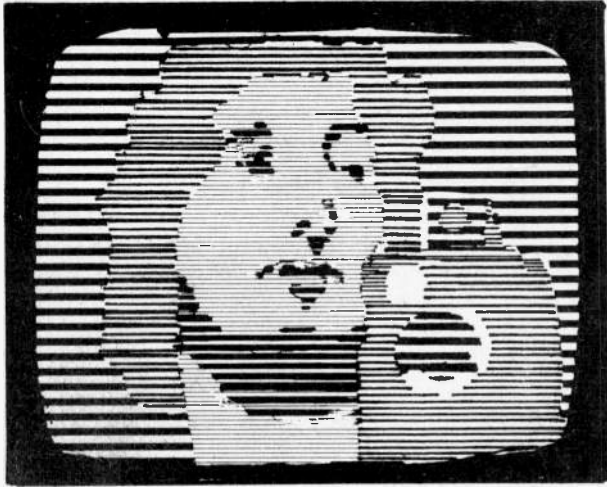

WHAT'S ON

In his new column, Steve Rimmer presents the high level topic of capturing television signals from satellites.

FOR VIDEOPHILES...

THIS COLUMN will be for videophiles.. which is not a party who makes a living wearing down television sets with a rasp. A videophile is just like an audiophile, really, except that the frequency response of his tape deck goes out to four and half megahertz.

Audiophilia (sounds like a disease, doesn't it?), began in the early days of sound, when tubes had five pins, one of which was on top, and amplifiers were class A right up to the speaker. Distortion was high, frequency response a joke, and subtleties like feedback unheard of. However, people bought the old sets because they were all that could be had, and most were satisfied with them, because they'd heard nothing better. The few who were not, and set about to modify, and even redesign the audio circuitry of their day were the first audiophiles.

Peering out over a sea of television sets that keep getting better and better, video tape recorders and disc players, plus a whole plethora of video accessories, it may seem hard to believe, but TV is still at the five pin tube stage. The low bandwidth of most sets considerably limits picture resolution, and the poor signal to noise ratios found in many commercial receivers make images look "fuzzy". Inherent scanning non-linearities mean that what the camera sees is not usually what you get. There is, at present, no reference by which a viewer can adjust colour controls to make his picture correspond to the one being transmitted, aside from twiddling the flesh tones until the actors don't look too much like martians. About three

quarters of the cable TV subscribers in this country experience interference generated by the cable company on one or more channels on a continuous basis, often making some programmes totally unwatchable.

This column will be designed to help readers use the many aspects of video more productively, more entertainingly, and, most importantly, more completely than the television industry presently has in mind. In future issues, we'll deal with such things as home made cameras, video tuners, the intricacies of VTRs, video discs and picture generators... and satellites...
UP IN THE AIR

Chances are, if you've been tinkering with video much in recent months you've probably run across the industry's latest little mystery by now: satellite television. If you already have a four foot projection screen to make you feel like you're in a theater, a VCR to give you a sense of déjà vu and a thirty channel converter to make family fights completely unsolvable, satellites may seem like the final frontier. Well, before you prepare to boldly go where no man has gone before, you might be interested in a few of the strange new worlds you are about to encounter.

Satellite TV, or, to be more precise, the reception of television programmes being relayed from orbiting artificial satellites, is hardly brand new. The broadcast networks have been using this medium for several years to bounce programming around the country, and transmit live "actualities", news events, sports and the like, back to their main

studios in New York and Toronto. More recently, the CBC has begun using a "bird" to bring the dubious benefits of the tube to scattered settlements across Northern Canada, in its ANIK programme.

What is new about satellites is mostly that private individuals have begun to tap into them, receiving material which is not specifically intended for consumer appreciation. There is, theoretically, no reason why one cannot duplicate, in one's back yard, what the commercial television stations use as ground based receivers. Since the satellite signals are not "beamed" specifically at their targets, but, rather, usually wind up blanketing half the continent with their transmissions, a home satellite station does not have to be any more elaborate than the ones used in professional applications. Five or six grand would probably cover it all nicely.

Discouraged yet? Well, don't be.

SYSTEM ANALYSED

Television relay satellites orbit about 22,500 miles above the surface of the Earth, in a "geo-stationary" orbit, which means that their positions relative to the surface remain relatively constant. Therefore, unlike, say, the OSCAR ham relay satellites, TV "birds" do not appear on the horizon and then disappear some time later, but, rather, are useable, in the areas in which they can be received, twenty four hours a day. The transmissions from the satellite to the ground, called a "downlink", take place on frequencies between 3.702 and 4.178 GHz, with

broadcasting power levels of around five watts.

The video information is frequency modulated on these rather high frequencies, as is the audio, with the addition of a sub carrier. This is done because FM is less susceptible to degradation by background noise than are conventional AM transmissions, and, by the time the flea powered signals from a satellite cover the twenty two odd thousand miles, they are all but buried in solar and terrestrial "grass".

There are scores of satellites floating around up there, but only five which are sending down material of any long term interest, each with a present capacity of up to twelve transponder frequencies. Many of the other "birds" are interesting to DX, trying to make something out of what you come up with (satellites also relay other types of signals, such as wire photo, teletype, various computer communications and voice), but may make you a bit strange in the head if you listen to them for too

long. Probably the singularly most interesting "bird" at the moment is RCA's SATCOM F1, which carries, among other things, HBO (Home Box Office), KTVU (San Francisco), WGN (Chicago) and the Warner "Star Channel". We'll use this satellite as an example.

As can be seen in figure 1, a signal level contour map for SATCOM I, most of the country is within the 36 dbw contour, which is an extremely high signal area.. for a satellite. This means that an antenna system in Toronto would need less overall gain to produce the same quality pictures than one in, say, Dawson City. By comparison, the 36 dbw contour for ANIK III encompasses just about all of Canada . . . but who really wants to go to all the trouble of building a satellite downlink just to get the CBC.

The hardware required to receive a satellite downlink transmission is, in all fairness, probably far more

complicated and difficult to arrive at than anything you've even dreamed of. First of all, an antenna is required, and no amount of lamp cord will suffice. In order to achieve the necessary gain and directional response, the antenna takes the configuration of a parabolic dish, of the sort often seen on microwave relay towers and as universal disintegrator ray guns. The dish can be made of either metal or fiberglass with metallic particles suspended in it.. Either way, though, the smallest diameter for a dish antenna is two meters, or about six feet, even in high signal level areas.

The dish must be aimed at the part of the sky in which the satellite which you wish to track resides. This entails that it be mounted on a steerable, and, once steered, lockable and very solid support. If you are not the sort who would enjoy running outside in twenty below zero just to change channels, the steering will entail the use of servo motors and feedback circuits. Fun, all by itself.

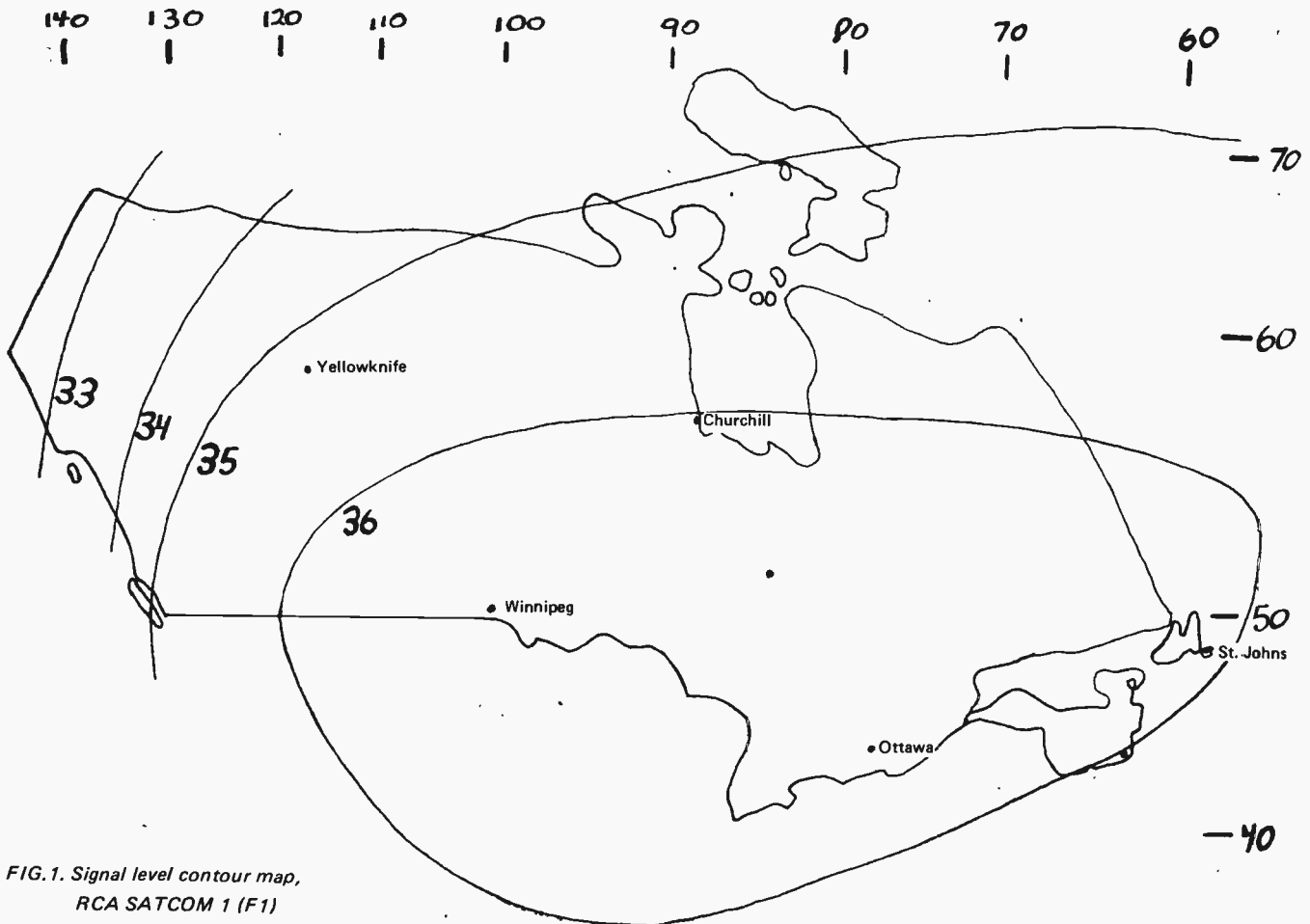

FIG. 1. Signal level contour map,
RCA SATCOM 1 (F1)

Video

A second consideration of the mount is that dish antennas have the potential for enormous wind resistance, requiring the mount to be extremely solid, lest the old antenna snap off, some blustery day, and float away like a six foot microwave frisbee.

The dish, despite what you might think, is not the most difficult component of a downlink. What the dish focuses its signal into is. You see, even with a very big dish, the signal at the focal point, or "feed", is still very tiny . . . all but lost in the grass. Therefore, the initial signal processing circuitry cannot be allowed to add much noise of its own. The initial stages of gain are comprised by a unit called an LNA, or Low Noise Amplifier, which is mounted directly on the feed. Commercial LNAs start at several thousand dollars.

Naturally, the bigger the dish, the greater the gain, and the less critical the noise factor of the LNA becomes, so what one spends on an antenna is reflected several times in the savings at the LNA . . . not to mention in the size of the plot of grass which will no longer need mowing. A six foot dish in a 36 dbw contour needs an LNA costing in excess of five thousand dollars, while a twenty foot one can get by with an amp costing no more than two thousand dollars. Mere petty cash, right?

The LNA needs a gain of between 50 and 55 db. This, alone, is not all that hard to achieve, even at three or four thousand megahertz. However, the noise contributed by the amp must be very, very small, as mentioned earlier, and this, combined with a pass band some thirty six megahertz wide, is what complicates the issue. LNA designs usually use GaAs FETs of very critical specifications to do the job . . . nasty and expensive.

The signal, upon emerging from the LNA, must be coupled into some manner of receiver. This is taken care of in much the same way as is the signal produced by a CB antenna: with a piece of coax. However, at these frequencies, trusty old RG-58/U simply will not suffice. The special microwave cable required, RG-214-A/U, goes for around four bucks a foot. It is very interesting stuff, in which the center core is suspended in an air dielectric by a spiral of plastic between it and the outer shell, which is almost an inch in diameter. Because of this unusual construction, it must be purchased with the necessary connectors already attached by the factory.

Lastly, the signal must be amplified and demodulated by what is, in essence, a microwave receiver. While

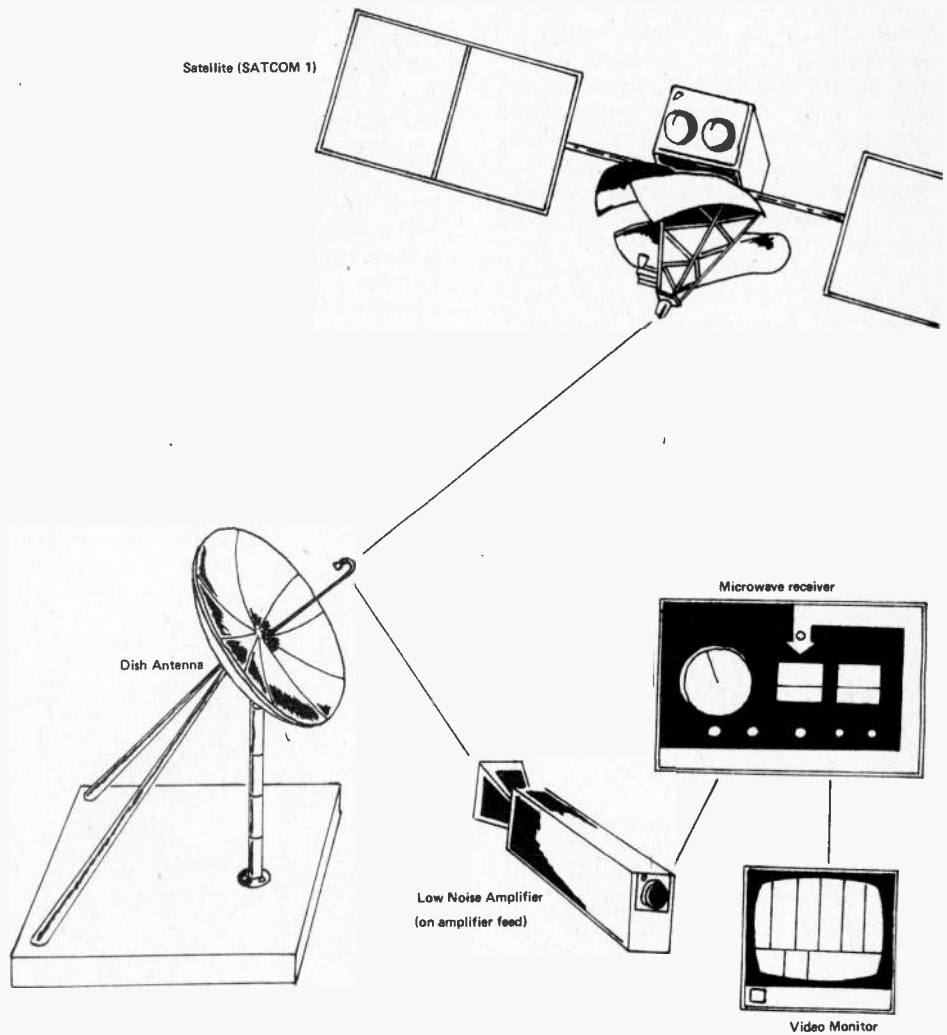

FIG.2. Satellite downlink

this is probably the least critical aspect of the system, it is still a very costly bit of hardware, still falling into the realm of a low noise, high gain, high frequency and low production run device.

All in all, a rather expensive TV aerial, wouldn't you say?

BRINGING IT CLOSE TO HOME

The big question involved in satellite TV, at least, from the point of view of a potential home user, is whether there is a possibility of building a downlink

oneself. Still in the earliest stages of tinkering, I think that there are several places where in one could experiment and possibly come up with a workable system without actually mortgaging anything. I am now going to proceed with a process called speculative percepto-guesstimation . . . I'm going to throw out some ideas.

First, the dish. Dishes are expensive if bought new, but they do occasionally crop up surplus. Alternately, there is the possibility of making one. A rather

clever approach is outlined in Ham Radio Magazine, in the August 1969 issue, entitled "A Large, Home Brew Parabolic Reflector".

The LNA is the most costly item, and is thus the most appealing target for home construction. I do not, however, think that the average experimenter has much hope of actually getting one going, given the available equipment and expertise for dealing with the frequencies and signal levels involved. There may be another approach, though.

The problem with the LNA is a double edged sword: low noise/high gain coupled with a very wide bandwidth. It has to cover, in one shot, twelve downlink transponder frequencies. However, suppose, instead, it were built like the front end of a receiver, that is, tuned to admit only one channel at a time. With the gain-bandwidth compressed, the noise which the system picks up should be reduced, making the whole thing a bit more tolerant of internal noise, and; secondly, the stage gain would be increased, so that with the same amount of noise contribution, each active element could yield a larger signal, resulting in the need for fewer active elements, and, therefore, less overall noise.

Now, before you go getting the coil winding charts out, remember that the tuned circuitry used with microwaves is quite different than that with which you may be familiar. If you'd like to get acquainted with exactly what they involve, there is a basic (very low power) microwave experimentation project described in Popular Electronics in the November, 1969 issue.

A second approach to getting around the LNA is to use a converter, possibly preceded by a tuned amplifier. The idea here is to beat the microwave signal down to VHF frequencies, where it could be dealt with using less expensive techniques. This, however, would require a local oscillator of uncommon stability and cleanliness (freedom from harmonics and other unwanted nasties), and a very, very quiet mixer. Hot carrier diodes might work in a high signal situation . . . a twenty foot dish and a 36 dbw contour, perhaps . . . or a rather superior sort of field effect transistor.

When considering how to go about building the circuitry of the downlink, some thought should be given to using vacuum tubes, if the cost of solid state becomes prohibitive. There are a

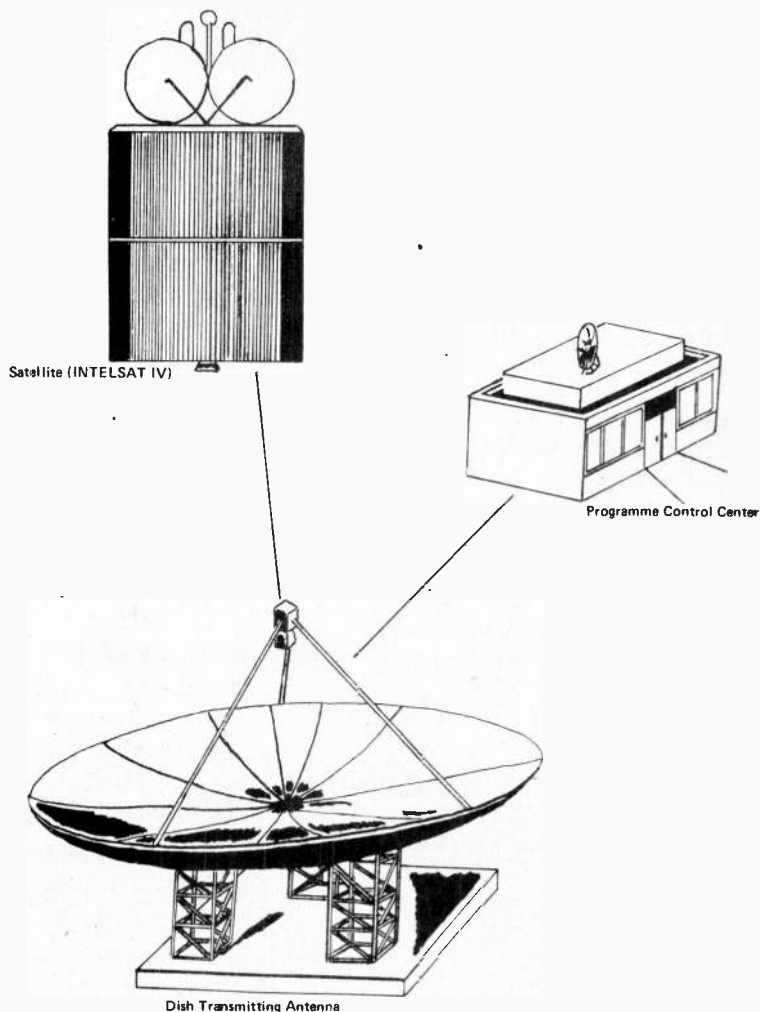

FIG.3. Satellite uplink

number of the more exotic "super tubes" which have the necessary specs, and, as they are generally considered to be obsolete in the age of large scale integration, can be had for considerably less than their silicon counterparts.

The last link in the system is the receiver. Again, I think that building a microwave system gets a bit beyond most experimenters capabilities. However, if a converter is used, a VHF approach may be taken to the receiver. The front end might be a re-worked TV tuner, and the IF strip made with readjusted television coils and limiting amplifiers. It might even be possible to use IC amps, like the 703s. Phase locked loop type circuitry would probably be best for the demodulators, as they will have to pull the signals out of a fair bit of noise, and then get the audio off its sub-carrier.

FINALLY . . .

Can one "home brew" a satellite downlink for substantially less than the cost of a professional installation? With enough research and experimentation. . . and some luck . . . the answer is probably "yes". Any readers having an interest, or better still, some experience in this area are welcome to share any questions, or answers, with other readers of this column. Please write me, care of ETI. Hopefully, an exchange of information can be set up, and, in so doing, the financial and technical aspects of a number of areas of video be made more manageable.

Next month, the column will cover some of the less spaced out, but perhaps more immediate aspects of video tape recorders, including some more finite details on video tuners and monitors. Until then, stay tuned.

Enjoy reading about electronics? Choose from the informative Babani Series and order using card!

Is electronics your interest? Then get into it more deeply in the special areas of your choice. Electronics Today carries a range of electronics books published by Babani Press and Bernards, amongst which are those described below. (If someone has already used the card, write to Electronics Today Magazine, Unit 6, 25 Overlea Blvd, Toronto, Ontario M4H 1B1)

IC 555 Projects

- Every so often a device appears that is so useful that one wonders how it was developed before without it. The 555 timer is such a device.
 - It was first manufactured by Signetics, but is now manufactured by almost every semiconductor manufacturer and is inexpensive and very easily obtainable.
 - Included in this book are Basic and General Circuits, Motor Car and Model Railway Circuits, Alarms and Noise Makers as well as a section on the 556, 558 and 559 timers.
 - An invaluable addition to the library of all those interested in Electronics.
- Price \$4.30 including 30¢ postage and handling.

52 Projects Using IC741

- IC741 is one of the most popular, inexpensive and easily obtainable devices available to the home constructor. It is also extremely versatile and can be used in a great number of various applications.
 - This unique book, originally published in Germany, shows fifty-two different projects that can be simply constructed using only the IC741 and a few discrete components.
 - An invaluable addition to the library of all those interested in electronics.
- Price \$2.70 including 30¢ postage and handling.

Mobile Discotheque Handbook

- The vast majority of people who start up "Mobile Discos" know very little about their equipment or even what to buy. Many people have wasted a "small fortune" on poor, unnecessary or badly matched apparatus.
 - The aim of this book is to give you enough information to enable you to have a better understanding of many aspects of "disco" gear.
 - The approach adopted is to assume the reader has no knowledge and starts with the fundamentals, hopefully the explanations given are amplified enough for almost anyone to understand but please note that this is by no means the full story.
 - The book is divided into six parts — Basic Electricity, Audio, Ancillary Equipment, Cables and Plugs, Loudspeakers, Lighting Equipment and the information has been considerably sub-divided for quick and easy reference.
- Price \$4.80 including 30¢ postage and handling.

28 Tested Transistor Projects

- Mr. Richard Torrins is a well experienced electronics development engineer and has designed, developed, built and tested the many useful and interesting circuits included in this book.
 - Some of the circuits are completely new and, to the best knowledge of the author, unlike anything previously published while others many bear similarity to more familiar designs.
 - The projects themselves can be split down into simpler building blocks, which are shown separated by boxes in the circuits for ease of description, and also to enable any reader who wishes to combine boxes from different projects to realise ideas of his own.
 - Most of the circuits are very economical on the use of components and in many cases the semiconductors employed are non-critical, commonly available and inexpensive types.
- Price \$3.15 including 30¢ postage and handling.

First Book of Transistor Equivalents and Substitutes

- Shows alternatives and equivalents to many popular transistors made in Great Britain, U.S.A., Europe, Japan and Hong Kong etc.
 - Companion Volume to BP14 — SECOND BOOK OF TRANSISTOR EQUIVALENTS AND SUBSTITUTES.
 - An invaluable addition to the library of all those interested in Electronics be they amateur or professional.
- Price \$2.30 including 30¢ postage and handling.

Second Book of Transistor Equivalents and Substitutes

- Shows alternatives and equivalents to many popular transistors made in Great Britain, U.S.A., Europe, Japan and Hong Kong etc.
 - Companion Volume to BP1 — FIRST BOOK OF TRANSISTOR EQUIVALENTS AND SUBSTITUTES.
 - All invaluable addition to the library of all those interested in Electronics be they amateur or professional.
- Price \$3.55 including 30¢ postage and handling.

Radio Circuits Using IC's

- This book describes integrated circuits and how they can be employed in receivers for the reception of either amplitude or frequency modulated signals. The chapter on amplitude modulated (a.m.) receivers will be of most interest to those who wish to receive distant stations at only moderate audio quality, whilst the chapter on frequency modulation (f.m.) receivers will appeal to those who desire high fidelity reception of local v.h.f. stations possibly with stereo (and even quadrophony at some future date). Stereo decoder circuits and the devices available at present for quadrophonic circuits are discussed. Voltage regulator devices are also covered because they are so convenient in all various tuned receivers and because they have so many applications in all types of circuit.
 - Brian Dance is a highly experienced author who regularly contributes to many of the popular electronic magazines that are available both in the U.K. and overseas.
 - An extremely valuable addition to the library of all Electronics enthusiasts.
- Price \$4.80 including 30¢ postage and handling.

50 (FET) Field Effect Transistor Projects

- Field effect transistors (F.E.T.'s) find application in a wide variety of circuits. The projects described here include radio frequency amplifiers and converters, test equipment and receiver aids, tuners, receivers, mixers and tone controls, as well as various miscellaneous devices which are useful in the home.
 - It will be found that in general the actual F.E.T. used is not critical and many suitable types will perform satisfactorily. The F.E.T. is a low-noise, high gain device with many uses, and the dual gate F.E.T. is of particular use for mixer and other applications.
 - This book contains something of particular interest for every class of enthusiast — shortwave listener, radio amateur, experimenter or audio devotee.
 - A valuable addition to the library of all electronic enthusiasts.
- Price \$3.95 including 30¢ postage and handling.

Popular Electronic Projects

- Included in this book are a collection of the most popular types of projects which, we feel sure, will provide many designs to interest all electronics enthusiasts.
 - All the circuits utilise modern, inexpensive and freely available components.
 - The 27 projects selected cover a very wide range and are divided into four basic areas: Radio Projects, Audio Projects, Household Projects and Test Instruments.
 - An interesting addition to the library of both the beginner and more advanced constructor.
- Price \$5.10 including 30¢ postage and handling.

Electronic Music and Creative Tape Recording

- Electronic Music is the new music of the 20th Century. It plays a large part in "Pop" and "Rock" music and, in fact, there is scarcely a group without some sort of electronic synthesiser or other effects generator.
 - It is possible with relatively simple apparatus to create complete compositions using electronic and sometimes non-electronic musical sources.
 - This book sets out to show how Electronic Music can be made at home, with the simplest and most inexpensive equipment. It describes how the sounds are generated and how these may be recorded to build up the final composition.
 - With the constructor in mind, several ideas are given to enable a small studio to be built including a mixer and various sound effect units.
 - Circuits are included for VCOs, VCFs, Envelope Shapers, VCFs, Active and Passive Mixers, Fuzz, Noise Generators, Metronomes and a 10-Note Programmable Sequencer etc.
 - All the units shown have been successfully built and used by the author and most of the projects can be built by the beginner.
 - An unusual, fascinating and highly rewarding application of electronics.
- Price \$4.50 including 30¢ postage and handling.

IC LM3900 Projects

- The purpose of this book is to introduce the LM3900 to the Technician, Experimenter and Hobbyist. It provides the groundwork for both simple and more advanced uses and is considerably more than just a collection of simple circuits or projects.
 - The LM3900 is different from conventional 'Op-Amps'. It can be used for many of the usual applications as well as many new ones. It is one of the most versatile, inexpensive and freely available devices on the market today.
 - The book is divided into six basic sections —
 - Introduction
 - Audio Applications
 - Simple Linear Applications
 - Simple Digital Applications
 - Signal Generator Circuits
 - Special Applications
 - The LM3900 can do much more than is shown here — this is just an introduction. Imagination is the only limitation with this useful device; but first the reader must know the basics and that is what this book is all about.
- Price \$4.80 including 30¢ postage and handling.

1st Book of Hi-Fi Loudspeaker Enclosures

- Contains 26 practical designs and over 40 drawings to enable the enthusiast to construct his own Hi-Fi Loudspeaker enclosures.
 - Includes the following types of enclosures: — Corner Reflex, Bass Reflex, Exponential Horn, Folded Horn, Tuned Port, Klipschorn Labyrinth, Tuned Column, Loaded Port, Multispeaker Panoramic etc.
 - Also covers general construction hints and embellishing of cabinets as well as a considerable amount of other useful information.
 - A must for the library of all audio enthusiasts.
- Price \$3.05 including 30¢ postage and handling.

50 Simple L.E.D. Circuits

- The author of this book, Mr. R.N. Soar, has compiled 50 interesting and useful circuits and applications, covering many different branches of electronics, using one of the most inexpensive and freely available components — the Light Emitting Diode (L.E.D.).
 - Also includes circuits for the 707 Common Anode Display.
 - A useful book for the library of both beginner and more advanced enthusiast alike.
 - Companion volume to book No BP36 — 50 CIRCUITS USING GERMANIUM, SILICON & ZENER DIODES by the same author.
- Price \$3.05 including 30¢ postage and handling.

Handbook of IC Audio Preamplifier & Power Amplifier Construction

- Shows what audio IC's are, as well as how to use them.
 - Includes practical constructional details of various IC and Hybrid IC/Transistor designs of about 250mW to 100W output.
 - This book is written by the very experienced and popular author Mr. F.G. Rayer who deals with the subject in four parts:
 - Part I Understanding Audio IC's
 - Part II Preamplifiers, Mixers and Tone Controls
 - Part III Power Amplifiers and Supplies
 - Part IV Hybrid Circuits
 - An ideal book for both beginner and advanced enthusiast alike.
- Price \$3.15 including 30¢ postage and handling.

50 Projects Using Relays SCR's & Triacs

- Relays, silicon controlled rectifiers (SCR's) and bi-directional triodes (TRIACs) have a wide range of applications in electronics today. These may extend over the whole field of motor control; dimming and heat control; delayed, timing and light sensitive circuits and include warning devices, various novelties, light modulators, priority indicators, excess voltage breakers etc.
 - In this book, the very experienced and popular author — Mr. F.G. Rayer — has given tried and practical working circuits which should present the minimum of difficulty for the enthusiast to construct.
 - In most circuits there is a wide latitude in component values and types, allowing easy modification of circuits or ready adaptation of them to individual needs.
 - An ideal book for both beginner and advanced enthusiast alike.
- Price \$4.05 including 30¢ postage and handling.

50 Projects Using IC CA3130

- The CA3130 is currently one of the more advanced operational amplifiers that is available to the home constructor. This means that it is often capable of a higher level of performance than many other devices and that it often needs fewer ancillary components.
 - In this book Mr. R.A. Penfold has designed and developed a number of interesting and useful projects which are divided into five general categories:
 - I Audio Projects
 - II R.F. Projects
 - III Test Equipment
 - IV Household Projects
 - V Miscellaneous Projects
 - An ideal book for both the beginner and more advanced enthusiast alike.
- Price \$3.15 including 30¢ postage and handling.

Electronic Projects for Beginners

- In this book the newcomer to electronics will find a wide range of easily made projects, many complete with actual component and wiring layouts. Furthermore, a number of projects have been arranged so that they can be constructed without any need for soldering and, thus, avoid the need for a soldering iron.
 - This book which is written by the very experienced author Mr. F.G. Rayer is divided into four sections: —
 - "No Soldering" Projects
 - Miscellaneous Devices
 - Radio and Audio Frequency
 - Power Supplies
 - An absolute 'must' for all beginners in electronics.
- Price \$4.60 including 30¢ postage and handling.

50 CMOS IC Projects

- CMOS IC's are probably the most versatile range of digital devices for use by the amateur enthusiast. They are suitable for an extraordinarily wide range of applications and are now also some of the most inexpensive and easily available types of I.C.
 - In this book Mr. R.A. Penfold has designed and developed a number of interesting and useful projects which are divided into four general categories:
 - I Multivibrators
 - II Amplifiers and Oscillators
 - III Trigger Devices
 - IV Special Devices
 - An ideal book for both the beginner and more advanced enthusiasts alike.
- Price \$3.10 including 30¢ postage and handling.

Electronic Calculator Users Handbook

- An invaluable book for all calculator users whatever their age or occupation, or whether they have the simplest or most sophisticated of calculators.
 - Presents formulae, data, methods of calculation, conversion factors etc. with the calculator user especially in mind, often illustrated with simple examples. Includes:
 - The way to calculate, using only a simple four function calculator: Trigonometric functions (sin, cos, tan)
 - Hyperbolic functions (sinh, cosh, tanh)
 - Logarithms, square roots and powers.
 - A comprehensive section of conversion factors covering such common conversions as length, area, volume and weight etc. through to more specialised conversions such as viscosity, illumination, and cargo shipping measures etc.
 - Formulae and data for VAT, discounts and mark up, currency conversion, interest, solutions of equations, binary and octal numbers, areas and volumes, statistics and mathematics etc.
- Price \$3.20 including 30¢ postage and handling.

Practical Guide to Reed Switches

PART 2

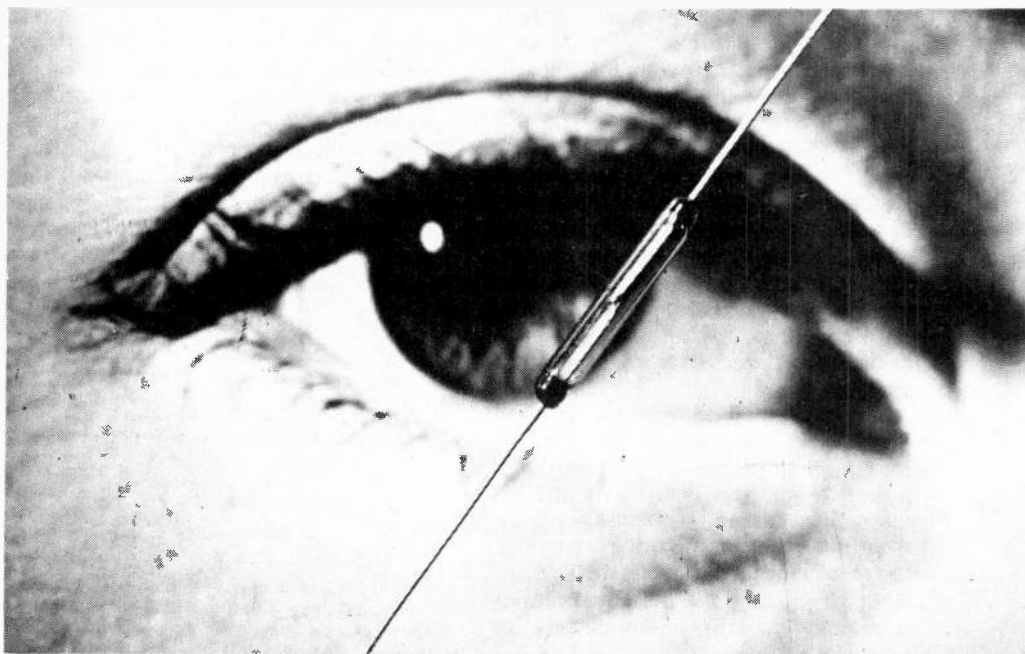

Fast switching and a 'reedable' article. Collyn Rivers continues his discussion of read...er.. reed switches...

REED switches are actuated by a magnetic field.

This field can be generated by a permanent magnet, or by an electrically energised coil. When coils are used, the reed switch is simply inserted within the coil form and it is then closed (or open) when current is passed through the coil.

It operates, in fact, as a relay, and in this form reed switches are used by the million, in telephone systems around the world.

When a reed switch is to be electrically actuated, an indication of the magnetic field strength that is required is generally quoted by the manufacturer in terms of so many ampere-turns. This figure may range from 50 AT to 250 AT (but as explained later, this may be substantially reduced by the judicious positioning of a bias magnet).

Various combinations of turns, wire sizes and dimensions may be used to close any specific type of switch, and these parameters will in turn be determined not only by the required number of ampere-turns, but also by the circuit voltage and current that is available. For example a switch that requires 100 ampere-turns may be actuated by a 220 ohm winding drawing 13 mA at 3.0 V., or by a

Turns	7,520	9,600	11,900	15,000	19,500	25,000	36,000	43,100	53,000	66,500	86,800												
Ohms	219	355	550	855	1,390	2,380	4,320	6,380	9,900	16,000	25,000												
Switch Sensitivity	50AT	1.5	6.5	1.8	5	2.3	4.2	2.8	3.3	3.5	2.5	4.8	2	6.1	1.4	7.3	1.2	9.4	0.8	12	0.75	15.7	0.6
	100AT	3.0	13	3.6	10	4.6	8.4	5.7	6.7	7.1	5.1	9.5	4	13	2.8	14.7	2.3	19	1.9	24	1.5	31	1.2
	150AT	4.5	20	5.3	15	6.9	12.6	8.5	10	11	7.5	14	6	18	4.2	22	3.5	28	2.7	36	2.3	47	1.8
	200AT	6.0	26	7.0	20	9.2	17	11	13	14	10.2	19	8	24	5.6	29	4.6	38	3.8	48	3.0	94	2.4
	250AT	7.5	33	8.8	25	11.5	21	15	16	18	12.7	24	10	30	7.0	37	5.8	47	4.6	60	3.8	110	3.0

Table 2. Data for standard size reed switch operating coils - bobbins to be 2" long x 0.220" inside diameter, winding build up will be approx. 0.2".

25,000 ohm winding drawing 1.2 mA at 31 V.

Table 2 provides all the data required to design operating coils for a wide variety of standard sized reed switches, (i.e., 2.75" overall, 2.0" long, 0.217" diameter).

The operating coil may either be wound on a bobbin manufactured specifically for the purpose (Fig. 11) or made up from a length of paper, aluminum or plastic tubing that is a neat fit over the outside diameter of the glass reed.

Another method of making operating coils is to wind them, using a cement coated wire, onto a form that is shaped to create the desired final

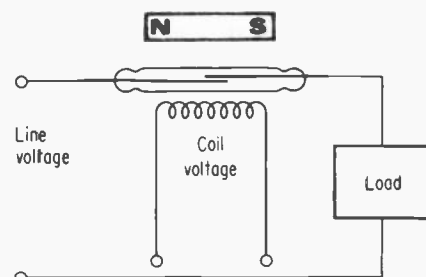

Fig. 12. Magnet assists reed switch to close, and thus reduces coil energy requirement.

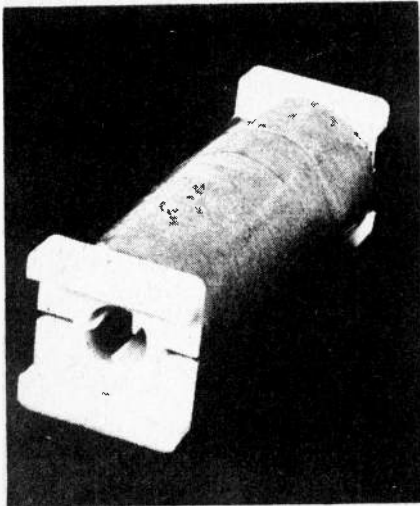

Fig. 11. Bobbin for standard sized reed switch.

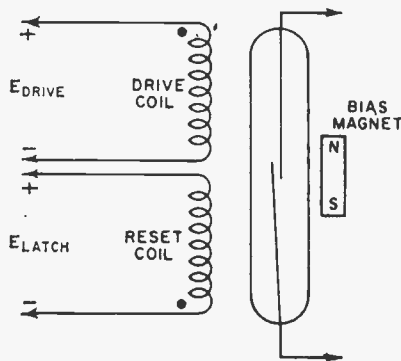

Fig. 13. In this circuit, reed switch is latched by aiding permanent magnet, and reset by magnetic opposition from reset coil field.

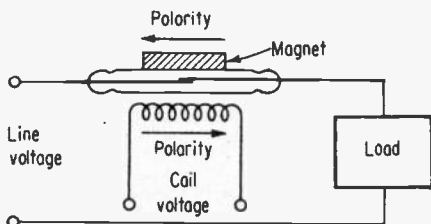

Fig. 14. Normally closed operation using magnetic bias.



Fig. 15. This type of reed switch may be used for either change-over or normally closed operation.

form. After removal from the arbour, the winding should be protected by a layer of insulating tape.

EXTERNAL MAGNETIC FIELDS

A reed switch is influenced by a magnetic field regardless of whether that field is produced by the operating coil or by some other magneto-motive

force. The magnetic force generated by the field winding can be modified or even completely cancelled by the field from a nearby permanent magnet, or by the alternating flux from a nearby choke, transformer or other inductive device. Even the proximity of a sheet steel chassis may affect the energy at which a reed switch will just actuate.

But the effect of external magnetic influences may be usefully exploited to modify the characteristics of the basic reed switch assembly.

For example the ampere-turns required to close any given switch, can be halved by placing a magnet a short distance away from the coil — the magnet's polarity must be the same as that of the operating coil. The positioning of the magnet is fairly critical and is best determined by trial and error,

A similar method can be used to obtain a latching action. In this case the method exploits the magnetic hysteresis of the reed switch. The magnet is placed far enough away from the coil so that it does not close the reeds magnetically, but sufficiently close so as to hold the reeds closed once they have been actuated by an electrical signal through the coil.

In this example the reed relay can be unlatched only by physically removing the magnet, or by applying opposite polarity drive through the operating coil.

A further modification of the magnetic latching principle is shown in Fig. 13. Here, whilst magnetic latching is still used, the operating coil has two windings, one of which is used to actuate the relay, and the other, which is connected in opposite polarity, is used to unlatch the relay.

A magnet may also be used to convert a normally open reed relay to normally closed operation. This is done by locating the magnet sufficiently close to the reed so that the contacts are held closed. (Fig. 14). The coil is wound so as to produce a magnetic flux of opposite polarity to the magnet. When the operating coil is energised, the resultant magnetic flux will cancel out that from the permanent magnet, and the reed will open.

Change-over action may be obtained either by using a reed switch specially made for the purpose (Fig. 15) or by using a magnet and two normally open reed switches actuated by a common operating coil (Fig. 16).

It is possible to actuate a number of separate reed switches located inside

one large operating coil, but due to variations in the sensitivity between one reed and another, and the positioning of individual reed switches within the operating coil, it is not possible to predict the contact action sequence. All other things being equal the most sensitive reed will operate first. This will then act as a magnetic shunt, retarding the operation of the remaining reed switches. This is a major difference from conventional electro-mechanical relays where a single armature or card drives all of the movable contacts and any pair of contacts can be adjusted to ensure synchronous operation or a specific contacting sequence.

Nevertheless if a current at least

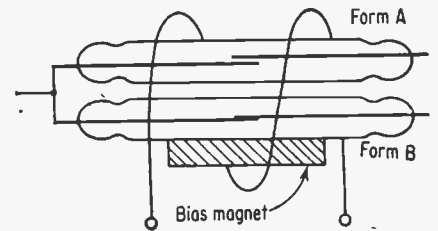

Fig. 16. Change-over action may also be obtained by combining a magnet and two normally open switches actuated by a common operating coil.

150% of the just-operate ampere-turns of the highest rated switch of the group is applied suddenly, this effect is less noticeable, and in most applications may be virtually neglected.

SWITCHING

CHARACTERISTICS

The moving blades inside a reed switch have very low mass and move only a few thousandths of an inch. The operating coil is not iron cored and so has little self-inductance thus allowing a magnetic field to build up very rapidly. These factors combine to ensure that a reed relay is an inherently quick-acting device, in fact, operating times of less than one millisecond are quite typical.

The speed at which any specific reed relay closes is primarily a function of the number of ampere-turns in the operating coil. But when the contacts close they normally bounce two or three times and the harder the relay is driven (i.e., the greater the number of ampere-turns) the greater the number of times that the contacts bounce. In general reed relay coils are designed so that nominal rated voltage produces approximately 50% more ampere-turns than the just-operate value. This gives

Practical Guide to Reed Switches Part 2

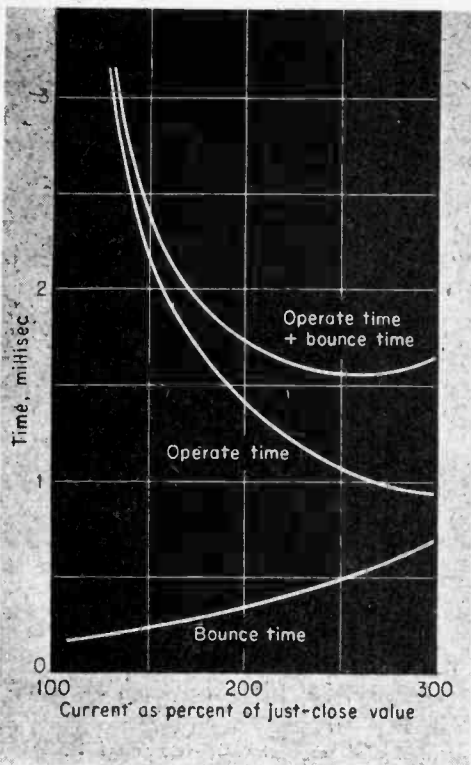

Fig. 17. Variation of operate and bounce time with energizing current.

optimum total operate time including the contact bounce time. (Fig. 17).

After the contacts have closed and have stopped bouncing, the reeds continue to vibrate for a short time. This vibration produces magnetostriction contact noise — a damped oscillatory voltage that decays to zero — and this may cause problems in low signal level circuits.

With no suppression devices across the operating coil, reed release time is very fast — it may be as short as 25 micro-seconds. Adding a suppression diode has little, if any effect on the operate or bounce times, but it does significantly lengthen the release time. For example, the release time of a standard type of reed without a suppression diode may be 50 micro-seconds, but with a diode the release time may be extended to a milli-second or so.

Due to the geometry of the reed switch construction, the capacitance between contacts is low, and with standard sized reed relays this will be about one pico-farad. The capacitance between the reeds and the operating coil will be about 2.5 pico-farads but this can be reduced to approximately 0.5 pico-farads by interposing a grounded electrostatic shield between the coil and the reed.

Some thermal EMF will be generated at the junction of dissimilar metals in reed switches due to the heating produced by energizing the coil. This thermally-generated EMF may be undesirable if the reeds are used to switch low level analogue signals — as for example in data-logging or thermocouple measurements.

For applications where the thermal EMF must be held to the minimum a bi-stable latching reed relay should be used. A short pulse to the set coil operates the relay, no heat generating holding current is then required. Another short pulse to the reset coil releases the relay. Using this type of operation, the latching relay thermal EMF remains below five micro-volts, compared to as much as 100 micro-volts for continuously energized relays.

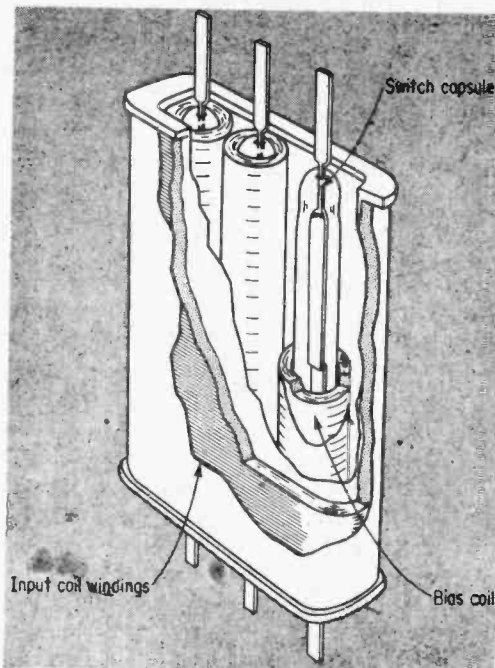

Fig. 18. Reed switch logic module.

NEXT MONTH we'll conclude this series with a look at some ordinary, and some rather exotic applications for reed switches.

CANADIAN PROJECTS BOOK NO. 1



Canadian Projects Book No 1.

Whether you want project plans to build from, or want to steal the designs to adapt to your own uses, this is a book for you. Includes audio designs (complete modular disco outfit, including Amps), sound or light triggered flash unit for photographers, test equipment, bio-electronics, guitar phaser and much more. Order yours for \$3.00 + 45c postage and handling from ELECTRONICS TODAY, Unit 6, 25 Overlea Bld, Toronto, Ont., M4H 1B1. Also available where ETI is sold.

Number one ETI CIRCUITS
The first in a new series of 'ideas books' for the experimenter

Includes: Thermometer, Disked supplies, Frequency Meter, DE, Community, Finish, Starting, Isolated He, Interface, Your Mains, Resistance on L, Voltage Electro, Crystal Chec, Good Bad B, Battery Test, Op-Amp Test, Op-Amp Che, Cheap Logic, Audible TTL, Audible Slow, Logic Probe, Logic Analys, I and O Diag, Simple High, Voltmeter, Audio RF Tra, Thermocou, Metering Sta, Simple Freq.

POWER CONTROL
LDR Mains Control, Floodlamp Control, Zero Crossing Sync, Train Controller, Low Differential Thermostat, Simple Temperature Control, Full Wave SCR Control

TIMERS &
Low Standby, 741 Timer, Phase Locked, Touch Doorbell, Phase Lock Control, Audio Mixer, Virtual Earth Mixer, Pop Eliminator, Loudspeaker Protection, Digital Capacitance Pro, Digital Tape Recorder, Breakdown Diode, Dual Function, Dual Mode, Cell Mode

SEND \$5.00 TODAY
To: ETI Circuits, ETI Magazine
Unit 6, 25 Overlea Boulevard
Toronto, Ont. M4H 1B1
Please add 45c for mailing and handling

FLASHER

BEFORE...

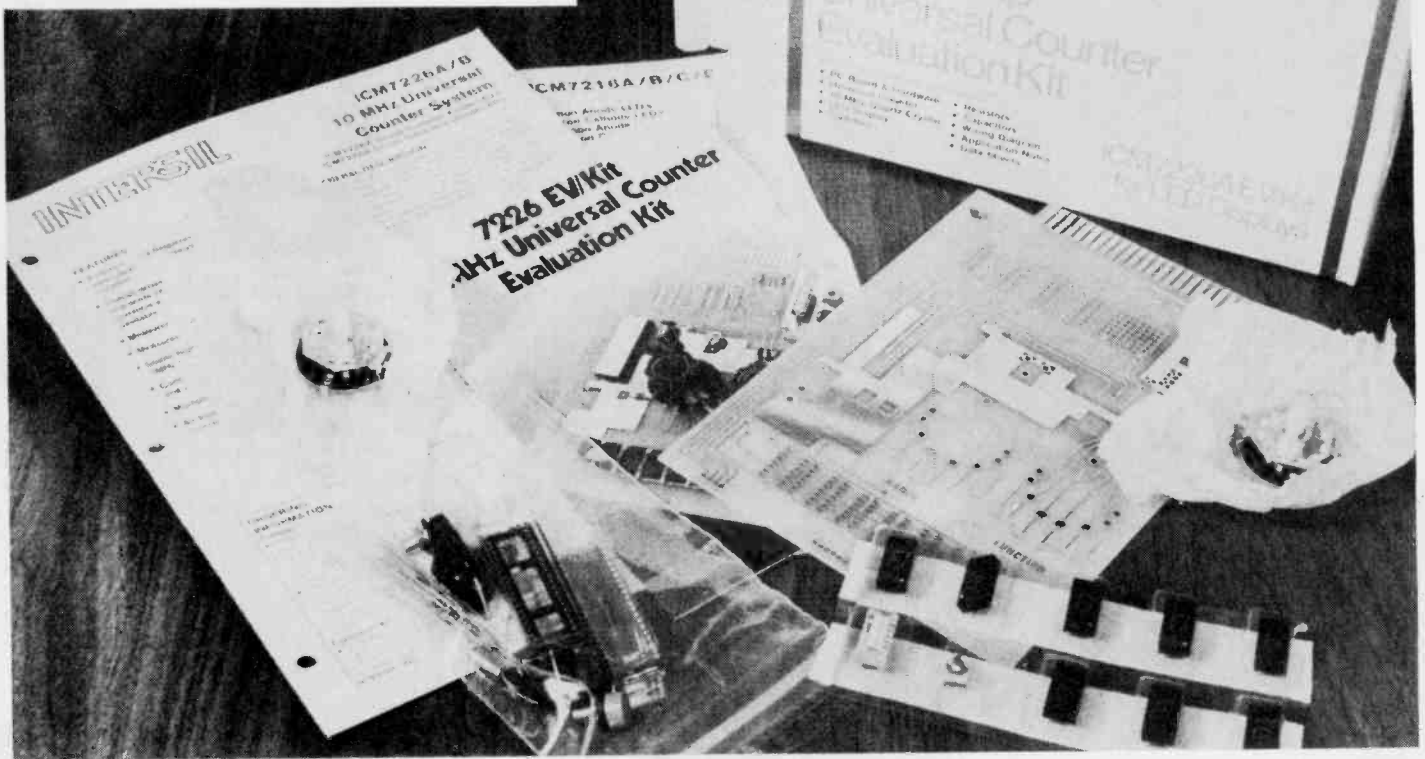

Schematic

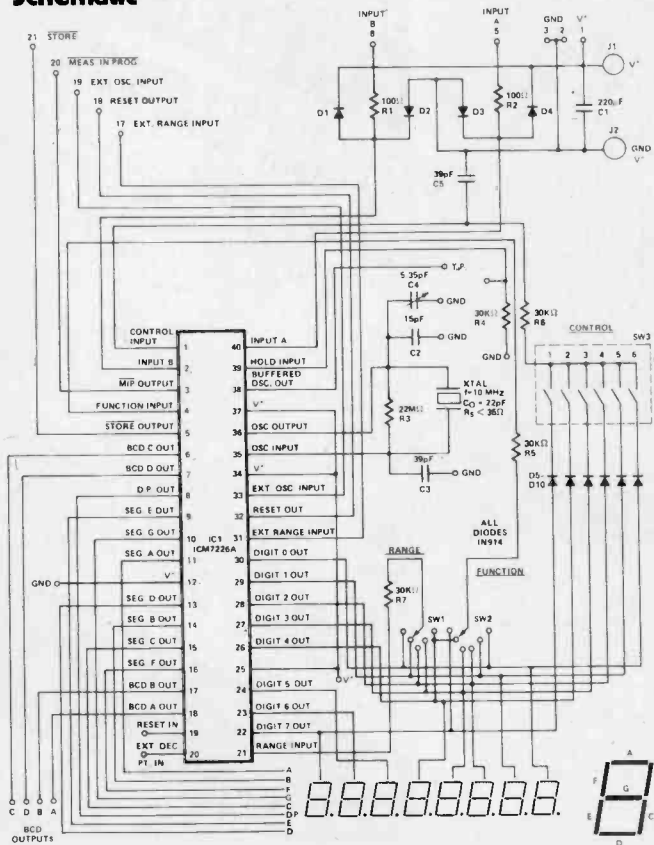

Intersil's ICM7226EV evaluation kit shows off the capabilities of their all-on-one chip counter chip.

SUPPOSE you want to measure frequency, time, period, or just count occurrences, what's the neatest, most hassle free way to do it? Especially if you've got eight digits of answer to handle? Well Intersil's got the answer in their 7226 and associated chips. The 7226, as you can see from the diagram, does all the work, containing the counters, registers, and also drives the displays as well. (Common cathode or anode models are available.)

The 7226 EV is the evaluation kit put out by Intersil to demonstrate the capabilities of the chip. Manufacturers and designers will thus be interested in the kit as an aid to checking out the IC for use in their products. But in addition, the kit makes a darned useful general purpose test instrument, measuring or counting up to 10MHz, and with crystal controlled stability. Input levels are normal TTL, or use the prototyping area on the board for conditioning input signals as you wish.

And all this for around \$80 (Can, 1-24 quantity, inc FST).

Contact Lenbrook Industries Limited, 1145 Bellamy Road N., Scarborough Ontario M1H 1H5 (416) 438-4610 for details on local sources of supply, or for data sheets.

AFTER....

Edge connector provides access to 7226 inputs, and supplies power.

Area available for prototype input circuitry.

DIP switch provides means for testing all features.

Oscillator Circuitry

The Intersil ICM7226A counter chip which does all the work

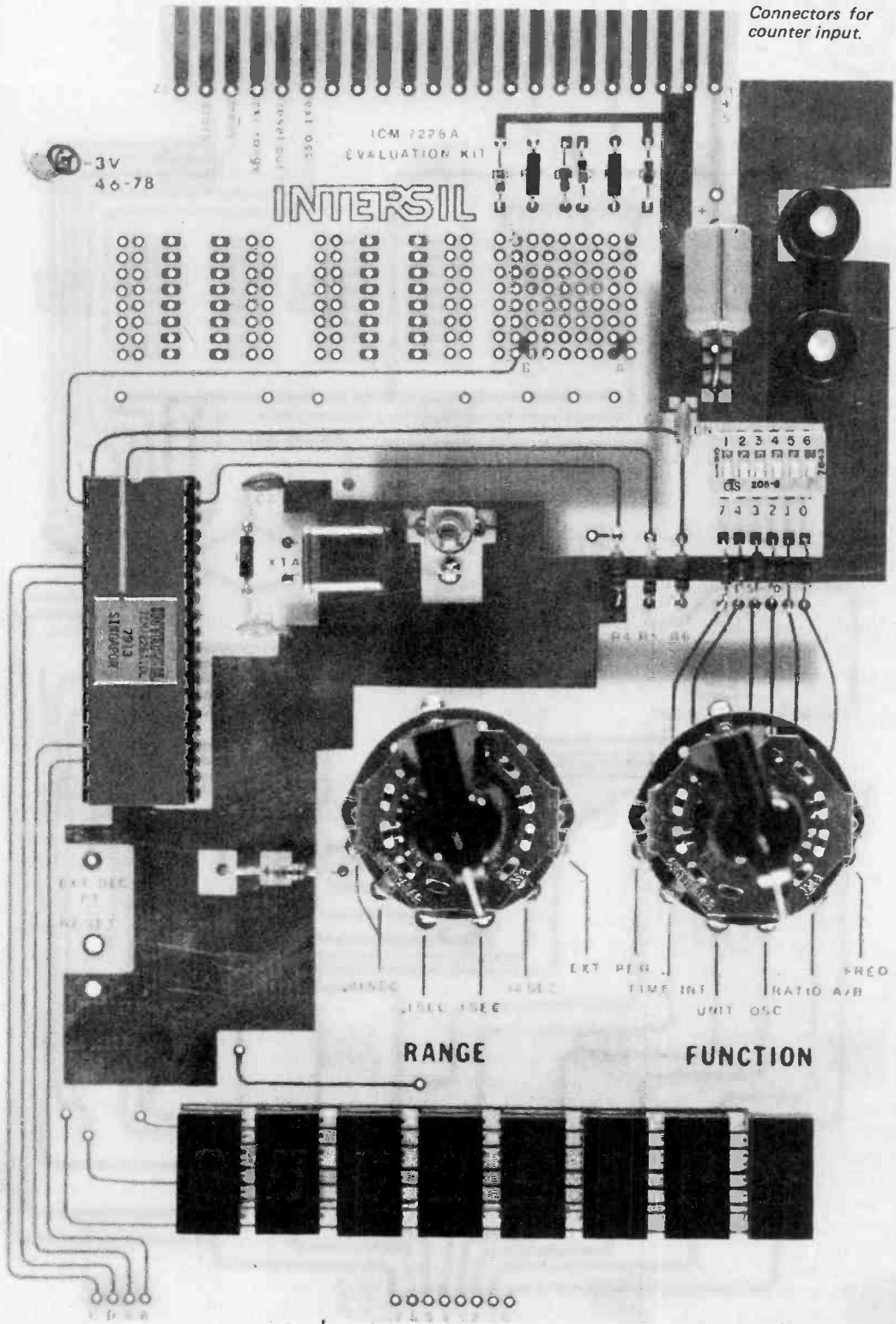

Connectors for counter input.

What it Does

FUNCTIONS:
 Period;
 Time;
 Units
 (Counter);
 Oscillator
 frequency;
 Ratio (A input
 frequency to B
 input frequency)
 Frequency;

RANGES:
 (For frequency
 measurement)
 .01 sec to 10 sec
 and external.

Connection points for remote display, digit and segment drives.

Magnetic Field Audio Amp

Carver Corporation's Model M400 amplifier using the unique 'magnetic cavity' was released in the US a few short months ago. Employing FETs throughout, except for bipolar silicon output transistors, Carver Corp. claims that the M400 has a slew rate around 80 volts per microsecond, hum and noise over 100 dB down, 0.05 % distortion and a frequency response from 1 Hz to 250 kHz — all for an unexpectedly low price! |

IT SEEMED A BIT HARD to take seriously even though we were totally aware of Bob's previous efforts such as the range of Phase Linear super-amps and the Autocorrelator noise reducer.

But it seems as if this revolutionary concept in audio amplifiers is for real — patent protection has been arranged and preliminary details have been released.

Bob's basic concept is to store energy in a magnetic field rather than very large value electrolytic capacitors — eliminating at the same time the need for a bulky expensive power transformer.

Our circuit drawing shows the essential features. The heart of the circuit is the magnetic cavity (MC). This is basically similar to the AM detector transformer used in conventional AM radios but constructed on a grand scale. A further and significant difference is that the transformer is arranged such that an output occurs as the primary field collapses rather than builds up.

The secondary winding of the magnetic cavity is centre-tapped and the resultant full-wave output is rectified by a pair of high current diodes — the output waveform is thus a conjugate pair of time-varying audio voltages. Further circuitry, described later in this article, provides a feedback loop to remove commutation noise and reduce distortion.

The primary of the magnetic cavity is energised by an amplitude-modulated current (corresponding to the audio signal voltage). The current signal is produced from the audio input, via the optical isolator and modulation and control logic, to the scanning SCR, the ramp SCR, a pair of scanning and commutating diodes, and L1, L2 and C1.

This current signal energises the primary of the magnetic cavity. The time taken for this is called the 'ramp period'. The primary energy is then reflected in the secondary windings (and thence to the speaker) during the subsequent 'scan period'.

As our graph shows, the ramp and scan periods are made up of four separate timing intervals. During the period $t_0 - t_2$ an incoming audio signal has caused a magnetic field to 'ramp' up in the primary of the magnetic cavity. At t_2 the field has reached its peak and is beginning to collapse. This collapsing field generates an associated decaying current i_1 and this decaying current falls to zero when the energy in the primary field falls also to zero (point t_3). During the time period $t_2 - t_3$, the control logic provides a positive signal on the gate of the scanning SCR, however this SCR will not again conduct until

sufficient voltage is applied between its anode and cathode.

Throughout the scanning period, energy is of course being transferred from the primary of the magnetic cavity to the secondary — and thence to the speaker load.

At time t_3 the direction of current is reversed — current being no longer maintainable by cavity inductance — and the scanning diode is reverse biased — this causes the scanning SCR to be forward biased and current flows as shown in our sketch.

Summarising then, energy stored in the magnetic cavity is caused to shuttle around the circuit of L1, L2, C1 and the speaker load depending on instructions from the control logic.

NOISE AND DISTORTION

Components Q1 — Q3 form a feedback loop which reduces the inherently poor bandwidth, noise and distortion to very acceptable levels. Theoretically the circuit has some quite strong objections — at low frequencies Q1 and Q2 will act much as switches except that the feedback correction voltage developed by Q3 will adequately cancel aberrations — but at higher frequencies, i.e. 10 kHz — 20 kHz the modulator circuit is unable to follow accurately the audio input

Magnetic Field Audio Amp

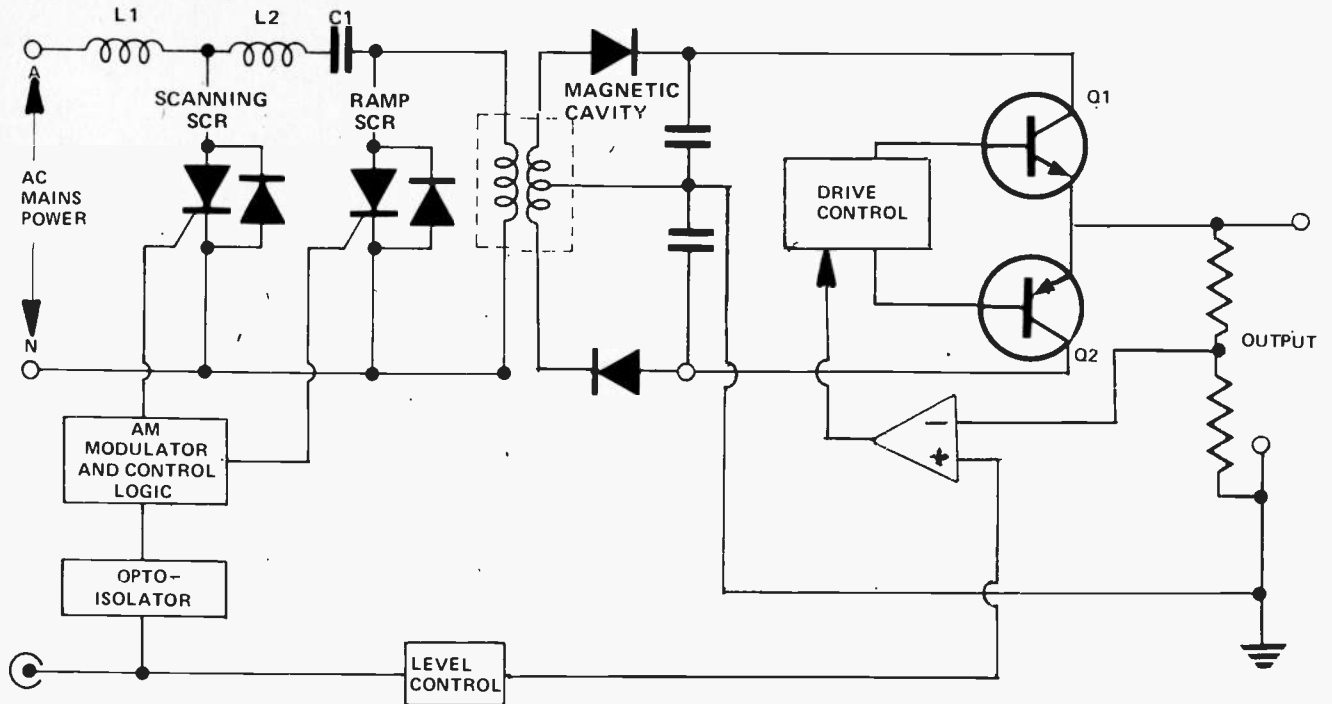

This schematic shows the major operating components

signal. Hence the filtered output from the magnetic cavity is a dc level with a superimposed ac signal and Q1 and Q2 thus operate much as any other conventional amplifier.

Nevertheless as less power is generally required at high audio frequencies than at mid frequency and low frequency, amplifier efficiency is very high if fed with music signals. This situation does not of course apply if the amplifier is fed with a high frequency steady tone.

Bob Carver's radical amplifier will be rated in accordance with FTC rules — the specification is expected to include power output: 200 watts-per-channel into eight ohms from 20 Hz to 20 kHz. Total harmonic distortion is expected to be less than 0.08% across this range.

Signal noise ratio is expected to be 100 dBA below rated maximum output. All-up weight is an incredible 5.5 kg.

As far as we are aware the magnetic field amplifier exists at present solely as a prototype unit but we understand that Bob Carver has very real plans for putting the unit in to production

It's a fascinating concept, one that will cause amplifier designers and manufacturers world-wide to furiously re-think their design philosophies. It may even herald the coming of a new hi-fi technology. ●

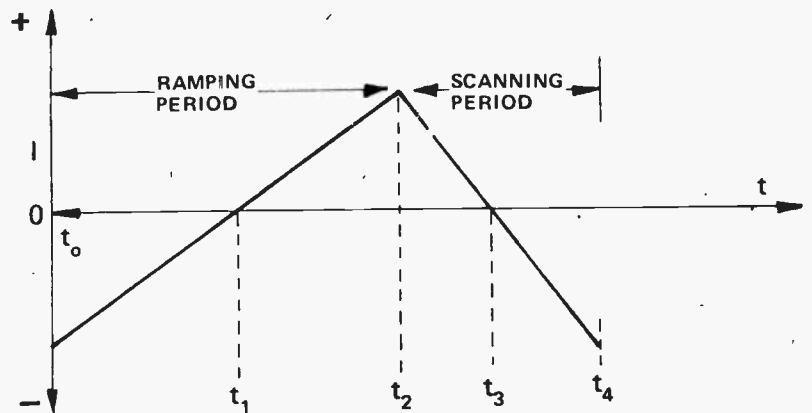

During the ramping period energy builds up in the primary of the 'magnetic cavity'. Throughout the scanning period energy is transferred from the primary to the secondary of the magnetic cavity and thence to the speaker load via Q1 and Q2.

QRM QRM QRM

Bill Johnson, VE3APZ, discusses packet radio et cetera.

WHILE THE WHEELS of government were turning in Ottawa last year, Canada's amateurs were imagining all sorts of things that would happen once the 'packet license' came into effect. One theory I heard put forward at a club meeting was that there was a company called the 'Packet Radio Company' that had a whole warehouse full of 220 MHz radios built for the Class E CB boom that never was.

Naturally, the above comment was made in jest, but it showed a feeling of uncertainty prevalent in amateur ranks at the time, somewhat similar to that often experienced by even the hardened veteran of many extractions when going to the dentist. Now that we have seen the new rules, realised that 220 will not be taken up entirely with packet transmissions, and some of us have taken the examination, what are we going to do with it?

I think it is very fitting that Canada should be the first country to give its amateurs the privilege of communicating using packets, because it was here that the world's first standard protocol for a packet switching network was formulated. This standard has been accepted by the CCITT, and labelled X.25. X.25 basically defines the signals, codes, and procedures needed to set up a system where a packet of information can be submitted to the network at one location and transmitted from computer to computer along its way, via the most efficient route, until it reaches its destination.

All the writing recently about amateur use of packets has centered around the Aloha system - the subject of Dr. DeMercado's PhD thesis, which relates to communication between several hundred time-sharing computer system users and their host computer over a pair of radio channels. Essentially, this system is dedicated to servicing the user

terminals' needs for communicating with the main computer to create, edit programs etc. Although most timesharing systems have a 'mail' facility whereby any user can leave a message for any other user, to be delivered when the latter logs onto the system, the Aloha system is not specifically designed to facilitate the transmission of messages or text between one user and another.

In the four years that it has taken myself and other directors of the TFM society to design, build, and now program a micro to run an amateur repeater system, we have come across some very interesting ideas in packet switching, and have talked about this as part of our micro presentation to clubs in the greater Toronto area. It is this subject that I am going to talk about this month.

The whole idea came up one evening at a director's meeting when we were talking about linking repeaters. The RPT machine has been linked to the Buffalo repeater since the early seventies, but due to unreliable 450 equipment and lack of access to the two sites, it has very infrequently been found to be working at both ends at the same time. I have always been ardently opposed to multi-hop linking, i.e. linking one repeater to another and then on to a third, because the more complicated the system gets, the harder it is to use it, and by simple logic it is clear that if you have lots of 'drops', each of whom can request a link to another 'drop' at any time, you must have many channels between the intermediate repeaters. The resulting logic at each site, as well as the radio equipment to accomplish this, is well beyond the scope of amateur funds. You might say that talking about putting a microprocessor at every repeater is going to be just as costly, and I will agree with you that it might just be, but there are many benefits to having a packet system over just having a system for voice links.

The system that I am proposing is a multi-node packet switching system using, for the most part, existing two metre and 450 MHz repeaters. Each repeater would have a microcomputer to control not only all the repeater functions, such as call-sign sending, timing, autopatch, etc, but also the inputting of data on another pair of VHF/UHF frequencies from low-speed teletype stations. In low-usage repeaters, the teletype could be sent into the repeater over the regular two metre talk channel, but this could not be done in the busier areas.

Every major centre would have at least one repeater, or NODE, that would have a floppy disc attached to store information on all messages sent to and from the repeaters in its area. In a city, one large club could handle message storage for smaller clubs that could not afford the equipment. Naturally, each repeater would have to have a link to the NODE for its area, and this would be a narrow bandwidth (10kHz) full-duplex 450 MHz channel. Although the end user would normally send data from his keyboard in a simple fashion, he would have to provide his local repeater with certain routing information, and a typical message might go like this:

```
HHHH
ZCZC
VE7MQ(VE7RPT)
DE
VE3APZ(VE3RPT)
BT
HI DAVE, HOW IS THE MICROCOM-
PUTER PROJECT GOING OUT IN BC?
HOPE YOU HAD A NICE VACATION.
73
BILL
NNNN
```

The above message shows the various parts that would be necessary to give the local repeater instructions on what to do with the message. It consists of:

1) HHHH - these are called learning ch-

acters. Because amateurs use teletype machines of various speeds, as well as both ASCII and Baudot codes, each system would have a learning code, to be transmitted at the beginning of each message. The local machine would keep changing its baud rate and code type until it found one that decoded the learning characters correctly. It would note the code and speed and use these parameters for the rest of the message.

2) ZCZC - a standard symbol to indicate the beginning of a message. Needed to tell the computer that an address follows.

3) VE7MQ(VE7RPT) - the destinee's address, and the call of the main repeater in his town. This is needed because it would be impossible for every repeater to know where every ham lived.

4) DE - the address separator.

5) VE3APZ(VE3RPT) - the sender's call and nearest NODE, to which a reply or service message can be sent.

6) BT - signal indicating break before text.

7) Message and signature, any format. This could contain an informal greeting, a message conforming to NTS standards, a computer program, or even a recipe for apple pie.

8) NNNN - signal indicating end of message.

As you can see, the above message could be sent easily by any amateur with a teletype machine. It does not require any special knowledge of computers or any calculations. The message would go into the local repeater, to which we will now give the name NIM - network interface machine.

It is only in the NIM that the marvels of modern computation will start to take place. Here, the message will be assigned an origination time, date, and number. The NIM will add its own identifier to the message so that any service message can be sent directly back to it. The NIM will count the words, and create a checksum character of all data in the message. (See Bits, Bytes, and Bauds, ETI Canada, FEB 78). It will then forward the message on to the nearest NODE. (In the case of a ham typing his message into the main repeater in the area, or the only one, the NIM and the NODE will be the same machine, quite often being controlled by the same processor. I say processor at this point because in such a case, especially in a large city, the amount of work to be done by the processor would be pushing one of today's micros to the limit. By the time such a system is built, however, the new generation of processors will be more than equal to the task required of them.

When the NODE has received the message from the NIM, it will check its files to make sure that the destination NODE required by the sender is part of its system.(i.e. It has been told certain things about it, such as where it is, how to send a message there, etc.) If no such NODE exists, the NODE will immediately send a service message back to the NIM, who will cancel the message and send a further message back to the originator.

Before I go on with the passage of the message through the system, let's just take a brief look at the service message. The NIM can't just blindly send a message out saying that the message was scratched because it didn't know how to handle it. How would it know that it got to the intended person? Also, if twenty hams had their teletype machines running, they would all get the message. The answer is a selective calling device at each station. When the NIM has a message for ham X, it will send a special tone signal that is unique to ham X, at which time ham X's machine will respond with its call-sign. Only when the NIM receives ham X's call-sign correctly does it send the message. It is in this way that any message will be sent to the destinee.

Back in the NODE, the message is all ready to go. How does the NODE know where to send it? The answer lies in a table of suggested routes that is built into the system's files. It sees from the message that it has to go to VE7RPT, so it looks in its files for the nearest NODE that can handle a message to VE7RPT. It then sends a request to that NODE, over a channel whose bandwidth is dependant on the amount of traffic between the two points. If the second NODE can't handle the traffic, or if the first doesn't get an answer from the first, it will try the next nearest node and so on until it clears the traffic. When the

first doesn't get an answer from the second it will try the next nearest node and so on until it clears the traffic. When the next NODE gets the traffic, it will get it to the next NODE in the chain in the same manner. In the end, after going through many nodes, it will arrive at the end NODE, which will look up the destinee's home repeater, and forward the message to it, for ultimate delivery via teletype.

Finally, the end NODE sends a service message back to the originating NODE to cancel the message. If the originating NODE doesn't get this message in a reasonable period of time, it will re-send the message, assuming that the original message was lost.

There is one other little piece of information that I haven't mentioned yet. There is a number included in the message, which starts out as 1 at the originating NODE and is incremented every time it passes through another node. If this number ever gets bigger than the total number of NODES in the system plus a few, then it is apparent that it is just going around and around. The NODE finding such a message would cancel it and send a service message back to the originating NODE saying that it was undeliverable.

It might take ten years to do it, but you can bet your bottom dollar that this kind of a setup will replace the National Traffic System. (See ETI Canada, FEB 78).

Since this has been an all-educational column, LESSON OF THE MONTH & QRM letters will have to wait until next month.

73

Bill Johnson, VE3APZ

ETI

PLEASE SEND IN YOUR ADVERTISEMENT IN THIS FORM. USE AN EMPTY SEALED ENVELOPE, WITH YOUR MESSAGE ON THE BACK.

ETI MARKETPLACE
UNIT 8, 53 DUNDAS BLVD,
TORONTO, ONTARIO
M4H 1B1

WRITE YOUR MESSAGE HERE.
DON'T FORGET YOUR NAME, ADDRESS, PHONE NUMBER

MARKET PLACE

WANTED: SUITABLE POWER SUPPLY KIT WITHOUT CHASSIS FOR MY ELECTRONICS STUDENTS' QUAN APPROX 100. PRICE APPROX \$15. ANY COMPANY WHO SELLS SUCH PLEASE CONTACT PETER CARRILLO TEACHER, CEGEP DE L'OUTAOUAIS' 124 MAISONAUVUE HULL QUE 592 1020.

WANTED: SCHEMATIC FOR SENCORE SWEEP CIRCUIT ANALYZER MOD:SS137 G. PARISIEN 9A BERIAULT HULL QUE J8X 1A1

WANTED: SCHEMATIC, PARTS LIST AND OWNERS MANUAL FOR A NYTONE STEREO AMP NS 12 OR ADDRESS WHERE I CAN OBTAIN. TIM TOCHOR, 31 MYRTLE ST ST THOMAS ONT N5R 2E6, CALL 519 633 4427.

FREE personal advertising! See above.

Service News

MANUFACTURERS... REPRESENTATIVES... ORGANISATIONS... SERVICE... DISTRIBUTORS...
Send us your news releases on upcoming seminars, new products, ideas for the successful shop. Address them to Service News, Electronics Today Magazine, Unit 6, 25 Overlea Blvd, Toronto, Ontario, M4H 1B1. Please note that your information must be received at least six weeks before the first of the month of the issue in which it is to appear. Any material published at our discretion.

Dick Cartwright keeps up with various ongoing situations, including CEASA, CSA and licencing in Alberta.

CEASA

On June 4th Mr. Alan Brooks, President, and Mr. W. A. White, General Manager, met with Mr. Frank Drea. The meeting, held at the request of CEASA, was to provide an opportunity for them to acquaint the Minister with the CEASA Code of Ethics, RSVP consumer help programmes, aims and objectives, etc. This will be the fifth provincial government to meet with CEASA to obtain first-hand information about their organization. Other governments CEASA have met with include British Columbia, Manitoba, Quebec, and the Federal Government in Ottawa, and they are looking forward to relating the CEASA story to other Provincial governments in the near future.

CEASA & CSA

A recent newsletter received at ETI: "Involvement of CEASA on senior consultative committees of the Canadian Standards Association has resulted in it being recognized as a member of CSA with full voting rights in the election of Directors and Executive Officers. As a member, CEASA has also been invited to attend the 60th Annual Meeting of the Association being held in Montreal in June. We in CEASA should be proud of the recognition by such an august body as CSA and the opportunity afforded a National Service Association to participate in top level decisions that not only affect the Canadian Service Industry but Canadian manufacturers and consumers as well."

ALBERTA LICENSE

About mid-May I received a letter from a Mr. Bob Collins of Stettler, Alberta. In this rather short communication he referred to a previous comment of mine re licensing systems used in Provinces other than Ontario. He most kindly sent a copy of "Opportunities in Apprenticeship" published by the Apprenticeship and Trade Certification Branch of the Alberta Provincial Government. He unfortunately did not go into details of the final certification procedure, but he did go on to point out that anyone caught servicing domestic electronic equipment without a licence faces very stiff penalties. From the tone of his letter he was obviously surprised to find out that here in Ontario absolutely no qualifications are required before any person would be allowed to hang out his shingle and service electronic equipment. Thanks very much, Bob.

I spent the next several days phoning various individuals and service organizations, both Association members and independents, in an endeavour to find out whether or not the qualified technicians of the Province had changed their minds about some form of Government legislation. I remember the early days of 1952/53 when RETA spent a good deal of time and money trying to push through a Private Member's Bill granting some sort of certification.

95% of all the people I spoke to were still adamant in stating that certification is necessary, and they would like to see

the Government take action forthwith, if only to protect those technicians who have so much time and money in furthering their skills and at this moment have absolutely no protection at all. Why, they ask, does one have to have a Provincial certificate to be a hairdresser, a plumber, an electrician, etc., and yet equipment costing thousands of dollars, and with a lethal possibility, can be serviced by anyone. Maybe a petition could be organized by one or other of the Associations and presented to our Provincial government.

APOLOGY TO OETA

In view of prior commitments I was unable to report on the MTTSA (Toronto Chapter OETA) annual dinner dance held on Saturday, April 7, 1979, at the Harbour Castle Hotel. The Board of Directors are to be congratulated on this extremely well organized social get-together. As I have mentioned before, one of the many advantages of belonging to your local Association is not only the technical seminars, etc, but the often too infrequent fun nights.

The Honourable Frank Drea, Ontario Minister of Consumer and Commercial Relations, addressed the guests briefly, stating that he felt he had assisted in the growth of the organization, and quoting from the Annual Year-Book of the MTTSA he states:

"At a time when the public is looking for government to do more and when many businesses are reluctant to become directly involved in consumer matters, it is refreshing to see such a

Service News

group as yours work for the betterment of not only your profession but for the entire marketplace.

"I realize it is difficult and quite often frustrating to attempt to do the remedial work that has made your Association so outstanding in the business community. It is a compliment, not only to the officers and directors of the Association, but to its members that have been willing to provide a remedy when there is difficulty, even though it costs in terms of time and often goes almost unnoticed.

"I look forward to working together with you in an equal partnership where we can both expand our perimeter; where we can find better ways of doing things and where your Association will receive the recognition is so richly deserves."

A number of presentations were made. To Zenith went the President's Award. R.C.A. and Phillips also received awards for "Friends of Service". A special award was also given Mr. Jim Smart of the Canadian General Electric Company for the special assistance freely given over the past many years. Keep up the good work, MTTSA. A more hardworking board of directors would be difficult to find.

To continue with local association news. The MTTSA held their quarterly general meeting on May 30th at the Airport Holiday Inn. The first guest speaker, a representative of The Computer Place, (186 Queen St. W., Toronto) gave a presentation on the state of the art (mini and micro computers). There followed a question and answer period, and according to Mr. David Van Ihinger the technicians present appeared to be extremely enthusiastic about the subject. This was followed by an address given by Mr. Paul Tuz (President of the Toronto Better Business Bureau). The subject was the Canadian economic future under the new Conservative government. The turn-out as usual was somewhat disappointing, some 33 members being present. As a matter of interest, 3 past presidents of the organization, and of course the present one, attended. Again, I know I am flogging a dead horse, but in view of the efforts of the present directorship and the number of MTTSA member in this area, it seems a shame that they (the directors) do not obtain the support they so obviously deserve.

Until next time, all the best.

Richard H. Cartwright.

Subscriptions

The ETI newsstand rate is \$18 a year. With a subscription you pay only \$14 dollars!

Please use the card to order your subscription now.

OR SEND a cheque, money order, Chargex, or Master Charge information, to Electronics Today Magazine, Unit 6, 25 Overlea Blvd., Toronto, Ontario, M4H 1B1.

Allow 6-8 weeks to receive your first issue.

Special Libraries Offer

Dear Librarian:

Electronics Today is a magazine aimed at electronics enthusiasts of all levels, from beginner and student, to teachers, technicians, and engineers who are professionally involved in the field. Something else you should know is that we are a Canadian magazine, and we've been around for 2½ years now. That means we not only have editorial related to electronics, we have information relating specifically to Canada. The ads too are Canadian, and we find our readers reading these intensely to find out where to get what in their own country.

In deciding whether to give us a shelf space, you no doubt have to decide if enough of your patrons will be interested in us. If you take Popular Electronics or Radio Electronics, then that decision has been made, for our readers are in many ways similar. In fact, our reader survey and letters we receive indicate that many readers not only like us better, they've "switched" from the "other two"

Please then accept our free "evaluation subscription" offer. We will send you the next 7 issues free, so you can see how we do.

Thank you.

Bebe

Mail to: Library Offer, ETI Magazine, Unit 6, 25 Overlea Blvd., Toronto, Ontario M4H 1B1.

Librarian: _____

Library: _____

Address: _____

Offer valid until Sept 30th 1979.

Please allow 6 to 8 weeks for first issue to arrive.

Zenith's full line of antennas, featuring

CHROMATENNA II

with 18 ways you can count on for optimum picture quality!



Transmission Line Termination bleeds off static charges thru antenna system ground. Terminal stub improves front to back ratio on lower channels.



Aluminum Construction of all key metal parts works to eliminate rusting—provides long life. **Golden-Color Alodine Finish** is conductive—helps improve electrical performance!



High-Impact Plastic Insulators double-lock each element to the boom for extra bracing and durability.

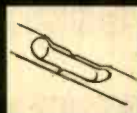

FM Block reduces FM gain up to 12dB. Remove to receive full FM gain.

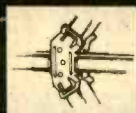

Corner Reflector Bracket improved with larger tabs. (Combination models only.)



Zenith Dipole on UHF. (Combination models only.)

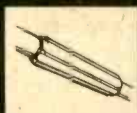

V-F Colinear Directors provide extra signal boost on both low and high band VHF.



Loading Straps—metal plates close to first VHF element insulators provide compensation for Lo and High band by tuning the first driven element with extra capacity.



Rugged 1" Square Boom provides extra strength compared to many round-type booms.

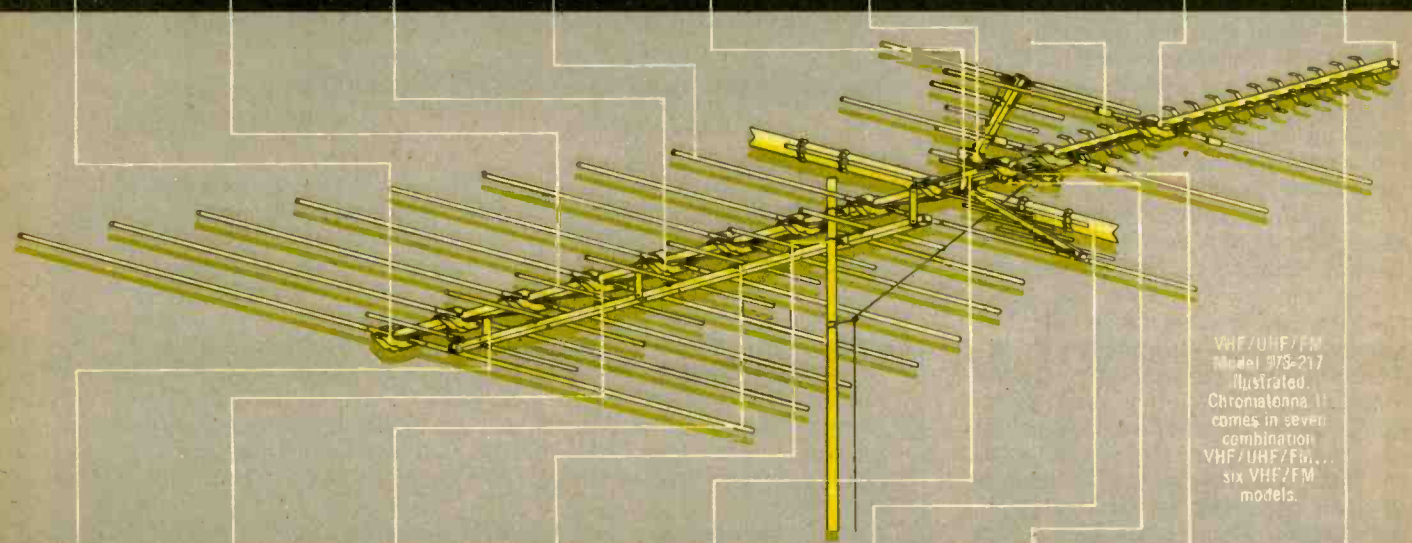

VHF/UHF/FM Model 975-217 illustrated. Chromatenna II comes in seven combination VHF/UHF/FM... six VHF/FM models.



Wide-Spaced, Heavy-Duty Feed Lines help prevent shorting from heavy build-ups of snow or ice.



Sleeved Elements of heavy-duty construction afford extra bracing and protection.

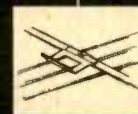

Hi-Bracket with angled ends for added strength.



U-Bolt Mounting provides a larger clamping area; larger locking nut with teeth an integral part assures a more rugged U-BOLT arrangement.



Dual solator Bars insure no loss of UHF to VHF signal transfer. (Combination models only.)



Proximity Spaced Signal Balancer (Z elements) provides automatic taper control of periodic driver, improves impedance matching and signal leveling on both Lo and High band channels. Improves Channel 7 pattern.



Electrically Matched Terminals With Stainless Steel Screws eliminate mismatch... protect against rusting, and provide positive electrical contact with improved to-strip stainless steel serrated washers for the take off terminals.



Strain Relief Insulator accommodates either 300-ohm twin-lead, foam lead or Coax downlead.

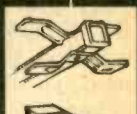

Optional Break-away UHF Wing Directors provide maximum gain of standard UHF channels with optional coverage of Hi UHF channels and translator frequencies when broken off. (Combination models only.)

Zenith has quality do-it-yourself antenna kits—UHF only, VHF YAGI and Stereo FM antennas as well as a complete line of reception aid equipment



Major Appliances Div., Acklands Ltd., 1725 Quebec Street, Vancouver, B.C. Phone-1-604-879-4631

B.R.E. Electric Ltd., 5544-5th Street S.E., Calgary, Alta. T2H 1L3 Phone-1-403-253-7171

B.R.E. Electric Ltd., 14640-115th Ave., Edmonton, Alta. T5M 3C1 Phone-1-403-455-7171

Major Appliances Div., Acklands Ltd., 1155 Sherwin Rd., Winnipeg, Man. R3H 0V1 Phone-1-204-633-6679

Zenith Radio Corporation of Canada Ltd., 1020 Islington Ave., Toronto, Ont. M8Z 5X5 Phone-1-416-231-4171

Zenith Radio Corporation of Canada Ltd., 900 Boul St. Martin O., Chomedey, Lav. PQ H7S 2B6 Phone-1-514-663-0430

Waldale Limited, Station Street, Box 339, Amherst, N.S. Phone-1-902-667-3308

Industrial Electronics

Mass production, manufacturing processes, and all industrial activity craves automation, and automation lives on ever more complicated control electronics. These factors have conspired to create a field of expertise known as "Industrial Electronics". How's a technician to learn what he needs to know? Jonathan Massey Smith at Toronto's George Brown College looks at the field, and how industry and his college are attempting to keep up.

MOST PEOPLE are becoming so accustomed to new electronic devices in their daily lives they forget that today's inventions were only yesterday the far-fetched dreams of researchers. But what is also not realized is that electronics has created significant changes in industry in the last few decades and developments here have filtered through to affect the lives of everyone.

People outside the electronics and electrical industry have at best a vague understanding of industrial electronics. Any electronic devices that are part of an industrial process are considered in the realm of industrial electronics. That means all applications in which electronics is the main ingredient of the process, as well as devices that help control the process, including storage of data about the process. From the control mechanisms of a large oil refinery to simple photoelectric safety controls on a punchpress, electronic controls come in endless varieties. And the mining, pulp and paper, food processing, printing, general manufacturing and other industries all employ industrial electronics tradesmen to look after them.

A BRIEF HISTORY

Tracing the origins of industrial electronics is not an easy task. Some sources claim that in the 1880's a process that electrically separated iron from ore was the true beginning. Others believe it began sooner with the discovery that metals could be heated with electro-magnetic fields, the basic

principle of induction heating. Whatever the case, historians will agree that the real backbone of industrial electronics the three-phase induction motor and generator (installed on a simple remote-controlled model boat) first appeared in the 1890's.

This discovery was so far ahead of its time, few realized the implications. It wasn't until after the Second World War that industrial electronics indirectly attracted the concern of millions with mass production for the rebuilding effort. When war veterans returned home in 1945, they had an opportunity to be retrained in various fields, including electronics. The Provincial Institute of Trades, one of the forerunners of George Brown College in Toronto, was opened about this time.

Since the war, industry has sought faster and more accurate methods of production, and adapted electronic equipment to its own needs. Electronic circuitry of sophistication borrowed from war-technology, was quick to find its way into fast, accurate control systems for industrial processes. In the 1950's, millions of dollars spent on research in aerospace technology again led to comparable growth in the industrial manufacturing environment. The Provincial Institute of Trades offered its first high school course in industrial electronics later the same decade. Within five years, the night courses had developed into full-time day programs for electrical apprentices.

The incredible development of electronic controls in industry is a remarkable feature of the last few decades. Tremendous amounts of

complex control can be squeezed into miniature modules.

Progress in transportation and communications on top of numerous other social and economic factors, has compelled industry to use mass-production operations to meet increasing competition in expanding consumer markets.

ELECTRONICS = AUTOMATION = \$\$

In dealing with mass-production, electronic devices can provide precise dimensional stability of mass-produced products; increase quality control by sorting, gauging, and inspecting, thereby creating higher safety standards and reliability.

Moreover, the transfer of work from one machine to another can be integrated into a unique computer-controlled automated production process. In this type of automated system, production goes on without the need for comparably expensive labor. But malfunctions in any one area of the process can lead to a breakdown of the entire system.

Skilled technicians are needed to maintain such automation dependent equipment, while technologists can concern themselves with devising new ways to minimize such costly shutdowns.

KEEPING ABREAST

As innovations reach the market with increasing rapidity, a much bigger problem arises. How do thousands of technicians and technologists in Canada keep up with new trends in

industry? Martin McBride, director of the Joint Apprenticeship Council for union electricians, says qualified tradesmen have a "half-life" of less than ten years. "Even in five years, they can become pretty shaky, unless they're constantly on top of new developments," he says. His organization spends more than \$150,000 a year training apprentices, and another \$60,000 a year was recently approved for upgrading journeymen. The courses reflect an increasing emphasis on industrial electronics, and more and more electrical contractors are becoming involved in industrial electronics training. "A few years ago, there was some shyness on the part of electrical contractors to engage in industrial electronics training, probably because they'd never had experience in the field." But electronic devices are here to stay, and these people have had to broaden their skills, he says.

INDUSTRY, MANUFACTURERS AND UNIONS

When new equipment reaches industry, manufacturers oblige by offering familiarization courses and equipment manuals. And more and more companies are devoting thousands of dollars to retraining their personnel. Even so, grievances arise when tradesmen are forced to maintain new equipment not outlined in their contract. When new electronic equipment was installed at Proctor and Gamble Limited, electricians didn't submit a formal complaint through the union to management, says Don Castle, associate personnel manager. But there was a request for job reclassifications. Proctor and Gamble is now on the verge of entering into an apprenticeship training scheme, he says.

And technicians seem to be learning something somewhere! Six years ago,

says Jerry Horbatiuk, chief electrician for Maclean-Hunter Limited, 80 per cent of job applicants had to be turned down, "because they didn't know enough." Today, the quality of applicants is much better, he says.

WHAT IS SCHOOL TO TEACH

While companies that offer in-house training programs can design courses in accordance with their own needs, public educational institutions, faced with training graduates to service all ages of equipment, must treat their curriculum with caution. "We've been criticised by certain sectors of industry for eliminating instruction of tube type controls. But it's our feeling a great number of people trained in the past to service tube equipment are now becoming more involved in solid state circuitry," says Harry Mooradian, chairman of the Electro/Mechanical Division at George Brown College.

Industries that haven't installed modern equipment (and they are numerous) may criticise the move towards more industrial electronics training. But McBride, who's seen four major developments implemented in his time, from tubes to transistors to integrated circuitry to micro-processors, says up to 25 per cent of an estimated 4,000 union electricians in Toronto are coming in contact with electronic devices at any one time. "And it's increasing all the time."

"That doesn't mean industry doesn't use tube type controls," says Doyle Stinnet, a teacher at the College. "Some companies are reluctant to switch from proven equipment to modern equipment, unless the cost can be offset by a greater profit margin in the future."

SCHOOL KEEPS UP-TO-DATE

Trying to fill the gap between industry and school, with time as the crucial factor, is demanding. So an advisory committee, composed of industry experts and College instructors, are continuously reviewing curriculum.

One example is the College's apprenticeship training program administered by the Industrial Training Branch of the Ministry of Education. Apprentices have tuition and a basic living allowance paid for by the Employment and Immigration Commission, and a three-way contract between the student, their employer and the Ministry must be signed. Some courses in the program were thought by the College's advisory committee members to be slanted towards the construction industry. In fact, when the

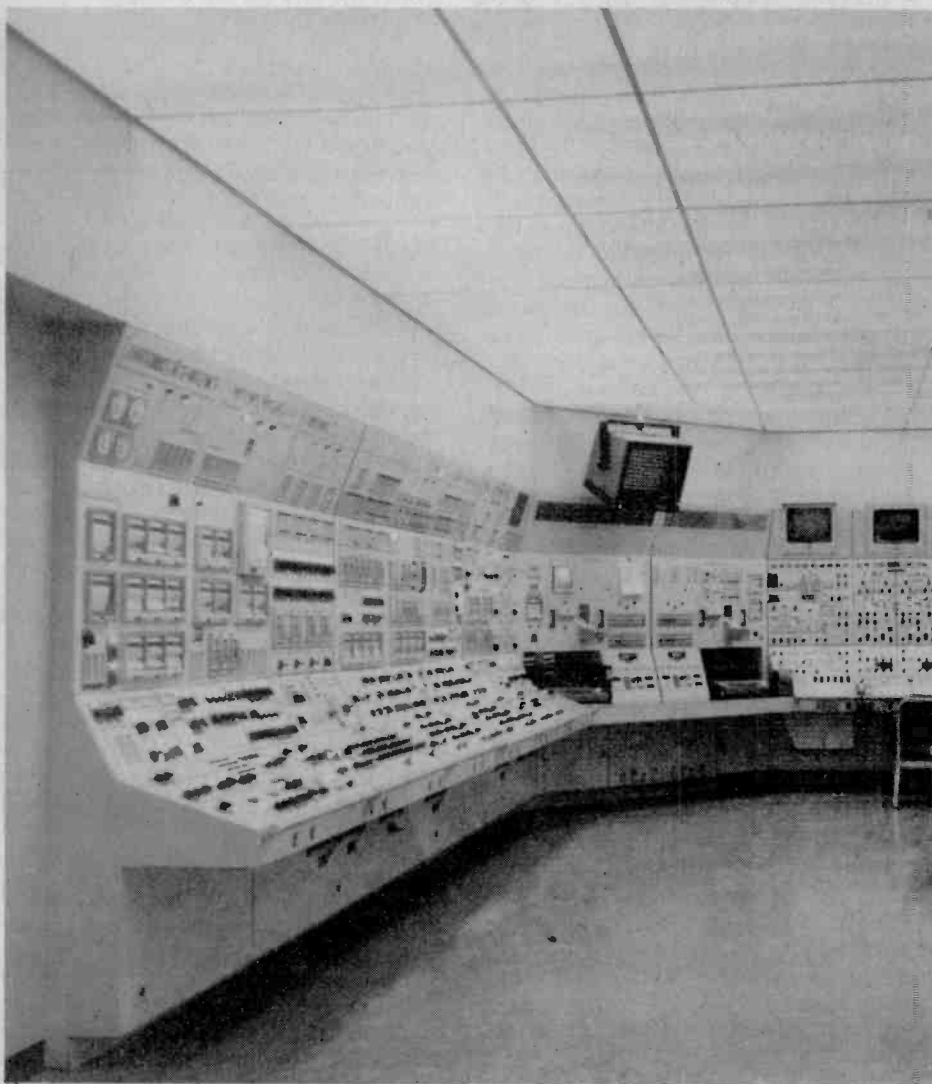

Here's an example of the control system you have to play with at a power station.
Photo courtesy Ontario Hydro.

Industrial Electronics

MANPOWER PROGRAM

In October, 1978, a Manpower-sponsored program for unemployed certified electricians and industry people who meet College requirements, was initiated. Forty students enrolled in the program, which is designed to upgrade and retrain students in basic theory and areas of industrial electronics with which tradesmen might not be familiar. The majority of graduates were placed in industrial electronics jobs through the electrical union.

CUSTOM COURSES

The College will design tailor-made programs for any company, provided a minimum of 20 students enroll. Over the past five years the Post Office has sent more than 600 employees for a special retraining program. About 50 per cent of the graduates are now maintaining the new automated industrial electronic letter sorting equipment.

FOR THE FUTURE

Trying to predict where industrial electronics is headed is an interesting and often frustrating task. Mooradian says that most sources available to the College indicate increased activity in the development of industrial electronic controls, which will replace traditional electro-mechanical devices.

"This includes modernization of existing systems in order to speed up and improve quality of production and safety," he says. As a result of the growth of the electronics field, including industrial electronics, Mooradian says the Electrical department at the College has been experiencing a significant increase in enrolment every year.

Instructor Charlie Paterson spent more than five months of his own time researching to find out what new developments are about to take place. "The most informed people who are knowledgeable about what's going to happen next are those in research and development. But don't even ask them about more than five years from now, because that's another world," he says. It is however fairly clear that one major challenge is the increased use of microprocessors in industrial systems. While these devices have been around for a few years now, it of course takes time for them to actually appear in control installations. Not the least of worries is that unlike some new sensor, microprocessors cannot be simply picked up overnight, they take time to learn and somewhere the time and place must be found to learn and teach.

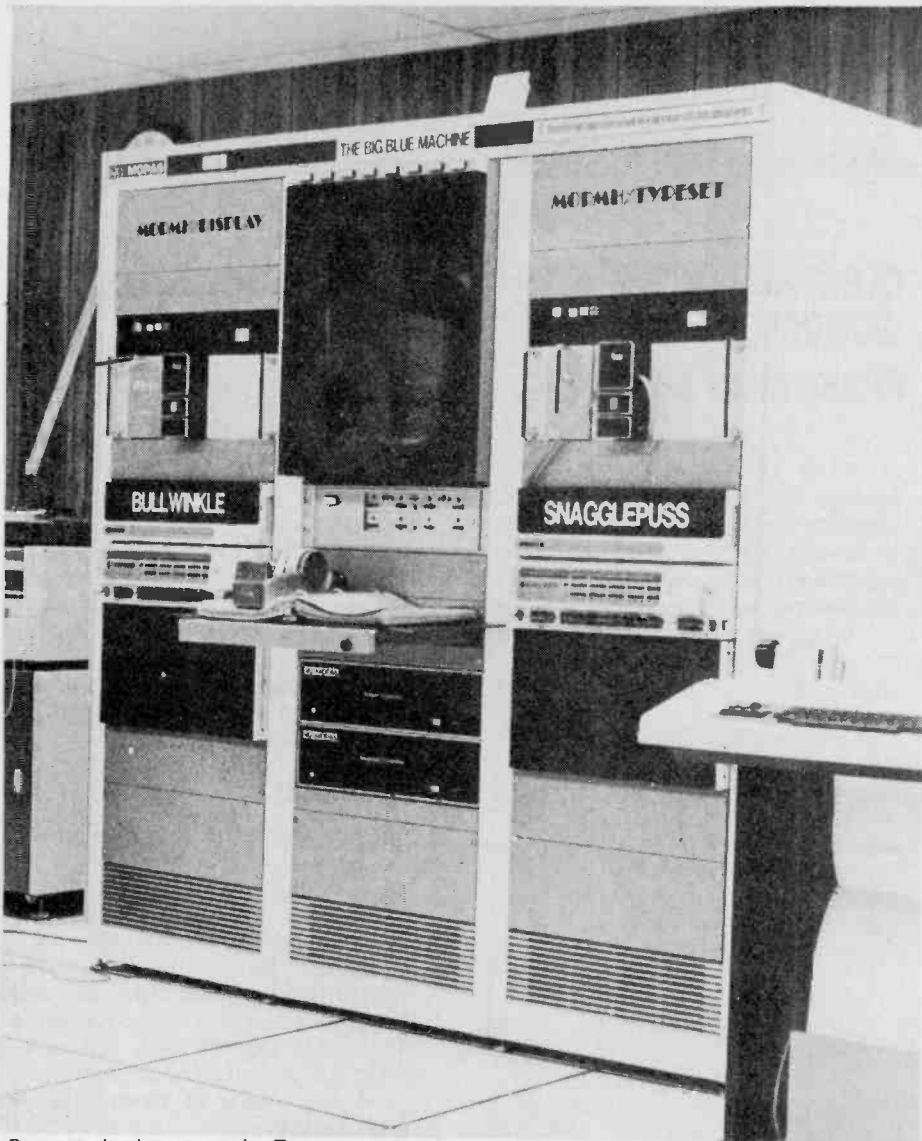

Computerization at a major Toronto publishing concern.

committee met in June, 1978, to discuss course content, some major changes were implemented. They agreed four hours a week allotted to welding in the electrical apprenticeship program would be better spent on electronic schematic and component lay-out interpretation, and circuit fabrication.

New additions to course content included detailed study of integrated circuits, electronic and hydraulic register controls, and commonly used equipment in the manufacturing and processing industries.

"But there's a reluctance on the part of some equipment manufacturers to supply detailed information on state of the art equipment," says Mooradian. "And when something new comes out, we usually learn about it after the fact." Instructors find it difficult keeping up with new developments, without the day-to-day learning process of actually working in the field. Reading trade journals, professional development days, visiting industry and difficult questions from knowledgeable students

encourage teachers to stay up to date with new innovations. "This requires continuous research which is very demanding," says instructor Charlie Paterson. In fact, a specialist electronics instructor was hired recently to teach some of the industrial electronics courses in the various programs.

POST-SEC. TECH

The College's two-year, post-secondary technician/technology programs concentrate on electrical fundamentals, a-c and d-c machines, electronic-control circuitry, micro-electronics, electrical drafting and related academic subjects. The technology program has an additional two semesters that can also be completed in two years, but with emphasis on designing and industrial processes. After completion of this program graduates will have met the educational requirements for acceptance by the Ontario Association of Certified Engineering Technicians and Technologists.

SHORTWAVE RECEIVERS SURVEY: October Issue

AS WITH ALL OUR PREVIOUS surveys we're sure we're going to discover that there are more shortwave receivers available than we thought. We'll see in October Issue!

We've already contacted all the short-wave receiver manufacturers and representatives we know of, but if you fall in that category and we've missed you, please rush information (including Canadian distributors, prices and photos) to us by August 10th and we'll try to squeeze you in.

Editorial Contact: Graham Wideman
Send Material To: Shortwave Receiver Survey, Electronics Today Magazine, Unit 6, 25 Overlea Blvd, Toronto, Ont. M4H 1B1. Phone 423 3262

Advertising Deadlines: October Issue:
Rough: August 7th
Camera Ready: August 14th
Contact: Mark Czerwinski
Phone (416) 423 3262

ELECTRONIC KIT SURVEY: November Issue

JUST IN TIME FOR CHRISTMAS buying, this survey is going to cover anything electronic that you can build to make a "finished" item. Again, we're contacting all manufacturers and distributors we know about, so if you think we've missed you contact us immediately for details of material we need.

Editorial Deadline: August 20th.
Editorial Contact: John Van Lierde.
Phone (416) 423 3262

Advertising Deadlines: November Issue.
Rough: September 7th
Camera Ready: September 14th.
Contact: Mark Czerwinski.
Phone: (416) 423 3262.

September Issue

NEXT MONTH WE'VE GOT SOME excitement for computer nuts, a close look at the **OSI CHALLENGER SUPERBOARD & 1P** microcomputer system. Plagued by supply problems, this machine is however very interesting.

Will we someday be receiving solar power via orbiting satellites which beam the energy to earth via microwaves? We'll look into some *very serious* moves in that direction.

Projects

If you liked the Intersil Counter in this issue but felt it a little too much for your modest counting application, then check out our simple 4 digit universal counter project next month. Also, for tuning up antennas or transmitters, a field strength meter. Which way and how fast does the wind blow? Our sophisticated, optical head design meter will tell you in style.

And lots more of course. See you next month!



Dad, are you sure this is how you calibrate it?

More Propagation

Heavy talk about thin ionized air. John Garner picks up where he left off last month.

LAST MONTH WE WERE discussing some of the various propagation conditions and how they affected shortwave reception. A second article in last month's ETI also gave you some useful information about these effects. This month we will continue our discussion with some more definitions.

PROMINENCES

Solar prominences are relatively cool masses of gas which form and dissipate within the hotter corona. They appear as bright clouds against a dark background when observed with special equipment.

The forms of prominences are nearly endless, but several well-defined types are easily recognizable. Sunspot prominences have the form of a long thin curtain, perhaps 60,000 miles long, 19,000 miles high, and 3,200 miles thick. Some prominences display a tree-like structure with many intricate branches and roots. The rare and spectacular loop prominences have a circular shape, perhaps 32,000 miles in diameter. Almost all prominences possess a fine structure composed of many fine threads of gas. These threads may outline the magnetic fields in prominences, but their real nature is still not established.

The gas in prominences appears to flow, predominantly downward, with speeds that range from 0.6 to 12 miles per second. Surge prominences are exceptional, in that they first rise with speeds up to several hundreds of miles per second, then fall more slowly. Prominences are born on the edges of sunspot groups and may persist for several solar rotations (corresponding to several terrestrial months).

The number and latitude distribution of prominences follows an eleven year cycle strongly resembling that of sunspots. A major difference is the appearance of a secondary belt of

prominences at high solar latitudes and the poleward drift of this belt near solar maximum. Why prominences form and how they maintain themselves within the hotter corona are questions for which no final answers are available at this time.

THE IONOSPHERE

In an attempt to explain the mechanism of auroral displays, it was postulated in the 19th century that an electrified region exists in the atmosphere. In the 20th century, radio experiments proved conclusively the existence of such a layer some 60 to 600 kilometres above the earth, which refracts radio waves. Electrical properties of this region are now known to arise from the ionization of the atmosphere gas, and for this reason the region is commonly referred to as the IONOSPHERE. The properties of the ionosphere affecting radio waves largely stem from the free electrons,

although large patches of ions are responsible for the phenomenon known as scattering.

Rocket and satellite observations have provided a mass of new information indicating that solar radiation is responsible for the ionization of the atmosphere. The sun emits a wide spectrum of radiation; the greatest fraction (over 90%) is concentrated in the region (called light) to which human eyes respond, from violet to red. Ultraviolet, of shorter wavelength and higher energy than violet, is emitted by hydrogen in the sun's inner atmosphere (the chromosphere). X-Rays, which are more energetic still, are emitted by gases in the sun's outer atmosphere (the corona).

This ever-present high-energy radiation is responsible for the normal (average) conditions in the ionosphere. Regular variation occurs in the normal

DR 22 C

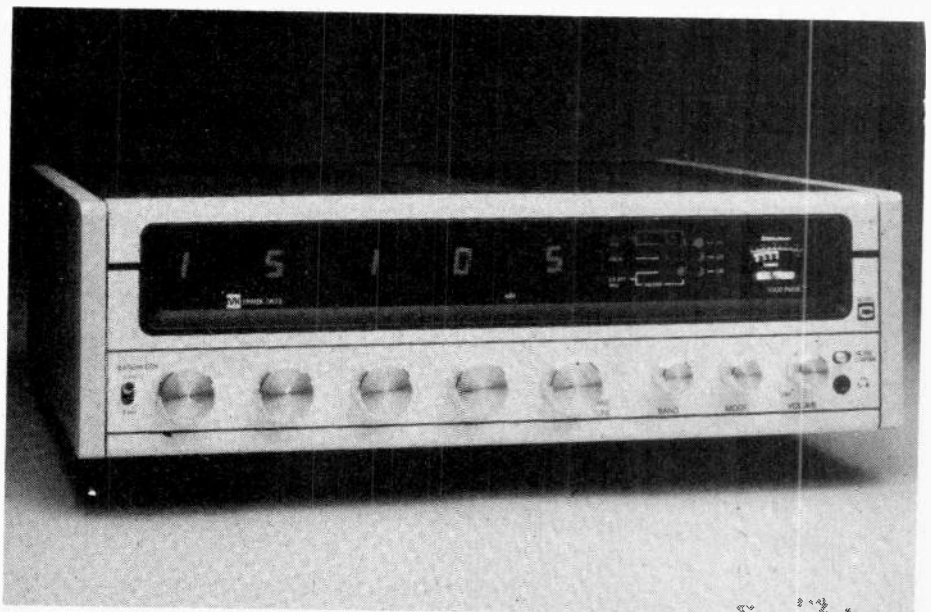

ionosphere in response to the daily rotation of the earth and the seasonal change in the elevation of the sun at noon, but there are also unpredictable and often violent changes in the ionosphere (see last month's ETI for more information about the ionosphere).

At last year's ANARC (Association of North American Radio Clubs) Convention held in Montreal, Dr. David Meisel of the Laboratory for Astronomy and Solar Physics, gave a talk on 'Sunspots — How Strong a Comeback'. Since his comments are based on predictions for the current solar cycle which is now nearing its peak, I will repeat some of them here.

There was some concern about four years ago that there would be virtually no sunspots on this go-around of the solar cycle. The higher the sunspot number above the average — the more ionization of the ionosphere — So everyone was concerned about the sunspot number. As we were going down in the sunspot minimum, Dr. Meisel's colleagues were very concerned because the predictions indicated it would be rock bottom. Fortunately these predictions were wrong. In fact the average sunspot number didn't get below 20. In the past there were times when the sunspot maxima hardly made it above 20. So it wasn't too bad but it was bad enough.

KEEPING TRACK

In the United States government there are two organizations who have been keeping track of sunspots. The first is NASA and their reasons were

DR 33 C

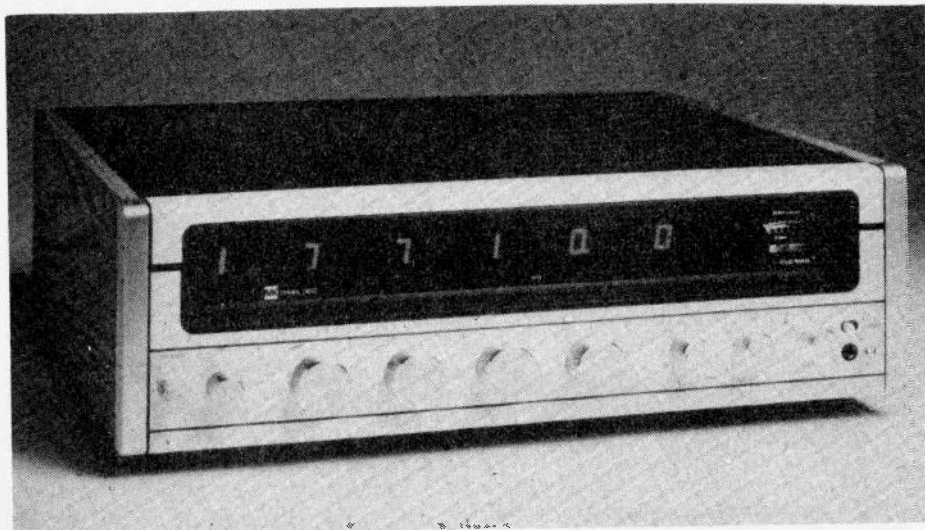

fairly selfish — if you're planning a space mission you have to go to extra trouble to protect the spacecraft in sunspot maxima compared with sunspot minimum so it is quite necessary when planning 10 years in advance to be able to predict as accurately as possible what is going to happen with the sunspots. The other organization is the National Oceanic and Atmosphere Agency in Colorado — they are interested in anything that goes on in the upper atmosphere.

It was very embarrassing to find that the predictions for the sunspot maxima for this current solar cycle by these two organizations disagreed very gravely. The NOAA prediction was for a maximum of 120, which is fairly high. The NASA estimate was about 80. Which one was right? In July 1978 the sunspot number was already about 80 and this was about 18 months away from the peak of the cycle. As time has shown this summer the sunspot number has been above 120 and the cycle should reach its peak soon and then start to decline.

The NASA embarrassment was even greater. When Skylab was launched they counted on the sunspot maxima of 80 and the craft was expected to stay in orbit until 1981 or 1982. Because of the error in predicting the sunspots, Skylab's orbit decayed and it came down much earlier than expected. So you see it isn't just radio reception that is affected by the sunspots.

There are a number of reasons for the difference in these two predictions. Between 1600 and 1700 there was a period of about 50 years in which very little sunspot activity took place. This period is known as the Maunder

Minimum and it affects everything by a count of about 40 — the difference in the two predictions. It seems that the sun can and does turn itself on and off and the NOAA people based their predictions on this fact and ignored the Maunder Minimum theory to come up with their estimate of 120.

To eliminate the short period fluctuations in the sunspot count, the numbers are averaged over a one year period and it would seem that the current cycle should reach a maximum of about 150. To give you some idea of what this means — a maximum of 50 would be a weak cycle; 110 would indicate medium intensity and a maximum of 200 would be extremely high. So with a sunspot maxima of 150 we are having a fairly high sunspot activity and radio reception should be very good.

LISTENING WITH THE SUN

How does all this affect our listening on the shortwave bands? As the sunspot number goes up so do the usable frequencies. The 11 metre band (25600 kHz to 26100 kHz) was inactive during the low point of the sunspot cycle but last winter and spring many stations began broadcasting on this band. Excellent reception on this band of stations thousands of miles away is possible in the daylight hours especially in the spring, fall and winter. In the summer reception will likely fall off slightly. The 13 metre band will show similar characteristics as the 11 metre band but many more stations will be using this band making for a lot of congestion. This band covers the frequencies from 21450 kHz to 21750 kHz.

Reception on all the other bands should also be very good as we approach sunspot maxima.

Bill Butuk of Thunder Bay has recently done some research into some work done by John Nelson of RCA Communications Inc. in the early 50's. This work was based on the planetary positions and how they affect the solar system and radio reception. There appears to be a definite relationship between the planetary positions and the solar activity. Copies of Bill's article, which appeared in the April, May and June issues of CANDIX, the monthly bulletin of the Canadian Short Wave Listeners International are available for 50¢ to cover the cost of mailing, from Canadian S-W-L International, P.O. Box 142, Thunder Bay, Ontario, P7C 4V5.

More Propagation

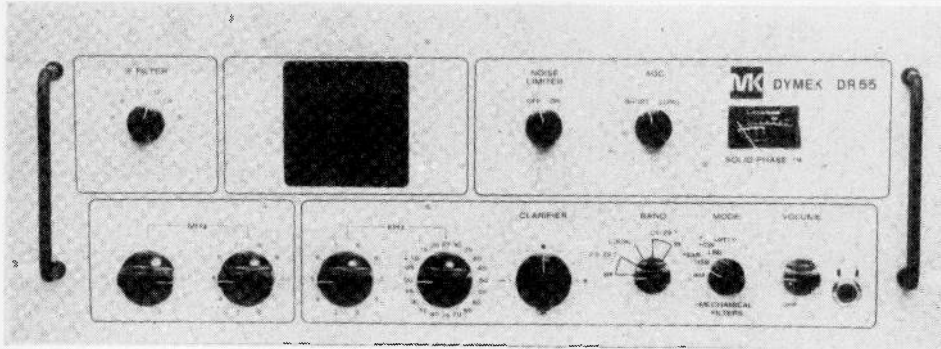

DR 55

RECEIVER REVIEW

This month we have some information on a fine line of receivers from McKay Dymek Company.

DR 22C General Coverage Receiver — The DR 22C is the product of years of receiver research and development. Many of the latest advances in design are incorporated into the fully solid state DR 22C. Tuning shortwave broadcasts from around the world is as easy on the DR 22C as tuning your TV set. A large digital display shows the tuned frequency. Other features of this set include solid state, phase-locked Digital Synthesis tuning, no mechanical tuning dial error or backlash, high level RF front end for excellent intermodulation rejection and sensitivity, full all wave coverage from 50 kHz to 29.7 MHz, no crystals to buy, crystal filters in 1st and 2nd IF amplifiers and ceramic filter in the 3rd IF provide outstanding selectivity, designed for use with hi-fi systems or as a self contained receiver, switch selectable 4 or 8 kHz RF bandwidth, and a built in noise limiter. The DR 22C measures 430 mm wide x 130 mm high x 370 mm deep (17½" x 5 1/8" x 15") and weighs 6.8 Kg (15 lbs). The price in Canada is \$1499. The DR 22 model which is similar to the DR 22C but without the noise limiter sells for \$1399. There is also a model DR 22C-6 with a

600 ohm audio output which sell for \$1579.

DR 33C Professional Receiver — The DR 33C fills the need for a high quality modestly priced receiver with professional performance and specifications. A Class D AM envelope detection is used giving much lower distortion levels than the conventional AM diode detector. A unique automatically adjusting threshold noise limiter provides greatly enhanced reception of CW, RTTY and SSB signals during conditions of extreme impulse noise interference. Other features are similar to the DR 22C. The performance and specifications of the DR 33C are unmatched under \$3000. Dimensions are the same as the DR 22C and the set weighs 7.3 Kg (16 pounds). The price is \$2249. The DR 33C-6 which has a 600 ohm audio output sells for \$2329 and an industrial, maritime, military version of the DR 33C, the DR-44 which is available in rack mount only sells for \$2399. The DR 44-6 with 600 ohm audio output is listed at \$2479.

DR 55 Communications receiver. This receiver is similar to the DR 33C but without the frills. It is a rack mounted model especially for commercial or maritime use. It does not have an LED frequency readout and tuning is done by adjusting two MHz knobs and two kHz knobs. The DR 55 has standard plug in integrated circuits for ease of

maintenance. Where a main receiver is required to be operated continuously this receiver is a good stand-by set for use when the main receiver is inoperable. Dimensions of the DR 55 are 480 mm wide x 180 mm high x 370 mm deep (19" x 7" x 15") and the weight is 7.3 Kg (16 lbs). The Canadian price is \$1199.

McKay Dymek also make other accessories for shortwave listeners.

DP 40 Preselector — A passive dual tuned circuit covering 0 Hz to 30 MHz. This preselector helps eliminate undesired receiver responses such as inter-cross modulation and desensitization caused by the operation of nearby transmitters, allowing reception in otherwise unuseable locations. The cost of the DP 40 is \$189. A rack mounted version, the DP 4044 sells for \$199.

DA 100 All Wave receiving antenna — This antenna operates on the principle of impedance conversion. The length of the whip antenna element is a very small fraction of the received wavelength causing it to have a very high source impedance. Through the use of a very high input impedance amplifier mounted directly at the base of the whip antenna element, the full signal voltage naturally induced in the whip antenna is accepted, amplified and delivered to a much lower receiver input impedance such as 50, 75 or 300 ohms. Wide dynamic range design is used to allow operation even in strong RF field environments.

A front panel Antenna Impedance-Attenuator switch serves a dual purpose. Not only will this allow impedance matching to receivers having impedances of other than 50 ohms, it also provides selectable attenuation to prevent possible receiver overload by extremely strong stations. The use of this switch allows the DA 100 to be used with any known receiver manufactured today.

The DA 100 allows coverage of the Long, Medium and Shortwave bands. The cost of the DA 100 is \$199. A marine version, for use at or near salt water, the DA 100M is available for \$249.

The prices for the McKay Dymek line have been supplied by WSI Sales Co., 18 Sheldon Avenue North, Kitchener, Ontario, N2H 3M2. Write to WSI for a catalog of what they have to offer. The catalog is free of charge. Tell them you saw their name in ETI.

Until next month 73 and good listening.

DP 40

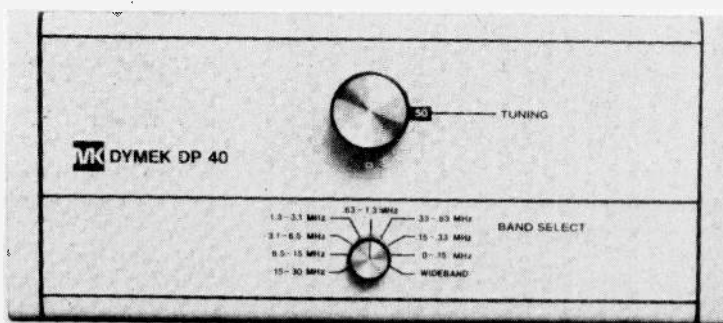

Tech Tips

(Note 90° phase shift of text. This is due to the effect of power line ripple on our typesetting machine.)

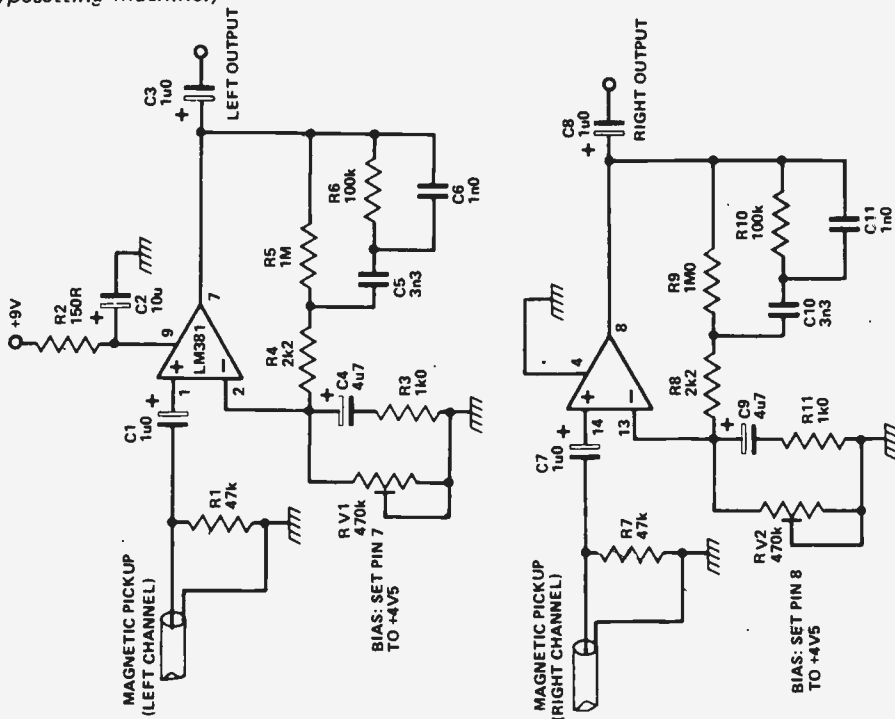

Tech Tips is an ideas forum and is not aimed at the beginner. ETI is prepared to consider circuits or ideas submitted by readers for this page. All items used will be paid for. Drawings should be as clear as possible, and the text should preferably be typed. Circuits must not be subject to copyright. Items for consideration should be sent to ETI Tech Tips, Unit 6, 25 Overlea Blvd., Toronto, Ontario, M4H 1B1

RIAA STEREO PREAMPLIFIER

There are two types of record player pickups, ceramic and magnetic. The first type is the cheapest and generally gives a large output voltage (0.5V). This type of pickup does not usually require any frequency response correction, but the sound quality produced is not as good as that which can be achieved with a magnetic pickup. Records are cut with a frequency response such that when they are replayed with a magnetic pickup and a preamplifier with a RIAA equalisation (Recording Industry Association of America) the reproduced sound will be as similar to the original as possible.

The disc is cut at constant amplitude, except from 500 Hz to 2120 Hz where it is cut at constant velocity. When this disc is replayed with a magnetic pickup, the relative output voltage rises with

frequency, this being due to the fact that the magnetically generated voltage is proportional to the velocity of the stylus as it moves sideways in the groove. To restore the original sound quality, a preamplifier with a frequency response that gives decreasing output with increasing frequency is required. This response curve is known as the RIAA equalisation and it is tailored accurately to fit the cutting and replay processes. The signal level from a magnetic pickup is low, generally 20 mV pp and so a low noise pre-amplifier is needed.

The circuit shows a realisation of this requirement. The low noise amplifier is the LM381 made by National Semiconductors. A DC bias control is included (RV1, 2), and the feedback components generate the RIAA curve. Use

screened cable for the wiring to the pickup, keep the circuit away from transformers (and the pickup and its wiring) and connect all the earths shown in the circuit diagram together, near to the IC.

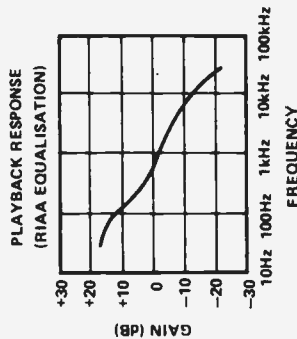

Jana kits are available from many dealers across Canada, including the following:

- Canadian Admiral QUEBEC CITY
- Cesco Electronics MONTRÉAL
- Cesco Electronics QUEBEC CITY
- Cité Electronique Inc. MONTRÉAL
- Cité Electronique Inc. QUEBEC CITY
- Cité Electronique Inc. SHERBROOKE
- Colonial Electronic Ltd. MONTRÉAL
- Commercial Radio MONTRÉAL
- Crobel Ltée. PARC JEAN TALON NORD
- Distribution J.M.C. Inc. MONT-JOLI
- Electronic Wholesalers (St. Jean) Ltée. ST. JEAN
- ETCO Electronics POINTE CLAIRE
- Gemobel Electronic CHICOUTIMI
- Gemobel Electronic SEPT ÎLES
- La Salle Distributors VILLE LA SALLE
- Lemco Distributors ST. JEROME
- Levelco GRANBY
- Levelco ST. HYACINTHE
- Master Vox Ltd. LONGUEUIL
- Matteau (Cité Electronique Inc.) MONTRÉAL EAST
- Matteau Electronics TROIS RIVIÈRES
- Matteau Electronics SHAWINIGAN
- Metropolltain Electronique MONTRÉAL NORTH
- Montcalm Electronique LAVAL
- P.L. Trambly JONQUIÈRE
- Payette Radio MONTRÉAL
- Simtronique NORANDA
- Transtronique Inc. ST. GEORGES DE BEAUCE
- Trejean AMOS
- Vision Tronics Ltd. SHERBROOKE
- Wackid Radio OTTAWA

For the names of other dealers or for institutional enquiry, write:

Jana Industrial
1777 Ellice Ave
Winnipeg Man R3H 0W5

HIGH NOON



AT Jana

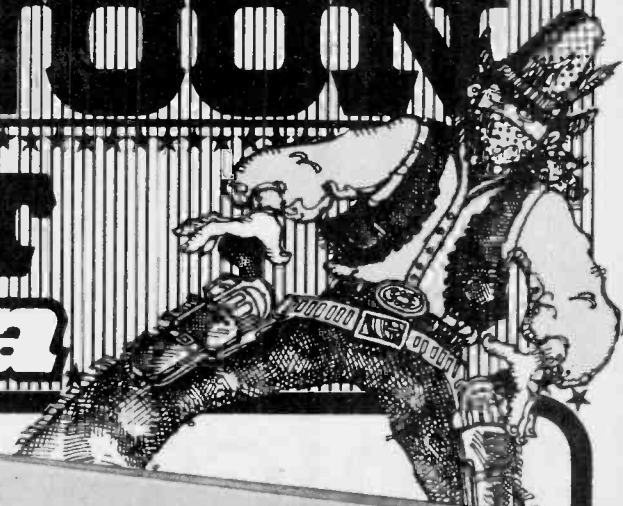

Jana SHOOT-OUT GAME PROJECT: Learn electronics making it... Have fun playing it!

Being quick on the trigger used to be an important skill. Now it's more important to know electronics!

You can develop both skills at once with Jana's Shoot-out Game project. The completed Shoot-out Game unpredictably signals to the itchy-fingered players when to shoot. They fire.

Immediately, an LED display announces the winner. There is never any doubt about who draws and fires fastest!

The Jana Shoot-out Game is also programmed to denounce cheaters. If anybody pulls the trigger before seeing the signal, a blinking LED display accuses that person of not fighting fairly. It keeps everybody honest!

Like all Jana project kits, the Shoot-out Game comes complete with the parts you need, detailed plans, and the carton serves as a case for the finished product. (PCB extra, if you want it ready-made.)

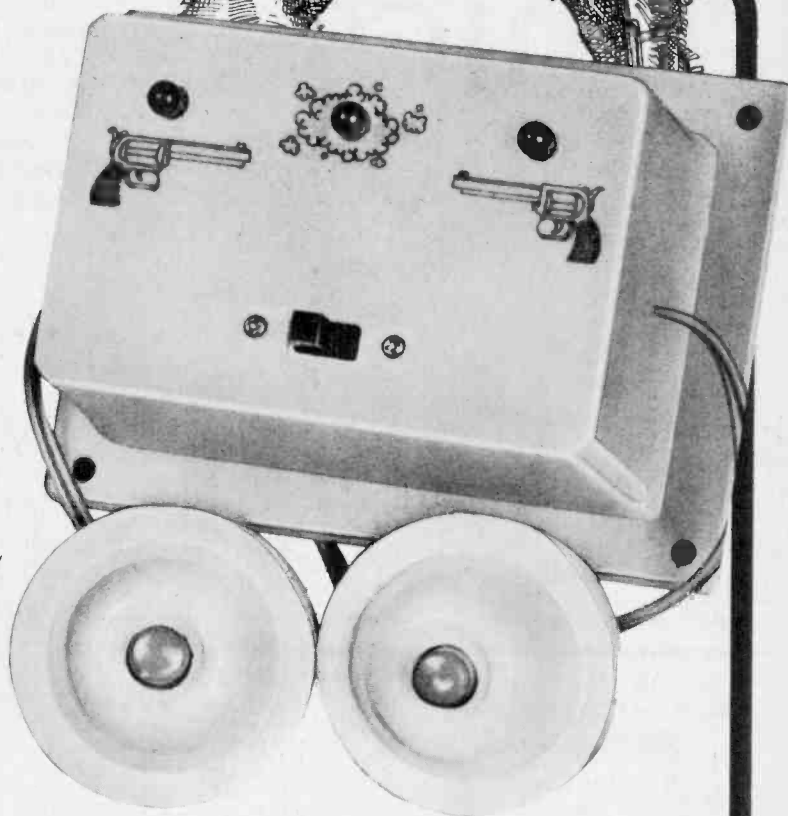

Check Jana's growing list of entertaining, useful, instructive electronic projects in convenient kit form.

- | | | | |
|---------------------------------------|--------------------------------|-----------------------------------|----------------------------|
| 1. Automatic Headlight Reminder | 11. Hi Power 12V DC Flasher | 20. 5 Transistor 1 Watt Amplifier | 28. Super Roulette |
| 2. Battery Operated Fluorescent Light | 12. Photo Electric Night Light | 21. Tube Continuity Checker | 29. FM Mini Broadcaster |
| 3. Bug Shoo | 13. 6V Power Supply | 22. Xenon Strobe | 31. Shoot Out |
| 4. Code Oscillator | 14. 9V Power Supply | 23. 3 Channel Color Organ | 32. Road Runner |
| 5. Crystal Radio | 15. 0-20V Power Supply | 24. Loudmouth Siren | 33. Love-O-Meter |
| 7. Curiosity Box II | 16. Single Channel Color Organ | 25. Roulette Wheel | 34. Soldering Iron Kit |
| 8. Dally Lighter | 17. Electronic Siren | 26. Electronic Skeet Game | 35. Audio Power Watt Meter |
| 9. Decision Maker | 18. Shimmer Strobe Light | 27. Electronic Dice | |
| 10. Fish Caller | 19. Tone Generator | | |

Available from many dealers, including those listed on the facing page, or from:

RAM CARD SUPPLY LTD

Vancouver
Kamloops
Calgary
Edmonton
Red Deer
Regina
Saskatoon
Winnipeg
Halifax
Fredericton
Moncton

For institutional inquiry contact

Jana Industrial

1777 Ellice Ave., Winnipeg, Man. R3H 0W5
Phone: (204) 786-3133

The Fun of Electronics

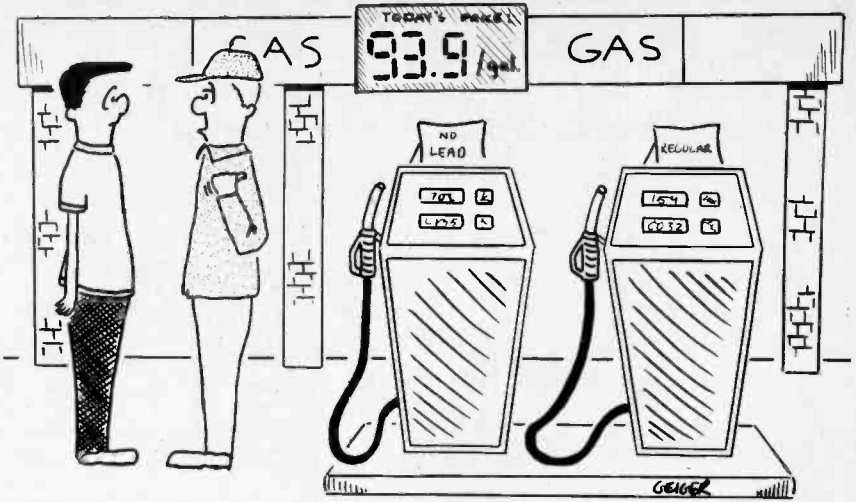

I DECIDED I'D SAVE A LOT OF TIME AND EFFORT BY POSTING THE GAS PRICE ON A LED DISPLAY ... NOW I'M THINKING OF ADDING A COUNTER THAT AUTOMATICALLY INCREASES IT EVERY HALF HOUR.



I'VE JUST INVENTED A 5000 VOLT DRY CELL - I THINK IT HAS A LOT OF POTENTIAL.

AS YOU CAN NO DOUBT SEE, THERE ARE A NUMBER OF INHERENT DESIGN DIFFICULTIES THAT ONE RUNS INTO WHEN TRYING TO BUILD QUADROPHONIC HEADPHONES.

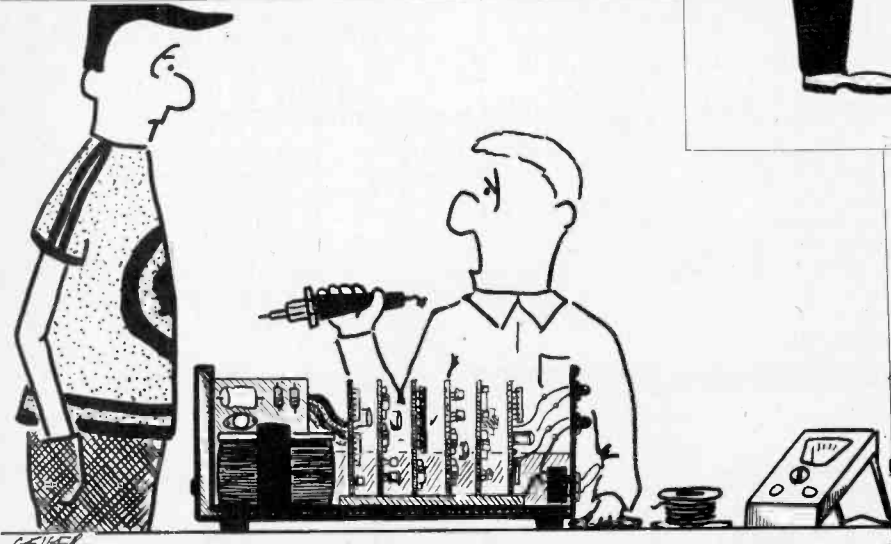
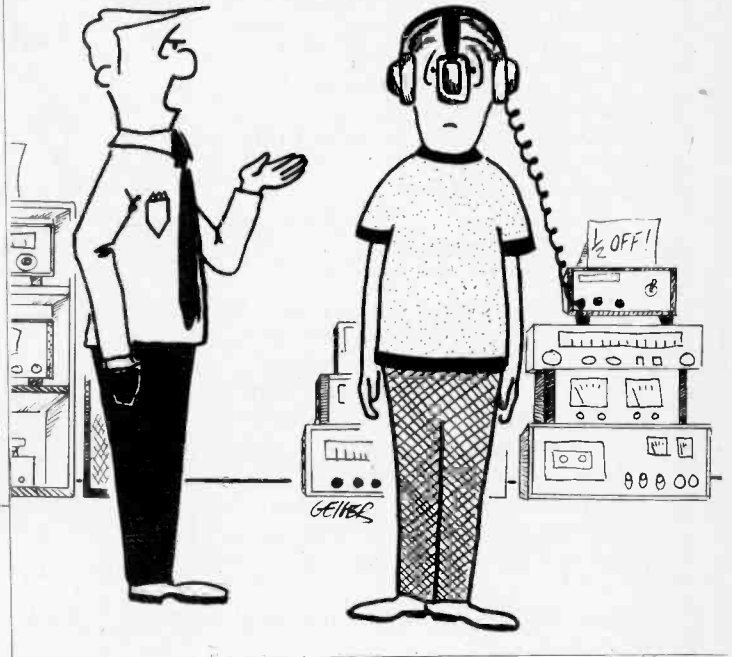

I WAS JUST ABOUT TO START TROUBLESHOOTING MY \$ 2000, 16 - BIT, MULTI-BOARD MICROCOMPUTER, BUT MY SOLDERING IRON BROKE - I'LL HAVE TO TAKE IT TO THE REPAIR SHOP SO THEY CAN PUT A NEW CORD ON IT.

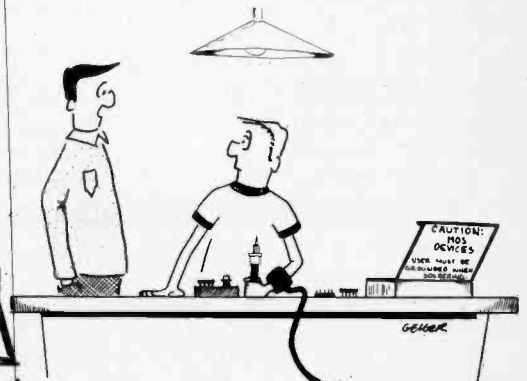

BOY! FRED, I THOUGHT MY WIFE DIDN'T TRUST ME, BUT SHE NEVER CHAINED ME TO THE WALL.....!

You can write for ETI



75 cents per word

ETI's new classified advertising section allows you to reach 30,000 readers nation-wide. For as little as \$15 (there's a 20 word minimum) you can promote your business from coast to coast.

WHAT DO YOU DO?

Send us your typewritten or clearly printed words, your permanent address and telephone number, and your money (no cash please). Make your cheque or money order payable to 'ETI Magazine'. We're at Unit 6, 25 Overlea Blvd, Toronto, Ontario, M4H1B1.

There's no charge for including your postal (or zip) code. If you want to test reader reaction you can include 'Dept. ETI' as part of your address (free of charge).

WHAT DO WE DO?

We typeset your words (and put the first word and your company name in bold capital letters).

If we get your message by the 14th of the month, it will appear in ETI 1½ months later. For example, if we receive it by November 14th, you (and thousands more) will see it in the January issue.

CLASSIFIED

NEW STORE! for the Hobbyist, Ham Audio, CB'r. Special: Video Camera and Monitor \$349.95. Ont res. add 7% sales tax. GENERAL ELECTRONICS, 5511 Yonge St., Willowdale, Ont. 221-6174.

WSI RADIO - SWL Radios - Ham radios - 18 Sheldon Avenue North, Kitchener, Ontario N2H 3M2. Telephone (519) 579-0536. Write for giant catalog, free of course!! (VE3EHC)

1N4148 - 15/1.00, Digital I.C.s - 10/1.50 \$10 Min. +. 50 P&H. S.A.S.E. for list. Electronics c/o Carl Muscott, Box 68E. Whitecourt, AB. T0E 2L0.

J&J ELECTRONICS LTD., P.O. Box 1437 E, Winnipeg, Manitoba R3C 2Z4. Surplus Semiconductor Specialists. Do you get our bargain flyer? Send \$1.00 to receive the current literature and specials and to be placed on the mailing list for future publications.

\$1.00 Unusual Canadian and American parts and surplus catalogs. Hundreds of bargains. ETCO, Dept 087, 183G Hymus, Pointe Claire, Que.

AMPLIFIER KITS: 140W Class AB Stereo \$129.00. 60W Class A Mono \$58.00. Stereo L.E.D. Power meter: 10 steps \$26.00. 18 steps \$56.00. Free Catalogue. Part-Time Business-Minded Audiophiles / Hobbyists wanted for development and sales of our kits on commission basis. Apply: AUDIOVISION, Box 955 Stn. B, Willowdale, Ont. M2K 2T6.

ETI Project File

Updates, news, information, ETI gives you project support

PARTS PARTS PARTS

We are continually besieged with letters from readers asking where they can get parts in their area. Since we can't take a country-wide tour to check where all the electronics parts-places are, how about sending us a note on any stores you have found useful, what they are good for (if you own the place you can contribute too!) and so on. At some time in the future we would like to help out the "lost" readers by publishing a rundown of where to get what.

PROJECT FILE is our department dealing with information regarding ETI Projects. Each month we will publish the Project Chart, any Project Notes which arise, general Project Constructor's Information, and some Reader's Letters and Questions relating to projects.

PROJECT NOTES

Since this magazine is largely put together by humans, the occasional error manages to slip by us into print. In addition variations in component characteristics and availability occur, and many readers write to us about their experiences in building our projects. This gives us information which could be helpful to other readers. Such information will be published in Project File under Project Notes. (Prior to May 78 it was to be found at the end of News Digest.)

Should you find that there are notes you wish to read for which you do not have the issue, you may obtain them in one of two ways. You can buy the back issue from us (refer to Project Chart for date of issue and see also Reader Service Information on ordering). Alternatively you may obtain a photocopy of the note free of charge, so long as your request includes a self addressed stamped envelope for us to mail it back to you. Requests without SASE will not be answered.

PROJECT CONSTRUCTOR'S INFORMATION

Useful information on the terminology and notation will be published each month in Project File.

ISSUE DATE	ARTICLE
Apr 78	Computer PSU & Neg.
Apr 78	Audio Delay Line & Neg.
Apr 78	Gas Alarm & Neg.
May 78	White Line Follower
June 78	Neg.
Apr 79	Note: C
May 78	Acoustic Feedback Eliminator
June 78	Neg.
May 78	Add-on FM Tuner
June 78	Neg.
June 78	Audio Analyser
June 78	Ultrasonic Switch & Neg.
June 78	Phone Bell Extender & Neg.
July 78	Proximity Switch
Aug 78	Neg.
July 78	Real Time Analyser MK II (LED)
Aug 78	Neg.
July 78	Acc. Beat Metronome
Aug 78	Neg.
July 78	Race Track
Aug 78	Neg.
Aug 78	Sound Meter & Neg.
Dec 78	Note: N
Aug 78	Porch Light & Neg.
Aug 78	IB Metal Locator & Neg.
Aug 78	Two Chip Siren & Neg.
Sept 78	Audio Oscillator
Nov 78	Neg.
Sept 78	Shutter Timer
Nov 78	Neg.
Sept 78	Rain Alarm
Oct 78	CCD Phaser
Nov 78	Neg.
Oct 78	UFO Detector
Nov 78	Neg.
Oct 78	Strobe Idea
Apr 79	Note: N

ISSUE DATE	ARTICLE
Nov 78	Cap Meter & Neg.
Nov 78	Stars & Dots
Nov 78	CMOS Preamp & Neg.
Dec 78	Digital Anemometer
Feb 79	Neg.
Mar 79	Note: C, D
Dec 78	Tape Noise Elim
Feb 79	Neg.
Dec 78	EPROM Programmer
Feb 79	Neg.
Jan 79	Log Exp Convert.
Feb 79	Neg.
Jan 79	Digital Tach.
Feb 79	Neg.
Jan 79	FM Transmitter
Feb 79	Neg.
Feb 79	Phasemeter & Neg
Feb 79	SW Radio
Feb 79	Light Chaser & Neg
Mar 79	Tape-Slide Synch
Mar 79	Synth. Sequ.
Mar 79	Dual Dice
Apr 79	Solar Control
Apr 79	Audio Compressor
Apr 79	Wheel of Fortune
May 79	Light Controller
May 79	AM Tuner
May 79	VHF Ant.
June 79	Easy Colour Organ
June 79	LCD Thermometer
June 79	Light Show Seq.
July 79	Note C
June 79	VHF Ant. 2
June 79	Bip Beacon
July 79	STAC Timer
July 79	Two Octave Organ
July 79	Light Activ. Tacho

ETI Project Chart

PROJECT CHART

This chart is an index to all information available relating to each project we have published in the preceding year. It guides you to where you will find the article itself, and keeps you informed on any notes that come up on a particular project you are interested in. It also gives you an idea of the importance of the notes, in case you do not have the issue referred to on hand.

Canadian Projects Book

Audio Limiter	Metal Locator
5W Stereo	Heart-Rate Monitor
Notes N, D May 79	GSR Monitor
Overled	Phaser
Bass Enhancer	Fuzz Box
Modular Disco	Touch Organ
G P Preamp	Mastermind
Bal. Mic. Preamp	Double Dice
Ceramic Cartridge Preamp	Reaction Tester
Mixer & PSU	Sound-Light Flash
VU Meter Circuit	Burglar Alarm
Headphone Amp	Injector-Tracer
50W-100W Amp	Digital Voltmeter
Note N May 79	

Key to Project Notes

C:- PCB or component layout
 D:- Circuit diagram
 N:- Parts Numbers, Specs
 Neg:- Negative of PCB pattern printed
 O:- Other
 S:- Parts Supply
 T:- Text
 U:- Update, Improvement, Mods

PROJECT CHART

This chart is an index to all information available relating to each project we have published in the preceding year. It guides you to where you will find the article itself, and keeps you informed on any notes that come up on a particular project you are interested in. It also gives you an idea of the importance of the notes, in case you do not have the issue referred to on hand.

Every few months we print a pull out section in the magazine which may be used as a photographic negative for making printed circuit boards (as described in our January 78 issue). Each edition of this sheet contains projects from the preceding few issues. Information on where to find which negative is included in the chart.

Write to: Project File
Electronics Today International
Unit 6, 25 Overlea Blvd.,
TORONTO, Ontario
M4H 1B1

Component Notations and Units

We normally specify components using an international standard. Many readers will be unfamiliar with this but it's simple, less likely to lead to error and will be widely used sooner or later. ETI has opted for sooner!

Firstly decimal points are dropped and substituted with the multiplier, thus 4.7uF is written 4u7. Capacitors also use the multiplier nano (one nanofarad is 1000pF). Thus 0.1uF is 100n, 5600pF is 5n6. Other examples are 5.6pF = 5p6, 0.5pF = 0p5.

Resistors are treated similarly: 1.8M ohms is 1M8, 56k ohms is 56k, 4.7k ohms is 4k7, 100 ohms is 100R, 5.6 ohms is 5R6.

Kits, PCBs, and Parts

We do not supply parts for our projects, these must be obtained from component suppliers. However, in order to make things easier we cooperate with various companies to enable them to promptly supply kits, printed circuit boards and unusual or hard-to-find parts. Prospective builders should consult the advertisements in ETI for suppliers for current and past projects.

Any company interested in participating in the supply of kits, pcbs or parts should write to us on their letterhead for complete information.

READER'S LETTERS AND QUESTIONS

We obviously cannot troubleshoot the individual reader's projects, by letter or in person, so if you have a query we can only answer it to the extent of clearing up ambiguities, and providing Project Notes where appropriate. If you desire a reply to your letter it must be accompanied by a self addressed stamped envelope.

PLEASE NOTE: WE CAN ANSWER PROJECT ENQUIRIES ONLY BY LETTER.

KITS

Now Available

ETI True RMS Voltmeter	\$89.95
ETI Bucket Brigade	
Audio Delay Line	\$59.95
ETI Frequency Shifter	\$69.95
ETI Ultrasonic Switch	\$29.95
ETI CCD Phaser	\$79.95
0-24V 1 Amp Power Supply	\$19.95
3 Channel Colour Organ	
500W SCR	\$19.95
1500W TRIAC	\$29.95
2W 12V Audio Amplifier	
	\$8.95
Strobe Light	\$14.95
Light Chaser Kit (10 LEDs, Variable Speed)	\$19.95

Cheque, Money Order or Mastercharge
Include card expiry date and number
Ontario residents please add 7% sales tax

DO NOT SEND CASH
Allow 3 weeks for delivery



**DOMINION RADIO &
ELECTRONICS**
535 Yonge St. Toronto
Ontario M4Y 1Y5

MORE CIRCUITS

\$4.50 Useful design ideas



Circuits to get you thinking how to solve your special tasks, or just for fun. From power controls to special effects to alarms, test circuits, and so on. Plus detailed sections on crystal oscillators, speaker crossovers and more. For ordering details see below.

Obtain yours now from us directly by using the order card in this issue, or by mailing \$4.50 + 45c for postage and handling to MORE CIRCUITS, Electronics Today Magazine, Unit 6, 25 Overlea Blvd, Toronto, Ontario, M4H 1B1. Or if your local magazine shop has ETI regularly, they'll be getting MORE CIRCUITS too.

Reader Service Information

Editorial Queries

Written queries can only be answered when accompanied by a self-addressed, stamped envelope, and the reply can take up to three weeks. These must relate to recent articles and not involve ETI staff in any research. Mark your letter ETI Query.

Projects, Components, Notation

For information on these subjects please see our Project File section.

LIABILITY: Whilst every effort has been made to ensure that all constructional projects referred to in this edition will operate as indicated efficiently and properly and that all necessary components to manufacture the same will be available, no responsibility whatsoever is accepted in respect of the failure for any reason at all of the project to operate effectively or at all whether due to any fault in design or otherwise and no responsibility is accepted for the failure to obtain any component parts in respect of any such project. Further no responsibility is accepted in respect of any injury or damage caused by any fault in the design of any such project as aforesaid.

Sell ETI

ETI is available for resale by component stores. We can offer a good discount and quite a big bonus, the chances are customers buying the magazine will come back to you to buy their components. Readers having trouble getting their copy of ETI could suggest to their component store manager that he should stock the magazine.

Back Issues and Photocopies

Previous issues of ETI-Canada are available direct from our office for \$2.00 each. Please specify issue by the month, not by the features you require. The following back issues are still available for sale.

1977	1978	1979
February	January	January
May	February	February
June	March	March
July	April	April
September	May	May
November	June	June
	July	July
	August	August
	September	
	October	
	November	
	December	

We can supply photocopies of any article published in ETI-Canada, for which the charge is \$1.00 per article, regardless of length. Please specify issue and article. (A special consideration applies to errata for projects, see Project File.)

Now Available!

OUR ALL NEW
LENLINE
ELECTRONIC
COMPONENTS
CATALOGUE.

60 pages contain
ing more than
400 items, all
fully illustrated
and described.

SEND FOR
YOUR FREE
COPY TODAY!



Please send me your LENLINE Electronic Components Catalogue and the name of my nearest LENLINE Dealer.

NAME _____

ADDRESS _____

CITY _____

PROV. _____ CODE _____

len finkler ltd

25 Toro Road, Downsview, Ontario M3J 2A6 • 630-9103



Advertisers' Index

Active Surplus Annex	23
Allan Crawford Associates	7
BCS Electronics	20
Classified Ads	71
Dominion Radio and Electronics	73
E. S. Gould Marketing	76
Gladstone Electronics	27
GTE Sylvania	39
House of Computers	27
Jana Industrial Electronics	68, 69
Len Finkler Limited	11, 74
McGraw-Hill	75
Sprague International	2
Zenith Radio Corp.	58

New from NRI! 25" color TV that tunes by computer, programs an entire evening's entertainment.

DIAGONAL

Just part of NRI's training in servicing TV, stereo systems, video tape and disc players, car and portable radios.

Only NRI home training prepares you so thoroughly for the next great leap forward in TV and audio... digital systems. Already, top-of-the-line TV's feature digital tuning, computer programming is appearing, and new digital audio recording equipment is about to go on the market.

NRI is the only home study school to give you the actual "hands-on" training you need to handle servicing problems on tomorrow's electronic equipment. Because only NRI includes this designed-for-learning, 25" diagonal color TV with electronic tuning, built-in digital clock, and computer programmer as part of your training. With this advanced feature, you can pre-program an entire evening's entertainment... even key lock it in to control children's viewing.

Exclusive Designed-for-learning Concept

The color TV you build as part of NRI's Master Course looks, operates, and performs like the very finest commercial sets. But behind that pretty picture is a unique designed-for-learning chassis. As you assemble it, you perform meaningful experiments. You even introduce defects, troubleshoot and correct them as you would in actual practice. And you end up with a magnificent, big-picture TV with advanced features.

Also Build Stereo, Test Instruments

That's just a start. You demonstrate basic principles on the unique NRI Discovery Lab,[®] then apply them as you assemble a fine AM/FM stereo, complete with speakers. You also learn as you build your own test instruments, including a 5" triggered sweep oscilloscope, CMOS digital frequency counter, color bar generator, and transistorized volt-ohm meter. Use them for learning, use them for earning as a full- or part-time TV, audio, and video systems technician.

Complete, Effective Training Includes Video Systems

You need no previous experience of any kind. Starting with the basics, exclusive "bite-size" lessons cover subjects thoroughly, clearly, and concisely. "Hands-on" experiments reinforce theory for better comprehension and retention. And your personal NRI instructor is always available for advice and help. You'll be prepared to work with stereo systems, car radios, record and tape players, transistor



radios, short-wave receivers, PA systems, musical instrument amplifiers, electronic TV games, even video tape recorders and tape or disc video playbacks.

Send for Free Detailed Catalog

Mail the postage-paid card today for our free 100-page catalog with color photos of all kits and equipment, complete lesson plans, convenient time payment plans, and information on other electronics courses. You'll also find out about NRI's new Computer Technology Course that includes your personal microcomputer. Or Complete Communications with 2-meter transceiver. If card has been removed, write to:



NRI Schools
McGraw-Hill Continuing
Education Center
330 Progress Avenue
Scarborough, Ontario M1P 2Z5
or telephone 416-293-1911

0.05%
NAB WRMS

0.05%
NAB WRMS

Neatness counts.

You are looking at graphic measurements of wow and flutter in two different cassette decks. The nice, neat one is ours. The one with the funny spikes is the competition. What is really interesting about this comparison is that the numerical specification for wow and flutter for both machines is identical: 0.05 percent.

How can that be?

The reason is that conventional measurements do not account for some kinds of disturbances caused by momentary tape speed variations. Many manufacturers simply ignore or overlook the spikes. We don't. Because we can hear them. And

if we can hear them, you can hear them. So we build tighter tolerances into our parts—such as our precision-machined reel tables and shafts that prevent cogging of the cassette hubs. The fact is that we use a lot of unconventional methods of getting rid of a lot of conventionally ignored distortions.

We figure our most important test instrument is our ears. You can build good cassette decks in the laboratory. But you build great ones in the listening room. That's why our engineers listen, under dynamic test conditions, to every single electrical and mechanical component of our cassette decks

that can affect the texture of the sound you hear.

You'll find that every one of the new Harman Kardon cassette decks has the features, specifications, the look and the feel you'd expect from equipment made by one of the world's great high fidelity manufacturers.

But you'll find something else too.

The clean, open sound that comes only when a company listens and pays attention to details that others tend to overlook.

That's what makes us so neat.

Come listen soon.



harman/kardon
Hear all the music.

Only available at Audio Specialists across Canada.

Pictured: The new hk3500 Dolby® cassette deck. Not shown: Models hk1500 and hk2500.