

\$5.00

YOUR COMPLETE GUIDE TO
THE SENSORY DELIGHTS OF
VACUUM TUBE AUDIO
TECHNOLOGY

T H E C O N N O I S S E U R ' S C O O K B O O K

A TASTE OF TUBES



Written for tube lovers of all persuasions and levels of expertise.
Presented for your enjoyment by:

 **SONIC FRONTIERS**
INCORPORATED



YOUR COMPLETE
GUIDE TO THE
SENSORY DELIGHTS OF
VACUUM TUBE AUDIO
TECHNOLOGY

A TASTE OF TUBES

THE CONNOISSEUR'S COOKBOOK



Written for tube lovers of all persuasions and levels of expertise.
Presented for your enjoyment by SONIC FRONTIERS, INC.

MANUFACTURER'S
OF THE

 **SONIC FRONTIERS**
INCORPORATED

&

ANTHEM

TUBE ELECTRONIC PRODUCT LINES

COPYRIGHT AUGUST 1997

The Menu

USING YOUR COOKBOOK	Page iv
APPETIZERS	Page 2
Tube History I: A Foretaste of Tubes	Page 5
Edison Discovers the Genie in the Lamp	Page 5
Fleming's Electronic Aerial	Page 6
De Forest Conjures a Triode	Page 6
Tubes on a Roll	Page 8
Tube History II: Amplifiers Du Jour	Page 9
Cocking Cooks Up Quality	Page 9
Williamson Stirs the Pot	Page 9
The Pentode's Revenge	Page 10
Quad's Potent Pentode Recipe	Page 10
McIntosh's Pentode Pièce de Resistance	Page 11
Hafler and Keroes Go Ultra	Page 12
Cooking the Signal: Tubes or Transistors?	Page 14
Cleaning the Kitchen	Page 15
MEAT & POTATOES	Page 16
"Let Them Eat Glass" (The Inner Workings of the Vacuum Tube)	Page 19
Cordon Bleu 101: Thermionic Emission	Page 20
Cleaning the Kitchen	Page 21
Tubes for All Tastes: Spicing the Circuits	Page 22
i. Diodes	Page 22
ii. Triodes	Page 22
Cordon Bleu 102: Cooking with Triodes	Page 24
iii. Tetrodes	Page 25
iv. Pentodes	Page 25
v. Beam Power Tubes	Page 26
vi. Other -odes	Page 27
vii. Sectional Tubes (Electronic Allspice)	Page 27
Cleaning the Kitchen	Page 28
Cooking with Tubes	Page 28
i. Rectifiers	Page 28
Cordon Bleu 103: Why Diodes are Directional	Page 29
ii. Regulators	Page 29



Cordon Bleu 104: Advanced Regulation	Page 30
iii. Amplifiers	Page 31
Cordon Bleu 105: Ohm's Law Distilled	Page 32
Cordon Bleu 106: Advanced Amplification	Page 33
Amplifier Flavors	Page 34
Single-ended	Page 34
Push-pull	Page 34
Parallel	Page 35
Ultra-Linear	Page 35
iv. Preamps	Page 36
v. Impedance Buffers	Page 36
Tube Cuisine In Three Easy Classes	Page 37
i. Class A	Page 37
ii. Class B	Page 38
iii. Class AB	Page 38
Cleaning the Kitchen	Page 39
Nourishing Your Playback System	Page 40
Sonic Secrets	Page 40
The Bitter Taste of Solid State?	Page 40
The Inaccurate Measuring Spoon	Page 41
They're Warm! They're Tasty! And They're Tubes!	Page 41
Cleaning the Kitchen	Page 41
JUST DESSERTS	Page 42
Feed 'em, Clean 'em, But Don't Step On Their Toes!	Page 43
Tasting Adventures: Trying New Tubes	Page 45
Cooking at the Right Temperature: Biasing	Page 48
Keep 'em Fresh!	Page 49
Onion Ice Cream: Some Final Thoughts	
on the Transistor	Page 50
Clearing the Table	Page 51
Tube Futures	Page 53
FOOD FOR THOUGHT	Page 54
Bibliography	Page 55
BITS & BYTES	Page 58
How to Reach Us	Page 59
Special Thanks	Page 59

—

USING YOUR COOKBOOK





Welcome to A Taste of Tubes. We've enjoyed writing it and sincerely hope you'll enjoy reading it. We think this little book will increase your knowledge of — and appreciation for — the efforts that tube lovers all over the world lavish on their audio systems.

A Taste of Tubes is your guide to the ever-finer subtleties in our auditory lives. You'll find the recipes here easy to follow. We'll take you step by step through the basics and show you the often hidden secrets that transform musical indifference into musical rapture.

There is food here for everyone — from nouvelle gourmand to advanced gourmet — so feel free to pick and choose. You'll find some sections on simple electronic theory, others that will clarify more esoteric distinctions, and even enjoyable bits of tube history so you'll really appreciate the rich tradition you've chosen to explore.

If you should feel hesitant to dive into some of the thicker batter, don't worry. You can easily skim the advanced "Cordon Bleu" sections on your first pass through the cookbook (just as the Cordon Bleu is the premiere French cooking school, these sections aren't for those without a little preparation). But don't worry. After reading a few chapters of A Taste of Tubes, you'll be ready for those challenges, too!

Our advice is simple – skim through A Taste of Tubes at your own pace. Then savor it slowly for maximum enjoyment.

APPETIZERS



Known by many names — vacuum tube, electron tube, valve — the “tube” played an immensely significant role in the development of our current audio technology. Tubes, in all their variety and complexity, were the essential building blocks of electronic circuits from the 1920s into the 1970s (Fig. 1).

Since then, however, the transistor has largely supplanted the vacuum tube. That’s understandable, at least in part, as the transistor is far smaller and less costly to manufacture and incorporate in today’s increasingly complex audio components.

But a sizeable faction within the audio industry continues to embrace the vacuum tube as a device that results in more musically satisfying sound. In fact, the past 15 years have seen a remarkable renaissance in high quality tube electronics.

Why? Transistors didn’t suddenly rot overnight to become foul tasting, did they? Probably not. Maybe our aural palates just developed a craving for something more satisfying, more sophisticated, more substantial?

To answer these questions, let’s look at the beginnings of the Tube Era. We suggest that you don’t view this as just a dried-out list of names and dates, but rather, as a savory foretaste of the banquet ahead.

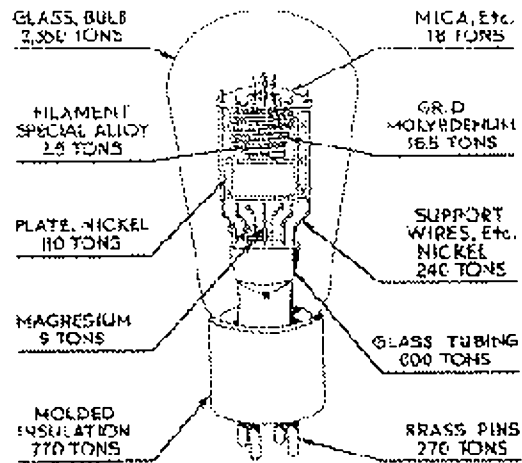
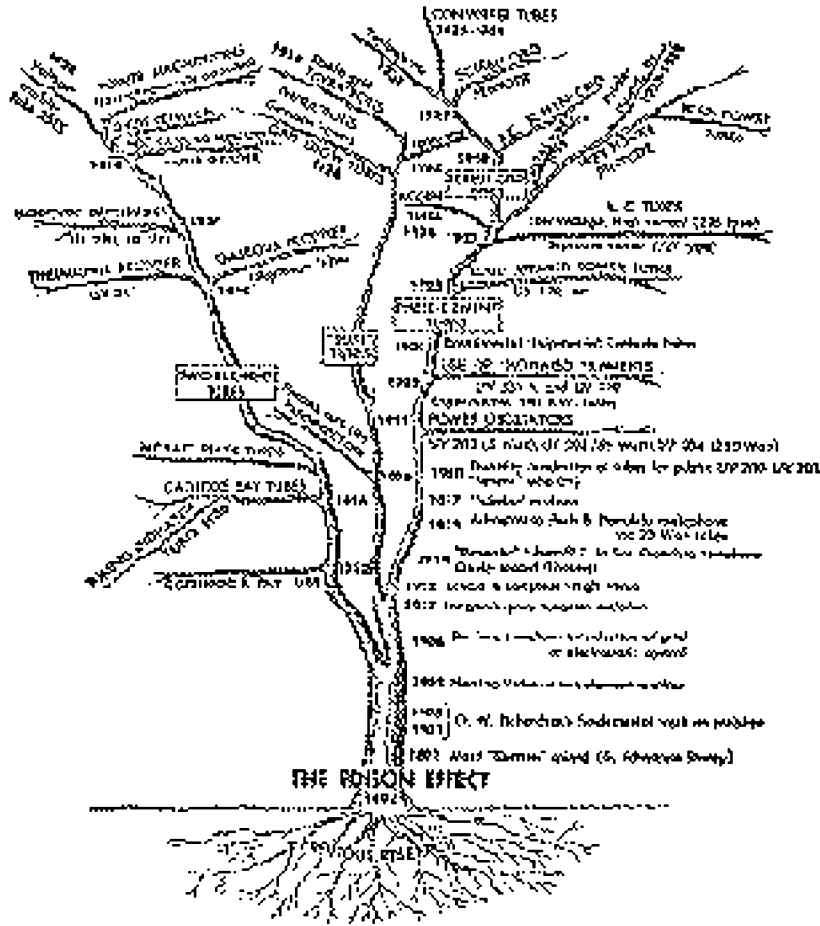

Fig. 1. Raw materials in tube manufacture (circa 1930).



The Family Tree of Thermionic Tubes.

Tube History I

A Foretaste of Tubes

Edison Discovers the Genie in the Lamp

You may be surprised to learn that inventors (England's Sir William Watson among others) produced the first crude tube-like devices in the mid-1700s. These early efforts were glass envelopes containing both a cathode (emitter) and an anode (collector), but with only a portion of the air pumped out. Given that sophisticated vacuum pumps were not available until about 1912, at this time, the flow of electricity through a tube was believed to be caused by ionization or gas discharge. Nonetheless, these early tubes facilitated the discovery of cathode rays (1858), and X-rays (1895).

It wasn't until 1880, however, that the idea of a pure electron discharge began to take root. The mystery began to unfold after Edison's discovery of a strange occurrence within his light bulbs. He noted that a dark spot appeared on the inside glass wall of his bulbs when a carbon filament was used, and correctly surmised that electrical particles drifted through the bulb and landed on the glass wall.

This led him to insert into the bulb a metal plate biased with a positive potential relative to the filament (Fig. 2). The effect of the positive plate was to divert the particles away from the glass wall. Edison couldn't explain why this occurred, but he found a practical use for it anyway: he patented the device as an ammeter for measuring current flow.



Fig 2
Replica of Edison's experimental
lamp.

Fleming's Electronic Aerial

Because Edison didn't see the far-reaching implications of his device, it was left to others — notably the British scientist John Ambrose Fleming — to develop further applications for the “Edison effect”.

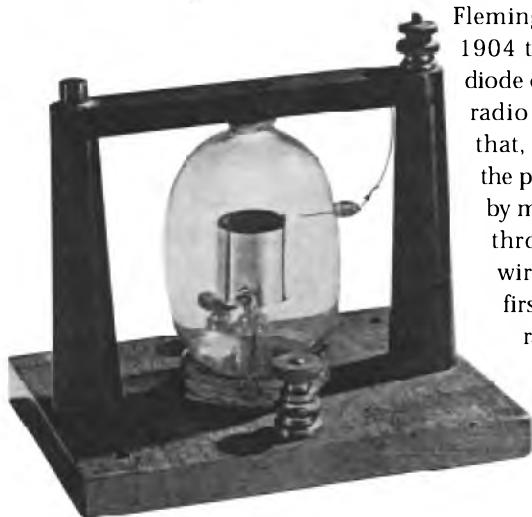

Fleming's experiments led him in 1904 to develop a vacuum tube diode capable of detecting wireless radio signals. Fleming surmised that, by connecting an aerial to the positive plate, he might thereby modulate the flow of current through the tube by means of wireless signals. This was the first practical example of a radio receiving tube (Fig. 3).

Fig. 3.
Production model of the Fleming detector valve.

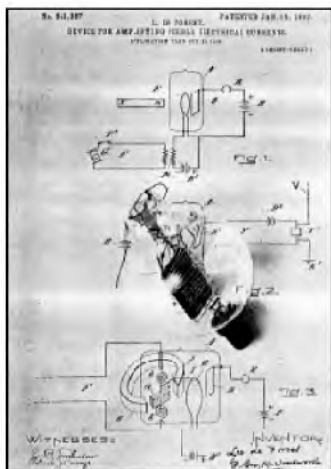

De Forest Conjures a Triode

In 1907, American inventor Lee De Forest, attempting to improve upon the Fleming diode, patented his famous Audion; a three-electrode tube containing a third element known as a grid. The following year, De Forest improved the grid and moved it more directly into the path between cathode and anode. This innovation is widely considered to be one of the most valuable in the patent literature (Fig. 4).

Fig. 4.
Front page of De Forest patent #841,387;
Jan. 15, 1907.

Like his rival Marconi, De Forest intended his new device to play a critical role in replacing the telegraph cable with wireless transmissions. The idea of instantly communicating across the continents fired De Forest's imagination like nothing else: "I early resolved come hell or high water, to achieve an envied position in the well-nigh virgin field by inventing outstanding wireless transmitting and receiving devices," said De Forest. "I foresaw that wireless telephony would ultimately supplement, if not supplant, the telegraph; that the human voice, and possibly music, would replace the time-honored dots and dashes of the Morse code." These were prophetic words indeed!

A few years later, De Forest began to experiment with his three-element tube as an amplifier. Although De Forest had some difficulty in getting his device to function as he thought it should, he was none-the-less able to build a working three-tube amplifier (gain = 42dB [more on this later]) that, in 1912, worked sufficiently well to attract behemoth AT&T's interest in the device as a telephone repeater amplifier. In 1913, De Forest produced a nifty looking four-tube amplifier (Fig. 5).



Fig 5
Lee De Forest
contemplating his four-stage amplifier,
developed in 1913

Tubes on a Roll

Additional tube developments occurred at a rapid pace as more and more air — and with it impurities that restricted performance, longevity, or both — was removed from successive tube designs. Large commercial interests, recognizing the tube's vast potential, soon added their considerable capabilities. Harold Arnold at Western Electric (by then an AT&T subsidiary) and Irving Langmuir at General Electric headed the teams that would soon make tubes viable commercial products. By 1915, Western Electric had developed a tube with a 4,000 hour lifespan — the Type L, later known as the 101B. It wasn't long before the race to place wireless reception in the home began in earnest.

By 1920, the Corning Glass Works was producing 25,000 glass bulbs per day. Uses ranged from receiving and transmitting to rectifying and amplifying. In short, everything needed to bring radio programming into the home. Radio broadcasters soon brought music, news, and sporting events into the homes of millions.

Throughout the 20s, home radio consoles were all the rage. Not surprisingly, companies such as Thordarson soon began producing powerful replacement amplifiers for these sets. By the 1930s, radio manufacturers began producing elaborate multi-tube amplifier designs — some with as many as eight triodes in one product. High quality radios, such as Zenith's "Stratosphere" and E.H. Scott's "Philharmonic" soon followed.



Tube History II

Amplifiers Du Jour

Cocking Cooks up Quality

In 1934, W. T. Cocking's seminal article on "quality amplification" appeared in the British DIY publication, *Wireless World*. In it, Cocking suggested that 5% distortion was too high for quality amplification. He went on to state that "the aim [of playback] being to reproduce in the listener's own home exactly what he would hear if he were in the studio."

This statement marks the conceptual origin of the era of high fidelity, insofar as we are able to trace it. Cocking is recognized as the harbinger of high fidelity not only because he was influential and authoritative, but because his amplifier was to evolve, by deliberate steps, into the famous Williamson amplifier.

After explaining his approach, Cocking compared triodes to pentodes and found triodes preferable for their ability to damp a moving-coil loudspeaker at resonance. He next compared push-pull to single-ended operation and concluded that the latter produced objectionable 2nd harmonic distortion.

Cocking's amplifier soon became known as "The *Wireless World* Push-Pull Quality Amplifier". This seed-pod or germinal amplifier was destined to become the touchstone of tube design for nearly twenty years.

Williamson Stirs the Pot

In April, 1947, D. T. N. Williamson's article "Design for a High Quality Amplifier" appeared in *Wireless World*. Williamson echoed Cocking's words when he summed up his analysis of the requirements for high quality amplification: "It appears then that the design of an amplifier for sound reproduction to give the highest possible fidelity should centre round a push-pull triode output stage and should incorporate negative feedback."

Thus, the evolution of Cocking's "Wireless World Push-Pull Quality Amplifier," (as begun in 1934), ultimately culminated in the famous Williamson amplifier of 1947. The distinguishing feature of each incarnation of this amplifier was the use of triode tubes (actually, KT66's wired for triode operation) in push-pull configuration. In spite of their reduced power output, triodes were preferred over pentodes because their distortion products were found to be less objectionable. This meant that, to obtain a given power output, more money had to be spent. Thus the identification of high fidelity with higher cost began to take root in the public mind.

In 1946, Avery Fisher introduced the first commercial high fidelity system. It included a 50-watt triode amplifier, Jensen co-axial speakers, AM/FM tuner, preamp and phonograph. The \$1,200 price, however, put this model out of the reach of most music lovers. Other companies like Altec-Lansing, Brook, Bogen, Bell, and RadioCraftsmen also joined in the fray. To save money, audio enthusiasts could buy hi-fi components in kit form from companies such as Heathkit, Eico, and, later, Dynaco. The kit-building craze was fueled by the large numbers of post-WWII military-trained electronics technicians.

The Pentode's Revenge

By 1949, Williamson's triode amplifier had become the prototype for high quality amplifiers the world over. In the face of this enormous interest, there arose a new generation of pentode amplifiers to challenge the long-standing triode tradition. The pentode movement — consigned to public address systems early on by engineers and audiophiles alike — was reinvigorated when new techniques were discovered that caused pentodes to sound/perform more like triodes.

Quad's Potent Pentode Recipe

Three companies in particular stand out for their achievements in pentode amplifier design. In 1945, Peter Walker of Quad found a way to dramatically reduce the high-order pentode distortion products. Taking a clue from Blumlein, Walker

found a way to turn the high pentode gain into local feedback. To obtain this feedback, Walker incorporated a tertiary cathode winding within his output transformer (Fig. 6).

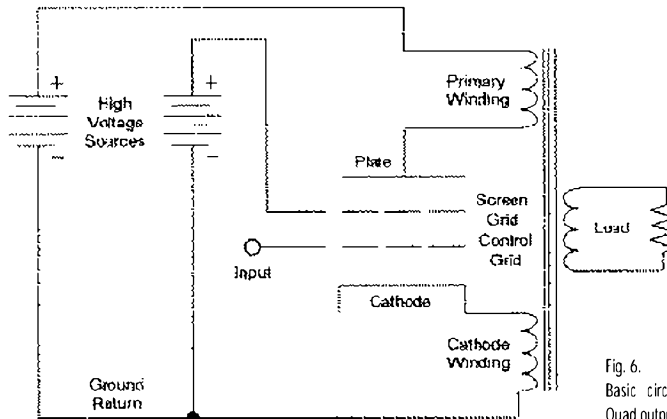

Fig. 6.
Basic circuit for the
Quad output stage.

This technique produced local feedback in accordance with the AC impedance of the cathode winding. This more sophisticated form of feedback provided a greater benefit than loop feedback alone, since there was only one high-frequency pole to create phase shift. Unlike loop feedback, the cathode feedback remained effective at the frequency extremes, thereby reducing the high-order distortion products associated with pentodes at no expense to power output!

McIntosh's Pentode Pièce de Resistance

In 1949, Frank McIntosh and Gordon Gow took Walker's technique a couple of steps further in their 50W-1 amplifier. First, they increased the number of turns in the cathode winding (Fig. 7) to obtain correspondingly more local feedback.

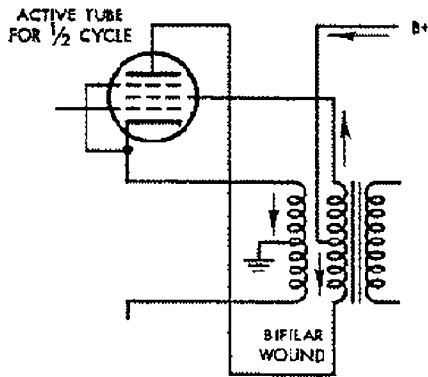

Fig. 7.
Basic circuit of the McIntosh
unity-coupled output stage.

Second, the plate and cathode coils were wound adjacent (bifilar) to one another to create a “unity coupling” between the two windings. This reduced transformer leakage reactance by a factor of 3-to-1, thereby extending transformer bandwidth and reducing phase shift. The reduced phase shift translated into more effective loop feedback at the frequency extremes, enabling McIntosh to claim the lowest distortion — across the widest spectrum — of any known power amp.

The editors of *Audio Engineering* hailed the McIntosh as “the first major change in years in amplifier coupling circuit principles.” No mention, however, was made of the Quad amp.

Hafler and Keroes Go Ultra

In 1951, David Hafler and Herbert Keroes approached the pentode from a different angle. They returned a portion of the plate voltage to the screen-grid (Fig. 8). This local feedback loop became known as the “ultra-linear” connection. It soon formed the basis of the Acro Ultra-Linear amplifier. Keroes, a transformer expert, knew that the screen-grid was a non-linear input terminal where feedback is concerned. Nonetheless, he found that the tapping point could be adjusted to enable linear feedback action. This narrow window of operation was claimed to provide “ultra linearity.”

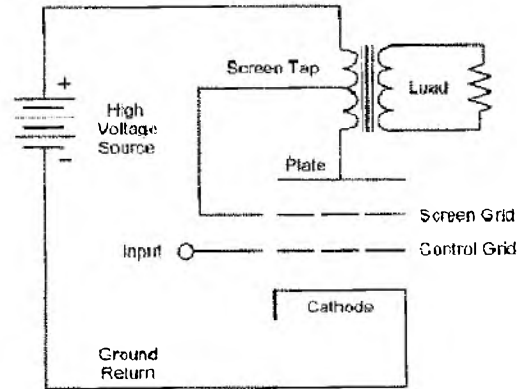

Fig. 8.
The basic ultra-linear connection is a tap connecting the screen grid to the output transformer primary winding (Hafler and Keroes used this connection, originally attributed to Blumlein, in a push-pull amplifier).

In their own words: “We have achieved a new tube type without designing a new tube. This tube is neither triode nor tetrode, but its improved linearity over either of those types justifies the designation ‘ultra-linear.’” In reality, this statement applies as much to the Quad and McIntosh amps as it does to the Ultra-Linear amp.

Nonetheless, because the Quad amp was little known in the US, the ultra-linear technique became widely adopted. During the Golden Era alone, more than twenty different manufacturers adopted the technique including Marantz, Harmon-Kardon, Fisher, Scott, Eico, and Dynaco. Indeed, the very name, “Ultra-Linear”, was to become generic; in that it ultimately came to refer to the technique itself, rather than to the amplifier that inspired the name.



Cooking the Signal:

Tubes or Transistors?

It wasn't until the late 1950s/early 1960s that transistors — solid state semiconductors named for the combination of “transfer” and “resistor” — began to enter the consumer electronic scene.

Purported to be more reliable than tubes, transistors certainly didn't produce as much heat (to be fair, most early transistor designs operated in what we call “Class B” mode; you'll see more about this in later sections of this book). In addition, transistors were thought to be more physically robust than tubes — after all, tubes did have glass envelopes, no?

Transistors certainly did allow manufacturers to make smaller, less expensive components. Moreover, the market responded very positively to reduced costs and promised performance benefits.

The reality, as it turned out, was somewhat different than expected. Early germanium-based transistors were actually very fragile outside the kind environments of the research laboratory. When one transistor in a circuit failed, for example, it sometimes caused a catastrophic collapse of all downstream components that could relegate an entire piece of equipment to the garbage heap.

High-powered output transistors in particular were extremely finicky and would instantly self-destruct if accidentally shorted. However, the cost benefits of transistor designs proved irresistible to manufacturers and, one by one, most gradually shifted to solid state circuitry. Of course, reliability steadily improved.

A few die-hard companies, however, bucked the transistor trend. These “high-end” tube electronics manufacturers stuck with tube designs because they felt that transistors didn't offer equivalent musical satisfaction as compared to tube-based electronics.



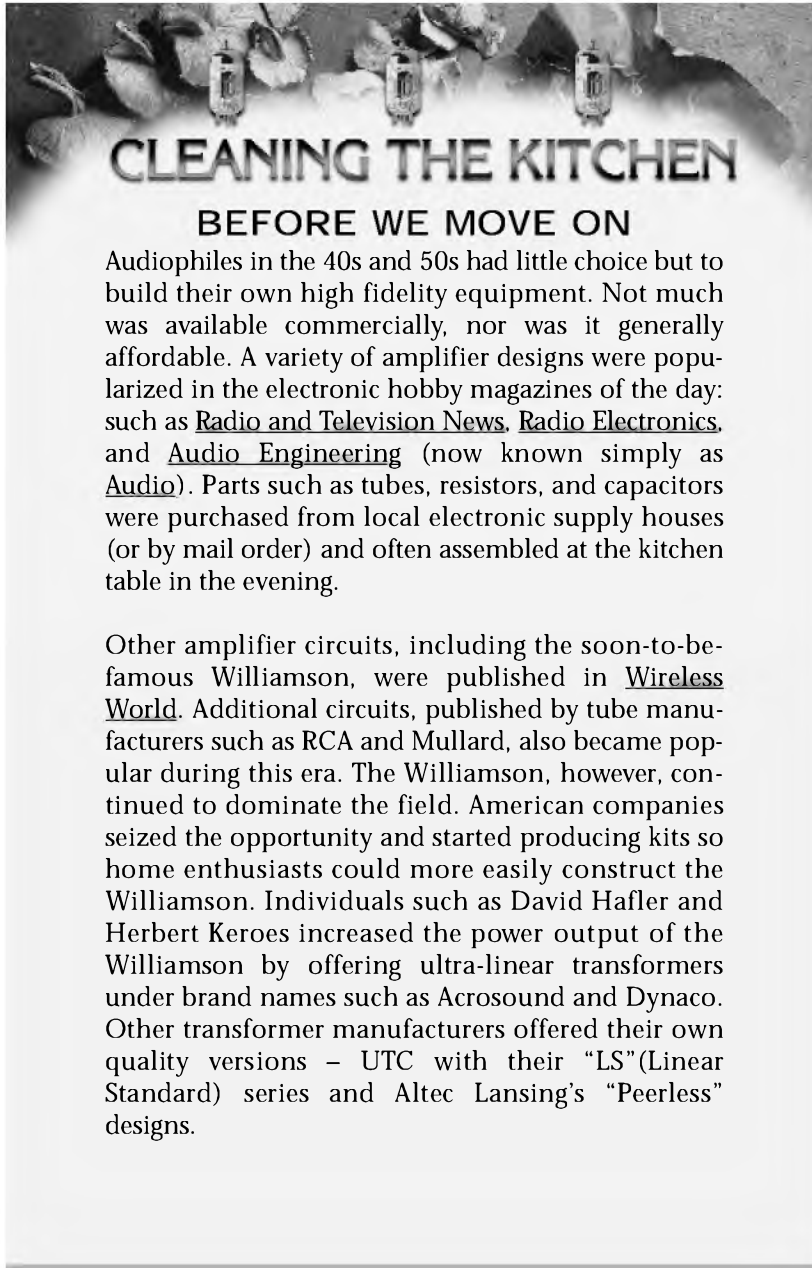

MEAT & POTATOES



Before we begin a more in-depth discussion of how tubes tenderize your music, let's start with a somewhat simplistic analogy: a tube is like a heart, controlling the flow of blood in a body, or in this case, controlling the flow of electrons in a circuit (that's one of the reasons the British still call them "valves").

As we mentioned before, tubes were necessary for all types of electronics, not the least of which being radio and television. In fact, early computers, for example — such as the office-building-sized ENIAC and UNIVAC — depended on tubes for their operation.

However, we should begin our review of vacuum tube technology by starting with the devices anatomy.

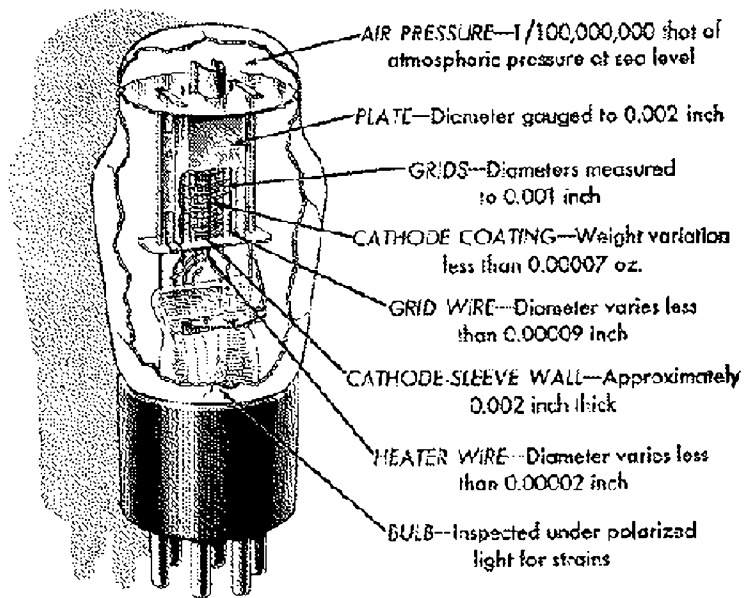
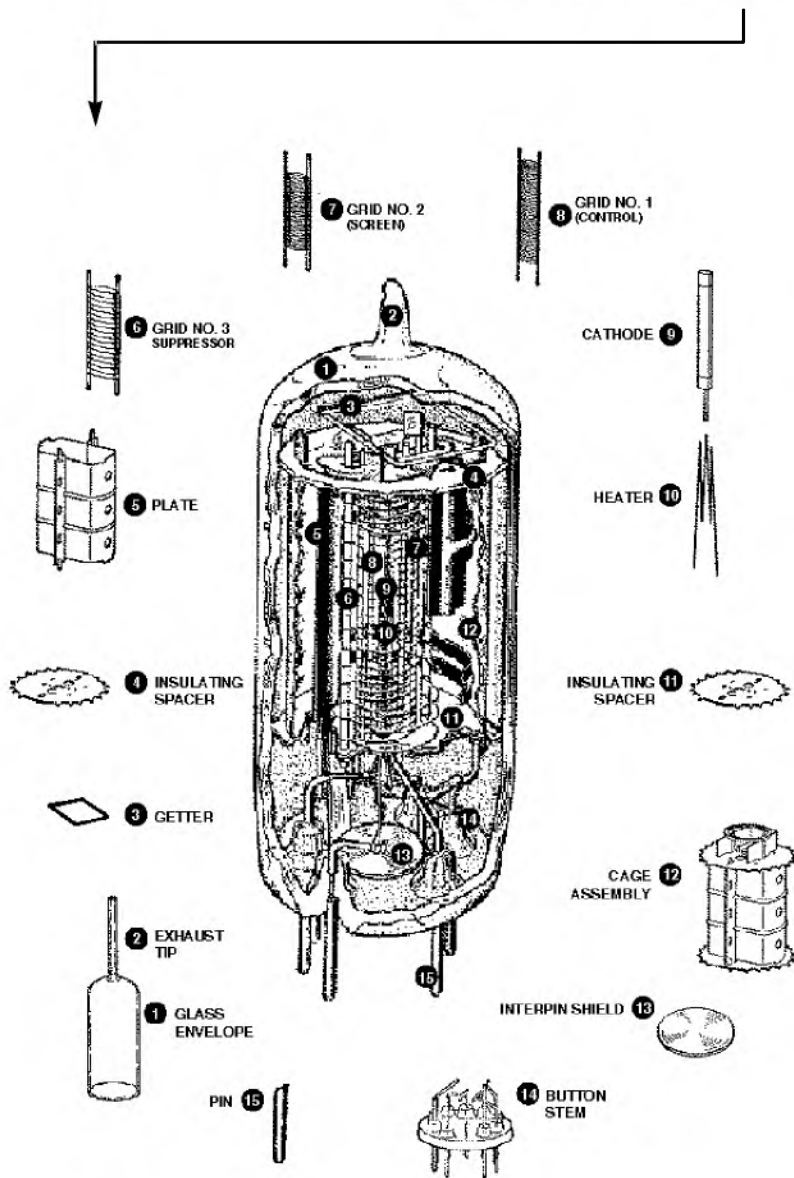

Fig. 9.
The internal details of a vintage RCA multi-grid tube.

ANATOMY OF A TUBE



“Let Them Eat Glass”

The outer shell of an audio tube is constructed of glass. Inside the shell, electrically biased grids and plates control the flow of electrons through the tube. Thin wires from the tube elements pass through the glass envelope and connect to pins on the tube's base (Fig. 9). These pins mate with sockets that connect the tube's innards to the external circuit.

The “vacuum tube” gets its name from the fact that almost all the air must be removed from inside the glass envelope before the tube will work properly. Getting the unwanted air out during manufacture is a critical though imperfect process. Even the best modern tube manufacturing facilities can't produce vacuums much below 100 millionths of an atmosphere at sea level. This presents a significant challenge to tube manufacturers because airborne contaminants drastically affect a tube's longevity.

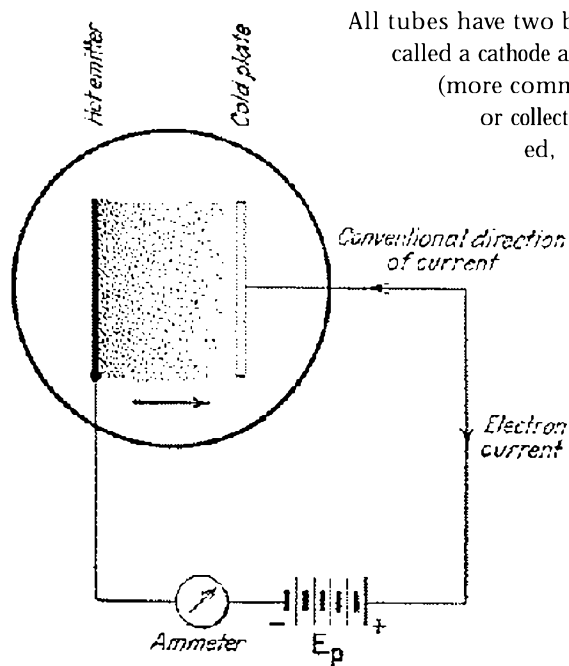

All tubes have two basic electrodes: one called a cathode and the other an anode (more commonly called the plate or collector plate). Briefly stated, an electric current heats the cathode which, in turn, emits electrons (Fig. 10).

...Cont. on pg. 20

Fig. 10.
The heated cathode is a profuse source of electron emission, especially when coated with the appropriate oxide, such as barium and/or strontium.

CORDON BLEU

101: Thermionic Emission

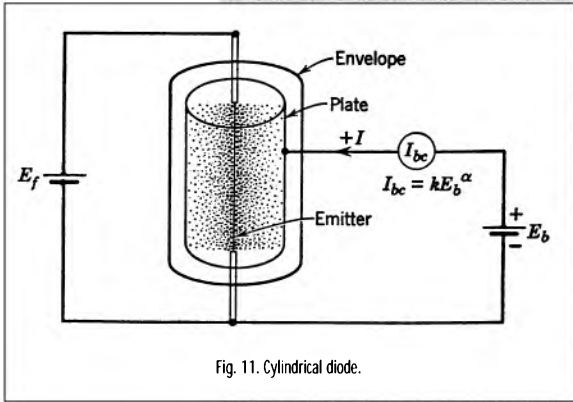

Fig. 11. Cylindrical diode.

The cathode of most tubes is coated with a material that emits a profusion of electrons when heated (this is known as "thermionic emission"). Electric current from an outside source passes through a nearby filament (a wire functionally identical to the one in an incandescent light bulb) to heat the cathode. The construction (or architecture) of a given tube design varies widely depending on its intended use. For example, some tubes have a directly-heated filament that doubles as the cathode, while others use a separate heater element to indirectly heat the cathode. Some have plates that are flat (as in Fig. 10) while other plates are cylindrical (Fig. 11).

Electrons are either directly attracted by the positively charged plate or indirectly guided toward it by an intervening control element called a grid. These additional elements are called grids because their physical structure consists of a frame of spaced parallel wires (Fig. 13). Although the electrons' exact path varies by tube type, they generally migrate directly toward the plate. The plate, in turn, pulls the electrons toward it due to the natural physical attraction between negative and positive charges.

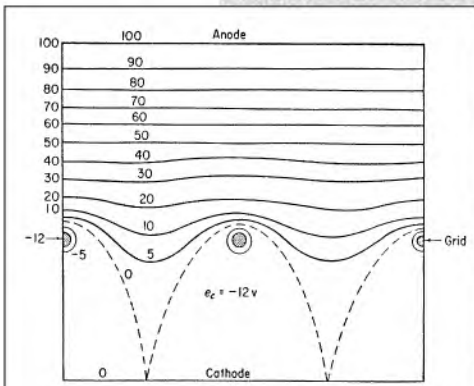

Fig. 12. Potential gradient from plate to grid. The potential at the plate is strong enough to attract electrons even when the grid is at ground potential (0V). This is why a negative bias is applied to the grid. The negative bias allows the grid to control electron flow, overriding the field at the plate.

Strictly speaking, the plate attracts electrons either directly or by neutralizing a portion of the negative grid field (Fig. 12). But you'll understand that better after reading the next section.

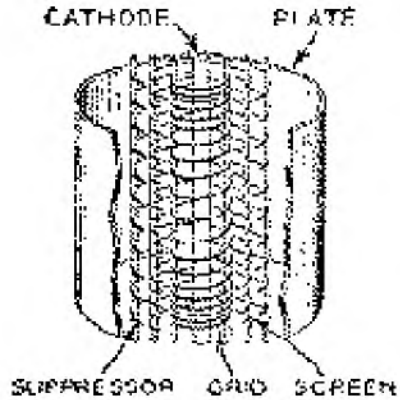

Fig. 13.
Cutaway view showing the three most commonly used grids.

Controlling the electron flow is critical, and specific tube designs handle this task in different ways. For example, a tube can increase a signal's amplitude (amplification) by incorporating additional control elements within the tube envelope.

CLEANING THE KITCHEN BEFORE WE MOVE ON

In summary, then, a vacuum tube (as used in a preamplifier) amplifies small voltage inputs from a source component like a phono cartridge, a CD player, or a tuner to produce the higher voltages necessary to drive a power amplifier, which then drives the loudspeaker. Thus, tubes help transform music signals into sound waves so we can all enjoy music in our homes. Of course, in this respect, tubes are functionally identical to transistors. Tubes, however, are significantly different in how they accomplish signal transfer. These differences are critical to the enhanced musical enjoyment many people attribute to tube designs. We'll see more on this

Tubes for all Tastes: Spicing the Circuits

Adding elements to the tube architecture changes the tube from diode (2 elements) to triode (3 elements), to tetrode (4 elements), all the way to pentode (5 elements).

i. Diodes

A diode is the vacuum tube's simplest incarnation. This two-element tube consists of an anode (plate) and a cathode. A diode conducts current only when its plate is made positive relative to its cathode. If the potential on the plate is reversed from positive to negative, the free electrons in the space surrounding the cathode will be forced back to the cathode and no plate current will flow. The effect is somewhat like that of a one way street in which the current can flow only in one direction. If the plate potential is alternated from positive to negative, plate current flows in one direction only thus changing the alternating current (AC) to direct current (DC). The diode finds applications in tuners as a demodulator (detector). In amplifiers, a diode is most often used as a power supply rectifier. Rectification is the first step in converting AC to DC (you'll see more on this shortly).

Common Tube Rectifiers: 5AR4, 5Y3GT, 6X4, 12X4, 5U4G, GZ37 (each contains 2 diode sections for full wave rectification).

ii. Triodes

Triodes are three-element tubes used primarily for amplification. A triode is created by adding a grid element in between the cathode and the plate (Fig. 14). This grid is called the "control grid" because its effect upon current flow is more pronounced than that of the plate.

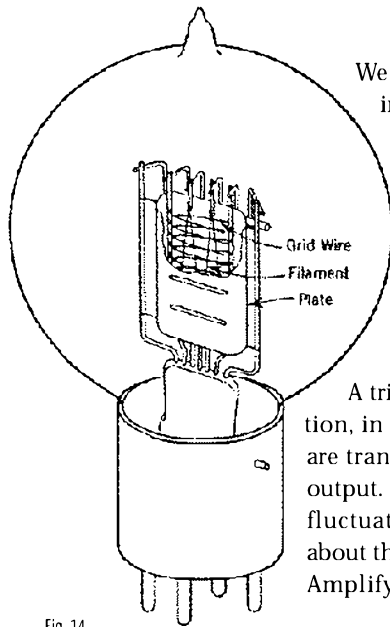
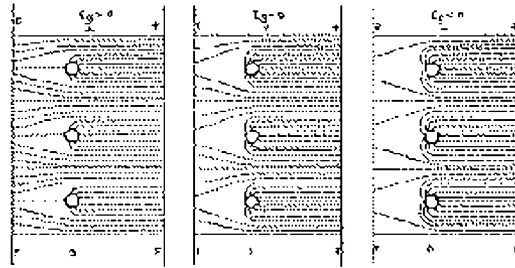

Fig. 14.
Cutaway depiction of a Western Electric
101-F triode (circa 1915).

Fig. 15.
When $E_g > 0$, current flow
increases (left); when $E_g = 0$,
current flow is nominal (mid-
dle); when $E_g < 0$, current
flow decreases.



We can test the basic action of the grid by applying different bias potentials to it. For example, when the grid is biased positive, plate current increases (Fig. 15). When the grid is biased at zero, only moderate current flows. When the grid is biased negative, plate current is minimized. The audio signal thus acts to vary the grid bias E_g and thereby control plate current.

A triode's most important function is amplification, in which small voltage variations at the input are transformed into much larger variations at the output. The object is to exactly replicate the delicate fluctuations of the input signal (you'll see more about this in the following sections). Amplifying such small signals effectively requires

that noise and interstage crosstalk be reduced to vanishingly low levels. This is accomplished by astute circuit design on the one hand and by low-impedance or elaborate power supply design on the other.

Common power triodes: 45, 71, 2A3, 6B4G, 50.

“Not” so common power triodes: 211, 300B, 845, 811.

Common small-signal (dual) triodes: 12AU7, 12AT7, 12AX7, 6DJ8, 6922, 6CG7, 6SN7, 6SL7, 5687, 6072, 7025, 6AQ8, 6201, 5751, 5691, 5692, 12BH7.

CORDON BLEU

102: Cooking with Triodes

One of the triode's most important characteristics is that small changes in grid voltage will have significantly greater effect on current flow through the tube than if the same voltages were applied directly to the plate itself. As an example, a one volt increase at the grid might result in a ten volt increase at the plate. Such a tube would have an amplification factor of 10. In practice, triodes are made with amplification factors as high as 100.

Designers, however, aren't limited to a particular tube's amplification factor. If you take two triodes, each with an amplification factor of 100, and connect them in a cascade (series) circuit, you'd achieve a total amplification factor of 10,000 (100×100 or 100^2). Adding a third tube to the chain gives you an amplification factor of 1,000,000 (100^3). A fourth tube would bring the amplification factor to 100,000,000 (100^4) and so on.

That's pretty impressive for such a simple device but remember that we need these amplification factors because the signal levels of source components (especially moving coil phono cartridges) are very small indeed — on the order of 200 millionths of a volt! (That's 200 microvolts or 0.0002 volt.)

iii. Tetrodes

Tetrodes contain four elements. The fourth element is a second grid, usually called the screen grid, positioned between the control grid and the plate (Fig. 16). The effect of the screen grid is to shield the input signal from the high grid-to-plate capacitance of the triode. The tetrode's low input capacitance makes it ideal for wideband circuits (radio frequency designs, for example).

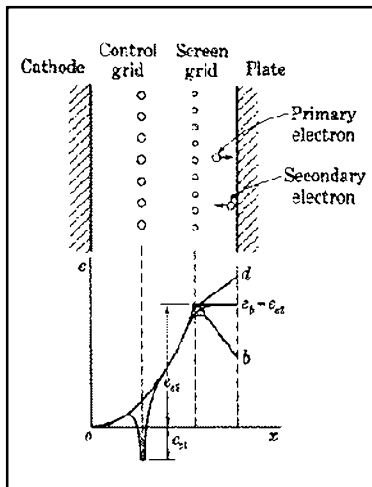

Fig. 16. Cross-section of a tetrode tube showing primary and secondary electron directions.

Whereas the control grid is negatively charged, the screen grid is positively charged. The gaps on the screen grid are much larger than those on the control grid; so that, even though the screen grid is biased positive, it allows most of the electrons to pass through to the plate. In addition to its shielding effect, the screen grid acts to assist the plate in attracting electrons from the cathode. Moreover, due to the increased positive voltage gradient introduced by the screen grid, it also acts to accelerate electrons.

The accelerated electron flow to the plate becomes quite turbulent, however, because now electrons develop sufficient speed to bounce off the plate and return to the screen

grid where they are subsequently dissipated as useless heat. These "secondary electrons" reduce the tetrode's overall efficiency. For this reason, the tetrode was soon supplanted by the pentode, which was designed specifically to address this problem.

iv. Pentodes

Pentodes add a third grid element. This element, referred to as a suppressor grid, is positioned between the screen grid and the plate (Fig. 17). The suppressor grid is biased with a very low negative potential to repel secondary electrons back to the plate, thus increasing overall efficiency.

Pentodes can be converted to triode operation simply by shorting the screen grid to the plate. In fact, some pentodes display outstanding audio characteristics when operated in triode mode.

Common pentodes: 6CA7, EL34, 6BQ5, EL84, 7189, 6K6, 6F6, 47, EF86, 12BY7.

v. Beam Power Tubes

Beam power tubes are the culmination of audio power tube design. The beam tube, like its sibling the tetrode, contains a cathode, a control grid, a screen grid, and a plate. However, the beam tube functions as a pentode. This identity crisis arises because the tube's directed electron beams create a virtual suppressor by setting up potential gradients between screen grid and plate. In addition, the two grids are aligned such that the gaps in the screen grid fall within the 'electrical shadow' of the gaps in the control grid (Fig. 18).

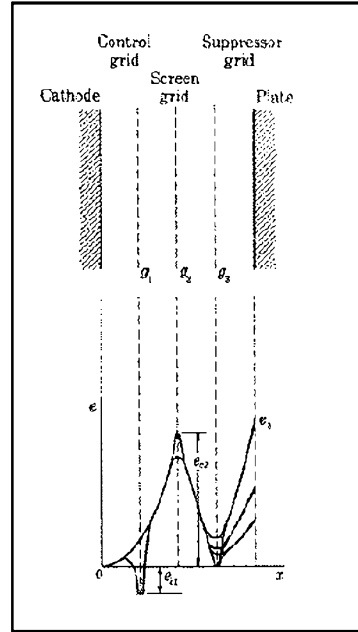
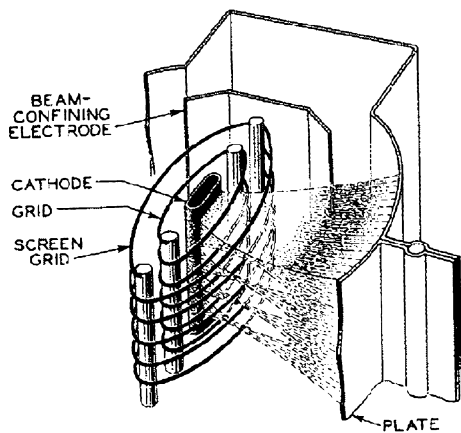

Fig. 17. Cross-section of a pentode tube showing a potential minimum at the negatively biased suppressor grid.



This orientation, assisted by a pair of beam forming elements, focuses the electron stream into an array of compact sheets. This further assists the virtual suppressor to reduce secondary electrons. Thus, more electrons make their way to the plate, and efficiency is increased even beyond that of a pentode.

Fig. 18. Interior view of a beam power tube. The electron stream flows out of the cathode in compact sheets.

Beam power benefits include high power output, high sensitivity, and high efficiency. Compared to the pentode, it produces slightly more power with less distortion.

Common beam power tubes: KT66, KT77, KT88, KT90, KT100, 6550, 5881, 807, 6V6, 6L6.

vi. Other -odes

Tubes with even more grids (hexodes, heptodes, and octodes) also exist but are used mostly in RF (radio frequency) circuits — such as radio and television tuners — for frequency conversion and mixing.

vii. Sectional Tubes (Electronic Alliance)

In addition to single-section tubes, many multi-section tubes also exist. For example, dual diode tubes are sometimes used for rectification. Small dual triodes frequently serve for low-level signal amplification.

Some tubes combine totally different architectures — a triode and pentode, for example — within a single tube envelope. (The 7199 used in the Dynaco Stereo 70 amplifier is a classic example of this hybrid approach.) The operating principles of each section are identical to the types described earlier (diode, pentode, etc.), but multi-section tubes help conserve space and shorten signal paths.





Cooking with Tubes

i. Rectifiers

Rectifiers come in a variety of flavors: half-wave; full-wave; full-wave bridge; bi-polar; and voltage-multiplier. The full-wave rectifier is the most common type of rectifier for tube circuits (Fig 19).

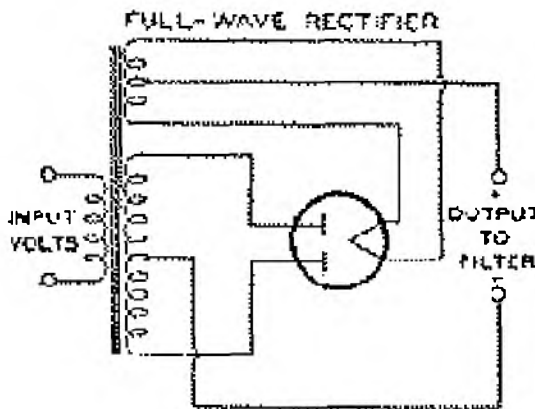

Fig. 19. Full-wave tube rectifier circuit.

Rectifiers convert wall-socket AC current into pulsating DC current. This one-way current can then be smoothed out so that no alternating components (AC harmonics) appear on the power supply rails, which would otherwise inject hum and noise into the audio cir-

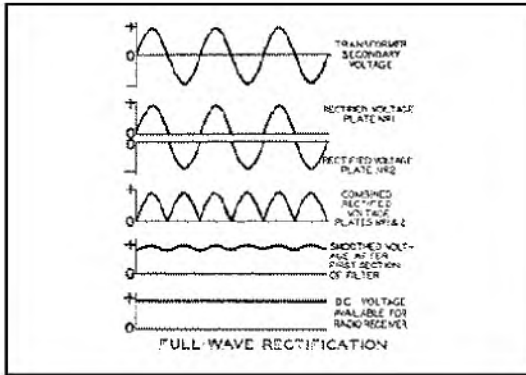

Fig. 20
 Due to the transformer connection, one diode plate conducts on the positive half-cycle and the other plate conducts on the negative half-cycle of the AC input waveform. The output waveform then appears as pulsating half-cycles. These half-cycles can be smoothed out by including filter elements after the rectifier.

CORDON BLEU

103: Why Diodes are Directional

The plate, when connected to an AC source, receives a charge that continually reverses between positive and negative. When negatively charged, the plate loses its attractive power, so no current passes through the tube. Thus, all the current pulses through a diode occur during the positive half-cycle of the AC waveform. The positive pulses then line up to create what is called “pulsating DC” (Fig. 20).

ii. Regulators

Once the AC wall-socket current is rectified, it can then be regulated. Regulation implies that the power supply voltage is maintained at a fixed voltage, regardless of AC line voltage fluctuations or load current variations. The object is to allow only the audio signal voltage to vary, and to suppress false signals from the power supply.

CORDON BLEU

104: Advanced Regulation

A regulator functions as a comparator circuit. In its most basic form, a power tube is utilized as a "pass device". This tube's grid is connected to a fixed reference voltage such as a zener diode or gas discharge tube. The output of the pass device is then

connected to the circuit (Fig. 21). A voltage fluctuation at the input is thus reduced by the amplification factor of the tube.

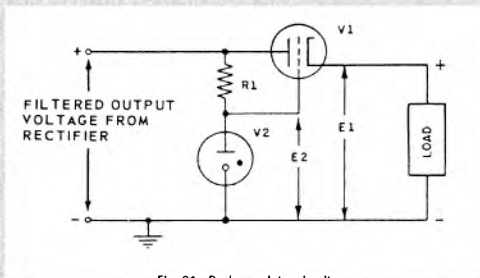

Fig. 21. Basic regulator circuit.

To increase the effectiveness of this arrangement, an error amplifier tube is often connected in between the voltage reference and the power tube's grid (Fig. 22). Now the fluctuations are reduced by the gain of the error amplifier times the gain of the power tube, greatly increasing the power supply rejection and approaching a zero output impedance. In practice, this output impedance will be somewhat greater than zero and will rise with frequency.

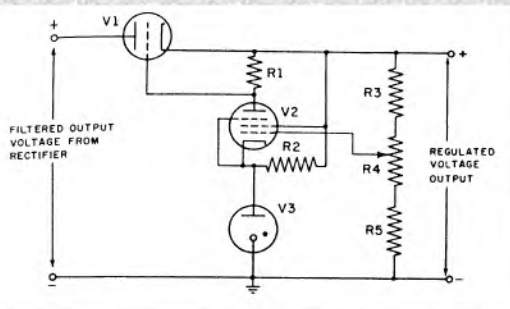

Fig. 22. Regulator circuit with error amplifier.

A complete power supply consists of a transformer; rectifier; filter; regulator; and dividing network (Fig. 23).

More advanced power supplies use additional regulators to reduce interstage and/or interchannel crosstalk.

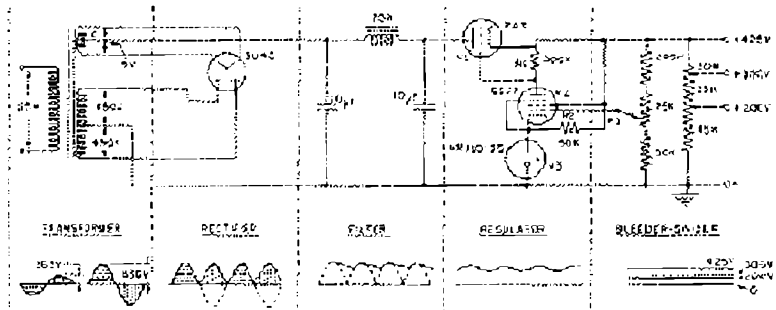

Fig. 23.
Complete power supply showing the change upon the input waveform (AC) at various stages within the circuit. The AC has effectively been reduced to steady current (DC) at the output.

iii. Amplifiers

Next, we come to the amplifier itself. This circuit is really no more nor less important than the regulator in obtaining good sound, just different in its requirements. Amplifier circuits come in a dazzling variety of flavors. In order to better appreciate these flavors, we here present a cook's tour of the main ingredients. The first thing to know about tubes (and about electricity in general) is that voltage stimulates electron flow. Voltage is defined as the difference in electrical potential across a conductor or across space — as in a vacuum tube (See Cordon Bleu 105 on the following page).

CORDON BLEU

105: Ohm's Law Distilled

A resistor subtracts or drops voltage whenever current flows through it. According to Ohm's Law, the voltage varies directly as the current varies. The defining statement of this law is:

$$E = I \times R \text{ (where } E = \text{voltage, } I = \text{current, } R = \text{resistance)}$$

This formula gives the voltage drop across any given fixed resistance for any given current flow through the resistor. Thus, potentials can be established as needed throughout the circuit merely by adjusting the resistor values. Once established, these potentials fix the current flow through any given circuit node. The object is to allow only the audio signal voltage to vary the current flow.

Amplification occurs by an adept combination of voltage source (power supply or battery), series resistance (or reactance), and active device (tube or transistor). Although the basic rules apply to transistors as well as to tubes, for present purposes we will use the triode. Note that the positive potential provided by a high voltage source causes current to flow through the triode as well as through any resistor that is placed in series with it (Fig. 24).

Because the input or control grid is the closest electrode to the cathode, a change in the electric field of the grid has a bigger influence on current flow than does the plate field. (Hence the name "control grid.") The current flowing to the plate will also flow through the external plate resistor in order to complete the circuit from voltage source to ground return. Thus, a voltage variation occurs (equivalent to $e = iR$, where i = the instantaneous plate current) through the plate resistor. The small signal variation at the input then creates a large signal variation at the output (amplification) (see also Figs. 12 and 15).

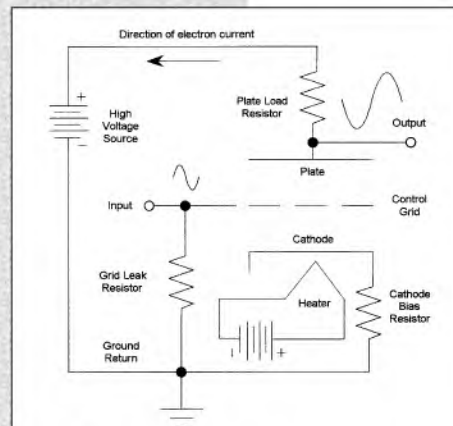

Fig. 24. The process of amplification requires an external plate load resistor in addition to the tube itself. The plate current flowing through this resistor produces a voltage variation that is an amplified version of the input waveform.

CORDON BLEU

106: Advanced Amplification

Accurate amplification demands that the overall circuit exhibit two essential characteristics. First, the power supply should exhibit zero internal impedance and therefore zero voltage variation as the load current varies. Of course, this is an ideal condition that is approached only by regulated power supplies. Second, each tube must be biased for linear response within a critically specified range of operation.

A designer uses a "load-line" (i.e., a working path of operation drawn across the graph of a given tube's conductance characteristics) to obtain the operating point, Q (Fig. 25). The range i_b shows the amount of plate current flowing at any given instant. It can be seen that at Q the tube is flowing about half its maximum current. When the input signal turns negative, less current flows; when the signal turns positive, more current flows (up to i_b max).

By this means, a complete cycle is reproduced, even though the electron current is flowing in one direction only through the tube. This is what is meant by "biasing the tube" or "setting the operating point". The designer tries to draw the load-line across the most linear portion of the plate characteristics.

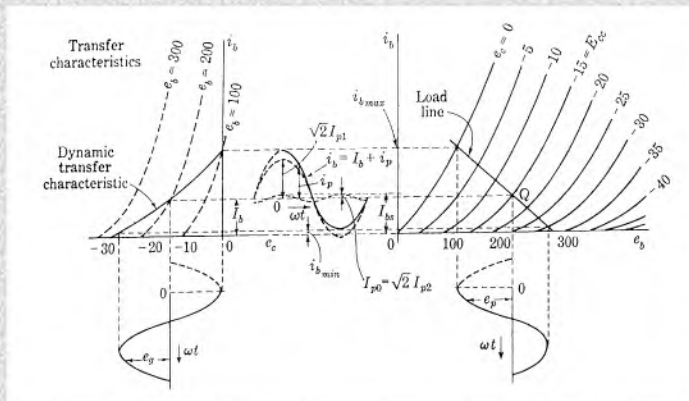

Fig. 25
The load-line shows the working characteristic of the tube, and allows the output waveform to be compared to the input waveform via the dynamic transfer characteristic; which, in a perfectly linear tube, would be a straight line.

Amplifier Flavors

Single-Ended

A single-ended amplifier uses one active device to produce both half-cycles of the audio signal (Fig. 26). The term “single-ended” implies that the circuit is not balanced. Single-ended tube designs are necessarily operated in Class A mode and, consequently, tend to be very inefficient. They have an advantage, however, in that they tend to produce smaller amounts of high-order harmonic distortion. This is because, in single-ended amplifiers, there is no possibility of crossover distortion (you’ll find more about this a little later).

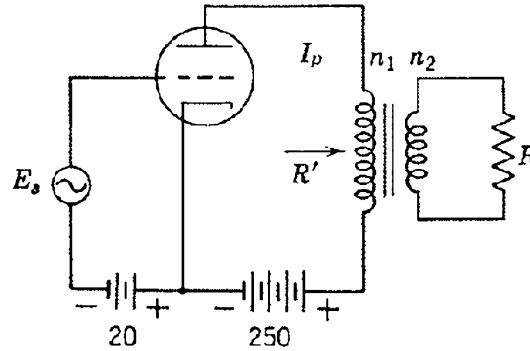

Fig. 26. Single-ended amplifier circuit.

While single-ended amplifiers are often touted as simpler - hence, better - this may not always be true in practice. For example, to obtain higher power outputs, multiple tubes must be paralleled in the output stage. In addition, if feedback is to be used, an additional gain stage must usually be added, just as in push-pull designs.

Push-Pull

Push-pull amplifiers employ a pair of tubes that operate alternately to reproduce the two halves of the audio signal (Fig. 27). Push-pull amplifiers necessarily employ a “phase splitter” to create a phase-inverted clone of the input signal (for single-ended inputs). For balanced inputs the phase inverter is not needed.

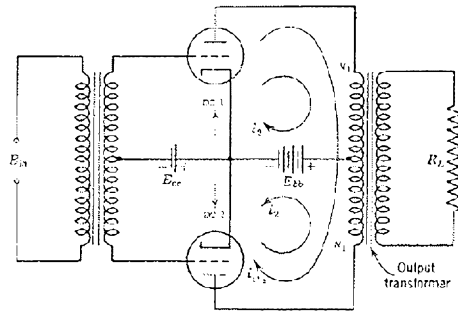

Fig. 27. Push-pull amplifier circuit. Even-order distortion products such as i_2 travel through the transformer in opposite directions. The resulting magnetic fields, being of opposite polarity, then cancel.

The phase-inverter's output drives the two sides of the push-pull output stage so that each tube in the pair "hands-off" the signal to the other to produce a complete waveform at the output. This hand-off operation can create crossover distortion if the amplifier is not carefully designed.

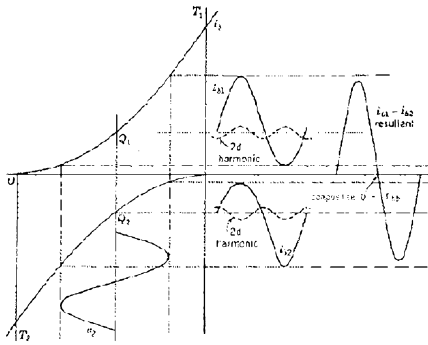

Fig. 28. The two tubes, T1 and T2, combine their anti-phase outputs to produce a composite waveform at the main output. In so doing, even-order harmonic products (especially 2nd harmonic) are drastically reduced.

harmonic residuals (Fig. 28). Since the second harmonic tends to dominate the distortion spectrum, push-pull amplifiers tend to have much lower total harmonic distortion figures. If not carefully designed, however, they can produce annoying high-order products due to crossover distortion (see also [The Bitter Taste of Solid State](#), pg. 40 and [They're Warm! They're Tasty!](#), pg. 41)

A push-pull output stage may be operated in Class A, B, or AB. The class of operation determines the amount of overlap between the half-cycles at the hand-off (you'll find more about this a little later). Depending on their degree of balance, push-pull amplifiers will cancel even-order distortion products, leaving odd-

Parallel

This is not really a separate category at all: both single-ended and push-pull topologies may use more than one tube (single-ended) or one pair (push-pull) connected in parallel. This does not change either mode's basic operation.

Ultra-Linear

If you've already read the section [Tube History II: Amplifiers Du Jour](#) (pgs. 9-13), you already know a lot about the Ultra-Linear approach. If you haven't yet read that section, maybe now would be a good time to do so. To summarize, the ultra-linear output stage configuration is a way of using a tetrode, pentode or beam power tube to achieve triode-like characteristics.

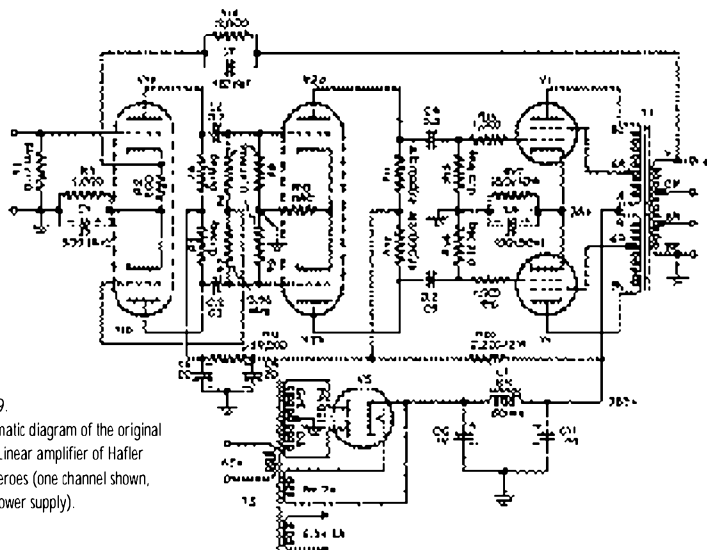

Fig. 29.
Schematic diagram of the original
Ultra-Linear amplifier of Hafler
and Keroes (one channel shown,
plus power supply).

while maintaining their high gain and efficiency. Simply put, the ultra-linear connection was an attempt to combine the advantages of both triodes & pentodes, with few drawbacks. Some of you who've read this far may be wondering what a complete amplifier circuit looks like. Fig. 29 shows the complete schematic diagram of the original Ultra-Linear amplifier of Hafler and Keroes, circa 1951.

iv. Preamps

Preamps come in two basic flavors: phono and line. The phono pre-amp is distinguished by its RIAA equalization filters, its high gain, and its low noise. The line stage is distinguished primarily by its control features, such as volume control and switching functions. Most line stages also provide gain.

v. Impedance Buffers

An impedance buffer, often known as a "cathode follower," is essentially a tube that uses up all of its available gain as feedback (Fig. 30).

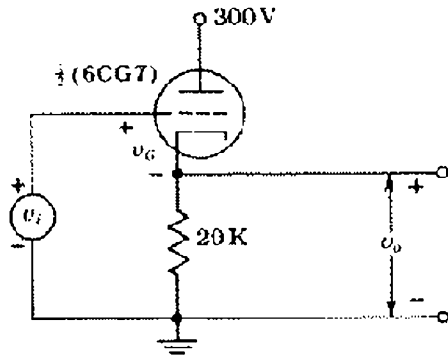

Fig. 30.
A cathode follower circuit produces local feedback due to the large value cathode resistor.

This gives the cathode follower a high input impedance, making it easy to drive. It also gives it a low output impedance, making it ideal as an output stage. That's because, with a low output impedance, the tube is more immune to cable capacitance and/or inductance, which would otherwise cause high-frequency roll-off.

Tube Cuisine in Three Easy Classes

There are three "classes" of amplifier operation commonly used for audio applications: Class A, Class B, and Class AB. These operating classes apply to all amplifiers, whether solid-state or tube.

i. Class A

Class A refers to a state of operation in which the operating point is set to a level at least half that of the maximum output current of the tube. In this mode of operation, the tube conducts current over the entire cycle of the input signal (Fig. 31). Thus, there is no crossover or notch distortion: the waveform is uninterrupted at the zero-crossing between its positive and negative half-cycles.

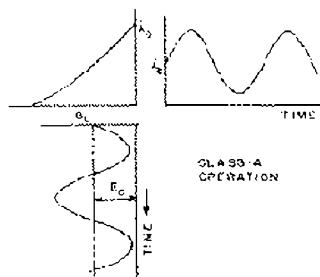

Fig. 31.
The Class A output waveform, shown as i_b , is a continuous cycle.

A Class A amplifier also has the lowest output impedance of any operating class. Its disadvantage is inefficiency. A Class A amplifier that develops even 50 watts will be a large piece of equipment

indeed; use lots of electricity, and, because the output tubes produce half their maximum current even at idle, produce a surprising amount of heat!

ii. Class B

More complex “push-pull” amplifiers drive two tubes alternately, and the negative cycle is allowed to cut-off. Class B refers to amplifiers having output stages with no idle current at all. True Class B designs “turn on” an output device at the exact instant it is needed to reproduce the positive or negative half of the waveform (Fig. 32). This abrupt transition between “off” and “on,” while tremendously efficient, produces substantial crossover distortion that makes these designs generally unsuitable for high fidelity applications.

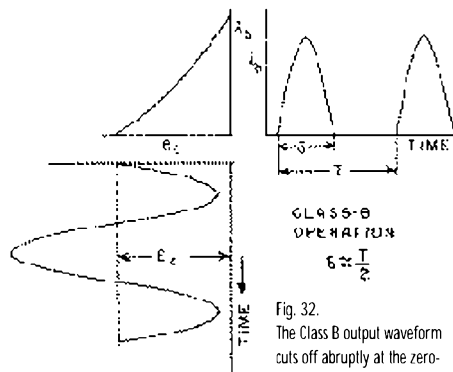

Fig. 32. The Class B output waveform cuts off abruptly at the zero-crossing (baseline or timeline).

iii. Class AB

In Class AB, the two alternating current pulses overlap to some extent during the hand-off (Fig. 33). Bear in mind that push-pull amps can also be operated in Class A. This is rarely done, however, because there is no penalty in allowing the negative cycle to cut-off, provided that there is sufficient overlap between the half-cycles.

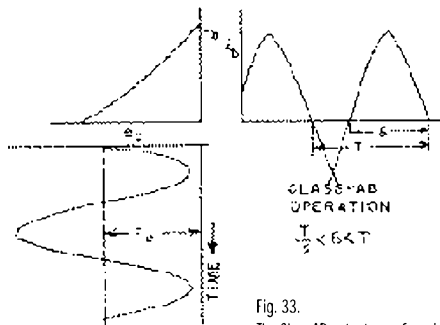

Fig. 33. The Class AB output waveform is permitted cut-off on the negative cycles. There is some overlap, however, between the push and the pull waveforms.

The term “Class AB” indicates that the operating point is set part-way between Class A and Class B. Thus, Class AB designs combine Class A’s linearity with Class B’s efficiency, with very few of the drawbacks of either. The overlap between the half-cycles largely eliminates crossover distortion (Fig. 34).

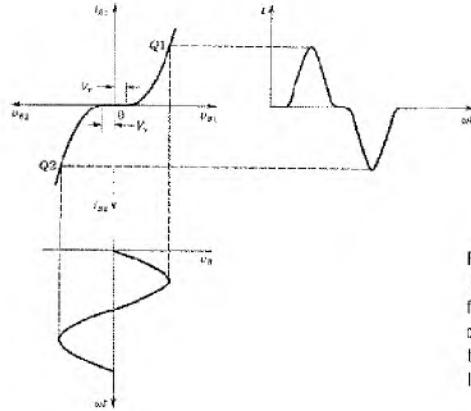

Fig. 34.
 Due to the lack of overlap, the two half-cycles fail to conduct at the zero-crossing, producing crossover distortion. This is due to curvature of the plate characteristics near the bottom of the load line (see Fig. 25).

Most high fidelity audio amplifiers operate in Class AB mode. A properly designed Class AB amplifier will perform at levels comparable to Class A designs.

**CLEANING THE KITCHEN
 BEFORE WE MOVE ON**

TO SUM UP: Class A amplifiers usually cost the most and are the least efficient. They also have the potential to sound the best. True, they waste power but give very clean reproduction. Class B amplifiers are used where high efficiency is a primary requirement — applications such as public address (PA) and similar non-critical applications. Class AB amplifiers dominate the audio market, and, with careful design, can rival Class A amps in sound quality. They're more efficient (i.e., use less power), and are usually less expensive, smaller, cooler, and lighter than their Class A cousins.

Nourishing Your Playback System

Sonic Secrets

Compared to most solid-state (transistorized) audio equipment, tube circuits offer several advantages. A tube's inherently simple operating principles mesh perfectly with the minimalist circuitry most high-end designers favor.

A firmly entrenched high-end canon states that every component added to the signal path imparts its sonic signature to the sound. That is why the best designers take so much care in their passive parts selection. Whether it be the choice of wire, connector, switch, resistor or capacitor, all will have a significant effect on the final sonic outcome. From a purely musical standpoint, simple signal paths usually have the least detrimental effect on the input signal. Once a low-voltage signal is retrieved and converted by a source component, it can't ever be improved. Unfortunately, however, it can be degraded. Complex signal paths often provide more ways to affect and modify the signal. We call that process coloration — the audible resonance's and signatures of the parts themselves — and it is something we need to minimize in any high fidelity system.

The Bitter Taste of Solid State ?

Transistor circuits have a strong tendency to produce what we call high-order distortion. These distortions are harsh sounding because they are dissonant with the original signal. Most early transistor-based audio equipment sounded harshly antiseptic due to the high crossover distortion of early Class B designs. In addition, another artifact, eventually identified as "transient intermodulation distortion" (TIM), resulted from poor implementation of negative feedback. Improperly applied feedback affected the sound in a negative way, even while it measurably reduced other, better known, forms of distortion.

It was around this tube-to-transistor transition that the term "listener fatigue" was first used to describe the "makes-me-want-to-pull-my-hair-out" reaction most listeners had to the edgy sound of early transistor products. In fairness, we must admit that solid-state designs have improved greatly over the years, both in terms of sound quality and reliability.

The Inaccurate Measuring Spoon

The aural impact of the different harmonic profiles exhibited by solid state and tube circuits points out some of the difficulties faced by high-end designers even today as they balance what may measure better against what may sound better. The two are not always synonymous, as conventional measurements do not always reflect instantaneous signal conditions found in music programs.

They're Warm! They're Tasty! And They're Tubes!

On the other hand, tube designs, even though they tend to produce more total distortion than their solid-state offspring, often produce a more agreeable form of it. Technically described as low-order distortion, the spurious second and third harmonics generated by tube designs are far more consonant with the original signal and thus less objectionable. In fact, tube circuits and people proved to be remarkably congruent as the human hearing mechanism tends to interpret low-order distortion as a welcome warmth and mellowness that can enhance our enjoyment of music.

**CLEANING THE KITCHEN
BEFORE WE MOVE ON**

In truth, we're still learning why tubes and transistors differ so remarkably in their audible characteristics. But we do know that tube electronics' relative simplicity means a less convoluted signal path. The fewer steps taken in that signal path, the less that can go wrong with the music. So, according to many audiophiles, there is just nothing more beneficial than vacuum tubes in your audio system!

JUST DESSERTS



Feed 'em, Clean 'em, But Don't Step on Their Toes!

(How to Care for Your Tubes)

Although some special purpose tubes (nuvitors and transmitting tubes in particular) have metal envelopes, almost all of the tubes we encounter in audio equipment are encased in glass. And, as we all know, glass does break occasionally. The good news, however, is that vacuum tubes are fairly robust devices. They're also self-contained and surprisingly immune to the external environment. This means, for one thing, that they can last almost indefinitely on the shelf.

Nonetheless, we don't recommend that you test a tube's ruggedness by deliberately dropping one on a concrete floor! If you do, you'll probably spend a bit of time on your knees apologizing to the Tube God as you sweep up tiny pieces of glass (Fig. 35).

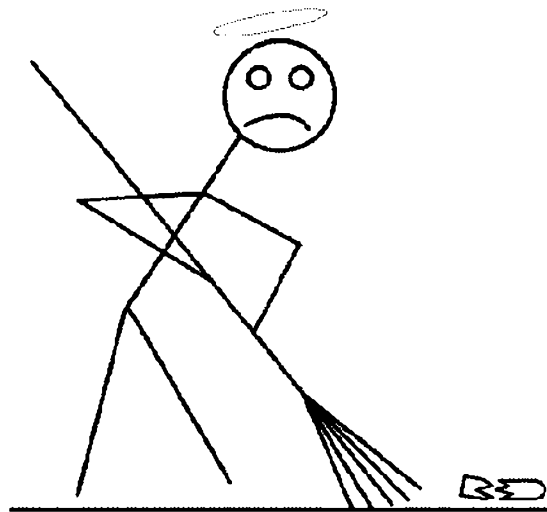

Fig. 35. Over-anxious tube jockey at work.

We do recommend that you read the following paragraphs for some tips on handling and preserving your tubes so you can enjoy their warm, soft glow and luscious music for many years.

Watch an experienced audio hobbyist change tubes in a valued component and you might think you're in a surgical operating room! See those little white cotton gloves? There's a reason for them: handling tubes with your bare hands usually means that some of your body oils and acids get transferred to the tube's glass envelope. Over time, the tube's high surface temperatures promote chemical reactions between these contaminants and the surface that can weaken the glass and cause a structural failure. Guarding against this potential problem is easy: use clean cotton gloves or simply wipe fingerprints from your tubes after you handle them.

Properly handling the bottom of a tube is also very important. Specifically, you need to exercise a little caution around the pins that protrude from its base as they're essential to the tube's operation. After all, they're the only contact between the tube and the rest of the circuitry in whatever component you're using them.

When you're changing tubes, make sure that these pins are clean. Also check to make sure that the tube sockets are clean and free of any debris that may have accidentally found its way into the pinholes.

Tubes can be inserted into their corresponding sockets in only one way. Smaller tubes (miniature, bantam, etc...) generally have a circular array of nine pins and a gap where a tenth pin would appear if it existed. The corresponding tube socket has nine holes and a corresponding gap. Larger, 8-pin (octal) tubes have a locating rib that can fit into the socket in only one way. Once you've aligned the rib with the key-way in the socket, proper pin matching is assured. There are also tubes with 4-, 5-, and 7-pin bases. But don't worry — these tubes are also designed so that you can't accidentally insert them the wrong way.

When pulling out or replacing tubes, let common sense be your guide. Don't yank out old tubes — while grasping by the

base, a steady, even pull with a little (usually VERY little) side-to-side rocking will get all but the most stubborn tube out of a socket. When replacing it, make sure to align pins and socket holes before seating the tube with a steady, even push. It's also a good idea to clean the pins occasionally with a small welder's brush. After a gentle scrub, you may wish to treat the pins with an electrical preservative.

Tasting Adventures: Trying New Tubes

There are a few simple guidelines to follow to insure the best possible sonic performance from your tube equipment.

Whenever possible, use identical tubes (the same tube type from the same manufacturer) for corresponding stages of both left and right channels of your equipment. For example, if you're using Svetlana 6550Cs in one channel of a stereo power amplifier, it probably isn't a great idea to use a different brand in the other channel, or to use a Yugo-EI KT90 if one of the Svetlana's suddenly goes to Tube Heaven. There are differences between brands — some subtle, some not — that might upset left-right musical balances.

But don't take this as a warning against experimenting. As we'll shortly explain in more detail, trying different tubes is one of the real pleasures available to the "tube-aholic." You may find a particular synergy in using tubes from one manufacturer in a phono circuit while another manufacturer's product might provide just what you're looking (or listening) for in line stage applications. Just make sure to try new tubes symmetrically between channels rather than in a haphazard manner.

Don't feel obligated to stick with the same brand of tubes that originally came with your components, either. As we've already implied, many audiophiles have an almost fervent devotion to one brand and will use it religiously in their equipment regardless of what was originally supplied.

Some audiophiles, generally those with healthy budgets, are fond of NOS (New Old Stock) tubes such as the Western

Electric 300B, Gold Lion KT-88, Mullard EL-34, and Telefunken 12AX7. These tubes went out of production many years ago and now sell for rapidly escalating prices due to the pressures of supply and demand. NOS prices will only increase as the finite number of those tubes gets smaller every year. (You may be interested to know that, even though Western Electric stopped producing 300B tubes some time ago, they started production again when they discovered that 300Bs were selling for upwards of \$500 each!)

Most tube types are made by more than one manufacturer. Different construction techniques, tolerances, and materials can result in differences in their sonic characteristics. For instance, military grade tubes are often built more ruggedly – they're more reliable and more consistent – than the same type of tube built strictly for commercial applications. Increased ruggedness also often translates into greater power-handling capability and thus longer life. In addition, this can result in reduced “microphonic” tendencies and/or hum and noise.

Microphonics is a term used to describe a tube's audible susceptibility to shock and vibration (whether acoustical or mechanical) due to loose mechanical elements inside the tube itself. This can be manifested as a ringing or pinging sound heard through your speakers when the component containing the microphonic tube(s) is touched (e.g. via front panel controls), exposed to severe mechanical vibration (e.g. foot stomps on the floor) or acoustical vibration (e.g. voices) in severe cases of microphony. Microphonics are often difficult to combat. Some solutions are to replace the microphonic tubes themselves, isolate the component containing the microphonics (via a compliant suspension), or use a commercially available compliant dampening ring on the tube itself to reduce the effects of minor vibration.

Also, it is important to note that tube quality will often vary between manufacturers – thus, some manufacturer's tubes carry a price premium. Moreover, tube prices can often vary depending on what you are actually buying – for example, you may buy raw, untested stock for one price or, the very same tube which has first been selected, tested and matched (via commercial or military tube testers or proprietary, computer-based, testing equipment) for a given set of characteristics, at another much higher price. However, given the application, your interest in doing the selecting yourself, and your budget,

these "premium" tubes may be more appropriate for your requirements. Trying different tube types is easy. First, find out what tubes are used in your system. Read your owner's manual or check out the tube sockets on the chassis – you'll frequently find the tube type marked for your convenience. Also, make a note of which tube types are installed in the unit for future reference.

Our best advice is to read the owner's manual that came with your equipment. Its designers know what works best in the equipment they crafted and there will probably be some valuable suggestions to follow.

When searching for alternative tubes, be aware that there are usually several different code designations – North American commercial (e.g. 6DJ8), European commercial (e.g. ECC88), manufacturer, military (JAN or JHS prefixes), industrial (e.g. 6922 or 7308) and special service application (e.g. STR prefix) – for each tube type. The following substitution chart will help:

Table 1

TUBE TYPE	ALTERNATES
12AX7	6681, 7025, 7729, ECC83, ECC803, E83CC
12AU7	5814, 5963, 6189, 6680, 7730, ECC82, ECC802, E82CC
12AT7	6201, 6679, 7728, CV4024, ECC81, ECC801, E81CC
6DJ8	6922, 7308, CV2492, ECC88, ECC808, E88CC
6SL7	6SU7, 5691*, 6188, ECC35, CV569, CV1985
6SN7	5692*, ECC32, CV1988
EL84	EL84M, 7189, 6BQ5
6CA7	EL34, E34L, KT77
6L6	5881, 5932, KT66*
6550	KT88, KT90, KT99, KT100

* These types should be checked for compatibility with the circuit they are intended to be used in as they consume higher filament current

Cooking at the Right Temperature: Biasing

Another factor to consider when changing tubes is bias. Briefly stated, bias is a voltage applied to a tube's grid to insure that the tube operates according to the designer's intentions. Bias is usually very important for output tubes in power amplifiers, and most amplifiers provide a means to adjust bias for best operation.

Remember George Orwell's famous book *Animal Farm*? If you do, you'll probably remember the classic statement, "All animals are equal but some animals are more equal than others." Unfortunately, all tubes are not the same. Subtle design differences, dissimilar materials, and manufacturing inconsistencies all contribute to the fact that even "matched" tubes are sometimes not perfectly identical.

Adjustable bias gives us a way to minimize the effects of these differences and to optimize each tube to work in sonic harmony with its peers. And there's a potential financial bonus here, too, as biasing makes the amplifier less dependent on expensive sets of closely matched tubes for optimum performance.

There are two types of bias adjustments: manual and automatic. Amplifiers with manual adjustments usually include a variable potentiometer for increasing or decreasing bias current and a way to monitor the current flow (with a meter or LED array).

Some amplifiers use what is called "cathode self-bias". This type of bias is somewhat misleading because, in order to obtain an optimum bias for each tube, both a DC balance and a bias adjustment are necessary. This operation is really no simpler than are conventional "fixed" bias adjustments. In fixed bias amplifiers (by far the most prevalent types) a simple bias adjustment is provided, usually for each individual tube. These amps have the advantage of greater measured power output as compared to cathode self-bias types.

Other amplifiers have automatic biasing in which the circuit automatically accommodates minor differences in tube properties. In most cases, a servo-mechanism or feedback comparator provides

these adjustments. In practice, these circuits often require internal adjustments to bring the tubes within a certain window of adjustment — especially when a new set of output tubes is installed. These internal adjustments are often more complicated than conventional adjustments! For this reason, servo-biasing is rarely seen in tube amplifiers.

If your amplifier has manual bias, you'll no doubt find detailed instructions in the owner's manual. In any case, don't worry — if you can turn on your kitchen stove, bias adjustment is not a challenge!

Keep 'em Fresh!

Nothing lasts forever but tubes operated at their rated voltage and current can and will last a long time, presuming, of course, that you start out with quality tubes.

Small signal tubes in particular will last for many years. Larger power tubes are also surprisingly long-lived but, because of their greater current consumption and heat generation, usually don't last as long as their smaller cousins.

Most tubes with dubious performance characteristics are weeded out before they leave the factory or by equipment manufacturers themselves before they're put into components. As tubes get older, they can start sounding softer and slightly less detailed. Tubes generally don't get old before their time. They have a life cycle very similar to humans. Their performance initially improves during the first few hundred hours, followed by an extended performance plateau region. Finally, after several thousand hours of use, they slowly f-f-fade away.

Running tubes outside their operational guidelines for voltage and current flow is the quickest way to insure their early demise. This usually happens for one of two reasons: it can be done deliberately (though ignorantly) through "over the edge" circuit designs that exceed a tube's SAO (Safe Area of Operation, aka "Design Maximum Rating"), or an internal component may unexpectedly fail and cease to maintain correct working conditions for the tube. Occasionally, a tube may self-destruct for no apparent reason.

To forestall this possibility, tubes ABSOLUTELY need adequate ventilation. Although this is true for ALL electronic components, it is particularly true for tube components as the amount of heat they generate is substantially higher than equivalent solid-state circuits. Tube power amplifiers in particular need unrestricted air flow and should generally not be placed in any small enclosed area.

Onion Ice Cream: Some Final Thoughts on the Transistor

In June, 1948, Bell Telephone Laboratories announced the development of a small device called the transistor that could duplicate practically all the functions of a vacuum tube while using far less energy (Fig. 36). The transistor was a truly staggering invention and earned its developers (Drs. William Shockley, John Bardeen, and Walter Brattain) the Nobel Prize for Physics in 1956.

Because of the transistor's small size, a whole new area of electronics opened up, allowing the development of such things as hearing aids, pocket radios, and other small devices that we now take for granted. Although the transistor has several advantages over the vacuum tube, these advantages are not necessarily beneficial in many audio applications, especially where size and power consumption are not major disadvantages.

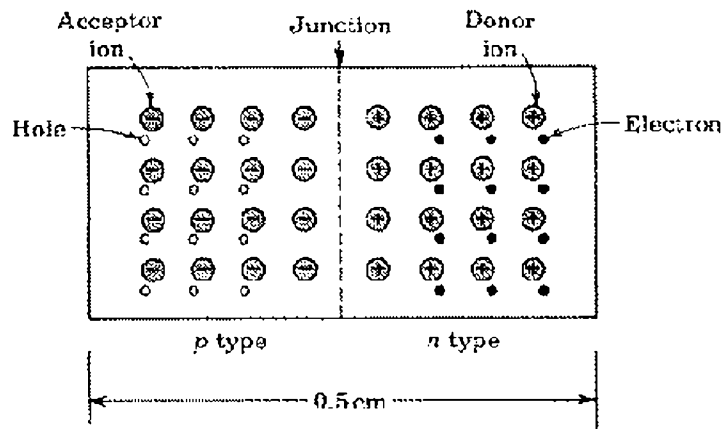

Fig. 36. Schematic diagram of a p-n junction.

Clearing the Table

In fact, tubes have several advantages over transistorized circuitry. Here's a summary for quick reference:

- Tubes produce predominantly low-order distortion. Transistors, in addition to low-order, produce greater levels of high-order distortion. Distortion which is low order is closer to the musical fundamental (e.g. 2nd or 3rd order harmonic), while high order is further away from the musical fundamental (e.g. 9th, 11th, 13th order harmonic). Although both are undesirable when reproducing an audio signal, high-order distortion products are the most objectionable as they are dissonant with (further away from the) musical fundamentals.
- Tubes have better manners. When pushed close to their power limits, all amplifiers “run out of steam” and sound quality generally deteriorates. Although different amplifiers behave differently in this regard, you can safely say that the sound gradually loses clarity and focus while becoming homogenized and strident. Tube circuits “lose their composure” far more gradually than do solid-state circuits and generally give you more coherent sound regardless of the music's dynamic range.

When pushed beyond their operating capabilities, all amplifiers limit, or clip, the output signal. Nonetheless, even under these extreme conditions, tube amplifiers usually exhibit far more tolerable behavior than solid-state components which often sound coarse and raspy when pushed. In contrast, tube amps are usually perceived to be more graceful, polite, and coherent while reproducing demanding musical peaks. This is one reason why many connoisseurs find that tube amps sound more powerful than similarly rated transistor amps – partially explaining the popular belief that “tube” watts are twice as powerful as “solid state” watts.

- Tube circuits are usually easier to repair. Although this might sound a bit strange at first, remember that tubes tend to age in a very gradual manner. Moreover, when there is a problem with a tube-based product, it is usually associated with the tube itself, not

the accompanying circuitry and thus, can be rectified by simply changing the tube. In addition, there are still a large number of tubes available to replace those originally used in components thirty years old! Even when you can't get original replacement types, chances are very good that there are equivalents still being made that will work just fine, thank you.

In contrast, transistors, even though fairly reliable, tend to fail in more catastrophic ways. They're more persnickety, too, in that they tend to be highly specialized devices that not only must be precisely matched in many cases, but in other cases must be replaced by the exact brand and type of transistor. If your component is more than ten years old, you may have real difficulty in getting the exact device you need to replace one that has failed. And don't forget the fact that tubes simply plug in! Compare that to the delicate soldering needed to replace defective transistors.

In fairness to transistors, they do have one tremendous advantage over tubes: they are complementary devices; i.e., there are two types of transistors, npn and pnp, that allow circuits to be designed that have zero DC offset at the output (this is known as "complementary symmetry"). They also have a low output impedance. These two factors allow transistors to drive loudspeakers directly without an output transformer. The quality of the output transformer thus becomes the key to high quality sound from tube amps.



Tube Futures

Tubes have a bright future!

They precipitated the electronics revolution and have a rich heritage dating back to the turn of the century. As the new millennium approaches, vacuum tube audio technology is still developing and prospering to levels of popularity greater than at any time over the last 25 years. Modern tube designs provide a level of musicality and performance which is unobtainable by any other electronic means, uniquely preserving the visceral emotional experience in the process.

There are dozens of manufacturers of tube (or valve) equipment offering you, the audio enthusiast, an almost limitless combination of design approaches, tube types, sonic flavors and price points. Therefore, given this richness of choice, there is bound to be a product which will suit your particular taste and budget.

We hope that this connoisseur's guide will contribute, in some small way, to the ongoing future of tube audio by giving you the background, knowledge and tools to fully appreciate, and participate in, this often passionate pursuit. The final, and most valuable test is to listen to your favorite music through a tube-based system or component.

When choosing tube gear for your system, some of the factors you will want to consider in your evaluation should include:

- does the design use commonly available tubes?
- has the manufacturer adopted a conservative design approach?
- does the unit look well built inside and exude craftsmanship outside?
- does the unit use high quality, brand name parts throughout the design?
- do I like the sound of the unit with MY equipment in MY home?
- does the manufacturer extend a reasonable warranty commensurate with the equipment's purchase price?

We hope you will enjoy the richly satisfying sound that tubes, at their best, can bring to your musical listening experience.

FOOD FOR THOUGHT



Bibliography

Basic Electronics and High Fidelity Techniques

Norman Crowhurst, *Understanding Hi-Fi Circuits* (Gernsback Library, Inc., NY, 1957)

Bernard Grob, *Basic Electronics* (McGraw-Hill, Inc., NY, 1959)

Robert Harley, *The Complete Guide to High-End Audio* (Acapella Publishing, Albuquerque, NM, 1995)

H.A. Hartley, "Aesthetics of Sound Reproduction" (*Wireless World*, Jul/Aug, 1944)

Henry Jacobowitz, *Electronics Made Simple* (Doubleday & Co., Inc., NY, 1958)

Walter G. Jung and Richard Marsh, "Picking Capacitors" (*Audio*, 64:2&3, 1980; Feb pp. 52-62; Mar pp. 50-62)

John H. Newitt, *High Fidelity Techniques* (Rinehart & Co., Inc., NY, 1958)

Circuits and Circuit Design

W.T. Cocking, "High Quality Amplification" (*Wireless World*, May 4, 1934, 34.18, pp. 302-304)

W.T. Cocking, "Phase-Splitting in Push-Pull Amplifiers" (*Wireless World*, Apr 13, 1939, pp. 340-344)

N.H. Crowhurst, "Output Transformer Specifications" (*Audio*, Jun 1957, pp. 20-23, cont. pp. 51-52)

J.L. Daley, ed., *Principles of Electronics and Electronic Systems* (United States Naval Institute, Annapolis, MD, 1956)

J.R. Edinger, "High-Quality Audio Amplifier with Automatic Bias Control" (*Audio Eng.*, Jun 1947, pp. 7-9, cont. p. 41)

Scott Frankland, "Single-Ended vs Push-Pull" (*Stereophile*, Dec 1996, Jan 1997, Feb 1997)

Irving M. Gottlieb, *Regulated Power Supplies* (TAB Books, Blue Ridge Summit, PA, 4th ed., 1992)

David Hafler and Herbert I. Keroes, "An Ultra-Linear Amplifier" (*Audio Eng.*, Nov 1951, pp. 15-17)

David Hafler and Herbert I. Keroes, "Ultra-Linear Operation of the Williamson Amplifier" (*Aud. Eng.*, Jun 1952)

F. Langford-Smith and A.R. Chesterman, "Ultra Linear Amplifiers" (*Radiotronics*, 20:5/6/7, May/Jun/Jul 1955)

F. Langford-Smith, ed., *Radiotron Designer's Handbook* (Amalgamated Wireless Valve Co. Pty. Ltd., Sydney, Australia, 4th ed., 1953)

J.D. Ryder, *Engineering Electronics* (McGraw-Hill, Inc., NY, 1957)

D.T.N. Williamson, "Design for a High Quality Amplifier" (*Wireless World*, Apr 1947, pp. 118-121; May 1947)

History

Henry B.O. Davis, *Electrical and Electronic Technologies: A Chronology of Events and Inventors from 1900 to 1940* (The Scarecrow Press, Inc., Metuchen, NJ, and London, 1983)

M.D. Fagen, ed., *A History of Engineering and Science in the Bell System, the Early Years (1875-1925)* (Bell Telephone Laboratories, Inc., 1975)

W. Rupert MacLaurin and R. Joyce Harman, *Invention and Innovation in the Radio Industry* (MacMillan Co., NY, 1949)

George Shiers, *Bibliography of the History of Electronics* (The Scarecrow Press, Inc., Metuchen, NJ, 1972)

Psychoacoustics and Distortion Products

D.E.L. Shorter, "The Influence of High-Order Products in Non-Linear Distortion," (*Electronic Eng.*, Apr 1950, pp. 152-153)



Harry F Olson, *Music, Physics, and Engineering* (Dover Pubs., Inc., NY, 1967)

Fritz Winckel, *Music, Sound, and Sensation* (Dover Pub., Inc., NY, 1967)

Reference Books

Norman Crowhurst, *Audio Measurements* (Gernsback Library, Inc., NY, 1958)

Rudolf F. Graf, *Dictionary of Electronics* (Howard W. Sams & Co., Inc., NY, 1962)

The Howard W. Sams Engineering Staff, *Tube Substitution Handbook* (Indianapolis, IN, 1973)

Bill Perkins, *The PEARL Archive* (Perkins Electro-Acoustic Research Laboratory, Calgary, Alberta, Canada, 1996). This is a prime resource for books and articles about tube circuits.

John W. Stokes, *70 Years of Radio Tubes and Valves* (1992). A gorgeous gallery of tube photography and lore. An indispensable resource for tube collectors.

World Tube Directory, (Glass Audio, Peterborough, NH, 1996). This directory is a prime resource for tube-related parts and equipment world-wide.

Tube Physics and Manufacturing

A.R. Balaton , "Tube Manufacturing at Western Electric: The WE 300B" (J. Audio Eng. Soc., 37:11, Nov 1989, pp. 950-958)

L.R. Koller, *The Physics of Electron Tubes* (McGraw-Hill Book Co., Inc., NY, 1934)

O.H. Schade, "Beam Power Tubes" (Proc. IRE, 26.2, Feb 1938, pp. 162-176)

Karl R. Spangenberg, *Vacuum Tubes* (McGraw-Hill Book Co., Inc., NY, 1948)

BITS & BYTES





How To Reach Us

SONIC FRONTIERS, INC.
2790 Brighton Road
Oakville, Ontario,
Canada. L6H 5T4.

Phone: (905) 829-3838
Fax: (905) 829-3033
E-Mail: SFI@sonicfrontiers.com
Website: www.sonicfrontiers.com

THE PARTS CONNECTION

2790 Brighton Road
Oakville, Ontario,
Canada. L6H 5T4.

Phone: (905) 829-5858
Fax: (905) 829-5388
E-Mail: TPC@sonicfrontiers.com
Website: www.sonicfrontiers.com/TPC

Special Thanks...

...to the technical staff at Sonic Frontiers for testing all the recipes, Scott Frankland for stirring the beaucoup spice into the technical ingredients, and TechniCom Corporation for beating the lumps out of the verbal gravy.

Scott Frankland's E-Mail:
audioeng@ix.netcom.com

TechniCom's E-Mail:
74437.3642@compuserve.com

SONIC FRONTIERS, INC. is the Manufacturer
OF THE



COPYRIGHT AUGUST 1997

