

# RADIO OPERATING QUESTIONS AND ANSWERS

**J. L. Hornung**

*Commander, United States Naval Reserve  
Supervisor, Radio Electronics, Walter Hervey Junior College  
New York, N. Y.; Senior Member Institute of Radio  
Engineers; Formerly Officer-in-Charge, Naval Training  
School (Radar), Massachusetts Institute of Tech-  
nology, Boston, Mass.*

TENTH EDITION  
THIRD IMPRESSION

NEW YORK TORONTO LONDON  
**McGRAW-HILL BOOK COMPANY, INC.**  
1950

RADIO OPERATING  
QUESTIONS AND ANSWERS

Copyright, 1921, 1929, 1930, 1932, 1933, 1936, 1940, 1946, 1948, 1950,  
by the McGraw-Hill Book Company, Inc. Printed in the United States  
of America. All rights reserved. This book, or parts thereof, may not  
be reproduced in any form without permission of the publishers.

The opinions or assertions contained herein  
are not to be construed as official or reflect-  
ing the views of the Navy Department or the  
Naval service at large.

THE MAPLE PRESS COMPANY, YORK, PA.

## PREFACE TO THE TENTH EDITION

This new edition of Radio Operating Questions and Answers has been prepared especially to cover the new examination questions recently released by the Federal Communications Commission for the radiotelegraph and radiotelephone operators' license examinations.

The new questions for both the telephone and telegraph examinations have been revised and expanded both in theory and practice to include frequency modulation, television, antenna systems, radar, loran, aircraft radio telegraph and marine operational procedure. Elements II, III, IV, V, VI, and VII now include many new questions and also show a revision and deletion of many questions previously asked in the examination.

In view of the wide scope of these new examinations and the many mathematical problems which have been included, all readers are urged to expand their knowledge by a careful review of electrical and radio fundamentals, with special emphasis on the new specialties such as radar, loran, frequency modulation, and television. Careful consideration should be given by the new student to complete some course in basic theory and operation in a reputable correspondence or residence school. Radio theory and operation in its various phases cannot be successfully mastered by the use of a question and answer book alone. It is not fair to the individual nor to the industry as a whole to expect it.

A new feature of this text is the inclusion of a special problem section comprising 45 questions and answers relating to the more advanced problems in general theory, radar, and loran. These questions have been designed so as to give the student a working knowledge towards a better understanding of these new subjects in order to cope with possible variations or interpretations in the actual examination questions.

The author wishes to acknowledge with gratitude the valuable suggestions and collaboration given by the faculty of the Walter Hervey Junior College, the engineering staff of the Cleveland Institute of Radio Electronics, and to Mr. Alex McKenzie of the Electronics staff of the McGraw-Hill Publishing Company in the preparation of this new edition.

The author also gratefully acknowledges the valuable assistance rendered by the American Airlines, La Guardia Field, New York Airport Station, New York; Bendix Aviation Corporation, Baltimore, Md.; Eclipse-Pioneer Division (Bendix) Teterboro, New Jersey; Federal Telecommunication Laboratories, Inc., Nutley, New Jersey; Collins Radio Company, Cedar Rapids, Iowa, and the Sperry Gyroscope Company, Great Neck, New York.

J. L. HORNING

VALLEY STREAM, N.Y.

*December, 1949*

## PREFACE TO THE NINTH EDITION

This edition includes a new Addenda section especially designed to cover the new supplementary elements recently released by the Federal Communications Commission for the radio-television license examinations for the broadcast service.

These new supplementary questions have been added by the FCC to the present Elements 2, 3, and 4 with the specific objective of expanding the scope of the radio-broadcast-operator's examinations to include standard and FM practical-broadcast operation, technical-broadcast theory and practice, and advanced broadcast theory and practice as related to the operation, adjustment, and maintenance of AM, FM, and television, including special antenna systems.

In view of the wide scope of these new examinations, all readers are urged to expand their knowledge on the technical aspects of all questions by the free use of standard reference textbooks, particularly those related to the field of FM and television. Each reader is also strongly urged to procure from the FCC rules, regulations, and information on good engineering practice\* regarding the operation of all broadcast stations.

The author wishes to acknowledge with gratitude the valuable suggestions given by the engineering staff of the Cleveland Institute of Radio Electronics and the Walter Hervey Junior College in the preparation of these new supplements.

\* These are now procurable from the Superintendent of Documents, Government Printing Office, Washington, D.C., at a nominal cost.

J. L. HORNING

VALLEY STREAM, N.Y.  
*September, 1948*



## CONTENTS

	PAGE
<i>Preface to the Tenth Edition.</i> . . . . .	v
<i>Preface to the Ninth Edition.</i> . . . . .	vii
<i>How to Use This Book.</i> . . . . .	xi
 <b>ELEMENT</b>	
✓ 1. Basic Radio Laws . . . . .	1
✓ 2. Basic Theory and Practice. . . . .	18
3. Radiotelephone . . . . .	102
4. Advanced Radiotelephony. . . . .	180
✓ 5. Radiotelegraph. . . . .	266
✓ 6. Advanced Radiotelegraphy . . . . .	338
7. Aircraft Radio. . . . .	427
Special Study Problem Section . . . . .	512
Appendix I. Operating Abbreviations . . . . .	541
Appendix II. Rules Governing Commercial Radio Operators . . . . .	553
Appendix III. Extracts from Radio Laws. . . . .	563
<i>Index of Diagrams and Illustrations</i> . . . . .	575
<i>Index of Subjects</i> . . . . .	579





## HOW TO USE THIS BOOK

Many old-time students of radio and many uninformed new students will need to approach radio-operator license preparation from a new viewpoint. Prior to July, 1939, when the so-called "new" examinations went into effect, preparation for a radio-operator license examination consisted mostly of learning the answers to certain standard well-known questions, the answers to which were easily available in published form to anyone. The disadvantages of this system were apparent to the examiners and to others who felt that the government examinations should be a real test of the applicant's knowledge and not a test of his ability to memorize answers. The revised examination procedure was evolved to correct this condition.

Under the new plan a publication entitled "Study Guide and Reference Material for Commercial Radio Operator Examinations" was issued by the Federal Communications Commission. In that book there were presented to the radio-license applicant approximately 1850 questions covering the entire scope of knowledge required of licensed radio operators. It is to be noticed that only the scope of the required knowledge was made available therein to all interested persons.

On the basis of this scope of knowledge a series of multiple-choice-type examinations was prepared from which certain sheets are selected to constitute an examination. Thus a great number of different examinations are available, all covering the same scope of knowledge. The student of this book should not be surprised, therefore, if the questions he meets on the examination are worded differently or approach the subject from a different angle from that given in the answers in this book. For example, Question 74 in Element 5 in the FCC's Study Guide reads, "Describe a superregenerative receiver." Obviously a multiple-choice question could

not be worded similarly. Instead, the multiple-choice question might read, "What is the purpose of the quench frequency?" This would be followed by five answers from which the correct answer must be picked. The applicant whose radio education and preparation have been guided by the Study Guide basic question, "Describe a superregenerative receiver," and the answer as given herein should have no difficulty with this question.

It is evident, therefore, that the questions in the FCC's Study Guide and their answers as given herein are, as the name of their source book implies, merely a guide to study. They are not intended to be replicas of the actual questions that the applicant will meet on the examination. Whereas the actual number of study-guide questions provided by the FCC totals almost 1900, it is possible that there may be three or four times that number available on the actual examinations.

The student preparing for a specific type of license should avail himself of the FCC Study Guide and the necessary supplementary Rules and Regulations pertinent to the particular field in which he is endeavoring to qualify. A complete listing of pamphlets, available at small cost, may be procured from the Superintendent of Documents, United States Government Printing Office, Washington, D.C.

It is hoped that the readers of this book will use it for what it was intended, that is, as a review of technical radio information for radio-operator license-examination preparation or any similar purpose. The man who has a good basic training in radio communication will find this book invaluable for reference and review purposes, according to the testimony of a very great many satisfied readers.

THE AUTHOR

# RADIO OPERATING QUESTIONS AND ANSWERS

## ELEMENT 1

### BASIC RADIO LAWS

**Ques. 101.01.<sup>1</sup>** Under what conditions may a distress message be retransmitted?

*Ans.* Any station which becomes aware that a mobile station is in distress may transmit the distress message in the following cases:

1. When the station in distress is not itself in a position to transmit the message.

2. In the case of mobile stations, when the master or the person in charge of the ship, aircraft, or other vehicle carrying the station which intervenes believes that further help is necessary.

3. In the case of other stations, when directed to do so by the station in control of distress traffic or when it has reason to believe that a distress call which it has intercepted has not been received by any station in a position to render aid.

**Ques. 101.02.** What tolerance in operating power is permissible under normal circumstances?

*Ans.* The operating power of all radio stations shall be maintained within the following tolerance of the assigned power:

<sup>1</sup> In the government publication, "Study Guide and Reference Material for Commercial Radio Operator Examinations," Ques. 101.01 to 101.05, inclusive, appear at the end of Element 1 instead of at the beginning.

## RADIO OPERATING QUESTIONS AND ANSWERS

1. When the maximum power only is specified, the operating power shall not be greater than necessary to carry on the service and in no event more than 5 per cent above the maximum power specified.

2. When an exact power is specified, the operating power shall not be more than 5 per cent above or less than 10 per cent below such power.

**Ques. 101.03.** Under what conditions may a station be operated in a manner other than that specified in the station license?

*Ans.* The licensee of any station, except amateurs, may, during a period of emergency in which the normal communication facilities are disrupted as a result of hurricane, flood, earthquake, or similar disaster, utilize such station for emergency communication service in communicating in a manner other than that specified in the station license, provided (1) that as soon as possible after the beginning of such emergency use notice be sent to the Federal Communications Commission (FCC) in Washington, D. C., and to the Inspector in Charge of the district in which the station is located stating the nature of the emergency and the use to which the station is being put, and (2) that the emergency use of the station shall be discontinued as soon as substantially normal communication facilities are again available and the Commission in Washington, D. C., and the Inspector in Charge be notified immediately when such special use of the station is terminated. The Commission may at any time order the discontinuance of such service.

**Ques. 101.04.** What is the Commission's rule with respect to measurement of the radio station frequency?

*Ans.* The licensee of each station shall provide means for the measurement of the station frequency. The measurement of the station frequency shall be made by a means independent of the frequency control of the transmitter and shall be

conducted in accord with the regulations governing the class of station concerned.

**Ques. 101.05.** When may operation be resumed after a station has been notified to cease transmission because of interference to distress traffic?

*Ans.* No station having been notified to cease operation shall resume operation on frequency or frequencies which may cause interference until notified by the station issuing the original notice that the station involved will not interfere with distress traffic as it is then being routed or until the receipt of a general notice that the need for handling distress traffic no longer exists.

**Ques. 111.01.** State five grounds on any one of which the FCC has authority to suspend a radio operator's license or permit.

*Ans.* The FCC has authority to suspend the license of any operator upon proof sufficient to satisfy the Commission that the licensee—

1. Has violated any provision of any act, treaty, or convention binding on the United States, which the Commission is authorized to administer, or any regulation made by the Commission under any such act, treaty, or convention; or

2. Has failed to carry out a lawful order of the master or person lawfully in charge of the ship or aircraft on which he is employed; or

3. Has willfully damaged or permitted radio apparatus or installations to be damaged; or

4. Has transmitted superfluous radio communications or signals or communications containing profane or obscene words, language, or meaning, or has knowingly transmitted—

a. False or deceptive signals or communications, or

b. A call signal or letter which has not been assigned by proper authority to the station he is operating; or

## RADIO OPERATING QUESTIONS AND ANSWERS

5. Has willfully or maliciously interfered with any other radio communications or signals; or

6. Has obtained or attempted to obtain, or has assisted another to obtain or attempt to obtain, an operator's license by fraudulent means.

**Ques. 111.02.** Is an operator subject to the penal provisions of the Act if he violates the terms of a radio treaty to which the United States is a party?

*Ans.* Any person who willfully and knowingly violates any rule, regulation, restriction, or condition made or imposed by the Commission under authority of this Act, or any rule, regulation, restriction, or condition made or imposed by any international radio or wire communications treaty or convention, or regulations annexed thereto, to which the United States is or may hereafter become a party, shall, in addition to any other penalties provided by law, be punished, upon conviction thereof, by a fine of not more than \$500 for each and every day during which such offense occurs.

**Ques. 111.03.** State at least two provisions made in the Communications Act to ensure the priority of communications or signals relating to ships in distress.

*Ans.* All radio stations, including Government stations and stations on board foreign vessels when within the territorial waters of the United States, shall give absolute priority to radio communications or signals relating to ships in distress; shall cease all sending on frequencies which will interfere with hearing a radio communication or signal of distress, and, except when engaged in answering or aiding the ship in distress, shall refrain from sending any radio communications or signals until there is assurance that no interference will be caused with the radio communications or signals relating thereto, and shall assist the vessel in distress, as far as possible, by complying with its instructions.

Stations in the mobile service shall be obliged to accept, with absolute priority, distress calls and messages regardless of their origin, to reply to them in the same manner, and to take any necessary action on them immediately.

**Ques. 111.04.** In what class of radio station and under what conditions is an operator permitted to adjust the transmitter for a maximum of radiation without regard to the interference produced?

*Ans.* The transmitting set in a radio station on shipboard may be adjusted in such a manner as to produce a maximum of radiation, irrespective of the amount of interference which may thus be caused, when such station is sending distress communications or signals or communications relative thereto.

**Ques. 111.05.** In what cases may a transmitter on shipboard be adjusted to produce a maximum of radiation irrespective of the interference which may be caused?

*Ans.* (See answer to Ques. 111.04.)

**Ques. 121.01.** What communications, if any, are not subject to the secrecy provisions of the Communications Act?

*Ans.* Any radio communication broadcast, or transmitted by amateurs or others for the use of the general public, or relating to ships in distress.

**Ques. 121.02.** State in your own words the prohibition, if any, against the transmission of false calls and communications relating to distress.

*Ans.* No person within the jurisdiction of the United States shall knowingly utter or transmit, or cause to be uttered or transmitted, any false or fraudulent signal of distress, or communication relating thereto.

**Ques. 121.03.** State in your own words the law regarding the transmission of false or fraudulent signals of distress or communications relating thereto.

*RADIO OPERATING QUESTIONS AND ANSWERS*

*Ans.* (See preceding answer for basic law.)

**Ques. 121.04.** State in your own words the substance of the Communications Act that is provided to ensure the secrecy of radiograms.

*Ans.* In general the law provides that no one receiving a radio or wire message not intended for the public shall divulge it to anyone except the addressee or his authorized agent or to another station for forwarding, unless required to do so by a court of competent jurisdiction, and no one not entitled to it shall receive any radio or wire communication and use it for his own benefit. The penalty is a fine not exceeding \$10,000 or imprisonment for a term not exceeding 2 years, or both.

**Ques. 121.05.** Does the Communications Act of 1934, as amended, contain any provision that prohibits the interception, use, and publication of radio communications?

*Ans.* Yes. (See answer to Ques. 121.04 for basic law.)

**Ques. 131.01.** What form of language if transmitted by an operator or other person makes him subject to the penal provisions of the Communications Act?

*Ans.* Nothing in this Act shall be understood or construed to give the Commission the power of censorship over the radio communications or signals transmitted by any radio station, and no regulation or condition shall be promulgated or fixed by the Commission which shall interfere with the right of free speech by means of radio communication. No person within the jurisdiction of the United States shall utter any obscene, indecent, or profane language by means of radio communication.

**Ques. 131.02.** What provisions are made in the Communications Act to ensure intercommunication between stations in the mobile service?



*Ans.* Every land station open to general public service between the coast and vessels or aircraft at sea shall, within the scope of its normal operations, be bound to exchange radio communications or signals with any ship or aircraft station at sea; and each station on shipboard or aircraft at sea shall, within the scope of its normal operations, be bound to exchange radio communications or signals with any other station on shipboard or aircraft at sea or with any land station open to general public service between the coast and vessels or aircraft at sea: PROVIDED, That such exchange of radio communication shall be without distinction as to radio systems or instruments adopted by each station.

**Ques. 131.03.** Does the FCC have authority to issue a radio operator's license or permit to a citizen of a country other than the United States?

*Ans.* No.

**Ques. 131.04.** Has the master of a ship radiotelephone station the authority to forbid the transmission of a message by anyone on board?

*Ans.* Yes. The radio installation, the operators, the regulation of their watches, the transmission and receipt of messages, and the radio service of the ship, except as they may be regulated by law or international agreement, or by rules and regulations made in pursuance thereof, shall in the case of a ship of the United States be under the supreme control of the master.

**Ques. 131.05.** Has the master of a ship station the authority to regulate the transmissions and reception of messages on shipboard?

*Ans.* Yes. (See preceding answer for basic law.)

**Ques. 131.06.** Under what conditions is the utterance or transmission of a false or fraudulent signal of distress or communications relating thereto permissible?

RADIO OPERATING QUESTIONS AND ANSWERS

*Ans.* (See answer to Ques. 121.02 for basic law.)

**Ques. 131.07.** Under what conditions is the utterance of obscene, indecent, or profane language by means of radio communication permissible?

*Ans.* Under no conditions. (See answer to Ques. 131.01 for basic law.)

**Ques. 141.01.** What is the radiotelephony safety signal?

*Ans.* In radiotelephony, the word SECURITY (corresponding to the French pronunciation of the word *sécurité*) repeated three times shall be used as the safety signal.

**Ques. 141.02.** Under what conditions may a mobile station, if necessary, disregard the General Radio Regulations (Cairo)?

*Ans.* No provision of these Regulations shall prevent a mobile station in distress from using any means available to it for drawing attention, signaling its position, and obtaining help.

**Ques. 141.03.** What is the radiotelephony urgent signal?

*Ans.* In radiotelephony the urgent signal shall consist of three transmissions of the expression PAN (corresponding to the French pronunciation of the word *panne*); it shall be transmitted before the call.

**Ques. 141.04.** What signals and messages are forbidden by international agreement?

*Ans.* The transmission of unnecessary or unidentified signals or correspondence shall be forbidden to all stations.

**Ques. 141.05.** What precaution must an operator observe before proceeding with a transmission?

*Ans.* Before transmitting, any station must keep watch over a sufficient interval to assure itself that it will cause no

harmful interference with the transmissions being made within its range; if such interference is likely, the station shall await the first stop in the transmission which it may disturb.

**Ques. 141.06.** What does the receipt of the signal PAN transmitted by radiotelephony indicate?

*Ans.* The urgent signal (PAN) shall indicate that the calling station has a very urgent message to transmit concerning the safety of a ship, an aircraft, or another vehicle, or concerning the safety of some person on board or sighted from on board.

**Ques. 141.07.** What should an operator do if he intercepts the word SECURITY repeated three times?

*Ans.* All stations hearing the safety signal must continue listening on the wave on which the safety signal has been sent until the message so announced has been completed; they must moreover keep silence on all waves likely to interfere with the message.

**Ques. 141.08.** Under what circumstances may the signal SECURITY be transmitted in radiotelephony?

*Ans.* The safety signal (SECURITY) announces that the station is about to transmit a message concerning the safety of navigation or giving important meteorological warnings. Hence, it should precede such a transmission.

**Ques. 141.09.** The urgent signal sent by an aircraft and not followed by a message indicates what?

*Ans.* In the aeronautical service, the urgent signal PAN shall be used in radiotelegraphy and in radiotelephony to indicate that the aircraft transmitting it is in trouble and is forced to land, but that it is not in need of immediate help. This signal should, as far as possible, be followed by a message giving additional information.

**Ques. 141.10.** What obligation rests on an operator intercepting the signal PAN?

*Ans.* The urgent signal shall have priority over all other communications, except distress communications, and all mobile or land stations hearing it must take care not to interfere with the transmission of the message which follows the urgent signal.

**Ques. 151.01.** What procedure must be followed by a radio station receiving a distress call from a mobile station which is unquestionably in its vicinity?

*Ans.* Stations of the mobile service which receive a distress message from a mobile station which is unquestionably in their vicinity, must acknowledge receipt thereof at once. If the distress call has not been preceded by an auto-alarm signal, these stations may transmit this auto-alarm signal with the authorization of the authority responsible for the station, taking care not to interfere with the transmission of the acknowledgment of the receipt of said message by other stations.

**Ques. 151.02.** What essential information should be transmitted in a distress message?

*Ans.* The distress call must be followed as soon as possible by the distress message. This message shall include the distress call followed by the name of the ship, aircraft, or the vehicle in distress, information regarding the position of the latter, the nature of the distress and the nature of the help requested, and any other further information which might facilitate this assistance.

**Ques. 151.03.** By what authority may the operator of a ship or aircraft station transmit a distress call or message?

*Ans.* The distress call and message shall be sent only by order of the master or person responsible for the ship, aircraft, or other vehicle carrying the mobile station.

**Ques. 151.04.** What is the international distress signal to be used in radiotelephony?

*Ans.* In radiotelephony, the distress signal shall consist of the spoken expression MAYDAY (corresponding to the French pronunciation of the expression *m'aider*).

**Ques. 151.05.** What does the interception of the word MAYDAY transmitted by telephony announce?

*Ans.* These distress signals shall announce that the ship, aircraft, or any other vehicle which sends the distress signal is threatened by serious and imminent danger and requests immediate assistance.

**Ques. 151.06.** What radio waves may be used under the provisions of the Treaty in transmitting distress messages in case of an emergency by aircraft stations?

*Ans.* Any aircraft in distress must transmit the distress call on the watching wave of the land or mobile stations capable of helping it; when the call is addressed to stations of the maritime service, the waves to be used are the distress wave or watching wave of these stations.

**Ques. 151.07.** State the priority of radio communications in the mobile service.

*Ans.* The order of priority of radio communications in the mobile service shall be as follows:

1. Distress calls, distress messages, and distress traffic.
2. Communications preceded by an urgent signal.
3. Communications preceded by a safety signal.
4. Communications relative to radio direction-finding bearings.
5. Government radiotelegrams for which priority right has not been waived.
6. All other communications.

## RADIO OPERATING QUESTIONS AND ANSWERS

**Ques. 151.08.** What information must be contained in a distress message transmitted in an emergency, from a radio station aboard aircraft flying over land?

*Ans.* As a general rule, an aircraft flying over land shall signal its position by the name of the nearest locality, its approximate distance from this point, accompanied according to the case, by one of the words NORTH, SOUTH, EAST, or WEST, or, in some cases, words indicating intermediate directions.

**Ques. 151.09.** What information must be contained in a distress message?

*Ans.* (See answer to Ques. 151.02 for basic law.)

**Ques. 151.10.** When, after having sent its distress message, an aircraft station is unable to signal its position, what procedure shall be followed to assist others in determining its approximate location?

*Ans.* When, in its distress message, an aircraft is unable to signal its position, it shall endeavor after the transmission of the incomplete message to send its call signal long enough so that the radio direction-finding stations may determine its position.

**Ques. 161.01.** State at least two classes of stations which cannot be operated by the holder of a restricted radiotelephone operator permit.

*Ans.* Standard Broadcast Stations and ship stations aboard compulsorily equipped ships.

**Ques. 161.02.** Under what conditions may the holder of a restricted radiotelephone operator's permit operate a station for which the permit is valid?

*Ans.* The holder of a *restricted radiotelephone operator's permit* may operate any station while using type A0, A3, or A4 emission; provided that—

1. Such operator is prohibited from making adjustments that may result in improper transmitter operation.

2. The equipment is so designed that none of the operations necessary to be performed during the course of normal rendition of service may cause off-frequency operation or result in any unauthorized radiation.

3. Any needed adjustments of the transmitter that may affect the proper operation of the station are regularly made by or in the presence of an operator holding a first- or second-class license, either telephone or telegraph, who shall be responsible for the proper operation of the equipment.

**Ques. 161.03.** State at least two classes of ship stations which the holder of a restricted radiotelegraph operator permit is prohibited from operating.

*Ans.* The permit is not valid for the operation of a ship station licensed to use type A3 emission for communication with coastal telephone stations.

The license [permit] is not valid for the operation of a radiotelegraph station on board a vessel required by treaty or statute to be equipped with a radio installation.

**Ques. 161.04.** Who is permitted to make adjustments or tests in the presence of the licensed operator responsible for the maintenance of the transmitter and under his responsibility for the proper operation of the equipment?

*Ans.* The licensed operator responsible for the maintenance of a transmitter may permit other persons to adjust a transmitter in his presence for the purpose of carrying out tests or making adjustments requiring specialized knowledge or skill, provided that he shall not be relieved thereby from responsibility for the proper operation of the equipment.

**Ques. 161.05.** Within what period of time must any person receiving official notice of a violation of the terms of the Com-

## RADIO OPERATING QUESTIONS AND ANSWERS

munications Act of 1934, as amended, Treaty, or Rules and Regulations of the Commission be answered?

*Ans.* Within 3 days.

**Ques. 171.01.** What is the obligation of an operator whose license or permit has been lost, mutilated, or destroyed?

*Ans.* An operator whose license or permit has been lost, mutilated, or destroyed shall immediately notify the Commission. A sworn application for duplicate should be submitted to the office of issue embodying a statement attesting to the facts thereof. If a license has been lost, the applicant must state that reasonable search has been made for it, and further, that in the event it be found either the original or the duplicate will be returned for cancellation. The applicant must also give a statement of the service that has been obtained under the lost license.

**Ques. 171.02.** How may the holder of a radiotelegraph or radiotelephone first- or second-class license indicate to representatives of the Commission that he is legally qualified to adjust equipment operated by holders of restricted radiotelephone operator permits?

*Ans.* The holder of a radiotelegraph or radiotelephone first- or second-class license who is employed as a service and maintenance operator at stations operated by holders of restricted operator permits shall post at such station his operator license or a verified statement from the Commission in lieu thereof.

**Ques. 171.03.** How may an operator show proof of his legal qualifications to operate a radio transmitter?

*Ans.* The original license of each station operator shall be posted at the place where he is on duty or kept in his possession in the manner specified in the regulations governing the class of station concerned.



**Ques. 171.04.** What is an operator of a radio station, who has submitted his license for renewal or applied for a duplicate license, required to exhibit as his authority to continue operation on the station, pending receipt of the license?

*Ans.* When a duplicate operator license or permit has been requested, or request for renewal upon service has been made, the operator shall exhibit in lieu thereof a signed copy of the application for duplicate, or renewal, which has been submitted by him.

**Ques. 171.05.** What is the holder of a radiotelegraph or radiotelephone first- or second-class license, who is employed as a service and maintenance operator at stations operated by holders of restricted operator permits, obligated to post at the stations?

*Ans.* (See answer to Ques. 171.02 for rule.)

**Ques. 181.01.** How may corrections be made in a log?

*Ans.* Any necessary correction may be made only by the person originating the entry who shall strike out the erroneous portion, initial the correction made, and indicate the date of correction.

**Ques. 181.02.** Is it lawful to erase an entry made in a station log?

*Ans.* No log or portion thereof shall be erased, obliterated, or willfully destroyed within the period of retention provided by the rules.

**Ques. 181.03.** What are the Commission's requirements with regard to the retention of a radio station log?

*Ans.* Logs of a radio station, when required in the rules and regulations to be made or kept, shall be retained by the licensee for a period of one year unless otherwise provided by the rules governing the particular service or class of station concerned.

*RADIO OPERATING QUESTIONS AND ANSWERS*

**Ques. 181.04.** How long must the licensee retain a station log which involves communications incident to a disaster?

*Ans.* Logs involving communications incident to a disaster or which include communications incident to or involved in an investigation by the Commission and concerning which the licensee has been notified, shall be retained by the licensee until specifically authorized in writing by the Commission to destroy them: PROVIDED, FURTHER, That logs incident to or involved in any claim or complaint of which the licensee has notice shall be retained by the licensee until such claim or complaint has been fully satisfied or until the same has been barred by statute limiting the time for the filing of suits upon such claims.

**Ques. 181.05.** What is the Commission's rule with regard to rough logs?

*Ans.* Rough logs may be transcribed into condensed form, but in such case the original log or memoranda and all portions thereof shall be preserved and made a part of the complete log.

**Ques. 191.01.** What procedure should one follow if he desires to resist an order of suspension of his operator's license or permit?

*Ans.* Make written application to the Commission at any time within 15 days for a hearing upon the order of suspension.

**Ques. 191.02.** What is the responsibility of a licensee of a radio station with respect to permitting it to be inspected by representatives of the Commission?

*Ans.* The licensee of any radio station shall make the station available for inspection by representatives of the Commission at any reasonable hour and under the regulations governing the class of station concerned.

**Ques. 191.03.** Who is responsible for the control of distress traffic?

*Ans.* The control of distress traffic shall devolve upon the mobile station in distress or upon the station which by application of the provisions . . . [See Ques. 101.01] has sent the distress call. These stations may delegate the control of the distress traffic to another station.

**Ques. 191.04.** Are logs subject to inspection by representatives of the Commission?

*Ans.* Yes. (See answer to next question.)

**Ques. 191.05.** By whom may the log of a radio station be kept?

*Ans.* Each log shall be kept by the person or persons competent to do so, having actual knowledge of the facts required, who shall sign the log when starting duty and again when going off duty. The logs shall be made available upon request by an authorized representative of the Commission.

## ELEMENT 2

### BASIC THEORY AND PRACTICE

**Ques. 2.01.** By what other expression may a "difference of potential" be described?

*Ans.* Difference of potential may be defined in any one of the following forms: e.m.f., voltage,  $IR$  drop, voltage drop, electrical pressure, or fall of potential.

**Ques. 2.02.** By what other expression may an "electric current flow" be described?

*Ans.* Electric current may be described as a flow of electricity, a flow or periodic displacement of electrons in a circuit, or, simply, the *amperes* flowing in a circuit.

**Ques. 2.03.** Which factors determine the amplitude of the e.m.f. induced in a conductor which is cutting lines of magnetic force?

*Ans.* The rate or speed of cutting, the density of the magnetic flux, the angular relationship between the conductor, and the field lines of force.

**Ques. 2.04.** Name four methods by which an electrical potential may be generated.

*Ans.* A voltaic cell or battery (chemical), generator (mechanical) photoelectric cell (light), thermocouple (heat), microphone (sound-mechanical).

**Ques. 2.05.** If the diameter of a conductor of given length is doubled, how will the resistance be affected?

*Ans.* The resistance will be decreased. This is due to the fact that the resistance of a wire varies inversely with its cross-sectional area.

**Ques. 2.06.** If the value of a resistance, to which a constant e.m.f. is applied, is halved, what will be the resultant proportional power dissipation?

*Ans.* The rate in which energy is dissipated (power) will be doubled.

$$\text{Power} = I^2R; \quad \frac{E^2}{R}; \quad E \times I \text{ watts.}$$

**Ques. 2.07.** What method of connection should be used to obtain the maximum no-load output voltage from a group of similar cells in a storage battery?

*Ans.* The cells must be connected in series.

**Ques. 2.08.** What is the sum of all voltage drops around a simple direct-current series circuit, including the source?

*Ans.* Zero. The algebraic sum of all the voltage drops around the circuit, including the source, is zero.

**Ques. 2.09.** What method of connection should be used to obtain the maximum short-circuit current from a group of similar cells in a storage battery?

*Ans.* The cells must be connected in parallel.

**Ques. 2.10.** If the value of a resistance, across which a constant e.m.f. is applied, is doubled, what will be the resultant proportional power dissipation?

*Ans.* The power dissipation will be halved. (See Ques. 2.06.)

**Ques. 2.11.** Name four materials which are good insulators at radio frequencies. Name four materials which are not

good insulators at radio frequencies, but which are satisfactory for use at commercial power frequencies.

*Ans.* Good radio-frequency insulators are quartz, polythene, stabilized polyethelene, polystyrene, isolantite, Steatite, Pyrex, and Mycalex.

Good commercial power-frequency insulators are glazed porcelain, glass, slate, micarta, fiber, hard rubber, and asbestos.

**Ques. 2.12.** Explain the factors which influence the resistance of a conductor.

*Ans.* The resistance of a conductor is dependent primarily upon the character of the material, the length of the conductor, and its cross-sectional area. Excessive current flow and surrounding temperature also affect the resistivity.

**Ques. 2.13.** What effect does the cross-section area of a conductor have upon its resistance per unit length?

*Ans.* (See Ques. 2.05.)

**Ques. 2.14.** Name four conducting materials in the order of their conductivity.

*Ans.* Silver, copper, aluminum, duralumin, tungsten, and zinc.

**Ques. 2.15.** What effect does a change in the dielectric constant of a condenser dielectric material have upon the capacitance of a condenser?

*Ans.* The capacity of the condenser will vary directly as the dielectric constant.

**Ques. 2.16.** Explain the effect of increasing the number of plates upon the capacitance of a condenser.

*Ans.* Increasing the number of plates increases the area and consequently its capacity.

**Ques. 2.17.** If the specific inductive capacity of a condenser dielectric material between the condenser plates were changed from 1 to 2, what would be the resultant change in capacitance?

*Ans.* The capacitance would be doubled.

**Ques. 2.18.** State the formula for determining (1) the amount of electricity a condenser will hold? (2) The energy stored in a condenser? (3) Give four typical dielectrics capable of storing electrical energy.

*Ans.*

$$(1) \quad Q = CE, \quad E = \frac{Q}{C},$$

$$(2) \quad W = \frac{1}{2} CE^2 = \frac{Q^2}{2C},$$

where  $C$  is in farads.

$E$  in volts.

$Q$  in coulombs.

$W$  in joules.

(3) Mica, paper, glass, oil, and air.

**Ques. 2.19.** Neglecting temperature coefficient of resistance and using the same gauge of wire and the same applied voltage in each case, what would be the effect, upon the field strength of a single layer solenoid, of a small increase in the number of turns?

*Ans.* The field strength will remain practically unchanged. The slight increase in turns will introduce a small increase in resistance thereby decreasing the current flow. This will *approximately* reestablish the original conditions.

**Ques. 2.20.** How will a magnetic compass be affected when placed within a coil carrying an electric current?

*Ans.* Within the coil the compass will align itself at right angles to the current flow with its north pole pointing toward the north pole of the coil.

**Ques. 2.21.** Which factors influence the direction of magnetic lines of force generated by an electromagnet?

*Ans.* The magnetic lines of force generated by an electromagnet will take a direction determined by the direction of the windings of the solenoid and the direction of current flow through the coil.

**Ques. 2.22.** Define the term "permeability."

*Ans.* "Permeability" may be defined as the ratio of the magnetic induction  $B$  in the substance and the strength of the magnetizing field to which it is subjected, field  $H$ . Simply stated, it is an expression of the ease with which a magnetic material will conduct lines of force as compared with air. The permeability ratio  $\mu$  of air is unity.

**Ques. 2.23.** What unit is used in expressing the alternating-current impedance of a circuit?

*Ans.* The ohm ( $Z$ ).

**Ques. 2.24.** What is the unit of resistance?

*Ans.* The ohm ( $R$ ).

**Ques. 2.25.** Explain the meaning of the prefix in "micro-microfarad."

*Ans.* The prefix "micromicro" means one-trillionth, or  $10^{-12}$ .

**Ques. 2.26.** What is the unit of capacitance?

*Ans.* The standardized unit is the farad. The capacitance is generally expressed in millifarads, microfarads, or micromicrofarads.

**Ques. 2.27.** What single instrument may be used to measure (1) Electrical resistance? (2) Electrical power? (3) Electrical current? (4) Electromotive force?



*Ans.* 1. Electrical resistance can be measured by using a voltmeter and a standard resistor (ohmmeter). Resistance may also be measured, but less accurately, by using a voltmeter whose resistance is known and applying the formula

$$R = \frac{E_1 - E_2}{E_2} \times R_m,$$

where  $E_1$  is the voltage without the unknown resistor in the circuit.

$E_2$  is the voltage with the unknown resistor in the circuit.

$R_m$  is the resistance of the voltmeter.

2. Electrical power is measured by a wattmeter.
3. Electrical current is measured by an ammeter.
4. Electromotive force is measured by a voltmeter.

**Ques. 2.28.** Define the term "residual magnetism."

*Ans.* "Residual magnetism" refers to the magnetic field which remains in a magnetic material after the magnetizing force is removed.

**Ques. 2.29.** What is the unit of electrical power?

*Ans.* The watt.

**Ques. 2.30.** What is the unit of conductance?

*Ans.* The ~~mho~~

**Ques. 2.31.** What is the unit of inductance?

*Ans.* The standardized unit of inductance is the henry. Fractional parts of this unit are generally expressed in millihenrys (mh) and microhenrys ( $\mu h$ ) ( $10^{-3}$  or  $10^{-6}$  henry, respectively).

**Ques. 2.32.** What is the meaning of the prefix "kilo"?

*Ans.* "Kilo" as a prefix means one thousand; thus, when compounded with other words, it means multiply by one thousand.

**Ques. 2.33.** What is the meaning of the prefix "micro"?

*Ans.* "Micro" as a prefix means one-millionth; thus, when compounded with other words, it means one-millionth part of the whole.

**Ques. 2.34.** What is the meaning of "power factor"?

*Ans.* "Power factor" in an alternating-current circuit is the ratio of the true watts expended in the circuit to the apparent watts expended in the circuit. It is an expression of the ratio of power consumed in a pure resistance to that returned to the source by the reactive component of the circuit. Power factor is always less than unity and is found by any of the following formulas:

$$\text{Power factor} = \cos \theta = \frac{P}{EI} = \frac{\text{real watts}}{\text{apparent watts}}$$

where  $P$  is the true power as indicated by a wattmeter and  $EI$  is the product of the voltmeter and the ammeter readings in the alternating-current circuit.

**Ques. 2.35.** What is the meaning of the prefix "meg"?

*Ans.* "Meg" from the Greek word *mega* means one million. For example, 1 megohm ( $1M\Omega$ ) = 1,000,000 ohms ( $\Omega$ ).

**Ques. 2.36.** Define the term "conductance."

*Ans.* "Conductance" is the reciprocal of the resistance in direct-current circuits. In alternating-current circuits, conductance is the ratio of the resistance to the impedance squared, expressed in mhos.

**Ques. 2.37.** What instrument is used to measure current flow?

*Ans.* Electrical current flow is measured by an ammeter.

**Ques. 2.38.** Define the term "decibel."

*Ans.* The "decibel" (db) is the unit used for expressing the ratio between two quantities, of either electrical or sound energy. The unit decibel is a relative measurement of electrical or sound energy levels and does not specify any definite current, voltage, or power. Using conventional symbols, the formulas for the decibel are as follows:

$$\text{db} = 10 \log_{10} \frac{P_1}{P_2}; \quad \text{db} = 20 \log_{10} \frac{E_1}{E_2}; \quad \text{db} = 20 \log_{10} \frac{I_1}{I_2}.$$

**Ques. 2.39.** What is meant by "ampere turns"?

*Ans.* "Ampere turns" = number of turns  $\times$  current.

**Ques. 2.40.** Define the term "inductance."

*Ans.* "Inductance" is that property of a coil or circuit to store up energy in an electromagnetic form. The inductance of a coil or circuit is 1 henry if a counter e.m.f. due to self-induction of 1 volt is developed when the current in the circuit changes at the rate of 1 ampere per second.

**Ques. 2.41.** Define the term "coulomb."

*Ans.* The unit of quantity of electricity passing a given point in a conductor in 1 second when 1 ampere is flowing is called a "coulomb." One coulomb is also the amount of electricity contained in a condenser having a capacitance of 1 farad when charged to a potential of 1 volt.

**Ques. 2.42.** State the three ordinary mathematical forms of Ohm's law.

*Ans.*

$$E = I \times R; \quad R = \frac{E}{I}; \quad I = \frac{E}{R}.$$

**Ques. 2.43.** State Ohm's law.

*Ans.* The current in an electric circuit varies directly as the e.m.f. producing it and inversely as the resistance of the conductor.

**Ques. 2.44.** If a vacuum tube having a filament rated at  $\frac{1}{4}$  ampere and 5 volts is to be operated from a 6-volt battery, what is the value of the necessary series resistor?

*Ans.* The voltage drop across the filament is 5 volts. Therefore, the voltage drop across the resistor must be 1 volt. Applying Ohm's law, we find that the necessary resistance is 4 ohms, calculated as follows:

$$R = \frac{E}{I} = \frac{1}{0.25} = 4 \text{ ohms.}$$

**Ques. 2.45.** If the voltage applied to a circuit is doubled and the resistance of the circuit is increased to three times its former value, what will be the final current value?

*Ans.* Assuming the initial conditions are as follows: e.m.f. = 1 volt,  $R = 1$  ohm; then the current flow is 1 ampere. If, then, the voltage is doubled to 2 volts and the resistance increased to 3 ohms, the current, according to Ohm's law, will be

$$I = \frac{E}{R} = \frac{2}{3} \text{ ampere,}$$

or two-thirds of the initial value.

**Ques. 2.46.** What should be the minimum power dissipation rating of a resistor of 20,000 ohms to be connected across a potential of 500 volts?

*Ans.* Theoretically, a 12.5-watt resistor would do. In practice, at least a 25-watt resistor would be used. The computations are as follows:

*Solution:*

$$\text{Power} = \frac{E^2}{R} = \frac{500^2}{20,000} = 12.5 \text{ watts.}$$

**Ques. 2.47.** If resistors of 5, 3, and 15 ohms are connected in parallel, what is the total resistance?

*Ans.* 1.66 ohms, computed as follows:

$$R = \frac{1}{\frac{1}{R_1} + \frac{1}{R_2} + \frac{1}{R_3}} = \frac{1}{\frac{1}{5} + \frac{1}{3} + \frac{1}{15}} = \frac{15}{9} = 1.66 \text{ ohms.}$$

**Ques. 2.48.** What is the maximum rated current-carrying capacity of a resistor marked "5,000 ohms, 200 watts"?

*Ans.* 200 milliamperes, computed as follows:

$$I = \sqrt{\frac{W}{R}} = \sqrt{\frac{200}{1000}} = 0.2 \text{ ampere.}$$

**Ques. 2.49.** A milliammeter with a full-scale deflection of 1 milliampere and having a resistance of 25 ohms was used to measure an unknown current by shunting the meter with a 4-ohm resistor. It then read 0.4 milliampere. What was the unknown current value?

*Ans.* Let  $I_1$  equal full-scale current through meter without shunt;  $I_2$  equal full-scale current through shunt;  $R_1$  equal resistance of meter;  $R_2$ , equal resistance of shunt. Then

$$\begin{aligned} I_1 &= R_2. && (\text{Let } I_2 = x.) \\ I_2 &= R_1. \\ \frac{1}{x} &= \frac{4}{25} \\ x &= 6.25 = I_2. \end{aligned}$$

Total current through the meter and shunt equals 7.25 milliamperes with full-scale deflection. With 0.4 deflection, the actual current is

$$0.4 \times 7.25 = 2.9 \text{ milliamperes.}$$

**Ques. 2.50.** What will be the heat dissipation, in watts, of a resistor of 20 ohms having a current of  $\frac{1}{4}$  ampere passing through it?

*Ans.*

$$\begin{aligned} \text{Power} &= I^2R \text{ watts} \\ &= \left(\frac{1}{4}\right)^2 \times 20 \\ &= \frac{1}{16} \times 20 = 1.25 \text{ watts.} \end{aligned}$$

**Ques. 2.51.** If two 10-watt 500-ohm resistors are connected in parallel, what are the power dissipation capabilities of the combination?

*Ans.* 20 watts.

**Ques. 2.52.** What is the formula used to determine the total capacitance of three or more capacitances connected in series?

*Ans.*

$$C = \frac{1}{\frac{1}{C_1} + \frac{1}{C_2} + \frac{1}{C_3} + \dots}$$

where  $C$  is in the same units, farads or microfarads, as are used to express  $C_1, C_2, C_3$ , etc.

**Ques. 2.53.** If condensers of 1, 3, and 5 microfarads are connected in parallel, what is the total capacitance?

*Ans.*

$$C = C_1 + C_2 + C_3 = 1 + 3 + 5 = 9 \text{ microfarads.}$$

**Ques. 2.54.** If condensers of 5, 3, and 7 microfarads are connected in series, what is the total capacitance?

*Ans.* The total capacitance is 1.48 microfarads, computed as follows:

$$C = \frac{1}{\frac{1}{C_1} + \frac{1}{C_2} + \frac{1}{C_3}} = \frac{1}{\frac{1}{5} + \frac{1}{3} + \frac{1}{7}} = \frac{1}{0.676} = 1.48 \text{ microfarads.}$$

**Ques. 2.55.** The charge in a condenser is stored in what portion of the condenser?

*Ans.* On the surface of the dielectric in the form of electrostatic lines of force.

**Ques. 2.56.** Having available a number of condensers rated at 400 volts and 2 microfarads each, how many of these

condensers would be necessary to obtain a combination rated at 1,600 volts 1.5 microfarads?

*Ans.* Twelve condensers connected into three series banks of four condensers each, the series banks then being connected in parallel.

**Ques. 2.57.** Calculate the voltage drop across an individual condenser of a group connected in series.

*Ans.* Let  $C_t$  equal the total capacitance,  $C_1$  equal the capacity of one of the condensers,  $E$  equal the potential across the group. Then the voltage across  $C_1$  can be found by

$$C_1 = E \times \frac{C_t}{C_1}$$

**Ques. 2.58.** What factors determine the charge stored in a condenser?

*Ans.* The charging voltage and the condenser capacity. (See Ques. 2.18.)

**Ques. 2.59.** Given two identical mica condensers of 0.1 microfarad capacity, each. One of these is charged to a potential of 125 volts and disconnected from the charging circuit. The charged condenser is then connected in parallel with the uncharged condenser. What voltage will appear across the two condensers connected in parallel?

*Ans.* 62.5 volts.

**Ques. 2.60.** What is the effect of an iron core in an inductance?

*Ans.* The inductance value will increase. In alternating-current circuits the iron core will increase the inductive reactance of the inductance coil.

**Ques. 2.61.** What will be the effect of a shorted turn in an inductance?

*Ans.* A shorted turn will decrease the inductance.

**Ques. 2.62.** What is the relationship between the number of turns and the inductance of a coil?

*Ans.* Inductance varies as the square of the number of turns, provided the length of the coil is the same. This holds true regardless of the character of the wire used.

**Ques. 2.63.** Define the term "reluctance."

*Ans.* "Reluctance" is the opposition offered to a magnetic path in a magnetic circuit. Reluctance is directly proportional to its magnetic path length and inversely to its cross-section.

**Ques. 2.64.** State the formula for determining the resonant frequency of a circuit when the inductance and capacity are known.

*Ans.*

$$f = \frac{1}{2\pi \sqrt{LC}} \text{ cycles per second,}$$

where  $L$  is in henrys.

$C$  is in farads.

**Ques. 2.65.** What is the formula for determining the power in a direct-current circuit when the voltage and resistance are known?

*Ans.*

$$P = I \times E = \frac{E}{R} \times E = \frac{E^2}{R}$$

Hence,

$$P = \frac{E^2}{R} \text{ watts.}$$

**Ques. 2.66.** What is the formula for determining the power in a direct-current circuit when the current and resistance are known?

*Ans.*

$$P = I^2R \text{ watts.}$$



**Ques. 2.67.** What is the formula for determining the power in a direct-current circuit when the current and voltage are known?

*Ans.*

$$P = EI \text{ watts.}$$

**Ques. 2.68.** What is the formula for determining the wavelength when the frequency, in kilocycles, is known?

*Ans.*

$$\lambda = \frac{3 \times 10^8}{f_1} = \frac{300,000}{f_2} \text{ meters,}$$

where  $f_1 = \text{cycles}$ ,  $f_2 = \text{kilocycles}$ .

**Ques. 2.69.** What is the frequency corresponding to a wavelength of 375 meters?

*Ans.* 800 kilocycles, computed according to the formula  $f = \frac{v}{\lambda}$ ; where  $v = \text{velocity of radio wave}$ ,  $3 \times 10^8$  meters per seconds,  $\lambda$  equals wavelength in meters, and  $f = \text{frequency in cycles per second}$ .

**Ques. 2.70.** State Ohm's law for alternating-current circuits.

*Ans.* Expressed mathematically Ohm's law adapted to alternating-current circuits reads:

$$E = IZ; \quad I = \frac{E}{Z}; \quad Z = \frac{E}{I}.$$

Stated in words these formulas show that the current  $I$  varies directly as the e.m.f.  $E$  and inversely as the impedance  $Z$ .

Ques. 2.71. Draw a simple schematic diagram showing a tuned-plate tuned-grid oscillator with series-fed plate. Indicate polarity of supply voltages.

Ans. See Fig. 2-1.

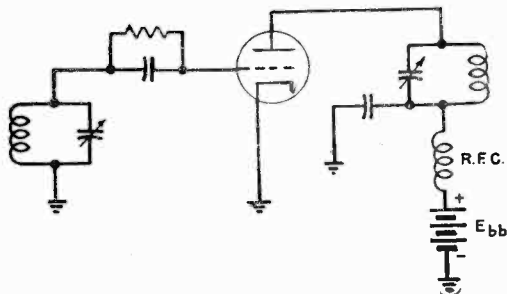

FIG. 2-1. Tuned-plate tuned-grid series-fed oscillator.

Ques. 2.72. Draw a simple schematic diagram showing a Hartley triode oscillator with shunt-fed plate. Indicate power-supply polarity.

Ans. See Fig. 2-2.

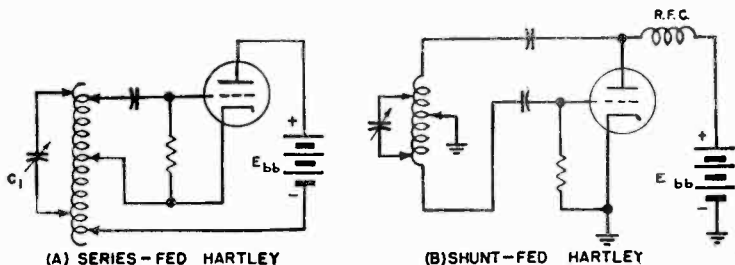

FIG. 2-2. Hartley oscillators.

**Ques. 2.73.** Draw a simple schematic diagram showing a tuned-grid Armstrong-type triode oscillator, with shunt-fed plate. Indicate power-supply polarity.

*Ans.* See Fig. 2-3.

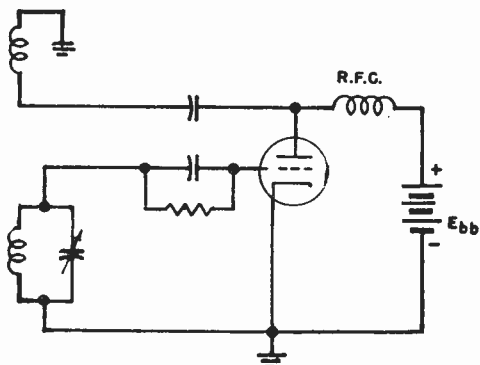

FIG. 2-3. Armstrong tuned-grid shunt-fed oscillator.

**Ques. 2.74.** Draw a simple schematic diagram showing a tuned-plate tuned-grid triode oscillator with shunt-fed plate. Indicate polarity of supply voltages.

*Ans.* See Fig. 2-4.

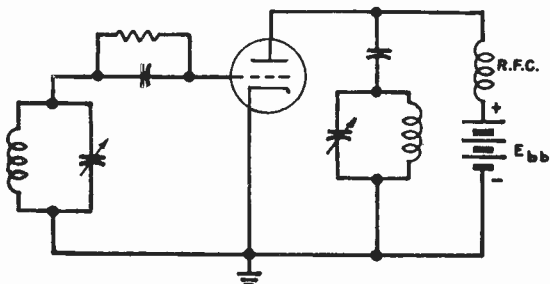

FIG. 2-4. Tuned-plate, tuned-grid, shunt-fed oscillator.

RADIO OPERATING QUESTIONS AND ANSWERS

**Ques. 2.75.** Draw a simple schematic diagram of a crystal-controlled vacuum-tube oscillator. Indicate power-supply polarity.

*Ans.* See Fig. 2-5.

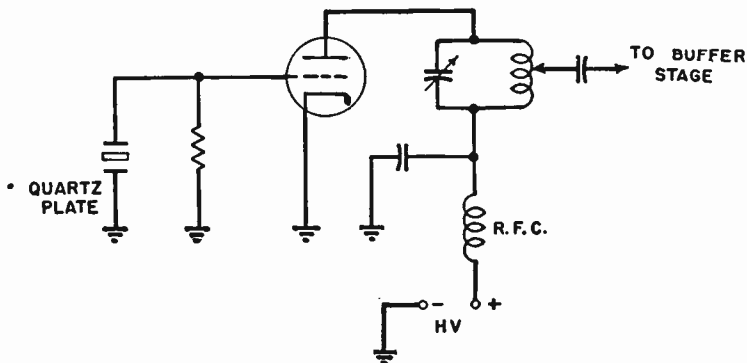

FIG. 2-5. Triode-type crystal-controlled oscillator.

**Ques. 2.76.** Draw a simple schematic diagram showing a Colpitts-type triode oscillator, with shunt-fed plate. Indicate power-supply polarity.

*Ans.* See Fig. 2-6.

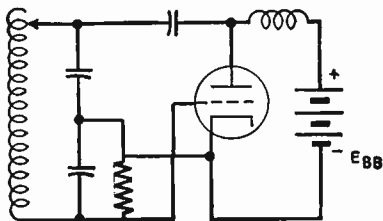

FIG. 2-6. Colpitts shunt-fed oscillator.

**Ques. 2.77.** Draw a simple schematic diagram showing a tuned-grid Armstrong-type triode oscillator, with series-fed plate. Indicate power-supply polarity.

*Ans.* See Fig. 2-7.

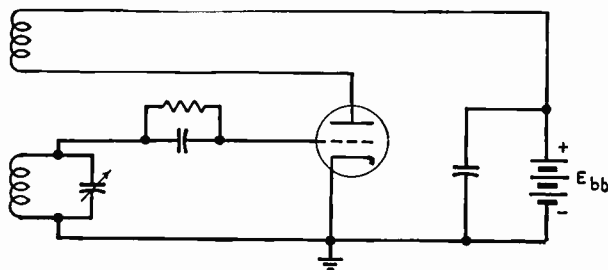

FIG. 2-7. Armstrong series-fed oscillator.

**Ques. 2.78.** Draw a simple schematic diagram of an electron-coupled oscillator, indicating power-supply polarities.

*Ans.* See Fig. 2-8.

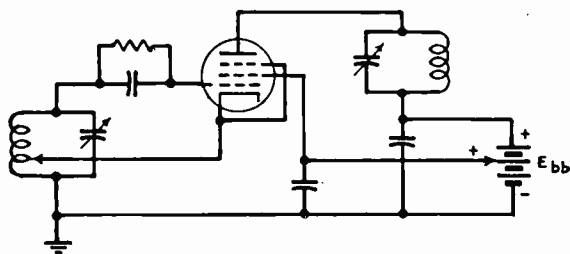

FIG. 2-8. Electron-coupled oscillator.

RADIO OPERATING QUESTIONS AND ANSWERS

**Ques. 2.79.** Draw a simple schematic diagram of a pentode-type tube used as a crystal-controlled oscillator, indicating power-supply polarities.

*Ans.* See Fig. 2-9.

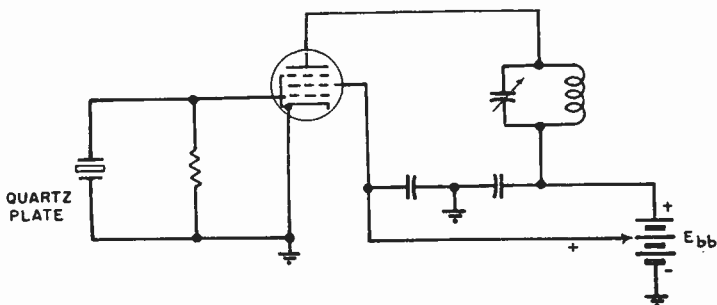

FIG. 2-9. Pentode-type crystal-controlled oscillator.

**Ques. 2.80.** Draw a simple schematic circuit showing a method of coupling a high-impedance loud-speaker to an audio-frequency amplifier tube without flow of tube-plate current through the speaker windings, and without the use of a transformer.

*Ans.* See Fig. 2-10.

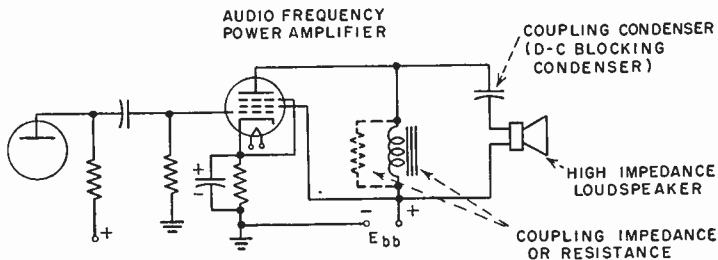

FIG. 2-10. Parallel feed loudspeaker coupling system.

**Ques. 2.81.** Draw a simple schematic diagram of a triode vacuum-tube audio-frequency amplifier inductively coupled to a loud-speaker.

*Ans.* See Fig. 2-11.

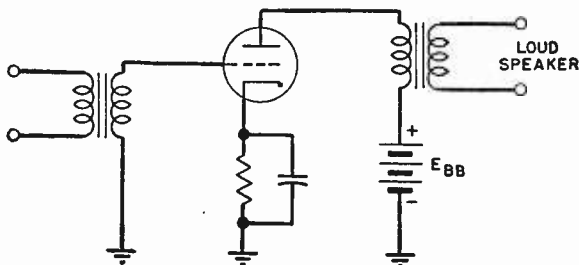

FIG. 2-11. Loud-speaker coupling arrangement.

**Ques. 2.82.** Draw a simple schematic circuit showing a method of resistance coupling between two triode vacuum tubes in an audio-frequency amplifier.

*Ans.* See Fig. 2-12.

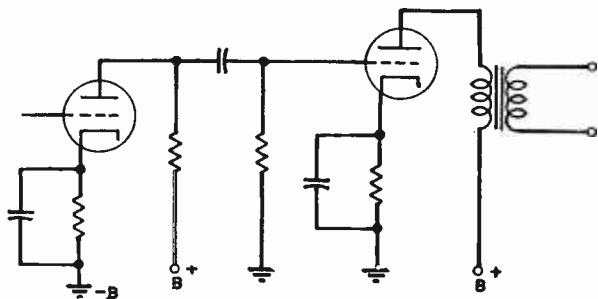

FIG. 2-12. Resistance coupling.

**Ques. 2.83.** Draw a simple schematic diagram showing a method of transformer coupling between two triode vacuum tubes in an audio-frequency amplifier.

*Ans.* See Fig. 2-13.

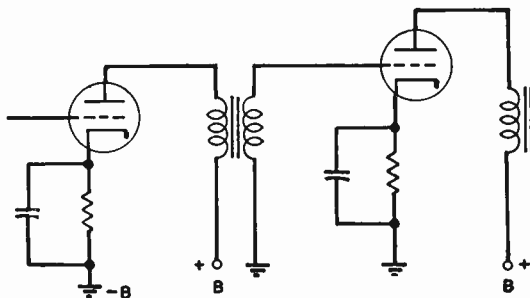

FIG. 2-13. Inductive or transformer coupling.

**Ques. 2.84.** Draw a simple schematic diagram of a method of impedance coupling between two vacuum tubes in an audio-frequency amplifier.

*Ans.* See Fig. 2-14.

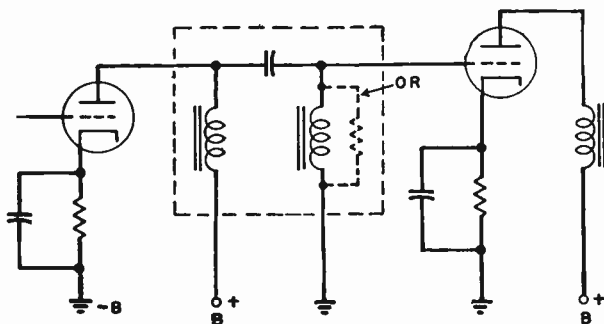

FIG. 2-14. Impedance coupling.



**Ques. 2.85.** Draw a simple schematic diagram showing a method of coupling the radio-frequency output of the final power-amplifier stage of a transmitter to an antenna.

*Ans.* See Fig. 2-15.

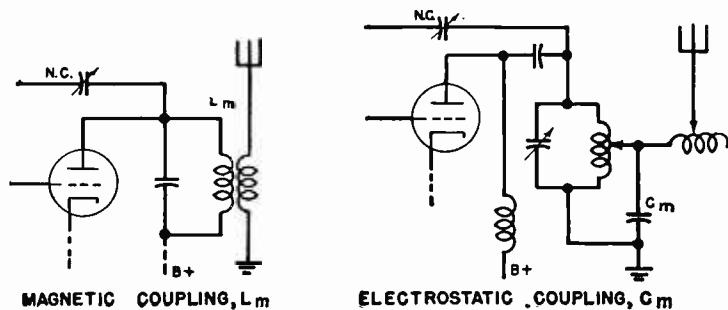

FIG. 2-15. Antenna coupling systems.

**Ques. 2.86.** Draw a simple schematic diagram showing a method of coupling between two tetrode vacuum tubes in a tuned radio-frequency amplifier.

*Ans.* See Fig. 2-16.

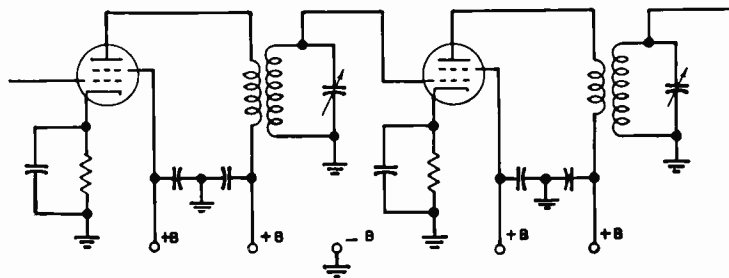

FIG. 2-16. Interstage coupling system.

RADIO OPERATING QUESTIONS AND ANSWERS

Ques. 2.87. Draw a simple schematic diagram showing a method of coupling between two triode vacuum tubes in a tuned radio-frequency amplifier, and a method of neutralizing to prevent oscillation.

Ans. See Fig. 2-17.

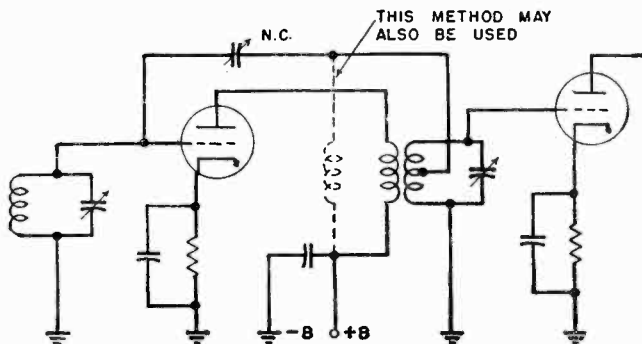
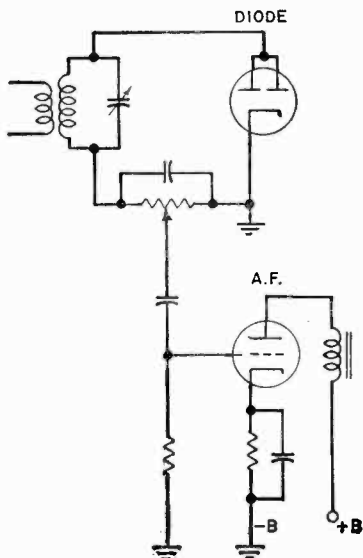

FIG. 2-17. Interstage coupling and neutralization.



Ques. 2.88. Draw a simple schematic diagram of a diode vacuum tube connected for diode detection, and showing a method of coupling to an audio amplifier.

Ans. See Fig. 2-18.

FIG. 2-18. Diode detector and audio-frequency amplifier.

Ques. 2.89. Draw a simple schematic diagram of a triode vacuum tube connected for plate or power detection.

Ans. See Fig. 2-19.

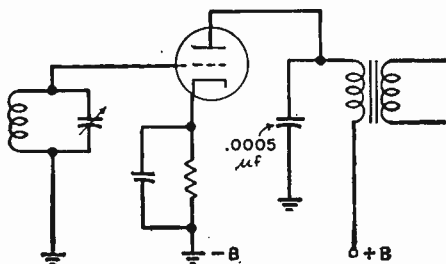

FIG. 2-19. Power or plate detection system.

Ques. 2.90. Draw a simple schematic diagram of a triode tube connected for grid-leak condenser detection.

Ans. See Fig. 2-20.

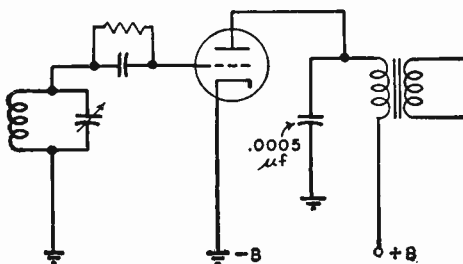

FIG. 2-20. Grid-leak detector.

Ques. 2.91. Draw a simple schematic circuit of a regenerative detector.

Ans. See Fig. 2-21.

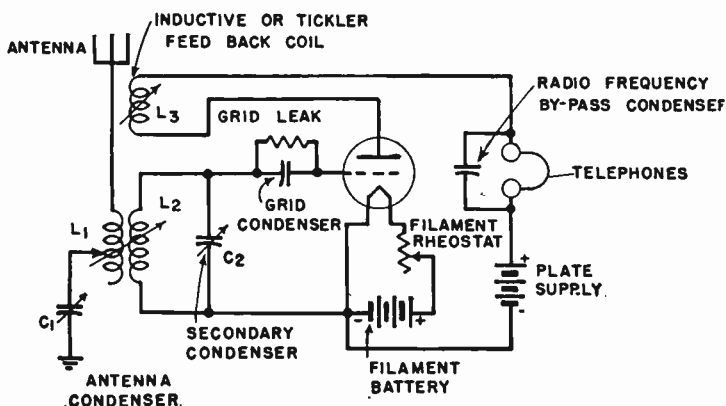

FIG. 2-21. Regenerative detector.

Ques. 2.92. Draw a simple schematic circuit of a radio-frequency doubler stage, indicating any pertinent points which will distinguish this circuit as that of a frequency doubler.

Ans. See Figs. 2-22 and 5-3. The doubler illustrated in Fig. 2-22 is identified only by its operating characteristics. The adjustment of the doubler circuit to obtain rich harmonic outputs is dependent upon grid bias, plate voltage, and output tuning. The tube should be operated at reasonably high plate potential, high grid bias (class C), and the plate-tank circuit tuned to the second or third harmonic of the input frequency, as required.

FIRST DOUBLER

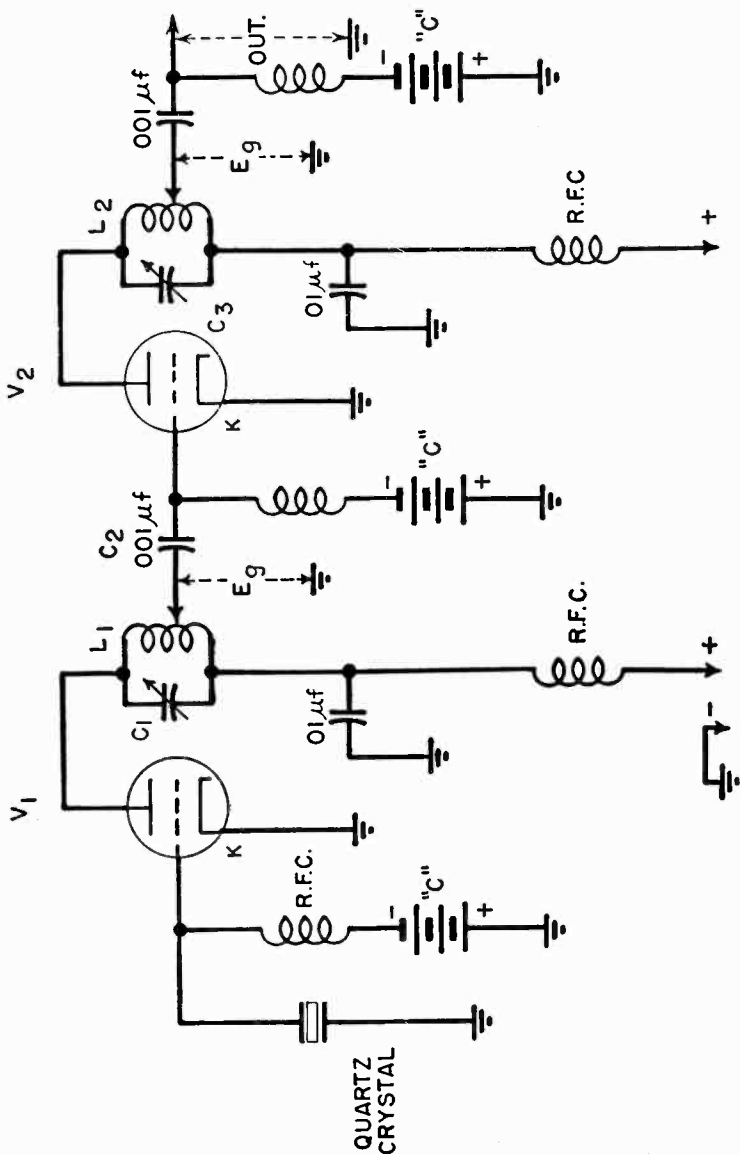

FIG. 2-22. A radio-frequency doubler stage.



FIG. 2-23. Parallel resistance combination.

Ques. 2.93. Draw a simple schematic diagram showing the method of connecting three resistors of equal value so that the total resistance will be two-thirds the resistance of one unit.

Ans. See Fig. 2-23.

Ques. 2.94. Draw a simple schematic diagram showing the method of connecting three resistors of equal value so that the total resistance will be  $1\frac{1}{2}$  times the resistance of one unit.

Ans. See Fig. 2-24.

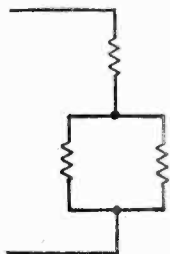

FIG. 2-24. Series-parallel resistance combination.

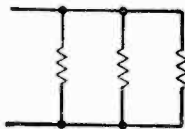

FIG. 2-25. Parallel resistance combination.

Ques. 2.95. Draw a simple schematic diagram showing the method of connecting three resistors of equal value so that the total resistance will be one-third of one unit.

Ans. See Fig. 2-25.

**Ques. 2.96.** Draw a simple schematic diagram showing the method of connecting three resistors of equal value so that the total resistance will be three times the resistance of one unit.

*Ans.* See Fig. 2-26.

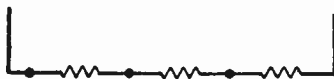

FIG. 2-26. Series resistance combination.

**Ques. 2.97.** Draw a diagram of a single-button carbon-microphone circuit, including the microphone transformer and source of power.

*Ans.* See Fig. 2-27.

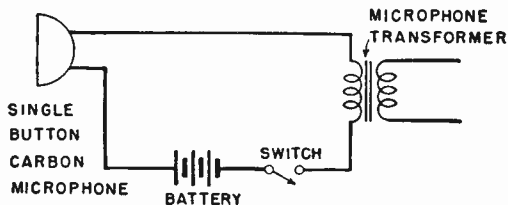

FIG. 2-27. Carbon-microphone circuit arrangement.

**Ques. 2.98.** What is meant by a "soft" vacuum tube?

*Ans.* A tube containing a small amount of gas which was not thoroughly exhausted during the manufacturing process.

**Ques. 2.99.** Describe the physical structures of the tetrode and pentode on a comparative basis.

*Ans.* The tetrode has four elements, namely, (1) cathode, (2) control grid, (3) screen grid, and (4) plate.

The pentode has five elements, including all those mentioned for the tetrode, and, in addition, a fifth element called the suppressor grid. The suppressor grid is generally (but not

always) connected directly to the cathode. Therefore, it assumes a negative potential with respect to the plate and retards secondary emission.

**Ques. 2.100.** Describe the electrical characteristics of the pentode, tetrode, and triode on a comparative basis.

*Ans.* The pentode is a five-element tube, the distinctive feature of which is a suppressor grid usually directly connected to the cathode and serving to prevent secondary emission. When the pentode is used as a power-output amplifier, the suppressor makes possible a large power output with high gain, because the plate swing can be made very large. When the pentode is used as a radio-frequency amplifier, high-voltage amplification is possible using moderate values of plate voltage. Because the pentode also has a screen grid, interelement capacitance is minimized and an external system of neutralization is generally unnecessary when the tube is used as a radio-frequency amplifier.

The tetrode is a four-element tube, the distinctive feature of which is a screen grid located between the control grid and the plate. The screen grid serves to neutralize or reduce the grid-to-plate capacitance, thus making the tube suitable for use in most types of radio-frequency amplifier circuits without the application of special neutralizing methods.

The screen grid is operated at a positive voltage lower than that of the plate. A desirable result achieved is that the screen grid makes plate current practically independent of plate voltage within limits. Because the screen grid is charged with a positive potential, it serves as an extra force for pulling electrons through the space charge. Because the plate current in the tetrode is independent of the plate voltage, a much higher gain per stage is possible with a tetrode than with a triode, other conditions being equal.

The triode is a three-element tube, consisting of cathode, grid, and plate. The purpose of the grid is to control the flow of electrons from the filament to the plate. When the tube



is used as an amplifier, the grid is usually operated with a negative bias. A negative charge on the grid tends to reduce plate current while a positive charge on the grid tends to increase plate current. Therefore, when an alternating signal voltage is applied to the grid, the plate current varies in accordance with the applied signal voltage. Because there is electrostatic capacity between the grid and the plate, allowing a feedback of radio-frequency energy between these elements, it is necessary to compensate this interelement capacitance by an external system of neutralization.

**Ques. 2.101.** What are the visible indications of a "soft" tube?

*Ans.* A "soft" tube may be detected by an excessive or erratic flow of plate current. If the plate voltage is sufficiently high to ionize the gas, a light-blue haze will be visualized between the cathode and the plate.

**Ques. 2.102.** Describe the physical structure of a triode vacuum tube.

*Ans.* A triode is a three-element vacuum tube, containing a cathode and filament heater or a filament alone, a control grid surrounding the cathode or filament, and a plate enveloping the grid and cathode elements. The filament or cathode may be of tungsten, thoriated tungsten, or oxide. The grid is composed of small-spaced wire laterals or spirals. The plate is generally a solid rectangle or cylinder. Grid and plate materials are usually of metal or metallized structures of molybdenum, nickel, iron, carbonized nickel, or manganese-nickel alloys.

**Ques. 2.103.** Describe the physical structure of a tetrode vacuum tube.

*Ans.* A tetrode is a four-element tube, containing the same elements as the triode but with the addition of a second grid spiral called a screen or shield grid. This screen grid is placed

between the control grid and the plate of the tube. Unlike the control grid, the screen grid is generally at positive potential with respect to the cathode. Its primary function is to reduce the internal-control grid-to-plate capacitance and to increase the over-all voltage amplification as compared with a triode. (The amplification properties are also dependent upon the output load impedance into which the tube functions.) Frequently, as in the case of wide-band amplifiers, the load impedance may be of such value as to give very little gain, the objective being primarily to improve the band width of the amplifier.

The control grid in a tetrode vacuum tube is shielded internally to reduce the capacity between it and the plate.

**Ques. 2.104.** Does a pentode vacuum tube usually require neutralization when used as a radio-frequency amplifier?

*Ans.* No. The reduced grid-to-plate capacitance minimizes the possibility of feedback. However, its use in very high-frequency circuits may necessitate neutralization.

**Ques. 2.105.** What is the meaning of "secondary emission"?

*Ans.* When primary electrons from the filament are drawn to the plate of a vacuum tube with such force that they, in turn, dislodge electrons from the surface of the plate by their impact force, the electrons so dislodged are called "secondary electrons." The emission of these electrons from the plate is called "secondary emission" to differentiate it from the primary emission from the filament. Secondary emission opposes and reduces the normal plate-current flow.

**Ques. 2.106.** What is the meaning of "electron emission"?

*Ans.* "Electron emission" is the liberation of electrons from a material when it is heated to a point at which electrons break through the surface of the material.

**Ques. 2.107.** Describe the characteristics of a vacuum tube operating as a class C amplifier.

*Ans.* This type of amplifier is very efficient because plate-current pulses flow only during brief periods; these pulses are of a duration appreciably less than one-half of each positive cycle. The class C amplifier runs cool, and its efficiency ranges between 60 and 95 per cent (average practical operational value approximately 65 per cent efficiency). The grid-bias adjustment of a class C amplifier is generally between  $1\frac{1}{2}$  to 4 times the cut-off bias value. The plate power varies approximately as the square of the plate voltage. High power outputs can be obtained in properly adjusted class C amplifiers.

**Ques. 2.108.** During what portion of the excitation voltage cycle does plate current flow when a tube is used as a class C amplifier?

*Ans.* (See Ques. 2.107.)

**Ques. 2.109.** Describe the characteristics of a vacuum tube operating as a class A amplifier.

*Ans.* The characteristics of a class A amplifier are that the output wave shape is essentially a linear reproduction of the grid voltage. The ratio of voltage amplification is high, but the efficiency of the tube as an amplifier is low. Plate current flows during the entire excitation cycle.

**Ques. 2.110.** Describe the characteristics of a vacuum tube operating as a class B amplifier.

*Ans.* The output power of a class B amplifier is proportional to the square of the excitation voltage. The practical operating efficiency is approximately  $33\frac{1}{3}$  per cent. Grid-bias adjustment is at or near the plate-current cut-off value.

This type of amplifier is frequently referred to as a "linear" amplifier owing to its excellent output characteristics.

**Ques. 2.111.** During what portion of the excitation voltage cycle does plate current flow when a tube is used as a class B amplifier?

*Ans.* Plate current flows in a class B amplifier for a period of approximately one-half of the grid excitation cycle.

**Ques. 2.112.** Does a properly operated class A audio amplifier produce serious modification of the input wave form?

*Ans.* No. Its operation is essentially linear.

**Ques. 2.113.** What is the meaning of the term "maximum plate dissipation"?

*Ans.* "Plate dissipation" refers to the quantity of power lost at the plate of the tube in heat radiation. Maximum dissipation is the amount of heat that can safely be accommodated at the plate without injury to the tube ( $e_b \times i_b$ ).

**Ques. 2.114.** What is meant by a "blocked grid"?

*Ans.* A tube has a "blocked grid" when the grid bias is of such a value as to shut off plate current.

**Ques. 2.115.** What is meant by the "load" on a vacuum tube?

*Ans.* The resistance or impedance into which the output of the tube is fed.

**Ques. 2.116.** What circuit and electron-tube factors influence the voltage gain of a triode audio-frequency amplifier stage?

*Ans.* The amplification factor of the tube, the value of load resistance or impedance  $R_L$ , the alternating current or plate resistance of the tube  $r_p$ , and the turns ratio of the coupling transformer, if used.

$$\text{Voltage gain (triode)} = \frac{\mu R_L}{r_p + R_L}$$

**Ques. 2.117.** What is the purpose of a bias voltage on the grid of an audio-frequency amplifier tube?

*Ans.* The purpose of the biasing voltage on a class A audio-frequency amplifier tube is to operate the tube at the center of the straight portion of the characteristic curve to obtain a symmetrical reproduction of the grid swing in the plate circuit. If the signal is restricted within the straight portion of the curve, distortion will be negligible.

In a class B amplifier the grid bias insures operation at or near the cut-off point of the tube and also limits the grid-current flow to the required value. It also permits considerably higher excitation as compared with a class A amplifier.

**Ques. 2.118.** What is the primary purpose of a screen grid in a vacuum tube?

*Ans.* (See Ques. 2.100, 2.103, and 2.104.)

**Ques. 2.119.** What is the primary purpose of a suppressor grid in a multi-element vacuum tube?

*Ans.* To retard the emission of secondary electrons from the plate, which otherwise would flow to the screen grid, reducing plate current and limiting permissible plate swing.

**Ques. 2.120.** What is the meaning of the term "plate saturation"?

*Ans.* "Plate saturation" is the condition present when practically all the electrons which are emitted from the filament of the tube reach the plate for the filament voltage applied.

**Ques. 2.121.** What is the most desirable factor in the choice of a vacuum tube to be used as a voltage amplifier?

*Ans.* The most desirable factor in a voltage amplifier tube is a high mutual conductance ( $g_m$ ).

**Ques. 2.122.** What is the principal advantage of a tetrode over a triode as a radio-frequency amplifier?

*Ans.* A tetrode does not require capacity neutralization unless used in ultra-high- or very high-frequency circuits. A tetrode in general also gives a higher voltage amplification than a triode tube owing to its relatively higher mutual conductance and amplification factor.

**Ques. 2.123.** What is the principal advantage of the tetrode as compared to the triode, when used in a radio receiver?

*Ans.* (See Ques. 2.122.)

**Ques. 2.124.** What is the principal advantage in the use of a diode detector instead of a grid-leak-type triode detector?

*Ans.* The diode detector will give less distortion, particularly on strong or high percentage modulated signals.

**Ques. 2.125.** Draw a grid-voltage-plate-current characteristic curve of a vacuum tube and indicate the operating points for class A, class B, and class C amplifier operation.

*Ans.* See Fig. 2-28.

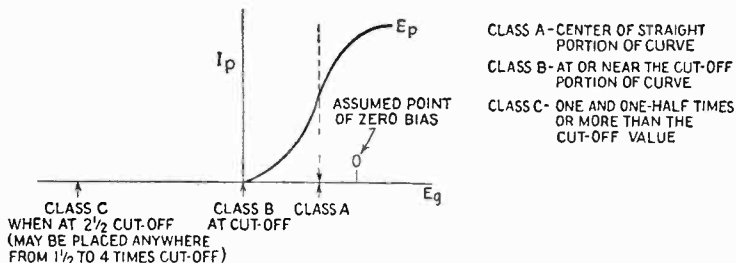

FIG. 2-28. Vacuum-tube operating-curve adjustments for class A, class B, and class C amplification.

**Ques. 2.126.** What operating conditions determine that a tube is being used as a power detector?

*Ans.* Power detection or large-signal detection may be obtained by either a diode, grid leak or plate-current cut-off

type of detector under certain operating conditions. The most frequently used types of power detectors in receivers are the grid-leak large-signal detector and diode detector. The operating conditions of power detection in general require a relatively lower impedance in the detector load circuit as compared with ordinary detectors. For example, in the grid-leak or diode large-signal detector the grid-leak resistance and diode load resistance are generally between 100,000 and 500,000 ohms as compared with 1 to 10 megohms in the ordinary weak-signal grid-leak detector. (See also Ques. 2-134.)

**Ques. 2.127.** Why is it desirable to use an alternating-current filament supply for vacuum tubes?

*Ans.* The use of alternating current on the filaments of vacuum tubes eliminates the necessity for cumbersome filament batteries and charging apparatus or rectifier units and filters for supplying direct current from an alternating-current line. In general, the entire operation of the system is simplified because filament power can be taken directly from the alternating-current line through a step-down transformer. (See Ques. 2.128.)

**Ques. 2.128.** Why is it advisable periodically to reverse the polarity of the filament potential of high-power vacuum tubes when a direct-current filament supply is used?

*Ans.* It is advisable periodically to reverse the polarity of the filament potential in order to lengthen the life of the filament. The electronic emission is not uniform over the entire length of the filament since the variable space current present all along the filament causes a difference in the temperature of the filament at various points along its length. Hence, the resistance of the filament is altered with a consequent change in the filament's potential gradient. All of these effects taken together, if allowed to operate without variation on a filament, will tend to shorten its life. By reversing the filament poten-

tial at regular intervals, this strain is periodically redistributed on the filament and its life lengthened.

**Ques. 2.129.** Why is it important to maintain transmitting-tube filaments at recommended voltages?

*Ans.* If the filament voltage is above normal, the life of the tube is shortened. If the filament voltage is below normal, the tube will not give optimum results because of a deficiency in its electron-emitting qualities. Hence, it is important to keep the filament voltage at the rated value.

**Ques. 2.130.** When an alternating-current filament supply is used, why is a filament center tap usually provided for the vacuum-tube plate and grid return circuits?

*Ans.* If the filament return circuits were connected to one side of the filament, the bias on the grid would be varied by an amount equal to the filament voltage at each reversal of filament polarity. This action would cause audio-frequency modulation in the tube and a hum in the circuit.

**Ques. 2.131.** Explain the operation of a grid-leak type of detector.

*Ans.* Grid-leak or square-law detection as illustrated in Fig. 2-2 operates upon the principle of diode rectification in the grid circuit with the exception that the rectified component is amplified in the plate circuit. It is in reality a diode rectifier and audio-frequency amplifier all in one.

When a modulated radio-frequency wave is applied to the grid circuit and between the cathode and grid of the triode tube, electrons will be attracted to the grid during the positive halves of the incoming cycle. The electrons will flow through the grid-leak resistance, which will develop an  $IR$  drop across it and make the grid negative with respect to the cathode. Hence, there is developed across the grid-leak resistance a direct-current voltage drop which varies in accordance with the amplitude changes of the modulated radio-frequency wave.



Since the effect of the increase in grid current due to rectification is to increase the  $IR$  drop across the grid leak, the average grid voltage increases in a negative direction as the modulated signal increases in amplitude. The average plate current therefore decreases during these grid peak periods. If therefore the input radio-frequency signal in the grid circuit is amplitude-modulated, the resultant decrease in plate current fluctuates at an audio-frequency rate, producing an amplified audio-frequency voltage across the plate-circuit load.

**Ques. 2.132.** List and explain the characteristics of a square-law type of vacuum-tube detector.

*Ans.* The grid-leak-and-condenser type detector is a square-law detector, the output wave shape varying as the square of the signal input voltage. This results in a detector which is very sensitive but has a high percentage of harmonic distortion. The square-law detector responds only to a modulated signal input on its grid circuit. Hence, the square-law detector cannot respond to continuous-wave (type A1) emission applied to its grid circuit.

**Ques. 2.133.** Explain the operation of a diode type of detector.

*Ans.* The operation of the diode detector is precisely the same as the grid-leak detector explained in Ques. 2.131 with the exception that the diode load is connected in the cathode return. The audio-frequency voltages developed across the diode load (Fig. 2-18) are then fed to the grid of an audio-frequency amplifier.

**Ques. 2.134.** Explain the operation of a power or plate rectification type of vacuum-tube detector.

*Ans.* In power or plate rectification the grid is biased almost to the cut-off point. Hence, plate current flows only during the positive alternation of the signal voltage impressed on the grid, causing a consequent rise in plate current. The

output wave shape conforms to that of the modulated radio-frequency signal voltage.

**Ques. 2.135.** Is a grid-leak type of detector more or less sensitive than a power detector (plate rectification)? Why?

*Ans.* The weak-signal type of grid-leak or square-law detector is the more sensitive because it operates at zero bias at which point the mutual conductance is maximum. The plate detector operates near cut-off at which point the mutual conductance is minimum.

**Ques. 2.136.** Describe what is meant by a class A amplifier.

*Ans.* A class A amplifier operates in such a manner that the plate-output wave form is essentially the same as the excitation grid voltage. Plate current flows during the entire excitation cycle. The grid must usually not go positive on excitation peaks, and the plate current must not fall low enough at its minimum to cause distortion. (Adapted from I.R.E. definitions.)

**Ques. 2.137.** What are the characteristics of a class A audio amplifier?

*Ans.* A relatively high voltage gain, low efficiency with linear output, and a constant direct-current plate component. Low harmonic distortion if properly adjusted and operating into a load impedance of at least  $2r_p$ .

**Ques. 2.138.** What will be the effect of incorrect grid bias in a class A audio amplifier?

*Ans.* An incorrect grid bias may cause nonsymmetry with consequent distortion of the output wave form.

**Ques. 2.139.** What are the factors which determine the bias voltage for the grid of a vacuum tube?

*Ans.* The efficiency to be achieved, the class of amplifier operation, the excitation voltage available, the plate potential

to be used, the permissible swing of the alternating-current component, and the second-harmonic content allowed are all factors which affect the final selection of bias voltage for the grid of a vacuum tube.

**Ques. 2.140.** Why are tubes operated as class C amplifiers not suited for audio-frequency amplification?

*Ans.* Class C amplifiers are not suited to audio-frequency amplification primarily because of the high grid excitation, grid bias, and plate-voltage requirements, also because the distortion content as compared with a properly operated class A amplifier is considerably greater.

**Ques. 2.141.** Draw a circuit of a frequency doubler and explain its operation.

*Ans.* See Fig. 2-22 for diagram. The tube is biased beyond the cut-off point. This produces a distorted plate-current wave shape which contains a large percentage of harmonics. The plate *L-C* circuit is tuned to twice the input frequency (second harmonic).

In Fig. 5-3 frequency doubling is accomplished as follows: The two grids are excited alternately 180 degrees out of phase. When one grid is positive, the plate tank circuit is shocked into oscillation, since both plates are connected in parallel. Owing to the flywheel action of the tank circuit a complete cycle is developed in the tank circuit for each excitation pulse. Hence, since a grid excitation frequency of, say, 1 megacycle is developed in the grid circuit, the plate circuit will oscillate at 2 megacycles. The parallel resonant adjustment of the plate tank circuit must be tuned to twice the frequency of the grid excitation frequency under these conditions.

**Ques. 2.142.** For what purpose is a doubler amplifier stage used?

*Ans.* The doubler amplifier is used when an output frequency greater than the maximum safe operating frequency

of a crystal oscillator is desired, and also, in the case of ordinary oscillators, to obtain better frequency stability by operating the oscillator at a lower frequency.

**Ques. 2.143.** Describe what is meant by "link coupling" and for what purpose(s) is it used?

*Ans.* "Link coupling" is the term applied to the coupling provided between two major circuits by an intermediate link circuit, which may, in turn, be defined as two inductors joined by a relatively short transmission line and inductively coupled to the major circuits. See Fig. 3-7.

**Ques. 2.144.** What factors may cause low plate current in a vacuum-tube amplifier?

*Ans.* Low plate current may be caused by defective tubes, excessive grid bias, or defective filter or by pass condensers, low operating voltages, insufficient grid excitation in a class B or C amplifier.

**Ques. 2.145.** Given the following electron-tube constants:  $E_b = 1,000$  volts,  $I_b = 150$  milliamperes,  $I_g = 10$  milliamperes, and grid leak = 5,000 ohms, what would be the value of direct-current grid-bias voltage?

*Ans.* 50 volts.  $E = IR = 0.01 \times 5,000 = 50$  volts.

**Ques. 2.146.** Explain how you would determine the value of cathode-bias resistance necessary to provide correct grid bias for any particular amplifier.

*Ans.* The correct value of resistance may be determined by reference to the static characteristics of the tube plate, screen-grid currents. The desired bias voltage required  $E_c$  for a given value of plate voltage.

$$R_{\text{bias}} = \frac{E \text{ (bias voltage required)}}{I \text{ (total cathode resistor currents)}}$$

**Ques. 2.147.** What is the chemical composition of the active material composing the negative plate of a lead-acid type of storage cell?

*Ans.* Pure sponge lead, Pb.

**Ques. 2.148.** What is the chemical composition of the active material composing the negative plate of an Edison-type storage cell?

*Ans.* Iron oxide.

**Ques. 2.149.** What is the chemical composition of the active material composing the positive plate of a lead-acid type storage cell?

*Ans.* Lead dioxide,  $\text{PbO}_2$ .

**Ques. 2.150.** How does a primary cell differ from a secondary cell?

*Ans.* A secondary cell can be recharged; a primary cell cannot be recharged. As used in radio the secondary cell is either the familiar lead-type or the Edison storage battery; the primary cell is a dry cell.

**Ques. 2.151.** What is the chemical composition of the active material composing the positive plate of an Edison-type storage cell?

*Ans.* Nickel hydroxide and exceedingly thin flakes of pure nickel.

**Ques. 2.152.** What is the chemical composition of the electrolyte used in an Edison-type storage cell?

*Ans.* A 21 per cent solution of potassium hydroxide mixed with distilled water to which is added a small amount of lithium hydrate.

**Ques. 2.153.** What is the chemical composition of the electrolyte of a lead-acid storage cell?

*Ans.* A dilute solution of sulphuric acid mixed with distilled water. Specific gravity at full charge, 1.250.

**Ques. 2.154.** What is "polarization" as applied to a primary cell, and how may its effect be counteracted?

*Ans.* "Polarization" is the formation on the surface of the positive electrode of a cell of a film of hydrogen bubbles. This film sets up a counter e.m.f. which results in a so-called "polarization current." Polarization also increases the resistance between the electrolyte and the positive plate, resulting in a further decrease in the capacity of the cell. The effects of polarization can be minimized by the use of a depolarizing agent. The depolarizer, when the electrolyte is sulphuric acid, may be cupric sulphate or, if the electrolyte is sal ammoniac, manganese dioxide.

**Ques. 2.155.** Describe three causes of a decrease in capacity of an Edison-type storage cell.

*Ans.* 1. Allowing the temperature to go above 115 degrees Fahrenheit.

2. The aging of the electrolyte.

3. The adding of impure water to replace that lost by evaporation.

**Ques. 2.156.** What is the cause of the heat developed within a storage cell under charge or discharge condition?

*Ans.* Charging or discharging the cell at too high a rate, raising the  $I^2R$  drop.

**Ques. 2.157.** How may a dry cell be tested to determine its condition?

*Ans.* By a voltage test under normal full-load conditions.

**Ques. 2.158.** What will be the result of discharging a lead-acid storage cell at an excessively high current rate?

*Ans.* The only damage from a too heavy discharge rate is to the connecting leads and wires. The battery itself will not be affected unless overdischarged.

**Ques. 2.159.** What is the approximate fully charged voltage of an Edison storage cell?

*Ans.* 1.37 volts.

**Ques. 2.160.** A 6-volt storage battery has an internal resistance of 0.01 ohm. What current will flow when a 3-watt, 6-volt lamp is connected?

*Ans.* The internal resistance is neglected. It may be assumed that the question reads, what current flows through a 3-watt, 6-volt lamp.

*Solution:*

$$I = \frac{W}{E} = \frac{3}{6} = 0.5 \text{ ampere.}$$

**Ques. 2.161.** What is the approximate fully charged voltage of a lead-acid cell?

*Ans.* 2.10 volts.

**Ques. 2.162.** Why is low internal resistance desirable in a storage cell?

*Ans.* The capacity of the cell is determined, in part, by its internal resistance. Therefore, the lower the internal resistance the greater will be the output capacity of the cell.

**Ques. 2.163.** How may the condition of charge of an Edison cell best be determined?

*Ans.* Inasmuch as the specific gravity of the electrolyte of the Edison cell does not vary during charge and discharge, the only practical method of ascertaining the condition of charge

in the Edison cell is to take a voltage reading under normal load conditions. An ampere-hour meter, if available on the charging panel, will show directly the amount of charge in a battery.

**Ques. 2.164.** If the charging current through a storage battery is maintained at the normal rate, but its polarity is reversed, what will result?

*Ans.* It is obvious that the battery would then be in series with the charging generator instead of being parallel to it. Hence, the battery would be discharged instead of charged. In time, severe sulphation would result and the battery might be ruined.

**Ques. 2.165.** What are the effects of sulphation?

*Ans.* When a cell discharges, sulphate of lead is being formed on the plates. When the cell is charged, this sulphate of lead is forced back into the electrolyte. If the charging process is discontinued before all the sulphate of lead is reconverted, a residue will remain. When the next discharge cycle occurs, this residue will be present in addition to the newly formed sulphate of lead. If, then, again the recharging process is not sufficient to reconvert all of the lead sulphate, a condition will be reached where an excessive amount of sulphate of lead is on the surface of the plate. The cell is then said to be "sulphated." The effects of sulphation are lowered cell capacity and output voltage.

**Ques. 2.166.** How may the state of charge of a lead-acid storage cell be determined?

*Ans.* There are three methods of testing a lead cell for state of charge, as follows:

1. Observe the reading of the ampere-hour meter.
2. Take a specific gravity reading of the electrolyte with a hydrometer.



3. Measure the voltage of the battery under load. The first two tests are most desirable.

**Ques. 2.167.** Why is laminated iron or steel generally used in the construction of the field and armature cores of motors and generators instead of solid metal?

*Ans.* To reduce eddy currents. If a solid core were used, excessive heating would result from the unhindered formation of eddy currents throughout the entire core material. By using laminated iron or steel, the formation of eddy currents is retarded to a negligible value.

**Ques. 2.168.** What is the purpose of commutating poles or interpoles in a direct-current motor?

*Ans.* Commutating poles are provided to counteract the self-induction in the armature coil, which is in contact with the brush. This reduces sparking at the brushes to a minimum because the reversal of current in the armature comes while the armature coils are still short-circuited by the brush, and the self-induction effect present is low.

**Ques. 2.169.** How may the output voltage of a separately excited alternating-current generator, at constant output frequency, be varied?

*Ans.* This may be accomplished by varying the excitation voltage through the medium of a variable rheostat (resistance) in series with the field.

**Ques. 2.170.** If the field of a shunt-wound direct-current motor were opened while the machine was running under no load, what would be the probable result(s)?

*Ans.* If the field of a shunt-wound machine is opened while the machine is running, the counter e.m.f., ordinarily generated in the armature by the field, disappears with the result that the machine will race badly and possibly damage itself by its excessive speed. The armature may burn out.

**Ques. 2.171.** Name four causes of excessive sparking at the brushes of a direct-current motor or generator.

*Ans.* There are many causes for excessive sparking at the brushes of a direct-current machine as follows:

1. Overloaded.
2. Poor brush fitting or worn brush.
3. Open in armature circuit.
4. High commutator bar.
5. Dirty commutator.
6. Too rapid starting.
7. Brushes off neutral point.

**Ques. 2.172.** What is the purpose of a commutator on a direct-current motor? On a direct-current generator?

*Ans.* On a motor, the purpose of the commutator is periodically to apply the correct polarity of current flow to each armature coil. On a generator, the purpose of the commutator is periodically to reverse the polarity of the output voltage. The commutator is effectively a rectifier.

**Ques. 2.173.** What is meant by "counter e.m.f." in a direct-current motor?

*Ans.* The "counter e.m.f." in a direct-current motor is the e.m.f. induced in the armature winding when it rotates in the motor field. The counter e.m.f. is of opposite polarity to the applied e.m.f. Therefore, it acts as a limiting device on the speed of the machine.

**Ques. 2.174.** What determines the speed of a synchronous motor?

*Ans.* The frequency of the alternating current ( $f$ ) supplied to the motor and the number of its pairs of poles ( $P$ ).  
( $S = 120f/P$  r.p.m.)

**Ques. 2.175.** Describe the action and list the main characteristics of a shunt-wound direct-current motor.

*Ans.* The principal characteristic of the shunt-wound motor is that it will maintain a fairly constant speed under varying load conditions. Action is such that when the motor has reached full speed without load, the counter e.m.f. is almost the same as the e.m.f. supplied to the motor. Hence, the motor is drawing a minimum current. As soon as a load is applied to the motor, it tends to slow down, but as it does so the counter e.m.f. becomes less, which compensates for the load drag by allowing the machine to increase its speed.

**Ques. 2.176.** Describe the action and list the main characteristics of a series direct-current motor.

*Ans.* See Ques. 6.226.

**Ques. 2.177.** Describe the action and list the main characteristics of a series direct-current generator.

*Ans.* The field of the series direct-current generator is in series with its armature. Hence, it must carry the full-load current delivered by the machine. For this reason, the field consists of a few turns of heavy wire. The principal characteristics of the series direct-current generator is variable output voltage under variable load conditions; *i.e.*, the output voltage depends on the amount of load the machine is carrying. Because of this characteristic the series direct-current generator has practically no useful applications.

**Ques. 2.178.** List the main advantages of a full-wave rectifier as compared with a half-wave rectifier.

*Ans.* The main advantages of a full-wave rectifier are low hum level, higher average output voltages, increased current-carrying capacity, and lower filter component requirements. The increased filtering advantages are obtained owing to the doubling of the output ripple frequency.

**Ques. 2.179.** Why may a transformer not be used with direct current?

*Ans.* An excessive current flow would result, and the transformer primary may burn out. The transformer works on the principle of induction, which requires a changing magnetic field to induce an electromotive force into its secondary winding. Only a pulsating direct current such as is developed by a mechanical vibrator or an alternating current will produce this effect. Another viewpoint is the fact that only pulsating or alternating current in the primary will limit the current flow because of its reacting effect upon the source electromotive force. The primary offers only its low direct-current resistance to the flow of direct current, while with alternating current the current flow through the winding is limited by resistance and reactance (impedance).

**Ques. 2.180.** What are the primary advantages of a high-vacuum rectifier as compared with the hot-cathode mercury-vapor rectifier?

*Ans.* The principal advantages of the high-vacuum rectifier are that it may have higher maximum-peak, inverse-voltage, and power-output ratings. Although the voltage regulation of the high-vacuum-type rectifier is not so satisfactory as the hot-cathode mercury-vapor rectifier, the high-vacuum rectifier will stand a greater amount of abuse under high-power load conditions than will the mercury-vapor type. This is particularly true of the filaments in these tubes, the mercury-vapor tube's filament being susceptible to damage under improper operating conditions.

**Ques. 2.181.** What are the primary characteristics of a gas-filled rectifier tube?

*Ans.* This type of amplifier tube operates upon the principle of "ionization due to collision." Some of its characteristics are as follows:

1. High current-carrying ability.
2. Low and constant voltage drop while conducting.
3. Good voltage regulation.

4. Cathode easily damaged by overload.
5. "Flash back" will result from excessive inverse peak voltages.
6. Must be used with choke-input filter to limit starting current.
7. Steep current wave fronts produce radio-frequency and audio-frequency "hash" which must be filtered to reduce interference.

**Ques. 2.182.** What are the primary advantages of a mercury-vapor rectifier as compared with the thermionic high-vacuum rectifier?

*Ans.* The primary advantage of a mercury-vapor rectifier is that it has a voltage drop in the tube of only 15 volts under normal operating conditions, regardless of load. The voltage drop in the high-vacuum rectifier tube varies with the load conditions. Because of the low drop in the mercury-vapor type, there is less heat dissipated in the tube, and the tube, therefore, is usually self-cooling. On the other hand, owing to the high-voltage drop under heavy load conditions in the high-vacuum type of rectifier, the tube must dissipate a considerable amount of heat. This makes it necessary to use a water jacket on the high-power type of tube. Also, because of the low internal voltage drop in the mercury-vapor rectifier tube, the voltage regulation is better with this tube than it is with the high-vacuum type. High-vacuum-type rectifier tubes are used in both receivers and transmitters. Water-cooling is necessary, of course, only in the high-power transmitter types.

**Ques. 2.183.** Why is it desirable to have low-resistance filter chokes?

*Ans.* The lower the resistance of the filter chokes the less the voltage drop around these chokes and the greater the value of voltage available at the output terminals.

**Ques. 2.184.** When filter condensers are connected in series, resistors of high value are often connected across the terminals of the individual condensers. What is the purpose of this arrangement?

*Ans.* To distribute the voltage strain evenly between the condensers and to discharge the condensers after shutdown.

**Ques. 2.185.** What is the primary purpose of a bleeder as used in a filter system?

*Ans.* The purpose of a bleeder as used in a filter system is to improve the regulation of the system. The bleeder also serves to discharge the filter condensers after shutdown, thus providing protection to the personnel against shock.

**Ques. 2.186.** Describe the construction and characteristics (1) of a thermocouple type of meter, (2) of a wattmeter.

*Ans.* Figures 2-29 and 2-30 illustrate the component parts of a thermocouple and a wattmeter, respectively.

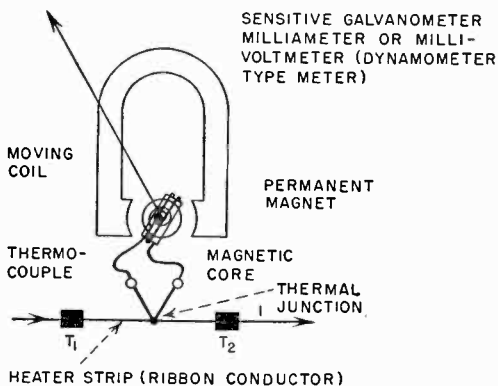

FIG. 2-29. Thermocouple type of meter.

The thermocouple ammeter consists of a sensitive millivoltmeter or a D'Arsonval moving-coil (galvanometer) type of meter. The thermocouple is connected to the leads of the mov-

ing coil through the spiral torque springs. The thermo junction of dissimilar metals is joined to a current-conducting strip. When an alternating high-frequency or low-frequency current flows along the strip, heat generated at the thermo junction develops a direct-current e.m.f. at the free ends of the thermocouple. The heating effect therefore is proportional to the square of the current. Both direct and alternating currents can be measured with this type of meter.

The wattmeter illustrated in Fig. 2-30 consists of a voltage coil and current coil connected as shown. This type of instru-

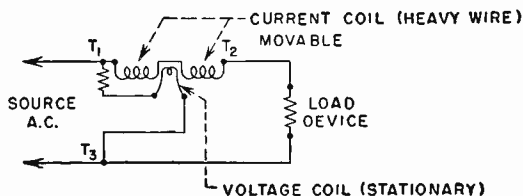

FIG. 2-30. Dynamometer type of wattmeter.

ment reads the true power  $EI$  power factor ( $\cos \theta$ ) directly in watts or kilowatts depending upon the calibration. True power is indicated because the torque of the movement is proportional to the product of  $EI \cos \theta$ .

**Ques. 2.187.** Describe the construction and characteristics of a D'Arsonval type of meter.

*Ans.* The D'Arsonval galvanometer or moving-coil type of meter illustrated in Fig. 2-29 operates upon the fundamental principles of a direct-current motor. A moving coil frame supported on pivots (armature) is positioned in the magnetic field of a permanent magnet. A current flowing through the coil creates a magnetic field which causes the lines of force produced by the coil and the permanent field to distort, resulting in a torque or twist of the moving-coil element. This type of instrument measures extremely small direct currents and is very sensitive. Only very small voltages must be applied to

avoid damage. The instrument can be used as a voltmeter or ammeter by providing series resistance or shunts, respectively. The deflection, when used on pure direct current alone, is proportional to the current and to the square root of the resistance.

In the measurement of alternating currents, the galvanometer, in conjunction with a copper oxide rectifier, is generally calibrated from a pure sine wave to give a scale indication which is the *effective* value of the wave. This effective value is evaluated from the average amplitude of the alternating-current wave.

If a rectifier and galvanometer are used for measuring direct-current values, the instrument measures the average value of the ripple or rectified frequency.

**Ques. 2.188.** Describe the construction and characteristics of a repulsion-type ammeter.

*Ans.* Figure 2-31 illustrates the construction of a repulsion or iron-vane type of meter.

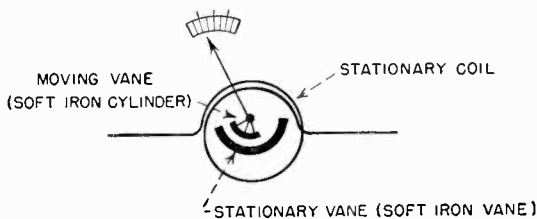

FIG. 2-31. Repulsion type of meter.

When a current flows through the stationary coil, a magnetic field is developed around it which, in turn, magnetizes the movable and stationary iron vane cylinders. The magnetization of the two vanes causes the two cylinders to repel each other, resulting in the displacement of the movable cylinder and corresponding movement of the pointer across the scale. It is important here to note that the induced magnetic polarity at each end of the cylinders is always the same, NN or SS, regardless of the direction of current flow. Hence the moving



coil and pointer will always move in one direction thus enabling the instrument to reach both direct- and alternating-current flow. This type of movement can be used to indicate effective values of volts and amperes.

**Ques. 2.189.** Describe the construction and characteristics of a dynamometer-type indicating instrument.

*Ans.* The dynamometer or electro-dynamometer type of meter is illustrated in Fig. 2-32. Its operation is the same as the galvanometer with the exception that no permanent mag-

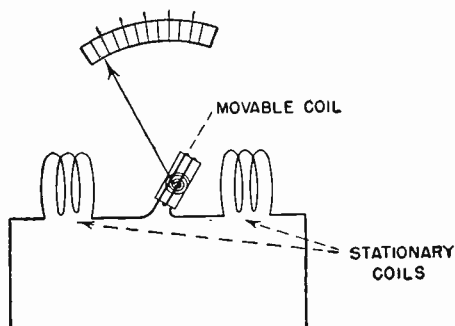

FIG. 2-32. Electro-dynamometer type of meter.

net is employed. The three coils are connected in series in such a manner that a current flowing through the coils in series results in a distortion of the magnetic field and causes the moving coil and pointer to move in a clockwise direction. The deflection is proportional to the square of the current. This type of meter can be used in both alternating- and direct-current circuits and reads the *effective* value of the voltage wave.

**Ques. 2.190.** If two voltmeters are connected in series, how would you be able to determine the total drop across both instruments?

*Ans.* The total voltage drop across both instruments would be the sum of the individual meter readings.

RADIO OPERATING QUESTIONS AND ANSWERS

**Ques. 2.191.** What type of meters may be used to measure radio-frequency currents?

*Ans.* The thermocouple ammeter and the hot-wire ammeter.

**Ques. 2.192.** If two voltmeters are connected in parallel, how may the total voltage drop across both instruments be determined?

*Ans.* The total voltage drop across both instruments would be the reading of either one of the meters.

**Ques. 2.193.** Why are copper oxide rectifiers, associated with direct-current voltmeters for the purpose of measuring alternating current, not suitable for the measurement of voltages at radio frequencies?

*Ans.* Copper oxide rectifiers are not suitable for the measurement of voltages at radio frequencies because at these frequencies the capacity of the rectifier unit would pass the radio-frequency current without rectification, thus making the reading inaccurate.

**Ques. 2.194.** If two ammeters are connected in parallel, how may the total current through the two meters be determined?

*Ans.* The total current through two ammeters connected in parallel is the sum of the individual meter readings.

**Ques. 2.195.** Is the angular scale deflection of a repulsion iron-vane ammeter proportional to the square or square root of the current or merely directly proportional to the current?

*Ans.* The scale deflection of a repulsion iron-vane ammeter is proportional to the square of the current.

**Ques. 2.196.** Does an alternating-current ammeter indicate peak, average, or effective values of current?

*Ans.* An alternating-current ammeter, exclusive of copper oxide types, indicates the effective value of current.

**Ques. 2.197.** If two ammeters are connected in series, how may the total current through the two meters be determined?

*Ans.* The total current through two ammeters connected in series is the average of the individual meter readings.

**Ques. 2.198.** How may a direct-current milliammeter, in an emergency, be used to indicate voltage?

*Ans.* By using it in series with a resistor of known value. This resistor must be of a value sufficiently great so that an excessive current will not flow through the meter and burn it out. The formula for figuring the value of the multiplier is as follows:

$$R = \frac{E_1 - E_2}{I} \text{ ohms,}$$

where  $E_1$  is the full-scale deflection desired.

$E_2$  is the voltage drop in the meter for full-scale deflection.

$I$  is the current flow in the meter for full-scale deflection.

**Ques. 2.199.** What is the purpose of multiplier resistance used with a voltmeter?

*Ans.* The purpose of the multiplier resistance, as used with a voltmeter, is to increase the range of the meter.

**Ques. 2.200.** What type of indicating instrument is best suited for use in measuring radio-frequency currents?

*Ans.* The thermocouple type of radio-frequency ammeter.

**Ques. 2.201.** What is the purpose of a shunt as used with an ammeter?

*Ans.* The purpose of a shunt  $R_s$  as used with an ammeter is to extend the current reading range of the instrument.

$$R_s = \frac{R_{\text{meter}}}{(N - 1)}$$

where  $N$  is the multiplication factor.

**Ques. 2.202.** What effects might be caused by a shorted grid condenser in a three-circuit regenerative receiver?

*Ans.* A short-circuited grid condenser in a three-circuit regenerative receiver would prevent rectification (detection) of the modulated signal. The automatic grid-biasing action due to the grid condenser and grid-leak combination would be eliminated. No regeneration or rectification would result unless a small amount of cathode bias is present in the circuit.

**Ques. 2.203.** What would be the effect of a short-circuited coupling condenser in a conventional resistance-coupled audio amplifier?

*Ans.* The effect of a short-circuited coupling condenser in a conventional resistance-coupled audio amplifier would be to allow the grid of the following tube to become positively biased, causing heavy grid and plate currents to flow. Under these conditions a continuous grid current and heavy plate current will flow, which completely alters the linearity of the operating curve and which results in severe distortion. In addition, the heavy  $IR$  drops in the plate circuit will result in a great decrease in plate potential and volume.

**Ques. 2.204.** What might be the cause of low sensitivity of a three-circuit regenerative receiver?

*Ans.* This condition may be the result of low plate voltage, reversed feedback coil winding, incorrect value or change in grid-leak resistance, leaky grid condenser, low filament potential, or defective tube.

**Ques. 2.205.** What is the effect of local action in a lead-acid storage cell, and how may it be compensated?

*Ans.* Local action tends to discharge the cell very slowly. Therefore, over a period of time, the capacity of a cell would be decreased. Local action is prevented as much as possible (1) by the manufacturer in making the active materials as pure as possible and (2) by keeping the cells on trickle charge.

**Ques. 2.206.** Why should adequate ventilation be provided in the room housing a large group of storage cells?

*Ans.* The room housing a large group of storage cells should be well ventilated in order to allow the escape of gas fumes generated during the charging process. Smoking must not be permitted, especially when the batteries are on charge. If covers are provided on the battery boxes, they should be removed during the charging period.

**Ques. 2.207.** When should distilled water be added to a lead-acid storage cell, and for what purpose is it added?

*Ans.* Distilled water should be added when the level of the electrolyte has been reduced below normal by evaporation. Distilled water is added because the batteries operate best when the plates are entirely covered by electrolyte.

**Ques. 2.208.** How may the polarity of the charging source to be used with a storage battery be determined?

*Ans.* If a suitable instrument is not at hand, the positive and negative sides of the line may be determined on circuits of 110 volts or less by dipping the ends of the two wires in a glass of water in which a very small amount of common table salt, potash, or acid electrolyte has been dissolved. Keep the wires about 1 inch apart. When there is current flowing, gas bubbles will form on both wires, but the wire where the greater amount of gas bubbles is being formed will be the negative side of the circuit.

Another method to determine the polarity of the line is to place the two wires about  $\frac{1}{4}$  inch apart on a wet piece of blue litmus paper. Where the positive wire touches the wet paper, a red mark will appear if current is flowing.

When employing these tests, the operator must use extreme care not to short-circuit the line or to get himself in contact with both sides of the line at once.

**Ques. 2.209.** Describe the care which should be given a group of storage cells to maintain them in good operating condition.

*Ans.* A battery equipment, regardless of type, should have careful attention. The electrolyte should be kept about  $\frac{1}{2}$  inch above the top of the plates by replacing loss due to evaporation with distilled water. The electrolyte level should never be maintained by replacing acid unless the electrolyte is in some way spilled out. The acid does not evaporate, it being the water in the electrolyte that is so reduced. It is important that the battery be kept fully charged, not only so that it may be ready for immediate use but also because it is best for the internal condition of the individual cells. The condition of charge of a lead-cell battery may be checked up by taking combined hydrometer and voltmeter readings of the individual cells. If the cells as a whole show comparatively low hydrometer readings, they should be charged. A low-voltage reading indicates the same condition. Radio batteries should be given a check-up about once a month. If a cell shows an unnatural condition such as low specific gravity reading and low-voltage reading, it may indicate sulphation or plate buckling, and it should be cut out of the circuit by disconnecting the lead-strap connectors and jumping the bad cell. As soon as possible the bad cell should be taken out and repaired. The battery should be promptly recharged when the voltage of the individual cell reaches 1.7 volts; therefore the voltage of the entire bank would read  $1.7 \times$  number of cells. A battery should not be charged more frequently than

once a week unless the service requires it. The few simple rules listed below apply to all cells.

1. Keep open flames away from the battery at all times.
  2. Replace spilled electrolyte before charging.
  3. When water in cell evaporates, add distilled or pure water.
  4. Never allow cells to remain in discharged condition.
  5. Mix electrolyte in clean earthen or glass jars.
  6. Allow solution to cool before putting into cell.
  7. Never pour water into sulphuric acid.
  8. Never allow salt to get into cell.
  9. Use only absolutely pure chemicals and water.
  10. Always provide plenty of ventilation.
  11. If burned by sulphuric acid apply ammonium hydroxide or baking soda.
  12. Don't charge at a too high rate.
  13. Don't discharge at a too high rate.
  14. When not in use, keep on trickle charge.
  15. Take frequent voltage readings.
  16. Take occasional hydrometer readings.
  17. Keep the level of the electrolyte about  $\frac{1}{2}$  inch above the plates by adding chemically pure water.
  18. Give an overcharge about once a month.
  19. Keep the tops of each battery dry to prevent current leakage.
  20. Keep all electrical connections free from corrosion by applying a very thin layer of vaseline after the connection has been made.
  21. Do not add acid unless some has been lost due to spilling or flooding, and not even then unless the specific gravity reading does not come up to normal after charging.
- Oversulphation may be caused by
1. Wrong specific gravity of electrolyte.
  2. Overdischarge.
  3. Allowing cell to remain too long in a discharged condition.

*RADIO OPERATING QUESTIONS AND ANSWERS*

**Ques. 2.210.** What may cause the plates of a lead-acid storage cell to buckle?

*Ans.* Overdischarge.

**Ques. 2.211.** What may cause sulphation of a lead-acid storage cell?

*Ans.* Sulphation is caused by improper charging over a long period of time. Overdischarge will also cause sulphation.

**Ques. 2.212.** What chemical may be used to neutralize a storage cell acid electrolyte?

*Ans.* Ammonia or sodium bicarbonate, commonly known as baking soda.

**Ques. 2.213.** What steps may be taken to prevent corrosion of lead-acid storage cell terminals?

*Ans.* The terminals should be kept clean and coated with a light coating of vaseline.

**Ques. 2.214.** Why are by-pass condensers often connected across the brushes of a high-voltage direct-current generator?

*Ans.* By-pass condensers are often connected across the brushes of a high-voltage direct-current generator to act as a protective device to prevent the generator windings from being punctured should a high-voltage kickback occur from the high-frequency circuits. These condensers are usually made up into a unit consisting of two condensers in series, the out terminals being connected across the generator and the center terminal to ground.

**Ques. 2.215.** What may cause a motor-generator bearing to overheat?

*Ans.* The bearing of a motor generator may be caused to overheat by the lack of sufficient lubrication. This, in turn, may be caused by a defective oil ring or, in the larger machines, by a defect in the lubricating oil line.



**Ques. 2.216.** How may the radio-frequency interference, often caused by sparking at the brushes of a high-voltage generator, be minimized?

*Ans.* Usually by the use of a ripple filter, consisting of two 1-microfarad condensers and a 10-henry heavy current capacity choke. In addition a radio-frequency filter consisting of radio-frequency chokes and radio-frequency by-pass condensers is sometimes used.

**Ques. 2.217.** Why are high-reactance head telephones generally more satisfactory for use with radio receivers than low-reactance types?

*Ans.* High-reactance or high-impedance telephones possess a greater ampere-turns ratio as compared with low-reactance types especially as related to weak-signal current flow. Hence they possess a greater sensitivity to weak signals. High-impedance-type telephones also provide a better load-impedance match to the output of an audio-frequency amplifier or detector tube.

**Ques. 2.218.** What may cause packing of the carbon granules in a carbon button microphone?

*Ans.* Excessive carbon current, jarring with current on.

**Ques. 2.219.** Why should polarity be observed in connecting head telephones directly in the plate circuit of a vacuum tube?

*Ans.* When the head telephones are connected directly in the plate circuit of a vacuum tube, direct current flows through their magnet windings. Unless the direction of this current is correct, this current will serve to demagnetize these magnets and render the head telephones insensitive. On the other hand, if the direction of this current is proper, the magnetic strength of the magnets will be kept up to normal.

RADIO OPERATING QUESTIONS AND ANSWERS

**Ques. 2.220.** What precautions should be observed in the use of a double-button carbon microphone?

*Ans.* The current should be balanced in each button and should not exceed 30 milliamperes. The microphone should not be handled with the current on. The sound level impressed on the diaphragm of the microphone should not be high enough to cause "blasting." This type of microphone should be kept dry and free from exposure to moisture.

**Ques. 2.221.** If low-impedance head telephones of the order of 75 ohms are to be connected to the output of a vacuum-tube amplifier, how may this be done to permit most satisfactory operation?

*Ans.* To do this satisfactorily, an output transformer must be used. The input side of this transformer must have an impedance equal to at least twice the tube's plate resistance. The output must be designed to make the head telephones' load reflect the desired impedance to the tube. This is done by using the proper turns ratio  $N$ , where  $N = \sqrt{\frac{R_p}{R_L}}$  (approximately), where  $R_p$  = plate resistance and  $R_L$  = the load resistance.

**Ques. 2.222.** What is the effect on the resonant frequency of adding an inductor in series with an antenna?

*Ans.* The resonant frequency of the antenna system will be decreased.

**Ques. 2.223.** What is the effect on the resonant frequency of adding a capacitor in series with an antenna?

*Ans.* The resonant frequency of the antenna system will be increased.

**Ques. 2.224.** What is the velocity of propagation of radio-frequency waves in space?

*Ans.* Three hundred million meters per second or 186,000 miles per second.

**Ques. 2.225.** What is the relationship between the electrical and physical length of a Hertzian antenna?

*Ans.* A Hertz antenna will radiate a wave equal to approximately twice its physical length.

**Ques. 2.226.** If you desire to operate on a frequency lower than the resonant frequency of an available Marconi antenna, how may this be accomplished?

*Ans.* This may be accomplished by adding an inductance in series with the antenna. This will make the antenna resonant at a lower frequency.

**Ques. 2.227.** What will be the effect upon the resonant frequency if the physical length of a Hertzian antenna is reduced?

*Ans.* The resonant frequency of the antenna will be higher.

**Ques. 2.228.** Which type of antenna has a minimum of directional characteristics in the horizontal plane?

*Ans.* The single-radiator vertical antenna.

**Ques. 2.229.** What factors determine the resonant frequency of any particular antenna?

*Ans.* The physical length of the antenna determines the resonant frequency, depending upon the type of antenna used, *i.e.*, whether it is grounded or ungrounded. The wavelength of the grounded antenna is approximately 4.2 to 4.5 times its physical length. The Hertz ungrounded antenna has a wavelength of twice its physical length.

**Ques. 2.230.** If the resistance and the current at the base of a Marconi antenna are known, what formula could be used to determine the power in the antenna?

*Ans.* The formula used would be  $I^2R$ , where  $I$  is the current at the base of the antenna and  $R$  is the radiation resistance.

**Ques. 2.231.** Does the resistance of a copper conductor vary with variations in temperature and if so, in what manner?

*Ans.* The resistance of a copper conductor varies directly with any change in temperature; *i.e.*, as the heat increases, the resistance increases and vice versa.

**Ques. 2.232.** What type of insulator is best suited for use as an antenna strain insulator which is exposed to the elements?

*Ans.* Electrical glazed porcelain is best suited for use as an antenna strain insulator.

**Ques. 2.233.** What material is frequently used for relay contacts? Why?

*Ans.* Silver, because it has low resistance, exhibits a minimum amount of corrosion, and does not pit easily. Tungsten is also commonly used.

**Ques. 2.234.** Describe the operation of a crystal detector (rectifier).

*Ans.* A simple radio receiver using a crystal detector is comprised of a radio-frequency transformer, a variable tuning condenser, a galena or silicon crystal, and a pair of high-resistance telephones (2,000 to 8,000 ohms) shunted by a small radio-frequency by-pass condenser (0.0001 to 0.0005 microfarads).

The unilateral conductivity of the crystal permits a current to flow through it in one direction only and thereby makes it possible to "detect" a modulated radio-frequency wave and produce an audible response in the telephones.

The operation is as follows: When the tuned circuit is adjusted to resonance for a given modulated signal frequency, an alternating high-frequency voltage, which is varying in amplitude in accordance with the modulating frequency, is

developed across the tuned circuit. Owing to the rectifying action of the crystal, the low-frequency and high-frequency components of the signal pass through the circuit in one direction only. The rectified radio-frequency pulses pass through the by-pass condenser, and the low-frequency tonal groups pass through the telephones. The high impedance of the small by-pass condenser to the audio frequencies enables the full audio-frequency voltage of the rectified modulated signal to act across the high-impedance telephones. Thus, a series of low-frequency pulses actuates the diaphragm through the telephone windings to produce an audible response. The detecting action is therefore simply a process of changing the high-frequency signal to a low-frequency signal by the crystal rectifying action.

**Ques. 2.235.** Define a "damped wave."

*Ans.* A "damped wave" may be defined as an oscillatory wave train, the energy of which gradually decreases with time until the wave is damped out. It may also be defined as a series of pulses in which the successive amplitude of each peak of a pulse group gradually diminishes or decays.

**Ques. 2.236.** Why is rosin used as soldering flux in radio construction work?

*Ans.* In soldering, any acid will in time cause corrosion, thus increasing the resistance of the electrical connection. Pure rosin when used as a flux produces no corrosion and is, therefore, used in all high-grade radio work.

**Ques. 2.237.** What is meant by a "harmonic"?

*Ans.* A "harmonic frequency" is a multiple of the fundamental frequency. In radio work, the initial frequency is regarded as the first harmonic, the second multiple of this frequency being the second harmonic, the third multiple of this frequency the third harmonic, and so forth.

**Ques. 2.238.** Why should all exposed metal parts of a transmitter be grounded?

*Ans.* To protect the operator from coming in contact with a high voltage, thus protecting him against serious or fatal shock. It is also employed to minimize electrostatic coupling of components with respect to ground.

**Ques. 2.239.** What is the difference between electrical power and electrical energy?

*Ans.* Energy is defined as work. The fundamental practical unit of work is the *joule* or *watt-second*. Power is the rate of doing work, or the rate at which energy is expended. The practical unit is the *watt*.

**Ques. 2.240.** How can the direction of flow of direct-current electricity in a conductor be determined?

*Ans.* The direction of flow of direct-current electricity can be determined by any one of the following means:

1. A direct-current ammeter.
2. Determining the polarity of the source e.m.f. The electron flow will be in the direction of the positive point of potential or away from the negative point in a closed electric circuit.
3. A compass needle placed near a conductor carrying a direct-current flow. Application of Fleming's right-hand rule and positioning of the compass needle with known polarity will determine the direction of current flow.
4. Passing the current through a saline solution. (See also Ques. 2.208.)

**Ques. 2.241.** What instrument measures electric power?

*Ans.* The wattmeter.

**Ques. 2.242.** What instrument measures electrical energy?

*Ans.* The watt-hour meter.

**Ques. 2.243.** What is an electron? An ion?

*Ans.* An *electron* is a negatively charged particle of electricity. An *ion* is a positively or negatively charged atom or group of atoms. An atom that has lost or gained one or more of its electrons is referred to in chemistry as a positive or a negative ion, respectively.

With gas-filled tubes the bombardment of electrons with gas atoms causes the atoms to lose one or more of their electrons. In this case only positive ionization occurs.

**Ques. 2.244.** With respect to electrons, what is the difference between conductors and nonconductors?

*Ans.* A conductor is a material in which the total atomic structure contains many *free electrons*. A nonconductor or insulator is a material in which the total atomic structure is lacking in the number of free electrons.

**Ques. 2.245.** Describe an electrolyte.

*Ans.* An electrolyte is a water solution of an acid, alkali, or a salt of sufficient concentration to carry an electric current. In such a solution the molecules break down to form ions that are the carriers of the current.

**Ques. 2.246.** What is an A battery? B battery? C battery?

*Ans.* The terms "A," "B," and "C" batteries are used to denote the filament voltage, plate voltage, and grid biasing supply voltages, respectively, for vacuum tubes.

An A battery is a battery for heating the filaments of vacuum tubes.

A B battery is a battery for supplying positive potentials to the plate, screen grid, and occasionally other electrodes of vacuum tubes with respect to the cathodes or filaments.

A C battery is a battery for supplying negative grid voltage (bias) to vacuum tubes with respect to the cathodes or filaments.

**Ques. 2.247.** What are the lowest radio frequencies useful in radio communication?

*Ans.* Frequencies between 10 and 30 kilocycles. These frequencies are called VLF or very low radio frequencies.

**Ques. 2.248.** What radio frequencies are useful for long-distance communications requiring continuous operation?

*Ans.* Frequencies in the VLF (10 to 30 kilocycles) range are commonly employed for long-distance point-to-point communications.

**Ques. 2.249.** What frequencies have substantially straight-line propagation characteristics analogous to those of light waves and unaffected by the ionosphere?

*Ans.* Frequencies between 30 and 30,000 megacycles possess substantially straight-line propagation characteristics. This range of frequencies is classified into three groups:

VHF (very high radio frequencies) 30 to 300 megacycles.

UHF (ultra-high radio frequencies) 300 to 3,000 megacycles.

SHF (super-high radio frequencies) 3,000 to 30,000 megacycles.

**Ques. 2.250.** What effect do sunspots and aurora borealis have on radio communications?

*Ans.* Sunspots and aurora borealis may produce severe fading and absorption of radio signals. Long-distance transmissions that depend upon the ionosphere for reflections may be completely blanketed during magnetic storms caused by aurora borealis or sunspots.

**Ques. 2.251.** What type of modulation is largely contained in "static" and "lightning" radio waves?

*Ans.* A highly damped (broad response) wave of amplitude-modulation characteristic.



**Ques. 2.252.** What type of radio receivers do not respond to static interference?

*Ans.* Receivers employing the principle of frequency modulation.

**Ques. 2.253.** What crystalline substance is widely used in crystal oscillators?

*Ans.* Crystal slabs cut from natural quartz.

**Ques. 2.254.** Why is the crystal in some oscillators operated at constant temperature?

*Ans.* Some crystals require constant temperature control to hold the frequency of the crystal to its assigned value. This is due to the fact that certain types of crystals have a positive-temperature coefficient while others have a negative temperature coefficient. (See also Ques. 3.110.)

**Ques. 2.255.** What is meant by "negative temperature coefficient" of a quartz crystal when used in an oscillator?

*Ans.* (See Ques. 3.113.)

**Ques. 2.256.** What is the seventh harmonic of 360 kilocycles?

*Ans.* 2,520 kilocycles.

*Solution:*

$$360 \times 7 = 2,520.$$

**Ques. 2.257.** Describe the directional characteristics of the following types of antenna :

- (a) Horizontal Hertz antenna
- (b) Vertical Hertz antenna
- (c) Vertical loop antenna
- (d) Horizontal loop antenna
- (e) Vertical Marconi antenna

RADIO OPERATING QUESTIONS AND ANSWERS

*Ans.* a. Bidirectional characteristic in the horizontal plane.

b. Bidirectional characteristic in the vertical plane.

c. Bidirectional characteristic in the horizontal plane.

d. Bidirectional characteristic in the vertical plane.

e. Equidirectional characteristic in the horizontal plane.

**Ques. 2.258.** What is meant by the "efficiency" of a radio device?

*Ans.* The efficiency of any ratio device is the ratio of the work performed to the energy supplied to it. It is a measure, usually expressed in percentage, of the ratio of the output to the input of any device, with both output and input expressed in the same unit of power or energy.

$$\text{Per cent efficiency } (n) = \frac{\text{output}}{\text{input}} \times 100.$$

**Ques. 2.259.** What form of energy is contained in a sound wave?

*Ans.* Sound is composed of mechanical vibrations (acoustic energy) lying within the frequency range of human audibility.

**Ques. 2.260.** What characteristic determines the pitch of a sound?

*Ans.* The pitch of a pure tone is primarily dependent upon the frequency or number of vibrations per second and to a slight degree upon the sound intensity.

**Ques. 2.261.** How many micromicrofarads are there in 1 microfarad?

*Ans.* One microfarad contains 1,000,000 or  $10^6$  micro-microfarads. A micro unit is a millionth part of one.

**Ques. 2.262.** What is the difference between a milliwatt and a kilowatt?

*Ans.* Milli = one-thousandth part of 1 or 0.001. Kilo = 1,000.

A milliwatt is one-thousandth part of 1 watt or 0.001 watt. A kilowatt is equal to 1,000 watts.

**Ques. 2.263.** What precaution should be observed when electrolytic capacitors are connected in a circuit?

*Ans.* The correct polarity must be observed, since the electrolytic type of capacitor functions as a condenser only when its positive terminal is connected to the corresponding potential point in the circuit.

**Ques. 2.264.** Show by a diagram how to connect battery cells in series.

*Ans.* (See Fig. 6-12.)

**Ques. 2.265.** Show by a diagram how to connect battery cells in parallel.

*Ans.* (See Fig. 6-12.)

**Ques. 2.266.** What material is used in the electrodes of a dry cell?

*Ans.* The electrodes in a dry cell are composed of a rod or plate of carbon material (positive plate) and a zinc container (negative plate). The electrolyte is an absorbent material saturated with a solution of sal ammoniac and manganese dioxide or zinc chloride.

**Ques. 2.267.** If the period of one complete cycle of a radio wave is 0.000001 second, what is the wavelength?

*Ans.* 300 meters.

*Solution:*

$$\text{Frequency } (f) = \frac{1}{T} = \frac{1}{0.000001} = 10^6 \text{ cycles,}$$

$$\text{Wavelength } (\lambda) = \frac{v}{f} = \frac{300,000,000}{10^6} = 300 \text{ meters,}$$

RADIO OPERATING QUESTIONS AND ANSWERS

where  $f$  = frequency in cycles per second.

$T$  = time period of one cycle in seconds.

$\lambda$  = wavelength in meters per second.

$v$  = velocity of light.

**Ques. 2.268.** Compare the selectivity and sensitivity of the following types of receivers: (a) tuned radio-frequency receiver, (b) superregenerative receiver, (c) superheterodyne receiver.

*Ans.* The comparative selectivity and sensitivity of tuned radio-frequency, superregenerative, and superheterodyne receivers are classified as follows:

Receiver	Sensitivity	Selectivity
Superheterodyne.....	Excellent	Excellent
Tuned radio-frequency.....	Good	Good
Superregenerative.....	Good	Poor

**Ques. 2.269.** What type of radio receivers contain intermediate-frequency transformers?

*Ans.* The superheterodyne receiver.

**Ques. 2.270.** What type of radio receiver is subject to image interference?

*Ans.* The superheterodyne receiver.

**Ques. 2.271.** What type of radiotelephone receiver using vacuum tubes does not require an oscillator?

*Ans.* The tuned radio-frequency type of receiver.

**Ques. 2.272.** Describe the operation of a regenerative type of receiver.

*Ans.* The theoretical operation of this type of receiver is based upon the principle of inductive or capacitive feedback

of radio-frequency energy from the plate to the grid circuit. (See also Ques. 2.91 and 6.46.)

**Ques. 2.273.** How may a regenerative type of receiver be adjusted for maximum sensitivity?

*Ans.* (See Ques. 6.46.)

**Ques. 2.274.** What effect does the reception of modulated signals have on the plate current of a grid-leak-grid-capacitor type of detector? On a grid-bias type of detector?

*Ans.* The plate current pulses will decrease when a modulated signal is applied to the grid circuit of grid-leak type of detector.

In the grid-bias type of detector the opposite holds true, since the grid is biased almost to the point of plate current cut-off when no signal is applied. An incoming modulated signal, therefore, will cause the negative bias to decrease, resulting in a rise in plate current. (See also Ques. 2.131, 5.45, 5.46, 5.47.)

**Ques. 2.275.** What is meant by "double" detection in a receiver?

*Ans.* Double detection is the name applied when demodulation (detection) occurs in two circuits of the same receiver. The superheterodyne receiver uses this principle. The first detector is the stage in which the mixing action necessary to produce the intermediate frequency takes place. The second detector follows the last intermediate-frequency stage and converts the modulated signal into the audio-frequency component. (See also Ques. 5.76.)

**Ques. 2.276.** What is the purpose of a wave trap in a radio receiver?

*Ans.* A wave trap is employed in a radio receiver to reject undesired signals. In practice, a series type of wave trap is sometimes shunted across the input terminals of a superheterodyne radio receiver to eliminate code interference.

## RADIO OPERATING QUESTIONS AND ANSWERS

Wave traps are also employed in certain wide-band receivers to isolate certain frequency bands.

**Ques. 2.277.** What is the purpose of an oscillator in a receiver operating on a frequency near the intermediate frequency of the receiver?

*Ans.* An oscillator operating near the intermediate frequency of a superheterodyne receiver is used for producing a beat frequency. This would permit the receiver to respond to continuous-wave signals for code reception or for continuous-wave calibration purposes in standard frequency transmissions. (See also Ques. 4.111.)

**Ques. 2.278.** Explain the purpose and operation of the first detector in a superheterodyne receiver.

*Ans.* (See Ques. 5.76.)

**Ques. 2.279.** What is a "getter" in a vacuum tube?

*Ans.* A "getter" in a vacuum tube is a small trough-shaped metal or ribbon made of barium or tantalum. This device is inserted in all types of vacuum tubes to remove stray gases that remain after the process of evacuation.

**Ques. 2.280.** What is "space charge" in a vacuum tube?

*Ans.* "Space charge" is the term used for the accumulation or field of electrons around the hot filament or cathode of a vacuum tube.

**Ques. 2.281.** Explain the operation of a triode vacuum tube as an amplifier.

*Ans.* Amplification is the process of increasing the amplitude of a signal through the control by signal input of power supplied from a local source to the output circuit. The amplification of a signal is the ratio of the signal output amplitude to the signal input amplitude, both expressed in the same terms.

The ability of a triode vacuum tube to amplify is based upon the fundamental fact that a small change in grid voltage applied between the grid and the cathode of such a tube will produce large changes of plate current. This is due to the effective control of the negative space charge by the grid because of its close proximity to the cathode. Hence, when small signal voltages are applied to the grid, the normal plate current is varied in accordance with the signal swing. This results in relatively larger voltages being developed across the plate load impedance or resistance.

The amplifying action of a triode, therefore, depends upon the geometry of the tube and its circuit relations.

$$\text{Amplification} = \frac{MuR_L}{R_p + R_L},$$

where  $Mu$  = amplification factor of the tube.

$R_L$  = plate-load resistance or impedance.

$R_p$  = plate resistance of the tube.

(See also Ques. 4.127.)

**Ques. 2.282.** What is the approximate efficiency of a class A vacuum-tube amplifier? Of a class B? Of a class C?

*Ans.* The approximate practical engineering operating efficiencies of the three main classes of amplifiers are

1. Class A, 20 to 25 per cent.
2. Class B, 33 per cent.
3. Class C, 50 to 60 per cent.

**Ques. 2.283.** Does direct-current grid current normally flow in a class A amplifier employing one tube?

*Ans.* No. If the signal voltage swing is maintained within the straight portion of the  $I_B-E_C$  characteristic curve and does not exceed the fixed biasing voltage during positive peaks, no grid current will flow.

**Ques. 2.284.** Why must some radio-frequency amplifiers be neutralized?

## RADIO OPERATING QUESTIONS AND ANSWERS

*Ans.* In general, triode radio-frequency amplifiers must be neutralized to prevent self-oscillation due to the possibility of feedback through the internal grid-plate capacitance of the tube. (See also Ques. 3.01.)

**Ques. 2.285.** Describe how a vacuum tube oscillates in a circuit.

*Ans.* A vacuum tube used in conjunction with an oscillatory circuit produces continuous oscillations if the plate-circuit energy is coupled either magnetically or electrostatically to the grid circuit, provided that the feedback energy is of proper amplitude and phase relationship. The grid must be out of phase with the plate by 180 degrees. The vacuum-tube oscillator is in reality a self-excited amplifier in which the feedback voltages supply the inherent grid-circuit losses.

**Ques. 2.286.** Is the direct-current bias normally positive or negative in a class A amplifier?

*Ans.* The direct-current bias in a class A amplifier is normally negative. The bias is generally maintained at a value that permits operation at the center of the straight portion of the  $I_B-E_C$  characteristic curve. This type of operation permits the symmetrical reproduction of the input wave form in the plate circuit.

**Ques. 2.287.** What is the composition of filaments, heaters, and cathodes in vacuum tubes?

*Ans.* Thoriated tungsten and oxide-coated metals are the most commonly used cathode and filament-emitting materials. The base is generally of tungsten, nickel, or konal alloy coated with thorium or barium carbonates.

**Ques. 2.288.** What is the direction of electronic flow in the plate and grid circuits of vacuum-tube amplifiers?

*Ans.* Electrons in the plate circuit of a vacuum tube flow from the cathode to the plate and return to the cathode



through the plate supply circuit. Electrons flow in the grid circuit from the cathode to the grid and through the grid return circuit to the cathode. Grid-current flow in general takes place only during periods in which the positive peaks of the grid-signal voltage exceed the negative grid-bias voltage.

**Ques. 2.289.** Draw a diagram showing a method of obtaining grid bias to an indirectly heated cathode type of vacuum tube by use of a resistance in the cathode circuit of the tube.

*Ans.* See Fig. 2-11.

**Ques. 2.290.** Draw a diagram showing a method of obtaining grid bias to a filament type of vacuum tube by use of a resistance in the plate circuit of the tube.

*Ans.* See Fig. 2-33.

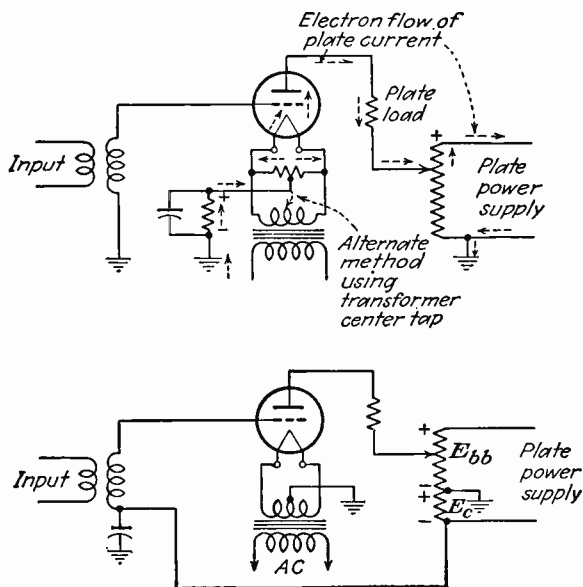

FIG. 2-33.

**Ques. 2.291.** What is the impedance of a solenoid if its resistance is 5 ohms and 0.3 ampere flows through the winding when 110 volts at 60 cycles is applied to the solenoid?

*Ans.* The impedance of the solenoid is  $366\frac{2}{3}$  ohms.

*Solution:*

$$Z = \frac{E}{I} = \frac{110}{0.3} = 366\frac{2}{3} \text{ ohms.}$$

**Ques. 2.292.** What is the conductance of a circuit if 6 amperes flow when 12 volts direct current is applied to the circuit?

*Ans.* The conductance  $G$  is 0.5 mhos.

*Solution:*

$$R = \frac{E}{I} = \frac{12}{6} = 2 \text{ ohms.}$$

$$G = \frac{1}{R} = \frac{1}{2} = 0.5 \text{ mho.}$$

$$G = \frac{I}{E} = \frac{6}{12} = 0.5 \text{ mho.}$$

(See also Ques. 2.36.)

**Ques. 2.293.** What is the relationship between the effective value of a radio-frequency current and the heating value of the current?

*Ans.* The effective value of an alternating current may be defined as that value which will produce the same heating effect as a direct current of the same amount. The heating effect of a current is proportional to the square of the current,  $I^2R$ .

**Ques. 2.294.** What safety precautions should a person observe when making internal adjustments to a television receiver to avoid personal injury?

*Ans.* The following safety precautions must be observed when making internal adjustments on *any* type of high-voltage equipment:

**DON'T BE CARELESS. IT MAY COST YOU YOUR LIFE!**

1. Make certain that the interlock switch is open.
2. Remove the high-voltage power-supply fuse before testing the circuit. Complete all tests on low-voltage power-supply circuits. If trouble in the high-voltage circuit is apparent and a test other than simple point-to-point resistance tests *must* be made, reinsert the high-voltage fuse and close the interlock switch but observe the following precautions:
3. Make voltage checks using only one hand. Keep the other hand in your pocket.
4. Do not allow any part of body to touch the chassis or other metal objects.
5. Use long insulated tools and test prods.
6. Exercise great care in the handling of the cathode-ray tube in a television receiver or transmitter. Careless handling may result in a serious implosion. Gloves and goggles provide an additional safety factor.

*Installation:* Keep antennas and lead-in wires away from all high-tension power circuits. Insulate all exposed wires wherever possible.

**Ques. 2.295.** With measuring equipment that is widely available, is it possible to measure a frequency of 10,000,000 cycles to within 1 cycle of the exact frequency?

*Ans.* No. Specially designed precision equipment is required for this high degree of accuracy.

**Ques. 2.296.** Do oscillators operating on adjacent frequencies have a tendency to synchronize oscillation or drift apart in frequency?

*Ans.* Coupled oscillators tend to *lock together* in frequency.

RADIO OPERATING QUESTIONS AND ANSWERS

**Ques. 2.297.** What form of energy is stored in lead-type storage batteries?

*Ans.* Chemical energy. A storage cell converts chemical energy into electrical energy.

**Ques. 2.298.** What precaution should be observed when using and storing crystal microphones?

*Ans.* A crystal microphone must be handled with care owing to the fact that physical shock or mechanical vibration may cause the voltages generated by both sides of the microphone to be out of phase. The crystal microphone is also very sensitive to moisture and temperature changes. It should be stored in a dry moistureproof wrapping or hood and not subjected to temperatures in excess of about 120 degrees Fahrenheit.

It is also desirable to avoid using a gain control between the crystal microphone and its associated amplifier, since such a control will seriously impair the low-frequency response.

**Ques. 2.299.** If a 1,500-kilocycle radio wave is modulated by a 2,000-cycle sine wave tone, what frequencies are contained in the modulated wave?

*Ans.* In amplitude-modulation systems the side-band and carrier frequencies of 1,498, 1,502, and 1,500 kilocycles will be contained in the modulated wave. (See also Ques. 6.28.)

**Ques. 2.300.** Why are laminated iron cores used in audio and power transformers?

*Ans.* To reduce eddy current losses.

**Ques. 2.301.** What are cathode rays?

*Ans.* Cathode rays are composed of a stream of negatively charged particles or electrons generally in the form of a circular beam and traveling at high velocities.

**Ques. 2.302.** Why is a high ratio of capacity to inductance employed in the grid circuit of some oscillators?

*Ans.* 1. To supply sufficient stored energy to meet grid-circuit requirements.

2. To increase oscillator frequency stability.

3. To reduce harmonics.

4. To increase the tank circuit  $Q$ .

**Ques. 2.303.** What is the purpose of a buffer-amplifier stage in a transmitter?

*Ans.* The buffer amplifier in a transmitter is used to isolate the oscillator stage from the succeeding amplifier stages. It is an effective medium for preventing succeeding amplifier load changes from reacting upon the oscillator circuit. The buffer amplifier thereby minimizes frequency drift in the oscillator.

An efficient buffer stage is biased with sufficient negative voltage to prevent grid-current flow during the excitation cycle.

**Ques. 2.304.** What determines the speed of a synchronous motor? An induction motor? A direct-current series motor?

*Ans.* The speed of a synchronous motor and an induction motor is determined primarily by the frequency of the source voltage. The speed of a direct-current series motor is dependent upon the source voltage and the loading. An increase in line voltage will raise its speed, while an increase in loading results in a decrease in speed. (See also Ques. 4.178.)

**Ques. 2.305.** What is the total resistance of a parallel circuit consisting of one branch of 10 ohms resistance and one branch of 25 ohms resistance?

*Ans.* 7.143 ohms.

*Solution:*

$$R_{\text{eff}} = \frac{R_1 \times R_2}{R_1 + R_2} = \frac{250}{35} = 7.143 \text{ ohms.}$$

## RADIO OPERATING QUESTIONS AND ANSWERS

**Ques. 2.306.** Draw a diagram of a resistance load connected in the plate circuit of a vacuum tube, and indicate the direction of electronic flow in this load.

*Ans.* See Fig. 2-33.

**Ques. 2.307.** Indicate by a drawing a sine wave of voltage displaced 180 degrees from a sine wave of current.

*Ans.* See Fig. 2-34.

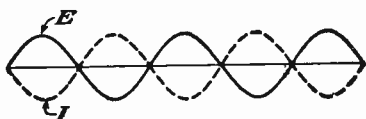

FIG. 2-34.

**Ques. 2.308.** Show by a diagram how a voltmeter and an ammeter should be connected to measure power in a direct-current circuit.

*Ans.* See Fig. 2-35.

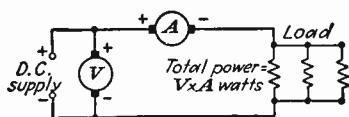

FIG. 2-35.

**Ques. 2.309.** Indicate by a diagram how the total current in three branches of a parallel circuit can be measured by one ammeter.

*Ans.* See Fig. 2-35.

**Ques. 2.310.** Draw a graph indicating how the plate current in a vacuum tube varies with plate voltage, the grid bias remaining constant.

Ans. See Fig. 2-36.

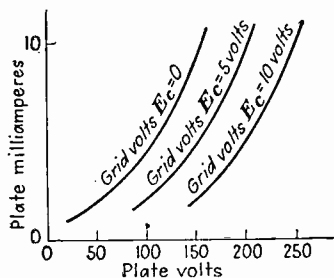

FIG. 2-36.

Ques. 2.311. Indicate by a drawing two cycles of a radio-frequency wave, and indicate one wavelength thereof.

Ans. See Fig. 2-37.

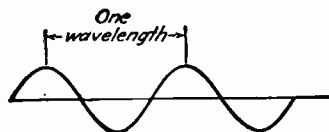

FIG. 2-37.

## ELEMENT 3

### RADIOTELEPHONE

**Ques. 3.01.** Explain the purposes and methods of neutralization in radio-frequency amplifiers.

*Ans.* Neutralization of radio-frequency amplifiers is generally required in triode and, in some cases, tetrode amplifiers to prevent self-oscillation due to feedback through the grid-plate capacitance of the vacuum tube. Figures 3-7 and 3-8 illustrate two commonly used methods of grid-plate capacitance neutralization. (See also Ques. 5.98 for the operating procedure in neutralizing a radio-frequency amplifier.)

**Ques. 3.02.** In a circuit consisting of an inductance having a reactance value of 100 ohms and a resistance of 100 ohms, what will be the phase angle of the current with reference to the voltage?

*Ans.* The phase angle will be 45 degrees.

$$\text{Phase angle} = \tan \theta \frac{\omega L}{R} = \frac{X_L}{R} = \frac{100}{100} = 1.000.$$

From a table of trigonometric functions. 1.0 = 45 degrees.

**Ques. 3.03.** What is the effective value of a sine wave in relation to its peak value?

*Ans.* Effective value = peak value  $\times$  0.707.

**Ques. 3.04.** What is the meaning of "phase difference"?

*Ans.* "Phase difference" is a term frequently used to denote the difference between the actual phase angle of a device or circuit and the ideal 90-degree angle. It is a measure in



electrical degrees of the separation between relative values of current and voltage in an alternating-current circuit or of either of these two relative quantities in the relation to the other in two or more circuits, the quantities all having the same frequency. Phase difference is generally expressed as an angle of lag or lead.

**Ques. 3.05.** What factors must be known in order to determine the power factor of an alternating-current circuit?

*Ans.* The true watts, as indicated by the wattmeter, and the volts and amperes in the circuit, as indicated by a voltmeter and ammeter.

$$\text{Power factor} = \cos \theta = \frac{W}{EI} \quad \frac{(\text{real watts})}{(\text{apparent watts})}$$

The ratio  $\frac{R}{Z}$  can also be used.

**Ques. 3.06.** What are the properties of a series condenser acting alone in an alternating-current circuit?

*Ans.* A series condenser acting alone in an alternating-current circuit will cause the current to lead the voltage by 90 degrees. The reactance of the condenser will vary inversely as the frequency varies.

**Ques. 3.07.** What is the reactance value of a condenser of 0.005 microfarad at a frequency of 1,000 kilocycles?

*Ans.* The reactance value is 31.8 ohms, computed as follows:

$$X_c = \frac{10^6}{2\pi fC} \text{ ohms.}$$

**Ques. 3.08.** State the mathematical formula for the energy stored in the magnetic field surrounding an inductance carrying an electric current.

*Ans.*

$$W = \frac{1}{2}LI^2 \text{ joules,}$$

where  $L$  = henrys.

$I$  = amperes.

**Ques. 3.09.** What is the current and voltage relationship when inductive reactance predominates in an alternating-current circuit?

*Ans.* When an inductive reactance predominates in an alternating-current circuit, the current lags the voltage.

**Ques. 3.10.** Given a series circuit consisting of a resistance of 4 ohms, an inductive reactance of 1 ohm, the applied circuit alternating e.m.f. is 50 volts. What is the voltage drop across the inductance?

*Ans.* The voltage drop across the inductance is 40 volts.

$$Z = \sqrt{R^2 + (X_L - X_C)^2} = \sqrt{17} = 4.13 \text{ ohms.}$$

$$I = \frac{E}{Z} = \frac{50}{4.13} = 12.1 \text{ amperes.}$$

Therefore  $E_L = IX_L = 12.1 \times 4 = 48.4$  volts.

**Ques. 3.11.** What would be the effect if direct current were applied to the primary of an alternating-current transformer?

*Ans.* The current in the primary would be limited only by the direct-current resistance of the circuit. Unless the applied voltage was very small, the current would either blow the fuses or burn out the transformer in a few seconds.

**Ques. 3.12.** If a power transformer having a voltage step-up ratio of 1:5 is placed under load, what will be the approximate ratio of primary to secondary current?

*Ans.* 5:1.

**Ques. 3.13.** What is the meaning of "skin effect" in conductors of radio-frequency energy?

*Ans.* The tendency of high-frequency currents to travel on the surface of a conductor is known as "skin effect." This effect is caused by the varying density of the electric field in the conductor, which acts to produce the lowest reactance path on the surface of the conductor.

**Ques. 3.14.** Neglecting distributed capacitance, what is the reactance of a 5-millihenry choke coil at a frequency of 1,000 kilocycles?

*Ans.* The reactance is 31,400 ohms.

$$X_L = 2\pi fL = 6.28 \times 10^6 \times 0.005 = 31,400 \text{ ohms.}$$

**Ques. 3.15.** What is meant by the term "radiation resistance"?

*Ans.* The term "radiation resistance" is analogous to the effective increase of a circuit resistance due to the heat dissipation in a wire or circuit. In antenna radiating systems, it is the ratio of the power radiated by the antenna to the squared effective value of the antenna current measured at the point where the power is supplied to the radiating system.

**Ques. 3.16.** What is the value of total reactance in a series resonant circuit at the resonant frequency?

*Ans.* Zero. The inductive and capacitive reactances are equal and opposite in sign and therefore cancel out in a series resonant circuit at the resonant frequency.

**Ques. 3.17.** What is the value of reactance across the terminals of the capacitor of a parallel resonant circuit, at the resonant frequency, and assuming zero resistance in both legs of the circuit?

*Ans.* The reactance is zero, and impedance is infinite under these conditions.

$$X = X_L - X_c = 0.$$

$$Z = \frac{X_L^2}{R} = \infty \text{ (infinity).}$$

**Ques. 3.18.** Given a series resonant circuit consisting of a resistance of 6.5 ohms and equal inductance and capacitive reactance of 175 ohms, what is the voltage drop across the resistance, assuming the applied circuit potential is 260 volts?

*Ans.* 260 volts. Since  $X_L$  and  $X_c$  are equal, their effects cancel out at the series resonant frequency. Hence, the entire source voltage of 260 volts appears across the 6.5-ohm resistance.

**Ques. 3.19.** Given a series resonant circuit consisting of a resistance of 6.5 ohms and equal inductive and capacitive reactance of 175 ohms, what is the voltage drop across the inductance when the applied circuit potential is 260 volts?

*Ans.* 7,000 volts.

$$I = \frac{E}{R} = \frac{260}{6.5} = 40.$$

$$E_L = IX_L = 40 \times 175 = 7,000 \text{ volts.}$$

**Ques. 3.20.** Under what conditions will the voltage drop across a parallel-tuned circuit be a maximum?

Ans. At resonance, when  $X_L = X_c$  and ohmic resistance is small (when the admittance of the two branches is equal).

Ques. 3.21. Draw a simple schematic diagram showing a method of coupling a modulator tube to a radio-frequency power-amplifier tube to produce plate modulation of the amplified radio-frequency energy.

Ans. See Fig. 3-1.

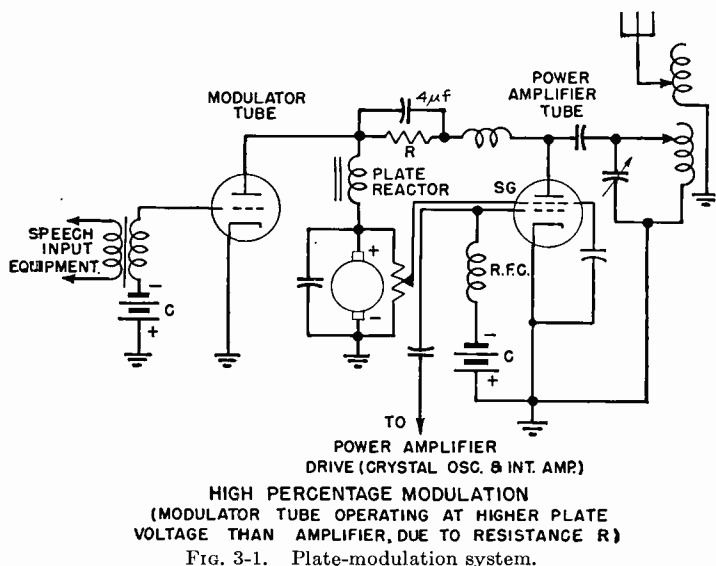

Ques. 3.22. Draw a diagram of a carrier-wave envelope when modulated 50 per cent by a sinusoidal wave. Indicate on the diagram the dimensions from which the percentage of modulation is determined.

Ans. See Fig. 3-2.

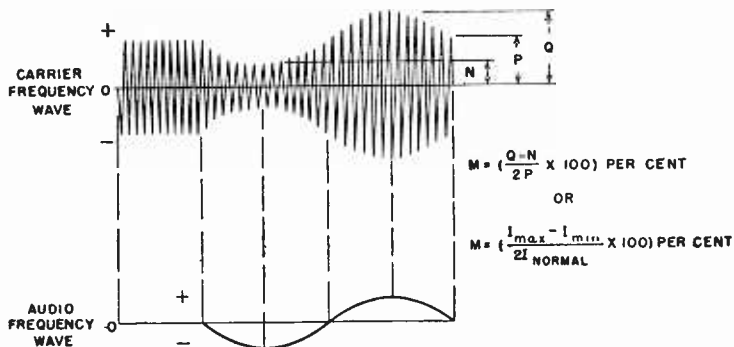

FIG. 3-2. Carrier-wave envelope.

Ques. 3.23. Draw a diagram of a condenser microphone circuit complete with two stages of audio amplification.

Ans. See Fig. 3-3.

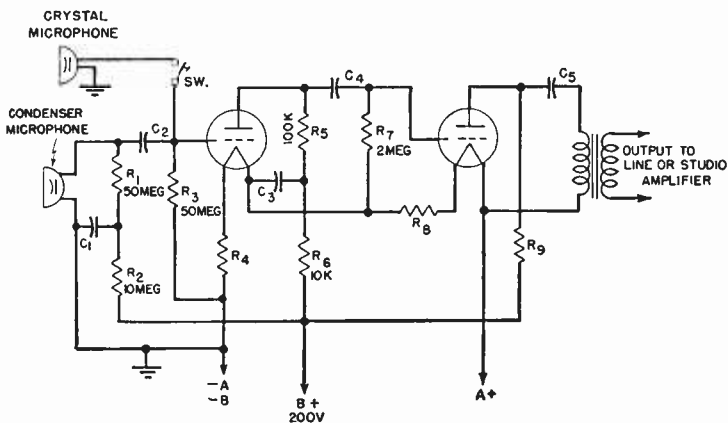

FIG. 3-3. Microphone amplifier.

**Ques. 3.24.** Draw a simple schematic diagram showing a Heising modulation system capable of producing 100 per cent modulation. Indicate power-supply polarity where necessary.

*Ans.* See Fig. 3-9.

**Ques. 3.25.** Draw a simple schematic diagram showing a method of suppressor-grid modulation of a pentode-type vacuum tube.

*Ans.* See Fig. 3-4.

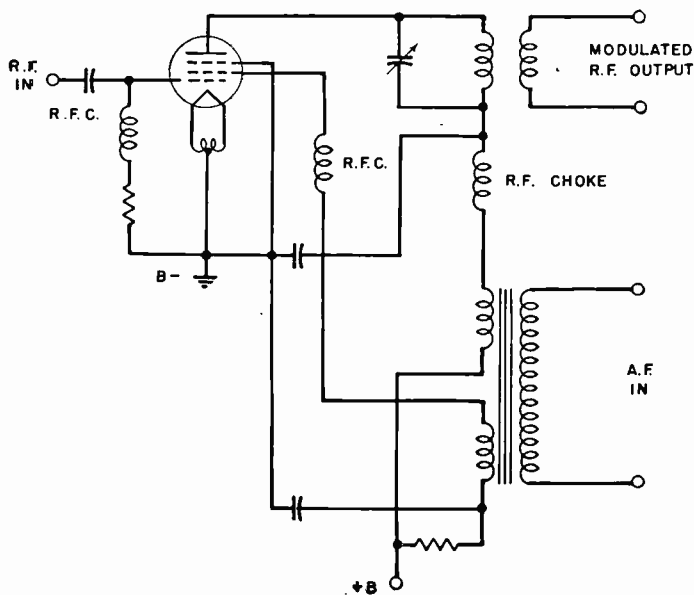

FIG. 3-4.

**Ques. 3.26.** Draw a simple schematic diagram showing a method of coupling a modulator tube to a radio-frequency power-amplifier tube to produce grid modulation of the amplified radio-frequency energy.

Ans. See Fig. 3-5.

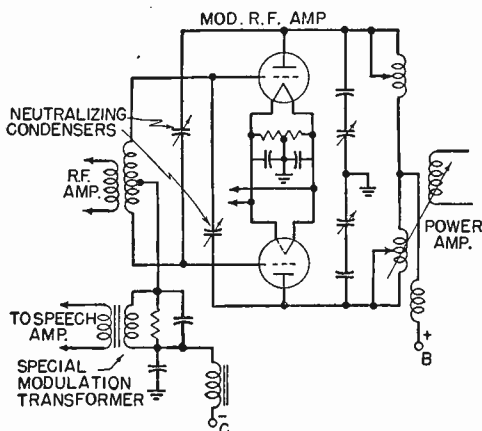

FIG. 3-5. Grid-modulation system.

Ques. 3.27. What is meant by "frequency shift" or "dynamic instability" with reference to a modulated radio-frequency emission?

Ans. "Frequency shift," "dynamic instability," or "carrier shift" is that condition in a modulated radio-frequency amplifier when the *average* value of the radio-frequency voltage envelope shifts in a positive or negative direction during modulation. If for any reason this average changes, then distortion is introduced, since the amplitude variation is no longer constant. An increase in the average is known as *positive carrier shift*, while a decrease is known as *negative carrier shift*.

Ques. 3.28. What is meant by "high-level" modulation?

Ans. "High-level" modulation is modulation produced in the last radio-frequency stage of the transmitter.

Ques. 3.29. What is meant by "grid modulation"? By "plate modulation"?



*Ans.* By "grid modulation" is meant modulation produced by the introduction of the modulating wave into any of the grid circuits of any tube in which the carrier-frequency wave is present. "Plate modulation" is modulation produced by the introduction of the modulating wave into the plate circuit of any tube in which the carrier-frequency wave is present.

**Ques. 3.30.** What is meant by "low-level" modulation?

*Ans.* "Low-level" modulation is modulation produced in a radio-frequency stage preceding the final radio-frequency stage.

**Ques. 3.31.** Describe the construction and characteristics of a crystal-type microphone.

*Ans.* The crystal microphone employs a piezoelectric crystal as its actuating unit, which is coupled to the diaphragm through a lever arrangement. The conventional crystal microphone is made up of several crystal cells arranged so that each cell aids the others to increase the over-all sensitivity. The microphone is affected very little by temperature changes. The output is approximately -85 db. Owing to the high impedance of the crystal, the output may be worked directly into the grid of the amplifier tube. The frequency response is excellent over the whole audio spectrum.

**Ques. 3.32.** Describe the construction and characteristics of a carbon-button type microphone.

*Ans.* A single-button carbon microphone consists of a tightly stretched diaphragm fixed in front of a metal cup filled with carbon granules, the cup assembly being called a "button." The natural frequency of the diaphragm is well above 5,000. The diaphragm is damped by an air cushion to improve its frequency response, which extends approximately from 60 to 5,000 cycles. A hiss is noticeable unless the sound level is high. This is the most sensitive microphone.

**Ques. 3.33.** What might be the cause of variations in plate current of a class B type of modulator?

*Ans.* Under normal conditions with complex modulation the plate current of a class B modulator is constantly varying, depending upon the amplitude of the speech input wave.

**Ques. 3.34.** What is the relationship between the average power output of the modulator and the modulated-amplifier plate-circuit input under 100 per cent sinusoidal plate modulation?

*Ans.* The correct ratio is 1:2, or 50 per cent. (See Ques. 6.26 for detailed explanation.)

**Ques. 3.35.** What would be the effect of a shorted turn in a class B modulation transformer? In a class A modulation transformer?

*Ans.* A shorted turn in both the class A and B modulation transformer would result in serious overheating and may cause the shorted primary section to burn out. In the class B amplifier one tube only would be inoperative and serious distortion would result. The class A amplifier using a single modulator tube would be entirely inoperative if the plate winding burned out. In both cases, however, the initial symptom is manifest in serious distortion due to the impedance mismatch.

**Ques. 3.36.** Why is a high percentage of modulation desirable?

*Ans.* High-percentage amplitude modulation in telephone transmitters increases the useful service range of the transmitter owing to the relatively higher ratio of modulated carrier-frequency power to the normal carrier-frequency power. The peak power in 100 per cent modulated systems is four times the normal carrier power. The use of high-percentage modulation systems increases the plate efficiency of the amplifiers, increases the ratio of useful power in the receiver system, and

decreases carrier interference at remote points. Interference between stations on adjacent channels is also minimized.

**Ques. 3.37.** What are some of the possible results of overmodulation?

*Ans.* Overmodulation results in a widening of the frequency band causing interference on adjacent channels. Overmodulation also causes distortion in the audio components of the radiated wave. Since the continuity of the carrier is interrupted, it means that there are harmonics radiated and that the transmission occupies a band which is wider than necessary, causing interference on adjacent channels.

**Ques. 3.38.** What might cause frequency modulation in an amplitude-modulated radiotelephone transmitter?

*Ans.* Phase or frequency shifts in the oscillator or amplifier circuits produced by excessive tube or load circuit changes. Poor voltage regulation.

**Ques. 3.39.** What percentage of antenna-current increase should be expected between unmodulated conditions and 100 per cent sinusoidal modulation?

*Ans.* The antenna current will rise approximately 22.5 per cent if the modulating wave has a sinusoidal characteristic. In practical broadcasting, owing to the unsymmetrical nature of the modulated wave, this increase in antenna current cannot be depended upon to indicate 100 per cent modulation.

**Ques. 3.40.** What might be the cause of a decrease in antenna current of a high-level amplitude-modulated radiotelephone transmitter when modulation is applied?

*Ans.* Overmodulation, improper neutralization, incorrect grid bias, low filament emission, poor regulation, open filter condenser in power supply, or improperly tuned antenna system.

**Ques. 3.41.** If a regenerative receiver oscillates too freely with minimum tickler coupling, what adjustment would reduce the feedback?

*Ans.* A reduction in plate or filament potential.

**Ques. 3.42.** Why is it necessary to use an oscillating detector for reception of an unmodulated carrier?

*Ans.* An oscillating detector is required for the reception of continuous-wave signals to produce an audible "beat" or "heterodyne" tone response in the telephones or loud-speaker.

**Ques. 3.43.** What is the purpose of shielding in a multi-stage radio receiver?

*Ans.* Shielding is required to prevent self-oscillation in radio-frequency amplifiers.

**Ques. 3.44.** Explain what circuit conditions are necessary in a regenerative receiver for maximum response to a modulated signal.

*Ans.* The regenerative feedback control must be adjusted critically to a point on the verge of oscillation.

**Ques. 3.45.** What feedback conditions must be satisfied in a regenerative detector for most stable operation of the detector circuit in an oscillating condition?

*Ans.* Stabilized oscillation is obtained when the feedback control is adjusted to an oscillating condition beyond the critical point at which oscillations begin. Practically, this condition is obtained when the feedback coupling is a maximum, the filament voltage normal, and the plate voltage is near the maximum operating limits. A high tank circuit  $Q$  or low  $L/C$  ratio is also desirable.

**Ques. 3.46.** What are the advantages to be obtained from adding a tuned radio-frequency amplifier stage ahead of the first detector (converter) stage of a superheterodyne receiver?

*Ans.* A preselector stage increases the over-all circuit selectivity and sensitivity and tends to eliminate image frequency interference. It also serves to prevent possible reradiation which might be caused by the coupling of the converter and oscillator circuits directly to the antenna system.

**Ques. 3.47.** What feedback conditions must be satisfied in a regenerative detector in order to obtain sustained oscillations?

*Ans.* (See Ques. 3.45.)

**Ques. 3.48.** How is automatic volume control accomplished in a radio receiver?

*Ans.* (See Ques. 4.214.)

**Ques. 3.49.** If a superheterodyne receiver is tuned to a desired signal at 1,000 kilocycles and its conversion oscillator is operating at 1,300 kilocycles, what would be the frequency of an incoming signal which would possibly cause "image" reception?

*Ans.* It is evident that the intermediate frequency is 300 kilocycles. Hence, at frequency of 1,600 kilocycles, the grid of the converter tube will produce an intermediate frequency of 300 kilocycles if the conversion oscillator is tuned to 1,300 kilocycles. Hence, 1,600 kilocycles is the image.

**Ques. 3.50.** If a tube in the only radio-frequency stage of your receiver burned out, how could temporary repairs or modifications be made to permit operation of the receiver if no spare tube is available?

*Ans.* The antenna could be connected to the grid of the succeeding tube or preferably to the plate prong of the burned-out tube through a 0.0005 microfarad coupling condenser.

**Ques. 3.51.** What are the characteristics of plate detection?

*Ans.* The plate-current flow increases during signal reception. When no signal is received, the plate current is low, since the tube is operating near the plate-current cut-off point of the characteristic. The primary characteristic of plate detection is a good linear output response with strong signal input voltages.

**Ques. 3.52.** What is the purpose of a radio-frequency choke?

*Ans.* To prevent radio-frequency current flow through power-supply circuit and also to improve the by-passing efficiency of the radio-frequency by-pass condenser. It is an effective high-impedance filter or isolating device.

**Ques. 3.53.** What would be the effect upon a radio receiver if the vacuum-tube plate potential were reversed in polarity?

*Ans.* The receiver would not operate.

**Ques. 3.54.** What would be the effect upon the operation of a receiver if the grid return is connected to the positive rather than the negative terminal of the filament battery?

*Ans.* The circuit sensitivity and selectivity will be decreased. The grid voltage may become slightly positive, causing a grid current to flow and a corresponding increase in plate current. Circuit linearity is impaired, and signal distortion will occur.

**Ques. 3.55.** Draw a simple schematic diagram of a system of coupling a single electron tube employed as a radio-frequency amplifier to a Hertz-type antenna.

Ans. See Fig. 3-6.

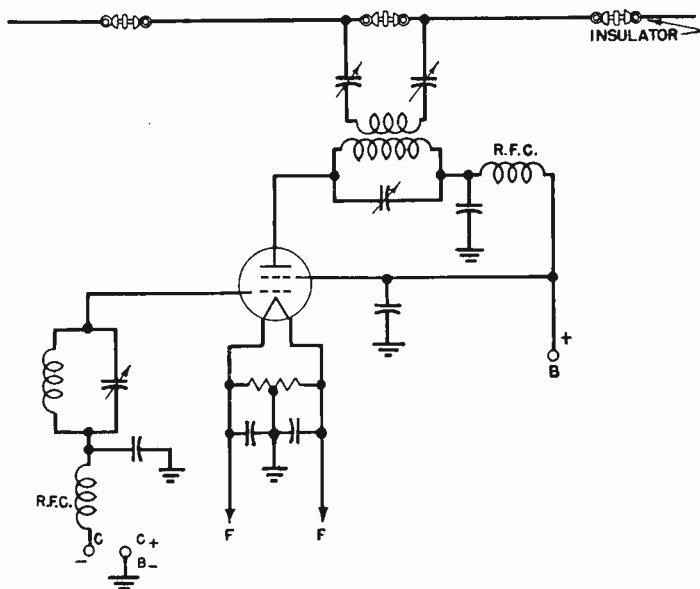

FIG. 3-6. Hertz-radiator coupling system.

Ques. 3.56. Draw a simple schematic diagram indicating a link coupling system between a tuned-grid tuned-plate oscillator stage and a single electron tube, neutralized amplifier.

Ans. See Fig. 3-7.

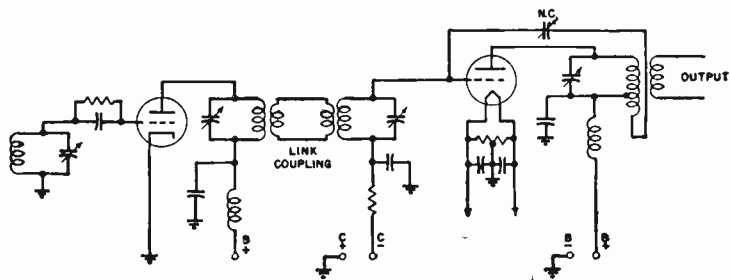

FIG. 3-7. Link coupling arrangement.

RADIO OPERATING QUESTIONS AND ANSWERS

Ques. 3.57. Draw a simple schematic diagram of a push-pull, neutralized radio-frequency amplifier stage, coupled to a Marconi-type antenna system.

Ans. See Fig. 3-8.

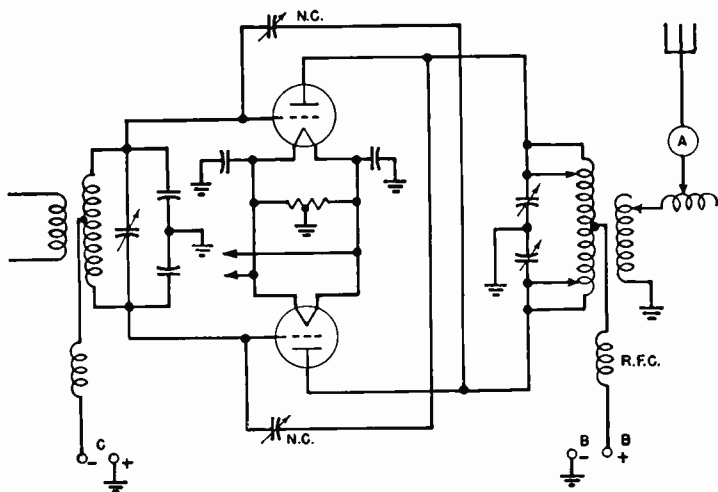

FIG. 3-8. Push-pull neutralized radio-frequency amplifier.

Ques. 3.58. Draw a simple schematic diagram of a system of neutralizing the grid-plate capacitance of a single electron tube employed as a radio-frequency amplifier.

Ans. See Fig. 3-7.

Ques. 3.59. Draw a simple schematic diagram showing the proper method of obtaining direct-current screen-grid voltage from the plate supply in the case of a plate-modulated pentode, class C amplifier.



Ans. See Fig. 3-4.

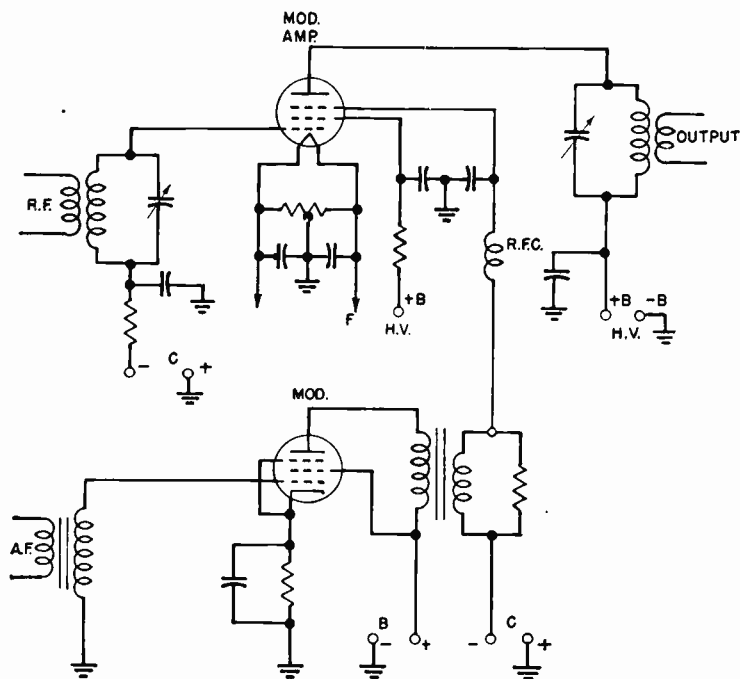

FIG. 3-9. Suppressor-grid-modulation system.

**Ques. 3.60.** What is the purpose of a buffer amplifier?

*Ans.* A buffer amplifier is essentially a frequency stabilizer. It serves as a voltage amplifier stage(s) to isolate the crystal oscillator from the radio-frequency amplifier circuits. It prevents circuit reactions and load changes from the power-amplifier stages from affecting the frequency stability of the oscillator.

**Ques. 3.61.** What is a "frequency doubler" stage?

*Ans.* A "frequency doubler" stage is a radio-frequency amplifier, the output frequency of which is double that of the

input frequency. A frequency doubler is used in connection with a crystal oscillator when the desired output frequency exceeds the safe operating limits of the crystal.

**Ques. 3.62.** What are the advantages of a master-oscillator power-amplifier type of transmitter as compared to a simple oscillator transmitter?

*Ans.* Improved frequency stability. An ordinary oscillator will be subject to frequency changes when coupled directly to an antenna system. Phase shift and reactance changes are therefore considerably reduced in the master-oscillator power-amplifier system.

**Ques. 3.63.** What are the differences between Colpitts and Hartley oscillators?

*Ans.* In the Colpitts oscillator the grid circuit receives its excitation from a split tank condenser. In the Hartley oscillator, the grid receives its excitation from a split tank inductance. (See also Ques. 2.72 and 2.76.)

**Ques. 3.64.** What is the primary purpose of a grid leak in a vacuum-tube transmitter?

*Ans.* A grid leak is used primarily to develop operating bias. It also serves to maintain a constant load on an amplifier to minimize overloading when the grid of a given stage is driven positive during excitation.

**Ques. 3.65.** By what means is feedback coupling obtained in a tuned-grid tuned-plate type of oscillator?

*Ans.* Through the grid-to-plate capacity of the tube.

**Ques. 3.66.** What may be the result of parasitic oscillations?

*Ans.* Parasitic oscillations may result in an erratic behavior and a heavy increase in plate current, which may cause serious overheating of the tube. The plate milliammeter or radio-

frequency choke coil may burn out. Normal output power on the operating frequency will also be decreased.

**Ques. 3.67.** How may the production of harmonic energy by a vacuum-tube radio-frequency amplifier be minimized?

*Ans.* (See Ques. 2.302 and 3.136.)

**Ques. 3.68.** What is a definition of "parasitic oscillations"?

*Ans.* "Parasitic oscillations" are undesired oscillations developed in a radio-frequency amplifier circuit at some frequency higher than the normal operating frequency. They are principally due to feedback resulting from the connecting lead capacitive and inductive effects when tubes are operated in parallel or push-pull. Parasitics are eliminated by introducing circuit losses to these spurious frequencies by the insertion of small radio-frequency choke coils shunted by a noninductive resistance in each plate and/or grid leads of the parallel-connected tubes. Parasitic oscillations are not necessarily a harmonic component of the fundamental frequency.

**Ques. 3.69.** What is the purpose of a Faraday screen between the final tank inductance of a transmitter and the antenna inductance?

*Ans.* The purpose of a Faraday screen is to minimize the radiation of harmonic frequencies. This it does by reducing the capacitive coupling between the amplifier and antenna circuits, by which the harmonics are chiefly transmitted.

**Ques. 3.70.** How may the distortion effects caused by class B operation of a radio-frequency amplifier be minimized?

*Ans.* Distortion effects are minimized by operating the amplifier tubes in a push-pull arrangement, a reasonably high tank circuit impedance, proper grid bias, a high  $Q$  tank circuit, and balanced tubes and by restricting the grid excitation voltage to the normal linear range of the amplifier. Proper tuning and loading adjustments are other important prerequisites.

**Ques. 3.71.** What is the effect of carrier shift in a plate-modulated class C amplifier?

*Ans.* Carrier shift causes unwanted harmonics and additional side-band frequencies, resulting in interference with other stations on adjacent frequencies. (See Ques. 6.42.)

**Ques. 3.72.** What are some possible indications of a defective transmitting vacuum tube?

*Ans.* Some possible indications of a defective transmitting vacuum tube are

1. Burned-out filament (dark tube).
2. Low emission as indicated by no reading or a low reading on the plate-current meter accompanied by a slightly high voltage reading.
3. A gassy tube, as indicated by a blue haze, red-hot plate, and/or fluctuations in plate current or by excessive grid-current flow.

**Ques. 3.73.** What would be possible indications that a vacuum tube in a transmitter has subnormal filament emission?

*Ans.* The general symptom is indicated by a low plate-current indication in the defective tube. Decreased excitation and radiation and low plate temperature (plate color) in power-amplifier tubes are other possible symptoms.

**Ques. 3.74.** What are possible causes of negative carrier shift in a linear radio-frequency amplifier?

*Ans.* A negative carrier shift is one in which the upward excursion of a modulated radio-frequency wave is not so great as the downward excursion when averaged over the modulation cycle. Circuit conditions which may produce a negative carrier shift are as follows: overmodulation, excessive radio-frequency excitation, poor filter circuit, or poor regulation.

**Ques. 3.75.** In a modulated class C radio-frequency amplifier, what is the effect of insufficient excitation?

*Ans.* Decreased radiation, low plate efficiency, decreased tank and plate currents, distortion, and carrier shift may develop owing to insufficient excitation.

**Ques. 3.76.** What is the purpose of a dummy antenna?

*Ans.* A dummy antenna is used to load a transmitter for testing purposes without radiation. The dummy antenna may consist of a bank of lamps or other equal resistors. The resistance of the dummy antenna must be equivalent to that of the working antenna.

**Ques. 3.77.** In a class C radio-frequency amplifier stage of a transmitter, if plate current continued to flow and radio-frequency energy was still present in the antenna circuit, what defect would be indicated?

*Ans.* On a radiotelegraph transmitter, this would indicate defective keying, usually a failure of the keying bias to block the tubes when the key is up, or that keying relay is closed. In a radiotelephone transmitter fitted with press-to-talk button, a continuous flow of plate current and antenna current may be due to a shorted bias supply or self-oscillation resulting from improper neutralization. Parasitic oscillations may also produce this effect.

**Ques. 3.78.** If the transmitter filament voltmeter should cease to operate, how may the approximately correct filament rheostat adjustment be found?

*Ans.* By observing the color of the filaments and by noting other meter readings to see that they are normal.

**Ques. 3.79.** What are some possible causes of overheating vacuum-tube plates?

*Ans.* Overheating may be due to any one of the following causes: parasitic oscillations, excessive drive, insufficient grid bias, plate tank circuit improperly tuned (off resonance), gassy

tube, self-oscillation due to improper neutralization, and excessive filament or plate voltage.

**Ques. 3.80.** Should the plate current of a modulated class C amplifier stage vary or remain constant under modulation conditions? Why?

*Ans.* The plate current should remain constant during sinusoidal modulation, since the average value of the direct-current component is essentially zero under these conditions.

**Ques. 3.81.** What is the effect of a swinging antenna upon the output of a simple oscillator?

*Ans.* Inasmuch as the antenna circuit is coupled directly to the plate circuit of a simple oscillator, any variation in antenna capacity, such as might be caused by a swinging antenna, would be reflected into the tube's plate circuit. This action would be equivalent to placing a fluctuating load on the oscillator and would result in frequency instability.

**Ques. 3.82.** What factors permit high conduction currents in a hot-cathode type of mercury-vapor rectifier tube?

*Ans.* High conduction currents in a hot-cathode type of mercury-vapor rectifier tube are permissible because the current is carried chiefly by ions in the tube rather than by electrons emitted from the cathode. The low (15-volt) voltage drop across the tube while conducting makes the plate power dissipation ( $EI$ ) low even for large values of plate current.

**Ques. 3.83.** List the principal advantages of a mercury-vapor rectifier over a high-vacuum-tube type of rectifier.

*Ans.* The principal advantages of the mercury-vapor rectifier over a high-vacuum-tube type of rectifier are its better voltage regulation and higher operating efficiency. In comparing the efficiency of the high-vacuum-tube type with that of the mercury-vapor type, it has been found that the latter may be approximately 99 per cent efficient as compared with approximately 87 per cent of the former.

**Ques. 3.84.** What is the effect, upon the voltage regulation of a rectifier and filter system, of the resistance of the filter chokes?

*Ans.* The less resistance in the filter chokes the better will be the regulation.

**Ques. 3.85.** Describe the theory of current conduction and rectification by means of cold-cathode, gassy-diode vacuum tubes.

*Ans.* When an alternating difference of potential is applied across the electrodes, one of which is a cold cathode and the other a rod-shaped anode, the strain exerted upon the gaseous atmosphere will result in the breakdown of the gas atoms (ionization due to collision). If the electrodes are identical in construction, an electron current will flow in both directions under conditions of ionization. However, in order that unilateral flow only shall take place under application of an alternating voltage, the plates are of different design with regard to each other. This special design permits electrons to flow from one element to the other when the gas ionizes but not in the reverse direction. This action permits the use of this type of tube for rectification purposes.

**Ques. 3.86.** Describe the principle of operation of a synchronous type of mechanical rectifier.

*Ans.* There are two general types of mechanical rectifiers, namely, the vibrating-reed and the synchronous-commutator types. The vibrating-reed rectifier consists of a metal strip or reed in which the reed forms the armature of an electromagnet excited from the alternating-current supply. The reed is arranged with contacts which are opened and closed periodically with the change of the alternating-current cycle. If one pair of contacts is used, the circuit will close during one-half of the cycle; if two contacts are used the circuit will close on both halves of the cycle. Thus the contacts may be closed at half-wave pulses or full-wave pulses, as desired.

The commutator type of synchronous rectifier employs a rotating arm with segmented pillars which is driven by a synchronous motor. Separate rectifying contacts are fixed in a stationary position near the movable arm. These make contact with the commutator. The stationary and rotary segments are so arranged that the connections are reversed at the instant that the current reverses and in this manner rectify the alternating current to direct-current pulses.

**Ques. 3.87.** What might be the result of starting a motor too slowly, using a hand starter?

*Ans.* Starting a motor too slowly, using a hand starter, may burn out the resistance units in the starting box, as they are made for temporary duty only and cannot stand a heavy current flow for more than a very short period.

**Ques. 3.88.** State the principal advantages of a third-brush generator for radio power supply in automobiles.

*Ans.* The principal advantage of the third brush in a generator is to improve the voltage regulation under generator speed changes.

**Ques. 3.89.** What materials should be used to clean the commutator of a motor or generator?

*Ans.* The commutator of the direct-current motor or generator is kept clean by polishing it with a piece of fine sandpaper, usually No. 0000. Emery cloth should never be used because it contains small metallic dust which would short-circuit the commutator segments. A piece of coarse canvas is also useful in giving the commutator a final polish. A special commutator paste is also available. This paste should be applied sparingly with a clean cloth, and the commutator then polished while the machine is running.

**Ques. 3.90.** List three causes of sparking at the commutator of a direct-current motor.



*Ans.* There are many causes for excessive sparking at the brushes of a direct-current machine as follows:

1. Overloaded.
2. Poor brush fitting or worn brush.
3. Open in armature circuit.
4. High commutator bar.
5. Dirty commutator.
6. Too rapid starting.
7. Brushes off neutral point.

**Ques. 3.91.** Why is it necessary to use a starting resistance when starting a direct-current motor?

*Ans.* A starting resistance is necessary to prevent an excessive current flow in the armature of the motor before it gets up to speed. When the motor is up to running speed, the armature generates enough self-induced counter e.m.f. to keep the current in itself down to safe limits.

**Ques. 3.92.** List the comparative advantages and disadvantages of motor-generator and transformer-rectifier power supplies.

*Ans.* The answer may be tabulated as follows:

MOTOR GENERATOR

ADVANTAGES

1. Easy voltage control.
2. Good regulation at full voltage.
3. Exceptionally rugged.
4. May be located at remote point.
5. May be operated from alternating-current or direct-current lines.
6. Very low maintenance costs.
7. Can stand considerable abuse.

DISADVANTAGES

1. Poor regulation at low voltages.
2. High first cost.
3. Difficult to repair.
4. May be noisy.
5. May cause vibration.
6. Requires constant attention to lubrication, commutator, and brushes.
7. May require long and dangerous high-voltage leads.
8. On direct-current generators output limited to about 12,000 volts.

## RADIO OPERATING QUESTIONS AND ANSWERS

### VACUUM-TUBE RECTIFIER

#### ADVANTAGES

1. Lower first cost than motor generator.
2. No moving parts, hence no lubrication or other care aside from cleaning.
3. Exceptionally high voltages available without danger of breakdown.
4. Mercury-vapor type has good regulation.
5. Quiet in operation; no vibration.
6. Easier repair than motor generator.
7. Can be enclosed in transmitter unit, thus no exposed high-voltage leads

#### DISADVANTAGES

1. Necessity to replace tubes.
2. High maintenance costs.
3. Requires careful operation, cannot stand much abuse.
4. High-vacuum type has poor regulation.
5. Must be operated from alternating-current line.

**Ques. 3.93.** If the reluctance of an iron-cored choke is increased by increasing the air gap of the magnetic path, in what other way does this affect the properties of the choke?

*Ans.* The inductance will be decreased and the filtering action impaired. Core saturation will not occur.

**Ques. 3.94.** What is the effect upon a filter choke of a large value of direct-current flow?

*Ans.* The effect of a large value of direct-current flow upon a filter choke would be to cause it to heat up excessively. If the current flow is large enough, the filter choke may burn out. Under any conditions an excessive direct-current flow will cause the choke to be saturated and have less inductance.

**Ques. 3.95.** What are the characteristics of a condenser input filter system as compared to a choke-input system?

*Ans.* The condenser-input filter will give a higher voltage output than the choke-input system, but the regulation of the condenser-input system will not be so good. Instantaneous

peak rectifier current is much higher with capacity-input filters. This is particularly true if a mercury-vapor rectifier is used.

**Ques. 3.96.** What is the principal function of the filter in a power supply?

*Ans.* The principal function of the filter in a power-supply system is to iron out the peaks of the ripple frequency and to provide an output voltage which has a minimum fluctuation characteristic.

**Ques. 3.97.** What are the characteristics of a choke-input filter system as compared to a condenser-input system?

*Ans.* Other things being equal, the choke-input filter system will give better regulation than the condenser-input system, but the output voltage will be lower with the choke-input system. (See Ques. 3.95.)

**Ques. 3.98.** What is the percentage regulation of a power supply with a no-load voltage output of 126.5 volts and a full-load voltage output of 115 volts?

*Ans.* The percentage of regulation would be 10 per cent, computed by the formula

$$\text{Regulation per cent} = \frac{E_{max} - E_{min}}{E_{min}} \times 100.$$

**Ques. 3.99.** What is the definition of "voltage regulation" as applied to power supplies?

*Ans.* "Regulation," as applied to power supplies, is the difference between no-load and full-load voltage, expressed as a percentage of the full-load voltage.

$$\text{Regulation in per cent} = \frac{E_{nl} - E_{fl}}{E_{fl}} \times 100,$$

where  $E_{nl}$  is the no-load voltage.

$E_{fl}$  is the full-load voltage.

**Ques. 3.100.** May two condensers of 500 volts operating voltage, one an electrolytic and the other a paper condenser, be used successfully in series across a potential of 1,000 volts? Explain your answers.

*Ans.* If the voltage is of an alternating character, this cannot be done, since the electrolytic condenser operates upon the principle of unilateral conductivity. That is, it is a conductor during one portion of the alternating-current cycle. Obviously at this instant the paper condenser will be subjected to abnormal strain and will puncture. In direct-current circuits the arrangement may be used provided equalizing resistors are used, the electrolytic condenser possesses a very low power factor, and proper polarity is observed.

**Ques. 3.101.** What is the principal function of a swinging choke in a filter system?

*Ans.* The swinging choke provides an inductance value which varies inversely with the current flow, thereby improving the regulation of the power supply. This is achieved by designing the choke coil with a relatively small iron core so that it will readily saturate with heavy current flow, with a consequent decrease in its inductance.

**Ques. 3.102.** What is the purpose of a bleeder resistor as used in connection with power supplies?

*Ans.* The purpose of a bleeder as used in a filter system is to improve the regulation of the system. The bleeder also serves to discharge the filter condensers after shutdown, thus providing protection to the personnel against shock.

**Ques. 3.103.** What does a blue haze in the space between the filament and plate of a high-vacuum rectifier tube indicate?

*Ans.* A blue haze indicates the presence of gas in the tube and may mean that the tube is approaching the end of its useful life.

A blue haze on the wall of the tube or inside the surface of the glass envelope is a form of X-ray effect. This has no injurious effect upon the operation of the tube.

**Ques. 3.104.** When condensers are connected in series in order that the total operating voltage of the series connection is adequate for the output voltage of a filter system, what is the purpose of placing resistors of high value in shunt with each individual condenser?

*Ans.* To distribute the voltage strain equally between the condensers and to discharge the condensers after shutdown thus protecting the personnel against shock.

**Ques. 3.105.** If a high-vacuum type, high-voltage rectifier tube should suddenly show heavy internal sparking and then fail to operate, what elements of the rectifier-filter system should be checked for possible failure before installing a new rectifier tube?

*Ans.* The rectifier condensers.

**Ques. 3.106.** If the plate of a rectifier tube suddenly became red hot, what might be the cause and how could remedies be effected?

*Ans.* Short-circuited filter condensers, or excessive external load, which might be caused by improper adjustment of the radio-frequency circuit to which the rectifier tube supplies power.

**Ques. 3.107.** Draw a simple schematic diagram of a quartz-crystal-controlled oscillator, indicating the circuit elements necessary to identify this form of oscillatory circuit.

*Ans.* See Fig. 2-5.

**Ques. 3.108.** Draw a simple schematic diagram of a dynatron type of oscillator, indicating the circuit elements necessary to identify this form of oscillatory circuit.

*Ans.* See Fig. 3-10. This type of oscillator may be identified by the anode (SG) being at a higher potential than the plate. This condition is necessary to accomplish the secondary emission on which the tube circuit depends for its operation.

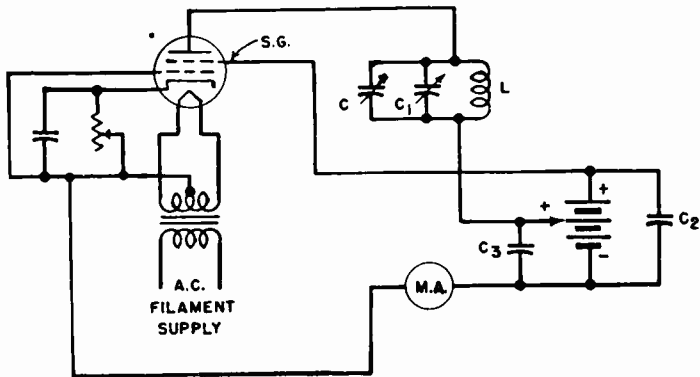

FIG. 3-10. Dynatron oscillator.

**Ques. 3.109.** Draw a simple schematic diagram of an electron-coupled oscillator, indicating the circuit elements necessary to identify this form of oscillatory circuit.

*Ans.* See Fig. 2-8. In this type of circuit the plate element acts only as an output-coupling medium while the screen-grid element serves as the actual oscillator plate.

**Ques. 3.110.** What does the expression “positive temperature coefficient” mean as applied to a quartz crystal?

*Ans.* The expression “positive temperature coefficient” means that the frequency of the crystal varies directly with the temperature; *i.e.*, when the temperature increases, the frequency of the crystal increases.

**Ques. 3.111.** Draw a simple schematic diagram of a crystal-controlled vacuum-tube oscillator using a pentode-type tube. Indicate power-supply polarity where necessary.

*Ans.* See Fig. 2-9.

**Ques. 3.112.** What will result if a direct-current potential is applied between the two parallel surfaces of a quartz crystal?

*Ans.* The parallel surfaces of a quartz crystal will either expand or contract, depending upon the polarity of the applied voltage. The crystal will not oscillate with a direct-current potential applied. If the applied potential is great enough in voltage value, the crystal will crack or split.

**Ques. 3.113.** What does the expression "negative temperature coefficient" mean as applied to a quartz crystal?

*Ans.* The expression "negative temperature coefficient" means that the frequency of the crystal varies indirectly with the temperature; that is, when the temperature increases, the frequency of the crystal decreases.

**Ques. 3.114.** What does the expression "low temperature coefficient" mean as applied to a quartz crystal?

*Ans.* The expression "low temperature coefficient" means that the frequency of the crystal varies very little with a change in temperature.

**Ques. 3.115.** What is the function of a quartz crystal in a radio transmitter?

*Ans.* The function of a quartz crystal in a radio transmitter is to keep the transmitter on its assigned frequency within the allowed frequency tolerances; *i.e.*, the quartz crystal functions as a frequency stabilizer.

**Ques. 3.116.** What may result if a high degree of coupling exists between the plate and grid circuits of a crystal-controlled oscillator?

*Ans.* A high degree of coupling between the plate and grid circuits of a crystal-controlled oscillator might result in excessive feedback with the danger of cracking the crystal.

**Ques. 3.117.** What is the purpose in maintaining the temperature of a quartz crystal as constant as possible?

*Ans.* It is necessary to keep the temperature of a quartz crystal constant in order to keep its oscillating frequency stable within limits.

**Ques. 3.118.** Why is a separate source of plate power desirable for a crystal-oscillator stage in a radio transmitter?

*Ans.* A separate source of plate power is desirable in order that the crystal-oscillator stage may operate with a maximum stability. If the crystal stage takes its power from the same source as the rest of the transmitter and the regulation of the power supply is not up to the required standard for crystal stability owing to variable load conditions in the power amplifier, the dynamic stability of the crystal frequency would be poor.

**Ques. 3.119.** What are the principal advantages of crystal control over tuned-circuit oscillators? How may a slight variation in a crystal oscillator frequency be effected?

*Ans.* High-frequency stability, highly selective tuning properties (high  $Q$ ), and critical control of fundamental frequency and harmonics by temperature adjustments.

The frequency can be raised or lowered by adding a small variable condenser in parallel with the quartz plate.

**Ques. 3.120.** What is the approximate range of temperature coefficients to be encountered with X-cut quartz crystals?

*Ans.* From  $-10$  to  $-25$  parts per million (p.p.m.) per degree centigrade.

**Ques. 3.121.** Is it necessary or desirable that the surfaces of a quartz crystal be clean? If so, what cleaning agents may be used which will not adversely affect the operation of the crystal?



*Ans.* Yes, it is necessary to keep the surfaces of a quartz crystal clean. This may best be done by using soap and water or carbon tetrachloride.

**Ques. 3.122.** List the characteristics of a dynatron type of oscillator.

*Ans.* The characteristics of a dynatron type of oscillator are as follows:

1. A well-designed dynatron has a frequency stability which compares favorably with that of the crystal oscillator without temperature control.

2. Its efficiency is low.

3. It can be used in a heterodyne wavemeter. When so used, the sharpness of indication of the meter is increased because the dynatron neutralizes the positive resistance of the wavemeter circuit. This it does by virtue of the negative resistance of the tube operating as a dynatron.

**Ques. 3.123.** List the characteristics of an electron-coupled type of oscillator.

*Ans.* The characteristics of an electron-coupled type of oscillator are as follows: In the electron-coupled oscillator, the plate circuit is isolated from its load. Hence, changes in load-circuit impedance do not affect the  $L \times C$  value in the oscillator circuit. Therefore, frequency stability is good. Modern practice is to use the electron-coupled oscillator in frequency meters because of its excellent frequency stability.

**Ques. 3.124.** Upon what characteristic of an electron tube does a dynatron type of oscillator depend?

*Ans.* Secondary emission.

**Ques. 3.125.** Describe a multivibrator and list its characteristics and uses.

*Ans.* The multivibrator or relaxation oscillator is a two-tube resistance-coupled oscillator in which the voltage devel-

oped by the output of the second tube is applied to the input of the first tube. The principle of operation is based upon the fact that the tubes invert the wave form. The output wave is nonsinusoidal in character. This type of oscillator may be used for any of the following purposes:

1. Master oscillator timer.
2. To produce rectangular control pulses of certain lengths, synchronized with excitation trigger pulses.
3. To introduce delay between input trigger pulses and a second circuit.
4. Frequency division. To synchronize or lock circuits at other than 1:1 ratio. (See Ques. 4.104 for circuit diagram.)

**Ques. 3.126.** If a wavemeter, having a deviation inversely proportional to the wavelength, is accurate to 10 cycles when set at 600 kilocycles, what is its error in cycles when set at 1,110 kilocycles?

*Ans.* The error is 18.5 cycles, computed as follows:

$$10:600 = x:1110; \quad x = 18.5$$

**Ques. 3.127.** What precautions should be taken before using a heterodyne type of frequency meter?

*Ans.* The following precautions should be observed:

1. See that the filaments are operating at the proper voltage.
2. Be sure all high potential voltages are correct.
3. Be certain all holding screws on the cabinet are tight before checking or using the instrument. Any looseness involves capacity changes in the circuit, which will introduce errors in the calibration.
4. Make certain the meter has been recently checked against a calibrated test oscillator for frequency accuracy.
5. Let tubes warm up.

**Ques. 3.128.** What is the meaning of "zero beat" as used in connection with frequency-measuring equipment?

*Ans.* "Zero beat" means zero-beat frequency, which is the condition achieved when the frequency of the frequency-meter oscillator and that of the oscillations under measurement are equal. Hence, if the frequency of the frequency-meter oscillator is ascertainable on a calibrated dial, then at "zero beat" the frequency of the oscillations being measured is that indicated on the calibrated dial.

Zero beat might also be defined as the condition under which maximum and minimum values of two different frequencies occur at the same instant.

**Ques. 3.129.** What precautions should be observed in using an absorption-type frequency meter to measure the frequency of a self-excited oscillator? Explain your reasons.

*Ans.* Place the instrument as far as workably possible from the circuit being measured to avoid mutual coupling reactions, which would alter the output frequency of the circuit being measured.

**Ques. 3.130.** If the first speech amplifier tube of a radio-telephone transmitter were overexcited, but the percentage modulation capabilities of the transmitter were not exceeded, what would be the effect upon the output of the transmitter?

*Ans.* Excessive distortion would result in the modulated amplifier and, consequently, in the radiated wave.

**Ques. 3.131.** What is the purpose of a preamplifier?

*Ans.* A preamplifier is used with certain low-output microphones such as a condenser microphone chiefly for two purposes: (1) to avoid cable loss ahead of the first stage of amplification thereby improving signal-to-noise ratio, (2) to isolate the impedance of the cable and load from the microphone.

**Ques. 3.132.** What are the advantages of using two tubes in push-pull as compared with the use of the same tubes in parallel in an audio-frequency amplifier?

*Ans.* By operating two tubes in push-pull rather than in parallel a more symmetrical output wave form is secured, which conforms periodically to both sides of the excitation cycle, resulting in a neutralization of even harmonics.

**Ques. 3.133.** List four causes of distortion in a class A audio-frequency amplifier.

*Ans.* The following will cause distortion in a class A audio-frequency amplifier:

1. Too much excitation voltage.
2. Improper operating potentials.
3. Improper load impedance.
4. Leaky by-pass or coupling condensers.
5. Improper bias.
6. Parasitic oscillations (singing).

**Ques. 3.134.** What is the purpose of by-pass condensers connected across audio-frequency amplifier cathode-bias resistors?

*Ans.* The purpose of the by-pass condensers is to provide a low-impedance path for the audio-frequency components of the plate current to increase low-frequency response and signal amplitude.

**Ques. 3.135.** What are the advantages of using a resistor in series with the cathode of a class C radio-frequency amplifier tube to provide bias?

*Ans.* When this method is used, the tube is safeguarded against the removal of bias in the event of the failure of the independent bias supply. With this method, as long as a plate current flows, a bias is provided. If the bias supply should be short-circuited from a class C radio-frequency

amplifier tube not provided with a resistor, the plate current would immediately rise and possibly damage the tube.

**Ques. 3.136.** How may the generation of even harmonic energy in a radio-frequency amplifier stage be minimized?

*Ans.* The generation of even harmonic energy may be minimized by the use of the following:

1. Push-pull circuits with matched tubes.
2. Faraday screen.
3. Optimum ratio of volt-amperes to watts in the tank circuit.

**Ques. 3.137.** What tests will determine if a radio-frequency power-amplifier stage is properly neutralized?

*Ans.* Plate voltages only are removed from the tube, leaving the tube in its proper position in the circuit. Then test for the presence of radio-frequency current in the plate tank circuit of the tube whose neutralization is being tested. To do this, the preceding amplifier must be operating and an indicator of radio-frequency current, such as the thermocouple meter attached to a very small loop of wire, a neon bulb, or a low-power carbon-filament lamp, must be brought close to the tank circuit. If no radio-frequency current is present in the tank circuit, the tube is properly neutralized. If the presence of radio-frequency current is indicated in the tank circuit, the neutralizing condenser should be varied until it is indicated that this radio-frequency current in the tank circuit is at a minimum.

Excessive plate current in an amplifier stage might indicate improper neutralization. Therefore, a proper reading on the plate-current ammeter would indicate proper neutralization of that stage. (See Ques. 3.144 and 5.98.)

**Ques. 3.138.** Why is the plate-circuit efficiency of a radio-frequency amplifier tube operating as class C higher than that of the same tube operating as class B? If the statement above is false, explain your reasons for such a conclusion.

*Ans.* The statement is true. The reason is that plate current flows only on the positive peaks of the excitation voltage at the instant when the voltage drop across the tube is low. Under these conditions, the largest portion of the plate power will be absorbed by the tuned plate circuit and transferred from there as useful output. (See Ques. 2.107.)

**Ques. 3.139.** Why does a class B audio-frequency amplifier stage require considerably greater driving power than a class A amplifier?

*Ans.* Because the grid of the class B amplifier is driven positive on the crest of each cycle and the grid input resistance of the tube is low. To avoid severe distortion the grid resistance must be very small so that the load on the driver does not change greatly when the grid goes positive. The low-resistance grid circuit consumes a relatively large amount of power. By contrast, the class A amplifier presents a high resistance at all times to the driver. Hence, it requires less driving power.

**Ques. 3.140.** Discuss the input circuit requirements for a class B audio-frequency amplifier grid circuit.

*Ans.* The most important consideration in the requirements of a class B amplifier is the proper design of the input circuit. The input to the grids of a class B audio-frequency amplifier is generally a balanced class A amplifier with a high load-impedance primary. The secondary winding which feeds the grids of the class B stage is of low impedance and low resistance to handle the heavy grid-current swings. The heavy power demands also require a well-regulated plate and bias supply to keep distortion at a minimum.

**Ques. 3.141.** When a signal is impressed on the grid of a properly adjusted and operated class A audio-frequency amplifier, what change in average value of plate current will take place?

*Ans.* There will be no change in the average value of the plate current.

**Ques. 3.142.** If the value of capacitance of a coupling condenser in a resistance-coupled audio amplifier is increased, what effect may be noted?

*Ans.* If the capacitance of the coupling condenser is increased, the low-frequency response will be improved, but if the capacity is increased to an excessive value, "motor-boating" or distortion may occur owing to a change in the time constants of the circuit.

**Ques. 3.143.** Why does a screen-grid tube normally require no neutralization when used as a radio-frequency amplifier?

*Ans.* Because the screen grid reduces the grid-to-plate capacity of the tube, which decreases the amount of feedback energy reaching the grid, thus preventing self-oscillation.

**Ques. 3.144.** What instruments or devices may be used to adjust and determine that an amplifier stage is properly neutralized?

*Ans.* Any of the following combinations may be used: a wavemeter in conjunction with a thermocouple galvanometer, a sensitive thermocoupled galvanometer connected in series with a small pick-up loop, a neon bulb or a low-power carbon-filament lamp connected in series with a pick-up loop. In modern broadcast transmitters it is generally unnecessary to use the above devices, since each transmitter is equipped with an extra "sensitive" thermocouple shunt. This sensitive thermocouple is part of the regular tank-circuit radio-frequency ammeter. A pair of metal links are provided to switch the ammeter from the high-current thermocouple to the sensitive couple for neutralizing purposes.

Great care must be exercised that the sensitive thermocouple is not connected in the tank circuit during the period

in which the plate voltages are applied, since it will burn out immediately.

**Ques. 3.145.** What is meant by the term unity "coupling"?

*Ans.* When all the lines of force of one coil cut the windings of a second coil coupled to it and vice versa, the coefficient of coupling is said to equal unity. A formula for coefficient of coupling is

$$k^2 = \frac{M^2}{L_p L_s},$$

where  $M$  is the mutual induction between the coils.

$L$  is the inductance value.

Under ordinary conditions, the value of  $k$  can approach, but never exceed, the value of unity. However, by the use of an iron core,  $k$  can be made almost equal to unity. Unity coupling is the condition when  $k$  equals unity or one.

**Ques. 3.146.** Draw a diagram illustrating "capacitive" coupling between two tuned radio-frequency circuits.

*Ans.* See Fig. 3-11.

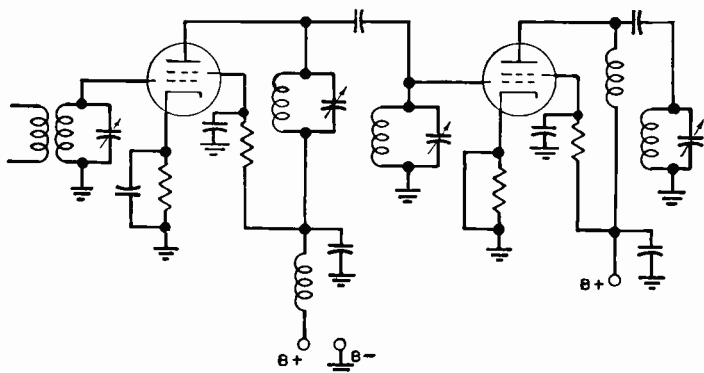

FIG. 3-11. Capacitive coupling system.

**Ques. 3.147.** Draw a diagram illustrating inductive coupling between two tuned radio-frequency circuits.



*Ans.* See Fig. 2-16.

**Ques. 3.148.** Draw a diagram illustrating direct or Loftin-White coupling between two stages of audio-frequency amplification.

*Ans.* See Fig. 3-12.

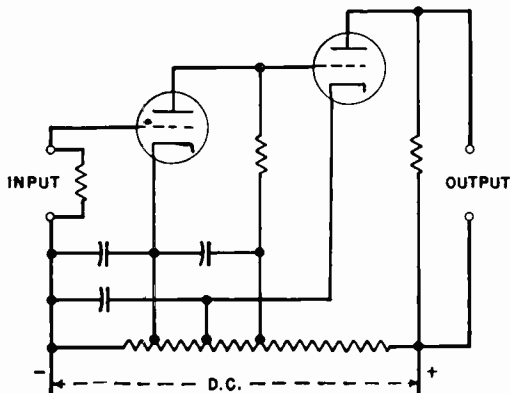

FIG. 3-12. Loftin-White direct-coupled amplifier.

**Ques. 3.149.** List four classes of stations which may be operated by a person holding a radiotelephone second-class license.

*Ans.* Any station while using type A0, A3, A4, or A5 emission except standard broadcast stations, international broadcast stations, or ship stations licensed to use power in excess of 100 watts and type A3 emission for communication with coastal telephone stations. Such stations might include any of the following:

1. General experimental.
2. Aeronautical.
3. Municipal police.
4. Television broadcast.

**Ques. 3.150.** List four classes of broadcast stations which may be operated by the holder of a radiotelephone second-class operator license.

- Ans.* 1. Experimental broadcast.  
2. Relay broadcast.  
3. Educational FM broadcast stations operating below 1 kilowatt.  
4. Auxiliary stations. (Studio-transmitter link, remote pick-up.)

**Ques. 3.151.** May the holder of a radiotelephone second-class operator license adjust and service or supervise the adjustment and servicing of any class of police radio station?

- Ans.* Yes, as long as such station is using type A3 emission.

**Ques. 3.152.** List four classes of stations, the equipment of which may be adjusted and serviced by the holder of a radiotelephone second-class operator license.

- Ans.* 1. General experimental.  
2. Aeronautical.  
3. Municipal police.  
4. Television broadcast.

**Ques. 3.153.** List three classes of stations which may not be serviced or adjusted by the holder of a radiotelephone second-class operator license.

- Ans.* 1. Standard broadcast (frequency modulation and television).  
2. Ship station compulsorily equipped.  
3. Zone police station.

**Ques. 3.154.** If an operator is employed at more than one station, how may the requirements of the Commission's Rules and Regulations be met with respect to the posting of operator licenses?

*Ans.* The holder of an operator license who operates any station in which the posting of an operator license is not required, may, upon filing application in duplicate accompanied by his license, obtain a verification card. This card may be carried on the person of the operator in lieu of the original operator license, provided the license is readily accessible within a reasonable time for inspection upon demand by an authorized Government representative.

The original license of each station operator shall be posted at the (principal) place where he is on duty or kept in his possession in the manner specified in the regulations governing the class of station concerned.

**Ques. 3.155.** Is it necessary that the original operator license be posted at an aeronautical station? An aircraft station? An airport station? A broadcast station? A ship station?

*Ans.* The original license of each station operator shall be conspicuously posted at the place he is on duty, or in the case of mobile units, either the license or verification card must be kept in his personal possession.

**Ques. 3.156.** What is a "verification card" and under what circumstances may it be used?

*Ans.* The holder of an operator license who operates any station in which the posting of an operator license is not required may, upon filing application in duplicate accompanied by his license, obtain a "verification card." This card may be carried on the person of the operator in lieu of the original operator license, provided the license is readily accessible within a reasonable time for inspection upon demand by an authorized Government representative.

**Ques. 3.157.** If a ship-telephone station is assigned the frequency of 2,738 kilocycles, and the maximum tolerance is

0.04 per cent, what are the highest and lowest frequencies within the tolerance limits?

*Ans.* 2,736.9 and 2,739.1 kilocycles.

**Ques. 3.158.** If an aircraft station is assigned the frequency of 3,105 kilocycles, and the maximum tolerance is 0.1 per cent, what are the highest and lowest frequencies within the tolerance limits?

*Ans.* 3,101.9 and 3,108.1 kilocycles.

**Ques. 3.159.** If a heterodyne frequency meter, having a calibrated range of 1,000 to 5,000 kilocycles, is used to measure the frequency of a transmitter operating on approximately 500 kilocycles by measurement of the second harmonic of this transmitter, and the indicated measurement was 1,008 kilocycles, what is the actual frequency of the transmitter output?

*Ans.* 504 kilocycles.

**Ques. 3.160.** Under what conditions may a log not be maintained by a radio station in the aviation or emergency service?

*Ans.* During an emergency the log may be neglected but must be made up immediately following the emergency and initialed by a person, other than the operator, who was present during the emergency.

**Ques. 3.161.** What information must be entered in the radio station log of an aircraft station not open to public service?

*Ans.* According to Rule 9.41 of the FCC which is quoted in the preceding answer, an aircraft station is not required to keep a log. However, if a log is kept, the information listed under Items 1, 2, 3, and 4 in the following answer should be entered.

**Ques. 3.162.** List four entries required to be entered in the radio station log of a station in the aviation service.

*Ans.* All stations in the aviation service, except aircraft stations, must keep an adequate log showing (1) hours of operation, (2) frequencies used, (3) stations with which communication was held, and (4) signature of operator(s) on duty.

**Ques. 3.163.** List four entries required to be entered in the radio station log of a station in the emergency service.

*Ans.* Each licensee shall maintain adequate records of the operation of the station, including (1) hours of operation, (2) frequencies used, (3) nature and time of each transmission, (4) name of operator on duty at the transmitter.

**AUTHOR'S NOTE**—In addition to the above items to be noted in the log, it is evident that anything of special significance not covered by the above items should also be entered in the log.

**Ques. 3.164.** Define the following types of emission: A0, A1, A2, A3, A4, A5.

*Ans.* Type A0. Waves the successive oscillations of which are *identical* under fixed conditions. (Standard frequency transmission.)

Type A1. Telegraphy on pure continuous waves. A continuous wave which is keyed according to a telegraph code.

Type A2. Modulated telegraph. A carrier wave modulated at one or more audible frequencies, the audible frequency or frequencies or their combination with the carrier wave being keyed according to a telegraph code.

Type A3. Telephony. Waves resulting from the modulation of a carrier wave by frequencies corresponding to the voice, to music, or to other sounds.

Type A4. Facsimile. Waves resulting from the modulation of a carrier wave by frequencies produced at the time of the scanning of a fixed image with a view to its reproduction in a permanent form.

Type A5. Television. Waves resulting from the modulation of a carrier wave by frequencies produced at the time of the scanning of fixed or moving objects.

In addition to the continuous-wave emissions, which are classed as type A, there is type B emission (prohibited), which is composed of successive series of oscillations the amplitude of which, after attaining a maximum, decreases gradually, the wave trains being keyed according to a telegraph code.

**Ques. 3.165.** In the adjustment of a radiotelephone transmitter, what precautions should be observed?

*Ans.* Tests and experiments are permitted to certain stations provided they do not interfere with the services of other stations. The operator should make certain before each test or adjustment that such interference will not take place.

**Ques. 3.166.** What is the meaning of "a station open to public service"?

*Ans.* A station open to public correspondence at published rates, *i.e.*, a paid or toll message service.

**Ques. 3.167.** Under what circumstances may an aircraft radio station call an airport station on 3,105 kilocycles?

*Ans.* The use of this frequency is restricted to communications pertaining solely to aircraft operation and the protection of life and property. This frequency is also a calling and working frequency for use primarily by nonscheduled aircraft.

**Ques. 3.168.** If, upon being called by another station, a called station is unable to proceed with the acceptance of traffic without a slight delay, what procedure should be adopted by the operator?

*Ans.* If the station called is prevented from receiving, it shall reply to the call as indicated in the Regulations, but it shall replace the letter K by the signal . . . (wait), followed by a number indicating in minutes the probable duration of

the wait. If this probable duration exceeds 10 minutes (5 minutes in the aeronautical mobile service), a reason must be given therefor.

**Ques. 3.169.** To what aircraft is an aeronautical station required to provide nonpublic service?

*Ans.* Aeronautical stations shall provide nonpublic service without discrimination to all scheduled aircraft the owners of which make cooperative arrangements for the operation and maintenance of the aeronautical stations which are to furnish such service and for shared liability in the operation of stations. In addition, this class of station shall provide reasonable and fair service to nonscheduled aircraft in accordance with the provisions of these rules.

**Ques. 3.170.** Under what circumstances will remote control of a radio transmitter, other than broadcast, with the operator at a point other than the location of the transmitter, be authorized by the Commission?

*Ans.* A licensed operator shall be on duty and in charge of the transmitter during all transmissions unless remote-control operation or operation without an operator in attendance is authorized by the terms of the instrument of authorization.

**Ques. 3.171.** Under what circumstances may aircraft equipment be tested in flight?

*Ans.* The licensees of all classes of stations in the aviation service are authorized to make such routine tests as may be required for the proper maintenance of the station provided that precautions are taken to avoid interference with any station. Tests on 3,105 and 6,210 kilocycles using a regular antenna system can be made only at such times when no interference will be caused and, if in range of an airport control station or Civil Aeronautics Authority station, only after permission is secured from such stations before commencing the tests.

**Ques. 3.172.** Explain the relation between the signal frequency, the oscillator frequency, and the image frequency in a superheterodyne receiver.

*Ans.* The image frequency is as far above the oscillator frequency as the signal frequency is below the oscillator frequency or vice versa. The difference between the oscillator frequency and the signal frequency equals the intermediate frequency. The difference between the oscillator frequency and the image frequency also equals the intermediate frequency.

**Ques. 3.173.** What means are used to prevent interaction between the stages of a multistage audio-frequency amplifier?

*Ans.* Adequate filters must be provided where necessary, and the various components oriented to the optimum position for minimum reaction between components. Iron shields are useful in keeping down this reaction. It is sometimes useful to ground the shields.

**Ques. 3.174.** Under what conditions, if any, may a station be operated by an unlicensed person or by an operator not holding a license of the grade normally required for that station?

*Ans.* The Commission, if it shall find that the public interest, convenience, or necessity will be served thereby, may waive or modify the law which requires a licensed operator of a specified grade at each transmitting station except (1) at stations for which a licensed operator is required by international agreement, (2) at stations for which licensed operators are required for safety purposes, (3) at stations engaged in broadcasting, or (4) at stations operating as common carriers on frequencies below 30,000 kilocycles. Hence, in an emergency the Commission may permit certain stations to be operated by a grade of operator not required in the regulations.



**Ques. 3.175.** For what period of time must a log containing distress entries be retained?

*Ans.* Logs containing distress entries shall be retained by the licensee until specifically authorized in writing by the Commission to destroy them.

**Ques. 3.176.** What effect, if any, does modulation have on the amplitude of the antenna current of a frequency-modulated transmitter?

*Ans.* In frequency-modulated transmitters the amplitude of the antenna current remains essentially constant during the process of modulation.

**Ques. 3.177.** Why is a high percentage of modulation desirable in amplitude-modulated transmitters?

*Ans.* (See Ques. 3.36.)

**Ques. 3.178.** How would loss of radio-frequency excitation affect a class C modulated amplifier when using grid-leak bias only?

*Ans.* A decrease in radio-frequency excitation will result in decreased value of grid-biasing voltage. The modulated amplifier would no longer operate as an efficient class C amplifier. Complete loss of excitation would result in excessive plate dissipation and probable damage to the modulated amplifier tube or tubes. (See also Ques. 5.60 and 6.157.)

**Ques. 3.179.** What is the purpose of a center-tap connection on a filament transformer?

*Ans.* A center-tap connection is provided on a filament transformer to provide a balanced grid and plate circuit return to the filament of a directly heated type of vacuum tube; to maintain constant equipotential relations between the grid, plate, and filament of the tube; and to equalize the plate current drain from both sides of the filament.

**Ques. 3.180.** What would be the result of a short circuit of the plate radio-frequency choke coil in a radio-frequency amplifier?

*Ans.* In a parallel-fed type of radio-frequency amplifier a short-circuited choke coil will effectively ground the radio-frequency plate potential. No radio-frequency energy will be supplied to the plate tank circuit. The possibility of a radio-frequency current flow through the defective choke may burn out the direct-current plate ammeter if not suitably protected by a radio-frequency by-pass condenser.

**Ques. 3.181.** What are the advantages of push-pull operation compared to single tube operation in amplifiers?

*Ans.* (See Ques. 3.132, 5.54, 5.155.)

**Ques. 3.182.** What class of amplifier is appropriate to use in a radio-frequency doubler stage?

*Ans.* A class C type of amplifier is most suitable in a radio-frequency doubler stage.

**Ques. 3.183.** What is the ratio of modulator power output to modulated amplifier plate power input for 100 per cent amplitude modulation?

*Ans.* A ratio of 1:2. (See also Ques. 6.26.)

**Ques. 3.184.** Draw a diagram of a Hartley oscillator. A Colpitts oscillator.

*Ans.* (See Ques. 2.72 and 2.76.)

**Ques. 3.185.** Describe the construction and characteristics of (a) a beam-power tube, (b) a thyratron tube, and (c) a battery-charging rectifier tube.

*Ans.* The beam-power tube is composed of a cathode, a control grid, a screen grid, a suppressor grid (optional), and a plate. A beam tube designed without an actual suppressor

grid contains specially designed beam-forming parabolic plates connected to the cathode. This plate structure produces an electron beam effect and also prevents stray electrons from the plate returning to the screen outside of the normal beam path. The screen and control grids are spiral-wound wires arranged so that each turn of the screen grid is shaded from the cathode by one of the grid wires. The plate characteristics are similar to those of the pentode except that the constant-current portion is reached at lower plate voltage.

The thyatron or gas-filled triode tube is similar to a standard triode type of vacuum tube with the exception that it contains mercury vapor or an inert gas of helium, argon, or neon. The cathode is generally of the cylindrical indirect heater type. The grid is a relatively large cylindrical sleeve with large perforations that completely shields the cathode from the plate. The plate is usually a button-shaped metallic disk and serves merely as a simple collector for the electrons.

A typical battery charger rectifier is the Tungar diode rectifier tube. This tube contains a tungsten filament and a button-shaped graphite plate. In the bulb there is an inert argon gas at low pressure.

The characteristics of the (a) beam-power, (b) thyatron, and (c) battery rectifier tubes are briefly as follows:

a. High power output, high power sensitivity, and high efficiency.

b. The grid serves as a critical electronic means for starting current flow. It cannot stop the flow as in the nongaseous types. The thyatron possesses rapid deionization time.

c. Low voltage, high current flow.

(See also Ques. 6.219.)

**Ques. 3.186.** What kind of vacuum tubes respond to filament reactivation, and how is reactivation accomplished?

*Ans.* The thoriated-tungsten type of vacuum tube. Reactivation is accomplished by a series of short-period flash tests of 30 to 60 seconds at voltages approximately twice that of the

normal filament operating potential. This should be followed with a seasoning test over a period of several hours at a slightly higher than normal operating potential. The plate voltage must be disconnected during these tests.

**Ques. 3.187.** What is the purpose of a bleeder resistor in the filter of a high-voltage direct-current power supply?

*Ans.* 1. Provide a suitable discharge path for the high-voltage condensers in the filter system after the power supply is cut off.

2. Improves voltage regulation.

3. Reduces surge transients.

4. Equalizes the filter-condenser voltages.

5. Minimizes filter-condenser breakdown due to momentary peak surges with changing loads.

(See also Ques. 5.122.)

**Ques. 3.188.** How much energy is consumed in 20 hours by a radio receiver rated at 60 watts?

*Ans.* 1,200 watt-hours or 1.2 kilowatt-hours. Energy in watt-hours = watts  $\times$  hours =  $60 \times 20 = 1,200$  watt-hours. Expressed in joules, 1 watt-hour = 360 joules

$$1,200 \text{ watt-hours} = 360 \times 1,200 = 432 \times 10^4 \text{ joules.}$$

The fundamental unit of work, or energy, is the erg; for practical purposes, the joule or watt-second is used. The watt-second is equivalent to the energy requirements of an electrical circuit in which one watt is supplied for one second. This is equal to  $10^7$  ergs.

**Ques. 3.189.** How does the value of resistance in the grid leak of a regenerative-type detector affect the sensitivity of the detector?

*Ans.* The grid leak of a condenser-resistance combination in a regenerative-type detector regulates the time constant of this network. This in turn controls the automatic grid bias developed during input signal or feedback voltages. With

weak-signal input the sensitivity of the circuit will be improved if a large value of grid leak (1 to 10 megohms) and a small condenser of 0.0001 to 0.00025 microfarad are employed. The larger the value of  $R$  and the smaller the condenser capacity the greater will be the circuit sensitivity for weak-signal-input voltages. (See also Ques. 2.204, 3.64, 5.45.)

**Ques. 3.190.** Compare the design and operating characteristics of class A, class B, and class C amplifiers.

*Ans.* (See Ques. 2.107 to 2.112, 2.136, 5.91, 5.163.)

**Ques. 3.191.** What are the causes of downward fluctuation of antenna current at an amplitude-modulated transmitter when the transmitter is modulated?

*Ans.* (See Ques. 3.40, 4.51, 4.123.)

**Ques. 3.192.** What may cause upward fluctuation of the antenna current at an amplitude-modulated transmitter when the transmitter is modulated?

*Ans.* The antenna current will normally rise during the process of modulation owing to the additive audio-frequency power delivered to the carrier. (See also Ques. 3.39 and 5.95.)

**Ques. 3.193.** Explain how grid-bias voltage is developed by the grid leak in an oscillator.

*Ans.* The feedback voltages applied to the grid circuit from the plate develop alternate positive and negative e.m.f.'s between the grid and the cathode of the oscillator tube. If a suitable value of grid condenser and grid leak is connected, as illustrated in Fig. 2-3, the grid will attract electrons during the positive half of the excitation cycle. The blocking action of the series grid condenser will force the electrons to flow through the grid-leak resistance, resulting in a voltage drop across the resistance. Hence, since electrons will continuously flow through the resistance from the grid to the cathode, the grid will be maintained negatively with respect to the cathode

during the period in which the tube circuit oscillates. (See also Ques. 5.50.)

**Ques. 3.194.** Explain why radio-frequency chokes are sometimes placed in the power leads between a motor-generator power supply and a high-powered radio transmitter.

*Ans.* Radio-frequency chokes are sometimes connected in this manner to prevent possible high-frequency high-power current surges from burning out one or more of the generator armature coils. They are also provided to filter out commutator transients.

**Ques. 3.195.** What effect does inductive reactance in an alternating-current circuit have on the power factor of the circuit?

*Ans.* An inductive reactance in an alternating-current circuit introduces a lagging power factor. It will decrease the power factor below unity by a value depending upon the reactance value of the inductance. (See also Ques. 2.34.)

**Ques. 3.196.** In which circuits of a radio station are three-phase circuits sometimes employed?

*Ans.* In the rectifier high-voltage power-supply circuits. The high-voltage transformer in these high-power three-phase installations is generally of the delta-Y type.

**Ques. 3.197.** Explain the operation of a vacuum-tube rectifier power supply and filter.

*Ans.* Figure 5-8 illustrates a typical full-wave vacuum-tube rectifier and power-supply system. The theoretical operation of this type of circuit is briefly as follows:

The alternating-current power-supply voltage is raised through the step-up action from the primary to the secondary winding on the transformer in accordance with the laws of induction as related to transformer theory. A step-down

winding is also provided to supply the filament voltage for the rectifier tubes.

When an alternating current flows in the primary winding, the filaments of the rectifier tubes are heated and electrons are emitted from the rectifier-tube filaments. The alternating voltage induced in the high-voltage secondary winding alternately charges the plates of the rectifier tubes positive with respect to the filaments. When the plate of one tube is positive, electrons will flow from the filament to the plate of that tube through one-half section of the high-voltage winding

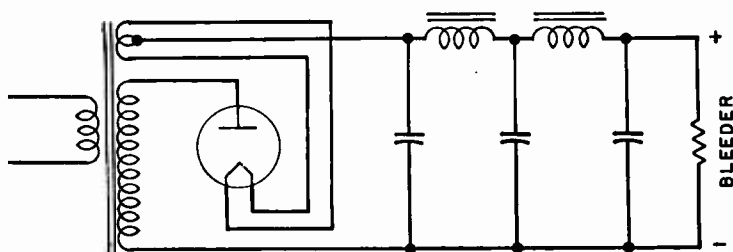

FIG. 3-13. Half-wave rectifier.

and through the voltage divider resistance and the choke coils, thus returning to the filament to complete the circuit. The complete flow is in the form of a half-wave pulsation.

When the alternating cycle reverses, the other tube will conduct a current flow through the other half of the high-voltage winding and the circuit components. Another half-wave pulsation is developed which completes two pulsations for the one cycle of alternating-current voltage.

The pulsations passing through the choke coils are partly smoothed but not sufficiently to develop a pure direct current. The filter condensers serve to fill in the slight irregularities or troughs of the pulsations in a sort of reservoir action to improve filtering further. The input filter condenser also tends to boost the voltage output developed across the voltage divider resistance.

The complete power-supply and vacuum-tube rectifier

system is essentially a device for changing the alternating line-voltage current to a direct-current voltage of greater amplitude.

**Ques. 3.198.** What are the merits of a frequency-modulation communication system compared to the merits of an amplitude-modulation communication system?

*Ans.* The primary advantage of a frequency-modulated communication system is the improvement shown in signal-to-noise ratio. A properly adjusted frequency-modulation type of receiver is practically devoid of man-made noise and static disturbances.

Frequency-modulated transmission also provides a more uniform service area. This is due to the fact that the signal-to-noise ratio remains high until the field intensity reaches a low value. Decreased interchannel interference and relatively lower power requirements are other important advantages of frequency-modulation over amplitude-modulation systems.

**Ques. 3.199.** What is meant by horizontal and vertical polarization of a radio wave?

*Ans.* The polarization of radio waves or light waves is the effect of these waves to exhibit different properties in different directions at right angles to the line of propagation. A vertically polarized wave is one in which all the lines of electric force lie in planes perpendicular to the ground plane. In a horizontally polarized wave, the lines of force are parallel to the ground plane.

In general, an antenna that is vertical with respect to the earth radiates a vertically polarized wave while a horizontal antenna radiates a horizontally polarized wave.

**Ques. 3.200.** How should a transmitting antenna be designed if a vertically polarized wave is to be radiated, and how should the receiving antenna be designed for best performance in receiving the ground wave from this transmitting antenna?



*Ans.* The antenna should be designed to stand in a vertical position with respect to the earth and close to the ground. Vertically polarized waves so constructed produce a stronger signal close to the earth than do horizontally polarized waves. Vertical polarization, therefore, depends upon the physical position of the antenna.

In general, vertically erected antennas, grounded or ungrounded, of a dimension from one-eighth to one full wavelength, are ideally suited for the transmission of vertically polarized waves close to the ground. In any event, the receiving antenna should conform exactly with the position and ground relationship of the transmitting antenna.

**Ques. 3.201.** Draw a block diagram of a frequency-modulation receiver and explain its principle of operation.

*Ans.* See Fig. 3-14.

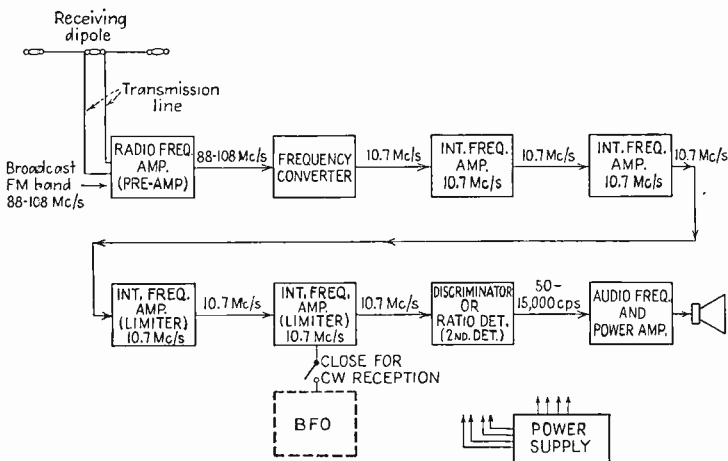

FIG. 3-14.

The radio-frequency components of a frequency-modulation superheterodyne receiver are essentially the same as in the conventional amplitude-modulation types of receivers. The pri-

mary difference lies in the increased band-width (50 to 15,000 c.p.s.) requirements, input signal clipping (limiter action), and the demodulation (detection) of the frequency-modulated wave.

A comparison of Figs. 3-14 and 3-18 illustrates the basic changes in the frequency-modulation receiver as compared with a typical amplitude-modulation type.

In the frequency-modulation system, the transmitted carrier frequency is practically of constant amplitude but varies in width during the process of modulation.

When the transmitted signal is picked up by the receiver dipole antenna, frequency-modulated signals will pass through the tuned radio-frequency amplifier into the frequency converter. Here the local oscillator and signal frequencies are combined in typical superheterodyne fashion to produce the desired heterodyne beat at the designated intermediate frequency. The signals are then amplified by the successive intermediate-frequency amplifiers and limiter stages.

The limiter stage(s) serve to clip off any amplitude variations of the signal input, thereby making its output constant to the discriminator or ratio detector system. The detector in a frequency-modulated receiver must be so designed that its output varies with the input frequency. This is obtained in the discriminator detecting system by feeding the signal from the final limiter intermediate stage to a balanced diode rectifier. The radio-frequency signal to the diodes is fed from the limiter stage into a double-tuned circuit (one for each diode) at two frequencies: one above the intermediate-frequency center frequency and the other below it. Hence, as the frequency of the carrier frequency swings due to the modulating frequency, the output across the diode load resistance varies in accordance with the audio frequency modulating the carrier. This audio frequency is then amplified in the usual manner by the audio-frequency voltage and the power-amplifier tubes.

**Ques. 3.202.** Draw a block diagram of a frequency-modulated transmitter and indicate the center frequency of the

master oscillator and the center frequency radiated by the antenna.

Ans. See Fig. 3-15.

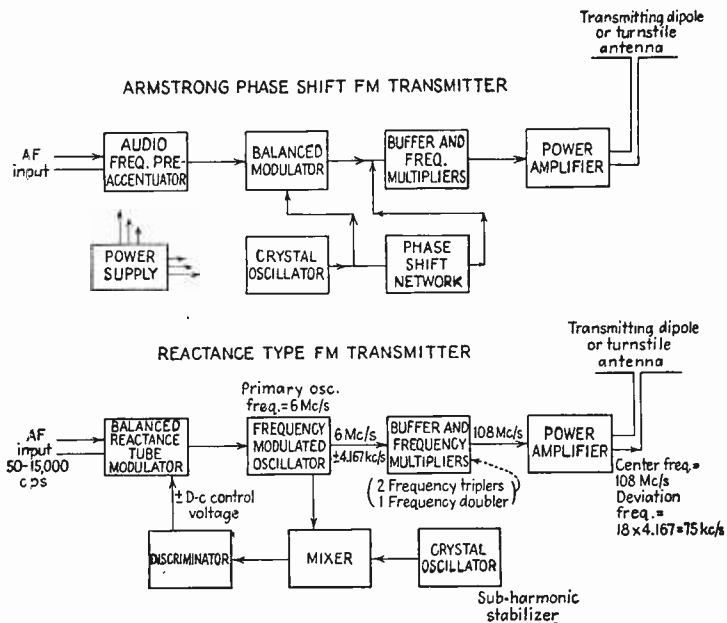

FIG. 3-15.

It is assumed in this example that an output center frequency of 108 megacycles is required, this output in turn to be frequency-modulated to produce a frequency deviation during the process of modulation of  $\pm 75$  kilocycles. Furthermore, since the primary or master oscillators in many frequency-modulated transmitters are in the vicinity of 6 megacycles, this latter frequency was chosen to represent the controlled master oscillator frequency.

Hence, to satisfy these conditions, it will be necessary to obtain a multiplication of eighteen times ( $3 \times 3 \times 2$ ) by

means of two tripler and one doubler amplifier stage to increase the frequency from 6 to 108 megacycles.

$$F = 18F_1 = 18 \times 6 = 108 \text{ megacycles.}$$

However, to satisfy the conditions of modulation, the master oscillator must have a corresponding maximum permissible swing of  $\frac{75}{18}$ , or 4.167 kilocycles. This deviation of the master oscillator frequency when multiplied by 18 (tripler and doubler stages) will yield a maximum swing of 75 kilocycles.<sup>1</sup>

**Ques. 3.203.** In a frequency-modulation radio communication system what is the meaning of modulation index? Of deviation ratio? What values of deviation ratio are used in a frequency-modulation radio communication system?

*Ans.* Modulation index is defined as the ratio of the frequency-modulated carrier frequency swing to the modulating (audio) frequency.

$$m = \frac{\text{maximum frequency swing}}{\text{frequency of signal voltage}}$$

The term "deviation ratio" relates more specifically to the ratio of a frequency swing of 75 kilocycles (100 per cent modulation) to the maximum audio frequency transmitted. The maximum audio frequency is standardized at 15 kilocycles. Hence, for broadcast transmitters the maximum deviation ratio is  $\frac{75,000}{15,000} = 5$ . In radio communication systems the deviation ratio is generally between 1 and 3.

**Ques. 3.204.** Why is narrow-band frequency modulation rather than wide-band frequency modulation used in radio communication systems?

- Ans.* 1. Improves signal-to-noise ratio.  
2. Provides maximum coverage for a given amount of power.

<sup>1</sup>A maximum deviation of 75 kilocycles is authorized by the FCC regulations for full frequency modulation.

3. Reduces interchannel interference.
4. Accommodates more stations in a given spectrum.
5. Does not require high fidelity for code and voice transmissions.
6. Gives simplified transmitter and antenna design.

**Ques. 3.205.** What is the purpose of a squelch circuit in a radio communication receiver?

*Ans.* A squelch circuit in a communications receiver is used to reduce the inherent noise developed in the receiver during the period in which no signal frequency is present.

**Ques. 3.206.** Discuss methods whereby interference to a radio receiver can be reduced.

*Ans.* The reduction of interference to a radio receiver can be improved by one or more of the following suggestions:

1. Thorough grounding of all metal components of the receiver.
2. Inserting shielded radio-frequency choke coils and by-pass condensers in the power-supply input to the receiver.
3. Directional antennas.
4. Balanced transmission lines or coaxial cables.
5. Shielded antenna lead-in wire. (Reduces normal signal gain to the receiver.)
6. Series-resonant trap circuit across receiver input. (Adjust to the interfering signal frequency.)
7. Parallel-resonant wave trap circuit in series with the antenna. (Adjust to the interfering signal.)
8. Insertion of a pretuner stage to the receiver input terminals.

(See also Ques. 6.49 and 6.55.)

**Ques. 3.207.** Draw a diagram of an absorption-type wavemeter and explain its principle of operation.

## RADIO OPERATING QUESTIONS AND ANSWERS

*Ans.* Figure 3-16 illustrates a typical circuit diagram of an absorption-type wavemeter. The coil of the wavemeter is loosely coupled to the circuit under measurement. The tun-

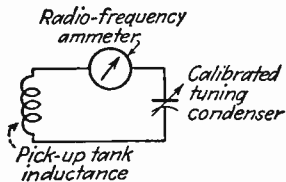

FIG. 3-16.

ing condenser is varied until resonance is indicated by a maximum deflection on the radio-frequency ammeter.

The frequency or wavelength at resonance is determined by a direct reading on the scale of the condenser or by reference to the instrument calibration chart. (See also Ques. 3.129.)

**Ques. 3.208.** Draw a diagram of an ohmmeter and explain its principle of operation.

*Ans.* Figure 3-17 illustrates a simple type of ohmmeter. In this instrument, small battery-type cells are used to supply

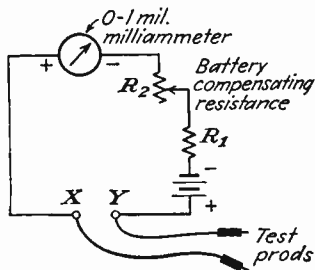

FIG. 3-17.

the voltage to operate a calibrated 1-milliampere type of ammeter when the external terminals to an unknown resistor are closed. Two standard calibrated resistors are employed.

One resistor  $R_1$  is of fixed value, and the other  $R_2$  is of the variable type to compensate for battery voltage changes.

Adjustment of the meter is accomplished by short-circuiting the terminals  $X$ - $Y$  and varying  $R_2$  until the milliammeter indicates a full-scale deflection (zero ohms on the calibrated scale).

When an unknown resistance is connected across the terminals, the current flow through the meter will decrease in proportion to the amount of the unknown resistance applied. Thus, since the scale is calibrated directly in ohms, the reading will give the value of the unknown resistance. Zero ohms are indicated at the extreme right, and maximum ohms are shown on the extreme left in this simple type of ohmmeter.

**Ques. 3.209.** Discuss Lecher wires.

*Ans.* Lecher wires are short-wavelength two-wire transmission lines. Two short parallel lengths of line are frequently used in ultra-high-frequency vacuum-tube oscillators to provide the necessary oscillatory constants for the circuit. Lecher wires are generally a quarter wavelength long or some multiple of a quarter wavelength, depending upon the frequency required.

Lecher wires present an excellent means for studying the phenomena of ultra-high-frequency transmission particularly as related to the measurements of standing waves and nodes on a transmission line.

**Ques. 3.210.** If a 0-1 direct-current milliammeter is to be converted into a voltmeter with full-scale calibration 100 volts, what value of series resistance should be connected in series with the milliammeter?

*Ans.* 100,000 ohms.

*Solution:*

$$R = \frac{E}{I} = \frac{100}{0.001} = 100,000 \text{ ohms.}$$

**Ques. 3.211.** What are wave guides? Cavity resonators?

*Ans.* A wave guide is a metallic pipe of rectangular or circular construction. It is used as a transmission line to guide or transfer electromagnetic waves in the microwave frequency spectrum between a generating source and an output device, such as a parabolic antenna system. Wave guides are used almost exclusively in the transmission of microwave frequencies between 1 and 10 centimeters in wavelength (10,000 to 3,000 megacycles).

A cavity resonator is a closed metallic chamber, either round or rectangular in cross-section. These resonant cavities develop standing-wave reflections which build up in the cavity and reinforce each other at some resonant frequency depending upon the physical construction of the cavity chamber.

The cavity resonator is to the microwave field what the conventional lumped inductance and capacity are to the lower radio-frequency field of high, medium, and low radio-frequency circuits.

**Ques. 3.212.** In what range of frequencies do magnetron and klystron oscillators find application?

*Ans.* Magnetron and klystron oscillators are used almost exclusively in the microwave and very high-frequency ranges between 1,000 and 30,000 megacycles.

**Ques. 3.213.** What is the purpose of a diversity antenna receiving system?

*Ans.* The diversity type of antenna system is extensively used in transoceanic telegraphy and telephone installations to reduce signal fading.

**Ques. 3.214.** Why are insulators sometimes placed in antenna guy wires?

*Ans.* Insulators are sometimes placed in antenna guy wires to prevent absorption and reradiation. If the physical length of a certain guy wire approaches a resonant relationship to



some multiple of the normal antenna frequency, harmonic radiation and serious interference may result. Series insulators connected in the guy wires help to break up these resonant properties and prevent harmonic radiation.

**Ques. 3.215.** Discuss the construction and operation of dynamotors.

*Ans.* A dynamotor is a motor-generator unit composed of a motor armature and a generator armature with common field excitation. The motor is generally a low-voltage direct-current type operating from a 6-volt or, in some cases, a 24-volt battery supply source. The generator armature develops a direct-current voltage ranging from 300 to 500 volts with power outputs ranging up to approximately 500 watts.

Some types of dynamotors utilize permanent magnets for their field excitation.

Dynamotors are commonly used for portable plate power-supply requirements. Minimum filtering is required as compared with the vacuum-tube rectifier types of power supply.

**Ques. 3.216.** Discuss the cause and prevention of interference to radio receivers installed in motor vehicles.

*Ans.* Interference is caused primarily by the ignition system in motor vehicles. Ignition interference is minimized by adhering to the following suggestions:

1. Bond and ground all cables to chassis.
2. Insert spark-plug suppressor resistors or chokes.
3. Shield all ignition wires.
4. Insert a 0.5-microfarad by-pass condenser across distributor points and dashboard ammeter.
5. Shield antenna lead-in wire from antenna to receiver terminal.
6. By-pass all overhead wires to lights and dome lights.

**Ques. 3.217.** Explain the process of neutralizing a triode radio-frequency amplifier.

*Ans.* (See Ques. 5.98.)

**Ques. 3.218.** A relay with a coil resistance of 500 ohms is designed to operate when 0.2 ampere flows through the coil. What value of resistance must be connected in series with the coil if operation is to be made from a 110-volt direct-current line?

*Ans.* A resistance of 50 ohms will be required to drop the voltage across the relay to the desired 100 volts.

*Solution:*

$$E = IR = 0.2 \times 500 = 100 \text{ volts.}$$

$$R_{\text{series}} = \frac{E}{I} = \frac{110 - 100}{0.2} = 50 \text{ ohms.}$$

**Ques. 3.219.** What value of resistance should be connected in series with a 6-volt battery that is to be charged at a 3-ampere rate from a 115-volt direct-current line?

*Ans.*  $36\frac{1}{3}$  ohms.

*Solution:*

$$R = \frac{E - e}{I} = \frac{115 - 6}{3} = 36\frac{1}{3} \text{ ohms.}$$

**Ques. 3.220.** What may cause "motorboating" in an audio amplifier?

*Ans.* "Motorboating" in an audio-frequency amplifier may be caused by any of the following defects:

1. Open output filter condenser in the power-supply system.
2. Open grid leaks.
3. Improper  $R$ - $C$  time constant in resistance-capacity coupled audio-frequency amplifiers.

**Ques. 3.221.** Why are pairs of wires carrying alternating-current heater currents in audio amplifiers twisted together?

*Ans.* Filament wires carrying alternating current are twisted in order that the 60-cycle magnetic fields around them will cancel out. This reduces the possibility of hum pickup in adjacent circuits.

**Ques. 3.222.** Draw a block diagram of a superheterodyne receiver capable of receiving amplitude-modulated signals and indicate the frequencies present in the various stages when the receiver is tuned to 2,450 kilocycles. What is the frequency of a station that might cause image interference to the receiver when tuned to 2,450 kilocycles?

*Ans.* See Fig. 3-18.

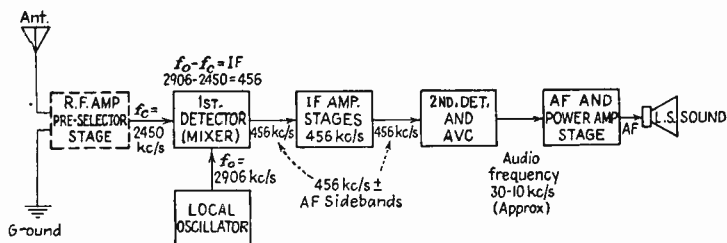

NOTE: Image interfering frequency without pre-selector stage =  $3362 \text{ kc/s } (f_c + 2IF)$

FIG. 3-18.

**Ques. 3.223.** Show by a diagram how to connect a wave trap in the antenna circuit of a radio receiver to attenuate an interfering signal.

*Ans.* See Fig. 3-19.

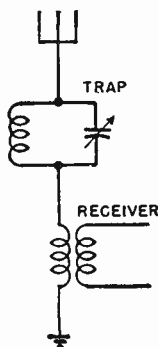

FIG. 3-19.

**Ques. 3.224.** Draw a diagram of a tuned radio-frequency type of radio receiver.

*Ans.* See Fig. 3-20.

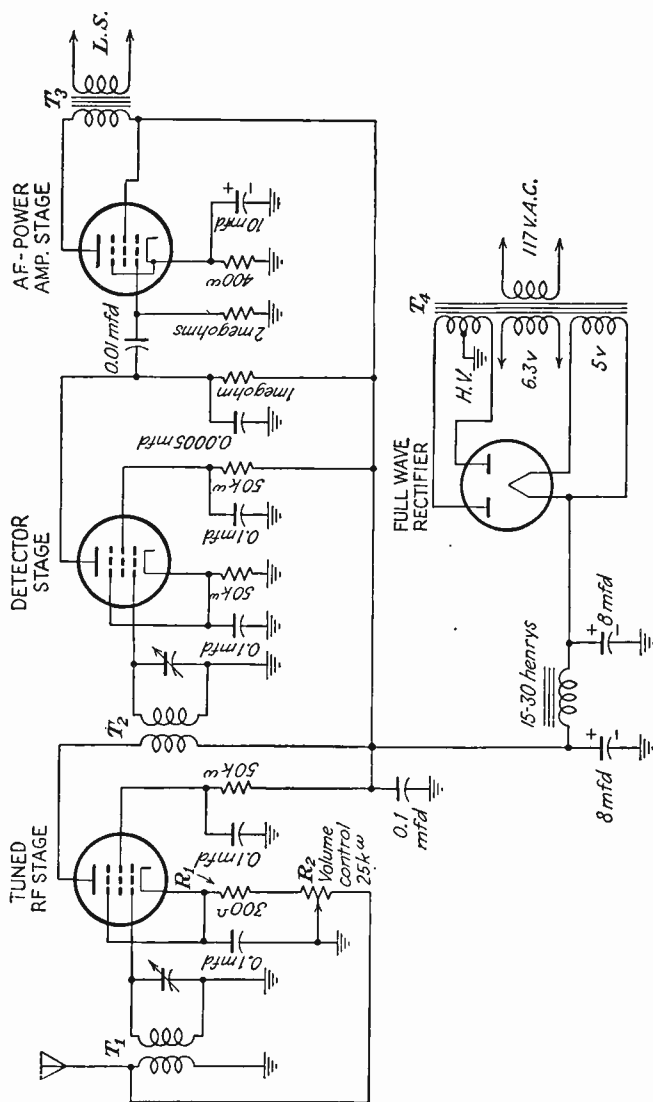

FIG. 3-20.

**Ques. 3.225.** What would be the effects of connecting 110 volts at 25 cycles to the primary of a transformer rated at 110 volts and 60 cycles?

*Ans.* The inductive reactance of the 110-volt 60-cycle primary winding will be lowered when the transformer is connected to a 25-cycle frequency source. The current flow through the primary winding will be more than double its normal value and may result in serious overheating and ultimate damage to the winding.

**Ques. 3.226.** Draw a diagram of a one-tube audio oscillator using an iron-core choke.

*Ans.* See Fig. 3-21.

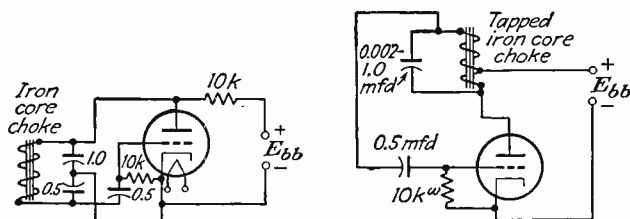

FIG. 3-21.

**Ques. 3.227.** Show by a diagram how a two-wire radio-frequency transmission line may be connected to feed a Hertz antenna.

*Ans.* See Fig. 3-22.

RADIO OPERATING QUESTIONS AND ANSWERS

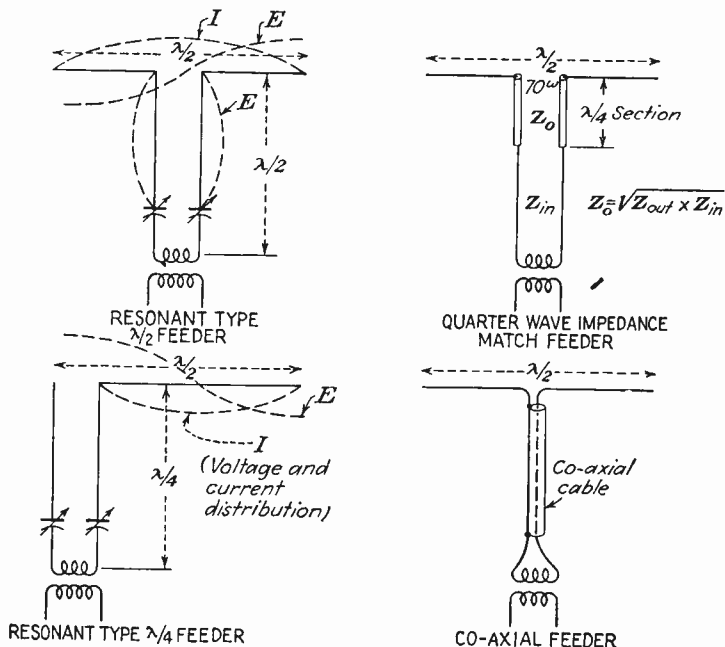

FIG. 3-22.

**Ques. 3.228.** Draw a diagram of a synchronous vibrator power supply. A non-synchronous vibrator power supply.

**Ans.** See Fig. 3-23.

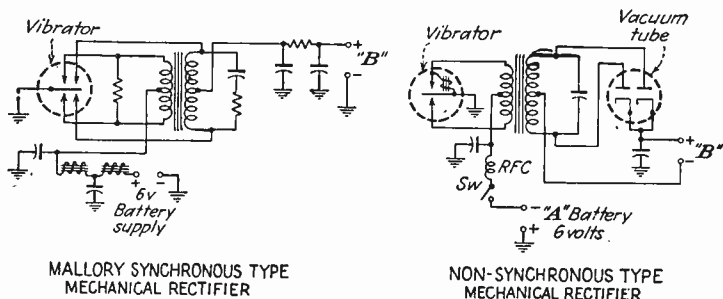

FIG. 3-23.

**Ques. 3.229.** What are the limitations in the use of the frequencies 2,638 and 2,738 kilocycles by ship stations?

*Ans.* These frequencies are designated for assignment to coastal-harbor stations upon the condition that excessive interference will not be caused to maritime mobile stations.

**Ques. 3.230.** In addition to the transmitting and receiving radio equipment at a ship radiotelephone station, what auxiliary equipment is required at the station?

*Ans.* Station logs and spare parts equipments are the only requirements.

**Ques. 3.231.** For how long a period are logs of a ship radiotelephone station required to be retained by the licensee of the station?

*Ans.* (See Ques. 181.03.)

**Ques. 3.232.** What is the calling and safety frequency for use by ship radiotelephone and coastal-harbor stations in the Great Lakes area?

*Ans.* The frequency 2,182 kilocycles is designated as a calling, answering, and safety frequency for use in the Great Lakes area.

**Ques. 3.233.** What is a coastal-harbor station?

*Ans.* The term "coastal-harbor" station means a coastal station used primarily for radiotelephone communication with ship-telephone stations which, by reason of the designated frequency or frequencies, have a limited communication range.

**Ques. 3.234.** What are the Commission's requirements for station identifications of a coastal-harbor station? A station in the railroad radio service?

## RADIO OPERATING QUESTIONS AND ANSWERS

*Ans.* Coastal-harbor stations, when calling a ship station, shall transmit the type of signal necessary to actuate the receiving equipment known to be installed in the particular ship station and normally used in the ship service for monitoring the coastal-harbor station frequency.

Stations in the railroad service shall be identified during each communication or exchange of a series of communications. During an exchange of communications exceeding 15 minutes in length, each station shall be identified at the end of each 15-minute period. In lieu of assigned call letters, identification may be made by the name of the railroad and the train number, caboose number, engine number, or name of fixed wayside station or, if that is not practicable, by such other number or name as may be specified by the railroad concerned for the use of its employees to identify the fixed point or mobile unit where the radio station is located. Where identification is made other than by train number, caboose number, or engine number, a list of such identifications shall be maintained by the railroad. An abbreviated name or initial letters of the railroad may be used where such name or initial letters are in general usage. In those cases where it is shown that no difficulty would be encountered in identifying the transmissions of a particular station, as for example where stations of one licensee are located in a yard isolated from other radio installations, approval may be given to a request of the licensee for permission to omit station identification.

**Ques. 3.235.** What is the frequency tolerance specified by the Commission's rules and regulations for coastal-harbor stations? Class 1 experimental stations? Police mobile radio units using frequency modulation in the 30-40 megacycle band?

*Ans.* Frequency tolerances for these services are shown in the table on page 175.



Station	Frequency	Tolerance, per cent
Coastal-harbor stations.....	100-500 kc	0.1
	1500-30,000 kc	0.02
	Above 30,000 kc	0.01 (FM)
	30,000 kc	0.02 (AI)
	Above 100,000 kc	0.01 (FM)
Experimental stations.....		0.04 (AI)
Experimental stations.....		0.01-0.02
Facsimile broadcast station.....		0.01
Developmental broadcast station.....		0.01
Remote pickup station.....		$\pm 0.02$
Television.....		$\pm 0.01$
Police mobile stations.....	30-40 Mc	$\pm 0.01$ (FM)

**Ques. 3.236.** What is the maximum power that may be licensed to radio stations in the railroad radio service?

*Ans.* The normal power shall not exceed 100 watts input to the final radio-frequency stage. Power in excess of this amount may be authorized where data in support of such a request are submitted, clearly showing the need for higher power.

**Ques. 3.237.** What requirements of the Commission must a person comply with in order to be qualified to operate stations in the railroad radio service?

*Ans.* Stations in the railroad radio service may be operated only by persons holding commercial radio operators' licenses issued by the Commission in accordance with the rules governing commercial radio operators or by employees of the station licensee meeting the qualifications prescribed by the FCC and in accordance with the limitations prescribed by the Commission in its Order No. 126 for operation by such employees.

**Ques. 3.238.** What are the requirements for the keeping of station records of stations in railroad radio service?

*Ans.* All stations in the railroad radio service operated at fixed locations shall maintain records showing

1. Names of employees using transmitters.
2. Results of maintenance tests.
3. Failure or improper operation of transmitting equipment.
4. Where an antenna or antenna-supporting structure(s) is required to be illuminated:
  - a. The time the tower lights are turned on and off, if manually controlled.
  - b. The time the daily visual observation of the tower lights was made.
  - c. Any observed failure of a tower light; the nature and time of such failure; time and nature of the adjustments, repairs, or replacements made; time notice given to the airway communication station.
  - d. Periodic inspection at least once each 3 months.

**Ques. 3.239.** How often are point-to-point radiotelephone stations in the fixed public radio service required to transmit identifying call letters?

*Ans.* Every point-to-point telegraph or telephone station shall transmit three times in succession at half-hour intervals during each 24-hour period the identifying call letters of the frequencies of 50 and below 50 megacycles.

**Ques. 3.240.** What are equipment and service tests of new stations in the utility radio service, and under what conditions are such tests authorized?

*Ans.* Equipment tests: Upon completion of construction of a radio station in exact accordance with the terms of the construction permit, the technical provisions of the application therefor, and the rules and regulations governing the

station. Prior to filing an application for a license, the permittee is authorized to test the equipment for a period not to exceed 30 days: provided, that the engineer in charge of the district in which the station is located is notified 2 days in advance of the beginning of tests and the permittee is not notified by the Commission to cancel, suspend, or change the date for the period of such tests.

**Service tests:** When construction and equipment tests are completed in exact accordance with the terms of the construction permit, the technical provisions of the application therefor, and the rules and regulations governing the station, and after an application for station license has been filed with the Commission showing the transmitter to be in satisfactory operating condition, the permittee is authorized to conduct service tests in exact accordance with the terms of the construction permit until final action is taken on the application for license: provided, that the engineer in charge of the district in which the station is located is notified 2 days in advance of the beginning of such tests and the permittee is not notified by the Commission to cancel or suspend tests or change the date for the period of such tests.

**Maintenance tests:** Any station may be tested as may be required for proper maintenance of the equipment. All necessary precautions shall be taken to avoid interference with other stations, and the test time shall be kept to a minimum commensurate with insurance of reliable communication.

**Ques. 3.241.** In accordance with the Commission's rules and regulations, what is the primary standard for radio-frequency measurements of stations in various radio services?

**Ans.** The primary standard of frequency for radio-frequency measurements shall be the national standard frequency maintained by the National Bureau of Standards, Washington, D.C. The operating frequency of all stations will be determined by comparison with the Bureau's standard signal station W.W.V.

**Ques. 3.242.** What is meant by carrier frequency? By carrier wave?

*Ans.* A carrier wave is

1. In a frequency stabilized system, the sinusoidal component of a modulated wave whose frequency is independent of the modulating wave; or

2. The output of a transmitter when the modulating wave is made zero; or

3. A wave generated at a point in the transmitting system and subsequently modulated by the signal; or

4. A wave generated locally at the receiving terminal which, when combined with the side bands in a suitable detector, produces the modulating wave. A carrier frequency is the frequency of the carrier wave.

**Ques. 3.243.** What is meant by a class 1 experimental station? A class 2 experimental station?

*Ans.* A class 1 experimental station is one concerned primarily with operational changes and experiments to improve predesigned circuit functions. A class 2 experimental station is one devoted exclusively to developmental and research projects.

**Ques. 3.244.** What is the national aircraft calling and working frequency for use by private aircraft radio stations?

*Ans.* 3,105 kilocycles.

**Ques. 3.245.** What is the very high-frequency (VHF) emergency frequency used in the aeronautical services?

*Ans.* 121.5 megacycles.

**Ques. 3.246.** How often is visual observation of the tower lights at an aeronautical land station required to be made?

*Ans.* Visual observation of the tower lights must be made at least once in 24 hours to insure that they are functioning properly.

**Ques. 3.247.** What are the requirements for station identification of a private aircraft station using radiotelephony?

*Ans.* Station identification for a private aircraft includes the location of the airways tower and the FCC letters and number of designation assigned to the particular aircraft. For example, a private aircraft approaching New York would call as follows: "Calling New York tower. This is NC 1234."

**Ques. 3.248.** What is the scope of authority of a person holding a radiotelephone second-class operator license?

*Ans.* (See Appendix II, Sec. 13.61.)

**Ques. 3.249.** For how long a period will a person who fails a radio-operator examination element be ineligible for reexamination in that examination element?

*Ans.* (See Appendix II, Sec. 13.28.)

## ELEMENT 4

### ADVANCED RADIOTELEPHONY, FREQUENCY MODULATION, AND TELEVISION

**Ques. 4.01.** A parallel circuit is made up of five branches, three of the branches being pure resistances of 7, 11, and 14 ohms, respectively. The fourth branch has an inductive reactance value of 500 ohms. The fifth branch has a capacitive reactance of 900 ohms. What is the total impedance of the network? If a voltage is impressed across the parallel network, which branch will dissipate the greatest amount of heat?

*Ans.* The first step in a problem of this character is to reduce the three parallel resistances to their effective or singular equivalent value.

$$R_{\text{eff}} = \frac{1}{\frac{1}{R_1} + \frac{1}{R_2} + \frac{1}{R_3}} = 3.27 \text{ ohms.}$$

Thus, a single resistance equivalent of 3.27 ohms is connected in parallel to an inductive reactance value of 500 ohms and a capacitive reactance of 900 ohms. Obviously, this low value of resistance in shunt to the two higher reactances will make the circuit impedance somewhere in the vicinity of 3+ ohms. To prove this contention, however, let us apply some arbitrary value of voltage to this combination of, say, 900 volts. The currents through the various branches may then be readily determined by Ohm's law,  $I = \frac{E}{R}$ ,  $I = \frac{E}{X_L}$ ,  $I = \frac{E}{X_C}$ . The total line current may then be obtained by the equation,

$$I_{\text{line}} = \sqrt{I_R^2 + (I_L - I_C)^2} = 276 \text{ amperes.}$$

Thus,

$$Z = \frac{E}{I} = \frac{900}{276} = 3.26 \text{ ohms.}$$

The greatest amount of heat will be dissipated by the 7-ohm unit.

**Ques. 4.02.** What is the reactance of a condenser at the frequency of 1,200 kilocycles if its reactance is 300 ohms at 680 kilocycles?

*Ans.* The correct answer is 170 ohms.

*Solution:*

$$\begin{aligned} \frac{Xc_1}{Xc_2} &= \frac{f_2}{f_1} \\ \frac{300}{Xc_2} &= \frac{1,200}{680} \\ Xc_2 &= 170 \text{ ohms.} \end{aligned}$$

**Ques. 4.03.** If the mutual inductance between two coils is 0.1 henry, and the coils have inductances of 0.2 and 0.8 henry, respectively, what is the coefficient of coupling?

*Ans.* The coefficient of coupling is 0.25.

*Solution:*

$$k = \frac{M}{\sqrt{L_1 \times L_2}} = \frac{0.1}{\sqrt{0.2 \times 0.8}} = 0.25 \text{ (25 per cent).}$$

**Ques. 4.04.** If, in a given alternating-current series circuit, the resistance, inductive reactance, and capacitive reactances are of equal magnitude of 11 ohms, and the frequency is reduced to 0.411 of its value at resonance, what is the resultant impedance of the circuit at the new frequency?

*Ans.* The resultant impedance of the circuit at the new frequency is 24.8 ohms.

*Solution:*

$$X_L = 11, \quad X_c = 11, \quad R = 11.$$

$$X'_L = 0.411 \times 11 = 4.52.$$

$$X'_c \frac{11}{0.411} = 26.76; \quad \text{New } X = X'_c - X'_L = 22.24 \text{ ohms.}$$

$$Z' = \sqrt{R^2 + X^2} = 24.8 \text{ ohms.}$$

**Ques. 4.05.** If an alternating current of 5 amperes flows in a series circuit composed of 12 ohms resistance, 15 ohms inductive reactance, and 40 ohms capacitive reactance, what is the voltage across the circuit?

*Ans.* The voltage across the circuit is 138.7 volts.

*Solution:*

$$E_A = \sqrt{E_R^2 + (E_c - E_L)^2} = \sqrt{3,600 + 15,625} = 138.7 \text{ volts.}$$

$$E_R = IR = 5 \times 12 = 60 \text{ volts.}$$

$$E_c = IX_c = 5 \times 40 = 200 \text{ volts.}$$

$$E_L = IX_L = 5 \times 15 = 75 \text{ volts.}$$

**Ques. 4.06.** A series circuit contains resistance, inductive reactance, capacitive reactance. The resistance is 7 ohms, the inductive reactance is 8 ohms, and the capacitive reactance is unknown. What is the value of the condenser reactance in order that the total circuit impedance is 13 ohms?

*Ans.* The capacitive reactance value must be 18.96 ohms.

*Solutions:*

$$Z = \sqrt{R^2 + X^2} = \sqrt{169} = 13 = 7 + X, \quad X^2 = 120,$$

$$X = \pm 10.96,$$

$$\text{but } X = X_L - X_c$$

$$\therefore \pm 10.96 = 8 - X_c \quad X_c = 8 + 10.96 = 18.96.$$

*Proof:*

$$Z = \sqrt{R^2 + (X_c - X_L)^2} = \sqrt{49 + 120} = \sqrt{169} = 13 \text{ ohms.}$$



**Ques. 4.07.** What is the total reactance of two inductances connected in series with zero mutual inductance?

*Ans.* The total reactance with zero mutual inductance is the sum of the two individual reactances,  $X_1 + X_2$ .

**Ques. 4.08.** If an alternating voltage of 115 volts is connected across a parallel circuit made up of a resistance of 30 ohms, an inductive reactance of 17 ohms, and a capacitive reactance of 19 ohms, what is the total circuit-current drain from the source?

*Ans.* The total current drain is 3.9 amperes.

*Solution:*

$$I_{\text{line}} = \sqrt{I_R^2 + (I_L - I_c)^2} = \sqrt{14.7^2 + .5^2} = 3.9 \text{ amperes.}$$

$$I_R = \frac{E}{R} = 3.83 \text{ amperes,} \quad I_L = \frac{E}{X_E} = 6.76 \text{ amperes,}$$

$$I_c = \frac{E}{X_c} = 6 \text{ amperes.}$$

**Ques. 4.09.** When two coils, of equal inductance, are connected in series, with unity coefficient of coupling and their fields in phase, what is the total inductance of the two coils?

*Ans.* The total inductance is the sum of the two equal inductances plus the product of  $2M$ , or  $4 \times L_1$  or  $4 \times L_2$ .

*Solution:*

$$M = \sqrt{L_1 \times L_2}, \quad L_x = L_1 + L_2 + 2M.$$

**Ques. 4.10.** If a transformer has a primary voltage of 4,400 volts and a secondary voltage of 220 volts, and the transformer has an efficiency of 98 per cent when delivering 23 amperes of secondary current, what is the value of primary current?

*Ans.* The current flow at 98 per cent efficiency is approximately 1.17 amperes.

*Solution:*

$$I_p = \frac{E_s \times I_s}{E_p} = 1.15 \text{ amperes at 100 per cent efficiency.}$$

$$P_p = \frac{220 \times 23}{0.98}$$

$$I_p = \frac{P_p}{E_p} = \frac{5,170}{4,400} = 1.175 \text{ amperes.}$$

Thus, at 98 per cent efficiency the value of primary current is 1.17 amperes.

**Ques. 4.11.** Three single-phase transformers, each with a ratio of 220 to 2,200 volts, are connected across a 220-volt three-phase line, primaries in delta. If the secondaries are connected in Y, what is the secondary line voltage?

*Ans.* In a delta-Y-connected transformer system the output voltage across the secondary may be computed from the formula

$$E_s = E_p T_r \times 1.732,$$

where  $E_s$  = secondary voltage.

$T_r$  = transformation ratio.

$E_p$  = primary voltage.

Thus, in this example, the secondary voltage is 3,810 volts.

**Ques. 4.12.** What factors determine core losses in a transformer?

*Ans.* The character of the core material and the physical structure of the core material. The core losses in transformers are mainly due to molecular friction or hysteresis and eddy currents. These are minimized by the use of special core material, such as silicon steel, and the arrangement of the core into sheets or laminations.

**Ques. 4.13.** What circuit constants determine the copper losses of a transformer?

*Ans.* The copper losses are primarily dependent upon the circuit load. These losses are generally expressed as the  $IR$  losses. The proper size of wire for given load conditions is essential to keep these losses at a minimum.

**Ques. 4.14.** Draw a schematic wiring diagram of a three-phase transformer with delta-connected primary and Y-connected secondary.

*Ans.* Figure 4-1 illustrates a delta-Y-connected transformer.

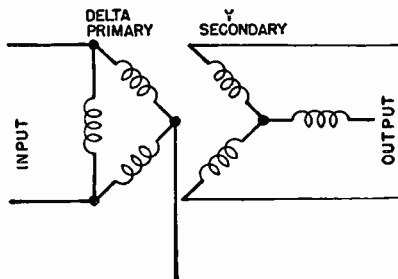

FIG. 4-1. Delta-star or Y transformer.

**Ques. 4.15.** What factor(s) determine the ratio of impedances which a given transformer can match?

*Ans.* The turns ratio.

$$\text{Turns ratio} = \sqrt{\frac{Z_p}{Z_s}}$$

**Ques. 4.16.** If a transformer, having a turns ratio of 10:1, working into a load impedance of 2,000 ohms and out of a circuit having an impedance of 15 ohms, what value of resistance may be connected across the load to effect an impedance match?

*Ans.* A load resistance of 6,000 ohms will effect an approximate match.

*Solution:*

$$\frac{n_1}{n_2} = \sqrt{\frac{Z_1}{Z_2}}, \quad \left(\frac{n_2}{n_1}\right)^2 = \frac{Z_2}{Z_1}$$

$$100 = \frac{Z_2}{15}$$

$$1,500 = Z_2.$$

Therefore  $R_x$  must be of such value as to give 1,500 ohms when in parallel with 2,000 ohms.

**Ques. 4.17.** In a class C radio-frequency power amplifier, what ratio of load impedance to dynamic plate impedance will give the greatest plate efficiency?

*Ans.* The theoretical ratio is infinity to one. For practical purposes this ratio is generally 1:1.

**Ques. 4.18.** If a lamp, rated at 100 watts and 115 volts, is connected in series with an inductive reactance of 355 ohms and a capacitive reactance of 130 ohms across a voltage of 220 volts, what is the current through the lamp?

*Ans.* The current flow through the lamp is approximately 0.86 ampere.

*Solution:*

$$R_{\text{lamp}} = 132 \text{ ohms (approx.)},$$

$$I = \frac{E}{Z} = \frac{220}{\sqrt{R^2 + (X_L - X_C)^2}} = 0.86 \text{ ampere (approx.)}.$$

**Ques. 4.19.** If an alternating-current series circuit has a resistance of 12 ohms, an inductive and capacitive reactance of 7 ohms, at the resonant frequency, what will be the total impedance at twice the resonant frequency?

*Ans.* The impedance will be approximately 15.9 ohms.

*Solution:*

$$2X_L = 14 \text{ ohms.}$$

$$\frac{1}{2}X_C = 3.5 \text{ ohms.}$$

$$Z = \sqrt{R^2 + (X_L - X_C)^2} = 15.9 \text{ ohms.}$$

**Ques. 4.20.** In a parallel circuit composed of an inductance of 150 microhenrys and a capacitance of 160 micromicrofarads, what is the resonant frequency?

*Ans.* The resonant frequency is 1,028 kilocycles.

*Solution:*

$$f_r = \frac{10^6}{2\pi \sqrt{LC}} = 1,028 \text{ kilocycles.}$$

**Ques. 4.21.** What value of capacitance must be shunted across a coil having an inductance of 56 microhenrys in order that the circuit resonate at 5,000 kilocycles?

*Ans.* Approximately 18 micromicrofarads.

*Solution:*

$$C_{\text{farads}} = \frac{1}{4\pi^2 f^2 L} = 18 \text{ micromicrofarads.}$$

**Ques. 4.22.** Why should impedances be matched in speech-input equipment?

*Ans.* Impedances should be matched to effect a maximum energy transfer and minimum line reflections. Improper impedance matching in speech-amplifier circuits not only might decrease the volume but might seriously affect the quality of reproduction. A piece of cable that is electrically short and is terminated in a resistance higher than its characteristic resistance is equivalent to a shunt capacity.

**Ques. 4.23.** What are the purposes of *H* or *T* pad attenuators?

*Ans.* Attenuators of the *H* and *T* pad variety effect proper impedance matching with desired attenuation.

**Ques. 4.24.** Why are grounded center-tap transformers frequently used to terminate program lines?

## RADIO OPERATING QUESTIONS AND ANSWERS

*Ans.* They effect a proper balance to ground. This will cause a reduction in stray field pick-up and also balance out unwanted line noises. The frequency response is also improved.

**Ques. 4.25.** What is the purpose of a line pad?

*Ans.* A line pad serves to introduce a proper amount of attenuation and at the same time effect an impedance match.

**Ques. 4.26.** Why are electrostatic shields used between windings in coupling transformers?

*Ans.* Electrostatic shields between windings in coupling transformers reduce the capacitive coupling between coils.

**Ques. 4.27.** Why is it preferable to isolate the direct current from the primary winding of an audio transformer working out of a single vacuum tube?

*Ans.* To prevent transformer core saturation. A saturated core will lower the primary inductance and seriously impair the quality of transmission. Heavy distortion will occur.

**Ques. 4.28.** Why are preamplifiers used ahead of mixing systems?

*Ans.* Mixing systems introduce a signal loss because they are attenuating networks and consequently require a preamplifier to compensate for these losses.

**Ques. 4.29.** What is the purpose of a variable attenuator in a speech-input system?

*Ans.* Variable attenuators are used to control the voltage gain of an amplifier. They permit the proper degree of adjustment for variable signal-input levels.

**Ques. 4.30.** In a low-level amplifier using degenerative feedback, at a nominal mid-frequency, what is the phase relationship between the feedback voltage and the input voltage?

*Ans.* Degenerative feedback, or feedback without the generation of sustained oscillations, is that condition in a vacuum-tube amplifying circuit in which energy from the plate circuit to the grid circuit causes the feedback voltage at a nominal mid-band frequency to be 180 degrees out of phase with the input voltage.

**Ques. 4.31.** Under what circumstances will the gain per stage be equal to the voltage amplification factor of the vacuum tube employed?

*Ans.* The gain per stage in a resistance-coupled amplifier is equal to the voltage-amplification factor of the vacuum tube employed. To achieve maximum gain from the tube, the load impedance into which the tube works must be high.

**Ques. 4.32.** Why is a high-level amplifier, feeding a program transmission line, generally isolated from the line by means of a pad?

*Ans.* This is done to prevent overloading the line and also to reduce the possibility of line reflections back to the final stage. Proper impedance relations are also maintained.

**Ques. 4.33.** What is the result of deliberately introduced degenerative feedback in audio amplifiers?

*Ans.* This will result in a decrease in the gain of the amplifier but will greatly improve the frequency characteristic of the amplifier.

**Ques. 4.34.** What unit has been adopted by leading program transmission organizations as a volume unit and to what power is this unit equivalent?

*Ans.* The volume unit, or *VU*. It has a power equivalent of 0.001 watt (600 ohms).

**Ques. 4.35.** What is the purpose of a line equalizer?

*Ans.* A line equalizer as used in telephone lines serves to compensate for the higher audio-frequency signal loss through the distributed capacity in the lines. It enables the output of the line to present a "flatter" frequency characteristic.

**Ques. 4.36.** Draw a diagram of an equalizer circuit most commonly used for equalizing wire-line circuits.

*Ans.* Figure 4-2 illustrates a telephone-line equalizer.

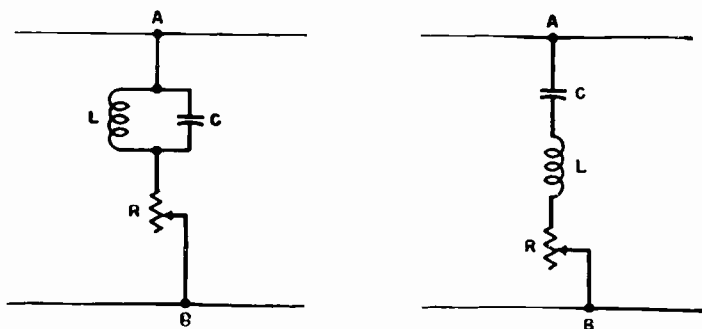

FIG. 4-2. Line equalizer.

**Ques. 4.37.** What type of microphone employs a coil of wire, attached to a diaphragm, which moves in a magnetic field as a result of impinging sound waves?

*Ans.* The dynamic microphone.

**Ques. 4.38.** What is the most serious disadvantage of using carbon microphones with high-fidelity amplifiers?

*Ans.* The possibility of carbon noises or "hissing."

**Ques. 4.39.** Why are the diaphragms of certain types of microphones stretched?

*Ans.* The diaphragms of certain types of microphones are stretched in order to obtain uniform response particularly at



the high audio frequencies. The stretching increases the resonant frequency of the diaphragm.

**Ques. 4.40.** Draw a simple schematic diagram of a grid-bias modulation system, including the modulated radio-frequency stage.

*Ans.* Figure 4-3 illustrates a simple schematic of a grid-bias modulation system.

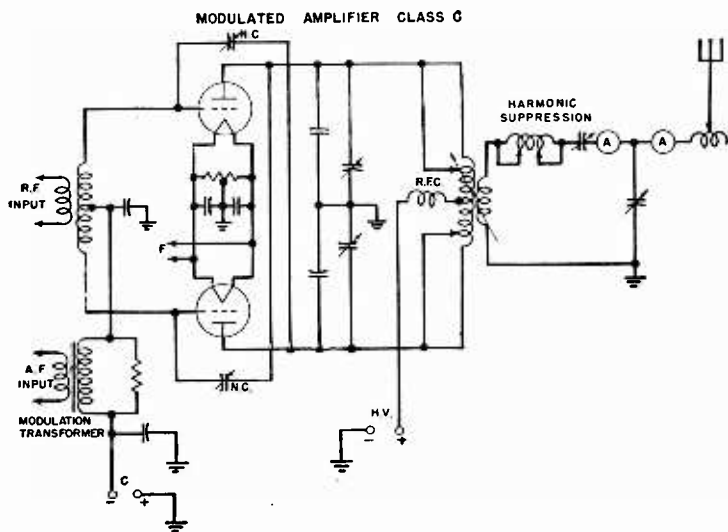

FIG. 4-3. Grid-bias modulated class C radio-frequency amplifier with inductive coupling to the antenna.

**Ques. 4.41.** Draw a simple schematic diagram of a class B audio high-level modulation system, including the modulated radio-frequency stage.

## RADIO OPERATING QUESTIONS AND ANSWERS

*Ans.* Figure 4-4 illustrates a simple schematic of a class B modulated radio-frequency stage.

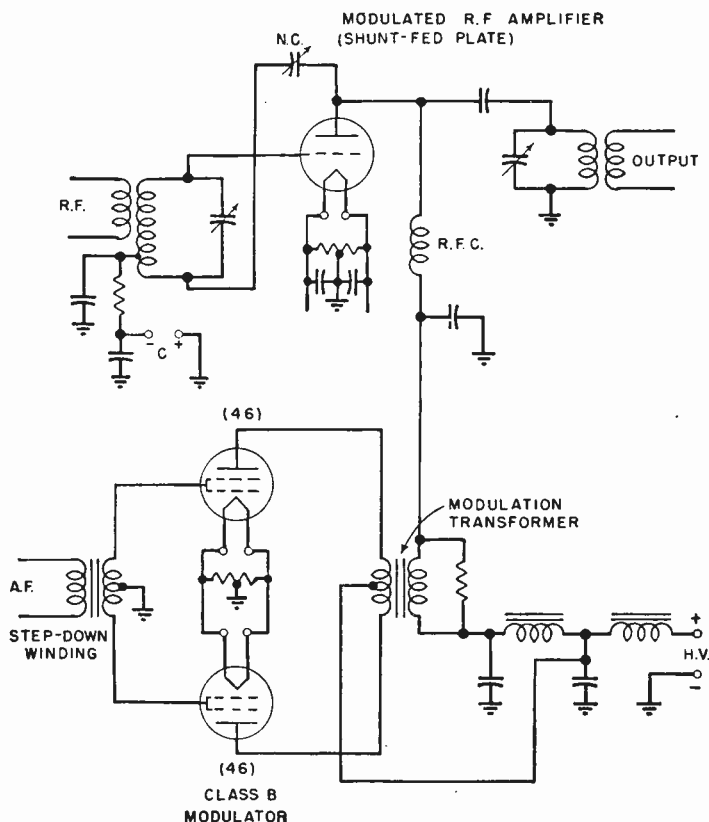

FIG. 4-4. Class B modulation system.

**Ques. 4.42.** Draw a simple sketch of the trapezoidal pattern on a cathode-ray oscilloscope screen indicating low per cent modulation without distortion.

*Ans.* Figure 4-5 illustrates a trapezoidal pattern as indicated on the screen of a cathode-ray tube under the conditions

of low percentage of modulation without distortion. The pattern for complete modulation and excessive modulation is also shown, for comparison.

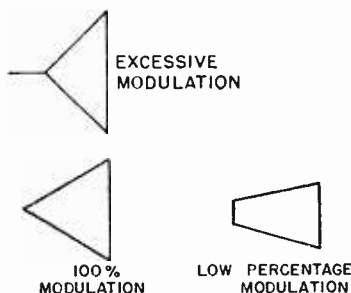

FIG. 4-5. Cathode-ray trapezoidal pattern.

**Ques. 4.43.** At 100 per cent modulation, what percentage of the total output power is in the side bands?

*Ans.* At 100 per cent modulation the percentage of total side-band power is equal to 33.3 per cent of the total output power.

**Ques. 4.44.** Draw a schematic diagram of test equipment which may be used to detect carrier shift of a radiotelephone transmitter output.

*Ans.* Figure 4-6 illustrates an arrangement for determining carrier shift of a radiotelephone transmitter.

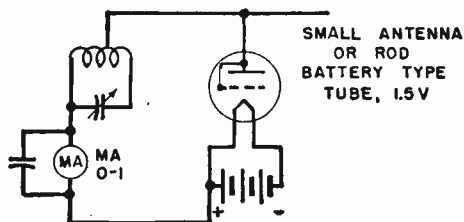

FIG. 4-6. Simple carrier-shift indicator.

**Ques. 4.45.** What are the advantages and disadvantages of class B modulators?

*Ans.* The class B system of modulation provides greater efficiency compared with the distortionless class A system. Class B, however, introduces a relatively greater degree of distortion than the class A system. In addition to the higher plate efficiency the class B modulator provides lower power consumption, since plate current flows only during the grid-excitation periods.

**Ques. 4.46.** Why is frequency modulation undesirable in the standard broadcast band?

*Ans.* High-fidelity frequency modulation requires a wider band than amplitude modulation, which would restrict the number of stations operating in this band.

**Ques. 4.47.** What is meant by "low-level" modulation?

*Ans.* "Low-level" modulation is the term applied to systems in which the modulated radio-frequency stage precedes the final power-amplifier stage.

**Ques. 4.48.** If a preamplifier, having a 600-ohm output, is connected to a microphone so that the power output is -40 db, and assuming the mixer system to have a loss of 10 db, what must be the voltage amplification necessary in the line amplifier to feed +10 db into the transmitter line?

*Ans.* The necessary voltage amplification to satisfy these conditions must be 1,000.

*Solution* (assuming 600-ohm terminations):

Input is -50 db at 600 ohms.

Output is +10 db at ? ohms.

$$\text{db} = 20 \log \frac{E_1 \sqrt{R_2}}{E_2 \sqrt{R_1}}$$

Decibel gain, therefore, is 60.

$$60 = 20 \log \frac{E_1 \sqrt{600}}{E_2 \sqrt{600}}$$

If

$$\log \frac{E_1}{E_2} = 3,$$

then,

$$\frac{E_1}{E_2} = 1,000.$$

**Ques. 4.49.** If the power output of a modulator is decreased from 1,000 watts to 10 watts, how is the power loss expressed in db?

$$\text{Ans. Gain or loss in db} = 10 \log \frac{P_1}{P_2} = 20 \text{ db.}$$

*Solution:*

$$10 \log \frac{P_1}{P_2} = 10 \log 100.$$

$$\log 100 = 2.$$

$$\text{db} = 20.$$

Since the power has been decreased, this is a 20-db loss, or -20 db.

**Ques. 4.50.** Under what circumstances will the plate current, as read on a direct-current meter, of a modulated amplifier vary?

*Ans.* Under normal conditions, the *average* value of the voltage on either side of the carrier frequency (direct-current component) remains constant throughout the modulating cycle. However, if during modulation the plate current varies, it is an indication that the average during the modulating cycle is being shifted up or down in accordance with the circuit defects (carrier shift).

The following are the most probable causes for these variations: overmodulation, parasitic oscillations, improper neutral-

ization, defective tube(s), poor regulation, low or excessive radio-frequency excitation, improper grid bias or plate-impedance adjustments.

**Ques. 4.51.** What could cause downward deflection of the antenna current of a transmitter when modulation is applied?

*Ans.* The most common causes of downward deflection of the antenna ammeter are low filament voltage or defective tubes in the modulating or power-amplifier stages, open filter condenser in the power supply, improper neutralization, improper load-impedance adjustment, overmodulation, or low radio-frequency excitation in the modulating or power-amplifier stages.

**Ques. 4.52.** If tests indicate that the positive modulation peaks are greater than the negative peaks in a transmitter employing a class B audio modulator, what steps should be taken to determine the cause?

*Ans.* Decrease the audio-frequency excitation to ascertain if the excessive positive peaks are caused by a high gain-control setting. Check the balance of the modulator tubes for equality of emission. Check the neutralization of the modulated amplifier. Increase the tank circuit capacity and return to resonance, as an insufficient C will also produce this result. Check the grid-bias adjustments. (See Ques. 6.42.)

**Ques. 4.53.** Under what circumstances will the direct-current plate current, as indicated on a direct-current meter, of a properly adjusted grid-bias modulated radio-frequency amplifier vary?

*Ans.* If *all* adjustments are assumed to be correct, the plate current as indicated on the direct-current ammeter will vary with excessive audio-frequency excitation (overmodulation).

**Ques. 4.54.** What percentage increase in output power is obtained under 100 per cent sinusoidal modulation?

*Ans.* A 50 per cent increase in output power will be obtained.

**Ques. 4.55.** In a class C radio-frequency amplifier stage feeding an antenna system, if there was a positive shift in carrier under modulation conditions, what could be the trouble?

*Ans.* This may be due to insufficient tank circuit capacity, antenna or tank circuits out of tune, insufficient excitation, improper neutralization, or overmodulation. (See Ques. 6.42.)

**Ques. 4.56.** Name four causes of distortion in a modulated-amplifier stage output.

*Ans.* Four causes of distortion in a modulated-amplifier output are

1. Overmodulation.
2. Excessive radio-frequency drive.
3. Insufficient load impedance adjustment.
4. Improper neutralization (self-oscillation or regeneration) and parasitic oscillations.

**Ques. 4.57.** If you decrease the percentage of modulation from 100 per cent to 50 per cent, by what percentage have you decreased the power in the side bands?

*Ans.* The side-band power will be decreased 75 per cent.

*Solution:* Assuming a 100-watt completely modulated carrier, we get

$$P_{sb} = \frac{m^2 P_c}{2} = \frac{1 \times 100}{2} = 50 \text{ watts.}$$

If modulation is reduced to 50 per cent, we get, by the same formula,

$$\frac{0.5^2 \times 100}{2} = 0.25 \times 50 = 12.5 \text{ watts,}$$

a reduction of 75 per cent.

**Ques. 4.58.** If a certain audio-frequency amplifier has an over-all gain of 40 db and the output is 6 watts, what is the input?

*Ans.* The input will be 0.0006 watt or 0.6 milliwatt.

*Solution:*

$$\text{db} = 10 \log \frac{P_1}{P_2}; \quad 40 = 10 \log \frac{6}{x}; \quad 10,000 = \frac{6}{x};$$

$$x = \frac{6}{10,000} = 0.0006 \text{ watt.}$$

**Ques. 4.59.** If the field intensity of 25 millivolts per meter develops 2.7 volts in a certain antenna, what is the effective height?

*Ans.* The effective height will be 108 meters.

*Proof:* A height of 1 meter will develop 0.025 volt.

**Ques. 4.60.** Draw a schematic diagram of a final amplifier with capacity coupling to the antenna which will discriminate against the transfer of harmonics.

*Ans.* Figure 4-7 illustrates a capacitive coupling system.

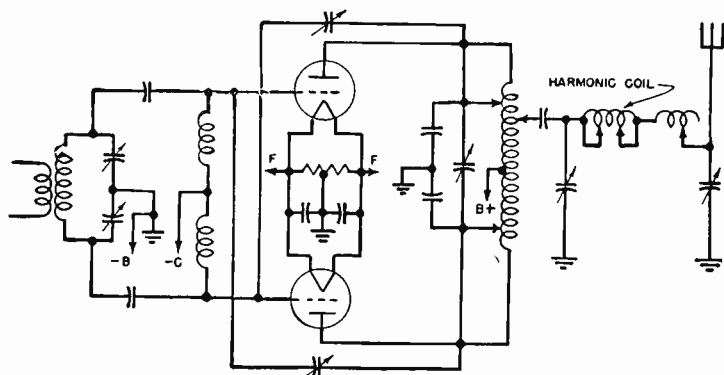

FIG. 4-7. Capacitive coupling and harmonic suppression arrangement.



**Ques. 4.61.** In what units is the field intensity of a broadcast station normally measured?

*Ans.* Field intensity is generally measured in millivolts or microvolts per meter.

**Ques. 4.62.** Draw a simple schematic diagram showing a method of coupling the radio-frequency output of the final power-amplifier stage of a transmitter to a two-wire transmission line, with a method of suppression of second- and third-harmonic energy.

*Ans.* Figure 4-8 illustrates a schematic arrangement of a final power-amplifier stage with transmission-line coupling and harmonic-suppression circuit.

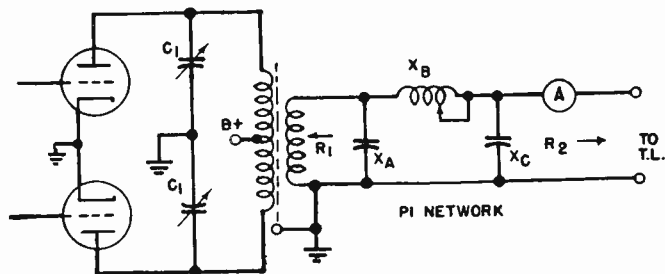

FIG. 4-8. Transmission-line coupling system.

**Ques. 4.63.** An antenna is being fed by a properly terminated two-wire transmission line. The current in the line at the output end is 3 amperes. The surge impedance of the line is 500 ohms. How much power is being supplied to the line?

*Ans.*  $P = I^2R = 9 \times 500 = 4,500$  watts.

**Ques. 4.64.** If the daytime transmission-line current of a 10-kilowatt transmitter is 12 amperes, and the transmitter is required to reduce to 5 kilowatts at sunset, what is the new value of transmission-line current?

*Ans.* The new value of current is 8.4 amperes.

*Solution:*

$$R = \frac{P}{I^2} = \frac{10,000}{144} = 70 \text{ ohms.}$$

$$I = \sqrt{\frac{P}{R}} = \sqrt{\frac{5,000}{70}} = 8.4 \text{ amperes.}$$

**Ques. 4.65.** If the antenna current is 9.7 amperes for 5 kilowatts, what is the current necessary for a power of 1 kilowatt?

*Ans.* For a power of 1 kilowatt the current necessary will be 4.3 amperes, computed as in the preceding answer.

**Ques. 4.66.** What is the antenna current when a transmitter is delivering 900 watts into an antenna having a resistance of 16 ohms?

*Ans.*

$$I = \sqrt{\frac{P}{R}} = \sqrt{\frac{900}{16}} = 7.5 \text{ amperes.}$$

**Ques. 4.67.** If the day input power to a certain broadcast station antenna having a resistance of 20 ohms is 2,000 watts, what would be the night input power if the antenna current were cut in half?

*Ans.* The night input power would be 500 watts.

*Solution:*

$$I = \sqrt{\frac{P}{R}} = \sqrt{\frac{2,000}{20}} = \sqrt{100} = 10 \text{ amperes.}$$

$$\frac{10}{2} = 5 \text{ amperes.}$$

$$P = I^2R = 25 \times 20 = 500 \text{ watts.}$$

**Ques. 4.68.** The direct-current input power to the final-amplifier stage is exactly 1,500 volts and 700 milliamperes.

The antenna resistance is 8.2 ohms and the antenna current is 9 amperes. What is the plate efficiency of the final amplifier?

*Ans.* The plate efficiency is 63.25 per cent.

*Solution:*

$$\text{Efficiency} = \frac{P_o}{P_i} = \frac{664.2}{1,050} = 0.6325 \text{ or } 63.25 \text{ per cent.}$$

**Ques. 4.69.** If the power output of a broadcast station is quadrupled, what effect will this have upon the field intensity at a given point?

*Ans.* The field intensity at a given point will be doubled.

*Solution:* An increase of power to 4 times will result in a current increase of 2 times. The field intensity, therefore, will increase in direct proportion.

**Ques. 4.70.** The ammeter connected at the base of a Marconi antenna has a certain reading. If this reading is increased 2.77 times, what is the increase in output power?

*Ans.* The increase in output power will be 7.67 times greater.

*Solution:*

$$P = I^2R \text{ watts.}$$

If the current is increased by 2.77 times, then the power must increase 2.77<sup>2</sup> times.

**Ques. 4.71.** If the power of a broadcast station has been increased so that the field intensity at a given point is doubled, what increase has taken place in the antenna current?

*Ans.* The antenna current under these conditions has been doubled.

*Solution:* Field power is proportional to antenna power which is proportional to antenna current squared. Field power is also proportional to field intensity squared. Therefore, field

intensity is proportional to antenna current. If the field intensity is doubled, the antenna current was also doubled.

**Ques. 4.72.** If a transmitter is modulated 100 per cent by sinusoidal tone, what percentage increase in antenna current will occur?

*Ans.* The antenna current will increase 1.225 times the unmodulated current or 22.5 per cent.

*Solution:*

$$I_{\text{eff}} = \sqrt{1 + \frac{m^2}{2}}$$

$$\text{At 100 per cent } I_{\text{eff}} = \sqrt{1.5} = 1.225.$$

**Ques. 4.73.** What relationship obtains between the currents at the opposite ends of a transmission line,  $\frac{1}{4}$  wavelength long, and terminated in an impedance equal to its surge impedance?

*Ans.* The current readings at the input and output ends of the line will be equal.

**Ques. 4.74.** The power input to a 72-ohm concentric transmission line is 5,000 watts. What is the peak voltage between the inner conductor and the sheath?

*Ans.* The peak voltage is 848.4 volts.

*Solution:*

$$E = \sqrt{PR} = \sqrt{5,000 \times 72} = \sqrt{360,000} = 600.$$

$$E_{\text{peak}} = E_{\text{eff}} \times 1.414 = 848.4 \text{ volts.}$$

**Ques. 4.75.** A long transmission line delivers 10 kilowatts into an antenna; at the transmitter end the line current is 5 amperes and at the coupling house it is 4.8 amperes. Assuming the line current to be properly terminated and the losses in the coupling system negligible, what is the power lost in the line?

*Ans.* The power lost in the line is 850 watts.

*Solution:*

$$R = \frac{P}{I^2} = \frac{10,000}{4.8^2} = 434.$$

$$\text{Power lost} = 5^2 \times 434 - 10,000 = 850 \text{ watts.}$$

**Ques. 4.76.** The power input to a 72-ohm concentric line is 5,000 watts. What is the current flowing in it?

*Ans.* The current flow is 8.35 amperes.

*Solution:*

$$I = \sqrt{\frac{P}{R}} = 8.35 \text{ amperes.}$$

**Ques. 4.77.** What is the primary reason for terminating a transmission line in an impedance equal to the characteristic impedance of the line?

*Ans.* Proper termination of a transmission line prevents standing waves and resultant line radiations. A maximum transfer of power to the radiating system also results. Harmonic radiation is minimized.

**Ques. 4.78.** If a vertical antenna is 405 feet high and is operated at 1,250 kilocycles, what is its physical height, expressed in wavelengths? (1 meter = 3.28 feet.)

*Ans.* The physical wavelength is 0.515 wavelength.

**Ques. 4.79.** What must be the length of a vertical radiator  $\frac{1}{2}$  wavelength high if the operating frequency is 1,100 kilocycles?

*Ans.* The height must be 136.2 meters.

**Ques. 4.80.** Draw a diagram of a crystal oscillator, including temperature control, with one stage of radio-frequency amplification. Power supplies need not be shown but indicate points at which the various voltages will be connected.

*Ans.* Figure 4-9 illustrates a crystal oscillator with temperature-control chamber coupled to one stage of radio-frequency amplification.

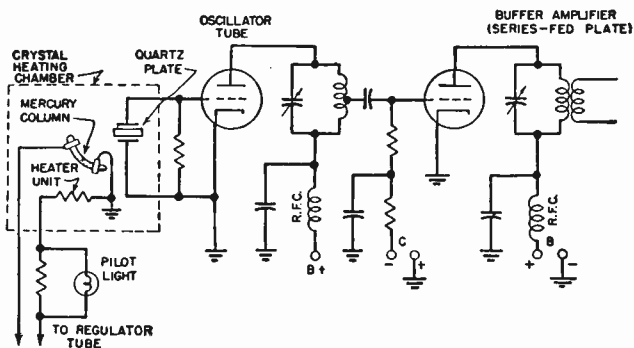

FIG. 4-9. Crystal-controlled oscillator with temperature-control unit and radio-frequency amplifier.

**Ques. 4.81.** Draw a diagram of a class B push-pull linear amplifier using triode tubes. Include a complete antenna coupling circuit and antenna circuit. Indicate points at which the various voltages will be connected.

*Ans.* Figure 4-7 illustrates a class B linear amplifier in push-pull arrangement coupled to an antenna system.

**Ques. 4.82.** Draw a diagram of a complete class B modulation system, including the modulated radio-frequency amplifier stage. Indicate points where the various voltages will be connected.

*Ans.* See Fig. 4-4.

**Ques. 4.83.** A certain transmitter has an output of 100 watts. The efficiency of the final, modulated-amplifier stage is 50 per cent. Assuming that the modulator has an efficiency of 66 per cent, what plate input to the modulator is necessary for 100 per cent modulation of this transmitter?

*Ans.* The plate-input power to the modulator is 151.5 watts. On the basis of 100-watt carrier requirements and an efficiency of 50 per cent the modulated amplifier must have an input power of 200 watts. At 100 per cent modulation the total of the load power and the plate dissipation will be increased by 50 per cent. Hence the modulator must supply 100 watts of audio-frequency power, and since it is operating at an efficiency of 66 per cent, the power input to the modulator must be 151.5 watts.

*Solution:*

$$\frac{P_o}{\text{Eff}} = \frac{100}{0.66} = 151.5 \text{ watts,}$$

where  $P_o$  is the power output required and Eff the efficiency.

**Ques. 4.84.** If an oscillatory circuit consists of two identical tubes, the grids of which are connected in push-pull and the plates in parallel, what relationship will hold between the input and output frequencies?

*Ans.* This arrangement may be used as a frequency-doubling system provided that the plate circuit is tuned to twice the input frequency. See Fig. 5-3.

**Ques. 4.85.** What undesirable effects result from over-modulation of a broadcast transmitter?

*Ans.* Overmodulation may cause serious interference on adjacent channels to which the transmitter may be operating. Overmodulation in a frequency-modulated transmitter or amplitude-modulated transmitter will also cause distortion of the output wave.

**Ques. 4.86.** What do variations in the final amplifier plate current of a transmitter employing low-level modulation usually indicate?

## RADIO OPERATING QUESTIONS AND ANSWERS

*Ans.* An abnormal variation may indicate a defective tube, improper load adjustment, improper radio-frequency excitation, or excessive modulation. Improper adjustments of the grid-biasing voltage in the modulating or final power amplifier may also result in excessive variations.

**Ques. 4.87.** If, upon tuning the plate circuit of a triode radio-frequency amplifier, the grid current undergoes variations, what defect is indicated?

*Ans.* Variation in grid current is normal during the tuning process due to the load impedance changes in the plate tank circuit. However, in triode amplifiers, excessive variations during tuning may indicate the presence of parasitics or improper neutralization.

**Ques. 4.88.** A 50-kilowatt transmitter employs 6 tubes in push-pull parallel in the final class B linear stage, operating with a 50-kilowatt output and an efficiency of 33 per cent. Assuming that all of the heat radiation is to the water-cooling system, what amount of power must be dissipated from each tube?

*Ans.* The power input to all of the tubes is

$$\frac{P_o}{\text{Eff}} = \frac{50,000}{0.33} = 151,515 \text{ watts}; \quad P_i - P_o = 101,515 \text{ watts.}$$

Each tube will therefore dissipate 16,919 watts, or 16.92 kilowatts.

**Ques. 4.89.** What is the value of voltage drop across the elements of a mercury-vapor rectifier tube under normal conditions?



*Ans.* The normal voltage drop across a mercury-vapor rectifier tube is 15 volts.

**Ques. 4.90.** Draw a diagram of a bridge rectifier giving full-wave rectification without a center-tapped transformer. Indicate polarity of output terminals.

*Ans.* Figure 4-10 illustrates a full-wave bridge-rectifier arrangement.

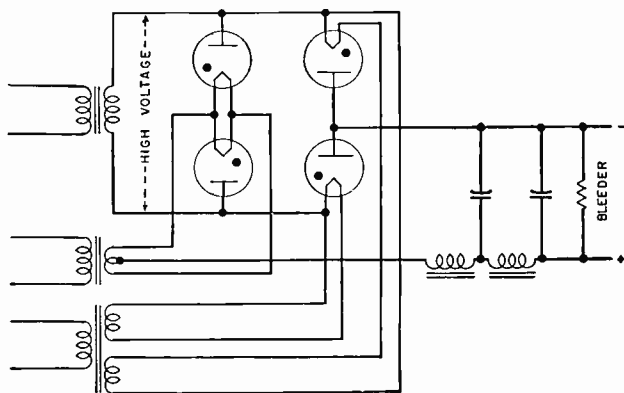

FIG. 4-10. Bridge rectifier, single-phase.

**Ques. 4.91.** Draw a diagram of a rectifier system supplying two plate voltages, one approximately twice the other and using one high-voltage transformer with a single center-tapped secondary, and such filament supplies as may be necessary.

Ans. Figure 4-11 illustrates a full-wave bridge rectifier for double voltage supply.

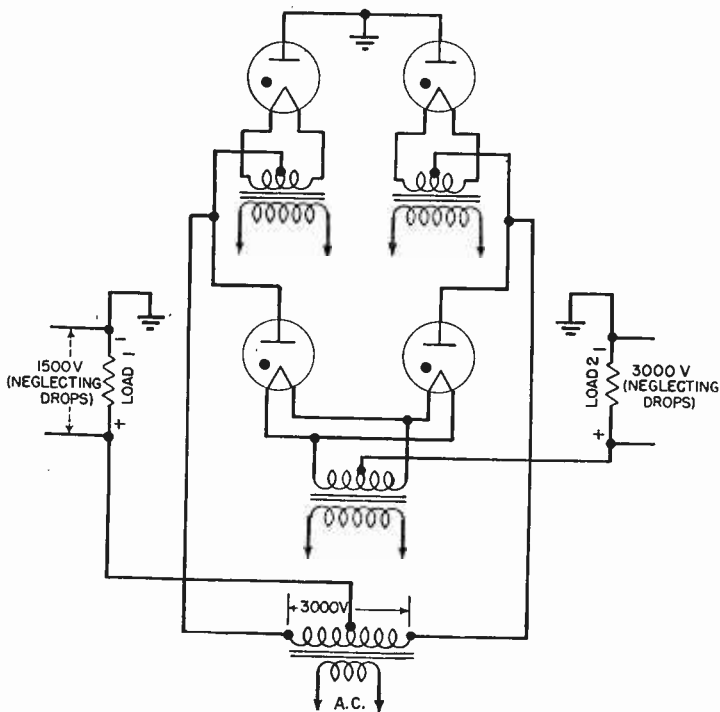

FIG. 4-11. Balanced single-phase full-wave rectifier.

**Ques. 4.92.** What is "arc back" or "flash back"?

Ans. "Flash back" or "arc back" is a condition in mercury-vapor rectifier circuits in which the rectifier tube is ionized to the point of conduction in the reverse direction. For mercury-vapor tubes there is a critical voltage above which this will occur. Under normal conditions arc back may suddenly occur, caused by the input condenser discharging back through the tube or by radio-frequency reactions from the operating circuit. Under such conditions the tube filament

will be subjected to abnormal ion bombardment and the tube may be ruined.

**Ques. 4.93.** What is meant by the "inverse peak voltage" rating of a rectifier tube?

*Ans.* "Inverse peak voltage" is the maximum potential difference which exists between the plate and cathode of a tube during that period of the cycle when the tube is not conducting.

**Ques. 4.94.** How may a condenser be added to a choke-input filter system to increase the load-voltage output?

*Ans.* Voltage may be raised by adding an input-filter condenser before the choke coil, but the system is then changed to the condenser-input type.

**Ques. 4.95.** Why is it not advisable to operate a filter reactance in excess of its rated current value?

*Ans.* An excessive current flow through a filter reactance may increase the possibility of core saturation and additional  $IR$  drop. Both conditions would affect the output regulation as well as the filtering. The inductance of any iron-core reactor will drop as the core becomes saturated.

**Ques. 4.96.** What is a low-pass filter?

*Ans.* The low-pass filter is used in any circuit where it is desired to attenuate all frequencies above a definite cut-off frequency and to pass without attenuation all frequencies below this point.

**Ques. 4.97.** Draw a diagram of a simple low-pass filter.

## RADIO OPERATING QUESTIONS AND ANSWERS

*Ans.* See Fig. 4-12. The high-pass filter is also shown, for comparison.

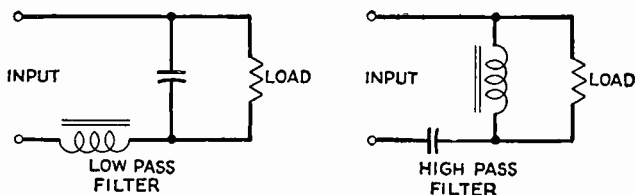

Fig. 4-12. Filter networks.

**Ques. 4.98.** If a power supply has a regulation of 11 per cent when the output voltage at full load is 240 volts, what is the output voltage at no load?

*Ans.* The no-load output voltage is 266.4 volts.

*Solution:*

$$E_{NL} = 240 \times 1.11 = 266.4 \text{ volts.}$$

*Proof:*

$$\frac{E_{NL} - 240}{E_{FL}} = 0.108 \text{ or } 11 \text{ per cent.}$$

**Ques. 4.99.** How is the inverse-peak voltage, to which the tubes of a full-wave rectifier will be subject, determined from the known secondary voltages of the power transformer? Explain.

*Ans.* The inverse-peak voltage is obtained by multiplying the known effective end-to-end secondary alternating-current voltage by 1.414 and subtracting the drop in the idle tube.

**Ques. 4.100.** If a power supply has an output voltage of 140 volts at no load and the regulation at full load is 15 per cent, what is the output voltage at full load?

*Ans.* The output voltage at full-load conditions is 121.7 volts.

*Solution:*

$$140 \div 1.15 = 121.7.$$

**Ques. 4.101.** Why is a time-delay relay arranged to apply the high voltage to the anodes of mercury-vapor rectifier tubes some time after the application of filament voltage?

*Ans.* The time-delay relay prevents the application of high plate voltages to the rectifier until the filament has been sufficiently heated. The preheating period in mercury-vapor tubes prevents the heavy overloading condition which would exist if the plate voltage were to be applied before the filament is up to proper temperature. Another reason for preheating before applying the plate voltage on mercury-vapor tubes is to vaporize the mercury deposits upon the filament caused by the condensation which takes place when the tubes are not in use.

**Ques. 4.102.** Why is it important to maintain the operating temperature of mercury-vapor tubes within specified limits?

*Ans.* Excessive filament voltage produces increased ionization and reduces the tube life, while insufficient filament voltages produce severe overloading and possible burn out. If the temperature of the tube itself is excessive, the inverse-peak-voltage breakdown rating will be considerably lowered and flash back will result. Too low a temperature will damage the filament by positive-ion bombardment.

**Ques. 4.103.** If a frequency-doubler stage has an input frequency of 1,000 kilocycles, and the plate inductance is 60 microhenrys, what value of plate capacitance is necessary for resonance, neglecting stray capacitances?

*Ans.* If the input frequency of a doubler system is 1,000 kilocycles, the output circuit must be tuned to 2,000 kilocycles. Hence, the capacity required would be 105 micromicrofarads. Computed according to the formula

$$C = \frac{1}{4\pi^2 f^2 L} \text{ farads.}$$

**Ques. 4.104.** Draw a simple schematic diagram of a multivibrator oscillatory circuit.

*Ans.* Figure 4-13 illustrates a simple schematic of a multivibrator circuit.

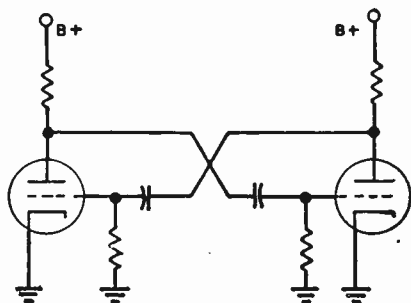

FIG. 4-13. Multivibrator oscillator.

**Ques. 4.105.** What precautions should be taken to insure that a crystal oscillator will function at one frequency only?

- Ans.*
1. The temperature must be kept constant.
  2. The crystal mounting must be proper and maintain correct pressure.
  3. The crystal must be accurately ground.
  4. The crystal must be perfectly clean, although coatings are sometimes used to change the frequency deliberately.
  5. The power-supply voltage must be kept constant.
  6. The load must be kept constant by use of a buffer amplifier.

**Ques. 4.106.** What are the advantages of mercury thermostats as compared with bimetallic thermostats.

*Ans.* Mercury thermostats insure better electrical contacts.

**Ques. 4.107.** A 600-kilocycle X-cut crystal, calibrated at 50 degrees centigrade and having a temperature coefficient of  $-20$  parts per million per degree, will oscillate at what frequency when its temperature is 60 degrees centigrade?

*Ans.* 599,880 cycles.

**Ques. 4.108.** Why are crystals usually operated in temperature-controlled ovens?

*Ans.* Crystals are usually operated in temperature-controlled ovens because they possess a temperature coefficient. A change in temperature will produce a change in frequency. A fixed value of temperature will hold the crystal at a precise frequency.

**Ques. 4.109.** What is the device called which is used to derive a standard frequency of 10 kilocycles from a standard-frequency oscillator operating on 100 kilocycles?

*Ans.* The device is called a multivibrator.

**Ques. 4.110.** What procedure should be adopted if it is found necessary to replace a tube in a heterodyne frequency meter?

*Ans.* The frequency meter must be rechecked against a standard calibrator for zero beats in accordance with the exact frequency calibrations. If a standard calibrator is not available, the plate currents and filament voltages of the replaced tubes should be carefully checked as compared with the previous readings, and any necessary voltages and current changes made so that the old and new readings correspond.

**Ques. 4.111.** If a frequency of 500 cycles is beat with a frequency of 550 kilocycles, what will be the resultant frequencies?

*Ans.* The resultant frequencies are  $f_m$ ,  $f_o$ ,  $f_1$ , and  $f_2$ , or 500 cycles, 550, 550.5, and 549.5 kilocycles, respectively.

**Ques. 4.112.** In what part of a broadcast-station system are phase monitors sometimes found? What is the function of this instrument?

*Ans.* Phase monitors are sometimes found in transmission systems where two or more directive transmission-line antennas

are employed. This is generally known as the Adcock principle and operates through the use of two or more vertical radiators excited from a common source but in such a manner that the two vertical antennas receive voltages 180 degrees out of phase with each other, so that the current flowing in each vertical antenna is in an opposite direction to that of the other antenna. This system is particularly applicable to cases in which energy is to be transmitted in the vertical plane only. The actual amount of phase departure between antennas may be accurately determined by a meter or so-called "phase monitor" which reads the actual angular variation in degrees. A mutual-inductance bridge such as is sometimes used in line amplifiers for determining the phase shift on an artificial line or filter system may also be called a phase monitor although this is more aptly called a phase-measuring device.

**Ques. 4.113.** If a broadcast station receives a frequency-measurement report indicating that the station frequency was 45 cycles low at a certain time, and the transmitter log for the same time shows the measured frequency to be 5 cycles high, what is the error in the station-frequency monitor?

*Ans.* The error in the reading of the station frequency meter is 50 cycles.

**Ques. 4.114.** If a heterodyne-frequency meter, having a straight-line relation between frequency and dial reading, has a dial reading of 31.7 for a frequency of 1,390 kilocycles, and a dial reading of 44.5 for a frequency of 1,400 kilocycles, what is the frequency of the ninth harmonic of the frequency corresponding to a scale reading of 41.2?

*Ans.* The frequency of the ninth harmonic of the frequency corresponding to a scale reading of 41.2 is 12,576 + kilocycles.

**Ques. 4.115.** What is the reason why certain broadcast-station frequency monitors must receive their energy from an unmodulated stage of the transmitter?



*Ans.* To insure that the frequency monitor shall not be affected by side-band frequencies.

**Ques. 4.116.** In what part of a broadcast-station system are limiting devices usually employed?

*Ans.* Limiting devices are used at the transmitter end of a broadcast-station system in conjunction with the speech-input equipment to the transmitter.

**Ques. 4.117.** What are the results of using an audio-peak limiter?

*Ans.* Audio-peak limiters prevent the modulation percentage of the transmitter from being exceeded. They are adjusted so that any degree of modulation peaks may be supplied to the transmitter and will not allow the percentage of modulation to exceed the preadjusted value regardless of the peak amplitude of the incoming audio-frequency wave.

**Ques. 4.118.** How is the load on a modulator, which modulates the plate circuit of a class C radio-frequency stage, determined?

*Ans.* (See Ques. 4.83.)

**Ques. 4.119.** Given a class C amplifier with a plate voltage of 1,000 volts and a plate current of 150 milliamperes which is to be modulated by a class A amplifier with a plate voltage of 2,000 volts, plate current of 200 milliamperes, and a plate impedance of 15,000 ohms. What is the proper turns ratio for the coupling transformer?

*Ans.* The calculation of the turns ratio for the coupling transformer is based upon the assumption that a class A amplifier for distortionless power output must work into a

load impedance of twice the alternating-current plate resistance  $R_p$ . Class A tube,

$$15,000 \text{ ohms} = R_p. \quad \therefore 2R_p = 30,000 \text{ ohms} = Z_1.$$

Class C tube,

$$Z_2 = \frac{E}{I} = \frac{1,000}{0.15} = 6,667 \text{ ohms.}$$

Hence,

$$\text{Turns ratio} = \sqrt{\frac{Z_1}{Z_2}} = \sqrt{\frac{30,000}{6,670}} = 2.12:1.$$

The turns ratio, therefore, is 2.12:1.

**Ques. 4.120.** Indicate, by a simple diagram, a shunt-fed plate in a radio-frequency amplifier.

*Ans.* Figure 4-14 illustrates a simple shunt-fed plate radio-frequency amplifier.

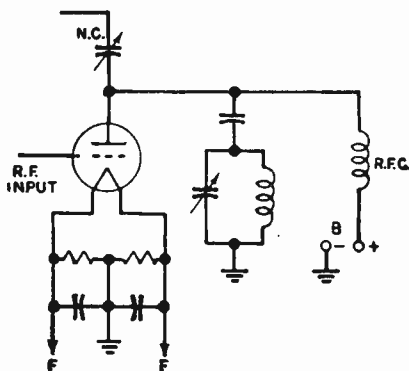

FIG. 4-14. Simple shunt-fed plate arrangement.

**Ques. 4.121.** Indicate, by a simple diagram, a series-fed plate in a radio-frequency amplifier.

*Ans.* Figure 4-15 illustrates a simple series-fed plate radio-frequency amplifier.

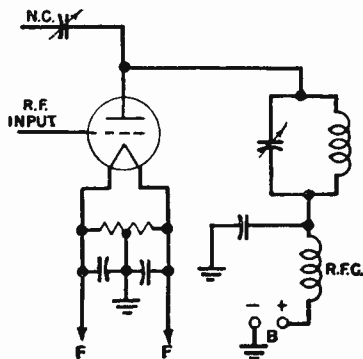

FIG. 4-15. Simple series-fed plate arrangement.

**Ques. 4.122.** With respect to the unmodulated values, doubling the excitation voltage of a class B radio-frequency amplifier will result in what increase in radio-frequency power output?

*Ans.* The radio-frequency power output will be increased four times if the excitation voltage is doubled, assuming steady carrier values.

**Ques. 4.123.** What may be the cause of a decrease in antenna current during modulation in a class B amplifier?

*Ans.* Downward deflection during modulation may be due to the following causes: poor tube, low-filament voltage, excessive value of load-impedance adjustment, open-filter condenser in power supply, improper excitation, or overloading.

**Ques. 4.124.** In adjusting the plate-tank circuit of a radio-frequency amplifier, should minimum or maximum plate current indicate resonance?

*Ans.* The direct-current plate milliammeter should show a minimum reading at the critical resonant point.

**Ques. 4.125.** What is the formula for determining the db loss or gain in a circuit?

*Ans.*

$$\text{Voltage gain or loss} = 20 \log_{10} \frac{E_1}{E_2} \text{ db.}$$

$$\text{Power gain or loss} = 10 \log_{10} \frac{P_1}{P_2} \text{ db.}$$

**Ques. 4.126.** What will occur if one tube is removed from a push-pull class A audio-frequency stage?

*Ans.* The second harmonic content, which is normally balanced out in a push-pull amplifier, will reappear. Distortion will occur, and the output power will be reduced. The hum component of the plate circuit will also be increased.

**Ques. 4.127.** What is the stage amplification obtained with a single triode operating with the following constants: plate voltage 250, plate current 20 milliamperes, plate impedance 5,000 ohms, load impedance 10,000 ohms, grid bias 5.4 volts, amplification factor 24.

*Ans.* The stage amplification will be 16.

*Solution:*

$$\text{Voltage gain} = \frac{\mu Z_0}{R_p + Z_0} = \frac{240,000}{15,000} = 16.$$

**Ques. 4.128.** Under what circumstances is neutralization of a triode radio-frequency amplifier not required?

*Ans.* Neutralization is not generally required in triode radio-frequency amplifiers when they are used as frequency doublers.

**Ques. 4.129.** Why is it necessary or advisable to remove the plate voltage from the tube being neutralized?

*Ans.* It is generally advisable to remove the plate voltage when neutralizing a radio-frequency amplifier, since the presence of the high plate-current flow may cause self-oscillation the moment power is applied. This may damage the tube even before neutralizing adjustments are begun. More critical adjustments of balance and less danger from shock make the disconnection of high-voltage supply advisable.

**Ques. 4.130.** Under what conditions may a broadcast station be operated at a reduced power other than specified in the station license?

*Ans.* The license of a broadcast station shall maintain the operating power of the station within the prescribed limits of the licensed power at all times, except that, in an emergency when, owing to causes beyond the control of the licensee, it becomes impossible to operate with the full licensed power, the station may be operated at reduced power for a period of not to exceed 10 days, provided that the Commission and the inspector in charge shall be notified in writing immediately after the emergency develops.

**Ques. 4.131.** When the transmitter of a regular broadcast transmitter is operated at 85 per cent modulation, what is the maximum permissible combined audio-harmonic output?

*Ans.* When the transmitter is operated with 85 per cent modulation, not over 10 per cent combined audio-frequency harmonics shall be generated by the transmitter.

**Ques. 4.132.** How frequently must the auxiliary transmitter of a regular broadcast station be tested?

*Ans.* The auxiliary transmitter shall be tested at least once each week to determine that it is in proper operating condition and that it is adjusted to the proper frequency, except that in case of operation in accordance with paragraph (c) of this section during any week, the test in that week may be omitted provided the operation under paragraph (c) is satisfactory.

## RADIO OPERATING QUESTIONS AND ANSWERS

A record shall be kept of the time and result of each test operating under paragraph (c). Tests shall be conducted between midnight and 9 A.M., local standard time. Paragraph (c) reads as follows:

(c) The auxiliary transmitter shall be maintained so that it may be put into immediate operation at any time for the following purposes:

(1) The transmission of the regular programs upon the failure of the main transmitter.

(2) The transmission of regular programs during maintenance or modification work on the main transmitter, necessitating discontinuance of its operation for a period not to exceed five days.

(3) Upon request by a duly authorized representative of the Commission.

**Ques. 4.133.** For what purpose is an auxiliary transmitter maintained?

*Ans.* An auxiliary transmitter is maintained for the following reasons:

1. For the transmission of the regular programs upon the failure of the main transmitter.

2. For the transmission of regular programs during maintenance or modification work on the main transmitter, necessitating discontinuance of its operation for a period not to exceed five days.

**Ques. 4.134.** If the plate ammeter in the last stage of a broadcast transmitter burned out, what should be done?

*Ans.* No instrument indicating the plate current or plate voltage of the last radio stage, the antenna current, or the transmission-line current shall be changed or replaced without written authority of the Commission, except by instruments of the same make, type, maximum scale reading, and accuracy. Requests for authority to change an instrument may be made by letter or telegram giving the manufacturer's name, type

number, serial number, and full-scale reading of the proposed instrument and the values of current or voltage the instrument will be employed to indicate. Requests for temporary authority to operate without an instrument or with a substitute instrument may be made by letter or telegram stating the necessity therefor and the period involved.

**Ques. 4.135.** The currents in the elements of a directive broadcast antenna must be held to what percentage of their licensed value?

*Ans.* Five per cent.

**Ques. 4.136.** What are the permissible positive and negative tolerances of power of a standard broadcast station?

*Ans.* From +5 and -10 per cent.

**Ques. 4.137.** What is meant by "equipment tests" and "service tests" where these are mentioned in the Rules and Regulations of the Commission?

*Ans.* Upon completion of construction of a radio station in exact accordance with the terms of the construction permit, the technical provisions of the application therefor and the rules and regulations governing the class of station concerned and prior to filing of application for license, the permittee is authorized to test the equipment for a period not to exceed 10 days. This test is referred to as the "equipment test."

When construction and equipment tests are completed in exact accordance with the terms of the construction permit, the technical provisions of the application therefor, and the rules and regulations governing the class of station concerned, and after an application for station license has been filed with the Commission showing the transmitter to be in satisfactory operating condition, the permittee is authorized to conduct service or program tests in exact accordance with the terms of the construction permit for a period not to exceed 30 days. This trial of the equipment is referred to as a "service test."

**Ques. 4.138.** At broadcast stations using the direct method of computing output power, at what point in the antenna system must the antenna current be measured?

*Ans.* At the point of maximum current, which is as close to the ground as possible.

**Ques. 4.139.** For what purpose may a regular broadcast station, licensed to operate daytime or specified hours, operate during the experimental period without specific authorization?

*Ans.* The term "experimental period" means that period of time between 12 midnight and 6 A.M. This period may be used for experimental purposes in testing and maintaining apparatus by the licensee of any standard broadcast station, on its assigned frequency and with its authorized power, provided no interference is caused to other stations maintaining a regular operating schedule within such period. No station licensed for "daytime" or "specified hours" of operation may broadcast any regular or scheduled program during this period.

**Ques. 4.140.** What is the allowable frequency deviation, in percentage, for a broadcast station operating on 1,000 kilocycles?

*Ans.* The operating frequency of each broadcast station shall be maintained within 50 cycles of the assigned frequency until January 1, 1940, and thereafter the frequency of each new station or each station where a new transmitter is installed shall be maintained within 20 cycles of the assigned frequency, and after January 1, 1942, the frequency of all stations shall be maintained within 20 cycles of the assigned frequency. Hence, the deviation for an old transmitter on 1,000 kilocycles could be as high as 0.005 per cent. The deviation for a new transmitter installed after January 1, 1940, must not exceed 0.002 per cent on 1,000 kilocycles. After January 1, 1942, all broadcast transmitters will be required to limit any deviation to within 20 cycles of the assigned frequency.



**Ques. 4.141.** What is the last audio-frequency amplifier stage which modulates the radio-frequency stage termed?

*Ans.* The last amplifier stage of the modulating wave which modulates a radio-frequency stage is called the modulator stage.

**Ques. 4.142.** How frequently must a remote-reading ammeter be checked against a regular-antenna ammeter?

*Ans.* Calibration shall be checked against the regular meter at least once a week.

**Ques. 4.143.** What factors enter into the determination of power of a broadcast station which employs the indirect method of measurement?

*Ans.* The operating power determined by indirect measurement from the plate-input power of the last radio stage is the product of the plate voltage ( $E_p$ ), the total plate current of the last radio stage ( $I_p$ ), and the proper factor ( $F$ ) as given by the following formula:

$$\text{Operating power} = E_p \times I_p \times F.$$

The factor  $F$  varies from 0.25 to 0.80, depending on the type of modulation used.

**Ques. 4.144.** What is the power that is actually transmitted by a regular broadcast station termed?

*Ans.* "Operating power" means the power that is actually supplied to the radio station antenna.

**Ques. 4.145.** Are the antenna current, plate current, etc., as used in the Rules and Regulations of the Commission modulated or unmodulated values?

*Ans.* "Plate-input power" means the product of the direct-plate voltage applied to the tubes in the last radio stage and

the total direct current flowing to the plates of these tubes, measured without modulation.

“Antenna current” means the radio-frequency current in the antenna with no modulation.

**Ques. 4.146.** With reference to broadcast stations, what is meant by the “experimental period”?

*Ans.* The term “experimental period” means that period of time between 12 midnight and 6 A.M. This period may be used for experimental purposes in testing and maintaining apparatus by the licensee of any standard broadcasting station, on its assigned frequency with its authorized power, provided no interference is caused to any other stations maintaining a regular operating schedule within such period. No station licensed for “daytime” or “specified hours” of operation may broadcast any regular or scheduled program during this period.

**Ques. 4.147.** What percentage of modulation capability is required of a broadcast station?

*Ans.* A licensee of a broadcast station will not be authorized to operate a transmitter unless it is capable of delivering satisfactorily the authorized power with a modulation of at least 85 per cent. When the transmitter is operated with 85 per cent modulation, not over 10 per cent combined audio-frequency harmonics shall be generated by the transmitter.

**Ques. 4.148.** Define the “maximum-rated carrier power” of a broadcast station transmitter.

*Ans.* “Maximum-rated carrier power” is the maximum power at which the transmitter can be operated satisfactorily and is determined by the design of the transmitter and the type and number of vacuum tubes used in the last radio stage.

**Ques. 4.149.** Define the “plate-input power” of a broadcast station transmitter,

*Ans.* "Plate-input power" means the product of the direct-current plate voltage applied to the tubes in the last radio stage and the total direct current flowing to the plates of these tubes, measured without modulation. "Antenna current" means the radio-frequency current in the antenna with no modulation.

**Ques. 4.150.** Define "high-level" and "low-level" modulation.

*Ans.* "High-level" modulation is modulation produced in the last radio stage of the system.

"Low-level" modulation is modulation produced in an earlier radio stage than the final.

**Ques. 4.151.** What is the tolerance that is applied to the antenna currents in the various elements of a directional array?

*Ans.* Five per cent.

**Ques. 4.152.** What is the frequency tolerance which must be maintained at the present time by a standard broadcast station?

*Ans.* The operating frequency of each broadcast station shall be maintained within 50 cycles of the assigned frequency until January 1, 1940, and thereafter the frequency of each *new* station or each station where a *new* transmitter is installed shall be maintained within 20 cycles of the assigned frequency, and after January 1, 1942, the frequency of all stations shall be maintained with 20 cycles of the assigned frequency.

**Ques. 4.153.** What is the frequency tolerance allowed an INTERNATIONAL BROADCAST STATION?

*Ans.* 0.005 per cent.

RADIO OPERATING QUESTIONS AND ANSWERS

**Ques. 4.154.** What is the required full-scale accuracy required in the ammeters and voltmeters associated with the final radio stage of a broadcast transmitter?

*Ans.* Accuracy shall be at least 2 per cent of the full-scale reading.

**Ques. 4.155.** If a broadcast transmitter employs seven tubes of a particular type, how many spare tubes of the same type are required to be kept on hand in accordance with FCC regulations?

*Ans.* Three, in accordance with the following schedule:

Number of Tubes of Each Type Employed	Spares Required
1 or 2	1
3 to 5	2
6 to 8	3
9 or more	4

**Ques. 4.156.** Describe the various methods by which a broadcast station may compute its operating power, and state the conditions under which each method may be employed.

*Ans.* After July 1, 1940, all broadcast stations shall employ the *direct-measurement method* of determining operating power. With this method, the antenna-input power (operating power) is determined by multiplying the antenna resistance by the square of the antenna current, both being measured at the base of the antenna, the point of maximum current.

In case of an emergency where the licensed antenna has been damaged or destroyed by storm or other cause beyond the control of the licensee, or pending completion of authorized changes in the antenna system, the *indirect measurement method* of determining operating power may be employed. With this method, the plate-input power to the last radio stage is taken as the operating power. (See Ques. 4.143.)

**Ques. 4.157.** What portion of the scale of an antenna ammeter having a square-law scale is considered as having acceptable accuracy for use at a broadcast station?

*Ans.* No scale division above one-third full-scale reading (in amperes) shall be greater than one-thirtieth of the full-scale reading.

*Example:* An ammeter meeting standard requirements and having a full-scale reading of 6 amperes is acceptable for reading currents from 2 to 6 amperes provided no scale division between 2 and 6 amperes is greater than  $\frac{1}{30}$  of 6 amperes, 0.2 ampere.

**Ques. 4.158.** Define: "Amplifier gain," "percentage deviation," "stage amplification," and "percentage of modulation." Explain how each is determined.

*Ans.* "Amplifier gain" is the ratio of output to input signal amplitude (voltage gain) or the ratio of output to input signal power (power gain). This ratio may be expressed in decibels.

"Percentage deviation" is the percentage which a carrier frequency varies from its stable frequency value.

"Stage amplification" is the ratio of the output to input voltage or power of a single amplifier tube with its associated input- and output-coupling system. This ratio is also expressed in decibels gain.

"Percentage of modulation" is the term applied when the modulation factor is expressed as a percentage, and is the ratio of the maximum departure, positive or negative, of the envelope of a modulated wave from its unmodulated value. (I.R.E. Standards definition, 1938.)

**Ques. 4.159.** Define "auxiliary broadcast transmitter" and state the conditions under which it may be used.

*Ans.* "Auxiliary transmitter" means a transmitter maintained only for transmitting the regular programs of a station in case of failure of or work on the main transmitter.

**Ques. 4.160.** What is the purpose of using a frequency standard or service independent of the transmitter-frequency monitor or control?

*Ans.* To assure that the transmitter is on the assigned frequency and within tolerance limits. It also permits a check upon the station monitor.

**Ques. 4.161.** Discuss the characteristics of a modulated class C amplifier.

*Ans.* The class C amplifier has very high efficiency. It is generally operated in the vicinity of 60 per cent efficiency for modulated stages. It operates with a grid-bias adjustment of approximately twice the cut-off value and a tank circuit impedance of three or four times the tube impedance. These adjustments permit a fairly linear adjustment between the tank current and plate voltage. The continuous power output with 100 per cent modulation is 1.5 times the power at zero modulation. It undergoes a power variation of from 0 to 4 times the carrier power under 100 per cent modulation.

**Ques. 4.162.** What is the purpose of neutralizing a radio-frequency amplifier stage?

*Ans.* To prevent the amplifier from going into self-oscillation and to avoid serious overloading.

**Ques. 4.163.** When the authorized nighttime power of a standard broadcast station is different from the daytime power and the operating power is determined by the "indirect" method, which of the efficiency factors established by FCC rules is used?

*Ans.* Use the efficiency factor given for the maximum licensed power of the station.

**Ques. 4.164.** Describe the technique used in frequency measurements employing a 100-kilocycle oscillator, a 10-kilo-

cycle multivibrator, a heterodyne-frequency meter of known accuracy, a suitable receiver, and standard-frequency transmission.

*Ans.* The principle involved in all primary-frequency standards is based upon the zero beat method. In the primary method, employing a 100-kilocycle oscillator of stabilized frequency, is a series of multivibrators that operates a clock in synchronism with the oscillator frequency. Now, if a secondary-frequency measuring system employing a heterodyne-frequency meter is adjusted to zero beat with a receiver tuned to a standard-frequency transmission station, these frequencies may be intercoupled for any degree of calibration desired. In this manner primary- and secondary-frequency standards may readily be obtained.

**Ques. 4.165.** What is the power specified in the instrument of authorization for a standard broadcast station called?

*Ans.* "Authorized power" or "licensed power."

**Ques. 4.166.** What is the effect of 10,000-cycle modulation of a standard broadcast station on adjacent channel reception?

*Ans.* This will cause strong interference, since it produces a sideband at the frequency of the carrier of the adjacent channel.

**Ques. 4.167.** What system of connections for a three-phase, three-transformer bank will provide maximum secondary voltage?

*Ans.* The delta-Y connection, where the primary is connected in delta and the secondary in "Y" as illustrated in Fig. 4-1.

**Ques. 4.168.** Draw a diagram and describe the electrical characteristics of an electron-coupled oscillator circuit.

*Ans.* Figure 2-8 illustrates a simple electron-coupled oscillator. The cathode, grid, and screen grid operate as a

Hartley triode oscillator. The circuit is very little affected by variations in plate-circuit impedance, since the current in a tetrode or pentode is nearly independent of plate voltage. Power, however, is delivered from the oscillator circuit to the plate circuit by the flow of electrons to the plate. The frequency stability of the oscillator is very good.

**Ques. 4.169.** In frequency measurements using the heterodyne "zero beat" method, what is the best ratio of signal e.m.f. to calibrated heterodyne oscillator e.m.f.?

*Ans.* An approximate 1:1 ratio is desirable in order that the resultant beat note shall be strong compared with the weaker beat notes also present.

**Ques. 4.170.** What is meant by the "Q" of a radio-frequency inductance coil?

*Ans.* The  $Q$  of a coil is an expression of the "figure of merit" of any coil carrying an alternating current. It defines the degree of selectivity or sharpness of tuning in a circuit containing an inductance. The  $Q$  of a coil is determined by the ratio  $\frac{X_L}{R}$  where  $X_L$  is the reactance to an alternating current expressed in ohms.  $R$  is the combined direct-current and radio-frequency resistance of the coil.

**Ques. 4.171.** What effect does a loading resistance have on a tuned radio-frequency circuit?

*Ans.* A loading resistance reduces the effective  $Q$  of a tuned radio-frequency circuit. This results in increased damping of the oscillatory circuit. The circuit thus tunes less sharply, resulting in a broadened frequency response or wider band width.

**Ques. 4.172.** What is meant by the "time constant" of a resistance-capacity circuit?



*Ans.* The "time constant" of a resistance-capacity circuit is the time in seconds required for the capacity to reach 63.2 per cent of its full charge after a voltage is applied, or for the capacity to discharge through the resistor to 36.8 per cent of its charged value when the circuit is short-circuited. This time constant is found by multiplying the resistance in ohms by the capacity in farads ( $T = RC$ ).

**Ques. 4.173.** A potential of 110 volts is applied to a series circuit containing an inductive reactance of 25 ohms, a capacitive reactance of 10 ohms, and a resistance of 15 ohms. What is the phase relationship between the applied voltage and the current flowing in this circuit?

*Ans.* The phase relationship or phase angle is 45 degrees.

$$\tan \theta = \frac{X}{R} = \frac{X_L - X_C}{R} = \frac{25 - 10}{15} = 1.$$

Therefore,

$$\theta = 45 \text{ degrees.}$$

**Ques. 4.174.** What does the term "power factor" mean in reference to electric circuits?

*Ans.* "Power factor" is a numerical expression ranging between zero and unity and denotes the ratio of the true power consumed in an alternating-current circuit divided by the product of the voltage and the current in the circuit.

$$\text{Power factor} = \cos \theta = \frac{\text{watts}}{E \times I}.$$

**Ques. 4.175.** What is the predominant ripple frequency in the output of a single-phase full-wave rectifier when the primary source of power is 110 volts at 60 cycles?

*Ans.* 120 cycles.

**Ques. 4.176.** When mercury-vapor tubes are connected in parallel in a rectifier system, why are small resistors sometimes placed in series with the plate leads of the tubes?

*Ans.* To prevent parasitic oscillations and balance ionization when tubes are connected in parallel. Small resistors are sometimes connected in series with plate leads to limit the instantaneous heavy surge currents that take place when the circuit is first closed. Without resistors, one tube may ionize first, thus lowering the voltage across the tubes in parallel to a point where it will be impossible to obtain ionization in the other tube. Resistors keep the total voltage drop high enough so that the slower tube will ionize.

**Ques. 4.177.** A rectifier-filter power supply is designed to furnish 500 volts at 60 milliamperes to one circuit and 400 volts at 40 milliamperes to another circuit. The bleeder current in the voltage divider is to be 15 milliamperes. What value of resistance should be placed between the 500- and 400-volt taps of the voltage divider?

*Ans.* 1,819 ohms. A voltage drop of 100 volts at 55 milliamperes is required between the 500- and 400-volt taps. Thus,

$$R = \frac{E}{I} = \frac{100}{0.055} = 1,819 \text{ ohms.}$$

**Ques. 4.178.** What is the approximate speed of a 220-volt, 60-cycle, 4-pole, 3-phase induction motor?

*Ans.* Approximately 1,800 r.p.m. The running speed of an induction motor is always slightly less than the synchronous speed due to the ratio of the difference between the synchronous and the rotor speeds to the synchronous speed. This ratio is called the "slip" and is generally expressed in per cent. In commercial practice the slip usually ranges between 2 and 3 per cent.

Assuming a slip of 0.025 or 2.5 per cent, the actual speed of the induction motor may be found as follows:

$$\text{Synchronous speed} = \frac{120 \times f}{N} = \frac{120 \times 60}{4} = 1,800 \text{ r.p.m.},$$

where  $f$  = frequency in cycles per second.

$N$  = number of field poles.

$$\begin{aligned} \text{Actual speed} &= \text{synchronous speed} \times (1 - S), \\ &= \frac{120 \times f}{N} (1 - S) = \frac{120 \times 60}{4} (1 - 0.025) \\ &= \frac{120 \times 60}{4} \times 0.975 = 1,755 \text{ r.p.m.}, \end{aligned}$$

where  $S$  = slip.

**Ques. 4.179.** Draw a diagram of a shunt-wound direct-current motor.

*Ans.* See Fig. 6-8.

**Ques. 4.180.** Draw a diagram of a voltage-doubling power supply using two half-wave rectifiers.

*Ans.* Figure 4-16 illustrates a voltage-doubling power supply system employing two half-wave rectifiers.

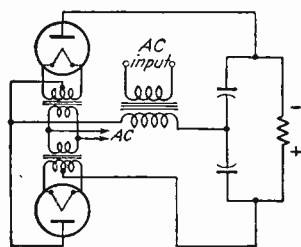
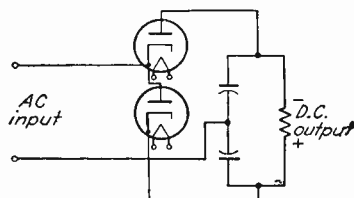

FIG. 4-16.

**Ques. 4.181.** Why is degenerative feedback sometimes used in an audio amplifier?

*Ans.* Degenerative feedback is sometimes employed in an audio-frequency amplifier to improve the frequency response of the amplifier and reduce the over-all amplifier distortion.

**Ques. 4.182.** What determines the fundamental operating frequency range of a multivibrator oscillator?

*Ans.* The fundamental operating frequency is determined by the resistance and capacitor values of the grid leak and grid condenser of each tube.

$$f = \frac{0.6}{R_1 C_1 + R_2 C_2} \text{ cycles per second.}$$

**Ques. 4.183.** Draw a diagram of an audio amplifier with inverse feedback.

*Ans.* Figure 4-17 illustrates a method of applying inverse feedback to an audio-frequency amplifier tube.

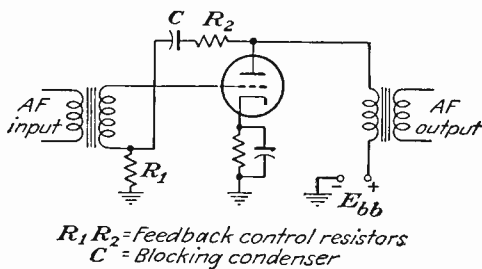

FIG. 4-17.

**Ques. 4.184.** What is the meaning of “mutual conductance” and “amplification factor” in reference to vacuum tubes?

*Ans.* “Mutual conductance,”  $g_m$ , is defined as the ratio of a change in plate current to a change in grid voltage that will produce that plate-current change (plate voltage held con-

stant). The practical unit of mutual conductance is the micromho =  $10^{-6}$  mho.

$$g_m = \frac{I_b \times 10^3}{E_c} \text{ micromhos} \quad (E_b = \text{constant}),$$

where  $I_b$  is in milliamperes.

Amplification factor,  $Mu$  or  $\mu$ , is defined as the ratio of a change in plate voltage to a change in grid voltage in the opposite direction that will maintain the plate current constant.

$$\mu = \frac{E_b}{E_c} \quad (I_b \text{ constant}).$$

**Ques. 4.185.** What is the purpose of a screen grid in a vacuum tube?

*Ans.* The screen grid in a vacuum tube serves as an electrostatic shield between the grid and the plate elements of the tube. This reduces the internal capacity of the tube between these two elements. (See also Ques. 2.118.)

**Ques. 4.186.** What is meant by secondary emission in a vacuum tube?

*Ans.* Secondary emission of electrons in a vacuum tube is that phenomenon which takes place when the electrons emitted from the hot cathode or filament strike the plate during the normal plate current flow. These primary electrons striking the plate at high velocity release electrons from the plate, and it is this effect which is called "secondary" emission.

**Ques. 4.187.** Why are grounded-grid amplifiers sometimes used at very high frequencies?

*Ans.* The grounded-grid amplifier using a triode-type vacuum tube is sometimes used at very high and ultra-high frequencies (VHF, UHF) because of its excellent stability. The low feedback capacity between the plate and the cathode due to the grounded grid prevents self-oscillation at these frequencies and therefore makes neutralization unnecessary.

**Ques. 4.188.** What material is used in shields to prevent stray magnetic fields in the vicinity of radio-frequency circuits?

*Ans.* Tin, copper, and aluminum are the most commonly used materials.

**Ques. 4.189.** For maximum stability, should the tuned circuit of a crystal oscillator be tuned to exact crystal frequency?

*Ans.* No. The plate-circuit load is generally inductive and must, therefore, be tuned so that its resonant frequency is slightly higher than that of the crystal.

**Ques. 4.190.** What is the principal advantage of a class C amplifier?

*Ans.* High plate efficiency. The class C amplifier may develop an efficiency of nearly 100 per cent if the current duration is limited to a very small value. The output power under these conditions, however, is very small. For practical purposes, the efficiency of class C amplifiers generally ranges between 50 and 80 per cent. (See Ques. 4.161.)

**Ques. 4.191.** Draw a diagram of a grounded-grid amplifier.

*Ans.* Figure 4-18 illustrates a circuit arrangement of a typical grounded-grid amplifier.

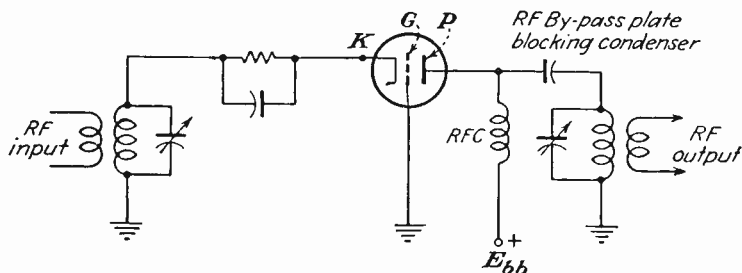

FIG. 4-18.

**Ques. 4.192.** A current-squared meter has a scale divided into 50 equal divisions. When 45 milliamperes flow through the meter, the deflection is 45 divisions. What is the current flowing through the meter when the scale deflection is 25 divisions?

*Ans.* 25 milliamperes. This is based upon the assumption that the scale divisions are equally divided and that the sensitivity of the meter is proportional throughout the scale. However, since deflection is proportional to the square of the current flowing through the meter with an equally divided scale, the ratio of two deflections is equal to the ratio of the square of the currents producing these deflections, thus,

$$\frac{D_1}{D_2} = \frac{I_1^2}{I_2^2}; \quad \frac{25}{45} = \frac{I_1^2}{45^2}; \quad I_1^2 = \frac{25 \times 45^2}{45}$$

$$I_1 = \sqrt{25 \times 45} = \sqrt{1,125} = 33.5 \text{ milliamperes.}$$

**Ques. 4.193.** What is the ohms per volt of a voltmeter constructed of a 0-1 direct-current milliammeter and a suitable resistor that makes the full-scale reading of the meter 500 volts?

*Ans.* 1,000 ohms per volt. A total resistance of 500,000 ohms in series with the source potential and including the milliammeter resistance will pass 1 milliampere at 500 volts.

Thus,  $\frac{500,000}{500} = 1,000$  ohms per volt.

**Ques. 4.194.** What is the power output of an audio amplifier if the voltage across the load resistance of 500 ohms is 40 volts?

*Ans.* 3.2 watts.

$$P = \frac{E^2}{R} = \frac{40^2}{500} = \frac{1,600}{500} = 3.2 \text{ watts.}$$

**Ques. 4.195.** What type of meter is suitable for measuring peak alternating-current voltage?

*Ans.* Any standard type of alternating-current voltmeter is suitable for measuring peak sine-wave alternating-current voltage, provided the meter reading is multiplied by 1.414, which is the conversion factor from effective to peak voltage. Vacuum-tube voltmeters may also be used. The peak reading types will read peak voltages directly on their scales.

**Ques. 4.196.** What type of meter is suitable for measuring the automatic-volume-control voltage in a standard broadcast receiver?

*Ans.* Any standard type of direct-current voltmeter that has an internal resistance of at least 20,000 ohms per volt.

**Ques. 4.197.** What type of meter is suitable for measuring radio-frequency currents?

*Ans.* A thermocouple or hot-wire type of radio-frequency ammeter.

**Ques. 4.198.** What type of voltmeter absorbs no power from the circuit under test?

*Ans.* Certain types of vacuum-tube voltmeters, notably the plate detection type. Although the diode-type vacuum-tube voltmeter absorbs some power from the circuit under test, this power is generally small compared with that taken by a standard-type voltmeter.

**Ques. 4.199.** What type of voltmeter is appropriate to measure peak alternating-current voltages?

*Ans.* The electronic or vacuum-tube type of voltmeter (VTVM). A direct reading of alternating-current peak voltages may be accurately obtained by the use of a calibrated scale on a cathode-ray oscilloscope.



**Ques. 4.200.** If the spacing of the conductors in a two-wire radio-frequency transmission line is doubled, what change takes place in the surge impedance of the line?

*Ans.* The characteristic or surge impedance  $Z_0$  of the two-wire transmission line will be increased.

$$Z_0 = 276 \log_{10} \frac{2D}{d},$$

where  $Z_0$  = surge impedance.

$D$  = separation of the conductors from center to center.

$d$  = diameter of the conductors.

Let us assume a two-wire transmission line in which the separation  $D$  is 5 inches and the diameter  $d$  is 1 inch.

$$Z_0 = 276 \log_{10} \frac{2D}{d}; \quad \log \frac{2D}{d} = \frac{10}{1} = 1.0$$

$$Z_0 = 276 \times 1.0 = 276 \text{ ohms.}$$

Doubling the spacing of the two conductors yields,

$$Z_0 = 276 \log_{10} \frac{2D}{d}; \quad \log \frac{2D}{d} = \frac{20}{1} = 1.301$$

$$Z_0 = 276 \times 1.301 = 359 \text{ ohms.}$$

**Ques. 4.201.** If the conductors in a two-wire radio-frequency transmission line are replaced by larger conductors, how is the surge impedance affected, assuming no change in the center-to-center spacing of the conductor?

*Ans.* Increasing the diameter of the conductors will decrease the surge impedance.

*Example* (refer to example of Ques. 4.200):

$$Z_0 = 276 \log_{10} \frac{2D}{d}.$$

When  $D = 10$  inches and  $d = 1$  inch,  $Z_0 = 350$  ohms. Increasing  $d$  to 2 inches, we obtain

$$Z_0 = 276 \log_{10} 2\frac{1}{2}; \quad \log 2\frac{1}{2} = 1.0$$

$$Z_0 = 276 \times 1.0 = 276 \text{ ohms.}$$

**Ques. 4.202.** Why is an inert gas sometimes placed within concentric radio-frequency transmission cables?

*Ans.* An inert nitrogen gas is sometimes placed within concentric radio-frequency transmission lines to prevent the entrance of moisture into the inner conductor area. This reduces dielectric losses, insulation breakdown, and arcing.

**Ques. 4.203.** What is the direction of maximum radiation from two vertical antennas spaced 180 degrees and having equal currents in phase?

*Ans.* Two vertical antennas spaced one-half wavelength (180 degrees) apart and having equal currents in phase will produce a bidirectional field pattern. The radiation will lie in a plane perpendicular to the array.

**Ques. 4.204.** Explain the properties of a quarter-wave section of a radio-frequency transmission line.

*Ans.* A quarter-wave section of a radio-frequency transmission line has the property of "inverting" the load as viewed from the input or source. This inverting property of a quarter-wave section can be used to match one impedance to another impedance of different value. For example, a 300-ohm line of any length can be matched to a terminating impedance of 72 ohms by the insertion of a quarter-wave transformer or matching section (also called "Q" section or "Q" bar) as illustrated in Fig. 3-22.

$$Z_0 = \sqrt{Z_S Z_L}$$

where  $Z_0$  = characteristic impedance of the quarter-wave matching section.

$Z_S$  = 300-ohm line impedance.

$Z_L$  = 72-ohm terminating impedance.

Thus,

$$\begin{aligned}Z_0 &= \sqrt{300 \times 72} = \sqrt{21,600} \\ &= 147 \text{ ohms.}\end{aligned}$$

A quarter-wave line, with one end open-circuited and the other end connected across a source of e.m.f., appears as a series-resonant circuit and presents a low impedance to the source e.m.f. at the resonant frequency of the line. A quarter-wave line with one end short-circuited appears as a parallel-resonant circuit and presents a high impedance to the source e.m.f. at the resonant frequency of the line.

**Ques. 4.205.** How does the field strength of a standard broadcast station vary with distance from the antenna?

*Ans.* The field strength of the waves radiated from a standard broadcast transmitting antenna is inversely proportional to the distance from the antenna or approximately  $\frac{1}{d}$  and is based on the assumption that there is zero ground-wave attenuation.

Maximum radiation from broadcast antennas takes place at or near the ground and travels directly to the receiving antenna also located near the ground, namely, at a height very low compared with a full wavelength at broadcast frequencies. Under these conditions, the field intensity at any point is directly proportional to the antenna current and inversely proportional to the distance from the transmitter.

**Ques. 4.206.** What pattern on a cathode-ray oscilloscope indicates overmodulation of a standard broadcast station?

*Ans.* The trapezoidal pattern for complete modulation illustrated in Fig. 4-5 will show a sharp increase in the slope of its sides and height during overmodulation.

**Ques. 4.207.** What is the Doherty amplifier?

*Ans.* The Doherty amplifier is a high-efficiency linear radio-frequency amplifier circuit designed to give increased

output efficiency as compared with the conventional class B and class C types. Average all-day working efficiency of the Doherty system is approximately 63 per cent at 100 per cent modulation as compared with  $33\frac{1}{3}$  per cent for conventional types.

The Doherty high-efficiency circuit uses a new principle in which the normal or carrier power is delivered at high-radio-frequency voltage and hence high efficiency by one tube alone, and the additional voltage required for modulation peaks is supplied by a second tube.

**Ques. 4.208.** Why do some standard broadcast stations use top-loaded antennas?

*Ans.* The most important factors are

1. Improvement in the horizontal radiation pattern.
2. Increased antenna terminal resistance.
3. Lower capacitive reactance of the antenna.
4. Increased antenna radiation resistance.
5. Improved radiation efficiency.
6. Economy made possible through reduction in physical height.

Top loading in a vertical radiating system is generally in the form of uniformly spaced umbrella wires connected at the ends with a wire hoop and placed at the top of the vertical antenna tower.

**Ques. 4.209.** How may a standard broadcast antenna ammeter be protected from lightning?

*Ans.* A standard broadcast antenna ammeter should be protected from lightning by connecting a shorting switch across the terminals of the meter. The meter case must be shielded and properly grounded. (See also Ques. 5.101.)

**Ques. 4.210.** What is the ratio of unmodulated carrier power to instantaneous peak power, at 100 per cent modulation at a standard broadcast station?

*Ans.* Four times the *instantaneous peak power* or eight times the *effective power* of the carrier.

**Ques. 4.211.** What effect do broken ground conductors have on a standard broadcast antenna?

*Ans.* Broken ground conductors decrease the total earth currents and may seriously reduce the antenna-radiated field intensity. An efficient ground system for practically all types of vertical antennas is generally one consisting of approximately 120 buried radial wires, each one-half wavelength long, placed directly under the antennas. Thus, a break in any of these ground wires will affect the field pattern and the ground resistance.

**Ques. 4.212.** What may cause unsymmetrical modulation of a standard broadcast transmitter?

*Ans.* Assuming proper  $E_b$ ,  $E_c$ , and  $E_g$  relations, unsymmetrical modulation of a carrier envelope may be due to one or more of the following causes:

1. Improper tube balance in the modulator or modulating amplifier.
2. Improper circuit balance in the grid or plate circuit of the modulating amplifier.
3. Improper linearity due to insufficient plate-load impedance.
4. Poor power-supply regulation.
5. Amplitude and phase distortion during modulation due to improper tuning of amplifier resonant circuits to the excitation carrier frequency.
6. Insufficient grid excitation due to low grid drive to the class C modulated amplifier stage.

**Ques. 4.213.** If the two towers of a 950-kilocycle directional antenna are separated by 120 electrical degrees, what is the tower separation in feet?

RADIO OPERATING QUESTIONS AND ANSWERS

*Ans.* The tower separation is approximately 345.25 feet.

*Solution:*

$$950 \text{ kc. per sec.} = 315.79 \text{ meters } (\lambda).$$

$$120^\circ = \frac{\lambda}{3}$$

A separation of one-third wavelength between towers at 950 kilocycles is

$$\frac{1}{3} \times 315.79 = 105.26 \text{ meters.}$$

$$1 \text{ meter} = 3.28 \text{ feet.}$$

$$105.26 \times 3.28 = 345.25 \text{ feet, the spacing between towers.}$$

**Ques. 4.214.** Draw a diagram showing how automatic volume control is accomplished in a standard broadcast receiver.

*Ans.* Figure 4-19 illustrates a typical automatic-volume-control (AVC) system used in modern broadcast receivers.

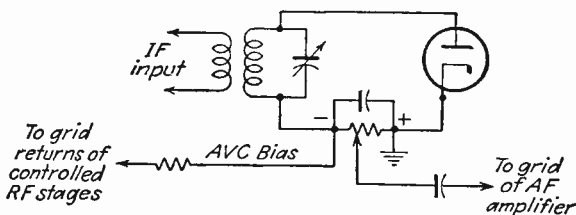

BASIC AVC SYSTEM

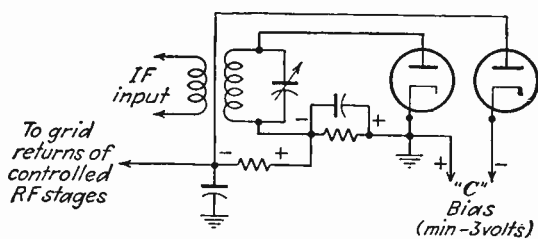

DELAYED AVC SYSTEM (DAVC)

FIG. 4-19.

**Ques. 4.215.** What is the required full-scale accuracy of the plate ammeter and plate voltmeter of the final radio stage of a standard broadcast transmitter?

*Ans.* A full-scale accuracy of 2 per cent is required.

**Ques. 4.216.** What is the maximum carrier shift permissible at a standard broadcast station?

*Ans.* Five per cent.

**Ques. 4.217.** In accordance with the Commission's standards of good engineering practice, what determines the maximum permissible full-scale reading of indicating instruments required in the last radio stage of a standard broadcast transmitter?

*Ans.* The Commission's standards relating to maximum permissible full-scale reading of indicating instruments are as follows:

1. Length of the scale shall not be less than  $2\frac{3}{10}$  inches.
2. Accuracy shall be at least 2 per cent of the full-scale reading.
3. The scale shall have at least 40 divisions.
4. Full-scale reading shall not be greater than five times the minimum normal indication.
5. Maximum rating to be such that the meter does not read off scale during modulation.

**Ques. 4.218.** When an X- or a Y-cut crystal is employed in the automatic-frequency-control equipment at a standard broadcast station, what is the maximum permitted temperature variation at the crystal from the normal operating temperature?

*Ans.* A temperature variation not to exceed  $\pm 0.1$  degree centigrade at the mid-band broadcast frequency of 1,000 kilocycles. This variation will maintain the assigned carrier frequency to within the required 20-cycle deviation.

The normal oven temperature in modern broadcast transmitters is generally maintained between 60 and 70 degrees centigrade depending upon the type of crystal cut used and the specific operating frequency.

**Ques. 4.219.** What is the purpose of a discriminator in a frequency-modulation broadcast receiver?

*Ans.* The discriminator or demodulator in a frequency-modulation receiver is a circuit designed to convert the frequency-modulated radio-frequency responses into amplitude variations at audio frequency. It is in reality the signal detector of a frequency-modulation type of receiver.

**Ques. 4.220.** Explain why high-gain antennas are used at frequency-modulation broadcast stations.

*Ans.* The transmission of frequency-modulated signals in the ultra-high-frequency spectrum requires specially constructed high-gain antennas to produce a radiation pattern that has circular symmetry in the horizontal plane and also to concentrate the signal strength toward the horizon.

Frequencies above 50 megacycles follow the line-of-sight characteristics which, in general, restrict their effectiveness to a limited area. The antenna design, therefore, must be such as to distribute a maximum signal intensity over the useful area in which the relatively smaller receiving antennas are located.

High-gain antennas provide more efficient utilization of power.

**Ques. 4.221.** What is the frequency swing of a frequency-modulation broadcast transmitter when modulated 60 per cent?

*Ans.* Plus or minus 45 kilocycles. For frequency-modulated broadcast stations, a frequency swing of  $\pm 75$  kilocycles is defined as 100 per cent modulation. Hence a 60 per cent



modulated frequency-modulation signal will produce a frequency swing of  $0.6 \times 75$  kilocycles, or  $\pm 45$  kilocycles.

**Ques. 4.222.** A frequency-modulation broadcast transmitter is modulated 50 per cent by a 7,000-cycle test tone. When the frequency of the test tone is changed to 5,000 cycles and the percentage of modulation is unchanged, what is the transmitter frequency swing?

*Ans.* Plus or minus 37.5 kilocycles. Since the carrier-frequency swing is independent of the modulating frequency, the frequency swing for 50 per cent modulation will be  $\pm 75$  kilocycles  $\times 0.5 = \pm 37.5$  kilocycles.

**Ques. 4.223.** What is a common method of obtaining frequency modulation in a frequency-modulation broadcast transmitter?

*Ans.* There are two common methods of obtaining frequency modulation in a frequency-modulation transmitter: (1) the Armstrong phase-shift system using balanced modulators and (2) the reactance-tube method. A third system recently developed by the General Electric Co. uses a specially designed type of modulator tube called the "phasitron."

**Ques. 4.224.** What is meant by "preemphasis" in a frequency-modulation broadcast transmitter?

*Ans.* This term is applied to the preamplification of audio frequencies above approximately 2,000 cycles. A special preemphasis circuit is placed in the transmitter audio-frequency channel to reduce the noise effects at the higher audio frequencies. The preemphasis circuit effectively accentuates the higher range of audio frequencies and thereby decreases the over-all transmitted noise-to-signal ratio.

**Ques. 4.225.** What is the purpose of a deemphasis circuit in a frequency-modulation broadcast receiver?

*Ans.* The deemphasis circuit in a frequency-modulation receiver acts as a restorative agent to reduce the amplitude of signals above approximately 2,000 cycles. The combined action of preemphasis at the transmitter and deemphasis at the receiver restores the over-all response of the received energy with a resultant decrease in noise level.

**Ques. 4.226.** A frequency-modulation broadcast transmitter operating on 98.1 megacycles has a reactance-tube modulated oscillator operating on a frequency of 4,905 kilocycles. What is the oscillator frequency swing when the transmitter is modulated 100 per cent by a 2,500-cycle tone?

*Ans.* Plus or minus 3.75 kilocycles.

*Solution:* For 100 per cent modulation the carrier frequency varies from

$$98.1 - 0.075 \text{ megacycles to } 98.1 + 0.075 \text{ megacycles} \\ = 98.025 \text{ to } 98.175 \text{ megacycles.}$$

$$\frac{f(\text{carrier})}{f(\text{oscillator})} = \text{frequency multiplication.}$$

$$\frac{98.1}{4.905} = 20.$$

The oscillator frequency swing will be  $\pm 75/20 = \pm 3.75$  kilocycles.

**Ques. 4.227.** What characteristic of an audio tone determines the percentage of modulation of a frequency-modulation broadcast transmitter?

*Ans.* The amplitude of an audio tone determines the percentage of modulation in frequency-modulation broadcast transmitter.

**Ques. 4.228.** What determines the rate of frequency swing of a frequency-modulation broadcast transmitter?

*Ans.* The rate of frequency swing in a frequency-modulation transmitter is determined by the *audio frequency* applied to the modulating amplifier stage.

**Ques. 4.229.** How wide a frequency band must the intermediate-frequency amplifier of a frequency-modulation broadcast receiver pass?

*Ans.* A band width of 200 kilocycles. The ideal requirement is a maximum over-all flat frequency response of 100 kilocycles above and 100 kilocycles below the frequency-modulation carrier or center frequency.

**Ques. 4.230.** A frequency-modulation broadcast transmitter is modulated 40 per cent by a 5,000-cycle test tone. When the percentage of modulation is doubled, what is the frequency swing of the transmitter?

*Ans.* Plus or minus 60 kilocycles. Doubling the modulation percentage from 40 per cent results in 80 per cent modulation. Since  $\pm 75$  kilocycle swing represents 100 per cent modulation, the swing at 80 per cent modulation is

$$\pm 75 \times 0.8 = 60 \text{ kilocycles.}$$

**Ques. 4.231.** If a frequency-modulation transmitter employs one doubler, one tripler, and one quadrupler, what is the carrier frequency swing when the oscillator frequency swing is 2 kilocycles?

*Ans.* A frequency swing of 48 kilocycles.

$$2 \times 2 \times 3 \times 4 = 48 \text{ kilocycles.}$$

**Ques. 4.232.** What is the purpose of a "reactance tube" in a frequency-modulation broadcast transmitter?

*Ans.* A reactance tube is commonly used as a modulator in frequency-modulation systems. Its basic function is to vary the frequency-modulation oscillator frequency in accordance with the applied audio-frequency tone voltage.

**Ques. 4.233.** At 100 per cent modulation, what is the ratio of unmodulated power output to modulated power output of a frequency-modulation broadcast station?

*Ans.* A ratio of 1:1. In frequency or phase modulation the peak amplitude of the composite signal remains practically constant during the process of modulation. The audio tone frequency is imparted to the carrier by a variation of the phase as a function of time.

**Ques. 4.234.** What is a ratio detector?

*Ans.* Figure 4-20 illustrates two typical detector circuits used in frequency-modulation and television receiver: (a)

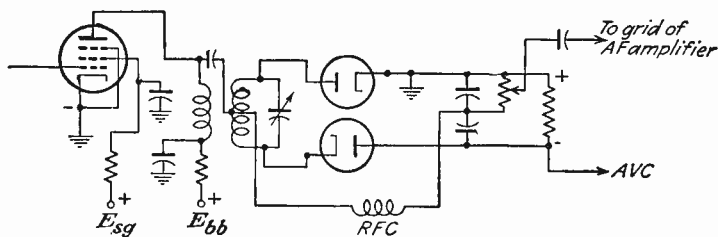
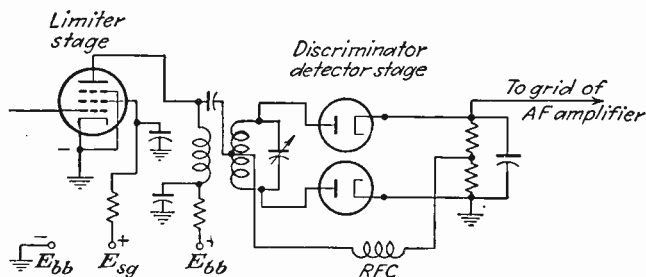

FIG. 4-20.

the discriminator type and (b) the ratio type of detector. In the ratio type of detector, two intermediate-frequency volt-

ages are applied to the diodes, and the sum of the rectified voltage is held constant. The resultant difference in voltage developed across the output load then constitutes the audio-frequency signal. The name "ratio detector" is derived from the fact that this circuit divides the rectified intermediate-frequency stage voltages into two components in such a manner that the ratio of the rectified voltages is proportional to the ratio of the applied intermediate-frequency voltages.

$$\text{Audio-frequency output} = \frac{E_1 - E_2}{2}.$$

**Ques. 4.235.** How does the amount of audio power required to modulate a 1,000-watt frequency-modulation transmitter compare with the amount of audio power required to modulate a 1,000-watt standard broadcast transmitter to the same percentage of modulation?

*Ans.* The audio-frequency power requirements in a frequency-modulation transmitter are small as compared with those in amplitude-modulation systems. This is due to the fact that the modulator tubes serve merely as a device to vary the frequency of the oscillator in step with the audio frequency or tone voltage.

**Ques. 4.236.** What is the purpose of a limiter stage in a frequency-modulation broadcast receiver?

*Ans.* The limiter stage in a frequency-modulation receiver precedes the discriminator and is used to ensure that all variations in the carrier amplitude due to noise and interference are removed and that a carrier of constant amplitude is maintained.

**Ques. 4.237.** If the transmission line current of a frequency-modulation broadcast transmitter is 8.5 amperes without modulation, what is the transmission line current when the percentage of modulation is 90 per cent?

*Ans.* 8.5 amperes. The transmission line current will remain constant during the process of modulation.

**Ques. 4.238.** A frequency-modulation broadcast transmitter has 370 watts plate-power input to the last radio-frequency stage and an antenna field gain of 1.3. The efficiency of the last radio-frequency stage is 65 per cent, and the efficiency of the antenna transmission line is 75 per cent. What is the effective radiated power?

*Ans.* The effective radiated power is approximately 304.83 watts.

*Solution:*

Effective radiated power = output power - losses  
 $\times$  antenna field gain squared.

Power output (operating power) = power input  $\times$  efficiency  
 $= 370 \times 0.65$   
 $= 240.5$  watts.

A transmission-line loss of 25 per cent decreases the power reaching the antenna 60.125 watts or a total of

$$240.5 - 60.125 = 180.375 \text{ watts.}$$

An antenna gain of 1.3 will raise the *effective* radiated power to  $1.3^2 \times 180.375$ , or 304.8337 watts.

**Ques. 4.239.** Draw a diagram of a frequency-modulation broadcast receiver-detector circuit.

*Ans.* Figure 4-20 illustrates two typical frequency-modulation broadcast receiver-detector circuits.

**Ques. 4.240.** Draw a diagram of a means of modulation of a frequency-modulation broadcast station.

Ans. Figure 4-21 illustrates the commonly used reactance tube modulation in frequency-modulation transmitters.

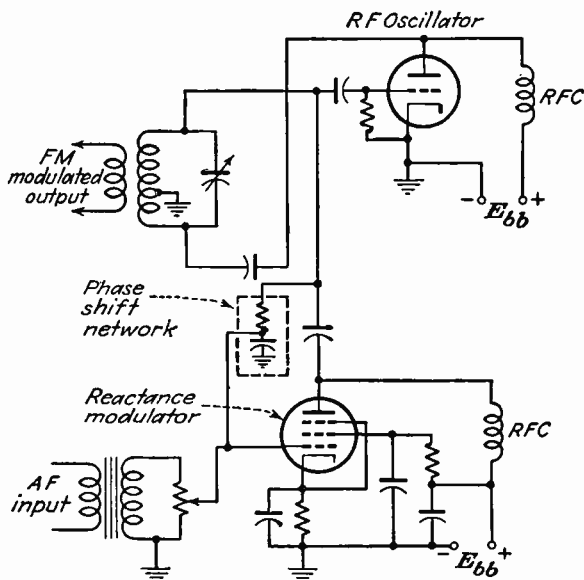

FIG. 4-21.

Ques. 4.241. Draw a diagram of a limiter stage in a frequency-modulation broadcast receiver.

Ans. Figure 4-22 shows a typical limiter stage used in frequency-modulation receivers.

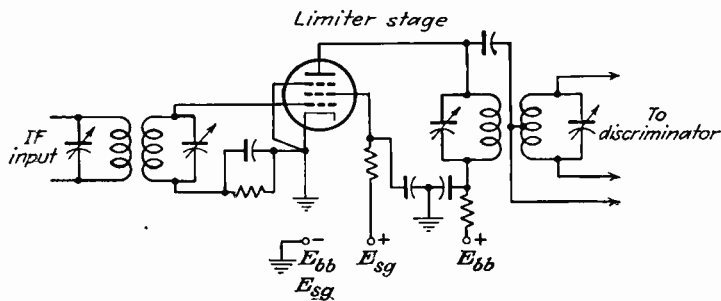

FIG. 4-22.

**Ques. 4.242.** How is the operating power of a frequency-modulation broadcast station determined?

*Ans.* The operating power of frequency-modulation broadcast stations shall be determined by the indirect method. This is the product of the plate voltage ( $E_b$ ) and the plate current ( $I_b$ ) of the final radio-frequency stage, and the efficiency. The efficiency is defined by the FCC as a factor  $F$ , which shall be established by the specific transmitter manufacturer.

$$\text{Operating power} = E_b \times I_b \times F.$$

The  $F$  factor is generally in the vicinity of 65 per cent.

**Ques. 4.243.** If a frequency-modulation broadcast station used a total of five tubes of a given type at the transmitter, what is the minimum number of spare tubes of this type required at the transmitter?

*Ans.* A minimum of two will be required. The spare tube requirements specified by the FCC are as follows:

No. Employed	Spares Required
1 or 2	1
3 to 5	2
6 to 8	3
9 or more	4

**Ques. 4.244.** What is the required frequency range of the indicating device on the frequency monitor at a frequency-modulation broadcast station?

*Ans.* The range of the indicating device on a frequency-modulation frequency monitor shall be at least from 2,000 cycles below to 2,000 cycles above the assigned center frequency.

**Ques. 4.245.** What is the audio-frequency range that a frequency-modulation broadcast station is required to be capable of transmitting?

*Ans.* From 50 to 15,000 cycles per second.



**Ques. 4.246.** How wide is a frequency-modulation broadcast channel?

*Ans.* The total band width of a frequency-channel is 200 kilocycles. Channels for frequency-modulation broadcast stations begin at 88.1 megacycles and continue in successive steps of 200 kilocycles to and including 107.9 megacycles.

**Ques. 4.247.** What frequency swing is defined as 100 per cent modulation for a frequency-modulation broadcast station?

*Ans.* A frequency swing of  $\pm 75$  kilocycles is defined as 100 per cent modulation in a frequency-modulation broadcast transmitter.

**Ques. 4.248.** What is the tolerance in operating power of frequency-modulation broadcast stations?

*Ans.* The operating power tolerances in a frequency-modulation broadcast station are as follows:

Standard Power Rating	Operating Power Tolerances
250 watts	250 watts or less
1 kw	250 watts to 1 kw
3 kw	1 to 3 kw
10 kw	3 to 10 kw
25 kw	10 to 25 kw
50 kw	10 to 50 kw
100 kw	50 to 100 kw

The operating power tolerance according to FCC standards is +5 per cent - 10 per cent.

**Ques. 4.249.** What is the meaning of the term "center frequency" in reference to frequency-modulation broadcasting?

*Ans.* Center frequency is referred to in frequency-modulation broadcasting as the assigned unmodulated radio-frequency wave. It is analogous to the unmodulated carrier frequency in amplitude-modulated transmitters. It may also

be defined as the "average frequency" of the emitted wave when modulated by a sinusoidal signal.

**Ques. 4.250.** Exclusive of monitors, what indicating instruments are required in the transmitting system at a frequency-modulation broadcast station?

*Ans.* Accurate indicating instruments to measure plate voltage, plate current, transmission-line currents, and antenna currents. Recording instruments for plotting plate-current and plate-voltage graphs are sometimes used. The indicating instruments required to fulfill the above conditions are as follows:

- Alternating-current and direct-current voltmeters.
- Alternating-current and direct-current ammeters.
- Direct-current milliammeters.
- Radio-frequency ammeters (thermocoupled types).

**Ques. 4.251.** What is the required accuracy of instruments indicating the plate current and the plate voltage of the last radio stage or the transmission line current or voltage at a frequency-modulation broadcast station?

*Ans.* Instruments indicating transmission line current or voltage shall meet the following specifications:

1. Instruments having linear scales shall meet the requirements specified in Ques. 4.215 and 4.217.
2. Instruments having logarithmic or square-law scales shall meet the following requirements:
  - a. The length of the scale shall be not less than  $2\frac{3}{10}$  inches for linear scale instruments.
  - b. Accuracy shall be at least 2 per cent of the full-scale reading for linear scale instruments.
  - c. No scale division above one-third full-scale reading (in amperes) shall be greater than one-thirtieth of the full-scale reading.

3. Radio-frequency instruments having expanded scales.
- a. Length of the scale shall not be less than  $2\frac{3}{10}$  inches for linear scale instruments.
  - b. Accuracy shall be at least 2 per cent of the full-scale reading for linear scale instruments.
  - c. Full-scale reading shall not be greater than five times the minimum normal indication for linear scale instruments.
  - d. No scale division above one-fifth full-scale reading (in amperes) shall be greater than one-fiftieth of the full-scale reading.
  - e. The meter face shall be marked with the words "expanded scale" or the abbreviation thereof (E.S.).

**Ques. 4.252.** What is the frequency tolerance of a frequency-modulation broadcast station?

*Ans.* A frequency tolerance of  $\pm 2,000$  cycles of the assigned center frequency is allowed.

**Ques. 4.253.** What is the meaning of the term "frequency swing" in reference to frequency-modulation broadcast stations?

*Ans.* "Frequency swing" is the term applied to the instantaneous departure of the frequency of the transmitted wave from the center frequency during the process of modulation.

**Ques. 4.254.** Why is a scanning technique known as "interlacing" used in television broadcasting?

*Ans.* Interlaced scanning is universally employed in standard television broadcasting to reduce the *flicker* effect caused by the persistence of vision. This system of scanning may be summarized briefly as a method in which the picture-repetition rate is either mechanically or electronically doubled. Technically, the term "interlaced scanning" is defined as a process of scanning in which successively scanned lines are spaced an integral number of line widths and in which the adjacent lines

are scanned during successive cycles of the field scanning frequency.

**Ques. 4.255.** Does the video transmitter at a television broadcast station employ frequency or amplitude modulation?

*Ans.* Amplitude modulation.

**Ques. 4.256.** Does the sound transmitter at a television broadcast station employ frequency or amplitude modulation?

*Ans.* Frequency modulation.

**Ques. 4.257.** What is a monitor picture tube at a television broadcast station?

*Ans.* The monitor picture tube is an image-reproducer cathode-ray tube generally used in conjunction with a cathode-ray oscilloscope. This combination is connected at the output circuit of the transmitter video line amplifier and also at the output of the studio control booth. The monitor permits a critical analysis of picture faults at several points between the picture transmitter and the various camera chains.

**Ques. 4.258.** Describe scanning as used by television broadcast stations. Describe the manner in which the scanning beam moves across the picture in the receiver.

*Ans.* Scanning in modern television is the process of analyzing successively the light values of picture elements constituting the total picture area.

In modern television stations the scanning of an image is obtained by an electronic process in which a narrow circular beam of electrons in a specially designed cathode-ray tube (iconoscope or image orthicon) is projected against a photo-sensitive screen within the tube. This beam is deflected back and forth across the screen in horizontal motion by electromagnetic coils around the neck of the tube controlled by a current variation which is in the form of a saw-tooth-shaped

wave. As the wave rises diagonally on the time base axis, the beam sweeps across the face of the tube almost horizontally from top left to right. When the peak of the saw tooth is reached, the beam reaches the extreme right of the screen and completes one scanning line. Now as the peak of the saw-tooth wave is reached, it will drop sharply to the zero axis of the time base and cause the beam to retrace back to the top left-hand portion of the picture screen but slightly below the first scanning line by a width separation of one line. As the wave again rises diagonally on the time base axis, the beam sweeps across the face of the tube parallel with the first beam trace. This process continues to the bottom of the picture at which time its positioning is again directed to the top of the picture. The return of the beam to the top, however, is now directed to a position in between the first and second lines. This is referred to as "interlaced scanning" or the process in which successively scanned lines are spaced an integral number of line widths and in which adjacent lines are scanned during successive cycles of the field-scanning frequency.

Thus, when a suitably illuminated image is passed through the optical lines of the camera tube to the photosensitive screen inside the tube, the photoelectric effect transforms the optical image into an electrical image corresponding to the light changes impressed upon the sensitive element of the tube.

The scanning beam in the receiver image-reproducing tube is caused to move in the same manner as and in proper time relation with the beam of electrons in the camera tube in the transmitting studio. The beam moves across the face of the tube from left to right almost horizontally with a slight vertical tilt in a downward direction in two series of alternate or interlaced lines. Each set of lines is referred to as the "field" frequency, and the total series as the "frame" frequency.

The total number of scanning lines has been standardized at 525 lines, interlaced 2 to 1. The frame frequency shall be 30 per second, and the field frequency 60 per second.

**Ques. 4.259.** What is a mosaic plate in a television camera?

*Ans.* The mosaic in the camera tube on which the image is focused takes the place of the film in the ordinary camera. The mosaic plate in a television camera tube usually consists of a sheet of mica on one side of which a large number of photo-electric-producing chemicals have been deposited and the other side of which is a conducting metallic film.

When the mosaic particles are illuminated, electrons will be emitted in an amount depending upon the degree of illumination. This leaves an excess of positive charges on the mosaic particles, which will vary in accordance with the degree of illumination. Thus, when the narrow circular electron beam from the hot cathode of the camera tube strikes the screen, a change in voltage results at this point between each mosaic particle and the metallic plate.

**Ques. 4.260.** What is the purpose of synchronizing pulses in a television broadcast signal?

*Ans.* Synchronizing pulses are used to maintain the proper time relationship of the scanning process between the transmitter and the receiver. These pulses are sent out by the transmitter as an integral part of the video carrier frequency between successive scanning lines and fields.

A horizontal pulse is sent out at the end of each scanning line to restore the beam to the left side of the screen, and a vertical pulse is sent out at the end of each field scan to return the beam to the top of the screen.

**Ques. 4.261.** What is the effective radiated power of a television broadcast station if the output of the transmitter is 1,000 watts, antenna transmission-line loss is 50 watts, and the antenna power gain is 3?

*Ans.* 2,850 watts.

*Solution:*

Effective radiated power = power output - losses  $\times$  antenna  
power gain.  
 $(1,000 - 50) \times 3 = 2,850$  watts or 2.85 kilowatts.

**Ques. 4.262.** Besides the camera signal, what other signals and pulses are included in a complete television broadcast signal?

*Ans.* 1. Frequency-modulation sound carrier and side bands.

2. Video carrier frequency.
3. Horizontal synchronizing pulses.
4. Vertical synchronizing pulses.
5. Horizontal blanking pulses.
6. Vertical blanking pulses.
7. Equalizing pulses.

**Ques. 4.263.** What are synchronizing pulses in a television broadcasting and receiving system?

*Ans.* Synchronizing pulses are short, accurately timed pulses employed for controlling the local scanning generator at the transmitter and receivers, thereby establishing the proper position of the scanning beam.

**Ques. 4.264.** What are blanking pulses in a television broadcasting and receiving system?

*Ans.* Blanking pulses developed by the synchronizing generator in a television system are pulses used for the purpose of cutting off the electron beam at the transmitter and the receiver during the horizontal and vertical retrace periods. Hence the blanking pulses are transmitted along with the video signal in order that the beam in the image-reproducer tube is cut off simultaneously with that in the camera tube.

**Ques. 4.265.** For what purpose is a voltage of saw-tooth wave form used in a television broadcast receiver?

*Ans.* A saw-tooth wave is generated to produce the sweep and retrace of the electron beam in the cathode-ray reproducing tube. It produces a linear motion of the scanning beam.

**Ques. 4.266.** In television broadcasting, what is the meaning of the term "aspect ratio"?

*Ans.* The numerical ratio of the frame width to the frame height as transmitted (4:3).

**Ques. 4.267.** How many frames per second do television broadcast stations transmit?

*Ans.* Thirty complete frames or pictures per second.

**Ques. 4.268.** In television broadcasting, why is the field frequency made equal to the frequency of the commercial power supply?

*Ans.* To permit the picture-repetition or frame frequency to coincide accurately with the 60- or 120-cycle ripple frequency developed by the rectified power supply. This is of particular importance, since the scanning and synchronizing circuits of a television system are controlled by the rectified power supply. Hence if some ripple frequency is present due to inadequate filtering, no difficulty will be experienced, since the field frequency and the power frequency coincide at every cycle. Thus, the ripple will not drift across the screen.

**Ques. 4.269.** If the cathode-ray tube in a television receiver is replaced by a larger tube such that the size of the picture is changed from 4 by 3 inches to 8 by 6 inches, what change if any is made in the number of scanning lines per frame?

*Ans.* No change.



**Ques. 4.270.** If a television broadcast station transmits the video signals in channel No. 6 (82 to 88 megacycles), what is the center frequency of the aural transmitter?

*Ans.* 87.75 megacycles. Transmission standards specify that the aural center frequency shall be located 0.25 megacycle lower than the upper frequency limit of the channel.

**Ques. 4.271.** What is the field frequency of a television broadcast transmitter?

*Ans.* The field frequency is the number of times per second the frame or picture area is fractionally scanned by the interlaced scanning method. The field frequency in modern television has been standardized at 60 per second and represents the scanning time of half the number of total lines ( $262\frac{1}{2}$ ).

**Ques. 4.272.** How is the operating power of the aural transmitter of a television broadcast station determined?

*Ans.* The operating power of an aural transmitter is determined by the indirect method.

$$\text{Operating power} = E_b \times I_b \times \text{efficiency.}$$

**Ques. 4.273.** Numerically, what is the aspect ratio of a picture as transmitted by a television broadcast station?

*Ans.* The aspect ratio of the transmitted picture shall be four units horizontally to three units vertically.

**Ques. 4.274.** What is meant by "vestigial side-band transmission" of a television broadcast station?

*Ans.* This term refers to a system of side-band transmission in which one of the generated side bands is partly attenuated at the transmitter and radiated only in part.

**Ques. 4.275.** What is the frequency tolerance of television broadcast transmitters?

*Ans.* The carrier-frequency tolerances for both visual and aural transmitters shall be automatically maintained to within  $\pm 0.002$  per cent of the assigned frequency.

**Ques. 4.276.** What is meant by "antenna field gain" of a television broadcast antenna?

*Ans.* Antenna field gain of a television antenna is defined as the ratio of the effective free-space field intensity produced at 1 mile in the horizontal plane expressed in millivolts per meter for a 1-kilowatt antenna input power to 137.6 millivolts per meter.

**Ques. 4.277.** How wide is a television broadcast channel?

*Ans.* A total band width of 6 megacycles per second.

**Ques. 4.278.** If standard broadcast emissions are classified as A3 emission, what is the classification of television broadcast video emissions?

*Ans.* Television broadcast emissions are classified as type A5. (See also Ques. 3.164.)

**Ques. 4.279.** What is the range of audio frequencies that the aural transmitter of a television broadcast station is required to be capable of transmitting?

*Ans.* A band of audio frequencies from 50 to 15,000 cycles.

**Ques. 4.280.** What is meant by 100 per cent modulation of the aural transmitter at a television broadcast station?

*Ans.* A frequency swing of  $\pm 25$  kilocycles is considered 100 per cent modulation.

**Ques. 4.281.** What is the frequency tolerance of a studio-to-transmitter broadcast station?

*Ans.* A studio-to-transmitter (S.T.) broadcast station requires a frequency tolerance of within 0.01 per cent of the

assigned frequency or 0.05 per cent if the station operates above 450 megacycles. The maximum frequency swing shall not be in excess of  $\pm 200$  kilocycles.

**Ques. 4.282.** What are the radio operator requirements of the person on duty at an experimental television broadcast station?

*Ans.* One or more radio operators holding radiotelephone first-class or radiotelephone second-class operator licenses shall be on duty at the place where the transmitting apparatus of any experimental television broadcast station is located and in actual charge of its operation. The licensed operator on duty and in charge of a broadcast transmitter may, at the discretion of the licensee, be employed for other duties or for the operation of another station or stations in accordance with the class of operator's license which he holds and the rules and regulations governing such stations. However, such duties shall in no wise interfere with the operation of the broadcast transmitter.

**Ques. 4.283.** What type of antenna is required at a studio-to-transmitter broadcast station?

*Ans.* A directive antenna. The antenna for both the transmitter and receiver is generally a dipole-fed parabolic reflector. For a frequency-modulation frequency range of 920 to 960 megacycles the parabola is approximately 40 inches in width.

**Ques. 4.284.** What is the frequency tolerance of a noncommercial educational frequency-modulation broadcast station?

*Ans.* Automatic means shall be provided to maintain the assigned center frequency within 2,000 cycles.

## ELEMENT 5

### RADIOTELEGRAPH

**Ques. 5.01.** What is the meaning of ampere turns?

*Ans.* The magnetomotive force produced by the flow of an electric current in a coil is proportional to the total quantity of charge circling the coil in one second. Thus, it is proportional to the product of the current in each turn and the total number of turns in the coil. The magnetomotive force can be conveniently expressed in ampere turns which are computed by the formula,

$$\text{ampere turns} = N \times I$$

where  $N$  is the number of turns and  $I$  the current flowing.

**Ques. 5.02.** What is the meaning of "electrolyte"? List four types of radio equipment in which it may be used.

*Ans.* "Electrolyte" may be defined as an acid or alkaline solution. Electrolyte is used in the following types of radio equipment:

1. Storage battery.
2. Electrolytic condenser.
3. Electrolytic rectifier.
4. Electrolytic interrupter.
5. Electrolytic detector.

**Ques. 5.03.** Name at least five pieces of radio equipment which make use of electromagnets.

*Ans.* Electromagnets are used in the following pieces of radio equipment:

1. Overload and underload circuit breakers.

2. Headphones.
3. Relays.
4. Meters.
5. Motors.
6. Generators.
7. Loud-speakers.

**Ques. 5.04.** How many watts equal 1 horsepower?

*Ans.* 746 watts.

**Ques. 5.05.** What is the meaning of "residual magnetism"?

*Ans.* The magnetism which still remains in temporary magnets after the magnetizing current has been removed.

**Ques. 5.06.** If two 10-watt 500-ohm resistors are connected in series, what is the total power-dissipation capability?

*Ans.* Each resistance has a capability of 10 watts dissipation, thus the total power-dissipation capability will be 20 watts.

**Ques. 5.07.** A milliammeter with a full-scale deflection of one milliamperere and having an internal resistance of 25 ohms is used to measure an unknown current, by shunting it with a 4-ohm resistance. When the meter reads 0.4 milliamperes, what is the actual value of current?

*Ans.*  $I = 2.9$  milliamperes, or 0.0029 ampere. (See Ques. 2.49 for details.)

*Solution:*

$$I = I_M \left( 1 + \frac{R_M}{R_S} \right) = 0.4 \left( 1 + \frac{25}{4} \right) = 2.9 \text{ milliamperes}$$

where  $I_M$  = meter reading,  $R_M$  = resistance of the meter,  $R_S$  = resistance of the shunt.

**Ques. 5.08.** If two 10-watt 500-ohm resistors are connected in parallel, what is the total power-dissipation capability?

*Ans.* The total power-dissipation capability will be 20 watts.

**Ques. 5.09.** What is the maximum current-carrying capacity of a resistor marked "5,000 ohms, 200 watts"?

*Ans.*

$$I = \sqrt{\frac{P}{R}} = 0.2 \text{ ampere.}$$

**Ques. 5.10.** What factors determine the heat generated in a conductor carrying an electric current?

*Ans.* The current-flow-squared value and the resistance.  
 $P = I^2R$  watts.

**Ques. 5.11.** Two resistances of 18 and 15 ohms are connected in parallel; in series with this combination is connected a 36-ohm resistance; in parallel with this total combination is connected a 22-ohm resistance. The total current flowing through the combination is 5 amperes. What is the current value in the 15-ohm resistance?

*Ans.* The current flow through the 15-ohm resistance will be 0.9+ amperes. To solve this problem by simple arithmetic and Ohm's law proceed as follows:

1. Reduce the parallel combination of the 15- and 18-ohm resistances to the effective resistance,

$$R_{\text{eff}} = \frac{R \times R}{R + R} = 8.18+ \text{ ohms.}$$

2. Add the effective resistance to the 36-ohm series resistance, 44.18 ohms.

3. Obtain the total effective resistance of the 44.18-ohm and the 22-ohm parallel combination,

$$R_{\text{eff}} = \frac{R \times R}{R + R} = 14.68 + \text{ ohms.}$$

4. Determine the applied voltage across the entire combination,  $E_a = IR = 5 \times 14.68 = 73.4$  volts.

5. Find the current flow through the 22-ohm resistance,  $I = \frac{E}{R} = 3.341$  amperes.

6. Find the current through the remaining branch,

$$5 - 3.341 = 1.659 \text{ amperes.}$$

7. Find the voltage developed across the 15- and 18-ohm effective combination of  $8.18 +$  ohms,

$$E = IR = 1.659 \times 8.18 + = 13 + \text{ volts.}$$

8. Thus the current through the 15-ohm resistance is found

$$I = \frac{E}{R} = \frac{13 +}{15} = 0.9 + \text{ ampere.}$$

**Ques. 5.12.** What method is used to obtain more than one voltage value from a fixed-voltage direct-current source?

*Ans.* By the use of a voltage-divider resistance or potentiometer.

**Ques. 5.13.** Two resistors are connected in series. The current through these resistors is 3 amperes. Resistance 1 has a value of 50 ohms; resistance 2 has a voltage drop of 50 volts across its terminals. What is the total impressed e.m.f.?

*Ans.* The total impressed e.m.f. is 200 volts. The current through the 50-ohm resistor is  $I \frac{E}{R}$  or,  $E = IR = 3 \times 50 = 150$  volts. Since a 50-volt drop is known to be present across resistance 2, the total or impressed e.m.f. must be the sum of the two  $IR$  drops or 200 volts.

**Ques. 5.14.** A circuit is passing a current of 3 amperes. The internal resistance of the source is 2 ohms. The total external resistance is 50 ohms. What is the terminal voltage of the source?

*Ans.* The terminal voltage of a source is always less than the open circuited voltage by an amount  $I \times R$  (internal resistance). Thus the terminal voltage in this circuit is 150 volts. Proof:  $E = IR = 3 \times 50 = 150$  volts.

**Ques. 5.15.** A 10,000-ohm 100-watt resistor, a 40,000-ohm 50-watt resistor, and a 5,000-ohm 10-watt resistor are connected in parallel. What is the maximum value of total current through this combination which will not exceed the wattage rating of any of the resistors?

*Ans.* The maximum value of current flow through this combination is 0.07 ampere. The power dissipated in each resistance,  $\frac{E^2}{R}$ , must not exceed the rating of the resistance.

Since all of the resistances are in parallel, it is obvious that the calculations are based upon the 5,000-ohm 10-watt resistor. Hence, we must determine what value of current flow through this resistor will not exceed 10 watts of power dissipation. Thus, we find the current value through this resistance by the equation,  $I = \sqrt{\frac{P}{R}} = \sqrt{\frac{10}{5,000}} = 0.0447$  ampere.

*Proof:*

$$P = I^2 \times R = 0.0447^2 \times 5,000 = 10 \text{ watts.}$$

The applied voltage may now readily be determined,

$$E_a = I \times R = 0.0447 \times 5,000 = 223.5 \text{ volts}$$

and 
$$P = \frac{E^2}{R} = \frac{50,000}{5,000} = 10 \text{ watts.}$$

The current flow through each of the remaining resistors is then obtained by Ohm's law,



$$I_2 = \frac{223.5}{40,000} \text{ amperes} \quad \text{and} \quad I_1 = \frac{223.5}{10,000} \text{ amperes.}$$

The sum of all the branch currents is, therefore, the total current, or 0.07 ampere.

**Ques. 5.16.** What is the ratio of peak to effective voltage values of a sine wave?

*Ans.* The ratio is  $\frac{1}{0.707} = 1.414:1$ .

**Ques. 5.17.** If a direct-current voltmeter is used to measure effective alternating voltages by the use of a bridge-type full-wave rectifier of negligible resistance, by what factor must the meter readings be multiplied to give corrected readings?

*Ans.* The meter reading must be multiplied by 1.11 to obtain corrected readings.

**Ques. 5.18.** By what factor must the voltage of an alternating-current circuit, as indicated on the scale of an alternating-current voltmeter, be multiplied in order to obtain the average voltage value?

*Ans.* Since the meter reading is an effective value indication it will be necessary to multiply the scale reading by 0.9 in order to obtain average values.

$$E_{av} = E_{eff} \times 0.9.$$

**Ques. 5.19.** By what factor must the voltage of an alternating-current circuit, as indicated on the scale of an alternating-current voltmeter, be multiplied in order to obtain the peak value?

*Ans.* The meter reading must be multiplied by 1.414 to obtain peak values.

**Ques. 5.20.** What is the ratio of peak to average value of a voltage sine wave?

*Ans.* The ratio is  $\frac{1}{0.637} = 1.57:1$ .

**Ques. 5.21.** What is the meaning of the term "phase difference"?

*Ans.* Phase difference is a measure of the time displacement of one sine wave from another at the same frequency. It is usually expressed in electrical degrees, of which there are 360 in each sinusoidal cycle.

**Ques. 5.22.** What is the meaning of the term "leading power factor"?

*Ans.* The power in an alternating-current circuit is equal to the product of voltage and current and the cosine of the angle between them. Power factor is the cosine of the phase angle expressed in per cent. The cosine of the angle is equal to the ratio of the resistance of the impedance  $R/Z$ . A "leading power factor" is an expression of that condition in an alternating-current circuit where capacitive reactance predominates since the current in that type of circuit is leading the voltage between zero and 90 degrees. (See also Ques. 2.34 and 3.05 for practical formulas.)

**Ques. 5.23.** The product of the readings of an alternating-current voltmeter and ammeter in an alternating-current circuit is called what?

*Ans.* This product is referred to as the "apparent power" or "volt-amperes."

**Ques. 5.24.** In what units is the alternator output ordinarily rated?

*Ans.* Preferably in volt-amperes, but radio manufacturers invariably rate output in watts.

**Ques. 5.25.** Define "power factor."

*Ans.* (See Ques. 2.34, 3.05, and 5.22.)

**Ques. 5.26.** What is the total inductance of two inductance coils, connected in series, but without any mutual coupling?

*Ans.*  $L_{\text{eff}} = L_1 + L_2 \pm 2M$ . In this case, therefore, the total inductance is the sum of the two inductances expressed in henrys.

**Ques. 5.27.** What is the total inductance of two inductances connected in parallel but without any mutual coupling?

*Ans.* When the coils are so far apart that mutual inductances are negligible, inductances in parallel are combined like resistances in parallel.

**Ques. 5.28.** A series inductance, acting alone in an alternating-current circuit has what properties?

*Ans.* It has the properties of generating a counter e.m.f., developing kinetic energy, and causing the current to lag behind the voltage by 90 degrees. It acts as an alternating-current resistance and is known as inductive reactance,  $X_L$ . The reactance value varies directly with frequency. The series inductance also has a smoothing effect on circuit variations and tends to improve the regulation.

**Ques. 5.29.** What is the total reactance of a series alternating-current circuit containing no resistance, and an equal value of inductive and capacitive reactance?

*Ans.* The total reactance is zero.

**Ques. 5.30.** What is meant by the "flywheel" effect of a tank circuit?

*Ans.* The circuit inertia set up by the kinetic energy of the inductance tending to keep the circuit oscillating. The condenser discharges through the inductance and the energy developed by the inductance in the collapsing field recharges the condenser in the opposite direction.

**Ques. 5.31.** What may be the effects of shielding applied to radio-frequency inductances?

*Ans.* The inductance of the coil decreases. The capacity of the coil increases. The  $Q$  of the coil decreases.

**Ques. 5.32.** What is the effect on the resonant frequency of connecting a capacitance in series with an antenna?

*Ans.* The effective capacity of the entire antenna system is reduced. The resonant frequency increases as the capacitive reactance increases, *i.e.*; as the size of the series capacitance is reduced.

**Ques. 5.33.** What is the total impedance of a capacitance and inductance having equal values of reactance, when connected in parallel?

*Ans.* The total reactance will be zero, and the impedance infinite, looking in.

**Ques. 5.34.** What factors determine the efficiency of a power transformer?

*Ans.* The core structure, the character of the core material, the size of the wire used, and flux leakage. The amount of loading.

**Ques. 5.35.** What factors determine the no-load voltage ratio of a power transformer?

*Ans.* The turns ratio  $N$ :

$$N = \frac{E_P}{E_S} = \frac{N_P}{N_S}$$

$$E_S = \frac{N_S}{N_P} \times E_P$$

**Ques. 5.36.** What factors determine the current ratios of primary and secondary in a power transformer?

*Ans.* The currents in the primary and the secondary of a power transformer are approximately in the inverse ratio of the corresponding turns.

$$\frac{I_P}{I_S} = \frac{N_S}{N_P}$$

The size of wire also affects the current ratio.

**Ques. 5.37.** A radio receiver has a power transformer and rectifier designed to supply plate voltage to the vacuum tubes at 250 volts when operating from a 110-volt 60-cycle supply. What will be the effect if this transformer primary is connected to a 110-volt direct-current source?

*Ans.* The primary winding will seriously overheat and burn unless adequately protected by fuses.

**Ques. 5.38.** What is the relationship between the turns ratio and the impedance ratio of the windings of a transformer?

*Ans.*

$$\text{Turns ratio} = \sqrt{\frac{Z_P}{Z_S}}$$

$Z_P$  = primary impedance.

$Z_S$  = secondary impedance.

**Ques. 5.39.** Why should the cathode of an indirectly heated type of vacuum tube be maintained at nearly the same potential as the heater circuit?

*Ans.* To prevent cathode leakage which might be caused by voltage breakdown between the cathode and the filament. Also to reduce stray fields existing between the cathode and the filament.

**Ques. 5.40.** Why is it impractical to reactivate oxide-coated filaments?

*Ans.* Because the oxide coating is nearly all on the surface of the filament. The reactivation process here applied would merely decrease the degree of oxide.

**Ques. 5.41.** What types of vacuum-tube emitting surfaces respond to the reactivation?

*Ans.* Thoriated-tungsten filaments.

**Ques. 5.42.** Describe how reactivation may be accomplished?

*Ans.* The filament is subjected to a momentary voltage surge of a higher value than the normal operating voltage and then to a slightly lower voltage, but for a longer period of time. It is important that the plate potential be disconnected during this operation. (See also Ques. 3.186.)

**Ques. 5.43.** Is a tungsten filament operated at a higher or lower temperature than a thoriated filament? Why?

*Ans.* The tungsten filament is operated at a higher filament temperature because the electron emission characteristic is considerably lower.

**Ques. 5.44.** What is indicated when a blue glow is noticed within a vacuum-tube envelope?

*Ans.* If the glow occurs between the plate and filament elements this indicates the presence of gas.

**Ques. 5.45.** What is the function of the grid leak in a grid-leak type of detector?

*Ans.* In a grid-leak type of detector, the grid and cathode act as a diode rectifier. The grid leak serves as a load resistance across which the modulation (signal) voltage is developed and applied to the grid of the tube which then operates as an audio-frequency amplifier. Operating bias is developed automatically by rectification of the signal and is zero in the absence of the signal. Since for small signals the bias is small, the  $g_m$  of the tube is maximum and the gain of the stage is high.

**Ques. 5.46.** What effect does an incoming signal have upon the plate current of a grid-leak type detector vacuum tube?

*Ans.* The automatic bias action decreases the plate current.

**Ques. 5.47.** What effect does an incoming signal have upon the value of plate current of a power detector tube?

*Ans.* The plate current rises during the signal periods.

**Ques. 5.48.** Why is it sometimes necessary to provide a radio-frequency filter in the plate circuit of a detector tube?

*Ans.* To by-pass the plate radio-frequency variations around the high impedance of the audio-transformer primary or headphones. This filter may be used to peak the 500-cycle audio beat note by effecting a parallel resonant condition.

**Ques. 5.49.** Explain how power detection is accomplished?

*Ans.* Power detection, or more accurately, linear detection, is accomplished by operating the detector tube with a large value of grid bias almost to the point of plate-current cut-off. The plate voltage is of a considerably higher value than normal. The name "power detection" is used because it generally operates with large applied signal voltages.

**Ques. 5.50.** Explain how grid-leak detection is accomplished.

*Ans.* Grid-leak detection is accomplished by the insertion of a grid condenser and shunt resistance connected in series with the grid. Operating bias is developed across the grid resistance by the flow of rectified grid current.

**Ques. 5.51.** Explain how diode detection is accomplished?

*Ans.* Diode detection is accomplished by using either a triode type or special diode type of tube. In the case of the former, the grid is used as the diode element while the plate is

connected to cathode or ground. The grid is then connected to one end of the radio-frequency input transformer while the other end of the transformer is connected through a high resistance (500,000 ohms) to the cathode of the tube. A small radio-frequency by-pass condenser of approximately 0.0001 microfarad is connected in shunt with the resistance. The audio-frequency voltage developed across the resistance by rectification is then applied to the grid of an audio-frequency amplifier tube. With the diode type of tube the diode plate or plates are connected together and then connected as the grid was in the preceding explanation.

**Ques. 5.52.** What is the principal advantage of transformer coupling compared to resistance coupling, as used in audio-frequency amplifiers?

*Ans.* Higher amplification may be obtained owing to the primary-to-secondary step-up ratios. Voltage step-up ratios with transformers range between 1:1.5 to 1:10. Resistance ratios are 1:1.

**Ques. 5.53.** Why is it necessary to use two tubes in class B audio amplification?

*Ans.* Since this type of amplifier operates at cut-off, a single tube would amplify only one-half of the signal cycle and serious distortion would result. Two tubes complete the cycle.

**Ques. 5.54.** What are the advantages of push-pull amplification as compared to single-ended amplification?

*Ans.* Push-pull amplification reduces harmonic distortion caused by the second harmonic, reduces hum, eliminates core saturation, and develops a more symmetrical reproduction of the input wave form than the single-ended amplifier.



**Ques. 5.55.** Why is it not feasible to employ a vacuum-tube operated class C as an audio amplifier, either singly or in push-pull?

*Ans.* Because there is too much distortion present in the output of the class C amplifier to make it feasible for use on audio frequencies. Hence, class C amplifiers are used primarily in the amplification of the unmodulated radio-frequency carrier wave in radio transmitters. Note that in radio-frequency circuits a tank circuit is available to minimize distortion.

**Ques. 5.56.** Why is an audio transformer seldom employed as the output device to be used in the plate circuit of a tetrode audio-amplifier stage?

*Ans.* The plate impedance of a tetrode ranges between 300,000 and 1,000,000 ohms. To satisfy load conditions, the transformer would require a primary inductance value of 300 to 500 or more henrys. This would necessitate a transformer with large physical dimension as well as one difficult to construct with a flat-frequency response. Another reason is that the tetrode possesses a large voltage amplification factor and, therefore, does not require large output step-up ratios.

**Ques. 5.57.** If a final radio-frequency amplifier, operated as class B linear, were excited to saturation with no modulation, what would be the effects when undergoing modulation?

*Ans.* The amplifier plate current would be unable to increase as it should on modulation peaks but would decrease on the troughs. This would result in serious audio-frequency distortion and a downward deflection of the plate current meter.

**Ques. 5.58.** Under what class of amplification are the vacuum tubes in a linear radio-frequency stage, following the modulated stage, operated?

*Ans.* Class B.

**Ques. 5.59.** What class of amplifier should be employed in the final amplifier stage of a radiotelegraph transmitter for maximum plate efficiency?

*Ans.* Class C.

**Ques. 5.60.** Discuss the effects of insufficient radio-frequency excitation on a class C modulated radio-frequency amplifier insofar as the output signal wave form is concerned.

*Ans.* The negative peaks of the modulation envelope will be flattened. A positive carrier shift will result.

**Ques. 5.61.** What factors are most important in the operation of the vacuum tube as a frequency doubler?

*Ans.* The most important factors are:

1. Very large value of grid-bias adjustment.
2. High plate voltages.
3. High radio-frequency voltage excitation.
4. Low C-tank circuit value.
5. Proper adjustment of the doubler plate circuit to the harmonic of the frequency applied to its grid.

**Ques. 5.62.** What is the primary purpose of the suppressor grid of a pentode?

*Ans.* To reduce *secondary emission* and improve the linearity of the plate characteristics.

**Ques. 5.63.** What is the primary purpose of the screen grid of a tetrode?

*Ans.* The primary purpose is to act as an electrostatic shield. It serves to reduce the interelectrode grid-plate capacity and raise the electron acceleration to the plate. Greater plate resistance and increased circuit stability are resultant contributing factors.

**Ques. 5.64.** What is the primary purpose of the control grid of a triode?

*Ans.* The control grid provides a means by which the signal voltage can vary the plate current while drawing little or no current from the signal source.

**Ques. 5.65.** A triode transmitting tube, operating with a plate voltage of 1,250 volts, has a filament voltage of 10, filament current of 3.25 amperes, and a plate current of 150 milliamperes. The amplification factor is 25. What value of control grid bias must be used for operation as a class C amplifier?

*Ans.* A grid bias of approximately -125 volts. For class C amplification the ratio  $\frac{E_p}{\mu} \times 2.5$  may be used for determining grid bias with fairly accurate results.

**Ques. 5.66.** Name four materials which can be used as crystal detectors.

*Ans.* Carborundum, galena, iron-pyrites, silicon, and zincite-bornite.

**Ques. 5.67.** Why do headphones have high impedance windings?

*Ans.* As radio headphones are sometimes called upon to act as the load on the final audio-amplifier tube, it is desirable that their resistance approach the impedance-match condition for distortionless amplification, which is twice the tube's plate resistance. Generally speaking, therefore, radio headphones should have a direct-current resistance of 2,000 ohms or more. Their alternating-current impedance would, of course, exceed this value owing to the reactance effect in the magnet windings.

**Ques. 5.68.** What are the objections to the operation of a regenerative, oscillating-detector receiver, when directly coupled to the antenna?

## RADIO OPERATING QUESTIONS AND ANSWERS

*Ans.* An oscillating detector is in reality a miniature transmitter. Heterodyne interference in nearby receivers will be produced.

**Ques. 5.69.** What controls determine the selectivity of a three-circuit tuner?

*Ans.* The regenerative feedback control, the secondary tuning condenser, the antenna series condenser, and the antenna coupling coil.

**Ques. 5.70.** A superheterodyne receiver is adjusted to 2,738 kilocycles. The intermediate frequency is 475 kilocycles; what is the frequency to which the grid circuit of the second detector must be tuned?

*Ans.* 475 kilocycles.

**Ques. 5.71.** Explain the reasons why a superheterodyne receiver may not be successfully used for reception of frequencies very near the frequency of the intermediate amplifier.

*Ans.* Frequencies near the intermediate-frequency range would pass through without any mixing effect. In other words, the intermediate frequency would function as a simple untuned radio-frequency amplifier to these frequencies. At the same time the mixer oscillator may cause a continuous squeal in the output.

**Ques. 5.72.** A superheterodyne receiver, having an intermediate frequency of 465 kilocycles and tuned to a broadcast station on 1,450 kilocycles, is receiving severe interference from an "image" signal. What is the frequency of the interfering station?

*Ans.* 2,380 kilocycles.

**Ques. 5.73.** A superheterodyne receiver is tuned to 1,712 kilocycles and the intermediate frequency is 456 kilocycles. What is the frequency of the mixer oscillator?

*Ans.* 2,168 kilocycles.

**Ques. 5.74.** Describe a "superregenerative" receiver.

*Ans.* The superregenerative receiver is essentially the same as a three-circuit regenerative receiver with the exception that a local generating frequency of, say, 25,000 cycles is coupled to the plate circuit. The purpose of this local oscillator is to increase the regenerative effect beyond the point in which the receiver would normally go into self-oscillation. In other words, the local oscillator supplies a *quench* frequency which continuously interrupts the oscillation frequency and, therefore, the degree of regeneration can be built up to tremendous proportions.

**Ques. 5.75.** Why are the unused portions of inductances in receivers usually shorted?

*Ans.* To eliminate "dead end" losses.

**Ques. 5.76.** What is the "mixer" tube in a superheterodyne?

*Ans.* The "mixer" tube or first detector is that tube in which the combining of the signal frequency and the local oscillator frequency takes place. It is in the mixer tube that the intermediate-beat frequency is generated.

**Ques. 5.77.** What is the purpose of a tuned radio-frequency amplifier stage ahead of the mixer stage in a superheterodyne receiver?

*Ans.* It serves as a preselector stage to eliminate image interference. It improves the signal-to-noise ratio in the lower frequency bands.

**Ques. 5.78.** What is the advantage of using iron cores of special construction in radio-frequency transformers and inductances?

*Ans.* This type of transformer permits more effective band-width adjustments in receivers thereby providing better

high-fidelity response. They also make for better circuit stability in the reception of unstable frequencies particularly in the ultra-high-frequency bands. Some types are adjustable for variable selectivity.

**Ques. 5.79.** If signals are heard with the headphones plugged into the detector plate circuit of a receiver, but no signals are heard when the phones are plugged into the first audio-frequency stage plate circuit, what might be the cause and how could it be remedied?

*Ans.* The primary or secondary winding of the audio transformer may have opened. Substitute resistance coupling for the opened section.

**Ques. 5.80.** Name three causes of an audio "howl" in a regenerative receiver.

*Ans.* Howling might be caused by a microphonic detector tube, too much regeneration, acoustic feedback, open grid leak.

**Ques. 5.81.** Name four reasons which would prevent a regenerative receiver from oscillating.

*Ans.* Open plate by-pass condenser, open grid condenser, insufficient plate voltage, low filament emission, coil losses resulting from moisture absorption, reversed tickler winding or shorted grid condenser.

**Ques. 5.82.** What is the advantage of heterodyne reception as compared to autodyne reception?

*Ans.* The heterodyne method of beat reception has the advantage over autodyne beat reception in slightly greater sensitivity and wider range of beat production.

**Ques. 5.83.** How is automatic volume control accomplished in a receiver?

*Ans.* Automatic volume-control action is generally developed in the diode load section of the diode detector. The rectified signal voltage developed across this load produces a direct-current voltage component which makes one end of the resistance negative with respect to the cathode. By connecting to the negative end through a filter resistor and a bypass condenser this voltage is fed to the return lead of the variable- $\mu$  radio-frequency tube(s) to be controlled. The grid voltage of the radio-frequency amplifier is, therefore, reinforced by the direct-current potential developed across the diode load and the radio-frequency signal peaks are diminished.

**Ques. 5.84.** What is a "crystal filter" as used in a superheterodyne receiver?

*Ans.* The "crystal filter" is a quartz-plate resonant circuit which has very high  $Q$  characteristics (very sharp tuning). This plate is generally connected between the mixer and first intermediate stages to effect extremely sharp tuning or give so-called "single-signal reception."

**Ques. 5.85.** How may image response be minimized in a superheterodyne receiver?

*Ans.* Image response may be minimized by the introduction of specially designed trap circuits or by adding a pre-selector stage before the mixer tube.

**Ques. 5.86.** Discuss the advantages and disadvantages of a self-excited oscillator and a master-oscillator power-amplifier transmitter.

*Ans.* The advantage of the self-excited oscillator transmitter is that only a single tube is required. The great disadvantage compared to the master-oscillator power-amplifier (MOPA) type is the frequency instability of the self-excited oscillator. Antenna-load changes produce variations in output frequency to such a degree that the output frequency may drift over thousands of cycles.

**Ques. 5.87.** Draw a simple diagram of a dynatron oscillator using a tetrode, indicating polarity of power-supply voltages.

*Ans.* Figure 3-10 illustrates a schematic diagram of a dynatron oscillator.

**Ques. 5.88.** What is the meaning of "carrier shift"?

*Ans.* "Carrier shift" is the unequal relationship of the positive and negative peaks of the modulated wave, which results in a carrier shift. It is due to the lack of symmetry of the modulation envelope, which causes a change in the average amplitude of the modulated wave. (See Ques. 6.42.)

**Ques. 5.89.** What effect upon the plate current of the final-amplifier stage will be observed as the antenna circuit is brought into resonance?

*Ans.* The direct-current plate milliammeter will show an increased reading.

**Ques. 5.90.** What will be the effect of a swinging antenna upon the output of a self-excited oscillator transmitter? A master-oscillator power-amplifier transmitter?

*Ans.* A swinging antenna will cause frequency instability in a self-excited oscillator. When a master-oscillator power-amplifier transmitter is used a swinging antenna will not affect the frequency of the transmitter because the antenna-capacity changes are not reflected back to the oscillator circuit. The radio-frequency power amplifier serves to isolate the oscillator from the antenna circuit. Hence, any capacity changes in the antenna cannot affect the frequency of the oscillator.

**Ques. 5.91.** Discuss the advantage and disadvantage of operating an amplifier as a class C stage.

*Ans.* The advantage is high efficiency. The efficiency of a class C amplifier may be brought up as high as 85 per cent in



practice. Perhaps the only disadvantage of this type of amplifier is the relatively larger excitation voltages required to overcome the large grid-bias voltage used. Also its output is not so linear as class B.

**Ques. 5.92.** What is the crystal frequency of a transmitter having three doubler stages and an output frequency of 16,880 kilocycles?

*Ans.* Three doubler stages will raise the crystal frequency 8 times; therefore the fundamental crystal frequency must be  $\frac{1}{8}$  of 16,880, or 2,110 kilocycles.

**Ques. 5.93.** What is the ratio of the frequencies of the output and input circuits of a single-phase full-wave rectifier?

*Ans.* The ripple ratio is 2:1. (The 60-cycle input is raised to a 120-cycle output.)

**Ques. 5.94.** What is meant by shock excitation of a circuit?

*Ans.* The generation of highly damped oscillations by pulse excitation of an oscillatory circuit.

**Ques. 5.95.** What increase in antenna current will be noted when a transmitter is modulated 100 per cent by a sinusoidal audio frequency?

*Ans.* An increase of 1.225 times.

**Ques. 5.96.** What may be the reasons why a zero reading is not obtained on the neutralizing indicator while neutralizing a radio-frequency amplifier stage?

*Ans.* This may be due to some tube losses thereby preventing an exact phase balance. A series resistance is sometimes inserted in series with the neutralizing condenser in order to obtain an exact balance or a phase angle of 90 degrees. Stray couplings between the circuit may also be the cause.

**Ques. 5.97.** What precautions should be observed in tuning a transmitter?

*Ans.* Care should be exercised in adjusting all high-voltage circuits to avoid shock. The high-voltage switch must be opened whenever making coil-tap or condenser-section changes. Filter condensers not shunted by a resistor should be discharged by short-circuiting with insulated-handle screw-driver.

**Ques. 5.98.** Describe a procedure which would be satisfactory in neutralizing a radio-frequency stage.

*Ans.* Open the plate-supply switch to the radio-frequency stage to be neutralized. Open up the main power switch to all tubes, and discharge all high-voltage condensers. Insert a thermocoupled galvanometer into the low potential side of the plate-tank circuit of the stage to be neutralized. Engage the neutralizing condenser about one-third position. Close the main power switch but leave the plate-supply switch of the amplifier open. Increase the radio-frequency drive gradually and tune all circuits to resonance. Observe the reading on the thermocouple galvanometer and vary the neutralizing condenser until this reading is a minimum or, preferably, zero. Remove the thermocouple galvanometer and insert the regular ammeter. Close the high-voltage plate-supply switch to the radio-frequency amplifier just neutralized. Carefully recheck and balance all circuits to minimum plate-current dips.

**Ques. 5.99.** Name three instruments which may be used as indicating devices in neutralizing a radio-frequency amplifier stage.

*Ans.* A thermo galvanometer, a sensitive hot-wire ammeter, a cathode-ray oscilloscope, a neon tube, or a wavemeter.

**Ques. 5.100.** Describe a means of reducing the sparking at the contacts of a key used in a radiotelegraph transmitter.

*Ans.* A condenser shunted across the contacts. A condenser with series resistance shunted across the contacts or a choke coil in series with a condenser shunted across the contacts. See Fig. 5-6.

**Ques. 5.101.** How may instruments used to indicate various direct currents and voltages in a transmitter be protected against damage due to stray radio-frequency energy?

*Ans.* Instruments may be protected by grounding the cases (if metal), shielding the leads and grounding, shunting a small radio-frequency by-pass condenser across them, inserting small radio-frequency chokes and by-pass condensers in the leads, and by placing the meters (ammeters) in the low potential side of the circuit.

**Ques. 5.102.** What is the purpose of the choke coil?

*Ans.* The choke coil in direct-current circuits serves to filter the power supply. The choke coil in radio-frequency circuits serves to isolate the radio-frequency currents from the power-supply circuits. The primary function of a choke coil is to filter or smooth out current variations.

**Ques. 5.103.** What currents will be indicated by a milliammeter connected between the center tap of the filament transformer of a tetrode, and negative high voltage (ground)?

*Ans.* The milliammeter in this position will read the combined plate and screen-grid currents.

**Ques. 5.104.** What emergency repairs may be made to an inductance coil having burned or charred insulation?

*Ans.* The charred or burned portions may be painted with an insulating varnish or liquid colloid provided both types of materials have low dielectric losses. If possible, the defective insulation should first be removed before applying the new insulation. Reduce operating voltage if possible.

RADIO OPERATING QUESTIONS AND ANSWERS

**Ques. 5.105.** Name four indications of a defective vacuum tube in a transmitter.

*Ans.* Low plate currents under normal filament and plate operating voltages, low tank currents, low antenna currents, blue glow inside envelope between grid and plate, and filament not lighting.

**Ques. 5.106.** What is the purpose of an air gap in the core of a filter choke coil?

*Ans.* An air gap increases the reluctance of the core, thereby reducing the flux density so that it will not be saturated by the rated flow of direct current. The gap in a swinging choke may be only a few thousandths of an inch wide.

**Ques. 5.107.** What are some uses of a low-pass filter network?

*Ans.* A low-pass filter network passes freely all frequencies below a certain point and attenuates all those above this value. This type of network is used in power-supply filter systems for transmitters and receivers. This type of filter is also used in special types of amplifying circuits where it is desired to amplify only a small band of low frequencies. Line noises and highly damped power-line surges may be attenuated by a low-pass type of filter.

**Ques. 5.108.** What is a "swinging choke"?

*Ans.* A choke coil designed to operate with varying loads is commonly referred to as a "swinging choke." The swinging action is obtained by providing an extremely small air gap which allows saturation with a heavy current flow. (See Ques. 3.101.)

**Ques. 5.109.** Indicate the approximate values of power-supply filter inductances encountered in practice.

*Ans.* The maximum value of choke coils generally found in power filters is in the vicinity of 30 henrys. The limiting

factor is generally the direct-current resistance and its consequent voltage drop. The average current requirement is .15 amperes. Average d-c resistance range is 200 to 600 ohms.

**Ques. 5.110.** Why is the core of a transformer made of sheets of iron rather than a solid piece of iron?

*Ans.* To reduce eddy-current losses.

**Ques. 5.111.** What factors determine the eddy-current losses in a transformer?

*Ans.* The character of the core material, the thickness of core laminations, and flux density.

**Ques. 5.112.** Name the losses which are present in transformers.

*Ans.* Eddy-current losses, hysteresis losses, air-gap losses, and copper losses.

**Ques. 5.113.** What factors determine the hysteresis losses in a transformer?

*Ans.* These losses are determined by flux density, the character of the magnetic material, and the operating frequency.

**Ques. 5.114.** What is the secondary voltage of a transformer which has a primary voltage of 100, primary turns 200, and secondary turns, 40?

*Ans.* The secondary voltage is 20 volts.

$$E_s = \frac{N_s}{N_p} \times E_p = \frac{40}{200} \times 100 = 20 \text{ volts.}$$

**Ques. 5.115.** Why should emery cloth never be used to clean the commutator of a motor or generator?

*Ans.* Emery cloth contains metallic ingredients. Possible short circuits might develop.

*RADIO OPERATING QUESTIONS AND ANSWERS*

**Ques. 5.116.** When increased output voltage is desired from a motor-generator set what is the usual procedure?

*Ans.* The output voltage is increased by strengthening the current through the generator field. This is done by decreasing the resistance in the generator-field rheostat.

**Ques. 5.117.** What will be the effect(s) of a short circuit in an armature coil in a direct-current motor?

*Ans.* Sparking will develop around the commutator and the speed under load will be reduced.

**Ques. 5.118.** When starting a direct-current motor-generator set, what adjustment should be made to the motor field?

*Ans.* The motor-field rheostat should be decreased to minimum resistance.

**Ques. 5.119.** What may be the trouble if a motor generator fails to start when the starter button is depressed?

*Ans.* Blown fuse, open armature, defective starter, open field.

**Ques. 5.120.** What load conditions must be satisfied in order to obtain the maximum possible output from any power source?

*Ans.* Maximum power is obtained when the load resistance matches the internal resistance of the source.

**Ques. 5.121.** Explain the principle of operation of an electrolytic condenser.

*Ans.* The electrolytic condenser functions upon the principle of unilateral conductivity, that is, the condenser offers a very high resistance to current flow in one direction and low resistance to the flow of current in an opposite direction. This type of condenser depends for its operation upon the fact

that certain metals when used as anodes in certain electrolytes become coated with a very thin film of insulation, caused by polarization. This film acts as a dielectric separating the two electrodes constituting the condenser.

**Ques. 5.122.** Why are bleeder resistances used in power supplies?

*Ans.* Bleeder resistors are used in filter circuits across condensers to equalize the charge and remove the strain upon the condensers. They are also used to stabilize the output voltage from power-supply circuits to the load circuits. The bleeder resistance in voltage-divider systems also permits reservoir action to accommodate increases in plate-current swings to the vacuum-tube plate circuits, improving regulation. Bleeder resistors also function to discharge the condensers after shutdown, thus preventing possible shock to the operator.

**Ques. 5.123.** Why is a condenser sometimes placed in series with the primary of a power transformer?

*Ans.* A condenser is very seldom, if ever, placed in series with the primary winding of a power transformer. If a condenser should be used in this manner it would be done for the purpose of resonating the secondary circuit with the primary or, possibly, for controlling the primary reactance to control the current flow. This arrangement might also be used for boosting the primary voltage.

**Ques. 5.124.** What factors determine the breakdown voltage rating of a condenser?

*Ans.* The character of the dielectric and the thickness of the dielectric.

**Ques. 5.125.** What is the effect of low temperatures upon the operation of a lead-acid storage cell?

## RADIO OPERATING QUESTIONS AND ANSWERS

*Ans.* Low temperatures temporarily decrease both the discharge voltage and the ampere-hour capacity which can be taken out of the cell.

**Ques. 5.126.** Why should the tops of the lead-acid cell or batteries be kept free from moisture?

*Ans.* To prevent leakage losses and terminal corrosion.

**Ques. 5.127.** How may the condition of charge of an Edison cell be determined?

*Ans.* By the use of a high-resistance voltmeter test under load.

**Ques. 5.128.** What special precautions should be taken when lead-acid cells are subject to low temperatures?

*Ans.* They should be given frequent charging in order to keep the discharge voltage and ampere-hour capacity as high as possible. The cells should be kept on continuous trickle.

**Ques. 5.129.** What should be done if the electrolyte in a lead-acid cell becomes low due to evaporation?

*Ans.* Refill with chemically pure water.

**Ques. 5.130.** What precautions should be used when an absorption type of frequency meter is used to measure the output of a self-excited oscillator?

*Ans.* Place the instrument as far as possible from the circuit being measured to avoid mutual coupling reactions which would alter the output frequency.

**Ques. 5.131.** What is the meaning of "zero beat" as used in connection with frequency-measuring equipment?

*Ans.* "Zero beat" is that condition which prevails when two radio-frequency oscillators are coupled to each other and adjusted to exactly the same frequency. An audible output



circuit, such as headphones, would produce no response under this condition.

**Ques. 5.132.** What precautions should be taken before using a heterodyne type of frequency meter?

*Ans.* The heterodyne-frequency meter should be placed as far as possible from the circuit being checked. The calibration should be checked against a known standard-frequency calibrator. Allow meter time to warm up.

**Ques. 5.133.** If a wavemeter, having a deviation inversely proportional to the wavelength, is accurate to 20 cycles, when set at 1,000 kilocycles, what is its error when set at 1,250 kilocycles?

*Ans.* The error at 1,250 kilocycles will be 25 cycles.

**Ques. 5.134.** What cleaning agents may be used to clean the surfaces of a quartz crystal? Is such cleaning ever necessary? Explain.

*Ans.* The best cleaning agent is carbon tetrachloride (Carbena). Alcohol or plain soap and water may be used. All quartz crystals should be cleaned whenever handled because any oily deposit or grit may prevent the unit from functioning.

**Ques. 5.135.** Name four advantages of crystal control over tuned circuit oscillators.

- Ans.*
1. Maximum frequency stability.
  2. Minimizes dynamic instability
  3. Gives better tone signal for radio telegraphy.
  4. Reduces necessary band width.
  5. Simplifies grid circuit.
  6. Reduces beat frequency of stations on same frequency.

**Ques. 5.136.** Why is a separate source of power desirable for crystal-oscillator units in a transmitter?

## RADIO OPERATING QUESTIONS AND ANSWERS

*Ans.* Common power supply for crystal- and power-amplifier units would produce frequency modulation and consequent serious frequency instability and distortion. This is due to load changes upon the oscillator plate circuit which in turn are caused by modulation or power-amplifier plate-load changes.

**Ques. 5.137.** Why is the temperature of a quartz crystal maintained constant?

*Ans.* Because the crystal possesses a temperature coefficient. Temperature changes will cause drifting of the crystal frequency.

**Ques. 5.138.** What will be the effect of a high degree of coupling between the plate and grid circuits of a quartz-crystal oscillator?

*Ans.* Excessive strain may be applied to the crystal and a possible cracking or chipping may result.

**Ques. 5.139.** What is the function of a quartz crystal in a radio transmitter?

*Ans.* The crystal serves as the frequency controlling unit of the oscillator to maintain a station at a critical frequency. It is the frequency stabilizer of the transmitting system.

**Ques. 5.140.** What does the expression "low temperature coefficient crystal" mean?

*Ans.* This term means that the variation in crystal frequency with positive and negative change in temperature is practically zero.

**Ques. 5.141.** What does the expression "the temperature coefficient of an X-cut crystal is negative" mean?

*Ans.* "A negative coefficient characteristic" is one in which the crystal frequency decreases as the temperature is raised.

**Ques. 5.142.** What will be the effect of applying a direct-current potential to the opposite plane surfaces of a quartz crystal?

*Ans.* The crystal will change in shape, the amount and direction of the change depending upon the cut of the crystal.

**Ques. 5.143.** What does the expression "the temperature coefficient of a Y-cut crystal is positive" mean?

*Ans.* "A positive coefficient characteristic" is one in which the crystal frequency increases as the temperature is raised.

**Ques. 5.144.** Draw a simple schematic diagram of a crystal-controlled oscillator using a tetrode-type tube. Indicate power-supply polarity where necessary.

*Ans.* Figure 2-9 illustrates a schematic diagram of a tetrode crystal oscillator. The basic circuit is the same as that using a pentode tube with the exception that the suppressor grid (next to the plate) is omitted.

**Ques. 5.145.** What is a "multivibrator"? Explain the principle of operation.

*Ans.* The multivibrator or relaxation oscillator is a two-tube resistance-coupled oscillator in which the voltage developed by the output of the second tube is applied to the input of the first tube. The principle of operation is based upon the fact that the tubes invert the wave form. The output wave is nonsinusoidal in character. This type of oscillator may be used for any of the following purposes:

1. Master oscillator timer.
2. To produce rectangular control pulses of certain lengths, synchronized with excitation trigger pulses.
3. To introduce delay between input trigger pulses and a second circuit.
4. Frequency division. To synchronize or lock circuits at other than 1:1 ratio.

**Ques. 5.146.** What is a dynatron oscillator? Explain its principle of operation.

*Ans.* A dynatron oscillator is a tetrode oscillator in which the screen-grid voltage is operated at a critical point above the plate-voltage potential. It operates upon the principle of the *negative resistance* characteristic used in regeneration and oscillatory circuits. As the plate voltage is gradually raised, the plate-to-cathode current is reduced, owing to a neutralizing effect at some critical point between the normal emission from the cathode and the secondary emission from the plate. When this particular point is reached, the plate-to-filament resistance will indicate a negative-resistance characteristic and the plate-tank circuit will continue to oscillate.

**Ques. 5.147.** What is an electron-coupled oscillator? Explain its principle of operation.

*Ans.* The electron-coupled oscillator is a tetrode oscillator in which the control grid, cathode, and screen grid serve as the triode section of an oscillator. The screen grid serves as the oscillator plate. The regular plate is coupled through the tube capacity to the triode elements. The variation of the space charge is controlled by the triode grid, and these variations in turn energize the plate circuit and its load impedance.

**Ques. 5.148.** Explain the principle of generation of radio-frequency energy by means of a spark discharge.

*Ans.* (See Ques. 6.251.)

**Ques. 5.149.** Explain the principle of generation of radio-frequency energy by means of an electric arc.

*Ans.* When the arc is struck, the high-potential current across the terminals begins to charge the condenser, which is made up of the antenna and the ground, as shown in Fig. 5-1. The condenser therefore takes some of the current away from the arc. Hence, the voltage across the arc increases until the condenser is fully charged.

When the condenser is fully charged, the current through the arc rises to normal value. This causes the voltage across the arc to drop. The condenser, however, is still fully charged

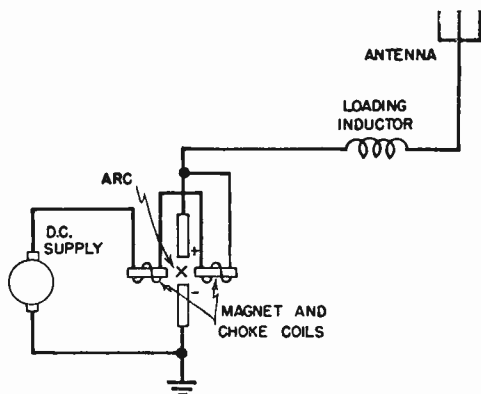

FIG. 5-1. Fundamental oscillating arc.

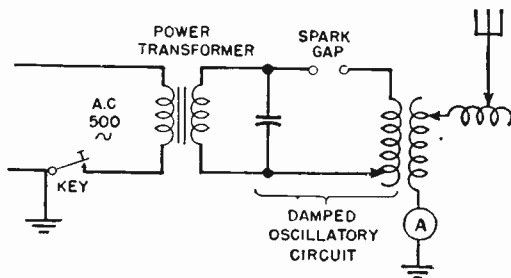

FIG. 5-2. Fundamental spark transmitter.

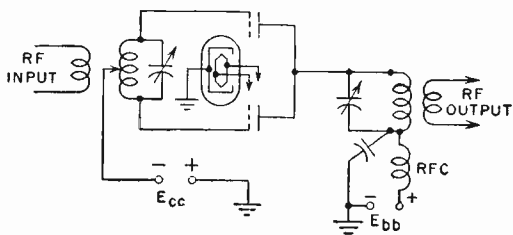

FIG. 5-3. Frequency doubler.

and its voltage value is now higher than that of the arc. The condenser, therefore, discharges across the arc. Because the discharge takes place through a circuit having oscillatory characteristics, undamped or continuous wave oscillations are produced.

At each oscillation the voltage rises and falls periodically, giving a constant source of energy to the condenser.

In order to signal with this system, it is necessary to provide some means of breaking up the continuous oscillations into code groups.

**Ques. 5.150.** Draw a simple schematic diagram of a crystal-controlled oscillator and means of coupling to the following radio-frequency amplifier stage, showing power-supply polarities.

*Ans.* See Fig. 4-9.

**Ques. 5.151.** Draw a simple schematic diagram of an oscillatory circuit involving the use of a spark-gap discharge, indicating the circuit elements necessary to identify this form of oscillatory circuit.

*Ans.* See Fig. 5-2.

**Ques. 5.152.** Draw a simple schematic diagram of an electron-coupled oscillator, indicating the circuit elements necessary to identify this form of oscillator circuit.

*Ans.* See Fig. 2-8.

**Ques. 5.153.** Draw a simple schematic diagram of a dynatron type of oscillator, indicating the circuit elements necessary to identify this form of oscillatory circuit.

*Ans.* See Fig. 3-10.

**Ques. 5.154.** Draw a simple schematic diagram of an oscillating-arc circuit, indicating the circuit elements necessary to identify this form of oscillatory circuit.

*Ans.* See Fig. 5-1.

**Ques. 5.155.** Why is a push-pull audio-frequency amplifier preferable to a single-tube stage?

*Ans.* A push-pull audio-frequency amplifier is preferable to a single-tube stage because by means of the push-pull circuit the even harmonics in the output are neutralized. A greater power output is also secured from a push-pull amplifier than is secured from a single-tube amplifier.

**Ques. 5.156.** Name four applications for vacuum tubes operating as class A audio amplifiers.

*Ans.* Four applications of vacuum tubes operating as class A audio amplifiers are as follows:

1. Audio-frequency voltage amplifiers in receivers.
2. Audio-frequency voltage amplifiers in speech input equipment.
3. Modulators.
4. Line amplifiers.
5. Microphone preamplifiers.
6. Audio-frequency power amplifiers in receivers.

**Ques. 5.157.** What is the chief advantage of class A audio operation as compared to other classes of audio-frequency amplifiers?

*Ans.* The chief advantage of class A audio operation is that the output is essentially linear, and distortion is reduced to a minimum. Also, it may be operated with a single-tube.

**Ques. 5.158.** Why is correct grid bias important in an audio-frequency amplifier?

*Ans.* The correct grid bias is important because it serves to locate the operating point of the tube at the proper location on the characteristic curve for the desired operating conditions.

**Ques. 5.159.** How may even harmonic energy be reduced in the output of an audio-frequency amplifier?

*Ans.* Harmonic energy may be reduced in the output of an audio-frequency amplifier by operating the tube with a limited grid-voltage swing so that the plate current is never driven off the straight-line portion of the characteristic. In addition, even harmonic energy may be reduced by working the tubes in a push-pull circuit, thus canceling out the even harmonics.

**Ques. 5.160.** Why are class A audio amplifiers not as critical, insofar as grid-drive requirements are concerned, as class B audio amplifiers?

*Ans.* Because plate current flows during the entire excitation cycle. Therefore, as long as an excitation voltage is present, an output component will be secured. On the other hand, with a class B audio amplifier the excitation voltage must be of the correct value within limits to cause the tube to operate on the desired portion of the grid-voltage plate-current characteristic.

**Ques. 5.161.** Name at least two uses of a class C radio-frequency amplifier in modern radiotelegraph and radiotelephone transmitters.

*Ans.* A class C radio-frequency amplifier may be used in the transmitting circuit as follows:

1. As a buffer amplifier.
2. As a power amplifier for class C telegraphy.
3. As a frequency multiplier (usually a doubler).
4. As a modulated radio-frequency amplifier.

**Ques. 5.162.** Name four causes of excessive plate current in a radio-frequency amplifier.

*Ans.* Excessive plate current may be caused in the radio-frequency amplifier by any of the following:

1. Plate circuit not tuned to resonance.
2. Parasitic oscillations.
3. Improper neutralization.
4. Excessive excitation voltage.



5. Defective vacuum tube.
6. Insufficient bias.

**Ques. 5.163.** What is the chief advantage of a class B radio-frequency amplifier, and for what is this type of amplifier commonly employed?

*Ans.* The chief advantage of a class B radio-frequency amplifier is its linearity of operation. It is, therefore, commonly used as a final power radio-frequency amplifier or as a power amplifier following a modulated class C amplifier.

**Ques. 5.164.** What class of amplifier should be used following a modulated radio-frequency amplifier?

*Ans.* A class B radio-frequency power amplifier.

**Ques. 5.165.** Define a class C amplifier.

*Ans.* A class C amplifier operates with a grid bias, which is appreciably greater than the cut-off value. The plate current in each tube is zero when no alternating grid voltage is applied. The plate current in a specific tube flows for appreciably less than one-half of each cycle when an alternating grid voltage is applied. (I.R.E. definition, 1938.)

**Ques. 5.166.** Why are by-pass condensers used across the cathode-bias resistors of a radio-frequency amplifier?

*Ans.* By-pass condensers are used across the cathode bias resistors of a radio-frequency amplifier to provide a low reactance path for the alternating plate component to return to the filament. This reduces degeneration and increases the stage gain.

**Ques. 5.167.** What is the main advantage of a tuned audio-frequency amplifier in a receiver used for the reception of radiotelegraph signals?

*Ans.* The main advantage of a tuned audio-frequency amplifier in a receiver used for C-W reception is that with a

tuned audio-frequency amplifier the receiver will respond to only one frequency. It is possible, therefore, to decrease interference by filtering out unwanted signals near the frequency to which the receiver is tuned.

**Ques. 5.168.** What is the purpose of decoupling networks in the plate circuits of a multistage audio amplifier?

*Ans.* When the plate voltage for several tubes of a high-gain amplifier is obtained from a single source, decoupling networks are used to prevent the internal resistance of the power source from acting as a coupling between stages. These circuits also prevent the coupling of the stages through bleeder circuit resistors when screen voltage for two or more tubes is taken from a common tap or through a bias resistor common to the control-grid circuits of several tubes.

**Ques. 5.169.** What is a "buffer" amplifier and what are its applications?

*Ans.* The purpose of the buffer amplifier is to isolate the oscillator from the succeeding stages of radio-frequency amplification. This prevents any reaction between the modulated radio-frequency amplifiers and the oscillator, which might cause frequency instability.

**Ques. 5.170.** For what purpose is a frequency-doubler stage used in a transmitter?

*Ans.* The doubler amplifier is used when an output frequency greater than the maximum safe operating frequency of a crystal oscillator is desired.

**Ques. 5.171.** Describe the operation of a frequency-doubler stage.

*Ans.* See Fig. 2-22 for diagram. The tube is biased beyond the cut-off point. This causes a distorted wave shape in the plate circuit. The plate *L-C* circuit is tuned to twice the input

frequency with the result that strong harmonic voltages are set up in it by the distorted wave.

Circuit adjustments in frequency-doubler stages (harmonic or distortion generators) must fulfill the typical class C amplifier requirements such as high grid bias, high plate voltage, and large grid driving power. The distortion characteristics are produced by the single-tube plate-circuit pulses which are rich in harmonics. The plate tank circuit is then adjusted to the desired harmonic of the fundamental frequency pulses.

Another type of frequency doubler is illustrated in Fig. 5-3. In this circuit the grids are excited in push-pull and the plates in parallel. Hence, if the plate tank is tuned to twice the input frequency, the output frequency is doubled.

**Ques. 5.172.** Why is neutralization generally necessary in a radio-frequency amplifier?

*Ans.* Neutralization is generally necessary in a radio-frequency amplifier to prevent erratic operation of the circuit which would occur if the amplifier went into self-oscillation owing to feedback. Neutralization prevents feedback.

**Ques. 5.173.** What is the purpose of shielding between radio-frequency amplifier stages?

*Ans.* The purpose of shielding in a multistage radio receiver is to prevent electrical interaction between the various receiver components, which interaction would disturb their normal operation and may result in regeneration or self-oscillation. Shielding prevents the lines of force surrounding the shielded component from leaving the area within the shield. Shielding also prevents any outside lines of force from entering the shielded compartment.

**Ques. 5.174.** Describe how a radio-frequency amplifier stage may be neutralized.

*Ans.* (See Ques. 5.98.)

**Ques. 5.175.** In neutralizing a radio-frequency amplifier stage of a transmitter, using a thermocouple galvanometer as indicator, what precautions must be observed?

*Ans.* When a thermocouple meter is used as an indicator, care must be taken not to burn the meter out. To prevent this, the thermocouple should be inserted in a pick-up loop, which, in turn, can be loosely coupled to the tank circuit of the amplifier stage being neutralized.

**Ques. 5.176.** Draw a complete schematic diagram of a system of inductive coupling between the output of a radio-frequency amplifier and an antenna system.

*Ans.* See Fig. 4-7.

**Ques. 5.177.** Draw a simple schematic diagram showing a method of link coupling between two radio-frequency amplifier stages.

*Ans.* See Fig. 3-7.

**Ques. 5.178.** Draw a simple schematic diagram showing a method of direct coupling between two stages of an audio-frequency amplifier.

*Ans.* See Figs. 2-12 and 3-12.

**Ques. 5.179.** Draw a simple schematic diagram showing a method of impedance coupling between two stages of a radio-frequency amplifier.

*Ans.* See Fig. 2-14.

**Ques. 5.180.** Draw a simple schematic diagram showing a method of inductive or transformer coupling between two stages of a radio-frequency amplifier.

*Ans.* See Fig. 2-16.

**Ques. 5.181.** Discuss the characteristics of a dynatron oscillator.

*Ans.* The characteristics of a dynatron type of oscillator are as follows:

1. A well-designed dynatron has a frequency stability which compares favorably with that of the crystal oscillator without temperature control.

2. Its efficiency is low.

3. It can be used in a heterodyne wavemeter. When so used, the sharpness of indication of the meter is increased because the dynatron neutralizes the positive resistance of the wavemeter circuit. This it does by virtue of the negative resistance of the tube operating as a dynatron.

**Ques. 5.182.** What type of oscillator depends upon secondary emission from the anode for its operation?

*Ans.* The dynatron oscillator.

**Ques. 5.183.** What is the primary reason for the suppression of radio-frequency harmonics in the radio-frequency output of a transmitter?

*Ans.* To prevent interference on other channels, which are in harmonic relation to the fundamental frequency being transmitted.

**Ques. 5.184.** In a radiotelegraph transmitter employing a direct-current generator as a source of plate voltage, an alternating-current generator as filament supply and grid-bias keying, if it is noted that when the key contacts are open the emission continues, what could be the trouble?

*Ans.* This would indicate that no blocking bias is being applied to the tubes. This might be caused by a burned-out bias resistor or a defect in the bias circuit. It might also be due to a short-circuited key-click condenser, the relay key contacts may have stuck, or the relay key may be defective.

**Ques. 5.185.** What is the purpose of an electrostatic shield?

*Ans.* An electrostatic shield, also known as a Faraday screen, is used between the plate-tank coil of the final radio-

frequency power amplifier and the antenna coil coupled to it. The purpose of this shield is to reduce the radiation of harmonic energy. This it does by effectively loosening the coupling between the two coils and providing a low-reactance path to ground for the harmonic frequencies.

**Ques. 5.186.** What is the advantage of link coupling between radio-frequency amplifier stages?

*Ans.* Link coupling reduces the radiation of harmonic frequencies. Another advantage of link coupling is that it permits the construction of the various amplifier stages as separate units, these units being effectively coupled by a low-impedance line with coupling loops, consisting of one or two turns of wire, at each end, known as the link circuit.

**Ques. 5.187.** Draw a simple schematic diagram showing how a radio-telegraph transmitter may be keyed by the grid-blocking method.

*Ans.* See Fig. 5-4.

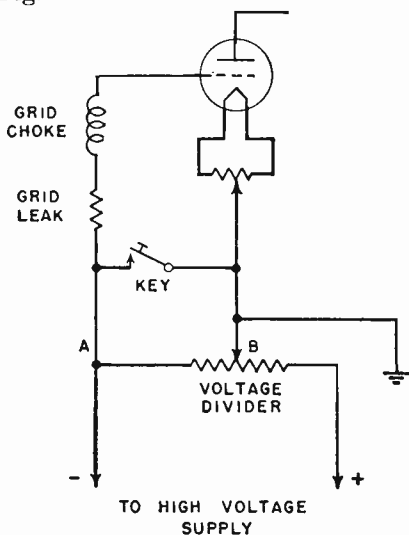

FIG. 5-4. Grid-blocking keying system.

**Ques. 5.188.** By what means may a high-power radiotelegraph transmitter be keyed?

*Ans.* The most satisfactory means of keying a high-power radiotelegraph transmitter is by the so-called grid-blocking system. With this system a grid bias sufficient to block the power amplifier is applied when the key is up. The key is connected to shunt the bias resistor, thus removing the bias when the key is down. When the bias is removed, the signal wave is emitted by the transmitter.

Another system is the grid-choke method. In this system a choke heavy enough to stop oscillation of the tube is placed in the grid of the oscillator tube and known as a "keying choke." This choke is short-circuited when the key or keying-relay contacts are closed which permits the tube to oscillate; hence, keying is accomplished.

In connection with crystal-controlled transmitters, it is generally undesirable to key the oscillator or the buffer amplifier, as to do so would disturb the frequency stability of the transmitter. The practice with these transmitters is to key the stages following the buffer amplifier, usually by the grid-blocking system.

**Ques. 5.189.** What is meant by "grid block keying"?

*Ans.* (See preceding answer.)

**Ques. 5.190.** Draw a simple schematic diagram of a key-click filter suitable for use when a vacuum-tube transmitter is keyed in the negative high-voltage circuit.

Ans. See Fig. 5-5.

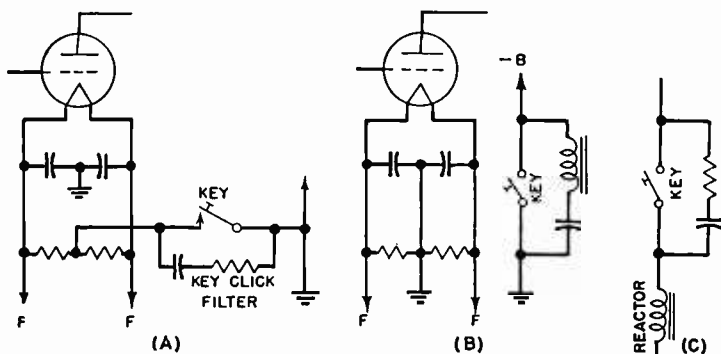

FIG. 5-5. Key-click filters.

Ques. 5.191. Draw a simple schematic diagram of a system of keying in the primary of the transformer supplying high voltage to a vacuum-tube transmitter. Indicate any values of inductance, resistance, capacitance which may be deemed necessary to fully understand the correct operation of this type of keying.

Ans. See Fig. 5-6.

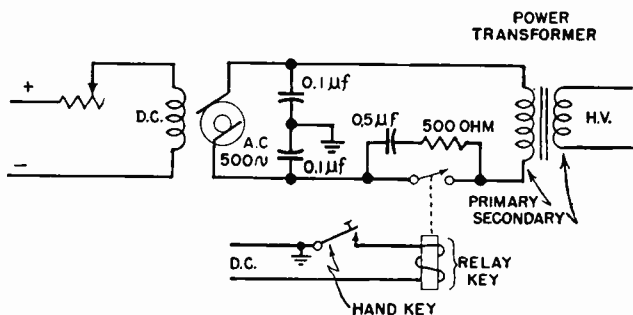

FIG. 5-6. Transformer-primary keying system.



**Ques. 5.192.** A transmitter is operating on 5,000 kilocycles, using a 1,000-kilocycle crystal with a temperature coefficient of  $-4$  cycles/megacycle/degree centigrade. If the crystal temperature increases 6 degrees centigrade, what is the change in the output frequency of the transmitter?

*Ans.* 4,999.88 kilocycles is the new frequency.

**Ques. 5.193.** What may cause a positive carrier shift in a linear radio-frequency amplifier output?

*Ans.* Some possible causes of positive carrier shift are

1. Improper neutralization.
2. Excessive grid bias.
3. Improper value of load impedance.
4. Overmodulation.
5. Insufficient excitation of modulated tube(s).

(See Ques. 6.42.)

**Ques. 5.194.** What is the second harmonic of 380 meters?

*Ans.* 190 meters.

**Ques. 5.195.** What is the effect of excessive coupling between the output circuit of a simple oscillator and an antenna?

*Ans.* Excessive coupling will cause what is known as a "split tuning." The load impedance coupled to the oscillator is an equivalent impedance which is the resultant of the impedances of the closed- and open-oscillatory circuits. It is impossible to keep both of these impedances exactly alike. Changes in tube constants during operation vary the impedance of the closed-oscillatory circuit, while changes in antenna capacity, caused by antenna movement, vary the impedance of the open-oscillatory circuit. If the coupling is tight, the difference between these two impedances is enough to present a broad or "two humped" load-impedance characteristic to the tube. However, it chooses the lowest impedance. If

the lowest value shifts from one circuit to the other, the frequency jumps with the shift. Split tuning can be avoided by using a loose coupling adjustment, although it must be borne in mind that loosening the coupling also reduces the radiated power. The plate current will rise and may seriously overheat the tube if coupling is too tight.

**Ques. 5.196.** A station has an assigned frequency of 8,000 kilocycles and a frequency tolerance of plus or minus 0.04 per cent. The oscillator operates at one-eighth of the output frequency. What is the maximum permitted deviation of the oscillator frequency, in cycles, which will not exceed the tolerance?

*Ans.* 400 cycles, computed as follows:  
 $3.2:8,000 = X:1,000$ ;  $X = 0.4$  kilocycle;  $X = \pm 400$  cycles.

**Ques. 5.197.** What is meant by "self-wiping" contacts as used in connection with relays?

*Ans.* "Self-wiping" contacts are contacts which slide together instead of butt together. All modern relays are constructed with self-wiping contacts.

**Ques. 5.198.** Why are permanent magnets used in head telephones? In direct-current meters?

*Ans.* To polarize the headphones so that positive current peaks deflect the diaphragm in one direction while negative peaks deflect it in the opposite direction.

Permanent magnets are used in direct-current meters to insure the operation of the meter according to the polarity markings on its terminals. Permanent magnets, as used in direct-current meters, serve to increase the accuracy of the meter and provide a fixed field which produces a torque in the moving coil in proportion to the current flowing in the coil.

**Ques. 5.199.** What devices may be used as indicators of radio-frequency energy?

*Ans.* The following devices may be used as indicators of radio-frequency energy:

1. Thermocouple galvanometer.
2. Hot-wire ammeter.
3. Neon bulb.
4. Carbon-filament glow lamp.

**Ques. 5.200.** What is the correct value of negative grid bias, for operation as a class B amplifier, for a vacuum tube of the following characteristics: Plate voltage 1,000, plate current 127 milliamperes, filament voltage 4 volts, filament current 5.4 amperes, mutual conductance 8,000 micromhos, and amplification factor 25?

*Ans.* 42 volts, computed as follows:

Cut-off point =  $\frac{E_p}{\mu} = \frac{1,000}{25} = 40$  volts plus one-half the filament voltage equals 42 volts.

**Ques. 5.201.** Is an oscillator ever neutralized? Discuss.

*Ans.* No. Neutralization is used for the purpose of preventing oscillation and the feedback of energy between the plate and grid circuits. As the primary purpose of an oscillator is to oscillate, and as the feedback of energy from the plate to the grid circuit is necessary for oscillation, the oscillator, obviously, is never neutralized.

**Ques. 5.202.** What is the definition of "type B" emission?

*Ans.* The "type B wave" may be defined as a damped wave. A damped wave is one in which the energy decreases progressively with each oscillation until the wave train dies out.

**Ques. 5.203.** Define type A1, A2, A3, and A4 emission.

*Ans.* (See Ques. 3.164 and 6.29.)

**Ques. 5.204.** In the aerial mobile service, what is the maximum period of time that operation of 333 kilocycles is permitted?

RADIO OPERATING QUESTIONS AND ANSWERS

*Ans.* In no case, in the aeronautical mobile service, must the work on 333 kilocycles (900 meters) exceed 5 minutes.

**Ques. 5.205.** Who may authorize tests or experiments by other than mobile stations?

*Ans.* The FCC inspector in charge of the district in which the transmitter is located.

**Ques. 5.206.** What is the maximum period of time during which test V's may be transmitted for purposes of adjusting a transmitter?

*Ans.* When it is necessary to make test signals, either for the adjustment of a transmitter before transmitting the call, or for the adjustment of a receiver, these signals must not last more than 10 seconds, and they must be composed of a series of V's followed by the call signal of the station transmitting for the tests.

**Ques. 5.207.** In all cases other than those in which the transmitter output must be maintained at a fixed value, what amount of power should be employed for routine communications?

*Ans.* In all circumstances, except in case of radio communications or signals relating to vessels in distress, all radio stations, including those owned and operated by the United States, shall use the minimum amount of power necessary to carry out the communication desired.

**Ques. 5.208.** What is the radiotelegraph urgent signal?

*Ans.* In radiotelegraph, the urgent signal shall consist of the group XXX transmitted three times, with the letters of each group, as well as the consecutive groups, well separated; it shall be sent before the call.

**Ques. 5.209.** What is the urgent signal for radiotelegraph use in the aeronautical service?

*Ans.* In the aeronautical service, the urgent signal PAN shall be used in radiotelegraphy and in radiotelephony to indicate that the aircraft transmitting it is in trouble and is forced to land, but that it is not in need of immediate help. This signal should, as far as possible, be followed by a message giving additional information.

**Ques. 5.210.** What is the meaning of the spoken expression MAYDAY?

*Ans.* In radiotelephony, the distress signal shall consist of the spoken expression MAYDAY (corresponding to the French pronunciation of the expression *m'aider*).

**Ques. 5.211.** In radiotelegraphy, what is the safety signal?

*Ans.* In radiotelegraphy, the safety signal shall consist of the group TTT, transmitted three times, with the letters of each group, as well as the consecutive groups, well separated. This signal shall be followed by the word DE and three transmissions of the call signal of the station sending it. It announces that this station is about to transmit a message concerning the safety of navigation or giving important meteorological warnings.

**Ques. 5.212.** What is the maximum transmission speed to be used in connection with distress, emergency, or safety transmissions?

*Ans.* When distress, emergency, or safety is involved, the telegraph transmission speed, in general, must not exceed 16 words per minute.

**Ques. 5.213.** What is the general call "to all" stations?

*Ans.* Two types of call signals "to all" shall be recognized:

1. The CQ call followed by the letter K.
2. The CQ call not followed by the letter K.

**Ques. 5.214.** What is the radiotelephone urgent signal?

*Ans.* In radiotelephony, the urgent signal shall consist of three transmissions of the expression PAN (corresponding to the French pronunciation of the word *panne*); it shall be transmitted before the call.

**Ques. 5.215.** What is the radiotelegraph distress signal?

*Ans.* In radiotelegraphy, the distress signal shall consist of the group . . . — — — . . . (SOS) transmitted as one signal, in which the dashes must be emphasized so as to be distinguished clearly from the dots.

**Ques. 5.216.** What classes of stations may be operated by the holder of a radiotelegraph permit?

*Ans.* Any station while using type B, A0, A1, A2, A3, or A4 emission, provided that, in the case of equipment designed for and using type A3 or A4 emission,

1. Such operator is prohibited from making adjustments that may result in improper transmitter operation.

2. The equipment is so designed that none of the operation necessary to be performed during the course of normal rendition of service may cause off-frequency operation or result in any unauthorized radiation.

3. Any needed adjustments of the transmitter which may affect proper operation of the station are regularly made by or in the presence of an operator holding a first- or second-class license, either telephone or telegraph, who shall be responsible for the proper operation of the equipment.

*Exceptions:* 1. The permit is not valid for the operation of any of the various classes of broadcast stations other than a relay broadcast station.

2. The permit is not valid for the operation of a ship station licensed to use type A3 emission for communication with coastal telephone stations.

3. The license is not valid for the operation of a radiotelegraph station on board a vessel required by treaty or statute to be equipped with a radio installation.

4. The license is not valid for the operation of any ship telegraph, coastal telegraph, or marine-relay station open to public correspondence.

**Ques. 5.217.** For what period of time must a station log, which contains entries incident to a disaster, be retained?

*Ans.* Logs containing distress entries shall be retained by the licensee until specifically authorized by the Commission to destroy them.

**Ques. 5.218.** Define meaning of "frequency tolerance."

*Ans.* The amount of frequency variation allowed under the regulations of the FCC for the particular class of station.

**Ques. 5.219.** Under what circumstances may a station be operated by an unlicensed person?

*Ans.* The actual operation of all licensed transmitting apparatus must be carried on by a licensed operator. However, it is provided that the Commission, if it finds that the public interest, convenience, or necessity will be served thereby, may waive or modify the provisions requiring the licensed operator, except under certain special conditions, as outlined in Section 318 of the Communications Act of 1934.

**Ques. 5.220.** If an operator is employed at more than one station, how may he comply with the rule requiring the posting of operator licenses?

*Ans.* The holder of an operator license who operates any station in which the posting of an operator license is not required may, upon filing application in duplicate, accompanied by his license, obtain a verification card. This card may be carried on the person of the operator in lieu of the original operator license, provided the license is readily

accessible within a reasonable time for inspection upon demand by an authorized Government representative.

**Ques. 5.221.** If, upon being called by another station, a called station is unable to proceed with the acceptance of traffic, what should the operator of the called station do?

*Ans.* If the station called is prevented from receiving, it shall reply to the call as indicated in the Regulations, but it shall replace the letter K by the signal .— . . . (wait), followed by a number indicating in minutes the probable duration of the wait. If this probable duration exceeds 10 minutes (5 minutes in the aeronautical mobile service), a reason must be given therefor.

**Ques. 5.222.** What is the definition of a "station open to public service"?

*Ans.* A station open to public correspondence at published rates, that is, a paid or toll message service.

**Ques. 5.223.** Under what circumstances may the Commission authorize the remote control of a radiotelegraph transmitter, with the operator at a point other than the location of the transmitter proper?

*Ans.* The Commission may modify the rule requiring an operator on duty at the place where the transmitter is located, provided that, upon proper application, a showing is made that such operator or operators may be on duty at the control station in lieu of the place where the transmitting apparatus is located.

In the case of two or more stations, except amateur and broadcast, using frequency above 30,000 kilocycles only, a licensed radio operator of any class, except amateur or holder of restricted radiotelephone or radio telegraph operator permit, who has the station within his effective control, may be on duty at any point within the communication of range of such



stations in lieu of the transmitter location or control point during the actual operation of the transmitting apparatus.

**Ques. 5.224.** How is an experimental station restricted with regard to message traffic?

*Ans.* Experimental stations shall not be used to conduct general message traffic of any kind, to demonstrate equipment for prospective sales purposes, to transmit programs for direct entertainment, to transmit the programs of any other station, except in conjunction with experimental programs, or to render any commercial communication service or communications involving advertising, either directly or indirectly, subject to specific limitations and restrictions which will be prescribed in individual cases by the Commission. This authority will be granted only for special reasons to obtain information or data which give promise of being of benefit to the radio art.

**Ques. 5.225.** Describe the procedure of a radiotelegraph transmission in which one station calls another.

*Ans.* The call shall consist of the following:

1. The call signal of the station called transmitted not more than three times.
2. The word DE.
3. The call signal of the calling station transmitted not more than three times.

**Ques. 5.226.** What is the total reactance when two capacitances of equal value are connected in series?

*Ans.* The reactance value in ohms is doubled.

**Ques. 5.227.** What are the effects of overexcitation of a class B amplifier grid circuit?

*Ans.* Overexcitation of the amplifier grid may cause an excessive value of grid current to flow which may seriously overload the tube and possibly ruin it. The regulation and

plate-circuit linearity will be completely lost owing to the loading effect upon the plate current. The plate efficiency will be greatly reduced and the power output correspondingly lowered. Plate dissipation may rise to abnormal values. Harmonic distortion will also be caused by overexcitation. (See also Ques. 5.57.)

**Ques. 5.228.** Name four devices that could be used to indicate oscillation in a crystal oscillator.

*Ans.* A direct-current milliammeter in series with the grid leak of the oscillator; the plate direct-current milliammeter; radio-frequency ammeter in the plate-tank circuit; radio-frequency galvanometer in the grid circuit; a neon tube placed near the grid or plate oscillatory leads; a wavemeter and lamp indicator placed near to the plate-tank circuit.

**Ques. 5.229.** What is the effect of loose laminations in a filter choke?

*Ans.* Loose laminations may produce a chattering or hum. The inductance may also be affected.

**Ques. 5.230.** What is a desirable feature of an electrolytic condenser as compared with other types?

*Ans.* Much greater capacity is obtainable with smaller physical dimensions as compared with other types. A wet type of electrolytic condenser also possesses self-healing properties.

**Ques. 5.231.** Why is an additional plate-grid feedback condenser sometimes necessary in a crystal oscillator?

*Ans.* The feedback condenser is sometimes employed to supply sufficient increment to start the crystal oscillating. This is particularly true where the internal grid-plate capacity of a tube is low, such as with the screen-grid types of tubes. The condenser must, however, be very small since excessive voltage surges to the quartz plate may fracture it.

**Ques. 5.232.** Who may authorize tests or experiments by stations other than mobile stations?

*Ans.* (This is a duplicate of Ques. 5.205.)

**Ques. 5.233.** Describe the construction and the operation of rectifier tubes that are used for charging batteries. Draw a diagram of a battery-charging circuit employing such a tube.

*Ans.* Figure 5-7 illustrates a typical Tungar rectifier for battery-charging requirements from an alternating-current supply source. (See also Ques. 3.185.)

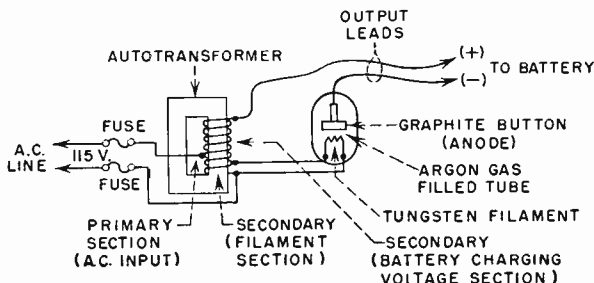

FIG. 5-7. Tungar-Rectigon type of rectifier battery charger.

**Ques. 5.234.** Draw a simple schematic diagram of a rectifier and filter for supplying plate voltage to a radio receiver.

*Ans.* See Fig. 5-8.

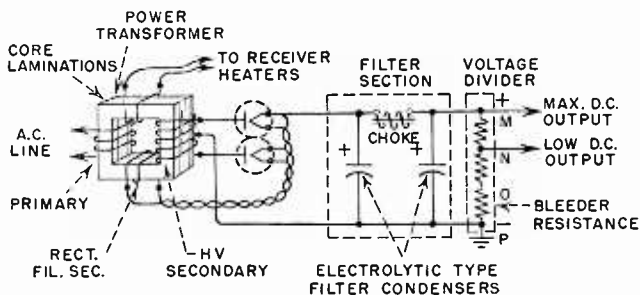

FIG. 5-8. Rectifier and filter plate supply system.

RADIO OPERATING QUESTIONS AND ANSWERS

**Ques. 5.235.** In a rectifier and filter power supply what is the relationship between the ripple frequency in the output of the filter and the input frequency to the rectifier?

*Ans.* (See Ques. 4.175, 5.93.)

**Ques. 5.236.** Compare the advantages and disadvantages of high-vacuum and hot-cathode mercury-vapor rectifier tubes.

*Ans.* (See Ques. 2.181, 2.182, 3.83, 4.176, 6.106, 6.107.)

**Ques. 5.237.** Draw a simple schematic diagram of a cold-cathode electron tube connected as a voltage regulator. As a rectifier.

*Ans.* See Fig. 5-9.

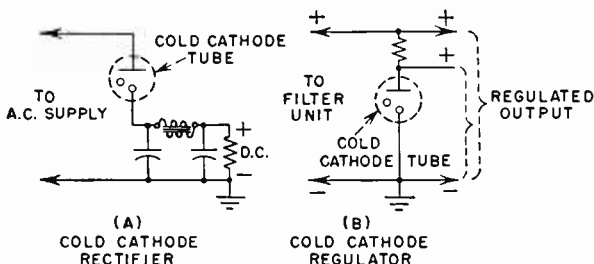

**NOTE:**  
USE OF GROUND DEPENDS ON  
CIRCUIT REQUIREMENTS

FIG. 5-9. Cold-cathode or glow-discharge tube rectifier and regulator.

**Ques. 5.238.** What is meant by "regulation" of a power supply? What causes poor regulation?

*Ans.* The "regulation" of a power supply is its ability to sustain a constant output voltage under normal varying load conditions.

Poor regulation may be due to excessive power-supply drain (overloading), insufficient or open bleeder resistance, open filter condenser, defective rectifier tube, defective voltage regulator tube (if used), insufficient filter capacitance, defec-

tive input coil, or high resistance in the filter chokes. (See Ques. 3.99.)

**Ques. 5.239.** Why are small resistors sometimes placed in series with each plate lead of mercury-vapor rectifier tubes connected in parallel?

*Ans.* (See Ques. 4.176.)

**Ques. 5.240.** Why should the temperature of the filament or heater in a mercury-vapor rectifier tube reach normal operating temperature before the plate voltage is applied?

*Ans.* The filament should be heated for approximately one-half minute before applying the anode potential to insure vaporization of the mercury and to protect the filament from excessive strain. If the plate voltage is applied before the filament temperature is raised to normal, the heavy positive-ion bombardment on the filament may break off the active material and decrease its effective emission. A new mercury-vapor tube should be heated for at least 20 minutes without plate potential to insure proper distribution of the mercury.

**Ques. 5.241.** A storage battery with a terminal voltage of 12.5 is to be trickle charged at a 0.5-ampere rate. What value of resistance should be connected in series with the battery if the trickle charge is to be made from a 110 volt direct-current line?

*Ans.* 195 ohms.

*Solution:*

$$R = \frac{E - e}{I} = \frac{110 - 12.5}{0.5} = 195 \text{ ohms.}$$

**Ques. 5.242.** If the power input to a radio receiver is 75 watts, how many kilowatt-hours does the receiver consume in 24 hours of continuous operation?

RADIO OPERATING QUESTIONS AND ANSWERS

*Ans.* 1.8 kilowatt-hours.

*Solution:*

75 watts = 0.075 kilowatts.

$0.075 \times 24 = 1.8$  kilowatt-hours (1,800 watt-hours).

**Ques. 5.243.** What is the purpose of a center-tap connection in a filament supply transformer?

*Ans.* (See Ques. 3.179.)

**Ques. 5.244.** Name two devices that are sometimes designed for use on a three-phase power supply. Does a radio receiver ordinarily use single-phase or three-phase power?

*Ans.* Transformers (delta, V, or Y), polyphase motors, mercury-arc and mercury-vapor rectifiers. Certain types of high-power transmitters, motor generators, and remote-control devices are sometimes designed for three-phase power supply. Radio receivers ordinarily use single-phase power supplies.

**Ques. 5.245.** What is a thermocouple?

*Ans.* A thermocouple or thermojunction is composed of two dissimilar metals or wires welded together at one point to form a contact of the two metals. When the junction is heated by the flow of alternating or direct currents, it will develop an e.m.f. at the free ends of the couple which may be used for deflecting a sensitive galvanometer to read the flow of radio frequency currents. See Fig. 2-29. Some types of thermocouples are composed of copper-constantan, nickel-zinc, cadmium-selenium, constantan-steel, or iron-tellurium.

**Ques. 5.246.** What are some uses of copper oxide rectifiers?

*Ans.* Copper oxide rectifiers are commonly used in conjunction with electric meters, battery chargers, plate power supplies, relays, and vacuum tubes for the conversion of alternating- to direct-current requirements.

**Ques. 5.247.** Explain methods whereby radio interference from motors and generators can be eliminated.

*Ans.* (See Ques. 3.206 and 3.216.)

**Ques. 5.248.** Describe the construction of a dynamotor. What are its operational characteristics?

*Ans.* (See Ques. 3.215.)

**Ques. 5.249.** Why do some superheterodyne receivers employ a crystal oscillator in the first detector?

*Ans.* Crystal oscillators are used in some types of commercial superheterodyne receivers in the first detector or mixer stage to insure a maximum frequency stability and calibration for one specified operating frequency. Each crystal (if a number are used) is limited mainly to one operating frequency where maximum precision and selectivity are desired. Its use is particularly desirable where single-channel reception is required.

**Ques. 5.250.** Draw a block diagram of an FM superheterodyne receiver capable of receiving continuous-wave radiotelegraph signals.

RADIO OPERATING QUESTIONS AND ANSWERS

Ans. See Figs. 3-14 and 5-10.

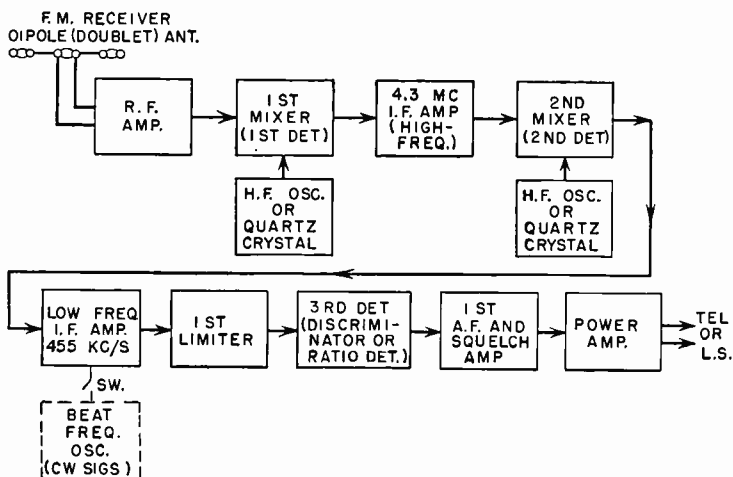

FIG. 5-10. Triple detection FM superheterodyne for mobile, land, and ship communication.

Ques. 5.251. Draw a block diagram of a superheterodyne receiver designed for reception of FM signals.

Ans. See Fig. 3-14.

Ques. 5.252. Draw a block diagram of a tuned radio-frequency type receiver.

Ans. See Figs. 3-20 and 5-11.

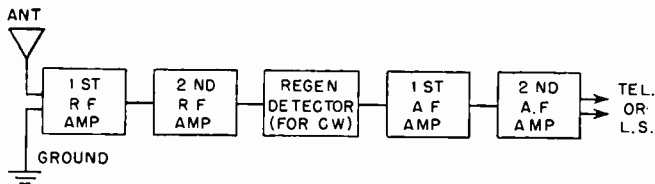

FIG. 5-11.



**Ques. 5.253.** How should a superheterodyne communications receiver be adjusted for maximum response to weak CW signals? To strong CW signals?

*Ans.* For weak-signal CW reception it is advisable to increase the radio-frequency gain control to a sufficiently high level and adjust the audio-frequency gain control to a point on which the output noise level is of a moderate intensity. The AVC switch should be in the ON position for general listening-in purposes but may be opened for weak signals reception. This would depend on the intensity of the prevailing noise level.

For strong-signal CW reception the adjustment is essentially the same with the exception that the AVC switch must be in the ON position and the radio-frequency and audio-frequency gain controls adjusted to a comfortable volume and low noise level. It is advisable sometimes when receiving very strong signals to increase the beat frequency oscillator beat response by reducing the RF gain and increasing the AF gain control settings.

**Ques. 5.254.** What is the purpose of a crystal filter in the IF stage of a superheterodyne communications receiver? Under what conditions is this filter used?

*Ans.* A crystal filter sharpens the signal response (decreases the band width) and thereby reduces interference during CW reception. It also increases the signal-to-noise ratio in the receiver.

The extremely sharp tuning provided by a crystal filter facilitates more selective CW code reception on a particular frequency in the narrow and crowded marine high-frequency bands. (See also Ques. 5.84.)

**Ques. 5.255.** Draw a simple schematic diagram of an FM receiver discriminator.

*Ans.* See Fig. 4-2J.

**Ques. 5.256.** After long periods of listening to a CW telegraph signal of constant tone, what adjustment can the operator make to a radio receiver to relieve hearing fatigue?

*Ans.* Adjust the beat frequency oscillator (BFO) frequency control or trimmer condenser to a different tonal beat frequency, preferably a low audio-frequency tone. Decrease the audio-frequency volume-control setting to a moderate tone level.

**Ques. 5.257.** Draw a simple schematic diagram of a diode detector.

*Ans.* See Figs. 2-18 and 4-19.

**Ques. 5.258.** Draw a simple schematic diagram of a two-stage audio amplifier.

*Ans.* See Fig. 2-13.

**Ques. 5.259.** Describe the construction of a pentode vacuum tube. A beam-power vacuum tube. In what types of circuits do these tubes find application?

*Ans.* (See Ques. 3.185.) Pentode tubes find their application primarily as radio-frequency voltage and power amplifiers in transmitting and receiving circuits.

Beam-power tubes are extensively used as class A power amplifiers in audio-frequency systems. They also find wide application as class B and class C radio-frequency amplifiers in marine and broadcast transmitting systems.

**Ques. 5.260.** Draw a simple circuit diagram showing the principle of operation of an ohmmeter.

*Ans.* (See Ques. 3.208.)

**Ques. 5.261.** In the operation of a class B audio-amplifier stage, should the plate current fluctuate or should it remain at a steady value?

*Ans.* The plate current will fluctuate during signal reception.

**Ques. 5.262.** What is the function of a grid leak in a class C amplifier?

*Ans.* The grid leak serves as a protective device during grid excitation in the event of a short circuit or open grid-bias supply. The grid leak under these conditions develops an automatic bias and thereby limits the plate-current rise and possible damage to the tube or other plate-circuit components.

**Ques. 5.263.** Draw a simple schematic diagram of a Hartley oscillator. A Pierce oscillator. A Colpitts oscillator.

*Ans.* See Figs. 2-2, 2-6, and 5-12.

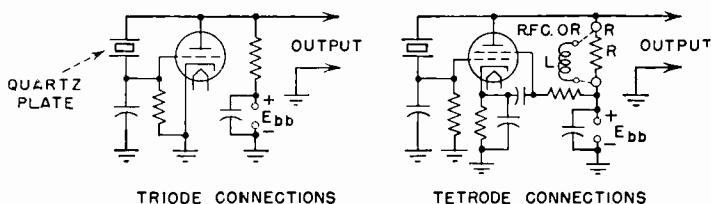

FIG. 5-12.

**Ques. 5.264.** In a series-fed plate circuit of a vacuum-tube amplifier, what would be the result of a short circuit of the plate by-pass condenser?

*Ans.* The power supply would be short-circuited, and a heavy current drain would flow in the power-supply circuit. The rectifier tube, choke coil, or plate milliammeter may burn out as a result.

**Ques. 5.265.** In a shunt-fed plate-circuit of a vacuum tube amplifier what would be the result of a short circuit of the plate RF choke coil?

*Ans.* (See Ques. 3.180.)

**Ques. 5.266.** What determines the fundamental operating frequency of a multivibrator oscillator?

Ans. (See Ques. 4.182.)

Ques. 5.267. Draw a block diagram of a MOPA radiotelegraph transmitter with the master oscillator operating on 2017.5 kilocycles and the transmitter output on 8,070 kilocycles per second.

Ans. See Fig. 5-13.

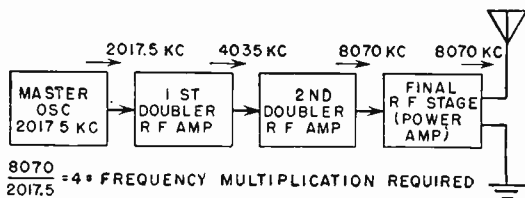

FIG. 5-13.

Ques. 5.268. Does the code speed or number of words per minute transmitted have any effect on the band width of the emission from a radiotelegraph transmitter?

Ans. At normal code speeds of 20 words per minute and with a transmitter designed for a minimum of transient responses under load changes (keying), the band width will increase slightly. However, at high-speed keying, the possibility of generating transients is considerably greater and consequently the band width may be increased to an even greater degree. Any condition in a transmitter which introduces abrupt voltage changes in the power supply during the keying process will increase the harmonic content of the wave and will therefore increase the band width.

The analysis of a keyed continuous wave may be based upon the consideration that the same situation would result by 100 per cent modulation of a square wave.

Since a square wave consists of an infinite number of odd harmonics, modulation by it will produce an infinite number of side frequencies. Fortunately, however, the amplitudes of these harmonics decrease very rapidly, so that the higher order

harmonics may be in general neglected. In practice, the first twenty-odd harmonics (1-39) are adequate to reproduce the square wave satisfactorily. On this basis, a wave keyed at 100 words per minute, which is equivalent to square-wave modulation at 40 cycles per second, will have significant side frequencies which will occupy a band width of approximately  $2 \times 40 \times 40 = 3,200$  cycles per second.

In actual equipment, there are often additional circuit transients during the keying process which may contribute higher order harmonics of considerable magnitude. This produces the well-known "key clicks."

**Ques. 5.269.** In the transmission of the International Morse Code what are the relative time lengths of dashes, dots, and spaces?

*Ans.* At code speeds of 16 words per minute the relative time length of dashes, dots, and spaces is *approximately* 3.5 to 4.5, 0.01, and 1 to 1.5 seconds, respectively. (See Ques. 6.184.)

**Ques. 5.270.** Draw a block diagram of an FM transmitter.

*Ans.* See Fig. 5-14.

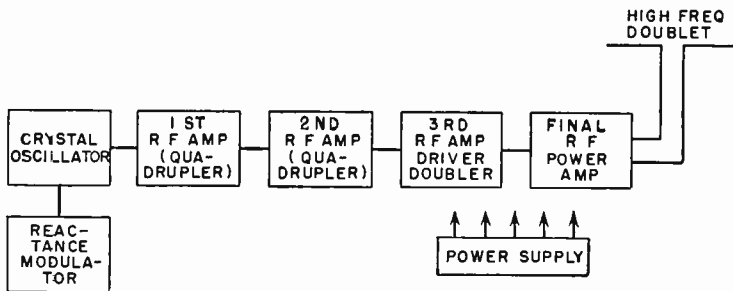

ASSUMING:-

AN OPERATING FREQ. OF 34.1 MC/S

THE CRYSTAL FREQ. REQUIREMENTS WOULD BE 1065.625 KC/S  
 [4x4x2 = 32 = FREQ. MULTIPLICATION REQUIRED]

Fig. 5-14.

**Ques. 5.271.** Show by a diagram how a radiotelegraph transmitter can be keyed by the use of a keying relay.

*Ans.* See Figs. 5-6 and 6-5.

**Ques. 5.272.** If a transmitter is adjusted for maximum power output for telegraph operation, why must the plate voltage be reduced if the transmitter is to be amplitude-modulated?

*Ans.* If the transmitter is adjusted to maximum power output for CW operation, the plate power must be decreased for amplitude modulation to accommodate the audio-frequency side-band power without overloading the power-amplifier tubes. (See Ques. 6.26.)

**Ques. 5.273.** List the various points in a radiotelegraph transmitter where keying can be accomplished.

*Ans.* In series with the center-tap or cathode return lead of the first or second amplifier tube or in the grid circuit of a separate keying tube. (See also Ques. 5.187 to 5.190.)

**Ques. 5.274.** A certain keying relay coil has a resistance of 500 ohms and is designed to operate on 125 milliamperes. If the relay is to operate from a 110-volt direct-current source, what value of resistance should be connected in series with the relay coil?

*Ans.* A 500-ohm relay coil of these specifications would require a series resistance of 380 ohms.

*Solution:*

$$E_{\text{relay}} = IR = 0.125 \times 500 = 62.5 \text{ volts.}$$

$$(110 - 62.5 = 47.5 \text{ volts})$$

$$R_s = \frac{E}{I} = \frac{47.5}{0.125} = 380 \text{ ohms.}$$

**Ques. 5.275.** What is meant by break-in operation at a radiotelegraph station, and how is it accomplished?

*Ans.* Break-in operation in a marine telegraph system is that condition which permits an operator to "listen in" during the period of transmission. When the Morse hand key is in the break or open position, a separate pair of relay contacts close the antenna and receiver circuits. This enables the other operator to interrupt transmission in the event of interference or break in message continuity.

**Ques. 5.276.** What is meant by frequency shift keying and how is it accomplished?

*Ans.* Frequency shift keying is essentially a narrow-band frequency-modulation system. In this system, information is transmitted by shifting the carrier frequency back and forth between two specific frequencies to designate marks and spaces, instead of the conventional on-and-off method of keying. It is used primarily for automatic code transmission and reception of telegraph, facsimile, teletype, and radiophoto signals.

Frequency shift keying in code transmission is generally accomplished by varying the crystal oscillator frequency through the means of an electronic modulator (reactance tube modulator) connected across the quartz plate. This causes the frequency of the crystal to be shifted in accordance with the required markers and spaces to be transmitted.

**Ques. 5.277.** Why does harmonic radiation from a transmitter sometimes cause interference at distances from a transmitter where the fundamental signal cannot be heard?

*Ans.* Harmonic radiation of high-frequency transmitters may cause interference at remote points due to the Heaviside or ionosphere layer reflections. Since harmonics are at higher frequencies than the fundamental operating frequency, their transmission characteristics may be entirely different from the normal frequency due to critical angles of reflection which vary throughout the season and time of the day. This phenomenon is commonly referred to as "skip distance."

**Ques. 5.278.** What is meant by polarization of a radio wave? How does polarization affect the transmission and reception of a radio wave?

*Ans.* (See Ques. 3.199 and 3.200.)

**Ques. 5.279.** What is meant by harmonic radiation?

*Ans.* Harmonic radiation refers to the transmission of the undesired frequencies which are an integral multiple part of the fundamental operating frequency. (See also Ques. 2.237.)

**Ques. 5.280.** How may harmonic radiation of a transmitter be prevented?

*Ans.* Harmonic radiation may be prevented by special attenuator or trap circuits in the output of the transmitter or transmission line. Such factors as high  $C/L$  tank circuit ratio, loose coupling, balanced power-amplifier outputs, impedance matching, and breaking up of metal supports such as guy wires are important requirements toward the reduction of harmonics. See also Figs. 4-7, 4-8.

**Ques. 5.281.** Draw a diagram showing how current varies along a half-wavelength Hertz antenna.

*Ans.* See Fig. 3-22.

**Ques. 5.282.** What is the difference between a Hertz and a Marconi antenna?

*Ans.* The Hertz antenna is a half-wave ungrounded radiator or dipole. The Marconi antenna is a quarter-wave grounded antenna of the inverted variety.

**Ques. 5.283.** Why is an artificial antenna sometimes used in testing a transmitter?

*Ans.* (See Ques. 3.76 and 6.140.)

**Question. 5.284.** Draw a simple schematic diagram of a wave trap in an antenna circuit for attenuating an interfering signal.



*Ans.* See Fig. 3-19. (See also Ques. 2.276.)

**Ques. 5.285.** What are the advantages and disadvantages of using an absorption-type wavemeter in comparison to other types of frequency meters?

*Ans.* The advantage of the absorption-type wavemeter is simplicity of operation. However, since it is generally placed near the transmitter and is a power-absorbing device, it is not very selective. Care must also be exercised to prevent burning out the galvanometer or lamp indicator when testing transmitters.

**Ques. 5.286.** Draw a simple schematic diagram of an absorption-type wavemeter.

*Ans.* (See Ques. 3.207.)

**Ques. 5.287.** What are cavity resonators, and in what type of radio circuits do they find application?

*Ans.* (See Ques. 3.211.)

**Ques. 5.288.** What are wave guides, and in what type of radio circuits do they find application?

*Ans.* (See Ques. 3.211.)

**Ques. 5.289.** What determines the operating frequency of a magnetron oscillator? A klystron oscillator?

*Ans.* The operating frequency of a magnetron is primarily dependent upon its physical structure and its associated powerful permanent magnet. The magnetron's physical structure is in the form of a cylinder of copper with holes, or cavities, and a cathode, inside. The holes are called the *resonant cavities*, because they are capable of sustaining a definite frequency. The cavity "tuning" depends upon the size and shape of the holes. The smaller the cavity the higher the frequency.

Other factors which affect the operating frequency are the

pulse voltage, the strength of the magnetic field, the cathode voltage, the anode potential, and the radio-frequency tuning adjustments. Split-anode-type magnetrons use either two-wire resonant lines with movable shorting bars or small tank circuits of  $L$  and  $C$  to vary the frequency.

The klystron oscillator also operates upon the principle of cavity resonance. Unlike the magnetron, however, the reflex klystron has an accelerating grid, a repeller plate, and two main grids connected to a split cavity or resonant chamber. The frequency is determined primarily by varying the volume of the resonant cavity.

The repeller voltage may also be varied over a narrow range to provide minor adjustments in operating frequency. Some tubes use an external cavity with screw plugs for tuning, while others have means for varying the grid spacings.

**Ques. 5.290.** In what radio circuits do klystron and magnetron oscillators find application?

*Ans.* The magnetron finds application in the field of pulse technics such as radar as a generator of super-high-frequency oscillations (microwaves) and also for continuous telegraph wave transmissions at these or lower frequencies.

The magnetron is used almost exclusively where extremely high power transmission is required at microwave frequencies between 1 and 10 centimeters in wavelength.

The klystron finds its application in the microwave field as a local oscillator in a superheterodyne receiver, a precision heterodyne frequency meter, a low-power oscillator transmitter, or a frequency multiplier for precision control applications and primary frequency standard measurements. The klystron is frequently used in the frequency spectrum of 1,000 through 30,000 megacycles.

**Ques. 5.291.** What is the primary standard of frequency for radio-frequency measurements for all licensed radio stations?

*Ans.* (See Ques. 3.241 and 4.164.)

**Ques. 5.292.** List five classes of radio stations which may be operated by the holder of a restricted radiotelegraph operator permit.

*Ans.* See Appendix II.

**Ques. 5.293.** Where should the operator on duty at a manually operated radiotelegraph station post his operator license or permit?

*Ans.* See Appendix II.

**Ques. 5.294.** How often should visual observation be made of the antenna lights at a radio station which has towers or antenna supporting structures which are required to be lighted?

*Ans.* (See Ques. 3.246.)

**Ques. 5.295.** What data relative to antenna lighting is required to be entered in the log of a radio station which has towers or antenna supporting structures that are lighted?

*Ans.* The operator is required to enter in his log the time of observed failure and the action taken. During normal operation an entry must be recorded at least once every 24 hours. He shall inspect at intervals of at least once each three months all flashing or rotating beacons and automatic control devices and record his findings in the log.

**Ques. 5.296.** What steps should be taken by an operator on duty at a radio station when failure of the antenna lights or beacons occurs?

*Ans.* The operator shall report immediately by telephone or telegraph to the nearest Airways Communication Station or Office of the Civil Aeronautics Administration (CAA) any observed failure of the tower lights not corrected within 30 minutes, regardless of the cause of such failure. Further notice shall be given immediately upon resumption of the required illumination.

## ELEMENT 6

### ADVANCED RADIOTELEGRAPHY

**Ques. 6.01.** What are the ratios between the average, effective, and peak values of a sinusoidal wave?

*Ans.* The various ratios are as follows:

$$\text{Peak to effective} = \frac{1}{0.707} = 1.414:1.$$

$$\text{Peak to average} = \frac{1}{0.637} = 1.57:1.$$

$$\text{Effective to average} = \frac{0.707}{0.637} = 1.11:1.$$

Any of these values may readily be transposed for another desired ratio.

**Ques. 6.02.** Define the following terms: "hysteresis," "permeability," "eddy currents."

*Ans.* "Hysteresis" is the molecular friction produced by the alternating-current reversals in a magnetic-core material. It is the lagging effect of the magnetic flux with respect to the magnetizing force that produces it.

"Permeability" is the ease of magnetic conduction through a magnetic material as compared to air. It is the measure of the relative conductivity of iron or any magnetic material compared with air.

"Eddy currents" are the circulation of small currents through the interior of a solid mass of conducting material. These currents are caused by the generation of small e.m.fs. owing to the movement of a magnetic field near a material or

the movement of the material itself in a magnetic field. These currents as set up are similar to swirls of water in their motion with respect to the flow of water which is causing them. Hence the term "eddy currents."

**Ques. 6.03.** What is the total impedance of a series alternating-current circuit having an inductive reactance of 14 ohms, a resistance of 6 ohms, and a capacitive reactance of 6 ohms?

*Ans.* The impedance is 10 ohms.

**Ques. 6.04.** What is the total impedance of a series alternating-current circuit having an inductive reactance of 14 ohms, a resistance of 6 ohms, and zero capacitive reactance.

*Ans.* The total impedance is 15.2 ohms.

**Ques. 6.05.** What changes in circuit constants will double the resonant frequency of a resonant circuit?

*Ans.* By halving the inductance and the capacitance values or dividing the  $LC$  value by 4.

**Ques. 6.06.** How may the  $Q$  of a parallel resonant circuit be increased?

*Ans.* The  $Q$  of a parallel resonant circuit is determined by the ratio,  $\frac{2\pi fL}{R}$ . Increasing the  $Q$  is generally accomplished practically by reducing the resistance and absorption losses of the coil and circuit by reducing the radio-frequency resistance of the coil and leads. In addition, by the use of special low-loss dielectric supporting forms made from materials such as quartz, isolantite, micalex, and so forth for both coils and tuning condensers. These are the general considerations for increasing the  $Q$  of oscillatory circuits although such factors as core material and mutual coupling must also be considered in changing the  $Q$ , the figure of merit for efficiency.

**Ques. 6.07.** If a parallel circuit, resonant at 1,000 kilocycles, has its values of inductance halved and capacity doubled, what will be the resonant frequency?

*Ans.* 1,000 kilocycles.

**Ques. 6.08.** Assume a resistance of 8 ohms in parallel with a resistance of 6 ohms: in series with this combination is a resistance of 77 ohms. What is the total resistance of the combination?

*Ans.* Reducing the parallel combination to its effective resistance we obtain,  $R_{\text{eff}} = \frac{R_1 \times R_2}{R_1 + R_2} = 3.42$  ohms.

Thus,  $R_3 + R_{\text{eff}} = 80.42$  ohms.

**Ques. 6.09.** Assume an inductance of 5 henrys in parallel with a capacitance of 1 microfarad. If there is no resistance in either leg of this circuit, what is the equivalent impedance of the parallel network at resonance?

*Ans.* The impedance looking into the network at resonance will be theoretically infinite. This may be seen from the parallel-resonance impedance equation,

$$Z = \frac{X_L^2}{R} \text{ ohms.}$$

As the denominator in the equation is reduced, the impedance rises. The impedance of the combination inside the circulating network will, on the other hand, be zero.

**Ques. 6.10.** Why are iron cores, of the type used in audio-frequency transformers, not used in radio-frequency transformers?

*Ans.* There are two primary reasons why this is not done:

1. The iron cores as used in audio-frequency transformers would present hysteresis and eddy-current losses of too high a value to allow practical efficiencies. Dust cores of iron and alloys have been successfully used at low radio frequencies.

2. Radio-frequency transformers generally respond to a narrow band of radio frequencies. They must possess selective qualities in order to effect sharp tuning. Large iron cores would defeat this purpose. The iron cores such as are used in audio transformers permit a broad-frequency response to enable the passage of the speech and musical frequencies. This range for the average audio-frequency transformer is between 30 and 6,000 cycles per second and for the higher grade types between 25 and 10,000 cycles per second.

**Ques. 6.11.** Why should the metallic case of a high-voltage transformer be grounded?

*Ans.* The metallic case of a high-voltage transformer is grounded to eliminate the building up of an electric field between the case and nearby objects. The grounding of the case also relieves the strain upon the high-voltage windings and the insulation. Grounding also serves as a physical protection against shocks between case and ground.

**Ques. 6.12.** What turns ratio should a transformer have which is to be used to match a source impedance of 500 ohms to a load of 10 ohms?

*Ans.* The correct turns ratio may be determined by the equation,

$$\text{Turns ratio} = \sqrt{\frac{Z_p}{Z_s}} = \sqrt{\frac{500}{10}} = 7.1, \text{ or } 7.1:1.$$

where  $Z_p$  = primary impedance.

$Z_s$  = secondary impedance.

**Ques. 6.13.** What would happen if a transformer, designed for operation on 500 cycles, were connected to a 60-cycle source of the same voltage?

*Ans.* The decrease in frequency would result in a heavy flow of current through the primary winding and may possibly cause it to burn out. This is due to the fact that the imped-

ance decreases as the frequency is lowered and would offer less opposition to the flow of alternating current.

**Ques. 6.14.** What would happen if a transformer, designed for operation on 60 cycles, were connected to a 120-cycle source of the same voltage?

*Ans.* The increase in frequency would lower the current flow through the primary winding due to the increase of the primary impedance. No damage would result, only a decrease in the output capabilities of the transformer.

**Ques. 6.15.** What is the principal disadvantage of using a dynamotor rather than a motor generator to furnish plate power to a small mobile transmitter?

*Ans.* The voltage output of a dynamotor is dependent upon the stability of the source voltage. Since the source voltage is generally of the battery variety the stability of the plate voltage may be affected with the change from full-load to light-load conditions. The variation in fully charged as compared with low-charged battery conditions will affect the generator output. The dynamotor, furthermore, does not possess the high degree of voltage output stability which the motor generator possesses.

**Ques. 6.16.** How may the voltage output of a dynamotor be regulated?

*Ans.* This may be accomplished by increasing or decreasing the source voltage.

**Ques. 6.17.** What is the line current of a single phase 7-horsepower alternating-current motor when operating from a 120-volt line at full-rated load and at a power factor of 0.8 and 95 per cent efficiency?

*Ans.* The line current under the above stated conditions will be 57.5 amperes. 1 horsepower = 746 electrical watts. 7 horsepower = 5,222 watts.



$$I = \frac{P}{E \times p.f. \times Eff.}$$

$$= \frac{5.222}{120 \times 0.80 \times 0.95} = 57.2 \text{ amperes.}$$

**Ques. 6.18.** What is the effect of an inductive load on the output voltage of an alternator?

*Ans.* An inductive load placed on the output terminals of an alternator will decrease its voltage and cause a lagging power factor.

**Ques. 6.19.** What is the principal advantage of the dynamotor, rather than the motor generator, to furnish plate power to a small mobile transmitter?

*Ans.* The principal advantage of the dynamotor over the motor generator is its compactness. In the dynamotor two separate armatures have their respective windings placed over a common iron core. The motor field and generator field are one unit which receives its excitation from the same source as the motor armature. It is a very compact and convenient unit for operation from a 6-volt storage battery to deliver plate supply voltages of 400 or more volts.

**Ques. 6.20.** Define "voltage regulation."

*Ans.* "Voltage regulation" is the change in voltage between full load and no load referred to the full-load value and expressed in per cent.

Voltage regulation in per cent may be determined by the following formula:

$$\text{Voltage regulation} = \frac{(\text{no-load voltage} - \text{full-load voltage})100}{\text{full-load voltage}}$$

**Ques. 6.21.** What means may be used to measure radio-frequency current?

*Ans.* Thermocouple ammeter, hot-wire ammeter.

**Ques. 6.22.** How may the range of a thermocouple ammeter be increased?

*Ans.* The range of a thermocouple ammeter may be increased by the insertion of a higher range thermocouple properly calibrated to fit the galvanometer for the higher range or by a low resistance (low-temperature-coefficient shunt) connected across the thermocouple current-carrying strip. The latter method is recommended only in cases of emergency. If the thermocouple is a separate unit, a multiplier resistor may be used in series with the meter.

**Ques. 6.23.** Does the scale of an alternating-current ammeter indicate peak or average current values? Explain your answer.

*Ans.* An alternating-current ammeter indicates neither peak nor average current values. The conventional alternating-current ammeter indicates effective current values. The average or peak values of a sinusoidal wave taken over a complete cycle is zero and consequently no deflection of these values can be obtained with ordinary alternating-current meters.

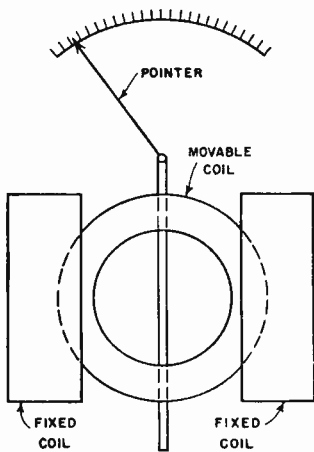

FIG. 6-1. Dynamometer-type meter.

The theoretical reason for this condition may be more clearly understood by analyzing the action of the electro-dynamometer. This is an alternating-current or alternating-voltage indicating device which operates upon the principle illustrated in Fig. 6-1.

Two stationary coils are connected in series with a movable coil and a pointer. The electrical connection to the moving coil is made through two springs which also serve to resist the turning

force of the coil produced by the current. The force which tends to move the coil is proportional to the product of the field strength of the stationary and movable coils. Now since the field strength of each is proportional to the current which is flowing through them, the force tending to turn the coil at any instant is proportional to the square of the current flowing at that instant. Therefore, as this current varies from zero to the peak value for every half cycle, the force will also vary from zero to peak value each half of the cycle. The inertia of the coil, however, does not permit it to move rapidly enough to follow these fluctuations and, therefore, the pointer attached to the moving coil moves to a point corresponding to the average value of the deflecting force. Now since this is a measure of the current squared it will, therefore, be proportional to the effective value of the current.

**Ques. 6.24.** How may the power in an alternating-current circuit be determined?

*Ans.* The true power expended in an alternating-current circuit may be determined by a direct reading wattmeter or by the readings of an alternating-current voltmeter and an alternating-current ammeter multiplied by the power factor of the circuit. The power factor of a circuit is determined by the ratio of the resistance to the impedance of the circuit,

$$\text{Power factor} = \frac{R}{Z} \text{ or } \frac{W}{EI}$$

$$\text{Power} = E \times I \times Pf \text{ watts.}$$

**Ques. 6.25.** A ship's transmitter has an antenna current of 8 amperes using A1 emission. What would be the antenna current when this transmitter is 100 per cent modulated by sinusoidal modulation?

*Ans.* When a continuous-wave transmitter is modulated by 100 per cent sinusoidal modulation the increase in antenna current will be 22.5 per cent. An increase of 22.5 per cent may be calculated by multiplying the unmodulated antenna current by 1.225, thus  $8 \times 1.225 = 9.8$  amperes.

**Ques. 6.26.** The direct-current plate input to a modulated class C amplifier, with an efficiency of 60 per cent, is 200 watts. What value of sinusoidal audio power is required in order to insure 100 per cent modulation? 50 per cent modulation?

*Ans.* For 100 per cent modulation, the modulator tube must supply audio-frequency power equal to 50 per cent of the unmodulated carrier plus 50 per cent of the power dissipated in the modulated-amplifier plate when unmodulated. Thus the audio-frequency power supplied by the modulator is,

$$P_{\text{mod}} = \frac{m^2 P_0}{2n}$$

where  $m$  = modulation factor.

$n$  = estimated efficiency of the class C amplifier.

$P_0$  = unmodulated carrier power.

Since the input power in this example is 200 watts and the plate dissipation at 60 per cent efficiency is 80 watts the output power will be 120 watts. Thus the audio-frequency power required at 100 per cent modulation may be found by the equation,

$$\frac{1^2 \times 120}{2 \times n} = 100 \text{ watts.}$$

Now since the modulation factor for 100 per cent modulation is equal to 1 the modulation factor for 50 per cent modulation will be 0.5 (modulation factor  $\times$  100 = percentage of modulation). Thus, for 50 per cent modulation the audio-frequency power required will be

$$\frac{0.5^2 \times 120}{2 \times n} = \frac{0.25 \times 120}{1.2} = 25 \text{ watts.}$$

**Ques. 6.27.** What increase in antenna current will be observed when a radiotelephone transmitter is 100 per cent modulated by a sinusoidal wave form?

*Ans.* The antenna current when modulated 100 per cent will show an increase of 22.5 per cent over the unmodulated value assuming single-tone sinusoidal excitation.

**Ques. 6.28.** What is the total band width of a transmitter using A2 emission with a modulating frequency of 800 cycles and a carrier frequency of 500 kilocycles?

*Ans.* The band width of a 500 kilocycles radio frequency wave modulated at a modulating frequency of 800 cycles is 1,600 cycles or 1.6 kilocycles. The band width is computed on the basis of the upper and lower side-band frequencies,  $500,000 + 800$ ,  $500,000 - 800$ . The width of the band, therefore, is the difference between the upper and lower side bands.

**Ques. 6.29.** What are the general characteristics of the emission of a radiotelegraph transmitter which uses a chopper to obtain A2 emission?

*Ans.* Figure 6-2 illustrates all types of emissions.



TYPE A0 AND A1

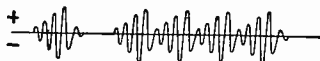

TYPE A2 (FULL WAVE)

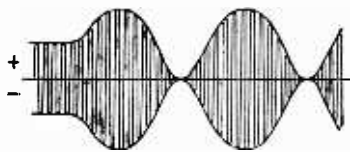

TYPE A3



TYPE A2 (CHOPPER)

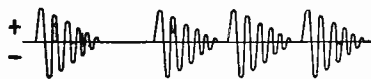

TYPE B

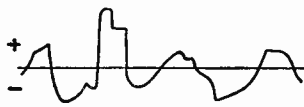

TYPE A4 AND A5

FIG. 6-2. Types of radio-wave emissions.

**Ques. 6.30.** How should the grid bias of a grid-modulated radio-frequency stage be adjusted?

*Ans.* The grid bias of a grid-modulated radio-frequency stage should be adjusted to a voltage value  $1\frac{1}{2}$  to 4 times the plate-current cut-off value.

**Ques. 6.31.** Compare the characteristics of plate and grid-bias modulation.

*Ans.* In the plate-voltage modulation (constant plate impedance) system the audio-frequency voltage is applied directly to the plate circuit of the radio-frequency stage to be modulated. In this system of modulation the source of signal voltage must supply a large part of the power supplied to the plate circuit. The operating efficiency is about 65 per cent.

In the grid-bias modulation (variable plate impedance) system the audio-frequency voltage, as well as the carrier voltage, is applied to the grid circuit. This system has the advantage over the plate modulation system in that it requires much lower exciting audio-frequency grid voltage, but gives a slight amount of increase in distortion. Efficiency is about 33 per cent.

Linear plate- and grid-modulation systems produce much less distortion compared with most systems at high modulation percentages. In addition, they are excellent for use in high-power transmission because of their high ratio of useful power output to the total power supplied to the plate circuit. The grid-bias adjustment in the modulated radio-frequency stage is  $1\frac{1}{2}$  to 4 times plate current cut-off in both systems.

**Ques. 6.32.** Is a high degree of modulation desirable in connection with a self-excited type of transmitter? Explain.

*Ans.* No. There are several very important reasons why a self-excited oscillator should not be modulated at a high degree of modulation. These are itemized as follows:

1. Frequency instability caused by power-supply load changes.

2. Frequency instability caused by changes in antenna constants, such as a swinging antenna, humidity changes, etc.

3. Rapid changes in frequency and amplitude, particularly with high percentages of modulation, will cause heavy changes in the output carrier frequency.

4. Poor quality of transmission.

5. Broader tuning response at the receiving station which may result in adjacent-station interference.

**Ques. 6.33.** What is meant by "low-level modulation"?

*Ans.* The term "low-level modulation" is applied to those types of radiotelephone transmitters in which the audio-frequency signal is applied to some one of the radio-frequency amplifier stages preceding the final power-amplifier stage.

**Ques. 6.34.** Why is a series resistor used in the direct-current plate supply of a modulated radio-frequency amplifier, between the amplifier and the modulator, in a Heising modulation system?

*Ans.* The dropping resistor is used in order that the radio-frequency amplifier will operate at a direct-current plate voltage lower than that of the modulator. This is necessary in order that the radio-frequency amplifier stage will be completely modulated. In other words, if the radio-frequency amplifier voltage is one-third less than that of the modulator, the radio-frequency amplifier will be completely modulated when the modulator develops a peak output voltage of two-thirds the direct-current plate potential.

**Ques. 6.35.** Should the efficiency of a grid-bias modulated stage be maximum at complete modulation or zero modulation? Explain.

*Ans.* The efficiency of a grid-bias modulated stage should be a maximum at complete modulation. This is so because the efficiency of plate-power conversion will be higher at complete modulation because some direct-current grid current

will be drawn at modulation peaks. It is, of course, important that the grid-current flow be not excessive, since that condition would introduce distortion. If the grid bias on a grid-modulated system is adjusted so that no grid current flows even on high peaks poor economy will result.

**Ques. 6.36.** What is the purpose of a plate choke as used in Heising modulation?

*Ans.* The primary purpose of the plate choke, or plate reactor, as it is commonly called, is to maintain a constant current in the modulator and modulated-amplifier plate circuits. The Heising system of modulation is often called the "constant current system" of modulation owing to the action of the plate reactor. The action of the choke may be more clearly understood from the following explanation: since the plate reactor is connected in the positive lead of the direct-current power supply and feeds simultaneously the voltage to the plates of both the modulator and the modulated-amplifier tubes any changes in the current flow in either plate circuit will be affected by the self-inductance of the coil. That is to say, when the grid of the modulator tube swings positive the plate current in this stage will increase. Owing to the large inductance of the reactor, however, the rise in current will change the polarity in accordance with the laws of induction. Thus the voltage developed across it by the expanding magnetic field will be 180 degrees out of phase with the direct-current voltage. This results in a decrease in the voltage on the plate of the modulated-amplifier tube owing to the bucking effect of the plate reactor upon the direct-current generator. When the grid of the modulator swings negative on the next half of the audio-frequency cycle the modulator plate current decreases. This causes the magnetic field around the plate reactor to contract thereby putting the reactor voltage in phase with the supply generator and increasing the voltage upon the plate of the modulated power-amplifier tube. This complete action varies the modulated-amplifier



voltage in accordance with the modulator changes and consequently varies the amplitude of the carrier frequency at an audio frequency.

**Ques. 6.37.** Does grid current flow in the conventional grid-bias modulated stage of a radiotelephone transmitter, under modulated conditions?

*Ans.* Yes. Grid current flows in slight amounts during the positive peaks of the audio-frequency excitation cycle. (See also Ques. 6.35.)

**Ques. 6.38.** If the first speech-amplifier tube of a radiotelephone transmitter were overexcited, but the percentage modulation capabilities of the transmitter were not exceeded, what would be the effect upon the output?

*Ans.* Overexcitation of the first tube in the speech input equipment would produce nonlinear distortion (amplitude distortion) in the plate circuit of the first tube which would be greatly amplified in each of the succeeding stages. Obviously this would badly distort the wave form of the modulated carrier and resulting transmission. The effect of amplitude distortion is generally referred to as *overloading* in the case of overexcitation.

**Ques. 6.39.** What types of microphones have a high impedance output?

*Ans.* Condenser and piezo-electric (crystal) types of microphones have a large output impedance. All microphones which operate upon the electrostatic principle are of the high-output impedance variety. Carbon microphones have a high-output impedance as compared with the low-impedance variety such as the dynamic or velocity types, but their impedance is low compared to the condenser and crystal types.

**Ques. 6.40.** What are the advantages of the single-button carbon microphone?

*Ans.* The main advantage of the single-button carbon microphone is that it does not require the careful adjustment of button balance since only a one-button current flows through the output transformer winding. In the double-button types the two currents in the respective halves must be carefully balanced for proper symmetry. Other advantages of the single button microphone are its relatively low cost, very high output, and low current consumption.

**Ques. 6.41. Why is a speech amplifier used?**

*Ans.* Speech amplifiers are used to build up the voltages developed by the microphones to higher voltage amplitudes. High-audio-voltage amplitudes are required to transmit speech and musical frequencies to the modulating circuits, line circuits, and reproducers. Speech amplifiers are generally referred to as "voltage" or "gain" amplifiers. In any case where it is required to increase the audio-frequency voltage output of feeble generating (alternating-current) sources, a voltage or speech amplifier may be used.

**Ques. 6.42. What might be the cause of a positive carrier shift during modulation?**

*Ans.* Carrier shift is that condition in a modulated wave in which the *average* value of the transmitted wave is changed in an upward or downward direction. Any situation which will change the average direct-current plate reading of the linear power-amplifier stage upward during modulation produces a positive carrier shift, and if downward, a negative carrier shift. In other words, any upset in the plate-circuit symmetry may cause a shift. Overmodulation *may* be the cause of either a positive or a negative carrier shift. Some other causes for a positive carrier shift are: excessive grid bias, poor bias-supply regulation, insufficient radio-frequency excitation. Negative carrier shift may be caused by: poor plate-supply regulation, insufficient grid bias or excessive radio-frequency excitation which causes grid current to flow,

**Ques 6.43.** What is the relation between the direct-current power input of the plate circuit of the stage being modulated, and the output audio power of the modulator for 100 per cent sinusoidal modulation?

*Ans.* For distortionless 100 per cent modulation capabilities the direct-current power input to the modulated radio-frequency amplifier stage should be twice the modulator's undistorted audio-frequency power output.

**Ques. 6.44.** In 100 per cent amplitude modulation, what is the ratio of peak antenna current to unmodulated antenna current?

*Ans.* The ratio of peak antenna current to unmodulated antenna current at 100 per cent modulation is 2:1, the peak modulated value rising to double the unmodulated value.

**Ques. 6.45.** In 100 per cent modulation, what is the ratio of instantaneous peak antenna power to unmodulated antenna power?

*Ans.* The peak power at 100 per cent modulation is four times the unmodulated power or, a ratio of 4:1

**Ques. 6.46.** Using a regenerative receiver, without radio-frequency amplifier stages, describe how you would adjust to receive radiotelegraph signals through interference.

*Ans.* To increase the selectivity of a regenerative receiver so as to reduce interference to a minimum, reduce the coupling between the primary and the secondary of the tuner and carefully retune the circuit to resonance by varying the secondary tuning condenser. Gradually increase the regeneration control to the point just before where self-oscillation is produced. Repeat the process critically by varying each of the tuning adjustments; namely, antenna series condenser, secondary tuning condenser, and the regeneration feedback control. Various degrees of loose coupling values should be chosen until

the proper degree of selectivity is obtained. It is important to remember however that each time the coupling is varied the circuit must be entirely retuned.

For continuous-wave reception the process is the same, with the exception that the regeneration control is increased to the point of self-oscillation so that an audible beat note may be produced.

**Ques. 6.47.** What is the effect upon the sound of received type B emission if the receiver detector is oscillating?

*Ans.* The tone frequency of the damped wave becomes badly distorted and it has a "mushy" tone characteristic.

**Ques. 6.48.** What effect does an incoming signal have upon the plate current of a triode detector of the grid-leak type?

*Ans.* The plate current will decrease. This is due to the fact that the grid-condenser blocking action causes a negative building up process or grid bias upon the grid with respect to the cathode. In other words, the grid leak develops an automatic grid bias during the periods in which the incoming signals prevail, thereby reducing the plate current.

**Ques. 6.49.** If broadcast signals interfered with your reception of signals on 500 kilocycles while aboard ship, how would you reduce or eliminate such interference?

*Ans.* The interference may be reduced or eliminated by the use of a tunable wave trap connected in the antenna circuit. The trap circuit is then tuned to the undesirable frequency. See Fig. 3-19.

**Ques. 6.50.** Describe how you could test a regenerative receiver to determine if the detector were in an oscillating condition?

*Ans.* One of the simplest tests to ascertain if the detector is in an oscillating condition is to touch the finger to the grid

of the tube. A loud "cluck" or "plop" should be heard in the telephones if the receiver is oscillating. Another simple test would be to bring the regeneration control up slowly from its minimum position towards maximum until a similar "plop" is heard. This will indicate that the circuit has gone into oscillation.

**Ques. 6.51.** Discuss the relative advantages and disadvantages of a stage of radio-frequency amplification as compared to a stage of audio-frequency amplification, for use in connection with a regenerative receiver.

*Ans.* The relative advantages of a stage of radio-frequency amplification in connection with a regenerative receiver are as follows:

1. Provides an increase in sensitivity.
2. Increases the circuit selectivity.
3. Eliminates reradiation from the oscillating detector into the antenna system.
4. Reduces the possibility of "dead spot" points when the oscillating detector is resonated with the antenna circuit.

The disadvantages of a stage of radio-frequency amplification before the oscillating detector are as follows:

1. A stage of radio-frequency amplification does not give so much audio-frequency volume as does one stage of audio-frequency amplification. This is particularly true if high step-up ratio audio-frequency transformers are used.
2. A radio-frequency stage requires careful shielding and filtering of all component parts to insure circuit stability. Design considerations are more exacting.
3. It generally requires an additional tuning stage.
4. It may require neutralization of inter-electrode grid-plate capacity to prevent amplifier self-oscillation.

**Ques. 6.52.** If a ship's regenerative receiver failed to oscillate when the regeneration control was advanced, explain the possible causes and remedies.

*Ans.* The following are the common causes for failure of a regenerative receiver to oscillate:

1. Low filament supply potential.
  2. Deactivated filament. (Poor filament emission.)
  3. Run-down plate-supply batteries.
  4. Open plate by-pass condenser.
  5. Open grid-coupling condenser.
  6. Open grid leak.
  7. High resistance contacts in some portion of the circuit.
- The remedies in each case are obvious.

**Ques. 6.53.** Explain how you would test the various components of a receiver of the three-circuit regenerative type in trouble shooting.

*Ans.* Two basic tests are essential in trouble shooting a three-circuit regenerative receiver, namely;

1. Point-to-point continuity test with an ohmmeter or a pair of telephones with a battery in series, and
2. Voltmeter test.

The first step in servicing a receiver is to replace the old tubes with new ones to eliminate this common source of trouble. Then proceed as follows:

1. Test the voltages of the filament supply and plate supply across the filament terminals and plate to filament respectively with the voltmeter.
2. If the voltmeter indicates a reading when it is connected between the plate and the cathode at the socket terminals, it is evident that the entire plate circuit is continuous.
3. Test the circuit continuity with the ohmmeter or battery-telephone combination from the control grid to the cathode.
4. Test the continuity of the antenna coil by the same method.
5. Test all condensers for leaks or shorts.

**Ques. 6.54.** What is the effect of connecting a high value of resistance in parallel with the primary of an audio transformer in a regenerative receiver?

*Ans.* A high resistance connected across the primary winding of an audio-frequency transformer in a regenerative receiver prevents the annoying condition known as "fringe howl." The value of resistance should be in the order of 100,000 ohms.

**Ques. 6.55.** Why should a superheterodyne receiver, used for reception of A1 signals, be equipped with at least one stage of radio-frequency amplification ahead of the first detector?

*Ans.* A stage of radio-frequency amplification before the first detector serves as a pre-selector and reduces the possibility of image interference.

**Ques. 6.56.** What is the chief advantage to be gained in the utilization of high intermediate frequencies in a superheterodyne receiver?

*Ans.* The chief advantage to be gained in using high intermediate frequencies in a superheterodyne receiver is the reduction of image-frequency interference.

**Ques. 6.57.** If a superheterodyne receiver is receiving a signal on 1,000 kilocycles and the mixing oscillator is tuned to 1,500 kilocycles, what is the intermediate frequency?

*Ans.* The intermediate frequency is the difference between the incoming signal and the mixing oscillator frequency or, 500 kilocycles.

**Ques. 6.58.** Why is a diode detector employed in most modern radio receivers?

*Ans.* Diode detectors are used in most modern receivers because they more closely approach the ideal detecting or signal rectifying characteristics. In other words, a detection characteristic is obtained which resembles a straight line or linear character and, as a result, develops an audio signal of minimum distortion.

## RADIO OPERATING QUESTIONS AND ANSWERS

**Ques. 6.59.** What is the purpose of an auxiliary receiving antenna installed on a compulsorily equipped vessel, which is also fitted with a direction finder?

*Ans.* On a vessel required by law to maintain a watch by a qualified operator or operators, an effective auxiliary antenna or other approved arrangement shall be provided whenever deemed necessary by the Commission to avoid unauthorized interruption of this watch during use of a radio direction finder on board the same vessel.

**Ques. 6.60.** What is the primary purpose of the "break-in" relay associated with a radiotelegraph transmitter?

*Ans.* A break-in relay permits rapid interruption of the sequence of transmission by the receiving station in the event of interference or a break in the copying of the message. It permits listening periods during the actual transmission of messages. That is to say, when the transmitting key is open the relay contacts connect the antenna to the radio receiver and when the key is depressed it disconnects the antenna from the receiver and transfers it to the transmitter.

**Ques. 6.61.** When an antenna is erected, why should precautions be taken to prevent the wire from kinking?

*Ans.* The kinking of the wire weakens its physical structure at the point of the kink. Obviously, if the wire is subjected to strain and constant swaying, it may eventually break. Another possibility, particularly at very high radio frequencies, would be a loss of energy due to an increase in the high-frequency resistance because of sharp bends or kinks.

**Ques. 6.62.** What may be the causes of noisy operation of a regenerative, three-circuit receiver having two stages of audio-frequency amplification?

*Ans.* Tube noises caused by a high degree of amplification, excessive or critical regeneration adjustment, defective regen-



eration control (potentiometer type), defective grid leak, run down plate-supply or filament batteries, high-resistance contacts or poor grounding.

**Ques. 6.63.** How may the frequency of the antenna circuit of a shipboard receiver be lowered?

*Ans.* By decreasing the natural resonant frequency of the antenna circuit. This is accomplished by "loading" the antenna with a series inductance or loading coil.

**Ques. 6.64.** How may the frequency of the antenna circuit of a shipboard receiver be increased?

*Ans.* By decreasing the loading inductance value at the taps or by inserting an antenna series condenser.

**Ques 6.65.** What is the directional reception pattern of a loop antenna?

*Ans.* Figure 6-3 illustrates the directional pattern of a loop antenna.

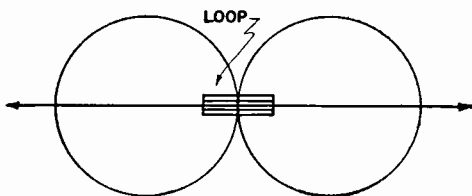

FIG. 6-3. Directional pattern of a loop antenna.

**Ques. 6.66.** What is the directional reception pattern of a vertical antenna?

*Ans.* Figure 6-4 illustrates the directional pattern of a vertical antenna.

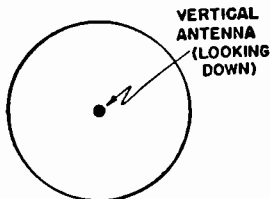

FIG. 6-4. Directional pattern of a vertical antenna.

**Ques. 6.67.** What is meant by "split tuning"?

*Ans.* Split tuning refers to the double-peaked characteristic obtained with tight coupling. (See Ques. 5.195.)

**Ques. 6.68.** Why should a transmitter be adjusted at reduced power?

*Ans.* To protect the transmitter.

**Ques. 6.69.** How is the power output of a vacuum-tube marine radiotelegraph transmitter usually adjusted?

*Ans.* By varying the resistance of the generator-field rheostat, thereby increasing or decreasing the output plate voltage.

**Ques. 6.70.** A marine transmitter uses 500 cycles alternating current for plate supply. It is rectified by a full-wave rectifier circuit, but is not filtered. How would the emission be classified?

*Ans.* This type of emission is classified as, A2 (ICW). See Fig. 6-2.

**Ques. 6.71.** In general, what advantages may be expected by the use of high frequencies in radio communication?

*Ans.* Transmission over vastly greater distances with a relatively smaller amount of input power. Greater compactness of component parts.

**Ques. 6.72.** How is the antenna aboard ship changed most rapidly from the transmitter to the receiver during the course of communication?

*Ans.* By the use of a break-in relay system.

**Ques. 6.73.** How can you determine the optimum coupling between the closed circuit of a spark transmitter and the antenna circuit?

*Ans.* Optimum coupling may be determined by the antenna radio-frequency ammeter when the maximum deflection is obtained. The optimum coupling position for most spark transmitters should be somewhere in the vicinity of  $2\frac{1}{2}$  inches between the primary and secondary coils, depending upon the power used. A peak antenna current should be indicated at the resonant point which falls off rapidly as the coupling is either tightened or loosened from the optimum coupling point.

**Ques. 6.74.** What are the primary factors which determine the frequency emission of a spark transmitter?

*Ans.* The group or spark frequency of a spark transmitter is determined primarily by the speed of the alternator (power-transformer input frequency) and by the type of spark gap used. The radio-frequency emission is dependent upon the closed-circuit oscillatory constants of  $L$  and  $C$ .

**Ques. 6.75.** What is the best method of reducing the power output of a spark transmitter?

*Ans.* By reducing the generator output voltage. This is accomplished by increasing the resistance of the generator field rheostat. It is also necessary to reduce the spark gap.

**Ques. 6.76.** Why are protective condensers connected across the low potential alternating-current circuit of a spark transmitter?

*Ans.* To prevent possible damage to the alternator armature, motor armature, alternator field, motor field, primary of the power transformer and line equipment, which might be caused by high-frequency kick-back surges.

**Ques. 6.77.** Upon what factor(s) does the spark, or note frequency, of a spark transmitter depend?

*Ans.* The spark or note frequency depends primarily upon the alternating-current generator frequency and the gap interrupting frequency. The latter can vary the tonal fre-

quency when a rotary spark gap is used. The frequency of the generator is, however, the most important determinant and is dependent upon the speed of the alternating-current armature and the number of field poles and the time factor, thus

$$\text{Frequency} = \frac{N \times S}{2 \times 60} \text{ cycles per second,}$$

where  $N$  = the number of field poles,

$S$  = the speed in revolutions per minute

**Ques. 6.78.** What factors determine the output frequency of a marine-arc type of radiotelegraph transmitter?

*Ans.* The output frequency of a marine-arc transmitter is dependent upon the antenna capacity, antenna inductance, and the antenna series-loading inductance.

**Ques. 6.79.** Why is it essential that pure water be used in the cooling system associated with an arc transmitter?

*Ans.* Since the water passes through the positive electrode pure water must be used to prevent grounding or short-circuiting the high-voltage generator. Pure water has high dielectric or insulating properties and is, therefore, a poor conductor.

**Ques. 6.80.** What is the purpose of the hydrogen gas, liberated from the injected alcohol, in the arc chamber?

*Ans.* The purpose of burning an arc in an atmosphere of hydrogen is to increase the degree of ionization to assist in the reduction of the arc resistance. This increase in arc conduction manifests itself in the following:

1. Makes possible the generation of radio frequencies.
2. Increases the output radio-frequency energy.
3. Makes the arc burn steadier (produces a "fatter" arc).
4. Insures a more stable radiated frequency.
5. Makes for quicker ignition.

**Ques. 6.81.** Describe the back-shunt method of keying an arc transmitter.

**Ans.** Figure 6-5 illustrates the back-shunt system of arc keying. The back-shunt relay is actuated by a solenoid

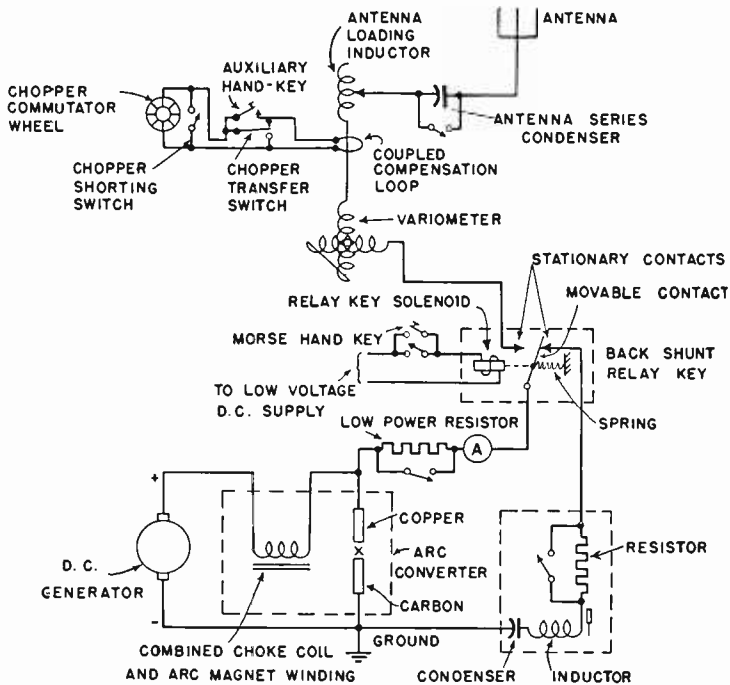

FIG. 6-5. Arc back-shunt signaling system.

excited from the ship's direct current and controlled by a small Morse hand key in series with the solenoid. When the key is open, the back-shunt relay arm is connected to a closed absorption circuit into which the arc oscillates. When the key is closed, the arc is transferred to the antenna oscillatory system. This results in a uniwave signal emission, enables the operator to adjust the arc for maximum stability when the key is open, and eliminates unnecessary adjustment interference.

**Ques. 6.82.** Of what material is the anode of a marine arc transmitter composed?

*Ans.* Copper.

**Ques. 6.83.** Compare the advantages and disadvantages of a modern marine-type vacuum-tube transmitter and a marine spark transmitter.

*Ans.* The modern marine vacuum-tube transmitter has several very important advantages over the spark transmitter, namely:

1. Greater transmission coverage.
2. Creates less interference.
3. Lower frequency deviation (greater stability).
4. Requires less adjustment.
5. Lower power consumption (relatively).
6. Covers a greater frequency band.
7. Permits large variation of tonal frequency.
8. Permits simpler antenna design (physical).
9. Possesses greater flexibility.
10. Efficient on low and high powers.

The spark transmitter has an advantage only in that it does not require replacements, such as tubes. It transmits a relatively broader wave, which is desirable for distress transmissions only. It has less component parts to go out of order. It is useless for high frequency (short wave) transmission. It has very poor efficiency.

**Ques. 6.84.** What is meant by a "self-rectified" circuit, as employed in marine vacuum-tube telegraph transmitters?

*Ans.* Figure 6-6 illustrates a typical marine "self-rectifying" circuit. The plates of the tubes receive their voltage supply from the secondary winding of a high-voltage transformer. Since the plates are excited by an alternating voltage each tube is conductive only on alternate portions of the charging cycle, hence the name of self-rectification. If one

tube is used in the oscillatory circuit, and the alternating-current plate frequency from the power transformer is 500 cycles, the tone frequency of the radiated wave will be 500 cycles. If two tubes are used, full wave self-rectification will result and the tonal frequency will be 1,000 cycles.

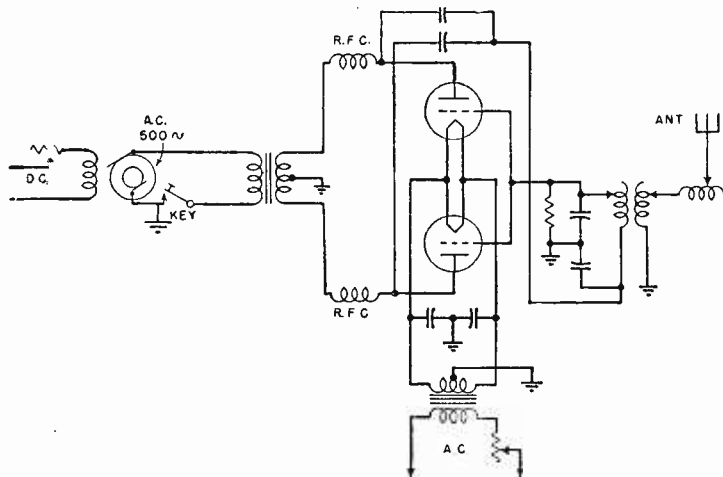

FIG. 6-6. Marine self-rectifying transmitter circuit.

**Ques. 6.85.** What is the principal advantage to be gained by the use of a crystal-controlled oscillator in a marine radiotelegraph transmitter?

*Ans.* The crystal-controlled oscillator reduces frequency drifting to a minimum and, therefore, insures more stabilized transmission.

**Ques. 6.86.** Discuss the advantages and disadvantages of self-excited as compared to master-oscillator power-amplifier transmitters?

*Ans.* The self-excited oscillator has one important advantage over the master-oscillator power-amplifier system in that

it requires only one tube. Greater power output can be obtained with a minimum of tubes. Less component parts are required and, therefore, simpler tuning is obtained. One of the great disadvantages, however, is the inability of this type of oscillating system to maintain a steady carrier frequency. Frequency variations are produced by circuit load changes, particularly the antenna system. Changes in the antenna constants, caused by swinging, and varying humidity and temperature greatly affect the carrier frequency. Certain systems in which the self-excited oscillator is also modulated causes considerable frequency fluttering and distortion. Broad tuning and interference may result. All of these disadvantages are overcome by the master-oscillator power-amplifier system.

**Ques. 6.87.** What is meant by the expression "motor generator is hunting"?

*Ans.* "Hunting" is the term applied to motors and generators which swing or oscillate in their armatures when they are accelerated above and below their normal average speed. This swinging action is set up primarily by variations in the rotative speed resulting from irregularity in the turning force.

**Ques. 6.88.** If the automatic starter for the transmitter motor generator failed to operate when the switch was closed, what might be the trouble?

*Ans.* The starter or plunger solenoid may be open, the starting switch itself may be defective, the line-fuse blown, or the armature circuit may be open.

**Ques. 6.89.** Why is a series motor not used in radio power-supply motors?

*Ans.* The series motor does not maintain constant speed under a varying external load. If it were used to drive a generator, the output voltage and frequency would be unstable.



**Ques. 6.90.** If a 3-horsepower motor, operated from 110 volts, direct current, is 85 per cent efficient when developing its rated output, what will be the line current?

*Ans.* Three horsepower is equal to  $3 \times 746$  watts, or 2,238 watts. The current flow at 100 per cent efficiency will be,  $I = \frac{P}{E} = 20.34$  amperes. At 85 per cent efficiency, therefore, the line current will be 23.9 amperes.

**Ques. 6.91.** If an auxiliary storage battery has a voltage of 12.4 volts on open circuit, and 12.2 volts when the charging switch is closed, what is the difficulty?

*Ans.* This condition indicates that the charging polarity is reversed.

**Ques. 6.92.** Why should an Edison storage battery not be charged at less than the normal rate specified by the manufacturer? Explain.

*Ans.* Because the chemical reaction or oxidation process which takes place during the charge cannot be sufficiently accomplished at low charging rates. The internal resistance of the Edison cell is relatively higher than that of the lead-plate cell. Low capacity results from charging at less than the normal rate.

**Ques. 6.93.** Lacking an hydrometer, how may the state of charge of a storage battery be determined?

*Ans.* By the use of a high-resistance voltmeter under load conditions. It may also be determined by the gassing period while undergoing a charge, or by an ampere-hour meter.

**Ques. 6.94.** Your emergency storage battery has a specific gravity reading of 1.120. What should be done?

*Ans.* The battery should be filled with chemically pure water and immediately placed on full charge.

**Ques. 6.95.** Why should care be taken in the selection of water to be added to a storage cell to replace the loss by evaporation?

*Ans.* Chemically pure or distilled water should be used to deter chemical or metallic impurities from entering the solution. Impure water would generate local action and may ruin the cell.

**Ques. 6.96.** A discharged storage battery of three cells has an open-circuit voltage of 1.8 volts per cell and an internal resistance of 0.1 ohm per cell. What potential is necessary to produce an initial charging rate of 10 amperes?

*Ans.* The charging potential must be 8.4 volts.

*Solution:*

$$3 \times 1.8 \text{ v.} = 5.4 \text{ volts.}$$

$$3 \times 0.1 = 0.3 \text{ ohm (internal resistance).}$$

The voltage drop across the internal resistance when a current of 10 amperes will flow is,  $E = IR = 10 \times 0.3 = 3$  volts. Thus the charging voltage must be sufficient to overcome the  $IR$  drops, or  $5.4 + 3 = 8.4$  volts.

**Ques. 6.97.** What capacity of storage battery is required to operate a 50-watt emergency transmitter for 6 hours, assuming a continuous load of the transmitter of 70 per cent of the key-locked demand of 40 amperes? The emergency light load is 1.5 amperes.

*Ans.* A storage battery having a rated capacity of 200 ampere-hours would satisfy this condition. The actual capacity rating of the battery in accordance with the values given in this example, however, need be only 177 ampere-hours.

**Ques. 6.98.** Why does the charging rate to a storage cell, being charged from a fixed-voltage source, decrease as the charging progresses?

*Ans.* As the charging progresses the gravity of the electrolyte increases, the cell voltage increases and produces greater opposition to the charging current flow. Also, gas bubbles forming on the plates greatly increase the internal resistance, thereby reducing current flow.

**Ques. 6.99.** If you placed the emergency batteries on charge and the overload circuit breakers refused to stay closed, what is the trouble?

*Ans.* The charging voltage is reversed, no charging voltage is present, the charging voltage may be too low, or the charging circuit may be grounded.

**Ques. 6.100.** If part of the secondary winding of the power transformer of a transmitter were accidentally shorted, what would be the immediate effect?

*Ans.* The momentary rise in secondary current due to the short circuit would react upon the primary winding to decrease its self-inductance, thereby raising the primary current. A fuse would probably blow.

**Ques. 6.101.** What are the relative advantages of the condenser-input and choke-input filter circuits?

*Ans.* The condenser-input arrangement permits the use of lower rated high-voltage secondaries since the condenser serves to increase the voltage. The choke-input system introduces an additional voltage drop, but improves regulation. It also prevents flash back in systems where mercury-vapor rectifier tubes are used.

**Ques. 6.102.** What is the principal function of the filter in the power supply?

*Ans.* To smooth out the rectified ripples in order to provide a steady direct current to the vacuum-tube plates.

**Ques. 6.103.** How may a filter condenser be checked for leakage?

*Ans.* By the use of a voltmeter in series with a source of direct-current potential, or by an ohmmeter.

**Ques. 6.104.** What is the maximum allowable total secondary voltage of a transformer to be used as a center-tapped full-wave rectifier in connection with rectifier tubes having a peak inverse voltage rating of 10,000 volts?

*Ans.*  $E_{\text{eff}} = E_{\text{max}} \times 0.707 = 7,070$  volts.

**Ques. 6.105.** Discuss the uses of copper oxide rectifiers.

*Ans.* Copper oxide rectifiers are used most commonly in conjunction with direct-current voltmeters to read alternating-current voltages. Any direct-current galvanometer may serve a universal function for direct- and low-frequency alternating-current measurements by using it in conjunction with a copper oxide rectifier. They are used commercially as power rectifiers and peak limiters.

**Ques. 6.106.** Explain the principle of operation of the cold-cathode gaseous rectifying diodes.

*Ans.* These tubes operate solely upon the principle of the ionization of gases between two oppositely charged electrodes. For example, if a potential difference is applied between two electrodes enclosed in a glass bulb including an inert gas, such as neon or argon, the potential difference will cause the gas molecules to be broken up into positive units and negative units. The positive charges or ions move to the plate charged with the negative potential while the negative charges, or electrons, move toward the plate charged with the positive source potential.

**Ques. 6.107.** What are the advantages of the high-vacuum rectifier tube as compared to the hot-cathode gas-filled tube?

*Ans.* The advantages of the high-vacuum rectifier tube as compared to the hot-cathode gas-filled tube are the ability of the high-vacuum tube to withstand high inverse peak voltages

and to operate immediately without preheating. Comparing the efficiency of the high-vacuum-tube type with that of the mercury-vapor type, it has been found that the latter may be approximately 99 per cent efficient as compared with approximately 87 per cent for the former.

**Ques. 6.108.** What action permits the high-conduction currents of the hot-cathode gas-filled rectifier tube?

*Ans.* Ionization due to collision.

**Ques. 6.109.** What factors determine the setting of the sensitivity control of an auto-alarm receiver approved for installation on a vessel of the United States?

*Ans.* Optimum sensitivity and the prevention of receiver blocking by heavy static.

**Ques. 6.110.** If you were a radio operator on a vessel of the United States, equipped with an approved type of auto alarm which employs a linear detector and an electronic selector, what factors cause the bell to sound? The warning lights to operate?

*Ans.* The bells will be caused to ring by any of the following:

1. Receipt of an auto-alarm signal.
2. Receipt of a false-alarm signal caused by a combined static and keying interference (rare).
3. Failure of ship's line voltage or junction-box fuse.
4. Burned-out tube filament.
5. Failure of the 6-volt battery supply.

The warning lights may be caused to glow by any of the following:

1. Reception of signals where the key is depressed for a period considerably greater than 4.5 seconds.
2. Sensitivity control set too high for the prevailing noise level.

Warning lights may glow intermittently because of:

1. Occasional long bursts of static.

2. Keying interference due to dashes in excess of 3.5 seconds.
3. Heavy 500-kilocycle interference due to simultaneous transmission of several radiotelegraph transmitters.

**Ques. 6.111.** If you were a radio operator on a vessel of the United States, equipped with an approved type of auto alarm which employs a linear detector and an electronic selector, what would result upon failure of a vacuum-tube filament?

*Ans.* The bells would ring.

**Ques. 6.112.** With an auto alarm of the type which employs a linear detector and an electronic selector, what is the most probable cause of the intermittent ringing of the bells?

*Ans.* This would probably be caused by a fluctuating line voltage beyond certain limits.

**Ques. 6.113.** With an auto alarm of the type which employs a square-law detector and a mechanical selector, what factors cause the bell to sound? The warning lights to operate?

*Ans.* The bells will ring upon (1) receipt of true alarm signal, (2) receipt of false alarm signal, (3) failure of equipment in auto alarm, such as (a) failure of any heater, (b) storage-battery voltage too low, (c) selector fuse on battery charger blown or 24-volt circuit open, (d) motor stopped or running too slow, (e) heater circuit or 24-volt circuit to receiver open, or (f) ground on alarm-bell circuit.

The warning lights will operate upon the reception of a long dash, or because of strong local noise or static conditions. The remedy is to reduce the sensitivity control. The warning lights also operate when the ship's direct-current power fails or falls below 70 volts, thereby switching in the auxiliary B batteries.

**Ques. 6.114.** If an auto-alarm bell rings, and upon pressing the release button it does not stop, what could be the cause (s)?

*Ans.* Since the button is designed to break the bell circuit (in series) it is evident that the bells are electrically grounded or the relay arm is stuck in the closing position.

**Ques. 6.115.** If an auto-alarm bell rings, and upon pressing the release button it stops, what could be the cause(s) of the ringing?

*Ans.* Receipt of alarm signal, true or false. This condition may also be caused by the closing of the selector relay and is brought about by a break after a series of four dashes has been received.

**Ques. 6.116.** With an auto alarm of the type which employs a square-law detector and a mechanical selector, why does this receiver not respond to type A1 emission?

*Ans.* Type A1 emission is a continuous wave of constant amplitude; hence it cannot produce detector action when impressed on the grid of the square-law detector.

**Ques. 6.117.** From how many simultaneous directions is a direction finder capable of receiving signals if adjusted to take unilateral bearings through 360 degrees?

*Ans.* From one direction only.

**Ques. 6.118.** What figure represents the reception pattern of a properly adjusted unilateral direction finder?

*Ans.* A cardioid figure as shown in Fig. 6-7, the heavy-line curve being the cardioid.

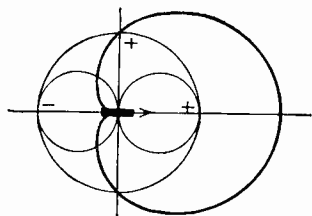

FIG. 6-7. Unilateral characteristic.

**Ques. 6.119.** What is the principal function of a vertical antenna, associated with a unilateral direction finder?

*Ans.* To determine definitely the "sense" of direction.

**Ques. 6.120.** What is the principal function of the vertical antenna associated with the bilateral direction finder?

*Ans.* To provide proper balance and thereby minimize distortion of local field by nearby metal objects.

**Ques. 6.121.** Why are loop antennas, associated with direction finders, metallically shielded?

*Ans.* Metallic shielding minimizes the so-called "antenna effect." It reduces deviation due to capacity effects with the ground.

**Ques. 6.122.** What is a "compensator" as used with direction finders, and what is its purpose?

*Ans.* A "compensator" as used in direction finders is a device attached to the loop shaft which mechanically compensates the error on the compass indicator for the deviation caused by antenna effect owing to the presence of nearby metallic objects. This mechanical compensator automatically causes the compass indicator to lag or lead the plane of the direction-finder loop by the necessary amount to assure correct compensation.

**Ques. 6.123.** How is the unilateral effect obtained in a direction finder?

*Ans.* By the use of a small vertical antenna coupled to the loop direction finder. If a small vertical antenna is coupled to the loop antenna and both are tuned to resonance, the two voltages at the input grid will have either a 0- to 180-degree phase relationship. A cardioid pattern such as illustrated in Fig. 6-7 will be obtained.

**Ques. 6.124.** What factors may affect the accuracy of a properly compensated and calibrated direction finder, after installation?

*Ans.* Antenna effect. This is generally due to direct pick-up from nearby metallic objects, but these may be



minimized by proper compensating adjustments. If all adjustments are properly made, the trouble is generally due to an erratic variation of the sky wave at night compared to ground waves. This is known as "night effect."

**Ques. 6.125.** What does the bearing obtained by the use of a bilateral radio direction finder indicate?

*Ans.* The line of direction along which the signal is traveling.

**Ques. 6.126.** What does the bearing obtained by the use of a unilateral direction finder indicate?

*Ans.* The sense of direction from which the signal emanates.

**Ques. 6.127.** If the vacuum-tube heater burns out, in an approved auto alarm, what causes the warning bells to ring?

*Ans.* The operation of a special relay in the receiver. This relay is in series with the heaters and controls the bell circuit.

**Ques. 6.128.** What is the function of the balancing condenser in a direction finder?

*Ans.* To provide the proper loop balance; that is, to balance out the stray capacity and inductive effects existing between the loop and ground. It permits the obtaining of a sharper null point.

**Ques. 6.129.** What signal will cause an approved auto-alarm receiver to ring the warning bell?

- Ans.*
1. Receipt of true-alarm signal.
  2. Receipt of false-alarm signal.
  3. Failure of equipment in auto alarm.

The following equipment troubles will cause the bell to sound:

1. Failure of any heater.
2. Storage-battery voltage too low.

## RADIO OPERATING QUESTIONS AND ANSWERS

3. Selector fuse on battery charger blown.
4. Motor stopped or running too low.
5. Vacuum-tube heater circuit or 24-volt circuit to receiver open.
6. Ground on alarm-bell circuit.

**Ques. 6.130.** To what frequency, or band of frequencies, is an approved auto-alarm receiver tuned?

*Ans.* A band of frequencies ranging from 487.5 to 512.5 kilocycles.

**Ques. 6.131.** What is the maximum permissible (root-mean-square) r.m.s. value of audio voltage which can be applied to the grid of a class A audio amplifier which has a grid bias of 10 volts?

*Ans.* Since the peak value must not exceed the 10 volts grid bias, the r.m.s. value of the audio signal must not exceed 7.07 volts.

$$E_{r.m.s.} = E_{peak} \times 0.707.$$

**Ques. 6.132.** What is the effect of leakage in the coupling condenser in an impedance or resistance-coupled amplifier?

*Ans.* Serious distortion will occur. This is so because the control grid of the succeeding tube will be positive with respect to cathode. A heavy rise in plate current and lowering in the plate voltage will occur, thereby seriously altering the plate  $I_p$ - $E_g$  curve.

**Ques. 6.133.** What is the direct-current plate voltage of a resistance-coupled amplifier stage which has a plate-supply voltage of 260 volts, a plate current of 1 milliampere, and a plate-load resistance of 100,000 ohms?

*Ans.* The potential difference between the plate and the cathode of the tube will be 160 volts.

$$E = IR = 100,000 \times 0.001 = 100 \text{ volts.}$$

$$260 - 100 = 160 \text{ volts}$$

**Ques. 6.134.** List four causes of distortion in a class A audio amplifier.

- Ans.* 1. Excessive grid excitation.  
 2. Improper grid-bias adjustment.  
 3. Improper plate-supply voltage adjustment.  
 4. Improper value of load impedance.

**Ques. 6.135.** In a radio-frequency amplifier stage having a plate voltage of 1,250 volts, a plate current of 150 milliamperes, a grid current of 15 milliamperes, and a grid-leak resistance of 4,000 ohms, what is the value of the operating grid bias?

*Ans.*  $E = IR = 0.015 \times 4,000 = 60$  volts.

**Ques. 6.136.** In a radio-frequency amplifier, employing fixed grid bias, as the plate circuit is varied in adjustment from a point below resonance to a point above resonance, what effect will be observed on the grid current?

*Ans.* The grid current will normally rise slightly as the plate tank circuit is tuned through resonance.

**Ques. 6.137.** What is the primary function of the power-amplifier stage of a marine radiotelegraph transmitter?

*Ans.* To develop the power input for the antenna system and to provide the suitable coupling transfer. It also permits better frequency stability by isolating the oscillator from the antenna.

**Ques. 6.138.** In a series-fed plate circuit of a vacuum-tube amplifier, what could be the effect of a short circuit of the plate-supply by-pass condenser?

*Ans.* It would short-circuit the power supply.

**Ques. 6.139.** In a shunt-fed plate circuit of a vacuum-tube amplifier, what would be the effect of an open circuit in the plate radio-frequency choke?

*Ans.* The plate voltage would be removed from the tube plates.

**Ques. 6.140.** What is the function of a dummy antenna?

*Ans.* The dummy antenna is a noninductive resistance which serves as a substitute for the antenna resistance in making circuit adjustments without the use of an antenna. It enables the operator or engineer to make his power-amplifier output adjustments without creating unnecessary interference. In other words, it is a load substitution for an antenna.

**Ques. 6.141.** What is the primary advantage to be obtained by shunting a high-resistance fixed resistor across each unit of a high-voltage series condenser bank in the power-supply filter circuit of a transmitter?

*Ans.* To equalize the voltage drop across each condenser, distribute the strain, and to discharge the condensers after shutdown.

**Ques. 6.142.** What is the effect of an inductance connected in series with the antenna circuit?

*Ans.* It increases the fundamental wavelength of the antenna; that is, it decreases the antenna resonant frequency.

**Ques. 6.143.** If a vacuum tube in the only radio-frequency stage in your receiver burned out, how could you make temporary repairs to permit operation of the receiver?

*Ans.* The plate winding of the radio-frequency transformer may be used as the antenna primary coil. A coupling condenser from the antenna to the plate side of the radio-frequency tube socket may be used.

**Ques. 6.144.** What is the meaning of "high-level" modulation?

*Ans.* "High-level" modulation is that system in which the modulated-amplifier stage is also the final power-amplifier stage.

**Ques. 6.145.** What is the meaning of "low-level" modulation?

*Ans.* "Low-level" modulation is that system in which the modulated radio-frequency-amplifier stage precedes the final power-amplifier stage.

**Ques. 6.146.** If the plate current of the final radio-frequency amplifier in a transmitter increased and radiation decreased, although the antenna circuit is in good order, what would be the possible causes?

*Ans.* This may be due to a shorted turn in the secondary of the output-coupling transformer, a short-circuited secondary-shunt tuning condenser, or poor neutralization.

**Ques. 6.147.** A master-oscillator power-amplifier type of transmitter has been operating normally. Suddenly the antenna ammeter reads zero, although all filaments are burning and plate and grid meters are indicating normal voltages and currents. What would be the possible cause(s)?

*Ans.* This may be due to any of the following causes: Overloaded or defective ammeter, defective antenna insulation, circuits not in resonance, poor connections on the antenna, or improper coupling.

**Ques. 6.148.** What could cause abnormally low voltage at the input power terminals of a lifeboat radiotelegraph transmitter, while it is in operation?

*Ans.* This may be due to a low state of charge of the supply battery or excessive overloading.

**Ques. 6.149.** What is the result of excessive coupling between the antenna and output circuits of a self-excited type of vacuum-tube transmitter?

*Ans.* Erratic operation, tube overloading, and frequency instability. (See Ques. 5.195.)

*RADIO OPERATING QUESTIONS AND ANSWERS*

**Ques. 6.150.** What is the purpose of the iron compound cylinders which are found in the inductances of certain marine radiotelegraph transmitters? The position of the cylinders, with respect to the inductances, is adjustable for what purpose?

*Ans.* These are provided for variable reactance tuning. They are adjustable so that the inductance value may be changed, thus effecting a change in frequency adjustment.

**Ques. 6.151.** What is the most common cause of split tuning?

*Ans.* Improper adjustment of mutual coupling.

**Ques. 6.152.** Should the antenna circuit of a master-oscillator, power-amplifier type of transmitter be adjusted to the resonant frequency before the plate-tank circuit of the final stage? Give the reason(s) for your answer.

*Ans.* No. The tank circuit should first be resonated to the excitation frequency for a minimum plate-current indication on the direct-current milliammeter. The antenna circuit is then tuned to resonance and the plate circuit readjusted to compensate for the antenna-loading effect. The minimum plate-current reading when the antenna is tuned to resonance with the plate-tank circuit will be higher than with untuned antenna conditions. Another reason for tuning the power amplifier first is that this stage must be neutralized before any antenna-transfer adjustments are made.

**Ques. 6.153.** In a transmitter involving a master oscillator, intermediate amplifier and final amplifier, describe the order in which circuits should be adjusted in placing this transmitter in operation.

*Ans.* From the master oscillator toward the antenna circuit.

**Ques. 6.154.** What is a "frequency-doubler" stage?

*Ans.* This is an amplifier in which the plate circuit is tuned to a harmonic of the grid-excitation frequency. It is generally adjusted to double that of the input frequency.

**Ques. 6.155.** Define "parasitic oscillations."

*Ans.* Spurious audio- or radio-frequency oscillations independent of the normal circuit frequency. They are commonly brought about by coupling between leads through parallel connecting of tubes.

**Ques. 6.156.** What is the effect of parasitic oscillations?

*Ans.* Erratic operation, circuit instability, possible serious overheating of the tubes, overloading, and decreased efficiency.

**Ques. 6.157.** What may cause a radio-frequency amplifier to have excessive plate current?

*Ans.* Improper neutralization, parasitic oscillation, excessive radio-frequency drive, insufficient load impedance, insufficient grid bias, excessive plate voltage, or improper output tuning.

**Ques. 6.158.** What are some of the indications of a defective vacuum tube in a transmitter?

*Ans.* Low plate-current readings if the trouble is due to low-filament emission, or excessive plate current if the tube has developed gas. Unstable readings during operation will result.

**Ques. 6.159.** At what point on a shipboard antenna system will the maximum potential be noted?

*Ans.* At the insulators, particularly at the one farthest away from the lead-in. This is generally referred to as the free or high-potential end.

**Ques. 6.160.** What is the effect upon a transmitter of dirty or salt-encrusted insulation?

*Ans.* Decreased radiation, erratic antenna, and plate milliammeter readings. Increased corona or brush discharge losses. Increased leakage losses.

**Ques. 6.161.** Why do many marine transmitters employ variometers rather than variable condensers as the tuning adjustments?

*Ans.* Because, in order to maintain a proper  $Q$  for various frequencies, the inductance rather than the capacity of the oscillatory circuit must be varied. The use of variometers also permits constant  $L-C$  ratio.

**Ques. 6.162.** What is the relationship between the antenna current and radiated power of an antenna?

*Ans.* The antenna current squared value  $\times$  the antenna resistance gives a true measure of radiated power.

**Ques. 6.163.** Why is a self-excited oscillator type of transmitter undesirable for shipboard service?

*Ans.* Because of its frequency instability.

**Ques. 6.164.** What is the fundamental difference(s) between the Hartley and Colpitts oscillators?

*Ans.* Both circuits obtain grid excitation directly from the resonant circuit, the Hartley from a portion of the tank coil, which is split for this purpose, and the Colpitts from a portion of the tank capacity through a split-condenser arrangement.

**Ques. 6.165.** How is the keying of a simple-oscillator type of emergency marine transmitter usually accomplished?

*Ans.* Transformer primary keying is generally used.

**Ques. 6.166.** If you found that it was impossible to keep the receiver-storage A battery charged, and at the same time maintain the required watch period, what remedy may be found?



*Ans.* The emergency power supply on board a cargo vessel (on which a separate main and emergency installation is not provided), subject to Title III, Part II of the Communications Act, while being navigated in the open sea, is authorized to be used only for emergency communication except that it may be used for routine communication for a period not to exceed one hour per day in the aggregate. However, a storage battery which is the emergency power supply or a part thereof, may be used at any time to maintain a watch for safety purposes if such use will not reduce the ability of the emergency power supply to energize the emergency installation for a period of at least six consecutive hours.

**Ques. 6.167.** What time zone shall be used in making log entries with respect to the observance of the international silent period?

*Ans.* The time of making an entry shall be shown opposite the entry and shall be expressed in Greenwich mean time (GMT) (counted from 00:00 to 24:00 o'clock, beginning at midnight). The first entry in each hour shall consist of four figures; additional entries in the same hour may be expressed in two figures by omitting the hour designation. The abbreviation "GMT" shall be marked at the head of the column in which the time is entered.

*Examples:*

Local Time	Greenwich Mean Time
12 midnight.....	0000
12:30 A.M.....	0030
6:00 A.M.....	0600
12:00 noon.....	1200
1:00 P.M.....	1300
4:00 P.M.....	1600
11:59 P.M.....	2359

**Ques. 6.168.** Under what circumstances must log entries be made regarding the observance of the international silent period?

## RADIO OPERATING QUESTIONS AND ANSWERS

*Ans.* During the period a watch is maintained by an operator, an entry shall be made twice per hour stating whether or not the international silent period was observed. In addition, entries shall be made indicating any signals or communications heard on 500 kilocycles (410 kilocycles on the Great Lakes) during this period. If no signals are heard on 500 kilocycles (410 kilocycles on the Great Lakes), an entry to that effect shall be made. The use of rubber stamps for making entries to show observation of the silent period is not authorized.

**Ques. 6.169.** At what time(s) are routine transmissions forbidden in the bands of 480 to 520 kilocycles?

*Ans.* In order to increase safety of life at sea (ships), and over the sea (aircraft), all the stations of the maritime mobile service which normally listen on the waves of the authorized bands between 365 and 515 kilocycles (822 and 583 meters) must, during their working hours, make the necessary provisions to insure the watch on the distress wave, 500 kilocycles (600 meters), twice per hour, for three minutes, beginning at x:15 and at x:45 o'clock, GMT.

**Ques. 6.170.** At what time(s) must the international silent period be observed?

*Ans.* (See Ques. 6.169).

**Ques. 6.171.** After a distress call has been transmitted, every distress-traffic radiotelegram shall contain what symbol in the preamble?

*Ans.* Every distress-traffic radiotelegram must include the distress signal preceding the call and repeated at the beginning of the preamble.

**Ques. 6.172.** Under what conditions may a mobile station, the service of which is not continuous, close?

*Ans.* Ship stations, the service of which is not continuous, may not close before having:

1. Finished all operations called for by a distress call.

2. Exchanged, as far as possible, all radiotelegrams originating in or destined to land stations which are within their range, and mobile stations which, being within their range, have signaled their presence before the effective cessation of work.

A mobile station which has no fixed working hours must advise the land station with which it is in communication of the closing and reopening hours of its service.

Any mobile station which arrives in a port and the service of which is accordingly about to close, must so advise the nearest land station and, if necessary, the other land stations with which it generally communicates. It must not close until it has cleared all traffic on hand, unless the regulations of the country where it calls prohibit. At the time of its departure, it must advise the interested land station or stations of its reopening, as soon as such reopening is permitted by the regulations in force within the country in which the port of departure is located.

**Ques. 6.173.** How long must mobile stations listen after hearing an urgent signal?

*Ans.* Mobile stations hearing the urgent signal must listen for at least 3 minutes. After this interval, and if no urgent message has been heard, they may resume their normal service.

**Ques. 6.174.** What space of time should elapse between the transmission of the international auto-alarm signal and the distress call?

*Ans.* When circumstances permit, the transmission of the distress call shall be separated from the end of the alarm signal by a two-minute silence.

**Ques. 6.175.** What exceptions are permitted to the regulation which states that a mobile station, which has no fixed working hours, must advise the land station with which it is in communication of the closing and reopening hours?

## RADIO OPERATING QUESTIONS AND ANSWERS

*Ans.* If the regulations of the country where the ship calls prohibit the use of the ship's radio transmitter while the ship is within the territorial waters of that country, the mobile station is not required by international law to report its closing to the nearest land station.

**Ques. 6.176.** How frequently must an entry be made in the marine radio log while a radio watch is being maintained?

*Ans.* Once every 15 minutes.

**Ques. 6.177.** During what periods must a distress message be repeated, following the initial transmission?

*Ans.* The distress message must be repeated at intervals until an answer has been received, and especially during the periods of silence.

**Ques. 6.178.** Upon what bodies of water is the frequency of 500 kilocycles not utilized as the international calling and distress frequency?

*Ans.* The frequency of 500 kilocycles is utilized as the international calling and distress frequency on all bodies of water.

**Ques. 6.179.** What station shall be in control of distress traffic?

*Ans.* The control of distress traffic shall devolve upon the mobile station in distress or upon the mobile station which has sent the distress call. These stations may delegate the control of the distress traffic to another station.

**Ques. 6.180.** What transmission should precede the transmission of the distress call?

*Ans.* The distress call, when sent in radiotelegraphy on 500 kilocycles (600 meters) shall, as a general rule, be immediately preceded by the alarm signal.

**Ques. 6.181.** Describe how a distress call should be made.

*Ans.* The distress call shall include:

1. The distress signal transmitted three times.
2. The word DE.
3. The call signal of the mobile station in distress transmitted three times.

**Ques. 6.182.** Under what circumstances, and by whom, may the international auto-alarm signal be transmitted to announce an urgent cyclone warning?

*Ans.* The only purpose of this special signal is to set into operation the automatic apparatus used to give the alarm. It must only be used either to announce that a distress call or message is to follow, or to announce the transmission of an urgent cyclone warning; in the latter case it can only be used by coast stations duly authorized by their government.

**Ques. 6.183.** While a vessel is at sea, how frequently must the auto alarm be tested?

*Ans.* While the ship is being navigated outside a harbor or port, the auto alarm shall be tested at least once every 24 hours by means of the testing device supplied as part of the alarm, the timing of the dashes to be made by reference to the second hand of the ship-station clock. A statement that the foregoing requirement has been fulfilled must be inserted in the radio-station log daily.

**Ques. 6.184.** Describe the number of dashes, or dots, and spaces which compose the international auto-alarm signal and indicate the time intervals involved.

*Ans.* The alarm signal shall consist of a series of 12 dashes sent in one minute, the duration of each dash being four seconds and the duration of the interval between two dashes, one second. It can be transmitted by hand or by means of an automatic instrument. Any ship station working in the band

## RADIO OPERATING QUESTIONS AND ANSWERS

of 365 to 515 kilocycles (822 to 583 meters), and which is not provided with an automatic apparatus for the transmission of the auto alarm signal must be permanently equipped with a clock distinctly marking the seconds, preferably by means of a moving hand completing one revolution per minute. This clock must be placed at a point sufficiently visible from the keying table so that the operator may, by watching it, easily and correctly time the different elements of the alarm signal.

**Ques. 6.185.** Describe the safety signal.

*Ans.* In radiotelegraphy, the safety signal shall consist of the group TTT, transmitted three times, with the letters of each group, as well as the consecutive groups, well separated. This signal shall be followed by the word DE and three transmissions of the call signal of the station sending it. It announces that this station is about to transmit a message concerning the safety of navigation or giving important meteorological warnings.

In radiotelephony, the word SECURITY (corresponding to the French pronunciation of the word *sécurité*) repeated three times, shall be used as the safety signal.

**Ques. 6.186.** During what periods must the safety signal be transmitted?

*Ans.* In the maritime mobile service, apart from messages transmitted according to a schedule, the safety signal must be transmitted toward the end of the first ensuing period of silence, and the message shall be transmitted immediately after the period of silence.

**Ques. 6.187.** Indicate the order of priority of the various types of radio communications.

*Ans.* The order of priority of radio communications in the mobile service shall be as follows:

1. Distress calls, distress messages, and distress traffic.
2. Communications preceded by an urgent signal.

3. Communications preceded by a safety signal.
4. Communications relative to radio direction-finding bearings.
5. Government radiotelegrams for which priority right has not been waived.
6. All other communications.

**Ques. 6.188.** Upon hearing a safety signal, what should the operator at the receiving station do?

*Ans.* All stations hearing the safety signal must continue listening on the wave on which the safety signal has been sent until the message so announced has been completed; they must moreover keep silence on all waves likely to interfere with the message.

**Ques. 6.189.** When the auto-alarm bell rings, what should the operator do?

*Ans.* The alarm bell may be caused to ring for one or the other of the following reasons:

1. Receipt of true alarm signal from a distant station.
2. Failure of equipment in auto-alarm installation.

If the alarm rings, the operator must first determine if the bells are caused to ring by a failure in the auto-alarm equipment. He can do this by pressing the release button provided for this purpose. If the alarm bell *does not stop* when this button is pressed, there is trouble with the auto-alarm equipment. The operator must take the proper action to correct the trouble.

If the alarm bell *does stop* ringing when the release button is pressed, this signifies that a true alarm has been received. Under these conditions, the operator must go on watch immediately and listen in on the distress frequency for the distress call, distress message, or meteorological warning which should follow the alarm signal within two minutes. (See also Ques. 6.174 and 6.192.)

RADIO OPERATING QUESTIONS AND ANSWERS

**Ques. 6.190.** If you received a distress call signed by a call signal composed of five letters, could you determine the type of craft which transmitted the signal?

*Ans.* The answer can be deduced from the following table:

1. Land stations have three-letter call signals.
2. Ship stations have four-letter call signals.
3. Aircraft stations have five-letter call signals.

**Ques. 6.191.** You intercept "CQ CQ WSV TFC QSY 735 AS." What does this mean?

*Ans.* CQ means general call "to all."

WSV is the call letter of a shore station.

TFC means "traffic."

QSY 735 means "shift to transmission on 735 meters."

AS means "wait" or "stand by for shift."

Hence, the above communication reads:

"All (ship) stations shift to 735 meters and listen to see if your call is included in the traffic list, signed WSV." (Consult Appendix I for further abbreviations.)

**Ques. 6.192.** Upon hearing an SOS, what should an operator do?

*Ans.* This call shall have absolute priority over other transmissions. All stations hearing it must immediately cease all transmission capable of interfering with the distress traffic, and must listen on the wave used for the distress call. This call must not be sent to any particular station and shall not require an acknowledgment of receipt.

**Ques. 6.193.** On a vessel of the United States equipped with an approved auto alarm where is the control button, which silences the warning bells, located?

*Ans.* Only one switch for stopping the audible warning apparatus from functioning is authorized and this shall be located in the main radiotelegraph operating room and shall be capable of manual operation only.



**Ques. 6.194.** What is the radiotelegraph urgent signal?

*Ans.* In radiotelegraphy, the urgent signal shall consist of the group XXX transmitted three times, with the letters of each group, as well as the consecutive groups, well separated; it shall be sent before the call.

**Ques. 6.195.** With what type(s) of emission and upon what frequency should a transmitter be adjusted to transmit a distress call?

*Ans.* In case of distress, the wave to be used shall be the international distress wave, that is, 500 kilocycles (600 meters); it must preferably be used with type A2 or B emission. Ship stations which cannot transmit on the international distress wave shall use their normal calling wave.

**Ques. 6.196.** Upon what band of radio frequencies must an approved auto-alarm receiver function?

*Ans.* From 487.5 to 512.5 kilocycles.

**Ques. 6.197.** Upon compulsorily equipped vessels, which are required to have an accurate clock in the radio room, how frequently must this clock be adjusted and compared with standard time?

*Ans.* At least once every 24 hours. For this purpose, authentic radio time signals received from land or fixed stations shall be acceptable as standard time.

**Ques. 6.198.** Within what frequency-band limits do all United States marine radio-beacon stations operate?

*Ans.* From 285 to 315 kilocycles.

**Ques 6.199.** Upon what frequency should a navy direction-finding station be called to obtain a radio bearing?

*Ans.* 375 kilocycles.

**Ques. 6.200.** Upon what band, in addition to the 350-515 kilocycles band, must a main receiver on a compulsorily equipped United States ship be capable of operation? What is the purpose of this additional band?

RADIO OPERATING QUESTIONS AND ANSWERS

*Ans.* From 100 to 200 kilocycles. To provide long-wave radiotelegraph long-distance communication.

**Ques. 6.201.** While a vessel is in port, how frequently should the emergency equipment be tested?

*Ans.* Not at all, except just prior to departure.

**Ques. 6.202.** How frequently must the quantity of fuel in the supply tank for use with an oil or gas-driven emergency generator be checked, while the vessel is in the open sea?

*Ans.* Once each day.

**Ques. 6.203.** While the vessel is in the open sea, how frequently must the specific gravity of the emergency battery be taken?

*Ans.* Once each day.

**Ques. 6.204.** While the vessel is in the open sea, how frequently must the emergency equipment be tested?

*Ans.* Once each day.

**Ques. 6.205.** What is the principal port of the United States, on the Pacific Coast, at which navigation lines terminate?

*Ans.* San Francisco.

**Ques. 6.206.** In what city is the major telecommunication center of the United States located?

*Ans.* New York City.

**Ques. 6.207.** What is the approximate latitude of Colon, Republic of Panama?

*Ans.* This can be found in the table below.

Port	Approximate	
	Latitude	Longitude
Colon, Panama.....	9.4°N	80°W
Los Angeles, Calif.....	34°N	118°W
New Orleans, La.....	30°N	90°W
New York, N. Y.....	41°N	74°W
San Francisco, Calif.....	38°N	122.5°W

**Ques. 6.208.** In what ocean is the island of Guam located?

*Ans.* Pacific Ocean.

**Ques. 6.209.** To what continent do the greatest number of telecommunication channels from the United States extend?

*Ans.* Europe.

**Ques. 6.210.** What is the principal Atlantic Coast port of the United States at which navigation lines terminate?

*Ans.* New York City.

**Ques. 6.211.** List four principles by which an e.m.f. may be generated by sound waves.

- Ans.*
1. Resistance variation (Carbon microphone).
  2. Dynamic (Dynamic, or ribbon microphone).
  3. Piezo-electric (Crystal microphone).
  4. Electrostatic (Condenser microphone).

**Ques. 6.212.** What is indicated in a radiotelephone transmitter by an increase in antenna current without carrier shift?

*Ans.* Modulation must be taking place.

**Ques. 6.213.** What methods may be used to reduce fringe howl in a regenerative receiver?

*Ans.* Fringe howl may be eliminated by shunting a 100,-000-ohm resistance across the primary winding of the detector audio-frequency transformer.

**Ques. 6.214.** Knowing the intermediate frequency and the signal to which a superheterodyne receiver is tuned, how would you determine the most probable frequency on which "image" reception would occur?

*Ans.* Any complement of frequencies other than the one to which the receiver is tuned which will give the value of the

intermediate frequency. In other words, the sum of the desired signal frequency and twice the value of the intermediate frequency is the "image" frequency.

**Ques. 6.215.** How is the degree of coupling varied in a  $\pi$  network used to transfer energy from a vacuum-tube plate circuit to an antenna?

*Ans.* A  $\pi$  network is shown in Fig. 4-8. The coupling is usually varied by adjusting the series inductance. To increase coupling decrease inductance, and vice versa.

**Ques. 6.216.** What means are usually provided to prevent operation of the ship's transmitter when the auto-alarm receiver is in use?

*Ans.* The transmitter key-relay power-supply circuit is opened when the auto-alarm receiver is in use.

**Ques. 6.217.** Explain how you would determine the value of the cathode-bias resistor for a specific-amplifier stage.

*Ans.* By referring to the tube characteristic chart for the proper operating voltages and currents, the bias resistor may be calculated by the formula

$$R_{\text{bias}} = \frac{E_c}{I},$$

where  $I$  = the total return currents flowing to the cathode, namely, the plate and screen-grid currents.

**Ques. 6.218.** In a class A audio-frequency amplifier, what is the main advantage obtained through the use of two triodes in push-pull as compared to parallel operation?

*Ans.* Balancing out of the second harmonic component, hum, and subsequent distortion. Greater power output and prevention of core saturation in the transformer plate winding.

**Ques. 6.219.** Explain briefly the construction and characteristics of a beam power tube.

*Ans.* The basic structure of the beam tube is practically the same as for any pentode with the exception that an extra reflecting or beam-forming plate is placed near the plate so that the electrons are uniform in their progress towards the plate. This concentration of the electron stream towards the plate gives rise to a perfectly uniform distribution of the space charge. The control and screen grids are so aligned that the wires of the latter fall in the shadow of the former. Far greater power-output capabilities are achieved.

**Ques. 6.220.** Explain the operating procedure employed in neutralizing a radio-frequency power amplifier, using a thermocouple ammeter as an indicating device.

*Ans.* Open the plate-supply switch to the radio-frequency stage to be neutralized. Open up the main power switch to all tubes and discharge all high-voltage condensers. Insert a thermocoupled galvanometer into the low-potential side of the plate-tank circuit of the stage to be neutralized. Engage the neutralizing condenser about one-third position. Close the main power switch but leave the plate-supply switch of the amplifier open. Increase the radio-frequency drive gradually and tune all circuits to resonance. Observe the reading on the thermocouple galvanometer and vary the neutralizing condenser until this reading is a minimum or, preferably, zero. Remove the thermocouple galvanometer and insert the regular ammeter. Close the high-voltage plate-supply switch to the radio-frequency amplifier just neutralized. Carefully recheck and balance all circuits to minimum plate-current dips.

**Ques. 6.221.** For what purposes are decoupling networks used in audio-frequency amplifiers?

*Ans.* Decoupling networks are employed to stabilize amplifier operation. These networks reduce the common impedance coupling relations between circuits and thereby prevent regenerative effects and self-oscillation. Distortion is reduced and quality of reproduction is greatly improved.

**Ques. 6.222.** Under what circumstances is a station in the mobile service not required to listen to distress traffic?

*Ans.* A station of the mobile service which, while following distress traffic of which it is aware, is able to continue its normal service, may do so, when the distress traffic is well established, under the following conditions:

1. The use of the distress wave, 500 kilocycles (600 meters), of the wave on which the distress traffic is taking place and type-B waves shall be forbidden.

2. The use of type A1 waves, with the exception of those which might interfere with the distress traffic, shall be permitted.

**Ques. 6.223.** What interval of time must elapse between the end of the auto-alarm signal and an urgent cyclone warning?

*Ans.* Two minutes.

**Ques. 6.224.** Describe the international auto-alarm signal.

*Ans.* The alarm signal shall consist of a series of 12 dashes sent in one minute, the duration of each dash being four seconds and the duration of the interval between two dashes, one second. It can be transmitted by hand or by means of an automatic instrument. Any ship station working in the band of 365 to 515 kilocycles (822 to 583 meters), and which is not provided with an automatic apparatus for the transmission of the auto-alarm signal must be permanently equipped with a clock distinctly marking the seconds, preferably by means of a moving hand completing one revolution per minute. This clock must be placed at a point sufficiently visible from the keying table so that the operator may, by watching it, easily and correctly time the different elements of the alarm signal.

**Ques. 6.225.** What is the international distress frequency for stations in the mobile service?

*Ans.* 500 kilocycles.

**Ques. 6.226.** Explain the principle of operation and list the main characteristics of a shunt direct-current motor, a series direct-current motor, and a compound direct-current motor. Explain how the speed of each can be regulated. Draw a simple schematic diagram of each of the types of motors including a starting device.

**Ans.** Figure 6-8 illustrates the circuit arrangement of a shunt, series, and compound motor with speed control and

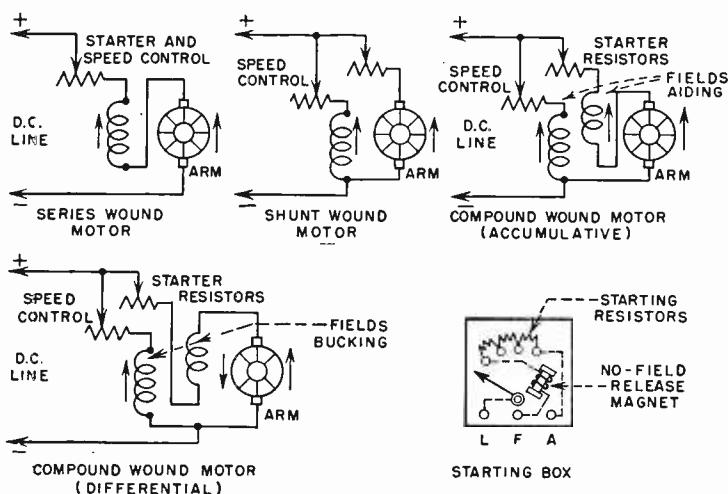

FIG. 6-8. Series, shunt, and compound d-c motors.

starting devices. The shunt-type motor possesses a fairly constant speed characteristic under no-load versus full-load conditions. The series motor on the other hand shows a relatively greater drop in speed when the load is applied. The compound-wound motor due to its series and shunt field connections provides the advantages of both the speed and torque characteristics of the series and shunt types. It provides a more effective starting torque and, on the whole, gives better speed regulation under changes in full-load to no-load

## RADIO OPERATING QUESTIONS AND ANSWERS

operating conditions than either the shunt or series types. (See also Ques. 2.170 and 2.304.)

**Ques. 6.227.** What is the danger of operating a direct-current series motor without a load?

*Ans.* The removal of the load in a direct-current series-type of motor will cause the motor to run at an abnormally high speed. When a series motor is operated without a load or if the load is suddenly removed, the instantaneous rise to a very high speed may cause the motor to be mechanically disrupted or tear apart. A series motor under these conditions develops an increased counter e.m.f. owing to the increased rate in which the magnetic field is cut. The line current therefore is relatively less than under full-load operating conditions.

**Ques. 6.228.** Explain the principle of operation and list the main operating characteristics of a direct-current shunt generator and a direct-current compound generator. Explain how the voltage of a direct-current generator can be controlled. Draw a simple schematic diagram of each of these types of generators.

*Ans.* The shunt-wound and compound-wound types of direct-current generators are illustrated in Fig. 6-9. The shunt-type generator has a tendency to lose excitation under an overload condition. This serves as a protective medium when the generator is subjected to overload. The output terminal voltage will be decreased in approximate proportion to the  $IR$  drop in the armature and the armature reaction.

The most important characteristic of the compound-wound type of direct-current generator is its more constant output voltage under load conditions. The additional series field winding compensates for the  $IR$  drop and field demagnetization and tends to regulate the output voltage to a steady level. It is also possible to increase the strength of the series winding so that the output voltage may rise slightly under loading



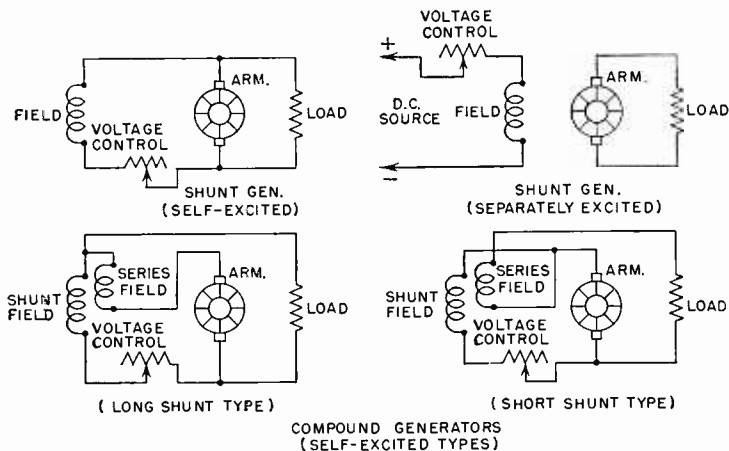

FIG. 6-9. Self- and separately excited shunt-compound generators.

conditions. The former is referred to as a *flat-compounded* generator, and the latter as an *overcompounded* generator.

**Ques. 6.229.** Explain the principle of operation of an induction motor and how such motors are started.

*Ans.* The induction motor operates upon a principle similar to that of a transformer with a rotatable secondary winding.

Starting of induction motors is accomplished by the insertion of a series resistance in the rotor circuit with a short-circuiting switch across the resistor for operation at normal load speeds. Other starting methods are the auto-transformer and double-winding types. In the former method, a tapped auto-transformer is connected across the line with the necessary taps to limit the current flow during the start period. In the latter method, two rotor windings are provided, one of high resistance for starting and the other of low resistance for normal running speeds. Induction motors below 3-horsepower rating generally do not require starting devices. Some types of single-phase induction motors employ capacitor starters

which include a condenser and a separate winding in series to effect the proper phase shift when starting. This circuit is automatically disconnected when the rotor comes up to normal running speed.

**Ques. 6.230.** What conditions must be met before two alternating-current generators can be operated in parallel?

*Ans.* The essentials for operating alternating-current generators in parallel are as follows: The terminal polarities of both generators must be the same, the voltage must be balanced between the generators both under no-load and full-load conditions, and both generators must be running at the same frequency and in phase.

**Ques. 6.231.** If a 220-volt, 60-cycle, single-phase line delivers 100 watts at 80 per cent power factor to a load, what is the phase angle between the line current and the line voltage? How much current flows in the line?

*Ans.* 0.568 ampere.

$$\text{Phase angle} = \theta = 37 \text{ degrees.}$$

Since

$$\text{Power factor} = \cos \theta = \frac{P}{EI} = \frac{\text{real watts}}{\text{apparent watts}}$$

then

$$0.8 \text{ (80 per cent)} = \frac{100}{\text{apparent watts}}$$

$$\therefore \text{apparent watts} = IE = \frac{100}{0.8} = 125,$$

but

$$E = 220 \text{ volts; } \therefore I = \frac{W}{E} = \frac{125}{220} = 0.568 \text{ ampere.}$$

From the table of cosines,  $\cos \theta = 0.800 = 36^{\circ}50'$ , or approximately 37 degrees.

**Ques. 6.232.** Draw diagrams showing various ways by which three power transformers can be connected for operation on a three-phase circuit. Show how only two transformers can be connected for full operation on a three-phase circuit.

*Ans.* See Fig. 6-10a and b.

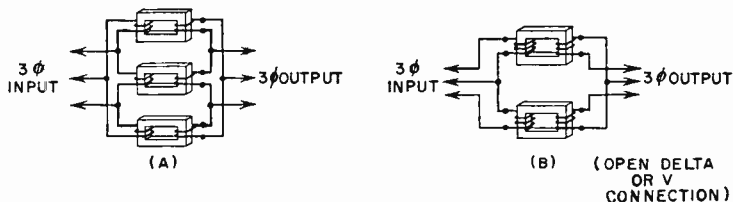

FIG. 6-10. (a) Method of connecting three single-phase transformers for 3-phase operation. (b) Method of connecting two single-phase transformers for 3-phase operation.

**Ques. 6.233.** How can low power factor in an electrical power circuit be corrected?

*Ans.* Power factor in an inductive circuit containing a transformer or motor can be corrected by inserting a capacitance (condenser) across the device.

**Ques. 6.234.** Draw a simple circuit diagram of a voltage-doubling power supply using two one-half wave rectifiers.

*Ans.* See Fig. 4-16.

**Ques. 6.235.** How can the condition of charge of dry "B" batteries be determined?

*Ans.* By the use of a high-resistance-type voltmeter under normal circuit-load conditions.

**Ques. 6.236.** What precaution should be observed in storing spare "B" batteries?

## RADIO OPERATING QUESTIONS AND ANSWERS

*Ans.* Dry batteries should be stored in a dark, dry compartment or container, preferably in a reasonably cool temperature. Excessive heat and moisture will increase deterioration.

**Ques. 6.237.** What are the main differences between Edison and lead-acid types of storage batteries?

*Ans.* (See Ques. 2.147, 2.151-153, 2.166, 5.127.)

**Ques. 6.238.** Draw a sketch showing the construction of a storage cell.

*Ans.* See Fig. 6-11.

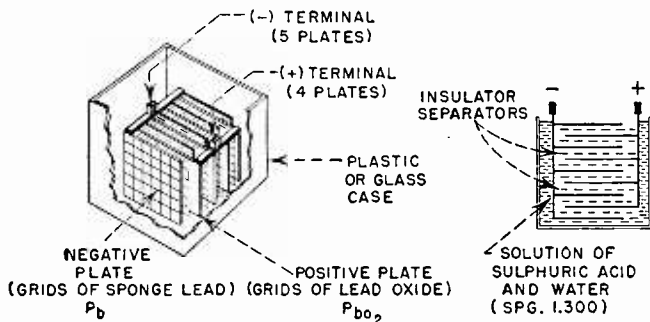

FIG. 6-11. Construction of a storage cell.

**Ques. 6.239.** Define "specific gravity" as used in reference to storage batteries.

*Ans.* "Specific gravity" refers to the density of the electrolyte used in storage cells. It is the ratio of the mass of a body to the mass of an equal volume of water at 4 degrees centigrade or other specified temperature.

**Ques. 6.240.** Draw a diagram of the charging circuits of two batteries using a four-pole double-throw switch such that, while one battery is on charge, the other is on discharge. Indicate the direct-current power source, voltage dropping resistors, and connections to the battery load.

Ans. See Fig. 6-12.

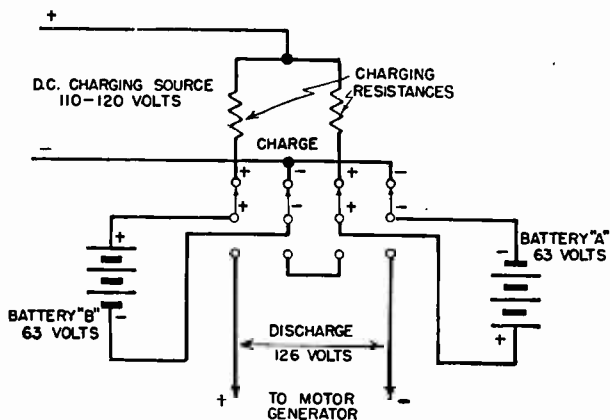

FIG. 6-12. Battery charging arrangement.

**Ques. 6.241.** What is indicated if, in testing a storage battery, the voltage polarity of some of the cells in the battery are found reversed?

*Ans.* If one or more cells in a storage battery are *weak* in relation to the other cell(s), a heavy overload or overdischarge rate will change the chemical reactions in the weak cell to such a degree that the polarity may be reversed. This condition is also possible due to a heavy charge in the reverse direction.

**Ques. 6.242.** If a hydrometer is not available, how can the condition of charge of a storage battery be determined?

*Ans.* (See Ques. 6.93 and 5.127.)

**Ques. 6.243.** What is indicated if a voltmeter connected between the negative side of a ship's direct-current line and ground reads the full line voltage?

*Ans.* If the negative side of the ship's generator is normally grounded, a voltage reading between the negative side of the ship's direct-current line to ground will indicate an open fuse

or contact in that portion of the line. The voltmeter will read because of its connection to the positive side of the line through the circuit load connections such as lamps, motors, etc.

**Ques. 6.244.** What is meant by the "time constant" of certain electrical circuits containing resistance and capacitance?

*Ans.* (See Ques. 4.172.)

**Ques. 6.245.** What is the reactance of a 0.01-microfarad capacitor at a frequency of 3,000 cycles? What is the reactance of a 2-henry choke coil at the same frequency?

*Ans.* A capacitive reactance of 5,308 and an inductive reactance of 37,680 ohms.

$$X_c = \frac{1,000,000}{2\pi fC} = 5,308 \text{ ohms.}$$

$$X_L = 2\pi fL = 37,680 \text{ ohms.}$$

**Ques. 6.246.** What is the resonant frequency of a series-tuned circuit consisting of a condenser of 500 micromicrofarads, a tuning coil of 150 microhenrys, and a resistance of 10 ohms?

*Ans.* 580.325 kilocycles.

$$f_{\text{eps}} = \frac{1}{2\pi \sqrt{LC}} = \frac{10^6}{1.71} = 581,000 \text{ cycles per second}$$

**Ques. 6.247.** Draw a diagram of a crystal detector receiver. Name two substances that can be used as the crystal in such a receiver.

*Ans.* (See Ques. 2.234 and 5.66.)

**Ques. 6.248.** In the operation of a regenerative-type receiver how is oscillation of the detector indicated?

*Ans.* The plate-current flow as indicated by a milliammeter in the detector circuit will show a sharp decrease when the detector goes into oscillation. (See also Ques. 6.50.)

**Ques. 6.249.** Draw a diagram of a superheterodyne receiver with automatic volume control, and explain the principle of operation.

*Ans.* Figure 6-13 illustrates a basic superheterodyne receiver with automatic volume control.

The operation of this circuit is briefly as follows: An incoming modulated signal impressed across  $G-K$  of the first detector, or mixer tube, develops a radio-frequency signal component in the plate circuit. The oscillator develops a similar plate-current variation in the same plate circuit but of a higher frequency. The two plate-current components develop a resultant "beat" or "intermediate-frequency" which alone passes through the intermediate-frequency amplifier. This signal is amplified through one or more of these stages and is then rectified in the diode detector circuit. The rectified or audible signal is then further amplified in the audio-frequency amplifier circuit.

A portion of the rectified signal is used to develop a negative voltage with respect to the diode cathode to apply an additional negative voltage to the grids of the intermediate-frequency amplifier tubes. This voltage varies in accordance with the signal amplitude and, when strong signals are applied, produces a control or throttling effect on very strong peak signal voltages. This leveling action is referred to as automatic volume control.

**Ques. 6.250.** Define the following terms in reference to vacuum tubes: amplification factor, plate resistance, mutual conductance, and maximum inverse plate voltage.

*Ans.* Amplification factor  $= \mu = \frac{de_p}{de_g}$  ( $i_p$  constant).

Plate resistance  $r_p = \frac{de_p}{di_p}$  ( $e_g$  constant).

Mutual conductance  $g_m = \frac{di_p}{de_g}$  ( $e_p$  constant).

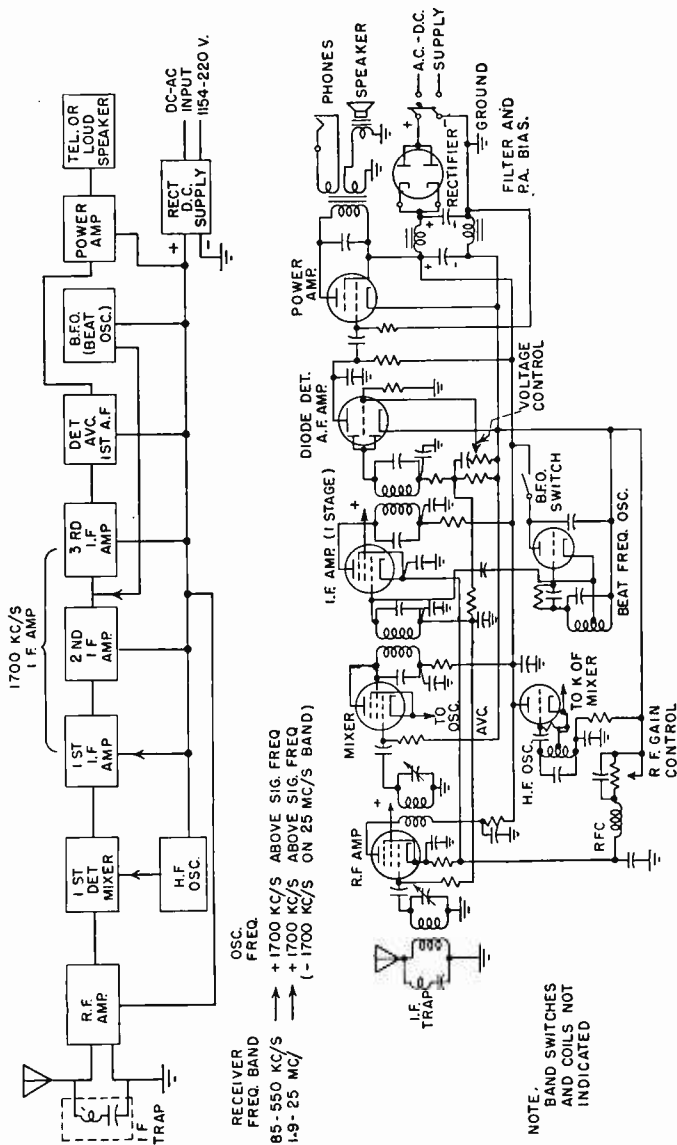

Fig. 6-13. Block diagram and simplified schematic of a marine type of superheterodyne receiver.



Plate resistance or plate impedance (alternating-current resistance),  $r_p$ , is expressed as the plate-voltage change divided by the resulting plate-current change in a vacuum tube, all other conditions being fixed. This must not be confused with the direct-current plate resistance, which is merely the steady plate voltage divided by the steady plate current flowing in the tube.

Maximum inverse plate voltage refers to the conduction ability of a gas or vacuum tube to conduct in the reverse direction at certain potentials. The maximum inverse plate voltage is approximately three to four times the normal direct-current output voltage. It is essentially the maximum voltage a rectifier tube will withstand across its plate cathode during the nonconducting portion of the rectified cycle without flash-back. (See also Ques. 4.93.)

**Ques. 6.251.** Draw a simple schematic diagram of a spark transmitter, and explain its principle of operation.

*Ans.* The spark-discharge oscillatory circuit consists of a transformer, which supplies power to the condenser of an oscillatory circuit consisting of a condenser, a spark gap, and an inductor in series. An analysis of the supply-line low-frequency charging cycle applied to the condenser would show that, from 0 to 90 degrees of the charging cycle, the condenser charges. Electrostatic lines of force around the condenser are gradually increasing. As the charging cycle approaches 90 degrees, an excessive electrostatic strain is manifested between the points of the spark gap. When the potential difference across the spark gap reaches the rupture point, there is a breaking up of air particles between the electrodes into ions. This is called ionization of the spark gap.

From 90 to 180 degrees on the charging cycle, the condenser discharges through the gap and the inductance, converting the electrostatic energy in the condenser into electromagnetic energy. Because of the "flywheel" effort of the oscillatory circuit, this energy charges the condenser in the opposite direc-

tion but to a decreased amplitude. The loss in energy is that caused by the dissipation of energy in the form of heat when the condenser made its first discharge through the gap and the inductance.

From 180 to 270 degrees, the same action as from 0 to 90 degrees takes place with the exception that the charge on the condenser is reversed owing to the reversal of the charging e.m.f. The energy involved has continued to decrease owing to heat and light losses.

From 270 to 360 degrees, the same action as from 90 to 180 degrees takes place. These cycles of discharge continue back and forth until all of the energy is dissipated in heat.

It can be seen from this explanation that the spark gap functions as a trigger or valve, and therefore, if the coil is inductively coupled to a secondary coil connected in series with an open radiating circuit and both circuits are in tune, then the alternating field about the primary coil will cut the secondary and induce into it an e.m.f., which will set the antenna into oscillation and radiate damped waves. If the proper discharge is to be obtained, the gap spacing must be carefully adjusted.

If the gap electrodes are too close, the condenser will not receive a full charge and may discharge before 90 degrees of the charging cycle. On the other hand, if the gap electrodes are too far apart, then the condenser dielectric will be subjected to abnormal strain which will result in a puncture of the dielectric.

The period of damping in a circuit of this type is another important factor. For example, if the type of gap used does not radiate the heat quickly (deionize), then the oscillations will not die out very rapidly (low damping) and, consequently, will not permit a wave of low decrement to be emitted from the antenna system. This is due to reaction of the primary and secondary circuits on account of the high conductivity of the gap circuit.

Hence, for every discharge of the condenser through the spark gap and the inductance, the electrostatic energy is converted into electromagnetic energy about the inductance and

the connecting wires, and since the oscillations are of a high-frequency character and of a constantly changing polarity, the magnetic field about the inductance will be rising and falling at a definite frequency depending upon the values of the inductance and the capacity in the circuit. Thus radio-frequency oscillations will be generated. See Fig. 5-2.

**Ques. 6.252.** Draw a simple circuit diagram of a transmitter using an oscillator coupled to the antenna, with the oscillator using a self-rectifying circuit for operation directly from an alternating-current generator.

*Ans.* (See Ques. 6.84.)

**Ques. 6.253.** Draw a circuit diagram showing the principle of operation of a telegraph keying relay.

*Ans.* (See Ques. 5.187 to 5.191.)

**Ques. 6.254.** If the power of a 500-kilocycle transmitter is increased from 150 watts to 300 watts, what would be the percentage change in field intensity at a given distance from the transmitter? What would be the db change in field intensity?

*Ans.* (a) Approximately 40 per cent. (b) 3 db.

(c) Field intensity or field strength is proportional to antenna current. Hence if the power is doubled, the antenna current will increase 1.414 ( $\sqrt{2}$ ) times the initial value, or 41.4 per cent. An increase of power to four times will increase the antenna current and field strength to twice ( $\sqrt{4}$ ) the initial value.

(b) The db change in field intensity may be computed as follows:

$$\begin{aligned} \text{db} &= 20 \log_{10} \frac{I_1}{I_2} \\ &= 20 \log 1.414 \\ &= 20 \times 0.151 \\ &= 3.02. \end{aligned}$$

(See also Ques. 4.69 and 4.71.)

**Ques. 6.255.** If the antenna current at a 500-kilocycle transmitter is reduced 50 per cent, what would be the percentage change in the field intensity at the receiving point?

*Ans.* The field intensity will be decreased 50 per cent. (See Ques. 4.69 and 4.71.)

**Ques. 6.256.** If a 500-kilocycle transmitter of constant power produces a field strength of 100 microvolts per meter at a distance of 100 miles from the transmitter, what would be the theoretical field strength at a distance of 200 miles from the transmitter?

*Ans.* 50 microvolts per meter. Assuming zero attenuation the theoretical field strength of a radiated wave is inversely proportional to the distance from the transmitting antenna. (See Ques. 4.205.)

**Ques. 6.257.** What care should be taken in hoisting the antenna of a shipboard radiotelegraph station to avoid damage to the antenna wire and insulators?

*Ans.* Guide rope(s) should be employed during the hoisting process to prevent possible damage to the antenna wire and insulators.

**Ques. 6.258.** Draw a sketch of a typical shipboard antenna for transmitting on 500 kilocycles showing the supporting insulators, the safety link, and the lead-in wire. How does voltage vary along the length of the lead-in and along the antenna?

*Ans.* Figure 6-14 illustrates a typical shipboard antenna installation.

A shipboard antenna designed for 500-kilocycle operation is generally of the single-wire Marconi grounded or quarter-wave type. The lead-in may be connected as a T or inverted L to the flat-top portion, depending upon physical limitations and frequency requirements.

The voltage distribution is illustrated in the diagram and is a maximum value at the free ends of the flat-top portion of the antenna. The voltage at the base or transmitter terminal is a

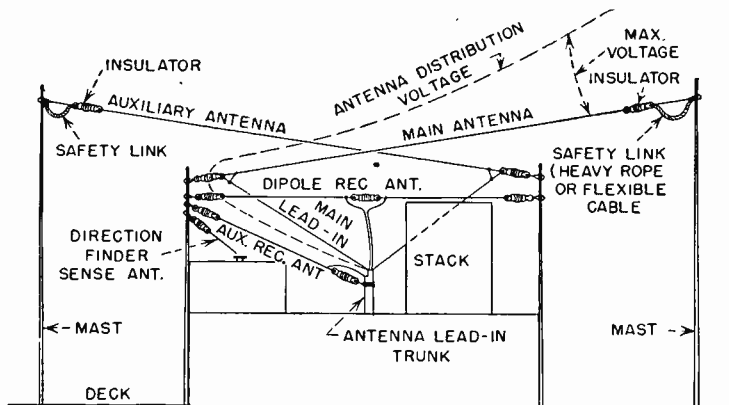

FIG. 6-14. A shipboard antenna installation showing lead-in and safety link.

minimum, while the current distribution is in reverse relationship throughout the antenna system.

**Ques. 6.259.** How do multivibrator oscillators differ from Hartley oscillators? In what circuits do multivibrator oscillators find application?

*Ans.* A multivibrator oscillator employs a resistance-capacity feedback network as compared with the inductive feedback method used in the Hartley series- and parallel-feed oscillators. The output wave form of a multivibrator has an approximate square-wave characteristic as compared with the sine wave output of a Hartley oscillator. (See also Ques. 2.72, 3.125, 4.104, and 4.109.)

**Ques. 6.260.** Draw a simple circuit diagram of a multivibrator oscillator.

*Ans.* See Fig. 4-13.

**Ques. 6.261.** List at least two essentials for making a good soldered connection.

*Ans.* The contact surfaces must be thoroughly cleaned and free of oxides and film. The soldering iron should be well cleaned and tinned. The iron should be sufficiently heated to provide a liquid flow of the solder at the joint. Use only a good grade of rosin core solder with a reasonably high tin content. (See also Ques. 2.236.)

**Ques. 6.262.** Draw a circuit diagram showing how a microphone can be connected to an audio amplifier.

*Ans.* (See Ques. 2.97 and 3.23.)

**Ques. 6.263.** An absorption-type wavemeter indicates that the approximate frequency of a ship transmitter is 500 kilocycles and at the same time the transmitter signal produces a zero beat on an accurately calibrated heterodyne frequency meter at a dial reading of 374.1. The frequency meter calibration book indicates dial readings of 367.0, 371.5 and 376.0 for frequencies of 499.4/998.8/499.6/999.2, and 499.8/999.6 kilocycles, respectively. What is the frequency of the ship transmitter?

*Ans.* 499.71 kilocycles.

*Solution:*

Dial div. 376.0 = 499.8 kilocycles per second 376.0

Dial div.  $\frac{371.5}{4.5}$  =  $\frac{499.6 \text{ kilocycles per second}}{1.9 \text{ div.}}$

4.5 = 0.2 kilocycles per second

$\frac{1.9}{4.5} \times 0.2 = 0.0844 \text{ kilocycle (difference)}$  499.8000 kilocycles

$\frac{-0.0844 \text{ kilocycle}}{499.7156 \text{ kilocycles}}$

374.1 div. = 499.7156 kilocycles.

**Ques. 6.264.** A certain frequency meter contains a crystal oscillator, a variable oscillator, and a detector. What is the purpose of each of these stages in the frequency meter?

*Ans.* The crystal oscillator serves as a substandard calibrator for adjusting the variable oscillator to zero beat with the harmonics of the crystal. The variable oscillator generates the various frequency bands of the instrument. The detector rectifies the radio-frequency component for audible response or to produce a visual deflection on a meter proportional to the frequency.

**Ques. 6.265.** What should be the approximate surge impedance of a quarter-wavelength matching line used to match a 600-ohm feeder to a 70-ohm antenna?

*Ans.* Approximately 205 ohms.

$$Z_0 = \sqrt{600 \times 70} = \sqrt{42,000} = 204.95 \text{ ohms.}$$

(See also Ques. 4.204.)

**Ques. 6.266.** What determines the surge impedance of a 2-wire nonresonant radio frequency transmission line?

*Ans.* (See Ques. 4.200.)

**Ques. 6.267.** How should a radar set be adjusted by the operator to reduce "sea return"?

*Ans.* The receiver gain or sensitivity control must be adjusted to the point in which the amplitude of the sea return is reduced below that of the target echo. Some radars have an automatic-volume-control circuit which reduces the gain for the first few microseconds (sea returns at close proximity to the ship) and then restores the gain to normal for sea returns at greater distances. This is referred to as sensitivity time constant control, or STC.

**Ques. 6.268.** Approximately at what speed does the antenna of a navigational radar rotate?

*Ans.* Approximately 12 revolutions per minute.

**Ques. 6.269.** What is the average plate-power input to a radar transmitter if the peak pulse power is 15 kilowatts, the pulse length is 2 microseconds, and the pulse repetition frequency is 900 cycles?

*Ans.* The average power is 27 watts.

$$T = \frac{1}{F} = \frac{1}{900} = 1,100.$$

$$\begin{aligned} P_{\text{avg}} &= P_{\text{peak}} \times \frac{\text{pulse width}}{T} = 15,000 \times \frac{2}{1,100} \\ &= 15,000 \times 0.00181 = 27 \text{ watts.} \end{aligned}$$

Alternative method:

$$P_{\text{avg}} = P_w \times \text{PRR} \times P_p = 0.000002 \times 900 \times 15,000 = 27 \text{ watts.}$$

**Ques. 6.270.** In what part of the radio-frequency spectrum do marine radar systems operate?

*Ans.* Marine radar systems operate in the super-high-frequency or microwave spectrum (3,000 to 30,000 megacycles or between 0.1 to 0.01 meters). The actual assigned frequencies are in the vicinity of 3,000 and 10,000 megacycles or 10 and 3 centimeters, respectively.

**Ques. 6.271.** If the velocity of a radio wave is 186,000 statute miles per second, how many nautical miles does a radar pulse travel in 1 microsecond?

*Ans.* 0.186 statute miles, approximately 0.162 nautical miles. 186,000 statute miles is equivalent to approximately 161,599 nautical miles.

$$1,760 \text{ yards} = 1 \text{ statute mile.}$$

$$2,026.8 \text{ yards} = 1 \text{ nautical mile.}$$

Since radio waves travel approximately 186,000 statute miles



in a second, they travel one-millionth of this distance, or 0.186 statute miles, in a microsecond. This corresponds to a time of 5.37 microseconds required for a wave or pulse to travel 1 statute mile.

Hence, since  $\frac{1,760}{2,026.8} = 0.8678$ , the pulse will travel

$$0.8678 \times 0.186 = 0.1614$$

or approximately 0.162 nautical miles.

**Ques. 6.272.** Draw a simple block diagram showing the essential components of a radar system. Label the components such as receiver, indicator, etc.

*Ans.* See Fig. 6-15.

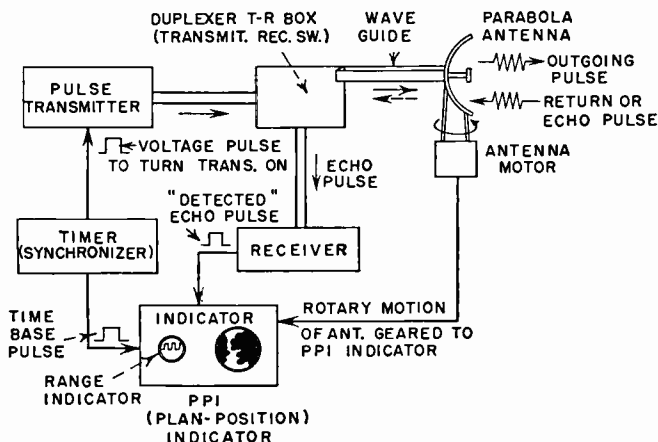

Fig. 6-15. Block diagram of radar components.

**Ques. 6.273.** How can the operator of a Loran receiver on shipboard identify the transmitting stations that are being received?

*Ans.* Standard Loran (long-range-navigation) stations can be identified by the specially assigned recurrence rates of pulses

transmitted for each pair of Loran stations. The Loran receiver can be adjusted to synchronize the pulses with any one of these assigned rates to identify a particular pair of stations. These pulses when received and synchronized appear stationary on the cathode-ray-tube screen, and their time difference can be accurately measured. In practice the operator merely adjusts the knobs until a stationary signal pattern is received. The reading of the channel selector switch and the pulse-recurrence-rate switch then identifies the transmitting station.

Hydrographic charts must be referred to from the dial readings for verification and accurate position "fixes." (See also Ques. 6.277.)

**Ques. 6.274.** During daytime hours approximately what is the maximum distance in nautical miles from Loran transmitting stations that Loran lines of position can be determined?

*Ans.* The normal day range over sea water is approximately 700 nautical miles and about 150 miles over land.

**Ques. 6.275.** In determining a "fix" or position by a marine Loran system, what is the *minimum* number of land transmitters involved?

*Ans.* A minimum of three transmitting stations. Although the basic requirements call for two pairs of stations as illustrated in Fig. 6-16, it is common practice to use a master (called a double master) and a pair of slave stations to furnish required sets of hyperbolas for a given area. A combination of one slave and two master stations could also be used.

**Ques. 6.276.** Explain why pulse emission rather than continuous waves is used by Loran transmitters. Approximately what pulse repetition frequency, pulse duration, and operating frequency are used in Loran systems?

*Ans.* Pulse emission permits accurate measurements of time difference between Loran stations at the receiver.

The repetition frequency of pulses emitted from a Loran transmitter is approximately 25 and 33 pulses per second. The pulse duration and operating frequency for a standard Loran system are approximately 50 microseconds and 1,700 to 2,000 kilocycles, respectively.

**Ques. 6.277.** When several pairs of Loran transmitting stations are operating on the same frequency, how does the operator at a Loran receiver select the desired pair of transmitting stations?

*Ans.* Three or more pairs of Loran transmitters operating on the same frequency can be selected by the operator by selecting one pair of recurrent rate pulses.

Practically, the signals from any given pair of stations can be identified by changing the knob settings marked basic pulse repetition rate, specific pulse repetition rate, and the station selector or channel switches to a setting where a pair of signals are stopped. A direct indication of the channel, pulse repetition rate, and specific pulse repetition rate may then be obtained by reading the characters on these three selector switches. For example, two Loran stations have the following markings at their base line extensions on the chart:

Master station base-line extension: 1H4-4,460.

Slave station base-line extension: 1H4-1,000.

1 = radio-frequency channel - 1,950 kilocycles per second

H = high basic pulse rate -  $33\frac{1}{3}$

4 = specific pulse repetition rate of station pairs =  $33\frac{1}{3} + \frac{4}{9}$   
 =  $33\frac{7}{9}$  cycles per second

(1,000 = time-difference reading or in this example the coding delay of 1,000 microseconds.)

**Ques. 6.278.** What is the relationship between a master and a slave station in reference to a Loran navigation system?

*Ans.* The Loran master station and slave station are two pulse transmitters located at fixed points on land approxi-

## RADIO OPERATING QUESTIONS AND ANSWERS

mately 300 miles apart. The pulses from each transmitter of a given pair are transmitted at slightly different time intervals instead of simultaneously. The timing synchronization must be rigidly maintained between the two stations. The pulse from the master station "triggers" the slave transmitter after an adjustable time delay of approximately 1,000 microseconds to make the time delay on the charts accurate.

**Ques. 6.279.** Draw a simple sketch showing relative positions of pairs of master and slave stations of a Loran navigation system, and indicate lines of position of each pair of stations.

*Ans.* See Fig. 6-16.

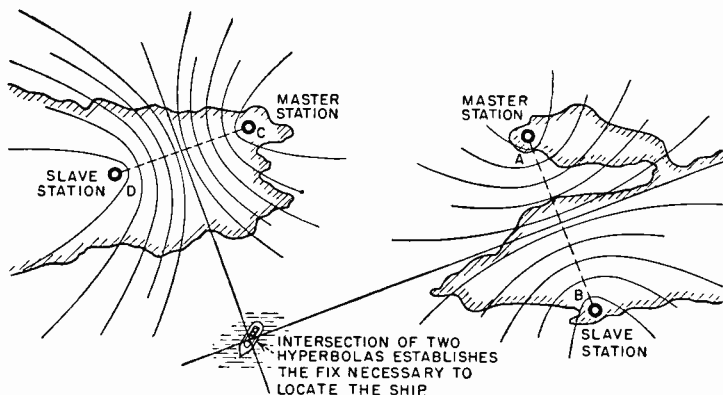

FIG. 6-16. Pairs of Loran stations and lines of positions.

**Ques. 6.280.** What is the purpose of "blinking" in a Loran navigational system, and how is blinking recognized at the receiver?

*Ans.* "Blinking" is that condition indicated on a Loran receiver when one of a pair of Loran stations is off frequency or improperly synchronized. The pulse on the indicator will shift to and fro, or in some types of receivers, it will "blink" periodically.

**Ques. 6.281.** What precautions should an operator or serviceman observe when working with cathode-ray tubes and the associated circuits of radar and Loran receivers?

*Ans.* (See Ques. 2.294.)

**Ques. 6.282.** What is the GMT time and the day of the week in Shanghai when it is Wednesday noon in New York City?

*Ans.* The time differential, standard time, between New York City and Shanghai is +13 hours. Hence, at noon New York City time on a given Wednesday, the time in Shanghai, China, will be 1:00 A.M. the following day, or Thursday. In GMT calculations the time is expressed from 0000 to 2400 or from 0 to 24 o'clock, beginning at midnight. For example, 1 A.M., 0100 GMT, 1 P.M., 1300 GMT; 2400, midnight; and so on.

For the specific example given the GMT time in Shanghai, China, will be 0100 Thursday when New York standard time is noon or 1200 GMT on Wednesday. (See also Ques. 6.167.)

**Ques. 6.283.** Explain the use and meaning of the following indicators or prefixes on radiotelegrams, and describe the difference in handling of the various types of radiotelegrams: RP, TC, PC, FS, PR, TR, MSG, CDE, OBS, PDH, CODH.

*Ans.* These prefixes serve as indicators in the transmission of radiotelegrams and are defined and exemplified as follows:  
RP (reply paid) radiotelegram.

*Example:* KTWY DE WSL RPI CK NEW YORK 1700  
RP \$3.05 Mr. John Doe SS William  
Black Yates WSL—Message—Signature.

RP \$3.05 is written as the first word in the address and charged as one word. No charge is made for RP in the preamble.

TC (telegram confirmation). The prefix is inserted in the

## RADIO OPERATING QUESTIONS AND ANSWERS

preamble and as the first word of the address. The latter is charged for as one word. This type of message is repeated back to the transmitting station as a confirmation to insure against possible transmission or reception errors. The message toll for a TC radiotelegram is an additional one-half toll added to the normal charge of the message.

PC: (paid confirmation or acknowledgment). This type of prefix is used to designate that the sender desires to be notified as to the time and date in which his telegram was transmitted. The charge rate on a TC radiotelegram is the same as an ordinary paid message but with an additional land-line charge to cover a six-word acknowledgment to the origin of the sender.

PR: (paid radiotelegram to be delivered by registered mail).

TR: (position report).

MSG: (telegram relating to ships' business). This type of message is used primarily for exchange of ship's business between the master of the vessel or the steamship company. It is also used between masters of ships to convey or request navigational information. The cost of this type of message is generally 13 cents a word for land and forwarding charges. Ship's charges are rarely included.

CDE: (code telegram). A telegram prefixed CDE may be comprised of all code words or a mixed combination of code and plain language. The toll for private messages of this type is generally 40 per cent below the normal 21 cents per word rate, or 13 cents. Ship's charges are eliminated if the message relates to company business.

OBS: (meteorological radiotelegram). Charges for this type of message are 8 cents per word unless transmitted through a company's own coastal station. In the latter case no charges are made. This type of message is generally an official weather bureau release to all radio stations including foreign government stations authorized to receive this service. No charge is made on official communications.

PDH: (paid deadhead). This type of message is commonly

used by the ship's personnel and the public. It is referred to as a "frank" or free charge rate authorized (within limits) by the steamship company to employees for social and personal radiotelegrams.

CODH: (company deadhead). This type of radiotelegram is free of all toll charges. It is intended solely for the exchange of company business and is originated and handled by the radio operator only.

FS: (follow service). This prefix is a "follow-up" designation similar to a "please forward" in mail correspondence. The normal toll rates are applied to the original point of destination. An additional charge for land-line rates must be collected to cover the costs of transmittal to the ultimate destination.

**Ques. 6.284.** Explain cable count and the use of standard service abbreviations, and show the difference between cable count and domestic word count.

*Ans.* The cable-count system of counting the check is used for radiograms. This system provides that all words in the address, text, and signature must be counted and charged for. In this system, messages are divided into two classes, namely,

1. Plain language.
2. Code language.

*Plain-language* messages must be written entirely in plain language. Words are counted on the basis of 15 characters to the word. Any fractional part of 15 characters is also counted as one word. Numbers up to 5 in a group would be counted as one word, over 5 as two words.

*Examples:*

Gymnasium . . . . .	one word	7,583 . . . . .	one word
Intellectualization . . . . .	two words	37,463 . . . . .	one word
Unconstitutional . . . . .	two words	987,641 . . . . .	two words
Constantinople . . . . .	one word		

## RADIO OPERATING QUESTIONS AND ANSWERS

*Code language* is made up of pronounceable words of no direct meaning not to exceed 5 characters in length. If a code word exceeds 5 characters in length it is counted as two words, and this is noted in the check. Words in which the meaning has been concealed by reversing the order of the letters or syllables will not be accepted as code words.

*Examples:*

JELHI.....one word (code language)  
X-ray.....two words (plain language)  
XQNOW.....Not accepted (unpronounceable)

When a message is written in mixed language, a careful checkup under the following rules must be made:

*Code and plain language:* Maximum length of words chargeable is 10 characters. The words street, road, park, or square are always counted as one word aside from their designator in the address. Hyphenated or compound words are counted as so many separate words depending on the number of parts.

Names of places, such as New York, New London, or Frankfurt am Main, are counted as one word in the address and two words in the text.

If New York is written Newyork or New London is written Newlondon and like examples, they are counted as one word in the text and so charged for. They should be written as two separate words in the address, but as the names of all cities count as one word in the address, they are charged for as one word. See Appendix for standard abbreviations.

**Ques. 6.285.** Construct a plain-language radiotelegram and indicate what portions comprise (a) the preamble, (b) the address, (c) the text, and (d) the signature.

*Ans.* A sample of a plain-language paid (P) radiotelegram showing the preamble, address, text, and signature follows:



WSL DE KTSX

(Preamble) P 1 CK 12 SS Wayne Victory 1300 Date

John Doe 100 Tremont Street

(Address) Boston Mass

(Text) Arriving about eleven tonight

(Signature) Bill  
KTSX K

**Ques. 6.286.** Why do some ship radiotelegraph stations that are equipped with a direction finder employ an auxiliary receiving antenna for the receivers in the radio room?

*Ans.* An auxiliary antenna is sometimes employed for the receivers in the radio room for the reception of continuous-wave or modulated signals independent of the main antenna system. (The main antenna system is disconnected during the period in which the direction finder is in use.) An auxiliary antenna may also be used in conjunction with the loop antenna to obtain a *sense* pattern or operation with a cardioid pattern. It is important under these conditions that the voltage from the sense antenna circuit feed a voltage to the receiver in the proper time phase with the direction-finder loop circuit in order to produce a unilateral or cardioid pattern.

**Ques. 6.287.** Describe the construction and operation of a shielded loop antenna as used with a marine direction finder.

*Ans.* The loop antenna of a modern marine direction finder is of either circular or diamond-shaped design. The loop inductance is *almost* completely shielded with a nonmagnetic metal, and the entire unit enclosed in a plastic rubber or bakelite housing. Complete shielding would short-circuit the magnetic field. The shielding is generally grounded in the exact center to balance out capacity effects.

The operation of a typical direction finder is briefly as follows: When the loop is rotated so that the plane of the coil is in the plane of the oncoming wave, a maximum e.m.f. is

induced. This indicates a line of propagation from either one of two directions or figure-of-eight polar characteristic. If a small vertical antenna is used in conjunction with the loop antenna, the line of direction or "sense" of signal arrival may be determined. This is due to the fact that a vertical antenna is nondirectional and develops a circular reception pattern. If, therefore, the energy from the antenna and the loop circuit are fed to the receiver in time phase, a cardioid or directional pattern will be produced.

A practical operating procedure follows: (1) Close direction-finder switch. (2) Disconnect the main antenna. (3) Tune for a desired radio beacon signal (rotate loop for maximum response). (4) Reorient loop for a minimum response in the telephones. (5) Adjust balance control for a sharp minima. (The minima should be critically adjusted by slight orientation of the loop and intensity control to obtain a zero or null point condition or no response in the telephones.)

**Ques. 6.288.** Draw a sketch showing how a "fix" on a ship station can be obtained by taking direction-finder bearings.

*Ans.* See Fig. 6-17.

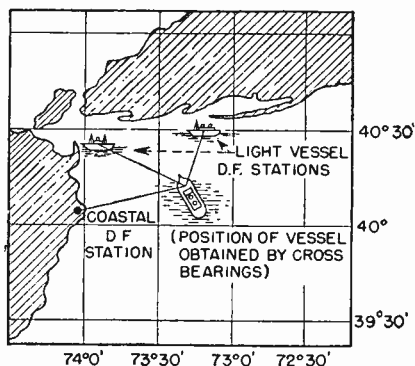

FIG. 6-17. Determining a fix with a direction finder on shipboard.

**Ques. 6.289.** For how long a period of continuous operation should the emergency power supply on a compulsorily equipped

ship station be capable of energizing the emergency radiotelegraph installation?

*Ans.* The emergency power supply must be in complete readiness at all times and must be capable of operating an electron-tube of emergency transmitter for a continuous period of six hours.

**Ques. 6.290.** Why is the clock on a compulsorily equipped ship radiotelegraph station required to have a sweep second hand?

*Ans.* A sweep second hand is required in a ship radiotelegraph station to facilitate accurate time adjustments to United States and foreign government time signals. An accurate adjustment of the ship's clock to standard time signals permits the ship's deck officers to check the accuracy of the ship's chronometer to the exact second. The station clock must also be accurate to the second to provide for correct time entries into the operator's log and also to observe at all times the International Silent Period. The law also requires that all intermediate ship stations operating on frequencies below 515 kilocycles be provided with a clock containing a sweep second hand for the operator's use in connection with the testing and timing of the international auto-alarm signal.

**Ques. 6.291.** Between what points on a ship, compulsorily equipped with a radiotelegraph installation, is a reliable inter-communication system required?

*Ans.* The law requires that a reliable communication system be provided between the radio room and the navigating bridge.

**Ques. 6.292.** What is the purpose of an automatic-alarm-signal keying device on a compulsorily equipped ship?

*Ans.* An automatic-alarm-signal keying device is a unit capable of automatically keying the radiotelegraph trans-

mitter(s) on board a ship so as to transmit the international auto-alarm signal, as this signal is specified by the International General Radio Regulations.

**Ques. 6.293.** What experience is the holder of a first- or second-class radiotelegraph operator license required to have before he is permitted to act as chief or sole operator on a compulsorily radio-equipped cargo ship?

*Ans.* The holder of either a first- or second-class radiotelegraph license is not permitted to act as chief or sole operator on a cargo ship until he has had at least 6 months' satisfactory service as a qualified radio operator on a vessel of the United States. See also Appendix.

**Ques. 6.294.** Are there any age requirements that a person must meet before he can be issued a radiotelegraph operator license?

*Ans.* See Appendix, Sec. 13.12.

**Ques. 6.295.** What action, if any, should a radio operator take when he observes a ship station flagrantly violating the international radio regulations and causing harmful interference to other stations?

*Ans.* An operator should prepare a detailed report to the FCC stating the complete details to support his accusations. The report should include such data as the nature of the interference, the operating frequency, the call letters of the interfering stations, and the time length of the interference.

For detailed information on radio-operating procedures relative to types of messages used in commercial operating, traffic handling, etc., the reader is referred to the "Marine Radio Manual," by M. H. Strichartz. Publisher, the Cornell Maritime Press.

## ELEMENT 7

### AIRCRAFT RADIOTELEGRAPH FOR FLIGHT RADIO OPERATOR

#### *Regulation and Treaty*

**Ques. 7.1.** Under what conditions is a flight radio operator required aboard scheduled aircraft engaged in flights outside the continental United States?

*Ans.* A licensed radio operator shall be required for flight over any area, route or route segment over which the Administrator has determined that radio telegraphy is necessary for communication with ground stations during flight.

**Ques. 7.2.** Under what conditions are flight radio operators required in U.S. irregular air carrier operation?

*Ans.* An airman holding a flight radio operator's certificate shall be required for flight over any area which the Administrator has determined that radio telegraphy is necessary for communication with ground stations during flight.

**Ques. 7.3.** Is it mandatory that one crew member other than the flight radio operator be capable of operating the radio equipment in an emergency?

*Ans.* Yes. If a flight requires only one radio operator, another crew member must be capable of operating the emergency equipment.

**Ques. 7.4.** What are the Federal Communication Commission's license requirements for an air radiotelegraph operator?

*Ans.* See Appendix II, Par. 13.61, and additional information contained at the end of this element.

**Ques. 7.5.** What is meant by "long distance" operation in scheduled air carrier flights outside the continental United States?

*Ans.* A long distance operation is one in which the time interval between stops is of sufficient duration to require that the dispatch be based entirely on forecasts of weather expected at the intended destination and alternates.

**Ques. 7.6.** An aircraft is engaged in "long distance" operation. What radio equipment is required aboard for this type of operation?

*Ans.* (a) One of two independent means must be provided whereby communications and meteorological information can be transmitted to at least one ground station from any point on the route from a distance of not less than 25 miles to airport traffic control towers located at airports approved for the route.

(b) Communications must at all times be receivable at any point on the route.

(c) In addition to (a) the equipment must provide for the reception of meteorological information on the route and receive instructions from ATC (Airport Traffic Control) towers located at airports approved for this route.

(d) Also by one of two independent means the equipment must facilitate the reception of radio navigational signals from any radio aid to navigation in accordance with the rules regarding the distance of operation, airport lighting facilities and so on. For long distance operation, the equipment must be capable of obtaining reliable radio bearings for a radius of within 200 miles of any regular or approved alternate airport.

**Ques. 7.7.** For "long distance" operation outside the continental United States, what ground radio navigational aids are required at scheduled stops and alternate airports?

*Ans.* In addition to (d) of the previous question, facilities must be provided too for making accurate instrument

approach: Provided, that the Administrator at a particular airport or airports, may approve facilities which provide less coverage than that required herein if he finds that adequate safety is provided.

**Ques. 7.8.** What are the requirements for a two-way air-to-ground communications system in scheduled air carrier operations outside the continental United States?

*Ans.* A two-way ground-to-aircraft radio communications system shall be available at such points as are necessary to ensure adequate communication between plane and ground over the entire route.

**Ques. 7.9.** For "long distance" scheduled air carrier operations outside the continental United States, what is the required communication range from aircraft to airport traffic control towers at airports approved for the route?

*Ans.* See Ques. 7.6 (a), (b), (c), and (d).

**Ques. 7.10.** For "long distance" scheduled aircraft operations outside the continental United States, what is the aircraft receiver requirements for receiving communications, meteorological, and navigational information?

*Ans.* See Ques. 7.6(d).

**Ques. 7.11.** For "long distance" scheduled air carrier operations outside the continental United States, what aircraft transmitting equipment is required and over what distance should this equipment operate?

*Ans.* See Ques. 7.6(a).

**Ques. 7.12.** What radio equipment is required aboard foreign flag aircraft operating into the United States and outlying possessions?

*Ans.* Each aircraft shall be provided with such radio equipment as is necessary to make use of the air navigation facilities

## RADIO OPERATING QUESTIONS AND ANSWERS

along or adjacent to the route to be flown within the United States and to maintain communication with ground stations along and adjacent to such routes.

**Ques. 7.13.** Discuss the requirements for electrical power and radio equipment required for continuance of flight.

*Ans.* The power equipment requirements are as follows:

(a) One or more storage batteries or other source of electrical supply sufficient to operate all radio and electrical equipment necessary for the flight. In addition, two of the following three units of radio equipment:

- (1) One transmitter for two-way communication.
- (2) One receiver for two-way communication.
- (3) One receiver capable of receiving navigational signals.
- (4) Three spare fuses of each capacity.

In addition, one of the radio navigational systems required in Ques. 7.6(d).

**Ques. 7.14.** An aircraft is at mid-ocean and experiences a communication failure. What procedure would the pilot follow after being advised by the flight radio operator that the aircraft is out of communication?

*Ans.* The following procedure shall be followed: Proceed according to the current flight plan, maintaining the minimum instrument altitude of the last acknowledged assigned altitude, whichever is higher, to the airport of intended landing and commence descent at approach time last authorized or, if not received and acknowledged, at the estimated time of arrival in the flight plan; or, if weather conditions permit, proceed in accordance with contact flight rules; or, land as soon as practicable.

**Ques. 7.15.** Define the point-of-no-return as used in air carrier operations.



*Ans.* This term refers to the condition in which an aircraft has insufficient fuel to return to the point of departure or any alternate for that point.

**Ques. 7.16.** If a flight operator noted an irregularity or hazard which, in his opinion, made for unsafe operation, to whom should he report such hazard or irregularity?

*Ans.* A report should be made immediately to the operations manager. If said report is found justified by the operations manager notice of the irregularity or hazard must be made to the Administrator at once.

**Ques. 7.17.** With regard to air-to-ground communication, what is the order of priority for communications on a channel that is used for point-to-point as well as air-to-ground contacts?

*Ans.* Priority shall be given to plane-to-ground and ground-to-plane communications.

**Ques. 7.18.** What is meant by "type certification" of radio equipment on U.S. scheduled air carrier aircraft?

*Ans.* A type certification refers to the CAA regulations which requires that all aircraft radio equipment must conform with certain requirements to satisfy airworthiness. To be eligible for a type certificate, an applicant must submit the following technical data:

Drawings, drawing list and parts list; in addition, complete technical data relative to design and tests together with inspections, identifications, and changes to prove airworthiness must be included.

**Ques. 7.19.** What is an air carrier operating certificate and by whom is it issued?

*Ans.* A certificate prescribing the type of operation, the routes over which such operation may be conducted, the airports that may be used, and other specifications and restrictions

## RADIO OPERATING QUESTIONS AND ANSWERS

as may reasonably be required in the interest of safety. An air carrier operating certificate is issued by the Administrator.

**Ques. 7.20.** What are the requirements regarding marker beacon receivers on U.S. irregular air carrier aircraft operating outside the continental United States?

*Ans.* The visual flight rules for aircraft operations outside the continental United States require each aircraft operating for long distances over water or uninhabited terrain to be equipped with two independent means of transmitting to at least one appropriate ground station from any point on the route.

At least one marker beacon receiver and such radio equipment as is necessary to receive satisfactorily, by either of two independent means, radio navigational signals from any other radio aid to navigation intended to be used. See also Ques. 7.6.

**Ques. 7.21.** Is it mandatory that U.S. irregular carriers operating outside the continental United States maintain a ground communication system to provide radio contact at all times with their aircraft?

*Ans.* Yes. See Ques. 7.6(b).

**Ques. 7.22.** When a U.S. irregular air carrier aircraft is operating outside the continental United States on long distance flights over water or uninhabited terrain, what transmitting means are required?

*Ans.* See Ques. 7.20.

**Ques. 7.23.** Define a "route segment" as used in scheduled air carrier operations.

*Ans.* A route segment is a portion of a route in which the boundaries are identified by a continental or insular geographic location, a point at which some specialized aid to air navigation is located, or, a point at which a definite radio fix is located.

**Ques. 7.24.** When an aircraft is in distress, upon what frequency or frequencies should the first radio transmission of distress call and message be made?

*Ans.* The call shall be made on the international distress frequency of 8,280 or 500 kilocycles. When the international telegraph distress frequency of 500 kilocycles is used, the distress call should, if possible, be immediately preceded by the automatic alarm actuating signal of twelve four-second dashes, with intervals of one second between each.

**NOTE:** The Atlantic City Radio Conference has specified 2,182 kilocycles as the world wide distress frequency for radiotelephone equipped stations.

**Ques. 7.25.** In event of an aircraft in distress, how often should the distress message be repeated?

*Ans.* The distress message should be transmitted at intervals until acknowledged.

**Ques. 7.26.** Under what condition should an aircraft, becoming aware that another aircraft is in distress, transmit the distress call and message?

*Ans.* Provided that the aircraft in distress is not itself in a position to transmit or if the intervening command believes that further help is necessary.

**Ques. 7.27.** What is the distress signal used on VHF A3 emission?

*Ans.* For VHF radiotelephony the signal MAYDAY is used.

**Ques. 7.28.** List the order of priority in the establishment of communications in aeronautical mobile radio service.

*Ans.* The order of priority in the transmission of messages in the aeronautical services is as follows:  
Messages bearing the priority prefix SOS, SVH and URGENT.

RADIO OPERATING QUESTIONS AND ANSWERS

These are followed by service prefixes in the order named: EXC, CTL, AMT, DEP, CHG, OBS, NOTAM, PLN, ARR, CNL, and other messages prefixed OPN, MET, DEL, RES, etc.

**Ques. 7.29.** A control station receiving a distress message from an aircraft shall forward the information immediately to what offices?

*Ans.* The information shall be forwarded immediately to the area TFC center or flight information center.

**Ques. 7.30.** In aircraft distress communications, what is the normal speed of radiotelegraphic transmission?

*Ans.* The speed should not normally exceed 16 words per minute.

**Ques. 7.31.** List the information that should be transmitted, if time permits, from an aircraft in distress.

*Ans.* The estimated position and time, true heading and indicated air speed, altitude, type of aircraft, nature of distress, and the intention of the person in command of the distressed aircraft as to the type of forced landing required.

**Ques. 7.32.** What action should be taken by the flight radio operator immediately prior to detaching or crash landing?

*Ans.* The telegraph keying or radiophone circuits should be closed to ensure continuous transmissions.

**Ques. 7.33.** List the emergency and distress frequencies for aircraft in the MF band.

*Ans.* The two international distress frequencies are 500 (MF) and 121.5 megacycles (VHF).

**Ques. 7.34.** What is the interim international safety and emergency frequency in the high-frequency band?

*Ans.* The interim calling and distress frequency is 8,280 kilocycles. A frequency of 121.5 megacycles is also provided for emergency and distress communications.

**Ques. 7.35.** What is the common VHF aircraft emergency frequency?

*Ans.* 121.5 megacycles.

**Ques. 7.36.** How would a flight radio operator alert the search and rescue facilities in his particular area?

*Ans.* The radio operator would notify the appropriate controlling authority, rescue unit, or other assisting organization to guard some radio frequency or stand by to proceed on a mission.

**Ques. 7.37.** What procedure is used by an aircraft to cancel a distress message?

*Ans.* The aircraft must transmit a message, on the distress frequency, canceling the state of distress.

**Ques. 7.38.** What is the meaning of: (a) air carrier aircraft station, (b) airdrome control radio station, (c) aeronautical land station, (d) aeronautical fixed station, (e) radio beacon station, (f) radio range station, (g) localizer station, (h) glide path station, (i) marker station, (j) ground control approach station, and (k) aeronautical public service station?

*Ans.* (a) A radio station aboard an aircraft engaged in, or essential to, transportation of passengers or cargo for hire.

(b) A radio station providing communication between an airdrome control tower and aircraft or aeronautical mobile utility stations.

(c) A land station in the aeronautical mobile service carrying on a service with aircraft stations, but which may also carry on a limited communication service with other aeronautical land stations.

## RADIO OPERATING QUESTIONS AND ANSWERS

(d) A radio station used in the fixed service for the handling of communications between fixed points relating *solely* to actual aviation needs.

(e) A special radio station, the emissions of which are intended to enable an aircraft to determine (1) Its radio bearing or direction with reference to the radio beacon station, or (2) the distance which separates it from the latter, or (3) both of these.

(f) A form of radio beacon, the emissions of which provide definite track guidance.

(g) A directional radio beacon normally associated with an instrument landing system which provides guidance in the horizontal plane to an aircraft for purposes of approach landing.

(h) A directional radio beacon associated with an instrument landing system which provides guidance in the vertical plane to an aircraft for purposes of approach in landing.

(i) A radio station marking a definite location on the ground as an aid to navigation.

(j) A station used for the purpose of controlling from the ground the approach and landing of aircraft.

(k) A radio station, ground or aircraft, operated in the aeronautical public communication service.

**Ques. 7.39.** In general, what language shall be used in radiotelephone communications between aircraft and aeronautical stations in the international service?

*Ans.* Communications shall, in general, be conducted in the language of the ground station.

**Ques. 7.40.** In event of noncommunication with an aircraft what offices should be advised immediately by the control station operator?

*Ans.* The ATC Office and the airline operating agency should be notified immediately.

**Ques. 7.41.** In communications between aircraft radio stations, what station controls the duration of continuous work?

*Ans.* The control is governed by the receiving station or intervening relay station.

**Ques. 7.42.** How should an aircraft flying over the sea signal its position?

*Ans.* The aircraft shall signal its position in latitude and longitude (GMT) but may give the true bearing and distance in nautical miles from some known geographical point.

**Ques. 7.43.** How should an aircraft flying over land signal its position?

*Ans.* The aircraft shall signal its position by the name of, and approximate distance and direction of, the nearest reference point.

**Ques. 7.44.** What procedure should an over-ocean aircraft follow if it is unable to establish communications for any reason other than transmitter failure?

*Ans.* The aircraft shall transmit periodic reports at scheduled times, or positions, on the assigned frequency.

**Ques. 7.45.** In air-to-ground radiotelephone communications, how is the "invitation to reply" spoken in standard voice procedures?

*Ans.* The word OVER is given to invite a reply.

**Ques. 7.46.** What is meant by the priority prefix SVH?

*Ans.* SVH is the prefix embodying all messages in the aeronautical service pertaining to the safety of human life.

**Ques. 7.47.** After communication has been established between an aircraft and its control station, is it permis-

sible to dispense with the radio call letters in subsequent communication?

*Ans.* After communication has been established the call letters may be abbreviated by using the first and last two characters of the call letters.

**Ques. 7.48.** Is it mandatory that an aircraft maintain continuous watch in flight on the air-to-ground route frequency?

*Ans.* Yes.

**Ques. 7.49.** In radiotelephone communications what word is spoken to denote that an error has been made in transmission?

*Ans.* The word CORRECTION is used.

**Ques. 7.50.** In radiotelephone communication, how is termination of communication indicated by the receiving station?

*Ans.* The phrase OUT.

**Ques. 7.51.** With which station should an aircraft normally communicate when flying over a particular route?

*Ans.* Communication should be maintained with the control station of the area in which the plane is flying unless receiving conditions demand otherwise.

**Ques. 7.52.** What is the radiotelephone spoken equivalent of radiotelegraph signal IMI?

*Ans.* The word, REPEAT.

**Ques. 7.53.** What is the radiotelephone equivalent of the radiotelegraph signal C?

*Ans.* The phrase, THAT IS CORRECT.

**Ques. 7.54.** What is meant by break-in procedures in aircraft radiotelegraph communications?



*Ans.* This term refers to the process of interrupting the transmission of another station for repeat or emergency purposes. Break-in is accomplished by transmitting the letters BK followed by a brief pause for acknowledgment from the transmitting station.

**Ques. 7.55.** What type of information is generally included in a broadcast service known as NOTAMS?

*Ans.* Information contained in scheduled broadcasts of notices to airmen, including general and urgent information affecting the safety of air navigation. These reports *do not* include meteorological information.

**Ques. 7.56.** Describe the structure of the NOTAM code as used in international flight operations?

*Ans.* The code is composed of five (5) letters, each of which has a specific meaning.

The first letter of the code group is always the letter Q to indicate that it is code abbreviation for use in the composition of NOTAMS. The second and fourth letters shall in all cases be a vowel. The third and fifth letters may be any letter of the alphabet.

**Ques. 7.57.** What is meant by the ICAO (International Civil Aviation Organization) priority prefixes such as: AMT, ARR, OPN, PLN?

<i>Ans.</i> AMT	Meteorological message for aircraft in flight, or for aircraft about to depart.
ARR	Arrival message
OPN	Company's operational message
PLN	Flight Plan message

**Ques. 7.58.** How are the ICAO complimentary code groups used in air-to-ground communications?

## RADIO OPERATING QUESTIONS AND ANSWERS

*Ans.* The complimentary code groups are abbreviations to be used in conjunction with Q signals to reduce the length of transmissions. Some typical examples are as follows:

ADC	Aerodrome Control
ADZ	Advise
GND	Relative to ground
RNG	Radio Range

**Ques. 7.59.** What radio information is contained in the IFR flight plan of scheduled air carrier operation outside the continental limits of the United States?

*Ans.* The information contained in an IFR flight plan is of considerable detail and includes such items as, type of aircraft, name of pilot in command, point of departure, cruising altitude, estimated time of arrival, and so on. The information relating specifically to radio includes, aircraft identification, (radio call letters) and the transmitting and receiving frequencies to be used.

**Ques. 7.60.** What is the intermediate frequency reserved for aircraft flying over the seas?

*Ans.* 457 kilocycles.

**Ques. 7.61.** Is it mandatory that U.S. air carrier aircraft operating within the United States and overseas be equipped with a radio altimeter?

*Ans.* The regulations do not indicate that a radio altimeter is mandatory.

**Ques. 7.62.** What are the requirements regarding a master switch in an aircraft electrical installation?

*Ans.* If electrical equipment is installed, a master switch arrangement shall be provided which will disconnect all sources of electrical power from the main distribution system at a point adjacent to the power sources.

The master switch or its controls shall be installed so that it is easily discernible and accessible to a member of the crew in flight.

**Ques. 7.63.** Air carrier aircraft electrical installations incorporate storage batteries in the primary systems. Discuss the requirements for battery vents, cooling, containers, and protection against acids.

*Ans.* The battery compartment must have provisions for releasing gases through suitable means outside the airplane. A completely enclosed compartment shall be provided to prevent acid and corrosive substances from coming in contact with other parts of the plane which are essential to safe operation. The aluminum container should be frequently examined for evidence of leakage. The battery compartment is cooled by adequate ventilation but care must be exercised by frequent inspection to make certain that the batteries are not overheating due to excessive charging rates.

**Ques. 7.64.** With reference to aircraft generators, what are the requirements concerning generator capacity, generator switch, generator rating, generator controls, and a reverse current cut-out?

*Ans.* The requirements are as follows: The generator must be designed to be capable of delivering its continuous rated power with a minimum of overheating. The generator switch must be capable of carrying the rated current and shall be of such construction that there is sufficient distance or insulating material between current carrying parts and the housing so that vibration in flight will not cause short circuiting. The generator rating must conform with the total load requirements of the installation. Its output capacity must be sufficient to supply the complete load demands on the basis of continuous operating conditions. The generator must be equipped with a suitable control device (carbon pile regulator) which is capable of dependably regulating the generator output within rated

limits. A reverse current cut-out must be provided for the purpose of disconnecting the generator from the batteries and other generators under conditions when the generator is developing a voltage below that of its normal value. It is in reality an underload relay which prevents the batteries or other generators from discharging back through the main generator when its voltage falls lower than that of the other parallel units.

**Ques. 7.65.** What type of radio waves are the most suitable for aircraft radio direction finding, vertically or horizontally polarized waves?

*Ans.* Vertically polarized waves are used because they are less easily reflected from the ionosphere or from obstructions (such as mountain ranges) than are horizontally polarized waves. Such reflections, usually resulting in waves with strong horizontal components, give rise to spurious signals that cause multiple course indications.

**Ques. 7.66.** Explain the term "quadrantal or aircraft error" and what is done to counteract this error in modern aircraft radio installations? How does quadrantal error vary with frequency?

*Ans.* Quadrantal or aircraft error, sometimes known as "loop deviation," is the error caused by the bending or reradiation of the incoming signal by the metal of the plane. These additional signals are often strong enough to cause the loop to give false indications. Loops are mounted well forward on the underside of the plane to minimize reflections. In addition, a correction chart, special azimuth scale, or built-in error-correcting cam is furnished to provide the pilot with an accurate indication.

The amount of error increases with frequency because shorter lengths of wire and metal become more effective reflectors at higher frequencies.

**Ques. 7.67.** Normally, what are the maximum and minimum frequencies upon which a standard transport aircraft D/F loop will give satisfactory operation?

*Ans.* Between about 100 and 1,800 kilocycles.

**Ques. 7.68.** An aircraft loop antenna is influenced by the field of a vertically polarized wave front. Will the magnetic lines of force cut the loop from top to bottom or from side to side?

*Ans.* The vertical lines of force will cut only the vertical sides of a loop. If the loop is oriented so that its plane is at right angles to the wave front, the current induced front and back will add. In a circular loop, any curved sector can be thought of as having both a vertical and a horizontal component, and therefore the loop as a whole will have electrical top, bottom, and sides.

**Ques. 7.69.** It is common practice to employ plastic housings to streamline electrostatically shielded loop antennas on air carrier aircraft. Do these housings have a conductive or nonconductive surface?

*Ans.* Such housings have a conductive coating. They are often impregnated with graphite. The conductivity of the surface should be such that the resistance from any square-inch area to the supporting metallic structure does not exceed 10 megohms.

**Ques. 7.70.** Explain how aircraft D/F loops are constructed so that they intercept electromagnetic waves and reject electrostatic charges.

*Ans.* A simple shielded D/F loop comprises a number or turns of wire insulated from and enclosed in a circular metal tube. The tube is not continuous but is split at the bottom, the gap being filled with insulating material. The loop is thus affected by electromagnetic waves but is shielded from electro-

static charges. (See also Ques. 6.287.) Newer types have powdered-iron cores and are physically smaller.

**Ques. 7.71.** When using a manual direction finder on a homing station how should the D/F loop and the associated receiver be adjusted?

*Ans.* The loop is oriented until the azimuth reads zero and a course is flown such that a null signal is always received. The receiver gain should be high and should not be materially reduced as the station approached. There is normally no cone of silence above such a station.

**Ques. 7.72.** In an aircraft D/F installation, is the loop calibration curve considered accurate for any frequency between 200 and 1,800 kilocycles?

*Ans.* Yes, but too much reliance must never be placed in an over-all calibration curve. It is desirable to make spot checks at frequencies frequently used.

**Ques. 7.73.** What effect does a coast line have upon radio bearings taken aboard an aircraft flying offshore?

*Ans.* If the radio beacon is located upon the shore and the path between it, and the aircraft is entirely over water, the coast line has no effect. Similarly, if bearings are taken on an inland station on a line at right angles to the shore line, there is no effect. However, bearings taken at an acute angle across the coast line are subject to an error that increases as the angle with the shore decreases. This effect, known as "coastal refraction" or "land effect," is caused by the refraction of a radio wave in crossing the boundary of land and water. A ray from a shore station to a plane over water would always be bent in towards the coast line. Systems such as Loran are essentially unaffected.

**Ques. 7.74.** In aircraft D/F work, is the minimum or maximum signal used to observe bearings? Explain.

*Ans.* The minimum signal is used to observe bearings. When a loop is pointed directly at the transmitting station, a maximum signal is received. However, a maximum is an indefinite quantity that may depend not only upon orientation of the loop but also upon other factors, such as propagation and receiver gain setting. The minimum or null position of the loop is a definite and also a much sharper indication. It is accordingly used as soon as the transmitter has been identified and the bearing is to be taken.

**Ques. 7.75.** In aircraft radio navigation, what is meant by a "reciprocal"?

*Ans.* A reciprocal is the direction of bearing plus or minus 180 degrees.

**Ques. 7.76.** Is quadrantal error in a loop installation aboard an aircraft maximum or minimum at the cardinal points of the azimuth?

*Ans.* It is minimum at the cardinal points and maximum at points midway between the cardinal points.

**Ques. 7.77.** Describe the function of the sense antenna used in conjunction with an aircraft ADF installation.

*Ans.* With a simple loop antenna, there is always a 180-degree ambiguity in the direction because there are always two positions that give a maximum (or null) signal. If, however, a separate sense antenna is connected to the receiver in such a way that the resultant pattern of the two antennas is a cardioid, the loop azimuth can be read directly as the direction of the transmitting station. The automatic direction finder (ADF) requires such a sense antenna in order to function automatically.

**Ques. 7.78.** What is the purpose of the threshold sensitivity control on an aircraft ADF unit?

*Ans.* The sensitivity control (usually a screwdriver adjustment) is a bias control on the thyratrons that control the loop motor. The loop seeks always to remain at null signal. If the aircraft changes position relative to the homing transmitter, one of the thyratrons will fire and cause the motor to turn the loop to null again. When the thyratrons are biased down, they do not fire so quickly and the system is not subject to "hunting" or continuous movement back and forth through the null.

**Ques. 7.79.** What circuits of an aircraft ADF use thyatron tubes?

*Ans.* The control circuits that drive the loop motor to seek a null position.

**Ques. 7.80.** What is the purpose of the silica gel crystals in an aircraft ADF installation?

*Ans.* The plastic housing of the loop, mounted externally to the aircraft, is kept airtight, but is subject to temperature extremes because of its exposed location. The changes of temperature allow breathing of warm moist air from the plane, and moisture condenses on the interior of the housing. The air opening (inside the plane) is connected via a rubber tube to a glass cylinder containing silica gel, a dessicant. Moisture is taken out of the air before it can leak into the housing, which is thus assured of dry air from which there is no moisture to condense.

**Ques. 7.81.** With reference to ground D/F stations, what is the principal advantage of the Adcock station over the early loop D/F stations?

*Ans.* Ground direction finding stations using Adcock antennas pick up essentially only vertically polarized waves and can therefore give more exact determinations of direction than earlier loop stations that often picked up other compo-



nents. The Adcock receiving antenna shares the same advantages for reception as for transmitting at a radio beacon.

**Ques. 7.82.** What is meant by the term "hunting" in an ADF system?

*Ans.* When the motor-control thyratrons in an ADF system are not sufficiently biased, the system responds to many small irregular impulses and the loop is shifted quickly back and forth over the null region. This phenomenon is called hunting.

**Ques. 7.83.** Will static crashes affect the operation of an aircraft ADF?

*Ans.* Yes. During a heavy thunderstorm off to one side of the course the ADF may spend a great part of its operating time taking a null on the storm, shifting back and forth between it and the desired beacon signal.

**Ques. 7.84.** What is the purpose of a compensator cam in an aircraft ADF installation?

*Ans.* Planes of a type and even those of different types have nearly the same quadrantal error characteristic. If the ADF loop is provided with a correction cam that removes the quadrantal error, the direction indicator can be made direct reading.

**Ques. 7.85.** What is an Autosyn as used with ADF systems and what device furnishes power to the Autosyn?

*Ans.* The Autosyn is essentially a three-phase motor, which, when properly connected to a similar motor, assumes the successive positions of the second motor as the latter is turned. It is powered by alternating current which is either furnished by a separate inverter run from the aircraft battery, or from the 400-cycle a-c system with which many large planes are equipped.

**Ques. 7.86.** What type of radio range gives satisfactory ADF operation? What type gives unsatisfactory operation?

*Ans.* The older loop-type of radio range often gives false readings. The newer Adcock-type radio range produces essentially pure vertical polarization and is entirely satisfactory for automatic direction finding.

**Ques. 7.87.** Why is it inadvisable to take ADF bearings on synchronized broadcast stations?

*Ans.* Synchronized broadcast stations operate on the same frequencies and broadcast the same programs. It is therefore practically impossible to distinguish which transmitter is being received, unless the aircraft is near one and the terrain can be distinguished. The automatic direction finder would tend to follow the nearer and stronger station. It would give wholly confusing indications when flying between the two stations.

**Ques. 7.88.** In reference to an ADF system, explain why the position of the loop determines when power will be delivered to the loop motor-control circuit.

*Ans.* If the loop is oriented towards a null, a minimum signal will be received and the thyatron motor control tubes will not fire. However, if the aircraft swings so that the loop shifts out of the null and a signal is received, a thyatron will be fired by this signal and power will be supplied to the loop motor in such a way as to move the loop back in the direction away from the signal. When the null is once again received, the thyatrons are extinguished and the motor turns off.

**Ques. 7.89.** Why is a low inertia-type motor used as the loop control motor in an ADF system?

*Ans.* A high-inertia-type motor that took some time to go into operation and to stop would increase the hunting in the system and result in a continual movement of the indicator

needle as the system tried unsuccessfully to find and maintain the orientation of the loop on the null during normal flying.

**Ques. 7.90.** When using the aircraft ADF receiver for aural flying of a low-frequency radio range, the function switch should be in the "Antenna" position instead of the "Compass" position. Explain.

*Ans.* When the switch is in the antenna position, the sense antenna, which has better pickup than the loop, is connected to the receiver and is used for maximum signal (rather than null) reception of the radio range. In the Compass position, the ADF receiver is arranged for null reception with the loop.

**Ques. 7.91.** What is the purpose of the rotatable scale on the aircraft ADF azimuth indicator?

*Ans.* The rotatable scale is connected with the gyro compass so that the magnetic direction of the radio beacon is immediately apparent to the pilot.

**Ques. 7.92.** Why is it important that an aircraft employ bonding and shielding of various radio and electrical units?

*Ans.* Different masses of metal acquire unequal charges or may rest at different potentials because of connection to sources of power. If sparking occurs as a result of voltage breakdown, or if vibration causes contact between circuits or equipment at slightly differing potential, the resulting sparking sets up an electrical disturbance that is readily picked up in sensitive receiving equipment. It is therefore necessary that all radio and electric equipment be grounded to a common lead or metal frame in order to avoid potential differences. Wires carrying high voltage alternating currents must be shielded to avoid pickup of these currents; wires to high-gain electronic equipment must be shielded from all extraneous disturbances.

**Ques. 7.93.** In bonding aircraft radio and electrical units on an aircraft, should the resistance of the bond be of a high or low value?

*Ans.* The resistance of bonds should be held to as low a value as possible.

**Ques. 7.94.** In a carbon-pile voltage regulator, is the carbon pile connected in series or in parallel with the shunt field of the generator?

*Ans.* It is connected in series with the shunt field.

**Ques. 7.95.** In the resistance element of a carbon-pile voltage regulator does the resistance vary inversely or directly with the amount of pressure on the carbon?

*Ans.* Resistance varies inversely with pressure.

**Ques. 7.96.** What operating characteristics of the carbon-pile voltage regulator makes it well suited for aircraft use?

*Ans.* Regulation of the generator output voltage is good because of the continuous resistance change. The resistance changes instantaneously to compensate for changes in the output voltage of the generator. Radio interference is reduced by avoiding the opening and closing of contacts. Its construction allows it to carry heavy currents without damage and its resistance variation makes it effective over a wide range of field current. It is relatively unaffected by vibration or shock experienced in aircraft.

**Ques. 7.97.** What is the purpose of the equalizer circuit in a parallel generator system using a carbon-pile voltage regulator?

*Ans.* The equalizer circuit permits the use of two generators for battery charging and effectively prevents voltage differences between the generators. The reverse-current relays and carbon-pile regulators are often assembled in a single cabinet sometimes called the load center.

**Ques. 7.98.** At what speed of the aircraft engine should the generator develop its normal voltage?

*Ans.* The generator should develop normal voltage at about 1,500 r.p.m. engine speed. Owing to usual gearing, the generator will be turning at about 2,250 r.p.m.

**Ques. 7.99.** How is the rating on an aircraft generator usually stated?

*Ans.* An aircraft generator is usually rated by its current-carrying ability in amperes.

**Ques. 7.100.** List at least two sets of figures for generator ratings on present day transport aircraft.

*Ans.*

d-c voltage, 30 volts	d-c voltage, 28.5 volts
d-c current, 50 amperes	d-c current, 200 amperes
power output, 1,500 watts	power output, 5.7 kilowatts
speed, 2,400/3,600 r.p.m.	speed, 2,500/4,500 r.p.m.
cooling, fan	cooling, air blast

**Ques. 7.101.** What is the purpose of employing differential-voltage reverse-current relays in aircraft generator systems?

*Ans.* Protective relays are employed in aircraft generator systems to disconnect the generator when the engine is idling because the generator voltage is low, and the battery would otherwise tend to discharge into it. Reverse current relays also protect the whole system in case the generator polarity should become reversed. If no protective device were employed, the generator and the battery would, in effect, short circuit into each other. A reverse current cut-out is also necessary when more than one generator is used.

**Ques. 7.102.** Discuss air carrier aircraft electrical systems with regard to general wiring (single wire, two wire).

*Ans.* Single-wire systems use a bus bar attached to the aircraft structure as ground return. This type of wiring is least

## RADIO OPERATING QUESTIONS AND ANSWERS

expensive, considering both materials and labor costs, and is generally employed in transport airplanes. If appreciable current is carried, magnetic fields are set up that disturb instruments like the magnetic compass. The more expensive two-wire system uses a pair of wires that are twisted together, thus canceling out the magnetic field and cutting down disturbances. It is customary to provide cables made up to serve given areas of a plane, rather than to run single cables for each use. These completely shielded cable sections are joined in junction boxes. This system allows maintenance or replacement of faulty sections. The ignition system, in particular, uses a harness and shielded cable made up as a unit. Voltage breakdown in this part of the electrical system is not only disastrous to the operation of the aircraft, but can also be a source of strong interference to the radio communication and navigation equipment.

**Ques. 7.103.** Describe the operational characteristics of "trip-free" and "nontrip-free" circuit breakers as used in aircraft radio and electrical installations.

*Ans.* A trip-free circuit breaker is one that cannot be overridden. Once it has blown, it is not possible to close the circuit against the heavy-current condition that caused the breaker to operate. If the heavy-current condition has cleared by itself, then the breaker can be reclosed normally. A non-trip-free circuit breaker is one that can be restored to its operating position even though the heavy current that caused it to blow is still flowing. Trip-free circuit breakers are used in all nonemergency circuits in aircraft. Emergency circuits, that is, those the failure of which may result in the inability of the airplane to maintain controlled flight, use the nontrip-free type. Such circuits must also employ flame resistant cable.

**Ques. 7.104.** Name one important reason why alternating current is not used for the primary power source on transport aircraft.

*Ans.* An aircraft is dependent upon its storage battery for such initial functions as starting (although large aircraft require special ground starting-generator sets). Since this battery must be kept charged, a generator for the purpose can be designed not only for charging but also to furnish additional current to other devices. Alternators for the production of alternating current must be brought up to speed before their voltage and frequency are generally useful. Devices operating from a battery and a generator in parallel are immediately useful and independent of the speed of the engines.

**Ques. 7.105.** Explain how transport aircraft generators are driven.

*Ans.* Aircraft generators are directly driven from the aircraft engine. The splined end of the generator rotor fits a geared coupling on the engine and has a step-up ratio of about 1.5 to 1 so that the generator revolves faster than the engine.

**Ques. 7.106.** What particular electrical system on an aircraft is difficult to shield by the use of filters?

*Ans.* The ignition system cannot be filtered to prevent interference to radio equipment, but it is shielded as completely as possible, with the shielding bonded to the engine or metal framework of the aircraft at least every 18 inches.

**Ques. 7.107.** Polyethylene-covered antenna wire is being used on many transport aircraft radio installations. What is the advantage of this type of antenna over the small diameter braided copper wire? Over solid copper wire?

*Ans.* Corona discharge from radio antennas is not the sole source of interference from precipitation static but it is one of the worst. Insulated antennas provided with special supporting fittings are vastly superior to small braided wire in reducing corona effects because the latter develops small, sharp points from which corona takes place at relatively low voltage. The insulated antennas prevent corona discharge

under all normal conditions. If the insulation is punctured, however, the polyethylene-covered antenna loses its effectiveness. It must be inspected periodically for punctures. Solid copper wire is superior to braid because it does not develop the sharp projections. If it has a sufficiently large diameter, its corona onset potential is high and it may be as useful as the insulated type from this point of view. It has no insulation to puncture, and when used for transmitting, it has lower  $I^2R$  loss. Installation and maintenance costs are low. However, the appreciable mass of large-diameter copper wire may often make it mechanically unsuitable.

**Ques. 7.108.** Name one advantage of using large-diameter bare aluminum wire for antennas on transport aircraft.

*Ans.* Besides advantages of large-diameter conductors as aircraft antennas listed in Ques. 7.107, large-diameter bare aluminum wire has the additional advantage of being light in weight.

**Ques. 7.109.** What is the purpose of using trailing wicks on the wing tips and tail surfaces of transport aircraft?

*Ans.* After the corona from antennas has been eliminated, the corona discharge from other surfaces becomes important as a source of interference. Static discharge wicks are placed as close as mechanically possible to the wing tips and trailing surfaces of wings, elevators, and rudder. These wicks provide a sort of coupling or connection between the aircraft and the atmosphere and tend to equalize the charges between them gradually, thus avoiding or minimizing corona discharge.

**Ques. 7.110.** With reference to electrostatic buildups on transport aircraft, which will produce the higher charging rate, dry snow and ice crystals, or wet snow and rain?

*Ans.* Dry snow and ice crystals produce higher charging rates than wet snow and rain, generally causing severe precipitation-static interference for long periods of time.



**Ques. 7.111.** Which one of the two, air speed or ground speed, is a contributing factor in the buildup of high electrostatic potential on an aircraft flying through sleet, snow, or dust?

*Ans.* Since the buildup of potential is a function of the speed of the moving particles against the aircraft, it is the air speed, or the actual speed of the particles relative to the plane, that is important rather than the speed of the plane in relation to the ground.

**Ques. 7.112.** Discuss the progress that has been made in recent years toward the elimination of precipitation static on aircraft.

*Ans.* One of the most important discoveries has been that the worst source of interference to radio reception is corona discharge from the receiving antenna itself. Development of polyethylene-covered antennas with suitable fittings to avoid corona has virtually eliminated disturbances from this source. Large-diameter, lightweight (aluminum) wires are also being used successfully. Although a charged metallic body suspended in the air will lose its charge in about 7 minutes, the continual charging of aircraft in motion does not allow it to lose its charge, and corona areas build up. Even the exhaust gases do not provide sufficient "connection" to the atmosphere to discharge the plane. Among many devices and methods tried, it was found that a soft cotton wick treated with colloidal metal is the most generally acceptable means of discharging the corona current without setting up appreciable disturbance. All the methods described have considerably reduced static discharge disturbances but have not completely eliminated them.

**Ques. 7.113.** Under conditions of severe precipitation static, why is a loop antenna superior to a fixed antenna in receiving radio signals?

*Ans.* A loop antenna in itself is usually inferior to other types in its amount of signal pickup. However, since it is electrostatically shielded, it can often be used for reception when other antennas are useless because of the high noise level from static.

**Ques. 7.114.** What is meant by corona, or St. Elmo's fire? What design in aircraft antennas aids in preventing corona?

*Ans.* Corona, or St. Elmo's fire, is a visible electrical discharge from a highly charged body to another of different charge or into the atmosphere. The resulting oscillation is of sufficient strength to obscure radio signals. Corona occurs first from sharp points. If these can be avoided in the construction of a radio antenna, corona can be eliminated. Large-diameter wires and particularly wires of small diameter covered with polyethylene insulation are now used to minimize corona discharge from the antenna.

**Ques. 7.115.** What is the advantage of the SBRA-type range station over the MRL-type range station when using the aircraft D/F for bearings?

*Ans.* The SBRA range is a scheduled broadcast station (B) with simultaneous transmission of range signals and voice (S). The range (RA) employs an Adcock antenna with vertical radiators. Its power is greater than 150 watts. The MRL range is simply a range with no provision for voice broadcasts and employs loop radiators. Its power is between 50 and 150 watts. If the aircraft direction finder loop is being used to pick up the transmitter, the stronger signal from the SBRA will be easier to use. Because it employs an Adcock antenna, there will also be much less night effect owing to reflections from the ionosphere. The SBRA has a cone of silence over it. With the MRL loop transmitting antenna, its horizontal component is often reflected from the ionosphere as a vertical component causing confusing readings.

**Ques. 7.116.** What are the principal advantages of the Adcock radio range over the loop-type radio range?

*Ans.* The Adcock radio range employs vertical antennas and transmits no appreciable signal with horizontal polarization. There is a definite cone of silence over the Adcock range. Horizontal signals from a loop-type range are often reflected from the ionosphere as vertical polarization, causing a swinging beam or confusing signals on which no null can be found. There is actually no null over a loop-type range although the receiving antenna characteristics may show one.

**Ques. 7.117.** Explain the principle of operation and the type of emission obtained from an aerophare.

*Ans.* Aerophare is the international designation for aeronautical radio-beacon station. As a generic term it may refer to any one of several types, such as Consol (Sonne), low-frequency range, MOR, VOR, and RACON. However, in current usage, the term commonly refers to a station that comprises a transmitter and antenna system that sends out continuous waves of approximately uniform strength in all directions so that aircraft equipped with a direction finder can determine azimuth with relation to the aerophare. The transmitting station operates somewhere in the region between 200 and 400 kilocycles. It is identified by dots and/or dashes and a silent period. The characteristic keying is at a modulation frequency of 1,020 cycles.

**Ques. 7.118.** What is the general shape of the radiation pattern of an aerophare?

*Ans.* The continuous-wave aerophare used for homing has a generally circular pattern.

**Ques. 7.119.** What aircraft equipment is necessary to make use of the service of an aerophare?

*Ans.* Direction finder receiver and loop.

## RADIO OPERATING QUESTIONS AND ANSWERS

**Ques. 7.120.** Explain the principle of operation of the omnidirectional range.

*Ans.* The omnirange illustrated in Fig. 7-1 uses a transmitter and complex antenna system of five antennas to transmit both a nondirectional signal and one that rotates at

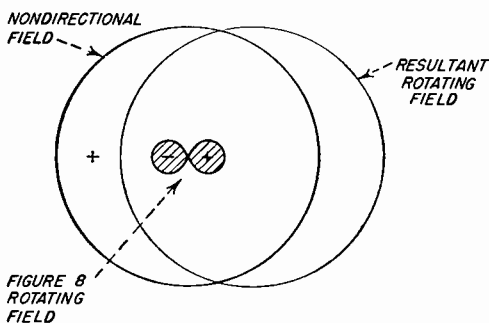

THE RECEIVING ANTENNA PICKS UP AN R-F SIGNAL VARYING IN AMPLITUDE AT 30 CYCLES PER SECOND. THE MAGNITUDE OF THIS VARIATION IS 30 PERCENT.

Fig. 7-1. Principle of the omnidirectional range.

1,800 r.p.m. or 30 cycles per second. Both radiated signals are in phase at one instant and out of phase by varying and measurable amounts for the rest of the rotation period. The nondirectional reference signal is transmitted on a 10-ke FM subcarrier so that the receiver in the aircraft can separate it and compare it with that from the rotating system. Because the in-phase relationship is established when the rotating signal is directed towards magnetic north, the amount of phase deviation can be made to represent azimuth from the transmitter. For example, when the receiving system senses a 96-degree phase difference, the indicator will show that the aircraft is magnetic north plus 96 degrees, or a little south of east. The low-frequency omnirange is known as the MOR facility and the more common VOR facility stands for VHF Omnidirectional Range.

**Ques. 7.121.** How is the rotating signal in an omnirange initially set with respect to true north, or magnetic north?

*Ans.* The rotating and reference signals are initially set in phase when the range is transmitting towards magnetic north.

**Ques. 7.122.** Upon what frequency do marker beacon receivers operate?

*Ans.* At 75 Mc.

**Ques. 7.123.** What is the purpose of the "HIGH-LOW" switch used in conjunction with the aircraft marker beacon receiver?

*Ans.* Two different values of receiver sensitivity can be selected. At high altitudes, with the switch in the "HIGH" position, the receiver is more sensitive to the weaker signal. At low altitudes, the switch can be set in the "LOW" position to make the receiver less sensitive and therefore capable of giving a sharper indication of the marker.

**Ques. 7.124.** Explain how overloading in a radio range receiver may cause apparent reversal of quadrant signals of a low frequency range.

*Ans.* Owing to the fact that range signals may often be used at great distances from the station, the receiver is provided with appreciable audio power output. If, as a pilot approaches the range transmitter, he does not decrease the gain control setting there will often be sufficient signal to overload the audio amplifier. When flying in the twilight zone, either the *A* or the *N* signal is much weaker than the other. With the amplifier overloaded, the louder signal driving the amplifier grid further positive will tend to cut off the amplifier output to the phones, while the weaker signal will allow the 1,020 beat signal to come through. As a result, the pilot will hear an *N* instead of *A*, or vice versa. This situation should, however, be quickly noted by the garbling of the station

identification caused by the inversion of the dots and dashes. A receiver with AVC may also give a similar effect.

**Ques. 7.125.** Explain the principle of operation of the radio range filter as used on U.S. aircraft radio installations.

*Ans.* The radio range signal consists of a steady carrier at a fixed frequency and two coded carriers exactly 1,020 cycles higher in frequency. In the aircraft, the output of the receiver is provided with a band-pass filter that has minimum attenuation at 1,020 cycles. Another portion of the range filter contains a circuit with a maximum attenuation at 1,020 cycles. A switch allows the pilot to connect either the band-pass filter for range work, or the band-elimination filter so that he can receive the voice broadcasts with which the steady carrier is occasionally modulated. A third switch position allows him to hear both the range and the broadcast together.

**Ques. 7.126.** What types of aircraft antennas are used for radio range flying?

*Ans.* An inverted-L or a fin antenna above the plane, or a vertical whip extending below the plane are often used. Inverted balanced-T, trailing wire, and other types are also in current use.

**Ques. 7.127.** What are compass locator stations and on what frequencies do they operate?

*Ans.* Compass locator stations are low-power, nondirectional radio beacons transmitting a circular pattern. They operate in the frequency band 200 to 400 kilocycles and transmit a continuous carrier modulated with the identifying code letter or letters, at 1,020 cycles. These facilities are installed at some outer or middle marker sites as interim ILS (Instrument Landing System) aids.

**Ques. 7.128.** List three disadvantages of the conventional low-frequency radio range.

*Ans.* Despite its widespread use and great utility, the low-frequency radio range has a number of disadvantages. Only four definite courses are provided and if a pilot is lost he does not know in which quadrant he is located until he completes a lengthy flying procedure. Static is prevalent in the frequency band (200 to 400 kilocycles) used for this facility. At the frequency used, the terrain or ionospheric effects often cause bending of the beam, multiple courses, and night effect.

**Ques. 7.129.** In actual flying practice, how many visual courses does VOR offer simultaneously at any given altitude level—(1) 4, (2) 16, (3) 90, and (4) 360?

*Ans.* (3) 90. Although there are, theoretically, an infinite number of courses, the width of the VOR beam is not infinitely small, but about 4 degrees wide. There are, therefore, 90 definable courses in a complete 360-degree circle.

**Ques. 7.130.** What is the frequency of the keyed tone producing the VOR station identification signal—(1) 500 cps, (2) 1020 cps, (3) 3010 cps, (4) 3000 cps, (5) 6210 cps?

*Ans.* The frequency of identification is 1,020 cycles per second.

**Ques. 7.131.** What is meant by the term MOR with respect to radio aids to air navigation?

*Ans.* The MOR facility is a low-frequency omnidirectional range, similar to VOR but operating in the frequency region between 365 and 415 kilocycles. The system is in development at this writing. Although it should more properly be designated LOR (and was, originally) the letters MOR have been chosen so as to avoid confusion with LORAN.

**Ques. 7.132.** How does the "Z" marker provide a definite means for the aircraft determining its position over the cone of silence?

## RADIO OPERATING QUESTIONS AND ANSWERS

*Ans.* The Z-marker transmitter provides a conical signal pattern within the cone of silence of a low-frequency radio range that positively identifies the region. This marker operates at 75 megacycles and is continuously modulated at 3,000 cycles. Its signal is received in the plane and normally actuates a white light on the instrument panel.

**Ques. 7.133.** What audio frequencies are associated with Z markers, fan markers, and inner and outer markers?

*Ans.* Modulation for Z markers is 3,000 cycles continuously. Fan marker modulation at 3,000 cycles is keyed to indicate the course, starting with one dash on the course clockwise from true north. If there is a second fan marker, the outer one is coded with the same number of dashes as the inner one but with two dots preceding the dashes. The outer marker for ILS is keyed to emit two dashes per second at 400 cycles. The middle marker for ILS is keyed to emit alternate dots and dashes at a frequency of 1,300 cycles. The boundary marker used at some special ILS installations is modulated at 3,000 cycles and keyed so as to emit six dots per second.

**Ques. 7.134.** What advantage, with respect to approach control, does the new bone-shaped marker offer over the standard fan-shaped marker?

*Ans.* The latest fan marker has a bone shape and is only 1.5 miles thick at the narrowest point at the 3,000 foot level. The pilot is therefore able to determine much more precisely the exact time he is over the marker site. The standard fan marker is 4 miles thick at the same altitude. The pilot can thereby vary his holding pattern to be inbound to the range station at the exact time specified by approach control.

**Ques. 7.135.** If the marker light indicator in the cockpit failed, would the flight personnel have available any other indication that signals from a marker were being received?



*Ans.* Yes, the markers are identified by continuous or keyed audio tones, depending upon the type of facility, and these tones can be received in headphones connected to the marker receiver.

**Ques. 7.136.** What is the signal called that is radiated from the center loop of a VOR radio facility?

*Ans.* The center loop radiates the reference phase. (See Ques. 7.120.)

**Ques. 7.137.** What may be considered as the normal reliable service radiation of the VOR radio facility—(1) 50 miles, (2) 2.5 miles, (3) 3 miles, (4) 3.5 miles, and (5) 100 miles?

*Ans.* (1) 50 miles. Although the signals may normally be received at 150 miles, facilities are installed approximately 100 miles apart.

**Ques. 7.138.** What are the three main advantages of the VAR radio facility?

*Ans.* The VAR (Visual Aural Range) facility gives the pilot: (1) instantaneous, unmistakable indication as to the quadrant in which he is located; (2) operating at VHF, it is not subject to the multiple courses and night effects of the older low-frequency ranges; (3) it serves admirably as an interim facility, particularly in using the ILS localizer pointer (of the crosspointer indicator) for the visual courses.

**Ques. 7.139.** What is the average usable range of the VAR facility?

*Ans.* Although VAR signals in the 108 to 112 megacycles band can often be heard by planes at high altitude 200 miles away, dependable operation under normal conditions is considered to be 50 miles.

**Ques. 7.140.** Why are the blue and yellow visual and the A and N aural areas of a VAR referred to as sectors rather than quadrants?

*Ans.* The visual and the aural ranges of interest to the pilot are extremely narrow beams referred to as sectors. These sectors form the boundaries that divide the air space into four quadrants identified by both a color and a Morse code letter; for example, the visual-blue aural-*N*, or the visual-yellow aural-*A* quadrants.

**Ques. 7.141.** Describe the method of orientation used in the VAR.

*Ans.* The standard sector orientation for Green and Red airways (east—west) is blue visual to the north, yellow visual to the south; while the *A* aural is to the west, and *N* aural to the east. On Amber and Blue airways (north—south) the VAR facility is oriented with blue visual to the west and yellow visual to the east; *N* aural is to the north and *A* aural to the south.

**Ques. 7.142.** How is the “On-Course” signal produced in a low-frequency radio range station?

*Ans.* A low-frequency radio range employs two pairs of antennas that radiate energy in a double figure-eight pattern, in the horizontal plane. The transmitter is alternately connected first to one and then to the other antenna system, being keyed with the Morse code *A* (. —) for one antenna and with *N* (— .) for the other. The dots and dashes of these code signals are interlocked so that if a pilot is flying a course midway between the two maximum *A* and *N* signals, he receives a steady equisignal. If he leaves the beam he then begins to distinguish the *A* or the *N* stronger, depending upon which side of the course he is now flying. In addition to the double pair, a center antenna transmits an omnidirectional signal at a frequency 1,020 cycles removed from that of the *A* and *N*

beams. Accordingly, the *A* and *N* indications are heard as a 1,020-cycle tone at the plane (see Fig. 7-2).

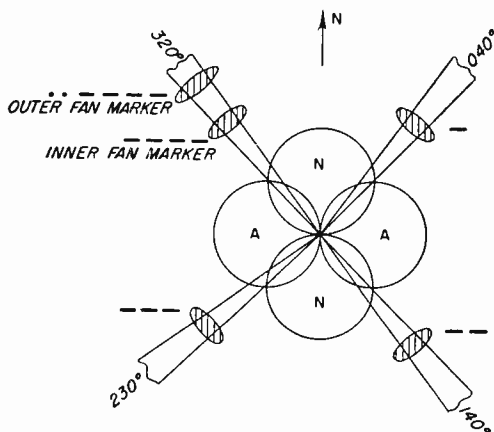

Fig. 7-2. Principle of the low-frequency range facility, showing markers.

**Ques. 7.143.** What is meant by the “twilight” zone in radio range flying?

*Ans.* On one side of the equisignal or steady-tone region of a low-frequency range beam, the Morse code *A* can be distinguished, while on the other side of the equisignal the *N* can just be heard. These regions are often called the twilight zones. Planes keep to the right of the equisignal region traveling in either direction in order to avoid collision.

**Ques. 7.144.** How is the cone of silence produced over a low-frequency radio range station?

*Ans.* The signals from a low-frequency radio range are vertically polarized and are normally received at the aircraft on an antenna that responds best to vertical polarization. Reception of the range in a small region above the transmitting antenna system is poor, resulting in the phenomenon known as the cone of silence, in which the signal is either

## RADIO OPERATING QUESTIONS AND ANSWERS

extremely weak or altogether absent, depending upon the transmitting antenna system and upon the gain control setting.

**Ques. 7.145.** In radio range flying what is meant by "multiple courses"?

*Ans.* Particularly in mountainous country, the equisignal of a radio range may be broken up into several segments over a space of 10, 15, or more degrees. Between the separate beams the *A* and *N* quadrant signals may be heard, sometimes in their proper relation to the on-course signal and sometimes reversed.

**Ques. 7.146.** If an aircraft is flying at right angles to a range leg affected by multiple courses, what signals would be heard in the radio range receiver?

*Ans.* A series of *A*, on-course, and *N* signals would be heard over a spread of 15 degrees more or less. The signals might occur in the order listed; in reverse order if the plane were flying in the opposite direction, or an *A* signal might both precede and follow the on-course equisignal. The same might be true of *N* signals.

**Ques. 7.147.** Explain the operation of the ground portion of an ILS.

*Ans.* The ground portion of the ILS system is shown in Fig. 7-3. It comprises a localizer transmitter operating on a frequency in the region between 108 and 110 megacycles. Sufficient power is transmitted so that an on-course signal can be received at least 25 miles from the runway. The course signal is produced by a field pattern modulated at two different frequencies. The approach sector to the right, looking towards the transmitter, is identified by a 150-cycle signal and is designated on charts and instruments as the blue sector. The left side of the on-course signal is identified by a 90-cycle modulation and is designated as the yellow sector.

The equisignal region is very sharp but the beam is about 70 feet wide at the touchdown point and more than a mile wide at a distance of 10 miles from the transmitter. Each localizer transmitter is identified by a three-letter code and voice modulation is generally used for approach control.

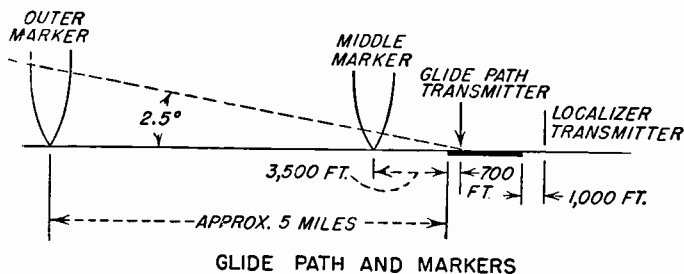

YELLOW SECTOR 90-CYCLE SIGNAL PREDOMINATES

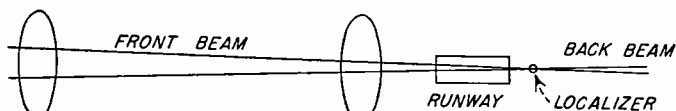

BLUE SECTOR 150-CYCLE SIGNAL PREDOMINATES

**RUNWAY LOCALIZER INSTALLATION**

FIG. 7-3. Ground portion of the ILS system.

The glide path transmitter is located 1,000 feet from the approach end of the runway and about 400 feet from the center line of the runway. It operates upon a frequency paired with that of the localizer and is somewhere in the region between 332 and 335 megacycles. Its course is formed in the same way as that of the localizer, except that it is at right angles so that the cross section in space is approximately a plus sign. The upper side of the beam is modulated at 90 cycles and the lower side at 150 cycles. There is no color identification used with the glide path that rises from the

ground at an angle of 2.5 degrees. It is 1 degree wide at the ground and spreads to a vertical thickness of nearly 1,400 feet ten miles away.

About 4.5 miles from the runway is located the outer fan marker, operating at 75 megacycles and modulated at 400 cycles with two dashes a second. A middle marker about 3,500 feet from the approach end of the runway operates at a carrier frequency of 75 megacycles and emits alternate dots and dashes of 1,300-cycle tone.

When used, a boundary marker is located 300 feet from the approach end of the runway, its housing 200 feet off the runway. This transmitter likewise operates on a carrier of 75 megacycles. It is modulated by a series of dots (six per second) transmitting 3,000-cycle tone.

Compass locators operating in the 200- to 400-kilocycle band transmit a single code letter (now being modified to two) with 1,020-cycle tone. They are often used as an interim facility to get aircraft into the ILS system, or for flying a holding pattern.

**Ques. 7.148.** In the ILS, which is the sharpest course—the localizer or the glide path?

*Ans.* The glide path is the sharper course of the two.

**Ques. 7.149.** On what frequency do marker beacons used in conjunction with ILS operate?

*Ans.* On 75-megacycle carrier frequency but with different audio modulation depending upon the location of the beacon.

**Ques. 7.150.** What aircraft radio equipment is necessary to make use of all units of ILS?

*Ans.* Required are ILS receiver for localizer and glide path, localizer and glide path antennas, cross-pointer indicator, marker receiver (with antenna) with frequency discriminating circuits and signal lights.

**Ques. 7.151.** What type of instrument is used for the cross-pointer indication on the instrument panel of an aircraft when using ILS?

*Ans.* A special dual microammeter.

**Ques. 7.152.** What is the purpose of the aircraft flag warning used with the ILS indicator?

*Ans.* The flag warning is actually a miniature voltmeter that is actuated when there is insufficient or no signal from either the localizer or the glide path transmitter, or both. If any part of the flag is showing, the pilot does not use the ILS system.

**Ques. 7.153.** Is the following statement TRUE or FLASE? "In the ILS, regardless of the position or heading of an aircraft, the localizer needle will always be deflected in that color area in which the aircraft is flying."

*Ans.* TRUE, but when approaching the airport on the back beam, the blue sector will be at the left and the yellow at the right of the craft, rather than as marked on the ILS cross-pointer instrument. It is not safe to use the back beam without first determining its characteristics.

**Ques. 7.154.** In flying the ILS, when the aircraft is above the glide path, will the horizontal needle be deflected UP or DOWN?

*Ans.* The needle will be deflected down. The pilot identifies the center of the meter with his craft and the meter needle with the path. He corrects so as to bring his plane onto the path.

**Ques. 7.155.** If noise breaks through in the headset on a VHF communications units, what adjustment can be made?

*Ans.* The threshold of the carrier-operated squelch circuit can be adjusted so that noise does not operate the receiver.

**Ques. 7.156.** Certain aircraft communications receivers have an antenna aligning control on the panel. Electrically, what is accomplished when this control is adjusted?

*Ans.* The alignment control tunes the input circuit to match the antenna characteristic to that of the receiver and effects an optimum transfer of energy to it.

**Ques. 7.157.** What are the approximate c-w, mcw, and voice power ratings of transmitters used in U.S. air carrier aircraft operating overseas?

*Ans.* Power ratings for a given equipment vary with type of modulation or absence of modulation. Power output from various types of equipment in current use ranges from 50 to 125 watts.

**Ques. 7.158.** What is the purpose of an isolation amplifier in an aircraft radio installation?

*Ans.* Various crew members may wish to listen to different combinations of signals from radio facilities or interphones. If phones are simply bridged across the several outputs, the facilities will then be paralleled for all listeners and the level will decrease. Isolation amplifiers are so arranged that the crew member can listen to the output of the appropriate amplifier to which various input signals can be connected through very high resistances. There will then be no noticeable crosstalk for those not desiring the particular combination of signals.

**Ques. 7.159.** What is the purpose of the side-tone feature in an aircraft radio installation? How is side tone obtained?

*Ans.* Side tone is a monitor signal derived from the transmitter so that the pilot can hear his own transmission. By this means, he is able to adjust the level of his voice to modulate the transmitter properly. Side tone can be obtained from the output of the microphone circuit, from the last



audio stage of the receiver, or more usually, from a special side-tone amplifier that is a part of the interphone system. One system using a dry-disc rectifier produces no signal unless the transmitter is sending out a modulated signal.

**Ques. 7.160.** What may cause severe arcing in aircraft transmitters at high altitudes?

*Ans.* Air at low pressures is a poor insulator. When high voltages are involved, corona takes place. High-voltage plate conductors and r-f leads, unless properly insulated or adequately spaced away from ground, will arc over at high altitudes.

**Ques. 7.161.** In tuning an aircraft radio transmitter can it always be expected that the same antenna current will be secured on all frequencies?

*Ans.* No. Maximum antenna current is usually an indication of optimum tuning, but the same maximums should not be expected for all frequencies using the same antenna. As the frequency is changed the current distribution along the antenna changes. The meter is fixed at one point in the antenna and reads the current at a given physical point.

**Ques. 7.162.** In aircraft communications, how does the line-of-sight communication range vary with the altitude of the aircraft? At an altitude of 5,000 feet over level terrain, what maximum line-of-sight VHF communication range may be expected from the aircraft to a ground station?

*Ans.* At VHF, the line-of-sight communication range increases as a function of altitude of the aircraft. At 5,000 feet, the line-of-sight range is approximately 87 miles. In many cases, however, communication might be carried on over a considerably greater distance than this.

**Ques. 7.163.** When using automatic keying on the AN/CRT-3 (modified Gibson Girl life-raft transmitter), what signals are transmitted and upon what frequencies?

## RADIO OPERATING QUESTIONS AND ANSWERS

*Ans.* A 500-kilocycle signal modulated with 1,000-cycle tone sends out six groups of SOS followed by a dash not exceeding 20 seconds in length. A switching mechanism then shifts frequency to 8,280 kilocycle and six groups of SOS are sent by continuous wave (no modulation) followed by a dash (for direction finding purposes) not exceeding 20 seconds in length.

**Ques. 7.164.** Discuss the advantages and disadvantages of the following aircraft antennas: fixed, trail, whip, stub mast, and loop.

*Ans.* The fixed antenna is desirable for reception and transmission of low and medium frequencies, but because of its length is subject to a considerable icing load. A trailing wire is even better for low-frequency work, but constitutes a hazard and is likely to be lost if not reeled in before landing. The whip suffers from its short length but is useful and less likely to be damaged than some other types. Because it is usually mounted below the body of the aircraft it tends to remain in a vertical position even when the craft is turning. A stub mast is somewhat hazardous to flight and its large area ices heavily. Although it does not vibrate appreciably, it may cause loss of signal when the plane turns since it is then going into a horizontal position. It can be mounted either above or below the body of the craft. The loop is mandatory for ordinary direction finding and is shielded against the worst effects of precipitation static, but it has poor signal pickup.

**Ques. 7.165.** What type of aircraft antennas will permit maximum radiation on such medium frequencies as 333 and 500 kilocycles?

*Ans.* The trailing wire or long wire from front to fin is best for these frequencies, with the fixed type a poor second.

**Ques. 7.166.** Explain the principle of operation of the antenna change-over relay in an aircraft radio installation. What is a vacuum antenna relay?

*Ans.* When an antenna is to be used for both transmitting and receiving, it is necessary that a quick means be provided to switch the antenna from one position to the other. The antenna is normally connected to the receiver and the antenna relay actuated only when the transmitter is turned on. For voice transmission, the antenna is switched to the transmitter for an appreciable length of time. For c-w transmissions, the antenna relay follows the keying. A vacuum antenna relay is one with contacts enclosed in an evacuated glass bulb. The contacts are protected thereby from dust, dirt, moisture, fumes, the oxidizing effects of air, and arc-over at high altitudes.

**Ques. 7.167.** How may an aircraft D/F loop be utilized for antistatic reception of radio range signals?

*Ans.* If the loop is directed towards the range, signal strength will be maximum and static will be at a minimum.

**Ques. 7.168.** Describe the physical construction of antennas used with the aircraft radio altimeter.

*Ans.* Antennas commonly used for the aircraft radio altimeter operating at 440 megacycles are two half-wave dipoles, usually mounted below the belly of the craft and some distance apart. Each antenna is a dipole about  $11\frac{1}{4}$  inches in over-all length with ceramic insulating material between the two halves at the center. The dipole is supported by  $5\frac{1}{2}$ -inch long quarter-wave tubes that are integral with the inner ends of the two halves. A metal base plate for the quarter-wave standoff tubes completes the rugged construction. A coaxial fitting makes connection to this plate and the center lead runs down inside one tube and through the inside of the insulator to connect to the half of the dipole supported by the other tube.

**Ques. 7.169.** Explain the principle of operation of the Flux Gate compass system.

*Ans.* The Flux Gate (a trade mark of Bendix Aviation Corp.) compass system comprises a Gyro Flux Gate transmitter, mounted in the wing or tail of the plane, a master direction indicator at the instrument panel, an amplifier, and a caging switch box convenient to the pilot. Other equipment, such as a repeater indicator, is either necessary or

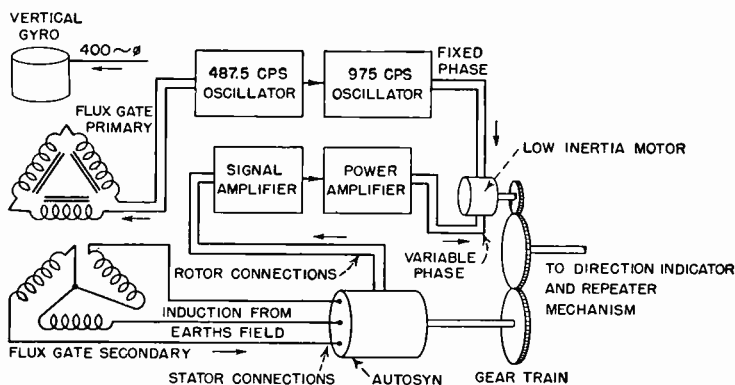

Fig. 7-4. Block diagram of a Flux Gate compass system.

customarily used. The essentials of the system are shown in the block diagram Fig. 7-4.

The Flux Gate primary is alternately saturated and demagnetized by current from the 487.5-cycle oscillator at a rate of 975 times a second. No inductive effects are produced in the secondary by this saturation of the core. However, the d-c magnetic flux of the earth's field cuts the secondary winding 975 times a second (by virtue of the alternate saturation and demagnetization action of the primary). The voltage induced in each secondary depends upon its position in the earth's magnetic field. Because it is desired to determine a plane's heading by the various unique induced-voltage combinations,

it is necessary to hold the Flux Gate horizontal at all times. A vertical gyro is used for this purpose.

Signals from the Flux Gate secondary are fed into a special self-synchronous motor, known under the trade names of Autosyn and Selsyn, and identified as a synchro by joint Army-Navy designation. The stator uses a wye connection. The two-pole rotor (with slip rings) picks up any change in the signal and feeds it to the signal amplifier. The signal is still further stepped up in the power amplifier and sent out to the variable-phase winding of the low-inertia induction motor. This motor is also supplied with fixed-phase voltage from the 975-cycle oscillator. The motor turns the gear train (in the proper direction, depending upon the phase of the signal) until signal voltage from the Autosyn rotor falls to a null. At the same time, the indicator dial and the repeaters have been turned to the new heading. As long as the aircraft flies this course, the Flux Gate secondary will detect no changes in the effect of the earth's field. If the aircraft turns, a new pattern of voltages will be induced in the Flux Gate secondary, a new field pattern will be set up in the stator of the Autosyn, the rotor will send a signal to the amplifiers, and the low-inertia motor will turn the Autosyn rotor to a new null. The indicators will show the new heading.

Although not specifically asked for, the student would be well advised to compare the Sperry Gyrosyn compass with the Bendix Flux Gate compass. The two systems have similarities, but the Sperry device employs a pendulously mounted Flux Valve and a horizontal gyro in the indicator. Similarly named parts, such as indicators and amplifiers, are not interchangeable between the two systems.

**Ques. 7.170.** What type of power supply is used in the Flux Gate compass system?

**Ans.** The Flux Gate compass system requires a source of 115-volt, 400-cycle, 3-phase power and 27.5 volts d-c.

RADIO OPERATING QUESTIONS AND ANSWERS

**Ques. 7.171.** Explain the purpose of the gain control on the amplifier unit of the Flux Gate compass system.

*Ans.* The gain control on the amplifier allows an adjustment of the sensitivity of the equipment under different operating conditions and over terrain with varying magnetic fields. The gain is set as high as possible without oscillation of the master indicator dial. If the gain is set too high, the system becomes too sensitive and tends to "hunt" about the null point.

**Ques. 7.172.** What functions are performed by the amplifier unit of the Flux Gate compass?

*Ans.* The amplifier is the power distributing center for the system as well as the source of voltage and power amplification for the signals. The 487.5- and 975-cycle oscillators are located here. The unit also serves as a junction point for conductors that have no connection to the amplifier circuits.

**Ques. 7.173.** Why is the sensitive compass element in the Flux Gate system usually located in a remote spot such as the aircraft wing tip?

*Ans.* The Flux Gate compass unit must be as far as possible from other wiring, ferrous metal, or anything capable of causing a magnetic disturbance, in order to avoid false direction indications.

**Ques. 7.174.** In what portion of the Flux Gate compass system is a low-inertia motor used?

*Ans.* A low-inertia induction motor is used to translate the signal (resulting from a change in heading) into a mechanical rotation that moves the indicator dial to show the new heading. At the same time, it resets the rotor of the Autosyn that has detected the signal resulting from the change in orientation of the Flux Gate element.

**Ques. 7.175.** In the Flux Gate compass system, the gyro is a self-erecting vertical gyro. Explain the function of the gyro.

*Ans.* The gyro supports the coils of the Flux Gate element so that they remain essentially horizontal at all times that the compass system is in use. Since the orientation of the element determines the indicated position of the plane with respect to the earth's lines of magnetic force, its indications would be wholly meaningless if it were not held horizontal at all times, despite the altitude of the aircraft.

**Ques. 7.176.** What is meant by "caged" and "uncaged" in a Flux Gate compass?

*Ans.* The vertical gyro in the Flux Gate unit is said to be caged when two pairs of roller arms are in such position that the gyro cannot be tilted in any direction. It is uncaged when these arms are withdrawn and the gyro is free to tilt. There is a visual signal to show the pilot that the gyro is either caged or uncaged.

**Ques. 7.177.** In Loran terminology, what would be indicated by the legend 1L3-2120?

*Ans.* In the legend, the figure 1 indicates that the radio frequency of the transmitter is 1,950 kilocycles; *L* shows that the basic pulse recurrence rate is 25 pps; the figure 3 denotes a station recurrence rate of 3 (for which the pulse recurrence rate is actually about  $25\frac{3}{17}$  pps). The remaining figures 2,120 are the *T* or reading for a particular line and denotes the time delay in microseconds between the arrival of the pulses from the master and the slave stations (see also Ques. 6.273 and 6.277).

**Ques. 7.178.** How is a Loran fix indicated on a Loran navigation chart?

*Ans.* A fix is indicated by the intersection of two or more Loran lines of position plotted on a Loran chart. Care should

be taken to use Loran stations generating lines of position that cross as nearly at right angles as possible. When crossing angles are small and no third line of position is available, several readings and times should be averaged for better accuracy.

**Ques. 7.179.** Does precipitation static affect operation of the Loran receiver-indicator?

*Ans.* Loran reception, like that of all airborne radio systems, is seriously affected by precipitation static.

**Ques. 7.180.** What is the approximate usable over-water range in nautical miles of the Loran system in both day and night operation?

*Ans.* During the day, Loran signals are generally usable over water up to 700 nautical miles via ground wave but utility is reduced to about 500 miles at night. However, first-hop *E*-layer reflections from the ionosphere can be used at night for distances up to about 1,400 nautical miles (see also Ques. 6.274).

**Ques. 7.181.** To what reading, or indication, is sky-wave correction applied in Loran navigation?

*Ans.* At great distances from Loran transmitters, particularly at night, and occasionally during the day, the first-hop *E*-layer reflections are used, rather than the ground wave. The *T<sub>s</sub>* (sky-wave reading in microseconds) must be corrected to remove the error caused by the longer travel to and from the ionosphere. The appropriate sky-wave correction and its algebraic sign are indicated on Loran charts and in tables.

**Ques. 7.182.** What frequency channels are used in the present Loran system?

*Ans.* Channel frequencies of 1,850 and 1,950 kilocycles are used.



**Ques. 7.183.** What type of power supply is used with the Loran receiver aboard aircraft?

*Ans.* Airborne Loran receiver-indicators are designed for operation at 117 volts, 400 to 2,400 cycles. Primary power from storage batteries is used to operate inverters that change 28-volt d-c to 117 volt 400 to 2,400 cycle power.

**Ques. 7.184.** Consol is a long-range radio aid to navigation undergoing considerable practical use in certain sections of the world. Explain briefly the principle of operation of the Consol system.

*Ans.* The Consol station comprises a directional antenna system and a transmitter operating in the region between 263 and 319 kilocycles. Three antennas in line are spaced at about three wavelengths at the operating frequency (see Fig. 7-5).

There are two coverage areas of useful signals, one on each side of the antenna array. The radiation pattern consists of sectors 15 degrees wide. Sectors in which dots are heard alternate with those in which the signal is broken into dashes. An equisignal region exists between these sectors.

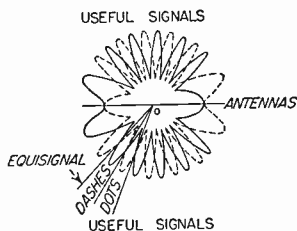

FIG. 7-5. Principle of Consol facility.

between these sectors. The pattern is caused to rotate through one sector during a 60-second period (tests are being made using a 40-second period). The observer listening on a communications receiver will hear a series of dots (or dashes) followed by an equisignal and then a series of dashes (or dots). The equisignal indicates the observer's bearing from the station, which he can interpret by means of his stop watch, and the number of dots and/or dashes he has counted, using a Consol table or map. After the above sequence, a steady note and the station call letters are transmitted for regular direction-finding procedures.

These are necessary in order to establish which one of the equisignals has been observed, in the event that the navigator has no idea of his position.

**Ques. 7.185.** What aircraft radio equipment is necessary to make use of Racon beacons?

*Ans.* RADar beaCONS (RACONS) are electronic beacons that give indications of both range and azimuth, as well as a coded identification signal. They must be triggered by radar signals on the proper frequency from the aircraft.

*Operating Procedures*

**Ques. 7.186.** In air traffic control procedures, what is meant by a service known as "approach control"? How are communications handled between aircraft and approach control?

*Ans.* Approach control is a service whereby the Civil Aeronautics Administration airport traffic control towers issue control directions in instrument weather conditions, by communicating *directly* with pilots over the voice feature of a radio range, or over a very high frequency channel of the control tower.

Communications between aircraft and approach control is made by the pilot to Approach Control giving all particulars as to time and altitude, change of flight level, and so on.

**Ques. 7.187.** A Constellation aircraft of Midway Airways, Trip 14, with radio call KHCBX, licensed as NC 18947, is entering the traffic pattern at a particular airport. What is the correct procedure to be followed by the air traffic control tower in establishing radiotelephone communication with this aircraft?

*Ans.* When an aircraft enters a traffic pattern at a particular airport the pilot transmits a message to the control tower including the following information: (a) Geographical

position; (b) Time (optional), (c) Flight altitude of the aircraft, (d) Request for information or clearance—if pertinent.

The air traffic control (ATC) tower will acknowledge as follows:

Tower: "Constellation 18947 Time Height Location.  
Cleared to enter Traffic Pattern  
Runway number. Wind. Over."

Aircraft: "Constellation 18947. Roger."

**Ques. 7.188.** Certain U.S. Coast Guard radio beacons have undergone modifications to permit satisfactory use with aircraft ADF (aircraft direction finders). Describe.

*Ans.* The U.S. Coast Guard Beacon station at Montauk Point, N.Y., for example, has been modified to continuous carrier transmission of the radio beacon system throughout 24 hours of the day.

The beacon transmits a continuous code signal (— . — —) with operating intervals of 60 seconds "On" and 120 seconds "Silent" during 24 hours of the day. Three beacons are utilized in this modification, each operating in proper sequence to provide continuous transmission of the signals.

**Ques. 7.189.** What aircraft radio equipment is needed to carry out a GCA (Ground Controlled Approach) problem?

*Ans.* Ground Controlled Approach is a system using radar technics at a specially designed ground station for providing information by which aircraft approaches may be directed via radio communications.

The standard aircraft receiver and headphones are the only requirements on board an aircraft for obtaining a GCA approach. The observers on the ground give the pilot his exact location by radiotelephone. At regular intervals, the observers tell the pilot what corrections must be made in the flight progress to stay on the proper glide path or course. In effect, the pilot is "talked-down" by radio phone.

**Ques. 7.190.** Define the following terms as used in air traffic control procedures: approach clearance, approach sequence, approach time, control area, control zone, control altitude, essential traffic, traffic pattern, IFR, VFR, downwind leg, base leg, and final approach.

*Ans.* Approach clearance: The clearance, issued to the pilot of an aircraft making a flight subject to instrument flight rules (IFR), authorizing an approach for landing by such aircraft.

Approach sequence: Two or more aircraft, vertically separated at the same holding point, awaiting an approach clearance.

Approach time: The time at which an aircraft is expected to commence its approach procedure preparatory to landing.

Control area: An air space of defined dimensions, designated by the Administrator, extending upwards from an altitude of 700 feet above the surface, within which air traffic control is exercised.

Control zone: An air space of defined dimensions, designated by the Administrator, extending upwards from the surface, to include one or more airports, and within which rules additional to those governing flights in control areas apply for the protection of air traffic.

Cruising altitude: A constant altimeter indication, in relation to sea level, maintained during a flight or portion thereof.

Essential traffic: Information on aircraft which are expected to be overtaken, passed, or approached within a distance of less than 10 minutes when such aircraft are within a level of 1000 feet, or less vertically, above or below the aircraft being cleared.

Local traffic: Aircraft operating in the traffic pattern of a specific landing area concerned.

Traffic pattern: The flow of aircraft operating in the vicinity of an airport during specified wind conditions as established by the appropriate authority.

**IFR:** This symbol is used to designate Instrument Flight Rules.

**VFR:** This symbol is used to designate Visual Flight Rules.

**Downward leg:** This term refers to that portion of the approach parallel to, but in the opposite direction to, the landing.

**Base leg:** Refers to that portion of the approach at a right angle to the landing direction on the downward side of the airport.

**Final approach:** Refers to that portion of the approach from the last turn into the landing direction until contact is made with the airport.

**Ques. 7.191.** Is it possible for an aircraft to contact U.S. radio range stations by using A-2 emission?

**Ans.** Contact with a radio range station is made only by type A-3 amplitude-modulated telephone (voice) transmissions. If a plane were to transmit telegraphic signals of inquiry to the radio range station, and the receiver of the latter is adjusted for continuous wave reception at the proper listening frequency, communications could be established in an emergency. Although the CAA operators are qualified to handle the Morse code, they would acknowledge by radio-telephone on the listening frequency.

**Ques. 7.192.** What is the "attention" signal used on U.S. radio range station transmissions?

**Ans.** United States radio range transmissions are composed of a series of dots and dashes comprising the letters A and N in Morse code. ( . — — . )

These are known as course signals and are broadcast for a period of 30 seconds. At the present time there are 12 "A's" and 12 "N's" transmitted between station identification signals from radio range transmitting stations.

**Ques. 7.193.** Explain how marker beacons identify the legs of a four-course radio range station. If the legs of a radio range station are spaced at 040, 140, 230, and 320, respectively, what range leg would an approaching aircraft be on if a marker beacon identification of two dashes (— —) were intercepted?

*Ans.* Fan markers are located at strategic points along the legs of the range beam to indicate the position of the aircraft. Their radiation is either a conical signal similar to that of the Z marker or a newer type of pattern that is bone-shaped in cross section. The 3,000-cycles-per-second modulation of the 75-megacycle fan marker is keyed in dashes to indicate the range course as shown in Fig. 7-2. The courses are numbered clockwise beginning with true north. When more than one marker is provided on a given leg, the outer employs the same dash signal as the inner marker but the dash signal is preceded by two dots (as indicated for the 320-degree course leg). For the example given the aircraft would be on the 140-degree leg.

**Ques. 7.194.** Explain the method of determining "overhead" on a radio beacon using the aircraft manual D/F loop.

*Ans.* "Overhead" or "cone of silence" is that area directly above the beacon pattern where no signal will be heard. For example, when a pilot is entering a given beacon pattern his signals will continue to increase until he passes directly over the transmitter. At this point the signal will fall off rapidly to a minimum or zero response. However, as the plane passes out of the cone of silence the signals will again reappear very strongly and then gradually diminish as the plane moves out of the beacon range.

The manual adjustment of the direction finder loop is rotated for a maximum signal as the plane approaches the pattern.

**Ques. 7.195.** What United States Government document gives the location, frequency identifier, and hours of operation of all marine radio beacon stations?

*Ans.* This information is contained in the United States Government publication Radio Navigational Aids, HO (Hydrographic Office) No. 205, United States Navy Department.

**Ques. 7.196.** What agency of the United States Government may be called upon to render emergency direction finding aid to aircraft? How is this agency contacted?

*Ans.* The FCC maintains an emergency D/F network to aid aircraft in distress. FCC is contacted through the regular air/ground station or control tower. At least 15 to 20 minutes advance notice is required before FCC personnel can offer aid.

**Ques. 7.197.** A control station operator desires to determine whether or not an aircraft is flying in accordance with visual flight rules (VFR). What is the appropriate signal to use?

*Ans.* The signal QDT is used. This signal carries the following meaning:

“Are you flying in accordance with VFR?”

**Ques. 7.198.** An aircraft is approaching its point-of-no-return and desires amendments to the flight forecast. What is the correct signal?

*Ans.* The signal QMZ is transmitted. See Ques. 7.206.

**Ques. 7.199.** An aircraft is preparing to make a QDM approach at a foreign terminal. What signals are used to request a series of QDM's from a ground direction finding

RADIO OPERATING QUESTIONS AND ANSWERS

station? [QDM is: "What is the magnetic course to steer with zero wind to reach you (or, place)?"]

*Ans.* The signals QUV or QUX are used (see Ques. 7.206).

**Ques. 7.200.** An over-ocean aircraft desires to check its distances out from an ocean station vessel (QSV) by using the vessel's radar equipment. What signals are used to obtain this information?

*Ans.* QGE NLM QTE IMI. "What is my distance to your station in nautical miles?" "What is my true bearing from you?" (QGE must be used in connection with QTE or some similar bearing-indication "Q" signal.) It means: "What is my distance to your station?"

**Ques. 7.201.** A flight operator copies the following signals from the control station: QAK QAH 8500 feet IMT. The pilot should be advised immediately. Why?

*Ans.* The signal QAK indicates there is a risk of collision at the altitude indicated. QAH is a request for altitude.

**Ques. 7.202.** What signal would the flight operator transmit to request the surface wind at a particular airport?

*Ans.* The signal QAN ("What is the surface wind at \_\_\_\_\_?") would be transmitted.

**Ques. 7.203.** An aircraft is estimated to be within D/F range of a certain radio beacon, but the signals cannot be heard on the aircraft. To request information as to whether or not the radio beacon is in operation, the "Q" signal \_\_\_\_\_ should be transmitted.

*Ans.* The signal QFS should be transmitted. This signal queries, "Is the beacon radio facility at \_\_\_\_\_ (place) in operation?"

**Ques. 7.204.** An aircraft cleared to cruise at 12,000 feet is climbing on course under IFR conditions. OATC, through



the control station, requests the aircraft to report immediately upon reaching cruising altitude. What are the correct "Q" signals?

*Ans.* The correct signal to use is QBV ["Have you reached the altitude of \_\_\_\_\_ (Height)?"]. The operator on the aircraft acknowledges by transmitting the signal QBV ["I have reached the altitude of \_\_\_\_\_ (height)."]

**Ques. 7.205.** What is meant by the terms POMAR, METAR, UCO, PP, NAREPS, RAWIN, PIBALS, PIREPS?

*Ans.* POMAR refers to observations of position and weather on reports from international overseas flights; METAR is the hourly weather broadcast made on c-w (this service was formerly known as UCO PP); NAREPS are Navy aerological reports. A RAWIN report concerns winds-aloft data obtained from radar-tracked balloons carrying reflectors; PIBALS are pilot balloon observations of winds aloft obtained from theodolite observations. PIREPS are weather reports from private pilots.

**Ques. 7.206.** What is the meaning of the following signals?

QAA through QAZ

QBC (used with QMI, QFT, QBJ, QMZ and QTH)

QBF, QBG, QBH, QBI, QBS, QBX, QCB, QCE, QDR,

QDX, QFE, QFG, QFH, QFM, QGJ, QGZ, QHH, QJD,

QLH, QMH, QNI, QNT, QUG, QUO, QUR, QUS, QUU,

QUV, QUX, QRF.

*Ans.*

QAA	No definition assigned.
QAB	What is your destination?
QAF	At what time were you over ____ (place)?
QAK	Is there any risk of collision?
QAL	Are you going to land at ____ (place)?
QAM	What is the latest meteorological observation for ____ (place)?
QAN	What is the surface wind?

RADIO OPERATING QUESTIONS AND ANSWERS

- QAQ What are the winds at \_\_\_\_ (position or zone) the following heights above MSL \_\_\_\_?
- QAP Am I near a prohibited area?
- QAR May I stop listening on watch frequency for \_\_\_\_ minutes?
- QAV Are you able to home on your D/F equipment?
- QAY Advise me when you are at, over, or abeam of \_\_\_\_ (place).
- QBC What are the present meteorological conditions from your aircraft?
- QMI What is the vertical distribution of clouds at \_\_\_\_ (position or zone)?
- QFT Between what altitudes above MSL (Mean Sea Level) has ice formation been observed?
- QBJ What is the height above MSL of the top of the clouds at \_\_\_\_ (position or zone)?
- QMZ I am approaching my points-of-no-return. Have you any amendments to the flight forecast in respect to section of route yet to be traversed?
- QTH What is your position in latitude or longitude?
- QBF Are you flying in cloud?
- QBG Are you flying above cloud?
- QBH Are you flying below cloud?
- QBI Is flight under instrument flight rules compulsory at \_\_\_\_ (place) or from \_\_\_\_ to \_\_\_\_ (place)?
- QBS Ascend or descend to an altitude of (height) before encountering instrument flight rules conditions or if visibility falls below \_\_\_\_ (distance) and advise.
- QBX Have you left the altitude of \_\_\_\_?

- QCB You are causing delay by answering out of turn.
- QCE When may I expect approach clearance?
- QDR What is my magnetic bearing from you (or from \_\_\_\_\_)?
- QDX I have accepted control (or responsibility of) for \_\_\_\_\_.
- QFE What is the present barometric pressure at official airdrome level?
- QFG Am I over the airdrome?
- QFH May I descend below the clouds?
- QFM What altitude should I maintain *or* What altitude are you maintaining?
- QGJ Reduce your communication to a strict minimum; I have to communicate with other aircraft.
- QGZ Hold on \_\_\_\_\_ direction of \_\_\_\_\_ facility.
- QHH Are you making an emergency landing?
- QJD Not assigned.
- QLH Will you use simultaneous keying on \_\_\_\_\_ (frequency) and \_\_\_\_\_ (frequency)?
- QMH Shift to transmit and receive on \_\_\_\_\_ (frequency); if communication is not established in five minutes, revert to present frequency.
- QNI Between what altitudes above MSL has turbulence been observed at \_\_\_\_\_ (position or zone) and with what intensity?
- QNT What is the maximum gust speed of the surface wind at \_\_\_\_\_ (place)?
- QUG Will you be forced to alight (or land)?
- QUO Shall I search for \_\_\_\_\_ (1. Aircraft, 2. Ship, 3. Survival craft) in the vicinity of \_\_\_\_\_ latitude \_\_\_\_\_ longitude (or according to any other indication)?

RADIO OPERATING QUESTIONS AND ANSWERS

- QUR Have survivors \_\_\_\_ (1. Received survival equipment, 2. Been picked up by rescue vessel, 3. Been reached by ground rescue party)?
- QUS Have you sighted survivors or wreckage? If so in what position?
- QUU Shall I home ship or aircraft to my position?
- QUV What is my magnetic bearing from you (or from \_\_\_\_)?
- QUX Will you indicate the magnetic course for me to steer towards you (or from \_\_\_\_)?
- QRF Are you returning to \_\_\_\_ (place)?

**Ques. 7.207. What is an ocean station vessel (OSV)?**

*Ans.* An ocean station vessel in the maritime service is a vessel located in strategic geographical areas to provide weather and radio beacon information. These vessels are normally under way in a given location and are not drifting. The area of coverage is approximately 10 miles square.

**Ques. 7.208. How are radio beacon transmissions from ocean station vessels identified?**

*Ans.* Radio beacon transmissions from ocean station vessels are continuous carrier waves with the identifying letters superimposed upon them. The signal consists of four letters. The first two letters comprise the characteristic signal of the station listed; the last two indicate its position within the ten-mile square and are obtained from a chart arranged in the form of a grid graph with lateral and vertical markings to determine a given position.

**Ques. 7.209. What type of radio beacon service is maintained by an ocean station vessel when it is off station and proceeding on a distress mission?**

*Ans.* No beacon service will be given under these conditions unless requested for homing purposes. In this case,

the station's international call letters will be used as the identifying signal.

**Ques. 7.210.** What type of radio beacon service is maintained by an ocean station vessel when it is driven off station with position unknown?

*Ans.* The same procedure is followed as in the previous explanation.

**Ques. 7.211.** How does an ocean station vessel indicate "On Station," "Off Station"?

*Ans.* For "On Station" (within the 10-mile square at the center) the last two letters transmitted will be OS, the latitude and longitude designators, respectively. If, on the other hand, the ship is "Off Station," but on the grid, the latitude and longitude designators of whatever square the ship is in are transmitted as the last two letters of the signal. *The latitude designation is always given first.*

**Ques. 7.212.** With reference to ocean station vessels, what is meant by the grid system? Explain its operation.

*Ans.* The grid system is a position-indicating system which enables a ship or plane to determine its position with reference to an ocean station vessel on a specially designed chart. The chart is arranged in squares or grid network in which the outside borders are arranged in alphabetical sequence. The center of the grid is indicated by a plus or zero with extensions vertically and horizontally marked from 10, 20, 30 . . . 100. In addition, a 360-degree circle to indicate degrees is located in the exact center of the chart. The center of the grid is the established location of the station. The grid lines are 10 nautical miles apart. The latitude designator on the chart is represented by the letter *O* and is located at the left and right center ends of the chart. The letter *S*, representing longitude, is located at the top and bottom center of the chart.

The position of the ship may be determined by the grid sys-

RADIO OPERATING QUESTIONS AND ANSWERS

tem as follows: Assume that an ocean station vessel transmits the characteristic signal, QJ (— — — . — — — —), followed by the letters LM. (L represents the latitude locator, and M the longitude locator.) Hence, by reference to the chart, it would be seen that the station vessel bears 125 degrees true and 35 miles from its assigned position. In other words, the designators reveal the grid square in which the ship is located, bearing in mind that the latitude designator is always given first. See also Ques. 7.195 for reference data.

**Ques. 7.213.** Name the frequencies used by station WWV, NSS, and NPG for transmitting time signals?

*Ans.*

<i>Station</i>	<i>Time Signals</i>	<i>Operating Frequencies</i>
WWV	Continuously (24 hr. per day)	2.5, 5, 10, 15, 20, 25, 30, 35
NSS	For 5 min. immediately preceding each even hour.	122, 4,390, 9,425, 12,630, 17,000 kilocycles
NPG	0255-0300	115, 9,255, 12,540 kilocycles
	0755-0800	115, 9,255, 12,540 kilocycles
	1455-1500	115, 9,255, 12,540 kilocycles
	1655-1700	115, 9,255, 12,540 kilocycles
	1955-2000	115, 9,255, 12,540 kilocycles
	2355-2400	115, 9,255, 12,540 kilocycles

**Ques. 7.214.** List one typical DAY c-w frequency and one NIGHT c-w frequency used in CAA Overseas Foreign Aeronautical Communications Station.

*Ans.* NIGHT operating frequencies are generally in the range between approximately 3,000 and 6,000 kilocycles. The DAY operating frequencies range approximately from 6,000 to 12,000 kilocycles. A typical NIGHT operating frequency is 2,912 kilocycles. A typical DAY operating frequency is 6,577 kilocycles.

**NOTE:** The International distress frequencies for the aeronautical services are 500 and 8,280 kilocycles. The Atlantic City Radio Conference has recommended the frequency of 8,364 kilocycles to replace the present frequency. When these regulations become effective, 8,364 kilocycles will replace 8,280.

**Ques. 7.215.** Which one of the following frequencies would work satisfactorily for CW air-to-ground communication and homing with the aircraft ADF: (1) 1,638 kilocycles, (2) 2,970 kilocycles, (3) 8,465 kilocycles, or (4) 11,319 kilocycles?

*Ans.* The frequency of 1,638 kilocycles since this particular frequency is also well suited for homing purposes.

**Ques. 7.216.** Under normal conditions in a daylight flight between two points of approximately 1,100 nautical miles apart, what would be a good pair of CW air-to-ground frequencies to select?

*Ans.* A frequency of either 6,577 or 11,319 depending upon the time of the day. See Ques. 7.214 for the approximate range of day operating frequencies in the OFAC service.

**Ques. 7.217.** Why do scheduled aircraft change from DAY to NIGHT frequencies in radio communications? Which frequency, 5,692 kilocycles or 3,162 kilocycles, is better suited for day operation?

*Ans.* The use of higher radio frequencies in the daytime is seasonally more effective than the lower frequencies because of their better reflecting effect from the surface ionization around the earth caused by the sun's radiations. The higher frequencies at night however are not as effective as the lower since they penetrate the ionosphere and as a result do not reflect back to earth thereby making long distance radio transmission practically impossible. In effect, as ionization varies with the activity of the sun's radiation, the *reflection* of sky waves varies, causing variations in the range of radio trans-

mission. In this case, the frequency of 5,692 kilocycles would be better suited for day operation.

**Ques. 7.218.** An over-ocean aircraft is circling at the scene of distress where another aircraft has ditched. What would be an appropriate frequency for the circling aircraft to transmit homing signals on in order to permit surface vessels and another aircraft to effect a rendezvous at the scene?

*Ans.* An ideal scene of action frequency for this purpose would be 333, 535, 757 kilocycles, a common VHF frequency, or the telephone distress frequency of 2,182 kilocycles.

**Ques. 7.219.** What is meant by simplex operation in air-to-ground communication?

*Ans.* Simplex operation is the term applied to the operation of a radiotelegraph system in only one direction at a time. In aeronautics, a frequency of 121.5 megacycles has been assigned as a universal simplex channel for emergency and distress communications.

**Ques. 7.220.** What is meant by "night effect" in reference to aircraft direction finding? What can be done to counteract night effect when taking aircraft radio bearings?

*Ans.* Night effect, or night error, is the phenomenon of reflection of radio waves during sunset and night periods caused by the ionosphere, or Heaviside layer. Night effect causes erratic behavior of radio direction finders and impairs the general null or sharp minima tuning conditions required in the effective use of radio direction finders. It is in reality a change in reflection due to the shifting of the ionosphere and a phase shift between the reflected sky waves and ground waves.

The adverse effects caused by night error may be overcome by using low-frequency bearing signals. The low-frequency signals are primarily ground waves and consequently do not penetrate into the ionosphere layers to produce sky-wave reflections.



Another means of correcting night error is obtained by the use of an Adcock loop antenna system. With this type of antenna, the vertical or sky-reflected wave is canceled out and only the horizontal ground wave will be received.

**Ques. 7.221.** How is wind drift compensated for when using a radio compass for homing?

*Ans.* Accurate compensation for wind drift can be accomplished only by making a precise comparison of the radio compass indications with the ship's stable magnetic compass, or with a directional gyro.

For example, a plane leaving an airport observes that the visual indicator shows a deviation from the direct route. The drift angle may be quickly determined by heading the airplane so as to center the indicator, and noting the difference in degrees from the original heading.

**Ques. 7.222.** Is it possible for one aircraft to use a second aircraft as a homing facility with the presently installed ADF equipment? Explain.

*Ans.* Yes, provided the aircraft is equipped with a transmitter capable of transmitting signals on the homing aircraft's ADF frequency.

**Ques. 7.223.** How is aircraft ADF equipment used to make an instrument approach?

*Ans.* In the modern automatic direction finders aboard aircraft, bearings are indicated by a pointer moving through a 360-degree azimuth scale. The only requirements necessary for the pilot to make an instrument approach with this equipment is to adjust the ADF receiver to the frequency of the station on which the approach is to be made. The automatic control unit provides the pilot with continuous visual bearing readings on the azimuth scale.

**Ques. 7.224.** What is the minimum number of ground stations required to provide an instantaneous radio fix with the aircraft D/F?

*Ans.* Two ground stations are required to obtain an instantaneous radio position fix.

**Ques. 7.225.** In aircraft radio direction finding, what is an instantaneous fix? A running fix?

*Ans.* An instantaneous fix is represented by the intersection of two lines of geographical bearing from two separate radio stations.

A running fix is a bearing obtained from two stations at two different time intervals in flight, or two bearings taken on two stations at short time intervals during the flight.

**Ques. 7.226.** Discuss briefly the D/F procedure known as "boxing."

*Ans.* The practice of rapid familiarization of the 360-degree system so that a pilot may visualize instantly the direction corresponding to any given number of degrees.

**Ques. 7.227.** Radio bearing errors due to terrain effect decrease as the altitude of the aircraft decreases. TRUE or FALSE?

*Ans.* The statement is false. Bearings taken over terrain at low altitude are erratic due to the bending or refraction of the radio waves.

**Ques. 7.228.** Will flying in or near the vicinity of a severe electric storm cause erratic functioning of an aircraft ADF unit?

*Ans.* Yes. Electric or magnetic storms may cause erratic functioning due to the fact that the ADF will be influenced by the storm's magnetic field and will tend to point or follow the direction of the storm area.

**Ques. 7.229.** Does the aircraft's heading affect the error in radio bearings caused by coast line refraction?

*Ans.* No. The heading of the airplane does not influence the error in radio bearings caused by coast line refraction.

**Ques. 7.230.** An aircraft is flying parallel to a coast line and observes a relative bearing of 10 degrees on a radio beacon located ahead of the aircraft's position. Will the correct relative bearing be greater or less than the observed 10 degrees relative? Explain.

*Ans.* The correct relative bearing will be greater. Due to coastal effects, the errors are greater when the bearings are taken within approximately 30 degrees of a line parallel to the coast (see Ques. 7.73).

**Ques. 7.231.** Explain fully the procedure in obtaining a radio fix on two stations using the aircraft D/F loop.

*Ans.* A fix from two transmitting stations may be obtained only on the basis that the airplane direction of movement, or "heading," is known. Otherwise, a fix can be obtained only by procuring three relative bearings from three different radio stations.

On the assumption that the airplane's magnetic compass is in operation, a fix may be established by adhering to the following procedure:

Adjust the D/F loop for a maximum response from station *A* and then rotate for minimum response and sharp null point. This establishes one line of direction in relation to the magnetic heading. Proceed immediately to obtain a line of direction from station *B*. We have now completed two relative bearings. Combining these with the airplane's heading, we obtain two geographical bearings. The geographical positions are then located on a chart in proper position. The two lines intersecting as a result of this plotting will establish the fix.

## RADIO OPERATING QUESTIONS AND ANSWERS

For accurate results, the relative bearings indicated on the azimuth scale in comparison with the magnetic compass facilitate rapid conversion into geographical bearings. The time elapsed between the reading of the two directional bearings must also be included in the calculations.

**Ques. 7.232.** What angular separation of transmitting stations will give best results when taking radio bearings to get a three-station fix?

*Ans.* The angular separation should be at least 10 degrees in order for each pair of stations to obtain proper accuracy.

**Ques. 7.233.** Explain the "45-90"-degree distance-off procedure of determining distance from an aircraft to a radio beacon station.

*Ans.* The 45- or 90-degree problem is a simplified means of determining a fix of an airplane in flight relative to a given beacon station. It is an effective method for obtaining a running fix from *one* station.

The procedure followed with this method is simply one in which the radio compass loop is adjusted to a null response position at a relative bearing that provides a 45-degree angle to the airplane's course. The exact time is then noted and another adjustment is made when the plane reaches a 90-degree angle to the airplane's course. The time differential between the 45 and 90-degree null settings, together with the speed of travel, will determine the exact distance and time at the instant the plane passes the station. For example, if the plane is traveling at 360 miles per hour, and the time difference is assumed to be 5 minutes between the two bearings, the airplane is 30 miles from the beacon station.

The 90-degree method is similar to the previous problem but has an advantage in that it enables the pilot to calculate the distance from the beacon station *before* he passes it.

**Ques. 7.234.** On which side of an aircraft is a radio beacon located if the relative bearings taken aboard the aircraft are progressively increasing?

*Ans.* An increase of the relative bearing readings during flight indicates that the beacon station is located on the starboard side of the plane.

**Ques. 7.235.** Describe the procedure for determining sense (orientation) using an aircraft manual D/F loop and an aerophare.

*Ans.* The characteristics of a loop antenna provide a definite line of direction—north or south, east or west—but it does not indicate a *definite* direction. However, if the loop is used in conjunction with a vertical, or sense, antenna the actual direction of the oncoming wave may be determined. The vertical antenna produces an equidirectional pattern, or circle, and can receive signals equally well from all directions. Hence, if the loop antenna is combined with a vertical antenna, it will be noted that a signal will be received from only *one* direction when the radio compass loop is oriented.

The pilot is merely required to set his receiver adjustment for "sense" antenna, tuning to the required aerophare (beacon) transmitter. The next step is the adjustment of the loop tuning and orientation for maximum loop signal. When a maximum signal is heard with both loop and sense antenna connected, the arrow on the azimuth scale will indicate the approximate bearing of the station.

**Ques. 7.236.** Upon what factors does the usable range of an aircraft D/F loop depend?

*Ans.* The usable range of an aircraft direction finder loop is dependent upon such factors as height of plane above terrain, distance from the transmitter, sensitivity of the receiver, loop dimensions, frequency, and the time of the day or night the equipment is used.

**Ques. 7.237.** With reference to loop orientation, what is meant by the "pointer-progression" method?

*Ans.* The pointer-progression system requires that the loop be set in a range position 90 degrees to null point position.

The pilot observes the direction of the pointer during flight for each adjustment to the null point signal. The direction of the loop rotation is carefully noted to determine the direction of the homing station. For example, if the rotation of the loop is in a counterclockwise direction, the homing station is located off the left wing of the airplane.

**Ques. 7.238.** An aircraft is establishing a fix with radio bearings on two stations. One station is dead ahead, the second station approximately abeam to the right. Which bearing is it advisable to secure first, the speed line or the course line?

*Ans.* It is advisable to secure the course line first since the distance a line (plotting) is moved during flight is always measured along the course.

**Ques. 7.239.** Explain the method of determining the aircraft's position by "doubling the angle."

*Ans.* This method is similar to the 45-degree problem previously discussed with the exception that the bearing is taken when the plane is ahead of the station from which the bearing is to be taken.

For example, an initial bearing is taken and the time noted. A second bearing is then taken with the loop adjusted to null position at a relative bearing on the azimuth scale which will be precisely double the first angle off the course. The time differentials between the two null points are then noted and the distance covered is calculated. Hence, with a given speed and time, the distance is readily calculated by trigonometric functions employing an isocetes triangle.

**Ques. 7.240.** Why is it necessary to maintain constant heading and level flight when taking radio bearings with the aircraft D/F?

*Ans.* A constant heading must be maintained to ensure an accurate relationship between the magnetic compass, or gyro, and the relative bearing.

**Ques. 7.241.** To increase the relative bearing on an aircraft D/F loop, should the aircraft be turned RIGHT or LEFT?

*Ans.* The aircraft should be turned towards the left to increase the relative bearing. For example, assume an airplane heading and bearing line to give a 30-degree relative bearing indication. Thus, if the plane is turned to the left, the angle between the bearing line and the airplane heading will be increased.

**Ques. 7.242.** Describe briefly the operational procedure for calibrating an ADF installation in flight.

*Ans.* The calibration of an automatic direction finder is generally made by the adjustment of a corrector cam during initial installation to compensate for deviations due to physical location and mounting. During flight, the calibration of the direction finder is primarily a matter of adjusting the radio loop to a given "On Station" signal so that the pointer indicator remains centered. On the automatic type of direction finder, adjustments must be made to permit true bearing readings on the instrument. A deviation correction adjustment is provided in all modern ADF's so that bearings may be used directly as read. This adjustment may be varied during flight to permit accurate calibration of the unit.

**Ques. 7.243.** Define the following: relative bearing, magnetic bearing, true bearing, Mercator bearing, true course, track, magnetic heading, compass heading, true heading, compass error, advanced bearing, retarded bearing, and radio line of position.

*Ans.* Relative bearing: The number of degrees between the bearing line (transmitting station and plane) and the air-plane heading line (direction in which the plane is flying or heading).

Magnetic bearing: The number of degrees between the magnetic north line and the heading line, plus the relative bearing angle.

For example, if the magnetic north is a variation of 15 degrees west of true north and the plane heading is 55 degrees with respect to true north, and the relative bearing is 35 degrees, the magnetic bearing is 70 degrees plus 35 degrees, or 105 degrees.

True bearing: The number of degrees between the true heading and the relative bearing, or as in the preceding example,  $55 + 35$  degrees, or 90 degrees.

Mercator bearing: A method of obtaining a bearing for long distance air navigation by the use of a Mercator projection chart. This method employs a straight line between two points (rhumb line) for determining a given bearing (see Ques. 7.244 for details).

True course: The indication of the directional gyro, or compass, as to the magnetic course to a station at any particular instant during flight. It does not refer to the heading direction of the plane.

Track: This term refers to the straight line between two points as employed in the plotting of all aeronautical charts. The two common terms used in connection with these charts is the *rhumb-line track* and the *great-circle track*.

Magnetic heading: This term applies to the direction toward which the airplane is heading as compared with the compass indication. It is the number of degrees between the airplane heading and the magnetic north.

Compass heading: The number of degrees between the airplane heading and the compass north. For example, if the airplane heading and true north represent 55 degrees, and 15 degrees variation exists between true north and magnetic



north, and 5 degrees deviation exists between magnetic north and compass north, then the total, or 75 degrees, is the compass heading.

**True heading:** The number of degrees between the airplane heading and true north.

**Compass error:** The degree of fixed error, or deviation, introduced into a magnetic compass by the local magnetic fields set up on the airplane.

**Advanced bearing:** This refers to the situation in which a pilot desires to plot a running fix on two or more stations. This practice is preferred over an instantaneous fix whenever the running time of the airplane is considerably longer than two minutes, or the ground distance covered is in excess of five miles. Two bearings are plotted at approximate intervals of ten minutes, one bearing from station *A*, at say 0800, and another bearing at 0810 from station *B*. The resultant plotting computations of these two running fixes will then reveal the airplane's movement between the two time periods or, in this case, an advanced fix is obtained at time 0810.

The fix can be established by either advancing or retarding the bearing to the upper or lower time period, as desired.

**Retarded bearing:** This term refers to the condition in which a pilot plots a running fix between two stations as in the previous explanation with the exception that the second bearing taken is moved back along the course instead of in advance of the first bearing.

Both advanced and retarded bearing indications obtained by a running fix serve as a means for determining an airplane's geographic position at a certain time by two or more bearings taken at different time intervals.

**Ques. 7.244.** Explain why Mercator charts are used in long range air navigation? What is a rhumb line? What is a great circle?

**Ans.** Mercator charts are used in long range air navigation because they utilize the projection method of charting

large oceanic areas. The projection method makes use of a straight line between two points rather than the arc of a great circle. This straight line is referred to in air navigation as a *rhumb line* and is one that crosses all meridians throughout its length at the same angle. A *great circle* is defined as the line of intersection obtained on the surface of the earth by *any* plane through the center of the earth.

**Ques. 7.245.** Give the rules for applying Mercator correction to a radio bearing taken by the aircraft; by the ground direction finder station.

*Ans.* If the bearings are taken by an aircraft, the sign of correction on the Mercator chart to convert a radio bearing to Mercator bearing is accomplished as follows:

The correction is  $\frac{\text{additive}}{\text{subtractive}}$  if the airplane is in *south* latitude and is flying  $\frac{\text{eastward}}{\text{westward}}$  of the ground direction finder station. If, on the other hand, the airplane is in a north latitude area but of the same  $\frac{\text{eastward}}{\text{westward}}$  relationship to the ground station, the correction will be  $\frac{\text{subtractive}}{\text{additive}}$ .

The same procedure is followed for ground stations with the exception that the sign of correction is reversed.

**Ques. 7.246.** On a Mercator chart, are the rhumb line and great circle tracks always represented by a straight line?

*Ans.* No. Any arc on the great circle is indicated on the Mercator chart as a curved line connecting the two points of the rhumb line. However, when the chart is used to determine a bearing, the curved line is not used and the bearing is plotted as a straight line by calculating the difference between the rhumb line and great circle tracks. This correction is then applied to the bearing and drawn on the chart as a rhumb line.

**Ques. 7.247.** Explain why it is necessary to apply Mercator correction to radio bearings?

*Ans.* Radio waves in the frequency spectrum of aircraft direction finders follow the great circle track and therefore do not represent the true line between two points on the Mercator chart. Hence, the angular direction of the radio wave and its relation to the rhumb line must be considered to obtain the proper correction factor.

**Ques. 7.248.** Under what conditions is it unnecessary to apply Mercator correction to an observed true bearing?

*Ans.* Mercator corrections are not required if true bearings are taken over small distances.

**Ques. 7.249.** What is meant by compass deviation? Magnetic variation?

*Ans.* The term *compass deviation* refers to the difference in degrees between the magnetic north and the compass north. *Magnetic variation* refers to the number of degrees variation between magnetic north and true north.

### Radio Navigation of Aircraft

**Ques. 7.250.** What is the relative bearing of an aircraft if the true bearing from a radio station to the aircraft is 060 degrees and the aircraft has a compass heading of 020 degrees with a compass error of 2 degrees west and a variation of 10 degrees west?

*Ans.* 232 degrees. Fig. 7-6 illustrates the vector solution of the problem.

*Solution:*

$$\begin{aligned} \text{True heading (TH)} &= \text{compass heading (CH)} - \\ &\quad \text{compass error (west)} - \text{variation (west)} \\ \text{True heading} &= 20 - 2 - 10 = 8 \text{ degrees.} \end{aligned}$$

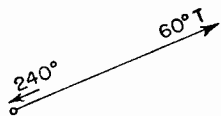

FIG. 7-6. Vector solution of a relative bearing problem.

RADIO OPERATING QUESTIONS AND ANSWERS

60 degrees + 180 degrees = 240 degrees

240 degrees *T* to the station from the aircraft.

60 degrees = true bearing of aircraft *from* station

240 degrees = *TB*

8 degrees = *TH*

232 degrees = relative bearing

**Ques. 7.251.** An aircraft is flying from station A to station B using the dual ADF with the RED pointer on station A and the GREEN pointer on station B. What ADF readings would indicate that the aircraft is on course with a 15-degree drift angle?

*Ans.*

Right semicircle of dial = GREEN = 15 and 195 degrees

Left semicircle of dial = RED = 340 and 165 degrees

**Ques. 7.252.** An aircraft is on a true heading of 225 degrees. Variation is 2 degrees west and deviation is 3 degrees east. What relative bearings would be necessary to obtain true bearings of 275 and 45 degrees?

*Ans.* 51 and 181 degrees.

*Solution:*

$$CH = TH + V - D = 225 + 2 - 3 = 224 \text{ degrees}$$

$$RB = TB - CH \pm 360 \text{ degrees}$$

$$(1) RB = 275 - 224 = 51 \text{ degrees}$$

$$(2) RB = 45 - 224 + 360 = 181 \text{ degrees}$$

**Ques. 7.253.** An aircraft is on a magnetic heading of 50 degrees and relative bearings are being taken on a station off to the RIGHT. If it is desired to turn directly toward the station when a QDM of 90 degrees is reached, what relative bearing will give the desired QDM?

*Ans.* 40 degrees.

*Solution:*

$$CH + RB = QDM$$

$$RB = QDM - CH = 90 - 50$$

$$= 40 \text{ degrees}$$

**Ques. 7.254.** An aircraft is on a true bearing of 100 degrees from a radio beacon. What is the relative bearing if the magnetic heading is 015 degrees and the variation is 10 degrees west?

*Ans.* 95 degrees. (Reciprocal = 275 degrees.)

*Solution:*

$$TH = CH - V \text{ (west)} = 15 - 10 = 005 \text{ degrees}$$

$$TH + RB = TB$$

$$RB = TB - TH = 100 - 5 = 95 \text{ degrees}$$

**Ques. 7.255.** An aircraft observes a relative bearing of 254 degrees on an aerophare. If the compass heading is 41 degrees, deviation 2 degrees east, variation 8 degrees west, what is the true bearing of the aerophare?

*Ans.* 289 degrees.

*Solution:*

$$TH = CH + D - V = 41 + 2 - 8 = 35 \text{ degrees}$$

$$TB = TH + RB = 35 + 254 = 289 \text{ degrees}$$

**Ques. 7.256.** What is the true bearing of an aerophare with respect to an aircraft flying a magnetic heading of 127 degrees if the loop reading is 10 degrees left, deviation 3 degrees west, variation 4 degrees east, and the quadrantal error is +2 degrees?

*Ans.* 116 degrees (calculated). Actual TB of aerophare = 123 degrees.

*Solution:*

$$TH = CH \pm D + V = 127 \pm 3 + 4 = 128 \text{ degrees}$$

$$RB = -(\text{loop reading} + \text{error}) = -(10 + 2) = -12 \text{ degrees}$$

$$TB = TH + RB = 128 - 12 = 116 \text{ degrees}$$

**Ques. 7.257.** An aircraft is flying on a CH of 058 degrees, in position 45 degrees 30 minutes north and 14 degrees 10 minutes west. A relative bearing of 250 degrees is taken

RADIO OPERATING QUESTIONS AND ANSWERS

on a radio station located at 47 degrees 35 minutes north and 16 degrees 00 minutes west. Compass deviation is 3 degrees east and magnetic variation is 10 degrees west. What bearing should be plotted on a Mercator chart?

Ans. 300 degrees, 30 minutes: (see Fig. 7-7).

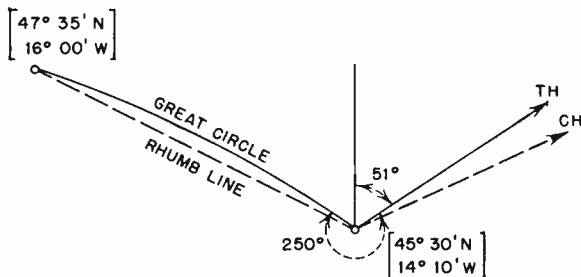

FIG. 7-7. Vector bearing solution.

*Solution:*

$$TH = CH + D - V = 58 + 3 - 10 = 51 \text{ degrees}$$

$$TB = TH + RB = 51 + 250 = 301 \text{ degrees}$$

$$\text{Correction on Mercator (table)} = -0.5 \text{ degrees}$$

$$\text{Plotted bearing} = 301 - 0.5 = 300 \text{ degrees } 30 \text{ minutes}$$

NOTE: This question does not state specifically which bearing should be plotted.

**Ques. 7.258.** An aircraft is tracking 315 degrees at a ground speed of 240 miles per hour. At 1800 GMT a radio station bears 315 degrees relative, and at 1805 GMT the same station bears 270 degrees relative. What is the distance from the aircraft to the ground station at 1805 GMT?

Ans. 20 miles.

*Solution:*

$$\text{Speed} = 240 \text{ miles per hour} = 4 \text{ miles per minute}$$

$$\text{Distance from 1800 GMT to 1805 GMT} = 20 \text{ miles}$$

$$\text{Bearings covered are } -45 \text{ degrees and } -90 \text{ degrees.}$$

Solving by an isosceles triangle:

Distance traveled = distance to ground station = 20 miles

**Ques. 7.259.** An observed relative bearing is 75 degrees. Which direction and how many degrees must the aircraft be turned to move the relative bearing to 125 degrees?

*Ans.* By simple vector representation, it will be evident that the plane must turn 50 degrees to the left.

**Ques. 7.260.** An aircraft is flying in extreme turbulence. The first relative bearing is 90 degrees and the second relative bearing is 95 degrees. Is it safe to assume that the station is on the RIGHT?

*Ans.* No. It is not safe to assume the station is on the RIGHT because in rough air, a 5-degree change in relative bearing is not sufficient to definitely indicate that the station is on the RIGHT.

**Ques. 7.261.** An aircraft is homing on a radio station. The correct relative bearing is zero. If the null moves slowly from 0 to 355, 350, 345, and the compass heading remains constant, is the drift RIGHT or LEFT?

*Ans.* The drift is towards the right.

*Solution:*

Drift =  $TH - \text{Track} = 360 \text{ degrees} - 355 = +5 \text{ degrees}$ , etc.

**Ques. 7.262.** The compass heading is 125 degrees. The aircraft is south of the radio beacon and both deviation and variation are 0 degrees. What relative bearing will be indicated when the aircraft intercepts the 175-degree azimuth from the station?

*Ans.* 230 degrees.

*Solution:*

$TB = 180 + 175 = 355 \text{ degrees}$

$TH = 125 \text{ degrees}$

$RB = 355 - 125 = 230 \text{ degrees}$  (relative bearing when on 175-degree azimuth).

RADIO OPERATING QUESTIONS AND ANSWERS

**Ques. 7.263.** Given: Compass heading:  $-195$  degrees  
Deviation:  $9$  degrees west  
Variation:  $6$  degrees east  
Find: True heading

*Ans.*  $192$  degrees.

*Solution:*

$$TH = CH - D + V = 195 - 9 + 6 = 192 \text{ degrees}$$

**Ques. 7.264.** If the compass heading is  $289$  degrees, deviation  $5$  degrees west, variation  $7$  degrees east, and the relative bearing on the station  $172$  degrees, what is the true bearing?

*Ans.*  $103$  degrees.

*Solution:*

$$\begin{aligned} TH &= CH - D + V = 289 - 5 + 7 = 291 \text{ degrees} \\ TB &= TH + RB = 291 \text{ degrees} + 172 \text{ degrees} = 463 \text{ degrees} \\ &= 463 - 360 = 103 \text{ degrees} \end{aligned}$$

**Ques. 7.265.** An aircraft is on a compass heading of  $236$  degrees. The relative bearing on a radio station is  $326$  degrees. Variation is  $23$  degrees east, deviation  $2$  degrees west, and the loop correction is  $-4$  degrees. What is the true bearing?

*Ans.*  $219$  degrees.

*Solution:*

$$\begin{aligned} TH &= CH + V - D = 236 + 23 - 2 - 4 = 253 \text{ degrees} \\ TB &= TH + RB = 253 + 326 = 579 - 360 = 219 \text{ degrees} \end{aligned}$$

**Ques. 7.266.** The true bearing from a radio station to an aircraft is  $068$  degrees. The aircraft is flying a compass heading of  $016$  degrees, deviation  $2$  degrees west, variation  $11$  degrees west. What is the relative bearing on the aircraft loop?



Ans. 245 degrees.

Solution:

$$CH = 16 \text{ degrees}$$

$$D = \underline{2 \text{ degrees}}$$

$$H = 14 \text{ degrees}$$

$$V = \underline{11 \text{ degrees}}$$

$$TH = \underline{3 \text{ degrees}}$$

$$\text{Reciprocal } TB = 68 + 180 = 248 \text{ degrees}$$

$$\text{Relative bearing} = 248 - 3 = 245 \text{ degrees.}$$

All candidates for the new Aircraft Radiotelegraph license examination, effective January 3, 1950 are requested to obtain a copy of Supplement No. 5 to "Study Guide and Reference Material for Commercial Radio Operator Examinations."

Supplement No. 5 to the Study Guide is available without cost at the field offices of the Federal Communications Commission and at the Commission's office at Washington 25, D.C.

The complete Study Guide for Commercial Radio Operator's Examinations is also made available by the Superintendent of Documents, Government Printing Office, Washington 25, D.C.

It is recommended that all candidates for this license review the reference material requirements listed in the Supplemental Study Guide No. 5. Many of the references listed cover the complete detail to the questions listed in element 7, both in theory and practice. Civil Aeronautics Bulletin No. 24, Radio Navigational Aids, Part 9, Rules and Regulations Governing Aeronautical Services (FCC), and the ICAO (International Civil Aviation Organization) published by the authority of the Secretary General, Montreal, Canada, are some of the most important requirements for detailed study purposes.

Much valuable information on Instrument Flight problems is also contained in the text *Radio Navigation for Pilots* by Colin H. McIntosh and in *Principles of Aeronautical Radio Engineering* by R. C. Sandretto, both of which are published by the McGraw-Hill Book Company, Inc., New York.

The author has included extracts from information contained in the FCC, Civil Aeronautics Authority, ICAO, and related publications as specifically related to Rules and Regulations important to the field of radio operating.

## SPECIAL PROBLEM SECTION

**Prob. 1. (a)** A 440-volt, 60-cycle, three-phase alternator has four poles. What is the speed at which it rotates?

*Solution:* 1,800 r.p.m. For an alternator, speed is directly proportional to the frequency and inversely proportional to the pairs of poles. Since the frequency is in cycles per second, the speed in r.p.s. is determined as follows:

$$\text{Speed in r.p.s.} = f \times \frac{2}{N} = 60 \times \frac{2}{4} = 30 \text{ r.p.s.,}$$

where  $f$  = frequency in cycles per second.

$N$  = number of poles.

$$\text{Speed in r.p.m.} = \text{speed in r.p.s.} \times 60 = 1,800 \text{ r.p.m.}$$

**(b)** What is the frequency of a 220-volt, 8-pole, three-phase alternator, which rotates at 375 r.p.m.?

*Solution:* 25 cycles. Alternator frequency is directly proportional to both the speed in r.p.s. and the pairs of poles.

$$\text{Speed in r.p.s.} = \frac{\text{speed in r.p.m.}}{60} = \frac{375}{60} = 6.25 \text{ r.p.s.}$$

$$\text{Frequency} = \text{speed in r.p.s.} \times \frac{N}{2} = 6.25 \times \frac{8}{2} = 25 \text{ cycles,}$$

where  $N$  = number of poles.

**Prob. 2.** What is the percentage slip of a 440-volt, 25-cycle, 6-pole, three-phase induction motor when the rated full-load speed is 485 r.p.m.?

*Solution:* 3 per cent. Speed differential between the synchronous and rotor speeds of an induction motor is usually

expressed as a percentage called the slip. The slip seldom exceeds 3 per cent for most types of induction motors.

$$\text{Synchronous speed} = \frac{120 \times f}{N} = \frac{120 \times 25}{6} = 500 \text{ r.p.m.,}$$

where  $f$  = frequency in cycles per second.

$N$  = number of field poles.

$$\begin{aligned} \text{Percentage slip} &= \frac{100 (\text{synchronous speed} - \text{rotor speed})}{\text{synchronous speed}} \\ &= \frac{100 (500 - 485)}{500} = 3 \text{ per cent.} \end{aligned}$$

**Prob. 3.** For a three-phase power-distribution system a 4,000/440-volt delta-star transformer is used, with the primary delta connected and the secondary star connected. What is the primary and secondary coil current?

*Solution:* Primary coil current = 5.02 amperes, and secondary coil current = 78.7 amperes.

$$\text{Primary } K_{va} = \frac{\sqrt{3} \times E_e \times I_e}{1,000},$$

$$I_e = \frac{1,000 \times K_{va}}{\sqrt{3} \times E_e} = \frac{1,000 \times 60}{1.732 \times 4,000} = 8.7 \text{ amperes.}$$

$$I_c = \frac{I_e}{\sqrt{3}} = \frac{8.7}{1.732} = 5.02 \text{ amperes.}$$

$$\text{Secondary } K_{va} = \frac{\sqrt{3} \times E_e \times I_e}{1,000}.$$

$$I_e = \frac{1,000 \times K_{va}}{\sqrt{3} \times E_e} = \frac{1,000 \times 60}{1.732 \times 440} = 78.7 \text{ amperes.}$$

$$I_c = I_e = 78.7 \text{ amperes,}$$

where  $E_e$  = line voltage.

$I_e$  = line current.

$I_c$  = coil current.

**Prob. 4.** A 2 K<sub>va</sub> 440/110-volt, 60-cycle transformer furnishes 8.12 amperes of current to an inductive load having a power factor of 60 per cent and a resistance of 10 ohms. What power is actually being furnished to the load, and how may the power factor be improved?

*Solution:* 660 watts at a power factor of 60 per cent. The power factor can be improved by adding a condenser of approximately 2 microfarads in series with the load. If the capacitive reactance of the condenser exactly equals the inductive reactance of the load, the power factor will be unity, or 100 per cent.

$$\text{Power factor} = \frac{\text{actual power}}{E \times I}$$

$$\begin{aligned} \text{Actual power} &= \text{power factor} \times E \times I = 0.6 \times 110 \times 8.12 \\ &= 535.92 \text{ watts.} \end{aligned}$$

$$\text{Power factor} = \cos \theta = 0.60$$

$$\phi = 53.1 \text{ degrees.}$$

$$\tan \phi = \tan 53.1 \text{ degrees} = 1.3319.$$

$$\tan \phi = \frac{X_L}{R}$$

$$X_L = \tan \phi \times R = 1.3319 \times 10 = 13.319 \text{ ohms.}$$

For unity power factor:  $X_c = X_L = 13.319$  ohms.

$$C = \frac{1}{2\pi f X_c} = \frac{1}{6.28 \times 60 \times 13.319} = 199 \text{ microfarads}$$

**Prob. 5.** For a 440-volt power supply a voltage divider is required which will furnish 20 milliamperes at 300 volts and 40 milliamperes at 200 volts when the bleeder current is 20 milliamperes. What are the total resistance required and the resistance of each section of the voltage divider?

*Solution:* Total resistance is 12,917 ohms with three sections of 10,000, 1,667, and 1,250 ohms in that order. Let the voltage at  $m = 400$  volts, at  $n = 300$  volts, at  $O = 200$  volts, and at

SPECIAL PROBLEM SECTION

$p = 0$  volts. If the current  $I_n = 20$  milliamperes,  $I_o = 40$  milliamperes, and  $I_b = 20$  milliamperes, then the resistances  $R_{mn}$ ,  $R_{no}$ , and  $R_{op}$  can be determined (see Fig. 5-8).

$$R_{mn} = \frac{E_{mn}}{I_n + I_o + I_b} = \frac{100}{0.02 + 0.04 + 0.02} = 1,250 \text{ ohms.}$$

$$R_{no} = \frac{E_{no}}{I_o + I_b} = \frac{100}{0.04 + 0.02} = 1,667 \text{ ohms.}$$

$$R_{op} = \frac{E_{op}}{I_b} = \frac{200}{0.02} = 10,000 \text{ ohms.}$$

$$\begin{aligned} R_t &= R_{mn} + R_{no} + R_{op} \\ &= 1,250 + 1,667 + 10,000 = 12,917 \text{ ohms.} \end{aligned}$$

**Prob. 6.** What value of shunt resistance must be connected across the terminals of a radio-frequency ammeter to change its full-scale deflection-current reading from 100 milliamperes to 1 ampere if the internal resistance of the meter is 10 ohms?

*Solution:* 1.11 ohms. The meter and shunt resistances are in parallel so that the current in the circuit divides between them. Since the current in a parallel circuit divides inversely as the resistance of each branch, the shunt resistance can be computed as follows:

$$\frac{R_s}{R_a} = \frac{I_a}{I_s}$$

and

$$R_s = \frac{I_a}{I_s} \times R_a = \frac{0.1}{0.9} \times 10 = 1.11 \text{ ohms,}$$

where  $R_s$  = shunt resistance.

$R_a$  = ammeter internal resistance.

$I_a$  = ammeter current.

$I_s$  = shunt current.

**Prob. 7.** If a milliammeter requires 100 milliamperes of current for full-scale deflection and has an internal resistance of 20 ohms, what value of multiplier resistance must be used in series with the meter for use as a 0 to 1,000-volt voltmeter.

*Solution:* 9,980 ohms. The multiplier and meter resistances are in series, and the total resistance can be determined by using Ohm's law, since the multiplier and meter current are the same. The meter resistance is then subtracted from the total resistance in order to determine the multiplier resistance.

$$R_t = \frac{E}{I_a} = \frac{1,000}{0.1} = 10,000 \text{ ohms,}$$

$$R_m = R_t - R_a = 10,000 - 20 = 9,980 \text{ ohms,}$$

where  $R_m$  = multiplier resistance.

$R_a$  = meter resistance.

$R_t$  = total resistance.

$I_a$  = meter and multiplier current.

$E$  = voltage for full-scale deflection.

**Prob. 8.** What is the internal resistance of a storage battery if the open-circuit battery voltage is 6.3 volts and the closed-circuit voltage is 5.7 volts for a load current of 10 amperes?

*Solution:* 0.06 ohms. Voltage drop in the battery is equal to the open-circuit voltage less the closed-circuit voltage. Battery internal resistance is determined using Ohm's law, since the battery current and internal voltage drop are known.

$$E_i = E_o - E_c = 6.3 - 5.7 = 0.6 \text{ volts,}$$

$$R_i = \frac{E_i}{I} = \frac{0.6}{10} = 0.06 \text{ ohms,}$$

where  $R_i$  = battery internal resistance.

$E_i$  = voltage drop in the battery.

$I$  = circuit current.

$E_o$  = battery open-circuit voltage.

$E_c$  = battery closed-circuit voltage.

**Prob. 9.** (a) For a given vacuum tube a 3-volt change in grid voltage will cause the same amount of plate current change as a 60-volt change in plate voltage. What is the amplification factor of the tube?

SPECIAL PROBLEM SECTION

*Solution:* Amplification factor is 20.

$$\text{Amplification factor } M = \frac{\text{change in plate voltage}}{\text{change in grid voltage}} = \frac{60}{3} = 20.$$

(b) What is the plate resistance of a vacuum tube if a 45-volt change in plate voltage results in a 5-milliamperere change in plate current?

*Solution:* Plate resistance is 9,000 ohms.

$$\begin{aligned} \text{Plate resistance } R_p &= \frac{\text{change in plate voltage}}{\text{change in plate current}} = \frac{45}{0.005} \\ &= 9,000 \text{ ohms.} \end{aligned}$$

(c) With a 4-volt change in grid voltage the plate current of a vacuum tube is varied by 5 milliamperes. What is the mutual conductance of the tube?

*Solution:* Mutual conductance is 1,250 micromhos.

$$\begin{aligned} \text{Mutual conductance} &= \frac{\text{change in plate current}}{\text{change in grid voltage}} = \frac{0.005}{4} \\ &= 0.00125 \text{ mhos} = 1,250 \text{ micromhos.} \end{aligned}$$

**Prob. 10.** For a 50-kva, three-phase, 4,600/230-volt, delta-delta transformer, what is the primary current at rated kilovolt-ampere for normal operation and for open-delta operation, assuming one section of the transformer is inoperative?

*Solution:* 3.62 amperes for normal operation and 6.27 amperes for open-delta operation.

For normal operation:

$$\text{Primary kva} = \frac{\sqrt{3} \times E_e \times I_e}{1,000}$$

$$I_e = \frac{\text{kva} \times 1,000}{\sqrt{3} \times E_e} = \frac{50 \times 1,000}{1.732 \times 4,600} = 6.27 \text{ amperes.}$$

$$I_c = \frac{I_a}{\sqrt{3}} = \frac{6.27}{1.732} = 3.62 \text{ amperes.}$$

If one transformer section is inoperative and the others are operated as an open-delta or V-connected transformer at rated load, the primary coil current will rise to 6.27 amperes representing a 73 per cent overload.

**Prob. 11.** Two uncharged capacitors of 100 and 1,500 micromicrofarads, respectively, are connected in series. What is the voltage across the 1,500-micromicrofarad capacity when the series combination is connected across a direct-current source of potential of 100 volts?

*Solution:*

$$\begin{aligned} E_{c_2} &= \frac{C_1}{C_1 + C_2} \times E \\ &= \frac{100}{100 + 1,500} \times 100 = 6.25 \text{ volts.} \end{aligned}$$

**Prob. 12.** Assuming both capacitors have previously been charged to 100 volts each and connected in series with their polarities in opposition. What is the voltage across  $C_1$  and  $C_2$  when the series bank is connected across a direct-current potential of 200 volts?

*Note:* The negative terminal of  $C_1$  is connected to +200 and the negative terminal of  $C_2$  to -200 volts.

*Solution:*

$$\begin{aligned} E_{c_2} &= 100 + 12.5 = 112.5 \text{ volts.} \\ E_{c_1} &= -100 + 187.5 = 87.5 \text{ volts.} \end{aligned}$$

*Proof:*  $112.5 + 87.5 = 200$  volts.

**Prob. 13.** Three condensers of 0.006, 0.004, and 0.002 microfarad are connected in series across a direct-current potential of 200 volts. (a) What is the total effective capacitance of this group? (b) How much voltage is developed across each condenser?



SPECIAL PROBLEM SECTION

*Solution:*

$$(a) \quad C_{\text{eff}} = \frac{1}{\frac{1}{C_1} + \frac{1}{C_2} + \frac{1}{C_3}} = 0.001091.$$

$$C_1 + C_2 + C_3 = 0.012.$$

$$\frac{0.012}{0.006} = 2; \quad \frac{0.012}{0.004} = 3; \quad \frac{0.012}{0.002} = 6.$$

$$\frac{1}{\frac{11}{0.012}} = \frac{0.012}{11} = 0.001091 \text{ microfarad.}$$

(b) By percentage ratio we find the largest voltage developed across the smallest capacitor, 0.002 microfarad, is 109.1 volts

*Solution:*

$$E_1 = \frac{C_t}{C_1} \times 200 = \frac{0.001091}{0.002} \times 200 = 109.1 \text{ volts.}$$

$$E_2 = \frac{0.001091}{0.004} \times 200 = 54.55 \text{ volts.}$$

$$E_3 = \frac{0.001091}{0.006} \times 200 = 36.33 \text{ volts.}$$

**Prob. 14.** Given a series-resonant circuit in which the inductive and capacitive reactances are 500 and 200 ohms, respectively, at a frequency of 1,000 kilocycles. What is the resonant frequency of this circuit?

*Solution:*

$$f_r = \frac{1}{\frac{1}{f_x} \times \sqrt{\frac{x_L}{x_c}}} \text{ cycles per second,}$$

where  $f_x$  is the frequency corresponding to the values of  $X_L$  and  $X_c$

$$f_r = \frac{1}{\frac{1}{10^6} \times \sqrt{\frac{500}{200}}} = \frac{1}{\frac{1}{10^6} \sqrt{2.5}}$$

$$= \frac{1}{158 \times 10^{-8}} = 632.911 \text{ kilocycles per second.}$$

Prob. 15. A parallel resonant circuit composed of an inductance, capacity, and resistance connected in parallel is resonant at a frequency of 4.59 megacycles. The inductive reactance at this frequency is 3,170 ohms. The equivalent resistance of the parallel combination is 28.32 ohms. Find the Q and the band width between the "half-power" points of this combination.

*Solution:*

$$Q = \frac{\omega L}{R_{eq}} = \frac{3,170}{28.32} = 112.0.$$

$$Q = \frac{f}{\Delta f}, \quad \Delta f = \frac{f}{Q} = \frac{4.59 \times 10^6}{112} = 41 \text{ kilocycles per second.}$$

The characteristic impedance of a transmission line is 320 ohms when air is the medium between the parallel conductors. Assume the two parallel wires to be molded into a dielectric material which has a specific inductive capacity (dielectric constant)  $K_e$  of 2.55. What is the new impedance of the line under this condition?

*Solution:*

$$Z_0^1 = \frac{Z_0}{\sqrt{K_e}} = \frac{320}{\sqrt{2.55}} = \frac{320}{1.6} = 200 \text{ ohms.}$$

Prob. 16. A high-frequency generating device has an internal resistance of 500 ohms and develops an electromotive force of 600 volts r.m.s. A load impedance of 500 ohms composed of an inductance of 400 ohms and a resistance of 300 ohms is connected across the output terminals of the generator. (a) Calculate the power absorbed by the load. (b) Calculate the power absorbed by the load when a capacitance is connected in series with the load to cancel the inductive reactance.

(c) What is the characteristic impedance of a quarter-wave-length transmission line which, when inserted between the source and the load, will result in a maximum power transfer? What is the magnitude of the power?

*Solution:*

(a)  $P_1$  = power absorbed by the load.

$$\begin{aligned} P_1 &= \frac{E^2 P_r}{(R_g + R_r)^2 + X_L^2} \\ &= \frac{360,000 \times 300}{(800)^2 + (400)^2} = 135 \text{ watts.} \end{aligned}$$

(b)  $P_2$  = power absorbed when  $X_L = X_c$ .

$$P_2 = \frac{360,000 \times 300}{640,000} = 169 \text{ watts.}$$

(c)  $Z_0 = \sqrt{500 \times 300} = 387$  ohms.

Since in this case,  $R_r = R_g$  and  $X = 0$ ,

$$P_{\max} = \frac{360,000}{4 \times 500} = 180 \text{ watts.}$$

**Prob. 17.** A concentric line one-quarter wavelength long is to be used to match a 50-ohm resistive load to a source which has an internal impedance of 200 ohms. Calculate the characteristic impedance  $Z_0$  of the quarter-wave matching line.

*Solution:*

$$\begin{aligned} Z_r &= \frac{Z_0^2}{Z_s}, \\ \therefore Z_0 &= \sqrt{50 \times 200} = 100 \text{ ohms.} \end{aligned}$$

**Prob. 18.** An ultra-high-frequency transmitter operating at a fundamental frequency of 250 megacycles (1.2 meters) is fed to an open wire transmission line. It is desired to suppress the even and odd harmonics by the insertion of a harmonic suppressing stub. See Prob. 18. What are the physical dimensions of the stub for (a) second, and (b) third harmonic suppression requirement?

*Solution:* A short-circuited quarter-wave line presents very high impedance to the fundamental frequency. At the second harmonic frequency the stub is one-half wavelength long and presents a very low impedance (short circuit) to the harmonic frequency.

$$(a) \quad \frac{\lambda}{4} = \frac{1.2}{4} = 0.3 \text{ meter}$$

$$= 11.811 \text{ inches.}$$

$$(1 \text{ meter} = 39.37 \text{ inches} = 3.28083 \text{ ft.})$$

(b) The open section must be  $\lambda/12$  long and the shorted section  $\lambda/6$  long.

An open section of a stub that is  $\lambda/12$  long at the operating frequency is  $\lambda/4$  long at the third harmonic. If therefore such an open section is connected at the output of the transmitter, the third harmonic content will be shorted out. At the fundamental frequency, the open  $\lambda/12$  section appears as a capacitive load, the effects of which are minimized by the  $\lambda/6$  wavelength closed section connected in parallel. Hence, at the operating frequency, the  $\lambda/6$  wavelength section will be in antiresonance with the  $\lambda/12$  open section.

Note: A short-circuited  $\lambda/4$  line appears, to any connection made along its length, the equivalent of a parallel-resonant circuit at the fundamental frequency. The open stub presents capacitive reactance, and the shorted stub inductive reactance, both of equal magnitude.

(b) Open-ended stub:

$$\frac{\lambda}{12} = \frac{1.2}{12} = 0.1 \text{ meter}$$

$$= 3.9 \text{ inches.}$$

Short circuited stub:

$$\frac{\lambda}{6} = \frac{1.2}{6} = 0.2 \text{ meter}$$

$$= 7.874 \text{ inches.}$$

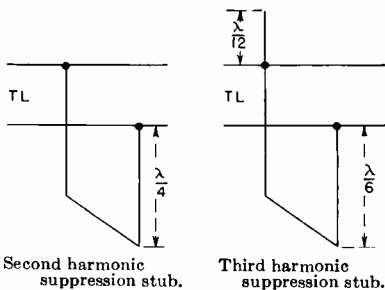

Second harmonic suppression stub.

Third harmonic suppression stub.

PROB. 18. Stub arrangement for suppression of harmonics.

SPECIAL PROBLEM SECTION

**Prob. 19.** If a microphone having a  $-60$ -db output, for a 6-milliwatt zero reference level, is connected to an audio amplifier through a microphone preamplifier, how much gain must the preamplifier provide if the audio amplifier has a gain of 10 db and the power output required is 20 watts?

*Solution:* 85.2 db or a voltage gain of 18,190.

Amplifier output is 20 watts.

Input is  $-60$  db for a 6 milliwatt zero reference level.

Amplifier power level is

$$\begin{aligned} \text{db} &= 10 \log \frac{\text{power output}}{\text{reference level}} = 10 \log \frac{20}{0.006} \\ &= 10 \log 3333.3 \\ &= 10 \times 3.5227 \\ &= +35.2 \text{ db.} \end{aligned}$$

Total db gain required from  $-60$  db to  $+35.2$  db is 95.2 db.

Gain of the preamplifier =  $95.2 - 10 = 85.2$  db.

Voltage gain of the preamplifier (assuming equal resistance terminations):

$$\begin{aligned} \text{db} &= 20 \log \frac{E_1}{E_2} \\ 85.2 &= 20 \log \frac{E_1}{E_2} \end{aligned}$$

Then

$$\begin{aligned} 4.26 &= \log \frac{E_1}{E_2} \\ \frac{E_1}{E_2} &= 18,190. \end{aligned}$$

**Prob. 20.** A given amplifier requires an undistorted power output of 10 watts. The reference level is assumed to be the standard of 6 milliwatts (0 db). What is the over-all gain of the amplifier when connected to a microphone pick-up which has an output of 1 milliwatt?

*Solution:*

$$\text{Microphone db} = 10 \log \frac{0.001}{0.006} = 0.167.$$

$$\log 0.167 = -1.22.$$

$$\text{Pick-up level in db} = 10 \log \times -1.22 = -7.8 \text{ db.}$$

$$\text{Amplifier db} = 10 \log \frac{10}{0.006} = 1,667.$$

$$\log 1,667 = 3.2216.$$

$$\text{db} = 10 \times 3.22194 = 32.2.$$

$$\text{Amplifier gain} = 32.2 \text{ db.}$$

$$\text{Over-all gain} = -7.8 \text{ db} + 32.2 \text{ db} = 40 \text{ db.}$$

**Prob. 21.** An amplifier consists of an input transformer with a step-up ratio of 4, an amplifier tube with an amplification factor of 13.8. The output of this combination is fed into a power-amplifier input transformer with a 1.5 step-up ratio and a power-amplifier tube with an amplification factor of 220. What is the gain in db of the two-stage amplifier when an input signal of 1 volt is applied across the primary of the first transformer?

*Solution:*

$$4 \times 13.8 \times 1.5 \times 220 = 18,216.$$

$$\text{Gain in db} = 20 \log \frac{E_2}{E_1} = \frac{18,216}{1} = 18,216.$$

$$\log \text{ of } 18,216 = 4.26.$$

$$\text{Gain} = 20 \times 4.26 = 85 \text{ db.}$$

(a) What is the power level in db for a 6F6 tube operating under conditions which will develop an undistorted power output of 3 watts?

(b) If the over-all gain of the power amplifier and preceding amplifiers is 80 db, what signal swing in db is required to deliver the required output?

SPECIAL PROBLEM SECTION

*Solution:*

$$(a) \quad \text{db} = 10 \log \frac{P}{0.006} = \frac{3}{0.006} = 500.$$

$$\log \text{ of } 500 = 2.70.$$

$$\text{Power level} = 10 \times 2.70 = 27 \text{ db.}$$

$$(b) \quad \text{db} = P_1 - P_2 = 27 - 80 = 53 \text{ db.}$$

$$\text{Signal input required} = -58 \text{ db.}$$

The over-all gain of an amplifier is 63.52 db. What is the voltage gain ratio?

*Solution:*

$$\frac{N \text{ db}}{20} = \frac{63.52}{20} = 3.176.$$

$$\text{Antilog of } 3.176 = 1,500.$$

$$\text{Voltage ratio} = 1,500.$$

**Prob. 22.** The field intensity of a broadcast transmitter is 10,000 microvolts per meter at a distance of 5 miles. What is the field intensity at 50 miles distance from the transmitter?

*Ans.* Let  $e$  = field intensity at 50 miles,  
then,

$$\frac{e}{10,000} = \frac{5}{50}$$

$$e = \frac{5 \times 10,000}{50} = \frac{50,000}{50} = 1,000 \text{ microvolts per meter.}$$

**Prob. 23.** (a) What would be the field intensity at 50 miles if the antenna current is doubled at the transmitter mentioned in Prob. 22?

*Ans.* Theory: Field intensity at any point varies directly with antenna current.

Thus,

$$e = 1,000 \times 2 = 2,000 \text{ microvolts per meter}$$

(b) The field intensity from a broadcast transmitter at a distance of 10 miles is measured and found to be 5,000 microvolts

per meter. Assuming no change in the transmitting antenna, what increase in transmitted power would be required to raise the 10-mile field intensity to 10,000 microvolts per meter.

*Ans.* Theory: Power in the antenna =  $I^2R$ , where  $R$  is the radiation resistance of the antenna.

Since field strength is to be doubled, the antenna current will also have to be doubled. This is because field strength is directly proportional to antenna current.

Let  $P_1$  = original transmitted power.

Let  $P_2$  = transmitted power after increase.

Thus

$$\frac{P_2}{P_1} = \frac{(2I)^2R}{I^2R} = \frac{2^2 \times I^2 \times R}{I^2 \times R} = 4.$$

$$P_2 = 4P_1.$$

**Prob. 24.** What is the db gain in field intensity resulting from the calculations in Prob. 23?

*Ans.* Theory: A 2:1 ratio or increase in field intensity resulted from the doubling of antenna current. This is a voltage ratio.

The formulas for db gain are

$$(1) \text{ db} = 10 \log_{10} \frac{P_2}{P_1}, \quad (2) \text{ db} = 20 \log_{10} \frac{E_2}{E_1},$$

where  $\frac{P_2}{P_1}$  is a ratio of powers.

$\frac{E_2}{E_1}$  is a ratio of voltages.

Since Prob. 23 gives us a voltage ratio, we substitute in formula (2) thus,

$$\text{db} = 20 \log_{10} 2.$$

From logarithm tables or slide rule,

$$\log_{10} 2 = 0.301,$$

$$\therefore \text{db} = 20 \times 0.301$$

$$= 6.02.$$



SPECIAL PROBLEM SECTION

**Prob. 25.** The transmitted power from a broadcast station is increased by a factor of 100. What is the db gain in field intensity at any given point?

*Ans.*

$$\begin{aligned} \text{db} &= 10 \log_{10} \frac{P_2}{P_1} \\ &= 10 \log_{10} 100 \\ &= 10 \times 2 = 20. \end{aligned}$$

**Prob. 26.** A given transmitter is operating at a frequency of 1,500 kilocycles. If two identical towers are employed and connected together at their feed points, what will be the spacing of the towers in feet for a 110-degree phase difference in tower feed currents?

*Ans.* Theory: For example, if the towers were spaced a half wavelength apart, the phase difference would be 180 degrees, since there are 360 electrical degrees in a wavelength. Thus, the spacing in terms of wavelength is given by the following formula:

$$d = \frac{\theta}{360} \times (\lambda + n\lambda),$$

where  $d$  = spacing of towers.

$\theta$  = phase difference in currents to the two towers.

$\lambda$  = wavelength.

$n$  = any integer or zero.

(Adding any number of full wavelengths to the tower spacing in no way changes the relative phase of currents fed to the towers.) Where  $\theta = 110$  degrees,

$$d = \frac{110}{360} \times (\lambda + n\lambda).$$

Let

$$n = 0,$$

$$\lambda = \frac{v}{f} = \frac{300,000}{1,500} = 200 \text{ meters},$$

$$\therefore d = \frac{110}{360} \times 200 = 61.1 \text{ meters},$$

$$1 \text{ meter} = 3.28 \text{ feet},$$

$$d = 61.1 \times 3.28 = 200.4 \text{ feet}.$$

**Prob. 27.** A heterodyne frequency meter has a straight-line relationship between frequency and dial reading. If the dial reading is 22.6 for a frequency of 1,000 kilocycles and 56.7 for a frequency of 1,600 kilocycles, what is the frequency of the fourth harmonic of the frequency corresponding to a scale reading of 40.3?

*Ans.* Theory: Since the dial reading is directly proportional to frequency, we can find the frequency corresponding to a dial setting of 40.3 by finding the percentage change in frequency from a setting of 22.6 to 40.3 with respect to the total variation between 22.6 and 56.7 which is given.

$$56.7 - 22.6 = 34.1 \text{ dial divisions.}$$

$$1,600 - 1,000 = 600 \text{ kilocycles variation in frequency in } 34.1 \text{ dial divisions.}$$

$$40.3 - 22.6 = 17.7 \text{ dial divisions.}$$

$$f = \left( \frac{17.7}{34.1} \times 600 \right) + 1,000$$

$$= 311.4 + 1,000$$

$$= 1,311.4 \text{ kilocycles, fundamental.}$$

The fourth harmonic of this fundamental is

$$4 \times 1,311.4 = 5,245.6 \text{ kilocycles.}$$

**Prob. 28.** A 1,200-kilocycle, X-cut crystal, calibrated at 20 degrees centigrade and having a temperature coefficient of -20 parts per million per degree C, will oscillate at what frequency when its temperature is 50 degrees centigrade?

*Ans.* Theory: As the temperature increases, the frequency of oscillation will decrease. For 1-degree change in temperature a 1,200-kilocycle crystal will vary 20 parts per million or 20 cycles per megacycle. Total variation would then be  $\frac{1,200}{1,000} \times 20 = 24$  cycles per centigrade degree. But tempera-

SPECIAL PROBLEM SECTION

ture change is given as  $50 - 20 = 30$  centigrade degrees. Thus, total frequency variation is

$$24 \times 30 = 720 \text{ cycles total variation.}$$

Since frequency deviation is negative, we subtract the variation with temperature change from the frequency at 20 centigrade degrees. Thus,

$$\begin{aligned} \text{Frequency} &= 1,200,000 - 720 \\ &= 1,199,180 \text{ cycles per second} \\ &= 1,199.180 \text{ kilocycles per second.} \end{aligned}$$

**Prob. 29.** A power supply is designed to furnish 1,000 volts direct current at 350 milliamperes load current. (a) What would be the percentage regulation of the power supply if the no-load voltage of the supply is 1,100 volts direct-current? (b) Express the drop in voltage from no-load to full-load in db.

Theory: The full-load voltage of a power supply is less than the no-load voltage for several reasons: (1) the  $IR$  drop through the choke or chokes, (2) tube drop (high-vacuum types), (3) poor regulation of input condenser (condenser-input supplies only), (4) transformer losses due to resistance in the transformer and transformer leakage reactance.

(a) Percentage regulation is given by the formula

$$\text{Regulation percentage} = \frac{E_{nl} - E_{fl}}{E_{fl}} \times 100,$$

where  $E_{nl}$  = no-load voltage output.

$E_{fl}$  = full-load voltage output.

Substituting,

$$\begin{aligned} \text{Regulation percentage} &= \frac{1,100 - 1,000}{1,000} \times 100 \\ &= \frac{100}{1,000} \times 100 = 9.09 \text{ per cent.} \end{aligned}$$

$$\begin{aligned} (b) \quad \text{db drop in voltage} &= 20 \log_{10} \frac{1,100}{1,000} \\ &= 20 \log_{10} 1.1. \end{aligned}$$

From log tables or slide rule,

$$\log_{10} 1.1 = 0.0414.$$

Thus,

$$\begin{aligned} \text{db drop in voltage} &= 20 \times 0.0414 \\ &= 0.828. \end{aligned}$$

**Prob. 30.** If a wavemeter, having a deviation inversely proportional to the wavelength, is accurate to 12 cycles when set at 560 kilocycles, what is its error when set at 1,500 kilocycles?

*Theory:* If the error in reading of a wavemeter varies inversely as the wavelength, it varies directly as the frequency.

This is because  $f = \frac{v}{\lambda}$ .

*Solution:*

$$\frac{12}{x} = \frac{560}{1,500}; \quad \text{or} \quad x = \frac{12 \times 1,500}{560} = \frac{18,000}{560} = 32.1 \text{ cycles}$$

where  $x$  = error at 1,500 kilocycles.

**Prob. 31.** Assuming the error in reading of a wavemeter increases directly with frequency, what error in reading would result at 80 meters if the error is 50 cycles at 240 meters?

*Theory:* Since the error is proportional to frequency, it must be inversely proportional to wavelength.

*Solution:* Thus,

$$\begin{aligned} \frac{50}{x} &= \frac{80}{240}; \quad x = \frac{50 \times 240}{80} = \frac{12,000}{80} \\ x &= 150 \text{ cycles, error at 80 meters.} \end{aligned}$$

**Prob. 32.** A superheterodyne receiver has an intermediate frequency of 465 kilocycles. When tuned to a broadcast station at 980 kilocycles, severe interference is experienced from an "image" signal. What is the frequency and wavelength of the interfering station?

## SPECIAL PROBLEM SECTION

*Theory:* The mixer stage in a superheterodyne receiver combines the local oscillator signal with the signal arriving on the antenna and produces sum and difference frequencies in its plate circuit. In this problem the resulting frequency must be 465 kilocycles, since the plate circuit of the mixer is tuned to this frequency. In normal operation the local oscillator frequency is higher than the incoming signal frequency by the value of the intermediate frequency. If, however, a strong signal should reach the mixer input having a frequency above that of the local oscillator by an amount equal to the intermediate frequency, a signal corresponding to the difference frequency would pass through the intermediate-frequency amplifier.

*Solution:*

Local oscillator frequency =  $980 + 465 = 1,445$  kilocycles.

Frequency of interfering station

$$= 1,445 + 465 = 1,910 \text{ kilocycles.}$$

Wavelength of interfering station

$$= \frac{300,000}{1,910} = 157 \text{ meters.}$$

**Prob. 33.** A superheterodyne receiver is tuned to 2,100 kilocycles, and the intermediate frequency is 456 kilocycles. What is the frequency of the mixer oscillator?

*Theory:* The "mixer oscillator," or as it is often called "local oscillator," is customarily tuned to a higher frequency than the incoming signal. The frequency difference between "local oscillator" and incoming signal is always equal to the intermediate frequency.

*Solution:* Thus, in this problem,

Signal frequency = 2,100 kilocycles.

Intermediate frequency = 456 kilocycles.

Oscillator frequency =  $2,556$  kilocycles.

**Prob. 34.** A class C plate-modulated radio-frequency amplifier draws 250 milliamperes at 1,000 volts direct-current. What is the load impedance presented to the modulator?

*Theory:* Plate current flows to a class C amplifier in radio-frequency pulses. A direct-current milliammeter in the plate circuit reads average current, and this current depends upon the direct-current voltage applied and the total effective resistance in the circuit. The total resistance includes the tube plate resistance and the effective class C amplifier plate-load resistance. (The class C amplifier plate-load impedance is pure resistance, since it is a parallel circuit of  $L$  and  $C$  tuned to resonance.)

*Solution:* Load impedance presented to modulator is numerically equal to the direct-current plate voltage divided by the direct-current plate current to the class C modulator radio-frequency amplifier.

$$Z = \frac{E_{dc}}{I_{dc}} = \frac{1,000}{0.250} = 4,000 \text{ ohms (pure resistance).}$$

**Prob. 35.** A superheterodyne receiver has a mixer stage, five stages of intermediate-frequency amplification, a diode detector, an audio-frequency amplifier. The output is fed through a matching transformer into a 500-ohm load. The input transformer has a turns ratio of 1:10. The mixer has a loss of five times. The intermediate-frequency amplifier stages have a gain of 15 for each stage. The audio-frequency amplifier has a total gain of eight times when properly matched into the output load of 500 ohms. What is the over-all gain of the receiver?

*Solution:* Let  $E_1$  = voltage across 70-ohm input terminals.

$E_2$  = voltage across the 500 ohms.

$$\begin{aligned} E_2 &= E_1(10)\left(\frac{1}{5}\right)(15)^5(8) \\ &= 4(15)^5 E_1. \end{aligned}$$

$$P_{\text{input}} = \frac{E_1^2}{70}, \quad P_{\text{output}} = \frac{E_2^2}{500} = \frac{[4(15)^5 E_1]^2}{500} = \frac{16(15)^{10} E_1^2}{500}$$

$$\begin{aligned} \text{Gain in db} = 10 \log_{10}, \quad \frac{P_o}{P_i} &= 10 \log_{10} \left[ \frac{16(15)^{10} E_1^2}{500} \times \frac{70}{E_1^2} \right] \\ &= 100 \log_{10} \frac{16(15)70}{500} = 152.6 \text{ db.} \end{aligned}$$

## RADAR

**Prob. 36.** A radar transmitter has an output of 60 watts average pulse power and 30 kilowatts of peak power. The pulse duration or pulse width is 1 microsecond. What is the pulse repetition period and the duty cycle frequency?

*Solution:*

$$\tau_r = \frac{30,000}{60} = 500 \text{ microseconds.}$$

$$F = \frac{1}{T} = \frac{1}{500 \times 10^{-6}} = 2,000 \text{ cycles per second.}$$

A radar pulse travels at a speed of 5.375 microseconds in 1 statute mile. The round-trip time of the pulse and its return echo therefore is 10.75 microseconds for one loop mile (2 linear miles = 1 loop mile).

$$\text{Distance (in miles)} = \frac{\text{echo time (microseconds)}}{10.75}$$

Five hundred feet corresponds to a round-trip time of approximately 1 microsecond, or more conveniently expressed, the round-trip time for a pulse to an object 1,000 yards away is 6.1 microseconds.

**Prob. 37.** A given radar transmitter has a pulse duration of 1 microsecond, a pulse repetition rate of 2,000 cycles, and an average pulse power of 60 watts. What is the peak power of the pulse?

*Solution:*

$$P_{\text{peak}} = \frac{P_{\text{avg}}}{\delta \times PRF} = \frac{60}{1 \times 10^{-6} \times 2,000} = 30,000 \text{ watts.}$$

**Prob. 38.** If an object is located 6 miles from a radar transmitter, what is the round-trip or echo time in microseconds of the transmitted pulse?

*Solution:*

$$6 \times 10.75 = 64.5 \text{ microseconds.}$$

**Prob. 39.** An echo pulse is received 215 microseconds after the transmitted pulse leaves the antenna. What is the distance of the object which caused the reflection?

*Solution:*

$$\frac{215}{10.7} = 20 \text{ miles.}$$

**Prob. 40.** A rectangular wave guide having a cross-section of 7 by 2 centimeters is found by calculation to have a wavelength of 14.3 centimeters (2,097.9 megacycles per second). What is the frequency requirement of the exciting oscillator (magnetron or klystron) to energize the wave guide properly?

*Solution:*

$$\lambda_a = \frac{\lambda_g}{\sqrt{1 + \left(\frac{\lambda_g}{\lambda_c}\right)^2}} = \frac{14.3}{\sqrt{1 + \left(\frac{14.3}{14}\right)^2}} = 10.064 \text{ centimeters}$$

where  $\lambda_g$  = the measured wavelength in the guide.

$\lambda_c$  = the critical or cut-off wavelength of the guide.

$\lambda$  = the free-space wavelength.

(The wavelength inside the guide is greater than in free space, and as the free-space wavelength approaches the cut-off wavelength of the guide, the wave-guide wavelength approaches infinity.)

**Prob. 41.** A magnetron designed to operate at a wavelength of 13 centimeters is fed into a rectangular wave guide (2 by 7 centimeters) which has a physical length of 10 meters between it and the antenna radiator. How long will it take a pulse to travel from the magnetron to the antenna?



SPECIAL PROBLEM SECTION

*Solution:*

$$\lambda_a = \frac{\lambda_a}{\sqrt{1 - \left(\frac{\lambda_a}{\lambda_c}\right)^2}} = \frac{13}{\sqrt{1 - \left(\frac{13.0}{14}\right)^2}} = 92.8 \text{ centimeters.}$$

$$V_a = \frac{13}{92.8} \times v = 42 \text{ megacycles per second.}$$

$$t = \frac{D}{V_a} = \frac{10}{4.2 \times 10^7} = 23.8 \text{ microseconds.}$$

**Prob. 42.** Calculate the theoretical (a) maximum, and (b) minimum ranges for a radar transmitter which has a recurrence frequency of 1,000 cycles per second and a pulse width of 1 microsecond.

*Solution:* (a) Maximum range is  $\frac{v}{2\tau}$  where  $v$  is the velocity of light or radio waves, 186,300 miles per second, and  $\tau$  is the pulse repetition frequency (PRF).

$$\frac{1}{1,000} \times \frac{186,300}{2} = 93.15 \text{ miles.}$$

(b) Minimum range is  $\frac{v}{2} \times \delta$  where  $\delta$  is the pulse width or duration.

$$\frac{186,300}{2} \times 10^{-6} = 0.0931 \text{ miles, or approximately 490 feet.}$$

**Prob. 43.** A pulse of 0.5-microsecond duration with a pulse repetition frequency of 400 cycles per second is to be received in a superheterodyne receiver. The mid-point frequency of the intermediate frequency is to be 60 megacycles per second. What are the approximate upper and lower limit requirements of the amplifier to accommodate this pulse width?

*Solution:*

$\delta$  = pulse duration =  $5 \times 10^{-7}$  second (0.5 microsecond).

$$\frac{1}{\delta} = \frac{1}{5 \times 10^{-7}} = 2 \times 10^6 \text{ cycles per second.}$$

The optimum band

$$= \frac{2}{\delta}$$

$$= 4 \times 10^6 \text{ cycles per second (4 megacycles per second).}$$

Hence, since the mid-frequency of the intermediate-frequency amplifier is 60 megacycles, the lower limit is 58 megacycles per second and the upper limit is 62 megacycles per second (a total bandwidth of 4 megacycles per second). Some allowance for frequency drift of the transmitter and the receiver oscillator (approximately 0.5 megacycles per second) should be included in the over-all bandwidth, or 57.75 and 62.25 for the lower and upper limits, respectively.

**Prob. 44.** The frequency of a single-anode type of magnetron is dependant upon the field strength developed by the permanent magnet. This field strength or flux density is expressed by the unit called the gauss,  $B$ . If a certain single-anode type of magnetron is found to work most effectively with a magnetic field of 1,600 gauss, what is the approximate wavelength in centimeters of the resulting output wave?

*Solution:*

$$\begin{aligned} f &= \frac{\omega_0}{2\pi} = \frac{17.8 \times 10^6}{2\pi} \times B \\ &= \frac{17.8 \times 10^6}{6.28} \times 1,600 = 4,540 \text{ megacycles per second.} \end{aligned}$$

$$\therefore \lambda = \frac{v}{f} = \frac{300}{4,540} = 0.066 \text{ meter (6.6 centimeters).}$$

(100 centimeters = 1 meter. Therefore,  $0.066 \times 100 = 6.6$  centimeters.)

$\omega_0$  is a constant,  $17.8 \times 10^6$ .

SPECIAL PROBLEM SECTION

**Prob. 45.** A long series of square pulses are transmitted from a certain radar transmitter. The pulses are of 2-micro-second duration and repeat 100 times in a second. (a) What are the five lowest frequencies contained in each pulse? (b) The two lowest frequencies with a coefficient equal to zero?

*Solution:*

$$(a) \quad \delta = 2 \times 10^{-6} = 0.000002 \text{ second.}$$

$$f_r = 100 \text{ cycles per second.}$$

$$\tau_r = \frac{1}{f_r} = \frac{1}{100} = 0.01 \text{ second.}$$

The five lowest frequencies are

$$0 = 0 \text{ cycles per second.}$$

$$f_r = 100 \text{ cycles per second.}$$

$$2f_r = 200 \text{ cycles per second.}$$

$$3f_r = 300 \text{ cycles per second.}$$

$$4f_r = 400 \text{ cycles per second.}$$

$$(b) \quad \frac{1}{\delta} = \frac{1}{0.000002} = 500,000 \text{ cycles per second.}$$

$$\frac{2}{\delta} = \frac{2}{0.000002} = 1,000,000 \text{ cycles per second.}$$

*LORAN*

**Prob. 46.** (See Ques. 6.277.) Given the master station base-line extension (4,460) and the slave station base-line extension (1,000). (a) What is the distance in nautical miles between the master and the slave station? (b) What should be the marking on the chart for the line of positions equally spaced between the master and slave stations? (c) If a ship at sea is located 280 miles from the master station and 420 miles from the slave station, what will be the interval between the arrival of the pulse from the master station and that from the slave station?

*Solution:*

$$(a) 4,460 - 1,000 = 3,460; \frac{3,460}{2} = 1,730 \text{ microseconds.}$$

$$\therefore \frac{1,730}{6.18} = 280 \text{ nautical miles.}$$

where 6.18 = feet in one nautical mile.

$$(b) 1,730 + 1,000 = 2,730.$$

Line should be marked: 1H4 - 2730.

$$(c) \text{ Time for 1 master pulse to reach slave station} \\ = 1,730 \text{ microseconds.}$$

$$\frac{1}{2} \text{ recurrence interval } \frac{30,000}{2} - \frac{400}{2} \\ = 14,800 \text{ microseconds.}$$

Coding delay = 1,000 microseconds.

$$\text{Difference in paths} = 420 - 280 = 140 \text{ miles} \\ = 865 \text{ microseconds.}$$

$$\text{Interval between master and slave pulse} \\ = 18,395 \text{ microseconds.}$$

*Note:* When the basic pulse repetition rate (BPRR) switch is set on *H*, the Loran indicator is adjusted for approximately  $33\frac{1}{3}$  pulses per second. This corresponds to a pulse interval of 30,000 microseconds when the specific pulse-repetition-rate switch (SPRR) is set at zero. When the specific pulse-repetition-rate switch is set on any number from 0 to 7, in combination with the setting of the basic pulse-repetition-rate switch, the indicator sweep rate is adjusted for stopping the signals at the specific pulse recurrence rates indicated in a Loran instruction book.

For example, when the basic pulse repetition rate switch is set on *H*, we note the following:

Specific PRR switch	Frequency, pulses per second	Pulse interval, microseconds
0	$33\frac{1}{3}$	30,000
4	$33\frac{1}{9}$	29,600

## *SPECIAL PROBLEM SECTION*

Additional information is as follows:

The time required for a radio wave to travel 100 nautical miles is 618 microseconds.

The pulse sent out by the slave station is delayed an amount calculated upon the time required for the pulse to travel from the master to the slave station, one-half the pulse recurrence interval, and the coding delay.

The advantages obtained by this delay are that it insures the master pulse will be the first one received at the ship's receiver, provides identification between the two pulses transmitted, and avoids possible error due to two lines of position with the same time-difference indication.



## APPENDIX I\*

TABLE 1.—ABBREVIATIONS TO BE USED IN RADIO COMMUNICATIONS  
Q CODE—ABBREVIATIONS TO BE USED IN ALL SERVICES<sup>1,2</sup>

Abbreviation	Question	Answer or statement
QRA	What is the name of your station?	The name of my station is . . .
QRB	At what approximate distance are you from my station?	The approximate distance between our stations is . . . nautical miles ( <i>or</i> . . . kilometers).
QRC	By what private operating enterprise ( <i>or</i> Government administration) are the accounts for charges of your station settled?	The accounts for charges of my station are settled by the . . . private operating enterprise ( <i>or</i> by the Government administration of . . .).
QRD	Where are you going and where do you come from?	I am going to . . . and I come from . . .
QRG	Will you tell me what my exact frequency (wavelength) is in kilocycles ( <i>or</i> meters)?	Your exact frequency (wavelength) is . . . kilocycles ( <i>or</i> . . . meters).
QRH	Does my frequency (wavelength) vary?	Your frequency (wavelength) varies.
QRI	Is the tone of my transmission regular?	The tone of your transmission varies.
QRJ	Are you receiving me badly? Are my signals weak?	I cannot receive you. Your signals are too weak.

<sup>1</sup> Abbreviations take the form of questions when they are followed by a question mark.

<sup>2</sup> The series of signals QA to QD and QF to QN are reserved for the special code of the aeronautical service.

\* Reprinted from the Government publication, "Study Guide and Reference Material for Commercial Radio Operator Examinations."

## RADIO OPERATING QUESTIONS AND ANSWERS

**TABLE 1.—ABBREVIATIONS TO BE USED IN RADIO COMMUNICATIONS  
Q CODE—ABBREVIATIONS TO BE USED IN ALL SERVICES<sup>1,2</sup>—(Continued)**

Abbreviation	Question	Answer or statement
QRK	What is the legibility of my signals ( <i>1 to 5</i> )?	The legibility of your signals is . . . ( <i>1 to 5</i> ).
QRL	Are you busy?.....	I am busy ( <i>or I am busy with . . .</i> ). Please do not interfere.
QRM	Are you being interfered with?	I am being interfered with.
QRN	Are you troubled by static? ..	I am troubled by static.
QRO	Must I increase the power?...	Increase the power.
QRP	Must I decrease the power?..	Decrease the power.
QRQ	Must I transmit faster?.....	Transmit faster ( . . . words per minute).
QRS	Must I transmit more slowly?	Transmit more slowly ( . . . words per minute).
QRT	Must I stop transmission?....	Stop transmission.
QRU	Have you anything for me?	I have nothing for you.
QRV	Are you ready?.....	I am ready.
QRW	Must I advise . . . that you are calling him on . . . kilocycles ( <i>or . . . meters</i> )?	Please advise . . . that I am calling him on . . . kilocycles ( <i>or . . . meters</i> ).
QRX	Must I wait? When will you call me again?	Wait ( <i>or Wait until I have finished communicating with . . .</i> ). I shall call you again at . . . o'clock ( <i>or immediately</i> ).
QRY	Which is my turn?.....	Your turn is number . . . ( <i>or according to any other indication</i> ).
QRZ	By whom am I being called?.	You are being called by . . .
QSA	What is the strength of my signals ( <i>1 to 5</i> )?	The strength of your signals is ( <i>1 to 5</i> ).



APPENDIX I

TABLE I.—ABBREVIATIONS TO BE USED IN RADIO COMMUNICATIONS  
Q CODE—ABBREVIATIONS TO BE USED IN ALL SERVICES<sup>1,2</sup>—(Continued)

Abbreviation	Question	Answer or statement
QSB	Does the strength of my signals vary?	The strength of your signals varies.
QSD	Is my keying correct; are my signals distinct?	Your keying is incorrect; your signals are bad.
QSG	Must I transmit . . . telegrams ( <i>or</i> one telegram) at a time?	Transmit . . . telegrams ( <i>or</i> one telegram) at a time.
QSJ	What is the charge to be collected per word to . . . including your internal telegraph charge?	The charge to be collected per word to . . . is . . . francs, including my internal telegraph charge.
QSK	Must I continue the transmission of all my traffic; I can hear you between my signals?	Continue the transmission of all your traffic; I shall interrupt you if necessary.
QSL	Can you acknowledge receipt?	I am acknowledging receipt.
QSM	Must I repeat the last telegram which I transmitted to you?	Repeat the last telegram which you transmitted to me.
QSO	Can you communicate with . . . directly ( <i>or</i> through . . . )?	I can communicate with . . . directly ( <i>or</i> through . . . ).
QSP	Will you relay to . . . free of charge?	I will relay to . . . free of charge.
QSR	Has the distress call received from . . . been attended to?	The distress call received from . . . has been attended to by . . .
QSU	Must I transmit ( <i>or</i> answer) on . . . kilocycles ( <i>or</i> meters) and/ <i>or</i> on waves of type A1, A2, A3, or B?	Transmit ( <i>or</i> answer) on . . . kilocycles ( <i>or</i> . . . meters) and/ <i>or</i> waves of type A1, A2, A3, or B.
QSV	Must I transmit a series of V's?	Transmit a series of V's.

## RADIO OPERATING QUESTIONS AND ANSWERS

TABLE 1.—ABBREVIATIONS TO BE USED IN RADIO COMMUNICATIONS  
Q CODE—ABBREVIATIONS TO BE USED IN ALL SERVICES<sup>1,2</sup>—(Continued)

Abbreviation	Question	Answer or statement
QSW	Do you wish to transmit on . . . kilocycles ( <i>or</i> . . . meters), and/or on waves of type A1, A2, A3, or B?	I am going to transmit ( <i>or</i> I shall transmit) on . . . kilocycles ( <i>or</i> . . . meters), and/or on waves of type A1, A2, A3, or B.
QSX	Will you listen to . . . ( <i>call signal</i> ) on . . . kilocycles ( <i>or</i> . . . meters)?	I am listening to . . . ( <i>call signal</i> ) on . . . kilocycles ( <i>or</i> . . . meters).
QSY	Must I shift to transmission on . . . kilocycles ( <i>or</i> . . . meters), without changing the type of wave? <i>or</i>	Shift to transmission on . . . kilocycles ( <i>or</i> . . . meters) without changing the type of wave. <i>or</i>
	Must I shift to transmission on another wave?	Shift to transmission on another wave.
QSZ	Must I transmit each word or group twice?	Transmit each word or group twice.
QTA	Must I cancel telegram no. . . . as if it had not been transmitted?	Cancel telegram no. . . . as if it had not been transmitted.
QTB	Do you agree with my word count?	I do not agree with your word count; I shall repeat the first letter of each word and the first figure of each number.
QTC	How many telegrams have you to transmit?	I have . . . telegrams for you ( <i>or</i> for . . .).
QTE <sup>3</sup>	What is my true bearing in relation to you? <i>or</i>	Your true bearing in relation to me is . . . degrees <i>or</i>
	What is my true bearing in relation to . . . ( <i>call signal</i> )? <i>or</i>	Your true bearing in relation to . . . ( <i>call signal</i> ) is . . . degrees at . . . ( <i>time</i> ) <i>or</i>

<sup>3</sup> In certain aeronautical services, "true course" and "true bearing" are called "geographic course" and "geographic bearing."

APPENDIX I

TABLE 1.—ABBREVIATIONS TO BE USED IN RADIO COMMUNICATIONS  
Q CODE—ABBREVIATIONS TO BE USED IN ALL SERVICES<sup>1,2</sup>—(Continued)

Abbreviation	Question	Answer or statement
	What is the true bearing of . . . ( <i>call signal</i> ) in relation to . . . ( <i>call signal</i> )?	The true bearing of . . . ( <i>call signal</i> ) in relation to . . . ( <i>call signal</i> ) is . . . degrees at . . . ( <i>time</i> ).
QTF	Will you give me the position of my station on the basis of bearings taken by the radio direction-finding stations which you control?	The position of your station on the basis of bearings taken by the radio direction-finding stations which I control is . . . latitude, . . . longitude.
QTG	Will you transmit your call signal during 50 seconds ending with a 10-second dash, on . . . kilocycles ( <i>or</i> . . . meters) so that I may take your radio direction-finding bearings?	I will transmit my call signal during 50 seconds, ending with a 10-second dash, on . . . kilocycles ( <i>or</i> . . . meters) so that you may take my radio direction-finding bearings.
QTH	What is your position in latitude and in longitude ( <i>or according to any other indication</i> )?	My position is . . . latitude, . . . longitude ( <i>or according to any other indication</i> ).
QTI	What is your true course?..	My true course is . . . degrees.
Q TJ	What is your speed?.....	My speed is . . . knots ( <i>or</i> . . . kilometers) per hour.
QTM	Transmit radio signals and submarine sound signals to enable me to determine my bearing and my distance.	I am transmitting radio signals and submarine sound signals to enable you to determine your bearing and your distance.
QTO	Have you left dock ( <i>or port</i> )?	I have left dock ( <i>or port</i> ).

## RADIO OPERATING QUESTIONS AND ANSWERS

TABLE 1.—ABBREVIATIONS TO BE USED IN RADIO COMMUNICATIONS  
Q CODE—ABBREVIATIONS TO BE USED IN ALL SERVICES<sup>1,2</sup>—(Continued)

Abbreviation	Question	Answer or statement
QTP	Are you going to enter dock ( <i>or port</i> )?	I am going to enter dock ( <i>or port</i> ).
QTQ	Can you communicate with my station by the International Code of Signals?	I am going to communicate with your station by the International Code of Signals.
QTR	What is the exact time?...	The exact time is . . .
QTU	What are the hours during which your station is open?	My station is open from . . . to . . .
QUA	Have you any news from . . . ( <i>call signal of the mobile station</i> )?	This is the news from . . . ( <i>call signal of the mobile station</i> ).
QUB	Can you give me, in the following order, information concerning: visibility, height of clouds, ground wind at . . . ( <i>place of observation</i> )?	This is the information requested: . . . . .
QUC	What is the last message you received from . . . ( <i>call signal of the mobile station</i> )?	The last message I received from . . . ( <i>call signal of the mobile station</i> ) is . . .
QUD	Have you received the urgent signal transmitted by . . . ( <i>call signal of the mobile station</i> )?	I have received the urgent signal transmitted by . . . ( <i>call signal of the mobile station</i> ) at . . . ( <i>time</i> ).
QUF	Have you received the distress signal sent by . . . ( <i>call signal of the mobile station</i> )?	I have received the distress signal sent by . . . ( <i>call signal of the mobile station</i> ) at . . . ( <i>time</i> ).
QUG	Will you be forced to come down on water ( <i>or on land</i> )?	I am forced to come down on water ( <i>or on land</i> ) at . . . ( <i>place</i> ).
QUH	Will you give me the present barometric pressure at sea level?	The present barometric pressure at sea level is . . . ( <i>units</i> ).

APPENDIX I

TABLE 1.—ABBREVIATIONS TO BE USED IN RADIO COMMUNICATIONS  
Q CODE—ABBREVIATIONS TO BE USED IN ALL SERVICES<sup>1,2</sup>—(Continued)

Abbreviation	Question	Answer or statement
QUJ <sup>3</sup>	Will you please indicate the proper course to steer toward you, with no wind?	The proper course to steer toward me, with no wind, is . . . degrees at . . . (time).
QUK	Can you tell me the condition of the sea observed at . . . (place or coordinates)?	The sea at . . . (place or coordinates) is . . .
QUL	Can you tell me the surge observed at . . . (place or coordinates)?	The surge at . . . (place or coordinates) is . . .
QUM	Is the distress traffic ended?	The distress traffic is ended.

<sup>3</sup> In certain aeronautical services, "true course" and "true bearing" are called "geographic course" and "geographic bearing."

TABLE 2.—SCALE FOR STRENGTH OR LEGIBILITY OF SIGNALS

Strength	Legibility
QSA 1 = scarcely perceptible	QRK 1 = unreadable
QSA 2 = weak	QRK 2 = readable now and then
QSA 3 = fairly good	QRK 3 = readable, but with difficulty
QSA 4 = good	QRK 4 = readable
QSA 5 = very good	QRK 5 = perfectly readable

# RADIO OPERATING QUESTIONS AND ANSWERS

## TABLE 3.—MISCELLANEOUS ABBREVIATIONS

Abbreviation	Meaning
C	Yes.
N	No.
P	Announcing private telegram in the mobile service (to be used as a prefix).
W	Word <i>or</i> words.
AA	All after . . . (to be used after a question mark to request a repetition).
AB	All before . . . (to be used after a question mark to request a repetition).
AL	All that has just been transmitted (to be used after a question mark to request a repetition).
AS	Waiting period.
BN	All between . . . (to be used after a question mark to request a repetition).
BQ	Answer to RQ.
CL	I am closing my station.
CS	Call signal (to be used in requesting that call signal be given or repeated).
DB	I cannot give you a bearing, you are not in the calibrated sector of this station.
DC	The minimum of your signal is suitable for the bearing.
DF	Your bearing at . . . ( <i>time</i> ) was . . . degrees, in the doubtful sector of this station, with a possible error of two degrees.
DG	Please advise me if you find an error in the bearing given.
DI	Doubtful bearing due to the bad quality of your signal.
DJ	Doubtful bearing due to interference.
DL	Your bearing at . . . ( <i>time</i> ) was . . . degrees, in the uncertain sector of this station.
DO	Doubtful bearing. Request another bearing later, or at . . . ( <i>time</i> ).
DP	Beyond 50 miles, possible error of bearing can attain two degrees.
DS	Adjust your transmitter, your minimum signal is too broad.
DT	I cannot give you a bearing, your minimum signal is too broad.
DY	This is a two-way station, what is your approximate direction, in degrees, in relation to this station?
DZ	Your bearing is reciprocal (to be used only by the control station of a group of radio direction-finding stations when addressing other stations of the same group).

APPENDIX I

TABLE 3.—MISCELLANEOUS ABBREVIATIONS.—(Continued)

Abbreviation	Meaning
ER	Here . . . (to be used before the name of the mobile station in the transmission of routing indications).
GA	Resume transmission (to be used more especially in the fixed service).
JM	If I may transmit, make a series of dashes. To stop my transmission, make a series of dots [not to be used on 500 kc. (600 m.)].
MN	Minute or minutes (to be used to indicate the duration of the waiting period).
NW	I am resuming transmission (to be used more especially in the fixed service).
OK	We agree.
RG	Announcing a request.
SA	Announcing the name of an aircraft station (to be used in transmitting transit data).
SF	Announcing the name of an aeronautical station.
SN	Announcing the name of a coast station.
SS	Announcing the name of a ship station (to be used in transmitting transit data).
TR	To announce sending of indications concerning a mobile station.
TU	Thank you for the cooperation given.
UA	Do we agree?
WA	Word after . . . (to be used after a question mark to request a repetition).
WB	Word before . . . (to be used after a question mark to request a repetition).
XS	Static.
YS	See your service notice.
ABV	Repeat ( <i>or</i> I repeat) the figures in abbreviated form.
ADR	Address (to be used after a question mark to request a repetition).
CFM	Confirm ( <i>or</i> I confirm).
COL	Collate ( <i>or</i> I collate).
ITP	The punctuation counts.
MSG	Announcing a telegram concerning the service on board (to be used as a prefix).
NIL	I have nothing to transmit to you (to be used after an abbreviation of code <i>Q</i> to show that the answer to the question asked is in the negative).

## RADIO OPERATING QUESTIONS AND ANSWERS

TABLE 3.—MISCELLANEOUS ABBREVIATIONS.—(Continued)

Abbreviation	Meaning
PBL	Preamble (to be used after a question mark to request a repetition).
REF	Reference to . . . (or Refer to . . . ).
RPT	Repeat (or I repeat) (to be used in requesting or giving repetition of all or part of the traffic, the abbreviation to be followed by the corresponding indications).
SIG	Signature (to be used after a question mark to request a repetition).
SVC	Announcing a service telegram concerning private traffic (to be used as a prefix).
TFC	Traffic.
TXT	Text (to be used after a question mark to request a repetition).



## APPENDIX I

### TABLE 4.—INTERNATIONAL MORSE CODE

*With extracts from the list of punctuations and other signs contained in the  
Telegraph Regulations of the Cairo Conferences, 1938*

#### LETTERS

a . —	i ..	r . . . .
b — . . . .	j . — — —	s . . .
c . . . . .	k — . —	t —
d — . . .	l . — . .	u . . —
e .	m — —	v . . . —
f . . . .	n — .	w . — —
g — — .	o — — —	x — . . . —
h . . . .	p . — — .	y — . — — —
	q — — . —	z — — — . .

#### FIGURES

1 . — — — —	6 — . . . .
2 . . — — —	7 — — . . .
3 . . . — —	8 — — — . .
4 . . . . —	9 — — — — .
5 . . . . .	0 — — — — —

#### PUNCTUATION AND OTHER SIGNS

Period . . . . .	.	. — . . . —
Comma . . . . .	,	— — . . . —
Colon . . . . .	:	— — — . . .
Question mark, or request for repetition of a transmission not understood . . . . .	?	. . — . . . .
Apöstrophe . . . . .	'	. — — — — .
Dash or hyphen . . . . .	—	— . . . . —
Fraction bar . . . . .	/	— . . . .
Parenthesis (before and after words) . . . . .	( )	— . — — — . .
Underscore (before and after words or part of sentence) . . . . .		. . — — — —
Equal sign . . . . .	=	— . . . . —
Understood . . . . .		. . . . .
Error . . . . .		. . . . .
Cross or end of telegram or end of transmission . . . . .		. — . . . .
Invitation to transmit . . . . .		— . —
Wait . . . . .		. — . . . .
End of work . . . . .		. . . . .
Starting signal (beginning every transmission) . . . . .		— . — . —
Separation signal for transmission of fractional numbers (between the ordinary fraction and the whole number to be transmitted) and for groups consisting of figures and letters (between the figure groups and the letter groups) . . . . .		. — . . . —

## RADIO OPERATING QUESTIONS AND ANSWERS

TABLE 4.—INTERNATIONAL MORSE CODE.—(Continued)

The following optional letters and signals may be used exceptionally on connections between countries allowing them:

ä . — . —	ñ — — . — —
á or â . — — . —	ö — — — .
ch — — — —	ü . . — —
é . . — . .	

In transmitting numbers involving a fraction, the separation signal must, in order to avoid confusion, be transmitted before or after the fraction, as the case may be.

*Examples.* Instead of  $1\frac{1}{16}$ , transmit 1 . — . . —  $\frac{1}{16}$  in order not to have it read  $1\frac{1}{16}$ ; instead of  $\frac{3}{4}$  8, transmit  $\frac{3}{4}$  . — . . — 8 in order not to have it read  $\frac{3}{4}$  8; instead of  $2\frac{1}{2}$  2, transmit 2 . — . . —  $\frac{1}{2}$  . — . . — 2 in order not to have it read  $2\frac{1}{2}$ .

A group consisting of figures and letters must be transmitted by inserting the separation signal (. — . . —) between the figure group and the letter group.

## APPENDIX II\*

### PART 13.—RULES GOVERNING COMMERCIAL RADIO OPERATORS

#### GENERAL

**13.1. Licensed operators required.**<sup>1</sup>—Unless otherwise specified by the Commission, the actual operation of any radio station for which a station license is required shall be carried on only by a licensed radio operator of the required class.<sup>2</sup>

**13.2. Classes of licenses.**—The classes of commercial operator licenses issued by the Commission are:

- a. Commercial radiotelephone group:
  1. Radiotelephone second-class operator license.
  2. Radiotelephone first-class operator license.
- b. Commercial radiotelegraph group:
  1. Radiotelegraph second-class operator license.
  2. Radiotelegraph first-class operator license.
- c. Restricted commercial group:
  1. Restricted radiotelephone operator permit.
  2. Restricted radiotelegraph operator permit.

**13.3. Dual holding of licenses.**—A person may not hold more than one radiotelegraph operator license (or restricted radiotelegraph permit) and one radiotelephone operator license (or restricted radiotelephone operator permit) at the same time.

**13.4. Term of licenses.**—Commercial operator licenses are normally issued for a term of 5 years from the date of issuance.

#### APPLICATIONS

**13.11. Procedure.**—The application form in duplicate for operator license, properly completed and signed, shall be submitted in person

\* Reprinted from the FCC publication, "Rules Governing Commercial Radio Operators."

<sup>1</sup> Wherever the term "license" is used generally to denote an authorization from the Commission, it includes both "license" and "permit."

<sup>2</sup> See Sec. 13.61.

or by mail to the office at which the applicant desires to be examined, which office will make the final arrangements for conducting the examination. If the application is for renewal of license,<sup>1</sup> it must be submitted during the last year of the license term and if the service requirements are fulfilled<sup>2</sup> the renewal license may be issued by mail. A renewal application shall also be accompanied by the license to be renewed.

**13.12.<sup>3</sup> Special provisions, radiotelegraph first class.**—An applicant for the radiotelegraph first-class operator license must be at least 21 years of age at the time the license is issued and shall have had an aggregate of 1 year of satisfactory service as a radiotelegraph operator manipulating the key of a manually operated radiotelegraph station on board a ship or in a manually operated coastal telegraph station.

### EXAMINATIONS

**13.21. Examination elements.**—Written examinations will comprise questions from one or more of the following examination elements:

1. *Basic law.*—Provisions of law and regulation with which every operator should be familiar.

2. *Basic theory and practice.*—Technical matters appropriate for every class of license except restricted radiotelephone operator permit.

3. *Radiotelephone.*—Additional matters, both legal and technical, including radiotelephone theory and practice.

4. *Advanced radiotelephone.*—Theory and practice applicable to broadcast station operation.

5. *Radiotelegraph.*—Additional matters, both legal and technical, including radiotelegraph theory and practice.

6. *Advanced radiotelegraph.*—Radiotelegraph theory and practice of wider scope, particularly with respect to ship radio matters (direction finders, ship radiotelephone stations, spark transmitters, etc.).

<sup>1</sup> All outstanding radiotelegraph licenses bearing an endorsement granting privileges comparable with a radiotelephone license of any class shall be considered as two separate licenses and application for renewal thereof shall be made separately.

<sup>2</sup> See Sec. 13.28.

<sup>3</sup> Radiotelegraph first-class licenses now held by persons under 21 years of age may be renewed without regard to the age limit provided by Sec. 13.12.

**13.22. Examination requirements.**—Applicants for original licenses will be required to pass examinations as follows:

- a. Radiotelephone second-class operator license:
  1. Ability to transmit and receive spoken messages in English.
  2. Written examination elements: 1, 2, and 3.
- b. Radiotelephone first-class operator license:
  1. Ability to transmit and receive spoken messages in English.
  2. Written examination elements: 1, 2, 3, and 4.
- c. Radiotelegraph second-class operator license:
  1. Ability to transmit and receive spoken messages in English.
  2. Transmitting and receiving code test of sixteen (16) code groups per minute.
  3. Written examination elements: 1, 2, 5, and 6.
- d. Radiotelegraph first-class operator license:
  1. Ability to transmit and receive spoken messages in English.
  2. Transmitting and receiving code test of twenty-five (25) words per minute plain language and twenty (20) code groups per minute.
  3. Written examination elements: 1, 2, 5, and 6.
- e. Restricted radiotelephone operator permit:
  1. Ability to transmit and receive spoken messages in English.
  2. Written examination element: 1.
- f. Restricted radiotelegraph operator permit:
  1. Transmitting and receiving code text of sixteen (16) code groups per minute.
  2. Written examination elements: 1, 2, and 5.

**13.23. Form of writing.**—Written examinations shall be in English and shall be written by the applicant in longhand in ink, except that diagrams may be in pencil.

**13.24. Passing mark.**—A passing mark of 75 per cent of a possible 100 per cent will be required on each element of a written examination.

**13.25. New class, additional requirements.**—The holder of a license, who applies for another class of license, will be required to pass only the added examination elements for the new class of license.

**13.26. Canceling and issuing new licenses.**—If the holder of a license qualifies for a higher class in the same group, the license held will be canceled upon the issuance of the new license. Similarly, if the holder of a restricted operator permit qualifies for a first- or

## RADIO OPERATING QUESTIONS AND ANSWERS

second-class operator license of the corresponding type, the permit held will be canceled upon issuance of the new license.

**13.27. Eligibility for reexamination.**—An applicant who fails an examination element will be ineligible for 2 months<sup>1</sup> to take an examination for any class of license requiring that element. Examination elements will be graded in the order listed,<sup>2</sup> and an applicant may, without further application, be issued the class of license for which he qualifies.

**13.28. Renewal examinations and exceptions.**<sup>3</sup>—A license may be renewed without examination provided the service record on the license<sup>4</sup> shows at least 3 years' satisfactory service in the aggregate during the license term and while actually employed as a radio operator under that license; or shows at least 2 years' service in the aggregate, under the same conditions, of which 1 year must have been continuous and immediately prior to the date of application for renewal.

If the above requirements have not been fulfilled, but the service record shows at least 3 months' satisfactory service in the aggregate, while actually employed as a radio operator under the license during the last 3 years of the license term, a license may be renewed upon the successful completion of a renewal examination which may be taken at any time during the last year of the license term.

<sup>1</sup> A month after date is the same day of the following month, or if there is no such day, the last day of such month. This principle applies for other periods. For example, in the case of the 2-month period to which this note refers, an applicant examined December 1 may be reexamined February 1, and an applicant examined December 29, 30, or 31 may be reexamined the last day of February, while one examined February 28 may be reexamined April 28.

<sup>2</sup> See Sec. 13.28.

<sup>3</sup> Paragraph (2) of rule 439 shall remain in effect with respect to renewals of 3-year licenses outstanding on July 1, 1939.

"RULE 439 (2) All operator licenses, except amateur, may be renewed without examination, provided—

"(a) The applicant has had 90 days' satisfactory service during the 6-month period prior to the date the application for renewal of license is due to be filed, namely, 60 days prior to the expiration date, or

"(b) The applicant has had at least 12 months' satisfactory service during the license term prior to the date the application for renewal of license is due to be filed."

<sup>4</sup> See Secs. 13.91 to 13.94, inclusive.

## APPENDIX II

Renewal examinations will consist of the same elements as for original licenses. However, the written examination will be directed toward a determination of the applicant's qualifications to continue to hold the license for which he has previously qualified. If the renewal examination is not successfully completed before expiration of the license sought to be renewed, or if the service is not acceptable, the applicant will be examined as for the original license.

### CODE TESTS

**13.41. Transmitting speed requirements.**—An applicant is required to transmit correctly in the International Morse Code for 1 minute at the rate of speed prescribed in these rules for the class of license desired.

**13.42. Transmitting test procedure.**—Transmitting tests shall be performed by the use of the conventional Morse key except that a semi-automatic key, if furnished by the applicant, may be used in transmitting code tests of 25 words per minute.

**13.43. Receiving speed requirements.**—An applicant is required to receive the International Morse Code by ear, and legibly transcribe consecutive words or code groups for a period of 1 minute without error at the rate of speed specified in the rules for the class of license for which application is made.

**13.44. Receiving test procedure.**—Receiving code tests shall be written in longhand either in ink or pencil except that in the case of the 25 words per minute code test, a typewriter may be used when furnished by the applicant.

**13.45. Computing word or code groups.**—Each five characters shall be counted as one word or code group. Punctuation marks or figures count as two characters.

### SCOPE OF AUTHORITY

**13.61. Operators' authority.**—The various classes of commercial operator licenses issued by the Commission authorize the holders thereof to operate radio stations, except amateur, as follows:

*a. Radiotelephone second-class operator license.*—Any station while using type A-0, A-3, A-4, or A-5 emission except standard broadcast stations, International Broadcast stations, or ship stations licensed to use power in excess of 100 watts and type A-3 emission for communication with coastal telephone stations.

## RADIO OPERATING QUESTIONS AND ANSWERS

b. *Radiotelephone first-class operator license.*—Any station while using type A-0, A-3, A-4, or A-5 emission except ship stations licensed to use a power in excess of 100 watts and type A-3 emission for communication with coastal telephone stations.

c. *Radiotelegraph second-class operator license.*—Any station while using type B, A-0, A-1, A-2, A-3, or A-4 emission except—

1. Any of the various classes of broadcast stations other than a relay broadcast station, or
2. On a passenger<sup>1</sup> vessel required by treaty or statute to maintain a continuous radio watch by operators or on a vessel having continuous hours of service for public correspondence, the holder of this class of license may not act as chief operator.
3. On a vessel (other than a vessel operated exclusively on the Great Lakes) required by treaty or statute to be *equipped* with a *radiotelegraph* installation, the holder of this class license may not act as chief or sole operator until he has had at least 6 months' satisfactory service as a qualified radiotelegraph operator on a vessel of the United States.

d. *Radiotelegraph first-class operator license.*—Any station while using type B, A-0, A-1, A-2, A-3, or A-4 emission except—

1. Any of the various classes of broadcast stations other than a relay broadcast station.
2. On a cargo vessel (other than a vessel operated exclusively on the Great Lakes) required by treaty or statute to be *equipped* with a *radiotelegraph* installation, the holder of this class license may not act as chief or sole operator until he has had at least 6 months' satisfactory service as a qualified radiotelegraph operator on a vessel of the United States.

e. *Restricted radiotelephone operator permit.*—Any station while using type A-0, A-3, or A-4 emission: *Provided, That*—

1. Such operator is prohibited from making adjustments that may result in improper transmitter operation.
2. The equipment is so designed that none of the operations necessary to be performed during the course of normal

<sup>1</sup> A ship shall be considered a passenger ship if it carries or is licensed or certificated to carry more than 12 passengers. A cargo ship means any ship not a passenger ship.



## APPENDIX II

rendition of service may cause off-frequency operation or result in any unauthorized radiation.

3. Any needed adjustments of the transmitter that may affect the proper operation of the station are regularly made by or in the presence of an operator holding a first or second class license, either telephone or telegraph, who shall be responsible for the proper operation of the equipment.

### Exceptions:

1. The permit is not valid for the operation of any of the various classes of broadcast stations other than a relay broadcast station.
2. The permit is not valid for the operation of a coastal telephone station or a coastal harbor station other than in the Territory of Alaska.
3. The permit is not valid for the operation of a ship station licensed to use type A-3 emission for communication with coastal telephone stations.

*f. Restricted radiotelegraph operator permit.*—Any station while using type B, A-0, A-1, A-2, A-3, or A-4 emission: *Provided, That,* in the case of equipment designed for and using type A-3 or A-4 emission—

1. Such operator is prohibited from making adjustments that may result in improper transmitter operation.
2. The equipment is so designed that none of the operations necessary to be performed during the course of normal rendition of service may cause off-frequency operation or result in any unauthorized radiation.
3. Any needed adjustments of the transmitter which may affect proper operation of the station are regularly made by or in the presence of an operator holding a first or second class license, either telephone or telegraph, who shall be responsible for the proper operation of the equipment.

### Exceptions:

1. The permit is not valid for the operation of any of the various classes of broadcast stations other than a relay broadcast station.
2. The permit is not valid for the operation of a ship station licensed to use type A-3 emission for communication with coastal telephone stations.

## RADIO OPERATING QUESTIONS AND ANSWERS

3. The license is not valid for the operation of a radiotelegraph station on board a vessel required by treaty or statute to be equipped with a radio installation.
4. The license is not valid for the operation of any ship telegraph, coastal telegraph, or marine-relay station open to public correspondence.

**13.62. Special privileges.**—(a) Any operator may operate any station in the experimental service, while using frequencies above 300,000 kilocycles.

b. Subject to the limitations set forth herein,<sup>1</sup> the holder of any class radiotelephone operator license may operate a radiotelephone point-to-point station, a coastal harbor, or coastal telephone station while using A-1 or A-2 emission, for testing or other transmission entirely secondary and incidental to the service of such station.

**13.63. Operator's responsibility.**—The licensed operator responsible for the maintenance of a transmitter may permit other persons to adjust a transmitter in his presence for the purpose of carrying out tests or making adjustments requiring specialized knowledge or skill, provided that he shall not be relieved thereby from responsibility for the proper operation of the equipment.

### MISCELLANEOUS

**13.71. Issue of duplicate license.**—An operator whose license or permit has been lost, mutilated, or destroyed, shall immediately notify the Commission. A sworn application for duplicate should be submitted to the office of issue embodying a statement attesting to the facts thereof. If a license has been lost, the applicant must state that reasonable search has been made for it, and further, that in the event it be found either the original or the duplicate will be returned for cancelation. The applicant must also give a statement of the service that has been obtained under the lost license.

**13.72. Exhibiting signed copy of application.**—When a duplicate operator license or permit has been requested, or request for renewal upon service has been made, the operator shall exhibit in lieu thereof a signed copy of the application for duplicate, or renewal, which has been submitted by him.

**13.73. Supervision of examinations for permit.**—Persons other than employees of the Commission may be authorized to supervise

<sup>1</sup> Section 13.61.

## APPENDIX II

examinations for Restricted Radiotelephone Operator Permits for one or more employees of a division of local or State Government:  
*Provided—*

a. That the absence of such employees for the purpose of taking an examination at a field office or designated examining city would interfere with the proper functioning of the division, and

b. That the chief of police, director of public safety, or other official of equal responsibility furnish the names of the persons to be examined and designate an official by name and title to supervise the examination. The application for supervisory examination shall be made to the inspector in charge of the district in which the applicants are located.

**13.74. Verification card.**—The holder of an operator license who operates any station in which the posting of an operator license is not required, may, upon filing application<sup>1</sup> in duplicate, accompanied by his license, obtain a Verification Card.<sup>2</sup> This card may be carried on the person of the operator in lieu of the original operator license: *Provided*, The license is readily accessible within a reasonable time for inspection upon demand by an authorized Government representative.

**13.75. Posting license or verified statement.**—The holder of a radiotelegraph or radiotelephone first or second class license who is employed as a service and maintenance operator at stations operated by holders of Restricted Operator Permits shall post at such station his operator license or a verified statement from the Commission<sup>3</sup> in lieu thereof.

### SERVICE

**13.91. Endorsement of service record.**—A station licensee, or his duly authorized agent, or the master of a vessel acting as the agent of a licensee, shall endorse the service record appearing on said operator license, showing the call letters and types of emission of the station operated, the nature and period of employment, and quality of performance of duty.

**13.92. Aviation service endorsement.**—If the operator has operated more than three stations in the aviation service, the service may be shown by giving the name of the aviation chain or company in lieu of listing the call letters of the several stations.

<sup>1</sup> Form 756.

<sup>2</sup> Form 758-F.

<sup>3</sup> Form 759.

## RADIO OPERATING QUESTIONS AND ANSWERS

**13.93. Service acceptability.**—Credit will be allowed only for satisfactory service obtained under conditions that required the employment of licensed operators, or when obtained at United States Government stations.

**13.94. Statement in lieu of service endorsement.**—The holder of a radiotelegraph license or a restricted radiotelegraph operator permit desiring an endorsement to be placed thereon attesting to an aggregate of at least 6 months' satisfactory service as a qualified operator on a vessel of the United States, may, in the event documentary evidence cannot be produced, submit to any office of the Commission a statement under oath accompanied by the license to be endorsed, embodying the following:

- a. Names of ships at which employed
- b. Call letters of stations.
- c. Types of emission used.
- d. Type of service performed as follows.
  1. Manual radiotelegraph operation only; and
  2. Transmitter control only; or
  3. Combination of (1) and (2) running concurrently.
- e. Whether service was satisfactory or unsatisfactory.
- f. Period of employment.
- g. Name of master, employer, licensee, or his duly authorized agent.

## APPENDIX III

### EXTRACTS FROM RADIO LAWS

Extracts of the Communications Act of 1934, as amended

SECTION 1. For the purpose of regulating interstate and foreign commerce in communication by wire and radio so as to make available, so far as possible, to all the people of the United States a rapid, efficient, Nation-wide, and world-wide wire and radio communication service with adequate facilities at reasonable charges, for the purpose of the national defense, for the purpose of promoting safety of life and property through the use of wire and radio communication, and for the purpose of securing a more effective execution of this policy by centralizing authority heretofore granted by law to several agencies and by granting additional authority with respect to interstate and foreign commerce in wire and radio communication, there is hereby created a Commission to be known as the "Federal Communications Commission," which shall be constituted as hereinafter provided and which shall execute and enforce the provisions of this act.

SEC. 301. It is the purpose of this Act, among other things, to maintain the control of the United States over all the channels of interstate and foreign radio transmission; and to provide for the use of such channels, but not the ownership thereof, by persons for limited periods of time, under licenses granted by Federal authority, and no such license shall be construed to create any right, beyond the terms, conditions, and periods of the license. No person shall use or operate any apparatus for the transmission of energy or communications or signals by radio (a) from one place in any Territory or possession of the United States or in the District of Columbia to another place in the same Territory, possession, or district; or (b) from any State, Territory, or possession of the United States, or from the District of Columbia to any other State, Territory, or possession of the United States; or (c) from any place in any State, Territory, or possession of the United States, or in the District of Columbia, to any place in any foreign country or to any vessel; or (d) within any State when

## RADIO OPERATING QUESTIONS AND ANSWERS

the effects of such use extend beyond the borders of said State, or when interference is caused by such use or operation with the transmission of such energy, communications, or signals from within said State to any place beyond its borders, or from any place beyond its borders to any place within said State, or with the transmission or reception of such energy, communications, or signals from and/or to places beyond the borders of said State; or (e) upon any vessel or aircraft of the United States; or (f) upon any other mobile stations within the jurisdiction of the United States, except under and in accordance with this Act and with a license in that behalf granted under the provisions of this Act.

SEC. 303. Except as otherwise provided in this Act, the Commission from time to time, as public convenience, interest, or necessity requires, shall—

(1) Have authority to prescribe the qualifications of station operators, to classify them according to the duties to be performed, to fix the forms of such licenses, and to issue them to such citizens of the United States as the Commission finds qualified;

(m) (1) Have authority to suspend the license of any operator upon proof sufficient to satisfy the Commission that the licensee—

(A) Has violated any provision of any Act, treaty, or convention binding on the United States which the Commission is authorized to administer, or any regulation made by the Commission under any such Act, treaty, or convention; or

(B) Has failed to carry out a lawful order of the master or person lawfully in charge of the ship or aircraft on which he is employed; or

(C) Has willfully damaged or permitted radio apparatus or installations to be damaged; or

(D) Has transmitted superfluous radio communications or signals or communications containing profane or obscene words, language, or meaning, or has knowingly transmitted—

(1) False or deceptive signals or communications, or

(2) A call signal or letter which has not been assigned by proper authority to the station he is operating; or

(E) Has willfully or maliciously interfered with any other radio communications or signals; or

(F) Has obtained or attempted to obtain, or has assisted another to obtain or attempt to obtain, an operator's license by fraudulent means.

### APPENDIX III

(2) No order of suspension of any operator's license shall take effect until fifteen days' notice in writing thereof, stating the cause for the proposed suspension, has been given to the operator licensee who may make written application to the Commission at any time within said fifteen days for a hearing upon such order. The notice to the operator licensee shall not be effective until actually received by him, and from that time he shall have fifteen days in which to mail the said application. In the event that physical conditions prevent mailing of the application at the expiration of the fifteen-day period, the application shall then be mailed as soon as possible thereafter, accompanied by a satisfactory explanation of the delay. Upon receipt by the Commission of such application for hearing, said order of suspension shall be held in abeyance until the conclusion of the hearing which shall be conducted under such rules as the Commission may prescribe. Upon the conclusion of said hearing the Commission may affirm, modify, or revoke said order of suspension.

(n) Have authority to inspect all radio installations associated with stations required to be licensed by any Act or which are subject to the provisions of any Act, treaty, or convention binding on the United States, to ascertain whether in construction, installation, and operation they conform to the requirements of the rules and regulations of the Commission, the provisions of any Act, the terms of any treaty or convention binding on the United States, and the conditions of the license or other instrument of authorization under which they are constructed, installed, or operated.

(r) Make such rules and regulations and prescribe such restrictions and conditions, not inconsistent with law, as may be necessary to carry out the provisions of this Act, or any international radio or wire communications treaty or convention, or regulations annexed thereto, including any treaty or convention insofar as it relates to the use of radio, to which the United States is or may hereafter become a party.

SEC. 318. The actual operation of all transmitting apparatus in any radio station for which a station license is required by this Act shall be carried on only by a person holding an operator's license issued hereunder, and no person shall operate any such apparatus in such station except under and in accordance with an operator's license issued to him by the Commission: *Provided, however,* That the Commission if it shall find that the public interest, convenience, or neces-

## RADIO OPERATING QUESTIONS AND ANSWERS

sity will be served thereby may waive or modify the foregoing provisions of this section for the operation of any station except (1) stations for which licensed operators are required by international agreement, (2) stations for which licensed operators are required for safety purposes, (3) stations engaged in broadcasting and (4) stations operated as common carriers on frequencies below thirty thousand kilocycles: *Provided further*, That the Commission shall have power to make special regulations governing the granting of licenses for the use of automatic radio devices and for the operation of such devices.

SEC. 321. (a) The transmitting set in a radio station on shipboard may be adjusted in such a manner as to produce a maximum of radiation, irrespective of the amount of interference which may thus be caused, when such station is sending radio communications or signals of distress and radio communication relating thereto.

(b) All radio stations, including Government stations and stations on board foreign vessels when within the territorial waters of the United States, shall give absolute priority to radio communications or signals relating to ships in distress; shall cease all sending on frequencies which will interfere with hearing a radio communication or signal of distress, and, except when engaged in answering or aiding the ship in distress, shall refrain from sending any radio communications or signals until there is assurance that no interference will be caused with the radio communications or signals relating thereto, and shall assist the vessel in distress, so far as possible, by complying with its instructions.

SEC. 322. Every land station open to general public service between the coast and vessels or aircraft at sea shall, within the scope of its normal operations, be bound to exchange radio communications or signals with any ship or aircraft station at sea; and each station on shipboard or aircraft at sea shall, within the scope of its normal operations, be bound to exchange radio communications or signals with any other station on shipboard or aircraft at sea or with any land station open to general public service between the coast and vessels or aircraft at sea: *Provided*, That such exchange of radio communication shall be without distinction as to radio systems or instruments adopted by each station.

SEC. 325. (a) No person within the jurisdiction of the United States shall knowingly utter or transmit, or cause to be uttered or transmitted, any false or fraudulent signal of distress, or communica-



### APPENDIX III

tion relating thereto, nor shall any broadcasting station rebroadcast the program or any part thereof of another broadcasting station without the express authority of the originating station.

SEC. 326. Nothing in this Act shall be understood or construed to give the Commission the power of censorship over the radio communications or signals transmitted by any radio station, and no regulation or condition shall be promulgated or fixed by the Commission which shall interfere with the right of free speech by means of radio communication. No person within the jurisdiction of the United States shall utter any obscene, indecent, or profane language by means of radio communication.

SEC. 358. The radio installation, the operators, the regulation of their watches, the transmission and receipt of messages, and the radio service of the ship except as they may be regulated by law or international agreement, or by rules and regulations made in pursuance thereof, shall in the case of a ship of the United States be under the supreme control of the master.

SEC. 501. Any person who willfully and knowingly does or causes or suffers to be done any act, matter, or thing, in this Act prohibited or declared to be unlawful, or who willfully and knowingly omits or fails to do any act, matter, or thing in this Act required to be done, or willfully and knowingly causes or suffers such omission or failure, shall, upon conviction thereof, be punished for such offense, for which no penalty (other than a forfeiture) is provided herein, by a fine of not more than \$10,000 or by imprisonment for a term of not more than two years, or both.

SEC. 502. Any person who willfully and knowingly violates any rule, regulation, restriction, or condition made or imposed by the Commission under authority of this Act, or any rule, regulation, restriction, or condition made or imposed by any international radio or wire communications treaty or convention, or regulations annexed thereto, to which the United States is or may hereafter become a party, shall, in addition to any other penalties provided by law, be punished, upon conviction thereof, by a fine of not more than \$500 for each and every day during which such offense occurs.

SEC. 605. No person receiving or assisting in receiving, or transmitting, or assisting in transmitting, any interstate or foreign communication by wire or radio shall divulge or publish the existence, contents, substance, purport, effect, or meaning thereof, except

## RADIO OPERATING QUESTIONS AND ANSWERS

through authorized channels of transmission or reception, to any person other than the addressee, his agent, or attorney, or to a person employed or authorized to forward such communication to its destination, or to proper accounting or distributing officers of the various communicating centers over which the communication may be passed, or to the master of a ship under whom he is serving, or in response to a subpoena issued by a court of competent jurisdiction, or on demand of other lawful authority; and no person not being authorized by the sender shall intercept any communication and divulge or publish the existence, contents, substance, purport, effect, or meaning of such intercepted communication to any person; and no person not being entitled thereto shall receive or assist in receiving any interstate or foreign communication by wire or radio and use the same or any information therein contained for his own benefit or for the benefit of another not entitled thereto; and no person having received such intercepted communication or having become acquainted with the contents, substance, purport, effect, or meaning of the same or any part thereof, knowing that such information was so obtained, shall divulge or publish the existence, contents, substance, purport, effect, or meaning of the same or any part thereof, or use the same or any information therein contained for his own benefit or for the benefit of another not entitled thereto: *Provided*, That this section shall not apply to the receiving, divulging, publishing, or utilizing the contents of any radio communication broadcast, or transmitted by amateurs or others for the use of the general public, or relating to ships in distress.

### INTERNATIONAL TELECOMMUNICATION CONVENTION, MADRID, 1932

#### ARTICLE 24

§1. The contracting governments agree to take all the measures possible, compatible with the system of telecommunication used, with a view to insuring the secrecy of international correspondence.

#### ARTICLE 34

§1. Stations carrying on radio communications in the mobile service shall be bound, within the scope of their normal operation, to exchange radio communications with one another irrespective of the radio system they have adopted.

## APPENDIX III

### ARTICLE 35

§1. All stations, regardless of their purpose, must, so far as possible, be established and operated in such a manner as not to interfere with the radio services or communications of either the other contracting governments, or the private operating agencies recognized by these contracting governments and of other duly authorized operating agencies which carry on radio-communication service.

### ARTICLE 36

Stations participating in the mobile service shall be obliged to accept, with absolute priority, distress calls and messages regardless of their origin, to reply in the same manner to such messages, and immediately to take such action in regard thereto as they may require.

### ARTICLE 37

The contracting governments agree to take the steps required to prevent the transmission or the putting into circulation of false or deceptive distress signals or distress calls, and the use, by a station, of call signals which have not been regularly assigned to it.

## GENERAL RADIO REGULATIONS (CAIRO REVISION, 1938)

Annexed to the International Telecommunications Convention  
(Madrid 1932)

### ARTICLE 2

44 The administrations agree to take the necessary measures to prohibit and prevent:

45 (a) the unauthorized interception of radio communications not intended for the general use of the public;

45 (b) the divulging of the contents or of the mere existence, the publication or any use whatever, without authorization, of the radio communication mentioned in No. 45.

### ARTICLE 3

47 §1. (1) No transmitting station may be established or operated by any person or by any enterprise whatever without a special license issued by the government of the country to which the station in question is subject.

## RADIO OPERATING QUESTIONS AND ANSWERS

### ARTICLE 6

69 §1. The waves emitted by a station must be kept on the authorized frequency as exactly as the state of the art permits, and their radiation must be as free as practically possible from all emissions not essential to the type of communication carried on.

71 §2. (1) The state of the art in the various cases of operation is defined in appendixes 1, 2, and 3, concerning the exactitude of the frequency, the level of harmonics, and the width of the frequency band occupied.

76 §3. (1) The administrations shall frequently check the waves emitted by the stations under their jurisdiction to determine whether or not they comply with the provisions of the present Regulations.

### ARTICLE 9

203 §2. The frequency of emission of mobile stations shall be verified as often as possible by the inspection service to which they are subject.

### ARTICLE 11

276 §1. The radio service of a mobile station shall be placed under the supreme authority of the master or the person responsible for the ship, aircraft, or any other vehicle carrying the mobile station.

278 §3. The master or responsible person as well as any persons who may have knowledge of the text or simply the existence of radio-telegrams, or of any information acquired by means of the radio service, shall be bound by the obligation to observe and insure the secrecy of the correspondence.

### ARTICLE 12

279 §1. (1) The competent governments or administrations of countries, where a mobile station calls, may demand the production of the license. The operator of the mobile station or the person responsible for the station must submit to this verification. The license must be kept in such a way that it may be furnished without delay. However, the production of the license may be replaced by a permanent posting in the station, of a copy of the license certified by the authority which has granted it.

## APPENDIX III

### ARTICLE 17

374 §2. (1) Before transmitting, any station must keep watch over a sufficient interval to assure itself that it will cause no harmful interference with the transmissions being made within its range; if such interference is likely, the station shall await the first stop in the transmission which it may disturb.

### ARTICLE 22

525 §1. (1) The transmission of unnecessary or unidentified signals or correspondence shall be forbidden to all stations.

527 (2) Tests and experiments shall be permitted in mobile stations if they do not interfere with the service of other stations. As for stations other than mobile stations, each administration shall judge, before authorizing them, whether or not the proposed tests or experiments are likely to interfere with the service of other stations.

### ARTICLE 24

542 1. No provision of these Regulations shall prevent a mobile station in distress from using any means available to it for drawing attention, signalling its position, and obtaining help.

548 3. (2) Aircraft. Any aircraft in distress must transmit the distress call on the watching-wave of the land or mobile stations capable of helping it; when the call is addressed to stations of the maritime service, the waves to be used are the distress-wave or watching-wave of these stations.

549 §4. (1) In radiotelegraphy, the distress signal shall consist of the group . . . — — — . . . , transmitted as one signal, in which the dashes must be emphasized so as to be distinguished clearly from the dots.

550 In radiotelephony, the distress signal shall consist of the spoken expression Mayday (corresponding to the French pronunciation of the expression "m'aidez").

551 (2) These distress signals shall announce that the ship, aircraft, or any other vehicle which sends the distress signal is threatened by serious and imminent danger and requests immediate assistance.

555 §5. (4) This call shall have absolute priority over other transmissions. All stations hearing it must immediately cease all transmission capable of interfering with the distress traffic and must

## RADIO OPERATING QUESTIONS AND ANSWERS

listen on the wave used for the distress call. This call must not be sent to any particular station and shall not require an acknowledgment of receipt.

556 §6. (1) The distress call must be followed as soon as possible by the distress message. This message shall include the distress call followed by the name of the ship, aircraft, or the vehicle in distress, information regarding the position of the latter, the nature of the help requested, and any other further information which might facilitate this assistance.

557 (2) When, in its distress message, an aircraft is unable to signal its position, it shall endeavor after the transmission of the incomplete message to send its call signal long enough so that the radio direction-finding stations may determine its position.

558 §7. (1) As a general rule, a ship or aircraft at sea shall signal its position in latitude and longitude (Greenwich) using figures, for the degrees and minutes, accompanied by one of the words North or South and one of the words East or West. A period shall separate the degrees from the minutes. In some cases, the true bearings and the distance in nautical miles from some known geographical point may be given.

560 (3) As a general rule, an aircraft flying over land shall signal its position by the name of the nearest locality, its approximate distance from this point, accompanied, according to the case, by one of the words North, South, East, or West, or, in some cases, words indicating intermediate directions.

561 §8. The distress call and message shall be sent only by order of the master or person responsible for the ship, aircraft, or other vehicle carrying the mobile station.

569 §11. (1) Stations of the mobile service which receive a distress message from a mobile station which is unquestionably in their vicinity, must acknowledge receipt thereof at once (see Nos. 587, 588, and 589). If the distress call has not been preceded by an auto-alarm signal, these stations may transmit this auto-alarm signal with the authorization of the authority responsible for the station (for mobile stations, see No. 276), taking care not to interfere with the transmission of the acknowledgment of the receipt of said message by other stations.

570 (2) Stations of the mobile service which receive a distress message from a mobile station which unquestionably is not in their vicinity, must wait a short period of time before acknowledging

### APPENDIX III

receipt thereof, in order to make it possible for stations nearer to the mobile station in distress to answer and acknowledge receipt without interference.

573 §14. The control of distress traffic shall devolve upon the mobile station in distress or upon the mobile station which, by application of the provisions of No. 567, has sent the distress call. These stations may delegate the control of the distress traffic to another station.

604 §22. (2) In radiotelephony the urgent signal shall consist of three transmissions of the expression PAN (corresponding to the French pronunciation of the word "panne"); it shall be transmitted before the call.

605 (3) The urgent signal shall indicate that the calling station has a very urgent message to transmit concerning the safety of a ship, an aircraft, or another vehicle, or concerning the safety of some person on board or sighted from on board.

606 (4) In the aeronautical service, the urgent signal PAN shall be used in radiotelegraphy and in radiotelephony to indicate that the aircraft transmitting it is in trouble and is forced to land, but that it is not in need of immediate help. This signal should, so far as possible, be followed by a message giving additional information.

607 (5) The urgent signal shall have priority over all other communications, except distress communications, and all mobile or land stations hearing it must take care not to interfere with the transmission of the message which follows the urgent signal.

608 (6) In case the urgent signal is used by a mobile station, this signal must, as a general rule, subject to the provisions of No. 606, be addressed to a definite station.

612 §25. (1) The urgent signal may be transmitted only with the authorization of the master or of the person responsible for the ship, aircraft, or any other vehicle carrying the mobile station.

613 (2) In the case of a land station, the urgent signal may be transmitted only with the approval of the responsible authority.

615 §26. (1) In radiotelegraphy, the safety signal shall consist of the group TTT, transmitted three times, with the letters of each group, as well as the consecutive groups, well separated. This signal shall be followed by the word DE and three transmissions of the call signal of the station sending it. It announces that this station is about to transmit a message concerning the safety of navigation or giving important meteorological warnings.

## RADIO OPERATING QUESTIONS AND ANSWERS

616 (2) In radiotelephony, the word Security (corresponding to the French pronunciation of the word "sécurité") repeated three times, shall be used as the safety signal.

619 §28. (2) All stations hearing the safety signal must continue listening on the wave on which the safety signal has been sent until the message so announced has been completed; they must moreover keep silence on all waves likely to interfere with the message.

### ARTICLE 26

#### *Order of Priority of Communications in the Mobile Service*

653. The order of priority of radio communications in the mobile service shall be as follows:

1. Distress calls, distress messages, and distress traffic;
2. Communications preceded by an urgent signal;
3. Communications preceded by a safety signal;
4. Communications relative to radio direction-finding bearings;
5. Government radiotelegrams for which priority right has not been waived;
6. All other communications.



# INDEX OF DIAGRAMS AND ILLUSTRATIONS

## ELEMENT 2

FIGURE	PAGE
2-1. Tuned-plate, tuned-grid, series-fed oscillator . . . . .	32
2-2. Hartley oscillators . . . . .	32
2-3. Armstrong tuned-grid, shunt-fed oscillator . . . . .	33
2-4. Tuned-plate, tuned-grid, shunt-fed oscillator . . . . .	33
2-5. Crystal oscillator . . . . .	34
2-6. Colpitts oscillator. . . . .	34
2-7. Armstrong series-fed oscillator . . . . .	35
2-8. Electron-coupled oscillator. . . . .	35
2-9. Pentode crystal oscillator . . . . .	36
2-10. Loud-speaker coupling system . . . . .	36
2-11. Loud-speaker coupling. . . . .	37
2-12. Resistance coupling. . . . .	37
2-13. Inductive or transformer coupling . . . . .	38
2-14. Impedance coupling. . . . .	38
2-15. Antenna coupling system . . . . .	39
2-16. Interstage coupling . . . . .	39
2-17. Interstage coupling and neutralization. . . . .	40
2-18. Diode detector . . . . .	40
2-19. Power detector. . . . .	41
2-20. Grid-leak detector. . . . .	41
2-21. Regenerative detector. . . . .	42
2-22. Radio-frequency doubler stage . . . . .	43
2-23. Parallel resistor connections . . . . .	44
2-24. Series-parallel resistor connections. . . . .	44
2-25. Parallel resistor connections . . . . .	44
2-26. Series resistor connections . . . . .	45
2-27. Carbon microphone circuit. . . . .	45
2-28. Vacuum-tube operating-curve adjustments. . . . .	52
2-29. Thermocouple ammeter . . . . .	68
2-30. Wattmeter connections . . . . .	69
2-31. Repulsion-type ammeter. . . . .	70
2-32. Electrodynamometer type of meter . . . . .	71
2-33. Grid biasing arrangement . . . . .	95

## RADIO OPERATING QUESTIONS AND ANSWERS

FIGURE	PAGE
2-34. Sine wave of voltage and current displacement . . . . .	100
2-35. Parallel resistor branch . . . . .	100
2-36. Vacuum-tube characteristic curve. . . . .	101
2-37. Sine wave illustrating one wavelength. . . . .	101

### ELEMENT 3

3-1. Plate-modulation system. . . . .	107
3-2. Carrier-wave envelope. . . . .	108
3-3. Microphone amplifier . . . . .	108
3-4. Suppressor grid-modulation system . . . . .	109
3-5. Grid-modulation system. . . . .	110
3-6. Hertz radiator-coupling arrangement . . . . .	117
3-7. Link-coupling system . . . . .	117
3-8. Neutralized push-pull radio-frequency amplifier. . . . .	118
3-9. Suppressor-grid-modulation system . . . . .	119
3-10. Dynatron oscillator. . . . .	132
3-11. Capacitive coupling arrangement . . . . .	142
3-12. Loftin-White direct-coupled amplifier . . . . .	143
3-13. Full-wave rectifier power supply . . . . .	157
3-14. Block diagram of a frequency-modulated receiver. . . . .	159
3-15. Block diagram of a frequency-modulated transmitter . . . . .	161
3-16. Absorption-type wavemeter . . . . .	164
3-17. Simple ohmmeter. . . . .	164
3-18. Block diagram of an amplitude-modulated superheterodyne receiver . . . . .	169
3-19. Wave-trap arrangements. . . . .	169
3-20. Tuned radio-frequency receiver (TRF). . . . .	170
3-21. One-tube audio-frequency oscillator arrangements. . . . .	171
3-22. Dipole (doublet) antenna systems. . . . .	172
3-23. Mechanical rectifiers . . . . .	172

### ELEMENT 4

4-1. Delta-star transformer connections . . . . .	185
4-2. Telephone-line equalizer. . . . .	190
4-3. Grid-bias modulated radio-frequency amplifier . . . . .	191
4-4. Class B modulation system. . . . .	192
4-5. Trapezoid patterns . . . . .	193
4-6. Carrier shift detector . . . . .	193
4-7. Capacitive-coupled amplifier with harmonic suppression . . . . .	198
4-8. Transmission-line coupling system. . . . .	199
4-9. Crystal-controlled oscillator with temperature control . . . . .	204

## INDEX OF DIAGRAMS AND ILLUSTRATIONS

FIGURE	PAGE
4-10. Bridge rectifier. . . . .	207
4-11. Balanced single-phase full-wave rectifier. . . . .	208
4-12. High-pass and low-pass filter network. . . . .	210
4-13. Multivibrator oscillator . . . . .	212
4-14. Shunt-fed plate arrangement. . . . .	216
4-15. Series-fed plate arrangement . . . . .	217
4-16. Voltage doubler system . . . . .	233
4-17. Inverse feedback arrangement . . . . .	234
4-18. Grounded-grid amplifier. . . . .	236
4-19. Automatic-volume-control (AVC) system . . . . .	244
4-20. Frequency-modulated detector . . . . .	250
4-21. Frequency-modulated transmitter . . . . .	253
4-22. Limiter stage. . . . .	253

### ELEMENT 5

5-1. Fundamental oscillating arc . . . . .	299
5-2. Fundamental spark transmitter . . . . .	299
5-3. Frequency-doubler arrangement . . . . .	299
5-4. Grid-block keying system . . . . .	308
5-5. Key click filters . . . . .	310
5-6. Transformer primary keying system. . . . .	310
5-7. Tungar-rectigon battery charger . . . . .	321
5-8. Rectifier and filter plate supply system . . . . .	321
5-9. Cold-cathode rectifier and voltage-regulator arrangements. . . . .	322
5-10. Frequency-modulated superheterodyne for reception of continuous-wave radiotelegraph signals . . . . .	326
5-11. Block diagram of a marine-type tuned radio-frequency receiver. . . . .	326
5-12. Pierce oscillator. . . . .	329
5-13. MOPA block diagram. . . . .	330
5-14. Frequency-modulated transmitter. . . . .	331

### ELEMENT 6

6-1. Dynamometer-type meter . . . . .	344
6-2. Emission characteristics . . . . .	347
6-3. Directional pattern of a loop antenna . . . . .	359
6-4. Directional pattern of a vertical antenna. . . . .	359
6-5. Back-shunt arc keying system . . . . .	363
6-6. Marine self-rectifying transmitter. . . . .	365
6-7. Loop antenna unilateral characteristics . . . . .	373
6-8. Series, shunt, and compound direct-current motor connections . . . . .	397
6-9. Self- and separately excited shunt-compound generators . . . . .	399

## RADIO OPERATING QUESTIONS AND ANSWERS

FIGURE	PAGE
6-10. Transformer connections. Open-V delta connection. . . . .	401
6-11. Construction of a storage cell. . . . .	402
6-12. Battery charge and discharge arrangement. . . . .	403
6-13. Superheterodyne receiver circuit diagram . . . . .	406
6-14. Shipboard antenna installation . . . . .	411
6-15. Block diagram of a radar transmitter and receiver. . . . .	415
6-16. Loran station arrangement and lines of position. . . . .	418
6-17. Direction-finder chart illustrating position or "fix" . . . . .	424

### ELEMENT 7

7-1. Principle of the omnidirectional range. . . . .	458
7-2. Principle of the low-frequency range facility, showing markers	465
7-3. Ground portion of the ILS system. . . . .	467
7-4. Block diagram of a Flux Gate compass system . . . . .	474
7-5. Principle of Consol facility. . . . .	479
7-6. Vector solution of a relative bearing problem. . . . .	505
7-7. Vector bearing solution . . . . .	508

## INDEX OF SUBJECTS

### A

"A" battery, 85

Abbreviations, message, 419-421,  
486-490

Absorption, wavemeter, 164, 335

Advanced bearing, 503

Aeronautical (*see* Aircraft)

Aerophare, 457

Aircraft radio, 427-511

distress frequencies, 434

navigation problems, 505-511

operating frequencies, 492-494

procedures, 480-505

regulations and treaty, 427-442

terms, 482, 483

theory, 442-480

Alternating current, ammeter, 68-  
70, 72

generators, 63, 398-400

problems, 102-106, 512-517

rectifiers, 65-67, 72

Ammeter, alternating current, 68-  
70, 72

connections, 72, 100

radio frequency, 68, 72

shunts, 73, 74

voltmeter, 70, 71, 73

Ampere turns, 25, 266

Amplification factor, 405

Amplifier, buffer, 99, 119, 304

class A, 56, 301

class B, 140

class C, 57

direct coupled, 143

distortion, 138, 377

Amplifier, efficiency, 139

frequency doubling, 42, 43, 57,  
119

grid bias, 56

grounded grid, 235

impedance coupled, 38

Loftin-White, 143

microphone, 108

MOPA, 120

neutralization, 93, 94, 102, 139

power, 116, 117

resistance coupled, 37

transformer coupled, 37, 38

troubles, 168

Antennas, Adcock type, 446

aircraft, 453, 454, 460, 472, 473

auxiliary, receiving, 358, 411

directional, characteristics of,  
81, 88, 158, 499

dummy, 123, 378

grounding of, 243

Hertz type of, 81, 117, 172

high gain, 246, 264

loop, 359, 443-450, 499

polarization effects of, 158, 159

power output of, 345

protection of, against lightning,  
242

receiving types of, 158

resonant frequency of, 81, 359

sense, 445, 499

shipboard, installation, 411

swinging, 286

top-loaded, 242

tower spacing of, 244

voltage distribution in, 172, 381

## RADIO OPERATING QUESTIONS AND ANSWERS

Approach control, 480-482  
 Arc generator, 298, 299, 362, 363  
 Aspect ratio, 262, 263  
 Audio-frequency amplifier, 36-38  
 Auto alarm, 371, 375, 376, 390,  
 394, 396, 425  
 Autosyn, 447  
 AVC, 244, 285

### B

"B" battery, 85, 401  
 Band width, effect of code speed  
 on, 330, 347  
 Battery, A-B-C types of, 85  
     charger, 321  
     current capacity, 19  
     Edison type, 59-61, 294, 367  
     lead cell type, 59, 75, 294, 402  
     primary, 59, 60  
     (See also Storage batteries)  
 Beacon, radio, 457, 490  
 Beam power tube, 152, 328, 394  
 Bearing, 502  
 Beat frequency, oscillator, 92, 214,  
 294  
     resultant effects of, 98, 213  
 Bias, calculation of, grid, 58  
     methods, 95  
 Blanking pulses, 261  
 Bleeder resistance, purpose of, 68,  
 130, 154, 293  
 Break-in, relay, 333, 358  
 Buffer amplifier, 304  
 By-pass condenser, 138

### C

"C" battery, 85  
 C/L Ratio, 99  
 Cable count, 421-423  
 Capacitance, charge stored in, 21  
     factors affecting, 20, 21, 28

Capacitance, problems 28, 29, 518,  
 519  
     unit of, 22  
 Carbon file, 450  
 Carrier shift, causes of 110, 122,  
 196, 197, 286, 311, 352  
     indicator, 193  
     permissible, 245  
 Cathode bias, 394  
 Cavity resonator, 166  
 Cells (see Battery)  
 Center frequency, 263  
 Characteristic impedance, 239-241  
 Choke coil, iron core, 128, 289  
     modulator, 350  
     radio frequency, 116, 156  
     shorted, radio frequency, 152  
     swinging type of, 130, 290  
 Circuit breakers, operation of, 452  
 Class A amplifier, 93, 138, 301  
     B amplifier, 93, 278, 279, 303  
     C amplifier, 57, 93, 215, 228,  
     236, 279, 280, 302, 303  
 Code, band-width, 330  
 Cold cathode, rectifier, 370  
     regulator, 322  
 Compass, deviation of, 505  
     error, 503  
     Flux Gate, 474-477  
     heading, 502  
 Condenser, by-pass, 138  
     connections, 131  
     electrolytic, testing of, 89  
     use of, 130, 293  
     problems, 28, 29, 518, 519  
     voltage ratings, 293  
     (See also Capacitance)  
 Conductance, definition of, 24, 234  
     problem, 96  
 Conductors, factors determining  
     resistance of, 20  
 Cone of silence, 465  
 Consol system, aircraft, 479

## INDEX OF SUBJECTS

Coulomb, definition of, 25  
 Coupling, antenna, systems, 39,  
     117, 191  
     capacitive, system, 142  
     excessive, 311, 379  
     feed-back, 120  
     interstage, 40  
     link, 58, 117  
     oscillator, 97, 98  
     unity, 142  
 Crystal, cleaning agent, 295  
     detectors, operation of, 82, 83  
     filter, 285, 325  
     microphone, 111  
     oscillators, 36, 132-134, 203, 204  
     substance used in detector, 281  
     temperature, coefficient of, 87,  
         132, 133, 245, 296  
 Current flow, electric, in cells, 18

### D

Decibel, definition of, 24, 25  
     problems, 194, 195, 198, 218,  
         219, 409, 522  
 Decoupling, network, 304, 395  
 Detection, crystal, 82, 83, 281  
     diode, 52, 55, 357  
     FM, 246  
     grid leak, 41, 52, 54-56, 276, 277  
     oscillator, 114  
     plate, 41, 116  
     power, 52, 53, 55  
     regenerative, 42, 114  
 Deviation ratio, 162  
 Dielectric, charge in, 28  
     constant, 19  
     materials, 19, 21  
 Diode (*see* Detection)  
 Direction finder (*see* Loop an-  
     tennas)  
 Directional antennas, 81, 88, 359  
 Discriminator, 246

Distortion, amplifier, 121  
 Doherty amplifier, 241, 242  
 Dummy antenna, purpose of, 123,  
     378  
 Dynamic instability, 110, 122  
 Dynamotor, construction of, 167  
     operation of, 167  
     use of, 342, 343  
 Dynatron oscillator, 132, 135

### E

Eddy currents, 338  
 Efficiency, definition of, 88  
     of vacuum tube amplifiers, 93,  
         201  
 Electrolyte, 266, 367, 368  
 Electrolytic condenser, 130, 292  
 Electromagnetic components, 266,  
     267  
 Electromotive force, amplitude of,  
     18  
     induced, 18  
     methods of generating, 18  
 Electron, definition of, 85  
     flow in plate circuit, 94  
 Electron-coupled oscillator, 35, 229  
 Electrostatic shield, 188  
 EMF (*see* Electromotive force)  
 Emission, types of, 147, 148, 313,  
     347  
 Energy, definition of, 84  
     problems, 154  
     stored in a magnetic field, 103, 104  
 Equalizer, 189, 190

### F

FCC Rules and Regulations (*see*  
     Radio laws)  
 Feedback, degenerative, 189, 234  
     regenerative, effects of, 42, 114

## RADIO OPERATING QUESTIONS AND ANSWERS

- Field frequency, 263  
Field strength, factors affecting, 21, 198  
    measurement of, 199, 241, 410  
Filament, center tap connection, 151, 324  
    construction of, 94, 275, 276  
    power supply, 53, 54  
    reactivation, 276  
    subnormal, emission, 122  
Filters, comparison of, 128, 129, 369  
    crystal, 325  
    key, 289  
    low-pass, 209, 290  
    operation of, power supply, 156, 157, 289  
    voltage regulation of, 125, 209, 210  
Fix, direction finder, 424, 497, 498, 500  
    instantaneous, 496  
    Loran, 416  
    running, 496  
Flux Gate compass, 474-477  
Fly-wheel effect, 273, 274  
Frequency, doubling, 42, 43, 57, 119, 249, 280, 287, 299, 330, 380  
    formulas, 30, 31, 362  
    frame, 262  
    generator, 362  
    measurements, 228, 229  
    meter, 137, 214  
    modulation, 151, 159-162, 194, 246-250, 253-257  
    shift, 110, 122, 333  
    tolerances, 225, 263, 265, 376
- G
- Generators, 63, 398-400  
    frequency of, alternating current, 362  
    Generators, hunting in, 366  
    Getter, definition of, 92  
    GMT, time differences, 383, 419  
    Great circle, 504  
    Grid, bias, 58, 95, 120, 154, 281  
        control, 280  
        grounded, amplifier, 236  
        leak resistance, 154, 276, 329  
    Grounded grid, amplifier, 235, 236
- H
- Harmonic, definition of, 83  
    radiation, 333  
    reduction of, energy, 121, 139, 307, 334  
    suppression circuit, 198, 199, 522  
Headphones, impedance of, 281  
    permanent magnets in, 312  
Heising modulation, 350  
Hertz antenna, 81, 117, 172  
Heterodyne, frequency meter, 214, 295  
Horizontal polarization, 158  
Hunting, 366, 447  
Hysteresis losses, 291, 338
- I
- Image frequency, 115, 285  
Impedance, matching, 80  
    problems, 96, 181, 185, 216, 239, 339, 340  
Inductance, definition of, 25  
    effect of iron core in, 29, 128  
    problems, 273  
    shorted turns in, 29, 112  
    unit of, 23  
Induction motor, 232, 399  
Inductive reactance, 105, 156, 343  
Instruments, alternating current, 69-71, 84, 344  
    connecting of, 11, 72



## INDEX OF SUBJECTS

- Instruments, D'Arsonval type, 68, 69  
 dynamometer type, 71  
 FCC requirements for, 245  
 milliammeter, 73  
 ohmmeter, simple, 164  
 problems relating to, 237, 267, 515  
 protection of, 289  
 repulsion type, 76, 71  
 resistance measuring, 22, 24  
 shunts for, 73  
 thermocouple type, 68, 72, 324, 344  
 voltmeter type, 70, 71, 73, 84, 238  
 wattmeter type, 69, 84, 345
- Insulators, guy wire, 166  
 material used in, 20, 82
- Interference, ignition, 167  
 reduction of, radio receivers, 163, 167, 354, 357
- Interlacing, 259
- Inverse feedback, 189, 234
- Inverse peak voltage, 209
- Ion, definition of, 85
- Isolation amplifier, aircraft, 470
- K
- Keying, filter, 289  
 frequency shift, 333  
 transmitter, 308-310, 382
- Klystron, applications of, 336  
 frequency range of, oscillator, 166, 335
- L
- Laws (*see* Radio laws)
- Lecher wires, 165
- Limiters, 215, 251, 253
- Link, coupling, 58, 117, 308
- Loftin-White direct-coupled amplifier, 143
- Loop antennas, aircraft, 443-449  
 antenna effect in, 374  
 construction of, 423, 424  
 directional pattern of, 359, 373  
 night effect in, 494  
 sense antenna, in connection with, 373, 374  
 shielding of, 374
- Loran, 415-419, 477, 478
- M
- Magnetic bearing, 502
- Magnetic field, effects, 21, 22  
 (*See also* Field strength)
- Magnetism, residual, 23, 267
- Magnetron, applications, 336  
 frequency range of, 166, 335
- Marker, bone-shaped, 462  
 fan-shaped, 462, 484  
 Z, 461, 462
- Mercator bearing, 502, 504
- Meters (*see* Instruments)
- Microphone, carbon, 79, 80, 111, 190  
 circuit arrangement, 45  
 crystal, 111  
 high impedance, 351  
 speech amplifier, 351, 352
- Milliammeter, 73, 165
- Mixer tube, 283
- Modulation, amplitude, 86, 107, 113, 151  
 class B, 112, 192, 194  
 comparison of, systems, 348  
 envelope, 108  
 frequency, 151, 159-162, 194, 247  
 grid, 110, 191  
 Heising system of, 349, 350  
 high level, 110, 225, 349, 378

## RADIO OPERATING QUESTIONS AND ANSWERS

- Modulation, high percentage, 112  
index, 162  
low level, 111, 194, 225, 379  
over, effects of, 113, 205  
percentage, in FM, 246-250, 265  
power, 152, 155, 193, 197, 205, 206, 226, 251, 346, 353  
reactance tube, 249, 253  
unsymmetrical, 243
- Monitor, picture tube, 258
- MOPA, block diagram of, transmitter, 330  
troubles in, transmitter, 379
- Motors, care of, 126  
characteristics of, 63, 126, 127, 232, 366, 397-400  
direct current, 63, 64, 397  
induction, 232  
problems, 342, 512  
sparking in, 64  
speed of, 64, 233  
starting resistors in, 127  
synchronous, 64, 513  
troubles in, 126, 292
- Multivibrator, 135, 136, 212, 213, 234, 297, 411
- Mutual conductance, 234, 235, 405
- N
- Navigation, aircraft, 505
- Neutralization, capacity, 102, 305, 313, 395  
circuits for, capacity, 40  
testing, 139, 141, 287, 288
- O
- Ocean station vessel, 490, 491
- Ohmmeter, simple, 164
- Ohms law, 25, 26, 31, 96
- Omnirange, 458
- Operational procedures, aircraft, 480-504
- Oscillator, Armstrong, 33, 35, 94  
audio-frequency, 171  
beat frequency, 92, 98, 114  
cavity, 166  
Colpitts, 34, 120  
crystal, 36, 132-134, 203, 204, 295, 365  
dynatron, 132, 288, 297, 306  
electron coupled, 35, 229, 298  
Hartley, 32, 120  
MOPA, 285, 365  
Pierce, 329  
stability, 97, 98  
tuned-plate tuned-grid, 32, 33
- P
- Pads, purpose of, 188
- Parallel, resistances in, 340  
resonance, 340
- Parasitic oscillations, 120, 121, 381
- Peak, power, 353
- Permeability, definition of, 22, 338
- Phase angle, 102, 231, 272
- Phase monitor, purpose of, 213, 214
- Pi network, 199, 394
- Pierce oscillator, 329
- Pitch, musical, 88
- Plate resistance, 405
- Polarization, 60  
horizontal and vertical, 158, 442
- Potential, difference of, 18
- Power, amplifier, 140, 198  
calculation of, 19, 30, 31, 100, 345  
definition of, 84  
dissipation, 19, 26  
factor, 24, 103, 156, 231, 272, 401  
filter, 156  
output, modulator, 112, 152, 205, 251, 346

## INDEX OF SUBJECTS

- Power, problems, 27, 28, 152, 155,  
195, 197, 200, 202, 267-270  
supply, operation of vacuum  
tube, 156, 157, 172
- Preamplifier, 137, 188
- Precipitation static, 454, 455
- Preheating, mercury vapor tube,  
323
- Problems, antenna, 239-241, 243,  
252, 260, 521-527  
battery, 323, 516  
condenser, 187, 514, 518, 519  
crystal oscillator, 312, 529  
decibel, 194, 195, 198, 523-533  
field strength, 410, 525-528  
frequency doubler, 249  
generator, 512-514  
heterodyne frequency meter, 528  
impedance, 181-183, 186, 239-  
241, 521  
Loran, 538  
meter, 515, 516  
modulator, 532  
motor, 342, 367, 400, 512  
mutual inductance, 181  
power, 27, 28, 152, 155, 195,  
197, 200, 202, 267-270, 521,  
532  
radar, 414, 415, 534-536  
reactance, 184, 404  
relay, 332  
resonant frequency, 187, 404,  
519, 520  
storage battery, 368, 516  
superheterodyne, 532  
transformer, 513, 514  
transmission line, 239-241, 251,  
413, 520, 534  
vacuum tube, 58, 313, 376, 377,  
516, 517  
voltage divider, 514, 515  
wavemeter, 528, 530
- Pulse, blanking, 261
- Pulse, radar, 414-416  
sync, 260
- Push-pull, advantages of, am-  
plification, 138, 278, 301, 394  
radio frequency, amplifier, 118
- ### Q
- Q, definition of, circuit, 230, 339  
Q signals, 390, 485-490  
Quadrantal error, 442, 445  
Quarter-wave transmission line, 240  
Quartz crystal (*see* Crystal)
- ### R
- Racon, 457
- Radar, antenna, speed of, 413  
beacons, 480  
block diagram of, system, 415  
problems, 413, 534  
reduction of, sea return, 413  
velocity of, waves, 414
- Radiation resistance, 105
- Radio frequency, ammeter, 68, 72  
amplifier, neutralizing of, 102,  
139, 141, 287  
atmospheric effects on, waves, 86  
choke coil, 116, 156  
excitation, 151, 287  
interference, 79  
spectrum, 86  
waves, velocity of, 80, 414
- Radio laws, aircraft, 146-149, 178,  
179, 427-442  
basic, 1-17  
broadcasting, 219-229, 254-257  
general, 143-151, 173-179, 263-  
265, 313-319, 337, 383-393,  
425, 426  
marine, 371-373, 383-393, 425,  
426  
television broadcast, 265

## RADIO OPERATING QUESTIONS AND ANSWERS

- Radio range, 456, 458, 461, 464-468
- Radio receivers, adjustment of, 91
- aircraft, 459
- AVC in, 115
- comparison of, sensitivity in, 74
- double detection type, 91, 326
- frequency modulation type, 159, 160, 247, 253
- image frequency in, 115
- interference in, reduction of, 163, 167
- Loran, 417, 538
- low sensitivity in, 74
- regenerative type, 90, 353-356
- static response in, 87
- superheterodyne, 90, 326
- superregenerative, 283
- squelch circuit in, 163
- troubles in, 74, 114, 115, 284, 378
- tuned radio frequency type of, 90, 114, 170, 283
- Ratio detector, 250
- Reactance, capacitive, 103, 181
- inductive, 104, 156, 181
- Rectifiers, arcbank in, 208
- bridge type, 207
- cold cathode type, 322, 370
- comparison of, 67, 124, 127, 370
- copper oxide, 72, 325
- crystal, 82, 83
- glow discharge type, 322
- inverse peak voltages in, 209
- mercury vapor, 66, 67
- ripple frequency in, 287
- synchronous, 125, 172
- trouble in, 131, 232
- Regenerative feedback, 114
- Regulation, power supply, 322
- voltage, 125, 129, 322, 343, 450
- Regulation and treaty, aircraft, 427-442
- Relative bearing, 502
- Relay, antenna, changeover, 473
- contacts, 82
- Reluctance, 30
- Residual magnetism, 23, 267
- Resistance, bleeder, 68, 180, 154, 293
- changes, 82
- factors determining, 19, 20
- grid bias, 58, 95, 120, 154
- measurements, 23
- multiplier, 73
- power dissipation in, 19
- problems, 23, 26, 232, 268-270, 514-516
- Resonant frequency, formula for, 30, 31
- effect on, adding inductance, 80
- adding capacitance, 80, 339
- series, problem, 106
- Rhumb line, 502
- Rules and regulations (*see* Radio laws)
- S
- Safety, precautions for, 96, 97
- Scanning, 258, 259
- Screen grid, purpose of, 280
- Sense antenna, 445
- SHF, 86
- Shielding, purpose of, 114, 121, 236, 274, 305, 307, 341, 374
- Shock excitation, 287
- Side bands, power in, 197, 198
- vestigial, 263
- Simplex operation, 494
- Sine wave, 100
- Skin effect, 105
- Slip, 232, 233
- Soldering flux, 83
- Sound, definition of, 88
- Spark transmitter, 299, 361, 407-409

## INDEX OF SUBJECTS

Specific gravity, 60, 85  
 Split tuning, 360  
 Squelch circuit, function of, 163  
 St. Elmo's fire, 456  
 S-T station, 264, 265  
 Storage batteries, 59-62, 75-78,  
     294, 367, 402, 403  
     care of, 76, 77, 294, 368  
     charging, 61, 62, 274, 367, 403  
     chemicals in, 59, 60  
     corrosion in, 78  
     discharge of, 61, 62, 78  
     Edison-type, 59, 61, 294, 367  
     electrolytes used in, 85, 294  
     problems relating to, 368, 516  
 Superheterodyne receiver, 90, 115,  
     169, 282, 326, 327, 405, 406,  
     531  
 Superregeneration, 283  
 Swinging choke, purpose of, 130,  
     290  
 Syne pulses, 260  
 Synchronous rectifier, 125

### T

Telephones, high resistance type  
     of, 79  
     polarity observation with, 79  
 Television, 258-265  
 Temperature, coefficient of, 132,  
     134, 213  
     controlled oscillator, 204, 213,  
         245, 296, 297  
     operating, in mercury vapor  
         tubes, 211  
 Thermocouple meter, 68, 72, 324,  
     344  
 Thyatron, 153  
 Time constant, 230, 231, 404  
 Time delay relay, purpose of, 211  
 Time signals, 492  
 Top-loaded antennas, 242

Track, 502  
 Traffic, aircraft, procedures for,  
     480-505  
     marine, procedures for, 419-426  
 Transformer, connections for, 156,  
     184, 401  
     core, 291  
     delta-wye type, 156, 185  
     efficiency, 274  
     grounding of, case, 341, 342  
     losses, 184, 291  
     modulation, 112  
     problems, 184, 274, 291, 513,  
         514  
     turns ratio, 341  
 Transmission line, coupling sys-  
     tem, 199  
     impedance, 239-241  
     problems, 239-241, 251, 521-  
         523  
     quarter wave, 240, 521  
 Transmitter, aircraft, 471  
     arc, 298, 299, 362, 363  
     comparison of, tube spark, 364  
     frequency modulation, 246-250,  
         331  
     MOPA, 330  
     pre-emphasis in, FM, 247  
     self-rectified, 364, 365  
     spark, 299, 361  
     tuning, precautions in, 288  
 TRF receiver, 170  
 True bearing, 502  
 True course, 502  
 Tungar-rectigon gas-filled tube,  
     153, 321  
 Twilight zone, 465

### U

UHF, 86  
 Units, capacitance, 22, 88  
     conductance, 23

## RADIO OPERATING QUESTIONS AND ANSWERS

Units, electrical power, 23  
  inductance, 23  
  resistance, 23

### V

Vacuum tube, amplification of, 50,  
  92, 517  
  beam type of, 152  
  blue haze in, 130  
  characteristics, 49, 50, 52, 101,  
    152, 153, 286, 395  
  construction and comparison of,  
    45-48, 51, 328  
  defects in, 122, 290  
  filament reactivation of, 153  
  getter in, 92  
  load, 50  
  maximum plate dissipation in, 50  
  oscillator, 94  
  overheating in, 123  
  plate saturation of, 51  
  problems, 58, 313, 517, 535  
  rectifiers, 65-67, 153  
  secondary emission in, 235  
  voltage gain, 50  
Velocity of radio waves, 80, 81

Voltage, doubler, 233  
  gain, calculation of, 218  
  regulation of, 125, 129, 322, 343  
Vertical polarization, 158  
Vestigial-side-band, 263  
VHF, 86  
Vibrator, rectifier, 172  
Video (*see* Television)  
VLF, 86  
Voltmeter connections, 72, 100

### W

Wattmeter, 69  
Wave, damped, 83  
  radar, 414  
  sawtooth, 262  
  sound, 393  
  trap, 91, 169, 354  
Wave guides, 166  
Wavelength, 89  
Wavemeter, 136, 164, 295, 335, 530

### Z

Z marker, 461, 462  
Zero-beat, 136, 230, 294

SUPPLEMENT  
TO THE TENTH EDITION  
(Including FCC Element VIII  
on Ship Radar Techniques)

**RADIO OPERATING  
QUESTIONS AND ANSWERS**

by J. L. Hornung

*Commander, United States Naval Reserve (Inactive)  
Senior Member, Institute of Radio Engineers  
Formerly Officer-in-Charge, Naval Training School (Radar)  
Massachusetts Institute of Technology, Boston, Mass.*

Edited by

Alexander A. McKenzie

*Associate Editor, ELECTRONICS Magazine*

NEW YORK    TORONTO    LONDON  
McGRAW-HILL BOOK COMPANY, INC.  
1951

SUPPLEMENT TO THE TENTH EDITION  
RADIO OPERATING QUESTIONS AND ANSWERS

Copyright, 1951, by the McGraw-Hill Book Company, Inc. Printed in the United States of America. All rights reserved. This book, or parts thereof, may not be reproduced in any form without permission of the publishers.

The opinions or assertions contained herein are not to be construed as official or reflecting the views of the Navy Department or the Naval service at large.

THE MAPLE PRESS COMPANY, YORK, PA.



## PREFACE TO TENTH EDITION SUPPLEMENT

In the period since 1947, there have been many changes in radio law, both at the international level (as a result of the International Telecommunication Convention, Atlantic City, 1947) and in the Rules and Regulations of the Federal Communications Commission. Increased use of radio for navigation and safety of aircraft, radar pilotage of ships, the rapid growth of the general mobile radio services that include police, fire, railroad and taxi dispatching, as well as new problems associated with broadcasting and television, have made necessary continual revisions of licensing and operating requirements.

For the convenience of those preparing to take examinations qualifying them as operators of radio stations, the Federal Communications Commission publishes a "Study Guide," listing a large number of questions on topics that are covered in the examinations. As the laws and regulations change, the "Study Guide" questions are modified to reflect the new requirements.

Ideally, the student should have before him a pile of documents about a foot high from which he could extract the latest and most correct answers to all the technical and legal questions. Actually, such a practice would be both expensive and inefficient. It is for these reasons that the author has brought together the "Study Guide" questions and their present, correct answers.

Because of the many changes and revisions that are even now going on, it has been thought advisable to issue this supplement to the Tenth Edition of "Radio Operating Questions and Answers" rather than to publish a complete, new

eleventh edition at this time. However, such a new edition is in preparation and will be available shortly after the next complete revision of the FCC "Study Guide" is published.

The student is urged to use this supplement and its associated Tenth Edition of "Radio Operating Questions and Answers" as a signpost in his study of the many aspects of radio theory and operating technique. Standard textbooks and schools, correspondence and resident, are available for those who need good grounding in the fundamentals.

It is particularly urged that the prospective operator equip himself with the latest legal information, either from the FCC, in Washington, D. C., or from the nearest FCC Field Engineering Office. A most useful document, together with its latest revisions, is "FCC Rules and Regulations, Part 13—Rules Governing Commercial Radio Operators," for sale by the Superintendent of Documents, U. S. Government Printing Office, Washington, D. C., at a price of 5 cents.

The author thanks the many individuals among his associates and in the radio industry who have contributed to this volume by suggestion or specific information from their particular fields. He is grateful for the assistance rendered by Mrs. Gladys T. Montgomery, Washington Editor, on the staff of *ELECTRONICS* magazine.

J. L. HORNUNG

YONKERS, N. Y.

July, 1951

## CONTENTS

	PAGE
PREFACE TO TENTH EDITION SUPPLEMENT. . . . .	iii
HOW TO USE THIS BOOK. . . . .	vii
Study Guide. . . . .	viii
ELEMENT I. Basic Law. . . . .	1
ELEMENT II. Basic Operating Practice . . . . .	3
ELEMENT III. Basic Radiotelephone . . . . .	18
ELEMENT IV. Advanced Radiotelephone . . . . .	25
ELEMENT V. Radiotelegraph Operating Practice. . . . .	25
ELEMENT VI. Advanced Radiotelegraph . . . . .	35
ELEMENT VII. Aircraft Radiotelegraph. . . . .	35
ELEMENT VIII. Ship Radar Techniques . . . . .	36
APPENDIX . . . . .	63
International Morse Code . . . . .	63
Abbreviations Available for All Services—Q Code. . . . .	65
Miscellaneous Abbreviations and Signals. . . . .	73
Radiotelephone Word List. . . . .	75
INDEX . . . . .	77



## HOW TO USE THIS BOOK

This booklet is a supplement to the Tenth Edition of "Radio Operating Questions and Answers." In these two books together are the answers to all questions given in the "Study Guide," prepared by the Federal Communications Commission. The "Study Guide" is now being revised by FCC; but as it stands, its complete content is made up of a booklet revised in July, 1948, and several mimeographed supplements. The questions asked in some of the earlier supplements already appear in the Tenth Edition. The rest are given in this booklet.

It will be explained later what elements are necessary for the various classes of commercial operator license examination. Equally important, it is also explained which questions make up the new, renumbered elements. For example, old Element 2 in the "Study Guide" is now part of new Element III, and it is likewise part of new Element VI! However, the table following and the notes throughout the text make it all clear.

In addition to the answers, this booklet also contains an Appendix with latest information on Q codes, standard abbreviations, and changes in the use of the International Morse Code. None of these changes has yet been published outside legal documents bearing upon the International Telecommunication Convention, Atlantic City, 1947.

## STUDY GUIDE

Class of License	New Examination Elements						What to Study	
	1	2	3	4	5	6	Tenth Edition	New Supplement
Radiotelegraph First	x	x			x	x	Pages 1-17* Pages 18-101 Pages 266-426*	Element I Element II Element V
Radiotelegraph Second	x	x			x	x	Pages 1-17* Pages 18-101 Pages 266-426*	Element I Element II Element V
Radiotelegraph Third Permit	x	x			x		Pages 1-17*	Element I Element II Element V
Radiotelephone First	x	x	x	x			Pages 1-17* Pages 18-172* Pages 180-265	Element I Element II Element III
Radiotelephone Second	x	x	x				Pages 1-17* Pages 18-172*	Element I Element II Element III
Radiotelephone Third Permit	x	x					Pages 1-17*	Element I Element II
Restricted Radiotelephone Permit	No oral or written examination							
Aircraft Radiotelegraph Endorsement	First- and second-class radiotelegraph operators only by examination in Element VII						Pages 427-511	
Ship Radar Endorsement	First- and second-class radiotelegraph or radiotelephone operators by examination in Element VIII							Element VIII

\* Omit 131.06, on page 7, and 131.07, on page 8. Omit 3.160 and 3.161, on page 146; 3.162 and 3.163, on page 147; 3.166, 3.167, and 3.168, on page 148; 3.169, 3.170, and 3.171, on page 149; 3.174, on page 150; 3.229, on page 173, through 3.249, on page 179. Also omit 5.149, on page 298, and 5.154, on page 300; 5.292 through 5.296, on page 337.

## ELEMENT I

### BASIC LAW

There are 70 questions on basic law, beginning page 1 of the Tenth Edition, "Radio Operating Questions and Answers." Stop at 131.06, on page 7. There will be 10 examination questions based on this material.

**Ques. 131.06.** Can any station be licensed under the Communications Act without first obtaining a construction permit from the Federal Communications Commission?

*Ans.* Yes. Government, amateur, or stations upon mobile vessels, railroad rolling stock, or aircraft require no construction permit.

**Ques. 131.07.** What class of land stations must, within the scope of normal operations, exchange radio communications or signals with ship and aircraft at sea?

*Ans.* Every land station open to general public service between the coast and vessels or aircraft at sea must so communicate.

**Ques. 131.08.** Where Government and private or commercial radio stations on land operate in such close proximity that interference with Government transmission cannot be avoided in simultaneous operation, during what periods must interfering private or commercial stations refrain from operation?

*Ans.* At all such places, the non-Government stations must not use their transmitters during the first fifteen minutes of each hour, local standard time.

## RADIO OPERATING QUESTIONS AND ANSWERS

**Ques. 131.09.** In general, must cargo ships of United States registry of less than 1,600 gross tons be equipped with an efficient radio installation in charge of a qualified operator or operators before leaving or attempting to leave any harbor or port of the United States?

*Ans.* No. But it is unlawful for any ship of the United States, other than a cargo ship of less than 1,600 gross tons, to be navigated in the open sea outside a harbor or port without such a radio installation.

**Ques. 131.10.** What class of passenger ships of United States registry must be equipped with a radio direction-finder apparatus (radio compass) before leaving or attempting to leave a harbor or port of the United States?

*Ans.* Any passenger ship of the United States of 5,000 gross tons or over must be equipped with a radio direction finder.

**Ques. 131.11.** How many qualified operators must, for safety purposes, be carried aboard a compulsorily radio-equipped ship of United States registry not fitted with an auto-alarm?

*Ans.* At least two qualified operators are required.

**Ques. 131.12.** When must the auto-alarm be in operation during the navigation of a ship fitted therewith, outside a harbor or port?

*Ans.* It must be in operation at all times during navigation when the operator is not on watch.

**Ques. 131.13.** What is the maximum fine, other than a forfeiture, and the maximum prison sentence provided for a person's willful and knowing violation of the Communications Act?

*Ans.* A fine of not more than \$10,000 or by imprisonment for a term of not more than two years, or both.



**Ques. 131.14.** What is the maximum fine, other than a forfeiture, provided for a willful and knowing violation of a rule or regulation of the Federal Communications Commission, or any treaty or convention to which the United States is a party?

*Ans.* A fine of not more than \$500 for each and every day during which such offense occurs.

**Ques. 131.15.** Must a person be a citizen of the United States in order to hold any class of radio-operator license or permit from the Federal Communications Commission?

*Ans.* Yes. The FCC has been given power to license only citizens of the United States.

Now turn back to 141.01, on page 8, of the Tenth Edition of "Radio Operating Questions and Answers," and read through 191.05, on page 17. That is the end of Element I.

## ELEMENT II

### BASIC OPERATING PRACTICE

There are 59 questions on basic operating practice, and they are all contained in this supplement. Do *not* study any of the *old* Element 2 questions; they have all been dropped from *this* section in the "Study Guide." There will be 50 examination questions based on this material.

**Ques. 2.01.** For what term are commercial radio-operator licenses normally issued?

*Ans.* Commercial operator licenses are normally issued for a term of 5 years from the date of issuance.

## RADIO OPERATING QUESTIONS AND ANSWERS

**Ques. 2.02.** Is the holder of a radiotelephone third-class operator permit authorized to make technical adjustments to the transmitter he operates?

*Ans.* A third-class radiotelephone operator may make technical adjustments only under the supervision and responsibility of a person holding a first-class or second-class commercial radio-operator license, either radiotelephone or radiotelegraph, as may be appropriate for the class of station involved.

**Ques. 2.03.** List three classes of stations which may not be operated by the holder of a radiotelephone third-class operator permit.

- Ans.*
1. Stations transmitting television.
  2. Stations transmitting telegraphy by any type of Morse code.
  3. Any broadcast station, except 10-watt noncommercial FM, remote pickup and STL (Studio Transmitter Link).
  4. Coastal telephone stations at which the power in the antenna of the unmodulated carrier wave is authorized to exceed 250 watts.
  5. Coastal harbor telephone stations over 250 watts (except Alaska).
  6. Ship or aircraft stations (except those employed solely for telephony under 250 watts).

**Ques. 2.04.** How often should station identification be made at a base or land radiotelephone communications station?

*Ans.* The name (and geographical location as approved by the Commission) of a coastal harbor station shall be announced upon the completion of each communication with any other station and at the conclusion of each transmission made for any other purpose.

(a) Each station in these (Public Safety Radio) services which is capable of being identified by transmission of its

assigned call signal shall transmit such call signal at the end of each transmission or exchange of transmissions or once each fifteen minutes of the operating period, as the licensee may prefer.

(b) In lieu of the requirement above, mobile units communicating with a base station which transmits on the same frequency may transmit, once during each exchange of transmissions, any unit identifier which is on file in the station records of such base station.

(c) In lieu of the first requirement, mobile units communicating with a base station which transmits on a different frequency may transmit, once during each exchange of transmissions, any unit identifier which is on file in the station records of such base station and the assigned call signal of either the mobile station or the base station.

(d) Stations which are entirely automatic in their operation, including automatic modulation of the carrier, will be considered for exemption from the requirements of paragraph (a) of this section in specific instances, upon request.

**Ques. 2.05.** What broadcast stations, if any, may be operated by the holder of a radiotelephone third-class operator permit?

*Ans.* A third-class radiotelephone operator may not operate any broadcast station except noncommercial FM with power ratings of 10 watts or less, remote pickup broadcast, and ST transmitter, provided that

1. The operator is prohibited from making any technical adjustments.
2. The equipment is so designed that it maintains a stable frequency output within the limits specified on the station license.
3. Technical adjustments are made by or under the supervision of a person holding a first-class or second-class operator license, whichever the station license warrants.

*RADIO OPERATING QUESTIONS AND ANSWERS*

**Ques. 2.06.** What daily attention should be given to the antenna tower lights at a radio station?

*Ans.* The licensee of any station having an antenna supporting structure required to be illuminated shall

1. Make a daily check of the tower lights, either by visual observation or by observation of an automatic indicator.

2. Every three months: inspect automatic lighting devices and also measure the voltage under load conditions at the socket of each light required to be installed (or compute the value from observation at some designated point).

3. (See also Ques. 2.07.)

**Ques. 2.07.** What should an operator do if he observes any failure of a code or rotating beacon light at the radio station he operates?

*Ans.* In the event of a failure of a code or rotating beacon light, the operator shall report this failure immediately by telephone or telegraph to the nearest Airways Communication Station or office of Civil Aeronautics Administration. Further notification shall be given by the same means immediately upon resumption of the required illumination.

**Ques. 2.08.** What entries regarding tower lights are required in station records or logs for stations whose antenna or antenna supporting structure is required to be illuminated?

*Ans.* Log entries must include

(1) Time the tower lights are turned on and off each day, if manually controlled.

(2) Time the daily check of proper operation of the tower lights was made.

(3) In event of any observed failure of a tower light,

(I) Nature of such a failure.

(II) Date and time failure was observed.

(III) Date, time, and nature of the adjustments, repairs, or replacements made.

(IV) Identification of Airways Communication Station (CAA) notified of the failure of any code or rotating beacon light not corrected within 30 minutes, and the date and time such notice was given.

(V) Date and time notice was given to the Airways (CAA) Station that required illumination was resumed.

(4) Upon completion of the periodic inspection required at least once each three months,

(I) Date of the inspection and the condition of all tower lights and associated tower lighting control devices, together with the socket voltages measured under load at the sockets or computed from measurements under load at other points.

(II) Any adjustments, replacements, or repairs made to ensure compliance with the lighting requirements and the date such adjustments, replacements, or repairs were made.

**Ques. 2.09.** Should a radio station that is operated by a licensed operator be a licensed radio station?

*Ans.* Yes. No radio transmitter shall be operated except under and in accordance with a proper station authorization granted by the Federal Communications Commission.

**Ques. 2.10.** Why is it important to avoid unnecessary calls by radio communication?

*Ans.* Unnecessary calls and communications by radio shall be avoided in order to prevent interference and to give an opportunity to others sharing the frequency.

**Ques. 2.11.** It is advisable to be courteous in radio communications as it is in other forms of communication?

*Ans.* Yes, the operator should be courteous at all times.

**Ques. 2.12.** Why is it a good policy to be brief in radio-telephone conversations?

## RADIO OPERATING QUESTIONS AND ANSWERS

*Ans.* 1. Emergency calls may be blocked until you are off the air.

2. Long conversations will interfere with other persons desiring to use the same frequency.

**Ques. 2.13.** Immediately prior to calling a station, why should the operator listen on the operating frequency?

*Ans.* Prior to a call, the operator should listen in on the operating frequency to make certain that his call will not interfere with communications already in progress.

**Ques. 2.14.** State two reasons why station identification should be clearly made by a radio transmitting station.

*Ans.* Station identification is necessary because

1. It speeds up communications among stations.
2. It enables monitoring stations clearly to identify calls.

**Ques. 2.15.** Why is it advisable during your absence from your radiotelephone-equipped vehicle always to lock the cab or compartment in which the radio equipment is located?

*Ans.* The cab or compartment that houses the radiotelephone equipment should be kept locked in the absence of the operator to prevent unauthorized persons from tampering with or operating the equipment.

**Ques. 2.16.** Why is it undesirable to leave a radiotelephone communications transmitter on the air during periods when voice transmissions are not in progress?

*Ans.* It is illegal to do so because carrier radiation from the transmitter will cause interference with other communications even when voice is not transmitted.

**Ques. 2.17.** When routine radio communications are unreliable, owing to static or fading, should the operator continue transmitting or wait for more favorable conditions?

*Ans.* It is a good practice to wait until adverse conditions have subsided. Transmission during a period when fading or static occurs may interfere with other stations not experiencing these atmospheric effects to the same degree.

**Ques. 2.18.** Are there any ill effects to radio communications if the operator shouts into the microphone?

*Ans.* Shouting into the microphone will probably result in a distorted signal and production of spurious, interfering signals on other frequencies.

**Ques. 2.19.** Is the working distance range of a transmitter affected by the loudness of speech spoken into the microphone?

*Ans.* Yes, to some extent. The working range, particularly for AM transmitters, is affected, but the operator must be certain that his voice will be reproduced intelligibly; otherwise, because of distortion, the working range will approach zero.

**Ques. 2.20.** Is it a good practice to shield the microphone with the hands when speaking into a microphone in a noisy location?

*Ans.* Yes, cupping the hands around the microphone top will tend to reduce the amount of extraneous noise transmitted.

**Ques. 2.21.** When using the microphone at a radiotelephone station, should the operator speak directly into the microphone or away from the microphone?

*Ans.* The operator should generally speak directly into a microphone. However, with older types, such as the carbon-granule, he should speak across the microphone, so as to avoid the effect known as "microphone hiss," which is caused by the breath striking the diaphragm of the microphone.

**Ques. 2.22.** For most effective operation, how far should the microphone be held from the speaker's lips?

RADIO OPERATING QUESTIONS AND ANSWERS

*Ans.* The microphone should be held from 2 to 6 inches from the speaker's lips.

**Ques. 2.23.** When speaking over a radiotelephone communications station, how should the operator adjust his voice: that is, should he speak in one tone of voice as much as possible, or should he articulate all his words and expressions?

*Ans.* The speaker should articulate all his words and expressions and should avoid speaking in a monotone as much as possible. However, he should try to maintain a fairly constant level, to prevent overmodulation.

**Ques. 2.24.** In radiotelephone communications, why should the operator use well-known words and phrases and simple language as much as possible?

*Ans.* Well-known words and phrases ensure accuracy and save time from undue repetition of words. They also facilitate better interpretation due to possible vocabulary limitations.

**Ques. 2.25.** What is meant by a phonetic alphabet in radiotelephone communications?

*Ans.* A phonetic alphabet is a word list that is useful in identifying letters or words that may sound like other letters or words of a different meaning. (See Appendix for standard word list.)

**Ques. 2.26.** Give an example of the use of a phonetic alphabet in transmitting a word that is difficult to understand.

*Ans.* The numeral 2 (two)  
T as in Tom  
W as in William  
O as in Oboe (See Appendix for standard word list.)

**Ques. 2.27.** What is indicated by the transmission of the word ROGER as the reply to a radiotelephone communication?



*Ans.* The word ROGER indicates that all of the last transmission has been received.

**Ques. 2.28.** What is the significance of the word OVER when transmitted at the end of a radiotelephone communication?

*Ans.* The word OVER indicates that the transmission is over and that an answer is expected.

**Ques. 2.29.** What is indicated by the word OUT when transmitted at the end of a radiotelephone communication?

*Ans.* The word OUT means that the transmission is ended and that no reply is expected.

**Ques 2.30.** Frequently the word WILCO is used in radiotelephone communications. Is this word generally used as a phonetic, or is it used as a procedure word? What does it mean?

*Ans.* WILCO is a procedure word and means: "The message was received and will be complied with."

**Ques. 2.31.** In radiotelephone communication, what would be a good choice of words to use if you wanted to request the operator at the other end of the circuit to speak more slowly?

*Ans.* "Speak slower" would be the proper words to use in the aviation service.

**Ques. 2.32.** Can a radio operator always consider his radiotelephone conversations completely confidential and not heard by other persons?

*Ans.* No. Radio signals normally travel in every direction, and any person who has the necessary equipment may receive them.

**Ques. 2.33.** What is the difference between "simplex" and "duplex" radiocommunication systems?

## RADIO OPERATING QUESTIONS AND ANSWERS

*Ans.* In a simplex operation, the stations in communication operate at the same frequency. In a duplex operation, the stations in communication do not operate on the same frequency.

**Ques. 2.34.** In calling a station by radiotelephony, how many times does the calling station generally repeat the call sign or name of the called station in each calling transmission? How many times does the calling station repeat its own call sign or name in each calling transmission?

*Ans.* The called station's sign or name is repeated not more than three times. The calling station repeats its own sign or name not more than three times.

**Ques. 2.35.** Why should the operator wait several seconds after turning on a transmitter before pressing the push-to-talk button?

*Ans.* The push-to-talk button should not be pressed for a few moments after the transmitter is turned on, in order to permit the tubes to reach their proper operating temperature.

**Ques. 2.36.** Why is it a good practice to remove a transmitter from the air while changing from one frequency to another?

*Ans.* It is a good practice to remove the transmitter from the air while changing from one frequency to another to avoid interfering with other stations operating on either the old or new frequency. In some cases, the transmitter may be damaged if left on during the frequency change.

**Ques. 2.37.** If you are alone in a radio-equipped automobile, why is it advisable to stop the car before using the radio equipment?

*Ans.* It is advisable to stop the car because

1. The operator-driver can concentrate on the transmission and reception of messages.

2. The hazard of driving without due attention to circumstances which may arise is avoided.

3. Spurious noises caused by the car in motion are avoided.

4. Reception at VHF or UHF may be facilitated by parking in a favorable location, such as a hilltop, or away from tall buildings.

**Ques. 2.38.** Why is it advisable to keep the engine in an automobile running, with the battery charging, while using the radiotelephone for long periods in the car?

*Ans.* The radio battery may become discharged if used for long periods of time; therefore, the engine should be kept running to maintain a charge in the battery.

**Ques. 2.39.** If a given mobile radiotelephone station is powered by a storage battery, what indication might an operator have that the battery needs recharging or other service?

*Ans.* A decrease in radiation as indicated by the antenna radio-frequency ammeter, plate-current milliammeter, or filament voltmeter. The car lights may be very dim, and the starter slow in turning over. Other service requirements may be determined by a careful check of the specific-gravity reading and the voltage output of each cell under no-load conditions. The latter test should preferably be made with a high-resistance type of voltmeter.

**Ques. 2.40.** In receiving radio signals in an automobile, is reception usually better in the open country and hilltops or in valleys and underpasses?

*Ans.* Reception is usually better in the open country and on hilltops.

**Ques. 2.41.** If a radiotelephone operator desires to make a brief test of a transmitter, what would be a good choice of words to use in the test?

## RADIO OPERATING QUESTIONS AND ANSWERS

*Ans.* "This is KB2185, testing." Tests of this nature should be as short as possible.

**Ques. 2.42.** If radio communication is difficult in an automobile parked at the wayside, what might the operator do to improve communication?

*Ans.* To improve communication, the operator should turn off his transmitter and find a more suitable location nearby from which to make his transmissions. (See also 2.37 and 2.40.)

**Ques. 2.43.** What is the purpose of the squelch control or switch on a radiotelephone communications receiver?

*Ans.* The squelch control on a receiver is used to prevent noise and static from being heard through the loudspeaker when the receiver is in the stand-by position.

**Ques. 2.44.** When receiving weak signals on a radiotelephone communications receiver, should the squelch switch be placed in the "on" or "off" position? In what position should the switch be placed when receiving strong signals?

*Ans.* The squelch decreases the sensitivity of the receiver; therefore, when receiving weak signals, the squelch switch should be in the "off" position. When receiving strong signals, the squelch switch should be in the "on" position.

**Ques. 2.45.** During periods of severe static, in what position should the squelch control be normally set?

*Ans.* In cases of severe static, the squelch switch should normally be in the "on" position. However, it may be necessary to leave squelch off and tolerate the noise so as to intercept weak signals.

**Ques. 2.46.** If a radiotelephone communications receiver has an "electric eye" to indicate correct tuning, how does the "eye" normally indicate the correct tuning when receiving a signal?

*Ans.* The eye will normally close when the receiver is properly tuned. However, since there are several types and a number of different circuits, the operator must determine the characteristics of that used on his particular receiver.

**Ques. 2.47.** What is the purpose of a fuse in a transmitter or receiver circuit?

*Ans.* Fuses are put into electrical circuits to protect the equipment when electrical-power faults such as short circuits or other abnormal overloads occur.

**Ques. 2.48.** When replacing a fuse in a transmitter or a receiver, why should the rating of the replacement be the same as that recommended by the manufacturer?

*Ans.* The replacement should be exactly the same as that recommended by the manufacturer so that if future faults occur, the fuse will burn out to prevent possible damage to the equipment.

**Ques. 2.49.** If a 5-ampere fuse in a circuit "blows out" after a long period of normal operation, what size fuse would be appropriate for replacement?

*Ans.* A 5-ampere fuse would be appropriate for the replacement after the reason for the increased current has been ascertained. It is never advisable to increase the capacity rating of the fuse beyond normal requirements.

**Ques. 2.50.** List two precautions that should be observed when replacing a tube in a receiver or a transmitter.

*Ans.* 1. The replacement should be of the same type number as the tube that was removed.

2. All sources of power should be disconnected from the transmitter or receiver.

3. Defective rectifier tubes should not be replaced until a test is first made to determine a possible leak or short circuit in the filter capacitor.

RADIO OPERATING QUESTIONS AND ANSWERS

4. Avoid burning the hands on a tube that has been heated for a long time.

**Ques. 2.51.** If smoke is observed emerging from a transmitter or a receiver, what should the operator do immediately?

*Ans.* 1. Disconnect all sources of power to the equipment.  
2. If flames can be detected, a carbon-dioxide type of fire extinguisher should be used to extinguish the flames.

**Ques. 2.52.** Why is it important that a fire extinguisher that is to be used for fighting fires in transmitters involving high voltage be of a type designed for fighting electrical fires?

*Ans.* A nonconducting type of extinguishing agent should be used, so as to prevent additional short circuits from causing a larger electrical fire, or shocking the person operating the extinguisher.

**Ques. 2.53.** Generally speaking, what is the approximate dependable working distance range of a transmitter working in an automobile?

*Ans.* A VHF mobile transmitter has a working range of from 5 to 35 miles, depending upon the surrounding terrain and effective output power.

**Ques. 2.54.** Why is it a good policy to make a daily test of a transmitter when it is in stand-by for long periods between transmission?

*Ans.* Daily tests of the transmitter may reveal any faults or defects, which if corrected immediately will not hamper the transmitter's operation when it is needed.

**Ques. 2.55.** Is it a good practice to make entries of station operation in a radio log prior to operating the station?

*Ans.* No. The log must reflect the exact operation of the equipment and the times of operation, not how it was proposed to operate it. It would, however, be proper to enter the date,

name of the operator coming on watch, or other preliminary data of this nature.

**Ques. 2.56.** When does the radio day, that is, the 24-hour period covered by a complete set of station records, of a station in continuous service, generally begin and end?

*Ans.* The 24-hour period covered by a complete set of station records generally begins at midnight, local standard time, and ends the following midnight.

**Ques. 2.57.** In reference to electric shock, what is meant by artificial respiration, and how is it administered?

*Ans.* Artificial respiration is administered for the purpose of restoring normal breathing to a person who has had a sufficient electrical shock to cause his respiratory system to cease functioning or become very faint in its operation. It is applied in the following manner:

1. The person is laid face down on a floor or level spot, with his legs spread apart and his head resting on one side of his face.

2. The person giving the aid kneels, resting one knee between the victim's legs and the other to one side.

3. The following steps are then performed:

- a. The hands are placed on each side of the victim's body just above the small of his back.

- b. With the hands in this position, pressure is applied in a downward direction.

- c. The pressure is then removed.

- d. The person administering the aid returns to a normal kneeling position.

This process is continued until normal respiration occurs within the victim.

**Ques. 2.58.** What should the operator at a radio station do immediately if he sees a person fall into contact with a high-voltage circuit?

## RADIO OPERATING QUESTIONS AND ANSWERS

*Ans.* 1. All power should immediately be removed from that circuit (assuming the switch is quickly accessible).

2. Pry the victim loose from the contacts with a dry board, dry wooden stool, or chair; avoid bodily contact with the victim.

3. The operator should call a doctor.

4. The operator should give first aid to the person until the doctor arrives.

**Ques. 2.59.** During electric storms, is it safe for a person to stand near high antennas or near antenna lead-ins?

*Ans.* It is not safe to stand near a high antenna or an antenna lead-in. This can be compared with standing under a tree during an electrical storm. If the tree cannot leak off enough of a charge, the difference in potential between the tree and the atmosphere becomes high enough to break down the air gap between them, and everything in the vicinity of the tree is affected.

Even though the antenna lead-in may conduct the discharge safely to ground, the high currents may melt small particles of metal and spray them about. In addition, the high current induces a secondary current into nearby objects.

This is the end of Element II.

## ELEMENT III

### BASIC RADIOTELEPHONE

There are 537 questions on basic radiotelephone theory. Most of them appear (some with different numbers) in the Tenth Edition of "Radio Operating Questions and Answers." The last 9 are in this supplement. Start



with 2.01, page 18, of the Tenth Edition; and read through 3.227, on page 171. Omit 3.160 through 3.163, 3.166 through 3.171, and 3.174. Also omit 3.229 through 3.249. Then study the questions below, numbered S3.01 through S3.09. In the examination, there will be 100 questions based upon this type of material.

**Ques. S3.01.** In accordance with the Commission's Rules and Regulations, what is the primary standard for radio-frequency measurements of radio stations in the various services?

*Ans.* The primary standard of frequency for radio-frequency measurements shall be the national standard of frequency maintained by the National Bureau of Standards, Department of Commerce, Washington, D.C. The operating frequency of all radio stations will be determined by comparison with this standard or the standard signals of station WWV of the National Bureau of Standards.

**Ques. S3.02.** What is meant by carrier frequency? Carrier wave?

*Ans.* Carrier frequency is the frequency of the transmitter output when the modulation is zero. The carrier wave of a frequency-stabilized system is a wave generated at a point in the transmitting system and subsequently modulated by the signal intelligence.

**Ques. S3.03.** Define land station; base station; mobile station; experimental station; domestic fixed service; public correspondence; facsimile; fixed service; Industrial Radio Services; Industrial, Scientific, and Medical Equipment; Land Transportation Radio Services; Public Safety Radio Services; and Citizens Radio Service.

*Ans.* A land station (FL) is a station in the mobile service not intended for operation while in motion.

A base station (FB) is a land station in the land mobile service carrying on a service with land mobile stations.

## RADIO OPERATING QUESTIONS AND ANSWERS

A mobile station (MOZ) is any mobile station other than a television pickup station.

An experimental station (EX) is a station utilizing Hertzian waves in experiments, with a view to the development of science or technique. This definition does not include amateur stations.

Domestic fixed service is a fixed service intended for the transmission of information between points, all of which lie within the 48 states and the District of Columbia, except for the domestic haul of international traffic.

Public correspondence is any telecommunication that the offices and stations, by reason of their being at the disposal of the public, must accept for transmission.

Facsimile is a system of telecommunication for the transmission of fixed images, with a view to their reception in a permanent form.

Fixed service is a service of radiocommunication between specified fixed points.

Industrial Radio Services are any service of radiocommunication essentially operated by, and for the sole use of, those enterprises which for purposes of safety or other necessity require radiocommunication in order to function efficiently; the radio transmitting facilities of which are defined as fixed, land, or mobile stations.

Industrial, Scientific, and Medical Equipment is radio transmitting equipment or other devices employing Hertzian waves for industrial, scientific, or medical purposes, including the transfer of energy by radio, and which are not intended to be used for radio communication.

Land Transportation Radio Services are any service of radio communication operated by, and for the sole use of, certain land transportation carriers; the radio transmitting facilities of which are defined as fixed, land, or mobile stations.

Public Safety Radio Service is any service of radiocommunication essential to either the discharge of non-federal governmental functions relating to public-safety responsibilities or

the alleviation of an emergency endangering life or property; the radio transmitting facilities of which are defined as fixed, land, or mobile stations.

Citizens Radio Service is a radio communication service of fixed, land, or mobile stations, or combination thereof, intended for use by citizens of the United States for private or personal radiocommunication (including radio signalling, control of objects by radio, and other purposes).

**Ques. S3.04.** What is the frequency range included in the following frequency subdivisions: MF (medium frequency), HF (high frequency), VHF (very high frequency), UHF (ultrahigh frequency), and SHF (superhigh frequency)?

*Ans.* The frequency ranges, together with their abbreviations, are shown in the table below:

Frequency	Range, kc	Range, mc
VLF (very low frequency)	10-30 kc	
LF (low frequency)	30-300 kc	
MF (medium frequency)	300-3,000 kc	0.3-3 mc
HF (high frequency)	3,000-30,000 kc	3-30 mc
VHF (very high frequency)	30,000-300,000 kc	30-300 mc
UHF (ultrahigh frequency)	300,000-3,000,000 kc	300-3,000 mc
SHF (superhigh frequency)	3,000,000-30,000,000 kc	3,000-30,000 mc
EHF (extremely high frequency)	30,000,000-300,000,000 kc	30,000-300,000 mc

**Ques. S3.05.** Explain what is meant by the following types of emission: F0, F1, F2, F3, F4, and P0 emission.

*Ans.* Type F emissions are frequency or phase modulated, and type P emissions are pulsed. Type A emissions indicate amplitude modulation. The complete list of the various combinations is shown in the table below.

# RADIO OPERATING QUESTIONS AND ANSWERS

## FCC EMISSION AND MODULATION SYMBOLS

Type of Modulation or Emission	Type of Transmission	Symbol	
1. Amplitude	Absence of any modulation	A0	
	Telegraphy without the use of modulating audio frequency (on-off keying)	A1	
	Telegraphy by the keying of a modulating audio frequency or audio frequencies or by the keying of the modulated emission (special case: an unkeyed modulated emission)	A2	
	Telephony:		
	Double side band, full carrier	A3	
	Single side band, reduced carrier	A3a	
	Two independent side bands, reduced carriers	A3b	
	Facsimile	A4	
	Television	A5	
	Composite transmissions and cases not covered by the above	A9	
	Composite transmissions, reduced carrier	A9c	
	2. Frequency (or phase) modulated	Absence of any modulation	F0
		Telegraphy without the use of modulating audio frequency (frequency shift keying)	F1
Telegraphy by the keying of a modulating audio frequency or audio frequencies or by the keying of the modulated emission (special case: an unkeyed emission modulated by audio frequency)		F2	
Telephony		F3	
Facsimile		F4	
Television		F5	
Composite transmissions and cases not covered by the above		F9	
3. Pulsed emissions		Absence of any modulation intended to carry information	P0
		Telegraphy without the use of modulating audio frequency	P1
		Telegraphy by the keying of a modulating audio frequency or audio frequencies, or by the keying of the modulated pulse (special case: an unkeyed modulated pulse)	
		Audio frequency or audio frequencies modulating their pulse in amplitude	P2d
	Audio frequency or audio frequencies modulating the width of the pulse	P2e	
	Audio frequency or audio frequencies modulating the phase (or position) of the pulse	P2f	
	Telephony:		
	Amplitude-modulated pulse	P3d	
	Width-modulated pulse	P3e	
	Phase- (or position-) modulated pulse	P3f	
	Composite transmissions and cases not covered by the above	P9	

**Ques. S3.06.** What are the requirements for posting of operator license for (a) the operator performing duties other than, or in addition to, service or maintenance, at two or more stations, and (b) the operator performing service or maintenance duties at one or more stations?

*Ans.* In the first case (a), the operator must post his license or permit of the diploma form at one such station and must post a verification card, Form 759, at all other such stations. An operator performing maintenance (b) must either post his license or have on his person a verification card, whenever the transmitter on which he is working is actually in operation. If the maintenance operator also performs operating duties, he must, of course, comply with the requirements for (a) above.

**Ques. S3.07.** If service or maintenance logs are required to be kept at a radio station, what entries are required to be entered in the log?

*Ans.* Where a log or service records are required and when service is performed that may affect the proper operation of the station, the responsible operator must sign and date an entry in the log or maintenance record. The entries consist of details of work performed; his name and address; class, serial number, and expiration date of his license. If the operator is regularly employed at the station full time, it is required only that he give the details of the work performed.

**Ques. S3.08.** In communication services such as the Public Safety Radio Services, (a) what percentage of modulation is normally required when amplitude modulation is used for radiotelephony, and (b) what maximum frequency deviation arising from modulation is permitted when phase or frequency modulation is used for radiotelephony?

*Ans.* For amplitude modulation (a), the percentage must normally be maintained about 70, but not to exceed, 100 per cent; for phase or frequency modulation (b), the maximum

## RADIO OPERATING QUESTIONS AND ANSWERS

deviation must not exceed plus or minus 15 kilocycles from the unmodulated carrier.

**Ques. S3.09.** In communication services such as the Public Safety Radio Services, how often should (a) transmitter frequencies be measured, (b) transmitter power be measured, and (c) percentage of modulation be measured? What entries relative to technical measurements are required to be entered in station records?

*Ans.* The transmitter frequency (a) must be measured at initial installation; when any change is made that may cause a change in frequency or stability; at least every six months for crystal-controlled transmitters; and at intervals not over a month for transmitters without crystal control. Transmitter power (b) must be measured at initial installation; when any change is made that might increase power input; and at intervals not to exceed six months. The percentage of modulation (c) must be measured at initial installation; when any change is made that might affect the modulation and at intervals not to exceed six months.

The station records must contain a notation of these various check measurements and must show whether the plate current or cathode current has been used to determine input power. The name of a qualified measurement service, together with address and the name of the person making the measurement, must be shown. Power and percentage of modulation can be determined at a test bench, provided the load conditions are the same as in actual service. If this is done, it is also necessary to make a receiving test after the transmitter has been reinstalled to ensure that it is working properly.

This is the end of *new* Element III.

ELEMENT IV

ADVANCED RADIOTELEPHONE

There are 284 questions on advanced radiotelephone theory, and all of them appear as Element 4 in the Tenth Edition of "Radio Operating Questions and Answers." Study from Ques. 4.01, on page 180, through Ques. 4.284, on page 265. There will be 50 examination questions based on this material.

ELEMENT V

RADIOTELEGRAPH OPERATING PRACTICE

There are 38 questions on radiotelegraph operating practice, and all of them appear in this supplement. Do *not* study any of the *old* Element 5 questions in the Tenth Edition of "Radio Operating Questions and Answers" at this time. There will be 50 examination questions based upon the type of material contained below.

**Ques. 5.01.** List three classes of stations which may not be operated by the holder of a radiotelegraph third-class operator permit.

*Ans.* A radiotelegraph operator third class may not operate broadcast stations, ship stations licensed to use A3 or F3 emission for communication with coastal telephone stations, a radiotelegraph station on board a vessel required to be equipped by treaty or statute, or coastal telegraph or marine-relay station open to public correspondence.

RADIO OPERATING QUESTIONS AND ANSWERS

**Ques. 5.02.** Is the holder of a radiotelegraph third-class operator permit authorized to make technical adjustments to a radiotelephone transmitter? To a radiotelegraph transmitter?

*Ans.* Such operator may make only operational types of adjustments to a radiotelephone transmitter that will not result in improper operation or any unauthorized radiation. He may not make technical adjustments to a radiotelegraph transmitter. Needed adjustments are made in the presence of or by an operator holding a first-class or second-class license.

**Ques. 5.03.** Where should the operator on duty at a manually operated radiotelegraph station normally post his operator license or permit?

*Ans.* He must post it at the transmitter, or at the operating position if that is at a different location.

**Ques. 5.04.** What are the requirements for station identification at radiotelegraph stations in the Public Safety Radio Services?

*Ans.* Each station in these services must transmit its call signal at the end of each transmission (or exchange of transmissions), or once each fifteen minutes. Mobile units communicating with a base station on the same frequency may use a unit identifying signal (like "car 15" or "pumper 4") each time if such identifier is on file at the base station. Mobile units on a different frequency may use an identifier during each exchange, together with the assigned call of either the base station or the mobile unit. Automatic stations are usually exempted from this requirement on request.

**Ques. 5.05.** What is the radiotelegraph distress signal? Urgent signal? Safety signal?

*Ans.* The distress signal is  $\overline{SOS}$ , sent as one character. The urgent signal is XXX. The safety signal is TTT.



**Ques. 5.06.** The speed of radiotelegraph code transmission in cases of distress, urgency, or safety must not, in general, exceed what speed?

*Ans.* In general, such messages should not be sent at a speed exceeding 15 words per minute.

**Ques. 5.07.** What radiotelegraph signal is generally used in a call "to all stations"?

*Ans.* The call to all stations is CQ.

**Ques. 5.08.** What is meant by the following radiotelegraph operating signals?

R,  $\overline{AS}$ ,  $\overline{IMI}$ , C,  $\overline{BT}$ , K,  $\overline{AR}$ ,  $\overline{VA}$ , DE

*Ans.* R means "understood" or "received ok";  $\overline{AS}$  means "wait";  $\overline{IMI}$  is a question mark or indication that something is not understood (when used after a Q signal, it asks a question); C means "yes";  $\overline{BT}$  is a break or space; K is an invitation to transmit, usually following a call sign or end-of-message operating signal;  $\overline{AR}$  indicates the end of a message, even though more messages may be coming during the whole transmission;  $\overline{VA}$  is the end of a transmission or series of them, sometimes termed the "Signoff"; DE comes from the French meaning "from" and is used between the call letters of the called station and the calling station.

**Ques. 5.09.** If a radiotelegraph operator makes an error in transmitting message text, how does he indicate that an error has been made?

*Ans.* By sending a series of dots, officially eight, although the number may vary in actual practice.

**Ques. 5.10.** When testing a radiotelegraph transmitter, what signals are generally transmitted?

*Ans.* Usually a series of V's, three groups of three, followed by the station call letters three times.

## RADIO OPERATING QUESTIONS AND ANSWERS

**Ques. 5.11.** In order to avoid confusion in transmitting numbers involving a fraction, how should such numbers be transmitted? Give an example of such a number, showing how it should be transmitted.

*Ans.* The ordinary fraction bar is sent as  $\overline{\text{TF}}$ . When a fraction and whole number must be sent, the hyphen  $\overline{\text{BA}}$  is used. For example,  $1\frac{3}{2}$  is sent as

$1\overline{\text{BA}}3\overline{\text{TF}}32$

**Ques. 5.12.** What is meant by the preamble in a radiotelegraph message? What information is usually given in the preamble?

*Ans.* The preamble of a radiotelegraph message is that part that precedes the actual message itself. The preamble usually includes a prefix denoting the type of message, the serial number, the check or word count, the office of origin and its call letters, the time of filing, the day of the month on which it was filed, and routing instructions. The sender is charged only for the part of the telegram that comes after the preamble.

**Ques. 5.13.** In addition to the preamble, what parts does a radiotelegraph message contain?

*Ans.* A complete message is made up of preamble, address, text, and signature.

**Ques. 5.14.** What is meant by a service prefix or indicator in a radiotelegraph message?

*Ans.* A service prefix, like RP or OBS, indicates the type of message and the handling it must be given.

**Ques. 5.15.** What does "word count," or "check," mean in a radiotelegraph message?

*Ans.* Word count, or check, as given in the preamble, indicates the number of words that are charged for in the

part of the message after the preamble. When certain service indicators showing how the message is to be handled appear in the preamble, they are also subject to charge.

**Ques. 5.16.** At what time, or times, does the serial numbering of radio messages begin? Does the period of numbering vary in some services?

*Ans.* Messages are numbered beginning with Nr 1 at 0000 midnight, GMT. In a purely local service, message numbering may begin at midnight, local standard time.

**Ques. 5.17.** Code or cipher groups are often used in radiotelegraph messages for what purpose?

*Ans.* Code or cipher groups are used sometimes for purposes of secrecy, to conserve charges in transmitting intelligence that would otherwise require a greater amount of plain language, or, as in the weather code, to reduce the amount of time necessary to disseminate essential public information.

**Ques. 5.18.** Immediately following the transmission of a radiotelegraph message containing figures or odd symbols, why are such figures sometimes collated?

*Ans.* The amount of information in figures and odd symbols is usually greater than that in plain language, and errors are less easily detected. For this reason, such symbols are collated or confirmed to ensure accuracy.

**Ques. 5.19.** If receiving conditions are bad and you want the transmitting station to send each word or group twice to facilitate reception, what operating signal would be appropriate to use?

*Ans.* Transmit each word or group twice; QSZ.

**Ques. 5.20.** In general, what is the purpose of a service message in radiotelegraph communications?

## RADIO OPERATING QUESTIONS AND ANSWERS

*Ans.* A service message (SVC) is one that is sent from one station to another and concerns a message already initiated, such as reporting that a message cannot be delivered or requesting further information on it.

**Ques. 5.21.** Why are Q signals or other arbitrary selected procedure signals used in radiotelegraph communications?

*Ans.* By their shortness and universal use, these special signals save a great deal of operating time. They are also distinctive and cannot be confused with message content.

**Ques. 5.22.** What is meant by the following signals : QRA, QRM, QRN, QRT, QRZ, QSA, QSV, QUM, QRL?

*Ans.* As questions, these signals are followed by a query signal IMI. Without, they mean, respectively: the name of my station is \_\_\_\_; I am being interfered with; I am troubled by static; stop transmission; you are being called by \_\_\_\_; the strength of your signals is \_\_\_\_ (1 to 5); transmit a series of V's; distress traffic is ended; I am busy. (See also the complete list of Q signals in the Appendix.)

**Ques. 5.23.** If the signal strength of a radiotelegraph signal is reported on a scale of 1, 2, 3, 4, 5, what scale number would indicate a very strong signal? What scale number would indicate a very weak signal?

*Ans.* High numbers indicate strong signals; QSA 5 is the strongest. Low numbers indicate weak signals; QSA 1 means a scarcely perceptible signal.

**Ques. 5.24.** If, upon being called by another station, a called station is busy with other traffic, what should the operator of the called station do?

*Ans.* He should so indicate (QRL) and also ask the calling station to wait (QRX) or (AS) a specified number of minutes

or until a specified time. Distress or urgent calls take precedence over other operations.

**Ques. 5.25.** Describe a procedure of radiotelegraph transmission in which one station calls another. Give an example.

*Ans.* If WLKH is calling KNIV, the calling procedure would be as follows:

KNIV, KNIV, KNIV de WLKH, WLKH, WLKH K

**Ques. 5.26.** Describe a procedure of radiotelegraph transmission in which one station answers the call of another. Give an example.

*Ans.* If KNIV hears the call of WLKH, he answers as follows:

WLKH, WLKH, WLKH de KNIV, KNIV, KNIV R K

**Ques. 5.27.** What is meant by the statement: "A station is open to public correspondence"?

*Ans.* Such a station, being at the disposal of the public, must accept suitable messages for transmission.

**Ques. 5.28.** Should the speed of transmission of radiotelegraph signals be in accordance with the desire of the transmitting or receiving operator?

*Ans.* The transmitting operator must adjust his speed of transmission in accord with the desire of the receiving operator.

**Ques. 5.29.** After long periods of listening to a CW telegraph signal of constant tone, what adjustment can the operator make to a radio receiver to relieve hearing fatigue?

*Ans.* He can adjust the setting of the beat-frequency oscillator to give a different or more pleasing pitch, or he can slightly detune a tuned-radio-frequency receiver to accomplish the same effect. Retuning a superheterodyne instead of

## RADIO OPERATING QUESTIONS AND ANSWERS

adjusting the beat oscillator will accomplish the effect but may result in a slight loss in sensitivity.

**Ques. 5.30.** What is meant by break-in operation at a radiotelegraph station?

*Ans.* Break-in operation means an arrangement of equipment so that the operator can hear signals from the other station between letters or even between the intraletter spacings. If the other station wishes to break the sending, he can therefore do so without waiting for the conclusion of a transmission.

**Ques. 5.31.** How should the automatic volume-control switch be set for reception of CW radiotelegraph signals on a communications receiver designed for both radiotelephone and radiotelegraph reception?

*Ans.* It is generally desirable to turn the automatic volume-control switch off when receiving CW signals and maintain the radio-frequency gain manually. On some receivers, the AVC can be left on, but the receiver will block on strong local signals, particularly if the gain control is set high.

**Ques. 5.32.** Explain the use of the crystal-filter switch on a communications receiver.

*Ans.* A crystal filter is often provided on a communications receiver to narrow the pass band of the receiver, thereby reducing the effects of noise and interfering signals on adjacent frequencies. When it is desired to use the crystal filter, the switch is turned on and the desired signal tuned in until it is at maximum strength. If the pitch of the signal is not satisfactory at maximum signal strength, the beat-frequency oscillator is then adjusted to obtain the proper pitch. The tuning at maximum signal is very critical. A phasing control is often furnished with the crystal filter. When this control

is manipulated, it is often possible to get a better ratio of desired-to-undesired signal strength.

**Ques. 5.33.** What adjustment should be made to a radiotelegraph receiver if the receiver "blocks" on the reception of strong signals?

*Ans.* The automatic volume control should be turned off and the radio-frequency gain reduced until the signal is received without blocking.

**Ques. 5.34.** Describe how to adjust a communications radio receiver for the reception of weak CW signals.

*Ans.* Most operators find that it is desirable to increase the audio-amplifier gain to maximum and raise the radio-frequency gain to sufficient level to copy the weak CW signals. The beat-frequency oscillator must, of course, be on and the AVC off.

**Ques. 5.35.** How should a radiotelegraph receiver be adjusted for the reception of type A2 emissions?

*Ans.* Although the beat-frequency oscillator can often be left on, it is generally more satisfactory to turn it off when receiving tone-modulated (A2) telegraph signals. In other respects, the receiver is generally adjusted as it would be for reception of radiotelephone signals. If there is danger of blocking, especially from the local transmitter during break-in, the AVC should be turned off.

**Ques. 5.36.** Sometimes a given radiotelegraph transmitting station can be heard at more than one place on the tuning dial of a receiver. Is this always an indication that the station is transmitting on more than one frequency?

*Ans.* No. The transmitter signal may be beating with some locally generated oscillation in the receiver. Images, having a frequency for which the receiver is tuned, plus twice

## RADIO OPERATING QUESTIONS AND ANSWERS

the intermediate frequency, are a most frequent source of unwanted signal in superheterodyne receivers.

**Ques. 5.37.** How should a manual radiotelegraph transmitting key be adjusted for good operation? Is the adjustment always the same for slow as it is for high speed?

*Ans.* The adjustment of a transmitting key is mostly a matter of operator preference. However, it should generally be adjusted so that the contacts are about  $\frac{1}{32}$  inch apart and have sufficient tension to break the contact sharply, but not so much as to tire the hand. Although the adjustments are essentially the same for all sending speeds, some fast operators tend to keep the contacts close together and the spring tension light so as to have the key more flexible to manipulate. They tend to depress and raise the key manually rather than to punch it and allow the spring to return it.

**Ques. 5.38.** Describe how an automatic key, or "bug," should be properly adjusted to send good readable radiotelegraph signals.

*Ans.* A bug key has a multiplicity of adjustments, most of them interdependent. For best readability, the bug should be adjusted for the speed at which most sending is to be done. The main consideration is to transmit dots and dashes in such a relationship that the dash is equal to three dots. The adjustable weight on the dot-forming arm has the greatest effect upon dot speed. The length of the dot is determined both by the arc of swing of the arm and upon the dot-contact adjustment. At slow speeds, the dots should ideally be longer in length than they are at high speeds. The various tension, travel, and contact adjustments for the dash portion should then be adjusted until the operator has no trouble forming perfect characters at the chosen speed. A bug adjusted for high speed will sound choppy at slow speed, making it difficult for inexperienced receiving operators. A slow bug at high speed will send dashes that are nearly the



## AIRCRAFT RADIOTELEGRAPH    Element VII

same length as the dots and will similarly cause copying difficulties.

This is the end of *new* Element V.

### ELEMENT VI

#### ADVANCED RADIOTELEGRAPH

There are 895 questions on the theory of advanced radiotelegraph operations, and all of them appear in the Tenth Edition of "Radio Operating Questions and Answers," under the *old* Elements 2, 5, and 6. Study 2.01, on page 18, through 2.311, on page 101. Then turn to page 266 and study 5.01 through 5.291, on page 336. Omit 5.292 through 5.296, on page 337. Study from 6.01, on page 338, through 6.295, on page 426. There will be 100 examination questions based upon the information contained in Element VI.

### ELEMENT VII

#### AIRCRAFT RADIOTELEGRAPH

There are 266 study questions on all aspects of aircraft radiotelegraph and navigation, and all of them appear in the Tenth Edition of "Radio Operating Questions and Answers." Study 7.01, on page 427, through 7.266,

## RADIO OPERATING QUESTIONS AND ANSWERS

on page 511. Only qualified radiotelegraph operators may obtain the Aircraft Radiotelegraph endorsement for their licenses after taking an examination of 100 questions based upon the material in Element VII.

### ELEMENT VIII

#### SHIP RADAR TECHNIQUES

There are 69 questions about commercial marine radar and its operation, and all of them are contained in this supplement. Only first- and second-class radiotelegraph or radiotelephone operators may obtain the Ship Radar endorsement on their licenses after passing an examination containing 50 questions based upon the material below.

**Ques. 8.01.** What are the FCC license requirements for the operator who is responsible for the installation, servicing, and maintenance of ship radar equipment?

*Ans.* All adjustments and tests during installation and maintenance must be performed by or under the supervision of a person holding a first-class or second-class radiotelephone or radiotelegraph license with ship radar endorsement. Persons not holding such licenses may replace fuses or receiving-type tubes.

**Ques. 8.02.** Who may operate radar in the Ship Service?

*Ans.* The master, or person designated by him, may operate a ship radar station licensed for shipboard use in the Ship Service.

**Ques. 8.03.** Under what conditions may a person who does not hold a radio operator license operate a radar station in the Ship Service?

*Ans.* Any person may operate such a station if the equipment is licensed, meets frequency-stability requirements, if the operation of the equipment is in accordance with radio law, if such person is subject to the authority of the master of the vessel, and if such adjustments and tests are made by a properly licensed operator.

**Ques. 8.04.** Who may make entries in the installation and maintenance record of a ship radar station?

*Ans.* Such entries must be made by or under the supervision of the operator concerned in each case, but the licensee has joint responsibility for the accuracy of the record.

**Ques. 8.05.** What entries are required in the installation and maintenance record of a ship radar station?

*Ans.* The following entries must be signed by the responsible operator concerned: Date and place of the initial installation; any steps necessary to remedy interference; nature of any complaint of interference since arising; reason for the trouble leading to the condition complained of, including the name of the faulty component; remedial measures taken and date thereof; the name, license number, and date of the ship radar operator endorsement of the first-class or second-class operator performing the work.

**Ques. 8.06.** Who has the responsibility for making entries in the installation and maintenance record of a ship radar station?

*Ans.* The licensed operator doing the work, but the licensee has an equal responsibility to see that the entries are accurately made.

## RADIO OPERATING QUESTIONS AND ANSWERS

**Ques. 8.07.** Within what bands of frequencies do ship radar transmitters operate?

*Ans.* Within 3,000 and 3,246 megacycles; 5,460 and 5,650 megacycles; 9,320 and 9,500 megacycles. These frequencies lie in what are very often referred to as the 10, 3, and 1.5 centimeter bands, respectively.

**Ques. 8.08.** May fuses and receiving-type tubes be replaced in ship radar equipment by a person whose operator license does not contain a ship radar endorsement?

*Ans.* Yes.

**Ques. 8.09.** Explain briefly why radar interference to a radiotelephone receiver is frequently characterized by a steady tone in the radio loud-speaker.

*Ans.* The magnetron in a radar transmitter is pulsed by a series of square waves generated in the modulator section of the transmitter. Since this wave train must have appreciable amplitude and because a square wave is made up of a large number of frequencies, there are emissions of considerable strength on up into the radio-frequency spectrum. The pulse recurrence rate (PRR) occurs at an audio frequency in the order of 1,000 pulses per second. The radio-frequency emissions resulting from the square-wave modulation are similar to ICW transmissions and appear in bands with varying intensity for various communications receivers.

**Ques. 8.10.** Describe how various types of interference from a radar installation may be apparent to a person when listening to a radio communications receiver.

*Ans.* The sources of interference from a radar installation are of two general types: (a) noise and (b) signals arising from the method of pulsing. Among the sources of noise are commutator noise, high-voltage arc over, and occasionally noise from imperfect contact between slip ring and brush.

All these noises are characteristic of static and sparking. The interference arising from the pulse recurrence rate of the modulator used to key the magnetron is a tone of about 1,000 cycles appearing throughout the radio-frequency spectrum. It is sometimes concentrated in bands of greater intensity. The frequency range of these bands is different for various receivers.

**Ques. 8.11.** How are the various types of radar interference recognized in (a) auto-alarm equipment and (b) direction-finding equipment?

*Ans.* (a) Interference in the auto-alarm is indicated by the red light being illuminated. Listening on the monitor jack of the alarm equipment will also indicate the type of interference. (b) Listening to the head telephones or loud-speaker connected to the DF equipment.

**Ques. 8.12.** On what frequencies should the radar serviceman look for radar interference to communication receivers on ships equipped with radar?

*Ans.* He should particularly check to see that no interference is being caused to the frequencies: 100-200 kilocycles; 350-515 kilocycles; 1,850-1,950 kilocycles; and 2-30 megacycles.

**Ques. 8.13.** In checking a direction finder for interference caused by radar equipment, would it be a good policy to check for interference while the DF loop is being rotated?

*Ans.* Yes. If the interference were coming from radar equipment on another vessel nearby, the orientation of the loop would determine the source. If interference were equally strong in all directions, it could safely be assumed that interference was coming from equipment on the same ship.

**Ques. 8.14.** List at least two types of indications on a Loran scope that signifies that a radar installation is causing interference to the Loran.

## RADIO OPERATING QUESTIONS AND ANSWERS

*Ans.* Noise from a radar installation shows up as "grass" on the slow-sweep display on a Loran scope, generally obscuring all but the strongest Loran signals. Spikes, usually moving to the right or to the left, indicate interference from the radar modulator. Occasionally these spikes may stand still on the slow-sweep display but usually begin moving right or left in a few moments.

**Ques. 8.15.** Is there any likelihood of a radar installation causing interference to radio receivers if long connecting lines are used between the radar transmitter and the radar modulator?

*Ans.* Yes. The connection between the magnetron oscillator and the pulsed modulator sections of the radar transmitter should be connected by as short a line as possible, properly terminated to avoid standing waves on the outer sheath, solidly connected at both ends, and properly grounded at both ends. All modern commercial radar equipments follow this practice to avoid generating pulse-type interference.

**Ques. 8.16.** What steps might be taken by a radar serviceman to eliminate a steady-tone type of interference to radio communication receivers, or interference to Loran receivers evidenced by "spikes"?

*Ans.* Since this type of interference is caused by radar modulator pulses, the line between modulator and magnetron should be checked for defective grounds at each end. Power leads into the radar equipment should be adequately filtered. As a last resort, it may be necessary to relocate the communications receiver or the Loran antenna in order to reduce pickup of the interfering signals.

**Ques. 8.17.** What steps might be taken by a radar serviceman to eliminate "grass" on a Loran scope or motor-generator noise in communication receivers?

*Ans.* If it is not possible to install filters directly on commutators or other sources of noise interference, the power

line to Loran and radio communications equipment should be equipped with noise filters. In addition, the frames and cabinets of all receiving equipment and the housings of motor generators should be solidly grounded.

**Ques. 8.18.** Name at least four pieces of radio or electronic equipment aboard ship that might suffer interference from the radar installation.

*Ans.* Among the equipment that might suffer interference are auto-alarm, Loran, Decca navigator, Consol, direction-finder, radio communications, and VHF ship-shore radio-telephone equipment. Under certain conditions, electronic intercommunication equipment might also be affected.

**Ques. 8.19.** Why is it important that all units of a radar installation be thoroughly bonded to the ship's electrical ground?

*Ans.* All radar, radio, and power equipment should be well bonded to the ship's electrical ground to avoid currents being carried by cable sheaths or other conductors between various units. Good grounding helps more than anything else in the elimination of interference. Of equal importance is the fact that if equipment is left "floating," harmful or annoying voltage gradients may exist between equipment and ground. The harmful effects of electrical shock are often secondary, like the fall from a ladder, owing to an involuntary reaction to slight shock.

**Ques. 8.20.** What may cause bright-flashing pie sections to appear on a radar PPI scope?

*Ans.* Flashing pie sections on the PPI scope, sometimes called "spoking," result from failure of the automatic volume-control circuit. While the most frequent cause of this type of failure is generally failure of the AVC crystal itself, the effects of failure of the magnetron, frequency shift of the

## RADIO OPERATING QUESTIONS AND ANSWERS

magnetron, or failure to key the magnetron with good square-wave pulses would manifest themselves in the same manner.

**Ques. 8.21.** What symptoms on a radar scope would indicate that the radar-receiver mixer crystal is defective?

*Ans.* Weak signals or lack of any signals on the PPI scope, especially when testing with the echo box, might indicate that the mixer crystal was defective.

**Ques. 8.22.** What tests may a radar serviceman make to determine whether or not the radar-receiver mixer crystal is defective?

*Ans.* There is usually a switch provided so that the crystal test current can be measured. This current should generally be about 0.4 milliamperes. A standard tester for crystals, such as that ordinarily carried by a service-company employee is safe and accurate. A 20,000-ohm-per-volt meter can also be used to check the front-to-back current ratio. With the test probes in one connection, there should be infinite resistance. Do not use an ohmmeter of lower resistance, or the crystal may be damaged by too high a measuring current. Be careful in removing and replacing crystals, to avoid static discharges that may damage them.

**Ques. 8.23.** In a radar set, what are indications of (a) a defective magnetron, (b) a weak magnet in the magnetron, and (c) defective crystal in the receiver converter stage?

*Ans.* A defective magnetron (a) may be indicated by high magnetron current or no current, overload or underload breakers open, bright-flashing pie sections on the PPI scope. A weak magnet (b) is indicated by high magnetron current or opening of the overload breaker. A defective crystal in the receiver converter stage (c) is indicated by weak signals on the PPI scope, particularly when testing with the echo box.



**Ques. 8.24.** What precautions should a radar serviceman take when working with or handling a magnetron to prevent weakening or damage to the magnetron?

*Ans.* The magnetron should be handled carefully and when removed from the equipment should be placed so that it can not fall or so that tools or other heavy material can not fall upon it. In particular, avoid cracking the glass or breaking the seal between glass and metal parts. Avoid bending or hitting the metal envelope or cooling fins. Prevent damage to the wave-guide connection and exclude dirt from this section. Be careful not to bend or break leads through the glass heater and heater-cathode terminal insulator. Avoid mechanical strain on these connections.

Care must be observed in handling the magnet. Do not heat it or strike it with a screw driver or other tool.

**Ques. 8.25.** What precautions should a radar serviceman observe when making repairs or adjustments to a radar set to prevent personal injury to himself or to other persons?

*Ans.* Possible injuries are of mechanical and electrical origin. Among the first are cuts and abrasions caused by striking sharp parts of the equipment, cuts sustained by implosion of the cathode-ray tube owing to careless handling, including poisoning by the fluorescent-screen materials, and burning the hands and arms from contact with hot vacuum tubes, particularly the metal types. Electrical injuries include shock from high-potential wires and connections and capacitors.

Whenever possible, turn off all equipment and allow it to cool before working on it. Be sure that the main power switch is off, and discharge all capacitors with a semipermanent ground lead. Wear gloves and glasses when handling cathode-ray tubes. Use a handkerchief or other cloth to protect the hands when removing hot tubes.

If it is necessary to maintain the equipment with power on,

always have a competent assistant standing by who has been instructed how to turn off the main power and administer first aid in case of accident.

**Ques. 8.26.** Is there any danger in testing or operating radar equipment aboard ship when explosive or inflammable cargo is being handled?

*Ans.* Yes. The superhigh frequencies used are capable of heating many materials and can therefore cause fires or explosions. For example, there have been instances in which photoflash bulbs have been ignited within their cartons when placed near radar equipment.

**Ques. 8.27.** What considerations should be taken into account when selecting the location of the radar antenna assembly aboard ship?

*Ans.* Other things being equal, the antenna assembly should be mounted as high and as clear of obstacles as possible. Its weight must be taken into consideration and adequate support provided for it. The location must also permit proper installation and adequate support for the wave guide between the transmitter and the antenna. It must be accessible for necessary maintenance. The antenna should be placed so that obstructions are toward the stern rather than in any forward direction.

**Ques. 8.28.** Describe briefly the construction of a wave guide. Why should the interior of the wave guide be clean, smooth, and dry?

*Ans.* Wave guides are commonly constructed of brass tubing having a rectangular cross section. The brass is commonly plated with silver to increase the conductivity, and the silver is in turn protected from corrosion by a flash plating of rhodium, gold, or other protective metal. The ends of the wave-guide sections are equipped with special flange joints so that they can be connected together to ensure

good mechanical and electrical junctions. Because of the manner in which the microwaves travel in a wave guide, the interior surface must contain no electrical discontinuities. Dirt or corrosion resulting from excessive moisture will spoil the proper propagation of the wave through the guide.

**Ques. 8.29.** When installing wave guides, why should long, perfectly level sections of wave guides be avoided? Why is a small hole about  $\frac{1}{8}$  inch in diameter sometimes drilled on the underside of an elbow in a wave guide near the point where it enters the radar transmitter?

*Ans.* It would be desirable to maintain wave guides under pressure of dry air or gas so that the guide would not breathe in moisture from the surrounding air. Since it is not always possible to maintain it under pressure, the wave guide should be installed so that it slopes gently. If moisture accumulates, it can then run off to a point at which absorbent material or a drain is provided. Because it is difficult to pressurize certain sections, such as the wave guide near a rotating joint where the guide is connected to the antenna, it is often necessary to drill a small drain hole through which condensed moisture can escape.

**Ques. 8.30.** Why are wave guides used in preference to coaxial lines for the transmission of microwave energy in most shipboard radar installations?

*Ans.* The losses in coaxial lines at superhigh frequencies (microwaves) are very much higher than in wave guides. Because of the very large physical size required at lower frequencies, wave guides are not generally used outside the microwave region.

**Ques. 8.31.** Why are rectangular cross-sectional wave guides generally used in preference to circular cross-sectional wave guides?

*Ans.* The losses in circular wave guides are greater than those in rectangular wave guides. However, a round wave

guide is often used at rotating joints because of the greater simplicity in construction.

**Ques. 8.32.** Describe how wave guides are terminated at the radar antenna reflectors.

*Ans.* The wave guide in a commercial marine radar is customarily coupled to a horn or wave-guide nozzle. Radio-frequency energy from this horn falls upon a parabola-section reflector and is reflected as a narrow beam.

**Ques. 8.33.** What precautions should be taken when installing vertical sections of wave guides with choke coupling flanges to prevent moisture from entering the wave guide?

*Ans.* The end of the wave guide bearing the choke section should always hang down to avoid collection of moisture in the choke joint. When provided, the gasket should be inserted between the choke and the plain flange and the bolts taken up sufficiently to make a weatherproof joint.

**Ques. 8.34.** Why are choke joints often used in preference to flange joints to join sections of wave guides together?

*Ans.* Choke joints prevent loss of energy from a wave-guide junction, even when the joint is not mechanically tight. It is difficult to confine the energy within a wave-guide junction made up of a simple flange joint.

**Ques. 8.35.** Draw a longitudinal section of a wave-guide choke joint, and explain briefly its principle of operation.

*Ans.* Refer to Fig. 8-1. The choke joint is used so that there will be only a small loss or reflection at the gap  $J$ . This means that the impedance of the gap  $J$  must be as close as possible to zero. It is achieved by making the distance  $\lambda_G/4$  appear like a short circuit at the inner surface of the guide, when  $\lambda_G$  is the wavelength in the guide. The impedance

of the slot opening into the gap  $J$  is made infinite by proportioning its depth to be equal to  $\lambda_A/4$  when  $\lambda_A$  is the free-space wavelength of the source. The slot can conveniently be thought of as a short length of coaxial line terminated in a short circuit at the far end.

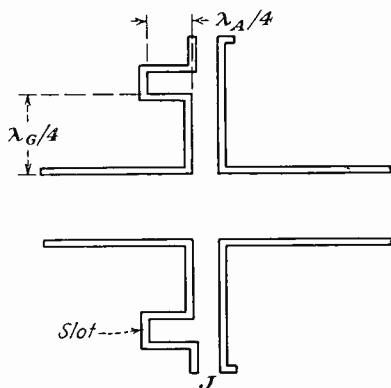

FIG. 8-1. Wave-guide choke joint.

**Ques. 8.36.** Describe how a radar beam is formed by a paraboloidal reflector.

*Ans.* Refer to Fig. 8-2. The antenna or source of radiation is located at the focus  $F$  of the parabola, which has a character-

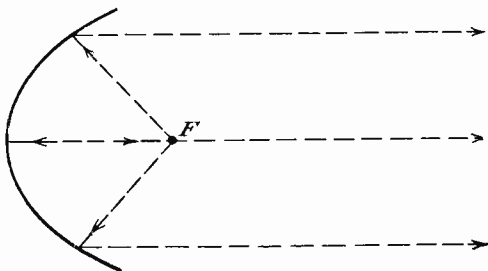

FIG. 8-2. Elementary parabolic reflector.

istic such that the resulting beam of radiated energy appears to come from many properly phased antennas. Any line drawn from the focus to the surface of the reflector will be reflected along a line parallel to those already drawn in the figure. It is customary in commercial marine radar to use a section of a parabola, sometimes called a "truncated parabola," to form the type of beam desired.

**Ques. 8.37.** What effect, if any, does the accumulation of soot or dirt on the antenna reflector have on the operation of ship radar?

*Ans.* Normal accumulation of soot or dirt has little noticeable effect on the operation of the ship radar. However, dirt on the plastic cover over the end of the wave-guide nozzle or horn will adversely affect operation. Moreover, this plastic cover should never be painted with ordinary paint.

**Ques. 8.38.** What is the purpose of an echo box in a radar system? Explain the principle of operation of the echo box. What indications may be expected on a radar scope when using an echo box and the radar set is operating properly? When the radar set is not operating properly?

*Ans.* An echo box is used to test the radar system in the absence of signals or when it is desired to compare performance with a previously attained standard. The echo box is actually a high-Q resonant cavity that is caused to ring by receiving energy from the radar transmitter. Since the ringing dies out relatively slowly, a portion of the energy is picked up by the radar receiver to give a PPI display. The length of the radial spoke or spokes from the center of the cathode-ray tube is a relative measure of the effectiveness of the system, as compared to a past setting. On some commercial equipments, the echo box tests only the output of the transmitter. On others, it tests the output of the wave-guide horn. When the

radar is operating properly, the radial line or lines on the PPI scope should extend out some distance from the center. If the equipment is not functioning properly, the length of these lines will be short compared to those obtained with some known previous setting of controls.

**Ques. 8.39.** Draw a block diagram of a radar system, labeling the antenna, duplexer, transmitter, receiver, modulator, timer, and the indicator.

*Ans.* See Fig. 8-3.

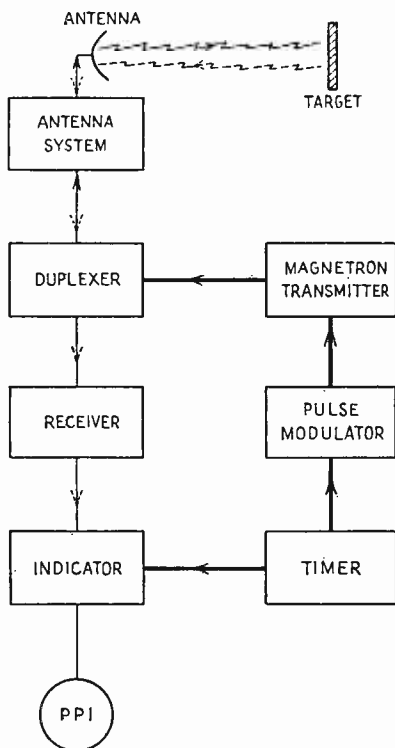

FIG. 8-3. Block diagram of a radar system.

**Ques. 8.40.** Explain briefly the principle of operation of a radar system.

*Ans.* Refer to Fig. 8-3. The purpose of a radar system is to gain knowledge about the presence, general size, and distance of above-water obstacles to navigation. In order to simplify commercial equipment, one antenna is used both for transmitting and receiving. A duplexer is provided so that power from the transmitter will not damage the sensitive receiver. This duplexer also prevents the loss of the received signal in the transmitting equipment. The heart of the radar system is the timer that sends out regular signals to operate the modulator. The modulator keys the magnetron transmitter on and off so that it sends out a uniform series of short pulses. The timer also sends blanking signals to the indicator so that any local signal leaking into the receiving system will not be displayed on the plan position indicator (PPI) oscilloscope tube. The indicator also provides distance-marker circles that facilitate accurate determination of the distance from the ship to the obstruction. The receiver converts radio-frequency energy into video signals that are displayed on the PPI scope.

**Ques. 8.41.** Draw a simple block diagram of a radar duplexer system, labeling the wave guide, the T-R box, anti T-R box, the receiver, and the transmitter.



Ans. See Fig. 8-4.

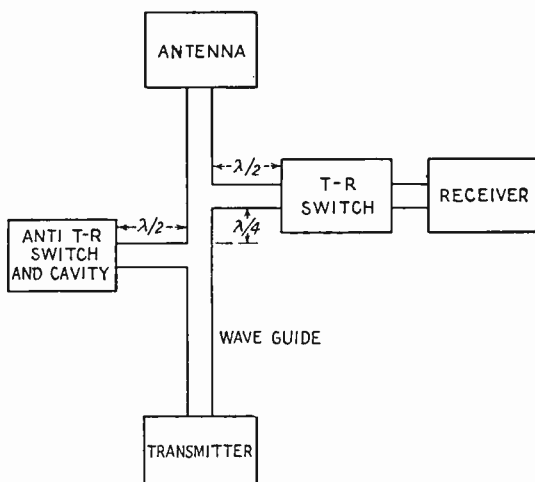

FIG. 8-4. Radar duplexer system.

**Ques. 8.42.** Draw a simple block diagram of a radar receiver, labeling the signal crystal, the local oscillator, the AFC crystal stage, the IF amplifier, and the discriminator.

Ans. See Fig. 8-5.

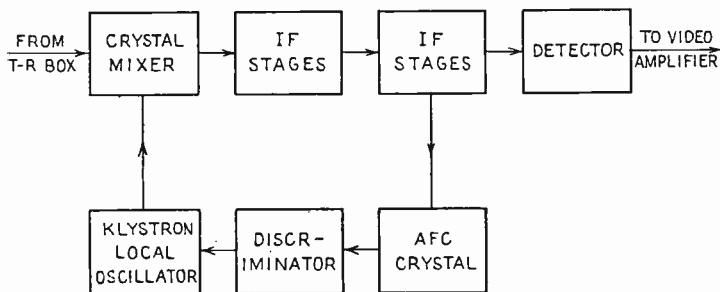
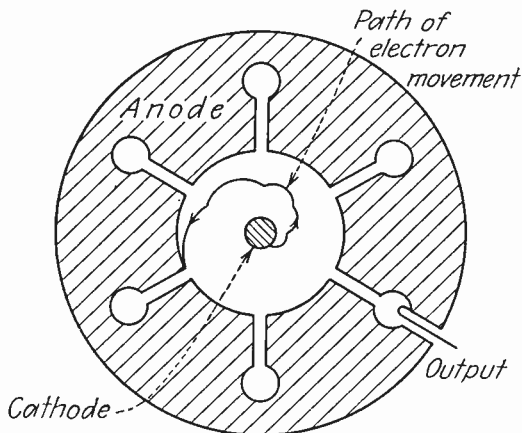

FIG. 8-5. Block diagram of radar receiver.

**Ques. 8.43.** Draw a simple cross-sectional diagram of a magnetron, showing the anode, cathode, and the direction

of electronic movement under the influence of a strong magnetic field.

Ans. See Fig. 8-6.



*Magnetic flux at right angles to page*

FIG. 8-6. Cross section of a cavity magnetron.

**Ques. 8.44.** Explain briefly the principle of operation of the magnetron.

Ans. Refer to Fig. 8-6. Electrons are emitted from the cathode when the magnetron is keyed or turned on by the modulator. Some of these return to the cathode and do no useful work. Others, like that for which the path is drawn, finally reach the anode. In their movement past the slots leading to the various cavities, they give up energy and cause the magnetron to oscillate. A strong magnetic flux is set up, usually by a permanent magnet, along the direction of the cathode. In the simple drawing, only the end of the cathode is shown. If the magnet is weakened, the electrons, instead of spiraling along the cathode, will go more directly to the anode, increasing the current to dangerously high values. Output is taken from a probe in one of the cavities.

**Ques. 8.45.** Why is the anode in a magnetron in a radar transmitter normally maintained at ground potential?

*Ans.* Although the anode must be maintained at a positive voltage, it is more convenient for mechanical reasons to ground the anode. The cathode, therefore, is carefully insulated and maintained at a large negative potential.

**Ques. 8.46.** Draw a simple frequency-converter circuit (mixer) as frequently used in radar superheterodyne receivers, and indicate which is the crystal stage.

*Ans.* See Fig. 8-7.

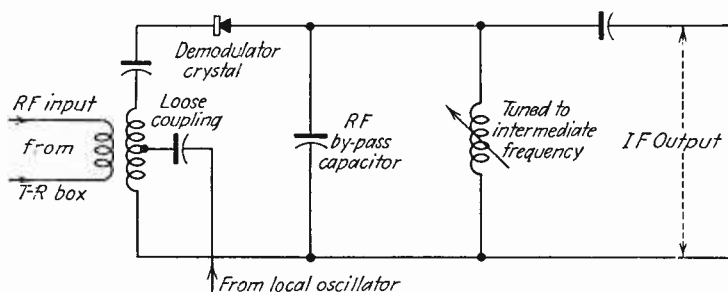

FIG. 8-7. Simplified radar frequency-converter circuit.

**Ques. 8.47.** What is the purpose of the klystron tube in a radar set?

*Ans.* The klystron tube in a radar set functions exclusively as local oscillator.

**Ques. 8.48.** Explain briefly the principle of operation of the reflex klystron.

*Ans.* In a reflex klystron tube, the electron beam is velocity modulated as it passes between the resonator grids. A retarding electric field beyond these grids causes the electron-beam velocity to decrease to zero and reflects the beam back through the grids. Bunching occurs during the transit interval

## RADIO OPERATING QUESTIONS AND ANSWERS

between reflections. When the proper negative voltage has been impressed on the repeller plate, the bunched electrons deliver energy to the resonator grids on the return trip.

**Ques. 8.49.** What care should be taken when handling silicon crystal rectifier cartridges for replacement in radar superheterodyne receivers?

*Ans.* The care that should be exercised when handling silicon crystal rectifier cartridges for replacement in radar superheterodyne receivers is the avoidance of mechanical shock, the accidental discharge of static charge through the crystal during insertion in the crystal holder, and exposure to strong electric fields.

**Ques. 8.50.** What nominal intermediate frequencies are commonly found in radar receivers?

*Ans.* Intermediate frequencies of from 15 to 60 megacycles are used in radar receivers. The intermediate and video frequencies are more readily separated when the higher frequencies are used. On the other hand, the tube capacitance will have minor effect on the alignment when the lower frequencies are used.

**Ques. 8.51.** Describe briefly the construction and operation of radar T-R and anti T-R boxes. What is the purpose of a "keep alive" voltage?

*Ans.* The T-R and anti T-R boxes are cavity resonators with a spark gap located one-quarter wavelength from the end. The T-R box functions as a double-pole double-throw switch. It connects the receiver to the common antenna during the resting period of the transmitter and disconnects it during the transmission period. The anti T-R box is located an odd number of quarter wavelengths from the T-R box and is shunted across the main transmission line. It works in conjunction with the T-R box to see that all the

available echo energy is absorbed by the receiver and that none of it reaches the transmitter during its resting period.

The purpose of the "keep alive" voltage is to ionize the spark gap so that it breaks down quickly under initial pulsing conditions. This increases the protection to the receiver's crystal.

**Ques. 8.52.** What is the purpose of the discriminator stage in a radar superheterodyne?

*Ans.* The purpose of the discriminator stage in a radar superheterodyne receiver is to provide an automatic frequency control voltage for the repeller electrode of the radar beating oscillator.

**Ques. 8.53.** What type of detector is used frequently in radar receivers?

*Ans.* One of the most frequently used types of demodulators used in radar receivers is the semiconductor diode detector.

**Ques. 8.54.** What is "sea return" on a radar scope?

*Ans.* The sea return is the reflection of the radar signal from the sea. These echoes are amplified and presented on the scope in the same manner as the target return.

**Ques. 8.55.** Explain briefly the purpose of the sensitivity-time-control circuit in a radar set.

*Ans.* The purpose of the sensitivity-time-control circuit in a radar set is to control the receiver gain so that the gain increases with range to offset the decrease of echo amplitudes, and so that nearby targets will not be obscured by sea return or blocking by the transmitted signal.

**Ques. 8.56.** What is the distance in nautical miles to a target if it takes 123 microseconds for a radar pulse to travel from the radar antenna to the target, back to the antenna, and be displayed on the PPI scope?

## RADIO OPERATING QUESTIONS AND ANSWERS

Ans. Reflection interval for 1 nautical mile = 12.361 microseconds.

$$\frac{123}{12.3} = \text{approximately } 10 \text{ nautical miles}$$

(See also Fig. 8-8 for information on time constant and range.)

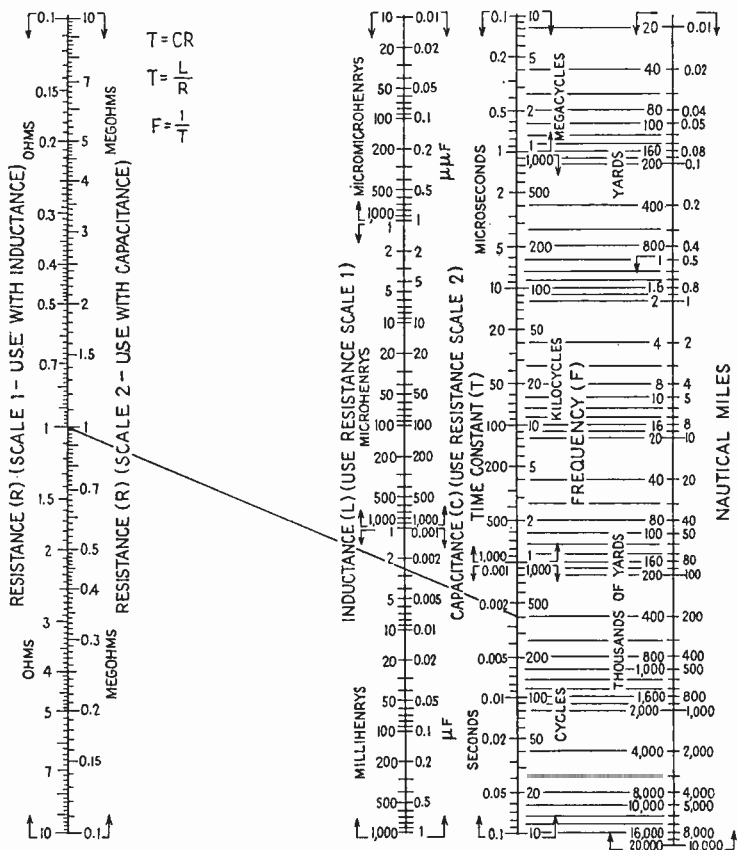

FIG. 8-8. Time constants for series circuits and radar ranges.

*Example:* Given a resistance of 1 megohm in series with a capacitance 0.0025 microfarad, find the time constant of the network. Placing a straight edge through these respective values (using resistance scale 2 and capacitance scale 2), the time constant scale is intersected at 0.025 second, a frequency of 400 cycles and a maximum possible range of 200 miles.

**Ques. 8.57.** What is the purpose of an artificial transmission line in a radar set?

**Ans.** Artificial transmission lines are employed for pulse formation in driver stages of modulators. The lines consist of a number of capacitors and inductors in certain combinations. The artificial line will deliver a voltage for a definite period of time to a load, in a similar way to the action of a battery rapidly switched on and off. Its advantage lies in the accuracy with which the magnitude and duration of pulses of energy can be delivered and in the extreme rapidity of the action.

**Ques. 8.58.** Draw a simple diagram of an artificial transmission line showing inductance and capacitance, source of power, the load, and the electronic switch.

**Ans.** See Fig. 8-9.

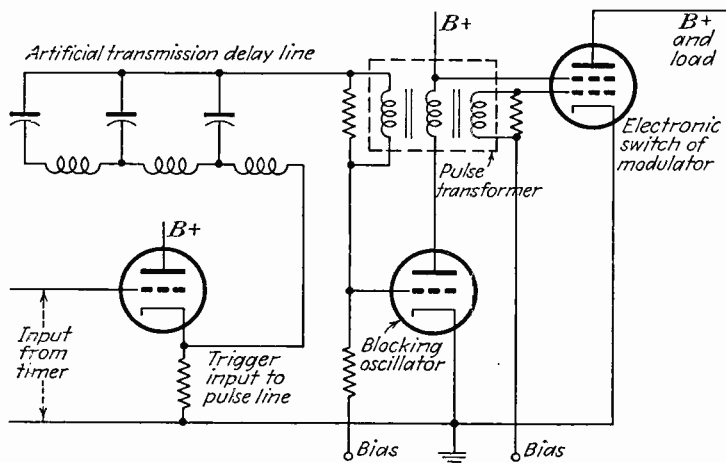

FIG. 8-9. Simplified artificial transmission-line radar pulser.

**Ques. 8.59.** What component in a radar set determines the pulse repetition rate?

*Ans.* The timer or synchronizer unit in a radar set determines the pulse repetition rate.

**Ques. 8.60.** What circuit element determines the operating frequency of the self-blocking oscillator?

*Ans.* An oscillator in which the plate and grid circuits are closely coupled through an iron-core transformer is called a "blocking oscillator" or "transformer-coupled multivibrator." The operating frequency depends principally upon the R-C time constant of the grid resistor and grid capacitor.

**Ques. 8.61.** What is the purpose of the rotary spark gap used in some radar sets?

*Ans.* The rotary spark gap is used in some radar sets (such as some Navy types) to function as a short-circuit switch for pulse-forming networks. One side of the gap is rotated on a wheel in such a way that it passes a fixed electrode at regular intervals. When the rotating electrode is directly under the fixed one, an arc is formed that discharges the pulse-forming network through its useful load. After the rotating electrode has passed the stationary one, the arc is extinguished. This action allows the storage elements of the network to be recharged. The process is then repeated.

**Ques. 8.62.** What is meant by "bearing resolution" of a radar set?

*Ans.* Bearing, or azimuth, resolution refers to the ability of a radar set to distinguish between two targets close together at the same range distance. This ability depends upon a number of factors, such as radio frequency of operation (being generally improved at higher frequencies), pulse width, antenna characteristics, and receiver adjustments.

**Ques. 8.63.** Explain how heading flash and range-marker circles are produced on a radar PPI scope.



*Ans.* Heading flashes can be reproduced on a radar PPI scope in the following manner: A snap-action switch is mechanically connected to the antenna so as to be closed by a cam. The switch closes on the dead-ahead position of the antenna (coinciding with the longitudinal axis of the mobile unit). When it is closed, a different bias is applied to the indicator sweep; as a result, the sweep coinciding with the mobile unit's heading is exceptionally bright.

Range markers can be produced in the following manner: A series of differentiating circuits produces a series of pips evenly spaced at intervals corresponding to the ranges desired. When these pips are injected into the video amplifier and appear on the indicator screen, the azimuth sweep forms them into circles of illumination that can be used for calculation of distance from the target.

**Ques. 8.64.** Draw a diagram of a cathode-ray tube as used in radar, showing the principal electrodes in the tube and the path of the electron beam.

*Ans.* See the labeled diagram in Fig. 8-10.

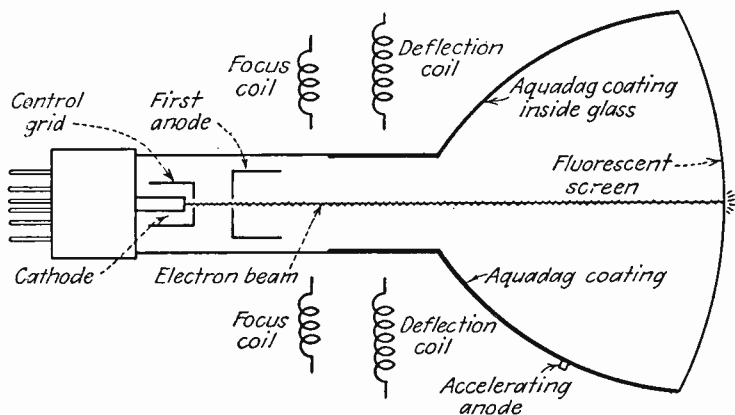

FIG. 8-10. Cross section of magnetic-deflection cathode-ray tube.

**Ques. 8.65.** What is the purpose of Aquadag coatings on radar cathode-ray tubes?

*Ans.* Aquadag is the trade name of a colloidal graphite conducting coating painted upon the inside of cathode-ray tubes in order to form an accelerating or second anode. This conducting coating also acts to some extent as an electrostatic shield to prevent external voltage gradients from deflecting the electron beam.

**Ques. 8.66.** Explain the principle of operation of the cathode-ray PPI tube, and explain the function of each electrode.

*Ans.* A simplified cross-sectional view of a typical electromagnetic-deflection cathode-ray tube is shown in Fig. 8-10. Within the electron-gun assembly at the left is a heater surrounded by a nickel cathode tube. This nickel tube is coated with oxides of various metals that give off electrons when heated. They are effectively shot out of the electron-gun assembly by the influence of the highly positive first anode through which they pass. A suitable negative voltage on the grid controls this electron flow. A still higher positive voltage on the second or accelerating anode speeds up the electron stream so that it strikes the fluorescent screen, causing light to appear wherever the screen is hit.

A movable permanent magnet or coil through which the current can be varied is used to focus the electron beam to make it hit the fluorescent screen in a small spot. Another electromagnetic-deflection coil causes the beam to move in response to signal currents.

In a set employing PPI, the antenna is rotated uniformly about a vertical axis so that the main axis of the radiated beam sweeps all angles in the horizontal plane. This gives a map-like representation of the area scanned on the screen. The range of the objects reflected back is determined by their calibrated distance from the center of the screen. Direction

is determined by the azimuth angle of the radial line from a predetermined reference point. One means of generating the sweep for the PPI is by means of a rotating yoke system, utilizing the deflection coil.

**Ques. 8.67.** What is the peak power of a radar pulse if the pulse width is 1.0 microsecond, pulse repetition rate is 900, and the average power is 18 watts? What is the duty cycle?

*Ans.* The peak power is 20 kilowatts, and the duty cycle is 0.0009.

$$\frac{\text{Average power}}{\text{Peak power}} = \frac{\text{Pulse width}}{\text{Pulse repetition time}} = \text{Duty cycle}$$

$$\text{Peak power} = \frac{(18) \times 10^6}{900} = 20,000 \text{ watts}$$

$$\text{Duty cycle} = \frac{\text{Average power}}{\text{Peak power}} = \frac{18}{20,000} = 0.0009$$

**Ques. 8.68.** What precautions should the service and maintenance operator observe when replacing the cathode-ray tube in a radar set?

*Ans.* (a) Be sure the main switch is off and all high-voltage capacitors are discharged.

(b) Wear safety goggles and gloves in case the tube should implode.

(c) When inserting horizontally into a socket, grip the neck for guidance only; support most of the weight at the screen end.

(d) If a tube does break and you get a small cut, wash all dirt away and remove the small particles. Fluorescent materials may prevent a wound from healing.

(e) Never place the tube face down unless it is protected by felt or similar soft material.

**Ques. 8.69.** Draw a simple diagram, showing how a synchro generator located in the radar antenna assembly

RADIO OPERATING QUESTIONS AND ANSWERS

is connected to a synchro motor located in the indicator to drive the deflection coils. Show proper designation of all leads, designating where a-c voltages (if needed) are applied.

Ans. See the drawing in Fig. 8-11.

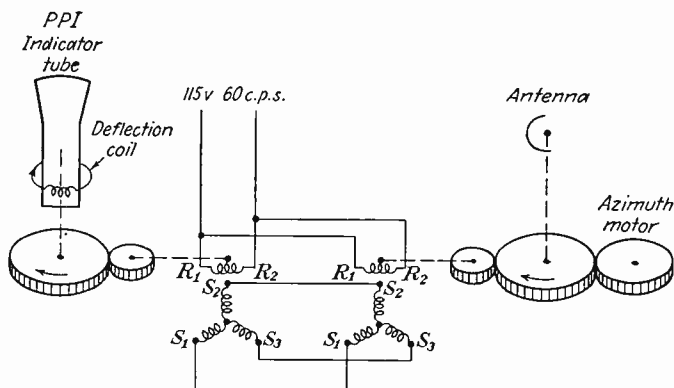

FIG. 8-11. Synchro-motor coupling between radar antenna and PPI scope.

This is the end of Element VIII.

## APPENDIX

Because of expansion of the standard miscellaneous abbreviations, official changes in the phraseology employed in the Q code, and some change in the use of punctuation and other signs in radiotelegraph procedure, it has been thought advisable to supplement the material appearing on pages 541 to 552 of the Tenth Edition of "Radio Operating Questions and Answers." This revision is based upon U. S. Department of State Publication 3509, being a literal print of the "Telecommunication Convention Final Protocol, and Radio Regulations, Atlantic City, October 2, 1947," and upon "Telegraph Regulation (Paris Revision) Annexed to International Telecommunication Convention, Atlantic City, 1947."

It is recommended that the student purchase the latest copy of "FCC Rules and Regulations, Part 13—Rules Governing Commercial Radio Operators," in order to supplement the material in the Tenth Edition, pages 553 to 562. Since these rules are still in revision, it is not practical to reproduce the current version here.

### INTERNATIONAL MORSE CODE

*With extracts from the list of punctuations and other signs contained in the  
Telegraph Regulations of the Atlantic City, 1947, Convention*

#### Letters

a · —	i ..	r · — ·
b — · · ·	j · — — —	s · · ·
c — · — ·	k — · —	t —
d — · ·	l · — · ·	u · · —
e ·	m — —	v · · · —
f · · — ·	n — ·	w · — — —
g — — — ·	o — — — —	x — · · · —
h · · · ·	p · — — — ·	y · — — — —
	q — — — · —	z — — · · ·

# RADIO OPERATING QUESTIONS AND ANSWERS

## INTERNATIONAL MORSE CODE (Continued)

### Figures

1 . — — — — —	6 — · · · · ·
2 · · — — — —	7 — — · · · ·
3 · · · — — —	8 — — — — · ·
4 · · · · — —	9 — — — — — ·
5 · · · · ·	0 — — — — — —

### Punctuation and Other Signs

Period.....	.	· — — — — —
Comma.....	,	— — — — — —
Colon.....	:	— — — — · ·
Question mark, or request for repetition of a transmission not understood.....	?	· · — — — · ·
Apostrophe.....	'	· — — — — —
Dash or hyphen.....	—	— · · · · — —
Fraction bar.....	/	— · · — — ·
Parenthesis (before and after words).....	( )	— · — — — — —
Inverted commas (quotation marks) (before and after words).....	“ ”	· — — — — —
Equal sign.....	=	— — — — —
Understood.....		· · · · ·
Error.....		· · · · ·
Cross or end of telegram or end of transmission....		· — — — — ·
Invitation to transmit.....		— — — —
Wait.....		· · · · ·
End of work.....		· · · · — —
Starting signal (beginning every transmission).....		— · — — — —

The following optional letters and signals may be used exceptionally on connections between countries allowing them:

ã · — · — —	ñ — — — · — — —
á or â · — — — —	ö — — — — ·
ch — — — — —	ü · · — — —
é · · — · ·	

Figures and letters are sent without intervening spaces. In transmitting numbers involving a fraction, a hyphen is transmitted before or after the fraction, as the case may be. For example, 44½ is sent as 44-½ (44 — · · · · — ½).

## APPENDIX

### ABBREVIATIONS AVAILABLE FOR ALL SERVICES—Q CODE

Abbreviation	Question	Answer or Advice
QRA	What is the name of your station?	The name of my station is _____.
QRB	How far approximately are you from my station?	The approximate distance between our stations is _____ nautical miles (or kilometres).
QRC	By what private enterprise (or State Administration) are the accounts for charges for your station settled?	The accounts for charges of my station are settled by the private enterprise _____ (or State Administration).
QRD	Where are you bound and where are you from?	I am bound for _____ from _____.
QRE	What is your estimated time of arrival at _____ (place)?	My estimated time of arrival at _____ (place) is _____ hours.
QRF	Are you returning to _____ (place)?	I am returning to _____ (place) or Return to _____ (place).
QRG	Will you tell me my exact frequency (or that of _____)?	Your exact frequency (or that of _____) is _____ kc/s (or Mc/s).
QRH	Does my frequency vary?	Your frequency varies.
QRI	How is the tone of my transmission?	The tone of your transmission is _____. 1. Good 2. Variable 3. Bad
QRK	What is the readability of my signals (or those of _____)?	The readability of your signals (or those of _____) is _____. 1. Unreadable 2. Readable now and then 3. Readable, but with difficulty 4. Readable 5. Perfectly readable
QRI	Are you busy?	I am busy (or I am busy with _____). Please do not interfere.
QRM	Are you being interfered with?	I am being interfered with.
QRN	Are you troubled by static?	I am troubled by static.
QRO	Shall I increase power?	Increase power.
QRP	Shall I decrease power?	Decrease power.

## RADIO OPERATING QUESTIONS AND ANSWERS

### ABBREVIATIONS AVAILABLE FOR ALL SERVICES—Q CODE (Continued)

Abbr- viation	Question	Answer or Advice
QRQ	Shall I send faster?	Send faster (___ words per minute).
QRR	Are you ready for automatic operation?	I am ready for automatic operation. Send at ___ words per minute.
QRS	Shall I send more slowly?	Send more slowly (___ words per minute).
QRT	Shall I stop sending?	Stop sending.
QRU	Have you anything for me?	I have nothing for you.
QRV	Are you ready?	I am ready.
QRW	Shall I inform ___ that you are calling him on ___ kc/s (or Mc/s)?	Please inform ___ that I am calling him on ___ kc/s (or Mc/s).
QRX	When will you call me again?	I will call you again at ___ hours [on ___ kc/s (or Mc/s)].
QRY	What is my turn? (Relates to communication)	Your turn is Number ___ (or according to any other indication.) (Relates to communication.)
QRZ	Who is calling me?	You are being called by ___ [on ___ kc/s (or Mc/s)].
QSA	What is the strength of my signals (or those of ___)?	The strength of your signals (or those of ___) is ____. <ol style="list-style-type: none"> <li>1. Scarcely perceptible</li> <li>2. Weak</li> <li>3. Fairly good</li> <li>4. Good</li> <li>5. Very good</li> </ol>
QSB	Are my signals fading?	Your signals are fading.
QSC	Are you a cargo vessel?	I am a cargo vessel.
QSD	Is my keying defective?	Your keying is defective.
QSG	Shall I send ___ telegrams at a time?	Send ___ telegrams at a time.
QSI		I have been unable to break in on your transmission. <i>or</i> Will you inform ___ (call sign) that I have been unable to break in on his transmission [on ___ kc/s (or Mc/s)].



APPENDIX

ABBREVIATIONS AVAILABLE FOR ALL SERVICES—Q CODE (Continued)

Abbreviation	Question	Answer or Advice
QJSJ	What is the charge to be collected per word to ____ including your internal telegraph charge?	The charge to be collected per word to ____ including my internal telegraph charge is ____ francs.
QSK	Can you hear me between your signals?	I can hear you between my signals.
QSL	Can you acknowledge receipt?	I am acknowledging receipt.
QSM	Shall I repeat the last telegram which I sent you, <i>or</i> some previous telegram?	Repeat the last telegram which you sent me [ <i>or</i> telegram(s) number(s) ____].
QSN	Did you hear me [ <i>or</i> ____ (call sign)] on ____ kc/s ( <i>or</i> Mc/s)?	I did hear you [ <i>or</i> ____ (call sign)] on ____ kc/s ( <i>or</i> Mc/s).
QSO	Can you communicate with ____ direct <i>or</i> by relay?	I can communicate with ____ direct ( <i>or</i> by relay through ____).
QSP	Will you relay to ____ free of charge?	I will relay to ____ free of charge.
QSQ	Have you a doctor on board [ <i>or</i> is ____ (name of person) on board]?	I have a doctor on board [ <i>or</i> ____ (name of person) is on board].
QSU	Shall I send <i>or</i> reply on this frequency [ <i>or</i> on ____ kc/s ( <i>or</i> Mc/s)] (with emissions of class ____)?	Send <i>or</i> reply on this frequency [ <i>or</i> on ____ kc/s ( <i>or</i> Mc/s)] (with emissions of class ____).
QSV	Shall I send a series of V's on this frequency [ <i>or</i> ____ kc/s ( <i>or</i> Mc/s)]?	Send a series of V's on this frequency [ <i>or</i> ____ kc/s ( <i>or</i> Mc/s)].
QSW	Will you send on this frequency [ <i>or</i> on ____ kc/s ( <i>or</i> Mc/s)] (with emissions of class ____)?	I am going to send on this frequency [ <i>or</i> on ____ kc/s ( <i>or</i> Mc/s)] (with emissions of class ____).
QSX	Will you listen to ____ [ <i>call sign(s)</i> ] on ____ kc/s ( <i>or</i> Mc/s)?	I am listening to ____ [ <i>call sign(s)</i> ] on ____ kc/s ( <i>or</i> Mc/s).
QSY	Shall I change to transmission on another frequency?	Change to transmission on another frequency [ <i>or</i> on ____ kc/s ( <i>or</i> Mc/s)].
QSZ	Shall I send each word <i>or</i> group more than once?	Send each word <i>or</i> group twice ( <i>or</i> ____ times).

## RADIO OPERATING QUESTIONS AND ANSWERS

### ABBREVIATIONS AVAILABLE FOR ALL SERVICES—Q CODE (Continued)

Abbreviation	Question	Answer or Advice
QTA	Shall I cancel telegram number _____ as if it had not been sent?	Cancel telegram number _____ as if it had not been sent.
QTB	Do you agree with my counting of words?	I do not agree with your counting of words; I will repeat the first letter or digit of each word or group.
QTC	How many telegrams have you to send?	I have _____ telegrams for you (or for _____).
QTE	What is my TRUE bearing from you? <i>or</i> What is my TRUE bearing from _____ (call sign)? <i>or</i> What is the TRUE bearing of _____ (call sign) from _____ (call sign)?	Your TRUE bearing from me is _____ degrees (at _____ hours) <i>or</i> Your TRUE bearing from _____ (call sign) was _____ degrees (at _____ hours) <i>or</i> The TRUE bearing of _____ (call sign) from _____ (call sign) was _____ degrees at _____ hours.
QTF	Will you give me the position of my station according to the bearings taken by the direction-finding stations which you control?	The position of your station according to the bearings taken by the direction-finding stations which I control was _____ latitude, _____ longitude, class _____ at _____ hours.
QTG	Will you send two dashes of ten seconds each followed by your call sign (repeated _____ times) [on _____ kc/s (or Mc/s)]? <i>or</i> Will you request _____ to send two dashes of ten seconds followed by his call sign (repeated _____ times) on _____ kc/s (or Mc/s)?	I am going to send two dashes of ten seconds each followed by my call sign (repeated _____ times) [on _____ kc/s (or Mc/s)] <i>or</i> I have requested _____ to send two dashes of ten seconds followed by his call sign (repeated _____ times) on _____ kc/s (or Mc/s).

APPENDIX

ABBREVIATIONS AVAILABLE FOR ALL SERVICES—Q CODE (Continued)

Abbreviation	Question	Answer or Advice
QTH	What is your position in latitude and longitude (or according to any other indication)?	My position is ____ latitude ____ longitude (or according to any other indication).
QTI	What is your TRUE track?	My TRUE track is ____ degrees.
QTI	What is your speed?  (Requests the speed of a ship or aircraft through the water or air respectively.)	My speed is ____ knots (or kilometres per hour).  (Indicates the speed of a ship or aircraft through the water or air respectively.)
QTK	What is the speed of your aircraft in relation to the surface of the earth?	The speed of my aircraft in relation to the surface of the earth is ____ knots (or kilometres per hour).
QTL	What is your TRUE heading (TRUE course with no wind)?	My TRUE heading is ____ degrees.
QTN	At what time did you depart from ____ (place)?	I departed from ____ (place) at ____ hours.
QTO	Have you left dock (or port)? or Are you airborne?	I have left dock (or port) or I am airborne.
QTP	Are you going to enter dock (or port)? or Are you going to alight (or land)?	I am going to enter dock (or port) or I am going to alight (or land).
QTQ	Can you communicate with my station by means of the International Code of Signals?	I am going to communicate with your station by means of the International Code of Signals.
QTR	What is the correct time?	The correct time is ____ hours.
QTS	Will you send your call sign for ____ minute(s) now (or at ____ hours) [on ____ kc/s (or Mc/s)] so that your frequency may be measured?	I will send my call sign for ____ minute(s) now (or at ____ hours) [on ____ kc/s (or Mc/s)] so that my frequency may be measured.
QTU	What are the hours during which your station is open?	My station is open from ____ to ____ hours.

## RADIO OPERATING QUESTIONS AND ANSWERS

### ABBREVIATIONS AVAILABLE FOR ALL SERVICES—Q CODE (*Continued*)

Abbreviation	Question	Answer or Advice
QTV	Shall I stand guard for you on the frequency of ____ kc/s (or Mc/s) (from ____ to ____ hours)?	Stand guard for me on the frequency of ____ kc/s (or Mc/s) (from ____ to ____ hours).
QTX	Will you keep your station open for further communication with me until further notice (or until ____ hours)?	I will keep my station open for further communication with you until further notice (or until ____ hours).
QUA	Have you news of ____ (call sign)?	Here is news of ____ (call sign).
QUB	Can you give me, in the following order, information concerning: visibility, height of clouds, direction and velocity of ground wind at ____ (place of observation)?	Here is the information requested.
QUC	What is the number (or other indication) of the last message you received from me [or from ____ (call sign)]?	The number (or other indication) of the last message I received from you [or from ____ (call sign)] is ____.
QUD	Have you received the urgency signal sent by ____ (call sign of mobile station)?	I have received the urgency signal sent by ____ (call sign of mobile station) at ____ hours.
QUF	Have you received the distress signal sent by ____ (call sign of mobile station)?	I have received the distress signal sent by ____ (call sign of mobile station) at ____ hours.
QUG	Will you be forced to alight (or land)?	I am forced to alight (or land) immediately. <i>or</i> I shall be forced to alight (or land) at ____ (position or place).
QUH	Will you give me the present barometric pressure at sea level?	The present barometric pressure at sea level is ____ (units).
QUI	Are your navigation lights working?	My navigation lights are working.

APPENDIX

ABBREVIATIONS AVAILABLE FOR ALL SERVICES—Q CODE (Continued)

Abbreviation	Question	Answer or Advice
QUJ	Will you indicate the TRUE course for me to steer toward you (or _____) with no wind?	The TRUE course for you to steer toward me (or _____) with no wind is _____ degrees at _____ hours.
QUK	Can you tell me the condition of the sea observed at _____ (place or coordinates)?	The sea at _____ (place or coordinates) is _____.
QUL	Can you tell me the swell observed at _____ (place or coordinates)?	The swell at _____ (place or coordinates) is _____.
QUM	Is the distress traffic ended?	The distress traffic is ended.
QUN	Will vessels in my immediate vicinity [(or in the vicinity of _____ latitude _____ longitude) (or of _____)] please indicate their position, TRUE course, and speed?	My position, TRUE course, and speed are _____.
QUO	Shall I search for _____ 1. Aircraft 2. Ship 3. Survival craft in the vicinity of _____ latitude _____ longitude (or according to any other indication)?	Please search for _____ 1. Aircraft 2. Ship 3. Survival craft in the vicinity of _____ latitude _____ longitude (or according to any other indication).
QUP	Will you indicate your position by _____? 1. Searchlight 2. Black smoke trail 3. Pyrotechnic lights	My position is indicated by _____ 1. Searchlight 2. Black smoke trail 3. Pyrotechnic lights
QUQ	Shall I train my searchlight nearly vertical on a cloud, occulting if possible, and if your aircraft is seen, deflect the beam up wind and on the water (or land) to facilitate your landing?	Please train your searchlight on a cloud, occulting if possible, and, if my aircraft is seen or heard, deflect the beam up wind and on the water (or land) to facilitate my landing.

## RADIO OPERATING QUESTIONS AND ANSWERS

### ABBREVIATIONS AVAILABLE FOR ALL SERVICES—Q CODE (Continued)

Abbreviation	Question	Answer or Advice
QUR	Have survivors ____? 1. Received survival equipment 2. Been picked up by rescue vessel 3. Been reached by ground rescue party	Survivors ____. 1. Are in possession of survival equipment dropped by ____ 2. Have been picked up by rescue vessel 3. Have been reached by ground rescue party
QUS	Have you sighted survivors or wreckage? If so, in what position?	Have sighted ____ 1. Survivors in water 2. Survivors on rafts 3. Wreckage in position ____ latitude ____ longitude (or according to any other indication).
QUT	Is position of incident marked?	Position of incident is marked (by ____).
QUU	Shall I home ship or aircraft to my position?	Home ship or aircraft 1. ____ (call sign) to your position by transmitting your call sign and long dashes on ____ kc/s (or Mc/s) 2. ____ (call sign) by transmitting on ____ kc/s (or Mc/s) courses to steer to reach you
QUV	What is my MAGNETIC bearing from you (or from ____)? <i>(This signal, in general, will not be used in the Maritime Mobile Service.)</i>	Your MAGNETIC bearing from me (or from ____) was ____ degrees at ____ hours. <i>(This signal, in general, will not be used in the Maritime Mobile Service.)</i>
QUX	Will you indicate the MAGNETIC course for me to steer toward you (or ____) with no wind? <i>(This signal, in general, will not be used in the Maritime Mobile Service.)</i>	The MAGNETIC course for you to steer to reach me (or ____) with no wind was ____ degrees at ____ hours. <i>(This signal, in general, will not be used in the Maritime Mobile Service.)</i>

## APPENDIX

### MISCELLANEOUS ABBREVIATIONS AND SIGNALS

Abbreviation or Signal	Definition
AA	All after ____ (used after a question mark to request a repetition).
AB	All before ____ (used after a question mark to request a repetition).
ABV	Repeat (or I repeat) the figures in abbreviated form.
ADS	Address (used after a question mark to request a repetition).
AR	End of transmission (· — · — · to be sent as one signal).
AS	Waiting period (· — · · · to be sent as one signal).
BK	Signal used to interrupt a transmission in progress.
BN	All between ____ and ____ (used after a question mark to request a repetition).
BQ	A reply to an RQ.
C	Yes.
CFM	Confirm (or I confirm).
CL	I am closing my station.
COL	Collate (or I collate).
CP	General call to two or more specified stations.
CQ	General call to all stations.
CS	Call sign (used to request a call sign).
DB	I cannot give you a bearing; you are not in the calibrated sector of this station.
DC	The minimum of your signal is suitable for the bearing.
DF	Your bearing at ____ (time) was ____ degrees, in the doubtful sector of this station, with a possible error of ____ degrees.
DG	Please advise me if you note an error in the bearing given.
DI	Bearing doubtful in consequence of the bad quality of your signal.
DJ	Bearing doubtful because of interference.
DO	Bearing doubtful. Ask for another bearing later [or at ____ (time)].
DP	Possible error of bearing may amount to ____ degrees.
DS	Adjust your transmitter; the minimum of your signal is too broad.
DT	I cannot furnish you with a bearing; the minimum of your signal is too broad.
DY	This station is not able to determine the sense of the bearing. What is your approximate direction relative to this station?

# RADIO OPERATING QUESTIONS AND ANSWERS

## MISCELLANEOUS ABBREVIATIONS AND SIGNALS (*Continued*)

Abbreviation or Signal	Definition
DZ	Your bearing is reciprocal. ( <i>To be used only by the control station of a group of direction-finding stations when it is addressing stations of the same group.</i> )
DE	Used to separate the call sign of the station called from the call sign of the calling station.
ER	Here _____.
ETA	Estimated time of arrival.
ITP	The punctuation counts.
JM	Make a series of dashes if I may transmit. Make a series of dots to stop my transmission ( <i>not to be used on 500 kc/s except in cases of distress</i> ).
K	Invitation to transmit.
MN	Minute ( <i>or Minutes</i> ).
MSG	Prefix indicating a message to or from the master of a ship concerning its operation or navigation.
N	No.
NIL	I have nothing to send to you.
NW	Now.
OK	We agree ( <i>or It is correct</i> ).
P	Prefix indicating a private radiotelegram.
PBL	Preamble ( <i>used after a question mark to request a repetition</i> ).
PTR	Used by a coast station to request the position and next port of call of a mobile station.
R	Received.
REF	Reference to _____ ( <i>or Refer to _____</i> ).
RPT	Repeat ( <i>or I repeat</i> ) ( <i>or Repeat _____</i> ).
RQ	Indication of a request.
SIG	Signature ( <i>used after a question mark to request a repetition</i> ).
<u>SOS</u>	Distress Signal ( <i>... — — — ... to be sent as one signal</i> ).
SS	Indicator preceding the name of a ship station.
SVC	Prefix indicating a service telegram.
SYS	Refer to your service telegram.
TFC	Traffic.
TR	Used as a prefix to indicate reply to PTR.
TTT	This group when sent three times constitutes the safety signal.
TU	Thank you.
TXT	Text ( <i>used after a question mark to request a repetition</i> ).



## APPENDIX

### MISCELLANEOUS ABBREVIATIONS AND SIGNALS (Continued)

Abbreviation or Signal	Definition
VA	End of work (· · · — · — to be sent as one signal).
W	Word(s) or [Group(s)].
WA	Word after — (used after a question mark to request a repetition).
WB	Word before — (used after a question mark to request a repetition).
XXX	This group when sent three times constitutes the urgency signal.

### RADIOTELEPHONE WORD LIST

International procedure in the Mobile Radiotelephone Service requires that when it is necessary to spell out call signs, service abbreviations, and words, the following table is used. However, stations of the same country may use, when communicating between themselves, any other list of words recognized by their administration.

A.....	Amsterdam	N.....	New York
B.....	Baltimore	O.....	Oslo
C.....	Casablanca	P.....	Paris
D.....	Danemark	Q.....	Quebec
E.....	Edison	R.....	Roma
F.....	Florida	S.....	Santiago
G.....	Gallipoli	T.....	Tripoli
H.....	Havana	U.....	Upsala
I.....	Italia	V.....	Valencia
J.....	Jerusalem	W.....	Washington
K.....	Kilogramme	X.....	Xantippe
L.....	Liverpool	Y.....	Yokohama
M.....	Madagascar	Z.....	Zurich

Figures and punctuation to be transmitted by radiotelephone. Each transmission of figures is preceded and followed by the words "as a number" spoken twice.

1	6	Comma
2	7	Fraction bar
3	8	Break signal
4	9	Full stop (period)
5	0	



## INDEX

### A

- Antenna, radar, effect of dirt on, 48
  - parabolic, 47
  - placement, 44
  - synchro to PPI, 61-62
- Anti T-R box, for radar duplexer, 50-51
- Aquadag coating in cathode-ray tube, 60-61
- Artificial respiration, how administered, 17
- Artificial transmission line, circuit of, 57
  - in radar set, 57
- Auto-alarm operation required, 2
- AVC, use of, in radiotelegraph, 32
  - in radiotelephone, 32
- Average power of radar pulse, 61

### B

- Bearing resolution of radar set, 58-59
- Blocking oscillator, operating frequency of, 58
- Blocking of receiver by strong signals, 33
- Break-in operation, 32
- Broadcast station, operator required, 5

### C

- Carrier frequency, definition of, 19
- Carrier wave, definition of, 19

- Cathode-ray tube, precautions in handling, 61
  - principle of operation, 60
- Code and cipher groups, 29
- Construction permit, when required, 1
- Crystal filter, use of, in receiver, 32-33
- Crystal rectifier, care in handling, 54

### D

- Detector in radar receiver, 55
- Direction finder, when required, 2
- Discriminator, purpose of, in radar receiver, 55
  - for radar receiver AFC, 51
- Distance measurement by radar, 55-56
- Distress signal, 26
- Duplex system, 11-12
- Duty cycle of radar pulse, 58

### E

- Echo box for radar test, 48-49
- Electric shock, rescue from, 17, 18
- Electric storms, 18
- Emission types, definitions of, 21-22
- Equipment, control of, by licensee, 8
- Equipment operation (*see* Operation)

## RADIO OPERATING QUESTIONS AND ANSWERS

### F

- Fire extinguisher for electrical fires, 16
- Fire in radio equipment, 16
- Flashing pie sections on ship radar, 41-42
- Fractions, procedure in radiotelegraph, 28, 64
- Frequency assignment for ship radar, 38
- Frequency deviation, FM mobile stations, 23-24
- Frequency ranges, definitions of, 21
- Frequency standard for radio stations, 19
- Fuse, purpose of, in equipment, 15  
replacement of, 15

### G

- General call, radiotelegraph, 27
- Grass on Loran, elimination of, 40-41
- Grounding equipment, importance of, 41

### H

- Hazard, of fire from radar, 44  
in handling cathode-ray tube, 61  
to radar serviceman, 43-44
- Heading flash of radar, how obtained, 59

### I

- Identification of station, 4, 8
- Image-frequency signals, 33-34
- Interference, to Government station, 1  
from long radar lines, 40

- Interference, from ship radar, 38, 39  
to communications receiver, 40  
to DF equipment, 39  
equipment affected by, 41  
frequency range of, 39  
to Loran, 39, 40

- Intermediate frequency in radar, 54

### K

- "Keep alive" voltage, purpose of, 54-55
- Keying technique, adjusting bug key, 34-35  
adjusting hand key, 34
- Klystron, reflex, principle of operation, 53-54  
use of, in radar, 53

### L

- License, to non-citizen, 3  
operator, term of, 3  
posting of, 26
- Lightning hazards, 18
- Listening fatigue, radiotelegraph, 31-32
- Log entries, operating, 16-17  
radar installation, 37  
radar maintenance, 37  
of routine measurements, 24  
of service and maintenance, 23  
time, 17

### M

- Magnetron, cross-sectional diagram, 51-52  
effect of weak magnet in, 42  
grounded anode in, 53  
precautions in handling, 43  
principle of operation, 51-52  
symptoms of defect in, 42

## INDEX

- Measurements, how often required, 24
- Message exchange, when required, 1
- Message handling, collating, 29  
forms used, 28  
meaning of preamble, 28  
service indicator, 28
- Mixer crystal, symptoms of defect in, 42  
tests for defects in, 42
- Modulation percentage, AM mobile stations, 23-24
- Multiple signals, cause of, 33-34
- N
- Numbering messages, 29
- O
- Operating procedure (*see* Procedure)
- Operating signals, error, 27  
in radiotelegraphy, 27, 65-75  
test, 27  
transmitting fractions, 28, 64
- Operation, battery charging, 13  
changing frequency, 12  
equipment warm-up, 12  
mobile transmitter, 12-13  
of receiver for A2 signals, 33  
receiving CW signals, 33
- Operator, privileges of, 4, 5, 25, 26  
required, for cargo vessel, 2  
in lieu of auto-alarm, 2
- Operator license, posting of, 23
- P
- Peak power of radar pulse, 58
- Penalty for violations, 2, 3
- Phonetic alphabet, 10, 75
- PPI, radar, synchro to antenna, 61-62
- PPI tube in radar, principle of operation, 61
- Privacy of communications, 11
- Procedure, abbreviations, 10, 11, 65-75  
answering a call, 31  
before calling, 8  
calling, 7, 12, 31  
dead-air time, 8  
during interference, 8-9, 11  
length of calls, 7-8  
microphone technique, 9, 10  
order of handling traffic, 30-31  
radio communications, 7  
requesting double sending, 29  
transmitter test, 13
- Public correspondence, definition of, 31
- Pulse-forming delay line in radar set, 57
- Pulse repetition rate, component controlling, 57-58
- Q
- Q code, definitions of, 30, 65-72  
reason for use of, 30
- R
- Radar duplexer, block diagram, 50-51
- Radar maintenance, operator license requirement, 36  
by unlicensed personnel, 38
- Radar operation, licensing requirement, 37
- Radar receiver, block diagram, 51  
discriminator, 51
- Radar system, block diagram, 49  
principle of operation, 50

## RADIO OPERATING QUESTIONS AND ANSWERS

- Radio communications services, definitions of, by FCC, 19-21
- Range markers of radar, how obtained, 59
- Receiver, radar, crystal mixer, 53
- Receiver operation (*see* Operation)
- S
- Safety signal, 26
- Sea return, definition of, 55
- Sending speed, of distress traffic, 27  
limit of, 31
- Sensitivity time control, purpose of, 55
- Service area, from mobile station, 13, 14, 16  
of transmitter, 9
- Service message, 29
- Service prefix, radiotelegraph, 28
- Signal strength, numerical scale, 30
- Silent period, when required, 1
- Simplex system, 11-12
- Smoke in radio equipment, 16
- Spark gap, rotary, in radar set, 58
- Squelch control, during static, 14  
purpose of, 14  
for weak signals, 14
- Station identification by radiotelegraphy, 26
- Station license, requirement for, 7
- Synchro system, radar set, 61-62
- T
- Target distance, in radar set, 55-56
- Testing after long stand-by, 16
- Time, system used for, 17, 29
- Tower lights, 6
- Transmitter operation (*see* Operation)
- T-R box for radar duplexer, 50-51
- Tube-replacement precautions, 15-16
- Tuning eye, in-tune position, 14-15
- U
- Urgency signal, 26
- W
- Wave guide, antenna feed, 46  
choke-joint, installation, 46  
principle of, 46-47  
vs. flange joint, 46  
vs. coaxial line, 45  
construction of, 44-45  
drain for moisture in, 45  
installation of, 45  
rectangular vs. round, 45-46
- Word count in messages, 28-29