

performance-tested

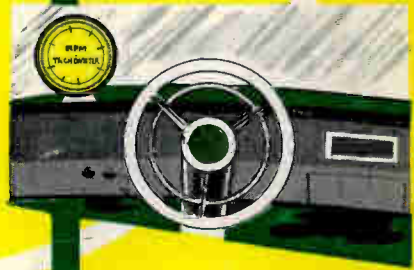

TRANSISTOR *Circuits*



*Contains
36
circuits*

**HOW TO BUILD
TRANSISTORIZED
TEST EQUIPMENT
HIGH FIDELITY COMPONENTS
PHOTOGRAPHY LIGHT METER
AUTOMOBILE TACHOMETER
BURGLAR ALARM
TRANSISTORIZED ORGAN
METRONOME**

SYLVANIA ELECTRIC PRODUCTS INC.



35c

PERFORMANCE - TESTED TRANSISTOR CIRCUITS

A Manual of Practical Applications



SYLVANIA ELECTRIC PRODUCTS INC.
SEMICONDUCTOR DIVISION
100 SYLVAN ROAD • WOBURN, MASS.

Copyright, 1958
SYLVANIA ELECTRIC PRODUCTS INC.
FIRST EDITION
2nd PRINTING

PREFACE

This manual of practical transistor circuits has been prepared from data obtained from the actual construction and testing of the many circuits.

While the booklet was written primarily for hobbyists, we believe that others associated with electronics will find the material of interest.

Basic theory has been held to a minimum since considerable theoretical discussion is readily available.

In presenting this booklet, which will join the Sylvania family of publications on the practical applications of transistors, we hope to satisfy the need voiced by innumerable hobbyists for practical circuits with which they may get acquainted with transistors.

Acknowledgment is given to the Sylvania Semiconductor Applications Engineering Group at Woburn, Massachusetts, and to Transistor Applications, Inc. of Boston, Massachusetts, for originating circuits and preparing text material for this booklet.

No license is to be implied with respect to any inventions described herein, and no responsibility is assumed for the application or interpretation of the information contained herein, or for any infringement of patent or other rights of third parties which may result from the use of that information.

Sylvania Electric Products Inc.

CONTENTS

	<i>Page No.</i>
Elementary Transistor Theory	1
1. Automobile Tachometer	7
2. Voice Actuated Relay	8
3. Remote Temperature Indicator	9
4. Burglar Alarm	10
5. Fire Alarm	11
6. Computer Logic Circuit	11
7. Computer Logic Circuit or Building Block	12
8. High Voltage Power Supply	13
9. Geiger Tube Counting Rate Circuit	14
10. Electrolysis Detector	15
11. Blinker Light	16
12. Blinker with Alternating Lights	18
13. Timer Circuit	19
14. Sensitive Photo-Relay Circuit	21
15. Differential Photo-Relay	23
16. High Sensitivity Differential Photo-Relay	25
17. 6 Volt Power Supply	26
18. 12 Volt Power Supply	27
19. 50-60 KC Power Oscillator	28
20. D.C. to D.C. Converter	29
21. 6 Volt D.C. to 12 Volt D.C. Converter	31
22. Stroboscope Circuit	32
23. Induction Transceiver	34
24. Code Practice Oscillator	35
25. 30 MW Audio Pre-amplifier	36
26. Class A, 2 Watt Audio Amplifier	37
27. Class B, 8 Watt Audio Amplifier	38
28. One Transistor Pocket Radio	39
29. Transistor Dynamic Microphone	40
30. Regenerative Broadcast Receiver	41
31. Wireless Phono Oscillator	41
32. 100-1000 KC Frequency Standard	42
33. Transistorized Organ	43
34. Metronome	45
35. Photography Light Meter	46
36. Binary Counter	47
Sylvania Transistors—Ratings & Characteristics	50

LIST OF SCHEMATIC DIAGRAMS

<i>Figure No.</i>	<i>Title</i>	<i>Page No.</i>
Figure 1-1.	Junctions Transistors Forms and Symbols	1
Figure 1-2.	Transistor Bias and Signal Connections	2
Figure 1-3.	Circuit to Demonstrate High Base Collector Current Amplification	3
Figure 1-4.	Transistor Configurations	4
Figure 1.	Automobile Tachometer Full Scale, 5000 r.p.m.	7
Figure 2.	Voice Actuated Relay	8
Figure 3.	Remote Temperature Indicator	9
Figure 4.	Burglar Alarm	10
Figure 5.	Fire Alarm	11
Figure 6.	Computer Logic Circuit	12
Figure 7.	Computer Logic Circuit or Building Block	12
Figure 8.	High Voltage Power Supply	13
Figure 9.	Geiger Tube Counting Rate Circuit	14
Figure 10.	Electrolysis Detector	15
Figure 11.	Blinker Light	17
Figure 12.	Blinker with Alternating Lights	18
Figure 13.	Timer Circuit	20
Figure 14.	Sensitive Photo-Relay Circuit	22
Figure 15.	Differential Photo-Relay	24
Figure 16.	High Sensitivity Differential Photo-Relay	25
Figure 17.	6 Volt Power Supply	26
Figure 18.	12 Volt Power Supply	27
Figure 19.	50-60 KC Power Oscillator	28
Figure 20.	D.C. to D.C. Converter	30
Figure 21.	6 Volt D.C. to 12 Volt D.C. Converter	31
Figure 22.	Stroboscope Circuit	33
Figure 23.	Induction Transceiver	34
Figure 24.	Code Practice Oscillator	35
Figure 25.	30 MW Audio Pre-amplifier	36
Figure 26.	Class A, 2 Watt Audio Amplifier	37
Figure 27.	Class B, 8 Watt Audio Amplifier	38
Figure 28.	One Transistor Pocket Radio	39
Figure 29.	Transistor Dynamic Microphone	40
Figure 30.	Regenerative Broadcast Receiver	41
Figure 31.	Wireless Phono Oscillator	42
Figure 32.	100-1000 KC Frequency Standard	43
Figure 33.	Transistorized Organ	44
Figure 34.	Metronome	45
Figure 35.	Photography Light Meter	47
Figure 36.	Binary Counter	48

Elementary Transistor Theory

The transistor performs many of the functions formerly possible only with vacuum tubes. As an amplifying device, the transistor is smaller than the tube, has no filament, and can be operated in any position. It also is non-microphonic, mechanically rugged, and makes more efficient use of its d-c power supply than the tube does. Transistors can oscillate with only a few microwatts of d-c input power.

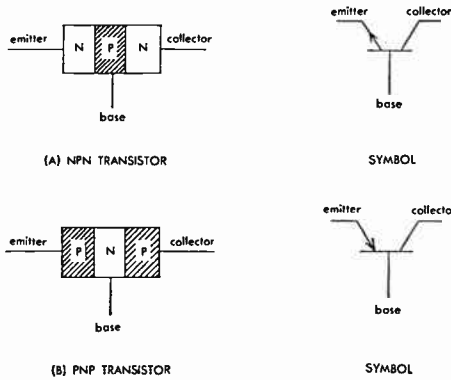

FIGURE 1-1—Junction Transistor Forms and Symbols.

Experimental transistors have been made from several semiconductor materials, but most commercial units presently are made from germanium. Sylvania was one of the pioneers in the use of the germanium in the crystal diode, predecessor of the transistor.

The heart of the junction-type transistor is a thin wafer of highly-refined germanium into which three distinct conduction regions have been created by introducing controlled amounts of certain chemical impurities. A wire lead is attached to each of these regions.

These regions are designated as *N-type* germanium when the added impurity is a material rich in electrons, and *P-type* when the material is deficient in electrons—or, to another way of saying, rich in *holes*. Electric conduction through an N-type semiconductor is by means of electrons, and through a P-type semiconductor by means of holes. Holes travel through the material somewhat more slowly than electrons.

The arrangement of the conduction layers in the germanium wafer is shown in Figure 1-1. In this illustration, the P and N regions have been magnified for the sake of clarity, but in reality they are quite thin. Figure 1-1 (A) shows the cross section and circuit symbol of the NPN type of junction transistor, while Figure 1-1 (B) shows the PNP type. In each type, one outer layer is termed the *emitter* electrode, the center layer the *base*, and the other outer layer the *collector*. Emitter, base, and collector correspond roughly to cathode, grid, and plate of a triode tube.

To complete the transistor, the processed 3-region germanium wafer is hermetically-sealed in a suitable casing and its three pigtail leads brought out through an insulating header for circuit connections.

The N-P and P-N junctions processed into the germanium (see Figure 1-1) form equivalent crystal diodes. When a d-c voltage is applied to either junction in such a way that the N region is made negative and the P region positive, a high forward current flows. Conversely, when the N region is positive and the P region negative, a low reverse current flows. Thus, the junction exhibits the properties of high forward current, low reverse current, and rectification which characterize the crystal diode.

In a transistor, the emitter electrode is so called because this electrode, when d-c biased for forward current flow, effectively injects or emits current carriers (electrons or holes) into the center base region of the germanium wafer. The collector receives its name from the fact that this electrode, when d-c biased for reverse current flow, apparently collects these carriers which then increase the reverse current. In the NPN transistor, the injected carriers are electrons from the N-type emitter layer; in the PNP type, they are holes from the P-type emitter layer.

DC Biasing. Figure 1-2 shows how the transistor is connected to sources of emitter and collector d-c bias voltage, and the points at which signals might be fed in and taken out. Figure 1-2 (A) shows connections for the PNP transistor; Figure 1-2 (B) for the NPN type.

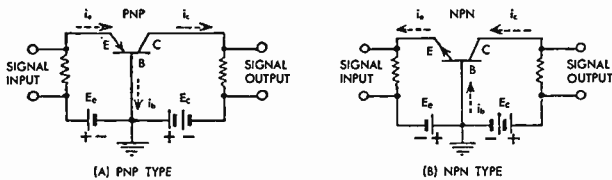

FIGURE 1-2—Transistor Bias and Signal Connections.

In each case, the emitter supply (E_E) biases the emitter junction in the forward (low resistance, high-current) direction, and the collector supply (E_C) biases the collector junction in the reverse (high-resistance, low-current) direction. Because of the difference in emitter and collector resistance, E_C can be much higher than E_E . A steady value of emitter current (I_E) flows through the emitter junction. The corresponding steady value of collector current (I_C) is proportional to the emitter current. When the emitter voltage is reduced to zero, while maintaining the collector voltage, a small static value of collector current (*cutoff* or *leakage* current, I_{CO}) flows through the high resistance of the collector junction.

Operation, Current Gain (Alpha). In the PNP transistor, the emitter injects positive holes. These carriers travel through the base region

where a few are neutralized by the electrons in the N-type germanium found there. But the base is very thin, so most of the holes survive to reach the collector junction where they are attracted by the strong negative field due to the high collector voltage. They succeed in increasing the collector current from the low I_{co} value to a higher level. If all of the holes injected by the emitter managed to reach the collector, the final collector current would equal the emitter current and the transistor would be considered to have an emitter-collector current gain (α , alpha) of 1. However, some holes do recombine with electrons in the base region and thus can contribute nothing to the increase in collector current. In practice, therefore, alpha for a junction transistor approaches unity but usually does not reach this value. Practical values range from 0.80 to 0.999 in commercial junction transistors. Alpha is comparable to the amplification, μ , of a vacuum tube.

The NPN junction transistor operates in the same manner, except that the injected carriers are electrons which pass through a P-type (hole-rich) base region toward a *positively*-charged collector.

The forward resistance of the emitter junction is designated R_E , the reverse resistance of the collector R_C , the emitter voltage drop V_E , and the collector voltage drop V_C . Base current I_B , is very small compared to either I_C or I_E because of the few carriers available for this current flow. From the current and voltage relationships, the emitter and base resistances are seen to be low in value and the collector resistance high.

Voltage and Power Amplification. Although the foregoing explanation shows the transistor essentially to be a current-operated device, the transistor can display voltage and power amplification as well. In Figure 1-2, input signal is applied in series with the d-c emitter bias, E_E . Signal-voltage fluctuations cause corresponding fluctuations in emitter current, I_E , and in turn in collector current, I_C . Although the current gain is slightly less than 1 in this case, the collector resistance level, as previously explained, is higher than the emitter circuit resistance level, and the output-signal voltage therefore is larger than the input-signal voltage. Power amplification also results because of this resistance ratio. The magnitude of voltage and power amplification depends upon various other parameters which must be taken into consideration in accurate calculations. These parameters include load resistance and generator resistance.

Base-Collector Current Amplification (Beta). In Figure 1-2, the base is the transistor electrode common to both input and output circuits.

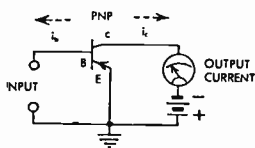

FIGURE 1-3—Circuit to Demonstrate High Base-Collector Current Amplification.

In this arrangement, the current amplification factor, *alpha*, is the ratio of a collector current change to the emitter current change and must be less than unity. A different situation results when the emitter is made the common electrode, as in Figure 1-3.

In this arrangement, a small current (I_B) flows out of the base and produces a large change in collector current (I_C). In practice, I_B is in microamperes and I_C in milliamperes. This base-collector current amplification, which is many times the alpha value for the same transistor, is designated β (beta) and is related to alpha in the following respect: $\beta = \alpha / (1 - \alpha)$.

A PNP transistor is shown in Figure 1-3, but an NPN type may be used with the same results if the battery polarities are reversed.

Transistor Circuit Configurations

Depending upon which of its terminals are used for input and output, a transistor may be connected into its circuit in any one of three ways. These configurations, illustrated in Figure 1-4, are termed common-base, common-emitter, and common-collector.

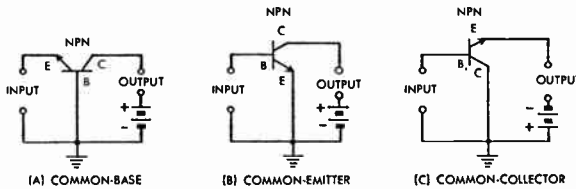

FIGURE 1-4—Transistor Configurations.

The common-base roughly is equivalent to the grounded-grid vacuum-tube amplifier, the common emitter to the grounded-cathode, and the common-collector to the cathode follower. The common-base will be recognized as the type of circuit shown earlier in Figure 1-2, and the common-emitter in Figure 1-3. While NPN transistors are shown in Figure 1-4, PNP units can be used by reversing the battery connections. The common-emitter is the only transistor configuration producing a phase reversal between output and input signals. In the common-base and common-collector circuits, output is in phase with input.

The frequency response and current gain of the common emitter and common collector circuits are essentially the same. This frequency response is lower than that of the common base circuit, whereas the current gain is greater than that of the common base circuit.

The common-base circuit has the lowest input impedance and the highest output impedance. The common-collector circuit has high input and low output impedances. Moderate input and output impedances are provided by common emitter circuits.

The configuration employed depends upon the requirements. The common-emitter, for example, while having an input impedance of the order of 1000 ohms, provides the highest voltage gain and power gain. The common-collector, on the other hand, provides much higher input impedance but, like the cathode follower tube amplifier, will not afford a voltage gain in excess of 1.

Transistor Parameters

Input and output impedances of the three configurations vary with junction transistor types and to a slight extent between individual units of the same type. However, representative values of input and load resistances are: 60 and 100,000 ohms respectively for the common-base; 600 and 20,000 ohms, common-emitter; and 0.5 megohm and 20,000 ohms, common-collector.

Unlike the vacuum tube, the transistor does not possess isolated input and output circuits. The output impedance, for example, depends upon the value of input impedance, and vice versa, and is affected also by the impedance of the generator (signal source). This interdependence of transistor parameters necessitates a different approach to circuit design than that employed with tubes.

The principal parameters of the junction transistor are: emitter-collector amplification factor (α), base-collector amplification factor (β), base resistance (r_b), collector resistance (r_c), emitter resistance (r_e), base voltage (V_b), collector voltage (V_c), emitter voltage (V_e), base current (i_b), collector current (i_c), emitter current (i_e), collector power (p_c), and emitter power (p_e). The external circuit into which the transistor operates can contain base resistance (R_b), collector resistance (R_c), and emitter resistance (R_e). It also includes one or more bias supply voltages; base voltage (V_{bb} or E_{bb}), collector voltage (V_{cc} or E_{cc}), and emitter voltage (V_{ee} or E_{ee}).

1. AUTOMOBILE TACHOMETER

Description of Operation:

C1 and C2 couple the sharp pulses from the spark plug. Since the size of the spark pulses may be 10,000 volts, these input capacitors have a combined rating of 20,000 volts. R2 is adjusted to eliminate erratic behavior of the meter due to an overdrive from the input.

Q1 and Q2 form a one shot multivibrator with Q1 normally conducting and Q2 cut off. The negative pulses, which occur when the spark plug fires, trigger the multivibrator and cause Q1 to turn off and Q2 to conduct. The period of conduction is determined by the multi RC time-constant. The amount of current per pulse through the meter is controlled by the potentiometer R11 in the collector circuit of Q2 and hence serves as a calibration control.

No Ico flows in the meter since the silicon diode CR2 is biased in the reverse direction and conducts only when the multivibrator fires due to a spark pulse.

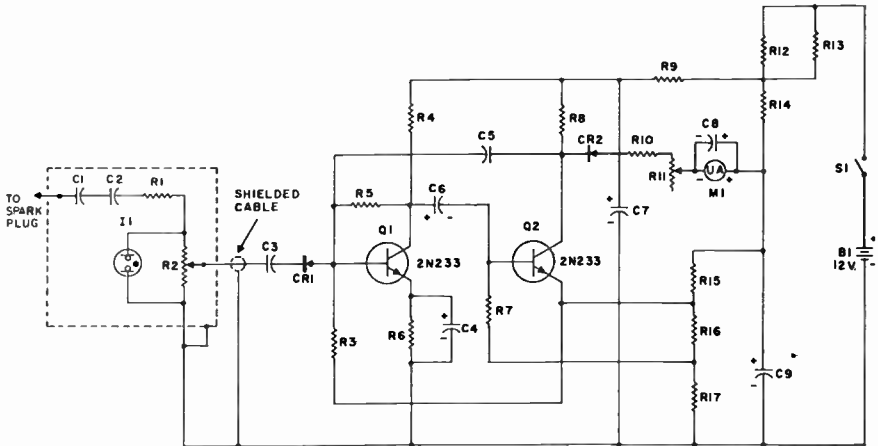

FIGURE 1—Automobile Tachometer Full Scale, 5000 r.p.m.

There are two revolutions of the motor between successive firings of one specific spark plug. Therefore, when the meter is calibrated to indicate 5000 RPM, the source of input pulses must be 2500 pulses per minute for full scale deflection.

Operation Notes:

Adjust R2 signal input control until the meter M1 smoothly indicates changes of engine R.P.M. Over-adjustment may cause erratic behavior of the meter.

Adjust R11 for full scale input rate of 2500 pulses per minute (there are two revolutions of the motor between successive firings of one specific spark plug).

For 6 Volt ignition systems, R12 and R13 are omitted and replaced with a short.

The contacts of K1 are used to complete the circuit for operating a control mechanism or alarm.

PARTS LIST

- | | |
|--|---------------------------------------|
| B1—9V. Battery, Burgess #2N6 with snap terminals or equivalent. | MK1—Microphone, single button carbon. |
| B2—22 ½ V. Battery, Burgess #51565C or equivalent. | Q1, Q2—Sylvania 2N233 Transistor. |
| C1—5 Mfd. Electrolytic Capacitor, 25V. or greater. | Q3—Sylvania 2N307 Transistor. |
| C2—50 Mfd. Electrolytic Capacitor, 30V or greater. | R1—3K ½ w. Resistor. |
| CR1—Sylvania SR776 Diode. | R2—15K ½ w. Resistor. |
| *K1—Relay, Potter & Brumfield, 5M5DS, 900Ω, 18V. DC., (fits 7 pin min. tube socket) or equivalent. | R3—820Ω ½ w. Resistor. |
| | R4—10K ½ w. Resistor. |
| | R5—100K ½ w. Resistor. |
| | R6—4.7K ½ w. Resistor. |
| | R7—10K Potentiometer. |
| | S1—D.P.S.T. Toggle Switch. |
| | T1—Transformer Triad TZ-15. |
- *The 5M5DS relay has contacts rated at 2 amperes, for non inductive load. If heavier current is required operate a heavy duty relay from the contacts of the 5M5DS.

3. REMOTE TEMPERATURE INDICATOR

Description of Operation:

In this application the transistor is used as a heat sensitive element. Place the transistor in the environment to be monitored. The remainder of the circuitry is placed at a remote point where a circuit will indicate the temperature. This device is valuable because a person can check the temperature at points he is not physically capable of reaching.

To calibrate this instrument place the transistor that is to be heated in a kitchen oven. Insert a sheet of plain paper over the meter face, with sufficient space for the needle of meter to show. Apply power with On/Off switch. Set the zero point with 250 ohm potentiometer and mark this point sheet on meter. Heat the oven in small steps allowing a

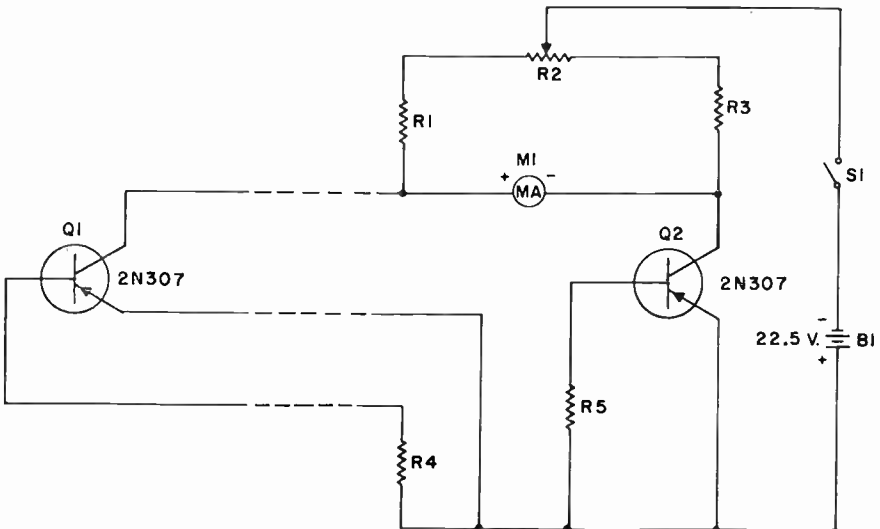

FIGURE 3—Remote Temperature Indicator.

few minutes for temperature to stabilize at each point. Use a thermometer to calibrate the meter at specific points on the meter face.

This circuit is a balanced bridge with the transistor as one leg of the bridge. As the temperature changes the transistor's resistance, the bridge becomes unbalanced. The amount of unbalance is a function of the temperature. The meter will indicate this.

PARTS LIST

- | | |
|--|----------------------------|
| B1—22 ½ V. Battery, Burgess #5156SC or equivalent. | R1, R3—1K ½ w. Resistor. |
| M1—Meter 0 to 25 Milliampers DC. | R2—250Ω Pentimeter. |
| Q1, Q2—Sylvania 2N307 Transistors. | R4, R5—10K ½ w. Resistor. |
| | S1—S.P.S.T. Toggle Switch. |

4. BURGLAR ALARM

Description of Operation:

This circuit will protect desks and windows from tampering. Place the fragile wire in the environment to be protected. The destruction of the wire is the key to the burglar alarm. It is necessary to make sure that the wire is hidden. The use of a very fine wire is recommended such as #40 wire.

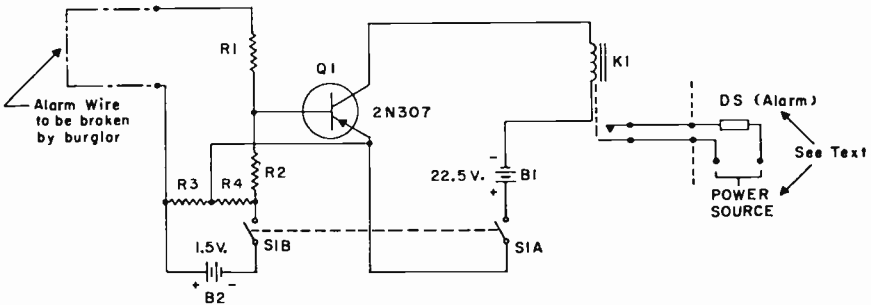

FIGURE 4—Burglar Alarm.

The circuit performs in the following manner. When the thief attempts to rob the protected area, he will break the fragile wire. This will change the bias on transistor Q1. Normally Q1 is biased so that virtually no current flows. With the destruction of the wire, the base goes negative. This enables transistor Q1 to conduct heavily and so actuate relay K1. Transistor Q1 is operating in a grounded emitter configuration.

The DS (Alarm) may be a light, bell, or buzzer with the appropriate power source voltage for the particular alarm used.

PARTS LIST

- B1—22 ½ V. Battery, Burgess #5156SC or equivalent.
 B2—1.5V. Battery, Burgess #2R or equivalent.
 DS—Bell, Buzzer or Light (See text).
 *K1—Relay, Potter & Brumfield, SM5DS, 900Ω 18V. DC., (fits 7 pin min. tube socket) or equivalent.
 Q1—Sylvania 2N307 Transistor (PNP type).
 R1, R2—560Ω ½ w. Resistor.
 R3, R4—10K ½ w. Resistor.
 S1—D.P.S.T. Toggle Switch.
- *The SM5DS relay has contacts rated at 2 amperes for non inductive load. If heavier current is required operate a heavy duty relay from the contacts of the SM5DS.

5. FIRE ALARM

Description of Operation:

Place transistor Q1 in sensitive area to be protected from fire. When transistor heats up the relay will close. To test the fire alarm, heat the transistor with a match. After the heat has been applied for a while, the relay will close. Upon removal of the flame for a minute, the transistor will return to its previous condition and the relay will open.

This circuit performs as per the following description. The transistor Q1 is biased so that negligible current flows in relay K1. With the application of heat to the transistor Q1 current increases in relay K1 and transistor Q1. All transistors leakage current varies directly with the

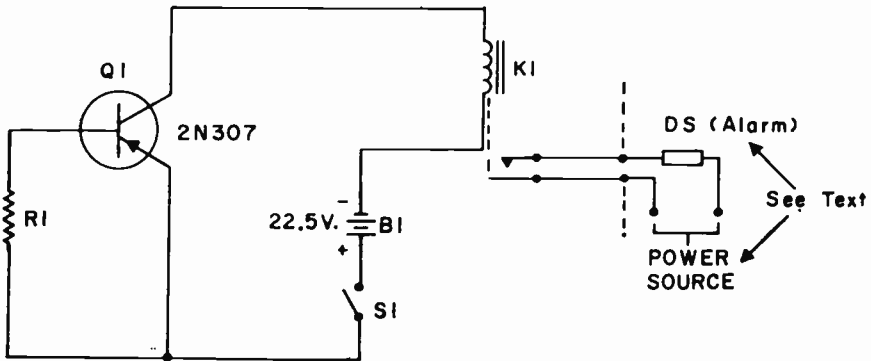

FIGURE 5—Fire Alarm

heat applied within some fixed temperature limits. When the temperature gets sufficiently high the current will have increased enough to actuate relay K1. The relay can activate the DS (Alarm) to indicate a fire.

The DS (Alarm) may be a light, bell, or buzzer with the appropriate power source voltage for the particular alarm used.

PARTS LIST

B1—22 1/2 V. Battery, Burgess #51565C or equivalent.

DS—Bell, Buzzer or Light (See text).

*K1—Relay, Potter & Brumfield, 5M5D5, 900Ω 18V. DC., (fits 7 pin min. tube socket) or equivalent.

Q1—Sylvania 2N307 Transistor.

R1—10K 1/2 w. Resistor.

S1—S.P.S.T. Toggle Switch.

*The 5M5D5 relay has contacts rated at 2 amperes for non inductive load. If heavier current is required operate a heavy duty relay from the contacts of the 5M5D5.

6. COMPUTER LOGIC CIRCUIT

Description of Operation:

This circuit can be used to make electronic combination locks or control devices in pre-arranged sequences. A device to test the intelligence of friends could be implemented by this circuit.

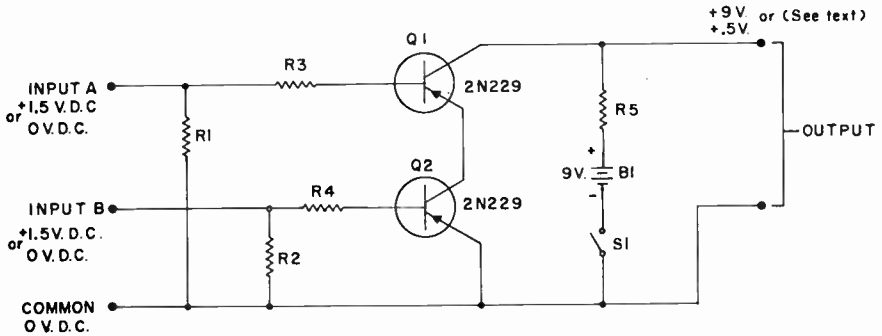

FIGURE 6—Computer Logic Circuit.

The circuit performs in the following manner. Transistors Q1 and Q2 are connected in series, therefore both Q1 and Q2 must be in a conducting position before current can flow through them in this series manner. It is for this reason that both inputs A and B must be at + 1.5 volts before the output will go to .5 volts. If either of the inputs is at 0 volts the output will be at +9 volts. The output is a +9 volts because no current flows through R5, therefore it is at the same potential as battery B1.

PARTS LIST

- B1—9V. Battery, Burgess #2N6 with snap terminals or equivalent.
 Q1, Q2—Sylvania 2N229 Transistor.
 R1, R2, R3, R4—1.2K $\frac{1}{2}$ w. Resistor.
 R5—1K $\frac{1}{2}$ w. Resistor.
 S1—S.P.S.T. Toggle Switch.

7. COMPUTER LOGIC CIRCUIT OR BUILDING BLOCK

Description of Operation:

This circuit is a fundamental building block for all digital computers. With this circuit and the previously discussed computer circuit, one can implement a giant brain.

This configuration performs in the following manner. Each of the input terminals is connected to a voltage of 0 volts or +1.5 volts. With terminal A at 1.5 volts and terminals B and C at 0 volts, the following

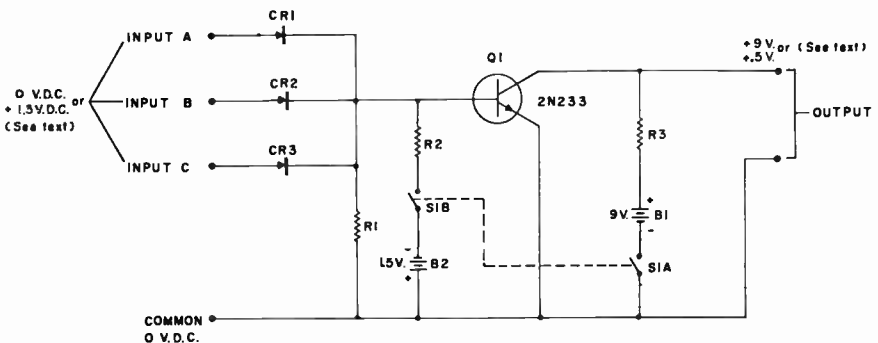

FIGURE 7—Computer Logic Circuit or Building Block.

occurs. With the anode of diode CR1 positive with respect to the cathode, the diode becomes forward biased. Now the potential at the base is at +1.5 volts which is sufficient to make the transistor Q1 conduct. The collector will be at +.5 volts. With all the input terminals at 0 volts the transistor doesn't conduct and so the collector is at +9 volts. With any of the input terminals at +1.5 volts the output will be +.5 volts.

PARTS LIST

- | | |
|---|-------------------------------|
| B1—9V. Battery, Burgess #2N6 with snap terminals or equivalent. | Q1—Sylvania 2N233 Transistor. |
| B1—1.5V. Battery, Burgess #2R or equivalent. | R1—2.7K ½w. Resistor. |
| CR1, CR2, CR3—Sylvania SR776 Diode. | R2—5.6 ½w. Resistor. |
| | R3—1K ½w. Resistor. |
| | S1—D.P.D.T. Toggle Switch. |

8. HIGH VOLTAGE POWER SUPPLY

Description of Operation:

Q1 functions as a free running blocking oscillator. Approximately 500 volts peak to peak appear across the High Voltage Secondary, pins 6 and 7. This is doubled by the 4 rectifiers CR1, CR2, CR3 and CR4, filtered by R3, R4, C5 and C6 and regulated by the 900 volt Corona regulator Tube, V1.

R2 is adjusted until a Vacuum Tube Voltmeter (10 megohms input impedance) across R5, 100K, reads 1 volt. This insures enough current flow through V1 without any undue drain in the Batteries. Battery drain is about 14 milliamps.

This power supply may be used to supply the 900V. DC required to operate the Geiger tube in the Geiger Tube Counting Rate Circuit shown as the following circuit in this book.

PARTS LIST

- | | |
|--|---|
| B1, B2, B3, B4—1.345V. Mercury Battery, Mallory RM-4R. | Q1—Sylvania 2N233 Transistor. |
| C1, C2, C3, C4—.01 Mfd. 500V. Disc Ceramic Capacitor. | R1—3.3K ½w. Resistor. |
| C5, C6—.01 Mfd. 2000V. Disc Ceramic Capacitor. | R2—25K Potentiometer. |
| CR1, CR2, CR3, CR4—Selenium Rectifier 200 Microamperes Bradley Laboratories, Inc. #SE8LA40H. | R3, R4—4.7 Megohm ½ w. Resistor. |
| | R5—100K ½w. Resistor. |
| | S1—S.P.S.T. Toggle Switch. |
| | T1—Transformer, U.T.C. Type 0-3 Ouncer. |
| | V1—Corona Regulator Tube, Victoreen 5841. |

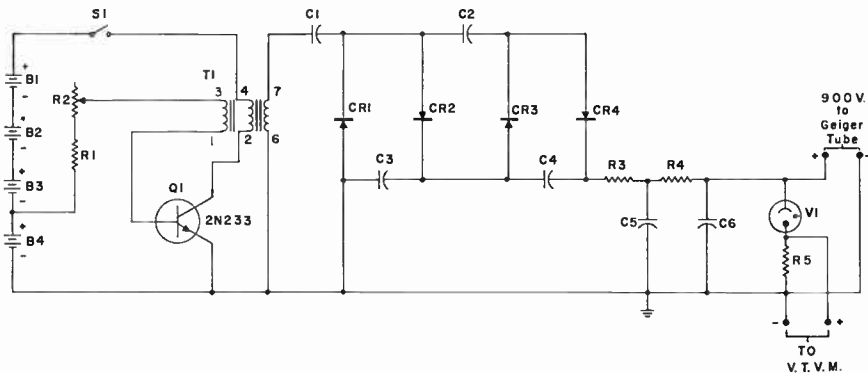

FIGURE 8—High Voltage Power Supply.

9. GEIGER TUBE COUNTING RATE CIRCUIT

Description of Operation:

A Geiger Counter may be used by the prospector to determine the presence of radiation from uranium or other radio-active ore. The meter will indicate a normal "background" which should be less than 50 counts per minute. Power to the geiger tube may be obtained from three (3) 300 volt batteries in series or from a transistor blocking oscillator type of power supply.

Q1 serves as an emitter-follower which matches the high impedance of the geiger tube to the counting rate circuit. Q2 and Q3 form a multivibrator with Q2 normally conducting and Q3 cut off. The negative pulse from the geiger tube triggers the multivibrator and it changes states, that is, Q3 conducts while Q2 cuts off. The time that Q3 is conducting depends on the multivibrator RC time constant. The pulse width and hence meter current per pulse is varied when the range switch is rotated.

The potentiometer R15 in the collector circuit of Q3 is adjusted to give a full scale count of 5000 counts per minute (cpm) on the middle range position 3 of S1.

No Ico flows in the meter since the silicon diode CR1 is biased in the reverse direction and only conducts when there is an input pulse from the geiger tube.

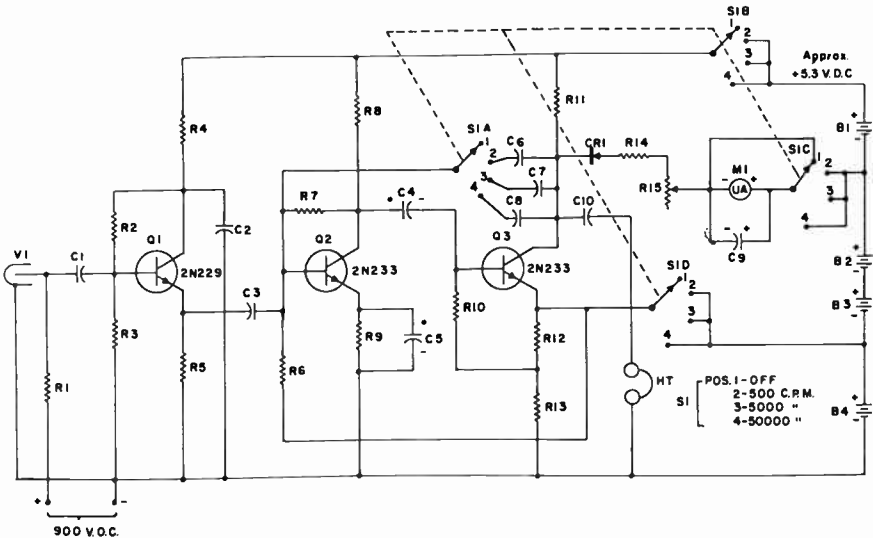

FIGURE 9—Geiger Tube Counting Rate Circuit.

For 900 Volts D.C. one may use the High Voltage Power Supply shown in this book.

PARTS LIST

- | | |
|---|---|
| B1, B2, B3, B4—1.345V. Mercury Battery Mallory RM-4R. | Q2, Q3—Sylvania 2N233 Transistor. |
| C1—500 mmfd. Capacitor, 1600V. or greater. | R1—1 megohm $\frac{1}{2}$ w. Resistor. |
| C2—0.1 mfd. Paper Capacitor. | R2—100K $\frac{1}{2}$ w. Resistor. |
| C3—330 mmfd. Ceramic or Mica Capacitor. | R3—47K $\frac{1}{2}$ w. Resistor. |
| C4, C5—25 mfd. Electrolytic Capacitor, 6V or greater. | R4—6.3K $\frac{1}{2}$ w. Resistor. |
| C6—0.5 mfd. Paper Capacitor. | R5—10K $\frac{1}{2}$ w. Resistor. |
| C7—.05 mfd. Paper Capacitor. | R6—3.9K $\frac{1}{2}$ w. Resistor. |
| C8—.005 mfd. Paper or Mica Capacitor. | R7—22K $\frac{1}{2}$ w. Resistor. |
| C9—300 mfd. Electrolytic Capacitor, 3V. or greater. | R8, R11—3.3K $\frac{1}{2}$ w. Resistor. |
| C10—.01 mfd. Paper Capacitor. | R9, R10—2.2K $\frac{1}{2}$ w. Resistor. |
| CR1—Sylvania Silicon Diode 1N456. | R12—470 Ω $\frac{1}{2}$ w. Resistor. |
| HT—Earphones, approximately 2000 ohms. | R13, R14—1000 Ω $\frac{1}{2}$ w. Resistor. |
| M1—Meter, 0 to 50 microamperes D.C. | R15—2500 Ω Potentiometer. |
| Q1—Sylvania 2N229 Transistor. | S1—Rotary Wafer Switch, 4 poles 4 position, or more positions used with a stop. |
| | V1—Geiger Tube, Victoreen 1B85 or Tracerlab TGC-6. |

10. ELECTROLYSIS DETECTOR

Description of Operation:

For boat owners or people whose work involves contact with salt water, electrolysis is a never ending problem. To detect electrolysis, the following circuit will be useful.

Electrodes A and B should be placed at two points of the affected area where we wish to determine the extent of the electrolysis. However, it should be remembered that the currents can flow between the two points in either direction from A to B or from B to A. As a consequence, it may be necessary to reverse the leads to the meter or a center reading meter can be used. This meter will indicate the amount of electrolysis present between the monitored points. The circuit is a balanced

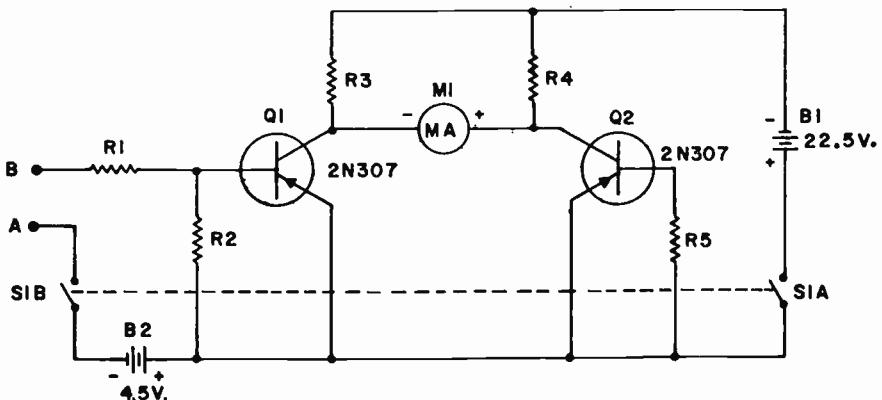

FIGURE 10—Electrolysis Detector.

bridge type of configuration, where the collector resistor and the transistor constitute one leg of the bridge. The changing bias causes the unbalance in the bridge which causes current to flow between legs of the bridge. The amount of unbalance in the bridge is proportional to the meter reading.

PARTS LIST

B1—22 1/2 V. Battery, Burgess #51565C or equivalent.	Q1, Q2—Sylvania 2N307 Transistor.
B2—4.5V. Battery, Burgess #5360 or equivalent.	R1, R2, R5—220Ω 1/2 w. Resistor.
M1—Meter, 0 to 15 Milliampere DC.	R3, R4—1000Ω 1/2 w. Resistor.
	S1—D.P.D.T. Toggle Switch.

11. BLINKER LIGHT

Description of Operation:

The (2-transistor) blinker light circuit operates to alternately turn a lamp off and on. Transistors Q1 and Q2 are part of a direct-coupled amplifier circuit with a lamp as a load in the collector circuit of Q2, a 2N307 power transistor. The output voltage across the lamp is of the same polarity as a signal applied to the base of Q1, i.e., the voltage across the lamp is in phase with the voltage applied to the base of Q1. Thus, if the signal voltage across the lamp is applied to the base of Q1 through C1 and R5, as shown in the diagram, the circuit becomes regenerative as the voltage gain from the base of Q1 to the collector of Q2 is greater than unity.

The operation of the circuit is as follows: Suppose the lamp to be initially off and the potentiometer advanced toward the positive voltage to cause Q1 to conduct slightly; the voltage across the lamp increases slightly and the base of Q1 is made more positive as the voltage across the lamp is coupled to the base of Q1 through C1 and R5. This causes Q1 to conduct more heavily and likewise Q2 until Q1 and Q2 are both saturated and nearly all the battery voltage is across the lamp causing it to light.

While the lamp is on, C1 is becoming charged and the current applied to the base of Q1 through C1 and R5 is diminishing. Finally C1 becomes charged to the point where the current supplied to the base of Q1 is insufficient to hold Q2 in saturation and the voltage across lamp begins to drop. When this happens the base current of Q1 decreases causing the voltage across the lamp to decrease further. This results in the lamp being rapidly extinguished and the base of Q1 driven negative due to the charge accumulated on C1 during the period that the lamp was on. Now both transistors are cut-off. The charge on C1 is now leaked off through R1, R2, R5 and the lamp and the base voltage of Q1 rises toward a positive value determined by the setting of R1. When the base of Q1 becomes slightly positive, Q1 commences to conduct and the cycle of operation is repeated.

The circuit is adjusted with R1. If R1 is set too near the positive end, the lamp will remain on continuously and if too near the low end, it

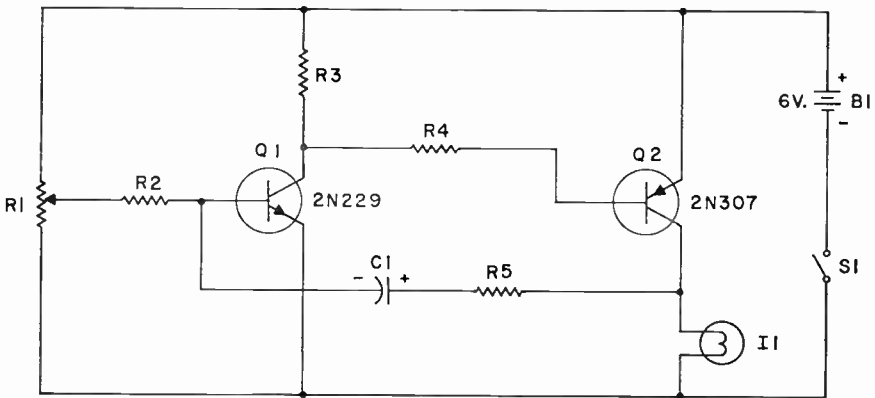

FIGURE 11—Blinker Light.

will not light. Between these extremes, the circuit will function with the setting of R1 determining to a limited degree the on and off times of the lamp. With the values shown in the circuit diagram, the on time of the lamp is about 2 or 3 seconds and the off time correspondingly about 4 to 5 seconds. If it is desired to increase or decrease the on and off times, this may be most conveniently accomplished by changing the value of C1. Doubling C1 will double the period of the cycle and reducing C1 by 2 will reduce the cycling period by 2, etc.

The time constant may also be changed by changing the value of R5 but this should be done with care. For 6V operation, R5 should not be smaller than about 250 ohms in order to protect Q1 from excessively large emitter current. On the other hand, R5 should not be so large as to stop the oscillations.

If it is desired to operate the circuit with a 12 volt supply using a 12V, 0.15 to 0.25 ampere, lamp (or two 6V lamps in series) resistors R3 and R4 should be made twice the value shown and R5 should not be made less than about 500 ohms. The voltage rating of C1 should then be greater than 12 volts.

Because transistor Q2 acts as a switch, its power dissipation is low. However, it is suggested that the practice of mounting power transistors on a metal plate be followed here.

PARTS LIST

- | | |
|--|-------------------------|
| B1—6V. Battery (such as lantern type). | R1—10K, ½ w. Resistor. |
| C1—100 Mfd., 6V. or greater Electrolytic Capacitor. | R2—6.8K, ½ w. Resistor. |
| I1—6-8V. between .15 and .25 A. Lamp. (such as Nos. 40, 44, 46, 47). | R3—1K, ½ w. Resistor. |
| Q1—Sylvania 2N229 Transistor. | R4—270Ω, ½ w. Resistor. |
| Q2—Sylvania 2N307 Transistor. | R5—1.8K, ½ w. Resistor. |
| | S1—S.P.S.T. Switch. |

12. BLINKER WITH ALTERNATING LIGHTS

Description of Operation:

The circuit above operates to light alternately one lamp and then the other. Transistors Q1 and Q2 are part of a multivibrator circuit which operates to cause Q1 to conduct while Q2 is off and vice versa with the conducting times determined by the circuit time constants. Transistors Q3 and Q4 are power transistors connected as emitter-followers and driven by transistors Q1 and Q2 respectively. When Q1 conducts, Q3 does also, causing lamp I1 to light. Similarly, when Q2 conducts, Q4 conducts causing lamp I2 to light.

This circuit arrangement is more flexible than the circuit entitled Blinker Light because the on and off times of the lights may be separately controlled (the on time of one lamp is the off time of the other).

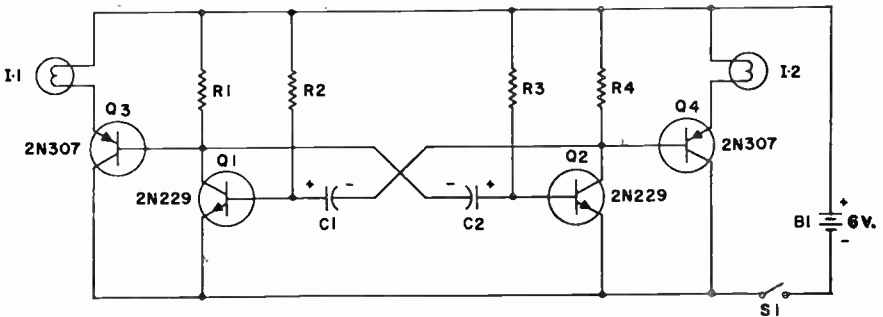

FIGURE 12—Blinker with Alternating Lights.

Also, if desired, one lamp and its associated power transistor may be removed from the circuit to have a single light flashing.

The following are the relationships allowing a determination of the on and off times of the lamps.

$$\left. \begin{array}{l} \text{On time Lamp I1} \\ \text{or Off time Lamp I2} \end{array} \right\} = 0.69 R3 C2 \quad 1)$$

$$\left. \begin{array}{l} \text{On time Lamp I2} \\ \text{or Off time Lamp I1} \end{array} \right\} = 0.69 R2 C1 \quad 2)$$

$$\text{Time of one cycle} = 0.69 (R2C1 + R3C2) \quad 3)$$

In the above expressions, R's are in ohms, C's are in farads, and time is in seconds.

For the values shown in the circuit diagram, both equations 1) and 2) give the same answers because the circuit is symmetrical (on and off times the same). Using the values in the circuit diagram in equation 1)

$$\left. \begin{array}{l} \text{On time Lamp I1} \\ \text{or Off time Lamp I2} \end{array} \right\} = 0.69 \times 5.6 \times 10^{-3} \text{ ohms} \times 100 \\ \times 10^{-6} \text{ farads} = .389 \text{ sec.}$$

Actually, the off and on times may depart appreciably from the calculated values, for those marked on electrolytic condensers are only approximate.

In choosing values of R2 or R3 for controlling the time constants, the selection should fall in the range of about 5.6K to 500 ohms. For values greater than this upper limit, the base current available may not be sufficient to cause a lamp to light (although with selected transistors the circuit may operate with much higher values). The lower limit is based on the possibility of damaging Q1 or Q2 by causing excessive current flow.

There is no restriction on the values of C1 or C2. One should not attempt to make the cycling too fast for it takes a small fraction of a second for a lamp to light.

A convenient way to adjust the time constants individually is to substitute the following circuit for R2 and R3:

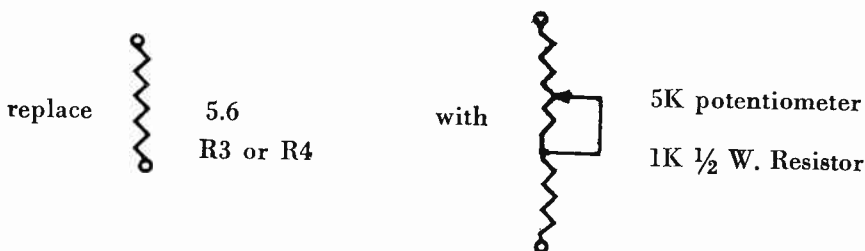

In this way, each resistor may be adjusted over a 6:1 range for a corresponding range of adjustment of the on and off times.

One might wonder if the blinker could not be made using only the power transistors in a multivibrator circuit and eliminating the 2N229's. The answer is yes, but that the resistors corresponding to R2 and R3 would have to be at least 1/10 the value used in the present arrangement and C1 and C2 10 times larger for the same on and off times. Thus the circuit shown is less expensive and less bulky.

PARTS LIST

B1—6V. Battery (such as lantern type).
C1, C2—100 Mfd., 6V. or greater Electrolytic Capacitor.
I1, I2—6-8V., 0.15 to 0.25 A. Lamp (such as Nos. 40, 44, 46, 47).

Q1, Q2—Sylvania 2N229 Transistor.
Q3, Q4—Sylvania 2N307 Transistor.
R1, R4—1.2K, 1/2 w. Resistor.
R2, R3—5.6K, 1/2 w. Resistor.
S1—S.P.S.T. Switch.

13. TIMER CIRCUIT

Description of Operation:

The function of the timer circuit is to close a relay for a selected period of time upon closing a switch. The relay contacts may then energize the device to be controlled such as a lamp used in photographic work. The amount of power that may be switched is dependent on the

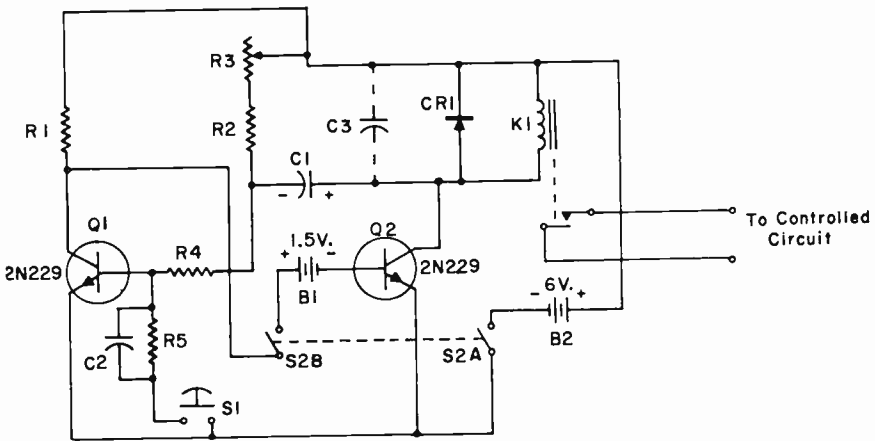

FIGURE 13—Timer Circuit.

rating of the relay contacts. For the Potter & Brumfield 6V, RS5D Relay, the contacts are rated at 2 amperes, 115 volts, with a non-inductive load. The power of the controlled device need not be restricted to this rating, however, for the relay in the circuit may be used to operate a higher power, less sensitive relay which in turn may be used to energize the circuit to be controlled.

The timer circuit is a one shot multivibrator. It holds the following advantages over simpler single transistor relay circuits: 1) a high sensitivity relay is not required, 2) more stable calibration, 3) less sensitivity to temperature variation, and 4) relatively insensitive to supply voltage variation. The combination of an additional transistor and an inexpensive relay is quite likely to be less expensive than the sensitive relay required in single transistor timer circuits.

Transistor Q1 is normally conducting and Q2 is cut off. When S1 is closed, the base of Q1 is brought to ground potential momentarily, as C2 has no voltage across it, causing the collector current of Q1 to be transferred to the base of Q2. Q2 conducts closing the relay, and the base of Q1 is driven negative by approximately 6 volts, which is the initial voltage across C1. Thus Q2 is conducting and Q1 is cut off. During the time Q2 is on, C1 is discharging through R2 and R3 toward +6 volts. When the base voltage of Q1 has become slightly positive, Q1 conducts and turns Q2 off, opening the relay. This completes the cycle. In this arrangement the operation of the relay is positive; the relay current being high when Q2 conducts and negligible when Q2 is off.

The operating time of the relay is controlled by C1 and the resistance R2 and R3 which is shown adjustable over the range of about 30 to 4.7 kilohms, a 6 to 1 range. The operating time is given by

$$T = .7 RC1$$

where T is in seconds, R is the sum of R2 and R3 in ohms and C1 is in microfarads. Because of high values of C1 required to obtain operating

times in seconds, C1 must of necessity be an electrolytic capacitor. For this reason the expression given above is to be regarded as approximate as the actual capacitance value of electrolytic capacitors may depart considerably from the labelled value.

Several ranges of operating times may be obtained by switching different values of C1 into the circuit. The circuit may be calibrated with a stop watch or if values of C1 are accurately known, the expression for T becomes quite accurate.

In the circuit, R4 protects Q1 from excessive emitter current surges; CR1 damps the positive overshoot appearing when the relay opens; R1 keeps C2 discharged until S1 is closed; and battery B1 insures Q2 being off when Q1 is conducting. B1 need not be disconnected from the circuit as only a few microamperes are drawn when the 6 volt supply is disconnected.

Condenser C3 may be necessary with some types of relay to suppress a negative jog in the relay transient appearing when the armature moves away from the pole piece and possibly retriggering the circuit. A .05 Mfd. value is likely to be sufficient.

PARTS LIST

- | | | | |
|---|--|--|---|
| B1—1 to 1.5V. Battery (such as penlite cell or small mercury cell). | B2—6V. Battery (such as lantern type or "A" type). | C1—Electrolytic Capacitor, 6V. or greater (see text for how timing is calculated). | CR1—1N34 Diode. |
| | | Relay ON Time | K1—6V., 300Ω or greater Relay (such as Potter & Brumfield R55D). |
| | | C1 Value (controlled by R3 setting) | Q1, Q2—Sylvania 2N229 Transistor. |
| | | 2000 Mfd. 1 min. to 10 sec. | R1—3.3K, ½ w. Resistor. |
| | | 1000 Mfd. 60 sec. to 5 sec. | R2—4.7K, ½ w. Resistor. |
| | | 200 Mfd. 6 sec. to 1 sec. | R3—25K Potentiometer. |
| | | 100 Mfd. 3 sec. to .5 sec. | R4—150Ω, ½ w. Resistor. |
| C2—.05 to 1 Paper Capacitor. | C3—.05 Paper Capacitor (see text). | | R5—1 meg. ½ w. Resistor. |
| | | | S1—Switch (any sort of normally open push-button, or may be toggle switch left normally open and closed momentarily to initiate relay closure). |
| | | | S2—D.P.S.T. Switch. |

14. SENSITIVE PHOTO-RELAY CIRCUIT

Description of Operation:

The photo-relay circuit operates a relay in accordance with changes in light intensity upon a Clairex CL-3 photocell. The circuit shown features high sensitivity, a wide range of adjustment, and positive relay operation. The circuit may be used to turn lights on at night and off in daylight automatically, or to indicate when a beam of light is interrupted by persons or objects.

The circuit is arranged to operate the relay when the light intensity decreases below the intensity set by adjustment of R1. The range of adjustment of R1 is such that the relay may be energized in bright daylight or held open in complete darkness.

Transistor Q1 is an emitter-follower presenting a high impedance at the input and a low impedance for driving Q2. Battery B1 is for bias purposes and need not be disconnected when the main 6V. supply is turned off as only a few microamperes are drawn from B1 under these conditions.

Transistors Q2 and Q3 are part of a trigger circuit which has the characteristic that if the base voltage of Q2 is above a certain value, Q3 is cut off and if the base voltage of Q2 is below another certain voltage (within a few tenths of a volt of the first) Q3 conducts heavily and the relay is closed. Thus the operation of the relay is positive, the relay current being either negligibly small or large. Only a few tenths of a volt change at the base of Q2 is required to turn the relay completely on or completely off.

The operating point of the circuit is adjusted with R1. When the photocell is exposed to light, and R1 set to the point where the relay just opens, a slight decrease in light intensity will cause the relay to close.

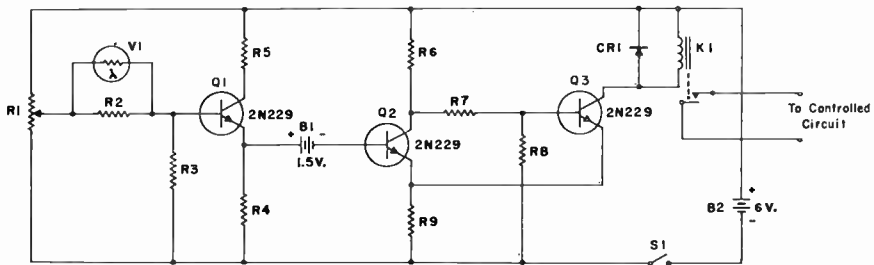

FIGURE 14—Sensitive Photo-Relay Circuit.

The setting of R1 will depend upon the intensity of the light about which the relay is to respond. The setting will then be different if one desires to have the relay respond to a change in light in bright daylight than it would be when set to respond between darkness and breaking dawn.

The amount of power that may be controlled depends upon the relay contacts. The Potter & Brumfield Type RS5D, 6V. Relay contacts are rated 2 amperes, 115 volts, non-inductive load. The relay of course may be used to control a heavy duty less sensitive relay to control larger amounts of power.

PARTS LIST

- | | |
|---|-------------------------------|
| B1—1 to 1.5V. Battery (such as penlite or small mercury cell). | R2, R3—100K, ½w. Resistor. |
| B2—6V. Battery (such as lantern type or "A" type). | R4—4.7 to 5.6K, ½w. Resistor. |
| CR1—1N34 Diode. | R5—200Ω to 1K, ½w. Resistor. |
| K1—6V., 300Ω or greater Relay (such as Potter & Brumfield Type RS5D). | R6—1.2K, ½w. Resistor. |
| Q1, Q2, Q3—Sylvania 2N229 Transistor. | R7, R8—3.3K, ½w. Resistor. |
| R1—10K Potentiometer. | R9—27Ω, ½w. Resistor. |
| | S1—S.P.S.T. Switch. |
| | V1—Clairex CL-3 Photocell. |

15. DIFFERENTIAL PHOTO-RELAY

Description of Operation:

The differential photo-relay circuit responds to the difference in light intensity falling upon two photocells to close a relay for predetermined time. The circuit does not respond to changes in light intensity that appear equally to both photocells nor to changes in light intensity that occur gradually. The circuit then responds to objects that move or appear to move such as a shadow cast by a person moving past the photocells. The advantage of the arrangement is that no special light source is needed; sunlight or room illumination is sufficient provided that the object to be detected either casts a slight shadow or reflection in passing the photocells. (The photocells are considered placed side by side pointing in the same direction.)

The circuit may be used to detect people passing a given location with the relay operating a bell or a buzzer as a signal, or to count objects moving past by connecting the relay to a counter. Another application is to detect smoke or flame as the circuit will respond to shadows cast by the former and to the flickering light of the latter.

An object passing the photocells causes a positive going and then a negative going (or vice versa) signal to appear at the base of Q1 which is amplified by Q2 and applied through C3 to a trigger circuit containing Q3 and Q4. The trigger circuit converts the waveform produced by the photocells into a pulse (either positive or negative depending upon the setting of R6) the negative going edge of which triggers the multivibrator Q5 and Q6 closing the relay for a length of time determined by the value of C5. The relay is closed whenever a signal large enough to operate the trigger circuit is produced independent of the direction the objects takes in passing the photocells and independent of whether the object casts a shadow or reflects light in passing.

The approximate length of time that the relay is closed is as follows:

C5	Time
2 mfd	40 milliseconds
10 mfd	0.2 seconds
20 mfd	0.4 seconds
100 mfd	2 seconds
200 mfd	4 seconds
1000 mfd	20 seconds

The time corresponding to other values of C5 may be determined by interpolating between values in the table.

The sensitivity of the circuit is adjusted by means of R6. The most sensitive setting is at the point where Q4 is close to being switched off or on. This may be determined by trial and error or by measuring the

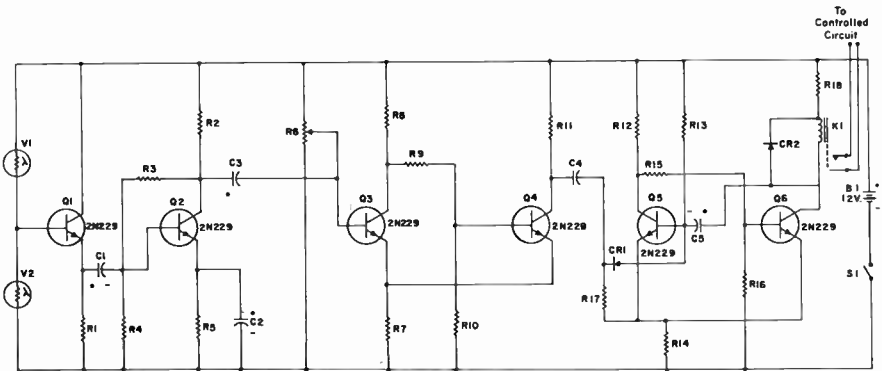

FIGURE 15—Differential Photo-Relay.

voltage at the collector of Q4 (the voltage is either about 12 volts or about 6 volts) while adjusting R6. R6 is turned one way or the other as necessary until the collector voltage of Q4 changes. R6 is then turned slightly back in the opposite direction but not far enough to cause the collector voltage to change again. It is immaterial whether this adjustment leaves the collector voltage high or low. The sensitivity of the circuit decreases as R6 is turned in either direction from the maximum sensitivity setting.

In many instances the setting of R6 will want to be other than the most sensitive. This may be the case when used in artificial light. Both incandescent and fluorescent lights flicker although not apparent to the eye. If under artificial light, the relay continuously cycles on and off, this is an indication that the circuit is responding to this flickering and that the sensitivity should be reduced.

PARTS LIST

B1—12V. Battery (such as 2-6V. lantern type or 2-6V. "A" type).
 C1, C3—10 Mfd., Electrolytic Capacitor 12V. or greater.
 C2—50 to 100 Mfd. Electrolytic Capacitor, 12V. or greater.
 C4—0.1 Mfd. Paper Capacitor.
 C5—Electrolytic Capacitor, 12V. or greater, (see text for value).
 CR1, CR2—1634A or 1N90 Diode.
 K1—6V, 300 to 400Ω Relay (such as Potter & Brumfield Type R55D).
 Q1 to Q6 Incl.—Sylvania 2N229 Transistor.
 R1—10K, ½w. Resistor.
 R2—18K, ½w. Resistor.

R3—330K, ½w. Resistor.
 R4—47K, ½w. Resistor.
 R5, R8—1.8K, ½w. Resistor.
 R6—50K Potentiometer.
 R7—2.2K, ½w. Resistor.
 R9, R10—820Ω ½w. Resistor.
 R11—5.6K, ½w. Resistor.
 R12—3.3K, ½w. Resistor.
 R13—27K, ½w. Resistor.
 R14—27Ω, ½w. Resistor.
 R15, R16—1K, ½w. Resistor.
 R17—30K to 100K, ½w. Resistor.
 R18—330Ω, ½w. Resistor.
 S1—S.P.S.T. Switch.
 V1, V2—Clairex CL-3 Photocell.

16. HIGH SENSITIVITY DIFFERENTIAL PHOTO-RELAY

Description of Operation:

This circuit is a higher sensitivity (by about a factor of 2) version of the circuit entitled Differential Photo-Relay. The application, operation and adjustments are as described in the other arrangement and corresponding parts are given the same numbers. The high sensitivity model requires in addition 2 resistors, 1 condenser, 1 transistor and a different value of R6.

The additional transistor provides a better impedance match between Q2 and Q3 (the latter should be driven from a low impedance source), and allows a larger value of R6.

R19 and C6 decouple Q1 and Q2 from the rest of the circuit to prevent transients due to the load on the power supply changing when the relay is energized from being amplified and causing erratic operation.

The sensitivity of the circuit is such that smoke from a cigarette rising past the photocells will operate the relay.

PARTS LIST

- | | |
|--|------------------------------------|
| B1—12V. Battery (such as 2-6V. lantern type or 2-6V. "A" type). | R3—330K, 1/2 w. Resistor. |
| C1, C3—10 Mfd., Electrolytic Capacitor, 12V. or greater. | R4—47K, 1/2 w. Resistor. |
| C2—50 to 100 Mfd. Electrolytic Capacitor, 12V. or greater. | R5, R8—1.8K, 1/2 w. Resistor. |
| C4—0.1 Mfd. Paper Capacitor. | R6—100K Potentiometer. |
| C5—Electrolytic Capacitor, 12V. or greater (see text for value). | R7—2.2K, 1/2 w. Resistor. |
| C6—100 Mfd., Electrolytic Capacitor, 12V. or greater. | R9, R10—820Ω 1/2 w. Resistor. |
| CR1, CR2—1N34A or 1N90 Diode. | R11—5.6K, 1/2 w. Resistor. |
| K1—6V., 300-400Ω Relay, (such as Potter & Brumfield Type R55D). | R12—3.3K, 1/2 w. Resistor. |
| Q1 to Q7 Incl.—Sylvania 2N229 Transistor. | R13—27K, 1/2 w. Resistor. |
| R1—10K, 1/2 w. Resistor. | R14—27Ω, 1/2 w. Resistor. |
| R2—18K, 1/2 w. Resistor. | R15, R16, R19—1K, 1/2 w. Resistor. |
| | R17—30K to 100K, 1/2 w. Resistor. |
| | R18—330Ω, 1/2 w. Resistor. |
| | R20—4.7K, 1/2 w. Resistor. |
| | S1—S.P.5.T. Switch. |
| | V1, V2—Clairex CL-3 Photocells. |

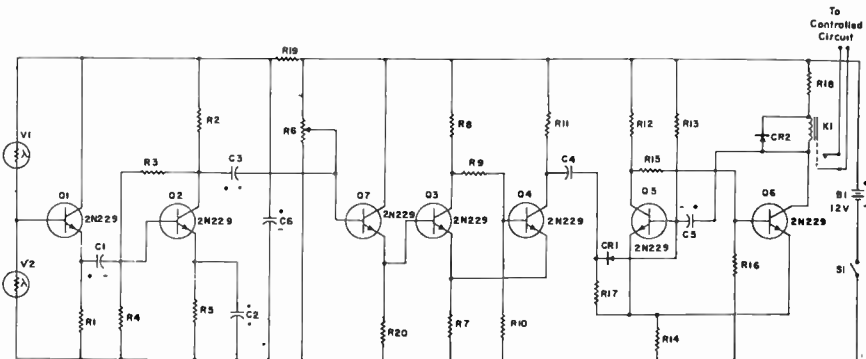

FIGURE 16—High Sensitivity Differential Photo-Relay.

17. 6 VOLT POWER SUPPLY

This power supply has a 6 volt filtered and regulated d.c. output and can supply current up to 1 ampere. Transistors Q1 and Q2 serve as efficient rectifiers. Condenser C1 filters the pulsating d.c. produced by Q1 and Q2. Q3, connected as an emitter-follower, supplies an output to the load which is within a few tenths of a volt of the reference voltage of 6 volt battery B1. Q3 provides further filtering making the voltage to the load essentially free of ripple.

Slb, which is part of the power switch, disconnects B1 from the circuit when the supply is not used.

Without R3 in the circuit, some current is drawn from the battery—approximately the load current divided by β , the collector to base

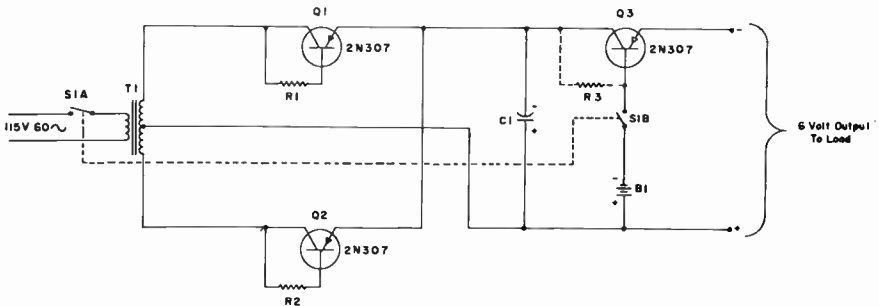

FIGURE 17—6 Volt Power Supply.

current gain of Q3. For example, if the load current were 0.5 amperes and β were 20, the battery would supply about 25 milliamperes. With R3 out of the circuit, the output is free of ripple.

With R3 in the circuit, the battery current may be brought to zero or even reversed to charge the battery thus making the life of the battery in the circuit the same as its shelf life. This may, however, introduce a slight amount of ripple into the output depending upon the internal impedance of the battery and the value of R3 used. If the internal impedance of the battery were zero, then the presence of R3 would have no effect.

The proper value of R3 may be determined by measuring the current in B1 with the desired load on power supply and inserting values of R3 to make the battery current zero or slightly reversed. Or R3 may be made adjustable by making R3 a 47 ohm resistor in series with a 250 ohm potentiometer. The ripple introduced will depend upon the amount of battery current to be balanced out (which is also dependent

on load current) and the internal resistance of the battery; it probably will not exceed a few tenths of millivolts at a 1/2 amp. load.

The transistors should be mounted on a heat sink.

PARTS LIST

B1—6V. Battery (such as lantern type).
 C1—Electrolytic Capacitor, 12V. or greater
 1000 Mfd. for loads to 0.5 amp.
 2000 Mfd. for loads to 1.0 amp.
 Q1, Q2, Q3—Sylvania 2N307 Transistor.

R1, R2—22Ω, 1/2 w. Resistor.
 R3—Resistor (see text).
 S1—D.P.S.T. Power Switch.
 T1—12.6V. C.T. Secondary Transformer (such as Triad F26X).

18. 12 VOLT POWER SUPPLY

Description of Operation:

This is a 12 volt filtered and regulated d.c. output power supply and can supply current up to 1 ampere. Transistors Q1, Q2, Q4 and Q5 are connected as efficient rectifiers in a bridge type circuit.

The function of C1, Q3, B1 and R3 are as described in the circuit entitled 6 Volt Power Supply. The selection and effect of R3 is identical in this circuit as in the 6 Volt Power Supply (preceding circuit).

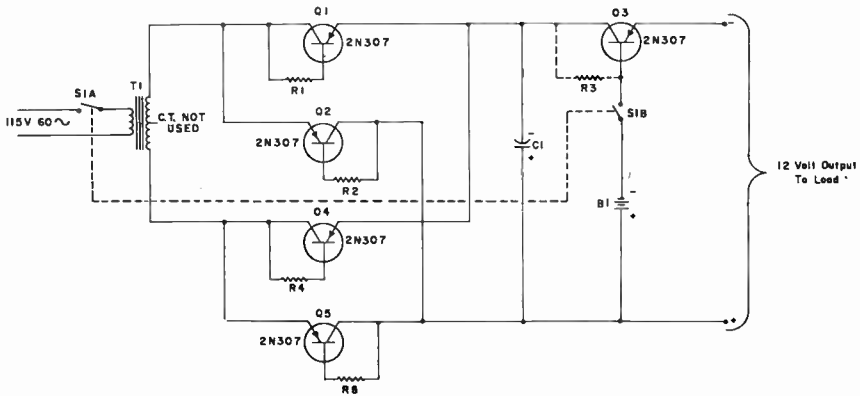

FIGURE 18—12 Volt Power Supply.

By replacing T1 with a transformer having a 6.3 volt secondary (2.5 amp or more rating) and B1 with a 6 volt battery, a 6 volt, 1 ampere bridge-rectified supply is obtained.

The transistors should be mounted on a heat sink.

PARTS LIST

B1—12V. Battery (such as 2-6V. lantern or 2-6V. "A" type).
 C1—Electrolytic Capacitor,
 1000 Mfd., 25V. for loads to 0.5 amp.
 2000 Mfd., 25V. for loads to 1.0 amp.

Q1 to Q5 Incl.—Sylvania 2N307 Transistor.
 R1, R2, R4, R5—22Ω, 1/2 w. Resistor.
 R3—Resistor (see text).
 S1—D.P.S.T. Power Switch.
 T1—12.6V. Secondary Transformer (such as Triad F-26X).

19. 50-60 KC POWER OSCILLATOR

Description of Operation:

This oscillator is capable of producing an output of about 1 watt at a frequency in the range of 50 kc. It may be used as a basis for a carrier current intercom using the house wiring. This may be done by modulating the voltage supplied the oscillator and coupling the oscillator to the power line. It also makes an interesting experiment in obtaining appreciable power output from a transistor at radio frequencies.

To obtain a 1 watt output at the relatively low voltages used in transistor operation and at the same time have a reasonable loaded Q in the tuned circuit means L1 must have a low inductance and that C1 and C2 must be correspondingly large. The unloaded Q of L1 should be high for the efficiency of the tuned circuit to be high (so that most of the power the transistor is capable of generating is available to the external load instead of being dissipated mostly in overcoming losses in L1).

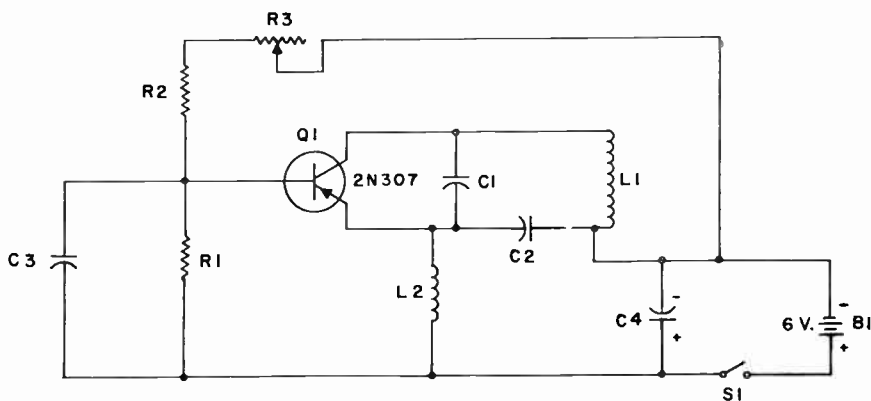

FIGURE 19—50-60 KC. Power Oscillator.

L1 should be wound with rather heavy wire to obtain a high Q. The following is data for a 20 microhenry coil suitable for L1. This gives a frequency of oscillation of 50-60 kilocycles depending somewhat upon the loading and biasing of the transistor and the amount C1 and C2 depart from their labelled values.

Coil Form. $1\frac{3}{4}$ " outside diameter (mailing tube is convenient)

Wire: No. 18 tinned

Turns: 33.5

Length of Winding: $3\frac{1}{2}$ "

Inductance: 20 microhenries

These dimensions allow ample space between turns so that the coil may be wound easily without the turns touching. It is rather important that heavy wire (such as No. 18) be used for L1. A 20 microhenry coil wound

with No. 26 wire was found to reduce the output available from the oscillator to about $\frac{1}{2}$ watt.

For those wishing to wind coils having other dimensions, the following relationship holds for single layer coils:

$$n = \frac{\sqrt{L(9a + 10b)}}{a^2}$$

where n is the number of turns, L is inductance in microhenries, a is the radius of the coil in inches and b is the length of the coil in inches.

L2 is a choke coil of noncritical value. It may be made by winding 100 turns of No. 30 enamelled wire in a random manner on a $\frac{3}{8}$ " diameter form (such as a wooden dowel) making a coil of about $\frac{1}{2}$ " long. Made in this manner, the coil has a resistance of about 1 ohm; thus the d.c. emitter current in the oscillator may be read with a volt meter connected across L2 as being about 100 milliamperes for each .1 volt indicated by the volt meter.

The bias is adjusted by R3 to bring the emitter current (or collector current) with the oscillator unloaded to 100 or 200 ma. When the oscillator is loaded the emitter current will increase. The oscillator may be loaded by connecting the load across a portion of L1 or by connecting the load to a secondary winding placed over the winding of L1. The operation of the oscillator may be tested by connecting a No. 40 or 47 pilot lamp (.9 watt) across L1. Some further adjustment of R3 may be necessary when the oscillator is heavily loaded.

The transistor should be mounted on a heat sink.

PARTS LIST

B1—6V. Battery (such as lantern type or "A" type).	L1, L2—Coil (see text).
C1—.5 Mfd. Paper Capacitor.	Q1—Sylvania 2N307 Transistor.
C2—2 Mfd. Paper Capacitor.	R1—47 Ω , $\frac{1}{2}$ w. Resistor.
C3—1 Mfd. Paper Capacitor.	R2—270 Ω , $\frac{1}{2}$ w. Resistor.
C4—10 Mfd. Electrolytic Capacitor, 6V. or greater.	R3—2K Potentiometer.
	S1—S.P.S.T. Switch.

20. D.C. TO D.C. CONVERTER

Description of Operation:

The D.C. to D.C. Converter operates to supply high voltage D.C. from a 12-14 volt source. Transformer T1 is a transformer having a rectangular hysteresis loop and is designed especially for this application. Transistors Q1 and Q2 oscillate at about 2 Kilocycles producing square waves. In effect the low voltage supply is switched alternately to one half and then to the other half of the winding connected to the collectors of the transistors. The transformer winding connected to the transistor bases provides positive feedback to maintain oscillation. Resistors R1 and R2

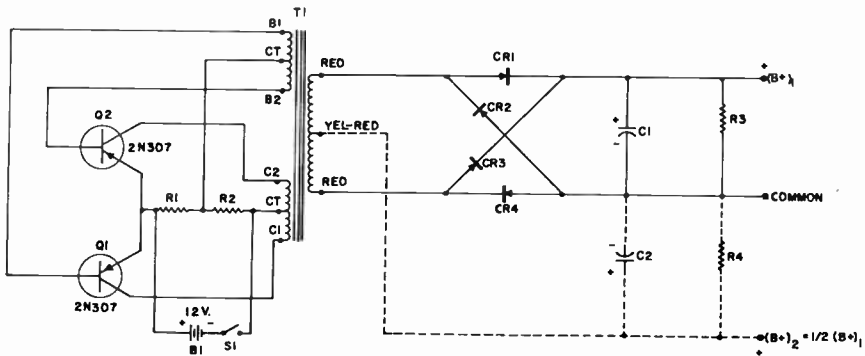

FIGURE 20—D.C. to D.C. Converter.

supply negative base bias to insure that the oscillations start when the power is applied. The voltage developed across the collector winding is stepped up to a high voltage in the secondary winding. The high voltage is rectified by a bridge rectifier containing diodes CR1, CR2, CR3 and CR4. Because the output of the secondary is a square wave very little filtering is required. A connection giving an output voltage $B+2$ equal to one-half $B+1$ is shown by the dotted lines.

Approximately 10 watts of power may be taken from the high voltage output without exceeding the 1 ampere maximum collector current rating of the 2N307's.

The transistors should be mounted on a suitable heat sink.

If the converter fails to work after carefully checking the connections try reversing leads to B1 and B2 of the transformer T1, as the transformer may be labeled incorrectly.

PARTS LIST

- B1—12 Volt Automobile Battery or equivalent capable of supplying 1 Ampere.
 C1, C2—8 Mfd. 450V. Electrolytic Capacitor.
 CR1, CR2, CR3, CR4—Sylvania SR776 Diodes.
 Q1, Q2—Sylvania 2N307 Transistors.
 R1— 27Ω $\frac{1}{2}$ w. Resistor.
 R2— 300Ω 1w. Resistor.
 S1—S.P.S.T. Switch with low resistance contacts.
 T1—Transformer.

For (B+1)	Use
250V.	Triad TY-685
300V.	Triad TY-695
325V.	Triad TY-705

21. 6 VOLT D.C. TO 12 VOLT D.C. CONVERTER

Description of Operation:

This circuit converts 6 volts D.C. to 12 volts D.C. through an oscillating circuit containing transistors Q1 and Q2 and transformer T1. The operation of the oscillator portion of the circuit is as described in the D.C. to D.C. Converter.

When transistor Q1 is conducting, the collector-to-emitter voltage of Q2 is -12 volts and similarly when Q2 is conducting, the collector-to-emitter voltage of Q1 is -12 volts. The 12 volt output is obtained by connecting transistors Q3 and Q4 in a diode configuration to the collectors of the oscillating transistors as shown in the schematic. Transistors, connected as Q3 and Q4, make very efficient diodes provided the inverse voltage is not exceeded. This is not one of the measurements included in the transistor specifications so the simple test shown in the schematic may be made to insure that Q3 and Q4 will function satisfactorily. Most 2N307's connected as diodes have an inverse voltage capability of 30 volts or more. Conventional diodes of suitable current rating may, of course, be used to replace Q2 and Q4 if desired.

About one ampere may be drawn from the 12 volt output without exceeding the 1 ampere maximum collector current rating of the transistors.

If it is desired to filter the output, a condenser, C1, and bleeder, R3, may be connected as shown in dotted lines.

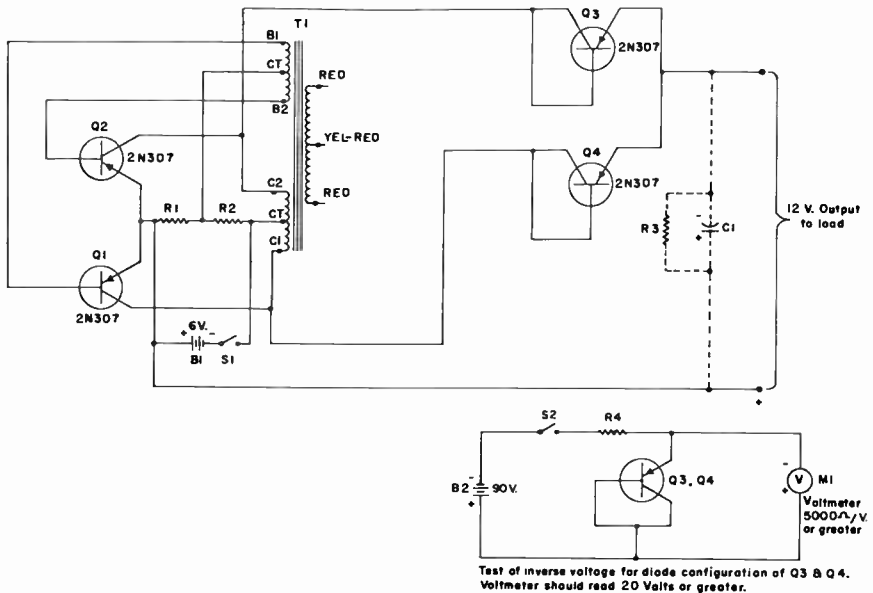

FIGURE 21—6 Volt D.C. to 12 Volt D.C. Converter.

If the converter fails to work after carefully checking the connections try reversing leads to B1 and B2 of the transformer T1, as the transformer may be labeled incorrectly.

PARTS LIST

B1—6 Volt Automobile Battery or equivalent capable of supplying 2 Amperes.
B2—90 Volt "B" Battery, Burgess #N60 (with snap terminals) or equivalent.
C1—1000 Mfd. Electrolytic Capacitor, 15V. or greater.
M1—Voltmeter, 100V. D.C., 5000 Ω N. or greater.
Q1, Q2, Q3, Q4—Sylvania 2N307 Transistor.
R1—30 Ω 1/2 w. Resistor.
R2—220 Ω 1w. Resistor.
R3—330 Ω 1w. Resistor.
R4—20K 1w. Resistor.
S1—S.P.S.T. Switch with low resistance contacts.
S2—S.P.S.T. Toggle Switch.
T1—Transformer, Triad TY685.

22. STROBOSCOPE CIRCUIT

Description of Operation:

The stroboscope circuit functions to turn on a neon lamp at a controllable rate. When the flashing light is directed upon some rotating object, as for example an electric fan, and the rate of flashing properly adjusted, the rotating object will appear to have been stopped. If the rate of flashing is slightly faster than the speed of rotation of the object observed it will appear to be reversed and vice versa. By calibrating the stroboscope, it may be used as a tachometer.

Transistors Q1 and Q2 are part of a free-running unsymmetrical multi-vibrator the frequency of which is adjusted by means of dual potentiometers R2 and R4 for a given set of condensers C1 and C2. C1 and C2 are chosen to make the on time of Q2 one-fifth the on time of Q1.

When Q2 is on, emitter-follower Q3 conducts applying a negative bias to the base of Q4 to cause it to conduct also. Q4 is connected in a blocking oscillator circuit to produce a burst of pulses whenever Q2 is conducting. These pulses are stepped up in the transformer secondary to about a hundred volts required to light the NE-36 neon lamp. R9 limits the current in the neon lamp which has a very low impedance when glowing. Both plates of the NE-36 glow because there is a reverse overshoot at the end of each pulse in the burst of pulses produced by Q4. The circuit should not be operated with the neon lamp disconnected because the over-shoots would then be very large and might be damaging to Q4.

The reason for making Q4 a blocking oscillator is, first of all, because a neon bulb cannot be directly ignited with a 6 volt source and, secondly, because an ordinary inexpensive transformer cannot support a single pulse of say 10 milliseconds as might be required at slow rates of flashing if Q4 were to be used as a switch applying 6 volts for this length of time to the transformer primary. Thus, in the blocking oscillator circuit, the 6 volt source is applied repeatedly to the transformer primary making it possible to light the neon bulbs for as long a period as desired.

C1, R3 and R2 determine the length of time that neon lamp is on and

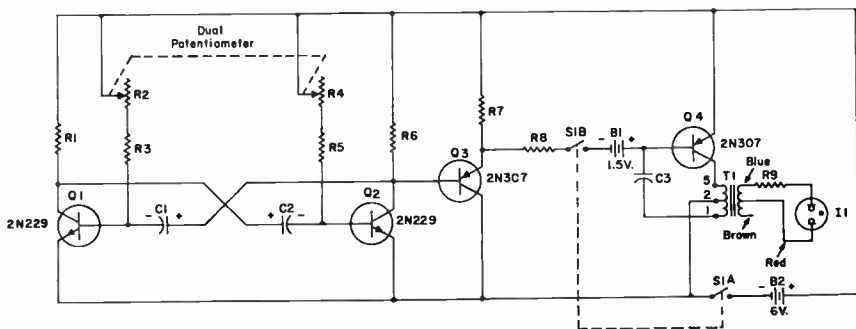

FIGURE 22—Stroboscope Circuit.

C2, R5 and R3 determine the length of time it is off. The period of one cycle is given by

$$P = .69 [C1 (R3 + R2) + C2 (R5 + R3)].$$

If the on time of the neon lamp is to be 1/5 of the time it is off, then $C1 = 1/5 C2$. $R3 + R2$ is the same as $R5 + R3$ so under these conditions the period may be expressed as

$$P (\text{sec}) = .69 \times \frac{6}{5} \times C2 \times (R3 + R2). \quad (C2 \text{ in farads, 'R3+R2' in ohms}).$$

The frequency is given by $F = \frac{1}{P}$. $(R3 + R2)$ is adjustable over a 6 to 1 range; therefore, the period or frequency is adjustable over a 6 to 1 range for a particular set of condensers C1 and C2. If C1 and C2 are electrolytic, they should be connected with the polarity shown in the diagram.

The following table gives the range of frequencies, the period, and the revolutions per minute of a rotating object that may be made to appear motionless with one flash for each revolution.

C1 (mfd)	C2 (mfd)	Frequency (cps)	Period	RPM
.02	0.1	400 to 2400	.41 to 2.5 millisecc	24,000 to 144,000
.1	0.5	80 to 480	2.1 to 12.5 millisecc	9,600 to 28,800
.2	1.0	40 to 240	4.1 to 25 millisecc	4,800 to 14,400
.4	2	20 to 120	8.2 to 50 millisecc	1,200 to 7,200
2	10	4 to 24	41 to 250 millisecc	240 to 1,440
10	50	.8 to 4.8	.21 to 1.25 sec	48 to 288

A rotating object may be made to appear motionless if the light flashes occur at a submultiple of the speed of rotation, i.e., one flash for each two revolutions. In this mode of operation, the object is illuminated less frequently and appears dimmer. The light from a neon lamp is quite dim, requiring observations to be made in a dimly lighted environment.

PARTS LIST

- | | |
|--|--|
| B1—1.3 to 1.5V. Battery (such as penlite or mercury cell). | R1, R6—3.3K, 1/2 w. Resistor. |
| B2—6V. Battery (such as lantern type or "A" type). | R2, R4—25K Dual Potentiometer. |
| C1, C3—Timing Capacitor (see text for value). | R3, R5—4.7K, 1/2 w. Resistor. |
| C3—.01 Paper Capacitor. | R7—1K, 1/2 w. Resistor. |
| I1—NE-36 Lamp. | R8—470Ω, 1/2 w. Resistor. |
| Q1, Q2—Sylvania 2N229 Transistor. | R9—1.2K, 1/2 w. Resistor. |
| Q3, Q4—Sylvania 2N307 Transistor. | S1—D.P.S.T. Switch. |
| | T1—Output Transformer (numbers show connections to be made to secondary terminals) (such as Triad Type 5-51X). |

23. INDUCTION TRANSCIEVER

Description of Operation:

A set of two of these transceivers are useful for short range communications or code practice. With the key of one unit held closed a tone will be heard in both pairs of earphones each time the other key is closed. The tone becomes inaudible at ranges of more than a few yards but an added transistor audio amplifier will increase the range several fold. Each transceiver is an ultrasonic oscillator functioning also as a heterodyne detector. The inductive field of each loop threads the other loop and induces signals in it.

A suitable loop can be wound on an eighteen inch diameter $\frac{5}{8}$ inch high cylinder such as the top of a peach basket. The collector coil L1 should consist of 5 turns of number 12 to number 20 wire and the emitter coil L2 of one turn. The turns should be spaced about $\frac{1}{8}$ inch

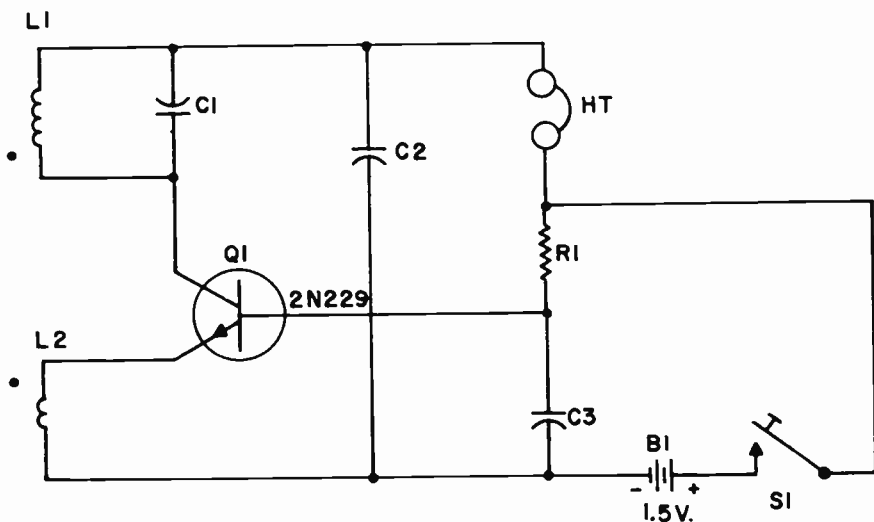

FIGURE 23—Induction Transceiver.

on centers. None of these dimensions are critical but the loops and their tuning capacitors must be very nearly identical for the tone to be heard. The rest of the circuit can be mounted on or within the support for the coil.

After construction of the two individual transceivers, headphones and batteries are inserted in each. Place the transceivers about a yard apart flat on a non-metallic floor or table. A click should be heard when the key of either is closed. Close both keys and adjust the spacing of the turns of either collector coil until a pure tone is heard and the frequency is shifted to be most clearly heard.

To receive, hold the key closed while someone sends on the other transceiver. To send, have the key on the other transceiver held closed. To show the directional effect of the magnetic field that links the loops

hold the keys closed and turn either loop until the tone vanishes. Turning the other loop to be parallel with the first will restore the tone to maximum intensity.

To increase the range replace the headphones by a 2200 ohm resistor and connect the collector side of this resistor to the input of a transistor audio amplifier with the headphones connected to its output. With such an amplifier the output will be sufficient to operate a transistorized relay for door opening or other remote control purposes.

If one is unable to get a tone reverse connections to either L1 or L2 but not to both.

PARTS LIST

B1—1.5V. Battery Burgess #2R or equivalent.
 C1—.005 Mfd. Paper Capacitor.
 C2, C3—.02 Mfd. Paper Capacitor.
 HT—Earphones, approximately 2000Ω.

L1, L2—See text.
 Q1—Sylvania 2N229 Transistor.
 R1—47K ½w. Resistor.
 S1—Telegraph Key preferably with circuit closing switch.

24. CODE-PRACTICE OSCILLATOR

Description of Operation:

Figure 24 is the circuit of a simple code-practice oscillator which requires no coils or transformers. The headphones themselves supply the required inductance. Magnetic headphones are necessary in this oscillator, since the transistor collector current must flow through them. No ON-OFF switch is needed, since no voltage reaches the circuit until the key is depressed.

The two capacitance values give a frequency of approximately 700

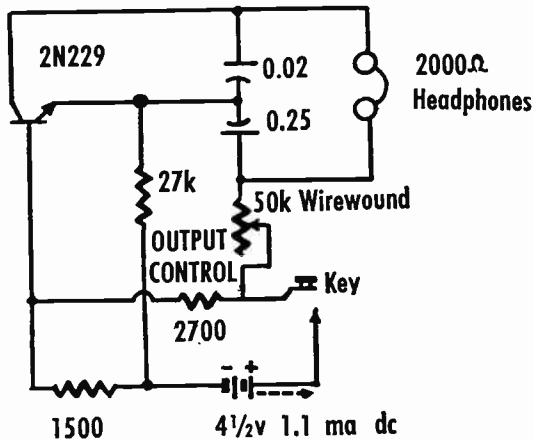

FIGURE 24—Code Practice Oscillator.

cycles when a pair of 2000-ohm headphones are in the circuit. This frequency may be changed to suit the ear by selecting other capacitances.

This oscillator follows rapid keying, giving smooth response without sharp transients. The low, intermittent current drain of 1.1 ma enables the use of three series-connected flashlight cells with good economy.

25. 30 MW AUDIO PRE-AMPLIFIER

Description of Operation:

Figure 25, shows the circuit of a pre-amplifier with 50 db. gain, suitable for driving either a two watt Class A amplifier, as illustrated in Figure 26, or an eight watt class B amplifier as shown in Figure 27.

A crystal phono pick-up, crystal microphone, or tuner may be operated directly into this preamplifier. All components are standard values and any inexpensive transformers can be used. However, improved

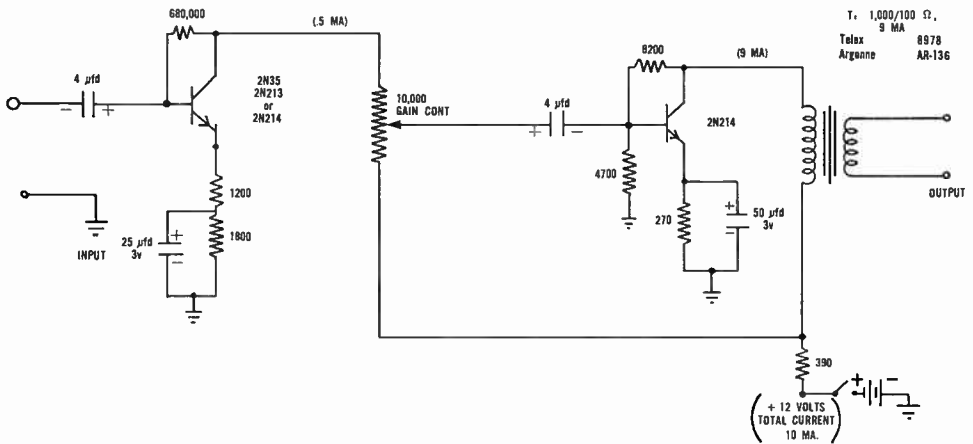

FIGURE 25—30 MW Audio Pre-Amplifier.

response can be expected by using large size high quality transformers.

In the first stage of the pre-amplifier in Figure 25, Types 2N35, 2N213, or 2N214 will perform with the same satisfaction using the value of components shown. However, any transistor substituted for the 2N214 in the output stage of the pre-amplifier must be capable of dissipating 125 mw.

At full gain, the noise level is 1.8 mv—with the input terminals short circuited.

26. CLASS A, 2 WATT AUDIO AMPLIFIER

Description of Operation:

The Sylvania 2N307 junction power transistor offers many possibilities in applications requiring useful audio power output. Although small in size and operating at low d-c voltage, this transistor is capable of 1.5 watts dissipation in free air and 7.0 watts when provided with heat sink. At -12V collector potential, a single 2N307 operated as a Class A amplifier will deliver 2 watts output. Class A collector efficiency is 35 percent. Power gain is 25 db and frequency response is greater than 10 kc.

This class A amplifier employs a single 2N307 and the transistor is operated as a common emitter. The required 30 mw. of driving power may be obtained from any transistor pre-amplifier of the type shown in Figure 25.

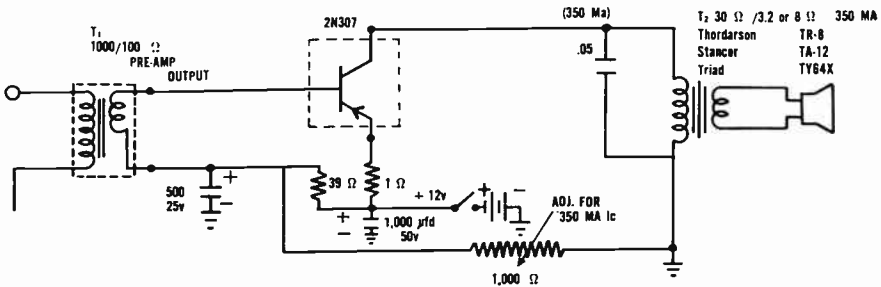

FIGURE 26—Class A, 2 Watt Audio Amplifier.

Transformers T1 and T2, must be fabricated especially for the low impedances of the 2N307, although T2 can be a conventional output transformer designed to operate into a loudspeaker voice coil. The primary impedance of T1 must be selected either to match a low impedance line from the pre-amplifier or the collector impedance of a transistor pre-amplifier.

In addition, to have a 30 ohm primary transformer, T2 must be able to handle the 350 ma. constant collector current of the transistor. The secondary impedance of the transformer will vary, depending of course on the size speaker used, such as 3.2 or 8 ohms.

In order to obtain 2 watts output, a heat sink (5" x 5" 1/16" Aluminum) must be provided for the type 2N307 power transistor. Care must be exercised to insulate the transistor from chassis if the chassis is used as common ground, because the collector of all Sylvania power transistors is internally connected to the case. If chassis is used as a common ground, it is recommended that a mica washer be used between the 2N307 and chassis to prevent any problems in transistor operation.

27. CLASS B, 8 WATT AUDIO AMPLIFIER

Description of Operation:

Two Sylvania type 2N307 power transistors in a push-pull Class B stage operated at -12V DC will deliver 8 watts of audio output power with less than $\frac{1}{2}$ watt of audio driving power. Figure 27 shows the circuit of a Class B amplifier of this type with a Class A, 2N307 driver.

Transformers T1, T3, and T4, must be fabricated especially for the low impedances of the 2N307, although transformer T4, may be a conventional output transformer designed to match a loudspeaker voice coil. As in Figure 26, the primary impedance of T1, must be selected to match either a low impedance line from the pre-amplifier or the collector impedance of a transistor pre-amplifier such as described in Figure 25.

The collector current in the Class A driver stage is constant at 70 ma. and is set by adjustment of base resistor R, starting with a large value, reducing it until the desired collector current (70 ma.) flows. The

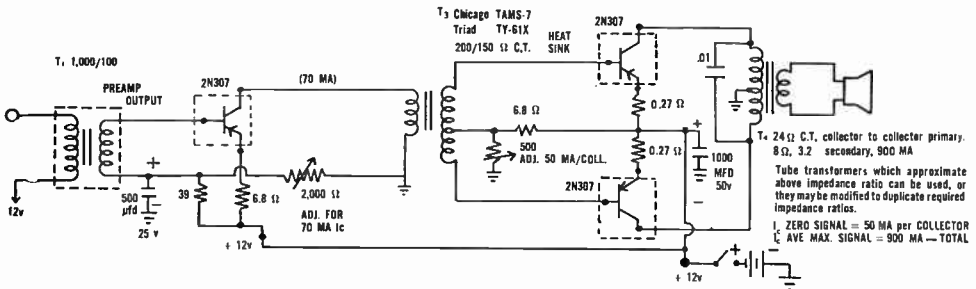

FIGURE 27—Class B, 8 Watt Audio Amplifier.

medium value for this resistance will be around 1,000 ohms. The zero signal total collector current in the Class B output stage is 100 ma., and the maximum total collector current 900 ma. The relative high currents demanded by the 2N307 necessitates that transformer T3 be able to handle peak current of 150 ma. and T4 1 amperes.

Because of the heat dissipation required, both transistors in the output stage must be mounted, utilizing the heat sink, and insulated from each other as well as the chassis. At least a 3" x 5" x 1/16" alum. surface should be used and preferably larger. These two dissipating surfaces can be mounted either on top or underneath the chassis whichever is convenient to the builder. Although the driver need not be mounted with heat sink, care must be exercised to insulate the metal container from the chassis as outlined in the Class A amplifier in Figure 26.

28. ONE-TRANSISTOR POCKET RADIO

Description of Operation:

This simple pocket radio is fun to make, handy to use. It's economical on power, as you can use readily available flashlight batteries rather than portable radio batteries.

Both sensitivity and audio output are provided by a single Sylvania type 2N229 audio transistor and a diode detector in a simple radio circuit. Schematic (Figure 28) shows the hook-up.

The tuned circuit consists of a high-Q ferrite antenna coil and 365 $\mu\mu\text{f}$ variable capacitor. The tuning capacitor is a new flat unit ($1\frac{1}{2}$ -inch square and $\frac{3}{16}$ -inch thick), which enables the entire radio, exclusive of headphones, to be built smaller than a cigarette package.

The antenna is a length of flexible, insulated wire from an ac-dc antenna hank. This wire may be draped from a window or door, or thrown across the floor to pick up strong local stations.

Align the set initially as follows: (1) Connect an amplitude-modulated signal generator, set to 1600Kc., to the antenna lead. (2) Set the tuning capacitor to its extreme counterclockwise position. (3) Using an insulated screwdriver, adjust the slug of the antenna coil for maximum signal in the headphones. (4) If a dial is attached to the tuning capacitor, it may be calibrated by setting the signal generator successively to various broadcast frequencies, tuning them in, and marking the dial with the frequency at each setting.

The 3-volt battery is composed of two $1\frac{1}{2}$ -volt penlight cells connected in series.

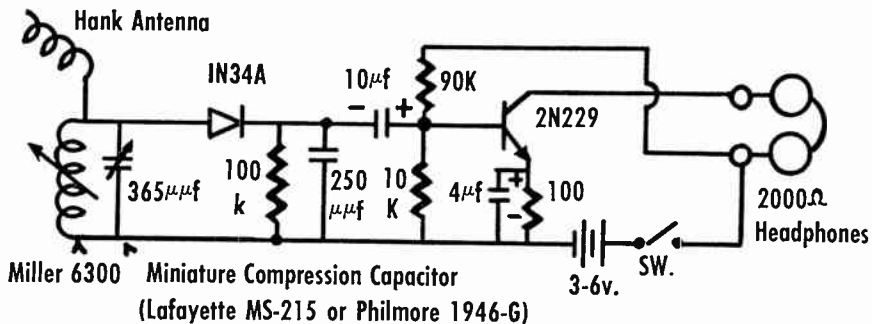

FIGURE 28—One-Transistor Pocket Radio.

29. TRANSISTOR DYNAMIC MICROPHONE

Description of Operation:

An unused permanent-magnet dynamic loudspeaker conveniently may be converted into a high-output dynamic microphone by adding to it a 1-stage transistor amplifier. The low input impedance of the normal transistor amplifier is compatible with the low impedance of the

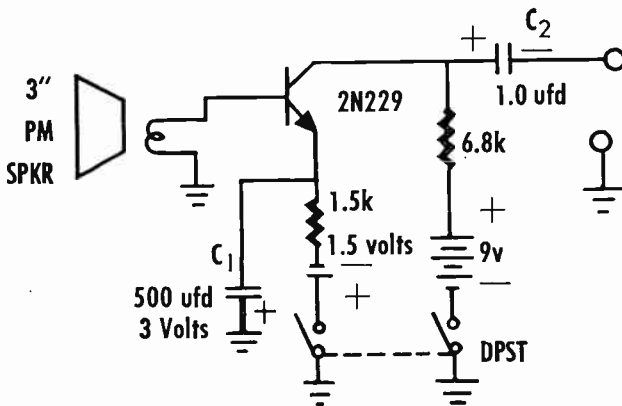

FIGURE 29—Transistor Dynamic Microphone.

speaker. A 3-inch speaker affords the smallest size, but a larger one will give the best tone quality. Such a microphone may be used directly or as the basis of a simple intercom system. Output from the circuit will be approximately 0.5 v. rms. for close talking into a three inch, permanent magnet speaker.

The unit was built into a 7" x 5" x 3" aluminum box, but could be made much smaller if required. In fact, the entire amplifier and batteries might be mounted on a plate attached to the back of the loudspeaker. A small 9-volt hearing aid battery is adequate for power supply.

30. REGENERATIVE BROADCAST RECEIVER

Description of Operation:

In a regenerative receiver, some R-F signal feeds back to input, thus re-amplifying for increased gain. Schematic shows a circuit of this type employing a 2N233 regenerative detector and 2N229 audio amplifier. With an outside antenna and ground, this arrangement delivers a strong headphone signal on local and nearby stations—without necessity for a volume control.

This receiver covers the standard broadcast band with a single 365- $\mu\mu\text{fd}$ tuning capacitor. A variable 75- $\mu\mu\text{fd}$ feedback capacitor serves as regeneration control. Current drain is 1.5 ma from a 6-volt battery.

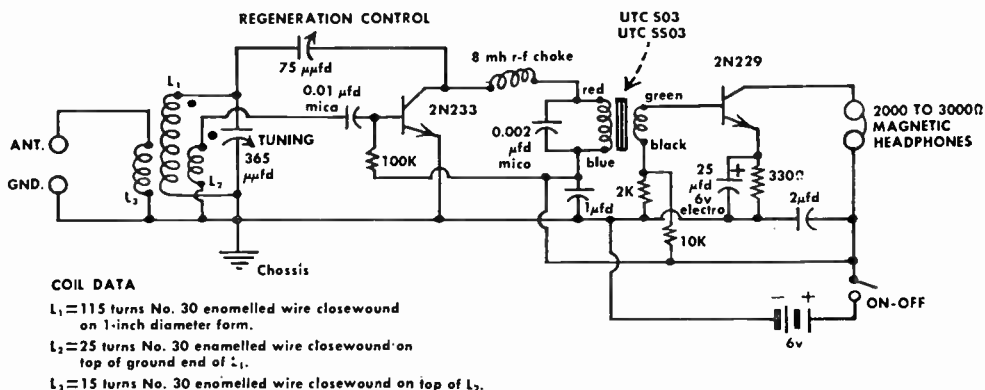

FIGURE 30—Regenerative Broadcast Receiver.

Follow the color coding in schematic for the miniature coupling transformer. If either the primary or secondary leads are reversed, the circuit will oscillate steadily, producing an annoying howl.

If difficulty is experienced in obtaining oscillations, try reducing the antenna coupling and/or increasing turns on L₂. Be sure that L₁ and L₂ are properly phased.

31. WIRELESS PHONO OSCILLATOR

Description of Operation:

This battery-powered unit takes signal from a record changer or turntable pickup and transmits it as a wireless signal to a radio in the same or nearby room. It is attractive because it requires no connection to the power line and hum free transistors make possible economical

battery operation. Tune the oscillator to an inactive frequency of the nearby radio. And the radio, when tuned to that frequency will receive and “play” the signal from the record changer’s pick-up.

Schematic shows the simple phono oscillator unit, employing a 2N233 transistor as a fixed-tuned r-f oscillator and a 2N229 transistor as a

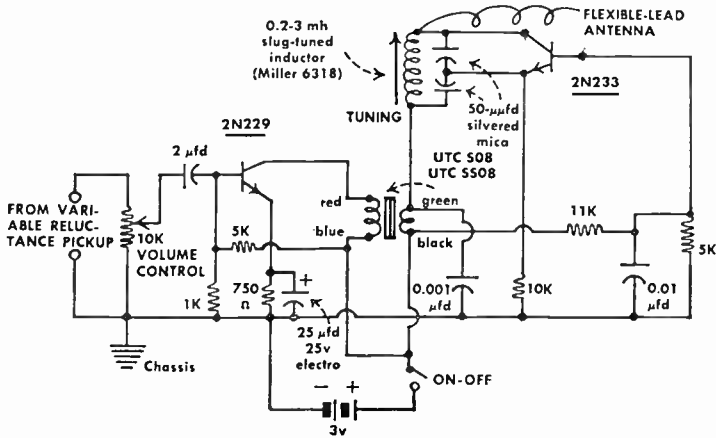

FIGURE 31—Wireless Phono Oscillator.

modulator. A short length of flexible, insulated wire (ac-dc antenna hank) serves as the transmitting antenna.

The oscillator frequency is adjusted by means of a 0.2 to 3-millihenry slug-tuned inductor. The frequency may be shifted throughout the broadcast band to any clear spot on the receiver dial. The oscillator is a Colpitts-type circuit.

Operated from a self-contained 3-volt battery, the circuit draws 1.6 ma.

32. 100-1000 KC FREQUENCY STANDARD

Description of Operation:

A transistorized crystal type secondary frequency standard has the advantage of low d.c. drain, independence from the power line, freedom from hum and heating. It's compact and completely self-contained.

Schematic shows a 100-1000-kc crystal-type standard-frequency oscillator. A Bliley Type SMC-100, dual mode, crystal is employed. This crystal will oscillate strongly on 100 or 1000 kc, provided the corresponding tuned circuit is operated in the collector output circuit.

Slug-tuned coils, L1 and L2, each shunted by a 200-µµfd silvered mica capacitor, are employed for tuning. L1 is the 100 kc inductor; L2 1000

kc. A single-pole, 3-position, non-shorting, rotary switch is the frequency selector. At its left-hand setting, this switch cuts the 100 kc tank into the collector circuit. At its center setting (OFF), the battery circuit is interrupted and the signal switched off.

To tune the oscillator: (1) Set the selector switch to its 100-kc posi-

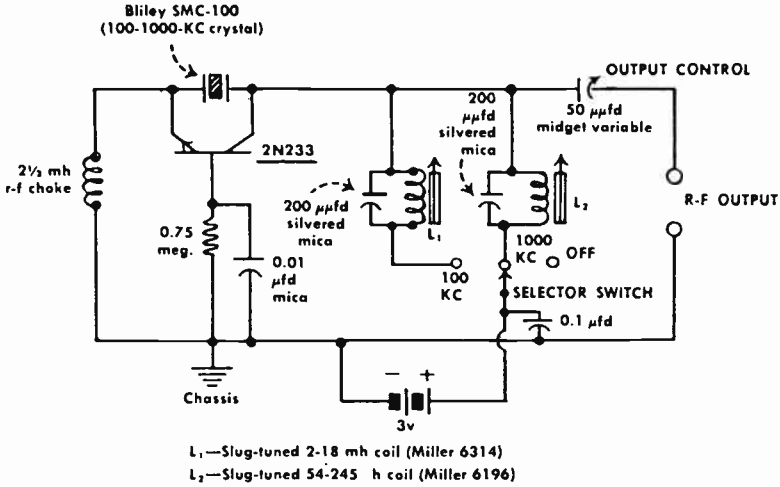

FIGURE 32—100-1000 KC. Frequency Standard.

tion. (2) Connect an r-f vacuum-tube voltmeter switched to its 0-1.5 or 0-3-volt range, to the R-F OUTPUT terminals. (3) With an insulated screwdriver, adjust the slug of inductor L_1 for peak deflection of the meter. (4) Set the selector switch to its 1000-kc position. (5) Adjust the slug of inductor L_2 for peak deflection of the meter.

The 50- $\mu\mu$ fd variable coupling capacitor serves as an r-f output control by varying the impedance in series with the high output terminal.

The low d-c drain of this oscillator allows the use of two 1½-volt penlight cells connected in series as the d-c source.

33. TRANSISTORIZED ORGAN

Description of Operation:

This instrument consists of an audio frequency oscillator or tone generator, a speaker to provide sound output and a small keyboard for selecting the various notes. This instrument will play one note a time. If more than one key is pressed at the same time, the resulting note produced will be by the key which is electrically nearest capacitor C_6 .

The combination of capacitors C_1 to C_6 have been chosen to provide an approach to the musical scale.

A Sylvania 2N229 transistor is connected as a grounded emitter audio

oscillator. The transformer primary of T1 is connected between the transistor collector and base to provide the necessary feedback and maintain oscillation. The secondary winding of T1 provides the low impedance output terminals to feed the voice coil of a PM speaker.

The keyboard may be made by using doorbell push buttons mounted on a suitable base board. If it is preferred, the keyboard may be made

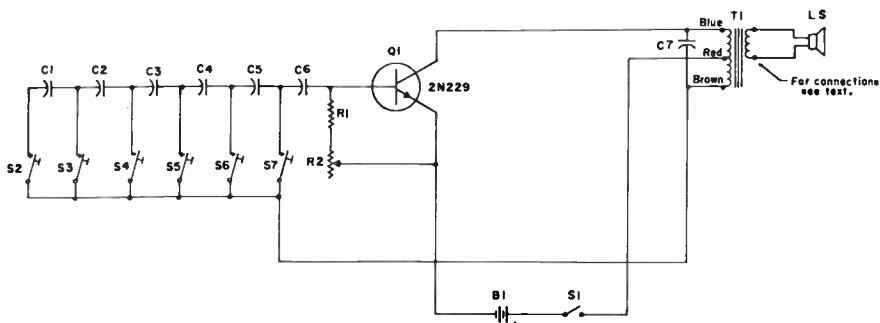

FIGURE 33—Transistorized Organ.

from brass strip approximately $\frac{1}{4}$ inch wide and $\frac{1}{32}$ inch thick. One brass strip serving as the common terminal for all keys. The individual key switches S2 to S7 can then be mounted at right angles to the common strip.

If the builder wishes to change the tonal range, this can be accomplished by changing capacitor C1. Increasing or changing this capacitor to 0.04 mfd. will lower all notes. Too large a capacitor will prevent the transistor from oscillating. Resistor R2 provides bias for the transistor and should be adjusted to set the frequency range of the instrument.

Since conventional loudspeakers are manufactured in various impedances, most 5 to 6 inch speakers have voice coil impedances of about 3 to 5 ohms. Accurate matching of impedances between transformer and speaker is not important in this case, therefore it is suggested that the speaker be connected to the secondary winding terminals #1 and #2. Other combination of terminals may be used if results are better.

PARTS LIST

- | | |
|---|---|
| B1—6V. Battery, Burgess Type F4BP or equivalent. | Q1—Sylvania 2N229 Transistor. |
| C1 through C7—Capacitor, 0.02 mfd., Paper or Ceramic Disc Type 12V. or greater. | R1—470 ohm, $\frac{1}{2}$ w. Resistor. |
| LS—Permanent Magnet Loudspeaker, 5 or 6 inch. | R2—100K Potentiometer. |
| | S1—S.P.S.T. Switch. |
| | S2 through S7—Switches or keys. (See Text). |
| | T1—Transformer, Stancor Type A-3856. |

34. METRONOME

Description of Operation:

This Metronome produces, without the benefit of clock works or other moving parts, a steady beat. The circuit consists of a multivibrator whose repetition rate is controlled by a 50K Potentiometer (R3). This "pot" varies the bias voltage on one transistor controlling the discharge rate of capacitor C1. A switch (S1) is provided so that the output

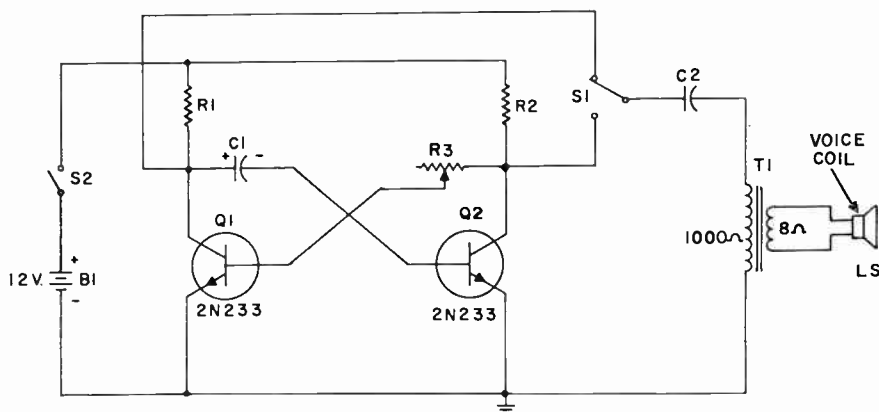

FIGURE 34—Metronome.

transformer may be placed across either side of the multivibrator to obtain different volume levels.

The type of multivibrator used here does not depend on external control voltages. It is called "astable." To explain the action of this type, assume first that both collector currents are equal. If the current through, say, Q2 were now to increase, the voltage across R2 would increase. The effect is that the voltage at the collector of Q2 is decreased (as it is in amplifiers). Only this time the base bias on Q1 is also decreased, by way of R3. Because this causes the collector current to be decreased, the voltage at the collector goes up. This, in turn, causes the base bias at Q2 to be decreased. While the process continues until Q2 saturates, it takes place, in effect, almost instantaneously. Thereupon the reverse process begins, with Q1 eventually stealing conduction from Q2, whereupon the process reverses.

This type of circuit is very versatile and has an almost endless number of applications. To pick one at random, Q1 can be immersed in ice water, while Q2 is placed in a warm place. The resulting frequency can

be calibrated in terms of temperature. (A mechanical counter could be used for a standard length of time, such as 30 seconds.)

If R3 were replaced by a bank of resistors of different values, and if this bank were connected to the collector of Q2 by means of a multi-position switch, a musical "organ" would result.

Adding a second multivibrator stage by way of a suitable coupling network provides a "count" of $\frac{1}{2}$ speed. Hence, division can be accomplished by means of hooking together several stages of this type of multivibrator.

If the cap of a transistor is removed, the transistor becomes light sensitive. Hence, a match over one transistor can change the multivibrator frequency. The presence of light of various wavelengths can thus be determined in terms of corresponding changes in frequency. This goes for infrared and ultraviolet which are not directly visible.

PARTS LIST

- | | |
|---|---|
| B1—12V. Battery—Two Burgess #A4 (6V.) batteries connected in series, or equivalent. | Q1, Q2—Sylvania 2N233 Transistor. |
| C1—50 Mfd. Electrolytic 25V. or greater Capacitor. | R1, R2—4.7K $\frac{1}{2}$ w. Resistor. |
| C2—0.1 Mfd. Paper Capacitor. | R3—50K Wire Wound 1w. Potentiometer. |
| L5—Speaker, 8 Ω voice coil. | S1—S.P.D.T. Toggle Switch. |
| | S2—S.P.S.T. Toggle Switch. |
| | T1—Output Transformer; primary 1000 Ω , secondary 8 Ω . |

35. PHOTOGRAPHY LIGHT METER

Description of Operation:

The circuit shown can be used by amateur photography fans as a light meter. It is a simple device to construct. The principle of operation is relatively straightforward.

The instrument operates in the following manner. With the light level in a low intensity condition, the photodiode is back biased so that its resistance is very high. Therefore the voltage on the diode is approaching the battery supply. This positive voltage on the base of the transistor results in Q1 conducting heavily. As the light intensity increases the back resistance of the photodiode decreases, decreasing the positive voltage on the base of Q1. Thus the current flowing through M1 decreases. At the intense light levels the photodiode will be a short circuit and the meter M1 will read zero current. Note that this scale is calibrated in a similar manner to an ohm meter where an increase of resistance causes a decrease of current. At a low intensity R1 and R3 should be adjusted for full scale deflection of M1. In constructing this device, be sure that the photodiode is placed in a position to sense the light level without any physical obstruction in the light path.

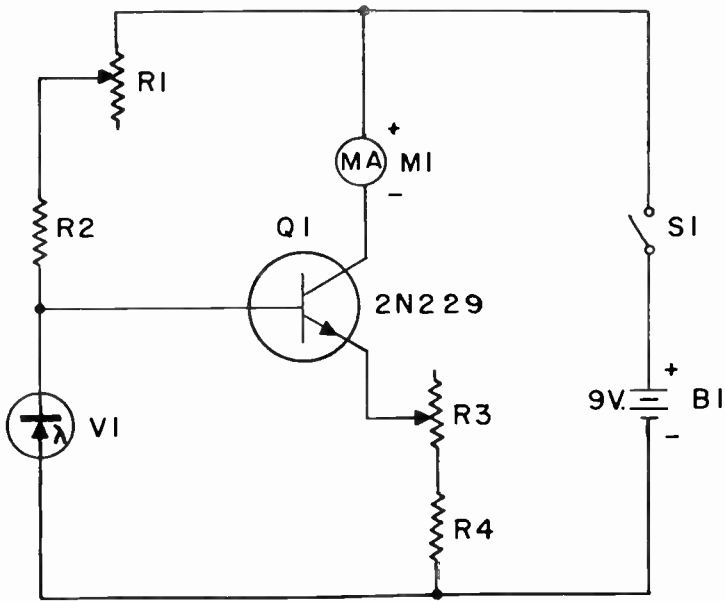

FIGURE 35—Photography Light Meter.

The photodiode V1 must be polarized correctly. The cathode end of the photodiode is indicated by a red dot on body of the unit.

PARTS LIST

- | | |
|---|-------------------------------|
| B1—9V. Battery, Burgess #2N6 with snap terminals or equivalent. | R2—27K, 1/2 w. Resistor. |
| M1—Meter, 0 to 15 milliamperes D.C. | R3—250Ω Potentiometer. |
| Q1—Sylvania 2N229 Transistor. | R4—68Ω, 1/2 w. Resistor. |
| R1—25K Potentiometer. | S1—S.P.S.T. Toggle Switch. |
| | V1—Sylvania 1N77A Photodiode. |

36. BINARY COUNTER

Description of Operation:

The binary counter consists of a cascade of flip-flop circuits containing indicator lights so that the state of each stage of the counter may be observed visually. The counter might be used by science or mathematics teachers for demonstrating binary addition or by students as part of a science fair display of computer type circuits. The circuit may be operated by a relay and be used to count objects moving on a conveyor belt or persons passing a photocell, etc.

The schematic diagram shows two stages but the counter may be extended to as many stages as desired. The counter counts from 0 to

$(2^N - 1)$, where N is the number of stages. The maximum count for a given number of counter stages is given in Table I.

N (number of counter stages)	$(2^N - 1)$
1	1
2	3
3	7
4	15
5	31
6	63
7	127
8	255
9	511
10	1023

TABLE I—Count capability as function of number of stages.

The counter operates as follows. Each time $S1$ is closed the flip-flop of stage 1 changes state. For example, if $Q1$ of stage 1 is conducting (lamp $I1$ lit), closing $S1$ causes a positive pulse to pass through $C1$ and

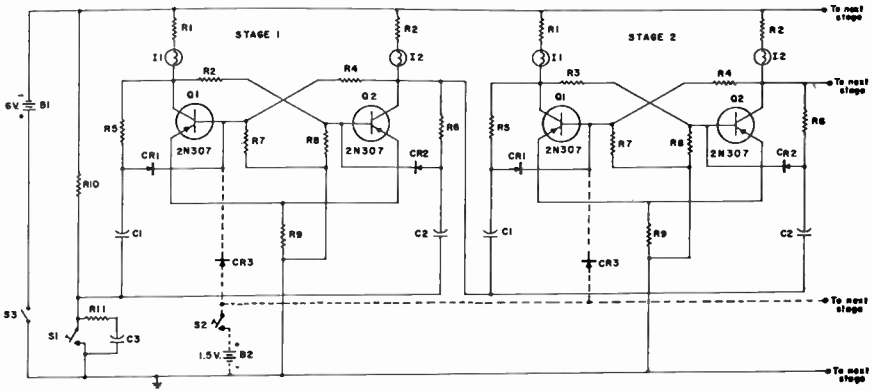

FIGURE 36—Binary Counter.

$CR1$ to the base of $Q1$ causing $Q1$ to be cut off and consequently $Q2$ to be turned on and lamp $I1$ to be lit. The positive pulse did not pass through $CR2$ because it was reverse biased through $R6$. The next time $S1$ is closed $Q2$ is turned off and $Q1$ turned on.

Each time $Q2$ of stage 1 is turned on the second counter stage changes state. Similarly each time $Q2$ of stage 2 is turned on stage 3 changes state. Thus the first stage changes state each time $S1$ is closed; the second stage changes state every second time $S1$ is closed; the third stage change state every fourth time $S1$ is closed, etc.

The way the count, or the number of times $S1$ has been closed, is displayed as shown in Table II.

Count	Stage 1		Stage 2		Stage 3	
	Lamp 11	Lamp 12	Lamp 11	Lamp 12	Lamp 11	Lamp 12
0	off	on	off	on	off	on
1	on	off	off	on	off	on
2	off	on	on	off	off	on
3	on	off	on	off	off	on
4	off	on	off	on	on	off
5	on	off	off	on	on	off
6	off	on	on	off	on	off
7	on	off	on	off	on	off
8	pattern	repeats				

TABLE II—Count display for 3 stage counter.

If one adapts the convention that lamp 11 of a particular stage being on represents 1 and Lamp 12 being off represents 0, then Table II may be written as shown in Table III. In Table III, the count is given in its binary representation written from right to left (least significant digit on right).

Count	Stage 1	Stage 2	Stage 3
0	0	0	0
1	1	0	0
2	0	1	0
3	1	1	0
4	0	0	1
5	1	0	1
6	0	1	1
7	1	1	1
8	pattern	repeats	

TABLE III—Binary representation of count (least significant digit on right).

Table III (and also correspondingly Table II) may be extended to an additional stage 4 by repeating the pattern for the two stages shown to give 15 count positions and in the stage 4 column writing 0's to count 7 and 1's to count 15. In this manner the table may be extended to any number of stages.

In the schematic diagram the part of the circuit shown in dotted lines (containing S2, B2 and diode CR3) may be included to reset the counter to zero by closing S2 momentarily.

The power dissipation in the transistors is low and they need not be mounted on a heat sink.

PARTS LIST

B1—6V. Battery, Burgess F4BP or equivalent.

B2—1.5V. Battery, Burgess #2R or equivalent.

C1, C2—.047 or .05 Mfd. Paper or Ceramic Capacitor.

C3—.1 Mfd. Paper Capacitor.

CR1, CR2, CR3—1N34A Diode.

I1, I2—Sylvania #48 or #49 2V., 60 ma. Pilot Lamp.

Q1, Q2—Sylvania 2N307 Transistors.

R1, R2—68Ω, 1/2 w. Resistor.

R3, R4, R7, R8—1.2K 1/2 w. Resistor.

R5, R6, R10—10K, 1/2 w. Resistor.

R9—4.7Ω 1/2 w. Resistor.

R11—27Ω 1/2 w. Resistor.

S1—Switch, normally open momentary contact pushbutton type such as Grayhill Type 2201 or equivalent.

S2—Same as S1.

S3—S.P.S.T. Toggle Switch.

NOTE: C1, C2, R1 through R9, CR1, CR2, CR3, I1, I2, Q1, Q2 must be duplicate for each stage used.

MAXIMUM RATINGS

CHARACTERISTICS

Type	Application	Class	Outline	Max. Diss. at 25°C Ambient	Max. V _{CB}	Max. V _{CE}	Max. I _C (ma)	Max. Junction Temp. (°C)	DC Current Gain, h _{FE}		Cutoff Current (at maximum at rated voltage)		Cutoff Frequency (Minimum Values)		Circuit Power Gain db (typical)	Sylvania Socket Number	
									Min.	Max.	I _{CBO}	I _{CES} (1)	f _β (mc)	f _α (mc)			
RF-IF AMPLIFIER																	
2N94	IF Amplifier	NPN	A	50mw	...	20	50	75	10	80	...	50	2	...	26(3)	7460-0013	
2N94A	RF-IF Amplifier	NPN	A	50mw	...	20	50	75	19(2,3)	50	5	7460-0013	
2N139	IF Amplifier	PNP	A, B(4)	35mw	...	-16	15	70	22	110	...	50	2	...	25(3)	7460-0013	
*2N169A	IF Amplifier	NPN	C	65mw	25	25	20	75	36(2)	220(2)	5(5)	...	2	...	25(3)	7460-0013	
*2N216	IF Amplifier	NPN	A	50mw	...	18	50	75	5	15	...	50	2	...	26(3)	7460-0013	
*2N233	IF Amplifier	NPN	A	50mw	10	10	50	75	10	15(2,3)	...	50	7460-0013	
2N233A	IF Amplifier	NPN	A	50mw	...	18	50	75	10	50	...	50	2	...	24(3)	7460-0013	
2N247	1.5mc Amplifier	PNP	D	35mw	-35	V _{BE} = -0.5	10	85	20(2)	175(2)	50	27(1.5mc)	...	
*2N292	IF Amplifier	NPN	C	65mw	-15	15	20	85	6(2)	44(2)	5(5)	...	5(6)	...	25(3)	7460-0013	
2N370	20 mc RF Amplifier	PNP	D	80mw	-20	V _{BE} = -1.5	10	85	40(2)	175(2)	18(7)	14(20mc)	...	
2N373	IF Amplifier	PNP	D	80mw	-25	V _{BE} = -0.5	10	85	20(2)	400(2)	6(7)	38(3)	...	
*2N384	VHF Amplifier	PNP	E(8)	120mw	-30	V _{BE} = -0.5	10	85	20(2)	175(2)	100	17(50mc)	...	
2N413A	IF Amplifier	PNP	F(9)	150mw	-20	-15	200	85	10(6)	...	2	...	30(3)	7460-0014	
2N414A	IF Amplifier	PNP	F(9)	150mw	-20	-15	200	85	10(6)	...	4	...	32(3)	7460-0014	
2N515	IF Amplifier	NPN	A	50mw	...	18	10	75	5(2,3)	15(2,3)	...	50	2	...	25(3)	7460-0013	
2N516	IF Amplifier	NPN	A	50mw	...	18	10	75	5(2,3)	15(2,3)	...	50	2	...	27(3)	7460-0013	
2N517	IF Amplifier	NPN	A	50mw	...	18	10	75	5(2,3)	15(2,3)	...	50	2	...	28.5(3)	7460-0013	
2N544	RF-IF Amplifier	PNP	D	80mw	-18	...	10	85	20(2)	175(2)	4(7)	35(1.5mc)	...	
2N624	12.5 mc Amplifier	PNP	G	100mw	-30	-20	...	100	20	...	30	20(10)	22(12.5mc)	7460-0014	
OSCILLATOR																	
2N193	Oscillator	NPN	A	50mw	...	18	50	75	4(2,3)	15(2,3)	...	50	2	7460-0013	
*2N211	Oscillator	NPN	A	50mw	...	10	50	75	5(2,3)	15(2,3)	...	20	2	7460-0013	
2N371	20 mc Oscillator	PNP	D	80mw	-20	V _{BE} = -0.5	10	80	20(2)	400(2)	20(7)	14(20mc)	...	
MIXER-CONVERTER																	
2N140	Converter	PNP	A, B(4)	35mw	-16	-12	15	85	6(7)	...	8(6)	...	30	7460-0013	
*2N168A	Converter	NPN	C	65mw	15	15	20	85	23(2)	135(2)	5	...	5	...	25	7460-0013	
2N194	Mixer	NPN	A	50mw	...	18	50	75	5(2,3)	15(2,3)	...	50	2	...	15	7460-0013	
2N194A	Converter	NPN	A	50mw	...	18	50	75	5(2,3)	15(2,3)	...	50	2	...	23	7460-0013	

MAXIMUM RATINGS

CHARACTERISTICS

Type	Application	Class	Outline	Max. Diss. at 25°C Ambient		Max. V_{CB}	Max. V_{CE}	Max. I_C (ma)	Max. Junction Temp. (°C)	DC Current Gain, h_{FE}		Cutoff Current (at maximum at rated voltage)		Cutoff Frequency (Minimum Values)		Circuit Power Gain db (typical)	Sylvania Socket Number	
				Max. V_{CB}	Max. V_{CE}					Min.	Max.	I_{CBO}	$I_{CER}(1)$	$f_{\beta B}$ (mc)	$f_{\beta E}$ (mc)			
MIXER-CONVERTER (cont.)																		
2N212	Converter	NPN	A	50mw	...	18	50	75	10(2,3)	30(2,3)	...	50	4	...	30	7460-0013		
2N372	20mc Mixer	PNP	D	80mw	-20	$V_{EB} = -0.5$	10	85	20(2)	400(2)	20(7)	14(20mc)	...		
2N374	Converter	PNP	D	80mw	-25	$V_{EB} = -0.5$	10	85	15(2)	400(2)	6(7)	40(3)	...		
2N409	Mixer	PNP	A, B(4)	50mw	...	-20	...	75	22(2)	110(2)	5(7)	26(3)	7460-0013		
*2N410	Mixer	PNP	E	50mw	...	-20	...	75	22(2)	110(2)	5(7)	26(3)	...		
2N411	Converter	PNP	A, B(4)	50mw	...	-20	...	75	22(2)	110(2)	5(7)	20	7460-0013		
*2N412	Converter	PNP	E	50mw	...	-20	...	75	22(2)	110(2)	5(7)	20	...		
2N1058	Converter	NPN	A	50mw	...	18	...	75	10(2)	23(2)	...	50	4	...	24	7460-0013		
AUDIO DRIVER and MEDIUM POWER																		
2N34	Audio Driver	PNP	A	150mw	-40	-25	100	75	25	125	50	100	...	10kc	37	7460-0013		
2N35	Audio Driver	NPN	A	150mw	40	25	100	75	25	125	50	100	...	10kc	37	7460-0013		
2N68	Audio Power	PNP	H	1.5w	-30	-30	1.5A	75	10.5	5ma(10)	.400(6)	...	23	7460-0009		
2N95	Audio Power	NPN	H	1.5w	30	30	1.5A	75	10.5	5ma(10)	.400(6)	...	23	7460-0009		
2N101	Audio Power	PNP	I	1w	-30	-30	1.5A	75	10.5	5ma(10)	.400(6)	...	23	7460-0009		
2N102	Audio Power	NPN	I	1w	30	30	1.5A	75	10.5	5ma(10)	.400(6)	...	23	7460-0009		
2N109	Audio Driver	PNP	A, B(4)	50mw	-25	...	75	85	50	150	12(11)	7460-0013		
2N141	Audio Power	PNP	H	1.5w	-60	-60	1.5A	75	10.5	5ma(10)	.400(6)	...	23	7460-0009		
2N142	Audio Power	NPN	H	1.5w	60	60	1.5A	75	10.5	5ma(10)	.400(6)	...	23	7460-0009		
2N143	Audio Power	PNP	I	1w	-60	-60	1.5A	75	10.5	5ma(10)	.400(6)	...	23	7460-0009		
2N144	Audio Power	NPN	I	1w	60	60	1.5A	75	10.5	5ma(10)	.400(6)	...	23	7460-0009		
2N213	Audio Driver	NPN	A	150mw	40	25	100	85	100(2)	500(2)	50	100	...	10kc	40	7460-0013		
2N214	Audio Output	NPN	A	180mw	40	25	100	85	50	100	50	100	...	10kc	28	7460-0013		
2N214	Matched Pair	NPN	A	180mw	40	25	100	85	(12)	7460-0013		
*2N217	Audio Driver	PNP	E	50mw	-25	...	75	85	50	150	12(11)		
2N228	Audio Output	NPN	A	50mw	40	25	100	75	50	100	100	100(5)	...	10kc	24.5	7460-0013		
*2N229	General Purpose	NPN	A	50mw	6	...	40	75	25	100	200	...	6	...	37	7460-0013		
*2N241A	Audio Output	PNP	...	200mw	-25	-25	200	85	50	100	16	10kc(6)	35	7460-0013		
2N270	Audio Output	PNP	B(13)	150mw	-25	...	75	85	50	100	12(11,16)	7460-0013		
2N306	Audio Driver	NPN	A	50mw	20	15	100	85	25	125	50	100	.600	...	37	7460-0013		
*2N321	Audio Output	PNP	...	200mw	-25	-25	200	85	50	100	16	10kc(6)	32	...		
*2N381	Audio Output	PNP	J	200mw	-25	-25	200	85	24	45	20	100(14)	...	10kc(6)	30	7460-0014		

MAXIMUM RATINGS

CHARACTERISTICS

Type	Application	Class	Outline	Max. Diss. at 25°C Ambient	V _{CE} Max.	Max. V _{CE}	Max. I _C (ma)	Max. Junction Temp. (°C)		DC Current Gain, h _{FE}		Cutoff Current (ux maximum at rated voltage)		Cutoff Frequency (Minimum Values)		Circuit Power Gain db (typical)	Sylvania Socket Number
								Min.	Max.	I _{CEO}	I _{CE(sat)} (1)	f _{ah} (mc)	f _{ac} (mc)				
AUDIO DRIVER and MEDIUM POWER (cont.)																	
*2N382	Audio Output	PNP	J	200mw	-25	-25	200	85	40	76	20	100(14)	...	10kc(6)	34	7460-0014	
*2N383	Audio Output	PNP	J	200mw	-25	-25	200	85	55	110	20	100(14)	...	10kc(6)	38	7460-0014	
2N405	Audio Driver	PNP	A, B(4)	150mw	-20	-18	35	85	15(2)	60(2)	14(7)	250(10)	.25C	7460-0013	
*2N406	Audio Driver	PNP	E	150mw	-20	-18	35	85	15(2)	60(2)	14(7)	250(10)	.25C	
2N407	Audio Output	PNP	A, B(4)	150mw	-20	-18	70	85	50	135	14(7)	250(15)	33	7460-0013	
*2N408	Audio Output	PNP	E	150mw	-20	-18	70	85	50	135	14(7)	250(15)	33	...	
2N525	Audio Output	PNP	J	225mw	-45	-30	500	100	30	...	10(16)	600	1	7460-0014	
2N591	Audio Driver	PNP	A	150mw	-40	-25	100	85	70(2)	300(2)	50	100	...	10kc	40	7460-0013	
2N1059	Audio Output	NPN	A	180mw	40	15	100	75	50(12)	100	50	50(14)	...	10kc	28	7460-0013	
2N1101	Audio Output	NPN	A	180mw	20	15	100	75	25(12)	50	50	100(14)	...	10kc	...	7460-0013	
2N1102	Audio Output	NPN	A	180mw	40	25	100	75	25(12)	50	50	100(14)	...	10kc	...	7460-0013	
HIGH POWER AUDIO																	
*2N155	Audio Power	PNP	K	8.5w(17)	-30	...	3A	85	24	...	1ma010	32	...	
*2N156	Audio Power	PNP	K	8.5w(17)	-30	...	3A	85	24	...	1ma	1.5(10)010	32	...	
2N176	Audio Power	PNP	K	10w at 80°C(17)	...	-30	3A	90	25(2)	90(2)	3ma010	35.5	...	
*2N235A	Audio Power	PNP	K	25w(17)	-40	...	3A	90	50(2)	...	1ma010	34(19)	...	
*2N235B	Audio Power	PNP	K	32w(17)	...	-35	3A	95	60(2,6)	100ma (6, 18)006	36(19)	...	
*2N236B	Audio Power	PNP	K	35w(17)	...	-40	3A	95	60(2,6)	200ma(18)007	36(20)	...	
2N242	Audio Power	PNP	K	50w(17)	-45	-45	2A	100	3ma(18)007	36(19)	...	
*2N250	Audio Power	PNP	K	25w(17)	-30	...	3A	85	50(2)	...	1ma	5ma(18)006	34(19)	...	
*2N255	Audio Power	PNP	K	6.25w(17)	-15	...	3A	85	15	3ma(18)	.100	...	21(19)	...	
*2N256	Audio Power	PNP	K	6.25w(17)	-30	...	3A	85	15	3ma(18)	.100	...	25(19)	...	
*2N257	Audio Power	PNP	K	25w(17)	-40	-25	2A	85	50(2)	...	2ma	5ma(18)007	33(19)	...	
2N268	Audio Power	PNP	K	25w(17)	-80	...	2A	85	35(6)	...	2ma006	28(19)	...	
*2N285A	Audio Power	PNP	K	32w(17)	...	-35	3A	95	150(2,6)	2ma(18)004	
2N296	Audio Power	PNP	K	25w(17)	...	-60	2A	100	20	2ma(18)004	
2N301	Audio Power	PNP	K	12w at 55°C(17)	-40	...	2A	85	5ma	300(21)	35(20)	...	
*2N301A	Audio Power	PNP	K	12w at 55°C(17)	-60	...	2A	85	5ma	300(21)	35(20)	...	
*2N307	Audio Power	PNP	K	10w(17)	-35	-35	2A	75	21	15ma(18)0035	
2N307A	Audio Power	PNP	K	17w(17)	-35	-35	2A	75	25	5ma(18)005	33(19)	...	
2N325	Audio Power	PNP	K	12w(17)	-35	-35	2A	85	30	60	500	3ma(10)	.150	

52

MAXIMUM RATINGS

CHARACTERISTICS

Type	Application	Class	Outline	Max. Diss. at 25°C Ambient	Max. V _{CE}	Max. V _{CB}	Max. I _C (ma)	Max. Junction Temp. (°C)		DC Current Gain, h _{FE}		Cutoff Current (ua maximum at rated voltage)		Cutoff Frequency (Minimum Values)		Circuit Power Gain db (typical)	Sylvania Socket Number
								Min.	Max.	I _{CEO}	I _{CEB} (1)	f _{ab} (mc)	f _{ac} (mc)				
HIGH POWER AUDIO (cont.)																	
2N326	Audio Power	NPN	K	7w(17)	35	35	2A	85	30	60	500	3ma(10)	.150
2N350	Audio Power	PNP	K	10w at 80°C(17)	—40	...	3A	100	20	60	3ma(16)005	31.5(20)
2N351	Audio Power	PNP	K	10w at 80°C(17)	—40	...	3A	100	25	90	3ma(16)005	33.5(20)
*2N399	Audio Power	PNP	K	29w(17)	...	—40	3A	90	40(2,6)	...	1ma(6)	200ma(6,18)007	38(19)
*2N401	Audio Power	PNP	K	29w(17)	...	—40	3A	90	40(2,6)	...	1ma(6)	200ma(6,18)007	33.5(19)
*2N419	Power Supply	PNP	K	32w(17)	...	—45	3A	95	9	44	1ma(6)	200ma(6,18)
*2N420	Power Supply	PNP	K	34w(17)	...	—40	5A	100	40	...	1ma(6)	200(18)
*2N554	Audio Power	PNP	K	10w at 80°C(17)	...	—28	3A	100	30(2,6)	100ma(22)008(6)	32(19)
*2N677	Power Switch	PNP	K	50w(17)	—50	—30	15A	100	20	60	20ma(23)	200ma(18,24)	t _r = 15usec at I _B = 10A(6)	
*2N677A	Power Switch	PNP	K	50w(17)	—60	—40	15A	100	20	60	20ma(23)	200ma(18,24)	t _r = 25usec at I _B = 1A(6)	
*2N677B	Power Switch	PNP	K	50w(17)	—90	—70	15A	100	20	60	20ma(23)	200ma(18,24)	(applies to all four types)	
*2N677C	Power Switch	PNP	K	50w(17)	—100	—90	15A	100	20	60	20ma(23)	200ma(18,24)	(applies to all four types)	
COMPUTER																	
2N123	Switching	PNP	F	100mw	—20	—15	125	85	30	150	6	600(22)	5	7460-0014
2N312	Switching	NPN	F	100mw	15	15	200	85	25	75	15	500	t _r + t _f = 1.5us max. t _{err} = 3.0us max.		7460-0014
2N356	Switching	NPN	F	100mw	20	18	500	85	20	50	25	100	3(6)	7460-0014
2N357	Switching	NPN	F	100mw	20	15	500	85	20	50	25	100	6(6)	7460-0014
2N358	Switching	NPN	F	100mw	20	12	500	85	20	50	25	100	9(6)	7460-0014
2N377	Switching	NPN	J	150mw	25	20	200	100	20	60	20	200	t _r + t _f = 2.5us max. t _f = 1.0us max.		7460-0014
2N385	Switching	NPN	J	150mw	25	25	200	100	30	110	10	100	4	7460-0014
2N388	Switching	NPN	J	150mw	25	20	200	100	60	180	10	50	t _r + t _f = 1.0us max. t _f = 0.7us max.		7460-0014
2N404	Switching	PNP	F	120mw	—25	—24	100	85	20	...	4	7460-0014
2N425	Switching	PNP	F	150mw	—30	—20	400	85	20	40	25	...	2.5	7460-0014
2N426	Switching	PNP	F	150mw	—30	—18	400	85	30	60	25	...	3	7460-0014
2N427	Switching	PNP	F	150mw	—30	—15	400	85	40	80	25	...	5	7460-0014

MAXIMUM RATINGS

CHARACTERISTICS

Type	Application	Class	Outline	MAXIMUM RATINGS			MAXIMUM RATINGS			DC Current Gain, h_{FE}		Cutoff Current (at maximum at rated voltage)		Cutoff Frequency (Minimum Values)		Circuit Power Gain db (typical)	Sylvania Socket Number	
				Max. Diss. at 25°C Ambient	Max. V_{CE}	Max. V_{BE}	Max. I_C (ma)	Max. Junction Temp. (°C)	Min.	Max.	I_{CBO}	I_{CES} (I)	f_{β} (mc)	$f_{\alpha e}$ (mc)				
COMPUTER (cont.)																		
2N428	Switching	PNP	F	150mw	-30	-12	400	85	60	...	25	...	10	7460-0014		
2N439	Switching	NPN	F	100mw	30	20	...	85	30	...	10	300 (22)	5	7460-0014		
2N440	Switching	NPN	F	100mw	30	15	...	85	40	...	10	300 (22)	10	7460-0014		
2N556	Switching	NPN	F	100mw	25	20	200	85	38	75	25	100	$t_r = 3.5\mu s$ max. $t_w = 2.0\mu s$ max.	...	7460-0014			
2N557	Switching	NPN	F	100mw	25	20	200	85	20	...	25	100	$t_r = 6.5\mu s$ max. $t_w = 2.5\mu s$ max.	...	7460-0014			
2N558	Switching	NPN	F	100mw	15	15	200	85	20	...	15	100	$t_r = 3.5\mu s$ max. $t_w = 2.0\mu s$ max.	...	7460-0014			
2N576	Core Driver	NPN	J	200mw	20	20	400	100	20	60	20	100	$t_r + t_w = 2.0\mu s$ max. $t_r = 1.0\mu s$ max.	...	7460-0014			
2N576A	Core Driver	NPN	J	200mw	40	20	400	100	20	60	40	100	$t_r + t_w = 2.0\mu s$ max. $t_r = 1.0\mu s$ max.	...	7460-0014			
2N585	Switching	NPN	F	120mw	25	20	200	85	20	...	25	100	3	7460-0014		
2N587	Switching	NPN	J	150mw	40	25	200	85	20	...	50	50	$t_r = 2.0\mu s$ max. $t_w = 2.0\mu s$ max.	...	7460-0014			
2N679	Switching	NPN	J	150mw	25	20	200	85	20	...	25	100	2	7460-0014		
2N1114	Switching	NPN	J	150mw	25	15	200	100	40	180	30	50	7	7460-0014		

- NOTES :**
1. Measured with $R_{BE} = 10K$ ohms.
 2. Small signal current gain, h_{FE} .
 3. Measured at 455kc.
 4. Either package may be furnished at manufacturer's option.
 5. Measured at $V_{CE} = 15$ volts.
 6. Typical value.
 7. Measured at $V_{CE} = -12$ volts.
 8. Also has a fourth center-located lead tied to case for shielding.
 9. Package may be furnished with or without indexing tab at manufacturer's option.
 10. Measured with base tied to emitter, I_{CES} .
 11. Measured with $V_{BE} = -5$.
 12. Ratings shown are for each unit. Single unit characteristics apply to matched pairs with h_{FE} ratio controlled at $I_C = 10$ and 35ma.
 13. Package diameter = .360" max., package height = .375" max.
 14. Measured with $R_{BE} = 1K$ ohms.
 15. Measured with $R_{BE} = 75$ ohms.
 16. Measured with $V_{CE} = -30$.
 17. Adequate heat sink required to maintain mounting base temperature at indicated value.
 18. Measured with $R_{BE} = 30$ ohms.
 19. Measured at 2.5 watts output.
 20. Measured at 4.0 watts output.
 21. Measured with $V_{CE} = -32$ volts with base tied to emitter, I_{CES} .
 22. Measured with base open, I_{CBO} .
 23. Measured at half rated voltage.
 24. Measured at reduced V_{CE} .

* Available only from Authorized Sylvania Distributors.
 ** For more complete technical data, refer to Engineering Data Service sheets for each type.

GET ALL 4 OF THESE USEFUL BOOKS!



CRYSTAL DIODE CIRCUIT KINKS

Contains 40 Germanium Crystal applications for the engineer, service technician, radio amateur and hobbyist.

PRICE 35¢

Order from Your Sylvania Distributor



ELECTRONIC SHORTCUTS FOR HOBBYISTS

24 Simplified crystal diode applications for the hobbyist, experimenter or model maker.

PRICE 35¢

Order from Your Sylvania Distributor



28 USES FOR JUNCTION TRANSISTORS

Contains basic transistor theory and both descriptions and schematics for 28 transistorized circuits.

PRICE 35¢

Order from Your Sylvania Distributor



HOW TO MAKE A TRANSISTORIZED PORTABLE RADIO

How to make a transistorized portable radio . . . and 20 other applications for R-F transistor. 40-page booklet.

PRICE 35¢

Order from Your Sylvania Distributor



SYLVANIA ELECTRIC PRODUCTS INC.
Semiconductor Division
100 Sylvan Road • Woburn, Mass.

*Sylvania Transistors are available from your
Sylvania Authorized Electronic Parts Distributor*