

**ELECTRONICS  
HOBBY-THEORY  
PROJECTS**

**THE FUN WAY TO LEARN ELECTRONICS**

VOLUME XV

\$3.95

# ELECTRONICS HANDBOOK

WPS 35286

IN CANADA \$4.50

**BUILD  
A MODERN  
REGENERATIVE  
SHORTWAVE  
RECEIVER**

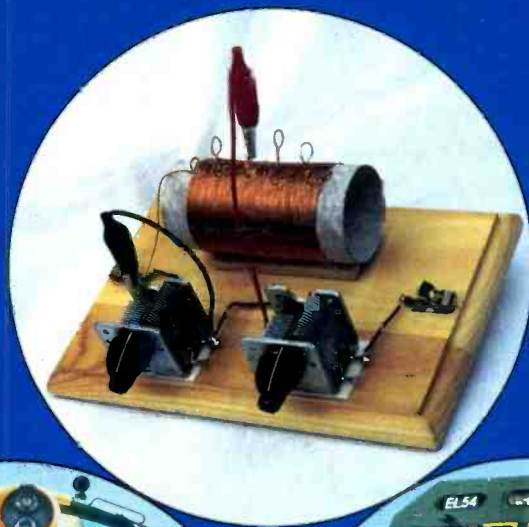
**BUILD A COMPACT  
FULL RANGE  
SPEAKER SYSTEM**

**INTRODUCING  
STEPPER  
MOTORS**

**BUILD A  
MASTER  
SWITCH**

**SERVICING  
CORDLESS  
TOOLS**

**BUILD A CRYSTAL SET  
ANTENNA TUNER**



**ELECTRONICS FOR THE  
MODEL RAILROAD HOBBYIST**



Lab Test  
**ELECTRONICS  
 HANDBOOK**  
 For Yourself

# Get switched on

In case you're not all that familiar with us, we're not a publication for electrical engineers and other wizards. No way, **ELECTRONICS HANDBOOK** is expressly for people who like to build their own projects and gadgets—and maybe get a little knee-deep in tape, solder and wire clippings in the process.

In fact, we have a sneaking suspicion that our readers like us because they think we're just as bug-eyed and downright crazy over great new project ideas as they are. And I guess they're right!

**ELECTRONICS HANDBOOK** thinks of you who dig electronics as the last of a special breed. It's more than just the "do-it-yourself" angle—it's also the spirit of adventure. In this pre-packaged, deodorized world, building your own stereo system, shortwave receiver, darkroom timer or CB outfit is like constructing a fine-tuned little universe all your own. And when it all works perfectly—it really takes you to another world.

**IF YOU'RE NEW TO ELECTRONICS YOU GET A "BASIC COURSE"!**

It gives you a complete, ground-floor lowdown on a variety of important electronic subjects. For example—Understanding Transistors...How Radio Receivers Pull In Signals...Cathode Ray Tubes Explained...How Capacitors Work...Using Magnetism In Electronics, and much, much more!



Of course, we can't make you a master electrician overnight. But we can show you the fundamentals of repair plus maintenance tips.

**TRY A FEW ISSUES AND EVALUATE OUR...**

- **HOW-TO-DO-IT HELP** Tips and pointers that add up to money saved. For example—tuning up your tape player...all about radios ...whys and hows of turntables...care and feeding of speakers.
- **EXCITING DISCOVERIES.** Whatever your particular interest in electronics, you'll be entering a world of discovery in the pages of the **ELECTRONICS HANDBOOK**

# Be a computer programmer!

## Only NRI gives you hands-on training with the latest programming tools:

- A 486sx computer with Super VGA color monitor, 200 meg hard drive
- Windows
- Visual Basic
- Power C
- QBasic
- DOS
- And much more!

**O**nly NRI at-home training gives you real-world programming skills in three in-demand languages: QBasic, C, and Visual Basic, today's hot new language designed for writing popular Windows applications. Best of all, you get hands-on training with a powerful Intel-based 486sx computer system, complete with Super VGA color monitor, 200 meg hard drive, Windows, and professional programming software you keep!

### NRI, the leader in at-home computer training, shows you how to take advantage of today's newest programming opportunities

Get in on the ground floor of computer programming one of today's fastest-growing career fields. The Bureau of Labor Statistics forecasts that job opportunities for programmers will increase much faster than average over the next 10 years, with as many as 400,000 new jobs opening up by 2005.

And the fastest-growing segment of programming jobs will be PC programming, fueled by the phenomenal popularity of Windows, the efficient power of C, and the ascent of exciting new languages like QBasic and Visual Basic.

Now, with NRI at-home training, you can get the new skills you need to build a top-paying career — even a full- or part-time business of your own — in this high-growth, high-opportunity field.

**Get hands-on experience with today's programming tools: a powerful 486sx computer, Super VGA color monitor, 200 meg hard drive, Windows, Visual Basic, and more — all yours to keep!**

Right from the start, NRI's unique Discovery Learning Method gets you actively involved in the challenge of real-world programming. Step by step, you learn to create the kinds of full-featured, powerful programs today's employers



**NEW!**  
Super VGA  
Color Monitor,  
200 Meg  
Hard Drive!

and clients demand...including programs designed for use in a Windows environment!

Only NRI gives you first-hand programming experience with a state-of-the-art Intel-based 486sx computer system, complete with Super VGA color monitor, 200 meg hard disk drive, a full megabyte of RAM, 1.44 meg 3.5" floppy drive, mouse, and more — all yours to train with and keep!

Plus you explore the extraordinary capabilities of three in-demand programming languages. You learn to design, code, run, debug, and document programs in QBasic, C, and Visual Basic. Best of all, since Visual Basic is specifically designed for creating Windows applications, you learn to generate fully functioning Windows programs, complete with text boxes, command buttons, and other sophisticated graphical interface elements.

### No previous experience necessary

Train with NRI, and immediately start getting the money-making job skills you need to be a computer programmer — no matter what your previous background.

NRI's step-by-step lessons and hands-on programming projects help you first master the design concepts used every day by successful PC programmers. Then, with the support of your experienced NRI instructor, you quickly move on to learn programming in three of today's hottest languages.

By the time you complete your course, you have a clear understanding of programming methods, languages, and techniques... and you're ready to handle any programming task with confidence.

### Send today for your FREE catalog

See how NRI at-home training gives you the programming know-how, the computer, and the software you need to get started in this top-paying field. Send today for your FREE catalog!

If the coupon is missing, write to us at the NRI School of Computer Programming, McGraw-Hill Continuing Education Center, 4401 Connecticut Avenue, NW, Washington, DC 20008.

IBM PC/AT is a registered trademark of the IBM Corporation. Windows, QBasic, and Visual Basic are trademarks of Microsoft Corporation. Intel Inside logo is a registered trademark of Intel, Inc.

## SEND TODAY FOR FREE NRI CATALOG!

**NRI** Schools

McGraw-Hill Continuing Education Center  
4401 Connecticut Avenue, NW, Washington, DC 20008

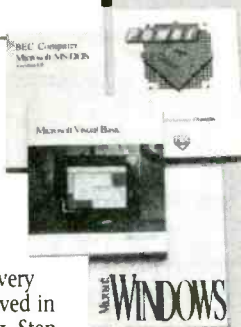
For career courses  
 approved under GI Bill,  
check for details

- Check one FREE catalog only
- COMPUTER PROGRAMMING
- PC Applications Specialist
- Programming in C++ with Windows
- Other Computer Career Courses**
- Microcomputer Servicing
- Desktop Publishing
- Bookkeeping and Accounting
- Multimedia Specialist

Name \_\_\_\_\_ (please print) Age \_\_\_\_\_

Address \_\_\_\_\_

City/State/Zip \_\_\_\_\_ Accredited Member, National Home Study Council **5492-0394**



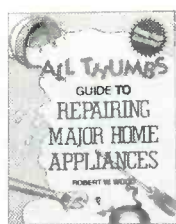
# ELECTRONICS HANDBOOK

## CONTENTS

FROM THE EDITOR'S DESK .....	6
NEW BOOK REVIEWS .....	8
NEW PRODUCTS PARADE .....	12
<b>CIRCUIT FRAGMENTS .....</b>	<b>16</b>
IN-LINE PHONE CHECKER .....	
TELEPHONE RING CONTROL .....	
CAR FUN BOX .....	
TEMPERATURE SENSING TRANSISTOR .....	
5V VOLTAGE REGULATOR .....	
LED AUTO NIGHTLIGHT .....	
PHONE OK INDICATOR .....	
LED SEQUENTIAL FLASHER .....	
ELECTRONIC VHF TUNER .....	
HEADLIGHT MINDER .....	
INTRODUCING STEPPER MOTORS .....	22
ELECTRONICS FOR THE MODEL RAILROAD HOBBYIST .....	26
UNDERSTANDING ELECTRICITY (PART VII) .....	34
<b>WORKBENCH PROJECTS .....</b>	<b>38</b>
HIGH IMPEDANCE BUFFER .....	
MICROPHONE HUM FILTER .....	
TRANSMITTER VERIFIER .....	
ELECTRONIC CRICKET .....	
BATTERY SAVER ALARM SYSTEM .....	
MINI-MOTOR CONTROL .....	
CIRCUIT TEST ADAPTER .....	
CLASSIFIED FLEAMARKET .....	44
BUILD A COMPACT FULL-RANGE SPEAKER SYSTEM .....	45
BUILD A CRYSTAL SET ANTENNA TUNER .....	49
BUILD A MODERN REGENERATIVE SHORTWAVE RECEIVER .....	57
SERVICING CORDLESS TOOLS .....	62
<b>IC TESTBENCH .....</b>	<b>69</b>
AN UNUSUAL OSCILLATOR .....	
POWER ADAPTER UPGRADE .....	
BATTERY OPERATED TOUCH LAMP .....	
ELECTRONIC METRONOME .....	
CAR BATTERY MONITOR .....	
HOBBY MOTOR SPEED CONTROL .....	
HEADS OR TAILS .....	
THE CATALOG CORNER .....	75
BUILD A MASTER SWITCH .....	79
SOLID STATE UPDATE .....	83
LAB REPORT (BK "TOOL KIT" 2704A) .....	86



4139H \$27.95 Hardcover



4061P \$9.95



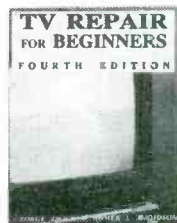
3258P \$19.95



3374P \$16.95



3550H-XX \$34.95 Counts as 2/Hardcover



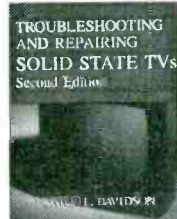
3627P \$19.95



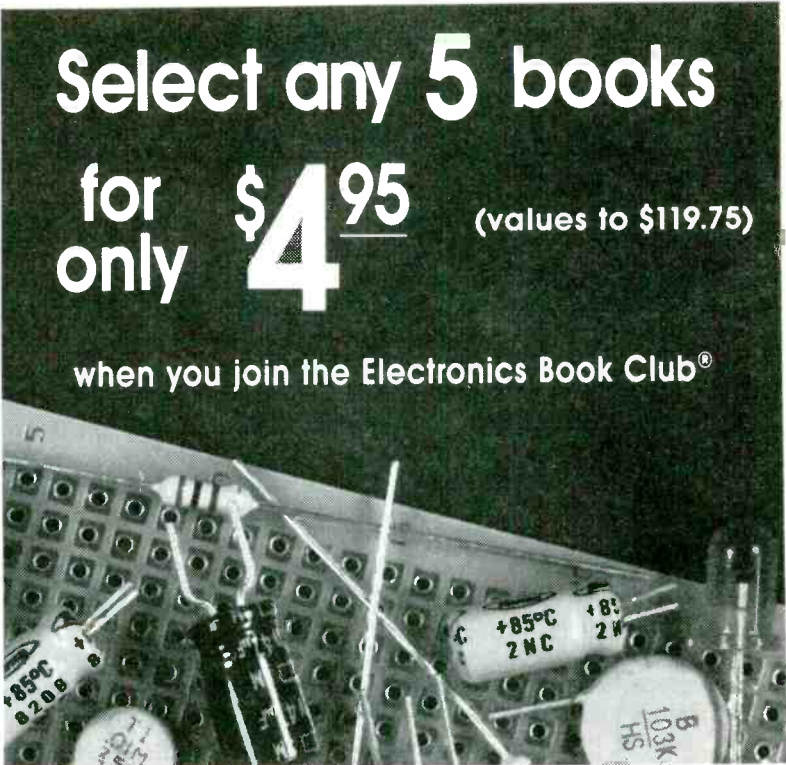
3687H \$26.95 Hardcover



1604P \$17.95



3700H-XX \$36.95 Counts as 2/Hardcover

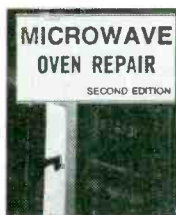


# Select any 5 books for only \$4.95 (values to \$119.75)

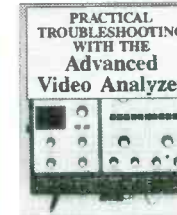
## when you join the Electronics Book Club®



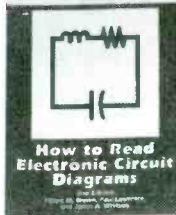
3765P \$19.95



3457P \$19.95



4358P \$24.95



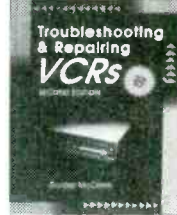
2880P \$15.95



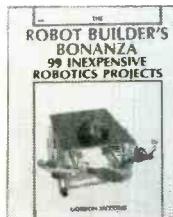
3279P-XX \$24.95 Counts as 2



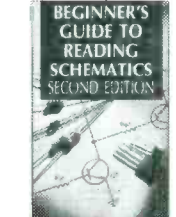
2790P \$15.95



3777H-XX \$32.95 Counts as 2/Hardcover



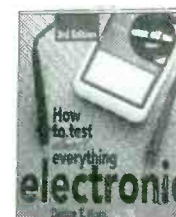
2800P \$17.55



3632P \$10.95



4362P \$16.95



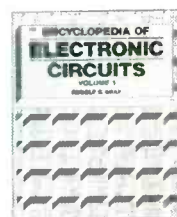
4227P \$14.95



003961H-XX \$40.00 Counts as 2/Hardcover



4089P \$18.95



1938H-XXX \$60.00 Counts as 3/Hardcover

### As a member of the Electronics Book Club . . .

... you'll enjoy receiving Club bulletins every 3-4 weeks containing exciting offers on the latest books in the field at savings of up to 50% off regular publishers' prices. If you want the Main Selection do nothing and it will be shipped automatically. If you want another book, or no book at all, simply return the reply form to us by the date specified. You'll always have at least 10 days to decide. And you'll be eligible for FREE BOOKS through our Bonus Book Program. Your only obligation is to purchase 3 more books during the next 12 months, after which you may cancel your membership at any time.

Publishers' prices shown. All books are softcover unless otherwise noted. If you select a book that counts as 2 choices, write the book number in one box and XX in the next. If you select a Counts as 3 choice, write the book number in one box and XXX in the next 2 boxes. A shipping/handling charge & sales tax will be added to all orders.

If coupon is missing, write to: 1994 EBC Electronics Book Club, Blue Ridge Summit, PA 17294-0810

### Your most complete and comprehensive source for the finest electronics books

## Electronics Book Club® Blue Ridge Summit, PA 17294-0810

**YES!** Please send me the books listed below, billing me for just \$4.95 plus shipping/handling & tax. Enroll me as a member of the **Electronics Book Club** according to the terms outlined in this ad. If not satisfied, I may return the books within 10 days without obligation and have my membership cancelled.


If you select a book that counts as 2 choices, write the book number in one box and XX in the next. If you select a Counts as 3 choice, write the book number in one box and XXX in the next 2 boxes.

Name \_\_\_\_\_

Address \_\_\_\_\_

City/State \_\_\_\_\_

Zip \_\_\_\_\_ Phone \_\_\_\_\_

Valid for new members only, subject to acceptance by EBC. Canada must remit in U.S. funds drawn on U.S. banks. Applicants outside the U.S. and Canada will receive special ordering instructions. All books are softcover unless otherwise noted. Publishers' prices shown. A shipping/handling charge & sales tax will be added to all orders.

CEHB594

## PUBLISHER'S NOTES

Putting this issue of the "Handbook" together has not been without its share of glitches (they go with the territory), not the least of which was acquiring an appropriate color transparency or photograph to identify with author, **Tony Lee's** excellent article on "**Electronics For The Model Railroad Hobbyist.**"

Since we were running out of time and could find nothing that seemed satisfactory, we decided to go to alternate plan "B" and prevailed upon author, **Lance Borden**, to provide us with a suitable color transparency of his "**Crystal Set Antenna Tuner,**" which he readily did and we were about to proceed accordingly, when we received a letter from "Down Under" (Tony Lee) and a selection of color transparencies from the **Australian Railways Commission** with a note from Tony, advising that the predecessors of these trains played an important part in the early days, opening up the continent. The "Ghan," for example, was named after the Afghanistan camel drivers, who were brought to Australia to transport the wool bales to the railhead. The "Indian Pacific" spanned the entire continent from the Indian Ocean to the South Pacific.

**We are indebted to Christina Holmdahl, Public Affairs Manager, of the Australian Railways for providing these excellent transparencies and permission to use them on the cover of this issue.**

As you can see, we decided to use the transparencies for both the "Crystal Set Antenna Tuner" and the "Electronics For The Model Railroad Hobbyist." We felt that this would be an appropriate compromise.

On another subject and to our embarrassment, it has been called to our attention that we neglected to include a parts list to the "Telephone Bug Detector" project on pages 85-86 of our last issue (Volume #14). We have hastened to mail a parts list to those readers who have called or written, however, for those who are interested, we are including a copy of this "missing parts list" in this issue, on page 33. . . . .



## WANTED: PROJECTS

How would you like to find your own home-brew project in a future issue of the **ELECTRONICS HANDBOOK**? It could happen. It's up to you! Build your project for yourself... It should have a real purpose. Then, if you think that it is good enough to appear in the **ELECTRONICS HANDBOOK**, let us know about it...

Write us a brief letter describing your project. Tell us what the project does. Provide us with a legible schematic diagram and a few black-and-white photographs of the project...photos, with good contrast, are important. After we have read your letter describing your project, we'll let you know, one way or the other, whether we would like to purchase your article describing the project.

If you would like some "Editorial Guidelines", send us a S.A.S.E. with your request...All correspondence should be addressed to:

**DON GABREE, PUBLISHER**    **C&E HOBBY HANDBOOKS**    **P.O. BOX #5148**    **NORTH BRANCH, N.J. 08876**

# ELECTRONICS HANDBOOK

PUBLISHER  
AND  
EDITORIAL DIRECTOR  
**Don Gabree**  
SECRETARY/TREASURER  
**L. M. Gabree**  
ASSOCIATE EDITOR  
**Holly B. Love**

CONTRIBUTING AUTHORS  
**Homer Davidson**  
**Walter Sikonowiz**  
**Tony Lee**  
**Lance Borden**  
**Steve Sokolowski**  
**Darren Yates**  
**William Hoffman**  
**Ron Johnson**  
**Ed Noll**  
**John Iovine**  
**Stephen Erst**  
**Allen Rolf**  
**William Templin**  
**Don Wilcher**

ISSN 0897-7631

ADVERTISING SALES  
**C&E Hobby Handbooks**  
P.O. Box #5148  
North Branch, NJ 08876  
(908) 231-1518

Published by C&E Hobby Handbooks, Inc. Editorial and Business address, P.O. Box #5148, North Branch, N.J. 08876 (908) 231-1518. PERMISSIONS: Material in this publication may not be duplicated or reproduced in any form without permission. Requests for permission should be directed to — Don Gabree, C&E HOBBY HANDBOOKS, INC. P.O. Box #5148, North Branch, N.J. 08876 (908) 231-1518.

EDITORIAL CONTRIBUTIONS must be accompanied by return postage and will be handled with reasonable care; however, the publisher assumes no responsibility for the return or safety of manuscripts, artwork or photographs. All contributions should be addressed to: PUBLISHER, C&E HOBBY HANDBOOKS, P.O. Box #5148, North Branch, N.J. 08876.

As a service to readers, C&E HOBBY HANDBOOKS publishes available plans and/or information relating to products, techniques of scientific and technological developments. Because of possible variances in the quality and condition of materials and workmanship used by readers, C&E HOBBY HANDBOOKS disclaims any responsibility for the safe and proper functioning of reader-built projects based upon or from plans and/or information published by C&E HOBBY HANDBOOKS.

Second Class Entry applied for. Copyright © 1994 by C&E HOBBY HANDBOOKS, INC.

## ECONOMICAL SINGLE BOARD COMPUTERS

- BASIC-52 Development Board Using Intel's 8052AH BASIC Microcontroller
- Completely Assembled & Tested
- Socketed EEPROM to save program using Tokenized Basic software (Included)
- Large Prototyping Area for interfacing 40 Pin Header for easy expansion
- Comes with RS-232 Interface Circuitry DB9 Male Connector for RS232
- Requires ONLY 5V DC Power
- Hi-Address Decoder Chip (2K Blocks)
- 8K External Memory Chip
- 11.0592MHz Operation
- Large 4.5 Inch by 6 inch High Quality PC Board with plated holes
- Compatible with Binary Technology's BXC51
- Create BASIC-52 Programs on 70691BASIC. Compile with BXC51. Use new.ASM software on our inexpensive 70691RAM Board. Programs run faster in .ASM You save \$\$\$.

**\$70.00 EACH**

(Plus \$2.90 S&H)

SUNCOAST TECHNOLOGIES  
P.O. BOX #5835  
SPRING HILL, FL 34606



ATTACH LABEL HERE

NEW ADDRESS HERE

PLEASE PRINT

NAME \_\_\_\_\_

ADDRESS \_\_\_\_\_

CITY \_\_\_\_\_ STATE \_\_\_\_\_

DATE \_\_\_\_\_ ZIP \_\_\_\_\_

V15

# FROM THE EDITOR'S DESK

## Ask The Editor, He Knows!

Got a question or a problem with a project — ask The Editor. Please remember that The Editors' column is limited to answering specific electronic project questions that you send to him. Personal replies cannot be made. Sorry,

he isn't offering a circuit design service. Write to:

The Editor  
C&E HOBBY HANDBOOKS INC.  
P.O. Box #5148  
North Branch, N.J. 08876

### Horns of a Dilemma

I like your magazine and trust what you guys say, so I thought I'd write to you about my problem in choosing a DMM. I'm trying to stay in the \$50-60 range. Although I realize my choices will be limited, I think I've found two good ones but can't decide between them. I am in school for electrical engineering and intend to use the meter for building projects and school work.

I want reasonable reliability and accuracy, resistance measurement to around 10 megohms, and AC/DC current capability (should I worry about getting down to the micro-amp range?). Capacitance measurement would be a nice feature, but do I really need it?

The two DMMs I'm vacillating between are the **Radio Shack/Micronta Model 22-186** and the **B&K Toolkit 2704A**. The Micronta has auto-ranging and data-hold, as well as a 31-dot bar graph; but the B&K has capacitance, a micro-amp current range, and a transistor-checking feature (which they don't bother to explain). At the moment, I'm leaning toward the B&K 2704A because of the company's reputation, but the Micronta with auto-ranging is pretty tempting. Given my status as a student, which one do you think I should buy?

— Mike Hardy, San Jose, CA

*You're obviously still a young fella, Mike. Some day you'll meet a nice girl, marry her, and she'll make decisions like this for you. Then, the best I can do is evaluate the various features of the two meters under consideration, and leave the ultimate decision to you. Here goes:*

*In practice, you will need some means of measuring capacitance,*

*if only to verify that a capacitor meets its specifications. You have two options: a DMM with capacitance-measuring capability, or a separate capacitance meter. It's cheaper to buy a DMM that can measure capacitance than to invest in both a DMM and a stand-alone capacitance meter. However, a DMM that can also measure capacitance will offer a limited range (typically, 1000 pf to 20 mf) and limited accuracy (2-4%). By comparison, you can expect a dedicated capacitance meter to measure from 1 pf to 2000 mf with an accuracy of 0.5% or better.*

*The ability to measure current in the micro-amp range can be very handy at times.*

*Transistor checking serves to measure a transistor's DC gain. It can be a desirable feature at times, particularly if you have no other instrument with which to make such a measurement.*

*Autoranging saves time, and I'd recommend it to anyone working in a production environment. For a student, though, it is not a crucial feature.*

*Data-hold is a feature you will seldom use. In theory, data-hold allows the operator to concentrate on the placement of his probes while the DMM stores the measurement. I suppose that situations exist where this might be important, but I can't think of one.*

*A bar-graph display is offered in order to shore up an essential weakness of most DMMs: they cannot readily follow a changing signal because the display is updated roughly three times a second. So, if you are monitoring a voltage while adjusting a pot, you turn, wait for the display to settle,*

*turn some more, and wait some more. It is a slow, sometimes exasperating process. One solution would be to use an analog meter, which has a fast, smooth response. The other alternative is to use the bar-graph display, which is updated much more rapidly than the digits. Check the specs of the bar-graph display. It should update 20-30 times a second. A bar-graph display is handy but not essential.*

*B&K and Micronta both offer adequate warranties. You should realize that for \$50 you are almost certainly getting a product manufactured in Taiwan or Korea. Furthermore, for all I know, B&K and Micronta could be using the same offshore facility to do their assembly work. So it is hard to differentiate between the two on the basis of reputation. Suffice it to say that both manufacturers sell a lot of DMMs, and I haven't heard any complaints about either company.*

*I hope this information will be of some help to you. Incidentally, Volume 13 of **Electronics Handbook** features a review of the **Triplet Model 2202**, another nice low-cost DMM.*

### The Taper Caper

Could you please explain to me the difference between audio-taper and linear-taper potentiometers? I assume they are not interchangeable.

— Brian Forbes, Houston, TX

*Your assumption is correct, Brian. They're not interchangeable. The resistance of a linear-taper pot is a linear function of the angle of rotation, while the resistance of an audio-taper pot varies as the logarithm of the angle of rotation. Often*





---

---

---

---

used as volume controls, audio-taper pots compensate for the ear's diminished sensitivity at low power levels. Finally, let us not forget the South American tapir. If you find one of these in your basement workshop, back out cautiously and call the SPCA.

---

### Balancing Act

I am happy to have found a magazine that is at my level and still a challenge to read. Your articles are very clear and provide a great alternative to a textbook.

Besides praise, I also have a question for you. I am currently involved in a hobby that requires the balancing of small motor armatures. The motors run to the tune of 100,000 rpm, and balancing is a must. One problem is that the armatures are about half an inch in diameter and one inch long. Any guidance you can offer regarding a no-frills dynamic balancer that I could make at home would be appreciated.

— **Geary Gaspord, Glenview, IL**

The dynamic balancers that I've seen, Geary, are complicated pieces of equipment costing several thousand dollars. I see no way of reducing them to anything even remotely resembling a no-frills home-brew project. Perhaps one of our readers has interests similar to your own and can offer further assistance. If so, we'll pass the information along to you.

---

### Looking For A Meter

I am in the process of building a metal detector and need to find a reasonably priced panel meter with a full-scale indication of 50 microamps DC. The catalogs that I've checked either lack such meters altogether, or charge exorbitant prices for them. Doesn't anyone sell reasonably priced meters anymore?

— **Wilfred Detcheverry, Glace Bay, Nova Scotia**

Nothing is reasonably priced anymore, Wilfred. In this instance, though, you're fortunate because the meter in a metal detector need not be highly linear or accurate. Hence, feel free to use the cheapest meter you can find. After a fairly exhaustive search through a stack of electronics catalogs, I managed to locate a decent 50-microamp DC meter that sells for about \$13. The source is **Ocean State Electronics (P.O. Box 1458, Westerly, RI, 02891)**.

You might also wish to check out the surplus dealers, who routinely sell meters for as little as 3-4 dollars. Two good sources are **Marlin P. Jones & Assoc. (P.O. Box 12685, Lake Park, FL, 33403)** and **Hosfelt Electronics (2700 Sunset Blvd., Steubenville, OH, 43952)**. Depending on how lucky you are, you may find just what you need or something close to it. For example, you could probably get by with a 100-microamp meter; just use a series current-limiting resistor that is one-half the size of the one specified. I doubt that an additional 50 microamps of current will severely tax the capability of whatever circuit you are building.

---

### More on PCBs

I just picked up the most recent edition of **Electronics Handbook** at a local supermarket and am quite impressed with the amount of information you've packed into the magazine. I especially enjoyed the article on PCBs. I am only a novice at electronics, but I feel that I learned more from this one magazine than I could from \$100 worth of other books and periodicals. I do have one bone to pick with you, however. I wasn't all that thrilled when you advised novices not to start off with PCB-design programs, but to design their boards manually instead. I realize that you wanted to save newcomers a bit of money, but there are numerous inexpensive

shareware PCB-design programs. I use one myself, and have obtained good results.

— **Aaron Waychoff, Coeur d'Alene, ID**

Glad you liked the magazine, Aaron. We didn't mean to imply that novices should avoid computer-assisted PCB design altogether, just that they should cut their teeth on manual methods first. How can you appreciate the wonders of computer design if you've never toiled over a manual layout?

---

### Crazy Cables

I see advertisements in audio magazines for Monster Cables and other special wires for hooking up loudspeakers. The manufacturers claim their hook up cables will make the hi-fi system sound better. I thought wires connecting amplifiers or receivers to speakers were just that—wires. It sounds like Hype to me. What's going on here? What am I not up on? —**J.R. Russel, Norcross, Georgia.**

You are up on this totally. This is one of the most popular, and profitable (for manufacturers and the store salesmen) hypes going. Some audio enthusiasts (audio nuts, if you prefer) will believe almost anything if it promises to make their stereo system sound better.

One of the most respected audio experts in the business, Julian Hirsh (of *Stereo Review*) ran careful blindfold tests a couple of years ago, using several such special cables and comparing them with ordinary electric lamp cord. He proved what I have always claimed; that there is no difference in the sound. But it's easy to believe you hear differences if you want to believe it. That's how so many speaker makers manage to get along.

# NEW BOOK REVIEWS



## HAM RADIO COMMUNICATIONS CIRCUIT FILES by Ed Noll, W3FQJ

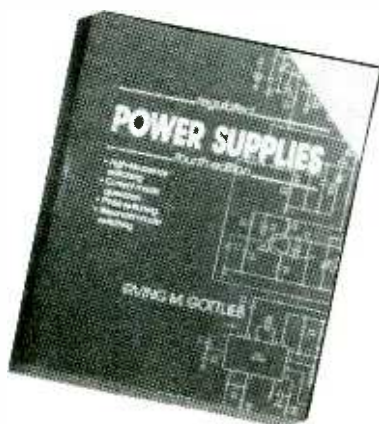
Looking for an entertaining, easy-to-understand introduction to the world of electronics? Then check out Ed Noll's **Ham Radio Communications Circuit Files**. Don't let the title fool you. This book isn't just for ham-radio operators; it's for anyone with a budding interest in electronic circuitry.

The book is divided into three sections covering bipolar-transistor circuits, FET (field-effect transistor) circuits, and linear integrated circuits. Sixty-one separate circuits are presented, complete with schematics, charts, tables, graphs, and a detailed description of how each circuit works. The bipolar-transistor section contains such things as a Twin-T audio oscillator, astable multivibrator, complementary-symmetry amplifier, and Darlington driver circuit. The FET section features a phase splitter, crystal oscillator, direct-conversion detector, double-sideband generator, and sawtooth-waveform generator, among other things. And, last but not least, the linear-IC section covers filters, timers, op amps, pulse generators, a frequency synthesizer and more.

By the way, this is not intended as

just another boring circuit collection to be perused and then stowed away on a bookshelf somewhere. The author has every expectation that you will build each circuit and see for yourself how it works. If you do this, not only will you learn about the circuits, you'll have fun at the same time. What more could you ask for?

**Ham Radio Communications Circuit Files**, 90 pages, 8.5 x 11" format, softbound: \$9.95. **MFJ Enterprises Inc.**, P.O. Box 494, Mississippi State, MS, 39762.



## REGULATED POWER SUPPLIES, 4th Ed. by Irving M. Gottlieb

With the proliferation of voltage regulator ICs like the LM7805 and its various kindred, many of us have come to regard the process of designing a regulated power supply as not much more than child's play: determine what voltage and current you need, then leaf through some catalogs until you find an IC that fits. Easy, huh? Well, not always. There are times when an off-the-shelf regulator won't meet your needs, particularly if the application demands inordinately high levels of voltage or current. When that happens, you need to be able to design your own voltage regulator. In order

to do that, you're going to need a good reference book—for instance, **Regulated Power Supplies** by Irving Gottlieb.

Virtually every form of voltage-regulator circuit is painstakingly examined in this comprehensive book. Mr. Gottlieb covers both linear and switchmode supplies, and the components that go into them. He explains the advantages of regulation, and the problems peculiar to each form of regulator. Linear regulators are relatively noise-free but inefficient, while switchmode regulators are just the opposite: efficient but noisy. Which to choose? It all depends on the application. Switchmode regulators are extremely popular in computers—particularly portable computers—because of their efficiency and light weight. In the already noisy environment of the computer, the noise of a switchmode supply is largely irrelevant. But putting a switchmode supply into a noise-susceptible circuit—for example, a high-gain, low-noise amplifier—could be disastrous without proper shielding and bypassing. In such a situation, it would be much simpler to use a linear supply.

**Regulated Power Supplies** provides excellent coverage of all the popular linear and switchmode regulator circuits, as well as some not-so-popular ones like the RF power supply. Meticulous attention to detail makes the subject of voltage regulation relatively easy to understand and apply. All things considered, this is as good a book as you are likely to find on regulators, and I recommend it highly.

**Regulated Power Supplies, 4th Ed.**, 460 pages, softbound: \$24.95. **TAB/McGraw-Hill Inc.**, Blue Ridge Summit, PA, 17294-0850. Telephone (800) 822-8138



**ANALOG DEVICES AMPLIFIER APPLICATIONS GUIDE**  
(no author credited)

If they gave out awards for most versatile integrated circuit, there is little doubt in my mind that the winner would be the operational amplifier. With an op amp and a handful of resistors and capacitors, you can build a wide variety of useful circuits—for example, filters, oscillators, integrators, regulators, adders, phase shifters, and a whole lot more. The trick lies in the feedback network you use. Change the feedback network, and you change the behavior of the circuit. And it's easy, too. That's why op amps are often the first electronic devices that a beginner will master.

We've reviewed beginner-level op-amp books here in the past—most notably, Walt Jung's **Op Amp Cookbook**. The book presently under consideration, **Analog Devices Amplifier Applications Guide**, is not for beginners. It assumes you already know the basics and want to learn some of the more subtle and sophisticated aspects of op-amp behavior. Don't worry, though; this is not a mind-numbing theoretical treatise, but a nice, practical, clearly written guide to advanced applications. Coverage includes

such topics as precision transducer interfaces; high-impedance, low-current applications; single-supply, low-power applications; high-quality audio; passive and active analog filtering; driving analog-to-digital converters; video and other high-speed applications; nonlinear circuits; unusual applications; hardware techniques; and analog circuit simulation. The writing is concise, understandable, and occasionally witty. Best of all, the schematic diagrams and graphs are huge by conventional handbook standards, which means you won't be suffering from eyestrain after reading the book. So, if you've been looking for an advanced yet readily comprehensible guide to op amps and their applications, don't miss this book. It is excellent.

**Analog Devices Amplifier Applications Guide**, 648 pages, 8.5 x 11" format, softbound: \$20 (price includes shipping). **Analog Devices Inc., One Technology Way, Norwood, MA, 02062-9902.**



**JOE CARR'S RECEIVING ANTENNA HANDBOOK**  
by Joseph J. Carr

What's more important—a good receiver or a good antenna? I'm not

going to answer that question because in reality it makes no more sense than asking which came first—the chicken or the egg? But it seems to me that in the minds of many people, the receiver is paramount, and the antenna just an afterthought. That's too bad, because you can't get outstanding reception of radio signals without both a good antenna and a good receiver. Moreover, even though you may not have enough money to afford the best receiver, you almost certainly can afford an optimal antenna, especially if you build it yourself using the plans in Joseph Carr's new book.

Reading the average antenna handbook will put me to sleep faster than listening to Bill Clinton deliver a speech. That's not the case here. Joseph Carr writes with verve and wit, and augments the technical data with plenty of anecdotes to keep the reader entertained (and alert). The author covers basic stuff like antenna theory, grounding, lightning protection, and transmission lines as a prelude to the main business of the book: building a practical antenna. Just about every antenna known to man is covered, including the dipole and its derivatives, various longwire antennas, the Windom, the double-extended Zepp, large loops, vertical antennas, directional beam antennas, small loop antennas (nice if you have limited space), the discone antenna, helically wound verticals, and a whole host of others. In addition, there is information on the use of preamplifiers, active antennas, noise bridges, VSWR analyzers, and clandestine antennas.

Combine good, solid technical information with humor and excellent illustrations, and what do you get? A book that readers will love, and that is exactly what Joseph Carr has done. Buy some other antenna book if you need help falling asleep at night, but if you want lots of prac-

# NEW BOOK REVIEWS

---

---

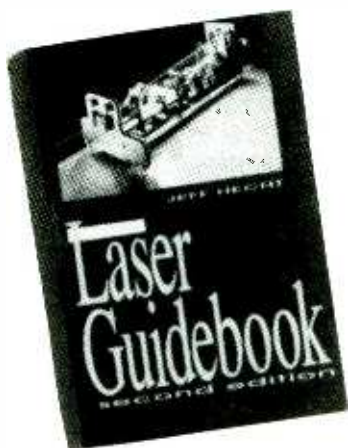
---

---

tical plans and a few good chuckles, this is the book for you.

**Joe Carr's Receiving Antenna Handbook**, 189 pages, 8.5 x 11" format, softbound: \$19.95 (plus \$3.00 shipping). **HighText Publications Inc., P.O. Box 1489, Solana Beach, CA, 92075. Phone (800) 888-4741.**

---



**THE LASER GUIDEBOOK,  
2nd Ed.  
by Jeff Hecht**

Over the course of the past twenty years or so, lasers have come to pervade almost every aspect of our lives, though often their influence is hidden from view. For example, somewhere inside your compact-disc player there is a laser that "reads" the disc. And should you be listening to the aforementioned compact disc in your car, and get so carried away with emotion that you fail to obey the speed limit, chances are some highway patrolman equipped with laser radar will soon be on your tail.

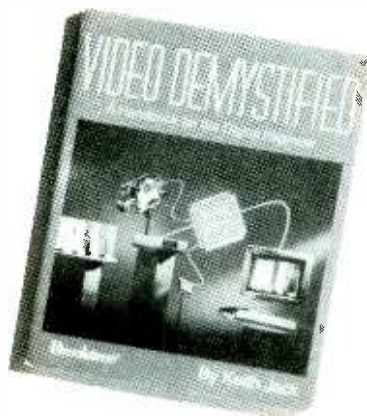
Yes, lasers really are everywhere. Paradoxically, though, information about lasers is so scarce as to be practically nonexistent. That's why I was pleased to get my hands on a copy of Jeff Hecht's **Laser Guide-**

**book.** This is the book that every would-be laser experimenter has been waiting for. A veritable encyclopedia of laser lore, the **Laser Guidebook** contains good, solid technical information on virtually every kind of laser in use today. That includes helium-neon lasers, noble-gas-ion lasers, helium-cadmium lasers, carbon-dioxide lasers, chemical lasers, excimer lasers, nitrogen lasers, dye lasers, semiconductor-diode lasers, neodymium lasers, ruby lasers, free-electron lasers, x-ray lasers, and more. Plus, the author provides several chapters on laser theory and optics for those readers with little or no laser experience.

All things considered, this is a great book for anyone with a serious interest in lasers. Strongly recommended.

**The Laser Guidebook**, 498 pages, softbound: \$29.95. **TAB/McGraw-Hill, Blue Ridge Summit, PA, 17294-0850. Telephone (800) 822-8138.**

---



**VIDEO DEMYSTIFIED  
by Keith Jack**

Designers of multimedia and digital-video products have found that implementing video on computers

can be difficult. Now, however, with the publication of **Video Demystified**, by Keith Jack, circuit designers have access to the kind of technical information they need.

"Digital designers wish that video looked just like any other type of computer image data," said Jack, who works as a digital engineer at Brooktree Corp. specializing in video encoder/decoder architectures. "But, until recently, video and computers had very little to do with each other. Many digital engineers are relatively unfamiliar with broadcast and recording standards, and it's hard to find published material that answers the kind of questions that come up when trying to implement video on any kind of computer system."

**Video Demystified** concentrates both on system issues, such as getting video into and out of a computer environment, and on video issues, such as video standards and new processing technologies. The book emphasizes the unique requirements of the computer environment. It is useful for designers of personal computers and workstations who need to learn more about video, VLSI circuit designers who want to build video products, and anyone else who wants to evaluate or simply learn more about such systems. Up-to-date information is provided on all existing and emerging international standards, both analog and digital, including timing details and diagrams. In addition, the book covers design architectures for incorporating video into computer systems, processing requirements, color-space conversion, video data compression and decompression, plus other issues crucial to developing a working video/computer system.

**Video Demystified** is a one-of-a-kind book. Anyone who designs multimedia or digital-video products will most certainly benefit from

reading it.

**Video Demystified**, 435 pages, softbound: \$29.95 (plus \$3.00 shipping). **HighText Publications Inc.**, P.O. Box 1489, Solana Beach, CA, 92075. Telephone (800) 888-4741.



**MASTERING SOLID-STATE AMPLIFIERS**  
by Joseph J. Carr

One of the most basic and useful functions of electronic circuitry is amplification of a signal. Many different electronic devices can be used to produce amplification, and it is the aim of this book to provide the beginner with an introduction to some of the more popular and useful amplifying techniques. A broad range of frequencies is covered—all the way from DC to VHF. The amplifying devices featured include bipolar-junction transistors, field-effect transistors (JFETs and MOSFETs), operational amplifiers, operational transconductance amplifiers, current-difference amplifiers, and instrumentation amps.

The theory of each of the devices mentioned is explained by means of diagrams, graphs, and simple mathematical equations. A knowledge of high-school algebra is probably all you'll need to follow the discussions, which are notably

clear and to the point. In addition to theory, the author also presents a series of practical circuits that you can build and experiment with. Included are audio preamplifiers, RF amplifiers, IF amplifiers, and microwave amplifiers. Along the way, the author also presents an assortment of valuable construction tips and safety precautions that beginners will find especially welcome.

This is a unique book, easy-to-understand yet filled with an abundance of useful technical information. For the beginner, I can't think of a better introduction to the world of electronic amplifiers.

**Mastering Solid-State Amplifiers**, 286 pages, softbound: \$19.95. **TAB/McGraw-Hill, Blue Ridge Summit, PA, 17294-0850. Phone (800) 822-8138.**



**FANTASTIC ELECTRONICS**  
by John Iovine

Tired of the same old unimaginative electronic projects? If so, you may be interested in a new book of hobby projects entitled **Fantastic Electronics**. Despite the title, not all of the projects presented are electronic in nature, but there are enough electronic projects here to make the book worth your while. And despite the exotic nature of most of the projects, they all appear

to be relatively easy-to-build and inexpensive.


The project lineup includes a negative-ion generator, a biofeedback monitor/lie detector, a device for monitoring extremely low-frequency magnetic fields, a hydrophone (so that you can listen to things underwater), a geiger counter, a demonstration of the shaped-memory effect in a Nitinol-alloy wire, an air-pollution monitor, a simple neural circuit designed to track the sun across the sky, an equatorial camera mount for astrophotography, a laser power supply, a holography project using the aforementioned laser, and a Kirlian photography device. The remaining projects and experiments, though not electronic, nevertheless do seem interesting. They include a recombinant DNA experiment, an experiment in magnetohydrodynamics, another one in plasma acoustics, a simple expansion cloud chamber, a demonstration of pin-hole photography, and various experiments dealing with the production of synthetic fuels. All in all, quite an imaginative collection of projects. Good science-fair material for those so inclined.

**Fantastic Electronics**, 220 pages, softbound: \$17.95. **TAB/McGraw-Hill, Blue Ridge Summit, PA, 17294-0850. Telephone (800) 822-8138.**

**RAIN FOREST RESCUE:  
TO HELP SAVE THE  
BIRDS OUTSIDE  
YOUR WINDOW**

Support Rain Forest Rescue. Help put a stop to the destruction of the planet's rain forests.

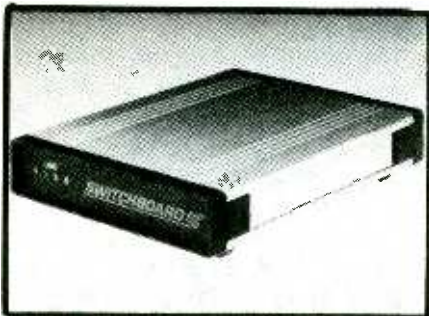
To contribute to Rain Forest Rescue, call 1-800-222-5312

 The National Arbor Day Foundation



# NEW PRODUCTS PARADE

## "SWITCHBOARD" DEBUT



Telephone Products has introduced **Switchboard**, a phone line sharing device. Switchboard allows customers to use one phone line for phone, fax and modem, each with an individual number.

"Switchboard is the best line sharing product available today," said James Baker, President of Telephone Products. "It's an inexpensive, easy way to give a home office the professional image of a larger office—separate numbers for fax and phone, with no clicks or tones to interfere with important business calls."

Switchboard needs only to be plugged into a phone jack and does not require an additional power pack.

Using the local phone company's "distinctive ringing" service, Switchboard automatically sends an incoming call to the appropriate phone, answering machine, fax or modem. (Distinctive ringing services are known in different areas by names such as Smart Ring, Custom Ringing, Personalized Ring, Ident-a-ring, Intel-i-ring, Ring Mate, Multi-Ring and Ringmaster.)

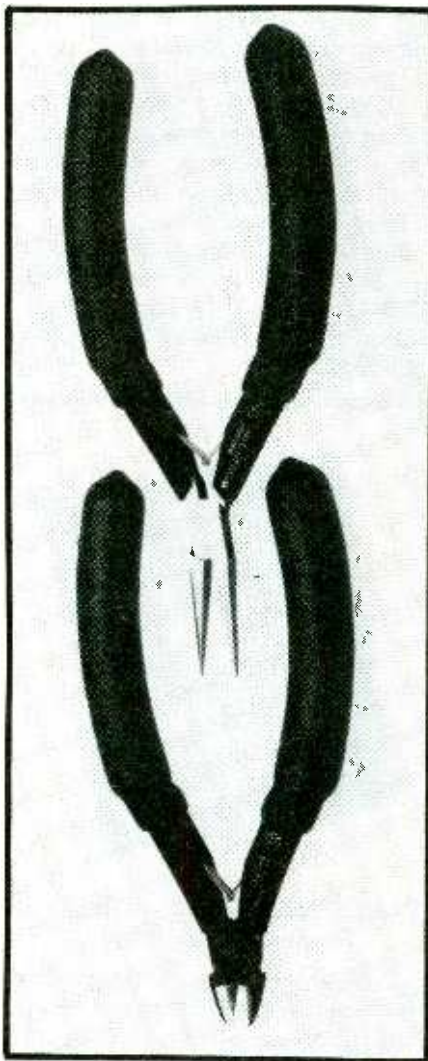
Switchboard works with any combination of two, three or four devices including phones, answering machines, faxes or modems. Using only one phone line, instead of as many as four, can save customers hundreds of dollars a year.

Switchboard retails for \$129.00 and can be ordered by calling (800) 829-5960. The model number is T4. Each Switchboard is backed by

a five-year warranty and made in the USA.

For further details, contact **Telephone Products, P.O. Box #31203 Seattle, WA 98103, Phone (800) 829-5960, FAX: (800) 829-3940.**

## ERGONOMIC HAND TOOLS



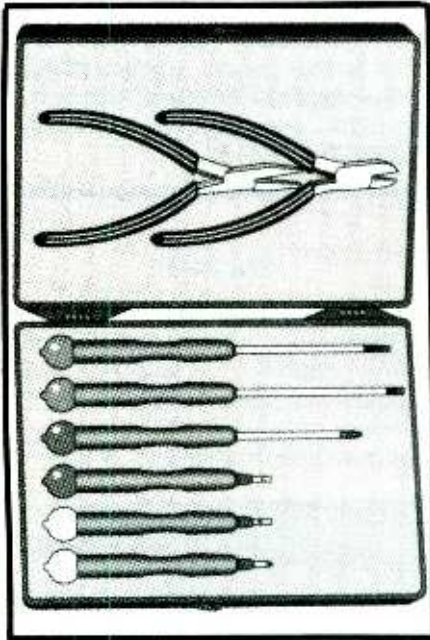
Repetitive motion injuries, especially of the wrist, have recently become news, with big money riding on workers' compensation claims and medical treatments. The best known among repetitive motion problems is Carpal Tunnel Syndrome, which causes pain, tingling,

numbness and, in severe cases, even permanent weakness of the fingers and thumb. The Hand-Saver™ line of hand tools, developed specifically to help reduce the factors which contribute to repetitive motion injuries such as Carpal Tunnel Syndrome, is available on selected diagonal cutters and assembly pliers. When used as part of a comprehensive ergonomic program, HandSaver™ can play an important role in improving the health and safety of the workforce while reducing the costs due to absenteeism and risk management. Hand-Saver™ handles are covered with two layers of smooth, non-slip, non-static-generative, compressible, medium-density sponge material. This reduces skin damage and muscle fatigue by minimizing grip pressure and transmitting optimal feedback to the operator. A handle length of 4½", combined with a shape that follows the natural inside curve of the fingers, eliminates pressure points between fingers and reduces skin, blood vessel, nerve, and tendon damage. A grip span of 2" to 4½" allows the tool to fit the widest variety of hand sizes and eliminates extreme muscle contractions which affect nerves and tendons. In addition, both handles are identically contoured to allow HandSaver™ tools to be used by either right or left-handed operators, preventing injury from improper ambidextrous use of dedicated right or left-handed tools.

For more information, contact **HUB MATERIAL COMPANY, 33 Springdale Avenue, Canton, MA 02021 Phone (617) 821-1870, FAX (617) 821-4133.**

## ELECTRO STATIC DISCHARGE KIT

Techni-Tool introduces a top quality ESD Precision Service Kit in a small, handy and sturdy plastic case. All tools come with dissipative handles for ESD safety. The



electronic service kit contains (1) Side Cutter, (1) Snipe Nose Pliers and (6) Precision superslim ceramic trimmer/alignment tools.

For more information on this Electro Static Discharge Kit and other ESD products, call (215) 941-2400, FAX (215) 828-5623, or write: **Techni-Tool, Inc., 5 Apollo Road, P.O. Box 368, Plymouth Meeting, PA 19462 USA.**

### ACCURATE CAR COMPASS

**Precision Navigation, Inc.** takes the guesswork out of navigation with the introduction of the Wayfinder electronic digital compass. Now, whether exploring the great outdoors or the "cement jungle," staying on course is convenient and easy. With electronic calibration, the Wayfinder overcomes the problem suffered by all mechanical compasses: they don't work well in a car.

The Wayfinder sets a new standard in consumer navigation. Utilizing the latest compass technology in the world, the Wayfinder is a boon to road travelers, hikers, and

sportspersons alike. Easy to use and read, the Wayfinder continuously displays directional headings on its large liquid crystal display.

The Wayfinder is also the first truly portable compass that works in the hand as well as in a vehicle. Its light weight and small size make it the ideal navigational tool for sportspersons or a visitor to a new city.

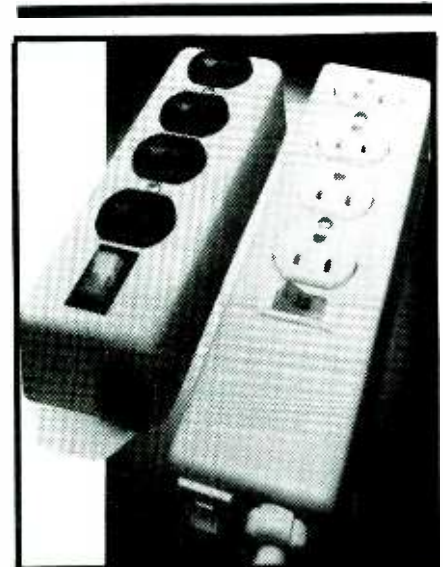


Drivers no longer need to second-guess the "floating" mechanical compasses that are frustrating and difficult to calibrate and are thrown off by any stray magnetic fields—including the strong fields emanating from a car's speaker magnets and steel frame. With the Wayfinder, calibration in a car, truck, or RV is simple—press a button once, make a U-turn, and press the button again. The microprocessor-controlled magnetometer will then be able to compensate for all stray magnetic fields inside the vehicle.

To use the Wayfinder outside the car, simply unclip the compass from its windshield bracket and press a button to switch to "hand-held" mode. In addition to traditional compass uses, the Wayfinder has a unique **Direction Memory** feature

that facilitates navigation without a map, or finding the way back to the main road, campsite, or even the car in a parking lot. The push of a button activates **Direction Memory**, storing a traveler's initial course. When the traveler is ready to return to their point of origin, the **Direction Memory Pointer** makes it easy to find the way back.

For further details, contact **Precision Navigation, Inc., 1350 Pear Avenue, Suite A, Mountain View, CA 94043 (415) 962-8776 or (510) 934-5385, FAX (415) 962-8776.**

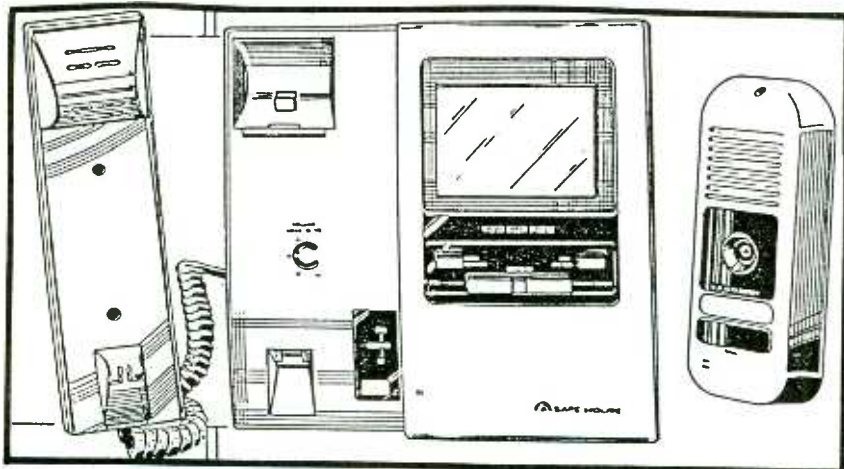


### ELECTRICAL OUTLET STRIPS

Safe, accessible outlets for office, lab or computer use. Units are housed in durable, seamless steel casing with an attractive baked-on beige finish. Features include lighted on/off switch, push-to-reset circuit breaker, individually-grounded 3-prong receptacles, and a choice of 6- or 15-foot power cord. Maximum rating: 125V, 15 amps, 60Hz and 1875 watts. All units are U.L. listed and come with a lifetime warranty. For more information, contact: **HMC, 33 Springdale Avenue, Canton, MA 02021 Phone. (617) 821-1870, FAX (617) 821-4133**

# NEW PRODUCTS PARADE

## VIDEO DOOR PHONE SYSTEM



Do you feel safe at home? Have you ever opened the door to strangers? The Safe House® Video Door Phone from Radio Shack® is an affordable security surveillance system that allows homeowners to hear the door chime, observe and talk to the person at the door, and decide whether to open the door.

The black and white monitor with handset can be mounted on a wall or placed on a desk or tabletop in any room of the home. The surveillance camera is installed outside and positioned near the entryway. When a visitor presses the CALL button on the camera, a doorbell or chime sounds to alert occupants inside the home. The homeowner can see the visitor's face on the monitor inside, and talk to the visitor either through the phone handset or through an intercom for hands-free discussion.

If preferred, the camera and speaker can be kept on continuously and sounds outside the home can be monitored—day and night.

The Safe House Video Door Phone system sells for \$399.95 at nearly 6,700 participating Radio Shack stores and dealers nationwide.

## FLUX-PEN



A unique tool for rework or touch-up soldering. Allows controlled application of flux, eliminating the mess and hazards of flux bottles. A spring-loaded, felt tip dispenses just the right amount of flux while limiting operator exposure to soldering chemicals. The tip's chisel point shape allows work in confined spaces while the spring valve prevents the flux inside of the pen from drying out. The Flux-Pen™ is ideally suited for TAB assembly, "no-clean" and surface mount rework applications because it can deliver flux only to specific areas as simply as writing. Available in three formula-

tions: mildly activated rosin, type RMA; low solids, halid-free, "no-clean"; and water soluble, type OA.

For further details, contact HMC, 33 Springdale Avenue, Canton, MA 02021 Phone (617) 821-1870, FAX (617) 821-4133.

## MINI-FAN

The Model 3037 mini-fan is ideal for dissipating smoke, fumes, and harmful vapors from soldering and desoldering operations. Its small, compact size (7½" x 6" x 4½") allows maximum utilization of bench



top space. The fan motor is quiet, dependable, and vibration-free. It moves air at approximately 130 CFM. The fan's body is molded in black plastic, with a grill to protect hands and tools from injury. The unit comes with a 3-way (high/off/low) speed selector switch, a metal stand that allows adjustment of air flow angles, and an 8-foot 2-wire cord. The Model 3037 is also UL listed.

For further information on the Mini-Fan, Contact HMC, 33 Springdale Avenue, Canton, MA 02021, Phone (617) 821-1870, FAX (617) 821-4133.



## Introducing a New Era In Technical Training.

World College, an affiliate of the Cleveland Institute of Electronics, was created to provide a four year, independent study, technical degree program to individuals seeking a higher education. The Bachelor of Electronics Engineering Technology Degree, offered by World College, prepares students for high-paying careers in electronics, telecommunications, electrical power, computer and control systems. World College's curriculum is taught in an effective, time-proven, independent study environment. With World College's flexible study schedule, students have the opportunity to work or spend time with their family without having to worry about rigid scheduling residential colleges offer.

### A Quality Education with a Flexible Schedule.

In a world heavily dependent on electronic equipment, people who understand electronics will have no problem putting their knowledge to work... in high-paying careers. The staff and faculty of World College have invested over ten years developing, what we believe to be, the finest independent-study, baccalaureate degree program available. World College's mission is to instill in each student the knowledge, *education*, and *training* that employers are seeking for the many technical positions available today. It's a program created to provide the best education and training possible with a flexible schedule to match your busy lifestyle.

World College is currently seeking approval to confer the Bachelor Degree from the Virginia Council of Higher Education.



# Earn A Bachelor of Electronic Engineering Technology Degree from



**WORLD COLLEGE**  
*Bringing Technology Home!*

Lake Shores Plaza  
5193 Shore Drive, Suite 113  
Virginia Beach, VA 23455-2500

### Send For Your Free Course Catalog.

Take the first step towards a new start in life. Send for World College's Free Independent Course Catalog today and discover how easy and affordable it is to get started on your Bachelor Degree.

World College is affiliated with



## Complete the Entire Degree Program Under One Roof. Yours!

Only World College offers an independent study, four year technical degree which can be completed through one school. All lab equipment\*, parts, and software are included in your tuition and the program's 300-plus laboratory experiments can be completed in your own home.

### You Pay Only For Time Actually Used.

World College not only provides a means to earn a Bachelor Degree while fulfilling current obligations, but there are no restrictions on how fast you can complete the program. At World College, you pay tuition only for the actual upper-level semesters it takes to graduate. The quicker you complete the program, the less you pay in tuition. It's an effective way to keep you motivated in order to complete the course and move on to a better paying position as quickly as possible.

Currently not available in Ohio.

\* Student must have access to a personal computer system.

**YES!** Please send me World College's Free Course Catalog detailing the full curriculum.

Name: \_\_\_\_\_

Address: \_\_\_\_\_

Apt: \_\_\_\_\_

City: \_\_\_\_\_

State: \_\_\_\_\_ Zip: \_\_\_\_\_

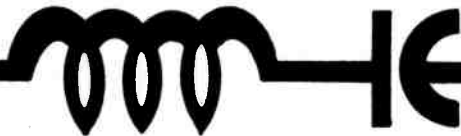
Phone: ( \_\_\_\_\_ ) \_\_\_\_\_

Age: \_\_\_\_\_

Return to: **WAB01**

World College  
Lake Shores Plaza  
5193 Shore Drive, Suite 113  
Virginia Beach, VA 23455-2500

# CIRCUIT FRAGMENTS



## LED AUTO-NIGHTLIGHT

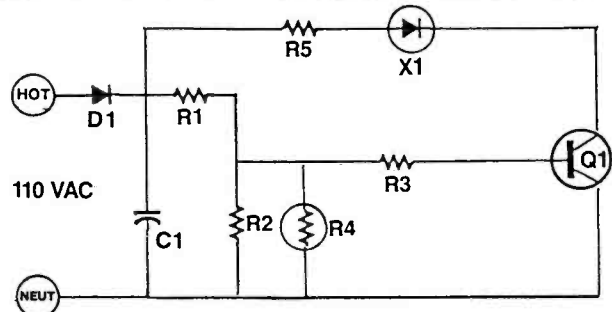
Night lights that you have to turn on and off manually are a pain. An automatic one is much more convenient, especially one with a source of light that lasts a long time. The new high brightness LEDs are ideal for this purpose. Not only do they save on power usage, they also last much longer than incandescent lamps and are easy to use.

Size is yet another advantage. This entire circuit fits easily on a board the size of a commemorative postage stamp.

Flexibility is still another advantage. The circuit can drive as many as 4 LEDs, each of which could be at a separate location as much as 20 feet apart.

For 2 LEDs, add the second one in series with X1. Duplicate R5 and put either 1 LED or 2 in series with the resistor. The LED/resistor is connected in parallel with R5-X1.

C1 can be any value from 1 Mfd to 100 Mfd, all it must do is filter into a 3.7 Megohm load on standby and a 12K load actuated.



### PARTS LIST FOR THE LED AUTO-NIGHTLIGHT

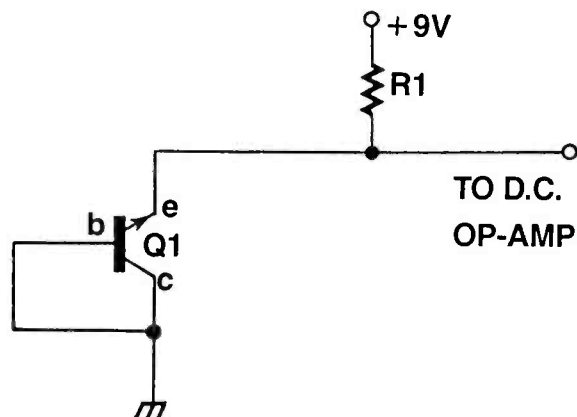
- D1 — 1N4007 Diode
- Q1 — Mpsa-42 Transistor
- X1 — High Brightness LED
- C1 — 1-22Nfd, 160 WVDC, electrolytic capacitor
- R1 — 3.7 Megohm, 1/4 watt resistor
- R2, 3 — 100K Ohms resistors
- R4 — Photoresistive cell.
- R5 — 12K Ohm resistor, 1 Watt.

## TEMPERATURE SENSING TRANSISTOR

A general purpose NPN transistor (Q1) can be connected as shown, to form a 2-terminal diode. In this mode, the transistor's output voltage will change as a function of temperature. The collector and base terminals are connected to ground and the signal is taken from the emitter. Resistor (R1) completes the divider chain, such that the voltage across the 'diode' decreases as the temperature rises. This small change in voltage can be amplified with a standard D.C. OpAmp. Typically, the D.C. output across the 'diode' changes by just over a millivolt for each degree "F" change in temperature.

### PARTS LIST FOR THE TEMPERATURE SENSING TRANSISTOR

- Q1 — 2N3904 general purpose NPN transistor, connected as a diode
- R1 — 15K ohm resistor



# 5V VOLTAGE REGULATOR

If you use a lot of TTL ICs, then you'll know the problems of running them. Because of their construction, they require a fairly exact 5V supply otherwise they will either not work or blow up.

Even though, these days, you can replace many TTL integrated circuits with CMOS versions, there are still many functions performed by TTL that have not as yet been copied into CMOS—they are too numerous to mention but you can make your own comparison.

The point is, if a 5VDC regulated supply is required for every project you build that uses TTL ICs, then your costs go up dramatically with the LM7805 regulator. The circuit here uses only a few low cost components and provides just about a perfect 5V supply with large amounts of supply decoupling using a little known but effective technique.

The circuit shown in Figure 1, also provides circuit protection, just in case you connect the supply the wrong way around the cause of many an IC destruction. This is provided by diode (D1). A diode will conduct a current as long as its anode is at a higher voltage than its cathode. Capacitor (C1) provides some initial supply bypassing.

The reason for this is to reduce the amount of AC ripple that may be present in the voltage. This can have mysterious effects on the operation of many digital ICs. You may get states which don't agree with your circuit design and this will be a result of voltage supply ripple.

The voltage regulating is done by resistor (R1) and zener diode (ZD1). This is a 5.6V zener diode for reasons which will become apparent in a moment. The voltage at the cathode of the diode is very smooth.

This voltage is fed into the base of transistor (Q1). This is an NPN device which has a base-emitter voltage drop of 0.6V—the same as most other transistors. This means that the voltage you get at the emitter is 0.6V less than that at the base. So if we had 5.6V originally, subtract 0.6V for the base drop and we get 5.0V at the emitter.

Because we are using the transistor in a buffer mode, we get a large current gain which allows us to drive up to 30 TTL ICs without worrying about the load current of the zener diode.

Capacitor (C3) provides some more bypassing to make sure that the power supply is squeaky clean. However, we haven't described the function of capacitor (C2).

Capacitor (C2) has two functions. First, it provides bypassing for the zener diode to remove any noise, hum or ripple that may remain after the diode has done its work, and secondly it works in conjunction with transistor (Q1) to produce a "super capacitor".

The transistor, in effect, multiplies the value of the capacitor by the gain or beta of the transistor. As an example if the gain of the transistor is 100 and the value of the capacitor (C2) is 10uF, then the effective bypassing capacitance at the output is 100 x 10uF or 1000uF. Simply, the more capacitance you have at the output, then the smoother the output voltage.

The transistor I have used here is a BD139 NPN power type, but you can use any typical NPN transistor that meets the power requirements of your circuit i.e. the more TTL ICs you have to power with this circuit, the higher the power rating the transistor needs to have. You may also need to use a heat sink on the transistor if it gets too hot otherwise you may destroy it.

## CONSTRUCTION

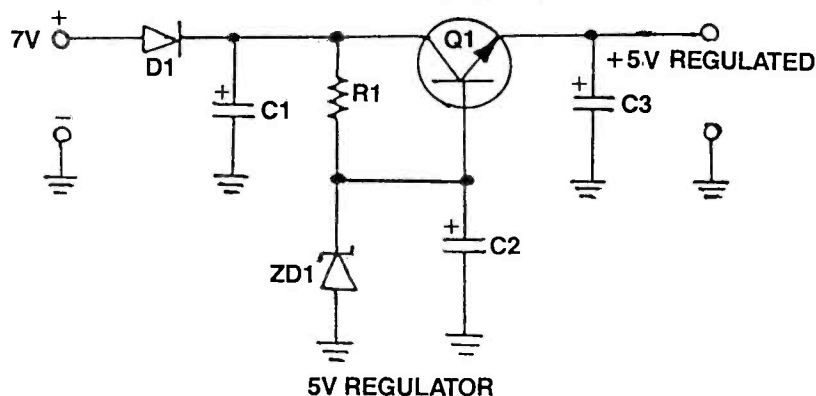
To start off, I recommend you build the circuit on a breadboard or some veroboard so that you can see how the circuit works, then you can include it with any of your circuits where a fixed, regulated supply is required.

The main thing is that the input voltage must be at least 1 volt higher than the desired voltage and you can replace the 5.6V zener diode with one of another voltage for any voltage you require. Remember that the output voltage =  $V_{(\text{zener diode})} - 0.6V$ .

## PARTS LIST FOR THE VOLTAGE REGULATOR

**C1-C3** — 100uF 16VW electrolytic capacitors  
**D1** — 1N4002 power diode  
**R1** — 470 ohm, 0.5W, 5% resistor

**Q1** — BD139 NPN power transistor or equivalent  
**ZD1** — any 5.6V zener diode  
**Misc.** — DC power supply, box, breadboard, wires, screws, nuts, washers etc.



# CAR FUN BOX

Ever see one of those talking alarms? It tells you to stay away from the car it is protecting if you get too close.

How about a device that mimics one of these alarms? Wouldn't it be fun to bug people with a "talking car?"

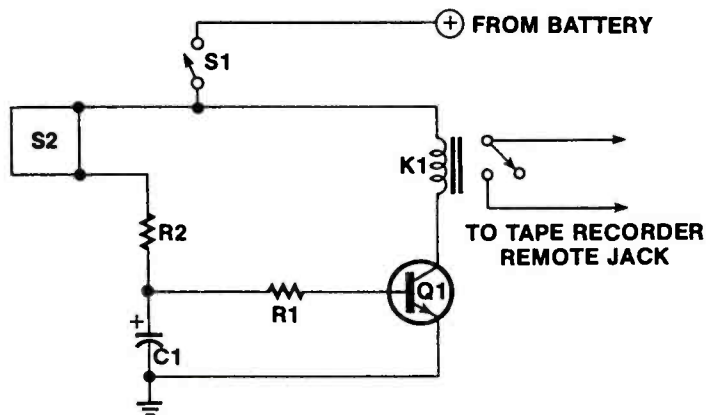
The "Fun Box" consists of two parts; a tape recorder and a recorder control. A "shaker switch" is used by the control circuit in a normally open mode.

When the car is bumped, the power is applied through the shaker switch to C1, charging it through R2. Transistor (Q1) turns on and stays on during the discharge of C1 through R1. This determines how long the tape will play.

K1 can turn on the Recorder with contact closure to the remote or by feeding power to the recorder. With a little imagination, you should have lots of fun with this device.

## PARTS LIST FOR THE CAR FUN BOX

- R1—10K Ohms, ¼ watt, resistor
- R2—18 Ohms
- C1—1000 Mfd, 35 WVDC capacitor
- S1—Shaker switch or Mercury switch
- Q1—2N2222 transistor
- K1—12 volt coil, SPDT contacts relay



# TELEPHONE RING CONTROL

This device can be quite useful. When the telephone rings, it will turn on a light, activate a horn or whatever other device you so desire.

For a deaf person or someone with a hearing impairment, this device can flash a light for each phone ring, for people that have difficulty with their hearing, a horn or a bell.

The circuit functions as a remote ringer control. Operation is simple. The DC normally, present in the phone line, does nothing, since it will not pass through the capacitors. The AC ring voltage does pass through the capacitors, lighting the LED (X1). Resistance of the photocell (R3) lowers drastically, turning on transistor (Q1), which pulls in relay (K1).

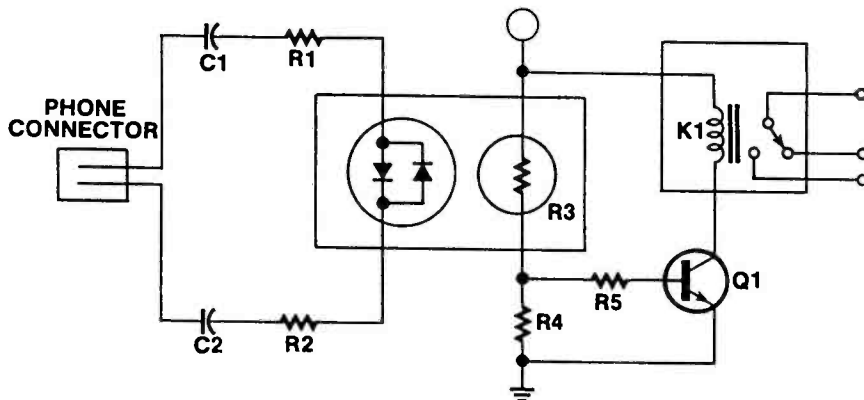
The power for this circuit is from a 9-12 volt supply.

You can power it from a battery but it would be best to power it from an AC power supply.

Be sure to tape the photocell to the LED with black tape to prevent a false actuation.

## PARTS LIST FOR THE TELEPHONE RING CONTROL

- R1, R2—4.7K Ohm, ½ watt resistors
- R3—Resistive photocell
- R4, R5—10K Ohms, ¼ watt resistors
- C1, C2—1.0 Mfd, 250 WVDC capacitors
- Q1—2N2222 Transistor
- X1—Bicolor LED
- K1—12 volt coil relay, 10 Amp contacts



# IN-LINE PHONE CHECKER

Here is a little device that will tell you whether or not your phone line is OK and even indicate the ring power.

This device can remain connected to the line with a phone plugged into it so it doesn't tie up a plug while being tested.

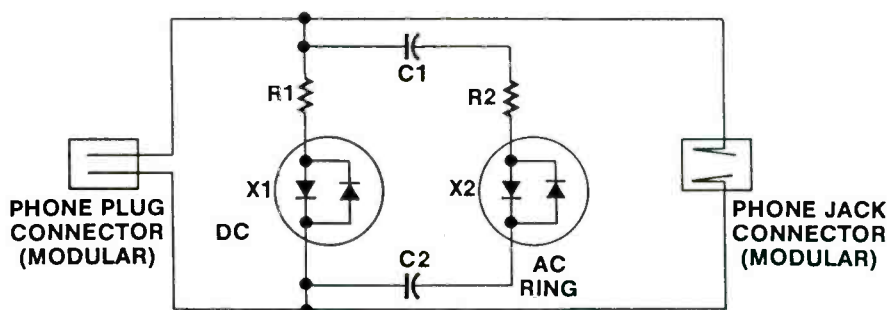
When the checker is plugged into the phone line, LED X1 indicates the presence of any polarity of the DC voltage on the line. Should the LED not light, check the phone line with a DC voltmeter. Absence of this DC voltage indicates that the phone line is dead. When a call comes in, the AC ring voltage passes through C1 and C2 and lights LED X2. This ring voltage peaks at 220 volts so be careful around live phone lines.

This little device is powered by the phone lines and can be assembled on a board smaller than a credit card.

Now you can monitor your phone lines without fancy equipment.

## PARTS LIST FOR IN-LINE PHONE CHECKER

- R1—27K Ohms, 1/2 watt resistor
- R2—10K Ohms
- C1, C2—1.0 Mfd, 250 WVDC capacitors
- P1—Phone plug with short lead
- J1—Phone jack for modular plug
- X1, X2—Bicolor LEDs or Red 7 Green LEDs wired back to back



# OK PHONE INDICATOR

You cannot tell just by looking at a telephone if it is functional. Looking at the phone line will not tell you if it is operational either. That is the job of the Phone OK Indicator. This little phone line powered device monitors the phone line and lights to indicate when the line is ready to use.

When a phone is off the hook for any reason, this device's LED darkens. This indicates that someone is making a call or something is wrong with the telephone line. Mostly, this would serve as a phone busy indicator.

The diodes allow the indicator to be wired to the phone line either polarity and eliminates polarity worries.

Installation of a small unit like the phone OK indicator may be facilitated by making it plug into a modular

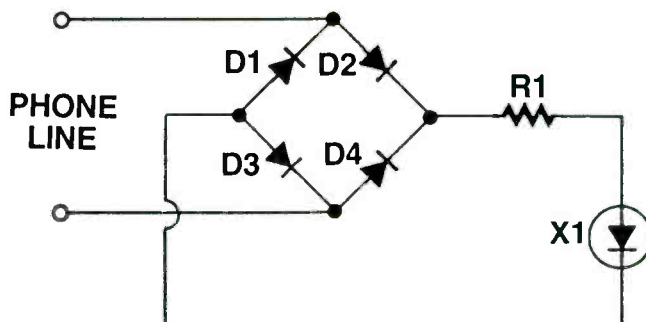
phone jack, or hardwiring it in. Red and green are the wires normally in use for the phone. In multiline systems or when in doubt about which wires are correct, a phone or a meter should be used to check to determine which wires are right.

This device is capable of being constructed behind a small postage stamp, so it can fit even inside a phone, or just about anywhere.

It could even be built into some hold button boxes. ■

## PARTS LIST FOR OK PHONE INDICATOR

- R1—10K ohm 1/2 watt resistor
- X1—LED, color your choice
- D1, 2, 3, 4—1N4007 Diodes



# 3-LED SEQUENTIAL FLASHER

This simple circuit is an extension of the usual twin LED flasher and will flash three LEDs on and off in sequence ... all for the price of three transistors.

This circuit is easy to build and is a little unusual. It can be used to dress up many other projects and it only uses three transistors that you probably have lying around your workbench or in your junkbox. The circuit is a simple but not well known extension of the common "twin LED flasher."

When power is first applied, two of the three 4.7 $\mu$ F capacitors will charge up before the third and turn the associated transistors on.

For example, if capacitor C1 and C2 charge up first, then transistors Q1 and Q2 turn on, which causes Q3 to be turned off, so LED 3 lights up.

After a certain time, capacitor C3 charges up to eventually turn Q3 on. This causes capacitor C1 to be pulled low, and because it has no charge on it, the base of transistor Q1 is also pulled low. This turns this transistor off and LED 1 lights up. Meanwhile transistor Q2 is turned on because of the 10K ohm resistor pulling its base high.

The circuit then keeps looping around continually whenever the power is applied to the circuit.

Current consumption is around 10mA which should allow even small penlite cells to be used adequately.

## CONSTRUCTION

As with all projects, construction is where the theory meets practice. If you follow the simple rules of construction, you should have no troubles with this circuit. It is quite robust and will handle voltages of up to 40V or more depending upon the transistors you use.

Remember the higher the voltage you use, the higher in value the collector resistors R2, R4 and R6 must be, so that the current through the LED doesn't become too high and damage them.

As an example, this project can be used as a simple traffic light system for a model train layout. Using suitably large capacitors, you can increase the time the circuit takes to cycle through each LED. The simple rule is the higher the capacitor, the longer the delay time. ■

## PARTS LIST FOR THE 3-LED SEQUENTIAL FLASHER

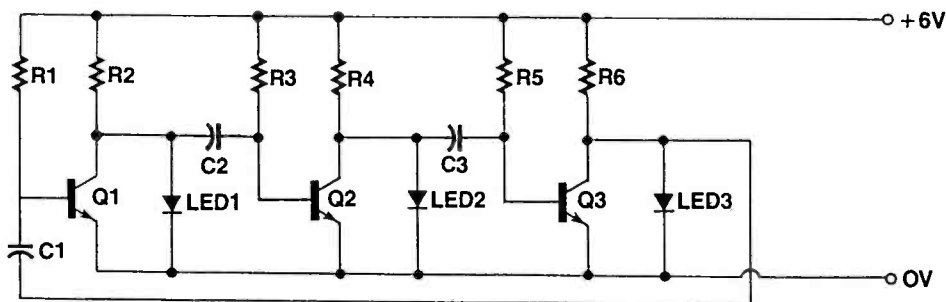
C1-C3—4.7 $\mu$ F, 25VW Electrolytic capacitors

R1, R3, R5—10K ohms, 0.25W Resistors

R2, R4, R6—1K ohms, 0.25W Resistors

LED 1-3—5mm RED Type

Q1-Q3—BC548 or any similar NPN (Hfe>100) type



# ELECTRONIC VHF TUNER

Most of us are familiar with the standard parallel inductor/capacitor combination found in the tuner section of radio circuits. For example, the crystal set has a coil or inductor at the front end with a variable tuning capacitor in parallel. Back in the old days, you could easily find these variable capacitors now, on the other hand, it's about as rare as a '55 Chevy. A common found bit of advice is to go and search in junk boxes at ham fests or the like. If, like me, you want a bit more solid advice then you'll like the suggestion below. As technology progresses the hobbyist unfortunately has to make do with whatever components the manufacturer decides to supply. So what can we use in place of the essentially defunct variable capacitor?

The varicap diode is the answer! Not only is it available now, it is also very simple to use & takes up less space. There is a trade off—extra components are

needed to drive it, but the design is still very simple. A varicap diode changes its capacitance as the voltage applied to it is varied. Hence when placed in parallel across an inductor, the resonant frequency will also change accordingly. The example shown here is configured for the VHF frequencies, around 88MHz to 108 MHz, as this is where they work best (for hobbyist purposes).

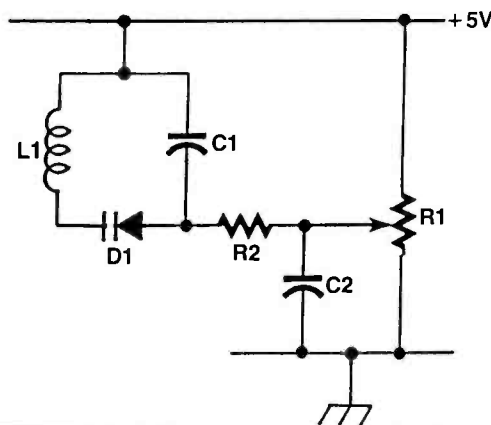
The tuning action is mechanically very smooth since a standard potentiometer acts as the tuner. Take a look at the circuit shown. The coil (L1) is the traditional VHF home wound item found in low power short range FM transmitter circuits. D1 is the varicap diode and has to be connected as shown to be reversed biased. The tuning voltage is supplied by R1. The rest of the components stabilize and buffer the voltages. There are many variations around this design, but this one is nice

## ELECTRONIC VHF TUNER

and simple to build and works very well. Next time you come across an FM transmitter circuit and can't find the variable capacitor, try this circuit instead. ■

### PARTS LIST FOR THE ELECTRONIC VHF TUNER

- L1 — Hand wound VHF coil to suit circuit being used.
- D1 — Motorola MV209 varicap tuning diode
- C1 — 0.1uF capacitor
- C2 — 0.1uF capacitor
- R1 — 100K potentiometer
- R2 — 100K resistor



## HEADLIGHT MINDER

Not every vehicle has one of these circuits, but every one should. Picture this: You are out in the middle of nowhere, miles from the nearest service station. You stop, and leave the vehicle. Since it is twilight, your headlights are on, but there is no alarm. When you return to the vehicle, the battery is drained. When you install the Headlight Minder, the whole picture changes. As soon as you open the door of your vehicle, the buzzer squawks, and the LED flashes. Now, you remember to shut off the headlights before they can discharge the battery.

Construction is simple and the small board can hide anywhere behind the dash. You might put the circuit in a small plastic box to protect it from the elements or damage. The only component that need be visible is the LED and it is not a necessity to use an LED if you have the buzzer. Also, it is not necessary that the LED flash, but it enhances its ability to catch your eye.

Make sure you make your connection to the load or lightbulb side of the headlights switch and door switch. In the unlikely event that your vehicle does not have a dome light, a door-activated switch can be added.

Wire one side of the switch to the battery through a 1K Ohm resistor of 1 watt, and the other side to the cathode of D2.

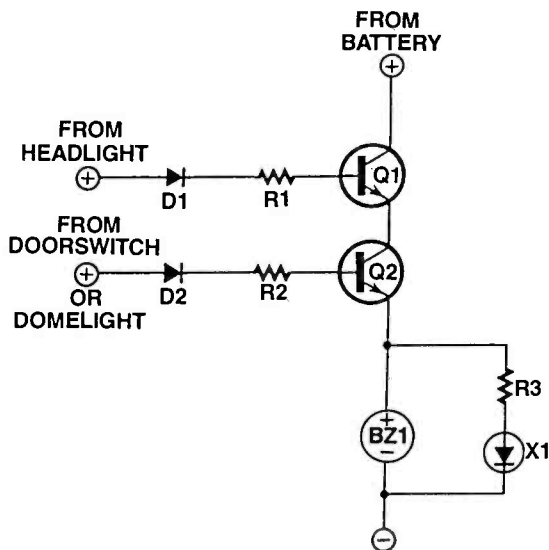
Test the device by turning on the headlights and opening the door of the vehicle. The buzzer should buzz and the LED should light. If so, the Headlight Minder is functioning properly.

This little device could be a lifesaver. ■

### PARTS LIST FOR THE HEADLIGHT MINDER

- R1, 2 — 10K Ohms 1/2 watt resistors
- R3 — 1K Ohm
- D1, 2 — 1N4007 diodes
- Q1, 2 — 2N2222 transistors
- X1 — Flasher LED
- BZ1 — 12 volt buzzer or sonalert.
- Misc. — Wire, solder, PC board, box, door switch if necessary.

### HEADLIGHT MINDER



# INTRODUCTION TO STEPPER MOTORS

By John Iovine

**Stepper motors are commonly used in robotics, automation and positioning control in commercial and industrial equipment. If you own a computer these motors are as close to you as your disk drive and printer. Stepper motors are used in these applications because they are easily controlled by digital circuits and most important, capable of precise positioning. This article will describe how to construct a simple stepper motor interface to examine the basic operating principals of stepper motors.**

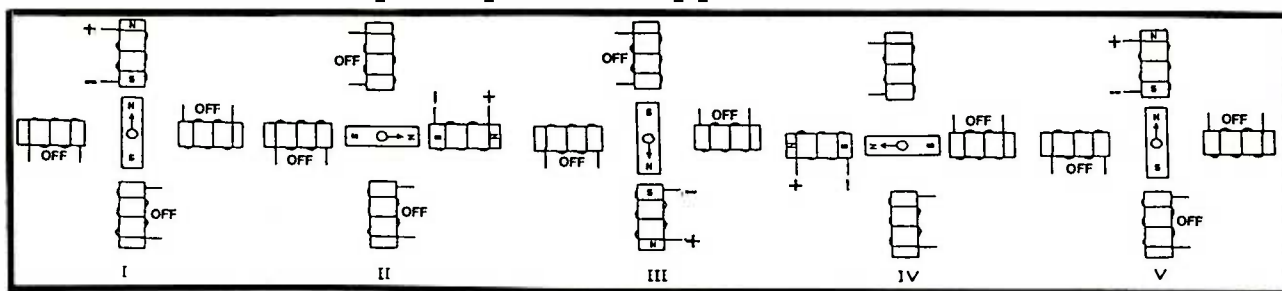


FIGURE 1

**S**tepper motors are different from normal electric motors. When you apply power to an ordinary motor the rotor turns smoothly. A stepper motor however, runs on a sequence of electric pulses to the windings (or phases) of the motor. Each pulse to the winding turns the rotor by a precise amount. These pulses to the motor are often called steps. Stepper motors are manufactured with different amounts of rotation per step (or pulse), depending upon the application it is designed and built for. The specifications of the stepper motor will state the degree of rotation per step. The range of rotation per step can vary from a fraction of a degree (i.e. .72 degree) to many degrees (i.e. 22.5 degrees).

## Basic Operations

Figure 1 is of a stepper motor stepping through one rotation. Stepper motors are constructed of strong permanent magnets and electromagnets. The permanent magnets are located on the rotating shaft; called the rotor. The electromagnets or windings are located on the stationary portion of the motor called the stator. The stator, or stationary portion of the motor surrounds the rotor.

In figure 1 position I, we start with the rotor facing the upper electromagnet that is on. Moving in a CW (clockwise) rotation the upper electromagnet is switched off, as the electromagnet on the right is switched on. This moves the rotor 90 degrees in a CW rotation, shown in position II. Continuing in the same manner, the rotor is stepped through a full rotation until we end up in the same position as we started, shown in position V.

## Resolution

The degree of rotation per pulse determines the resolution of the stepper motor. In the illustrated example, the rotor turned 90 degrees per pulse, not very practical. A real world stepper motor, for instance, one that steps 1 degree per pulse would require 360 pulses to achieve one revolution. Another motor with less resolution (greater degree per step), that steps say 3.75 degrees per pulse would only require 96 pulses for one full rotation.

Without getting into gearing or gear ratios. Let's assume that the stepper motor is used for positioning in a linear motion table, and further that each revolution of the motor is equal to one inch of linear travel on the table. It becomes apparent that each step of the motor defines a precise increment of movement.

In making a comparison between the two stepper motors, the ability to locate and position more precisely on the table would be with the stepper motor with the higher resolution (one that requires the most steps per revolution). For the motor that steps 3.75 degrees per step, the increment of movement is approximately .01 inch per step. If this resolution is sufficient for your table it's fine to use this stepper motor. If however you required greater resolution the 1 degree per step motor would give approximately .0027 inch per step. So you see the increment of movement is in proportion to the degrees per step.

## Half Step

It is possible to double the resolution of some stepper



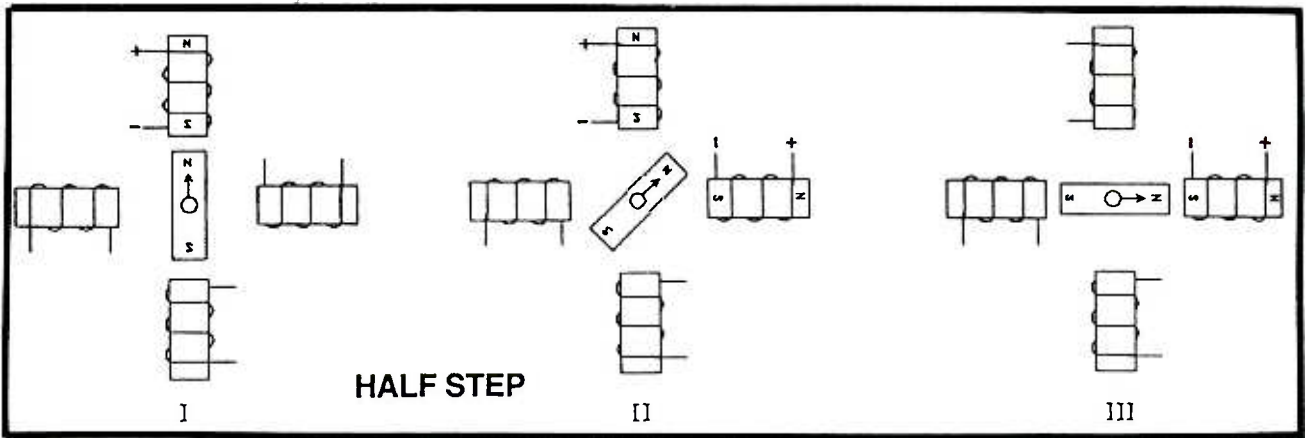


FIGURE 2

motors by half stepping. In figure 2, this is illustrated. In position I, the motor starts with the upper electromagnet switched on, as before. In position II the electromagnet to the right is switched on while keeping power to the upper coil on. Since both coils are on, the rotor is equally attracted to both electromagnets and positions itself in between both positions (a half step). In position III the upper electromagnet is switched off and the rotor completes one step. Although we are only showing one half step, the motor can be half stepped through the entire rotation.

to its immediate left is switched on. This causes the rotor to rotate CCW by a precise amount. It continues in this same manner for all the steps. Examine the pole relationship between IV and V. The rotor is still moving CCW, and in position V the stator poles are in the same orientation as position I. This is where the sequence of electric pulse would begin to repeat themselves and keep the rotor turning CCW.

Figure 4 illustrates the half step with the multi-pole position. It is identical to the half step described before.

**Other Types of Stepper Motors**

You may run a 4-wire stepper motor. These stepper motors have two coils, with a pair of leads to each coil. Although the circuitry of this stepper motor is simpler than the one we are using, it requires a more complex driving circuit. The circuit must be able to reverse the current flow in the coils after it steps.

**Real World**

As stated, the stepper motors diagramed for illustration wouldn't be of much use in the real world, rotating 90 degrees per step. Real world stepper motors employ a series of mini-poles on the stator and rotor which improves the resolution of the stepper motor. Although figure 3 may appear more complex than the previous figures it is not really so. Its operation is identical, and to prove the point we'll step through the illustration.

In figure 3 the rotor is turning in a counter clockwise (CCW) rotation. In position I the north pole of the permanent magnet on the rotor is aligned with the south pole of the electromagnet on the stator. Notice that there are multiple positions that are all lined up. In position II the electromagnet is switched off and the coil

**Test Circuit**

With this manual circuit, you can check and verify your wiring of the stepper motor. In addition it's an excellent tool to use if you are checking out a different stepper motor from the one used in this article.

Look at figure 5. The circuit is the epitome of simplicity. Switches S1 thru S4 are normally open subminiature push button switches, see parts list. The four switches allow you to drive the stepper motor manually. By changing the sequence of the steps we can do full step and half step increments in either direction (CW or CCW). The diodes D1 thru D4 are used to prevent sparking and protect the balance of the circuit. These diodes become more important when the motor is interfaced to a computer. The batteries used in the circuit are two small 12 volt batteries in series to generate the 24 volts required. The stepper motor we are playing with is a 24 volt model. The rectangular box at the top of the diagram with six head screws are six PC Board Terminals interlocked together, see parts list. This simplifies connecting the wiring from the motor to the circuit.

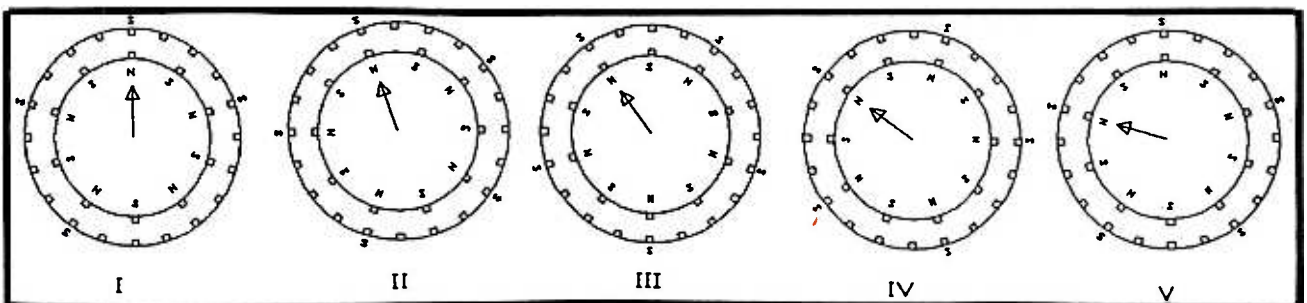


FIGURE 3

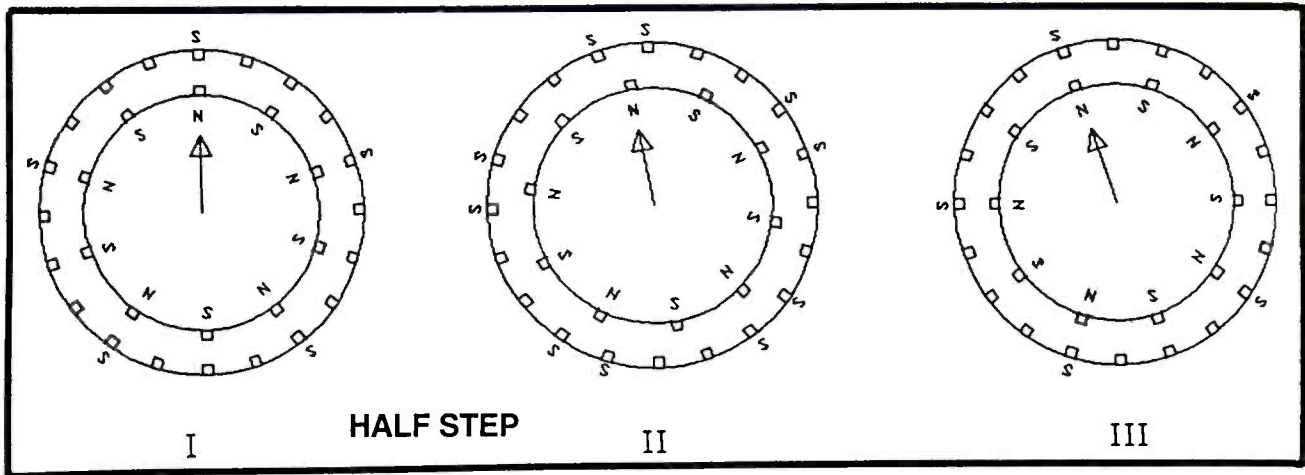


FIGURE 4

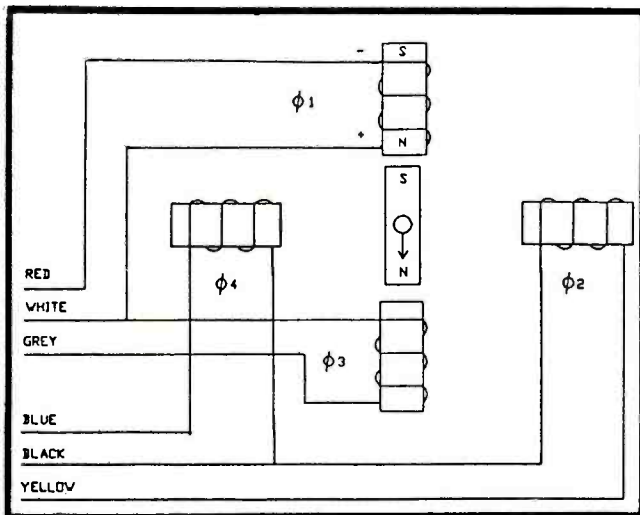


FIGURE 5  
Stepper Motor

Figure 6 is an electric equivalent circuit of the stepper motor we are using. The stepper motor has 6 wires coming out of the casing. We can see from figure 6 that 3 leads go to each half of the coil windings. And that the coil windings are connected in pairs. If you just selected this stepper motor and didn't know anything about it, the simplest way to analyze it would be to check the electrical resistance between the leads. By making a table of the resistances measured between the leads you'll quickly discover which wires are connected to which coils.

On the motor we are using there is a 60 ohm resistance between the center tap wire and each end lead, and 120 ohms between the two end leads. A wire from each of the separate coils will show an infinitely high resistance (no connection) between them. Armed with this information you can just about tackle any 6 wire stepper motor you come across. The stepper motor we are using rotates 3.75 degrees per step.

**Test Circuit Demo**

When you have finished wiring the test circuit and connecting the stepper motor, use the following two tables to step or half step the motor.

FULL STEP				HALF STEP			
S1	S2	S3	S4	S1	S2	S3	S4
on	-	-	-	on	-	-	-
-	on	-	-	on	on	-	-
-	-	on	-	-	on	-	-
-	-	-	on	-	on	on	-
-	-	-	-	-	-	on	on
-	-	-	-	-	-	-	on
-	-	-	-	on	-	-	on

When you reach the end of the table the sequence repeats starting back at the top of the table.

If you want to reverse the direction of travel just reverse the sequence of the table, starting from the bottom and working to the top.

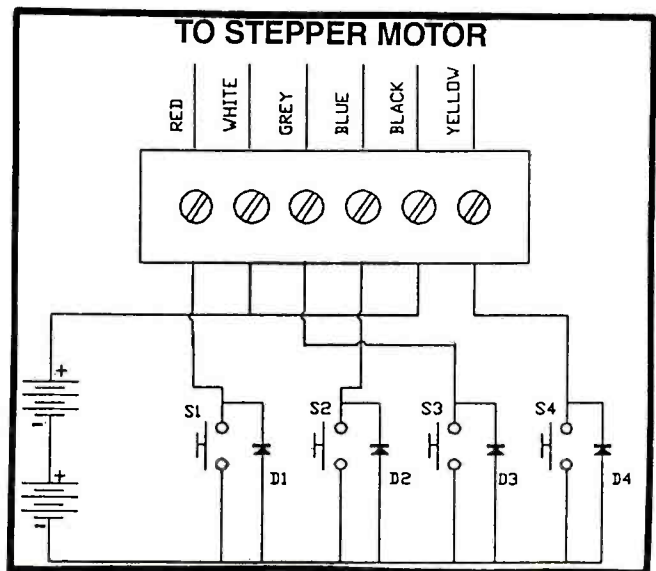


FIGURE 6

**Trouble Shooting**

If you use the stepper motor listed in the parts list I don't think you'll run across any problems. If you should, the first thing to check is the diodes, make sure you have them in properly, facing in the direction shown in the schematic.

(Continued on page 33)

## Just like these Fully Trained Electronics Professionals



"Thanks to CIE I have tripled my previous salary, and I am now in a challenging and rewarding new field where only the sky is the limit."  
**Daniel Wade Reynolds**  
*Industrial Electrician*  
*Ore-Ida Foods*



"CIE was recommended to me by my boss. It was appealing since I could study at my own pace at home and during business travel."  
**Dan Parks**  
*Marketing Manager/Consumer Products*  
*Analog Devices, Inc.*



"I loved the flexibility CIE offered. It was the only way I could continue both school and my demanding job."  
**Britt A. Hanks**  
*Director of Engineering*  
*Petroleum Helicopters, Inc.*

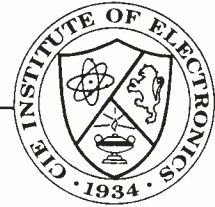


"I liked the way the school was set up with laboratory assignments to enforce conceptual learning. The thing which impressed me the most about CIE's curriculum is the way they show application for the theory that is presented."  
**Daniel N. Parkman**  
*Missile Electro-Mechanical Technician*  
*U.S. Air Force*



"Completing the course gave me the ability to efficiently troubleshoot modern microprocessor based audio and video systems and enjoy a sense of job security."  
**Tony Reynolds**  
*Service Manager/Technician*  
*Threshold Audio & Video*

# Graduate with an Associate Degree from CIE!



CIE is the best educational value you can receive if you want to learn about electronics, and earn a good income with that knowledge. CIE's reputation as the world leader in home study electronics is based solely on the success of our graduates. And we've earned our reputation with an unconditional commitment to provide our students with the very best electronics training.

Just ask any of the 150,000-plus graduates of the Cleveland Institute of Electronics who are working in high-paying positions with aerospace, computer, medical, automotive and communications firms throughout the world. They'll tell you success didn't come easy...but it did come...thanks to their CIE training. And today, a career in electronics offers more rewards than ever before.

### CIE'S COMMITTED TO BEING THE BEST...IN ONE AREA...ELECTRONICS.

CIE isn't another be-everything-to-everyone school. CIE teaches only one subject and we believe we're the best at what we do. Also, CIE is accredited by the National Home Study Council. And with more than 1,000 graduates each year, we're the largest home study school specializing exclusively in electronics. CIE has been training career-minded students for nearly sixty years and we're the best at our subject...  
**ELECTRONICS... IT'S THE ONLY SUBJECT WE TEACH!**

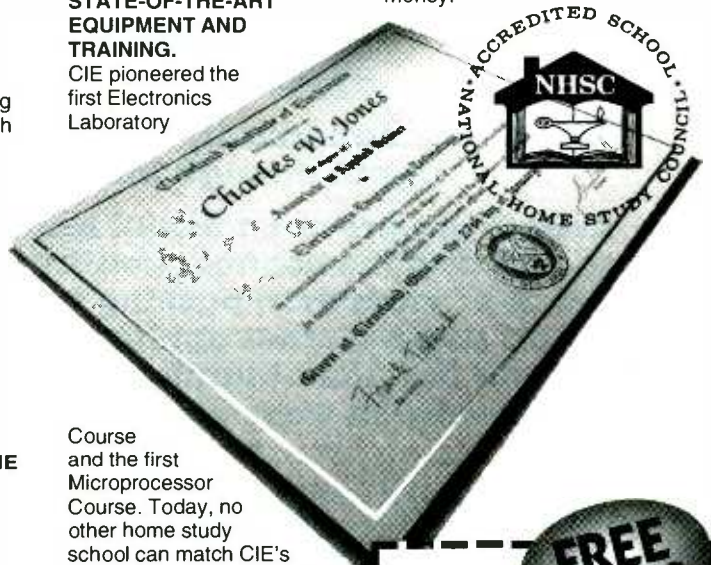
### CIE PROVIDES A LEARNING METHOD SO GOOD IT'S PATENTED.

CIE's AUTO-PROGRAMMED® lessons are a proven learning method for building valuable electronics

career skills. Each lesson is designed to take you step-by-step and principle-by-principle. And while all of CIE's lessons are designed for independent study, CIE's instructors are personally available to assist you with just a toll free call. The result is practical training... the kind of experience you can put to work in today's marketplace.

### LEARN BY DOING...WITH STATE-OF-THE-ART EQUIPMENT AND TRAINING.

CIE pioneered the first Electronics Laboratory



Course and the first Microprocessor Course. Today, no other home study school can match CIE's state-of-the-art equipment and training. And all your laboratory equipment, books and lessons are included in your tuition. It's all yours to use while you study and for on-the-job after you graduate.

### PERSONALIZED TRAINING....TO MATCH YOUR BACKGROUND.

While some of our students have a working knowledge of electronics others are just starting out. That's why CIE has developed twelve career courses and an A.A.S. Degree program to choose from. So, even if you're not sure which electronics career is best for you, CIE can get you started with core lessons applicable to all areas in

electronics. And every CIE Course earns credit towards the completion of your Associate in Applied Science Degree. So you can work toward your degree in stages or as fast as you wish. In fact, CIE is the only school that actually rewards you for fast study, which can save you money.



## YES!

I want to get started. Send me my CIE course catalog including details about the Associate Degree Program. (For your convenience, CIE will have a representative contact you - there is no obligation.)

Please Print Clearly

AEE08

Name \_\_\_\_\_

Address \_\_\_\_\_

City \_\_\_\_\_

State \_\_\_\_\_ Zip \_\_\_\_\_ Age \_\_\_\_\_

Phone No. \_\_\_\_\_

Check box for G.I. Bill Benefits.

Veteran  
 Active Duty

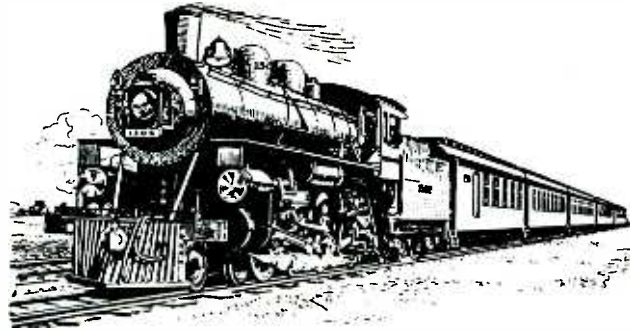
Cleveland Institute of Electronics, Inc.  
 1776 East 17th Street  
 Cleveland, OH 44114

*A School of Thousands.  
 A Class of One. Since 1934.*

Send for CIE's FREE Course Catalog and See How We Can Help Your Career Too!

# ELECTRONICS FOR THE MODEL RAILROAD HOBBYIST

By  
Tony Lee



Here is your opportunity to add realism to your model railroad layout through the medium of electronics.

Even if you are not a model railroad enthusiast yourself, you should find the control circuitry techniques presented in this article of more than passing interest, and quite possibly they could suggest other applications of a practical nature. And you will find the ubiquitous 555 timer IC once again pressed into service in ways possibly never intended by the original designers at Signetics.

If you have an old "train set" gathering dust in the attic, with an old-fashioned rheostat and nothing much else, now you can upgrade it with improved controls and accessories.

The article covers nine useful circuits and although they are each examined in detail later in the article, perhaps first an overview of the part they play in the overall scheme of things would be appropriate.

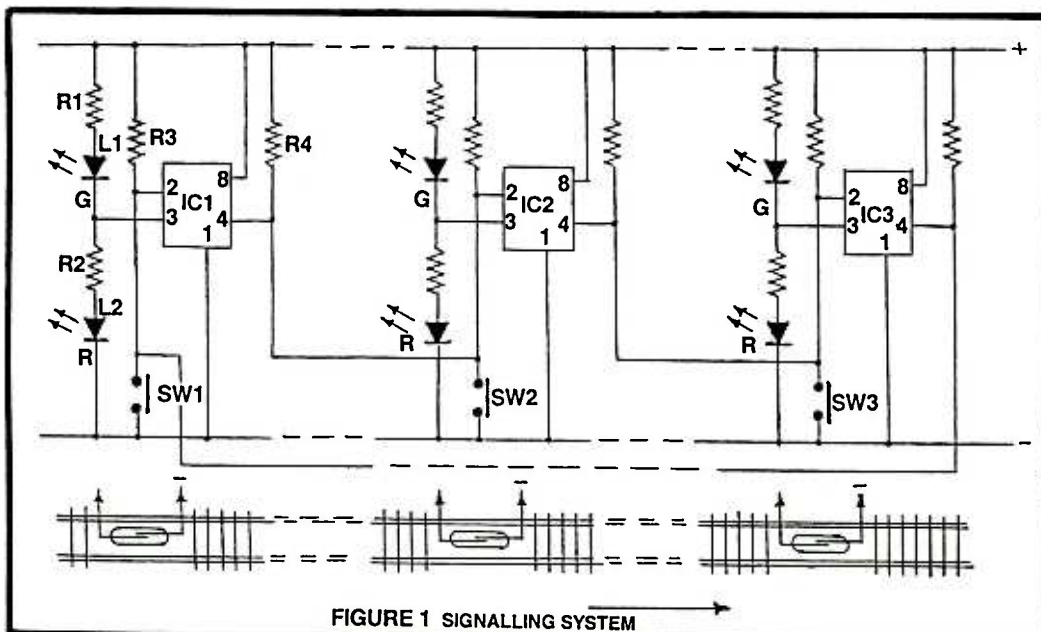


FIGURE 1 SIGNALLING SYSTEM

**Train signalling system:** This circuit operates warning lights for the engine driver—red for stop, green for go. A signal will remain on green until a train passes it, whereupon it changes to red, warning the driver of a following train that there is another train up ahead. When the first train passes the next signal, it too will change to red but at the same time, the preceding signal will revert to green, giving permission for the second train to proceed to the next signal.

If the distance between the two trains increases, it is quite possible that the following train driver will find the next signal or two on green, indicating there is nothing in the vicinity and it is safe to proceed. In short, a train passing a signal will turn it red and a preceding signal will turn green. Their interaction will be better understood in the circuit description.

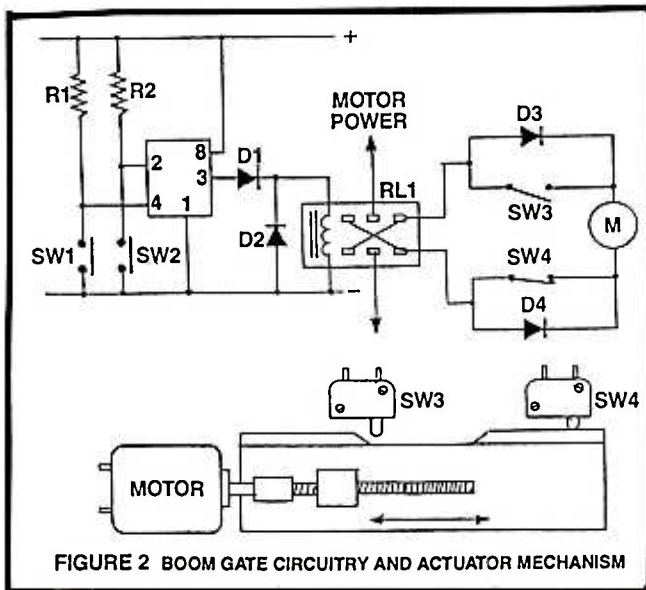


FIGURE 2 BOOM GATE CIRCUITRY AND ACTUATOR MECHANISM

**Boom gate operation:** Here we combine electronics with mechanics which should prove to be a challenging project. Only the principle is shown, the actual mechanical work being left to the inventiveness of the constructor.

The gates may be activated manually or by an approaching (and receding) train. The lowering and raising of the boom gate is performed by a sliding plate moving forward and backward via a miniature geared motor with a long threaded shaft. The general arrangement can be seen in Fig. 2.

Its distance of travel in each direction is determined by two limit switches. These switches, in conjunction with diodes, switch off the power to the motor at just the right time. Reversing the rotation of the motor spindle is performed by the electronic circuitry via a relay.

**Crossing flashing lights:** These two alternating red flashing lights may be installed with or without the boom gates. Again, you may activate them manually at your control panel or let a train do it for you automatically.

For added realism, you may be able to find a suitable bell-sounding device capable of being operated by the same circuit. During the preparation of this article, a sounder from an old telephone handset produced a fairly close likeness to a railroad warning bell. In fact, it

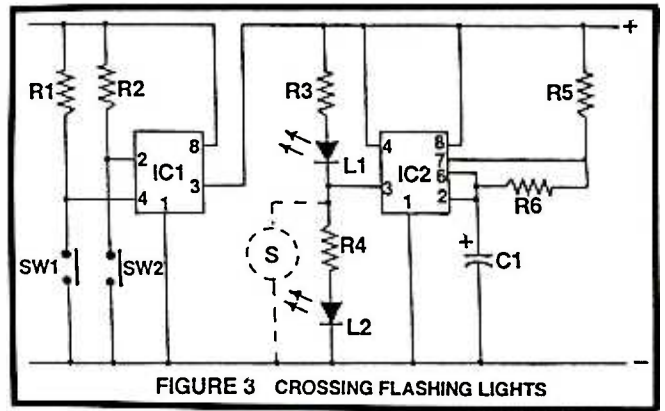


FIGURE 3 CROSSING FLASHING LIGHTS

was quite pleasing albeit not terribly loud on a 12 volt system. Another alternative is to build an electronic bell simulator using an envelope shaper for that attack/decay effect, but that's a subject for another time.

**Circuit interface:** It is recommended that motors, solenoids and other heavy inductive loads be isolated from the electronic circuitry, and have their own power supply. Fig. 4 shows how and more will be said about this later.

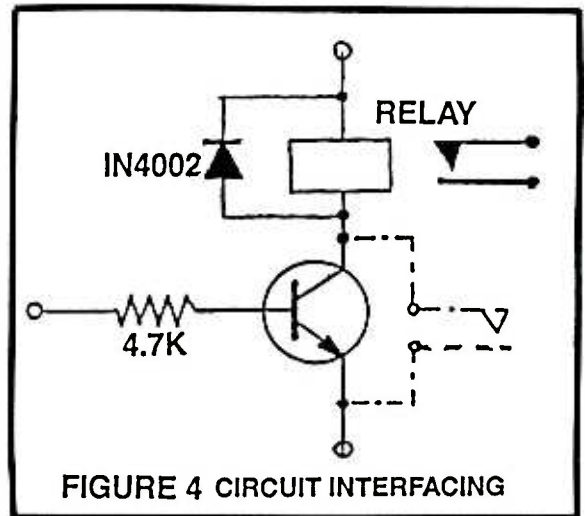


FIGURE 4 CIRCUIT INTERFACING

**Points switching system:** One of the most practical methods of switching points in a model railroad is with a back-to-back solenoid, otherwise known as a switching machine or point motor. With such a device, the forward and reverse motion of a slug within the solenoid coil opens and closes the blades of the points.

Usually, all that is required is a quick pulse from, say, a manually operated push-button to energize the solenoid, but such a system can have its disadvantages. The solenoid coils draw an enormous amount of current which can deprive other equipment using the same power supply. Furthermore, they are susceptible to overheating that can lead to irreparable damage. And to add to the doom and gloom, a hefty reverse voltage generated by the collapsing field can be enough to weld the contacts of a switch.

All these gremlins are eliminated in the simple circuit design shown in Fig. 5.

**Traffic lights:** For once we use 555 timers in the conventional mode, unlike some of the others in previous circuits. The three timer modules seen in Fig. 6 are arranged for continuous cycling and can be set to

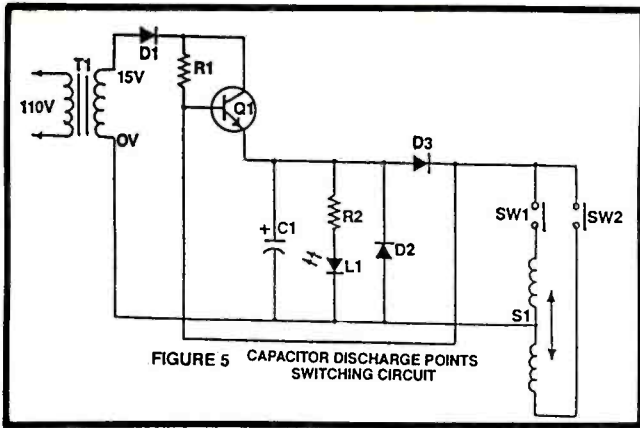


FIGURE 5 CAPACITOR DISCHARGE POINTS SWITCHING CIRCUIT

switch on the red, green and yellow lights in the correct sequence for their individual time periods.

It is a basic circuit for a set of traffic lights suitable for, say a pedestrian crossing but two sets can be run off the same circuit for two-way traffic. The synchronization of traffic lights at an intersection is more involved, and digital circuitry might be the better approach for such an application.

**Electronic throttle:** Most model railroad enthusiasts will be familiar with the usual form of train control—the commercially available rectified transformer with the wire-wound rheostat (or variable resistor).

They will also be aware of their shortcomings: the poor performance when the train begins to move off, and the loss of power on gradients. It can take off like a projectile and stall under load. Worst of all, if the controller isn't fitted with a fuse, you could be up for a new one when a well-meaning visitor drops the proverbial screwdriver across the rails.

All these problems are overcome in the delightfully simple circuit shown in Fig. 7. It allows the train to move off in a realistic manner and maintain constant speed under varying loads. And if a short-circuit should occur, it is fully protected and an indicator lamp will glow to let you know of a malfunction—without having to replace a fuse!

**Power supply for the electronics:** Little explanation is needed for the fairly conventional circuit diagram shown in Fig. 8—a rectified and voltage regulated sys-

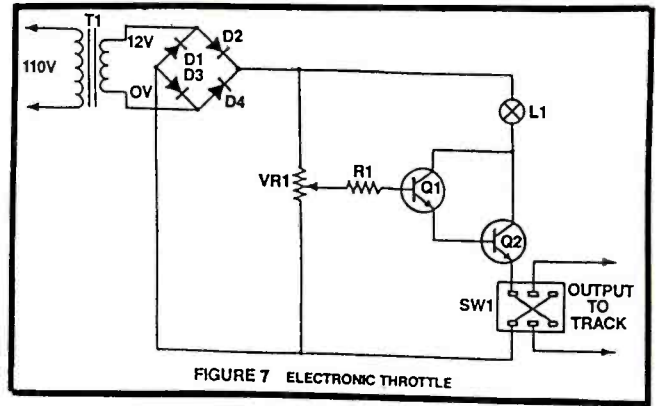


FIGURE 7 ELECTRONIC THROTTLE

tem, providing 12 volts output for all the circuitry.

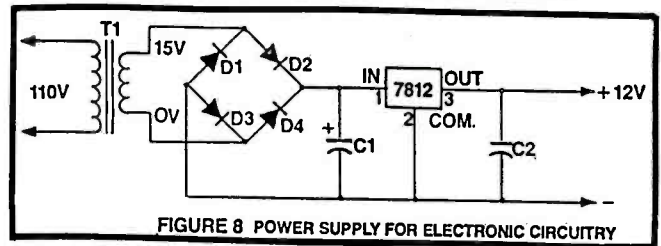


FIGURE 8 POWER SUPPLY FOR ELECTRONIC CIRCUITRY

### How the circuits work

When it became apparent that timers, flip flops and oscillators would be required for a number of the projects chosen for this article, an initial decision had to be made on their method of construction. Firstly, digital or linear components? If digital, should committed IC's be used, i.e. RS flip flops, binary counters, multivibrators? Or perhaps make them up from quad NOR gates, hex schmitt inverters, etc?

In the case of linear circuitry, a number of approaches came to mind, including 555 timers, operational amplifiers or even fabricating them from discrete components. To some extent, it's a matter of personal choice, but for versatility, stability in the presence of troublesome electric fields, not to mention popularity with constructors, the 555 won the day.

Now, let's examine each circuit diagram in greater detail.

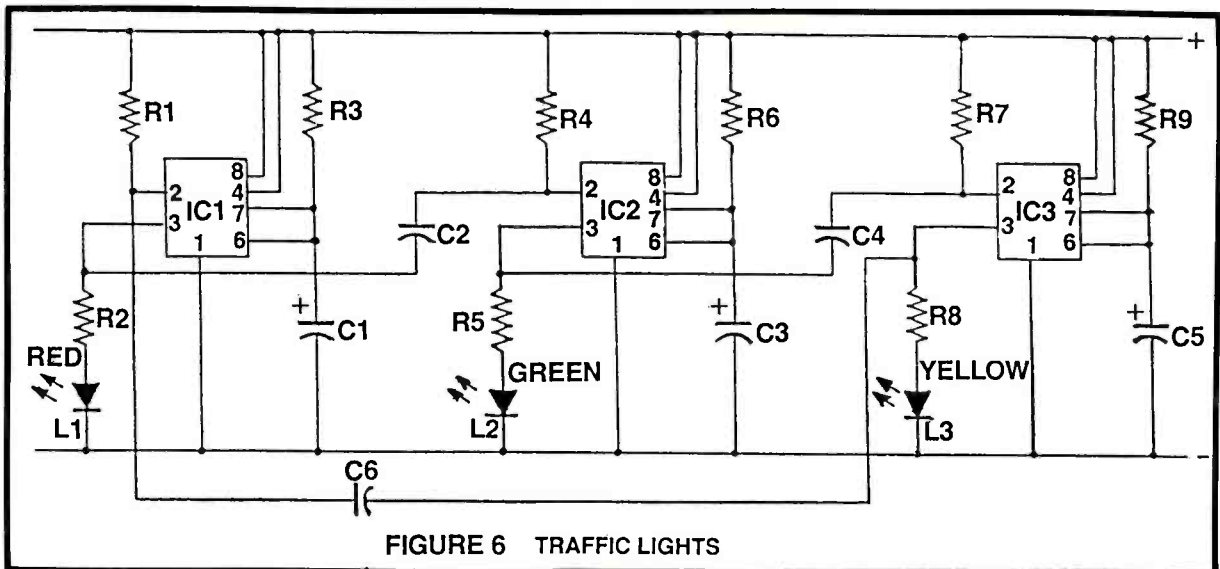
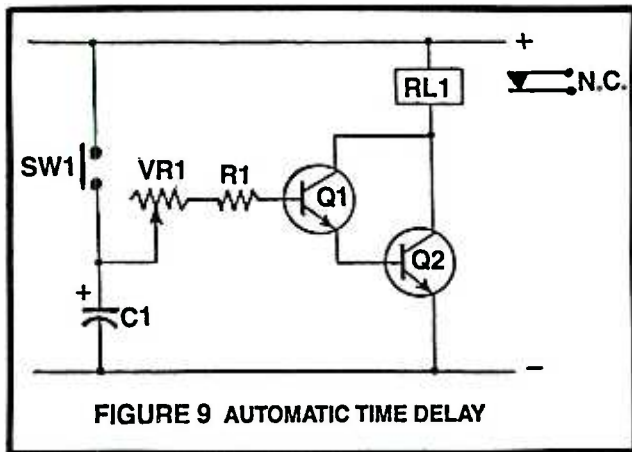


FIGURE 6 TRAFFIC LIGHTS



Signalling system — Fig. 1

A 555 module is required for each signal and although only three are shown in the diagram, any number can be installed around the track. Note the word 'timer' for the 555 is not used in this instance to avoid confusion. It is being used as a flip flop only. Pin 2 and pin 4 are the 'set' and 'reset' functions.

Only five connections to the chip are required, the ancillary timing components being unnecessary in this application.

Assume we start with all LED's on green. Also, note the direction in which the train is travelling. SW1 is a reed switch fitted lengthwise between the rails. A magnet attached to the underside of the train closes the switch as it passes over, momentarily grounding pin 2 and setting the flip flop. An output is produced at pin 3, switching on the red LED and switching off the green.

Reset, pin 4 is connected to pin 2 of the next 555. When the train passes over SW2, the red LED of the second 555 comes on, at the same time, resetting the first 555 by grounding pin 4, changing its status back to the green LED.

The 555 IC, therefore, has the capability of **sourcing** a current (the red LED) or **sinking** a current (the green LED). Pin 2 and pin 4 require a negative-going pulse to set or reset them, no matter how fleeting.

Again, when the train passes over the third reed switch, SW3, there is a similar interaction. The third signal turns red and the preceding signal changes back to green. Since our circuit is only a three signal system, pin 4 of the third signal must be fed back to pin 2 of the first signal to complete the loop. Note the connecting wire shown below the ground line in the diagram.

Now, when the train closes SW1 once again, the third signal reverts to green, so completing one cycle around the track.

As previously stated, any number of signals can be installed, subject of course, to current availability. Each draws 20—30mA; not a lot but it adds up. Only the components in the first 555 module are called up in the parts list; subsequent modules being identical.

Pins 2 and 4 are tied to the positive rail via resistors R3 and R4 when in the standby state. Some experimentation may be required in the location of the reed switches and the magnet to ensure reliable results when the train is travelling at a fairly high speed.

## Boom Gate circuitry and Actuator Mechanism— Fig. 2

Again we use the 555 as a flip flop. When SW1 closes momentarily, an output at pin 3 energizes a double pole, double throw relay. By cross-coupling the contacts as shown and connecting the poles to the motor power source, it is possible to reverse the polarity of that source to obtain rotation of the motor spindle in both directions.

The motor should preferably be powered by a supply other than that used by the electronic circuitry. When SW2 is closed, the relay is de-energized and reverse rotation is effected.

Diode (D1) removes any residual voltage that may still be present after pin 3 goes low, ensuring the relay completely switches off. Diode (D2) protects the 555 from the heavy back EMF generated by the coil when it switches off.

The method of switching off the motor at the end of the desired travel of the sliding plate is ingenious in its simplicity, and the writer makes no claims on its originality. The diagram has been drawn showing limit switch SW3 open and SW4 closed. Current can flow through D3, through the motor and return via SW4. As the slide starts its travel, a cam closes SW3, and for a short distance, both switches are closed. Towards the end of its travel, SW4 opens but SW3 remains closed. The switches are now reversed and the motor switches off.

It will remain off until the relay contacts change over when the reverse procedure applies. Current will flow through D4 and return via SW3.

The threaded shaft can be coupled to the motor spindle with a short piece of flexible plastic tubing, which will allow for any misalignment. As previously stated, the mechanical linkage connecting the slide with the boom gate is not discussed here, however, it could be something as simple as a pulley and cable attached to the slide to raise it, and a counter-weight on the boom to lower it.

Provision must be made for adjustment to the limit switches to obtain the desired travel. There is a range of micro-switches from which to choose. Most require only the smallest displacement of the plunger to actuate them.

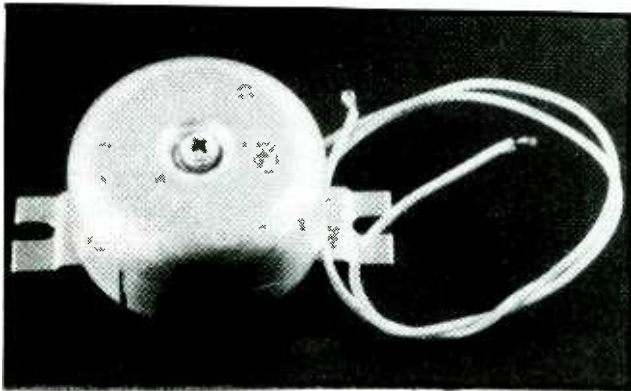
## Crossing Flashing Lights—Fig. 3

Yet again we employ a 555 IC as a reset/set flip flop. When SW2 is closed, it provides power from pin 3 to a second 555 module which is wired in the astable mode; in our case, a slow-running oscillator which alternately switches the two red LED's.

Components R6 and C1 determine the rate of flash, and those specified in the parts list appear to approximate (in scale) the real thing. If you wish to experiment with the frequency after construction of the circuit board, it is simpler to change just the capacitor.

By placing the reed switches at strategic positions along the track, i.e. SW2 before the crossing and SW1 after it, flashing will commence when the approaching train is 'half a mile' down the track, and cease when it has completely cleared the crossing.

If you can obtain a bell from an old telephone handset, it can be connected in parallel with R4 and L2 as shown dotted in the diagram, but first check that it is of the high impedance type—at least several kilohms. The unit tested was of the solenoid type with a reciprocating plunger inside a bell housing. Because it probably worked on 18 or 24 volts, it was not very loud, but by tipping the assembly at about 35 degrees from the horizontal, it produced an acceptable bell sound in conjunction with the flashing lights.



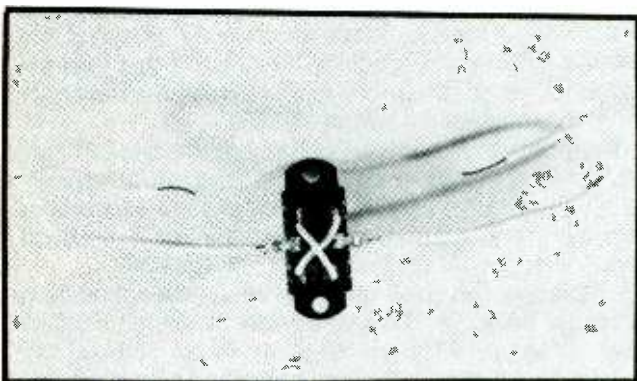
A bell sounder from an old telephone can provide the audible warning for boom gates.

#### Circuit Interfacing — Fig. 4

This simple little circuit is recommended for interfacing the electronic controls with current-thirsty equipment powered by its own heavy-duty supply. A small base current fed to the buffer transistor via the 4.7k Ohm resistor drives the relay, which in turn, switches on (or off) the required device.

It can be used to switch motors, solenoids or miniature incandescent lamps. It is not normally needed for 555 IC circuitry because a relay can be operated directly from the pin 3 output, provided the relay coil has a resistance above 60 Ohm, using a 12 volt supply.

The dotted (normally open) relay contacts connected across the transistor demonstrate the method of latching on the relay after the transistor switches off. To do this, of course, a double pole, double throw relay is required, i.e. two sets of contacts. The diode fitted across the relay protects the transistor. The transistor can be any general purpose type with a collector current of 100mA or more.



Cross-coupling a DPDT manual switch or relay to obtain reverse polarity.

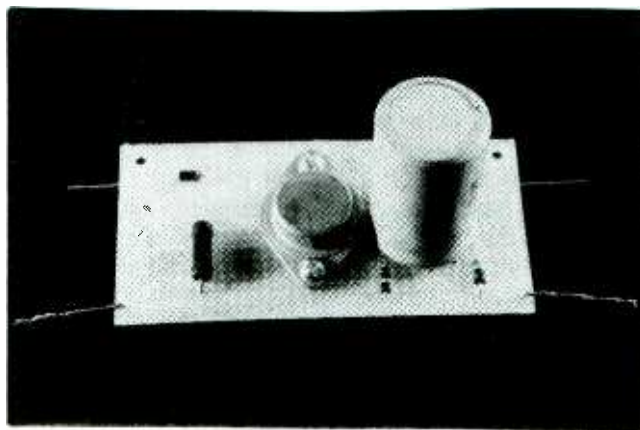
#### Capacitor Discharge points switching circuit—Fig. 5

With solenoid switches SW1 and SW2 open, the transistor switches on via D1 and R1. D1 provides the half-wave rectification to DC. Current flowing into capacitor C1 charges up and when fully charged, the LED glows to indicate that the unit is ready to operate the solenoids.

Now, when SW1 or SW2 is closed, a surge of current occurs as the capacitor discharges through the solenoid coil, so energizing it.

The direction the slug moves depends on which switch is pressed. If the switch is held closed for a prolonged period, current will continue to flow through the solenoid via R1, placing the transistor out of contention and preventing the capacitor from recharging.

Although most solenoids are very low impedance (several Ohms), R1 restricts current consumption to less than 40mA. When the solenoid switch opens, current immediately feeds the base of the transistor, once again charging the capacitor, ready for the next operation. Diodes D2 and D3 protect the circuit from the back EMF as described for previous circuits.



The capacitor discharge Points-switching unit built on a piece of insulation board. A heat sink is not required for the power transistor. Note the 1Watt resistor used in the base line.

#### Traffic Lights — Fig. 6

The three 555 timer modules are wired up in the monostable mode, otherwise, timing circuits. The R/C network of each (R3/C1, R6/C3 and R9/C5) determines their individual timing periods.

As each timer switches off, it initiates the time cycle of the next timer, and so on in an endless loop. This is achieved by connecting the set, or trigger pin (2) of each 555 to the output pin (3) of the preceding 555. In other words, at the end of a time period, pin 3 goes low, grounding pin 2 of the next timer, thus initiating its time period. It was seen in previous circuits that a negative-going pulse at pin 2 is necessary to produce an output at pin 3.

C2, C4 and C6 are small decoupling or blocking capacitors between each timer module. If any instability should occur, fit .01uF capacitors between Pin 5 and the ground line (not shown in diagram) of each 555.



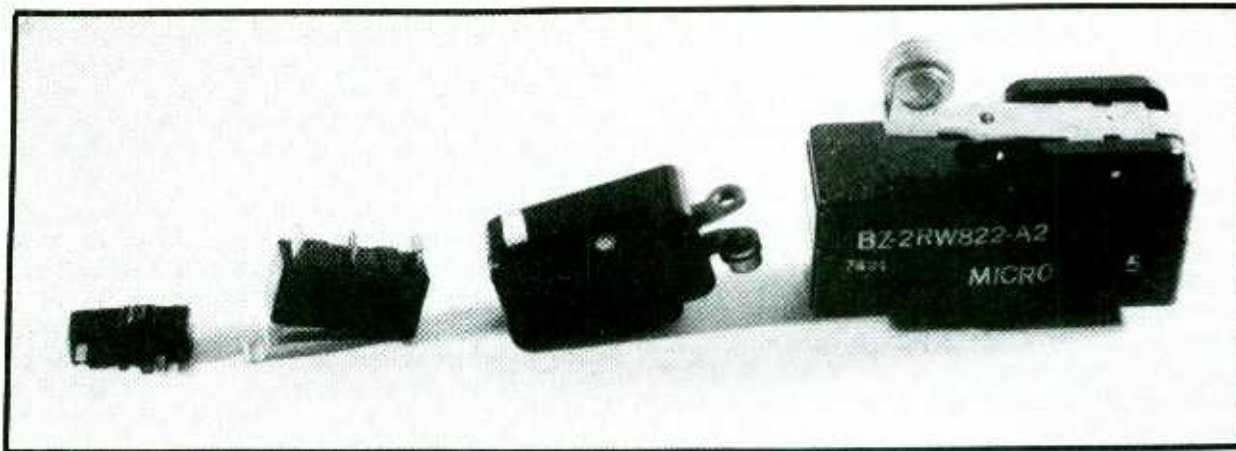


Photo showing various limit switch designs available for the boom gates.

The choice of timing capacitors is left to the constructor, but as a general guide, the formula is  $T = \frac{1.1RC}{1000}$ , where T = seconds, R = k Ohms and C = uF. Thus, a 100kOhm resistor and a 50uF capacitor will produce approximately 5.5 seconds.

#### Electronic Throttle— Fig. 7

The two transistors connected as shown comprise a Darlington pair, providing a very high current gain by virtue of the gain of each can be multiplied together. In this manner, only a tiny current fed to the base of Q1 via the 'throttle'— variable resistor VR1 is necessary to power up the train motors. R1 in the base is necessary to protect the transistor in the event of the 'pot' being turned to its minimum resistance.

During normal operation, the filament in the lamp (L1) is low resistance and the lamp remains cold. If, however, a short-circuit should occur, the lamp behaves rather like a non-linear variable resistor.

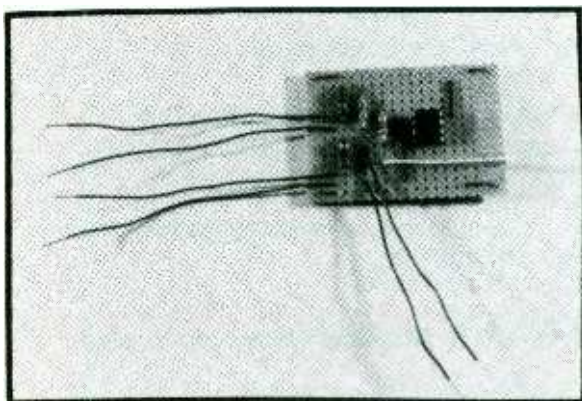


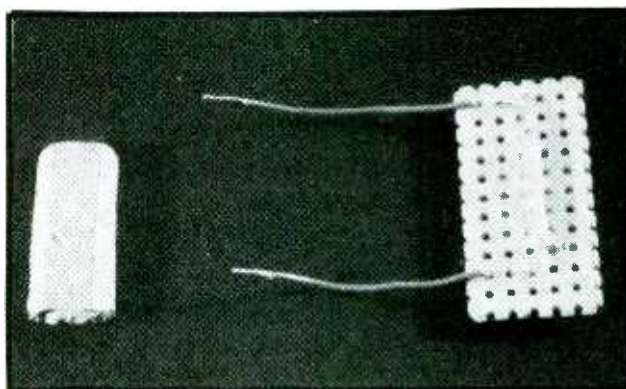
Photo shows a basic 555 flip flop module built on a piece of Perfboard (1½" x 2"). Only the R/C Circuitry need be added on the R/H side of the chip for a timer or oscillator.

When the current increases, the filament gets hot and its resistance increases accordingly, limiting the current to the transistor. The advantage of using this type of overload protection is that it gives visible warning of a malfunction when the filament glows. The lamp can be mounted on your control panel for convenience.

A 12 volt tail light from a car makes an ideal indicator.

but depending on your power requirements, it may be necessary to wire two in parallel. The worst that can happen is a blown lamp, resulting in an open-circuit.

SW1 is a DPDT cross-coupled three-way reversing switch, midway being the off position. The supply for this circuit can be a commercial train transformer/rectifier unit, or you can build your own as shown in the diagram.



A reed switch on a piece of Perfboard with an actuating magnet. Use an alligator clip as a heat sink when soldering wires to the reed switch.

Note the absence of smoothing capacitors after the rectifier. They are hardly necessary and it is often claimed that train motors and the like perform better on 'dirty DC.' The speed control potentiometer, by the way, must be of the linear type. You may also run other equipment from this power supply, providing they are wired in front of the throttle and the transformer is adequate to the task. The components called up in the parts list are intended for a 3 Amp supply.

A heat sink should be attached to the tab of the power transistor, ensuring that it doesn't come into contact with other parts of the circuitry.

#### Power Supply for Electronic Circuitry— Fig. 8

This power supply is full-wave rectified, smoothed and regulated for 12 volts at 1 Amp. It should cater for all the circuits included in this article, subject to, of course, the number of signals, flashing lights, etc, installed. For larger railroad layouts you might need a heavier transformer and regulator, for example, the volt-adjustable LM350 version.

## Other considerations

A model railroad is distinguishable from a train set when it has spur lines, sidings, sections of track that can be isolated from the power supply, and two or more trains running at the same time.

These embellishments usually involve more than one power pack, remote manual switching and yards of connecting wire, and as such, involve work of an electrical nature which we will not delve into here.

If your system lacks some or all of the above, here is a simple little electronic circuit that will go a long way to upgrading it: a device that stops your train at a station, waits for a short period of time, then moves off—automatically. See Fig. 9.

SW1 is a reed switch fitted between the rails. A train passing over it charges up capacitor C1. It then begins a slow discharge through the Darlington pair, switching them on and energizing the relay. The rate of discharge is governed by the values of the capacitor and the combined resistance of VR1 and R1. As a guide, a 22uF capacitor and a resistance of 100kOhm will provide a time delay of around half-a-minute, keeping in mind the voltage can drop to as much as two volts before the relay contacts 'drop out'.

The normally-closed set of relay contacts are wired into the feeder wires from the throttle so that when the relay is energized, they open, cutting off power to the track. If you are operating more than one train, you will need to break the track into sections (or blocks), using plastic rail joiners to isolate each section. These are available from hobby stores. You will also need a time delay unit for each stopping place.

The Darlington pair ensure sufficient gain when VR1 is set at a high resistance. The reed switch should be positioned along the track where it will cut the power at the right time for the train to come to a halt at the desired stopping place. You, the engine driver, will adjust the throttle, bringing the train expertly into the station, yard, etc.

Note the absence of a protective diode across the relay. The gradual current decay in the relay coil obviates the need for one due to the insignificant transient generated.

### A few pointers

1. When constructing the circuit boards, the importance of correct orientation of transistors, diodes and electrolytic capacitors cannot be overstressed. Imagine the consequences if, say, a protective diode were to be fitted the wrong way round. And large capacitors have been known to go off like hand-grenades!

2. Fit 0.01uF capacitors to pin 5 and ground of 555 IC's if instability should occur. Normally, they are not necessary.

3. Reed switches are normally fast-acting and sensitive to a moving magnet within about 1/4 inch of it. If you do encounter problems when a train is moving at fairly high speed, two magnets in line can be fitted to the underside of the train to ensure satisfactory closure of the switch. Use only the magnets intended for reed switch operation.

4. 555 modules can be made up on separate boards,

or built on one large one. Separate boards allow greater flexibility for later modifications, if required. The values of capacitors, resistors, etc specified in the parts lists are by no means mandatory. They only indicate their suitability. For example, the current limiting resistors for the LED's could be 1kOhm. You may lose a little brilliance but you economize on current consumption. Too often, newcomers to the hobby rush off to the nearest electronics dealer for the exact item when a substitute in the junk-box could do the job!

5. A heat sink is not required for the power transistor in the capacitor discharge project but it is for the electronic throttle. Since the tab of this transistor is connected to the positive rail, the heat sink must not touch any other part of the circuitry. ■

### Parts List for Traffic Lights

IC1, IC2, IC3 — 555 Timer IC (not CMOS type)  
R1, R4, R7 — 22k Ohm resistor 1/4W  
R3, R6, R9 — 100k Ohm resistor 1/4W (or as req'd)  
R2, R5, R8 — 470 Ohm resistor 1/4W  
C1, C3, C5 — Elect. capacitor 25V (see text)  
C2, C4, C6 — 0.001 or 0.002uF capacitors  
L1 — Red LED  
L2 — Green LED  
L3 — Yellow LED

### Parts List for Electronic Throttle

T1 — Transformer 110/12V secondary, 2A  
D1, D2, D3, D4 — IN5404 diodes 3A (or similar)  
VR1 — 2.2k Ohm linear Pot. (Var. resistor)  
R1 — 2.7k Ohm resistor 1/4W  
Q1 — 2N2222 NPN Transistor  
Q2 — TIP3055 Power transistor and heat sink  
L1 — 25-35W 12V tail lamp or similar (see text)  
SW1 — DPDT — 3 way (center off) switch

### Parts List for Power Supply for Electronic Circuitry

T1 — Transformer 110/15V secondary 1A  
D1, D2, D3, D4 — IN4002 Diodes  
7812 Voltage regulator  
C1 — 1000uF Elect. capacitor 25V  
C2 — 0.22uF capacitor

### Parts List for Automatic Time Delay Unit

Q1, Q2 — 2N3904, 2N2222, etc NPN Transistor  
VR1 — 100k Ohm linear Pot. (Var. resistor)  
R1 — 47k Ohm resistor 1/4W  
C1 — 22uF Elect. capacitor 25V (or greater as req'd)  
SW1 — Reed switch  
RL1 — 12V SPDT relay

### Parts List for Signaling System (one module)

IC1 — 555 Timer IC (not CMOS type)  
R1, R2 — 470 Ohm resistor 1/4W  
R3, R4 — 22kOhm resistor 1/4W  
L1 — Green LED  
L2 — Red LED  
SW1 — Reed switch

### Parts List for Boom Gate circuitry

IC1 — 555 Timer IC (not CMOS type)  
R1, R2 — 22k Ohm resistor 1/4W  
D1, D2, D3, D4 — IN4002 diodes  
SW1, SW2 — Reed or push-button switches N.O.  
RL1 — 12V DPDT Relay  
SW3, SW4 — Micro-switches, as req'd

### Parts List for Crossing Flashing Lights

IC1, IC2—555 Timer IC (not CMOS type)  
R1, R2—22k Ohm resistor 1/4W  
R3, R4—470 Ohm resistor 1/4  
R5—10k Ohm resistor 1/4W  
R6—100k Ohm resistor 1/4W  
C1—3.3uF Elect. capacitor (or as req'd)25V  
L1, L2—Red LED's  
SW1, SW2—Reed or push-button switches N.O.

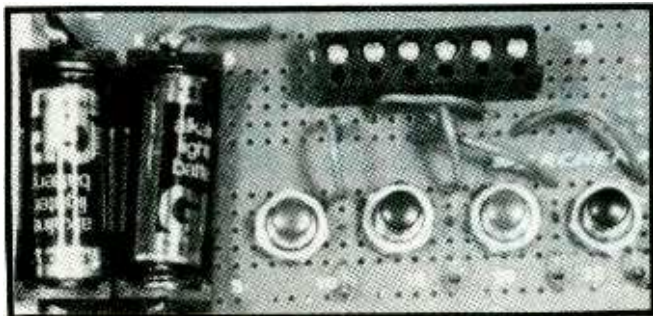
### Parts List for Capacitor Discharge Points Switching Circuit

T1—Transformer 110/15V secondary, 2A.  
Q1—2N3055 Power Transistor  
D1, D2, D3—1N4002 diodes  
R1—470 Ohm resistor 1W  
R2—470 Ohm 1/4W  
L1—Red LED  
C1—2200uF Elect. capacitor 25V  
SW1, SW2—Push-button switch  
S1—Switching machine

(Continued from page 24)

## INTRODUCTION TO STEPPER MOTORS

If the stepper motor moves slightly and quivers back and forth, chances are the batteries are too weak to power the motor, replace them with fresh batteries. The batteries do wear out pretty quick. This problem can be solved by modifying your existing circuit board to use line voltage with a step-down transformer, rectifier and capacitor.



Going Further

There are a number of dedicated integrated circuits available for powering and controlling stepper motors.

### SUPPLIER INDEX

IM-Step 3.75	Stepper Motor 6 wire postage	\$10.00 \$ 2.50
--------------	------------------------------	--------------------

Available from:  
Images Company  
P.O. Box 140742  
Staten Island, NY 10314-0024

### PARTS LIST

D1-D4 1N914 Diode  
PC Board Terminals Stackable  
S1-S4 Momentary push switch (4/pak)  
Battery holder  
Battery  
PC Board

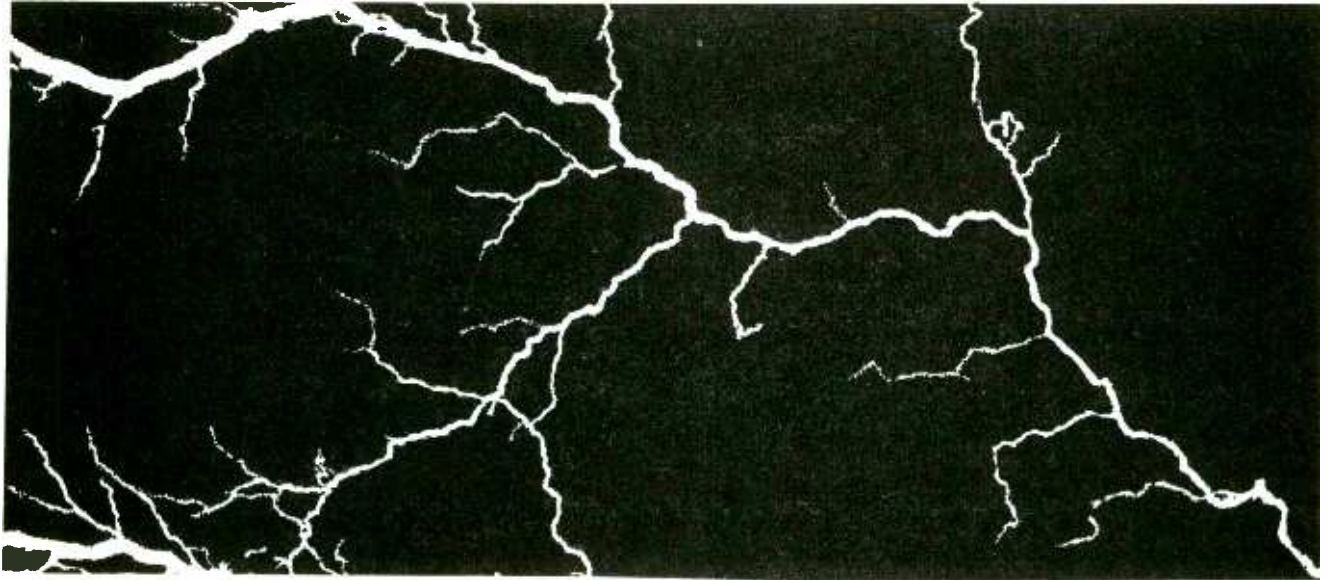
### RADIO SHACK

RS#276-1620  
RS#276-1388  
RS#275-1547c  
RS#270-405  
RS#23-144  
RS#276-170

RS = Radio Shack (local)

### PARTS LIST FOR THE TELEPHONE BUG DETECTOR (PAGE 85) VOLUME #14

D1-D4—1N4004, 1 Amp rectifier diodes  
D5—Red, 1/4" LED  
IC1—741 OpAmp  
R1—100K Ohm, 1/4 Watt, 20% resistor  
R2—4.7K Ohm, 1/4 Watt, 20% resistor  
R3—50K Ohm, multiturn trimpot  
R4—820 Ohm, 1/4 Watt, resistor  
Miscellaneous—Project box, 9 volt battery clip, modular phone cord with male and female terminals, 8 pin IC socket.



# **UNDERSTANDING ELECTRICITY**

**By Ron C. Johnson, C.E.T.**

## **PART VII**

**We said in the last issue that we were going to talk about magnetics this time. And possibly you are all wondering why we would want to know about magnetics for basic electricity. As my students often tell me, they wonder even more after they have wallowed around in this stuff for a while. It's true: magnetism and electromagnetism is a "cat's breakfast" of new terms, formulas and relationships (most of them non-linear) which can be confusing. On the other hand, an understanding of this area is not only useful, but necessary to make sense out of stuff like: inductors, relays, motors, tape recorders.. The list goes on.**

**So we are going to take a run at it on a non-mathematical basis. And if the new terms start to come at you too fast and furious just kick back and imagine yourself listening to one of those foreign language instructional tapes with surf in the background. If it puts you to sleep I want to know.**

**Maybe I'll market it...**

## THE MAGNETIC FIELD

To start with we are not going to try to explain what magnetism is in its most fundamental form. Call it one of those mysteries of the universe that only Phd's and people confined to institutions truly understand. For our purposes we want to know the *how* more than the *why*.

All of us are familiar with those strange new life-forms which appear out of nowhere and then multiply on the doors of our refrigerators. Yes, the fridge magnet beings have insinuated themselves into the very fabric of our homes, attaching themselves to our appliances under the guise of grocery list holders, real estate advertisements and kindergarten crafts... What? Ah, yes...the magnetic field. Back to business.

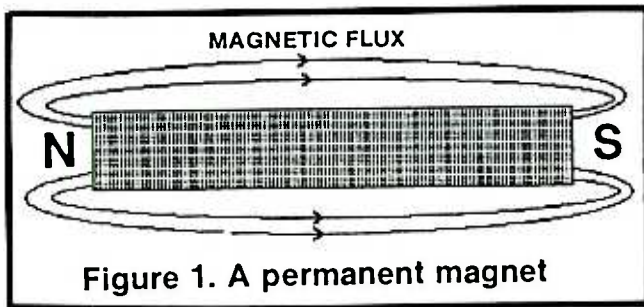


Figure 1. A permanent magnet

As I said, we are all familiar with magnetism from its various household uses and no doubt we have all played with magnets enough to have a first-hand knowledge of how they are attracted to objects with iron in them. We have also seen how bringing two magnets together will cause either attraction or repulsion depending on how they are oriented with respect of each other. Figure 1 shows a bar magnet with a set of lines (with arrows) extending out of one end and re-entering the other end. These lines are called lines of flux. You will notice that the lines of flux exit the end labelled N (for North) and re-enter the end labelled S (for South). The reason the ends, or poles, of the magnet are labelled North and South is that if the magnet were suspended freely the end labelled N would orient itself toward the magnetic North Pole of the earth (like a compass). The same force that causes this is the force that causes the attraction or repulsion between two magnets. When a North and a South pole are brought together they attract; when two North's or two South's are brought together they repel.

Yes, I know that this is nothing new to most of you but the basics bear repeating before we launch into the other good stuff. And there really is an application here: The magnets we are used to seeing are natural or synthetic magnets which are relatively weak. Also, we don't have much control over them other than moving them physically closer or farther away from an object. But if we could control those lines of flux (and the magnetic force that they produce) with electricity, we would be able to build a number of useful things such as: meter movements, relays, breakers, solenoids, motors, etc. (Love that word "etc." It covers a whole range of things I can't remember.)

Okay, let's look at Electromagnetism. First a history lesson:

### History and yer Right Hand Rule

In 1820, the Danish physicist Hans Christian Oersted discovered (history always starts out the same way, doesn't it?) that the needle of a compass would deflect if brought near a current-carrying conductor. This proved that electricity and magnetism are related. Actually, what Hans proved was that a magnetic field always occurs in conjunction with current flow. The magnetic flux (same as the lines around a magnet) form concentric rings around the conductor and we can predict the direction of the lines (remember the arrows on the bar magnet lines of flux) by using the "good ol' basic" Right Hand Rule.

The Right Hand Rule is simple. If you were to imagine yourself holding a current carrying conductor in your right hand with your thumb pointing in the direction of conventional current flow (opposite of electron flow, remember), the rest of your fingers point in the direction of the lines of flux as they curve around the conductor. (See Figure 2a)

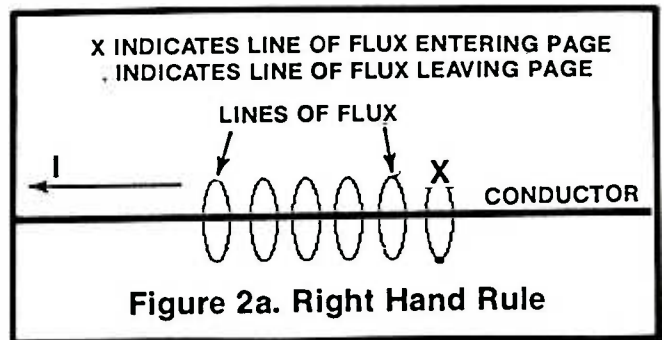


Figure 2a. Right Hand Rule

So that means that any conductor with current flowing through it will produce a magnetic field.

Is that important?

Actually, the strength of the field is small in most cases but there is a way of putting that field to use and making it more powerful. Take a look at Figure 2b. At

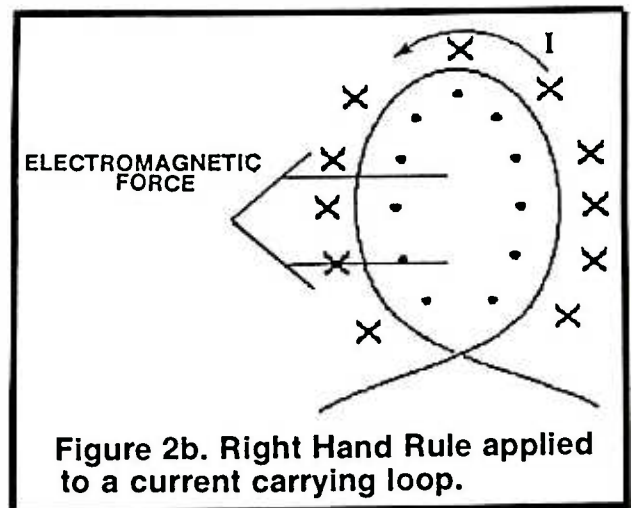
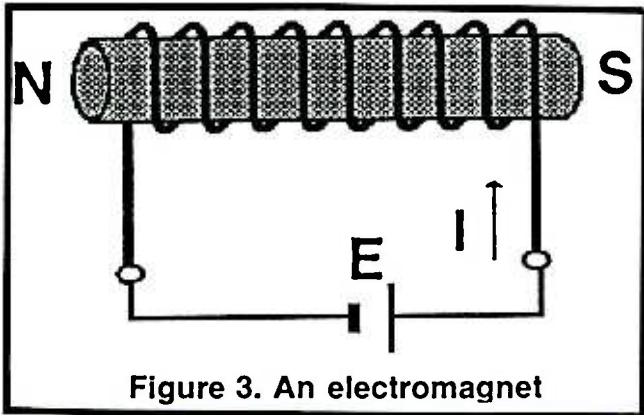


Figure 2b. Right Hand Rule applied to a current carrying loop.

this point we have to start imagining what is happening in three dimensions. Let's use the convention that an "x" indicates a line of flux entering

the page from above. A dot, “.”, indicates a line of flux exiting the page. Figure 2b shows a loop of wire with current flowing through it. If we use the Right Hand Rule to determine the direction of the lines of flux and try to visualize it in three dimensions we will find that the lines from one side of the loop point in the same direction as the lines from the other side of the loop. This causes the lines of flux to be concentrated in the middle of the loop. If we were to add several more loops all the lines would reinforce each other increasing the strength of the magnetic field.



**Figure 3. An electromagnet**

That's what we have done in Figure 3. Not only have we used several turns of current carrying wire (supplied by the battery), but we have added a "core." The core is a ferrous material which concentrates the lines of flux. This increases what we call the "flux density" because there are more lines of flux in a smaller space. Up to a certain point increasing the flux density increases the "field strength" of the electromagnet, in other words making it a stronger magnet.

### SOME APPLICATIONS

Before we get into the nitty-gritty of all this, let's look at what it means in practical terms. As I said before, a single conductor with current flowing which creates a magnetic field around it doesn't accomplish much for us. But when we wind a number of turns of wire on a ferrous core and run current through we now have a fairly strong magnetic force produced. Have you ever seen those electromagnets used in junk yards for moving wrecked cars around? That gives an idea of the amount of force that can be produced with an electromagnet. But we have lots of good examples closer to home.

Electric door latches used for security locks in apartment buildings are electromagnets. Normally a spring latching mechanism keeps the latch locked but when the button is pushed in the apartment current flows through the coil of an electromagnet in the latch pulling back a metal bolt which allows the door to be opened. For those of you who have experimented with relays the application is similar: The electromagnet, when energized, pulls in a metal linkage that forces the contacts together (or apart in some cases) positioning the relay contacts in the energized condition. (When you hear the term "normal" as in "normally open contacts" this means that the relay coil is not energized and the contacts are either open or closed when the relay is at rest.)

Another application for electromagnets is solenoid valves. They are used in common household appliances like your dishwasher to control the water. A valve is controlled by an electromagnet moving a ferrous plunger in or out of position. In this case the ferrous core of the electromagnet is not fixed in place but moves within the winding of the electromagnet when the line of flux acts on it.

Enough of that. Let's look at some of the characteristics of the electromagnetic field and how we use them. As I said before, there are lots of new terms.

### Outstanding in yer Magnetic Field

We said that magnetic force, (which we call magnetomotive force, similar to electric force called electromotive force), is developed by winding a current carrier around a core. The amount of magnetomotive force (mmf), then, is determined by the number of turns, (N) and the amount of current flowing, (I). Increase either and the mmf increases. The symbol is F, and the units are ampere-turns.

$$F = N \times I$$

In magnetic circuits the lines of flux are analogous to current in an electric circuit. Flux is symbolized by  $\Phi$ , (phi) and has the unit, Webers. (Don't ask me why, I jus' does as I's tol'.) Again, I said that by choosing a ferrous core we could concentrate the flux. This is because various materials have different abilities to set up magnetic lines of force. This ability is called permeance, (p) and the units are Henrys. Quite often we use the reciprocal of permeance instead, which is called reluctance. We would have to define reluctance then as the opposition to the setting up of magnetic lines of flux. Compare that to resistance in electric circuits. Reluctance is symbolized by R and is usually expressed in "per Henrys." (In other words the reciprocal of Henrys)

Keep in mind that I warned you! And it gets worse. Take a deep breath...

So permeance and reluctance are reciprocals. Believe it or not, so are permeability and reluctivity, but don't worry, we don't use these much. If you are interested, reluctivity is the magnetic equivalent to resistivity (in electricity) that we talked about way back when in the first article of this series. Resistivity, we said, was the characteristic of a material that determined how well it conducted electricity, and hence, determined the resistance of a particular shape and size of the material. Well, reluctivity is the characteristic of a material which determines how well it sets up lines of flux and hence, the reluctance or a given piece of that material. In this case we most often use permeability, the reciprocal of reluctivity, which is symbolized,  $\mu$ , and has the units, Henry/metre.

Now that we have looked at flux and reluctance we can backtrack and look at how they relate to magnetomotive force. We know about Ohm's Law from electricity; here is its equivalent in magnetics: Ampere's Circuital Law.

Ampere's Circuital Law says that magnetomotive force equals the magnetic flux, ( $\Phi$ ), times the reluctance of the material, (R) or:

$$F = \Phi \times R$$

This operates in the same way as Ohm's Law. For various materials in a magnetic circuit (which have different reluctances), the amount of flux present in that section times the reluctance will give the magnetomotive force developed across that section. The same relationships we talked about with respect to Kirchhoff's Voltage Law around a loop apply around a magnetic loop and series and parallel principles apply in the same way. (Figure 4)

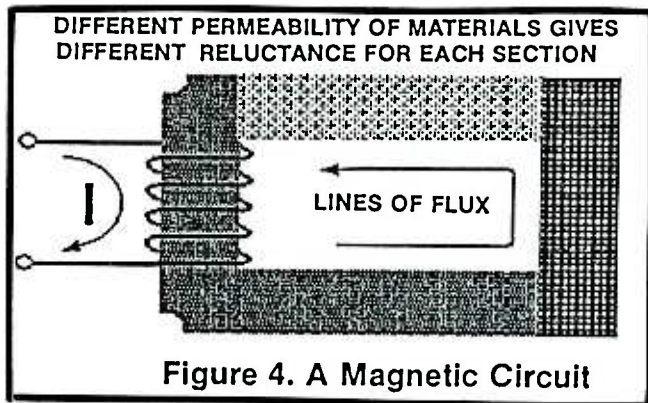


Figure 4. A Magnetic Circuit

Not that it matters...

Actually, you won't find hobbyists, technicians, technologists or even very many engineers use this stuff quantitatively in practical applications. Designing transformers or other special magnetic equipment would require it, but usually we just buy that kind of thing with ready-made specifications available. Even so, the concepts are interesting and help to understand what is going on. In fact, as we continue, we'll see how they help us understand some very practical applications.

Coffee's over. Back to work.

### Magnetic Field Strength

We all know that when we move a magnet closer to a ferrous object the pull is greater than when it is farther away. How strong the force of that "pull" is can be expressed as magnetic field strength (or intensity) and is symbolized, H, with units, Oersteds. (Well, they had to name *something* after the guy.) It is determined by the magnetomotive force, (F) divided by the distance, (l).

$$H = F/l$$

Another important variable in magnetics is called magnetic field density or flux density, (B), given in Teslas. (Some other guy who, incidentally, also liked to play with high voltage.) Basically, flux density is the number of magnetic lines of force per unit area, (A). (If you go back and sort through some of the previous stuff, you would find that the number of lines of flux is determined by the magnetomotive force and the reluctance of the material.) So the formula is:

$$B = \Phi/A$$

Okay! believe it or not, we're going to tie this all together now.

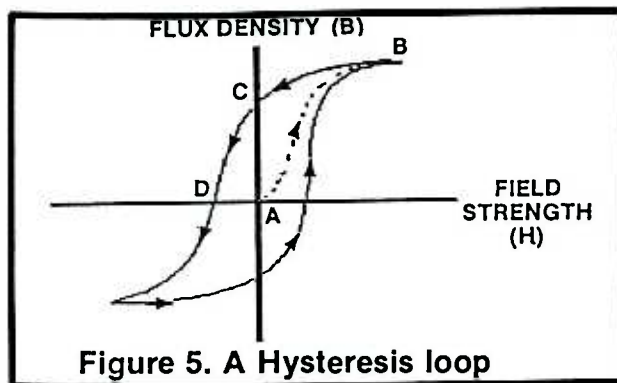


Figure 5. A Hysteresis loop

Figure 5 shows a graph called a Hysteresis Loop where the vertical axis is labelled B for flux density and the horizontal axis is labelled H for field strength. An interesting thing happens when you use an electromagnet to magnetize a ferromagnetic material: To begin with, before any current flows through the coil, there is no magnetic field strength present and so no flux density (point A). As current is applied field strength is created by the electromagnetic field set up and this causes a certain flux density to be present in the ferromagnetic material (this material could be the core of the electromagnet or adjacent but within the field). As the field strength (H) is increased eventually the flux density levels off and even though H is increased B will stay the same. (Point B) This is called flux saturation.

Now let's start to reduce the current through the coil (and hence the field intensity). The arrows in Figure 5 show that the flux density does not follow the same path back to zero. In fact, when the field strength is zero, B is still quite high. (Point C). Why would this be?

Of course, you have magnetized the material and even though there is no electromagnetic force acting on it, it still retains some flux at the density shown. If we were to reverse the polarity of the current through the coil and force the field intensity to be set up in the opposite direction eventually we could bring the flux density down to zero. (Point D). Continuing on, we could eventually reach a saturated point in the other direction.

What's it all about?

We've just invented core memory! We'll be rich! All we have to do is...

That's what core memory was about: thousands of tiny ferrous toroids with coils through them which would magnetize them in one direction when a pulse of current was supplied. After the power was removed they retained their magnetism. Non-volatile memory. (As long as nobody got silly with a magnet in the vicinity.)

And that's magnetism. Sort of. It actually gets pretty complex when we look at how electromagnetism is used to create electric motors because not only do we have to consider three dimensional vectors but alternating voltages, currents and phase angles come into it as well.

Maybe we'll look at it in another article.

Meanwhile, hopefully this will help understand the basic concepts without losing you in the jungle of terms. Next time we look at inductors... ■

# WORKBENCH PROJECTS



**Reading about electronics can be fun and instructive, but the only way to become a knowledgeable technician is to get hands-on experience, by actually connecting resistors and capacitors together in circuits that do something. These circuits can be as simple as turning a light on or off, or making some kind of alarm sound. As long as we have a power source and a load connected together by wires, we have a functioning circuit.**

**Another way to think about circuits is to consider one part as the input and another part as the output, This is notably true of amplifiers. You will note that the projects in this section usually “do something,” that is, they accomplish some useful purpose. With a little experimentation and/or expansion, you may be able to find other uses for these circuits. If you study them and put several combinations together, you will increase your understanding of how all electronic components and circuits work.**

## CIRCUIT TEST ADAPTER

When you build a circuit it would be nice to know if it will work before you plug it in to the 110 VAC power.

No matter how careful you may be, there could still be problems. For your protection and also for the protection of the circuit, it would be wise to plug it in to this device first. Another feature of this device is its ability to test shorted equipment. X3 allows about  $\frac{3}{4}$  Amp of current maximum, and will drive into a dead short without exceeding that current. This allows the troubleshooting of shorted circuits with power on them. When the short is found and cleared, the adapter can be switched to normal power.

Each component used has a specific function. Fuse (F1) protects from overloads and should be easily accessible so it can be changed to match the instrument under test. Range for F1 is from 1 to 12

amperes.

R1-X1 monitor the fuse and indicate if it blows, with R2 acting as a load to complete the indicator circuit. S1 is the switch for normal power, and S2 is a pushbutton with momentary contacts, to give only a few seconds of power. X3-S3 are used for shorted circuits, or current-limited testing. C1, L1, and M1 function as an RF suppressor and spike suppressor, and L1 limits current changes and sets a high limit on output current.

R3-X2 serve to indicate the presence of power on the output.

### Construction:

This device should be built in a box large enough to allow air flow around X3, as this bulb runs HOT. Vents above the bulb and at the bottom of the box are appropriate. R1-X1 and R3-X2 could be neon



## CIRCUIT TEST ADAPTER

light assemblies, to facilitate construction. R2, C1, L1 and M1 could be mounted on a small PC board or perfboard, or tie strips could be used. X3 should be in a standard Edison socket to allow it to be changed for different output currents:

LAMP WATTS	APPROX. CURRENT
7	.05 Ampere
15	.1 Ampere
26	.2 Ampere
40	.3 Ampere
60	.5 Ampere
75	.6 Ampere
100	.8 Ampere

Always use the bulb that will not allow the circuit to receive too much current:

### Using The Adapter

First, plug the adapter into the 110 VAC power. Next, with all switches off, plug in the device to be

tested. Then, push S2 on for an instant. If the fuse doesn't blow, try it on longer. If still ok, then switch S1 to on. If the power remains on after that, the device under test is OK.

Should the fuse blow at any time during the test procedure, turn on S3 after the fuse is replaced. Lightbulb X3 will restrict current so you can trace the circuit and find the short. ■

### PARTS LIST: FOR THE CIRCUIT TEST ADAPTER

R1-X1, R3-X2 — Neon light assemblies.

R2 — 100K Ohm, 1/2 watt resistor

C1 — .01 Mfd, 2000 WVDC capacitor

M1 — MOV for 110 Volt AC, 80 Joules

S1, 3 — SPST switches

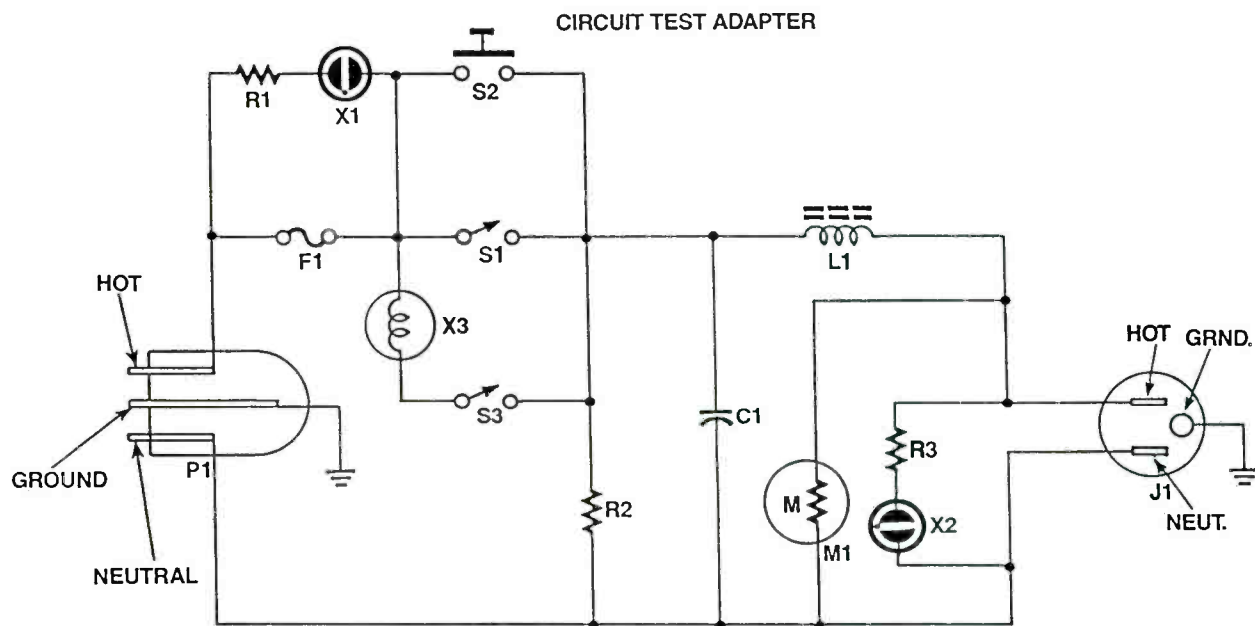
S2 — Normally open pushbutton

F1 — Fuse/fuseholder: Range of 1-12 Amps

P1, J1 — 110 VAC power plug and receptacle

L1 — 22 turns #16 wire on 1" diameter core.

Misc: — Wire, solder, box, socket for X3



## BATTERY SAVER ALARM SYSTEM

Most electronic devices draw power even in standby, more power than this circuit. With the alarm in the armed mode, the draw will be in the nanoampere range!

Another big advantage of this circuit is physical size. It can be assembled on a 1"×2" piece of perfboard. Most batteries are as big or bigger than this circuit.

Operating voltage is another benefit of this circuit. From 5 to 15 volts DC, it functions properly with no change of components. In fact, Q1 could be almost any small NPN transistor that will switch on and stay on with an open in the normally closed loop.

Similarly, Q2, the SCR, can be any SCR from 1 Amp up with at least 100 PIV, that will gate in the circuit. Many 4 and 8 Amp units will work. Even some higher current units will work. Connect a relay, whose coil voltage equals the supply voltage, to the output and you can control whatever you want, even contactors for large motors.

Do not view this as only an alarm circuit. It can be used as a control circuit, with microswitches or other contacts as sensors and a motor, contactor, relay, etc as the output load. This circuit lends itself to being used as a zone in a multizone system. As each zone draws only a small amount of power, many zones

## BATTERY SAVER ALARM SYSTEM

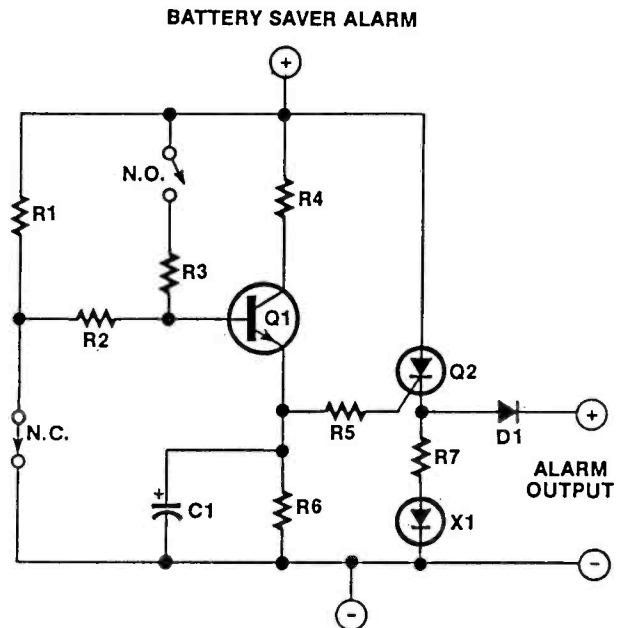
could be used on a small power source. The only limiting factor is horn power requirements.

This circuit is ideal for small self-contained systems for such things as cabinets, toolcases, and luggage.

Several tiny sonalert type buzzers are available for use with this type alarm. ■

### PARTS LIST FOR THE BATTERY SAVER ALARM

- R1—1 Megohm resistor, ¼ watt
- R2, 3, 6—10K Ohm resistor
- R4—1K Ohms resistor
- R5—100 Ohms resistor
- R7—390 Ohms resistor
- C1—10 Mfd, 35 WVDC, capacitor
- D1—1N4004 Diode
- Q1—2N3904 Transistor
- Q2—SCR 1 Amp @ 100 PIV minimum
- X1—LED



## MINI MOTOR CONTROL

Hobby motors and small toy motors are made to run full speed. However, some uses for these motors may involve running them slower. This small circuit will do just that.

A motor that operates from 3 to 12 volts with a current of 2 Amps or less can be controlled by this unit. A heat sink is recommended for Q1 since it will get hot at slow speeds.

The resistor values given are good, but you might want to adjust them for optimum performance with the voltage and the motor of your choice.

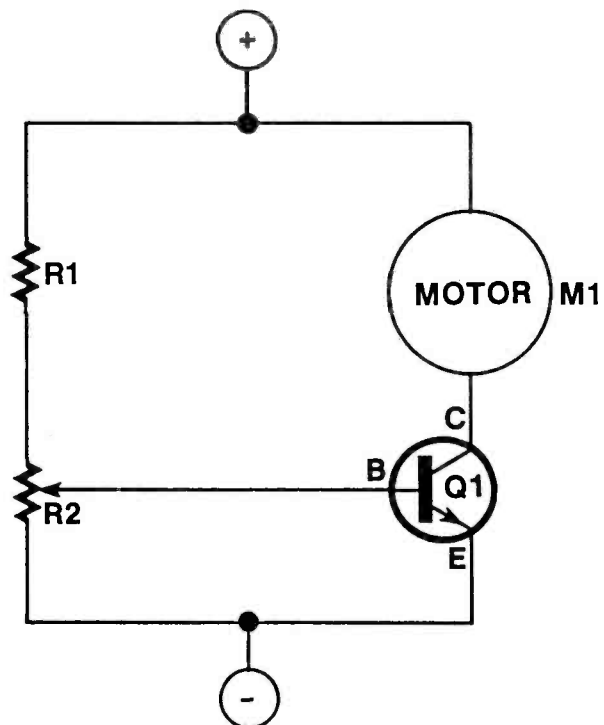
Operation of the motor control is simple. R1 and R2 are a voltage divider. R1 limits the power available to R2 so an excess bias can not be applied to Q1. R2 sets the bias on Q1, from cutoff to saturation, and should be a linear taper potentiometer.

Q1 controls the motor by increasing the power available to it or decreasing according to its base bias from R2.

Now you can make them fast or slow without wasting power in a big reostat.

### PARTS LIST FOR THE MINI MOTOR CONTROL

- R1—330 Ohm ½ watt resistor
- R2—5K Ohm potentiometer
- Q1—TIP 3055 Transistor
- M—Motor, see text



# HIGH-IMPEDANCE BUFFER

There are times when the signal you want to use has just too much impedance to be hooked up to an ordinary audio amplifier. The signal coming from a crystal radio is one example. This simple circuit is called a "Bootstrapped Darlington Emitter Follower" and has an input impedance of about 20 Megaohms.

With their collectors tied together, transistors Q1 and Q2 form a Darlington transistor with the emitter of Q1 feeding the base of Q2. The total current gain, beta, of the two transistors is now  $B1 \times B2$ . So if each transistor has a gain of 100, then the total current gain is now  $100 \times 100 = 10,000$ .

The audio input is fed to the circuit via decoupling capacitor C1. The signal goes straight to the base of transistor Q1 and is immediately processed.

The DC bias is set up through resistors R1 to R3. The initial voltage at the base of Q1 is set up by the potential divider of R1 and R2, while R3 provides DC isolation. This resistor plays a vitally important role as we shall see in a moment.

The emitter resistor (R4) is the load resistor and the output is taken from here. The output signal is also coupled back to the DC voltage divider.

The circuit has no voltage gain since we are using a current gain configuration i.e. the emitter follower. So, effectively, the same voltage that appears at the base also appears at the emitter.

Now with capacitor (C2) coupling this signal back to the voltage divider, you can see that both sides of resis-

tor R3 have the same AC voltage, i.e. whatever appears from the input also appears at the voltage divider end of R3.

This raises the input impedance of the circuit enormously, to the value of  $R4 \times$  the gain of the two transistors. If the beta of the two transistors is 10,000 as above, and we have a value of 100 kilohms for R4, then the input impedance becomes 1,000 Megaohms.

However this is theory only. Because of leakage currents through the capacitors and the transistor, this value drops to around 20 Megaohms, but this is still much higher than can be obtained through normal transistor circuits.

## Construction

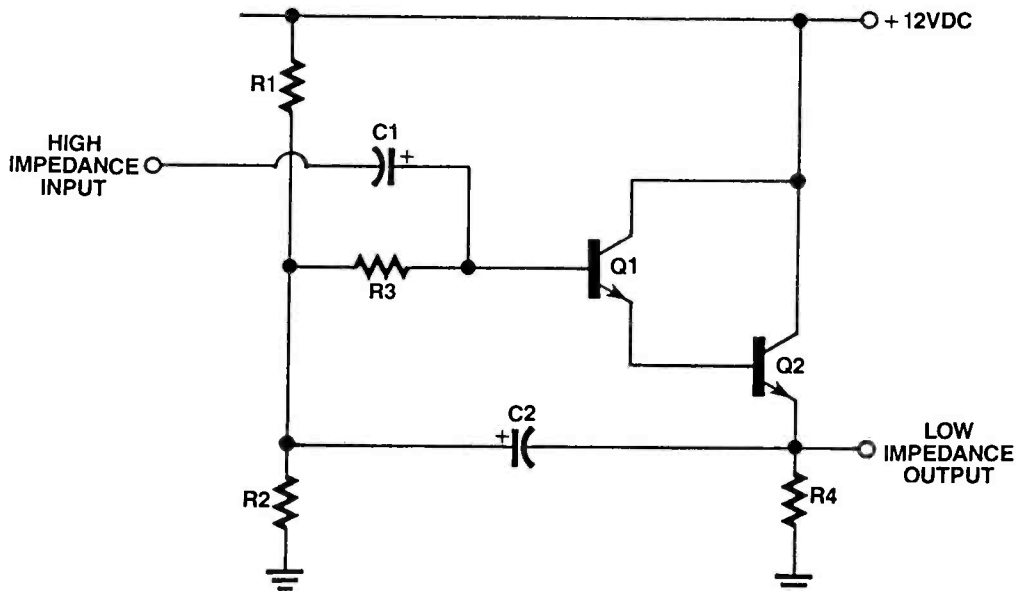
The important thing here is to use transistors that have a beta value of at least 100. Also keep the component leads as short as possible otherwise, in some cases, the circuit will pick up radio frequency signals and amplify them as well.

Note that this circuit is not a voltage amplifier but a power amplifier. The circuit produces the same output voltage as the input voltage but the output impedance is much, much lower than the input impedance. i.e. 20M to 10K. So we have amplified the current, rather than voltage.

With this lower output impedance, the signal can then be taken to any ordinary audio amplifier such as your stereo or to an OpAmp preamplifier etc. ■

## PARTS LIST FOR THE HIGH-IMPEDANCE BUFFER

- C1, C2—4.7uF, 16VW electrolytic capacitors
- Q1, Q2—Any small signal NPN transistor with beta = 100 (2N2222 or Equiv.)
- R1-R3—100K, 0.25W, 5% resistor
- R4—10K, 0.25W, 5% resistor



# THE ELECTRONIC CRICKET

Every now and then, it's great to have a project that is a little less serious and a lot more fun. This project fits this perfectly. It uses just four transistors and can be put together in only an hour or two.

It can be called the Electronic Cricket or just about anything else you like. As soon as the power is applied, it begins making the repetitive chirp of a cricket.

The project can be made as small as you like. You can then hide it in an inconspicuous spot. The sound carries so that it's difficult to find its location.

Let's take a look at how the circuit works. If you look closely, you can see that it consists of two transistor multivibrators. The first is made up of transistors Q1 and Q2 and the second is made of transistors Q3 and Q4.

The difference here is that the second multivibrator is driven by the first. This can be seen from the fact that the emitters of transistors Q3 and Q4 are switched in and out of circuit by transistor Q2.

Now we'll look at the function of both multivibrators. If we look at the first multivibrator, it has two timing capacitors—a 470uF and a 100uF electrolytic capacitor. These produce the time delay between chirps so that there appears to be some "dead time" ie, time where there is no sound at all. This is important to make it sound realistic.

The way this works is that because the two capacitors are different in value, one transistor will switch on longer than the other and the way the circuit is connected, this will be transistor Q1. In fact, it will be on for about 80% of the time. This also means that transistor Q2 will only be on for about 20%. When Q2 is on, this switches in the other half of the circuit.

Transistors Q3 and Q4 are set up to make the chirping sound. Again we have two unbalanced timing capacitors—a 4.7uF and a 0.1uF capacitor. This

## Construction

This project is very easy to construct because it doesn't use any "easy-to-blow-up" components. You can put it together using perfboard or the European style VEROboard—whatever you use, the only thing is to make sure you don't use too much solder and make sure every contact is secure.

It produces an audio oscillator that has a very narrow duty cycle i.e. the output is "low" for much longer than it is "high," and this sound is very much like that of a cricket chirping away.

The output is taken from the collector of transistor Q4 via a 470uF capacitor to the speaker which can be any 8 ohm type.

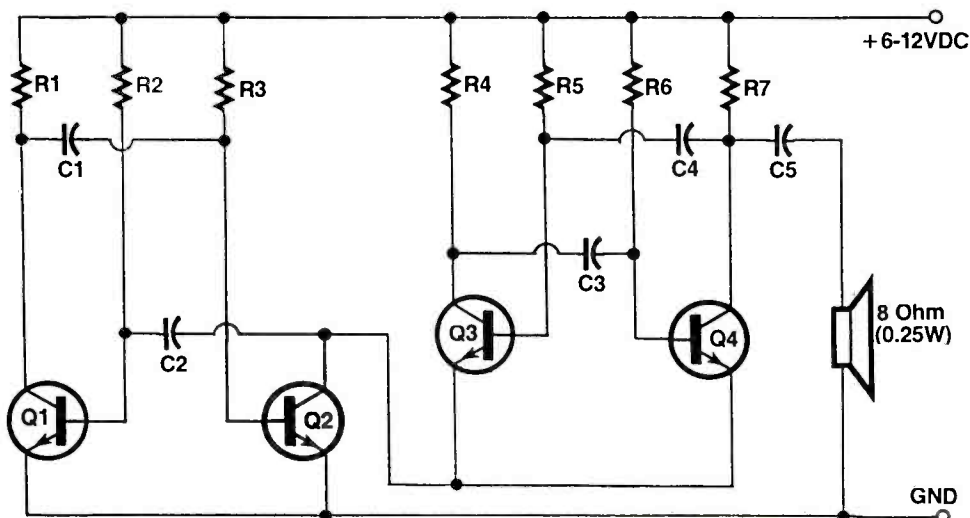
Every time transistor Q2 is on, you'll hear the chirp coming from the speaker. And every time you hear a chirp you'll see the two LEDs light up for an added special effect. It looks great in the dark.

The power supply can be anywhere from 6 to 12VDC. The current consumption is very low so you can use penlite cells if you like.

If you have a small case, this would be ideal so that the cricket can be self contained in its own little body. Now go off and have fun with your insect friend.... ■

## PARTS LIST FOR THE ELECTRONIC CRICKET

- C1, C5**—470uF, 16VW, Electrolytic capacitors
- C2**—100uF, 16VW Electrolytic capacitor
- C3**—4.7, 16VW, Electrolytic capacitor
- C4**—0.1uF Mylar capacitor
- Q1-Q4**—BC548 NPN Transistors or 2N2222 or G.P. Silicon
- R1, R4, R7**—1K ohm, 0.25W, 5% Resistors
- R2, R3, R5, R6**—10K ohms, 0.25W, 5% Resistors
- 18 Ohm, 0.25W Speaker



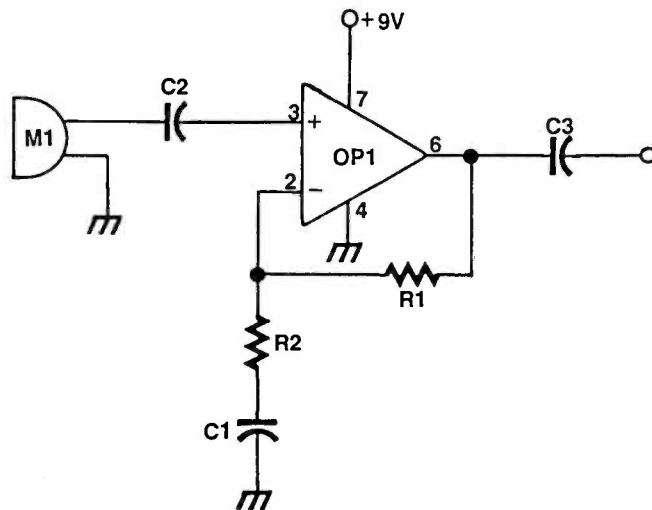
# MICROPHONE HUM FILTER

Pre-amplifiers for microphones generally operate at high gain levels in order to boost very small signals. With high gain levels, hum (low frequency 60Hz) pickup can be a problem. For OpAmp based circuits, in the non-inverting mode, a solution is to place a capacitor, C1, in the resistor feedback loop as shown. OP1 is shown configured in a standard A.C. coupled non-inverting mode. Resistors R1 and R2 are the gain setting components. R2 is normally connected to ground. By adding a capacitor however between R2 and ground, the gain at low frequencies is reduced and hence hum

pickup is also reduced. Component values are not critical and can be changed to suit your objectives. ■

## PARTS LIST FOR THE MICROPHONE HUM FILTER

- OP1 — TL081 low noise OpAmp
- C1 — 10Mfd capacitor
- C2 — 0.1Mfd capacitor
- C3 — 0.1Mfd capacitor
- R1 — 100K ohm resistor
- R2 — 1K ohm resistor
- M1 — crystal microphone



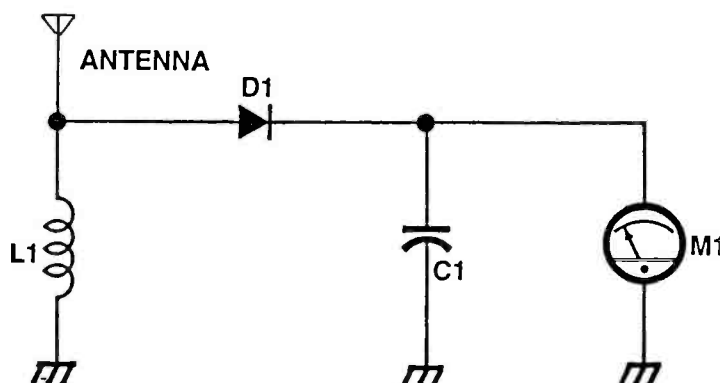
# TRANSMITTER VERIFIER

Low power F.M. transmitter circuits for the VHF broadcast band (88-108 MHz) are popular construction articles. The simple circuit shown here checks for the presence of RF emission. The antenna is 12 inches of solid hook-up wire coupled to inductor (L1), which is made by winding 7 turns of close-wound solid hook-up wire over a standard HB pencil, used to give the coil form. Diode (D1) rectifies the signal, which is further enhanced by capacitor (C1). The AC output is displayed on a sensitive 0-20 uA meter. To use, merely

place the antenna as close as possible to the tuned circuit of the transmitter.

## PARTS LIST FOR THE TRANSMITTER VERIFIER

- Ant. — 12" solid hook-up wire
- C1 — 0.1 uF Capacitor
- D1 — Germanium diode, 1N60
- L1 — Custom inductor (7 turns close-wound solid hook-up wire on pencil former)
- M1 — 0-20 uA DC Meter



# CLASSIFIED FLEAMARKET



**PC BOARD** and schematic design software for the IBM PC/compatible. Create professional PCB layouts (with autorouting—requires EGA) and electronic schematics (CGA) with these inexpensive shareware programs. Both for \$7.00. **Suncoast Technologies**, PO Box 5835EH, Spring Hill, Florida 34606.

**LOOK INSIDE YOUR PROJECT!** We sell used electronic equipment. (Oscilloscopes, 8Mhz, \$99.00) (Digital Volt Meters, \$35.00) Shipping and Handling is extra. **PRO-AM Electronics**, Rt. 6, Box 587, Guthrie, OK 73044 — (405) 282-8573 — CompuServ 71344-1440.

**TELEPHONE CONTINUITY TESTER** Instructional guide to building your own. Indispensable for the electrical enthusiast: for trouble-shooting, communications and much more! \$4.95 **MCG ADVANCED**, P.O. Box #155, Waterville, ME 04901.

**SPACE ENERGY RECEIVERS**—Power from the Wheelwork of Nature Send \$6.50 plus \$1.00 (P&H) to **Simplified Tech. Service**, P.O. Box 2140A, Champaign, IL 61825. Space energy receivers may be defined as a class of devices, which apparently collect electrical energy from the surrounding space without applied force, by some process other than chemical or mechanical action. This book describes eight inventors and their devices, covering the years 1901 to 1945.

**FREE!** Fabulous catalog of sensational electronic kits. **LNS TECHNOLOGIES**, 20993 Foothill Blvd. Suite 307H, Hayward, CA 94541-1511.

**Design Tesla Coils!** Any size, any power, quickly and easily on your IBM computer. Fantastic, fully graphic program! Only \$29.95. **W.C.N.**, 3283 Belvedere, Riverside, CA 92507

**SHOCK BOX! FM BUG! TV JAMMER!** 3 sets of plans, \$3.00. **Gallimore Electronics**, P.O. Box 70150-A, San Diego, CA 92167

## ELECTRONICS HANDBOOK V15

P.O. Box #5148, N. Branch, N.J. 08876

- Yes. Enter my subscription — 4 issues ONLY \$15.00  
(Canada \$18.00...Foreign Postage add \$10.00 U.S. Funds)
- Payment enclosed. (Payable to: C&E Hobby Handbooks)

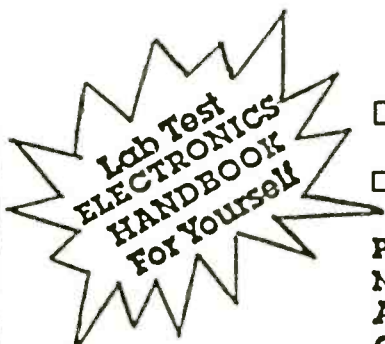
PLEASE PRINT

NAME: \_\_\_\_\_

ADDRESS: \_\_\_\_\_

CITY: \_\_\_\_\_

STATE: \_\_\_\_\_ ZIP \_\_\_\_\_





# BUILD A COMPACT FULL-RANGE SPEAKER SYSTEM

By William R. Hoffman



**A good quality full range speaker system that can be built with simple hand tools for about \$20 each. Sound too good to be true with today's prices? Not at all. Pioneer (that big Japanese corporation) now has a line of quality loudspeaker system drivers readily obtainable from several suppliers and with a little proper engineering of an enclosure, which we have done for you here, you can build a real speaker suitable for a small second stereo system, or for extension use. Also, it makes an excellent surround sound speaker for a home audio-video system (see "Video Surround Sound," *Electronics Handbook*, Fall 1987).**

**D**etails for our little system are shown in the photograph above and in Figure 1. A single cone, wide range driver with a very large magnet is used here, which can accommodate a substantial amount of power, is usable with any receiver or amplifier rated 5-30 watts per channel and can fill a bedroom or apartment sized living room with quite loud levels of sound that is very smooth and easy to listen to. Sounds like just the ticket for you? Then let's proceed.

Fig. 1, and its accompanying materials list gives us all the dimensions and quantities of wood for our system. Note here that we are using #3 pine shelving, 1 x 8 size (which as purchased is actually finished to 3/4" x 7 3/4"). The reason this is used, and not the usual "chip board" or MDF underlayment material is that it is easily cut, even with hand tools, and ready to finish with nothing more than some sandpaper and a paint brush. (But if you do have the appropriate wood working skills and equipment, then by all means use any material you choose.) Besides the wood shown in the list, the only other materials you will need are some wood glue (white glue or equivalent), a small quantity of 2" finishing nails, and a tube of silicon sealer. Tools needed are a circular saw, sabre saw, a drill with bits, and a hammer, plus some standard electronics hand tools and a soldering iron.

## CONSTRUCTION STEPS

In order, here are the steps to building our speaker system.

1. Obtain all the cabinet materials as shown in the list with Fig. 1. Note that this is only for one speaker: dou-

ble the order for two systems, etc. Wood can come from any lumber supply store or lumber yard. Buy it in planks with enough running length to accommodate the number of cabinets you want to build. And be sure that they are flat; sometimes they come warped or twisted, which makes them difficult to work with.

from the inside of the box around the back panel to be sure it will be well sealed. In the same way, place the front panel into the front of the box, being sure to observe the 1/4" recessing called for (see Fig. 1 again). Nail and glue it into place like the rear panel, except add the bead of glue from the front side. Use your finger tip to smooth the glue bead and spread it evenly around the entire face edge.

4. Now we are ready to finish our enclosure. You may sand and stain it, or paint it a color to match its intended surroundings. Or an even simpler finish is to sand and clean the cabinets outside surface so it is very smooth, and apply a self adhesive plastic film type material to give it a wood or other finish. This is both easy and inexpensive, and provides a good looking finished cabinet with a minimum of expense and effort. Rolls of the plastic film material are readily available at most hardware stores for a few dollars.

5. With the outside of our enclosure done, it is now time to start wiring our speaker. Start by cutting two 12" lengths of #18 stranded insulated wire and stripping about 3/8" of insulation off one end of each. Then solder each to one of the input terminals connection tabs. When this is done, thread the wires thru the holes in the rear of the enclosure and mount the terminal strip with two #8 x 1/2" wood screws. Then, from the inside of the

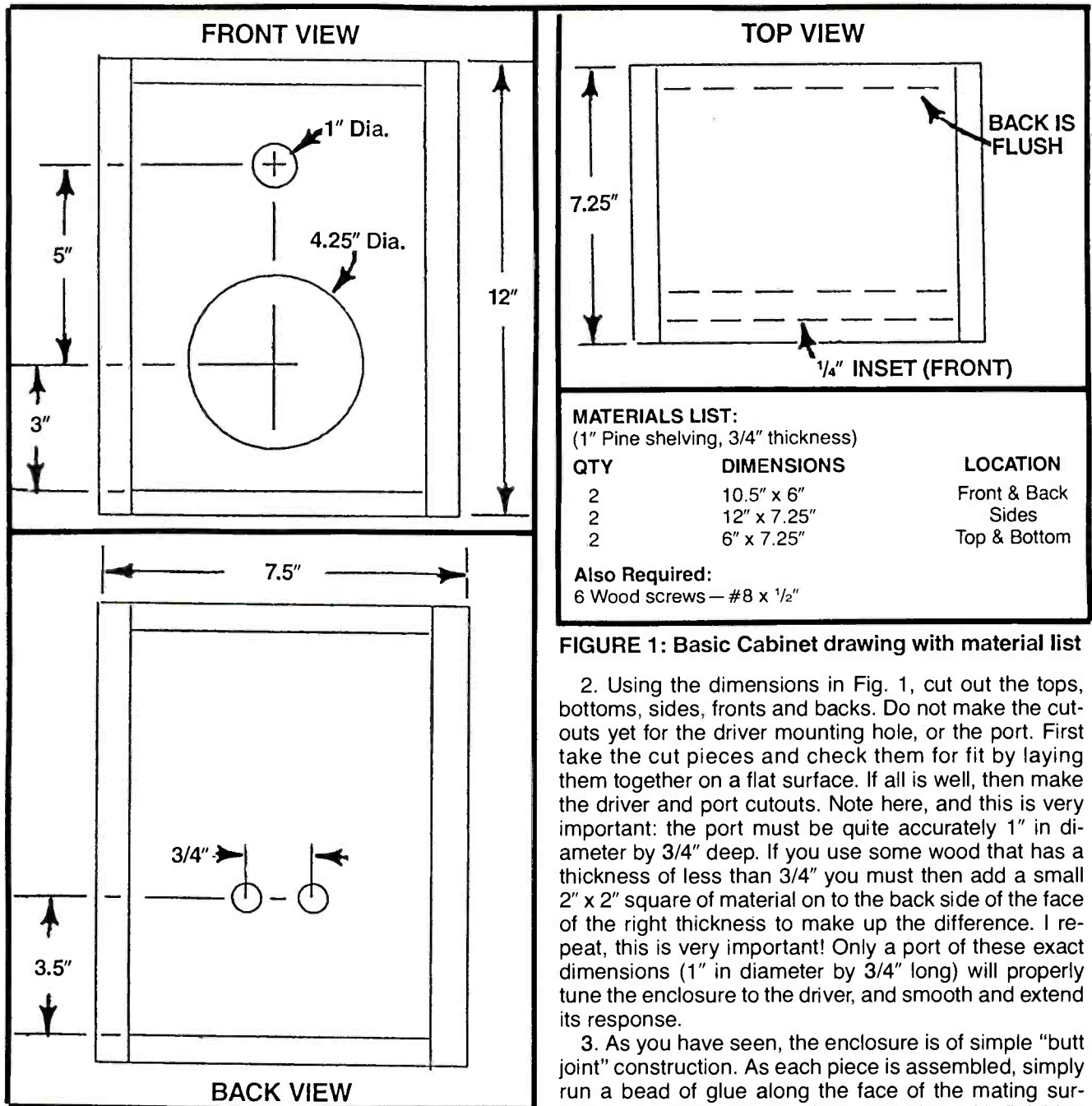


FIGURE 1: Basic Cabinet drawing with material list

2. Using the dimensions in Fig. 1, cut out the tops, bottoms, sides, fronts and backs. Do not make the cut-outs yet for the driver mounting hole, or the port. First take the cut pieces and check them for fit by laying them together on a flat surface. If all is well, then make the driver and port cutouts. Note here, and this is very important: the port must be quite accurately 1" in diameter by 3/4" deep. If you use some wood that has a thickness of less than 3/4" you must then add a small 2" x 2" square of material on to the back side of the face of the right thickness to make up the difference. I repeat, this is very important! Only a port of these exact dimensions (1" in diameter by 3/4" long) will properly tune the enclosure to the driver, and smooth and extend its response.

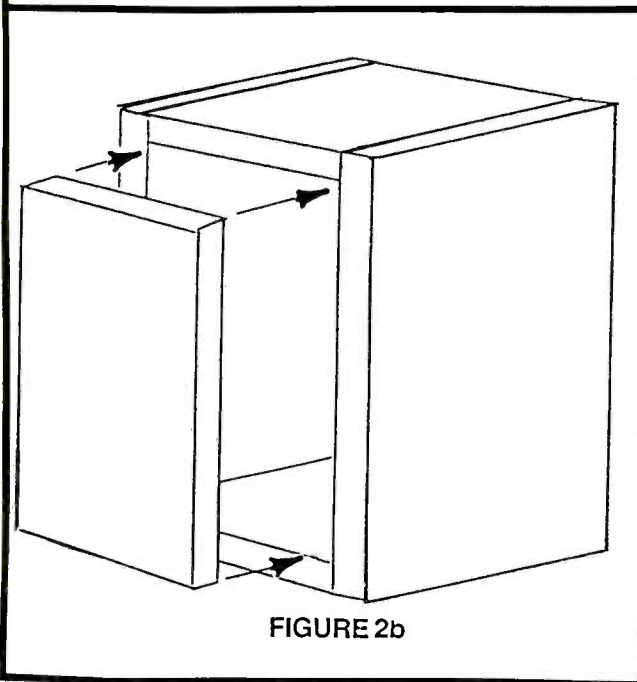
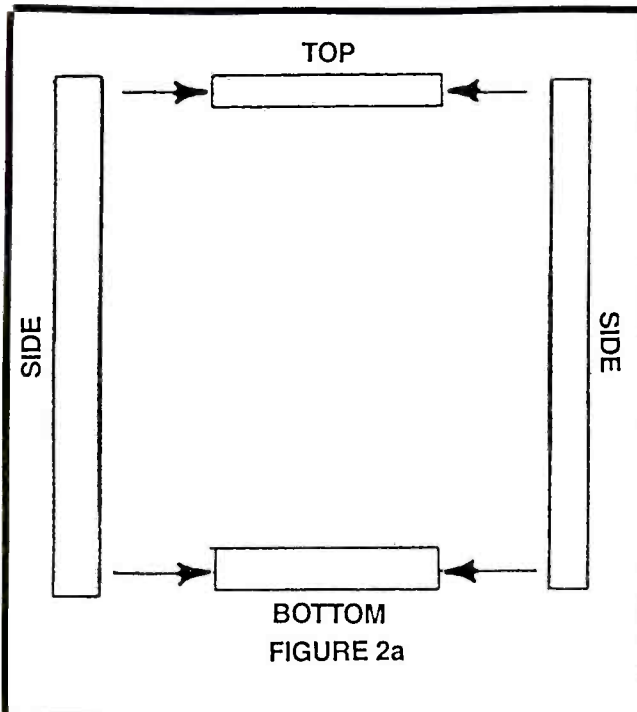
3. As you have seen, the enclosure is of simple "butt joint" construction. As each piece is assembled, simply run a bead of glue along the face of the mating surfaces, and then nail the pieces together with finishing nails. Start first by joining a side to a top and bottom, and then add the other side (Fig. 2a.) Once this is done, make a quick check of the alignment of the assembled pieces by laying them down on a flat surface. Does the incomplete box rock or tilt? If everything is okay, then proceed to place the back piece flush into the box's back, and nail it into place (Fig. 2b.) Add a bead of glue

And now finally, cut one 8" by 16" piece of fiberglass from the material specified, and fold it over once to make an 8" by 8" pad. Place this thru the hole into the area of the enclosure that is just behind where the driver will be mounted. (Do not be tempted to fill the rest of the enclosure with more fiberglass. Doing so will adversely effect the tuning of the system.) Dress the speaker wiring around the edge of the fiberglass so it will not tangle or rattle against the driver or cabinet

cabinet use some silicon sealer to seal up the holes that the wires have come thru.

With this done, cut down the two speaker wires to a length just sufficient so that they will reach the driver when it is set right next to its mounting hole. Then strip their ends back about 3/8", and solder the wires to the terminals on the driver, being sure that the connection polarity is correct. The wire that comes from the red input terminal on the enclosure back must go to the red terminal on the driver. This is very important. If the connections are accidentally reversed, a pair of speakers in stereo will be "out of phase" with each other, and there will be a noticeable lack of bass response because of it.

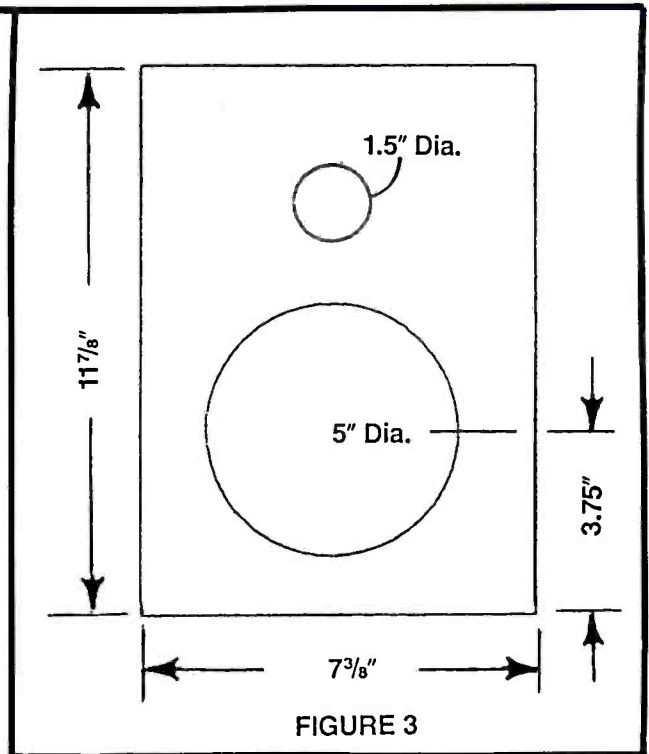




walls. And finally, put a bead of silicon sealer around the driver mounting hole and set the driver into it. Secure the driver firmly with four more #8 x 1/2" wood screws and the job is done.

### A GRILLE FOR THE SYSTEM

Although a grille panel was not constructed for the prototype system, it can be very easily done. Fig. 3 gives the dimensions for a piece of 1/8" or 1/16" masonite (pressed board) material. This is usually dark brown in color, and comes in sheets. Cut a piece for each system that has been built, and make the cutout for the driver and port as indicated. Then stretch and staple (or glue with contact cement) a nice open weave material of your choice over the outside of the panel. You can fasten the grille onto the cabinets front with



double sided tape, or very small finishing nails. Either will make a good, non-rattling mounting.

### ABOUT THE SYSTEM

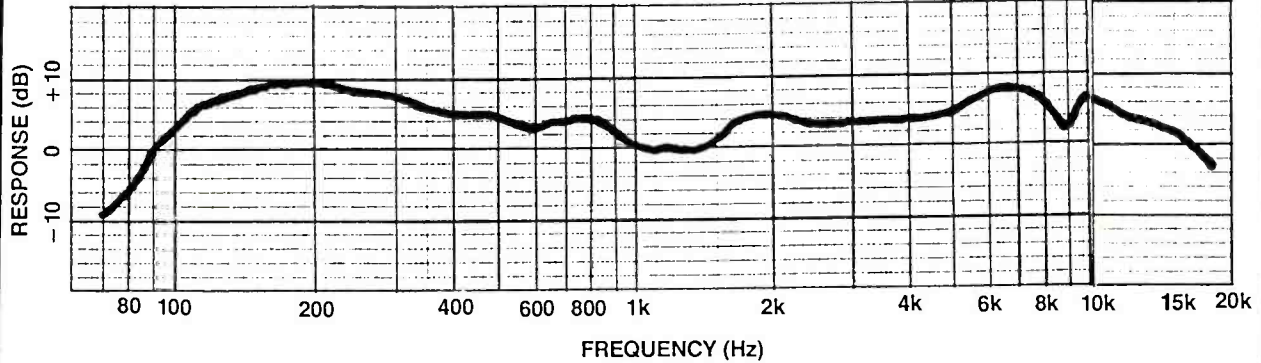
As the accompanying specifications show, our little speaker has a very wide frequency response range. With the bass reflex tuning action to extend its bass range, it has an overall frequency response of 85Hz to 18kHz +/- about 6 dB. See Graph 1. Not bad for such a small, simple, inexpensive system! Also, because of the smoothness of its response, some bass or treble boost may be added with the tone controls of the amplifier, which it will accept very graciously. In fact, it is recommended that the amplifier loudness switch be turned on. This will balance out the bass response in most listening situations exceptionally well. In addition, the system can take a substantial amount of power without noticeable distortion. Observe that it does have some power limitations: if you start to hear some distortion, turn down the volume just a little bit. Also, it cannot generate great amounts of bass without distortion or damage, so don't push it too hard.)

### HOW DOES IT SOUND?

So how does a pair of speakers, set up as part of a stereo system sound? When placed on a bookshelf or desk, near a wall; very good indeed. A very smooth, natural sonic balance is immediately obvious. This makes them very easy to listen to. Voices and instruments are real and natural. A piano sounds as if it were between and behind the speakers. Indeed, music that contains some of the acoustics of the place it was recorded at seems to bring that place to your listening room.

So now we have it, a small speaker system with a clean, open sound, and we have only spent a few dollars and a little of our time to get it.

Good listening. ■



GRAPH 1: Measured frequency response of system. Measurement made 12" on axis.

**SPECIFICATIONS: 4" Full Range Speaker System.**  
**FREQUENCY RESPONSE: 85Hz to 18kHz +/- 6 dB.**  
**POWER CAPACITY: 20 watts continuous, 35 watts maximum.**  
**NOMINAL IMPEDANCE: 8 ohms.**  
**MINIMUM IMPEDANCE: 7.8 ohms.**  
**SENSITIVITY: about 90 dB/W/M.**  
**CABINET TYPE: tuned port.**  
**CABINET TUNING: approx. 110Hz**  
**INTERNAL CABINET VOLUME: 0.18 cu. ft.**

**SUPPLIERS:**

Parts Express, 340 E. First St., Dayton, OH, 45402  
 1-800-338-0531  
 Radio Shack. Any convenient store location.

**PARTS LIST FOR THE COMPACT FULL-RANGE SPEAKER SYSTEM**

(parts are for one system, except the fiberglass, which is enough for about 6 systems.)

- DRIVER:** Pioneer Model #A11EC80-02F (4.5" full range, 10 oz. magnet.) Parts Express #290-010. Qty. = 1.
- SPEAKER TERMINAL:** quick release, spring loaded, surface mount. Parts Express #260-300 (or equivalent). Qty. = 1.
- FIBERGLASS FILLING:** one square yard standard size x 1" thickness. From any Radio Shack store. Radio Shack #42-1082.
- WIRE:** #18 insulated, stranded. Radio Shack #278-1226 or equivalent. About 2.5' per speaker.

# THE 80 TUNE COMPUTER

The 80-Tune Computer is a project which is not only easy to build but also fun to use. Its uses are many and are limited only by the imagination of the builder. This is an excellent beginner's project because of its simplicity. A masked microprocessor (special Integrated Circuit, or IC) does all the work. Any of the 80 songs can be selected by the telephone-style keypad. A push of the *Play* button makes the selection. The *Stop* button resets the microprocessor. The selected tune will start each time the *Play* button is pushed as long as power is on and no *Reset* (or *Stop*) occurs.

**80 TUNE COMPUTER SONG LIST**

- |                          |                         |                          |
|--------------------------|-------------------------|--------------------------|
| 0 AMERICA                | 27 IN HEAVEN IS NO BEER | 53 BUCKLE DOWN WINSOCKI  |
| 1 ANCHORS AWEIGH         | 28 JIMMY CRACK CORN     | 54 CHARGE                |
| 2 BATTLE HYMN REPUBLIC   | 29 KING BELLS           | 55 DEAR OLD NEBRASKA U.  |
| 3 CHAIRSON GO ROLLING    | 30 KING OF ROAD         | 56 THE EYES OF TEXAS     |
| 4 CALL TO COLORS         | 31 LA CUCARACHA         | 57 ABOVE CAYUGA'S WATERS |
| 5 CAVALRY CHARGE         | 32 LONE RANGER          | 58 FIGHT ON USC          |
| 6 DIXIE                  | 33 MODEL T              | 59 GO, NORTHWESTERN      |
| 7 HAIL BRITANIA          | 34 THE OLD GREY MARE    | 60 HAIL PURDUE           |
| 8 YANKEE DOODLE DANDY    | 35 POPEYE               | 61 HEY LOOK ME OVER      |
| 9 LA MARS ELLAISE        | 36 RAINDROPS            | 62 HOLD THAT TIGER       |
| 10 MARINE HYMN           | 37 SAILORS HOORPIPE     | 63 ILLINOIS LOYALTY      |
| 11 REVEILLE              | 38 SAN ANTONIO ROSE     | 64 INDIANA, OUR INDIANA  |
| 12 STARS & STRIPES       | 39 SEE THE USA          | 65 I'M A JATHAWK         |
| 13 TAPS                  | 40 OUT TO THE BALLGAME  | 66 IOWA FIGHT SONG       |
| 14 WILD BLUE YONDER      | 41 TIJUANA TAXI         | 67 LOVE YA BLUE          |
| 15 ALOUETTE              | 42 TWO BITS             | 68 MICHIGAN STATE FIGHT  |
| 16 AILVEULICHII HOMA     | 43 WADASHI CANNONDALL   | 69 MINNESOTA HOUSSLR     |
| 17 CAMPTOWN RACES        | 44 SAINTS GO MARCHING   | 70 NITTANY LION          |
| 18 CANDY MAN             | 45 WOODY WOODPECKER     | 71 NOTRE DAME FIGHT      |
| 19 CIATTANOOGA CHOO-CHOO | 46 YELLOW ROSE OF TEXAS | 72 OLE MISS              |
| 20 CLEMENTINE            | 47 ACROSS THE FIELD     | 73 OH, BRAVE ARMY TEAM   |
| 21 DALLAS THEME          | 48 AGGIE WAR HYMN       | 74 OH WISCONSIN          |
| 22 EL PASO               | 49 ARKANSAS FIGHT SONG  | 75 WRECK FROM GA. TECH   |
| 23 THE ENTERTAINER       | 50 RE BISHOP            | 76 ROLL ON TULANE        |
| 24 JULY UUUU FELLOW      | 51 BOOMER BOOMLIH       | 77 THE VICTOIRS          |
| 25 FUNERAL MARCH         | 52 BOW DOWN WASHINGTON  | 78 WASHINGTON/AAE SWING  |
| 26 HAVA NAGILAH          |                         | 79 YEA ALABAMA           |

Complete plans to build the "80-Tune Computer" \$2.95

U1 Custom Microprocessor \$9.00

PCB Printed Circuit Board \$4.95

Add \$2.00 for postage & handling

For each combination of the above items, send check or money order (U.S. funds) to: C&E Hobby Handbooks, Inc. P.O. Box #5148, North Branch, N.J. 08876

Payment enclosed. to: C&E Hobby Handbooks

PLEASE PRINT

NAME: \_\_\_\_\_

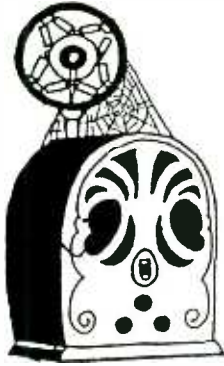
ADDRESS: \_\_\_\_\_

CITY: \_\_\_\_\_

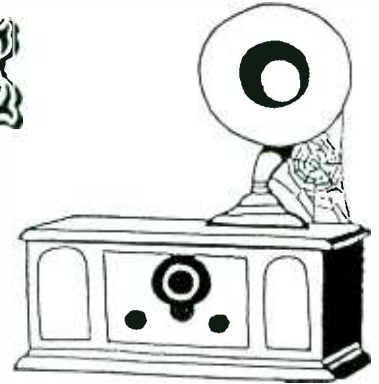
STATE: \_\_\_\_\_ ZIP: \_\_\_\_\_

Foreign Postage add \$8.00...U.S. Funds

V15



# ANTIQUE RADIO CORNER



## HOW TO BUILD AND USE A CRYSTAL SET ANTENNA TUNER

By Lance Borden WB5REX

**Ever since the earliest days of radio, antenna systems have been used to capture the weak electromagnetic oscillations that transverse the space between transmitters and receivers. In the wireless days, very low frequencies were used because it was believed that the lower frequencies, with their long wavelengths, would propagate farther than short waves because the "near" fields of the long waves extended many miles farther than they did for short waves. Ionospheric bounce, or skip, was unknown to those early pioneers. All radio communication was accomplished by the use of "ground waves."**

**T**heoretically, the ground waves, at lower frequencies, would travel much farther than they would at higher frequencies because the lower frequencies have such a "long wavelength." The physicists told us, and experiment proved, that frequency and wavelength were directly related. It was also proven that there was a direct relationship between frequency and wavelength compared to the speed of electromagnetic propagation; the speed of light.

It is universally accepted that electromagnetic waves **always** travel 300,000,000 meters, or 186,363.6 miles, in one second in free space (one meter is equal to 39.36 inches). This is a **universal constant** and, as far as we know, doesn't vary anywhere in the universe that there is free space for the waves to travel.

From this fact comes the formula for figuring out the wavelength of a signal if only the frequency is known:

$$\text{WAVELENGTH IN METERS} = \frac{300,000,000}{\text{FREQUENCY IN CYCLES (HERTZ or HZ)}}$$

$$\text{WAVELENGTH IN FEET} = \frac{984,000,000}{\text{FREQUENCY IN HZ}}$$

...and the formula for figuring out the frequency of a signal if only the wavelength is known:

$$\text{FREQUENCY IN HZ} = \frac{300,000,000}{\text{WAVELENGTH IN METERS}}$$

$$\text{FREQUENCY IN HZ} = \frac{984,000,000}{\text{WAVELENGTH IN FEET}}$$

Figure 1A shows an example of the relationship between frequency and wavelength. Because of the large numbers of cycles or Hertz involved in radio, we usually refer to frequency in **KILOHERTZ (KHZ)** for thousands of cycles and **MEGAHERTZ (MHZ)** for millions of cycles.

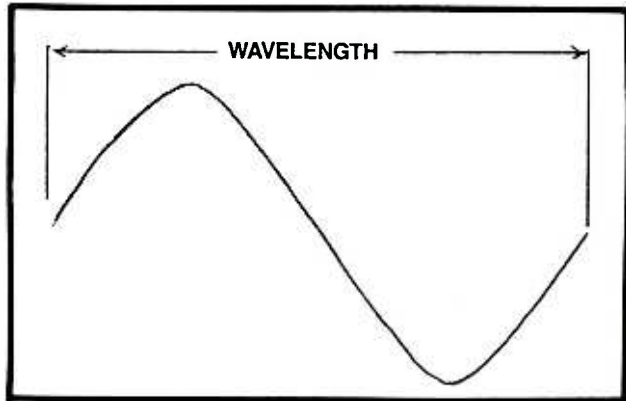


Figure 1A: One Cycle (HZ) of a radio wave

We don't need to go into any complicated math or theory to give you a fair understanding of how all of this works. Antenna theory and design is a very complex science in itself. There are now many different types of antennas for a vast number of applications. For our purposes, with crystal sets and other radios that cover a wide range of frequencies, we normally use what is known as a "**Random Wire**" antenna. This is an antenna that consists of a random length of wire that is not designed for any particular frequency. Because of this, we will only discuss how the random wire antenna works and how it applies to our particular application; crystal sets and other simple radios.

In simple terms, random wire antennas usually work best when their "electrical" length is equal to one-half the wavelength of the signal that is being received. This allows "space" for each half-cycle of the radio wave to transfer the greatest amount of energy possible to the antenna. When an antenna is tuned to the frequency (wavelength) of the desired signal, it is said to be **RESONANT** at that frequency.

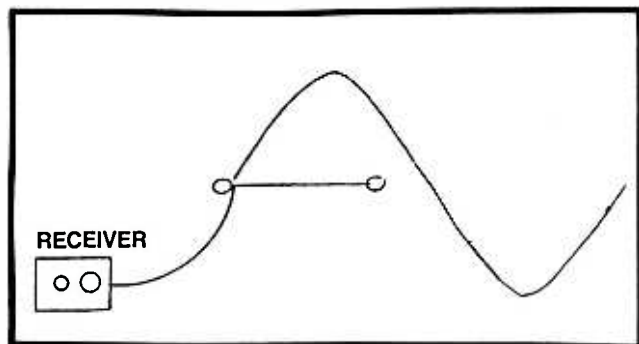


Figure 1B: Antenna is too short and is tuned "above resonance"

If an antenna is too short to be resonant at a certain frequency, it is said to be "tuned above resonance" and would appear to the signal as in Figure 1B. When the antenna is too long to resonate at a given frequency, it is "tuned below resonance" for that frequency and would appear to the signal as in Figure 1C. Figure 1D

shows what happens when an antenna is "tuned to resonance" at a particular frequency.

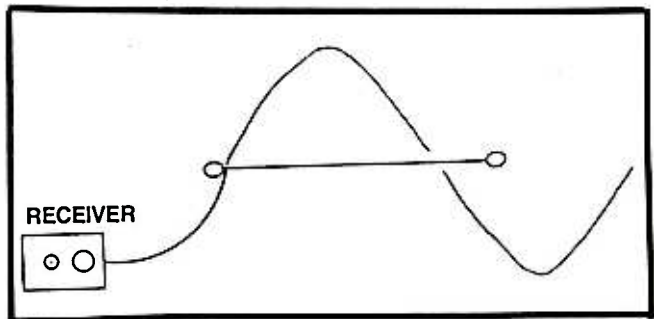


Figure 1C: Antenna is too long and is tuned "below resonance"

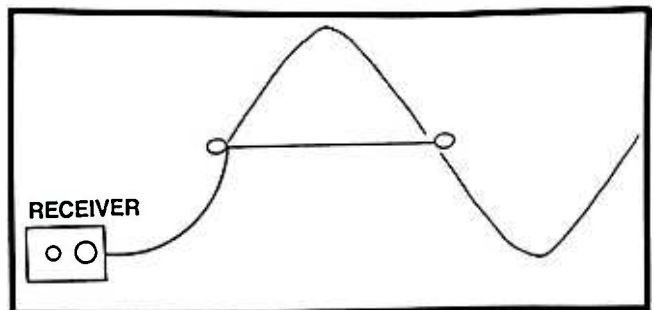


Figure 1D: Antenna length is just right and is tuned "to resonance"

In the early days of wireless, when low frequency, long wave, transmissions were common, wavelengths ran into thousands of meters. Because of these extremely long wavelengths, it would have been very impractical to have antennas thousands of meters long; especially on board ships where space was very limited! Because "necessity is the mother of invention," the early designers found a way around this problem by artificially, or "electrically," tuning their antennas to resonance by using **LOADING COILS**. These "loading coils" were adjustable coils of wire, or **INDUCTORS**, that were connected in series with the antennas to "electrically" add length to them in order to bring about resonance at lower frequencies than would have been possible with the length of the antenna wire alone. A variable capacitor was often connected in parallel with the loading coils to "fine tune" them. Figure 1E shows how loading coils with parallel variable capacitors were used to lower the resonant frequency of antennas.

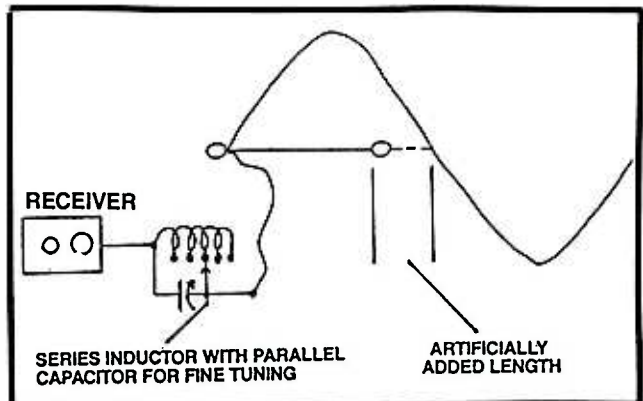


Figure 1E: Antenna is electrically tuned to resonance by using a series inductor to artificially add to its length

During the 1920's, experimenters discovered that shorter wavelength signals could bounce, or **SKIP**, off of the charged gases that formed the **IONOSPHERE**. This skipping action allowed the short wave signals to travel very long distances around the World by "bouncing" from the Earth to the ionosphere and back a number of times. Figure 1G shows how this happens.

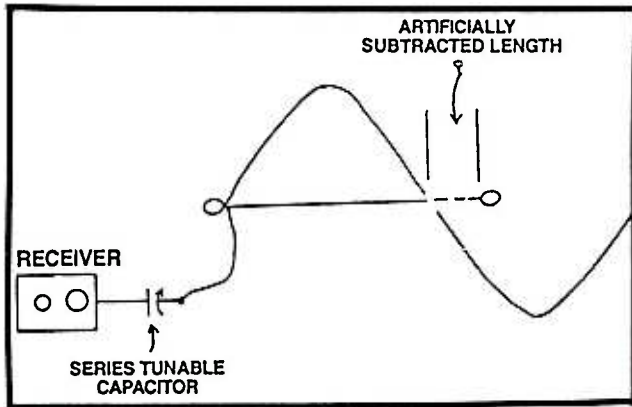


Figure 1F: Antenna is electrically tuned to resonance by using a series capacitor to artificially subtract from its length

The discovery of ionospheric skip brought about the advent of international broadcasting and long distance communications by amateur radio operators (or **HAMS**), commercial, and military stations. Along with the use of short waves came a problem that was opposite to the earlier need for lengthening antennas; many antennas were now **too long** to operate efficiently at these higher frequencies! Necessity again forced the designers to come up with a solution, and of course they did just that by connecting variable capacitors in series with long antennas to artificially shorten them. Figure 1F shows how this was done.

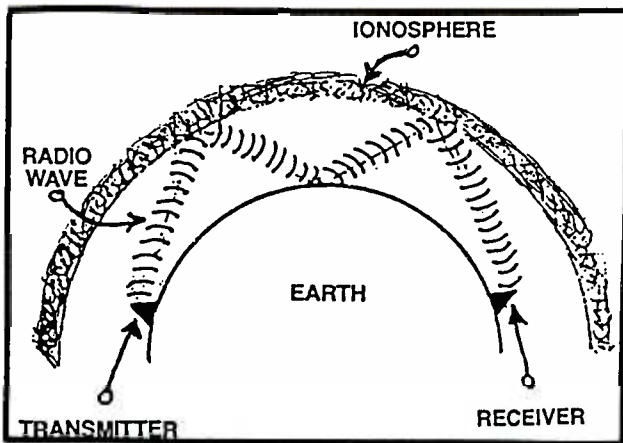


Figure 1G: Radio wave is refracted by the ionosphere and reflected by the earth

Many receivers and transmitters were designed to operate on a wide range of frequencies and it would have been impractical to have a "farm" of antennas tuned to cover them all. The High Performance Crystal Set described in Vol. 14 of **ELECTRONICS HANDBOOK** covers frequencies from the bottom of the A.M. Broadcast band at approximately 500 meters, to the short wave bands at 25, 41, and 60 meters.

Because of this multiple frequency usage, loading coils and series capacitors were combined in order to tune antennas to a large spectrum of frequencies. These combined circuits were called **ANTENNA TUNERS**.

The following is a description of how to build and use an antenna tuner that will work to tune antennas for crystal sets and more complex radios on the short wave and Broadcast bands. By tuning your antenna to resonance, it will transfer the energy from the received radio wave to your set more efficiently. This will result in a louder signal that will allow weaker DX stations to be heard that were not audible before. The antenna tuner can also be used to increase the selectivity of simple receivers. This can help separate the faint DX stations from the strong locals. Assembly of this antenna tuner is accomplished using simple construction techniques and readily available materials.

### CONSTRUCTION

Begin construction by acquiring all of the parts and materials you will need before you start. A list of parts, materials, and sources is included at the end of this article. (See Photo #1)



Photo #1: Parts required to build the Antenna Tuner; including acrylic spray, screws, and double-sided foam mounting tape.

Refer to the parts list, photos, and illustrations while building the antenna tuner.

**STEP 1.** Spray the coil form inside and out with one good coat of clear acrylic spray and let it dry. Spray the board with three coats, letting it dry between coats.

**STEP 2.** (Refer to Photo #2 and Figure #2) Punch two small holes in the coil form, 1/4 inch apart and 1/2 inch from the end. Pass 4 1/2 inches of the 22 AWG coil wire through one hole from the outside of the coil form and then pass it back through the other hole. Repeat this process once more and pinch the resulting loops with pliers to hold the coil lead in place.

**STEP 3.** (Refer to Photos #2 and 3, and Figures 3 and 4) Wind ten turns, close but not overlapping, on the coil form and make a tap by securing the coil with a piece of tape, then looping the wire around a pencil. Twist the loop twice and then remove the pencil and tape. Wind ten more turns and make another tap using

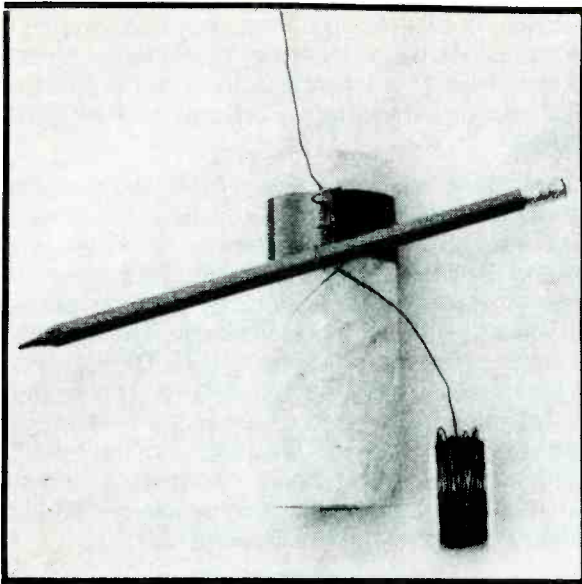


Photo #2: Winding the coil, using tape to hold the coil wire while twisting the taps with a pencil.

the pencil and tape as described above. Repeat this process every ten turns until the ninth tap has been made at the ninth turn. Punch two holes as in Step 2 and secure the end of the coil at the last tap, using pliers to pinch the wire the same as before. No lead wire is required at this end of the coil.

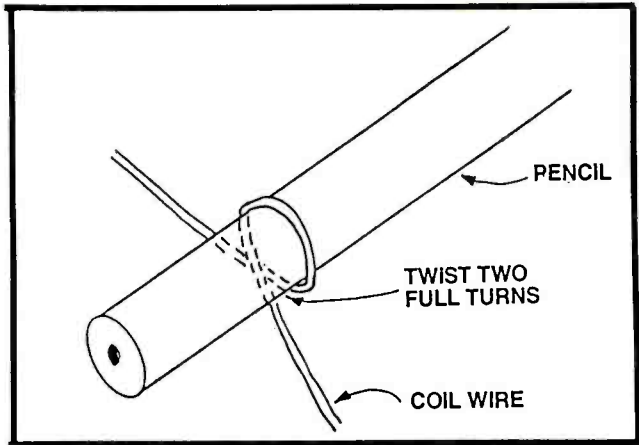


Figure 3: How to twist a coil tap

**STEP 4.** Spray the coil with three coats of clear acrylic, letting it dry between coats. The clear acrylic will hold the coil winding in place and also will prevent moisture from affecting the coil's efficiency.

**STEP 5.** The tuning capacitors are 365 picofarad units obtained from one of the suppliers referred to in the parts and source list at the end of this article. Old tuning capacitors obtained from junk AC-DC radios will work fine by connecting the stators of the small sections to the stators of the large sections in order to increase the total capacitance. (The stators are the plates that don't move). Scrape the left rear upper corner (when viewed from the front) of each tuning capacitor frame to remove oxides and deposits, then solder a three inch piece of insulated hook-up wire to it.

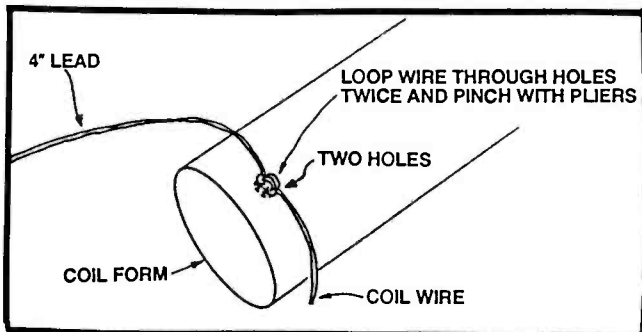


Figure 2: Attaching wire to the coil form

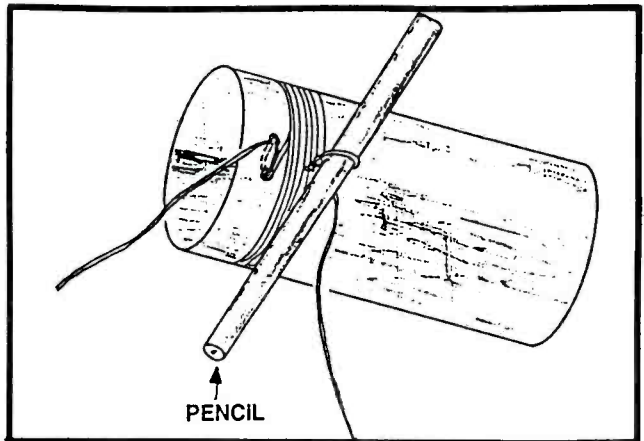


Figure 4: Coil detail

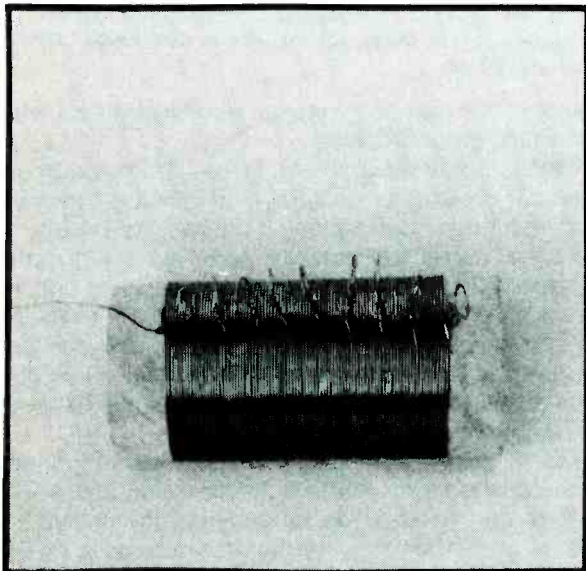


Photo #3: The finished coil.

**STEP 6.** (Refer to Photos #4 and 5 and Figures 5 and 6) Temporarily place the tuning capacitors, coil, and fahnestock clips on the board and lightly outline their locations with a pencil. Use super glue to attach the 3 inch by 1/4 inch coil mounting strips, one inch apart, to the board.

Cut strips of double-sided foam mounting tape to the size of the capacitor bases and press into place on the board. Place the capacitors on the mounting tape and press down hard, being careful not to bend the capacitor plates. Install the fahnestock clips with #4 x 1/2 inch round-head wood screws. Glue the coil to the wood strips with super glue, with the taps pointed up and the

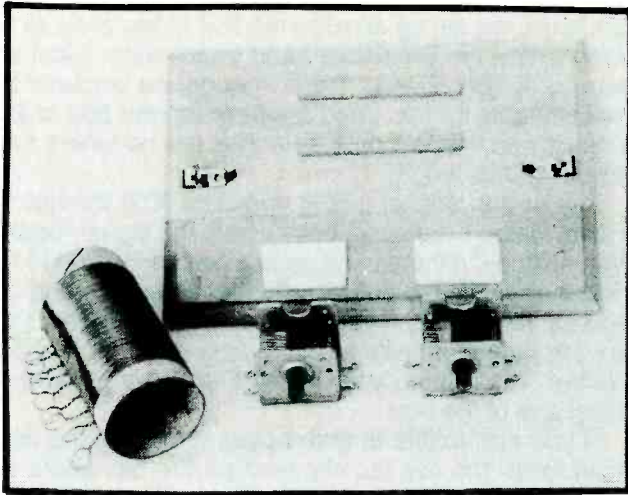


Photo #4: Locating coil, mounting strips, fahnestock clips and double-sided foam mounting tape for capacitors.

lead wire to the left. Install the knobs on the capacitor shafts.

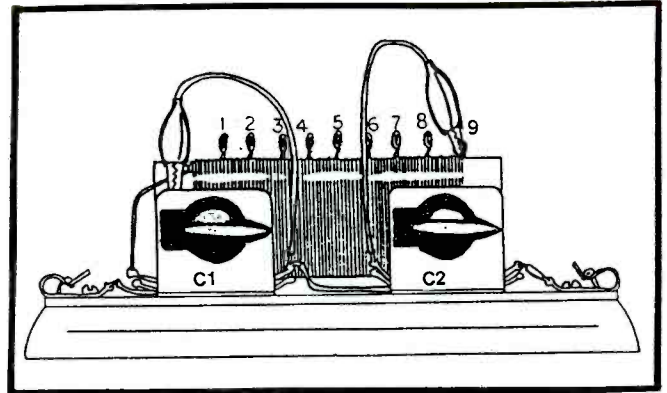


Figure 6: Front view

Cut a piece of insulated hook-up wire to fit between the stator lug of capacitor C2 and the receiver fahnestock clip. Solder this wire in place.

Trim the case lead wire of capacitor C2 to the proper length and connect it to the stator lug of capacitor C1. Do not solder this connection yet.

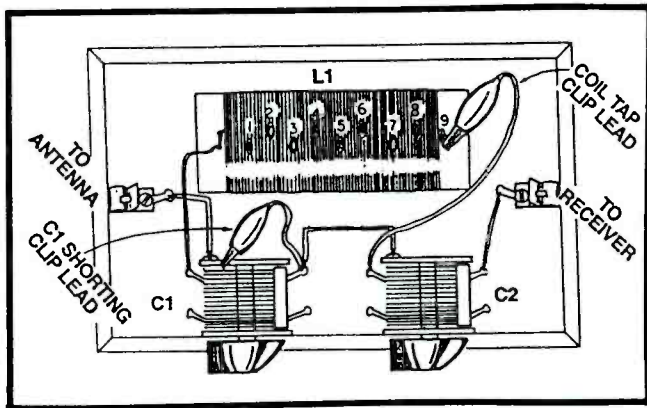


Figure 5: Top view

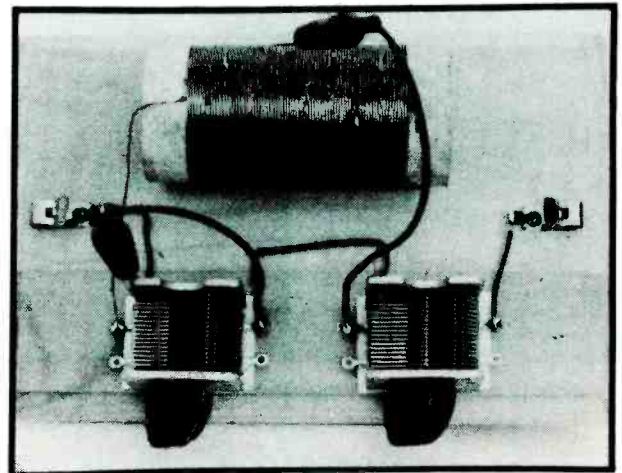


Photo #6: Top view of the completed antenna tuner, showing wiring.

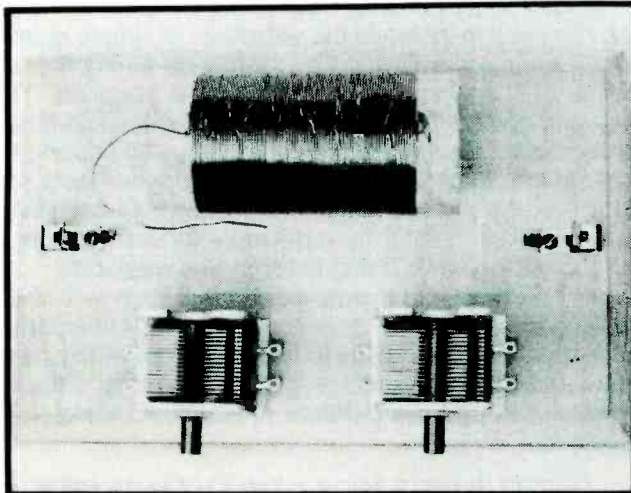


Photo #5: Board with all major parts in place, before wiring.

**STEP 7.** (Refer to Photo #6 and Figures 5, 6, and 7) Begin wiring the tuner by scraping the enamel off of the end of the coil lead wire and soldering it to the stator lug of capacitor C1, as shown in Figure 5. Trim the case lead wire of capacitor C1 to the proper length and solder it to the antenna fahnestock clip.

**NOTE**

Make the clip lead wires as short as possible, while still being able to reach their connections. Making these wires too long will introduce stray capacitance into the circuit that could affect its efficiency; especially at higher frequencies.

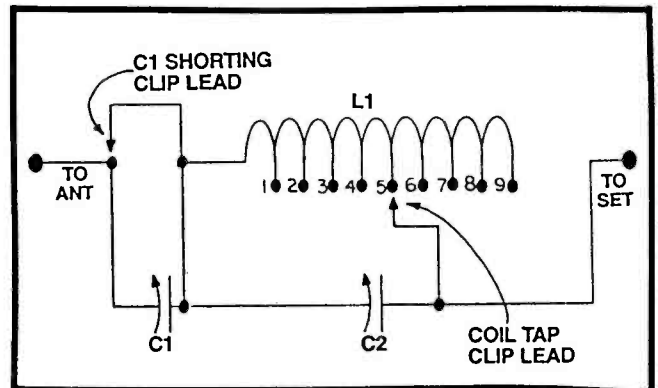


Figure 7: Schematic

Cut the capacitor (C1) shorting clip lead wire to reach from the C1 stator lug to clip onto the C1 upper case. Solder this clip lead wire and the capacitor (C2) case lead wire to the C1 stator lug.

Cut the coil tap clip lead wire to reach from the capacitor C2 stator lug to coil tap #1. Solder this lead wire to the capacitor C2 stator lug.

Use an Exacto knife or razor blade to scrape the enamel off of the coil taps where the coil tap clip lead will connect. This is very important because the weak R.F. (Radio Frequency) signals will not conduct through the enameled coating on the coil wire.

Bend the coil taps alternately to the rear and to the front to facilitate connection with the coil tap clip lead.

This completes the wiring of the antenna tuner.

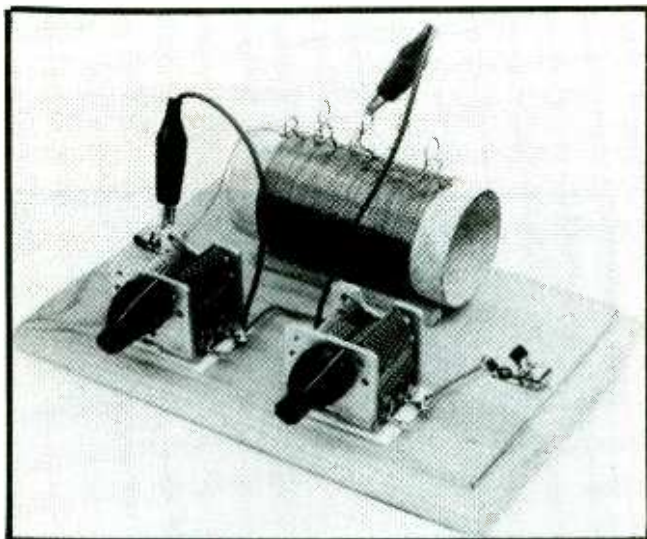


Photo #7: The completed crystal set antenna tuner.

## OPERATION

This antenna tuner can be used with crystal sets, one and two-tube sets, antique TRF sets, and any other receivers designed to operate in the A.M. Broadcast band and short wave bands, up to around 30 Mhz. The following is a description of how to connect and operate the antenna tuner on both the Broadcast and short wave bands:

### BROADCAST BAND (540 to 1750 KHz)

To use the tuner on the Broadcast band; begin by connecting the antenna fahnestock clip to your antenna and then connect the receiver fahnestock clip to your receiver antenna connector. Connect a good ground, such as a ground rod or metal pipe that has been driven into the ground, to your receiver ground connector.

Bypass the tuner by clipping the C1 shorting clip lead to the case of the series capacitor, C1. Clip the coil tap clip lead to the case of the parallel capacitor, C2. This effectively connects the antenna directly to the receiver without any benefit from the antenna tuner.

Tune the receiver to a weak station in the desired portion of the band. Disconnect the coil tap clip lead from the case of the parallel capacitor C2, and connect it to tap #9 of the coil. This will provide maximum in-

ductance for tuning an antenna that is too short to be resonant at the Broadcast band frequencies. Most antennas are too short at these frequencies because the wavelengths for this band are from around 500 to 200 meters and typical home antennas are no where near even half this length.

Adjust the parallel tuning capacitor (C2) through its range to find if there is a point where the signal "peaks" in amplitude. If there is no peak when connected to tap #9, then move the coil tap clip lead to tap #8 and adjust C2 for a peak. If you still can not find a peak, then try this procedure with all of the taps on the coil, one at a time. You will probably be able to find a peak on at least one of the taps.

If you are unable to find a peak on any of the taps, then leave the coil tap clip lead on the tap where the best signal was obtained and activate the series tuning capacitor (C1) by disconnecting the series capacitor shorting clip lead from C1's case. Tune C1 through its range until you find a point where C2 can be peaked. The series capacitor (C1) can be used to "fine tune" the antenna and is usually most effective at the high end of the Broadcast band. Once parallel capacitor (C2) has been peaked, the antenna has been tuned to resonance.

When changing stations, the Parallel capacitor C2 will require adjusting for maximum amplitude. At the high end of the band the lower numbered taps are usually most effective, and at the low end, the higher numbered taps normally work best.

When used with crystal sets and other simple receivers, it is important to tune the receiver first with the antenna tuner bypassed by connecting the clip leads to the capacitor cases, as previously mentioned. The reason for this is that the antenna tuner will affect the receiver's tuning and can actually be used to change stations with sets like these.

Because of this tuning interaction, the antenna tuner can be used to increase the selectivity of simple receivers. This is accomplished by slightly de-tuning the antenna until an increase in selectivity is apparent. The coil and parallel tuning capacitor C2 can also be tuned as a "notch" filter to help reject a particularly strong local station. Experimentation and practice will help you learn to use this technique. This increased selectivity can really be helpful by reducing interference from a strong station while trying to listen to a weak one.

All antennas differ and experimentation will show which taps and capacitor settings work best in a particular situation. It is helpful to keep a record of tap numbers and capacitor settings that work best for different frequencies and if a different antenna or receiver are used.

### SHORT WAVE BANDS (1750 KHZ to 30 MHZ)

The antenna tuner is connected the same way for short wave as it is for the Broadcast band. When initially using the tuner on short wave, the series and parallel tuning capacitors should be shorted with the clip leads to bypass the tuner the same as is done for the A.M. Broadcast band.

Once a station is selected, the taps and capacitors are selected and adjusted the same as they are for the



lower frequency Broadcast band. With most antennas, the parallel tuning capacitor C2 and the lower numbered taps will have the greatest effect on frequencies below about 6 Mhz. As the frequency is increased, the series tuning capacitor C1 will have more influence on the antenna and the coil will begin to have less effect.

Experimentation and practice will show the operator which taps and capacitor settings to use. Again, a record of settings is a useful aid for the operation of this antenna tuner on short wave.

### HOW IT WORKS

In order for an antenna to transfer the maximum signal to a receiver at a given frequency, it must be resonant at that frequency. To be resonant at a certain frequency, an antenna must be physically or electrically tuned in length to the wavelength of that frequency. At the lower Broadcast band frequencies, the wavelength exceeds 500 meters and at the higher short wave frequencies, it is less than 10 meters.

For general reception, it is not practical to physically tune an antenna to a particular wavelength by shortening or lengthening the antenna wire. Instead of physically changing the length of an antenna, tuned circuits can be connected between the antenna and receiver that electrically change its length by tuning it to resonance.

If the desired frequency is higher than the antenna's natural resonant frequency, the antenna acts inductively and can be tuned to resonance by using a tunable capacitor in series with it. With our antenna tuner, series capacitor C1 provides this tunable capacitance.

If the desired frequency is lower than the antenna's natural resonant frequency, the antenna acts capacitively and can be tuned to resonance by using a variable inductor connected in series with it. With this tuner, tapped inductor L1 provides this inductance. Parallel tuning capacitor C2 is used to fine tune the inductor to resonance with the antenna.

### CONCLUSION

In conclusion, very good results can be expected with this antenna tuner. It has been used successfully with the high performance crystal set described in **ELECTRONICS HANDBOOK**, Volume 12, and with a

one-tube set, antique sets, and a commercial multi-band communications receiver.

It will tune random wire antennas from approximately fifty feet and longer, to resonance on the A.M. Broadcast and short wave bands up to about 30 Mhz. Shorter antennas, such as whips, can be tuned successfully on the shortwave bands using this tuner.

When connected to a crystal set at this location, signals were louder and more stations could be heard than with just the antenna alone. As a bonus, powerful local stations could be tuned out so weaker, more distant stations could be received clearly.

Good luck with your crystal set antenna tuner and happy DX'ing!!

### REFERENCES

(1) **RADIOS THAT WORK FOR FREE, K.E. Edwards**, Hope and Allen Publishing, P.O. Box 926, Grants Pass, OR 97526 (Available from **Antique Audio and Antique Electronics Supply** for \$7.95 plus shipping. Addresses are in the parts/source list.)

(2) **ELECTRONICS SIMPLIFIED-CRYSTAL SET CONSTRUCTION, F.A. Wilson** Barnard Babani Publishing Ltd. The Grampians Shepherd's Bush Road London W6 7NF, England (Available from **Electronic Technology Today Inc.** P.O. Box 240 Massapequa Park, NY 11762-0240 Book #BP92, \$5.50 plus shipping)

(3) **THE RADIO AMATEUR'S HANDBOOK** American Radio Relay League 225 Main Street Newington, CT 06111 (Available at electronic supply houses and book stores)

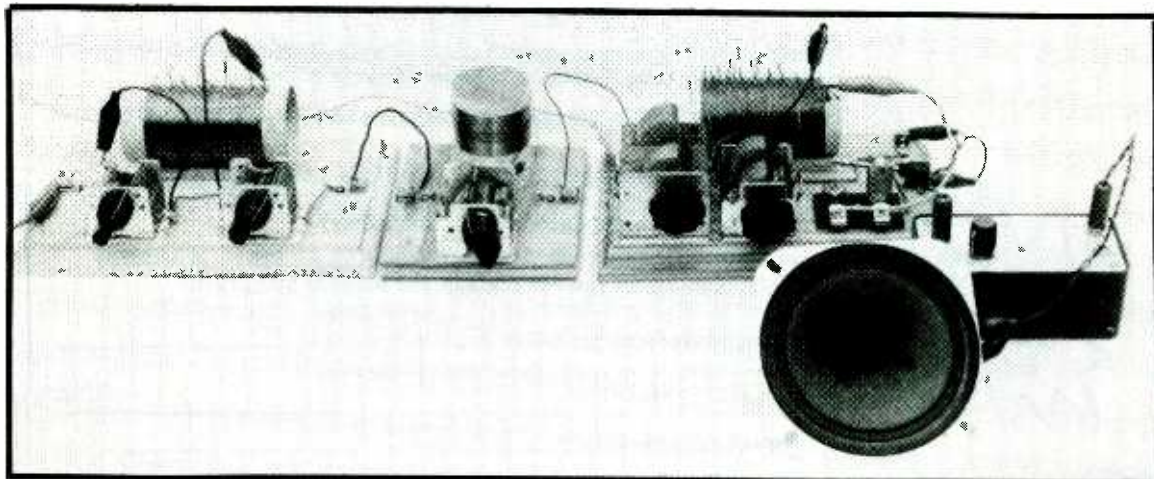


Photo #8: An **ELECTRONICS HANDBOOK** crystal set listening post, consisting of (left to right):  
1. Crystal set antenna tuner from this volume (#15)  
2. QRM/interference rejector from volume #13  
3. High-performance crystal set from volume #12  
4. Crystal set amplifier & speaker from volume #14

**PARTS AND SOURCE LIST FOR CRYSTAL SET  
ANTENNA TUNER**

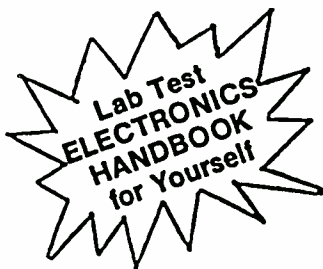
ITEM	SOURCE	ITEM	SOURCE
<b>Coil Form</b>	Cardboard toilet paper tube or paper towel tube. Approx. 1 1/2 x 4 1/2 inches. <b>Note:</b> Some brands of toilet paper come on tubes that are less than 1 1/2 inches in diameter. Be sure to use a tube that is 1 1/2 to 1 3/4 inches in diameter.	<b>Tuning Capacitors,</b> Approximately 365 Pf variable capacitors	<b>Antique Electronic Supply</b> 6221 Maple Avenue Tempe, AZ 85283 (602) 666-1541  P/N CV-231, @ \$6.95 Plus shipping. They too carry fahnestock clips and crystal set parts. Ask for their catalog.
<b>Coil Wire,</b> 40 feet of #22 AWG enameled copper magnet wire.	Radio Shack or other electronic supply. Radio Shack P/N 278-1345 contains #22, #26, and #30.		<b>Modern Radio Laboratories</b> P.O. Box 14902 Minneapolis, MN 55414 MRL sells crystal set kits, parts, and plans. Send \$1.00 for their catalog.
<b>Clip Leads</b>	Radio Shack or other electronic supply. Radio Shack P/N 278-1157 contains eight, double-ended clip leads.		<b>NOTE:</b> Old tuning capacitors salvaged from scrap AC-DC radios will work fine. See text.
<b>Knobs and Hook-up Wire</b>	Radio Shack or other electronics supply.		
<b>Fahnestock Clips</b>	Fahnestock clips are available from the three suppliers listed below.	<b>Mounting Board,</b> Approximately 4 1/2 x 7 inch plaque or plain board.	Plaques can be purchased at hobby and craft stores. A plain board will work fine as long as it is very dry before spraying with acrylic.
<b>Tuning Capacitors,</b> Approximately 365 Pf variable capacitors	<b>Antique Audio</b> 5555 N. Lamar Suite H-105 Austin, TX 78751 (512) 467-0304 P/N CV-365, @ \$7.95 Plus shipping. They also carry fahnestock clips, crystal set kits, magnet wire, and parts. Send \$2.00 for their catalog.	<b>Miscellaneous</b>	<b>Local Hardware Store.</b> Clear acrylic spray, #4 x 1/4 inch round head wood screws, double-sided foam mounting tape, and super glue. Coil mounting strips are 3 inch x 1/4 inch balsa wood, but any type wood strips will work.

## ELECTRONICS HANDBOOK

### THE FUN WAY TO LEARN ELECTRONICS

Subscriptions to the semi-annual ELECTRONICS HANDBOOK are available at the following rates, postpaid, delivered to your address:

Please specify the Volume number of the Issue that you would like to start your subscription:



- TWO SUCCESSIVE ISSUES: \$7.50 (U.S.A.) \$9.00 (CANADA)**
- Foreign orders (except Canada and Mexico) add \$5.00 for postage and handling (U.S. funds only).
- FOUR SUCCESSIVE ISSUES: \$15.00 (U.S.A.) \$18.00 (CANADA)**
- Foreign orders (except Canada and Mexico) add \$10.00 for postage and handling (U.S. funds only).

**TOTAL CHECK OR MONEY ORDER (U.S. FUNDS ONLY): \$ \_\_\_\_\_**

Please send my copies to the address below: (Please print)

**NAME:** \_\_\_\_\_ **V15**

**STREET ADDRESS:** \_\_\_\_\_

**CITY & STATE:** \_\_\_\_\_ **ZIP:** \_\_\_\_\_



# A MODERN REGENERATIVE SHORTWAVE RECEIVER

By Ed Noll W3FQJ

**The regenerative receiver and its feedback detector go back to the early twenties. Regenerative detection is little used except by those old-timers who like to experiment with the old circuits or the hobby fans who buy, sell and restore antique radios. A new solid-state version may create renewed interest in this sensitive, few-component receiver.**

Edwin H. Armstrong invented various regenerative techniques. Other Armstrong inventions that followed were super-regeneration and the modern super-heterodyne receiver. He was the inventor of the modern frequency modulation (FM) broadcast system that we are all familiar with today. As a very young person I had the pleasure of attending one of his early lectures on frequency modulation at Columbia University in New York City. He was a true radio genius. He probably would have enjoyed the return of the regenerative process in a small shortwave receiver such as this, marketed in 1993 by MFJ Enterprises.

The MFJ-8100 is a solid-state regenerative shortwave receiver composed of three FET stages and an audio amplifier chip. Audio output is supplied to a pair of earphone jacks. One or two people can listen in using small headsets such as those supplied for Walkman and other small portable radios.

The receiver can be purchased in kit or wired form. The latter is suggested if you have little or no experience wiring circuit boards. If you make a mistake you cannot return the kit version. Even those of you who have circuit board construction experience may want to forego this step so that you can enjoy checking out an inexpensive shortwave receiver. Also you may wish to experiment with external accessories, such as a crystal calibrator, loudspeaker audio amplifier, antenna, code practice set-up, etc.

You must not expect the polished performance and convenience of expensive shortwave receivers costing hundreds of dollars more. It will be fun to learn how to tune a regenerative receiver and learn how careful adjustments have such a decided influence on output quality and sensitivity. The receiver comes supplied

with an excellent instruction manual that details this tuning process. The results will surprise you. It is so sensitive that most times I can copy Radio Australia early in the morning with the same clarity as I do on a large desk-top shortwave receiver. My listening post is in an apartment and I use an indoor antenna. Less electrical interference, freedom from the shielding effect of a high rise apartment, plus a 24 to 100 foot antenna all do marvels for this four-device shortwave radio.

The 8100 not only demodulates AM signals, its stable regenerative oscillator also permits the reception of sideband and CW signals. A bit of tuning experience and you'll do very well. All of this is covered in the manual. The shortwave and ham bands covered are:

<b>RANGE A</b>	<b>SW BAND</b>	<b>HAM BAND</b>
3.5-4 MHZ	75 METERS	80 METERS
<b>RANGE B</b>	<b>SW BAND</b>	<b>HAM BAND</b>
5.85-7.4 MHZ	41 METERS	40 METERS
<b>RANGE C</b>	<b>SW BANDS</b>	<b>HAM BAND</b>
9.5-12 MHZ	31 and 25 METERS	30 METERS
<b>RANGE D</b>	<b>SW BANDS</b>	<b>HAM BAND</b>
13.2-16.4 MHZ	21 and 19 METERS	20 METERS
<b>RANGE E</b>	<b>SW BANDS</b>	<b>HAM BAND</b>
17.5-22 MHZ	16 and 13 METERS	15 METERS

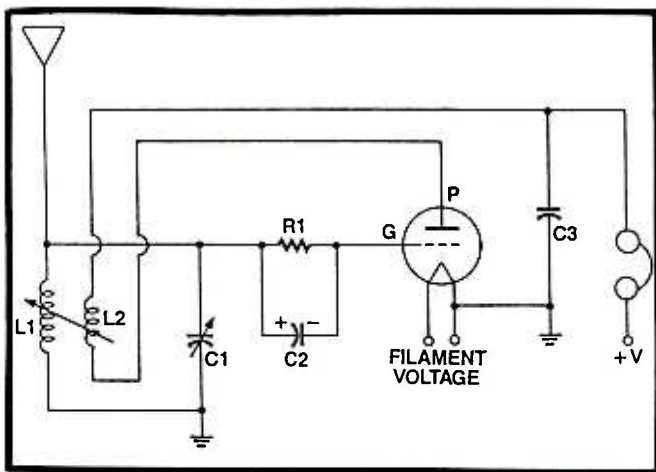
## REGENERATIVE CAMEO

The regenerative detector evolved in the very early days of radio broadcasting. I appreciate that most of you were not born at the time. In fact, there are some of you who have never tuned a tube radio and more of you may not have studied vacuum-tube theory and opera-

tion. Quite a volume of writing would be necessary to provide that coverage. However, a brief introduction will give you some insight into the feedback concept used at that time. The solid-state regenerative detector of the 8100 operates in a similar manner. However, the circuitry is quite different.

Old-timers will recall hand-capacity effect and other tuning frustrations in trying to pull in a weak signal on the AM broadcast band with a regenerative set up. The influence of these effects has been minimized in the 8100 despite the fact that the receiver tunes over much higher frequencies than the broadcast band.

A common vacuum tube-detector was the 01A or similar triode which has a plate, grid and cathode. These can be compared very approximately in function to the drain, gate and source respectively of the field-effect transistor. This fact permits an explanatory comparison of the old and the new because FET's are used in the 8100.



**Figure 1** This is an early vacuum tube version of a regenerative detector. It goes back to the twenties and shows how a feedback coil (called a "tickler" coil) produced regeneration with magnetic coupling between coils L1 and L2.

In the regenerative detector circuit of Fig. 1 the incoming modulated r-f signal is applied to an input resonant circuit L1 and C1, which is tuned to its resonant frequency. Detection or recovery of the sound portion of the r-f wave occurs because of the negative grid bias that appears on capacitor C2 as the result of the grid current flow in resistor R. Such biasing causes non-linear operation and, as in a diode detector, the modulated r-f wave is rectified and the radio is demodulated and appears across capacitor C3 in the plate output circuit.

There is a path for the r-f signal from the plate back to the input by way of feedback coil L2. The magnetic field from L2 induces a reinforcing radio-frequency component into L1 which develops an amplified in-phase r-f voltage across the input circuit. A proper amount of feedback, up to a point, amplifies the signal producing a stronger and stronger output. This is known as positive feedback. If oscillation is allowed to build up to an excessive level, self-oscillation of the tube circuit begins and knocks out the input signal. Thus it is necessary that the amount of feedback be

controlled to a proper level for the best reception of AM, SSB and CW signals. The feedback level is controlled by the spacing and angle of the feedback coil, L2, relative to the fixed position of the input coil L1.

For the best reception of an AM signal the feedback is set just to the point at which oscillation begins and, then, it is backed away from oscillation very slightly. In the reception of CW and sideband signals, the strongest signal is demodulated with feedback set just to the point at which oscillations begin.

The above critical settings are disturbed by hand capacity when making adjustments. Both influence the frequency and the regeneration activity in the L1 and L2 circuits. Just touching the antenna lead could detune the circuits. Consequently shielding and other steps were important in the design and operation of the early regenerative receivers. However, the early regenerative sets were never completely free of these problems.

### 8100 REGENERATIVE OSCILLATOR/DETECTOR

The MFJ-8100 employs one of the three field-effect transistors as an r-f amplifier (Q3), Fig. 2. There follows the detector (Q2) and oscillator feedback path. A radio-frequency component from the source of Q2 passes through the regeneration control potentiometer and the injection transistor Q1, back to the input of the detector. This feedback link functions in the same manner as does the feedback coil of Fig. 1. However, with the no-coil arrangement, hand capacity and other signal instability effects are reduced considerably.

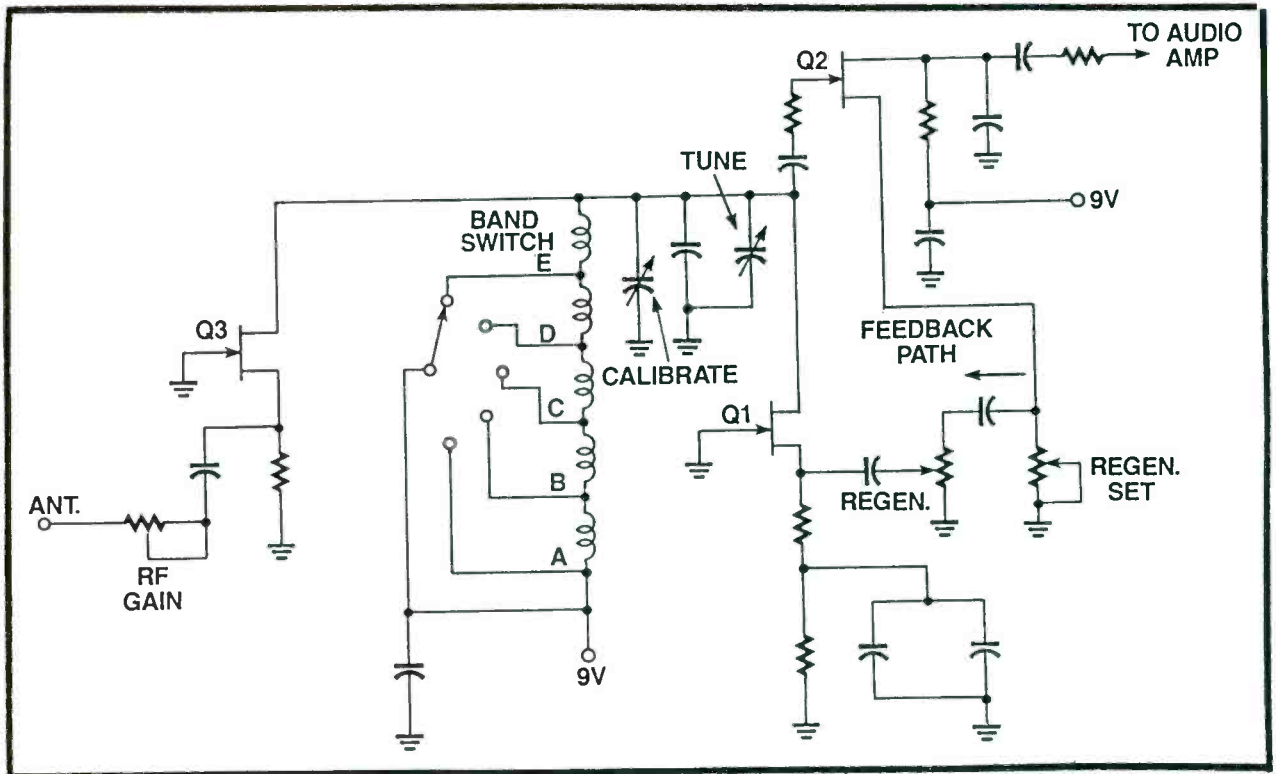
The level of the feedback is controlled by the front-panel regeneration control. The regeneration control is factory adjusted for optimum and smooth control of regeneration on all five bands. In the reception of AM signals the regeneration circuit is set just below the oscillation crossover. To receive CW and side-band signals, the regeneration is set to the oscillating position, slightly on the other side of the crossover. The manuals supplied with the receiver are well done and emphasize proper tuning of the regenerative radio in detail.

The input r-f stage operates as a ground-gate amplifier. It has a low-impedance input and isolates the antenna from the oscillating section to prevent hand-effect and radiation of a spurious signal from the oscillator of the detector/oscillator section of the receiver. The band-switching resonant circuits are in the Q3 drain circuit. The amplified radio-frequency signal passes from here to the gate input of the detector, Q2. The feedback signal also arrives here from the drain of transistor Q1.

The tune control and bandswitch are on the front panel as is the regeneration control. The regeneration-set control and the calibrate capacitor are mounted internally and can be seen when the cover is removed, Fig. 3. The r-f gain control is also inside but is accessible for adjustment through a hole at the rear of the receiver. The volume control is located on the right side of the panel. However, it is a part of the audio-chip circuit which is not shown in Fig. 2.

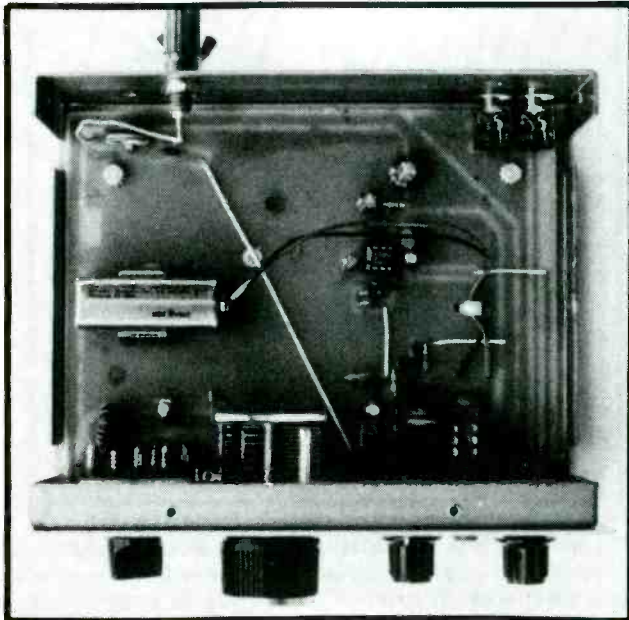
### SET-UP FOR A POOR LOCATION

My location is an apartment in a poured-concrete



**Figure 2** This circuit uses two Field-effect transistors to produce regeneration without inductive feedback. As a result, adverse capacitive effects are minimized compared to the use of a Feedback coil or winding.

high-rise building. Couple that with cable noise, TV sets and harmonic radiation from a local broadcast station less than two miles away and you have a tough site for a receiver to operate but it does. It was interesting to try the small solid-state regenerative receiver in this environment. There were some successes and some problems too. Also, there were some answers as to



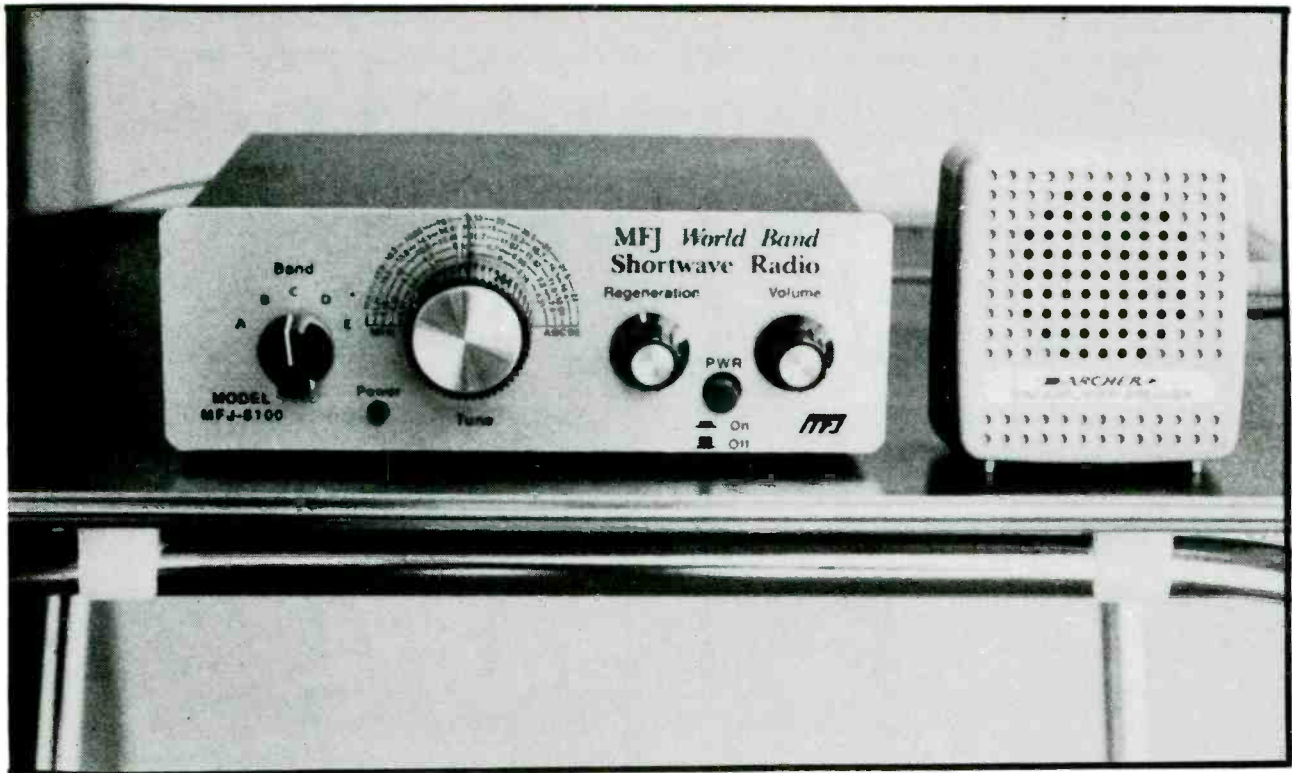
**Figure 3** Internal view of receiver. Antenna terminal shows at lower right. R-F gain control is to the right. Coils are at the top with calibrate-control nearby.

how to improve results. A major objective is to come up with a procedure for obtaining the best results despite a difficult site situation. The fun was to realize just how much short-wave listening enjoyment can be gained with a little package of three FETs and an audio chip. It was quite a surprise to note what the little set could do. Away from such a site, it is bound to perform even better and it did.

I learned quickly that a small external audio amplifier was a necessity to enjoy the lower signal levels present in the apartment. Radio Shack had just what was needed, Fig. 4. I had one of these units for a number of years to help boost weak signals when I didn't want to use a headset. It was a special help for me because of my own hearing which is less than good. The current Radio Shack model number is 277-1008 (\$11.95). It requires a 9V battery and has 1/8th inch mono-output and input jacks. Since the receiver output uses stereo jacks, one must insert the mono-plug on the line from the external amplifier into one of the output jacks of the receiver until contact is made. If you push further you will short-out the receivers audio signal.

If you wish to listen to the **external amplifier output on a headset**, insert the headset stereo plug part way into the auxiliary output jack of the amplifier. When you do so the speaker of the amplifier also disconnects. You now have a very strong headset signal.

The stereo jacks were designed into the radio set because most headsets (such as Walkman) use stereo plugs. You certainly don't receive stereo signals with the receiver. The arrangement above is just a mechanical convenience in making connections between the



**Figure 4** Small amplifier/speaker combination raises audio level for better listening when signals are weak. You can plug headset into amplifier auxiliary output if you want more audio with loudspeaker off.

receiver output (stereo jack) and the input (the mono-input jack) of the amplifier.

### ANTENNA

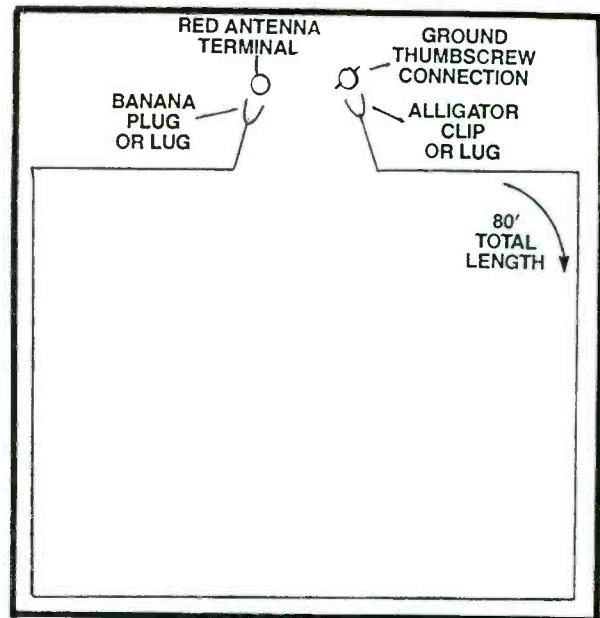
A good antenna is essential in improving results in any bad situation. There are many types to try and evaluate on each band. You can do your own experiments over a period of time. This too is a part of the fun of enjoying a regenerative receiver.

The antenna that did the most for this location was an 80-foot loop squared around the apartment borders as best you can. Use thin wire that is insulated and pliable so that it can be hidden along the baseboard or run under the carpet. Keep clear of metallic surfaces. Reasonable wire is insulated LITZ wire, if you can find it. Number 22 or 24 gauge hook-up wire is fine.

Route the wire from the antenna binding post over the loop path and then back to the point at which the radio is to be operated. Mount a banana plug on one wire and an alligator clip on the other. The banana plug can be inserted into the antenna post. The alligator can be clipped to the ground screw. The results vary. On some bands or parts of one band the sensitivity may be better with the clip connected. The alligator clip makes it easy to connect and disconnect the side of the antenna from the receiver ground post. At times harmonics of the nearby local AM broadcast transmitter gave me trouble on low frequency bands with the clip connected. However, the hand-effect problem, in particular, is less severe with the clip of the loop connected to the ground post.

### SOME TUNING TIPS

The same regenerative receiver tuning procedures as given earlier in this article, as well as the procedures as given in the 8100 manuals are appropriate for tuning



**Figure 5** This is an illustration of a Horizontal Loop Antenna. The loop need not be squared or a rectangle. Just wind it around the edges of your apartment as best you can. Three possible connections can be made, according to performance. Antenna total length can be more or less, depending upon available space.

the receiver in a poor location. These procedures, you will learn quickly for good receiving locations and high level signals. In the case of a poor location, it must be done more finely and carefully. You must move the tune and regenerative controls very slowly. It takes patience and concentration to tune in the weak signals. If it is a weak AM signal coming in, you must gently move the regeneration control across the regeneration to the no-generation crossover point. Then you must barely move the tune control for best clarity. You must have a gentle touch in adjusting the tune and regenerative controls on weak signals.

When you tune to a station on some other frequency, you can expect that the crossover point moved also and you must repeat the procedure again. It is important to emphasize that the stronger the signal, the easier the tuning. In the evenings when signals are strong, one setting of the regeneration control may be practical for use over quite a span of frequency. Then you are able to use the tune control to choose several stations. In this case it is just like tuning a dial-type AM radio except that only a limited number of stations can be brought in over a rather narrow range of frequency.

When you have made a modest change in fre-

quency, or change bands, the first thing you must do is find the crossover point. Then start the previous procedure when you hear the heterodyne whistle of a station you tuned past. You will soon catch on.

Try tuning in strong signals and then work down to weaker and weaker ones. First tune in some strong evening stations and then some that are a bit weaker. The best band to select for initial tuning experience at night is the 31 meter band which covers a range between 9500 and 9000. This is position C on your band switch.

Next try some strong day station, such as Voice of America, Radio Canada, WRNO, Christian Science Monitor News Service and other strong North American stations. Then you can try some of the weaker DX signals transmitting on the shortwave bands picked up on positions D and E of your band switch. Mail-in information and other program listing data can be found in my MFJ book, "Short Wave Listeners Guide for Apartment/Condo Dwellers." Short wave listening is fun and there is something special about it when you use circuits designed many years ago but which have now been adapted for use with solid-state devices. Happy listening. ■

## SHORTWAVE LISTENERS GUIDE FOR APARTMENT/CONDO DWELLERS

By Ed Noll

### Shortwave Listener's Guide for Apartment/Condo Dwellers

Edward M. Noll, W3FQJ



Voice of America  
K239 Radio Receiver



Germany Radio Broadcast Center  
Federal Republic of Germany



Radio Prague, Czechoslovakia



Radio Beijing, China



Radio Canada International  
Ottawa, Canada



Radio Atlantic Canada  
Antigonish, Canada



IC-20 Dynamic Mechanism of Portable Antenna  
(Previously called the "egg antenna")  
K239 Radio Receiver

A starter book about shortwave program listening with instructions for effective use of indoor antennas and accessories. You will learn where and when to listen for those signals that permit you to enjoy program content from remote corners of the world despite the limitations of your location.

Instructions help you to layout thin hook-up wire into effective antennas. Accessory items can be added to further boost weak signals. Information in this book will be helpful to all shortwave listeners, regardless of age, who are interested in enjoying programs being broadcast in English and directed to North America each evening from all over the world.

The hobby of **Shortwave Listening** has been revolutionized by numerous reasonably-priced Portable Receivers with digital frequency displays that make tuning easy. This "Guide" allows you to take advantage of a Receiver's Memory positions in planning your listening schedule. High cost, poor performance, and poor location are no longer valid excuses for not enjoying this rewarding hobby. For those of you who have retired and now live in apartments and condos, you will find the selectivity of modern Receivers makes **Shortwave Listening** a stimulating hobby...especially for Senior Citizens.

**Shortwave Listening** offers much for the younger generation also. It provides young people a means to evaluate different cultures, languages, music, news, geography and world politics. Shortwave Receivers are now being used extensively at all levels of High School and College. Any student can set up a **listening post** at home and enjoy good night-time reception and weekend programs.

**SHORTWAVE LISTENER'S GUIDE (\$9.95) plus shipping and handling (\$3.00 USA \$8.00 Overseas)** Contact MFJ Books, P.O. Box #494, Mississippi State, MS 39762.

# SERVICING CORDLESS TOOLS

By  
Homer L. Davidson



**The most common cordless power tools found on the hobbyists workbench are the cordless soldering iron, the screwdriver and the drill. Since they all operate from batteries, these tools can be operated anyplace. They usually operate from 2 to 5 small nickel-cadmium batteries. These rechargeable batteries have a normal charge of 1.2 dc volts.**

**T**he cordless soldering iron and the cordless screwdriver may have their own charging cradles, while the power drill may be charged through a jack or plug. When the batteries run down, the motor may run slow and stop, the pilot light will go dim, and the soldering iron will take a long time to heat up. All of these cordless tools have a charging device that comes with the tool. Proper battery charging and simple tool repairs will keep these cordless tools operating for many years.

## BATTERY CHECKS

The nickel-cadmium battery should be charged after the motor slows down or the soldering iron will not heat up. Charge the cordless tool batteries just like you do a cordless razor. When the tools are not used for three months or more, charge them up again. If the cordless tool is left out in the garage, truck or car, it may take several days to charge up, however, most cordless tools will charge up in 2 to 3 hours.

Check the battery voltage with a VOM or DMM pocket tester (Fig. 1). Remember the total voltage is 1.2 volts, compared to 1.5 volts of a flashlight battery. These batteries are wired in series to provide correct

operating voltage for a motor or soldering iron. The small cordless screwdriver may operate from 2 batteries in series, while the cordless drill has five batteries (Fig. 2).

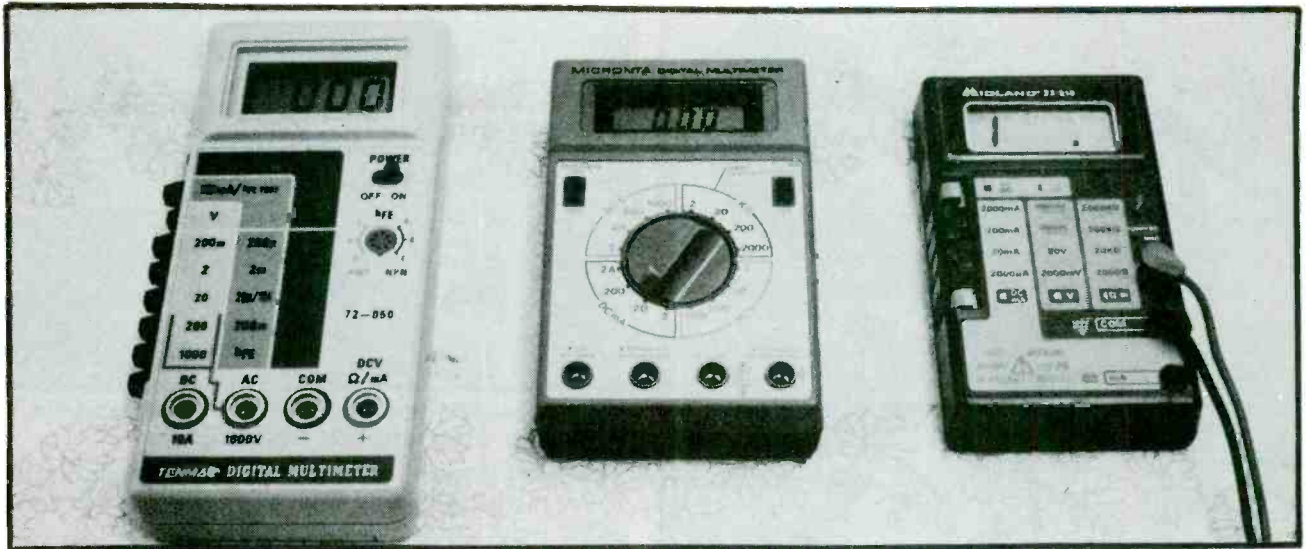
Simply measure the total voltage at the dc motor terminals. If the battery voltage is good at the motor terminals and there is no rotation, suspect a defective motor. Check the battery terminals for clean and good soldered connections. Test for motor continuity with the low-ohm scale of the DMM. Charge up the batteries if the voltage test at the motor is low (Fig. 3).

## CONTINUITY TESTS

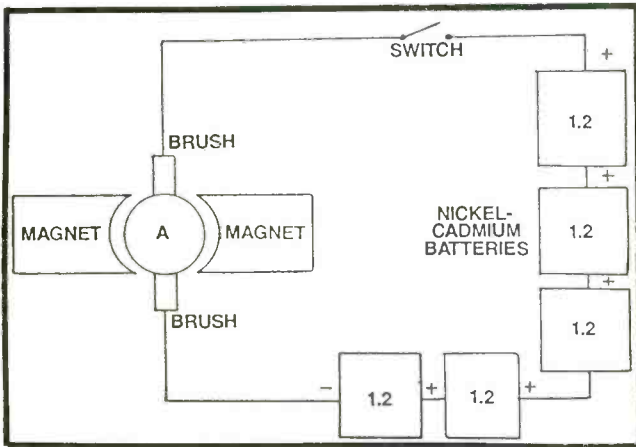
Set the DMM or VOM at Rx1 scale and take continuity measurements when the motor will not rotate, the iron does not heat up or the switch does not function. First, take voltage measurements across the batteries in series or at the motor terminals.

A resistance or continuity measurement across the motor terminals should have a normal reading of less than 1 ohm (Fig. 4). No measurement may indicate an open armature winding, poor brush contacts or broken internal wiring. Rotate the motor armature by hand and take another measurement.





**Figure 1: Choose a DMM if you do not have a small VOM to make continuity and resistance measurements on the cordless tools.**



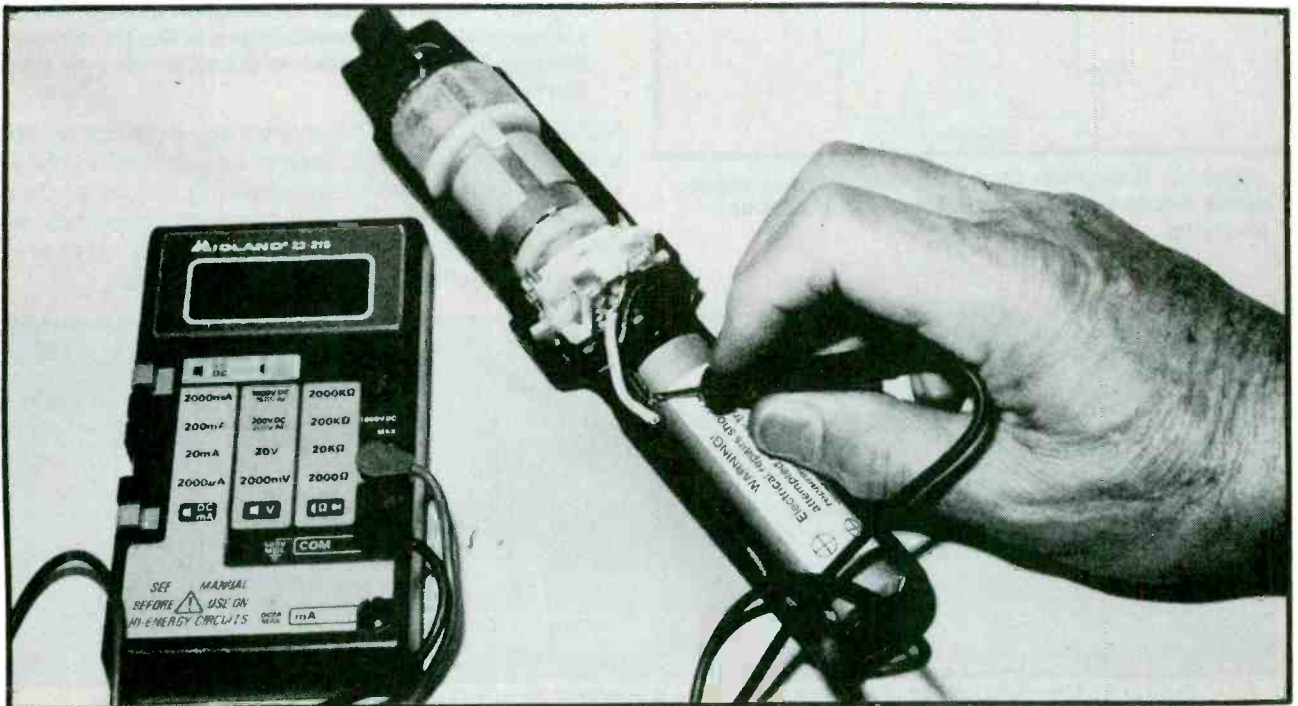
**Figure 2: The cordless screwdriver or drill may have 2 or more nickel-cadmium batteries.**

For intermittent operation, check continuity of the on/off and speed switches. A dirty or worn switch may show an intermittent reading or higher resistance than 1 ohm. Check the charging plug or jack and the polarity diode when the battery will not charge up. Inspect the soldering connections (Fig. 5).

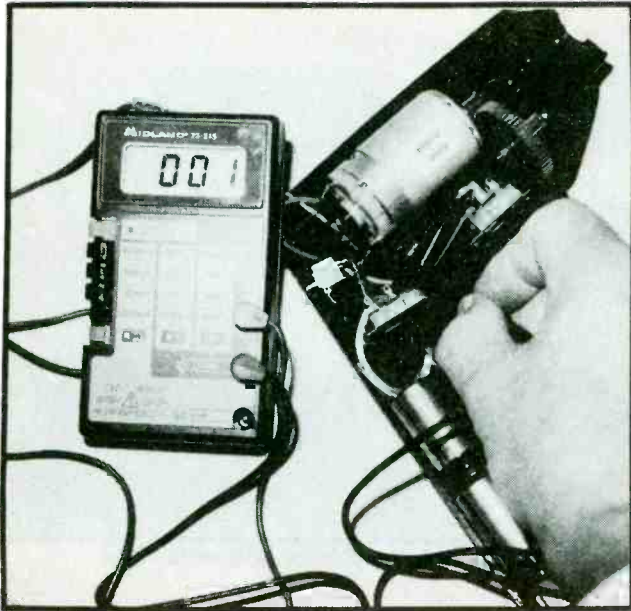
### THE DC MOTOR

The small motor found in the cordless screwdriver or drill is a dc motor. Instead of field coils, permanent magnets are used. The dc motor circuits of slip-type brushes, commutator or armature winding, field magnets and end bearings (Fig. 6). A drop of light oil on the end bearings may quiet a squealing bearing. Most dc motors do not require outside lubrication.

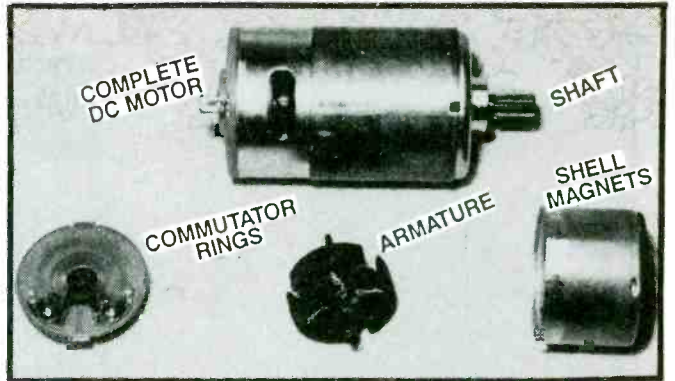
Besides the dc motor, the cordless screwdriver or drill, may have a reversible switch. To simply change di-



**Figure 3: Check the batteries or battery pak when the cordless tool will not operate.**



**Figure 4:** Take a continuity check across the motor terminals when the motor will not operate.

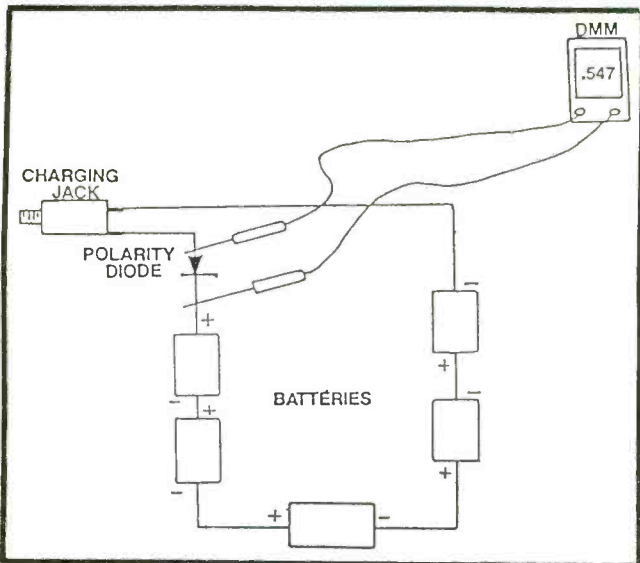


**Figure 6:** The dc motor consists of a commutator, brushes, armature, and field magnets.

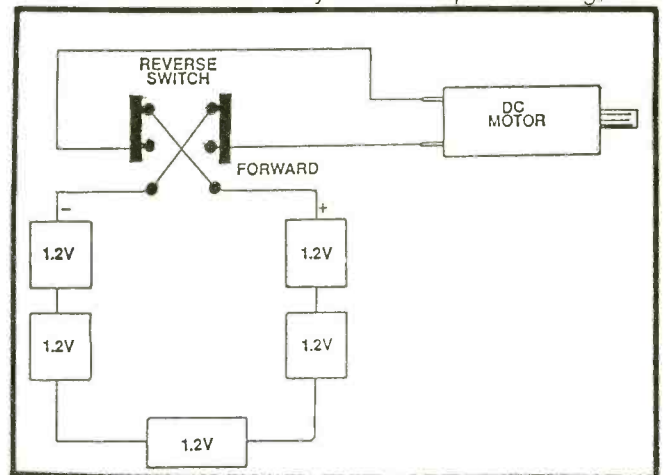
rection of the motor, reverse the battery polarity applied to the motor terminals (Fig. 7). A high or low speed switch may be found in some models.

### MOTOR PROBLEMS

The small dc motor may have an open winding, de-

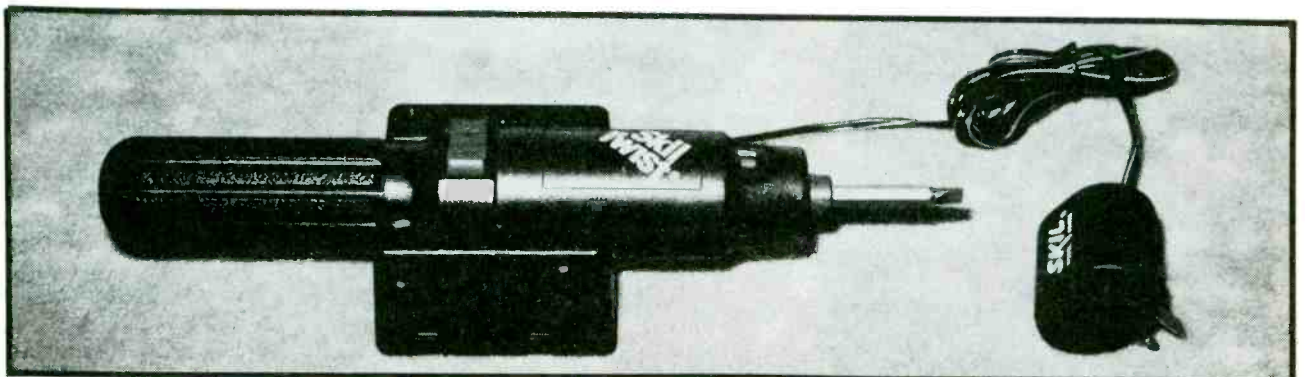


**Figure 5:** Check the charging diode with a DMM-diode test or battery connections for improper charging.

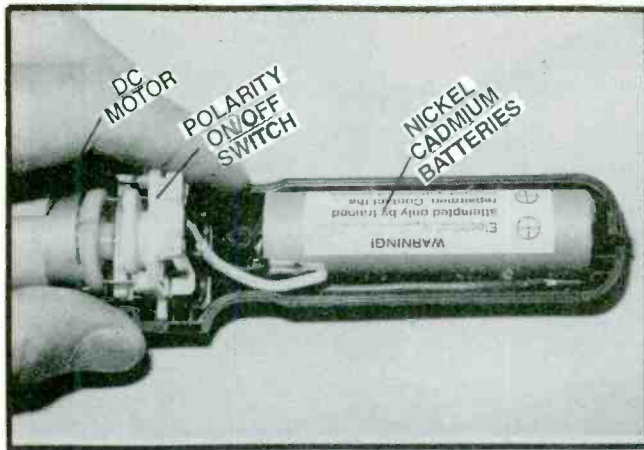


**Figure 7:** To reverse the screwdriver or drill, the dc voltage polarity is interchanged to the dc motor. Usually, a D.P.D.T. switch is found for reverse and forward motion.

fective brush, broken internal wiring, dirty commutator, and/or frozen bearings. Suspect oil on the brushes or worn brushes when excessive arcing occurs inside the motor. Open continuity or high motor resistance may result from an open brush, hung up brush, open armature winding, and/or a real dirty commutator.



**Figure 8:** The cordless screwdriver may have a straight or pistol-grip body. This cordless screwdriver clips into the holder for charging.



**Figure 9: The spring loaded rocker switch changes the polarity of batteries to reverse or forward the small dc motor.**

Motor repair is fairly limited. A dirty commutator can be cleaned with sandpaper and cleaning fluid. Broken wires can be spliced together. Replacing worn brushes and broken slip-type rings are major problems. Spray cleaning fluid on the end bearings and lubricate with light oil for a frozen or squeaky bearing. Check for cost of motor replacement before ordering a new motor.

#### THE CORDLESS SCREWDRIVER

The cordless screwdriver can remove and replace screws and bolts in a very short time. Most power screwdrivers have a greater torque factor than a regular screwdriver. Extra power can be applied to a stubborn screw with a pistol-grip type cordless screwdriver.

Like most cordless tools, the screwdriver has its own stand or transformer (Fig. 8). The cordless screwdriver has interchangeable screw tips to remove the many different type screws or bolts. Keep the cordless screwdriver in the charging stand when not in use.

The cordless screwdriver must be able to remove or drive in the screw or bolt. So a reversible switch is found to change polarity upon the small dc motor. The pistol-grip screwdriver may have a trigger off/on switch, plus a reversible direction switch. The rocker-type switch is found in the straight-body screwdriver. Simply, push down on one side of the switch for reverse and the other side for forward motion (Fig. 9).

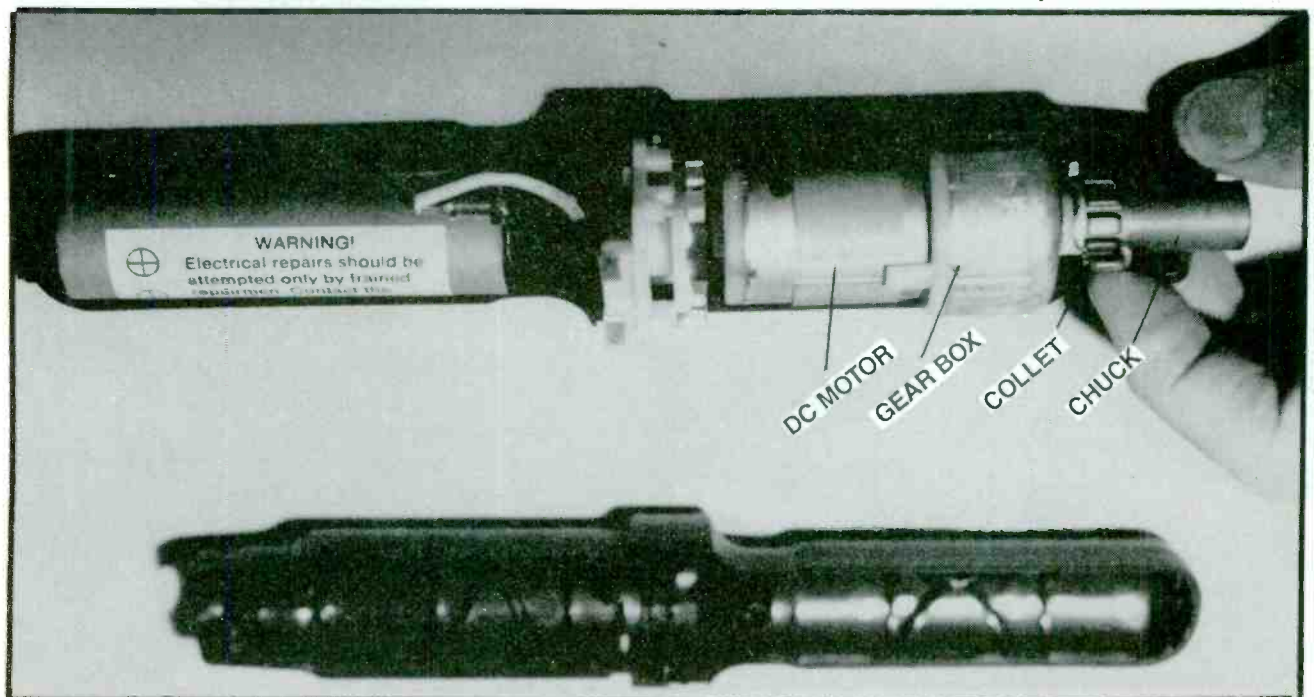
The cordless screwdriver may be powered with 2 or more batteries. The nickel-cadmium batteries may be in a pak or separate. A reduction gear assembly provides extra torque and power. The collet chuck locks the screwdriver so it can be used manually. Do not apply power with chuck locked into position (Fig. 10).

Most screwdriver problems are weak batteries, poor switch contacts, and broken internal wiring. Measure the voltage applied to the motor contacts. Check for motor continuity when correct voltage is applied. Remember a 2-cell battery pak produces only 2.4 volts dc. The five batteries wired in series equals 6 volts.

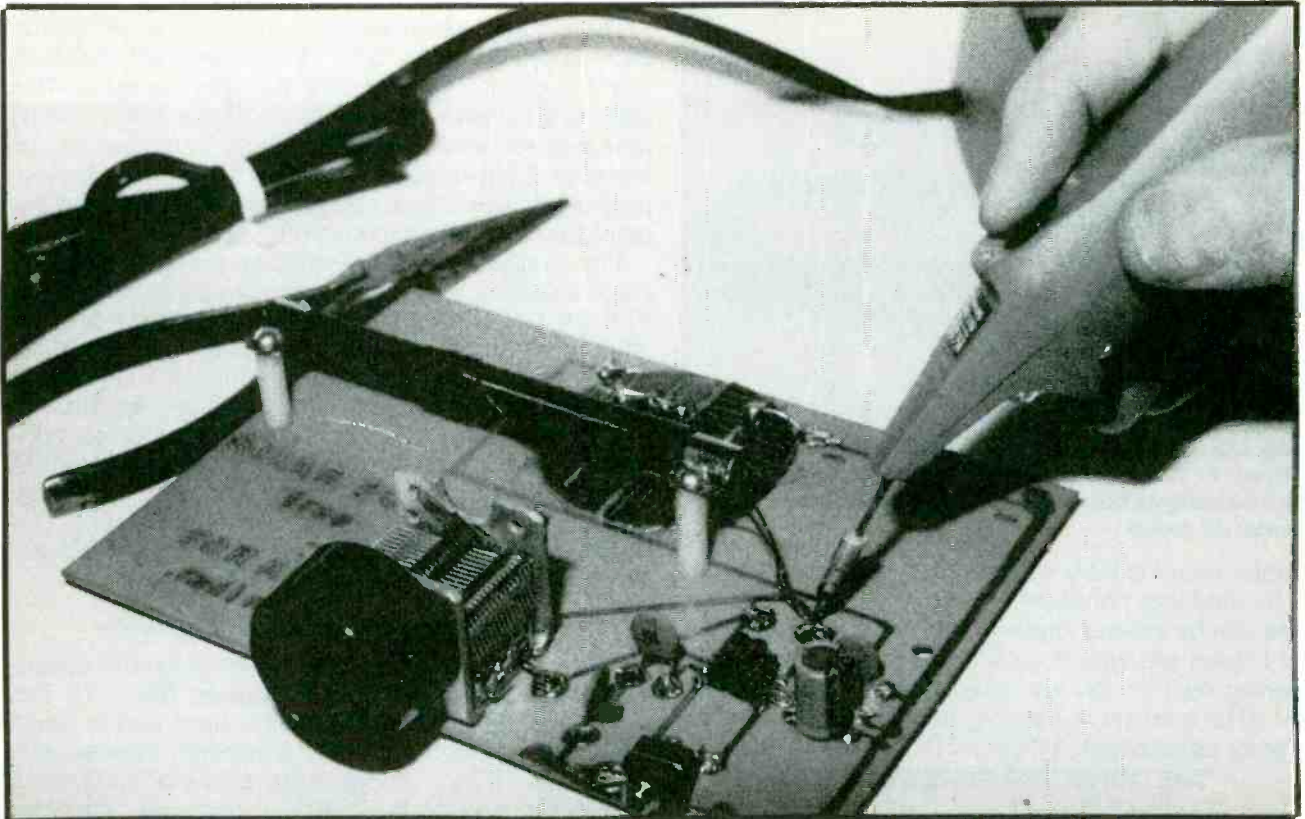
#### THE CORDLESS SOLDERING IRON

The battery operated soldering iron is ideal in soldering up transistors and IC components (Fig. 11). The small iron tip provides adequate heat and is small enough to prevent overlapping soldered connections. Of course, a pair of long nose pliers or heat sinks should be used on the transistor terminals, since too much heat may destroy the solid-state component.

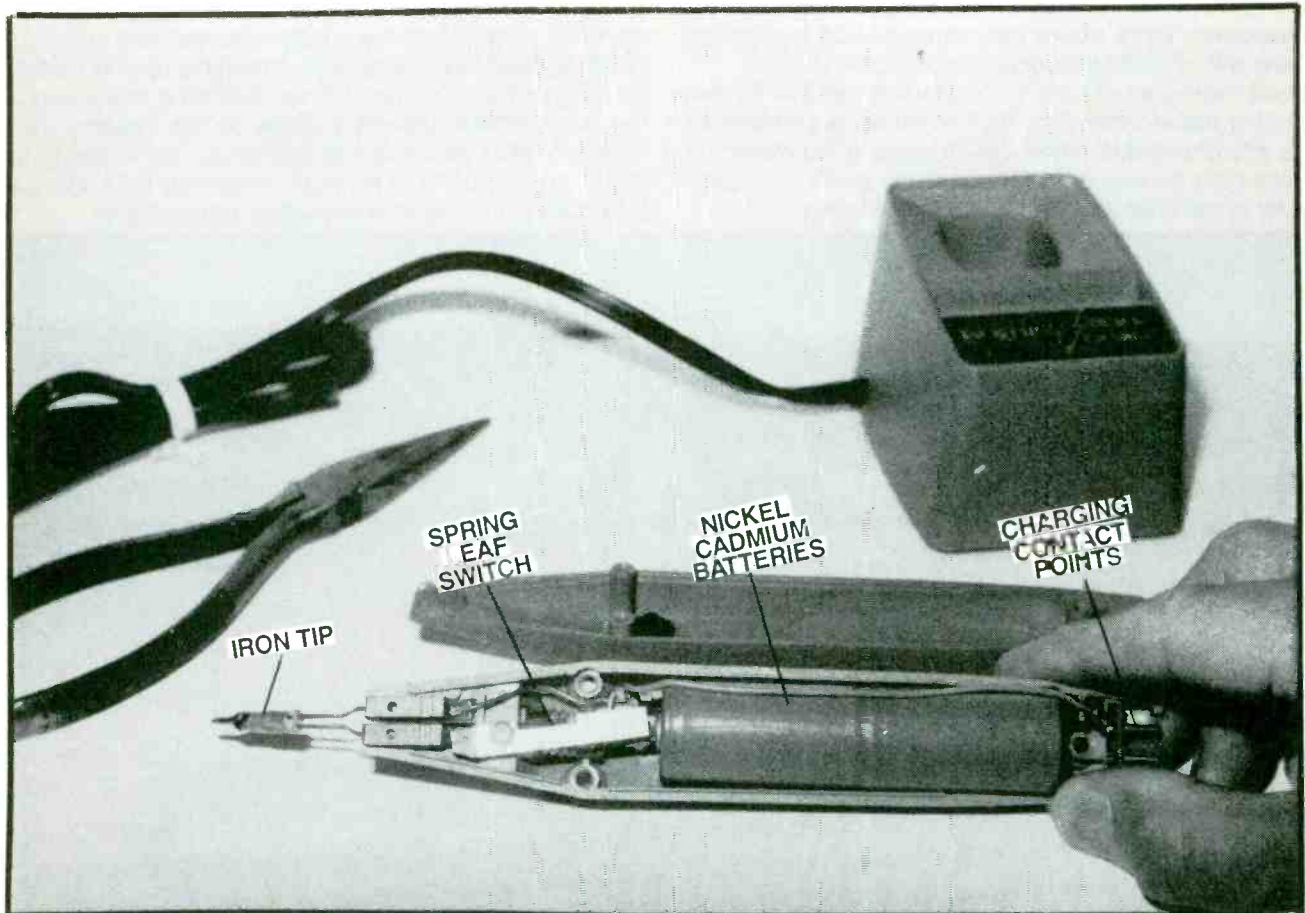
The nickel-cadmium batteries or battery pak is charged when left in the cradle. The two iron contacts short against loading springs, charging up the batteries. A finger type button pushes against a metal shorting lever which applies voltage to the heating iron circuit. Within seconds the soldering iron is ready to make connections. The light soldering iron can be taken anywhere where electricity is not available.



**Figure 10: Always, push in on collet lever to release chuck from a locked position, before applying voltage to the dc motor.**



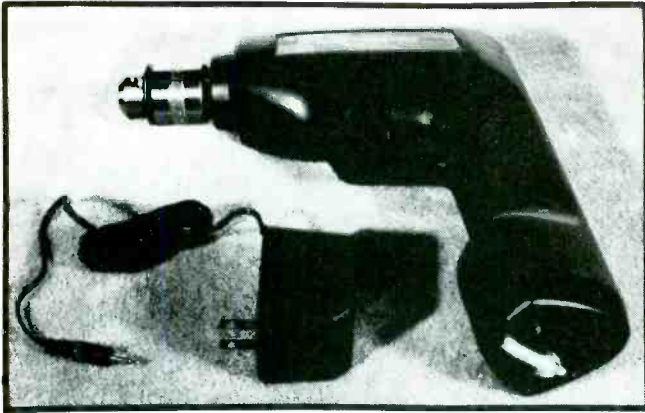
**Figure 11: The cordless soldering iron is ideal for soldering solid-state devices.**



**Figure 12: Check the switch controls, weak batteries or defective iron tip when the iron will not melt down solder.**

## CORDLESS DRILL

Usually, the pistol-grip cordless drill has the nickel-cadmium batteries in the handle area. You may find 4 or 5 batteries in series to operate the single or two speed drill (Fig. 13). A separate plug is used when charging up the batteries from the ac power line. Notice the chuck key is mounted in the bottom area of the handle for safe keeping.



**Figure 13:** The pistol grip cordless drill may have one or two different speeds and charging plug.

Poor switch contacts may cause poor iron heating, intermittent or no voltage applied to the iron tip (Fig. 12). Check the push switch contacts with an ohmmeter. Clean the points with fine sandpaper and contact cleaner solution. Make sure the lever is in line with clean contacts.

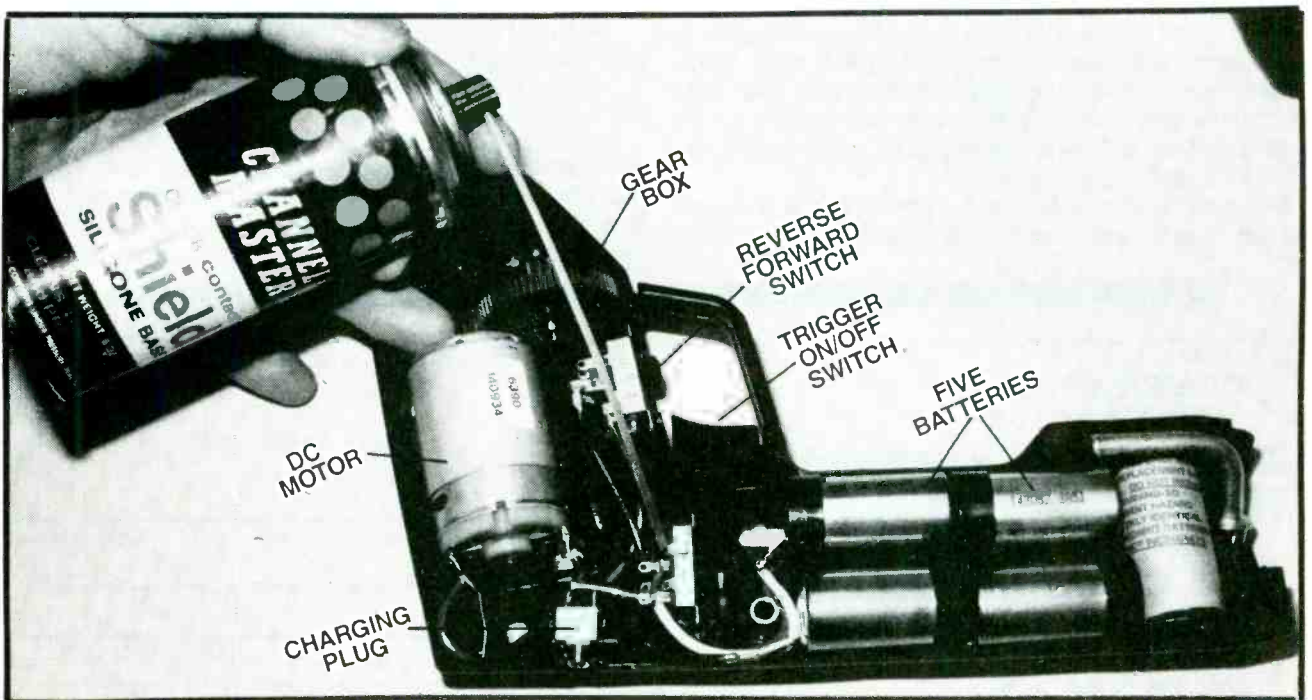
Check the battery voltage applied to the switch assembly. The fully charged battery pak should be around 2.4-2.56 volts. If the battery is normal, check the small iron tip. Some of these iron tips are held tight with small screws, while in the latest models the tip just plugs in. The small iron tip may be damaged when extra pressure is applied while soldering. Replace the defective tip with proper battery voltage.

Clean up the battery charging contacts if charging is intermittent or slow in charging. Look for foreign material down inside the holder. Measure the dc voltage of the charger to determine if the charger consists of only a small power transformer and diode.

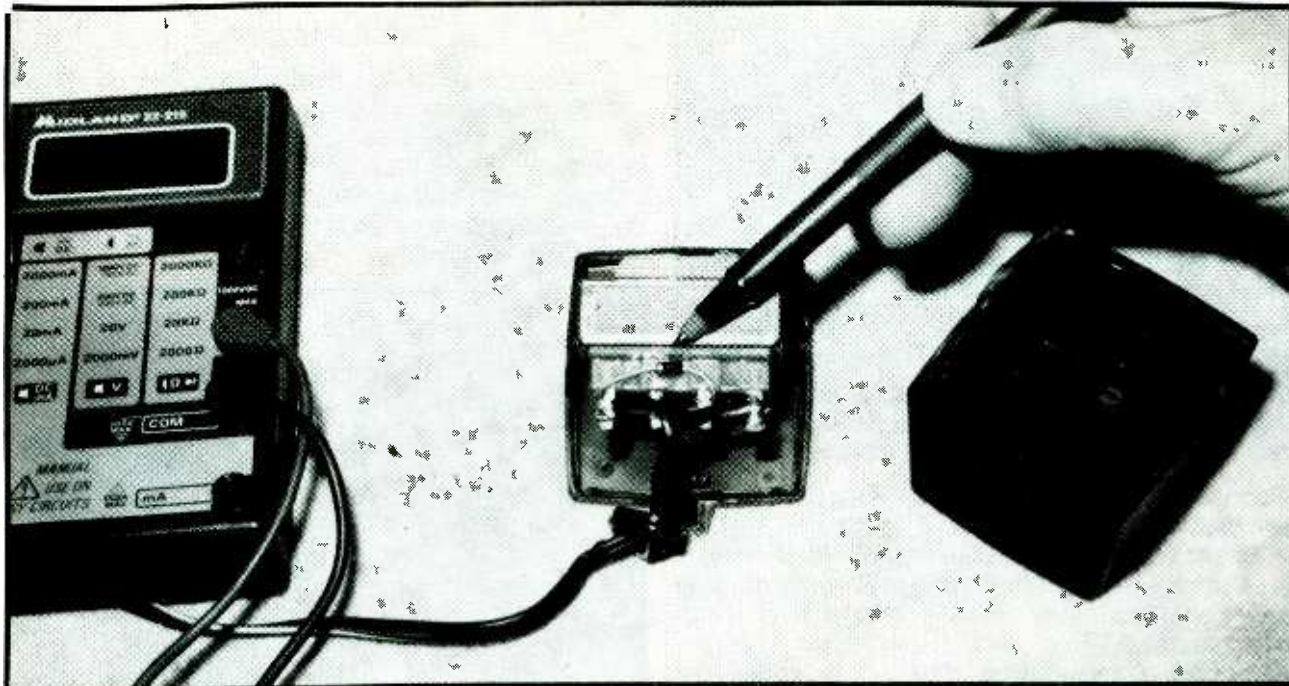


**Figure 14:** Check the motor continuity when normal battery voltage is measured at the motor terminals.

The defective drill may have a defective motor, frozen reduction gear assembly, intermittent switch, or low batteries. The drill will barely rotate with a weak battery.



**Figure 15:** Clean up the slide switches for erratic or intermittent operation. Spray cleaning fluid down inside the switch area.



**Figure 16: Inspect the ac cord, transformer and diode for improper or no battery charging. Check for dc voltage at the charging plug.**

Charge up the batteries if the drill will not rotate. Remove the plastic covers if the batteries will not charge up after 2 or 3 hours.

Check the total voltage of all batteries. If the batteries are normal, remove motor wires and check motor continuity (Fig. 14). The resistance should be less than 1 ohm. If open, rotate the shaft of the motor with a meter attached. Notice if measurement is erratic or intermittent. Inspect internal parts of motor for broken wires or poor brush contacts. Clean up commutator with cleaning fluid or alcohol.

If the on/off or speed switch is erratic or intermittent, spray cleaning fluid down inside the switch area. Work switch back and forth to clean up contacts (Fig. 15). Most of the defective slide switches can be replaced. In larger cordless drills most parts can be ordered through the manufacturer parts depot.

Remove the motor assembly from the drill if chuck will not rotate. Clean up the reduction gear assembly

with cleaning fluid. Remove old grease and replace. Lubricate bearings with light oil. Apply a couple of drops of light oil on both ends if noisy or frozen. Spray silicone cleaning fluid in the noisy gear box assembly.

Check the dc charging voltage when the batteries will not charge up. Inspect the ac cord where it goes into the plastic charger housing. Set DMM scale at Rx1 and check resistance across the ac plug terminals. Intermittent or no resistance may indicate an open or broken ac cord. Check the small half-wave diode on the DMM diode test (Fig. 16).

You may find one or two batteries that will not charge up. Most can be replaced individually or the whole battery pak. They are easily removed with spade wire connections to the drill circuits.

Sometimes nickel-cadmium batteries can be charged by placing a higher dc voltage across the battery pak. **Be real careful. Place a cloth or towel over batteries to be charged.** Replace batteries if not charged up within 2 or 3 hours with this method. ■

**SUBSCRIBER SERVICE**

**CHANGE OF ADDRESS**

Planning to move? Please let us know six weeks in advance so you won't miss a single issue of

**ELECTRONICS HANDBOOK**

Attach old label and print new address in space provided.

**ELECTRONICS HANDBOOK**

P.O. Box #5148  
N. Branch, N.J. 08876



ATTACH LABEL HERE

NEW ADDRESS HERE

PLEASE PRINT

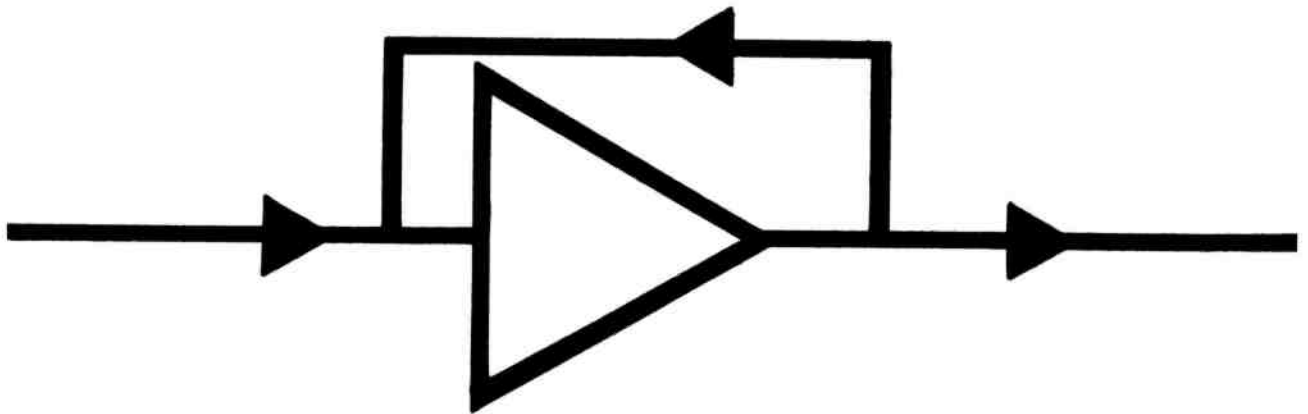
NAME \_\_\_\_\_

ADDRESS \_\_\_\_\_

CITY \_\_\_\_\_ STATE \_\_\_\_\_

DATE \_\_\_\_\_ V15 ZIP \_\_\_\_\_

# IC TESTBENCH



## POWER ADAPTER UPGRADE



Power adapters commonly used for powering calculators come in a variety of useful DC voltages (3, 6, 9, 12 volts typically). Cassette recorders, portable radios, etc., often are powered by 4 (1.5) volt batteries i.e. a total of 6 volts. These low cost adapters are excellent potential sources for powering cassette recorders, where the heavy current drain from the motor soon drains the batteries. In their original form, however, power adapters are inadequate for the following reasons:

1. The actual output voltage will depend upon the load connected. An, as labelled, 9V adapter such as the Radio Shack (273-1455), will measure several volts above 9 volts, depending upon the impedance of the meter used to measure the voltage.

2. For use with radios, there is often discernible hum from the speaker.

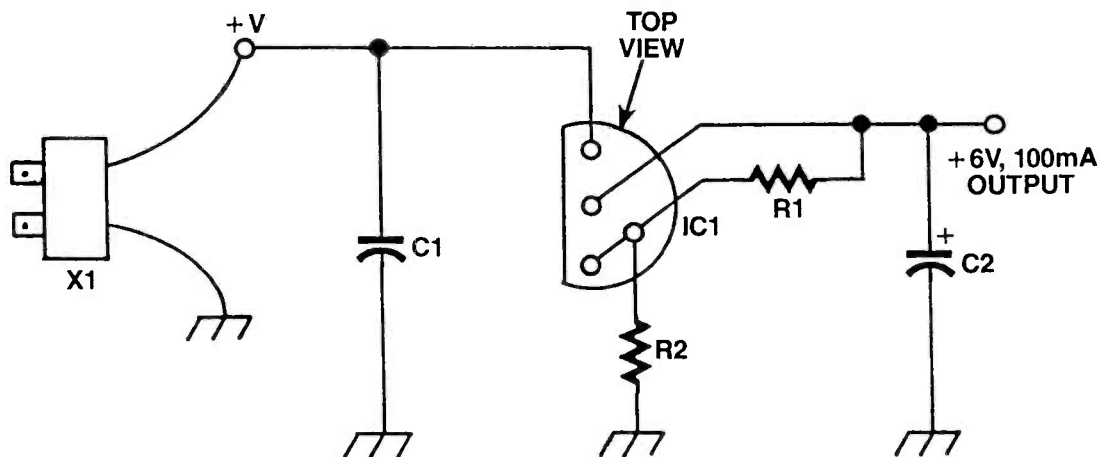
We, therefore, need to provide an upgrade. The circuit shown here uses a three terminal regulator (IC1), to provide an accurate 6 volts output. The output is controlled by R2. R1 is part of the regulator require-

ments. Capacitor C1 is also part of the required design. Capacitor C2, a large electrolytic, on the output smooths away most of the annoying hum. Changes in load resistance are controlled by IC1 so the output is constant irrespective of the load. The value of R2 is that measured across a variable resistor, after a 6 volt output has been obtained. The value is not critical—any value of R2 to give an output voltage of 5.8V to 6.2V is satisfactory.

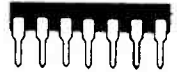
100mA of output current can be supplied from the IC shown. For most applications, this is quite adequate. Other adapters can also be used. The output stability is excellent! ■

### PARTS LIST FOR THE POWER ADAPTER UPGRADE

- IC1 — LM317 3 terminal adjustable regulator
- R1 — 210 ohm resistor
- R2 — 745 ohm resistor (for 6 volt output)
- C1 — 0.1 microfarad capacitor
- C2 — 1000uF/35 volt capacitor
- X1 — 9 volt adapter (Radio Shack 273-1455 or similar)



# HOBBY MOTOR SPEED CONTROL



These days, there are plenty of small high-speed drills that can be run from a small power supply. This little project gives much greater control to your drill at low speeds and uses pulse width modulation.

If you've ever made your own printed circuit boards, then you'll know how handy a little hobby drill can be. These are used to drill the 1mm holes that the components fit through onto the board. The great thing is that they only require 12VDC at currents of 1 amp or so—this in a package which fits easily into the palm of your hand.

However, as with all motors, they don't run particularly well at low speeds when you're trying to line up the bit or do that special job. The speed can jump around all over the place and make the task almost impossible.

This little circuit uses a technique called Pulse Width Modulation and does it all using just one IC and a few other components. Let's take a look and see how it all works.

## Circuit Diagram

IC1 is a CMOS 4011 quad NAND gate IC with IC1a and IC1b connected as a variable-pulse-width oscillator. The frequency of this oscillator is set by VR1 and C1 while VR1 sets the pulse width.

Looking at this section of the circuit in more detail, diode D1 restricts flow by redirecting it so that the capacitor can be charged and discharged at rates set by VR1, which sets the pulse width.

By pulse width, we are talking about the ratio of time the output is high to the time that it is low. If the output is high for only half the time, the average DC voltage is

half the supply. If the output is high for only 25% of the time, then the average DC voltage is only a quarter of the supply.

When VR1 is turned so that the wiper is closest to D1, the pulse width will be at its minimum and when it is closest to D2, the pulse width will be at its maximum.

The subsequent signal from the output of IC1b is coupled to IC1c and IC1d which are coupled in parallel to increase the current output. This circuit arrangement is valid so long as the two gates being paralleled perform the same function.

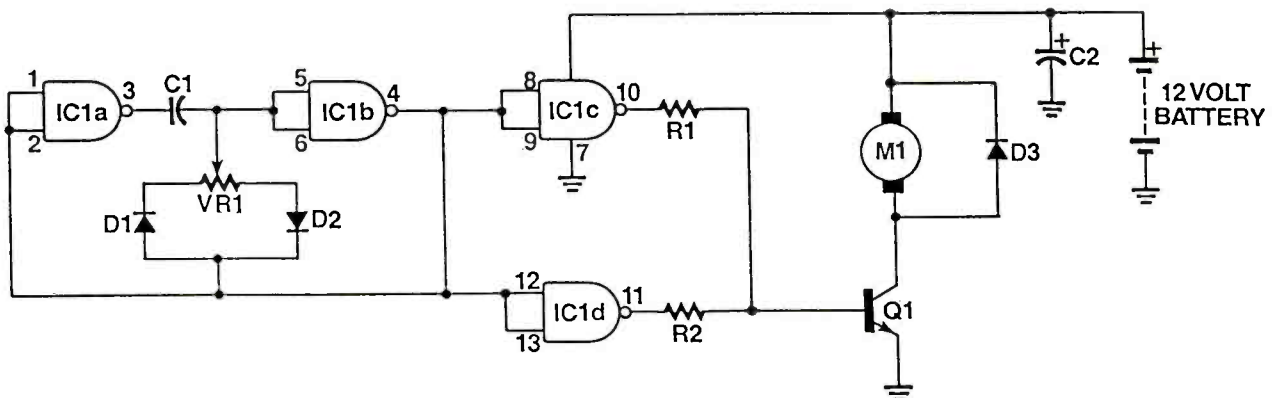
The outputs at pins 10 and 11 feed resistors R1 and R2, which in turn drive transistor Q1 and turn the motor on and off at varying rates. Although the frequency remains the same, it is the pulse width or 'duty cycle' which sets the speed of the motor. The thing is that the motor cannot respond as quickly to the on-off-on-off power that is applied and instead, integrates or averages out the power being applied.

The benefit though is at low speeds the motor will no longer stall since the pulses of power will still give the motor enough torque to turn, albeit slowly. Diode D3 protects transistor Q1 from negative voltage spikes which are produced by the motor's coil. Capacitor C2 supplies the circuit with decoupling and stabilizes the speed circuitry.

This controller can be built into a small box where the rotary control of VR1 can be put on the front panel within easy reach of the drill. It shouldn't be used for motors that pull more than 2 amps of current and Q1 should be mounted on a small heatsink if the current consumption goes beyond 1 amp. ■

## PARTS LIST FOR THE HOBBY MOTOR SPEED CONTROL

- C1—0.1 $\mu$ F, mylar, capacitor
- D1, D2—1N4148, small signal, silicon, diode
- D3—1N4004, rectifier, diode
- IC1—CMOS, 4011 IC
- M1—12VDC, motor, (PCB drill etc.)
- C2—470 $\mu$ F, 16VW, electrolytic, capacitor
- D1—BD679, NPN, Darlington, transistor
- R1, R2—1.5k $\Omega$ , 1/4W, 5%, resistor





# HEADS OR TAILS



Have you ever been stuck trying to make a decision between something you have to do and something else you'd prefer to do? Well, here's your chance to blame your decision on a small piece of electronics!

In days gone by, the easy way to make a decision was to just toss a coin yet it was never too hard to make the coin land on the side you wanted—by cheating. Now you can make the decision as close to random as you can get with this tiny circuit. It uses two low-cost CMOS ICs and a few other components—whatsmore, you can have it up and running in just a couple of hours.

It will also help to explain how logic circuits work and you can learn quite a bit about digital logic just by building this simple project. Let's take a look at the circuit diagram.

## Circuit Diagram

IC1 is a CMOS 4011 quad NAND IC. IC1a and b are connected to form a squarewave oscillator which runs as soon as the power is applied.

IC2a is one part of a CMOS 4013 dual-D flip flop IC which is connected in a toggle mode. What we mean by 'toggle' mode is that on each incoming clock pulse, the Q output goes alternately high and low. This is achieved by connecting the Q-bar output back into the D input.

The Q-output at pin 1 is connected via resistor R2 to two complementary NPN/PNP transistors which are connected in parallel with two LEDs, LED 1 and 2.

When the Q-output is high, Q1 turns on, since it is an

NPN device, which shorts out LED 1 and allows LED 2 to light. When the Q-output goes low, the reverse happens: Q2 turns on, shorting out LED 2 and lighting up LED 1.

When switch S1 is pressed, it couples the square-wave signal from the output of IC1b into the clock input of IC2a. While it is pressed, the flip flop will be toggling so quickly that it will appear that both LEDs are on all of the time but this is not true. Because our eyes cannot respond quickly to flashing light, it just appears as though they are on continuously.

When you release the button, the toggling will stop as the clock signal is removed. Depending on the state of the flip flop, either of the two LEDs will be lit up and it is impossible to say which since the clock frequency is so high, around 1kHz. The push button should be a momentary-on type.

The project can be run off anything from 6 to 12V but I suggest a 9V battery is as convenient as anything else. ■

## PARTS LIST FOR HEADS OR TAILS

C1—0.01 $\mu$ F, mylar, capacitor

C2—100 $\mu$ F, 16VW, electrolytic, capacitor

R1, R2—10k $\Omega$ , 1/4W, 5%, resistor

R3—680 $\Omega$ , 1/4W, 5%, resistor

IC1—CMOS, 4011, IC

IC2—CMOS, 4013, IC

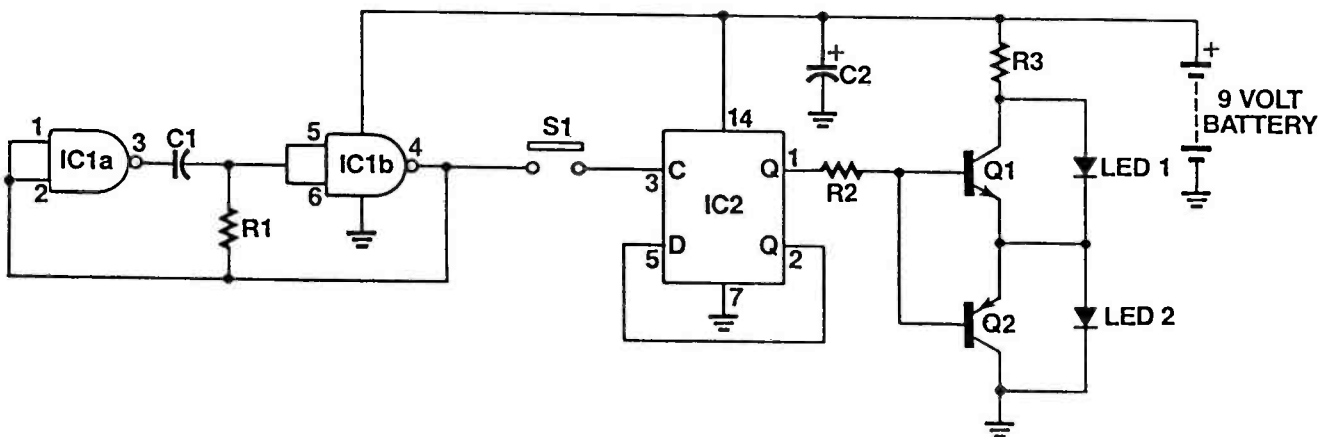
Q1—BC548, NPN, transistor

Q2—BC558, PNP, transistor

S1—SPST, momentary, switch

LED 1, 2—5mm, red, LED

By Darren Yates



# BATTERY OPERATED TOUCH LAMP



Have you seen those 'magic lamps' that turn on and off as soon as you touch them? Well, now you can make your own touch lamp that runs off batteries using only one IC and a handful of other components.

There's no doubt about it. Touch lamps are convenient! You don't have to go fumbling around for a tiny switch somewhere. All you have to do is touch the base of the lamp and it's either on or off as you please!

You can make your own entirely safe battery operated model, which can be used in the car or caravan using only a handful of components in only a couple of hours. Let's take a look and see how the Touch Lamp circuit works.

## Circuit Diagram

As you can see, the circuit uses two NAND gates from a CMOS 4011 quad NAND gate IC, a few resistors and a couple of other components.

IC1a and IC1b are cross connected to form what's called a 'flip flop'. It may sound like a funny name, but the Flip Flop is a basic memory element. If you have a computer, then there may be thousands, maybe even millions of these inside.

Also connected to the inputs of the two gates are two touch pads. They can be made out of thin sheets of aluminum, or even a small piece of perfboard. You need two sets of these — one for the ON switch and one for the OFF switch.

Make sure that these pads don't touch each other, otherwise the circuit will trigger.

What happens is that if you now touch your finger be-

tween the two pads of the ON switch, this pulls the inputs of IC1b high. This forces the output of IC1a high, while holding the output of IC1b and the inputs of IC1a low. The high output of IC1a now turns on transistor Q1 which switches on the light.

What we've done is to flip the circuit into one state. Now let's look at what happens when we touch the OFF pads. This causes the exact same thing to occur but in the opposite direction. The inputs of IC1a are now pulled high, which forces its output low as well as the inputs of IC1b. The output of IC1b goes high and keeps the circuit flopped back into the OFF state.

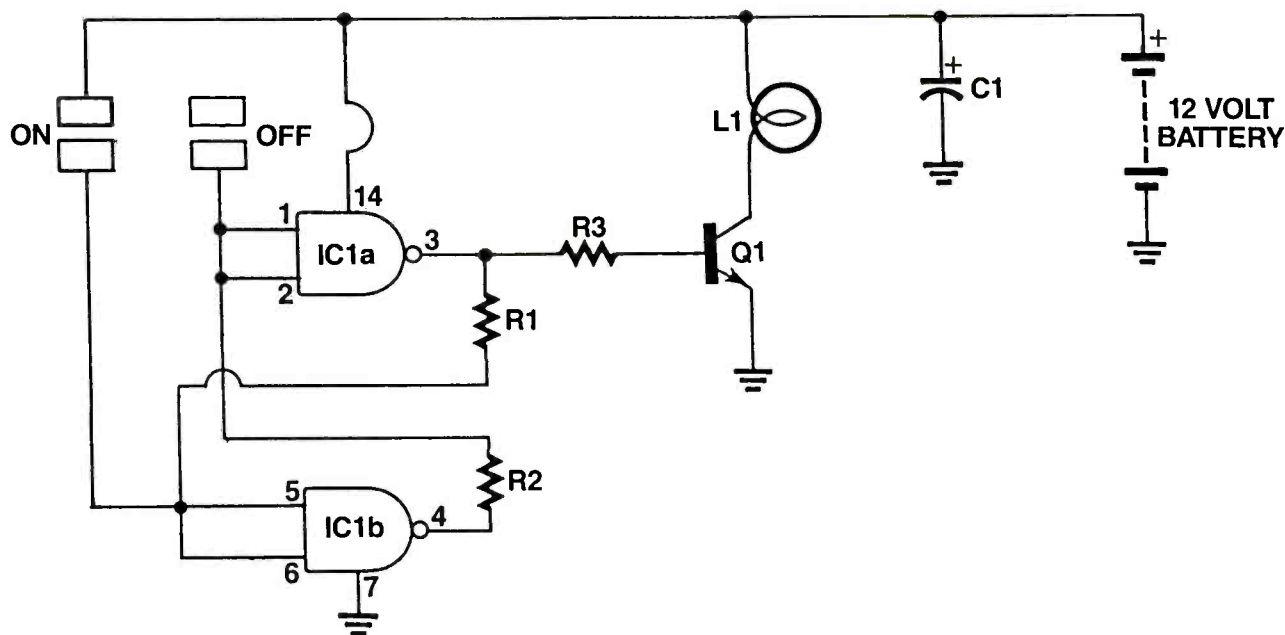
The low output of IC1a now switches Q1 and the light OFF.

This circuit is very reliable and will last indefinitely, if built well. Since, unlike a switch, there are no moving parts in this circuit, there is very little chance of anything breaking, except maybe the light but that goes without saying.

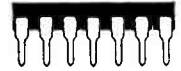
You can power the circuit from any 12V battery but under no circumstance should you ever connect this circuit up to your household power supply. ■

## PARTS LIST FOR BATTERY OPERATED TOUCH LAMP

- C1 — 470uF, 16vw, electrolytic capacitor
- IC1 — CMOS 4011 IC
- Q1 — BD679, NPN, Darlington, transistor
- L1 — 12V, 400mA, (approx.) Globe
- R1, R2 — 10m $\Omega$ , 1/4W, 5%, resistors
- R3 — 2.2K $\Omega$ , 1/4W, 5%, resistor



# AN UNUSUAL OSCILLATOR



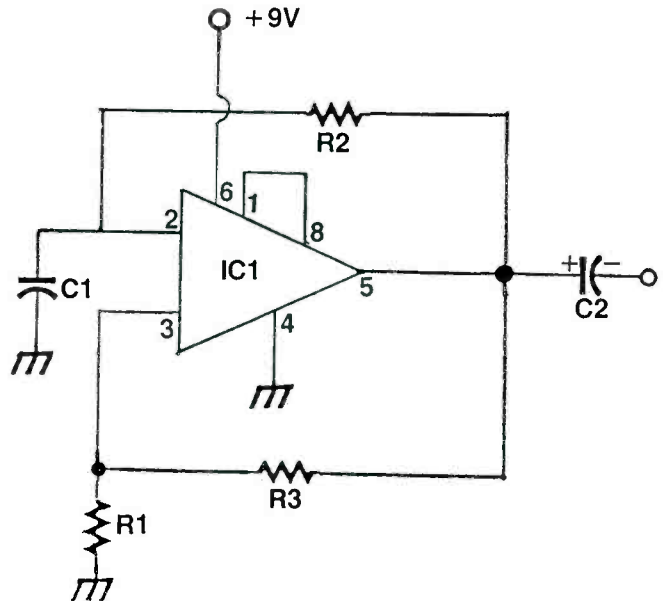
Here's a circuit you're unlikely to see very often. It's a square wave oscillator generating signals in the audio frequency range, but uses the LM386 audio power amplifier rather than the 555 timer chip. Apart from its rarity, it has a distinct advantage over the 555 circuit. This circuit will drive a low impedance 8 ohm load directly! It is after all, the audio power amplifier, configured in a somewhat unusual mode. Try it and see — you'll be surprised that it's actually an oscillator and low frequency driver in the same design! What that means is that you can drive low impedance loads directly without going to the trouble of using an emitter follower or Darlington high current driver.

IC1 is of course the ever popular LM 386 audio power integrated circuit. The connections are fairly easy to follow. R1, R2 and R3 with C1 form the frequency controlling components. With the values shown the output frequency is around 1 kHz. All the components interact to some extent, hence the actual values are not too critical. C2 is the customary A.C. coupling capacitor feeding the signal to a low impedance load, e.g. 8 ohm speaker. Note pins 1 and 8 are linked. These are the normal gain control pins for the LM 386. Supply voltage can be the usual 9 volt battery.

Either of the feedback resistors i.e. R2 or R3 can be used as the prime controlling device, if you wish to keep the rest of the components fixed. In this way you can vary the frequency over a limited range. None of the values have been found to be too critical in practice. ■

## PARTS LIST FOR THE UNUSUAL OSCILLATOR

- IC1 — LM 386 audio power integrated circuit
- R1 — 1K ohm
- R2 — 30K ohm resistor
- R3 — 10K ohm resistor
- C1 — 0.1uF capacitor
- C2 — 50uF capacitor



# ELECTRONIC METRONOME



If you're a musician and also a hobbyist then it's quite likely that music related circuits will be of particular interest to you, e.g. guitar amplifiers, fuzz units etc. For solo practicing a metronome is very useful for precise timing. The actual frequency of 'clicks' is less critical than the regularity of the timing pulses. The circuit as shown here produces an appropriately tailored sound that is in 'sympathy' with regular mechanical metronomes. The power supply is from a single 9 volt battery. For adequate output levels, feed the metronome signal to an audio power amplifier, such as the LM386 or even directly into one of the auxiliary inputs of a guitar amplifier.

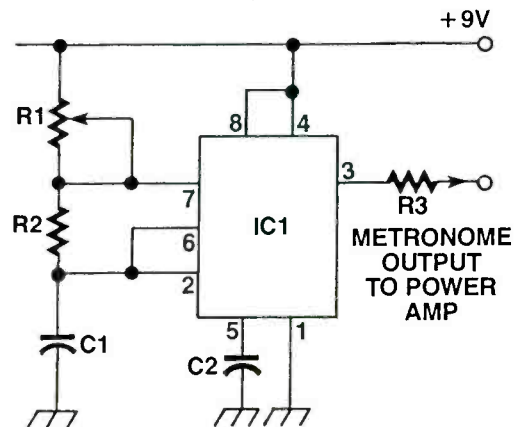
IC1 is the ever popular 555 timer chip, configured to produce a continuous stream of variable frequency pulses. To obtain the characteristic clicking sound of mechanical metronomes, the resistor values are chosen so that R1 is higher than R2. Additionally, R1 is made variable so that the beat rate can be adjusted to suit the tempo of music played. Capacitor (C1) is the final component for the timing section. The value is fairly high since the beat rate has to be relatively low, typically between 35 to 350 beats per minute is used for music purposes. The final components are C2, for decoupling and R3, for isolating the output.

For initial testing, you can connect a pair of high im-

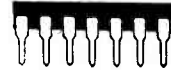
pedance headphones to the output from Pin 3, to find the best range of R1 that suits your music preferences. Component values are not critical and can be varied to suit the circumstances. ■

## PARTS LIST FOR THE ELECTRONIC METRONOME

- IC1 — 555 timer integrated circuit
- R1 — 1M potentiometer
- R2 — 1K resistor
- R3 — 1K resistor
- C1 — 2 uF capacitor
- C2 — 0.01uF capacitor



# CAR BATTERY MONITOR



Have you ever gone out to the car on a cold winter's morning only to find that the battery is flat dead and you're going nowhere fast? Well, you need not worry about flat batteries anymore with this handy car battery monitor. It uses only one IC but gives you three clear levels of battery charge indication.

There's nothing worse than being caught with a dead battery and there's basically nothing you can do unless you carry a spare in the trunk. However, you can catch it before it happens if you look out for the warning signs.

When a battery is about to give its last, you'll notice that when you try and start your car, you'll notice that the starter motor will run quite slowly—yes, your car may still start because the starter motor represents a much bigger load on your car's battery than the spark plugs do.

This circuit monitors your car battery's voltage and lights up one of three LEDs depending on its voltage. Let's take a look at how it works.

## Circuit Diagram

The first problem we have to overcome is the fact that if we want to use the car battery to measure itself, how do we do it? This is actually quite easy. By using a voltage regulator, we can obtain a steady DC voltage which, although lower than the battery voltage, is stable enough for us to use as a reference, which is what we need. In order to measure the battery, we need to compare it with a steady, accurate reference.

IC2 is a 7808 3-terminal regulator which produces a steady voltage of 8V. This provides our reference and also powers the rest of the circuitry.

The reference in our case is derived from just three resistors, R3, R4 and R5. The two tapoff points are fed into the non-inverting inputs of two opamps, IC1a and b which form an LM358 dual package. The inverting inputs are joined together and fed with half of the battery voltage.

Note that the input resistor divider made from R1 and R2 are connected to the battery before the regulator so the tap off point between R1 and R2 is exactly half of whatever the battery voltage is; not what the regulator is. The job of the R1/R2 resistor divider is to ensure that the input to the opamps doesn't rise any higher than the supply voltage, which in our case is 8V.

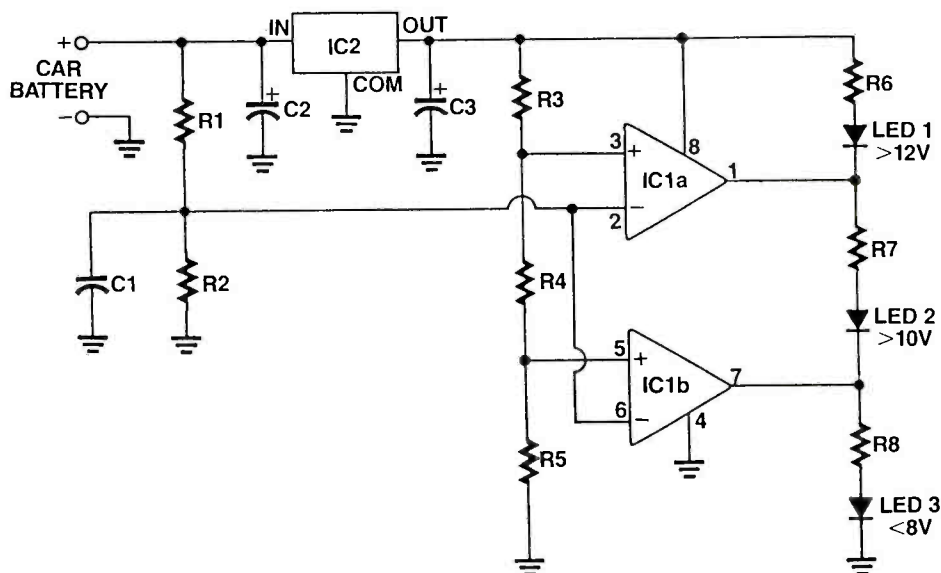
This means that the car battery voltage would have to reach 16V. If this did happen, there would be something more seriously wrong with the car than just a 'bad' battery.

If the voltage on pins 2 and 6 is less than the voltage on pin 5 then LED 3 will light indicating that the battery voltage is below 8V. If the voltage on pins 2 and 6 is higher than pin 5 but lower than pin 3, then LED 2 lights up, indicating that the battery voltage is greater than 10V but less than 12V. If the voltage on pins 2 and 6 is higher than pin 3 then LED1 lights up, indicating that the battery voltage is higher than 12V.

Construction of the Car Battery Monitor is not critical so long as you follow standard construction techniques. Vero-type or perboard is more than adequate and you can also fit the project into a box and install it on your dashboard if you so wish. It's entirely up to you. ■

## PARTS LIST FOR THE CAR BATTERY MONITOR

- C1—0.1 $\mu$ F, mylar capacitor
- C2, 3—10 $\mu$ F, 25VW, electrolytic capacitors
- IC1—LM358, opamp IC
- IC2—7808 8V, regulator
- R1, R2—22k $\Omega$ , 1/4W, 5%, resistor
- R3—3.9k $\Omega$ , 1/4W, 5%, resistor
- R4—2.2k $\Omega$ , 1/4W, 5%, resistor
- R5—10k $\Omega$ , 1/4W, 5%, resistor
- R6–R8—680 $\Omega$ , 1/4W, 5%, resistor
- LED 1—5mm, green LED
- LED 2—5mm, yellow LED
- LED 3—5mm, red LED



# THE CATALOG CORNER

If you live in a relatively remote area that doesn't have ready sources for electronic parts, you can send away to numerous supply houses, who have good catalogs of electronic parts and assemblies...many of them real bargains.

Following are several catalogs that we have recently received in the mail, with brief descriptions and comments. Most of these suppliers send out new catalogs every four to six months, with many of the items repeated and new ones added, plus some new "specials"...usually on the first couple pages and the last few pages of each issue.

## TAB/McGRAW-HILL

If reader response is any indication, one of the most popular columns we feature in **Electronics Handbook** is the book-review section, presumably because the books we choose cover electronic topics in an understandable fashion. Regular readers are probably aware that one of the principal suppliers of books for review is the **TAB/McGraw-Hill Book Company**. As it happens, TAB/McGraw-Hill has just come out with a new, comprehensive catalog of its books—several thousand in all—including the electronics titles that we review, plus books on a wide variety of other interesting subjects.

The topics covered include graphic arts, architecture, model building, woodworking, psychology, high-school science, aviation, military history, real estate, legal self-help, business management, broadcasting, and, of course, electronics. To get a copy, contact **TAB/McGraw-Hill, Blue Ridge Summit, PA, 17214-9988. Telephone (800) 822-8138.**





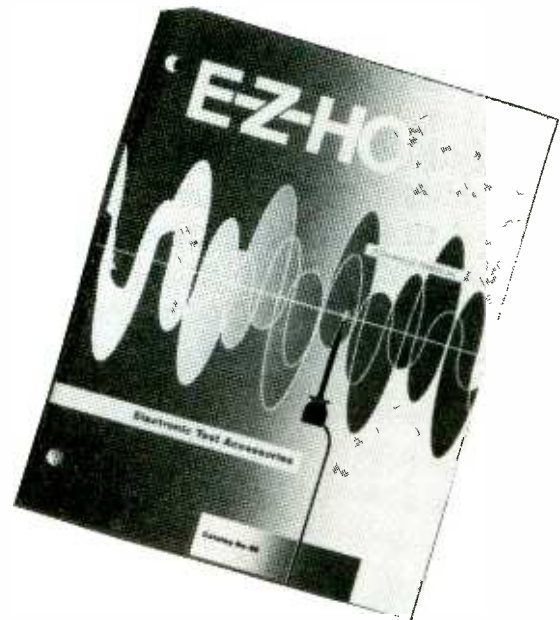
## DALBANI CORPORATION

Dalbani announces the publication of a new 176-page catalog of electronic components and replacement parts that is sure to be of interest to electronics enthusiasts. First off, there is a fifty-page listing of replacement semiconductors complete with a handy cross-reference. Even hard-to-find Japanese semiconductors are included.

In addition to this, they've got the usual components like LEDs, lamps, connectors, batteries, and so forth. Of special importance, however, is Dalbani's lineup of repair and replacement parts. For example, the firm carries xenon flashtubes, magnetic tape heads, VCR heads, VCR mechanical parts, motors, TV and monitor flyback transformers, focus dividers, and batteries for camcorders and handheld telephones. So, if you've got equipment to repair, this is the catalog to get. Contact **Dalbani Corp., 2733 Carrier Ave., Los Angeles, CA, 90040. Telephone (800) 325-2264.**

## E-Z-HOOK

If the name E-Z-Hook conjures up images of embroidery equipment in your mind, you're reading the wrong magazine, friend. In actual fact, as many of you probably know, E-Z-Hook is one of the major manufacturers of electronic connectors, cables, and test accessories. E-Z-Hook products are carried by many electronics distributors, but if you want access to the entire E-Z-Hook line of products, your best bet is to get hold of the firm's latest 138-page catalog. In it, you'll find hundreds of different connectors and related products, including such essentials as multimeter test leads; jumper wires; DIP connector assemblies; banana plugs; alligator clips; patch cords; a wide variety of E-Z's famous micro-hooks, mini-hooks, and macro-hooks; binding posts; test leads and harnesses; and oscilloscope probes. To get your hooks into this interesting catalog, contact **E-Z-Hook, P.O. Box 450, Arcadia, CA, 91066. Phone (800) 995-HOOK.**



## OCEAN STATE ELECTRONICS

All right, it's time now for a pop quiz: Which state in the union is known as "The Ocean State"? No, it's now Hawaii or California. The correct answer is Rhode Island. For all those who got it right (and even those who didn't), we've got great prizes: free copies of the new catalog from Ocean State Electronics.

More than 20,000 electronic components are featured in Ocean State's 112-page catalog. You'll find such things as integrated circuits, potentiometers, optoelectronic devices, heatsinks, capacitors, printed-circuit supplies, robot kits, enclosures, connectors, and test gear. Of special note are products for the radio amateur, including Morse-code keyer chips, RF power transistors, crystals, toroids, baluns, air-wound inductors, variable capacitors, wire antennas, SWR meters, linear amps, transmitter and receiver kits, and amateur-radio books. Write to **Ocean State Electronics, P.O. Box 1458, Westerly, RI, 02891. Phone (800) 866-6626.**



## AMERICAN SCIENCE & SURPLUS

Quick perusal of this catalog of “deficit-dropping detritus” from American Science & Surplus leaves you wondering whether those responsible could have suffered one too many jolts to the head. On closer inspection, though, it becomes clear that you’ve stumbled on a rare find, a catalog that is actually fun to read. Eccentric, irreverent, hilarious—this is no ordinary mail-order catalog, and the merchandise it contains is likewise far from ordinary. Where else could you expect to find a sphygmomanometer, a weather balloon, magnets, laboratory glassware, printed circuit material, wool fleece, an anvil, ball bearings, a steering wheel, rubber snakes, lenses, prisms, fiber optics, polarizing film, fans, a World War II-vintage gyro compass, solenoids, gears, motors, and Halloween masks—all at discount prices? Nowhere but at **American Science & Surplus, 3605 Howard St., Skokie, IL, 60076. Telephone (708) 982-0870.**

## HOSFELT ELECTRONICS

From Hosfelt Electronics comes news of a 132-page catalog of electronic components and test equipment. Looking for semiconductors? Hosfelt’s got linear and digital ICs, transistors, LED displays, optoelectronic devices, and the complete NTE line of replacement semiconductors.

How about passive components? Hosfelt carries all the resistors, capacitors, potentiometers, knobs, connectors, and cabinets an experimenter could ask for. What’s more, they’ve got woofers and tweeters for you hi-fi buffs, and a good selection of motors for robotics.

Unlike some other electronics suppliers, Hosfelt has no minimum-order requirement, which is good news for hobbyists. Moreover, prices are reasonable—especially so on some special-purchase items. Why not see for yourself by writing to **Hosfelt Electronics, 2700 Sunset Blvd., Steubenville, OH, 43952-1158. Or telephone (800) 524-6464.**



## LECROY DIGITAL INSTRUMENTS

For thirty years now, the LeCroy Corporation has been at the forefront of digital-instrument technology, beginning with instruments for particle-physics experiments, and progressing to the firm’s present broad spectrum of digital-storage oscilloscopes and workstations. LeCroy’s latest catalog is more than just a listing of features and prices; it also contains a wealth of application notes that explain what the various LeCroy instruments can do in an assortment of common industrial settings.

In addition to digital oscilloscopes, the catalog features such things as arbitrary-waveform generators, pulse generators, and computer software for data acquisition and analysis. Add to this over 100 pages of application notes, technical tutorials, and reference data, and you’ve got one heck of a technical resource. For a copy, write to **LeCroy Corporation, 700 Chestnut Ridge Rd., Chestnut Ridge, NY, 10977. Or call (914) 425-2000.**





## DC ELECTRONICS

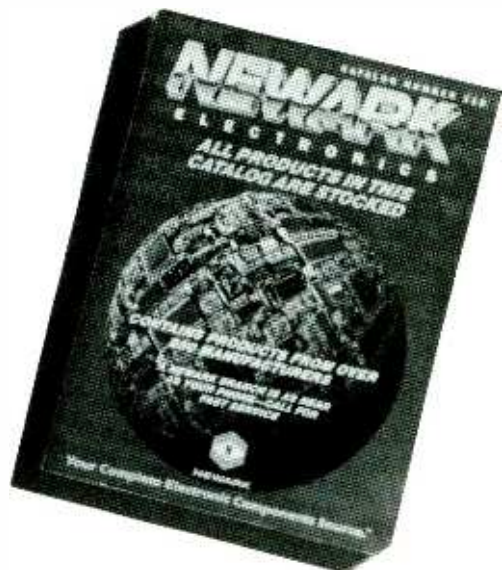
Need electronic parts, but don't know where to find them? Well, why not get your hands on the latest catalog from the folks at **DC Electronics**. In the space of some 50-odd pages, you'll find drawings, pictures and descriptions of virtually every component needed by the electronics experimenter.

A quick perusal of this catalog reveals such things as tools, resistors, capacitors, transistors, integrated circuits, transformers, printed-circuit supplies, plugs, jacks, LEDs, project kits, inductors, heat sinks, meters, cabinets, books, breadboards, batteries, potentiometers, switches, flash tubes, optocouplers, rectifiers, and fiber optics. All of which leads us to the inescapable conclusion that anyone who builds or services electronic equipment is sure to find something he needs in the DC Electronics catalog. Write to **DC Electronics, P.O. Box 3202, Scottsdale, AZ, 85271**. Or else call **(800) 467-7736**.

## NEWARK ELECTRONICS

Every industry has its leaders, companies that dominate the field. Among suppliers of electronic components, Newark Electronics certainly ranks as one of the biggest fish in the pond. Even its catalog is big—1200 pages brimming with every imaginable kind of electronic component and system. Who needs such a catalog? Well, certainly engineers and technicians do, and you could add inventors, repair men, and experimenters to that list, as well.

Newark carries books, integrated circuits, discrete semiconductors, optoelectronics, passive components, switches, hardware, relays, solenoids, transformers, power supplies, test instruments, motors, batteries, connectors, cables, chemicals, cabinets, fans, tools, and a whole lot more. If all this sounds interesting, why not write to **Newark Electronics, 4801 N. Ravenswood Ave., Chicago, IL, 60640**. Or call **(312) 784-5100**.



## MCM ELECTRONICS

From MCM Electronics comes news of a catalog of electronic parts comprising more than 20,000 items in its 247 pages. For starters, you'll find the expected things like integrated circuits, transistors, test equipment, resistors, capacitors, books, chemicals, connectors, and tools.

But there's more. They've got replacement parts for appliances like electric stoves and microwave ovens, flyback transformers, high-fidelity speakers and speaker kits, CATV equipment, cellular-phone replacement parts and accessories, computer boards and systems, PA sound systems, VCR parts and accessories, mechanical components, and parts for video games. For anyone who has ever had to repair home electronic equipment, the MCM catalog is an essential resource. To get a copy, contact **MCM Electronics, 650 Congress Park Dr., Centerville, OH, 45459**. Or telephone **(800) 543-4330**.





# MASTER SWITCH

By Eric Hoppe



**If you have purchased a new stereo TV with infra-red remote control and then hooked it up to your existing stereo system that does not have remote control then the MasterSwitch could be exactly what you need. The MasterSwitch will allow you to turn your entire entertainment system on and off by simply switching the TV on and off using its remote control! It's the ultimate channel surfer accessory! But that's not all the MasterSwitch can be used for. If you have a computer system that doesn't have a switched convenience outlet for peripherals (and/or the monitor) then the MasterSwitch will simplify its operation by allowing you to switch the entire system on and off by using the keyboard switch or CPU switch only. The MasterSwitch is fun and easy to build using these instructions and only costs about \$36.**

## Operation

The MasterSwitch is an AC Switching device with two AC outlets: one MASTER and one SLAVE. Any device which is plugged into the SLAVE outlet will be switched on or off according to the on or off status of the device which is plugged into the MASTER outlet. The current level threshold at which the SLAVE outlet switches is adjustable by means of a sensitivity control. The sensitivity control can be used to make the unit "ignore" small amounts of current being drawn from the MASTER outlet. This function is useful if the device that is plugged into the MASTER outlet is a television set with remote control or other device (such as a VCR with a clock) which requires some power in order to retain its memory even when the device is turned off. The unit also includes an AUTO/MANUAL switch. In the AUTO position the MasterSwitch will function as described above. The manual position is used to turn the SLAVE outlet on and off separately when desired. The maximum current rating for each outlet is 4 amps, 480 watts (8 amps, 960 watts, total for both outlets).

## PC Board Assembly

Start by soldering all of the components to the p.c. board as shown in the parts placement diagram. Refer to the schematic and parts list for identification of parts. Observe proper orientation of the IC chip, diodes, and capacitors. After all of the components have been mounted on the board, wire the potentiometer (R4) and

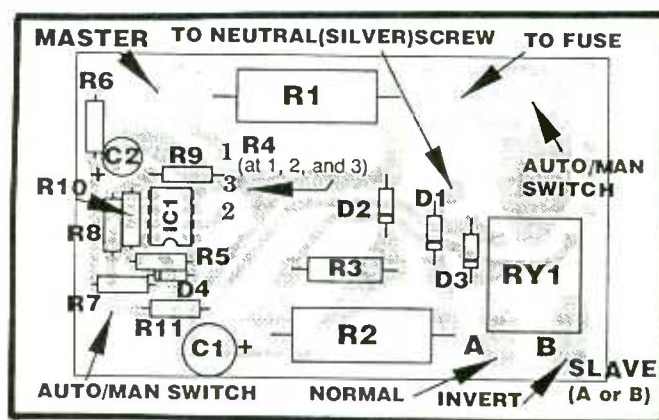


Figure 1: Parts Placement Diagram

switch (S1) to the board using 3 1/2" long pieces of #22 wire or ribbon cable. A pinout of the potentiometer is shown in figure 2. Refer to the parts placement diagram for proper wiring. Use heat shrink tubing on all wire connections. Next, solder a 3" piece of #18 wire to the board at the hole marked "MASTER." Also solder a 4" piece of #18 wire to the hole marked "A, NORMAL" for the SLAVE outlet (Note: for the inverted operation, i.e. the SLAVE outlet switches OFF when the MASTER device is turned ON, connect this wire to the hole marked "B INVERT"). Skin off about 3/4" of shield from the ends of these two wires and leave them for now. Check all of your soldering up to this point. If everything looks good then you are ready to begin construction.

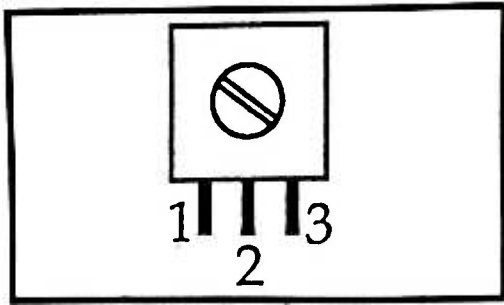


Figure 2: Pinout of R4

### Construction

The MasterSwitch is designed to fit in a 5" x 2<sup>5</sup>/<sub>8</sub>" x 1<sup>5</sup>/<sub>8</sub>" plastic enclosure with an aluminum lid. It will be necessary to drill two holes in one of the 2<sup>5</sup>/<sub>8</sub>" x 1<sup>5</sup>/<sub>8</sub>" sides of the box to accommodate the fuse holder and AC cord. Refer to figure 3 for position and size of the holes. Drill slowly so that the plastic won't tear. Mount the fuse holder and AC cord as shown in figure 4. Trim back the outer insulation of the AC cord so there is 4" of shielded wires exposed. Position the AC cord in the strain relief so that only 1/4" of the outer insulation is protruding into the box. Solder the black lead of the AC cord to the side terminal of the fuse holder and insulate it with heat shrink tubing. Cut a 3" long piece of #18 wire and solder it to the remaining terminal of the fuse holder. This connection should also be insulated with heat shrink tubing. Next, attach the green lead of the AC cord to the green screw terminal on the AC outlet. The end of the wire should be twisted together, bent into a "u" shape, and tinned with solder. Prepare the stripped ends of the two wires on the p.c. board (MASTER and SLAVE wires) in the same way. This will prevent the wires from fraying when the outlet screws are tightened down on them.

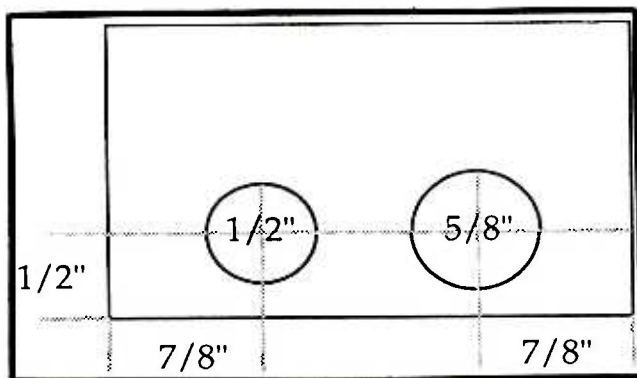


Figure 3: Position and size of holes

Notice that the AC outlet has two silver colored screws on one side and two brass colored screws on the other. Make sure that the metal bridge between the two silver colored screws is intact. Also make sure that the metal bridge between the two brass colored screws is removed. It can be snipped off with cutter pliers or bent back and forth until it snaps off. This will allow each outlet to be wired individually. Connect the white lead of the AC cord to one of the silver colored screws. Again, bend and tin the wire, as described above, for a good connection. Next, connect the two wires from the

p.c. board marked MASTER and SLAVE to the brass colored screw on their corresponding outlet. Check the faceplate for orientation of the outlets. Connect a 3" piece of #22 wire from the remaining silver colored screw to the p.c. board as shown in the parts placement diagram. Now put two wraps of black electrical tape all the way around the bottom of the AC outlet to shield these connections. This is a good time to check out all of your wiring for errors. Also check to see that all solder joints on the potentiometer and switch wires are completely insulated with heat shrink tubing. If everything looks good then the unit is ready for final assembly.

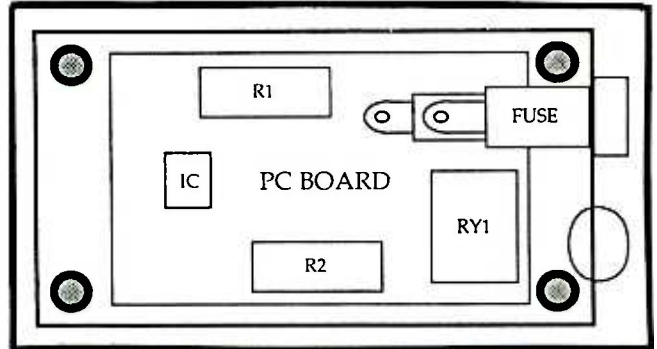


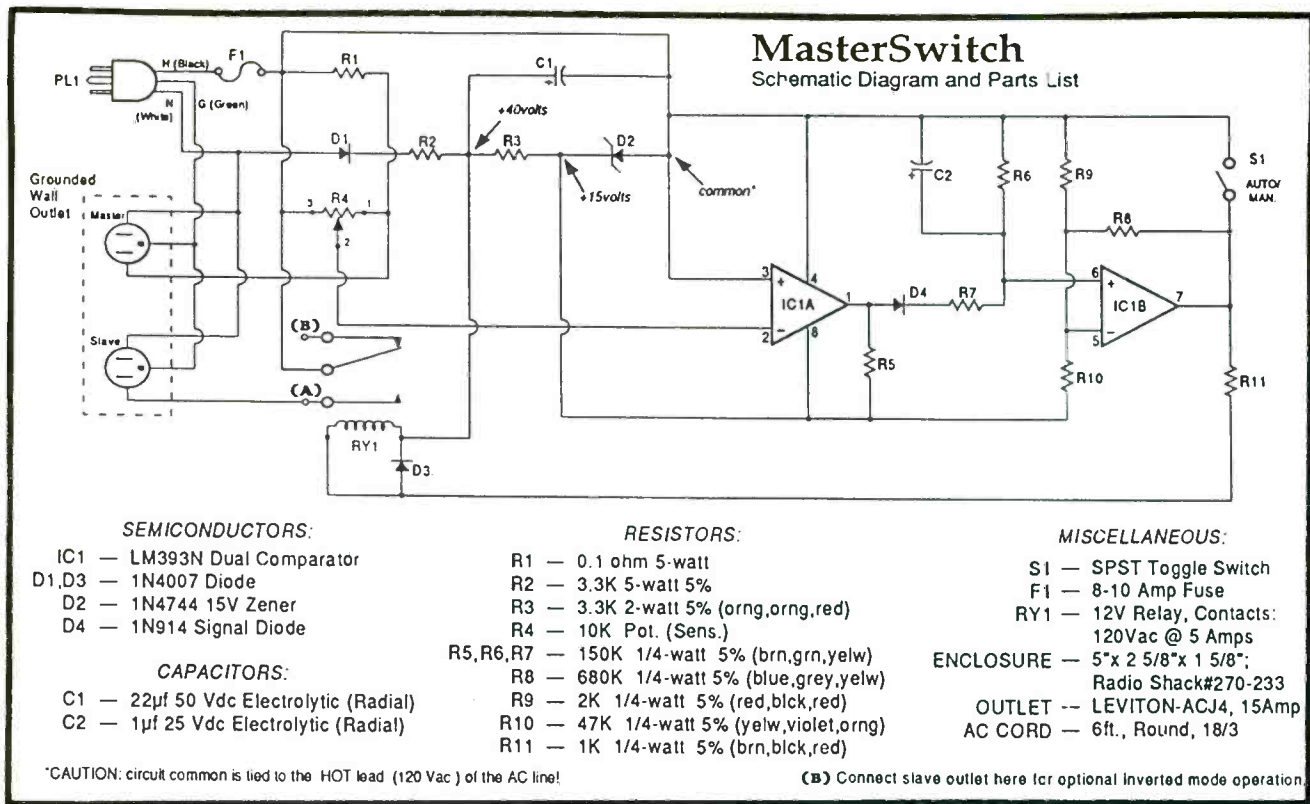
Figure 4: Position of the p.c. board inside of the box

### Final Assembly

Position the AC outlet so it is hanging over the outside edge of the box and out of the way of the p.c. board. The p.c. board should now be positioned inside of the box. Tip the board in on an angle and slide it into position under the fuse holder as shown in figure 4. Next, fasten the AC outlet to the face plate using the center screw. Also mount the AUTO/MAN switch (S1), so that the outside terminal which has a wire on it is facing towards the word "AUTO," on the face plate. The potentiometer can be held onto the back side of the face plate with epoxy, super glue, or other instant type glue. The back side of the face plate should first be cleaned with rubbing alcohol to ensure a good bond. Be careful to not get any glue into the moving part of the potentiometer. After the glue has dried, gently guide all of the wires into the box and then position the face plate onto the top of the box. Finally, insert the four cover screws and the unit will be ready for its first test run.

### Testing The Unit

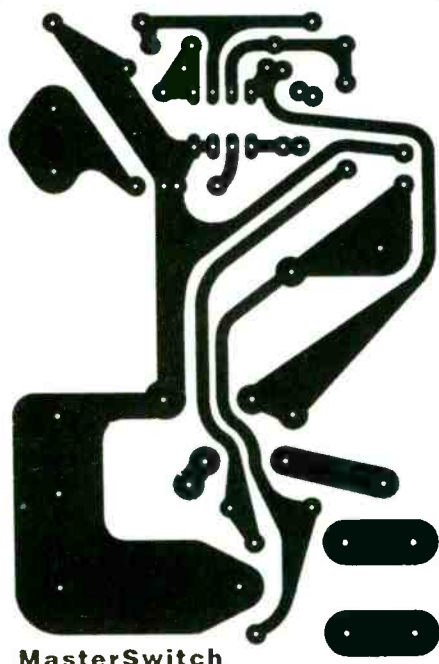
Insert the fuse into the fuse holder and then plug in the AC cord. Set the AUTO/MAN switch to the AUTO position. Plug a table lamp into the SLAVE outlet and make sure that the power switch on the lamp is in the ON position. Turn the sensitivity control fully COUNTERCLOCKWISE. Plug another table lamp into the MASTER outlet and make sure it is also turned ON. Now slowly turn the sensitivity control CLOCKWISE until the SLAVE lamp switches ON. When the lamp in the MASTER outlet is turned on and off the lamp in the SLAVE outlet should also switch on and off automatically (If this doesn't occur, refer to the troubleshooting guide below).



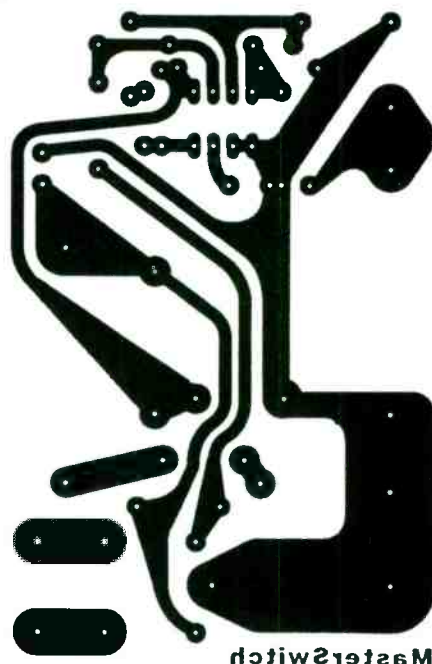
The unit is now completed, tested, and functioning properly. Some adjustment of the sensitivity control may be necessary when the MasterSwitch is used in its final application. However, once the sensitivity control is set properly it should not require any further adjustments.

### Using The MasterSwitch

Plug in the actual items that you will be using with the MasterSwitch. If you wish to have more than one device switched on and off automatically you can use a 3-way tap or power strip in the SLAVE outlet. Just be sure that the total current used by all of the items in the



(FORWARD)



(REVERSE)

FULL SIZE POSITIVE FOIL PATTERN ARTWORK

SLAVE outlet does not exceed 4 amps or 480 watts (8 amps total for both). Set the sensitivity control for best operation and then sit back and enjoy using your new MasterSwitch!

### Troubleshooting Guide

1. Check the wall outlet that the MasterSwitch is plugged into with a table lamp to be sure it is live.

2. If neither lamp lights check the fuse for continuity. If the fuse blows repeatedly then unplug the unit and check your wiring for shorts. If the fuse is good, check the fuse holder for good connections at both sides.

3. If a lamp that is plugged into the MASTER outlet lights but the relay doesn't engage even with the sensitivity pot fully clockwise, unplug the unit and check the p.c. board for wiring errors, bad connections, or bad parts.

NOTE: Opening the unit while it is plugged in is not recommended. The faceplate is grounded and the p.c. board is floating at 120 volts AC with respect to earth ground. If you must open the unit while it is plugged in PLEASE USE CAUTION!!!

### About The Circuit

The power supply for the MasterSwitch is comprised of D1, R2, R3, C1, and D2. Line current is rectified by D1 and then dropped by R2 to create two voltages. A 40 volt supply is found at the junction of R2 and R3. A 15 volt supply for IC1 is found at the junction of R3 and zener diode D2. It was necessary to form two supplies because of the current and space requirements of the circuit. While the IC chip and related circuitry uses 15 volts at a relatively low current, the relay requires 12 volts at approximately 30 mA. In order to provide both the circuit and relay with sufficient current from a single supply a whopper of a resistor and zener diode or a transformer would be necessary. At first, a transformer may seem like a good solution but space inside the enclosure is limited. So instead the dual voltage supply was implemented so the relay could get sufficient cur-

rent without having to use massive resistors, diodes or a transformer. Also notice that the power supply is achieved by rectifying the negative half-cycle of the AC so that the power supply common could be tied to the HOT AC lead. This is important and necessary so that the voltage comparator could also be referenced to this point. The 40 volt supply is fed directly to one side of the relay coil and drops to approximately 20 volts when the relay engages. R11 limits voltage and current to the relay coil and D3 is a flyback diode for RY1. The 15 volt supply is fed to IC1 and remains at 15 volts thanks to D2.

When current is drawn from the MASTER outlet, a small voltage drop is developed across R1. This voltage is fed through the sensitivity potentiometer R4 to the negative input of IC1A. The positive input of IC1A is tied directly to the incoming AC line at the junction of F1 and R1. Since IC1 sinks voltage at its outputs, R5 is necessary in order to supply voltage to pin 1 of IC1A. This voltage is allowed to charge C2 through D4 and R7 whenever the voltage at pin 2 of IC1A is negative with respect to pin 3. It just so happens that pin 2 is pulled negative by the voltage drop across R1. But that's AC, so it only goes negative for one half of every AC cycle, which is why C2 is used to help smooth out the pulsing voltage from D4 and R7. The value of C2 was kept low because a larger value would slow down the reaction time of the circuit. The voltage on C2 is compared at IC1B with the voltage from a voltage divider formed by R9 and R10. While the voltage on C2 is pretty smooth it still has a small amount of ripple on it which would cause the relay to chatter at the moment it switches on. This problem is solved by R8 which serves to assist the comparator in making up its mind (so to speak). When the voltage at pin 6 of IC1B (from C2) is positive with respect to pin 5, pin 7 is pulled low which, thanks to R8, also pulls pin 5 slightly lower thereby insuring that pin 6 will be more positive than pin 5. This causes the output of IC1B to toggle more reliably. ■

### NOTE: THE FOLLOWING ARE AVAILABLE FROM:

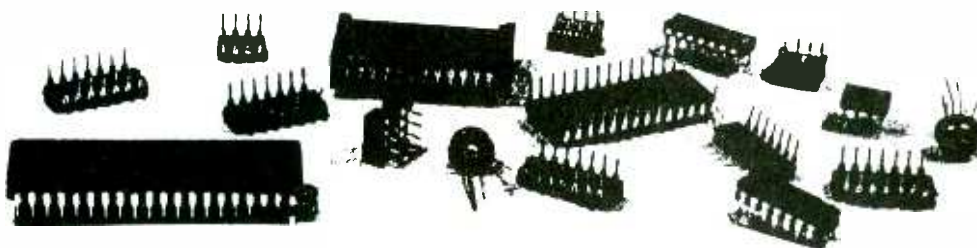
**Progressive Concepts**  
1434 N. Mills Avenue  
Claremont, CA 91711  
(909) 626-4969

1. Etched, plated and drilled p.c. board—\$10.00.
2. Partial kit: includes p.c. board and all electronic components for the p.c. board—\$26.95.
3. Enclosure with machined and silk screened faceplate (gives your project a professional look)—\$8.50.
4. Complete Kit: Includes p.c. board, all electronic components listed in the parts list, including miscellaneous items (enclosure has machined and labeled faceplate), fuse holder, #18 wire, and ribbon cable for potentiometer—\$36.95.
5. Fully assembled and tested MasterSwitch—\$46.95.

Please add \$3.00 (Shipping & Handling) to all orders. California residents, please add 8.25% sales tax. Please send check or money-order for final total in U.S. funds. Sorry we cannot accept phone orders.

# SOLID STATE UPDATE

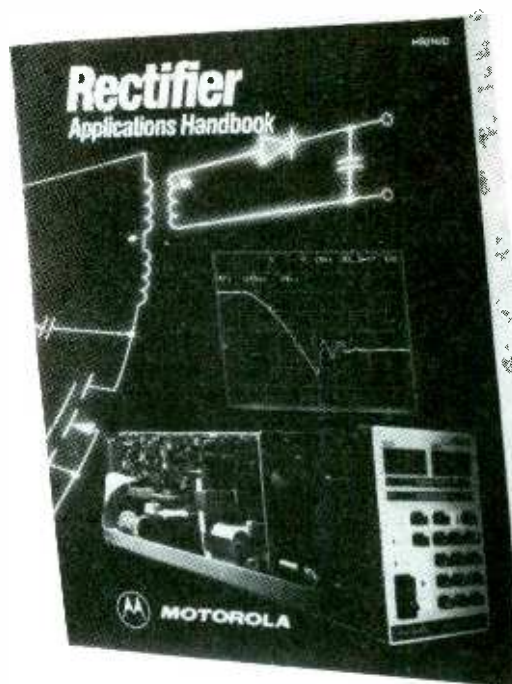
Each month, the manufacturers of solid state components release literally hundreds of new devices. While we cannot report on all of these, we do intend to feature some of the devices that are most likely to interest our readers. For further information on any of these solid-state components, write directly to the manufacturers. They can provide you with data sheets and application notes at no charge.

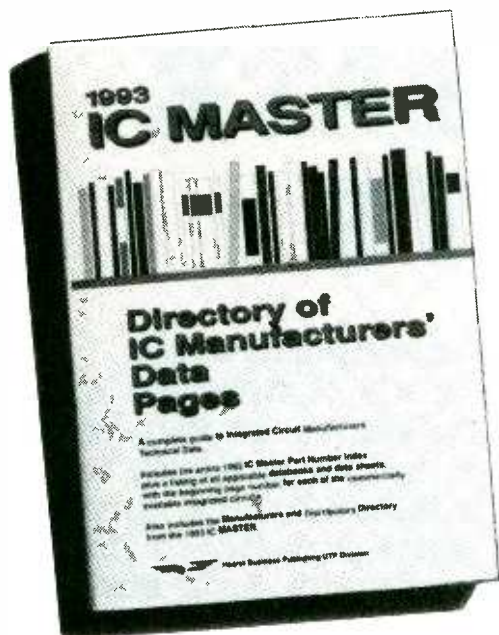


## MOTOROLA RECTIFIER HANDBOOK

For almost thirty years, the Motorola Rectifier Handbook has been a source of information as well as inspiration to circuit designers around the world. Now, Motorola announces the availability of a newly revised version of its Rectifier Applications Handbook.

The Handbook covers the basic electrical characteristics of rectifier diodes, rectifier specifications and ratings, single-phase and multi-phase rectifier circuits, capacitor- and choke-input filters, voltage-multiplier circuits, transient protection, and cooling techniques. Newly added material deals with such topics as power-factor correction, high-frequency applications, Schottky-diode theory, surface-mount technology, SPICE modeling, and reliability. The cost of all this information? Just \$4.20 plus \$1.50 shipping. Request HB214/D. Motorola Literature Distribution, P.O. Box 20924, Phoenix, AZ, 85063.





## DATA PAGE DIRECTORY

The IC Master Directory of IC Manufacturers' Data Pages has been published by Hearst Business Publishing/UTP Division. The directory is a unique quick-reference guide for identifying the manufacturers' most current data-book and data-sheet references to a specific integrated circuit.

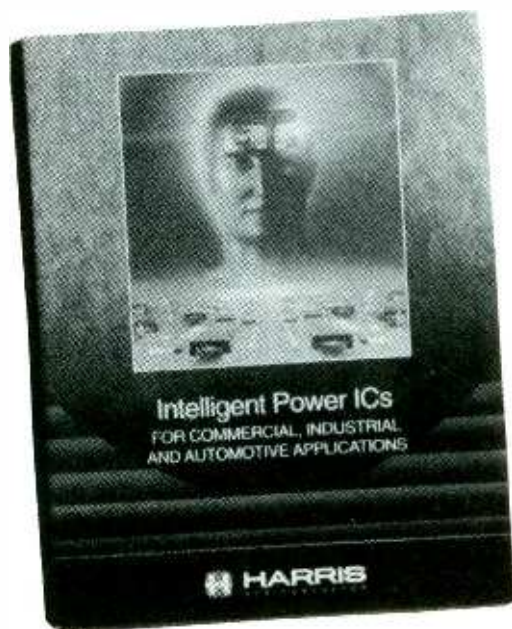
The user can look up a specific integrated circuit by complete part number or base number, and then find the title and issue date of the manufacturer's most current data book on the device. A total of 587 data books are indexed. Once the data book or data sheet has been identified, it is a simple matter for the user to contact the manufacturer directly by phone, FAX, or mail and request the information desired. Complete vendor contact information is contained in the directory. Price is \$84.50. **Contact Hearst Business Publishing/UTP Division, 645 Stewart Ave., Garden City, NY, 11530. Telephone (516) 227-1300.**

## INTEL EMBEDDED APPLICATIONS

The operation and application of Intel's 8- and 16-bit embedded controllers and microprocessors are described in this 1344-page collection of application notes. The 1993/1994 edition contains more than 40 article reprints, technical briefs, and application notes devoted to Intel's MCS-48, MCS-51, and MCS-96 families of processors. A general section on microcontroller operation is also included.

Architectural information, charts, diagrams, and technical data abound. Equal consideration is given to both hardware and software implementation. Topics covered include keyboard scanning, motor control, data acquisition, bus timing, and memory expansion—to name but a few.

Intel's Embedded Applications Handbook costs \$21.95 and is available from **TAB/McGraw-Hill Inc., Blue Ridge Summit, PA, 17214-9988. Phone (800) 822-8138.**



## INTELLIGENT POWER ICs

A data book entitled **Intelligent Power ICs** is available now from Harris Semiconductor. The book is a compendium of information on ICs whose function is to control electrical power. The roster of devices covered includes low-side switches, high-side switches, half-bridge transistor drivers, full-bridge drivers, AC-to-DC converters, voltage regulators, power supplies, protection circuits, and special functions.

Included in the data manual is the added bonus of 150 pages of application notes. These notes cover such topics as zero-voltage switching, power MOS-FETs, speed controls, the theory of IGBTs, switch-mode power supplies, and SPICE modeling.

For a copy of the **Intelligent Power ICs** data book, contact **Harris Semiconductor, P.O. Box 883, Melbourne, FL, 32901.**

# THE FUN WAY TO LEARN ELECTRONICS

## Get switched on

Lab Test  
**ELECTRONICS  
HANDBOOK**  
For Yourself

In case you're not all that familiar with us, we're not a publication for electrical engineers and other wizards. No way, **ELECTRONICS HANDBOOK** is expressly for people who like to build their own projects and gadgets — and maybe get a little knee-deep in tape, solder and wire clippings in the process.

In fact, we have a sneaking suspicion that our readers like us because they think we're just as bug-eyed and downright crazy over great new project ideas as they are. And I guess they're right!

**ELECTRONICS HANDBOOK** thinks of you who dig electronics as the last of a special breed. It's more than just the "do-it-yourself" angle — It's also the spirit of adventure. In this pre-packaged, deodorized world, building your own stereo system, shortwave receiver, darkroom timer or CB outfit is like constructing a fine-tuned little universe all your own. And when it all works perfectly — it really takes you to another world.

**ELECTRONICS HANDBOOK** knows the kinds of projects you like — and we bring 'em to you by the truckload!

Of course, we can't make you a master electrician overnight. But we can show you the fundamentals of repair plus maintenance tips.

**IF YOU'RE NEW TO ELECTRONICS YOU GET A "BASIC COURSE"!**

It gives you a complete, ground-floor lowdown on a variety of important electronic subjects. For example — Understanding Transistors...How Radio Receivers Pull In Signals...Cathode Ray Tubes Explained...How Capacitors Work...Using Magnetism In Electronics, and much, much more!

**TRY A FEW ISSUES AND EVALUATE OUR...**

- **HOW-TO-DO-IT HELP.** Tips and pointers that add up to money saved. For example — tuning up your tape player...all about radios ...whys and hows of turntables...care and feeding of speakers.

- **EXCITING DISCOVERIES.** Whatever your particular interest in electronics, you'll be entering a world of discovery in the pages of the **ELECTRONICS HANDBOOK**

**ORDER  
TODAY**



**"PLUG IN"**

to the excitement and satisfaction of

**ELECTRONICS HANDBOOK**

P.O. Box #5148, N. Branch, N.J. 08876

Yes. Enter my subscription — 4 issues **ONLY \$15.00**  
(Canada \$18.00...Foreign Postage add \$10.00 U.S. Funds)

Payment enclosed. (Payable to: C&E Hobby Handbooks)

**PLEASE PRINT**  
NAME: \_\_\_\_\_

ADDRESS: \_\_\_\_\_

CITY: \_\_\_\_\_

STATE: \_\_\_\_\_

ZIP \_\_\_\_\_

V15

# LAB REPORT

## BK PRECISION'S

### 2704A DMM

By Mike Hardy

**Does the multitude of budget-priced DMMs make your head spin? Having trouble deciding what is a useful feature and what is a bell or whistle?**

**Can you get respectable accuracy, AC/DC current and voltage functions, resistance to 20 megohms, as well as diode and continuity functions for less than \$60 bucks? Sure! Want a 2000 picofarad to 20 microfarad capacitance function and transistor testing thrown in for the heck of it — from a company that has been building test equipment for nearly forty years? If so, then take a look at one of B&K Precision's latest offerings — the 2704A, which has the selection of functions and ranges that should fit most hobbyists needs.**

Unless your work requires costly high-precision from your DMM, it doesn't make a lot of sense to spend an inordinate amount of money for a blisteringly precise DMM if you sacrifice the functions and ranges you'd really like to have — not to mention the functions and ranges you may get the most use out of. Well with B&K Precision's 2704A DMM you don't have to. The 2704A is B&K's contribution to the budget-priced DMM market and is ably accurate for any task the hobbyist or student may call on it to perform.

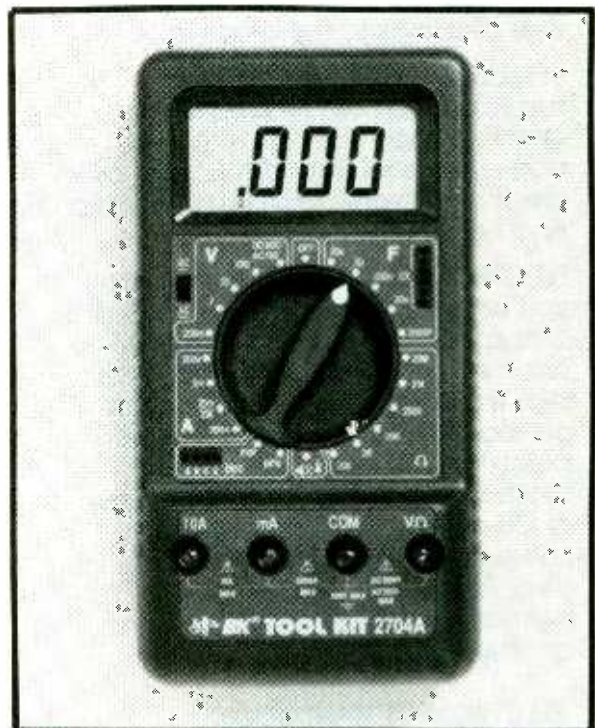
#### SPECIFICATIONS — (the 'Nuts and Bolts'):

The B&K "Tool Kit" 2704A is a manual ranging, auto-polarity, auto-zero DMM with overrange indication for all ranges and a specified DC accuracy of  $\pm 0.5\%$  which is pretty good for a meter in this price range.

The high-contrast 3½ digit, 1999 count LCD includes 0.7" numbers updated 3 times per sec., as well as a floating decimal point to quickly identify the selected range. To signify a negative voltage or current, a minus sign appears on the LCD when appropriate.

A battery symbol annunciator warns you when 90% of the 9V battery supply is exhausted. Of course, don't run the meter (or any meter for that matter) too long once you hit this point since readings become increasingly untrustworthy. You can expect around 200 hours of service from the lone 9V battery.

Many other similar priced DMMs cut costs (and offer you less of a meter) by making the AC voltage and current ranges less sensitive than their DC counterparts (if



they even offer an AC current function at all). In other words, a less sensitive (read: less capable) meter may start the DCV range in millivolts, while the ACV's lowest range is in volts. Not the 2704A. The AC/DC voltage as well as AC/DC current functions use common range settings and you choose either AC or DC by a small,



easily operated switch in the upper left of the case.

Current measurements for both AC and DC run from 0.2 milliamps (200 microamps) and proceed up to 10 amps in five ranges, with fuse protection of 630mA for the mA range. For the DC ranges, specified accuracy is  $\pm 1.0\%$  + 1 digit with a burden voltage of 325mV max. For the unfused 10 amp setting, you're looking at  $\pm 2.0\%$  + 3 digits, with a burden voltage of 750mV. As is typical, the ACmA/A settings are only slightly less accurate.

The AC/DC voltage function has five ranges from 200mV on up to 750 volts AC and 1000 volts DC. Accuracy for DCV is  $\pm 0.5\%$  + 1 digit. Again, AC readings are less accurate at  $\pm 1.0\%$  + 4 digits up to 200 ACV and  $\pm 1.5\%$  + 4 digits up to 750ACV. Maximum overload protection for ACV/DCV ranges is a comfortably reassuring 1200V (dc + ac peak) and AC 800V (rms), but B&K Precision does not recommend this meter for high power applications. Input impedance for the 2704A (which can lessen the degree to which the meter itself affects the circuit under test) is 10 megohms—standard fare.

As mentioned, the resistance ranges run up to 20 megohms, starting with a 200 ohms range at a resolution of 0.1 ohms. Overload protection here is 500V (dc + ac peak). Burden voltage is 3.2V for the ohms range and 0.3V for the kilo and megohms ranges. The specified accuracy for the lowest of the six resistance settings is  $\pm 1.0\%$  + 3 digits for the 200 ohm range;  $\pm 0.8\%$  + 1 digit up to 2 megohms;  $\pm 3.0\%$  + 1 digit for the 20 megohms range.

The diode function, using 1.6mA of test current, measures the forward voltage drop (in mV) to aid in identifying as well as testing the soundness of the diode under examination.

The transistor gain function tests the condition of PNP and NPN transistors, with a base DC current of 10 microamps and collector/emitter voltage of 2.8V.

The continuity buzzer, its whistling tone easily distinguishable, kicks in at around 100 ohms, with a response time of <100ms.

### CAPACITANCE TESTER

Unless you're interested in shelling out some good money to obtain a dedicated capacitance meter, the 2000 picofarad to 20 microfarad range should handle most of the hobbyists' capacitance chores.

Since in this price range you can buy many good meters with just the current, resistance and voltage functions alone, you can consider the capacitance function as a real bonus. This feature can be very handy when you've got a drawer full of ceramic caps with only their archaic markings as a clue to what value they are—and even if you're good at deciphering the markings, they still can't tell you if you're about to put a leaky capacitor into your circuit.

The trade-off for the luxury of having a capacitance tester in a multi-purpose hand-held DMM is in accuracy—but again, barring high-precision circuitry, this trade-off can be considered inconsequential. (If your work hinges on a high degree of precision you shouldn't be looking to a hand-held DMM to solve your capacitance testing woes anyway).

Using a test voltage of 50mV and test frequency of 400Hz, specified accuracy for the capacitance function in all five ranges is  $\pm 3.0\%$  + 10 digits.

A quick check of the value and ability of a capacitor to hold a charge prior to dropping it into a circuit can actually save you time in the long run and the 2704A makes quick work of this.

The meter has six holes in the upper right of the case, used two at a time depending on the distance the leads are from each other. For instance, polystyrene caps have short, stiff leads that are not easy to bend and the extra holes come in handy.

When testing capacitors they do need to be tested prior to being in circuit, or removed from the circuit if you suspect that it is your culprit. You insert the capacitor leads (discharged of course!) into two of the holes, set the range and read the LCD to get the value and see if the capacitor is leaking. What could be easier? (You could insert hookup wire into the capacitance test holes and attach them to jumpers and then attach the jumpers to the capacitor leads but this is an unwise practice and could cause damage to you or the meter.)

### TAKING THE 2704A FOR A SPIN

The B&K 2704A has a 'down-to-business, no-nonsense' look about it—just the demeanor a good piece of test equipment should convey.

The 2704A's case is smartly appointed with easily readable white lettering which stands out well against the flat black case. Even at arm's length, the markings are easy to make out and your selector setting is quickly distinguishable. All the major range functions (voltage, farads, ohms and amps) are clearly marked, each occupying roughly one quarter of the face of the meter giving the meter a pleasant and balanced look.

The meter itself is light and easy to handle as well as comfortable in the palm thanks to the rounded corners of the case. It stays put in your hand due to a very slight amount of stippling on the finish but primarily owing to the ribbing on each side where your hand grasps the case.

The tactile response of all functions on the meter are positive and sure. I didn't find any sloppiness in any of the controls.

With the fold-out stand deployed, the meter sits at about a 40 degree incline, which keeps the LCD in clear view whether you're sitting or standing above it.

If you're not using a fold-out stand, you won't need to chase this meter around the countertop when switching functions. To keep it in place when laying flat, there are two rubber strips at the top and bottom on the back of the case which makes the meter stick to a flat surface as if it were glued down tight.

Thanks to the design of the range selector (whether intentional or not), the meter can be operated while being held in your hand by using the thumb of the holding hand to move the range selector while holding both test probes in the other hand. Of course you definitely do not want to do this in the current or voltage ranges, but it's handy when trying to pin down a resistance value with a minimum of fuss.

While the case does not feel like (and thankfully not priced like) it is built rock-solid and bullet-proof, it is still

reasonably solid and should withstand drops from around four feet. I'll take the manufacturer's word for that because surviving a four foot drop onto a hard surface seems a little optimistic. But if B&K has tested it and found it to hold up with drops from four feet, then they have the advantage over me—I couldn't afford to drop more than a couple of these meters to see if they would still function.

In any case, if you're like me and take a \$50-60 purchase seriously and don't expect a meter to bounce back to you when you drop it no matter what brand, then I don't think this limitation is cause for much concern. In other words, treat it with the respect a piece of quality test equipment deserves.

The test probes are of good quality and 'relax' easily. By that I mean that some cheap DMM test leads have a nasty habit of holding their shape (usually all kinked up) which can make them bothersome to use since they stay tangled up and won't straighten out. That may be a petty annoyance, but it can be an annoyance nonetheless.

The right-angled plug ends of the test probes are shrouded for safety and have the added bonus that insertion into one of the meter's four sockets is sure and the plugs hold fast.

Just about at the tip of the probe end there is a recessed ring encircling the probe tip which makes them perfect to get a secure fit on a resistor (or other part) in circuit without the probe continually slipping onto a nearby component and fouling up your measurement or worse, perhaps damaging you or the meter. The grooves also make it easy to make measurements while holding both test probes with just one hand when the need arises.

I added a piece of heat-shrink tubing to each probe end covering it completely except for the tip and recessed ring. That way, when making measurements on a live circuit, you don't have to worry as much about inadvertently touching another component and shorting something out.

After a fair amount of use with the 2704A I thought I might miss an auto-ranging feature but that turned out to not be the case. Auto-ranging is nice when you have to make numerous measurements and you're not sure of the range. Otherwise, auto-ranging can unnecessarily slow down the testing process, since the meter circuitry autonomously starts at one end of the scale and must continually change ranges until it reaches the proper one.

## PANS

- I would have preferred something a bit sturdier than the plastic fold-out stand provided.
- A solitary ON/OFF switch would have been a nice touch instead of having the OFF position on the function/range selector itself.
- I would swap positions of the ohms function with the capacitance function since to reach the lowest resistance range from the OFF position, 11 clicks of the selector is needed—half the 360 degree travel of the selector. That's a lot of dial twisting to go from OFF to ohms and back again.
- Even with the smooth, positive detents from setting to setting of the range selector, an annunciator of your chosen function such as "mV" or "DCA" on the LCD would be nice to remind you of your setting when you get your test reading.

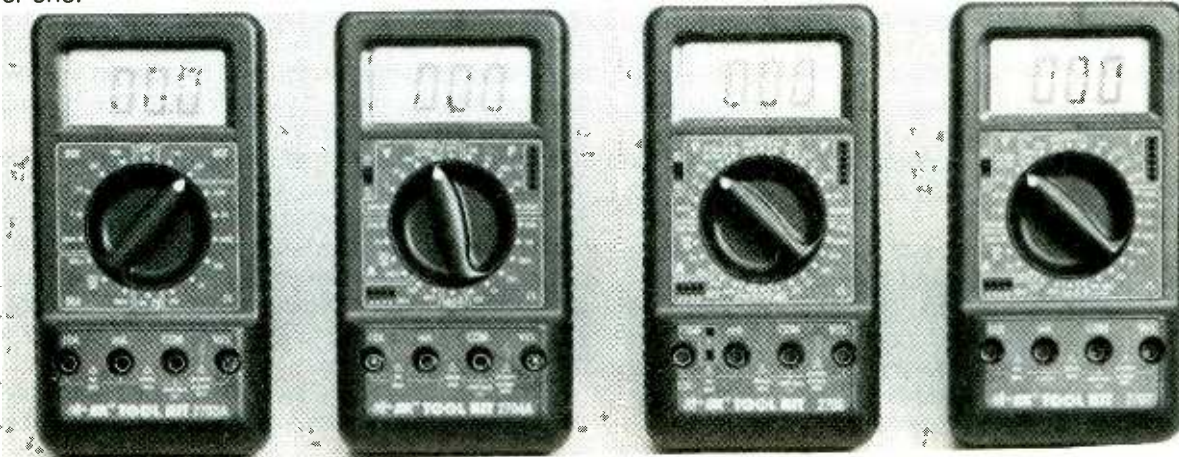
The complaints are few and rather meaningless, especially when you compare what you get for what you pay. This DMM is, I consider, a real bargain when factoring in capability of the meter, reputation of the company, and price paid. And even though a lot of DMMs on the market have one seemingly necessary feature or another, all in all this is a handy package at a reasonable price with just the functions and ranges the hobbyist or student will get the most use out of.

The **B&K Precision "Tool Kit" series DMMs** come in four incarnations—the **2703A, 2704A, 2706 and 2707**. The prices are \$39.95, \$59.95, \$79.95 and \$89.95 respectively. (You can find all four priced for less). Comparing them to the 2704A, the 2703A lacks the capacitance, transistor testing and AC current capabilities; the 2706 adds a temperature probe function; and the 2707 lacks the temperature probe function but adds frequency and logic functions.

B&K Precision also offers a full line of accessories for the "Tool Kit" series including various special-purpose probes such as a clamp-on current probe, as well as cases to protect the meter. Included with the 2704A are test probes, instruction booklet, battery and a one year parts and labor warranty.

## SUMMARY:

If you're like me, wanting a meter that does many things relatively well and not just one or two things perfectly, on a budget and wanting to make one smart choice, the 2704A may be for you. Considering its range of functions, as well as quality commensurate with price, the B&K 2704A is an attractive package. ■



# AMAZING Electronic and Scientific Products

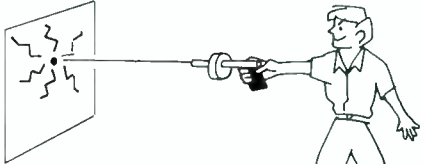
## Mystery Levitating Device!

Remember War of the World? Objects float in air and move to the touch. Defies gravity, amazing gift, conversation piece, magic trick or great science project.

ANT1K Easy to Assemble Kit / Plans ..... \$19.50



## Laser Ray Gun



**DANGER**  
INVISIBLE LASER RADIATION  
AVOID EYE OR SKIN EXPOSURE  
TO DIRECT OR SCATTERED RADIATION  
CLASS IV LASER PRODUCT

Advanced project produces a burst of light energy capable of burning holes in most materials. Hand-held device uses rechargeable batteries. 500 joules of flash energy excite either a neodymium glass, yag or other suitable 3" laser rod. This is a dangerous CLASS IV project (individual parts/assemblies available).

LAGUN1 Plans ..... \$20.00  
LAGUN1K Kit / Plans ..... Price on Request

## Extended Play Telephone Recording System



READY TO USE! Automatically controls and records on our X-4 extended play recorder, taping both sides of a telephone conversation. Intended for order entry verification. Check your local laws as some states may require an alerting beeper.

TAP20X Ready to Use System ..... \$129.50



## Shocker Force Field / Vehicle Electrifier

Neat little device allows you to make hand and shock balls, shock wands and electrify objects, charge capacitors. Great payback for those wise guys who have wronged you!

SHK1KM Easy to Assemble Electronic Kit ..... \$24.50



## Blaster Pulsar

Pocket-sized wand produces 100,000 watts of power for personal defense, field and lab use, etc. BLS3 Plans ..... \$10.00  
BLS3K Kit / Plans ..... \$69.50

## Homing / Tracking Transmitter

Beeper device, 3 mile range.  
HOD1 Plans ..... \$10.00 HOD1K Kit / Plans ..... \$49.50

## Listen Through Walls, Floors

Highly sensitive stethoscope mike.  
STETH1 Plans ..... \$8.00 STETH1K Kit/Plans ..... \$44.50



**NEW!**

## INFINITY TRANSMITTER++

### Room Monitor / Phone Line Grabber

**ALL NEW! The Ultimate in Home or Office Security & Safety!** Simple to Use! Call your home or office phone, push a secret tone on your telephone keypad to access either: A. On premises sounds and voices; or B. Existing telephone conversation with break in capability for emergency messages. CAUTION: Before assembly or use, check legalities with your state Attorney General's office as you may require "beepers" or other 3rd party alerts.

TELEGRAB1 Plans Only ..... \$10.00  
TELEGRAB1K Kit / Plans ..... \$99.50

## Ultrasonic Blaster

Laboratory source of acoustical shock waves. Blow holes in metal, produce "cold" steam, atomize liquids. Many cleaning uses for PC boards, jewelry, coins, small parts, etc.

ULB1 Plans ..... \$10.00 ULB1K Kit/Plans ..... \$69.50



## 100,000V Intimidator / Shock Wand Module

Build an electrical device that is effective up to 20 feet. May be enclosed for handheld, portable field or laboratory applications.

ITM2KM Easy-to-Assemble Electronics Kit ..... \$49.50  
ITM2 Plans only, credit-able to kit ..... \$10.00



## Ion Ray Gun

Projects charged ions that induce shocks in people and objects without any connection! Great science project as well as a high tech party prank. IOG3 Plans ..... \$8.00  
IOG3K Kit/Plans ..... \$69.50

## Invisible Pain Field Generator

Shirt pocket size electronic device produces time variant complex shock waves of intense directional acoustic energy, capable of warding off aggressive animals, etc.

IPG7 Plans ..... \$8.00 IPG7K Kit/Plans ..... \$49.50  
IPG70 Assembled ..... \$74.50



## 1000 Ft++ Potato Cannon

**NOT A TOY.** Uses electronic or piezo ignition. CAUTION REQUIRED!  
POT1 Plans ..... \$10.00  
(Dangerous Product)

## FireBall Gun

Shoots flaming ball - two shot capacity Great for special effects and remote fire starting. CAUTION REQUIRED!  
FIREBALL Plans (Dangerous Product) ..... \$10.00



## TV & FM Joker / Jammer

Shirt pocket device allows you to totally control and remotely disrupt TV or radio reception. Great gag to play on family or friends. Discretion required. EJK1KM Easy to Assemble Electronic Kit ..... \$24.50

## Visible Beam Laser

High brightness red HeNe laser visible for miles. Produce your own light show! Projects a visible beam of red lite clearly visible in most circumstances. Can be used to intimidate by projection of a red dot on target subject. Also may be used to "listen in" using our laser window bounce method #LLIS1 below. Easy to build module makes A working visible laser!

LAS1KM Kit w/1mw Laser Tube, Class II ..... \$69.50  
LAS3KM Kit w/2.5mw Laser Tube, Class IIIA ..... \$99.50



## "Laser Bounce" Listener System

Allows you to hear sounds from an area via a lite beam reflected from a window or other similar objects. System uses our ready-to-use LATR1 Laser Terminator gun site as the transmitter. The receiver section is supplied as an easy-to-build kit, including our cushioned HS10 headsets. LLIST2 Plans ..... \$20.00

LLIST1K Kit of Both Transmitter and Receiver ..... \$199.50  
LLIST20 Assemble with Laser Gun Site ..... \$299.50



## 3mw Visible Red Pocket Laser

Utilizes our touch power control!  
VRL3KM Kit / Plans ..... \$74.50



## Electronic Hypnotism

Puts subjects under control using highly effective electronic stimuli. Intended for parties and entertainment but must be used with caution. Includes valuable text book reference and plans.

EH2 Plans and Text Book ..... \$19.50

## Pocket Sized Night Viewer

Uses Low Level Starlight to See in the Dark!

- Low Cost
- Ultra-Hi Lite Amplification!
- Auto Brightness Control!
- Limited Amount Available
- Made in USA • Night surveillance • Animal studies, etc.

Can be used to fly an airplane or drive a car!

PKV7 Plans ..... \$15.00  
PKV7K Easy to Assemble Kit ..... Price on Request  
PKV70 Ready to Use ..... Price on Request



## 3 Mi FM

### Wireless Microphone

Subminiature! Crystal clear, ultra sensitive pickup transmits voices and sounds to FM radio. Excellent for security, monitoring of children or invalids. Become the neighborhood disk jockey, or go "under cover" using our sunglasses FM radio (see catalog). FMV1 Plans ... \$7.00  
FMV1K Kit and Plans ..... \$39.50  
SUGL10 Sunglasses with built in FM Radio ..... \$29.50



## Telephone Transmitter - 3 Mi

Automatically transmits both sides of a telephone conversation to an FM radio. • Tunable Frequency • Undetectable on Phone • Easy to Build and Use • Up to 3 Mile Range • Only transmits during phone use.  
VWPM7 Plans ..... \$7.00  
VWPM7K Kit/Plans ..... \$39.50

## CATALOG

With many more items!  
Free with Order or send \$1 P&H

Order by Mail or by 24 Hour Orders-Only Phone  
**800-221-1705**

**INFORMATION UNLIMITED**

Dept EH16, Box 716, Amherst, NH 03031  
Phone: 603-673-4730 FAX 603-672-5406

MC, VISA, COD, Checks accepted Please add \$5.00 Shipping & Handling

# Don't Despair...REPAIR!

Here's how to troubleshoot and repair your electronics successfully!



## You Can Be Your Own Repair Expert!

For VCRs, camcorders, audio equipment, TV equipment, computer hardware, office equipment, home appliances, automobile electronics, and outdoor equipment.

- Pinpoint and analyze problems quickly.
- Successfully complete repairs with hands-on troubleshooting instructions.
- Become skilled understanding flowcharts and schematic diagrams.
- Confidently use test equipment such as oscilloscopes, frequency counters, and video analyzers.
- Keep your equipment in top condition with effective preventive maintenance techniques.

## Continue to Broaden Your Repair Expertise!

You'll receive quarterly supplements, up to 160 pages, with new step-by-step repair and maintenance instructions, valuable schematics and new repair techniques. Learn how to repair a growing variety of appliances with hands-on repair projects that will keep you up-to-date with later models and technology. You'll be thrilled with your ability to repair a growing list of electronic equipment! Supplements may be returned or cancelled at any time.



## One Source For All Your Repair Needs!

Better organized than a magazine, more current than a book.

- 900-page manual
- easy-to-follow, detailed instructions
- trouble analysis flowcharts
- safety precaution checklists
- comprehensive replacement parts list
- directory of manufacturers

### Save \$10

Call our toll-free number, pay by credit card, and mention this ad. We'll deduct \$10!

We'll also waive shipping and handling.

Order today for your 30-day, no-risk review of The Electronics Repair Manual.

For Faster Service Call Toll-Free  
**1-800-222-WEKA**

Or Fax to: 1-203-944-3663

### MONEYBACK GUARANTEE

There's no risk in trying the ELECTRONICS REPAIR MANUAL to see if it's right for you. If you are not delighted, simply return the manual after the 30-day trial period and receive a prompt refund.



1077 Bridgeport Ave  
Shelton, CT 06484

**Yes!** Please rush me a copy of the new Electronic Repair Manual for only \$59.95 plus \$6.50 shipping and handling. I understand that if I am not satisfied I may return the manual within 30 days for a complete refund. Supplements are sent quarterly for 25¢ per page (never more than \$30) and may be returned or cancelled at any time.

VISA  MasterCard  Bill Me (No P.O. Boxes)

Check Enclosed

Credit Card Number \_\_\_\_\_ Exp. Date \_\_\_\_\_

Signature \_\_\_\_\_

Phone # \_\_\_\_\_  
(Signature and phone number required on all orders)

Name \_\_\_\_\_

Address \_\_\_\_\_

City \_\_\_\_\_ State \_\_\_\_\_ Zip \_\_\_\_\_

All payments must be in U.S. funds. Canada add \$10  
All other countries add \$15. CT residents add 6% sales tax.

400072

Mail to: WEKA Publishing, Inc.  
1077 Bridgeport Ave., Shelton, CT 06484