

**COYNE  
APPLIED  
PRACTICAL  
RADIO-  
TELEVISION**

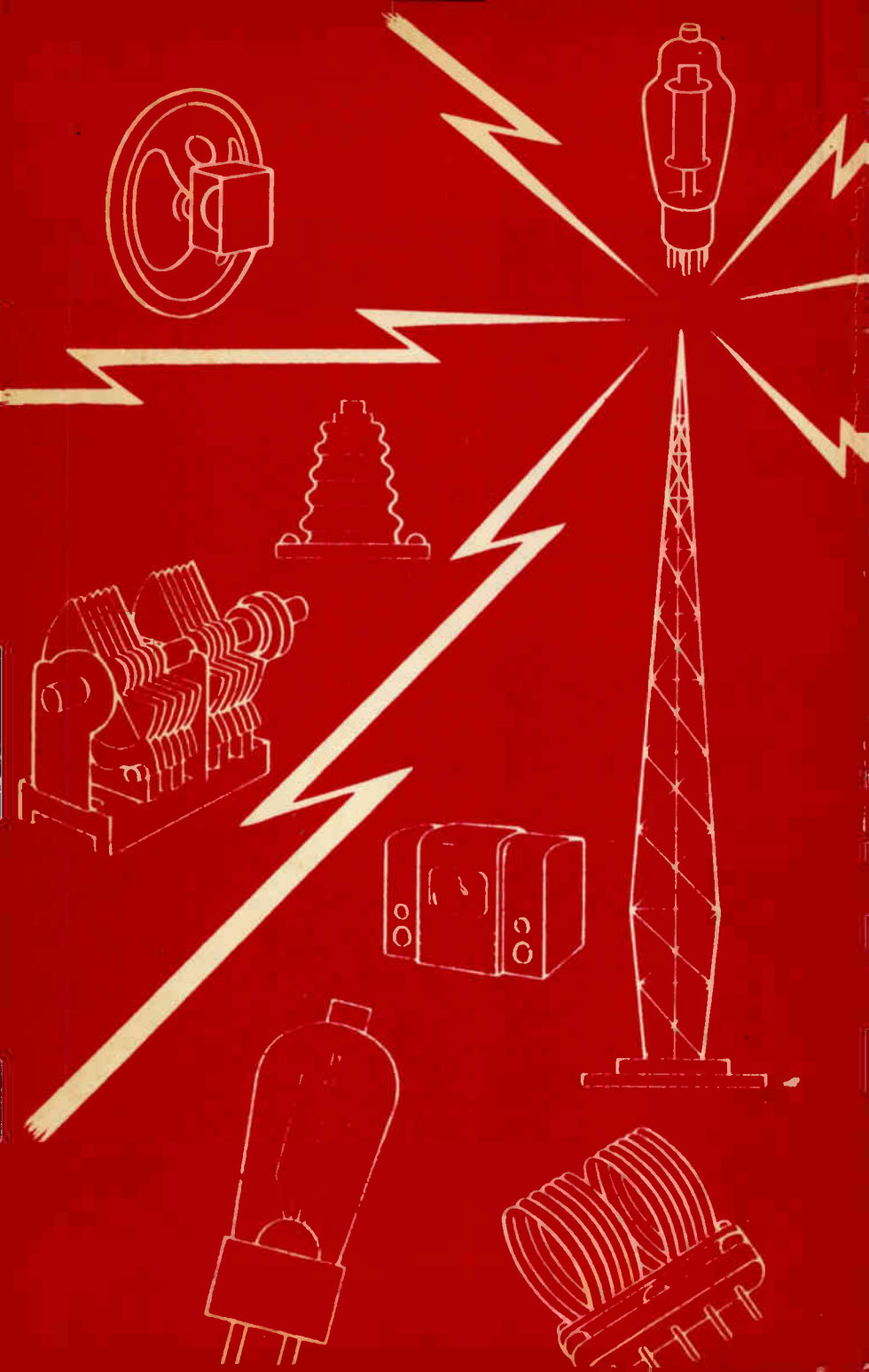

**APPLIED  
PRACTICAL  
RADIO-  
TELEVISION**

# APPLIED PRACTICAL RADIO-TELEVISION

---

---

---

*A Practical Book  
Covering*

RECTIFIERS  
POWER SUPPLIES  
WAVE RADIATION  
ANTENNAS  
TRANSMISSION AND RECEPTION  
AMPLIFIERS  
SUPERHETERODYNE RECEIVERS  
AUTOMATIC VOLUME CONTROL  
AUTO RADIO  
PUBLIC ADDRESS SYSTEMS  
HIGH FREQUENCY  
SHORT WAVE  
FREQUENCY MODULATION FM  
FM RECEIVERS  
TELEVISION

*by*  
THE TECHNICAL STAFF  
*of*  
COYNE ELECTRICAL & RADIO-TELEVISION SCHOOL  
CHICAGO 12, ILLINOIS

Copyright, 1953, by  
COYNE ELECTRICAL SCHOOL, INC.  
500 So. Paulina St.  
Chicago, Illinois

---

All rights reserved. This book or any parts thereof may not be reproduced in any form without written permission of the publishers.

1957 EDITION

Printed in the United States of America

## FOREWORD

This is a *practical* book on many phases of radio and television. It is practical because the publishers developed the book for use, either as a text and reference book in the radio course at Coyne Electrical, Radio and Television School, or as a field reference book for the experienced radioman.

The book is written in easy to follow language. The illustrations and examples are down to earth, with no high sounding theories. In most chapters of the book a brand new method in explaining technical subjects is used. By this method, wherever we are explaining a piece of radio or television apparatus, *a series of illustrations are used*. One photo will show the unit intact, then step by step the apparatus will be taken apart, just as though you had it in your own hands and disassembled it to see what "makes it tick." This is *practical photo instruction* helpful to both the student and experienced radio man.

Although every subject in this book has been carefully selected because of its importance in the radio field, we particularly call your attention to the instructions on the following.

We have amazingly clear, "show how," easy to follow chapters on amplifiers, superheterodyne receivers and auto radio.

We have also devoted two entire chapters to the increasingly important subject of Frequency Modulation or F.M., as the term is commonly used in radio. These chapters not only explain the principles of F.M., but cover actual service procedure on F.M. receivers.

Television, an industry offering great opportunities, is very closely allied to radio. Tremendous progress has been made in this field. The radiomen of the future will have to know television—it is *part of his industry*. The importance of this subject in

## FOREWORD

the future of radio, rates two complete introductory chapters at the end of this book and an entire volume later on.

Naturally, since this is a practical book, you will find hundreds of photos, charts, diagrams, etc. These, obviously, are provided to make it easier for the reader to understand the explanations. Like most Coyne books we include Review Questions at the end of each chapter. These help to let the reader know how he is understanding the subject—they act as a guide for him.

We feel this book represents the latest data on the subjects covered. The information combines the efforts of the Coyne staff, one of America's leading staffs of instructors (who are teaching practical radio and television every day), cooperating with a technical author of over thirty-five years of experience. These men *not* only know radio by actual field experience, *but* know how to teach it—they are experts in their line. *In addition*, we have also had the cooperation of the leading radio and television companies in the preparation of this book. They have supplied a great deal of practical radio and television data from their own research laboratories. These facts, we feel, should make this book outstanding in its class. A book that should be valuable to both the radio student or experienced serviceman.



B. W. COOKE, *President*  
*Educational Book Publishing Division*  
Coyne Electrical, Radio and Television School

# TABLE OF CONTENTS

	Page
<b>RECTIFICATION AND RECTIFIERS</b> .....	1-30
Half Wave Rectifiers, Full Wave Rectifiers, Filters, Rectifier Transformers, Bleeders, Voltage Doublers, Voltage Dividers, Multipliers, Vibrators, Review Questions.	
<b>RADIO WAVE RADIATION AND ANTENNAS</b> .....	31-74
Wave Form Energy, Frequency and Wave Length, Antenna Circuits, Current Flow in Antennas, Tuning and Resonance, Types of Antennas, Capacity of Antennas, Modulation, Detectors, Volume Controls, Transmission and Reception, Review Questions.	
<b>AMPLIFIERS AND LOUD SPEAKERS</b> .....	75-104
Grid Bias for Amplifiers, Plate Circuit Load, Audio-Frequency Amplifiers, Loud Speakers, Baffles, Phasing Two or More Speakers, Transformer Calculations, Impedance, Review Questions.	
<b>SUPERHETERODYNE RECEIVERS</b> .....	105-140
Heterodyning, Image Frequencies, Frequency Converter, Intermediate-Frequency Amplifier, Grid Bias, Loop Antenna, Pre-Selector Stage, Tracking, Multi-Band Tuning, Converters and Mixers, Alignment, Signal Generator, Preliminary Adjustments, I-F Transformer Alignment, Antenna Alignment, Alignment with Iron-Core Coils.	
<b>RECEIVER CONTROLS</b> .....	141-172
Volume Controls, Controls for Diode Detectors, Automatic Volume Control, Delayed Avc, Tuning Indicator Tubes, Tone Control.	
<b>AUTOMOBILE RADIOS</b> .....	173-204
Automobile Antennas and Circuits, Tube Arrangements, Tone Controls, Power Supply System, Battery Circuit, High-Voltage Circuits, Vibrators, Interference Elimination and Filters.	
<b>PUBLIC ADDRESS SYSTEMS</b> .....	205-248
Sound, Decibel Measurements, Voltage Outputs, Gains and Losses, Microphones, Microphone Outputs and Impedances, Directional Response, Phonograph Records, Phonograph Pickups and Connections, Volume Expansion and Compression, Mixing Circuits, Loud Speakers, Power Requirements.	
<b>HIGH-FREQUENCY OR SHORT-WAVE RECEPTION</b> .....	249-274
Meters and Kilocycles, Band Switching, Tuning Capacitance and Inductance, Bandsread Tuning, R-F Stages, Wave Traps, Oscillator, Short-Wave Alignment, Antenna Systems, High-Frequency Peculiarities.	
<b>FREQUENCY MODULATION</b> .....	275-304
Frequency vs. Amplitude Modulation, Deviation, F-M Frequencies and Channels, Very-High-Frequency Waves, Antennas for Very-High Frequencies, Dipoles and Doublets, Transmission Lines, F-M Receiver, Tuning, I-F Amplifier.	
<b>THE F-M RECEIVER</b> .....	305-330
Limiter Requirements and Action, Discriminator Principles and Performance, Discriminator Circuits, Producing Frequency Modulation.	
<b>ALIGNMENT OF F-M RECEIVERS</b> .....	331-346
Output Measurements, Signal Generators, Alignment of Discriminator, I-F Transformers, Oscillator, R-F, and Antenna Stages, Oscilloscope for Visual Alignment, Generator for Visual Alignment.	
<b>TELEVISION</b> .....	347-368
Television Camera, Image Scanning, Picture Tube, Deflection and Focusing, Television Frequencies, Television Signal, Transmission, Receiving Antennas.	
<b>TELEVISION RECEIVERS</b> .....	369-403
The Twenty-Four Parts of the Receiver, Antenna, Mixer, and Oscillator, Television and Sound Separation, Wide Band Tuning, Wave Traps, Receiver Attenuation, Detector, Phase Inversion, Beam Control, Brightness Control, D-C Restoration, Separating Synch and Picture Signals, Synch Separation, Beam Deflection, Deflection Oscillators and Amplifiers.	



## **ACKNOWLEDGMENT**

We wish to acknowledge and express our appreciation for the assistance and co-operation given to us by the following companies in supplying data and illustrations for the preparation of Coyne's Applied Practical Radio.

WESTINGHOUSE ELECTRIC & MFG. Co.

GENERAL ELECTRIC Co.

DUMONT COMPANY

CROSLEY RADIO & TELEVISION CORP.

P. R. MALLORY COMPANY

STRUTHERS DUNN Co.

J. P. CLARE COMPANY

SYLVANIA ELECTRIC PRODUCTS Co.

WELCH SCIENTIFIC COMPANY

R. C. A. MANUFACTURING Co.

AMERICAN STANDARDS ASSOCIATION

PHILCO RADIO & TELEVISION Co.

## Chapter 1

### RECTIFICATION AND RECTIFIERS

**General.**—A simple 2-electrode vacuum tube containing only a cathode and plate for anode, is more specifically called a “diode.” When a diode is connected as shown in Fig. 21-1, so that the plate is positive with respect to the cathode, electrons will flow from the cathode to the plate within the tube and they will complete the circuit by flowing externally through the meter, the load in the plate circuit, through the battery and back to the cathode. This electron flow is measured by the d-c milliammeter and is known as the plate current.

In Fig. 21-1, if the plate battery connections are reversed, so that the plate is negative with respect to the cathode, electrons from the cathode will be repelled by the negative plate and no plate current will flow. This behavior shows that diodes permit

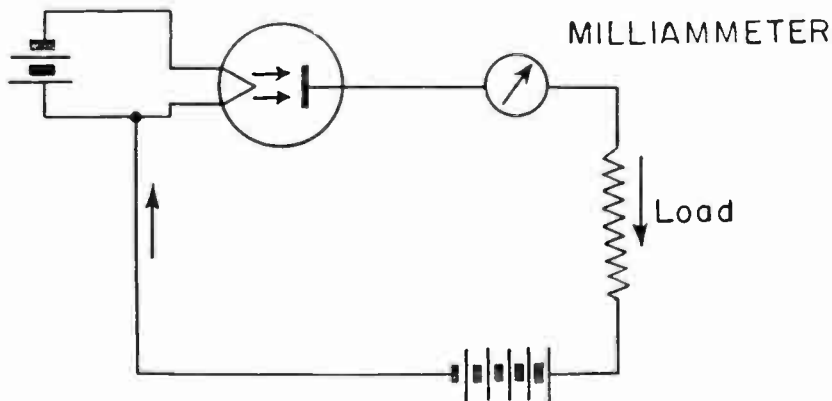

Fig. 21-1.—A diode as a rectifier.

electrons to flow from the cathode to plate but not from plate to cathode.

Inasmuch as such a device conducts current in one direction only, it suggests itself as a means for rectifying alternating current. This voltage can be either 60 cycles as ordinary power line frequency or 15,750 cycles such as the horizontal circuit of a

Television set. The principle is the same. If the battery in Fig. 21-1 is replaced with a-c voltage, the plate is made alternately positive and negative. Plate current can flow only during the time that the plate is positive, with the result that the current through the tube flows always in one direction, and is said to be rectified. Just how this rectifying action takes place for the circuit of Fig. 21-1, but with a-c on the plate instead of the battery, is shown graphically (by means of curves) in Fig. 21-2. The diode characteristic is a curve showing the change of plate current with the plate voltage for a diode. This curve is furnished by tube manufacturers and is obtained by setting up a circuit such as Fig. 21-1, plotting the plate current values obtained for different plate voltages. When the plate battery of Fig. 21-1 is replaced by a-c voltage, the a-c voltage is shown as a sine curve on the vertical axis of Fig. 21-2. All the a-c voltage values on the right side of the vertical axis are positive, whereas the a-c voltage values on the left side of the vertical axis are negative. With a-c on the plate, we have in effect, the same condition as in Fig.

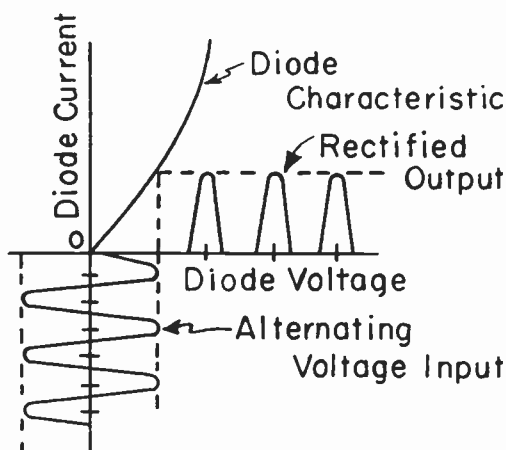

Fig. 21-2.—A diode as a rectifier with A-C on the plate.

21-1 when a plate battery is used and its voltage varied in order to get the plate current for different plate voltages, except that the plate voltage changes continuously in value and polarity. Inasmuch as 60-cycle voltage has 60 positive loops and 60 negative loops per second in its wave form, the 60 positive loops will

show up as 60 pulses of current through the tube, whereas the 60 negative loops will be blocked off, as the tube does not pass current when the plate is negative. The rectified pulses of output voltage from the diode are shown in Fig. 21-2. Since the load of Fig. 21-1 is made up of resistance only, the voltage across it will have the same wave form rectified a-c pulsations as shown in Fig. 21-2. Such a rectifier is called a half-wave rectifier. Another way of showing the input and output of wave forms and the rectifier circuit is shown in Fig. 21-3. Rectifiers may be divided into two classes: half-wave and full-wave rectifiers.

**Half-Wave Rectifiers.** — Half-wave rectifiers pass current when the plate is positive and block the flow of current or have zero output when the plate is negative. In other words, current through such rectifiers flows only during one half of the a-c

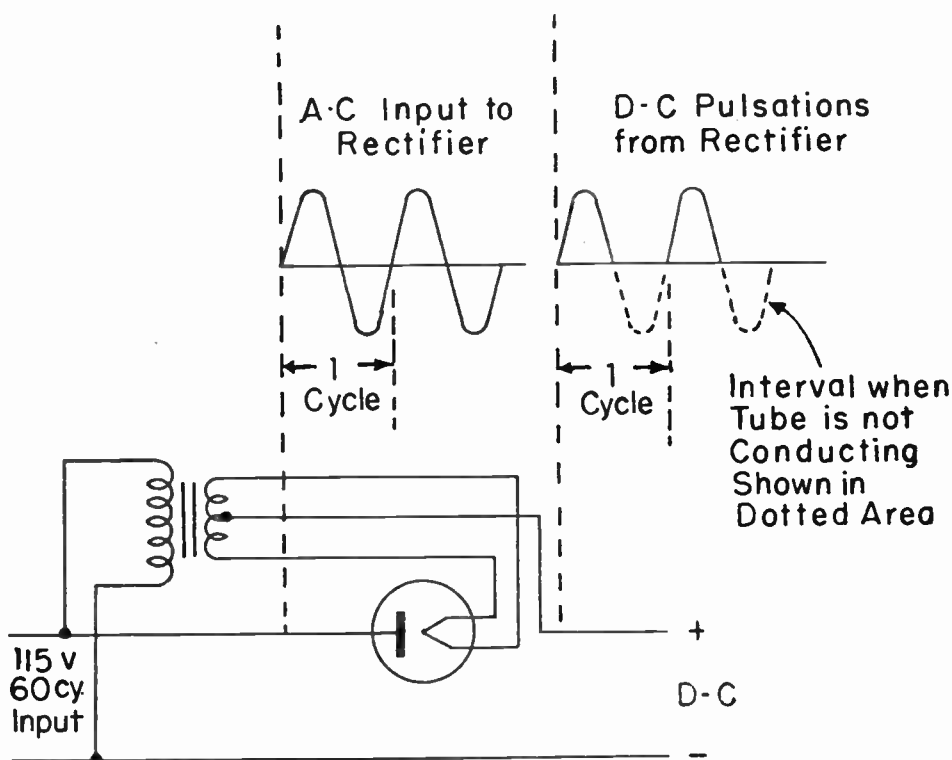

Fig. 21-3.—A half-wave rectifier circuit and its waveforms.

cycle. The output voltage is pulsating and before it can be applied to the plate or grid of vacuum tubes, the pulsations must be converted to smooth direct current with the use of filters. Filtering is more difficult and voltage regulation (a measure of the change of voltage with changing load) is poorer with half-wave than with full-wave rectifiers, because the rectified pulses of voltage are of the same frequency as the input a-c voltage; the load connected to the rectifier draws current continuously while current is delivered by the rectifier for only one-half of the a-c cycle. When a half-wave rectifier is connected directly to the a-c line as shown in Fig. 21-3, the output d-c voltage from the rectifier is much less than that of the input a-c line. Where a higher output than input voltage is wanted, a step-up transformer must be used as shown in Fig. 21-4. In this circuit, the pulsating

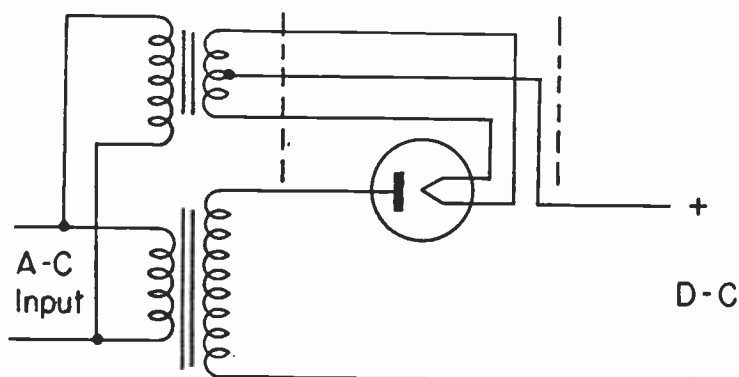

Fig. 21-4.—A rectifier circuit showing use of transformer to get higher output than line voltage.

d-c in the transformer secondary always flows in one direction, thereby tending to saturate the iron and reducing transformer efficiency, making necessary a larger transformer than would be required if no d-c were present. For these reasons, the half-wave rectifier is used only when very small currents are required.

**Full-Wave Rectifiers.** — If two half-wave rectifiers are connected so that they alternately pass current so as to utilize both halves of the a-c cycle, we have a full-wave rectifier, as in Fig. 21-5. The full-wave rectifier may consist of two plates and one or more cathodes in the same tube (such as the 5T4, 80, 5Z4

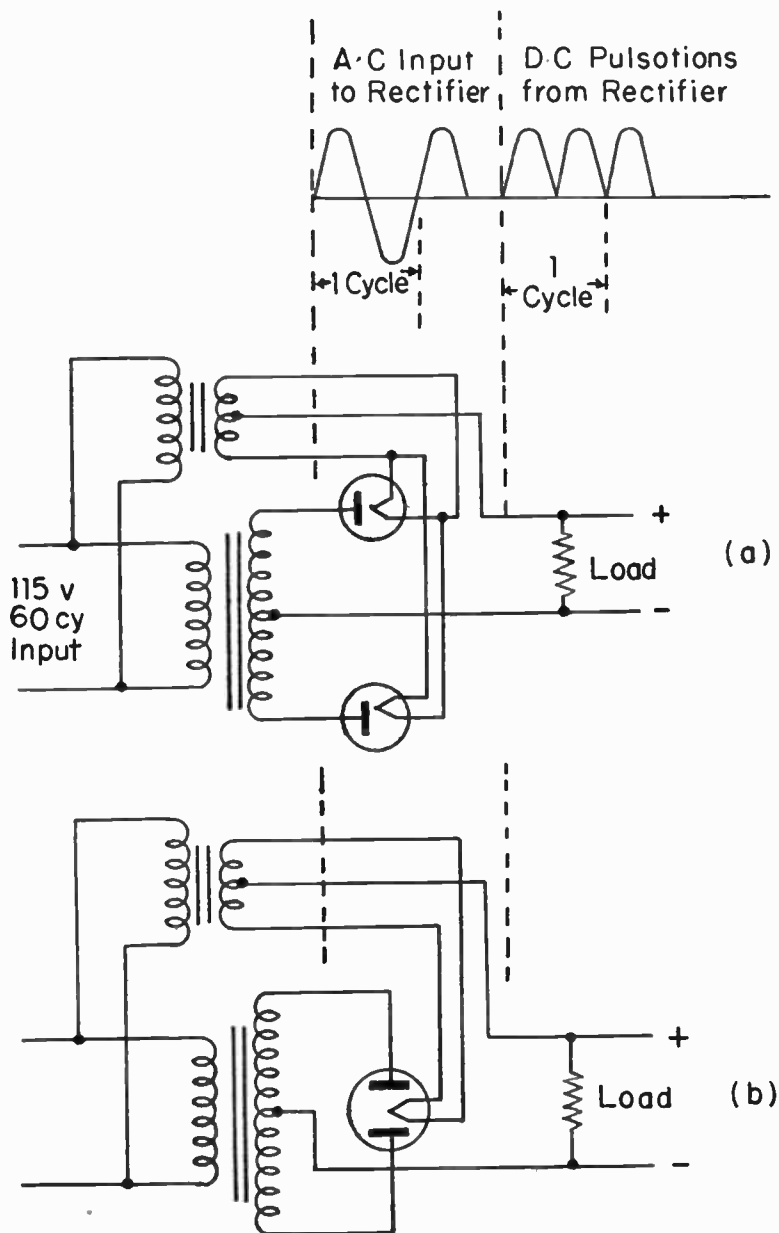

Fig. 21-5.—A full-wave rectifier and its waveforms.

or 5Z3) for relatively low plate voltages or it may consist of two separate tubes to handle the high voltages required in transmitters. The plates are connected across the step-up transformer so that at any moment one plate is positive with respect to the center tap and at the same time the other is negative with respect to the center tap. As the polarity of the transformer changes from plus to minus, the individual plates and cathodes pass current alternately, producing a combined output wave form as shown in Fig. 21-5.

The center tap of the secondary is the negative side of the d-c output and is usually although not always grounded. Full-wave rectifiers pass current on both halves of the a-c cycle so that the voltage regulation is much better than with half-wave rectifiers. The d-c output pulsations have twice the frequency of the input. This means that the output pulsations will be moved closer together as can be seen in Fig. 21-2 and Fig. 21-7. Less filtering will be necessary to smooth out the pulsations.

**Rectifier Filters.** — The output wave forms shown in Figs. 21-3 and 21-4 constitute a pulsating d-c current flowing in the same direction but varying continuously in value. Such d-c would be satisfactory for operation of d-c relays, battery charging, etc., but these pulsations or ripples must be reduced to as near pure d-c as is economically possible before this output can be used satisfactorily on the plates and grids of vacuum tubes. Smoothing out of the rectified pulsations is accomplished by the use of filters.

Filters consist of series choke coils and shunt condensers through which the output from the diode rectifier passes before reaching the load. Rectifier filters can be divided into two groups: condenser-input or choke-input, depending on whether the filter presents a shunt condenser or a series choke coil to the output

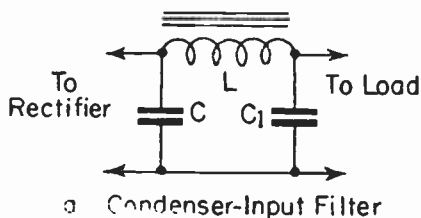

Fig. 21-6a.—A condenser-input filter.

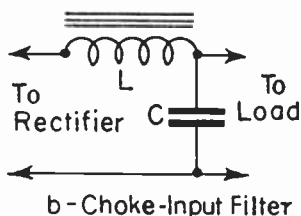

Fig. 21-6b.—A choke-input filter.

from the rectifier. Fig. 21-6a shows a condenser-input filter sometimes referred to as a *pi* section and Fig. 21-6b shows a choke-input filter. Further subdivisions of these filters can be made according to the number of sections of filter elements used.

The degree of filtering required for a specific purpose depends on the amount of a-c hum or ripple voltage permissible in the circuit. However, referring to Fig. 21-5 one a-c cycle is really 2 half waves: one above and one below the reference line. The full wave rectifier puts both waves above the line. The frequency of the pulsations in the output from the rectifier tube, or briefly the ripple frequency, is dependent on the supply voltage frequency and the type of rectification (half-wave or full-wave). A half-wave rectifier has a ripple frequency equal to the frequency of the input voltage to the rectifier. A full-wave rectifier has a ripple frequency twice the supply frequency. The frequency of the pulsations in the output of the rectifier tube determines the average value of the filter condenser needed. An ordinary a-c—d-c power supply such as used in small table model sets operating on a 60 cycle line will use about a 30 MF input condenser in the filter system. A TV set which has a high voltage supply working at 15,570 cycles has an average value of filter condenser of 500 mmf—or .0005 mf. The coating on a TV picture tube is grounded and it acts like a .0005 mf condenser also. It is quite common to use a 470K resistor between the 2 condensers. This resistor takes the place of the filter choke of Fig. 21-10. Because of this difference in ripple frequency, a half-wave rectifier requires approximately twice the filtering of a full-wave rectifier if the same a-c hum or ripple voltage is to be attained in both cases.

**Condenser-Input Filter.** — The simplest form of this type of filter consists of a condenser connected in parallel with the load as shown in Fig. 21-7. While the rectified voltage is increasing, the tube is delivering current to the load and charging the condenser which acts as a reservoir of current storage. After the maximum value of the rectified pulse is reached, the voltage from the rectifier tube increases and continues to do so until the one-half cycle is completed. During this decrease in rectifier tube output, the condenser has a higher potential than the output voltage from the rectifier because of the charge on the condenser accumulated during the time that the output voltage from the



rectifier was increasing. The condenser cannot discharge through the tube because of the one way condition of the tube (plate is negative and cathode positive when condenser is discharging), so it must discharge energy through the load. A small load will cause the condenser to discharge slowly as shown in Fig. 21-7b, whereas a heavy load will cause it to discharge more rapidly as shown in Fig. 21-7c. The amount of energy which the condenser can store is dependent on the capacitance of the condenser and the applied voltage.

As compared with the unfiltered d-c output obtained in Fig. 21-3, a simple filter of this kind may reduce much of the ripple voltage in the rectifier output. However, the amount of ripple

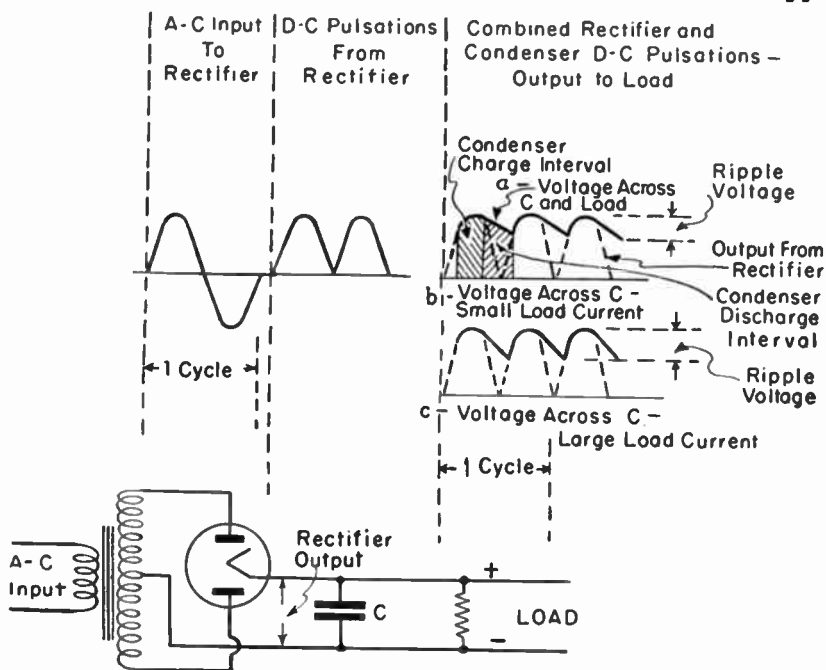

Fig. 21-7.—Condenser input filter and output waveforms with small and large loads.

voltage still present in the output is too great for use as a plate supply for receivers and transmitters and must be filtered to smooth out the ripple voltage, since any ripple in the power supply will be amplified by each tube and passed along until it becomes objectionable.

Another disadvantage of the condenser-input filter is the heavy current drawn through the rectifier tube while the condenser is charging. In combination with the load current, it may be great enough to cause damage to the rectifier tube. The voltage regulation under varied loads is very poor. This is indicated in Fig. 21-7 by the change in voltage across  $C$  when the load is changed from small to large.

The first condenser in a condenser-input filter should be rated for a working voltage greater than 1.41 times the r-m-s (root-mean-square) voltage out of the rectifier to withstand the peak voltage value from the rectifier and avoid breakdown. If electrolytic condensers are used, they must be connected with proper

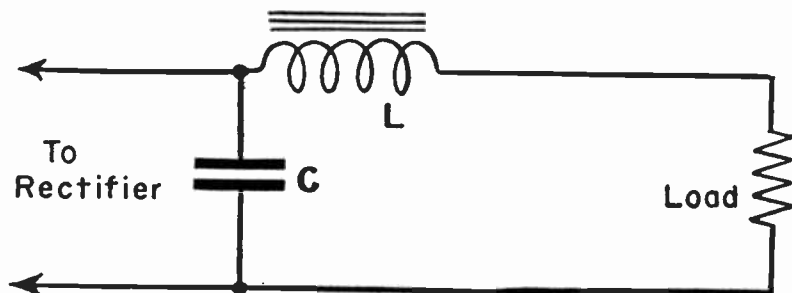

Fig. 21-8.—Choke added to simple capacitor filter to improve filtering action.

polarity.

The ripple voltage from a simple condenser filter can be smoothed to a greater extent with the use of an iron core choke (10 to 45 henries), as shown in Fig. 21-8. The choke offers a high impedance or opposition to the flow of pulsating current and "chokes out" the ripple voltage before it reaches the load. Because the load current flows through the choke, it should have a small resistance to d-c.

The charge and discharge of the condenser when used with the series choke is similar to that of the simple condenser filter previously described except for the additional smoothing effect produced by the choke. Fig. 21-9 shows the sequence of operation

for this filter. Assuming the first half cycle of the rectifier output from  $E$  to  $F$ , condenser  $C$  is charged while the voltage from the rectifier is increasing until the peak voltage  $A$  is reached. In the same half cycle  $E$  to  $F$ , current flows to the load through the choke coil  $L$ . Inductance of the choke coil opposes any rapid change of flow of pulsating current to the load and in that way, allows the condenser  $C$  to store up energy. After point  $A$  in Fig. 21-9 is reached, the voltage from the rectifier begins to decrease from  $A$  to  $F$ . However, the inductive property of the choke coil opposes the decrease in the load current, and from  $A$  to  $F$ , the condenser, because it is charged with a higher potential than the voltage on

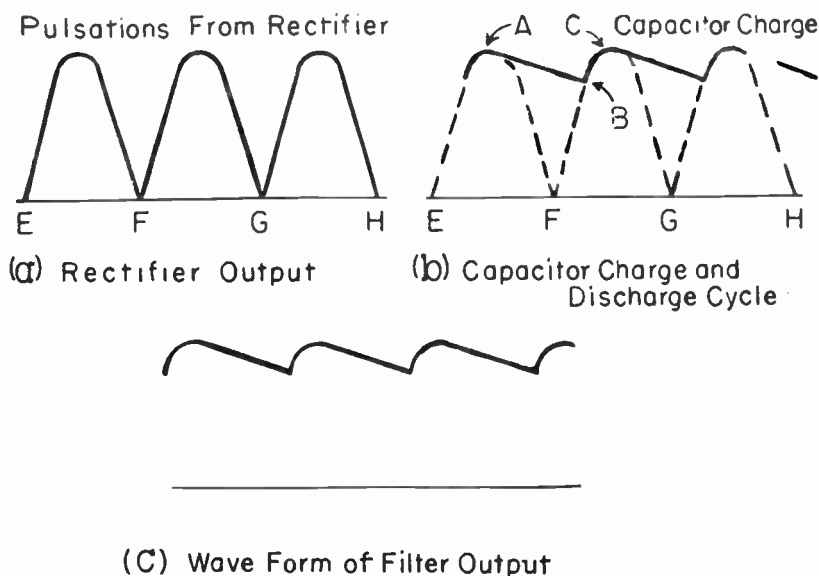

Fig. 21-9.—Waveforms of filter of Fig. 8.

the rectifier, begins to discharge slowly through the choke coil into the load. This interval of condenser discharge is from  $A$  to  $B$  as shown in Fig. 21-9. As the condenser charge diminishes from  $A$  to  $B$ , the next rectifier half cycle  $F$  to  $G$  has begun at  $F$  and the voltage increases to  $B$  at which point the rectifier again charges the condenser from  $B$  to  $C$  to approximately the peak voltage of the rectifier output. The behavior of the choke and condenser for the rest of the rectifier half cycle  $F$  to  $G$  is the same as for the first

half cycle  $E$  to  $F$  and repeats itself every half cycle. The resulting output from the simultaneous action of the rectifier, condenser and choke coil as delivered to the load, is shown in Fig. 21-9c, which is much smoother than the other output of Fig. 21-7.

If a second condenser  $C-1$ , is connected across the filter as shown in Fig. 21-10a the ripple voltage of Fig. 21-9c is reduced further as shown in Fig. 21-10b. The current-storage property of the second condenser helps to "fill in" the "troughs" of the filter output in the form of Fig. 21-9c and smooths the output to a better approximation of steady d-c. If the load current suddenly increases, the choke coil tends to prevent a sudden decrease. This tends to decrease the output from the filter, but the condenser  $C-1$  discharges to the load because it has momentarily a higher potential than the output from the preceding filter and supplies the necessary increase in current. In this way it helps to keep a more uniform load voltage.

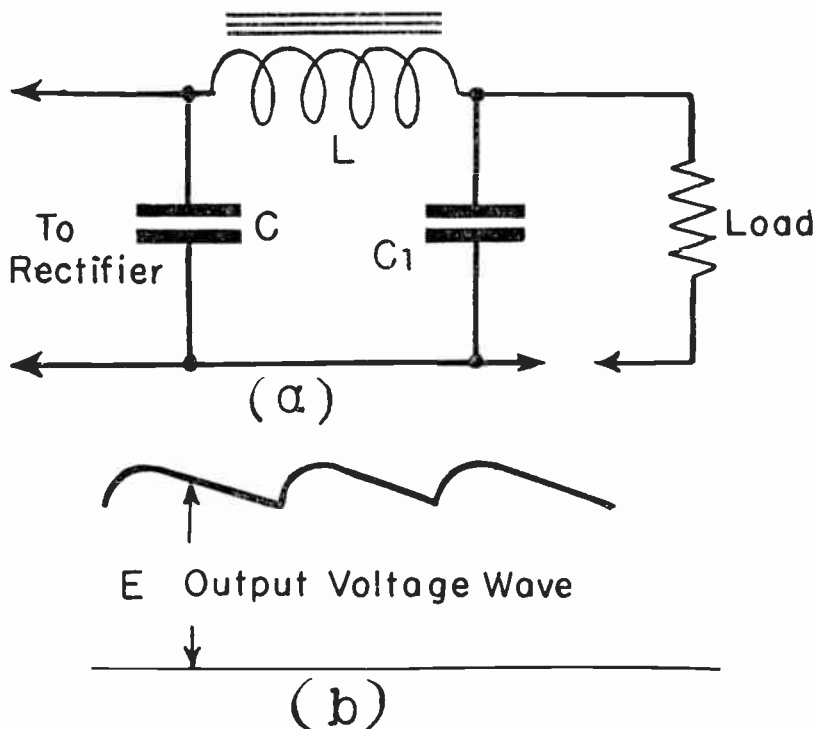

Fig. 21-10.—Circuit of complete filter section, and waveform of output.

For a higher degree of filtering, a single  $\pi$  filter of Fig. 21-10 can be followed by a second  $\pi$  filter with resulting smoother d-c output as shown in Fig. 21-11.

Condenser-input filters are used with full-wave rectifiers for delivering small amounts of power at fairly high plate voltages (50 watts or less at voltages up to 400 volts) where good voltage regulation is not an important requirement.

**Choke-Input Filter.** — In flowing through the inductance  $L$ , the rectified current meets a high resistance at ripple frequency but only a small d-c resistance, with the result that the ripple is greatly reduced. Just how the choke brings about this result is shown in wave forms of Fig. 21-12. When the rectifier output voltage, which is the same as the filter input voltage, increases from  $A$  to  $B$ , the tube and load current build up more slowly than with the condenser-input filter.

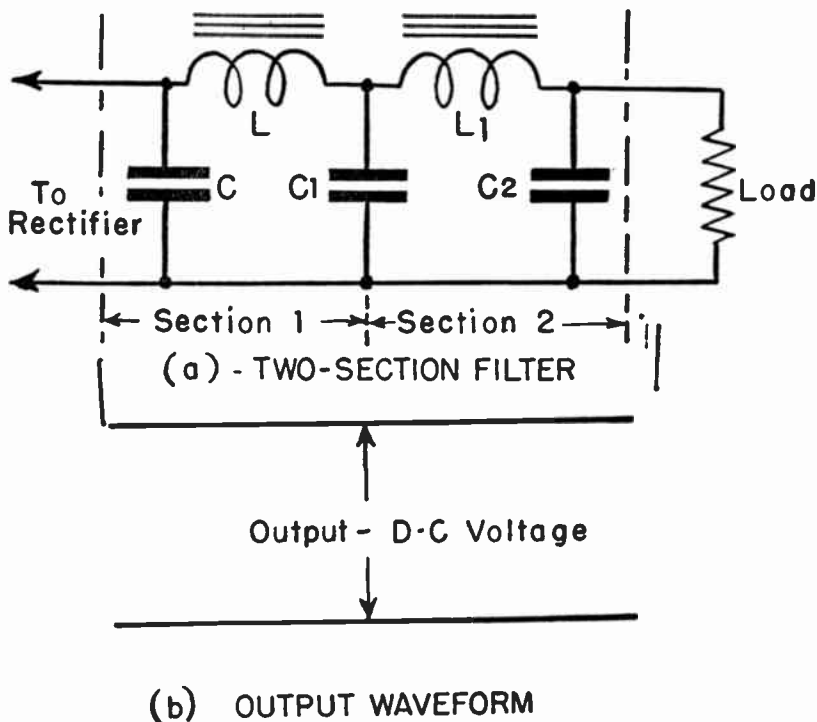

Fig. 21-11.—Two section filter and out-put waveform: (a) Two-section filter  
(b) Out-put waveform.

The inductive property of the coil opposes any rapid changes of current regardless of whether the current be increasing or decreasing, and in this way smooths out the ripple voltage and tends to keep the current at a steady state, when the rectifier output begins to decrease from *B* to *C*. This function is duplicated at each half cycle. The ripple voltage is decreased further if the condenser is connected across the load. Such an arrangement may make up a single section filter and the resulting improvement in output is shown in Fig. 21-13-a. More elaborate filtering involving an additional filter section and further smoothing of the ripple voltage, is shown in Fig. 21-13-b.

**Comparison of Condenser-Input and Choke Input Filters.**—Both of these filters are similar in that they suppress the rip-

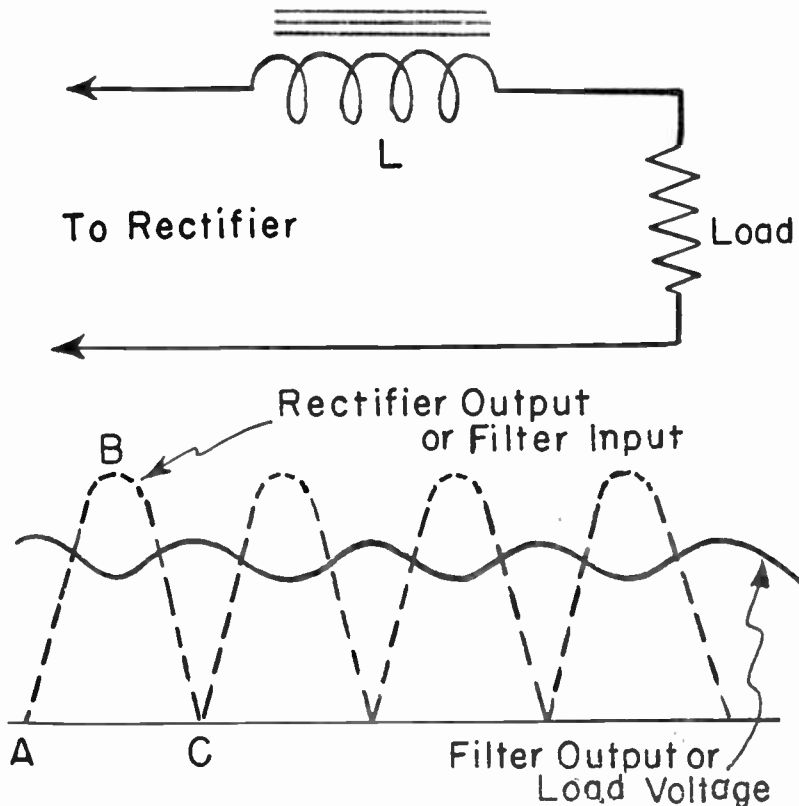

Fig. 21-12.—Choke filter; input and output waveforms.

ple voltage. However, they have other characteristics which distinguish them from each other. In the condenser-input filter, the condenser next to the rectifier tube is charged to nearly maximum instantaneous value of the rectified pulses from the rectifier tube. It does not discharge completely between pulses and it is this current storage property which helps in maintaining

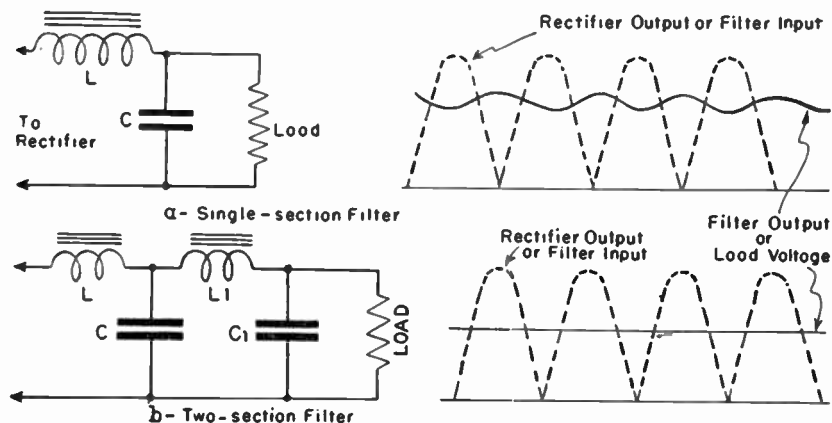

Fig. 21-13.—Single section and two-section choke-input filters, showing input and output waveforms.

the output voltage from the filter in the interval between pulses from the rectifier tube. When the load current is very small, the voltage from the filter is approximately equal to the peak voltage of the rectified pulses. When the load current increases, the filter output voltage drops off quickly. In brief, for small load currents, this filter has a high output voltage, but voltage regulation is poor.

As seen from the output wave forms of the choke-input filter, this filter does not permit its output voltage to reach the peak value of the rectified pulse as was the case with the condenser-input filter. If the same rectifier-output voltages are applied to either type filter, the choke-input filter would deliver less voltage to the load than the condenser-input filter. In Fig. 21-14, curve A shows the d-c voltage and filter output for various load currents of 400 volts r-m-s on the rectifier plate, when using the condenser-

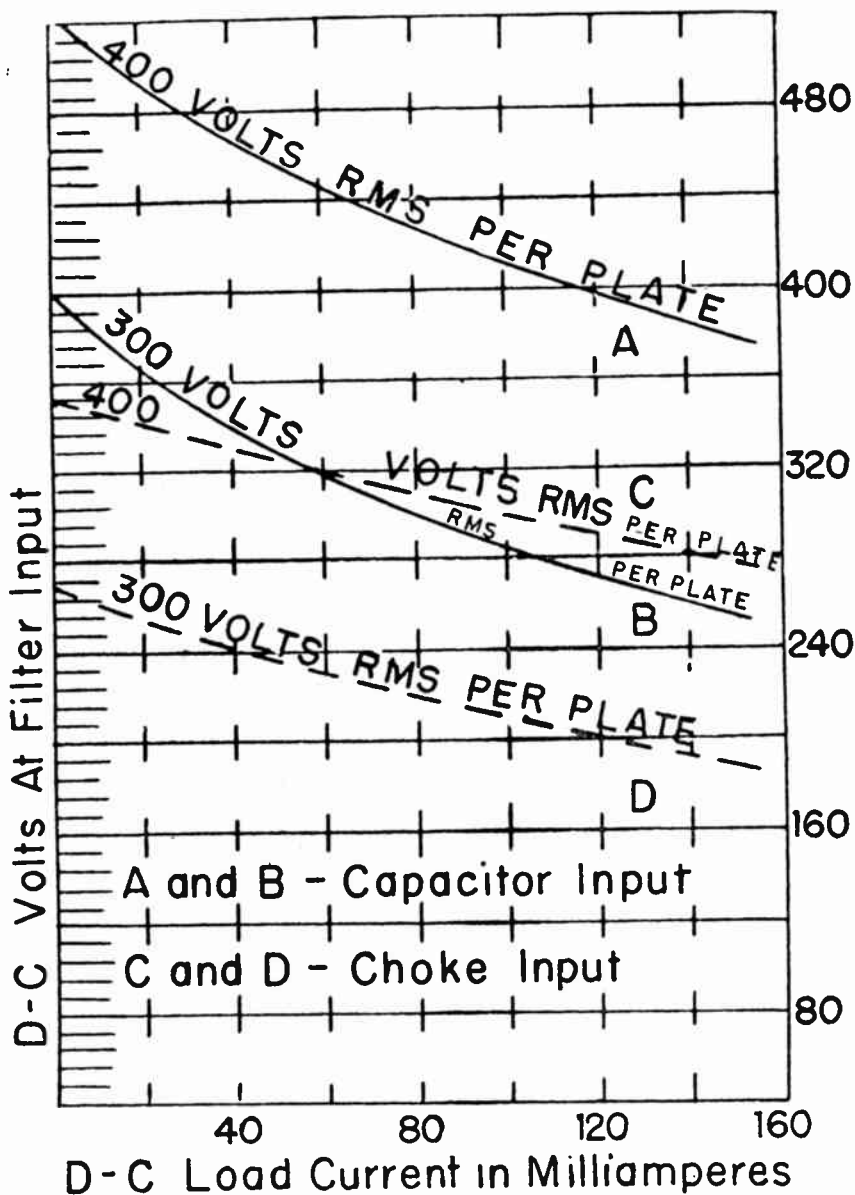

Fig. 21-14.—Comparison of condenser input and choke output filters.



input filter. Curve *C* shows the same characteristics with the same voltage on the rectifier plate but using a choke-input filter. Note how much lower the output voltage is for *C* as compared to *A*. Also note how much quicker the voltage of *A* drops off with load as compared to *C*, showing that the voltage regulation is better with the choke-input filter than for a condenser-input filter. Curves *B* and *D* show a similar relationship but for lower plate voltage (300 volts) on the rectifier. Curves similar to these are furnished by tube manufacturers as part of technical data supplied with their rectifier tubes.

The choke coil is usually connected in the positive lead of the power supply, although it may be used in the negative side without changing the filtering. When used on the positive side, the insulation between the windings and the core is stressed at a higher voltage than when the choke is used in the negative lead.

Choke-input filters are used chiefly where large amounts of power and good voltage regulation are required. Choke-input filters are used with mercury-vapor rectifier tubes whereas the use of condenser-input filters is not advisable. This is because the maximum voltage drop across this type of tube is about 22 volts and while the voltage will remain practically constant, the heavy rush of current to charge the condenser causes the voltage drop to exceed 22 volts and the heavy gas ions are accelerated toward the filament, thereby bombarding and destroying it.

The d-c which flows through the choke coil lowers the inductance effect (or inductance of the coil) because it saturates the iron which makes up the core. Choke coils used in condenser-input filters have sufficient air gaps in their cores to prevent the d-c from saturating the core. Choke coils used in choke-input filters have no air gaps, and normally the d-c saturates the core. In these choke coils the effective inductance may be lowered appreciably when the load current is increased. When the current decreases, the effective inductance of the choke tends to rise. However, if the current through the choke coil is too small, the input inductance loses its effect and the filter behaves like a condenser-input filter. To maintain the desirable characteristics of the choke-input filter, a certain minimum value of inductance must be in the circuit at the time of maximum and minimum load current. This value of input-choke inductance is called the critical

inductance. For a single-phase full-wave rectifier operating at 60 cycles, the approximate formula is:

$$L = \frac{R}{1200}$$

L is the inductance of the filter choke in henries. R is the d-c load resistance in ohms.

Thus, if a rectifier is to deliver 100 ma (bleeder current plus current taken by all other vacuum tubes) at 300 volts d-c, the load resistance is

$$R = \frac{E}{I} = \frac{300}{.1} = 3000 \text{ ohms.}$$

The minimum required inductance of this filter choke will be:

$$L = \frac{3000}{1200} = 2.5 \text{ henries}$$

If the load current is to vary between 25-100 ma, this 2.5 henry choke will not be satisfactory at the lower values of tube current. At the 25 ma current, the d-c load resistance in ohms is 4 times the value of 3000, since the current is one-quarter of the former value, the resistance must be 4 times the former value. The necessary inductance required is:

$$L = \frac{R}{1200} = \frac{12000}{1200} = 10 \text{ henries}$$

The choke having this inductance or larger, for a maximum load current of 100 ma, will provide satisfactory choke-input filter operation. Such chokes, called swinging chokes, have large inductance at low current, with appreciably smaller inductance at maximum current.

**Rectifier Transformers.**—The voltages for the various elements of a vacuum tube may range from 1 volt for the filament of the receiving tube to ten or fifteen thousand volts for the plate of the high voltage rectifier tube in a TV set. The cathode voltage is a step-down transformation whereas the plate voltage is usually a step-up transformation, exceptions being in the small a-c—d-c sets which operate directly from the a-c or d-c line, that is, without any plate or filament voltage transformers.

The average radio receiver has a plate voltage less than 400 volts — it usually approximates 300 volts. This relatively low

voltage permits assembly of the high voltage and various filament windings as separate secondaries over the same primary and core. Such transformers are rated by the current they can deliver at a specified plate voltage. A transformer suitable for a 5-tube receiver, may be rated 50 ma and 250 volts while one suitable for a 9-12 tube receiver may be rated at 110 ma and 250 volts. In addition, these transformers have filament windings of specified voltage and current ratings.

In a-c operated receivers, the cathodes of the tubes are usually of the separate heater type so that a-c may be used for these filaments. The voltage rating for these tubes is from 1.5 to 117 volts, with 6.3 volts being the most common.

The filaments of transmitter tubes operate on voltages of 2.5 to 14 and can be used on a-c as well as d-c, the only requirement for proper operation being that the grid and plate circuits return to the electrical center of the supply system. This connection is necessary to avoid introducing hum into the signal, and is usually the center tap on the filament winding.

The power supply of a TV set consists generally of a standard supply such as is used on a very large a-c receiver and a high voltage supply which delivers 10,000 to 15,000 volts but at very low current, usually on the order of .0005 amperes. This high voltage is used to supply the picture tube 2nd anode.

**Bleeders.**—The resistance connected across the output of the filter circuit is called the “bleeder.” Its purpose is to prevent excessive rise in voltage that would otherwise occur if the load were suddenly removed, thereby causing a break-down of the insulation used throughout the circuit. In most radio power supplies, when the set is just turned on, the rectifier tube and the other tubes do not begin full operation at the same time. They do not operate in synchronism until a few seconds elapse since turning on the set. When the rectifier tube is of the filament type it begins to pass current immediately after it is turned on. The tubes in the receiver, however, are usually of the separate heater type and do not begin operating as soon as the plate voltage from the rectifier is supplied. The bleeder resistor is an ever-present load on the power supply and prevents any high voltage surge that could occur under such conditions. The bleeder resistor also



condenser is charged to the peak voltage of the supply as at time (a) in Fig. 21-16-b. During the time interval (o) to (a) the current flowing through the rectifier is the sum of the current flowing through  $C$  and  $R$ . When the peak (a) has been reached the condenser will start to discharge through the load resistor and the rectifier will also pass current through the resistor until such a time (b) when the voltage on the condenser exceeds the value of the line voltage applied to the rectifier. The condenser continues to pass current which drops off in value as shown from (b) to (c). During the interval from (b) to (c) the rectifier voltage drops to zero, goes through the negative half cycle, starts through the positive half of the cycle and increases in value until at (c) it begins to exceed the condenser voltage, thereby again charging the condenser and supplying current to the load resistor. This sequence of rectifier and condenser operation is repeated every cycle of input voltage. The current flowing in the condenser while it is charging is heavy, and for this reason the maximum current through the rectifier may be many times the

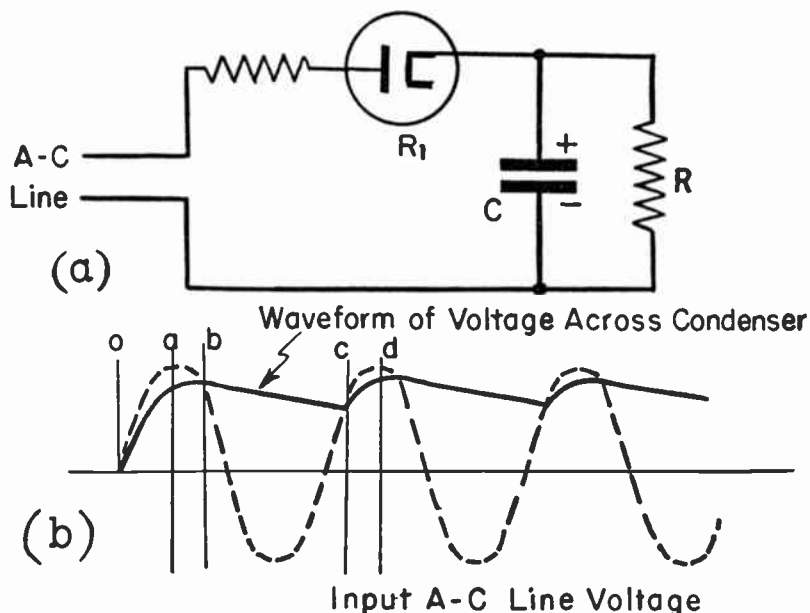

Fig. 21-16.—Half wave rectifier with condenser input.

d-c current through the load resistor. For each rectifier tube, there is a maximum plate current. For the 25Z5 and 25Z6 this rating is 450 ma. If this rating is exceeded, a short rectifier life may result. This consideration limits the size of the input condenser which may be used safely, unless a series resistor  $R-1$  of 30 to 50 ohms is used in the plate circuit to limit the peak plate current. Such a resistor causes a few volts drop in the plate voltage but provides protection to both tube and condenser; where a series resistor is used, a higher value of condenser is chosen to offset the loss in plate voltage caused by the series resistor. The ripple voltage is determined by the size of the condenser, load resistor and the line frequency. The frequency for the half-wave rectifier is the same as the line frequency.

There are two types of voltage doubler circuits, (a) symmetrical or balanced type and (b) series or common line type. Sometimes these circuits are referred to as full-wave and half-wave doublers, respectively. The latter designation probably arises from the fact that the former has a ripple frequency of twice the line frequency from the rectifier, while the latter has a ripple of line frequency.

Fig. 21-17 is the most common voltage doubler circuit. A current limiting resistor ( $R-1$ ) and ( $R-2$ ) have been discussed previously in connection with the half-wave rectifier. Filaments  $T-1$  to  $T-4$  represent the heaters of other tubes of the receiver, connected in series with the rectifier filament and the resistor  $R-3$  and the rectifier filament circuit connected directly to the line. The resistor  $R-3$  reduces the voltage across the individual tube filaments to the rated operating value. Condensers  $C-a$  and  $C-b$  are assumed to be of identical value. Fig. 21-17-b is a simplified version of a schematic diagram showing only the essential portions of the circuit.

The operation of the circuit is explained as follows. At the instant, point 1 is positive and point 2 negative, current will flow in the direction of the solid arrow through the rectifier tube  $T-1$ , thus charging condenser  $C-a$ , making point A positive with respect to point 0. During this half cycle, no current will flow through the rectifier  $T-2$  since the plate is negative with respect to its cathode. During the next half cycle, current will flow only through  $T-2$ , since point 2 has been positive with respect to

a - SCHEMATIC DIAGRAM

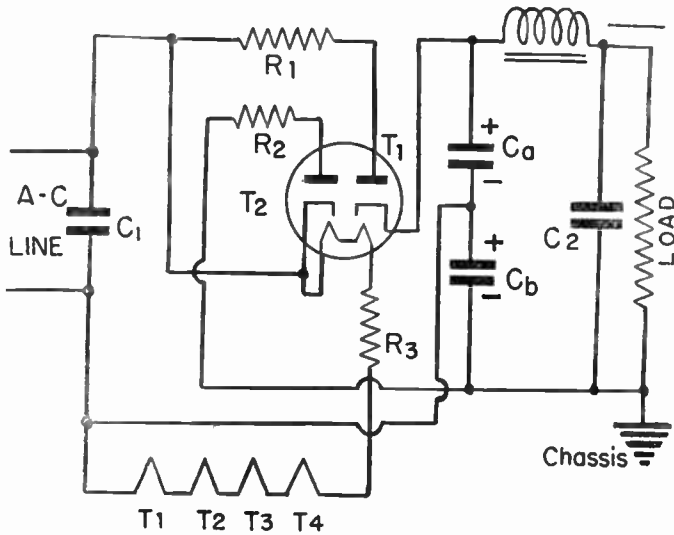

b-SIMPLIFIED DIAGRAM OF DOUBLER CIRCUIT

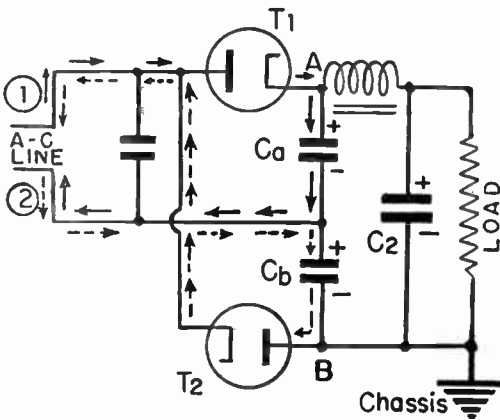

SOLID LINE  $\longrightarrow$  Indicates Direction of Charging Current Flow When (1) is Positive

DOTTED LINE  $\dashrightarrow$  Indicates Direction of Charging Current Flow When (2) is Positive

Fig. 21-17.—Symmetrical or balancer type of voltage doubler.

point 1, and charging current will flow as shown by the dotted arrows, charging  $C-b$  with polarity as shown. The potential difference between points  $A$  and  $B$  if the condensers did not discharge, would be twice the line peak voltage. Actually one condenser is discharging through the load while the other is being charged, in much the same manner as the input condenser discharges in Fig. 21-16 during the alternate half cycles. If the dotted curve of Fig. 21-18 represents the sine wave of the power supply line a-c voltage corresponding to polarities 1 and 2, then  $A$  and  $B$  represent the instantaneous potentials of condensers  $C-a$  and  $C-b$  respectively, with regard to 0. The potential difference between points  $A$  and  $B$  in the simplified diagram as shown by curve  $E$  which is obtained by adding curves  $A$  and  $B$ . Curve  $E$  is the total voltage from the rectifier and it is the voltage input to the filter. The ripple or hum frequency is twice line frequency, being the same as for a full-wave rectifier.

The operating characteristics of the voltage doubler circuit are approximately similar to the half-wave rectifier of Fig. 21-16

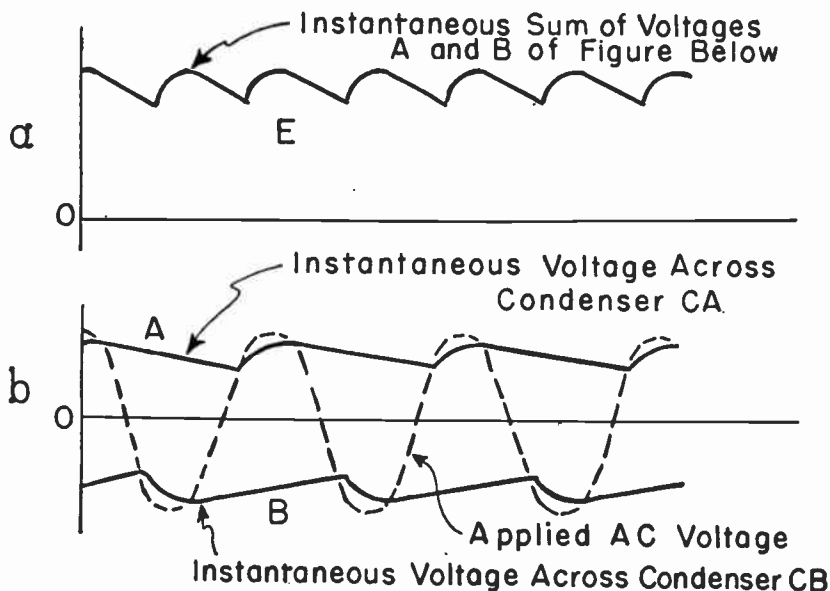

Fig. 21-18.—Potentials in a symmetrical voltage doubler.



except that the higher output voltages are obtained. The 25Z5 and 25Z6 have a maximum rating of 75 ma for doubler circuits, with a peak value of 450 ma for plate. The use of series resistors in the plate helps to keep the peak current within safe limits.

The voltage rating of the condenser *C-a* and *C-b* is 150 d-c working volts and capacitance is 20-40 mfd—the same as for the half-wave rectifier of Fig. 21-16. Condenser *C* is usually rated 250 d-c working volts. It is to be noted that condenser *C-b* has the negative lead connected to the chassis and thus if it is of a metal can construction, the unit may be mounted on the receiver chassis. Condenser *C-a*, on the other hand, must have its can insulated from the chassis and be suitably covered to prevent accidental contact with any grounded parts. One side of the power line is connected to the junction of the two condensers as designated as Point *O* in Fig. 21-17. Since either side of the power line may be grounded depending on the way the line plug is inserted into the power outlet, the full power line voltage can occur between the chassis and any other actual ground such as a water pipe, radiator pipe, or grounded conduit or outlet base plate. These are the reasons why transformerless types of circuits are enclosed so that no metal part of the chassis is accessible for accidental contact by the user.

Fig. 21-19 is another voltage doubler circuit called the common line, series line feed type, or half-wave doubler. This circuit operates in a somewhat different manner from the balanced type of voltage doubler, and might be more properly called a voltage addition or multiplier circuit than a doubler circuit. The circuit is shown in schematic form in Fig. 21-19-a and in simplified form in Fig. 21-19-b. The operation of the circuit may be explained as follows: Assuming point *1* is positive with respect to point *2*, during the first half cycle, charging current will flow in the direction shown by the solid arrow to the rectifier tube *T-1*, until condenser *C-a* shows a charge equal to approximately maximum potential of the line. During the next half cycle, when point *2* becomes positive with respect to point *1*, the charge of the condenser *C-a* will add to that of the line and the current will flow through the rectifier tube *T-2*, charging condenser *C-b* to a potential equal to the sum of the charge in *C-a* plus the feed line voltage. The path of this current flow is shown by the dotted

## (a) SCHEMATIC DIAGRAM

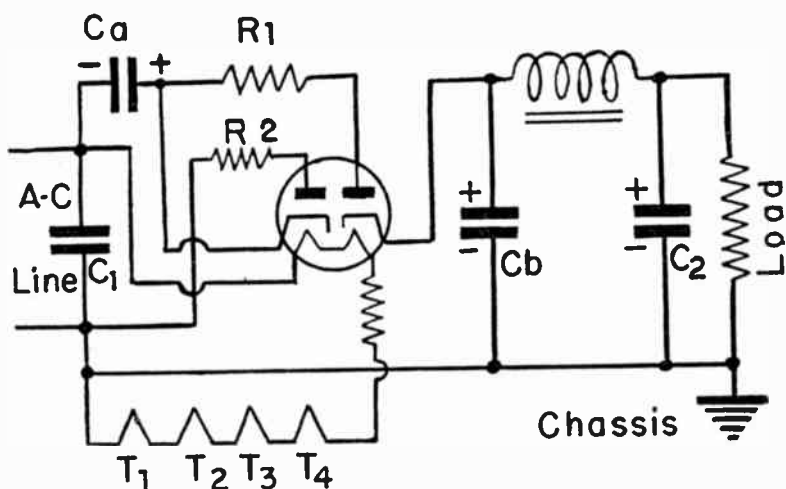

## (b) SIMPLIFIED DIAGRAM OF DOUBLER CIRCUIT

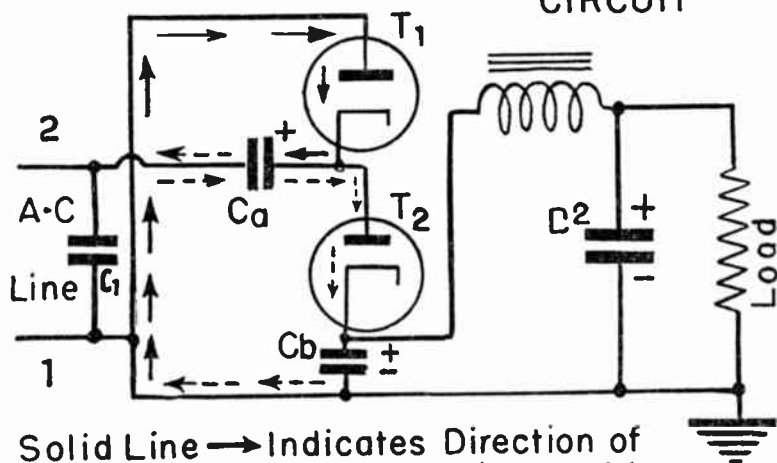

Solid Line  $\rightarrow$  Indicates Direction of Charging Current When (1) is Positive

Dotted Line  $\dashrightarrow$  Indicates Direction of Charging Current When (2) is Positive

Fig. 21-19.—Common line or series feed of voltage doubler.

arrow. This action would result in a charge of condenser *C-b* of twice the peak line potential if it were not for the fact that this condenser begins to discharge through the load the instant that current starts flowing through the rectifier tube *T-2*. Although the current flow through *C-a* is in one direction on one half cycle and in the reverse direction on the other half cycle, the polarity of this condenser always remains the same.

Unlike the balanced type of voltage doubler circuit, this voltage doubler has two different functions for the condensers *C-a* and *C-b*. *C-a* acts as a reservoir of energy and adds its charge to the line during the succeeding cycles. *C-b* is similar in its function to the input filter condenser of the half-wave a-c—d-c circuit of Fig. 21-16, except for the fact that it is worked at a higher voltage. *C-a* is of a 150 volt rating and approximately 30-40 mfd. *C-b* should be of 250 or 300 volts rating depending on the load current. If *C-b* is large, the safe estimate of the ripple current through *C-b* is 2.4 times the load current. When considering load currents for practical usefulness, such as 50 ma or more, the ripple current through the condenser *C-a* can be figured safely as 3.2 times the load current. Based on these considerations, the peak value (450 ma) of ripple current for a 25Z5 or 25Z6 is reached when the load current is about 75 ma. For conditions of greater d-c load current, two rectifier tubes should be operated in parallel.

**Voltage Multipliers.**—An interesting extension of the principle of circuit in Fig. 21-19 is shown in the voltage multiplier circuit of Fig. 21-20. In this application, the principle does not stop with the doubling of the voltage but is extended to as many times the line voltage as desired. Condenser *C-1* operates in the same manner as *C-a* of Fig. 21-19, and delivers its charge plus the peak line voltage of the succeeding cycle to the condenser *C-2*. Condenser *C-2* adds its contribution of double voltage to the line voltage on the next half cycle when diodes *T-1* and *T-3* are passing current. This action continues in chain fashion to condensers and diodes 3, 4, and 5 and 6 in turn. This circuit has been included here chiefly as an extension of the principles discussed rather than as a suggested practical power supply system. Very high voltage such as used in surge voltage generators for studies of lightning, are based on this circuit principle.

Voltage doublers are also used in TV sets in the high voltage section. The high voltage in a TV set normally 10,000 to 15,000 volts is obtained by a transformer action in connection with the horizontal output transformer. By using 2 tubes in a voltage doubler circuit the initial voltage from the transformer does not have to be so high and results in less break-downs in the transformer.

**Voltage triplers:** Some of the early projection TV sets required 25,000 volts for the picture tube. This was obtained by adding one more tube to a voltage doubler and making it a tripler (RCA and Philco both used it).

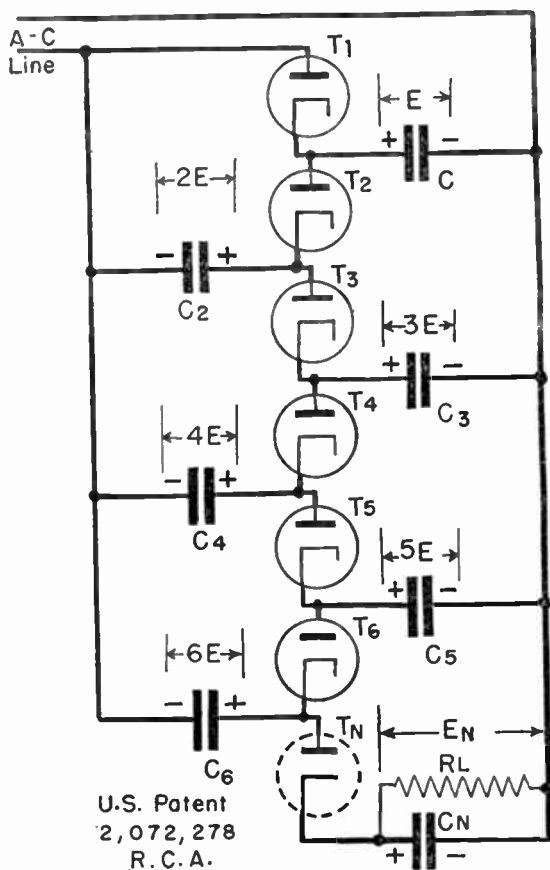

Fig. 21-20.—Voltage multiplier circuit.

**Auto Radio Vibrator Power Supply.**—To avoid the necessity of having extra "B" batteries for plate and screen voltage supply, auto radios are equipped with vibrator interrupters and step-up transformers to change the voltage from the 6 volt car battery to the higher voltage needed for plate and screen grid circuits.

The vibrator interrupter changes the smooth d-c from the battery to a pulsating d-c which is transformed to a higher value of pulsating d-c by a transformer and filtered to smooth d-c suitable for radio circuits.

**Non-Synchronous Vibrators.**—A vibrator supply using vacuum tube rectification is shown in Fig. 21-21-a. A vibrator of this type in which magnetically vibrator reed contacts are used, merely as interrupters to provide a-c to the step-up transformer and rectifier tubes, is known as a non-synchronous vibrator. The operation of this vibrator is explained as follows: current flows from the positive side of the battery as shown by the large open arrow, through the fuse, r-f choke, upper half of the primary of the transformer, through coil *L* of the vibrator magnet, and through the ground connection to the negative side of the battery. This excites the upper section of the transformer primary and also energizes the coil *L* and its magnet core, causing the vibrator reed *R* to be attracted and close contact *A*. This allows current to flow through the vibrator reed to ground and shorts out coil *L*, thus releasing the vibrator reed *R*. The spring action and the momentum of the weighted end of the reed *R* causes it to then close contacts *B* and permit current to flow through the lower half of the transformer primary as shown by the large closed arrow.

Thus as reed *R* is caused to vibrate by magnet *L*, it causes current to flow in the opposite direction, first through the upper half and then through the lower half of the transformer primary. This induces alternating voltage of a higher value in the secondary, the ends of which are connected to the plate of the full-wave rectifier tube. Current flows first from one plate, then the other, to the cathode and then through the filter choke to the *B* plus terminal for the plate circuits of the receiver tubes. The return for this circuit is through the receiver chassis ground to the secondary center tap as shown by the dotted line.

The resistors shown across the transformer primary are used

to stabilize the circuit and improve filtering action. The r-f choke and the .5 mfd condenser are used to filter out radio interference from the vibrator contacts.

The .02 mf condensers shown in Fig. 21-21 are commonly called buffer condensers. The value of this condenser is rather critical

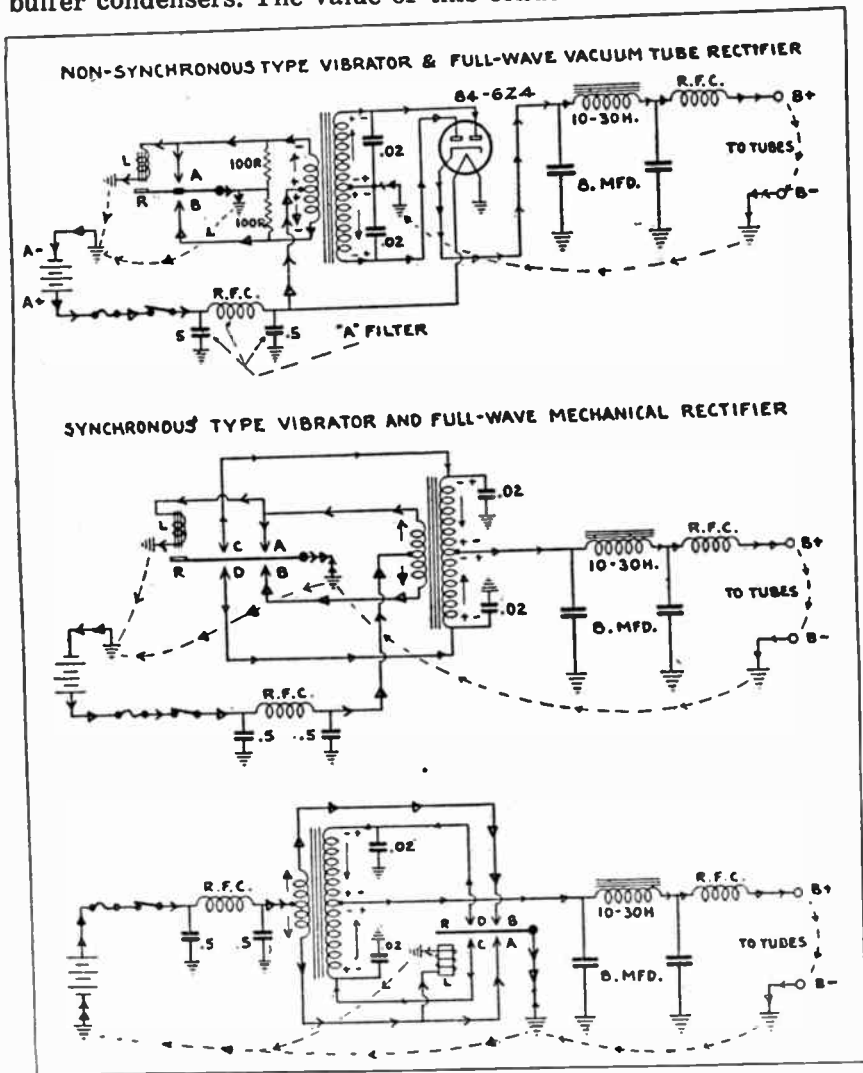

Fig. 21-21-a & b.—Diagrams of Synchronous and Non-Synchronous Types of Auto Radio Vibrators and Rectifiers.

and its value is determined by a combination of factors including the frequency of the reed of the vibrator, the overall inductive value of the vibrator transformer and the load. For replacement purposes the original engineered value must be adhered to or damage to the vibrator points will result from excessive sparking. This applies to both non-synchronous and synchronous vibrators.

**Synchronous Vibrator Units.**—Fig. 21-21-b shows a diagram of an auto radio power unit using a synchronous vibrator which has a double set of contacts which operate in synchronism, and serve both as interrupters for the transformer primary current and as rectifiers for the secondary current.

The operation of this vibrator circuit is explained as follows: the current flows from the battery through first the upper and then the lower sections of the transformer primary and can be traced by the large open and closed arrows, the same as in Fig. 21-21-a. However, with the synchronous vibrator, the center tap of the secondary of the transformer forms a positive connection for the plate supply to the tubes. With the vibrator reed *R* in the up position, closing contacts *A* and *C*, primary current flows through the upper half of the transformer primary coil. Secondary current flows out of the secondary center tap, through the filter to the tube plates, back through the chassis ground, to the grounded end of the reed *R*, then through the contact *C*, to the top half of the secondary coil, as shown by the small open arrow. When vibrating reed *R* is down, closing contacts *D* and *B*, primary current flows through the lower section of the transformer primary. Secondary current flows out of the center tap of the secondary winding, through the tubes, back through ground to reed *R*, through contact *D* to the lower end of the secondary coil, as shown by the small closed arrow.

Another way of representing this same type of circuit is shown in Fig. 21-21c.

#### REVIEW QUESTIONS

1. Name the two general classes of vacuum tube rectifiers.
2. What are the differences between half-wave and full-wave rectifiers?
3. Why are filters necessary in vacuum tube rectifiers?
4. Name the two most common types of rectifier filters. What is the ripple frequency for each type of filter?
5. What are the recommended uses of each type of rectifier filter?

## Chapter 2

### RADIO WAVE RADIATION AND ANTENNAS

**Early Radio History.**—The word *radio*, coming from the word radiate, applies particularly to the general radiation or broadcasting of messages and radio entertainment and education. Before 1920 when radio broadcasting began to get its start, the term wireless was used almost entirely with reference to such equipment. The first known attempts at wireless communication were made by Professor Steinheil of Munich, Germany, in about 1837. Approximately thirty years later, between 1860 and 1870, a famous mathematician in England, named Maxwell, proved by theoretical analysis and calculations that wireless communication was possible, but Maxwell did not put his ideas into practical operation.

The next development along this line was made by Heinrich Hertz of Germany, who within a few more years discovered and established the various laws of electric wave transmission, or transmission of energy through space without wires. The laws established by Hertz are still used and found dependable today, so Hertz is often called the founder or inventor of wireless. Due to his early death, Hertz was unable to complete this work and put his discoveries into actual practice, but very shortly afterward Marconi successfully accomplished the first wireless communication, thus completing the work started by Hertz and also proving that such communications were possible over great distances. For this reason Marconi is also often called the father or inventor of wireless.

The first transmission of wireless energy was accomplished by means of what was called a spark transmitter. These transmitters made use of a high-voltage spark or arc across a pair of adjustable electrodes, to set up high frequency current or oscillations in a local condenser and inductance coil circuit, and also in the antenna and ground circuit. This high frequency energy in the antenna circuit sets up combined electrostatic and electromagnetic waves of energy which are transmitted a considerable



distance through the air, of course becoming weaker and weaker as the distance from the transmitter is increased. With this type of wireless transmitting and receiving equipment, signals could be successfully transmitted and received only a very short distance. Spark transmitters have become obsolete because of their low efficiency, poor tuning characteristics, and the interference they cause.

A little later the crystal detector came into use and, being more sensitive to feeble electric impulses, made possible the detection of signals over distances of quite a few miles. In the early part of this twentieth century came the invention of the vacuum tube, and its development and perfection made possible wireless telephony or voice transmission in addition to code signals. The vacuum tube also made possible broadcasting and reception of radio and television entertainment and education as we know it today. It was not until 1920 that this means of radio transmission and reception became popular for the purpose of entertainment, thus making a general demand for radio equipment in the homes throughout the country, and making much more efficient and reliable the equipment used for sending commercial messages and radio telephone conversations.

**Wave Form Energy.**—As radio signals are transmitted through space by energy in wave form, it is very important to first obtain a general knowledge of wave form energy and how it is produced and transmitted. Almost everyone has seen waves in water, set up by wind or by dropping some object into it. These waves represent traveling energy, as can be observed from the way they will bob a small boat up and down, or even rock a large steamer. The small circular waves set up by dropping a stone in a pond and which radiate outward in all directions from the source, gradually dying out in the distance, are very illustrative of the nature of radio waves set up by a transmitting antenna.

Let us next consider sound waves. Sound is also energy in the form of air waves and is created by anything that sets up vibrations of the air. Air waves or vibrations ranging between 16 and 15,000 per second create audible sounds, or sounds which can be heard by the average human ear. So all frequencies between 16 per second and 15,000 per second are called *audio frequencies*, abbreviated a-f. A very interesting and important fact to note

about sound waves is the manner in which certain objects will vibrate in tune with them if their natural rate of vibration happens to be the same as the frequency of the sound waves. This can be readily demonstrated with a pair of tuning forks of the same pitch. Striking one fork will set up audible vibrations of the other one some distance away, by the energy radiated through the air. This same thing is often noticed in connection with the strings of a piano or some other instrument, or even a tin pan, vibrating very noticeably when sound of the proper pitch or frequency strikes them.

Now if sound consists of air waves or vibrations, and will travel through the air, it is easy to see that air must be a conductor of sound. Sound travels through air at a speed of about 1100 feet per second. Water will also conduct sound and various solids will carry sound more or less according to their nature. At the rate sound travels through air we can readily see that it would be impractical for long distance communication, because of the time it would take the sound to travel any great distance. The time required for a sound echo to return from a distant hill or building well illustrates this. You have probably also noticed the fact that thunder is often heard considerably later than the distant flash of lightning is seen, due to the fact that the sound travels so much slower than light.

**Radio Energy or Waves.**—Radio energy, instead of being in the form of air waves, consists of electromagnetic and electrostatic waves set up around conductors by the high frequency currents flowing in them. These radio waves are thrown off into space in all directions and for great distances if sufficient electrical energy is used. See Fig. 1, which roughly illustrates radio waves traveling from a transmitter antenna in all directions to be picked up by various receiver antennas. Radio waves travel through most substances and all space, even where no air is present. So we find that air, which is the conductor of sound waves, is not the carrier of radio energy.

Radio waves are said to be set up in an invisible something which exists in all space and in all materials. Ether is the name which has been given to the medium by which radio waves are carried. Radio waves cannot be insulated by any known material, although they can be shielded or kept out of certain spaces by

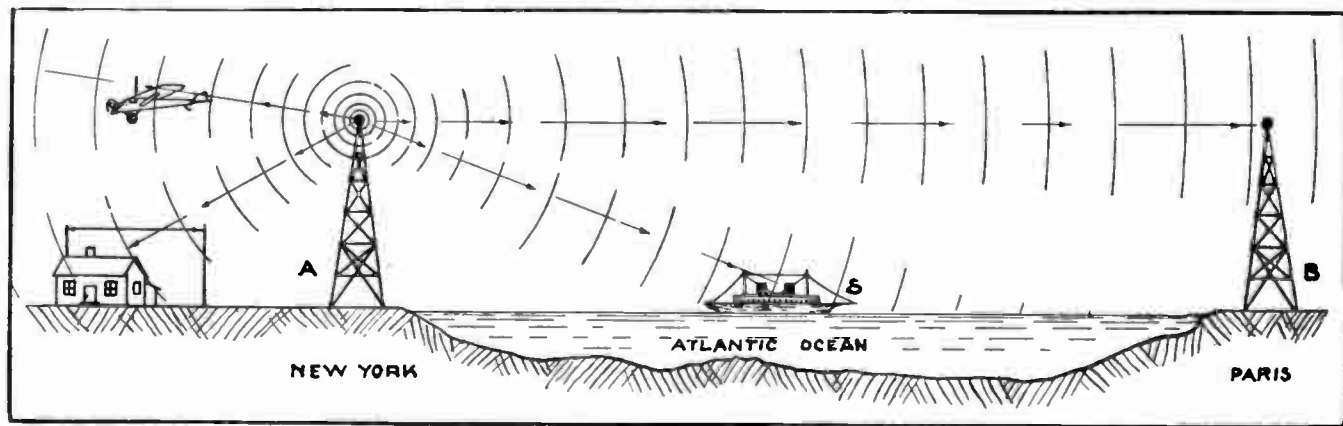
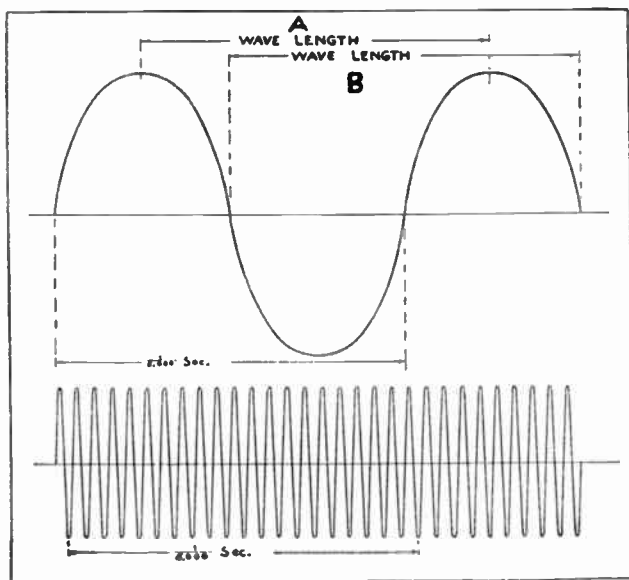

Fig. 22-1.—Diagram illustrating the manner in which radio waves are sent in all directions from a transmitting antenna. These waves can be received by a number of different aerials at various distances from the transmitter as shown in the sketch.

using metal shields. Large steel buildings often shield their interiors and certain spaces near them in this manner. Natural mineral deposits and hills also produce shielding effects on radio energy. Radio waves travel at a speed many thousands of times faster than sound waves—186,000 miles per second, or 300,000,000 meters per second, which is the same as the speed of light. At this rate a radio signal will travel about seven times around the earth in one second, or from New York to San Francisco in a time period so short it is usually not worth considering.

**Frequency and Wave Length.**—Radio waves are set up around transmitting antennas by passing through the antenna wires alternating current of very high frequencies. In addition to referring to radio waves by their frequency, they are also classified according to wave length. The length of each wave produced by a cycle of the radio frequency current can be accurately measured



**Fig. 22-2.**—The above two sets of curves illustrate the difference between the frequency of sound waves and radio waves. The contrast between ordinary 60 cycle alternating current and the radio waves would be still greater.

or calculated. Radio wave lengths are expressed in meters and one meter is equal to 39.37 inches. The length of one wave can be measured either from the crest of one wave to the crest of the next of the same polarity as at *A* in Fig. 22-2 or from the start to the finish of a wave as at *B* in this same figure.

When the frequency of radio energy is known, the wave length can be easily calculated by dividing the distance in meters which the waves travel in one second, by the frequency or number of waves per second. For each cycle of current applied to the transmitting aerial there will be one complete wave radiated from it.

Therefore

$$\text{Wave length in meters} = \frac{300,000,000}{f}$$

in which 300,000,000 — speed of wave travel in meters per second,  
 $f$  — frequency of current in cycles per second (c.p.s.)

For example a station transmitting at a frequency of 1,000,000 cycles will have a wave length of

$$\frac{300,000,000}{1,000,000} \text{ or } 300 \text{ meters.}$$

Checking the ordinary broadcast frequencies of 500,000 to 1,500,000 cycles (500 to 1500 kilo-cycles) in this manner will show that they cover a wave band of 200 to 600 meters.

This formula can also be transposed and used to find the frequency of a station when the wave length is known as follows:

$$f = \frac{300,000,000}{\text{wave length in meters}}$$

For example if a certain station is using a wave length of 400 meters, the frequency will be

$$f = \frac{300,000,000}{400}, \text{ or } 750,000 \text{ cycles of } 750 \text{ kilo-cycles}$$

One kilocycle (k.c.) is 1,000 cycles.

One megacycle is 1,000,000 cycles (m.c.)

**Sources of High Frequency Energy.**—We have mentioned that radio waves are set up at the transmitter antenna by the flow of high frequency current in the antenna circuit. This alternating voltage causes current to flow back and forth through the circuits, setting up a constantly changing and reversing magnetic field around the conductors. While low frequency current in con-

ductors sets up changing magnetic flux around them, and this flux will induce energy in other conductors or coils even several feet away, high frequency currents throw off or radiate their magnetic and static energy much more efficiently and much farther into space. Radio signals sent out at this high frequency energy with very low power are often received on the opposite side of the earth.

Radio frequency currents can be produced by means of oscillating circuits using power vacuum tubes. Vacuum tube oscillator systems for radio transmitters are much more economical and efficient than the other sources of high frequency. They can be adjusted to produce almost any desired frequency and they produce a pure continuous wave that is quite ideal for either radio telephone or telegraph use, and which can be very sharply tuned, thus minimizing interference and making it possible to cover great distances with comparatively small amounts of energy.

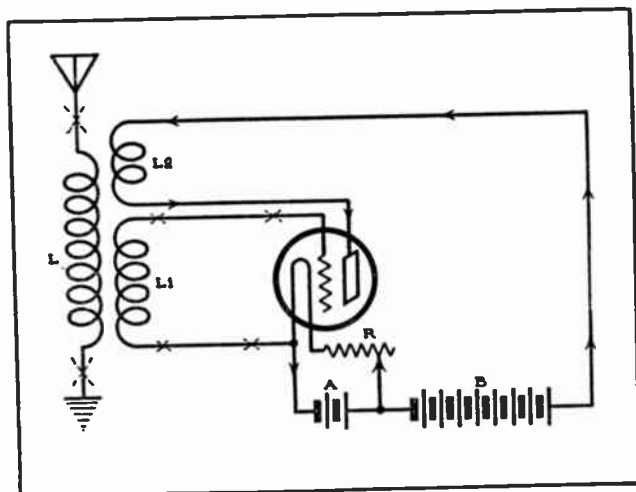

Fig. 22-3.—Diagram of a simple vacuum tube oscillator circuit for producing radio frequency energy.

Vacuum tube oscillators use high voltage direct current from d-c generators, rectifiers or batteries and convert it into high frequency a-c. Fig. 22-3 shows a tube connected in a simple circuit with the necessary devices for setting up high frequency

oscillations. The frequency of these oscillations depends on the inductance and capacity of the tuned circuit, including the coils, the tube parts, and any condensers that may be used to tune the circuit. Inductance determines the length of time required for the current and flux to build up to full value in each direction through a coil. As these coils usually consist of only a few turns and have no iron cores, their inductance is low enough to allow very rapid oscillations or frequencies, ranging up to millions of cycles per second in some cases. A variable condenser can be connected across either the grid coil  $L1$  or plate coil  $L2$  and also used to vary the frequency of the oscillations as desired.

**The Antenna Circuit.**—Now that we know the nature of the energy used in radio transmission and how it is produced, we will next want to know how this modulated wave or energy is radiated or thrown out into space from the transmitter. This is done with an aerial or antenna, but you may have wondered how current can flow in the antenna as it is not a complete metallic circuit. When high frequency alternating voltage supplied by the transmitter is applied to the antenna circuit, either by direct connection or by induction to the antenna coil, current does actually flow due to the condenser or capacity effect between the antenna and ground. This current is measurable with special high frequency ammeters of the thermocouple or hot wire or other types.

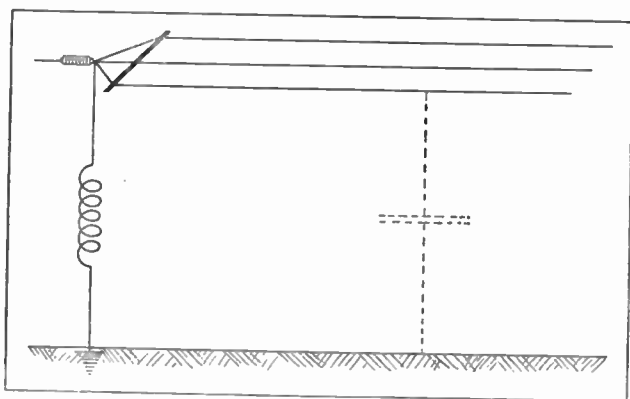

Fig. 22-4.—Sketch showing the antenna circuit of a radio transmitter, completed by capacity to earth. A single wire is often used instead of several wires as shown above.

A condenser consists of two or more conductors of conducting surfaces or plates separated by insulation of some kind. Transmitting aerials for medium or long wave stations often consist of one or more long wires, supported horizontally or parallel to the earth's surface. If several parallel wires are used, they are all connected together to form a network. These wires are attached to their supporting poles or towers by high voltage insulators, and are further insulated from the earth by the air between the aerial and the ground. This construction forms a simple condenser as shown in Fig. 22-4. The dotted lines simply show that the aerial acts as one plate, the earth as the other, and the air as the dielectric of the condenser.

**Current Flow in Antennas.**—When d-c voltage is applied to a condenser it will charge the condenser with one plate or group of plates positive, and the other plate or group negative. While the condenser is being charged current flows into it, even though it does not pass through the condenser dielectric. Then when the applied voltage is removed and the condenser shorted or merely left connected in a closed circuit, it will discharge and cause current to flow out of it in the opposite direction to that of the charging current. A condenser can be charged in either direction

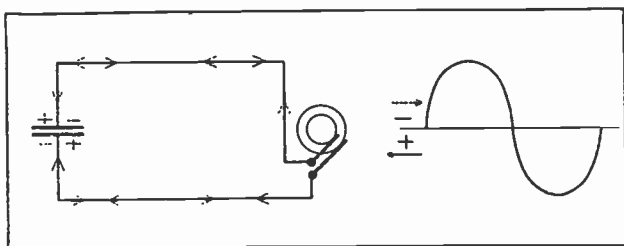

Fig. 22-5.—On the left is shown a curve for one cycle of alternating current. On the right is shown the manner in which the alternating charge of a condenser and set up current flow in its circuit.

by simply reversing the polarity of the applied voltage. If alternating voltage is applied to a condenser by connecting it in an a-c circuit, alternating current will flow in the condenser leads as the condenser charges and discharges with the rise and fall of the applied voltage during each alternation as shown in Fig. 22-5. The amount of charging current that will flow to a condenser depends



directly upon the voltage and frequency of the a-c energy applied, as well as upon the size or capacity of the condenser.

As radio transmitters supply extremely high frequency to the antenna circuit and usually at several thousand volts potential, considerable current will flow, even though the actual capacity between the aerial and ground may not be very great in microfarads. As the high voltage, high frequency current flows in the antenna of a transmitter each cycle sets up a complete electromagnetic wave, and also a complete electrostatic wave around the antenna. These waves travel through space with the speed of light, and when they strike or cut across a receiving aerial they induce very feeble voltages in it.

Transmitting aerials are not always horizontal, some being merely a vertical wire or mast. There is sufficient capacity between a long vertical wire and the earth, to allow current to flow in such antenna circuits. Fig. 22-6 shows an illustration of electrostatic waves leaving a vertical antenna. The magnetic waves are not shown in this sketch. It is very important that transmitting antenna circuits, including their ground connections be of low resistance in order to avoid resistance losses as much as possible. Due to the skin effect or tendency of high frequency currents to flow close to the outer surface of a conductor, rather large conductors are often used in transmitting antennas.

**Tuning and Resonance.**—A variable inductance, or a condenser can be used to change the frequency or oscillation period of a transmitter oscillating circuit. The same is true of the antenna circuit and as the length of this circuit, including the antenna,

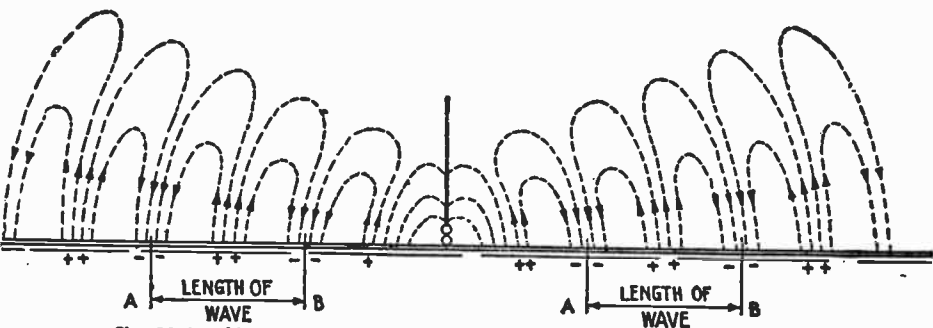

Fig. 22-6.—This diagram shows the manner in which electro-static waves are assumed to radiate in all directions from a vertical radio transmitting aerial.

lead in wire and ground lead, determines the amount of inductance and capacity of the circuit, it should be made of the proper length for the wave length of the station. In addition to making this circuit the proper length, variable inductance coils and variable condensers are used, either in series or parallel, to tune the antenna circuit to the frequency of the energy produced by the transmitter. Generally they are connected in series with the antenna for tuning.

When the open antenna circuit is adjusted to the same natural frequency as that of the closed oscillating circuit of the transmitter, the two are said to be in resonance with each other. Proper tuning of the antenna circuit enables maximum current to flow and produces best results and efficiency with a transmitter. Tuning of radio transmitters has another very great advantage, in that it makes possible the sending of signals of one certain wave length, which can be received only by receivers that are also tuned to that wave length, without interfering with other stations that are operating on different wave lengths. This makes possible the operation of many transmitting stations at the same time without confusion, and also makes possible the selection of the desired station by the receiver. The height of an antenna also influences its wave length, both by changing its capacity to earth and by changing the length of the lead-in wire.

**Receiving Antennas.**—Receiving aerials do not need to handle much current and so generally consist of just one small wire, about No. 12 or 14 B & S gauge, and of the proper length for desired results. Either solid or stranded copper or bronze wires are very good for receiving antennas.

With early forms of radio receivers such as crystal sets, where all of the energy to operate the headphones come from the antenna, or even with sets using only one or two tubes, long high receiving aerials were needed to pick up sufficient induced voltage to give good signals. But with modern multiple tube sets and the great amount of amplification they accomplish, very little receiving aerial is needed.

It is well to remember, however, that the higher a receiving aerial is located and the more free it is kept from surrounding trees, buildings, or other tall objects, the more energy it will usually receive. Also remember that increasing the length of a

receiving antenna increases the energy it will pick up; of course, keeping in mind that the antenna should not be so long that its natural wave length is much greater than that of the energy to be received. In rural communities and certain out of the way places which are a long distance from any radio station, long, high, outdoor antennas may still be used to good advantage.

If one were to really understand all the technical problems to be considered in producing an ideal antenna installation, intensive study of complete treatises on the subject would be necessary. Such a process is recommended if the individual desires the finest possible performance. However, since the number of locations where it is convenient to erect such an antenna would represent only a fraction of one per cent of radio users, and also because it is possible to achieve quite acceptable results with the more common types of antennas, this discussion is purposely limited to the generally practical receiving types. A study of the advantages and disadvantages of each type is presented.

**Lead-ins for Receiving Antennas.**— The lead-in includes all antenna circuit connections running from the horizontal portion of the antenna, down the side of the building and to the receiving set. If there is anything more generally neglected than the antenna itself, it is the lead-in. Too many radio enthusiasts seem to think that the chief purpose of the lead-in is to provide for final disposition of any scrap wire that may be lying around the premises. The first rule for the lead-in is to make it short. A lead-in, like an antenna, has inductance, capacity, and resistance, but the inductance and capacity can not be used to such a good advantage as when used in the antenna itself. For example, a lead-in 100 feet high used with an antenna only 30 feet long would have three times the inductance and capacity of the antenna itself, but if the lead-in for this 30 foot antenna were reduced to 40 feet, its inductance and capacity would be only about 20% more than that of the antenna.

The lead-in is part of the antenna circuit and should be well insulated by proper use of stand-off insulators wherever they are required. Because insulated wire is used for the lead-in does not mean it may be dropped over the edge of a roof without any protection. There is no objection to using insulated wire for the

lead-in if the wire is properly supported but neither is there any advantage. The lead-in wire should be kept away from, or insulated from, walls, ceilings, mouldings, etc., in the room through which it passes on its way to the receiver. Lead-in wires should always be at least as large as the aerial wire, or with an area equal to all aerial wires in parallel where a number of wires are used. Remember that the length of lead-in wires should be added to that of the antenna proper, when calculating the effective length of natural wave length of the antenna. That is, with the exception of certain special types of transmitting aerials. Long ground leads will also affect the wave length of the antenna circuit. Sometimes, the lead-in is connected nearer the center of the antenna rather than at one end. Then the effective length of the antenna is equal to about  $\frac{1}{2}$  of its physical length, or half that of an antenna of the same length in feet but having the lead-in at one end. Where the lead-in enters the building it should be run through a porcelain or glass insulator. Such an insulator may be passed through  $\frac{9}{16}$  to  $\frac{3}{4}$  inch hole bored in the window frame.

The outer end of the lead-in wire should be scraped perfectly clean and a secure mechanical joint made between it and the end of the antenna wires, which has also been thoroughly cleaned of all insulation or oxide. This joint should then be thoroughly soldered. If it is impossible to solder the joint, wrap it tightly with tin foil, then cover the foil with a layer of rubber tape, followed by a layer of friction tape. If rubber tape is not available, use two layers of friction tape and cover the outside with a heavy coating of shellac. If the lead-in wire enters a wall or window through a porcelain tube insulator, drill the hole for the insulator with a slant so that the out-door end will tilt downward, thus preventing entrance of rain into the building. In case it is objectionable to bore holes in the window frames, it may be best to cut a notch in the top edge of the sash, pass the bushing through this opening and push the window up against the bushing to hold it.

Various kinds of special lead-ins may be purchased. Some of these consist of flat ribbon copper incased in a covering of insulation. Such a device may be laid over the window-sill and the window closed tightly over it. The danger in this constructor

comes from the fact that the insulating covering may be broken through and water from rain or snow will ground the antenna, which means weak signals or no signals in the receiver. Never use a lead-in device in the ends of which wires are held by spring clips or similar devices. All such joints corrode with wet weather and after they corrode for a few months, the antenna might just about as well be disconnected. Every joint from the farthest end of the antenna to the binding post of the receiver must either be soldered or else solidly bolted, and well shellacked to keep water from the joint. After the lead-in has entered the building, it should be carried along the walls, baseboards or mouldings until it reaches the receiver. This inside part should be made of well insulated stranded copper wire. From the standpoint of appearance, a silk-covered wire is best, although any other insulated wire will be as good from the standpoint of radio reception. As a final precaution, bring the lead-in from the building entrance to the receiving set in the straightest line possible, avoiding unnecessary turns.

**Types of Receiving Antennas.**—The frequency coverage of the all-wave receivers ranges from .55 megacycles to 15 megacycles. For purposes of antenna design requirements this wide coverage is roughly divided into two sections. The first section extends from .55 megacycles to 1.5 megacycles (the present broadcast band) and the second from 1.5 megacycles to 15 megacycles (police, aircraft, amateur and foreign transmission). The major requirements of these two sections as to physical location to obtain the largest possible signal energy, the most favorable signal to noise ratio, and the methods for conveying the signal energy to the receiver are very similar.

Probably the most common types of receiving antennas in use at the present time are still the "Old faithful" single wire "T" and inverted "L" types, illustrated in Fig. 22-7. These antennas are used in the Marconi system, that is, installations employing ground as an essential part. The "T" and inverted "L" types are convenient to install and generally satisfactory in operation. No better testimonial need be given than the one usually included on the installation instructions of a newly purchased receiver. From an antenna standpoint the instructions read somewhat as follows: "satisfactory results may usually be obtained with an

antenna of 25 to 75 feet in length, suspended as high as possible. The directional characteristics of these antennas for broadcast use are shown in Fig. 22-8.

Two illustrations are given for the "L" type because the length of the flat top (FT) as compared to the length of the lead-in (L)

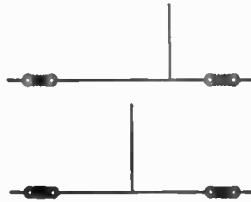

Fig. 22-7.—Single wire "T" and inverted "L" type receiving antennas.

has a bearing on the directional effect. If, as in Fig. 22-8 the lead-in (L1) has more length than the flat-top (FT), the reception pattern is found to be almost non-directional (equally effective in any direction). Fig. 22-8 also shows the reception pattern when the lead-in (L2) is shorter than the flat top (FT2).

The directional effects noted are characteristics of an antenna erected over an open plain. In actual practice the pattern is greatly distorted by the presence of nearby metallic objects such

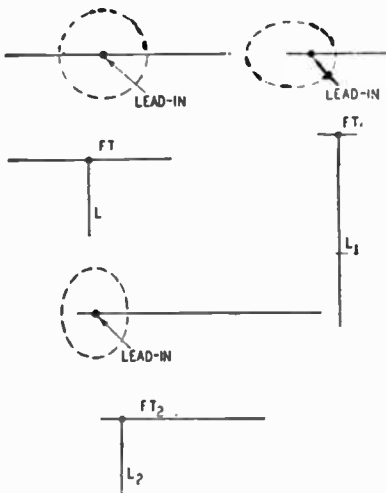

Fig. 22-8.—Directional characteristics of the "T" and inverted "L" antennas.

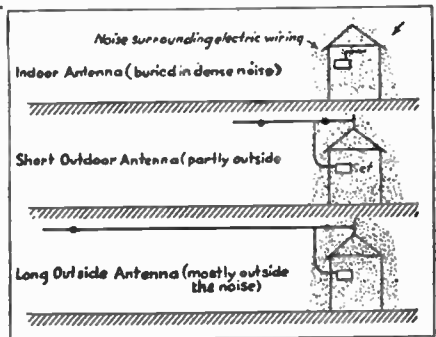

Fig. 22-9.—Why a long outside antenna often increases signal-to-noise ratio.

as metal roofing, telephone and electric wires, gutters, down spouts, etc. In practical applications this means that if reception is poor from a desired direction, the situation can be improved by shifting one end of the antenna. Sometimes moving or rotating an antenna only a few feet will make a decided difference in its performance on the reception of more distant stations. The effects noted are more pronounced on the short wave bands.

A third type of antenna is one in which the wire is suspended in a vertical manner. This type antenna has a non-directional reception pattern. When the average person thinks of a vertical antenna, he immediately visions large supporting masts, difficult installation and prohibitive cost. However, this picture is not necessarily true. If the operation of the "T" antenna previously described is analyzed, it will be found that the system operates mainly on the ability of the lead-in wire to pick up the signal for the receiver. If the "T" type antenna has its lead-in attached at the electrical center, the two halves formed effectively counteract each other with the result that little or no signal is fed to the lead-in. It naturally follows that it is possible to erect a vertical antenna in much the same manner. However if no masts are used, the only other logical way to support the vertical antenna is by fairly close mounting to a building or similar objects. This, of course, destroys the antenna's non-directional properties and much of its pick up efficiency since it is effectively shielded in one or more directions by the absorption qualities of the supporting object.

Before proceeding with a discussion of the noise reducing types, let us see just what improvements can be made by alterations in the designs previously described. One of the most obvious methods of improving a short outside antenna (almost completely in the noise area created by household appliances and utilities) is by increasing its length in a direction so that a major part of it is in a comparatively noise-free location as shown in Fig. 22-9.

The same remedy may be applied to an indoor installation. While this method does not actually decrease the noise pickup, it increases the noise-free pickup and results in a more favorable signal-to-noise ratio. However, there is the following factor to be considered, especially in the case of all-wave receivers, before installing a very large antenna.

Any wire has a certain amount of inductance. It also has a certain distributed capacity with relation to surrounding objects and to ground. As in the case of any tuned circuit, at some definite frequency, the inductive and capacitive reactances will be equal and opposite, resonance will occur, and maximum efficiency realized. The larger the antenna, the larger the inductance and associated capacity, and the lower the frequency at which the antenna system is naturally resonant. The very large antenna tends to have its resonant point either in or near the broadcast band.

It should be remembered that the lead-in wire of the "T" and "L" types of antennas also functions as a pickup medium. When any calculations are made, the lead-in length should be included as an integral part of the antenna. Since the ordinary lead-in wires are capable in intercepting signals, they are also capable of receiving noise impulses. Through the antenna itself may be located is a noise-free area, the lead-in, forced to pass through the noise field to the receiver, may contribute heavily to the noise level. (Fig. 22-9).

The fact that any vertical pickup medium is especially prone to intercept waves of vertical polarization, makes conditions even worse, since most man-made interference is radiated in vertically polarized waves (or in waves leaning toward the vertical). Several methods have been designed to eliminate the property of the lead-in to intercept either signal or noise impulses and make it more suitable for its true purpose, that of conducting the energy accumulated by the antenna to the input circuit of the receiver.

One such method uses a completely shielded lead-in wire. Although it is possible to make this system perform in a fairly satisfactory manner on the broadcast band, it is practically useless for short wave reception unless a proper matching network is employed. The impedance matching network consists of impedance matched transformers, one of which is connected at the lead-in end where it connects to the horizontal portion of the antenna, the other connects to the receiver end of the lead-in. These transformers are for the purpose of reducing the loss of energy in the lead-in due to the grounded shield. Fig. 22-10c. The energy loss at broadcast frequencies, due to the relatively



high capacity between the lead-in and the shield, is serious enough even considering the tremendous power of some of the popular broadcasting stations. Keeping in mind that this energy loss will increase with any increase in frequency, it is easily understood why this method is not generally recommended. Most of the short wave stations are of relatively low power as compared to average broadcast band transmitting stations, and any appreciable loss in signal energy to be delivered to the receiver should be avoided. Fig. 22-10 illustrates this point.

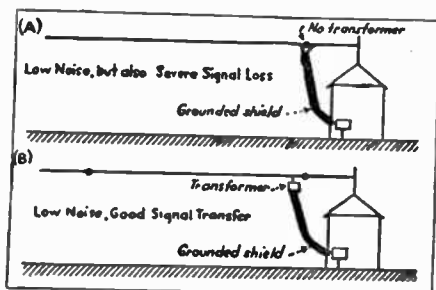

Fig. 22-10-A-B.—Shielded lead ins—poor (A) good (B).

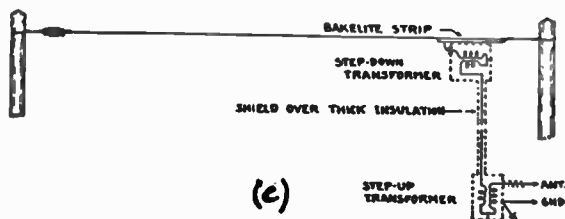

Fig. 22-10-C.—Wiring diagram of lead in.

A second and extremely popular method is that of using a transmission line to transfer the signal energy from the antenna to the receiver with minimum signal pickup by the transmission line. Since this development has come about largely as a result of the demand for noise reduction on the short wave bands of commercial all-wave receivers, it would seem in order to discuss the basic antenna requirements of these all-wave receiving sets.

In the short wave spectrum a new condition arises in that the physical dimensions of a half wave length antenna are small enough (for given frequencies) that its length is within the

restrictions of the practical installation. Antenna systems designed on this principle are capable of delivering a much stronger signal to the receiver in the frequency ranges for which they are designed.

The signal voltage that is generated in the antenna is due to the fact that the antenna is cut by electric lines of force created by the incoming signal. The value of the voltage generated in the antenna is somewhat proportional to the length of the antenna until this length approaches a half wave length with respect to the frequency of the signal under consideration. At this point the antenna become resonant. The voltage or power built up in the antenna itself at or near this frequency is much larger than it would be if the antenna length was not a half wave length or some multiple thereof.

This explanation may seem a bit involved and unnecessary but it should be understood that this basic action or principle is incorporated in the design of almost all of the commercially available all-wave antenna systems. These include such types as the doublet, double-doublet, "V" doublet, the staggered doublet (one having uneven flat top sections), the selective beam type and the combination web types.

Up to this point it seems that the design for the standard broadcast range (.55 to 1.5 megacycles) has been somewhat neglected in the all-wave antenna design. This is true to a certain extent. In the first place both transmission and reception are more stable in the broadcast band frequency range. This band is not merely as much affected by fading, skip distance and unusual refraction properties peculiar to high frequency signals. Secondly, the power of the average broadcast band transmitter is much greater than a corresponding short wave station. As a result, if any compromise must be made in the antenna design, it should favor the short wave design so that the listener may have a performance on the higher frequency stations similar to the performance he expects and gets on the broadcast band. In the third place, manufacturers of all-wave antenna systems have made it possible either through ingenious design of the matching transformer at the set, or by a simple switching arrangement, to convert the antenna into the equivalent of an ordinary single wire antenna of equal length for broadcast band use.

**Doublet Antenna.**—As previously pointed out, doublet or dipole antennas are usually designed to give maximum efficiency when used upon a certain predetermined frequency band or bands. It is well to remember that any section or combination of sections in the doublet systems can operate not only at the given frequency or frequencies but may also be operated quite efficiently at some harmonic of the fundamental design.

All of the doublet types use some form of transmission line (either shielded, twisted or transposed). This line under ordinary conditions will not have any tendency to pick up signal or noise impulses. Such a system provides the very useful advantage of allowing the antenna proper to be as much as several hundred feet from the receiver. In many cases this permits the antenna installation to be made in a noise-free area. The addition of large amounts of like transmission line should produce little or no change in the impedance match at the transformer.

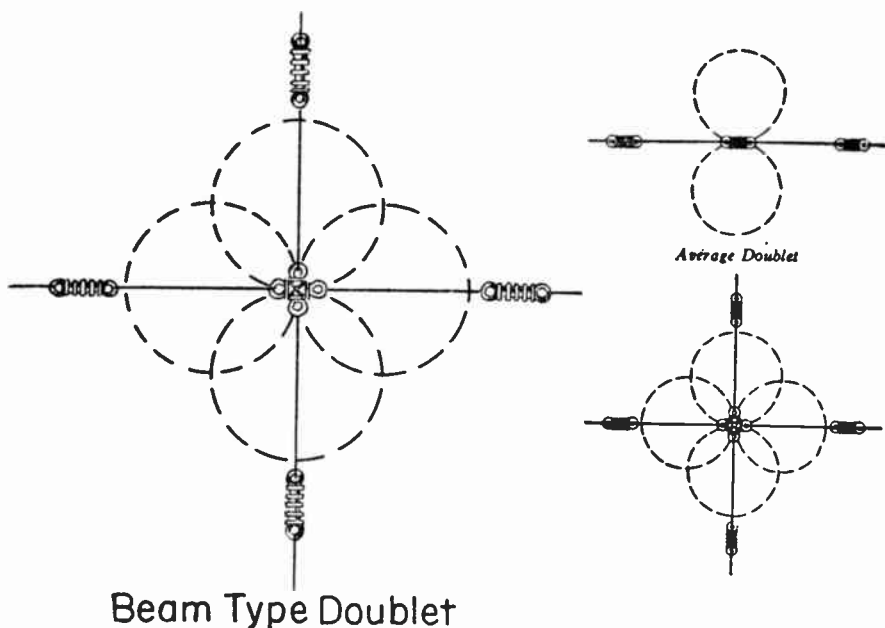

Fig. 22-11

In the matter of locating the noise-reducing antenna types, the following precautions should be observed. The prime need is, of course, to get the antenna as high as possible. Locate the antenna as far above and away from any noise radiating utility wires as practical, at any cost stay away from elevator penthouses and any rotary electrical equipment.

In the matter of directional characteristics, the average double system has what is termed a broadside reception pattern. This means that the antenna is most effective when it is located at a right angle (90 degrees) with relation to the desired direction. If two doublets are located at right angles to each other, the result is a non-directional pattern inasmuch as one or the other section can always produce an essentially broadside effect to any desired signal. Fig. 22-11.

So far, except for the doublet antenna, we have talked mostly about antennas which use a ground connection. Marconi first used such antennas; accordingly we call them Marconi antennas. Observe (Fig. 22-7) that there is always more or less "up and down" to them. They start at the earth and go up. Sometimes they go horizontally also, but invariably they go up. In a moment we shall show why that is important.

The Hertz antenna or doublet uses no ground connection whatever. Accordingly it need not run up and down at all; it is possible to make it a straight horizontal antenna if so desired. For the best short wave reception, this feature is very desirable.

**Vertical or Horizontal Antennas.**—Near the radio transmitting station the waves are departing in the manner of Fig. 22-13A. They are mainly vertical and are best received by a vertical (or partly vertical) receiving antenna—an antenna that has some height. The Marconi antennas of Fig. 22-12 will work best for such reception, as will the vertical Hertz type of Fig. 22-12.

At a great distance we have a different picture. We find that short waves arrive in the manner of Fig. 22-13B. It is at once apparent that this leaning of the waves ("polarization toward the horizontal") gives the horizontal Hertz antenna a chance which it did not have on the nearby reception of Fig. 22-13A. For that reason the horizontal Hertz antenna is very useful in short wave long-range reception. Fig. 22-14 shows the best theoretical and practical locations of antenna and receiver to

keep the antenna out of the noise area and also to keep it from being shadowed by surrounding objects.

One of the most popular forms of doublet antenna systems is

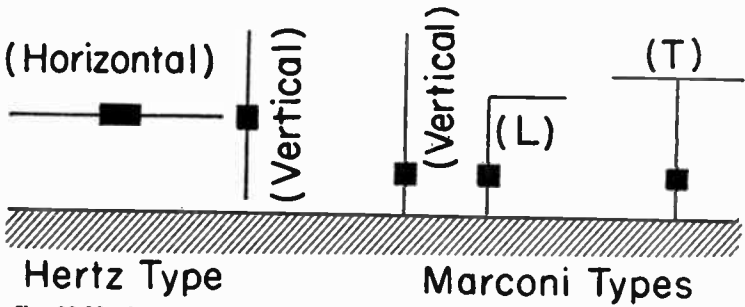

Fig. 22-12.—Hertz (ungrounded) antenna types are becoming more and more popular for short wave work

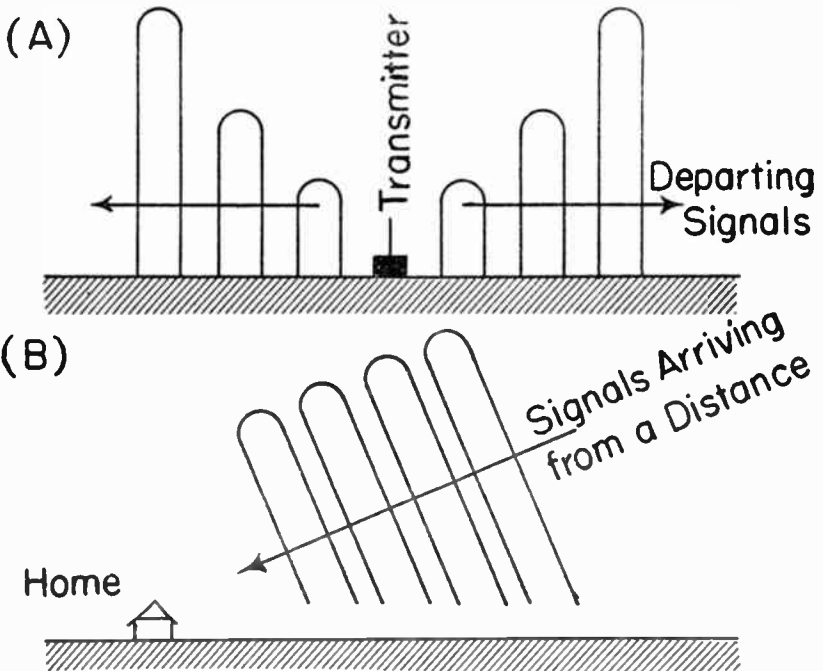

Fig. 22-13.—Why vertical receiving antennas are best on locals, while horizontal types favor distance.

shown in Fig. 22-15. If we make the top about 70 or 75 feet long, the best performance will appear in the 49 meter band, but at other wave lengths, the line no longer acts as a pure line; the upper part participates in varying degree in the antenna action and the losses vary materially with frequency. However, a theoretical shortcoming can often be tolerated commercially, and the

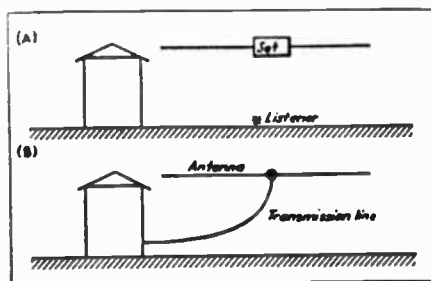

Fig. 22-14.—The theoretical ideal (A) and the practical substitute (B).

extreme simplicity of this arrangement is evident. Its anti-noise action leaves little to be desired, it is easy to erect, the line can be of any convenient length upward of some 40 feet (be sure to use that much and coil up any you don't need inside the set cabinet) and strong wind does little damage.

The real shortcoming of this or any other horizontal Hertz type is in the relative ineffectiveness of such an antenna near 500 kcs. To make the antenna long enough to get around this difficulty results in preposterous clumsiness. Accordingly one must accept reduced reception in the ordinary broadcast band for the sake of a more favorable signal to noise ratio in the short wave range.

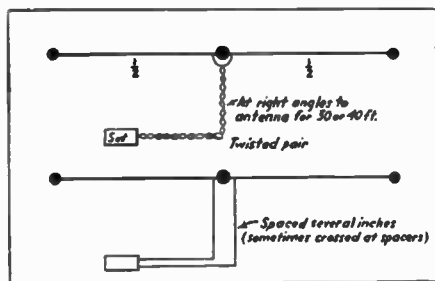

Fig. 22-15.—Two efficient transmission line systems using Hertz collectors.

The importance of a good r-f ground cannot be over-emphasized. This statement may seem contradictory to the explanation of the doublet systems designed to operate with no ground. However, the purpose of the ground in such cases is to prevent chassis pickup and possible pickup from the light line. The ground in these cases has no function in the signal pickup design of the antenna system. A separate ground for the radio set other than water pipes, etc., is recommended for the best possible results. A good noise-filter in the 110-volt line which supplies power to the set may be of assistance when the noise condition is extremely bad.

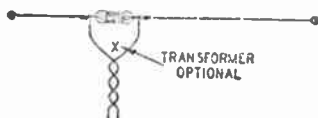

Fig. 22-16.—Staggered doublet antenna.

In Fig. 22-16 we have a modification of the original doublet system. This design is sometimes known as the staggered doublet because its sections are unequal in length. The staggered system is used for the purpose of providing resonance properties on the higher frequencies.

Fig. 22-17 shows another type doublet known as the "V" doublet. In this system, the tapered "V" at the center has the property of effectively matching a relatively high impedance antenna to a low impedance line.

In the "V" doublet, Fig. 22-17 the length of Sections *A* and *B* are equal, Sections *C*, *D* and *E* should form an equilateral triangle. The effect of systems employing two doublets mounted at

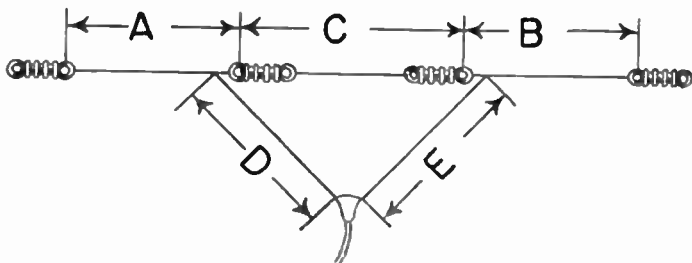

Fig. 22-17.—"V" doublet antenna.

right angles to each other has been previously discussed and is illustrated in Fig. 22-11.

Another widely used design is shown in Fig. 22-18. This particular design represents not only a combination of the resonance properties of its possible sections, but also has the additional factor of improvement where wave polarization is considered.

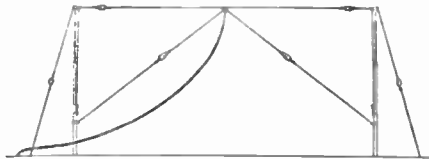

Fig. 22-18.—This antenna combines resonance properties and wave polarization.

Fig. 22-19 shows the web type of antenna. A thorough explanation of this somewhat complicated design would be very long. This system has roughly the same properties as the type shown in Fig. 22-18.

A final point to be considered lies in the choice of an antenna for a receiver of a given manufacturer. In every case it is well to follow the manufacturer's recommendation as to the type antenna to be used with his particular receiver, inasmuch as he specifies the one which has the best matching properties for his set design.

**Capacity of Antennas.**—Considering the horizontal portion of an antenna, the capacity or condenser effect of the antenna increases almost directly with its length up to 100 feet but

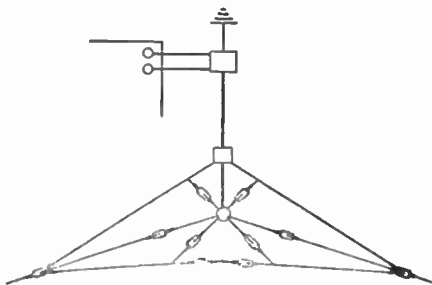

Fig. 22-19.—Web type antenna.



increases less rapidly for greater lengths. This might be expected since an increase of antenna length increases the area of the condenser which is formed by the antenna and ground. There is only a small change in capacity as the height of the antenna above the ground is increased above 30 feet. From a height of 30 feet up to a height of 120 feet, the decrease in capacity is only about 7%, but as the antenna is lowered under 30 feet, the capacity increases quite rapidly. This effect might also be expected because lowering the antenna brings the parts of this condenser closer together. The capacity of a vertical lean-in wire increases directly with the length of the lead-in. The capacity of a vertical lead-in must be added to that of the antenna to obtain the total capacity of the whole antenna system.

In the accompanying table is given the capacity in mmfs of mmfs of the horizontal portion and following the hyphen is the of the horizontal is 107 mmfs and the vertical portion, or lead-in is 71 mmfs a total of 178 mmfs for the entire antenna system.

Thus for an antenna 60 feet long and 40 feet high, the capacity of the horizontal is 107 mmfds and the vertical portion, or lead-in is 71 mmfds a total of 178 mmfds for the entire antenna system. The capacity of the lead-in must be added to that of the antenna.

CAPACITY OF HORIZONTAL AND VERTICAL PORTION OF A SINGLE WIRE ANTENNA IN MICRO-MICROFARADS

Antenna Height in Feet	Length in Feet of Horizontal Portion of Antenna					
	30 Feet Hor.-Vert.	45 Feet Hor.-Vert.	60 Feet Hor.-Vert.	75 Feet Hor.-Vert.	100 Feet Hor.-Vert.	
20	59-40	83-40	111-40	139-40	182-40	
30	58-56	81-56	109-56	131-56	175-56	
40	57-71	80-71	107-71	123-71	172-71	
60	57-103	80-103	105-103	121-103	170-103	
100	56-166	79-166	104-166	119-166	168-166	

The effective capacity of the antenna system is somewhat greater at the higher frequencies or lower wave lengths used in broadcasting than at the other end of the scale. Taking the effective capacity at 1000 K.C. or approximately 300 meters as represented by 100%, the following changes are found in practice.

At 1500 K.C. or 200 meters, the capacity is 120% and at 600 K.C. or 500 meters, it is 90% of the value at 1000 K.C.

**Inductance of Antenna.**—The horizontal portion of the antenna and vertical lead-in not only have capacity but also have inductance even though they are straight wires. The following table gives the value in microhenries of the horizontal portion of the antenna and of the vertical lead-in. (A microhenry equals one millionth part of a henry or 1,000,000 microhenries equal one henry.)

INDUCTANCE OF ANTENNA SYSTEM IN MICROHENRIES

Antenna Height in Feet	Length in Feet of		Horizontal Portion of		Antenna
	30 Feet Hor.-Vert.	45 Feet Hor.-Vert.	60 Feet Hor.-Vert.	75 Feet Hor.-Vert.	100 Feet Hor.-Vert.
20	20-10	30-10	41-10	50-10	66-10
30	20-15	30-15	51-15	51-15	69-15
40	20-21	30-21	42-21	52-21	71-21
60	20-34	30-34	42-34	53-34	72-34
100	20-61	30-61	42-61	52-61	72-61

MODULATION AND DEMODULATION

**Modulation.**—Radio waves are much higher in frequency than sound or audio frequency waves. Frequencies above 15,000 cycles per second and up to many millions of cycles per second are known as radio frequencies (r-f). The radio waves used in the ordinary broadcast band are from 500,000 to 1,500,000 cycles per second. The frequency spectrum as recognized today is:

- 500 to 1,500 Kilocycles — Ordinary Radio
- 10 to 30 Kilocycles — Very Low Frequencies
- 30 to 300 Kilocycles — Low Frequencies
- 300 to 3,000 Kilocycles — Medium Frequencies
- 3 to 30 MC — High Frequencies
- 30 to 300 MC — Very High Frequencies
- 300 to 3,000 MC — Ultra High (UHF) Frequencies
- 3,000 to 30,000 MC — Super High Frequencies

Fig. 22-20 shows a comparison of the frequency of sound and radio waves, the upper curve representing a simple sound wave of 5,000 cycles per second, which is quite a high frequency in the sound range; and the lower curve represents a constant radio wave of 100,000 cycles frequency, which is in the lower range of radio frequencies.

The high frequency oscillation or carrier waves necessary for radio transmission are not audible to the human ear. In order to send music or voice it is necessary to impress the audio frequency sound waves on the radio frequency carrier wave, in such a manner that they will vary or control the amplitude of

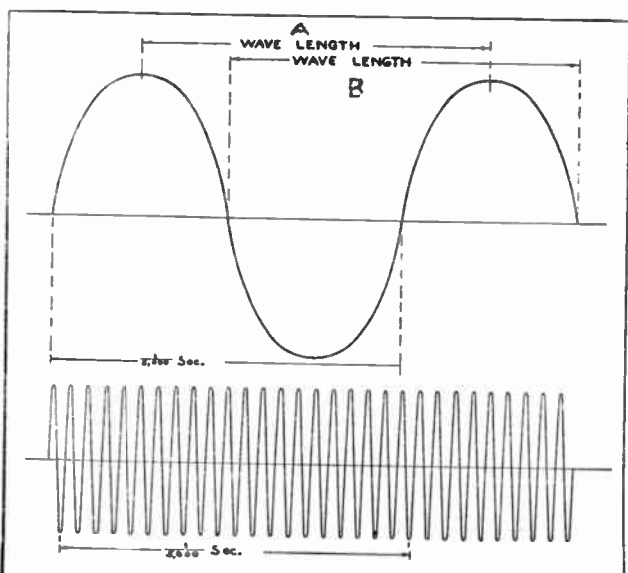
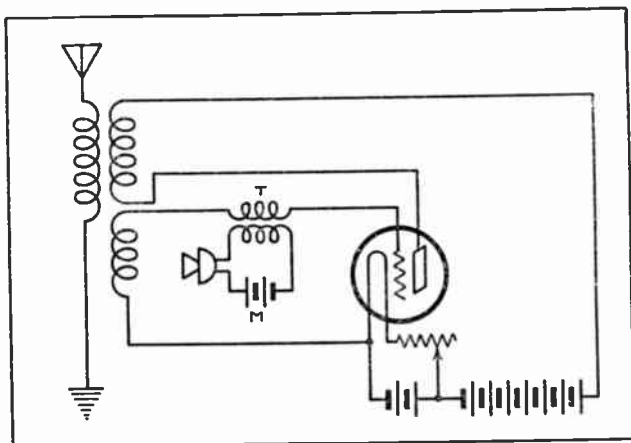

Fig. 22-20.—The two sets of curves illustrate the difference between the frequency of sound waves and radio waves.

the carrier wave directly with the volume and frequency variations of the sound. This is known as *modulation* of the carrier wave, by a voice or music wave. A *modulator* is a circuit arrangement which will impress the audio frequency energy on the radio frequency carrier.

Fig. 22-21 shows a simple low power radio telephone transmitter circuit with one oscillator tube and with a microphone coupled to the grid circuit by means of a microphone coupling transformer *T*. The microphone control varies the current from a battery in impulses that correspond exactly to the value and frequency of the sound waves striking the diaphragm. In Fig. 21, the microphone is connected in series with the microphone battery *M* and the primary of the coupling transformer. Therefore,

the pulsating current set up through this primary coil when voice or music waves strike the microphone diaphragm, induces alternating current of corresponding value and frequency in the secondary coil, which is connected in series with the grid circuit of the oscillator tube. Fig. 22-22a and 22-22b show curves representing the pulsating d-c of the microphone circuit and the varied value

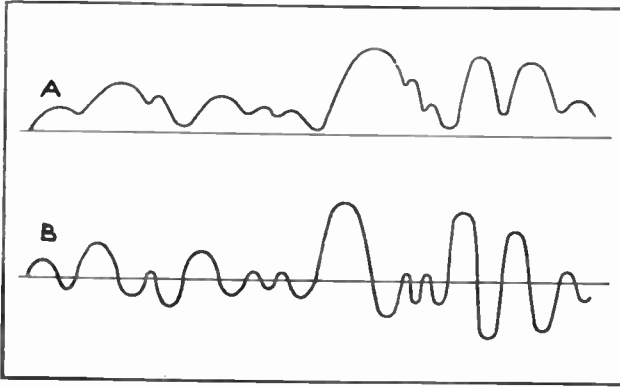

*Fig. 22-21.—Diagram showing how a microphone can be coupled to an oscillator circuit of a simple radio transmitter to modulate the carrier wave with the audio frequency voice energy. This circuit uses what is known as grid modulation.*

of a-c which will be induced by the secondary of the coupling transformer. Any change in the grid voltage of a vacuum tube causes a corresponding change in the plate current. So as the microphone transformer supplies alternating voltage of varied value and frequency to the grid of this tube, the plate current will vary accordingly. If the tube is already oscillating and delivering a radio frequency carrier current to the antenna, the audio frequency variation is impressed on the radio frequency waves and will cause them to vary in value, the variation being at audio frequency and corresponding to the original sound wave at the microphone. Fig. 22-23 shows a modulated carrier wave on which the value and amplitude of the high frequency wave has been varied by impressing the audio frequency upon it. This modulated wave is what reaches the antenna and is sent out

through space to produce voice and music at the distant receiver.

**Demodulators or Detectors.**—The transmitted radio energy or carrier wave is much too high in frequency to be audible to the human ear. After modulation by audio frequency current, the signal energy or current induced in the receiving aerial circuit is alternating current of such high frequency that the diaphragm



*Fig. 22-22.—The curve at "A" illustrates the nature of pulsating current set up in the circuit of a microphone. At "B" is shown the curve for the alternating current of varying value which is induced in the secondary winding of a microphone coupling transformer.*

of the headphones or loud speaker cannot respond to it, because even their slight inertia prevents them from vibrating at such high speed. The detector is a device which makes it possible to hear the signals received. It is the job or function of the detector

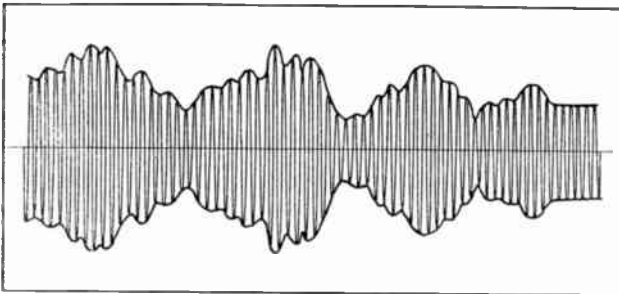

*Fig. 22-23.—Curve showing a high frequency carrier wave modulated or varied in value by the audio frequency voice waves.*

to rectify the received high-frequency current into pulsating d-c. In the early stages of radio, the crystal detector was one of the devices used for this purpose whereas in the radios of today, the vacuum tube detector is used exclusively.

**Crystal Detectors.**—There are a number of crystals which have more or less the property of rectifying the high frequency alternating current used in radio transmission into uni-directional or pulsating d-c. In the past, one of the most commonly used was the galena crystal which is a natural crystal formation of sulphide of lead and is found in lead mines. A crystal mounting with its feeler contact or adjustable "cat-whisker," was used to explore the surface of the crystal for sensitive spots. When a crystal such as galena is connected to an a-c circuit, it will allow current to pass freely in one direction, and will almost entirely prevent its flow in the opposite direction. This rectifier action is thought to be due to either electro-chemical or electro-thermal action between the layers within the crystal structure or at the point of contact between the tip of the cat-whisker wire and the crystal surface.

Fig. 22-24 shows a method of connecting a crystal and a pair of headphones to a tuning coil to form a simple radio detector or receiver. When the high frequency waves, or a damped wave, for example, strike against the receiving antenna of such a circuit they induce alternating voltage in the antenna. This

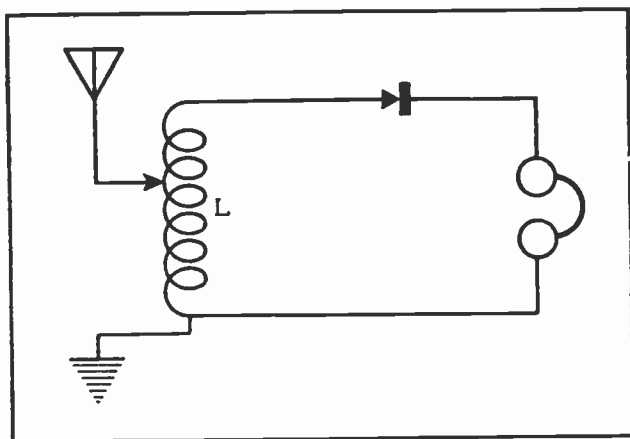

Fig. 22-24.—This sketch shows a circuit for a simple crystal detector radio receiver.

voltage tends to set up in the tube coil, during each wave train, an alternating current such as illustrated by the curve at *A* in Fig. 22-25. The voltage drop across the coil *L* in Fig. 22-24 will cause part of the current to flow through the crystal and headphones.

If the crystal were left out, the high frequency current would not produce any sound at the phones, because it could not flow to any appreciable extent through the high impedance of the phone coils which are wound on iron cores. Even if the current could get through the coils in any useful amount, the phone diaphragms could not vibrate at such high frequency nor could the human ear hear it if they did. With the crystal in the circuit as shown in Fig. 22-24, however, the current is allowed to flow through it and the phone in only one direction, and is practically all cut off in the reverse direction. This is illustrated by the curves at *B* in Fig. 22-25.

Thus practically all that gets through the phone is pulsating d-c or current in one direction. The current through the phones does not vary with, or follow each of the high frequency pulsations of these rectified groups, but due to the impedance of the phone calls, the current builds up to a sort of average value. in the form of one pulsation for each group or wave train, as illustrated by the large dotted curves *C* in Fig. 22-25. These longer and slower current impulses through the phone magnets, all in one direction, cause the diaphragms to be attracted and released or vibrated

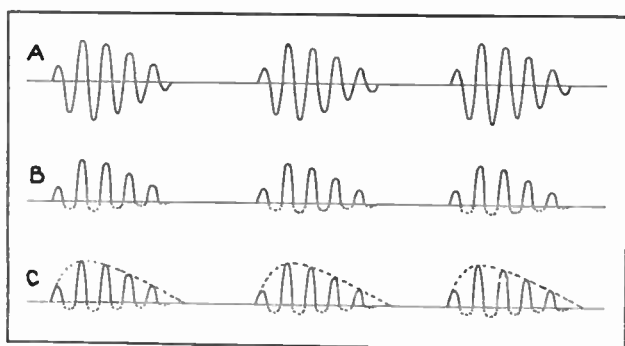

Fig. 22-25.—The curve of "A" represents the alternating current induced by damped wave trains striking the aerial. At "B" is shown the curve for this energy after it has been rectified into pulsating D.C. by the crystal. At "C" the large dotted curves illustrate how each group of pulsations supply line current impulse to the headphones.

at audio frequency, thus setting up audible signals.

The same general action takes place with modulated radio frequency waves. The crystal rectifies the energy to high frequency pulsating d-c by cutting off the flow in one direction. Then the impedance of the phone causes the uni-directional pulsations to build up current through the phone magnet, which does not vary much with each high frequency impulse, but varies or pulsates with the slower variations which are due to the audio frequency modulation of the waves, as was shown at *C* in Fig. 22-25. Thus detection, or a change from radio frequency to audio frequency, takes place as a result of the combined rectifying action of the crystal and the choking action of the phone.

Galena crystal detectors have the disadvantages of a lack of any amplifying ability and a need of frequent adjustment. They have been entirely replaced by vacuum tube detectors which are more dependable and, in some types, are capable of amplification.

The latest type of crystal detector is the Mercurianium crystal. A common type is numbered 1N34. It is used in radio and television for detector or demodulator purposes. Some specialized types are even used as detectors in the very high frequency tuners of TV sets.

**Fundamentals of Vacuum Tube Detectors.**—If a diode is placed in series with a source of a-c voltage, current will flow through the tube and the circuit only during the half-cycle in which the plate is positive and the cathode negative. Current cannot flow in the opposite direction because there can be no electron emission from the cold plate, consequently, the alternating voltage can produce pulses of current only during the half of each cycle, and all these pulses are in the same direction as shown by Fig. 22-26. Any current which flows always in one direction is a direct current so the diode is delivering pulsating direct current from

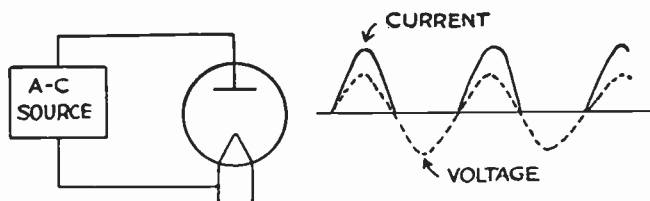

Fig. 22-26.—A RECTIFIER allows pulsating direct current to flow when an alternating current is applied.



an alternating voltage. The diode is a rectifier. Negative electrons leaving the cathode make the cathode somewhat positive, so a cloud of electrons remain near the cathode because of the attraction between the relatively positive cathode and the negative electrons. These electrons near the cathode form the space charge. Since two negative bodies repel each other, the space charge repels additional electrons being emitted from the cathode. Voltage applied between plate and cathode, called plate voltage, overcomes the effect of the space charge and draws emitted electrons from the cathode to the plate. This corresponds to a current flow from plate to cathode.

Fig. 22-27 shows how current in the plate-cathode circuit changes with plate voltage. With the first increases of plate voltage the current rises slowly, because of the space charge effect. As voltage is increased, and the plate made more positive with respect to the emitter, it draws many more electrons from the space charge, the space charge effect is lessened, and the current increases at a rapid rate. If the plate voltage is still further increased, the space charge electrons are completely removed from around the cathode. Thereafter, even with further increase of plate voltage, the plate current can increase only if the rate of emission is increased by heating the cathode to a higher temperature. Plate current levels off at a value called saturation current.

Now we shall add a third element to the tube, as in Fig. 22-28, to

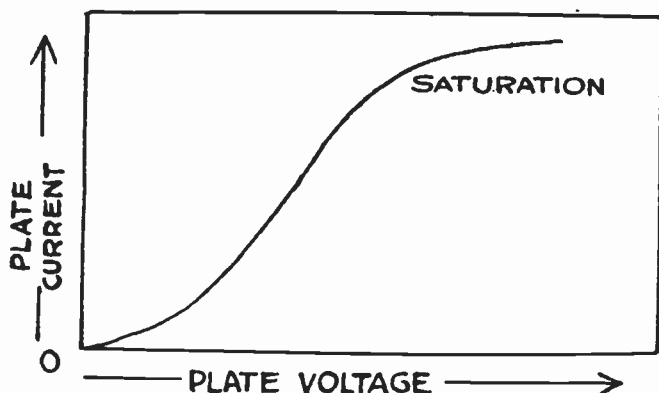

Fig. 22-27.—Plate current increases from zero to saturation as plate voltage is increased.

form the type of tube called a triode. If the grid is made positive with reference to the cathode, the positive charge of the grid will counteract much of the effect of the negative space charge. Then it will take but moderate plate voltage to cause a large current flow or electron flow between cathode and plate. On the other

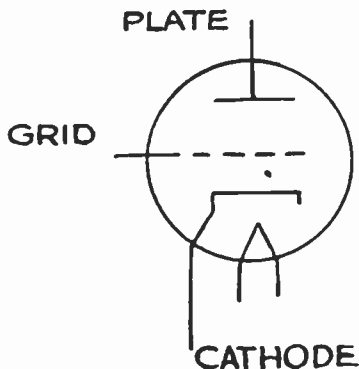

Fig. 22-28.—The control grid at the triode is between the cathode and plate.

hand, if the grid is made negative with reference to the cathode, the effect of the negative charge on the grid is added to that of the negative space charge and emission of electrons from the cathode is strongly opposed. Then even a high plate voltage can draw relatively few electrons from cathode to plate, and there is but small plate current. The voltage of the grid with reference to the cathode, which is the voltage between these two elements, is called grid voltage.

Fig. 22-29 shows the effect on plate current of varying the grid voltage in one type of triode while maintaining a plate voltage of 100. When the grid voltage is zero, meaning that it is the same as the cathode voltage, the plate current is 10.7 milliamperes. With the grid 2 volts positive, the plate current becomes 15.6 milliamperes. With the grid successively 2 volts and 4 volts, negative, the plate currents are 5.7 and 1.6 milliamperes, and when the grid is made 6.4 volts negative, the plate current is stopped completely, which is called cutoff.

**Vacuum Tube Detectors in Radio Circuits.**—The detector of Fig. 22-30 produces small a-c-changes of voltage in the plate circuit because it is operated with a highly negative grid bias; hence

this form of detector may be called a *grid bias detector*. Another name for this particular method is *plate detection*, because of the fact that detection occurs in the plate circuit voltages. At *A* in Fig. 22-31 is shown the circuit for such a detector and at *B* is shown its action. The characteristic curve of Fig. 22-31 shows the relation between plate current and grid voltage changes. At the

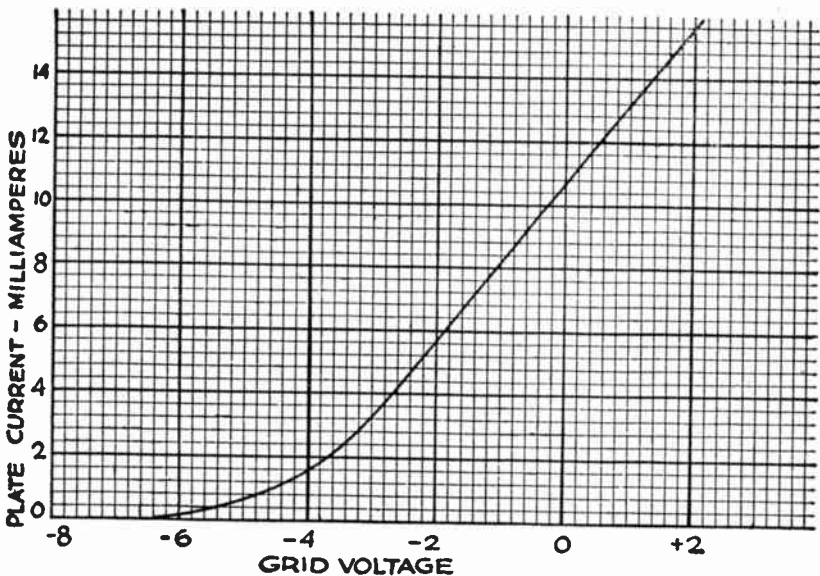

Fig. 22-29.—How the plate current varies with changes of grid voltage while the plate voltage remains constant.

bottom of the diagram is represented the r-f voltage which is applied to the grid of the detector tube. The bias is so far negative that the negative half-cycles of the applied r-f voltage bring the grid voltage to the cutoff point. Consequently, as shown toward the right from the characteristic curve, these alternations of grid voltage reduce the plate current to zero. The positive alternations of the applied r-f voltage make the grid less negative, so that the operation is higher up on the characteristic curve. These positive alternations thus produce corresponding changes of plate current, as shown toward the right. In the plate circuit we now have a pulsating direct current flowing always in the same direction. The average value of these one-way pulsations

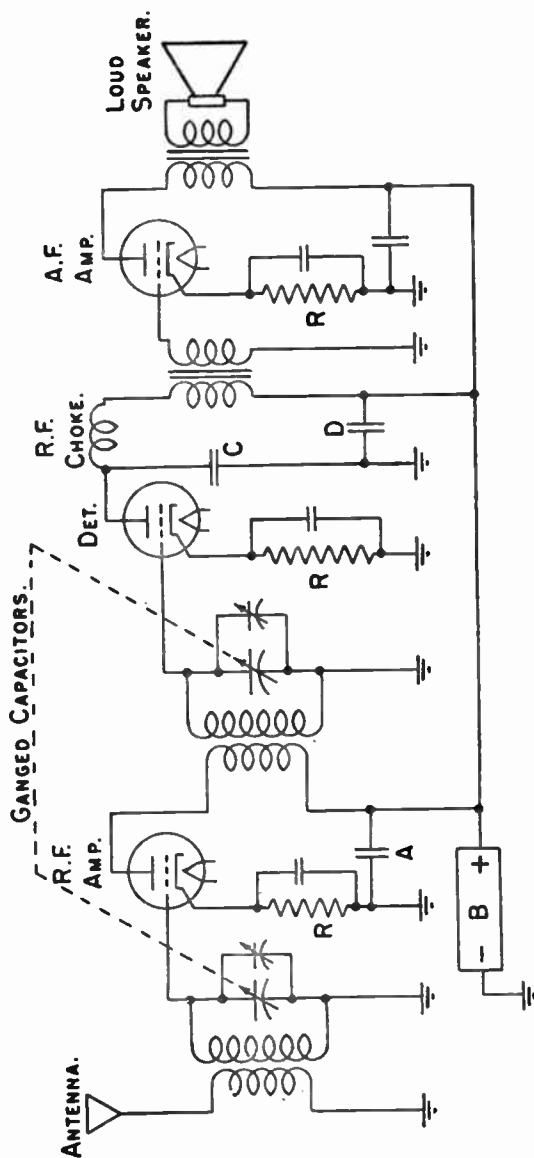

Fig. 22-30.—The circuits of a complete 3 tube receiver, including one r-f amplifier, a detector and one a-f amplifier.

follows the modulation, consequently this average plate current follows the audio frequency.

The high-frequency changes in the plate circuit of the detector are bypassed to ground through capacitor  $C$  of Figs. 22-30 and 22-31. As a further preventative against allowing high-frequency voltages to reach the primary of the following iron-cored trans-

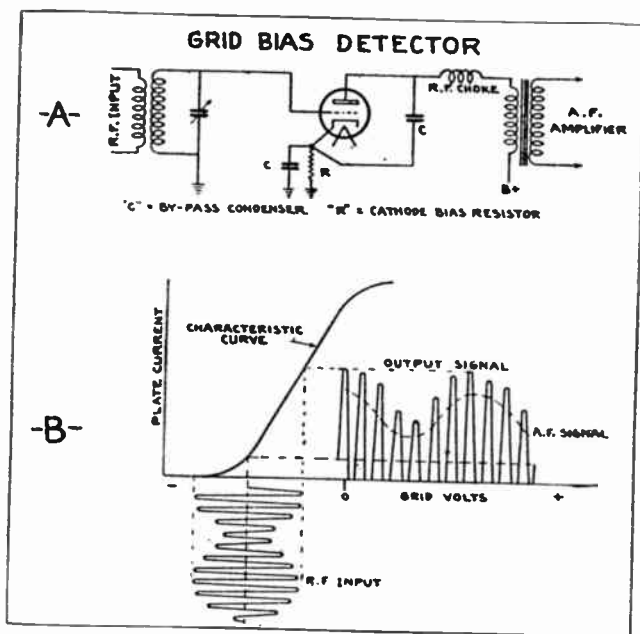

Fig. 22-31.—The circuit for a grid bias detector "A" and the manner in which alternating grid voltage produces a partially rectified plate current whose average value changes at audio frequency (B).

former, a radio-frequency choke coil is placed between plate and transformer. This choke has high impedance at radio frequencies, but very low impedance at audio frequencies which are to reach the transformer. The audio-frequency circuit for the detector plate is completed through the large-capacitance capacitor  $D$  to ground and through ground to the detector cathode, so that a-f changes need not go through the B-supply. Note that we have amplification as well as detection.

Another method of detection, seldom used nowadays, produces a grid voltage varying at audio frequency by means of a resistor

and capacitor in parallel with each other and in series between the r-f transformer and the grid of the tube. The resistor, called a grid leak, usually is of about one megohm resistance and the capacitance is about 0.00025 microfarad. Such an arrangement makes a *grid leak detector*.

A *diode tube* may be used as a detector with the circuit of Fig. 22-32. One end of the tuned r-f transformer is connected to the plate of the diode, while the other end is connected to the cathode

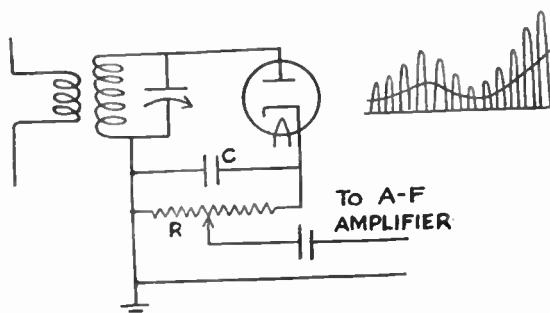

Fig. 22-32.—Using a diode tube for a detector.

through capacitor  $C$  and the adjustable rheostat or potentiometer  $R$ . Radio-frequency voltages are rectified by the diode; only the positive half-cycles producing current in the diode and its connected circuit. The result is a series of d-c current pulses whose average value follows the modulation or the a-f signal.

The diode current passing through resistor  $R$  produces voltage changes at audio frequency across this resistor. These voltage changes are delivered to the following audio-frequency amplifier. Radio-frequency changes pass through capacitor  $C$ , which is of such capacitance as to have low reactance to the r-f changes, but high reactance to the a-f changes which thus are forced through the resistor. Audio-frequency voltage to the a-f amplifier is increased as the slider on  $R$  is moved to the right and are decreased as it is moved to the left. Thus the potentiometer  $R$  may be used as a volume control.

Diode detectors and grid leak detectors allow current to flow in the tuned circuit, which reduces selectivity. A well designed diode detector produces less distortion than either a grid leak or a grid bias detector. A grid bias detector usually has less distor-

tion that the grid leak type. The grid leak detector is very sensitive to weak signals but its high sensitivity is not needed with modern high-gain r-f amplifiers between antenna and detector.

**Volume Controls.**—Volume controls may be inserted in almost any circuit of a receiver where they reduce or increase the r-f or a-f voltages delivered to following stages. Some receivers have volume controls in more than one circuit. A common method employs an adjustable biasing resistor in the cathode lead of a variable- $\mu$  tube, thus making the grid more or less negative to decrease or increase the amplification of the tube.

Automatic volume control, abbreviated AVC, may be had by taking the bias for one or more variable- $\mu$  tubes from a rectified portion of the r-f signal. The amplification of a variable- $\mu$  tube thus may be decreased when signal strength increases, and increased for weak signals; by this method a fairly uniform loud speaker output is obtained as the antenna signal varies. Fig. 22-33 shows how a connection may be taken from a diode detector for grid bias of variable- $\mu$  tubes.

Variable- $\mu$  tubes are designed to operate with a minimum bias of about 3 volts, which usually is provided by a cathode biasing resistor with the AVC bias voltage in series. With simple AVC circuits even a weak signal causes some reduction of amplification. This fault is avoided with delayed automatic volume control, for which one type of circuit is shown by Fig. 34. This circuit includes a duplex-diode triode tube containing two diode plates, a triode plate and grid, and a single cathode for all three. Duplex-diode pentodes are used similarly, with an additional connection for screen voltage.

The upper diode plate and the cathode of the tube in Fig. 22-34

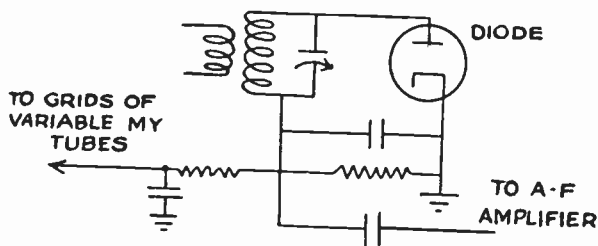

Fig. 22-33.—Automatic volume control voltage for variable- $\mu$  tubes may be taken from the circuit of the diode detector.

act as the diode detector, with the diode plate connected to the tuned circuit  $T$  and with the other end of the tuned circuit connected to the cathode through resistor  $R$  with its bypass capacitor, just as in the circuits of Figs. 22-32 and 22-33. The a-f output from this diode detector is taken through the connection shown to the a-f amplifier.

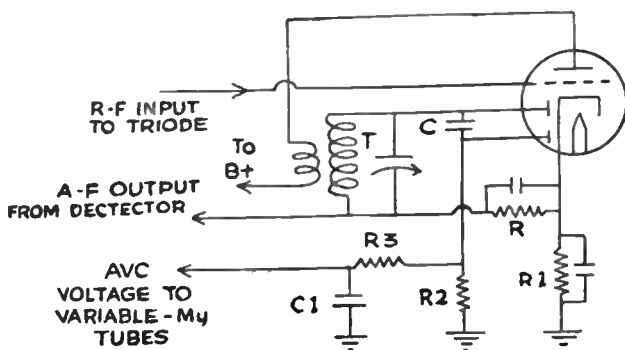

Fig. 22-34.—A circuit used for delayed automatic volume control with which weak incoming signals are not affected by the automatic features.

The lower diode plate and the cathode form the AVC diode. Part of the energy going to the plate of the detector diode goes through the small capacitor  $C$  to the AVC diode section. Biasing resistor  $R1$  keeps the plate of the AVC diode at a negative voltage which prevents it from rectifying and from producing an AVC voltage until the peak voltage reaching it through capacitor  $C$  counterbalances this negative voltage. Thus no AVC voltage is produced with very weak signals, which do not provide enough voltage on the plate of the AVC diode to overcome its negative voltage. Thus, for weak signals, the sensitivity of the receiver remains the same as though there were no AVC system.

When stronger signals are received, enough voltage reaches the AVC diode to overcome its negative plate voltage. Then there will be current through resistor  $R2$  and a voltage drop across this resistor. The r-f and a-f variations of this voltage are filtered out by the impedance of resistor  $R3$  and the bypass effect of capacitor  $C1$ . The remaining variations of direct current are applied to the grids of the variable-mu tubes just as with any other AVC system. The triode section of the tube acts merely as



the r-f amplifier which precedes the detector. We have in the single envelope an r-f amplifier tube, a detector tube and an AVC tube.

#### TRANSMISSION AND RECEPTION

Fig. 22-35 shows what happens at a transmitter, from which radio signals are sent through space to be picked up at a distance. First we have sound waves, which may be voice or music. Sound waves are air vibrations occurring at frequencies between about 16 and 16,000 cycles per second, depending on the pitch of the sounds. These are audio frequencies, abbreviated a-f. The microphone acts like a telephone transmitter, in which the sound waves produce corresponding audio-frequency changes of voltage. These small audio-frequency voltages are increased in the a-f amplifier and are passed along to the modulator.

The oscillator produces voltages and currents which, for broadcasting, have frequencies of from 500,000 to 1,600,000 per second. These are radio frequencies, abbreviated r-f. Instead of speaking about the number of cycles at these high frequencies, we usually speak of kilocycles, which are thousands of cycles. In broadcasting we have radio frequencies of 500 to 1,600 kilocycles.

The r-f voltages are fed into the modulator where they combine with the a-f voltages from the a-f amplifier. The result is modulated radio frequency voltages, which are voltages whose frequency is radio frequency but whose strengths or amplitudes vary according to the audio frequencies from the a-f amplifier. The modulated radio frequency voltages are strengthened by the r-f amplifier and then go to the aerial or antenna where they produce electromagnetic radiations which travel through space with the speed of light.

In Fig. 22-36, the radiation is reaching the antenna of a radio

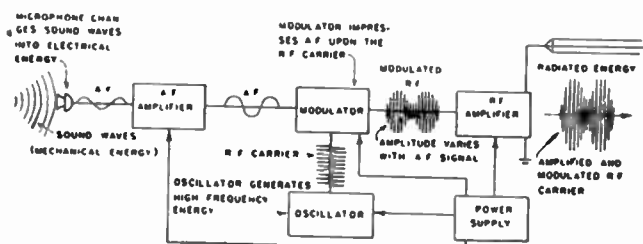

Fig. 22-35.—A radio transmitter from microphone to aerial.

receiver. In the antenna circuit are produced modulated r-f voltages which are applied to the r-f amplifier. These weak r-f voltages are strengthened in this amplifier and are passed along to the demodulator, which usually is called the detector. The detector gets rid of the r-f changes and leaves only the changes which occur at audio frequencies. These a-f voltages are strengthened in the a-f amplifier and fed into the loud speaker, which changes

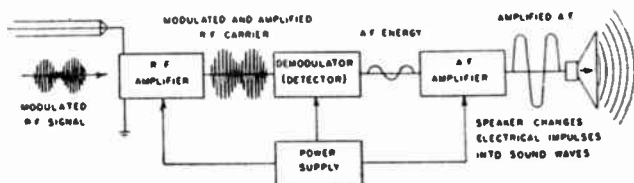

Fig. 22-36.—A radio receiver from antenna to loud speaker.

them to sound waves which are heard at practically the same instant that the original sound waves enter the distant microphone.

Part of the radiation travels for possibly 50 miles as a ground wave. Some of the remainder is reflected back from an ionized layer in the atmosphere about 70 miles above the surface of the earth, as shown by Fig. 22-37, while part of the radiation passes through this layer and is lost. Between the farthest point reached by the ground wave and the nearest point at which reflected waves come back to earth there is a *skip distance* within which signals from the transmitter cannot be received.

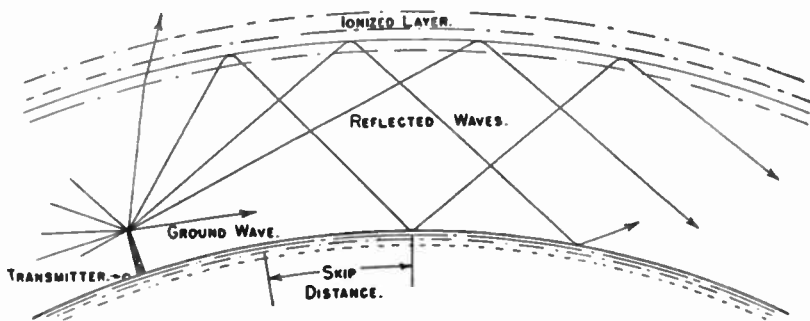
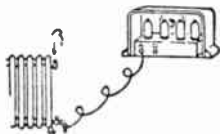

Fig. 22-37.—The ground wave and the sky wave as they travel away from a transmitter.

## Choosing an Antenna

*"No Radio Can Be Better Than Its Antenna"*



**Ground as Antenna**—Fair reception on local broadcast stations in some homes. Seldom satisfactory in suburban areas and useless for shortwaves. Use only where other systems cannot readily be installed, or for temporary service.



**Built-In Wire**—Good reception on local broadcast stations in all but extremely noisy buildings. Receives reasonably distant stations when used on upper floors in electrically quiet areas. Rarely effective on shortwaves and invariably noisy in large apartment houses.

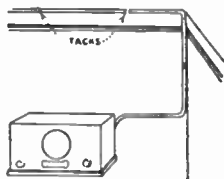

**Moulding-Strip**—Good reception on local broadcast stations in all but extremely noisy buildings. Receives reasonably distant stations when used on upper floors in electrically quiet areas. Rarely effective on shortwaves and invariably noisy in large apartment houses.



**Ordinary Outdoor System**—Excellent on both broadcast and shortwave bands when building and vicinity are electrically quiet. Recommended for homes away from trolley-lines, high-tension wires, motors and busy roads.

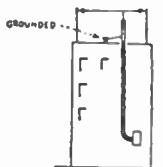

**Shielded Lead-In**—Reduces noise pickup by downlead where this wire must pass through electrically disturbed areas. Good reception on broadcast band but not recommended for shortwaves. In common with other noise-reducing types, must have antenna proper mounted out of noisy area for maximum benefit.

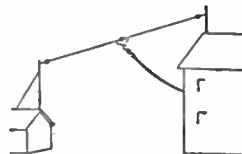

**Simple Doublet**—Reduces noise pickup by downlead where it must pass through noisy areas. Good reception on shortwave band and satisfactory for broadcast reception. Especially efficient at certain frequencies, which may be those most often desired.

### REVIEW QUESTIONS

1. In what form and manner is radio energy radiated?
2. What relation or formula exists between the frequency and wavelength of radio energy?
3. Is the lead-in wire considered a part of the antenna?
4. Name some types of receiving antennas, and their properties.
5. What do you understand by the words "modulation of the carrier wave"? Why is it necessary?
6. What is a demodulator or detector? Why is it necessary in radio reception?
7. Describe the use of a vacuum tube as a detector in radio circuits.
8. Describe in words or by wave form what happens at a transmitter where the sound begins and continues through the receiver until the sound is heard from the radio loudspeaker.

## Chapter 3

### AMPLIFIERS AND LOUD SPEAKERS

One of the most remarkable things about the modern radio receiver is its ability to amplify signals millions of times and build up their energy to a point where it will operate loud speakers with sufficient sound volume for a large room or with sufficient volume for large outdoor public address equipment. The underlying principle of vacuum tubes and amplifiers is the fact that the small change in grid voltage and power will cause a much greater change in plate current and power. For amplification, the vacuum tube is operated on the straight portion of the characteristic plate current curve so that all variations or increases and decreases in grid voltage will be amplified equally, and the waves or impulses kept unchanged in shape and increased

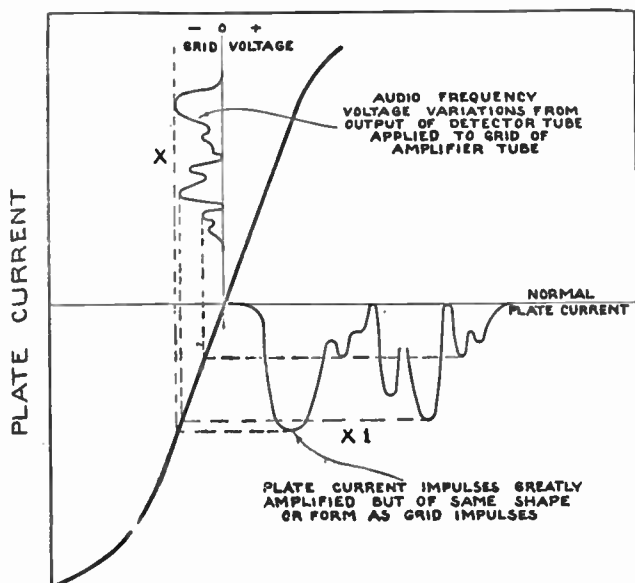

Fig. 23-1.—Amplifier action illustrated with audio frequency curves of the average variations caused in the grid voltage and plate current by the voice modulation on the carrier wave.

in amplitude or volume. Fig. 23-1 illustrates this amplifier action. The average voltage for output impulses of the detector tube are applied to the grid of the amplifier tube as shown at X. These are greatly amplified by the pulsations of plate current in the amplifier tube as shown at X1, but with their original shape or form.

Amplifier tubes are also used to increase the strength of the signal before it reaches the detector tube. This is called r-f or radio frequency amplification, as it is done before the energy is rectified and converted to audio frequency. Fig. 23-2 shows the manner in which r-f amplifier tubes increase the voltage or

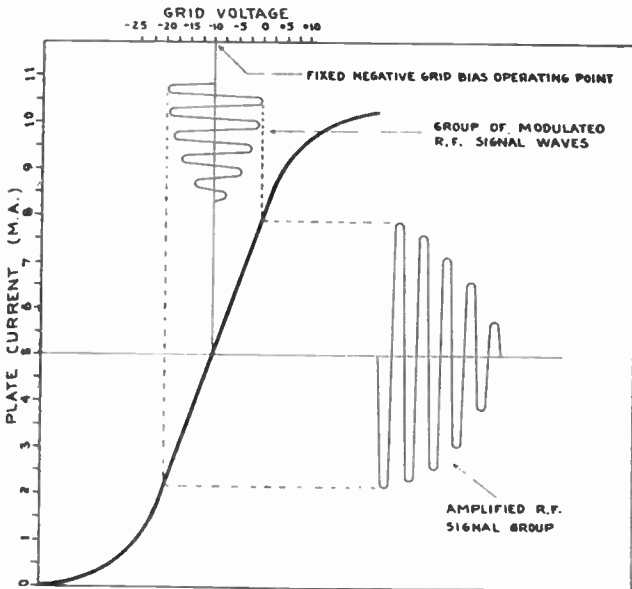

Fig. 23-2.—Curves illustrating amplifier action of a vacuum tube. Note that the grid voltage impulses are greatly amplified or increased in the plate current impulses but are kept in the same form instead of being rectified.

amplitude of the incoming r-f signals without rectifying or changing the shape of these r-f waves. In this figure is shown how a signal is applied to the grid and its effect on the plate current. When amplifying radio signals, the variations in plate current have the same form as the changes in grid voltage, so it

is necessary to operate the amplifier within the limits of the straight portion of the characteristic curve. This will require a fixed negative grid bias, in order to locate the operating point on the curve in such a position that variations of the grid voltage, due to the applied signal, will cause changes in plate current which are of exactly the same form as the signals, only greatly enlarged and amplified. The grid signal must not be allowed to become too great or the tube will be operating in the bend or knee region of the curve causing the output waveform to change from that of the original signal, resulting in distortion of the waveform and sound at the speaker. Also too much or too little grid bias will shift the operating point one way or the other, thereby limiting the grid signal which can be applied to somewhere below normal in order to keep it from getting off the straight portion of the curve. Different types of tubes require different values of bias, depending on their characteristics.

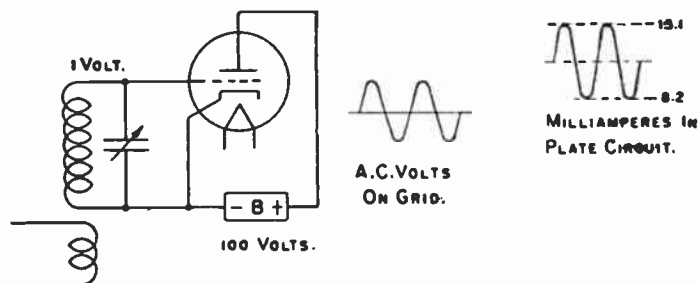

Fig. 23-3.—Grid voltage changes come from the secondary winding of a tuned r-f transformer.

In Fig. 23-3 the secondary of a tuned r-f transformer is connected between the grid and cathode of the tube whose performance is shown by Fig. 23-4. If the a-c peak voltage as developed in the transformer and applied to the grid is one volt, the grid voltage will change from one volt positive to one volt negative in each cycle. The plate current will change accordingly, from 13.1 milliamperes to 8.2 milliamperes in each cycle. Note that the plate current is a pulsating direct current, flowing always in one direction, but pulsating between 13.1 and 8.2 milliamperes.

**Grid Bias for Amplifiers.**—During half of each cycle of grid

voltage in Fig. 23-3, the grid is positive with reference to the cathode. Electrons flow from the cathode to a positive grid just as to a positive cathode, although the small grid voltage causes but small flow. The resulting current in the grid must flow

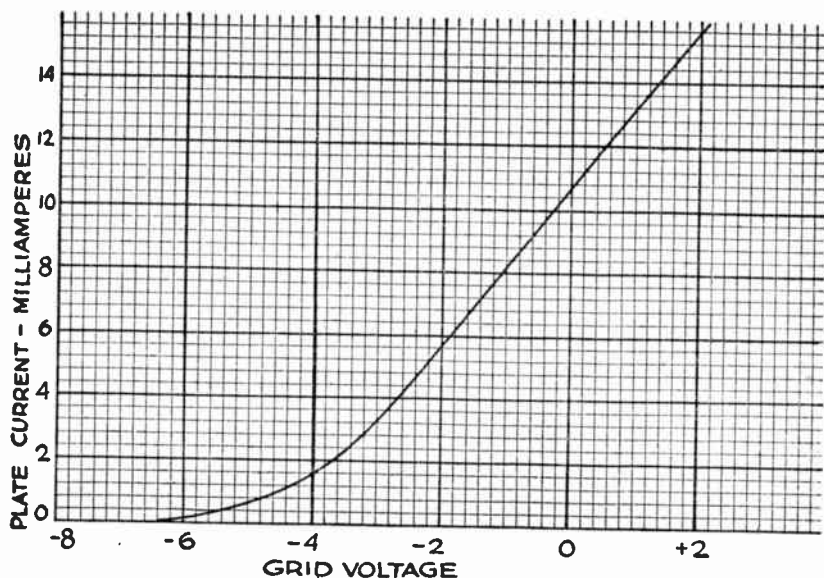

Fig. 23-4.—How the plate current varies with changes of grid voltage while the plate voltage remains constant.

through the transformer to the cathode. This path from grid to cathode is called the grid circuit. When grid current flows through whatever impedances there may be in the grid circuit, there are corresponding voltage drops. These voltage drops, which occur only while the grid is positive, combined with the r-f voltage induced in the transformer, to make the total voltage during the positive half-cycle differ from that during the negative half-cycle, when there is no grid current. The result is distortion, which means that the variations in plate current do not faithfully follow the form of variations in r-f voltage applied to the grid circuit.

To overcome distortion due to grid current, the grid must remain negative with respect to the emitter during the whole cycle of applied voltage. This we do by applying to the grid a

negative voltage which is independent of the a-c voltage coming from the transformer. In the case of Fig. 23-3 we might make the grid one volt negative. Then, when the voltage from the transformer becomes one volt positive, it will just balance the original negative grid voltage and the actual grid voltage with respect to the emitter will be zero. When the transformer voltage (to the grid) becomes one volt negative, it will add to the original negative grid voltage and the actual grid voltage will be two volts negative. Instead of the grid voltage varying from one volt positive to one volt negative, as in Fig. 23-3, it will vary from zero to two volts negative and always will remain on the negative side of the zero point. The grid voltage which maintains the grid always negative is called grid bias voltage.

A commonly used method of obtaining negative grid bias is to place between the cathode of the tube and the grid circuit a resistor as at the left in Fig. 23-5. Plate current returning from

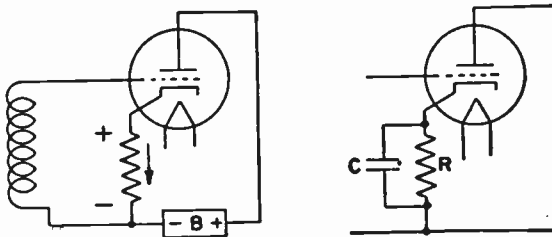

Fig. 23-5.—Negative bias for the grid may be obtained with a resistor in the cathode lead.

the cathode to the  $B$  source flows in the direction of the arrow through the bias resistor. The cathode end of the resistor becomes positive and its other end, connected through the coil to the grid, becomes negative. Thus the grid is maintained negative with reference to the cathode.

With the bias resistor used alone, the changes of plate current cause changes of voltage across the resistor, and the grid bias varies with every change of plate current. This difficulty is avoided as shown at the right in Fig. 23-5 where there is a



bypass capacitor  $C$  in parallel with the bias resistor  $R$ . The varying plate current of Fig. 23-3 really is a combination of a steady direct current and an alternating current. Most of the fluctuations, which are the a-c "component" of the plate current, go through the capacitor  $C$  of Fig. 23-5, if the capacitance is great enough, while the average steady-current component goes through resistor  $R$  to produce a practically constant grid bias.

The grid of a tube may be negatively biased not only with the arrangement of Fig. 23-5 but by connecting the cathode end or filament end of the grid circuit to any point which is more negative than the cathode of the tube which is biased.

**Plate Circuit Load.**—We have produced in the plate circuit of the tube a pulsating direct current whose pulsations correspond to the pulsations of a-c voltage applied between grid and cathode. But in order to make use of these plate current pulsations we need some kind of load in the plate circuit. The load might be the primary of another high-frequency transformer, it might be a resistor, or anything else in which a voltage is to be developed.

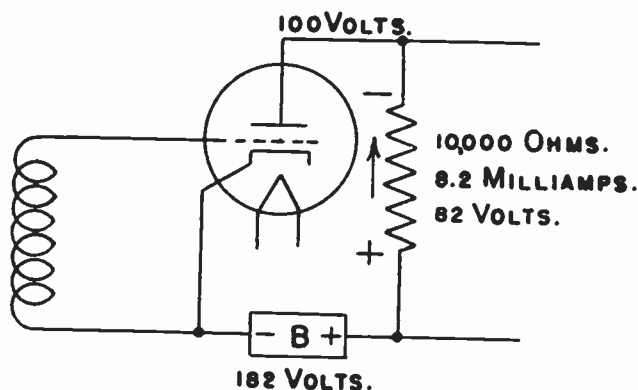

Fig. 23-6.—A load in the plate circuit of the tube.

In Fig. 23-6 we have a plate load represented by a 10,000-ohm resistor. Any other resistance or impedance load would act generally in the same manner. Let's assume that we have a 1-volt negative bias on the tube whose performance is shown by Fig. 23-4 and that we are applying 1-volt a-c to the grid. The grid

voltage then will vary between zero and 2 volts negative. With no signal applied to the grid, the grid voltage will be 1 volt negative and, with 100 volts on the plate, the plate current will be 8.2 milliamperes. With 8.2 milliamperes (0.0082 ampere) flowing through the plate circuit resistor of 10,000 ohms, the voltage drop in this resistor will be 82 volts. In order that the plate-to-cathode voltage may be 100 volts the source *B* must furnish this 100 volts and in addition the 82 volts which forces plate current through the 10,000-ohm resistor. Thus the source *B* must furnish 182 volts in order that we may have 100 volts for the plate.

Now let's see what happens when alternating voltage is applied to the grid. During the half-cycle in which the alternating voltage is positive, it makes the grid less negative with respect to the emitter. With the grid less negative, more plate current will flow. More plate current through the plate load resistor increases the voltage drop in this resistor. Then more of the 182 volts from the *B*-supply is used in the resistor and we no longer have 100 volts on the plate. Consequently when the grid reaches zero voltage, we do not have 10.7 milliamperes of plate current as shown by Fig. 23-4, but, because of the reduced plate voltage, we have only about 9.4 milliamperes as shown by Fig. 23-7. On the opposite half-cycle signal voltage, the grid is made more negative and less plate current flows. But the lessened plate current produces a smaller voltage drop in the plate load resistor, so more of the 182 volts from the *B*-supply remains for the plate. This higher plate voltage causes the plate current to be about 7.0 milliamperes with the grid 2 volts negative (Fig. 23-7), instead of the 5.7 milliamperes shown by Fig. 23-4. The curve of Fig. 23-7 shows how plate current varies when the plate voltage resistance (impedance) is 10,000 ohms, and the *B*-supply voltage is 182 volts. This is a curve of "dynamic" performance, showing what happens when the tube is working. In Fig. 23-4, is the curve of "static" performance showing the changes when the tube does not work, but merely varies the plate current with no plate circuit load.

**Voltage Amplification.**—With 1-volt of alternating potential on the grid of the tube in Fig. 23-6, with the negative bias of 1-volt, with the load resistance of 10,000 ohms and the *B*-supply

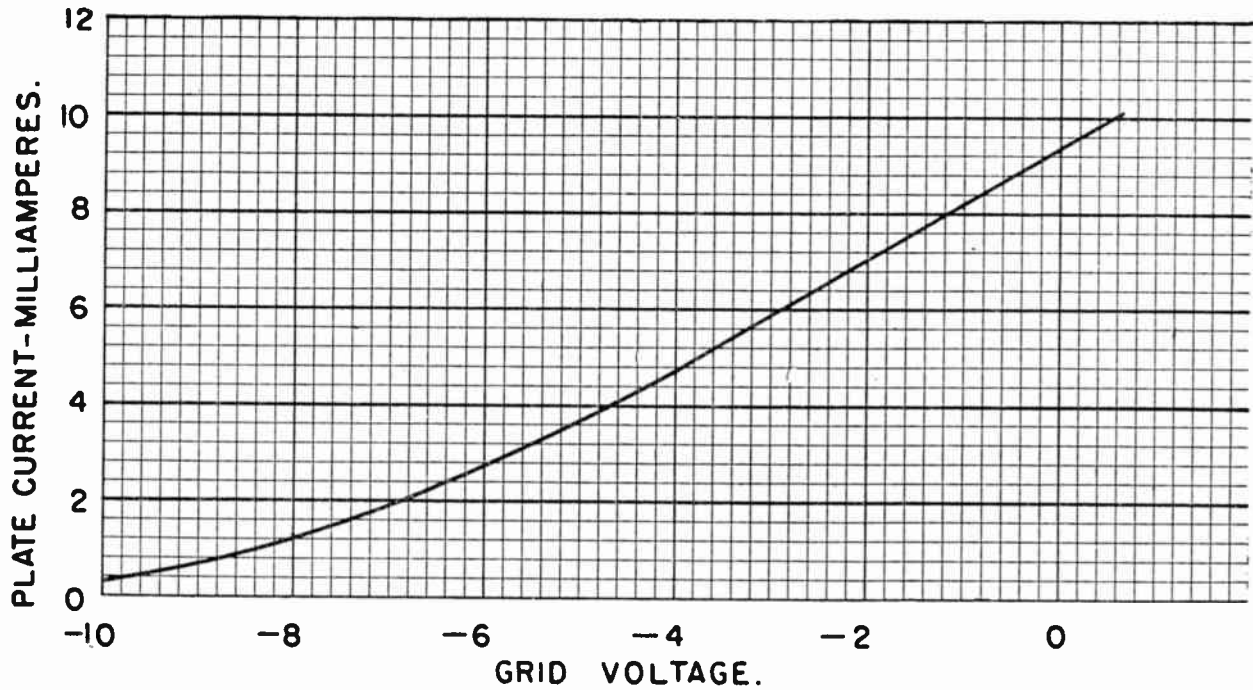

Fig. 23-7.—The grid voltage plate-current curve which shows dynamic performance of the tube

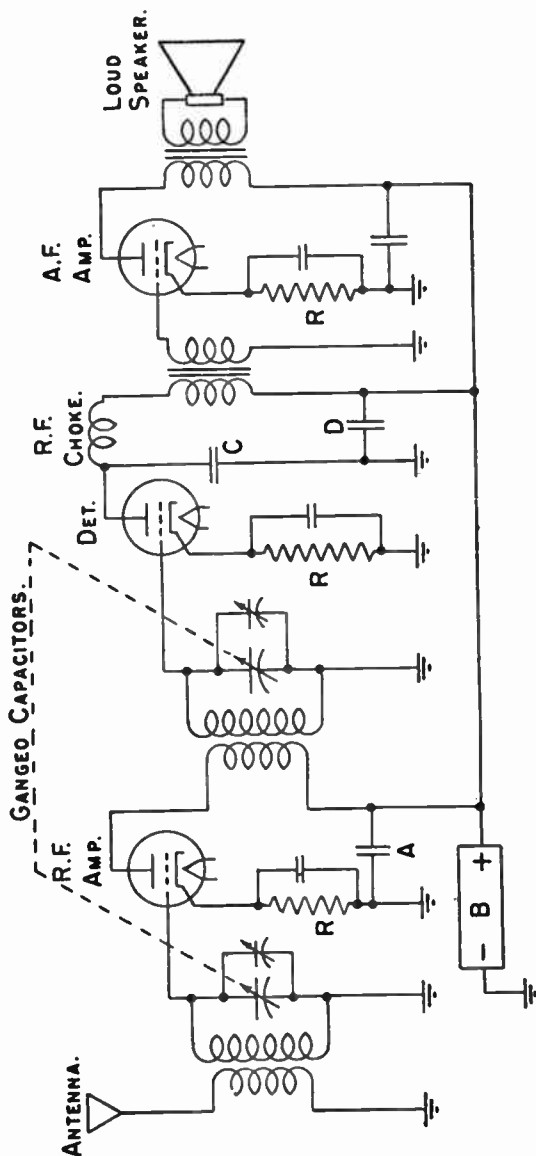

Fig. 23-8.—The circuits of a complete 3 tube receiver including one r-f amplifier, a detector and one a-f amplifier.

of 182 volts, the plate current varies between 7.0 and 1.4 milliamperes. The plate voltage will vary between 90 and 113.0 since the B-supply maintains 182 volts, the voltage drop in the load resistor will be the difference between the B-supply voltage and the plate voltage, so the voltage across the resistor will vary between 69 and 92 volts. The resistor voltage varies by 23 volts due to an a-c grid voltage change of 1-volt. We have amplified the grid voltage 23 times by using the tube. The amplification of this tube worked under these conditions is 23. The amplification factor is a number found by dividing the change of plate volts and the change of grid volts, which accompanies it, with the plate current remaining unchanged.

Since the grid remains negative at all times, there is no grid current to consume power. The power pouring into the grid circuit is only the very small amount necessary to maintain the currents which circulate back and forth between coil and capacitor. Yet in the plate circuit we have a power corresponding to a change of 7.0 to 9.4 milliamperes, which is a change of 2.4 milliamperes or 0.00024 amperes in 10,000 ohms of resistance. This is about 58 milliwatts of power. Other types of tubes may be designed and operated to deliver any watts of power to the plate load.

**Audio-frequency Amplifiers.**—Fig. 23-8 shows the rather common practice of connecting (or coupling) a detector to an a-f amplifier tube, and the a-f tubes to a loud speaker, by means of iron cored audio-frequency transformers. Such transformers often have a step-up voltage ratio, primary to secondary, so that there is a certain amount of voltage gain in the transformers in addition to that obtained through the tube. Transformer response may fall off at low audio frequency because the reactance of the primary increases with the frequency. High-frequency response may be limited by the bypassing effect on the secondary winding of the grid-tube cathode capacitance in the following tube. There is capacitance between the grid and the cathode just as there is between the grid and plate.

Fig. 23-9 shows the circuits in a resistance coupled a-f amplifier. The detector is like that of Fig. 23-8 but instead of having in its plate circuit the primary of an iron-cored transformer, there is the resistor  $R_p$  of Fig. 23-9. The a-f changes of plate current

produce a-f changes of voltage across this resistor. These a-f voltages pass through capacitor  $C1$  to the grid of the first a-f amplifier tube. Resistor  $Rg$  connects the grid of the a-f tube through ground to the cathode of this tube, and, in combination with the biasing resistor in the cathode lead, maintains the necessary negative bias in the grid. With a negative bias such as to

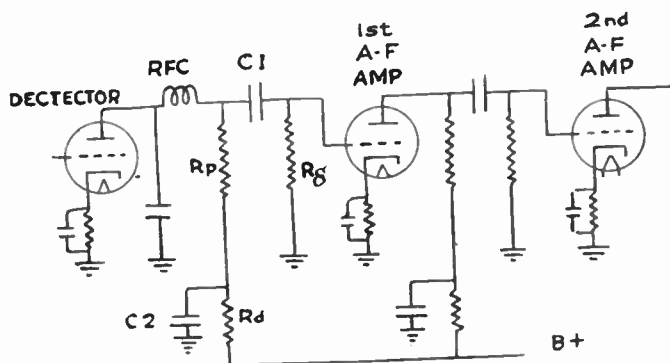

Fig. 23-9.—The circuits used for resistance coupled audio-frequency amplification.

prevent grid current there is no current and no voltage drop in the resistor  $Rg$ , so the grid bias depends entirely on the regular biasing resistor.

Capacitor  $C1$  not only passes a-f voltages from tube to tube, but at the same time prevents the high d-c voltage for the plate of the detector from reaching the grid of the first a-f tube. Resistor  $Rp$  is the coupling resistor, while resistor  $Rg$  merely serves to complete the grid circuit from the grid of the amplifier tube to its cathode. The impedance to a-f currents of resistor  $Rd$  forces the a-f changes to return to the cathode of the detector through bypass capacitor  $C2$ . Otherwise these a-f changes would go through the B-supply and in the resistance of the B-supply would produce voltage drops which would affect the other tubes connected to the same B-supply.

The amplification of a resistance coupled amplifier falls off at low audio frequencies because, at these low frequencies, the impedance of capacitor  $C1$  becomes greater. This effect is noticeable chiefly below 50 cycles. The amplification falls off at audio fre-

quencies above about 5,000 cycles because the capacitances of the elements in the tubes tend to bypass these high frequencies around the coupling resistors and thus to reduce the voltage drops across the resistors. At frequencies between about 50 and 5,000 cycles, the resistance coupled amplifier may be designed to give very uniform amplification.

If coils having high inductance are used instead of resistors  $R_p$  and  $R_g$  of Fig. 23-9, we have what is called an impedance coupled amplifier. The inductance coils have high impedance to a-f currents, but have low resistance to direct currents. Thus there is less d-c voltage drop in the inductors than in resistors, and the voltage of the B-supply may be considerably less than for resistance coupling. The amplifications of an impedance coupled amplifier at various audio frequencies is about the same as that of a resistance coupled amplifier.

#### LOUD SPEAKERS

So far we have learned how radio energy is produced, transmitted, received, detected, and amplified. Now in order to reproduce at the receiver the audible sounds which were impressed on the carrier wave at the transmitter, we must use headphones or loudspeakers. Radio headphones operate on the same general principle as a telephone receiver, and by means of magnetic action on a diaphragm convert the electrical impulses from the amplifier output back into air waves or audible sound. Ear phones for use with radio receivers are generally made in pairs and fastened together with a head band. The two units are connected in series and equipped with a cord with metal tips or plugs for convenient connection to the set.

Ear phones for radio use are made in thin flat units like a telephone operator's head set, and are made as light in weight as possible for comfort to radio operators or testers who may wear them for long periods. The coils of the electro-magnets in these phones are usually wound with several thousand turns of very fine enameled copper wire and good headphone sets have a resistance of 2,000 to 5,000 ohms. The amount of current supplied by radio receivers is very small, so the phone magnets should have a great number of turns to give them as many ampere turns magnetic strength as possible with the small cur-

rents which operate them. It is also desirable to use phones with large numbers of turns on their coils when the phones are to be used with vacuum tube receivers, because if the impedance of the phones is about the same as that of the tube plate circuit, best results will be obtained from the tube.

Most earphones have a ring shaped or horseshoe shaped permanent magnet in the case, and the coils of the electro-magnets are usually placed over the ends or poles of these permanent magnets, as shown in Fig. 23-10. In this sketch a sectional view of the ring shaped permanent magnet is shown at *P*, with the pole pieces *N* and *S* attached. The coils *C* are placed over these pole pieces as shown. When no current is flowing through the coils, the permanent magnet poles hold the thin iron diaphragm slightly attracted as at *D*. When current is passed through the electro-magnet coils it sets up flux and polarity which either aids or opposes that of the permanent magnets, according to the direction of current flow. If this current is either a-c or pulsating d-c it will cause the diaphragm to vibrate and produce sound waves.

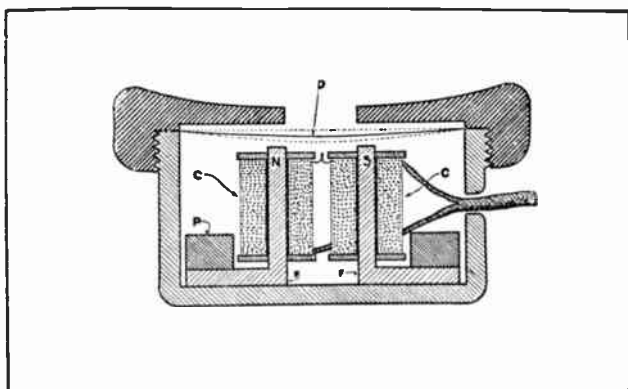

Fig. 23-10.—Sectional sketch showing the construction and operation of the earphone unit. Note the arrangement of the permanent magnet and the electro-magnet coils.

When a pair of phones is connected in the plate circuit of a vacuum tube, a small amount of current (the normal plate current) flows through them all the time the tube filament is lighted. When signal variations are impressed on the grid of



the tube the plate current pulsates or decreases and increases and the pulsating d-c causes the phone diaphragms to vibrate as shown by the dotted lines in Fig. 23-10 and thus reproduce the sound. When a loudspeaker or phones are connected to the secondary of an output transformer, instead of directly in the plate circuit, the current flowing through them will be alternating, but will also vary in value with the signal variations, so the phone or speaker diaphragm will still vibrate and reproduce the sound.

When handling headphones, care should be taken not to allow the diaphragms to become permanently bent or loose. Sometimes a piece of dirt or magnetic material will become lodged between one of the magnet poles and the diaphragm and will interfere with the operation of the phone. The cap can be unscrewed, the diaphragm carefully removed and the dirt cleaned out.

Great care should be used in cleaning or working around the coils, as their wires and connections are so fine that they are easily broken. Headphones can be quickly and easily tested for open circuits by connecting them directly across a  $1\frac{1}{2}$ -volt dry cell. If the circuit is complete, a click should be heard in the phones when the connection to the cell is made and broken. Headphones are very useful with small low power receivers, for receiving very weak signals from distant stations and also for testing receivers.

A loud speaker is a reproducing unit which usually has a larger diaphragm than headphones have. One type of loud speaker reproducing unit known as the balanced armature type, is shown in the larger sketch in Fig. 23-11. In this type of unit a large horseshoe permanent magnet is used to provide a field in which a small balanced iron armature moves. This armature is pivoted at its center and has a thin rod or stiff wire connecting its end to the diaphragm. The movable armature has a small lightweight coil wound on it, or in some cases around it in solenoid form, but not touching it. In either case this coil is connected to the radio receiver output and when current flows through it in the direction indicated by the arrows, it creates *N* and *S* magnetic poles in the armature as shown, causing its right end to swing down and its left end up, because of the attraction and repulsion of the poles of the horseshoe magnet. If pulsating d-c or a-c is

passed through this armature coil, it will rapidly change the magnetic strength of the armature and cause the armature and diaphragm to vibrate.

In another unit of very similar design the coils are wound on the pole tips of the permanent magnet as shown in the small sketch at *B* in Fig. 23-11. Pulsating current through these coils causes certain poles to be strengthened and others to be weakened, and the shifting flux causes the armature coil to be vibrated as before.

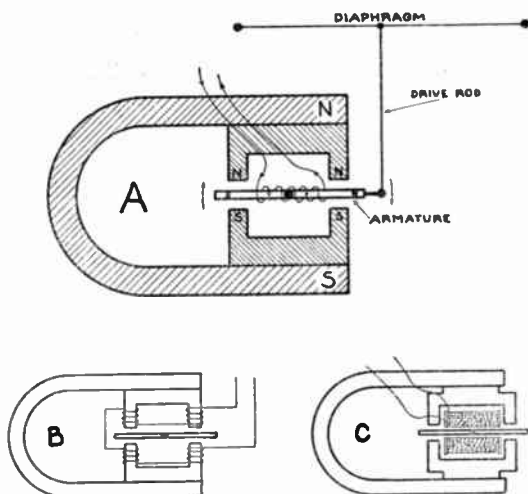

Fig. 23-11.—These sketches show the construction of the loudspeaker driving units or reproducers of the balanced armature type.

Another type of speaker unit operating on this principle, constructed as shown at *C* in Fig. 23-11, uses a stationary solenoid coil to induce the magnetic polarity in the iron armature. This relieves the armature of all unnecessary weight and eliminates the necessity of having a moving coil, with its possibility of breaking the flexible connections, etc.

The diaphragm used with speaker units of this type do not

need to be metal as there is no direct magnetic pull on them so they are generally made of non-magnetic materials.

In one type of speaker called the cone type, the driving rod of the speaker unit is connected to the center of a large cone instead of to a small flat diaphragm. These cones are made of paper, fibre, treated cloth, etc.

Cone speakers are capable of moving large volumes of air and of producing great sound volume with very good tone quality. They reproduce the low frequency bass notes of music much better than the small horn speakers.

**Dynamic Speakers.**—One of the best and most popular types of loudspeakers is the dynamic speaker which is used on the great majority of modern radio receivers. Fig. 23-12 is a sketch illustrating the construction and operation of this type of speaker.

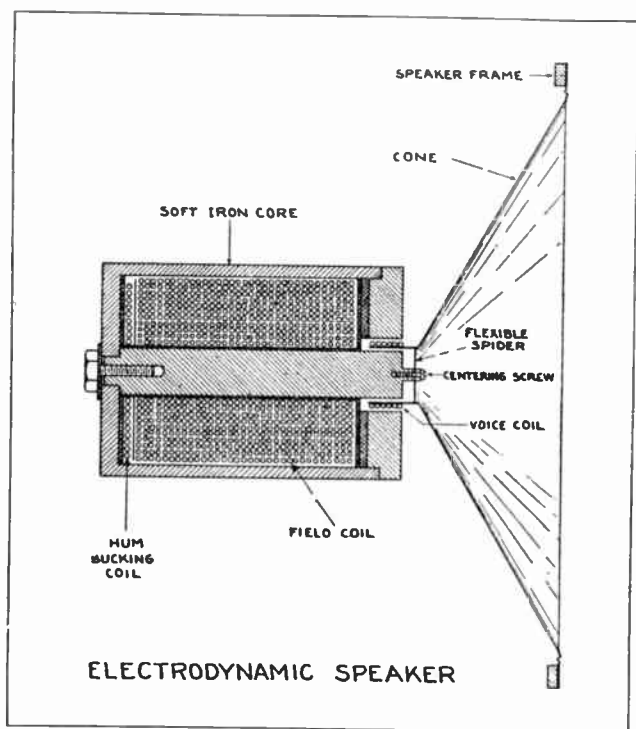

Fig. 23-12.—This sketch shows the construction of a dynamic speaker. Note the large field coil, small voice coil, the core, cone, etc.

The unit consists essentially of a powerful electromagnet for producing a magnetic field, and a small cone coil or "voice coil" attached to the apex or point of a stiff paper cone. The electromagnet or field magnet is wound with a great number of turns of wire around a heavy iron core. When the unit is in operation the coil of this magnet is excited by d-c, either from the power supply unit of the receiver or from a separate rectifier. This direct current sets up a powerful magnetic field around the end of the iron core, and across the turns of the small movable cone coil. Dynamic speaker fields operate on d-c voltages ranging from 6 volts on auto radios to 250 volts on a-c receivers for home use.

When pulsating or alternating current from the receiver output is passed through the cone coil, the reaction between the flux of its turns and that of the field magnet exerts a varying force to vibrate the small coil. As this coil is attached to the cone it causes the cone to vibrate also. The edge of the cone is cemented to a soft flexible leather or buckskin ring or edging, which in turn is fastened to the frame ring of the unit. The cones are often ribbed or corrugated.

The large coil of a dynamic speaker not only serves as field coil, but also acts as a very effective filter choke to smooth out the ripple in the d-c from the rectifier. When these units are built into a radio receiver, this coil often serves as one of the choke coils in the power pack filter. When used with a separate rectifier of its own, the speaker is equipped with filter condensers connected across its own field coil to filter out the pulsations of the rectified d-c. Fig. 23-13 shows a dynamic speaker with its field coil connected in series with the B-return lead of the power unit and serving as one of the filter chokes. The voice coil or cone coil is connected to the secondary of the output transformer from the power tube of the receiver. The balance of the receiver is not shown.

The voice coils of dynamic speakers consist of only a few turns of wire, in some cases only one turn and, therefore, we have a very low impedance of somewhere between 1.5 to 15 ohms. The impedance of a moving coil speaker is measured at 400 cycles for matching purposes and at this frequency the load is practically resistive. A rough approximation can be made by measuring the d-c resistance of the voice coil with a bridge or ohmmeter and

multiplying this value by 1.5. The impedance of a speaker is a combination of electrical and acoustical components and depends upon the motion of the diaphragm, the way in which the diaphragm vibrates, that is, as a unit or in segments, the cabinet in which the speaker is mounted and other factors. The value of the impedance increases steadily with the increase in frequency,

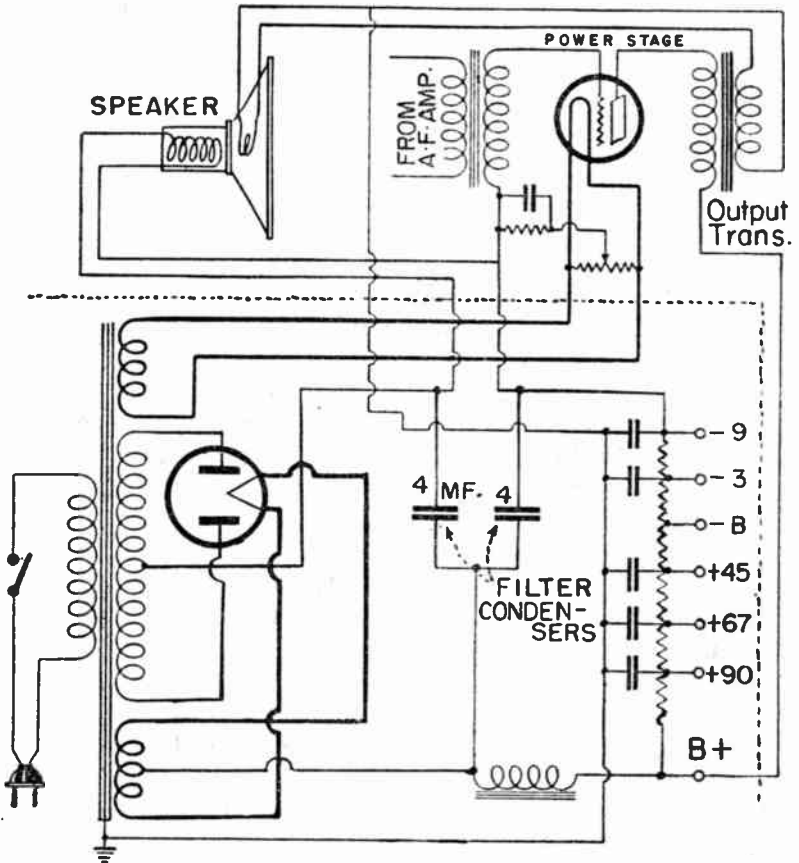

Fig. 23-13.—Diagram of a power supply unit, dynamic speaker, and the last stage of power amplification of a receiver. Note the field coil of the speaker is connected in series with the negative lead of the D.C. plate supply and serves as one of the filter chokes. Also note the connection of the cone coil, or voice coil to the secondary of the output or speaker coupling transformer.

and at low frequency, the resonance point of the speaker rises sharply in the region of 50 to 150 cycles, depending on the size and construction of the speaker.

The rated or optimum load resistance for any tube is determined by the grid, plate and screen voltages, if any, and the tube construction. All leading tube manufacturers publish recommended conditions of operation for any one type of tube which they make, and these should be followed closely as possible. Best results are obtained if a tube operates into a pure resistance load and all values given in the tube data book assume this condition. In most cases, triodes and beam tubes require a relatively low plate load resistance; pentodes require relatively high plate load resistance. Low power tubes, especially battery operated tubes, work best with comparatively high plate load, even up to 20,000 ohms in some cases. In order to effectively transfer the energy from the high impedance plate circuit of the vacuum tube to the voice coil, which is low impedance, it is necessary that a step-

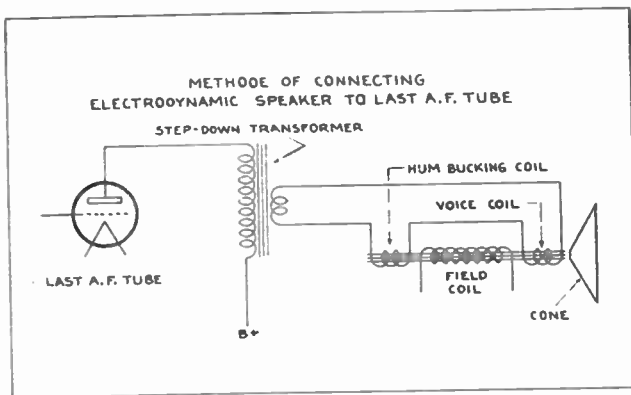

Fig. 23-14.—This figure shows a dynamic speaker connected to the last stage of a radio receiver. Note how the hum bucking coil is connected in series with the voice coil.

down transformer be used. This is really a device for matching impedances, thereby giving a good transfer of audio frequency with least distortion. The connection of such a transformer can

be seen in Fig. 23-14. Here is also shown a hum bucking coil found on some types of speakers.

In cases where the speaker field coil is used as a choke in the filtering system of the power pack, there may be a slight pulsation of the d-c thru this coil, setting up a small a-c voltage in the voice coil. This will cause a steady hum to be heard from the speaker. The hum bucking coil, consisting of a few turns of wire, is placed next to the field coil as shown on the left in Fig. 23-14 and has induced in it a small a-c voltage equal to that existing in the voice coil. By use of a series connection with the voice coil and transformer secondary, the a-c from the hum bucking coil is made to buck out or neutralize the a-c in the voice coil, thereby eliminating the speaker hum.

One type of dynamic speaker has no field coil, a permanent magnet being used to furnish the magnetic field. This type is used in any type of receiver. It has an advantage in battery operated sets, where the additional current required by a field coil is a major factor.

For the reproduction of the extreme upper range of audio frequencies, in high fidelity sound, an additional speaker is often used and is known as a "tweeter." Such a unit is helpful, due to the fact that the average large diameter speaker reproduces more efficiently the lower and middle range of frequencies.

In dynamic speakers, one of the most common troubles is due to the voice coil being off center and rubbing on the pole faces of the field magnet. An inspection of the opening in which the voice coil moves will reveal that the clearances are very small, consequently the coil must be exactly located or it may rub, setting up a distinct distortion in the sound output.

If a speaker is suspected of this trouble, disconnect it from the set and very gently push the cone up and down, by placing the fingertips on either side of center and near the outer edge. If the voice coil is rubbing, a scraping movement will be felt. Now loosen the centering screw and insert through the spider openings speaker shims equally spaced and so located that they pass between the center pole and voice coil form. All shims must be the same size and must have a snug fit. Tighten the centering screw, remove the shims and the speaker is ready for trial.

Occasionally dirt or metal filings will lodge in the voice coil

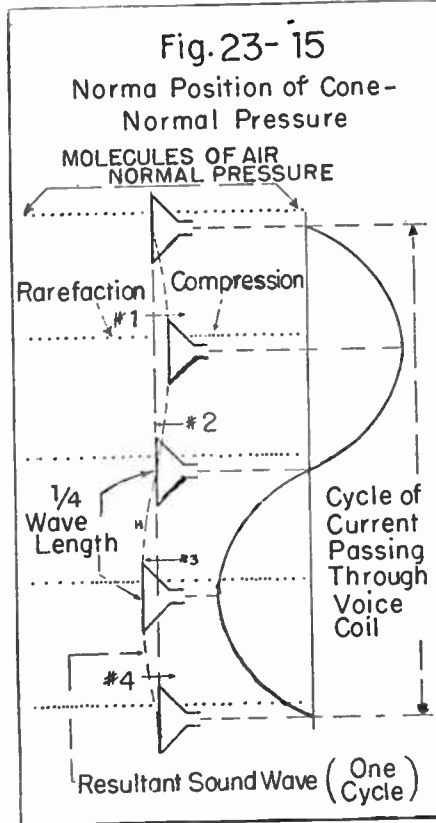

Fig. 23-15.

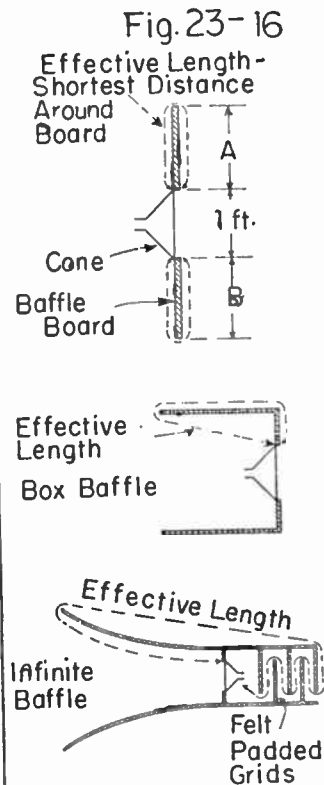

Fig. 23-16.

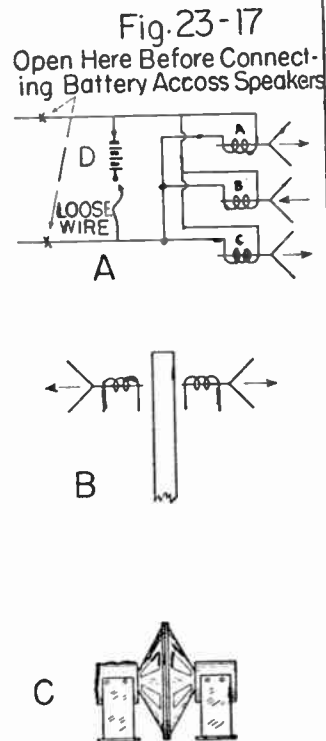

Fig. 23-17.



opening and these may be cleaned out by the use of compressed air or in some cases it may be necessary to entirely remove the cone and voice coil while the foreign material is forced out with a piece of stiff wire or other prod.

**Speaker Baffles and Size of Baffle Boards.**—The action of the speaker cone is similar to that of a piston since it moves forward and backward, pushing the air as it goes and setting up air waves, which reach our ears as sound. When the cone moves forward it pushes the air out in front of it and at the same time creates a partial vacuum at the rear of the cone. If no baffle is used, the air compressed in front has a tendency to immediately flow around to the back of the cone and fill in the space formed by the vacuum. Such an action would prevent the low frequency sound waves from traveling ahead to the listener. The higher frequencies would be adequately reproduced as the cone is large enough to act as its own baffle for these higher frequencies. In order to more faithfully reproduce the low notes the dynamic speaker is generally mounted on a baffle, whose purpose is to increase the distance of the sound wave which it must travel in passing from the front to the back of a speaker and vice versa.

Referring to Fig. 23-15, you will note that the cone passes through four distinct movements as shown by the arrows numbered from 1 to 4 inclusive. This produces a complete sound wave, as indicated by the dotted curved line through the speakers. The time required to produce each distinct movement is equal to the time required to produce  $\frac{1}{4}$  wave length of the sound wave being produced. Note also that the pressure changes produced on opposite sides of the cone are at any given instant opposite to each other, that is, a pressure exists on one side and a rarefaction on the other.

These pressure disturbances which are actually the sound waves, travel away from the cone at a speed of about 1,100 feet per second, and have a tendency to pass around the edge of the cone. If the sound wave has time to pass from one side of the cone to the other during one distinct movement, a maximum compression will combine with a maximum rarefaction resulting in suppression of that particular sound wave. This explains why a baffle board should be used to increase the effective length of the sound path as shown in Fig. 23-16.

When the cone is producing a low frequency note, it is moving more slowly than when operating on high frequency notes, therefore, a low frequency note would have a greater length of time to travel to the opposite side of the cone, making necessary the use of a larger baffle board—to prevent suppression of low notes—than is required for high notes. If all edges of the board are free so that the sound can pass around them, the cone should be mounted in the center of the board. In case one side of the baffle board is fitted tightly against a wall or ceiling, the cone may be mounted close to wall or ceiling, since these surfaces will serve as an extension to the baffle board. The effective length of the baffle is always equal to the shortest distance around the edge of the board. Since the time required for sound to travel around the edge of the board to produce maximum suppression is equal to the time required to produce  $\frac{1}{4}$  wave length of the sound wave being produced, it is evident that we must make the "effective length" equal to  $\frac{1}{4}$  wave length of a given frequency, to prevent suppression of all sound above this frequency. But

$$\text{Wave length} = \frac{\text{Velocity}}{\text{Frequency}}$$

Therefore

$$\text{Effective length} = \frac{1}{4} \times \frac{1130}{\text{Frequency}} = \frac{282}{\text{Frequency}}$$

The following example shows a practical application of this formula. Suppose that we wish to find the distance from edge to edge of a baffle board required to bring out all frequencies, down to 50 cycles per second with a 12-inch cone speaker.

By the formula:

$$\text{Effective length} = \frac{282}{\text{Frequency}}$$

By substitution:

$$\text{Effective length} = \frac{282}{50} = 5.6 \text{ ft.}$$

Assuming the cone to be in the center of the board, then  $A$  will equal  $B$ . But  $A$  plus  $B$  = effective length. Therefore,  $5.6$  plus  $1$  =  $6.6$  ft. = distance from edge to edge of board.

The box type baffle of Fig. 23-16 illustrates how a baffle board, large enough to bring out very low notes, can be confined to a

small space. The infinite baffle is designed to prevent suppression of all frequencies down to the lowest frequency range of the human ear. The felt padded grids will absorb a large amount of the back sound wave and will help a great deal to prevent acoustical feedback when a microphone is located back of the speaker.

The type and shape of the proper baffle to use depends upon the shape of the territory to be served. It is desirable to have as near a uniform value distribution as possible. If the area served is square, then a flat baffle board would give best distribution of sound. If the room is rectangular, then a directional baffle is best. The trumpet type horn will serve an area of about 30 angular degrees directly in front of the speaker, making it the best type of baffle for long distance coverage; hence, very desirable for outdoor installation.

The baffle board must never act as a sounding board. It should be made of some non-resonant material such as  $\frac{3}{4}$ " thick celotex, papier-mache, or soft wood at least  $\frac{3}{4}$ " thick.

**Phasing Two or More Speakers.**—When two or more speakers are connected to a common amplifier and are serving the same area, it is necessary that they produce the same changes in the air pressure at the same time. If this condition exists the speakers are said to be in phase, and they will deliver to the air the greatest amount of acoustical power possible.

If one is close to the speakers when they are thrown alternately in and out of phase, the change in volume is barely perceptible; but if one is some distance from the speakers, the reduction in volume when the speakers are out of phase is very evident.

It is well to keep in mind that sound waves are pressure variations and that the volume of sound depends upon the amplitude of these variations. It is possible to have a large amount of air movement, such as exists with high winds, and still have very little sound produced.

In Fig. 23-17-B, the speakers are facing opposite directions as sometimes desired in outdoor installations. In this case, the speakers are in phase when they are moving in the opposite directions at the same time, as shown in the sketch.

A very simple way to check speakers for the purpose of phas-

ing, is to disconnect speakers from amplifiers and connect a battery into the speaker circuit as shown in Fig. 23-17-A. The end of the loose wire serves as a switch. The wire is pressed against the battery terminal and then removed, thus closing and opening the battery circuit. The battery circuit should normally be left open and closed for only an instant, because the voice coils have such a low resistance that enough current will flow to overheat them. With the field coils excited, place your finger on the center of one cone and then close the battery circuit for an instant. Make a mental note of the direction in which the cone of the speaker moves. Then place the finger on the center of the cone of another speaker and check the direction in which it moves when the battery circuit is closed. The cone of all speakers should move in the same direction. Reverse the voice coil connections on any speaker that moves in a direction opposite to that desired. If the movement of the cone is not perceptible when the battery circuit is closed, increase the battery voltage to get a noticeable movement. The direction of any cone can be reversed with respect to its former movement by reversing the connections to either the voice coil or the field coil, but not both at the same time.

Fig. 23-17-C shows another method of checking phasing. The speakers are connected to the amplifier and are placed tightly against each other as shown in the sketch. When the speaker cones are caused to move—by touching the grid of the first detector or first audio amplifier tube—they should move toward each other, or away from each other, at the same instant; this action will cause air to rush in and out between the contacting cone surfaces and will vibrate a piece of thin paper held close to the cone edges. This test is not generally as satisfactory as the test previously mentioned, and should not be used in preference to those outlined earlier in this article.

**Matching Loud Speakers.**—Sometimes it is desired to attach unlike speakers to one output transformer. The following considerations apply when two speakers of unequal impedance are to be attached to the same amplifier or when speakers of unequal wattage rating as well as voice-coil impedances are to be connected to the same amplifier, and each one is to receive its proper proportion of the total power.

As a simple example: We need to connect a pair of 5-watt speakers with 16-ohm voice coils and one 20-watt speaker with an 8-ohm voice coil to a 30-watt amplifier. How are we going to hook up the speakers so that the power will be properly distributed. Remember that the speakers have to be connected across the secondary of a universal output transformer, and the speaker load must be properly matched to that required by the tubes.

**Transformer Calculations.**—The chief reason for an output transformer is to match the plate circuit impedance of the output tubes (usually between 2,000 and 50,000 ohms) to that of the speaker voice coils (commonly between 1.5 and 15 ohms). If the voice-coil impedance is 6 ohms and that required by the output plate circuit—for best results—is 6,000 ohms, the impedance ratio is 1,000 to 1. The basic idea behind these calculations is that the voltage ratio between the plate side and the voice coil side of the matching transformer is equal to the square root of the impedance ratio, or in mathematical terms:

$$\sqrt{Z_1 / Z_2} = E_1 / E_2 = N_1 / N_2$$

The transformer for proper impedance matching in this case then has a voltage step-down of  $\sqrt{1,000}$  or about 31.5. It is likely to have about 2,000 to 3,000 turns of wire on its primary and from 60 to 90 turns on its secondary.

The impedances of a universal output transformer are usually marked, but the turns or voltage ratios are not. Our only interest in these voltage ratios is that they help us to understand some of the electrical sections of the transformer, and thereby to figure out to which of the secondary terminals we attach our speakers.

To get the underlying principles straight, let us try the simplest possible hookup Fig. 23-18-(1). The whole 30 watts is being fed into one 8-ohm speaker. Voltage across the 8-ohm voice call winding is 15.5 roughly ( $W = \frac{E^2}{R}$ , or  $30 = \frac{E^2}{8}$ ). Amperage is

1.94. The impedance ratio  $Z_1/Z_2$  is 6,000/8 and the voltage ratio is the square root of that, about 27.4. The primary voltage is  $15.5 \times 27.4 = 426$  approximately. This can be checked by calculating direct from the primary watts ( $30 = \frac{E^2}{6000}$ ).

Now we can try a hookup like that of Fig. 23-18-(2) which

has two secondaries. We connect the two 16-ohm speakers in parallel, making in effect an 8-ohm unit connected across one secondary. The 20-watt speaker, also an 8-ohm unit, goes across the other. What should be the impedance of the primaries?

First, 10 watts must be fed to the two-speaker unit. Using our formula  $10 = \frac{E^2}{8}$  or  $80 = E^2$ , the voltage across the voice

coil works out to slightly less than 9. To get the voltage ratio, we divide 425 by 9, which is 47.2. Since  $Z_p/Z_s = (E_p/E_s)^2$ , we square 47.2, giving us 2,228. The secondary impedance is  $6,000/2,228$  or roughly 2.68, which should be the rated impedance of a winding to supply the two small speakers.

The single speaker is to draw 20 watts. The same calculation shows the voltage 12.65 about ( $20 = \frac{E^2}{8}$  or  $160 = E^2$ ).

Dividing that into 425, the turns (voltage) ratio is near 33.6.

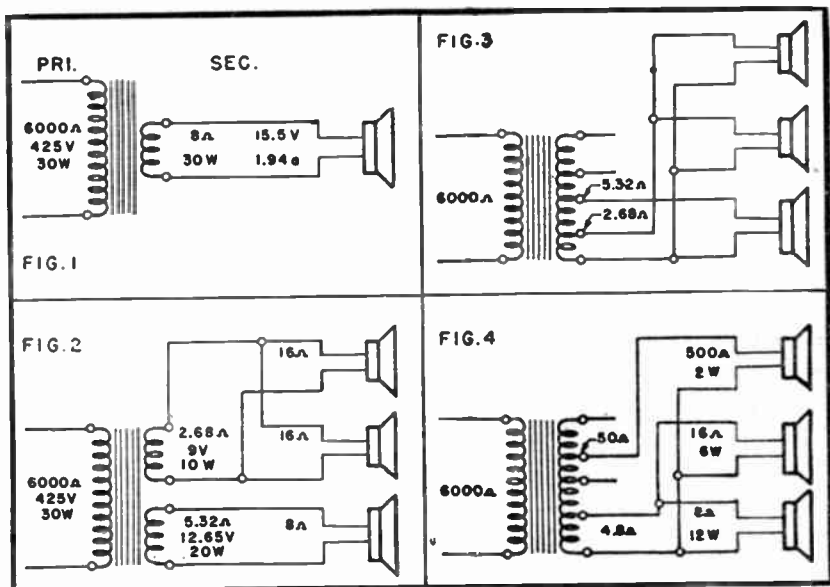

Fig. 23-18.—(1) Simplest speaker matching problem—(2) How three speakers could be matched—(3) All three on one output transformer—(4) Matching widely different speakers

Squaring this, we get 1128. The impedance of the secondary coil is  $6,000/1128$ , or roughly 5.32 ohms.

Since the secondary impedances are effectively in parallel, two separate windings are unnecessary. It is easier to hook each speaker to the proper impedance tap on a universal speaker as in Fig. 23-18-(3). This is what is done in actual practice.

**The Reflected Impedance.**—Now, are these impedances correct? On the surface, it would not seem so. One 8-ohm winding is attached to a tap whose impedance is slightly less than 3-ohms—the other to one of a little over 5-ohms impedance. Let us see if anything like 6,000 ohms is reflected back into the primary. If so, the speakers are matched to the output tubes.

The impedance reflected into any primary winding is due to the resistance of the secondary load and the transformer ratio. From our calculations for Fig. 23-18-(1), an 8-ohm load across an 8-ohm tap reflects the rated impedance (6000 ohms in the case of our transformer) back into the primary. Placing the same load across a 4-ohm tap would reflect 12,000 ohms or  $4/2$  the normal impedance.

One of our windings will, therefore, reflect  $8/2.68 \times 6,000 = 17,900$  ohms and the other  $8/5.32 \times 6,000 = 9,060$  ohms; adding the two parallel impedances, we get  $1/17,900 + 1/9,060 = 1/6,000$ . The impedance reflected into the primary is 6,000 ohms. The speakers are effectively matched to the amplifier.

In many cases the required impedance taps are not found on the output transformer. Connect to the nearest tap, checking the effect on power distribution and so averaging the mismatch of individual taps that the total reflected impedance will be as nearly correct as possible. If it is necessary to err in either direction, connection should be made to taps of slightly lower than correct impedance. Thus the reflected impedance will be a little high. This will merely reduce the power slightly, whereas too low an impedance facing the output tubes would harm fidelity.

Speakers may also be matched by their output transformer primaries. Thus two 12,000 ohm primaries could be connected in parallel across the 6,000 ohm impedance of the output tube. This method is useful where speakers are some distance from the amplifier.

A quicker method of calculating the correct taps can be worked

out from the example calculations given for Fig. 23-18-(3). Each speaker in Fig. 23-18-(3) was so matched to its transformer winding that it got its own share of power, yet all speakers when paralleled reflected the correct impedance back into the primary.

The method of distributing power is simple enough. Many servicemen do it unconsciously. With two 8-ohm speakers to attach to an output transformer, few would have to be told they could both be connected in parallel across a 4-volt tap. Each speaker is faced with an impedance half its own and receives half the power. What could be more simple, if we wish to divide the power in parts of one-third and two-thirds, to tap one speaker across a tap  $1/3$  and the other across  $2/3$  its impedance? All we have to do is multiply the voice-coil impedance by the fraction of the output we want to take.

But will matching to the output tubes be correct? Back to the 8-ohm speaker and 4-ohm tap again. A 4-ohm speaker would reflect the correct impedance back into the primary and maximum power would be drawn from the amplifier. The 8-ohm speaker reflects  $8/4$  or twice the correct impedance back into the primary. If two of them are paralleled, each reflects its 12,000 ohms. The resultant of these two 12,000-ohm impedances in parallel is 6,000, the correct load. If our two 8-ohm speakers are connected to divide the load into  $2/3$  and  $1/3$ , the reflected impedances will be  $8 \times 3/2 \times 6,000 = 9,000$  and  $8 \times 3/1 \times 6,000 = 18,000$ . Adding these impedances in parallel, the resultant impedance is 6,000, which is what we want.

The method can be extended to several speakers, as in the example in Fig. 23-18-(4). Here we wish to supply 2 watts to a 500-ohm line, 6 watts to a 16-ohm and 12 watts to an 8-ohm speaker. This works out to 0.1, 0.3 and 0.6 of the total output, (20 watts). Again assuming a primary of 6,000 ohms, we can get correct matching and power distribution by calculating output taps as follows:

For the 2-watt 500-ohm line,  $500 \times 0.1 = 50$  ohms; for the 6 watt, 16-ohm speaker,  $16 \times 0.3 = 4.8$  ohms; and for the 12 watt, 8-ohm tap,  $8 \times 0.6 = 4.8$  ohms also. Reflected impedances are  $6,000 \times 10 = 60,000$ ;  $6,000 \times 10/3 = 20,000$  and  $6,000 \times 10/6 = 10,000$ . These parallel impedances add up to 6,000 ohms.

By the above method it is possible to hook up the most com-



plicated speaker combination. All that is necessary is to know the impedance of each speaker and the portion of the total amplifier power we want to put into each one. Another essential is an output transformer with a variety of taps. It might be well to point out that an output transformer has a large number of impedances not marked. For example, the impedance between the 2-ohm and 16-ohm tap is 6.6 ohms. Sometimes these odd ohmages make possible a closer match than would otherwise be the case.

### REVIEW QUESTIONS

1. Why is a vacuum tube called an amplifier? What is the condition for satisfactory amplifier operation?
2. Describe the use of a cathode resistor as a means of obtaining grid bias.
3. How is the amplification factor of a tube derived?
4. Describe the operation of a resistance coupled amplifier stage, as shown in Fig. 23-9.
5. Describe the construction and operation of a dynamic loudspeaker.
6. Why are speaker baffles used?
7. Why is speaker phasing necessary?
8. Why is chief reason for using an output transformer between the loudspeaker and the output tube?

## Chapter 3A

### SUPERHETERODYNE RECEIVERS

The feature which distinguishes superheterodyne receivers from all other types is that in the superheterodyne all of the different radio frequencies of signals received at the antenna are converted to the same lower frequency at which most of the amplification ahead of the second detector is carried out. The superheterodyne principle is employed for reception of both amplitude-modulated and frequency-modulated signals; the f-m receiver differing from the a-m type only in having such modifications of design as are necessary because of the very high f-m signal frequencies and because of the requirements for separating frequency modulation from the high-frequency signals. The TV receiver is even more so a specialized type in which a-m and f-m are both accommodated and 2 different i-f systems are used.

Fig. 1 shows the principal parts of a superheterodyne receiver. Signal potentials from the antenna pass to the frequency converter. The converter retains the original sound modulation whether it is amplitude or frequency, while getting rid of the high carrier frequency and combining the modulation with a lower

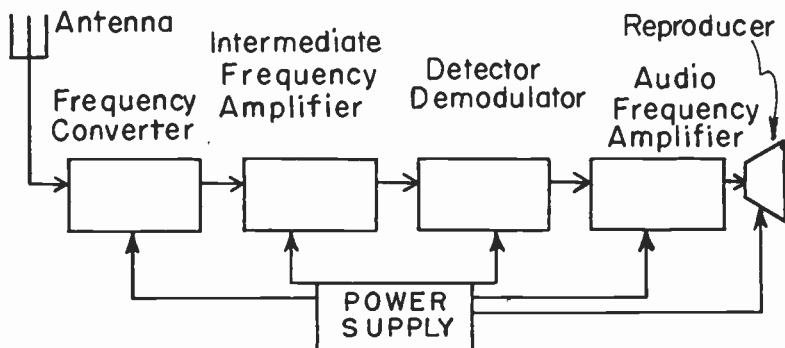

Fig. 1.—Principal parts of a superheterodyne receiver.

intermediate frequency. This intermediate frequency remains the same regardless of the received frequency.

The modulated intermediate frequency from the converter is amplified in the intermediate-frequency amplifier, which usually

consists of resonant circuits tuned to this single frequency. The advantages of amplifying this one frequency, which is lower than the carrier frequencies include: No variation of tuning is required no matter what carrier frequency is received; the gain per stage may be made high, and it is not affected by changes of received frequency; and each stage may be designed for excellent selectivity through the use of transformer couplings with both primary and secondary tuned to resonance.

The amplified intermediate frequency goes to the detector or demodulator, where the audio-frequency modulation is separated from the intermediate frequency and is passed on to the audio-frequency amplifier. The detector for amplitude modulation would be a diode or any of the other types which have been described. For frequency modulation we would use a different type of circuit, called a discriminator, which is adapted to frequency modulated signals.

Amplified audio-frequency potentials and the corresponding currents are passed on to the *reproducer*, which, for broadcast reception of music and speech, would be a loud speaker. The *power supply* furnishes direct and alternating potentials and currents which are necessary for operation of each of the other parts of the receiver.

**Heterodyning.**—"Hetero-" comes from a Greek work meaning different, and "dyne" is the name of a unit of force; so the word heterodyne means different forces. The different forces used in superheterodyne reception are two different frequencies applied simultaneously in a single circuit which permits electron flow in only one direction.

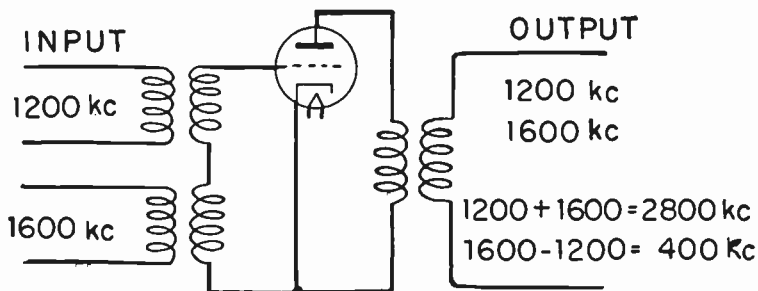

Fig. 2.—Output frequencies produced from two input frequencies.

In Fig. 2 input frequencies of 1200 kc and 1600 kc are introduced into the grid circuit of a triode, which we are to keep in mind permits electron flow only from its cathode to its plate or anode. In the output circuit or plate circuit there will be the two original frequencies and, in addition, two new *beat frequencies*. One of the beat frequencies is equal to the sum of the two input frequencies, which will be 2800 kc in this example, while the other beat frequency is equal to the difference between the input frequencies, which here will be 400 kc.

At the left-hand side of Fig. 3 the two input frequencies are represented by an incoming radio-frequency signal at 1200 kc and by an alternating potential at 1600 kc generated by an oscillator circuit which is a part of the receiver. In the plate circuit of the tube has been placed the primary of a transformer which is tuned to 400 kc. Since this primary is a parallel resonant circuit it has maximum impedance at 400 kc to currents in the plate circuit. It is at this frequency that maximum potential drops occur across the primary winding, and at which there is maximum transfer of energy into the secondary circuit of the transformer.

At the other three frequencies, which are 1200 kc, 1600 kc and 2800 kc, the parallel resonant primary circuit has but little im-

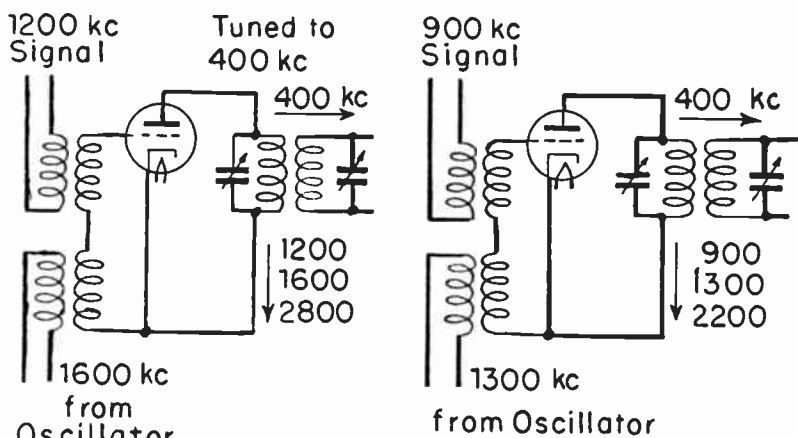

Fig. 3.—Different signal frequencies produce the same intermediate frequency when the oscillator frequency is varied.

pedance, and so currents at these three frequencies pass freely through the primary and return to the cathode of the tube.

In the right-hand diagram of Fig. 3 a 900 kc signal is being received. The oscillator frequency has been changed from the former 1600 kc to a new value of 1300 kc. In the plate circuit of the tube there are now the signal and oscillator frequencies of 900 and 1300 kc, also the beat frequency which is their sum, 2200 kc, and another beat frequency which is their difference, 400 kc. The transformer in the plate circuit remains tuned to resonance at 400 kc, therefore, the transformer transfers maximum energy to the secondary at this frequency while permitting the other three frequencies to pass freely through to the cathode of the tube.

By changing the oscillator frequency so that the difference between it and the frequency of an incoming signal is that to which the tuned output transformer is resonant, any signal frequency may be received. The modulation of the signal appears in the beat frequency which is the difference between the oscillator and signal frequencies, because that difference frequency is produced with the modulated signal as one of its components. Thus a modulated signal of any frequency within the tuning ability of the oscillator may be changed to similarly modulated potentials and currents at the beat frequency to which the output transformer is tuned. This tuned frequency is the *intermediate frequency*.

**Image Frequencies.**—The simple circuit at the right-hand side of Fig. 3 has its oscillator tuned to a frequency, 1300 kc, with which a 900 kc signal will “beat” to produce an intermediate frequency of 400 kc. This is because the difference between 1300 kc and 900 kc is 400 kc. But supposing that there is simultaneously another incoming signal having a frequency of 1700 kc. This and the oscillator frequency of 1300 kc will beat together to produce the intermediate frequency of 400 kc, because the difference between 1700 kc and 1300 kc is 400 kc. This second signal frequency is called an *image frequency*. The image frequency is as far above the oscillator frequency as the desired signal is below the oscillator frequency, and, of course, the image frequency differs from the oscillator frequency by an amount equal to the intermediate frequency. If the signals of desired frequency and

of image frequency are of equal strength they will reach the intermediate-frequency amplifier in equal strength, and both will be reproduced in equal volume by the loud speaker.

The simplest and most generally used method of preventing amplification of image frequencies is by tuning the input circuit to resonance at the frequency of the desired r-f signal. Such a tuned input circuit responds strongly to signals of the tuned radio-frequency, and only weakly to other frequencies such as the image. The principle of a possible method for such input tuning is shown by Fig. 4. Oscillator frequencies are introduced into the grid circuit by inductive coupling with the oscillator circuit. These frequencies will appear also in the plate circuit.

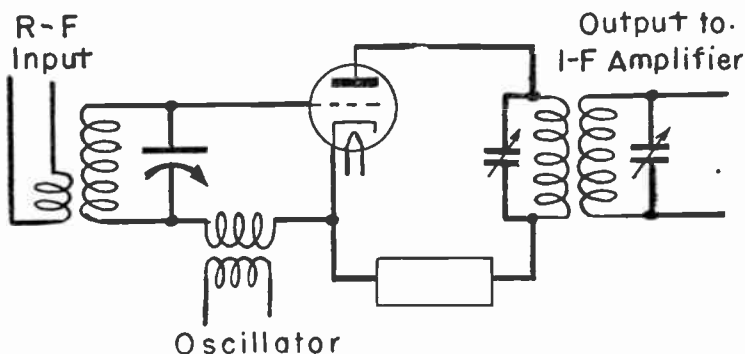

Fig. 4.—Adding the oscillator frequency to the tuned input circuit.

This diagram illustrates three essentials of any superheterodyne receiver. They are, (1) the introduction of signal frequencies and local oscillator frequencies into the plate circuit of a tube acting as a frequency mixer, (2) an input circuit which may be tuned to desired signals and which will not respond to image frequencies, and (3) a tuned output circuit or plate circuit which is resonant at the adopted intermediate frequency and which does not respond strongly to other frequencies.

**Frequency Converter.**—Fig. 5 shows a frequency conversion circuit such as used, sometimes with modifications, in many superheterodyne receivers. The radio-frequency input, at the left, may be from an antenna-ground circuit or may be from a preceding stage of radio-frequency amplification which is between the

antenna and the frequency conversion circuit. The output, at the right, goes to the intermediate-frequency amplifier.

The tube is a *pentagrid converter* which acts both as the local oscillator and as the *mixer* in which are combined the oscillator and signal frequencies to produce the beat frequency for the i-f amplifier. Grid 1 may be called the oscillator grid. Grids 2 and 4

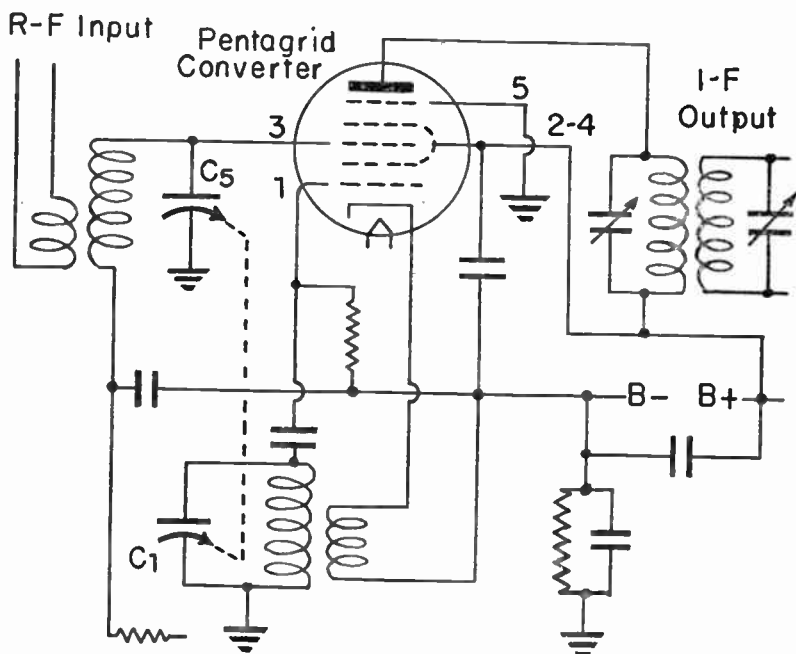

Fig. 5.—The circuits connected to a pentagrid converter tube.

are internally connected together to form screen grids surrounding grid 3, which may be called the signal grid. The fifth grid is a suppressor grid connected externally to ground.

Fig. 6 shows separately the oscillator circuit for the converter of Fig. 5. Grid 1 is the oscillator control grid. Grid 2 acts as the oscillator anode or plate. The tuned grid circuit for the oscillator consists of variable capacitor C1 and coil L1. High frequencies or oscillator frequencies in the grid circuit follow the path from grid 1 through capacitor C2 and the tuned circuit to ground, then

return from ground through capacitor  $C3$  and coil  $L2$  to the tube cathode. Coil  $L2$ , inductively coupled to  $L1$ , provides the feedback of energy from the oscillator anode circuit to its grid circuit for overcoming losses in the grid circuit and maintaining oscillation

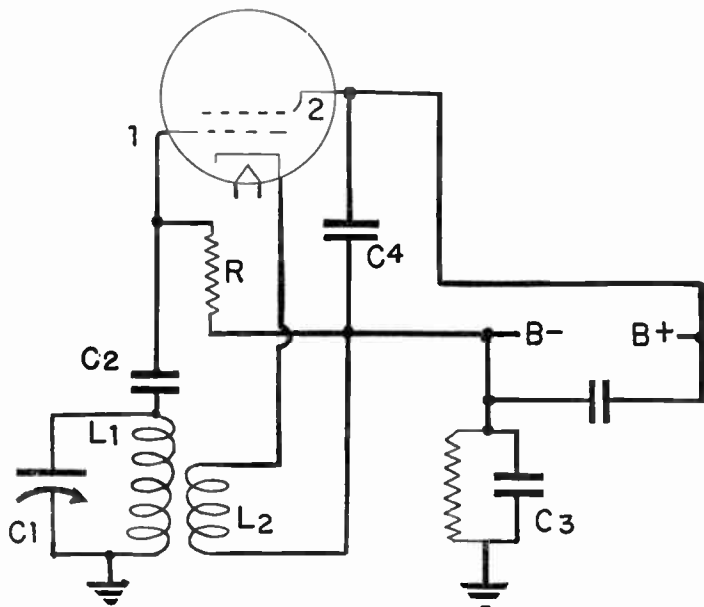

Fig. 6.—The oscillator circuit of the converter.

at the resonant frequency of tuned circuit  $C1-L1$ . The conductive circuit for the grid passes from the grid through resistor  $R$  and coil  $L2$  to the cathode.

The high-frequency circuit for the oscillator anode passes from the anode grid 2 through capacitor  $C4$ , coil  $L2$  and to the cathode. Screen potential for grids 2 and 4 (as shown by Fig. 5) is provided by the conductive connection of these grids to  $B+$  of the power supply, with the conductive return for screen current from  $B-$  through coil  $L2$  to the cathode. Variations of potential at the oscillator frequency are applied to grid 1, and they cause corresponding variations at this frequency in the electron flow passing from cathode to plate in Fig. 5.



The mixer circuits for the converter are shown separately by Fig. 7. Here the tube acts as a pentode with grid 3, the control grid and grids 2 and 4, the screen grid. The cathode, suppressor grid, and plate act as in any other pentode. Biasing potentials for the control grid are obtained through the grid bias connection, which leads to the detector circuit of the receiver. The lower end of coil  $L3$  is connected to the lower end of tuning capacitor  $C5$  through the path leading through capacitors  $C6$  and  $C3$  to ground, and through ground back to capacitor  $C5$ . The conductive circuit for the control grid passes through the biasing system mentioned, and back to the cathode.

The electron stream passing from cathode to plate in the tube, which already is varying at the frequency of the oscillator, now is further varied by signal potentials applied to control grid 3 and originating in the received modulated signal. Thus the electron stream, which forms the plate current, is caused to vary at both the signal and oscillator frequencies, and when this occurs in a one-way electron flow there are produced the beat frequencies which are the sum and difference of the signal and oscillator frequencies.

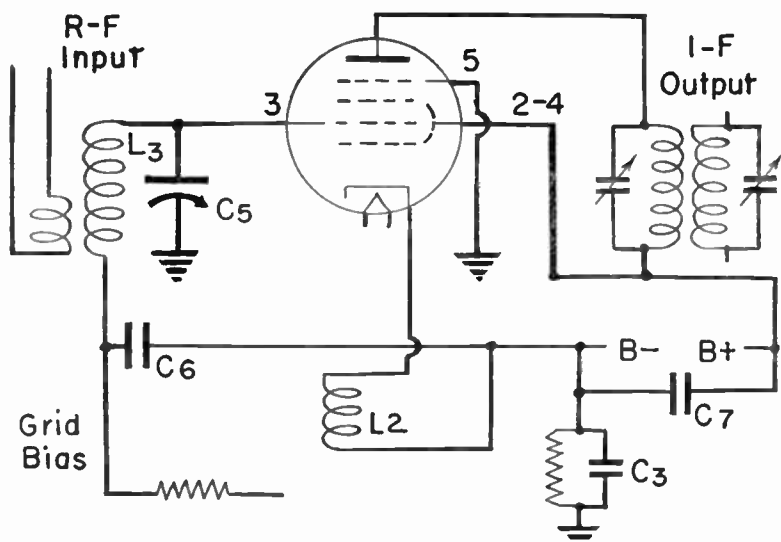

Fig. 7.—The mixer circuit of the converter.

The path for high frequencies in the plate circuit of Fig. 7 is from the plate through the tuned primary of the output transformer, then through capacitor  $C7$  and coil  $L2$  back to the cathode of the tube. Plate potential is applied from  $B+$  on the power supply through the tuned primary of the output transformer.

The signal circuit tuning capacitor  $C5$  and the oscillator tuning capacitor  $C1$  are varied simultaneously, usually by building them as a single two-gang unit. The mechanical connection is indicated by broken lines in Fig. 5. Thus capacitor  $C5$  is varied to tune the desired signal while capacitor  $C1$  is varied to produce the oscillator frequency which, beating with the desired signal frequency, will result in the beat frequency which is the intermediate frequency. The intermediate frequency is not changed at any time during operation of the receiver.

**Intermediate-frequency Amplifier.**—Fig. 8 shows the circuits for an intermediate-frequency amplifier stage and a detector stage such as might be used following the frequency conversion system of Fig. 5. The input transformer,  $T1$ , is the same as the

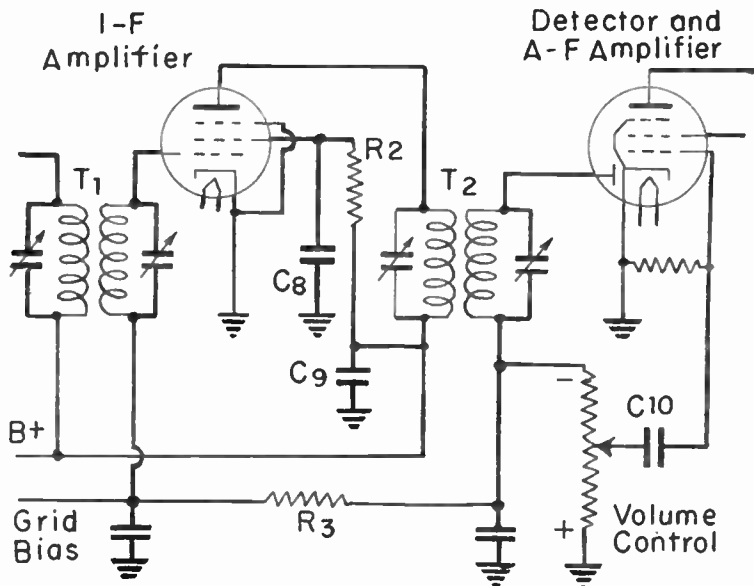

Fig. 8.—An intermediate-frequency amplifier stage and a diode detector which would follow the converter.

output transformer for the converter. The i-f amplifier tube is a pentode, with its control grid connected to the secondary of transformer *T1*. The screen grid is bypassed to ground with capacitor *C8* and is connected through voltage-dropping resistor *R2* to B+ of the power supply.

The plate of the i-f amplifier tube is connected to the primary of tuned transformer *T2*. Transformers *T1* and *T2* are called intermediate-frequency transformers. Both the primary and the secondary of both of these i-f transformers are tuned to the intermediate frequency. The other end of the primary of *T2* is connected to B+ and is bypassed to ground through capacitor *C9*.

The detector tube is a diode-pentode containing, in one envelope, a cathode and a diode plate and also the control grid, screen grid, suppressor grid, and output plate of a pentode. The detector following the intermediate-frequency amplifier often is called the "second detector" because the tube which acts as mixer for the signal and oscillator frequencies sometimes is called the "first detector."

The diode detector of Fig. 8 demodulates the intermediate-frequency potentials applied to it from the secondary of transformer *T2*. Rectified current in the detector circuit flows through the volume control resistor, which is a voltage divider with its slider connected through capacitor *C10* to the control grid of the pentode section of the tube. The pentode section acts as an audio-frequency amplifier tube.

As explained in connection with the subject of coupling, the tuned coupled windings of the i-f transformers have high impedance and carry large circulating currents at a band of frequencies extending from one frequency below that to which they are tuned to another frequency above it. By suitable coupling between the windings and, if necessary, by slight differences between resonant frequencies of the primary and secondary, the frequency band is made wide enough to accommodate the audio-frequency range with amplitude modulation or the range of modulating frequencies with frequency modulation, and to have rather sharp cutoff at frequencies either lower or higher than this band. Thus there is combined good selectivity and high amplification.

Various intermediate frequencies are employed. The one most

generally used is 455 kilocycles for reception of amplitude modulated signals in the broadcast range, and also for reception of frequencies as high as 10 to 20 or more megacycles. At the higher of these received frequencies a stage of radio-frequency amplification is used between the antenna and the frequency converter, while in the lower range the antenna often is coupled to the tuned input circuit of the converter.

Video i-f frequencies as low as 25 mc and as high as 45 mc have been used. Sound i-f frequencies as low as 4 mc to as high as 41 mc have been used.

The use of relatively high intermediate frequencies for receiving signals in any given range, such as broadcasting, tends to prevent amplification of image frequencies. The reason is that the image is separated from the desired signal by twice the intermediate frequency in any case. High intermediate frequencies also tend to prevent variations of tuning of the mixer circuits from affecting the frequency of the oscillator, an action which is called "pulling."

Relatively low intermediate frequencies bring the image nearer the desired signal and increase the tendency toward pulling, but they permit greater selectivity and greater amplification or gain in the i-f amplifier.

**Grid Bias.**—The potential for the control grid bias of the i-f amplifier in Fig. 8 is obtained from the detector circuit. In the detector circuit, electron flow from cathode to diode plate in the tube goes through the secondary winding of  $T_2$ , to ground through the volume control resistor, and from ground back to the cathode. With this direction of electron flow the upper end of the volume control resistor is negative with reference to its lower grounded end. The control grid of the i-f amplifier connects through the secondary winding of  $T_1$  and resistor  $R_3$  to the upper, negative, end of the volume control resistor. The cathode of the i-f amplifier connects through ground to the lower, positive, end of the volume control resistor. Thus the amplifier grid bias is negative, and is equal to the potential drop across the volume control resistor so long as there is no potential drop across resistor  $R_3$ . The line marked *grid bias*, which furnishes biasing potential for the i-f amplifier, extends to the similarly marked connection in Fig. 7 and furnishes a negative bias for the signal grid of the converter tube.

I-f amplifier tubes often are variable-mu pentode types in which amplification decreases when the grid bias becomes more negative, and increases when the bias becomes less negative. In the circuit of Fig. 8 the amplifier bias will vary with changes of electron flow and potential drop in the volume control resistor. This electron flow, which is that through the diode detector, increases when strong signals are being received, amplified, and detected. Strong signals thus make the upper end of the volume control resistor increasingly negative. An increasingly negative grid bias is applied to the i-f amplifier tube, and its amplification is reduced. This is the action of automatic volume control by which amplification is lessened for strong signals and is allowed to increase for weak ones. Automatic volume control ordinarily is applied to the intermediate-frequency amplifier or amplifiers, to the mixer section of the converter, and to any radio-frequency amplifier tubes which precede the converter.

**Loop Antenna.**—In the diagram at the left-hand side of Fig. 9 is a symbol for a loop antenna. A loop antenna is an inductance coil of large diameter and very short length, or one which is wound in the form of a large oval or else a rectangle. Loop antennas usually are mounted within the cabinet of the radio receiver. The inductance of the loop is tuned to resonance at the frequency of a desired radio-frequency signal by means of a variable tuning capacitor,  $C$  in the diagram. The tuned circuit

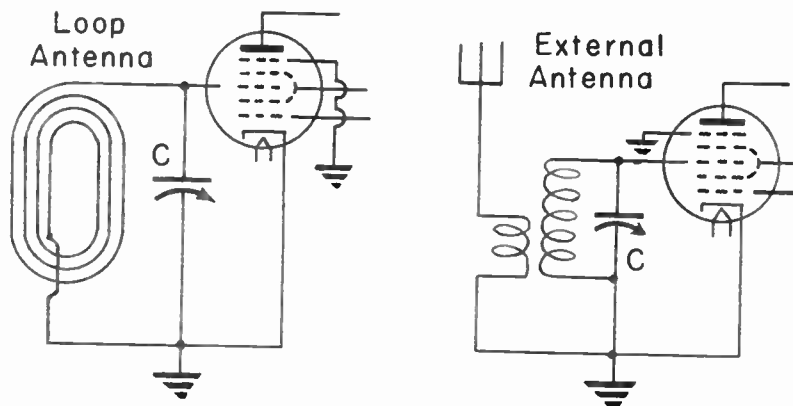

Fig. 9.—Input circuits for a loop antenna and for an external antenna.

is connected between the control grid and cathode of a tube. In Fig. 9 the tube is represented as the pentagrid converter, and the connection is made to the signal grid.

Radio waves which reach the loop induce in its conductors emf's which are of the same frequency as the waves. The induced emf's are in the same direction in both sides of the loop, and, as a consequence, the emf's in opposite sides oppose each other where the side conductors join at the top and bottom. However, the incoming wave reaches one side of the loop a very small fraction of a second before it reaches the other side, which places the opposing emf's slightly out of phase with each other and leaves a net difference to cause electron flow in the loop conductors. When the loop circuit is tuned to resonance the small net emf's are capable of causing considerable circulating electron flow and a corresponding potential difference which is applied between grid and cathode of the tube.

At the right-hand side of Fig. 9 is a circuit which may be used to introduce signals from an external antenna into the control grid circuit of a tube, which again is shown as the signal grid circuit of a converter. An external antenna is any wire or other conductor which extends outside of the radio apparatus, being located either indoors or outdoors. Between the external antenna and ground is the primary winding of a transformer whose secondary is tuned to resonance for a received signal by means of variable tuning capacitor  $C$ . The secondary circuit is connected between the grid and cathode of the tube.

**Preselector Stage.**—In Fig. 10 a loop antenna circuit is combined with one for an external antenna, and signal potentials from the combination are applied to the control grid-cathode circuit of a radio-frequency amplifying tube used between the antenna and the converter stage. This radio-frequency amplifying circuit may be called a *preselector* because it selects ahead of the converter the desired r-f signal while tending to exclude or to bypass to ground signals of other frequencies, especially the image frequencies.

Around the outer part of the loop are wound a few turns connected between the external antenna and ground. These antenna turns act like the primary of the transformer at the right in Fig. 9. The secondary, which is the loop, is tuned to resonance

by variable capacitor  $C$ . Potentials from the tuned antenna circuit are applied to the control grid of the r-f amplifier through capacitor  $C_2$ . This r-f amplifier tube is a variable-mu or super-control pentode. Its screen grid is connected directly to the B+ line, and its suppressor grid is connected to the cathode. The

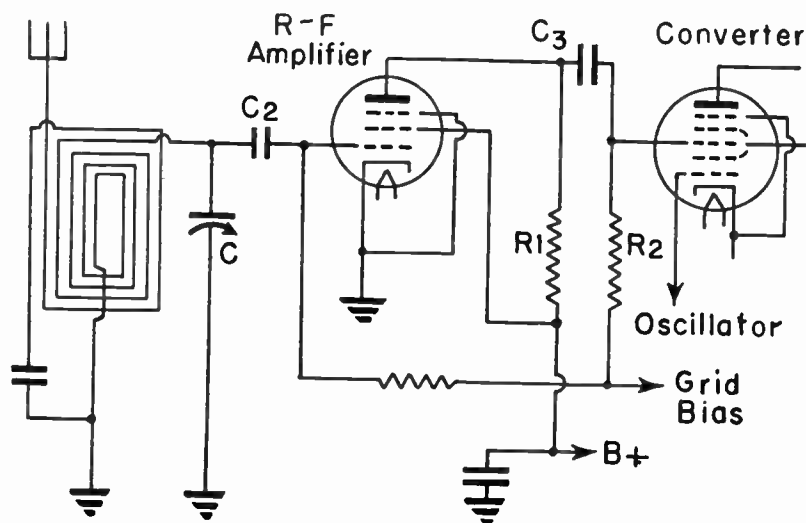

Fig. 10.—Preselector or radio-frequency amplifier stage coupled to a converter.

plate circuit of the r-f amplifier delivers potentials at the amplified signal frequency to the signal grid of the converter tube through the resistance-capacitance coupling system consisting of plate resistor  $R_1$ , coupling capacitor  $C_3$ , and grid resistor  $R_2$ . Grid bias, which usually is from an automatic volume control circuit, is applied to the r-f amplifier and the converter from the line marked *grid bias*.

In the circuit of Fig. 10 the antenna input is tuned by capacitor  $C$ . The oscillator frequency for the converter would be controlled by another variable capacitor in the oscillator circuit ( $C_1$  in Fig. 5). These two tuning capacitors would be built together and operated by a single control. There are other preselector systems in which three simultaneously operated tuning capacitors are used; one for the antenna input, another for a separate tuned

circuit coupled to the antenna circuit and connected to the control grid of the r-f amplifier, and a third used for tuning the oscillator circuit.

**Tracking of Signal and Oscillator.**—As the tuning capacitors for the tuned signal circuit and the tuned oscillator circuit are simultaneously varied by operation of their single control it is necessary that the capacitances in the two circuits change together so that the difference between their frequencies remains exactly equal to the intermediate frequency. In order that the two circuits may be made to thus “track” over the entire tuning range it is necessary to use small adjustable capacitors which usually are connected in parallel with the tuning capacitors. These are called trimming capacitors or *trimmers*.

At the left in Fig. 11 is shown the connection of a trimmer as usually employed for either the signal circuit or the oscillator circuit. The trimmer ordinarily is built as a part of the main

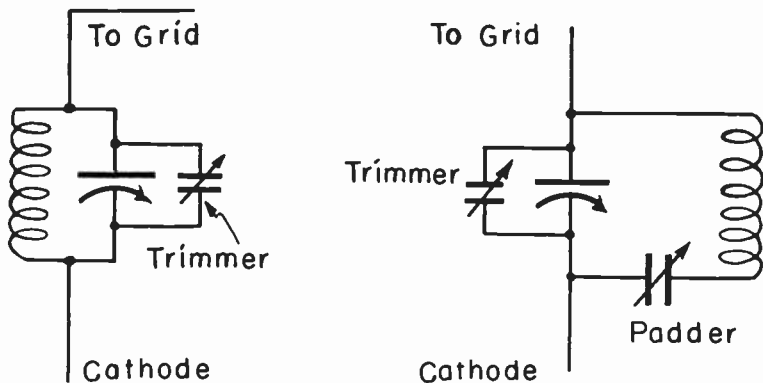

Fig. 11.—Connections for trimmer and padder capacitors.

tuning capacitor, and is arranged for adjustment of its capacitance by means of a screwdriver or wrench. For a 360 mmfd tuning capacitor the trimmer may have a maximum capacitance of 15 to 25 mmfd. The trimmer capacitance is a small percentage of the maximum capacitance of the tuning capacitor, but is a large percentage of its minimum capacitance. Consequently, adjustment of trimmers has greatest effect at high frequencies where



the main tuning capacitor is used near its minimum capacitance.

The tuned circuit for the oscillator grid may have, in addition to a trimming capacitor, a padding capacitor or a *padder* connected, as at the right-hand side of Fig. 11, in series with the coil winding of this circuit. The series padder ordinarily will have as much capacitance or more capacitance than the tuning capacitor. Sometimes the padder is made up by a fixed capacitor of rather large capacitance, across which is connected an adjustable unit of small capacitance. Where the trimmer is used for adjustment at the high end of the frequency range, the padder is used for adjustment at the low end of the range. For the broadcast range, trimmer adjustment would be made at or near 1,400 kc and padder adjustment at or near 600 kc.

**Multi-band Tuning.**—A single tuning capacitor and its inductance coil may be adjusted to resonance throughout a range of frequencies having a ratio, high to low, of not much more than three to one. For example, in broadcast reception the tuning range might be from a high of 1500 kc to a low around 500, or from a high of 1650 down about 550 kc. When a single receiver is to operate in the broadcast band, and also for short wave or high-frequency reception, it is necessary to provide separate coils for the additional bands.

Fig. 12 shows signal and oscillator tuned circuits for a two-band receiver. Band switching is done with switches *a*, *b*, *c* and *d*, which are incorporated in a single unit operated by a single control knob. When the switch arms are in their upper positions, as shown, tuning is in the broadcast range, and when they are down, as shown by broken lines, tuning is in the short wave range. In making such a change of frequency ranges it is necessary to switch the coils for only the mixer section of a converter and for the oscillator, or, if a preselector is used, to switch coils for the preselector, converter and oscillator. This means that all tuned circuits except those for the intermediate frequency are switched. Were more than two frequency bands to be provided for, there would be additional coils and switch positions for the extra bands.

In Fig. 12 variable capacitor  $C_s$  is the main tuning capacitor for the signal circuits and  $C_o$  is the main tuning capacitor for the oscillator circuits. Capacitor  $C_s$  connects to the signal grid

of the converter and to switch *b*. Switch *b* connects to the antenna-loop circuit for broadcast reception and to transformer *SW* for short wave reception. Switch *a* makes the corresponding changes for the primaries of these tuned circuits. The trimmer for broadcast reception is connected across the ends of the loop, and the

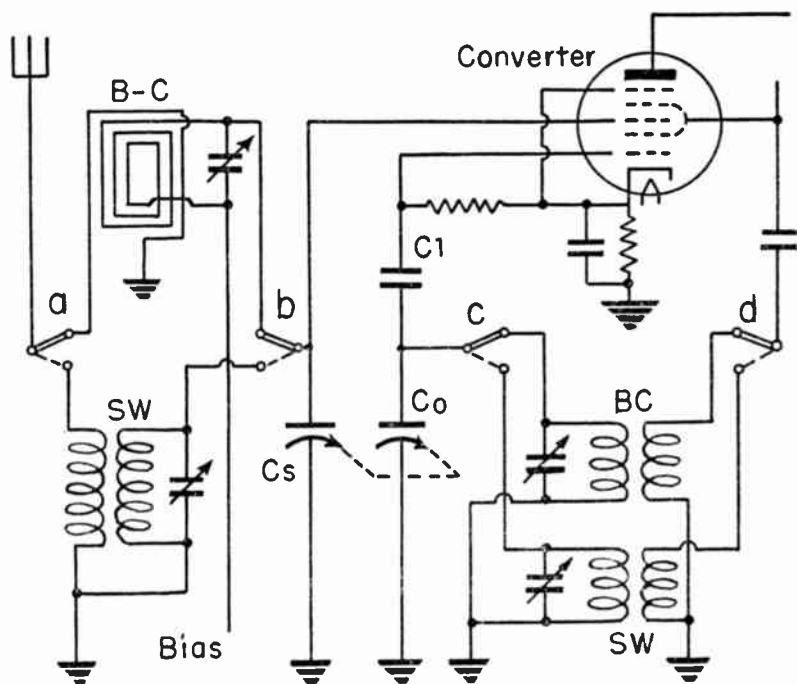

Fig. 12.—Band switching arrangements for a two-band receiver.

trimmer for short wave reception is across the secondary of transformer *SW*. Thus each trimmer may be adjusted separately for its frequency range.

Tuning capacitor *C<sub>0</sub>* connects to the oscillator grid through *C<sub>1</sub>*, and also to switch *c*. Switch *c* changes between the broadcast and short wave tuned secondaries of the oscillator transformers, while switch *d*, connected to the oscillator anode of the converter, changes between the oscillator transformer primaries. Trimmers for the oscillator tuning capacitors are connected across the ends of the transformer secondaries.

In receivers which cover many frequency bands there may be two sets of coils for the intermediate-frequency transformers, or two complete sets of transformers. One set is switched in for broadcast and moderately high-frequency bands, with the other used for still higher frequencies.

**Converters and Mixers.** — In addition to the commonly used converter tube and circuit shown by Figs. 5 to 7 there are several other tubes and circuits performing generally similar functions. In Fig. 13 is shown another type of pentagrid converter and one method of employing it. Grid 1, next to the cathode, is the oscillator grid. Grid 2 is the oscillator anode, which acts as a plate for the oscillator circuit. Grids 1 and 2 are connected to the tuned secondary and the feedback primary of the oscillator transformer. The conductive circuit for grid 1 is completed to the cathode through resistor  $R_1$ .

Grids 3 and 5 are screen grids surrounding the signal grid number 4, which is connected to the tuned secondary of the input transformer, and which is provided with bias potential from a cathode-bias system consisting of resistor  $R_2$  and bypass capacitor  $C_2$ . This tube has no suppressor grid and, consequently, the

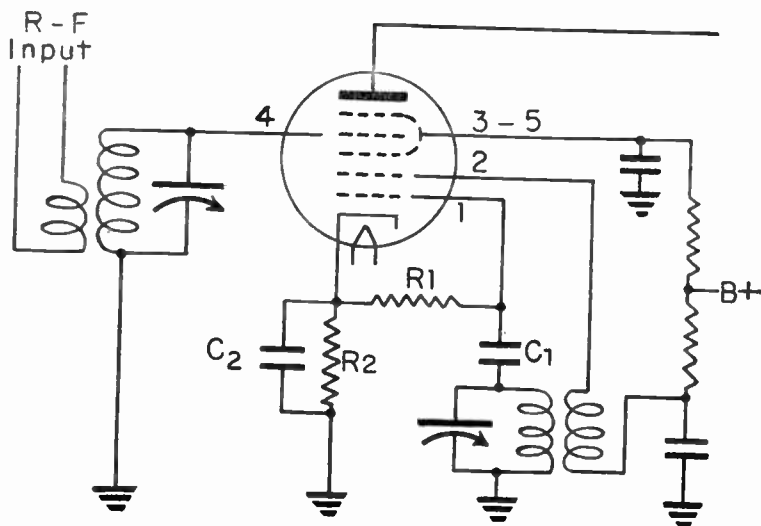

Fig. 13.—Connections for a second type of pentagrid converter

mixer section acts as a screen grid tetrode rather than as a pentode. The electron stream between cathode and plate is varied at oscillator frequency by the action of grids 1 and 2, and at signal frequency by the action of grid 4. Number 4 grid in this converter acts like number 3 grid in the one of Fig. 5, while grid 2 acts like grid 2 in the type shown earlier. The type of converter shown by Fig. 5 usually gives better performance at high frequencies than the type shown in Fig. 13, chiefly because, in the type shown earlier, the potentials and charge of the signal grid have less effect on space charge and total emission from the cathode, and the oscillator circuit is less affected by changes of bias on the signal grid.

**Separate Oscillator and Mixer.**—At television frequencies it may be difficult to prevent interaction, and pulling between mixer and oscillator circuits when a single tube performs both functions. In some receivers these difficulties are avoided by using a pentode

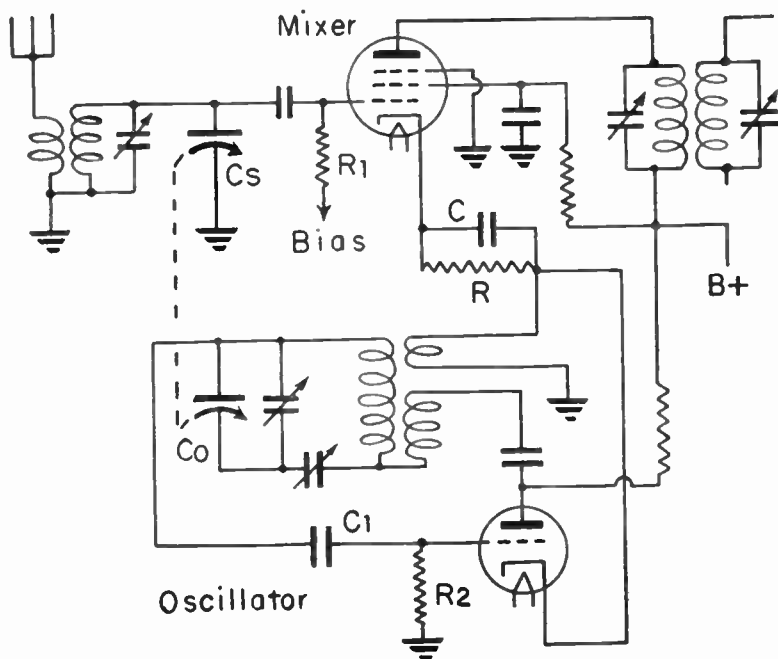

Fig. 14.—Circuits for separate mixer and oscillator tubes.

tube as a mixer and a separate triode tube as an oscillator. One such circuit is shown by Fig. 14.

Signal frequencies enter the pentode mixer at its control grid, which is next to the cathode. Oscillator frequencies are introduced by connecting the cathode circuits of mixer and oscillator together through resistor  $R$  and capacitor  $C$ . Since the cathode of any tube forms a part of the circuits for all other elements of that tube, frequencies introduced into the cathode circuit, and not filtered out, must appear in the output circuit or plate circuit of the tube. Other than the cathode connection, there is nothing unusual about the mixer circuit of Fig. 14. The control grid is biased by its connection through resistor  $R1$  to the automatic volume control system. The screen grid is bypassed to ground and connected through a resistor to  $B+$ . The suppressor grid is grounded. The plate is connected to the primary of the first intermediate-frequency transformer, and through this transformer to  $B+$ .

The oscillator triode is biased by the action of capacitor  $C1$  and resistor  $R2$ , whereby a negative potential is maintained across the two units. The oscillator plate is connected through a capacitor to the feedback primary winding of the oscillator transformer, and is connected to  $B+$  through a resistor.

The signal tuning capacitor  $Cs$  and the oscillator tuning capacitor  $Co$  are operated together by a single control. Trimmer capacitors are connected across each of the tuning capacitors, and in the oscillator tuned circuit there is a padding capacitor. The coils, together with the trimmers and padder, ordinarily would be switched into the active circuits by some such arrangement as shown by Fig. 12. The oscillator circuits for a multi-band receiver may be of different types for broadcast reception and for short wave reception, since less coupling is required for oscillator feedback at high frequencies than at lower ones, and also because smaller inductances often are used for the high-frequency oscillator. For operation in the broadcast range the oscillator frequency usually is higher than the signal frequency, the difference being the intermediate frequency. For short wave operation the oscillator frequency may be either higher or lower than the signal frequency, since either arrangement will produce the intermediate frequency as one of the beats.

The same type of pentagrid tube used in Fig. 5 as a combined oscillator and mixer, or as a converter, may be used only as a mixer in a circuit that includes a separate oscillator. One such arrangement is shown by Fig. 15. The oscillator grid circuit

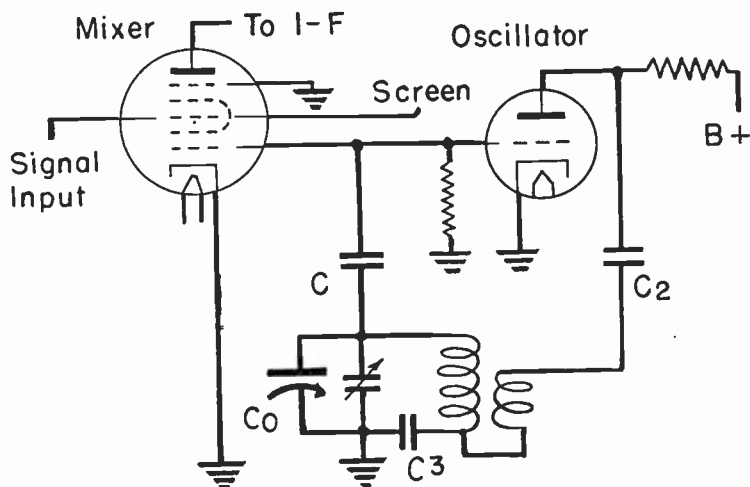

Fig. 15.—Using a pentagrid tube as a separate mixer.

extends from the triode grid through capacitor  $C$  and the tuned circuit to ground, then through ground back to the triode cathode. There is a direct connection from this circuit to the oscillator grid of the pentagrid mixer. The result is that oscillator potentials are applied between the oscillator grid and cathode of the mixer, because the grid circuit of the mixer extends from its oscillator grid through capacitor  $C$  and the tuned oscillator circuit to ground, then through ground and back to the mixer cathode.

Connections for the signal input circuit and connection to the first i-f transformer from the mixer of Fig. 15 are the same as in other circuits which have been shown. High-frequency oscillator currents go through capacitor  $C_2$  to the feedback winding of the oscillator transformer and through  $C_3$  to ground, from where they return to the oscillator cathode.

Another pentagrid tube, called a *pentagrid mixer*, is used with connections as indicated at the left-hand side of Fig. 16. The

signal input is applied to grid number 1 and the oscillator input is applied to grid number 3, which is the reverse of these connections as made to the pentagrid converter tube. The screen grids, 2 and 4, surround the oscillator grid. The suppressor, grid number 5, is internally connected to the cathode.

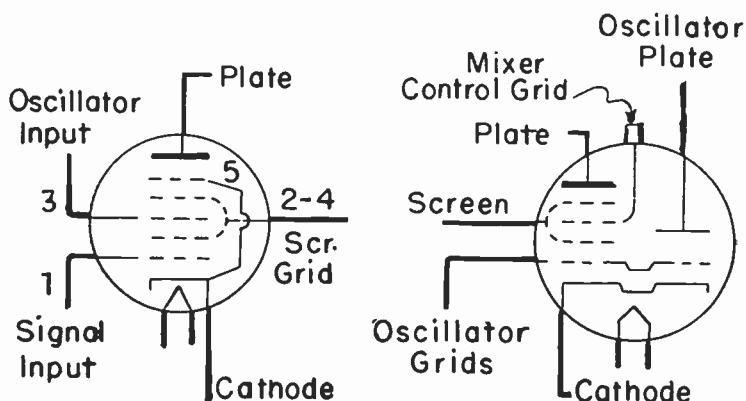

Fig. 16.—A pentagrid mixer (left) and a triode-hexode converter (right).

At the right-hand side of Fig. 16 is shown the symbol for another type of combined mixer and oscillator called a *triode-hexode converter*. The three triode elements shown at the right inside the envelope (a cathode, grid and plate) are employed as the oscillator unit. The six hexode elements, shown at the left inside the envelope, are employed as the mixer. The oscillator grids for both sections are connected together inside the tube. The mixer control grid, to which is applied the signal frequency, is surrounded by the screen grids.

Still another combined mixer and oscillator is called a *triode-pentode*. Combined in a single envelope are a triode section, which is used as the oscillator, and a pentode section used as the mixer. The arrangement is generally similar to that of the tube at the right-hand side of Fig. 16, except that the hexode with its double screen grid is replaced by a pentode with a screen grid and with a suppressor grid, the latter being internally connected to the cathode. In the triode-pentode there are separate external connections for the two oscillator grids, one in the triode and the other in the pentode.

**Alignment of Tuned Circuits.**—When we speak of aligning a superheterodyne receiver we refer to making adjustments of capacitances, inductances, or both, which maintain necessary resonant conditions in a number of tuned circuits. Points of alignment for a typical superheterodyne receiver are shown in the diagram of Fig. 17. This diagram shows connections such as generally found between the antenna and the a-f output of the detector in a receiver containing one r-f amplifier tube, a converter serving the purposes of mixer and oscillator, one i-f amplifier tube, and a combined detector-avc-af tube. The r-f and i-f tubes are pentodes. The converter is a pentagrid type. The detector-avc-af tube is a double-diode triode. The antenna circuit consists of a built-in loop connected to the control grid circuit of the r-f tube, with turns on the outside of the loop which may be connected to an external elevated wire antenna and to a ground.

The alignment adjustments are as follows:

- A. Trimmer for secondary of the second i-f transformer.
- B. Trimmer for primary of the second i-f transformer.
- C. Trimmer for secondary of the first i-f transformer.
- D. Trimmer for primary of the first i-f transformer.
- E. Trimmer for grid winding tuning capacitance for the oscillator coils.
- F. Trimmer for antenna tuning capacitance.
- G. Adjustable capacitor for a wave trap on the converter signal grid circuit.

These adjustments are most often made in the order of their listing, except that the wave trap adjustment, if a trap circuit is included in the receiver, often is made following the adjustments on the i-f transformers, and before the adjustments on the oscillator and antenna circuits.

In Fig. 17 there is untuned resistance-capacitance coupling between the r-f tube and the signal grid of the converter. In some receivers there is a tuned coupling in this position, with one section of the ganged tuning capacitor in this coupling. In such a case the adjustment of the trimmer in this coupling would be made following settings on the i-f transformers, and before adjusting the oscillator trimmer.

The adjustments on the i-f transformers, *A* to *D*, are for the purpose of resonating the secondary and primary windings at the



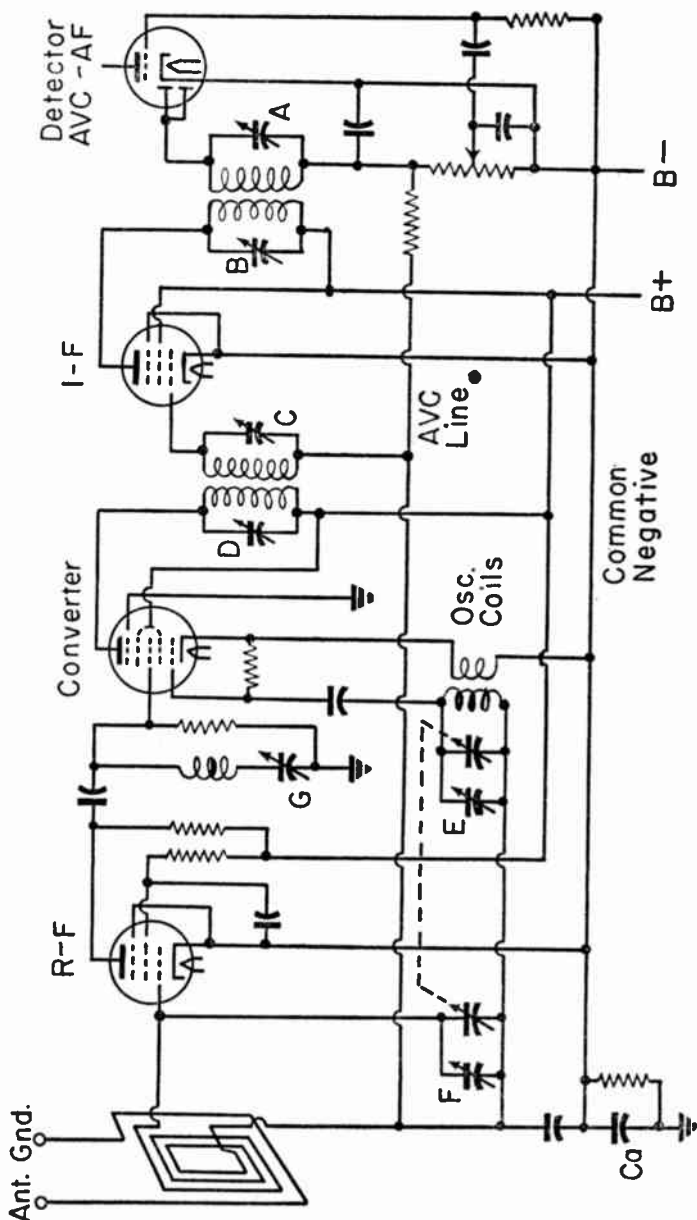

Fig. 17.—A superheterodyne circuit on which are shown the points for alignment adjustment\*

intermediate frequency. The purpose of the wave trap adjustment is to prevent signals at the intermediate frequency from reaching the signal grid of the converter. Adjustments of the oscillator and antenna circuit trimmers, and a trimmer in the rf-converter coupling if this coupling is tuned, is to allow correct tracking of these circuits as they are simultaneously tuned by the ganged tuning capacitor operated from the receiver tuning dial.

Although the alignment adjustments are shown in Fig. 17 as being made with adjustable capacitors called trimmers, which alter the tuning capacitances in the circuits, any or all of the adjustments may be made with adjustable inductances used in connection with fixed capacitors. Inductance adjustments in all except the loop circuit are made with movable powdered-iron cores for the coils. Loop inductance sometimes is adjusted by moving one or more turns of the loop with reference to other turns.

Adjustments ordinarily are of the screw type, with slotted, hexagonal, or other shaped screw heads which may be turned by means of a screw driver or wrench with a long insulated handle or made entirely of insulating material. These adjustments for the i-f transformers are reached through holes in the shield cans, or the screw ends may extend to or through the can surfaces on the tops, sides, or bottoms. Trimmer capacitors for the oscillator and antenna circuits, and a tuned r-f coupling if used, usually are mounted on the ganged tuning capacitor sections, with one trimmer on each section.

**Signal Generator.**—Although it is possible to make the alignment adjustments with the help of a broadcast carrier signal coming through the regular antenna, it is more accurate, and is usual practice in servicing, to employ a suitable signal frequency or frequencies furnished by a calibrated signal generator.

The signal generator is a radio-frequency oscillator whose output frequency may be adjusted to any of a wide range of carrier frequencies and of intermediate frequencies. Panel controls on one style of generator are shown by Fig. 18. At the upper center are dials indicating frequencies to which the oscillator is tuned. At the left is a band selector switch for various ranges of frequencies. Down below, at the left, are the attenuator adjustments which permit limiting the generator output signal

to any required intensity or amplitude. Between the attenuator knobs is the output jack from which connections are made to the receiver being aligned. At the right is a modulation selector switch. In one position of this switch the high-frequency output of the generator is modulated with an audio frequency, which usually is 400 cycles. In another position the high-frequency output is unmodulated. In a third position the output consists of the 400-cycle frequency alone. Other items on the generator panel include the pilot lamp, the off-on switch, and a replaceable fuse.

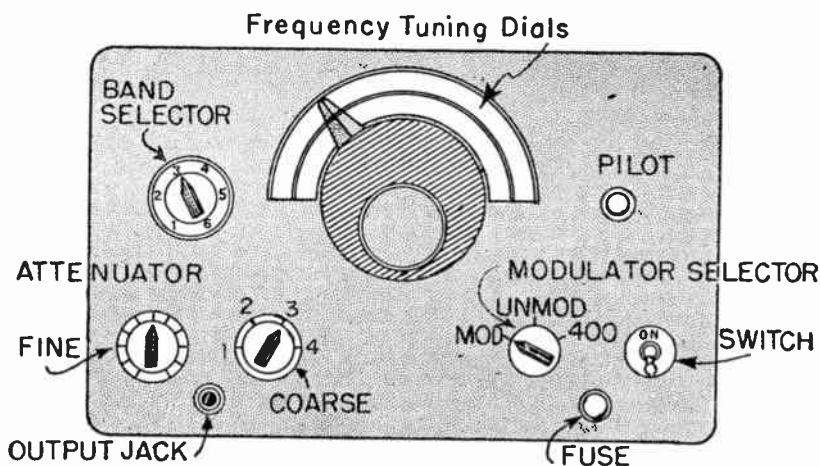

Fig. 18.—Adjustments and controls on the panel of a signal generator.

With the generator output taken through a jack the output cable for the plug is a single-conductor type with external metallic shield. The cable shield, which is the ground or low-side connection, is attached to the receiver chassis, to the receiver B—connection or common negative, or to the receiver ground terminal. The insulated cable conductor is the high-side connection which is run to the receiver antenna post or to some of the control grid circuits as will be explained.

The high-side connection always is made through a *dummy antenna* which, for standard broadcast work, is a fixed capacitor, and for short-wave work usually is a fixed resistor but sometimes is a fixed capacitor. Capacitance values will be listed later.

When working on a-c receivers where their power line circuits are insulated from the B-supply circuits by a power transformer with insulated primary and secondary windings the low-side connection from generator to receiver may be made through a conductive connection, or a continuous wire. But with ac-dc receivers and with any type where one side or the other of the power line may connect through to the B-supply or heater circuits, a conductive connection between generator and receiver may permit burnout of the generator attenuator system. In such cases the low-side connection should have in series a high-voltage paper or mica capacitor of 0.1 mfd capacitance.

Instead of transmitting the generator output to the receiver through conductive or capacitive connections as just described, the output may be radiated to a receiver having a built-in loop antenna by attaching a loop radiator to the output jack or terminal posts of the generator. The generator loop may consist of two to four turns of insulated wire formed into a circle of about one foot diameter. The generator or receiver is placed so that the radiator loop is in a plane parallel to the receiver loop, and so that the two loops are one to two feet apart. Several stock radiator loops are available from supply houses.

Sometimes a small one-turn radiator is connected to the high-side of the generator through a 0.0002 mfd mica capacitor, with the other end of this radiator left open. The low-side of the generator output is connected to the receiver through a 0.1 mfd capacitor. The radiator is supported one or two inches from the receiver loop. In other cases a wire attached to the high-side of the generator output is laid near the receiver loop.

When a receiver with a built-in loop has also connections for an external antenna and ground, the output of the generator may be connected to these receiver terminals or leads through the usual dummy antenna capacitor.

With the input to the receiver taken from the signal generator, the output of the receiver is observed during the progress of alignment adjustments by means of an output meter. The output meter usually is a rectifier type voltmeter. Output meter connections are shown by Fig. 19 as made for either a single power tube or for push-pull power tubes. When the meter is connected on the B+ and plate side of the output transformer the meter

must be protected by connecting in one of its leads a high-voltage paper or mica capacitor of 0.1 mfd or greater capacitance. This is not necessary when the meter is connected across the output

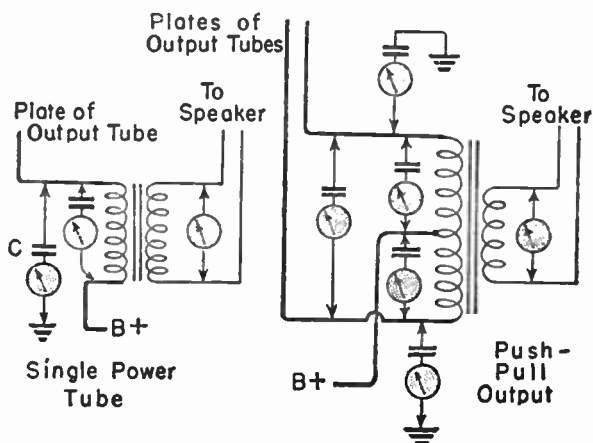

Fig. 19.—Methods of connecting a voltmeter-type output meter to the receiver.

transformer secondary or across the voice coil of the speaker, which amounts to the same thing. The voice coil connection is the one most often used.

**Preliminary Adjustments.**—The position of the receiver tuning dial pointer should be checked before alignment of the circuits, and the pointer correctly placed if a change is necessary. Usually there are marks on the dial at the positions which should be occupied by the pointer when the ganged tuning capacitors are either fully meshed (maximum capacitance) or else are all the way out (minimum capacitance). With permeability tuning the movable cores operated by the tuning dial will be all the way in or else all the way out, or at other specified positions in relation to the dial pointer. The exact method of dial adjustment varies with the make and model of receiver. Usually the pointer may be shifted after releasing its drive, which often is a cord running over a dial pulley.

The receiver volume control should be set for maximum volume during alignment. The tone control should be set for normal re-

production, which usually would be the voice position or else the treble position instead of a position for low note emphasis. A range selector switch should be set for broadcast reception or for short-wave reception, depending on the band in which alignment adjustments are to be made.

After the signal generator is connected or coupled to the receiver, both should be turned on and allowed to warm up to normal operating temperature. This will take several minutes at the least.

The generator output is adjusted, by means of the attenuator, so that the output meter reads somewhat below mid-scale at the beginning of the alignment procedure. As alignment proceeds, and the meter reading increases, the generator output should be reduced to maintain only readable indications on the meter. If this is not done, the avc system of the receiver will act to disguise the effects of adjustments. In order that the a-c rectifier type of output meter may operate when connected as shown in Fig. 19, the generator signal must be modulated with the audio frequency which, as mentioned, usually is of 400-cycle frequency.

**I-f Transformer Alignment.**—During alignment of the i-f transformers the modulated signal from the generator is to be put into the control grid circuit of the tube preceding the transformer being worked on. For alignment of the second i-f transformer in Fig. 17 the generator signal would be put into the control grid circuit of the i-f tube. Then, for aligning the first i-f transformer, the generator input would be moved back to the signal grid circuit of the converter. Unless the receiver is badly out of adjustment to begin with, it usually is satisfactory to feed the generator signal into the signal grid circuit of the converter while aligning first the second i-f transformer and then the first i-f transformer.

The dummy antenna lead from the generator is attached directly to the socket prong for the grid just mentioned, or to the top cap when this cap is for the grid, or to any wire leading directly to the grid without intervening resistors or capacitors. The low-side lead from the generator must go to the cathode of the tube whose grid is connected to the high side. In Fig. 17 the low-side lead could be connected to the common negative of the receiver and thus would run to the cathodes. Because this connection would include one of the oscillator coils in the cathode

line it might be necessary to temporarily shut off the oscillator section of the converter by connecting the oscillator grid of the converter to the cathode of this tube.

Sometimes the generator signal might be bypassed through grid circuit connections which are between the grid and cathode of the tube, so that very little signal strength would be applied to the tube input. In Fig. 17 such bypassing would occur through the wave trap consisting of the capacitor at *G* and the coil above, since this is a series resonant circuit tuned to the intermediate frequency and leading through the chassis ground connection and capacitor *Ca* to the common negative. Were the converter signal grid connected to the antenna circuit, with no r-f stage, the generator signal might be bypassed through the low impedance path in the loop or other grid circuit coil.

To prevent bypassing of the generator input, the connections of Fig. 20 may be used. Here the lead originally on the signal grid of the converter or on the control grid of any other tube is dis-

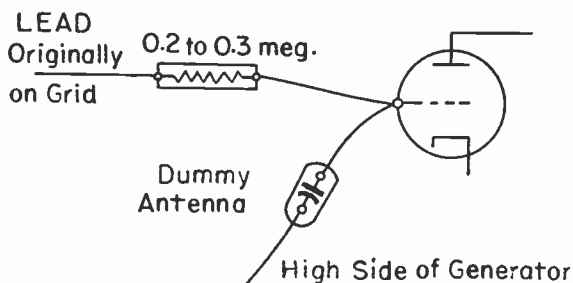

Fig. 20.—Connection of dummy antenna to signal grid or control grid.

connected and then re-connected to the grid through a series resistor of 0.2 to 0.3 megohm resistance. To the grid is attached also the lead from the dummy antenna for the generator. It would not do to simply disconnect the original grid lead and attach the dummy antenna to the grid, for this would prevent the biasing potential from reaching the grid. Using the series resistor maintains the connection of the grid to the source of biasing potential.

The dummy antenna capacitance for i-f alignment may be almost any value between 0.01 and 0.50 mfd, but most often is 0.1 mfd.

The signal generator frequency is adjusted to whatever intermediate frequency is used in the receiver. This frequency usually is 455 kilocycles in late models.

The tuning dial of the receiver is set at any point near the high-frequency end where the receiver is quiet except for the generator signal. That is, the receiver dial is set so that no external signals can be heard from the loud speaker, or noted as movement of the pointer on the output meter. Although placing the receiver dial in the high-frequency range is usual practice, it may be set at the low-frequency end of the scale if a quiet spot is found there. The exact frequency setting is not important, since in no case will it match the generator frequency.

The trimmers or cores of the i-f transformers now are adjusted for *maximum* reading on the output meter; reducing the generator input during the process to maintain the lowest meter readings which give positive indications.

If there is a wave trap circuit in the receiver it is adjusted to give *minimum* output meter reading when the signal generator input is at the intermediate frequency which has been used for the i-f adjustments. For wave trap adjustment the dummy antenna lead from the generator is moved to the control grid of the preceding tube, which would be the r-f tube of Fig. 17, with the low-side generator connection remaining as before. Now the generator output is increased during adjustment of the wave trap until there is minimum output with a rather strong generator input. The receiver tuning dial should be tried at various positions as the adjustment proceeds. The wave trap adjustment may be made also with the signal generator connected between the receiver antenna post and ground post if there is no r-f stage.

Should the receiver have a tuned transformer or impedance coupling between an r-f tube and the converter or mixer, this coupling would be aligned next. However, because such a tuned coupling is not generally employed, and because the adjustment is similar to that for the antenna circuit, it will be described later.

**Oscillator Alignment.**—For alignment of the oscillator in a receiver having a built-in loop antenna the signal generator input may be introduced by radiation from a loop attached to the generator, as previously explained. If there is no built-in loop the dummy antenna from the generator may be connected to the



antenna post of the receiver, with the low-side of the generator connected to the receiver chassis ground or to the B— or common negative line. This method of feeding the generator signal may be used also with built-in loops which have terminals for an external antenna. In some cases it is recommended that the dummy antenna lead be attached to the converter signal grid when there is no r-f stage, or to the control grid of the r-f tube if one is included. These tube connections would be made as shown by Fig. 20.

The dummy antenna for oscillator alignment is a fixed capacitor whose capacitance may be almost anything between 0.00005 and 0.00030 mfd, although values of 0.0001 or 0.0002 mfd usually are employed.

The generator output frequency is set somewhere between 1,400 and 1,750 kc; usually around 1,600 kc, and is modulated with the audio frequency. The receiver dial is set at the same frequency used for the generator output. The oscillator trimmer now is adjusted for maximum reading on the output meter; reducing the generator output as necessary to keep the meter reading on the low side of its scale.

Oscillator adjustments usually are made only at the high-frequency end of the tuning range. However, in some oscillator circuits there is a padder capacitor in series with the secondary winding of the oscillator coils, and this padder is adjusted with the generator set for 600-kc output with the receiver dial also set at 600 kc frequency. The ganged tuning capacitors should be rocked back and forth through the point of resonance while the padder is being adjusted. The padder is adjusted while using the same dummy antenna and generator connections as employed for the oscillator trimmer.

**Antenna Circuit Alignment.**—During adjustment of the antenna circuit trimmer the signal generator input may be through radiation from a loop on the generator to a built-in loop of the receiver, or else the dummy antenna lead from the generator may be run to an external antenna post of the receiver with the generator low-side connection to the receiver chassis, B—, or the common negative. The dummy antenna capacitor is the same as for oscillator alignment.

The generator output frequency is adjusted to somewhere between 1,300 and 1,500 kc, or even at a higher frequency. The

receiver dial is brought to approximately the same frequency setting, and then is adjusted to bring in the generator signal as heard from the loud speaker or as indicated by the output meter. The antenna circuit trimmer now is adjusted for maximum reading of the output meter, always reducing the generator output as much as possible while obtaining readable indications on the meter. The ganged tuning capacitors should be rocked back and forth to obtain maximum output meter reading.

Although the antenna circuit usually is adjusted only at the high-frequency end of the tuning range, some receivers have provision for changing the inductance in this circuit (as by shifting loop turns) for adjustment with the generator and receiver dial both set for 600 kc.

If there is a tuned r-f stage its trimmer (usually located on a section of the ganged tuning capacitor) is adjusted with the same generator frequency and connections, and the same tuning dial settings, as used during alignment of the antenna circuit.

Having finished all of the alignment adjustments from the second i-f transformer back to the antenna circuit, each one of

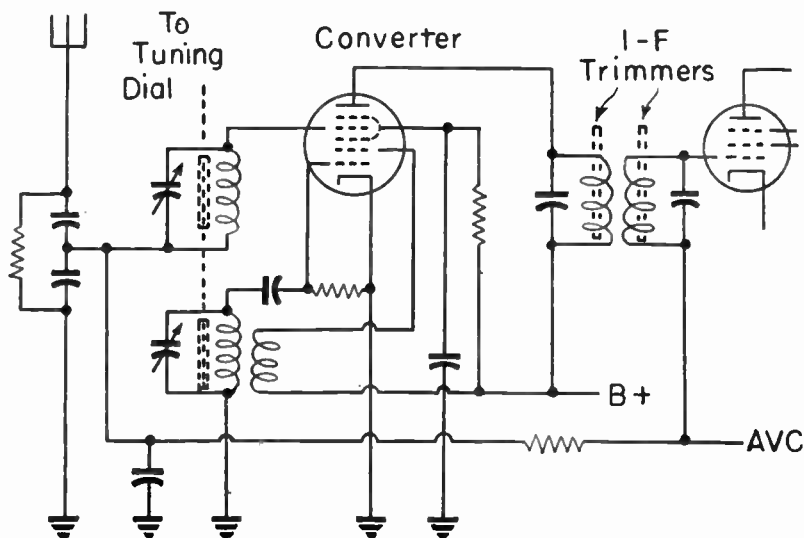

Fig. 21.—Receiver tuning and i-f alignment by means of adjustable cores in the coil windings.

them now should be checked over again by going through exactly the same procedure that has been described in detail. It is somewhat easier, and generally as satisfactory, to re-check the i-f alignments after making them for the first time and before going to the oscillator and antenna alignments. Then the oscillator and antenna alignments, and alignment of the r-f stage or wave trap, are checked over again after completing them for the first time.

**Alignment With Iron-core Coils.**—When the only alignment adjustments are those made by moving powdered iron cores, instead of using adjustable trimmer capacitors, the alignment procedure is the same as previously described for the several parts of the receiver. Such adjustments are quite generally used for the i-f transformers. There are many receivers also in which tuning is accomplished by movable iron cores in the coils for the antenna circuit, the oscillator circuit, and the r-f coupling when it is of the tuned type. With such permeability tuning the alignment adjustments are made by means of adjustable capacitors connected across the iron-core coils. Fig. 21 shows the antenna, converter, the first i-f coupling for a receiver having permeability tuning with capacitor alignment adjustments for the antenna and oscillator circuits.

In circuits such as this one the movable cores of the coils are operated together from the tuning dial through attachment of the cores to the dial mechanism. The cores also are adjustable in relation to the dial mechanism, so that, with the dial at a given frequency setting, the cores may be adjusted to extend farther into or out of the coil windings. Adjusting a core farther out of the winding lessens the inductance and increases the operating frequency. Adjusting a core farther into the windings increases the inductance and lowers the operating frequency.

The procedure for alignment of the capacitor trimmers and the coil cores is as follows for most receivers.

1. The signal generator connections and the dummy antenna are the same as earlier described for alignment of antenna, oscillator, and r-f stages.

2. The receiver tuning dial is set at the high frequency end of its scale, and a check is made to see that the coil cores are all the way out of the windings, or nearly so.

3. The generator frequency and the receiver dial setting are

placed at some frequency between 1,600 and 1,750 kc, and the capacitor trimmers for the oscillator, an r-f stage if used, and the antenna coupling, are adjusted for maximum reading on the output meter.

4. The generator frequency and the receiver dial setting are changed to some lower frequency, usually between 1,300 and 1,500 kc. The coil cores for the oscillator, an r-f stage if used, and the antenna coupling, now are adjusted for maximum output.

5. The trimmer capacitor adjustments are re-checked as in step 3 above.

There are some receivers in which the only adjustable coil core is in the oscillator circuit, and in which both the oscillator and antenna circuits have trimmer capacitors. In this case the capaci-

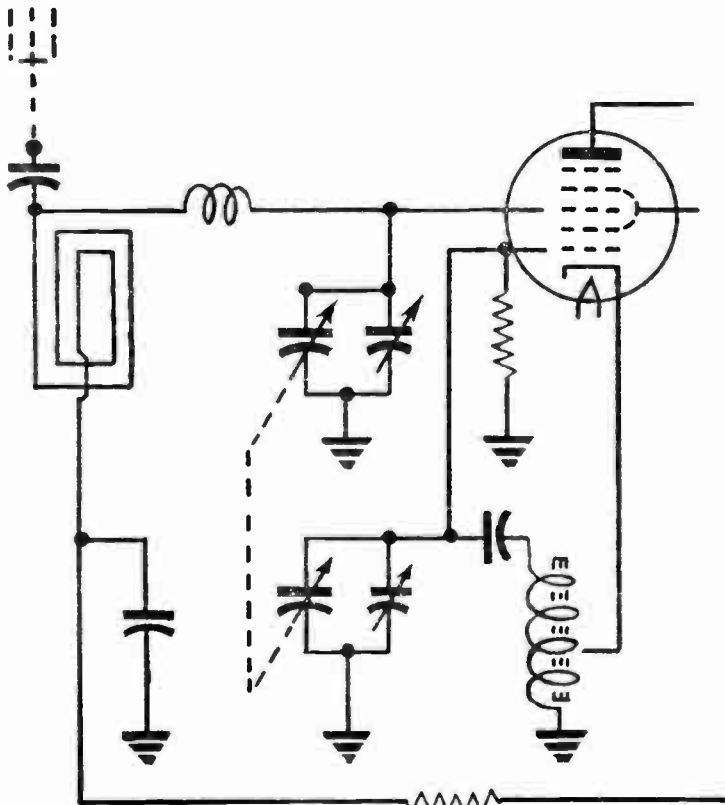

Fig. 22.—Oscillator coil with adjustable core for low-frequency alignment.

tor trimmers are aligned at the high-frequency end of the tuning range according to the procedures previously explained. Then the adjustable core in the oscillator circuit is adjusted with the generator frequency and the receiver dial set at 600 kc, with the dial rocked back and forth during the adjustment. This is employing the core adjustment for the same purpose as the adjustment of a padder capacitor when such a capacitor is used in the oscillator circuit. An oscillator circuit of this type is shown by Fig. 22.

In still other receivers the oscillator and antenna coils have both adjustable cores and capacitor trimmers, with tuning by means of the usual ganged capacitor. In this case the capacitor trimmers are adjusted with the generator and receiver dial set at a frequency in the high end of the tuning range, say at 1,400 to 1,500 kc, and the coil cores are adjusted with generator and dial set for 600 kc.

When the i-f transformers are aligned by means of adjustable cores in the windings, as shown in Fig. 21, all steps are exactly the same as when the trimmers are of the adjustable capacitor type. The cores are adjusted for maximum output just as are capacitor trimmers.

All of the alignment instructions which have been given apply in a general way to receivers having circuits of the types mentioned. However, when specific instructions are available for the receiver being aligned, these specific methods should be followed exactly rather than using the more general methods which have been outlined.

### REVIEW QUESTIONS

1. What is the distinguishing feature of a superheterodyne receiver?
2. When two frequencies are combined in a radio receiver, two beat frequencies are produced. To what are these frequencies equal?
3. For what purpose is the pentagrid converter tube used?
4. For what purpose are trimmer capacitors used in a superheterodyne receiver?
5. To what frequency are the primary and secondary circuits of the intermediate transformer circuits tuned?

## Chapter 4

### RECEIVER CONTROLS

The operator of a modern radio receiver is called upon to make only a few simple adjustments in order to obtain high quality of sound output from the loud speaker. With a broadcast receiver it is necessary only to set the tuning control for the station to be heard, and to adjust the volume control for the desired sound level. Of course, it is necessary also to have a switch for turning the receiver on and off, but most often this switch is combined with the volume control so that the first part of the control movement places the set in operation, and remaining movement regulates the sound volume or intensity.

If the receiver is designed for operation in various short-wave or high-frequency bands as well as for broadcast reception, there will be an additional control for switching to the desired wave band. This control may act also to change from radio to phonograph as the audio signal source, or to a microphone if one is provided for.

One additional operating control may be supplied for varying the tone. Tone controls usually provide for emphasis on the low notes, for emphasis on the high notes, or for normal tone with neither the lows nor the highs emphasized.

**Volume Controls.**—Nearly all types of volume controls have for the adjustable unit a voltage divider, usually called a potentiometer, with the sliding contact operated by the control knob. The resistance element may be wire-wound for resistances up to about 20,000 ohms or even higher, but is made of carbon and graphite compositions for resistances above the ranges available in wire-wound types. The resistance values seldom exceed one or two megohms.

The signal which is to be reproduced from the loud speaker reaches the receiver in the antenna circuit, and then may go through an r-f amplifier, an i-f amplifier, a detector, the a-f stage or stages, and finally to the loud speaker. The sound output may be varied in strength by volume control adjustments placed

in any part from the antenna to the audio output, or by placing adjustments in two or more places with provision for operating them by a single control knob accessible to the operator. Any type of adjustment which will waste part of the signal strength or reduce the amplification at any point in its progress from antenna to speaker will reduce the sound volume, and anything which will conserve signal strength or increase the amplification brings the volume closer to the maximum which is possible with the signal strength reaching the antenna and with the amplification built into the apparatus.

Simple volume controls in the antenna circuit are shown by Fig. 1. In both cases there is a voltage divider connected between the antenna and ground, and connected across more or less of the divider is the primary winding of an r-f transformer which has

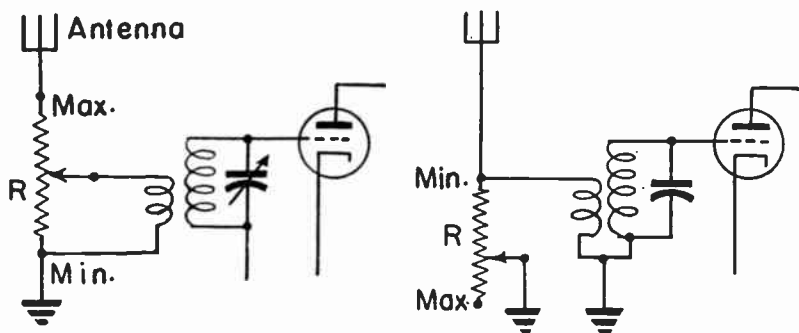

Fig. 1.—Volume controls in the antenna circuit.

a tuned secondary circuit connected to the control grid of the first tube. In the left-hand diagram the slider is moved to the antenna end of the resistance element for maximum volume and to the grounded end for minimum volume. The antenna signal potential is distributed as a voltage drop in the entire resistance, and a variable portion of the total drop is picked off by adjustment of the control. In the right-hand diagram movement of the slider changes the amount of resistance in the antenna circuit, between antenna and ground, and all of the signal potential across the included resistance is applied to the primary of the transformer. The greater the included resistance the higher will be the signal potential and the greater the input to the transformer.

Fig. 2 shows simple volume controls placed in the control grid circuits of amplifier tubes. The left-hand diagram applies to a radio-frequency or other high-frequency amplifier. Signal potentials developed across the tuned secondary of the transformer are applied to the ends of the voltage divider. With the control slider moved upward, more of this signal potential is included between the control grid and the cathode of the tube and the volume is maximum. Moving the slider downward brings the grid connection closer to the cathode end of the resistance; the cathode connection being completed through capacitor  $C$  and ground.

The right-hand diagram applies to an audio-frequency amplifier. The signal from the plate of a preceding amplifier tube is developed across resistor  $R$  and is applied through capacitor  $C$  to the control voltage divider which is in the grid circuit of the

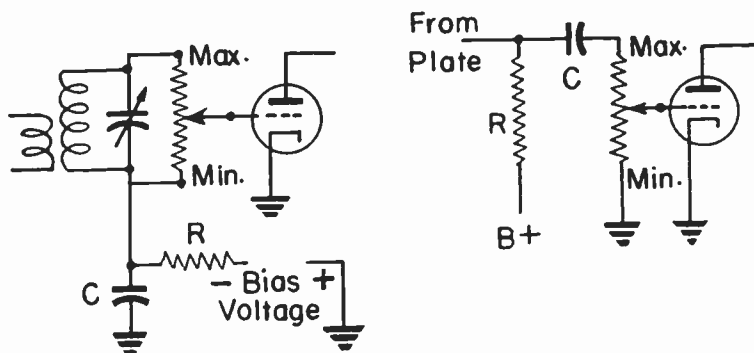

Fig. 2.—Volume controls in amplifier control grid circuits.

tube shown. Maximum signal potential is applied to this grid with the slider at the top, and minimum signal is applied with the slider at the bottom where it brings the control grid to the ground connection and through ground to the cathode potential.

Although the tubes shown in the various diagrams are represented as triodes, the same principles of volume control would apply were the tubes to have additional elements. Representing the tubes as triodes simplifies the diagrams while illustrating the manner in which the controls operate.



In the left-hand diagram of Fig. 2 grid biasing voltage is applied through resistor  $R$  and through the voltage divider resistance to the control grid. The other end of the source of bias voltage, whatever this source may be, is connected through ground to the cathode. The high-frequency signal potentials are bypassed around  $R$  and the biasing source by capacitor  $C$ . The same biasing arrangement might be used with the a-f volume control of the right-hand diagram.

Fig. 3 shows volume controls connected in the plate circuits of amplifier tubes; a radio-frequency amplifier at the left, and an audio-frequency amplifier at the right. At the left the plate voltage is varied by movement of the volume control slider. Moving the slider toward the more positive end of the divider, at  $B+$ , increases the plate voltage, the plate current, and the signal output of the tube. Moving the slider toward the grounded end of the resistance has the opposite effects.

In the right-hand diagram the potential applied to the plate of the amplifier tube is not altered by the volume control, since all of the control resistance is between the plate and  $B+$  at all times. The portion of the signal in the resistance which is applied through capacitor  $C$  to the grid resistor of the following tube is

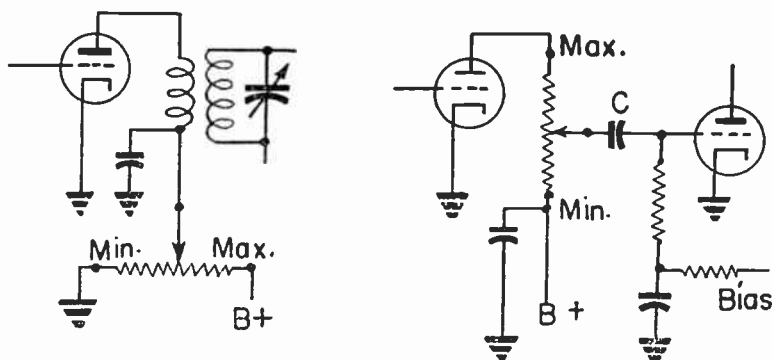

Fig. 3.—Volume controls in amplifier plate circuits.

the portion appearing between the slider and the lower end of the resistance; this end being connected to ground through a bypass capacitor. Moving the slider toward the plate end of the resistance

causes more of the signal potential to be applied to the following grid circuit, and increases the volume. Opposite movement lessens the volume.

Fig. 4 shows adjustable controls for control grid bias used as volume controls. Since anything which varies the control grid bias of an amplifier tube varies the plate current, or average plate current, and also the output power of the tube, any biasing method will act as a volume control provided the bias voltage is made variable. In the left-hand diagram the biasing voltage is developed by plate current flowing in resistors *A* and *B*, which are in series with the cathode of the tube. The adjustable resistance is in section *B*, while section *A* is non-adjustable and provides a fixed minimum biasing voltage such as will prevent excessive plate current. Either or both parts of the biasing resistance may be bypassed with a capacitor, as shown with

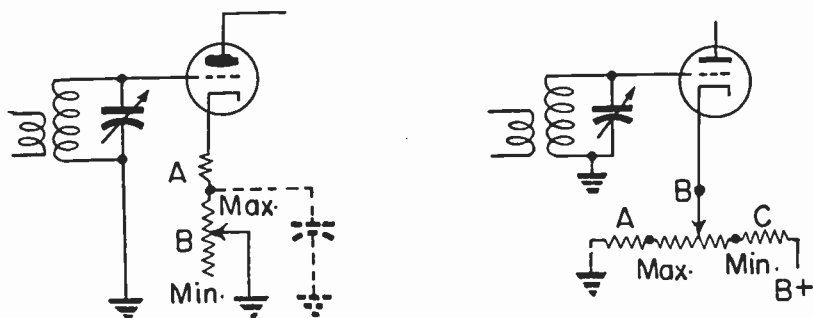

Fig. 4.—Volume control by variation of cathode potential and grid bias.

broken lines for the adjustable control in the diagram. The more negative the bias is made the less is the output of the amplifier tube and the lower is the volume. Making the bias less negative increases the volume.

The right-hand diagram of Fig. 4 shows an adjustable bias from the plate power supply system. Here the tube cathode is connected to the slider of voltage divider *B*, which is the volume control unit. The tuned grid circuit is connected through ground to one end of resistor *A*, hence the grid biasing voltage is the potential difference between the grounded end of *A* and the slider on *B*. Resistor *A* is of fixed value to prevent adjusting the bias to

a value so little negative as would allow excessive plate current. That is, resistor *A* provides the fixed minimum bias. Resistor *C*, in series between divider *B* and the  $B+$  of the power supply, is a protective resistor which prevents excessive current from flowing in *B* and *A*.

With an adjustable grid bias employed for volume control, as in the diagrams of Fig. 4, the cathodes of two or more amplifier tubes may be connected together and to the same point on the biasing system, thus subjecting all the tubes so connected to the same grid bias and the same changes of grid bias. Several i-f amplifiers may be controlled with a single adjustable bias, or such a control may be applied to both r-f and i-f amplifiers, and may be applied to either of these types of amplifiers and at the same time to the signal section of a converter tube in a superheterodyne receiver.

When r-f or i-f amplifier tubes are controlled for volume by means of adjustable grid bias it is common practice to have these tubes of the variable- $\mu$  or super control type. In this type of tube there is a rather sharp reduction of plate current as the bias is varied from zero through the first few negative volts, followed by a much more gradual reduction of plate current with the bias made increasingly negative. These tubes are said to have a remote cutoff; meaning that plate current is not completely cut off until the bias is made somewhere between 30 and 50 volts negative. With tubes of the sharp cutoff type the plate current is reduced to zero with a negative bias of only six to eight volts under usual operating conditions. The variable- $\mu$  or super control tubes are varieties of pentodes.

**Controls for Diode Detectors.**—Fig. 5 illustrates the principles most often employed for volume control in connection with a diode type of detector. The diode usually is in the same tube with a triode or a pentode section, with a single cathode common to both the diode and the triode or pentode. The majority of combination tubes in this class have two diode plates. The two diode plates may be used separately, as when the detector is to be of the full-wave type, but generally they are tied together and used with a half-wave detector circuit, as in the diagrams. The triode or pentode section of the combination tube is here used as an audio-frequency amplifying tube following the detector.

Considering the left-hand diagram of Fig. 5, when a high-frequency signal is applied to the tuned transformer which is in the diode circuit, the rectified audio-frequency potentials which correspond to the modulation appear in resistor  $R$ , while the high-frequency component of the currents in the diode circuit is bypassed around  $R$  through capacitor  $C$ .

Resistor  $R$  is the resistance element of a voltage divider used for volume control. The a-f potentials between the slider and the grounded end of the resistance are applied between the triode control grid and the cathode, and are amplified by the triode

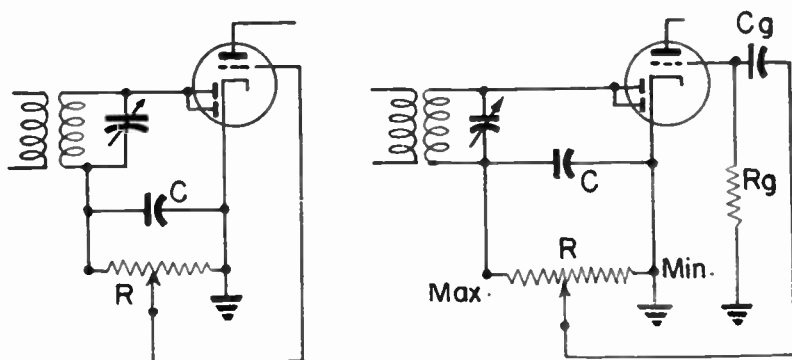

Fig. 5.—Volume controls in diode detector circuits.

section of the tube. The strength of the a-f potential applied to the triode may be varied by moving the slider on  $R$ , and thus the volume is regulated.

The simple volume control circuit of the left-hand diagram usually is modified somewhat as shown at the right in practical applications. The functions of  $R$  and  $C$  are the same as before, but instead of connecting the slider of  $R$  directly to the amplifier grid it is connected to the grid through a grid capacitor  $C_g$  which prevents direct potentials in the detector circuit from reaching the grid, while allowing the flow of a-f potentials. The conductive circuit for the amplifier grid is completed through grid resistor  $R_g$  to ground and from ground to the cathode.

The bypass capacitor  $C$  may be of 150 to 250 mmfd capacitance,

which offers low capacitive reactance to the high-frequency currents, but high reactance to audio frequency. Grid capacitor  $C_g$  may have a capacitance of about 1,000 mmfd, which offers low reactance to the a-f currents and potentials. The resistance of  $R_g$  may be five to ten megohms. The combination of capacitor  $C_g$  and resistor  $R_g$  allows some grid rectification in the triode grid and the cathode, and provides a small negative bias for the ampli-

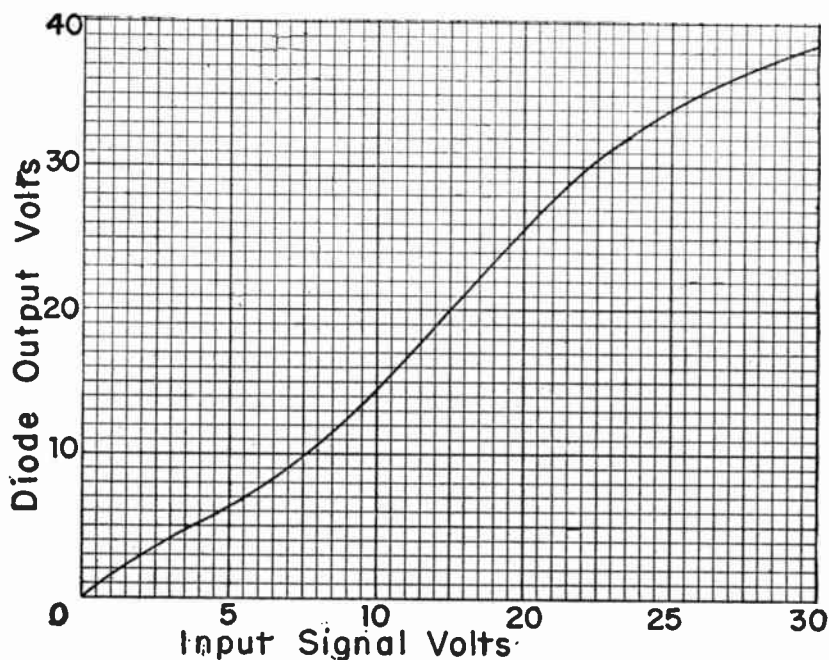

Fig. 6.—Output and signal voltages for a typical diode used for detection.

fier section when alternating a-f potentials are applied to the grid circuit from the detector circuit.

The output voltage of a typical double diode with diode plates tied together for a half-wave detector is shown by Fig. 6, where the output voltage developed across the load resistor is related to the input high-frequency voltage applied to the diode circuit.

Note that the output voltages of Fig. 6 are greater than the input voltages. This is explained by the fact that the input volt-

ages are r-m-s or effective a-c voltages, while the output voltages approach the corresponding peak a-c voltages. The output approaches peak values because it is the voltage developed across capacitor  $C$  of Fig. 5 as this capacitor is charged by the rectified pulses of current, while discharging but slowly through the resistance of  $R$ . The peak value of any sine-wave a-c potential is equal to 1.414 times its r-m-s or effective value.

With commonly used values of load resistance ( $R$  in Fig. 5), and any constant input signal voltage there is little change in output voltage across the resistance when the resistance is changed in value. However, the rectified current in the resistance varies about inversely with the value of resistance. For instance, changing the resistance from a half megohm to one megohm would halve the rectified current, but the voltages developed across the one-megohm resistor would be hardly any greater than across the half-megohm unit.

Volume control circuits of more elaborate design often are used in connection with diode detectors. Such a circuit is shown by Fig. 7. The rectified a-f potentials are developed in resistor  $R$ ,

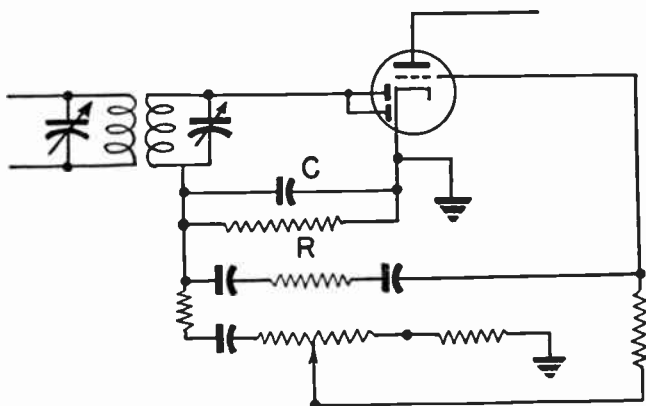

Fig. 7.—A diode detector volume control having added resistance elements.

which is bypassed by capacitor  $C$ . Audio potentials and currents are taken from the left-hand end of  $R$  and fed through the volume control circuit which forms the lower part of the diagram, and which leads to the control grid of the amplifier section of the tube. The additional resistors and capacitors in the volume control

section serve to filter out any remaining traces of high-frequency potentials so that these will not overload the amplifier or cause audio distortion, and they may serve also to make the change of volume more uniform with rotation of the control knob. The basic principles of volume control with a diode detector are not altered.

Fig. 8 shows a circuit for a full-wave diode detector with a volume control leading to the control grid of the a-f amplifier section of the combination tube. The two diode plates are connected to the outer ends of the secondary winding of the tuned transformer. The connection for volume control voltage divider  $R$  is taken from the center tap on the secondary winding. Otherwise the circuit is like that at the right in Fig. 5. The action of the diode plates, the tapped secondary winding, and the cathode,

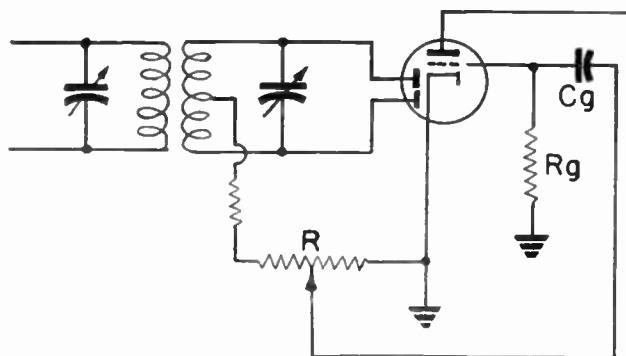

Fig. 8.—Volume control on a full-wave diode detector.

is exactly like that of a full-wave rectifier. Both the positive and the negative alternations of signal potential are rectified and cause flow of current through  $R$ .

With the same applied signal potential the full-wave detector has a rectified voltage output of only about half that of the half-wave detector shown in preceding diagrams. Consequently, the full-wave arrangement is used less often than the half-wave type.

With the circuits shown at the right in Fig. 5, and in Fig. 8, the amplifier grid may be given any desired negative bias by connecting the lower end of grid resistor  $R_g$  to a source of biasing voltage instead of to ground.

**Automatic Volume Control.**—All of the types of volume control

which have been shown will regulate the final sound output to various levels when the antenna input signal remains constant. But if these volume controls are adjusted for some certain sound level, and if there is an increase of signal strength reaching the antenna, the sound level will increase proportionately even though the volume control remains as originally adjusted. And, of course, a decrease of antenna signal strength will lower the sound output. Unless a receiver is located within a few miles of the antenna of a powerful transmitter there are more or less continual variations in the strength of the signal reaching the receiver; and with any of the simple volume controls previously explained there will be more or less continual variations in sound output level.

To prevent the variations of sound output which result from variations of antenna signal strength it is necessary to have, in addition to the manually operated volume control, a second control system which will be actuated by the strength of the received signals. This second system, called automatic volume control and abbreviated *avc* or *AVC*, acts to increase the receiver amplification or gain when antenna signals become weaker, and to decrease the amplification when the antenna signals become stronger.

Automatic volume control does not maintain a constant level of sound output with variations of antenna signal strength, but it materially lessens the changes of sound level which would occur with no such control. In a typical receiver operated without automatic volume control an increase of antenna signal strength of 10 times might cause an increase in sound level or in audio power of 84 times. With automatic volume control the same increase of antenna signal might cause a sound level increase of only 7 times. There must be some increase in sound level, even with automatic volume control in use, because it is this increase that is depended upon to reduce the amplification.

A simple *avc* circuit is shown by Fig. 9. Comparing this diagram with that at the right in Fig. 5, it will be seen that both circuits are identical so far as they include the double-diode triode tube, the tuned secondary connected to the diode circuit, and also resistors and capacitors  $R$ ,  $C$ ,  $R_g$  and  $C_g$ . This means that the actions of the detector circuit and of the manual volume control leading to the audio amplifier grid are not changed for the addition of automatic volume control.



The additions consist of resistor  $R_f$ , which is connected to the left-hand end of  $R$ , also of capacitor  $C_f$ , and of the connection from the avc line to the grid return of the i-f amplifier tube.

Electron flow in the diode circuit is from cathode to diode plates inside the detector tube, and in returning to the cathode through the external circuit this flow is in such direction through  $R$  as to indicate that the left-hand end of  $R$  is negative with respect to its right-hand end, which is grounded. There are connections, not shown in the diagram, from ground through the i-f bias source to the cathode of the i-f tube. There is a connection from the negative end of  $R$  through  $R_f$ , the avc line, and the secondary of

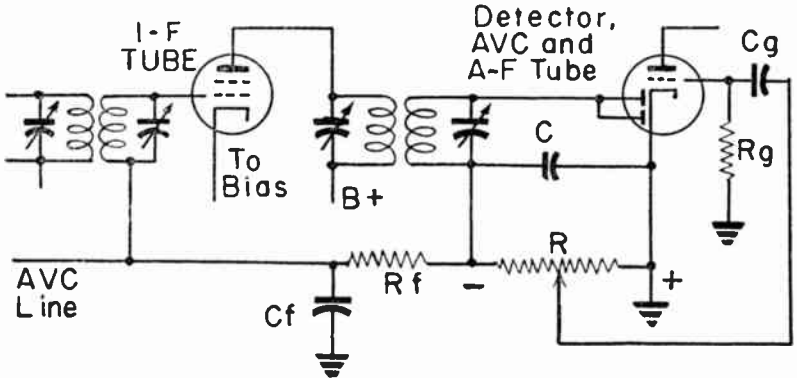

Fig. 9.—The elements of a simple automatic volume control circuit.

the tuned i-f transformer to the control grid of the i-f tube. Then the grid of this i-f tube is at a potential more negative than its cathode, and has a negative bias. There is no electron flow in  $R_f$  because it is in the grid circuit of the i-f tube, and in this circuit for a negatively biased grid there is no electron flow. Then there is no voltage drop across  $R_f$ , and the potential of the i-f control grid is the same as that at the left-hand end of  $R$ . Thus the grid bias of the r-f tube is negative by an amount equal to the potential across resistor  $R$ .

When signal strength increases at the antenna of the receiver the increase passes through the several amplifiers and eventually

reaches the diode detector to cause an increase of average electron flow in the detector circuit and in resistor  $R$ . This increased flow means an increased potential difference across  $R$ , and, since this difference is the bias potential for the i-f tube, the bias on this i-f tube becomes more negative and its amplification is reduced. Thus the increase of antenna signal strength automatically reduces the amplification of the i-f tube shown in the diagram. The avc line may be extended toward the left and connected to the grid returns of preceding amplifier tubes so that these tubes too may be regulated as to their amplification by variations of their grid bias.

A decrease of antenna signal strength lessens the rectified electron flow in resistor  $R$ , reduces the potential drop across  $R$ , and thus makes the bias of the controlled amplifier tubes less negative. The less negative bias allows increased amplification in these tubes, and the decrease of antenna signal strength is partially compensated for.

Resistor  $R_f$  and capacitor  $C_f$  act together as a low-pass filter to prevent audio-frequency variations of potential in resistor  $R$  from getting into the avc line and thus permit this line to be maintained at the average potential of the a-f variations. The resistance of  $R_f$  may be about 0.5 megohm, and the capacitance of  $C_f$  about 0.1 mfd. During increase of a-f potentials in  $R$ , the capacitor  $C_f$  is charged through the high resistance of  $R_f$  and, as a consequence of the high resistance, charges rather slowly in comparison with the a-f variations. During decrease of a-f potentials in  $R$  there is a slow discharge of  $C_f$  through the resistances of  $R_f$  and  $R$  which are in series between  $C_f$  and ground.

The voltage on capacitor  $C_f$  increases and decreases with changes in the average value of potentials from the diode circuit, but because of the filter system the voltage cannot vary at the relatively rapid a-f rate. It really is the voltage on  $C_f$ , which varies with antenna signal strength, that is applied as a bias voltage to the amplifier tubes.

Many modifications are possible in the simple avc arrangement without materially altering the basic operation. Some such modifications are shown by Fig. 10. There is an additional resistor  $R_a$  and an additional capacitor  $C_a$  which, in combination with capacitor  $C$  form a low-pass filter system which prevents flow of currents at the intermediate frequency to the audio volume

control  $R$  and to the avc filter system consisting of  $R_f$  and  $C_f$ . The high-frequency or i-f currents complete their circuit to the tube cathode through capacitor  $C$ , the a-f variations representing the modulation go through  $R_a$  and  $R$  to the cathode, while the average variations of the a-f currents are smoothed out by the additional filtering of  $R_f$  and  $C_f$  and then pass to the avc line.

In Fig. 10 the grid capacitor  $C_g$  is placed near the voltage divider  $R$ , and the grid resistor  $R_g$  is connected directly to the tube cathode rather than through ground. In spite of this repositioning of parts in the diagram, the actual circuit is the same as that of Fig. 9 for the grid capacitor and resistor. It is possible

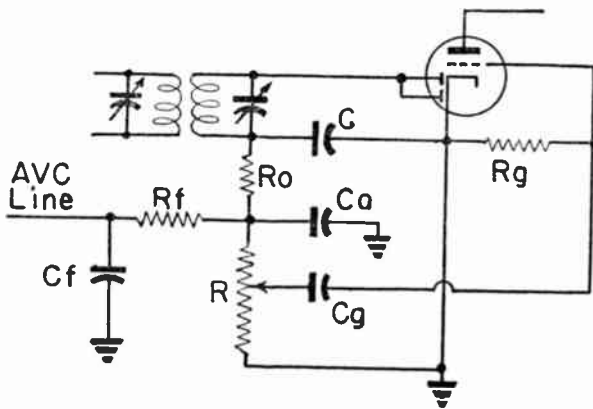

Fig. 10.—Modifications of the simple avc circuit for a diode detector.

to draw any given circuit in a great many different ways to produce diagrams which appear radically different with no changes whatever being made in the actual connections of the units. The lines followed by the biasing potential in any simple avc system may be traced by starting from the control grids of the high-frequency amplifier tubes and following through to the diode circuit of the detector or avc tube. Such paths are not difficult to follow if it is kept in mind that the biasing d-c potential must come through a complete conductive path consisting of wires and resistors, and cannot come through any capacitors.

The avc biasing voltage may be applied to all the amplifier tubes, as well as the converter tube, which are between the antenna and the avc tube or detector, or else the avc may be applied to only some of these tubes. The closer any controlled tube is to the antenna end of the amplifying circuits the more effective is the avc biasing voltage in maintaining a constant output sound volume with varying antenna signal strengths; this because the signals are weaker and more easily controlled toward the antenna.

In view of the preceding statement, the avc voltage is most effective when applied to a r-f amplifier tube which is between the antenna and the converter. If there is no r-f stage ahead of the converter, the avc voltage is most effective when applied to the signal input section of the converter, or to the signal grid of this tube, and under such conditions is practically always applied to the converter. If there is only one i-f stage between the converter and the detector, the avc bias is applied to the i-f amplifier tube. However, if there is more than one i-f stage the avc voltage quite often is applied to the first such stage while the second i-f stage is operated with a fixed bias for the control grid.

Fig. 11 shows the avc circuit for a superheterodyne receiver having a converter and two i-f stages. All of the parts of the detector-avc tube circuits have been previously explained. The reference letters in this portion of the diagram are the same as used for equivalent parts or units in earlier diagrams.

The avc line connects to the control grid of the first i-f tube through the secondary of the tuned i-f transformer, just as the connection is made to the i-f tube in Fig. 9. Note, however, that there is a different type of avc line connection to the control grid of the second i-f tube; this connection being made through the grid resistor of the tube. The coupling between the first and second i-f tubes here is of the resistance-capacitance type, with capacitor  $Cb$  acting as the blocking capacitor to isolate the control grid circuit from the plate circuit of the first i-f tube. The connection of the avc line to a control grid through a grid resistor may be used also when interstage coupling is by means of transformers. Then the transformer secondary is not connected directly to the control grid of the i-f tube, but is connected to the grid through a blocking capacitor.

Resistor  $Rd$  and capacitor  $Cd$  of Fig. 11 form a decoupling filter

between the converter and the first i-f stage and prevent interaction between these stages through their connection to the common avc line. The grid resistor of the second i-f tube acts as a decoupling resistor between the first and second i-f stages. Were a transformer used to couple these stages, with no grid resistor, a decoupling resistor might be placed in the avc line between the stages.

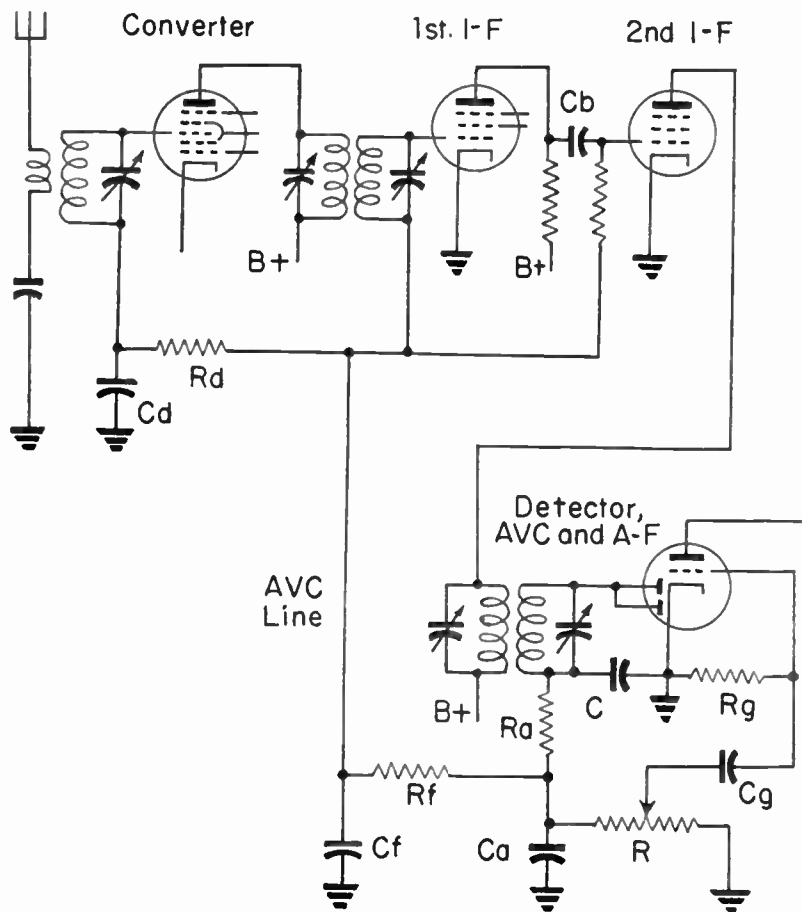

Fig. 11.—A circuit for automatic volume control of three stages in a superheterodyne receiver.

Fig. 12 shows a circuit in which a diode-pentode is used as the final i-f amplifier, or possibly the only i-f amplifier in the receiver, and also as a detector and avc tube. The pentode section of this tube acts as the i-f amplifier, and the first a-f amplifier is a separate tube, also a pentode type.

The input from a preceding i-f stage, or else from the converter, comes through a tuned i-f transformer  $T-1$  to the control grid of the i-f pentode section of the diode-pentode tube. The output from the plate of this tube goes to the primary of another tuned i-f transformer  $T-2$ , and from the secondary of this transformer the i-f signal goes to the diode circuit of the diode-pentode tube. The diode circuit performs the functions of a detector and also sup-

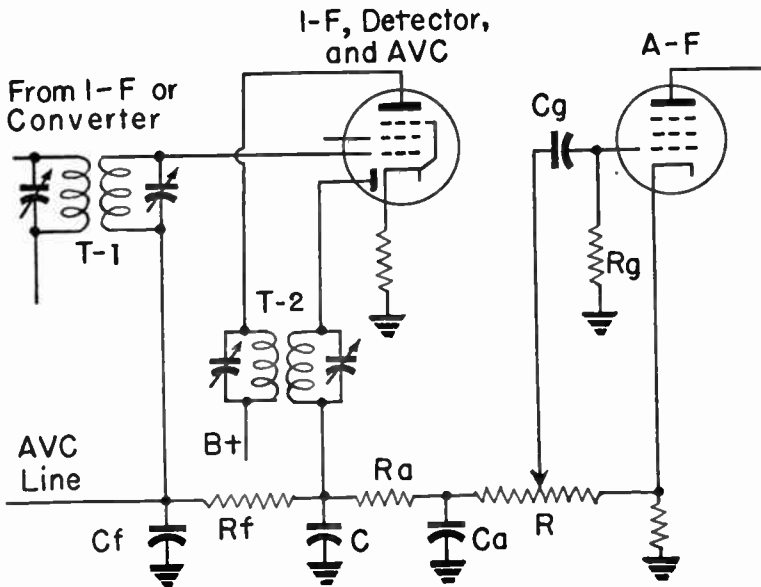

Fig. 12.—A tube used as an i-f amplifier, detector, and avc tube.

plies the negative potential for the avc line. There is nothing new in this diode circuit. All of its parts have been given the same reference letters as equivalent parts in preceding circuits. The detector output, from the slider of volume control voltage divider  $R$ , now goes to the control grid of the separate a-f tube instead of

to the control grid of a triode section which is part of the detector-avc tube in earlier diagrams.

Note that in Fig. 12 the avc voltage is applied to the control grid of the diode-pentode tube in which the diode section rectifies the voltage for avc. The avc line might be extended toward the left for the control grid returns of preceding stages, either i-f or converter.

The time required for any avc filter capacitor to charge and discharge has an important bearing on the performance of the control. This is the capacitor marked  $C_f$  in the circuit diagrams. This capacitor is charged through all of the resistors which are between it and the diode plate. In some of the preceding diagrams the only resistor in this path is  $R_f$ , while in others we have  $R_f$  and  $R_a$  in series between the diode plate and the avc capacitor. The time constant for charging is equal, in seconds, to the product of the capacitance in microfarads and the series resistance in megohms. In Fig. 9 the time constant would be equal to  $C_f \times R_f$ . In Fig. 10 the time would be equal to  $C_f \times (R_f + R_a)$ , because  $R_f$  and  $R_a$  are in series and act together. But when we come to the case of Fig. 11 the charging time is affected also by the resistance of  $R_d$  and the capacitance of  $C_d$ , and the time constant becomes equal to,

$$\text{Seconds} = (C_f + C_d) (R_f + R_a) + (C_d \times R_d)$$

This computation for a particular time constant is given here, not because it is necessary to make such computations except when designing, but to bring out the fact that the time constant is affected by all of the resistances and by all of the capacitances in the avc line. The time does not depend only on  $R_f$  and  $C_f$ .

The avc capacitance discharges through all of the resistances between it and ground. Total discharge resistance is increased by resistances in series with one another, and is decreased by resistances in parallel with one another. The time for discharge is affected by all of the resistances between the capacitance, or capacitances, and ground, and also by all of the capacitances which are in the avc line.

If the time constant is too short, low-frequency audio modulation will get into the avc line and amplification will vary at such frequencies. The amplification will be varied by every brief

change of antenna signal, and reproduction of low audio tones will be reduced. If the constant is too long the amplification changes will not follow changes of antenna signal strength, and the control loses its effectiveness. A time which is too long also allows static and other outside disturbances to reduce the amplification and hold it down for long intervals.

Avc time constant recommendations for ordinary types of broadcast receivers run from 0.1 to 0.3 second. For high fidelity reproduction of low audio frequencies the constant may be longer; say from 0.25 to 0.50 second. Where there may be rapid fading, as on some short-wave bands, the constant may be shorter than 0.2 second.

**Delayed Automatic Volume Control.**—A possible objection to all of the automatic volume control systems so far considered is that they commence to act even on the weakest signals, and tend to reduce the amplification of these signals which often must receive full amplification if they are to be heard at all. This objection may be overcome by systems called delayed automatic volume control; a name which may be abbreviated to *davc* or to *DAVC*.

In *davc* systems we introduce a second biasing potential which opposes the regular automatic control biasing potential. If the opposing potential is, for instance, 3 volts, the automatic volume control system cannot commence to operate until the signal reaching the detector or avc tube rises to a value which produces a 3-volt automatic bias. All signals which are weaker will be unaffected by the automatic control.

A circuit for delayed automatic volume control is shown by Fig. 13. The first point to be noted is that the two diode plates are not tied together. The upper diode plate in the diagram is used for a detector diode, and the lower diode plate is used for the avc diode.

The circuit for the detector diode is no different from other detector circuits examined earlier. The diode plate is connected to one end of the secondary of the tuned input transformer. The other end of this transformer is connected through bypass capacitor *C* and the manual volume control resistor (voltage divider) *R* to the tube cathode. The slider of the volume control connects



as usual to the control grid of the audio amplifier section of the tube.

The circuit for the avc (lower) diode plate goes through resistor  $R_c$  to ground, from ground through the cathode-bias resistor  $R_b$ , and to the tube cathode. Energy from the tuned transformer secondary is introduced into the avc diode circuit through coupling capacitor  $C_c$ . Electron flow in the tube is from cathode to the avc diode plate, thence downward through  $R_c$ . This direction of flow indicates that the top of  $R_c$  is negative with reference to the bottom. The negative potential for the avc bias is taken from the top of  $R_c$  and goes through filter resistor  $R_f$

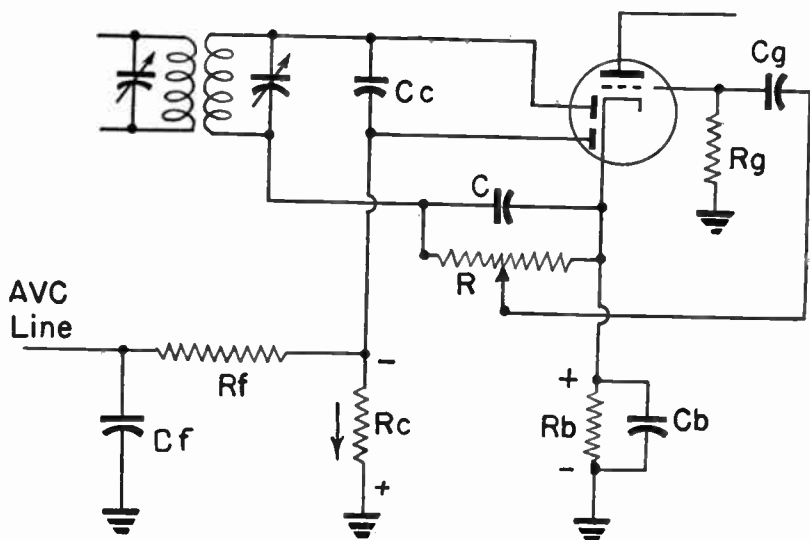

Fig. 13.—A circuit for delayed automatic volume control.

to the avc line. Capacitor  $C_f$  is the one whose voltage forms the avc biasing potential, just as in other circuits at which we have looked.

The avc biasing potential is developed across resistor  $R_c$ ; becoming greater with increasing electron flow due to stronger signal potentials from the tuned transformer, and less with weaker signals. The potential which opposes the avc bias, and delays the avc action, is the potential across the cathode-bias

resistor  $R_b$ . This potential is the grid bias for the amplifier section of the tube. Its value depends almost wholly on the value of amplifier plate current, since this plate current will be on the order of 0.5 milliampere (500 microamperes) or more, while the diode current will be on the order of 20 microamperes or less with usual operating conditions. Consequently, the opposing bias potential is but little affected by the changes of diode current which are the changes that vary the automatic bias. The result is that the avc diode is kept from rectifying until the potential across  $R_c$  exceeds that across  $R_b$ , because, until this happens, the avc diode plate remains negative with reference to the tube cathode.

Were the same diode, or two diodes tied together, used for both detection and for delayed avc, there would be no detection until the signal at the detector exceeded the opposing bias potential. Then weak signals would not be detected and amplified in the a-f system.

Fig. 14 shows a modification of the delayed avc system in which energy coming to the avc diode circuit through coupling capacitor

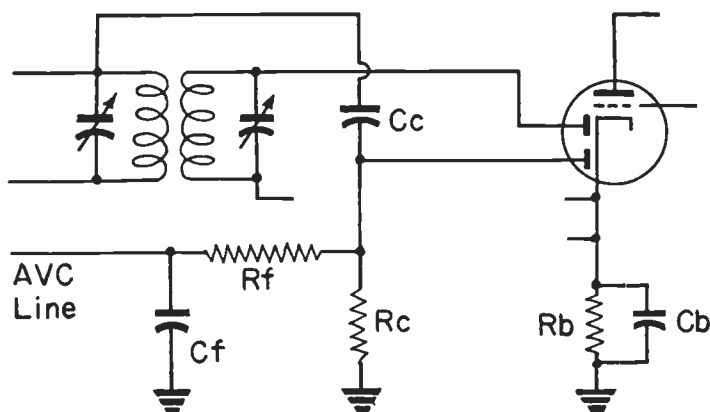

Fig. 14.—A delayed avc circuit connected to the primary of the input transformer.

$C_c$  is brought from the primary rather than the secondary of the tuned input transformer. The energy in the primary circuit, connected to the plate of a preceding tube, is greater than in the secondary of the transformer. Consequently, for a given signal

strength, this modification gives somewhat greater avc potential than does the arrangement of Fig. 13. The diagram of Fig. 14 shows only the delayed avc circuits, since the detector circuits and their connection to the a-f amplifier are not changed.

**Tuning Indicator Tubes.**—A tuning indicator tube, called also an electron ray tube or a “Magic Eye” is pictured in Fig. 15. The construction and the basic circuit generally used for a type commonly employed are shown by Fig. 16. The tube is used in radio receivers to indicate whether or not the adjustment of the tuning control is correct for the station being received. The indication is given by a shadow that varies in width on a glowing disc, called the target, which is visible in the end or top of the tube. The narrowest shadow which can be obtained by adjustment of the tuning dial indicates correct tuning. Wider shadow areas indicate incorrect tuning.

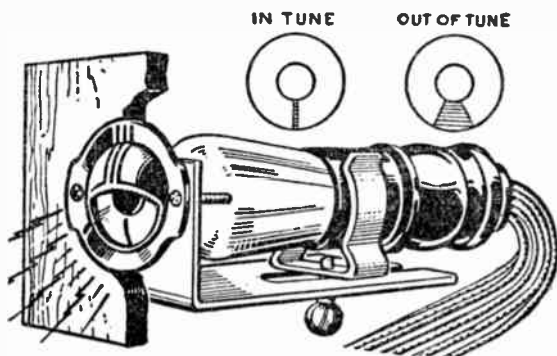

Fig. 15.—An electron ray tube for indicating correct tuning.

Referring to Fig. 16, the target which is visible through the end of the tube is of conical shape, coated on the inner surface with material which fluoresces or glows visibly when this surface is bombarded by electrons coming from the cathode which extends up into the center of the target. The red-hot cathode is made invisible by a cathode light shield. On one side of the cathode, between the cathode and the target, is a ray-control electrode. When this control electrode is made negative with reference to the target, or is made less positive than the target, the electric field around the electrode repels electrons coming from the cathode, and in a space corresponding in width to the electric field

the electron flow does not reach the target and there is a darkened region or a shadow over this portion of the target. The less positive the control electrode is made the wider is the space in which electrons are repelled, and the wider becomes the shadow on the target.

In the lower part of the tube are a plate, control grid, and cathode which form a triode. The same cathode extends through both the triode and the target portions of the tube. The ray control electrode is fastened to and is an electrical extension of the triode plate, so that the potential is the same on these two elements at all times.

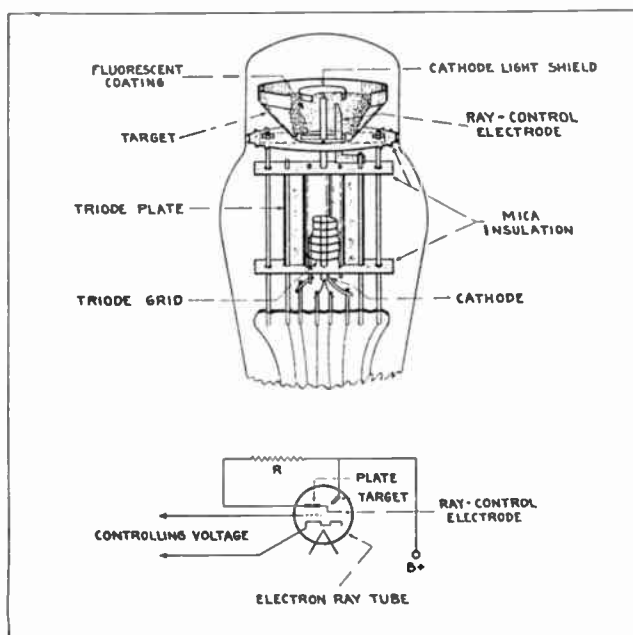

Fig. 16.—Internal construction and basic circuit for an electron ray tube.

Typical circuit connections for an electron ray tube are shown by Fig. 17. The target is connected directly to a point,  $B+$ , on the d-c power supply system having a potential somewhere between 100 and 250 volts positive. The plate and control electrode are connected through a resistor  $R$  to the same point on the d-c

supply system, and, of course, to the target through this resistor. The resistance at  $R$  usually is one megohm. Electron flow from the plate goes through  $R$  in the direction indicated by the arrow, meaning that the plate and control electrode connected to the left-hand end of  $R$  are negative with reference to the target, connected to the right-hand end, when there is electron flow. The greater the rate of electron flow, or the greater the plate current, the more negative the control electrode becomes with reference to the target and the wider becomes the shadow on the target.

Plate current and width of shadow on the target are controlled by the potential of the triode grid with reference to the cathode; just as plate current is controlled in any triode. The more negative the grid is made the less will be the plate current,

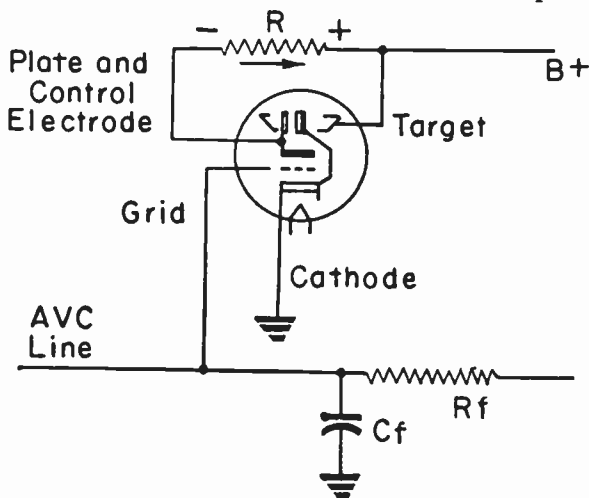

Fig. 17.—Circuit connections for an electron ray tuning indicator.

the closer the potential of the control electrode will approach the potential of the target, the less will be the repelling action of the control electrode on electron flow to the target, and the narrower will be the shadow on the target. Thus a highly negative triode grid causes a narrow shadow, which is to indicate correct tuning. A less negative grid has opposite effects.

The triode grid is connected to the avc line and the triode cathode is connected to ground. Then the grid is maintained at the negative potential of the avc line. As we know from our discussion of avc systems, the stronger the signal coming to the diode detector or to the avc diode the more negative becomes the

potential in the avc line, for it is the increasingly negative potential that reduces amplification on strong signals. But it is true also that when a receiver is correctly or exactly tuned to an incoming signal the sound output, and signal strength at the detector or avc tube, is greater than when tuning is not exact. Then correct tuning produces the maximum possible negative potential in the avc line and on the grid of the electron indicator tube, and narrows the shadow on the target in the manner explained earlier.

When a tuning indicator is used with delayed avc the indicator grid usually is connected not to the avc line but to the detector diode circuit through a resistor and filter capacitor similar to those for the avc circuit. Otherwise the tuning indicator would not operate on signals weaker than those which overcome the voltage delay in the delayed avc system.

Triode sections of electron ray tubes are made of either the sharp cutoff type or else of the remote cutoff type. With the sharp cutoff type the plate current and the target shadow are reduced to zero with grid potentials or avc potentials which are 4 to 8 volts negative. With the remote cutoff type the plate current and shadow are reduced to zero with negative potentials of 8 to 22 volts on the electron ray grid. With any given tube the cutoff grid potential depends on applied plate potential, increasing with increase of plate potential. Which type of electron ray triode is used depends on how much the avc potential will vary during operation of the tuning control.

There are types of electron ray tubes having no triode section, but having two ray control electrodes on opposite sides of the cathode and within a single target. This indicator tube is used with a separate triode, or with a pentode connected as a triode, so that two similar shadows are produced at the same time. This double indicator tube may be used also with one control electrode actuated on weak signals and the other one on strong signals. The operating principles are the same as for the type previously explained in detail.

There are also special types of tuning eyes such as the 6AL7 which are used for f-m and television in connection with its f-m section. These are double indicators to show the center point in the f-m tuning curve.

**Tone Control.**—If it were possible to have the audio-frequency modulation in a received signal perfectly uniform at all fre-

quencies from 50 to 5,000 cycles per second, and to have a receiving and reproducing system amplifying all these frequencies uniformly, the final sound output might be represented by the curve on graph A of Fig. 18. Although such a flat response is

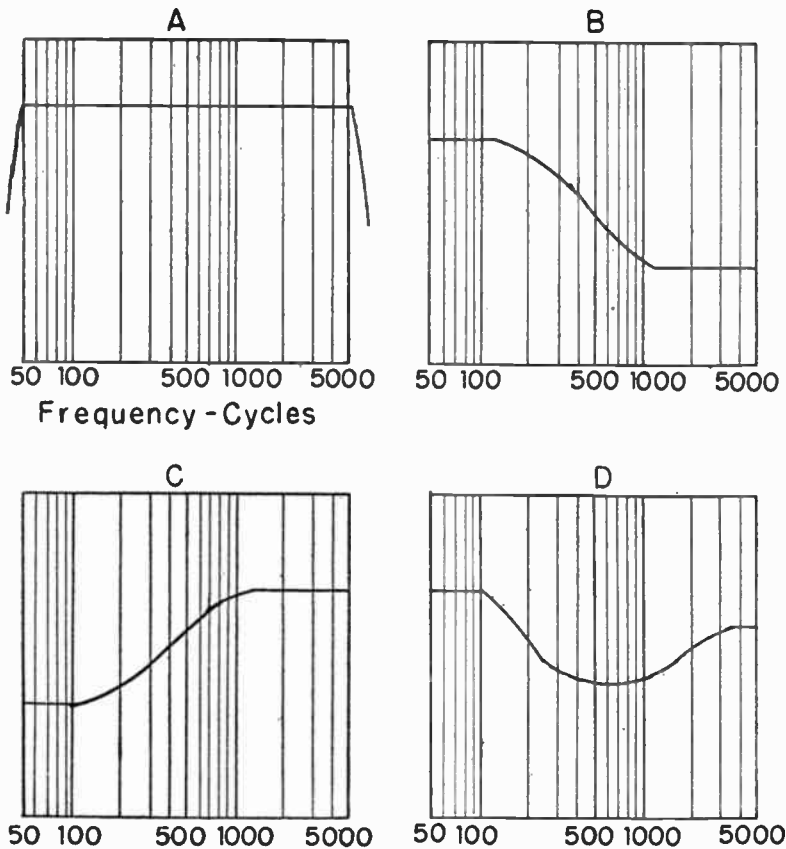

Fig. 18.—Sound output responses. The ideal response is at A. Tone modifications are at B, C and D.

practically impossible to attain, we shall assume that it exists and that it may be modified to effect tone control.

If the audio-frequency amplifying system of the receiver is modified in such manner as to decrease the response at the higher

audio frequencies the resulting response might be shown as in graph *B*. Actually we have lessened the high-frequency response, but because this leaves the lower frequencies with the greater amplification and power than the highs the effect on our ears will be an increase of low-frequency response. The condition of graph *B*, or any approximately similar condition, seems to emphasize the low notes, or it "boosts the bass."

If the audio-frequency amplifying system is modified in such manner as to decrease the response at the low audio frequencies the result will be on the general order of that shown by graph *C*. Now, because the low frequencies have been greatly weakened while the higher frequencies are only very slightly weakened, the sound output will affect our ears as emphasis of the high notes. The high audio frequencies are stronger than the low ones. Here we "boost the treble."

The average human ear is most sensitive to sounds in the range around 500 to 1,000 cycles, or somewhat higher, and becomes increasingly less sensitive to sounds at lower and higher fre-

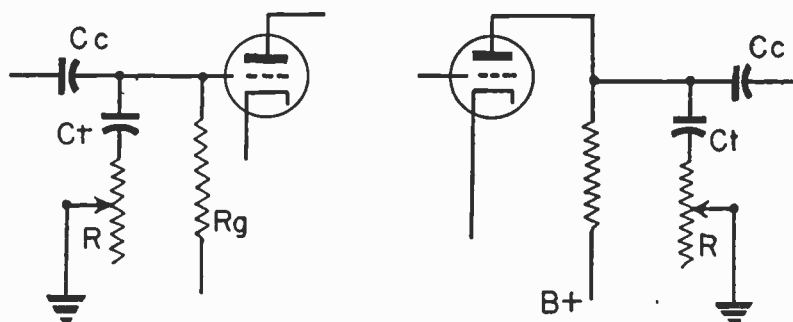

Fig. 19.—Tone control in a grid circuit (left) and in a plate circuit (right).

quencies. If the sound output is adjusted to a low level by means of the volume control, the low notes and the high notes may seem to almost disappear and we hear only the middle tones. This effect sometimes is partially compensated for by modifying the audio-amplification in the general manner shown by graph *D*. Here the response is lowered in the middle frequency range, leaving



the lows and highs relatively stronger, and, to our ears, giving the effect of fairly uniform frequency response over the entire range. Tone controls which act in this manner usually are combined with and operated with the manual volume controls, so that the effect of graph *D* is brought about only when the volume control is turned down.

Fig. 19 shows tone controls which attenuate or reduce the high frequencies, and which seem to boost the bass notes. In the left-hand diagram the tone control is on the control grid circuit of the first a-f amplifier tube. This control consists of a capacitor *Ct* and

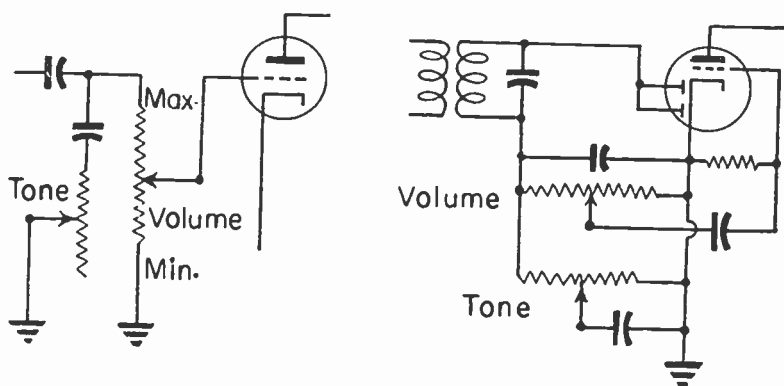

Fig. 20.—Tone controls in the some circuits with volume controls.

an adjustable resistor or rheostat *R* in series with each other and between the control grid and ground. The coupling capacitor is *C<sub>c</sub>* and the regular grid resistor is *R<sub>g</sub>*. Capacitor *C<sub>t</sub>*, like all capacitors, has decreasing reactance with increase of frequency, and bypasses to ground the higher audio frequencies to give the general effect of graph *B* in Fig. 18. The degree of bypassing and the consequent reduction of high frequencies is regulated by adjustment of the slider on resistor *R*. With the slider at the top the capacitor is connected directly to ground, and there is maximum reduction of highs with apparent maximum emphasis on lows. Moving the slider downward inserts more and more resistance in series with the capacitor, and lessens the tone control effect.

At the right in Fig. 19 is a tone control connected to the plate circuit of an a-f amplifying tube. The action is similar to that of the control shown at the left, except that here it is the high frequencies in the plate circuit that are bypassed to ground through capacitor  $C_t$  and adjustable resistor  $R$ .

Either of the continuously adjustable controls of Fig. 19, and all other controls shown continuously adjustable in other diagrams, might be replaced by a tapped resistor and a tap switch to permit certain definite steps of control rather than a continuous variation from minimum to maximum effect.

The left-hand diagram of Fig. 20 shows the same tone control as at the left in Fig. 19, but here the fixed grid resistor is replaced with a volume control in the grid circuit.

At the right in Fig. 20 are shown a volume control and a tone control connected in the diode circuit of a diode detector. The volume control is like others which we have examined. The tone control resistor and capacitor form an adjustable bypass for the higher audio frequencies. With the slider of the tone control

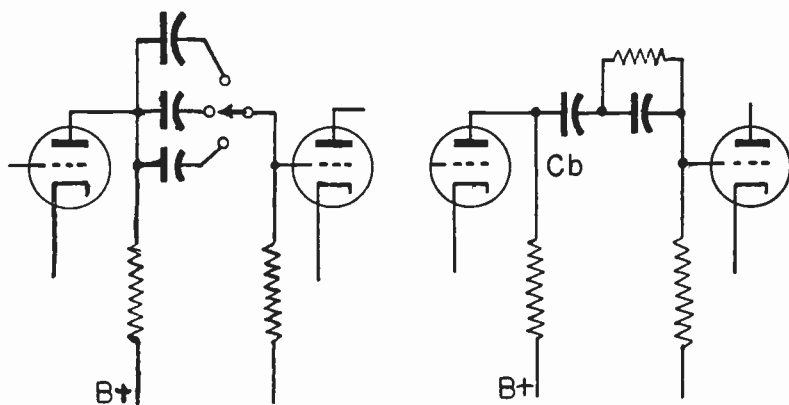

Fig. 21.—Tone controls which reduce the response at low audio frequencies.

resistor all the way to the left, the capacitor is connected directly between the diode circuit and ground, and there is maximum attenuation of highs and maximum emphasis on lows. Moving the slider to the right places resistance in series with the capacitor, and lessens the effect of the tone control.

Fig. 21 shows tone control circuits whose operation depends on the fact that a smaller coupling capacitor in a resistance-capacitance coupling between amplifying stages lessens the response at lower audio frequencies. In a typical case, changing the coupling capacitor from 0.002 to 0.001 mfd might change the frequency for a given output level from 40 to 80 cycles. Stated differently, this change of capacitors might reduce the original good response at 40 cycles to almost no response at all. The left-hand diagram of Fig. 21 shows three different capacitors connected through a tap

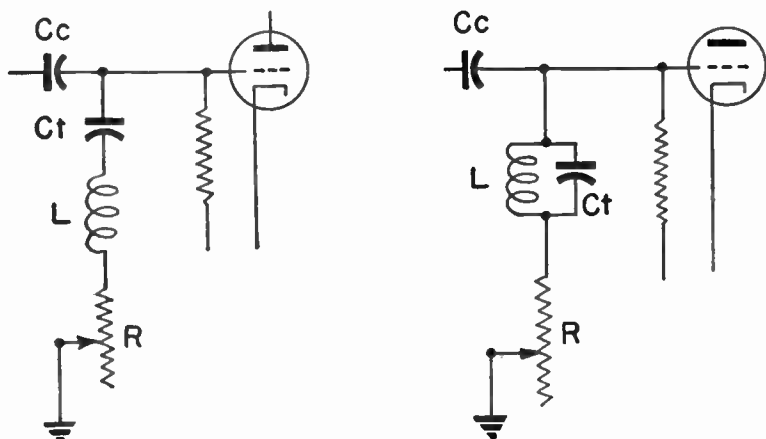

Fig. 22.—Tone controls employing tuned resonant circuits.

switch so that either of them might be cut into the circuit. The largest capacitance would give the best low-note response, and the smallest would give the greatest low-note attenuation. The effect is that of graph *C* in Fig. 18.

If the slope of the attenuation curve is to be made less abrupt, the coupling capacitor may have a resistor connected in parallel, as at the right in Fig. 21. Then, assuming that originally we had the response of graph *C* of Fig. 18, the slope might be made to extend from something like 60 to 2,000 cycles instead of from about 100 to 1,200 cycles as in the graph. With the resistor across the coupling capacitor it is necessary to use an additional block-

ing capacitor,  $C_b$ , to insulate the plate circuit from the grid circuit.

Another method of attenuating or weakening the lower notes is to use a smaller capacitance in the bypass capacitor for a cathode-bias resistor on the first a-f amplifier. This method introduces degeneration and lessens the overall amplification, so may be used to only a limited degree for tone control.

The left-hand diagram of Fig. 22 shows a tone control circuit by means of which any range or band of audio frequencies may be weakened or attenuated to produce a response on the order of that shown by graph  $D$  of Fig. 18. With the method of control illustrated there is connected between the control grid of the a-f tube and ground a series resonant circuit consisting of capacitor  $C_t$  and inductance  $L$ . This resonant circuit is in series with an adjustable resistor  $R$ , which regulates the degree of attenuation.

The capacitance and inductance are selected of such values as are resonant at the frequency to receive greatest attenuation. Maximum attenuation at and near this frequency will be had with the least series resistance in  $R$ , and the least effect will be had with greatest resistance in  $R$ . For audio-frequency resonance the inductance of  $L$  usually is one henry or more. Because of the great variation of resistance which must be provided at  $R$ , the continuously adjustable resistor may be replaced with a tap switch and several resistance units.

At the right in Fig. 22 is shown a tone control circuit which will apparently emphasize or accentuate any band of audio frequencies; doing this because it really attenuates the frequencies on both sides of the band. This would mean a response curve of similar shape to the one in graph  $D$  of Fig. 18, but turned upside down. In this arrangement we have a parallel resonant circuit consisting of capacitance  $C_t$  and inductance  $L$ , with this resonant circuit in series with an adjustable resistor  $R$ . More resistance in  $R$  lessens the effect, and less resistance increases the effect. The values of capacitance and inductance for the resonant circuit have to be about the same as for the one in the left-hand diagram.

Either of the arrangements of Fig. 22 may be adapted for use in the plate circuit instead of in the grid circuit of the a-f tube; much as the control shown in the grid circuit at the left in Fig. 19 is put over into the plate circuit at the right.

REVIEW QUESTIONS

1. What kind of material would you expect to find in a volume control with a resistance value of 100,000 ohms?
2. Is a manual type volume control necessary on receivers that are equipped with an automatic volume control?
3. What is the advantage obtained by using delayed automatic volume control?
4. What is the target indication on a tuning indicator when the receiver is correctly tuned?
5. What kind of a control would you select for purposes of emphasizing either high or low frequencies?

## Chapter 5

### AUTOMOBILE RADIOS

The handicaps to satisfactory operation which have to be overcome by a radio receiver operated inside of a moving automobile are so many that it is remarkable that there is any recognizable reproduction of programs, yet such receivers have been perfected to a degree which permits performance comparable in all respects to that of first class receivers for the home.

The automobile radio must be of small size to fit into the limited space available, yet it must have great amplification or gain, and must have a level of sound output from the loud speaker which is as great or greater than that of much larger home radios. The high sound level is needed to override the sounds of the wind, the surrounding traffic, and the engine of the motor car. The high gain is needed because of the low signal strength available from the antenna. The small space inside of an automobile body, and the presence of so many surfaces which tend to absorb sound energy, make for a limited range of audio-frequency reproduction. The small-diameter loud speakers which must be used do not help matters. Consequently the automobile radio requires special compensation for tone, and usually has an effective tone control.

One of the major difficulties to be overcome arises from the great variety of electrical interference present all around the automobile radio. Strong interference comes from the ignition system of the automobile engine. Additional interference comes from the battery-charging generator and from any windshield wipers, fans, or other electrically driven devices. Interference is produced by electric charges developed on any parts which have relative movement, even by movement of the tires over the road, and by charges which may form on any parts of the automobile which are wholly or partially insulated from the main framework or chassis.

Although electrical interference always is present, and always is strong, the desired signal reaching the antenna often drops to

very low values. At other times the signal may, relatively, be as much as one hundred times the maximum. This calls for the incorporation into the automobile radio of an effective system for automatic volume control.

After designing a receiver of minimum size with ability to overcome all of the hindrances to good reproduction, the whole mechanism must be made mechanically strong, and all of the parts must be securely held in place, to resist the vibration which always is present while the automobile is in motion.

So far as the amplifying and sound reproduction systems of the automobile radio are concerned, their basic design differs little or none from that of home radios. All of the automobile sets are superheterodynes. The chief differences between automobile and home radios are found in the antenna systems and in the high-voltage d-c power supply systems which supply potentials and currents to plate, screen grid, and control grid circuits. The antenna of the automobile radio has so little pickup ability for desired signals that its impedance must be matched

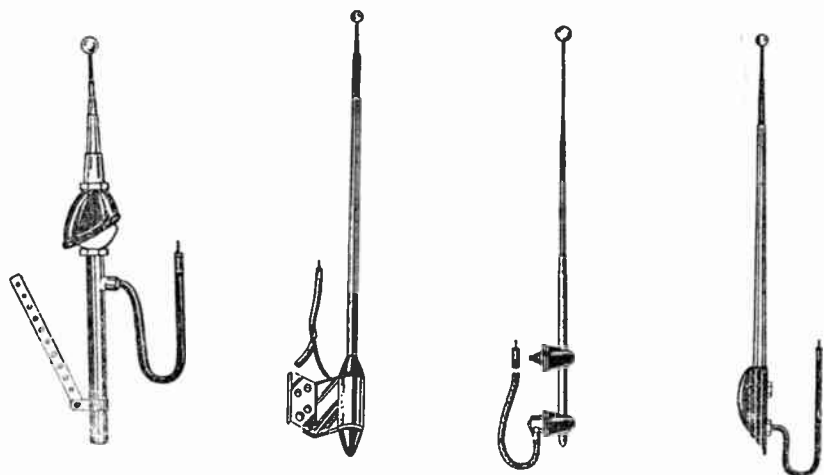

Fig. 1.—Telescoping types of auto-radio antennas. (Spirling)

to the input impedance of the receiver to get all possible signal energy into the receiver. The power supply for the automobile radio is the six-volt storage battery of the motor car, which sup-

plies low voltage direct current rather than the high-voltage alternating current which is the usual supply for home receivers.

**Automobile Antennas.**—Antennas which are in most common use are of the general type illustrated by Fig. 1. They consist of tubular metallic sections which telescope one within another to form a vertical conductor which may be extended to various lengths. The supporting bracket or brackets may be attached at a variety of places on the automobile; on a fender, on the cowl either at the section enclosing the engine or the one extending over the body, on some parts of the hood, on a door hinge, or on the body itself. Some of these antennas may be collapsed until they almost disappear. The greatest extension may be eight or nine feet, depending on the number of telescoping sections and their individual length.

To the lower section of the vertical conductor is conductively connected a lead-in conductor which has weatherproof low-loss insulation, and which is enclosed with a woven or braided metallic shielding sheath which is grounded. The vertical conductor is well insulated from its supporting brackets and from the car framework.

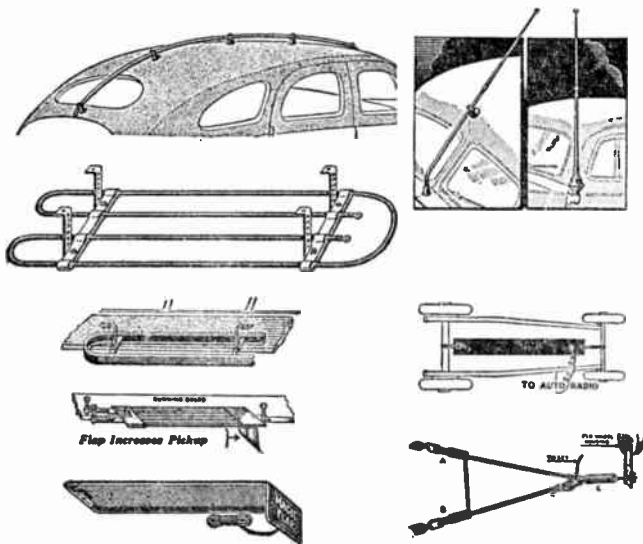

Fig. 2.—Antennas for installation on the top, under the running board, and on the chassis of the automobile.



Because an automobile rides on rubber tires, no part of its metallic chassis is at the potential of the earth, and we cannot have an antenna system of the capacitor type having the earth as one plate. However, the large mass of metal in the chassis and body of the automobile provides a satisfactory "lower plate" or counterpoise, while the elevated antenna conductor provides the upper plate. The signal potentials are developed between these two plates by the radiated fields of the signal.

It follows that any metallic part which is well insulated from the car chassis and body might be used as one plate of the antenna capacitor. Fig. 2 illustrates some such antennas formerly used, as well as the present type shown in the upper right-hand corner. The other types have been mounted on the car top, underneath the running board or boards, and down around the axle level of the running gear. Bumpers and other large metallic parts have been insulated and used as antennas.

The shielded lead-in conductor extends from the bottom of the antenna to the metallic housing which encloses the receiver, and there the lead-in ordinarily terminates in a connector of the plug-in or else the bayonet type. The connector grounds the shielding of the lead-in to the receiver housing. The lead-in conductor may be of number 20 gage standard copper wire, with the external diameter over the insulation and shielding something between  $3/16$  and  $1/2$  inch.

**Antenna Circuits.**—Fig. 3 shows several antenna circuits such as are found between the elevated antenna conductor and the control grid of the first tube in the automobile radio receiver. In this figure all of the tubes are r-f amplifiers, but generally similar antenna circuits might be used where the input is to the signal grid of a converter tube. In each diagram *A* indicates the capacitor that is adjusted in order to match the capacitance of the antenna with the inductance of the input circuit to permit maximum transfer of energy into the receiver. These capacitors are called antenna trimmers.

Note that in all of the diagrams the line which furnishes variable grid bias for automatic volume control, the line marked *AVC*, goes either directly to the control grid or else through an inductance, which is a conductive circuit, to the control grid of the first tube.

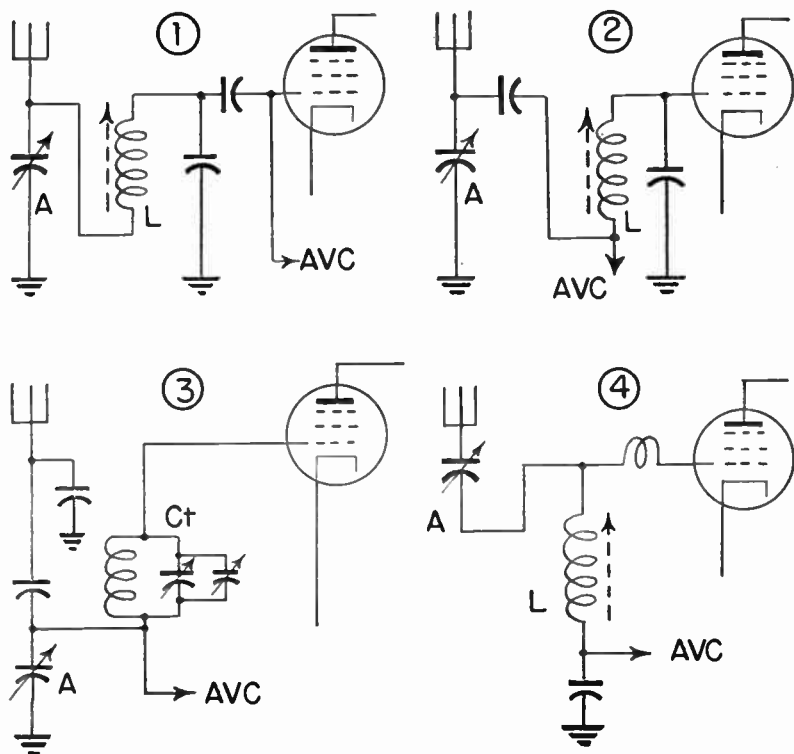

Fig. 3.—Typical auto-radio antenna circuits.

In diagrams 1, 2 and 4 the control grid circuit is tuned to resonance by varying the value of inductance  $L$ . That is, we have tuning by means of an adjustable powdered-iron core in these coils, or have what often is called permeability tuning. The tuning adjustment is indicated by broken line arrows alongside the symbols for the coils. In diagram 3 the grid circuit is tuned by an adjustable tuning capacitor  $C_t$ , in parallel with which is a trimmer capacitor. The tuning inductors, or the tuning capacitor, would be operated by the same tuning dial or control that operates the tuning in the grid circuits of a following converter and in the tuned circuits for the oscillator section of a converter.

The antenna trimmer is adjusted when the receiver is first installed, or when alterations have been made, and is not there-

after changed. Usually the adjustment is made by extending the antenna conductor to its maximum length, tuning in a weak station in the high-frequency end of the tuning range, and then adjusting the trimmer for maximum volume.

Additional antenna circuits are shown by Fig. 4. The antenna trimmer capacitors again are marked *A*, adjustable tuning inductances are marked *L*, and the avc lines are marked *AVC*. The tubes in diagrams 1 and 4 are shown as pentagrid converters, and in diagrams 2 and 3 as r-f amplifying pentodes.

In diagram 1 the antenna circuit is tuned to resonance at the received signal frequency by the left-hand adjustable inductance, while the control grid circuit is tuned to resonance with the

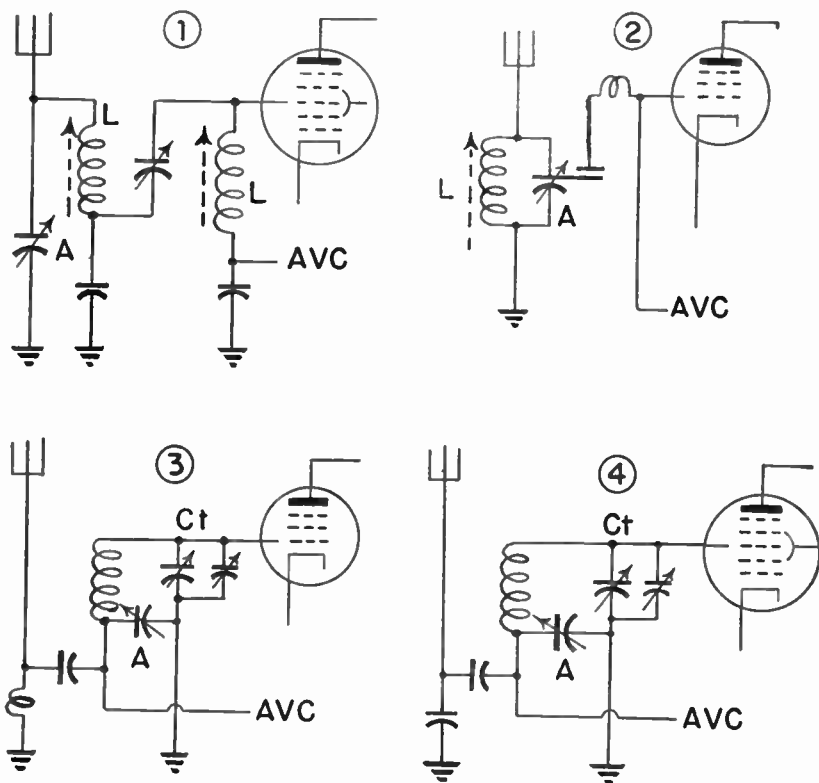

Fig. 4.—Antenna circuits feeding into radio-frequency amplifying tubes and converters.

signal by the right-hand adjustable inductance. These two adjustments would be operated from the same tuning control that operates the oscillator tuning. Adjustable coupling between the tuned antenna circuit and the tuned control grid circuit is provided by the adjustable capacitor connected between the respective circuit inductances.

In diagram 2 the capacitance in the tuned circuit is provided by the antenna and by the antenna trimmer *A*. This circuit, which is in the control grid circuit for the tube, is tuned to resonance at the signal frequency by adjustment of the adjustable inductance *L*, which would be operated in connection with the tuning for the following converter signal circuit and oscillator circuit. Potential changes from the tuned circuit of the diagram are applied to the control grid through a capacitive coupling on the antenna trimmer capacitor, and go through a small choke coil which reduces high-frequency interference.

In diagrams 3 and 4 the antenna trimmer capacitor is in series between the coil of the tuned resonant circuit and the tuning capacitor, and its trimmer, in this circuit. Here the antenna trimmer is in a position which makes it correspond to the padding capacitor used in some oscillator tuned circuits. Trimmers which are in this position, rather than in the antenna circuit, usually are adjusted while the receiver is tuned to a station near the low-frequency end of the tuning range, say to a station around 600 kilocycles in the broadcast band.

Although antenna trimmers usually are present, they are not absolutely essential provided the receiver has sufficiently high gain. In some automobile radio receivers there are no trimmers for matching the antenna to the receiver input.

**Tube Arrangements.**—Fig. 5 represents the types of tubes, and their functions, as generally employed in automobile radio receivers. The tubes shown here include all of those in the amplifying portion of the receiver, but do not include the rectifier tube which is used with some kinds of d-c power supplies.

At the top is a four-tube arrangement in which the antenna input circuit would connect directly to the r-f signal grid of the converter tube. The converter is followed by a single stage of i-f amplification. Then comes a single tube acting as a diode detector, automatic volume control tube, and first audio-frequency ampli-

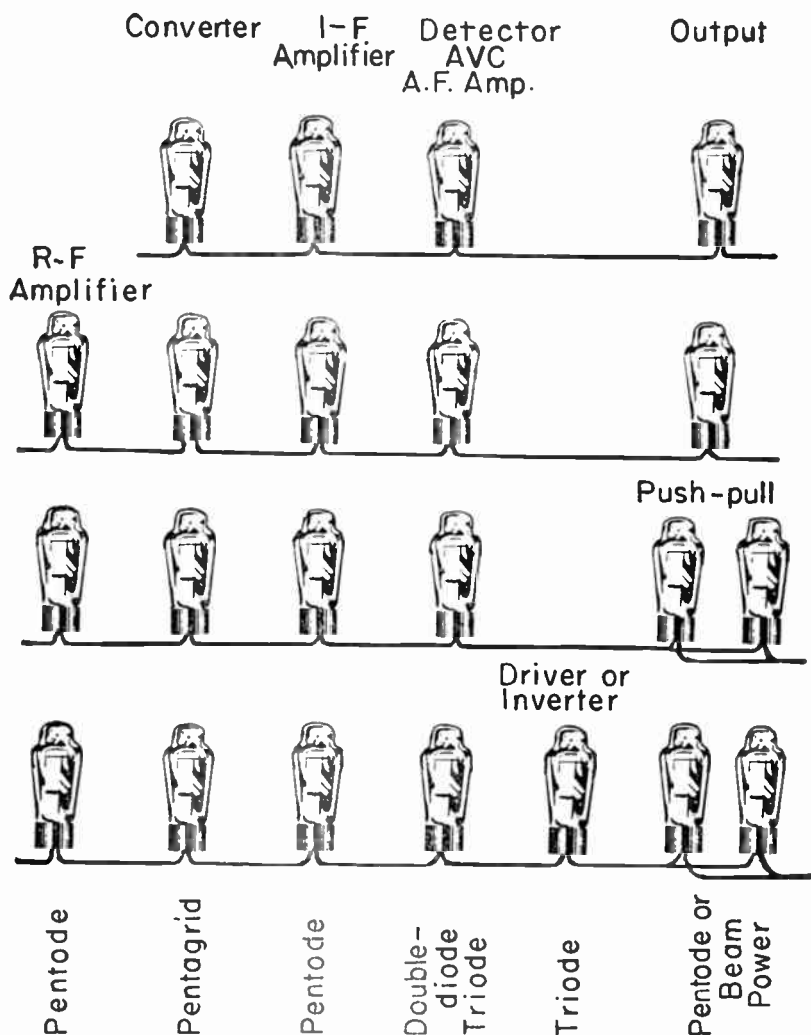

Fig. 5.—Some of the orders in which tubes follow one another in auto-radios.

fier. The a-f section of this tube is coupled to a single output tube or power tube, which feeds the loud speaker.

The second arrangement is like the first one except that there is a single stage of r-f amplification between the antenna and the converter. The third arrangement is like the second with the

exception that the single output tube is replaced with two output tubes in a push-pull amplifier circuit. The two separate push-pull tubes may be replaced by a single double-triode or double-pentode tube which handles both sides of the push-pull circuit.

In the arrangement at the bottom there is an additional tube between the a-f section of the detector-avc-af tube and the push-pull output tube or tubes. With transformer coupling to the push-pull stage this added tube is in a driver stage, while with resistance-capacitance coupling to the push-pull stage the added tube is a phase inverter tube.

The types of tubes ordinarily used in the several stages are: A voltage amplifying pentode in the r-f stage, a pentagrid converter in the converter stage, another voltage amplifying pentode in the i-f stage, a double-diode-triode for the detector-avc-af circuit, a voltage amplifying triode for driver or inverter, and either power pentodes or beam power tubes for two separate push-pull output tubes.

The avc systems are like those for home receivers, which have been explained in another chapter. Either straight avc or else delayed avc may be used.

**Tone Control.**—As explained when discussing the principles of tone control, it is possible to reduce the response at high audio frequencies, and thereby emphasize the low frequencies, or to reduce the lows and thereby emphasize the highs. However, no method of tone control will bring about the reproduction of frequencies which do not come through the amplifying system. In automobile receivers it is desirable to have good high-frequency response because such frequencies bring the sound reproduction above noises of traffic and above mechanical noises, also because fairly high frequencies are necessary to make speech most intelligible, and because high frequencies are absorbed or deadened more than are low frequencies by the materials used for automobile upholstery. It is desirable to amplify the lowest frequencies which can be reproduced by speakers of the limited sizes used with automobile radios, this because many people like to have these low frequencies in musical reproduction.

The highest and lowest frequencies which are amplified and brought to the voice coil of the loud speaker depend on the design of the amplifiers, especially the audio amplifier. Here, as we know,

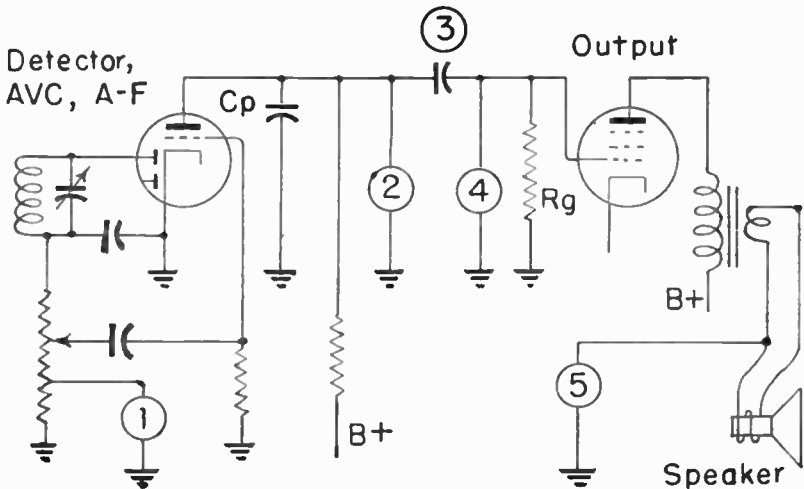

Fig. 6.—Positions at which tone controls may be connected in the a-f amplifier.

the frequency range is determined by choice of plate and grid impedances or resistances in resistors, by choice of capacitance in interstage coupling capacitors, and other factors.

Tone controls for automobile receivers most often are of the types which attenuate or weaken the higher audio frequencies. For high-frequency reproduction, sometimes identified as the "voice" position of the tone control, the attenuation system is simply cut out of circuit. For intermediate frequencies, or "music," the effect of the control may be limited by series resistance, and for emphasis on low frequencies or "bass," the full attenuation of highs is employed.

Fig. 6 shows five places at which tone controls often are connected in auto radio receivers. At 1 the control is connected to the grid circuit of the first a-f tube, or to the diode detector circuit. The control may consist of a capacitor and adjustable resistor in series between some point in the grid or diode circuit and ground.

Many tone controls are found at position 2, between the plate of the first a-f tube and ground, and paralleling a plate bypass capacitor  $C_p$  which bypasses the high intermediate frequencies which get into the plate circuit. Controls at this point may consist of a capacitor having capacitance between 0.001 and 0.05 mfd.

connected or disconnected by a tone switch. The greater the capacitance the more the high frequencies are attenuated. Instead of a capacitor alone, the capacitor may be in series with an adjustable resistor whose resistance may be as high as one or two megohms. Varying the resistance varies the tone. The less the resistance in circuit the more the high frequencies are attenuated.

At position 3 there may be adjustable coupling capacitance, the adjustment usually being by the use of capacitors of different capacitances which are switched in and out of the position. The greater the capacitance at this point the lower are the frequencies amplified.

A control in position 4 may be of the same general types as used in position 2. That is we may use a bypassing capacitor or else a capacitor in series with an adjustable resistor which is the control unit. The control unit is used in addition to the regular grid resistor  $R_g$ , since the control grid must have a conductive connection to ground and the cathode circuit in order to permit grid biasing.

The final position, 5, shows the volume control connected between the voice coil circuit of the loud speaker and ground. The control at this point will consist of a capacitor and resistor, or resistors, in series. Any of the controls mentioned may be used alone, as the sole tone control, or almost any two of them may be used together and operated from the same control knob or switch to produce several steps of tone variation. The types of controls mentioned and the positions indicated are not the only ones found in automobile radios, but they represent common practice. Some receivers have no manually operated tone controls, being designed to produce a generally satisfactory range of audio frequencies.

**Power Supply System.**—Fig. 7 shows the principal parts of the power supply system for the automobile radio receiver, also their relations to one another and to the units to which currents and potentials are supplied.

The source of power is the automobile battery which supplies also power for the lamps, starter, horn, and all other electrically operated accessories, and which is given its own energy by the charging generator driven by the automobile engine. One side of



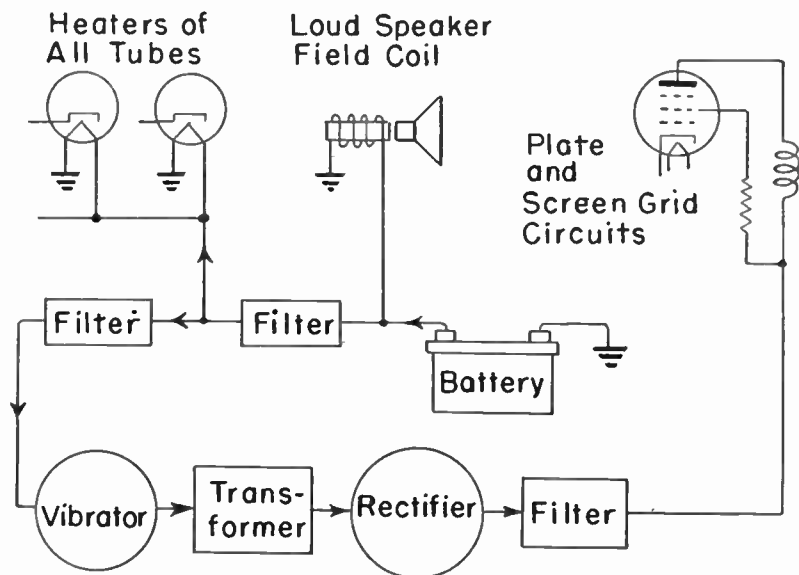

Fig. 7.—Principal units in the power supply system.

the battery is grounded to the framework or chassis of the automobile. From the ungrounded or "hot" side of the battery current is taken through the field winding of the electrodynamic loud speaker used in the majority of automobile installations. The resistance of the field coil usually is 4.0 ohms or very near this value, which means that with a battery potential difference of 6.0 volts the field current is 1.5 amperes. The total current taken from the storage battery for radio, including the field coil current, usually is between 7 and 8 amperes; depending, of course, on the number of tubes and the general operating requirements.

Following the take-off to the speaker field comes a filter unit which reduces high-frequency interference coming through the battery line. Then comes a connection leading to the heaters of all the tubes. Heaters are in parallel between this line and ground. Each output tube, and the rectifier if one is used, take from 0.4 to 0.8 ampere each in usual types, while all other tubes usually are of types taking 0.3 ampere for the heater. All of the heaters are of the 6.3-volt type. A few receivers use other arrangements, among these being the connection of 1.4-volt filaments in series.

Following the take-off for the heaters is a second filter unit which further reduces interference potentials.

Next in line comes a vibrator which is a device for changing the low-voltage direct current from the battery into low voltage alternating current. This low-voltage alternating current is passed through the following transformer, which changes it to high-voltage alternating current. This current then goes through a rectifier which changes it to high-voltage pulsating direct current. The rectifier may be a tube, or else may be a part of the vibrator mechanism. From the rectifier the pulsating direct current goes through a filter system which is similar to the one used following any rectifier in a d-c power supply system. From this final filter system there is delivered to the plate and screen grid circuits of the tubes a smooth direct current at the necessary high potentials. Now we may take up the several units or sections of the complete power supply system and examine their operation.

**Battery Circuit.**—Typical circuit arrangements found between the car battery and the vibrator of the d-c power supply are shown by Fig. 8. None of these circuits apply specifically to any one make of car or radio receiver, but they show the features usually present in various combinations for all installations.

In all cases the circuit starts from the ungrounded terminal of the car storage battery, from which a lead which is part of the car wiring runs to one terminal of the ammeter mounted on the car dash or instrument panel. From the other terminal of this meter there are leads going to the lamps and other electrically operated accessories, and there is a lead coming from the charging generator. Generator current which charges the battery flows through the meter in such direction as to make the instrument indicate "charge," while current taken from the battery for lamps and accessories flows the opposite direction, and causes the meter to indicate "discharge."

The connection to the radio apparatus may be made to either side of the ammeter. If it is made to the generator and lamp side, as in the upper diagram, the radio current will be shown on the ammeter as a discharge. If the connection is made to the battery side of the meter, as in the center diagram, the radio current will not show on the meter.

The lead from ammeter to radio usually is a cable with a

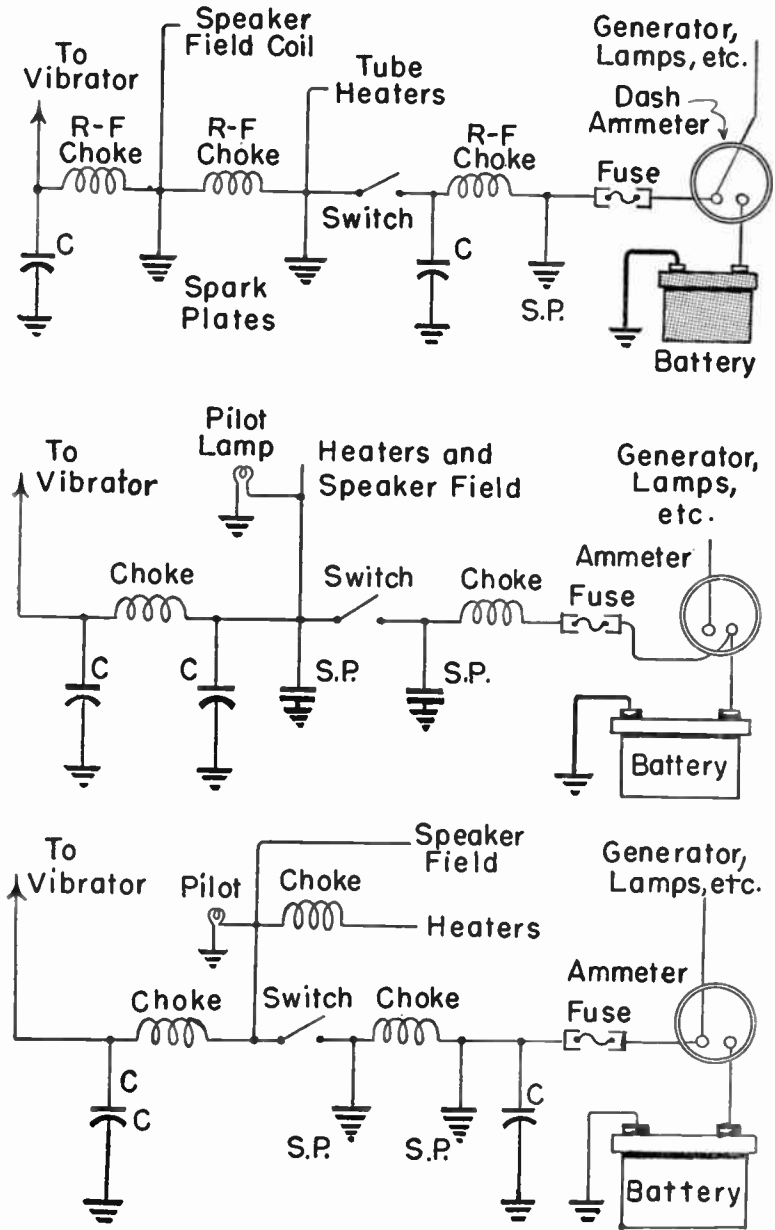

Fig. 8.—Circuit connections used between the car battery and the vibrator.

terminal suitable for the ammeter stud at one end, and a plug fitting the battery receptacle of the radio at the other end. The cable often contains the radio fuse, enclosed within a bayonet type of connector which is a part of the cable assembly. The fuse capacity or rating, in amperes, usually is about double the normal current taken from the battery by the radio apparatus. Common fuse ratings are between 4 and 30 amperes.

Following the fuse in the upper diagram, and at various points in this and the other diagrams, are units called "spark plates" designated by *S.P.* in the diagrams. A spark plate is a capacitor, usually of only about 0.00025 mfd capacitance, whose chief peculiarity is that it is riveted or soldered to the radio set chassis or to the shielding framework or housing of the set, thus bringing one plate of the capacitor very close to this grounded metal. These small capacitors are effective in bypassing to ground much of the high-frequency interference potentials which come from the battery-generator circuits and the connected lamp and accessory circuits. The name spark plate came to be used because the units first were used for reducing the interference due to ignition sparks and spark currents.

Somewhere in the line or lines from ammeter to radio apparatus are two or more high-frequency or radio-frequency choke coils. The purpose of these coils is to offer high impedance to high-frequency currents which cause interference, and to force these currents to take the bypass paths to ground. For this purpose the chokes need to have only small inductance. Furthermore, the chokes must not have large inductances because the vibrator draws current in rapid pulses, and the necessary rapid changes of current would develop such high reactance in large inductances as to prevent correct operation. The chokes are of air-core construction, sometimes bank-wound to reduce their distributed capacitance, and made with wire large enough to keep down the resistance. The resistance in the whole battery circuit must be low, because the battery potential is only six volts to begin with, and because the current is large enough to result in considerable voltage drop were there any high resistance in the line.

Note that there always is one choke coil between the ammeter and the line or lines going to tube heaters and loud speaker field coil. This first choke carries the currents for the heaters and field

in addition to that for the high-voltage power supply, and consequently will have larger wire and lower resistance than the chokes which are beyond the take-off for the heaters and field coil.

The switches shown in the diagrams of Fig. 8 are the on-off switches for the receiver. They may be operated in conjunction with the volume control; as is home radios. The high-frequency bypass capacitors, *C*, between the battery line and ground, usually are of 0.5 mfd capacitance. Ordinarily there are two of these bypass capacitors, placed at various points in relation to the choke coils.

Note that in the upper diagram there are separate take-offs for the tube heaters and for the speaker field coil, with a choke between them. In the other diagrams the same take-off goes to both heaters and field coil. In the bottom diagram there is an additional choke coil in the line going to the heaters. We find that all of the battery circuits contain high-frequency choke coils, bypass capacitors, spark plates, the radio fuse, and the on-off switch. The exact arrangement of these parts in relation to one another may vary widely between different cars and between different makes and models of radio receivers; the particular connections used being dependent on the design of the radio apparatus and on the methods which have been found most effective in eliminating interference.

When a pilot lamp is used for the radio receiver, this lamp is connected anywhere beyond the on-off switch, but usually at the take-off for heaters and field coil.

The purpose of all the filter elements used in the battery line is to deliver to the vibrator system of the high-voltage power supply a direct current which is as free as possible from interference potentials. Interference arises in practically every one of the many car circuits which are connected to the battery and the ammeter.

**High-voltage Supply Circuits.**—Fig. 9 shows the elementary principles of a vibrator and rectifier system for furnishing high-voltage direct current to the plate and screen grid circuits of the radio receiver. The principal elements include the car battery, the vibrator which changes direct current to alternating current, the transformer which raises the voltage, and the rectifier which

changes the alternating potentials to direct potentials and currents.

The vibrator consists essentially of a flexible reed carrying one contact point, and of two stationary contact points with which the one on the vibrating reed makes alternate contacts. The reed is connected to one terminal of the car storage battery, usually through ground in the automobile chassis. The two stationary contacts of the vibrator are connected to the outer ends of the

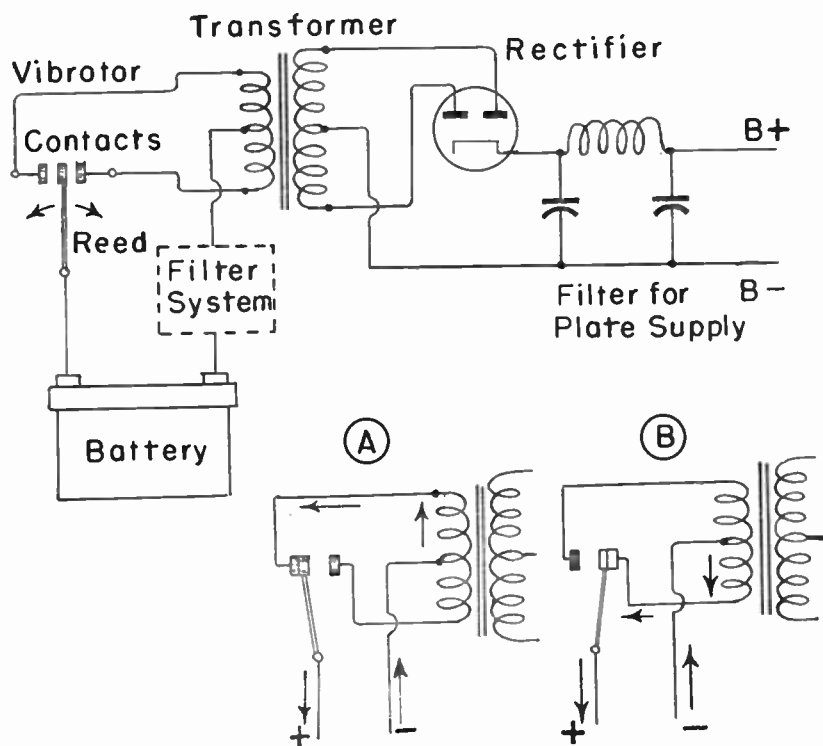

Fig. 9.—A circuit containing a vibrator, a step-up transformer, and a tube type of rectifier.

center-tapped primary winding of the transformer. The primary center tap is connected to the other terminal of the battery, usually through the interference filtering system such as was shown in Fig. 8.

The center-tapped secondary winding of the transformer is connected at its ends to the plates of a full-wave rectifier tube. The center tap of the secondary is connected to the B— line for the plate and screen grid circuits; this line often being carried through ground. The cathode of the rectifier connects through a filter choke, as shown, or through a filter resistor to the B+ line for the plate and screen grid circuits. There are bypass capacitors on both sides of the filter choke or resistor, just as in most other low-pass filter systems designed for smoothing the pulsating direct current from the rectifier and supplying a steady output current and potential.

The action of the vibrator is shown in the sketches at the bottom of Fig. 9. At *A* the reed has moved to the left and makes contact with the left-hand stationary contact. Electron flow then is as shown by arrows, from the battery through the upper half of the transformer primary and back to the battery. At *B* the reed has moved to the right, and makes contact with the right-hand stationary contact. Then electron flow, shown by arrows, is through the lower half of the primary winding and, which is the important point, is in a direction opposite to the direction through the upper half of the primary with the reed at the left. Thus the battery current is alternately reversed in direction through the transformer primary, and actually is an alternating current. The alternations cause changes of core magnetism which induce alternating potentials in the secondary winding. These high-voltage secondary potentials are rectified and filtered just as in any conventional d-c supply system.

The reed is caused to vibrate by magnetic action. One method is shown by Fig. 10. Attached to the upper end of the flexible steel reed is a soft steel armature. Above the armature and a little to one side is a stationary steel core on which is wound a coil of many turns. The ends of this coil are connected between the reed and one of the stationary contacts. When the battery switch is closed there is electron flow from the battery through half of the transformer primary to point *A*, through the coil to point *B*, and back to the battery. The magnetic field produced in the core attracts the armature which is on the end of the reed, and the reed is bent over to the position shown by the right-hand diagram. This brings the contact point mounted on the reed against the

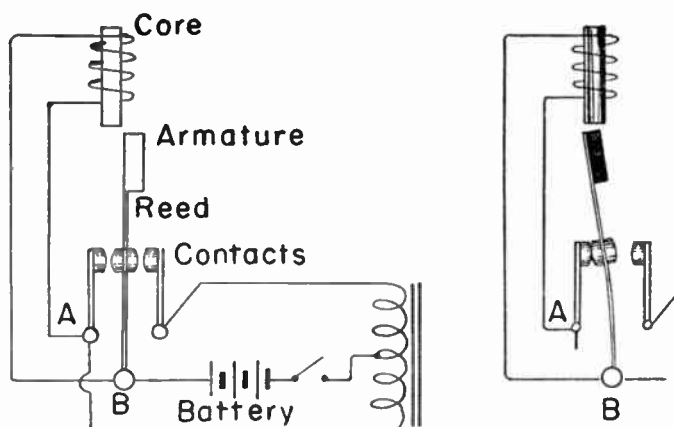

Fig. 10.—How the vibrator reed is made to swing by magnetic action.

left-hand stationary contact to short circuit the coil through the low-resistance contact connection between *A* and *B*.

Short circuiting the coil allows the core to lose its magnetism and its attraction for the reed armature. The springiness of the reed swings it to the right, and the momentum gained by the rather heavy armature carries the reed far enough to bring its contact point against the right-hand stationary contact. Then electron flow passes through the other half of the transformer primary. But when the swing of the reed opens the contact points between *A* and *B* the coil is again energized and the reed is carried to the left, first by its own springiness and then by the magnetic attraction, until the left-hand contacts close. Thus the action continues as long as the battery switch remains closed. Vibrators usually operate at a frequency of 115 cycles per second, although both lower and higher frequencies have been used and may be used.

The internal construction of a typical vibrator is illustrated by Fig. 11. At the top is the magnet coil, with the core extending downward close to the armature on the reed. The reed contacts are not attached directly to the spring leaf, but are carried by small offsets. The vibrator mechanism is connected through flexible wire leads to pins or prongs in an insulating base. The pins are arranged similarly to those on a tube base, so that the vibrator



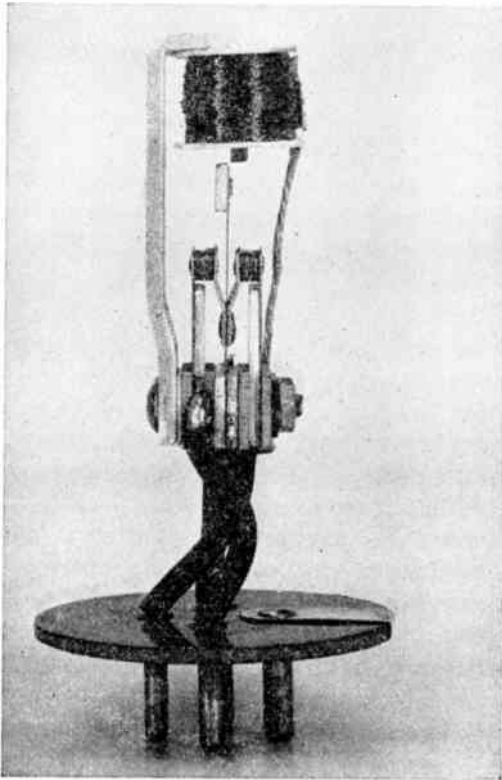

*Fig. 11.—The internal construction of a vibrator.*

may be mounted on a socket to which the external circuits are connected just as to a tube socket. The vibrator is enclosed by a housing or "can" of thin sheet metal. On the insulating base in Fig. 11 may be seen a metallic strap connection which goes from one of the pins over to the edge of the base, where it makes contact with the can for grounding the can. To prevent mechanical vibration and audible sounds from reaching the base and can, the vibrator mechanism is supported from the base on a mass of sponge rubber, and the can is lined with a sheet of this material about  $3/16$  inch thick.

The vibrator contacts close and open a highly inductive circuit, the transformer winding circuit, and as a consequence it is neces-

sary to absorb or dissipate the potential surges and the currents which might occur at the contacts, especially when they separate. These surges would cause damaging sparking at the contacts, would impose considerable stress on insulation, and would cause an undesirable waveform of potentials and currents in the transformer circuit.

Fig. 12 shows some of the more common methods of suppressing the surges. In these diagrams the vibrator is represented by a conventional symbol, at  $V$ , showing only the reed, the two stationary contacts, and the base pin connections. In diagram 1 there is a resistor  $R$  between the stationary contacts. The resistance usually is in the neighborhood of 200 ohms. Across the transformer secondary is a capacitor  $C$ , whose capacitance may

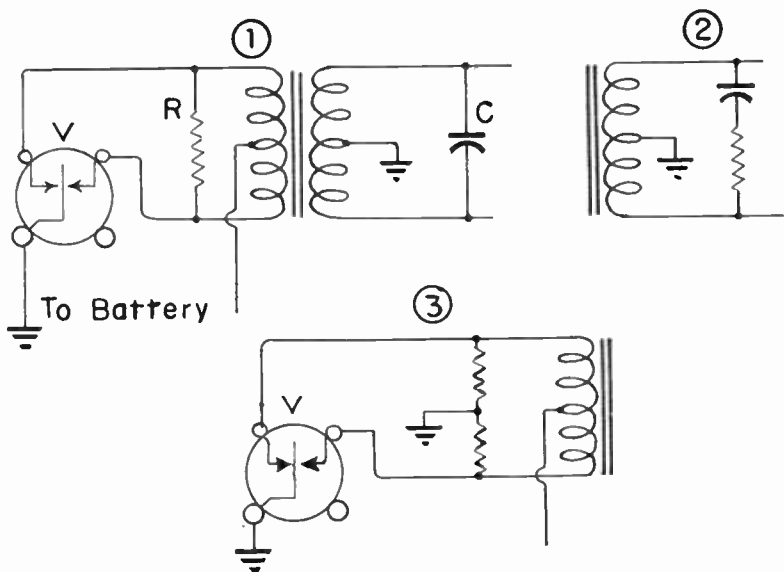

Fig. 12.—Methods of reducing sparking at vibrator points.

be almost anything between 0.002 and 0.01 mfd, all depending on the particular installation and its requirements. In diagram 2 the capacitor across the transformer secondary is in series with a resistor, whose value may be between 1,000 and 15,000 ohms. In diagram 3 there are two series resistors between the stationary contacts of the vibrator, with both resistors connected to ground

and through ground to the vibrator reed. Each resistor may have resistance around 50 to 100 ohms. Still other combinations of resistors and capacitors are used, but the three diagrams show representative practice.

Vibrator transformers are larger than the power transformers used in systems operated from lighting and power a-c lines. The greater size occurs because more iron must be used in order to operate at the required lower flux densities, also because of larger wire in the primary to carry the greater currents at the low battery voltage, and because there are really two primary windings which work alternately, rather than the single primary of the ordinary power transformer.

The full-wave rectifier tube used in the power supply systems illustrated may be a hot-cathode type or else a cold-cathode type. Both types have been used and are being used. When working with cold-cathode rectifiers, you should keep in mind that these tubes require an applied potential of several hundred volts for their initial "breakdown," and must be operated with currents which remain above some certain minimum in order that the ionization inside the tube does not cease. For example, an OZ4 cold-cathode rectifier requires a peak potential of 300 volts (minimum) for breakdown, and must be operated with a minimum d-c output of 30 milliamperes to maintain ionization.

The vibrators which have been discussed up to this point are of types which alternately reverse the direction of battery current in the transformer primary. These types of vibrators must be used with a rectifier tube of some kind. They may be called *non-synchronous* vibrators. There are other types of vibrators, called *synchronous* types, which alternately reverse the battery current in the transformer primary and at the same time change the alternating currents from the secondary winding into pulsating direct currents. The synchronous vibrator acts as a primary reversing switch and as a rectifier, and no tube type of rectifier is needed.

An elementary circuit for a synchronous vibrator is shown by Fig. 13. The vibrator has a single reed carrying four contact points, and there are now four stationary contact points; two for the transformer primary circuit marked *P-P*, and two more for the transformer secondary circuit, marked *S-S*. Movement of

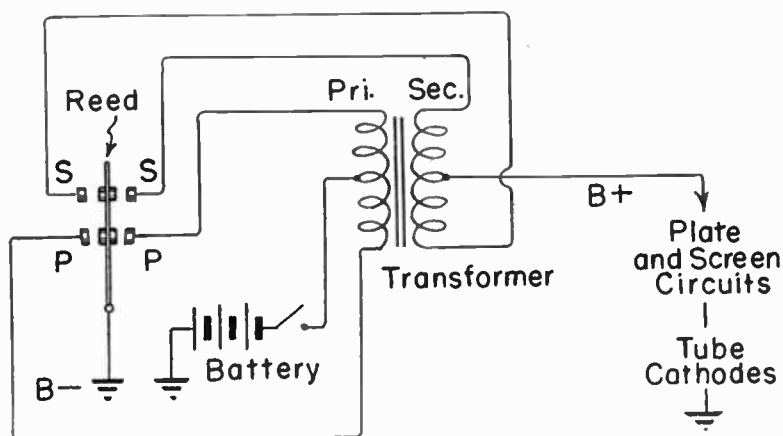

Fig. 13.—Circuit connections for a synchronous vibrator.

the reed reverses the secondary connections at the same time that it reverses the primary connections.

When the reed of Fig. 13 swings to the left the battery circuit is completed through the lower half of the transformer primary through left-hand contact *P*. At the same time the output from the lower end of the secondary winding passes to the left-hand stationary contact *S*, through the reed to ground, through ground to the tube cathodes, and from the tube plates and screen grids back through the *B+* line to the secondary center tap. When the reed swings to the right there are similar results, using then the upper halves of the primary and secondary windings of the transformer. Thus the reed contacts and contacts *S-S* rectify the high-voltage low-current output from the transformer secondary and cause it to flow always in the same direction through the tube cathode, plate, and screen grid circuits.

In the *B+* output lead from the center tap of the secondary in a synchronous vibrator system there usually are high-frequency filtering units preceding the regular smoothing filter which reduces the pulsations to smooth direct current. The high frequency filtering may be accomplished with a r-f choke coil in series with the line and with capacitors of 0.0001 to 0.01 mfd capacitance before the r-f choke and after it.

Other than providing additional stationary contacts for the

transformer secondary circuit, the construction of a synchronous vibrator may differ hardly at all from that of the non-synchronous type. The reed ordinarily is caused to vibrate by a magnetic coil connected and operated just as for the non-synchronous vibrator.

Fig. 14 illustrates a construction which may be used for synchronous units. The two stationary contacts which are on one side of the reed may be clearly seen. One contact is for the primary circuit and the other for the secondary. There is a similar

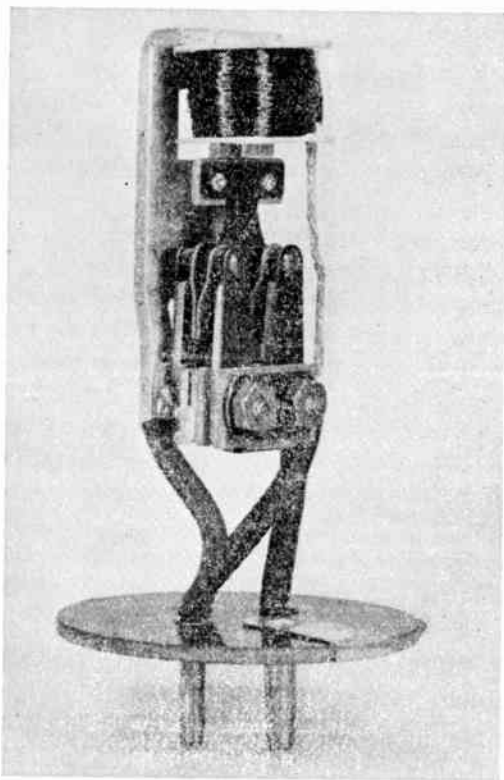

*Fig. 14.—The four pairs of contacts used in a synchronous vibrator.*

pair of stationary contacts behind the reed. The mechanical construction here is the same as for the unit of Fig. 11 for a non-synchronous unit. The difference is that the two stationary con-

tacts on each side of the reed are insulated from each other in the synchronous type, while in the non-synchronous type the two on either side are electrically connected together to act like a single contact.

Most of the newer types of vibrators have no built-in adjustments for reed operation or contact position. The cans are difficult to remove from the bases in any way that allows later putting the parts back together. Even though opened, it would be practically impossible to make any adjustments without having available a suitable oscilloscope and accurate meters for current and potential. Vibrators may be tested for operation with the help of specially designed vibrator testing instruments, or a check may be made by removing a suspected vibrator from the radio apparatus and temporarily substituting another one known to be in good order. A defective vibrator should be replaced with a new one. The most usual cause for vibrator failure is excessive current which causes such internal overheating as to destroy the contact surfaces and to draw the temper from the reed spring or springs. It is for this reason that line fuses never should be replaced with others of larger current rating than the ones originally installed as standard equipment.

**Interference Elimination.**—The major difficulty to be overcome in obtaining satisfactory operation of a radio receiver in an automobile is that of eliminating the great variety of electrical interference which is present in the automobile. We have examined the filtering methods used between the car battery and the high-voltage d-c output of the power supply system, but often it is necessary to install additional filtering outside of the radio apparatus.

Interference may arise from the operation of any electrically driven part on the motor car, or from relative movement between non-electrical parts which may generate electric charges, or from contacts between any metallic parts where the contact may be of high or variable resistance and where the parts may accumulate electric charges.

The radio receiver and its power supply are placed right in the middle of a maze of electrical devices and wiring connections. Fig. 15 is a simplified diagram showing the principal parts of the electrical system of a typical automobile. The source of elec-

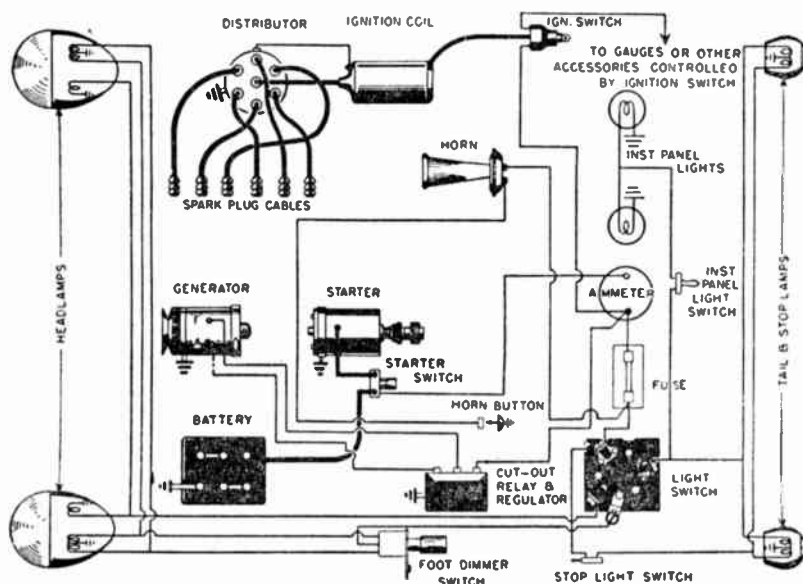

Fig. 15.—The principal parts and their connections in a complete electrical system for an automobile.

trical energy is the generator, from which leads go to the cutout relay (an automatic switch preventing battery discharge when the generator is idle) and the regulator which automatically controls the charging voltage or current from generator to battery. The line to the battery goes from the cutout relay to the ammeter at which the radio line is connected, then to a terminal on the starter switch and to the ungrounded battery terminal.

From the ammeter a line goes through a car fuse to the horn and horn button, also to the light switch. From this switch lines run all over the car to the various lamps and to auxiliary switches for lamp control. Another line runs from the ammeter to the ignition switch, then to the ignition coil from which lines go to the distributor and to the spark plugs. There may be lines from the ignition switch to various accessories. There is a line from the starter switch to the starter motor. The diagram makes plain the fact that the radio receiver and power supply are connected, at the ammeter or through it, to every electrical circuit on the car. Most of these circuits contain parts which may generate inter-

ference potentials, and even where there are no such parts interference is picked up by the connecting wiring.

Interference pickup is reduced or eliminated in three principal ways, which are:

1. The grounding of metallic parts to the car frame and chassis to maintain everything as nearly as possible at the same potential; to make everything into a single large low-resistance electrical conductor.
2. By shielding to prevent radiation of either electric or magnetic fields from parts producing such fields, and to prevent passage into other parts of such fields as are radiated.
3. By filtering the wires and connections with capacitors which bypass the interference potentials and currents to ground, and with high-frequency chokes which impede flow of interference currents away from the parts where they are produced.

Shielding is provided by enclosing the entire radio apparatus in a sheet steel housing which is well grounded to the car chassis. Additional shielding may be provided by steel partitions which divide the housing into compartments for the power supply and for the amplifying and reproducing sections of the apparatus. It is desirable that the power supply transformer, the vibrator, and the rectifier tube be individually shielded. The can of the vibrator is grounded through one of the base prongs, but usually is grounded also through springy metal clips which are riveted to the radio chassis framework and which grip the vibrator can. The rectifier tube may have its own shield, or may be enclosed with other parts of the power supply. Oftentimes the radio power supply parts are on one side of a partition with the remainder of the receiver on the other side within the main housing. As mentioned earlier, the antenna lead-in is carried through shielded cable from the antenna conductor into the receiver housing.

The kinds of interference which are eliminated by effective grounding connections are the ones arising from any parts of the car which may be loose, which may be attached with insulating supports (such as rubber for vibration reduction), or in the supports wherein the entrance of rust or dirt may have caused high resistance. Good electrical connections must be provided by joining the offending parts to the main car structure with grounding straps. These usually are of flexible conductor made with



woven or braided copper strands and provided with suitable soldered or screwed terminals.

Some of the parts which may require grounding include: The engine, which often needs a connection to the main dashboard at the back of the engine compartment. The hood, to be grounded to the dash. Any control rods, flexible shafts, or cables which go through the instrument panel or through the dashboard. The starter pedal and starter gearing, and sometimes even such things as the muffler tail pipe. Electric charges generated at the wheels, by such things as tire friction and brake friction, may be dissipated by using wheel static eliminators. These are arrangements of spiral springs which make electrical connection between hub caps and the ends of the axles.

The worst interference comes from the ignition system. This whole system is, in effect, a spark type of radio transmitter with each plug acting as a spark gap, the coil windings as the inductances, and the wiring as the radiating circuit. It is this radiated interference which makes necessary the complete shielding and grounding of the radio receiver and antenna lead-in.

The earlier methods of reducing ignition interference included the connection in the high-tension ignition circuits of suppressors, which are resistors of either the wire-wound or carbon type

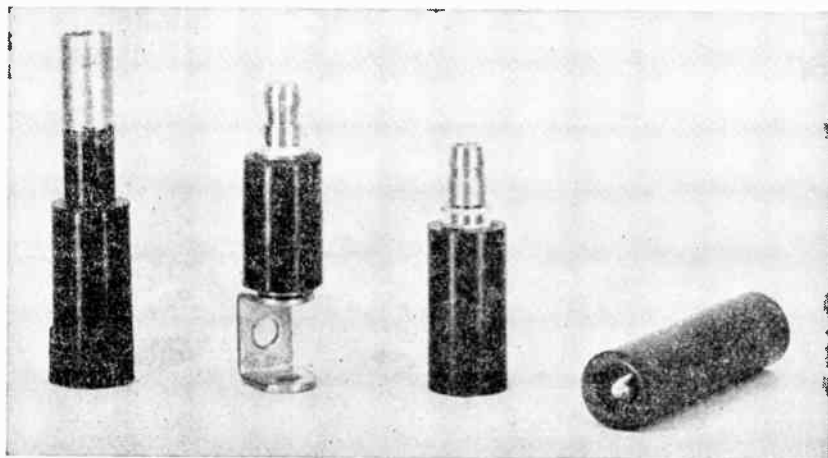

*Fig. 16.—Suppressors used for reduction of ignition interference.*

having resistances anywhere from about 3,000 to 20,000 ohms each. One suppressor always was connected to the center terminal on top of the ignition distributor, and oftentimes additional suppressors were placed at the top connection of each spark plug. Suppressors help to extinguish the ignition sparks quickly, and thus to damp and lessen the radiation, but they are thought to also reduce the efficiency of the ignition system in firing the charges in the cylinders.

Fig. 16 is a picture of typical suppressors. The one at the left is for connection to the center terminal of the ignition distributor. The next two are for fastening to spark plugs. The one at the right, with screw threads in both ends, is for insertion at some intermediate point in an ignition cable.

Fig. 17 is a diagram of the principal units in an automobile ignition system. Current from the battery flows through the

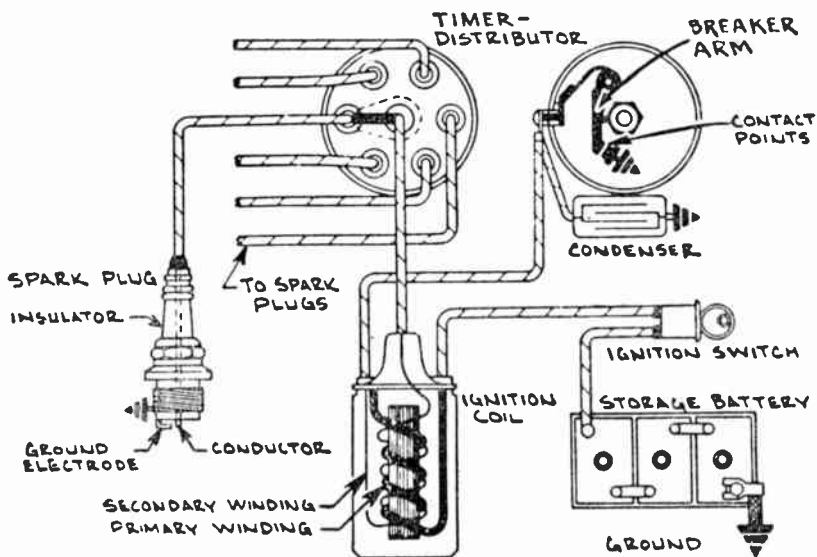

Fig. 17.—The parts and their connections in an automobile ignition system.

ignition switch and the large-wire primary winding of the ignition coil to the breaker arm which is in the breaker or interrupter section of the timer-distributor. With the breaker contacts closed the current path is completed through them to ground and

back to the battery. As the cam opens the contacts the current is cut off, and its rapid drop in the coil primary causes a collapse of the magnetic field around the coil core to induce a high potential in the secondary winding of the coil.

Between the breaker arm and ground is a capacitor which is charged as the contacts separate, and which discharges back through the primary of the coil when the contacts again come together. If this capacitor is open circuited or defective it will cause severe radio interference.

From the secondary of the coil the high potential goes to the center of the distributor and is delivered to the spark plug wires in correct order by the rotating distributor arm. The high potential causes current to jump across the spark plug gap from the central conductor to the ground electrode. Excessively wide gaps in the plugs, or between the distributor rotor and terminals for spark plug lines will cause much radio interference. Interference is caused also by breaker contact points that are rough or corroded.

**Interference Filters.**—When some certain electrical part on the automobile causes interference the trouble usually may be eliminated by connecting a capacitor from that part to ground. If the capacitor alone does not remedy the trouble, a r-f choke coil may be connected in series with the line from the offending part, and in extreme cases it may be necessary to run the line from that part as shielded cable with the shielding grounded. As shown by Fig. 18, the capacitor or the capacitor and choke, must be connected directly to the terminal of the interfering part. If they are placed far from the part, the cable which connects to it will radiate the interference.

Interference capacitors connected to parts in the battery charging system may be of one-half to one mfd capacitance, and for lamp and accessory circuits may be one-quarter to one-half mfd. The choke coil should be wound with large wire, preferably little if any smaller than the wire in the circuit wherein the choke is connected. Automobile lighting and accessory lines are run with wires of 16, 14, and even 12 gage size, while battery and charging circuits are run with 14, 12 and 10 gage cables. A choke coil made with 40 or more turns on an insulating form an inch or less in diameter usually will be effective.

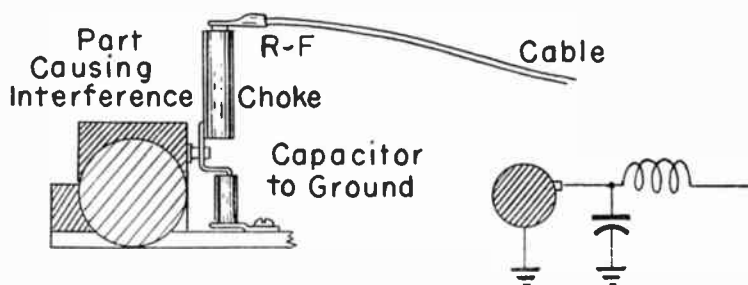

Fig. 18.—Connections of capacitor and choke coil to a part causing interference.

Interference filtering may be needed at the battery charging generator, connected to a generator terminal leading to a separate regulator or to the terminal or lead running from generator to a cutout mounted on the generator. Much interference may be eliminated by cleaning the generator commutator and dressing the brushes when there is considerable sparking while the generator runs. Filtering may be needed also at the terminals of a separate cutout and regulator. Although the starter causes interference while in operation, this occurs infrequently with the radio in use, and as a rule no filtering is used in the starting circuit.

Filtering may be needed at the terminal of the ammeter to which the radio line connects, also at the lighting switch terminal connected to the ammeter. Filtering may be needed at the ignition switch. Some types of capacitors installed between the breaker arm and ground are not effective for high-frequency interference and it may be necessary to install an 0.002 mfd mica type capacitor between the arm and ground or across the breaker points inside the breaker housing. Other sources of interference which may need filtering include the horn or horns, electric gasoline and oil gages, electric fans in heaters, and long isolated lighting lines, such as may run to lamps inside the car body.

To determine whether interference is coming from parts of the automobile or from outside, temporarily ground the antenna at its connection to the lead-in. If this stops the interference the trouble is coming from outside, through the antenna. If the interference continues it is coming from parts of the automobile and wiring.

REVIEW QUESTIONS

1. How are the wide variations in signal strength controlled in automobile radios?
2. Since tires insulate the automobile chassis from ground, what makes up the capacitor type antenna in automobile radio reception?
3. Describe the operation of a non-synchronous vibrator and rectifier system using Figs. 9-10-11.
4. What is the chief difference between non-synchronous and synchronous vibrators?
5. What is the most usual cause of vibrator failure?
6. What are the three principal ways of reducing or eliminating interference pickup in automobile radios?
7. What is the worst source of interference in automobile radio reception?
8. What radio parts make up interference filters and how are they connected?

## Chapter 6

### PUBLIC ADDRESS SYSTEMS

A public address system consists of apparatus for the production and amplification of audio-frequency potentials, and for the reproduction and projection of sound in such volume and over such distances as are required for large numbers of listeners.

The essential parts of a public address system are shown by Fig. 1. The sound signals or a-f potentials originate in a phonograph pickup, in a microphone, or in a radio tuner and detector. These potentials are strengthened in the amplifier, which is of the a-f type, and the resulting a-f power is fed to one or more loud speakers.

The final output power from the tubes which feed the speaker or speakers usually will range from five to 60 or more watts,

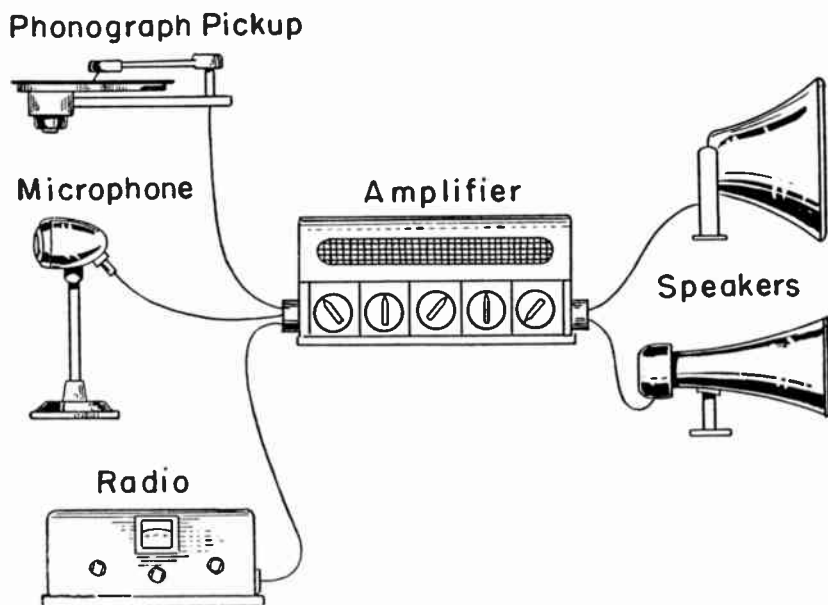

Fig. 1.—The essential parts of a public address system.

depending on the requirements fixed by the size of audience and on the space to be covered. In a typical power amplifying stage the signal applied to the control grids of the tubes may be on the order of 40 volts. From a microphone such as commonly used with public address systems the a-f signal potential may be as little as 0.001 to 0.002 volt. Such a microphone output must be amplified 20,000 to 40,000 times to bring it up to the level required at the power tube control grids.

The output from a phonograph pickup may be several volts. Consequently, reproduction from a phonograph record requires much less amplification than from a microphone. From a radio detector stage the output may be anything from a fraction of a volt to several volts, depending on the antenna signal strength and on the gain in the r-f amplifying system. In general, the same public address a-f amplifier will serve for radio detector input and for phonograph input.

**Sound.**—The object of a public address system is to reproduce and distribute sounds. A sound is a sensation perceived by our sense of hearing. The sensation of sound ordinarily results from vibrations of the air on our ear drums. These vibrations originate at some body which causes the air to vibrate or to be subjected

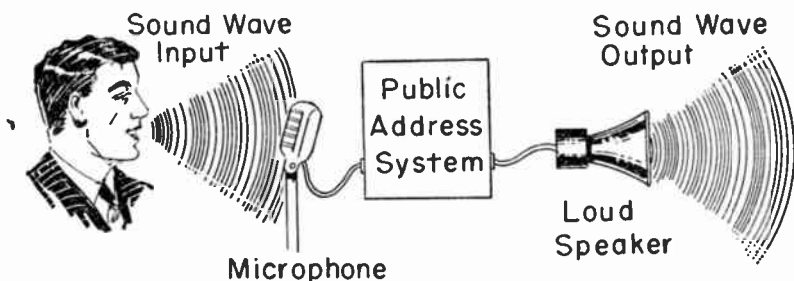

Fig. 2.—Sound is radiated in a form of wave motion.

to alternate compressions and rarefactions. The regions in which the air is compressed or squeezed together and the intervening rarefactions where it is stretched and thinned out follow one another in a kind of motion which we call sound waves. Sound waves move away from sources of sound as in Fig. 2.

We shall have much to do with the frequency of the sound waves, which means the number of compressions and rarefactions (complete waves) which are produced and which reach our ears during each second of time. The range of sound-wave frequencies to which our sense of hearing responds are audio frequencies. The average listener is capable of perceiving as sounds those frequencies which are as low as 20 cycles per second and as high as 15,000 cycles per second. This great range of frequencies is perceived as sound only when there is enough energy or power in the sound waves at the very low frequencies and also at the high ones.

Fig. 3 shows a curve for average hearing sensitivity. The curve shows the relative amounts of sound-wave power at the various audio frequencies which permit the sound to be just perceptible. The values on the scale of relative powers are chosen to allow convenient comparison. Actually, all of the powers represented

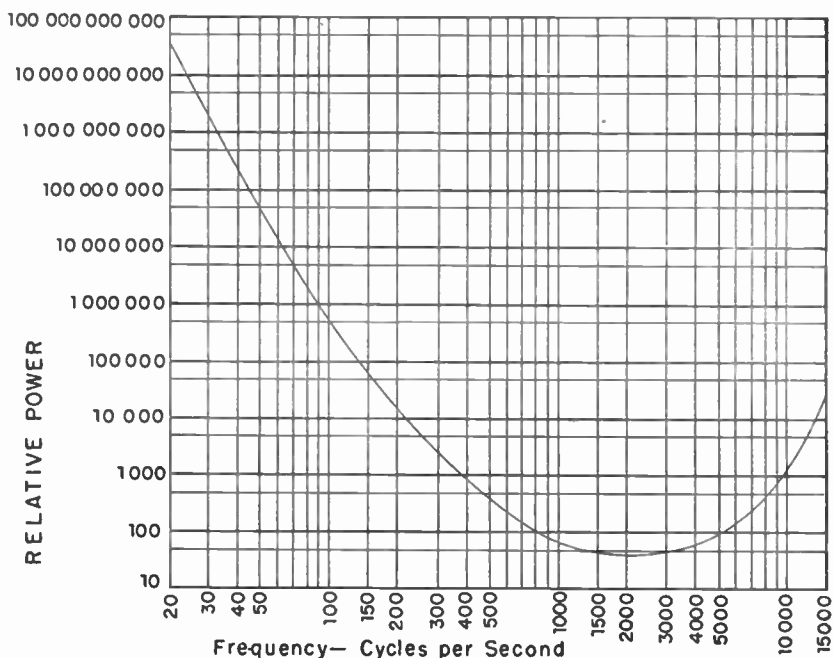

Fig. 3.—Average hearing sensitivity of the human ear.



here are exceedingly small. The maximum power value, which is required at a frequency of 20 cycles, is about 33 micro-microwatts on each square centimeter of surface. A centimeter is equal to about 0.4 inch, and a square centimeter is equal to about 0.155 square inch. On the graph this power is shown as about 33 billions of units, so one unit as shown on the graph would be equal to one billionth of a micro-microwatt.

The important point is not in the absolute values of power required to make a sound just audible, but in the great differences of power needed at the various frequencies. It is apparent that the average ear is most sensitive to sounds having frequencies in the neighborhood of 2,000 cycles per second, for at these frequencies the sound is perceptible when the power is only about 38 of our units. To make a 100-cycle sound barely perceptible takes about 500,000 units of power, which is more than 13,000 times as much power as is needed around 2,000 cycles. The power needed to make a 50-cycle sound just audible is about 50,000,000 of our units, or 100 times as much power as is needed at 100 cycles.

Supposing that there were available a maximum of only 10,000 of our power units, regardless of frequency. The line for 10,000 power units crosses the curve at a lower frequency of about 210 cycles and at a higher frequency of about 13,500 cycles. With this power limit the average hearing range would be only from 210 to 13,500 cycles. Were only 1,000 units of power available, the limits of audibility would narrow to the range between about 360 and 9,500 cycles.

**Decibel Measurements.**—In public address work, and in some other fields of radio, we have to deal with powers between which there are great differences. An example appeared in Fig. 3. We have to deal also with great differences of voltage. An example appeared in our mention of the amplification or gain needed between a microphone and a power tube. It is inconvenient to make our measurements in absolute units such as watts and volts, because we get into such large numbers and into such small fractions and because we have to do a lot of multiplying and dividing with decimal numbers.

To get around such difficulties, and to provide other real advantages, it is common practice to express the relative values of powers and of voltages in a unit called the *decibel*, which is

abbreviated *db*. One of the added advantages of using decibel measurements is that they indicate powers and voltages relating to sound in accordance with the way in which our hearing is affected by such powers and by the results of such voltages when the voltages are sound signals. This particular advantage may be explained with the help of Fig. 4.

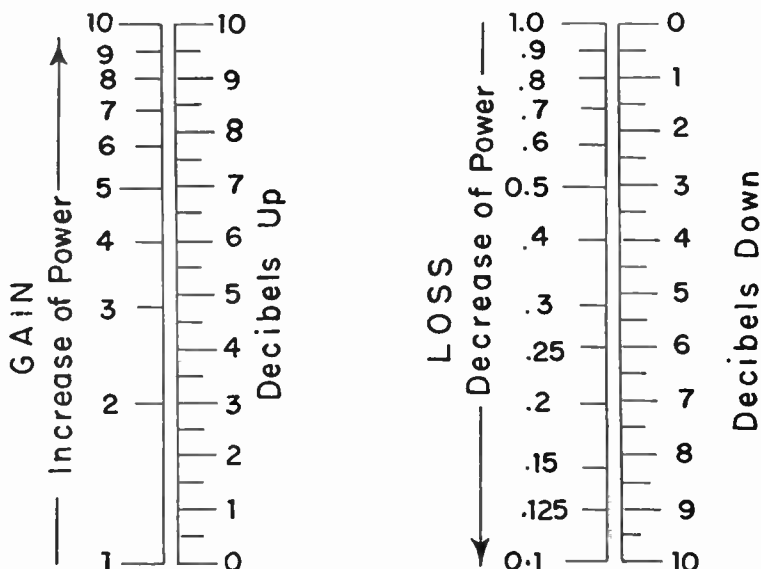

Fig. 4.—Relations between gain or loss and decibel measurements.

The two parallel scales marked *Gain* at the left in Fig. 4 show relations between increases of sound power and the decibel measurements of such increases. The impression given to our ears by some original sound power will be represented by the value 1 on the power scale. If the power is doubled, bringing it to a value represented by 2, it will impress us as being twice as loud as before. To get a third impression which seems twice as loud as the second the sound power again must be doubled, and it becomes 4. For still another apparent doubling in power or

loudness the power value must be made 8. So we may continue doubling the power until the ear impression becomes one of pain rather than of sound.

The power increase from 1 to 2 is an increase of one unit of power; from 2 to 4 the increase is two units; and from 4 to 8 it is four units. Yet each of these increases affects our ears like all the others so far as the *change* of loudness is concerned.

Now compare the scale of power increases with the adjoining scale of "decibels up." The power value of 1 corresponds to zero decibels. The power value of 2 corresponds to three decibels, which is an increase of three decibels from the original zero. The power value of 4 corresponds to six decibels, another gain of three decibels, the power value of 8 corresponds to nine decibels, still another gain of three decibels. Every time the power, loudness or intensity of the sound is doubled there is a gain measured as three decibels, and this holds true no matter at what level of power the increase takes place.

The two parallel scales at the right in Fig. 4 show how decibels measure loss or attenuation of power. Here we start from the top of the scales, which are the same as the bottoms of the scales at the left, and we proceed downward from the original power of 1.0, and zero decibels.

If the power is reduced to half (0.5) of its original value the decibel measurement becomes *minus* three decibels, or is three decibels *down*. With another halving of sound power, bringing the value down to 0.25, we are down to minus six decibels. Still another halving of the power, which drops the value to 0.125, brings us to minus nine decibels. Each time that we halve the power we drop down by three more decibels. When using the left-hand scales, for gain, every time that we doubled the power we went up by three decibels.

Any change of power represented by a difference of some certain number of decibels seems to our ears the same relative change as any other actual change represented by an equal number of decibels. This is true whether the actual sound powers are at the level of whispers or at the level heard in a boiler factory.

The scales of Fig. 4 extend only to gains of 10 times the original value of power, and to losses down to  $1/10$  or 0.1 of the original value. They extend to only 10 decibels in each direction. In Fig. 5, using the top horizontal scale for *Decibels—Power* and the left-hand vertical scale for relative values, we have the relations between decibels and power values from 50 decibels loss through to 50 decibels gain, and from a power loss that brings the value down to 0.00001 or  $1/100,000$  of the original value of 1 through to a power gain that brings it up to 100,000 times the original value. Note that every change of 10 decibels means that the power either is multiplied 10 times or else is reduced to  $1/10$  of the starting value.

Decibel measurements, taken by themselves, indicate nothing more than changes of power or voltage with reference to some original or starting value, which is called the *reference level*. In our graph the reference level is taken as 1, but this might mean one of anything, or the 1 might represent "one unit" of any value in watts or fractions of a watt.

For measurements of the power in sound waves existing in air the reference level usually is taken as 0.000 000 000 1 microwatt per square centimeter of surface area. For measurements of powers in amplifying and loud speaker systems the reference level often is taken as 6 milliwatts or 0.006 watt of power. Whatever the reference level may be, it always corresponds to zero decibels. Unless we know the reference level being used, values expressed in decibels cannot be translated into equivalent values of power. However, a gain of 10 decibels of power always means that one power is multiplied 10 times, a loss of 10 decibels means that one power is reduced to  $1/10$  of a former value, and other comparative decibel measurements indicate ratios of gain or loss even though we do not know the reference level.

**Voltage Outputs, Gains and Losses.** — The outputs of microphones, phonograph pickups, and radio detector stages often are measured in voltages rather than in powers. Amplifying system gains or amplifications, and losses or attenuations, also are measured in voltages all the way from the input to the control grid circuits of the output tubes or power tubes. The relative values or the ratios of all these voltages may be measured in decibels.

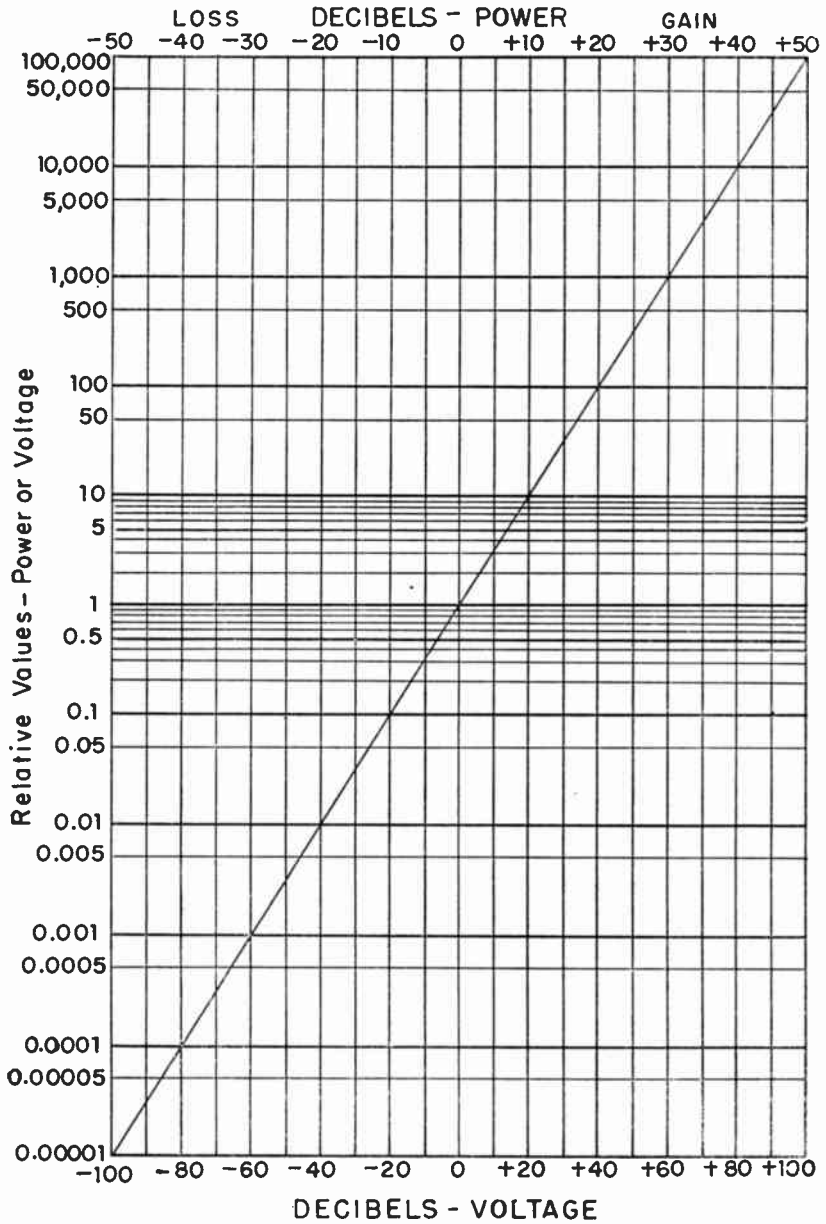

Fig. 5.—The chart for relative values of power or voltage and the corresponding numbers of decibels loss or gain.

Naturally, we wish to have our decibel measurements for voltages and for powers in agreement with the true relations between voltages and powers, so let's stop and check the true relations. One of our voltage formulas is,

$$E = \sqrt{P \times R}$$

Here  $E$  represents voltage or potential difference,  $P$  represents power, and  $R$  represents the resistance across which the potential difference exists. If we take  $R$  as 1 ohm we always will be multiplying  $P$  by 1, which will not change the value of  $P$ , and so we may rewrite the formula (for one ohm of resistance) as,

$$E = \sqrt{P}$$

Thus we learn that voltage always is proportional to the square root of power.

Supposing that we have two powers whose relative values are 100 and 10,000. From Fig. 5 we find that these relative values (on the vertical scale) correspond to +20 and to +40 decibels of power (on the top scale). We have determined that the voltages for these two powers must be proportional to the square roots of the powers. The square root of 100 is 10, and of 10,000 it is 100. So the relative values of the two voltages must be 10 and 100 when the corresponding power values are 100 and 10,000. To have the same decibel measurements for both powers and voltages we must have,

Voltage change:	10 to	100
Power change:	100 to	10,000
Decibel change:	+20 to	+40

To bring all decibel measurements of voltages and power similarly into agreement with the facts we use for voltage measurements the *Decibels—Voltage* scale across the bottom of Fig. 5. By using this scale we find that the relative values of voltages for +20 and +40 db are, respectively, 10 and 100, which we know to be correct. It works out that a given change or ratio of voltages always is shown by a decibel change twice as great as for an equal ratio between powers.

When sources, such as microphones and phonograph pickups, are given output ratings in decibels it is necessary that we know the reference level in order to translate such ratings into voltages of output. A reference level often used for microphones is 1.0

volt, meaning that 0 db = 1 volt. With this reference level Fig. 5 would apply directly. For example, if the voltage output of a certain microphone is 60 db down, we read directly from the left-hand vertical scale that the output is 0.001 volt.

With an amplifier gain specified as so many decibels of voltage we are not particularly concerned with the reference level, because the rated gain tells how many times an input voltage is multiplied.

If we know the voltage amplification, in decibels, for each of several successive stages in an amplifying system the numbers of decibels may be added together to give the overall gain. For example, with stage gains of 10, 20 and 5 decibels the overall gain is equal to  $10 + 20 + 5 = 35$  decibels.

Were there gains of 10 and 20 decibels in two stages, and a loss of 5 decibels in some control circuit or in any part of the amplifier, the total overall gain would be equal to  $10 + 20 - 5 = 25$  decibels. That is, we add the voltage gains and subtract the voltage loss or losses, all in decibels.

If we require a final voltage output that is, for example, 40 decibels up, and if the input from whatever the source may be is 50 decibels down, the amplification system must provide a voltage gain of  $40 + 50 = 90$  decibels of voltage.

If a voltage input and a voltage output given in decibels are to be comparable both voltages must appear across equal resistances or equal impedances. Should the input voltage be measured across something like a half-megohm of resistance, with the output voltage across some much lower resistance or impedance we could not correctly give the overall gain in decibels. The reason depends on the fact that decibels of voltage must match decibels of power, as explained earlier, the power ratio of input and output would be quite unlike the voltage ratio of input and output in the different resistances.

The outputs of microphones and of other sources may be given in decibels of power instead of voltage. Reference levels for powers may be 1, 6 or 10 milliwatts, or 0.001, 0.006 or 0.010 watt, and sometimes are of still other values. In the case of microphones we should know the reference level used, and, in addition, should know the sound pressure applied to the microphone when the output is measured. A pressure often used as a standard is one

dyne per square centimeter, which is equivalent to a power of one micro-microwatt per square centimeter.

When ratings are given in decibels of either voltage or power there should be specified also the audio frequency at which the measurements are made. All sources have maximum outputs at some intermediate frequency, with smaller outputs at lower and higher frequencies. Gains of amplifiers vary similarly with change of frequency. Output ratings and ratings of gain often apply at a frequency of 1,000 cycles per second, but may be taken at other frequencies.

It must now be apparent that a rating of any public address unit in decibels, without much other information being included, has little meaning.

**Microphones.**—There are five basic types of microphones which are employed and which may be employed in public address

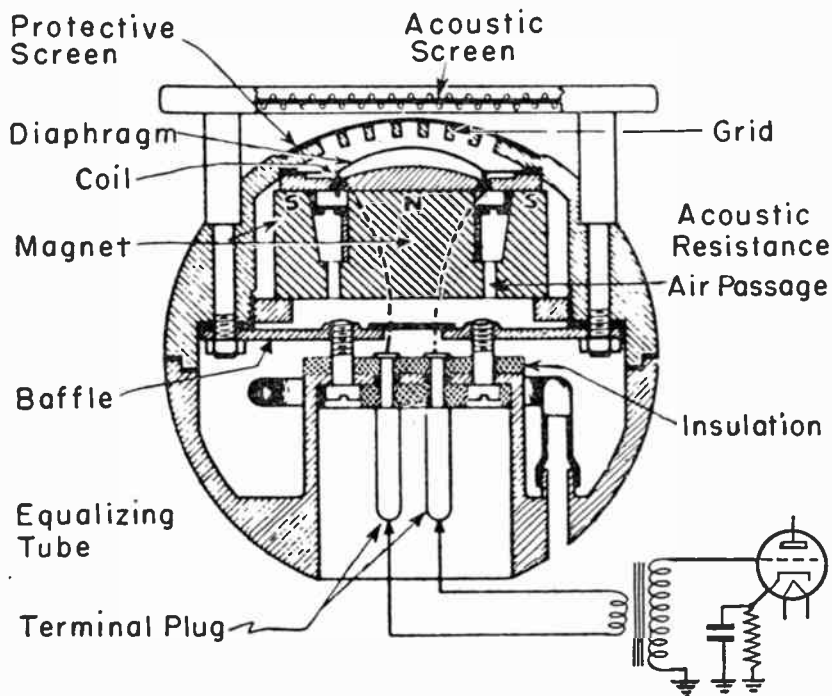

Fig. 6.—Construction of a dynamic or moving coil microphone.



systems. The types include (1) the dynamic or moving coil microphone, (2) the crystal microphone, (3) the ribbon or velocity microphone, (4) the condenser microphone, and (5) the carbon button microphone. Each type will be described.

The construction of one style of *dynamic* or *moving coil* microphone is shown in cross section by Fig. 6. The diaphragm which is reached and vibrated by sound waves in the air is rigidly attached to a coil of a few turns suspended between the poles or in the field space of a strong permanent magnet. When movement of the diaphragm causes the coil to move in the magnet field there are emf's induced in the coil. The emf's alternate in direction as the movements of diaphragm and coil alternate, the frequency of the emf's follows the sound frequency, and the amplitude of the emf's follows the extent of movement of diaphragm and coil.

The moving coil of the microphone is connected through leads to the primary of a transformer whose secondary is in the grid circuit of the first amplifying tube. The impedance of the moving coil is small. The coil may connect to a line leading to the transformer and amplifier, or the transformer may be housed with the microphone.

*Crystal* microphones make use of the fact that when certain crystalline substances are bent, twisted, or otherwise deformed from their natural shape there are emf's developed in the substances, and potential differences appear across opposite faces of a suitably cut piece of the substance. This action is called a piezo-electric effect, and pieces of crystalline substances which are cut and formed in such manner as to exhibit the effect are called piezo-electric crystals.

The two crystalline substances most often used for their piezo-electric effects are quartz and pieces of Rochelle salt. Quartz crystals are employed for maintaining constant frequency in oscillators and for other frequency-control applications. Rochelle salt crystals are commonly employed in crystal microphones and also in the crystal type of phonograph pickup. The crystals are cut into the form of slabs or discs with opposite sides flat and parallel.

If a piezo-electric crystal is supported at one side or end, as at A in Fig. 7, and then is bent as indicated by broken lines, there

will be produced a potential difference between the opposite sides or faces of the crystal. Bending the other direction will produce a potential difference in opposite polarity. Potential differences are produced also by twisting the unsupported end or edge of the plate, as shown at *B*. This twisting motion is employed in many

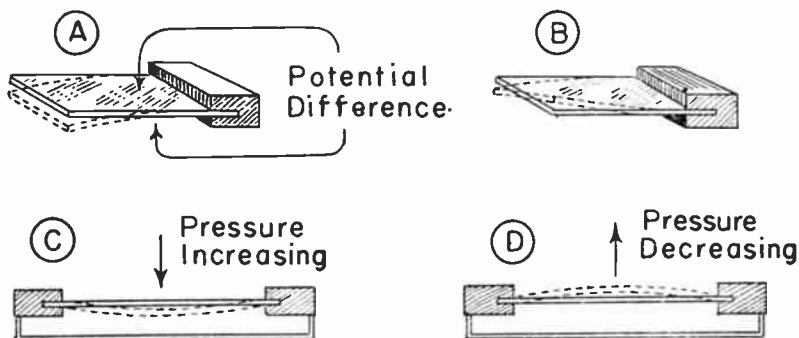

*Fig. 7.*—The flexing of a piezo-electric crystal produces potential differences between the crystal faces.

phonograph pickups. It should be understood that the bending, twisting, or other deformation indicated by broken lines in the diagrams is very greatly exaggerated in extent. Actual motions may be in fractions of a thousandth of an inch.

Diagrams *C* and *D* of Fig. 7 show how piezo-electric crystals are used in microphones. The crystal is firmly supported at its edges, sides or ends, and the exposed area of the crystal is acted upon by changes of pressure in sound waves. The sound waves may act directly against the crystal surface or they may act first on a diaphragm which is mechanically attached to the crystal.

In the upper part of Fig. 8 is shown one unit, called a sound cell, as used in a type of crystal microphone where the sound waves apply their varying pressures against a pliable moisture proof film and through the film to the surface of the crystal. On each side of the cell are two crystal slabs. In one construction the slabs are about one-quarter inch square and 1/100 inch thick. The two crystals on either side of the cell are arranged so that pressure in one direction causes the same polarity, positive or nega-

tive, to be developed at the surfaces in contact, while the opposite polarity appears at the outside surfaces. External connections are made so that all of the positive polarities go to one terminal and all of the negative polarities to the other terminal at any one instant.

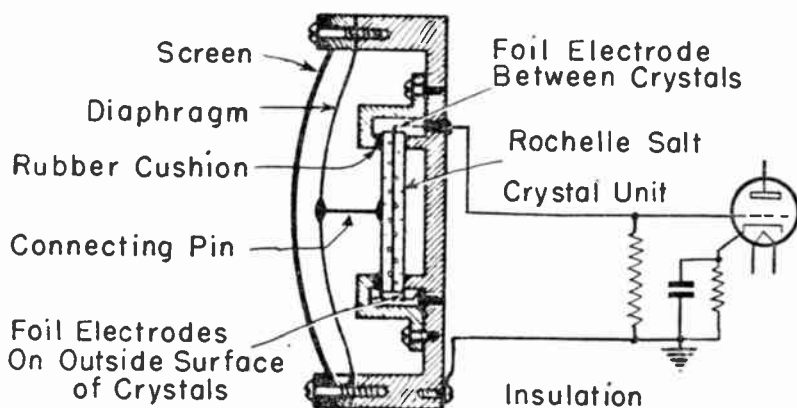
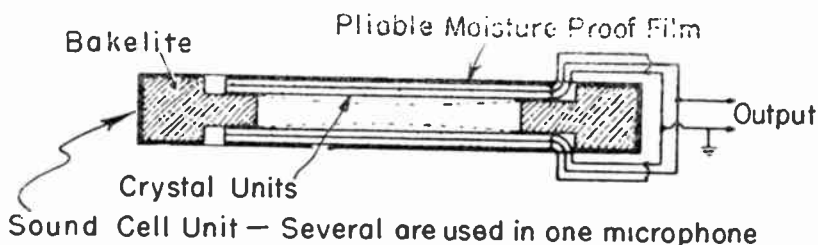

*Fig. 8.—Two types of crystal microphones; a sound cell type at the top and a diaphragm type at the bottom.*

In the lower part of Fig. 8 is shown the constructional principle of a crystal microphone in which sound waves act against a diaphragm that is rigidly connected through a small pin to the center of the two-part crystal element. The difference between this and the sound cell type is in the manner of applying sound-wave pressures to the crystal elements; the fundamental action of developing potential differences in the crystal elements being the same in both types.

The construction of one kind of *ribbon* microphone, called also a *velocity* microphone, is shown by Fig. 9. This type, like the dynamic microphone, makes use of the principle of electromagnetic induction. In both types a conductor which is vibrated by sound waves is placed in a strong magnetic field. Upon movement of the conductor through the field, emf's are induced in the conductor. In the dynamic microphone the vibrating conductor is a coil. In the ribbon microphone the vibrating conductor is a corrugated ribbon of dural, an aluminum alloy, only about 1/10,000 inch thick, somewhat less than 1/4 inch wide and about two inches long in one style of construction.

In Fig. 9 the suspended ribbon is supported at top, center, and bottom, so that the upper "pressure ribbon" section may be

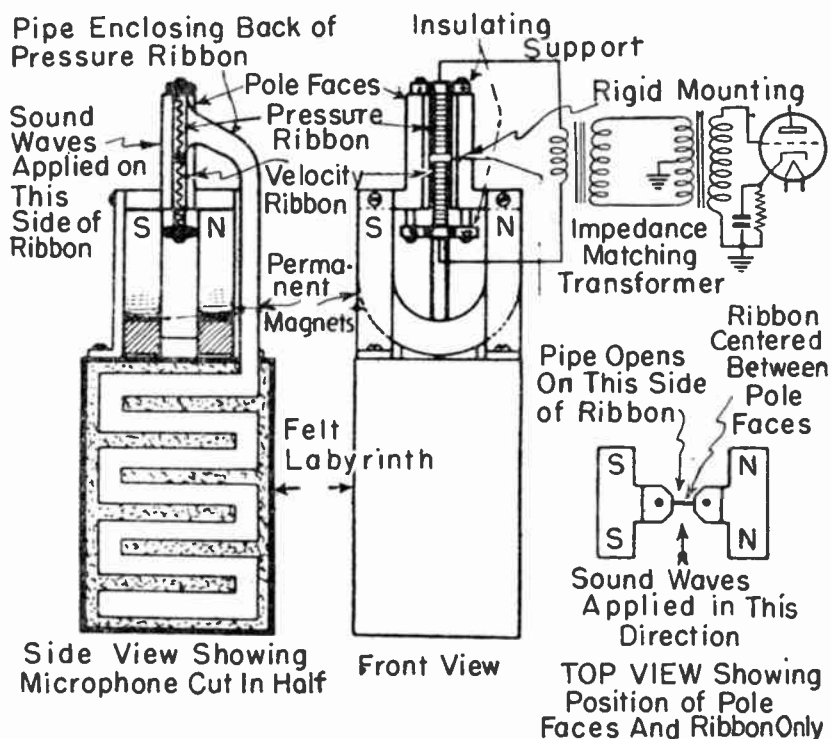

Fig. 9.—Construction of one style of ribbon or velocity microphone.

affected by changes of pressure due to sound waves while the lower "velocity ribbon" section is affected by the velocity or speed of the air particles which are moving in the sound waves. A true velocity microphone would have its entire ribbon operated by velocity of air particles, and would have the entire ribbon open on both of its flat sides to air movements which are sound waves.

The pressure ribbon is open to the air on only one of its sides, the left-hand side in Fig. 9, with the right-hand side backed up by an opening leading down into a long chamber wherein the contained air is compressed and allowed to expand by vibrations of the pressure ribbon.

The *condenser* microphone makes use of the fact that when the two plates of a capacitor are moved farther apart the capacitance is reduced, while the capacitance is increased when the plates are moved closer together. In the condenser microphone there is one movable plate and one stationary plate. The movable plate is the diaphragm which is vibrated by varying air pressure in the

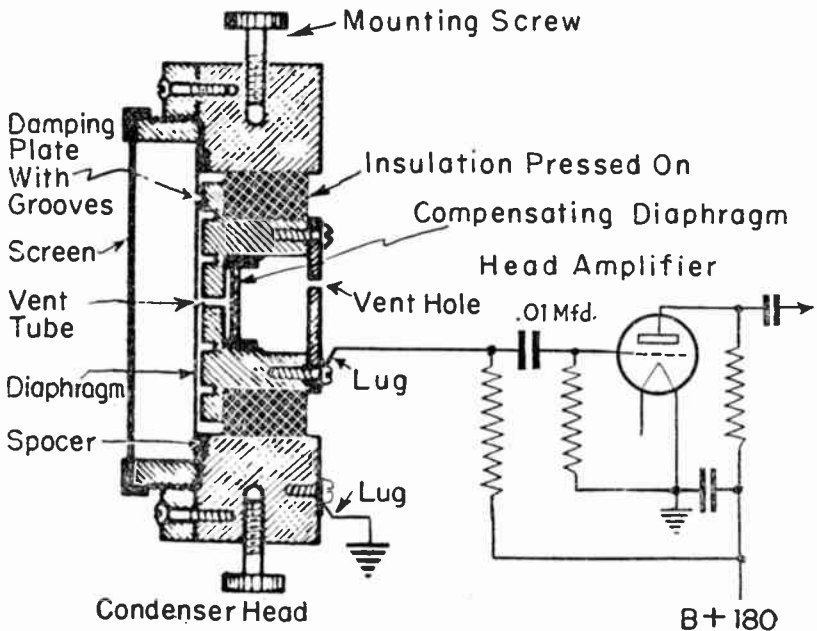

Fig. 10.—The parts of one style of condenser microphone.

sound waves that reach the diaphragm. Separated from the diaphragm by an air space of about  $1/1,000$  inch is the stationary back plate or damping plate. The construction of one style of condenser microphone is shown by Fig. 10.

The stationary damping plate or back plate is connected through a resistor to the positive side of a source of high direct potential. The negative side of the source and the diaphragm of the microphone are connected to ground. The capacitance between diaphragm and back plate usually is about 0.0002 mfd. As the capacitance is varied by vibration of the diaphragm there is a varying charging current taken from the source. The variations of charging current pass through the resistor connecting the back plate to the source. The accompanying variations of potential difference across this resistor are applied through a coupling capacitor to the grid of the first amplifying tube. The first stage of amplification, called the *head amplifier*, usually is mounted right at the microphone.

Several variations of the condenser or capacitor principle are used in microphones. In one type the movable diaphragm is replaced with a series of flat dural ribbons mounted between two plates of insulating material which have perforations for admission of sound wave pressures. This type may be called an electrostatic velocity microphone, or a static velocity microphone, because it makes use of velocity ribbons in combination with capacitance changes.

Carbon microphones make use of the changing electrical resistance in a mass of small particles or granules of carbon which are pressed together and released by changes of pressure in sound waves. The construction of a simple type of carbon microphone, called a *single-button* type, is shown at the top in Fig. 11. The carbon granules are contained in a "microphone button" which is a cup closed on one side by the diaphragm against which act the sound waves. Inward movement of the diaphragm compresses the carbon granules and lowers the resistance through the mass, while outward movement releases the compression and allows the resistance to increase.

The microphone button is in series with a circuit containing the primary winding of a transformer, a source of current (shown as a battery), and a potentiometer or sometimes a rheo-

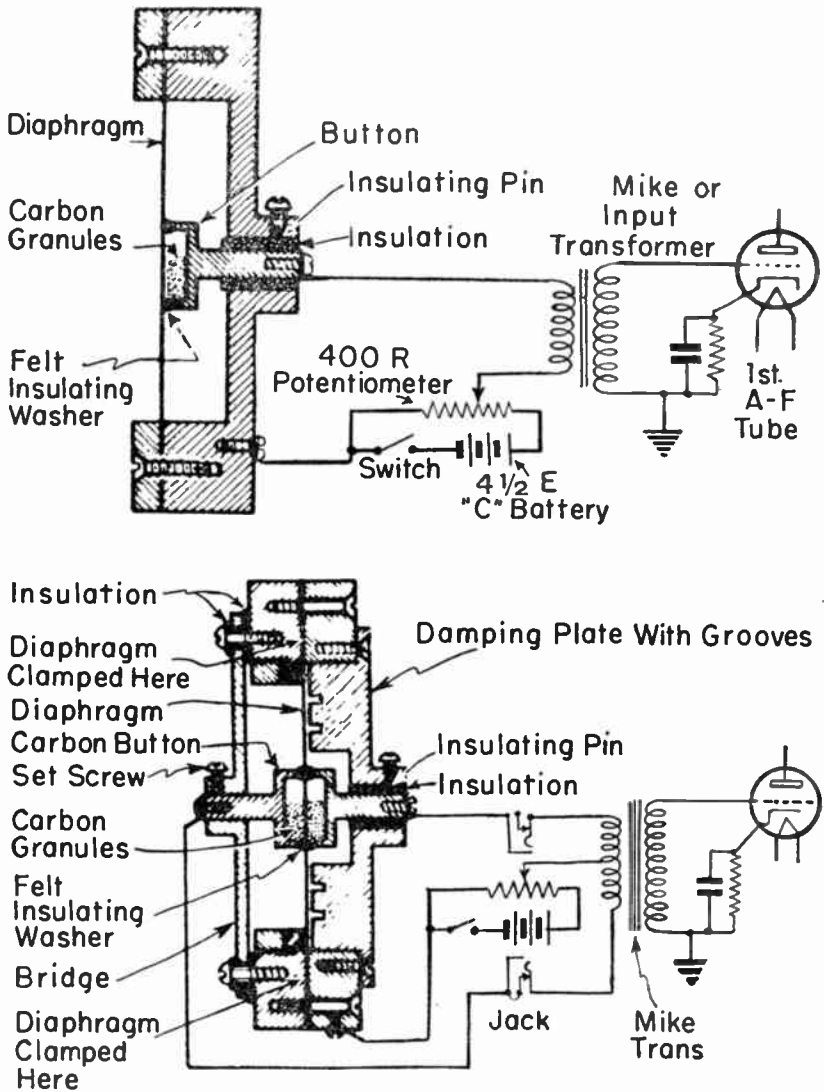

Fig. 11.—A single-button carbon microphone (top) and a double-button type (bottom).

stat for adjusting the rate of current flow in this circuit. The varying resistance of the carbon mass with variations of sound wave pressure causes a correspondingly varying current in the transformer primary. The secondary is in the grid circuit of the first amplifying tube. The single-button carbon microphone has a limited frequency range and is used only for speaking voice, not for music, either vocal or instrumental.

The *double-button* carbon microphone, shown at the bottom of Fig. 11, has two microphone buttons between a single diaphragm. Movement of the diaphragm compresses the granules in one button and lowers the resistance on that side while releasing the granules in the other button and increasing the resistance. Thus the microphone current increases in one side while decreasing in the other side. The two buttons are connected to opposite ends of a center-tapped primary winding on a transformer, so that the opposite changes of current in the buttons cause flow in the same direction through both halves of the primary. Microphone current is furnished by a d-c source and is adjusted by means of a potentiometer or rheostat. The double-button microphone has good frequency response from about 60 cycles up to 5,000 or 6,000 cycles, and is used for all purposes in public address work.

**Microphone Outputs.**—In the selection of a microphone for public address work it is necessary to know the microphone output in volts or decibels so that the unit may feed enough input to the available amplifier. The type of microphone tells little about the output. We cannot say, for example, that crystal types have some certain output level, while dynamics have another level, and velocity types a third, for the output depends on the exact design of the particular unit considered. Taking, to illustrate the point, a representative group of ten or more crystal microphones suitable for public address purposes, their outputs are found to run all the way from 0.0007 to 0.0300 volt; a variation of more than forty to one.

The impedance or resistance connected across the microphone output, or the impedance at the input to the microphone amplifier, changes the voltage available. The voltage will be high across high resistance or impedance, and will be relatively low across low resistance or impedance when sound input power to the microphone is unchanged. Even with a high-impedance amplifier



input the voltage from the microphone will be no more than half of the voltage on an open circuit.

**Microphone Impedances.** — With a microphone for a public address input the microphone is a source of power. In order that there may be maximum transfer of power from any source to any load, such as to the amplifier input circuit, the internal impedance of the source and the impedance of the load must be equal, or else they must be matched through impedance matching transformers. Usually there will be no serious reduction of power transfer with a slight mis-matching of impedances; especially when the load impedance is greater than the source impedance.

Microphones divide themselves into two general classes; high impedance and low impedance types. In the high impedance class we have the crystal microphone, whose crystal elements and their foils or plates for voltage takeoff act as capacitors of small capacitance which, as we know, have high capacitive reactances at audio frequencies. In the high-impedance class are also the condenser microphones, which again have elements which are essentially capacitors of small capacitance.

All of the other general types of microphones are in the low-impedance class. There is low impedance at audio frequencies in the moving coil of the dynamic microphone, in the moving ribbon of the velocity microphone, and in the carbon buttons of the carbon microphones.

Output connections from high-impedance microphones are shown by Fig. 12. At the upper left is represented a crystal microphone, by its standard symbol, and connections to the grid circuit of the first amplifying tube. The coupling resistor  $R$  is across the microphone and is also between grid and cathode of the tube. The microphone impedance is so high that with a resistance of between one and three megohms at  $R$  there will be satisfactory matching and also a satisfactory grid-circuit resistance for the tube. Better voltage output from some crystal microphones is had with about five megohms across the microphone, but this is too much resistance for the grid circuit of most tubes. Then resistor  $R$  may be made of two or three megohms resistance, and a resistor of three or two megohms may be placed between points  $a$  and  $b$ .

If the amplifier tube for the crystal microphone is to be a few feet from the microphone the conductor between  $a$  and  $b$  may be

the central insulated wire of a shielded cable, with the shield grounded and acting as the portion of the circuit shown by a broken line between the grounded points in the diagram. If the amplifier tube is to be something like 50 or more feet from the microphone a step-down transformer may be connected across

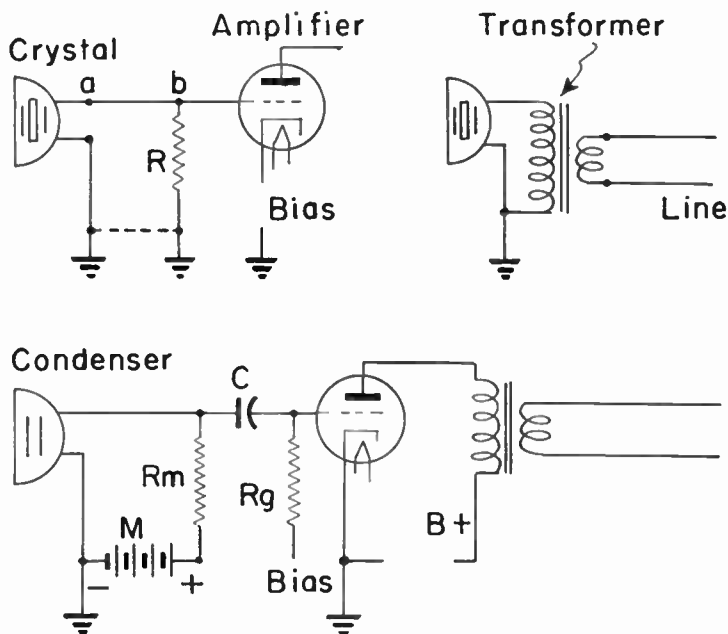

Fig. 12.—Output connections for high-impedance microphones.

the microphone, as at the upper right in Fig. 12, with the primary impedance matched to the microphone and the secondary a match for the line running to the amplifier.

Connections for a condenser microphone are shown at the bottom of Fig. 12. Here  $M$  is the source of high potential, usually 180 to 250 volts, for the microphone,  $R_m$  is the coupling resistor in the microphone circuit,  $C$  is the coupling capacitor, and  $R_g$  is the grid resistor for the amplifier tube. The resistance at  $R_m$  may be one or more megohms and at  $R_g$  may be from a half to two megohms. Capacitance at  $C$  may range from 0.01 to 0.1 mfd. The

amplifier stage shown here is mounted at the microphone, and its output or the plate resistance of the amplifier tube is matched through a transformer to a line or sometimes to a second amplifying stage.

Low-impedance dynamic and velocity microphones may be connected as shown by Fig. 13. Across the microphone is a step-up transformer which matches the microphone impedance to the grid circuit impedance or resistance of the first amplifying tube, as in the upper diagram, or to a long line as in the lower diagram.

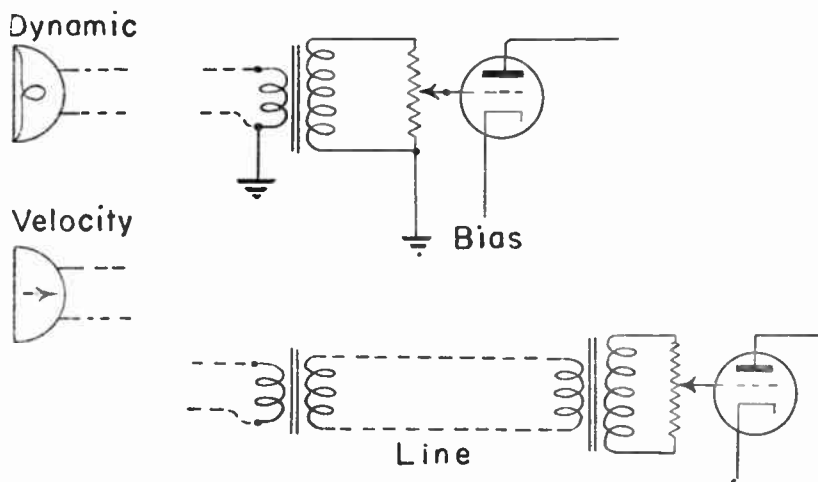

Fig. 13.—Connections from low-impedance microphones.

Output connections for low-impedance carbon microphones were shown in Fig. 11. Impedances of single-button types usually are between 50 and 100 ohms, and of double-button types are between 100 and 200 ohms. Currents for the single-button type may be 50 or more milliamperes, and for the double-button type may be almost anything up to 50 milliamperes with 15 milliamperes representing a common value.

Line impedances to which microphones and tube circuits are matched by transformers are of three general ranges; 35 to 50 ohms, 200 to 250 ohms, and 500 to 600 ohms. Microphone cables are made with either single or twin conductors, over which is a

layer of insulation followed by a woven or braided flexible shield and an outer covering of insulating material which will withstand rather rough usage.

Turns ratios for impedance matching transformers are quite easily determined with the help of a few formulas. The symbols used in the formulas are,

$N_p$ , Number of turns in primary winding.

$N_s$ , Number of turns in secondary winding.

$Z_p$ , Impedance, ohms, of source, line or other unit to which primary is connected, or the impedance which would give best operation were it the impedance of a load on the source, etc.

$Z_s$ , Impedance to which the secondary is connected.

Then the formulas are,

$$\frac{N_s}{N_p} = \sqrt{\frac{Z_s}{Z_p}} \qquad \frac{N_p}{N_s} = \sqrt{\frac{Z_p}{Z_s}}$$

$$N_s = N_p \times \sqrt{\frac{Z_s}{Z_p}} \qquad N_p = N_s \times \sqrt{\frac{Z_p}{Z_s}}$$

The first two formulas give respectively the turns ratios, secondary to primary and primary to secondary.

When the secondaries of matching transformers are in control grid circuits they carry practically no current and may be made with very small wire. This applies also to primaries which are connected to all except the carbon types of microphones, since in other types there is almost negligible current. All such matching transformers may be of small size, yet have the necessary impedance relations. Carbon microphones carry considerable direct currents, which flow also in the primaries of the microphone transformers. Consequently, the primaries of these transformers must be of wire that will carry the current and the core must have enough iron to prevent saturation or near-saturation by the direct current.

**Directional Response of Microphones.** — Some types of microphones respond to sounds about equally well from all directions at the same time. Such types usually are constructed so that the diaphragm points toward the ceiling, or so that the plane through the diaphragm is horizontal. Others are designed to respond equally to sounds from opposite directions, but to have little

response to sounds from in between. That is, these types will respond to sounds coming from front and back, but not to those coming from the sides. Some velocity microphones are in this class, and are said to be bi-directional.

Fig. 14 shows a response pattern much favored for use in public address systems. It is called a *cardioid* pattern; the word cardioid means heart-shaped. If we consider the microphone response to be 100 per cent for sounds coming from directly in front the percentage responses for sounds coming from other directions are shown by the heart-shaped figure. For example,

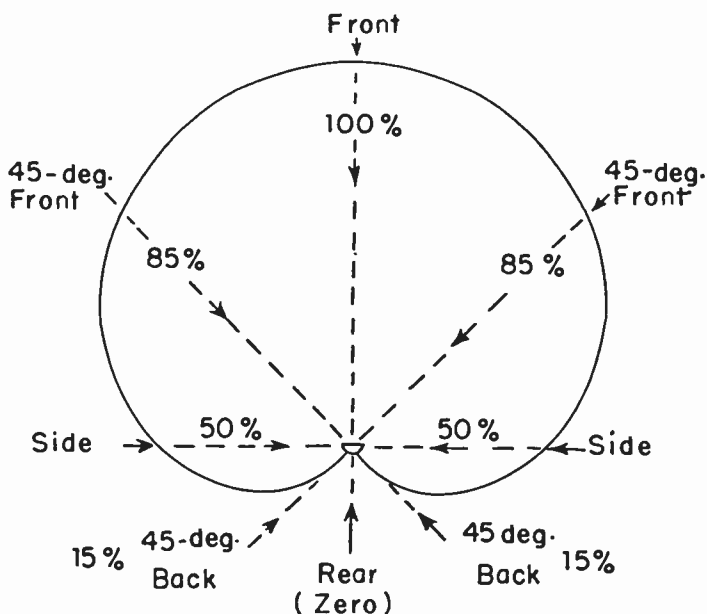

Fig. 14.—The cardioid pattern of microphone response.

sounds coming from 45 degrees either side of the direct line are received with a response only 85 per cent as great as sounds of equal power from directly in front. From the two sides the response is 50 per cent. It drops to 15 per cent at 45 degrees either side of the back, and is zero or very nearly so for sounds coming directly from the back. The response to sounds of equal

powers coming from any other directions is proportional to the relative distances from the microphone position to the cardioid outline.

The cardioid and generally similar response patterns, also patterns having an even narrower angle of response, characterize microphones that are called directional types or unidirectional. Such types may be placed to eliminate noises arising in the rear of the microphone. They may be used also to prevent acoustic feedback from the loud speaker or speakers, which occurs when sound waves from the loud speakers reach the microphone being used in the same system to cause a sort of uncontrollable "regeneration" of all amplified sounds.

**Phonograph Records.** — In Fig. 15 at A is a top view of a phonograph record which is carried by a motor-driven turntable. On the surface of the record is a spiral groove which starts from near the outer edge of the record disc and ends toward the center. In the groove rests the point of a needle made of steel or of other suitable material. The needle is carried

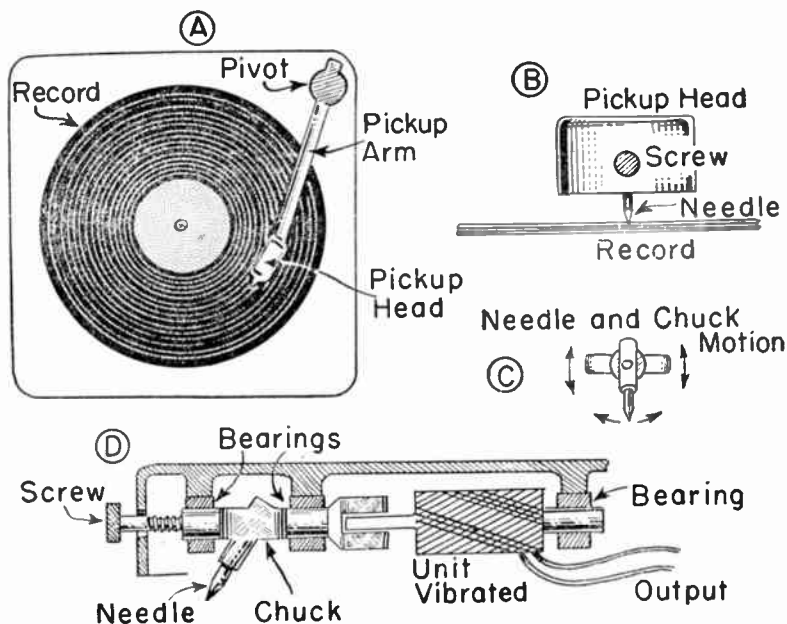

Fig. 15.—The application and structural details of a phonograph pickup.

in a pickup head mounted on one end of a pickup arm which is pivoted at its other end so that the pickup head may move from outside to inside of the record disc as the needle follows the spiral groove. At *B* is a front end view of the pickup head and the needle, with the needle point resting on the surface of the record.

Side-to-side irregularities or undulations in the record groove cause the needle point to swing rapidly or to vibrate from side to side, as indicated at *C*. The pickup head and arm have enough weight in themselves to hold them practically still, except for gradual travel across the record, as the needle is vibrated. That is, the vibrations of the needle are not strong enough to overcome the inertia of the head and arm. The needle is held in a part called the needle chuck, usually by means of a screw. When the point of the needle is vibrated from side to side, the chuck and parts attached to it have the corresponding motion shown by arrowheads.

At *D* is a side sectional view showing details to illustrate general principles employed in pickup heads, although exact constructions will differ rather widely between different makes and models. The needle chuck is carried in bearings of rubber or other resilient material which allow the motion shown in diagram *C*. To the chuck is mechanically coupled a unit which is vibrated by motion of the chuck and in which this mechanical movement is translated into emf's and changes of potential which form the electrical output of the pickup.

In pickups in most general use the unit vibrated contains crystals of Rochelle salt. The crystals are twisted as in diagram *B* of Fig. 7 and produce potential differences at frequencies and amplitudes which follow the mechanical frequencies and amplitudes of the system that carries the needle as shown by Fig. 15. These are called *crystal pickups*. In other designs the unit vibrated from needle motion is an iron armature which is part of the magnetic circuit of a permanent magnet. Movement of the armature, around which are coils, changes the strength of the magnetic field through the turns of the coils and induces emf's in the coils. The resulting potential differences and currents form the audio-frequency electrical output of the pickup. These are called *magnetic pickups*.

In Fig. 16 are represented short sections of a few adjacent turns of the spiral groove on a record. The end of a needle is shown resting in turn 2. The turns numbered 1, 2 and 3 follow the spiral path are practically uniform curves. In turn number 4 the smooth curvature shown in full lines has been altered to make the groove follow the broken-line path. This undulating section of groove makes the tip of the needle swing or vibrate from side to side.

The frequency of needle vibration and of sound reproduction depends on the number of times per second that the needle tip goes from one side to the other and back again, to complete

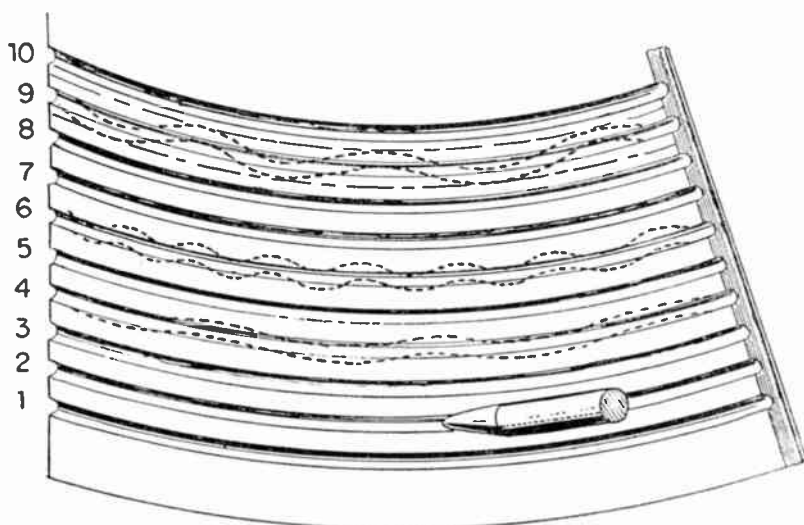

Fig. 16.—Groove sections and undulations on a phonograph record.

one cycle. The undulations of the groove shown by broken lines on turn number 6 represent a higher frequency than those in turn 4, because in turn 6 there are more undulations in a given length of the groove and, consequently, in a given length of time.

The amplitude of needle vibration and of sound reproduction depends on how far the needle tip is swung from the path followed in an "unmodulated" groove, such as numbers 1 to 3 and others. The amplitudes in turns 4 and 6 are about equal, but those shown by broken lines on turn 9 are much greater in



extent. In fact, on turn 9 the swings extend all the way to the center lines drawn on the spaces between adjacent turns. Were the amplitude greater than this, the groove of one turn might cut right through into the groove for an adjacent turn were there such high amplitudes in both turns.

The standard speed for record rotation is 78 revolutions per minute. On the outer turn of the groove on a 12-inch (nominal outside diameter) record this means a speed of about 46.4 inches per second, and on a 10-inch record a speed of about 38.8 inches per second. At a sound frequency of 1,000 cycles each cycle then would take in 0.0464 inch for the 12-inch record and 0.0388 inch for the 10-inch size. The inner turn of the groove has a diameter and circumference so much smaller than those of the outer turns that the speed is relatively low. On either size of record the speed on the inner turn is about 15.3 inches per second, and one cycle at a frequency of 1,000 cycles will cover a distance of 0.0153 inch. The greater lengths per cycle in the outer turns allow easier high-frequency reproduction near the outside of the groove than near the inside.

Good quality records cover a range of frequencies from about 80 to 5,000 cycles. Some high-quality records cover a range from somewhat lower than 60 cycles up to more than 8,000 cycles per second. The output power and voltage always are less at frequencies below some limit between 250 and 500 cycles than they are for frequencies between this limit and the high-frequency at which there is a rather sharp drop. The low-frequency reduction is due to the necessity for limiting the amplitude so that one turn will not cut through to an adjacent turn. Were uniform power or voltage output to be maintained it would be necessary to increase the amplitude as the frequency drops, and, for the reason mentioned, the amplitude is limited by danger of cutover.

**Pickups and Connections.** — The crystal pickup, in which is generated a potential difference, acts like a capacitor having a capacitance of 0.001 to 0.002 mfd. The reactance of such a capacitance becomes quite high at low frequencies; running to about two megohms at 50 cycles and to more than one megohm at 100 cycles. In order to have good power transfer at the low frequencies this high-reactance or high-impedance source must be connected to a high-resistance load.

Several circuits used between crystal pickups and the control grids of a-f amplifier tubes are shown by Fig. 17. In all of these circuits the volume control voltage divider or potentiometer  $VC$  is in series with the output from the pickup, with the slider connected either directly or through a coupling capacitor  $Cc$  to the control grid of the amplifier. Capacitor  $Ca$ , which is in series with the pickup, has values usually between 0.02 and 0.1 mfd. Volume control resistances usually are from 0.5 to 1.0 megohm. Grounding capacitor  $Cd$ , used alone, may be of 0.1 mfd capacitance. In diagram 3 this capacitor is a 1.0-mfd bypass for the 0.25 megohm resistor  $Rd$ .

Coupling capacitors  $Cc$  run from 0.002 to 0.01 mfd capacitance with grid resistors  $Rg$  as high as 10 megohms. In diagram 2 there is cathode-bias for the amplifier with resistor  $Rb$  and capacitor  $Cb$ . In this diagram the amplifier tube is a power

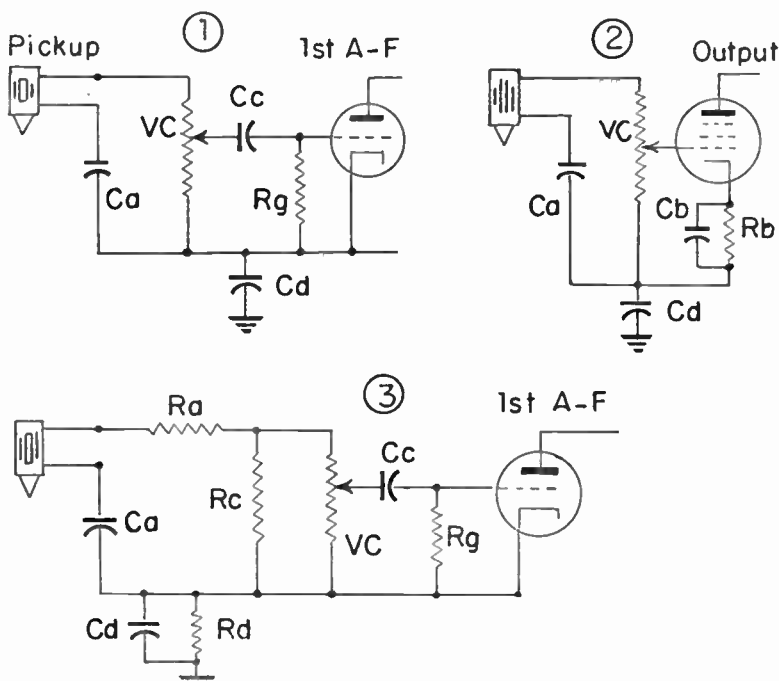

Fig. 17.—Connections used between crystal pickups and amplifier tubes.

pentode or beam power type whose output is coupled to the loud speaker without any other amplifier tubes in the system. The other two diagrams show connections to a first a-f amplifier which is followed by a power amplifying stage for the output.

The arrangement of resistors in the pickup circuit shown by diagram 3 serves to give an apparent increase of output at the low frequencies, or a reduction of the highs which leaves emphasis on the lows. In somewhat similar circuits there is a capacitor in series with resistor  $R_c$ . The parallel resistances of  $R_c$  and  $VC$  are series with the resistance of  $R_a$ . The total effective resistance of this parallel combination should be that which suits the characteristics of the pickup used. The higher the resistance of  $VC$  in this or in any generally similar circuit the higher will be the voltage output from the pickup circuit at frequencies below about 1,000 cycles, with the greatest voltage gains in the range from 50 to 200 cycles. The value of  $VC$  has little effect on frequencies above 1,000 cycles.

Magnetic pickups have inherently low impedance and are coupled to control grid circuits through transformers which give a satisfactory match between the low impedance of the pickup and the high impedance required in the grid circuit. The connections are much the same as for dynamic and other low impedance microphones.

In the construction of phonograph amplifiers it is desirable to have short leads between pickup and amplifier tube or between pickup and a matching transformer with high impedance pickups. Grounding is important in reducing hum. A crystal pickup lead usually is made through a shielded single-conductor cable, with the shield acting as a second conductor and well grounded. The pickup arm should be grounded, as should also the turntable and the frame of the driving motor.

The entire structure which includes the motor, the turntable, and the pickup, with the supporting base, may be on cushion mountings. In addition, the pickup arm may be insulated against vibration by its own cushion support of sponge rubber or equivalent material.

There must be enough pressure on the needle to keep it in the record groove. Needle pressures for crystal pickups run from less than an ounce up to about  $2\frac{1}{2}$  ounces, depending on the

make and model. Pressures for magnetic pickups average higher than for crystal types. To insure reasonably correct pressure the pickup arms are counterbalanced, either with weight or by means of a spring that carries part of the weight of the arm. Screw adjustments sometimes are provided for needle pressure.

Phonograph amplifiers for public address work usually are provided with tone controls; sometimes with two separate controls, one for boosting the highs and the other for boosting the lows. Attenuation of the frequencies above 3,000 cycles often is desirable to reduce the scratching sounds which result from needle travel in the slightly roughened groove of worn records, and of some new ones. Control for both high and low frequencies often helps overcome difficulties due to local conditions where the surroundings may give excessive echo effects, may cause too long continuation of some tones, may be such as to greatly absorb and weaken some frequencies, or may cause other troubles associated with certain frequencies.

**Volume Expansion and Compression.**—Previously it was mentioned that amplitudes, which represent sound volume, must be limited at certain frequency ranges in the production of records. The resulting compression of volume on loud sounds may be compensated for in a phonograph amplifier by including circuits wherein the output increases at a greater rate than the input so that the greater the input the more it is amplified.

An opposite condition may exist when sound pickup is through a microphone. Then excessively loud sounds, as when the speaker approaches the microphone too closely, may be automatically held down by a circuit that amplifies high input powers or voltages to a smaller degree than weaker inputs.

Circuits for volume expansion or compression employ a separate amplifier tube, a voltage amplifying triode or pentode, whose a-f output is fed to a diode or double-diode tube wherein the a-f potentials are rectified to provide a direct potential that varies with the sound signal input to the amplifier. This rectified potential is applied either to the control grid circuit of the regular first a-f amplifier or else to the signal grid of a pentagrid mixer tube in which the grid ordinarily used for the oscillator is being used as the a-f signal grid. If the added potential is in such polarity as to increase the a-f variations in the controlled tube.

we have volume expansion, and if it is applied in the opposite polarity we have volume contraction.

**Mixing Circuits.**—Most public address systems have provision for using two or more sound sources, which may be microphones, phonograph pickups, or radio detectors. These sources may be used one at a time or some of them may be used together, as when phonograph music is to provide background for some other program feature.

Simple connections for handling a microphone and a phonograph pickup are shown by Fig. 18. Connections are shown for a high-impedance microphone and for a high-impedance pickup, but these might be altered to any of the types previously shown as adapted to the outputs of various types of sources of any impedance. Both sources in the diagram connect to volume con-

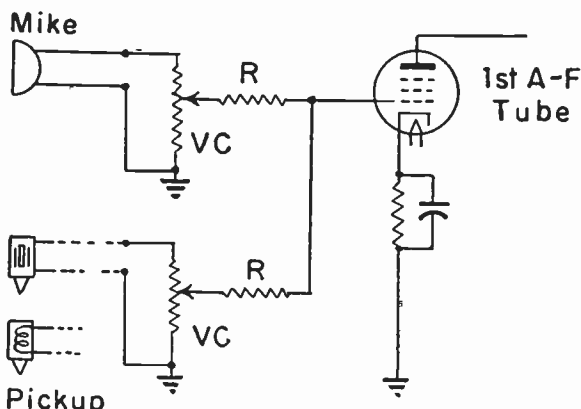

Fig. 18.—Mixing circuits for a microphone and a phonograph pickup.

trol voltage dividers,  $VC$  and  $VC$ , whose sliders connect through isolating resistors  $R$  and  $R$  to the control grid of the first a-f amplifier tube. The tube is provided with cathode-bias, which is independent of changes in resistance through resistors  $R$  and  $VC$ .

Moving either slider upward increases the input from the respective source. Moving either slider all the way down to the grounded end of the divider cuts off that source. Obviously, the two sources may be used separately, or may be combined in any proportions of volume from each.

Fig. 19 shows connections from two sources, *A* and *B*, through volume controls, *VC* and *VC*, to the control grids of a twin-pentode amplifying tube. Since the electron paths through the tube grids are quite distinct from each other, we need no isolating resistors in the grid leads. Amplified outputs from the two sources in combination will unite in the common plate connection of the amplifier, and are fed through coupling capacitor *Cc* to the control grid circuit of the following amplifying stage.

A twin-triode tube may be used as shown in the sketch at the lower right, being placed instead of the twin-pentode. However, to avoid excessive distortion at high output levels, the plate cir-

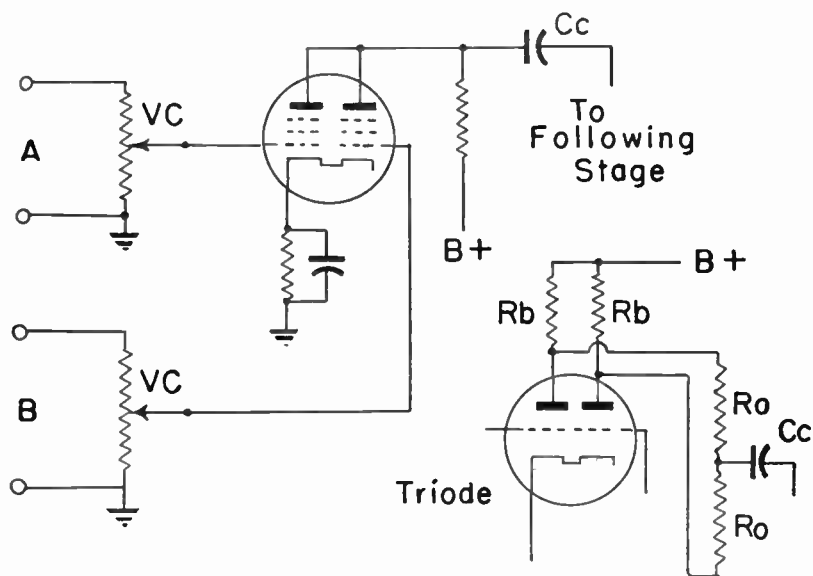

Fig. 19.—Mixing circuits for twin-pentode and for twin-triode amplifiers.

uits of the triode sections should be isolated from each other through separate voltage-dropping resistors *Rb* and *Rb* and the resistors *Ro* and *Ro* from between which a connection is made to the coupling capacitor for voltage feed to the following stage. The value of resistors *Rb* and *Rb* is chosen in accordance with the type of tube and the supply voltage applied. Resistors *Ro* and *Ro* may be of one-half to one megohm each.

Connections between the sources and the terminals indicated at A and B would be made to suit the type of input; microphone, phonograph pickup, or radio detector connected to each position. The two volume controls are used in the same manner as explained for similar units in Fig. 18. Any such volume controls may be used as "faders," so that the volume from one source may gradually be reduced as that from the other is brought in, thus fading from one to the other.

Fig. 20 shows an arrangement for providing greater amplification for a microphone input than for a phonograph pickup input, while mixing and fading the two sources as usual. The input

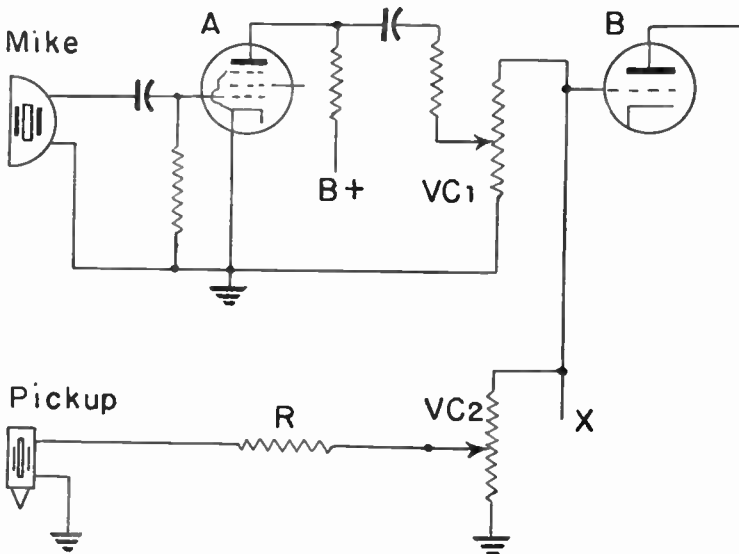

Fig. 20.—An additional amplifying stage for microphone input.

from most types of microphones is normally of less power or voltage than from commonly used phonograph pickups, and the microphone signal must be brought up to the approximate level of the pickup before the two signals are applied to a common amplifying tube.

The output from the microphone is applied to the control grid circuit of pentode A. No volume control is shown between micro-

phone and amplifier because it is assumed that the low level microphone output cannot overload the pentode. A volume control could be inserted if necessary. The output of the microphone amplifier tube is applied through volume control *VC-1* to the control grid of the second amplifier tube *B*. The output of the pickup is applied through isolating resistor *R*, usually about one megohm, to volume control *VC-2* and from there is carried to the control grid of amplifier *B*. A third source, such as a radio detector output, might be connected to point *X*.

Fig. 21 shows connections for handling one microphone and two phonograph pickups. The microphone connections to the microphone amplifier tube *A* are practically the same as in Fig. 20, except that here the tube *A* is shown as a triode rather than a pentode. The output from tube *A* is applied to the control grid circuit of a second microphone amplifier tube *B* through volume control *VC-1*.

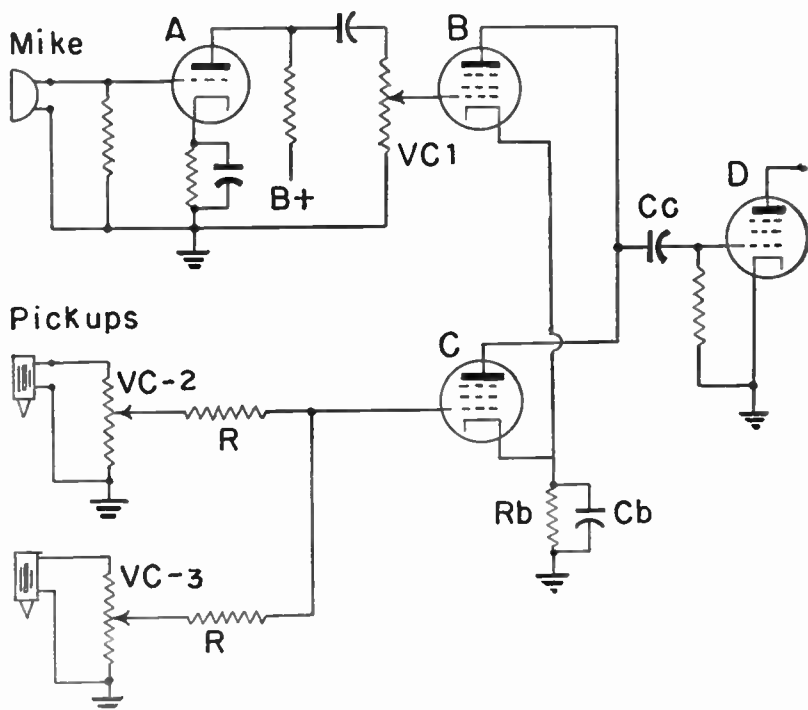

Fig. 21.—Controls for one microphone and two phonograph pickups.



The connections from the two pickups to the control grid of phonograph amplifier tube *C* are similar to those from the two sources in Fig. 18, with a separate volume control for each pickup, and isolating resistors *R* in the leads from the sliders to the grid. The outputs from microphone amplifier *B* and phonograph amplifier *C* combine in the common connection to the plates, and are fed through coupling capacitor *C<sub>c</sub>* to the control grid of the a-f amplifier tube *D*. Tubes *B* and *C* are shown as having a common cathode-bias resistor *R<sub>b</sub>* and bypass capacitor *C<sub>b</sub>*. The arrangement in this diagram allows mixing the microphone and phonograph signals, and fading the two phonograph inputs in and out in connection with announcements through the microphone. It allows also for changing the record on one turntable while the other record is playing, as would also be true in Fig. 19 were both of the sources to be phonograph pickups.

An advantage of placing the microphone volume control following the first amplifier rather than immediately following the microphone in Figs. 20 and 21 is that the slight noise resulting from operation of the volume control is not amplified by tubes *A*, but only by the following ones.

Either a triode or a pentode might be used at *A* in either Fig. 20 or Fig. 21. A pentode will give considerably greater gain than a triode but is more subject to hum pickup and to microphonic noise from the tube itself. The pentode preferably is of a type having a top cap connection for the control grid, with the grid lead shielded and the shielding grounded. Grid and plate leads must be kept away from a-c lines. The a-c leads should be of twisted pair. The heater connections for microphone amplifiers often come from a center-tapped heater winding with the tap grounded, or have a center-tapped resistor across the leads, with the tap grounded. Microphonic tube troubles may be lessened by using special non-microphonic voltage-amplifier pentodes. To lessen noises due to current flow it is essential that all resistors in microphone amplifier circuits of the high gain type be of good quality.

**Loud Speakers.**—Public address loud speakers are considered as consisting of two principal parts; a driver and a projector. The driver usually is an electro-magnetic unit in which there is a voice coil supported in a strong magnetic field and coupled

to the output tubes or power tubes of the amplifier. The voice coil of the driver may be attached to a cone just as in types of speakers employed for home radio, or else it may be attached to a metallic diaphragm as shown in a general way by Fig. 22. The projector is a horn, which may be of various types, proportions and sizes suited to the requirements of the installation. The horns

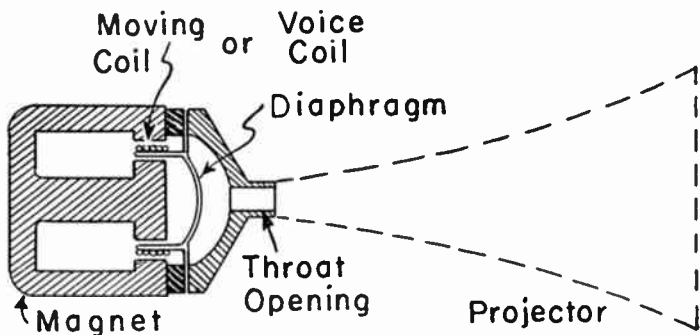

Fig. 22.—A loud speaker driver unit with rigid metallic diaphragm.

sometimes are of wood, or may be of some light-weight composition, but most often are of metal. Vibration in the metal of the projector is prevented by stiffening members in the structure, by the use of relatively heavy rims at the openings, and by use of rubber rings and pads, any or all of which act as vibration dampers.

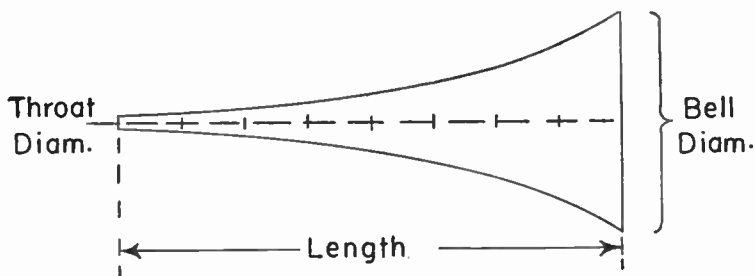

Fig. 23.—An exponential horn doubles its cross sectional area at equal intervals of length.

The basic form of most projectors is the *exponential* horn, or some modification of it, which is shown in Fig. 23. The distinguishing characteristic of an exponential horn is that the cross sectional area doubles at equal intervals of length from the throat to the bell or mouth. Such intervals of length are marked on the axis line of the horn in the diagram, which is assumed to be of circular section. If the intervals at which the area doubles were to be shortened and the bell diameter kept the same as shown, the horn would have a more rapid outward flare, but still would be of exponential form. The bell diameter might be changed in relation to the length, but so long as the cross sectional area increased at equal intervals the exponential form would remain.

The greater the length of the horn and the greater the bell diameter the greater will be its sound output at low audio frequencies. To provide good low-frequency performance the total length becomes many feet and the bell diameter becomes quite large. Although straight and curved exponential horns have been

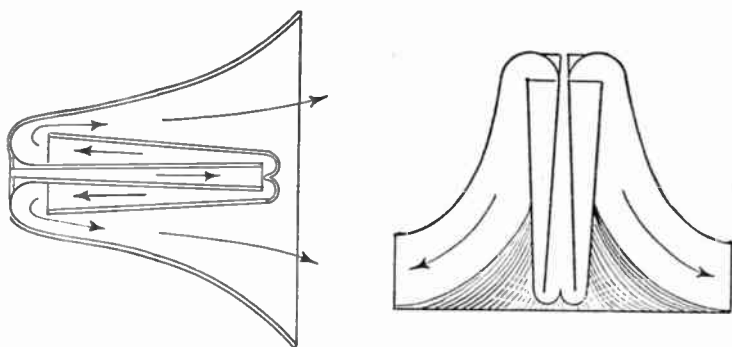

Fig. 24.—Sectional diagrams of folded exponential horns.

used and are used, it now is more common practice to obtain equivalent results in smaller overall length by “folding” the horn as shown by Fig. 24. Compressions and rarefactions in the contained air column travel as shown by arrows from the central throat at the left to the bell opening at the right in the horn shown at the left-hand side in the figure.

The projector shown at the left in Fig. 24 is designed to radiate sound chiefly in one horizontal direction. The type shown at the right is designed for mounting with its axis vertical, and for radiation of sound in all horizontal directions at the same time. Other projectors employing the folded principle are made so that there is only one reversal of direction between throat and bell; the driver then being mounted at the bell end so that sound waves travel first toward the back end and then come back and out of the bell around the driver.

Sound waves which are at low frequencies spread out after leaving the speaker bell more than do waves at high frequencies. This effect of frequency is illustrated by Fig. 25 where, at the left, is an outline showing the limits of equal sound powers at

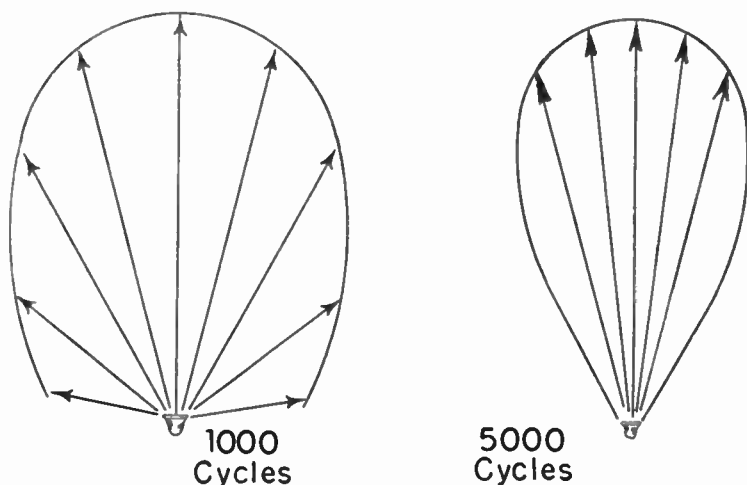

Fig. 25.—Relative spreads of high- and low-frequency sounds from a loud speaker.

1,000 cycles, and at the right is an outline of equal sound powers at 5,000 cycles. The diagrams apply to an exponential horn having the proportions of length and bell diameter commonly used for public address, but apply to no particular make or type of horn. Maximum distances are shown as the same in both diagrams, but either the highs or the lows might reach the farther, depending on their relative powers as projected from the

horn. For still higher frequencies there would be some additional narrowing of the sound beam, but not a great deal.

For greater sidewise spread than available from a single unit, two or more may be operated together and pointed in directions that give the desired coverage. When such units are side by side, horizontally, the horizontal spread is increased with little or no change in the vertical spread. If more vertical spread is needed, two or more units or banks may be used, one above the other.

The horn types of speakers, either straight or folded, have marked ability to project sound to considerable distances, hence they nearly always are used in preference to cone types for outdoor applications. To satisfactorily reproduce low tones the horn type speakers must have large-diameter bell openings, and there must be a long air column, making these types of large overall size.

Indoor applications often are satisfactory when made with regular cone type speaker units in flat baffles, arranged in suitable housings for mounting either on walls, ceilings, or standards. The flat baffle gives the widest possible spread for sound, and gives good results where there are large numbers of people indoors. Enough speaker units are used in various positions to cover the indoor area.

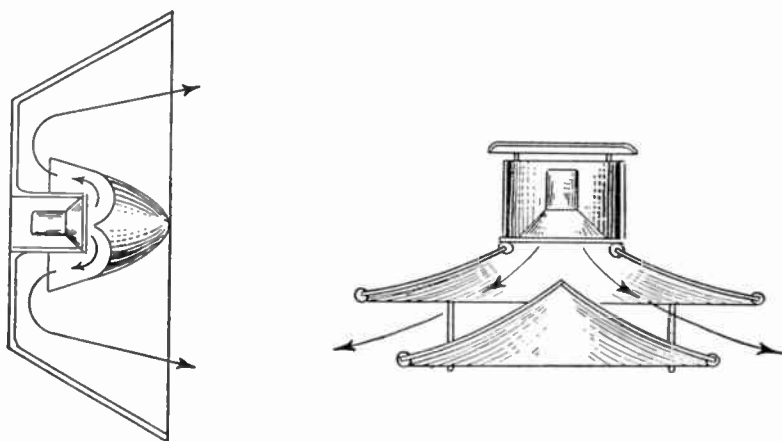

Fig. 26.—Drivers of the cone type mounted in directional projectors.

For large indoor or enclosed spaces, such as arenas and other places housing sporting and entertainment events, directional horns are used to get sound into the more remote spaces. Cone type speaker units may be mounted in housings such as shown at the left in Fig. 26 to provide considerable directivity of sound projection. Here the cone is the driver for a short folded horn of approximately exponential form. For projection of sound in all directions around the 360 degrees of a full circle a cone type unit may be used as shown at the right. The effect on direction of sound projection is the same as the effect with the folded horn arrangement shown at the right in Fig. 24.

When a very wide range of frequencies is to be covered a cone type driver and short projector may be used for the lows, and a small diaphragm type driver and horn for the highs. One method of combining the two drivers and their projectors is shown at the left in Fig. 27. Here the drivers are back to back, with the cone opening toward the back of the cone projector. The high frequency unit is a folded horn type such as shown at the left in Fig. 24. Other combinations are in use. In one of them the high-frequency horn opening is in the center of the vibrating cone for the low-frequency unit.

With combination high and low frequency units the input to the speaker, coming from the amplifier power tubes, is filtered to send most of the power below frequencies around 500 cycles to the driver for the cone, with most of the power for higher fre-

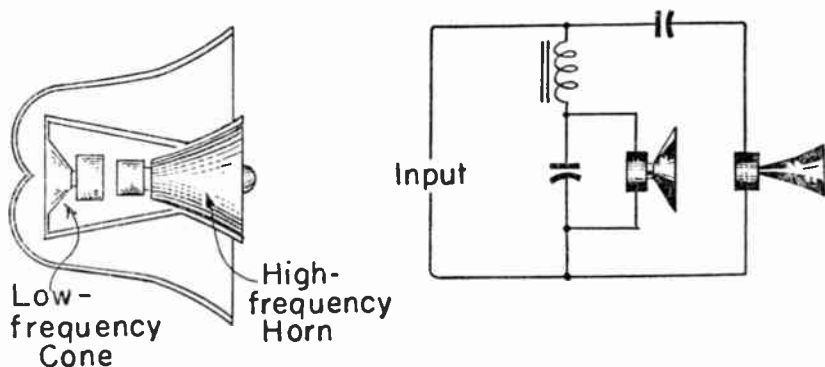

Fig. 27.—High-frequency and low-frequency drivers and projectors in a single unit

quencies going to the horn. A low-pass filter network may feed the cone, and a high-pass net the horn. Capacitance may be connected in parallel or across the leads for the cone, to bypass the highs and leave the lows, while a capacitance may be in series with the leads for the horn, to pass the highs and offer high impedance to the lows. The principle is shown at the right in Fig. 27. The drivers may be further isolated from each other by using a separate coupling transformer for each driver unit.

**Power Requirements.**—The power that must be put into the projection of sound usually is measured as the normal power output of the final tubes in the public address amplifier, and when we say that a power of a certain number of watts is needed for a given installation we are referring to the power output of

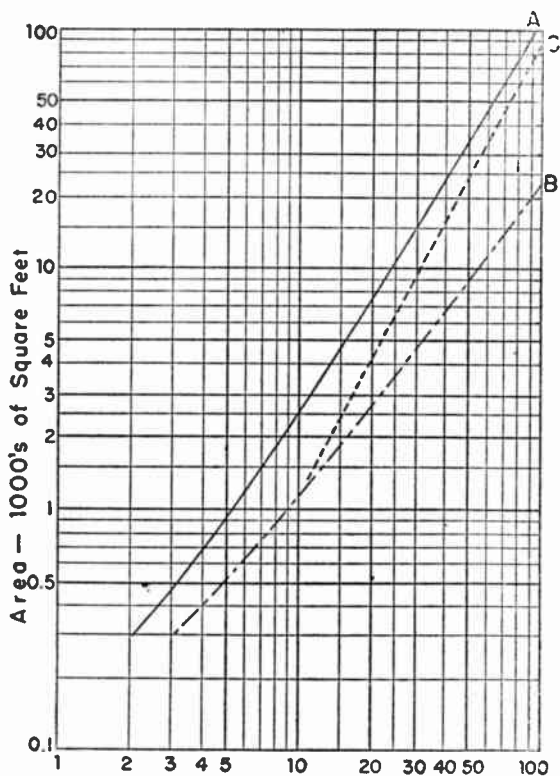

Fig. 28.—Power outputs of amplifiers for coverage of areas in public address work.

the tubes. An amplifier rated for a certain power output should be capable of delivering possibly 15 to 50 per cent more than its rating without excessive distortion, so that peaks may be handled. There is some loss of power in the connections between output tubes and loud speakers, and there is additional loss in the speakers where the electrical power is changed into acoustic power of sound waves.

The amplifier power required for a given installation varies with so many factors, many of them unpredictable, that only the most general values may be given as a guide. Such values are shown by Fig. 28, where the relation is between areas in thousands of square feet to be covered by sound, and amplifier output power in watts. The solid line curve (*A*) applies to average indoor conditions where the space is fairly well filled with people and where the noise level is only moderate, as in theatres, churches, dining places, and some auditoriums. The dot-dash curve (*B*) applies indoors where there is a high noise level, as where there is dancing or roller skating. The broken-line curve (*C*) which starts from 1,000 square feet and 10 watts of power applies out of doors where the listeners are congregated within the measured area and where the projectors are of types which deliver the sound to this area. When requirements are based on number of listeners instead of on area, the number may be multiplied by 5 to 8 (square feet per person) to get the equivalent area. When requirements are based on cubic-foot room volume the volume may be divided by 9 to 12 (average room heights in feet) to find the equivalent area.

Indoor installations require smaller powers for given areas and number of listeners than outdoor installations because indoors there are reflections of sound waves which are confined within the enclosure. To oppose the reflections, which increase the sound power at a given point, we have the absorption of power by furniture, carpets, draperies, and other objects and surfaces within a room.

Smooth, hard surfaces absorb only one to four per cent of the sound power reaching them, and reflect the remainder. Such surfaces include glass, tile, stone, finished wood, and others of like characteristics. Fabrics of moderate thickness, such as carpets, some wall coverings, and thin felts, absorb 10 to 30 per



cent of the sound power and reflect the remaining 90 to 70 per cent. Materials which are designed especially for absorption of sound power and the prevention of excessive echo effects will absorb 30 to 70 per cent of the power reaching them. These materials include the many varieties of "acoustic" coverings used for wall and ceiling covers. In this latter class are also thick felts, soft upholstery, and heavy folded draperies.

A certain amount of sound absorption is necessary. In a large unfurnished room with bare walls and floor, and only a few persons present, the echos and re-echos will continue for so long as to make speech unintelligible. Such echo effects are called reverberation. Enough sound absorption must be present or must be added to prevent excessively long reverberation. All materials absorb greater percentages of power at high frequencies than at lower ones. Consequently, high audio frequencies are deadened more than low ones, and to preserve original proportions in speech or music indoors it is necessary to increase the power at high frequencies in accordance with the degree of absorption present. This is a reason why some public address systems have separate controls for regulating high-frequency power.

### REVIEW QUESTIONS

1. What is the advantage of using decibel measurements?
2. What is the usual reference level for measurements of power in amplifier or loud speaker systems?
3. What are the five basic types of microphones used in public address systems?
4. Specify the two general classes into which microphones are divided.
5. Why is impedance matching important in speech amplifier input circuits?
6. Describe the construction and operation of a crystal and magnetic phonograph pickup.
7. What is the basic form of sound projector and what is its distinguishing characteristic?
8. What percentage in excess of its rated watts output should a public address amplifier be capable of delivering without excessive distortion? Why?

## Chapter 7

### HIGH-FREQUENCY AND SHORT-WAVE

Many radio receivers are designed to operate not only at frequencies in the standard broadcast range between 550 and 1,600 kilocycles, but also at higher frequencies extending through to about 25,000 kilocycles or 25 megacycles. In the frequencies above the broadcast band are found communications in the police, aviation, and marine fields, also amateur transmissions and various government services, and, of great interest to many listeners, a number of bands on which occur international broadcasting from the United States and from many foreign countries.

Television in channels 2 to 13 use part of the spectrum between 54 and 216 megacycles.

The various "bands" for transmission and reception are becoming more and more generally designated in accordance with the ranges of frequency in megacycles, but the designations in the past have been in accordance with wavelength in meters, and this practice still is found convenient and is used in many present receivers.

Any wavelength in meters is changed to the equivalent frequency in *kilocycles*, and any number of kilocycles is changed into the equivalent number of meters, by dividing 300,000 by whichever value is known. If the change is to be made between meters and *megacycles*, from either one to the other, the known value is divided into 300 instead of into 300,000. That is,

$$\begin{array}{l} \text{Kilocycles} = \frac{300000}{\text{meters}} \\ \text{Meters} = \frac{300000}{\text{kilocycles}} \end{array} \quad \text{or} \quad \begin{array}{l} \text{Megacycles} = \frac{300}{\text{meters}} \\ \text{Meters} = \frac{300}{\text{megacycles}} \end{array}$$

The arrangement in most common use is for reception in either of two bands. One is the standard (amplitude-modulation) broadcast band. The other band, called "foreign," "short-wave," "international," or some other descriptive name, usually extends from somewhere around five to eight megacycles up to around 12 to 20 megacycles. Here there is quite a gap between the highest standard broadcast frequency (1,600 kc or 1.6 mc) and the low

end of the high-frequency band. Three-band receivers often have an intermediate band for frequencies immediately above those in the standard broadcast range.

The international broadcast bands, all or part of which may be covered by a multi-band receiver, usually are designated in meters of wavelength. Following are the wavelength designations of such bands as have been used for this class of service, also the ranges in meters and in megacycles for each band.

Band Name	Range, megacycles (approximate)	Range, meters (approximate)
49-meter	6.19 to 6.02	48.5 to 49.8
31-meter	9.69 to 9.51	30.9 to 31.6
25-meter	11.89 to 11.71	25.2 to 25.6
19-meter	15.33 to 15.11	19.6 to 19.9
16-meter	17.84 to 17.76	16.8 to 16.9
14-meter	21.75 to 21.45	14.5 to 14.7
12-meter	25.85 to 25.57	11.6 to 11.8

Fig. 1 shows connections between antenna and converter tube for a two-band, broadcast and short wave, receiver. The chief difference between such a receiver and one for reception in only

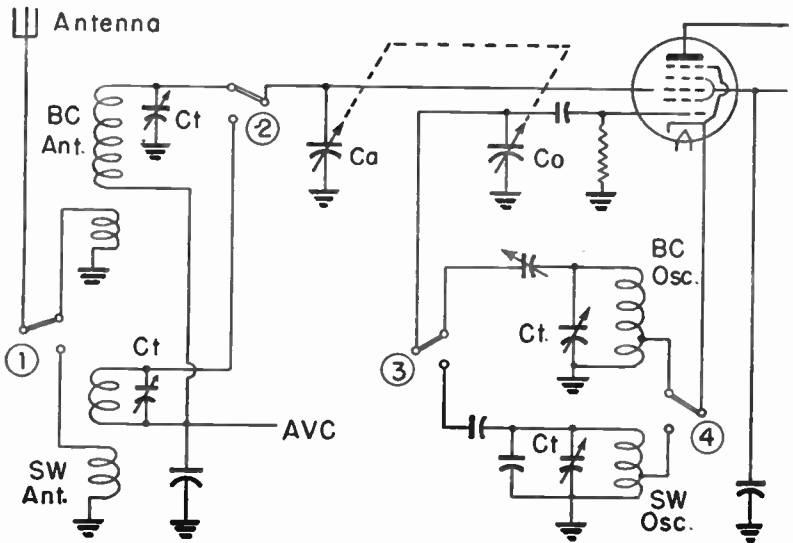

Fig. 1.—Circuits from antenna to converter in a two-band receiver.

the broadcast band is the inclusion of an extra set of coils or tuned transformers for the antenna circuit and the oscillator circuit. The same tuning capacitors are used for both bands. Connected to each of the coils which is to be tuned is a trimmer capacitor used for the frequency range in which the coil operates.

Referring to Fig. 1, the antenna circuit or signal-grid circuit coils for the broadcast range are marked *BC Ant* and those for the short-wave range are marked *SW Ant*. The oscillator coils for the two ranges are marked *BC Osc* for broadcast, and *SW Osc* for short wave. The two units in the ganged tuning capacitor are marked *Ca* for the antenna circuit or signal grid circuit, and *Co* for the oscillator circuit.

There are four two-position switches for shifting the connections between broadcast and short-wave bands. These switches, numbered 1 to 4, are shown in the broadcast position. With the contact arms moved downward the connections would be for the short-wave band. Switch 1 changes the antenna between the primary windings of the broadcast and short-wave antenna coils. Switch 2 connects either the broadcast or short-wave secondary winding to tuning capacitor *Ca* and the signal grid of the converter. Note that the separate trimmer capacitors *Ct* and *Ct* are connected directly to their respective coils, and are switched when the coils are switched.

Switch 3 controls the connection from the oscillator grid of the converter, and oscillator tuning capacitor *Co*, to the secondary windings of the oscillator coils. Switch 4 connects the converter cathode to ground through either the broadcast or short-wave oscillator coils. There are trimmer capacitors *Ct* and *Ct* on each of the oscillator coils.

There is nothing unusual, so far as principles are concerned, about the tuned circuits for either the signal grid or the oscillator sections of the converter. Any standard circuits, and standard converter tubes, may be used for short-wave reception up to about 25 megacycles or 12 meters with suitable arrangements for band switching.

In Fig. 2 a built-in loop is used in the signal grid circuit of the converter for reception in the standard broadcast band, the loop replacing the secondary of the broadcast antenna coils used in the preceding diagram. This loop, like all those in general use,

consists of many turns acting as the secondary and of fewer turns wound around the outside to act as a primary in the circuit of an external antenna. The antenna turns of the loop connect through to the primary of the coil used for short-wave reception, and from this primary to ground. The oscillator circuits and switching for Fig. 2 might be like those of Fig. 1, or of any other type used with pentagrid converter tubes.

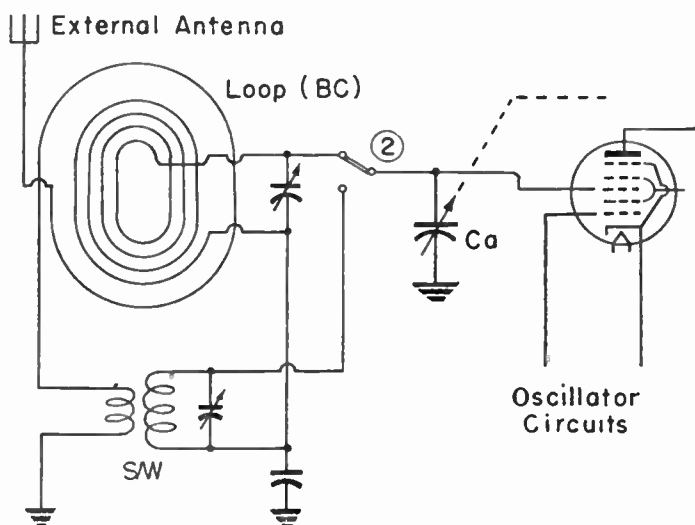

Fig. 2.—Antenna circuits with a built-in loop for broadcast reception.

**Band Switching.**—In the two diagrams which have been examined the band switches are shown by the symbol for a double-throw knife switch. This is done to make the diagrams easy to follow, but in actual practice the band switches nearly always are of the rotary selector type having as many gangs as may be needed on a single operating shaft, and having connections on both the front and back of each gang.

A single section or gang for a rotary switch is shown at the left in Fig. 3. The section consists of an outer stationary ring of insulating material to which are riveted inwardly extending contact arms. Inside the stationary ring is a rotor ring, of insulating material, which is turned by a shaft through a center

hole. To the rotor ring is fastened the metallic rotor on which rest the inner ends of the contact arms to complete various circuit connections. The rotor illustrated has gaps wherein the diameter is smaller than the outside measurement, so that a long contact

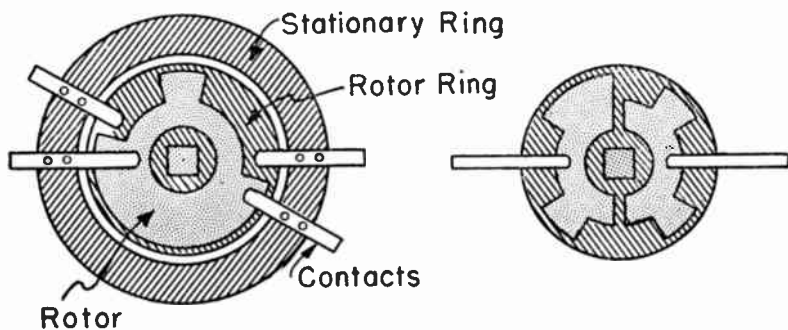

Fig. 3.—One unit of a rotary selector switch.

arm rests on the rotor metal in all positions of rotation, while the shorter arms make contact only when the rotor is turned to bring its greater diameter under the short arms.

By varying the shape of the rotor metal, or by varying the positions and lengths of the gaps between portions of large diameter, and by placing contacts at suitable positions or by making connections to only certain contact arms, the switch may be arranged to make almost any conceivable circuit changes in any order that may be desired.

A single switch section may have a split rotor, as at the right in Fig. 3, with one or more long contact arms making connection with each side of the rotor metal. Each side then will make or break connections to one or several shorter arms as the rotor is turned through half of a complete revolution. Rotors may be divided into three segments or into four segments so that many circuits may be switched at one movement of the switch. A rotor of one shape or of some certain number of segments may be attached to one side of a rotor ring, and to the other side of the insulating ring may be fastened a second rotor of different shape or of different number of segments.

Rotary selector switch sections often are shown in wiring

diagrams as the simplified outline at the left in Fig. 4. Long arrows indicate contact arms which rest on the rotor in all positions, while the short arrows indicate arms that make connections only when the greater diameter of the rotor is brought opposite them.

If you look at the front end, shaft end, or control knob end of a section of a rotary switch, and this section or rotor is assumed to be turned clockwise, then the back or the opposite side of the same member will be turning counter-clockwise as you

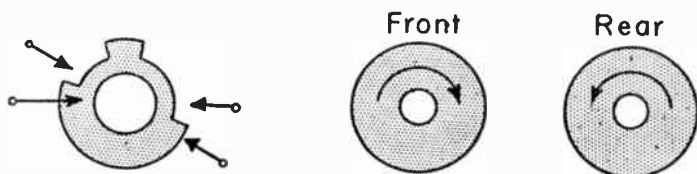

Fig. 4.—Selector switch symbol (left) and rotation directions as viewed from opposite sides (right).

look from the back. This is indicated at the right in Fig. 4. Front and rear views of switch sections usually are plainly marked on wiring diagrams, and it is assumed that you are looking at the connections from the front in one case and from the back in the other case, just as you would look at them when actually making wire connections to the switch.

Tone switches often are combined with band selector switches. A common arrangement for two-band receivers is (1) broadcast band with normal tone, (2) broadcast band with low-note emphasis, and (3) short-wave band with low-note emphasis. The reason for the number 3 combination is that much objectionable noise is cut out on short-wave reception by attenuating the high audio frequencies. When a receiver is designed for radio reception and also for phonograph reproduction, the band selector switch usually will have one position for phonograph reproduction and the remaining positions for radio bands.

**Tuning Capacitance and Inductance.** — To become acquainted with what may be accomplished when using the same tuning capacitor for standard broadcast and short-wave bands we may make computations for a typical 2-band arrangement. We shall

assume the use of a tuning capacitor having maximum capacitance of 300 mmfd and a minimum of 15 mmfd, and assume further that the fixed and distributed capacitances in wiring, tube, and minimum of a trimmer capacitor make a total of 20 mmfd. Then our change of capacitance will be,

Tuning capacitor	15 min.	300 max.
Fixed items	20	20
Total	<u>35 min.</u>	<u>320 max. mmfd.</u>

To tune to a low frequency of 540 kc in the broadcast band with maximum capacitance of 320 mmfd requires inductance of approximately 271.5 microhenrys.

With inductance of 271.5 microhenrys and the minimum tuning capacitance of 35 mmfd the highest tuned frequency will be 1,632 kc.

Then the broadcast tuning range will be from 540 to 1,632 kc.

For the short-wave range we shall assume a low frequency limit of 5.5 megacycles. To tune to this frequency with the maximum capacitance of 320 mmfd requires inductance of 2.62 microhenrys, approximately. Our assumed and computed values are shown in Fig. 5.

With this inductance of 2.62 microhenrys and the minimum tuning capacitance of 35 mmfd the highest tuned frequency will be 16.64 megacycles.

Then the short-wave tuning range will be from 5.5 to 16.64

C = 35 to 320 mmfd  
L = 271.5 microhenrys  
540 to 1632 kc

C = 35 to 320 mmfd  
L = 2.62 microhenrys  
5.5 to 16.64 mc.

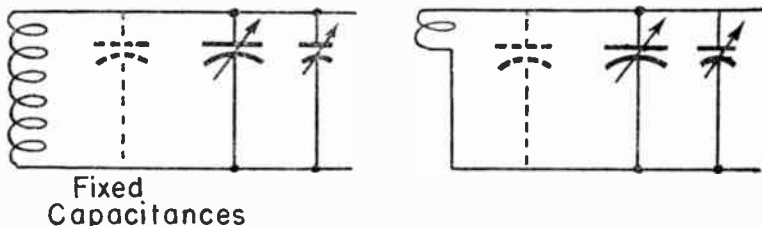

Fig. 5.—Capacitances and inductances for tuning in two bands.



megacycles. This range will take in the international broadcast bands from 49 meters to 19 meters, inclusive, since the range of frequencies in these bands runs from 6.19 to 15.11 megacycles.

We may note that the ratio of lowest to highest frequency in each band is about one to three. With the same change of tuning capacitance used for both bands the frequency ratios will be equal. Using the same tuning capacitor we might provide inductance coils allowing tuning over other frequency ranges having ratios of about one to three.

**Bandspread Tuning.** — Although the ratios of low to high frequencies are the same in the broadcast and short-wave bands for which computations just were made, the differences between low and high frequencies and also the number of transmission channels are decidedly different. In the broadcast band the channels are each 10 kilocycles wide. For instance, a station transmitting on a carrier of 1,000 kilocycles may radiate frequencies between 995 and 1,005 kilocycles. Between 540 and 1630 kc, our computed broadcast range, there would be room for 110 of these 10-kc channels.

Our lowest short-wave frequency was taken to be 5.5 megacycles, which is 5,500 kilocycles, and the highest was computed to be 16.32 megacycles, which is 16,320 kilocycles. Between 5,500 and 16,320 kilocycles there would be room for 1,083 channels each 10 kc wide. With both bands covered by the same variation of the tuning capacitor, the average width of a short-wave channel on the tuning dial or scale will be one-tenth the width of a broadcast channel. This makes for difficult tuning, because a signal will come in and go out with only an exceedingly small movement of the tuning control.

There are many possible ways of spreading the frequencies or channels in any given band over all or nearly all of the dial. A fairly common method is shown at A in Fig. 6 where are shown the connections between the control grid or signal grid of the tube and the tuned coil or transformer for the short-wave band. Across the secondary winding is the usual trimmer capacitor and also a bandspread capacitor having a maximum capacitance of 25 to 50 mmfd. The larger band setting capacitor is the tuning capacitor that would be used also for covering the broadcast band. With this large capacitor set for the frequency in the

middle of a band, the capacitance and resonant frequency may be varied either way by operation of the bandspread capacitor, which becomes the tuning capacitor for the band selected. A suitable capacitance in the bandspread unit permits it to be varied over very nearly its whole dial travel in covering the narrow range of frequencies in the band which has been selected.

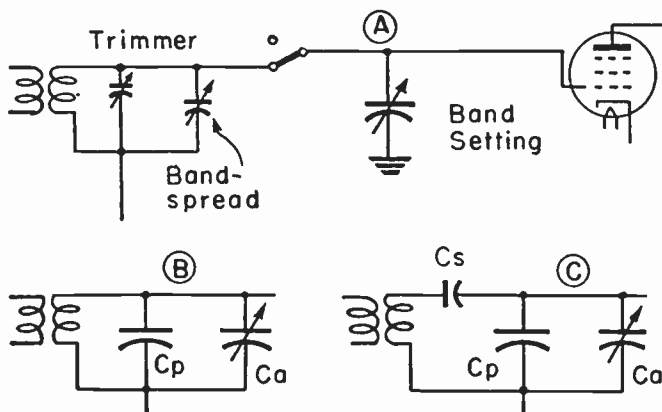

Fig. 6.—Arrangements of tuning capacitors for band spreading.

When bandspreading is used in the antenna or radio-frequency tuning system it must be used also in the oscillator tuning circuits, and there must be correct tracking of the bandspread frequency adjustment as well as of the main tuning capacitances which become band setting capacitances. If the bandspread capacitances do not track, the oscillator and signal frequencies cannot remain in their relationship or difference for producing the intermediate frequency.

The basis of bandspreading methods is reduction of the ratio between minimum and maximum tuning capacitance used for a given band. This ratio might be reduced by placing in parallel with the tuning capacitor  $C_a$  in diagram B of Fig. 6 a large capacitance  $C_p$ . For example, with an original tuning capacitance varying from 35 to 320 mmfd the ratio is about 1 to 9.6. If parallel capacitor  $C_p$  is of 500 mmfd, the combined capacitances will be 535 minimum and 820 maximum mmfd, a ratio of about

1 to 1.5. But such large tuning capacitance would require an excessively small inductance. It is desirable to maintain the highest practicable ratio of inductance to capacitance in the tuned circuit.

To reduce the tuning capacitance we may place in series with the tuning capacitor and the paralleled capacitor another unit,  $C_s$  in diagram *C* of Fig. 6. Were this series capacitance 350 mmfd, and the other capacitances the same as before, the effective change of capacitance with full rotation of the tuning capacitor would be from 212 to 245 mmfd, which is a ratio of about 1 to 1.15. Other values of parallel and series capacitance might be chosen to provide almost any desired values of minimum and maximum capacitance with full rotation of the regular tuning capacitor.

Still another method of bandspreading would be to place the series capacitor in series with the tuning capacitor only, and to have the paralleled unit in parallel with the other two which are in series with each other. In any of these cases of series and parallel capacitors the added units, or one of them, will take the place of a trimmer capacitor. The added units would have to be adjustable in order to align or track the circuits with other tuned circuits.

**Radio-Frequency Stages.** — In the receivers for which diagrams have been shown the tuned circuit coupled to the antenna is connected to the signal grid of the converter tube. There are many other receivers in which there is a radio-frequency amplifying stage between the tuned antenna circuit and the converter signal grid.

Fig. 7 shows connections which may be used when there is a radio-frequency amplifying tube between the antenna and the converter. As was shown also in Fig. 2, a built-in loop with turns from an external antenna is used for broadcast reception, and a coil coupler or transformer is used for short-wave reception. Trimmers  $C_t$  are across the loop and across the short-wave secondary winding. The band switch is shown as a rotary selector type, with the rotor and contacts on the back of the single gang used also in the antenna circuit. The antenna rotor is shown in the short-wave position, connecting one end of the loop winding to the control grid of the r-f tube. As the antenna rotor ring is



ing is removed to leave both of the r-f transformers in action for broadcast reception. Note that as the front of the band switch is rotated in the indicated clockwise direction the back rotates in a counter-clockwise direction.

The oscillator coils or transformers are connected between the oscillator grid and the cathode of the converter, as is common practice in oscillator circuits. The upper oscillator coil *SW Osc* is used for short-wave reception, and the lower one *BC Osc* for broadcast reception.

With the band switch in the position shown, for short-wave reception, segment *c* of the switch short circuits the primary winding of the broadcast oscillator coil with both ends of this coil connected to ground. At the same time, segment *d* of the switch connects the upper end of the oscillator coil to the oscillator grid of the converter tube. Note that the upper end of the secondary of the broadcast oscillator now is open-circuited at the band switch.

When the band switch is turned clockwise, to the broadcast position, segment *c* moves off the contact leading to the top of the broadcast primary and removes the short circuit from this winding. At the same time segment *d* moves into the position which opens the connection to the top of the short-wave oscillator coil, and completes a connection from the top of the broadcast secondary winding to the oscillator grid of the converter. The oscillator coils have connected with them the usual trimmers and a padder capacitor on the broadcast coil.

There are three main tuning capacitors built as a three-unit gang and shown in the diagram as operated together by the broken line. These capacitors are in the antenna circuit, the r-f circuit, and the oscillator circuit.

The r-f amplifier tubes always are voltage amplifying pentodes, since a triode with both its grid and plate circuits tuned would tend to oscillate at all short-wave frequencies. The grid returns nearly always are connected to the automatic volume control (avc) line. The tubes may be of either the sharp or remote cutoff type, but most often are the latter. The control grid may be brought either to a top cap or to a base pin.

Pentodes of the types regularly used for broadcast reception are satisfactory in all of the short-wave bands through to a

high-frequency of 25 megacycles so far as gain and selectivity are concerned, but these standard types of tubes tend to produce more noise within themselves as the frequency approaches the upper limit of usual short-wave reception. High-frequency pentodes such as used in frequency-modulation and in television receivers provide greater gain and less tube noise in frequency ranges above 20 to 25 kilocycles.

Many two-band receivers have a radio-frequency amplifying tube with an untuned coupling between the plate of the r-f tube and the signal grid of the converter. A circuit diagram for such an arrangement is shown by Fig. 8. The antenna circuits here are generally similar to those which have been examined earlier, with switching through unit *a* of the four-unit band switch whose parts *a*, *b*, *c* and *d* are shown by the broken line connection as being operated together. This switch might also be of any suitable rotary type, such as the "front" rotor and connections

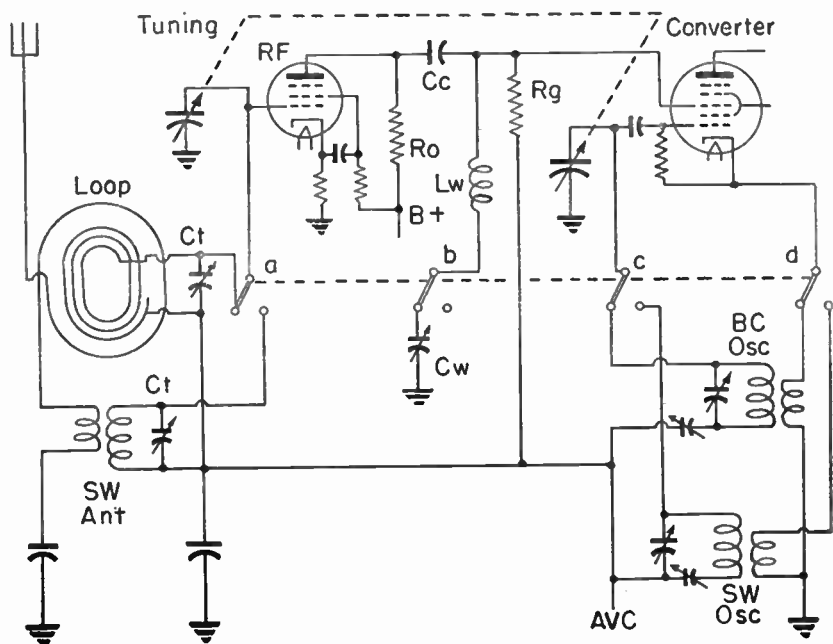

Fig. 8.—An r-f stage with untuned coupling between r-f tube and converter.

of Fig. 7 where there are four rotor segments. The switch units are shown in the broadcast position.

The coupling between the r-f and converter tubes is of the resistance-capacitance type. The coupling capacitor (about 100 to 250 mmfd) is at  $C_c$ . The plate resistor is  $R_o$ , whose resistance depends on the type of tube and the plate voltage required. The grid resistor is  $R_g$  (usually between 0.25 and 1.0 megohm, but sometimes of less resistance). In the signal grid circuit of the converter is an inductance coil  $L_w$  which, for broadcast reception, is connected through band switch unit  $b$  and  $C_w$ , an adjustable capacitor, to ground.

The oscillator circuits of Fig. 8 are of the commonly used type, with the oscillator grid of the converter connected to either the broadcast or short-wave oscillator coils through band switch unit  $c$ , and the converter cathode connected through unit  $d$  and the primaries of the oscillator transformers to ground.

The untuned couplings between the r-f and converter tubes often have the general form shown by Fig. 9. In series with the plate lead of the r-f tube, and ahead of coupling capacitor  $C_c$ , is a high-frequency choke coil  $L$  in parallel with a resistor  $R$ . This

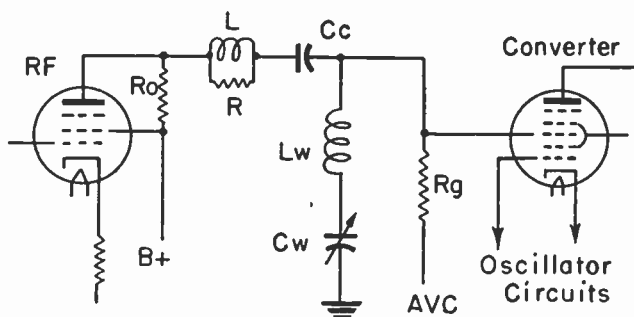

Fig. 9.—A typical untuned coupling between r-f and converter tubes.

choke opposes passage through it of frequencies higher than those which the receiver is designed to handle. The parallel resistor  $R$  broadens the range of frequencies in which the choke is effective and prevents sharp resonant peaks which might result from the inductance and self-capacitance of the choke and associated circuit elements.

**Wave Traps.** — The inductance coil  $Lw$  and adjustable capacitor  $Cw$  of Fig. 9, and the similarly marked units of Fig. 8, form what is called a *wave trap* circuit. The two units connected as shown form a series resonant circuit which, when tuned to some certain frequency by adjustment of  $Cw$ , offers very low impedance to potentials and currents at the tuned frequency, while offering relatively high impedance to frequencies both lower and higher.

As most often used, the wave trap is tuned to the intermediate frequency used in the i-f amplifying system of the receiver. This frequency should not appear in the input to the converter, but only in the output from converter to i-f amplifier. When the intermediate frequency does appear in the input (signal grid) circuit, it is bypassed to ground through the tuned wave trap circuit.

The wave trap for intermediate frequencies is adjusted with the receiver tuned to some point near the middle of the broadcast band and with the signal generator being used for adjustment

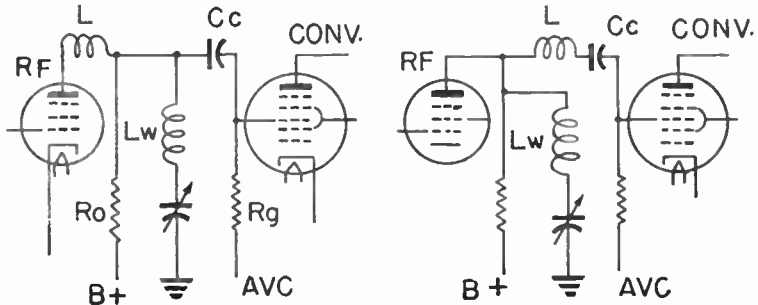

Fig. 10.—Wave traps in the plate circuit of an amplifier tube.

set at the intermediate frequency to be eliminated. The trap capacitor,  $Cw$  in the diagrams, then is adjusted for the least possible audio-frequency output at the loud speaker circuit of the receiver, or at whatever other point the output is measured. The signal generator would be used with audio-frequency modulation in the generator output, generally at a frequency of 400 cycles.



Fig. 10 shows wave traps in the plate circuit of the r-f amplifier tube rather than in the signal grid circuit of the converter. In the left-hand diagram the high-frequency choke  $L$  is directly on the r-f plate, followed by plate resistor  $R_o$  and the wave trap coil  $Lw$  with its series adjustable capacitor leading to ground. Then comes the coupling capacitor  $Cc$  leading to the signal grid of the converter. In the right-hand diagram the high-frequency choke  $L$  follows the takeoff from the r-f plate to the plate resistor  $R_o$  and the wave trap coil  $Lw$ . In either arrangement the series resonant wave trap bypasses undesired frequencies to ground.

At the left in Fig. 11 a series resonant wave trap is connected between the antenna and ground. When the trap is tuned to a frequency whose strength is to be lessened, the trap provides a

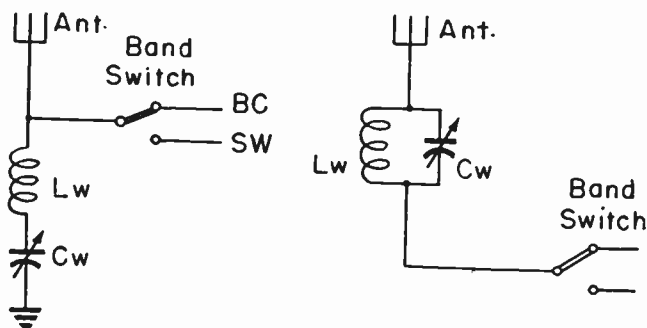

Fig. 11.—Wave traps in the antenna circuit.

low impedance path to ground for this and nearby frequencies, while offering high impedance to lower and higher frequencies which are thus diverted to the band switch and its connected circuits.

At the right in Fig. 11 there is shown a parallel resonant wave trap in series with the antenna and the band switch. When a parallel resonant circuit is tuned to resonance at a certain frequency the circuit offers maximum impedance at that frequency in the line through the circuit, while offering relatively little impedance to other frequencies which are lower and higher. The parallel resonant circuit is tuned to the frequency which is to be rejected.

Wavetraps are most often used for reduction of the intermediate frequency employed in the receiver, but may be used also for reduction of other interfering frequencies. Interference sometimes results from a frequency-modulation intermediate frequency of 8.25 or 8.30 megacycles, which is a wavelength of about 36 meters.

**The Oscillator.**—The oscillator frequency, as we know, must differ from the frequency of a received signal by the amount of the intermediate frequency. It is usual practice in broadcast reception to maintain the oscillator frequency higher than the frequency of the received signal, and in most of the short-wave receivers the oscillator frequency is kept above the received frequency for all bands, short-wave as well as broadcast. However, to lower the maximum frequency at which the oscillator must operate the oscillator frequency sometimes is below the signal frequency on the short-wave bands, while being above the frequency on the broadcast band, also on long-wave bands if they are handled.

In the broadcast band the oscillator frequency always is well separated from the signal frequency as considered on a basis of percentages. For example, with an intermediate frequency of 455 kilocycles, and at the high broadcast frequency of 1,500 kilocycles, the oscillator frequency is about one-third more than the signal frequency—because then the oscillator frequency would be  $1,500 + 455$ , or 1,955 kilocycles.

But in the short-wave bands the oscillator frequency comes closer and closer to the signal frequency, on a percentage basis, as the signal frequency increases. For example, with a received frequency of 17,800 kilocycles (17.8 megacycles) and the intermediate frequency of 455 kilocycles the oscillator frequency (18,255 kilocycles) is only about 1/40 higher than the signal frequency, and, so far as tuning is concerned, the two frequencies are very close together. This closeness may get us into difficulty when aligning the oscillator for short-wave work.

To see what may happen let's check with the frequency combinations shown by Fig. 12. We shall assume an intermediate frequency of 455 kilocycles, and assume that the oscillator frequency is to be kept above the signal frequency. If you are testing with a 10,000-kc input signal, as at A in Fig. 12, the correct

oscillator frequency will be 10,455 kc and the resulting intermediate frequency will be 455 kc. But supposing that you misalign the oscillator to make its frequency 9,545 kc, as in diagram B. The difference between the 10,000-kc signal frequency and

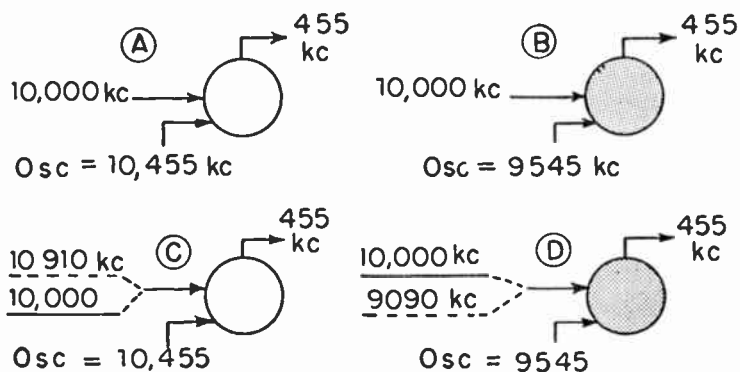

Fig. 12.—Relations between image frequencies and oscillator settings.

this incorrect oscillator frequency is 455 kc, which is correct for the i-f amplifier, and the signal will come through. How are you to determine whether the oscillator frequency is correct or incorrect?

If the oscillator has been correctly aligned to a frequency higher than the signal, in this case 10,455 kc as in diagram C, you will be able to receive the 10,000-kc signal and also a signal at 10,910 kc which may be produced by the signal generator. The 10,910-kc signal is at the image frequency, a frequency higher than the signal by twice the intermediate frequency. The image is received because the difference between 10,910 kc and the oscillator 10,455 kc is the intermediate 455 kc.

If the oscillator has been incorrectly aligned to a frequency lower than the signal frequency you will have the conditions of diagram D. You will be able to receive the 10,000-kc signal, just as in diagram B, but you won't be able to get the image frequency of 10,910 kc (diagram C). However, you will be able to receive an image at 9,090 kc when it is produced by the signal generator, because this image frequency is 455 kc lower than the incorrect oscillator frequency.

The test just outlined would have to be made with the signal generator output connected through a capacitor to the signal grid of the converter, because were the generator output introduced at the antenna connection of the receiver the image-frequency signal would be rejected or highly attenuated by the tuned circuits ahead of the converter.

Oscillator frequency more often is checked by first tuning in a signal from the generator, then turning the receiver dial to a frequency which is lower by twice the intermediate frequency (910 kc lower with a 455-kc intermediate), and increasing the generator output to receive an "image signal" at this lower setting of the receiver dial. If this lower-frequency tuning does not bring in a signal, the oscillator frequency is incorrect.

Another method of checking is by first adjusting the oscillator trimmer capacitor to its maximum capacitance to produce a low oscillator frequency, then slowly changing the adjustment for less and less capacitance and higher and higher frequency. A generator signal at some given frequency will come in twice; once when you make the oscillator frequency lower than the signal (by the amount of the intermediate frequency) and again when you make the oscillator frequency higher than the signal by the same amount. The higher frequency setting of the oscillator trimmer is the correct one when the oscillator is to operate above the signal, and the lower frequency setting is correct when the oscillator is to operate below the signal, as it does in some short-wave receivers.

Image separation would be increased were it possible to use a high intermediate frequency, but for appreciable improvement the intermediate frequency would have to be several megacycles for use in the usual short-wave bands. This would call for an extra set of i-f transformers tuned to the higher intermediate, and for extra switching to bring these transformers into the circuit for short-wave reception. Two sets of i-f transformers are used in some receivers which are designed for covering a great range of frequencies. With the usual broadcast intermediate frequencies it is important that oscillator circuits and signal grid or mixer circuits be effectively shielded from each other to prevent "pulling" of the oscillator.

**Short-wave Alignment.**—The short-wave antenna and oscillator

tuned circuits, also a tuned r-f circuit if used, are aligned after this type of work has been completed on the i-f transformers and on the tuned circuits used for broadcast reception. When there are two or more short-wave bands, the alignment is made in the order of lowest frequency band to highest frequency band.

For short-wave alignment the output of the signal generator usually is fed to the receiver connection or terminal for the external antenna, with a 400-ohm resistor, or sometimes a lesser resistance, between generator and antenna terminal. Instead of the series resistor the recommendation sometimes is to use a series capacitor of something between 50 and 250 mmfd while

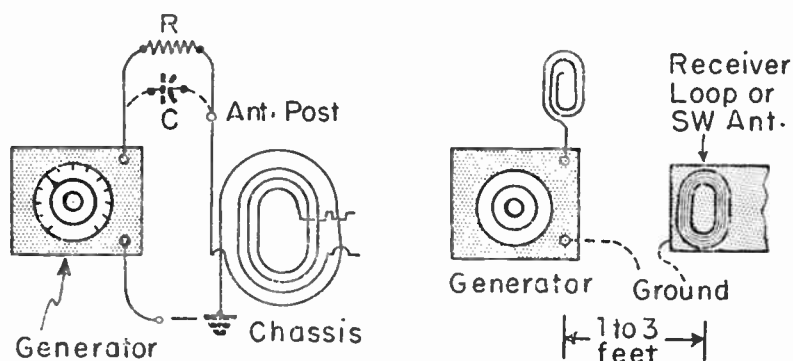

Fig. 13.—Signal generator connections for short-wave alignment.

making the oscillator alignment, and a larger capacitance, up to 0.1 mfd, while making the antenna circuit alignment. Such connections are shown at the left in Fig. 13.

Another method sometimes used is shown at the right in Fig. 13. Here a few feet or a few turns in a coil of wire are connected to the high side terminal of the signal generator to act as a radiator for a signal which is picked up by the loop or by the wire or rod used for the short-wave antenna in the receiver. The generator and receiver are placed from one to three feet apart.

When the receiver has only one short-wave band the signal generator and the receiver tuning dial are both set at the highest frequency in this band, and the trimmer on the short-wave oscillator coil is adjusted for maximum output from the receiver on

whatever type of output meter is being used. The next step is to check the oscillator frequency to determine whether it has been set above or below the signal frequency. Methods for making this check have been explained earlier.

Now the signal generator and receiver dial may be left at the highest frequency setting, or both may be adjusted to some frequency a few megacycles lower while adjusting the trimmer for the short-wave antenna coil. This trimmer is set to bring the generator signal through the receiver, then is moved a little at a time first one way and then the other while moving the tuning dial of the receiver, and the ganged tuning capacitors, slowly back and forth through the point of resonance. This is continued until finding the trimmer adjustment at which there is maximum output from the receiver as shown by the output meter.

There may be a padding capacitor in addition to the trimmer capacitor on the short-wave oscillator coil. Such a capacitor is shown in series with the oscillator coil of Fig. 8. For frequencies of 5 mc and higher the padder often is not needed and is not included. When there is an oscillator padding capacitor it is adjusted or aligned while the signal generator and receiver dial are set for a frequency only a few megacycles above the lowest frequency to which the receiver tunes in this band.

When the receiver is designed for tuning in any of several short-wave bands, usually with bandspread tuning for each band, the antenna and oscillator trimmers are adjusted at a single frequency near the center of the band or at a frequency corresponding to the number of meters of wavelength for the band. The signal generator frequency must be of a high order of accuracy for these adjustments, because even a small deviation from the assumed frequency will bring about large errors in the band spread tuning.

In some receivers the antenna and oscillator short-wave tuning coils have adjustable powdered iron cores for "permeability tuning" of their inductance. The trimmer alignment for these coils is made by changing the position of the core; following the same procedure as when alignment is made by means of adjustable capacitors. Frequency is increased by moving the cores farther out of the cores, to lessen the inductance, and is lowered by moving the cores into the coils.

If trimmer capacitors are connected across coils which have adjustable iron cores, the core adjustment may be carried out at a frequency near the lower limit of the short-wave band, and the capacitor adjustment at or near the high end of the frequency range.

**Antenna Systems.**—For the sake of simplicity and economy of installation it is usual practice to use the same external antenna for both standard broadcast and short-wave reception. Fortunately, an overhead horizontal wire 20 or 30 or more feet in length, with the lead-in taken from one end or the center, will usually pick up plenty of signal strength in the short-wave bands up to 25 megacycles or even somewhat higher in frequency.

There are also in use for combined short-wave and standard broadcast reception vertical metallic poles or rods of various lengths, but usually something between three and twelve to fifteen feet. These antenna rods are mounted on any solid part of the building with insulating brackets, and are provided with the usual lead-in, lightning arrester, and ground connections.

Antennas of the types mentioned act as the upper plate of a capacitor, with the ground as the lower plate and with the field of the signal waves acting between the plates. The higher the

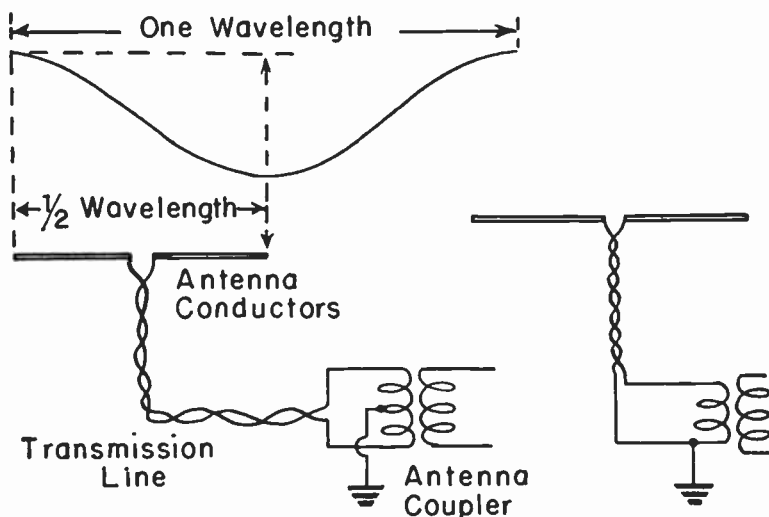

Fig. 14.—The doublet or half-wave dipole antenna.

antenna, the more secure the ground connection, and the better the conductivity between the ground connection and moist earth, the stronger will be the received signals.

The principal fault with these antennas is the pickup of interference and noise as well as signal. This comes about chiefly because the vertical lead-in is a part of the antenna, and the lead-in usually comes through spaces in which there are strong interference fields. Such trouble is lessened by using for the lead-in a single conductor with a woven or braided shield, and by grounding the shield at as many places as possible along its length.

A type of antenna well suited for reception of high-frequency signals of all kinds is the half-wave doublet or dipole shown by Fig. 14. The antenna consists of two straight conductors, either rigid rods or suspended wires, which are in line with each other and whose overall length is approximately equal to one-half of the signal wavelength to be most efficiently received. As may be seen from the upper curve which represents one cycle and one wavelength of signal, there is maximum potential difference between two points in space separated by a half-wavelength, and this is the distance apart of the ends of the dipole.

The inner ends of the dipole conductors are connected through a twisted pair cable, as shown, or through any of several other types of paralleled conductors, to the ends of an antenna coupler having a center tap which is grounded. Interference potentials induced in the "transmission line" from antenna to receiver act in opposite directions in the tapped coupler coil and thus cancel out. However, at the same time, one of the dipole conductors is at a positive field potential and the other is at a negative field potential, so that these opposite potentials cause a one-way current through both halves of the tapped coil. Interference cancels, but signals do not cancel.

The dipole antenna sometimes is connected to the ends of an untapped coil, as shown by the right-hand sketch in Fig. 14, and one side of the coil and one side of the line are grounded. The two sides of the line now are not balanced to ground, and there will be more interference pickup than when they are balanced as at the left. Balanced lines sometimes are run with shielding, which is grounded, to further lessen interference. Balanced lines,



shielded or not, may be run for long distances through regions having high interference potentials and still deliver to the receiver a fairly noise-free signal.

As is apparent from the relation between wave potentials and antenna length, the dipole is ideally suited for reception on only one wavelength or frequency when the antenna conductors are of a given overall length. For longer waves (lower frequency) the antenna length must be increased, and for shorter waves (higher frequency) it must be lessened, making it impractical to receive over a very great frequency range with a single dipole of ordinary construction. There are modifications of the dipole which allow tuning over a fairly broad band, but since the ordinary capacitance antennas serve very well in the short-wave bands covered by most receivers it is not necessary to discuss all these modifications in connection with short-wave receivers. High-frequency antenna systems of various types are described in chapters dealing with frequency-modulation reception and with television.

**High-frequency Peculiarities.**—When working with short-wave circuits it must be remembered that the high frequencies of operation bring about conditions never encountered in the broadcast band. The reactances of even small values of inductance become very great, and the reactances of small capacitances become very small.

The inductance of six inches of number 20 gage copper wire is only about 0.132 microhenry, but at a frequency of 20 megacycles the inductive reactance of this bit of wire becomes nearly 17 ohms. This would mean, in practice, that were this length of wire to be included in two circuits such as those for two elements of a tube there would be provided a reactance coupling proportional to a resistance coupling through 17 ohms of resistance. If this wire were parallel to and separated by a full inch from another similar piece the capacitance between them would be about 0.01 mmfd and the capacitive reactance about 0.76 megohm; and so the two wires might as well be connected together through this much resistance so far as high-frequency leakage is concerned. The wires are represented at the left in Fig. 15.

Supposing that you wished to bypass a 1,060-ohm resistor with

a capacitor having reactance equal to the resistance. The required values of capacitance are shown at the right in Fig. 15. At 1,500 kc it would take 100 mmfd, at 5 mc it would take 30 mmfd, and at 20 mc only  $7\frac{1}{2}$  mmfd for the bypass capacitor.

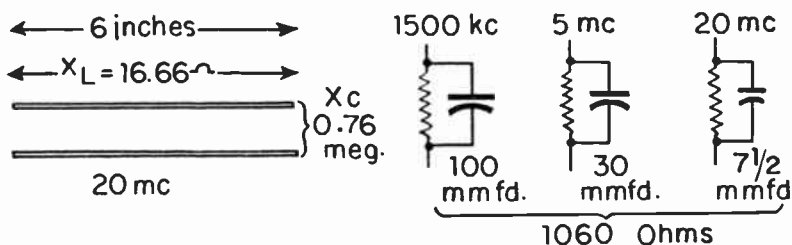

Fig. 15.—Reactances at high frequencies in the short-wave bands.

Distributed and stray capacitances become of great importance. Control grid and plate leads must be kept well separated, which requires well planned wiring layouts when single-ended tubes are used. Wire leads must be held securely in original positions or else the changing values of capacitance between them will upset the trimmer adjustments. Wire shielding preferably is soldered to the chassis metal at both ends, and in between for long leads. Between the adjacent rotors and contact arms of band switches will be capacitances which may provide many undesired couplings unless the switch gangs are well spaced from one another. Low-loss dielectric materials are worth while in high-frequency switches and other parts acting as insulation.

All leads in control grid, screen grid, and plate circuits should be as short and direct as they can be made. Long leads for bypass capacitors are to be avoided because these leads will have high reactances, as in Fig. 15. Oscillator circuits and signal grid or mixer circuits require effective shielding from each other. Leads for oscillator coils should be kept away from one another as well as away from other leads.

Careful electrical layout, effective shielding, rigid mechanical construction, and first class workmanship in assembly and wiring become more and more important as the operating frequency

increases. These things are fully as important as the type of circuit, and often are more important, in securing satisfactory performance in the short-wave bands.

#### REVIEW QUESTIONS

1. Name some possible ways of spreading the frequencies or channels in any given band over all or nearly all of the dial.
2. Refer to Figs. 8-9-10-11. Identify the wave trap circuits and explain how they reduce interfering frequencies.
3. What is the difference in frequencies between the oscillator and received signal called?
4. How do you determine that the oscillator alignment is correct or faulty?
5. What is the order of alignment of the different tuned circuits on combination broadcast and short-wave receivers?
6. How is the signal generator usually connected to a receiver for short-wave alignment?
7. Describe the half-wave doublet or dipole antenna shown in Fig. 14 and explain why it is suited for reception of high frequency signals.
8. Why are stray capacitances, short leads and shielding, very important in high frequency circuits?

## Chapter 8

# FREQUENCY MODULATION

A radio or television carrier wave may be quite completely described by specifying its frequency in kilocycles or megacycles per second, and also its amplitude in terms of the field strength, which usually is expressed in millivolts or microvolts per meter of height of a receiving antenna. Either the amplitude or the frequency may be varied. In television the picture signal is amplitude modulated and the sound signal is frequency modulated. If either of these characteristics is varied in a manner that corresponds to changes in an audio-frequency voltage, and if the variations can be seen in checking a receiver, it becomes possible to transmit

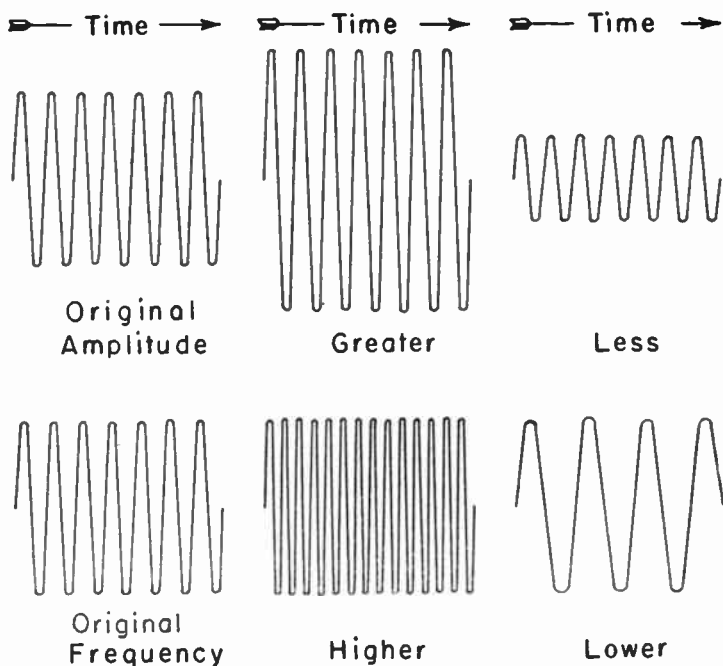

**Fig. 1.**—How variations of amplitude (top) and of frequency (bottom) may be shown by curves or waves.

through space the audio-frequency signals and to reproduce the original sounds at the loud speaker of the receiver. Such variation of the carrier characteristics is called *modulation*. If the amplitude of the carrier is varied while the frequency remains constant we have *amplitude modulation*. If the frequency is varied while the amplitude remains constant we have *frequency modulation*.

Radio waves, also the potentials and currents induced in receiver circuits, usually are represented as in Fig. 1. Variations of amplitude may be shown, as at the top, by differences between relative heights of the curves in the graphs. Variations of frequency may be shown, as at the bottom, by placing successive

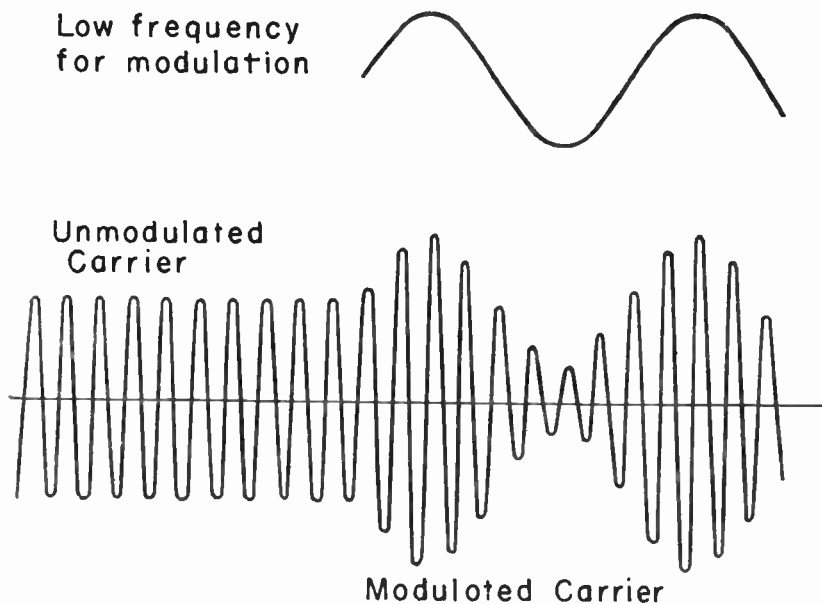

Fig. 2.—Amplitude modulation of a carrier wave.

alternations closer together for higher frequency and farther apart for lower frequency; assuming that a given horizontal distance represents the same period of time in all cases.

In Fig. 2 is shown the principle of amplitude modulation. At the top is shown a curve representing rise and fall of amplitude in a low-frequency or audio-frequency signal which is to be transmitted. The carrier amplitudes are shown below. At the

left the carrier is unmodulated, meaning that its amplitude does not vary. At the right the carrier is modulated with the low-frequency signal. In effect, the instantaneous amplitudes of the signal are combined with the instantaneous amplitudes in the carrier. When the modulating signal amplitude rises above its average value, the amplitude of the carrier is proportionately increased at every instant, and when the signal amplitude falls below its average the carrier amplitude is proportionately decreased. The modulated carrier then is transmitted at constant frequency and with varying amplitude.

Note that with amplitude modulation we are transmitting two characteristics of the a-f signal; its frequency and its intensity or loudness. The frequency of the a-f signal is represented in the modulated carrier by the time intervals between successive maximum or minimum carrier amplitudes, and by the number of such intervals per second, which corresponds to the signal frequency in cycles per second. The strength or intensity of the a-f signal is represented by the difference between maximum and minimum amplitudes in the carrier. A loud sound causes greater amplitude differences than does a weak sound. The carrier frequency never changes.

The principle of frequency modulation is shown by Fig. 3. At the top are represented variations of amplitude in an a-f modulating signal. Down below are shown the corresponding variations of frequency produced in the carrier while the carrier amplitude remains unchanged.

Starting from the left, where the modulating signal has zero amplitude, the carrier frequency has its unmodulated value such as was shown for "Original Frequency" in Fig. 1. As the signal amplitude becomes more positive, the carrier frequency increases. How much the carrier frequency increases depends on the amplitude of the modulating signal; the louder the sound and the greater the a-f amplitude the greater becomes the carrier frequency. As the signal amplitude returns to its zero value the carrier frequency returns to its unmodulated value, which we may call the *center frequency*. As the signal amplitude then goes negative in the second part of its first cycle, the carrier frequency decreases from the center frequency. When the signal amplitude reaches its maximum negative value the carrier frequency will

have reached its minimum value. Then, as the signal amplitude returns to zero the carrier frequency will return to the center value.

With frequency modulation we are transmitting the same two characteristics of the a-f signal as with amplitude modulation; we are transmitting sound frequency and sound intensity or loudness. Sound frequency corresponds to the time intervals between successive instants of maximum carrier frequency, or of minimum carrier frequency. In Fig. 3 we have two complete

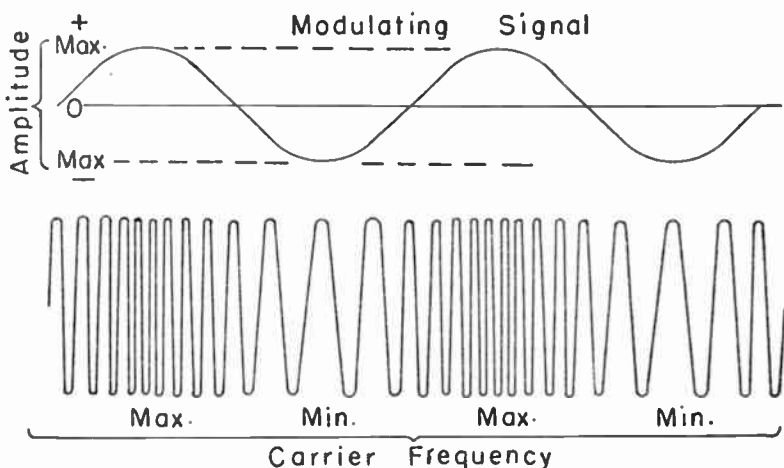

Fig. 3.—Frequency modulation of a carrier wave.

cycles of modulating signal. During each cycle the carrier frequency starts from its center value, goes to maximum, then to minimum, and back to the center value. The number of times per second that the carrier frequency goes through these changes is the same as the cycles per second of the modulating sound frequency.

The extent of change in carrier frequency above and below the center frequency corresponds to the loudness or intensity of the sounds represented by the modulating signal. It is important to keep in mind that sound intensity is represented by the extent to which the carrier frequency changes, and that sound frequency is represented by the number of changes per second in the carrier frequency.

**Deviation.** — The number of kilocycles by which the f-m carrier frequency varies above and below the center frequency is called the *deviation*, or the frequency deviation. So far as transmitter and receiver operation are concerned the deviation might be made almost any number of kilocycles, but it has been agreed that the maximum amplitude (sound loudness) of the modulating signal which is to be transmitted shall be represented by a deviation of 75 kilocycles above and below the center frequency of the carrier. This means that the total maximum change of carrier frequency will be twice this deviation, or will be 150 kilocycles. On this basis each f-m transmitted signal will occupy a frequency band 150 kc wide.

The ratio of the maximum deviation to the maximum sound frequency transmitted is called the *deviation ratio*. With maximum deviation of 75 kilocycles (75,000 cycles), were the highest audio frequency transmitted to be 15,000 cycles, the deviation ratio would be  $75,000/15,000$  or would be 5.

**F-m Transmission Frequencies and Channels.** — With maximum deviation of 75 kc each way from the carrier center frequency, the minimum width for one f-m channel must be 150 kc. To provide freedom from interference from stations in adjacent channels the width of each channel usually is made 200 kc, extending 100 kc above and below the frequency of the unmodulated carrier. This is several times the width of channels for standard a-m broadcasting, where most of the channels are only 10 kc wide.

Largely because of the wide channels required for f-m transmission, but also because of technical advantages, f-m broadcasting is regularly carried on in the frequencies between 88 and 108 megacycles, which is a range of 20 megacycles or 20,000 kilocycles. Frequency ranges higher than 150 megacycles are used for some special classes of f-m transmission. Prewar standards for f-m transmission provided a frequency range from 42 to 50 megacycles. Some transmission continued in this range to provide service for those owning early types of receivers.

**Behavior of Very High Frequency Waves.** — Radio waves at the frequencies used for f-m transmission and for television transmission behave in many ways much like rays of light, which also are a kind of electromagnetic radiation through space. When light rays pass through a medium, such as air, having uniform



characteristics at all points the rays travel in straight lines, and this is true also of very high frequency radio waves.

F-m and television radio waves, like light rays, are subject to refraction, to diffraction, and to reflection, as shown by Fig. 4. A wave originally traveling in the direction  $a-b$  will be bent to some degree when passing through the boundary between masses

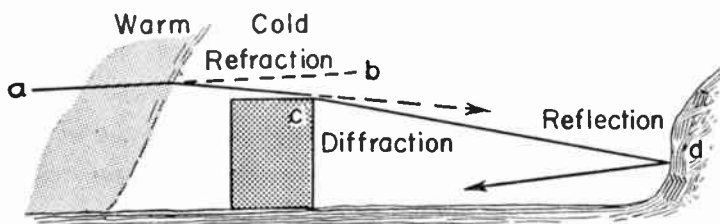

Fig. 4.—A radio wave at very high frequency may be deflected or bent away from its original direction in space.

of warm and cold air, also between masses of moist and relatively dry air. Such bending is called *refraction*. A wave passing the edge of any large solid object will bend very slightly, as at  $c$ . This action is called *diffraction*. When waves at very high frequency strike the surface of some material whose electrical properties are different from those of air, as at  $d$ , the waves

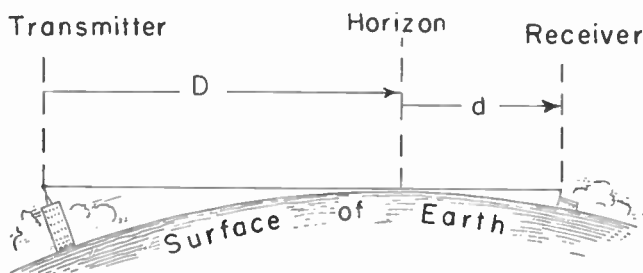

Fig. 5.—Transmission distances and reception distances extend practically only to the visible horizon.

are *reflected* back from the surface. The reflecting object may be a high hill, a building, a large water or gas tank, or almost any solid mass.

Assuming that the waves travel in a straight line away from the transmitter, they could reach only to the horizon, where they

would strike the conductive earth. Waves which glance across the horizon line, as in Fig. 5, will travel onward and may be picked up by the antenna of a receiver. The distance from the horizon line to the receiver at which the waves may be received will depend on the height of the receiving antenna above the earth. The distance from the transmitting antenna to the horizon depends on the height of this antenna above the surface of the earth. The maximum reception distance then is equal to the sum of the distance from transmitter to horizon,  $D$ , and of the distance from receiver to horizon,  $d$ .

The maximum receiving distance is only a little more than the line-of-sight distance between transmitting and receiving antennas. It is slightly more than this distance over which you could see because of some diffraction at the horizon line; assuming that there are no high intervening objects to cause reflection,

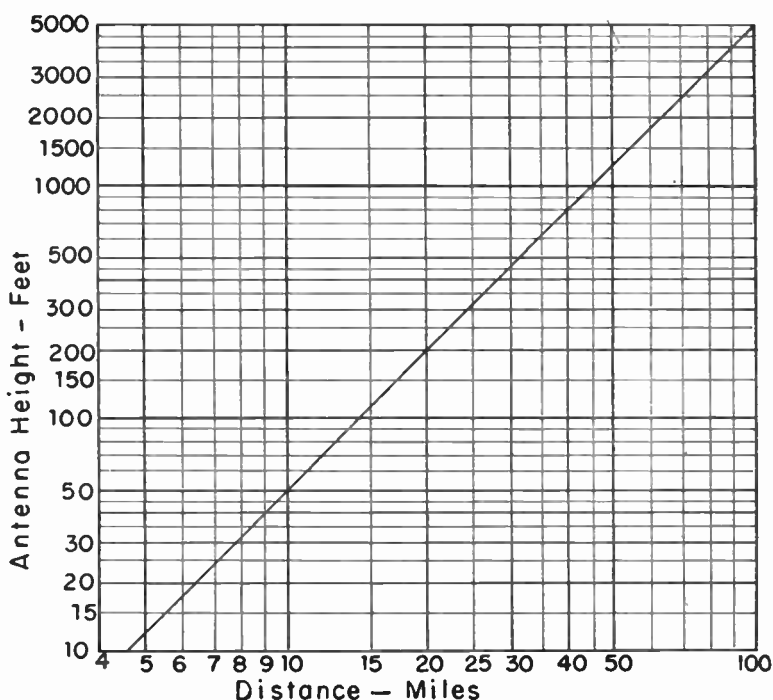

Fig. 6.—Transmission and reception distances as related to antenna height.

and that there are no atmospheric conditions to cause refraction upward.

Fig. 6 shows practical maximum distances from a transmitting antenna to the horizon and from the receiving antenna to the horizon as related to the heights of the respective antennas. As an example, we might assume a transmitting antenna 1,000 feet above the average earth level and a receiving antenna 20 feet above this level. The graph shows that the distance for the transmitting antenna is 45 miles (for a height of 1,000 feet) and for the receiving antenna is about 6.3 miles (for the 20-foot height). The sum of these two distances is 51.3 miles, which is the approximate maximum distance for reception with these two antenna heights. Note that doubling the height of either antenna does not double the distance over which that antenna is effective.

We see here the reason why transmitting antennas for frequency modulation and for television are erected on the tops of high buildings in cities, or on hills and high elevations when such locations are possible. We see also one reason for erecting the receiving antenna as high as possible. Another reason for a high receiving antenna is for clearing by the greatest practicable distances such things as power lines, roadways on which there is much automobile traffic with its ignition interference, and buildings in which there may be all kinds of electrical machines and apparatus which cause interference.

The peculiarities of very high frequency transmission are not the result of using frequency modulation, but are the result of the high frequencies. Just the same things happen with transmission of amplitude modulation on the same ranges of carrier frequency.

**Antennas for Very High Frequencies.** — Most antennas which are designed for reception of the very high frequencies, including frequency modulation and television, are of the type called a *half-wave dipole* or are some modification of this basic type. A half-wave dipole, as shown by Fig. 7, consists of two straight conductors of equal length and in line with each other, with the overall length of the two conductors equal to one-half the wavelength of carrier frequencies to be most efficiently received. The inner adjoining ends of the two conductors are separated far enough to permit insulation and support, and are connected to

the two conductors of a "transmission line" which runs to the receiver.

The two antenna conductors are mounted so that their axes are normally horizontal when the received waves are horizontally polarized, which is the usual practice for very high frequency transmission. Due to the presence of various deflecting objects between transmitter and receiver the waves may be rotated in some degree from their original polarization, and then the dipole conductors have to be tilted from the horizontal in order to have best reception.

There is maximum strength of reception from the two directions which are at right angles to the dipole conductors, and there is strong reception through all angles quite a ways on both sides of these directions. But waves coming from either direction

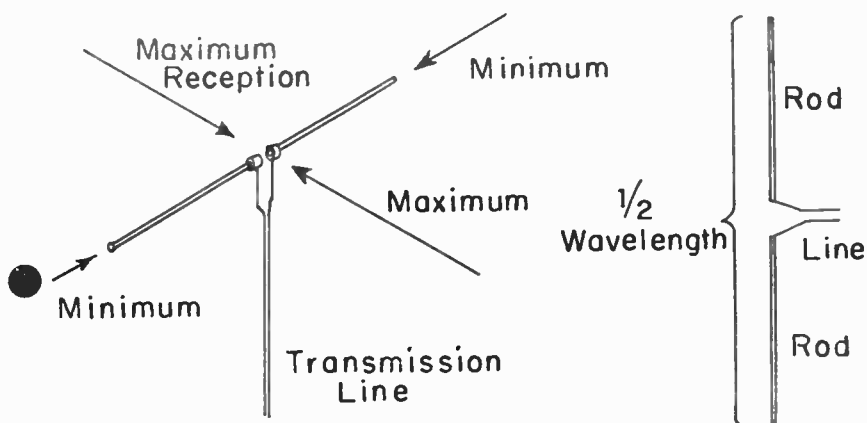

Fig. 7.—A half-wave dipole antenna.

exactly in line with the antenna conductors produce hardly any response. Consequently, this general type of antenna may be turned to cut out interference signals by pointing either end toward the direction from which such signals arrive while still permitting satisfactory reception of desired signals from other directions.

The characteristics of horizontally polarized waves are shown by Fig. 8 where the long arrows drawn from left to right represent the direction of wave travel from transmitter to receiver.

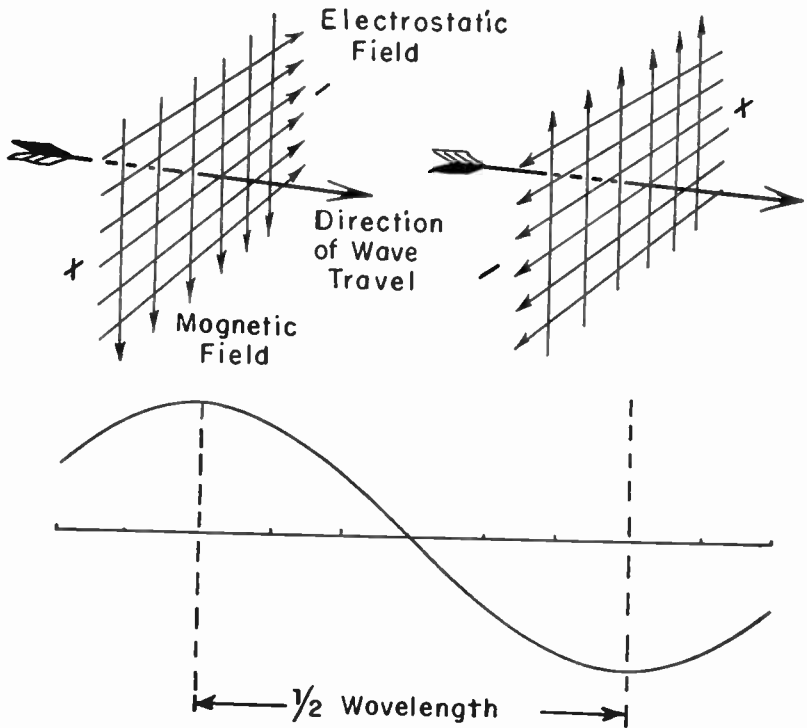

Fig. 8.—Electrostatic and magnetic fields in a horizontally polarized wave.

At one instant in time and at one position in space we have the conditions shown at the upper left. The wave consists of an electrostatic or electric field whose lines of force are horizontal and of a magnetic field whose lines are vertical. Any wave is said to be polarized in the direction of its electrostatic field, so here we have a horizontally polarized wave. Note that the directions of the two fields are at right angles to each other, while both of them are at right angles to the direction of wave travel.

At a half-cycle later the directions of the electric and magnetic lines will have reversed, as shown at the upper right. This reversal occurs in space at a distance equal to one-half of a wavelength, and in a time equal to a half-cycle. Then at a distance of one full wavelength, and an instant of time which is later by the period for one full cycle, we again will have the conditions shown

at the left. The changes of electrostatic polarity in the wave may be represented by the portion of a sine wave shown at the bottom of Fig. 8, which includes the time, or distance, from the maximum value in one polarity to the maximum in the opposite polarity.

When the length of the dipole is equal to one-half of a wavelength, the outer ends of the dipole conductors will be simultaneously affected by maximum field strengths in opposite polarities, and this potential difference will cause maximum electron flow in a corresponding direction through the transmission line and through an antenna coil of the receiver which is connected to the line. A half-cycle later the field polarities at the antenna will have reversed, and there will be maximum current in the opposite direction.

It is apparent that if the length of the dipole is either more or less than a half-wavelength it will not be affected by maximum field strengths of opposite polarities. It is equally true that longer or shorter wavelengths (lower or higher carrier frequencies) will have a similar result in received signal strength. However, as may be seen from the shape of the sine wave in Fig. 8, the waves may be quite a bit longer or shorter without having a very serious effect in reducing the received signal strength.

The approximate length of a half-wave, in inches, may be found from dividing the number 5,900 by the frequency in megacycles. When making computations of dipole length we have to make allowances for certain capacitance effects at the ends of the conductors, and, consequently, may use a smaller number in the division. Then,

$$\text{Dipole length, in inches} = \frac{5600}{\text{frequency, megacycles}}$$

Using this formula, we find the overall dipole lengths to be as follows for the lowest, highest, and middle frequencies in the f-m broadcast reception range.

88 megacycles = 63.6 inches

98 megacycles = 57.2 inches (middle of range)

108 megacycles = 51.8 inches

The length of 57.2 inches, best suited to the middle of the range, would be in error by only about 10 per cent at either extreme.

For reception with a single antenna structure in both the older and newer f-m channels, and throughout the rather wide range of the television channels, modified forms of dipole are used. Several types are shown by Fig. 9. All of the antennas require suitable insulating supports for the conductors and also a vertical pole or mast on which they are carried. These parts are not shown. The *folded dipole* consists of a conductor bent around at

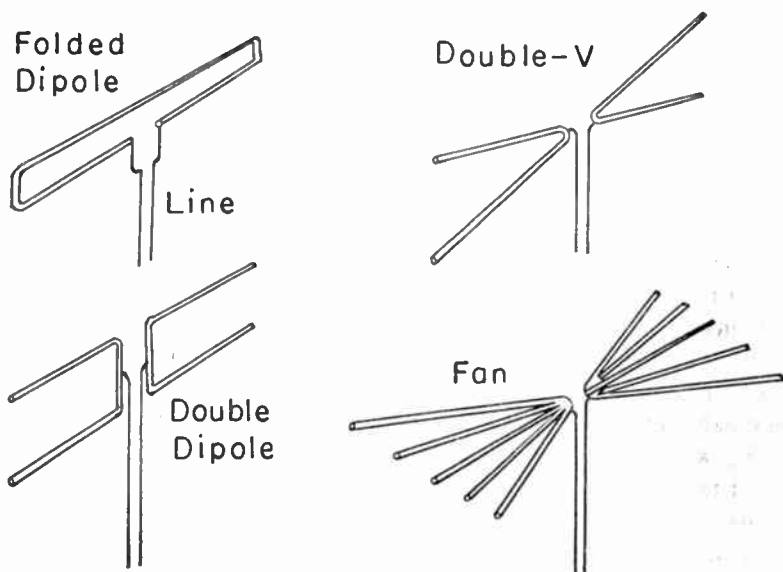

Fig. 9.—Types of dipole antennas used for reception throughout wide frequency bands.

its outer ends and brought nearly together at the ends where the transmission line is attached. The *double dipole* consists of two U-shaped conductors supported so that they lie in a single vertical plane. The *double-V* antenna has two V-shaped conductors supported so that they lie in a vertical plane, like the double dipole. The *fan type* antenna consists of a number of horizontal conductors lying in a single horizontal plane. All of these types receive equally well from directions which are generally at right angles to the length of the antenna, and have minimum response for signals coming end-on toward the conductors.

Rigid dipole antennas have conductors of brass, bronze, or aluminum alloys, usually tubular and often made up with telescoping sections. A dipole may be constructed also of wires stretched between supports at their ends, with an insulator at the center where the transmission line is connected. Dipoles sometimes are called *doublets* or doublet antennas.

When a receiver is within a few miles of a transmitter satisfactory reception often may be had with nothing more than a few feet of wire connected to the antenna terminal of the receiver, or may be had with an ordinary overhead L-type antenna such as used for standard broadcast a-m reception.

There are several types of combination antennas designed for reception in the f-m bands and also in the standard a-m broadcast band. Some of these are doublets with each conductor 20 to 30 feet long, connected to the primary of a transformer whose secondary connects to the line. Another coupling transformer usually is used between the line and the receiver terminals. Ordinary L-type antennas sometimes are used in connection with a dipole; signal separation and signal feed to the line being secured with wave filters or with special transformers. Most receivers designed for reception in both the standard broadcast and the f-m bands have separate terminals for antennas in each range, and are used with a dipole for f-m reception and with a loop or an L-antenna for the standard broadcast band.

**Transmission Lines.** — With dipoles and modified dipoles we require for their connection to the receiver a two-conductor line, called the transmission line, instead of the single-conductor lead-in commonly used with L-type antennas for standard broadcast reception. The two conductors of a transmission line never are separated very far from each other. The emf's induced in the side-by-side conductors by any surrounding electric or magnetic fields, either signals or interference, are of equal strength and act in the same direction as shown by Fig. 10 by the broken-line arrows. When these emf's enter the receiver coil at its opposite ends, they act oppositely in the coil and cancel each other. Emf's and currents which are due to the desired signal, and which originate in the dipole conductors, act in opposite directions through the transmission line and cause alternating currents in the receiver coil.



Transmission line conductors must be well insulated to prevent leakage losses from one to the other and from either one to surrounding objects. The insulation should have good dielectric properties, meaning that it does not absorb much energy when subjected to high-frequency fields. If the line runs through regions of strong interference it may have to be shielded over

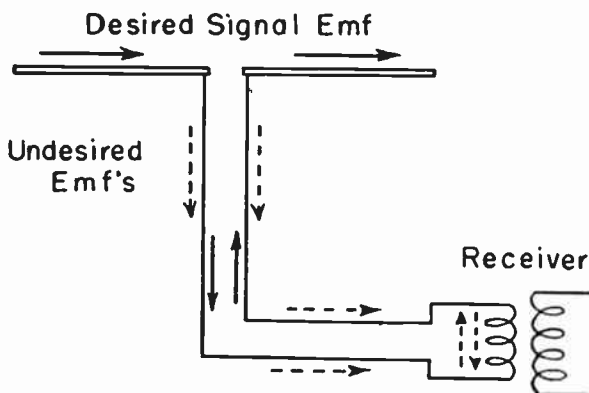

Fig. 10.—Potentials or currents induced in the antenna and transmission line.

the insulation, with the shield grounded at several points along its length. The line should be supported at intervals of a few feet along its entire length, so that there will be no swinging or displacement by winds.

Transmission lines not over 50 feet long often are run with twisted pair conductor having high grade or "low-loss" insulation. For greater lengths, and for shorter ones where all possible signal strength is to be conserved, it is common practice to use a parallel conductor line formed by two stranded copper wires embedded in a thin ribbon of low-loss plastic insulation. At f-m and television frequencies these parallel conductor lines have energy losses which are small fractions of the losses in twisted pair.

Obtaining maximum energy transfer from antenna to receiver depends also on correct matching of impedance. The impedance of an antenna acts like a pure resistance when the antenna is made resonant at a received frequency by suitable adjustment of antenna length and of disposition of its conductors. This im-

pedance for a half-wave dipole is about 73 ohms. The impedance increases with lengths more or less than a half-wavelength, also at higher and at lower frequencies which change the wavelength.

The various types of transmission lines have certain *characteristic impedances*. Twisted pair made with good insulation has an impedance in the neighborhood of 100 ohms. Parallel conductor lines usually are available in either of three impedances; 75 ohms, 150 ohms, and 300 ohms. This impedance is a sort of a theoretical quantity which describes the performance characteristics and construction of the line. It is equal to the square root of the product of the impedances with the far end of a line first short circuited and then open circuited. The impedance is related to the ratio of the spacing between the two parallel conductors to their separation. The impedance is increased by greater spacing or separation between the two wires, also by using wires of smaller diameter. The impedance is affected also by the dielectric constant of the supporting insulation, since this constant affects the capacitance between the two wires.

The present standard for the input impedance at the f-m antenna terminals of a receiver is 300 ohms, and so we use 300-ohm transmission lines between the antenna and the receiver. So long as the impedance of the line is not much less than the impedance of the antenna there will be good energy transfer into the line, and this holds true for line impedances several times greater than the antenna impedance. For closer matching of antenna and line impedances it is possible to connect the terminals of the antenna to the primary of a high-frequency high-Q impedance matching transformer, with the secondary connected to the line. A matching transformer may be used between the line and the receiver antenna terminals when the line impedance and receiver input impedance are different.

**The F-m Receiver.**—The principal parts of a receiver designed for reception of frequency-modulation signals are shown by the block diagram in Fig. 11. Most such receivers are arranged to also receive standard broadcast signals and short-wave signals, both of which are amplitude modulated. To the antenna coupling circuits may be connected a dipole or modified dipole for f-m reception, usually also a built-in loop for standard broadcast

reception, and an external L-type or capacitance antenna for standard broadcast and short-wave reception.

Any one of the bands may be selected by operation of band selector switches similar to the switches used with receivers for standard broadcast and short-wave. Band switching is required between the antenna circuits and the control grid circuit of an r-f amplifier tube, also between the r-f output and the signal input to the converter or mixer, and in the tuned circuits for an oscillator or the oscillator circuit of the converter.

The i-f amplifier employs the same tubes for both f-m and a-m reception, but the i-f transformers have one section for f-m and another for a-m coupling. The a-m sections connect through to the a-m detector, which is of the usual diode type. The f-m sections connect to a *limiter* stage which normally removes any amplitude modulation of the signal which may have come through preceding stages or which may have been introduced by the receiver circuits. The f-m output of the limiter goes to the

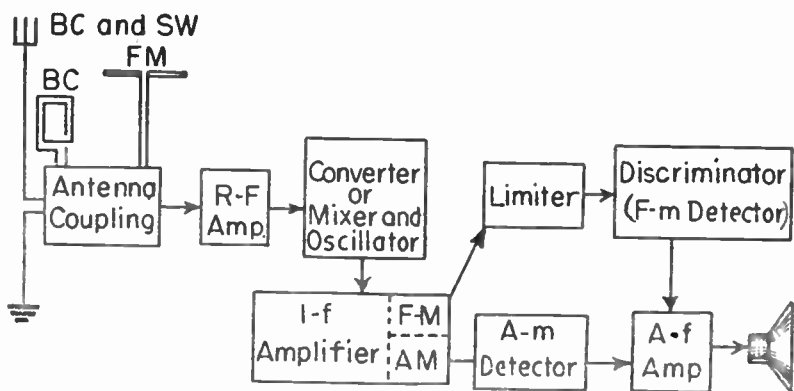

Fig. 11.—Principal parts of a receiver designed for both f-m and a-m reception.

*discriminator* stage wherein the variations of frequency produce corresponding variations of audio-frequency amplitude, thus doing for the f-m signal what the detector does for the a-m signal. The output of the discriminator goes to the same a-f amplifier that serves for the output of the a-m detector.

The f-m receiver is a superheterodyne type because it employs

an intermediate frequency for most of the gain. The limiter has no counterpart in a-m receivers. The discriminator acts as a "frequency detector."

**Tuning at Very High Frequencies.**—With f-m reception in the band from 88 to 108 mc we have these frequencies in the tuned circuits for the antenna and for the r-f amplifier tube. In the oscillator tuned circuit we have still higher frequencies required to generate the beats which produce the intermediate frequency. We obtain resonance at these very high frequencies by using inductances and capacitances which are small in comparison with those used for standard broadcast reception.

For resonance at 88 mc the product of the number of microhenrys of inductance and the number of micro-microfarads of capacitance must be 3.271, which is called the oscillation constant for this frequency. If we assume a certain capacitance, dividing 3.271 by the number of mmfd will give the required number of

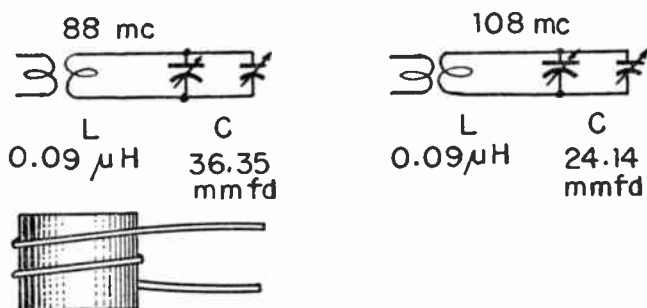

Fig. 12.—Inductances and capacitances for resonance in the f-m range.

microhenrys of inductance. If we assume a certain inductance, dividing 3.271 by the number of microhenrys will give the required number of mmfd of capacitance. For the higher frequency of 108 mc the oscillation constant is 2.172.

Typical values of inductance and capacitance are shown by Fig. 12. Here we assume a tuning inductance of 0.09 microhenry. Such an inductance would be obtained by winding two turns of wire in a length of  $\frac{5}{8}$  inch on a form giving a winding diameter of one inch, with short leads to the coil providing a small part of this total inductance. Dividing the oscillation constants by this

value of inductance shows that for 88 mc we require 36.35 mmfd capacitance, and for 108 mc require 24.14 mmfd. These capacitances represent the combined capacitances of the variable tuning capacitor, the adjustable trimmer capacitor, and the distributed capacitances in all of the connections and the coil.

A typical tuning capacitor for this service might have a maximum capacitance of 25.0 mmfd and a minimum (with plates all the way out) of 8.0 mmfd. Assuming that the trimmer would be set for an average capacitance of 6.0 mmfd, and that the total distributed capacitance is 8.0 mmfd, we would have the following minimum and maximum capacitances when varying the tuning unit throughout its range.

	At 88 mc	At 108 mc
Tuning capacitor .....	25.0 mmfd	8.0 mmfd
Trimmer capacitor .....	6.0 mmfd	6.0 mmfd
Distributed capacitance....	8.0 mmfd	8.0 mmfd
Total capacitance .....	39.0 mmfd	22.0 mmfd

Thus the possible change of total capacitance would be from somewhat above to somewhat below the required variation, which was found to be from 36.35 to 24.14 mmfd. The values used in this example merely illustrate the orders of inductances and capacitances with which we are dealing in f-m tuned circuits. Other combinations of values might be used to give generally similar results.

Sometimes there is an r-f amplifying tube between antenna and converter circuits, and sometimes the r-f stage is omitted. R-f tubes, when used, are pentodes of types designed for very high frequency operation. They may have remote cutoff, semi-remote cutoff, or sharp cutoff. The r-f stage must be designed to amplify with fair uniformity a range of frequencies somewhat greater than the maximum deviation. With maximum deviation 75 kc each way from the center frequency, making a total deviation of 150 kc, the r-f amplifier would be designed to handle a range of about 200 kc.

Fig. 13 shows circuits such as may be used in f-m receivers between the antenna and the input to the i-f amplifier. Here the antenna is inductively coupled to the control grid circuit of the r-f amplifier. Between the plate of the r-f tube and the signal



capacitance in the oscillator circuit in such manner as to oppose the tendency to drift of frequency.

**Intermediate-frequency Amplifier.**—Usually there are two, and sometimes more than two i-f stages for the f-m circuits in the receiver, whereas for a-m receivers we ordinarily find only one i-f stage. More stages are needed in the f-m system because of the wider frequency range which must be passed and the reduction of gain per stage which is characteristics of wide-band amplifiers. The i-f tubes are high-frequency pentodes; with the first one having remote or semi-remote cutoff and the second sometimes being of the sharp cutoff type.

The intermediate frequency for the f-m system is made much higher than the 455-kc or 0.455 mc frequency commonly used for the a-m system for standard broadcast reception; this being done to provide adequate separation of the image frequency, which, as we have learned, is separated from the carrier frequency by twice the oscillator frequency.

It is desirable that none of the carrier frequencies to be received be the image frequency of any other received carrier, for this avoids interference between two carriers which may enter the amplifiers at the same time. If, for example, the lowest

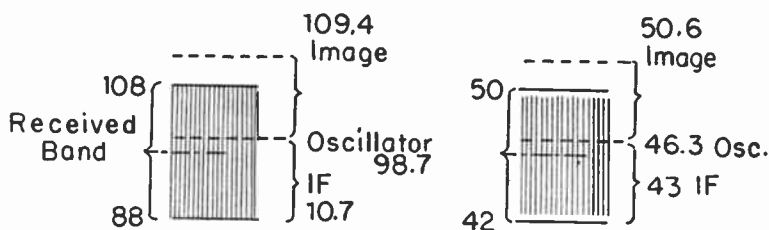

Fig. 14.—Relations between intermediate and image frequencies in two f-m bands.

received carrier is at 88 mc and the highest is at 108 mc, we desire that the image of the 88-mc frequency be higher than 108 mc. We know that the image of the 88-mc frequency will be higher by twice the intermediate frequency, and to get this image above the high limit of the band it must be above 108 mc. If we make the intermediate frequency 10 mc, twice its value will be 20 mc, and 20 mc added to our 88 mc makes 108 mc, which is just at the top of the band. Then to throw the image a little higher

we must use an intermediate frequency of more than 10 mc. It works out in all cases that the intermediate frequency should be more than one-half of the full frequency range of carriers to be received. In our present example the full range is from 88 to 108 mc, a band of 20 mc, and we have found that the intermediate frequency should be more than 10 mc, which is half of the 20-mc band width.

An intermediate frequency commonly used for f-m reception in the 88-108 mc band is 10.7 mc. For the older f-m band of 42 to 50 mc, with a difference of 8 mc, the generally used intermediate frequency was 4.3 mc, which is more than half of the difference between bottom and top of the band. Intermediates greater than half of the band width may be used. For the older band we may find such intermediates as 8.25 and 8.3 mc, and for the newer band may find such intermediates as 13.7 mc. Frequency relations in the older and newer bands are shown by Fig. 14.

Fig. 15 shows the relative gains of a typical i-f amplifier system, as measured at the input to the limiter tube control grid, for frequencies deviating from the center intermediate frequency (0 on the scale) up to 200 kc each way from this center frequency. The relative gains, for which the maximum is shown as 100, may be read as percentages.

We may assume that the maximum deviation in each direction will be 75 kc. At  $-75$  kc and again at  $+75$  kc we have gains of about 63 per cent of maximum. At the center frequency, which would be the unmodulated intermediate frequency, the gain is about 70 per cent. The peak gains occur at around  $-40$  and  $+50$  kc. From the general shape of the curve it is evident that the broadness of tuning is obtained by rather close coupling between primaries and secondaries of double-tuned transformers, for such coupling produces the double-hump resonance seen here. The band sometimes is broadened by connecting resistors across one or more of the secondary windings, and by constructions giving less than maximum possible Q-factors for the tuned circuits.

The relative gains shown by Fig. 15 may be thought of as relative amplitudes when there is an input of constant amplitude to the i-f system. Because we have gains or amplitudes which vary between 63 and 100 per cent of maximum in the range from



—75 to +75 kc we do not come to the limiter tube with a constant amplitude (and variable frequency) signal, even though the received carrier has constant amplitude. In effect, the i-f amplifier system, and quite likely the preceding r-f amplifier and converter stages, have introduced a certain amount of amplitude modulation, or amplitude variation with frequency, regardless of the characteristics of the f-m carrier.

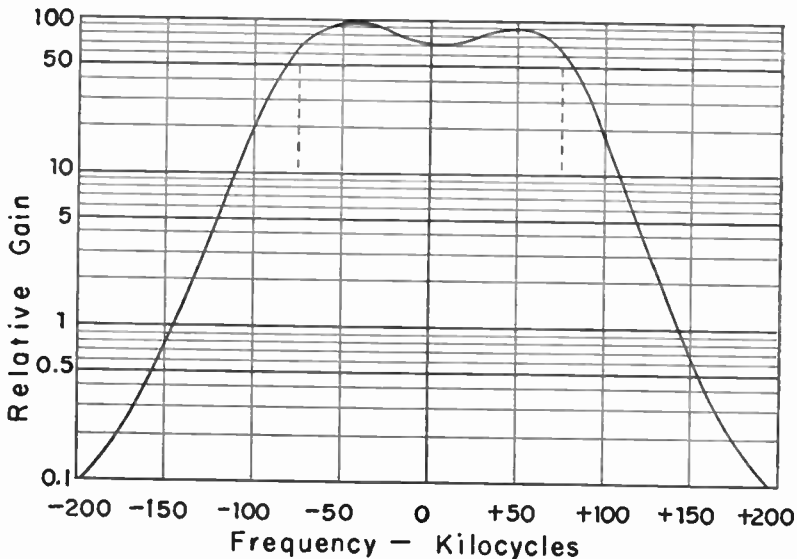

Fig. 15.—Gain at various deviations in a typical i-f system.

The limiter stage, to be described later, is relied upon to remove whatever amplitude modulation is introduced by the amplifier stages. With an input to the limiter such as represented by Fig. 15, we might operate the limiter tube in such manner that its own maximum output can be only that corresponding to a gain of 50 on the curve. That is, the limiter may be constructed and operated so that, no matter how much the input exceeds a certain value (our assumed 50 per cent for example) the limiter output will remain constant. The points for 50 per cent input on the graph of Fig. 15 occur at about —83 kc and +83 kc. Then, regardless of the variations of input amplitude which are above

50 per cent, the limiter output will remain constant for all deviation frequencies between  $-83$  kc and  $+83$  kc, which more than covers the maximum allowed frequency deviation of 75 kc in each direction. This maximum deviation extends between the broken lines on the graph.

If the i-f amplifier characteristics were such as to produce a curve much narrower at the top than the one shown by Fig. 15, the maximum deviation frequencies would not be sufficiently amplified to come through the limiter at constant amplitude. As you will recall, the extent of the deviation in frequency corresponds to loudness of sounds. If we do not amplify up to the required minimum (50 per cent in our example) the louder sounds will not come through and be reproduced at the speaker.

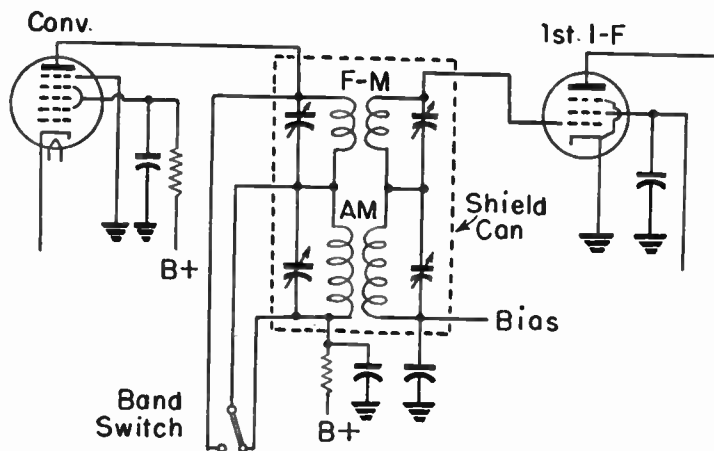

Fig. 16.—A dual i-f transformer for f-m and a-m coupling.

All sounds which should be in the general range of maximum loudness will be reduced to the level of weaker sounds. This would be audio-frequency amplitude distortion.

Fig. 16 shows an i-f transformer connected between a converter tube and the first i-f amplifier tube. The transformer consists of two sections, each with a tuned primary and a tuned secondary. The upper section is designed for resonance at the f-m intermediate frequency, and the lower one for resonance at the a-m intermediate frequency. The two frequencies might be

respectively 10.7 mc and 455 kc. The two primaries are in series with each other, and the two secondaries are in series with each other. The resonant frequencies of the two sections are so far apart that in neither section is there much reactance to the frequency of the other section, and either the f-m or a-m signals pass through the other transformer with little loss.

The transformer represented by Fig. 16 is the first i-f transformer. In the plate circuit of the converter are the several sum and difference frequencies of the carrier and oscillator, as well as both of the latter frequencies, and possible harmonic frequencies. To keep these unwanted frequencies out of the input to the first i-f tube we may use a section of the band selector switch to short-circuit the f-m primary during a-m reception, and to short the a-m primary during f-m reception. Transformers following the first one do not require this switching. Instead of short-circuiting one or the other of the primaries, the switching may be arranged to connect either one or the other of the

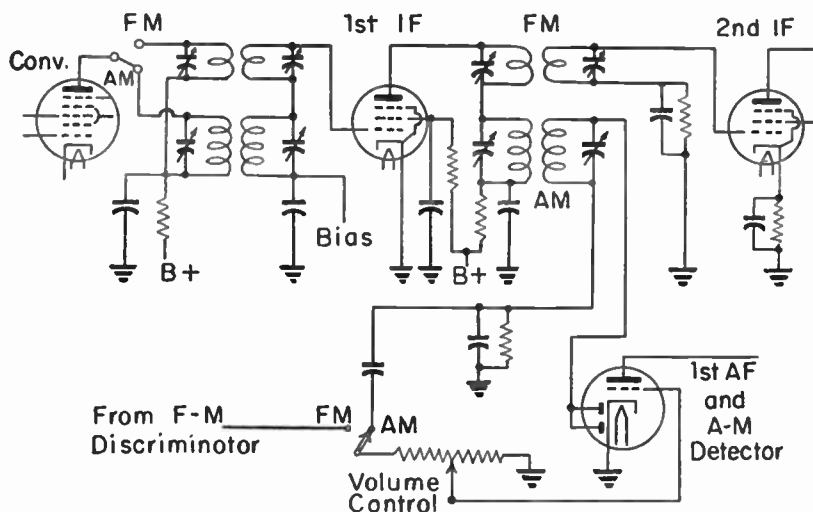

Fig. 17.—Employing the first i-f tube for amplification of both f-m and a-m signals.

primaries to the plate of the converter; leaving one end of the other primary open, but with the opposite end effectively connected to ground through leads and bypasses for the plate supply.

This latter method of switching is shown between the converter and first i-f tube of Fig. 17.

Fig. 17 shows also the manner in which the first i-f tube may be used for both f-m and a-m amplification, with the second i-f tube used only for f-m amplification. Both secondaries of the first i-f transformer connect to the control grid of the first i-f tube. In the plate circuit of this tube are the two primaries of the second i-f transformer. But it is only the f-m secondary of this second transformer that connects to the control grid of the second i-f tube.

One end of the secondary of the a-m section of the second transformer connects to the diode plates of a double-diode triode tube which acts as the a-m detector and the first a-f amplifier. The other end of this secondary connects through a section of the band selector switch to the volume control voltage divider, whose slider connects to the grid of the a-f amplifying triode section of the tube. When reception is to be in the f-m band, the volume control is switched onto the output of the discriminator, which is the detector for frequency modulation.

Sometimes the first and second i-f amplifier tubes are used for both f-m and a-m amplification. Then the connections to the a-m detector as shown by Fig. 17 would be from the transformer following the second i-f tube rather than from the transformer which is ahead of this tube.

Automatic volume control systems sometimes are used in f-m receivers, but more often are omitted or else are applied only to the amplifier tubes which handle amplitude modulation as well as frequency modulation. An avc system, as usually designed, acts to limit the amplitude of the signal voltages and to prevent the amplitudes from becoming so great on strong signals as to overload the tubes. With f-m receivers the amplitude is supposed to remain constant, and what variations do occur are removed by the limiter. Furthermore, it is desirable that the output from the i-f system rise to the minimum value for limiter action even on weak received signals, and automatic volume control ahead of the limiter would lessen the gain on very weak signals.

**Producing the Frequency Modulation.**—It will be interesting to briefly examine the principles employed in one method of modulating the frequency rather than the amplitude of a trans-

mitted signal. The transmitter antenna may be excited by any suitable oscillator and amplifier which will operate satisfactorily at the very high frequencies employed. Fig. 18 shows one style of oscillator with the tuned plate circuit or "tank" circuit coupled to the antenna circuit, with any intervening amplifiers omitted for the sake of simplicity.

The operating frequency of the oscillator is determined chiefly by tuning of the resonant circuit consisting of coils  $L_a$  and  $L_b$ , and of adjustable capacitor  $C$ , to the center frequency of the carrier. Departure from the center frequency would, in practice, be prevented by a drift correction circuit not shown. One method

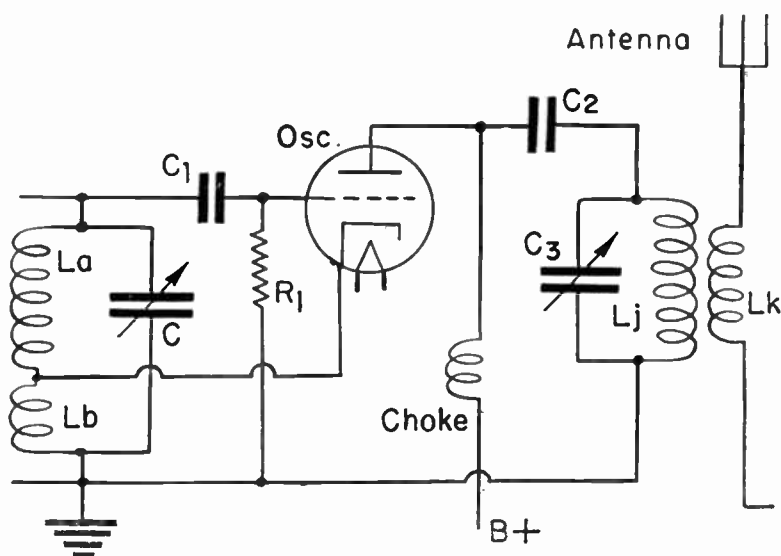

Fig. 18.—The principle of an oscillator circuit for f-m transmission.

of correcting any frequency drift is to use a mixer tube in which the output frequency beats with another steady frequency which is maintained by crystal control. The resulting beat frequency is applied to a discriminator circuit whose output varies proportionately to any difference between the oscillator output frequency and the crystal-controlled frequency. This discriminator output is used to vary the operating frequency of a reactance

tube, which will be described, and thus the oscillator frequency is constantly corrected for any drift.

Returning now to the circuit of Fig. 18, where the chief factors in determining the resonant frequency are the inductance and capacitance in the circuit including coils  $L_a$ - $L_b$  and capacitor  $C$ : If either the inductance or the capacitance were to be varied at an audio-frequency rate it is apparent that the oscillation frequency would be varied accordingly. This frequency would mo-

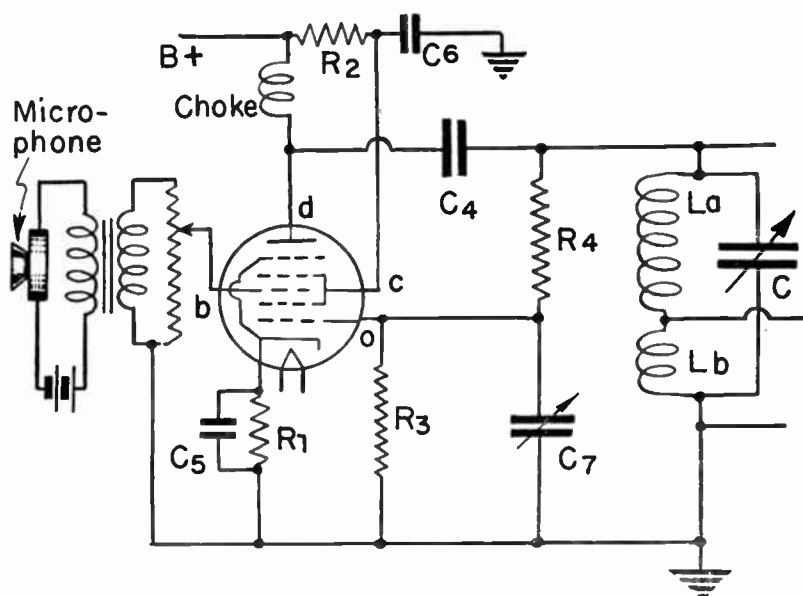

Fig. 19.—Frequency modulation by means of a reactance tube.

mentarily be lowered by every increase of either inductance or capacitance, and would be momentarily be raised by every decrease of inductance or capacitance. Then the oscillation frequency, which is the frequency of the radiated wave, would be varied or would be modulated at the audio-frequency rate, and there would be frequency modulation. With the arrangement shown by Fig. 19 there is produced in the oscillatory circuit the same effect as through the inductance of this circuit were varied at an audio-frequency rate. Here the oscillatory circuit consisting of coils  $L_a$  and  $L_b$  and capacitor  $C$  is the same oscillatory circuit

as shown in Fig. 18. That is, the right-hand side of Fig. 19 is the same as the left-hand side of Fig. 18. The microphone system of Fig. 19 represents any microphone and microphone amplifier which might be used.

The modulating tube in Fig. 19 is a pentagrid mixer type. At the bottom of the tube symbol is the cathode. Next above the cathode is the first control grid, *a*. A second control grid, *b*, which is connected to the sliding contact on the resistor across the microphone transformer, is surrounded by a screen grid, *c*. The screen grid prevents potentials on the two control grids from affecting each other, and thus permits the two control grids to act independently on the electron stream flowing from cathode to anode. Each control grid potential varies the rate of electron flow in accordance with changes of that potential. Between the screen grid and the plate, *d*, is a suppressor grid internally connected to the cathode. The action of the suppressor grid in reducing secondary emission is the same as in a pentode.

The high-frequency path for plate potentials and currents of the modulator tube passes through capacitor *C4*, through the oscillatory circuit, and back to the tube cathode. *R1* is a cathode-bias resistor, and *C5* is its bypass capacitor. The modulator plate is connected to B+, of the power supply through a choke coil which keeps the high frequency currents out of the power supply circuit and forces them to go through capacitor *C4*. The B— side of the power supply (not shown) is connected to ground. The screen grid of the modulator tube is connected to B+ through resistor *R2* which provides a potential drop to make the screen potential less than the plate potential. High-frequency currents that get into the screen grid are bypassed to ground through capacitor *C6*. Resistor *R3* provides the necessary conductive connection between control grid *a* and the cathode of the tube.

The manner in which the oscillating frequency is varied or modulated may be explained as follows: Resistor *R4* and capacitor *C7* are in series with each other and are connected across the oscillatory circuit, so that potential differences of the oscillatory circuit are applied to *R4* and *C7*. The resistance of *R4* is high in comparison with the reactance of *C7* at the frequencies being handled, and as a result the currents in *R4* and *C7* are very nearly in phase with the potentials across the oscillatory circuit. Con-

sidering the capacitor  $C7$  by itself, its current must lead its voltage by practically 90 degrees, just as in any capacitor. This means that the voltage across  $C7$  is lagging the capacitor current by 90 degrees, and, since the capacitor current is in phase with oscillatory circuit potentials, the voltage across  $C7$  is lagging the oscillatory circuit potentials by practically 90 degrees.

The lagging potentials across capacitor  $C7$  are applied between the first control grid  $a$  and the cathode of the modulator tube by connection of the capacitor to these two elements. Then the plate current in this tube, which must be in phase with the potentials on control grid  $a$ , lags the potentials of the oscillatory circuit by 90 degrees. When this lagging plate current flows through capaci-

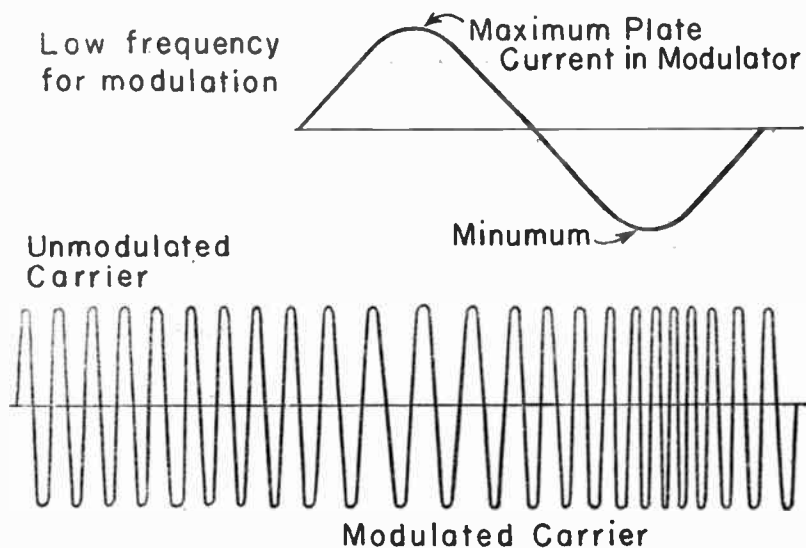

Fig. 20.—Effect of reactance modulator plate current on carrier frequency.

tor  $C4$  and the oscillatory circuit it has the same effect in the oscillatory circuit as would be had by additional inductance in this circuit, because an inductive current lags the potential in any inductive circuit.

The lagging effect of modulator plate current flowing in the oscillatory circuit depends, of course, on the value of this plate current, or on its rate of flow in amperes or milliamperes. The



rate of flow is controlled by variations of potential on the second control grid *b* of the modulator tube, and these potential variations correspond to variations of sound frequencies at the microphone. Thus the inductive effect in the oscillatory circuit is varied at the sound frequency rate, and the high-frequency oscillating potentials and currents are varied or modulated at the sound frequency.

The result of the frequency modulation just described may be shown as in Fig. 20. The unmodulated carrier is of constant frequency and constant amplitude. When modulator plate current is maximum there is maximum inductive effect in the oscillatory circuit, and the frequency is made less. With minimum modulator plate current there is minimum inductive effect, and the frequency is increased. Then the modulated carrier wave is of varying frequency, but still is of constant amplitude.

#### REVIEW QUESTIONS

1. Define the term modulation.
2. Describe the principle of amplitude modulation.
3. Describe the principle of frequency modulation.
4. What is the band width for *f-m* transmission?
5. What is the formula for the approximate length of a half-wave dipole antenna for *f-m* reception?
6. Why is impedance matching important in transmission lines?
7. Name the principal parts of a receiver designed for both *f-m* and *a-m* reception.
8. Is the *f-m* receiver a super-heterodyne type and why?

## Chapter 8A

### THE F-M RECEIVER

As has been shown in the preceding pages there are no radical differences between superheterodyne receivers for frequency modulation and for standard broadcast reception with amplitude modulation in all of the parts from the antenna circuits through to the end of the i-f amplifier. But there are great differences between the two types of receivers in the parts between the i-f amplifier and the a-f amplifying system, and it is in the action of these latter parts that we find the peculiarities of the f-m receiver.

Following the i-f amplifier in the f-m receiver we have the limiter stage, which is intended to remove any amplitude modulation which has come through the i-f amplifier, and leave only frequency modulation. The output of the limiter goes to the discriminator stage, wherein variations of frequency produce corresponding variations of amplitude which go to the a-f amplifying system.

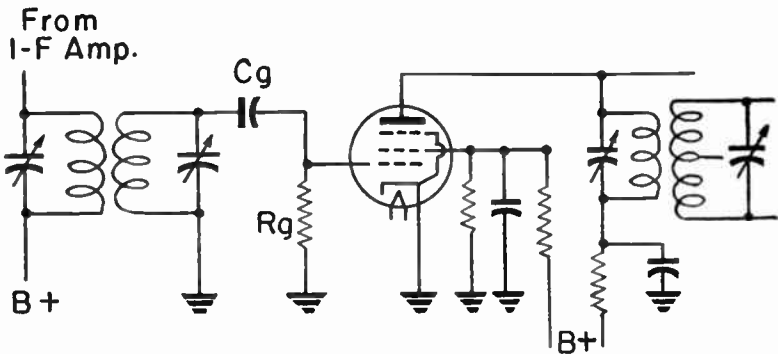

Fig. 1.—The circuit for a limiter stage.

**Why a Limiter Is Used.**—The primary purpose of the limiter is to remove any variations of amplitude which are at audible frequencies, and leave only frequency variations at constant amplitude for the input to the following discriminator. In the original signal modulation there are no variations of amplitude, but only of frequency. Should amplitude variations enter the modulated

carrier or the modulated intermediate frequency those variations could only cause sounds (noises) which were not present in the original modulation. Although the discriminator acts normally on frequency variations, it will act also on amplitude variations (noises) and these would be reproduced from the a-f system.

A circuit diagram for a typical limiter stage, such as the one in Fig. 1, looks much like the diagram for an i-f stage, with the notable exception that the grid of the tube is biased by grid rectification with capacitor  $C_g$  and resistor  $R_g$ . Upon measuring plate and screen grid voltages we would find them to be very low, usually somewhere between 15 and 60 volts. The tube is a pentode of the sharp cutoff type. Operation is at the f-m intermediate frequency. The transformers are of the broad frequency band type, such as used in the preceding i-f stages. The extra connections on the right-hand transformer are required for operation of the following discriminator stage.

Certain relations between input voltage applied to the control grid, and output current in the plate circuit for a sharp cutoff pentode tube are shown by Fig. 2. By using low voltages on the plate and screen grid we will have plate current cutoff when the control grid is only two or three volts negative, and will have a plate current of only three or four milliamperes when the control grid voltage becomes zero.

In diagram 1 the peak amplitude of the input voltage for the control grid is just equal to the control grid bias, which has a value  $o-b$  on the graph. Then the signal will swing the grid voltage from  $a$  to  $o$ , which is from the value for plate current cutoff ( $a$ ) to the value of zero grid voltage ( $o$ ). The resulting variations of plate current or output current are shown at the right of diagram 1. These variations extend from zero plate current up to the maximum current which may exist without the control grid going positive.

In diagram 2 the amplitude of the input voltage has increased. Now the positive peaks of input voltage have amplitudes greater than the grid bias  $o-b$ , and the control grid is made positive during each positive input peak. The negative peaks of input voltage now make the control grid more negative than the value for plate current cutoff, and as a result the corresponding downward peaks of plate current are cut off.

In diagram 3 the amplitude of the input voltage is the same as in diagram 2, but the control grid bias has been made more negative than before. Now we are cutting off even more of the downward peaks of plate current, because the negative peaks of

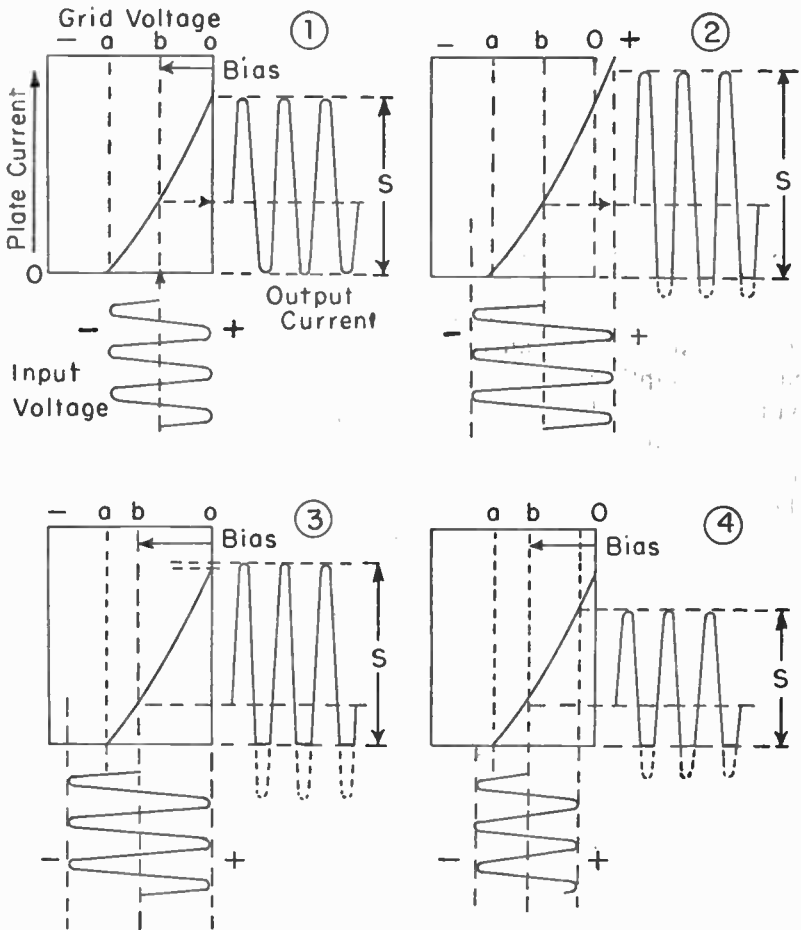

Fig. 2.—Some of the relations between input voltage and output current for a sharp cutoff tube used as a limiter.

input voltage extend even farther beyond the value for plate current cutoff (*a*). The positive peaks of input voltage now are equal to the control grid bias, they swing the control grid to zero

voltage, and cause corresponding upward peaks of plate current.

In diagram 4 the amplitude of the input voltage is the same as in diagram 1 and the control grid bias is the same as in diagram 3. The negative input amplitudes make the control grid more negative than the value for plate current cutoff, and the downward peaks of plate current are cut off proportionately. The positive input peaks are less than the grid bias voltage, and they do not swing the grid voltage to zero but rather leave it somewhat negative to produce corresponding upward peaks of plate current.

The peak-to-peak swings of plate current are proportional to the lengths of arrows *S* in the several diagrams. Amplitudes are equal to half of the peak-to-peak swings. In diagrams 1 and 3 the peak-to-peak swings and the amplitudes of plate current are of the same value, although the input voltage has greater amplitude in diagram 3 than in diagram 1. If we can automatically produce the operation that causes this observed result we shall have effective amplitude limiting, for then changes of input amplitude will not change the output amplitude, which will remain constant.

Between diagrams 1 and 3 the control grid bias has been made more negative. Apparently our object is to automatically vary the control grid bias so that it becomes more negative with increases of input amplitude, and so that the control grid is permitted to go only a very little bit positive no matter how great the positive swings or positive peaks of the input voltage. These are the requirements which have been met in diagram 3.

Using low voltages on plate and screen grid permits plate current cutoff with only moderately great negative swings of input voltage, and thus permits limiting of the downward swings and peaks of plate current. The variation of control grid bias in accordance with varying amplitudes of input voltage is accomplished automatically by the grid rectification action brought about by grid capacitor *C<sub>g</sub>* and grid resistor *R<sub>g</sub>* of Fig. 1. This action will control the upward swings of plate current. Thus we shall confine the total swing of plate current within satisfactory limits.

The action of the grid capacitor and grid resistor in providing a negative bias is shown by Fig. 3. At the right we have the limiter tube from Fig. 1, together with grid capacitor *C<sub>g</sub>*, grid resistor *R<sub>g</sub>*, and the secondary winding of the preceding trans-

former whose alternating signal potentials are applied in this control grid circuit. Positive alternations charge the grid capacitor in the polarity shown. During negative alternations a small portion of the charge leaks off through resistor  $R_g$ , with electron flow in the direction of the arrow. The control grid is on the negative sides of the capacitor and the resistor, whose positive sides are toward the tube cathode, and the control grid thus is negative with reference to the cathode.

The charge and discharge action is shown at the right in Fig. 3. Each positive alternation of applied signal potential causes enough electron flow from cathode to grid to charge the grid capacitor. Between successive positive peaks the capacitor discharges as shown by broken lines between the peaks. By employing suitable values of capacitance and resistance the discharge is made slow enough in relation to the signal frequency that but little of the charge leaks off before it is restored by the following positive peak. Thus the charge voltage of the capacitor, which is

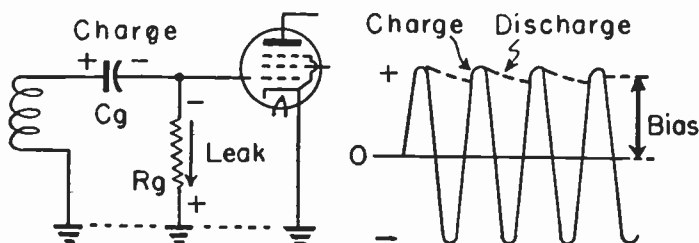

Fig. 3.—How the limiter is biased by grid rectification.

the grid bias voltage, is maintained at a value almost as high as the potential of the signal peaks. Although it is the positive signal peaks that do the charging, the grid bias is negative, as shown by the left-hand diagram. This is the action which we call grid rectification, because the cathode and control grid of the tube act as the elements of a rectifier.

It is apparent that, in grid rectification, we have a means for maintaining a negative grid bias that is proportional to the amplitude of the input voltage, which is just what is needed to provide the limiting action explained in connection with Fig. 2. The greater the input voltage the more negative the bias is made, because the bias always is nearly the same as the input positive

peaks. The less the input voltage the less negative will be the resulting control grid bias.

Should the input voltage remain at constant amplitude there will be a grid bias corresponding to this amplitude. But should there be a sudden variation of input voltage (amplitude) as might result from external interference, these variations will almost instantly alter the grid bias to maintain a practically constant output amplitude in the limiter plate circuit. If the input voltage (amplitude) varies with frequency deviation, because of non-uniform amplification of high and low frequencies in preceding stages, the resulting shifts of input amplitude will vary the grid bias to maintain a constant output amplitude from the limiter.

The voltage input to the limiter always must be great enough to swing the control grid potential from a maximum which is very slightly positive to a minimum which is at least the negative value for plate current cutoff if we are to have limiter action as shown by diagrams 1 and 3 of Fig. 2. With an input which is too low the limiter acts as an amplifier rather than a limiter. Fig. 4 shows relations between input volts and output volts from the plate

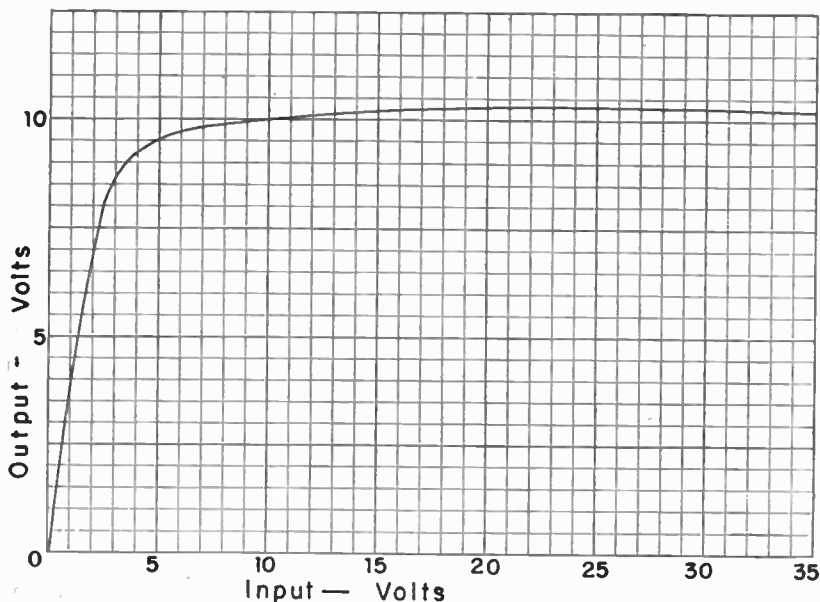

Fig. 4.—Input and output voltage relations for a typical limiter stage.

circuit with a limiter stage designed and operated to have a 10-volt output when there is a 10-volt input. Note that with a 1-volt input the output is about 3.8 volts, with a 2-volt input the output is about 6.8 volts, and that it is not until the input reaches about 3 volts that limiting action commences. Then, at a 7-volt input the output is about 9.8 volts, there is maximum output of about 10.3 volts with a 22-volt input, and with still higher inputs there is a slight dropping off of output voltage.

With the limiter stage whose performance is shown by Fig. 4 any input of much less than four or five volts will be amplified, but not limited. Slightly greater inputs will be only partially limited, or will be limited only for amplitudes which rise to the value required for limiting. The amplitude variations will be passed through to the discriminator and to the audio output, where they will result in noise. For all carrier signals which are to be reproduced without noise due to interference causing amplitude variation, the amplification or gain between antenna and limiter control grid must be enough to bring the signal amplitude up to or above the value which causes limiting action to occur. Noise cannot be eliminated from weaker signals. It is true also that all frequencies, or all deviations of frequency, must be amplified at least to an amplitude at which limiting commences. This is the reason for using broad band amplifiers ahead of the limiter. Gains ahead of the limiter usually are between 200,000 and 1,000,000 or between about 100 and 120 decibels in voltage.

The limiter grid capacitor and resistor are not necessarily connected only as shown by Fig. 3, but may be anywhere in the grid circuit so long as they are in parallel with each other and in series between the control grid and cathode. One possible connection is shown by Fig. 5, where the capacitor is marked *C* and the resistor *R*.

The time constant of the capacitor and resistor is chosen chiefly with reference to the highest audio-frequency to be reproduced, which will be also the highest noise frequency reproduced. In order that a series of high amplitudes in the signal, such as would result from a noise pulse, shall not drive the limiter grid bias to the plate cutoff point, and hold it there, the time constant must be considerably shorter than the period of the highest audio frequency. This means that the charge of the grid capacitor must



be allowed to leak off between successive pulses of excess amplitude when these pulses are recurring at some audio frequency. The highest audio frequency reproduced usually is about 15,000 cycles, for which the time period is  $1/15000$  or 0.000067 second, or is 67 millionths of a second. Then it follows that the time constant of the capacitor and resistor should be much less than

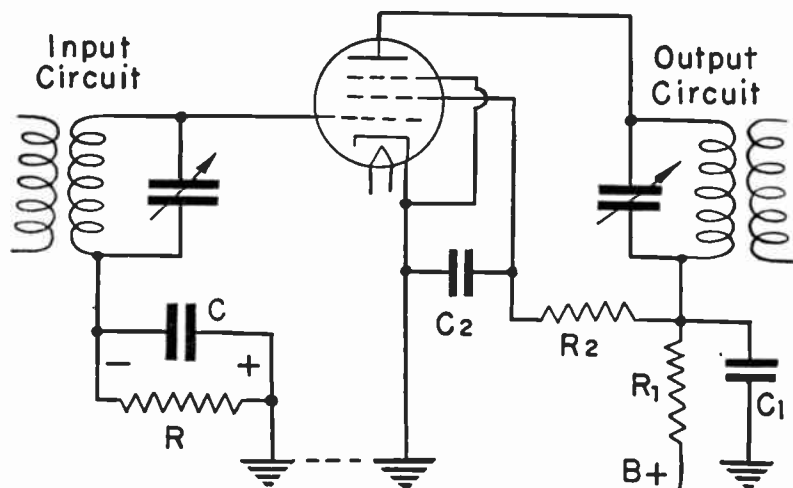

Fig. 5.—A grid capacitor and resistor at the grounded side of the limiter control grid circuit.

67 millionths of a second. Time constants actually used range from about 2 to 35 millionths of a second. The time constant, as you know, is the fraction of a second which is equal to the product of capacitance in microfarads and resistance in megohms. Capacitance values usually are between 20 and 50 mfd, and resistances are between 0.05 and 0.20 megohm.

The time constant must be considerably longer than the period corresponding to the intermediate frequency. For an intermediate frequency of 10.7 megacycles the period is less than one-tenth of a millionth of a second. With any of the time constants mentioned there would be hardly any leaking away of the capacitor charge and lessening of the grid bias in a period so brief.

In some f-m receivers there are two limiter stages between the i-f amplifier and the discriminator. The diagram for one such arrangement is shown by Fig. 6. The grid capacitors and resistors

which determine the time constants are marked  $C_g$  and  $R_g$ . Capacitors marked  $C$  are bypasses or decoupling capacitors having capacitance usually of about 0.01 mfd, whose reactance at 10.7 mc would be about  $1\frac{1}{2}$  ohms. The time constant in one stage is made about double the constant for the other stage so that the two together will limit a wider range of audio frequencies. In some two-stage limiters the control grid bias for the first stage is not secured by grid rectification, but instead by either cathode bias or fixed bias from the d-c power supply. Limiting action in

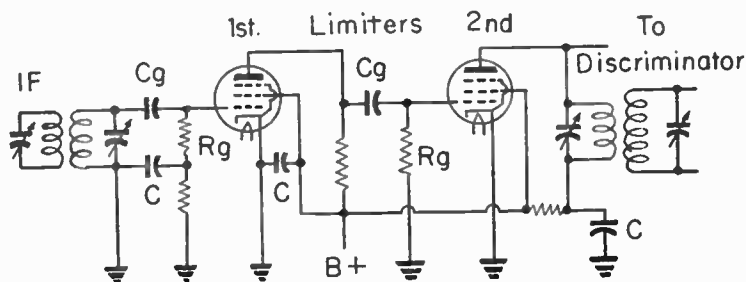

Fig. 6.—Circuits for two limiter stages in cascade.

this stage then is due to the low plate and screen grid voltages and to a grid bias which permits plate current cutoff.

It should be kept in mind that, although the limiter restricts amplitude changes, it does not affect changes of frequency, and the frequency deviations which represent the signal modulation pass freely through the limiter stage.

When the downward peaks of plate current are cut off there is distortion of the waveform, which becomes flattened. Somewhat the same thing, but in lesser degree, occurs at the upward peaks where total cathode current divides between plate current and the pulses of grid current. However, any new harmonic frequencies introduced by the waveform distortion are not within the ranges amplified or passed through the discriminator and a-f system, and no harm results.

Although the limiter stage removes amplitude modulation which represents interference noise, and amplitude modulation resulting from non-uniform amplification of high and low deviation frequencies, it is not absolutely necessary to have a limiter stage in an f-m receiver. The discriminator will operate to change

frequency modulation into audio-frequency changes of amplitude whether or not the discriminator input is of constant or of varying amplitude.

When automatic volume control is used with an f-m receiver the voltage for regulating the control bias on i-f and other tubes preceding the limiter may be taken from across the grid resistor in the limiter circuit. This is resistor  $R_g$  in Figs. 1, 5 and 6. The potential drop across this resistor increases as the input voltage to the limiter stage increases. This comes about because the  $R_g$  potential drop is practically equal to the charge on capacitor  $C_g$  and to the grid bias, and the grid bias becomes more and more negative as the input voltage increases. As has been shown, the grid bias must remain approximately equal to the maximum positive amplitude of the input voltage in order to have limiting action. This grid bias which increases with input voltage, or a part of it, may be applied to preceding control grid circuits to make the amplifier grids more negative, and thus to provide automatic volume (amplitude) control.

**The Discriminator.**—In the discriminator stage of f-m receivers we find a rather wide variety of circuit arrangements, all of

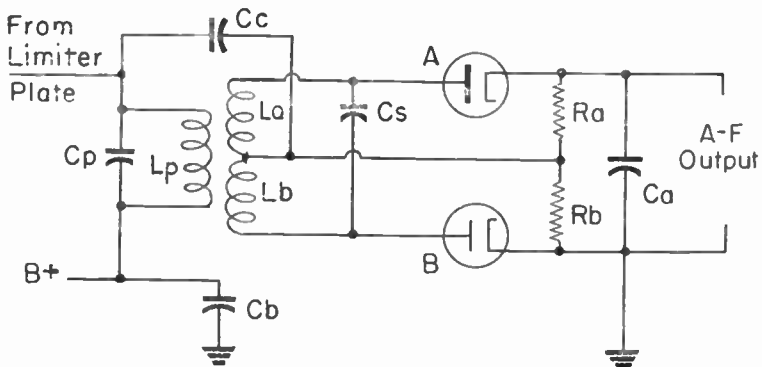

Fig. 7.—A circuit illustrating the general principles of the discriminator.

which produce essentially the same results. The principles employed in most discriminator circuits may be explained with the help of Fig. 7.

The transformer at the left is the one whose primary  $L_p$  is in the plate circuit of the limiter. The secondary winding is center

tapped, with a connection coming from the limiter plate through capacitor  $C_c$  to the tap. Connected to each of the outer ends of the secondary is a half-wave rectifier. The rectifiers are shown here as separate diodes,  $A$  and  $B$ . In practice the diodes would be in a single tube, and usually the same tube would contain additional elements, such as those for a triode used in other circuits. That is, the discriminator diodes would be parts of a multi-purpose tube, just as the a-m detector diodes are parts of such tubes in a-m receivers.

The cathodes of the diodes are connected to series resistors  $R_a$  and  $R_b$ , and from between the resistors a return lead goes to the center tap of the transformer secondary. Between the cathodes, and across the ends of the resistors, is capacitor  $C_a$  in which are produced audio-frequency voltages which are fed to the a-f amplifier. Capacitor  $C_p$  tunes the transformer primary, and  $C_s$  tunes the entire secondary. These may be adjustable trimmer capacitors, or else they may be fixed capacitors with the trimming adjustments made with movable cores for the coils. Capacitor  $C_b$  is a bypass to ground from the transformer primary.

In Fig. 8 several portions of the diagram in Fig. 7 have been drawn separately. Diagram 1 shows the rectifier circuits in their relation to the secondary winding of the transformer. Potential differences applied to diode  $A$  result from emf's induced in section  $L_a$  of the winding, and those applied to diode  $B$  result from emf's in section  $L_b$ . When the diode plates are made positive during alternations of applied potential there will be electron flow as shown by arrows. These flows are from cathode to plate in the diode, then through the transformer sections to the return connection at the center tap, and through resistors  $R_a$  and  $R_b$  to the cathodes.

Electron flows in the two resistors are in opposite directions, so that potential differences developed across the resistors oppose each other. If the electron flows are equal in the two diodes and in the two resistors, the opposing potential differences will be equal and they will counterbalance each other to leave no net potential difference applied to capacitor  $C_a$  and to the a-f amplifier which follows. If, as at 2, there is greater electron flow in the upper resistor than in the lower one, the greater potential difference across the upper resistor will more than counter-

balance the potential difference across the lower one, and will make the upper end of the combination more positive than the lower end. If, as at 3, there is greater electron flow in the lower resistor, the lower end of the combination will be more positive than the upper end.

When the electron flows in the two diodes and the two resistors alternate in strength at audio-frequency rates, the net potential

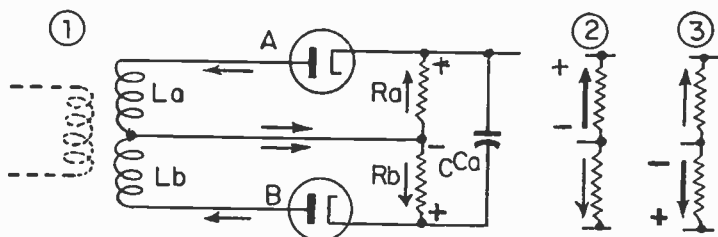

Fig. 8.—The direct-current circuits for the discriminator diodes.

differences across the two resistors, and the potential differences applied to  $C_a$ , will alternate in polarity. These alternations are to form our cycles of audio frequency amplitudes, as shown by Fig. 9. When electron flow in diode  $A$  and resistor  $R_a$  is greater than in diode  $B$  and resistor  $R_b$  we will have a positive alternation. When the relative flow rates reverse in strength we will have a negative alternation. When the flows are equal we will have the zero points in the a-f cycle.

The amplitude (volume or loudness) of the audio signal will vary with the rates of electron flow in the diodes and with the resulting charge voltage on capacitor  $C_a$ . The greater the electron flows the greater will be the a-f amplitudes.

The frequency in the audio output will be the frequency with which changes on capacitor  $C_a$  are reversed in polarity. The more rapid the reversals of polarity, the higher will be the audio frequency.

You will recall that in the original frequency modulation the audio amplitude is represented by the extent of frequency deviation away from the center frequency. Then it follows that, in the discriminator, the greater the deviation of frequency away from the center intermediate frequency the greater must be the rate of electron flow produced in the diodes or rectifiers and their

resistor loads  $R_a$  and  $R_b$ . Thus we shall change frequency deviation into a-f amplitude, and have these two proportional to each other.

In the original frequency modulation the audio frequency is represented by the number of times per second that there is frequency deviation extending from the center frequency to maximum deviation one way, then to maximum the other way, and back to the center frequency. If we translate frequency deviations into a-f amplitudes we cannot help but get the correct translation into output audio frequency, because our audio ampli-

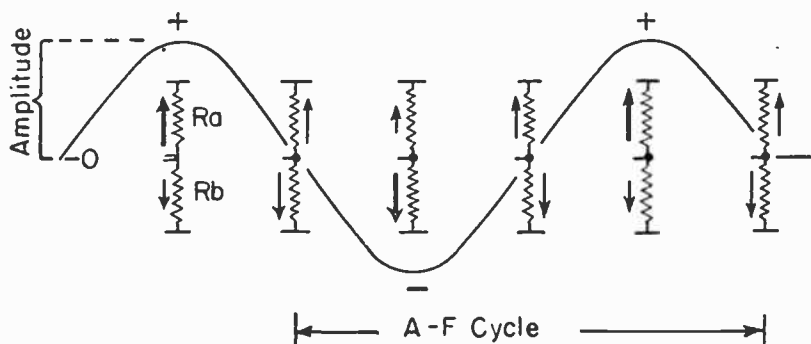

Fig. 9.—Audio-frequency potentials result from variations of electron flows and potential differences in the discriminator resistors.

tudes will occur at the same times as the frequency deviations.

At the input to the discriminator we have a frequency-modulated intermediate frequency whose center frequency may be 10.7 mc, which is far above audibility. In the audio output we must have frequencies ranging to only about 15,000 cycles per second. The intermediate high frequency is gotten rid of, and the lower audio frequency is brought forth, just as in an a-m diode detector system. There are pulses of electron flows in the diodes or rectifiers at the intermediate frequency. These pulses cause corresponding pulses of potential which charge capacitor  $C_a$ . The time constant of the resistors  $R_a$  and  $R_b$ , and capacitor  $C_a$ , is such that the average charge on  $C_a$  varies at the audio frequency of modulation rather than at the intermediate frequency. The charge cannot leak off at the i-f rate, but only at the a-f rate. The pulses of potential shown in Figs. 8 and 9 occur at the i-f rate and at the rates due to deviations, but the average charge on  $C_a$  in-

creases and decreases proportionately to the variation of the pulses over periods which are at the a-f rate; this because of the fairly long time constant of the resistors and capacitor.

Now we may proceed to Fig. 10. Here are shown the circuits for each diode as the circuits include the transformer primary winding as well as half of the secondary winding. We have seen how each diode is subjected to potentials developed in the corresponding half of the secondary. Now we shall see how potentials

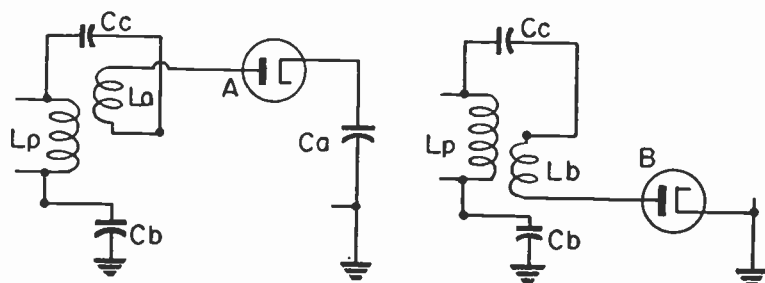

Fig. 10.—The diode rectifier circuits which include the primary of the transformer.

from the primary are combined with those from the secondary, so that each diode is subjected to the combined effects of the two potentials at the same instants of time.

At the left in Fig. 10 is the circuit for diode A. We may start from ground and go through the high-capacitance low-reactance capacitor  $C_b$ , then through primary winding  $L_p$ , coupling capacitor  $C_c$ , the upper half  $L_a$  of the secondary, and to the diode plate. From the cathode of this diode the circuit goes through capacitor  $C_a$  to ground, and thus the one circuit is completed. At the right is the circuit for diode B. This circuit goes from ground through the bypass  $C_b$ , the primary  $L_p$ , capacitor  $C_c$ , the half secondary  $L_b$ , and to the plate of the diode. From the cathode there is a return to ground. Capacitor  $C_a$  has a reactance of only about 300 ohms at 10.7 mc, and so its inclusion in the circuit for diode A and its omission from the circuit of diode B, makes little difference. In each circuit the primary winding is in series with half of the secondary and with one of the diode rectifiers. Consequently, each diode will be simultaneously subjected to the primary potential and to the potential from its half of the secondary. Now we are ready to observe how the primary and secondary

potentials combine to vary the electron flows in accordance with deviations of frequency.

In Fig. 11 are shown variations of current and voltage in the transformer primary, and of voltage in the secondary during two i-f cycles. In the first vertical column are shown relations when the deviation is zero, in the middle vertical column are shown relations when there is deviation to a higher frequency, and in the right-hand column are shown relations when there is deviation to a lower frequency. The vertical lines indicate certain instants of time, which are the same along a given line for the current and all the voltages.

With zero deviation (left-hand column) the applied frequency is the center frequency, it is the frequency to which both the primary and secondary windings are tuned, and so it is the

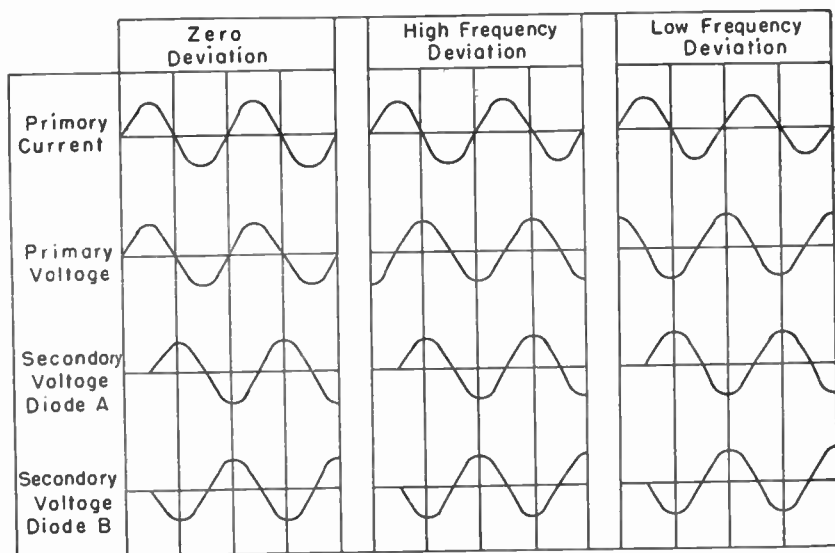

Fig. 11.—The phase relations at the same instants of time in the primary and secondary windings of the transformer, for three degrees of deviation.

resonant frequency. At a resonant frequency the reactances in a tuned circuit are balanced, leaving only resistance to oppose flow of current, and consequently the primary current and primary voltage are in phase with each other. This is shown by the upper two curves.



Secondary voltage, or emf, is induced by changes of primary current and of magnetic fields which accompany the primary current. This secondary voltage, like counter-emf in the primary, leads the primary current by 90 degrees as shown by the third curve from the top in the left-hand column. This will be the secondary voltage which affects one of the diodes, which we assume to be diode *A*.

As shown by Fig. 8, the two diodes are connected to opposite ends of the secondary. When one end of the secondary winding is positive the other end must be negative. Consequently, when the plate of one diode is positive the plate of the other must be negative, and so the secondary potentials applied to the two diodes are of opposite phase. At the bottom of the left-hand column, we show the secondary voltage for diode *B* as being opposite in phase to the secondary voltage for diode *A*.

Now we go to the middle column of Fig. 11, where phase relations are shown for a deviation to a higher frequency. We assume that the primary current, which is also the plate current for the preceding limiter tube, is controlled by changes of potential applied to the limiter grid, and so in this column we start at the top with the same primary current as for zero deviation.

At frequencies higher than resonant the capacitive reactance of the tuned primary circuit decreases and the inductive reactance increases. This is because the reactance of a capacitor decreases with rise of frequency, and the reactance of an inductor increases with rise of frequency. If the deviation could be made so great, and the frequency so high, as to result in practically no capacitive reactance and very great inductive reactance the primary would act like a circuit containing only capacitance and some resistance. In the extreme case, the primary current then would lead the primary voltage, and the primary voltage would lag the primary current, by 90 degrees. These relations are shown by the two curves at the top of the middle column.

The secondary voltage, as applied to the two diodes, still has the same phase relations to the primary *current* as before, or the same as with zero deviation. These secondary voltages for the two diodes are shown by the two curves at the bottom of the middle column.

The right-hand column of Fig. 11 shows phase relations when

the deviation is to a lower frequency. At a lower frequency the capacitive reactance of the primary increases, and the inductive reactance decreases. With a very great deviation and a very low frequency the inductive reactance would become so small and the capacitive reactance so great as to leave nearly all the current in the inductor. Then the circuit would act like one containing only inductance and a little resistance, and the voltage would lead the current by 90 degrees. These relations are shown by the two upper curves in the right-hand column. Again we have no change in the secondary voltages, which are shown by the two lower curves in this column.

In Fig. 12 we combine the primary and secondary voltages applied to the two diodes. The three columns apply to zero deviation and to high and low frequency deviations, just as in

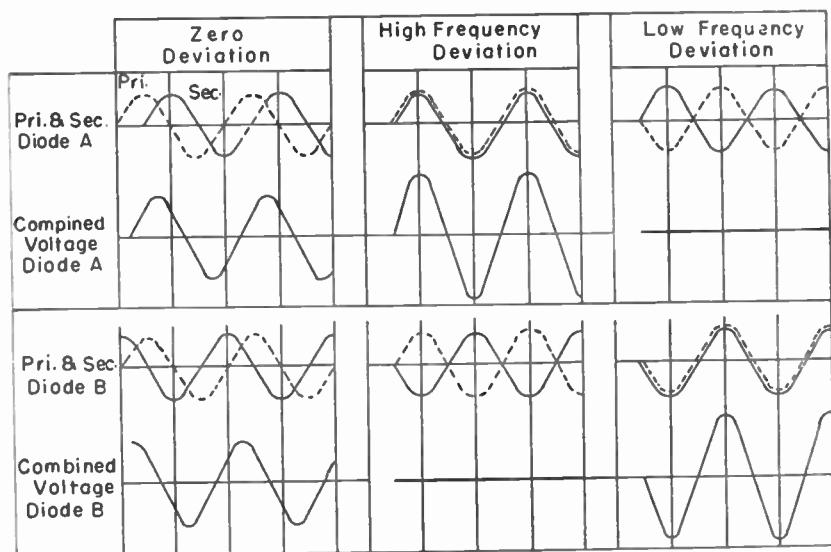

**Fig. 12.**—How the instantaneous primary and secondary voltages combine in the circuits for the two diode rectifiers.

the preceding graph. The separate primary and secondary voltages are taken from that preceding graph. Primary voltages are shown by broken-line curves, and secondary voltages by full-line curves. The resulting diode voltages are shown by full-line curves. These curves show the instantaneous voltages which are

the combinations of primary and secondary voltages in the same circuit.

With zero deviation (left-hand column) the combined voltage in the circuit for diode *A* has exactly the same amplitudes as the combined voltage in the circuit for diode *B*. The fact that these two combined voltages are out of phase with each other makes no difference, because they are in the separated circuits shown by Fig. 10. These equal voltages cause equal electron flows in the two diodes and their load resistors. The resulting equal potential differences across the two load resistors oppose, as in Fig. 8, and cancel to leave no net voltage for the audio frequency output.

With high-frequency deviation (center column) the primary and secondary voltages are in phase with each other for diode *A*, and combine to form a high voltage in the circuit for this diode. In the circuit for diode *B* the primary and secondary voltages are in opposite phase. They cancel to leave zero voltage for this diode. Then with deviation toward higher frequencies we have increasing voltage and current for diode *A*, and decreasing voltage and current for diode *B*. How far the voltage increases for diode *A* and decreases for diode *B* depends on how much the frequency deviates. As the frequency deviates from zero the voltages on the two diodes will change from the equal values shown in the left-hand column toward the maximum possible values shown in the middle column.

With low frequency deviation (right-hand column) the phase relations for diodes *A* and *B* are reversed with respect to those shown for high frequency deviation. Again the separate primary and secondary voltages are taken from Fig. 11, and are shown combined here. With deviation toward lower frequencies the voltage for diode *A* decreases from the value shown in the left-hand column toward the zero value shown in the right-hand column, while the voltage for diode *B* increases from the value in the left-hand column to the maximum value shown in the right-hand column.

Now we have seen how deviation of frequency causes changes of voltages and currents for the two diodes and their load resistors in the discriminator circuit. The resulting changes of potential drop across the load resistors,  $R_a$  and  $R_b$  of Fig. 8, may be shown as in Fig. 13. We are assuming that the diode currents when

deviation is zero are such as to cause a potential drop of 9 volts across each of the load resistors. This would correspond to the conditions in the left-hand column of Fig. 12. As deviation goes to higher frequencies the potential drop across  $R_a$  increases, while the drop across  $R_b$  decreases. This corresponds to conditions in the center column of Fig. 12. With deviation toward lower frequencies the changes of potential difference are reversed in the two resistors.

In Fig. 13 we show maximum and minimum potential drops of 15 and 3 volts respectively, and show frequency deviation as

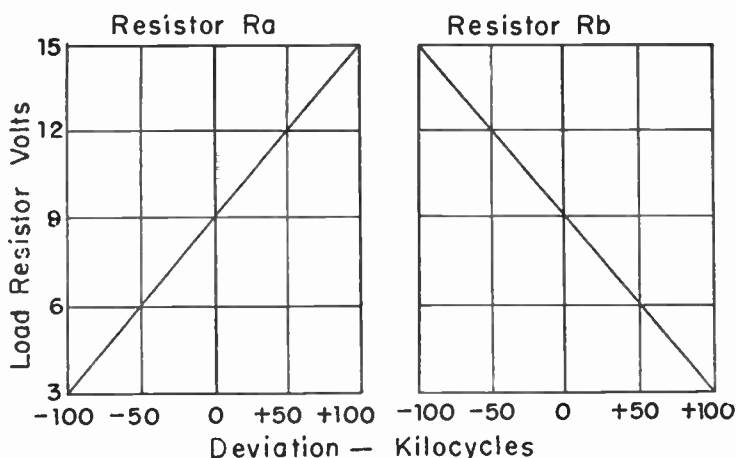

Fig. 13.—Load resistor voltages which result from frequency deviation.

far as 100 kc each way from the center frequency of zero deviation. With the zero diode potentials shown for certain conditions in the middle and right-hand columns of Fig. 12 there would be zero diode currents and zero potential drops across resistors  $R_a$  and  $R_b$ . Such extreme conditions would not occur in practice, because there would never be enough deviation to cause them. Consequently, we take for our minimum potential drop in Fig. 13 a value of 3 volts rather than one of zero.

Now we must recall the fact that potential drops in the two load resistors oppose each other, as shown by Fig. 8. The audio output voltages built up across capacitor  $C_a$  in that figure will result from the *differences* between the potential drops in the

two resistors. These differences are shown by Fig. 14. As an example, from Fig. 13 we read for a deviation of  $+50$  kc a drop across  $R_a$  of 12 volts, and a drop across  $R_b$  of 6 volts. The difference is 6 volts. On the graph of Fig. 14 we show this 6-volt difference as positive (above the center horizontal line) because we are assuming that a greater potential difference across  $R_a$  means a positive audio output, as shown by Fig. 9. Of course, we should keep in mind that positive and negative in alternating quantities are assumed merely for convenience to show opposite directions of flow and potential differences. Either direction

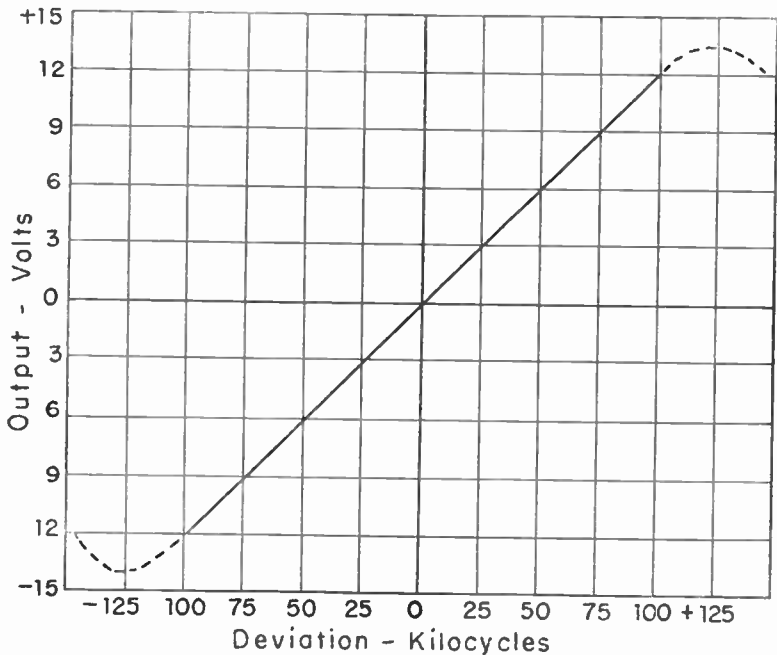

Fig. 14.—A discriminator characteristic showing a-f output voltages corresponding to frequency deviations.

might be called positive, and then the other direction would be called negative.

All of the remaining points along the curve of Fig. 14 are similarly derived from the values shown by Fig. 13. When the greater potential drop is across  $R_a$  we call the net voltage positive, and

when the greater drop is across  $R_b$  we call the net voltage negative. The curve of Fig. 14 is called a *discriminator characteristic*. The values shown are quite typical of general practice, but other combinations of output voltage and deviation frequency would result from using different constructions and values of parts in the discriminator circuit.

At the top and bottom of the straight portion of the characteristic are curved broken-line extensions. These peaks are due to the fact that the discriminator transformer acts like any other closely coupled tuned transformer in having output peaks above and below the frequency to which the primary and secondary are tuned, or in having the familiar double-hump resonance curve. In Fig. 14 the portion of the characteristic on the left of the zero deviation line really is turned upside down to show the reversal of output voltage that occurs when one diode carries more current than the other. The curve would appear more familiar were

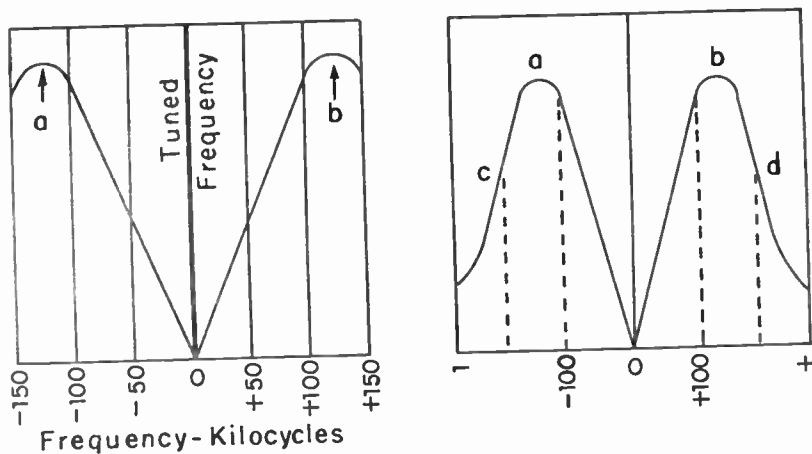

Fig. 15.—The discriminator characteristic drawn to show the double-hump resonance effect produced by the transformer.

it drawn as at the left in Fig. 15 where we have one resonant peak, *a*, at a frequency below the tuned frequency, and another peak, *b*, at another frequency above the tuned frequency. The tuned frequency is the frequency to which both primary and secondary are tuned. It is the center frequency or the intermediate frequency without frequency deviation.

Were the graph extended over a greater range of frequencies the response of the discriminator circuit would appear as at the right in Fig. 15. The frequency separation between the resonant peaks is increased by closer coupling between primary and secondary windings of the transformer, also by anything which lowers the Q-factor of the tuned circuits. This is true of any double-tuned transformer.

The straight portion of the discriminator characteristic in Fig. 14 must extend in each direction at least to the maximum deviation frequency, which we have taken as 75 kilocycles, in order that the audio output may be undistorted in relation to the deviation. It follows that the coupling and the Q-factor of the tuned circuits must be such as will bring the peaks beyond the maximum deviation by enough to insure the necessary length of the straight portion of the characteristic in between the peaks.

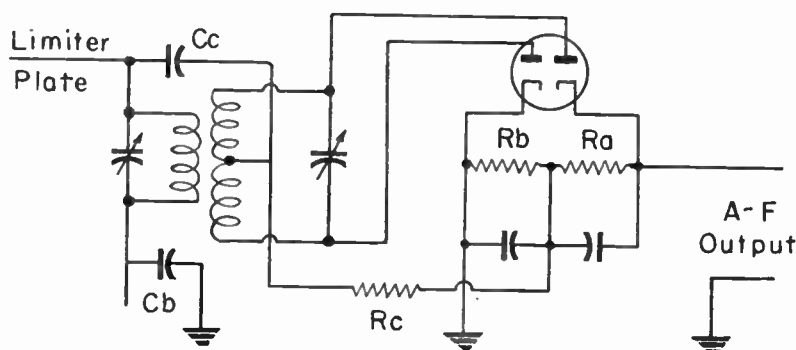

Fig. 16.—One practical form of discriminator stage.

In Fig. 14 we have a straight portion extending over a total range of 200 kc for our assumed total deviation of 150 kc.

The discriminator will demodulate a frequency-modulated signal anywhere along a straight or nearly straight portion of the response curve. If, during alignment of a discriminator transformer, we were to tune the primary and secondary to a frequency corresponding to point *c* at the right in Fig. 15, rather than to the intermediate frequency, the audio signal would come through because we would be working on a straight portion of the response curve. There would be reception also with tuning to

a higher frequency at point *d*. The straight portions of the curves are relatively short at these points, and large deviations would be distorted.

**Discriminator Circuits.**— Our explanations of discriminator action have been based on the circuits shown by Figs. 7 and 8. Many variations of this circuit are employed in practice. We find that certain rather basic principles are common to all of the circuits in general use. In all of them there are produced two voltages whose phase relations are varied by changes of frequency which are the deviation frequencies. The out-of-phase voltages are combined to produce in the output of two rectifiers an alternating potential which varies at audio frequency in accordance with frequency deviation.

One type of discriminator circuit is shown by Fig. 16. The tube is a double-diode, but might be a double-diode triode or

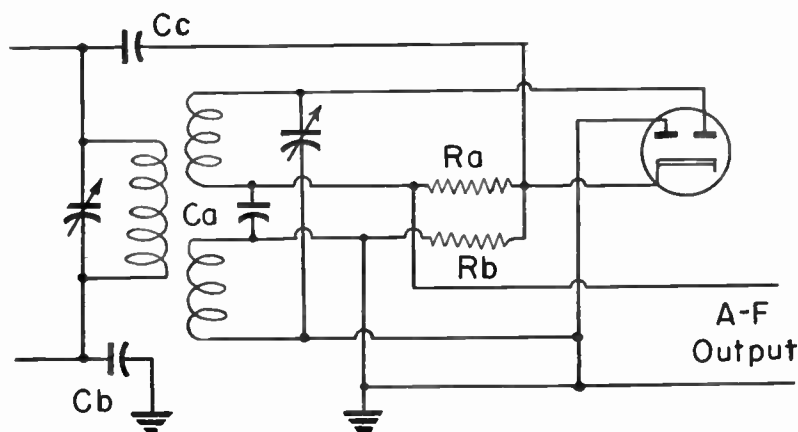

Fig. 17.—A discriminator circuit employing a double-diode tube with a single cathode.

other combination type with the diodes used as the discriminator section. Instead of a single capacitor across both  $R_a$  and  $R_b$  there are two separate capacitors in series. In the return line from the connection between  $R_a$  and  $R_b$  to the center tap of the transformer secondary there is a resistor  $R_c$ . Instead of this resistor we find a radio-frequency choke coil in some circuits. The action in this circuit is the same as has been described in detail.

Fig. 17 shows a discriminator circuit employing a double-diode



tube having only a single cathode for operation with both plates. The halves of the transformer secondary are connected together through capacitor  $C_a$ . Resistors  $R_a$  and  $R_b$  have their common connection run through coupling capacitor  $C_c$  to the limiter plate, and their other ends connect across capacitor  $C_a$ . The a-f output is taken from across capacitor  $C_a$  and the ends of resistors  $R_a$  and  $R_b$ . It is apparent that the action in this circuit will be essentially the same as in the one previously explained.

Fig. 18 shows still another discriminator circuit. Here the plate circuit of the preceding limiter contains a tuned coupling impedance consisting of coil  $L_p$  and its trimmer capacitor. Coupling capacitor  $C_c$  feeds directly to the right-hand diode plate, and through the tuned parallel-resonant circuit  $L_a$  to the left-hand diode plate. Thus a deviation of frequency above or below

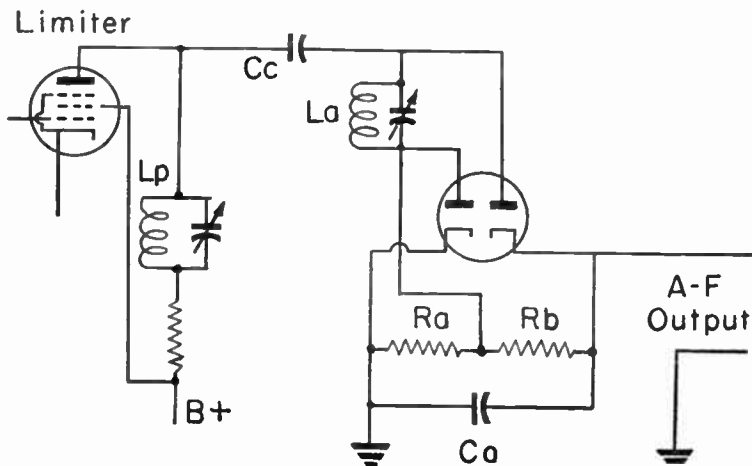

Fig. 18.—A discriminator circuit having phase displacement for only one of the rectifier lines.

the tuned frequency will cause a phase shift in the line to the left-hand diode plate with reference to the right-hand plate, and currents in the two diodes will be shifted with reference to each other. The a-f output connections, including resistors  $R_a$  and  $R_b$ , and capacitor  $C_a$ , are like those previously examined.

The three diagrams just shown illustrate some of the modifications which may be made in discriminator circuits while retaining the operating principle of variation of phase shift and output

amplitude in accordance with frequency deviation. Various other circuit modifications are used in f-m receivers. Any of the circuits shown as having double-diode tubes may have other combination tubes containing diode plates. Some of them contain the two discriminator diodes and also an additional diode acting as the a-m detector. Instead of diode tubes for the discriminator, some f-m receivers have crystal detectors which are especially designed for high-frequency operation. Then each diode, with its cathode and plate, is replaced with a crystal unit. Germanium crystals are used at frequencies up to 200 megacycles.

**Audio Coupling Circuits.**—Typical circuits used between the discriminator and the first audio-frequency amplifying tube are shown by Fig. 19. At the left are shown connections to an a-f amplifier which has cathode bias, and at the right are connections which may be used when the a-f tube is biased by a grid capacitor and resistor,  $C_g$  and  $R_g$ . The control grid of the a-f tube is fed from the slider on the volume control voltage divider  $VC$ .

The a-f output from the discriminator, as shown by many preceding diagrams, is taken from one end of the resistors and

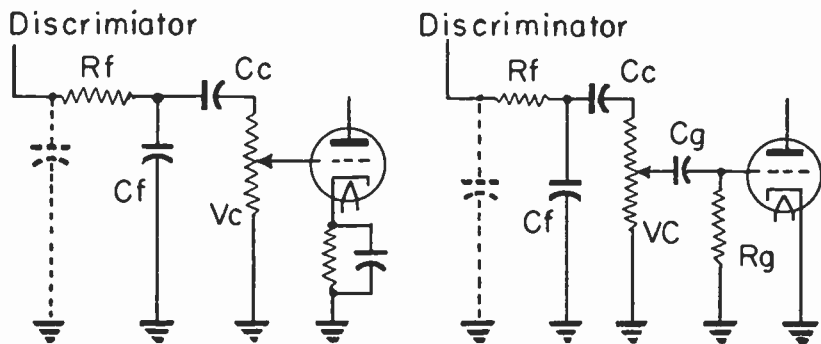

Fig. 19.—Circuits used between discriminator and first a-f amplifier.

capacitor or capacitors which are between the cathodes of the discriminator diodes or rectifiers. This may be called the "high side" of the a-f output. The other side of the a-f output is through ground, to which is also connected the other end of the resistors and capacitor which are between the discriminator cathodes. The connections shown by Fig. 19 are those from the "high side" through to the a-f amplifier. As mentioned before, the a-f ampli-

fier elements may be in the same tube envelope with the diodes for the discriminator.

Both of the circuits shown by Fig. 19 include low-pass filters which attenuate or weaken the higher audio frequencies. The filters consist of series resistor  $R_f$  and bypass capacitor  $C_f$ , with sometimes the addition of another bypass capacitor shown by broken lines. Capacitor  $C_c$  is a coupling capacitor between the filter and the volume control.

Attenuation of the higher audio frequencies is required because these frequencies have been accentuated at the transmitter. The accentuation or strengthening of the higher audio frequencies usually is called *pre-emphasis*, and their attenuation in the receiver is called *de-emphasis*. Audio pre-emphasis increases the deviation at high audio frequencies without increase of amplitude. Interference which adds itself to the modulated carrier has, in relation to signal strength, more strength at these higher frequencies than at lower ones in the audio range. Then the pre-emphasis brings about a more favorable ratio of signal to noise in the modulated carrier, and the accentuation of the higher audio frequencies is easily eliminated by the de-emphasis circuits in the receiver.

The range of audio frequencies in high-fidelity f-m transmission and reception may extent up to 15,000 cycles per second, although in many commercial receivers the a-f response does not extent to more than 9,000 or possibly 10,000 cycles. To reproduce both the high and low audio frequencies the receiver may be equipped with a dual loud speaker; one section for lows and another for highs, much as used for some public address systems.

#### REVIEW QUESTIONS

1. What two circuits are present in f-m receivers between the i-f and a-f stages which are not present in a-m receivers?
2. Why is a limiter stage used in f-m receivers?
3. What is the purpose of the discriminator stage?
4. Describe how the limiter is biased by grid rectification? Refer to Fig. 3.
5. Why are broad band amplifiers used ahead of the limiter stage?
6. What is the basic principle of all discriminator circuits?
7. Refer to Fig. 21 and explain briefly how the oscillating frequency is varied or modulated.

## Chapter 8B

### ALIGNMENT OF F-M RECEIVERS

In an earlier chapter we learned that, for alignment of a receiver which reproduces amplitude-modulated signals, we may feed an amplitude-modulated high-frequency signal to one of the r-f or i-f control grid circuits and measure the resulting audio-frequency output by means of an a-c meter connected to the loud speaker coupling circuits. But were we to feed into the r-f or i-f control grid circuits of an f-m receiver a signal having a constant carrier frequency which is amplitude-modulated with an audio frequency, the audio-frequency variations would be removed in the limiter, the discriminator output would be balanced, and the result would be zero output to the a-f amplifier. This means that the procedures for a-m receiver alignment cannot be used for f-m alignment.

There are two distinctly different methods of handling f-m alignment. With one method we employ an input signal of constant high frequency, not modulated in any way. The resulting output from the receiver circuits is measured by either a voltmeter or a current-indicating meter which responds to the amplified input after the input has been rectified either in the control grid circuit of the limiter or else in the output circuit of the discriminator. We shall call this procedure the *constant-frequency* method of alignment.

Constant-frequency alignment is carried out, as shown at the top of Fig. 1, with the same type signal generator used for aligning a-m receivers, but with its output unmodulated and adjusted for whatever frequency is required during the alignment steps. The receiver output is measured by either a high-resistance voltmeter, a vacuum tube (electronic) voltmeter, a sensitive milliammeter, or a microammeter.

The other method of f-m alignment employs an input signal which is frequency-modulated, just as the high-frequency carrier normally coming to the receiver is modulated, or just as the intermediate frequency is varied above and below its center value

by frequency deviation. With this method, shown at the bottom of Fig. 1, the receiver output is observed as an illuminated visible trace or curve on the screen of a cathode-ray tube in an oscilloscope or oscillograph. We actually watch the changes in shape of a resonance curve while making the i-f alignment, and watch the changes in shape of a discriminator characteristic or S-curve

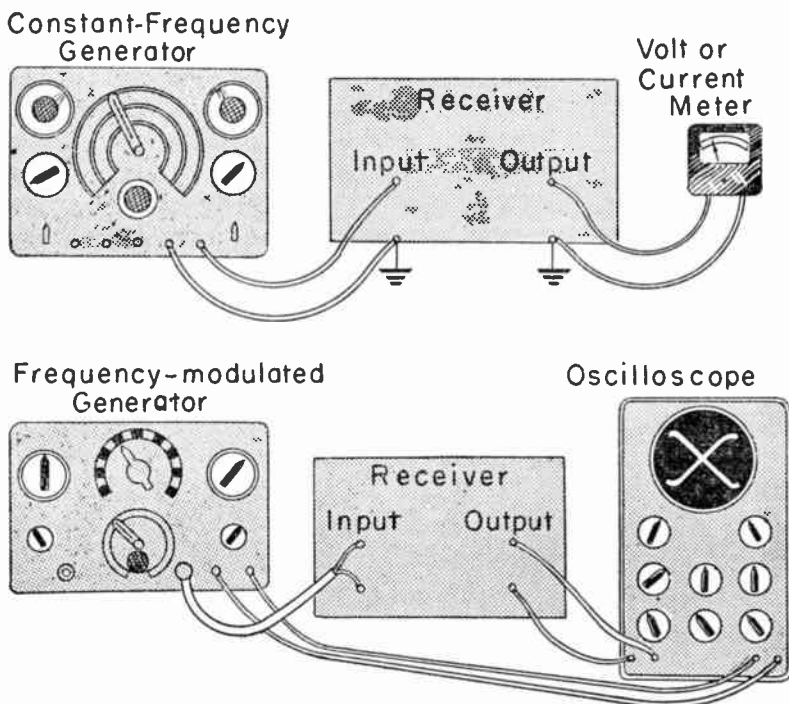

Fig. 1.—Alignment of f-m receivers. Constant-frequency method at the top, and visual method at the bottom.

while aligning the discriminator circuit. This method is called *visual alignment*.

Visual alignment requires a frequency-modulated signal generator whose output frequency is automatically varied through the required deviation range above and below any selected i-f center frequency, and sometimes above and below any selected carrier frequency as well. The receiver output is observed on an oscilloscope or oscillograph.

Which of the two methods of f-m alignment is employed depends chiefly on the kind of equipment you have available. Of course, either type of signal generator must be capable of furnishing the f-m carrier frequencies and the intermediate frequencies for which the receiver is designed.

All of the steps in either method of alignment are carried out by adjusting the capacitance or inductance in the secondaries and primaries of the several i-f transformers between converter and limiter, and of the discriminator transformer or other tuned circuits between limiter and discriminator, and in the oscillator, r-f, and antenna circuits in the "front end" of the receiver. These alignment adjustments may be trimmer capacitors for varying the capacitance, or may be movable powdered-iron cores for varying the inductance. Whether it is capacitance or inductance that is adjusted makes no difference in the signal input and output connections, measurements, and responses which will be described.

We shall first take up the constant-frequency method of alignment, and later the visual method.

**Output Measurements.**—When using a constant-frequency signal input there are several places at which the resulting receiver output may be measured. During alignment of all circuits between the antenna and the limiter tube we may use either of the arrangements shown by Fig. 2. The circuits thus handled would include the i-f transformers, oscillator, r-f, and antenna.

At the left in Fig. 2 there is connected across the limiter grid resistor a high-resistance voltmeter. This meter may be a d-c moving coil type having a resistance not less than 20,000 ohms per volt, or it may be a vacuum-tube or electronic voltmeter which inherently has very high input impedance. The object is to measure the relative potential drops which occur across the grid resistor with variations in flow of grid current through this resistor. As you have learned, the greater the amplitude of the signal coming to the limiter grid the more grid current will flow. The greater the grid current the greater will be the potential drop across the grid resistor, for this is the grid bias potential for the limiter. As trimmer adjustments bring the preceding circuits more nearly into resonance at the signal generator input frequency there will be increasing grid current and increasing

potential drop in the limiter grid resistor. There will be maximum potential drop and maximum reading on the voltmeter when the circuits are correctly adjusted.

With this method of measurement the resistance or impedance of the voltmeter is in parallel with the grid resistor. Consequently, the resistance in the grid circuit is lowered and the operation of the limiter tube is affected to some extent. If the meter is of the

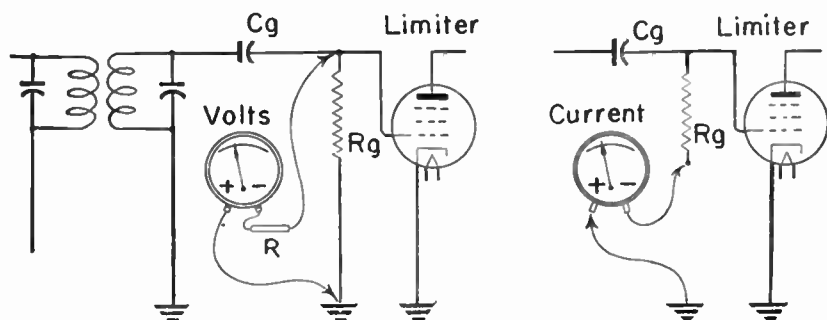

Fig. 2.—Output measurements at the grid resistor of the limiter tube.

electronic type its impedance is so great as to have little effect, but if the meter is a moving coil type we should place in series with the meter the resistor  $R$  of Fig. 2. The greater the resistance of the regular grid resistor the greater should be the resistance used at  $R$ . A common value for  $R$  is in the neighborhood of one-half megohm.

At the right in Fig. 2 is shown a current-indicating meter connected in series with the limiter grid resistor for direct measurement of grid current. The meter may be a microammeter having full-scale reading of 100 microamperes or more, or it may be a one-milliamperere milliammeter. This method of measurement has the advantage of not shunting the grid resistor with a meter resistance, but it requires that the grounded or biasing end of the grid resistor be disconnected and temporarily attached to the negative terminal of the current meter.

If the limiter is not biased by grid rectification, with grid resistor and capacitor, we cannot use the methods of output measurement shown by Fig. 2, and will have to go to the output of the discriminator for all measurements.

Fig. 3 shows how receiver output measurements may be made at the load resistor connections of the discriminator. The method may be used whenever there are two load resistors,  $R_a$  and  $R_b$ , between diodes or other rectifiers, and whether the remainder of the discriminator circuit is as shown here or has some other arrangement.

A high-resistance voltmeter is connected across both load resistors. With one end of one resistor grounded, as usually is the case, one side of the meter may be connected to ground. The other side of the meter is connected to the end of the load resistor whose connection goes through the filter to the volume control and first a-f tube. When the primary and secondary of the discriminator transformer are aligned to the frequency of the signal coming through from the generator, currents and potential drops in the two load resistors will be equal and of opposite polarities.

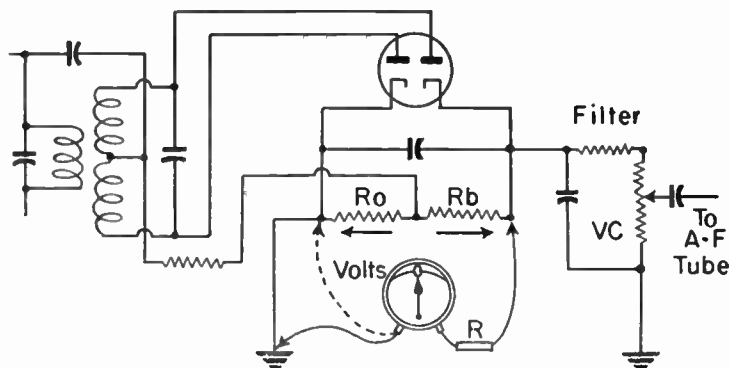

Fig. 3.—Output measurements across the entire load resistance of the discriminator rectifiers.

Then the meter will read zero on its scale. If the generator frequency is "deviated" to a higher or lower value the currents and potential drops in the load resistors will be unbalanced and the meter will read to one side or the other from zero. Time will be saved if the meter is of the zero-center type, with zero at the center of its scale, and positive and negative readings on opposite sides of zero. Otherwise the connections to the meter or to the load resistors may be reversed to get both readings when zero is at one end of the meter scale.



With this testing arrangement it becomes possible to align the discriminator transformer for zero a-f output when there is no deviation from the intermediate center frequency. It is possible also, by deviating the generator frequency equally above and below resonance, to observe the resulting deflections on the meter. The deflections should be equal for equal deviations of frequency within the band of frequencies which should be uniformly amplified. During this check on response to frequency deviation, the meter reading need not be the same for various values of frequency deviation. That is, the reading may be, and doubtless will be, somewhat less for deviations such as 100 kc than for deviations such as 25 or 50 kc. But the meter reading for a 100-kc deviation above resonance should be the same as for a 100-kc deviation below resonance, and likewise should be the same for other high and low deviations which are equal.

Meter connections equivalent to those shown by Fig. 3 may be had other than with the meter leads run directly to the outer ends of the load resistors, or to ground and the a-f output end of one resistor. With the a-f output circuit shown, the meter might be connected between the upper end of the volume control voltage divider  $VC$  and ground, because there is a conductive connection from load resistor  $Rb$  through the filter resistor to the volume control. However, were there a capacitor between  $Rb$  and the top of the volume control, as sometimes happens, the d-c voltmeter would give no indications when connected across the volume control.

The meter connections of Fig. 3 are commonly used for aligning the primary and secondary of the discriminator transformer, but they would not be suitable for aligning circuits preceding this transformer. Fig. 4 shows meter connections which may be used for aligning the preceding circuits. Here the voltmeter is connected across either one of the discriminator load resistors, not across both of them. The usual meter connection would be, as at the left, between the center connection to the resistors and ground. However, as shown in broken lines, the meter may be connected between the a-f output of the discriminator and the center connection to the load resistors.

With the connections of Fig. 4 we will have a meter reading which is of a certain value when the input signal frequency is

the intermediate center frequency. This, as you will realize, is the frequency at which currents and potential drops in the two load resistors should be equal and of opposite polarity—but remember that now we are measuring only one of the potential

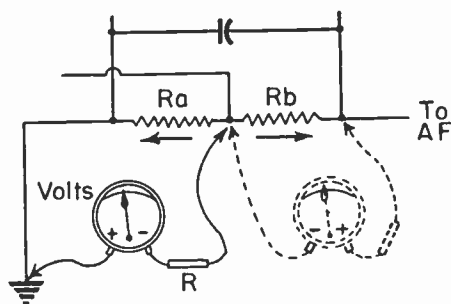

Fig. 4.—Output measurements across either half of the discriminator load resistance.

drops. As the input frequency is made higher or lower than the center value the meter reading will increase or decrease as current in one diode or rectifier circuit increases or decreases with deviation. This is what will happen when we vary the generator frequency.

If we set the generator to deliver the intermediate frequency, and then adjust trimmers in circuits preceding the limiter, the amplitudes delivered through to the discriminator will increase up to the point at which full limiter action occurs, and currents in the discriminator load resistors will increase, as the preceding circuits are aligned closer and closer to resonance at the center frequency. If the input signal is kept weak enough so that the limiter does not function we may use the connections of Fig. 4 for output measurement during alignment of circuits ahead of the limiter.

The meter used in Fig. 4 may be either a moving coil type or an electronic type. To prevent excessive shunting with a moving coil meter the meter should be of the high-resistance type. A half-megohm resistor,  $R$ , may be used in series with the meter with connections of Figs. 3 and 4. The meter should have a range of about 10 volts at full scale, or the 10-volt range should be used with a multi-range meter.

**Signal Generator Connections.** — The low side of the signal

generator output is connected to the receiver chassis ground or to B-minus, just as for alignment procedure with a-m receivers.

For discriminator transformer alignment the dummy antenna in series with the generator high side usually is a capacitor of 0.05 mfd capacitance, although smaller and larger capacitances sometimes are used. The dummy antenna usually is connected to the limiter control grid, although it may be connected to a preceding i-f tube control grid or even to the converter signal grid.

For alignment of the i-f transformers the dummy antenna is the same as used during discriminator alignment. Connection usually is made to the control grid of the tube preceding or feeding the transformer being aligned; working back until the first i-f transformer is aligned with the dummy antenna on the signal grid of the converter. This sequence of connections is shown by Fig. 5. Sometimes connection is made to the converter signal grid for alignment of all i-f stages. Such a connection assumes that there is no serious mis-alignment of any of the following transformers, since such mis-alignment would prevent getting the signal through to the end of the amplification line.

For alignment of oscillator, r-f, and antenna circuit trimmers the dummy antenna usually is a resistor of about 300 ohms resistance, although values from 50 to 500 ohms are used here. The generator, with the dummy antenna in the high-side lead, is connected from the high-side to the f-m antenna post of the

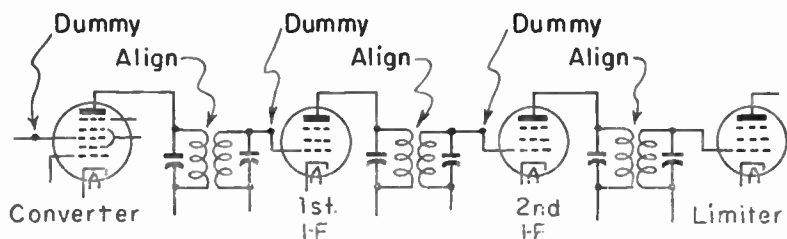

Fig. 5.—Generator connections are made to the control grid of the tube preceding the transformer being aligned.

receiver, with the external antenna disconnected, and from the low side to the ground post or to the chassis ground. If the f-m antenna is a rod on the antenna post, the signal may be radiated from a similar rod or a smaller one on the high side of the generator, with the low side connected to the receiver ground as usual.

To prevent short-circuiting the generator output through any part of a grid circuit not providing parallel resonance at the generator frequency, it may be necessary to remove the original grid connection and re-connect it to the grid through a resistor of a quarter-megohm or greater resistance. This method is explained in the chapter on superheterodyne receivers. If there is any possibility of power line potentials getting from the receiver ground into the generator attenuator, a capacitor of 0.1 mfd

**Discriminator Alignment.**—The usual practice in discriminator transformer alignment is as follows. The signal generator, without modulation, is adjusted to the i-f center frequency of the receiver, and is connected through a dummy antenna to the limiter control grid. The meter for output measurement is connected across half of the discriminator load, as in Fig. 4. The primary trimming adjustment then is made for maximum meter reading. Now the meter is re-connected across the entire discriminator load as in Fig. 3, and the secondary trimmer adjustment is set for zero meter reading.

With another method the meter for output measurement is connected across the entire discriminator load (Fig. 3) for both primary and secondary trimming adjustments. With generator operation and dummy antenna connection as above, the secondary trimming adjustment is set slightly off resonance from the input signal frequency, or is "detuned." Then the primary trimming adjustment is set for maximum meter reading, and finally the secondary trimming adjustment is set for zero meter reading. capacitance should be placed in series with the low side.

The receiver tuning dial should be set where no external signal is heard, and the external antenna may be disconnected. The input signal from the generator should be strong enough to permit easily readable deflections of the meter pointer each side of zero while the secondary trimming adjustment is varied either way from resonance at the generator frequency. The final setting should be made as accurately as possible where the meter reading is zero. With wide variations of trimmer adjustment there may be three points of zero or minimum meter reading; one below resonance, one at resonance, and another above resonance. The reason for this was explained in connection with development of the discriminator characteristic in an earlier chapter.

**I-f Transformer Alignment.**—The signal generator, without modulation, is adjusted to the i-f center frequency of the receiver, and is connected through a dummy antenna to the control grid of the tube preceding the transformer aligned, as in Fig. 5, or is connected to the converter signal grid for the whole process. The meter for output measurement is connected to the limiter grid resistor as in Fig. 2 when the limiter circuit contains such a resistor, or is connected to half of the discriminator load as in Fig. 4.

The secondary and then the primary of each i-f transformer are aligned for maximum meter reading, working backward from the last to the first i-f transformer. The generator output strength is reduced as necessary to maintain only easily readable indications on the meter, except while adjusting the transformer which is in the control grid circuit of the limiter. For this adjustment the generator output should be enough to make the limiter function normally and to cause grid current in the limiter control grid circuit. The receiver dial should be set where no external signals are heard, as is the case for all adjustments with a signal generator input. After all of the i-f transformers have been aligned, the whole process on these transformers should be repeated.

**Oscillator, R-f, and Antenna Circuit Alignment.** — The signal generator, without modulation, is connected through a dummy antenna resistor to the f-m antenna post, or the signal is fed by radiation between rod or wire antennas as previously explained. The meter for output measurement is connected to the limiter grid resistor (Fig. 2) if there is such a resistor, or to half of the discriminator output (Fig. 4). All trimming adjustments are set for maximum reading of the meter.

The generator may be set at a frequency in the center of the received band, as at 98 mc for the 88-108 mc band, for all trimming adjustments. With this method the alignment is checked by finally tuning in generator frequencies near the top and near the bottom of the band while slight readjustments are made if they improve the overall performance.

The receiver tuning dial is set at the generator output frequency during all adjustments. The dial may be rocked through resonance while making the final checks on oscillator and r-f

trimmers. In making the oscillator adjustment nearly equal output readings may be found with two positions of the trimmers. One response is with the oscillator frequency above the signal frequency, the other is with oscillator frequency below the signal. Which adjustment should be used depends on receiver design.

**Oscilloscope for Visual Alignment.** — The cathode-ray tube used in an oscilloscope is of the same general design, and operates according to exactly the same principles, as the picture tube used in television receivers. Such tubes are described in the chapters dealing with television. The essential parts of a cathode-ray tube are shown by Fig. 6. There is an electron gun consisting of an electron-emitting cathode and of several positive-potential anodes which accelerate the electrons leaving the cathode and focus them into a beam having a small diameter where it strikes a screen in the large end of the tube. The screen is fluorescent, so that a small bright spot appears where the beam strikes. Just

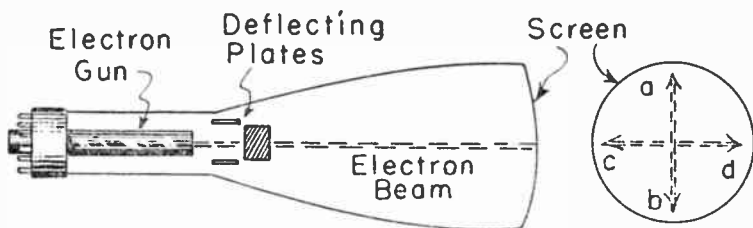

Fig. 6.—The electron beam which is deflected in a cathode-ray tube.

ahead of the electron gun are four deflecting plates arranged in two pairs. When the plates of one pair are made positive and negative with respect to each other, the electron beam is bent toward the positive plate. When the plate polarities reverse, the beam is bent the opposite direction.

Alternating potentials applied between one set of plates will deflect the beam vertically, as between *a* and *b* on the end view of the screen, while alternating potentials on the other pair of plates will deflect the beam horizontally, as between *c* and *d*. During one cycle of applied potential the beam starts from its normal center position, moves all the way up (or to the right), then back through center and all the way down (or to the left), and returns to the center.

Supposing that we apply to the vertical deflecting plates an alternating potential whose positive and negative variations during one cycle cause the beam to rise from the instants represented on the screen circle at the left in Fig. 7 as 1 through 2 to 3, then to drop during instants represented as 3 to 7, and then to return through 8 to the starting point at 1. During this same period of time we shall apply to the horizontal deflecting plates a potential which, were the vertical deflecting potential not present, would cause the beam to travel horizontally, as in the center circle, through the positions represented by instants 1 through 8 and to 1 at the end of the travel. The two deflecting potentials acting simultaneously will deflect the beam through the positions and instants of time numbered from 1 through to 1

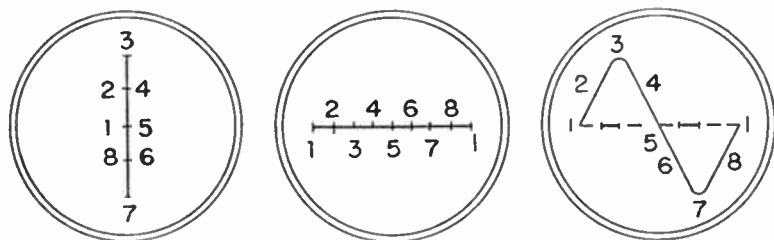

Fig. 7.—Vertical and horizontal deflections combine to trace a curve.

again on the screen circle at the right. That is, by the time the beam is deflected vertically from 1 to 2 at the left, it has been simultaneously deflected horizontally from 1 to 2 at the center, and the result is travel from 1 to 2 on the right. There are simultaneous vertical and horizontal deflections throughout the cycle, and on the screen we see a luminous trace which here follows the familiar pattern of an a-c sine-wave cycle.

If the frequency of the horizontal "sweep" potential from 1 through to 1 on the center circle matches the frequency of the potential applied to the vertical plates, every succeeding cycle of the vertical potential will similarly be traced on the tube screen and we will see a continuing pattern. Every change of waveform in the potential applied to the vertical deflecting plates will appear in the screen trace as a corresponding change in the pattern.

By applying to the vertical deflection system of the oscilloscope

the output from one or more i-f stages of the f-m receiver we will have a screen trace such as at the left in Fig. 8, which shows the receiver output as far as the limiter, in the form of a rather flat-

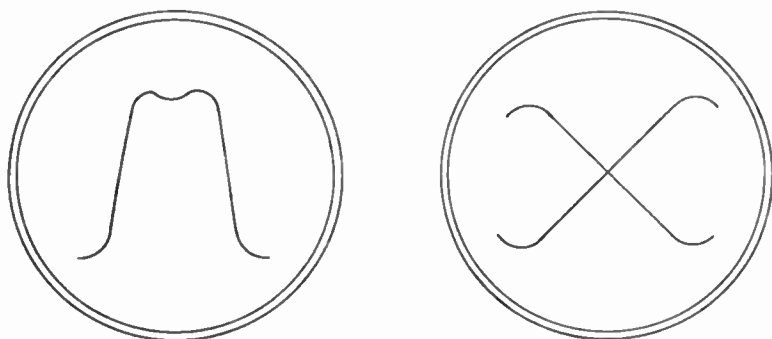

Fig. 8.—An i-f alignment curve (left) and a discriminator alignment curve (right) as seen on the oscilloscope screen.

topped double-hump resonance curve. By applying to the vertical deflection system the output from the discriminator we will have, as at the right, a trace of two discriminator characteristics crossing at or near the center of the screen.

Among the adjustments on the panel of the oscilloscope is one for regulating the "vertical gain." This is set so that the curves on the screen are high enough for easy observation. There is also a control for horizontal width of the curves on the screen. These controls do not alter the waveform, but only the height and width of the trace.

**Generator for Visual Alignment.**—There are two types of frequency-modulated signal generator, in both of which the output frequency is automatically and continually varied or deviated above and below the center value for which the output is adjusted. In one type of generator the frequency swing is brought about by using a reactance tube in much the same way as described in an earlier chapter where such a tube is used at the f-m transmitter. In the other type of generator the output frequency is continually varied by having in the tuned circuit of the oscillator a motor-driven rotating capacitor whose variations of capacitance as the plates are rotated changes the tuning of the oscillator and causes corresponding changes in output frequency.

The rate at which the generator frequency is deviated above



and below the center frequency corresponds to frequency of modulation, and is the equivalent of the audio frequency used for modulation in generators for a-m alignment. This audio-frequency rate of deviation may be 400 cycles per second. This 400-cycle frequency might be secured by suitable speed of a motor-driven capacitor, or it might be produced by a separate oscillator circuit and applied to the control grid of the reactance tube in a generator using such a tube. In such cases the 400-cycle frequency is taken from the signal generator and is fed to the horizontal sweep circuits of the oscilloscope, so that horizontal travel of the electron beam and the spot on the screen will keep time with the rate of deviation of generator output frequency.

A horizontal sweep frequency and signal deviation rate of 60 cycles per second is quite commonly used. If the generator output frequency is deviated at the 60-cycle rate it is possible to use the 60-cycle sweep frequency produced internally in most oscilloscopes, and to synchronize or time the oscilloscope sweep with the frequency deviation of the generator to produce the traces or curves on the screen. In other cases the 60-cycle frequency which controls the deviation in the generator is taken from the generator to the oscilloscope to control and time the sweep frequency.

The signal generator must be capable of delivering a frequency deviation at least as great as, and preferably somewhat greater than, the deviations over which the receiver circuits respond. For example, if the receiver is designed to amplify with fair uniformity a range of frequencies extending to 100 kc above and below the center frequency, then the generator should deliver a deviation of at least 100 kc each way.

**Intermediate-frequency Alignment.**—For alignment of the i-f transformers by the visual method the signal generator connections to the receiver are the same as for the constant-frequency method. That is, the high side of the generator is connected through a dummy capacitor to the control grid of the i-f tube preceding the transformer being aligned. The low side is connected to the receiver chassis. The receiver dial is set to a quiet point, and the external antenna is disconnected.

The vertical input and ground of the oscilloscope are connected across the limiter grid resistor just as the voltmeter is connected during constant-frequency alignment (Fig. 2). In series with

the high side connection is placed a resistor of 0.1 to 0.5 megohm resistance. The generator output for supplying the deviation rate, which usually is either 400 cycles or 60 cycles, is connected to the oscilloscope horizontal input for control of the horizontal sweep, or else the internal sweep of the oscilloscope is synchronized with the rate of deviation in the generator. The vertical gain adjustment of the oscilloscope is set for a curve height which will allow for some increase during alignment of each transformer, and the horizontal gain control is set to spread the curve across the screen.

The secondary and then the primary trimmer on each transformer now is adjusted, working from the limiter back to the converter by shifting the signal generator connection as in Fig. 5.

The adjustments are made to obtain a rather flat-topped curve with the sides similar and opposite, or symmetrical, in shape. The curve should appear somewhat as shown at the left in Fig. 8. Such a curve, more completely developed, was shown in the chapter dealing with f-m receivers. After all transformers have been aligned the whole process should be repeated; again working from the limiter back to the converter. As the curve increases in height during alignment of successive transformers, the generator output may be reduced in strength as necessary.

**Discriminator Alignment.**—For visual alignment of the discriminator transformer the signal generator adjustments and connections to the receiver may remain as at the finish of the i-f alignment; with the generator connected to the converter signal grid.

The vertical input connections of the oscilloscope, still with the 0.1 to 0.5 resistor in series with the high side, are shifted to the discriminator output. The connections would be the same as those for a voltmeter for constant-frequency alignment (Fig. 3). The oscilloscope is connected across both load resistors, or between ground and the high side of the ungrounded load resistor, or possibly between the high side of the volume control and ground. It may be necessary to adjust the vertical gain control of the oscilloscope to keep the curves on the screen.

The transformer primary trimmer now is adjusted to obtain the longest straight portions of the curves shown at the right in Fig. 8, or to obtain maximum vertical deflection on the screen.

It is especially important that the parts of the curves each side of the crossing point be straight. The peaks at the ends of the curves should be symmetrically disposed, which means that the general shapes and overall lengths of both curves should be very nearly alike.

The secondary trimmer now is adjusted to bring the crossing point of the two curves at a mid-point measured vertically on the screen, or midway vertically between the peaks at the ends of the curves. The symmetry or similarity of the curves should be retained. Usually it is necessary to make some slight readjustment of the primary trimmer to straighten the mid-sections of the curves.

When visual alignment is used for the i-f stages and for the discriminator, the oscillator circuits, r-f tuned circuits, and antenna tuned circuits may be aligned by the constant-frequency method as described earlier in this chapter.

With receivers designed for reception of standard broadcast a-m signals as well as f-m signals, the a-m sections of the i-f transformers and also the oscillator, r-f, and antenna circuit alignments are completed before aligning the f-m sections of the i-f transformers and the discriminator transformer. If the receiver handles standard broadcast, short-wave, and f-m signals, the standard broadcast alignments are made first, followed by alignments of the short-wave circuits, and then by the f-m alignments which have been described in this chapter.

#### REVIEW QUESTIONS

1. Why can't the procedures for a-m receiver alignment be used for alignment of f-m receivers?
2. Name two methods for aligning f-m receivers.
3. Describe several circuit connections at which f-m receiver output may be measured, when using a constant frequency signal input for alignment.
4. How are signal generator connections to the various stages in f-m alignment?
5. Describe the procedure for alignment of the discriminator.
6. Describe the procedure for alignment of the i-f transformer.
7. Describe the procedure for alignment of the oscillator, r-f and antenna circuits.
8. Describe two types of f-m signal generators that may be used for visual alignment.

## Chapter 9

### TELEVISION

In radio we have means for reproducing sounds which actually originate at a distance. This is not so difficult, because a sound consists of changes of air pressure which occur one after another, and at any one instant of time there is only one degree of pressure

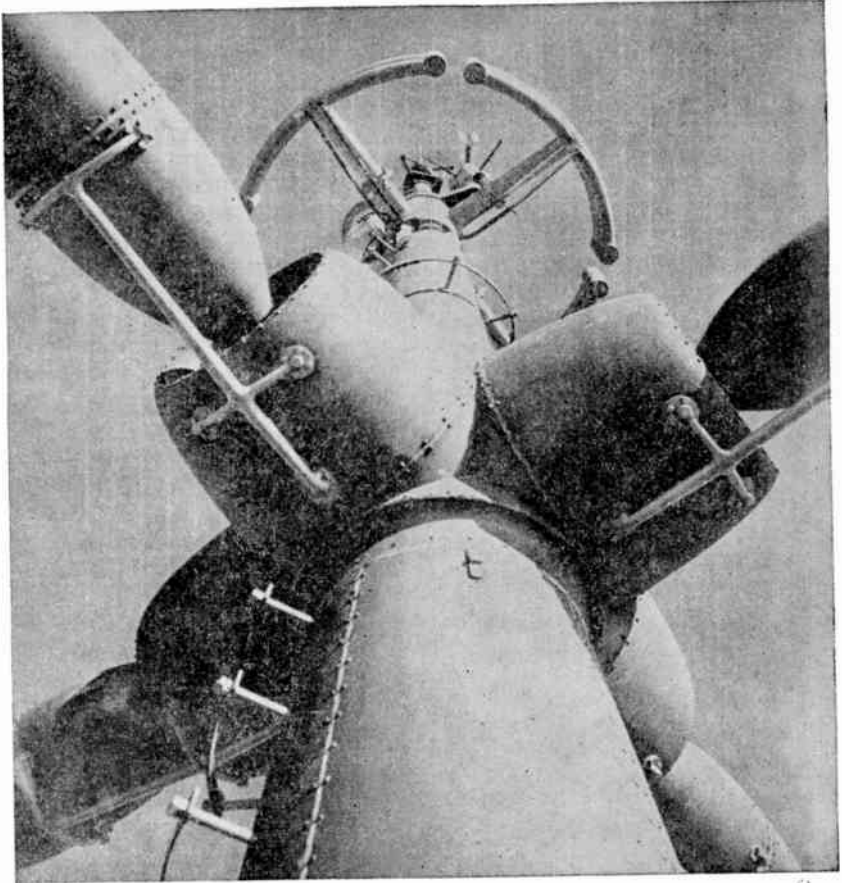

**Fig. 1.**—The television antenna of NBC station WNBT is on top of the tower of the Empire State Building in New York City.

to be reproduced as the changes follow one another in correct order.

But in television we have means for reproducing at a distance from the original scene all of the simultaneous motions of all the people and objects in a scene. We must reproduce continually varying lights and shadows. Brightness decreases at some points while increasing at others, and remaining unchanged at still other points in the scene—all during the same instant of time.

The television signals which are to represent all the simultaneous motions and changes of light are transmitted through space with the same kinds of modulated carrier waves that are used for sound radio. As you know, these modulated waves have either varying amplitudes or varying frequencies, but at any one instant of time and in any one point in space there can exist only one amplitude or only one frequency.

Right here we are confronted with the problem of converting hundreds of variations of light which are occurring simultaneously, and in different degrees, into variations of carrier modulation which must occur one after another, and cannot occur simultaneously. Then, at the television receiver, we must take these carrier variations which come in one after another and put them together so that all of the changes of light and motion in the original scene appear at the same time, in the correct relative positions, and in the correct order.

Television is possible because of a peculiarity of our eyes called "persistence of vision." It means this: When you look at a light, and the light suddenly goes out, you seem to see the light for a period of  $1/30$  to  $1/15$  second after it no longer is there.

If an artist possessing some kind of magic could paint and erase a complete scene within  $1/30$  second, then paint and erase another complete scene in the following  $1/30$  second, and during every succeeding  $1/30$  second, you would not see the scenes as separate but rather as a single continuing picture. Were there gradual changes in the positions of people and objects in the successive scenes, and also gradual changes of light, you would see smooth motion from one place to another, and gradual changes between degrees of brightness. Television provides the magic for doing this.

The original scene with all its movement and light is viewed

through a television camera in which are lenses like those in high-quality still cameras and movie cameras. Fig. 2 pictures a television camera with the housings opened to expose the "works." This is a rear view, showing the lens through which the camera operator watches the scene being televised, much as you might watch a scene through the view finder of your own camera. The photographic taking-lens system is at the front end of the camera.

The taking lens focuses an image of the scene. In a still camera or movie camera the image is focused on the surface of a light-sensitive film which forms the negative after being developed.

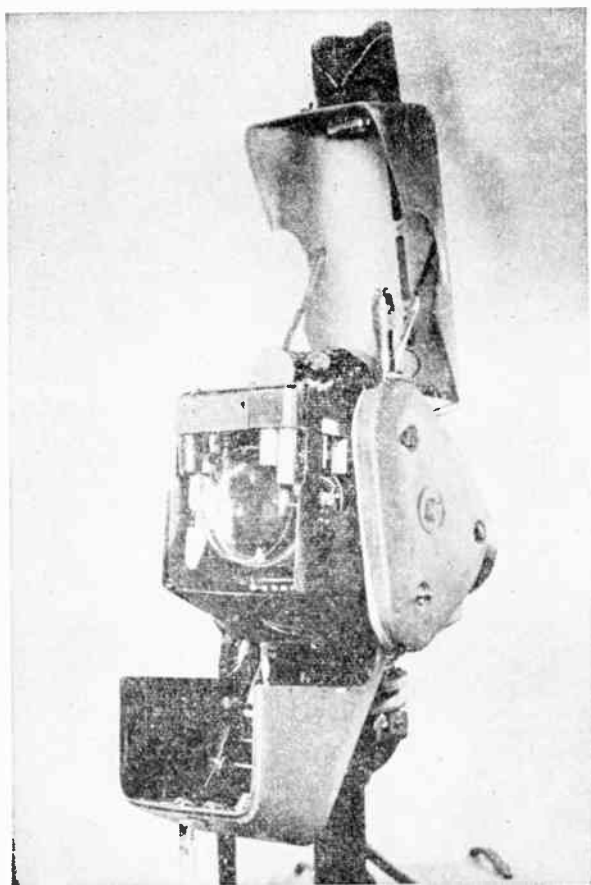

*Fig. 2.—A Balaban and Katz television camera used at station WBKB in Chicago.*

In the television camera the image is focused on the surface of a *mosaic* which is inside the camera tube, as shown in principle by Fig. 3.

The surface of the mosaic which is reached by light is covered with photo-emissive material, which is a material that emits electrons because of energy added to the electrons from the light rays, just as the thermal-emissive surface of the cathode in a

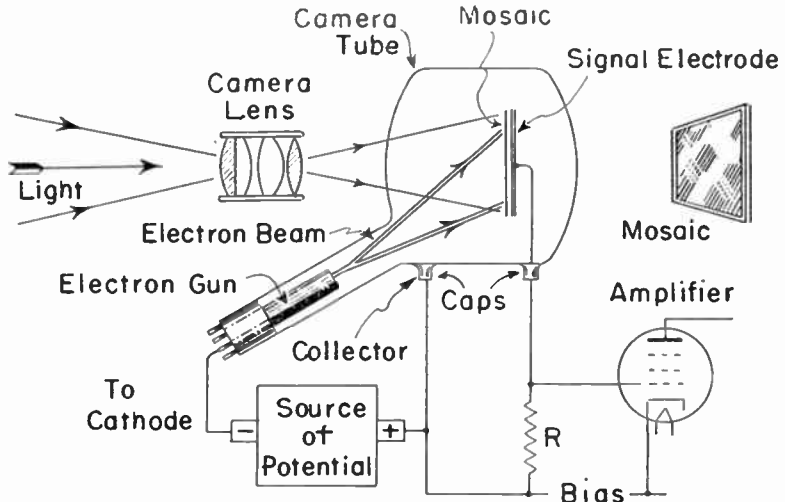

Fig. 3.—The relation of the lens and picture tube in a television camera.

radio tube emits electrons which have gained energy from heat applied to the cathode.

Back of the mosaic, and separated by insulation or dielectric, is a conductive plate called the *signal electrode*. Normally the quantities of electrons, or the electric charges, are balanced on the mosaic and signal plate. When there is an increase of electron emission from the mosaic the charges become unbalanced, and electrons from the signal electrode flow from the signal electrode through its cap on the tube, downward through resistor  $R$ , through the source of potential, and by way of a beam of electrons to the mosaic. When there is a decrease in the rate of electron emission from the mosaic the quantity of electrons on the mosaic is increased by electrons flowing to the mosaic by way of the electron beam. Again the charges on the mosaic and signal electrode become unbalanced, and the excess of electrons on the mosaic flows

through the vacuum inside the tube to the collector electrode (a metallic coating on the inside of the tube) and from the cap of this collector upward through resistor  $R$  and to the signal electrode.

Electron emission from the cathode is increased by more light. Then there is downward electron flow through  $R$ , and the upper end of  $R$ , connected to the control grid of an amplifier tube becomes negative with reference to the bottom. Less light decreases emission from the mosaic, and there is upward electron flow through  $R$  to make the upper end of  $R$  and the amplifier control grid positive with reference to the lower end of  $R$  and the amplifier cathode. Note that more light makes the amplifier

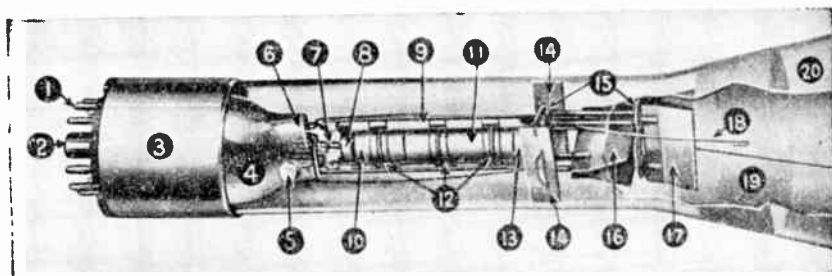

*Fig. 4.—The electron gun in one type of DuMont cathode-ray tube. 1, 2 and 3; base collar, base pins, and locating key. 4, 5 and 6; glass stem, getter for gas removal, and glass press. 7 and 8; heater and cathode. 9; supports. 10; control grid. 11; focusing anode. 12; supporting collars. 13; accelerating anode. 14 and 15; supports. 16 and 17; plates for deflecting electron beam. 18 and 19; static shield and connection. 20; glass envelope of tube.*

grid relatively negative, and decreases amplifier plate current, while less light makes the grid relatively positive, and increases the amplifier plate current. Amplifier output varies oppositely to changes of light.

In talking about the camera and the camera tube we have gotten somewhat ahead of our story, for we have not yet discovered how the simultaneous changes of light in the focused image are converted to successive changes of signal modulation. This conversion process begins with the action called scanning.

**Scanning the Image.**—The electron beam represented in the camera tube of Fig. 3 issues from a part called the electron gun which is inside of a tubular extension on the lower left-hand side



of the tube. The electron gun is a device for emitting electrons from a heated cathode, for forming the stream of emitted electrons into a narrow beam, and for accelerating the beam electrons to a very high velocity so that they may travel away from the end of the gun and, in the present case, to the mosaic.

Fig. 4 shows the parts of an electron gun, numbers 7 to 13 inclusive, and toward the right additional plates, 16 and 17, which are used for bending or deflecting the beam away from the straight course it is following when leaving the gun.

How the deflection plates are used is shown by Fig. 5. The electrons in the beam are negative. They are attracted toward any positive charge, and are repelled from any negative charge. If, as in diagram A, we make the upper plate of a pair negative with reference to the lower plate of the same pair, or make the

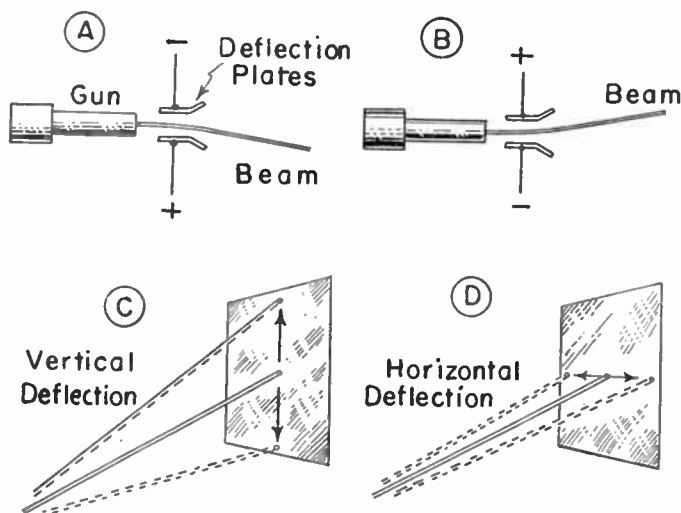

Fig. 5.—How the electron beam is bent by electrostatic charges on deflection plates.

lower one positive with reference to the upper one, the electrons in the beam will be attracted toward the lower plate, repelled from the upper plate, and the beam will be bent or deflected downward during its travel through the electric field which is between the plates. If the relative polarities of the deflection plates are reversed, as at B, the beam will be deflected upward from its original straight path. By varying the potential differ-

ence between the plates, or by varying the strengths of their charges, the beam may be caused to travel up and down on the mosaic or on any other surface, as in diagram *C*.

Now look again at diagrams *A* and *B*, but imagine that you are looking straight down on the gun and on a second pair of plates; the original pair and this second pair being arranged as are the pairs 16 and 17 in Fig. 4. By varying the potential difference or the charges for this second pair of plates the beam may be deflected toward the right or left, sideways. This second pair of plates will cause the beam to move as in diagram *D*.

By varying the potentials on the vertical deflection plates we may bring the end of the beam to the top of its travel, and by suitable variation on the horizontal deflection plates we may, at the same time, bring it all the way to the left. Then, looking at the surface of the mosaic or any other surface struck by the beam, the end will be in position 1 of diagram *A* in Fig. 6. If the polarity then is reversed on the horizontal deflection plates the end of the beam will be moved across the surface to position 2. Another reversal, bringing us back to the original polarity, will move the end of the beam to position 3, and the next reversal will move it to 4, and so on.

While the potentials on the horizontal deflection plates are being reversed with great rapidity, the potentials on the vertical deflection plates are going through a much slower change, so

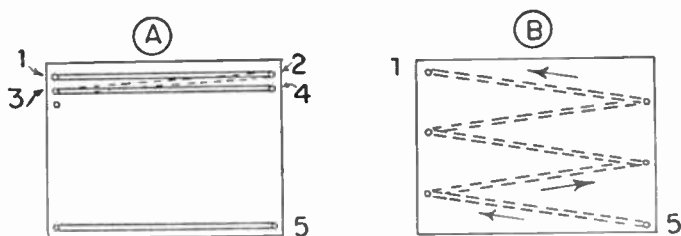

Fig. 6.—How an area is scanned by deflecting the beam sideways and downward.

that the beam gradually moves downward while flying back and forth from side to side, until the end of the beam reaches position 5.

Now we shall continue the reversals of potential on the horizontal deflection plates while rather quickly varying the potentials on the vertical plates to bring the end of the beam back to

position 1. This upward travel is shown by diagram B. Then the whole process may be repeated, over and over again.

The end of the beam has reached for the briefest moment every minute area on the surface it strikes. The separation between adjacent "lines", such as 1-2 and 3-4, and the diameter of the beam are so related that there are no gaps between adjacent lines. Actually, the beam exists only during the active lines, which are those traced from left to right during the gradual downward travel. During *horizontal retraces*, as from 2 to 3, and during the *vertical retrace*, from 5 back to 1, the electron flow from the cathode of the electron gun is stopped, although the reversals of deflection potentials continue.

During the instant in which the end of the beam reaches one small area on the mosaic we have the action described in connection with Fig. 3 and in resistor  $R$  of that diagram there is electron flow proportional to the light on the tiny area then being struck by the beam, and in a direction that corresponds to whether the light is brighter or less bright than during the travel of the beam over the preceding small area in the image. Thus we have in resistor  $R$  and in the output of the amplifier tube, changes of electron flow and potential difference that correspond not only to the absolute values of light on each area of the image, but also to whether the light is more or less than on adjacent areas. The changes of electron flow and potential, which form the *video signal*, follow one another in the same order that the end of the electron beam travels across each minute element or area in the image. This is the process of scanning the image, and of forming the video signal.

**The Picture Tube.**—Now we shall go all the way to the other end of the television system, where is reproduced a moving picture of the moving image being scanned in the camera tube. The picture is reproduced on the screen of a picture tube. In the picture tube is an electron gun like the gun in the camera tube, and there is an electron beam like the beam in the camera tube. But instead of the mosaic of the camera tube we have in one end of the picture tube a coating of phosphors, which are substances that glow brightly when struck by the end of an electron beam.

A side view and a front-end view of a picture tube are shown by Fig. 7. In the neck of the tube are the electron gun and the

deflecting plates, horizontal and vertical. The opposite end of the tube is of large diameter and nearly flat over much of its area. On the inside of this large end are coated the phosphors. Wherever the electron beam strikes the inside of the screen surface the phosphors glow with a nearly white light. The intensity or the degree of brightness varies almost directly with

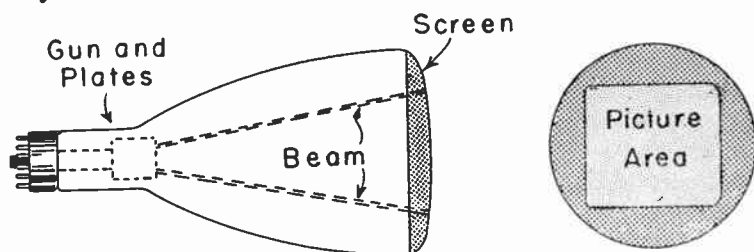

Fig. 7.—A typical picture tube.

the rate of electron flow through the beam to the coated screen.

The electron beam in the picture tube is made to scan the picture area of the screen just as the beam in the camera tube scans the area of the mosaic. The deflections of the two beams are precisely timed or synchronized. When the camera tube beam is at position 1 of Fig. 6 the picture tube beam is at the exactly corresponding position on the screen, and throughout all the travels of the camera tube beam the picture tube beam follows exactly in timing and in position. When the camera tube beam is stopped, which we call *blanking*, during the horizontal and vertical retraces, the picture tube beam is blanked during exactly the same periods.

Then it is necessary only to vary the rate of electron flow in the picture tube beam to correspond with the degrees of light and shadow on the image in the camera tube in order to reproduce on the picture tube screen the same changes of light that are occurring in the scene being viewed by the camera.

**Deflection and Focusing.**—In Fig. 5 we examined the method of deflecting the electron beam by means of potential differences or charges on pairs of plates. This is called *electrostatic deflection*. Another method, called magnetic or *electro-magnetic deflection*, is in common use. The principle is illustrated in Fig. 8. At the left are two electromagnets placed one above the other with their center lines or axes passing through the line followed by

the beam when the beam is not deflected. When current flows in the magnet coils, and a magnetic field is produced in the space between the poles, the electron beam tries to get out of the field in a sidewise direction. Whether the beam is deflected one way or the other depends on the direction of magnetic field and of coil current. Reversing the direction of current flow reverses the direction of deflection.

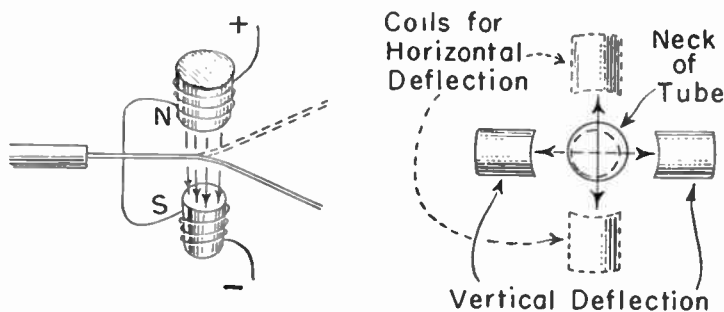

Fig. 8.—The principle of magnetic or electromagnetic deflection.

By placing four magnetic coils around the neck of the tube as at the right in Fig. 8, with the axes of two coils vertical and of the other two horizontal, we may deflect the beam both horizontally and vertically for scanning. The pair of coils whose axes are vertical cause horizontal deflection, and the pair whose axes are horizontal cause vertical deflection.

Fig. 9 shows the elements which make up the electron gun in a typical tube. The electrons which are emitted from the heated cathode pass first through an opening in the control grid. This grid acts similarly to the control grid of any radio tube. The more negative the grid with reference to the cathode the less is the rate of emission. A grid sufficiently negative will stop the beam completely. This is the way that blanking is accomplished during the retrace periods.

Electrons which have passed through the control grid go through openings in the focusing anode, whose potential may be two or three hundred volts higher than that of the cathode, then through the accelerating anode, whose potential may be 1,000 to 1,500 volts higher than that of the cathode. The high potentials on the anodes accelerate the electrons to high velocity.

The electrons tend to spread out into an ever widening beam

because of mutual repulsions between their negative charges. The potential difference between the two anodes produces a strong electric field between them. Curvature of the lines of force in this field is such that electrons passing through are turned back toward the axis or center of the beam. With correct relative potentials on the two anodes the electrons come to a sharp focus at the surface of the screen in a picture tube, or the mosaic in a camera tube. Focusing is necessary in order that the glowing spot may be small enough to produce a sharply defined picture.

The method of focusing shown by Fig. 9 is called electric or

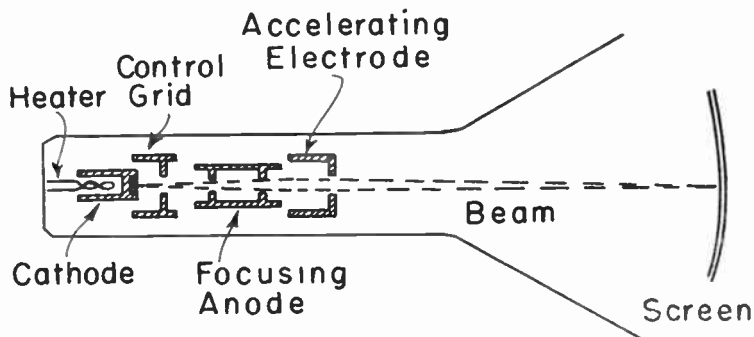

Fig. 9.—Electrostatic focusing of the electron beam in a picture tube.

*electrostatic focusing.* Many picture tubes do not have electrostatic focusing, but focus the electron beam by means of magnetic fields. For *magnetic focusing* we use a coil of many turns, which is slipped over the neck of the tube as shown in Fig. 10. Inside the neck would be the heated cathode, a control grid, and usually one accelerating anode for pulling electrons through the grid and giving them a start toward the screen. As the electron stream from this internal gun structure passes through the magnetic field of the focusing coil, the combination of the forward velocity of the electrons and the magnetic force which tends to rotate them around their line of travel gives the electrons a spiral motion. When current in the focusing coil is correctly related to potentials on the anodes, the spiral motion brings all of the electrons to the small small area or spot where they strike the screen.

The generally used types of picture tubes may be designed (1)

for electrostatic deflection and electrostatic focusing, (2) for magnetic deflection and electrostatic focusing, or (3) for magnetic deflection and magnetic focusing.

**Television Frequencies.**—We examined the basic principle of scanning in Fig. 6. In actual practice the electron beam makes two complete traverses from top to bottom in covering the entire

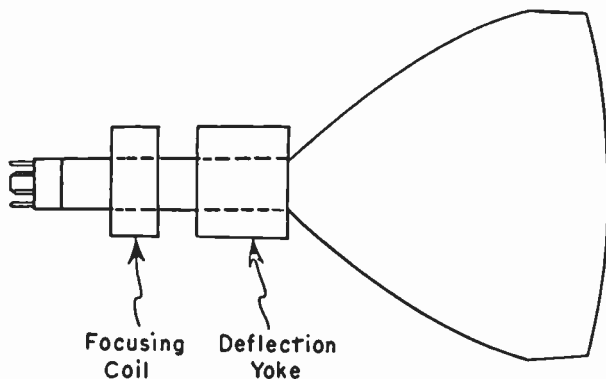

Fig. 10.—Position of the coil for magnetic focusing of the electron beam.

area of the picture. As shown in Fig. 11, the beam starts at position 1, in the upper left-hand corner of the picture area, traces an active (illuminated) line from 1 to 2, makes a blanked retrace from 2 to 3, another active line from 3 to 4, and continues thus to the lower right-hand corner. Active lines 1-2, 3-4, and those following are not close together, but between each pair is a space equal to the width of one line which is not covered by the beam. This first downward travel is called the first *field*.

The vertical retrace now brings the beam or the spot to point 6 on the right-hand diagram. This point is half way across the picture area, as is also the end of the final active line in the first field, at point 5. The last active trace in the first field, and the first one in the second field, are half lines. The second field is scanned from 6 to 7, from 8 to 9, and so on until the beam reaches the lower right-hand corner of the picture area at 10. The following vertical retrace brings the beam back to position 1 for the following field, which again is a first field.

Active line 8-9 of the second field is midway between active lines 1-2 and 3-4 of the first field, and all other active lines in one field are midway between those in the other field. The entire area

is covered by the beam or spot during the two fields. Two fields make up what is called one *frame*. This method of scanning is called *interlaced scanning*.

According to one standard of practice there are 525 active lines per frame. Other numbers of lines have been used, and may be used, but we shall use the 525-line standard for our examples to illustrate the principles involved.

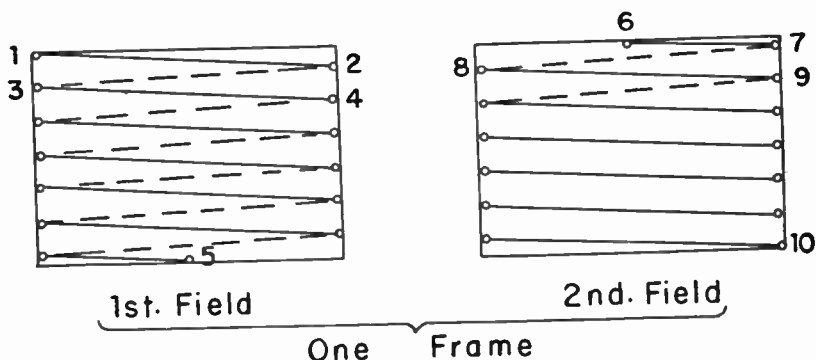

Fig. 11.—Two fields make up one frame with interlaced scanning.

With 525 lines, the picture, regardless of its actual height in inches, is divided into 525 narrow horizontal strips during scanning. Any two areas which differ in degree of illumination, and which are separated by not less than  $1/525$  of the picture height, will be clearly defined and distinguished from each other. If we pick out any one of these horizontal lines, which really are narrow strips of the picture, the illumination along the line will vary between light and dark as various parts of the image are scanned. Each change from light to dark and back to light causes one cycle of potential and current in the video signal.

There would be no object in being able to distinguish changes of illumination in a horizontal direction which are closer together than those which are separated in the vertical direction. Then in a horizontal distance equal to the vertical height we need distinguish no more than 525 changes of illumination.

The standard ratio of width to height for television pictures is  $4/3$ , or four units (inches or anything else) in width and three equal units in height. With this ratio, which is called the *aspect ratio*, we will have  $4/3$  times 525 elementary areas across the



width of the picture, which equals 700 areas or changes of illumination per line.

With 525 lines and 700 elementary areas per line we will have  $525 \times 700$ , or 367,500 possible changes of illumination per frame. With 30 frames per second, which is standard for television, the number of changes of illumination per second may be  $367,500 \times 30$ , or a total of 11,025,000. It takes two changes to cause one cycle in the video signal; changes of white to black and back again, or of black to white and back again. Then the maximum video frequency for 525 lines and 30 frames will be 5,512,500 cycles per second, which is a frequency of more than five and one-half megacycles. Actually we do not need quite so much horizontal as vertical definition in the picture, but even so we shall have a video frequency of four megacycles for good definition.

The television carrier must have a frequency considerably greater than that of the video signal, for otherwise there would not be enough carrier waves for each change of modulation. The result of this requirement is that much television broadcasting is carried out with carrier frequencies ranging from 44 to 88 megacycles, while additional broadcasting and other television services use carrier frequencies up to more than 200 megacycles.

In the broadcasting of amplitude-modulated waves there are transmitted at any one instant the carrier frequency and two other frequencies which are higher and lower by the amount of the audio-frequency modulation used during this instant. Thus the range of frequencies transmitted and the channel width of the transmission are equal to twice the modulation frequency. Were this practice followed in television, and were the maximum video frequency to be four megacycles, each television channel would occupy eight megacycles. In addition there would have to be additional channel width for the sound which accompanies the television signals, and for at least some space between adjacent channels for different stations. Frequency distribution would be somewhat as shown at the top in Fig. 12.

Referring to the upper diagram of Fig. 12, to permit good reproduction up to a video frequency of 4 megacycles the lower and upper sidebands would have to be each about 4.5 megacycles wide. The sound channel would be 4.5 megacycles above the television carrier, and above the sound channel would have to

be a small "guard band" to avoid interference with other stations in the adjacent television channel. The whole television channel for one station would have to be about 9.25 megacycles in extent.

To avoid occupying such a great range of frequencies only a portion of the lower side band is transmitted, as shown by the lower diagram, in Fig. 12. This method is satisfactory because the modulation for a lower side band is the same as for the accompanying upper side band, except for having opposite po-

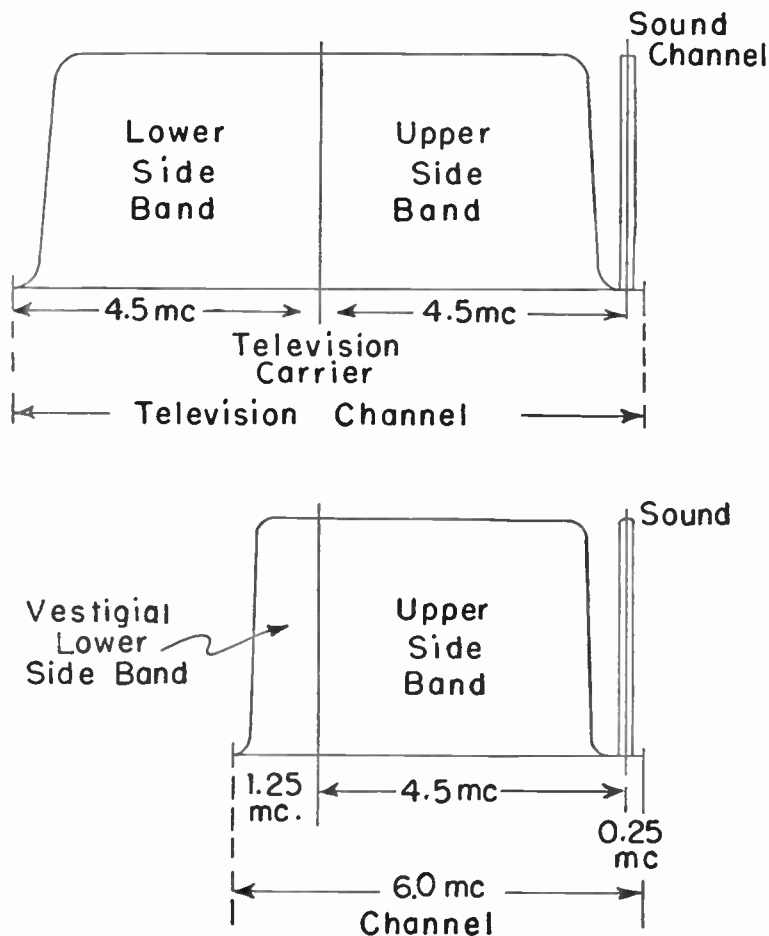

Fig. 12.—Television channel widths for double sideband transmission (top) and for vestigial sideband transmission (bottom).

larity, and either side band will transmit the modulation signal. The remaining *vestigial* lower side band is 1.25 mc wide. The upper side band may extend all the way to the sound channel, which is 4.5 mc above the television carrier frequency, and then 0.25 mc is allowed for prevention of interference. Thus the entire television channel becomes only 6.0 mc wide.

The sound signal which accompanies the television is transmitted by means of frequency modulation, and the sound section of the television receiver is of the f-m type. The television signal is transmitted by means of amplitude modulation and the portion of the receiver which reproduces the picture operates on the principles suited to amplitude modulation.

**Television Signal.**—It has been explained that the electron beam in the picture tube and the electron beam in the camera tube must do the same things at the same instants. The two beams must remain in step with each other, or they must be perfectly synchronized with each other. All parts or circuits which have to do especially with synchronizing or synchronization are specified as “synch” parts or circuits. The abbreviation *synch* is pronounced like *sink*.

Let's see what the television signal has to do in transmitting both the picture signal and the synch signals.

1. The picture signal or video signal consists of rapid variations of modulation which represent changes of light and shadow in the image. This part of the signal must show two features. First, it must show relative changes between light and dark, as showing some one thing twice as light or half as light as something else. Second, it must show the absolute level of light. For example, one object might be twice as light as another one in a daytime scene, and one might be twice as light as another in a night-time scene. But the whole level of general illumination would have to be shown as brighter for the daylight scene, and darker for the night-time scene. The first requirement is one of *contrast* between objects. The second is of general illumination or of background *brightness*.

Three successive lines of a video signal are shown by Fig. 13. You will recall that in the output of the camera tube we had less potential with brighter light, and more potential with dimmer light. Consequently, in the signal we have the minimum amplitude

as representing white and greater amplitudes as representing progressively darker shades. At 75 per cent of the maximum amplitude we have black, and all greater amplitudes leave the picture black. Amplitudes between 75 and 100 per cent of maximum are used for synchronizing while the picture is black, which means while the beam is blanked. Signal variations on line 1 are

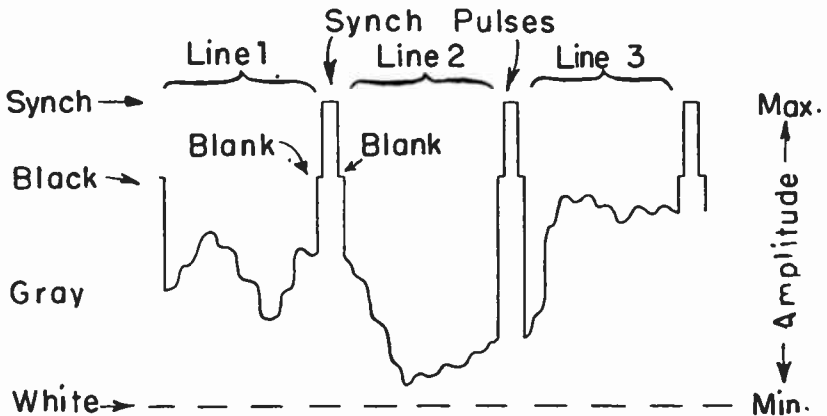

Fig. 13.—Three successive lines of a video signal, showing changes of amplitude which correspond to the modulation.

confined to the middle grays. Those in line 2 range toward white, indicating a light background. Those in line 3 run toward the black, indicating a dark background.

2. At the end of every horizontal line the beam must be blanked by bringing the signal amplitude to the black level.

3. While the beam is blanked, the potentials controlling travel of the beam must reverse to bring the beam into correct position for starting the next line. This is done by means of brief (horizontal) synch pulses in which amplitude rises to maximum, and which occur during each horizontal blanking period.

4. Each line begins when the blanking interval ends with a drop in amplitude, and ends when the blanking interval commences with a rise of amplitude.

5. Upon completion of all the lines, horizontal blanking periods, and horizontal synch pulses for one field the beam must be blanked during the vertical retrace by bringing the signal amplitude to the black level.

6. During the vertical blanking there must be produced a synch pulse which brings the beam to the top of the picture area. This vertical synch pulse must be of different form from the horizontal synch pulse, so that the receiving apparatus may distinguish them apart.

7. As was shown in Fig. 11, every alternate field must start on a half line, and fields between must start with a full line.

All of the synchronizing pulses or signals originally are produced at the television transmitter in parts composing the synch generator of Fig. 14. These pulses go to the camera for controlling its beam. The video signal from the camera goes to amplifying and modulating apparatus where it is combined with synch pulses from the generator to form the modulation for the television signal. The modulation is combined in high-frequency amplifying

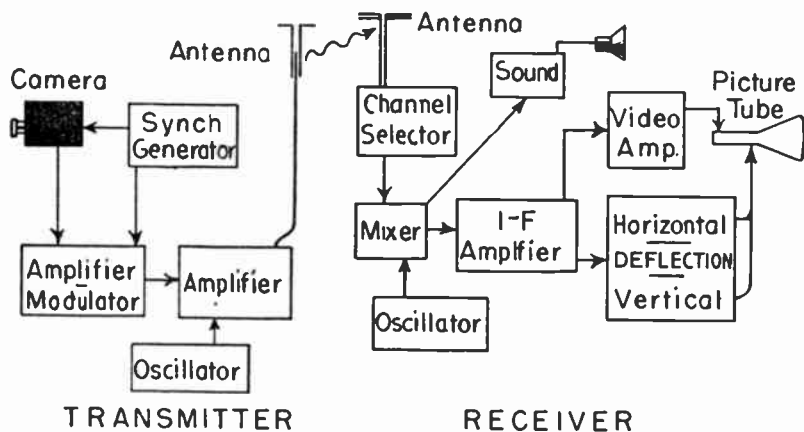

Fig. 14.—Relations between the principal parts at the television transmitter and at a receiver.

apparatus with high-frequencies from the oscillator, and the complete modulated signal goes to the transmitting antenna. There is separate apparatus and a separate antenna for transmitting the accompanying sound.

The television and sound signals go through space to the antenna of the receiver represented at the right in Fig. 14. Channel selector circuits are tuned to the television channel to be received. Then the signal goes to the superheterodyne mixer and is combined with a frequency from the oscillator to produce a

sound-signal intermediate frequency which goes to the sound amplifying and reproducing system, and at the same time a television intermediate frequency which goes through the television i-f amplifier and a following detector. The i-f signal is separated into a video (picture) portion that goes through the video amplifier to the control grid of the picture tube, and into a synchronizing portion that goes through the horizontal and vertical deflection systems of the receiver and to the deflecting elements for the picture tube. Note that the same synch signals that control the camera tube are carried with the signal all the way through to the picture tube.

**Television Transmission.**—Television carrier frequencies are in the same general range as those used for frequency modulation; extending both below and above the f-m range. Consequently, in television we have the same general behavior of the waves, which act much like light waves. Reception is limited to distances (transmitter to receiver) between which might be extended a practically straight line without having the line cut below the horizon at any point.

Reflection of television waves causes more trouble than reflection of sound-modulated waves, as will be seen from the example in Fig. 15. Here we have a wave-reflecting surface 1,000 feet from the receiving antenna, and on the side opposite the transmitter. Radio waves, regardless of their frequency, travel at about 186,000 miles per second, which means about one one-billionth of a second per foot of travel. The reflected wave will have traveled 2,000 feet farther than the direct wave when both reach the antenna, so the reflected signal will arrive about one half-millionth of a second later than the direct signal.

The spot formed by the end of the electron beam travels across the width of the picture in about 54 millionths of a second (0.000054 second) during one active line. If the reflected signal is a half-millionth of a second (0.0000005 second) behind the direct signal there will be two pictures separated on the screen by about 1/100 of the screen width. The weaker picture which is due to reflection is called a "ghost." On a screen area 8 inches wide the separation would be about 1/12 inch between the outlines of the regular picture and the ghost. The greater the distance between the receiving antenna and the reflecting surface, the

greater will be the time delay and the farther the two outlines will be separated in the reproduction.

In the reproduction of sound from a high-frequency carrier the matter of reflection is relatively unimportant. The time delay in any reflection distance which would permit a noticeable extra signal would be so short in comparison with audio-frequency time periods as to have no appreciable effect.

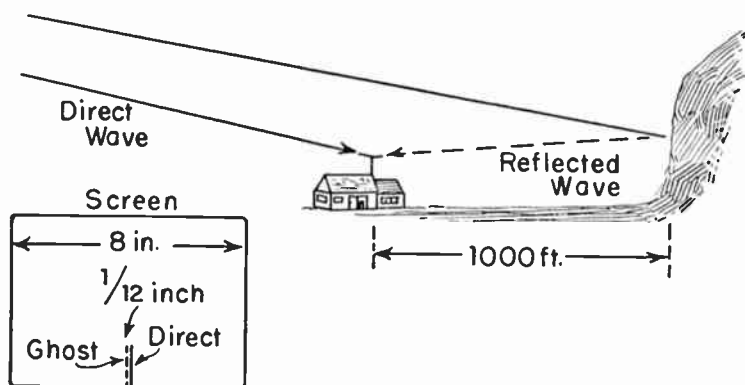

Fig. 15.—Ghost images in the reproduced picture may result from reflected waves.

**Receiving Antennas.**—Television receiving antennas are of the half-wave dipole type or some modified form of this general type, such as described in connection with f-m reception. Transmission lines are run with twisted pair, with parallel conductors, or with coaxial cables, all depending on how efficient the transmission line must be to avoid excessive loss between antenna and receiver.

The following list gives overall lengths for the dipole conductors which are equal to half-wavelengths in various television channels. In actual practice the dipole length usually is made about five or six per cent less than a half-wavelength.

Frequency	Half-wavelength
44 to 50 megacycles	130 inches
54 to 60 megacycles	170 inches
60 to 66 megacycles	96 inches
66 to 72 megacycles	88 inches
76 to 82 megacycles	76 inches
82 to 88 megacycles	71 inches

It is apparent from the list of half-wavelengths that there would be a great difference between the overall lengths of dipoles ideally suited for reception in the lower and higher channels. If a plain straight dipole antenna is made of a length best suited for reception at 60 megacycles, as an example, its effectiveness at the lowest and highest frequencies for the channels listed will be down around 40 per cent.

To permit satisfactory reception in any of a number of channels with the same antenna there are used many modified forms of the basic dipole structure. Any of these modified forms will have maximum effectiveness in some one rather narrow range of frequencies, but with many of them the effectiveness in channels throughout the whole listed range may remain at 70 per cent or more of the maximum. Compared with normal varia-

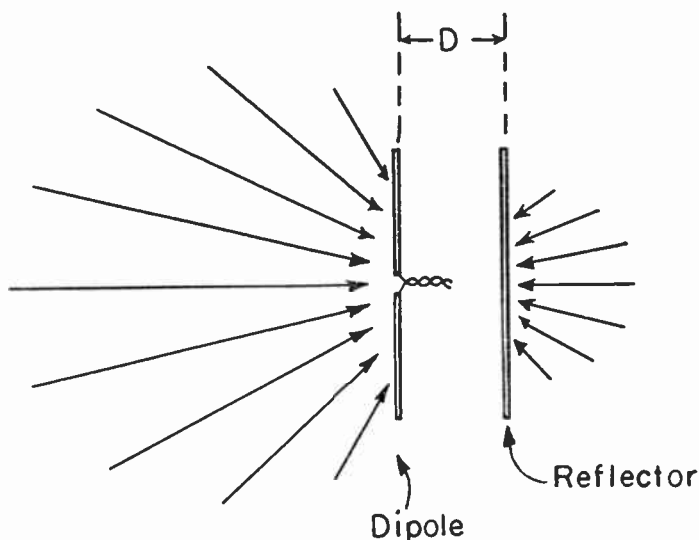

Fig. 16.—A reflector used with a dipole antenna.

tions of signal strength or field strength due to atmospheric and other causes this is not a great variation, and such antennas serve satisfactorily within the regular service ranges of television stations.

To reduce the effect of reflected waves, also of any other interference, coming chiefly from a direction about opposite to that



from which come the desired waves a reflector may be placed on one side of the dipole antenna as in Fig. 16. The reflector consists of a straight continuous conductor as long or a little longer than the overall length of the dipole, and spaced from the dipole by a distance  $D$  which is best determined by experiment, but usually is equal to between one-quarter and one-half the overall length of the dipole. The reflector is supported with insulation, and is not grounded or otherwise connected to anything else.

The relative pickup effectiveness for signals coming from various directions is shown approximately by the lengths of the arrows in Fig. 16. There is little pickup of signals from the reflector side. Use of a reflector increases the signal strength in the dipole antenna by 25 per cent or more over the response when no reflector is used. With modified forms of dipoles the reflector may be of the same shape as the antenna conductors, or may be only a straight rod or wire.

The television antenna should be erected as high above the earth and all surrounding objects as is practicable. The antenna should be rotated, and sometimes tilted, to obtain the best reception from desired stations, with minimum interference. This usually requires trying various positions and locations while signals are being received and reproduced. In cities and in all built-up sections the position and location of the antenna are all-important in securing satisfactory reception.

#### REVIEW QUESTIONS

1. What do you understand by the expression "persistence of vision"?
2. In a general way and with the use of Figs. 3-4-5-6 describe the process of scanning the image and of forming the video signal.
3. Describe how a moving picture of a moving image is reproduced on the screen of a picture tube.
4. Explain the methods used for deflecting and focusing the electron beam.
5. In a television receiver what kind of modulation is used for the sound section; for the picture section?
6. Describe what the television signal must do in transmitting both the picture signal and the synch signals.
7. How does the reflection of television waves compare with the reflection of radio sound-modulated waves?
8. Describe television receiving antennas. How is the undesirable effect of reflected waves reduced?

## Chapter 10

### TELEVISION RECEIVERS

Compared with any type of sound receiver the television receiver is a highly complicated piece of apparatus. This is true, partly, because the television receiver includes most of the parts for a f-m sound receiver in addition to those for picture reproduction. Television receivers may contain from fifteen to more than twenty tubes. In the television portion of the receiver we encounter nearly all of the principles employed in sound receivers, and in addition find many new principles never used in sound reproduction systems.

Fig. 2 shows the travel of the television and sound signals

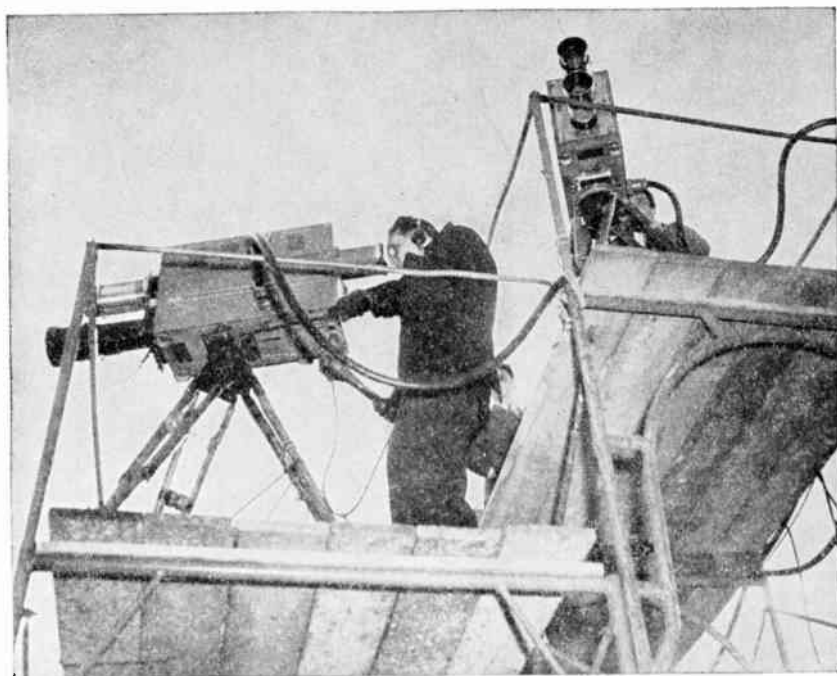

*Fig. 1.—NBC portable cameras televising a Navy Day parade.*

from antenna to picture tube and loud speaker in a typical television receiver. It will be well to briefly consider the purposes of the different parts before taking up their action in more detail.

1. The channel selector consists of a number of circuits, each permanently tuned for one 6-megacycle television channel, and arranged so that any one of these circuits may be switched into connection between the antenna and following mixer. The arrangement is similar to that used for band-switching of short-wave stations in a multi-band sound receiver.

2. The mixer is similar to the mixer which might be used in any superheterodyne receiver, but may be a separate tube rather than the combination converter type such as used in sound receivers.

3. The oscillator, when a separate tube, may be of any type which operates satisfactorily at the high frequencies used in television.

4. The mixer produces two intermediate frequencies, one for television and another for sound. These two intermediates must be separated so that one may go to the television i-f amplifier and the other to the sound i-f amplifier. Separation may be accomplished with or without a tube.

5. The sound i-f amplifier is of the high-frequency broad-band type such as used for any frequency-modulation amplifier.

6. The limiter and discriminator are of the same types used with any other f-m system.

7. The audio-frequency amplifier and loud speaker are of standard types for sound reproduction systems.

8. The television intermediate-frequency amplifier must handle with good uniformity a frequency range covering as much as four or more megacycles, so must be broadly tuned. Broad tuning means low gain per stage, and so we find more i-f stages in the television system than in a sound system where the band is narrower and the gain per stage may be much greater.

9. The automatic gain control (agc) system serves the same general purpose as the avc control in a sound amplifier.

10. The i-f amplifier amplifies a high-frequency a-c signal modulated with both the picture and the synch pulses. This combination signal is rectified in the detector to produce a direct current carrying both picture and synch pulse variations.

11. Now the video or picture portion of the rectified signal may be separated from the synch pulses, either with or without the use of a tube or tubes.

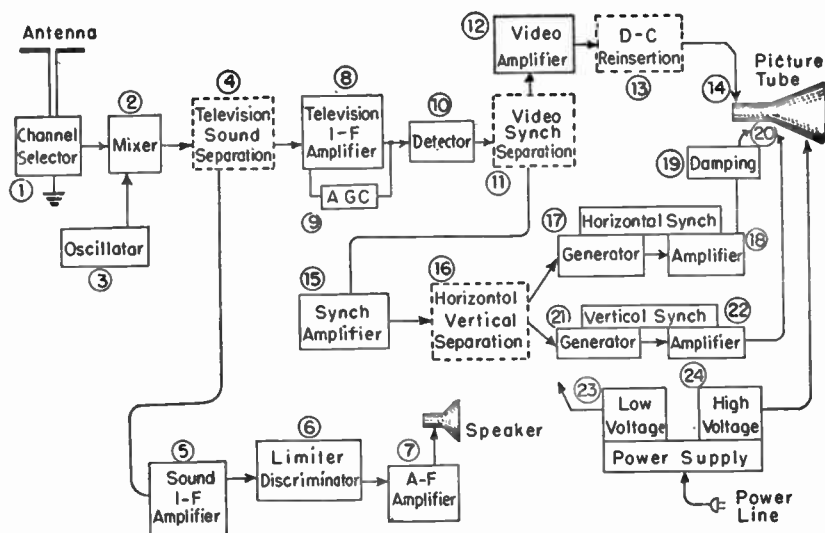

Fig. 2.—Paths followed by various signals through principal parts of a television receiver.

12. The video amplifier, usually a resistance-capacitance coupled stage or stages, is especially designed to uniformly amplify the picture or video signal whose range of frequencies may extend to four or more megacycles.

13. Now we come to circuits, which may or may not use tubes, which provide "D-c reinsertion" or "D-c restoration." This means that the picture signals are given such average amplitude that they correctly represent the average brightness or background brightness of the scene as well as representing the degrees of contrast between lighter and darker parts of the image. We speak of *d-c* reinsertion because the resistance-capacitance coupled video amplifier passes only a-c signal potentials, and it is the restored or reinserted d-c component of the original signal that determines the average brightness of the reproduced picture.

14. The signal which has come through the video amplifier and d-c restorer is applied to the control grid of the picture tube

to regulate the rate of electron flow in the beam and the instant-to-instant brightness of the spot that travels over the screen. If the video and synch signals were not separated at point 11 in the diagram, and if both came through the video amplifying system, the separation is made at the control grid of the picture tube by means to be explained later.

15. The synch amplifier is designed for efficient amplification of the synch signals, whose frequency is much lower than the maximum frequency of the video signals. If video and synch signals were not separated at point 11, and if both come to the synch amplifier, the amplifier is arranged to amplify the synch pulses while not amplifying the video or picture variations.

16. Now the horizontal synch pulses and the vertical synch pulses are separated from each other, either with or without the use of a tube or tubes.

17. The horizontal synchronizing pulses are applied to the horizontal synch generator. This generator is a low-frequency type of oscillator whose operating frequency is adjusted to be just a little slower than the frequency of the horizontal synch signals. Each of these incoming signals then "triggers" the oscillator so that it goes through one cycle, with the cycles occurring at the frequency of the synch signals. That is, the synch signals operate the oscillator just before it would operate due to the characteristics of its own circuit, and thus bring it into time with the synch signals. The potential changes in the output of the horizontal generator are of such form as will move the picture tube beam horizontally during the active lines and the horizontal retraces between lines.

18. The output of the synch generator is amplified and is delivered to the deflection elements of the picture tube as voltage changes for electrostatic deflection or as current changes for magnetic deflection.

19. With magnetic deflection the moderately high frequencies for horizontal motion of the beam may result in oscillations in a resonant circuit formed by the inductance of the horizontal deflecting coils and the distributed capacitances in the coil circuit. Such oscillations are almost instantly stopped, or are damped out, by the damping circuit, which may or may not contain a tube. This circuit is not found with electrostatic deflection systems.

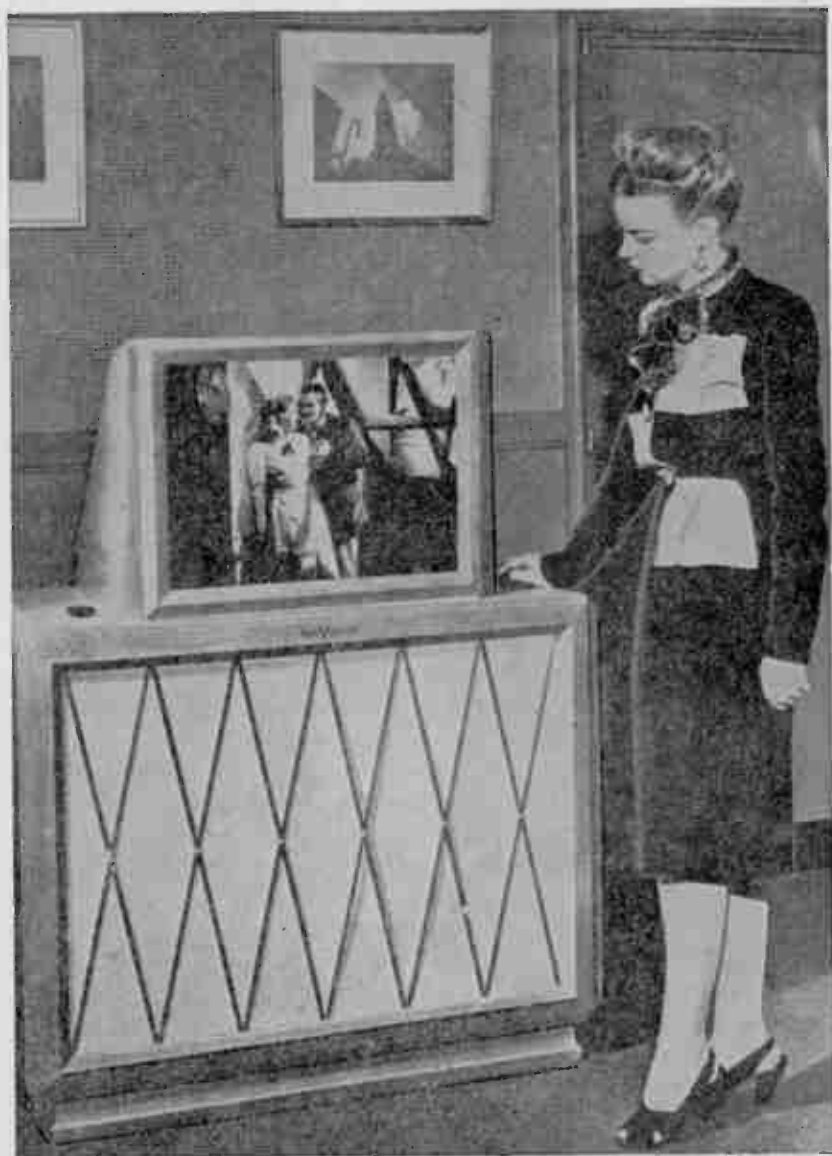

*Fig. 3.—An RCA Victor television receiver with which images from the picture tube are projected through a lens and mirror system to form a reproduction 18 inches high and 24 inches wide.*

20. The amplified horizontal synch potentials or currents are delivered to the horizontal deflection elements at the picture tube.

21 and 22. The vertical synch generator and amplifier are generally similar to the horizontal synch generator and amplifier, but are designed to operate at the lower frequency needed for vertical deflection of the picture tube beam. The amplifier output is delivered to the vertical deflection elements (20) at the picture tube.

23. There is a low-voltage power supply, usually containing one or more full-wave rectifier tubes, which furnishes plate, screen grid, and control grid biasing potentials and currents for the amplifiers, mixer, oscillator, and detector, also for low-voltage elements in the picture tube.

24. There is a separate high-voltage power supply, usually containing one or more high-voltage low-current rectifiers of the half-wave type. This supply furnishes the high voltages required for the accelerating anodes in the picture tube.

**Antenna, Mixer, and Oscillator.**—Fig. 4 shows one method of coupling and connections for the antenna and channel selector, the tuned control grid circuit of the mixer tube, and the tuned circuits of the oscillator tube. Connections are shown for four channels with four sets of coils. For fewer channels or for more channels it would simply require fewer sets or more sets of coils with connections similar to those shown.

The channel selector switch has four sections. Section *A* connects any one of the upper coils into the mixer grid circuit. Each coil is individually tuned by an adjustable core which is correctly set during alignment of the receiver for one of the channels to be received. Sections *B* and *C* of the selector switch connect the dipole antenna to the two ends of any one of four antenna coils which are inductively coupled to the grid coils up above. Section *D* of the selector switch connects any one of the lower set of coils into the tuned plate circuit of the oscillator. Each oscillator coil is individually aligned for its channel by an adjustable core. The oscillator coils are represented as inductively coupled to the coils in the grid circuit of the mixer, thus introducing the oscillator frequency into the mixer. Various other methods of coupling might be used between oscillator and mixer.

The mixer tube is a high-frequency voltage amplifying pentode,

connected to the coil circuit through capacitor  $C_c$ , and biased through resistor  $R_g$ . The output of the mixer goes to the intermediate-frequency amplifiers for television and sound.

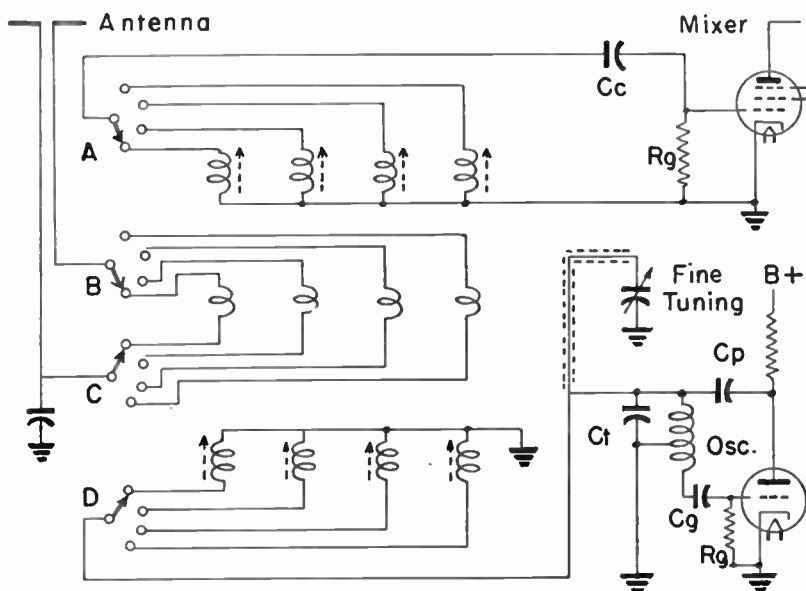

Fig. 4.—A channel selector system having tuned circuits for mixer and oscillator.

The oscillator tube is a triode which is biased by grid rectification with capacitor  $C_g$  and resistor  $R_g$ . Feedback from plate to grid is through the upper and lower sections of the coil common to both circuits, with the plate connection to this coil through capacitor  $C_p$ . The plate section of the coil is tuned by capacitor  $C_t$ , which might be adjustable for initial alignment.

The adjustable capacitor marked *Fine Tuning* is brought out onto the control panel of the receiver, and is manually variable by the operator. It is in parallel with tuning capacitor  $C_t$  and the oscillator coils in the band selector system, and is used during tuning to bring the oscillator circuits into exact resonance at the frequency required for best reception in the channel for which the selector is set. This is the operator's tuning control for use after a channel has been selected. The lead to this panel control is shielded, as shown in the diagram.



Various other oscillator circuits may be used instead of the tuned plate variety shown in Fig. 4. Modified Hartley oscillators are in general use. In a Hartley oscillator both parts of the coil or coils in the plate-grid circuit are tuned by a single capacitor. Instead of the adjustable coil cores for variable inductance alignment this tuning function may be handled with adjustable trimmer capacitors across the tuned coils, or both an adjustable core and a trimmer capacitor may be used for the same coil.

**Separation of Video and Sound.** — It is standard practice to operate the oscillator at a frequency just eight megacycles higher than the high limit of the channel being received. For example, when reception is to be in the 66-72 mc channel the oscillator frequency will be 80 mc, which is 8 mc higher than 72 mc. In this channel the video carrier will be, as in any other channel, 1.25 mc above the low limit of the band, and will be at a frequency of 67.25 mc. As in all channels, the sound carrier will be 4.50 mc higher than the video carrier, and here will be 71.75 mc. The differences between the oscillator frequency and these carriers will be the intermediate frequencies, as follows:

Oscillator frequency .....	93.85 mc
Television carrier .....	67.25 mc
<hr/>	
Television intermediate .....	26.60 mc
Oscillator frequency .....	93.85 mc
Sound carrier .....	71.75 mc
<hr/>	
Sound intermediate .....	22.10 mc

With the sound carrier 4.50 megacycles above the television carrier, the sound intermediate frequency will be 4.50 megacycles below the television intermediate. The mixer output may be fed to any of a variety of different filter systems which will effectively separate the two intermediate frequencies, with the filter outputs going to the two intermediate-frequency amplifiers.

In some receivers the mixer output goes through the primary circuits of two i-f double-tuned transformers as shown by Fig. 5. The upper primary circuit is tuned for the television i-f band, for which its parallel resonant arrangement has high impedance to cause transfer of the television frequencies into the tuned secondary circuit. Here there is relatively small impedance for the

sound i-f band, whose frequencies go through to the primary of the lower tuned transformer which has high impedance in the sound-frequency band. The tuned secondaries of the transformers are connected respectively into the control grid circuits of the first television i-f amplifier tube and of the first sound i-f amplifier tube.

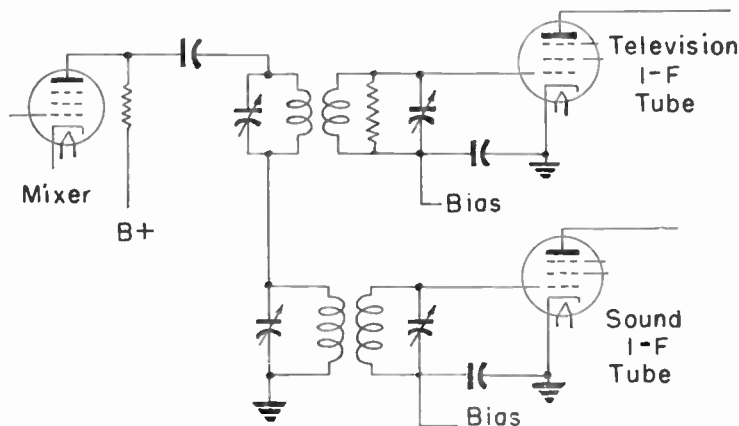

Fig. 5.—I-f transformers for television and for sound, with the primaries in series.

**Wide-band Tuning.**—All of the tuned circuits which handle the video signal and the synch signals must have good response throughout a band of frequencies running from as low as 30 cycles up to 4,000,000 cycles or more. Wide-band coverage may be attained to a considerable degree in a double-tuned coupling transformer by using close coupling, but too close coupling brings about two distinct resonance peaks. The peaks may be widened and flattened by adding resistance anywhere in one or both of two tuned and coupled circuits. In the secondary of the television i-f transformer of Fig. 5 there is a resistor across the tuned circuit, placed there to broaden the frequency response. Such resistors have values usually between 1,000 and 25,000 ohms. They may be across only the secondary, or across both primary and secondary circuits.

**Wave Traps.**—The intentional broadness of tuning which permits coverage of a wide frequency band by the television i-f

amplifier means that the tuned circuits are less able to prevent amplification of nearby interfering frequencies than as though the i-f circuits could be more sharply tuned. The broad-band tuned circuits are inherently rather non-selective. To help get rid of interfering frequencies which are especially troublesome we resort to the use of various types of wave trap circuits. These are varieties of filter circuits which either reject or bypass the interference frequencies, or which may do both.

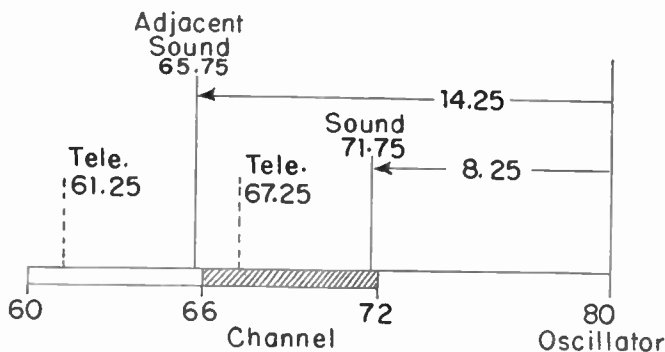

Fig. 6.—How interfering frequencies result from beating of oscillator and carrier frequencies.

There are two troublesome frequencies. One is the sound intermediate frequency of 8.25 mc, which may be referred to as the "associated sound" frequency. The other interference results from the sound carrier frequency in the channel next below the one in which there is reception, this sound carrier being called the "adjacent sound." What happens is shown by Fig. 6 for reception in the 66-72 mc channel when the oscillator frequency is 80 mc. The difference between the oscillator frequency and that of the sound carrier in the same channel is 8.25 mc. Between the oscillator frequency and the sound carrier in the next lower channel (which is 65.75 mc) the difference is 14.25 mc. This 14.25 mc is the second of the two interfering frequencies to be reduced in strength.

Three commonly used trap circuits are shown in Fig. 7. At *A* is a series resonant trap connected between the plate circuit of the first tube and ground. At *B* is a parallel resonant trap con-

nected in series with the control grid of the second tube. At *C* is a parallel resonant trap which is inductively coupled to one or both of the windings in the tuned coupling transformer, and is connected to ground. The trap capacitors are adjusted so that the circuit is resonant at the frequency to be reduced; either 8.25 or 14.25 megacycles. The type of trap at *A* provides a low impedance path to ground for the unwanted frequency. The type at *B* pro-

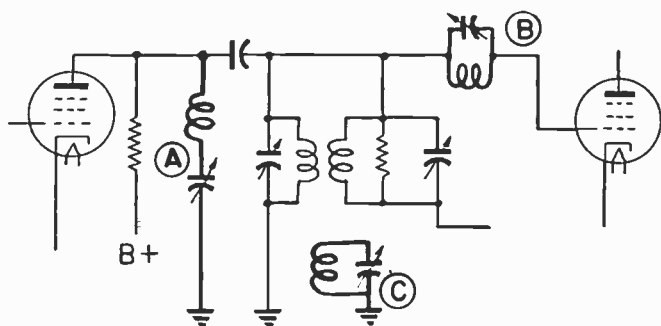

Fig. 7.—Same wave trap circuits, and points at which they may be used.

vides a high impedance that greatly retards passage of the unwanted frequency. The type at *C* absorbs energy at the unwanted frequency, and dissipates this energy to ground.

Traps are used in the mixer circuits and in the first, or first and second, i-f stages. Usually there will be one trap tuned to 14.25 mc, and either one or two traps tuned to 8.25 mc. Trap circuits are of sharply tunable construction, since it is desired to eliminate only a rather narrow band of frequencies.

**Receiver Attenuation.**—Previously it was mentioned that only part of the lower sideband frequencies are transmitted in the picture signal. This is shown at the left in Fig. 8, where the ideal lower sideband extends to  $-1.25$  mc below the carrier frequency, and where the complete upper sideband extends almost to  $+4.5$  mc above the carrier. It is evident that all of the modulation frequencies between  $-1.25$  mc and  $+1.25$  mc (with reference to the carrier) are transmitted in both lower and upper sidebands, and consequently have double the strength of the modulation frequencies which are between  $+1.25$  and  $+4.5$  mc. Unless

correction were made at the receiver, the lower modulation frequencies, up to 1.25 mc, would be reproduced with too much strength.

Correction is made at the receiver by adjusting the i-f amplifier for television to have a response such as shown at the right in Fig. 8. There is 50 per cent attenuation, leaving 50 per cent of

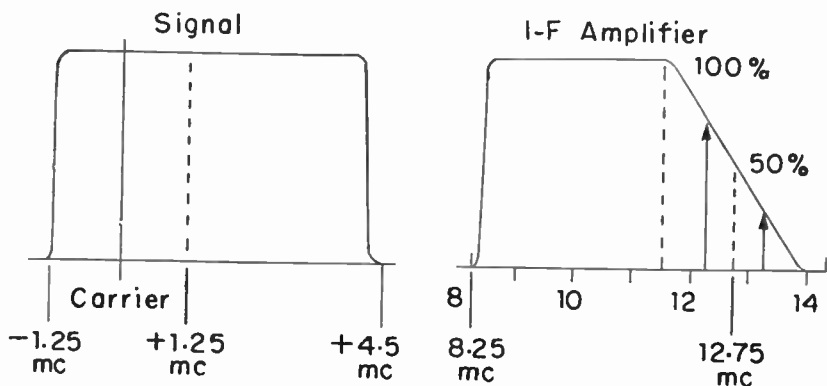

Fig. 8.—Ideal distribution of field strength in the modulated carrier (left), and ideal response of the i-f amplifier (right).

maximum signal strength, at the intermediate frequency of 12.75 mc, which corresponds to the carrier in the original signal. There is 100 per cent response at a frequency 1.25 mc below the intermediate frequency, and zero response at 1.25 mc above the intermediate. Then any modulation frequencies which are equally below and above the intermediate will get part of their total strength from below the intermediate and the remainder from above. The sum of these two strengths always will be equal to 100 per cent. This is apparent from the lengths of the two arrows, which are equally below and above the intermediate. Their combined length is equal to the distance from the base line to the 100 per cent line at the top of the graph.

Since, as just explained, all frequencies within 1.25 mc of the intermediate have combined strengths equal to 100 per cent, and since all those more than 1.25 mc below the intermediate have strengths of 100 per cent, all of the modulation frequencies come

through the i-f amplifier with equal strengths in spite of the partial lower sideband in the signal.

**The Detector.**—In the detector circuits which follow the television i-f amplifier we find a rather wide variety of designs, although all of the detector tubes are diode types, sometimes with only the diode elements and again with a triode or pentode amplifier in the same envelope.

Fig. 9 shows a circuit containing a double-diode tube used as a full-wave detector. The detector plates connect to the two ends of the last tuned transformer in the i-f amplifier. The center tap

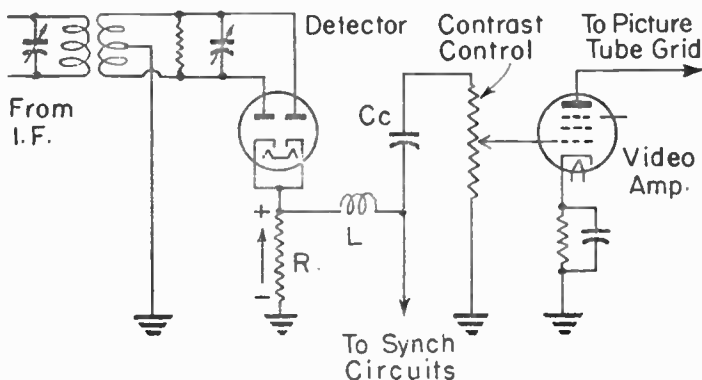

Fig. 9.—A full-wave diode detector circuit.

of the transformer secondary connects to ground, and by way of ground to the detector cathodes through detector load resistor  $R$ . The rectified direct or one-way electron flow in  $R$  is upward toward the cathodes, as indicated by an arrow. The relatively high intermediate frequencies which appear in the load resistor are kept out of following circuits by high-frequency choke coil  $L$ . Part of the detector output potential, which contains both picture and synchronizing signals, goes to the synch circuits from the right-hand end of the choke.

The remainder of the detector output potential, still containing both picture and synchronizing signals, goes through coupling capacitor  $C_c$  to the voltage divider resistor marked *Contrast Control* and to ground. The potentials going through  $C_c$  are, of course, only the alternating component which carries the modula-

tion. Movement of the slider on the contrast control increases or decreases the signal potential changes applied to the control grid of the video amplifier tube. More grid input results in an increased plate circuit output of the signal amplitudes, and then there is a greater difference between high and low amplitudes which represent the various degrees of brightness in the picture image. Thus there is increased contrast between light and dark.

The output of the video amplifier goes to the control grid circuit of the picture tube. There are many arrangements of detector and video amplifier other than the one shown by Fig. 9, but all of them accomplish essentially the same ends. Control of contrast or gain may be effected in the i-f amplifier instead of in the video amplifier, by providing a manual adjustment for control grid bias of one or more i-f tubes and possibly of the mixer also. However, with automatic gain control applied in the i-f amplifier, it is common practice to place the manual contrast control in the detector output and video amplifier sections.

**Phase Inversion.** — Whenever a signal goes through an amplifying tube the phase or relative polarities in the signal are

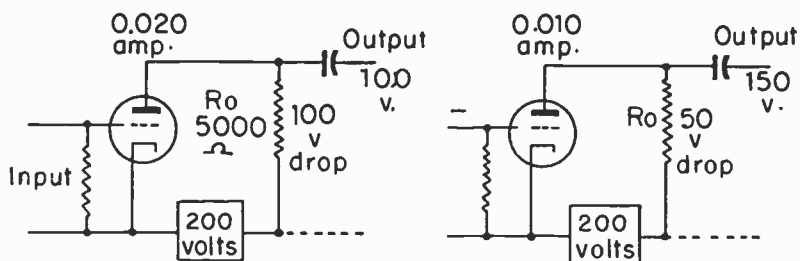
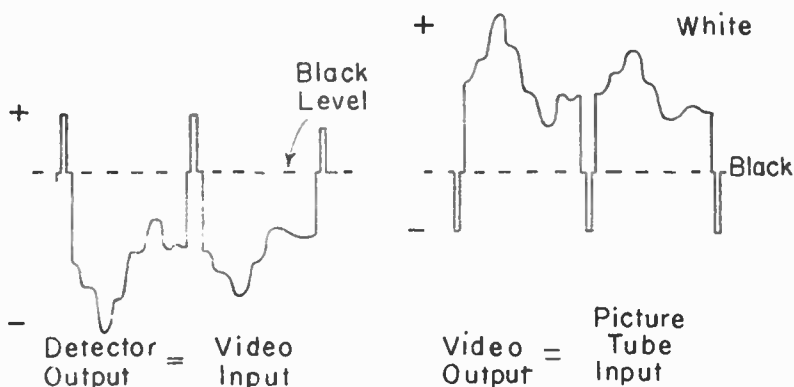

Fig. 10.—How phase inversion occurs in an amplifying stage.

inverted. The reason is shown in Fig. 10. At the left is a tube whose grid potential is assumed to be such that the plate current is 20 milliamperes or 0.020 ampere. This plate current flows in plate load resistor  $R_0$  whose resistance is 5,000 ohms. The potential drop in  $R_0$  must be 100 volts. The plate supply potential difference is shown as 200 volts. With 100 volts drop in  $R_0$  the potential at the top of  $R_0$ , and at the output of the amplifier stage, must be the remaining 100 volts.

At the right the grid potential has been made more negative, or the input has been reduced, and the plate current has dropped to 0.010 ampere. Now the drop in  $R_o$  is only 50 volts, and the potential at the top of  $R_o$  and at the output is the difference between the supply potential and the drop in  $R_o$ , which makes the output 150 volts. So, making the control grid more negative has made the output more positive. This happens with any type of amplifier tube, triode or otherwise. Making the grid less negative, or more positive, would increase the plate current, increase the potential drop in  $R_o$ , and would make the output less positive.



**Fig. 11.**—Phase inversion makes the picture signal positive, with maximum amplitude corresponding to white.

Now let's see why phase inversion is important in television amplifiers. At the left in Fig. 11 is shown the rectified output of the detector tube, the output which appears across resistor  $R$  of Fig. 9. This output has the waveform of the positive side of the i-f modulation, since it is only the positive amplitudes from the i-f amplifier which cause electron flow in the diode rectifier. This output waveform is applied to the control grid of the video amplifier. The sync pulses cause the grid to become positive, or less negative, and the picture signal causes the grid to become negative, or more negative.

At the output of the video amplifier the signal is inverted, and appears as at the right in Fig. 11. Now the picture signal has positive polarity, with reference to the black level, while the



synch pulses have negative polarity. This is the signal waveform that goes to the control grid of the picture tube. Now the white level has been made more positive than the black level, whereas in the original signal the white level was more negative than the black level. With our inverted signal, increasingly positive amplitudes applied to the picture tube grid will increase the rate of electron flow in the beam and will make the spot on the screen brighter, while the less positive amplitudes will decrease the beam electron flow and make the spot darker—all of which is just what we want in order to have a picture with correct relations between lights and shadows, or with the same relations as in the scene being televised by the camera.

With the detector output polarity secured in Fig. 9 we may have one video stage and we come to the picture tube grid with the signal right side up, or we might have three stages for a double inversion. If we wish to have only two video amplifying stages we must have a detector output which is the reverse of that in Fig. 9. This can be done by placing the detector load resistor in the diode plate circuit rather than in the cathode circuit. Then we would have a right side up signal from the detector, it would become upside down after the first video stage, and right side up after the second video stage.

**Picture Tube Beam Control.** — To reproduce on the picture tube screen the variations of brightness which compose the picture, while eliminating the synch pulses, it is necessary only to apply to the picture tube control grid the signal potentials shown at the right in Fig. 11, and to observe one highly important provision. The provision is that the signal voltage corresponding to the black level must be made to coincide with the picture tube grid voltage that causes cutoff of beam current, and must be held there at all times.

What we wish to accomplish is shown by Fig. 12. Here we have a curve showing the relations between beam current and control grid voltage in a typical picture tube. Maximum permissible beam current occurs with the control grid at zero volts, with reference to the picture tube cathode, because the grid must not be allowed to go positive. Beam current and spot brightness decrease as the control grid is made more negative, until, at  $-45$  grid volts, the beam current becomes zero or is cut off.

At the left in Fig. 12 is shown the signal for the last active line from the right-hand diagram of Fig. 11, together with the preceding and following horizontal blanking periods and sync pulses. As applied to the control grid of the picture tube the black level of the signal must make the control grid 45 volts negative. The highest or most positive peak of our picture signal then will

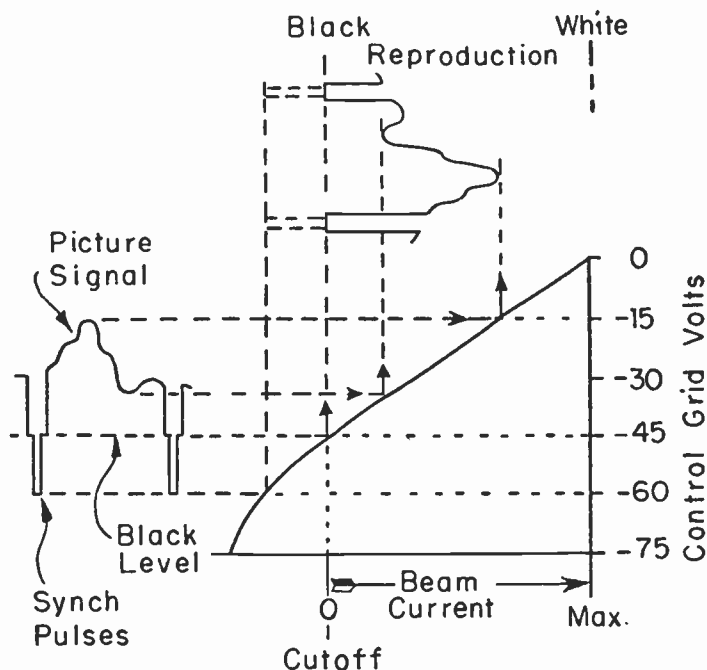

Fig. 12.—Biasing the picture tube control grid for beam cutoff at the black level of the signal eliminates the sync pulses.

make the control grid less negative, and will bring the grid potential to 15 volts negative to cause an increase of beam current and a bright spot on the screen. The various signal potentials are carried as broken lines to the curve on the graph, and from the curve are carried upward as broken lines to the variations of beam current shown up above.

At the beginning of the line the beam current starts from zero, on the black level or blanking level, then varies to produce changes

of light and shadow on the screen, and at the end of the line drops back to zero on the black level for blanking. The synch pulses of the incoming signal, which are below the black level, change the picture tube control grid voltage from 45 to 60 volts negative. But any grid potential more negative than 45 volts keeps the beam cut off, and so the synch pulses have no effect on beam current and do not appear in the reproduced picture.

**Brightness Control.**—If the black level of the signal is not held at the picture tube grid voltage for beam cutoff we get into difficulties. If the black level of the signal makes the control grid less negative than for beam cutoff, parts of the synch pulses will cause flow of beam current and the pulses will appear in the picture. If the black level makes the control grid more negative than required for cutoff the entire picture signal will make the control grid more negative than it should be, the beam current will be too small during the whole picture, and the picture will appear too dark or will have a darker background than in the original scene being televised.

The potentials of the incoming signal, including the black level potential, may be brought into any desired relationship with the grid potential of the picture tube by varying the control grid bias of the picture tube. It is just the same as varying the control grid bias of any amplifier tube in order to make an applied signal vary the control grid potentials above and below whatever bias potential is used.

The elementary principle of one method of applying variable control grid bias to the picture tube is shown by Fig. 13. A d-c power supply furnishes a potential difference of 300 volts. Potentials at various points in the circuit are marked in volts, all of which are positive with reference to ground, which is taken as being at zero potential. The plate of the video amplifier tube is connected directly to the control grid of the picture tube, so that these two elements remain at the same potential. The picture tube cathode is connected to the slider on a voltage divider marked *Brightness Control*. Directions of electron flows are shown by arrows.

Electron flow in the video amplifier circuit is from the negative side of the supply through ground, the cathode, the plate, load resistor  $R_0$  and back to the positive side of the supply. There is

a 100-volts drop on  $R_o$ , which leaves the video amplifier plate and picture tube control grid 200 volts above ground potential. In the brightness control resistance there is a drop of 100 volts, from 300 to 200 volts, and with the slider at the center of the resistance the slider and picture tube cathode are at 250 volts above ground potential. With the picture tube grid at 200 volts and the cathode at 250 volts, the grid potential is 50 volts lower than that of the

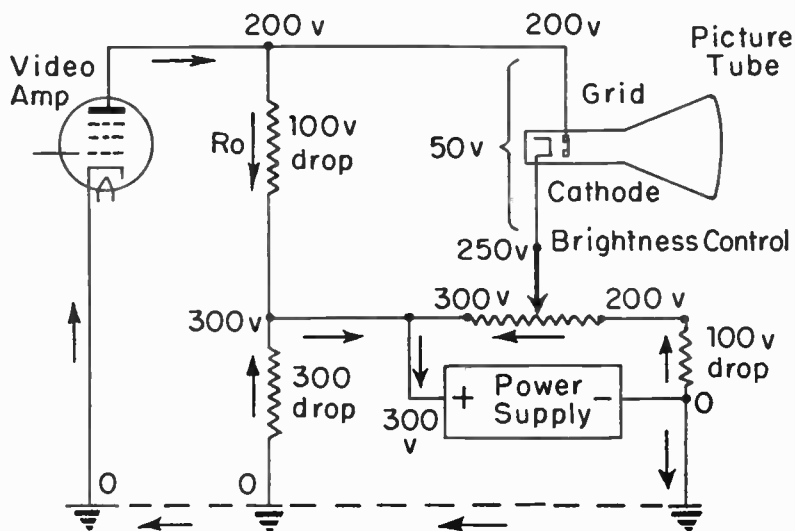

Fig. 13.—A control grid circuit for a picture tube.

cathode, and there is a 50-volts negative bias on the grid. This bias may be varied by moving the slider on the brightness control to bring the black level of the signal to the cutoff grid voltage of the picture tube.

**D-c Restoration.**—The brightness control will be manually adjusted for correct reproduction at the beginning of a period of reception from a certain station, but unless we provide additional means for automatically varying the point on the curve of Fig. 12 at which the average signal potential is applied, the background illumination will not change when there are changes in the scene being televised.

In Fig. 14 are represented picture signals for three different lines. All three signal variations are alike, all have the same contrast. But variations for the bright picture are up toward the white level, those for the medium picture are about midway between white and black levels, and those for the dark picture are down near the black level. In resistor  $R_o$  of Fig. 13 we would have variations or *changes* of potential difference corresponding to signal variations such as shown by Fig. 14. But in  $R_o$  we would have at the same time an *average* potential difference, which is shown as 100 volts in Fig. 13. The changes of potential which represent the picture and the synch pulses would vary the potential drop in  $R_o$  above and below the average potential drop in  $R_o$ .

From left to right through each of the signals in Fig. 14 is a dashed line representing the average potential of all the momen-

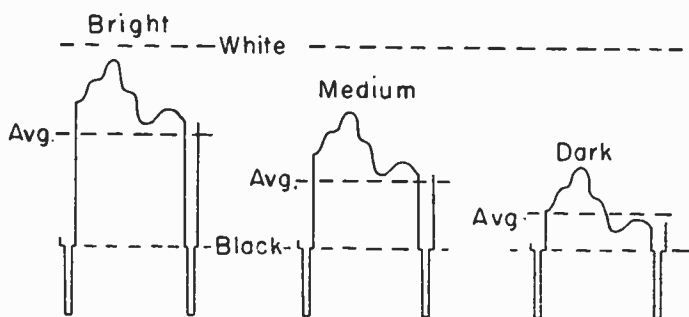

Fig. 14.—Picture signals for backgrounds which are bright, medium, and dark.

tary variations above and below this line. Were the three signals applied between grid and cathode of the picture tube, with the grid bias fixed at some certain value by the brightness control, the *average* potentials of all the signals would come on the value of grid bias. This is just the same as when we apply an a-c signal to the control grid of an amplifier tube whose grid is biased to some certain potential; the average of the signal comes on the bias value, and changes of the signal vary the grid potential above and below the bias value.

But to correctly distinguish between bright, medium and dark backgrounds we do not want the *average* signal potential to come

on the picture tube grid bias; rather we want the *black level* of the signal to stay on the grid bias voltage. Then the picture variations will be raised to their correct values above the black level.

If the signals are considered with reference to their average potentials, as divided above and below the average lines of Fig. 14, the signals are, in effect, alternating potentials or currents. If the signals are considered with reference to the black level, the picture portions of the signal are direct (one-way) potentials or currents with all of their values on the positive side of the black level. For this reason we speak of "D-c reinsertion" or "D-c restoration" when making the black level rather than the average potential act as our reference level for the picture tube grid.

If we employ the picture tube input circuit shown in principle by Fig. 13, we must increase the *average* potential drop across  $R_o$ , as from 100 to say 115 volts, for a picture with a bright background. This will make the average potential of the picture tube grid more positive, or less negative, will increase the average beam current, and will make the picture appear brighter on the screen. Conversely, for a picture with dark background we must decrease the average potential drop across  $R_o$ ; making the average grid potential of the picture tube more negative than before, decreasing the average beam current, and darkening the reproduction.

All that we need do to automatically vary the potential drop across  $R_o$  is change the average plate current of the video amplifier tube, and to change the average plate current we may automatically vary the grid bias of this tube in accordance with picture brightness.

The video amplifier grid bias may be automatically varied by using grid rectification in the control grid circuit. This means a biasing capacitor in series with the control grid, and a biasing resistor between control grid and cathode. When an a-c signal is applied to a tube thus biased, the greater the amplitude of the applied signal the more negative becomes the grid bias and the less the average plate current.

In Fig. 15 we have part of the circuit of Fig. 13, and, in addition, have a biasing capacitor  $C_g$  and a biasing resistor  $R_g$  in the control grid circuit of the video amplifier. We shall assume that a

“bright” signal of large amplitude comes to the video amplifier grid circuit. The grid bias becomes more negative than before, and there is a decrease of average plate current. Say that the plate current decreases to a value which is accompanied by an 80-volt drop in  $R_o$  instead of the 100-volt drop of Fig. 13. This makes the

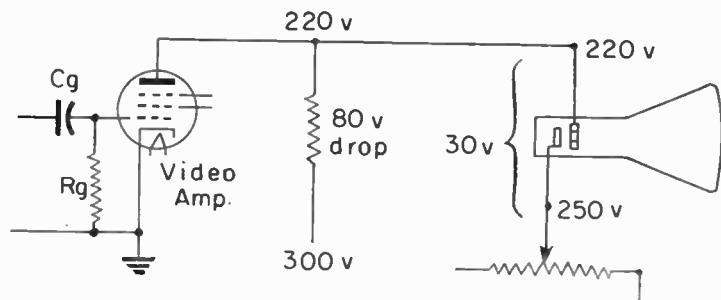

Fig. 15.—D-c reinsertion with automatic (grid rectification) bias on the video amplifier tube.

average potential of the picture tube grid change to 220 volts. With the picture tube cathode still at 250 volts the grid now is only 30 volts negative with reference to the cathode, whereas in Fig. 13 it is 50 volts negative. Thus the average beam current is increased to correctly show the bright picture.

A signal for a “dark” picture of small amplitude applied to the video amplifier grid would make the grid bias less negative, would allow an increase of average plate current, would increase the drop across  $R_o$ , would lower the picture tube average grid potential and make the grid more negative with reference to the cathode. Then we would have less average beam current and a darker reproduction.

The method described is not the only way of accomplishing d-c restoration. Another way is to use a rectifier tube in the video amplifier plate circuit, and apply the rectified (d-c) potential to the grid circuit of the picture tube to change its bias. The biasing potential varies with amplitude of the signal, and is applied to the picture tube grid circuit in such polarity as to make the grid less negative for large amplitudes (bright pictures) and more negative for small amplitudes (dark pictures).

**Separation of Synch From Picture Signal.**—We have followed the picture signal all the way through to the control grid of the picture tube. Now we may go back to Fig. 9, where there is a downward pointing arrow marked *To Synch Circuits*, and follow the synch pulses from here to the deflection system of the picture tube.

The signal taken from the detector output is shown at the left in Fig. 11. The synch pulses are more positive than the picture variations. We wish to retain the positive synch pulses and get rid of the negative picture signal. One of the simplest methods is to feed the signal to the grid circuit of a tube so biased as to cut off its plate current at the potential of the black level in the signal. Then everything more negative than the black level, which includes all of the picture signal, causes no plate current, while everything more positive than the black level, which means the synch signals, causes pulses of plate current which correspond to the synch pulses of the signal. The necessary negative bias is conveniently produced by grid rectification; with a grid capacitor and grid resistor such as shown for a video amplifier in Fig. 15.

Another method is to use a diode as a rectifier, with a "biasing" potential applied between diode plate and cathode. This bias must be overcome before there can be electron flow. If the diode plate is made negative (with reference to the cathode) by a potential corresponding to the black level of the signal, this negative bias will be counterbalanced when black level potential is reached, and then the more positive synch potentials will cause pulses of electron flow or current through the diode tube. These pulses are the desired synch signals. The picture signals are too far negative to overcome the bias and so do not cause electron flow.

With either method of separation, or with any method which might possibly be used, the separated synch potentials or pulses may be amplified by a synch amplifier stage employing either a triode or a pentode tube.

**Vertical and Horizontal Synch Separation.**—The synch pulses consist of those which are to control timing of the active horizontal lines and the horizontal retraces, also those which are to control downward travel of the beam and the vertical retraces.

The synchronizing signals which occur during a vertical blanking period are shown by Fig. 16. There are shown also, at the



extreme left, the picture signals during the last two active lines of the second field, with their intervening horizontal synch pulses. At the extreme right are shown the picture signal for the first line of the following field, and the horizontal synch signal following that active line.

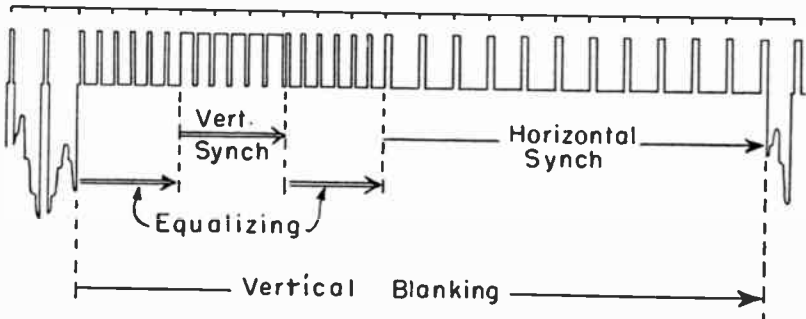

Fig. 16.—Synchronizing pulses which occur in the television signal during one period of vertical blanking.

At the end of the last line on the left of the graph the signal potential rises to the black level. Then follow six very brief positive pulses marked *Equalizing*. These equalizing pulses are spaced apart, in time, by only half the interval for a scanned line. Line intervals, which are continued by suitable divisions of the pulses throughout the whole time represented on this graph, are indicated by the short vertical dashes at the top of the graph. Note that there is a rise of potential, or there is the beginning of a positive pulse, at the beginning of every line period of time. Thus the timing for horizontal synchronization is carried without interruption through the whole period or vertical blanking. Were this not done, the horizontal synch generator would get quite a ways out of correct timing and would be difficult to control.

Following the first series of equalizing pulses come six relatively long pulses which, taken together, occupy the same time as three lines. These pulses are interrupted by such brief dips of potential that they act about like a single continuous pulse which is three line periods in duration. These six long pulses form the vertical synchronizing signal. They are followed by six more brief

equalizing pulses, and then the remainder of the time during the vertical blanking is filled with regular horizontal synch pulses between which there are no picture signals, but which have the same timing as though there were picture signals.

It is not very difficult to separate the horizontal and vertical pulses, because the frequency of occurrence of the horizontal pulses is 15,750 per second (with 525 lines in each of 30 frames per second), while the vertical synch pulses occur only 60 times per second for the two fields which make up one frame during  $1/30$  second.

One type of frequency separator circuits, and their outputs, are shown by Fig. 17. The synch signals, horizontal and vertical, enter from the left. Capacitor  $Ch$  is of small capacitance. It is charged by the high-frequency horizontal synch pulses and discharges across grid resistor  $Rh$ . The pulses of potential applied between grid and cathode of the horizontal synch amplifier tube, produce in the output sharp peaks of positive potential occurring at the horizontal synch frequency. These positive peaks go to the horizontal synch generator.

The capacitance of  $Ch$  is small enough to offer high reactance

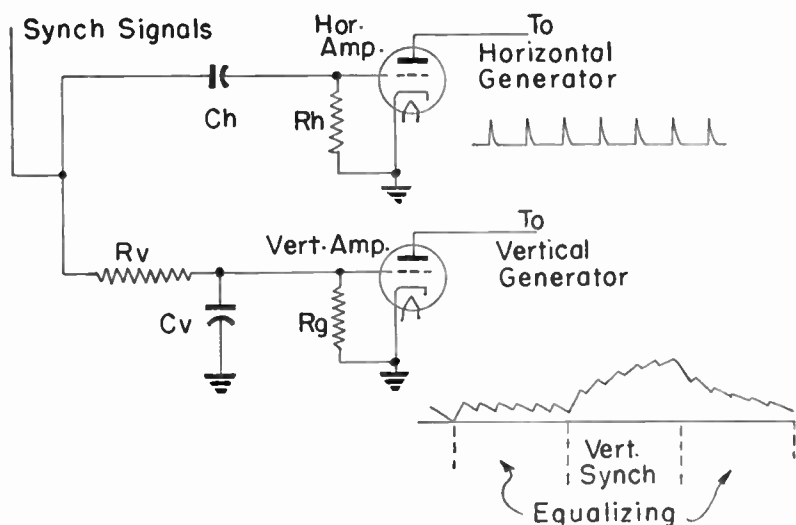

Fig. 17.—A circuit for separating the horizontal and vertical synch pulses, with the effects of the pulses shown toward the right.

at the relatively low frequency of the vertical synch pulses, but these vertical pulses are fed through resistor  $Rv$  to charge capacitor  $Cv$ . The time constant of  $Rv$  and  $Cv$  is long enough so that the voltage across  $Cv$  increases and decreases as shown at the right of the vertical synch amplifier tube. The equalizing pulses are so brief that most of the charge leaks off through  $Rg$  every time it is accumulated. But with the long vertical synch pulses, shown by Fig. 16, the charge accumulates faster than it can leak off through  $Rg$ , and there is a continued rise of capacitor voltage and of grid-cathode voltage across  $Rg$ . Thus there is fed to the vertical synch generator a relatively long pulse of potential, from the output of the vertical synch amplifier, for each vertical synch signal.

Note that the potentials sent to the synch generators must be positive in order to time or trigger the generators. Were the detector output at the left in Fig. 11 fed to the amplifier grids of Fig. 17, the signal polarity would be inverted in these amplifiers and the potentials sent to the generators would be negative instead of the required positive. However, if we insert one stage of synch amplification (for the combined horizontal and vertical synch signal) between the detector and the amplifiers of Fig. 17, that intervening stage will invert the detector signal, then it will again be inverted by the amplifiers of Fig. 17, and potentials to the synch generators will be positive. Defector output or load polarity and the number of amplifying stages always must be so related with respect to phase inversions as to deliver signals of correct polarity both to the picture tube grid and to the synch generators. The two triode amplifiers of Fig. 17 usually would be replaced by a twin-triode tube.

**Beam Deflection.**—The purpose of the horizontal generator is to produce changes of current or of potential which are so timed as to cause correct horizontal deflection of the picture tube electron beam during active lines, and during the blanking periods to return the currents or potentials to the values required for starting a new line. Changes of current are required for a magnetic deflection system using deflection coils at the picture tube, and changes of potential are required for the plates of an electrostatic deflection system. The purpose of the vertical generator is to produce changes of current or of potential which control downward travel of the beam, and to return the currents or potentials

to their starting values during the vertical retrace period. We shall now examine the operating principles of a horizontal deflection system, with the understanding that the same general principles may be employed for vertical deflection when we make suitable allowances for the difference between vertical and horizontal deflection frequencies.

With 525 lines and 30 frames per second, making a horizontal deflection frequency of 15,750 cycles per second, each complete line period (active and retrace) takes about 63.5 millionths of a second. About 10 millionths of this time is required for the retrace during the horizontal blanking, leaving about 53.5 millionths for the active horizontal line. For magnetic deflection, current in the

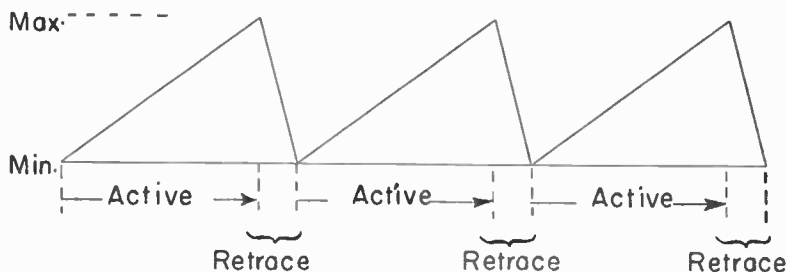

Fig. 18.—The sawtooth wave of current (or potential) required for deflecting the electron beam.

deflecting coils then must increase steadily from a minimum to a maximum value during 53.5 millionths of a second in order to carry the beam from one side to the other of the screen, and during the following 10 millionths of a second the current must decrease to its original minimum value. Such changes of current are shown by Fig. 18.

For electrostatic deflection the potential difference between the horizontal deflection plates would increase to maximum during 53.5 millionths of a second, and drop back to minimum in the following 10 millionths, and so the changes of potential could be shown by the jagged line of Fig. 18. A current or voltage rising and falling in this manner is said to be of *sawtooth* form, or to be a sawtooth wave.

Whether the output of the horizontal deflection system is to be

a sawtooth current for deflection coils or a sawtooth voltage for deflection plates, the input to the grid of the deflection amplifier tube will be a sawtooth voltage—because control by means of a grid results from changes of grid potential, not current. The sawtooth voltage for the grid circuit of the deflection amplifier is obtained by alternate charging and discharging of a capacitor in the grid circuit. One method of doing this is shown by Fig. 19, where the capacitor which is charged and discharged is marked *Cd*. This capacitor is charged from the d-c power supply through the resistance of the voltage divider marked *Width Control* and resistor *R*. The maximum voltage to which the capacitor is charged during one line depends on the relation between the capacitance and the total resistance in *R* and the width control voltage divider, or on the time constant of this capacitance and resistance.

The resistance which affects the time for charging the capacitor may be varied by the width control. Adjustment of this control thus varies the heights of the peaks in Fig. 18 and varies the distance which the beam will travel across the screen during the active lines. Varying this distance alters the width of the picture from left to right on the screen, which is the reason for using the name width control. The picture width is controlled because

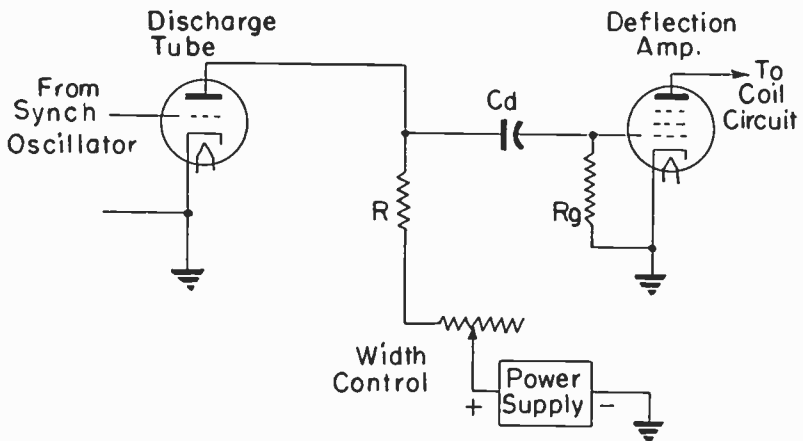

Fig. 19.—How a capacitor may be charged and discharged to produce a sawtooth wave of potential.

the greater the change of voltage (or current) the greater will be the deflection of the beam one way and the other.

Charging of capacitor  $Cd$  must stop at the end of the time period for one line, and then the capacitor must be discharged during the following horizontal retrace period. This is accomplished by connecting the capacitor to the plate of a *discharge tube* shown in Fig. 19. When the control grid of the discharge tube is made positive with reference to the cathode in that tube there will be relatively free flow of electrons between cathode and plate, and the capacitor will be discharged through this path.

Now it remains only to make the control grid of the discharge tube positive at the instants in which the capacitor  $Cd$  should commence to discharge; these being the instants for starting the horizontal retrace, as is evident from Fig. 18. It is the function of the oscillator in the horizontal synch generator to control the timing of changes of grid potential in the discharge tube.

**Deflection Oscillator.**—Fig. 20 shows the elementary circuits for one type of horizontal synch generator which includes a deflection oscillator and also the discharge tube whose function was explained in connection with Fig. 19. The oscillator tube is a triode with the plate circuit coupled back to the grid circuit through an oscillation transformer. Feedback through the transformer tends to maintain oscillatory potentials and currents in plate and grid circuits. The operating frequency of the oscillator,

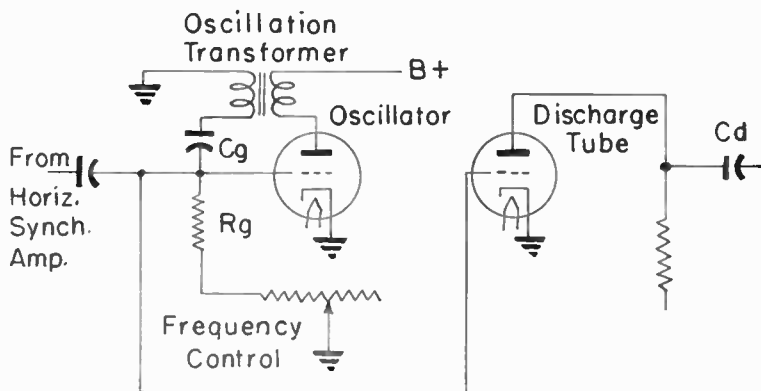

Fig. 20.—A horizontal synch generator including a deflection oscillator and a discharge tube.

were it to depend only on the feedback action, would be determined by the inductance of the transformer winding which is in the grid circuit and by the distributed capacitance of the winding and connections. Each complete oscillation at this "natural frequency" would, as at *A* in Fig. 21, cause the grid potential to rise to a positive peak, fall back through zero and go to a negative peak, and then come back to zero. Such changes of grid potential would follow one another without interruption.

What we now desire to do is cause interruptions of oscillation in such manner that we have a positive peak of grid potential only at each instant in which an active horizontal line is to end, and a horizontal retrace to begin. These peaks, when correctly timed, will make the control grid of the discharge tube (directly connected to the oscillator grid) enough positive to discharge capacitor  $C_d$  and produce the effect shown in Fig. 18. The interrupted peaks should occur as at *B* in Fig. 21, where successive peaks are separated by an interval equal to the time period for one horizontal line, and where the oscillator is inactive at other times.

The interruption is brought about by grid capacitor  $C_g$  (Fig. 20) and by the combined resistance of grid resistor  $R_g$  and of the

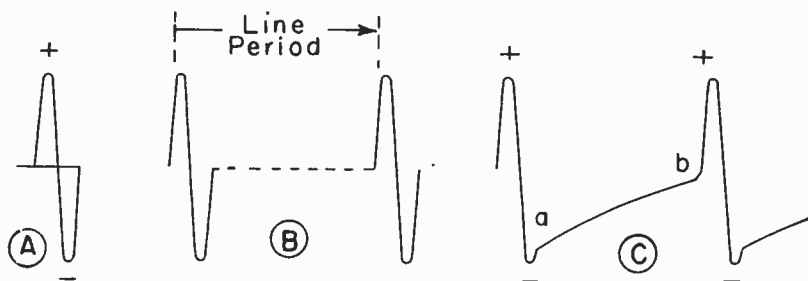

Fig. 21.—The output from a deflection oscillator of the blocking type.

voltage divider marked *Frequency Control*. The capacitance and resistance of these elements produce grid bias by means of grid rectification. A positive synch pulse coming to the oscillator grid circuit from the horizontal synch amplifier (upper tube in Fig. 17) charges capacitor  $C_g$  in such polarity as to make the oscillator grid negative. The grid will remain negative while the charge

leaks off through the resistance of  $R_g$  and the frequency control. So long as the grid is held so far negative as to prevent flow of plate current in the oscillator tube there can be no further oscillations. How long the grid is held so far negative depends on the time constant of the capacitance in  $C_g$  and the resistance in  $R_g$  and the control divider.

The action is shown at  $C$  in Fig. 21. First there is a positive peak of grid voltage due to the positive synch pulse from the preceding synch amplifier. Then  $C_g$  charges and drives the oscillator grid negative. The grid potential returns toward zero only as fast as  $C_g$  can discharge. This slow discharge is shown from  $a$  to  $b$  of the diagram. When  $C_g$  is sufficiently discharged there occurs one more oscillation, and so the action continues. Here we have what is called a *blocking oscillator*. Other types of oscillators may be used to produce the intermittent discharge of the capacitor.

The frequency control for the oscillator may be called the *hold control* or any of various other names denoting its general purpose. This control is adjusted so that the intervals between positive pulses would be a little longer than the time periods for horizontal lines. Then the positive synch pulse applied to the oscillator grid circuit from the preceding synch amplifier starts an oscillation just before it would start otherwise due to the timing action of the grid capacitor and resistances. The synch pulses increase the oscillator frequency so that it is brought into exact synchronization with the timing required for horizontal deflection.

In the vertical synch generator system there will be a frequency control for regulating the blocking frequency of the vertical deflection oscillator. There will be also a *height control* which regulates how far the beam travels vertically in forming the picture on the screen, just as the width control regulates the horizontal distance. In both the horizontal and vertical synch generators the oscillator tube and the discharge tube may be replaced with a twin-triode with one section acting as oscillator and the other acting as discharge tube. It is possible also to use a single triode as both oscillator and discharge tube, with the discharge occurring between cathode and plate when the grid is made positive.



**Deflection Amplifiers.**—With electrostatic deflection the potential on one plate of a pair must be changing from positive to negative while the potential on the opposite plate is changing from negative to positive. Then one plate will be highly positive while the other is highly negative, and the beam will be deflected toward the positive plate. To provide such oppositely changing potentials we may use circuits similar to those in push-pull amplifiers. With resistance-capacitance coupling from deflection amplifier to plates we would require one tube acting as a phase inverter, just as for push-pull amplification. The feed-through amplifier may be one section of a twin-triode, with the other section the inverter.

With magnetic deflection we do not need a push-pull amplifier circuit, because the two coils in either the horizontal or vertical pair are wound so that one has a north pole toward the tube neck while the other has a south pole toward the neck. This is shown in Fig. 22. The two coils are in series with each other and with the

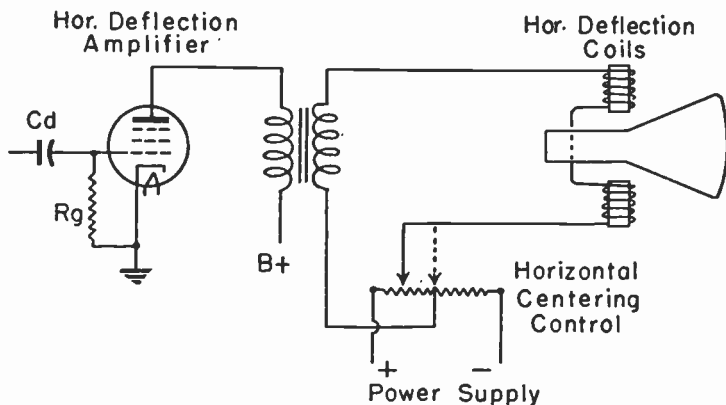

Fig. 22.—A magnetic horizontal deflection system for the picture tube.

secondary winding of the transformer whose primary winding is in the plate circuit of the horizontal deflection amplifier tube. This is the same tube shown at the right-hand side of Fig. 19. Increases and decreases of plate current flowing in the primary cause reversing emf's in the secondary, and reversing or al-

ternating currents in the deflection coils. While the current flows one direction the beam is deflected in a corresponding direction, and when the current reverses the beam is deflected in the opposite direction as the magnetic polarities of the coils are reversed.

Due to inequalities in the coil circuit it is possible that there may be more current flow in one direction than in the other, so that the beam is deflected more toward one side than the other side to throw the picture off center toward the right or left on the picture tube screen. Such a condition is corrected by the horizontal *centering control* which consists of a voltage divider connected into the d-c power supply system in such manner that there is a small potential difference across the ends, and so that one end is positive and the other negative with reference to the center of the divider resistance. These parts are shown in Fig. 22.

If, with the polarities shown for the voltage divider, the slider is moved to the full-line position we find that the slider (connected to the lower deflecting coil) is more positive than the center of the divider (connected to the transformer). This will introduce into the coil circuit a small direct potential difference acting upward through the transformer secondary and downward through the coils. With the slider in the broken-line position no additional potential difference is introduced from the power supply, and with the slider moved to the right of center there would be an additional potential difference acting downward through the transformer and upward through the coils. The slider is adjusted to compensate for any original unbalance which throws the picture off center. The centering control really introduces a small potential difference in such polarity as to counterbalance the original uneven flow in the coils.

In the vertical deflection system there would be a similar control for vertical centering of the picture. With electrostatic deflection there are voltage dividers which shift the changes of potential in the sawtooth waves to counteract either horizontal displacement or vertical displacement of the picture, or, of course, both displacements occurring together.

Fig. 23 shows the essential parts of one style of electrostatic deflection system from the horizontal and vertical deflection amplifier tubes, at the left, through to the deflecting plates in the

picture tube. The horizontal and vertical amplifiers are twin-triodes with the sections toward the right in each tube acting as inverters. The outputs of the two sections of the horizontal amplifier connect through capacitors at  $C_c$  to the two horizontal deflecting plates, and the outputs of the vertical amplifier connect similarly to the two vertical deflecting plates.

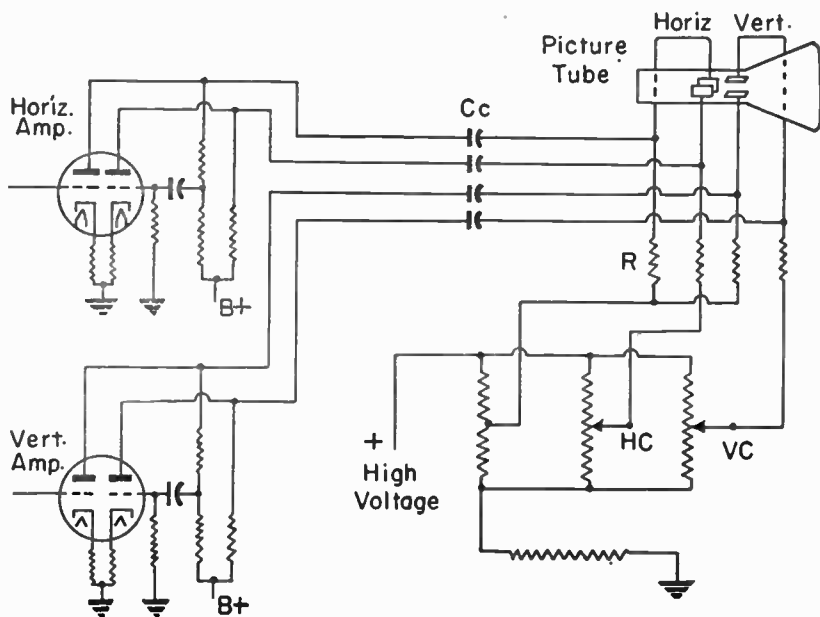

Fig. 23.—Electrostatic horizontal and vertical deflection systems for the picture tube.

The centering controls are shown in the lower right-hand part of the diagram. Here there are three voltage dividers connected in parallel with one another, and between the positive side of the high-voltage supply and resistance leading to ground. One of the horizontal deflecting plates and one of the vertical deflecting plates connect to the mid-point on the left-hand voltage divider. The other horizontal plate connects to the slider on the horizontal centering control  $HC$ , and the other vertical plate connects to the slider on the vertical centering control  $VC$ . With the sliders at

the centers of their resistance elements the plates connected to them are at the same potential as the plates connected to the center of the left-hand divider. Moving a slider one way or the other will make the connected deflection plate either more positive or more negative than the opposite plate in the same pair, and will deflect the beam more toward one direction than the opposite direction.

The potentials applied to the deflecting plates by the centering control system are in addition to, and independent of, the regular deflecting voltages from the amplifier tubes. Any mis-placement of the beam horizontally or vertically with respect to the centered position may be corrected by adjustment of the controls.

Now we have traced the television signal from the receiver antenna through all of the separations into picture and synchronizing portions, through the circuits which control performance, and have seen all of the parts of the signal come together at the picture tube. All of the important functions have been examined, and, while many of them may be performed in various ways, the methods which have been described would result in the reproduction of a picture were they used together in a single receiver.

### REVIEW QUESTIONS

1. With the use of Fig. 2 briefly name or state the function or purpose of the different parts of a television receiver.
2. How are television and sound carrier waves separated?
3. Refer to Fig. 7 and describe the types of wave traps shown and how they operate.
4. How is correction made at the receiver, for the fact that only part of the lower sideband frequencies are transmitted in the picture signal?
5. Describe the detector circuit shown in Fig. 9.
6. Why is phase inversion important in television amplifiers?
7. With the use of Figs. 11 and 12 describe how the variations of brightness which compose the picture are reproduced on the picture tube screen while eliminating the synch pulses.
8. Describe brightness control and the automatic means for varying the point on the curve of Fig. 12 (d-c restoration).

# INDEX

## A

Acoustical treatment, public address, 247  
Address systems, public. See *Public address*.  
Adjustments. See *Alignment*.  
Aerials. See *Antennas*.  
Alignment  
  antenna, automobile radio, 178  
    f-m receiver, 340  
    superheterodyne, 186  
  constant-frequency, f-m receiver, 331-341  
    generator connection for, 338  
    output measurement, 333  
  discriminator, constant-frequency, 339  
    visual, 345  
  f-m receiver, 331-346  
  generator for, 129-132  
  high-frequency receiver, 268-270  
  i-f transformer, 133-135  
  iron core coil, 133-140  
  oscillator, f-m receiver, 340  
    superheterodyne, 136  
  r-f, in f-m receiver, 340  
  short-wave receiver, 268-270  
  superheterodyne receiver, 127-140  
  visual, f-m receiver, 332, 341-346  
    oscilloscope for, 341  
    signal generator for, 343  
All-wave antennas, 49  
Amplification, 75-86  
  voltage, 81  
Amplifiers, 75-86  
  audio-frequency, 84  
  deflection, television, 400  
  grid bias for, 77  
  head, microphone, 221  
  impedance coupled, 86  
  intermediate-frequency, 113  
    f-m receiver, 294-299  
    grid bias for, 115  
  phonograph, 234-240  
  plate load for, 80  
  public address, 246  
  radio-frequency, f-m receiver, 292  
    short-wave receiver, 258-262  
    superheterodyne receiver, 117  
  resistance coupled, 84  
  transformer coupled, 84  
  untuned r-f, 261  
Amplitude modulation, 57-60, 276  
Antenna  
  alignment, superheterodyne, 136  
  all-wave, 49  
  am-fm types, 287  
  automobile radio, 175-179  
  broad band, 286  
  capacitance of, 55-56  
  circuit of, 38  
    automobile radio, 176-179  
    resonance in, 40  
    television receiver, 374  
  dipole, 50  
    half-wave, 271, 282  
    reflector for, 367  
  directional effects of, 45  
  double dipole, 286  
    V type, 286  
  doublet. See *Antenna, dipole*.  
  dummy, 130  
    short-wave alignment, 268  
  fan type, 236  
  fm-am types, 287  
  folded dipole, 286  
  height, for transmission distance, 281  
  Hertz, See *Antenna, dipole*.  
  high-frequency, 282-287  
  horizontal, 51  
  impedance of, 288

## Antenna—(Cont.)

  inductance of, 57  
  lead-in for, 42  
  loop type, 116  
  Marconi type, 44  
  noise reducing, 47-48  
  reflector for, 367  
  selection of, 51-55, 74  
  short-wave receiver, 270-272  
  signal-noise ratio of, 46  
  television receiving, 366  
  transmission lines for, 287  
  tuning of, 40  
  types of, 44-49  
  types compared, 51-55  
  vertical, 51  
Attenuation, receiver, television, 379  
Attenuators, public address pickup, 236-240  
Audio-frequency amplifiers, 84  
Automatic volume control, 70, 150-161  
  delayed, 70, 159-162  
  f-m receiver, 814  
  time constant for, 158  
Automobile electrical system, 198  
  ignition system, 201  
  radios, 173-204  
  antennas for, 175-179  
    circuits of, 176-179  
    battery circuit for, 185  
    interference elimination for, 197-203  
    power supply for, 183-197  
    tone control for, 181  
    tube arrangements in, 179  
    types for, 179  
  vibrators, 28-30, 188-197

## B

Baffles, loud speaker, 96  
Balanced armature loud speaker, 88  
Band selector switch, 252  
  spread tuning, 256-258  
  switching, 252  
Battery power supply, auto radio, 185  
Beam deflection, television, 394  
Beat frequencies, 107  
Bias, grid, amplifier, 77  
  cathode type, 79  
  i-f amplifier, 115  
Bleeders, filter, 18  
Blocking oscillator, television, 399  
Brightness control, television, 386

## C

Camera, television, 349  
  tube, television, 350  
Capacitance, antenna, 55-56  
  short-wave tuning, 254  
Capacitor, filter, 8-9  
  input type of filter, 7-12, 18-17  
  padder, use of, 120  
  trimmer, adjustment of, 127-140  
  auto radio antenna, 178  
  use of, 119  
Carbon microphone, 221  
Cardioid microphone pattern, 228  
Cathode bias, 79  
  -ray tube, oscilloscope, 341  
Centering control, television, 401  
Channels, television, 361  
Characteristic, discriminator, 325  
Choke, filter, 16-17  
  speaker coil as, 94  
  input type filters, 12, 13-14  
  rectifier filter, 9

Coil, iron-core, alignment with, 138-140  
voice, loud speaker, 91  
Condenser input filter, 7-12, 13-17  
microphone, 320  
Constant-frequency alignment, 331-341  
generator connection for, 338  
output measurement with, 333  
time, automatic volume control, 158  
f-m limiter, 311  
Contraction, volume, phono amplifier, 285  
Control, automatic volume. See *Volume control automatic*  
brightness, television, 386  
centering, television, 401  
fine tuning, television, 395  
frequency, television, 398  
height, television, 399  
hold, television, 399  
intensity, television, 386  
receiver, 141-172  
tone, 165-171  
    auto radio, 181  
    volume. See *Volume control*  
width, television, 396  
Converter, frequency, f-m receiver, 293  
    pentagrid, 111, 122  
    superheterodyne, 109-113  
    triode-hexode, 126  
    triode-pentode, 126  
Critical inductance, filter choke, 17  
Crystal detector, 32, 61-63  
    microphone, 216-218  
    pickup, phonograph, 230, 232-234  
    piezo-electric, action of, 217  
Current, rectified pulsating, 4

## D

Decibels, measurements in, 208-211  
    gain, 211-215  
    voltage, 211-215  
De-emphasis, f-m receiver, 330  
Deflection, television, 394  
    amplifier, 400  
    electromagnetic, 355  
    electrostatic, 352, 356, 402  
    oscillator for, 397  
Delayed automatic volume control, 70,  
    159-162  
Detector, crystal, 32, 61-63  
    diode, 63, 69  
    volume controls with, 146-150  
    frequency. See *Discriminator*  
    grid bias, 66-68  
    leak, 69  
    plate rectification, 66-68  
    second, 114  
    television receiver, 381  
    vacuum tube, 63-69  
Deviation, frequency modulation, 279  
    discriminator affected by, 324  
    ratio of, 279  
Diffraction, radio wave, 280  
Diode detector, 69  
    principle of, 63  
    volume controls with, 146-150  
    rectification with, 1  
Dipole antenna, 50, 287, 366  
    half-wave, 271, 282  
    reflector for, 367  
Direct-current restoration, 371, 387  
Directional effects, antenna, 45  
    pattern, loud speaker, 243  
    response, microphone, 227-229  
Discharge tube, television, 397  
Discriminator, 290, 314-329  
    alignment, constant frequency, 339  
    visual, 345  
    characteristic, 325  
    circuits used for, 327  
    deviation effect on, 324  
    phase relations in, 319

Distance, skip, 73  
    transmission, antenna height, 281  
Double button microphone, 223  
dipole antenna, 286  
    V type antenna, 236  
Doublers, voltage, 19-26  
Doublet antenna. See *Antenna, dipoles*  
Dummy antenna, 130  
    short-wave alignment with, 268  
Dynamic loud speaker, 90-94  
    microphone, 216

## E

Earphones, 36-88  
Electrodynamic loud speaker, 90-94  
Electromagnetic deflection, 355  
Electrostatic deflection, 352, 356, 402  
    focusing, 357  
Electron ray tube, 162-165  
Energy, high-frequency, 36  
    radio wave, 33  
    wave-form, 32  
Equalizing pulses, television, 392  
Expansion, volume, phonograph amplifier,  
    235  
Exponential horn, 242

## F

Faders, public address, 236-240  
Fan antenna, 286  
Feedback oscillator, 37  
Field, speaker, as filter choke, 94  
    radio wave, 284  
Filter, interference, auto radio, 202  
    power supply, 6-17  
    auto radio, 185-188  
    bleeder for, 18  
    capacitor input, 7-12, 13-17  
    choke, action in, 9  
    choke-input, 12, 13-17  
    requirements for, 16-17  
    speaker field for, 94  
    condenser-input, 7-12, 13-17  
    requirements for, 7  
    selection of, 13-17  
    transformer used with, 17  
    types compared, 13-17  
    voltage divider for, 19  
    wave, short-wave receiver, 263  
Fine tuning control, television, 375  
F-m. See *Frequency modulation and Frequency modulation receiver*  
Focusing, electrostatic, 357  
    electromagnetic, 357  
Folded dipole antenna, 286  
    horns, 242  
Foreign short-wave bands, 249  
Frame, television picture, 369  
Frequency, beat, superheterodyne, 107  
    control, television, 398  
    converters. See *Converter, frequency*  
    detector. See *Discriminator*  
    deviation, 279  
    high, characteristics of, 272, 279-282  
    image, 108  
    short-wave receiver, 267  
    intermediate, 115  
    f-m receiver, 295  
    production of, 108  
modulation, 275-304  
    deviation in, 279  
    frequencies used in, 279  
    principle of, 277  
    production of, 299-304  
    receiver, 289-299, 305-331  
    alignment of, 331-346  
    antennas for, 282-287  
    audio coupling circuits for, 329  
    automatic volume control in, 299, 314  
    converter tube for, 293

## Frequency, beat, superheterodyne—(Cont.)

- de-emphasis in, 330
  - discriminator in, 290, 314-329
  - discriminator circuits for, 327
  - i-f amplifier for, 294-299
  - limiter in, 290, 296
  - limiter action in, 305-314
  - limiter amplification in, 311
  - limiter time constant, 311
  - mixer for, 293
  - oscillator for, 293
  - r-f stage for, 292
  - transmission distance for, 281
  - frequencies for, 279
  - oscillator, short-wave receiver, 265
  - ripple, 7
  - separation, television, 393
  - short-wave band, 250
  - spread tuning, 256-258
  - television, 358-362
  - wavelength relation to, 35, 249
- Full-wave rectifier, 4

## G

- Gain, decibel measurement of, 209, 211-215
  - f-m receiver i-f amplifier, 296
- Generator, signal, 129-132
- f-m alignment with, 338
  - visual alignment with, 343
  - synchronizing, television, 372, 394-399
- Ghost images, television, 366
- Grid bias, amplifier, 77
- detector, 66-68
  - i-f amplifier, 115
  - leak detector, 69

## H

- Half-wave dipole antenna, 282
  - rectifier, 3-4
- Head amplifier, microphone, 221
- phones, 86-88
- Hearing, sensitivity of, 207
- Height control, television, 399
- Hertz antenna. See *Antenna, dipole.*
- Heterodyning, action of, 106
- Hexode converter, 126
- High frequency, antennas for, 282-287
- characteristics of, 272, 279-282
  - energy, sources of, 35
  - receiver. See *Short-wave receiver.*
  - tuning, 291
  - impedance microphones, 224
- History, radio, 31
- Hold control, television, 399
- Horizontal antennas, 51
- polarization, radio wave, 284
- Horn, exponential, 242
- folded, 242

## I

- Ignition system, automobile, 201
- Image Frequencies, 108
- short-wave, 267
  - television, scanning of, 351-354
- Impedance, antenna, 288
- coupled amplifier, 86
  - matching, microphone, 226-227
  - transformer, 100, 227
  - microphone, 224
  - reflected, loud speaker, 102
- Indicator tube, tuning, 162-165
- Inductance, antenna, 57
- critical, filter choke, 17
  - high-frequency effect of, 272
  - short-wave tuning, 254
- Intensity control, television, 386
- Interference, auto radio, 197-208
- Interlaced scanning, 359

- Intermediate frequency, 115
  - amplifier, 113
  - f-m receiver, 294-299
  - grid bias for, 115
  - production of, 108
  - transformer alignment, 133-135
- International short-wave bands, 249
- Inversion, phase, 382
- Iron-core coil, alignment of, 138-140

## L

- Lead-in, antenna, 42
  - Level, reference, decibel, 211
  - Limiter, 290, 296
  - action of, 305-314
  - amplification in, 311
  - time constant for, 311
- Line, transmission, antenna, 287
- Loop antenna, 116
- Loud speaker. See *Speaker, loud.*
- Low-impedance microphones, 224

## M

- Magic eye tube, 162-165
- Magnetic deflection, 355
- focusrs, 357
  - pickup, phonograph, 230, 234
- Marconi antennas, 44
- Matching impedance, loud speaker, 99
- microphone, 226-227
  - transformer for, 100, 227
- Meter, output, use of. See *Alignment.*
- Microphone, 215-229
- carbon, 221
  - cardioid pattern, 228
  - condenser, 220
  - connections to, 224-227
  - crystal, 216-218
  - directional response of, 227-229
  - double button, 223
  - dynamic, 216
  - high-impedance, 224
  - impedance of, 224
  - matching for, 226-227
  - low impedance, 224
  - matching impedance of, 226-227
  - moving coil, 216
  - output of, 223
  - ribbon, 219
  - single button, 221
  - types of, 216
  - velocity, 219
- Mixer, circuits for, 286-240
- converter tube as, 112
  - f-m receiver, 293
  - pentagrid, 125
  - separate type, 123
  - superheterodyne, 109-113
  - television receiver, 375
- Modulation, amplitude, 57-60, 276
- frequency. See *Frequency modulation.*
- Modulator, frequency, 299-304
- Mosaic, camera tube, 350
- Moving coil microphone, 216
- speaker, 90-94
- Multi-band tuning, 120
- Multiplier, voltage, 26
- Noise elimination, auto radio, 197-208
- reducing, antennas, 47-48
- Non-synchronous vibrators, 28, 189-194

## O

- Oscillator, alignment of, 136
- alignment type of, 129-132
- blocking, television, 399

Suppressors, auto radio, 200  
Switching, band, 252  
Synchronizing generator, 372, 394-399  
pulses, television, 392  
Synchronous vibrators, 29, 194-197

## T

Television, 347-368  
camera, 349  
channels for, 361  
deflection methods, 355  
focusing in, 357  
frequencies used for, 358-362  
receiver, 399-403  
antenna for, 366  
circuits for, 374  
brightness control, 386  
centering controls, 401  
deflection in, 394  
amplifier, 400  
oscillator, 397  
detector, 381  
d-c restoration, 371, 387  
fine tuning control, 375  
frequency control, 398  
height control, 399  
hold control, 399  
intensity control, 386  
intermediate frequency for, 376  
mixer circuit, 375  
oscillator circuit, 375  
parts of, 264, 370  
picture tube, 354  
separation of sound, 376  
synch pulses, 391  
synch generators, 372, 394-399  
wave traps in, 377  
width control, 396  
scanning, 351-354  
signal, 362-365, 392  
transmission of, 365  
transmitter parts for, 364  
Time constant, avc, 158  
limiter, f-m receiver, 311  
Tone control, 165-171  
auto radio, 181  
Tracking, superheterodyne, 119  
Transformer coupled amplifier, 84  
i-f, alignment of, 133-135  
impedance matching, 100, 227  
speaker output, 100  
rectifier, 17  
vibrator, 194  
Transmission distance, antenna height for  
281  
lines, antenna, 287  
principle of, 72  
television, 365  
vestigial sideband, 362  
Transmitter, principle of, 72  
spark, 31  
Trap, wave, alignment of, 135  
short-wave receiver, 263  
television, 377  
Trimmers, adjustment of, 127-140  
auto radio antenna, 178  
use of, 119

Triode-hexode converter, 126  
-pentode converter, 126  
Tube, camera, 350  
cathode-ray oscilloscope, 341  
discharge, television, 397  
electron ray, 162-165  
magic eye, 162-165  
picture, 354  
Tuning, antenna circuit, 40  
band spread, 256-258  
high-frequency, 291  
indicator tube, 162-165  
magic eye for, 162-165  
multi-band, 120  
permeability, 138-140  
short-wave, 254  
wide-band, 377  
Twisted pair transmission line, 288

## V

Velocity microphone, 219  
Vertical antenna, 51  
Vestigial sideband transmission, 362  
Vibrators, 28-30, 188-197  
non-synchronous, 28, 189-194  
synchronous, 29, 194-197  
transformers for, 194  
troubles with, 197  
Video signal, television, 354  
Vision, persistence of, 348  
Visual alignment, 382, 341-346  
oscilloscope for, 341  
signal generator for, 348  
Voice coil, loud speaker, 91  
Voltage amplification, 81  
decibel measurements of, 211-215  
divider, power supply, 19  
doubler rectifier, 19-26  
multiplier rectifier, 26  
output, signal source, 211  
Volume contraction, 235  
control, 70 141-161  
antenna circuit, 142  
automatic, 70, 150-161  
time constant for, 158  
delayed automatic, 70, 159-162  
diode detector types of, 146-150  
grid circuit, 143  
bias, 145  
plate circuit, 144  
public address, 236-240  
expansion, 235

## W

Wave energy, 32  
filters. See *Trap, wave*.  
length, frequency relation to, 35, 249  
short-wave band, 250  
polarization, 284  
radio, 33  
fields in, 284  
sawtooth, television, 395  
sound, 32  
trap, alignment of, 135  
short-wave receiver, 263  
television, 377  
Wide band tuning, 377  
Width control, television, 396



Oscillator, alignment of—(Cont.)

- deflection, television, 397
  - feedback type, 37
  - f-m receiver, 298
    - transmitter, 300
  - separate type, 123
  - short-wave receiver, 265-267
  - television receiver, 375
- Oscilloscope, visual f-m alignment, 341
- Output meter, use of. See *Alignment*.
- microphone, 223

P

- Padder capacitor, use of, 120
- Pentagrid converter, 111, 122
  - mixer, 125
- Permanent magnet loud speaker, 94
- Permeability tuning, 138-140
- Persistence of vision, 348
- Phase inversion, amplifier, 382
- Phasing loud speakers, 98
- Phone, ear or head, 86-88
- Phonographs, 229-240
  - amplifiers for, 234-240
  - pickups for, 230, 232-234
  - records for, 229-232
- Pickup, phonograph, 230, 232-234
  - crystal, 230, 232-234
  - magnetic, 230, 234
  - mixing circuits for, 238-240
- Picture tube, television, 354
- Piezo-electric crystal, action of, 217
- Plate detection, 66-68
  - load, amplifier, 80
  - rectification detector, 66-68
- Polarization, radio wave, 284
- Power, decibel measurements of, 208-211
  - public address requirements for, 246
  - supply system, 6-19
    - auto radio, 183-197
    - voltage divider for, 19
- Pre-emphasis, f-m signal, 330
- Preselector stage, superheterodyne, 117
- Projectors, directional patterns of, 243
  - exponential, 242
- Public address systems, 205-248
  - acoustic treatment for, 247
  - amplifiers for, 246
  - attenuators, pickup, 236-240
  - decibel measurements in, 208-215
  - faders for, 236-240
  - microphones for, 215-229
  - mixing circuits for, 236-240
  - phonograph amplifiers for, 234-240
  - pickups for, 230, 232-234
  - records for, 229-232
  - power requirements for, 246
  - projectors for, 240-246
  - sound characteristics in, 206
  - speakers for, 240-246
  - tone controls for, 165-171
  - transformer impedance matching, 227
  - volume controls for, 236-240
    - expansion and contraction, 235
- Pulsating rectified current, 4
- Pulses, equalizing, television, 392
  - synchronizing, television, 392

R

- Radiation, principle of, 72
- Radio-frequency amplifier, f-m, 292
  - short-wave, 258-262
  - superheterodyne receiver, 117
  - untuned, 261
- waves, 33
  - fields in, 284
- Reactance tube modulation, 301

- Receiver attenuation, television, 379
- automobile. See *Automobile radios*.
- frequency-modulation. See *Frequency modulation receiver*.
- high-frequency, 249-274
- short-wave. See *Short-wave receiver*.
- superheterodyne. See *Superheterodyne receiver*.
- television. See *Television receiver*.
- Receiving antennas. See *Antennas*.
- Records, phonograph, 229-232
  - speeds of, 232
- Rectification, 1-30
- Rectifiers, 1-30
  - filters for. See *Filters, power supply*
  - full-wave, 4
  - half-wave, 3-4
  - voltage doubler, 19-26
    - multiplier, 26
- Reference level, decibel, 211
- Reflected impedance, loud speaker, 102
- Reflection, radio wave, 280
- Reflector, antenna, 367
- Refraction, radio wave, 280
- Reinsertion, d-c, television, 371, 387
- Resistance coupled amplifier, 84
- Resonance, antenna circuit, 40
- Restoration, d-c, television, 371, 387
- Retraces, television scanning, 354
- Reversal, phase, 382
- Ribbon microphone, 219
- Ripple frequency, 7

S

- Sawtooth wave, television, 395
- Scanning, image, 351-354
  - interlaced, 359
- Second detector, 114
- Selectors, band, 252
- Shielding, automobile radio, 199
- Short-wave receivers, 249-274
  - alignment of, 268-270
  - antennas for, 270-272
- Sideband, vestigial, 362
- Signal generator, 129-132
  - f-m alignment with, 338
  - visual alignment, 343
  - noise ratio, antenna, 46
  - television, 362-365, 392
  - video, television, 354
- Single button microphone, 221
- Skip distance, 73
- Sound characteristics, 206
  - waves, 32
- Spark suppressors, auto radio, 200
  - transmitter, 31
- Speaker, loud, 86-104, 240-246
  - baffles for, 96
  - balanced armature, 88
  - directional patterns of, 243
  - dynamic, 90-94
  - impedance matching for, 99
  - permanent magnet, 94
  - phasing of, 98
  - public address, 240-246
  - reflected impedance with, 102
  - transformers for, 100
  - troubles with, 94
- Spread frequency tuning, 256-258
- Superheterodyne receiver, 105-140
  - alignment of, 127-140
  - beat frequencies in, 107
  - converters in, 111
  - i-f amplifier for, 113
  - mixer for, 123
  - multi-band type, 120
  - oscillator for, 123
  - preselector stage for, 117
  - r-f stage for, 117
  - tracking in, 119