

By the Same Author

Practical Wireless Encyclopedia
Wireless Transmission
Everyman's Wireless Book
Wireless Coils, Chokes and Transformers
Practical Wireless Circuits
Practical Wireless Service Manual
Radio Engineer's Pocket Book
The Superhet Manual
Radio Training Manual
A Refresher Course in Mathematics
Newnes Slide Rule Manual
Newnes Mathematical Tables and Formulæ
Wire and Wire Gauge
Radio Valve Data Pocket Book
Newnes Television Manual

NEWNES SHORT-WAVE MANUAL

*A Treatise on the Design, Construction, Operation
and Adjustment of Short- and Ultra-Short-Wave
Receivers, Aerials and Equipment, with Designs
for Seven Short-Wave Receivers*

EDITED BY

F. J. CAMM

(Fellow, Royal Society of Arts)

Editor of "*Practical Wireless*"

WITH 100 ILLUSTRATIONS

LONDON
GEORGE NEWNES LIMITED
TOWER HOUSE, SOUTHAMPTON STREET, STRAND, W.C.2

<i>First published</i>	.	.	.	<i>March 1940</i>
<i>Second Edition</i>	.	.	.	<i>July 1940</i>
<i>Third Edition</i>	.	.	.	<i>May 1941</i>
<i>Fourth Edition</i>	.	.	.	<i>Jan. 1942</i>
<i>Fifth Edition</i>	.	.	.	<i>October 1944</i>
<i>Sixth Edition</i>	.	.	.	<i>March 1946</i>

*Made and Printed in Great Britain
by Jarrold & Sons, Ltd., Norwich*

PREFACE

I HAVE endeavoured to make this new work on short-wave and ultra-short-wave receivers as comprehensive as possible, and the chapters have been arranged sequentially to give the student a progressive introduction to the subject. Thus, the first chapter explains the various factors affecting short-wave receivers and their design ; the second chapter deals with the important question of operation, and the third deals with the now popular band-spread tuning. Hand-capacity effects, the short and the ultra-short wavelengths, high-frequency amplification and the relative advantages and disadvantages of the tuned H.F. receiver and the superhet follow. The morse code, interference, short-wave aerials, the screened aerial coupler, aerial coupling, reflector aerials, coil design, wavelength and frequency measurement, the ultra-short-waves, converters and adaptors for ultra-short-waves, measuring ultra-short wavelengths and the construction of one-valve, two-valve, three-valve, and four-valve receivers for battery and mains operation complete the chapter sequence. At the end of the book important reference tables are given. Short-wave technique forms a regular section of *Practical Wireless*, the journal of which I am the editor.

F. J. CAMM

CONTENTS

CHAPTER	PAGE
I. AN INTRODUCTION TO THE SHORT WAVE	9
II. OPERATING YOUR FIRST SHORT-WAVER	14
III. BAND-SPREAD TUNING	18
IV. HAND-CAPACITY EFFECTS	23
V. SHORT AND ULTRA-SHORT WAVELENGTHS	26
VI. H.F. AMPLIFICATION	30
VII. TUNED H.F. VERSUS THE SUPERHET	34
VIII. METRES, KILOCYCLES AND MEGACYCLES	41
IX. MASTERING THE MORSE CODE	44
X. MINIMISING INTERFERENCE	49
XI. TUNING SHORT-WAVE AERIALS	59
XII. MAKING A SCREENED AERIAL-COUPLER	63
XIII. COUPLINGS FOR AERIALS	66
XIV. MORE AERIAL COUPLINGS	72
XV. REFLECTOR AERIALS	82
XVI. COIL DESIGN	86
XVII. MEASURING WAVELENGTHS OR FREQUENCIES	98
XVIII. ULTRA-SHORT-WAVE SECTION	111
XIX. ULTRA-SHORT-WAVE CONVERTERS AND ADAP- TERS	120
XX. FINDING AND MEASURING WAVELENGTHS OF FIVE METRES AND BELOW	128
XXI. TWO SIMPLE ONE-VALVERS	136
XXII. TWO SIMPLE TWO-VALVERS	144
XXIII. AN A.C. TWO-VALVER	154
XXIV. A STANDARD THREE-VALVER	161
XXV. AN A.C. FOUR-VALVER	171

TABLES

	PAGE
INTERNATIONAL MORSE CODE	177
PHONETIC ALPHABET	177
INTERNATIONAL AMATEUR CALL SIGNS	178
QSA CODE (SIGNAL STRENGTH)	179
QRK CODE (AUDIBILITY)	179
RST CODE (READABILITY)	179
RST CODE (SIGNAL STRENGTH)	180
RST CODE (TONE)	180
MISCELLANEOUS INTERNATIONAL ABBREVIATIONS	180
AMATEUR ABBREVIATIONS	180
INTERNATIONAL "Q" CODE	181
AMATEUR WAVEBANDS (BRITISH)	182
WORLD SHORT-WAVE STATIONS	184
INDEX	191

CHAPTER I

AN INTRODUCTION TO THE SHORT WAVES

THE term "short waves" is now recognised as applying to wavelengths below 200 metres, but not going below 10 metres. Wavelengths below 10 metres are known as "ultra-short waves" and they call for different treatment from that required for normal short-wave working. In its turn short-wave working also calls for treatment on different lines for that needed for ordinary broadcast reception, and this is mainly due to the fact that short waves are of high frequency and thus losses become important. Perhaps it would be as well to explain this a little more fully before passing on to a discussion of the types of apparatus and components which are required.

Wireless waves travel through the ether in the form of waves similar to the ripples on the surface of water, and on normal broadcast wavelengths the frequency with which these waves occur is of the order of 1,000,000 per second (this actually corresponds to a wavelength of 300 metres). A wavelength of 30 metres, however, gives a frequency of 10,000,000. Expressed technically these frequencies are 1,000 kilocycles per second and 10,000 kilocycles per second. A kilocycle being, of course, 1,000 cycles. There is a further term applied to the very high frequencies, namely megacycles, but this will be discussed in a later chapter. It is intended at this stage to point out that the higher the frequency the greater the risk of loss and therefore the first important point in short-wave design is the efficiency of components, etc.

Short-wave experimenters are invariably prolific readers and keen students of design and development. Whilst they are collectively in agreement as to the pleasures, thrills, interest and instruction to be derived from short-wave listening and experimental work respectively, they do not agree so far as technical considerations are concerned.

For example, at club meetings and wherever members of the short-wave fraternity forgather, individual opinions are expressed and arguments entered into, and in no uncertain manner. To the beginner, reading or listening to the views expressed, it is apt to be a little confusing, and the problem, so far as he is concerned, is that of knowing who is right.

Chassis or Baseboard?—Chassis and baseboard construction, compact, layouts, circuits, etc., are all subjects of discussion, and opinions expressed are usually based on practical and individual experience. Baseboard construction is favoured in many instances because every component is accessible. Accessibility is a commendable feature, but there is absolutely no point in carrying it to extremes. Admitted, quick changes can be carried out conveniently. On the other hand, however, it must be remembered that experimental work does not consist of building a receiver, and then fitting alternative components of different values throughout.

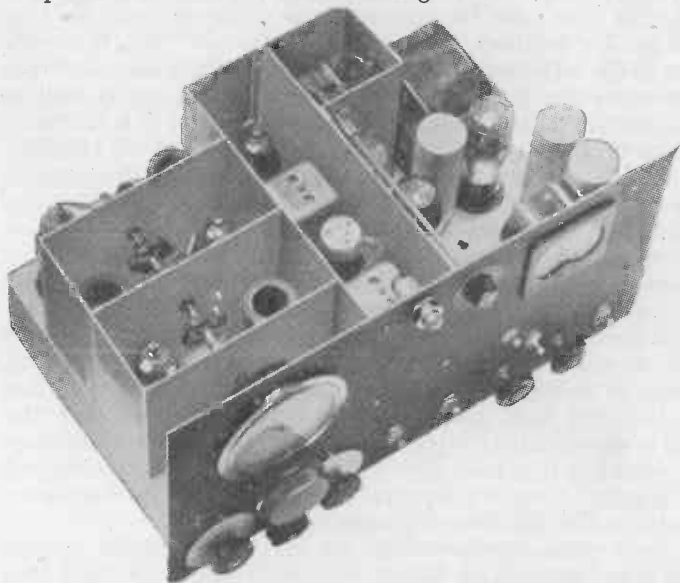

Fig. 1.—A good example of a home-made short-wave communications receiver, with elaborate screening. Its construction is described at the end of this book.

Fixed Components.—For example, there are certain definite values for decoupling condensers and resistances; also definite combinations of resistances and fixed condensers associated with resistance-capacity coupling, according to the type of valve used. It is unlikely that decoupling components will be altered and values chosen against accepted recommendations, and as resistance-capacity values are based on the

characteristics of the preceding valve, such values will be decided upon, or should be, during the initial stages of construction, and if different types of valves are to be tried it is quite possible to build up resistance-capacity coupling components in unit form.

Accessibility allows quick changes of components to be made, but does not offset the disadvantages associated with necessity for a baseboard of comparatively large dimensions in order that the various components can be suitably spaced, or for long leads and an excessive amount of wiring in circuit.

"Yes!" you may say, "but by using copper foil under the baseboard, wiring can be reduced." Granted, but in doing so; are not chassis principles being adopted?

The general trend appears to be to do things in a violent hurry, overlooking the fact that there is a vast difference between a hook up and a "lash up." Even an experimental receiver should be built as a finished job, devoid of time considerations.

Whilst chassis construction is in some instances not in favour, a metal panel or some form of screening is used, and thus the earth potential sides of the tuning condensers are earthed directly. This is a great advantage, yet it is offset by the extra amount of metal panel which is necessary, due to the comparatively large baseboard. In deciding one's policy so far as experimental work is concerned, is it not advisable to follow current practice, bearing in mind that there must be a reason for the present trend, and that increased efficiency must be obtained, otherwise, designers and manufacturers are wrong, and if this is so, there must be, one would imagine, millions of sets which are not as they should be. Clearly such reasoning is unsound.

Standard Circuits.—Let us examine and discuss the matter from an entirely different, but most practical view-point. We will not take into consideration modern receiving circuits of the tuned radio-frequency and super-heterodyne types, but the simple straight circuits of the O-V-1 and O-V-2 types, because they were originally used for short-wave reception, and are still deservedly popular.

Simple Sets.—During the early days, receivers employing the above types of circuit were built on baseboard lines. The foil-lined base-board was unknown, metal panels were also unknown.

All points at earth potential were taken directly to the earth terminal of the receiver. Thus a considerable amount of wire was in circuit, and comparatively long leads were common due to this, and the fact that all components were mounted above the baseboard.

The result was instability, poor sensitivity and volume due to excessive damping. Whilst valves and components as used in those days left much to be desired, the following proved that chassis construction was much better. An old O-V-2 was reconstructed on modern chassis lines, using all the



Fig. 2.—A typical modern short-wave receiver of the "communications" type, utilising all-metal construction.

original components, including valves. This receiver was used for over two years for DX work and proved entirely satisfactory and far ahead of the original model in every way.

Benefits of Modern Components.—Nowadays we have available special components in which losses have been reduced to the absolute minimum, and therefore, in order to obtain the last ounce of efficiency, it is advisable to adopt modern methods of construction. To do otherwise is to introduce avoidable complications. The advantages of the chassis method of construction are many. Wiring is reduced to the minimum, and due to the fact that decoupling components, R.C.C. components G.B., batteries, etc., can be fitted underneath the chassis, it is possible to build short-wave receivers in compact form without fear of interaction.

The advantages of chassis construction are many, and entirely offset the featuring of inaccessibility as a colossal disadvantage. Whether our receivers are permanent or experimental, we must choose wisely, and in deciding as to the form of construction to be adopted, ask ourselves this question: Which is to be preferred, a high standard of efficiency, i.e., sensitivity, stability, average selectivity and volume, or accessibility?

To the serious and methodical experimenter, the correct answer will be obvious. Modern components and modern applications go hand in hand. To recognise this fact means progress, otherwise one's receivers will never be anything else but experimental.

In any case, whatever changes are necessary, do not depend upon working to a split second, and the excuse that when testing on actual S.W. signals it is necessary to make quick changes appears to be weak and does not take into account that signal volume may increase or decrease considerably during even a quick change of components such as resistances, condensers, etc.

Choosing a Circuit.—Whilst choice of circuit is a most important factor, it should not be imagined that, taken type for type, there are some circuits which function when built in practical form, and others which do not. The beginner usually possesses one great fault, and that is, he thinks big. For example, how many who read this built and use either experimental or sponsored two- or three-valvers to suit their pockets, yet have visions of seven-valve superheterodynes?

Whilst ambition is commendable so far as the average experimenter is concerned, and may in due course be realised, it is better to start in a modest way and progress in easy stages. It will be found that during the early part of an experimental career, the realisation that all circuits function, but apparently someone else knows how and why, but you do not seem to get away with it, comes to the fore.

It is much better to start with simple circuit receivers and get to understand them fully. By doing so, when the big receiver is about to become a realisation, its construction will be easier and its good points more easily appreciated.

CHAPTER II

OPERATING YOUR FIRST SHORT-WAVER

WHEN a listener acquires his first short-wave receiver he will undoubtedly find that its operation is totally different from that of a standard broadcast receiver. This is partly on account of the details which have already been given in the preceding chapter, but also due to the general design of the receiver.

We do not suggest that a modern S.W. outfit calls for exceptional skill in handling. The difference in results obtained when the set is used correctly and incorrectly is far more marked than when dealing with a broadcast receiver. That is, the short-wave set reflects to a greater extent the "touch" of the user. One obvious reason for this is that tuning is far more accurate, a given movement of the condenser spindle producing a much greater effect on short than on medium waves. The reason for this is that any S.W. coil, even when used in conjunction with a tuning condenser of '00016 mfd. capacity, covers a far wider frequency range than does a broadcast coil with a condenser with a capacity of '0005 mfd.

Frequency Range.—For example, the average extent of the medium-wave tuning range is from 200 to 550 metres, which is equivalent to the band of frequencies from 1,500 to 545.4 kc/s. A typical S.W. coil with '00016 mfd. condenser, on the other hand, will tune from about 20 to 45 metres, or 15,000 to 6,666.6 kc/s. This means that in one instance the total "coverage" is rather under 1,000 kc/s. whereas in the other it is more than 8,000 kc/s. Expressed in practical terms, therefore, the sharpness of tuning on the S.W. band mentioned is eight times as great as on the medium-wave band.

From this it is not hard to appreciate that if the tuning condenser is not operated very slowly a signal might well be missed. One good method of making the sharpness of tuning comparable on the two bands is by connecting a tuning condenser with a capacity of about '000015 mfd. (described as a 15 m.mfd. condenser) in parallel with the main tuning condenser. This gives what is commonly known as band-spread tuning. Even when this is done, the small condenser should be fitted with a good slow-motion drive.

Slow-Motion Tuning.—When band-spread is not used—and it cannot always be conveniently incorporated in the design—it is imperative to use a good slow-motion drive and to turn the knob as slowly as possible. In the case of a superhet there is nothing else to do; you simply turn the knob slowly and steadily until the required signal is received. If the set is connected to a normal and fairly long outdoor aerial and to an earth lead the set might become "dead" at certain condenser settings. The usual remedy is to include a small-capacity variable condenser in series with the aerial lead-in and adjust this until the set "comes to life" again; generally until a faint "hissing" or "rustling" noise is heard as a background.

In other cases it is necessary to disconnect the earth lead before the set remains uniformly sensitive throughout the tuning range. If that is done it is generally helpful to place a metal plate or sheet of foil under the set (unless it is built on a metal chassis) and to join this to the earth terminal on the set. This system is frequently worth while when it is necessary to use a long lead to reach an earthed point.

When using a S.W. superhet converter the same general rules apply, but there is another point that might be watched if a variable reaction condenser is fitted. This is slightly to vary the reaction capacity as tuning is varied. Although the converter must be in continuous oscillation it is not unusual to find that if reaction is advanced too far there is a certain damping effect. If the unit is battery-operated it is also worth while to try the effect of varying the H.T. voltage.

Reaction-Tuning Control.—A "straight" S.W. set, especially if it is of the Det.-L.F. type, usually calls for more skill and experience in handling, although the procedure is little different from that followed when using a set with the same type of circuit on broadcast bands. The most important requirement is that the detector valve should be kept just on the verge of oscillation while searching for stations. Oscillation is indicated by a faint "breathing" sound, and the beginner should make himself familiar with this. Turn the reaction condenser to zero and then slowly advance it; at first the 'phones or speaker will be silent; then a point will be reached at which the sound is heard; further rotation of the condenser will cause the sound to fade away again very slowly, although a point might be reached at which a "screech" becomes audible due to the valve falling into violent self-oscillation. When searching for stations the reaction control should be set to

the point at which the "breathing" is first heard, and then eased off very slightly. In these conditions the valve will be just short of the oscillation point and telephony signals will be heard as speech or music, probably rather distorted. A further slacking off will remove the distortion. Powerful signals will often cause the valve to oscillate so that the whistle or carrier wave is heard instead of the actual telephony. In that case, reaction will have to be reduced to a greater extent.

The method outlined appears simple enough, but in practice it is not simple until experience has been gained. The difficulty is in *keeping* the correct reaction setting as tuning is varied, because reaction is automatically altered with the tuning. That is why the skilled operator turns both reaction and tuning knobs simultaneously. Generally, reaction control requires to be turned through only a small arc while the tuning pointer moves from end to end of the scale, and one has to learn to turn the two knobs by the correct proportional amounts. The whole object is to "hold" the faint background noise and maintain it at constant strength.

Listening Times.—The beginner to short waves should not despair if his initial efforts meet with little success, for with a little perseverance he will soon master the operations involved. Incidentally, it should be pointed out that reaction control is much steadier when the best setting of the aerial series condenser has been found. In adjusting this the object should be to find a setting at which the minimum variation of reaction capacity is required to maintain the set in steady oscillation over the full tuning range.

One of the best times for trying out a short-wave set is on Sunday mornings, when there are in normal times literally thousands of amateur transmitters at work on the 20-metre and 40-metre bands. They are also to be found on 10 and 5 metres, but there are not usually as many signals on these bands, whilst tuning is somewhat more difficult until the experimenter has fully mastered the operation of the set. If the set is being tested during the early evening the 19-metre band will probably yield a few good signals; later in the evening the 31-metre and 47-metre bands are better for reception of American stations. Continental transmissions can be heard at most times of the day on the 19-, 25- or 31-metre bands, and one of the Daventry Empire transmissions can generally be picked up. Surprisingly enough, however,

these transmissions are not well received at distances of less than 100 miles, due to "skip-distance" effects.

There will also be a difference in the particular wavebands which are receivable at different times of the year. This varies according to particular atmospheric conditions, but very roughly in January, February, March and April, the 31-metre band will be heard best from midnight to the middle of the morning, the 20- to 25-metre band will be best up to the middle of the afternoon, and the 10-metre band will come in best during the hours just before darkness. Thereafter the 20-25-metre band will be best, followed by the 31-metre band up to midnight again.

In June and July the 15 to 17-metre band will be most effective throughout the entire 24 hours, the 20- to 30-metre bands only being heard well round about midnight. From July onwards the conditions reverse until the end of the year, that is, August will be similar to June, and so on. It will thus be seen that the 10-metre band is practically useless in the midsummer, whilst in mid-winter the 14- to 17-metre band is of little use. Sunspots and other phenomena will, however, considerably modify reception conditions in different parts of the world.

When testing during the day, especially when in search of long-distance stations, it will be found that the shorter waves down to about 13 metres are received better in the morning, and that the optimum wavelength range increases as darkness approaches. This is not an invariable rule, for one of the most interesting features of short-waves is their variation. Signal strength also varies from day to day—even hour to hour—so if initial tests are not very successful, wait an hour or two and try again before concluding that the receiver is defective. Once you have "got the hang" of tuning you will find that there is always something to be heard on short waves unless conditions are unusually bad.

CHAPTER III

BAND-SPREAD TUNING

It has already been mentioned that tuning may prove difficult, but the system known as band-spread tuning removes this difficulty. The advantages of this form of tuning cannot be over-emphasised, and various systems are available. Both mechanical and electrical band-spreading may be used, and the extra trouble and additional outlay required are more than justified.

Dealing first with mechanical methods, the average slow-motion dial has a ratio of about 16 to 1, and, whilst a useful compromise, it cannot be regarded as a satisfactory arrangement from the short-wave enthusiast's point of view. There are, however, a number of specially designed open-scale twin-ratio dials available, employing ratios of 18 to 1 and 100 to 1 or 150 to 1. Thus quick band-setting and slow searching over the bands are possible. A further aid, in some instances, is the fitting of an extra graduated dial scale. There are also the popular slow-motion driving heads, which are fitted with a comparatively long indicating pointer, and a large calibrated scale.

Where space is definitely limited, so that the incorporation of electrical band-spreading components is impossible, the use of mechanical methods will prove to be a great advantage so far as ease of tuning and station logging are concerned.

Electrical Methods.—There are various methods of incorporating electrical band-spreading both simple and complicated, depending mainly upon the type of receiver and the operator's requirements. For example, large communication type short-wave receivers in which elaborate coil switching units are included, add to the designer's problems and call for the introduction of equally elaborate and complicated methods of applying band-spreading.

Such arrangements are definitely reliable because of sound engineering and design, but are somewhat beyond the scope and ingenuity of the average home constructor and experimenter.

Fig. 3 shows the popular parallel method in common use. When this method is used, the band setting condenser *A*

should be of .0001 mfd. or .00016 mfd. capacity, and condenser *B* which is the band spreader of 15 m.mfd., or even lower capacity.

Fig. 4 shows the series condenser method, *C* being the band setter and *D* the spreader, the respective capacities being .00016 and 15 m.mfd. or lower. The disadvantage of this method is that in the case of one of the variable condensers,

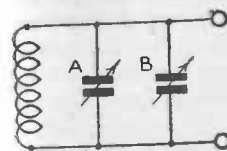

Fig. 3.—The standard parallel method of band-spreading.

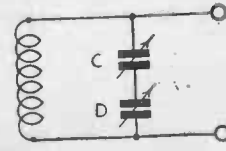

Fig. 4.—The series band-spread arrangement.

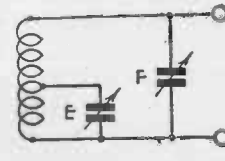

Fig. 5.—How band-spreading is accomplished with a tapped coil.

both sides with respect to H.F. currents are alive, and ebonite bushing is therefore necessary when an aluminium panel is used.

Fig. 5 shows different arrangement in which a tapped coil is used. This is a very adaptable system, especially for specialised amateur reception, but great care in the selection of suitable coils and correct tapping point is most desirable. Condenser *F* is included for trimming purposes.

A little experiment is necessary in order to find the correct tap position, and once this is ascertained, the trimming adjustment will enable the amount of spread to be adjusted to suit individual requirements with reasonable limits.

Condenser Values.—It should be remembered that in dealing with various systems of band-spreading, the suggested condenser capacity values will not always hold good. For example, coil design and circuit differences, especially in home constructed receivers using home constructed coils, must be taken into account.

If, however, commercially manufactured coils are used in the receiver in which it is desired to incorporate band-spread tuning, the coil manufacturers will be only too willing to advise as to the most suitable values to use in conjunction with their products.

This brings to mind the fact that certain manufacturers of short-wave coils also market specially designed band-setting

and spreading variable condensers for use in conjunction with their own particular coils.

Due to careful choice of capacity values and care in design of coils, users of such products are enabled to undertake the inclusion of band-spread tuning, confident of satisfactory results, and a definite spread coverage per coil.

Sufficient spread over various ranges is a very important factor. The user of commercial coils and their associated tuning condensers will, however, experience no difficulties

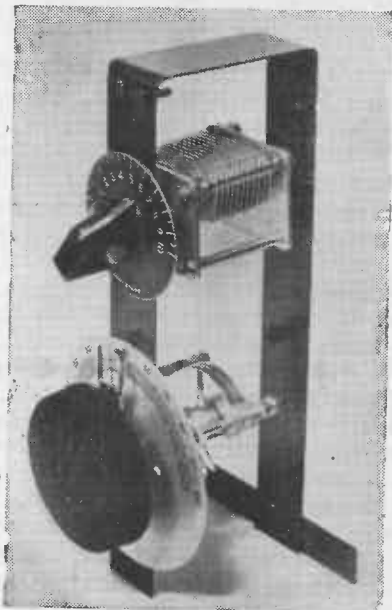

Fig. 6.—A commercial band-spread assembly with a special ten-section dial.

in this respect. Others, using home-made coils and various types of tuning condenser, are less fortunate, and must undertake the necessary spade-work, using cut-and-try methods.

Bearing this in mind, the reasons why some favour band-spreading whilst others who have tried it do not, are fairly obvious. The subject is another example of viewing matters

from the wrong angle. Not willingly perhaps, but due to being misled and placing a too literal interpretation on the statement that one form of band-spread consists of a small capacity vernier condenser wired in parallel with the main tuning condenser.

The explanation is simply that unsuitable values of setting and spreading capacities are used in conjunction with a particular coil, and the result is that the wanted bands are put right off the dial in some instances, due to too high a value of band-spreader being used.

Problems of this nature can be overcome if a midget type .0001 mfd. tuning condenser which can be dismantled is to hand.

All that is necessary when the parallel method is chosen is to reassemble the midget condenser as a two fixed and one moving plate double-spaced condenser, and run a practical test. If it is found that the desired amount of spread is not obtainable, the condenser should be taken out and one of the fixed vanes removed, and a further test carried out, etc.

Generally it will be found that by the adoption of cut-and-try methods, matters can be so arranged that a useful degree of band-spread is obtainable over various ranges. The popular 15 m.mfd. type of band-spreading condenser now available will be found to meet most requirements, and can, if desired, be modified without difficulty to meet special requirements.

Instances come to mind in which experimenters incorporate band-spread tuning, but complain that the amount of spread appears to be very limited. Examination usually discloses that a plain knob that is without calibrated markings is fitted to the band-spreader, and under these circumstances it is difficult to determine the exact amount of spread obtainable.

Whether it is desirable invariably to fit slow-motion dials to band-spreaders is a matter of opinion, depending on various other factors about which more will be said.

Multi-Stage Receivers.—The application of band-spreading to multi-stage receivers of the T.R.F. type may appear at sight to be difficult. In the case of receivers incorporating a single S.G., H.F. stage, it is a more or less simple undertaking.

For example, the H.F. stage in a well-designed receiver will be arranged so that it does not tune sharply, but with more of a volume control effect yet not too broad so as to make the set unselective. In this case it will be found that band-spreading

need **only** be applied to the detector stage, because the comparatively small increase in capacity due to the spreading effect of the additional condenser will not have an adverse effect on the tracking of the detector and H.F. stage to any appreciable extent.

The correct method is of course to incorporate ganged band-spreading condensers according to the number of tuned stages, and the above applies to home-constructed receivers of the single H.F. type, and is suggested as a compromise.

Band-spreading undoubtedly increases the usefulness of any receiver, and makes all the difference between DX with ease or difficulty.

When using electrical methods, it is sometimes difficult to decide on which condenser to fit an illuminated or other S.M. dial. Various problems of design will govern the final choice. A slow-motion drive fitted to the tank condenser with a direct drive, using a graduated dial in conjunction with the band-spreader, will be found quite satisfactory when it is desired to keep panel dimensions to a minimum, and in addition has the further advantage of combining mechanical and electrical methods, yet allowing calibration with a useful degree of accuracy to be carried out. (Fig. 6 shows a commercial form of such a device.)

The beginner and more experienced experimenter will find that once having incorporated electrical methods of band-spreading, and realised the advantages and simplicity, its incorporation in subsequent receivers will be carried out as a matter of course.

CHAPTER IV

HAND-CAPACITY EFFECTS

THE building of a receiver to a published design is more or less a straightforward undertaking, but the design of a receiver to your own ideas is a more difficult process. Bearing in mind the improvements which have been effected in components and circuits the beginner may be pardoned for wondering why one of the troubles invariably associated with short-wave receivers of old vintage may still be experienced. We refer, of course, to hand, or more correctly, body capacity effects.

Unsuitable circuits, incorrect layout and wiring, aerial coupling, voltages, unsuitable components and various other factors may produce body capacity effects.

Extension Rods and Screening-Boxes.—The use of extension rods will remove the effects of body capacity, but not the root cause of the trouble, which cannot be otherwise but detrimental to overall receiver performance. To enclose an unstable receiver in a metal box is apt to make matters worse. Extension rods and metal screening-boxes are to be commended as features of design, but should not be incorporated as after-thoughts. In any case a metal screening-box should be regarded as an integral component, and not a playground for straying H.F. currents.

Now let us get down to the discussion of effective cures, for one cannot hope to tune in DX, or properly judge performance, with an unstable receiver.

The earth lead may be comparatively long or just right. Try series tuning it with an .0003 mfd. air dielectric variable condenser; alternatively, try operating the set without an earth lead.

In the first instance, it is sometimes possible to find a setting which totally eliminates body capacity effects. In the second, the receiver may be found to function better, and be free from capacity effects. In both instances a reduction of interference will be noticed.

Wiring Connections.—Whilst care and neatness is the rule so far as set wiring is concerned, many experimenters pay but little attention to external battery leads. It is advisable to use solid wire for the set-to-earth lead, and L.T. accumulator

leads, the latter being insulated, of course, in order to avoid any possibility of short-circuiting the L.T. accumulator.

Tests have shown that for short-wave purposes, copper wire is best from the aerial right through the receiver down to earth. To use either aerial or earth wires which include strands of iron is probably asking for trouble.

A sure guard against instability is to introduce efficient by-passing. A 600 ohms resistance in each H.T. lead and G.B. lead with a 2 mfd. fixed condenser connected to the receiver side of each resistance and to earth is one method.

Another method is to couple by-pass condensers of .0005 mfd. capacity between the plate and earthed filament terminals (or direct to chassis), on the L.F. side of the receiver, when transformer coupling is used.

A fixed condenser of .002 mfd. or .01 mfd. across the output terminals, in addition to helping matters so far as instability is concerned, will improve the tone and cut off excessive top response, and, if carefully chosen, reduces background without sacrificing volume to any extent.

Grid stoppers are also worthy of consideration, and a 100,000 ohms non-inductive resistance between the grid of the first L.F. valve and its associated L.F. transformer terminal, is a refinement worth the cost of a suitable resistance.

A very effective cure during the early days was to use two separate H.F. chokes coupled in series, and take the centre via a .0003 mfd. fixed condenser to earth. It did not, however, suit every circuit, and now that efficient H.F. screened chokes are available, it is hardly necessary. To those, however, who use unscreened H.F. chokes, the tip may be of use.

L.F. Chokes.—L.F. output chokes are not favoured generally nowadays, due to the development of the moving-coil speaker with integral output matching transformer. An L.F. choke incorporated in a short-wave receiver, intended for headphone reception, is well worth considering, and in some instances is a definite cure for head capacity effects.

Metal panels and various forms of screened chassis are common practice in present day short-wave receiver construction. There are aluminium, steel, copper, tin or copper foil panels and chassis, for instance, from which to choose. Correctly used, they provide effective and efficient screening, but in every case if incorrectly used will introduce capacity effects in the most chronic form. It is preferable to make the chassis suit the design, and not to design to suit a chassis or

cabinet, of greater or lesser dimensions than normally required. It is safe to assume that failures due to insensitive receivers are, in 50 per cent of instances, traceable to excessively long wiring and bad lay-out, and a desire to use a chassis much too big; and the other 50 per cent due to the cramping of components on a small chassis, and consequent instability.

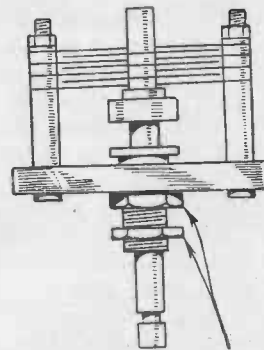

REVERSE THESE NUTS
(SEE TEXT)

Fig. 7.—Overcoming a difficulty by reversing a lock-nut.

Taking the broad view, it will be appreciated that to tolerate troubles of this nature when resistances, fixed condensers, plywood, foil and H.F. chokes are comparatively cheap is false economy.

On the other hand, to attempt a permanent cure, when lay-out, wiring, or the use of unsuitable components is obviously the root cause, is a waste of time and effort, and cannot in the end prove to be other than an unsatisfactory method of procedure.

CHAPTER V

SHORT AND ULTRA-SHORT WAVELENGTHS

A FEW years ago, we were content if our receivers functioned efficiently between 16 metres and 100 metres. Nowadays, a range of from 9 metres to 180 metres is desirable, and recent experiments show that using low-loss ceramic insulated tuning condensers, a ceramic insulated coil-holder, and valve-base plug-in coils, it is possible to obtain oscillation in the region of $4\frac{1}{2}$ metres to 5 metres.

Lay-out and Wiring.—In order to achieve this, however, careful lay-out and the minimum of wiring is essential, and such apparatus is in fact ultra-short-wave apparatus, adapted to suit the higher short-wave bands. Generally, however, a 9-metres minimum should be aimed at with a view to receiving the various 9.4 metres American experimental transmission as radiated by commercial stations, in addition to the reception of world-wide 10-metre transmissions.

Plywood, copper and tinfoil are comparatively cheap, and if experimenters who experience trouble due to capacity effects will give a little time and thought to chassis dimensions, and start right in that respect, disappointment will be avoided.

Steel Chassis.—How many, having tried to build an experimental receiver on a steel chassis, cadmium or copper-plated, underneath a top covering of enamel, and finding on test that the whole chassis is alive, have condemned steel chassis as unsuitable for the construction of S.W. receivers, and on further examination have discovered that the earth potential side of the circuit was in effect 'up in the air', due to the enamel coating? Chassis of this description are worth trying, but are only satisfactory if correctly used.

Components such as screens, also mooring bolts at earth potential, should bed down and make good contact with the bare copper or cadmium plating, otherwise chronic capacity effects will be experienced.

The subject has been reviewed from the point of view of those who appreciate the desirability of using suitable components, and doing so put the same into practice. Consequently, it is unnecessary simply to list every known cure,

and in the majority of instances, the suggested procedure will have the desired effect.

The fact that it is desired to receive ultra-short as well as short-wave transmissions introduces complications in design and construction. For example, it is accepted and sound practice to use self-supporting coils of about $\frac{3}{4}$ inch diameter, and of comparatively heavy gauge wire for ultra-short-wave reception.

As we desire to receive also on wavelengths up to 180 metres the idea of fitting dual coil mountings, i.e. a ceramic 4 or 6-pin coil base in parallel with a 4- or 6-socket ultra-short-wave coil base comes to mind.

This idea can in some instances be made to work. The additional wiring between the two coil mountings, however, introduces considerable losses even when shortened to extreme limits, and although workable, must be regarded as a compromise.

Condenser Capacities.—Now comes the problem of tuning capacity. Tuning condenser capacities of .00005 mfd. are recommended. Obviously in the case of full S.W. range receiver this capacity value will call for additional coils in order to cover the higher ranges. Selectivity on the higher ranges will thus be effected.

From the theoretical point of view, a capacity of .0001 mfd. is unsuitable for ultra-short-wave reception, nevertheless it has been found possible to receive below 10 metres using a tuning capacity of .0001 mfd., a modified 15 m.mfd. band-spreading condenser, and standard plug-in coil formers. It must, however, be admitted that careful attention was paid to lay-out and wiring of the receiver, and careful choice given to the type of detector valve used.

The latter, was, however, of standard H.L. type. A ceramic coil-base and valve-holder were also incorporated.

H.F. Chokes.—One of the snags experienced with experimental ultra-short-wave receiving apparatus centres around H.F. choking. When it is desired to tune from $4\frac{1}{2}$ metres to 180 metres, there is a problem to solve.

There are a number of single H.F. pile-wound chokes of various makes, which will prove to be most efficient from 5 metres to 180 metres, and entirely free from peak resonance points.

The Eddystone No. 1010, 5 to 180 metres type is strongly recommended. Such components, however, should be carefully

handled as the choke windings are of fine-gauge wire soldered to heavier gauge short connecting wires.

To those who are making their first ultra-short-wave, and short-wave combination type receiver, adaptor or converter, metal panel and chassis construction is not recommended. Condenser extension rods, a wooden chassis and panel are advisable.

Ceramic coil bases and valve holders, together with special ceramic and end-plate type tuning condensers, should be used to reduce losses to the minimum.

Condenser Mountings.—This brings to mind the subject of condenser mountings. There are various makes and types of mounting brackets available. Both adjustable and non-adjustable as regards height. When using an Eddystone type bracket, together with a tuning condenser of the same make, everything is straightforward and trouble-free. If, however, it is desired to use them in conjunction with the Raymart R.M.X., or Premier Trolitul type condenser, a snag arises, and some modification is necessary.

For example, twin nuts are fitted to the condenser bushes which are of the one-hole fixing type. The back nut which holds the moving plates assembly in place is the thicker nut of the two. The thinner nut being for panel mounting the condenser.

The combined thickness of the back nut and mounting bracket is such that it is at the most only possible to obtain a purchase of one thread if an attempt is made to fix the condenser in place. Now one thread is insufficient, and any attempt to tighten up will result in stripped threads on bush, nut, or both. If however, these condensers are mounted on a 20-gauge metal bracket or panel, everything would be satisfactory, as they are obviously intended for this purpose, and designed accordingly.

The most satisfactory modification is to reverse the locking (thick) and fixing (thin) nuts, using the latter as the assembly holding nut and the former as the panel fixing nut. The sketch on page 25 will make the necessary modification clear.

A.C. Operation.—The operation of short-wave receivers from A.C. mains is one of increasing interest. There are no doubt many who have endeavoured to adapt existing receivers to mains operation and have failed or achieved but a small measure of success.

When we come to consider A.C. operation, we think of A.C. mains hum and its elimination. If the receiver is to be all A.C. operated the possibilities of hum are increased, and due precautions must be taken to safeguard it, and provision should therefore be made for additional smoothing. Here, however, is a point worth noting, which, whilst generalising, applies specifically to American type valves, and to receivers even of a type in which additional smoothing has been included to meet short-wave requirements.

Change the detector valve, especially if this is of the S.G. type. Hum is in some instances accentuated due to pinch leakages in the detector valve, and having found a satisfactory substitute stick to it, and if H.F. valves of the same type are used, replace them with the same make as the detector. To test for this fault, note if hum is increased when reaction is applied.

H.T. Eliminators.—Now we come to the problem of operating battery type S.W. receivers from A.C. mains for H.T. supply. The majority of standard eliminators are not suitable or designed for this purpose. Nevertheless, some of those produced years ago and in the then high-price class, and employing valve rectification, will, with a new rectifying valve fitted, be found suitable for hum-free headphone operation on short and ultra-short-waves providing decoupling and choke output arrangements incorporated in the receiver.

In the case of existing H.T. eliminators, where it is found that A.C. hum is not too pronounced, additional smoothing arrangements will prove effective.

Attention to detail and a little pains-taking experiment will prove worth while. But remember, that to use an H.T. eliminator which causes persistent A.C. hum in headphones or speaker, simply because it is to hand, is foolish.

The H.T. eliminator, correctly applied to a short-wave receiver, together with accumulator L.T. supply, is probably the finest combination one can have, because it assures constant and never-failing voltage and a dead silent background.

In conclusion, a note of warning. If an H.T. eliminator is to be used with S.W. and U.S.W. receiving apparatus for headphone reception, incorporate choke output arrangements in the receiver in the interests of safety.

CHAPTER VI

H.F. AMPLIFICATION

THE advantages of H.F. amplification ahead of the detector stage in short-wave receivers is generally appreciated by short-wave enthusiasts, but the question arises whether the H.F. stage should be tuned or untuned.

The technical point of view is that if an H.F. stage is to be used, it should be tuned in order to obtain the full benefits to be derived from the screen-grid valve as an H.F. amplifier which includes improved selectivity and increased signal volume.

An untuned stage whilst contributing some measure of H.F. amplification, acts principally as a buffer, and is instrumental in the prevention of dead spots in tuning, whilst on the other hand its use tends to broaden tuning. It should be noted, however, that there is a wide difference between broad tuning and flat tuning. The latter providing in effect very poor selectivity.

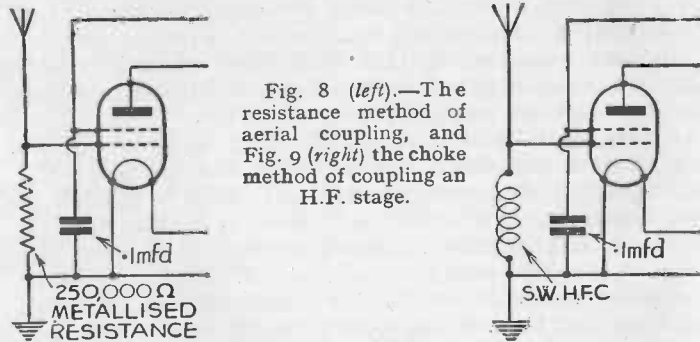

Fig. 8 (left).—The resistance method of aerial coupling, and Fig. 9 (right) the choke method of coupling an H.F. stage.

It should also be borne in mind that if the experimenter simply desires a buffer stage, and to take precautions against dead spots in tuning, or on the other hand is quite prepared to remain satisfied with the comparatively low gain in amplification, there is no reason why an untuned stage of H.F. amplification should not be used.

The question of cost also arises. It may not be convenient to consider the purchase of additional coils, and associated components, in order to build a tuned H.F. stage. If an S.G. valve is to hand, it can be used. The untuned stage will not introduce additional tuning complications, and will ensure a uniformity of efficiency throughout the tuning range of the receiver, together with some degree of amplification.

Coupling Methods.—Fig. 8 shows the resistance coupling method and Fig. 9 the choke coupling method. Although the beginner may prefer the arrangement shown in Fig. 8, it is advisable to try out and experiment with both resistance and H.F. choke arrangements.

Both these systems are in common use, but there is another method which, whilst its merits are appreciated, is not so widely used.

Before going further it will be as well to revert to the comparative merits and demerits of tuned and untuned high-frequency stages. A tuned stage enables us to peak all signals by tuning to resonance with the detector stage. An untuned stage, however, is semi-aperiodic.

Some method of compromise would appear to be acceptable, preferably one which would enable us to enjoy, at least in some measure, the advantages to be derived from a fully tuned H.F. stage.

Untuned H.F. Circuit.—Reference to Fig. 10, shows a conventional untuned H.F. short-wave receiver circuit, consisting of a stage of untuned high frequency, and triode

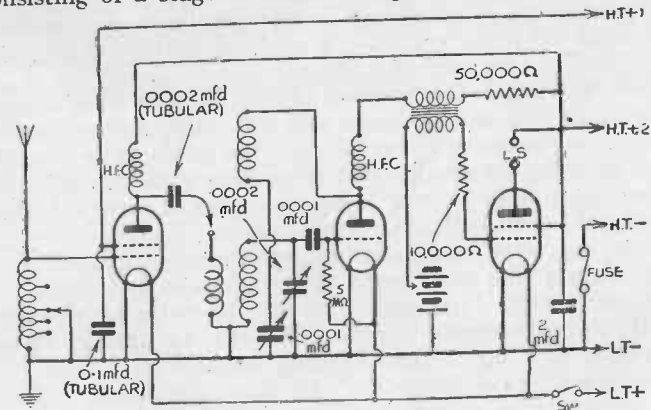

Fig. 10.—A conventional untuned H.F. short-wave 3-valve receiver.

detector transformer-coupled to an L.F. pentode. There is, however, one modification, and that is the coupling between aerial and untuned H.F. stage. Instead of employing an H.F. choke or resistance, a tapped coil is used.

By employing a tapped coil, we are enabled to bring the aerial in resonance with the grid circuit. Thus, in effect, we have a semi-tuned H.F. circuit instead of a semi-aperiodic H.F. circuit.

Amateurs who at some time or other have experimented with aerial tuning devices, in order to tune the aerial in resonance with received signal frequencies, will have noted that whilst it is possible to obtain satisfactory results with a tuning coil, and parallel capacity arrangement, better results are obtained if the aerial or earth lead is tapped on to the coil, and that comparative tests prove that altering the tap position to another turn, or part of a turn, results in increased gain when the aerial tuner coil is returned after tapping adjustment. This illustrates in a practical manner the importance of resonance, especially in the case of directional reception, and the use of rotary aerial systems.

To take another aerial tuner example, there is the solenoid type fitted with a slider which makes contact with the bared portion of the coil. Thus adjustment of the slider in relation to different numbers of turns, semi-tunes the aerial.

In the instance outlined a definite signal gain is obtainable. But as the tapped coil is untuned, the gain to be expected is less than that obtainable when using a tuned H.F. stage.

Nevertheless, it is sufficient to warrant its use, and is definitely superior to the resistance and choke methods of coupling as common to untuned H.F. stages.

Coil Winding.—The winding of suitable coils offer a most interesting field of experiment and will, so far as the number of turns are concerned, depend upon the bands to be covered. The following data will assist in making a start, and other coils consisting of more or a lesser number of turns can then be wound to suit individual requirements.

1½ in. diameter paxolin former. 38 turns—26 gauge D.C.C. wire, close wound and tapped at 7, 10, 17 and 32 turns.

A coil of this type will cover the 18-metre to 75-metre bands approximately. A crocodile clip or rotary switch arrangement being used for tapping selection.

As an additional suggestion, experimenters should consider the construction of coils on plug-in lines, using seven-pin

valve bases as formers, or making up a series of bare wire space-wound coils with or without self-contained switching. To duplicate the coils used in the detector circuit, i.e., grid windings, is a good idea on which to base experiments.

Screening in the case of an untuned stage is unnecessary, but in view of possible conversion to T.R.F. the screen and additional panel space for tuning condenser mounting are included, thus obviating a complete rebuild. A slight modification of wiring only being necessary when the extra coil base and condenser, etc., are fitted in position.

Mounting the Coil.—The tapped coil should be mounted horizontally, and supported above the chassis by means of small stand off insulators. A crocodile clip being used for tapping purposes.

Alternatively, and when some method of switching is to be used the coil may be made on plug lines, and mounted vertically in a suitable folder. The number of sockets depending upon the number of tappings in addition to the two full winding connections.

Whilst arrangements for band-spreading are not shown in the circuit diagram, there is nothing to prevent the experimenter incorporating band-spread. In fact it will prove advantageous to do so.

Careful attention to correct tapping, and a series of cut-and-try experiments, will enable the operator to obtain a satisfactory standard of efficiency on all bands, especially the amateur bands. In the interests of calibration, and in order to avoid confusion, it is advisable to make a note of the tapping points in relation to the various bands covered, and the same applies to the individual coils if more than one is used.

CHAPTER VII

TUNED H.F. VERSUS THE SUPERHET

SELECTIVITY and sensitivity are factors of vital importance, and the superhet is undoubtedly the most selective and sensitive type of short-wave receiver available, and in addition, the colossal stage gain of this type of receiver cannot be disregarded. Superheterodynes, however, have their disadvantages, some of which can be overcome if one is prepared to pay the price.

Many, however, cannot afford to do so, yet desire short-wave reception via the loudspeaker, and consequently the T.R.F. receiver still enjoys a measure of popularity. If carefully designed and used in conjunction with a suitable aerial and earthing system, a reasonable degree of selectivity and sensitivity is obtainable. Selectivity and sensitivity, however, are much below superhet standards, although some improvement is noticeable when modern coils and H.F. pentodes are employed.

Tuned and Untuned H.F. Stages.—It is, however, generally realised that in order to obtain the maximum of H.F. amplification, the H.F. stages should be tuned. This, however, does not mean that untuned H.F. stages are absolutely useless. An untuned stage of H.F. has limitations, and so long as such are realised, and definitely understood, can be used to serve a purpose within those limitations. Usually, untuned H.F. stages are associated as buffers between the aerial and the detector stage.

A receiver in which two tuned H.F. stages are used requires very accurate coil matching and condenser ganging in order to obtain maximum sensitivity, selectivity and volume. To achieve all this is by no means a simple matter.

The degree of effective H.F. amplification obtained on the higher frequencies, falls a long way below broadcast standards, and whilst two tuned stages will obviously prove to be better than one, comparative tests have shown that the difference between a tuned H.F. stage, followed by an untuned H.F. stage as an alternative to the use of two tuned stages, is in

many instances not sufficiently marked to justify the extra controls and coil matching procedure.

Thus it will be appreciated that the use of a tuned H.F. stage, followed by an intermediate untuned stage, is under the circumstances worthy of consideration, as the loss in selectivity and sensitivity is very slight indeed.

An Experimental Receiver.—Whilst tuned and untuned H.F. amplification is under discussion, further applications of the latter might form a basis for useful experiment. For example, a carefully designed receiver, employing one or two tuned H.F. stages, is usually comparatively trouble free and simple to operate, especially when ganged tuning is incorporated.

Experimental models, however, sometimes behave in quite a different manner, and one of the most common symptoms experienced is instability due to self oscillation in the H.F. amplifiers, over which the operator has no control, and a definite cure must be found before any useful work can be done.

If, however, controlled oscillation or, to be correct, controlled regeneration in the H.F. stage, could be introduced, both sensitivity and selectivity would be considerably improved.

Whilst an attractive proposition, it is by no means a simple one, because the application of reaction during operation to one stage, would throw the other into oscillation.

The regenerative stages must, therefore, be effectively isolated, and the inclusion of an untuned intermediate H.F. stage would accomplish this successfully, because whilst allowing signals to pass through the set in the normal way, it would prevent feed-back between the detector and regenerative H.F. stage. The complete screening of each stage, and separate control of each reaction circuit, would be necessary, although there appears to be no reason why the tuned circuits should not be ganged, and a drum type dial used.

Experiments along the lines suggested, cannot be regarded as straightforward, due to the fact that the method adopted in order to overcome one snag, may create others. One fact, however, must be borne in mind, namely, that whilst some means of increasing the selectivity and sensitivity of the T.R.F. receiver is desirable, simplicity of control must not be sacrificed in order to do so.

Providing, however, that the application of high frequency regeneration can be applied, and simplicity of control retained.

there is no reason why the T.R.F. receiver should not regain the popularity lost to the benefit of the superheterodyne.

The Superhet.—For the benefit of those who are not familiar with this type of receiver, it can be explained, briefly, that it is a special type of circuit designed to provide a very high degree of selectivity and H.F. amplification. It will be appreciated by those who have had any experience with ordinary H.F. amplification that very definite limits are imposed, as regards the amount of amplification obtainable, by the general stability of the circuit. Special precautions have to be taken with even two H.F. stages, and if one attempts to obtain the maximum efficiency from each valve, additional troubles are introduced; therefore, more often than not, one has to compromise between maximum gain and stability.

With the superhet receiver these difficulties are practically eliminated by the principles involved in a circuit of this type, and these can be briefly outlined in the following manner. The wavelength (or, more correctly, the frequency) of the incoming signal is changed to a pre-arranged frequency at which all subsequent H.F. amplification is carried out. The input circuit is of perfectly standard design, but there is a special stage known as the frequency-changing stage. This may be the first stage in the receiver, or it may be preceded by one or more stages of standard H.F. amplification in which all the usual features are found. The frequency-changing stage may use a simple pentode with a separate stage consisting of a triode oscillator, or a special frequency-changing valve known as a heptode, octode, pentagrid, or triode-hexode. In all circuits the action is the same, namely local oscillations are generated and mixed with the oscillations of the incoming signal. A beat note is set up having a frequency which is equal to the difference between these two oscillations and, by suitably arranging the oscillator circuit, this beat note may be kept at a constant value. This is known as the intermediate frequency. Special transformers, known as I.F. transformers are then used to couple the remaining stages and only small pre-set condensers are fitted to these to compensate for circuit capacities. Thus no actual tuning is required at the I.F. and subsequent amplification is thereby possible to provide the necessary high signal strength and simplicity of tuning. It is possible to use up to three I.F. stages, each subsequent stage increasing selectivity and amplification, and then a

second detector is provided to rectify the signal from whence L.F. amplification is applied in the usual manner.

The usual intermediate frequency now in use is 465 kc/s. To avoid difficulties on the input side due to poor input selectivity one or two H.F. stages may be used and these are generally known as signal frequency stages. They remove various forms of interference, especially that known as second-channel interference which arises due to the fact that a signal may be present in the input circuits which has a frequency corresponding to a harmonic of the intermediate frequency or to the oscillator frequency.

Specialised types of superhet receivers make use of the above features plus additions designed to add to the advantages which have been explained. Amongst these may be mentioned the crystal gate, which is a special form of I.F. circuit where a piezo crystal is incorporated to increase still further the selectivity. As a superhet is not capable of being used for the reception of continuous wave signals it is necessary to introduce some form of controllable oscillation in order that the signal may be heterodyned and the continuous-wave signal thereby made audible. This special addition is known as a beat-frequency oscillator or B.F.O. and is coupled to the last intermediate frequency or the second detector stage.

Communication Type Receivers.—The communication type of superhet short-wave receiver, of which there are many excellent examples, stands undoubtedly in a class by itself. In its design are incorporated all the most desirable features which contribute individually and collectively towards outstanding performance and reliability. Efficiency and flexibility are the basic requirements, and all other considerations are of secondary importance.

For example, in one receiver the panel carries eight separate controls, in another six, and in yet another twelve controls. Ease of operation as associated with the domestic all-wave type receiver is not the subject of consideration. Maximum performance, electrical efficiency and precision mechanism, are the hall marks of modern communication receiver design.

The crystal filter incorporated in the single communication type superheterodyne receiver is by no means a new idea. The idea of employing a quartz crystal in order to sharpen considerably the selectivity of a tuning circuit was suggested at least sixteen years ago.

Apart from the fact that at that period, super-selectivity was

not called for, the cost factor relative to satisfactory quartz crystals made the idea impracticable. About nine years ago, however, Dr. Robinson, the inventor of the The Stenode Radiostat, utilised a quartz crystal filter in much the same way as at present.

The present conditions prevailing on the amateur bands can best be described as chaotic. A few years ago they were sufficiently bad enough to call for a super-selective receiver in order to assure some measure of dependability relative to consistent contacts. Taking into account the number of amateur operators in the U.S.A. an idea as to the congestion experienced is not difficult to imagine.

Single-signal Receiver.—The single-signal receiver uses a quartz crystal filter in the intermediate-frequency amplifier and enables extreme selectivity, more appropriately expressed in cycles as against kilocycles to be obtained.

In some instances the use of the crystal filter system enables selectivity hundreds of times greater to be obtained, as against any other method of selectivity increase.

Now this brings us to the factor which so far as the average short-wave listener is concerned matters most, and around which many erroneous ideas centre. The degree of selectivity obtainable enables the operator to tune in a complete mixture of continuous-wave telegraphy signals which can be best described as, and is, noise, due to the complete jumbling and overlapping of signals, and by switching in the crystal filter circuit the selectivity is increased to such an extent that the separation of individual continuous-wave signals is possible, unless, of course, more than one signal occupies the same frequency.

Now in achieving such a high degree of selectivity most of the side bands are removed, and the question arises as to how the reception of speech will be affected. The same principle applied to speech or music will result in unintelligible reception of a given transmission.

Increased Band-Width.—Where, however, provision is made to enable the selectivity as obtained by means of the crystal filter to be varied, it is possible to increase the band-width sufficiently to obtain intelligible speech.

For example, where series-parallel arrangements are provided in the crystal filter circuit, the series position allows a cut off of a few hundred cycles off resonance, and thus allows perfectly intelligible speech, but of course affects

quality, whilst by means of the parallel position the crystal phase control enables an interfering carrier to be reduced, and in some cases eliminated on one side of the desired frequency.

The foregoing gives some idea of the the communication type receiver, and the purpose for which it is designed and intended. It will thus be appreciated that the amateur communication type receiver is designed first to meet the exacting requirements of amateur and commercial communication.

This type of receiver can, of course, be used for short-wave broadcast, DX reception, and also medium-wave reception. High usable sensitivity, independent high-frequency and low-frequency volume or gain control enabling the operator to receive many transmissions which would otherwise be overridden by noise.

These features, together with short and broad intermediate tuning adjustments, and push-pull output, make high fidelity reproduction possible, exclusive, of course of the crystal filter.

The crystal filter cannot be used in this instance, due to the extended range of the musical frequencies as compared with those necessary for continuous wave and intelligible speech reproduction. To sum up, the communication type receiver as a DX short-wave broadcast and amateur proposition is undoubtedly an outstanding instrument. There is one point, however, which must not be overlooked. Price is a certain indication as to performance, and as we get into the higher price class even better performance is obtainable.

Now the average short-wave enthusiast cannot afford a receiver of this class, and is prepared to content himself with something less ambitious, preferring as it were results to ambition. He will be satisfied with a lesser standard of selectivity, and amongst the non-communication type receivers there is a wide field from which to choose. Thus a compromise can be struck.

So far as continuous-wave reception is concerned, the big and little sets compete on level terms, for whilst the former has higher sensitivity, and greater range plus greater output, the little set has a very low noise level, i.e., high signal to noise ratio.

Whilst it is possible to bring in at good strength telephony signals which are weak on the little set, the latter can, and often

does receive weak signals which due to the prevailing noise level are missed by the big set.

General Considerations.—For headphone reception of world-wide short-wave broadcasting, and amateur phone on all bands, many favour the straight two-valve receiver, in preference to a straight three in the interests of low noise, and also prefer to tune the aerial system in harmonic relation which, in addition to other advantages, assures maximum signal gain.

The straight three-valve receiver, however, enables occasional loud-speaker reception of the more powerful transmissions to be obtained.

The ideal dual purpose receiver for headphone and loud-speaker reception under average reception conditions is, to many minds, the tuned H.F. detector and one L.F. combination, or T.R.F.

For loud-speaker reception a four-valve untuned H.F. detector L.F. and pentode output is a useful arrangement—a similar arrangement with a tuned H.F. stage being, of course, better owing to increased H.F. gain and selectivity, and by the introduction of regeneration in the H.F. stage, sensitivity and selectivity can be further increased.

When receivers designed on the foregoing lines are contemplated it should be remembered that the maximum of amplification is governed by the permissible noise level, and that as we amplify the signal, so also is noise level increased. It is better therefore to amplify at high frequency, rather than at low frequency, in multi-stage regenerative combinations.

For world-wide short-wave loud-speaker reception, the superheterodyne with its high sensitivity, selectivity and output, is without a peer, and the prospective listener has a wide choice from which to select one most suitable to his requirements.

A careful study of the various points discussed in this chapter will, it is hoped, assist both active and prospective short-wave enthusiasts to decide as to future equipment and policy with some degree of certainty.

CHAPTER VIII

METRES, KILOCYCLES AND MEGACYCLES

THE majority of modern receivers are now provided with a tuning dial or scale marked in kilocycles or megacycles, and some difficulty is often experienced in being able to convert these into the more commonly used metre-scale. Most listeners think in terms of wavelengths in metres, but as will have been seen in the previous chapter the intermediate frequency of a superhet, for instance, is calibrated or reckoned in kilocycles. Incidentally the intermediate frequency mentioned in that chapter was 465 kc/s and this, in metres, would be 645·161 metres. Thus it is much simpler in many cases to refer to frequency in kilocycles or megacycles.

There are several other good reasons, one of which is that the wavelength range of a coil or receiver gives but a poor impression of the number of stations which can be accommodated within that range, or of the degree of selectivity which would be required in tuning. Thus, the long-wave range of 1,000 to 2,000 metres seems very extensive, whereas a short-wave range of 4·3 to 6·7 metres appears terribly restricted by comparison. Change the wavelengths to frequencies, and you find that the long-wave range is from 300 to 150 kc/s, and the range on the ultra-short waves referred to is from approximately 70,000 to 45,000 kc/s. In other words the long-wave range covers a band of only 150 kc/s, but the U.S.W. range represents as much as 25,000 kc/s, or more than 160 times as much.

The importance of this is apparent when it is appreciated that a minimum of 9 kc/s is required for any one telephony transmission. In consequence, it is clear that the number of stations which could be accommodated on the long-wave band without serious interference taking place is only 17, whilst in the same conditions nearly 3,000 transmissions could be accommodated on the U.S.W. band. The same conclusions show that tuning on the ultra-short-wave band mentioned is 160 times as sharp as on the long-wave band.

The mere fact that the band-width required for any transmission is given, and can only be given, in terms of frequency is also a strong point in favour of this method of expression.

Megacycle Bands.—Even if we are to assume that the frequency notation is unnecessary on medium and long waves, it is at least very desirable on short waves. Those who make a habit of listening to amateur transmissions will find that the transmitters generally speak in terms of frequency, and if those terms are not understood a good deal of interest is lost. Besides, a difference of, say, 20 kc/s is the same on any wavelength, whereas a difference of 1 metre varies considerably according to the wavelength range which is being considered.

As many amateurs are no doubt aware, the ranges over which amateur transmitters can work are given in terms of megacycles. Thus, the so-called 20-metre amateur band is referred to as the 14-megacycle band, and the 40-metre range as the 7-megacycle band. It should be explained here that 1 megacycle is equal to 1,000,000 cycles, and that 1 kilocycle is equal to 1,000 cycles (per second). Now that quartz-crystal control of wavelength is used universally, the transmitter must order his crystal according to the frequency for which it is required; these crystals are not sold in wavelength gradations.

Going a little further, we have the main tuning bands used for short-wave broadcasting stations, these being the 21, 15, 11, 9, and 6 mc/s bands, which correspond with wavelengths in the regions of 13, 19, 25, 31 and 49 metres respectively.

Wavelength to Frequency.—It is, of course, a fairly easy matter to convert the tuning point in wavelength to the frequency in kilocycles or megacycles, but it is far better to try to *think* in terms of frequency than to think in wavelengths and constantly have to make mental calculations to convert from one to the other. In this respect, the matter is not unlike that of learning a foreign language. Those who are at all fluent in foreign languages tell us that in order to gain fluency it is essential to think in the foreign language, rather than to think in terms of the mother tongue and then to translate the thoughts.

In any case, it is better to have one system of notation than two; and since the frequency notation is a practical essential, for reasons given above, it is better to use this alone.

Those who are at present familiar with the wavelength notation can easily become accustomed to the other system after a little practice and by making an effort to think in

terms of frequency. For example, 300 metres is equivalent to 1,000 kc/s or 1 mc/s. As wavelength is increased, frequency is reduced, and vice versa. Thus, a wavelength of 600 metres is equivalent to a frequency of 500 kilocycles, whilst a wavelength of 150 metres corresponds to a frequency of 2,000 kc/s or 2 mc/s. In the same way, a wavelength of 30 metres (one-tenth of 300 metres) is the same as a frequency of 10 mc/s (ten times 1 mc/s). Carrying this idea further, it can be seen that 5 metres is the same as 60 mc/s, or that 10 metres is 30 mc/s.

Another Method.—Another method of conversion, which might be considered more convenient by some amateurs is to divide the wavelength into 300,000 to obtain the result in kc/s. From this we can see that 20 metres is equal to 15,000 kc/s or 15 mc/s. It can also be seen that the answer can be obtained in megacycles by dividing the wavelength into 300; 5 metres is 60 mc/s. The reason is that wireless waves travel at the same speed as light, which is 300,000,000 metres per second (equivalent to about 186,000 miles a second). Thus, if one wave were 300 metres long, for example, 1,000,000 such waves would be created in one second. This is the same as saying that the frequency of the waves is 1,000,000 per second. One alternation (or frequency) is referred to as a cycle, and thus 300 metres is equivalent to 1,000,000 cycles, 1,000 kilocycles, or 1 megacycle per second.

Frequency in megacycles can be converted to wavelength in metres by dividing the frequency into 300.

CHAPTER IX

MASTERING THE MORSE CODE

MUCH greater interest may be added to short-wave listening if you are able to understand the Morse Code, as many transmitting amateurs make use of this method of communication and practically the majority of real long-distance work is carried out by code. Thus, if you can read these signals you will be able to add to your records as well as increase the interest which your radio set brings you on the short waves.

ALPHABET	FIGURES
A ---	1 - - - - -
B - - - - -	2 - - - - -
C - - - - -	3 - - - - -
D - - - - -	4 - - - - -
E -	5 - - - - -
F - - - - -	6 - - - - -
G - - - - -	7 - - - - -
H - - - - -	8 - - - - -
I - -	9 - - - - -
J - - - - -	0 - - - - -
K - - - - -	
L - - - - -	
M - - - - -	
N - - - - -	
O - - - - -	
P - - - - -	
Q - - - - -	
R - - - - -	
S - - - - -	
T - - - - -	
U - - - - -	
V - - - - -	
W - - - - -	
X - - - - -	
Y - - - - -	
Z - - - - -	

OPPOSITES	
A ---	N - - - - -
B - - - - -	V - - - - -
C - - - - -	D - - - - -
D - - - - -	U - - - - -
E -	F - - - - -
F - - - - -	L - - - - -
G - - - - -	G - - - - -
H - - - - -	W - - - - -
I - -	Q - - - - -
J - - - - -	Y - - - - -

Fig. 11.—The morse alphabet with opposites shown for memorising.

The first step is, of course, to acquire a knowledge of the code, and for those who have not yet done so we give in Fig. 11 the alphabet, and also the grouping of the letters in "opposites", and by learning the latter it is not such a difficult matter to remember the symbols. It is necessary to learn the symbols by the "tune" of the letter, and not merely to remember, for instance, that *J* is dit, dah, dah, dah. As an aid to memory in this connection you may make use of the following phrases for certain letters. For the letter *F* memorise the phrase "Did it 'urt yer"; for the letter *L* (the opposite of *F*), remember "Of course it did". *Q* memorise "God Save the Queen"; As an opposite to *Q*—the letter *Y*, remember the opposite of the *Q* phrase—"Queen, the God Save".

Figures.—The figures are quite easy to remember, the numbers 1 to 5 being dots in that order and 6 to 0 being dashes in that order, each number totalling five dots or dashes. Thus 1 is one dot followed by four dashes; 2 is two dots followed by three dashes and so on. Having memorised the

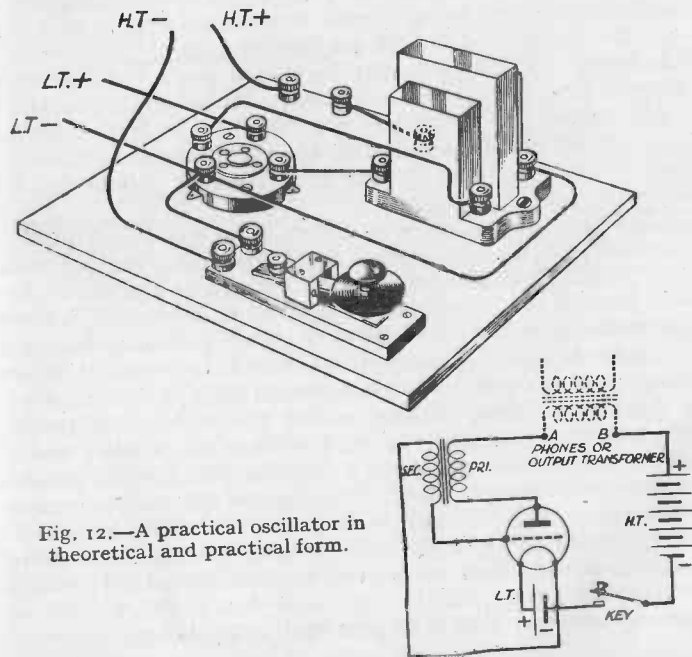

Fig. 12.—A practical oscillator in theoretical and practical form.

symbols it is now necessary to acquire practice in reading and recognising them and in this connection there are two simple schemes. In the first you can obtain gramophone records; and in the second you can send the symbols by means of a key and oscillator—listening to your sending over a loud-speaker or in a pair of headphones. For the oscillator you need a valve of the general purpose type, an L.F. transformer—any ratio will do—and the necessary H.T. and L.T. supplies. These are wired as in Fig. 12 and the key inserted in the H.T. negative lead. The H.T. voltage is critical and if too low or too high an audible note will not be obtained when the key is depressed. Adjust the H.T. until a suitable note is obtained, and thus an H.T. battery tapped at frequent intervals should be used. The records are obtainable from Columbia (Nos. 3262/4) and from F. L. Masters. The former consists of a set commencing with the code and figures and passing on to commercial messages all sent at a nominal speed of about 20 w.p.m. A book is supplied with the records giving the translation, but unless you have a clockwork gramophone motor capable of being slowed down considerably you may find these records are a little too fast for a start. The majority of electric turntables cannot be slowed down to bring these records slow enough for a beginner. However, if practice is first carried out in sending the messages from the printed copy, facility will be gained in the identification of the various symbols and the records may then be played and the messages more easily read.

The Masters record is at a nice slow speed and may be speeded up with a clockwork motor to 20 w.p.m., but again the small speed control afforded with most electric motors will probably only enable the speed to be controlled between approximately 6 w.p.m. and 12 w.p.m. The main feature of this disc is the nice musical note which is provided, in distinction to the rather 'spark' tone of the Columbia discs.

Acquiring Speed.—These records are mainly for reading practice, but both may be used for sending practice and at the same time will enable you to increase your reading practice or powers of concentration by adopting the following procedure. An amplifier with an input mixing circuit is needed so that the output from the pick-up and the output from an oscillator such as already been mentioned may be mixed. If you do not possess an amplifier you can use your ordinary radio receiver, provided that it is provided with pick-up sockets or

terminal. Two separate volume controls are needed, one across the pick-up and one across the output from the oscillator. These are connected as shown in Fig. 13 the two leads being joined to the pick-up terminals or sockets. Using, for instance, the first Columbia record in the set mentioned, adjust the volume control until the note from the record is approximately the same level as that delivered from the small oscillator when the

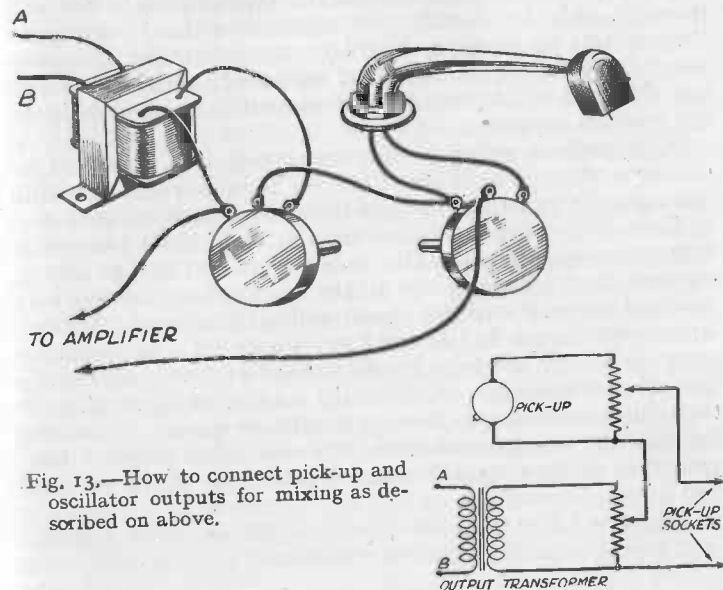

Fig. 13.—How to connect pick-up and oscillator outputs for mixing as described on above.

key is depressed. With the copy of the message before you start the pick-up and take hold of the key. The moment the message on the record commences, start to send and endeavour to read from the copy both the letter and the symbol as printed, at the same time sending the appropriate dots and dashes, keeping the note from the oscillator in step with the pick-up note. At first you will probably find it difficult to obtain *one* note from the speaker, but as your oscillator will undoubtedly be of a different pitch from the record note, you will quickly see whether you are lagging behind or sending too fast. This practice will not only enable you to concentrate better, but will control your sending speed and ensure correct

spacing and at the same time familiarise you thoroughly with the symbols for each letter.

Speed Aids.—The drawback normally with a record is that you will become familiar with the message, but this method of sending with the record will give you ideal practice in sending and by speeding up the record you can acquire perfect practice at sending up to 20 or 25 w.p.m. with correct spacing. If you can devote one hour a day to this type of practice you will soon be able to identify the symbols without having to "translate" each one and will soon acquire the necessary speed. By tuning on the short waves at special times you can also pick up amateur transmissions in slow speed designed for practice purposes.

When endeavouring to increase speed it is desirable to obtain a message at a speed greater than you can normally manage. It will then be found that you have to work two or three letters behind, but when a symbol comes which you cannot immediately identify, don't wait and try to sort it out but forget it and go on to the next letter. In this way you will keep up with the speed and gradually the "faulty" letters will drop into line until every symbol is immediately recognised. Do not keep trying to read at speeds which you can do comfortably. Always try and work beyond your capabilities so that you force yourself into speed. Thus with the records, set them so that they are going just too fast, and when picking up code stations select one which you find just a little beyond you.

CHAPTER X

MINIMISING INTERFERENCE

DESPITE the great improvements which have been effected in short-wave working the interference problem is still one which calls for a good deal of attention. This is the case on short waves, in particular, because many forms of electrical disturbance which are quite inaudible on a broadcast set are "received" strongly with a short-waver. The reason for this is obvious, for it is simply that the electrical charges are roughly tuned to a frequency corresponding to a wavelength on the short-wave band.

A case in point is the crackling heard when a car passes fairly close to the aerial. In the case of the average broadcast set the radiation from the ignition equipment passes entirely unnoticed. But tune the receiver to 20 metres, for example, and the interference is easily picked up. When the receiver is tuned to a still lower wavelength the interference very often increases in intensity, so that on 7 metres its field strength might be greater than that of the signal it is wished to receive. In every case, the most important factor is the ratio between signal strength and the strength of the oscillations comprising the interference. Thus, even in the face of powerful interference pick-up, good reception might be obtained from the local station—because signal strength is much greater than interference strength, if such a term can be accepted.

Signal-Interference Ratio.—There are two important reasons for this, one of which is that a strong signal has the effect of "wiping out" weaker interference in just the same manner as a loud noise tends to "kill" one of lesser intensity. The other reason is that, when the signal is sufficiently powerful, the volume control can be turned down to such an extent that the receiver does not respond to any measurable extent to the interference.

In referring to interference above it has been assumed that this is of the type which is radiated; not transmitted along the mains leads into the power supply portion of the set. The latter form of interference must be treated differently. Radiated interference is picked up, as a rule, by the

aerial-earth system, although long speaker leads, battery leads or unscreened connecting wires might occasionally act as "collectors".

Lead-in "Pick-up".—If it is assumed that the receiver has been properly designed so that connecting leads are short, and if a by-pass condenser has been fitted (Fig. 13a) to lead away to earth any interference picked up by the speaker leads, it will nearly always be found that by far the most prolific "collector" of interference is the aerial lead-in. It must not

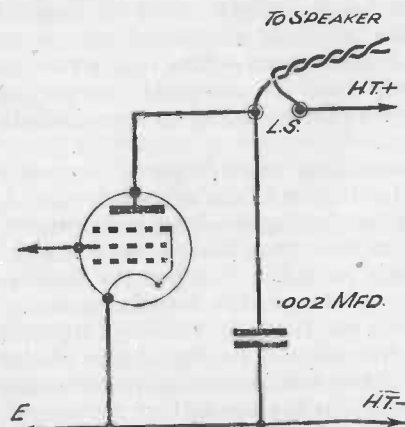

Fig. 13a.—A by-pass condenser on the output stage to prevent instability.

be overlooked, however, that a long earth lead—especially if it has a fair resistance and is insulated—might prove equally troublesome. This is a point which is often overlooked, but it is evident that an earth lead a few yards long can have a very high resistance to high frequencies (short wavelengths), and thus a strong "interference signal" might be built up along it.

Aerial-Matching Transformers.—One method of overcoming this trouble is to use a pair of high-frequency transformers, connected as shown in Fig. 14. These are of special design and are made by several manufacturers. The transformer connected between the aerial and the lead-in provides a step-down ratio, whilst that between the lead-in and the set steps

up the signal voltages. Roughly, the consequence is that the low voltage (H.F.) passing down the screened lead-in has less tendency to leak away through the screen to earth. On reaching the second transformer the voltage is stepped up to its original figure before being applied to the set.

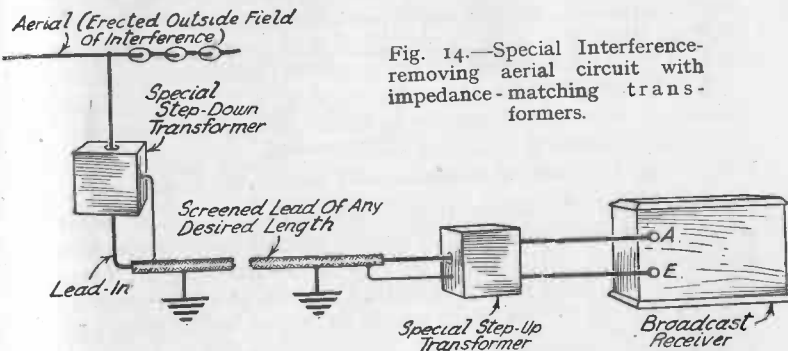

Fig. 14.—Special Interference-removing aerial circuit with impedance-matching transformers.

Special Aerial Systems.—This arrangement has proved extremely successful, but improved systems have more recently been developed which are more satisfactory for short-wave work. In fact, the question of short-wave aerial design as a whole has been very thoroughly investigated during the past few years, and several novel systems have been developed. A good deal of rather advanced mathematics is involved in working out the ideal aerial system for no loss, anti-interference reception, for which reason several manufacturers have now placed on the market complete aerial systems designed after considerable research in their laboratories. These special aerals are definitely worth while, although they are rather expensive, and prove that our old ideas of aerals were rather crude. The experimenter who is familiar with mathematics might work out his own design, but most readers have no great liking for calculations and prefer to experiment with more "rule-of-thumb" methods.

The Doublet Aerial.—There is no reason why this should not be done satisfactorily once the main features are understood. It has been found that the best type of simple aerial for the amateur is that known as the doublet, and which is arranged as shown in Fig. 15. It will be seen that the aerial is a mixture of a T and an inverted-L. There are actually two inverted-L aerals arranged end to end, the two lead-in wires

being twisted together, and the most important point is that the length of the two horizontal portions be correctly chosen. Theoretically, this length should be different for every wavelength, but it is obvious that this could not be arranged except in the case of a transmitter. Each of the horizontal

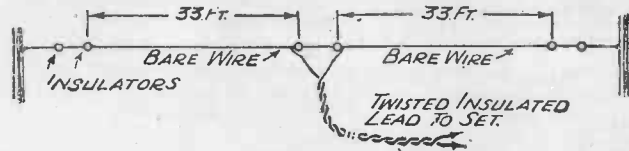
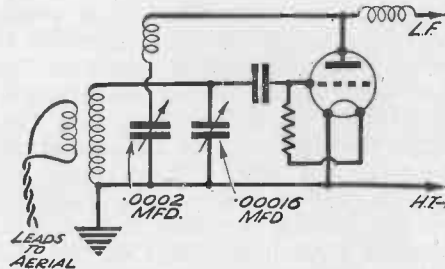

Fig. 15.—General arrangement of the Doublet Aerial.

portions should be one-quarter wavelength long, or, in other words, their combined length should be one-half wavelength. As an example, if the aerial were to be designed for 20-metre use, each horizontal span should be 5 metres, or approximately 16½ ft.; for 30 metres, each would be about 25 ft. long, and so on.

Fig. 16.—How a doublet or similar aerial is connected to a standard receiver circuit.



It is worth noting, however, that a 40-metre doublet will also operate at almost maximum efficiency at 20 metres and 10 metres. But although an aerial of this type is most sensitive at half its resonant frequency, it can be used satisfactorily at other frequencies within a good range. Because of this, a doublet made for 40-metre working is satisfactory for all the most frequently used short wavelengths, which are the bands around 19, 20, 31 and 40 metres. The first and third wavelengths mentioned are those used by broadcasting stations, the second and fourth being those employed very largely by amateur transmitters.

Simple Matching.—Even when using a doublet aerial it is sometimes preferable to insert some form of matching device,

in the shape of an H.F. transformer, but this can be avoided simply by connecting the two lead-in wires to the ends of a separate aerial-winding on the input coil, as shown in Fig. 16. It is, however, very well worth while to experiment with different numbers of turns for this winding, whilst it is a good plan for the experimenter to make a few alternative tappings, so that the best can be found for any particular wavelength. For most purposes it will be found that the most suitable number of turns on the aerial winding is about half that on the grid winding, but it is definitely worth while to experiment.

Another point is that for theoretically-best results the lead-in should be of approximately the combined length of the two horizontal spans, but this must very largely be governed by circumstances.

The Lead-in.—As to the practical arrangement of the aerial it should

be pointed out that the twisted lead-in should consist of vulcanised-rubber wire which is not affected by the atmosphere, although another system which is just as good is to use bare wire supported by the special separating blocks which are now made by two or three firms.

A set of these is shown in Fig. 17, from which it may be seen that the wires are crossed at intervals and are insulated by the blocks. It is generally satisfactory to place the separators at about 18 in. intervals in the run from the aerial to the leading-in point, from which the lead to the set can be of ordinary good-quality twisted flex.

Despite the fact that the top span of the aerial are shown and have

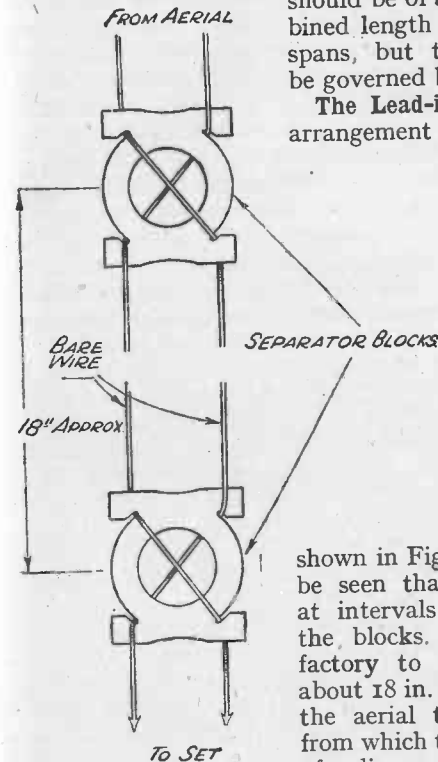

Fig. 17.—The transfeeder or crossfeeder system of aerial lead-in.

been described as horizontal it is not essential that excessive care should be taken in this respect, and it is often more convenient to allow the complete aerial to slope from the house to a convenient post or other fixing. It is better that the two spans should be in a straight line, but it has been found that efficiency is not seriously impaired by mounting them at right-angles; other angles are not recommended and are rarely as good.

Screened Transformer.—When interference is in evidence despite the use of a doublet, a simple shielded-primary transformer can be used as shown in Fig. 18. This can be

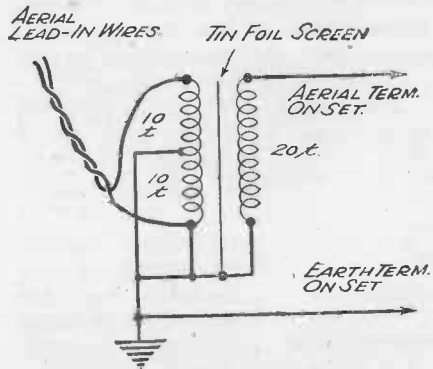

Fig. 18.—A special shielded primary aerial transformer.

made by winding 20 turns of 22-gauge D.C.C. wire on a 2-in. diameter paxolin former, and taking a tapping at the exact centre. This winding should be covered, except for a gap of about $\frac{1}{4}$ in. with tinfoil, after which the secondary—consisting of 20 turns of the same wire—can be wound over it. The tinfoil acts as an electrostatic screen with the result that the coupling between the two windings is purely inductive. Notice that the screen, as well as the centre tap of the primary and one end of the secondary, is earthed.

Screening Aerial Down-leads on Short Waves.—Until recently it had been well-established that screened aerial down-leads would only exclude electrical interferences on medium and long-wave broadcast wavelengths. Whereas those of small diameter and high capacity necessitate impedance matching to cover wavelengths between about 200 and 2,000 metres, the type having a large diameter and low capacity can be employed on wavelengths as low as 75 metres, merely by careful choice of a low tapping on the aerial coil in the set.

Below 75 metres the self-capacity of even the low capacity screened lead, bearing in mind that lengths of 20 to 50 feet are usually employed, begins to assume a capacity-reactance which is only of a few ohms. At wavelengths bordering on 16 metres there is virtually a short-circuit to earth of the minute high-frequency signal currents, and hence the losses are such that the signal pick-up from the aerial is non-existent at the aerial terminal on the receiver.

Due to the heavy signal losses encountered on short-waves, it has been the universally acknowledged practice amongst designers and manufacturers to dispense with screened down-leads for all-wave aerial kits. The main purpose of those aerial systems evolved has been directed to efficient and noise-proof short-wave reception, and although the writer may be taken seriously to task, it must be stated that generally little regard has been taken to provide for similar noise-free results on medium and long waves.

Now in fairness to all concerned, it should be made quite clear that it is an extremely difficult matter technically, to design an all-wave aerial which while completely excluding electrical static on the downlead on medium and long waves, does so to an equal extent, or alternatively without serious losses, on short wavelengths. The position is best explained by merely considering simple unadorned aerial schemes.

Reducing Length of Aerial.—Whereas a simple T or inverted-L aerial will provide a high measure of signal current on broadcast wavelengths (including long waves), its efficiency rapidly deteriorates the lower the wavelength the set is tuned below 200 metres. By reducing the length of the horizontal-span so that it *approximates* in length to the actual fundamental or $\frac{1}{2}$ or $\frac{1}{4}$ of the actual transmitted frequency (wavelength), much better results are achieved on short waves. Note the singular "frequency"; the length of a short-wave aerial span can only be adjusted to one particular wavelength. The problem is obviated by using two horizontal spans of dissimilar lengths, each of which is adjusted to cover a band of wavelengths each side of its natural resonance point. Connection to the receiver is made by means of a twin cable, which according to present-day practice, can either be twisted or arranged as a cross-over type with insulators spaced at regular intervals. Both kinds of turn down-leads are un-screened, it being a condition of the coupling unit at the receiving end that it should cancel out and earth

interfering currents due to electrical static induced equally into both leads. Owing to the true signal currents being of an oscillating nature, they are passed on to the receiver *via* suitably coupled windings. To avoid attenuation, the windings in question must be tightly coupled, but the transference of interfering currents due to the resulting mutual capacity can be avoided by statically connecting the coils. In any event, some loss of efficiency is bound to occur, but it will be found that it is of small magnitude compared to that on medium and long waves, due to the cutting down of the aerial spans.

The use of dissimilar horizontal aerial spans theoretically does not provide an equal signal oscillatory current in the twin down-lead, and hence some makers arrange their kits with aerial spans of similar length to achieve this object. Furthermore, the lengths of wire chosen are at the best a compromise with regard to the natural aerial wavelength and complete all-wave coverage. It is perhaps fortunate that most all-wave receivers have a considerable reserve of amplification, which together with the usual A.V.C. action, completely masks losses due to the serial and at short wavelengths somewhat removed from the resonance point.

Twin-feeder down-lead aerial systems undoubtedly provide a large measure of relief from electrical static on short waves but due to these interferences being of a different character on higher wavelengths, the noise-reducing properties described become increasingly less effective towards the medium waveband. One solution which has been consistently advocated by some experts for overcoming the difficulty of electrical static elimination is to employ two separate and distinct aerials, the first to be used for reception between 13 and 75 metres and the other 75 and 2,000 metres.

Each aerial would be arranged in the most desirable manner for reception at the particular frequency ranges desired and of course without the necessity for compromise in design. It is a regrettable fact that very few listeners view the proposed scheme with favour, as objection is often raised to the use of even a single outdoor aerial, which is essential if carrier-wave radiations are to be received clear of local zones of interference.

All-Wave Aerials.—Much thought has recently been given by designers to the problem, that is, to arrange an all-wave aerial with a screened down-lead which at the same time will not too seriously attenuate short-wave transmissions. The

first commercial model of this type is the "Eliminoise" produced and described by Belling and Lee in *Bulletins* Nos. 26 and 27. This consists of a twin-screened twisted down-lead of the standard "Rejectostatic" type, coupled to triple-range step-down aerial and step-up receiver transformers, the former having a ratio of 6 to 1 to match the 110-ohm twin-screened transmission line. Although insertion losses occur, these are carefully apportioned to fall at the least used wavebands. In terms of noise-free signals, where the volume control may be advanced without the introduction of static, it may be said that the actual result is a gain in aerial input at the set. Readers who desire further detailed information are advised to refer to the bulletins.

An opening statement to the effect that even a single conductor low-loss screened down-lead reduces short-wave signals to a negligible value at the receiver input is only true when the screening acts as an earthed casing for the central down-lead conductor. Every twin and single-screened down-lead, has a surge impedance which can vary between wide limits, although usually between 70 to 120 ohms and depending on the physical construction. By matching the aerial impedance to that of the down-lead—whatever the screened type—the latter no longer acts merely as a capacity, but as a transmission line or feeder. A twin *unscreened* down-lead acts in a similar manner except for one important difference. Whereas it can be affected by intense static radiation, particularly if created within a few feet on it, the screened equivalent, with the outer metal sheathing earthed, completely guards the "live" central conductors even when *touching* an offending electrical appliance.

Single-screened Leads.—For general all-wave reception there is reason to assume that the usual small diameter twin-screened feeder offers better possibilities of consistent results than equivalent single-screened conductors. Low-loss single-screened leads, or coaxial cables, of large diameter (such as "Metocel") on the other hand are more suited for *fixed* ultra-short wavelengths, such as used for television. By careful matching, the aerial and down-lead can be made very efficient at the fixed wavelength for which they are designed. It is a question of coupling a 7-metre aerial, which can be a single half-wave vertical or a twin quarter-wave horizontal di-pole, each of approximately 5,000 ohms to a coaxial feeder of "Metocel" which has a surge impedance of about 96 ohms.

In the former case the vertical aerial being half-wave, would necessitate a physical length of 3.5 metres or 11 ft. 6 in. Matching is effected by parallel wires approximately 4 in. apart and each 5 ft. 9 in. long (1.75 metres). One wire is an extension of the central coaxial conductor and terminates vertically as a dead-end. The *equivalent* parallel wire is a bottom extension of the vertical aerial, and connects to the screening of the down-lead.

To erect this aerial clear of interference zones it should be hung from, say, a 20 ft. to 25 ft. mast, mounted on the roof, and at a point as far removed from the roadway as can be arranged. The reason for this precaution is that ignition static due to motor cars, is vertically polarised and can impinge on the vertical collector. An even better plan is to erect the aerial on a high mast at the back end of the garden and run the coaxial feeder to the receiver along the fence on insulators.

Horizontal Di-pole.—For a 7-metre quarter-wave horizontal di-pole each span will be 5 ft. 9 in. long. The impedance at the centre will be approximately correct for the "Metocel" feeder, the inner conductor and external metal sheathing of which will connect direct to the inner aerial ends respectively. In both cases the outer metal screening of the cable can be earthed, a condition satisfying electrical static exclusion.

A low-loss coaxial cable can be fitted with a pair of twisted insulated conductors to provide a variety of aerial arrangements and not necessarily for fixed wavelength reception. The provision of an all-wave noise-proof aerial system with screened down-lead to extend down to 7 metres can hardly be considered a practical proposition, that is, if severe attenuation is to be avoided.

It has been clearly demonstrated that high efficiency on short waves down to about 13 metres is wrapped up with aerials, which must bear a physical relationship to the actual frequency to be received, and that any departure from this practice results in losses.

CHAPTER XI

TUNING SHORT-WAVE AERIALS

A WELL-DESIGNED receiver of the O-V-I type is capable of really good average performance, within defined limits, especially if fitted with band-spread tuning. A T.R.F. receiver will provide higher sensitivity and selectivity, and consequently superior performance. Where amateur phone reception is the chief interest, the need for increased selectivity is apparent, and for this reason comparatively short aerials are favoured in some instances. The essential factors of an aerial system are many. One of the most important is pick-up. The greater the pick-up the greater the signal input to the receiver. With an aerial of extreme length and average height the signal pick-up will be high, so also will the level of background noise, and in addition, tuning will be comparatively flat, and selectivity poor.

On the other hand if we make the aerial extremely short, with a view to greater selectivity as the motive, we find that signal pick-up, and consequently, signal output, is reduced, and additional amplification at high frequency is necessary if the minimum of noise is to be obtained.

Eliminating Background Noise.—In some instances low-frequency amplification is resorted to, with the result that background noise is increased beyond the permissible level.

Where a powerful receiver of the two H.F. type, and with one or more L.F. stages is used on a half-wave type aerial, it is usually found that the ratio of signal to noise is well balanced and selectivity of a reasonable order.

If, however, an attempt is made further to improve selectivity by means of a shorter aerial, the reduced pick-up and resultant decreased output calls for a readjustment of the pre-detector volume control in order to increase the input. Here again we find that the background noise is above permissible level.

A considerable improvement can be effected by means of an external tuned circuit, which enables the operator to tune the aerial in harmonic relation and sub-harmonic relation to the received frequency.

Such arrangements, whilst comparatively simple in design,

must be carefully designed and constructed to meet individual requirements, and are a subject for careful experiment in order to obtain the maximum of efficiency.

Rotary Aerials.—This applies especially where used in conjunction with rotary receiving aerials, as the correctly designed tuner, whilst providing additional gain, will also increase the over-all sensitivity of the aerial system so that the increased voltage set up by directional alignment will result in peak volume being obtainable, simple by rotating the aerial system. Unsuitable tuners, provide considerably less gain than the recommended types.

Whilst the foregoing example gives an idea as to the importance of correct tuner design we are only concerned in this chapter with tuners suitable for use with single wire aerials.

Details of Tuner.—Fig. 19 shows a very simple method of aerial tuning. It will be noted that the aerial coupling is of the series capacity type, a $.00005$ mfd. pre-set condenser being used in series with the aerial. The coils are of the four-pin type.

The tuner can be built up as a separate unit, consisting of a coil tuned by a $.0003$ mfd. condenser in parallel. This coil is wired across the aerial and earth terminals of the set, the lead on the aerial side being broken by a switch. Coils of various diameters and numbers of turns, but of stout gauge wire, and spaced one diameter of wire can be tried, the number of turns being varied to suit the ranges covered by the receiver. 3-in. diameter is suggested as a basis of experiment. Turns 2-, 4-, 6- and 8-spaced.

Operating Notes.—The operating procedure is as follows. With the switch open, tune in the desired signal on the receiver. Follow this by closing the switch, and tuning the coil *A* of the aerial-tuner unit until the absorption point is reached. The signal will be absorbed, as in the case of an absorption wave-meter. The tuner condenser should be backed off just below the absorption point, and the necessary adjustments made to the receiver tuning to bring in the signal with

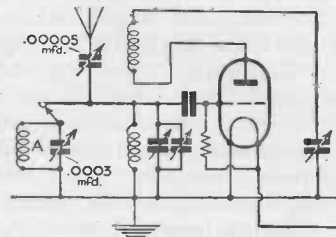

Fig. 19.—An easy method of arranging for aerial tuning.

maximum volume and lowest noise. Arrangements of this type can prove tricky at first in operation, but this is due to maladjustment causing interlocking, and instability.

A little practice, and the logging of various tuning positions and tuner-coil combinations, etc. will enable the operator to derive full benefit from this simple arrangement, such as stability, increased volume, and improved selectivity with minimum background noise.

Link-Coupled Tuner.—Fig. 20 shows a more complicated link-coupled arrangement. This consists of a series-aerial tapped coil, tuned by a $.0003$ condenser in parallel, and with the coupling-link between it and the grid coil of the receiver.

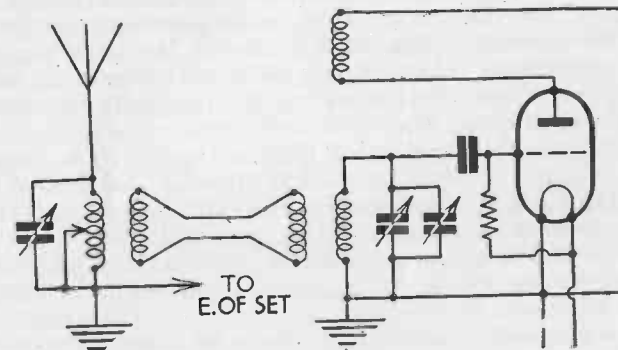

Fig. 20.—A very simple method of link-coupling.

This arrangement offers considerable scope for experiment, and requires very careful adjustment for optimum results. A $2\frac{1}{2}$ -in. diameter former with 28 turns of 16-gauge tinned-copper wire, spaced $\frac{1}{8}$ -in., is suggested as a basis of experiment, and the link-coupling coils should consist of 2 or 3 turns of 28-gauge D.C.C. wire interwound at the aerial end of the former with the main coil. The link, however, should not be of twisted flex, as this would cause the adjustment of the tuned circuits to be very critical, and prone to instability.

A good twin-feeder line is most suitable for this purpose. Link lines may be of any reasonable length, which thus allows tuners to be used under circumstances in which the receiver is located some distance from the aerial.

Correct coil tap adjustment, and also link adjustment is essential. If this is done by means of adjustable primary

couplers to the receiver grid coil, as described elsewhere in this book, the link to the grid-coil coupling can be varied, and some similar form of variable coil-coupling is applied to the tuner tapped coil, an adjustment which will provide a high signal ratio with low noise component, and improved selectivity will be possible.

Experiments of this nature are unsuitable for the half-an-hour lash-up type of experimenter, as they require patience, careful construction, and adjustment, in order to achieve the most satisfactory results.

The use of link-coupling definitely increases the selectivity factor, but the possibilities of interlock are also increased.

Maximum Signal Gain.—Where additional signal gain is the ultimate objective, experimenters in some instances go all out for the tightest possible coupling between the aerial and grid coil respectively, thus obtaining maximum volume. In doing so, however, selectivity is decreased, and instability introduced. On the other hand, where sufficient amplification at high and low frequency is available and increased selectivity is desired, the coupling between the additional aerial resonance tuner and the receiver, is slackened to the extreme limit, and thus the noise level is increased beyond practical limits.

This state of affairs prevents the advantages of additional sensitivity, as derived by the use of resonance aerial tuning, from being used to advantage.

It is necessary to keep in mind that as we increase selectivity, some decrease is to be expected in output signal volume, therefore it is necessary to strike a compromise between signal output, selectivity, and sensitivity.

When six-pin type coils are to hand, the link system can be used to considerable advantage, as the primary winding can be used as the link to the grid coil, this system of coupling combining the advantages of tuned doublet coupling, to single-wire aerials of the Marconi type.

Generally, where tuners are built as separate units, it is advisable to use metal panels at earth potential in the interests of stability. With careful design, increased gain equal to that of a stage of H.F. is possible.

CHAPTER XII

MAKING A SCREENED AERIAL-COUPLER

REFERENCE has already been made to aerial-couplers for the elimination of man-made interference, and the following is a description of a suitable device of this type. The diagrams show connections for the doublet type of aerial, as it is assumed that the ordinary single wire aerial will not be in use where man-made static is prevalent. The same arrangement can also be used where an ordinary conventional aerial is employed, but it is not so effective.

Figure 21 shows the conventional coupling for a doublet aerial, and readers' attention is directed to two points. The transference of energy from *A* to *B* is only considerable when

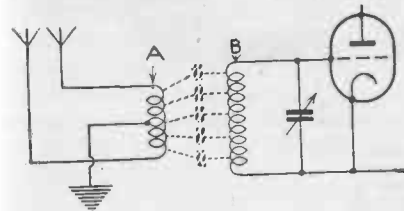

Fig. 21 (left).—This diagram indicates the self-capacity which exists between aerial and grid coils.

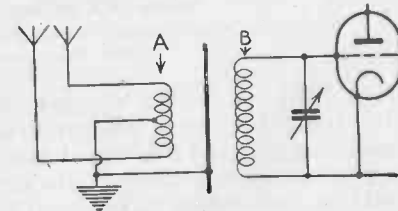

Fig. 22 (right).—This shows how the interposition of an electro-static screen removes the self-capacity effect.

B is tuned to the frequency of such energy, but the transference of any voltage by means of capacity between *A* and *B* will be quite considerable, irrespective of frequency considerations; consequently if the transferred energy from *A* to *B* by virtue of the capacity between them could be eliminated, a considerable amount of electrical interference would be avoided. The capacity existing between these two coils is diagrammatically represented by a series of condensers, shown dotted. Figure 22 shows an earth screen interposed

between coils *A* and *B*, which reduces the capacity existing between them to a negligible extent while not greatly affecting the magnetic coupling between them.

Coil Construction.—The construction of such a coil is shown at Fig. 23, which indicates both end and side views. The grid coil (coil *B*) is wound on a paxolin former, and wrapped round with insulating material, either thin sheet ebonite, or Empire

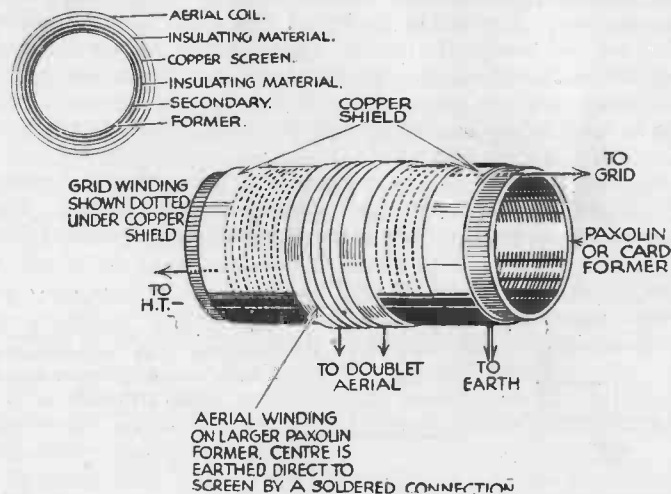

Fig. 23.—Constructional details of the screened coil referred to in this chapter.

cloth. The coil is then wrapped round with copper foil, and then round the centre the aerial coil with, of course, suitable insulating material between it and the copper foil. Where a coil of lower loss is desired, the conventional air-spaced grid coil may be wound with sufficient glass beads threaded on the wire to form a stand-off insulator for the copper screen, which can be of sufficiently stout material to prevent it from getting out of shape and touching the grid coil between the glass beads. You can make a series of very efficient coils using circular copper screening cans with the closed end cut off to form a tube, and the grid coil made to fit snugly inside supported by the glass beads above referred to. The aerial coil can be wound on the outside of the tubular screen by using glass beads once more as separators the gauge, of course,

being sufficiently thick to prevent the wire from sagging and touching the metal.

Copper Screen.—The centre of the aerial coil can be earthed direct on to the metal below it, an arrangement that is both convenient and efficient, and it should be specially noted that the length of the metal tube should be at least 50 per cent longer than the grid coil. Copper is strongly recommended for the screen, although aluminium is a fairly efficient substitute. The glass beads referred to should be of considerable size to ensure reasonable spacing between the coil and shield—and also to allow of adequate gauge wire being threaded through them. Glass beads having a diameter of rather more than $\frac{5}{16}$ in. may be used to permit 18-gauge wire to be threaded through them, although 16-gauge wire could be threaded through the majority.

Suitable beads may be obtained loose at fancy needlework shops or the popular one-price stores, although the special insulating beads made for the purpose are still available from certain electrical stores. They will cost about 6d. per dozen. With regard to the advantages of the copper over aluminium, the electrical properties are almost identical, but copper may be soldered and joined easily, whilst aluminium cannot. The latter is, of course, softer and easier to work than copper, whilst the latter may be polished if it is desired to reduce surface friction.

CHAPTER XIII

COUPLINGS FOR AERIALS

THERE is a link in between aerial and receiver which is often overlooked by users of home-constructed receivers, i.e., efficient coupling between the aerial and the receiver.

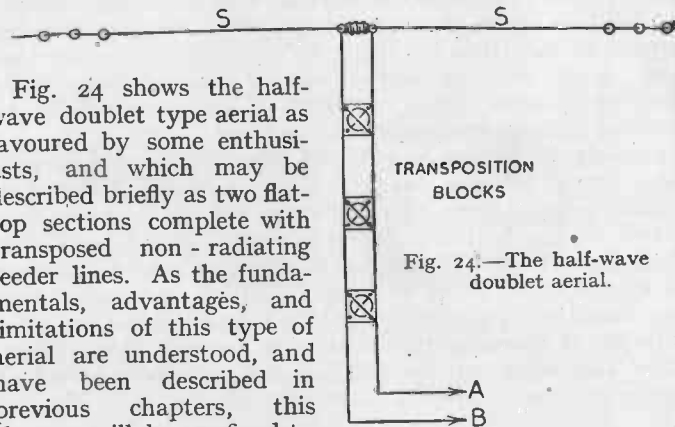

Fig. 24.—The half-wave doublet aerial.

Fig. 24 shows the half-wave doublet type aerial as favoured by some enthusiasts, and which may be described briefly as two flat-top sections complete with transposed non-radiating feeder lines. As the fundamentals, advantages, and limitations of this type of aerial are understood, and have been described in previous chapters, this chapter will be confined to coupling as applied to home-constructed receivers, of experimental design.

If a census of receivers as used by short-wave experimenters were possible, it is probable that simple regenerative types would be in the majority, followed by various high frequency types.

Regenerative Circuit.—Fig. 25 shows in theoretical form a regenerative circuit in which six-pin coils are incorporated, and the necessary modification in order that a doublet aerial can be used. This is a very simple method as the primary or aperiodic winding is used to provide inductive coupling between the doublet aerial and the receiver grid coil.

In some instances four-pin coils are used, and consequently a different arrangement is necessary to achieve the same purpose.

Doublet-Coupling.—Fig. 26 shows a method of doublet-coupling for use in conjunction with four-pin coils. This consists of a

short length of Paxolin former, or tube, about $\frac{1}{4}$ in. less in outside diameter than the inside diameter of a standard coil former.

An ebonite disc is fitted with two banana-plug sockets, this disc being in turn fitted inside the former. Cork or rubber distance pieces, or spacers, of small diameter are glued to the outside of the former as shown at X. These should be of

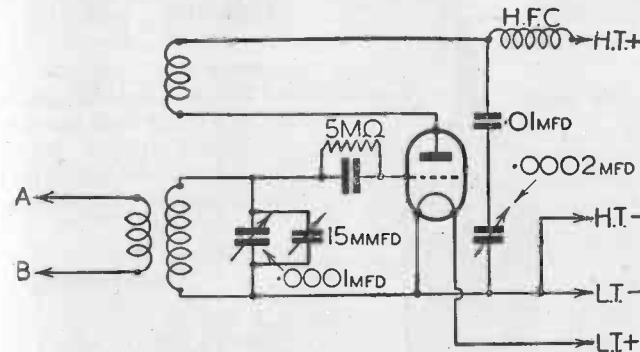

Fig. 25.—Theoretical circuit of a regenerative one-valver.

sufficient length to allow the coupler former to be inserted inside the standard coil former to make a sliding fit, which will allow the coupler to be lifted or lowered at will with ease, and to retain any desired position within the limits of travel. Too tight a fit will require undue force to alter adjustment, and will fracture and break the ceramic coil former.

If four coils are used to cover a series of tuning ranges, four units as outlined should be made.

Coil Windings.—Next comes the winding of the single coil, as shown, the number of turns, however, should be found by experiment.

Two, three, four and five turns will cover most requirements, and any fine-gauge wire can be used such as 28-gauge D.C.C.

A coil to cover the 160-metres band, however, will require from twelve to sixteen turns. Much depends on the type of coil used in the receiver, and cut and try methods are advisable.

This single-winding coil is wound $\frac{1}{8}$ in. from the bottom of the coupler former, and the ends are taken to the sockets in the top disc A and B.

Banana plugs are fitted to the twin transmission line, which in turn are coupled via the sockets *A* and *B* to the coupler.

The complete coupler is now fitted inside the receiver coil former, as shown at Fig. 27. Thus we have inductive coupling between the aerial and grid coil of the receiver, and in addition, an adjustable primary which enables us to increase or decrease the coupling between the receiver and the aerial within defined limits at will.

Figs. 26, 27, and 28.— Suggestions for coupling various aeri- als to stand- ard short- wave coils.

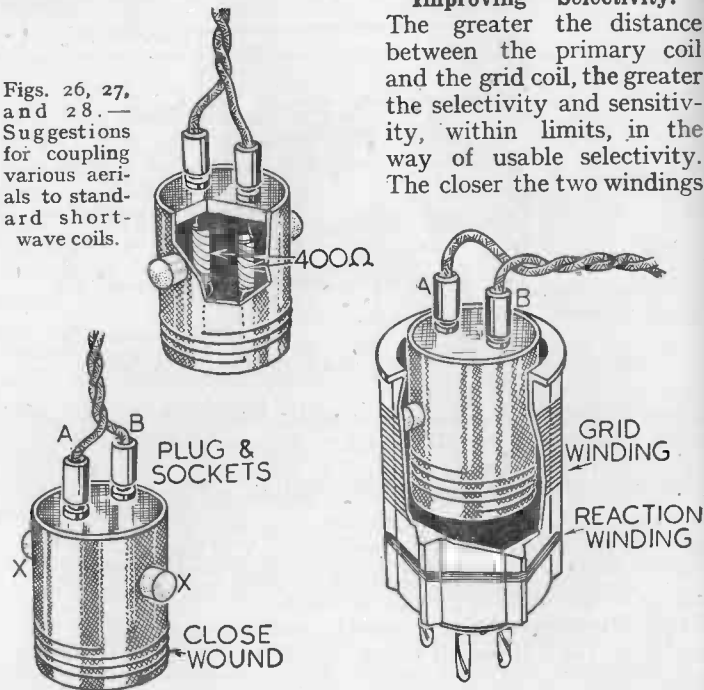

Improving Selectivity.—

The greater the distance between the primary coil and the grid coil, the greater the selectivity and sensitiv- ity, within limits, in the way of usable selectivity. The closer the two windings

the greater the volume, and the lower the selectivity and sensitivity.

In the desire for improved selectivity it should not be forgotten that a compromise between volume and sharper tuning is desirable, as by endeavouring to increase the selectivity by means of excessive slackness of coupling, this will drastically reduce volume, and the application of reaction in an endeavour to boost up the signal will result in an increase in the noise level which will entirely over-ride the signal.

Passing to Fig. 28, we have another arrangement which is slightly different, as two 400 ohms resistors are fitted inside the former, and in series with the coil, as shown at Fig. 29 in theoretical form. Reverting to Fig. 28, this sketch gives a cut-away view, and shows the resistors in place. They must, of course, be of small physical dimensions in order to make possible this method of internal mounting.

Spacers as shown at Fig. 26 *X* and *X* are fitted, and the coupler is fitted and used inside the receiver coil in the same way as the coupler previously described.

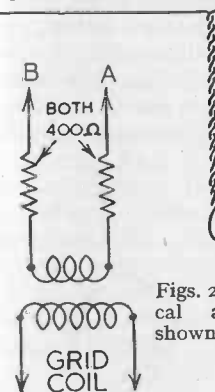

Figs. 29 (left) and 30 (above).—Theoretical arrangement of the scheme shown in Fig. 27, and a twisted-flex transmission line.

This arrange- ment is parti- cularly applicable for use in conjunction with T.R.F. receivers, and by its use it is possible to obtain selectivity approaching superheter- odyne standards, and as in the previous example any degree of coupling within limits. In this instance the

coupler is inserted inside the first H.F. stage coil.

It should be understood, however, that whilst this method correctly applied will prove very satisfactory, it requires a little patient experiment in order to strike a compromise between selectivity and volume, and to avoid tricky operation and high noise level.

In using couplers of this type every precaution should be taken to avoid the breaking of the internal wiring of the coils. With this in view, the coupler former can be marked, and accidents thus avoided.

Ultra-Short-Wave Doublets.—Next for consideration is the coupling of ultra-short-wave doublets and receivers. Fig. 30 shows an ultra-short-wave doublet with twisted flex transmission line.

Here the three coil inductive coupling system can be used to advantage, *C* being the coupling coil, *G* the grid, and *R* the reaction coil respectively (see Fig. 31).

In ultra-short-wave experimentation, the diameter of coils, turns, spacing, and the distance between coil windings are

matters of importance and experiment in themselves. There is also considerable scope for experiment with aerial coupling arrangements in this field. For example, present day ultra-short-wave coils are in many instances separate and self-supporting coil units. In these respects they are similar to early type short-wave coils.

Whilst those early coils had certain disadvantages, and lacked the efficiency and small magnetic field of modern coils, they offered one advantage in that the aperiodic coupling between the primary and grid coil was adjustable, and variations in coupling could be carried out by means of an adjustable coil holder, removing a coil-base holding-down screw, and setting the latter at an angle to the grid coil base, etc.

The Dimic type, for example, had a swinging base which enabled the coil to be swung within certain limits across the grid coil face. Thus sensitivity and selectivity could be varied at will.

In addition dead spots could be removed.

Semi-Adjustable Coupling.—Fig. 32 shows a method of construction which can be adopted by the experimenter to

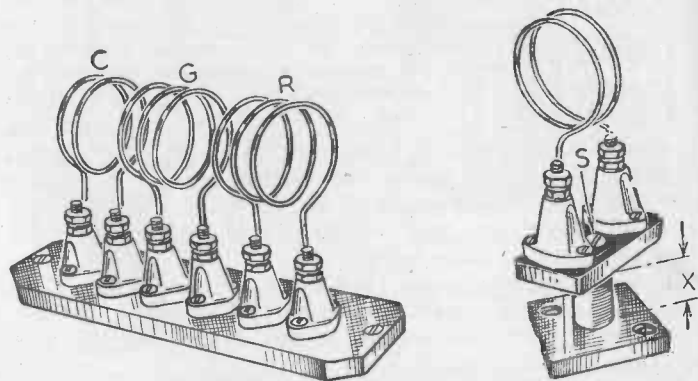

Figs. 31 and 32.—Mountings for coils of the type shown in Fig. 25 and a variable coupling suggestion.

provide semi-adjustable coupling of the doublet coupling coil in ultra-short-wave receivers.

The coil sockets are mounted on an ebonite base, which in turn is fastened by a single screw to a short length of $\frac{1}{2}$ -in. dowel X-Y. Thus the coupling between this coil and the grid coil can be varied within limits, and the centre screw

tightened to hold it in position. A piece of ebonite rod tapped to take a 2-BA bolt would be an even better arrangement.

Aerial coupling offers ample scope for the experimenter, and by making it a variable factor, much useful data can be obtained. In the case of high-frequency receivers, such as various T.R.F. types, and also superheterodynes, the use of a simple oscillator and output meter is to be recommended, and because the signal is constant, a visual indication as to the effect of coupling variations is possible, and leaves nothing in doubt.

Final Hints.—In conclusion, just a few remarks which are applicable not only to doublet-type aerials, but to all types, whether home-constructed from sponsored data, or of commercial manufacture. It seems to be an all too common practice to cut and alter here and there, and to introduce original ideas which lead to disappointment. An aerial system, no matter what type or design, should be erected as instructed and advised by the technical sponsor or manufacturer, and if home-made should fully conform to accepted data and fundamentals. Recognition of these facts is a definite step towards satisfaction. This applies especially to cutting, and to the ignoring of height recommendations, two factors which are responsible for reduced pick-up, and consequent unsatisfactory results.

CHAPTER XIV

MORE AERIAL COUPLINGS

FOR receivers operating only on the medium- and long-wave bands, the natural resonant characteristics of the aerial are not a critical factor owing to the comparatively low order of the signal frequencies, and invariably a reasonably long aerial conductor positioned well outside the field of any local interference will suffice, the down-lead system being screened so that the collected signal is transferred with a minimum of superimposed stray electric currents picked up from nearby parasitic radiations.

As the natural wavelength of an aerial conductor is proportionate to the frequency at which it would resonate, it will be apparent that on reducing the receptive wavelength, thus increasing the frequency, there will be a greater tendency for some of the collected energy to leak away, a point which will be well appreciated by those who have experimented on the ultra-high-frequency bands, and to reduce this attenuation as much as possible, special attention is paid to the actual characteristics of the non-resonant conductors of the aerial scheme; this will be clearly noticed as one reviews some of the more modern arrangements.

All-Wave Reception.—In all-wave reception the inefficiency of an aerial system can considerably influence not only the quality and power in reproduction, but the actual control, causing less experienced listeners to wonder whether in the case of a new receiver, the investment was worth while, and it is such considerations which will give added interest to the following data.

A good short vertical or horizontal aerial is far better than a long aerial scheme in which the points just mentioned have not been considered, and to obviate leakage, background noises, and the effects of a swaying conductor, the installation should be kept as far from any trees and metal work or house wiring as possible, the strain of the aerial conductor wire and feeders being taken up by suitable springing.

As the more conventional forms of screened down-leads have been dealt with in previous chapters, it is proposed to deal only with some of the more recent designs, the individual

merits of which will provide interesting comparative data when considering the wide field of requirements.

One of the more popular forms of aerial installation for average conditions of reception is the single or dipole vertical aerial surmounted on a mast, or by suitable stays.

Use of Bamboo.—Some of these systems are of the self-supporting rod or tube type, whilst others are of the telescopic principle, and it is only recently that advantages have been realised in the use of bamboo for supporting light gauge conductors in the form of rod, tube and wire.

Lightness, durability, rigidity, and economy are a few of the merits to be found in the use of bamboo, whilst the ease of erection is an incentive to its use.

One example showing the convenience in the employment of bamboo from the home constructor's point of view, is given in the illustration Fig. 33. This erection comprises two fractional-wave conductors of light-gauge copper rod for use on the ultra-high frequencies, but any longer system could be fitted having the same basic design, providing, of course, due regard be given to the question of "whip" tendency when installing in a windy location.

Methods of Fixing.—One of the many problems with which the listener is faced when contemplating the erection of an aerial concerns the most suitable method to adopt for fixing the main support to a chimney-stack or other brick-work, since apart from the possibility of awkwardness of access, it may not be desirable to interfere with the brick-work by driving in screws or bolts.

In Fig. 34, therefore, is depicted a sturdy type of clamp support for mounting an aerial mast or radiators on a fire wall or parapet, and is one of the wide range of products made by "Premax", of New York, and obtainable from Holliday & Hemmerdinger Ltd., Manchester.

It will be noticed that the framework is of very rigid design,



Fig. 33.—Using bamboo for supporting U.S.W. conductors.

Holliday & Hemmerdinger Ltd., Manchester.

the clamping adjustment being arranged by contracting each section by threaded rods and lock-nuts, the limits of fixture being governed by the five fixing holes provided in each stay.

In Fig. 35 is illustrated a typical installation of the Belling & Lee "Skyrod" range, where the mast is lashed to the chimney

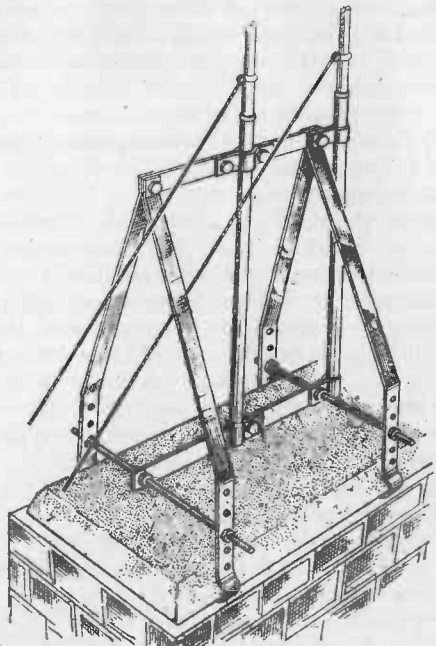

Fig. 34.—A clamp support arrangement for mounting an aerial mast on a parapet.

stack by means of adjustable brackets having corner angle strips for binding and protecting the masonry.

In the inset illustrations is shown the neat method of fitting the "Eliminose" system. If there is little interference in the location, the mast need not be used, the aerial conducting rod being mounted directly to the form of insulated bracketing exemplified in Fig. 36.

Uni-Directional Aerial.—The most suitable position for the installation of a uni-directional aerial is best determined by trial and error methods, but this is in most cases very inconvenient, particularly in roof mast erections, and so to obtain

the best results under such conditions, a transfeeder system coupled to a di-pole aerial having rectangular conductors provides one of the simpler, and most satisfactory methods, for a wide variety of purposes including operation on the shorter wave bands.

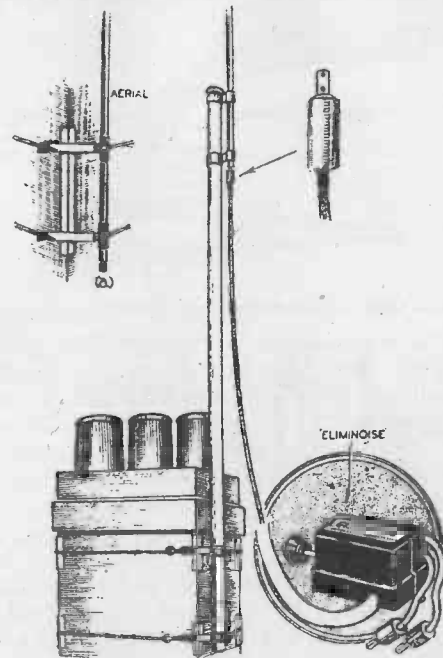

Figs. 35 and 36.—A typical installation of the Belling and Lee "Skyrod" aerial system.

In Fig. 37 is shown a system embodying the advantage of combining the 'L' type aerial with that of the di-pole, so helping the user to determine quite closely the most suitable condition.

The aerial and receiver transformers in this particular system, chosen from the "A.S." Major and Minor series manufactured by A. H. Hunt Ltd., are matched to very fine limits, and sealed in wax having a high melting point which ensures thorough protection in all types of atmosphere and weather, whilst the mechanical design is along symmetric and robust lines.

Twin-Feeder Systems.—To reduce signal attenuation as much as possible, not only is it necessary correctly to match twin-feeder systems from the point of view of the H.F. transformers connecting the aerial to the receiver, but the natural impedance of the down-leads or feeders require correct balancing.

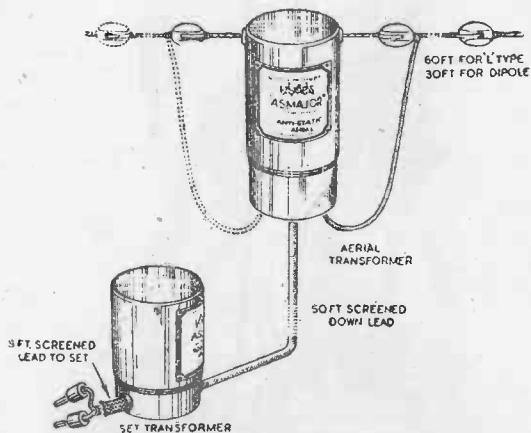

Fig. 37.—A combined "L" type aerial and di-pole, showing the aerial and receiver transformers.

To this end then, the dielectric constant of the feeder insulated sleeving, and the distributed capacity of the conductors to the screening braid have to be taken into account, the spacing and different gauges of conductor resulting in very appreciable variation in the natural characteristic.

For transmitting purposes, where a considerably greater order of radio frequency current is being handled, this becomes of major importance, since the conductor "surface" requires absolute protection against corrosion brought about through hygroscopic effects such as dampness, gaseous atmospheres, and the like.

Coaxial Cables.—To obtain very close impedance balancing and constant capacity distribution in such cases as the above, coaxial cables are used, these having the conductor, or conductors, centrally maintained when the cable is curved in the installation.

Fig. 38 shows one such cable having a solid dielectric construction of the finest Brazilian Para rubber compound. The sheathing is of weatherproof tough rubber, and the screening braid of tinned copper wire (6-strand).

The impedance of the conductor, which comprises 14/36 stranded tinned-copper wire, lies between 70 and 80 ohms.

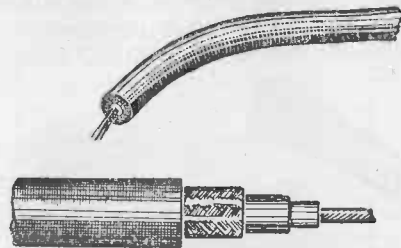

Fig. 38.—A type of coaxial cable of solid dielectric construction.

In locations where electrical interference and damping proves a difficult problem to eliminate, particularly when the television and short-wave bands are being operated, this form of coaxial cabling will be found to meet the majority of requirements, considerably improving the performance of receivers, including those of the all-wave type, where the more simple type of screened feeder system is used, which invariably has a varying natural characteristic. Further details of this type can be had on applying to the Sterling Cable Co., Ltd., Queensway, Ponders End, Middlesex.

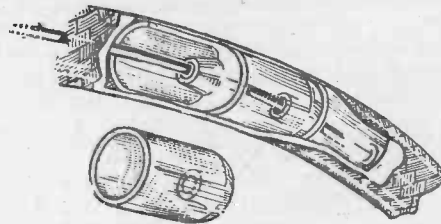

Fig. 39.—Section of a special transmitting aerial, showing the inter-bearing insulators.

Transmitting Aerials.—For more critical requirements such as are met in transmitting aerials, the dielectric constant is of considerable importance to ensure the minimum of signal

attenuation, and special lateral insulators have to be fitted for centering the non-resonant feeder or feeders.

One highly efficient and interesting cable construction in this class is shown in Fig. 39.

Referring to this pictorial illustration, which for clarity gives an exploded view, it will be seen that each insulator which is made of a non-hygroscopic substance similar to Trolitul, is inter-bearing, in this way permitting very appreciable curves to be had during the installation.

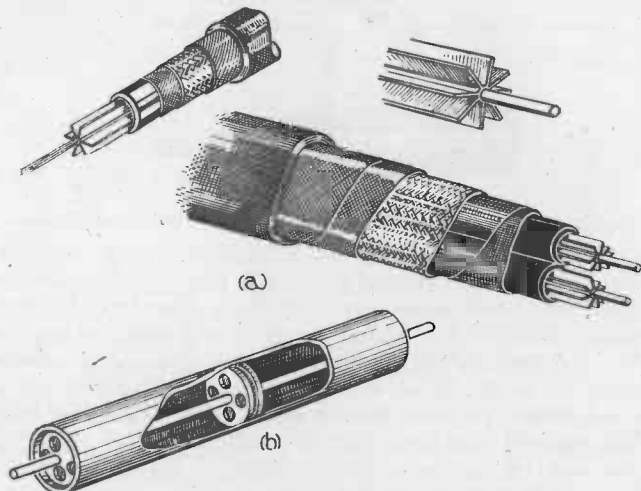

Fig. 40.—A very interesting form of low-loss cable construction shown in detail.

The centre conductor, which is not confined to one gauge, is passed through each insulator as shown, and so maintained centrally whatever the position of the cable within the wide limits of its flexibility, thus not only is an even capacity distribution obtained under the most trying conditions of use, but owing to the mean dielectric constancy being of such a low order, the transmitted or received H.F. currents at almost any frequency will be handled with negligible loss over considerable lengths of feeder.

Two further examples of H.F. coaxial cabling are given in Fig. 40, showing the different commercial methods for obtaining low attenuation, and at *A*, it will be seen that the conductors are centred in narrow longitudinal fins, which in

turn are set in "Telconax" tubing which provides protection mechanically, and also from the hygroscopic aspect.

The twin-feeder type cable shown is critically balanced, and the insulation properties assure absolute protection against deteriorating influences of gaseous and moist atmospheres.

The air-spaced disc conductor type, illustrated in Fig. 40 (*b*), is an interesting comparison, and a product of the same company; The Telegraph Construction & Maintenance Co.

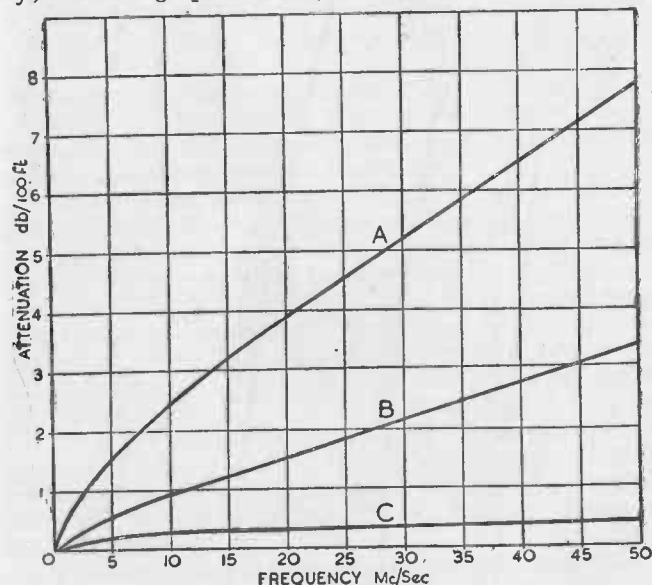

Fig. 41.—Graph showing the performance of three different types of cable.

The centre conductor is centred in this case by what are known as "Polystyrol" discs. This is a synthetic substance possessing very good electrical characteristics for high frequency work.

Steel Tape Armouring.—For conditions where flexibility is not an essential consideration, but where protection against deterioration from external influences is of primary importance, the finish is armoured by steel tape, whilst for more ordinary uses such as television installations, etc., a very flexible cable of the same basic characteristics is available.

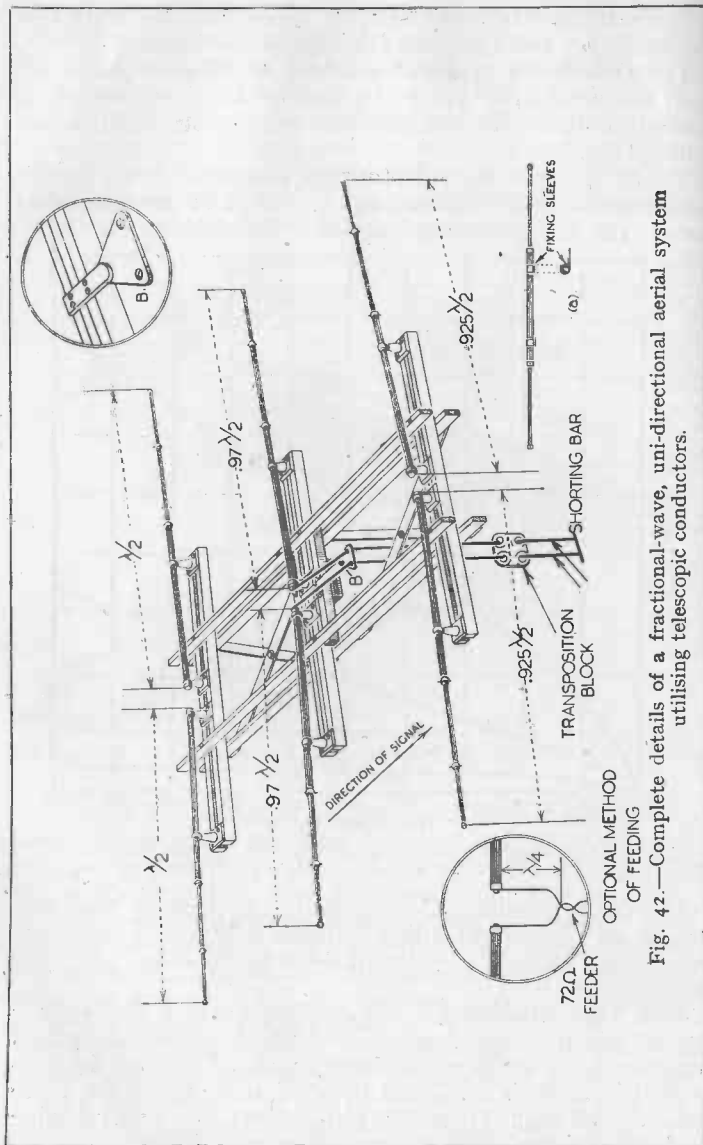

Fig. 42.—Complete details of a fractional-wave, uni-directional aerial system utilising telescopic conductors.

The attenuation of such cables at certain frequencies is determined on a comparative basis over a given length, and the graph in Fig. 41 shows three types of cabling, *A*, *B* and *C*.

It will be clear from the curves that the air-spaced type *C* has a much more constant performance with very low attenuation, whilst the solid dielectric type *A*, although within very good limits for this class of cable, shows a steady increase in attenuation as the signal frequency increases.

The curve *B* is included to show the gradual straightening out of the curve as the dielectric constant is improved. This curve is characteristic of the semi-air-spaced type coaxial cable.

In conclusion, there is one particularly interesting aerial installation which illustrates the modern trend of design to obtain the greatest efficiency consistent with mechanical stability, ease of erection and control.

Fractional-Wave Conductors.—The type illustrated in Fig. 42 is of the uni-directional class, and it will be seen that six fractional-wave conductors of the telescopic type are used, mounted horizontally on a framework of wood.

The assembly, as shown with the quoted conductor lengths, is for 10-metre work, and can be made up from kits of parts supplied by "Premax", whilst if desired for a different form of installation, the required parts only may be obtained individually.

The wooden framework is of unique design, and for durability, a careful choice of the type of wood which will weather considerable temperature variations, and climatic conditions, was made by the manufacturers during the preparatory stages in the design.

The telescopic corulite conductors can be obtained double-ended, the limits of each end extension providing a maximum length of $17\frac{1}{2}$ ft.; this double-ended type is depicted in the inset diagram (a) Fig. 42.

On referring to the specification of the system illustrated in Fig. 42, it is interesting to note that with one such scheme used for reception in America recently, it was found possible to separate three stations working on the same frequencies with practically the same intensity, the only adjustment necessary in this instance, being the rotation of the framework.

REFLECTOR AERIALS

THE reflector or beam aerial is of the greatest use to the transmitter, and those readers who have been on the air, will no doubt, have experimented with this type of aerial and have found its advantages in obtaining maximum radiation in a given direction with the minimum of power in the aerial. But it is not only for transmitting that this type of aerial proves its worth. The user of a receiver—either for broadcast or for the short wavelengths—will very often find that the erection of a reflector aerial system will enable signals to be received at greater strength than otherwise, and also may result in a reduction of outside interference, or in other words a greater signal to noise ratio. It must be remembered, however, that the directional properties of this type of aerial are not so marked on the medium waves, although experiments at one particular location show that there is definitely an increase in signal strength when a reflector is employed. More of this will be dealt with later.

Principles of the Reflector.—The principles upon which the reflector aerial are designed are really quite simple, and in the crudest form, a reflector consists merely of a duplicate aerial erected in such a position that the aerial proper is situated in a line between the reflector and the station which it is desired to receive.

Fig. 43 shows this diagrammatically, where the aerial and

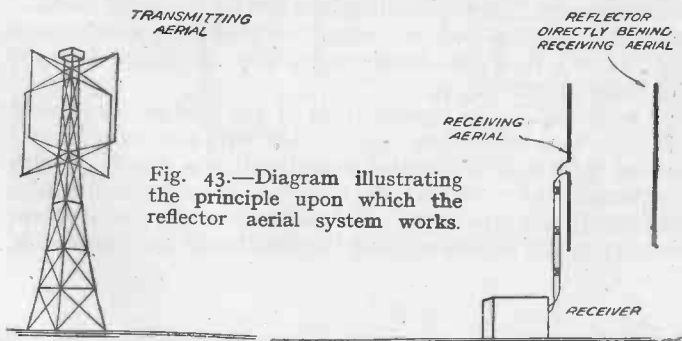

reflector are indicated as vertical wires or rods. In the most advanced form, a reflector may consist of a number of wires or rods arranged in various patterns round the aerial and the particular type of aerial to use will depend upon the wavelength upon which the signal is radiated, the location at which it is being received, and the amount of interference which is to be cut out. Thus, for the reception of television, for instance, maximum signal strength would be required on the television wavelength, and provided that there is no interference-producing apparatus in the vicinity, a single reflector will suffice.

In this connection also, it is important that the receiving aerial shall be polarised, or erected so that it is in the same plane as the transmitting aerial. For the normal television transmissions, for instance, a vertical transmitting aerial is employed, and consequently the receiving aerial must also be in a vertical plane and the reflector or reflectors must be vertically arranged behind it.

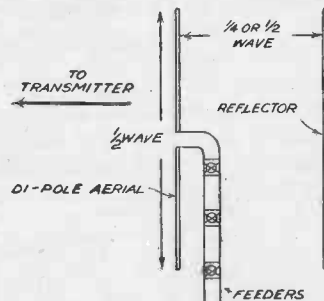

Fig. 44.—Leading dimensions for a simple reflector aerial system.

Various Assemblies.—Thus we see that the first consideration in erecting a reflector aerial is to ascertain the direction from which the signal is arriving at the receiving location, and then to ascertain the source of any interference which may exist. If the latter is spread over a wide region, the reflector may have to be extended so that the aerial is inside it—except for a space in the direction of the transmitter. This indicates that for general purposes, the aerial array will have to be mounted on some form of rotatable table so that it may be directed to the required transmitter, although if it is to be used only for the television signals, it may be made a permanency.

The first consideration is to erect the aerial and this may be of the single type or a di-pole. The latter is, of course, a wire or rod having a total length which is one-half of the wavelength being received. It is not restricted to that wavelength, however, and acts quite efficiently over a wide band, maximum signal strength being obtained at harmonics of the wavelength as has already been explained. The di-pole may be split into two sections, each one-quarter of a wavelength, and a twin

feeder taken from the centre point. The reflector will, however, not be split but will be a continuous wire or rod half-wavelength long as in the case of the first type of aerial.

- Should it be necessary to erect more than one reflector, then each must be identical in length and the only difficult point to arrive at is the spacing between reflector or reflectors and the aerial, and also between individual reflectors.

Reflector Spacing.—The transmitter is favoured in designing his reflector aerial as he can arrange for listeners to measure

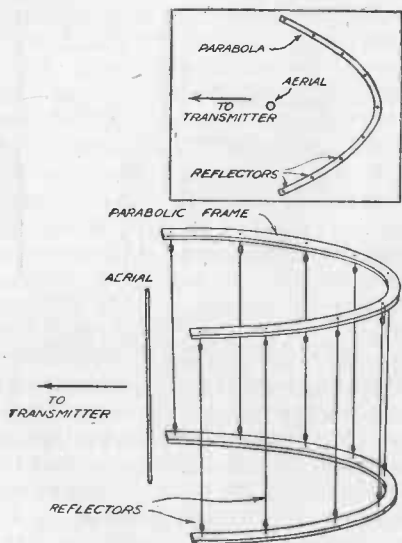

Fig. 45.—A more elaborate reflector aerial system. This may be made to rotate for special directional properties.

field strengths over different distances and in different directions and find the best arrangement for his particular situation. The listener is not so fortunate, although if a suitable signal-strength measuring apparatus is to hand, he can rig up different arrays and ascertain the improvement on a given station—always taking into account, of course, the fact that a distant station may fade, and that signal strength may vary from day to day, especially on the shorter wave-lengths. In the case of the television signals, however, a fixed station is available for experimental purposes in normal times. For measuring the signal strength, the simplest arrangement is to include an ordinary milliammeter in the detector stage and to note the needle deflection when the station is tuned in. Alternately, the Bulgin Neon signal strength indicator may be connected to the output valve and used for the purpose. In most cases it will be found that the reflector will give best results on a receiving aerial when it is arranged as far behind the aerial as the length of the aerial. Thus, if the aerial is 5 ft.

in length, a 5 ft. reflector would be arranged 5 ft. in the rear of the aerial. In some cases, it should be only one quarter of the wavelength behind—that is, a di-pole aerial 5 ft. in length would need a 5 ft. reflector arranged 2 ft. 6 in. behind the aerial. If a number of reflectors are to be used they may be mounted on a light wooden framework, and the positions first planned with the framework on the ground. Tests indicate that the parabola is the best form of multi-reflector and the shape must be very carefully plotted before the supporting wooden strips are fitted together. Tests on the television signals in some cases show that the parabola gives no increase over a single reflector, but there is a remarkable reduction in the background noise which is received when a parabola is employed. Furthermore, using an aerial for this particular signal made from copper tubing, and with reflectors made from tubing and also from ordinary 7/22 copper wire, there is no noticeable difference, and the wire is lighter and cheaper.

CHAPTER XVI
COIL DESIGN

APART from the aerial and receiver design there is little doubt that the design of the coils plays a most important part in the results obtained on the short waves. In this respect the short-wave coil is of much greater importance than the coil used in a medium or long-wave receiver, and there are, in addition, many alternative forms of coil which may be used in a short-wave receiver. A glance through radio component catalogues shows many different types, and in the plug-in variety there are 4- and 6-pin components, and many amateurs seem unable to make a selection regarding the type of base to adopt. Fig. 46 shows a standard 4-pin plug-in coil, whilst the theoretical circuit indicates a simple detector stage utilising one of these coils. It will be seen that there are two windings only, and in the circuit shown these are employed for the grid and for the reaction windings. If, however, the coil is required

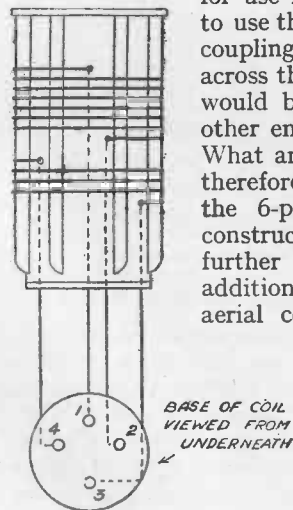

Fig. 46.—Details of the standard 4-in. short-wave plug-in coils.

for use in an H.F. stage, it would be possible to use the smaller winding (L2) for an aerial-coupling coil, in which case L1 would remain across the grid-filament circuit, but the aerial would be joined to one end of L2 and the other end of this would be joined to earth. What are the advantages and disadvantages, therefore, of this type of coil compared with the 6-pin component? The difference in construction is that the 6-pin coil has a further winding, joined across the two additional pins, and this is employed as an aerial coil in the manner just mentioned, thus leaving a winding for reaction purposes. It will be obvious, therefore, that in a simple detector stage such as that shown, the 6-pin coil will provide an additional winding which may be used or omitted as desired. Thus for experimental purposes alone, this type of coil is to be preferred.

Aerial Damping.—If the aerial is joined direct to coil L1 in the theoretical circuit shown, it will be found in most cases that reaction will be difficult to obtain. This is because the aerial and earth leads, when connected to the coil have the effect of what is known as “damping” the circuit. That is to say, they “load” the circuit and prevent the valve from

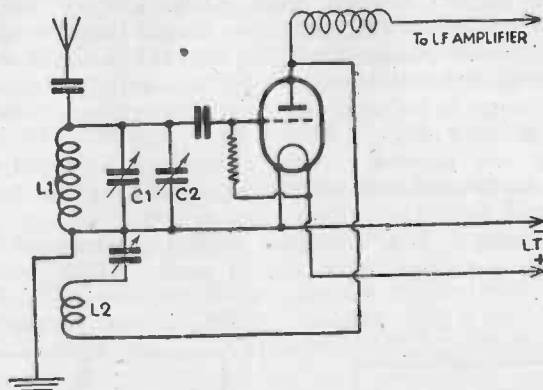

Fig. 47.—Theoretical diagram of a simple detector stage in which a 4-pin coil may be used.

oscillating easily. To remove the damping effect the aerial is therefore connected to the coil through a small condenser, which may be fixed or of the semi-variable type. This may then be adjusted to provide the required degree of damping, or in other words to remove damping so that the valve will oscillate.

If a separate coil is coupled to the L1 coil, and this additional coil is joined between aerial and earth, it will not only remove the damping effect but will also be found to provide better selectivity, although it is important to see that the coil is carefully chosen, both as regards the number of turns and their relation to the grid coil. If a commercial coil is obtained, the coil may be relied upon to provide the correct degree of coupling, but when a home-made coil is used, it may be found desirable to experiment and carry out some tests with a view to finding the best coupling and the best position for the coil. Naturally, one is able, with this type of coil, to ignore the aerial coupling winding and use the standard connections shown in the theoretical diagram, Fig. 47.

Fig. 50 shows in theoretical form the once popular Hartley circuit. In this arrangement an earth tap is used, and in which one half of the coil acts as the reaction coil.

Coil Construction.—Reverting to Paxolin formers, Fig. 51 shows a spaced coil wound on a former of this type in which a slot has been drilled out, and finished with a flat file. It will be seen that the tapping clip has a good surface of wire to grip, thus ensuring good contact.

Fig. 49.—Theoretical one-valve circuit showing how it may be modified to include a 6-pin coil.

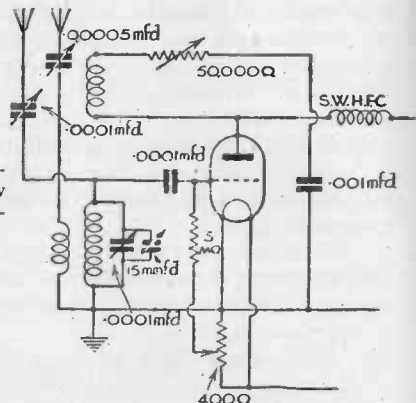

Fig. 52 shows an alternative idea in which short pieces of wire or stubs are soldered at different points of the coil, A, B, C, D, as designated. Fig. 53 illustrates a sound and modern method of mounting coils. Small stand off insulators are used, and these provide a most rigid method of support.

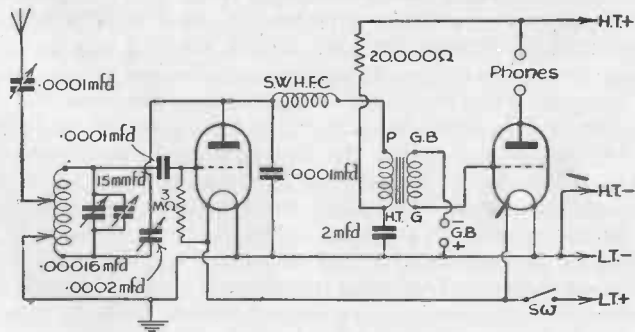

Fig. 50.—A two-valver with the Hartley circuit suitable for home-made coils.

The tapped coil principle can of course be applied to the short-wave adaptor, and Fig. 54 shows a suitable circuit. This arrangement is very flexible, and with suitable coils can be used to cover all bands between 10 metres and 160 metres, and higher. The aerial tap being altered to suit the various bands covered by individual coil and condenser combinations and tap position.

Fig. 51.—A spaced coil wound on a slotted former to facilitate tapping.

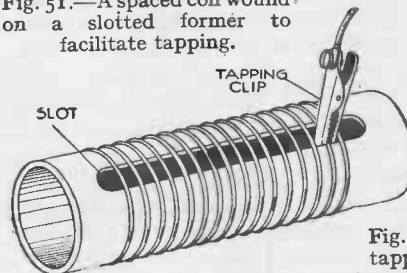

Fig. 52 (below).—In this coil tapping points are provided.

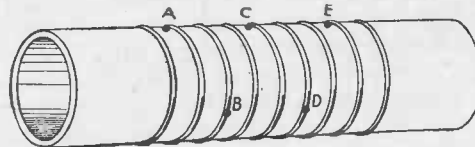
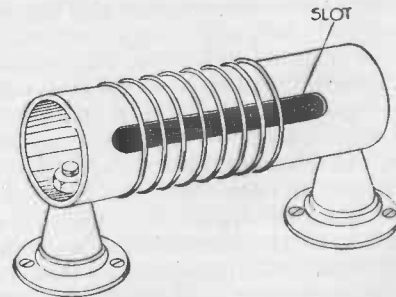

Fig. 53.—This method of mounting provides rigidity.



In commenting on the variable tapping system as applied to short-wave receivers the writer wishes to stress the following points. Dead end losses must not be forgotten. It must also be understood that the overall efficiency will be lower than in the case of commercially designed coils.

Calibration.—There is also another most important point, and this appertains to calibration. To calibrate a tuning dial

with the tap at a fixed point of the coil, and to alternate between different tappings, cannot be done with any hope of retaining accuracy of calibration. If tapping stubs are soldered to the coil-turns, one is assured of tapping to the same position, but even so only a fair degree of accuracy is to be expected.

When accurate calibration to the degree possible in amateur work is desired, the most satisfactory method is to use standard commercial coils of the four and six-pin type, or alternatively, one of the many dual or triple-wave tuner units.

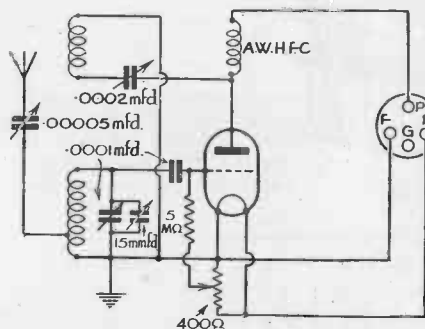

Fig. 54.—A typical circuit for a one-valve short-wave adapter.

From the tables on pages 95-7 the constructor has at his disposal accurate data of 360 combinations of coils, of various diameters, coil lengths and inductance values. The widely different physical dimensions of the coils offer even to the experienced designer a means of obtaining the maximum efficiency in the design of multi-band short-wave receivers, where compactness is the first requirement or where the best coil efficiency is desired, irrespective of the physical size of the coil.

Choice of Wire.—A coil with a winding width equal to its diameter is generally accepted to have the best electrical efficiency, all things being equal, i.e., the insulation factor of the coil former, and readers are advised to keep this in mind when choosing a coil from the table. Before proceeding to explain the table, two factors which enter into the construction of high-grade coils, where one wishes to obtain the best possible efficiency, are the choice of wire used, and the material of the coil former. For the very short-wave bands up to 25 metres, silver-plated wire is to be preferred, and has the great advantage of lowering the H.F. resistance of the coil,

which is of the greatest importance when one appreciates the extremely minute signal voltage which a radio receiver is called upon to handle. As regards the coil former this must be of the lowest loss material—preferably with eight ribs instead of just being of the plain round type, and should have unshrinkable characteristics. It should be borne in mind that silver-plated wire and a cardboard coil former do not go well together.

Coil Sizes.—In looking at the tables you will find the diameter sizes are from $\frac{1}{2}$ in. to $1\frac{1}{2}$ in. as follows: $\frac{1}{2}$ in., $\frac{3}{4}$ in., $\frac{7}{8}$ in., 1 in., $1\frac{1}{4}$ in., and $1\frac{1}{2}$ in. The coil winding widths are $\frac{1}{2}$ in., $\frac{3}{4}$ in., 1 in., $1\frac{1}{2}$ in., and $1\frac{1}{2}$ in., the windings being spaced approximately one diameter of the wire gauge. In deciding the tuning range to be covered, the first requirement is to be definitely certain of the maximum and minimum capacity of the tuning condenser, for this requirement tells you the wave-range coverage of the coil you select. The lower the minimum capacity of any tuning condenser, the greater the actual tuning range of the coil-condenser combination—the range extending on the lower end of the wavelength. Assuming your condenser has a minimum capacity of 15 mmfd. when placed in circuit, valve capacities, wiring and trimmer capacities, are immediately added to the minimum capacity of the coil and condenser circuit, the 15 mmfd. readily changes to an increased value reaching up to 30 mmfd. or even more. This you will see immediately chops off a portion of your tuning range.

Minimum Capacity.—In looking at the tables you will find that for all coil-combinations a minimum capacity of 30 mmfd. has been selected for the computation of the highest tunable frequency (lowest wavelength). This value was chosen after many measurements on hundreds of actual radio receivers, and the reader can be safely assured that in many cases this value will be less, which will extend the tuning range over the coil combination he has chosen, which is all to the good. Do not forget also that the tuning range of any coil in the table is for the coil only—it is very important that you remember this, for in wiring from the coil to plugs or switches, although the extra wiring length itself be only small, this will again extend the tuning range and $\frac{1}{2}$ in. of extra wire will make a great deal of difference—try it against a pre-calibrated scale. The tables are quite easy to follow, so let us take an example. We have a former 1 in. in diameter, some 18 S.W.G. wire, a

tuning condenser with a maximum capacity of .00015 mfd. and we wish to wind a coil which will tune to 25 metres. Looking at the tables we find in the diameter of former column for 1 in. using 18 S.W.G. wire and moving along to the maximum tuning column under .00015, that with winding $7\frac{7}{8}$ turns, wound over a width of $\frac{3}{4}$ in. which is spaced at $10\frac{1}{2}$ turns per inch we shall have a coil which will tune from 12 metres to 26 metres. With this same coil, using a .0001 condenser, our tuning range will be from 12 to $21\frac{1}{2}$ metres, and using a .00035 condenser, our tuning range will be from 12 to 40 metres

COIL SIZES

Diam. of Former	No. S.W.G.	Turns per in. spaced approx. one diam. of S.W.G.	Length of Winding in.	No. of Turns	Tuning Range		(Min. Cap. 30 mmfd.)	
					.0001 Max.	Max.	.00015 Max.	.00035 Max.
1 in.	18	$10\frac{1}{2}$	$\frac{1}{2}$	$5\frac{1}{2}$	5	9	11	16
$\frac{1}{2}$	18	$10\frac{1}{2}$	$\frac{3}{4}$	$7\frac{7}{8}$	$6\frac{1}{2}$	$11\frac{1}{2}$	$14\frac{1}{2}$	22
$\frac{3}{4}$	18	$10\frac{1}{2}$	1	$10\frac{1}{2}$	$7\frac{1}{2}$	$13\frac{1}{2}$	17	26
1	18	$10\frac{1}{2}$	$1\frac{1}{4}$	$13\frac{1}{2}$	$8\frac{1}{2}$	$15\frac{1}{2}$	19	30
$1\frac{1}{4}$	18	$10\frac{1}{2}$	$1\frac{1}{2}$	$15\frac{3}{4}$	$9\frac{3}{4}$	18	$21\frac{1}{2}$	33
$1\frac{1}{2}$	18	$10\frac{1}{2}$	$1\frac{3}{4}$	$5\frac{1}{2}$	$6\frac{1}{4}$	$12\frac{1}{2}$	$15\frac{1}{2}$	$24\frac{1}{2}$
$1\frac{3}{4}$	18	$10\frac{1}{2}$	2	$7\frac{7}{8}$	$9\frac{1}{4}$	17	$20\frac{1}{2}$	32
2	18	$10\frac{1}{2}$	2	$10\frac{1}{2}$	11	20	$24\frac{1}{2}$	37
$2\frac{1}{4}$	18	$10\frac{1}{2}$	$2\frac{1}{4}$	$13\frac{1}{2}$	$12\frac{3}{4}$	23	28	43
$2\frac{1}{2}$	18	$10\frac{1}{2}$	$2\frac{1}{2}$	$15\frac{3}{4}$	$14\frac{1}{4}$	26	$31\frac{1}{2}$	48
$2\frac{3}{4}$	18	$10\frac{1}{2}$	$2\frac{3}{4}$	$5\frac{1}{2}$	8	$14\frac{1}{2}$	$17\frac{1}{2}$	$26\frac{1}{2}$
3	18	$10\frac{1}{2}$	3	$7\frac{7}{8}$	$10\frac{1}{2}$	$19\frac{1}{4}$	$23\frac{1}{2}$	36
$3\frac{1}{4}$	18	$10\frac{1}{2}$	$3\frac{1}{4}$	$10\frac{1}{2}$	$12\frac{1}{2}$	23	28	43
$3\frac{1}{2}$	18	$10\frac{1}{2}$	$3\frac{1}{2}$	$13\frac{1}{2}$	$14\frac{1}{2}$	$26\frac{1}{2}$	32	50
$3\frac{3}{4}$	18	$10\frac{1}{2}$	$3\frac{3}{4}$	$15\frac{3}{4}$	$16\frac{3}{4}$	30	36	55
4	18	$10\frac{1}{2}$	4	$5\frac{1}{2}$	$8\frac{3}{4}$	16	$19\frac{1}{2}$	30
$4\frac{1}{4}$	18	$10\frac{1}{2}$	$4\frac{1}{4}$	$7\frac{7}{8}$	12	$21\frac{1}{2}$	26	40
$4\frac{1}{2}$	18	$10\frac{1}{2}$	$4\frac{1}{2}$	$10\frac{1}{2}$	14	$25\frac{1}{2}$	31	47
$4\frac{3}{4}$	18	$10\frac{1}{2}$	$4\frac{3}{4}$	$13\frac{1}{2}$	16	30	$35\frac{1}{2}$	55
5	18	$10\frac{1}{2}$	5	$15\frac{3}{4}$	18	$33\frac{1}{2}$	40	62
$5\frac{1}{4}$	18	$10\frac{1}{2}$	$5\frac{1}{4}$	$5\frac{1}{2}$	$10\frac{1}{2}$	19	$23\frac{1}{2}$	36
$5\frac{1}{2}$	18	$10\frac{1}{2}$	$5\frac{1}{2}$	$7\frac{7}{8}$	$14\frac{1}{2}$	26	$31\frac{1}{2}$	49
$5\frac{3}{4}$	18	$10\frac{1}{2}$	$5\frac{3}{4}$	$10\frac{1}{2}$	$17\frac{1}{2}$	$31\frac{1}{2}$	$38\frac{1}{2}$	58
6	18	$10\frac{1}{2}$	6	$13\frac{1}{2}$	20	36	44	66
$6\frac{1}{4}$	18	$10\frac{1}{2}$	$6\frac{1}{4}$	$15\frac{3}{4}$	23	42	50	73
$6\frac{1}{2}$	18	$10\frac{1}{2}$	$6\frac{1}{2}$	$5\frac{1}{2}$	12	22	27	41
$6\frac{3}{4}$	18	$10\frac{1}{2}$	$6\frac{3}{4}$	$7\frac{7}{8}$	$16\frac{1}{2}$	30	37	56
7	18	$10\frac{1}{2}$	7	$10\frac{1}{2}$	20	36	44	67
$7\frac{1}{4}$	18	$10\frac{1}{2}$	$7\frac{1}{4}$	$13\frac{1}{2}$	23	43	52	78
$7\frac{1}{2}$	18	$10\frac{1}{2}$	$7\frac{1}{2}$	$15\frac{3}{4}$	$26\frac{1}{2}$	48	58	90
$7\frac{3}{4}$	18	$10\frac{1}{2}$	$7\frac{3}{4}$	7	$6\frac{1}{2}$	12	$14\frac{1}{2}$	22
8	20	14	$10\frac{1}{2}$	$10\frac{1}{2}$	$8\frac{3}{4}$	16	19	29
$8\frac{1}{4}$	20	14	14	14	10	$18\frac{1}{2}$	$22\frac{1}{2}$	34
$8\frac{1}{2}$	20	14	$1\frac{1}{4}$	$17\frac{1}{2}$	$11\frac{1}{2}$	21	25	40
$8\frac{3}{4}$	20	14	$1\frac{1}{2}$	21	13	$23\frac{1}{2}$	29	45
9	20	14	$1\frac{3}{4}$	7	9	17	21	32
$9\frac{1}{4}$	20	14	$10\frac{1}{2}$	$10\frac{1}{2}$	$12\frac{1}{2}$	22	27	42
$9\frac{1}{2}$	20	14	14	14	14	27	33	50
$9\frac{3}{4}$	20	14	$1\frac{1}{4}$	$17\frac{1}{2}$	17	30	37	57
10	20	14	$1\frac{1}{2}$	21	19	35	42	65
$10\frac{1}{4}$	20	14	$1\frac{3}{4}$	7	11	19	23	35
$10\frac{1}{2}$	20	14	10	$10\frac{1}{2}$	14	25	$31\frac{1}{2}$	48
$10\frac{3}{4}$	20	14	14	14	17	30	37	57

Diam. of Former	No. S.W.G.	Turns per in. spaced approx. one diam. of S.W.G.	Length of Winding	No. of Turns	Tuning Range		(Min. Cap. 30 mmfd.)	
					.000r		.00015	.00035
					Max.	Max.	Max.	Max.
in.			in.					
7/8	20	14	I 1/4	17 1/2	19	34 1/2	42 1/2	65
7/8	20	14	I 1/2	21	22	40	48	72
I	20	14	I 3/4	7	11 1/2	21	26	40
I	20	14	I 1/2	10 1/2	15 1/2	28	34 1/2	53
I	20	14	I	14	18 1/2	34	41	63
I	20	14	I 1/4	17 1/2	21 1/2	39	48	71
I	20	14	I 1/2	21	24	45	54	82
I 1/4	20	14	I 3/4	7	14	25 1/2	31	47
I 1/4	20	14	I 1/2	10 1/2	19	35	43	65
I 1/4	20	14	I	14	23	42	51	74
I 1/4	20	14	I 1/4	17 1/2	27	48 1/2	59	90
I 1/4	20	14	I 1/2	21	30	55	67	103
I 1/2	20	14	I 1/4	7	16	29	35 1/2	54
I 1/2	20	14	I 1/2	10 1/2	22	40	49	73
I 1/2	20	14	I	14	26 1/2	48	59	90
I 1/2	20	14	I 1/4	17 1/2	31	56	69	105
I 1/2	20	14	I 1/2	21	35	63	78	120
I 1/2	22	18	I 3/4	9	8 1/2	15	18 1/2	28
I 1/2	22	18	I 1/2	13 1/2	11	20	25	38
I 1/2	22	18	I	18	13	24	29	44
I 1/2	22	18	I 1/4	22 1/2	15	27	33	51
I 1/2	22	18	I 1/2	27	17	31	37	57
I 1/2	22	18	I 3/4	9	12	21 1/2	26	40
I 1/2	22	18	I 1/4	13 1/2	16	29	35	54 1/2
I 1/2	22	18	I	18	19	34	42	64
I 1/2	22	18	I 1/4	22 1/2	22	40	48	72
I 1/2	22	18	I 1/2	27	25	45	54 1/2	82
I 1/2	22	18	I 3/4	9	13 1/2	25	30	45
I 1/2	22	18	I 1/2	13 1/2	18	32	40	62
I 1/2	22	18	I	18	22	40	47	71
I 1/2	22	18	I 1/4	22 1/2	25	45	55	82
I 1/2	22	18	I 1/2	27	28	50	62	92
I 1/2	22	18	I 3/4	9	15	27	33	50
I 1/2	22	18	I 1/2	13 1/2	20	36	45	68
I 1/2	22	18	I	18	24	44	53	81
I 1/2	22	18	I 1/4	22 1/2	27	50	61	92
I 1/2	22	18	I 1/2	27	31 1/2	57	70	107
I 1/4	22	18	I 3/4	9	18	33	40	61
I 1/4	22	18	I 1/2	13 1/2	25	45	55	82
I 1/4	22	18	I	18	30	53	65	100
I 1/4	22	18	I 1/4	22 1/2	34	62	76	115
I 1/4	22	18	I 1/2	27	39	70	85	135
I 1/4	22	18	I 3/4	9	20	36 1/2	46	70
I 1/4	22	18	I 1/2	13 1/2	28	51	62	96
I 1/4	22	18	I	18	34	62	76	115
I 1/4	22	18	I 1/4	22 1/2	40	72	88	135

Diam. of Former	No. S.W.G.	Turns per in. spaced approx. one diam. of S.W.G.	Length of Winding	No. of Turns	Tuning Range		(Min. Cap. 30 mmfd.)	
					.000r		.00015	.00035
					Max.	Max.	Max.	Max.
in.			in.					
I 1/2	22	18	I 1/4	27	45	83	100	150
I 1/2	24	22 1/2	I 1/2	11 1/2	11	19	23 1/2	35 1/2
I 1/2	24	22 1/2	I 3/4	16 7/8	14	25	30	42
I 1/2	24	22 1/2	I	22 1/2	16	29	36	55
I 1/2	24	22 1/2	I 1/4	28	18 1/2	34	41	63
I 1/2	24	22 1/2	I 1/2	33 3/4	21	38	46	72
I 1/2	24	22 1/2	I 3/4	11 1/4	15	27	33	50
I 1/2	24	22 1/2	I 1/2	16 7/8	20	36	45	68
I 1/2	24	22 1/2	I	22 1/2	23	43	52	80
I 1/2	24	22 1/2	I 1/4	28	27	50	60	92
I 1/2	24	22 1/2	I 1/2	33 3/4	30	56	68	105
I 1/2	24	22 1/2	I 3/4	11 1/4	16 1/2	31	37	56
I 1/2	24	22 1/2	I 1/2	16 7/8	22 1/2	41	51	76
I 1/2	24	22 1/2	I	22 1/2	27	49	60	90
I 1/2	24	22 1/2	I 1/4	28	31	55	67	100
I 1/2	24	22 1/2	I 1/2	33 3/4	35	64	78	120
I 1/2	24	22 1/2	I 3/4	11 1/4	17 1/2	33	41	65
I 1/2	24	22 1/2	I 1/2	16 7/8	25	46	56	86
I 1/2	24	22 1/2	I	22 1/2	29 1/2	54	65	100
I 1/2	24	22 1/2	I 1/4	28	34	63	77	115
I 1/2	24	22 1/2	I 1/2	33 3/4	39	70	86	135
I 1/2	24	22 1/2	I 3/4	11 1/4	22	41	50	76
I 1/2	24	22 1/2	I 1/2	16 7/8	31	55	68	105
I 1/2	24	22 1/2	I	22 1/2	36 1/2	65 1/2	80	125
I 1/2	24	22 1/2	I 1/4	28	43	78	95	147
I 1/2	24	22 1/2	I 1/2	33 3/4	48 1/2	88	107	165
I 1/2	24	22 1/2	I 3/4	11 1/4	26	47	57	88
I 1/2	24	22 1/2	I 1/2	16 7/8	35	63	78	120
I 1/2	24	22 1/2	I	22 1/2	43	78	94	145
I 1/2	24	22 1/2	I 1/4	28	50	91	110	170
I 1/2	24	22 1/2	I 1/2	33 3/4	56 1/2	103	125	192

CHAPTER XVII

MEASURING WAVELENGTHS OR
FREQUENCIES.

A FREQUENCY meter of some sort is one of the most important pieces of equipment on the experimenter's bench, and those who possess one are not only able to do all kinds of useful and interesting work with it, but can also save themselves a lot of unnecessary trouble in, say, the calibration of a new receiver, to mention only one of the possibilities.

Further, if the intention is eventually to go in for amateur transmission, a frequency meter is virtually a necessity, even if finally used only as a listening monitor. Actually, a frequency meter of the heterodyne type, to be described later, has a number of applications—apart from the obvious one of measuring and checking frequencies—which make it extremely useful in any station, whether transmitting or receiving.

Frequency meters vary from the complicated laboratory design to the most elementary form of measuring instrument—the absorption wavemeter, consisting simply of a coil and condenser, with perhaps a coupled circuit for sharper tuning. A meter of this kind can do no more than give an indication of wavelength (frequency), and there its functions end, though a well-designed instrument can be made very accurate over a limited range of frequencies. The theoretical circuit of such a meter is shown in Fig. 55 and is sufficient to convince the most sceptical that there is nothing complicated about the wiring or components, and the illustrations showing the assembly of the unit will prove that the constructional work is equally simple.

It is not intended to claim that this form of wavemeter is all that one can desire, but, bearing in mind that the more elaborate types require many more components, a valve, careful construction and consistent operating conditions, it will be appreciated that the often despised absorption meter has a great many factors in its favour.

It does not require a buzzer, valve or batteries.

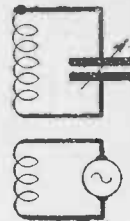

Fig. 55.
The theoretical
circuit of the
meter.

It is always ready for immediate use, without preliminary checking or adjustment of operating conditions, and providing a reasonable amount of care is taken in its simple construction and calibration, it will stay "put" indefinitely.

The receiving station owner is often at a loss, even during these days of calibrated tuning scales, to identify a particular transmission, and, if a wavemeter is not available, he has to hang on with the hope of hearing and recognising a call

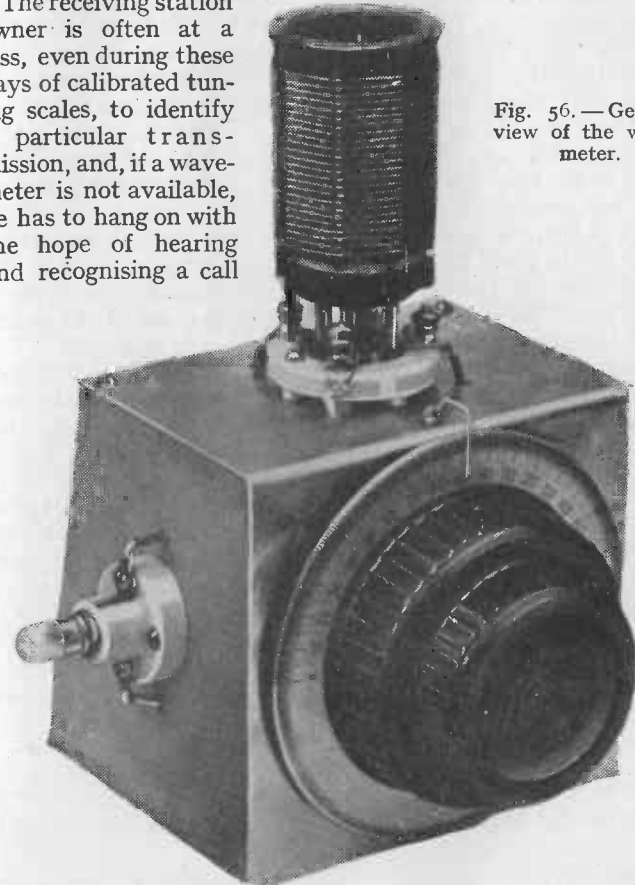

Fig. 56.— General
view of the wave-
meter.

sign, or on the other hand, switching off without completing his log.

This, of course, applies in particular to the short waves, and for this reason the calibration curves given in this chapter have been compiled to cover the wave-bands usually covered by the short-wave listener.

Construction.—The unit is constructed from 5-ply wood, obtained from an old baseboard, and a small piece of 18-gauge aluminium measuring $4\frac{1}{2}$ in. by 7 in. Although the metal panel and top appeared to be quite secure when screwed to the front edge of the small baseboard, it was decided, as rigidity is very important, to make quite sure that movement would not take place by fitting the two side pieces as shown. The complete meter is shown in Figs. 56 and 57 where it will be noted that fillets are fitted to strengthen the joints formed between the sides and the base, and the bottom of the metal panel and the base. After cutting the 5-ply to the shapes indicated, make sure that all edges are square and finish them off with fine sandpaper. The metal should be marked out while it is still flat, the hole for the fixing of the variable condenser being in the dead centre of the upright panel. The four-pin valveholder, of the baseboard mounting short-wave type, is mounted in the centre of the horizontal portion of the panel, while the lampholder can be fixed to one side as shown.

Six holes are drilled, four round the valveholder and two round the lampholder, to allow connecting wires to pass through the metal. When making the connections, use good insulating sleeving, and see that no burrs are left which would cut it through.

The slow-motion knob will have to be fitted according to the type selected. It is not a super-critical item, but in your own interests, it should be remembered that smooth constant action is *essential*, and that the scale must be marked off in degrees, the more the better.

The one used on the unit illustrated is an Accuratune dial and the size of the front panel was cut to suit it, but if a larger dial is used then the panel can be increased accordingly providing the wiring is not lengthened.

One of the two items which is very important, is that, if full use of the calibration curves is going to be made, is the variable condenser. This is the "Special" short-wave type produced by Messrs. Jackson Bros., its value being .00015 mfd.

This component is provided with two forms of fixing, and it is quite immaterial which is used though many will find that the single-hole arrangement is quicker and quite satisfactory. If other types are used, it is possible that the calibration curves will not hold good over all frequencies, as the condenser might have higher or lower maximum and minimum

values of capacity or its vanes might be so shaped that the variation in capacity would not follow the same law as the "J.B.". It is very essential to see that the component is firmly fixed to the front panel, and that the connections are made as indicated in the diagram.

The second of the two important items for this unit are the coils which have been specially produced by Messrs. Peto-Scott. They are of the four-pin two windings type, and are designed to cover a total waveband of 84 metres in three sections, namely,

Fig. 57.—This view of the absorption wavemeter shows the condenser and mounting.

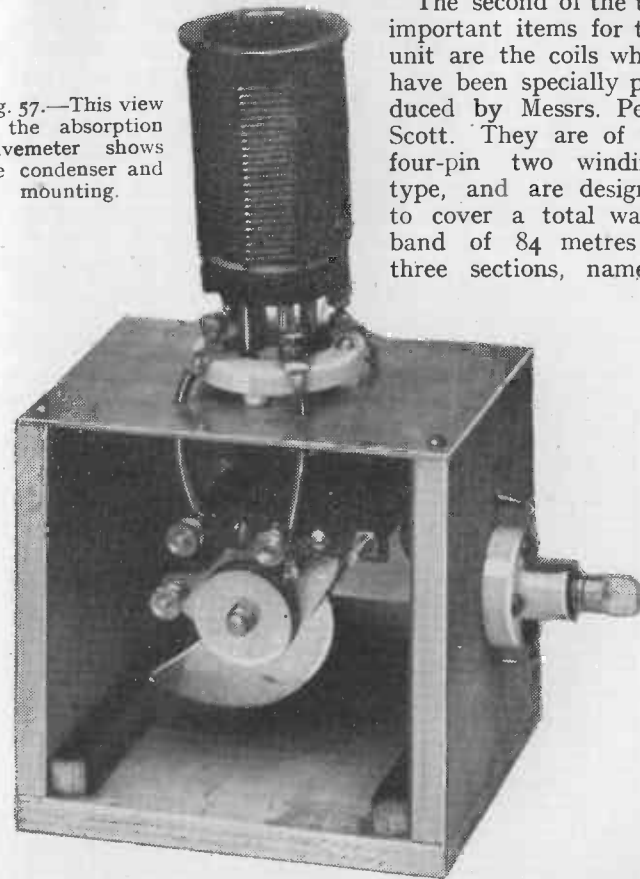

12 to 26 metres, 22 to 47 metres, and 42 to 96 metres.

The normal grid winding is connected across the tuning condenser, and the reaction section is used for the separate inductively coupled circuit across the indicator lamp.

It will be noted that the graphs are plotted between frequencies and dial readings: therefore, those not too familiar with wavelengths in terms of frequencies must remember

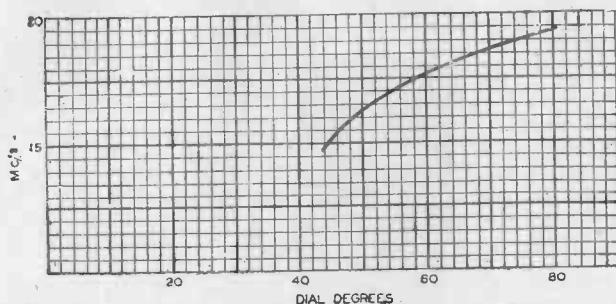

Graph of the Blue Spot Coil, covering from 15.6 to 20.2 metres.

that frequency in kc/s equals $\frac{300,000}{\text{wavelength}}$ or, the other way round, wavelength equals $\frac{300,000}{\text{frequency (kc/s)}}$ and get in the habit of thinking in frequencies rather than wavelengths, especially for the short-wave bands.

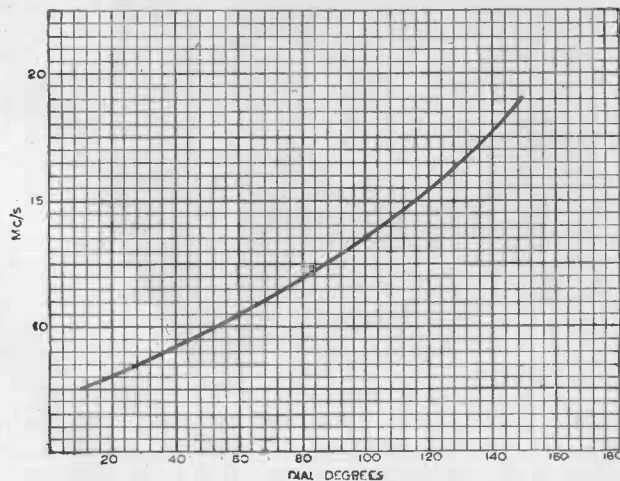

Graph of the Yellow Spot Coil, covering from 15.5 to 40 metres.

Operation.—As the operation of the unit depends, as its name implies, on actual absorption of the signal under identification, it is necessary, in the case of a receiving station, to bring the coil of the wavemeter close to the aerial lead-in after the receiver is tuned, spot on, to the transmission.

By rotating the tuning condenser of the unit very slowly, a setting will be reached which will produce a silent point in the reproduction from the receiver. This will indicate that the meter circuit is tuned to the exact frequency of the station being received, and it is then only necessary to refer to the graph for the coil in use to determine what that frequency is. This is readily done by finding the point on the horizontal scale which corresponds with the dial setting of the meter, and then drawing an imaginary line upwards until the curve is reached. Tracing this point to the left until it intersects the vertical scale will give the frequency.

The degree of coupling required between the meter coil and the aerial lead-in will vary according to the strength of the incoming signal and the receiver, so it will be necessary to experiment to discover that degree of coupling which will give

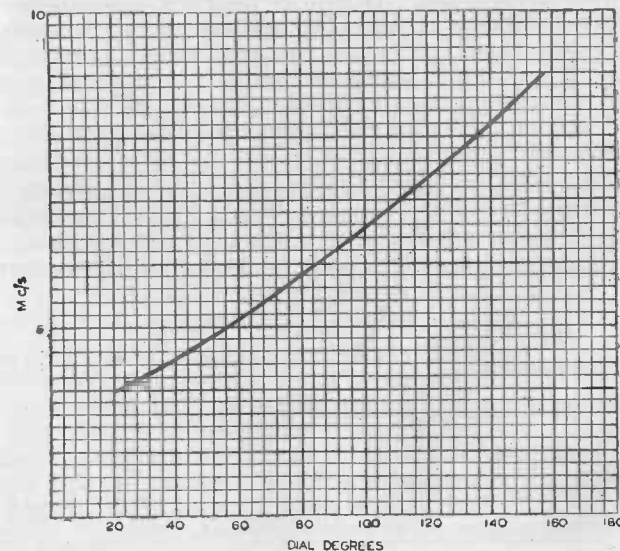

Graph of the Red Spot Coil, covering from 32.2 to 79 metres.

the greatest and sharpest effect. If the receiver is very close to the oscillation point when tuned to the transmission, it will be noticed that very little coupling will be necessary for the meter to be effective. In some cases it is sufficient to lay the lead-in across the coil winding while in others the lead-in may have to be loosely coiled, say, a couple of turns, round the meter coil before definite indications are obtained. Always remember that the weakest coupling, consistent with results, will be the most accurate.

A Heterodyne Wavemeter.—When a higher degree of accuracy is required, it becomes essential to use apparatus of more complicated design, but for amateur work, there are several simple types of valve frequency-meter which can maintain, through fairly wide supply voltage variations, a degree of accuracy quite high enough for practical purposes. They are all single-valve oscillators, depending on the harmonic principle to cover a wide frequency range, and use either the dynatron circuit, the electron-coupled arrangement, or the ordinary triode oscillator. This latter is of course the same thing as the reacting detector valve in a receiver.

Harmonic Operation.—To explain the point about harmonic operation, consider Fig. 58. This diagram shows the amateur bands, and it will be seen that they are in approximate "harmonic relation" with one family of frequencies—the shaded sections—in true harmonic relation. Now, it is well known that an oscillating valve generates harmonics; if they are sufficiently strong, they can be detected right down to the fourth and fifth, even with simple apparatus. Therefore, if a valve frequency-meter is set oscillating at, say, 3,582 kc/s in the 80-metre amateur band, harmonics will appear at 7,164 kc/s in the 40-metre band, 14,328 kc/s in the 20-metre

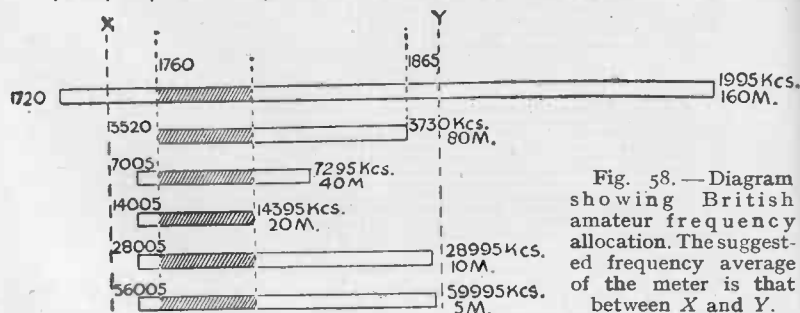

Fig. 58.—Diagram showing British amateur frequency allocation. The suggested frequency average of the meter is that between X and Y.

and so on. Similarly, an "overtone" (or second harmonic beat from the receiver's detector valve) will be heard at 1,791 kc/s in the 160-metre band. This illustrates the most valuable property of a valve frequency meter. The instrument can be built and calibrated to cover one particular band of frequencies, and providing the harmonic output is sufficiently rich, it is equally effective, within practical limits, on any other band above or below.

From a further consideration of Fig. 58, it will be apparent that there is actually a difficulty in this owing to the relative "widths" of the bands. If the meter is designed to cover the 160-metre band, it will automatically cover all others, but the calibration for 20 metres will be too close for convenience, and it is on the high-frequency bands that the greatest accuracy is usually required. This difficulty is overcome by a compromise which takes into account the practical aspects of the matter. 160 metres is, comparatively speaking, not much used and most stations operate between the frequencies 1,760 and 1,865 kc/s, as shown in Fig. 58, so as to be able to "double" from their crystals. Hence, by arranging that the 80-metre band is fully covered—between the dotted lines X and Y in the diagram—the useful part of 160 metres is brought in and the best possible spread obtained on the high-frequency bands. A further point here is that the nearer the fundamental of the frequency meter is brought to the H.F. bands, the stronger will be the harmonics in the 10- and 5-metre region, but this cannot be taken too far or instability will result.

Considerations of Design.—Turning now to the design of a suitable instrument, it can be shown that if the proper precautions are taken, the accuracy obtainable with either of the three circuits previously mentioned is much the same, but there are advantages and disadvantages with each. The dynatron, a very simple circuit using a screen-grid valve, suffers from the fact that it cannot conveniently be used as a listening monitor, i.e., to listen to one's own transmission; also a separate L.T. supply is essential and, for reasonable accuracy, a 0–5 milliammeter is needed in the circuit. The electron-coupled oscillator, also using a screen-grid valve, can be operated as a monitor, but is somewhat complicated from the constructional point of view, as filament chokes must be used under certain conditions. Both circuits require modification depending upon whether mains or battery valves are used.

In Fig. 59 is shown the third type of circuit, the triode oscillator which is probably the most suitable for all-round use. It is simple to construct and either mains or battery valves can be employed; if calibrated to a good degree of accuracy, it will maintain this for long periods; it is equally effective as a listening-monitor and generates strong harmonics. The condensers C_4 , C_5 and C_6 should be noted. While helping to increase harmonic output, they are also "swamp capacities" across grid-filament, grid-plate and plate-filament,

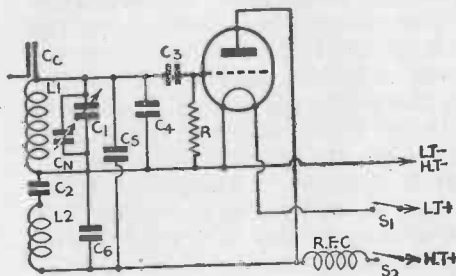

Fig. 59.—This shows a triode oscillator as used in the heterodyne frequency meter.

L_1 —42 turns No. 32 enamelled wire wound on 1-in. diameter former.
 L_2 —14 turns do. do. do. do. do. (same former).
 R.F.C.—See text.

C_c —See text. C_n —"J.B." Neutralising condenser, see text.
 C_1 —0002 mfd. SLF. "J.B." Short-Wave Special.
 C_2 —005 mfd. C_3 , C_4 , C_5 , C_6 —0001 mfd.
 R —3 megohm grid-leak.
 S_1 , S_2 —D.P.S.T. switch.
 "J.B." Short-wave slow-motion dial, 0-100 in 200 divisions.

the idea being that after calibration small changes in the coils L_1 and L_2 , or within the valve itself, will not materially affect the calibration of the meter since these changes will necessarily be minute compared with the condenser capacities, which will thus swamp them.

Layout and Connections.—The condenser C_1 , the tuning capacity, is most important and should be of good manufacture, fitted with a positive clear-reading slow-motion dial. The parallel variable condenser C_n is a very small one, of the neutralising variety, for trimming purposes only, and its function will be explained later. R.F.C. can be a standard short-wave choke with a broadcast choke in series, or a short-wave choke can be made up by putting three sections of 75, 50 and 100 turns of No. 32 enamelled wire on a 1-in. diameter former, spacing the sections about $\frac{1}{4}$ in. Any available broadcast choke can be put in series with this. The coils L_1 and L_2 are important and the values, given with the

other circuit data in Fig. 59, cannot be definitely stated, as variations in the layout and the oscillator valve used will affect them to a certain extent. With a valve of the HL210 class (anything similar which may be to hand will do) the turns data given should bring the frequency range between X and Y in Fig. 58. It is, however, necessary to be prepared for a certain amount of adjusting. The condenser C_c is for coupling the output of the meter into the receiver. It is a very small capacity consisting simply of two pieces of aluminium or thin brass, 1 in. long by $\frac{1}{2}$ in. wide, each bent at right angles in the middle, the two sections then being mounted on a strip of ebonite so that they are $\frac{1}{8}$ in. apart. One side is connected to the grid of the meter valve, as shown, and to the other side is taken an insulated lead which can either be clipped to the aerial terminal of the receiver if it has an H.F. stage, or brought near (but *not* actually connected to) the receiver grid-coil if the set is a detector-L.F. arrangement. This serves to increase pick-up from the meter, though it may not be necessary in some instances. In any case, the pick-up will be quite good on the 160-, 80- and 40-metre bands if a common battery supply is used. This is the simplest and most economical method of coupling the meter to the receiver.

The construction of the instrument does not call for much comment, as it will be a matter of individual preference. It is essential, however, that it should be solidly constructed as one unit, preferably on an aluminium chassis—base 5 in. square by $1\frac{1}{2}$ in. deep, with a panel 7 in. high, will be ample—which can then be put into a screening box.

Method of Calibration.—Before commencing the calibration, make sure the required frequency-coverage is being obtained by checking against the receiver, and also that there is a good pick-up on 20 metres. This will, of course, be an audible beat-note which will be heard in the receiver with the detector just oscillating as the meter dial is swung through its tuning range. The effect is exactly similar to tuning in a station, and the meter is nothing more than a very low-power transmitter local to the receiver, to which it is coupled. If a good pick-up is not at first obtained, adjust the loose lead attached to C_c in Fig. 59, as previously explained, till a comfortable beat-note is heard, and then fix the lead down in that position.

For the best results, *the meter should be calibrated in the condition under which it will normally be operated; that is,*

with the valve always to be used and in the position on the bench it will ordinarily occupy.

If the experimenter can read sufficient morse to identify the various commercial stations at the ends of the amateur bands, which will be covered by the meter, a skeleton curve can easily be drawn. And here another point comes up for explanation. It is convenient to base the curve on the 80-metre band, but this does not mean that only stations in or near that band can be used for calibration. A little thought will show that all signals heard within the range of the meter, provided their frequencies are known with certainty, can be referred to the 80-metre band for calibration purposes. Remembering the harmonic principle, it follows that it is only necessary to make a simple calculation to put a frequency near, say, 20 metres on its correct spot on the 80-metre curve. For instance, suppose one evening a station on 6,950 kc/s is heard at the top of the 40-metre band. Tune this on the receiver and adjust to zero beat ("silent point"). Tune the frequency meter till its beat note is heard on the receiver and also adjust it to zero beat. Then, receiver and frequency-meter will both be tuned to the station on 6,950 kc/s. Suppose the meter dial reading is 94 degrees. This will correspond to frequencies of 1,737.5, 3,475, 6,950, 13,900 kc/s, in or near the 160-, 80-, 40- and 20-metre bands respectively.

To get points for the portion of the curve which actually passes through the amateur bands, and on which there are no commercial stations, the best thing to do is to rely on amateur transmitters' crystal frequencies. Tune in a station to which a report would be sent in the ordinary way. Set the frequency meter and adjust to zero beat, as before. Make a careful note of the dial setting, and when sending the amateur his report, ask specifically for his crystal frequency, and explain that this is being requested for calibration purposes. A stamp will help a quick reply. In this way, a curve can be built up quite quickly and accurately, but it pays to take time and trouble in the work, and to make sure that reliable stations only are selected.

Plotting the Curve.—Before drawing the final curve which will be of the shape shown in Fig. 60 a few "roughs" are necessary. Try and get centimetre-squared paper rather than the ordinary inch-squares divided in tenths, as the former allows of greater accuracy. Then plot the points just as they come, and draw a smooth curve through as many as possible.

One or two will probably be wildly out, due either to inaccurate logging or the station being off-frequency. These should be rejected, as it is of course on the neatness and accuracy with which the final curve is produced that the usefulness of the meter ultimately depends. All four communication bands can be marked, with their limits shown, so that whatever band the receiver may be on, a required frequency can be "shot" right away.

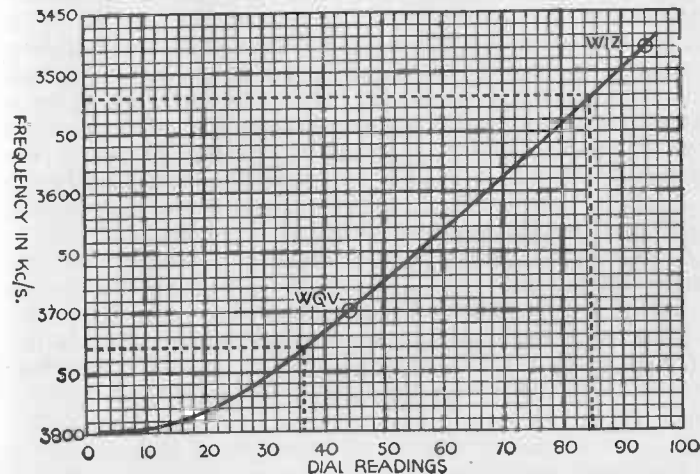

Fig. 60.—Calibration curve obtained with the meter described in this chapter.

Periodically, the calibration should be checked on the original stations or from other standard frequency transmissions. The use of the small parallel condenser C_N across C_I now becomes clear. This, which should be set in the *mid-way position before calibration*, can always be used to bring the frequency "back on the curve" if any wandering is experienced. Thus, supposing a station, originally at 94 degrees, is found to be on 95.5 degrees and other stations are similarly affected, it is only necessary to set the frequency-meter dial at 94, the correct reading, and then to adjust condenser C_N till the meter beat-note is again heard on the receiver, thereby correcting the meter for the change which has taken place.

Such an instrument as that described will maintain its calibration for long periods, and should give an accuracy of plus or minus 2 kc/s on 40 metres.

Uses for the Meter.—Finally, a few words on other uses to which a frequency meter like this can be put. Apart from its function and usefulness in checking and measuring frequencies and calibrating receivers, it can be used as a separate heterodyne for continuous-wave reception through heavy interference. The required continuous-wave signal is tuned in as closely as possible on the receiver and the reaction backed off as for 'phone reception; the meter note will then beat with the incoming continuous-wave signal, giving greatly increased selectivity on that particular signal. Another use is as a listening monitor for the amateur transmitter, whereby one's own signals can be heard, either by putting 'phones in the frequency-meter H.T. lead or by coupling its output into the L.F. stage of the receiver, in which case it is not necessary to change the 'phones over when switching from "Send" to "Receive" if the meter connections are taken through the send-receive switch.

Lastly, the short-wave listener can find yet another outlet for his energies by logging and checking amateur station frequencies, which will not only prove to be very interesting, but will greatly enhance the value of his reports.

CHAPTER XVIII

ULTRA-SHORT-WAVE SECTION

THE wavelengths from 10 metres down are generally referred to as the "ultra-short waves" and they call for slightly different treatment. Whilst standard circuits may be used, improved results are obtained by using special arrangements, of which the super-regenerative circuit is undoubtedly the most popular. Regeneration is, of course, merely another name for reaction.

In an ordinary regenerative receiver, the reaction control has to be adjusted with care, otherwise, if the circuit is allowed to oscillate during, for example, the reception of telephony an audible whistle will be produced. When reaction is adjusted to the "whistle" stage, the set is in its most sensitive condition but unfortunately distortion will set in and speech may be rendered unintelligible. If, however, we could devise some means whereby this high sensitivity could be obtained, without the audible whistle and the distortion, it would obviously be desirable, and, in fact, this is the effect which is obtained by means of the super-regenerative circuit.

This effect is accomplished by arranging for the application of the reaction or regeneration in such a manner that the oscillation thereby produced is above audibility (supersonic) and at the same time it is suppressed, or quenched, at every half cycle. The quenching frequency is applied to the grid or the anode circuit and is obtained from a separate valve, or, in some cases, may be generated in the same valve, in which case the circuit is known as a "self-quenching circuit". In this chapter there will be found constructional details of two super-regenerative receivers, embodying the separate quench valve and the self-quench principle. First of all, however, we will deal with the straight or ordinary type of ultra-short-wave receiver, and Fig. 61 shows the circuit. The basic idea has been to build on ultra-short-wave principles, yet retain component values suited to reception on the usual short-wave bands. It is designed to use a Cossor type 210HL detector valve, a temporary half-wave 5-metre aerial, a four-turns reaction coil and a $\frac{3}{4}$ in. diameter loop with two straight legs, and totalling in all $4\frac{1}{4}$ in. of 18-gauge wire,

In order to mount the latter the fixing nuts will require to be reversed, in order to obtain sufficient purchase on the condenser bush. Baseboard and panel dimensions will be governed by the physical dimensions of the various components used, and it is advisable to keep them down to reasonable dimensions but to avoid cramping. The valve and coil holders respectively, should be placed as near as possible to the tuning condensers in order that wiring may be kept as short and direct as possible, in the interests of efficiency.

Coil Data.—It is assumed that standard commercial coils will be used for wavelengths above 10 metres, but in Fig. 63 the general construction and winding data is given for the 10-metre coil of the valve-base type. The original coil from which this data is taken, tuned in the 10-metre band at fifty degrees on the tuning condenser scale.

Owing to circuit differences some little experiment may be necessary to strike this band, but the data given will assure that the band will be found between 5 and 50 degrees or so.

To increase the number of turns on the grid coil will in most instances put the tuning in the minimum position above 10 metres. There are some who favour 5-metre coils wound on standard coil formers or valve bases, but for those who prefer the self-supporting type coil, these can be made in a form which allows them to be used in conjunction with the standard four-pin coil base.

Fig. 63 shows the method of construction. This consists of a cut-down valve base with the centre drilled out between the pins, and saw cuts made as shown at Fig. 64, all of which reduce the high-frequency losses to the minimum, and increase the leakage paths.

With reference to the 5-metre band, and apart from circuit differences, it is difficult to locate this band with certainty during initial tests, even though coils are made to given data, and used in conjunction with the recommended tuning capacity.

There is, however, a very helpful method which may be adopted in order to gain an approximate idea where actual 5-metre transmissions are not receivable.

Inductive Coupling.—An 8 ft. 3 in. length of 16-gauge copper wire is looped at one end and suspended so that the loop is inductively coupled to the grid coil. Thus, following the principle of the absorption meter, the receiver will cease to oscillate completely, or a considerable reduction in

oscillation will be noticeable when it is tuned in resonance to the loop rod.

With reference to the self-supporting coils, as shown at Fig. 65, the experimenter is advised to make a series of twin coil combinations as complete units, with soldered connections to coils and base. By this means various combinations can be tried, in conjunction with the loop rod, until the 5-metre band is located, and the calibration point noted for future reference.

Coil Combinations.—The following are suggested coil combinations:

Internal diameter— $\frac{3}{4}$ in., 18-gauge wire. Fig. 63.—Details of the home made coil.

Two turns grid—three turns reaction.

Three turns grid—four turns reaction.

Four turns grid—five turns reaction.

Five turns grid—five turns reaction.

Six turns grid—six turns reaction.

Spaced twice the thickness of the wire.

A series of coils as outlined will cover the 5-metre, 7-metre, 10-metre and 11-metre bands.

Super-Regeneration.—Passing now to the super-regenerative circuits, Fig. 66 shows a circuit incorporating the self-quench valve: Fig. 67 shows a circuit with a separate quench valve, whilst Fig. 68 shows a more ambitious circuit in

which an H.F. stage has been added. Furthermore, in this circuit the detector has separate quench adjustments which can be cut out as desired. It will be noted that a screen-grid valve is used as detector, and the quench frequency applied to the screening grid. This makes for better

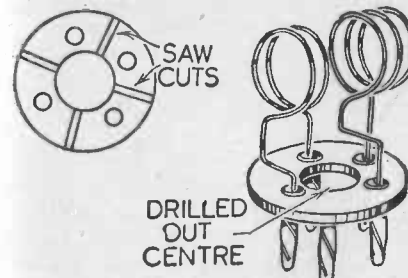
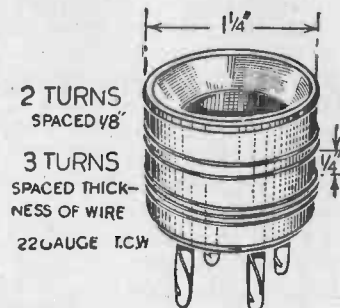

Figs. 64 (left) and 65 (right).—Saw-cuts in a valve base to reduce losses and a self-supporting coil on base.

stability and higher efficiency, as comparing the circuit of Fig. 66, it will be seen that the quench control is by variation of the detector plate voltage, which reduces the detector sensitivity when the plate voltage has to be set below the optimum to quieten the quench. With a separate quenching valve, this does not occur. The general efficiency is increased by using a screen-grid valve as in Fig. 68. In this circuit, either the new "Acorn" valves could be used, or the midget type for the H.F. and detector stages, though quite good results will be obtained with ordinary valves of the SG215 and HL210 type in any of these circuits. Suitable values are given under each circuit. All H.F. leads should be kept short and direct and the detector stage completely

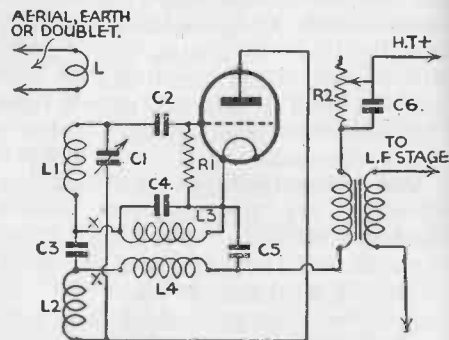

Fig. 66.—Self-quenching detector.

L—1 turn 18g. enamelled, $\frac{1}{2}$ -in. diam.
 L1-L2—3 turns 18g. enamelled, $\frac{1}{2}$ -in. diam., turns slightly spaced.
 L3, L4—Quenching coils. See text.
 C1—Three-plate midget variable condenser.
 C2, C3, C5—.0001 mfd. C4—.002 mfd. C6—.001 mfd. R1—3 megohm leak. R2—50,000 ohm 2-watt quench control resistor.
 (Try U.S.W. RF chokes at X.X.)

screened. In the case of the receiver in Fig. 68 the three H.F. stages should be in separate screening boxes, though all the circuits will perform without any screening at all.

Quench Coil Construction.—The quench coils are constructed as follows, a dimensioned sketch of one being given in Fig. 69, although any other form of construction would be equally effective.

The former consists of a $\frac{3}{8}$ -in. diameter wooden dowel about 1 in. long on which are mounted three cardboard cheeks $1\frac{1}{4}$ in. diameter and spaced $\frac{1}{4}$ in. These are fixed in position with sealing wax. One section L3 is wound with 1,400 turns of No. 40 enamelled wire, and the other section L4 with 900 turns. Less than $\frac{1}{2}$ -oz. of wire is needed. The windings can be put on quite quickly and easily by mounting the former

in the chuck of a breast-drill which is then fixed horizontally in the vice. The turns are run on from a bobbin of wire set up so that it is free to rotate. One hand is used for operating the drill handle and the other for guiding the wire. Meticulous precision is not at all necessary, but the layers should be put

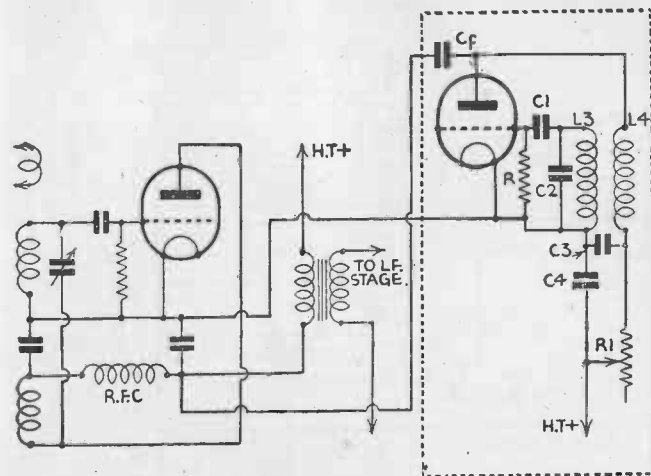

Fig. 67.—U.S.W. Detector with separate quench.

(Section enclosed by dotted lines can be made up as quench unit.)

Cf—Quench feed condenser, .002 mfd.
 C1—.0005 mfd. C2—.002 mfd. C3—.002 mfd. C4—1 mfd.
 R—50,000 ohm leak. R1—50,000 ohm 2-watt quench control resistor.
 L3, L4—Quench coils. See text.
 RFC—U.S.W. RF choke. For construction, see text. All other values as in Fig. 66.

on as evenly as is reasonably possible. Find out how many revolutions of the chuck go to one turn of the drill handle and divide this into 1,400 and 900 respectively. This will give the number of handle revolutions required. The ends of the windings are brought out through small holes in the cardboard cheeks, and a piece of insulated sleeving slipped over them. These leads are then spotted to the terminals on the strip, to which the heavier circuit connections can be taken without risk of breaking the leads. The former should be varnished before being mounted to finish the job.

The various ultra-short-wave chokes required can be made up very easily by putting about fifty turns of 40-gauge enamelled wire, slightly spaced, on a $\frac{3}{8}$ -in. diameter former.

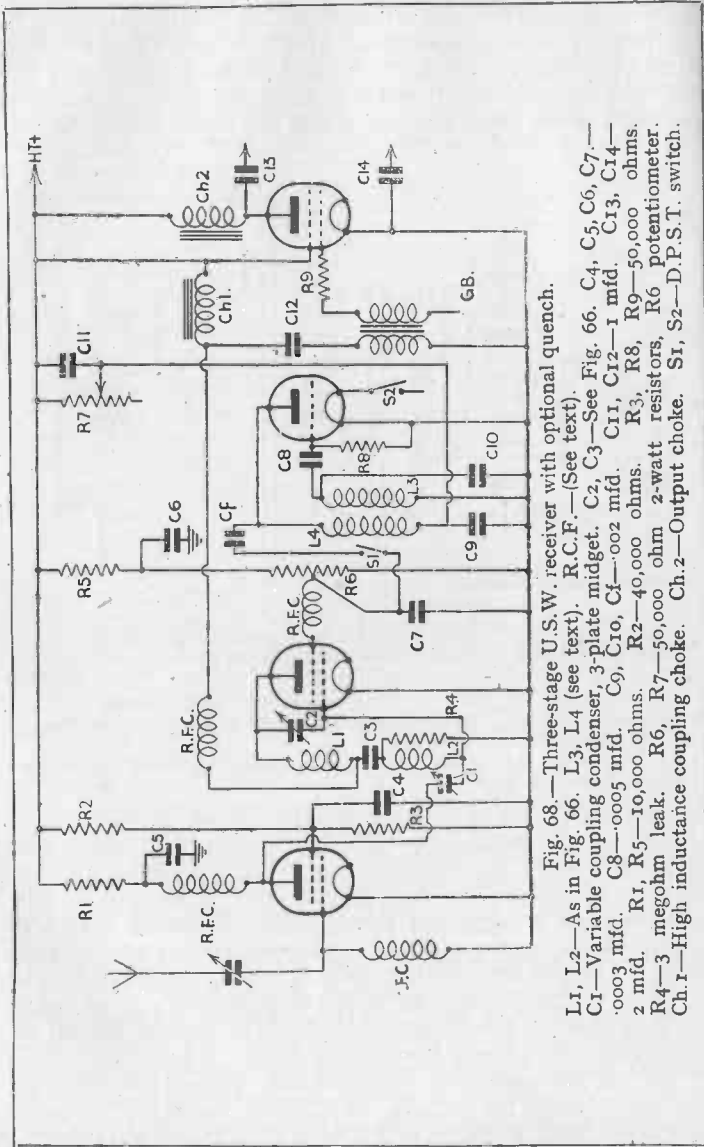

Fig. 68.—Three-stage U.S.W. receiver with optional quench. L1, L2—As in Fig. 66. L3, L4 (see text). R.C.F.—(See text). C1—Variable coupling condenser, 3-plate midget. C2, C3—See Fig. 66. C4, C5, C6, C7—0.003 mfd. C8—0.005 mfd. C9, C10—0.002 mfd. C11, C12—1 mid. C13, C14—2 mfd. R1, R5—10,000 ohms. R2—40,000 ohms. R3, R8, R9—50,000 ohms. R4—3 megohm leak. R6, R7—50,000 ohm 2-watt resistors, R6 potentiometer. Ch.1—High inductance coupling choke. Ch.2—Output choke. S1, S2—D.P.S.T. switch.

It will be readily apparent that an existing straight ultra-short-wave receiver can be made super-regenerative simply by introducing the quench coils L3 and L4 in the grid and plate circuits respectively, following Fig. 66. Alternatively, a quench unit can be built up consisting of the portion of circuit Fig. 67 enclosed by the dotted lines. Super-regeneration can then be

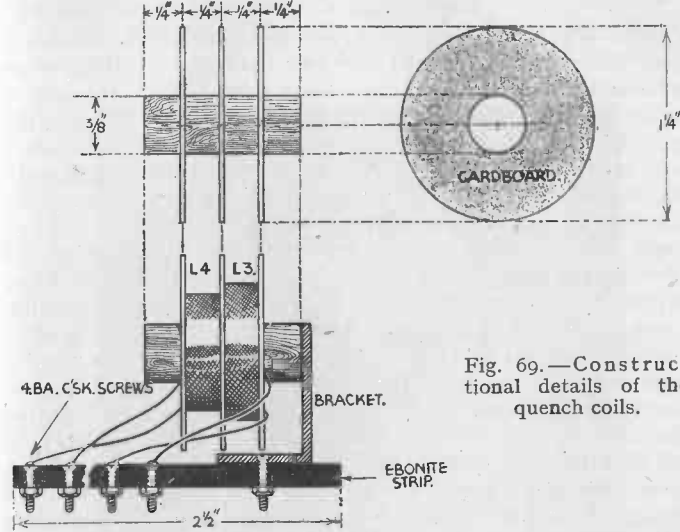

Fig. 69.—Constructional details of the quench coils.

applied to any receiver simply by connecting the feed condenser Cf to the H.T. end of the R.F. choke in the plate circuit of the detector valve, using a common battery supply. A point to notice is that if, with either circuit arrangement, the quench effect is not obtained, one of the coils L3 or L4 should have its connections reversed.

The quench noise will be found to be almost unbearable at the maximum, but when searching for signals, it should be kept low, and then adjusted for maximum signal strength when something is heard. Weak signals will not be found if the quench is too loud, while strong signals like a strong quench to bring the strength up.

CHAPTER XIX

ULTRA-SHORT-WAVE CONVERTERS AND ADAPTERS

IN spite of the fact that the super-regenerative and superhet types of receiver are used by the majority of short-wave enthusiasts there is obviously a very wide field of interest in the simpler types of receiver for this work. This is probably due to the fact that a very simple one-valve set, for instance may, with a little modification, be used in conjunction with another existing broadcast receiver, giving to the latter an extension of application which increases its utility. If the simple detector stage, built for short waves is added to the L.F. stages of an existing receiver it is known as a short-wave adaptor: if, however, it is built in a slightly different manner it may be added to any broadcast receiver employing H.F. amplification and it then converts the combination into a superhet and accordingly this type of single-valve set is then known as a short-wave converter. By the choice of suitable coils and tuning condensers the adaptor or converter may be used on either the normal short waves or on the ultra-short waves. Fig 70 shows a short-wave adaptor, whilst the theoretical circuit employed is shown in Fig. 71, and this particular circuit is interesting as it combines an electron-coupled oscillator with a battery triode, but feed-back is controlled by the conventional anode to earth capacity. The circuit and constants were evolved after considerable experimenting, and the circuit may be tried out without any fear of difficulty of obtaining or controlling oscillation down to below 5 metres.

Since a battery valve is used it is necessary in the electron-coupled circuit to maintain both sides of the filament at a potential above earth. This is done by tapping the negative side to the centre of the tuning coil, and inserting an ultra-short-wave H.F. choke in the positive lead. The 10,000 ohm resistance in the anode of the valve acts as an H.F. choke, and deflects energy back through the reaction condenser to the grid circuit by means of the tapped portion of the coil. The input side of the anode resistance is by-passed by a .003 mfd. condenser. The tuning condenser *C* has a value

of 25 mmfd., the reaction condenser also having the same value. Plug-in coils are used, as three coils are necessary to cover the 5- to 10-metre range completely. The make of coil specified is supplied with a base.

There is little difficulty about this ultra-short-wave adapter, but it must be remembered that care, both in construction and operation must be used.

Constructional Details.—Turning to the practical construction of the unit, it will be seen that a small home-made

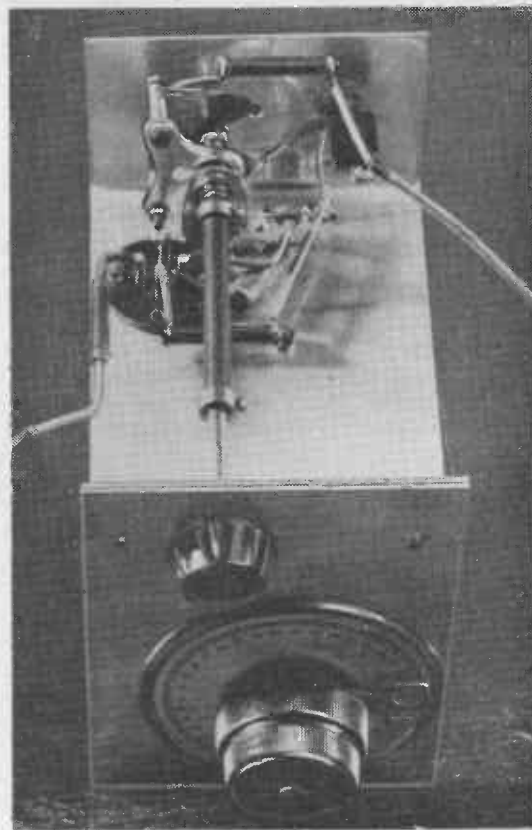

Fig. 70.—View of the completed short-wave adapter.

chassis is used, consisting of a strip of 16-gauge aluminium 14 in. by 5 in. The aluminium is bent at right angles 3 in. from each end to form the chassis. This can be done in a vice, or with the help of a piece of wood. The small panel, also of aluminium, measures 7 in. by 5 in.

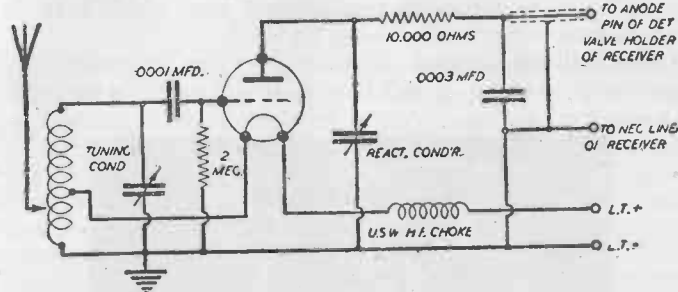

Fig. 71.—Theoretical circuit of the short-wave adapter.

A 1-in. diameter hole must be drilled for the valveholder, this being done with a carpenter's bit; also the smaller holes for mounting the other components of which the positions can be seen in Fig. 72. There is a single earth terminal mounted at the back of the chassis. The reaction condenser is mounted underneath the chassis in such a position that one side of the fixed vanes comes as near to the anode pin of the valveholder as possible. It may be noted also that the bolt holding the fixed vanes of the reaction condenser is withdrawn and pushed through the reverse way (care being taken to replace all the spacing washers) so that the bolt, or soldering tag, can be soldered direct to the valveholder anode pin.

The tag of the moving vane of the reaction condenser is wired direct to earth. Here, it must be mentioned that although the chassis is at earth potential, it is advised that all the earth wiring is taken direct to the earth terminal. Since the by-pass condenser is anchored direct to the earth terminal there are only three other wires to earth, one from the tuned circuit, one from the grid resistance, and one from the reaction condenser. The anode resistance is wired between the top fixed vanes of the reaction condenser, and the other side of the by-pass condenser. From this latter junction is taken the screened output lead. All the underneath chassis wiring is clearly shown in Fig. 72.

Looking at the unit from the front, the right-hand side of the coil base is taken to the fixed vanes of the tuning condenser.

The other side of the coil base is taken to the moving vane, also a lead is taken from this side of the coil base to connect with the negative terminal of the accumulator. The soldering tag to the moving vane of the tuning condenser is located at the back of the condenser.

Coil and Valve.—The coil has to be centre tapped, so a short length of 18-gauge wire was soldered to the coil, and a

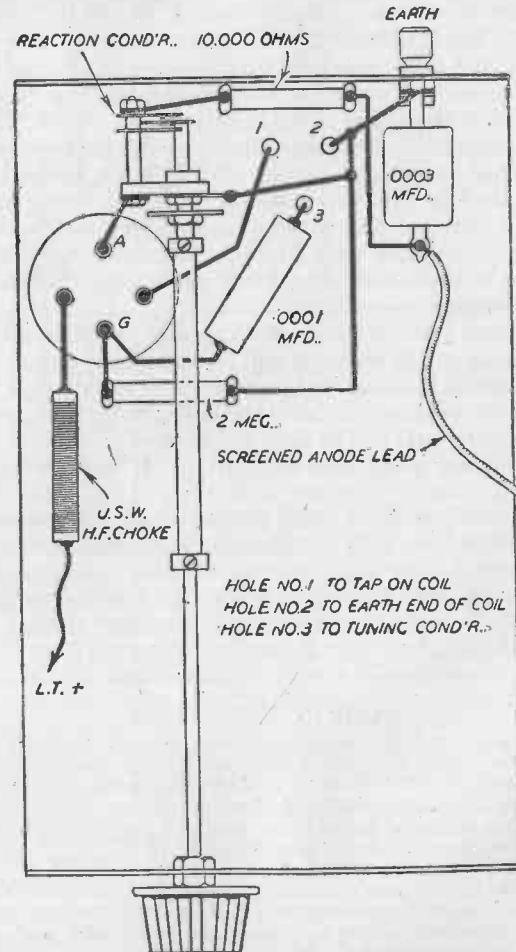

Fig. 72.—Wiring diagram of the short-wave adapter

crocodile clip was connected to the wire coming through the chassis from one side of the filament. It is important to note the filament wiring and not take the leads from the L.T. battery direct to the filament pins of the valveholder, as is usually the case in a battery set.

The valve chosen for this adapter was of medium impedance, special detector type, was found perfectly suitable for this ultra-short-wave unit. There should be little difficulty in operating the adapter. The detector valve of a receiver is removed, and the anode lead from the unit is plugged in to the anode pin of the detector valveholder in the receiver. A connection is also made to the negative line. The L.T. positive and negative leads are taken direct to the battery, and these leads should be as short as possible. It is not advised that the unit be used in the conventional way, that is by taking all leads to a four-pin plug to the receiver detector valveholder. The unit can be used with a mains receiver, but it is necessary to keep the unit well away from the mains transformer, or any A.C. wiring.

A separate connection to earth should be taken direct from the terminal on the unit. It will be seen in the circuit diagram that the aerial is shown taken direct to the grid coil. Due to the electron-coupled circuit this is quite satisfactory and a long outdoor aerial can be used in this way without preventing the valve from going into oscillation. It will be found that oscillation is fairly constant over most of the dial, except at the lower end of the tuning range, when it is necessary to increase the reaction condenser considerably to obtain oscillation. A full H.T. voltage can be used, and indeed this is advocated. The valve will go into oscillation smoothly irrespective of the H.T. voltage, another tribute to this particular circuit.

LIST OF COMPONENTS.

- Two 25 mmfd. tuning condensers (Premier Supply).
- One 6-turn ultra-short-wave coil (Premier Supply).
- One ultra-short-wave H.F. choke (Eddystone).
- Two extension outfits (Eddystone).
- One .003 condenser (T.C.C. type M.).
- One .0001 non-inductive condenser (T.C.C.).
- One 2 megohm resistance (Erie).
- One 10,000 ohm resistance (Erie).
- One 4-pin chassis mounting valve holder (Clix).
- Strip of aluminium for chassis and panel, wire, etc.
- One valve Hivac D 210.

Mains Version.—A mains version of this unit may be built and will be found to operate quite as well as the battery arrangement. The circuit of the mains version is shown in Fig. 73. There is, of course, no need to use the ultra-short-wave choke with an indirectly heated valve. The cathode is simply tapped into the tuning coil. A grid leak with a value of 500,000 ohms was used, otherwise all the rest of the circuit values remained the same.

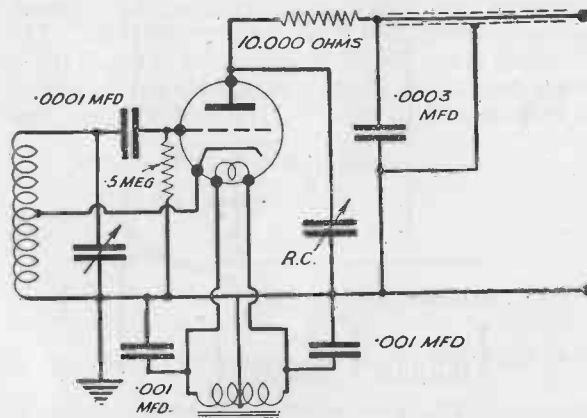

Fig. 73.—Circuit diagram of the A.C. version of the short-wave adapter.

Oscillation with the indirectly heated valve is smooth, but some trouble may be encountered with various kinds of hum. It must be remembered that a reacting detector on such low wavelengths will be extremely sensitive to any external A.C. fields. If, when the valve is in oscillation, a modulated hum occurs, filament by-pass condensers may help in effecting a cure; these are shown in the circuit diagram. It is most essential that the adapter should have its own filament transformer, or alternatively a separate winding on the power transformer in the receiver; otherwise if the heater leads are taken direct to the receiver, to valves already supplied with heater voltage, a bad ripple may result. Wiring to the heater pins of the valveholder must be carried out carefully, and kept as far away from the grid wiring as possible. There should be no hum with the valve in or out of oscillation, and it is worth while spending a little time in getting rid of any of these troubles.

Several different types of valve were tried and in the 4-volt 1-amp. class, an M.H.4 was as good as any. If it is desired to use a valve with a 6.3 volt heater an American metal octal 6C5 was found very suitable, and this valve will need an American octal valveholder.

Aerial System.—With either the mains or battery version of the ultra-short-wave adapter, the aerial system can play an important part in improving results, in fact in all ultra-high frequency reception as much gain can be obtained with a proper aerial system as from the receiver itself. The best known system is the simple di-pole which is tuned (by means of cutting to correct length) to a half-wavelength of the station it is desired to receive. This self-resonant tuning is

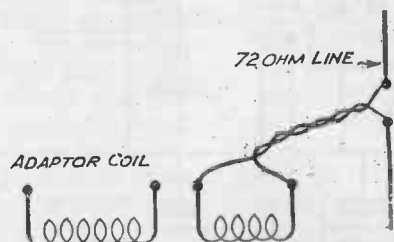

Fig. 74.—A simple di-pole aerial system.

broad, and will hold good over a wide band of frequencies. If a di-pole is used with the ultra-short-wave adapter it should be erected as high as possible, and connected to the adapter by means of a 72-ohm transmission line, as in Fig. 74. A loose-coupled coil may then be used.

For receiving the television transmissions each half of the aerial should be 5 ft. 4 in. long, and a further improvement can be made by using a reflector placed a quarter-wave (5 ft. 4 in.) behind the aerial. The reflector should be a little longer than the aerial itself, and still further improvement can be made by using a director, as well as a reflector. The arrangement is shown in Fig. 75. The director is placed at three-eighths of a wavelength in front of the aerial in the direction of the stations to be received. The measurements given are for the 5-metres band; a similar arrangement can be used for the television stations by altering the measurements accordingly. It is in reality a simple beam system of reception.

Reception Conditions.—Regarding reception conditions on the ultra-short waves it will be found that over comparatively long distances signal strength varies much the same as with other short-wave bands except, if it is possible to receive the station at all, complete wipe-out will not take place, though signal strength will vary from night to night, and will remain more or less the same for the whole transmission.

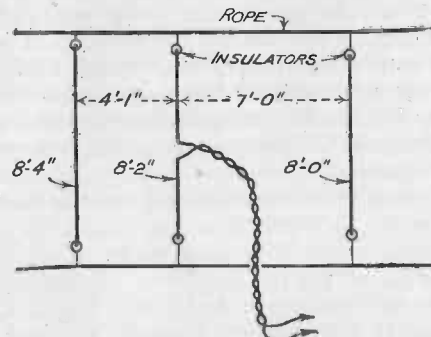

Fig. 75.—Simple beam aerial system for ultra-short-wave reception.

It is also necessary to remember that reception conditions will vary according to the waveband or frequency band upon which the receiver is used. This point has been dealt with earlier in the book, but there are some other factors which will vary the results. On the ultra-short wavelengths results will be affected by various astronomical conditions, of which the sun-spot is probably the most important. The vagaries of reception conditions have been studied and it has been found that certain effects have been coincident with sun-spot activity, although at the moment full data has not been collected and the exact effects may not, therefore, be tabulated.

CHAPTER XX

FINDING AND MEASURING WAVELENGTHS OF FIVE METRES AND BELOW

It is more than likely that a number of experimenters, in making their initial efforts to get results on 5 metres, have had considerable difficulty in "finding the band". It is also very probable that a number of receivers, though built strictly to specification, are not covering the 5-metre band at all—not because of any fault in the design followed, but due to those individual differences in interpretation which mean so much on the high frequencies.

For in truth it is often very difficult on a home-built set to find even 20 metres, let alone 10 and 5, and on the latter band experienced transmitters have gone sadly astray when using self-excited oscillators for the first time. A classic instance of this occurred some years ago in the West of England, when two groups of amateur transmitters, though they had been conducting tests practically in sight of one another for months, yet failed to get contact. After consultation, it was somewhat belatedly decided to check wavelength, and it was then found that one group's "standard" wavemeter had been calibrated not to five, but to six metres. When the necessary adjustment had been made, QSO was immediately obtained.

In this case, the method of finding the band had been by counting harmonics. Starting at the lowest known harmonic (in wavelength) they were carefully traced down through the wave-range of two receivers till the neighbourhood of 5 metres was reached. This is where the mistake arose, as the oscillator, being in the 80-metre amateur band, was giving harmonics very close together in the 5-metre region. It only needed a miscount to throw the results right out, and this is what had actually happened.

It is obvious, therefore, that some accurate method of locating the waveband and also of measuring the wavelength of received signals should be in the hands of every short-wave enthusiast. An absorption wavemeter will enable the wavelength of signals to be read, provided that the wavemeter is accurately calibrated, whilst a small radiating oscillator which has also been calibrated would enable a receiver to

be adjusted accurately to any desired range within the scope of the oscillator. A wavemeter could also be used in a similar manner, although some discrepancy might arise when the meter is coupled to the receiver, and therefore both instruments are really desirable. We will begin first by describing the construction of the absorption wavemeter and then pass on to a description of the oscillator. The wavemeter is of a type which might be called a "read-calibrated" instrument, as this avoids the difficulties which might be experienced in obtaining suitable signals for calibration purposes.

It follows from this that it is essential to work *exactly* to the specification; no other condenser than that given can be used—though this does not mean that other makes of condensers will not work, but only that as the model has been calibrated with the condenser specified, the use of another make will obviously affect the calibration seriously. Similarly, the

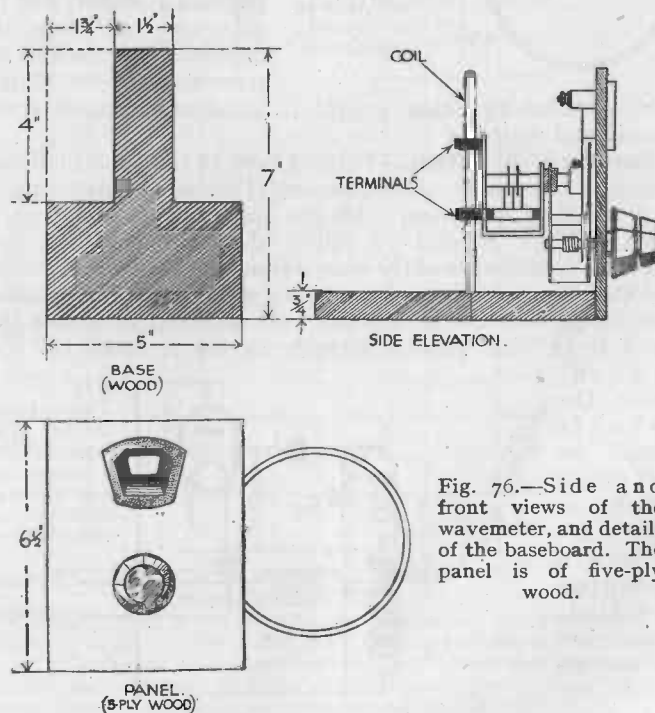

Fig. 76.—Side and front views of the wavemeter, and details of the baseboard. The panel is of five-ply wood.

coil described must be reproduced as accurately as possible. In practice, all this will be found quite easy, as the apparatus required is readily obtainable and construction is simplicity itself.

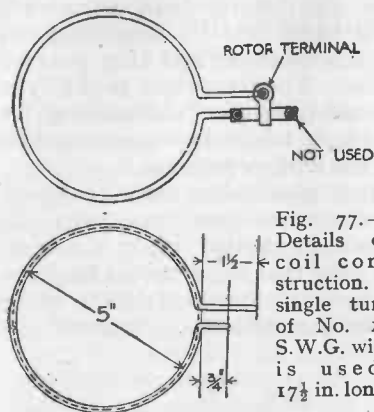

Fig. 77.—Details of coil construction. A single turn of No. 14 S.W.G. wire is used, 17½ in. long.

ards obtained by other groups of amateurs from different sources and methods.

Constructional Details.—Turning now to the constructional details of the model, the fundamental circuit consists simply of a coil and condenser. All the necessary information is given in Figs. 76 and 77, which show the constructional features; a plan view of the base, a front elevation, a side view, and the details of the coil-condenser assembly. The peculiar base shape with the handle has been adopted to enable the meter to be used without actually having to touch the coil and condenser. The details should be followed exactly as given. When clamping the dial, make sure the moving vanes are

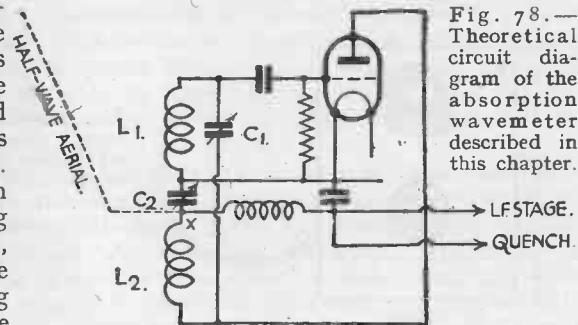

Fig. 78.—Theoretical circuit diagram of the absorption wavemeter described in this chapter.

all in. The wire for the single-turn coil consists of 17½ in. of No. 14 bare copper, which can be polished before fixing and lacquered afterwards. A suitable lacquer can usually be obtained at an ironmonger's store.

In Fig. 79, the full line shows the actual calibration curve obtained with the model as described. The dotted curves A and B above and below are the possible limits which may be obtained in individual instances. From experiment, it has been found that these represent a degree of error which only careless work can produce. Therefore, it follows that by taking the limits of the band as lying between 53 and 66 degrees, it is practically certain that the instrument made up by you, as a particular reader, will cover the 5-metre band with a degree of accuracy ample for ordinary purposes.

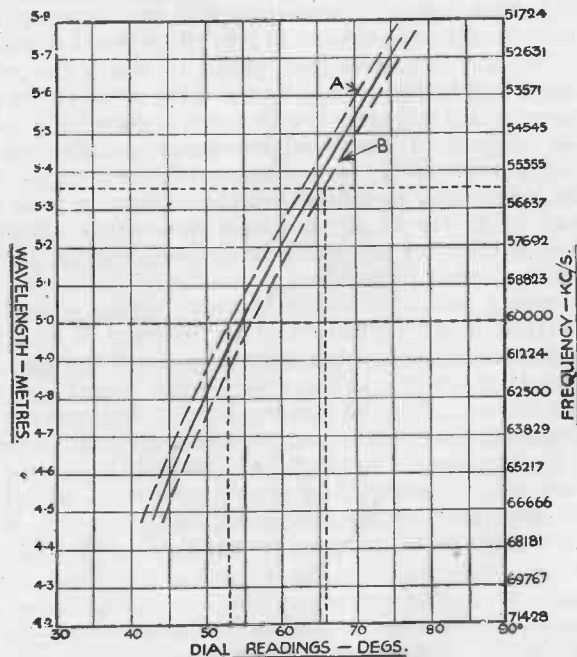

Fig. 79.—The full line is the actual curve obtained for the wavemeter, as described; dotted curves A and B are positive and negative limits explained in text. Horizontal and vertical dotted lines show limits of the 5-metre amateur band in terms of wavelength (5.00–5.36 metres), frequency (56005–59995 kc.), and dial reading (53–66 degrees).

Using the Wavemeter.—In practice, the best way to use it is to set the ultra-short-wave receiver in operation with the quench comfortably audible. The wavemeter is then held within two or three inches of the coils L_1 and L_2 in Fig. 78 and the meter tuning condenser adjusted till the quench noise is taken out. The tuning will be found fairly sharp (it flattens as the coupling is increased) and the point at which the quench is inaudible or at a minimum is, of course, the wavelength to which the receiver is tuned, which can be read off from the curve. If the receiver does not respond the first time, try a different setting of the tuning condenser C_1 , and swing through the meter tuning range again. When the upper limit, say, of the band has been found, the lower can be ascertained in the same way and the receiver will be calibrated.

Two further points in connection with any super-regenerative receiver of the type shown in Fig. 78 are worth mentioning here. The first is that the waveband to which the receiver will tune is somewhat affected by the value of C_2 , the coupling condenser, which can therefore be made a .00005 mfd. midget variable instead of the fixed condenser usually specified. This helps considerably in adjusting the wave-range of the receiver, which may be found from the wavemeter to be either above or below the band. A simple wave-range adjustment can also be made by squeezing in or spreading out the coils L_1 and L_2 , as may be required.

The second point is that it is worth trying a half-wave semi-vertical aerial, tapped direct to the point X in Fig. 78. This will often result in a big increase in signal strength, even if the aerial is indoors, as it would usually have to be under these conditions. For the 5-metre band, a half-wave wire is 8 ft. long, and for outside portable work, try a quarter-wave wire 4 ft. long tapped to the "cold" end of the plate coil in the same way. These figures are approximate, and though actually dependent on the frequency being received, will be found close enough to give good results over a wide frequency-range.

LIST OF COMPONENTS.

- "J.B." .000025 mfd. midget ultra-short-wave condenser.
- "J.B." short-wave slow-motion dial.
- (The above fit together so that no special condenser mounting is required.)

The other method which we have referred to is the use of an oscillating circuit, which is used to excite a half-wave aerial. Fig. 80 shows a suitable circuit which makes use of a PX.4 valve in a series tuned ultra-audion type of oscillator.

This circuit will oscillate readily, the only really critical component being the H.F. choke feeding the plate coil. If this component is omitted or a wrong type of choke used, the circuit will not oscillate. Most of the commercial ultra-short-wave chokes now on the market will be quite satisfactory.

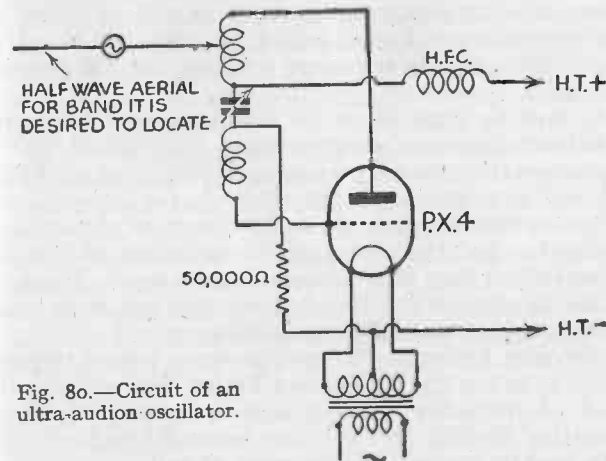

Fig. 80.—Circuit of an ultra-audion oscillator.

It will be seen that a half-wave aerial—for the particular waveband it is desired to check—is tapped on the centre turn of the anode coil, with a 60 mA. type of fuse bulb connected in the centre of the aerial. The tuned circuit consists of two 3-turn coils of 16-gauge tinned copper wire, split in the centre with a .0001 variable condenser.

Tuning procedure is quite simple, the condenser being rotated until the lamp lights up to its maximum brilliancy. At this point the oscillator reading should be transferred to an absorption wavemeter, one preferably with a flashlamp bulb in series with the tuned circuit so that a visual indication of the exact tuning point will be obtained. Plenty of H.F. energy will be obtained from this oscillator with 250 volts on the anode. One important point must be mentioned, this circuit must be used for the purpose of wave measurement only, and it must not be used for any kind of communication,

as it really constitutes a miniature transmitting circuit. For radiation purposes a special licence is necessary. Though even so, it must be remembered that it is an unstabilised circuit, and turns out a poor note for this work.

Additional Waveband Check.—Although the above is reasonably accurate for waveband checking, after having obtained a wavemeter check should be replaced in the centre of the aerial with a single-turn coil. When this coil is brought into close proximity with the receiver grid coil of an oscillating detector or super-regenerative circuit, it will be found that the detector valve will cease oscillating when the tuned grid circuit is brought into resonance with the natural frequency of the aerial.

This must be regarded as an additional waveband check and will not give very great accuracy, particularly with the super-regenerative receiver, because it will be found that the aerial will not have any effect above the non-oscillation point on the receiver dial, but below this point the aerial will be inclined to pull the circuit out of oscillation all the time, if the coil is not kept at a critical distance away. This is due to a loading effect of the tuned circuit with minimum capacitance as in using an aerial in the ordinary way.

Lecher-wire System.—The most accurate way of frequency checking is to use the well-known Lecher-wire system. This method of frequency measurement is usually applied to transmitting circuits, and it is not generally realised that it may be used for receiver measurement as well.

In using the Lecher-wire system the detector circuit should be in an oscillating condition, this is, of course, complied with if the receiver is a superhet or a super-regenerative receiver. Two wires of 18-gauge bare copper are stretched out side by side about 2 in. apart, terminating in a single-turn loop which is coupled to the receiver tuned circuit, as in Fig. 81. A low reading milliammeter is then connected in the H.T.

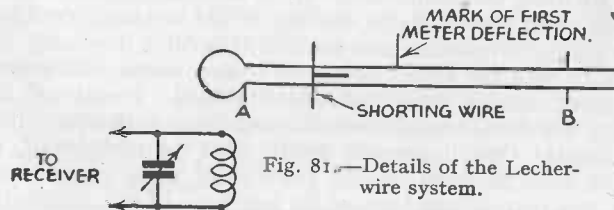

Fig. 81.—Details of the Lecher-wire system.

feed to the detector anode circuit, and here it might be mentioned that if a very small amount of current is being drawn by the detector valve, things may be "hotted-up" a bit by an increase in anode voltage, for the purpose of the check.

A stiff, short length of bare wire is drawn down the two wires, insulated from the hand, by means of a piece of ebonite tubing. At a certain point of shorting the two wires a flicker will be noted on the meter, this point on the wires should be carefully marked, and the shorting wire should be drawn still further along the wires until another flicker is noted. The two distances will then be each half-wave at which the detector valve is oscillating, or the distance *A* to *B* of Fig. 81 will indicate the exact wavelength to which the receiver is tuned.

It will be understood that this system of wave checking will be of most use to the experimenter on wavelengths of 5 metres and below. Using this method, it can easily be discovered which is the lowest wavelength that any valve or circuit will oscillate. During the next few years the ultra-short and micro-waves will be used more and more, and the experimenter will be wise to familiarise himself with making accurate frequency measurements in this critical part of the radio spectrum.

CHAPTER XXI

TWO SIMPLE ONE-VALVERS

THERE is little doubt that the one-valver is the ideal set for the beginner to short-wave working, and in this chapter we describe two such receivers—one built from standard parts and the other of the "home-made" type—in which every component which can be home-made is described. This will offer greater interest for the home-constructor, but the results may not be fully up to those which will be obtained when properly made parts are available, although in this respect a great deal will depend upon the quality of the workmanship and the materials used. The circuit of this home-made set is given in Fig. 82 and a full wiring plan in Fig. 83. This has been drawn in pictorial form to simplify the details for the benefit of those who are not fully familiar with the theoretical type of circuit.

In the first place it is necessary to explain why the $\cdot 0005$ -mfd. variable tuning condenser is connected in series with a $\cdot 0003$ -mfd. fixed condenser, since this is unusual. The reason is that a tuning condenser for short waves should have a maximum capacity of not more than about $\cdot 0002$ mfd. and the lowest possible minimum capacity. This condition is approximately satisfied by connecting the two condensers in

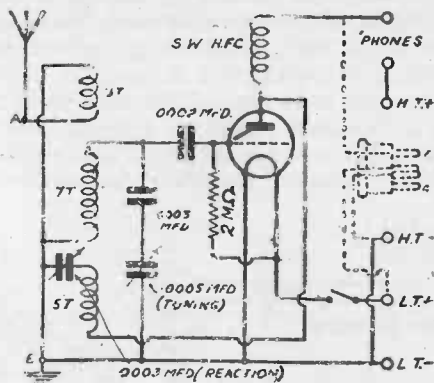

Fig. 82—Circuit of a home-made one-valve set.

series. Condensers of the required value can be bought very cheaply, but most constructors will have a $\cdot 0005$ -mfd. component available, and no doubt, a few fixed condensers of various capacities. And as this initial set is not intended to cost more than a few shillings we think that the idea suggested will meet with approval. At a later date a standard short-wave condenser of either $\cdot 00016$ mfd. or $\cdot 0002$ mfd. can be bought.

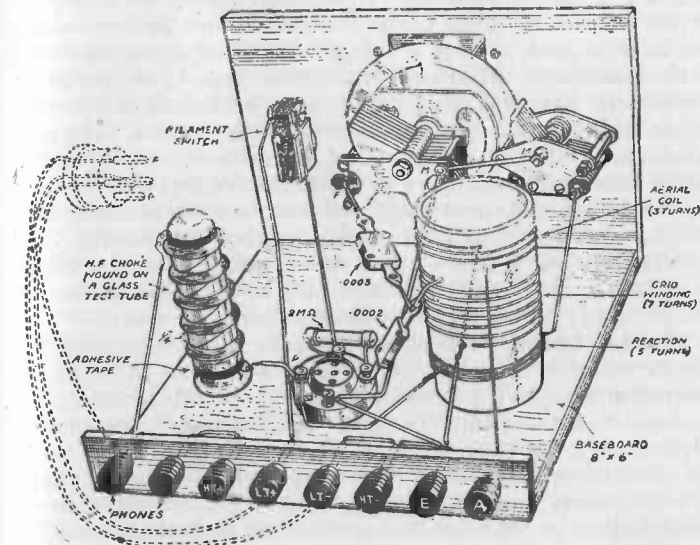

Fig. 83.—Wiring plan for the circuit shown in Fig. 82.

Making the Coil.—The coil, it will be seen, consists of 15 turns of wire—in three sections of 3, 7 and 5 turns each—wound on a length of 2-in. diameter cardboard tube. Ordinary postal tube is suitable for use as the former, and this should for preference be given a liberal coating of shellac varnish before use. The 3-turn winding is for aerial coupling, the 7-turn winding is for tuning the grid circuit, and the 5-turn winding is for reaction. The grid coil is wound with 20-gauge enamelled wire, the turns being spaced by about the diameter of the wire used, but the other two windings have side-by-side turns of about 26-gauge enamelled wire. Actually, it is not essential

that these exact gauges be employed, but they are probably most suitable. All the turns are wound in the same direction, and the ends of the windings are anchored by passing the wire through pairs of small holes made in the tube with a drill or a pricker. As to the connections, these are as shown and care is needed only to see that the coil leads are connected in the order shown; that is, the leads from any winding must not be reversed.

The coil can be attached to the small baseboard either by fitting a Meccano angle bracket to the former, or by making the latter a push-fit over a wooden disc or large cork screwed to the baseboard. The reaction condenser may be any ordinary component having a capacity of .0003 mfd., but it is better to use one of the air-spaced variety if this is to hand. The grid condenser and lead are standard components which nearly every constructor will have in the junk-box, but even if they are to be bought new they will not cost more than two shillings. A valveholder of normal baseboard-mounting type is indicated, but if a new one is to be bought it will be better to obtain a short-wave one such as the Clix, Eddystone or B.T.S. Any "on-off" switch will serve perfectly well.

The H.F. Choke.—The next item is the H.F. choke, and this can be made very easily by winding 150 turns of 36-gauge enamelled wire on a $\frac{3}{4}$ -in. diameter test tube (obtainable from a chemist for a penny or so). The turns are continuous (electrically), but are wound in five sections of 30 turns each. No special care is called for here, for you simply wind 30 turns in a pile about $\frac{1}{4}$ in. wide, leave a gap of $\frac{1}{4}$ in., wind 30 more turns, and so on. As will be seen, the two ends of the winding are held in position by winding a strip of adhesive tape or insulating tape round the tube. On completion, this simple choke can be fixed to the baseboard by means of a cork which fits the open end. When desired, an Eddystone type 948 choke can be bought to replace the simple home-made one.

Eight terminals are fitted to the rear edge of the baseboard and are mounted on a strip of ebonite $1\frac{1}{2}$ in. wide. In connecting up see that all the leads are as short as possible, and cut those from the coil and choke so that they are just long enough to reach to the appropriate terminals.

Wavelength Covered.—The finished receiver will tune from about 20 to 40 metres, and will therefore cover the wavelengths used by many amateurs (working on about 40 metres) as well as by a number of short-wave broadcasting stations working

on wavelengths in the region of 31 metres. Probably the transmissions which will be received most easily are those of Rome on 25.4 metres, Vatican City on 25.55 metres, Huizen (Holland) on 25.58 metres, and perhaps Schenectady (New York) on 31.41 metres, but there are many American stations which are well within range when conditions are favourable.

The method of operation is the same as that in the case of a detector-L.F. receiver, designed for medium- and long-wave reception, except that greater delicacy of operation is necessary. This means that the tuning condenser—which must have a reasonably good slow-motion drive—must be controlled slowly, and that the reaction condenser must be employed more frequently so as to keep the set just on the verge of oscillation; this is indicated by a faint "breathing" sound in the 'phones.

For Loudspeaker Reception.—Should it be desired to operate a loudspeaker, the set can be used as an adapter by fitting an old valve-base or an adapter plug to the two L.T. terminals and to one of the 'phone terminals, as shown in broken lines in Figs. 82 and 83, and short-circuiting the H.T.—and L.T.—terminals. The detector valve of the broadcast receiver is then removed and the plug inserted in its place. It might be added that the most suitable valve for use in the short-wave set is a type H.L. or L., but in any case the detector valve from the broadcast receiver can be used satisfactorily.

Using Commercial Parts.—The receiver now described is made from standard parts, and the circuit is shown in Fig. 84. A standard short-wave 6-pin plug-in coil is specified, but the constructor may build a suitable set of coils for himself from the data given in Chapter 16. It should be noted that a 4-pin coil is not recommended. The reason is that the aerial has a marked effect upon the performance of the receiver, and a 6-pin coil permits of a loose-coupled aerial arrangement being employed with the result that the damping effect of the aerial is removed. A condenser may, of course, be connected between the aerial and the grid winding (thus, omitting the aerial coupling coil) but the effect is not so good as when the coupling coil is employed (see Fig. 87).

The Circuit.—Reaction is obtained by means of a standard reaction condenser and winding on the coil, and a capacity of .0002 mfd. or .0003 mfd. should be employed. In most cases the larger value will be found of most use. A normal tubular or mica fixed condenser is connected in the grid circuit

with a fixed grid-leak of 3 megohms; but again this value may be modified and up to 5 megohms employed. The choke is most important and although it is possible to make a very efficient component at home it is recommended that a really reliable commercial article be employed. This will avoid difficulties due to "dead spots", erratic reaction, etc.

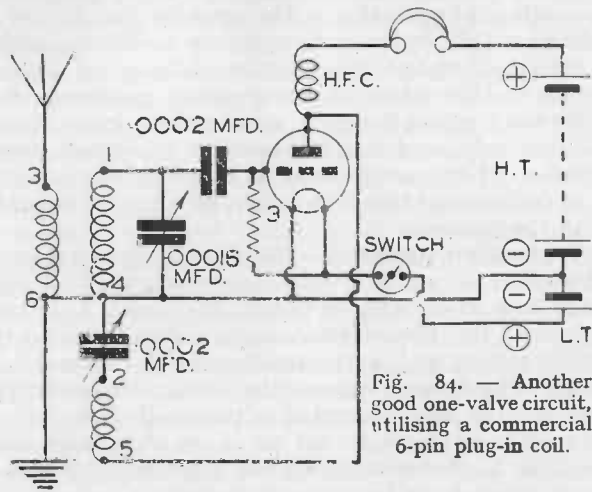

Fig. 84. — Another good one-valve circuit, utilising a commercial 6-pin plug-in coil.

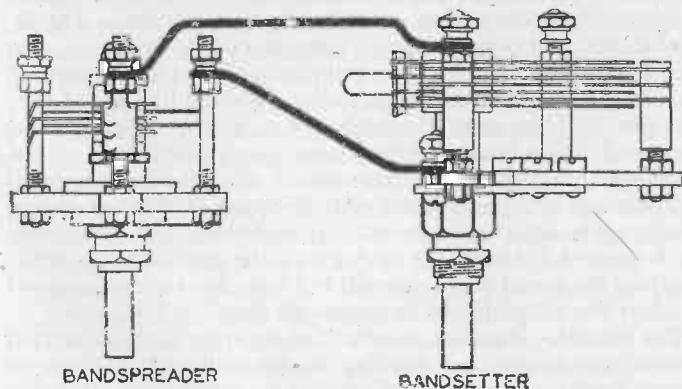

Fig. 85.—How to connect an additional condenser for band-spread tuning.

A simple baseboard form of construction is used, as there are only a few components, and a chassis is not called for. A good quality coil-holder should be used, and although a metal panel is not a necessity it will be found very useful in assisting in the removal of hand-capacity effects. If desired, a wooden or ebonite panel may be employed and a thin sheet of metal or foil fitted behind the panel and connected to earth. It is preferable to cut holes in this so that it does not come into contact with any of the panel components, and then to connect a separate earth lead to it.

Construction.—The terminals should preferably be mounted on separate mounts well separated, to avoid any loss which might be introduced by a leakage path between them through

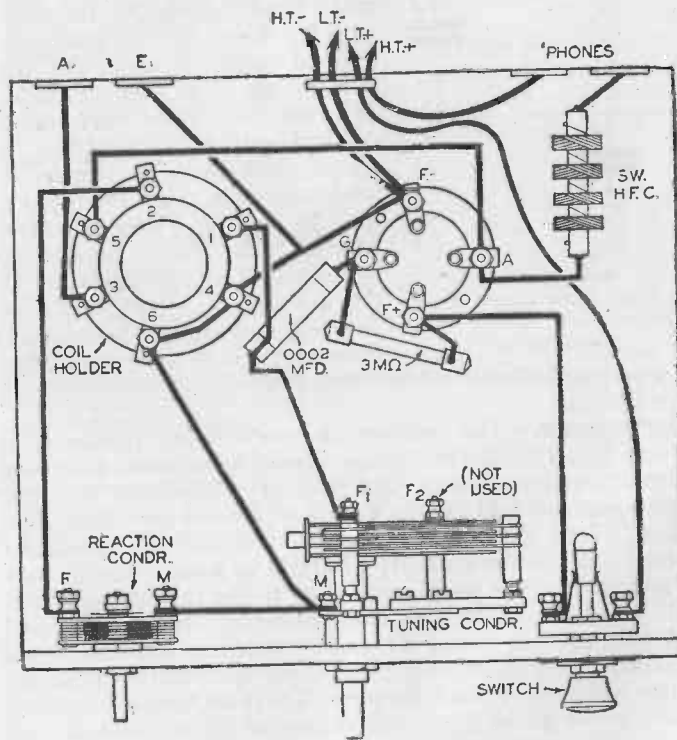

Fig. 86.—Practical wiring plan of the one-valve set shown in Fig. 84.

inferior ebonite or other material. The coil and valveholders should be firmly attached to the baseboard, and the panel components firmly locked to the panel. Remember that any looseness, either in the mounting or in the subsequent wiring, will result in tuning difficulties and perhaps in erratic effects resembling fading. The wiring should be carried out with fairly stiff wire to avoid any subsequent movement, and bare

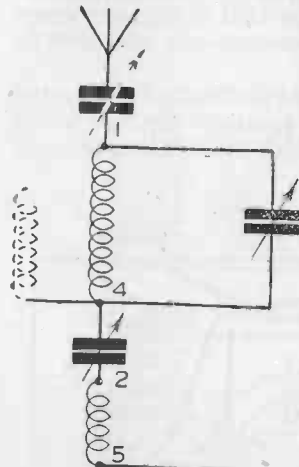

Fig. 87.—How to use 4-pin coils in place of the 6-pin components.

on wavelengths below 10 metres an ultra-short-wave set should be made up.

Refinements.—The receiver is operated by means of a 66-volt battery and the voltage should be adjusted to give a smooth reaction control. By way of refinements the first improvement would be the fitting of a band-spreading condenser. This should consist of a small variable condenser having a maximum capacity of about 20 mmfd. and it may be mounted on the panel quite close to the tuning condenser. It is wired in parallel with that condenser—that is the fixed and the moving vanes of each condenser are connected together as shown in Fig. 85. When this addition is made, tuning will be very much simpler. The main tuning condenser is simply advanced about one degree at a time, and at each setting the smaller condenser is turned throughout its range,

wire may be used and all connections should preferably be soldered. The tuning condenser specified has a maximum capacity of .00016 mfd., but if desired you may use temporarily a .0005 mfd. standard condenser with a .0003 mfd. fixed condenser in series with it. A .00025 mfd. condenser may of course be used but will give rather more difficult tuning due to the wider wave-range covered with that capacity. A set of coils may be bought or made and with these the receiver may be used to cover all wavelengths from 9 or 10 metres up to 2,000. It is not advisable to try and use a set of this type to tune below 10 metres, and therefore if it is desired to listen

thus spreading-out the waveband which each adjustment of the main condenser covers. Good slow-motion dials will be found of the utmost value in a set of this nature as they enable the smallest movement of the condensers to be made and many stations which would otherwise be missed will thereby be heard. This will be especially noticeable where two or more stations are found very close together on the main tuning condenser. A slight adjustment of this, and the band-spreading condenser will enable quite a large movement to be made with the dial to separate these stations and overlap will be avoided.

Coil Ranges.—In the Eddystone range there are nine coils of the 6-pin type which may be used and to enable the constructor to obtain some idea of the ranges covered, the following are the type numbers and the bands which are covered with a .00016 mfd. condenser:

6BB	9-14 metres	6P	150-325 metres
6LB	12-26 metres	6G	260-510 metres
6Y	22-47 metres	6BR	490-1,000 metres
6R	41-94 metres	6GY	1,000-2,000 metres
6W	76-170 metres		

LIST OF COMPONENTS.

- One .00016 mfd. tuning condenser, type 1131 (Eddystone).
- One .0003 mfd. reaction condenser (Polar).
- One 6-pin coil-holder, type 969 (Eddystone).
- One 4-pin valveholder (B.T.S.).
- One H.F. choke, type 1010 (Eddystone).
- One .0002 mfd. fixed condenser, tubular type (T.C.C.).
- One 3-megohm grid leak (Dubilier).
- One on-off switch (Bulgin).
- Four terminals (Clix).
- One wooden baseboard 8 in. by 7 in.
- One ebonite panel (see text) 8 in. by 8 in.
- Flex, connecting wire, screws.

CHAPTER XXII

TWO SIMPLE TWO-VALVERS

IN this chapter will be found full constructional details of two two-valve receivers, the first a modification of the home-made one-valve set described in the previous chapter, and the second a standard receiver. The theoretical circuit of the first receiver is given in Fig. 88, and a wiring diagram is also given in pictorial form in Fig. 89. From these it will be seen that a pentode valve has been added as a low-frequency amplifier, and the construction is now carried out on a wooden or metallised chassis, instead of on a simple baseboard.

This layout makes for a more modern appearance as well as tending towards rather better efficiency; nevertheless, there is no objection to using a baseboard as before, provided that the components in the detector circuit are grouped in a manner similar to that of the original set.

Standard Components.—As in the original design, there are no special components to be bought, and the receiver can be built by those constructors who have not previously done any short-wave work, and who, therefore, have no short-wave components at hand. It is, of course, necessary to use a special coil and choke, but these items are home-made, and

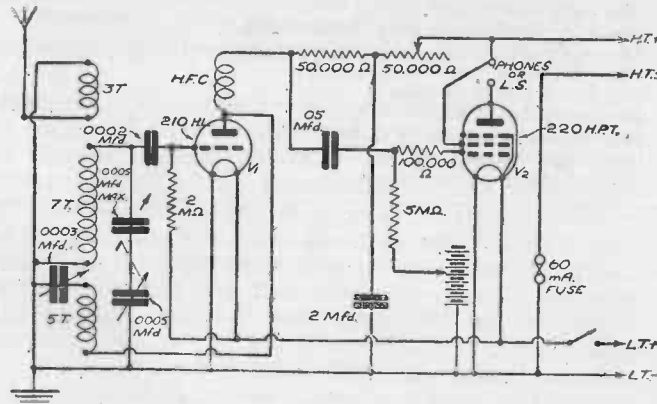

Fig. 88.—Theoretical circuit of a two-valve set for short waves.

need cost no more than a few coppers. A $\cdot 0005$ -mfd. tuning condenser is used, in conjunction with any really good slow-motion drive, and there is a $\cdot 0005$ -mfd. (maximum) pre-set condenser in series with this. The reaction condenser has a capacity of $\cdot 0003$ mfd., and should be of the air-dielectric type and can, to advantage, be fitted with a reduction drive or slow-motion scale.

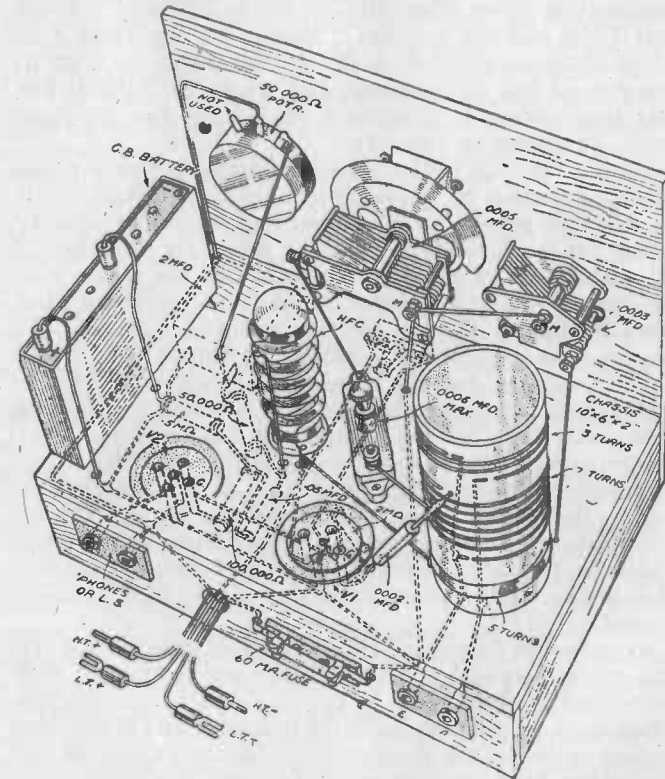

Fig. 89.—Pictorial plan of the two-valve, showing all wiring.

The object in using two condensers in series for tuning is that the capacity of the tuning condenser on short-waves should be about one-third of that used in a broadcast receiver; this is to render tuning reasonably easy, and to ensure

maximum efficiency over the tuning range. By varying the adjustment of the pre-set condenser it is possible to alter the maximum tuning capacity from less than .0001 mfd. to approximately .00025 mfd., and thus a value can be found which best suits the slow-motion condenser drive which is employed. The highest capacity is obtained when the pre-set is adjusted to its maximum capacity, whilst a total tuning capacity of about .00016-mfd. (and this is generally most convenient) is given when the pre-set is adjusted approximately to its midway position. Should the condenser drive employed have an extremely high reduction ratio the capacity of the pre-set can be increased, but where the ratio is low, tuning is considerably simplified by turning the condenser towards its minimum capacity.

Another advantage of the pre-set condenser is that it makes possible a variation of wavelength range over certain limits. Thus, when the pre-set is at about one-half maximum capacity, a tuning range of, roughly, 20 to 40 metres is provided. A slight adjustment of the pre-set will enable the range to be taken down to about 17 metres, or up to the 49-metre band.

The L.F. Stage.—The low-frequency amplifier consists of a resistance-capacity-coupled pentode. It might be argued that R.C. coupling does not give any step-up, and therefore that it is inefficient by comparison with transformer coupling. This is partly true, but R.C. coupling is less expensive and is generally completely free from instability troubles which are sometimes present when using an L.F. transformer. In any case, the amplification provided by the pentode itself is sufficient to ensure loudspeaker signals from many transmissions, and to give amply loud 'phone signals from any station in the world—provided that a fairly good aerial is employed.

A 100,000-ohm "stopper" resistance is included in the grid circuit of the pentode, and this is sufficient to prevent H.F. from "escaping" into the L.F. circuit. Apart from this, the low-frequency amplifier is perfectly standard, and is the same as is used on broadcast wavelengths. This resistance, as well as the other fixed resistances used, should be of the non-inductive (not wire-wound) pattern, and any good make can be used. The resistances can all be of the $\frac{1}{2}$ -watt type if desired, but there is, of course, no harm in using components of higher wattage rating.

Principal Parts Required.—None of the components, other

than the coil and choke, is critical, but they should all be of good quality. The valveholders can be standard Clix components, but it is worth while to use the pattern with low-loss ceramic base; it should be observed that one is of the 4-pin and the other of the 5-pin type, but two 5-pin holders can be employed if preferred by leaving the centre socket of V.1 disconnected.

A rather unusual arrangement is the use of a 50,000-ohm variable resistance or potentiometer for decoupling the anode circuit of the detector. This provides an excellent method of feeding the optimum H.T. voltage to the valve, and of pre-setting the most suitable conditions for smooth reaction. It is also useful when a very fine reaction setting is required when receiving a "difficult" station. The resistance can be set initially by adjusting the reaction condenser to its midway position and then turning the knob of the variable resistance until the detector just commences to oscillate, with the tuning condenser turned to its midway position.

The variable resistance should, for preference, be of the carbon-track pattern, since a wire-wound component is likely to be rather "noisy" when used in this part of the circuit. It is worth mentioning, however, that the variable component can actually be replaced by a fixed resistance of similar value if the constructor is prepared to forego the additional refinement which it confers.

Making the Coil.—Constructional details of the coil and H.F. choke have been given in the previous chapter, but they will be repeated briefly. The coil consists of three windings on a 2-in. diameter shellaced cardboard or paxolin tube; the aerial winding consists of 3 turns of 26-gauge enamelled or D.C.C. wire slightly spaced; the grid coil has 7 turns of 20-gauge D.C.C. or enamelled wire spaced by the diameter of the wire; and the reaction coil has 5 turns of 26-gauge wire (the same as used for the aerial winding) placed side by side. The disposition of the windings is shown in Fig. 89, where it can also be seen that they are all wound in the same direction. After winding it is a good plan to apply a couple of thin coats of shellac varnish to the coil, since this prevents the windings from slipping. It can also be seen from Fig. 89, that the ends of the windings are anchored by passing them through pairs of holes in the former.

Note carefully the connections to the three windings, since if these are reversed, reaction will not be obtained. The coil

can be attached to the chassis (or baseboard) by means of small angle brackets or by making it a push-fit over a disc of wood, or a large cork, screwed to the chassis.

H.F. Choke Details.—The choke consists of a total of 150 turns of 36-gauge enamelled wire wound on a glass test tube $\frac{3}{4}$ -in. in diameter. A length of ordinary glass or paxolin tubing could be used as an alternative. The test tube can be bought for about a penny from any chemist, and can later be mounted on the chassis by pushing it on to a cork attached by means of a wood-screw. The turns are arranged in five "piles", as shown in Fig. 89, these being placed about $\frac{1}{4}$ -in. apart to reduce the self-capacity. The ends of the winding are secured by binding a strip of insulating tape round the tube, and it is best to solder short lengths of flex to the thinner wire for making connection to the other components. As with the coil, two coats of thin shellac varnish should be given to the choke after winding, to hold the wire in position.

Tuning.—All other constructional details will be evident from the pictorial view of the receiver given in Fig. 89. With regard to the operation of the set, this is the same as with any other Detector-L.F. short-waver. When the detector has been brought to the verge of oscillation—indicated by a "breathing" sound in the 'phones—the tuning condenser should be operated slowly. If necessary, the reaction condenser should be adjusted meanwhile, in order to keep the detector just at the oscillation point. When a carrier-wave whistle is heard, reaction should be eased off, and the tuning condenser finally adjusted. It is best to use an H.T. voltage of 120, when the Cossor 220 HPT will require 4.5 volts grid bias; if the H.T. voltage is reduced to 100 it will be possible to cut down the G.B. to 3 volts. A wide range of H.T. voltages can be applied to the Cossor 210 HL detector by means of the variable decoupling resistance.

Another Design.—Fig. 90 shows the theoretical circuit of a receiver capable of providing world-wide short-wave reception in which the popular and efficient six-pin coils are used. The numbers given being those of standard connections as recognised by coil manufacturers. It will be noticed that two aerial inputs are provided, and thus it is possible to use aperiodic coupling by connecting the aerial to socket A2, whilst in the event of dead spots being experienced, the .00005 mfd. pre-set condenser can be introduced into the circuit by transferring the aerial to socket A1.

It will be noted that standard low-frequency transformer coupling is included. Whilst the advantages of R.C.C. and parallel feed are appreciated, some are of the opinion that

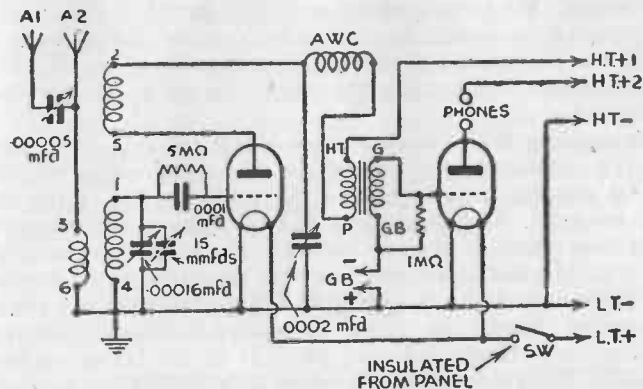

Fig. 90.—A two-valve short-wave circuit suitable for headphone working.

providing a good make of L.F. transformer is used, and care exercised during the construction and wiring of the receiver, there is no reason why a set using this type of L.F. coupling should not provide satisfactory results.

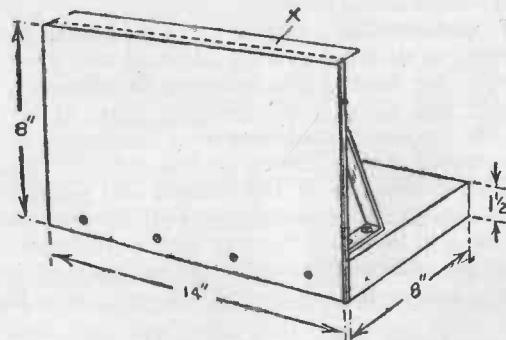

Fig. 91.—Details of panel and baseboard for the two-valver.

Moreover, an L.F. transformer is usually to be found amongst the home constructor's spare components. The inclusion of band-spreading, as shown, is a very valuable feature, and more than justifies the expense of the bandspread condenser. We have specified one of 15 mmfd. capacity, and in purchasing a suitable condenser, readers should keep in mind the Raymart product which is capable of modification within limits, and enables the overall spread to be increased if desired.

Concerning H.F. Chokes.—Now a few remarks concerning the H.F. choke. As plug-in coils are used it is possible with the aid of suitable coils to extend the tuning range of the set. For example, Eddystone and B.T.S. make a full range of coils from 9 metres to 2,000 metres. The short-wave enthusiast will, in most instances, limit his reception to 80 metres, but later may desire to extend the range to cover the 160- to 170-metre bands, in order to receive top-band amateur 'phone, and trawler 'phones, etc. It is far better to look ahead in this respect, and therefore to fit one of the screened type all-wave H.F. chokes.

The average range of choking efficiency as stated by various makers is 12 metres to 2,000 metres. In some instances, it is possible to obtain efficient choking down to 10 metres, but in any case should reception on the latter band be desired, an ultra-short-wave choke and the all-wave choke in series, will enable satisfactory results to be obtained.

Having decided to use the circuit shown in Fig. 90 as the basis of an experimental receiver, the first consideration is the method of construction to adopt.

Chassis Construction.—Chassis construction should be decided upon, as we must exercise care and look ahead a little. For example, we wish in the interests of efficiency, to keep wiring short and direct, yet cramping must at all costs be avoided. On the other hand, however, the chassis dimensions must not exceed certain limits, as this will introduce longer wiring. The dimensions of the chassis and panel therefore, as shown in Fig. 91, have been chosen with those considerations in mind, and will be found to meet most requirements, and in addition, leave sufficient space for the inclusion of decoupling components, and a L.F. output choke, etc., at a later date, if desired.

It is a good plan to carry the foil the full length of the underside, and then fasten the end runners in place.

Another important point concerns panel brackets, but before discussing this, we must first consider the panel requirements. A heavy gauge metal panel, whilst the most satisfactory, must in this instance be ruled out on the score of expense. The cheapest method is to use a plywood panel, and an aluminium sub-panel, the former of $\frac{3}{16}$ -in. plywood, and the latter of 20-gauge sheet aluminium.

Now various types of available short-wave variable condensers are designed to suit metal panels of about $\frac{1}{8}$ -in. thickness, and consequently, if we attempt to mount them on the panel arrangement outlined, it will be found that the fixing nut has only about one thread hold, and to tighten extremely will result in stripped threads.

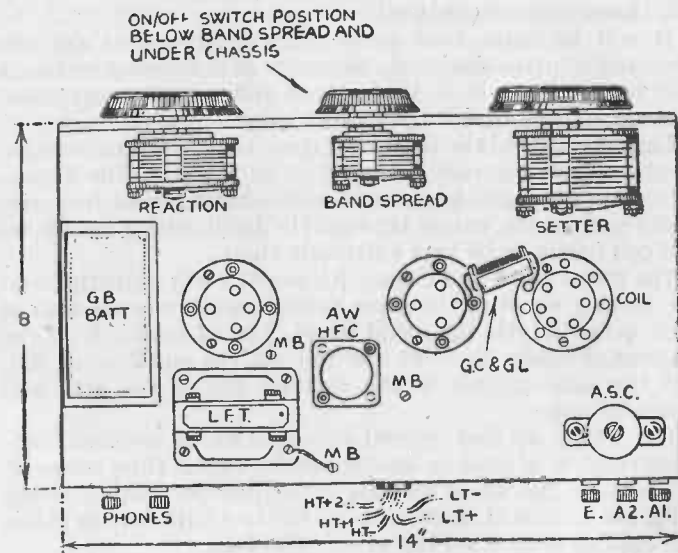

Fig. 92.—Layout of receiver for the circuit shown in Fig. 90.

The most satisfactory procedure under the circumstances, is to drill the aluminium panel to suit the condenser bushes, and in the wooden panel drill clearance holes of sufficiently large diameter to clear the condenser fixing nuts. Before doing so, however, the sub-panel and front panel together with

brackets should be set up as a unit. After this, remove panels leaving brackets fastened to them, and mark out the centres on the aluminium panel. Next, dismantle and drill to individual requirements.

Reverting to panel brackets, etc., "whip" must be avoided, and as the front panel is simply an overlay, it is advisable to fit wooden blocks butting against back metal face under the chassis, and screw firmly. In addition, by allowing an extra $\frac{1}{2}$ in. width, and bending over the top edge of panel, as at X, Fig. 91, a more rigid assembly will be obtained.

The panel mounting brackets should have as much bearing on the chassis face as possible, and the wider they are at the base the more rigid the assembly. If, however, panel component bushes are of sufficient length to mount satisfactorily through the double panel thickness, the possibilities of whip will be considerably reduced.

It will be noted that panel drilling dimensions are not given in Fig. 91, as dials and condensers of different dimensions will be used, so it is better that individual constructors arrange matters to suit circumstances.

Layout.—One of the most important considerations relative to short-wave receiver construction is layout. The layout shown in Fig. 92 has been found to be a most satisfactory one, which enables the wiring between the band-setting condenser and coil holder to be kept extremely short.

The metal panel and chassis foil are at earth potential, and the moving vanes of the three tuning condensers are also at earth potential, via the metal panel. The earthed side of the filament is made direct to the foil via the small bolts MB, and the same applies to the earthed end of the grid and aperiodic coils.

The wiring up and general construction of a simple two-valve receiver is more or less straightforward. It is, however, advisable to use small washers in conjunction with mooring bolts, one to face of chassis, one to foil face with wire in place, and another washer on top of the wire loop.

Double nuts will assure a satisfactory connection, but this should not be taken for granted, and a continuity test between bolts and earth terminal common to foil and sub-panel, should be carried out. This applies to every chassis type receiver.

A receiver of this type when put on test will, providing care has been exercised during construction, prove to be satisfactory

and a general run around the various tuning ranges will bring in a variety of signals.

At first the beginner should just tune around to see what he can find, get a general idea as to the various ranges covered, and regard learning how to operate the set as the chief concern of the moment. Later, calibration of band-setter and spreader over all ranges can be carried out, and DX listening to schedule undertaken.

What you will hear.—It is not possible with any receiver to state exactly what stations may be heard. Conditions vary in different parts of the world, and even in different districts in the same town, and therefore it may be misleading to give some indication of the range of a receiver. It is also important to bear in mind that conditions vary from day to day not only so far as concerns the time of the year, but also hour by hour. In other parts of this book indications are given as to the most suitable times of listening on various wavebands, and therefore care should be taken to select the most appropriate wavelength when making first tests with a new receiver. Do not be disappointed if nothing is heard at the first try, as the particular band which has been selected may be "dead" or in other words entirely unproductive of signals. This would be the case even with the most powerful mains receiver and in that even the waveband should be changed.

AN A.C. TWO-VALVER

(BLUEPRINT No. 453)

THIS is a two-valver for all the usual short-wave channels, working entirely from its self-contained mains power pack—suitable for all A.C. supplies from 20 to 250 volts, and frequencies from 40 to 100 cycles.

It is a detector and pentode combination (see Fig. 93), the third valve being a full-wave rectifier for the mains supply of high tension. The detector valve comes under the heading of "high slope" which means that it has a very good amplification factor for a medium impedance. The factor is 40—and in practice this means a very sensitive valve.

Then the pentode output valve has an amplification factor of 100, which again helps to strengthen the weakest of input signals. Altogether, this two-valve combination with its robust power from the mains gives great amplification to the faintest whispers from the world at large.

The Power Supply.—This incorporates a mains transformer having a normal output of 230 volts—but the valve needs 250 volts. It operates quite well, however, on the output which is delivered. The only alternative would have been a much larger transformer than is actually needed.

Smoothing is a very great point about a short-wave mains set. But it is not a difficult business, especially with modern

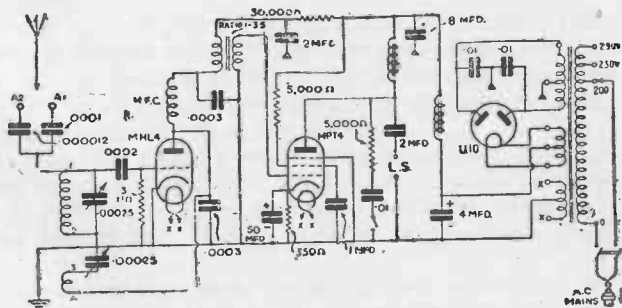

Fig. 93.—The circuit of the A.C. short-wave two.

components: Two electrolytic condensers are used for the capacity part of the smoothing. In conjunction with these is a specially low-resistance choke of high inductance. There are 12 mfd. of capacity with this choke—more than enough to ensure absolute silence.

Silence until the oscillation point, anyway. Then there comes into the picture a thing called modulation—which can be cured with two .01 mfd. fixed condensers across the anodes of the mains rectifying valve. These have therefore been included in the circuit.

The smoothing in this set is so complete that you can hear absolutely no sign of hum unless the set is actually oscillating.

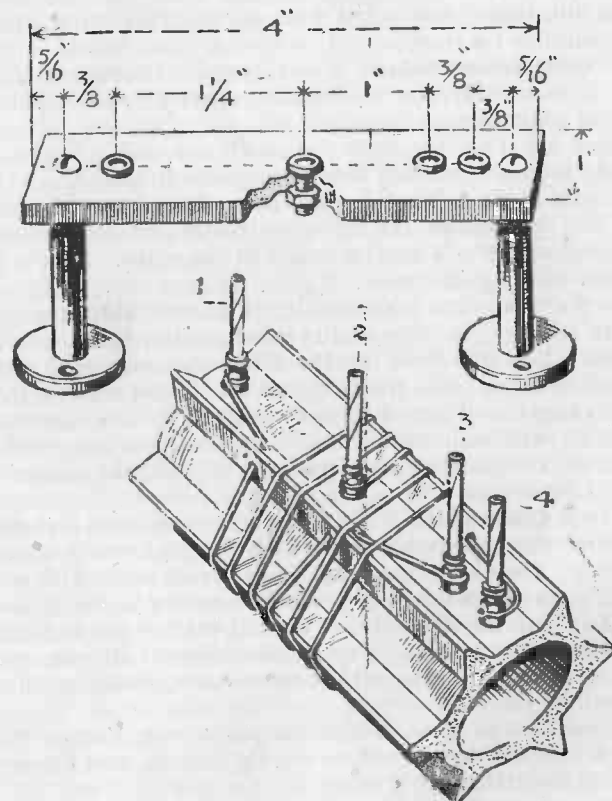

Fig. 94.—Details and dimensions of coil and coil base for the short-wave two.

As you will never be listening with the set in this condition, the slight hum that comes up then does not matter.

So much for the power supply. The set itself is designed to take advantage of home-made short-wave coils, which are made as follows. (See Fig. 94.)

A set of three coils is needed, the smallest coil tuning from about 12 up to 28.5 metres. Although this coil goes up to 25 metres it is not intended that you should tune in 25-metre signals on that coil.

The second-sized coil does that. It tunes from 19 to 59 metres, and thus gives you the 25-metre signals with a high inductance-to-capacity ratio—signal strength will, therefore, be good.

The third-sized coil tunes from 55 to 175 metres, and is quite suitable for reception of 160-metre band signals.

All these ranges assume a .00025 mfd. tuning condenser with a reasonably low minimum capacity—and a similar value of condenser for reaction.

There are two windings for each coil unit. These are entirely separate, making four connections in all. No. 1 goes to the grid of the valve, No. 2 to earth. That is for the tuning coil. No. 3 goes to the moving plates of the reaction condenser and No. 4 to the anode of the valve. That is the reaction winding, of course.

Now for the actual construction. You want three pieces of ebonite tubing, 3 in. long and $1\frac{1}{2}$ in. diameter, this including the ribs. You will want twelve Clix valve pins with three nuts for each pin. For the complete set of coils about 6 ft. of No. 20-gauge round tinned-copper wire and 8 ft. of No. 20-gauge enamelled wire will be needed. The tinned-copper wire is needed for the smallest and middle-sized coils, the enamelled for the largest coils.

Order of Construction.—The order of construction is simple. Drill first the ebonite former to take the pins, which should fit tightly. Then with pliers and a vice stretch some of the wire until it gives, when it will be ready for winding on the former.

Dealing with the smallest coil, start at the first pin and wind on as tightly as possible 3 turns, finishing off at pin two. Start again at pin three with 3 more turns, finishing off at what will be pin four.

The middle coil is wound in the same way, except that between pins one and two there are eight turns, and between three and four there are 5 turns.

Now we come to the largest of the short-wave coils, wound with the No. 20-gauge enamelled wire. There is no spacing between the turns, the coil being wound simple solenoid fashion. You need 23 turns between pins one and two, and 10 turns between three and four.

Don't forget when anchoring the ends of this wire that the enamel must be scraped off, otherwise there will be no pin contact.

The base for the coils is quite easily made from a strip of ebonite and two supports as shown by the sketch. The sockets are spaced exactly the same distances as the pins in the coils, of course. You will notice that the reaction winding pins are closer together than the tuning-coil pins. This avoids the possibility of wrongly inserting the complete coil unit in the base.

The three coils tune easily over all the useful wavebands on short waves, with the wavelengths overlapping in such a way that you can always be sure of a high inductance-to-capacity ratio for the most-used wavebands.

Many persist in using a longish aerial. For such readers, we have included a specially small input condenser, so that even with the longest aerial, the set will still be able to muster up a good oscillation. There are actually two series aerial condensers, the smaller being of only .000012 mfd. and the larger the usual .0001 mfd. With the average 45 to 60 ft. aerial the larger condenser connection is advisable.

For detection, we have employed the usual leaky-grid system, but note that the grid-leak itself, which is of 3 megohms, goes direct to the chassis or earth.

We come now to the very important question of anode by-passing—an aspect of short-wave technique often sadly overlooked. If you will glance at the circuit, you will see that we have used the usual anode H.F. choke—actually it is a special short-wave one—but with it there are associated two by-pass condensers.

Both have the same value—.0003 mfd., these going to earth from each side of the choke. In this way, the high-frequency by-passing is complete—and no high-frequency will trickle through into the low-frequency section to introduce hand-capacity effects when you want to wear phones.

It is much more scientific to eliminate the high-frequency as soon as its job is over—rather than to let it wander about in the low-frequency side and then by-pass it at the phones.

The low-frequency coupling for the pentode output valve is perfectly standard. There is the usual decoupling circuit in the primary winding, of course. This consists here of a 30,000 ohms resistance and a 2-mfd. fixed condenser. Rather essential, all this, as the set is working from the mains.

The pentode circuit, too, is perfectly standard. Perhaps it is worth noting that there is a 50-mfd. electrolytic across the automatic bias resistance—thus ensuring complete stability of operation. The 350 ohms resistance in the cathode lead provides the correct working bias for the specified valve—this bias being derived from the main high-tension supply in the usual way. In the anode circuit of the pentode there are one or two very important points to note. For one thing, you will see that a choke-filter system is included to isolate the phones or loudspeaker winding from the mains high-tension current. A choke takes the place of the phones or loudspeaker winding, and the A.C. speech currents pass to the desired winding through a 2 mfd. condenser that effectively prevents the passage of the direct current.

If you are going to use headphones, this filter is absolutely essential unless you want to risk a nasty shock. Even with the filter, you may possibly notice a slight tingling when you touch one of the leads—this being quite harmless, though—the A.C. currents representing the actual signal.

Secondly, across the loudspeaker terminals—or virtually so—is what we are pleased to refer to as a static suppressor. Actually, this is our old friend, the high-note cutter—a 5,000 ohm resistance in series with a .01 mfd. fixed condenser. In series with these two components is a little on-off switch, so that the effect of the high-note cutter can be brought in as required by conditions.

When static is bad, you will want to cut down the background as much as possible—and this you can do by switching in the high-note cutter. Most of the noise is at high frequencies and an appreciable easing of the torments of static—especially on phones—can be noticed when the device is in circuit.

Under good conditions you will want to make the most of the pentode incisive quality—and then is the time to switch out the high-note cutter, enabling the pentode to reproduce speech with clarity, and music with great brilliance.

There is really nothing more to say about the circuit, except

that it is a sound piece of engineering that will give no trouble when interpreted as a metal-chassis set.

Which brings us to one or two points in the construction you ought to know about before embarking on the assembly. The set is built on an all-metal chassis.

If you obtain a flat sheet of aluminium, you can bend it into chassis shape yourself. Do the bending on the edge of the bench or table with a smooth piece of wood—don't hammer the metal or you will spoil the job. No need for a sharp bend—the chassis may be nicely rounded.

One of the modern tuning condensers with a very open scale dial has been specified. This is provided with fast and slow motions—the slow motion being a real short-wave asset. The scale is marked from 0 to 180 degrees—the only really satisfactory method of divisioning on the short waves with a set of this type.

Reaction is applied in the usual way with a variable condenser which you will find mounted on the left of the tuning condenser. On the right of the tuning, is the little mains on-off switch. That completes the front controls—but don't overlook the switch at the back for the static suppressor.

LIST OF COMPONENTS.

- One aluminium chassis, 12 in. by 9 in. by 3 in. (Peto-Scott).
- One H.F. choke, type S.W. (B.T.S.).
- One L.F. choke, type CC38M (Savage).
- One L.F. choke, type HT35 (Wearite).
- One Set of home-made coils with holder, as described (Wearite, or Peto-Scott).
- One fixed condenser, .000012 mfd., type 929 (Stratton).
- One fixed condenser, .0001 mfd., type tubular (Dubilier).
- One fixed condenser, .0002 mfd., type tubular (Dubilier).
- Two fixed condensers, .0003 mfd., type tubular (Dubilier).
- Three fixed condensers, .01 mfd., type tubular (Dubilier).
- Two fixed condensers, 2 mfd., type BB (Dubilier or T.C.C.).
- One fixed condenser, 1 mfd., type BB (Dubilier or T.C.C.).
- One fixed condenser, 4 mfd., type electrolytic, 500 volt (Dubilier or T.C.C.).
- One fixed condenser, 8 mfd., type electrolytic, 500 volt (Dubilier or T.C.C.).
- One fixed condenser, 50 mfd., type electrolytic, 50 volt (Dubilier).
- One variable condenser, .00025 mfd., short-wave (J.B.).
- One variable condenser, .00025 mfd., Popular Log (J.B.).
- One full-vision dual-ratio slow-motion dial, type Arcuate (J.B.).
- One 4-pin chassis-mounting valveholder (Clix).
- One 5-pin chassis-mounting valveholder (Clix).
- One 7-pin chassis-mounting valveholder (Clix).
- One strip, marked L.S. + and L.S. - (Clix).

- One strip marked A1, A2, and E (Clix).
- Four plugs, marked Aerial, Earth, L.S. +, L.S.—(Clix), type 16.
- One fixed resistance, 350 ohm (Erie).
- Two fixed resistances, 5,000 ohm (Erie).
- One fixed resistance, 30,000 ohm (Erie).
- One fixed resistance, 3 megohm (Erie).
- Connecting wire and sleeving (Goltone).
- Four dozen $\frac{3}{8}$ in. 6B.A. bolts and nuts (Peto-Scott).
- 1 $\frac{1}{2}$ yards twin flexible lead (Goltone).
- One double-pole on-off switch, type S104 (Bulgin).
- One single-pole on-off switch, type S102 (Bulgin).
- One L.F. transformer, 1.3.5 ratio, type Niclet (Varley).
- One mains transformer, with windings 230-0-230 volts, 35 mA.; 2.0-2 volts, 1 ampere; 2.0-2 volts, 2 amperes.
- One permanent magnet loudspeaker, type PM52 (W.B.).
- One MHL₄ met valve (Osram).
- One MPT₄ valve (Osram).
- One U10 valve (Osram).

CHAPTER XXIV

A STANDARD THREE-VALVER

THE normal three-valve combination in which the valves are arranged in a detector and two L.F. sequence, is probably one of the most popular arrangements in use to-day. The only failing of such a circuit is its limited range, the addition of an H.F. stage making a remarkable difference to the normal detector stage. The receivers in the previous chapters were of the detector and one L.F. combination, and therefore the addition of a further L.F. stage would provide a standard arrangement which will fulfil many requirements. The receiver now to be described has, however, been designed in such a manner that when desired an H.F. stage may be added to convert it into a four-valver, and in this chapter are the full constructional details of the three-valve assembly whilst further on we describe the modification to convert it into the four-valve arrangement. The theoretical circuit is given in Fig. 95 from which it will be seen that the initial aerial circuit consists of an Eddystone three-winding coil, one of which is used for aerial coupling, another for the grid input circuit, and the other one for the reaction. It will be noted that no band spreading, in the ordinary sense, is provided. This was found to be unnecessary, as the special type of

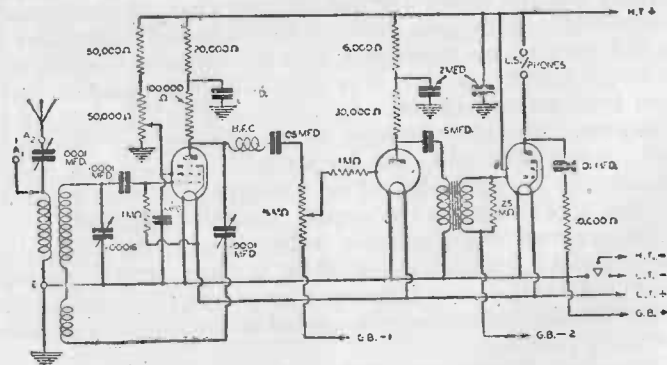

Fig. 95.—A standard battery three-valve circuit, which may be modified as described in the next chapter.

mechanical drive used in the slow-motion tuning gear, provides an identical effect with the advantage of definite dial recordings.

The grid coil, which is tuned by an Eddystone 00016 mfd. variable condenser, type number 1131, feeds the detector via the usual leaky-grid coupling condenser. As sensitivity and gain are important factors, it was decided to use a screen-grid valve in this position as it not only gives a greater output on a weak signal, but it also allows a very efficient form of reaction to be obtained.

The output from the detector is fed into the first L.F. stage by means of a resistance-capacity coupling, and it will be noted that a volume control has been fitted across the grid circuit of the first L.F. to enable the ultimate output volume to be regulated so that headphones or speaker can be used as desired.

The coupling between the first L.F. valve and the output stage is provided by an L.F. transformer of the Varley-Niclet type but, to prevent the primary receiving an excessive current load it is arranged in the normal parallel-feed method which incidentally, also provides a certain degree of decoupling. The output valve is a Cossor 220 HPT pentode which is quite capable of providing adequate output for all normal purposes, and providing the volume control is used in the manner intended, it will handle all the input necessary for full output.

It will be seen from the above description that there is nothing fanciful about the circuit, and that no unnecessary components or gadgets have been embodied, therefore it should present no difficulties to any enthusiast as regards its construction; in fact, it is quite a safe proposition for a keen beginner to consider.

Layout.—The plan drawing of the chassis, Fig. 96, shows that a very clean and clear layout has been obtained and it should also be noticed that no attempt has been made to sacrifice space to make the overall dimensions smaller.

The main tuning condenser, together with its mechanical band-spreading drive is located in a dead central position which not only gives a pleasing appearance to the panel but also allows the controls to be placed at the most convenient operating points.

As a steel chassis was used in the original model, it was decided to use the special low-loss baseboard-type valve-

holders produced by Eddystone, and, as each valve-pin socket on these holders is made in one piece, the possibility of contact noises is considerably reduced. By employing a chassis, the majority of the components are housed out of sight and well protected, whilst the wiring is considerably simplified as is evident by the plan drawing of the underside of the chassis.

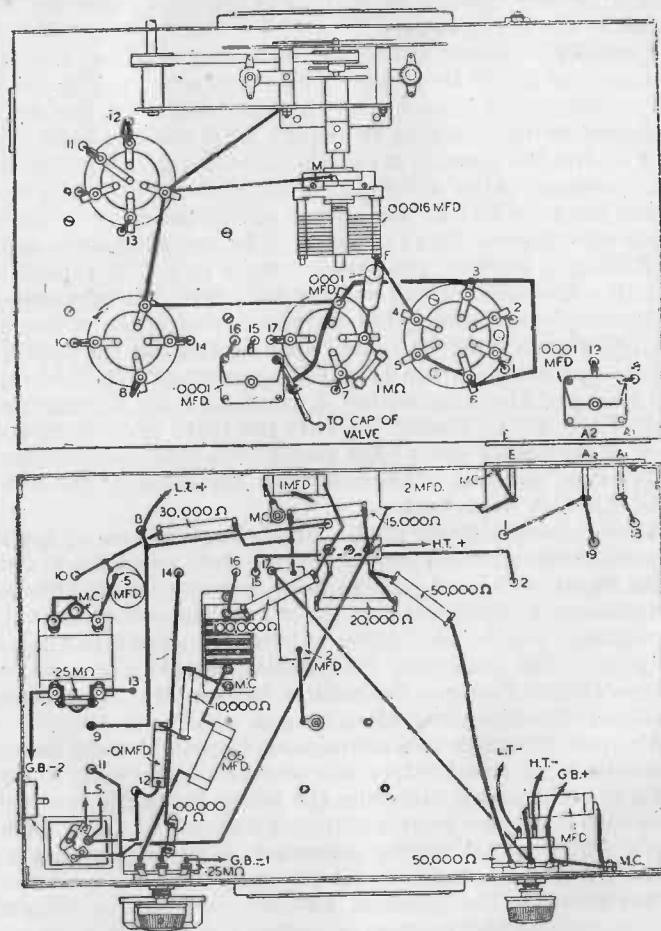

Fig. 96.—Wiring Plan of the Battery Three.

To avoid the use of plugs and jacks the special Clix switching output panel is employed, and for convenience sake, it has been fitted on the right-hand side of the chassis when it is viewed from the front. This simple device allows a most rapid change over to be made from headphones to loudspeaker, and when housing the completed set in a cabinet no difficulty should be experienced in making a suitable aperture for access to this component.

Assembly.—Before proceeding with any drilling, lay out the components to be mounted on the top of the chassis on the actual metal chassis and carefully mark off the exact positions for the holes to be drilled, after making *quite* sure that all the components are in the positions indicated by the plan drawing. After drilling, clear all holes of burrs, and then repeat the procedure for those parts which have to be mounted inside the chassis. Don't attempt to fix anything down until all drilling is finished, otherwise damage might be caused to certain components which will not only spoil the appearance of the completed assembly but also possibly affect the efficiency. Particular care must be taken when setting up the bracket which supports the main tuning condenser, and the locating and fixing of the slow-motion drive. Don't try to rush this part of the work. Remember that the drive is dead central along a horizontal line of the panel, and that the distances of its fixing, and that of the condenser bracket from the front panel, are very important.

For satisfactory fixing of all parts, bolts should be used, and for a thorough job, use shakeproof washers under each nut.

The Panel.—This can be purchased, the same as the chassis, from Messrs. Peto-Scott ready drilled, but if you wish to do it yourself, check all drilling points before starting that operation. The large hole for the dial should be scribed on the metal, and then cut out with a fretsaw, the edges being smoothed off with a small file. (See Fig. 97.)

When handling this part of the assembly, see that the bench is free from all metal filings, and covered with two or three layers of stout paper, otherwise the fine polished finish of the panel will soon be marred. It is attention to these little details which makes all the difference in the appearance of the set when completed.

The Wiring.—The filament circuits can be wired right through even to the point of including the flexible leads for the accumulator. The next item should then be all the

connections to the coils holder, the aerial and earth sockets, the series condenser, the reaction condenser and the screened lead for the detector anode, not forgetting to earth the metalised sleeving. One side of the grid condenser can be secured

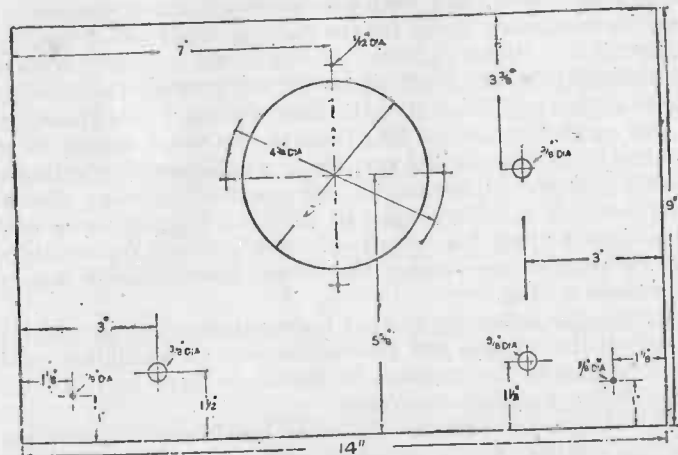

Fig. 97.—Panel dimensions and drilling details for the Battery Three.

in position together with one side of the grid leak, the other side of which is then anchored under the positive filament terminal of the detector valveholder.

When the wiring of the components inside the chassis is commenced, pay particular attention to all wiring and components are made of the H.T. supplies. See that good connections are made and that all live parts are firm enough to prevent them from moving and coming in contact with the chassis or any other wiring at a lower potential.

The loud speaker switching panel might at first appear a little confusing, but if the drawing given on page 163 is examined, no trouble should be experienced.

Operation.—In this particular circuit the reaction is produced by a combination of the usual condenser-controlled reaction circuit together with a variation in the operating conditions of the detector valve set up by varying the H.T. voltage applied to the screening grid. The latter can be

controlled at will by the potentiometer which is fitted in the bottom left-hand corner of the panel.

With the coil in position, aerial, earth, batteries and phones connected, and with the reaction condenser at its minimum, turn the screen control potentiometer to a position just past half of its travel, and with the volume control somewhere near its maximum, listen for the rushing sound which usually indicates if a circuit is alive. If this is not audible, increase the capacity in the reaction circuit by turning the moving vanes of that condenser into the fixed section. This operation is best carried out with a long piece of thin wood shaped off at the end to fit into the slot provided. If all operating voltages are correct, the adjustment of the reaction condenser should soon produce audible sounds of the circuit being alive, and when that setting has been reached, additional regeneration will be possible by turning the screen potentiometer nearer maximum setting.

It must be remembered that the most sensitive point of a circuit of this type is just below the point of oscillation, and when searching for stations, it should be kept in this condition but not *actually oscillating*.

The degree of selectivity, and incidentally, complete reaction control, will be governed by the setting of the aerial series condenser, so for any given aerial arrangement experiments must be carried out with the aerial series condenser in and out of circuit to determine the most satisfactory arrangement.

Adding the H.F. Stage.—An examination of Figs. 98 and 99 will show what modifications are necessary to add the fourth valve as an H.F. amplifier. Bearing in mind that the receiver is such that it can be built as a three- or four-valver, very few alterations have to be made, but to avoid any possibilities of mistakes creeping in, careful checking is advisable when it comes to the point of wiring the extra components.

The change over can be made in a way to suit individual conditions. For example, when the receiver is in operation as a three-valver, the additional parts can be secured and fixed in position whenever desired, without putting the set out of service. When, however, all parts have been fixed, then it is advisable to make one complete job of the wiring alterations thus reducing considerably the period when the set is off the air.

New Layout.—An examination of the drawings, Fig. 99

show that another 4-pin valveholder, a 6-pin coil holder and another .00016 mfd. variable condenser, of the same type as the previous one, have been added so far as the upper part of the chassis is concerned. Inside the chassis, another H.F. choke of the short-wave type, a rotary switch, two fixed resistances and another fixed condenser have been added.

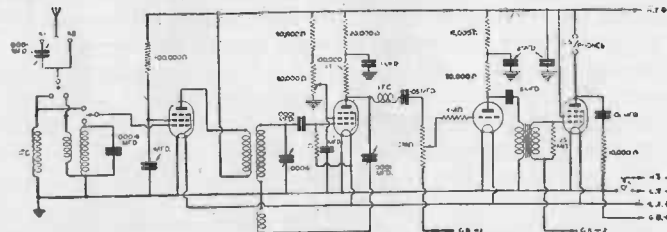

Fig. 98.—The Battery Four, which is the previous receiver with the addition of an H.F. stage.

The manner in which these parts are embodied in the complete four-valve circuit is shown in Fig. 98, while Fig. 99 shows that the additional tuning condenser has been so located that it does not upset the symmetrical appearance of the panel.

The object of including the switch, H.F. choke and additional coil in the aerial circuit, is to enable the H.F. valve to be used as a tuned or untuned stage. The switch transfers the aerial and the grid of the H.F. valve to the upper end of the H.F. choke when an untuned circuit is required, or switches them over to the grid circuit of the aerial coil when it is desired to tune the aerial input to the grid.

Space does not permit any discussion about the pros and cons of tuned or untuned H.F. stages in this chapter, but it is generally recognised that very little benefit can be obtained below 40 metres by the tuning of such circuits. With the method shown, therefore, it is possible to have the switch in the untuned position and carry out all station selection by the simple adjustment of the very fine mechanical band-spreading tuning control provided. Once the signal is received at its best, a flick of the switch will enable the H.F. stage to be tuned and greater efficiency and selectivity obtained according to the frequency of the transmission being received. It is

obvious that this makes for simplified tuning, elimination of ganging troubles over the various wavebands covered by the average short-wave receiver and easy identification or dial logging by means of the main tuning dial.

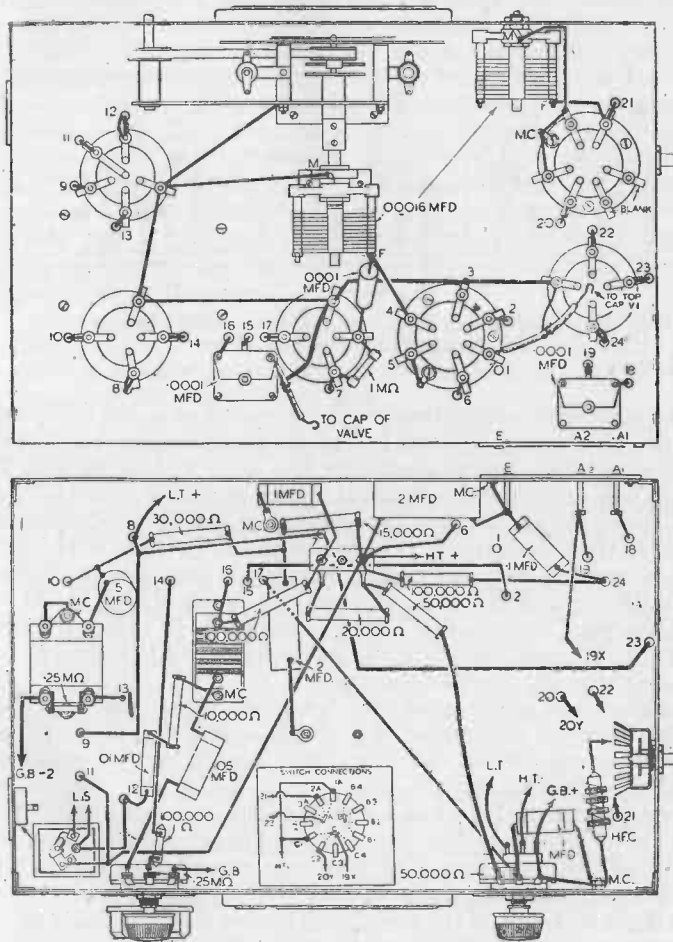

Fig. 99.—Wiring Plan of the Battery Four.

Below 40 metres, appreciable gain is not likely to be experienced by tuning the H.F. stage but this does not mean that the H.F. valve becomes merely a passenger. It serves a very useful purpose of a buffer between the aerial system and the grid circuit of the detector, and it will be found that this tends to increase efficiency, selectivity, and general reaction control, to the extent of eliminating blind spots.

Wiring.—Particular attention should be paid to the alteration of the wiring to the coil which was originally the aerial coil, but which now becomes the H.F. transformer forming the coupling between the H.F. valve and the detector. Instead of the primary being connected to aerial and earth, it now has to be connected to the anode of the H.F. valve and the positive H.T. supply, so be sure and remove the original connections to this winding, particularly the earth side. The grid and reaction windings remain unaltered.

The connections from the aerial input sockets now go to the primary winding on the new coil via the switch. The grid of the H.F. valve is also taken to one section of the switch to enable it to be connected to the new H.F. choke or the grid winding of the coil mentioned above.

LIST OF COMPONENTS.

Three-Valve Section

- One variable condenser, 160 mmfd., type No. 1131 (Eddystone).
- One 6-pin coil-holder, type No. 969 (Eddystone).
- Two 4-pin valveholders, type No. 949 (Eddystone).
- One 5-pin valveholder, type No. 950 (Eddystone).
- Two variable condensers, .0001 mfd., type No. 2146 (J.B.).
- One H.F. choke, type No. HF3 (Bulgin).
- Fixed condensers: .0001 mfd., type 4601/S; .01 mfd., type 4602/S; .05 mfd., type 4602/S; type 4603/S; 0.5 mfd., type 4608/S; 1 mfd., type 4609/S (Dubilier).
- Two fixed condensers 2 mfd., type 3016 (Dubilier).
- One chassis 14 in. by 9 in. by 3 in. (Peto-Scott).
- One panel 14 in. by 9 in. (Peto-Scott).
- Fixed resistances, $\frac{1}{2}$ watt: One 1 megohm; one 0.25 megohm; one 10,000 ohm; one 0.1 megohm; one 50,000 ohm; one 20,000 ohm; one 100,000 ohm; one 15,000 ohm; one 30,000 ohm (Erie).
- Potentiometers: 0.25 megohm; 50,000 ohm with switch (Erie).
- One L.F. transformer, type D.P.21 (Varley Niclet).
- Loudspeaker panel (Clix).
- A1, A2 and E socket strip (Clix).
- Valves: 210 S.P.T.; 210 H.L.; 220 H.P.T. (Cossor).
- Coils, 22-47 metre, No. 959.6Y (Eddystone).

Additional Parts for the H.F. Stage.

- One coil-holder, No. 969 (Eddystone).
- One variable condenser, 160 mmfd., No. 1131 (Eddystone).
- One 4-pin valveholder, No. 949 (Eddystone).
- One H.F. choke, No. 1010 (Eddystone).
- One rotary switch, No. S.203 (Bulgin).
- One fixed resistance, $\frac{1}{2}$ watt 100,000 ohm (Erie).
- One condenser, 0.1 mfd., type No. 4603/S (Dubilier).
- One coil, No. 959.6Y (Eddystone).

CHAPTER XXV

AN A.C. FOUR-VALVER

(BLUEPRINT No. 391)

THE circuit Fig. 100 utilises an untuned high-frequency stage as an "aerial buffer". No amplification is expected from this stage; if a little is obtained, so much the better. This valve is parallel-fed and coupled through a neutralising condenser to the grid circuit of the detector.

The detector circuit is absolutely conventional except for the use of a 10,000-ohm resistance in place of the more usual H.F. choke. The resistance gives an equally smooth reaction control and completely does away with the risk of dead spots due to choke resonance.

The first L.F. stage is resistance-coupled, R.C. suiting the average short-wave detector very well. The values of the coupling components have been chosen to give a certain amount of correction, since full use is generally made of the reaction control for short-wave work and the usual values are apt to lead to "boomy" reproduction.

Circuit Details.—The anode resistance is of 50,000 ohms, the grid condenser .002 mfd. and the grid leak 2 megohms. The valve used, an AC/HL, has a fairly high gain and is capable of fully loading the output valve (AC/P) on strong signals.

Transformer coupling is used between the last two valves, and a volume control of 250,000 ohms is provided across the secondary of the transformer. Choke output with a coupling condenser of 2 mfd., completes the story.

Automatic grid-bias has naturally been provided for the three valves requiring it. Each valve except the detector has a 1,000 ohm resistance, by-passed by a 2 mfd. condenser in its cathode earth-return.

There are only two H.T. terminals—positive and negative—all voltage-adjusting being looked after in the set itself.

The screen volts are provided by a fixed potentiometer. From the screen terminal a 30,000-ohm resistance goes to earth and a 50,000 to H.T. +. The screen is by-passed to

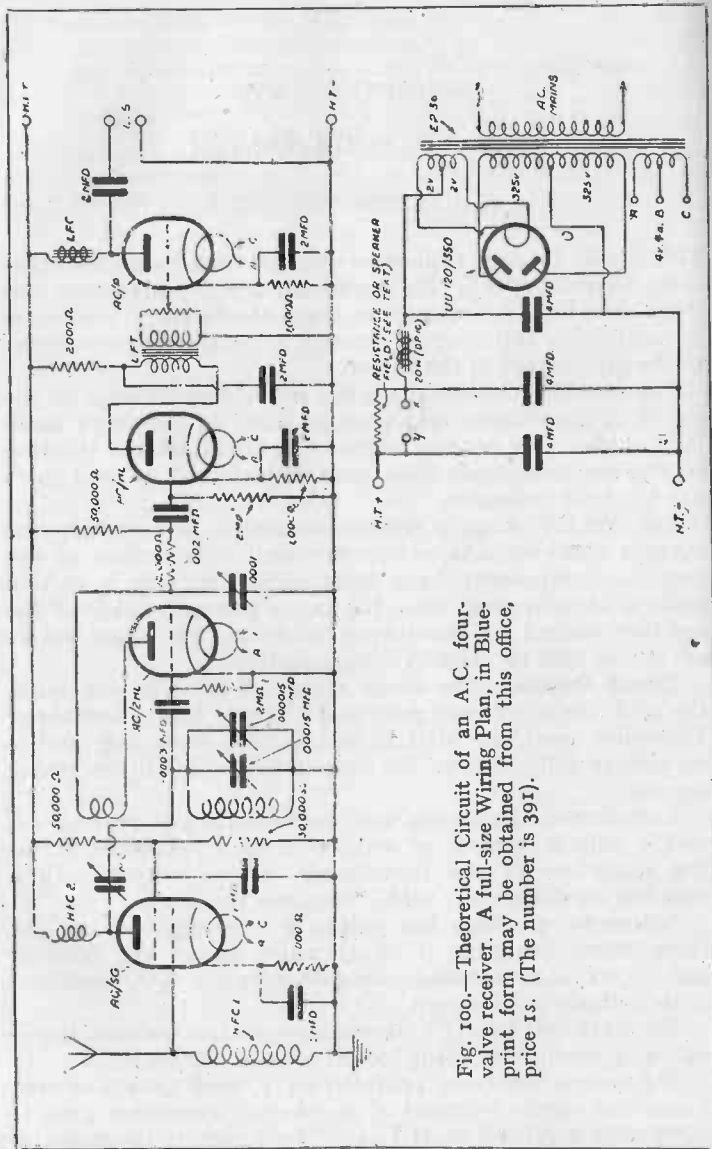

Fig. 100.—Theoretical Circuit of an A.C. four-valve receiver. A full-size Wiring Plan, in Blueprint form may be obtained from this office, price 15. (The number is 391).

earth by a 1 mfd. condenser and obviously receives about three-eighths of the total high-tension voltage.

The latter being about 160 under working conditions, we have a steady 60 volts on the screen. This needs no adjustment and no provision has been made for such.

Decoupling.—No elaborate decoupling arrangements have been made. The detector, largely by virtue of the 50,000-ohm resistance in its anode circuit, is perfectly stable; the first and last valves receive the full high-tension voltage; and the first L.F. stage is decoupled by means of a 2,000-ohm resistance and 2 mfd. condenser to earth.

All these points are clearly shown in the full-size blueprint.

Band-Spreading Scheme.—The main tuning condenser—on the left—is of .00015 mfd. capacity, but in parallel motion with it, and driven by the slow dial in the centre, is one of .000015 mfd. All final tuning is carried out on this, and it is possible to set the larger condenser for each interesting band in such a way that the band is really well spread out on the dial of the other.

Tuning is in no sense a "three-dial business" however. That is, the operator does not require three hands and only has to think of tuning on one condenser or the other and reaction control. The latter is an easy business and only implies an occasional lazy movement of the dial of the reaction condenser.

Power-Pack Circuit.—We must now proceed to the power unit. Valve rectification has been chosen, using a full-wave rectifier rated at 350 volts R.M.S. and 120 mA. Actually the total consumption of the set is less than 30 mA.

The transformer chosen is rated at 325-0-325 volts and this necessitates the use of smoothing condensers of the 400-working-volt type. Directly across the rectifier output is connected a 4 mfd. condenser; following this there is a 20-henry choke in the positive lead, with another 4 mfd. condenser on the other side of it; finally there is a pair of terminals, marked X and Y, on the far side of which is a third condenser of the same size.

Output Voltage Adjustable.—The purpose of these terminals is, in a way, to make the final output voltage adjustable; but their chief use is that they allow the individual reader to use an energised moving-coil loudspeaker if he so desires. Any loudspeaker with a 2,000- or 2,500-ohm field winding is

suitable, if a permanent-magnet type is used a 3,000-ohm resistance of the 3-watt type should be connected across the terminals *X* and *Y*. The supply to the whole set may be reduced further by substituting a 5,000-ohm resistance.

High-Tension Voltages.—Under these conditions the high-tension voltage applied to the set is about 160, at which voltage the last valve will pass about 14 mA. The voltage actually measured at the detector anode was about 70, and on the screen of the first valve 60.

The power transformer has two 4-volt windings, one for the rectifier filament and the other rated at 4 amperes for the heaters of the four valves in the set. The connections to the latter have been brought out to the three terminals marked *A*, *B* and *C*. The A.C. terminals *A* and *C*, are in any event, connected straight to the heater terminals, at the rear of the set. The high-tension terminals, similarly, are connected in the appropriate places.

The point at which a little doubt may possibly occur is in the connection of the *B* terminal—the centre-tap. In some cases this will be connected, in quite the conventional manner, to the H.T. — terminal either on the power unit or on the set—it doesn't matter which. This connection has not been made permanently, as it might have been, because in one or two cases there was quite a trace of hum under these conditions.

Avoiding Hum.—Hum-free reception was possible, however, by connecting the H.T. — terminal to either *A* or *C*, but *not B*. This is doubtless due to the fact that the heater winding likes to have a definite high-frequency earth at one end. If the earth connection goes to the centre there is, of course, quite an appreciable amount of inductance between it and the heaters themselves, whichever side of them we may be thinking of.

In the ordinary way the connection of a condenser of .01 mfd. across each half of the heater winding would put things right; but this particular set definitely preferred to have one end of the winding earthed.

Try your H.T. — connection, therefore, on each terminal, *A*, *B* and *C* in turn, and leave it on the one that gives the greatest freedom from hum.

The omission of a direct earth connection from the set does not seem to have any effect whatever upon results. It is therefore worth while trying yet another adjustment—no earth at all on the set and a direct earth-lead *and nothing else*

on terminal *B*. This arrangement worked very well with the original set, but it is impossible to give a ruling that will suit each individual case.

Should you be absolutely unable to dispose of trouble from hum—particularly if it is that type of modulation hum that occurs only on the point of oscillation, it may be necessary to connect condensers of .01 mfd. from each anode of the rectifier valve to one filament terminal. These have not been installed permanently because they should rarely be necessary.

A Valuable Tip.—The tip is worth passing on, though—and don't connect one from each anode to the centre-tap of the filament winding for it is better to take one to each side of that winding or, as stated before, to each filament terminal on the rectifier valveholder.

The primary of the power transformer is readily adjustable for A.C. inputs of 200, 215, 230 and 245 volts merely by the placing of a wander-plug. Look to this small point before you connect up.

Heater Wiring.—The heater wiring in the set itself has been carried out with ordinary tinned wire in insulating sleeving, tightly twisted. The connections from the set to the power unit should similarly be made with twisted wire, preferably heavy flex. It is an advantage to leave the power unit quite a few feet away from the set; if a semi-permanent installation is contemplated lead-covered cable may be used for the H.T. and L.T. leads.

The transformer is provided with a primary screen brought out by a separate lead from a hole marked *S*. This is connected to H.T. — on the unit itself.

The foregoing cover all the important practical points concerning the construction of the receiver and power pack. There are one or two hints however, chiefly from the point of view of sets that give trouble with a small amount of residual hum.

If your own happens to be stubborn and you have already tried out all the dodges referred to with the *B* terminal, the first thing to try is a reduction in the value of the detector grid-leak. Some A.C. valves seem to be much happier with a grid-leak of .5, or even .25 megohm. If you can make this substitution without upsetting the reaction control, by all means do; but don't try it unless it is absolutely necessary.

If the changing of the detector grid-leak has no effect, do the same with the first L.F. stage and give it a leak of .5 megohm.

LIST OF COMPONENTS.

- One chassis to specification (Peto-Scott).
 One H.F. short-wave choke (Bulgin).
 One H.F. short-wave choke (Eddystone).
 One L.F. output choke, type DP23 (Varley).
 One set short-wave coils (B.T.S.).
 One fixed condenser, .002 mfd. (T.C.C.).
 One fixed condenser, .0003 mfd. (T.C.C.).
 One fixed condenser, 1 mfd. 300-volt working (T.C.C.).
 Five fixed condensers, 2 mfd. 300-volt working (T.C.C.).
 One variable condenser, .00015 mfd. slow-motion short-wave, type C (Polar).
 One variable condenser, .0001 mfd. slow-motion short-wave, type C (Polar).
 One variable condenser, .000015 mfd. short-wave, type 900 (Eddy-stone).
 One variable condenser, neutralising (J.B.).
 One variable condenser vernier slow-motion drive, type 933B (Eddystone).
 Four 5-pin valveholders, air-sprung type (Clix).
 One 4-pin valveholder, air-sprung type (Clix).
 One fixed resistance, 10,000 ohm, 1-watt type (Erie).
 One fixed resistance, 2,000 ohm, 1-watt type (Erie).
 Two fixed resistances, 2 megohm, 1-watt type (Erie).
 Two fixed resistances, 50,000 ohm, 1-watt type (Erie).
 One fixed resistance, 30,000 ohm, 1-watt type (Erie).
 Three fixed resistances, 1,000 ohm, 1-watt type (Erie).
 One variable resistance, 250,000 ohm potentiometer (Erie).
 Tinned wire for connecting.
 Oiled cotton sleeving.
 One anode connector (Belling-Lee).
 One terminal strip (Peto-Scott), with
 Eight terminals (Belling-Lee) marked A, E, L.T. (2), H.T., H.T. —, L.S. (2).
 One L.F. transformer, type AF8 (Ferranti).
 One valve AC/SG (Mazda).
 One valve AC/2HL, metallised (Mazda).
 One valve AC/HL (Mazda).
 One valve AC/P (Mazda).
 One loudspeaker, standard model in cabinet (W.B. Stentorian).

List of Components for Power Pack.

- One smoothing choke, 20-henries, type DP10 (Varley).
 Three fixed condensers, 4 mfd. 400-volt working (T.C.C.).
 One resistance, 3,000 ohm, 3-watt type (Erie). (See text).
 Two strips with two Belling-Lee terminals (Peto-Scott).
 One strip with three Belling-Lee terminals (Peto-Scott).
 One baseboard 12 in. by 9 in.
 One mains transformer, semi-shielded, type EP36, giving 325-0-325 volts., 2-0-2 volts, 2.5 amperes, and 2-0-2 volts, 4 amperes (Varley).
 One 4-pin valveholder, type 501 (Eddystone).
 One rectifying valve (Mazda UU120/350, or Marconi-Osram U12, or Mullard DW3).

INTERNATIONAL MORSE CODE

A	dit dah	..	T	dah	.
B	dah dit dit dit	U	dit dit dah	...-
C	dah dit dah dit	V	dit dit dit dah-
D	dah dit dit	...-	W	dit dah dah
E	dit	..-	X	dah dit dit dah-
F	dit dit dah dit-	Y	dah dit dah dah-
G	dah dah dit	...-	Z	dah dah dit dit-
H	dit dit dit dit			
I	dit dit	..	Number Code.		
J	dit dah dah dah-	1	dit dah dah dah dah-
K	dah dit dah	...-	2	dit dit dah dah dah-
L	dit dah dit dit	3	dit dit dit dah dah-
M	dah dah	--	4	dit dit dit dah-
N	dah dit	..-	5	dit dit dit dit dit-
O	dah dah dah	---	6	dah dit dit dit dit-
P	dit dah dah dit-	7	dah dah dit dit dit-
Q	dah dah dit dah-	8	dah dah dah dit dit-
R	dit dah dit	...-	9	dah dah dah dah dit-
S	dit dit dit	...-	0	dah dah dah dah dah-
	Note of interrogation	..-..		dit dit dah dah dit dit-
	Note of exclamation	..-.-		dah dah dit dit dah dah-
	Apostrophe	...-.		dit dah dah dah dah dit-
	Hyphen	..-..		dah dit dit dit dit dah-
	Fractional bar	..-.-		dah dit dit dah dit-
	Brackets	...-.		dah dit dah dah dit dah-
	Inverted commas	..-.-		dit dah dit dit dah dit-
	Underline	...-.		dit dit dah dah dit dah-
	Preliminary call	..-.-		dah dit dah dit dah-
	Break sign	..-.-		dah dit dit dit dah-
	End of message	...-.		dit dah dit dah dit-
	Error	...-.		dit dit dit dit dit dit dit dit-

PHONETIC ALPHABET

To avoid the possibility of the letters of a call sign being misunderstood, it is usual to use the words given below in place of the letters. For example, G6PY would be given as G6 Paris Yokohama.

Letters to be spelt	Words to be used for spelling	Letters to be spelt	Words to be used for spelling
A	Amsterdam	N	New York
B	Baltimore	O	Oslo
C	Casablanca	P	Paris
D	Denmark	Q	Quebec
E	Edison	R	Roma
F	Florida	S	Santiago
G	Gallipoli	T	Tripoli
H	Havana	U	Upsala
I	Italy	V	Valencia
J	Jerusalem	W	Washington
K	Kilogram (or Kilowatt)	X	Xanthippe
L	Liverpool	Y	Yokohama
M	Madagascar	Z	Zurich

INTERNATIONAL AMATEUR CALL SIGNS

AC4	Tibet	FP	St. Pierre and Miquelon	ON	Belgium
AR	Syria			OQ5	Belgian Congo
CE	Chile	FQ	French Equatorial Africa	OX	Greenland
CM	Cuba			OY	Farøe Islands
CN1	Tangier Zone	FR	Reunion Island	OZ	Denmark
CNB	Morocco	FT	Tunisia	PA	Netherlands
CO	Cuba (fone)	FU	French New Hebrides	PJ	Curaçao
CP	Bolivia			PK	Dutch East Indies
CR4	Cape Verde Is.	FY	Guyane (French Guiana)	PX	Andora
CR5	Portuguese Guinea	G	British Isles (G—England ; GM—Scotland ; GW—Wales)	PY	Brazil
CR6	Angola			PZ	Surinam
CR7	Mozambique			SM	Sweden
CRS	Portuguese India	GI	North Ireland	SP	Poland
CR9	Macao	HA	Hungary	ST	Sudan
CR10	Timor	HB	Switzerland	SU	Egypt
CT1	Portugal	HC	Ecuador	SV	Greece
CT2	Azores	HH	Haiti	SV6	Crete
CT3	Madeira Island	HI	Dominican Republic	TA	Turkey
CX	Uruguay			TF	Iceland
D	Germany	HK	Colombia	TG	Guatemala
EA	Spain	HP	Republic of Panama	TI	Costa Rica
EA6	Balearic Islands			U. UE. IK.	U.S.S.R.
EA8	Canary Islands	HR	Honduras	VE	Canada
EA9	Spanish Morocco	HS	Siam	VK	Australia
EI	Irish Free State	HZ	Hedjaz	VO	Newfoundland, Labrador
EL	Liberia	I	Italy	VP1	British Honduras
EP	Iran (Persia)	J	Japan	VP2	Leeward Is. and Windward Is.
EQ	Iran (Persia)	J8	Chosen (Korea)	VP3	British Guiana
ES	Estonia	J9	Formosa	VP4	Trinidad and Tobago
ET	Ethiopia (Abysinia)	K4	Virgin Islands	VP5	Jamaica, Cayman Is., Turks and Caicos Is.
F	France	K5	Canal Zone	VP6	Barbados
FA	Algeria	K6	Hawaii	VP7	Bahamas
FB	Madagascar	K6	Guam	VP8	Falkland Is., South Georgia Is.
FD	French Togoland			VP9	Bermuda
FE	French Cameroons	K7	Alaska	VQ1	Zanzibar
FF	French West Africa	KA	Philippines	VQ2	Northern Rhodesia
FG	Guadeloupe	LA	Norway	VQ3	Tanganyika
FI	French Indo-China	LU	Argentina	VQ4	Kenya
FK	New Caledonia	LX	Luxembourg	VQ5	Uganda
FL	French Somaliland	LY	Lithuania	VQ6	British Somaliland
FM	Martinique	LZ	Bulgaria	VQ8	Mauritius
FN	French India	MX	Manchukuo		
FO	French Oceania	NY	Canal Zone		
		OA	Peru		
		OE	Austria		
		OH	Finland		
		OK	Czechoslovakia		
		OM	Guam		

INTERNATIONAL AMATEUR CALL SIGNS—continued.

VQ9	Seychelles	VU4	Laccadive Is.	ZD1	Sierra Leone
VR1	Gilbert and Ellice Is.	W. WA	United States of America	ZD2	Nigeria, British
VR2	Fiji	XE	Mexico	ZD3	Gambia
VR3	Fanning Is.	XU	China	ZD4	Gold Coast, British Togo-land
VR4	British Solomon Is.	XZ	Burma	ZD6	Nyasaland
VR5	Tonga	YA	Afghanistan	ZD7	St. Helena
VR6	Pitcairn	YI	Iraq	ZD8	Ascension Is.
VS1	Straits Settlements	YL	Latvia	ZD9	Tristan da Cunha
VS2	Fed. Malay States	YM	Danzig	ZE1	Southern Rhodesia
VS3	Non.Fed. Malay States	YN	Nicaragua	ZK1	Cook Is.
VS4	Sarawak North Borneo	YR	Rumania	ZK2	Niue
VS5	Labuan, Brunei	YS	Salvador	ZL	New Zealand
VS6	Hong Kong	YT. YU	Jugo-Slavia	ZM	Western Samoa
VS7	Ceylon	YV	Venezuela	ZP	Paraguay
VS8	Bahrein	ZA	Albania	ZS	Union of S. Africa
VS9	Maldive Is.	ZB1	Malta	ZS3	South West Africa
VU	British India	ZB2	Gibraltar		
		ZC1	Transjordanian		
		ZC2	Cocos Is.		
		ZC3	Christmas Is.		
		ZC4	Cyprus		
		ZC6	Palestine		

QSA CODE (Signal Strength)

QSA1	..	Hardly perceptible; unreadable.
QSA2	..	Weak, readable now and then.
QSA3	..	Fairly good; readable, but with difficulty.
QSA4	..	Good; readable.
QSA5	..	Very good; perfectly readable.

QRK CODE (Audibility)

R1	..	Unintelligible.
R2	..	Weak signals; barely readable.
R3	..	Weak signals; but can be copied.
R4	..	Fair signals; easily readable.
R5	..	Moderately strong signals.
R6	..	Good signals.
R7	..	Good strong signals.
R8	..	Very strong signals.
R9	..	Extremely strong signals.

RST CODE (Readability)

1	..	Unreadable.
2	..	Barely readable, occasional words distinguishable.
3	..	Readable with considerable difficulty.
4	..	Readable with practically no difficulty.
5	..	Perfectly readable.

RST CODE—continued.

(Signal Strength)

1	..	Faint, signals barely perceptible.
2	..	Very weak signals.
3	..	Weak signals.
4	..	Fair signals.
5	..	Fairly good signals.
6	..	Good signals.
7	..	Moderately strong signals.
8	..	Strong signals.
9	..	Extremely strong signals.

Tone

1	..	Extremely rough hissing note.
2	..	Very rough A.C. note, no trace of musicality.
3	..	Rough, low-pitched A.C. note, slightly musical.
4	..	Rather rough A.C. note, moderately musical.
5	..	Musically modulated note.
6	..	Modulated note, slight trace of whistle.
7	..	Near D.C. note, smooth ripple.
8	..	Good D.C. note, just a trace of ripple.
9	..	Purest D.C. note.

(If the note appears to be crystal-controlled add an X after the appropriate number).

MISCELLANEOUS INTERNATIONAL ABBREVIATIONS

Abbrev.	Meaning	Abbrev.	Meaning
C	.. Yes	GA	.. Resume sending
N	.. No	MN	.. Minute/minutes
W	.. Word	NW	.. I resume transmission
AA	.. All after	OK	.. Agreed
AB	.. All before	UA	.. Are we agreed?
AL	.. All that has just been sent	WA	.. Word after . . .
BN	.. All between	WB	.. Word before . . .
CL	.. I am closing my station	XS	.. Atmospheric

AMATEUR ABBREVIATIONS

Abbrev.	Meaning	Abbrev.	Meaning
ABT	.. About	FM	.. From
AGN	.. Again	GA	.. Go ahead, or Good afternoon
ANI	.. Any	GB	.. Good-bye
BA	.. Buffer amplifier	GE	.. Good evening
BCL	.. Broadcast listener	GM	.. Good morning
BD	.. Bad	GN	.. Good night
BI	.. By	HAM	.. Radio amateur
BK	.. Break in	HI	.. Laughter
BN	.. Been	HR	.. Hear, here
CK	.. Check		

AMATEUR ABBREVIATIONS—continued.

Abbrev.	Meaning	Abbrev.	Meaning
CKT	.. Circuit	HRD	.. Heard
CLD	.. Called	HV	.. Have
CO	.. Crystal oscillator	LTR	.. Later
CUD	.. Could	MILS	.. Milliamperes
CUL	.. See you later	MO	.. Master Oscillator
DX	.. Long distance	ND	.. Nothing doing
ECO	.. Electron-coupled oscillator	NIL	.. Nothing
ES	.. And	NM	.. No more
FB	.. Fine business (good work)	NR	.. Number
FD	.. Frequency doubler	NW	.. Now
OT	.. Old timer	OB	.. Old boy
PA	.. Power amplifier	OM	.. Old Man
PSE	.. Please	TNX	.. Thanks
R	.. Received all sent	TPTG	.. Tuned plate tuned grid.
RAC	.. Rectified A.C.	TX	.. Transmitter
RCD	.. Received	U	.. You
RX	.. Receiver	UR	.. You are
SA	.. Say	VY	.. Very
SED	.. Said	WDS	.. Words
SIGS	.. Signals	WKG	.. Working
SIGN	.. Signature	WL	.. Will
SSS	.. Single Signal super-heterodyne receiver	WUD	.. Would
SKD	.. Schedule	WX	.. Weather
TKS	.. Thanks	YF	.. Wife
TMN	.. To-morrow	YL	.. Young lady
		YR	.. Your
		73	.. Kind regards
		88	.. Love and kisses

INTERNATIONAL "Q" CODE

Abbrev.	Question	Answer for Advice
QRA	What is the name of your station?	The name of my station is . . .
QRB	How far approximately are you from my station?	The approximate distance is . . . miles
QRD	Where are you bound and where are you from	I am bound for . . . from . . .
QRG	Will you tell me my exact frequency in kilocycles?	Your exact frequency is . . . kc.
QRH	Does my frequency vary?	Your frequency varies.
QRI	Is my note good?	Your note varies.
QRJ	Do you receive me badly?	I cannot receive you.
QRK	Are my signals weak?	Your signals are too weak.
QRK	Do you receive me well?	I receive you well.
QRK	Are my signals good?	Your signals are good.
QRL	Are you busy?	I am busy. Please do not interfere.
QRM	Are you being interfered with?	I am being interfered with.
QRN	Are you troubled by atmospheric?	I am troubled by atmospheric.
QRO	Shall I increase power?	Increase power.

INTERNATIONAL "Q" CODE—continued.

Abbrev.	Question	Answer for Advice
QRP	Shall I decrease power? ..	Decrease power.
QRQ	Shall I send faster? ..	Send faster (. . . words per minute).
QRS	Shall I send more slowly? ..	Send more slowly (. . . words per minute).
QRT	Shall I stop sending? ..	Stop sending.
QRU	Have you anything for me? ..	I have nothing for you.
QRV	Are you ready? ..	I am ready.
QRX	Shall I wait? When will you call me again?	Wait (or wait until I have finished communicating with . . .) I will call you at . . . GMT.
QRZ	Who is calling me?	You are being called by . . .
QSA	What is the strength of my signals? (1 to 5). ..	The strength of your signals is . . . (1 to 5).
QSB	Does the strength of my signals vary?	The strength of your signals varies.
QSD	Is my keying correct? Are my signals distinct? ..	Your keying is indistinct; Your signals are bad.
QSL	Can you give me acknowledgment of receipt? ..	I give you acknowledgment of receipt.
QSM	Shall I repeat the last telegram (message) I sent you? ..	Repeat the last telegram (message) you have sent me.
QSO	Can you communicate with . . . direct (or through the medium of)?	I can communicate with . . . direct (or through the medium of . . .).
QSP	Will you retransmit to . . . ? ..	I will retransmit to . . .
QSV	Shall I send a series of V's? ..	Send a series of V's.
QSX	Will you listen for . . . (call sign) on . . . kc?	I am listening for . . . (call sign) on . . . kc.
QSZ	Shall I send each word or group twice?	Send each word or group twice.
QTH	What is your position in latitude and longitude? ..	My position is . . . latitude . . . longitude.
QTR	What is the exact time? ..	The exact time is . . .

AMATEUR WAVEBANDS (BRITISH)

Five-metre Band
56,020—59,980 kcs.

Ten-metre Band
28,010—29,990 kcs.

Twenty-metre Band

Metres	Kilocycles	Metres	Kilocycles
20.9	14,353	21.2	14,151
21.0	14,285	21.3	14,085
21.1	14,218	21.4	14,019

AMATEUR WAVEBANDS (BRITISH)—continued.

Forty-metre Band

Metres	Kilocycles	Metres	Kilocycles
41.2	7,281.5	42.1	7,125.9
41.3	7,263.8	42.2	7,109.0
41.4	7,246.3	42.3	7,092.2
41.5	7,228.8	42.4	7,075.4
41.6	7,211.5	42.5	7,058.8
41.7	7,194.2	42.6	7,042.2
41.8	7,177.0	42.7	7,025.7
41.9	7,159.9	42.8	7,009.3
42.0	7,142.8		

Eighty-metre Band

Metres	Kilocycles	Metres	Kilocycles	Metres	Kilocycles
80.5	3,726.6	82.2	3,649.7	83.9	3,575.6
80.6	3,722.0	82.3	3,645.2	84.0	3,571.3
80.7	3,717.4	82.4	3,640.7	84.1	3,567.1
80.8	3,712.8	82.5	3,636.3	84.2	3,562.9
80.9	3,708.2	82.6	3,631.9	84.3	3,558.7
81.0	3,703.6	82.7	3,627.5	84.4	3,554.5
81.1	3,699.1	82.8	3,623.1	84.5	3,550.3
81.2	3,694.5	82.9	3,618.7	84.6	3,546.1
81.3	3,690.0	83.0	3,614.3	84.7	3,541.9
81.4	3,685.5	83.1	3,610.0	84.8	3,537.7
81.5	3,681.0	83.2	3,605.7	84.9	3,533.5
81.6	3,676.5	83.3	3,601.4	85.0	3,529.3
81.7	3,672.0	83.4	3,597.1	85.1	3,525.2
81.8	3,667.5	83.5	3,592.8	85.2	3,521.0
81.9	3,663.0	83.6	3,588.5	85.3	3,516.9
82.0	3,658.5	83.7	3,584.2	85.4	3,512.8
82.1	3,654.2	83.8	3,579.9	85.5	3,508.7

Note.—Wavelengths in Metres are not given for the 5- and 10-metre bands, owing to the narrow band width, which would result in awkward decimal fractions.

WORLD SHORT-WAVE STATIONS

Call	K.C.	Metres	Location	Schedule, Address, etc.
W4XA	20150	11.47	Nashville, Tenn., U.S.A.	Addr., C/- National Life and Accident Insurance Co. Daily 2-4 a.m.; 8:30-2 p.m.
W6XKG	25950	11.56	Los Angeles, Calif., U.S.A.	Addr., Washington Blvd. & Oak St. Relays KGFJ; 24 hours daily.
W8XNU	25950	11.56	Cincinnati, Ohio, U.S.A.	Addr., Crosley v Corp. Relays WSAI; 10 p.m.-4 p.m.
WPIT	21540	13.93	Pittsburgh, Pa., U.S.A.	Addr., Grant Building. Relays KDKA; 8:30-11 p.m.
GSJ	21530	13.93	Daventry, England.	Addr., B.B.C., London. Trans. 2: 8.45 p.m.-3 a.m.
GSH	21470	13.97	Daventry, England.	Addr., B.B.C., London. Trans. 2: 8.45 p.m.-3 a.m.
DJS	21450	13.99	Berlin, Germany.	Addr., Broadcasting House. 3.05-10.55 p.m.
TPB-3	17850	16.81	Paris, France.	Addr., 98 Bis Blvd. Haussmann. "Paris Mondial." 11 p.m.-1 a.m.
DJH	17845	16.81	Berlin, Germany.	Addr., Broadcasting House. 3.05-10.55 p.m.; 11-11.55 p.m.; midnight-2 a.m.
W2XE	17830	16.83	New York City, U.S.A.	Addr.: C.B.S., 485 Madison Ave. Daily, 8-8 a.m.; 9:30 p.m.-midnight; Sat. and Sun., 10 p.m.-2 a.m.
2RO-8	17820	16.84	Rome, Italy.	Addr., EIAR, 5 via Montello. 9 a.m.-noon; 8-11.45 p.m.
GSV	17810	16.84	Daventry, England.	Addr., B.B.C., London. Trans. 2: 8.45 p.m.-3 a.m.
XGOX	17800	16.85	Chungking, China.	Daily 12.30-2.30 p.m. Will change in near future.
GSG	17790	16.86	Daventry, England.	Addr., B.B.C., London. Trans. 2: 8.45 p.m.-3 a.m.
JZL	17785	16.86	Tokyo, Japan.	Addr., Overseas Section, B'casting Corp. of Japan. 7.30-8.30 a.m.; 11 a.m.-noon
WNBI	17780	16.87	Bound Brook, N.J., U.S.A.	Addr., N.B.C., New York. Daily 7 a.m.-noon
PHI-2	17770	16.88	Huizen, Holland.	Addr., N.V. Phillips Radio. Daily, 10.10-11.15 p.m. Sundays, 9.10 p.m.-12.35 a.m.
DJE	17760	16.89	Berlin, Germany.	Addr., Broadcasting House. Daily, 7.55 a.m.-noon; 3.05-8.50 p.m.; 9-10.45 p.m.; also 3.10-4.25 a.m. on Mondays.
RV-96	15400	19.47	Moscow, U.S.S.R.	Addr., Radio Centre. Daily, 7-10 p.m.; also irreg. 10 a.m.-12.15 p.m.
HAS-3	15370	19.52	Budapest, Hungary.	Addr., Radiolabor, Gyali Ut 22. Sunday, midnight-1 a.m. Monday.
DJR	15340	19.56	Berlin, Germany.	Addr., Broadcasting House. Daily, 7.55 a.m.-1.50 p.m.
WGEA	15330	19.56	Schenectady, N.Y., U.S.A.	Addr., General Electric Co. Relays WCV, 1.15-8 a.m.
KGEI	15330	19.56	San Francisco, Calif., U.S.A.	Addr., General Electric Co., Treasure Island. Daily, 9.30 a.m.-1 p.m. 10 p.m.-1 a.m.
GSP	15310	19.60	Daventry, England.	Addr., B.B.C., London. Trans. 4b: 6.30-9 a.m., and Trans. 1: 3.57-8 p.m.
2RO-6	15300	19.61	Rome, Italy.	Addr., EIAR, via Montello 5. Daily, 1-3.05 a.m.; 4.38-8.30 a.m.; 9 a.m.-noon; 7.05-7.55 p.m.
VUD-3	15290	19.62	Delhi, India.	Addr., All India Radio. Daily, 11 a.m.-1 p.m.; 4.30-6.30 p.m.; 10.30 p.m.-3.30 a.m.
DJQ	15280	19.63	Berlin, Germany.	Addr., Broadcasting House. Daily, 7.50 a.m.-noon; 12.05-1.50 p.m.; 3.05 p.m. 2 a.m.
GSI	15260	19.66	Daventry, England.	Addr., B.B.C., London. Trans. 1: 3.57-8 p.m.
TPA-2	15245	19.68	Paris, France.	Addr., 98 Bis Blvd. Haussmann. "Paris Mondial." Daily, 8 p.m.-1 a.m.

Call	K.C.	Metres	Location	Schedule, Address, etc.
OLR5A	15230	19.70	Prague, Bohemia.	Daily 10.55 a.m.-1.20 p.m.; 7.55-11.15 p.m.
PCJ-2	15220	19.71	Huizen, Holland.	Addr., N.V. Phillips Radio. Daily, 10.40 p.m.-12.10 a.m.; Sundays 9.25 p.m.-12.45 a.m.; also Tuesdays, 4-5.30 p.m.; Thursdays, 12.30-2.30 a.m.
WPIT	15210	19.72	Pittsburgh, Pa., U.S.A.	Addr., Grant Building. Relays KDKA, 11 p.m.-4 a.m.
DJB	15200	19.74	Berlin, Germany.	Addr., Broadcasting House. Daily, 7.50 a.m.-1.50 p.m.; 3.05 p.m.-2 a.m.; also 3.10-4.25 a.m. on Mondays.
TAQ	15195	19.74	Ankara, Turkey.	Addr., Correspondence Dept., Radio Ankara. Daily, 8.30-10 p.m. Will soon replace 16 m. transmitter.
XGOX	15190	19.75	Chungking, China.	Addr., B.B.C., London. Trans. 4b: 6.30-9 a.m.
GSO	15180	19.76	Daventry, England.	Addr., Radio Centre. Daily, 10 a.m.-12.15 p.m.; 3.45-6.45 p.m.
RV-96	15180	19.76	Moscow, U.S.S.R.	Addr., Norsk Rikskringkasting, Stortingsgaten 28. Daily, 9.40 p.m.-1 a.m.
LKV	15166	19.76	Oslo, Norway.	Addr., Overseas Section, B'casting Corp. of Japan. Daily, 5-7 a.m.; 3-4.30 p.m.; 10 p.m.-12.30 a.m.
JZK	15160	19.79	Tokyo, Japan.	Daily, 4-7.15 a.m.
SBT	15155	19.79	Motala, Sweden.	Addr., N.I.R.O.M. Daily, 9-10.30 a.m.; 1.30-5 p.m.; 7.30 p.m.-1.30 a.m.
YDC	15150	19.80	Bandoeng, Java.	Addr., B.B.C., London. Trans. 2: 8.45 p.m.-3 a.m.; Trans. 4b: 6.30-9 a.m.; Trans. 5: 9.22 a.m.-12.15 p.m.; Trans. 6: 12.37-3.30 p.m.
GSF	15140	19.82	Daventry, England.	Addr., 98 Bis Blvd. Haussmann. "Paris Mondial." Daily 4-7 p.m.
TPB-6	15130	19.83	Paris, France.	Addr., National B'casting Stn. Irreg. 9-11 p.m.
CSW-4	15120	19.84	Lisbon, Portugal.	Addr., Broadcasting House. Daily, 1.40-7.25 a.m.; 3.05-5 p.m.; 11 p.m.-mid'n't.
DJL	15110	19.85	Berlin, Germany.	Addr., EIAR, via Montello 5. Testing irreg.: heard about 7 a.m.
2RO-12	15100	19.87	Rome, Italy.	Addr., Radio Centre. Daily, 10 a.m.-12.15 p.m.; also 3.15-5.30 a.m.
RKI	15083	19.89	Moscow, U.S.S.R.	Relays to U.S.A. Saturdays, noon-1 p.m.; 5-5.30 p.m.; Sundays, 2-2.30 p.m.
KQH	14920	20.11	Kahuku, Hawaii.	Addr. as 2RO stations. In Arabic. 7.30-8 p.m.
IQA	14795	20.28	Rome, Italy.	Addr. as DJ stations. South American programme, 7.50 a.m.-noon.
DZH	14460	20.75	Berlin, Germany.	Relays special programmes to Hawaii on Sundays till 2.45 p.m.
KKZ	13690	21.91	Bolinas, Calif., U.S.A.	Addr., Box 691. Daily, 2.30-4.30 a.m.; 7.45 a.m.-1.15 p.m.; 10-11.15 p.m.
HCJB	12460	24.08	Quito, Ecuador.	Addr., Radio Centre: Daily, 1-1.30 a.m.; 4-4.30 a.m.; 6-8.30 a.m.; 11.30 a.m.-1 p.m.; 9-9.30 p.m.; Sundays, 9 p.m.-1 a.m.; Mondays 4-9 a.m.; noon-1 p.m.
RNE	12000	25.00	Moscow, U.S.S.R.	Daily, 10 a.m.-2 p.m.
CB-1180	11970	25.06	Santiago, Chile.	Addr., Box 642. Relays CB-69, 1-4 a.m. 6-9 a.m.; 10 a.m.-2 p.m.
CD-1190	11910	25.19	Valdivia, Chile.	Daily, 2-2.30 a.m.; 7-9.30 a.m.; 8.30 p.m.-1.30 a.m. Will change to 81 m. in near future.
XGOY	11900	25.21	Chungking, China.	Addr., EIAR, via Montello 5. Testing irreg. 9 a.m.-noon.
2RO-13	11895	25.23	Rome, Italy.	Addr., 98 Bis Blvd. Haussmann. "Paris Mondial." Daily, 1.15-8 a.m.; 4-7 p.m.
TPA-3	11885	25.24	Paris, France.	Addr., as TPA-3. Daily, 9-11.15 a.m.; 11.30 a.m.-2 p.m.
TPB 7	11885	25.24	Paris, France.	Addr., Box 1686. Now used during mornings.
VLR-3	11880	25.25	Melbourne, Australia.	

Call.	K.C.	Metres.	Location.	Schedule, Address, etc.
WPIT	11870	25.26	Pittsburgh, Pa., U.S.A.	Addr., Grant Building. Relays KDKA. 4 a.m.-1 p.m.
GSE	11860	25.29	Daventry, England.	Addr., B.B.C., London. Trans. 1: 3.57-8 p.m.
DJP	11855	25.31	Berlin, Germany.	Addr., Broadcasting House. Irreg.; heard testing 2-3 p.m.
XMHA	11850	25.32	Shanghai, China.	Addr., Racecourse Rd. Daily, 8 p.m.-2 a.m.
W2XE	11830	25.36	New York City, U.S.A.	Addr., C.B.S., 485 Madison Ave. Daily, 11 a.m.-1.30 p.m.
2RO-4	11810	25.40	Rome, Italy.	Addr., EIAR, via Montello 5. Daily, 1-5.30 a.m.; 9 a.m.-noon; 7.30-11.45 p.m.
DJZ	11801	25.42	Berlin, Germany.	Addr., Broadcasting House. Daily, 7.50 a.m.-1.50 p.m.
COGF	11800	25.42	Matanzas, Cuba.	Addr., Gen. Betancourt 51. Relays CMGF 4-5 a.m.; 7-8 a.m.; 9 a.m.-3 p.m.
JZJ	11800	25.42	Tokyo, Japan.	Addr., Overseas Section B'casting Corp. of Japan. Daily, 5-7 a.m.; 10 p.m.-12.30 a.m.
WIXAL	11790	25.45	Boston, Mass., U.S.A.	Addr., University Club. Daily, 6.30-9.30 a.m.; Sundays from 5 a.m.
Saigon	11780	25.47	Saigon, French Indo-China.	Addr., Box 412. Daily, 2.15-3.15 p.m.; 11.30 p.m.-12.45 a.m.
MTCY	11775	25.48	Hsinking, Manchukuo.	Daily 7-7.45 a.m.
DJD	11770	25.49	Berlin, Germany.	Addr., Broadcasting House. Daily, 2.30-7.35 a.m.; 7.50 a.m.-1.50 p.m.
GSD	11750	25.53	Daventry, England.	Addr., B.B.C., London. Trans. 1: 3.57-8 p.m.; Trans. 4a: 3.17-6.15 a.m.; Trans. 4b: 6.30-9 a.m.; Trans. 5: 9.22 a.m.-12.15 p.m.; Trans. 6: 12.37-3.30 p.m.
COCX	11735	25.57	Habana, Cuba.	Addr., Box 32. Relays CMX, 11 p.m.-4 p.m.
LKQ	11735	25.57	Oslo, Norway.	Addr., see LKV, 19 m. Daily, 1-6 a.m.; 5-9.40 p.m.
WIXAR	11730	25.58	Boston, Mass., U.S.A.	Addr., University Club. Daily, 10 or 10.30 a.m.-noon; 12.15-2 p.m.; Sunday and Monday, 5.30-8 a.m.
CJRX	11720	25.60	Winnipeg, Canada.	Addr., James Richardson & Sons, Ltd. Daily, 9 p.m.-3 p.m.; Sundays till 7 p.m.
ZP-14	11720	25.60	Villa Rica, Paraguay.	Irreg. 8.25-10.55 a.m.
JVW-3	11720	25.60	Tokyo, Japan.	Addr., International Tele-Communications Co., Ltd. Daily, 4.50-10.40 p.m.
TPA-4	11715	25.61	Paris, France.	Addr., 98 Bis Blvd., Hausmann. "Paris Mondial." Daily, 9-11.15 a.m.; 11.30 a.m.-2 p.m.; 4-7 p.m.
JLG-3	11705	25.63	Tokyo, Japan.	Addr., see JVW-3. Daily, 5-7 a.m.
SBP	11705	25.63	Motala, Sweden.	Daily, 4-7.15 a.m.
HP5A	11700	25.65	Panama City, Panama.	Addr., Apartado 954. Daily, 1-4 a.m.-8 a.m.-1 p.m.; 10-11.30 p.m.
CB-1170	11700	25.65	Santiago, Chile.	Addr., Box 706. Relays CB-89, 1-5 a.m.; 6.30 a.m.-2 p.m.
IQY	11676	25.70	Rome, Italy.	Addr., EIAR, via Montello 5. Daily, 3.07, 3.56 a.m.; 4.50-5.30 a.m.; 9 a.m.-noon; 8.20-8.40 p.m.
CSW-5	11040	27.17	Lisbon, Portugal.	Addr., National B'casting Stn. Daily, 2-7.30 a.m.
PLP	11000	27.27	Bandoeng, Java.	Addr., N.I.R.O.M. Relays YDC, 19.8 m.
EAJ-43	10360	28.96	Teneriffe, Canary Is.	Daily, 5.30-7 a.m.; 7.30-10 a.m.; 10.45-11.45 a.m.; noon-1 p.m.
ORK	10330	29.04	Russelede, Belgium.	Daily 4.30-6 a.m.
PMN	10260	29.24	Bandoeng, Java.	Addr., N.I.R.O.M. Relays YDC, 19.8 m
PSH	10220	29.35	Rio de Janeiro, Brazil.	Addr., Box 709. Daily 9-10 a.m.

Call.	K.C.	Metres.	Location.	Schedule, Address, etc.
DZC	10050	29.86	Zeesen, Germany.	Addr., as DJ stations. Special Arabic session, about 4 a.m.
COBC	9985	30.04	Habana, Cuba.	Addr., Box 132. Relays CMBC, 9.55 p.m.-4 a.m.
JDY	9920	30.24	Dairen, Manchukuo.	Relays JQAK, 10-11 p.m.
Burgos	9855	30.45	Burgos, Spain.	Has replaced EAQ on this frequency; schedule unknown.
EAQ	9855	30.45	Madrid, Spain.	Replaced by Radio Burgos (or possibly sharing frequency). Addr., Box 951.
IRF	9830	30.52	Rome, Italy.	Addr., as 2RO stations. Daily, 3-4 a.m.; 4.50-6.30 a.m.; 9 a.m.-noon; 8.20-8.40 p.m.
COCM	9805	30.60	Habana, Cuba.	Addr., Box 33. Relays CMCM, 11-4 p.m.
CSW-7	9735	30.82	Lisbon, Portugal.	Addr., National B'casting Stn. Daily 9.13 a.m.-noon.
CB-970	9730	30.83	Valparaiso, Chile.	Daily, 8.30 a.m.-2.30 (or 3) p.m.
LRA-1	9690	30.96	Buenos Aires, Argentine.	Addr., Post & Telegraph Bldg. 8 a.m.-noon; Saturdays from 7 a.m.; Sundays from 10 a.m.
ZHP	9690	30.96	Singapore, Malaya.	Addr., Broadcasting House, 2 Orchard Rd. Sundays 8.40 p.m.-12.40 a.m.; Wednesdays, 3.40-4.40 p.m.; Mon.-Fri., 7.40 p.m.-12.40 a.m.; Saturdays 3.25-4.40 p.m., 7.40 p.m.-12.40 a.m.
GRX	9690	30.96	Daventry, England.	Addr., B.B.C., London. Trans. 2: 8.45 p.m.-3 a.m.; Trans. 4b: 6.30-9 a.m.; Trans. 5: 9.22 a.m.-12.15 p.m.
TGWA	9685	30.97	Guatemala City, Guatemala.	Daily 1-2.30 p.m. Special Dx programmes till 6.30 p.m. on alternate Sundays.
Paris	9680	30.99	Paris, France.	Addr., "Paris Mondial," as TP stations. Same programme as TPA-3 and TPA-4 during afternoons.
DJX	9675	31.01	Berlin, Germany.	Addr., Broadcasting House. Daily, 1.40-7.25 a.m.
WRCA	9670	31.03	Bound Brook, N.J., U.S.A.	Addr., N.B.C., New York City. Daily, 8 a.m.-3 p.m.
2RO-9	9665	31.04	Rome, Italy.	Addr., EIAR, via Montello 5. Daily, 3.40-8.30 a.m.; and irreg. from 9 a.m.
LRX	9660	31.06	Buenos Aires, Argentine.	Addr., El Mundo, Calle Maipu 555. Daily, 12.15 a.m.-1 p.m.; 9-9.45 p.m.
IABA	9650	31.09	Addis Ababa, Ethiopia.	Daily, 2-3 a.m.; 4-6 a.m.; 6.55-7.05 p.m., 7.15-7.45 p.m.; and Sundays 6.30-6.55 p.m.
CXA-8	9640	31.12	Colonia, Uruguay.	Addr., Belgrano 1841, Buenos Aires-Argentine. Relays LR-3, 8 p.m.-1.45 p.m.
JFO	9636	31.13	Taihoku, Taiwan.	Relays JFAK, 7 p.m.-1.30 a.m.
2RO-3	9635	31.13	Rome, Italy.	Addr., EIAR, via Montello 5. Daily, 3.07 a.m.-noon. Also special test for N.Z. at 4 p.m.
TIPG	9620	31.19	San Jose, Costa Rica.	Addr., Box 225, Daily from 10 p.m.
CXA-6	9620	31.19	Montevideo, Uruguay.	Relays CX, 7 a.m.-noon.
RAL	9600	31.25	Moscow, U.S.S.R.	Addr., Radio Centre. Daily, exc. Mon., 9 a.m.-1 p.m.; Mon. 9-10 a.m., 12.15-1 p.m.
CB-960	9600	31.25	Santiago, Chile.	Daily, 10 p.m.-7.30 a.m.; 10 a.m.-3 p.m.
HP5J	9590	31.28	Panama City, Panama.	Addr., Box 867. Daily, 3-4.30 a.m. 9 a.m.-1.30 p.m.; from 10 p.m.
VUD-2	9590	31.28	Delhi, India.	Addr., All India Radio. Daily, 11.30 a.m.-1.30 p.m.; 4.30-6.30 p.m.; 10.30 p.m.-3.30 a.m.

Call.	K.C.	Metres.	Location.	Schedule, Address, etc.
PCJ	9590	31.28	Huizen, Holland.	Addr., N.V. Philips Radio. Mon., 45-a.m., 10.15 a.m.-12.25 p.m.; Wed., 4.45-6.30 a.m., 10-11.30 a.m., 11.45 a.m.-1.15 p.m.; Thurs., 10.15-11.40 a.m.; Sat., 11 a.m.-noon.
VK6ME	9590	31.28	Perth, W.A.	Addr., A.W.A. Daily, exc. Sunday, 9-11 p.m.
VK2ME	9590	31.28	Sydney, N.S.W.	Addr., 47 York St. Sundays, 4-6 p.m.; 8 p.m.-midnight; Mons. 1.30-3.30 a.m.
WCAB	9590	31.28	Philadelphia, Pa., U.S.A.	Addr., C.B.S., 485 Madison Ave., New York City. Tues. and Fri., 8.30-9.15 a.m., 9.30 a.m.-1.30 p.m., 2-3 p.m.; Sun. 8.30-9 a.m., 9.30 a.m.-1.30 p.m.
GSC	9580	31.32	Daventry, England.	Addr., B.B.C., London. Trans. 4a: 3.17-6.15 a.m.; Trans. 4b: 6.30-9 a.m. Trans. 5: 9.22 a.m.-12.15 p.m.
VLR	9580	31.32	Melbourne, Vic.	Addr., Box 1686. Now used during afternoons and nights.
KZRM	9570	31.35	Manila, P.I.	Addr., Box 288. "Radio Manila." Daily, 7.30-9 a.m.; 8 p.m.-midnight (or 1 a.m.)
WBOS	9570	31.35	Boston, Mass., U.S.A.	Addr., Westinghouse Electric & Mfg. Co. Daily, 9 p.m.-3 p.m. (Sundays from 10 p.m.)
CXA-2	9570	31.35	Montevideo, Uruguay.	Exact schedule unknown; heard about 7 a.m., and after 1 p.m.
OAX4T	9566	31.37	Lima, Peru.	Daily, 2.30-4.30 a.m.; 11 p.m.-midnight.
DJA	9560	31.38	Berlin, Germany.	Addr., Broadcasting House. Daily, 9.30 a.m.-1.50 p.m.
WGEA	9550	31.41	Schenectady, N.Y., U.S.A.	Addr., General Electric Co. Daily, 8.15-11.15 a.m.
YDB	9550	31.41	Soerabaya, Java.	Addr., N.I.R.O.M. Same schedule as YDC, 19.8 m.
DJN	9540	31.45	Berlin, Germany.	Addr., Broadcasting House. Daily, 7.55 a.m.-1.50 p.m.; 3.05-5.30 p.m.
VPD-2	9538	31.46	Suva, Fiji Isl.	Addr., A.W.A., Ltd. Daily, exc. Sunday, 8.30-10 p.m.
SBU	9535	31.46	Motala, Sweden.	Daily, 7.15-8 a.m.
JZI	9535	31.46	Tokyo, Japan.	Addr., Overseas Section, B'casting Corp. of Japan. Daily, 7.30-8.30 a.m.
KGEI	9530	31.48	San Francisco, Calif., U.S.A.	Addr., General Electric Co., Treasure Island. Daily, 10 p.m.-1 a.m.
WGEO	9530	31.48	Schenectady, N.Y., U.S.A.	Addr., General Electric Co. Daily, 6 a.m.-2 p.m.
ZBW-3	9526	31.49	Hong Kong.	Addr., Box 200. Daily, 2.30-4.15 p.m.; 8 p.m.-1 a.m.
OZF	9520	31.51	Skamlebaek, Denmark.	Addr., Statsradiofonien, Heiberghsgade 7, Copenhagen. Daily, 11 a.m.-2 p.m.
RV-96	9520	31.51	Moscow, U.S.S.R.	Addr., Radio Centre. Daily, 4-6 a.m. 7-10 a.m.
YUA	9510	31.55	Belgrade, Yugo-Slavia.	Addr., Emetteur a Ondes Courtes. Testing 4-8.30 a.m.
GSB	9510	31.55	Daventry, England.	Addr., B.B.C., London. Trans. 1: 3.57-8 p.m.; Trans. 5: 9.22 a.m.-12.15 p.m.; Trans. 6: 12.37-3.30 p.m.
HS8PJ	9510	31.55	Bangkok, Siam.	Four nights a week--11 p.m.-1 a.m.
XEWW	9503	31.57	Mexico City, Mexico.	Addr., Box 2516. Daily, 10.45 p.m.-3.30 p.m.
VK8ME	9500	31.58	Melbourne, Vic.	Addr., 167 Queen St. Daily, exc. Sun. 7-10 p.m.
XGOY	9500	31.58	Chungking, China.	Will replace 25 m. transmitter in near future.
OFD	9500	31.58	Lahti, Finland.	Addr., Finnish B'casting Co., Helsinki. Daily, 3.15-8 a.m.
KZIB	9497	31.59	Manila, P.I.	Daily, 10 p.m.-12.05 a.m.
TAP	9465	31.70	Ankara Turkey.	Addr., Correspondence Dept., Radio Ankara. Daily, 2.30-8 a.m.

Call.	K.C.	Metres.	Location.	Schedule, Address, etc.
COCH	9437	31.80	Habana, Cuba.	Addr., 2 B St., Vedado. Daily, 11 p.m.-12.30 p.m. (Mondays till 3 p.m.).
OAX5C	9390	31.95	Ica, Peru.	Addr., "Radio Universal." Daily, 10 a.m.-2.30 p.m.
COCB	9350	32.08	Habana, Cuba.	Addr., Box 2294. Relays CMCD, 1 a.m.-2.30 p.m.
OAX4J	9340	32.12	Lima, Peru.	Addr., Box 1166. Daily, 4-6 a.m., 8 a.m.-4 p.m.
COBX	9200	32.61	Habana, Cuba.	Addr., San Miguel 194, Altos. Relays CMBX, 11 p.m.-2.30 p.m.
COCA	9100	32.91	Habana, Cuba.	Addr., Galliano 102. Relays CMCA, 3 a.m.-3.15 p.m. (or later).
COBZ	9030	33.32	Habana, Cuba.	Addr., Box 866. "Radio Salas." Daily, 10.45 p.m.-4.15 p.m.
COCQ	8830	33.98	Habana, Cuba.	Addr., 25 No. 445, Vedado. Daily, 9.55 p.m.-4 p.m. Varies in frequency at times.
COJK	8665	34.64	Camaguey, Cuba.	Daily, 8.30-9.30 a.m.; 11 a.m.-2 p.m.; and from 9.55 p.m.
TPB-11	7280	41.21	Paris, France.	Addr., 98 Bis Blvd. Haussmann. "Paris Mondial." Daily, 1.15-8.15 a.m.
CSW-8	7260	41.30	Lisbon, Portugal.	Addr., National B'casting Stn. Daily, 7-8 a.m.
GSW	7230	41.53	Daventry, England.	Addr., B.B.C., London. Trans. 1: 3.57-8 p.m.
YDX	7220	41.55	Medan, Sumatra.	Daily, 1.30-5 p.m.; Sunday, 10.30 a.m.-4.30 p.m. Also from 7.30 p.m.-midnight. Both native and N.I.R.O.M. programmes.
XPSA	7000	42.80	Kweiyang, China.	Daily, 8.30 or 9 p.m.-2 a.m.
XOJD	6880	43.60	Hankow, China.	Daily, 9-11.30 p.m.
PMH	6720	44.64	Bandoeng, Java.	Addr., N.I.R.O.M. Native programme, 7.30 p.m.-2 or 2.30 a.m.
TGWB	6490	46.20	Guatemala City, Guatemala.	Daily, 3.45-6.45 a.m.; 10.30 a.m.-3.15 p.m.; 10.45 p.m.-midnight. Also special Dx programmes on alternate Sundays--as TGWA.
IAC	6355	47.20	Rome, Italy.	Addr. as 2RO stations. Daily, 6-6.35 a.m.
COCW	6324	47.40	Habana, Cuba.	Addr., Box 130. "La Voz del Radio Philco." Daily, 9.55 p.m.-3 p.m.
TG-2	6190	48.47	Guatemala City, Guatemala.	Addr., Director-General of Electrical Communications. Tues.-Sat., 9 a.m.-2 p.m.; Sun. 9 a.m.-6 p.m.; 10 p.m.-2 a.m.; Mon. 6-11 a.m.
KGEI	6190	48.47	San Francisco, Calif., U.S.A.	Addr., General Electric Co., Treasure Island. Daily, 3-6 p.m.
TILS	6165	48.66	San Jose, Costa Rica.	Addr., "Radio Parati." Opens at 10 p.m.
WPIT	6140	48.86	Pittsburgh Pa., U.S.A.	Addr., Grant Building. Daily, 1-3 p.m.
Manila	6140	48.86	Manila, P.I.	Announces variously as KZRM, KZRF and KZEG. Daily, from about 8.30 p.m.
CR7AA	6137	48.87	Lourenco Marques, Mozambique.	Addr., Box 594. Daily, 12.30-2 a.m., 3.05-7 a.m., 3.05-4 p.m., 7.30-9.30 p.m. Sundays, 8-10 p.m.; Mondays, 1-5 a.m.
XEXA	6133	48.90	Mexico City, Mexico.	Addr., Dept. of Education. Daily, 5.30-7 a.m., 10.30 a.m.-3.45 p.m., 11 p.m.-2 a.m.
LKJ	6130	48.94	Jeloy, Norway.	Addr., see LKV, 19 m. Daily, 3-9 a.m.
MTCY	6125	48.93	Hsinking, Manchukuo.	Strong at night; time of opening varies from 9 to 11 p.m.
FK8AA	6122	49.00	Noumea, New Caledonia.	Addr., 44 Rue de l'Alma. Daily, 5.30-7 p.m.
Saigon	6116	49.05	Saigon, French Indo-China.	Addr., Box 412. Daily, 9.45-10.15 a.m.; 3.15-3.45 p.m.; 9-11.30 p.m.

Call	K.C.	Metres.	Location.	Schedule, Address, etc.
KZRH	6110	49.10	Manila, P.I.	"The Voice of the Philippines." Daily about 9 p.m.
YUA	6100	49.18	Belgrade, Yugo-Slavia.	Daily, 3-9.30 a.m., 4-6 p.m., 9.30-11.30 p.m.
ZRK	6097	49.20	Klipheuveel, S. Africa.	Addr., S. African B'casting Co., Johannesburg. Daily, 3-7 a.m. (Monday till 5.20 a.m.).
ZRJ	6097	49.20	Johannesburg, S. Africa.	Addr. as ZRK. Daily, 12.01-2.30 a.m.; 2.45-3.50 p.m.; 6.15-10.30 p.m.
VQ7LO	6088	49.31	Nairobi, Kenya.	Addr., Cable & Wireless, Ltd. Tues., Sat., 2.15-5.15 a.m.; Sun. 2.15-6.15 a.m.; Mon. 1.45-4.45 a.m.
ZHJ	6080	49.34	Penang, Malaya.	Daily, 9.40-11.40 p.m.
OAX4Z	6077	49.35	Lima, Peru.	Addr., Radio Nacional. Daily, exc. Mon., 10 a.m.-4.30 p.m.
SBO	6065	49.46	Motala, Sweden.	Daily, 7.15-8 a.m.
YDD	6060	49.50	Bandoeng, Java.	Addr., N.I.R.O.M. Daily, 8.30 p.m.-1 a.m.
WLWO	6060	49.50	Cincinnati, Ohio, U.S.A.	Addr., Crosley Radio Corp. Relays WLW Schedule uncertain—from 8.45 p.m. till 4 p.m.
GSA	6050	49.59	Daventry, England.	Addr., B.B.C., London. Trans. 4b: 6.30-9 a.m.; Trans. 5: 9.22 a.m.-12.15 p.m.
KZIB	6040	49.67	Manila, P.I.	Transmits simultaneously with 9497 kc. transmitter.
RV-96	6030	49.75	Mospow, U.S.S.R.	Addr., Radio Centre. Daily, 4-6 a.m., 7-10 a.m.
DJC	6020	49.83	Berlin, Germany.	Addr., Broadcasting House. Daily, 2.30-7.25 a.m.
PRA-8	6015	49.85	Pernambuco, Brazil.	Addr., Radio Club of Pernambuco. Daily, 7 a.m.-noon.
COCO	6010	49.92	Habana, Cuba.	Addr., Box 98. Daily, 10.55 p.m., 3 p.m.
XYZ	6007	49.94	Rangoon, Burma.	Addr., Director-General of Posts & Telegraphs. Daily, noon-2 p.m., 9.30 p.m.-1 a.m.
ZRH	6007	49.94	Roberts Heights, S. Africa.	Addr. as ZRK. Daily, 12.30-6.30 a.m. 2.45-3.50 p.m.
HP5K	6005	49.96	Colon, Panama.	Addr., Box 33. Daily 10 p.m.-midnight.
CS2WD	5977	50.15	Lisbon, Portugal.	Addr., Rua Capelo 5. Daily, 6.30-9 a.m.
PMY	5145	58.31	Bandoeng, Java.	Daily, 8.30 p.m.-2 a.m.
VUD-2	4960	60.48	Delhi, India.	Addr., All India Radio. Daily, 10.30 p.m.-3.35 a.m.
VUM-2	4920	60.98	Madras, India.	Addr., All India Radio. Daily, 9.30 p.m.-3.10 a.m.
VUB-2	4880	61.48	Bombay, India.	Addr., All India Radio. Daily, 10.30 p.m.-3.30 a.m.
VUC-2	4840	61.98	Calcutta, India.	Addr., All India Radio. Daily, 9.30 p.m.-3 a.m.
YDE-2	4810	62.37	Solo, Java.	Native programmes. Daily, 7.30 p.m.-1 a.m.
RV-15	4273	70.21	Khabarovsk, Siberia, U.S.S.R.	Daily, 4 p.m.-1 a.m.

INDEX

A
 A.C. four-valver, 171
 — operation, 28
 — two-valver, 154
 Abbreviations, amateur, 180
 — international, 180
 Adapters, ultra short-wave converters and, 120
 Aerial coil, tapped, 88
 — coupler, screened, 63
 — couplings, 72
 — damping, 87
 — doublet, 51
 — down-leads on short waves, screening, 54
 — matching transformers, 50
 — system, 126
 — uni-directional, 74
 Aerials, coupling for, 66
 — rotary, 60
 — transmitting, 77
 — tuning short-wave, 59
 All-wave aerials, 56
 Amateur abbreviations, 180
 — wavebands (British), 182
 Amplification, H.F., 30
 Armouring, steel tape, 79

B

Background noise, eliminating, 59
 Bamboo, use of, 73
 Band-spread tuning, 18

C

Cables, coaxial, 76
 Calibration, 91
 — method of, 106
 Call signs, international amateur, 178
 Chassis or baseboard?, 10
 — steel, 26
 Choke, H.F., 138
 Chokes, H.F., 27
 — L.F., 24
 Coaxial cables, 76
 Coil and valve, 123
 — combination, 115
 — construction, 64, 99
 Coil and data, 114
 — design, 86
 — mounting, 32
 — ranges, 143
 — sizes, 93, 95
 — winding, 32, 67
 Coils, H.F., 88
 Communication type receivers, 37
 Component lay-out, 113
 Condenser capacities, 27
 — mountings, 28

Condenser values, 19
 Conductors, fractional-wave, 81
 Converters and adapters, ultra-short wave, 120
 Copper screen, 65
 Coupling methods, 31
 — semi-adjustable, 70
 Couplings for aerials, 66
 — more aerial, 72
 Curve, plotting, 108

D

Di-pole, horizontal, 58
 Doublet aerial, 51
 Doublets, ultra-short-wave, 69

E

Electrical methods, 18
 Eliminating background noise, 59
 Eliminators, H.T., 29
 Experimental receiver, 35
 Extension rods and screening-boxes, 23

F

Finding and measuring wavelengths of five metres, 128
 Four-valver, A.C., 171
 Fractional-wave conductors, 81
 Frequencies or wavelengths, measuring, 98
 Frequency range, 14
 — wavelength to, 42

H

H.F. amplification, 30
 — choke, 138
 — chokes, 27
 — circuit, untuned, 31
 — coils, 88
 — stages, tuned and untuned, 34
 H.T. eliminators, 29
 Hand-capacity effects, 23
 Harmonic operation, 104
 Heterodyne wavemeter, 104
 Horizontal di-pole, 58

I

Increased band-width, 38
 Inductive coupling, 114
 Interference, minimising, 49
 International amateur call signs, 178
 — abbreviations, 180
 — morse code, 177
 — Q code, 181

K

Kilocycles and megacycles, 41

L

L.F. chokes, 24
 Layout and connections, 106
 Lead-in pick-up, 50
 Leads, single-screened, 57
 Lecher-wire system, 134
 Link-coupled tuner, 61
 Listening times, 16
 Loud-speaker reception, 139

M

Mastering the morse code, 44
 Measuring wavelengths or frequencies, 98
 Megacycle bands, 42
 Megacycles, metres, kilocycles, 41
 Meter, uses for, 110
 Metres, kilocycles and megacycles, 41
 Minimising interference, 49
 Minimum capacity, 93
 Miscellaneous international abbreviations, 180
 More aerial couplings, 72
 Morse code, international, 177
 — mastering, 44
 Mounting the coil, 32
 Multi-stage receivers, 21

O

One-valvers, two simple, 136
 Operating your first short-waver, 14

P

Phonetic alphabet, 177
 Pick-up, lead in, 50

Q

Q code, international, 181
 QRK code, 179
 QSA code, 179
 Quench coil construction, 116

R

RST code, 179
 Reaction, tuning and, 112
 — control, 15
 Receiver, experimental, 35
 Reflector aerials, 82
 — principles of, 82
 — spacing, 84
 Regenerative circuit, 66
 Rotary aerials, 60

S

Screened aerial-coupler, 63
 — transformers, 54
 Screening aerial down-leads on short waves, 54

Screening boxes, extension rods and,

23

Selectivity, improving, 68
 Semi-adjustable coupling, 70
 Short and ultra-short wavelengths, 26
 — wave aerials, tuning, 59
 — wave stations, world, 184
 — waver, operating your first, 14
 — waves, introduction to, 9
 Signal-interference ratio, 49
 Single-screened leads, 57
 — signal receiver, 38
 Slow-motion tuning, 15
 Standard three-valver, 161
 Steel chassis, 26
 — tape armouring, 79
 Super-regeneration, 115
 Superhet, 36

T

Tapped aerial coil, 88
 Three-valver, standard, 161
 Transformer, screened, 54
 Transformers, aerial-matching, 50
 Transmitting aerials, 77
 Tuned and untuned H.F. stages, 34
 — H.F. versus the superhet, 34
 Tuner, details of, 60
 — link-coupled, 61
 Tuning and reaction, 112
 — band-spread, 18
 — short-wave aerials, 59
 Twin-feeder systems, 76
 Two simple one-valvers, 136
 — two-valvers, 144
 Two-valver, A.C., 154
 Two-valvers, two simple, 144

U

Ultra-short-wave converters and adapters, 120
 — doublets, 69
 — section, 111
 — wavelengths, short and, 26
 Uni-directional aerial, 74
 Untuned H.F. circuit, 31
 — stages, tuned and, 34

W

Wavebands, amateur (British), 182
 Wavelength covered, 138
 — to frequency, 42
 Wavelengths or frequencies, measuring, 98
 Wavemeter, heterodyne, 104
 — using, 132
 Windings, details of, 89
 Wire, choice of, 92
 Wiring connections, 23
 World short-wave stations, 184