

# RADIO REVIEW AND TELEVISION News

Over  
**100**  
NEW  
WORLD-WIDE  
**RADIO**  
HOOK-UPS

HUGO GERNSBACK, Editor





# You're sure to Save Money on these Radio Parts!

Begin your 1933 savings on radio parts NOW. Here are some typical bargains from the NEW 1933 WHOLESALE RADIO SERVICE CATALOG, just off the press. Every

part is brand new, carefully selected from our stock of over 100,000 items. Each part is guaranteed and backed by the oldest and largest Radio Mail Order house in the East.

## Rauland R-14 Audio Transformer

This is the "Little Brother" to the Rauland R-10 and Laboratory Grade, R-500 Audio. That burnt-out transformer in your set affords an opportunity to improve radio results—replace with Rauland R-14. Ratio 5:1. Primary, 1200 ohms. Secondary, 8000 ohms D.C. resistance, size, 2 1/2 x 3/16 x 3/16 inches. RT4C2266—Shpg. Wt., 4 lbs. Your Cost **55¢**

## Jefferson Universal Tapped Audio

Can be used for either straight or push-pull audio stage, for use with all types of tubes. Its special bracket and its being equipped with both lugs and flexible silver leads, make it a universal replacement transformer. Primary, 900 ohms. Secondary, 3000 ohms total. Shpg. Wt., 2 lbs. Size, 1 1/2 x 2 1/2 x 2 1/2 inches. RT4C1906—Your Cost **98¢**

## Polymer Flat Mounting Power Transformer

For: 5-275, 24s, or 35s; 2-145s, or 47s pentodes, and 1-800 tubes. A heavy duty power transformer for replacement in commercial sets using the flat mount type. Windings terminate with lug on an insulated terminal strip. Sufficient filament and plate voltages to supply any commercial radio tubes. Finished in japanned black. Size 1 1/2 x 3/4 x 1 inches. Shpg. Wt., 10 lbs. RT2C1480—Your Cost **\$1.95**

## Kellogg Matched P.P. Input and Output

To improve tone quality and volume of your radio, install a pair of this Kellogg Matched P.P. input and output audio transformers. Laboratory matched to insure perfect audio balance throughout the entire frequency range. For Public Address Systems and Power Amplifiers. Size, 3 1/2 x 2 1/2 x 3/4 inches. Shpg. Wt., pair, 6 lbs. RT4C2332—Your Cost **\$1.29**  
Per pair P.P. INPUT RT4C2333—Your Cost **75¢**

## Special Audio Transformers

The same quality Audio Transformer as the Large Rauland Laboratory Grade, R-500. Open Frame strap mounted, cadmium plated. Can be used as 1st or 2nd straight Audio Stage. For use with all types of tubes. Available in either upright or horizontal type. Size overall, 2 1/2 x 3/4 x 3/4 inches. Shpg. Wt., 3 lbs. Upright Type Mounting RT4C2334—Your Cost **39¢**  
Horizontal Type Mounting RT4C2335—Your Cost, either type

## Paradon Filter Condenser

2 Mfd. 1.5 Mfd. 450 Volts. Size, 3/4 x 1/4 x 1/4. 1 1/2 lbs. Ideal replacement unit for general purpose work. For use in radio receivers and power amplifiers. Shpg. Wt., 2 1/2 lbs. RT2B679—Your Cost **15¢** Each

## For Edison and Split-dorf Receivers

Can be used in many other sets and circuits. 50 Wait rating. RT2X20492—12,000 ohms **10¢**  
RT2X20493—10,000 ohms **10¢** Your Cost, Each

## General Electric VICTOR

3 Mfd. 600 Volts. RE-45—RE-75. The official recapping part No. DL 2961390, for the above Victor sets. 1 1/2 A.C. volt rating. Metal container. Size 2 1/4 x 5/8 x 3/4 in. Mounting bracket. Flexible leads. Shpg. wt., 2 lbs. RT2B487 Your Cost **45¢**

## Multi-Unit By-Passes

Stock No.	Cap'y	Volt- age	Your Cost
RT2D3273	1-1	200	.20
RT2D3274	1-1-1	200	.37
RT2D3275	25-25	200	.25
RT2D3276	5-5	200	.41

## MULTI-UNIT FILTER In Drawn Metal Containers

Stock No.	Cap'y	Volt- age	Your Cost
RT2D3281	1-1	300	\$0.22
RT2D3282	25-25	300	.30
RT2D3283	5-5	300	.54
RT2D3277	1-1	400	.23
RT2D3278	1-1-1	400	.42
RT2D3279	25-25	400	.33
RT2D3280	5-5	400	.53

## For Victor Models

R-32 RE-45  
R-52 RE-75  
Part No. 60R35—1 Mfd. RT2B480—Your Cost **10¢**

## RCA Victor Hand Microphone

Substantially constructed from standard telephone parts. Carbon chamber, especially designed for radio telephone work. Ideal for "Ham" use. Single button. Requires a 6-volt battery and 8 to 10 mills for operation. Complete with handle and cord. Shipping weight about 2 lbs. RT2M13435—Your Price **\$1.95**

## Trutest Power Transformer

FOR 9 and 10 Tube Sets  
Mounting Area: 4 1/4 x 3 7/16 ins.; Mounting Dimensions: 3-7/16 x 2 1/2 ins.; Primary: 110 volt, 60 cycle; Secondary: 720 volts C. T.—110 M.A.; Secondary: 5 volts at 2 amps. (280); Secondary: 2.5 volts at 3 amps; Secondary: 2.5 volts at 12.25 amps. Shpg. Wt., 9 lbs. FLUSH MOUNTING TYPE RT4C1509—Your Cost **\$2.65**

## HORIZONTAL MOUNTING TYPE

Same tube characteristics as above. Size, 3 1/2 x 4 1/2 x 3-11/16 ins. Centers, 2 1/2 x 3-7/16 ins. RT4C1510—Your Cost, Each **\$2.85**

## 5 and 6 Tube Receivers

FOR Three or Four 2 1/2 Volt Heater Tubes, One 2 1/2 Volt Heater Tube and One 280 or 282 Rectifier. Mounting Area: 3 1/2 x 3 1/2 ins.; Mounting Dimensions: 2 1/2 x 3 1/2 ins.; Primary: 110 volts, 50-60 cycles; Secondary: (1) 700 volts C. T.—70 M. A. (plate); (2) 5 volts, 2 amps. (one 280 filament); or 2 1/2 volts, 3 amps. (one 282 filament); (3) 2.5 volts, 8.75 amps. (3 or 4 heaters and 1 power tube). Shpg. Wt., 6 lbs. FLUSH MOUNTING TYPE RT4C1492—Using 280 Rectifier RT4C1498—Using 82 Rectifier Your Cost, **\$1.38**

## HORIZONTAL MOUNTING TYPE

Same tube characteristics as above. Size, 3 1/2 x 3 1/2 ins. Mounting centers, 2 1/2 x 3 1/2 ins. RT4C1504—Using 280 Rectifier Your Cost, **\$1.50**

## 4 Tube Midget Receivers

FOR Two 2 1/2 Volt Heater Tubes, One 280 or One 282 Rectifier. Mounting Area: 2-13/16 x 3 1/2 ins.; Mounting Dimensions: 2 1/2 x 3-13/16 ins.; Primary: 110 volts, 50-60 cycles; Secondary: (1) 700 volts C. T.—50 M. A. (plate); (2) 5 volts, 2 amps. (one 280 filament); or 2 1/2 volts, 3 amps. (one 282 filament); (3) 2.5 volt C. T., 5 amps. (2 heaters and 1 power tube). Shpg. Wt., 3 lbs. FLUSH MOUNTING TYPE RT4C1494—Using 280 Rectifier RT4C1496—Using 82 Rectifier Your Cost, **\$1.25**

## HORIZONTAL MOUNTING TYPE

Same tube characteristics as above. Size, 3 1/2 x 3 1/2 ins. Mounting centers, 1 1/2 x 2-13/16 ins. RT4C1495—Using 280 Rectifier Your Cost, **\$1.35**

## RCA 4 Mfd. Filter Condenser

800 Volt Working Voltage  
The RCA 4 mfd. 800-volt condenser is used in Model 104 loud-speaker and Model 92 A.C. receiver. This condenser replaced the 7 and 3.9 mfd. condenser at first used in the RCA sets. For use in all high power amplifiers, using 210 or 250 type tubes. All are brand new and packed in individual cartons, and are guaranteed. Metal container, 1 1/4 x 1 1/4 x 5 inches. Two insulated soldering lugs. Shpg. Wt., 2 lbs. RT8667—Your Cost, Each **95¢**  
6 for \$5.00

## Mershon Electrolytic Condensers

The two most popular types used for replacement purposes. Both are standard size and will fit most receivers without any difficulty. The single 8 mfd. is furnished in Stud or in upright type. Inverted mounting: the triple 8 mfd. Peak Voltage Your Cost  
Stock No. Cap'y Price  
RTD2700 8 455 \$0.29  
RTD2707 8-8-8 430 1.35

## G.E. Motor Board with Turn Table

Less Pick-up  
This is the genuine RCA-VICTOR Electric Phonograph Unit as used in their costly combinations. G.E. MOTOR: A heavy duty induction motor is employed, resulting in a steady rate of speed and smooth operation. (This alone is worth the price.) AUTOMATIC STOP-ON-RECORD: SWITCH—NEEDLE CUPS. Board measures 20 x 13 inches. Our sensationally low price will move these fast. Our quantity is limited. For 110 volts, 50-60 cycle only. Shpg. Wt., 30 lbs. RT4Y19769—Your Cost, Special **\$4.45**

## Transformer and Capacitor Pack

RADIOLA 33 D. C. Part No. 8404  
The RCA P.P. Input and P.P. Output Transformer with Filter Capacitor. Input primary 1400 ohms, secondary 3500 and 4500 ohms. Output primary 154 and 184 ohms, secondary 624 ohms. Filter condensers, one 3 mfd. two 2 mfd. Shpg. wt., 5 lbs. RT4C2167—Your Cost **75¢**

## 3-Stage Power Amplifier Push-Pull "250" Tubes

A quality power amplifier using the new type High Gain Tubes: 1st stage, 1-58; 2nd stage, 1-56; 3rd stage, 2-250 push-pull; 2-251 full wave rectification. The high gain of the new tubes, nearly fourteen watts of undistorted output from the 250's, low hum level, and an unusually fine frequency response result in an amplifier ideally suitable for installation in theatres, auditoriums, dance halls, etc. INPUT—To any high impedance pick-up. Coupling transformer should be used for microphone input or low impedance pick-up. Equipped with a tapered volume control. OUTPUT—Low impedance output direct to 10 to 15 ohm voice coil. High impedance output to couple to 4000 ohm input transformer. MAXIMUM UNDISTORTED POWER OUTPUT—13.8 Watts. Gain at 1000 cycles—58 db. Will supply up to 5 large dynamic speakers, or 25 magnetic speakers. Will furnish current to a dynamic field of 750 ohms. Constructed on a heavy steel base, all parts being electrically and mechanically shielded. Finished in black lacquer. Size, 17 1/2 inches long, 11 1/2 inches wide, 7 1/2 inches high. Shpg. Wt., 40 lbs. RT4P15733—Less Tubes Your Cost, Special **\$19.50**  
Set of RCA Tubes—\$10.75

Latest, greatest edition of radio's bargain book—just off the press! WHOLESALE RADIO SERVICE COMPANY'S new 1933 catalog is crammed full of bargains. Everything in radio at the lowest wholesale prices. LAFAYETTE REFRIGERATORS, TRIPLEX PAINTS, speakers, kits, accessories. FREE short-wave sets and apparatus, amplifiers, public address systems, REPLACEMENT PARTS, etc. Send for your FREE catalog TODAY.



## The Great, New WHOLESALE RADIO Catalog!

SMASHING SELECTION OF 1933 VALUES  
Latest, greatest edition of radio's bargain book—just off the press! WHOLESALE RADIO SERVICE COMPANY'S new 1933 catalog is crammed full of bargains. Everything in radio at the lowest wholesale prices. LAFAYETTE REFRIGERATORS, TRIPLEX PAINTS, speakers, kits, accessories. FREE short-wave sets and apparatus, amplifiers, public address systems, REPLACEMENT PARTS, etc. Send for your FREE catalog TODAY.

## Scoville "Low Type" 4-Gang Condenser

An exceptional Condenser at a low price. The construction is extra heavy with solid brass plates. It is securely soldered to sturdy brass spacer bars. Frame is cadmium plated to prevent rusting. Steel shaft 3/8 inch in diameter; heavy steel collars. Self adjusting bearings that provide smooth, easy rotation. Capacity .00035 mfd. Clockwise rotation. Flat mountings. Size, 3 1/4 inches wide, 3 1/2 inches high (fully opened) and 10 inches long. Shpg. Wt., 6 lbs. RTH9906—List Price, \$5.00 Your Special Price **45¢**

## C.R.L. Volume Controls

Specials  
This "Specials" C.R.L. volume controls can be used in many of the commercial receivers.  
RTH9697—5,000 Ohms Radiolium Your Cost **22¢**  
RTH9698—25,000 Ohms Pot.  
RTH9699—75,000 Ohms Pot.  
Replacement for Earl and Reed Receivers  
Dual, 10,000—250,000 ohms. RT4H9695—Your Cost Each **30¢**  
Dual Volume Control  
5,000 ohms Wire wound and 15,000 earl on strip. RT4H9696—Your Cost Each **25¢**

Our large shipping facilities enable us to ship your order the same day that we receive it. Buy from WHOLESALE RADIO SERVICE and know that you are saving money and that you will be satisfied.

# WHOLESALE RADIO SERVICE CO.

100 Sixth Avenue, New York, N. Y.

If you wish your shipment to be sent C. O. D., remit 20% with your order. Balance must be paid on delivery. If full amount of order is sent, you may deduct 2% for cash. Send money order or check. Register letter if it contains cash or unused U. S. stamps.



# I WILL TRAIN YOU AT HOME

TO FILL A

# BIG PAY RADIO JOB



## Here's Proof



### MADE \$10,000 MORE IN RADIO

"I can safely say that I have made \$10,000 more in Radio than I would have made if I had continued at my old job."  
VICTOR L. OSGOOD, St. Cloud Ave., West Orange, N. J.



### FROM \$10 TO \$50 A WEEK IN SPARE TIME

"Besides being employed by the Power & Light Company to locate Radio interference in this district, which is a very good position, I have a service business of my own that nets me from \$10 to \$50 a week in spare time. I owe all my success to the National Radio Institute."  
H. L. PENIP, 812 W. High St., Piqua, Ohio.



OWES A LOT OF N.R.I. "After finishing my tenth lesson, I started on my first job. After that jobs came rolling in and I found myself with a surplus of money with which to continue paying for my course. My first year's record was 108 Radio jobs. I have cleared \$2,305 to date in spare time."  
JOHN HEAHL, 66-53 Jary Ave., Maspeth, L.I., N. Y.



\$400 EACH MONTH "I spent fifteen years as traveling salesman, making good money but saw opportunities in Radio. I am not sorry, for I have made more money than ever before. I have made more than \$400 each month and it was your course that brought me to this."  
J. G. DAEL-STEAD, Radio Station KYA, San Francisco, Cal.

If you are dissatisfied with your present job. If you are struggling along in a rut with little or no prospect of anything better than a skinny pay envelope—clip the coupon NOW. Get my big FREE book on the opportunities in Radio. Read how quickly you can learn at home, in your spare time, to be a Radio Expert—what good jobs my graduates have been getting—real jobs with real futures.

### Many Radio Experts Make \$50 to \$100 a Week

In about ten years the Radio industry has grown from \$2,000,000 to hundred of millions of dollars. Over 300,000 jobs have been created by this growth, and thousands more will be created by its continued development. Many men and young men with the right training—the kind of training I give you in the N.R.I. course—have stepped into Radio at two and three times their former salaries.

### Get Ready Now for Jobs Like These

Broadcasting stations use engineers, operators, station managers, and pay up to \$5,000 a year. Manufacturers continually employ testers, inspectors, foremen, engineers, service men, buyers, for jobs paying up to \$6,000 a year. Radio operators on ships enjoy life, see the world, with board and lodging free, and get good pay besides. Dealers and jobbers employ service men, salesmen, buyers, managers, and pay up to \$100 a week. My book tells you about these and many other kinds of interesting Radio jobs.

### Many Make \$5, \$10, \$15 a Week Extra in Spare Time Almost at Once

The day you enroll with me I send you material which you should master quickly for doing 28 jobs common in most every neighborhood, for spare-time money. Throughout your course I send you information on servicing popular makes of sets! I give you the plans and ideas that have made \$200 to \$1,000 a year for N.R.I. men in their spare time. My course is famous as the course that pays for itself.

### Television, Short Wave, Talking Movies Money Back Agreement Included

Special training in Talking Movies, Television, and Home Television experiments, Short-Wave Radio, Radio's use in Aviation, Servicing and Merchandizing Sets, Broadcasting, Commercial and Ship Stations are included. I am so sure that N.R.I. can train you satisfactorily that I will agree in writing to refund every penny of your tuition if you are not satisfied with my Lesson and Instruction Service upon completion.

### 64-page Book of Information FREE

Get your copy today. It's free to all residents of the United States and Canada over 15 years old. It tells you where Radio's good jobs are, what they pay, tells you about my course, what others who have taken it are doing and making. Find out what Radio offers you without the slightest obligation. ACT NOW!

J. E. SMITH, President  
National Radio Institute  
Dept. 2MC4  
Washington, D. C.

### Some of the Jobs N. R. I. Trains Men For

- |  |   |   |
|--|---|---|
| Broadcast Engineer                           | Operator of Airway Beacons                      | Sales Manager for Retail Stores         |
| Maintenance Man in Broadcasting Station      | Service Man on Sound Picture Apparatus          | Service Manager for Retail Stores       |
| Installation Engineer of Broadcast Apparatus | Operator of Sound Picture Apparatus             | Auto Radio Installation and Service Man |
| Operator in Broadcast Station                | Ship Operator                                   | Television Broadcast Operator           |
| Aircraft Radio Operator                      | Service Man on Public Address Systems           | Set Servicing Expert                    |
|  | Installation Engineer on Public Address Systems |   |

## Special Free Offer

For the first time this authoritative book on Television is made available to the general public. Until now only my students could have it. Act promptly, and I'll send you a copy FREE, in addition to my big free book "Rich Rewards in Radio." This book on Television gives you the fundamental facts about Television. Its status, a comparison of sound and visual communication, and describes in detail the typical devices used in the six fundamental steps of Television. Get the facts about this coming field of great opportunity. Mail the coupon NOW.



## SPECIAL Radio Equipment for Broad Practical Experience Given Without Extra Charge

My Course is not all theory. I'll show you how to use my special Radio Equipment, for conducting experiments and building circuits which illustrate important principles used in such well known sets as Westinghouse, General Electric, Philco, R.C.A., Victor, Majestic, and others. You work out with your own hands many of the things you read in our lesson books. This 50-50 method of training makes learning at home easy, interesting, fascinating, intensely practical. You learn how sets work, why they work, how to make them work when they are out of order. Training like this shows up in your pay envelope—when you graduate you have had training and experience—you're not simply looking for a job where you can get experience.

I have doubled and tripled the salaries of many. Find out about this tested way to **BIGGER PAY**



FILL OUT AND MAIL THIS COUPON TODAY

J. E. SMITH, President  
National Radio Institute, Dept. 2MC4  
Washington, D. C.

I want to take advantage of your Special Offer. Send me your book "The Principles of Television" and "Rich Rewards in Radio" which points out the opportunities for spare time and full time jobs in Radio and your famous 50-50 method of training men to become Radio experts through home study.

Name.....  
Address.....  
City..... State.....

## The Famous Course That Pays For Itself

**IN THIS ISSUE:** Radio features, circuits, ideas and kinks--the best of their kind--gathered from the leading radio magazines of the world. Also--the latest in television construction.



# CONTENTS FOR NOV.-DEC. 1932

**HUGO GERNSBACK, Editor**  
**H. WINFIELD SECOR, Managing Editor**  
**ROBERT HERTZBERG, Associate Editor**

VOLUME II NUMBER 5

**RADIO REVIEW AND TELEVISION NEWS**—Bi-monthly. Entered as second class matter at the post office at Paterson, N. J., under the act of March 3, 1879. Trademarks and copyrights by permission of H. Gernsback, 98 Park Place, N. Y. C. Text and illustrations of this magazine are copyright and must not be reproduced without permission.

**RADIO REVIEW AND TELEVISION NEWS** is published on the 15th of every other month. Six numbers per year. Subscription price is \$1.50 a year in the United States and possessions. Canada and foreign countries, \$1.75 a year. Single copies 25c. Address all contributions for publication to Editor, **RADIO REVIEW AND TELEVISION NEWS**, 96-98 Park Place, New York, N. Y. Publishers are not responsible for lost manuscripts. Contributions cannot be returned unless authors remit full postage.

**RADIO REVIEW AND TELEVISION NEWS** is for sale at all principal newsstands in the United States and Canada. European agents: Brentano's, London and Paris. Printed in U. S. A. Make all subscription checks payable to Popular Book Corporation.

COPYRIGHT, 1932, BY H. GERNSBACK

Published by **POPULAR BOOK CORPORATION**

**HUGO GERNSBACK**, President - **H. W. SECOR**, Vice-President  
**EMIL GROSSMAN** - - - - - Director of Advertising  
 Chicago Adv. Office - **L. F. McCLURE**, 737 No. Michigan Blvd.  
 Publication Office - - - 192 Jefferson St., Paterson, N. J.  
 Editorial and General Offices - 96-98 Park Place, New York, N. Y.  
 London Agent: **HACHETTE & CIE**, 16-17 King William St., Charing Cross, W.C.2

Paris Agent: **HACHETTE & CIE**, 111 Rue Reaumur  
 Australian Agents: **McGILL'S AGENCY**, 179 Elizabeth St., Melbourne

**RADIO FEATURES:**

Two Magazines in One—An Editorial by Hugo Gernsback ..... 215

New Antennas Reduce Fading Effects ..... 216

How To Mount and Use Gang Condensers ..... 217

Is The Variable Condenser Doomed? ..... 218

Locating Metal Pipes by Radio ..... 219

Radio Tubes and How They Work ..... 220

Make Your Own Electric Music! ..... 222

A Two-Tube 7 Meter Receiver ..... 223

One-Tube D.C. Loud Speaker Set ..... 224

Kinks From Abroad That You Will Find Useful..... 225

World Wide Hook Ups ..... 226 to 233

Review of American Radio Magazines ..... 234

How The Baffle Works ..... 235

Radio Patents ..... 236

**TELEVISION FEATURES:**

How To Make a Single Channel Sight and Sound Receiver by A. C. Matthews ..... 238

New Radio Tube Produces Powerful "Cold Light" 240

Television Set Like a Camera ..... 241

Diode Detection in Television by C. Bradner Brown 242

Television Circuits ..... 243

A Powerful Seven-Meter Super-Regenerator by Norman B. Krim ..... 244

List of Television Stations ..... 245

Television Question Box ..... 246

News Events by Television by Ernest H. Traub ..... 254



# OPPORTUNITIES *are many* for the Radio Trained Man

Don't spend your life slaving away in some dull, hopeless job! Don't be satisfied to work for a mere \$20 or \$30 a week. Let me show you how to get your start in Radio—the fastest-growing, biggest money-making game on earth.

**Jobs Leading to Salaries of \$50 a Week and Up**  
Prepare for jobs as Designer, Inspector and Tester—as Radio Salesman and in Service and Installation Work—as Operator or Manager of a Broadcasting Station—as Wireless Operator on a Ship or Airplane, or in Talking Picture or Sound Work—HUNDREDS of OPPORTUNITIES for a real future in Radio!

## Ten Weeks of Shop Training

We don't teach by book study. We train you on a great outlay of Radio, Television and Sound equipment—on scores of modern Radio Receivers, huge Broadcasting equipment, the very latest and newest Television apparatus, Talking Picture and Sound Reproduction equipment, Code Practice equipment, etc. You don't need advanced education or previous experience. We give you—**RIGHT HERE IN THE COYNE SHOPS**—the actual practice and experience you'll need for your start in this great field. And because we cut out all useless theory and only give that which is necessary you get a practical training in 10 weeks.

## TELEVISION *and* TALKING PICTURES

And Television is already here! Soon there'll be a demand for THOUSANDS of TELEVISION EXPERTS! The man who learns Television now can have a great future in this great new field. Get in on the ground-floor of this amazing new Radio development! Come to COYNE and learn Television on the very latest, new-

est Television equipment. Talking Picture and Public Address Systems offer opportunities to the Trained Radio Man. Here is a great new Radio field just beginning to grow! Prepare NOW for these wonderful opportunities! Learn Radio Sound Work at COYNE on actual Talking Picture and Sound Reproduction equipment.



### Many Earn While Learning

You get Free Employment Service for Life. And don't let lack of money stop you. Many of our students make all or a good part of their living expenses while going to school and if you should need this help just write to me. Coyne is 32 years old! Coyne Training is tested—proven beyond all doubt. You can find out everything absolutely free. Just mail coupon for my big free book!

H. C. Lewis, Pres. RADIO DIVISION Founded 1899  
**COYNE Electrical School**  
500 S. Paulina St., Dept. 82-1M Chicago, Ill.



### All Practical Work At COYNE In Chicago

**ALL ACTUAL, PRACTICAL WORK.** You build radio sets, install and service them. You actually operate great Broadcasting equipment. You construct Television Receiving Sets and actually transmit your own Television programs over our modern Television equipment. You work on real Talking Picture machines and Sound equipment. You learn Wireless Operating on actual Code Practice apparatus. We don't waste time on use'less theory. We give you the practical training you'll need—in 10 short, pleasant weeks.

### Mail Coupon Today for All the Facts

H. C. LEWIS, President

**Radio Division, Coyne Electrical School**  
500 S. Paulina St., Dept. 82-1M Chicago, Ill.

Dear Mr. Lewis:— Send me your Big Free Radio Book, and all details of your Special Offer.

Name .....

Address .....

City ..... State .....



# **Shortwave and Television Corporation**

AN AFFILIATE OF GENERAL ELECTRONICS CORPORATION

## **Radio and Television Consultants and Engineers**

---

Owners and Operators of Television Station WIXAV; 1000 watts, Sound Station WIXAU, 500 watts and Ultra-short wave station WIXG, 43 megacycles. Operators of International Short Wave Station WIXAL, 5,000 watts power.

---

### **Shortwave and Television Corporation**

LABORATORIES, STUDIOS AND STATIONS LOCATED AT 70 BROOKLINE AVENUE, BOSTON, MASS.



# General Electronics Corporation

AFFILIATES AND SUBSIDIARIES

SHORTWAVE AND TELEVISION CORPORATION  
SHORTWAVE AND TELEVISION LABORATORY, INC.  
AERADIO CORPORATION OF AMERICA  
ELECTRONICS RESEARCH CORPORATION

---

SHORT WAVE RADIO RECEIVERS  
BROADCAST RADIO RECEIVERS  
TELEVISION RECEIVERS  
SHORT WAVE RADIO TRANSMITTERS  
TELEVISION TRANSMITTERS  
AVIATION RADIO  
NEON LAMPS, ETC., ETC.  
PUBLIC ADDRESS SYSTEMS  
REMOTE CONTROL SYSTEMS  
INDUSTRIAL ELECTRONIC APPLIANCES  
X-RAY AND ULTRA-VIOLET RAY APPARATUS  
PHOTO-ELECTRIC CELLS  
CATHODE RAY TELEVISION TUBES

---

## General Electronics Corporation

EXECUTIVE OFFICES—70 BROOKLINE AVENUE

BOSTON, MASSACHUSETTS



AROUND THE WORLD RECEPTION A CERTAINTY

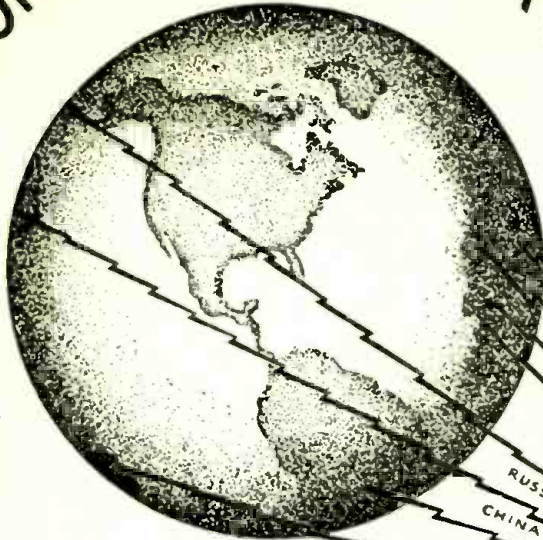

Every Day  
in the Year

with the New  
15-550 METER

SCOTT  
ALL-WAVE  
Deluxe

SCOTT-TRAVEL to the ends of the earth! Spin the whole globe's wealth of entertainment into your own home with the twirl of a dial. True single dial control does it — no trimmers or auxiliary dials, no fussing with plug-in or tapped coils. Here is performance so perfected that this receiver is GUARANTEED to bring in foreign stations, 10,000 miles or more away, with full loud speaker volume in all seasons, every week throughout the year.

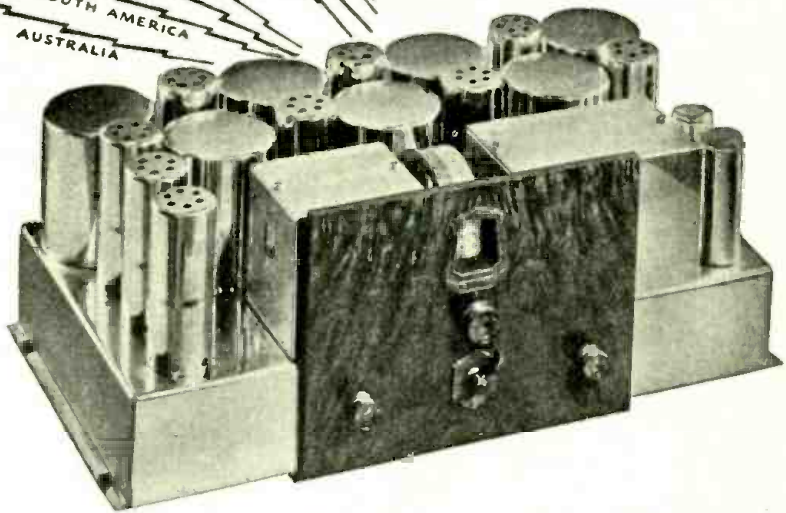

**Guarantee Based on  
History's Most Impressive Radio Performance Record**

Verified Chicago reception, by a SCOTT ALL-WAVE operating under ordinary home conditions, of every scheduled program broadcast over a whole year's time from VK2ME, Sydney, Australia—more than 9,500 miles away . . . more than 19,000 logs of foreign stations submitted by SCOTT ALL-WAVE owners this year . . . are but two of many accomplishments.

It takes advanced, precision engineering—laboratory technique in custom construction—a background of nearly a decade of experience in building superfine receivers—to make such records possible, and to permit such a guarantee.

Yet here it is! Try it yourself. Thrill to the reception of stations in England—France—Germany—Spain—Italy—South America—far-off Australia. Listen in on gabbing telephony amateurs—hear land-to-plane messages—foreign news flashes on the short waves—a dozen and one new radio thrills await you. Get American, Canadian and Mexican stations you've never dreamed were on the air. Get them *all*—even those thousands of miles away—with full loud speaker volume and lifelike fidelity of tone. Tone so perfect

that, in studio tests, music critics fail to distinguish between the actual playing of a hidden pianist, and the SCOTT ALL-WAVE DELUXE reproduction of a pianist's broadcast program.

Such performance results from micrometer-measured accuracy in custom building. It testifies to the incorporation of every worthwhile development in radio, plus many exclusive innovations made by Scott engineers. These betterments include full automatic volume control; visual tuning; the ultimate in selectivity; highest degree of sensitivity ever developed in a radio receiver; lowest known noise level of reception; new Class "A" linear amplification giving tremendous volume without distortion; new-type tubes; many other absorbingly interesting technical achievements.

Still, with all these superiorities, a SCOTT ALL-WAVE DELUXE costs no more than many models of ordinary receivers. And it is the *only* receiver with an iron-clad warranty. Every part (except tubes) is guaranteed for five years against breakage or service failure, instead of the ordinary 90-day period.

Learn about this new wonder of the radio world! The set that not only gets 'round-the-globe reception, but that is used around the world—Scott owners in 75 different foreign countries enjoy this remarkable performance. The whole story of the SCOTT ALL-WAVE DELUXE is the most vitally interesting news of radio quality, performance and value ever published. Get it today! Mail the coupon below for complete information, including technical data, performance proofs, and everything you want to know.

**SEND COUPON NOW FOR PROOF**

E. H. SCOTT RADIO LABORATORIES, INC.  
4450 Ravenswood Ave.,  
Dept. RRT-6 Chicago, Illinois

Send me complete information about the New Scott All-Wave Deluxe Receiver, including technical details, performance proofs, prices, etc. This request is not to obligate me in any way.

Name.....  
Address.....  
City.....  
State.....

**E. H. SCOTT RADIO LABORATORIES, INC.**  
4450 Ravenswood Avenue Dept. RRT-6 CHICAGO, ILL.





VOLUME II NUMBER 5  
NOVEMBER-DECEMBER, 1932

HUGO GERNSBACK, Editor  
H. WINFIELD SECOR, Managing Editor  
ROBERT HERTZBERG, Associate Editor

# TWO MAGAZINES IN ONE

An Editorial by HUGO GERNSBACK

● WHEN TELEVISION NEWS first appeared in March, 1931, I was confident that the television industry had advanced sufficiently to support an authoritative magazine.

While the magazine was welcomed by the readers, the industry, up to this time, sad to relate, has made little progress. Indeed, television in the home is no nearer now than it was in 1930.

In a former editorial I mentioned that people in the television industry, with a few notable exceptions, identified themselves so much with selling worthless stock to the public that they did not have much time to turn out merchandise. This condition of late has become so aggravated that today only a few reliable television manufacturers are left.

A magazine of the type of TELEVISION NEWS cannot exist by selling copies to readers only, even though it has sold very well thus far. It is well known that the advertising pages have to make up the loss incurred in publishing and selling a magazine under our present economic system.

For this reason, I have found it necessary to include other material in the magazine in order to broaden its scope. This is the reason for the change of name, and the magazine henceforth will be known under the title of RADIO REVIEW AND TELEVISION NEWS.

While it was necessary to reduce the television section, there will be found in that section a sufficient amount of material to please television enthusiasts. As the magazine grows I hope to increase that section again, always providing that the television industry supports the magazine.

In the "RADIO REVIEW" section, I believe I present an entirely new thought to American radio readers.

A recent trip through Central Europe convinced me that there is a tremendous amount of new radio building and experimenting going on, unrealized today by most Americans. There are,

outside of the United States, over 160 radio magazines! Due to the new tubes and the activities of European radio constructors, there is so much new in radio that it is difficult for American radio readers to realize this. The few existing American radio magazines naturally must take care of American radio developments first, and therefore they have not space left to feature the latest foreign developments.

For that reason, the American radio experimenter and constructor has been left in the cold up to now, when it comes to new circuits and new foreign radio developments.

The "RADIO REVIEW" section will fill this important void in the future. Each issue of this magazine will bring out the latest radio developments, the latest hook-ups, and the latest radio thoughts from all foreign countries, whether they are from England, France, Germany, Australia, or even Japan. *In other words, this magazine will now be a real digest of the world's best radio literature* as it pertains to the radio experimenter and builder.

With this issue, I am also originating an entirely new thought in radio publishing, and that is that all worthwhile foreign circuits will be built by us in this country with American parts. In other words, if I see a new circuit that is worthwhile, it will promptly be translated not only into the English language, but it will be translated into American components as well so that the American reader will have no difficulty in building it.

Please look over the first issue carefully, and be sure to write me a letter stating what your impressions are. Naturally, we are open to ideas as to the new combination magazine, and we cannot have too many suggestions.

And finally, if you like this magazine, be sure to recommend it to your friends. A tremendous amount of labor has gone into the first issue, yet I hope to make subsequent issues even better, with your help.

---

RADIO REVIEW AND TELEVISION NEWS IS PUBLISHED ON THE 5th OF EVERY OTHER MONTH — THE NEXT ISSUE WILL BE PUBLISHED JANUARY 5th

---

Editorial and Advertising Offices, 96-98 Park Place, New York, N. Y.

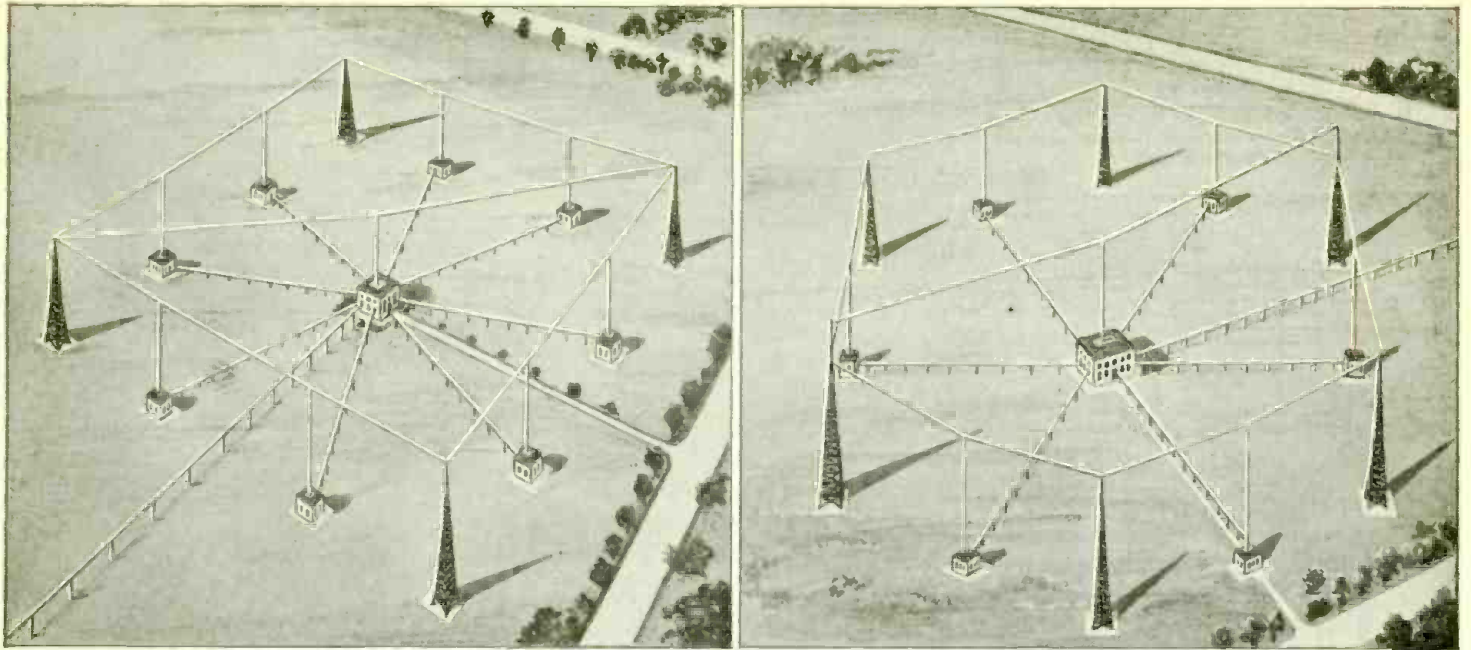

Two forms of special reflector antennas designed by German engineers to reduce fading and skip phenomena.

# NEW ANTENNAS REDUCE FADING EFFECT

● THE range of a radio transmitter is primarily determined by its reception zone which is free from fading. Enlarging it cannot be attained by increasing the transmission energy, for the near fading which bounds the fading-free reception zone is an interference fading. It is caused by the coming together of the space wave, reflected by the Heaviside layer, with the ground wave, according to *Das Funkmagazin*, (Berlin). The fading phenomenon is determined by the ratio of the intensities of the space and ground waves, something which cannot be altered by increasing the transmission energy. If, however, the space radiation of the transmitting antenna is negligibly small in comparison with its ground radiation, then the near fading would be eliminated, and the range of the transmitter would be accordingly increased and would be determined primarily only by the transmission energy.

## The "Radiation Angle"

If the radiation from a transmitting antenna is graphically represented in terms on the vertical angle of radiation, then there results the vertical characteristic of the antenna, which is also designated as the "radiation diagram in the vertical plane." By "radiation angle" should be understood the angle which a ray forms with the horizontal. For a transmitting wire directed vertically upward and excited at its fundamental wave (Marconi antenna), Fig. 1 shows the vertical characteristics. The numbers de-

note the angular degrees. The sizes of the individual radiation sections (so-called radiation vectors) correspond in each case to the distance of the curve point in question from the middle point of the curve drawn. One recognizes from the diagram that in the case of this antenna form the portions of the space radiation which come out at the angles critical for the near fade-out (around 70 degrees) are relatively considerable in quantity (equal to about 16% of the ground radiation), particularly if one considers that the space radiation en route to the receiver is exposed to far less loss than the ground radiation.

For the purpose of eliminating the near fading it is a question, according to the above remarks, of essentially reducing the portions of radiation in the critical angles, i.e., to flatten the vertical characteristic of the antenna, as shown in Fig. 2. For comparison the curve of Fig. 1 is at the same time drawn in, as a dotted line.

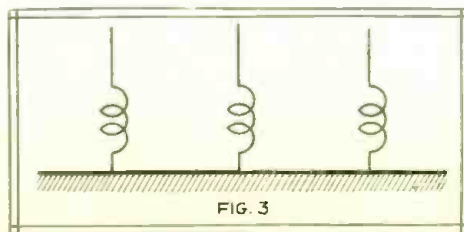

A series antenna for perpendicular radiation.

For a flattening of the vertical characteristic there are two methods. One can materially increase the extent of the antenna both vertically and horizontally, in comparison with the now customary dimensions.

The first way makes necessary a raising of the antenna to about half the wavelength. The resulting difficulties are hard to overcome in the ordinary radio field; for example, for a wave length of 400 meters a mast height of at least 200 meters (more than 600 feet) would be necessary. (Such aerials are actually being used in the United States.) On the other hand, in the short wave field this way can be taken, as will be shown in another part of this article.

## Horizontal Increase Effective

The second method, increasing the horizontal extent of the antenna system beyond the usual measure, has now been tried in actual practice. At the instigation of the German Postal Department, together with the C. Lorenz Co., experiments were performed on the experimental tract of this company in Eberswalde. The results correspond with the theoretical premises: the near fading was actually for the first time eliminated or, as the case might be, suppressed, and the fading-free reception zone was thereby expanded. At the same time the experimental results represent proof of the correctness of our ideas regarding the cause of the fading phenomena.

The experimental antenna, Fig. 3, consisted of three individual radiators



(Marconi antennas), which were set up side by side in a vertical plane. Each of the two outer radiators had the same distance from the middle one. Then the determining vertical characteristic is secured, 1) by the distance of the outer radiators from the middle one, and 2) by the ratio of the current intensity in the middle radiator to that in the two outer ones (as well as the phase relations). In this case it results that an improvement, i.e., a flattening, of the vertical characteristic, always makes the degree of efficiency worse, but the degree of efficiency is more favorable if the vertical characteristic is chiefly influenced by the mutual distance between the radiators. In Figs. 4 and 5 these energy relations are not considered, or else the curves are equalized to the same ground radiation. For comparison, as in Fig. 2, the characteristic of an individual radiator is shown in dotted lines.

Figure 4 shows two radiation diagrams, for a distance from the outer to the middle radiator of half a wavelength, and in the case of  $b$  of a quarter of a wavelength. On the other hand, Fig. 5 shows how the radiation

at a short distance from the transmitting antenna.

Such a series antenna (Fig. 3) is also a directional antenna. It radiates only in directions perpendicular to its plane and therefore does not come into consideration for broadcasting purposes, where uniform radiation in all horizontal directions is needed. The same vertical characteristic as in the above discussed series antenna can also be obtained if the outside radiators are arranged in a circle around a centrally located middle radiator (or even several concentrically located ones). This might well be the form of antenna to be used for broadcasting if the near fading is to be overcome.

The introduction of such antennas will depend on whether the advantages sufficiently compensate for the greater technical outlay. Perhaps on the occasion of the reconstruction of the Munich station these new antenna forms will be taken into account. Likewise the new large transmitting station in Vienna is to have a similar transmitting antenna, also, however, with directional action.

In the German world-wide short

from two opposite corners of the dipole squares, in each case. The two excitation conductors lead at the foot of the antenna tower together into the connection house. From here a line is run to the transmitting building, some 250 feet away.

The reception of the German world-wide radio station has been materially improved in all parts of the world by this new antenna, which radiates in all directions.

## How To Mount and Use Gang Condensers

● MULTIPLE-UNIT ganged condensers may fairly be called instruments of precision nowadays; if they were not, the good results so widely attained with sets having single-knob tuning would be quite out of the question. But, although the rigidity of these components has been greatly improved of late, a warning as to the need for taking reasonable care in handling them will not be out of place. Indeed, one can justly say that no part of a set—not excepting the tubes—should be handled with more respect. The matching of individual units of even the best of condensers is likely to be impaired if they are dropped on the floor, and much less harsh treatment may well have a prejudicial effect on the accuracy of the average specimen.

If the sections of a gang condenser are not uniform, it becomes very difficult to balance up the circuit in which it is used.

Apart from the question of accidents, there is a possibility that the whole frame may be distorted when the condenser is mounted in position if unequal pressure be exerted by the holding-down screws. Consequently, great care should be taken to see that the condenser is mounted on a flat surface, or else strains may be avoided by the use of packing washers of suitable thickness. An alternative, and perhaps better, plan is to avoid rigid mounting altogether by interposing bushings of resilient material; this practice is exemplified in some of the latest super-heterodynes, although flexible mounting is here adopted mainly for another reason.—*Wireless World* (London).

**We have become accustomed to the idea that fading and skipping of radio signals are due to atmospheric conditions, and are therefore beyond human control. However, German radio engineers have proved that much of this trouble can be reduced by transmitting antennas of special construction. The results of some of their experiments are described in this interesting article.**

diagram is influenced by the changing of the current relations. In the case of  $c$ ,  $d$ , and  $e$  the proportion of the current in the middle radiator to that in the outer radiator is as 4:1, 1:1, and 0:1. At the same time it is assumed in all cases that the middle radiator is displaced in phase one-half a period with respect to the current in the outer radiators, which operate both in the same phase (and with equal current intensity). In case  $e$  one recognizes pronounced space radiation. It is reported that in this case extremely quick and strong fading occurred even

wave radio station at Zeesen, there arose the problem of flattening the vertical characteristic, since formerly a part of the radiant energy was radiated upward at a steep angle and thereby was lost for reception. In view of the short wave (31.38 meters) it was possible to enlarge the antenna system upward. The new antenna built by the Telefunken Co. is shown in diagram in Fig. 6. It consists of four squares, which are suspended on four guy-ropes run obliquely down from the traverses of the antenna tower. The excitation takes place

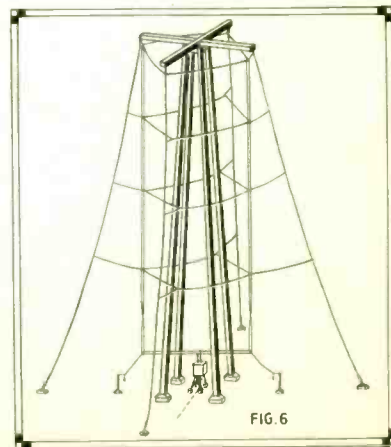
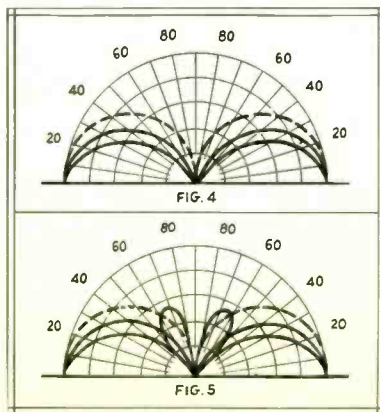
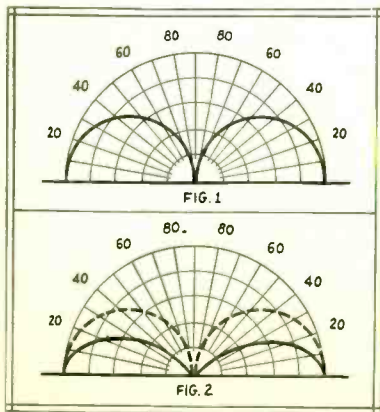

Special antenna used by the German short wave station at Zeesen.

Fading and skip characteristics of various types of transmitting antennas.

# IS THE VARIABLE CONDENSER DOOMED?

● SINCE the earliest days of broadcasting, variable condensers have been used for tuning the necessary circuits in receivers. It is, of course, equally possible to use a fixed condenser and vary the inductance of the coil used, and attempts have been made in various ways to utilize this possibility, says "Wireless Magazine" (London).

No marked success has attended the experiments, however, and the variable-condenser method of tuning has held the field.

## Taken for Granted

If the problem is examined we find there are objections to the present methods. These disadvantages have long been accepted as inevitable, and we have grown accustomed to them.

The fundamental portions of a receiver are the tuned circuits, which are adjusted to resonance with the incoming signals.

The rate of vibration is determined by the inductance of the coil and the capacity of the condenser, and when we tune the circuit we adjust these values so that the natural frequency of the circuit corresponds to that of the oscillations being received.

When this happens a very large amplification of the oscillations takes place, and this enables us to select the signal we require.

As already stated, the customary method is to use a fixed coil and to tune this with a variable condenser, which is a device of which the capacity can be altered according to the setting of the dial. Such an arrangement works and is generally satisfactory, but there are several defects, of which two only need be mentioned as being the most important.

The first is that the voltage produced across the condenser by the signal is dependent upon the value of the condenser. As the capacity is increased the voltage developed falls off considerably. Since it is this voltage across the condenser which we utilize by applying it to a tube amplifier or detector, it means that the sensitivity of the receiver is not constant, but

falls off as we increase the condenser capacity.

Readers will be familiar with this effect. Almost every receiver in common use today is more lively at the bottom end of the tuning scale, and we have to bring up the sensitivity with regeneration or by other suitable means as we increase the setting of the tuning condenser.

As a logical, though not very obvious, development of the same idea we must remember that the selectivity of the circuit is not constant. We obtain our best selectivity when the capacity is large, which is not where we want it.

If we can use a fixed condenser and vary the inductance, then the defects are remedied to a large extent. If we can arrange that the ratio of the inductance to the resistance of the coil is approximately constant, both the sensitivity and the selectivity are uniform over the whole scale. Unfortunately the methods adopted for varying the inductance do not comply with this condition.

From time to time radio engineers have attempted to eliminate the variable condenser as a tuning device, and to use other means. Most of the substitutes have been failures, but here is an idea that promises to develop into something really useful and practical.

The simplest form of variable inductance is the variometer, in which one coil is rotated inside another. In the position of maximum inductance the two coils are in the same direction as each other, whereas in the reverse position they oppose each other, giving us a very much smaller inductance, and a continuous variation is obtained between these two extremes.

It is clear that with this arrangement the effective resistance does not change appreciably over the whole

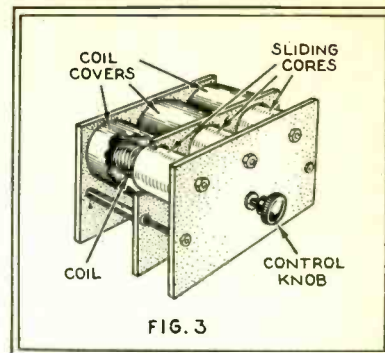

FIG. 3

How a three-coil unit with ganged control could be arranged.

scale, whereas we require the resistance to decrease as the inductance decreases.

Now it is well known that if an iron core is inserted in a coil the inductance increases considerably. The increase in inductance, however, is only marked at low frequencies, and when we deal with very rapidly oscillating currents, such as those in a radio set, we find the variation of inductance becomes almost negligible. What is more, the losses due to circulating currents set up in the iron are very heavy and render such a system impracticable under normal conditions.

Attempts have been made to overcome these disadvantages, with some degree of success, by using very thin sheets of iron only 1,000th of an inch thick but, even so, the performance was not entirely satisfactory.

More recently the British Post Office designed a form of iron which was distinctly more successful. This consisted of very finely powdered granules of iron compressed under hydraulic pressure to form a semi-solid block. Even this, however, was not as good as was desired owing to the difficulty of obtaining really finely divided iron.

Two American scientists, Polydoroff and Johnson, have found a method of obtaining iron powder in such fine granules that it will float in the air. The particles are only about 14-1,000ths of an inch in diameter. This, in itself, is not sufficient, however.

The losses due to the iron are caused by circulating currents which flow in the mass of the iron itself. These can only be limited if the volume of iron within which they circulate is restricted.

These two inventors have devised a method of spraying the particles with varnish to an almost infinitesimal thickness so that each one is individually insulated from its neighbour. They then use this powdered iron mixed with a little bakelite powder to form a moulded product which is quite solid and which is, in fact, about 29 per cent iron by weight.

Due to the isolated nature of the individual particles, however, it does not behave like a metal at all, but lies intermediate between metals and insulators. Consequently very little circulating current is produced in the

(Continued on page 247)

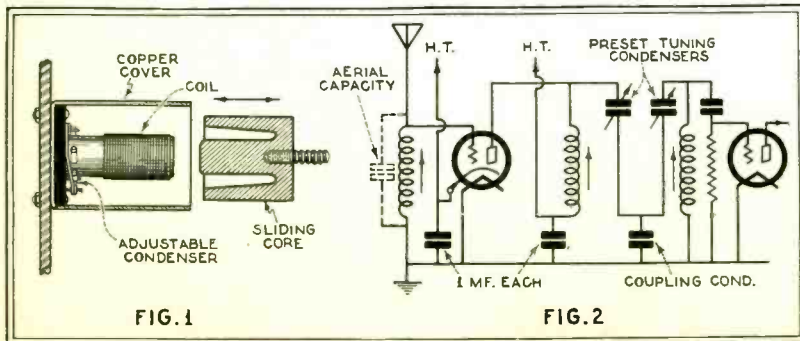

Fig. 1: How the sliding core fits over the tuning coil.  
Fig. 2: Suggested circuit for the new tuning devices.



# LOCATING METAL PIPES BY RADIO

Novel method of using radio receivers is accurate but simple and saves considerable time. It makes use of the signals transmitted by ordinary broadcasting stations.

● HAVE you ever had occasion to dig for, or to pay somebody else to dig for, a lost water-pipe or gas-pipe in the road or in the grounds round your house?

There is a simple way of finding a lost water-pipe, gas-pipe, metal sewer, or, in fact, a metal pipe of any description, and that is by the use of radio, says E. H. Chapman in "Wireless Magazine" (London).

Although there may be a good deal of doubt as to whether metallic-ore bodies at depths of a few hundred feet can be found by wireless waves, there is absolutely no doubt whatever that metal pipes a few feet in the ground can be located, to an inch, one might almost say, by radio.

Experimenters who are familiar with direction-finding apparatus are aware that a mass of metal buried in

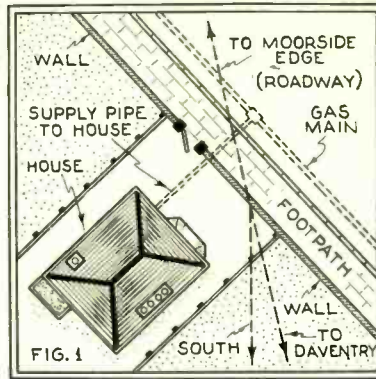

Plan showing position of gas main in roadway outside of house.

The first attempt to observe the difference in reading of the apparatus between a normal position and a position over the gas-pipe was made with the apparatus tuned to the North Regional transmitter. The normal position is shown as position 1 in the plan of Fig. 1, and the position over the pipe is shown as position 2. The readings were as in Table I.

We have in Table I a somewhat remarkable result. With this piece of wireless apparatus, the received strength of the North Regional transmitter, forty miles away, is increased four times by placing the apparatus over a buried gas-pipe.

The swinging of the readings in three out of the four sets of readings given in Table I was due to the fact that the observations were taken within the half-hour before sunset.

Table II

	North Regional	Midland Regional	North National
Normal position 1	20 14 10	30 19 10	44 27 17
Over pipe, position 2	67 56 42	63 38 23	82 63 41

The next readings to be taken with the apparatus were taken in the afternoon and early evening on the three transmissions—North Regional, Mid-

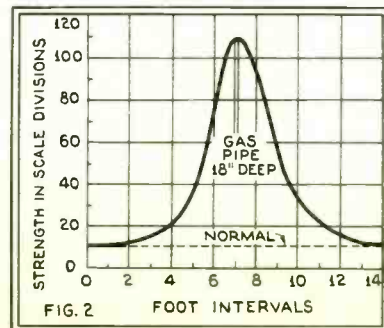

This curve graphically illustrates the great increase in signal strength obtained when the receiving apparatus passed over the buried gas pipe.

land Regional, and North National. These readings are given in Table II.

It is perhaps necessary to explain that the readings were made with the apparatus adjusted to different degrees of sensitivity, or, as we should say in wireless, to different degrees of amplification. This varying degree of sensitivity is one of the valuable features of the apparatus, and one which makes it suitable for numerous purposes in work of this kind.

Now there is one very striking point about the readings given in Table II. For the North Regional transmission the readings over the pipe are roughly four times the readings in the normal position. For the North National transmission, the readings over the pipe are roughly two and a half times the normal readings.

The Midland Regional readings are scarcely comparable with the readings for North Regional and North National, for the Midland Regional transmitter is much more distant and, moreover, has only half the power of the other two transmitters.

From Table II it is clear that the effect of a buried pipe is greater the longer the wavelength of the transmission used. Accordingly, in the next observations made with the apparatus, the Daventry National transmission was used.

The readings obtained on this transmission were quite astonishing. In the normal position, the reading of the galvanometer was 11 scale divisions. Over the pipe the reading was 110 scale divisions, that is, ten times as great as the reading in the normal position. It sounds almost incredible, but nevertheless it is true.

With this simple piece of apparatus, the strength of Daventry National is increased ten times by the mere placing of the apparatus over a buried gas-pipe.

Table III

Over Footpath	Pipe	Over Road
11 11 12 15 21 35 78	110	82 50 30 22 15 12 13

So interesting were these Daventry National figures that a series of readings were taken across the road at intervals of one foot, the pipe being crossed at right angles. The readings are given in Table III.

The observations given in Table III are illustrated graphically in Fig. 2. It should be noted that the effect of the pipe is felt for distance of 4 ft. either side of it.

As a further test, the apparatus was taken to a road under which one of the main pipes of the Derwent Valley Water Board passes. This pipe is of 45 in. diameter and it is buried at a depth of 42 in. to the top of the pipe. The pipe runs almost in the direction of Daventry.

With the apparatus tuned to Daventry National and set to the same degree of sensitivity as when the readings of Table III were taken, the observations of Table IV were made.

(Continued on page 252)

Table I

	First adjustment	Second adjustment
Normal position on footpath	10 10	11 15-18
Over pipe	45 42-44	43-47 60-65

the ground may cause large errors in the compass bearings taken of distant stations.

Direction-finding apparatus may well be used to locate pipes in the ground, or even shallow ore bodies for that matter, but the results obtained would not be quite so precise as those which can be obtained with other apparatus.

In the application of wireless methods to the location of ore bodies in the earth's crust, there are several very difficult problems. The most difficult is the problem of penetration. How far does a wireless wave penetrate into the ground over which it travels?

While working on this difficult problem of penetration, I built a piece of wireless apparatus by means of which a buried pipe could most easily be located.

Briefly, the apparatus consists of a carefully shielded loop aerial, a stage of high-frequency amplification using a screen-grid tube with transformer coupling, and a specially designed type of tube voltmeter.

The actual measuring instrument is a sensitive galvanometer, the dial of which is divided into 120 equal scale divisions. The whole of the apparatus is assembled in portable form.

Fig. 1 is a plan showing the position of a galvanized-iron gas-pipe in the road outside my house. This pipe is of 2 in. diameter and it is buried at a depth of 18 in.

The actual geographical direction of the pipe is 35 degrees east of south. The direction of Daventry is 15 degrees east of south, and the direction of Moorside Edge is almost exactly opposite, namely 15 degrees west of north. It will be seen, therefore, that the waves from the four transmitters—Daventry National Midland Regional, North Regional and North National—all cross the pipe at the same angle, 20 degrees.



# RADIO TUBES AND HOW THEY WORK

If you have been confused by the recent avalanche of new tubes, read this clear explanation of tube theory and you will have no further trouble. No mathematics -- just plain English.

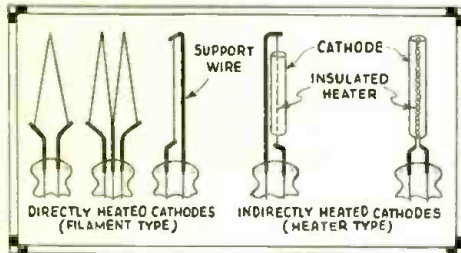

Left: three types of tube filaments. Right: two types of indirectly heated cathodes.

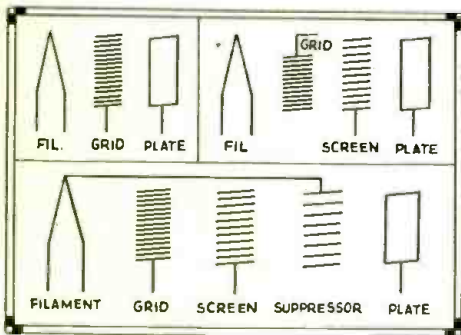

Top left: the "triode" or three-element tube. Top right: the "tetrode" or four-element tube. Bottom: the "pentode" or five-element tube.

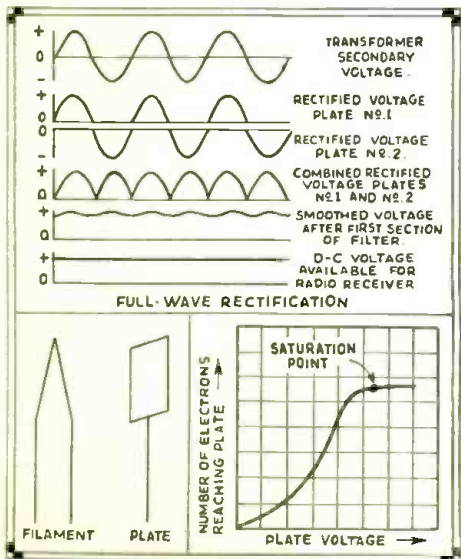

Top: curves illustrating rectifying action. Bottom left: the "diode" or two-element rectifier tube. Bottom right: Curve showing saturation effect.

● THE radio tube consists of a cathode and one or more additional electrodes—all enclosed in an evacuated glass bulb—with their electrical connections brought to exterior terminals. The cathode supplies electrons while the other electrodes control and collect them, explains "The Cunningham Tube Manual."

All matter exists in the solid, liquid, or gaseous state. These three forms of matter consist entirely of minute divisions known as molecules. Molecules are assumed to be composed of atoms. According to a present accepted theory, atoms have a nucleus which is a positive charge of electricity. Around this nucleus revolve tiny charges of negative electricity known as "electrons." Scientists have estimated that these invisible bits of electricity weigh only 1/46 billion, billion, billion, billionths of an ounce since they may travel at speeds of thousands of miles per second.

Electron movement may be accelerated by the addition of energy. Heat is one form of energy which can be conveniently used to speed up the electron. For example, if the temperature of a metal is gradually raised, the electrons gain velocity. When the metal becomes hot enough to glow, some electrons may acquire sufficient speed to break away from their nuclei. This action is utilized in the radio tube to procure the necessary electron supply.

## Cathodes

A cathode is an essential part of a radio tube since it supplies the electrons necessary for tube operation. In general, heat is the form of energy applied to the cathode to release the electrons. The method of heating the active material of the cathode may be used to distinguish between the different forms of cathodes. For example, a directly-heated cathode, or filament-cathode, is a wire heated by the passage of an electric current. An indirectly-heated cathode, or heater-cathode, is an assembly of a filament, or heater, enclosed in a metal sleeve. The sleeve carries the active material on its outside surface and is heated by radiation and conduction from the heater.

A filament-, or directly-heated cathode, may be further classified by identifying the filament or electron emitting material. The materials in regular use are, tungsten, thoriated-tungsten, and metals which have been coated with alkaline earth oxides. Tungsten filaments are made from pure metal. Since they must operate at high temperatures (a dazzling white) to emit sufficient electrons, a relatively large amount of filament power is required. Thoriated-tungsten filaments are drawn from tungsten slugs which have been impregnated with thoria. Due to the thorium, these filaments liberate electrons at a more moderate temperature (a bright yellow) and are, therefore, much more economical of filament power than are pure tungsten filaments. Alkaline earths are usually

applied by coating a nickel alloy wire or ribbon with a mixture containing the materials. This coating, which is dried into a substantial layer on the filament, requires only a very low temperature (a dull red) to produce a copious supply of electrons. Coated filaments operate very efficiently and require relatively little filament power.

Filament-cathode types of tubes are particularly well suited for operation from a steady source of filament supply voltage such as a battery. Tubes for this service can be designed with cathodes which give economical production of electrons and, consequently, economical set operation. Tubes constructed primarily for economical battery operation are not very satisfactory for use with alternating current filament supply, due to the variation in electron emission and potential in the space charge region which occurs with each alternation of the current. This variation is amplified by the tube and produces hum in the loudspeaker. When filament-cathode types of tubes are to be used on a-c filament supply, special precautions are taken in the design to reduce hum disturbances to a point where the hum will not be troublesome. These precautions include such features as the utilization of massive filaments which minimize temperature fluctuations, the use of filaments which have sufficient excess electron emission so that a very large temperature change is required to reduce the emission below the value needed for normal tube operation, and the proportioning of tube parts to minimize the electrostatic and magnetic effects produced by a.c. on the filament. The '26 is an example of a filament-cathode type of tube particularly useful for operation on a.c.

## Heater Tubes

Heater-, or indirectly-heated cathodes, comprise an assembly of a thin metal sleeve coated with active material and a heater contained within and separated from the sleeve. The heater is made of tungsten wire and is used only for the purpose of heating the sleeve and its coating to an electron-emitting temperature. The tungsten wire is operated at a moderate temperature and supplies the energy for heating the sleeve.

The heater-cathode construction is well adapted for use in radio tubes intended for operation from a-c power lines. The use of separate parts for emitter and heater functions, the electrical insulation of the heater from the emitter, and the shielding effect of the sleeve may all be utilized in the design of the tube to prevent the a-c heater supply from causing hum. Representative types are the '24-A, '27, and '35. From the viewpoint of circuit design, the heater-cathode construction offers advantages in connection flexibility due to the electrical separation of the heater from the sleeve and active cathode surface. This feature, in conjunction with the freedom from electrical disturbances which might be introduced through the fila-



ment supply lines, has led to the use of this construction in a series of tubes ('36-'39) designed particularly for automobile or d-c line radio sets.

#### Diodes

The simplest form of radio tube contains two electrodes, a "cathode" and a "plate" and is often called a "diode," the family name for two-electrode tubes.

The electrodes are enclosed in a bulb with the necessary connections brought out through air-tight seals. The air is removed from the bulb to allow free movement for the electrons and to prevent injury to the emitting surfaces. When the cathode is heated, electrons leave the cathode surface and form an invisible cloud in the space around it. Any positive electric potential within the evacuated bulb will offer a strong attraction to the electrons (unlike electric charges attract; like charges repel). In a diode, the positive potential is applied to the second electrode, known as the anode. The potential is supplied by a suitable electrical source connected between the plate terminal and a cathode terminal. Under the influence of the positive plate potential, electrons flow from the cathode to the plate and return through the external plate battery circuit to the cathode, thus completing the circuit. This flow of electrons is known as the plate current and may be measured by a sensitive current meter.

#### One-Way Flow

If a negative potential is supplied to the plate, the free electrons in the space surrounding the cathode will be forced back to the cathode, and no plate current will flow. Thus, the tube permits electrons to flow from the cathode to the plate but not from the plate to the cathode. If an alternating voltage is applied to the plate, the plate is alternately made positive and negative. Plate current flows only during the time when the plate is positive. This phenomenon makes the tube useful as a rectifier of alternating current, that is, to provide a current flow always in the same direction. Rectifying action is utilized in a-c receivers to convert a.c. to d.c. for supplying "B," "C" and screen voltages to the other tubes in the receiver circuit. Rectifier tubes may have one plate and one cathode. The '81 is of this form and is called a half-wave rectifier, since current can flow only during one-half of the alternating-current cycle. When two plates and one or more cathodes are used in the same tube, current may be obtained on both halves of the a-c cycle. The '80 is an example of this type and is called a full-wave rectifier.

Not all of the electrons emitted by the cathode reach the plate. Some return to the cathode while others remain in the space between the cathode and plate for a brief period to form an effect known as space-charge. This charge has a repelling action on other electrons which leave the cathode surface, and impedes their passage to the plate. The extent of this action and the amount of space-charge is greatly dependent upon the cathode temperature and the plate potential. The higher the plate potential, the less is the tendency for the space electrons remaining to repel others. This effect

## "RADIO CITY" PLAQUE

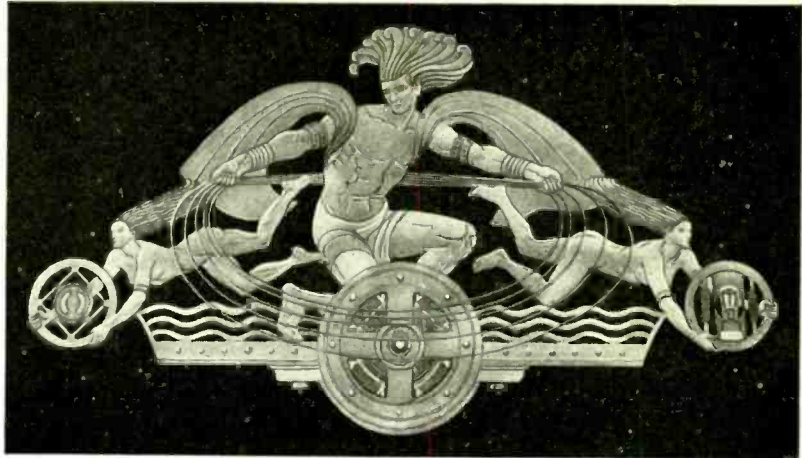

● THE largest of the decorative metal plaques which will form a part of the extensive ornamental scheme for Rockefeller Center, New York, was set in place on the north wall of the Radio-Keith-Orpheum sound motion picture theatre during the month of October, 1932.

It is a brilliantly colored metal and enamel piece 18 feet wide and 35 feet long, one of four designed by Miss Hildreth Meiere, American artist and first vice president of the National Society of Mural Painters.

In keeping with the central beautification theme symbolizing some of the moving forces in modern civilization, the rectangular plaque is intended to represent radio and television encompassing the earth. Three circular pieces by Miss Meiere being set in the

walls of the International Music Hall are each 18 feet in diameter and represent the spirit of song, dance and the drama. The artist's designs were executed by Oscar B. Bach.

The plaques are said to be the largest of their type and represent the first use of this form of decoration on a pretentious scale on a building exterior.

Officials of Rockefeller Center explain that they are intended to form a "striking relief from the usual severe wall surfaces of theatre buildings."

The plaques are centered about sixty feet above the street level, and are among the first of the decorative works to be completed for the Rockefeller buildings.

may be noted by applying increasingly higher plate voltages to a tube operating at a fixed cathode voltage. Under these conditions, the maximum number of available electrons is fixed, but increasingly higher plate voltages will succeed in attracting a greater proportion of the free electrons.

Beyond a certain plate voltage, however, additional plate voltage has little effect in increasing the plate current because all of the electrons emitted by the cathode are being drawn to the plate. This maximum current is called saturation current, and because it is an indication of the total number of electrons emitted, it is also known as the emission current, or, simply, emission.

If space-charge effects were not present, it follows that the same electron flow could be produced at a lower plate voltage. One method of reducing the space-charge effect is utilized in several types of rectifier tubes, represented by the mercury vapor rectifier 82. This tube contains a small amount of mercury which is partially vaporized when the tube is operated. The mercury vapor consists of tiny mercury atoms permeating the space inside the bulb. These atoms are bombarded by the electrons on their way to the plate. If the electrons are moving at a sufficiently high speed, the collisions will tear off electrons from

the mercury atoms. When this happens, the mercury atom is said to be "ionized," that is, it has lost one or more electrons and, therefore, is charged positive. When ionization due to bombardment of mercury atoms by electrons leaving the filament occurs, the space-charge is neutralized by the positive mercury ions so that increased numbers of electrons are made available. A mercury vapor rectifier has a small voltage drop between cathode and plate (about 15 volts.) This drop is practically independent of current requirements up to the limit of emission of electrons from the filament but is dependent to some degree on bulb temperature.

#### Triodes

When a third electrode, called the grid, is placed next to the cathode, the tube is known as a "triode." This is the family name for three-electrode types. The grid usually consists of a wire mesh or grating, the appearance of which suggests its name. Its construction allows practically unobstructed flight of the electrons from the cathode to the plate.

When the grid of a tube is made positive or negative with respect to the cathode, the plate current correspondingly increases or decreases. The grid is located much nearer the cathode than the plate, so that a small

(Continued on page 250)



# MAKE YOUR OWN ELECTRIC MUSIC!

With the aid of this simple and easily constructed local oscillator, "beating" against an oscillating receiver, you can have loads of fun. Build it in less than an hour's time.



In accordance with our policy of building up worthwhile instruments described in foreign magazines, we present herewith an American version of an electric music device of the Theremin type. The parts required are inexpensive and readily obtainable, as they are of standard domestic make. The oscillator has been tested thoroughly and produces interesting results.

● AT the Berlin Radio Show, held a few months ago, considerable interest was displayed by visitors in electrical musical instruments, among which were electrical pianos and oscillators of the Theremin type. Instruments of the latter type have been made and sold commercially in the United States, but have not achieved much popularity because of their high cost.

The amateur constructor who wants to enjoy some interesting experiments can easily make a small oscillator of the Theremin variety, using spare parts. This will operate on either A.C. or D.C. without change in connections. The diagram on this page shows the hook-up, which is simple in the extreme. All the parts are mounted on a wood baseboard measuring 7½ by 11 inches.

This instrument is nothing but an oscillator with an upright brass rod twenty inches long acting as a radiator of the generated radio frequency energy. With the coil and the condenser specified and shown in the illustrations, the oscillations fall in the broadcast band. If the device is then placed near a broadcast receiver which can be made to oscillate, or at least regenerate very strongly, and the tuning knobs of both instruments adjusted, a heterodyne squeal will be heard from the loud speaker in the receiver. The pitch or frequency of the squeal will depend on the arithmetical difference in frequency between the oscillator and the receiver, and will further be varied by the presence of a person's body or hands near the sensitive radiating rod.

The trick of obtaining variable hetero-

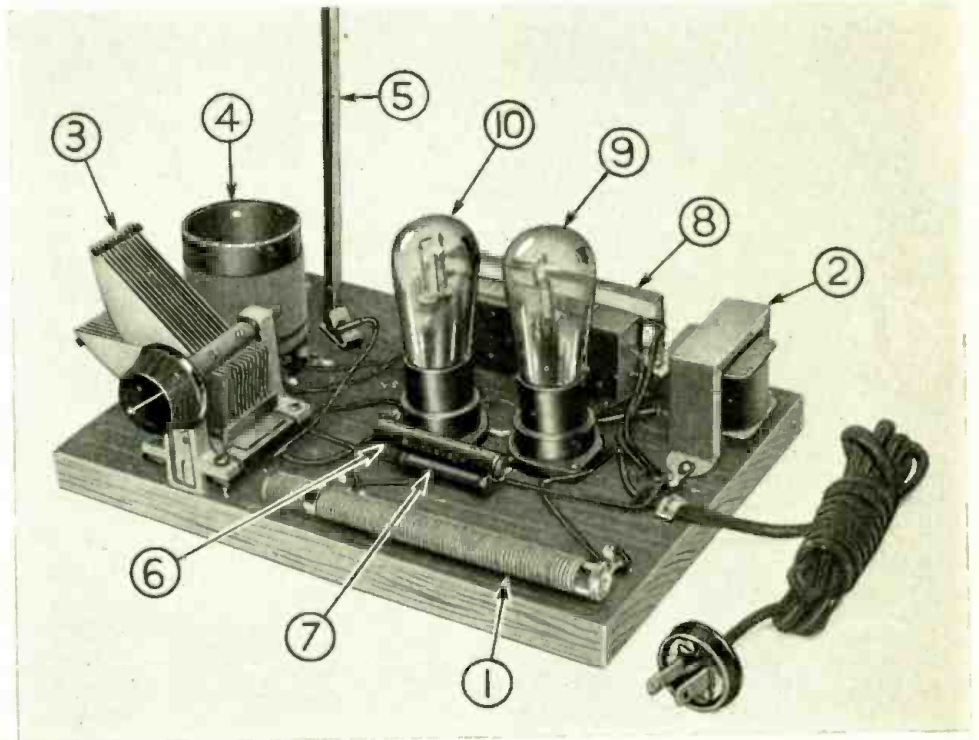

Above: parts of the oscillator: 1) 360 ohm resistor. 2) audio choke. 3) tuning condensers. 4) oscillator coil. 5) rod radiator. 6) .1 mf. condenser. 7) 2,000 ohms. 8) filter condenser. 9, 10) tubes. Below: full schematic diagram. This oscillator was described originally in "Basstetbriefe" (Dusseldorf).

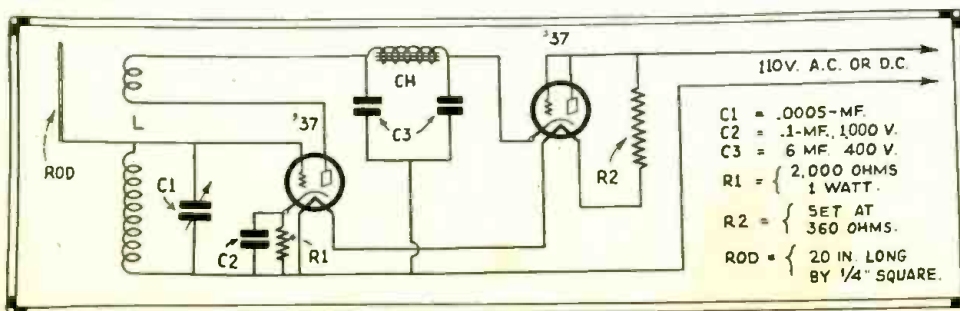

dyne whistles that sound like music then depends on how you wiggle hands and fingers around or near the rod. A fluttering motion is necessary in order to simulate musical tones. Of course every radio fan will recognize the phenomenon as nothing more than old fashioned "hand capacity," against which elaborate precautions are taken in all present day radio receivers.

If the broadcast receiver is pretty well shielded, you may find it necessary to place the "Theremin" quite close to it, or to bring the aerial wire near the rod. If the receiver is of the screen grid type and cannot be forced into self-oscillation even with the volume control fully advanced, tune in a strong broadcast station and adjust the oscillator condenser

(Continued on page 248)



# A TWO TUBE 7 METER RECEIVER

Here is a simple but effective little set for ultra-short-wave television and telephone reception. It is of the straight regenerative type, which means it is quiet and easy to operate. Only a few parts are needed.

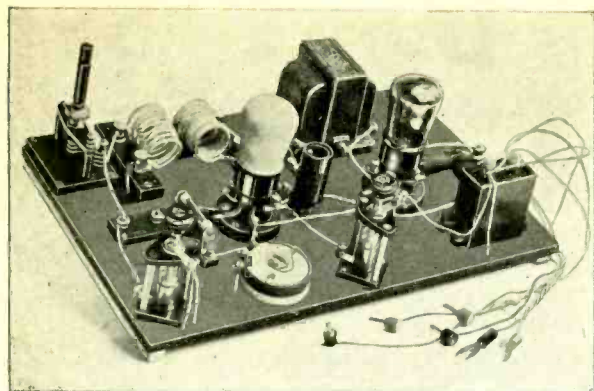

This "breadboard" model shows the open arrangement of the parts. The tuning condensers, along the front edge, are midgets of the sliding tube type. Regular plate condensers may be used.

● A receiver for use on the "quasi-optical" waves is quite easy to handle, says *Amateur Wireless* (London). A glance at the schematic diagram will prove how inexpensive the construction of a suitable two-tube receiver will be. Readers may possibly wonder why we have chosen a conventional "detector and audio-frequency" receiver. Considering the various possibilities we find there are three workable alternatives:

1. A super-het.
2. A standard screen-grid three receiver.
3. A simple detector and audio frequency arrangement.

A super-het is inclined to be unstable and somewhat difficult to handle on wavelengths below 10 metres. Furthermore the average amateur will agree that the cost entailed would not be worth while, considering the restricted nature of the transmissions at present available.

A screen-grid three would have been quite satisfactory except that no appreciable amplification would have been obtained from the screen-grid tube on such high frequencies and, beyond giving selectivity, the tube would have been a passenger.

The receiver arrangement finally selected has proved itself to be very

satisfactory and has the advantage that it can be assembled for a very small sum.

In a number of cases the constructor will probably have many of the components on hand. The coils, which are usually a very expensive item in the construction of a receiver, can in this case be made for a few cents.

Variations in tube capacity will vary the wavelength range of the coils, so in some cases it may be advisable for the reader to experiment a little with the number of turns employed. The coils used in this receiver were constructed in the following manner:

Grid coil, eight turns of No. 16 d.c.c. wire (approximately 25 in.) wound tightly round a 1-in. form. The regeneration coil is wound in a similar manner, except that it has sixteen turns of No. 16 d.c.c. wire, approximately 50 in. in length. The sixteen turns are unspaced.

When the coils are removed from the winding form, they will spring out to about 1 1/4 in. in diameter.

It is best to measure the exact length of wire for each coil to avoid making a mistake in the inductance.

Before starting to wind the coils, clamp one end of the wire in a vice and stretch it until it is quite straight. Then cut off 25 in. and wind this

tightly round the 1-in. form, evenly spacing the turns. The coil should be arranged to accommodate itself for length between the terminals on the coil block.

These coil blocks consist of a strip of bakelite or hard rubber 3 1/2 in. by 3/4 in. by 3/4 in., the terminals being spaced approximately 1 1/2 in. apart.

The grid coil, when tuned with the specified "neutralising" condenser, will tune between 5.5 and 8.8 metres. Both the tuning and the regeneration condensers have a minimum capacity of 1.5 micromicrofarads and a maximum capacity of 20 micromicrofarads.

The condenser in series with the aerial is of a different type from the tuning condenser and has a maximum capacity of 50 micromicrofarads.

It must be clearly understood that this receiver is very sensitive to aerial damping and an aerial having a total length of 15 to 20 ft. will be ample. Any increase over this length will not make any improvement in the results obtained and may cause the receiver to stop oscillating.

If any difficulty is experienced in obtaining satisfactory oscillation, this can easily be overcome by adjusting the series aerial condenser towards its minimum position.

(Continued on page 252)

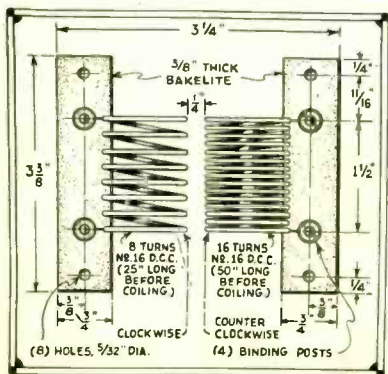

Above: details of the "wound on air" coils used in the 7 meter receiver. Right: full schematic diagram. Note that regeneration is obtained by a shunt tickler system, with condenser B controlling the feedback action.

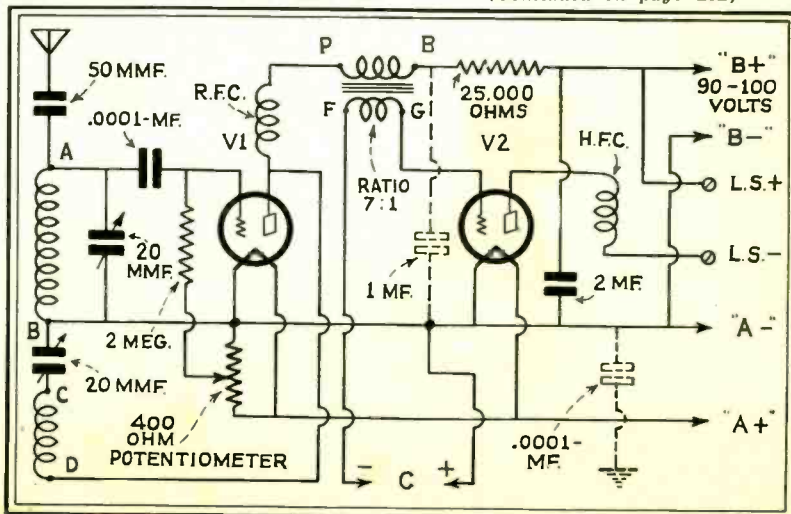



# A ONE TUBE D. C. SET THAT OPERATES A LOUD SPEAKER



Residents of D. C. districts have long felt that they have been neglected by radio designers. There have been hundreds of good A. C. circuits, but few good D. C. circuits. Here is a novel D. C. receiver that uses only one tube, yet works a loud speaker with surprising volume. This is another "built-to-order" special presented by RADIO REVIEW & TELEVISION NEWS.

● DIRECT Current electric sets have not received much attention from set designers. This has left a wide field of experimentation open to the fellow residing in sections where this is the only current available. Here is a one tube receiver, suggested by "Radio Welt" (Vienna) that will give satisfactory results on local signals, cost about .3 cent per hour to operate and has a dynamic speaker.

These results are made possible by the choice of the type 38 power pentode. A coil and a tuning condenser with a minimum of losses, plus regeneration, give surprising results. A dynamic speaker is used as this type of speaker was found more satisfactory on three counts: freedom from rattle, ability to approximately match the plate impedance of the pentode and greater sensitivity for such a small speaker.

A modernistic treatment of the simple front panel provides an attractive appearance without a complete, expensive cabinet and the small over-all size permits its use in any room of the house. It is an ideal set for those living in hotels, where a tremendously loud signal is a source of disturbance. As all of the more popular programs are sent over the chains it is not necessary to have a receiver with distance getting ability to enjoy the program you like.

In general, this receiver should be used with an antenna 75 to 100 feet in length. Longer antennas can be used with a material increase in volume. Care should be used in tuning this set as far as the regeneration control is concerned to prevent radiation when the set is oscillating.

Note that no provision is made for grounding the set. The ground is obtained when the set is plugged into the lighting socket. The 200 volt condenser in series with the antenna coil primary will serve as a guard, preventing shorts and burn-outs if the antenna is grounded by accident.

Lay out the front panel and the base board as shown in the illustrations and give all wooden surfaces a coat of stain. This will improve the appearance a great deal. Use a small piece of silk cloth to cover the front of the speaker, to give a finished look.

Mount the tuning assembly, power switch and tuning coil on the front panel as shown in the photographs. Mount the speaker with through bolts. This will give a more sturdy construction as the front panel is not made of thick wood. The rest of the parts are mounted on the base-board and can be fastened down with wood screws after the front panel has been fastened to the base.

Right: inside view of the One-Tube D.C. Special. 1) loud speaker. 2) three-circuit tuner. 3) tuning condenser. 4), 6) filter condenser. 5) filter choke. 7) series resistor. 8) grid leak. 9) antenna condenser. 10) tube. 11) grid condenser. 12) speaker bypass condenser.

Below: schematic diagram of the entire receiver.

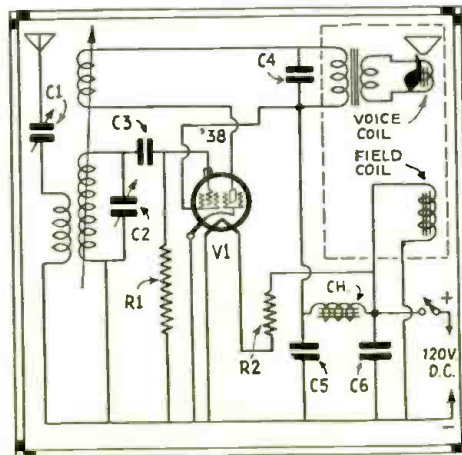
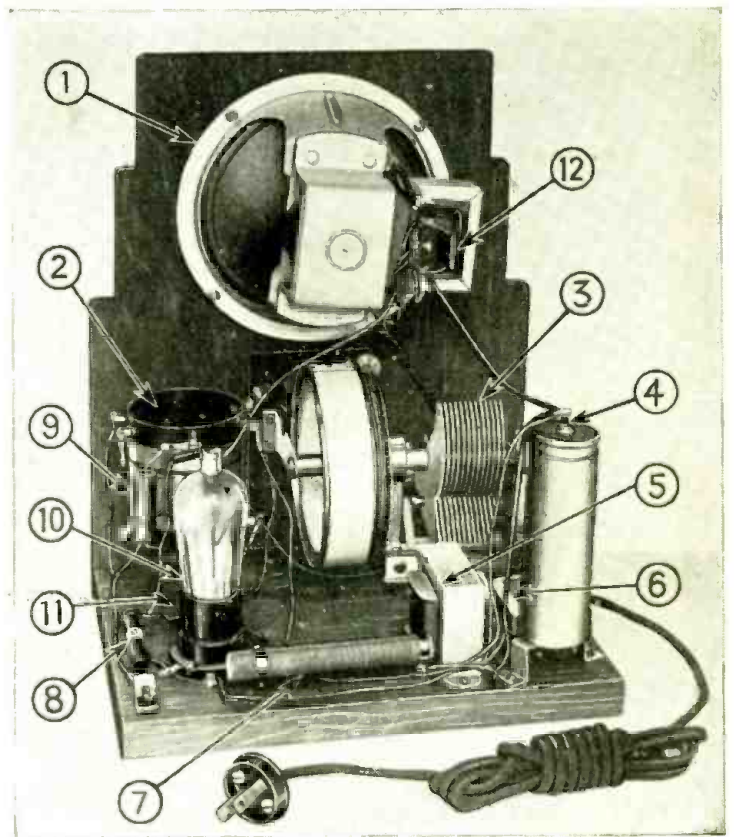

Place all parts in position, fasten firmly and solder all connections well. The set is so simple that there should be no difficulty for the builder to complete the job in jig time.

Be sure and place the speaker field in the circuit so that the field is directly across the line after the power switch. Do not connect the field so that the current required for its operation will flow through the filter choke.

When placing the set in operation allow the tube to heat up for a while. If no signals are heard when the tuning dial is rotated then reverse the power plug. Do not leave the power on too long when the polarity is not correct (Continued on page 249)



# KINKS FROM ABROAD THAT YOU WILL FIND USEFUL

## Remote Volume Control

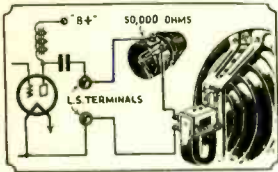

A very convenient form of volume control, which may either be mounted on the set itself or carried on an extension to another room, is that operating on the loud speaker itself. Provided the rest of the set is working satisfactorily, control in this manner is perfectly satisfactory.

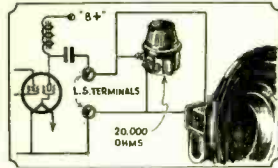

Two methods may be employed. If the output tube is of the three electrode type, the volume is controlled by a series resistor in the loud speaker line. It is necessary of course to use an output filter of some kind to keep the local plate current out of the speaker. A value of 50,000 ohms is suitable. With a pentode output tube, use a shunt resistor of about 20,000 ohms, as illustrated.—Amateur Wireless (London).

## Cutting Panels

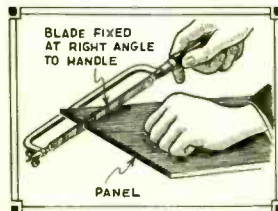

It is sometimes quite a trick to cut a long, narrow strip off a bakelite or aluminum panel. However, the operation becomes quite simple if the blade of an ordinary hack saw is turned at right angles to the frame, as shown in the illustration above. The panel should be clamped along the edge of a table or other firm support (the cellar steps are good for this purpose), so as to avoid all possibility of slipping.—Modern Wireless (London).

## Automatic Grid Bias

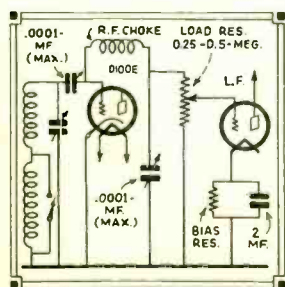

Automatic bias for an indirectly heated audio frequency tube, following a diode detector, may be obtained with the arrangement shown above. The values shown may be varied to suit American tubes and circuits. Note that the "diode" is a triode with only two elements in use. Wireless World (London).

Among these little kinks, gathered from numerous foreign radio magazines, you may find a time or money saving suggestion that will pay your cost of this issue several times over. Read them and save them! They may be useful in the future.

## Loud Speaker Filter

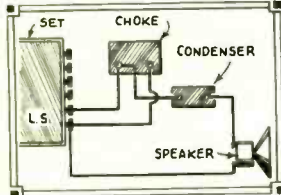

The value of a filter of some kind to protect the delicate windings of magnetic speakers cannot be over-emphasized. The sketch above shows how a simple filter consisting of a 30 henry choke and a 2 mf. fixed condenser can be added to a receiver not already equipped with such a protective device. Note that the choke is connected to the two binding posts on the receiver that normally take the loud speaker tips. With this hookup no direct current enters the speaker.—Modern Wireless (London).

## Efficient Wave Trap

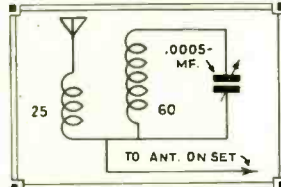

Don't overlook the simple wave trap as a means of eliminating interference from a strong local or nearby station. Such a trap is easily made by winding 25 and 60 turns of No. 24 or 26 cotton covered wire on a three-inch form, with a space between of 1/4 inch. Both coils are in the same direction. The large coil, the secondary, is shunted by a .0005 mf. variable condenser. The other connections are made as indicated in the circuit above. If the trap is tuned to the wavelength of the interfering station, the latter will be eliminated.—English Mechanics (London).

## Hydrometer Protection

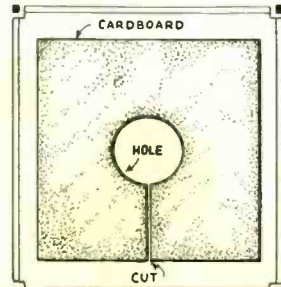

The tubular construction of practically all hydrometers makes them something of a nuisance around the radio room, as they are continually rolling off tables and damaging themselves. A simple preventive is a square piece of heavy cardboard or fiber, cut as shown in the sketch. Merely bend this around the barrel of the hydrometer and you will not experience trouble again.—Amateur Wireless (London).

## Holding Round Drills

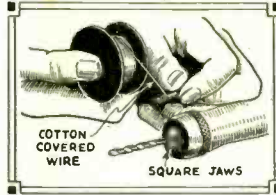

A round peg in a square hole! Sounds impossible, but it isn't if you want to use an ordinary round shank twist drill or countersink in the jaws of a brace. Simply wind some cotton covered wire of any size between No. 26 and 20 over the shank of the drill. Tie the ends so that they won't unravel and then rug the drill in the brace chuck. You will find that the latter "bites" into the wire and holds the drill very firmly.—Modern Wireless (London).

## Selectivity Adjustment

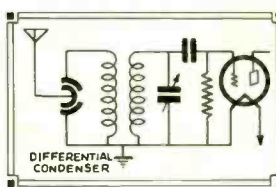

Don't regard the volume control as nothing but a loudness adjustment. Many pre-detector controls also affect the selectivity to a large extent, and are therefore to be avoided. To turn things around, it is sometimes possible to design a selectivity control that will also control volume. The arrangement in the hookup above is worth trying in this connection. The differential condenser is the kind that has one rotor meshing into two opposing stators.—Modern Wireless (London).

## Handling Threaded Rod

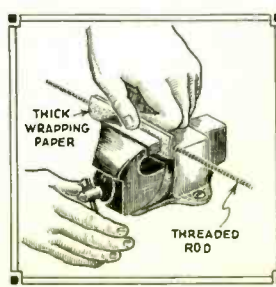

Every radio constructor who has used threaded rod has experienced difficulty in preventing the threads from becoming stripped or flattened by the jaws of the vise when a length of rod is being cut. To get around this trouble, wrap the rod in several thicknesses of heavy wrapping paper, and hold it in the vise as shown. Tighten the jaws only enough to prevent the rod from turning while it is being cut.—Modern Wireless (London).

## Water Pipe Ground

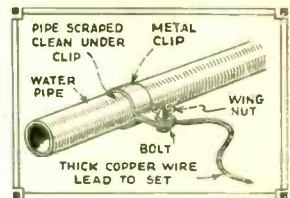

If you find that ordinary ground clamps have a habit of snapping off just when you are getting the strap good and tight, make your own clamp out of a strip of heavy brass, and hold it tight with a heavy bolt and wing nut. Of course do not fail to scrape the pipe bright and clean.—Amateur Wireless (London).

## Novel Indoor Aerial

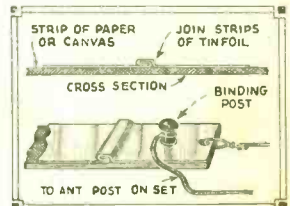

A novel indoor aerial may be made of strips of paper or canvas about 30 feet long, having pieces of tinfoil glued on it to form a continuous chain. The tinfoil from cigarette packages can be used. A lead is attached to one end by means of a screw type binding post.—English Mechanics (London).

## Buried Ground

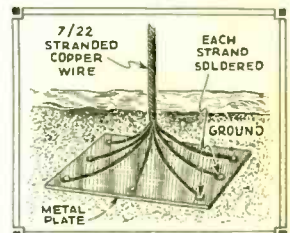

In districts in which the water pipes are very short, or there are no water pipes at all, use a buried ground made as shown above. Bury the plate (copper, brass, galvanized iron, etc.) about three feet under the surface, and pour water over it occasionally.—Amateur Wireless (London).

## New Double Shield

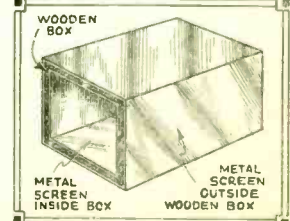

For short wave station monitors and test oscillators, very thorough and complete shielding is important. An effective and cheap shield can be made as shown. The double boxes, of thin aluminum, are very "tight" electrically.—Popular Wireless (London).

# WORLD WIDE HOOK UPS

## THE "APEX 3"

● THE good points of the "Apex 3," as outlined in "Popular Wireless" (London), are as follows: It is inexpensive; it is easy to build; it is compact; it is easy to operate—there are only three panel controls.

As may be seen from the schematic diagram on the right, the circuit comprises one stage of tuned radio frequency amplification, regenerative detector and one audio stage. Although this combination may not sound very impressive to Americans, it really is quite effective.

For battery operation the first tube may be a 32, the detector a 30, and the audio tube a 31. For A.C. operation: a 24 or 35, a 27 and 71A. The connections as shown are for battery tubes, but may readily be modified for A.C. in accordance with standard practice.

The tapped coil and switching arrangement is necessary in Great Britain because of the fact that several important stations broadcast above 1000 meters. For the medium wave range, the bottom sections of the coils are short circuited; on the high wave

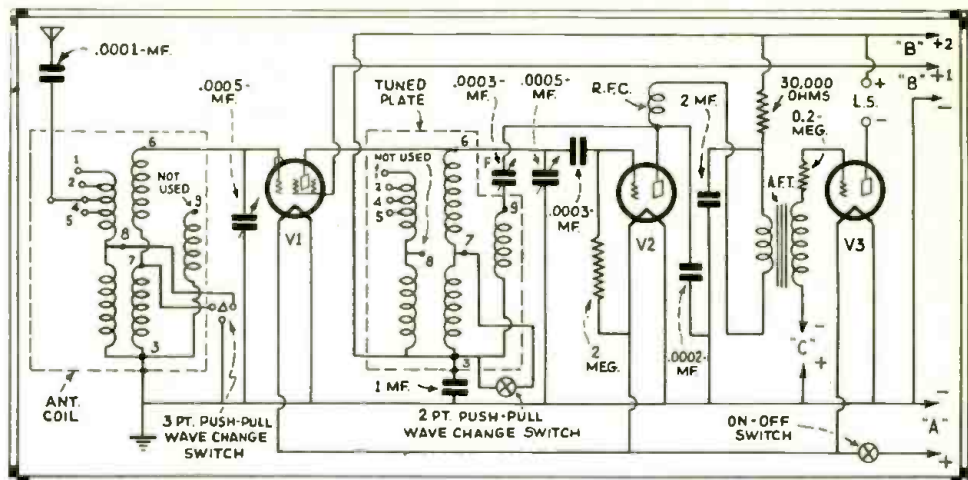

range they are simply thrown in series with the top sections, and thus increase the range of wavelength response. This scheme may furnish American experimenters with a few ideas in the way of wavechanging on the medium short waves, just below the American broadcast band, without the necessity for changing plug-in coils.

Notice that regeneration is obtained by the shunt feed method, coil 9 being the tickler. This method requires a good R.F. choke coil in the detector plate circuit. A poor one, with a lot of distributed capacity, will short circuit the R.F. current through the "B" circuit and prevent regeneration from taking place.

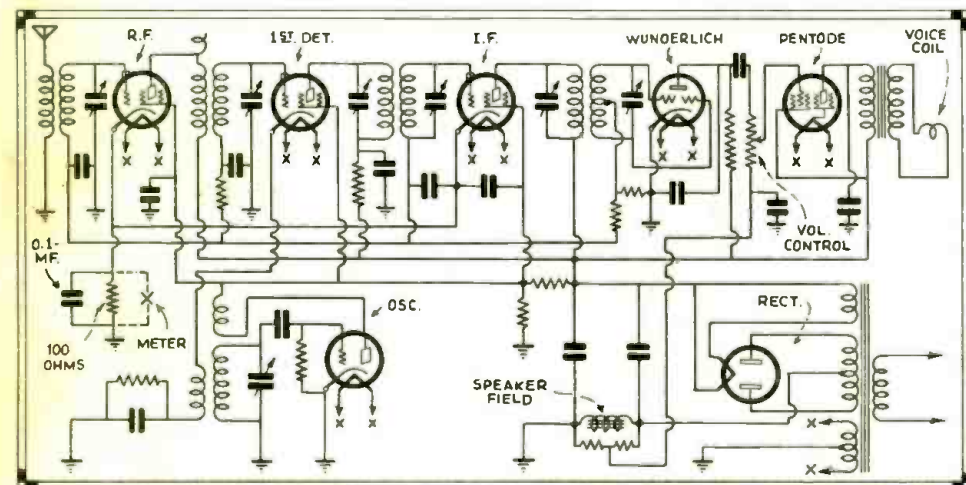

## DOUBLE ACTING VOLUME CONTROL

● THE essentials of a very effective continuous volume control arrangement is shown diagrammatically at the right; the volume-regeneration regulating potentiometer is so connected that it both controls the aerial input and the extent of feed-back.

This system is not difficult to understand; if it be imagined that the potentiometer slider is at the end of the resistance marked X, it will be realized that the aerial is virtually short-circuited to ground, and, further, by tracing out the regeneration circuit from the plate of the detector tube, it will be seen that the maximum available amount of resistance is in series with this circuit. Thus it follows that regeneration effects are also at minimum.

As the potentiometer slider is moved towards the end of the resistance ele-

ment marked Y, the aerial short-circuited is progressively removed, and simultaneously an increasing amount of R.F. energy is allowed to pass from the detector plate through the regeneration coil and back to ground.—"Wireless World" (London).

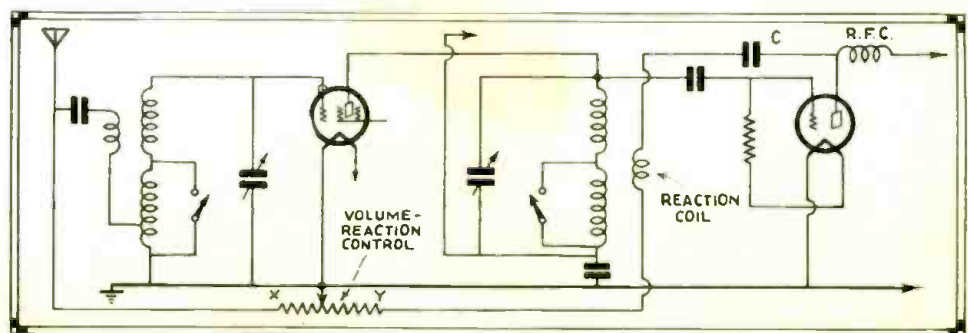

## AUTOMATIC GAIN CONTROL

● THE diagram at the left shows a six-tube superheterodyne using the Wunderlich tube and an effective system of automatic gain control, as described in "Wireless World" (London). It will be noted that the coils of the R.F., 1st detector and I.F. stages are insulated above ground by means of .05 mf. fixed condensers. If a larger capacity is used it will require a longer time to charge and discharge, thus slowing up the automatic gain action. By using a condenser as large as .25 mf., the delay may be so great as to allow the set to be tuned from one local station to another before the set returns to full sensitivity. The value of .05 mf., however, is about right for practical purposes, and with the circuit shown, gives a time constant of about one-twentieth of a second.

When the R.F., 1st detector and I.F. tubes are all connected to the common AGC lead, a .5 megohm resistor should be inserted in the lead to the 1st detector grid coil to act as a filter.



# THE "PROSPERITY 3" FOR SHORT WAVES

● THAT British radio experimenters are not overlooking the possibilities of the short waves is indicated by the number of descriptions of S.W. sets that appear in their technical press. A typical circuit, "The Prosperity 3," as published in "The Wireless Magazine" (London), is reproduced herewith in two forms, one for D.C. operation and the other for batteries.

This set covers four wave bands, 15-35, 35-80, 230-550 and 1000-2000 meters, with fixed tapped coils. On the last two ranges the sets functions with one T.R.F. stage, regenerative detector and transformer coupled pentode stage. The upper tuning coils are tapped, and short-circuiting switches for the long wave loading sections are provided.

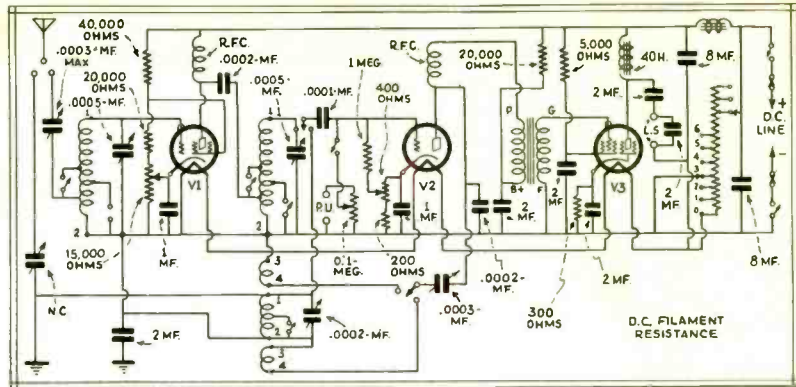

For the two short-wave ranges, the aerial connection is switched through the coupling condenser NC directly to the grid circuit of the regenerative detector. The plate connection of the latter is similarly switched from the longwave tickler to the short wave tickler, and the receiver then functions as a straight two-tube regenerator without benefit of extra R.F. amplification.

Connections are provided in the grid circuit of the detector for a phonograph pickup. Provision of this kind is found in practically all European radio receivers, as phonograph music is still very popular on the other side.

American tubes for the battery set are the 34, 30 and 33; for the D.C. model the 36, 37 and 38.

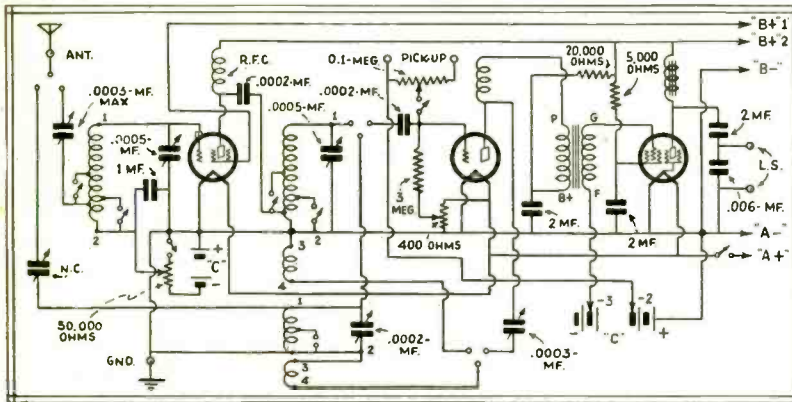

# THE 1933 "DIAMOND OF THE AIR"

● THE 1933 "Diamond of the Air," described in "Radio World" (New York), is the latest edition of a receiver that has enjoyed continued popularity since 1925. The hook-up below shows the complete circuit, with voltages, currents, resistances and the values of all parts included.

Two units have to be insulated from the metal chassis of the Four-Tube 1933 Diamond of the Air. They are the 8 mf. electrolytic condenser next to the rectifier, and the volume control.

The reason why the 8 mf. must be insulated is that the negative side, or can, is connected to B minus, the center of the high-voltage secondary, and not to ground. The chassis is grounded, hence the negative side of the condenser must not connect metallically to chassis, or the field coil would be shorted out.

The volume control has to be insulated because one side connects to the plate circuit filter of the detector, the other side to maximum B plus, while the arm goes to one side of the 0.01 mf. stopping condenser, the other side of which connects to grid of the output tube.

This type of volume control does not contribute to detuning. However, it has the slight drawback of producing a scratchy sound when moved in the region of highest sensitivity. The fact that a volume control has a fault need distress nobody, as there is no

complete satisfactory volume control. Most of the other types cause serious detuning, and while that of itself would not be prohibitive in a circuit that has a manual trimmer, such a volume control commonly alters the R.F. bias, and such alteration should not be made possible in the present receiver, because the detector bias depends considerably on the R.F. bias.

The antenna and ground connections may be made to a twin post, and thus an anchorage is provided for the 20 mmf. series condenser. This is set at minimum, with plates disengaged as much as possible. The strong brass lug may be bent to a right angle and

fastened to the antenna post at the inside back of the chassis, the small copper lug connecting to the 800-ohm series resistor in the antenna circuit and the G lug of the antenna impedance coil and to the other side of this resistor to the grid of the first tube (58). It will be found that these connecting points are within a few inches of the series condenser.

As the receiver stability depends a little on the aerial length, the general rule applies that the longer and higher the aerial, the greater the pickup, but not much of an aerial is needed, and indeed, 20 feet strung indoors under the moulding may prove too much.

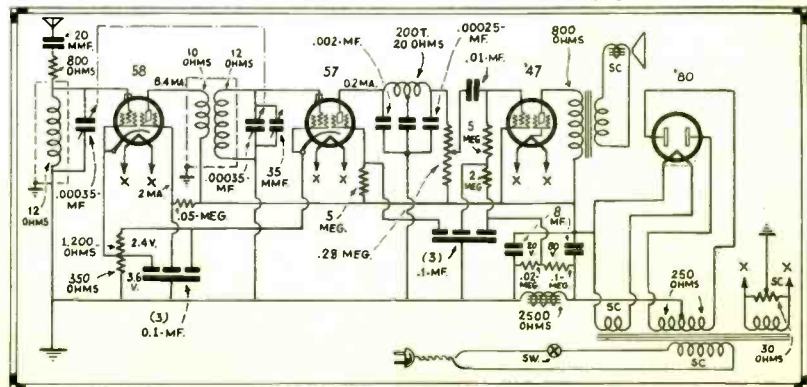



# HOW TO ADD AUTOMATIC VOLUME CONTROL

Sometimes the grid returns are not made to the same point on the load resistance, the connections being made as in Fig. 3. Only part of the voltage drop in the load resistance is here used for the first controlled tube, but the entire voltage is used on the sec-

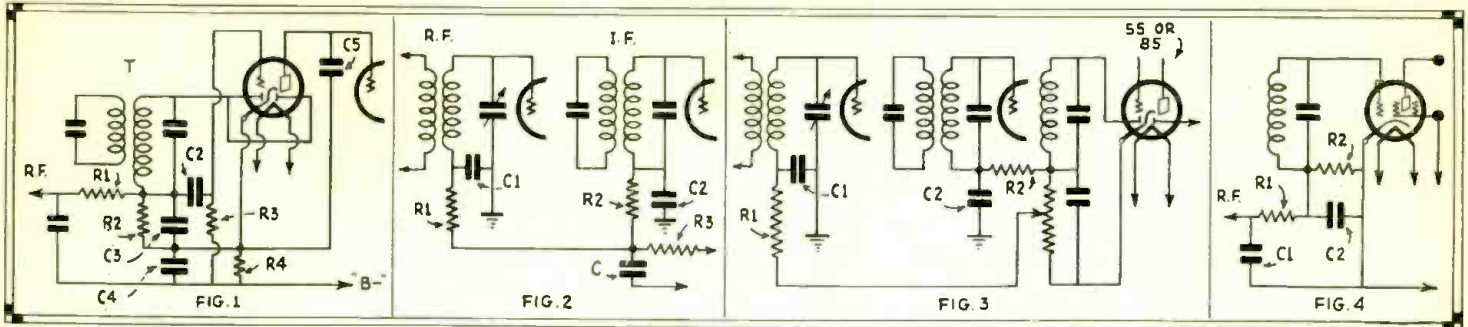

● THERE is ever an increasing demand for receivers with automatic volume control, and particularly no automobile set is considered complete without a. v. c., states "Radio World" (New York). Countless sets are in use which do not have a. v. c. and the owners are asking for information on how to change the sets so as to incorporate automatic volume control.

There are two tubes especially suitable for automatic volume control, both duplex diode triodes. The 55 is for sets requiring a 2.5-volt filament and the 85 for automobile sets or for d-c operated receivers. Other tubes can be used also because any tube can be used as a diode detector, or as a grid leak detector, and either type may be used as an automatic volume control.

## Typical Circuits

In Fig. 1 we have a typical circuit utilizing a duplex diode triode tube in its triple function. The applicability of this circuit is not confined to the XYZ receiver but may be used with any receiver where the 55 or the 85 may be used. It is best to use it in a superheterodyne where there is no necessity of grounding the tuning condenser next to the rectifier, but it can also be used in a t-r-f receiver if we tune the primary instead of the secondary. Other reasons for using it in a superheterodyne only are that the selectivity is impaired by the diode and that there is less amplification in the t-r-f receiver to be controlled.

Due to rectification there will be a direct current flowing in R2, from the plates to the cathode in the external circuit. If the signal is not modulated this current will be steady, but if it is modulated the current will pulsate in conformity with the signal fluctuations. If the condenser C3 were not connected across R2 there would be a strong carrier component in the circuit, but this is removed almost completely with the condenser. Since there is a current fluctuating at audio frequency in R2 there will be a voltage across this resistance, a voltage containing a strong d-c component and also an audio component.

The audio component is transferred to R3, the grid leak of the triode, and to the control grid. If C2 is made larger than 0.01 mf. and if the grid is of the order of 0.5 megohm, the audio component will be transferred to the grid of the triode without any appreciable reduction, even on the lowest audio frequencies.

The d-c component is used for automatic bias on the controlled tubes. But the automatic bias voltage should not contain any carrier or audio components. Hence it is necessary to put in a filter to take out these components. The filter consists of a high resistance R1 and a condenser C1. R1 really serves two purposes. In addition to its function as a filter it serves to prevent short circuit in the input to the audio amplifier through various capacities, of which C1 is one. The usual value for R1 is 0.5 megohm and the value of C1 is 0.25 mf. However, both R1 and C1 may be larger.

The arrowhead marked RF may be regarded as C minus and it is to be connected to the grid returns of the controlled tubes. There may be several of these tubes, but all of them should be of the remote cut-off type, like the 235, 58 and 239, depending on what tubes are used in the circuit. Naturally, the 235 and 58 would go with the 55 and the 239 with the 85.

Sometimes oscillation may occur in the controlled circuits if all the grid returns are connected to the same point, that is, the arrowhead. In that case the grid returns should be isolated by means of individual filters. How this is done is shown in Fig. 2.

The values of R1 and R2 may be half megohm each and of C1 and C2, 0.25 mf. each.

ond. This, of course, requires that the load resistance be made up of two units.

In Fig. 1 the bias for the triode part of the detector is obtained from the drop in a resistance R4 placed between the cathode and B minus. The value of this resistance depends on the type of load that is used on the triode. The recommended load resistance is 20,000 ohms, in which case the bias resistance should be 2,500 ohms. About the same value will do if the load is a transformer. In case the load resistance is 250,000 ohms, which it may well be notwithstanding the recommended 20,000 ohms, the bias resistance should be larger, but it is not necessary to make it larger than 5,000 ohms. A condenser C4 of 2 mf. or higher capacity will improve the operation of the amplifier.

In Fig. 4 is a simple detector circuit in which grid current is used for automatic bias. The grid leak R2 and the grid condenser C2 are placed on the low potential side of the tuned input circuit and the voltage for the automatic bias is obtained by connecting the grid returns of the controlled tubes to the negative end of the grid leak, that is, the end that is nearer the grid. The usual filter R1 and C1 are used to prevent short circuiting the audio signal and to avoid carrier and audio feedback to the controlled tubes.

## ONE-TUBE LOUD SPEAKER SET

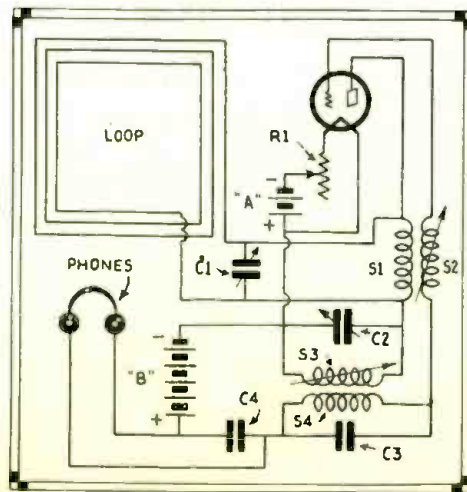

The tube in this circuit may be a type 30 or 01A.

● THE super-regenerative circuit is without doubt one of the most interesting of all radio hook-ups. If carefully balanced, it is capable of really tremendous amplification. If you want to spend an enjoyable evening, try this one-tube hook-up, suggested by "Tous les Montages de T.S.F." (E. Chiron, Paris). Use a loop aerial about a yard square, containing 12 turns of any available insulated wire. C1, C2, C3, .0001 mf. variable condensers; C4, .0001 mf.; R1, filament rheostat. Coil S1, 60 turns of No. 24 or 26 wire on 3" tube, sliding inside coil S2, about 4" in diameter, with 85 turns. The "quenching" or variation frequency is supplied by S3 and S4, which are 1000 or 1500 turn honeycomb coils or their equivalent. The coupling between S1 and S2, and between S3 and S4, will require considerable adjustment.



# THE "S.T. 300" EXHIBITION RECEIVER

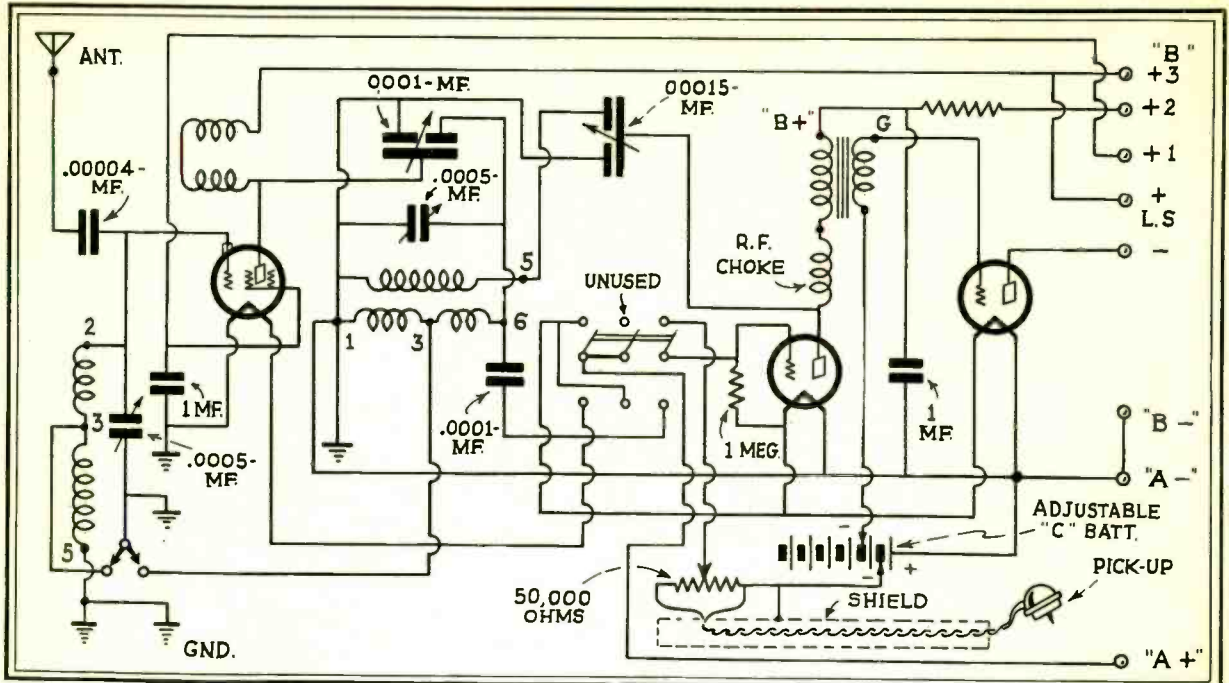

● THE S.T. 300 Exhibition Radio-Gram, featured by "The Wireless Constructor" (London) is intended for both radio and phonograph reproduction. A special changeover switch is provided, which also acts as the on-off switch for the entire instrument.

In common with other European sets, this one has tapped tuning coils for the purpose of covering the medium

and long wave broadcasting stations of the continent. The circuit uses one stage of T.R.F., regenerative detector and one audio output stage. American tubes that may be used in the respective positions are the 24A, 27, and 45, for A.C.; and the 32, 30 and 31 for battery operation. Regeneration is controlled by a .00015 mf. variable condenser of the differential type, the feedback taking place through a shunt tickler.

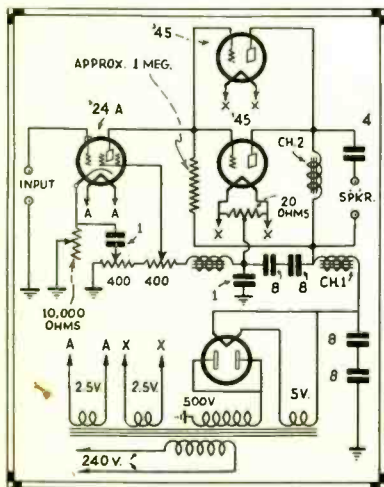

## LOFTIN--WHITE AMPLIFIER

● AN excellent Loftin-White amplifier designed for American tubes is shown above. This is taken from "Wireless Weekly" (Sydney). Notice that the two 45 output tubes are in parallel, not push-pull. This amplifier will work with phonograph pickup or radio.

## GAS TESTING CIRCUITS

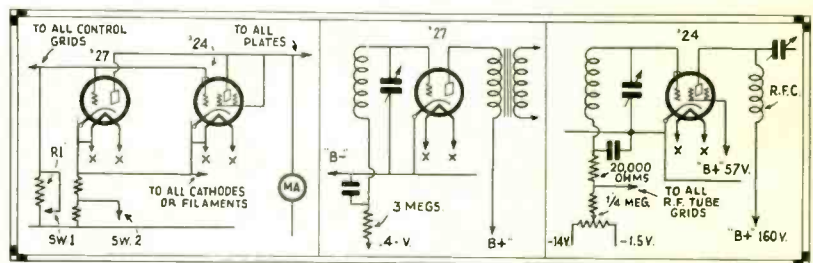

● THE presence of gas in tubes is the cause of many complaints of fading and creeping of volume, states "Radio World" (New York). Tests with ordinary testers do not reveal this defect, a more delicate indication being needed. Figure 1, above, shows a typical tester, except that SW1 and R1 are included, instead of a continuous wire, to enable a gas test to be made. Figure 2 shows the detector stage of a Grebe SK-4. The tester showed 3.8 ma. change in plate current. Figure 3 is the first R.F. stage of a Grebe SK-3. The plate current change was 3 ma.

The use of the tester is not changed in any manner except that opening SW-1 will indicate the presence of gas in the envelope, even in small quantity,

by a noticeable increase in the plate current of the tube under test. This increase will be evident with SW-2 either open or closed, but the additional needle swing will be much greater if the gas test is made while SW-2 is closed. In other words, merely flipping SW-1 will tell whether the tube is gassy, and the experience gained in a few tests will indicate the amount of gassiness. Now let us open SW-1 and take a look at the meter readings of the three tubes referred to:

37 tube, minimum, 5.7 ma; maximum 8.4 ma; gas change, 2.7 ma.  
27 tube, minimum, 3.8 ma; maximum, 7.4 ma; gas change, 2.0 ma.  
24 tube, minimum, 3.7 ma; maximum, 6.7 ma; gas change, 2.1 ma.

## INTERESTING "REINARTZ" VARIATION

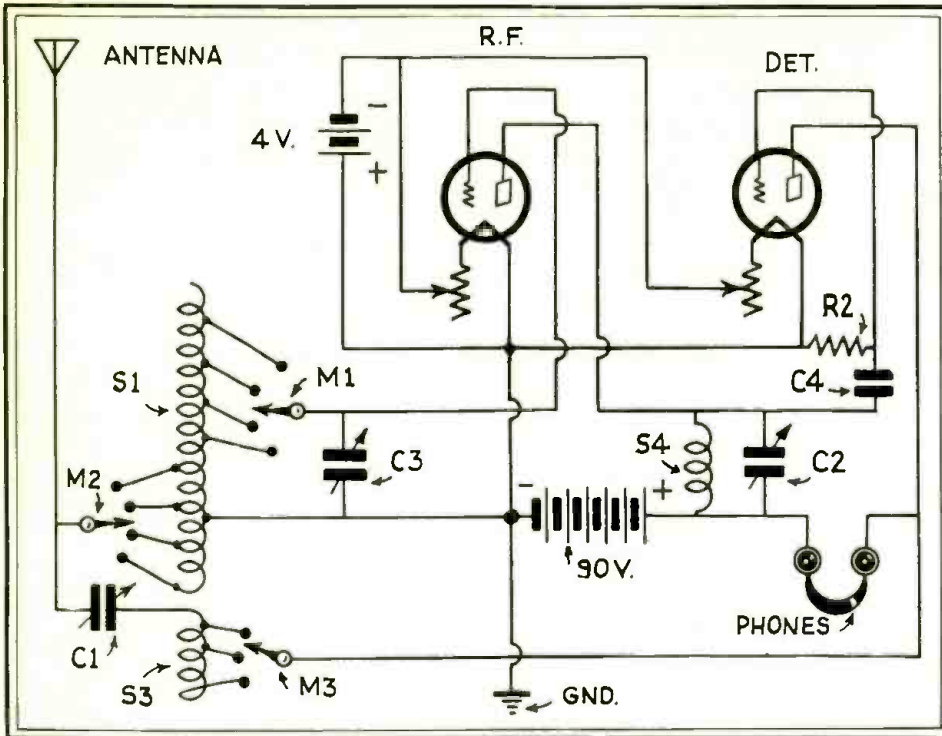

● THE so-called "Reinartz" circuit, which was very popular in the United States about ten years ago, is still very widely used in Europe, where simple sets are the rule. One interesting variation of the original hook-up, taken from "Tous les Montages de T.S.F." (E. Chiron, Paris), is shown in the accompanying diagram. Notice that a stage of radio-frequency amplification is used, with the detector tube regenerating back into the first tube! This scheme has possibilities and is recommended to experimenters.

The values of the various parts will depend on the wavelength range to be covered. Most experimenters can probably find enough loose parts in their junk boxes to try the circuit on at least one of the short wave ranges.

## ELIMINATING SUPERHET RADIATION

● IT is customary in a superheterodyne circuit to introduce the local oscillation into the grid circuit of the detector tube. This usually restricts the use of the system to a loop aerial as, if an ordinary aerial were connected to the circuit, re-radiation would be caused by the presence of the continuous oscillation in the aerial.

The trouble is not always serious because the aerial circuit is tuned to a different frequency to that of the oscillation. If the aerial circuit is sharply tuned, therefore, the radiation may not be serious, but this is not usually the case and quite a small oscillation in the aerial circuit is capable of causing appreciable interference for some distance around.

The trouble is even more aggravated on short waves, where the difference in frequency between the local oscillation and the incoming signal is relatively much smaller.

The difficulty may be overcome by using a screen-grid high-frequency stage prior to the first detector, or even by using a band-pass tuner in the aerial circuit, since this tends to restrict the response of the aerial circuit to the oscillator frequency.

The circuit shown, however, enables re-radiation to be reduced to a minimum with only a simple arrangement. The oscillation is not introduced in-

to the grid circuit, but into the plate circuit. A somewhat stronger oscillation is necessary in order to maintain the same signal strength, but otherwise the arrangement is quite satisfactory. It will be seen that the high-voltage supply to the first detector tube is obtained through the oscillating circuit so that the plate voltage varies at a high frequency, and this produces the necessary mixing of the two oscillations.

The first detector must, of course, be a screen-grid tube, so that there shall be no transmission of energy through the tube capacity, and the oscillator circuits should be screened to avoid any direct induction on to the aerial coil.—*Wireless Magazine* (London).

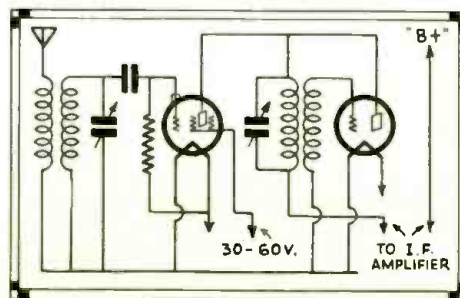

Non-radiating oscillator arrangement.

## Short Circuiting Switch

● THIS switch is very useful for grounding or short-circuiting the various points of a dual-range coil. It is adapted from a discarded rheostat.

The winding has been removed, and two or three slots cut in the form so that taps from the coil can be attached and left standing above the edge. The original narrow wiper has been replaced by a wide plate, which, as the knob is revolved, will connect the various taps.

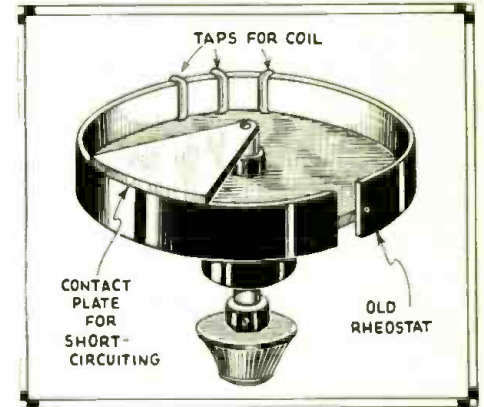

As the centre spindle is grounded, it is possible to short-circuit the various parts of the long-wave section when it is desired to work on the medium band. The usual thin wire used for winding coils will not stand much friction, so it is better to make the connections to the switch with wire of much stouter gauge.—*Modern Wireless* (London).

## Adjusting New Receiver

● THE suggestion is often made that some form of measuring instrument—even if it be nothing more elaborate than a detector plate milliammeter—should be employed when making initial adjustments on a new receiver, and particularly when carrying out the operation of setting the trimming condensers which are included in all receivers with ganged tuning.

It would be foolish to attempt to belittle the soundness of this advice, for it is a demonstrable fact that, however carefully adjustments may be made with the ear as a guide, results can nearly always be improved upon with the help of a more certain and definite indication. But it is also a fact that too great a reliance upon the meter can be dangerous, as all sorts of puzzling effects may arise if the old-fashioned "listening test" be ignored entirely.

For instance, meter deflections may actually be due to self-oscillation of one or more tubes of the receiver, or perhaps to a carrier wave instead of a local oscillator, to the emanation of which it is imagined that the receiver is being tuned.

Unless one has a great deal of experience in instrument work, it is perhaps best to make rough initial adjustments by aural means, and then, with the meter as a guide, to give the final touches which make all the difference to the ultimate success of a modern set.—*Wireless World* (London).



# 'VM-THREE' IS SIMPLE AND INEXPENSIVE

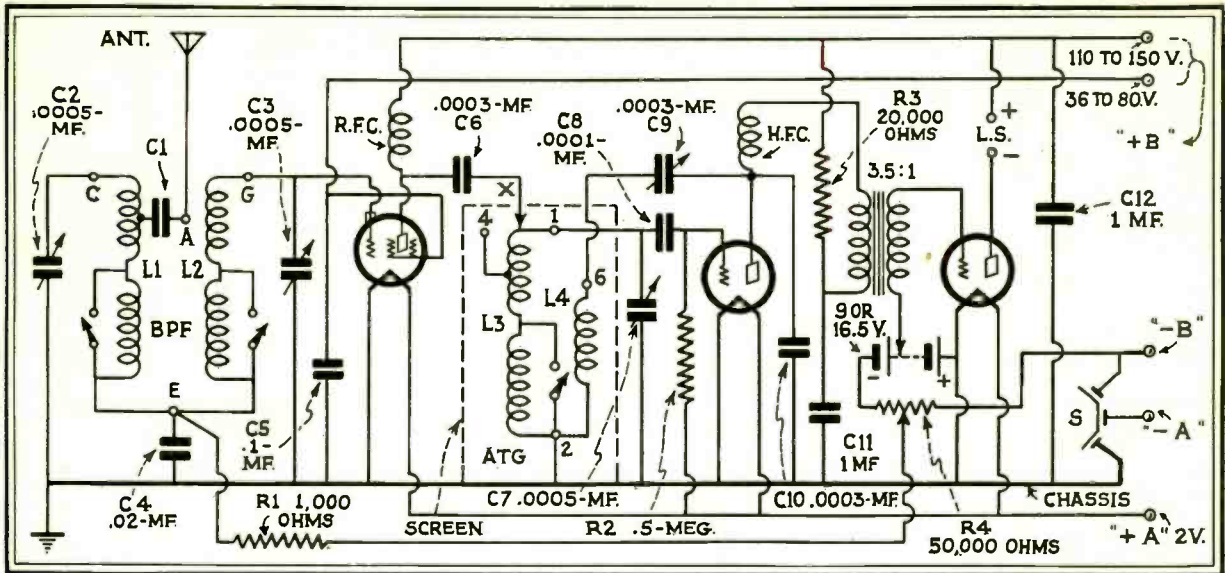

● IT is surprising in these days of ultra refinement in radio receivers to discover how much can still be achieved in the direction of sensitivity and selectivity with a set of simple and cheap design. Even screening can be cut down to the mere shrouding of two or three components, provided that great care is taken in the positioning of parts and wiring; practical proof of this will be found in the results obtainable with the "V-M-Three" receiver described in "Wireless World" (London).

The circuit is quite straightforward, and needs little explanation. There is magnetic linkage between the two input band-pass coils as well as common capacity-coupling, the two effects acting in such a way as to keep the peak separation practically constant over the tuning ranges. So that a closer coupling is obtained on the long waves, the coils are set at an angle, and resembled the twin-cylinder arrangement of a motorcycle. To prevent the coupling condenser  $C_4$  from being short-circuited when the slider of the bias potentiometer is moved to maximum, a

non-inductive resistance  $R_1$  of 1,000 ohms is interposed in the grid return circuit. This, together with  $C_4$ , decouples the grid circuit of the screen grid tube, and so obviates the necessity of a one- or two-mf. condenser between the slider and the earth line. A series aerial condenser  $C_1$  of small capacity is built into the base of the band-pass assembly, and, being tapped into the medium-wave coil at a point near the center, allows a slightly different proportion of the aerial capacity to be transferred on the two wavebands. To compensate for this the inductance of the two band-pass coils is not exactly the same, but the ganging of the coils  $L_1$  and  $L_2$  is found to hold well over both wave ranges.

To ensure absolute simplicity of construction and to give latitude in the choice of components, the third tuned circuit—that in the interval coupling—is tuned with a separately controlled condenser which will be found to run almost in step with the two-gang band-pass condenser.

## A BATTERY SUPER FOR SHORT WAVES

● MANY have asked for a short-wave superheterodyne utilizing the two-volt battery tubes. A usual demand is that the circuit be the most sensitive possible. Let us see what can be done with a 5-tube circuit.

The first of these tubes might be a 232 mixer, the second a 230 oscillator, the third a 234 intermediate frequency amplifier, the fourth a 232 detector, and the fifth a 233 power amplifier.

This combination of tubes allows us to use on R.F. tuner in from the first tube, an oscillator tuner, two I.F. transformers, and a resistance coupler between the detector and the power tube, says "Radio World" (New York).

The first tuning coil consists of a single winding with a 140 mmf. condenser across it. The antenna is connected to the high side of this tuner through a small variable condenser that has a range from 100 mmfd. to as near zero as possible.

The oscillator coil contains three windings, one for the frequency-determining circuit, one for the tickler, and one for the pick-up. The circuit is arranged so that these windings may be put on a form

provided with a 5-prong base. Of course, a six-prong base can be used also.

The intermediate transformers are adjustable to 450 kc. and they are of the doubly tuned type, that is, the two coils are loosely coupled and both windings of each transformer are tuned to 450 kc.

Since the battery tubes do not have independent cathodes we cannot put the pick-up coil in the cathode lead, as is done with heater type tubes. The next

best place to put it is in the screen lead. But it is desirable to arrange the circuit so that the oscillator coil have as few terminals as possible, for that makes the problem of switching from one wave band to another simpler, whether we use plug-in coils or switches. In this circuit one side of the pick-up coil is grounded and the other is connected to the screen through a 100 mmf. condenser.

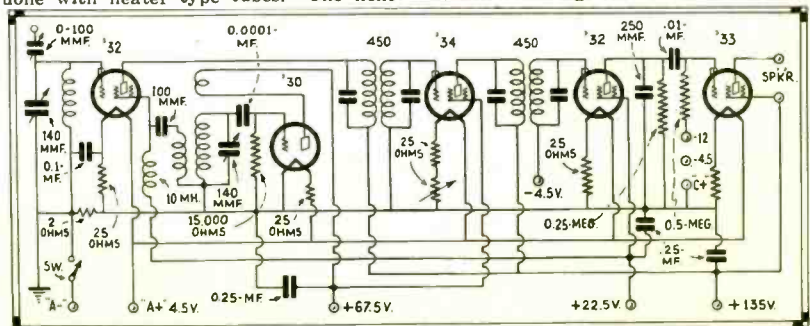



# THE "CATHODYNE"

## A Two-Tube A. F. Amplifier

● THE "Cathodyne" is a direct coupled audio amplifier of simple but efficient design, with excellent volume and tone quality. As described in "La T.S.F. Pour Tous" (E. Chiron, Paris), this unit employs only two tubes, a triode and a tetrode, in the circuit shown below.

The illustrations at the right show a completed amplifier constructed with French parts. It measures only eight inches long and about 2½ inches square on end.

Experienced constructors will recognize the hookup as an adaptation of the well known Loftin White circuit, which enjoyed a wave of popularity in the United States about three years ago and is still very widely used. The values of the various resistors may require a little "juggling" to suit whatever American tubes are selected.

The terminals marked "pick up" connect to a phonograph pick-up or to the output of a radio detector through a suitable coupling transformer.

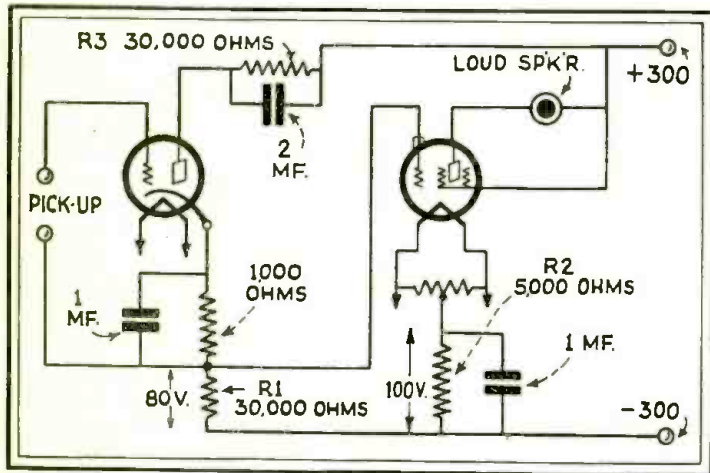
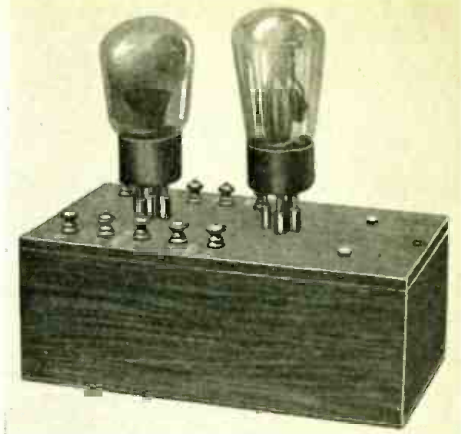

Left: Schematic diagram of the "Cathodyne" amplifier.

Top right: View of the completed amplifier in its box. Bottom right: the under side. The transformer in the box is a coupling transformer to the radio set.

While the parts shown are of French make, a similar arrangement can be followed with American components.

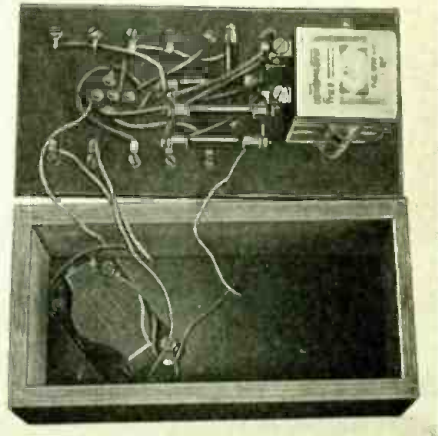

# SENSITIVE "SUPERHET" FOR D.C.

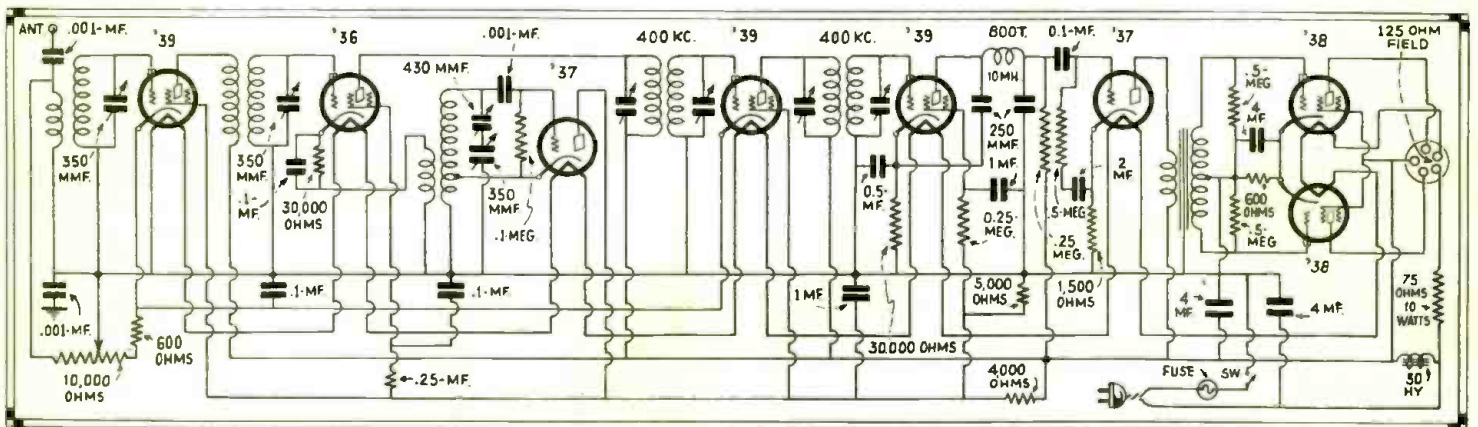

● THE superheterodyne is well adapted for use on DC lines, and the most practical tubes are those of the automobile series, says "Radio World" (New York). The best combination of tubes of this series in an eight-tube superheterodyne is 239s for RF. and IF. amplifiers, 236s for detectors, 237s for the oscillator and the audio frequency amplifier, and 238s in the push-pull output stage. In other words, there are two of each type of the automobile series.

The heaters are connected in series. The first tube has its heater connected to the chassis. Then the series continues until we come to the loudspeaker socket. A 125 ohm speaker field is supposed to be used. In addition to the resistance in the speaker field we need 75 ohms to take up the excess voltage. The eight tubes require a voltages of 50.4 volts and the speaker 37.5 volts. Thus if the line voltage is 110 we need a ballast of nearly 75 ohms. If the voltage is slightly higher allowance should be made for it by adding 3½ ohms for each excess volt.

The oscillator used in the circuit is different from that used in the automobile set, being simpler. It is of the

Hartley type and employs only two windings, with a tap on the tuned.

Parts required are as follows: Two RF shielded midget type transformers, for 350 mmf. tuning condensers; One oscillator coil; Two 400 kc. IF transformers; One 800 turns RF choke coil, about 10 millihenries; One push-pull input transformer; One 30 henry choke coil; One three gang tuning condenser, each section 350 mmf.; One 350-450 mmf. padding condenser; Three 0.001 mf. fixed condensers; Three 0.1 mf. condenser, all in one case; One single 0.1 mf. condenser; Three 4 mf. by-pass condensers; Two 1 mf. by-pass condensers; One 2 mf. by-pass condenser; One 0.5 mf. by-pass condenser; Two 250 mmf. condensers; Two 600 ohm bias resistors; Two 30,000 ohm resistors; One 100,000 ohm leak; Three 250,000 ohm resistors; One 1,500 ohm resistor; Three 0.5 megohm resistors; One 4,000 ohm resistor; One 5,000 ohm resistor; One 10,000 ohm potentiometer with line switch attached; One 70 ohm 10 watt resistor; One special 125 ohm, 0.3 ampere speaker with push-pull transformer.



# DIODE DETECTION IN "DIODION"

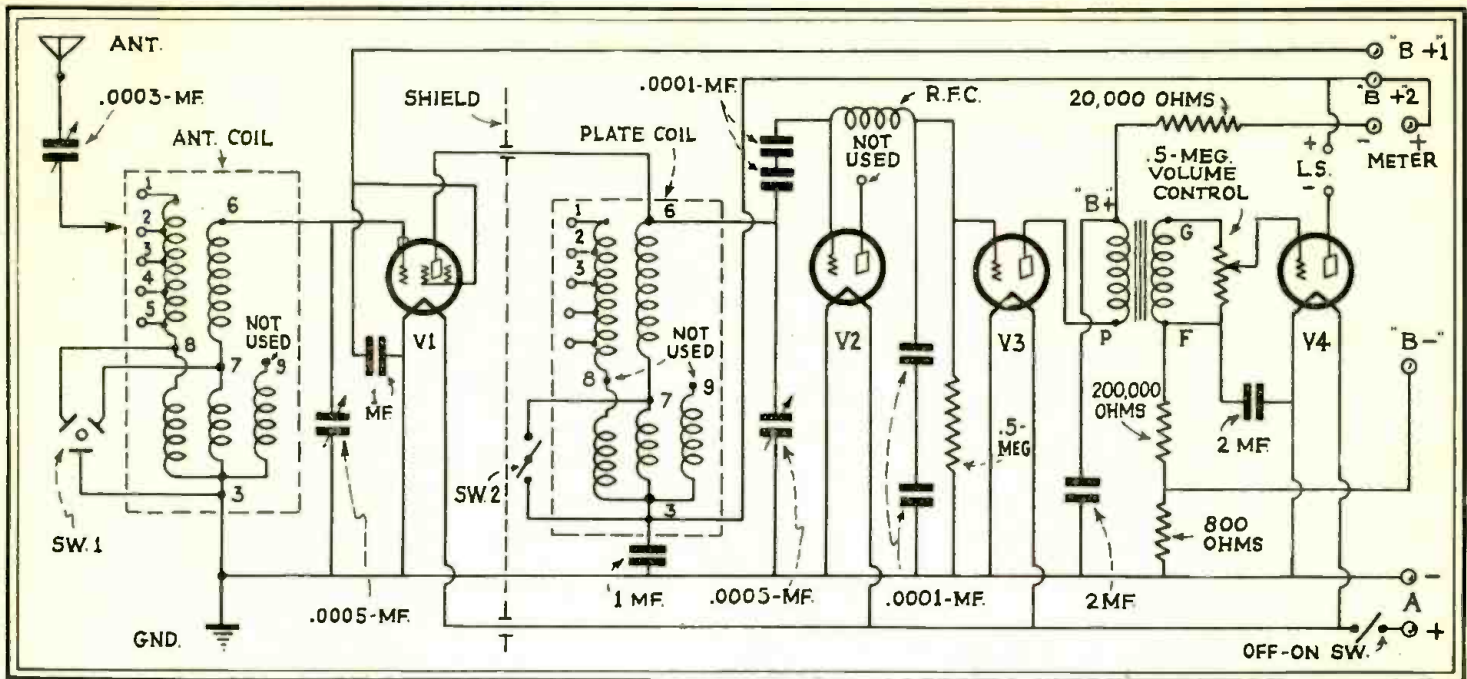

● THE circuit of the "Diodion" has been made as simple as is consistent with the obtaining of selectivity and quality of reproduction. This receiver is given considerable space in "Modern Wireless" (London).

It will be seen to consist of a screen-grid stage coupled by plain tuned plate, to a diode detector which is connected to two A.F. stages. These latter are automatically biased, so that there is no need to have a separate battery.

The aerial coupling is adjustable by means of the four taps on the aerial coil and the series condenser.

There is a most valuable predetector volume control, and the sensitivity of the set is such that many stations need the condenser well towards the minimum position.

It can be seen that the damping of the tuned-anode circuit is extremely low (the circuit is not shunted so that the full value of it is obtained), due to the two .0001-mfd. condensers in series with the grid connection to the diode and the complete absence of any leak across the circuit.

The .5 leak and its parallel condensers on the L.F. side of the diode do not affect the tuning circuit, for they are isolated from it in an R.F. sense by the R.F. choke between the diode and the R.F. valve grids. This choke, therefore, must be of good design, and "any old" choke, as explained later, will not do.

Automatic grid bias is obtained quite easily with the aid of the 800-ohm resistance between the B- and A- terminals of the set.

Wave-changing is carried out by the usual push-pull switch method, but what will probably strike the reader most is the absence of regeneration.

The "Diodion" is intended primarily for economical reception of local stations and one or two of the more powerful stations on the continent. For this purpose there is no need for re-

generation, for you will find, owing to the very small damping effect of the diode on the tuned circuit, and the loose-coupled aerial which applies little damping to the S.G. grid coil, that the screen-grid valve is enabled to give a very high degree of amplification — much more than is usually the case.

No use is made of the plate of the diode detector, as this is not required, the grid being more suitable for acting as the anode in this particular circuit.

Thus we have a true two-element rectifier, which has in itself no powers of amplification. Used as shown in this circuit it is much more sensitive than the old type, where a positive bias was applied to the plate and the tube was placed across the tuned circuit of a receiver, in parallel with the grid and filament of an amplifier valve. In that case the damping caused by the tube was quite considerable, and there-

fore the sensitivity of the arrangement (for it has not any amplifying properties like the grid-leak rectifier, and it does not make use of reaction) was not very high.

Provision has been made for the inclusion of a meter in the plate circuit of the first R.F. valve. This meter is not an essential part of the circuit arrangement, for it can be shorted out if desired without in any way altering the operation of the set.

It was included, or rather the terminals for it were included, so that those who want to get visual indication of the tuning of the set (a very useful check when dealing with distant-station searching, or when you want to test the strength of a transmission), as well as audible indication, can insert a small milliammeter across the terminals when the exact tuning point will be shown by the maximum deflection of the needle.

It can thus act as a useful indication, not only that the set is in tune, but of the strength with which any particular transmission is coming in, the degree of deflection giving an idea of the strength.

The R.F. choke is a most important factor in the operation of the receiver, for it is essential that no, or extremely little, R.F. impulses shall reach the grid of the first A.F. valve. For this reason also it is essential that the bypass condenser across the plate resistance of the diode be used, its value being kept as low as possible consistent with quality requirements.

As this condenser is right across the grid circuit of the L. F. valve, it is obvious that if it has a large capacity it will operate excellently as regards an R.F. decoupler, but it will also tend to by-pass the highest audio-frequency impulses.

Thus the capacity must be kept as low as is barely sufficient for R.F. by-pass purposes. Hence the vital need for an efficient choke.

## Protection for Wires

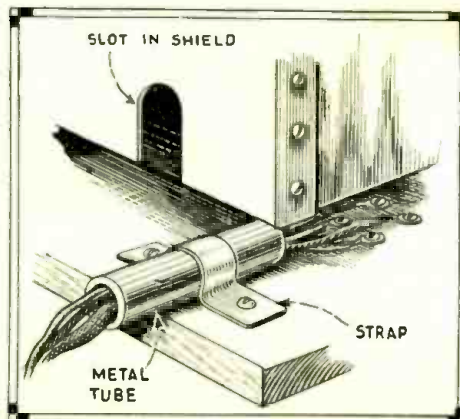

Many set constructors neglect to provide protection for wires entering a shielded compartment, and short circuits sometimes occur. The drawing above shows a simple means of preventing this trouble.



# REVIEW OF AMERICAN RADIO MAGAZINES

● IN reviewing the American radio magazines herewith we are giving brief resumés of the outstanding articles in each issue. Occasionally a diagram will be included if its reproduction is desirable, but in general we will not reprint whole articles. If any particular subject appeals to you, you can easily obtain a copy of the magazine directly from the publisher. This review service may save you a lot of useless reading and put you on the track of valuable information that you may not otherwise learn about.

*Radio News* (New York), November, 1932.

"Rejectostatic Reception," by Lewis M. Clement. This article is very timely, as the problems of noise elimination is assuming major importance. The author describes a complete "noiseless" receiver system which includes a balanced feeder antenna for eliminating electrical interference from the input circuits.

"Everything on the Air," by John M. Borst, Constructional data on a 10-700 meter receiver that includes provision is assuming major importance. reception. No plug-in coils are used, all wave changing being done by a complex switch in connection with fixed tuning coils.

"Heavy Duty Public Address System," by Bernard J. Montyn. The amplifier described is capable of operating up to fifty dynamic speakers and is particularly suited to meet the coverage requirements of outdoor arenas, hotel installations, etc. The final output stage uses two 845 tubes. The response curve of this amplifier is claimed to be substantially flat from 30 to 10,000 cycles.

"How the Amateur Can Make Accurate 5-Meter Measurements," by James Millen. The many amateurs who are investigating the interesting transmission phenomena in the ultra-short-wave regions will welcome this valuable contribution. Although there are many good frequency meters for the longer waves, suitable instruments for the tricky 5-meter stuff have received little attention. Practical constructional data are given.

*Modern Radio* (Hartford, Conn.) October, 1932.

"Curing Noises in Auto Radio," by F. W. Schor. If your car radio sounds like a tin can full of stones when the engine is running, read this article for some useful hints on eliminating the racket. Specific advice is given

for more than a dozen different makes of cars.

"Real Transmission News." This is a report of a rather formidable program of measurements taken by a university professor with a view to establishing something in the way of a definite basis for determining what powers and frequencies are needed to deliver a commercially satisfactory broadcast signal in a desired service area.

*Electronics* (New York) September, 1932.

"Shall We Widen the Broadcasting Band?" The question of widening the broadcasting band, now being fought

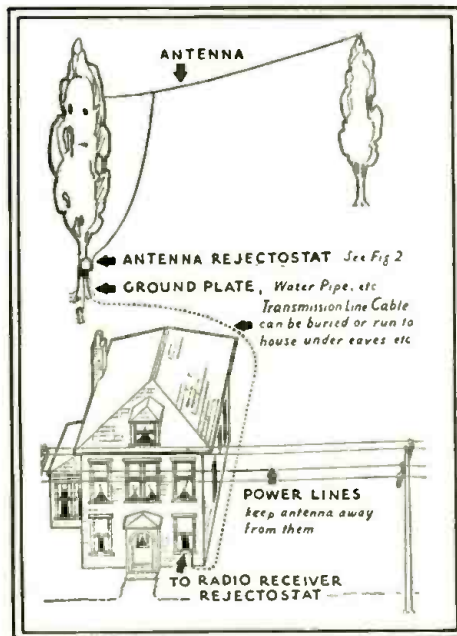

Above: A typical "Rejectostatic" installation. Below: Schematic diagram of the connections between the antenna and the receiver. (from RADIO NEWS)

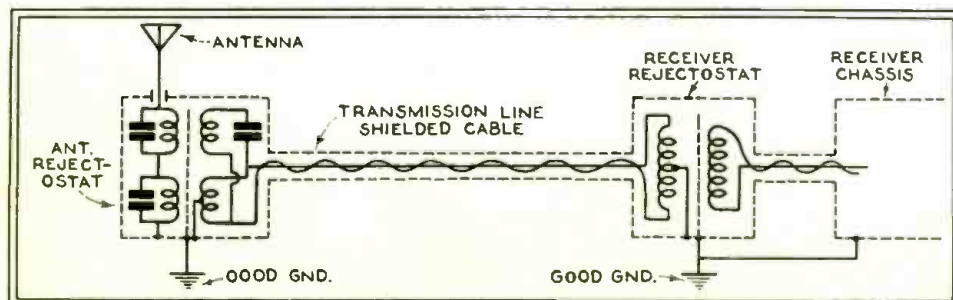

out at the international radio convention at Madrid, is discussed pro and con in this excellent article. Since any change in the present situation will have a serious and far reaching effect, every radio man should acquaint himself with the pertinent facts in the case.

"New Forms of Short Wave Tubes," by I. E. Mourontseff, G. R. Kilgore and H. V. Noble. Ordinary radio tubes are notoriously poor for ultra-short-wave work, because of their high internal capacity and of leakage through the connections in the stem. A number of special tubes designed for this class of service are described and illustrated.

"Transformers for Gaseous Discharge Tubes," by Russell F. Trimble. One of the most troublesome problems encountered in the neon-sign field is that of assigning the proper transformer to each circuit. The author draws on his experience as a neon sign specialist to make recommendations for specific operating conditions.

"Electronic Devices in a Testing Laboratory," by Dr. Clayton H. Sharp. Electronic devices have found a wide and varied field of usefulness in connection with the work a testing laboratory is called on to do. Actual applications in one of the largest laboratories of this kind in the country are listed and described.

"Pitch Control for an Electronic Musical Instrument," by T. R. Bunting. An important problem in the design of a musical instrument concerns the placement of a player's hands in order to secure a desired pitch sequence or melody. The author takes up this problem with respect to the beat frequency class of instruments played by inductance variation, as contrasted with the RCA Theremin and the Martenot, which are played by capacity variation. The subject is rather interesting and is well handled.

*Scientific American* (New York) September, 1932.

"Radio in the Forest Service," by A. Gael Simson. One of the most important factors in fighting forest fires is communication. Until recently very little use was made of radio because of the weight and complexity of the available equipment. This article tells of the development of various portable outfits concluding with some new combination transmitter-receivers that weigh only ten pounds.

*Radio Craft* (New York) November, 1932.

"How to Build the Diode-Triode Reflex Receiver," by R. D. Washburne and Francis R. Harris. The authors present a complete description of a novel receiver design incorporating a modern tube in an old-style circuit. Controlled regeneration permits the operator to locate stations by the zero-beat method. Local stations operate a loud speaker with excellent volume.



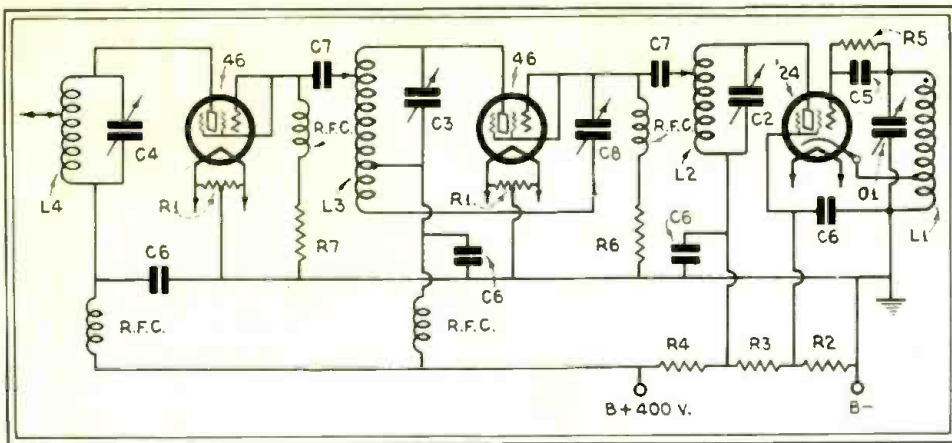

**RECOMMENDED ELECTRON COUPLED OSCILLATOR CIRCUIT FOR THREE-BAND OPERATION:**

Using a 24 oscillator, 46 amplifier on either 3500 or 7000 kc., and a 46 doubler on 14,000 kc. only. On the first two bands the tap on  $L_3$  is disconnected from  $C_7$  and connected to the grid circuit of the following amplifier.

$C_1$ —500-mmf. variable condenser.  $C_2, C_3$ —250-mmf. variable condenser.  $C_4$ —150- or 250-mmf. variable condenser.  $C_5$ —100 mmf.  $C_6$ —.002 mf.  $C_7$ —250 mmf.  $C_8$ —50-mmf. midget condenser.  $R_1$ —20 ohms, center-tapped.  $R_2$ —10,000 ohms.  $R_3$ —3000 ohms.  $R_4$ —4000 ohms. R.F.C.—Any good short-wave choke.  $R_5$ —50,000 ohms.  $R_6$ —2000 ohms.  $R_7$ —20,000 ohms.  $L_1$ —4 turns No. 16 d.c.c. on 2½-inch form, spaced to occupy 1½ inches. From QST.

"The Velocity Microphone," by J. P. Taylor. All of the microphones developed and used in the past utilize for their action the pressure variations of the impressed sound. In this latest development the action of the microphone depends on the velocity of the impinging waves.

"A Uni-Directional Loop Adapter," by C. Walter Palmer. An ordinary loop cannot be used with a broadcast receiver because of ganging and additional tuning difficulties. With the circuit described by the author the loop may easily be adapted to any receiver and has uni-directional response characteristics.

"The Specialty Tester," by Jack Grand. A description of an extremely small size tester capable of measuring and testing small and large condensers and resistors. It also incorporates an A.C.-D.C. voltmeter for output measurement work.

"Constructing Adapters for Test Equipment," by F. L. Sprayberry. Adapters for the new tubes, intended for use with various Jewell analyzers, are shown pictorially for the assistance of Service Men.

Short Wave Craft (New York) October, 1932.

"The Super-Regenerator Four," by H. B. Dent. The one circuit that has perhaps greater possibilities than most others for short-wave work is the super-regenerator. A number of new ideas are incorporated in the circuit here described, which is the result of numerous experiments by the author.

"Mysteries of the 5-Meter Band," by C. H. West. Amateurs who have had considerable experience on the other short-wave bands are often stumped by the 5-meter "stuff," which is really very simple. Many interesting stunts are described, and directions are given for duplicating them.

"Band Spreading," by James Millen. The broadcast fan who has just become acquainted with the wonders of the short waves will be particularly

thus render short-wave tuning easier.

"Making a Short Wave Transmitter from a Neutrodyne," by Louis F. Leuck. The once famous neutrodyne receivers are being sold today at bargain prices—anywhere from \$1.00 and up. Mr. Leuck tells how he built a fine combination code and telephone transmitter from an old set of this type.

## HOW THE BAFFLE WORKS

● A BAFFLE is more than a support or container for the chassis. It plays a big part in the reproduction, says "Amateur Wireless" (London).

Let us see how the baffle works, and then we can decide what its construction should be like to give the desired effect.

We have a cone-shaped diaphragm vibrating in sympathy with the backwards and forwards movements of the little coil attached to the center of the cone. This vibration sets up air waves, not only in front of the cone but also behind it.

If the intensity of the sound waves set up by the movements of the air is great enough the waves at the front of the cone will mingle with the waves at the back of the cone. The mingling of the back and front waves causes some of the energy to be cancelled out, with the result that the total sound output of the loud-speaker is reduced.

How are we going to stop this loss—which has the effect of cutting out much of the low-note response from the reproduction? Simply by preventing the front waves from affecting the back waves—by intercepting the back and the front with a large board, called a baffle.

Always remember that the baffle is not meant to work as a sounding board, therefore it is not intended to vibrate itself. The way to stop this vibration, which actually spoils the baffle effect by absorbing low notes, is to use at least inch thick wood.

For normal requirements a 3-foot baf-

"The Bearcat 3; a Five Meter Super-Regenerative Receiver," by Clifford E. Denton. A good 5-meter receiver is in big demand just now, with numerous amateur and television stations operating on the very low waves. Not interested in this article, which describes the theory and practice of how to spread signals over the dial and only must the 5-meter receiver be selective, but it must also possess powerful amplification properties. The "Bearcat 3" possesses these qualities. Data are given on some new antenna resonance coils which greatly increase the signal strength.

"A Receiver That Laughs at Static," by John L. Reinartz. The unusual circuit devised by Mr. Reinartz reduces the interference from non-tunable sources such as static and line disturbances; it also permits two signals of different frequencies to be received simultaneously through the same amplifier system.

"Ultra-Seven Portable All-Wave Super-Het," by Harry Georges. A wavelength range of 9 to 550 meters is covered by this exceptionally fine portable super-heterodyne. It employs seven 6.3 volt automobile tubes. It has been tested by several radio engineers and it actually brought it VK2ME, Sydney, Australia, and other distant stations. This set "packs a wallop" and with only a short aerial operates a loud speaker in fine shape.

"A Real 3-Tube Receiver," by I. O. Meyers. This is a simple but efficient little short-wave set designed for the man with a limited pocketbook. The circuit comprises one stage of untuned R.F. amplification, regenerative screen-grid detector, and pentode output stage.

fle board is sufficiently large, though progressive increase in the low-note response, assuming the set and speaker are capable of dealing with the lowest frequencies, will be noted up to about 5 feet.

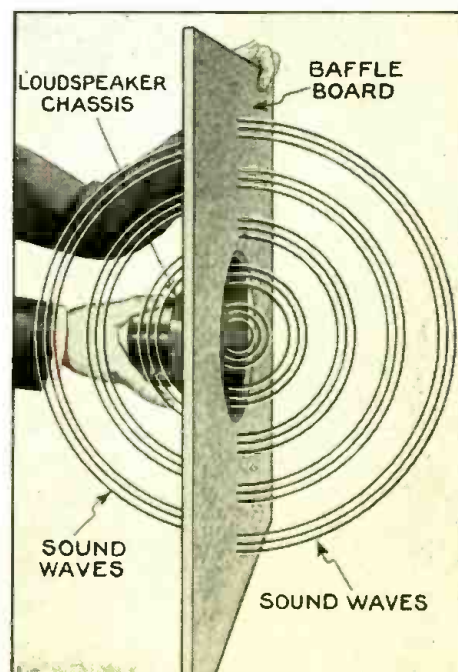



# DIGEST OF RADIO PATENTS

## Tube Amplifier

British Patent No. 362504

The circuit shown is designed to prevent distortion due to the flow of grid current, without the use of a definite biasing voltage and corresponding restriction in power output. Incoming signals are applied across the grid G of what may be called a "compensating" tube V, and the filament F1 of the amplifying tube proper V1. Variations of the voltage on the grid G alter the internal resistance of the tube V, and since a part F1, G, of this internal resistance is in the grid-filament circuit of the tube V1, the potential of the grid

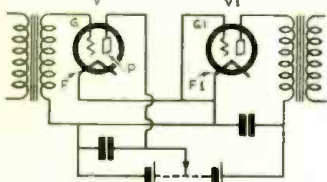

No. 362,504

G2, is also varied relatively to its filament F1 so as to control the effective output of the tube V1. So long as the grid G1 is negative, no current will flow in the lead connecting G1 and F1, and the signals are amplified without distortion. When the grid G1 is positive, electrons will flow from F1 to G1, but current is also flowing between the filament F and the plate P in the same direction. A circuit through F1, G1, F, and P is therefore completed, and the potential drop across this circuit varies automatically in such a manner as to prevent any distortion due to grid current during the positive half-cycle of the grid G1.

## External-Grid Tubes

British Patent No. 370541

In tubes of the kind in which the usual control grid is replaced by an external plate A, the latter is utilized to form part of the tuning-condenser A B Fig. 1, of the input coil L. Tuning is

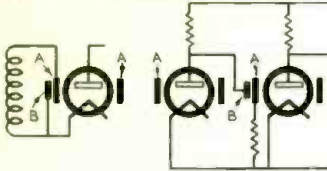

FIG. 1

FIG. 2

No. 370,541

effected by varying the distance between the plates A, B. The plates may also be used as a neutralizing condenser for stabilizing the tube. In Fig. 2, the plates A, B constitute an interstage coupling which, it is stated, also serves to suppress "hum" when the tube is fed from A.C. lines.

## Microphones

British Patent No. 370188

A highly sensitive microphone of the electrostatic type consists of a metal diaphragm M separated by a distance of the order 0.02 mm. from the metallized surface of a glass or crystal electrode G. The glass admits of a high degree of grinding to give a perfectly flat surface

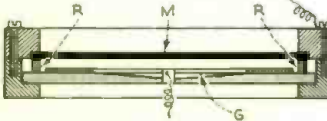

No. 370,188

on which a metal coating having a thickness which does not vary by more than 0.0001 mm. is deposited chemically. The spacing-ring R may be formed by a slightly thicker deposit of the metal. The instrument is suitable for detecting very feeble sounds, or for distinguishing between allied types of sounds as in auscultation and similar forms of medical diagnosis.

## Interference Reducer

British Patent No. 360305

To reduce interference from undesired signals, the input is applied to a pair of tubes in push-pull, while the local oscillations are applied across the grid

The most interesting radio patents granted recently to inventors in the United States and Europe are reviewed here for the benefit of amateur experimenters and research engineers who have neither the time nor the inclination to wade through stacks of irrelevant patents in a search for information. While it does not pretend to be a complete review of the patent situation, it undoubtedly will prove of considerable value to many of our readers.

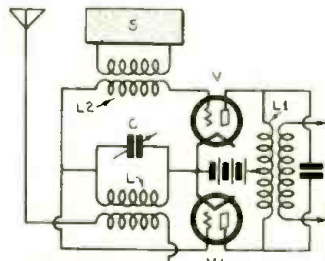

No. 360,305

and filament of one only of the pair of tubes. As shown the aerial is coupled to a tuned circuit L, C which energizes the tubes V, V1 in phase, so that the input frequencies and harmonics thereof are cancelled out in the output coil L1 feeding the intermediate-frequency amplifier. Local oscillations from a source S are applied to a coil L2 so as to produce beat frequencies in the output from the tube V only. In a modified arrangement the local oscillations are applied in phase to both tubes, and the aerial input is coupled to the coil L2.

## Television Lamp

American Patent No. 1,847,308

This invention relates to the art of television, and to an improved form of lamp for transforming the television signals into corresponding light signals.

An important object of the invention is to provide a television lamp having electrode plates which are shaped to concentrate the light generated in the lamp so as to give a more intense beam for projection on a screen or other image receiving area.

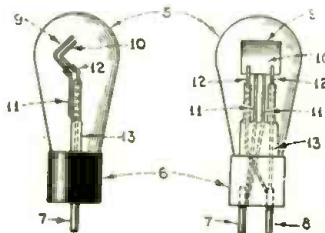

FIG. 1

FIG. 2

No. 1,847,308

This television lamp comprises a sealed envelope having positive and negative electrodes positioned therein, said negative electrode being in the form of a plate bent to form an angle of approximately ninety degrees, said angle opening away from the positive electrode.

## Electric Discharge Device

American Patent No. 1,836,829

This invention relates to electric discharge devices of the gas containing type. The principal object of this invention is to increase the life of discharge devices of this character by reducing bombardment of the filament by positive ions.

Another object of the invention is to increase the efficiency of the device by decreasing the rate of emission of electrons per unit surface of the cathode.

These objects are accomplished by forming the cathode into a helix, or solenoid of two or more turns. One advantage of this structure is that a larger portion of cathode is active in delivering space current to the anode and the cathode

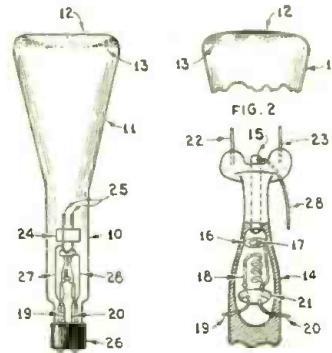

FIG. 1

FIG. 3

No. 1,836,829

can therefore be operated at a lower temperature. A further advantage results from the more uniform electric field produced by this structure between the cathode and anode.

## Glow Lamp

American Patent No. 1,834,072

This invention relates to glow-discharge lamps as adapted to the photographic or visible recording of current variations, particularly for television, producing sound records on moving picture films, etc.

Fig. 1 shows one of the circuit arrangements adapted to this purpose and to the operation of such lamps, the latter being operated mostly in connection with an amplifier; Fig. 2 shows a preferred form of glow lamp construction; and, Fig. 3 shows a circuit arrangement for utilizing the lamp shown by Fig. 2.

Referring to Fig. 1, the glow-discharge lamp 1 is inserted in the circuit of a D. C. source, say, a battery 2, the current being adjusted to a definite value by the aid of resistance 3. By means of transformer 4, the D. C. potential derived from 2 has superposed thereon a controlling A. C. potential whose amplitude and frequency is indicated or recorded by the light variations. Transformer 4, is contained in the plate circuit of the last tube of an amplifier which amplifies telegraphically received picture signals. Inasmuch as a D. C. potential exists between the electrodes of the glow lamp 1 upon which the controlling A. C. potential of 4 having comparatively low amplitude is superposed, it will be seen that one half wave of the A. C. potential which is of the same direction as the D. C. potential will cause

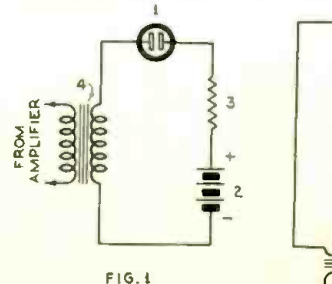

FIG. 1

FIG. 3

No. 1,834,072

Detail of the glow lamp suitable for television, the talkies, etc.

a larger flow of current and consequently will increase the luminous radiation of the lamp, while the other half wave of the A. C. potential will counteract the D. C. potential so that the discharge current and the luminous intensity of the lamp are correspondingly diminished.

## Photo-Electric Relay

American Patent No. 1,870,017

A number of liquids are known, for instance the so-called liquid crystals, and further several colloidal solutions among other things, pentoxide of vanadium, which, under the influence of an electric field applied thereto or to an electric current sent therethrough, exhibit phenomena of double refraction. These liquids may therefore be called optically active.

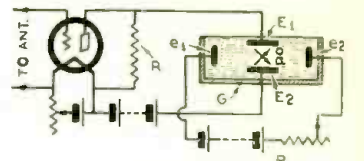

FIG. 1

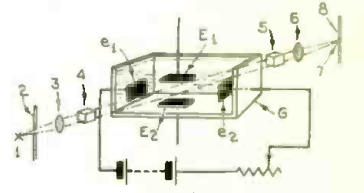

FIG. 2

No. 1,870,017

However, this arrangement exhibits too much inertia to be useful for practical work.

According to the present invention, this inertia or sluggishness in action is removed by artificial means. An auxiliary electric field is applied which serves to orientate the constituent particles of the liquid in such a way that perfect refraction in a definite direction is permanently produced and present. The polarizer and the analyzer are then so positioned with reference to each other that darkness prevails. If, then, another electric field, that is, the control field is used which occupies an angle with relation to the direction of the electric field first mentioned, reorientation of the two axes corresponding to the ordinary and the extraordinary ray, is produced, with the result that a brightening of the field of vision occurs. As soon as the controlling field vanishes, the particles without appreciable inertia will be caused to assume a position as governor by the first or auxiliary field, with the result that darkness is restored immediately.

## Synchronizing Arrangement

American Patent No. 1,856,076

This invention is concerned with an arrangement for synchronizing moving mechanisms for picture transmission or other purposes serving as a means of intelligence transmission. It more particularly relates to the case in which, in transmitter and receiver, synchronization and its maintenance is effected by the aid of time tappers priority tuned or synchronized with each other during the picture transmission process itself.

The invention provides suitable means to supply the main driving power at both the transmitting and receiving ends of the system. This is accomplished through the use of synchronous main motors roughly adjusted to the proper speed. From the shaft of the synchronous motors, or of a driving or gear part connected therewith, are supplementary or auxiliary synchronous motors to which alternating



current energy produced by the vibrating tuning fork is fed. This energy supply to the auxiliary motor serves as a corrective energy only and furnishes but a small part of the whole driving energy. On account of the fact that the amplifier is called upon only to furnish a part of the whole driving energy, no such high amplification is required and the supply

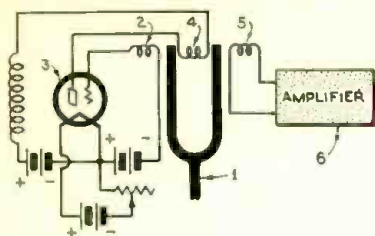

NR. 1,856,076

thereof is insured by simpler means, while the danger of reactions in the form of forced oscillations ("entraining") of the tuning fork frequency by that of the synchronous motor is more effectively precluded. It has been found that, if the total driving power of the transmitter or receiver apparatus amounts to around 50 watts, only from 3 to 5 watts are needed in the shape of synchronizing alternating current energy.

**Interference Eliminator**

German Patent No. 541,776

Fly-wheel circuit, in which a short circuiting member tuned to an undesired frequency is connected between the points provided for securing the network high frequency, characterized by the fact that the variable impedance provided for tun-

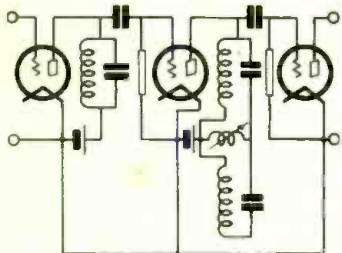

NR. 541,776

ing the short circuiting member lies between equipotential points on the fly-wheel circuit tuned to the net frequency and that the connections of the net frequency circuit lie at an equipotential point and at the connection point of unlike impedances of the fly-wheel circuit.

**Light Valve**

American Patent No. 1,834,044

The present invention relates to Kerr cells and particularly to a method and means for obtaining a higher Kerr constant for the solution employed as the double refracting medium.

It has been found from considerable experimentation that it is possible to decrease the bias voltage necessary for operating Kerr cells efficiently when the temperature of operation is lowered, and therefore, we have sought to provide a method and means by which the Kerr cell used with our invention may be at all times cooled to a considerable degree so that the Kerr constant may be increased to a material extent.

In accordance with the Present disclosure, we have arranged the cell 7 so that it is provided with a water jacket surrounding the same. Light from the polarizer 5 may be passed through the window 15 of the cell between the electrodes 23 and 25 and leave the cell through the window 17 so as to pass through the analyzer 9 in the manner above described. While the invention has been illustrated in its conventional embodiment as being applied to a Kerr cell of the two-electrode type, it is, of course, recognizable that the cell may be of the multiple-electrode type, as has been previously disclosed by Karolus.

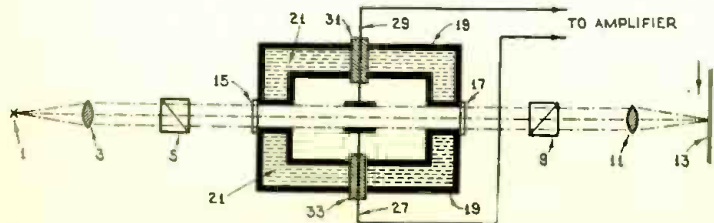

NR. 1,834,044

Cooling arrangement for light cells of the Kerr type.

**A.C. Tube Feed**

German Patent No. 540,480

Arrangement for feeding tube sets with A.C., especially for heating cathode filaments, with common connection of plate and grid at one end of the filament of the A.C. heated cathode, characterized by

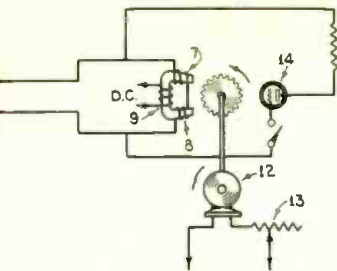

the fact that the positive pole of the plate current source is connected via a resistance of about 100 times the resistance of the space between cathode and grid to a

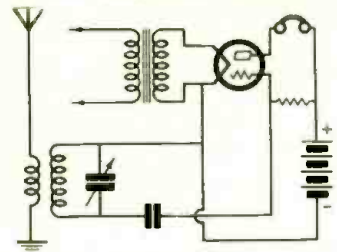

NR. 540,480

point on the grid circuit, which lies between the grid and a condenser connected in the grid circuit.

**Suppressed Transmission**

German Patent No. 538,922

Process for production of modulated high frequency oscillations, in which the side band and the carrier wave are suppressed, characterized by the fact that of two high frequency oscillations of like

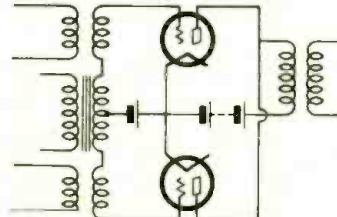

NR. 538,922

wavelength and phase the one is modulated in phase and the other in amplitude in a like degree of modulation (less than 1/2) by means of the same low frequencies, which are, however, mutually displaced by a phase difference of 90 degrees, and are afterward combined together.

**Automatic Volume**

German Patent No. 525,207

The automatic volume control (fading control) takes place by changing of the

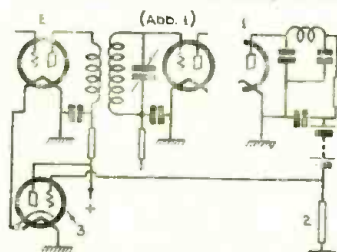

NR. 525,207

heating, as follows: A part of the received energy is conducted to the grid of the rectifier 1 (FIG. 1), and the direct current flowing through same produces at a resistance 2 a drop in potential, which changes the bias of a tube 3. The positive plate potential is conducted to tubes E and 3 at the point marked with a plus sign. Since the negative points of the heater and also the plate batteries are grounded, there flows from the plate potential connection point a current through tube 3 through the heating filament of tube E to the grounded end of the same. Thereby the emission current through tube 3, a current which is regulated by the

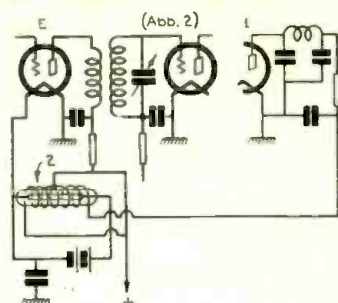

strength of the signals, is used for heating tube E of the receiver. In the case of great reception amplitude, i.e. great D.C. through tube 1, there results a greater negative grid bias of 3, which causes a small heater current. Thereby the amplification of receiver tube E is reduced. At smaller amplitude it is the reverse. The advantage of this arrangement is that the amplification of a tube can be reduced from 1:1000, without the occurrence of distortion.

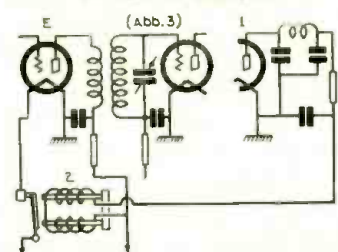

DRP. 525,207

In the case of an intermediate frequency receiver one can change the heating of the heater tube, being then independent of the quality of the neutralization. Instead of the ordinary heated cathode tube 3 one uses according to FIG. 2 a magnetron 2, through whose magnet coil flows the D.C. of rectifier 1. Thereby in the case of reception amplitude fluctuations the emission current of the magnetron and consequently the heating of a tube E of the amplifying arrangement is changed. According to FIG. 3 the D.C. of the rectifier flows through a relay 2, which in the case of great currents switches into the heater conductor of the tube to be regulated a resistance and in the case of smaller currents switches the resistance out.

**Anti-Fading Antenna**

German Patent No. 543,903

Process for reducing the fading effect in radio reception by means of a multiple number of antenna systems of different fading properties. In every amplifier system connected with one of the different antennas and the indicator arrangement there are present stages whose amplification is regulated according to the strength of the reception current of the antenna in question, and other stages, whose amplification is regulated oppositely to the strength of the reception currents of the other antennas.

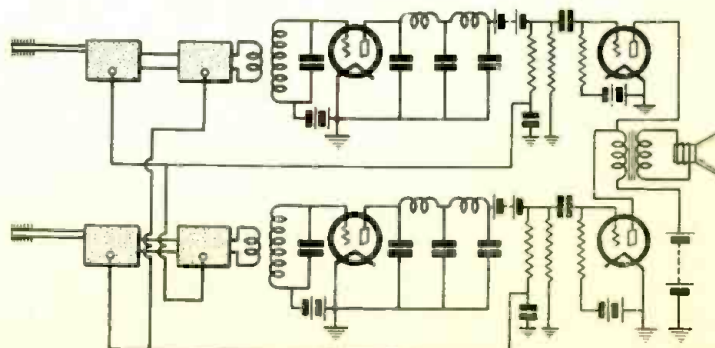

NR. 543,903

Anti-fading system employing two antennas and two receivers.

**Tube Generator**

German Patent No. 543,690

Back-coupled tube generator, characterized by the fact that for conduction of

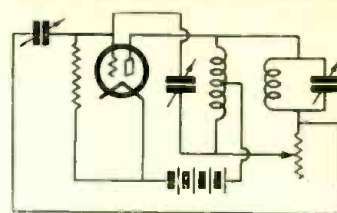

NR. 543,690

Phase-true energy from the output to the input circuits there are provided two high frequency paths, which give, only for the desired frequency, phase displacement different by the amount of 180 degrees.

**Electron Heater**

German Patent No. 534,368

Hook-up for discharge tubes with a glowing cathode heated by a heater electrode by electron bombardment, characterized by the fact that between the cathode and the heating electrode heated by an A.C. source, there are arranged

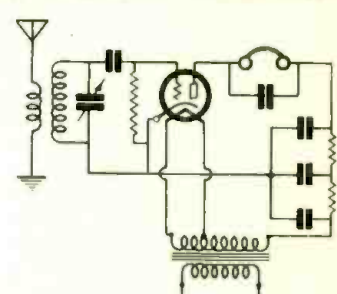

NR. 534,368

one or more condensers, which are charged by the electron stream flowing between the electrode and the glowing cathode, and by the fact that the direct potential thereby obtained at the condensers is used as plate voltage to operate the tubes.

**Amplifier Hook Up**

British Patent No. 366,683

The tube amplifier has a variable ohmic resistance 3, which is in series with the output transformer 2. The potential falls in accordance with the resistance 3 or parts of it. The potential drop is

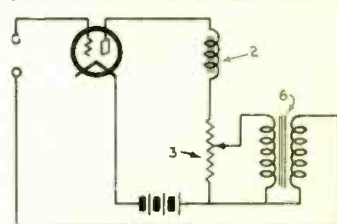

NR. 366,683

brought through transformer 6 to the input side, so that for all frequencies the potentials are directly proportional to the signal potentials. The impedance of transformer 6 is great in proportion to that of resistance 3. The conversion ratio is 1:1.



# TELEVISION SECTION

## HOW TO MAKE A SINGLE CHANNEL VOICE AND IMAGE RECEIVER

Here is a practical set, actually built by a competent radio engineer and giving good results on the Columbia Broadcasting System's combined sight-and-sound transmissions. You can build this outfit with the full assurance that it will work when finished.



Here is Mr. Matthews' receiver in use with a lens disc scanner and a lens disc glass screen.

● RECENTLY the Columbia Broadcasting System announced its new system for simultaneous transmission of television and synchronized sound on the same channel. This system of transmission is commonly known as the "double modulation method," getting its name from the fact that the radio frequency carrier is modulated by an intermediate frequency which in turn is modulated by an audio frequency. Referring to Fig. 2 a cross section of a television channel being double modulated is shown. Station W2XAB is authorized to use the 100 kc. channel between 2,750 and 2,850 kc. The carrier frequency is therefore 2,800 kc. This is modulated in the usual way by the television impulses in the form of sidebands extending on each side of the carrier for approximately 40,000 cycles. Simultaneously with the television impulses another frequency slightly higher than the television impulses is also used to modulate the same carrier. This is represented in the diagram as line C. It is on this frequency of approximately 45,000 cycles that the audio or synchronized sound frequencies are introduced, thus modulating it to the desired degree. The audio frequencies now occupy 5,000 cycles each side of the 45,000 cycle carrier as shown at D, and are found at the extremities of the 100 kc. channel.

by  
A. C.  
MATTHEWS

The principle of double modulation, while not new, has been used but very little. In Germany it has been employed in the ultra short wave band to a certain extent. In this case the ultra short wave band has been modulated by broadcast frequencies, which in turn were modulated at audio frequencies, making it only necessary to have a short wave converter ahead of a regular broadcast receiver. The broadcast receiver is then tuned to the particular sideband wanted and in this way several programs may be transmitted from a central station without mutual interference.

So much for the transmission. Now let us consider the reception. A regular television receiver is tuned to the desired station. The carrier is amplified by the R.F. amplifier and demodulated by the detector. In the plate circuit of the detector now appear two groups of frequencies, one consisting of the television impulses and the second a single frequency of the order of 45,000 cycles. At this stage we employ a filter system to segregate the frequencies and apply them to their respective amplifiers. A low pass filter

eliminates the 45,000 cycle sideband and allows all of the other frequencies to pass undisturbed to the A.F. amplifier, where they are further amplified before being transformed into light impulses by the crater tube. The 45,000 cycle frequency passes through a high pass or band pass filter, thus insuring the complete absence of the television impulses before it is again demodulated in a separate detector circuit. Upon detection and after being filtered again to suppress the R.F., all that remains in the circuit is A.F. corresponding to the synchronized sound of the television signals. This is now further amplified before being fed into a loud speaker.

No doubt this sounds rather involved but in reality it is fairly simple with the exception of the filter systems. These must be effective and shielding must be complete otherwise mutual interference between the voice and picture would result.

The block diagram in Fig. 1 shows the general layout of a receiver designed for the double modulation system of reception. Referring to the diagram we see that the signal goes through six distinct stages, viz; (1) R.F. amplification; (2) first demodulation; (3) filtration; (4) television impulse amplification; (5) second demodulation; (6) voice amplification.

The R.F. amplifier, as may be seen in the schematic wiring diagram, consists of two stages of tuned radio frequency amplification employing the new type 58 super control radio frequency pentodes. Data for winding the tuning coils are given in table 1. R.F. chokes whose resonant point is slightly below the television band in frequency are used in the plate circuits of the tubes. This tends to make the plate load capacitive in the television band and thereby increases the circuit stability. Separate bias and screen resistance-capacity filters

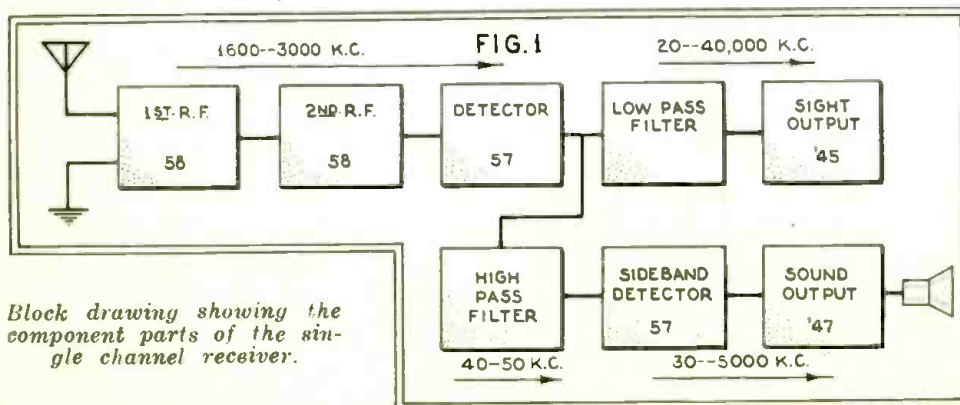

Block drawing showing the component parts of the single channel receiver.



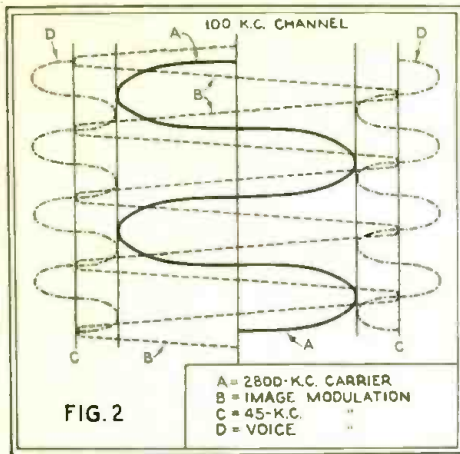

Above: diagram of double modulation system. Right: full schematic diagram of the Matthews receiver.

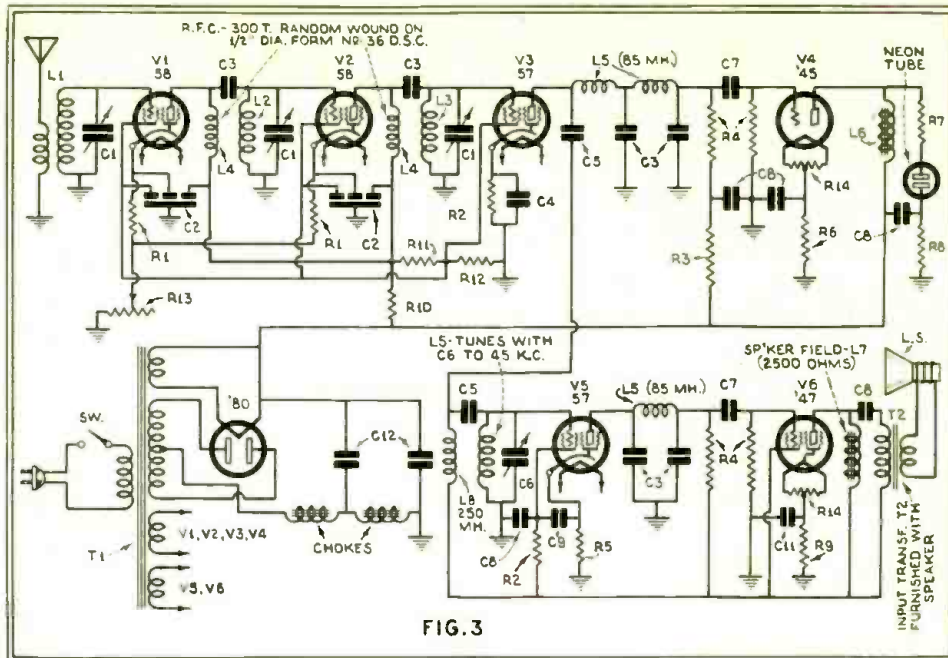

are employed to prevent common coupling in these circuits. It is essential that the R.F. bypass condensers be located in close proximity to their associated sockets. Shielding must be complete and the new type shields are recommended.

The first and second demodulators are essentially the same as far as circuits are concerned. Both operate on the lower bend of their characteristic curve and are self-biased by resistors in the cathode circuit. An R-C filter is employed in the voice detector to isolate its screen grid from the picture detector, thus preventing common coupling being introduced into the circuit.

Special consideration as to frequency response has been given the television amplifier and the values indicated should not be deviated from if good pictorial quality is wanted. The voice amplifier is orthodox in every respect and requires no further description.

The filter system is one of the most important parts of the receiver. The low pass filter must take out all of the 45,000 cycle component in the first detector plate circuit and pass the other frequencies undisturbed to the high quality audio amplifier. The L-C network shown does this very effectively so that there is no distortion of the received image.

The high pass filter eliminates all of the television impulses from the voice receiver. The filter is terminated into a circuit tuned to 45,000 cycles, and

In this clear article Mr. Matthews explodes the notion that a receiver for the interesting C.B.S. single-channel voice and television broadcasting is hopelessly complicated. He tells how to build an efficient, sensitive set with ordinary parts.

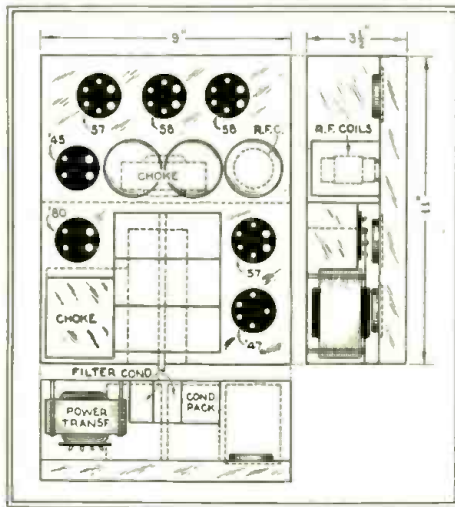

forms the input to the second or voice detector.

A drawing of the chassis is shown in Fig. 4 and if carefully followed no trouble should be experienced in building this receiver. Sheet steel 0.05" thick was used and finished in a dull black to prevent rusting. Note that the television section is shielded from the voice section by a steel partition. This partition or shelf is the mounting for most of the R.F. and first detector circuits. If desirable another tube may be added in the television output circuit in parallel with the single 245 now employed. The choke in the output circuit provides the necessary phase reversal for giving a positive picture.

Parts List

- | Item | Description   |
|------|---|
| L-1  | Antenna coil (see separate specification).                              |
| L-2  | R.F. Coil (see separate specification).                                 |
| L-3  | Detector Coil (see separate specification).                             |
| L-4  | R.F. Choke Coil—300 turns random wound on 1/2" form No. 36 d.s.c. wire. |
| L-5  | R.F. Choke 85 millihenry—National or General Radio.                     |
| L-6  | Output Choke Acra-test—15 henry 65 ma.                                  |
| L-7  | Speaker field 2500 ohms—Rola.   |
| L-8  | 250 mh. choke—Hammerlund or equivalent.                                 |
| C-1  | Three gang 0.000180 mf. condenser.                                      |
| C-2  | Three 0.1 mf. units in can. Can to be common terminal.                  |
| C-3  | 0.0001 mf. mica dielectric condenser.                                   |
| C-4  | 2.0 mf. paper or dry electrolytic condenser 50 volts d.c.               |
| C-5  | 0.001 mf. mica dielectric condenser.                                    |
| C-6  | 0.0001 mf. variable trimmer condenser—Hammerlund or equivalent.         |
| C-7  | 0.25 mf. 400 volt D.C. paper dielectric condenser.                      |
| C-8  | 1.0 mf. 400 volt D.C. paper dielectric condenser.                       |
| C-9  | 0.1 mf. 200 volt D.C. condenser.  |
| C-10 | 0.02 mf. 400 volt D.C. condenser.                                       |
| C-11 | 4.0 mf. dry electrolytic condenser 50 volts D.C.                        |
| C-12 | 8.0 mf. dry electrolytic condenser 500 volts D.C.                       |
| T-1  | Power Transformer—"Acra-test" No. 2532.                                 |
| T-2  | Output transformer supplied with speaker.                               |
| R-1  | 300 ohms 1/2 watt carbon resistor.                                      |
| R-2  | 30,000 ohms 1/2 watt carbon resistor.                                   |
| R-3  | 50,000 ohms 1/2 watt carbon resistor.                                   |

(Continued on page 248)

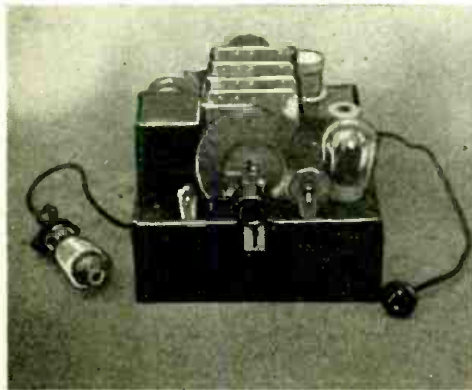

Above, right: chassis layout. Below, left: front view of the completed receiver. Above, right:

back view. The crater tube is shown next to the chassis, but actually it mounts behind the disc.



# NEW RADIO TUBE PRODUCES POWERFUL "COLD LIGHT"

"Inductively energized" bulb, filled with mercury, generates 250,000 candlepower under influence of radio currents. Successfully demonstrated for large screen television, and is intended also for motion picture projection, photography and numerous other applications. Inventor is Elman B. Myers, radio pioneer.

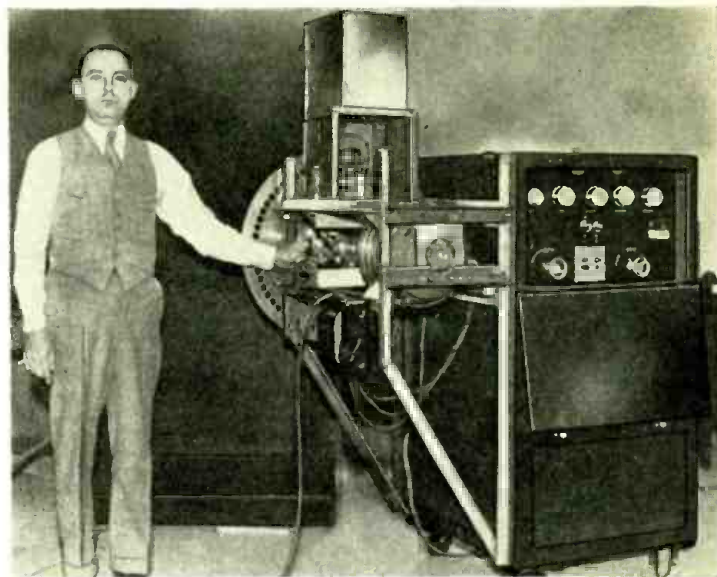

E. B. Myers with the television projector employing his new "cold light" tube. The cabinet on the right contains the R. F. oscillator that energizes the lamp inductively.

● A NEW radio tube, heralded as a practical source of unlimited "cold light" with which television screens can be flooded, was demonstrated October 12th, 1932 by the Myers Electrical Research Laboratory in the Chrysler Building, New York. The engineers asserted the bulb had overcome a tremendous obstacle in television by responding instantaneously and completely to the rapid fluctuations of radio waves that carry images.

The lamp generates 250,000 candlepower of light, and that, according to research engineers, is what television needs to flood the screen with illumination that clarifies the pictures. The efficiency of the new lamp is estimated by the engineers as twenty times that of the best incandescent lamp and from six to seven times as brilliant as the carbon arc lamp. It is called a "cold" light because most of the electric energy goes to produce light and not heat, as is the case with an incandescent lamp.

## Efficiency Is High

It was pointed out at the demonstration that the incandescent lamp gives a mean illumination of approximately 1.67 candlepower to the watt. The arc lamp (yellow) generates about 2.94 candlepower to the watt, and the "cold" bulb produces upwards of twenty candlepower for each watt of electricity consumed. So little heat is generated that the "cold" tube in operation can be held in the hand. It can be used in all processes of record-

ing or projecting film pictures without heat-protective devices. There is no radiant heat to shrink the film.

"An adequate source of light of great brilliancy and quick responsiveness has been the limiting factor in television," said Elman B. Myers, the inventor. "The mechanics of television have been fairly well established, but a satisfactory light source was lacking."

The new tube is known as "an inductively energized lamp" which cre-

ates light by the disassociation of the mercury atom. This is accomplished by placing the lamp inside a coil of copper tubing through which a high-frequency current circulates. Vacuum tubes generate the current.

The lamps vary in size from an inch in diameter to about two and a half inches. The larger lamps are capable of greater illumination. The small lamp is employed in the television circuit. A thimbleful of mercury is used inside of each bulb.

Mr. Myers foresees numerous applications for the tube, including medical diagnosis, therapeutics, sun lamps, photography, lithographic operations, flood-light lamps, mineralogy, beam telephony, fog beacons, sound-on film recording and motion-picture projection.

## Large Images Obtained

In the television tests images were intercepted from station W2XAB, atop the Columbia Broadcasting System's Building at 485 Madison Avenue. The pictures were shown on a screen about 26 inches square, although the glass lens measures 3 feet.

"We can develop these tubes to produce 1,000,000 candlepower," said Mr. Myers, who was one of Dr. Lee de Forest's assistants when the vacuum tube was first built for radio work. "And at that brilliancy the bulb will be about 100 times as efficient as an ordinary incandescent lamp. We plan to cast television images on a theatre-size screen and expect no difficulty because we have plenty of light. The tube in use in our receiving set has been in operation 7,000 hours and we can build tubes for that size for \$10.

"We propose to build a high-power television transmitter rated at 10,000 watts and also television-equipped trucks that will flash scenes back to the main station for relay to theatres. We are also designing tubes to replace the arc in motion picture projectors."

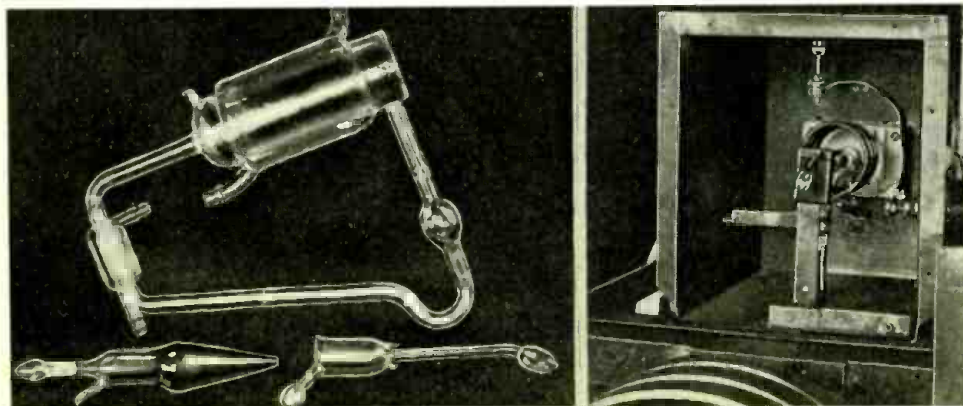
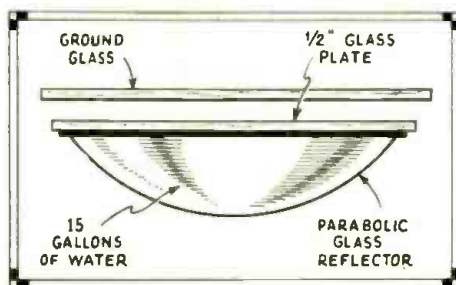

Right, above: Arrangement of the novel "magnifying glass" screen used for the television demonstration. Bottom, left: Three forms of Myers "cold light"

tubes. The large one can be made to develop a million candlepower of light. Bottom, right: Close-up of the Myers tube inside the modulating coil.



# TELEVISION SET LIKE A CAMERA

New Baird televisor is first home machine to use nicol prisms for modulation of light. Images are reproduced in black and white instead of customary red and black, and measure four by nine inches.

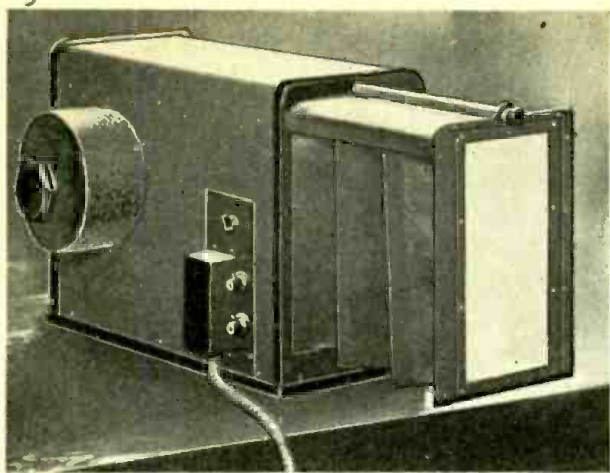

● JOHN BAIRD, the English television inventor, having replaced his scandisc with a mirror drum and made the receiving set like a camera, has won through on his system. It has been officially accepted by the British Broadcasting Corporation, which is now conducting all its visual transmissions by the Baird system.

The new television set is made, on license, by all the leading manufacturers, and can be purchased and made up from a kit for about \$60. The finished article is retailed at about \$150.

Revolutionary changes have been made in the principles of this instrument, which is far in advance of the old model, in which the image could only be seen by two people at a time and was of a reddish color streaked with moving lines.

Now instead of looking into a lens, the image is thrown—in the home model—upon a screen which pulls out like a camera and measures nine inches high by four wide. Its brightness is such that it can be viewed in comfort in a brightly lit room and can be seen with ease by a number of people.

The image, instead of being a reddish color due to the lighting of the neon tube, is black and white and is also free from one of the early television defects, the apparent traversal of vertical lines across the whole field.

The apparatus is simply plugged into the electric lines, no batteries being required, and it can be operated from any good radio set, if it is bought separately.

The home televisor is extremely compact, measuring when closed, 1 foot



Top left: the new Baird televisor with the screen pulled out. Above: John L. Baird, noted television inventor, with his latest machine.

6 inches long, 8 inches wide, and 13 inches high.

For public television the small screen is replaced by one measuring three feet high by seven wide, and this is being used in many motion picture theatres for the televising of public events. Only recently the Derby horse race was televised in this manner to an audience of several

thousand. (See October issue of TELEVISION NEWS.)

It will be of interest to American television "fans" to follow the plans of those across the sea and for their benefit, so that they may compare the systems that are being used.

The most important part of the Baird instrument is the nicol prism, two of which are used with a Baird grid cell between. It is common knowledge that a beam of light consists of vibrations in two directions at right angles to one another. The action of a nicol prism is to extinguish the vibrations in one direction, or, in other words, to upolarize it. If no cell were interposed and the second nicol prism was arranged to polarize the light in the opposite plane, the net result would be that no light would get through.

The Baird grid cell, consisting principally of small condenser plates immersed in a liquid called nitro-benzene, has the effect of turning the plane of polarization through an angle. The result is that the extinction of light is not complete and a certain proportion of the light from the lamp passes through the second nicol prism.

(Continued on page 252)

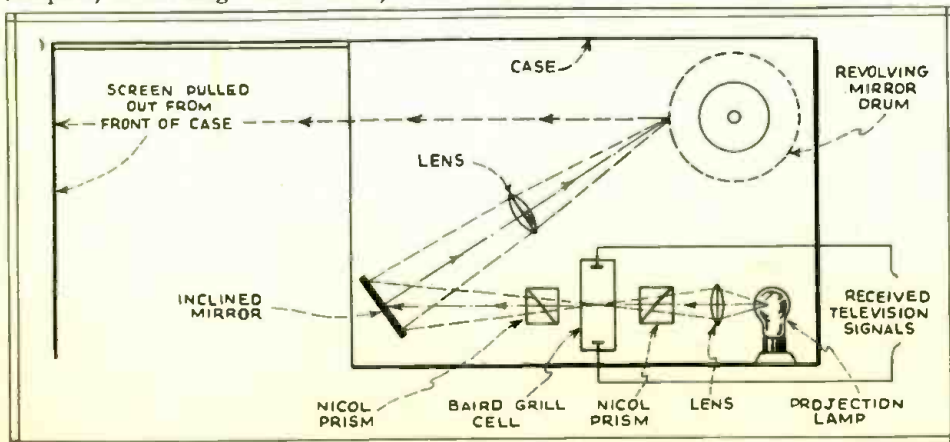

Arrangement of the parts in the new Baird televisor. The projection lamp provides a source of white light.



# DIODE DETECTION IN TELEVISION

by C. BRADNER BROWN

The diode, or two-element rectifier, is enjoying considerable use in the latest broadcast receivers, but few experimenters have thought of using it for television. Its characteristics are very favorable for this work, as the author points out in this practical article.

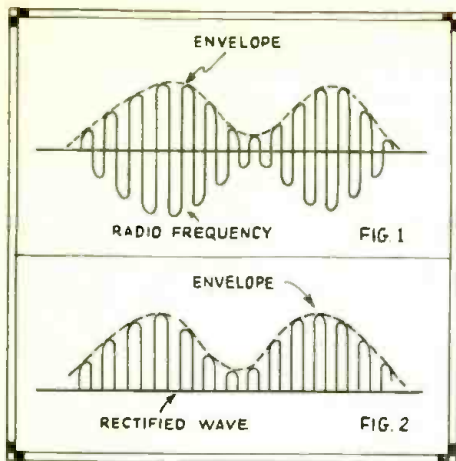

Action of perfect rectifier

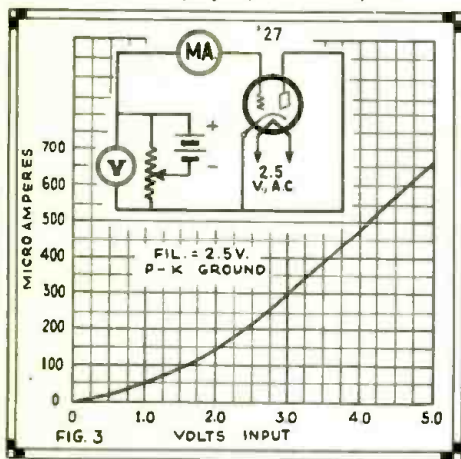

The 27 as a diode detector; below, its circuit hookup.

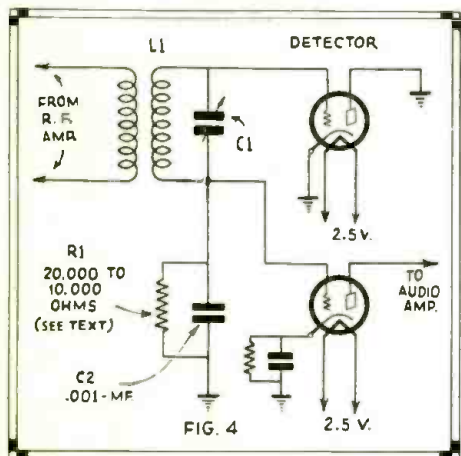
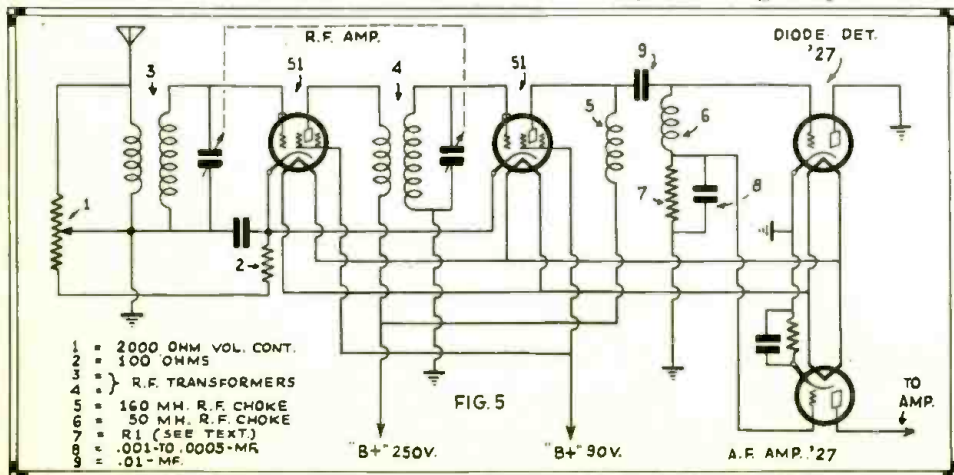

Figure 5, below:



- 1 = 2000 OHM VOL. CONT.
- 2 = 100 OHMS
- 3, 4, 5 } R.F. TRANSFORMERS
- 6 = 160 MH. R.F. CHOKE
- 7 = 50 MH. R.F. CHOKE
- 8 = R1 (SEE TEXT)
- 9 = .001-TO .0005-MF
- 10 = .01-MF

● ALTHOUGH much has been written on detection in television, little thought has been given to the diode detector. Whether this is due to lack of information on the subject, or to some prejudice against the system, the author cannot say. However, although not perfect, the diode detector has some characteristics which the television designer may well consider before discarding it entirely.

At this point, an examination of the characteristic of a vacuum tube which constitutes its ability to detect signals is in order. Detection is primarily rectification, although the term must be used in its broadest sense. It should actually be called *demodulation* in order to fully cover the complex action taking place in various detectors. Coming from the radio frequency amplifiers, we have a modulated radio frequency wave such as that shown in Fig. 1.

## The Modulation Envelope

The envelope, which is represented by the dotted line, varies as the audio signal impressed at the transmitter in the modulation action. It is this envelope that must be operated on so as to produce a current which will vary in the same manner as the envelope in detection or demodulation. The best known method of obtaining a current varying as the envelope is to rectify the R.F. wave with some device that will remove one half of the wave, either positive or negative. Grid bias and grid leak detectors are *distortion rectifiers*; that is, their operating characteristics are such that the application of a positive voltage gives a greater swing than the application of a negative voltage, or vice versa. Hence, the resulting wave form in the plate circuit does not follow exactly the envelope shape, especially for weak currents. Although this action makes but little difference in the reproduction of music or speech, it greatly influences

the results when used in television. This distortion takes the form of blurring the image detail and in reducing contrast. It is not so noticeable when the signal is fed to a grid bias detector at a high level, but when used with weak signals, the blurring effect is quite noticeable. Figure 2 shows the results obtained when the R.F. wave is rectified with an absolute rectifier.

It will be noticed that the current never goes below the line, showing the absence of the most important type of distortion. This action is typical of the crystal detector, but it is a well known fact that crystal detectors are notoriously unreliable. This is true both from the point of contact pressures and a general steadiness of action. Inasmuch as the exact operating characteristics of crystal detectors are not known definitely, it is difficult to predict accurately the operating curve. Hence, it is almost impossible to match impedances, predict output voltages, etc., all of which is extremely important to the television experimenter.

However, the diode detector has precisely the same operating characteristics found in the case of the crystal detector minus the erratic operation. Figure 3 shows the characteristic curve of a type 27 operating as a diode detector. The connections for this circuit are shown in Fig. 4.

## Diode Not New

The diode detector was used by de Forest in his early experiments and makes use of the familiar "Edison Effect", in which current flows from plate to filament by electronic emission. It is, in effect, a half-wave rectifier with a few refinements. Since the tube does not act as an amplifier, it must be fed with relatively strong signals. It was abandoned in the early days because the same number of tubes connected so as to utilize grid leak detection could be made to offer stronger audio signals. This, however, is not of prime importance in modern design, since in modern multi-tube sets an extra tube makes but little difference.

The diode detector will handle the strongest signals without distortion or overloading. Since its characteristics are of the linear order, the reproduction of the R.F. envelope is faithful. In Fig. 4, it will be noticed that the



# "VISIONETTE" CIRCUIT

plate is grounded. The grid is used as the electron collector in order to reduce the interelectrode capacity, while the plate is used as a static shield to reduce stray charges and prevent the accumulation of any charges that might influence the action at low signal levels. The diode detector is particularly adapted to operation in a super-heterodyne circuit, in which case the tuning condenser  $C_1$  can be of the pressure screw type entirely insulated from the frame or chassis.

The size of the resistance  $R_1$  depends on the signal input at which the detector is to be operated. From the curve in Fig. 3, we find that the impedance of the type 27 as a diode detector ranges from 20,000 ohms to 6,000 ohms. At signal levels of 1 volt and under, the impedance is of the order of 20,000 ohms. Hence, if the detector is to be used at this point,  $R_1$  should be made equal to it or 20,000 ohms.

However, the impedance decreases to 12,000 ohms at 1.5 volts input and still further to 6,000 ohms at 3 volts input. Hence if the detector is to be used as a power detector at input voltages ranging from 1 to 5 volts, it is best to lower  $R_1$  to about 10,000 ohms for best performance and quality. The distortion due to impedance mismatch will be almost unnoticeable for these values.

## Complete Circuit

If the diode detector is to be used in the conventional T.R.F. type set, some adaption must be made. Figure 5 shows the connections used in a two stage R.F. amplifier operating into a diode detector.

The use of the type 51 tubes as R.F. amplifiers gives the necessary gain, without cross talk or undesirable cross modulation. This is especially valuable in the larger cities where strong local signals from broadcasting stations are very prominent. The use of tuned secondaries in the R.F. stages with large primaries wound directly over the center of the secondaries offers large coupling coefficients and at the same time broadens the tuning of the R.F. stages to prevent clipping the sidebands.

The second R.F. stage is coupled into the diode detector with a double choke impedance system. A value of 10,000 ohms for  $R_1$  at 7 gives good results. The bypass at 8 is not entirely necessary, and the constructor will do well to omit it if possible. The value of the choke coil 5 will not be found to be critical. Some juggling of these choke coil sizes will no doubt prove helpful in obtaining best results.

The writer is interested in knowing what results other experimenters find in using this new type of detection.

● NOISY tuning in a short-wave set can often be traced to the pigtail connection rubbing against some part of the condenser frame. When working down on 15 meters and thereabouts, the rubbing of the pigtail turns against themselves will sometimes even cause a scraping noise. Keep the pigtail connection as short as possible and spaced away from the condenser frame. —*Amateur Wireless* (London).

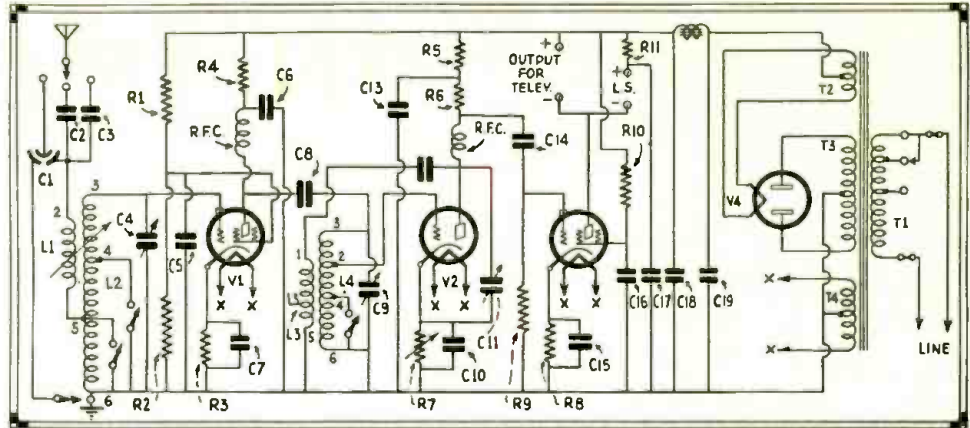

● EVERY EFFORT has been made to give the best quality of reproduction in the "Visionette" receiver, as distortion of the signal in television is a factor which must be carefully guarded against, as "Television", (London). The circuit comprises a single stage of R.F. amplification, detector and pentode output stage, for full A.C. operation. American tubes of the 35, 27, 47 and 80 types may be employed.

The value of the parts are as follows:  $C_1$ , .0001 mf. split rotor condenser.  $C_2$ , .0002 mf.  $C_3$ , .005 mf.  $C_4$ , .0005 mf. gang condenser.  $C_5$ ,  $C_6$ ,  $C_7$ , 1 mf.  $C_8$ , .001 mf.  $C_9$ , .0005 mf.  $C_{10}$ , .0003 mf.  $C_{11}$ , .0001 mf.  $C_{12}$ , (connects to  $L_3$ ), .0003 mf.  $C_{13}$ , .0001 mf.  $C_{14}$ , .0001 mf.  $C_{15}$ ,  $C_{16}$ ,  $C_{17}$ , 2 mf.  $C_{18}$ ,  $C_{19}$ , 4 mf. The values of the various resistors will naturally depend on the tubes selected. The power transformer must have two 2½-volt windings for the radio tubes and one 5-volt winding for the rectifier, in addition to the high voltage winding.

# TELEVISION ON 4 TUBES

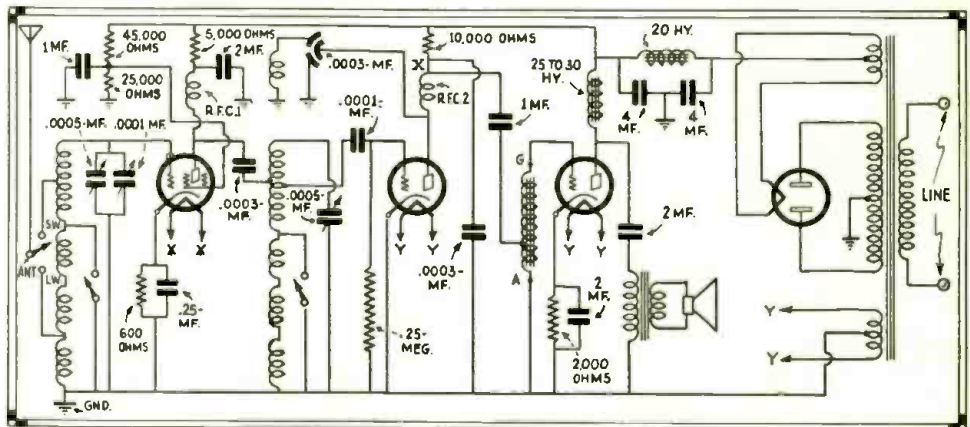

## Canada Now Has 8 Television Stations

There are now eight television stations on the air in Canada, according to a pamphlet issued by the Department of Commerce in Washington. The complete list is as follows:

- VE9AU, London, Ont., 2,000 to 2,100 kc.
- VE9ED, Mont Joli, P. Q., 2,850 to 2,950 kc.
- VE9AF, Montreal, P. Q., 2,850 to 2,950 kc.
- VE9DS, Montreal, P. Q., 2,100 to 2,200 kc.
- VE9EC, Montreal, P. Q., 2,000 to 2,100 kc.
- VE9AR, Saskatoon, Sask., 2,850 to 2,950 kc.
- VE9RM, Toronto, Ont., 2,000 to 2,100 kc.
- VE9BZ, Vancouver, B. C., 2,750 to 2,850 kc.

● HERE is another simple four-tube television receiver, also described in "Television" (London). An auto-transformer arrangement is used between the R.F. tube and the detector. The latter is regenerative, with the feed back controlled by a split rotor condenser as shown.

Note that the audio amplifier is also of the auto-transformer type. Of course this may be replaced by a high grade transformer or resistance coupled stage, as auto transformers for A.F. work are no longer generally available in the United States.

The power system is of straightforward design. The rectifier tube may be an 80 or an 82, depending on the power transformer on hand. The R.F. tube may be a 24 or 35, the detector a 27 and the audio output tube a 47 or any of the newer power tubes.



# A POWERFUL SEVEN - METER SUPER - REGENERATOR

This small, simple three-tube unit packs a strong "wallop" on the ultra-short-wave bands. Its features are complete shielding, absence of microphonic noises, and high amplification. It can be used with any good audio frequency amplifier.

by NORMAN B. KRIM

● EXPERIMENTERS throughout the country have found this little receiver virtually foolproof, an oddity for receiving equipment designed to operate below fifteen meters. With the advent of television on seven meters, suitable receiving equipment must be offered for reasonable success on these quasi-optical waves. The ordinary Reinartz or Schnell detector units with radio frequency amplification are useless because of very low efficiency and instability on the seven meter wavelength. Of course it is possible to build up a suitable detector unit with very low capacitive and inductive properties, but each set will be difficult to coax into operation and the signal strength will be comparatively poor. The only solution to the problem with the present equipment is super-regeneration in the detector unit. Radio frequency stages are not worth the copper in their leads with the tubes and circuits available.

In the following discussion only the detector unit will be treated, for the output can easily be fed into any of the usual amplifier circuits with little

trouble. Unlike most 1932 equipment, direct current is used throughout, for two reasons. Firstly, the usual filtered "B" supply is noisy on the very short waves in most every case; secondly, the new automobile tubes used, the '37's, are lighted from a storage battery supply which can vary from 5.5 to 8.5 volts with little effect on the operation of the tubes. Their real worth lies in the fact that they are non-microphonic. Another desirable feature which they possess is a smaller inter-electrode capacity than any tube of similar function. The '27 has also been used successfully in a very similar circuit with an appreciable hum which could not be entirely eliminated.

The detector unit must be completely shielded and carefully constructed. The main tuning condenser used was a Cardwell mid-line 404 B, of .0001 mf. Due to its position in the circuit, it could not be mounted on the front aluminum panel. Mounting was effected on a small angle about three inches behind the panel to minimize hand capacity. A large diameter dowel was

converted into an extension for the condenser shaft to reach the dial on the panel. It should be apparent that a good vernier dial is absolutely necessary for any ease of tuning. Directly on the back of the tuning condenser is the coil mounting—an odd one indeed. There are four pin jacks set in the strip mounted on the back of the condenser. The two center ones should be about  $\frac{5}{8}$ " apart; two on one side are for one coil, L1, and the two on the other side receive the second coil, L2. The coils themselves are the limit in size—wound in the same direction on a pencil, spaced one turn width, ends fitted with plugs to match the jacks, of heavy copper wire, they are odd!

Directly in back of this coil mounting is the socket which is turned so that the grid and plate leads which go directly to the coils are shortest. With a short lead to the grid leak and then to the cathode, the important portion of the detector unit is completed. The R.F. choke was not very critical; it was wound on a wood dowel mounted horizontally on the baseboard. The

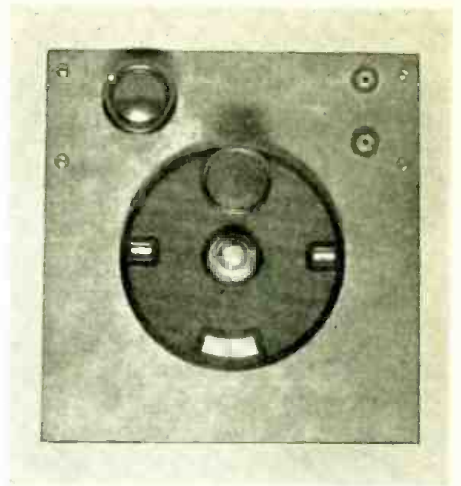

Front view of the tuning unit, showing the simplicity of the panel.

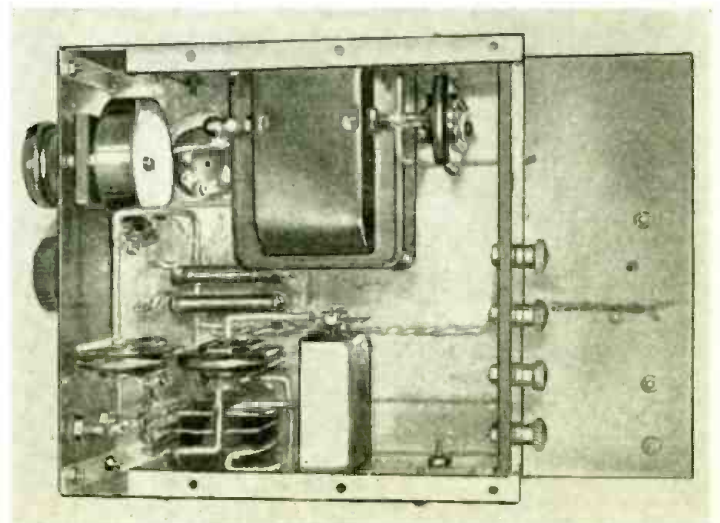
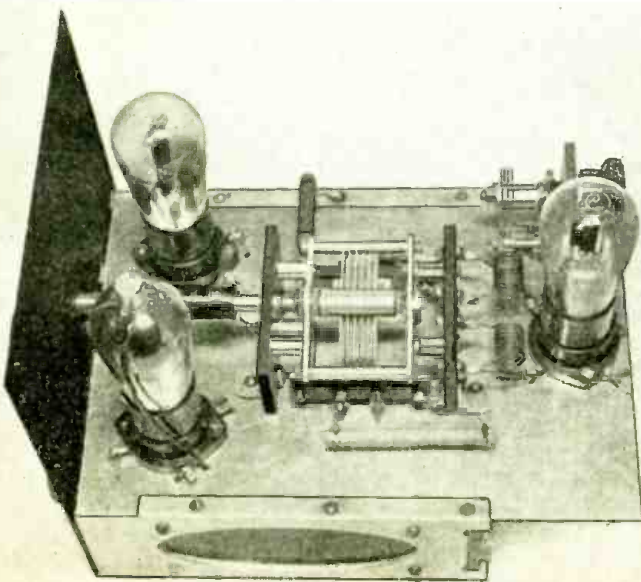

Left: Inside view of the tuner. Note the small tuning coils behind the variable condenser. Above: Under view of the chassis.







# THE TELEVISION

# QUESTION BOX

Conducted by C. H. W. NASON

### Negative Images

Joseph Zalinski,  
1637 Blackhawk Street,  
Chicago, Ill.

Q.—The New York Sun Second Prize Television Receiver would not work for me as shown in the diagram published in the March issue of TELEVISION NEWS. After making the changes shown by the circles on the attached diagram (Fig. 1) the set performed well, but gave negative images. Can you tell me the probable cause?

A.—The probable cause of the negative images depends upon two things. First, it is possible that the receiver is functioning correctly and that the station received is deliberately transmitting a negative image for experimental purposes. The second possibility lies in the fact that in the arrangement shown the two direct coupled tubes will function as a combination detector. The phase of the output might, under such conditions, depend upon the magnitude of the input voltage. It is also possible that the '47 is hopelessly overloaded. We note the fact that the second grid is attached to the low potential side of the neon tube. The voltage drop across the neon tube will then give the plate a much lower voltage than the screening grid, with malfunctioning of the device a sure result. Try a 5,000 to 10,000 ohm resistance in series with the screening grid, by-passed to ground at the 2nd grid terminal of the socket by a condenser of about 1 mfd.

### Special Optical System

Harry Lipnick,  
493 Springfield Ave.,  
Newark, N. J.

Q.—I seek an optical system which will make every ray of a beam reflected from an object being televised parallel. I wish to use this in a television employing the Skala system (Pat. 1,678,132) this being the only practical system I have seen which does away with scanning.

In the July-August issue of TELEVISION NEWS there is an article by H. F. Dalpayrat—Page 124, Fig. 1—I notice here a lens system which supposedly accomplishes this object.

How could all the light coming from a 40 or 60 watt lamp be made parallel? I might add that in both instances the parallel rays are to pass through Nicol Prisms.

A.—Light from a point source may be converted into a parallel beam by placing it at the focal point of a lens. You require a system in which the focus is infinity. It is sometimes a misfortune that the Patent Office no longer requires a working model—some of the boys would be hard put for wall paper. That last remark may be bitterly put—but it is simply a plea for measures protecting those who would spend money on pat-

ents from which they can reap no benefit. For example—the cathode-ray tube seems a simple answer to the problem of home television. Yet cathode ray television is just around the same corner as two years ago. Why not purchase a small C-R tube for about fifteen dollars and try to get an even scanning field—not an image but a simple field of view free from messiness. Try getting the field in such a way that the scanning is controlled by the 60 cycle power line so that the synchronizing waves may be done away with in local reception. Not a large problem! And every piece of apparatus will be useful later. With regard to the necessity for parallel rays in your system—try an optical arrangement similar to that of the telescopic camera—but in reverse. It is the only possibility—and unfortunately I am not in a position to do the job for you. The arrangement is as shown in Fig. 2. The rays are drawn roughly for your guidance. A trip to the offices of one of the larger lens manufacturers, where an optical bench is available, might serve to indicate the possibility or the fallacy of my offering. I suggest the Hugo Neyer Optical Company in New York.

### Transmission Data

J. Eugene Fay, Middletown, Ohio.

Q.—Which stations transmit negative images and which transmit positive images?

Is the stand frame six to five ratio for all stations?

Do all stations transmit a synchronizing signal? How are they received?

A.—All stations within the writer's knowledge transmit a positive image in which the maximum carrier amplitude is coincident with maximum image brilliancy—save only those of the Western Television Corporation, which sees fit to transmit a negative image for reasons involved in the overload characteristics of the transmitter.

The aspect ratio of 1.2 (7.2:6) is correct for all stations except those named above as employing negative transmissions. Without just reason it is the writer's conviction that these stations trans-

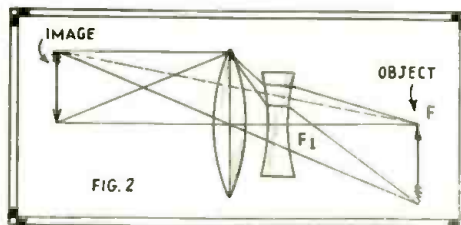

Special optical system suggested by Mr. Mason.

mit an image having an aspect ratio equal to unity (a square image).

Some stations block off a portion of one edge of the image to give a strong component of the scanning frequency to the output. For a 60 line image at 20 images per second this frequency is 1200 cycles; for a 45 line image at 15 per second, 675 cycles. Even where the edge of the image is not blocked off to give a definite component of the

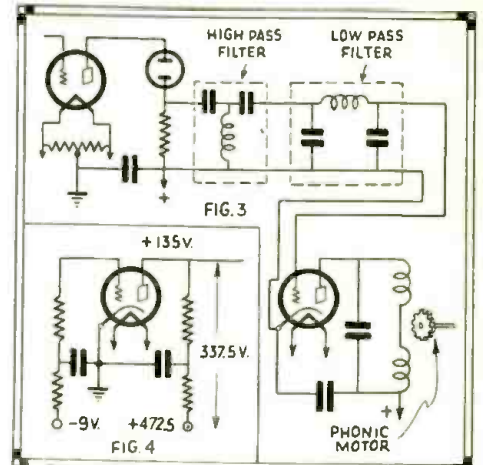

Fig. 3: Tapping off the scanning frequency to operate a phonic motor.

Fig. 4: Voltage distribution system in amplifier circuit.

line frequency a strong signal is to be found. Figure 3 gives the method for tapping off this frequency for application to a phonic wheel synchronizer.

In the figure we find the output tube, the crater lamp, a resistor in series with the crater lamp across which a portion of the signal may be taken off. A band pass filter section cutting out all signal components save the 1200 scanning wave. The output of the filter is fed to an amplifier which in turn feeds a 1200 cycle, 1200 r.p.m. synchronous motor.

### Photo-Cell Amplifier Query

Q. Will you kindly show across the terminals the voltage drops in the photo-cell amplifier shown on page 141, July-August issue.

I would also like to know which can be supplied by the power pack.

Should the terminals labelled "plus" be the voltage required at the plate of the tube or should they include the drop along each resistance?

A.—In designing an amplifier for any purpose the method is based upon the grid bias required at the input to the tube to prevent any possible overload. In screen grid tubes voltages are also dependent upon the fact that the tube must not be operated over the curved portion of its characteristic curve. All this is covered in a series of two articles which began in the October issue of TELEVISION NEWS covering completely the design of television amplifiers. In order that no mistake be made, however, we will restate the case. Suppose that a '45 tube must be given its full allowable grid swing of 50 volts (peak) from a '27 tube having an active plate load impedance of about 50,000 ohms. A 50,000 ohm load permits of an amplification at some mid-range frequency of about 8. Dividing 50 by 8 we have arrived at the figure 6.25 for the peak voltage input necessary to develop 50 volts for the grid of the '45. The grid bias of the '27 must then be 6.25 volts or greater. The "dope" gives us a logical operating point at  $E_b$ —135 volts,  $E_c$ —9 volts and  $I_p$ —4.5 m.a. With a load resistance (active) of 50,000 ohms and a filter resistor of 25,000 we have a voltage drop of 337.5 volts—the terminal voltage required being 472.5 volts. The voltage distribution is shown in Fig. 4.

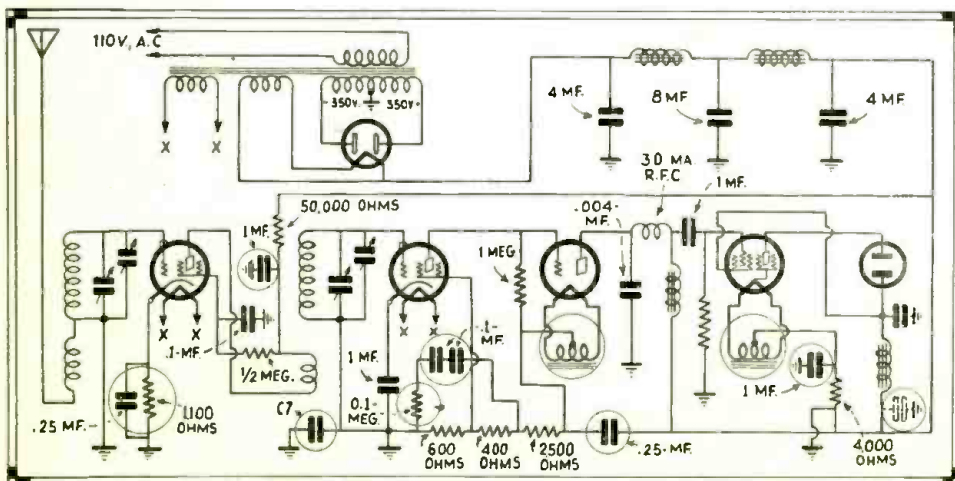

Fig. 1: New York Sun Prize Winning Television Receiver.



## IS THE VARIABLE CONDENSER DOOMED?

(Continued from page 218)

material, even though it be inserted right inside a tuning coil.

On the other hand it does still have a very marked effect on the inductance of the coil, increasing the inductance just as an ordinary iron core will increase the inductance at low frequencies. The total variation of inductance with the core completely inserted, as compared with the inductance with no core, is about 8:1, which is quite sufficient to tune a coil over the normal waveband.

The tuned circuits are made up with a small coil tuned with a fixed condenser to the shortest wavelength required. As the iron core is inserted the wavelength of the circuit increases steadily until, with the core completely in position, it tunes to the highest wavelength (for example, 550 meters).

The "core" is arranged to go both inside and outside the coil itself and the whole arrangement is included in a metal can for shielding purposes as shown in Fig. 1.

Now we come to a second important advantage of this system. The variation of the inductance is always of the same order, namely, 8:1, irrespective of the actual inductance of the coil.

Consequently we can have two coils of different inductances and tune them both together by merely inserting cores into each. In other words they will be ganged up just in the same way as we gang condensers, and will tune to the same frequency throughout the tuning range, although their actual inductances and tuning capacities are quite different.

Needless to say, the tuning capacities must be so adjusted that the circuits tune to the same frequency without the core in position but, once this has been done, the mere act of inserting cores in the coils at the same time and the same rate causes the circuits to tune in unison.

This is a very considerable advance over the present practice, where it is necessary not only to make the coils exactly equal, but also to match up all stray capacities before the circuit can be properly matched.

One obvious development of this idea is shown in Fig. 2, where we have three tuning circuits. The aerial circuit is tuned with its own capacity, there being no necessity to tap down on the coil as is usually done. The plate circuit of the tube is then tuned and finally the grid circuit of the second tube is tuned, the energy being handed on from one to the other through a capacity coupling.

These three inductances can all be different in order to obtain the greatest efficiency from the circuit. Yet if the tuning capacities are initially adjusted as already described, then the circuits can be tuned in unison over the whole scale by merely inserting three cores into the coils by a suitable mechanical arrangement (Fig. 3) which moves all three at the same time.

Pending any practical tests of the system, which cannot yet be made because the special iron is not, so far, available, it is not possible to comment any further on the system.

# USE THESE NATIONAL PARTS

WHEN YOU BUILD

## Short-Wave

When you build a short-wave receiver or transmitter—get the maximum efficiency and performance with these NATIONAL parts, designed for short-wave use. NATIONAL Company, pioneer in the radio field and in the manufacture of electrical apparatus since 1914, has developed a full line of parts for ultra short-wave use in its Research Laboratories. Some of these are shown below. The full NATIONAL Company line of the famous Velvet Vernier Dials, Variable Condensers for Receiving and Transmitting Use, Transformers—RF, Audio and Power, Tube Shields, SW-58 and SW-3 Short-Wave Receivers, NC-5 Short-Wave Converter, Ultra High Frequency Receiver HFR (5 meters), Ultra High Frequency Converter HFC, Communications Type Receivers AGS and 58C, MB-32 Deluxe Broadcast Tuner, Speaker Amplifier and Power Supplies, are all shown in the new NATIONAL 16-page Bulletin No. 200, sent free on receipt of coupon below.

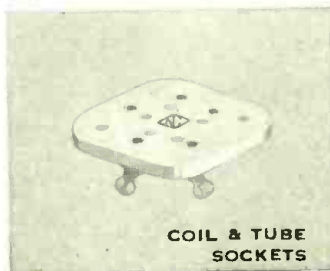

COIL & TUBE SOCKETS

### SEU S-W CONDENSER

For short-wave work only. Heavy double-s p a c e d, rounded edge 270° plates, insulated front bearing, constant low impedance pigtail, Isolantite insulation, single hole panel or base mounting. Any capacity up to 25 mmf. For ultra short-wave tuning or neutralizing in low power transmitters.

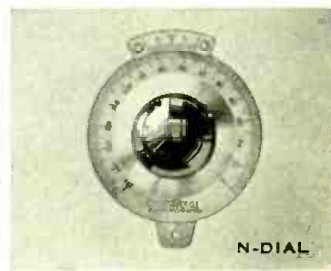

N-DIAL

### NATIONAL SOCKETS

Isolantite tube and coil sockets, glazed upper surface, give maximum efficiency in ultra high frequency circuits, suitable for sub-panel or base-board mounting, available in standard 4, 5 and 6-prong types.

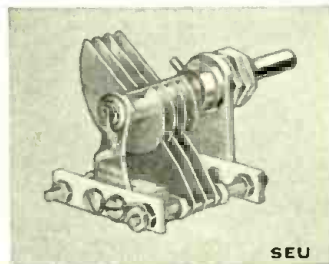

SEU

### "N" VERNIER DIAL

A 4" solid German-silver precision dial with the original and matchless Velvet Vernier mechanism and a real vernier permitting accurate reading to 1/10 division. Has 3-point attachment for easy and accurate mounting.

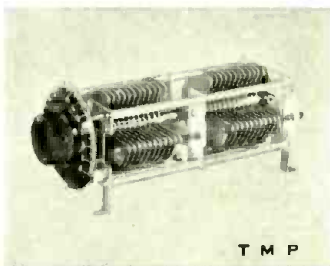

T M P

### MIDGET R-39 COIL FORMS

Made of improved R-39, low-loss ultra HF material. Have best form factor for ultra S-W work and lowest power-factor. insure stability, maintain calibration. Also available in larger size with either 4, 5 or 6-prong for regular short-wave use.

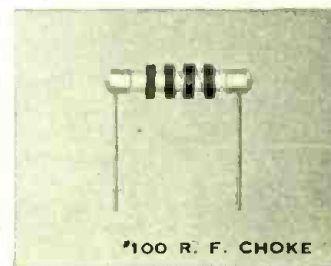

100 R. F. CHOKE

### TYPE TMP Transmitter Condenser

Split-stator type, for medium power push-pull transmitters. Fine for 5-meter work—give extremely accurate balance between both sides of tank coil. Heavy polished plates, rounded edges, self-aligning conical bearings, rigid frame construction, 3000 and 6000 volts.

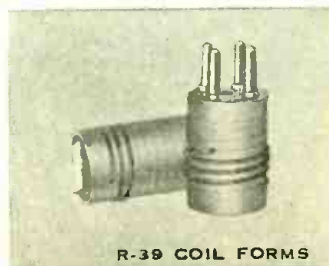

R-39 COIL FORMS

### COUPON

National Co., Inc., 61 Sherman Street, Malden, Mass.

Please send me your new Bulletin No. 200, giving full particulars and prices of NATIONAL Short-Wave and other parts and apparatus. (Write your name and address in margin below and mail today.)

R-12-32



# VISITRON

The Premier Photoelectric Cells for Television and Sound-on-Film



- High Sensitivity
- High Frequency Response
- Stability
- Long Life
- Large Plate Area (Visitron 75A for television work.)
- High Response to Incandescent Light Sources.
- Small gas amplification (extremely desirable for Television and Sound-on-Film)

Write for further particulars as to why Visitrons are the choice of leading television and sound engineers.

**G-M LABORATORIES INC.**

1739 Belmont Ave., Chicago, U.S.A.

## ENGINEERS EXPERIMENTERS RADIO MEN

Capitalize on your spare time with a G-M

### FOTO SWITCH

The new, low-cost  
PHOTOELECTRIC RELAY  
(The practical unit for commercial and experimental work)



**Only \$15.00**  
fully assembled as shown

Express  
Prepaid  
for Cash  
with  
Order

G-M No. 1222-A Foto-Switch—the product of seven years' experience in Photoelectric work.

FOR OPERATION ON 110 VOLT, 60 CYCLE A.C.

This new unit is an actual Photoelectric Relay containing all the principal parts used in the more costly industrial units. It comes fully equipped with a VISITRON Type B Caesium Cell, Magnetic Relay with special winding and silver contacts, Transformer of large capacity, Amplifier Tube, Wire-Wound Potentiometer, Condensers, Terminal Strip, Sockets, Chassis, etc. This unit can be made the foundation of such photoelectric applications as burglar alarms, door-opening equipment, illumination control, face timing, counting, control of window displays and illumination, and myriad other installations. A complete line of accessory equipment is also available—information on request.

#### SPECIAL ENGINEERING INFORMATION

Special instructions for the use of photoelectric equipment for such applications as burglar alarms, door openers, illumination control, etc. will be issued periodically. All Foto-Switch purchasers who request it will be placed on our mailing list to receive these bulletins.

**G-M LABORATORIES INC.**

Chicago, U.S.A.

G-M LABORATORIES, Inc.  
1739 Belmont Ave., Chicago.

Enclosed find \$15.00 (bank draft or money order will facilitate shipment) for which send me a No. 1222A Foto-Switch, complete as shown in illustration.

Name \_\_\_\_\_

Street & No. \_\_\_\_\_

City \_\_\_\_\_

Check here if you wish to receive engineering bulletins on photoelectric applications.

## MAKE YOUR OWN ELECTRIC MUSIC!

(Continued from page 222)

so that the locally generated oscillations "beat" or heterodyne with the carrier signal. This method is not always altogether satisfactory, as the modulations of the broadcast programs themselves will tend to complicate the hand capacity control. However, it is worth trying.

If you have a regenerative short-wave receiver you can apply the same methods, probably with greater success because strong local oscillations can be produced in the receiver circuit without much coaxing. Simply disconnect the aerial and ground wires from the short-wave receiver, spill it into oscillation, and you are all set. Of course, with this arrangement it is necessary to change the coil and condenser constants of the oscillator to match the wavelength range of the set. Simply use a coil and condenser combination that equals the combination in the receiver.

Do not be disappointed if the results of these experiments are not satisfactory immediately. Try shifting the oscillator in relation to the receiver. Try removing some of the tube shields from the latter, and also some of the coil shields, if they are accessible. In many T.R.F. receivers strong oscillation can be obtained by exposing a couple of the R.F. transformers to each other, as is naturally to be expected.

The parts required for the construction of the oscillator shown in the illustrations are as follows:  
L—Radio frequency transformer (Genwin or any two circuit broadcast corpler.

- CH—oo Henry Filter choke (Acratest No. 2505)
- C1—.0005 mf. variable condenser (Hammarlund)
- C2—.1 mf. (Flechheim)
- C3—Dual 6 mf. electrolytic condenser (Acratest No. 7160)
- R1—2000 ohms, 1 watt (International Resistor)
- R2—360 ohms (Electrade Truvolt)
- 2—5 prong sockets (Eby)
- 1—Brass rod, 1/4 inch square, 20 inches long
- 2—Type 37 tubes.

## SINGLE CHANNEL RECEIVER

(Continued from page 239)

- R- 4—250,000 ohms 1/2 watt carbon resistor.
  - R- 5—500,000 ohms 1/2 watt carbon resistor.
  - R- 6—1600 ohms 2 watt carbon resistor.
  - R- 7—1000 ohms wire wound 5 watt resistor.
  - R- 8—7000 ohms wire wound 5 watt resistor.
  - R- 9—400 ohm 1 watt carbon resistor.
  - R-10—10,000 ohms 1 watt carbon resistor.
  - R-11—30,000 ohms 3 watt carbon resistor.
  - R-12—25,000 ohms 1 watt carbon resistor.
  - R-13—25,000 ohm variable resistor with a.c. switch.
  - R-14—20 ohm center tap resistor.
- Tube Requirements:  
2 type 58 super control R.F. pentodes.  
2 type 57 R.F. pentodes.  
1 type 45 power amplifier.  
1 type 80 rectifier.
- Socket Requirements:  
4 Six prong sockets with shield.  
2 Four prong socket.  
1 Five prong socket.

#### TABLE I. Coil Specifications:

	L-1	L-2	L-3
Primary turns	12	56	55
Secondary turns	56	55	55

No. 36 dsc.  
No. 23e

Coil forms to be 1.0" o.d. bakelite with secondary wound 50 turns per inch. Coil to be placed in 2.0" diameter by 2.25" shield and spaced equally from each end.

## ROUND THE WORLD RECEPTION WITH THE NEW POWERTONE BATTERY OPERATED RECEIVER

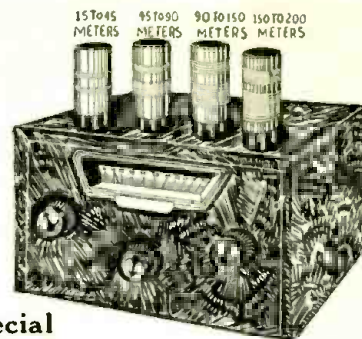

Special  
**\$9.95**

Amazing results of this set will convince you that the utmost in the reception of shortwaves with a battery set has been reached.

The use of the new two volt tubes greatly increases reception, sensitivity, and selectivity, and at the same time, current consumption is kept at a minimum. A 232 screen grid tube, and a 233 power Pentode amplifier greatly increases the far-reaching performance of this set.

A Hammarlund condenser is used in the construction of this set as it is the most efficient for shortwave reception.

Install one in your home, store or "lab" and get your share of enjoyment—or increase your business by selling this low-priced shortwave set.

It will tune from 14 to 200 meters.  
Price of set with coils \_\_\_\_\_ \$9.95  
Set of matched tubes \_\_\_\_\_ 3.00  
Set of full sized batteries \_\_\_\_\_ 3.50

Send for Circular on 4-Tube "Diamond of the Air," which uses the new 57-58-47 and 80 tubes. Kit, \$7.45.

Kellogg Hand Mikes \$1.95  
Sangamo Input & Output Transformers \$2.89 per pair

**TRY-MO RADIO CO., Inc.**

Three Stores:

85 Cortlandt Street  
178 Greenwich St. 179 Greenwich St.  
New York City  
SEND IN FOR CATALOG

## St. Charles

An Entire Block  
On the Boardwalk

ATLANTIC CITY

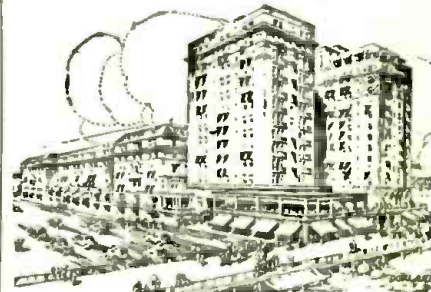

A Smart Hotel in  
America's Smartest Resort

SELECTED America's foremost seashore resort hotel, the St. Charles is as popular in December as in May. It is open throughout the winter, because Atlantic City is free from excessive cold and the semi-oceanic climate is characterized by absence of prolonged cold spells. At the St. Charles there is warmth, comforts, good meals, and guest-entertainment to speed the winter by. Very special rates for the season to those who wish to escape the effects of winter's harshness. Make the St. Charles your winter home.

European or American Plan  
French and German Cuisine



## PERPETUAL TEST ADAPTER

NEW FEATURE TAKES THE PLACE OF FORTY ADAPTERS. CAN BE USED WITH YOUR PRESENT SET ANALYZER OR TUBE TESTER

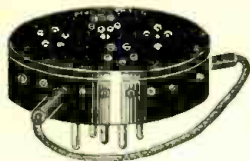

and provides for testing all FIVE, SIX and SEVEN prong tubes developed in the future. Fits all standard and custom-built set analyzers and tube testers. Permits the testing of all new tubes, including the types 29, 33, 34, 39, 41, 42, 43, 44, 46, 47, 51, 55 (diode), 56, 57, 58, 64, 65, 67, 69, (both plates of 80, 82, 83), 85, 89, Wunderlich, 91 (triple-twin), 93 and 95.

Dealers and Servicemen **NET PRICE \$2.75** Post- MONEY BACK GUARANTEE

Send no money. Pay the postman, or Remit in Full and we pay the postage.

**FREE** New tube charts and socket layouts supplied by Postal Radio with each adapter. Dealers, Servicemen, and Experimenters send 3c stamp for our 1933 General Catalogue.

### POSTAL RADIO

137T Liberty St., New York, N. Y.



### FREE

### 13th ANNIVERSARY RADIO CATALOGUE



124 pages containing the most complete listing of radio items for the amateur and experimenter at real bargain prices.

Send for your copy now!

**AMERICAN SALES COMPANY**  
Wholesale Radio Distributors  
RTSW—44 W. 18th St., N. Y. C.  
The Oldest Amateur Supply House,  
Est. 1919

### REDUCED PRICES!

on General Electric Sync Motors, Scanners, Lens Discs, Punched Discs, Crater & Plate Neon Lamps.

We build precision parts for advanced experimenters.

Enclose 10c for 1933 catalogue—no stamps accepted.

**Hartman Television Laboratories**

1304-18 N. Howard St.  
Phila., Pa.

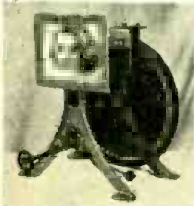

## ONE TUBE D. C. RECEIVER

(Continued from page 224)

as the flow of current in the electrolytic condenser will be great and may damage the condenser and the choke.

Tune slowly and keep the regeneration control below the point of oscillation. This is a simple matter and it should be observed at all times. Weak stations can be tuned in by advancing the regeneration until the familiar whistle is heard; then the regeneration control can be moved back a step.

Remember a good antenna is half the battle, as it is necessary to give as great a signal to the tube as possible. The more signal, the more energy can be fed-back and the greater the amplification.

### Trouble Shooting

#### SET WILL NOT WORK, BUT TUBE LIGHTS.

- Tube defective
- Power plug reversed
- Grounded antenna
- Open in the coil
- Wires not properly connected (check connections)

#### SET WORKS BUT NO REGENERATION

- Reverse leads to the feed-back coil
- Defective tube

#### TUBE WILL NOT LIGHT

- No power
- Burnt out tube
- Filament supply resistor open
- Defective power switch
- Poor connections

#### EXCESSIVE REGENERATION

- Reduce the size of the mica condenser connected across the primary of speaker voice coil transformer.

#### POOR SIGNAL

- Antenna grounded
- Poor connections
- Defective tube
- Antenna shielded by steel buildings (increase length).

#### NO FIELD ON DYNAMIC SPEAKER

- Bad wiring
- Field coil open

### Parts List

- One Utah "Bear Cub" Dynamic Speaker with pentode output transformer and 2,500 ohm field.
- One Acratest tubular condenser .01 mfd. 200 volts. C1
- One Genwin Three circuit tuner. L1
- One National .0005 mf. tuning condenser C2
- One Aerovox mica condenser .00025 mfd. C3
- One Eby 5 prong socket V1
- One Acratest carbon resistor. 1 meg. 1 watt R1
- One Micamold .001 mf. mica condenser C4
- One Concourse Electrolytic condenser 8 mfd., 400 volts. C5
- One Flechtheim 1 mf. 200 volt bypass condenser C6
- One Electrad 400 ohm, 50 watt resistor with sliding contact. R2
- One National tuning dial
- Solder, wire and hardware.

### 7-Meter Super-Regenerator

(Continued from page 245)

Coils L3 and L4 consist of 800 and 1200 turns, respectively, of No. 36 enamelled wire. Coils L1 and L2, 10 turns each of No. 16 bare wire, spaced width of one turn.

# If You were a WATCHMAKER

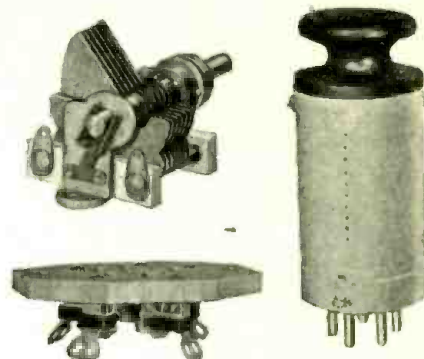

**S**UPPOSE you planned to build yourself a watch, instead of a radio. Would you use shoddy parts?

Not if you expect it to last and keep accurate time.

Quality parts in a radio are as essential as quality parts in a watch. You can't get out of them any more than is engineered into them. That is why the Hammarlund reputation means so much to the radio builder who prefers performance to promises.

In its thirty years' history Hammarlund has never built a cheap part. Prices today are attractive, because manufacturing costs are lower—but Hammarlund quality is never sacrificed to price.

The new Hammarlund Catalog "33" describes condensers, coil forms, sockets, transformers, chokes, couplings, equalizers and shields for all types of radio work—transmitting, or standard and low-wave reception. Your copy free on request.



Write to  
Dept. RR-1  
for  
**COMPLETE CATALOG "33"**

## HAMMARLUND MFG., CO.

424 W. 33rd St., New York

For Better Radio  
**Hammarlund**  
PRECISION  
PRODUCTS



# Two Great MAGAZINES for One Price



**A Magazine  
Combination**  
that covers practically  
every branch of Radio

Until the 15th of December, this opportunity is yours—this chance to read radio's two great magazines, **SHORT WAVE CRAFT** and **RADIO-CRAFT**, at a saving of \$2.00.

Regularly the rate for eight months of **RADIO-CRAFT** and **SHORT WAVE CRAFT** is \$4.00. For a brief period only, our readers can enter their subscription to receive both magazines for \$2.00. This is a reduction of 30 per cent and represents a saving of \$2.00.

**SHORT WAVE CRAFT** you have read, and it is needless for us to say that you are well pleased and want to read every issue. It is the "Town Crier" of new developments in the short wave field.

And **RADIO-CRAFT**, also edited by Hugo Gernsback, is the radio magazine selected by the greatest number of service men, dealers and radiotricians. Of course, thousands of amateurs read **RADIO-CRAFT**, too. Each month, men of outstanding prominence in the radio field contribute articles of real interest to all.

**Mail Coupon TODAY!**

**SHORT WAVE CRAFT** RR-2-5  
100 Park Place, New York, N. Y.

As per your special offer, I enclose \$2.00, for which you are to enter my subscription to **SHORT WAVE CRAFT** and **RADIO-CRAFT** for the next eight months.

Name \_\_\_\_\_  
Address \_\_\_\_\_  
City \_\_\_\_\_ State \_\_\_\_\_

## RADIO TUBES AND HOW THEY WORK

(Continued from page 221)

voltage change on the grid will have the same effect on the plate current as a larger voltage change on the plate. A grid requires very little power, serving merely as a valve to control the plate current.

A negatively charged grid tends to force the space electrons back toward the filament. This action decreases the plate current. Plate current, in fact, may be reduced to zero (cut-off) by making the negative grid charge sufficiently large. On the other hand, when a positive charge is applied to the grid, the electrons are accelerated and increased plate current results.

It should be noted that this control action of the grid permits the use of the tube as an amplifier. A small grid voltage change produces a much larger plate current than would the same change in plate voltage. Typical three-electrode tubes are the '20, '27, 56, and '45.

The control grid circuit (input circuit) includes any device or devices connected between the control grid and cathode of a tube for the purpose of impressing an input or signal voltage on the control grid. It may consist of an antenna coupling coil, a transformer secondary, or any unit having one or all the factors of inductance, resistance and capacity. Since it is usually desirable to maintain the grid at some negative voltage (called grid bias) with respect to the cathode, the grid circuit will, in such cases, also include a source of voltage supply for that purpose. The grid bias supply (C-supply) may be a battery or other source of d-c voltage. The output circuit is considered to include the parts of the circuit connected between the plate and cathode.

The electrodes of a radio tube form an electrostatic system, each electrode acting as one plate of a small condenser. For a three-electrode tube the capacitances are known as *interelectrode capacitances* and are those existing between the grid and plate, the plate and cathode, and the grid and cathode. Of these, the capacity between the grid and plate is generally of most importance. In high gain radio-frequency amplifier circuits, this capacity may act to produce undesired coupling between the input and output circuits and, thereby, cause uncontrolled regeneration.

### Tetrodes

The effect of grid-plate capacitance in causing excess regeneration may be minimized or eliminated in a number of ways. One scheme requires the use of complicated circuit arrangements which set up counteracting effects to counterbalance the action of the grid-plate coupling. The second and preferable method is to eliminate as much as possible the grid-to-plate capacitance in the tube itself. This is accomplished by employing a fourth electrode in the tube which is known as the screen. The screen is placed between the plate and the grid and thus makes a four-electrode tube, or "tetrode." With this type of tube intricate circuits and balancing difficulties may be eliminated. Since the screen voltage (Concluded on next page)



An Unusual  
Christmas  
Gift

## Stoppani Belgian Compass

May Be Used As a Galvanometer

Because of its uniform magnetic properties, high sensitivity, and delicate frictionless bearings, the Stoppani compass may be utilized to advantage as a highly precise galvanometer for detecting electric currents in experimental or conventional radio circuits. The Compass is easily and readily converted into said galvanometer by merely winding several turns of ordinary radio wire completely around the face and lower case of the compass; leaving small spaces between turns to observe the movements of the needle. The ends of the wire are brought out as test leads to be inserted in series in circuits under test. A deflection of the compass needle in either direction indicates the presence of an electric current. Incidentally the intensity of the current may be closely approximated since the force with which the needle vibrates is proportional to the intensity of the current flowing through the wire. Stoppani Compass is an ideal SURVEYORS instrument with elevated sights. It is made of Solid Bronze, Parkersized, non-rusting, graduated in 1/10, Ruby Jewelled, 4 inches square. Fitted in a hardwood case, with set screw in corner to hold needle rigid when not in use. The United States Government paid more than \$30.00 for this precision instrument.

Our Price \$4.50

**Gold Shield Products Company**

102 Chambers Street, T.N. New York, N. Y.

### LENSES

FOR LENS DISC PROJECTORS

Write for Free Lens Disc Data.

13/16" Lenses, each	12c
1/2" Lenses, each	15c
3/8" Lenses, each	18c
Tube of Cement for Mounting Lenses	25c
18"-24" Blank Duraluminum Disc (1/16") thick	\$3.50
6 1/2" Cast Aluminum Hub for Spring Drive	\$2.50
18"-24" Guaranteed Lens Disc	\$25.00

Send Money Order, Cash or Check to  
**TELEVISION OPTICAL EQUIPMENT COMPANY**  
476 Broadway, New York City

**PATENT** **Z.H. POLACHEK**  
YOUR IDEAS REGISTER YOUR TRADE-MARK BY **31st NEW YORK**  
REG. PATENT ATTORNEY PROF. ENGINEER

CALL or SEND your SKETCH or Simple Model for Confidential Advice  
No Charge for Consultation

--- COUPON ---

Dear Sir:—Please send me full information and literature about Patent Protection, without obligation.

Name \_\_\_\_\_  
Address \_\_\_\_\_

D  
O  
I  
T  
N  
O  
W

No radio library is complete unless you have two very instructive books—**HOW TO BUILD AND OPERATE SHORT WAVE RECEIVERS** and **HOW TO BECOME A RADIO AMATEUR**.  
Order your copy now from:  
**SHORT WAVE CRAFT**

RADIO REVIEW & TELEVISION NEWS



# DATAPRINTS

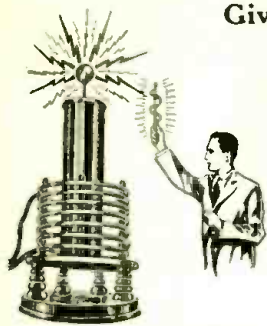

Give  
**Technical  
Information  
on the  
Building  
of  
Worthwhile  
Apparatus**

Dataprint containing data for constructing this 3 ft. spark Oudin-Tesla coil.

**\$.75**

Includes condenser data.

## OTHER "DATAPRINTS"

### TESLA OR OUDIN COILS

12 Volt D.C. solenoid. lifts 2 lb. through 1 inch 0.50  
36 inch spark. data for building. including condenser data \$0.75  
8 inch spark. data for building. including condenser data 0.75  
Violetta type. high frequency coil data; 110 volt A.C. or D.C. type; 1" spark; used for giving "violet ray" treatments 0.75  
How to operate oudin coil from a vacuum tube oscillator 0.75

**MOTOR**—1/10 H.P., 110 volt A.C. 60 cycle (suitable for driving 12" fan or light apparatus), constructional data \$0.50  
1200 cycle Synchronous Motor 0.50  
60 cycle Synchronous Motor 0.50

### MAGNET COIL DATA

Powerful battery electro-magnet; lifts 40 lbs. \$0.50  
110 volt D.C. magnet to lift 20 lbs. 0.50  
110 Volt D.C. solenoid; lifts 2 lb. through 1 inch 0.50  
110 Volt D.C. solenoid, lifts 6 lb. through 1 inch 0.50  
A.C. Solenoid. Powerful. 110 volt. 60 cycle 0.50

### TRANSFORMER DATA

Any size. 200 to 5000 watts. (1 primary and 1 secondary voltage data supplied—specify watts and voltage desired) \$1.00  
1 K.W. 20,000 Volt Transformer Data. 110 volt, 60 cycle primary. Suitable for operating 3 ft. Oudin Coil 0.50  
1/4 K.W. 15,000 Volt Transformer Data. 110 volt, 60 cycle primary. Suitable for operating 8 inch Oudin Coil 0.50  
1 to 12 inch Spark Data 0.75

**REFRIGERATION MACHINE — Dataprint —**  
How to Make Data 1.00

**TELEGRAPHONE** — Records Voice or "Code" signals on steel wire by magnetism. Code can be recorded "fast" and translated "slow". Constructional data (special) \$0.50

Treasure Locator \$0.50  
100 Mechanical Movements, for Inventors 0.50  
Polarized Relay—Ultra Sensitive 0.50  
Electro-Medical Coil (Shocking Coil) 0.50  
**CLOCKS**—Electric chime ringer. How to make one to fit on any ordinary clock 0.50

### MISCELLANEOUS DATAPRINTS—

Electric Ice Skates—How to make 0.50  
How to Thaw Pipes by Electricity 0.75  
20 motor circuits—hook-ups 0.75  
20 practical telephone hook-ups 0.50

### SLIDE RULES—Specially Selected

Students' 10-inch wood slide rule, accurately engraved (prepaid) \$1.10  
**ELECTRICAL** Slide Rule, 10 inch size, with special electrical law ratios and indexes, wood with white Ivorine scales (prepaid) 5.75  
5" "Pocket" slide rule 4.00  
"Circular Pocket" slide rule. Fits vest pocket. 2 1/2" diameter, leather case 4.00  
Students' Circular Slide Rule 1.50  
(Postage 10 cents extra on last three slide rules.)

## The DATAPRINT COMPANY

Lock Box 322

RAMSEY, N. J.

largely determines the electron flow, small changes of plate voltage have little effect on plate current. This is desirable from the viewpoint of stability. The screen is constructed so that the flow of electrons is not materially obstructed, yet it serves to establish an electrostatic shield between the plate and grid. The screen is operated at some positive voltage lower than that of the plate and is bypassed to the cathode through a condenser. This by-pass condenser effectively grounds the screen or high-frequency currents and assists in reducing grid-plate capacitance to a minimum value. In general practice the grid-plate capacitance is reduced from an average of 8.0 micromicrofarads for a triode of 0.01 or less for a screen grid tube. The reduction permits the attainment of stable amplification from screen grid tubes many times as high as that possible from three electrode tubes. Tubes of this type are represented by the '24-A, '32 and '35.

### Pentodes

In all radio tubes, electrons striking the plate may, if moving at sufficient speed, dislodge other electrons. In two and three electrode types, these vagrant electrons usually cause no trouble because no positive electrode other than the plate itself is present to attract them so that they are eventually drawn back to the plate. Emission from the plate caused by bombardment of the plate by electrons from the cathode is called *secondary emission*, because the effect is secondary to the original cathode electrons. In the case of screen grid tubes, the proximity of the positive screen to the plate offers a strong attraction to these secondary electrons and particularly so if the plate voltage swings lower than the screen-voltage. This effect lowers the plate current and limits the permissible plate swing for tetrodes.

The plate current limitation is removed when a fifth electrode, known as the suppressor, is placed in the tube between the screen and plate. The family name for five-electrode types is "pentode." The suppressor is usually connected to the cathode. Because of its negative potential with respect to the plate, it retards the flight of secondary electrons and diverts them back to the plate, where they can cause no trouble.

The suppressor is utilized at the present time in pentodes designed for two different functions. In power output pentodes, the suppressor makes possible a large power output with high gain, due to the fact that the plate swing can be made very large. Tubes of this type are represented by the '33, '38 and '47. In radio-frequency amplifier pentodes, the suppressor permits of obtaining a high voltage amplification at moderate values of plate voltage. In fact, the plate voltage may be as low as or lower than the screen voltage without serious loss in the gain capabilities of this type. Representative of this type are the '34 and '39. Further advantages in adaptability of tube design and application may be obtained by providing the suppressor with its own base terminal. With this arrangement, it is possible to obtain special control features by variation of the voltage applied to the suppressor. Typical tubes of this type are the 57 and 58.

# ANNOUNCING

... a new method of mastering the code

... a complete scientific course in Radio Code

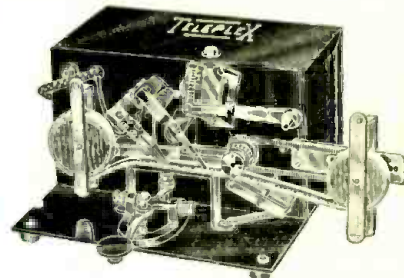

The Master TELEPLEX records your own sending in visible dots and dashes and then repeats them to you audibly on the headphones. 5000 words on each tape and the number of tapes available unlimited.

The only instrument of its kind ever made that will record your own sending and repeat it back to you.

Originally this machine was not intended for individual instruction, because it is too expensive. It was developed for the United States Signal Corps to be used for classroom instruction. However, we have formulated a plan that makes this instrument available to any and all individuals.

This machine will give you a complete course in radio telegraphy that will qualify you to pass the Government Examination.

Professional radio operators will find this instrument of inestimable value to increase their speed and accuracy in sending and receiving and also in mastering the American Morse code and qualifying you for an extra class license. Test your own ability by receiving your own signals.

This machine cannot be purchased through dealers. It is obtainable only from us.

## Teleplex

TELEPLEX COMPANY,  
76 S. Cortlandt Street,  
New York City.

Please send me your plan how I can get the full use of this machine without buying it.

Name .....

Address .....

City..... State.....



**LOCATING PIPES**  
(Continued from page 219)

Table IV

100 ft. to East	Pipe	100 ft. to West
22	37	22

This increase in reading of 15 on 22, or roughly two-thirds, is small compared with the tenfold increase over the small gas-pipe as shown in Table III, and illustrated in Fig. 2. Is this small increase over a comparatively large pipe at a depth of 3½ ft. of any significance?

To me, the great difference obtained in the effect of a small pipe at a depth of 1½ ft., and a large pipe at a depth of 3½ ft. can point to one thing only, and that is that the wave of Daventry National does not penetrate to more than 10 or 15 ft. in the ground in this district.

Recent experiments with submerged submarines have proven that wireless waves will not penetrate more than 50 ft. into seawater. This depth of penetration, however, probably varies with the wavelength used, and with the sensitivity of the receiving apparatus on board the submarine.

**A TWO-TUBE FOR 7 METERS**

(Continued from page 223)

If a ground is used, it should preferably be a counterpoise of about 15 ft. of wire. As no ground or aerial terminals are provided, the connections should be made as follows: The aerial to the terminals on the top of the series condenser and the earth to the negative terminal of the "B" battery. If a direct ground is used, a .0001-microfarad fixed condenser should be joined in series with it.

The 25,000-ohm resistance in the anode of the detector tube is sufficient to balance the effects of different battery voltages.

It is important to arrange a 2-microfarad condenser across the positive and negative terminals of the "B"; it serves as a terminal point for the batteries.

A 400-ohm potentiometer is used to vary the potential applied to the grid of the leaky-grid detector tube.

**TELEVISION CAMERA**

(Continued from page 241)

The grid cell has no inertia and the amount of rotation of the plane of polarization varies exactly with the strength of the signal applied to the plates of the cell. By applying the received television signals to the cell, the amount of light passing out of the second nicol prism is proportional to the magnitude of the signal strength and thereby a light variation is secured which is proportional to the reflected light picked up at the transmitting end.

Having passed through the nicol prism and grid cell combination the light reaches an inclined mirror, is turned through an angle and finally passes through another lens and is focused on to a revolving mirror drum.

This drum has 30 mirror around its edge inclined at different angles. As the drum revolves the light on each mirror is projected as a spot on to the screen, the spot moving vertically from the bottom of the screen on to the top.

The drum revolves at 750 revolutions a minute and is synchronized by the Baird automatic synchronizer which makes use of the radio signals.

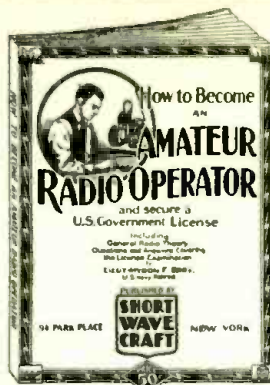

● This book covers literally everything from "soup to nuts" on the subject, in such a clear and lucid manner that it will be of great value to every student. If you intend to become a licensed code operator, if you wish to take up phone work eventually, if you wish to prepare yourself for this important subject—this is the book you must get.

50c the Copy

● We commissioned Lieut. Myron F. Eddy, U. S. Navy, Retired, to write a book on this subject that would answer EVERY possible question in such a way as has never been done before. We chose Lieut. Eddy because his long years of experience in the amateur field have made him preeminent in this line.

**PARTIAL LIST OF CONTENTS**

**Chapter 1.** Ways and means of learning the code. A system of sending and receiving with necessary drill words is supplied so that you may go right to work on approved methods.

**Chapter 2.** Concise, authoritative definitions of radio terms, units and laws, brief descriptions of commonly used pieces of radio equipment. This chapter gives the working terminology of the radio operator. All graphic symbols used to indicate the various parts of radio circuits are shown so that they may be readily recognized when studied in the following chapters.

**Chapter 3.** General radio theory, particularly as it applies to the beginner. The electron theory is briefly given, then waves—their creation, propagation and reception. Fundamental laws of electric circuits, particularly those used in radio, are explained next and typical basic circuits are analyzed.

**Chapter 4.** Description of modern receivers

72 Pages—Over 150 Illustrations

**THIS BOOK IS NOT SOLD ON NEWSSTANDS**

Clip and Mail Coupon Today!

that are being used with success by amateurs. You are told how to build and operate these sets, and how they work.

**Chapter 5.** Amateur transmitters. Diagrams with specifications are furnished so construction is made easy.

**Chapter 6.** Power equipment that may be used with transmitters and receivers, rectifiers, filters, batteries, etc.

**Chapter 7.** Regulations that apply to amateur operators.

International "Q" signals.

**SHORT WAVE CRAFT.**

98RR Park Place, New York City RR-2-5

Gentlemen:

I enclose herewith 50c. for which please send me, prepaid, a copy of your new book, "How to Become a Radio Amateur and Secure a U. S. Government License," the book to be sent to me immediately upon publication. (Send Money Order, Check, Cash, or new U. S. Stamps. Register letter if it contains currency or stamps.)

Name \_\_\_\_\_  
Address \_\_\_\_\_  
City \_\_\_\_\_ State \_\_\_\_\_



**RADIO REVIEW AND TELEVISION NEWS**  
98 Park Place RR-3-5  
New York City

Gentlemen:  
As per your special offer, I enclose \$1.25 (Canada and Foreign \$1.50) for which enter my subscription to **RADIO REVIEW AND TELEVISION NEWS** for one year.

Name \_\_\_\_\_  
Address \_\_\_\_\_  
City and State \_\_\_\_\_

**The "Literary Digest" of the Radio and Television Fields**

The European radio publications are abounding with new circuits and new radio developments that have found their way slowly over to the United States. The reason is that, since there is such a tremendous amount of original radio engineering going on in this country, there has been no publication that catered to the foreign developments. All the American radio publications must, of necessity, report the American activities first and as a rule, have no room left for what is going on in Europe unless an epoch-making development appears.

We therefore conceived the idea of bringing to our American readers a totally different radio publication, the like of which has never been published before; and the result is **RADIO REVIEW AND TELEVISION NEWS**.

This is not entirely a new magazine; it is, really, two magazines in one. A section devoted to television has been retained, which will report in every issue, the major American and European television advances; but the big, front section is given over to an international radio digest. This magazine, therefore, will perform the function that, for instance, the **LITERARY DIGEST** is servicing in literature. You may not be aware of the fact that there are some 160 radio publications printed outside of the United States; but from all of these publications **RADIO REVIEW** is extracting the best—the **Radio Meat**—which you want.

There are literally thousands of new circuits, due to the new tubes, and there is so much new material for the experimenter that we would have to fill several pages to tell you all about it.

**RADIO REVIEW AND TELEVISION NEWS** then is a new mirror, which will accurately show you a true perspective of what is going on in radio all over the world, and will give you material in such profuseness as you never have seen before. Hundreds of new radio hook-ups, special circuits, new time-saving kinks, new money-making ideas galore. You will find here the latest radio circuits and sets from France, Germany, England, Italy, Russia, Norway and even Japan.

Dozens of translators have been busy to make the first issue of the new combination magazine a memorable one, that you will not soon forget, and you will wonder why we hadn't done it before.



# DECEMBER SPECIALS!!

EVERY month we list on this page certain **STAR** items, which are NOT LISTED IN OUR CATALOG. These are all specials of which the quantities on hand are not sufficient to catalog them. Once sold out, no more can be had. First come, first served. **ORDER NOW, TODAY.**

**STOP SHOPPING.** The lowest prices are right on this page. No one undersells us. We meet any price on ANY NEW Merchandise. Order direct from this page and save money. 100% satisfaction on every transaction. Take advantage of these special offers. **ORDER NOW, TODAY.**

## G-M PHOTO-RELAY SWITCH For 110-20 Volts 60 Cycle A.C.

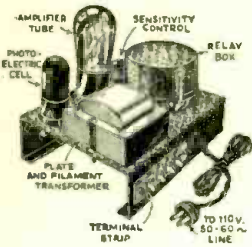

This new unit is an actual Photoelectric Relay containing all the principal parts used in the more costly industrial units. It comes fully equipped with a VISION Type B Caesium Cell, Magnetic Relay with special winding and silver contacts.

Transformer of large capacity, Amplifier Tube, Wire-Wound Potentiometer, Condensers, Terminal Strip, Sockets, Chassis, etc. This unit can be made the foundation of such photoelectric applications as burglar alarms, door-opening equipment, illumination control, race timing, counting, control of window displays and illumination, and myriad other installations. The Photo-Switch No. 1222A—Photo-Switch. Your Price **\$15.00**

## "MEGADYNE" ONE-TUBE PENTODE LOUDSPEAKER RECEIVER KIT

In the front part of our catalog—get your FREE copy now—there is presented a thoroughly illustrated discussion on the construction and operation of the

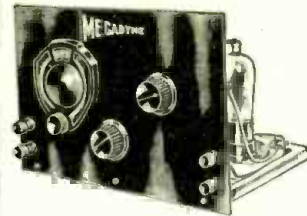

MEGADYNE Receiver by Hugo Gernsback, editor. This ingenious circuit was originally described in the July issue of the **RADIO CRAFT** Magazine. FREE copy of which will be given with each purchase. This receiver is indeed one of the most outstanding

developments in the radio industry. It is the first real one-tube receiver which will actually operate a loud-speaker. Thousands of experimenters and radio fans will want to build this remarkable receiver. For their convenience, we have compiled a complete list of parts required for its construction. These parts are of the highest quality and are exactly as specified by the author. The following parts comprise the complete kit.

1 B.M.S. Fixed Crystal Detector; 1 6-ohm Filament Rheostat; 1 3-circuit tuner for use with a .0005 mf. tuning condenser; 1 Na-ald type 481 UY 5-prong socket; 1 Hammarlund type ML-23 Variable Condenser; 2 sets of Cinch double binding posts; 1 Polymet .00025 mf. fixed condenser; 1 X-L Variocoupler; 1 Polymet .00025 mf. fixed condenser, or 1 Polymet .0005 mf. fixed condenser. (NOTE: Only one of the latter two condensers is actually employed in the circuit); 5 Fahnestock binding posts; 1 25-ft. roll of hook-up wire; 2 black Bakelite 1 1/2" knobs; 1 Kurz-Kasch vernier dial with 0 to 100 scale reading clockwise; 1 type 38 pentode tube, "Triad" or "Speed"; 1 Bakelite Panel already drilled with all holes, size 7 x 10 x 3/16 inch; 1 hardware assortment. The wooden base is not included.

No. 2545—Megadyne Receiver Kit. Your Price **\$10.25**

## ELIMINATES NOISE AND CROSS-TALK

Service men throughout the world are beginning to realize the importance as well as the advantages obtained through the use of a shielded lead-in wire from antenna to radio receiver. More than 75 per cent of the complaints of "noisy" and "ineffective" receivers may be eliminated by merely replacing the old, unshielded wire which leads from the aerial on the roof to the radio set with this new type of wire. Not only does it help to clear radio noises but to a certain extent, it makes the receiver more selective due to the capacity effect between the wire core and the metal shield. Easily installed. The wire core is connected between aerial on the roof and antenna post on receiver. The outer shield is connected to ground. Every service man should carry at least one spare roll of shielded wire in his service kit.

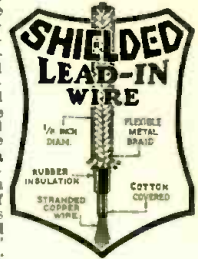

No. 1665, 50 Ft. Roll. Shielded Lead-In Wire... **\$ .85**  
No. 1668, 100 Ft. Roll. Shielded Lead-In Wire... **1.60**

## \* "PEERLESS" DIRECT COUPLED AMPLIFIERS



All the latest features in amplifier design have been incorporated in this direct coupled amplifier. Input terminals for permitting phonograph attachment, and in addition, by attaching the proper microphone transformer, also dry cell batteries, a microphone may be used for public address work. Any type of receiver can be connected to the input terminals without fear of loss of energy. These amplifiers are for use with dynamic speakers.

Amplifiers supply field current of 2500 ohms to dynamic speakers. Resistors are furnished when A.C. speakers are used. Amplifiers operate on 110 volts, A. C., 60 cycles.

Model SP-5003 uses 1-224, 1-245 and 1-280. Output is rated at 3 watts.

No. SP-5003—Your Price... **\$10.95** (less tubes) Exactly the same amplifier, but employs a power pentode in place of the 245 tube. Output 3.5 watts.

No. SP-5004—Your Price... **\$12.95** (less tubes) Model SP-5005 uses 1-221, 1-250 and 1-281. Consumption is 85 watts; maximum undistorted output, 6 watts. Gain rated at 1000 cycles, 35db; gain at 10,000 cycles, 51.5. Input direct to 224 control grid; output direct from 250 plate.

No. SP-5005—Your Price... **\$15.25** (less tubes)

## \* SYNCHROMATIC ELECTRIC CLOCK

Never was such a first class electric clock sold at such a ridiculously low price. An electric clock using the famous synchronomatic movement. Naval observatory time light from your light socket! No spring to wind, no batteries. Never out of order. Lubricated for a life-time at the factory. Enclosed in a dust-proof and shockproof genuine molded Bakelite case. The case is of walnut brown finish with simple but artistic design. For 110 volts, 60 cycle A.C. operation only. Complete with cord and attachment plug. Size 3 3/4" x 4 1/4" x 1 1/4". Weight 1 lb. Service men now sell these fine clocks by the hundreds. Be the first in your locality to handle them.



List Price **\$3.00**

No. 1689—Synchronomatic Electric Clock. Your Price **\$1.00**

## FREE RADIO AND SHORT WAVE TREATISE

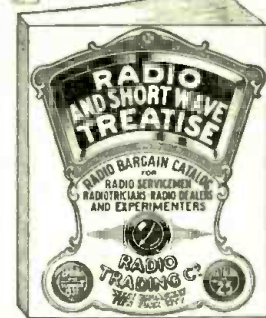

The new and enlarged Summer edition of our Radio and Short Wave Treatise, No. 25, has just come off the press—100 solid pages of useful information, radio items, diagrams and illustrations. Positively the greatest book in print—NOT JUST ANOTHER CATALOG. Contains a large editorial section with valuable information not found anywhere else. Considerable space is devoted to a TREATISE ON SHORT WAVES for both, beginners and regular "hams." Among the new technical information listed are the following: Modernizing old radio sets—repairing speakers and headphones—making superhets out of old sets—data on constructing two-volt battery and automobile receivers—circuit of the famous Gernsback Megadyne One-Tube Loudspeaker Set—short wave coil winding data—discussion on S.W. adapters, converters and receivers, etc., etc.

100 New Hook-Ups, Etc. 1000 Illustrations.

WRITE TODAY. Enclose 4 cents for postage. Treatise sent by return mail.

## \* SILVER-MARSHALL AUDITORIUM AMPLIFIER

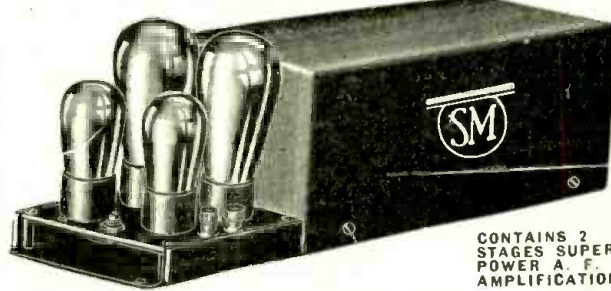

Ideal for theatres seating approximately 3,000 people, dance halls, schools, lectures, hospitals, auditoriums, outdoor gatherings, etc., etc. The gigantic power is at all times within control—for that matter it can be used in any home, as the volume can be regulated down to a whisper!

Supplies all necessary A, B and C, power to its own tubes. Operation requires one type X250 power tube, one X226 A.C. tube and two type X281 rectifier tubes. Attractive crystalline finish metal cabinet. 21x5 1/2 x 5 1/2 in. Shipping weight, 38 lbs.

No. SP-5006—Your Price **\$12.75**

## \* METALLIZED PIGTAIL RESISTORS AT ROCK BOTTOM PRICES

A very fortunate purchase enables us to offer these fine resistors at prices which surprise even ourselves—prices more than three times lower than in our own catalog. Resistors are guaranteed to maintain their ohmage under even adverse operating conditions. The resistance element is based on the famous metallized principle which has proven its superiority wherever accuracy and uniformity are paramount requisites. The special ceramic casing of these resistors is of sturdy construction and affords maximum heat dissipation. A feature of these resistors is their molded end-caps, tapered so they can be mounted in all standard resistor mounts. By means of their pigtails, they may also be soldered in any convenient position. Available in the following sizes—all rated at one watt: 300, 450, 600, 8,000, 10,000, 12,000, 350,000. Act fast to take advantage of this offer, as the supply is limited. Sold only in lots of six or more.



Values Clearly Marked on Each Unit  
No. SP2226, Metallized Resistors. NOW YOUR PRICE... **6c** 12 for 60c. EACH

## \* PORTABLE PUBLIC ADDRESS SYSTEM

Comprises Microphone, Loftin-White Amplifier and Dynamic Speaker. A recently completed all-electric A.C. development incorporating all the features and advantages of the direct-coupled Loftin-White



Amplifier principle. The amplifier is a high quality two stage job, having some RADICALLY NEW IDEAS IN AUDIO FREQUENCY AMPLIFICATION and employing 1-27, 1-35 power tube and 1-80 full-wave rectifier. It is remarkably free from A.C. hum.

The design is adaptable to all purposes, i.e., microphone, radio and phonograph. Has an undistorted power output of approximately 3.5 watts; SUFFICIENT TO OPERATE FROM 2 TO 3 ADDITIONAL DYNAMIC SPEAKERS.

The portable address system is sold COMPLETE WITH THE NEW R.C.A. VICTOR HAND MICROPHONE.

Put up in a single compact and perfectly balanced carrying case, the front of which is utilized as a baffle for the self-contained dynamic speaker. Complete with microphone and accessories the weight is only 30 pounds. For 50-60 cycles, 110-120 volts A.C. operation, Shipping weight, 38 pounds.

List Price, **\$75.00**  
No. SP-5011—Versatile Portable Address System Your Price, com- **\$24.95** plete with microphones...

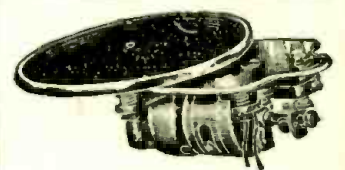

## \* PRIME "GREEN GIANT" Electric Phonograph Motor

Induction type model with newly improved, humless motor. Equipped with speed regulator, also "on and off" switch. Completely equipped with large turn-table—takes records up to 12" in diameter. An Ideal motor for electrifying the old phonograph. When used in conjunction with any amplifier on this page superb electrical reproduction is obtained.

No. 100—Your Price... **\$7.50**

WE ARE A WHOLESALE HOUSE AND CANNOT ACCEPT ORDERS FOR LESS THAN \$3.00. If C. O. D. shipment is desired, please remit 20% remittance, which must accompany all orders. If full cash accompanies order, deduct 2% discount. Send money order—certified check—U. S. stamps.

**Radio Trading Co.**  
25T West Broadway  
New York, N. Y.

ORDER FROM THIS PAGE. You will find special prices from time to time in this magazine. Get our big FREE catalog for the greatest Radio Bargains. Should you wish goods shipped by parcel post, be sure to include sufficient extra remittance for same. Any excess will be refunded.



# NEWS EVENTS BY TELEVISION

Instead of attempting to "televise" scenes directly, German engineers record them photographically and have the complete film ready for television scanning in only TEN seconds. This new method of 'covering' news events is more practical than any other system suggested to date. The apparatus is compact and fully portable.

by ERNEST H. TRAUB

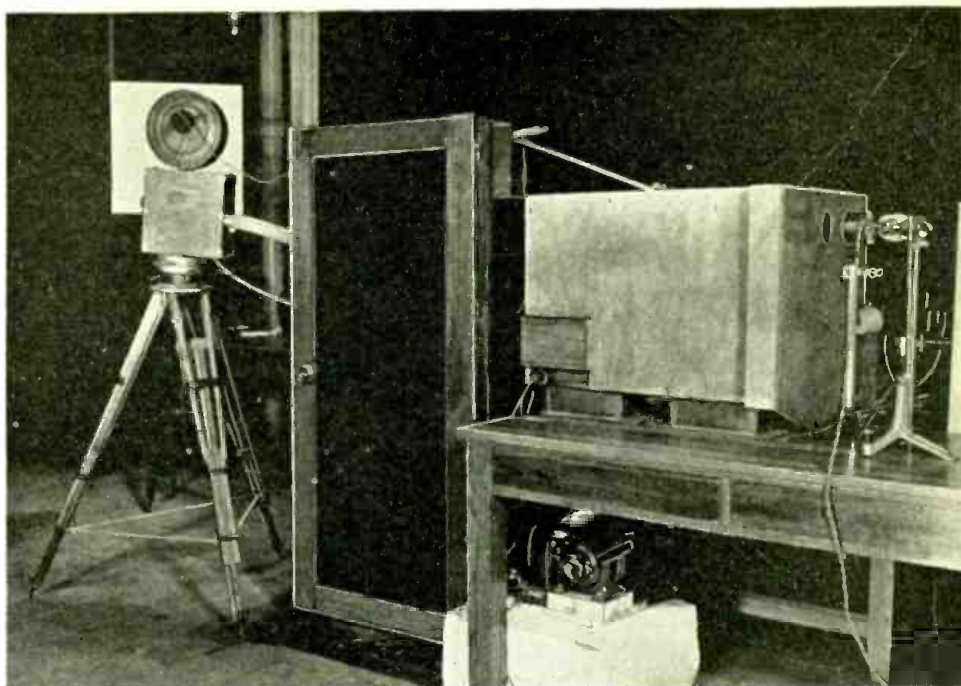

The complete television camera set up. Left to right: movie camera, developing and fixing chamber, scanning box, photo-cell (on stand).

● TELEVISION progress in recent times has shown clearly that a regular and satisfactory service can only be conducted using a high number of scanning frames of the order of 100 or more. Ultra short wave television tests in Berlin using 90 frames are at present being conducted and the number of frames is likely to be increased to the standard of 120 in the near future.

This brings us to the problem of how the various types of transmitters behave at these high image frequencies, and whether the old dream of transmitting topical events can be realized.

The most developed type of transmitter today is the tele-cine transmitter. They have been satisfactorily constructed up to 120 frames and there seems no technical barrier to using a still higher number. Next we have the spot-light type, which has been developed as far as 120 frames in the United States, but reports indicate that the results obtained were far from good. Moreover, calculations show that satisfactory results cannot be expected from this type at more than 90 frames. Finally we have the "daylight" or "camera" type. For stage purposes it can be employed up

to 90 frames using however, lighting which is almost unbearable to the naked eye. Daylight transmitters cannot be used for more than 60 frames in cloudy weather; in direct sunlight up to 90.

From the above remarks one gathers that the possibilities of transmitting directly current topical events at a high scanning speed are extremely poor. Thus television in the future will be robbed of one of its chief attractions.

In order to overcome this difficulty the Fernseh Company, the greatest television research firm in Europe, has constructed an entirely new type of transmitter, in which the event to be transmitted is photographed by a movie-camera, immediately developed and fed to a tele-cine transmitter as a negative. The image is turned positive in the photo cell amplifier.

The arrangement is shown diagrammatically in Fig. 1. An ordinary standard movie camera is used to take the event. The film is then fed through a light-tight tube to the developing tanks; after being fixed and washed, it is run through the tele-cine trans-

mitter. The film image is then projected on to the scanning disc and the photo cell. The current variations produced are now amplified and transmitted in the usual way.

The main difficulty encountered was the long time taken up by the developing and fixing processes. Working in conjunction with the famous firm of Zeiss, the Fernseh engineers managed to reduce the development time from 20 seconds to  $\frac{1}{2}$  a second, and the time for fixing from  $1\frac{1}{2}$  minutes to 5 seconds! The total time for all the processes including washing now takes less than 10 seconds!

It may be of interest to note that the holes in the scanning disc are arranged in a circle instead of the conventional spiral. This method can only be used when the film moves down continuously, instead of the usual jerky movement. The motors driving the camera, the tele-cine projector and the scanning disc are run synchronized off the same power line. The accompanying photograph shows the new transmitter in the laboratory. On the extreme left is the movie camera connected by the light tight tube to the developing and fixing tanks. On the table is seen the case containing the tele-cine transmitter and scanning disc. The whole apparatus is at present being developed in a portable form.

We therefore now have a transmitter which is capable of sending any type of subject which can be photographed at 120 frames, only 10 seconds after the actual event has taken place. Although it does not matter to the visualist in the least that he is seeing the event in question 10 seconds late, it would be unbearable if it were accompanied by simultaneous sound commentary. This snag can easily be overcome by recording the sound on the film as the scene is being "shot"; it can then be developed and transmitted synchronously with the image.

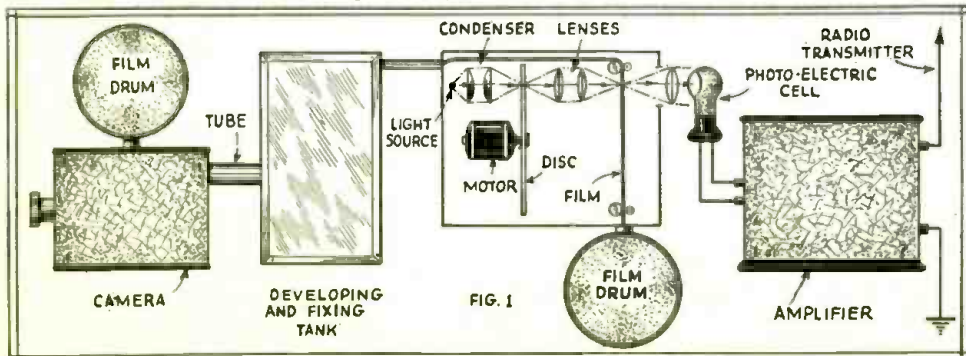

Schematic layout of the apparatus used for ten-second television news reporting. Note that the film feeds from the camera through the developing and fixing box into the scanning mechanism.



## WHAT IS THE BEST WAVE FOR TELEVISION?

● TWO groups of wavelengths have been assigned by the Federal Radio Commission for the development of television. The first group of these frequencies is in the region just above the regular broadcasting band, running from 1,600 to 2,800 kilocycles. Four television bands have been allotted in this range, the four centering on 1,650, 2,050, 2,150 and 2,800 kilocycles. Each of these waves covers a spread of 100 kc., which gives free scope for the transmission of 60-line pictures. On the other hand, if 120-line pictures are transmitted on these channels it is assumed that some scheme of frequency compression to prevent overlap into adjacent wave channels and consequent interference will be used.

The second group set aside for television is in the ultra high frequencies, about which relatively little is yet known. Here the television frequencies extend from 43,000 to 46,000 kc., 48,500 to 50,300 kc., and from 60,000 to 80,000 kc. The former band is 3,000 kc. wide or thirty times as great as each of the medium frequency bands. The highest frequency range covers 20,000 kilocycles or a spread of 200 times the normal television channel. Obviously there is ample "frequency space" here to allow transmission of 120-line pictures.

The primary disadvantages of the normal frequencies are supposed to be the few channels available and the fading and multiple image effects often observed in television transmission. According to John V. L. Hogan, whose experimental work in television is being carried on from W2XR, he believes many of the comments as to inevitable scrambling of pictures has been much exaggerated. "Our station," he says, "has been on the air transmitting pictures on 2,920 kc., for more than a year and only recently shifted to the 1,370 band. On both of these waves we have found that the multiple image problem could be mitigated if not entirely solved for a reasonable service area."

He further stated that many comparative observations have been made by engineers, and with reports received from unofficial observers, show that even at considerable distances from New York there is little fading or "ghosting" of images from W2XR. Thus, it seems entirely feasible to deliver a dependable television service on the medium frequency waves in spite of many claims to the contrary.

The ultra high frequency waves, he says, do not show the same kind of ghost images, but do suffer from irregular absorption and reflection effects. W2XR has had a 250 watt transmitter in experimental operation at 44,000 kilocycles for many months and has made special measurements of reception from it both in the heart of the city and in the suburbs. To receive the ultra high frequency signals effectively at all times and all locations is not yet a simple problem, not only because of transmission irregularities, but on account of various kinds of electrical noise interference. Considerable work remains to be done before a regular television service can be provided over large areas on the ultra frequencies waves.

NOVEMBER-DECEMBER, 1932

# PACENT

## INTRODUCES THE

# RADIOFORMER

### NOISE or MAN-MADE STATIC ELIMINATION

Since the inception of radio, one of the greatest problems standing in the way of perfect reception has been the difficulty of eliminating noise or man-made static.

The Pacent Radioformer solves this problem in a thoroughly satisfactory manner and in addition installation is simple. No more crackling, no more interference or noise from motors, vacuum cleaners, refrigerators, elevators, high tension lines, etc.

Radio Dealers and Service Men will find the Pacent Radioformer the most profitable and fastest moving accessory of the day. Sell it with every set sale—use it to make new contacts with old customers—make complete aerial installations at a good profit. Try it out in your own store—arrange for trial demonstrations to your customers—one demonstration is one sale. Send order for sample aerial unit only or complete kit thru your jobber or directly to us.

Aerial Unit Cat. No. 20  
List \$2.00

Shielded lead-in cable furnished separately. If desired, 50 foot length \$1.00 list. 100 ft. length \$2.00 list. Including Aerial Unit, Cat. No. 20.

Radioformer Kit—List \$4.00

Set Unit, Cat. No. 21.  
Shielded lead-in cable furnished. If desired—  
50 ft. length \$1.00 list.  
100 ft. length \$2.00 list.  
This kit combination which includes both aerial and set unit, is for those desiring the very finest results. Complete installation instructions furnished with each model.

## PACENT ELECTRIC CO., Inc.

91 SEVENTH AVE.  
NEW YORK, N. Y.

I am interested in your Radioformer. Please tell me more about this device and where I may obtain it.

Name \_\_\_\_\_

Address \_\_\_\_\_

City \_\_\_\_\_

State \_\_\_\_\_



## WHAT THE WELL VERSED SHORT WAVE FAN IS READING THESE DAYS

### Partial List of Contents

The "S. W. C." Two Tube Portable Works "Speaker"—Clyde Fitch  
How to Operate a Short Wave Receiver Two-Volt Tube Receiver  
A "Plug-less" S. W. Receiver—John M. Avery  
"My Favorite" Short Wave Receiver—F. H. Schnell  
The HY-7B Super-Het for A.C. Operation—L. W. Hatry  
The "Egert" SWS-9 Super-Het—How to Make It—Joseph I. Heller  
A Super Sensitive Short Wave Receiver—Thomas A. Marshall  
A. S. W. Power Amplifier—H. Winfield Secor

72 Pages  
100 Illustrations

If your friend has a copy of this valuable book, you've probably thumbed through it and noted the worthwhile information contained in its 72 pages. HOW TO BUILD AND OPERATE SHORT WAVE RECEIVERS is just chock full of good Short Wave Receivers—from a simple 1-Tube to a 9-Tube Super-Het.

SHORT WAVE CRAFT  
96-98 Park Place,  
New York City.

RR-2-5

Gentlemen:—

I enclose herewith fifty (50c) cents for which please send me a copy of your new book, HOW TO BUILD AND OPERATE SHORT WAVE RECEIVERS. (Send money order, check, cash, or new U. S. Stamps. Register letter if it contains currency or stamps.)

Name \_\_\_\_\_

Address \_\_\_\_\_

City and State \_\_\_\_\_

Mail  
Coupon  
Now

If you have a library of Short Wave books, your collection is incomplete without this instructive text. If you haven't a library as yet, let HOW TO BUILD AND OPERATE SHORT WAVE RECEIVERS be the forerunner of a group of ready references. Our "Partial List of Contents" is just an idea of the topics that this book covers, and of the experts that have written for it. You should own a copy if you want to be well versed in the art of Short Waves.



# WORLD'S BEST RADIO BOOKS

IT IS always the well-trained man who wins out over the horde of thousands of superficially trained and incompetent men. You are reading this magazine because you are interested in radio. Sooner or later, the time will come when you will wish to cash in on your knowledge. Your chance may come over night, and then the big and vital question will be, "How well equipped am I to fill the job?" You are in radio because you like it. You also realize that, at the present time, there are many branches of the radio art which you do not know as thoroughly as you should. Knowledge, these days, can be gotten cheaper than ever before. It isn't necessary for you to go to college to become proficient in radio. Start today, to build a REAL radio library and become acquainted with all branches of this great and growing art. In this page are listed the world's best radio books. We have combed the market for the really important books in radio; so that, no matter what branch you are interested in, you can pick out the best books that are now printed. Start, now, to build a complete radio library. You do not have to get all the books at once, but make up your mind to get one book a month; so that, when your chance comes, you will be fully equipped to win out over the others not so well equipped.

**IMPORTANT.—This list is changed every month to include the latest books. Note also new low prices.**

**THE RADIO HANDBOOK**, by James A. Moyer and John F. Westrel. Flexible covers, size 5½x8", 886 pages, 650 illustrations. Price **\$5.00**

Comprehensive data on short-wave apparatus, vacuum tubes, modern radio receivers and transmitters, photoelectric cells, television, sound motion pictures, tables, graphs, diagrams, etc. No radio man should miss it.

**RADIO FREQUENCY ELECTRICAL REQUIREMENTS**, by Huxh A. Brown. Cloth covers, size 6x9", 386 pages, 235 illustrations. Price **\$4.00**

One of the few great books on this important subject. Everything from thermionic-tube coefficients to piezo-electric measurements.

**PRACTICAL TELEVISION**, by E. T. Lerner. Cloth covers, size 5½x8½", 223 pages, 127 illustrations. Price **\$3.75**

This book explains television in full, including elementary principles, photo-electric cells, and all important types of television sets as well as basic principles of optics, images, mirrors, lenses, etc.

**MAGNETIC PHENOMENA**, by Samuel Robinson Williams. Cloth covers, size 6x9", 230 pages, 150 illustrations, and numerous tables. Price **\$3.00**

All electric motors, coupling coils, magnetic and dynamic loud speakers, transformers, choke coils, etc., are dependent on magnetic phenomena. This fine book is complete on the subject.

**CINEMATOGRAPHY**, by James R. Cameron. Stiff covers, size 7½x5", 240 pages, 150 illustrations. Price **\$4.00**

Everything on the subject from "silent" and "talkie" 16 mm. film to its manufacture and to the final projection in this marvelous volume.

**AUDELS RADIOMAN'S GUIDE**, by Frank D. Graham. Cloth covers (flexible), size 5x6¾", 220 pages, 300 illustrations. Price **\$1.00**

A practical, concise book presenting the theoretical and practical information for the proper operation, maintenance and service as applied to modern radio practice.

**THE RADIO AMATEUR'S HANDBOOK**, (New Revised Edition), by A. Frederick Collins. Cloth covers, size 5½x7¾", 394 pages, 118 illustrations. Price **\$2.00**

If you wish to become a radio amateur (radio ham) this book tells you how. Everything in receiving and transmitter sets and how to build them.

**EXPERIMENTAL RADIO**, by R. R. Ramsey, Prof. of Physics, Indiana University. Cloth covers, size 7½x5½", 256 pages, 168 illustrations. Price **\$2.75**

A marvelous book for the experimenter. Experiments galore in easy comprehensible language.

**RADIO THEORY AND OPERATING**, by M. T. Loomis. 5th revised Edition. Cloth-bound; size 5½x8½" thick; 1,000 pages; over 800 illus.; 450 review questions and answers. Price **\$4.50**

Written in textbook style, a tremendous amount of useful information has been crammed into this thin-paper, compact reference work. Radio transmission and reception have been covered, "from soup to nuts." A truly great book.

**G. GERNSBACK'S RADIO ENCYCLOPEDIA** (Second Edition). Red Morocco Flexible Binder. 352 pages, 2201 radio definitions, 1253 illustrations, 34 tables. Price **\$3.25**

The most comprehensive encyclopedia of its kind in print. Remarkably up-to-date in every way, with marvelous illustrations.

**DRAKE'S CYCLOPEDIA OF RADIO AND ELECTRONICS**, by H. P. Manly. Cloth covers, size 6x9", 1050 pages, 1080 illustrations. New 1932 Edition. Price **\$5.00**

The largest work of its kind ever put between two covers. New and up-to-date; a standby for every radio man.

**FUNDAMENTALS OF RADIO**, by R. R. Ramsey, Professor of Physics, Indiana University. Cloth covers, size 9½x8", 372 pages, illustrated. Price **\$3.50**

The backbone of the radio art. This book gives you the foundation on radio from A to Z.

**RADIO OPERATING QUESTIONS AND ANSWERS**, by Nilsson and Hornung. Fourth Edition. Cloth covers, size 5½x8", 350 pages, 131 illus. Price **\$2.50**

Contains over 600 questions and answers covering all phases of licensed radio operation. Revised to contain much new material. Nothing better in print for the transmitting and receiving amateur.

**OFFICIAL RADIO SERVICE MANUAL, Volume I**, by Hugo Gernsback and Clyde Fitch. Flexible loose-leaf binder, size 8x12", over 2,800 illustrations, 650 pages. **COMPLETE WITH SIX SUPPLEMENTS.** Price **\$4.50**

The Service Man's Bible. Greatest book ever published on the subject. Contains all old circuits of every imaginable commercial radio set up to 1931.

**THE RADIO MANUAL**, by George E. Sterling and Robt' S. Kruse. E.E. 2nd enlarged edition. Flexible fabrikoid covers. Size 5½x8", 805 pages, 348 illustrations. Price **\$6.00**

A complete Radio Course for the operator, the technician, the amateur, the student and experimenter. Everything imaginable in the whole radio art is covered in this great book—the "radio Bible" of the amateur. **DON'T MISS THIS.**

**PRACTICAL RADIO CONSTRUCTION AND REPAIRING**, by J. A. Moyer, S.E., A.M. and J. F. Westrel. Cloth covers, size 8x5", 354 pages, 163 illustrations. Price **\$2.50**

A handbook that every radio set tester and general student must have. The diagrams alone are worth the price of the book.

**A POPULAR GUIDE TO RADIO**, by H. Francis Dashiell. Cloth covers, size 5½x8½", 286 pages, profusely illustrated. Price **\$3.50**

The fundamental principles of radio. From crystal rectifiers to the latest electron tube amplification, etc.

**PRINCIPLES OF RADIO COMMUNICATION**, by J. H. Morecroft, Prof. of Electrical Engineering, Columbia University. Cloth covers, size 9½x8", 988 pages, profusely illustrated. Price **\$7.50**

The radio classic, by the dean of radio. Covers entire radio art as does no other book.

**ELEMENTS OF RADIO COMMUNICATION**, by Professor John H. Morecroft. Cloth covers, size 9x6", 270 pages, 170 illustrations. Price **\$3.00**

An authoritative volume embracing every imaginable phase in radio communication.

**RADIO SERVICE MAN'S HANDBOOK WITH ADDENDA DATA SHEETS**. Flexible covers, size 9x12", 200 pages, 400 illustrations. Price **\$1.49**

The Service Man's standby. Contains the latest practical information on radio servicing.

**HOW TO PASS U.S. GOVERNMENT RADIO LICENSE EXAMINATIONS**, by R. L. Duncan and C. E. Drew. Flexible covers, size 9½x7", 170 pages, 92 illustrations, appendix. Price **\$2.00**

The most important book on the subject ever published. Gives every conceivable angle which will help you to pass a radio license examination successfully.

**RADIO MOVIES AND TELEVISION**, by C. Francis Jenkins. Cloth covers, size 9½x6", 144 pages, profusely illustrated. Price **\$1.00**

A complete volume by the master of television, giving everything in television, including construction details for building your own television sets.

**RADIO PHYSICS COURSE** (2nd enlarged edition), by Alfred A. Ghirardi. Cloth covers, size 7½x9¾", 992 pages, 510 illustrations, numerous tables. Price **\$3.50**

The finest and most popular book on electricity and radio. Each subject is clearly discussed, with the aid of dozens of excellent drawings. Chapters on talkies, television, electronics and service work, etc. Biggest buy in radio books.

**RADIO VISION**, by C. Francis Jenkins. Cloth covers, size 9½x6", 144 pages, profusely illustrated. Price **90c**

An excellent book. The Jenkins television system, as well as many other modern television systems fully described.

We herewith present the most complete collection of recent important radio books. We have, after an exhaustive study, selected these volumes because they represent the foremost radio books of their kind in print today. There is just a great variety that we are sure it will satisfy any taste as well as any requirement that the student of radio might have. We publish no catalog and ask you to be kind enough to order direct from this page. Prompt shipments will be made to you direct from the publishers. We merely act as a clearing house for a number of radio publishers and **OUR PRICES ARE AS LOW AS FOUND ANYWHERE.** Remit by money order or certified check. If you send cash, be sure to register it.

**SHORT WAVES**, by C. R. Leutz and R. B. Gable. Stiff covers, size 6x9", 384 pages, 258 illustrations. Price **\$3.00**

The biggest and most complete book on short waves. Covers every imaginable phase, including S. W. Superheterodynes. The authors are famous S. W. authorities.

**SOUND PICTURES AND TROUBLE SHOOTERS MANUAL**, by Cameron and Rider. Cloth covers, size 8x5½", 1120 pages, profusely illustrated. Price **\$7.50**

The standby of every operator. It is the most thorough book on the subject.

**ELECTRICITY AT HIGH PRESSURES AND FREQUENCIES**, by Henry L. Transtrom. Cloth covers, size 7½x5½", 218 pages, 141 illustrations. Price **\$2.35**

A marvelous book for the student in electricity and radio. General fundamentals lead up to a complete discussion of every type of Tesla and Oudin high-frequency coils, Geissler tubes, etc.; construction details of Tesla coils are given in great profusion. **THE ONLY BOOK OF ITS KIND.**

**OFFICIAL RADIO SERVICE MANUAL, Volume II**, by Hugo Gernsback, C. E. Denton and C. H. W. Nason, with 1932 Free Supplements, 1000 pages, 2000 illustrations. Flexible Loose-leaf Binder, size 8x12". Price **\$4.00**

The talk of the radio industry. This marvelous volume contains everything in radio, circuits and radio developments, for 1932. Not a line of duplication between 1931 and 1932 volumes. (Vol. I and Vol. 2.)

**RADIO RECEIVING TUBES**, by Moyer and Westrel. Cloth covers, size 7½x5½", 298 pages, 181 illustrations. Price **\$2.50**

One of the finest books on vacuum tubes. Everything worthwhile on the subject treated in a masterful manner.

**RADIO TELEGRAPHY AND TELEPHONY**, by R. L. Duncan and C. E. Drew (New Edition). Cloth covers, size 9½x8", 950 pages, 468 illustrations. Price **\$7.50**

Everything from Ohms Law to vacuum tubes and detectors, to oscillographs and radio compasses thoroughly treated in this great book.

**PHOTOELECTRIC PHENOMENA**, by Arthur Liewellyn Hughes and Lee Alvin Dzubridge. Cloth covers, size 6x9¾", 531 pages, 292 illustrations. Price **\$5.00**

A critical survey of the whole field of photoelectric phenomena. Intended as a reference book for research workers, students and teachers. The most complete work in print.

**RADIO SERVICING COURSE**, by Ghirardi and Freed. Cloth covers, size 5½x7¾", 192 pages, 124 illustrations; 174 test questions; 28 test-instrument circuits. Price **\$2.50**

A practical book beginners and old-timers in radio service will find useful. Nine chapters discuss measuring instruments and tests, and trouble-shooting; the chapter, "Useful Information for Servicemen," closes the book.

**EXPERIMENTAL TELEVISION**, by A. Frederick Collins. Cloth covers, size 8x6", 312 pages, 185 illustrations. Price **\$2.50**

In words of one syllable the author discusses fundamental principles; in the same way he proceeds to build up descriptions of television equipment, each step being supported by simple, home-made experimental set-ups.

**PRINCIPLES OF RADIO**, by Keith Henney, M. A. Cloth covers, size 8x5½", 478 pages, 306 illustrations. Price **\$3.50**

A marvelously written textbook with the latest radio principles, including screen grid and pentode, amplifiers, etc.

## NEW LOW PRICE RADIO BOOKS

Here are 13 new, up-to-date books on every conceivable radio subject, just published. Modern in every sense. **ALL BOOKS UNIFORM** from 64 to 72 pages; 50 to 120 illustrations. All books written by well-known radio authors.

- No. 1 **RADIO SET ANALYZERS**, by L. Van Der Mel
- No. 2 **MODERN RADIO VACUUM TUBES**, by Robert Hertzberg
- No. 3 **THE SUPERHETERODYNE BOOK**, by Clyde Fitch
- No. 4 **MODERN RADIO HOOK-UPS**, by R. D. Washburne
- No. 5 **HOW TO BECOME A RADIO SERVICE MAN**, by Louis Martin
- No. 6 **BRINGING ELECTRIC (RADIO) SETS UP TO DATE**, by Clifford E. Denton
- No. 7 **RADIO KINKS & WRINKLES** (for Experimenters) by C. W. Palmer
- No. 8 **RADIO QUESTIONS & ANSWERS**, by R. D. Washburne
- No. 9 **AUTOMOBILE RADIO & SERVICING**, by Louis Martin
- No. 10 **HOME RECORDING AND ALL ABOUT IT**, by Geo. J. Saliba
- No. 11 **FUNDAMENTAL PRINCIPLES OF RADIO**, by Louis Martin
- No. 12 **HOW TO BUILD AND OPERATE SHORT-WAVE RECEIVERS**, by the Editors of SHORT WAVE CRAFT
- No. 13 **HOW TO BECOME AN AMATEUR RADIO OPERATOR**, by M. F. Eddy.

PRICE PREPAID **\$ .45**  
EACH BOOK  
PRICE PREPAID FOR ALL 13 BOOKS **\$4.85**

**HOW TO ORDER** We cannot ship C. D. D. Our prices are net, as shown. Some of the books sent prepaid (in U. S. only). Those that are not thus listed will be shipped by express collect if sufficient postage is not included by you.

**FOUNDATIONS OF RADIO**, by Rudolph L. Dunoan. Cloth covers, size 5½x8", 346 pages, 145 illustrations. Numerous tables. Price **\$2.50**

This textbook gives you the fundamentals of electricity as applied to radio. It equips you for further study in the field of radio.

**EXPERIMENTAL RADIO ENGINEERING**, by John H. Morecroft. Cloth covers, size 6x9", 346 pages, 250 illustrations. Price **\$3.50**

A student's book; devoted to the principles of radio apparatus; intended to accompany a course in electricity. The best of its kind.

**ORDER DIRECT FROM THIS PAGE**

**RADIO PUBLICATIONS**

245 T GREENWICH STREET

NEW YORK, N. Y.



# HARRISON RADIO CO.

★ QUALITY MERCHANDISE

★ LOWEST PRICES

★ REAL SERVICE

★ EVERYTHING GUARANTEED

## 3 Stage 250 Push Pull Power Amplifier

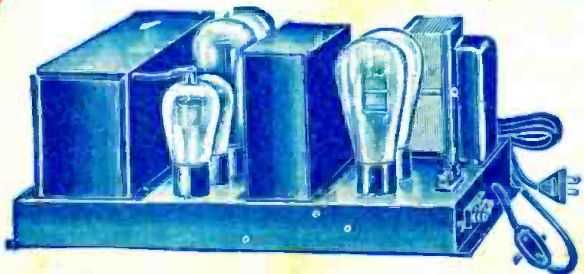

This remarkable new six tube amplifier combines quality of performance, finest materials, all worth-while improvements and low cost in a manner that is practically unbelievable. Using the latest tubes in a distinctly modern design it easily delivers 14 watts of clear, undistorted power, enough for up to 5 large dynamic speakers. Its response curve is practically flat resulting in crisp, life-like reproduction usually lacking in the ordinary low priced amplifier. Built in volume control. Input—2000-1000 ohms. Output—10-15 ohm voice coils and 4000 ohms. Gain at 1000 cycles—58 db. Will supply field current to large field of 750 ohms. Tubes: 1-58, 1-56, 2-250, 2-281, 1 1/4" x 1 1/2" x 1 1/4". 32 lbs. (unrated).

OUR PRICE **\$19.75** WITH TUBES **\$27.75**

## Thordarson 250 Power Transformer

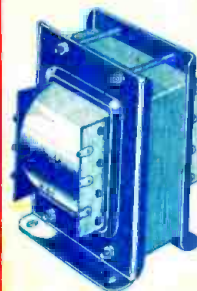

An oversize power transformer that will easily supply the heaviest demands of a 250 P.P. amplifier or 210 transmitter. High voltage 750-0-750 volts AC. Will deliver 650 volts DC at a drain of 250 mls. Filament windings for 2-281's, 2 or 3-250's or 210's, 2 1/2 volts at 10 amps, and 1 1/2 volts at 5 amps. 2 1/2 volt winding can be used for 82, 87's, or 86's. Tapped primary to compensate for different line voltages. Completely mounted, 15 lbs. 6"x5"x3 3/4". Others sell this transformer for \$8.75.

Harrison Price is **\$4.25**

Same as above but delivers 550 volts DC at 150 MA and has no 1 1/2 volt winding. Fully cased, 5"x4"x3 3/4". 9 lbs. SPECIAL **\$3.75**

SPECIAL POWER TRANSFORMER Delivers 700 volts at 120 MA. 7 1/2 v. at 7 1/2, and 2 1/2 at 12 amps. 200 Watts. Electrostatic shield. 5 1/2"x4"x3 3/4". 9 lbs. SPECIAL **\$2.35**

## Heavy Duty Filament Transformers

For transmitters, amplifiers or receivers where a separate filament supply is desired. Fully shielded to prevent hum. Excellent for converting old battery sets. Good regulation. Insulation tested at 2000 volts. All windings are center-tapped. 3"x3"x3 3/4". Ship. wt. 1 lb.

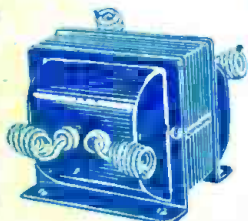

2 1/2 volts at 4 amps. **95¢**  
 1 1/2 volts at 4 amps. **\$1.25**  
 2 1/2 volts at 12 amps. **\$1.40**  
 5 volts at 4 amps. **\$1.30**

10 volts at 4 amps. **\$1.95**  
 2 1/2 v. at 10 amps. **\$1.75**  
 2 1/2 v. at 4 amps. **\$1.95**  
 & 7 1/2 v. at 3 amps.

## Compact 5 Mfd. 1000 Volt Filter Block

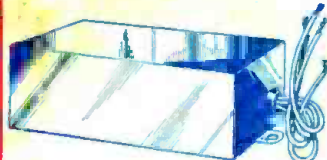

No breakdowns or leakages in your 250, 210, 247, or 245 amplifier, power supply, receiver, etc. when used with this quality high voltage block. Metal case containing three 1 mfd. and a 2 mfd. section. All 1000 volt DC working. Case is common ground connection.

A STAR SPECIAL—Each **\$1.85**

Four for \$5.95

## PUSH BACK WIRE

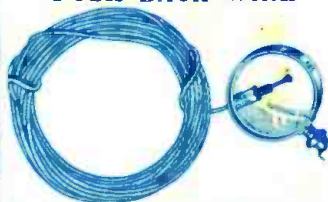

No danger of shorts or leakage with this high grade push-back wire! Heavy stranded wire, equivalent to No. 14, tinned for easy soldering. Spaghetti insulation covered by black braid that will not unravel. Both insulations push back for neat connections! Ideal for wiring amplifiers, transmitters, receivers, etc. 25 foot coils 25¢ | 200 feet for \$1.50 | 40 foot coils 35¢ | 500 feet for \$2.75

**Send For BARGAIN BULLETIN**

## By-Pass Condensers



Six .25 mfd. 500 volt units in a neat drawn metal case 2x 2x1. Case is common ground connection. General replacement and experimenters' block. At least one is needed in every set. Better stock up while they last! **43¢**

Same as above but containing six .1 mfd. 500 volt sections. **39¢**

Per dozen \$4.10

## ROYAL SHORT WAVE RECEIVERS

A complete line of receivers for the amateur and the short wave fan that combines high standards of performance with surprisingly low cost. Incorporating such ultra-modern features as dual-ratio, full vision dial—screen grid detector—pentode output—"TRANS-X" coupling—heavy metal chassis—attractive crystal finished metal cabinet with hinged cover—smooth regeneration control—etc. and the scientific design of experienced Royal engineers, these remarkable receivers are superior to all others in the same price class and compare favorably with sets commanding much higher prices. Order your Royal today and be convinced! Supplied with four coils covering from 14 to 200 meters or with band spread coils for the 20, 40, and 80 meter amateur bands.



### The Royal Star

(The Famous model RP)

A two tube with an enable reputation! Uses a 232 super sensitive detector and a 233 power pentode.

List Price \$25.00 **\$14.70**  
 Complete Kit \$11.76  
 Set of Tubes \$2.55

### The A C Star

Uses one of the new type 58 super-control screen grid pentodes, a 247 pentode audio amplifier, and a 280 rectifier. Especially designed for humless, quiet operation on Short Waves. Ready to plug into AC line.

List Price \$40.00 **\$23.52**  
 Complete Kit \$20.58  
 Set of Tubes \$2.15

### The Royal Chief

A three tube set embodying all of the well-known superior features of the Royal Star plus a stage of high gain screen grid radio frequency amplification (232).

List Price \$30.00 **\$17.64**  
 SPECIAL Complete Kit \$14.70  
 ROYAL Tested Tubes \$3.75  
 Set of Batteries \$3.95

### The A C Chief

The AC Star with an additional type 78 used as screen grid radio frequency amplifier.

List Price \$45.00 **\$26.46**  
 Complete Kit \$23.52  
 ROYAL Tested Tubes \$2.95  
 160 Meter coil \$1.17  
 Broadcast coil \$1.17

### The Royal Olympic

The Royal Chief with an additional stage of 230 audio amplification for super-dynamic power. The Royal Olympic makes new records!

List Price \$35.00 **\$20.58**  
 SPECIAL Complete Kit \$17.64  
 ROYAL Tested Tubes \$4.50

### The A C Olympic

A Deluxe AC operated Receiver employing two 58's, a 56, a 47, and a 280.

List Price \$50.00 **\$29.40**  
 SPECIAL Complete Kit \$26.46  
 ROYAL Tested Tubes \$3.60

## VERNIER TUNING DIALS

Smooth friction drive with spring take-up insuring life-long trouble-less operation. Translucent celluloid scale 0-100 for illumination. For 1/4" shaft. Outside diameter 4". **28¢**  
 DIAL ONLY  
 Pilot lite socket 8c Escutcheon Plate 12c



## CORNELL VERNIER DIALS

Attractive art metal vernier dial for regular front of panel mounting on any receiver. Friction drive. Translucent scale 0-100-0. 4" long. **39¢**  
 Lowest price ever

## FILTER CHOKES

For those who demand quiet, humless operation of a receiver or amplifier this choke is excellent. It consists of a 50 Henry 100 Mill choke and a 30 Henry 125 MA (200 ohms) choke in a neat metal case. Electrostatic shield between chokes prevents transduction. Terminals on bakelite board. 1-2: 50 Hy. 1-3: 30 Hy. 2"x3"x3 3/4". 8 lbs. No choke as good as this one has ever been offered at the low **\$1.95** price of **Three for \$5.00**



## RF Chokes

A compact 200 Turn duolateral wound r.f. choke of exceedingly low distributed capacity. Can be used in any short wave receiver where an R.F. choke is called for. 3/4" dia. 8 for **50¢**

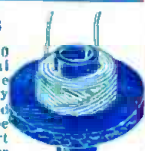

GREBE TRANSMITTING RF CHOKES 1"x4". Will pass 300 MA. Each **23¢**  
 Five for \$1.00

## Resistors

Wire wound and enameled. We can supply dividers for any receiver or power pack.  
 2500-5000-8250-2500-3500 5"x3/4" **38¢**  
 2000-5000-5000 For 215 sets. 4"x1/2" **38¢**  
 25,000-25,000 4"x3/4" **42¢**  
 30,000-20,000 5"x3/4" **55¢**  
 10,000-60 Watts 5"x3/4" **45¢**  
 5,000-5,000 4"x3/4" **45¢**  
 20,000 2"x1/2" **28¢**  
 Variable resistors in stock.

**REMEMBER!**— We are national distributors for the following lines and we can supply all your radio material at **REAL WHOLESALE PRICES!**  
 ROYAL NATIONAL HAMMARLUND  
 UNIVERSAL MICROPHONE  
 MAYO CARDWELL  
 JEWELL  
 WENTON  
 BURGESS  
 EBY  
 READRITE  
 ETC., ETC.  
**SEND YOUR ORDER NOW OR WRITE FOR PRICES**

All prices F. O. B. New York  
 No order can be accepted for less than \$2.50  
 Deposit Required  
**VISIT OUR NEW SALES ROOMS**  
 One block south of Cortlandt Street

**HARRISON RADIO CO.** Dept. V-6 New York City  
 142 Liberty Street  
 ★ ★ THE HOME OF FOUR STAR SERVICE ★ ★



**They Have Copied Everything—**

## **Except CERTIFIED TRIAD Quality**

**IT IS WRITTEN—**

*“Imitation is the sincerest form of flattery”*

**TRIAD** Appreciates the compliment it receives each month from other tube manufacturers who have copied our sales plan—our method of advertising—our discount schedules

**TRIAD** Was first to recognize the Service Man

**TRIAD** Was first to make double-tested tubes

**TRIAD** Was first to offer a plan which really makes money for the dealer and Service Man

**OTHERS** have made every effort to do the same thing

**BUT**

**THEY HAVE NOT BEEN ABLE TO DUPLICATE**

**CERTIFIED**

# **TRIAD → Quality**

## **TUBES**

CERTIFIED Triad Dealers and Service Men everywhere have sold many thousands of these tubes,—they are making money—there hasn't been a single complaint. Mail the coupon today and learn how you can sell these super-grade tubes at a real profit. We protect you in your territory and you are sure of all of the inducements offered by other manufacturers, plus quality which is in a class by itself. **GET THE FACTS!**

**TRIAD** Manufacturing Co.  
Pawtucket, R. I.

Gentlemen:

Please send me the outline of the CERTIFIED TRIAD Sales Plan for Dealers and Service Men.

Name.....

Address.....

City..... State.....

My letterhead or business card is attached