

"Talking Machine Merchants of the Nation  
Look for Prosperity in 1926"

VOL. XXII. NO. 1

Read Symposium on Pages 83 to 90

SINGLE COPIES, 25 CENTS  
PER YEAR, TWO DOLLARS

# The TALKING MACHINE WORLD

For dealers  
wholesalers  
& manufacturers  
of phonography  
& radio products

Published Each Month by Edward Lyman Bill, Inc., at 383 Madison Ave., New York, Jan. 15, 1926



NOW - the Complete  
Musical Scale - by Electricity

The  
BRUNSWICK  
PANATROPE



*The Sign of Musical Prestige*

# Brunswick

Manufacturers Established 1845

© B. B. C. Co. 1926

PANATROPE - THE ENTIRE MUSICAL SCALE



# Sonora

Speakers for those who  
want better tone quality  
from their "Christmas  
Radios"

Exclusive Sonora Distributors:

Baltimore Phonograph Dist. Co.  
422 North Howard Street, Baltimore, Md.

The Commercial Associates  
531 Mateo Street, Los Angeles, Cal.

Doerr, Andrews & Doerr  
Minneapolis, Minn.

Gibson-Snow Co., Inc.  
Syracuse, N. Y.

Greater City Phonograph Co., Inc.  
234 West 39th Street, New York, N. Y.

Hassler Texas Co.  
1101 Young Street, Dallas, Texas  
612 Broadway, San Antonio, Texas  
1715 Main Street, Houston, Texas

Kiefer-Stewart Company  
Indianapolis, Ind.

The Kohler Distributing Co.  
63-67 Minna St., San Francisco, Cal.

Long Island Phonograph Co.  
68 Thirty-fourth Street, Brooklyn, N. Y.

Moore-Bird & Company  
1720 Wazee Street, Denver, Col.

The New England Phonograph Dist. Co.  
221 Columbus Avenue, Boston, Mass.

Pennsylvania Phonograph Dist. Co.  
1015 Chestnut Street, Philadelphia, Pa.  
917 Wabash Building, Pittsburgh, Pa.  
1747 Chester Avenue, Cleveland, Ohio

James K. Polk, Inc.  
181 Whitehall Street, Atlanta, Ga.  
811 West Broad St., Richmond, Va.

C. A. Richards, Inc.  
279 Broadway, New York, N. Y.  
Canadian & Export Distributors

C. D. Smith Drug Company  
St. Joseph, Mo.

Strevell-Paterson Hardware Co.  
Salt Lake City, Utah

The Tay Sales Company  
6 North Franklin Street, Chicago, Ill.

Yahr & Lange  
Milwaukee, Wis.  
442 East Lafayette Ave., Detroit, Mich.

SONORA PHONOGRAPH COMPANY, INC.

279 Broadway, New York



# The Talking Machine World

Vol. 22. No. 1

New York, January 15, 1926

Price Twenty-five Cents

## Complete Line of New Phonographs to Be Placed on Market by Columbia Co.

New Instruments, Which The World Representative Was Privileged to Hear, Embody Important Acoustical and Constructional Improvements That Cannot Fail to Interest the Trade

The Columbia Phonograph Co., Inc., will place on the market in the near future a complete line of phonographs representing important radical improvements acoustically which mark a great advance over all former types of Columbia instruments. The executives of the company are now working out the various details incidental to cabinet design and production and it is expected that the new line will be complete and ready for the market in a few months.

In developing its plans in connection with its new line of phonographs, the Columbia Phonograph Co., Inc., has refrained from giving out advance information to the public concerning its product in order that Columbia dealers may have the new instruments in their warerooms coincident with the announcements to the general public. Rapid progress has been made in the perfection of these plans during the past two months, and it will be only a short while before the company will be ready to demonstrate the new Columbia phonograph to the trade.

A representative of The World was privileged to hear a demonstration of a working model of the new Columbia during the course of a visit to the offices of Henry C. Cox, president of the company and W. C. Fuhri, vice-president and general sales manager. While entirely informal this demonstration served to emphasize the fact that in its new product the Columbia Phonograph Co., Inc., has a line of instruments that cannot fail to meet with the hearty approval of critical lovers of the best in music and of Columbia dealers everywhere as well.

The new Columbia phonograph represents an entirely new and radical departure in construction, through the application of a most effective amplifying chamber, together with complete new tone arm and sound box equipment. The amplifying chamber and the reproducing equipment were perfected in the Columbia engineering laboratories under the direct supervision of prominent experts as well as the executives of the company, and reflect an intimate knowledge of phonograph manufacture and the requirements of the trade.

In demonstrating the new Columbia phonograph every type of record was used and the instrument reproduced the records with a tone quality that was amazing, coupled with a clarity of reproduction and a degree of volume that should satisfy the most exacting requirements of music lovers. In its reproduction the new Columbia phonograph is notably free from all extraneous noises, including record surface noises, scratches and blast. In the instrumental selections each and every instrument in the orchestra or band was reproduced with absolute fidelity, maintaining a perfect balance of all instruments, including the bass, and in vocal selections the voice was particularly noteworthy for its human quality, clarity, range and beauty. In reproducing dance music the new Columbia instrument brought out the melody and accompaniment most satisfactorily, thereby giving each dance orchestra its own individuality. Of special interest was the remarkable reproduction on the new instrument of the Columbia record "Adeste Fideles," made by 4,850 voices, one of the recognized sensations in record production, having won well deserved fame the world over.

No one who has heard the new Columbia instrument can fail to predict that the new Colum-

bia phonograph line will be one of the outstanding successes in the phonograph industry for 1926, for in manufacturing and marketing its product, the company has at its command the knowledge and experience of some of the foremost executives in the industry.

The Columbia Phonograph Co., Inc., closed in 1925 a successful year as to increase in volume of sales and in the development and building of good will among retailers from one end of the country to the other. The company starts the New Year with every indication that its success the past twelve months will be materially enhanced along the lines profitable for Columbia dealers, for it has gained the respect and esteem of every factor in the talking machine industry.

## Electric Corp. Appointed Coast Federal Distributor

The Electric Corp., of Portland, Ore., and Seattle, Distributing Federal Ortho-Sonic Radio Sets to the Trade in These Territories

The Federal Radio Corp., of Buffalo, N. Y., announces the appointment of the Electric Corp. of Portland, Ore., and Seattle, Wash., as Federal wholesaler in its respective territories.

Reports from this wholesaler are to the effect that Federal Ortho-sonic radio receivers are in big demand in those territories. These wholesalers are carrying the complete line to supply interested retailers.

The Federal advertising campaign in the Fall of 1925, together with the efficient operation of Federal Ortho-sonic receivers, has increased the popularity of the Federal line on the Coast.

## Columbia Phonograph Co. to Open Branch at Syracuse

In order to enhance its service to Columbia dealers throughout New York State, the Columbia Phonograph Co., Inc., has made arrangements to open a branch at Syracuse, N. Y., which will be under the direction of the New York branch, of which E. W. Guttenberger is manager. The demand for Columbia records from dealers in Syracuse territory increased far beyond all expectations during 1925, and W. C. Fuhri, general sales manager of the company, decided upon the opening of a Syracuse branch, so that the dealers in this important territory will receive maximum service during 1926.

## E. J. Dingley Resigns From Victor Talking Machine Co.

E. J. Dingley, for a number of years associated with the sales department of the Victor Talking Machine Co. in various capacities, resigned from the service of that company on January 5. No announcement has been made as to Mr. Dingley's successor.

Landay Bros., Inc., New York, recently declared an initial dividend of 60 cents on Class A participating stock, payable February 1. This covers the period from November 18, 1925, to February 1.

## General Phono. Corp. Uses New Recording Principle

Records in Okeh Laboratories Now Being Made by the Truetone Recording Process, Which Is Said to Be a Remarkable Improvement Over the Old Method of Recording

Ralph S. Peer, general sales manager of the Okeh record division of the General Phonograph Corp., issued this week the following important announcement regarding a new recording process just perfected by the company: "After many years of research work, C. L. Hibbard, recording engineer of the General Phonograph Corp., has discovered a new recording principle which is now being applied in the Okeh laboratories. By using this new device it is possible to transmit to the master record

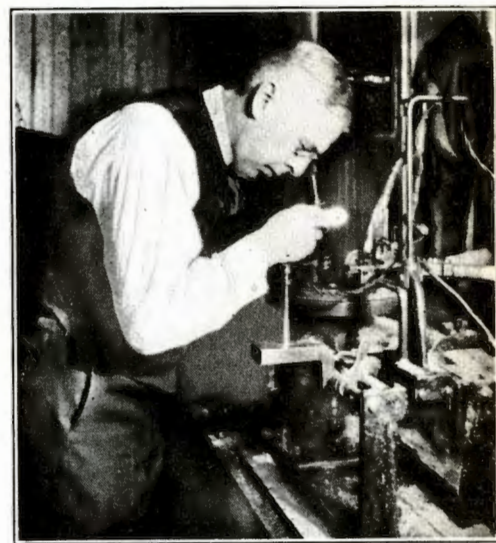

C. L. Hibbard

the exact sound vibrations produced by the artist, and the result is a record having a very natural tone. The volume of sound on a phonograph record has heretofore been limited by the tendency to 'blast.' Okeh is now able to make records without any indication of 'blasting,' having practically the same volume as the original artist. Because of this naturalness of reproduction, the new method has been christened the 'Truetone Recording Process.'

"This discovery can be applied to either acoustic or electric recording and has been of particular value in eliminating the uncertainties from electric recording. Samples of the new Truetone records are now being distributed to the trade and have been very enthusiastically received."

## R. Robert Smith Promoted

R. Robert Smith, formerly assistant advertising manager of the Freed-Eisemann Radio Corp., of Brooklyn, N. Y., has been appointed advertising manager of the company, succeeding Philip V. D. Stern, who has resigned because of ill health. Mr. Stern sailed for Europe on the French liner "Paris" on January 9, where he will spend several months enjoying a well earned rest.

## Appointed Fada Dealer

The Reynolds Music Houses of Mobile, Ala., and Pensacola, Fla., have been appointed Fada radio franchised dealers in both cities. W. H. Reynolds, proprietor of these stores, is well known in the music trades, having been in the retail and wholesale phonograph and music business for more than twenty-five years.



# Balancing the Retail Sales Curve in 1926

Continuation of Intensive Efforts to Secure Business Will Be Rewarded by a More Consistently High Sales Volume Each Month

The advertising manager of a very successful manufacturing concern, when asked by the business manager of a trade publication to increase his space from one to two pages the month before Christmas, replied:

"No, I will just run the one page this month. I must reserve some of my advertising appropriation until after the holidays. That is when the tendency to let up on merchandising efforts makes itself felt. This year I am going to try to even the sales curve. You know as well as I do that the bulk of retail as well as wholesale distribution takes place just before the holidays. The sales curve takes a sharp jump and then an equally sharp drop. No business can live an entire year on the sales volume gained in two months."

The new year is here and with it come new opportunities for every retail dealer. Last year saw momentous developments in the talking machine trade which should be realized on during the next twelve months. To what extent the individual retailer profits will depend this year, as it has in past years, on the effectiveness of his merchandising program—what he puts into his business in good clean merchandising and quality selling of quality products. The sloth will just grub along on the fringes of prosperity as he has in the past. The worker will get the business. The cut-price artist will find it hard to fight against the message of the legitimate retailer who offers high-grade merchandise and service. The gyp will not find it so easy to get volume business this year as last. The trade has been going through a process of evolution which increases the sales oppor-

tunities of the dealer handling the right merchandise and extending the kind of service that builds good will. The gyms realize that the stabilization of business which has been increasingly manifest during the last year and which is certain to gain momentum will slowly strangle his business. The gyp realizes that

*The let-down in effort during the so-called "off" season is largely responsible for the drop in the sales volume. The momentum gained by extensive and intensive sales drives during the year just closed can be carried well into the present year if an equally strong effort to turn over the stock is made.* . . . . .

the good thing he has had in the past will not continue indefinitely. He must either get into another line of business eventually or revise his merchandising policies. National advertising of the manufacturers has done much to educate the public regarding the new and improved talking machines, records and radio. The people know what they want and they will go where they can get it—in the store of the legitimate dealer, not the fly-by-night who is here to-day and gone to-morrow.

The statement of the advertising manager appearing in the first paragraph contains much food for thought. He said: "No business can live for an entire year on the sales volume gained in two months." It is true that in the talking machine business, in many stores at least, the holiday period and one or two other periods of the year represent the busy seasons. The talking machine business is not a seasonal business. It never has been and it never will be. However, the dealers who state that it is, showing their books to prove by the sales volume during the various months of the year that during certain periods sales drop to almost nothing and at other periods large sales volume is enjoyed, have themselves to blame. Take the pre-holiday period for example. During a month or more before Christmas most live dealers are doing more extensive advertising than at any other time of the year. The window displays are more carefully arranged and consequently they are so striking that the passers-by stop to look. Direct mail sends the message of the talking machine, records, or radio set to selected prospects as a suitable gift. Outside salesmen work harder than at any other time to make sales. What is the effect of all this? Naturally, this intensive and extensive sales promotion program gets results. It would get results also at any other period of the year, although the appeal to potential customers would have to be couched in different language.

The main reason for the uneven sales curve reported by dealers is because of the unevenness of the sales campaign. Prosperity in 1926 will be measured by promotional efforts.

## NYACCO

Five

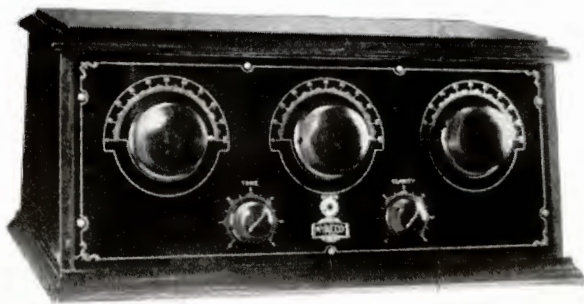

Tube

T. R. F.

This popular model of the NYACCO line is a five tube tuned radio frequency receiver. It is constructed with expert care and of the finest materials obtainable, including straight line frequency condensers and bakelite panels, sub-panel knobs and rheostats. NYACCO *must* function efficiently and *does*.

NYACCO compares favorably in construction, appearance, with sets selling at three figures. The straight line Frequency Condensers assure ease of tuning on low or high wave lengths. The tuning coils mounted and all the wiring beneath the sub-panel eliminate the accumulation of dust.

### HOME ENTERTAINMENT AT NOMINAL COST

NYACCO five-tube radio frequency set is equal in performance to the *expensive* sets, and we are certain that the most exacting radio enthusiast will gladly attest to the unequalled satisfaction to be found in the possession of the NYACCO.

Dealers write your jobbers for details on the complete NYACCO line or address:

## New York Album & Card Co., Inc.

23-25 Lispenard Street, New York





*The Brunswick Panatrobe . . .  
a new cabinet design now  
in production . . . Model P10*



## Thos. A. Edison, Inc., to Market a New Record That Plays Over Twenty Minutes

New Record Only Twelve Inches in Diameter and Can Be Played With Slight Adjustments on Any Edison Disc Phonograph—Other Important Improvements Promised Soon by "Wizard"

A phonograph record playing continuously for from twenty-one to twenty-two and one-half minutes, or some five times longer than the average ten-inch record of the present day, is now an actuality, as a result of the work of Thos. A. Edison and his staff, and the new long-playing Edison records have reached a point of development where it is expected that initial shipments will be made to dealers within a comparatively few weeks.

The formal announcement of the new record was made at the Edison Laboratories at Orange last week, after development work had reached a point where the records were ready for introduction to the trade on a sound commercial basis. For many years experimenters and inventors have heralded new types of records playing for twenty minutes or more and with sufficient capacity to take complete musical works on one side, obviating the necessity of changing records frequently. It remained for Mr. Edison, however, to work the idea out in a practical manner, and demonstrations given at Orange indicate that the new record is, and should be, a complete success.

The new long-playing records, a number of which have been produced with five complete songs or instrumental numbers with choruses on each side, are only twelve inches in diameter, and the remarkable part of it is that any Edison disc machine that has ever been sold by the company may be utilized for their reproduction upon the installation at a moderate cost of a new reproducer and a clever gear-shifting arrangement to regulate the speed of travel of the tone arm across the record in accordance with the closeness of the grooves.

The secret of the ability of Mr. Edison to get so much music on one side of a record lies in the successful efforts in increasing the number of sound grooves per inch of record surface, the number of grooves being increased from 150 as in the regular Edison record to 450, or a direct ratio of three to one. With the special reproducer, both the standard form of records and the new twenty-two-minute records may be played at will on one machine by shifting the gears to regulate the movement of the tone arm.

Mr. Edison himself is most enthusiastic over the new records, for he declares that although on a unit basis they would naturally cost more than the old type, the greater capacity will mean much more music for the same money. For those who are not desirous of listening to the ambitious musical compositions that require twenty minutes or so in their playing, there will be provided the new records with five popular or semi-popular selections on each side, or ten in all, it thus being possible to enjoy the full

repertory of five songs and instrumental numbers without touching the machine or changing records. It is believed that the idea is most desirable for the playing of music for dinners, for dancing, or for entertainment purposes.

So far as tonal quality goes the new records measure up fully to the Edison standards as reflected in all Edison products. Arrangements have already been made for shipments to dealers of the new records and phonographs equipped with the new reproducer and gear-shift device, and they will also be supplied shortly with reproducers and gear attachments for installation in Edison phonographs at present in the homes of customers.

### Frank Dorian in Important Post With Columbia Co.

Well-Known Trade Executive Rejoins Concern as Assistant to President H. C. Cox

H. C. Cox, president and general manager of the Columbia Phonograph Co., Inc., has announced the appointment of Frank Dorian as assistant to the president. Mr. Dorian was formerly with the Columbia Co. for over thirty years in many important positions up to 1920. Recently he was assistant to the president (Walter Eckhardt) of the Music Master Corp., of Philadelphia.

Mr. Dorian entered the service of the Columbia Co. September 2, 1889, as secretary to E. D. Easton, founder and president, and in November, 1896, he was made general manager of the company. In August, 1897, he relinquished the position of general manager in America in order to proceed to Europe to establish Columbia in that field. He opened the first European branch in Paris in September, 1897, and opened the German branch in Berlin in 1898. Other branches were established in Milan, Italy, and Vienna, Austria, in 1899.

The first European factory was established in Paris in 1898. Early in 1900 the London branch was opened and Mr. Dorian's European headquarters were transferred to that city. The opening of the London branch was quickly followed by a second European factory at Wandsworth, a suburb of London, and by additional sales branches in all parts of Europe and Australia, all operating under London headquarters.

In 1909 Mr. Dorian resigned as European general manager and returned to the United States organization. After a few months' service as manager of the recording department, he was appointed general manager of the dictaphone division and remained in that capacity

It was stated at the Edison Laboratories that the new long-playing record is the result of some five years of study and experimenting, and the wizard is at present actively engaged in the development of other improvements for Edison phonographs which will probably be announced in the very near future and will, in keeping with his policy, be available to present Edison phonograph owners at moderate cost. The details of these new improvements are not available for publication just now, but they are of sufficient importance to arouse widespread interest when officially presented to the trade.

Mr. Edison after some strenuous periods in his laboratory will leave shortly after February 1 for his Winter home at Fort Myers, Fla., where he will remain for several weeks. He was visited recently by his friend, Henry Ford, of automobile fame, who was one of the first outside the Edison organization to hear the long-playing record, and who became most enthusiastic over it.

for eight years, earning the sobriquet of "the man who put the dictaphone on the map." Later, for two years, he was in charge of the Columbia business on the Pacific Coast, with



Frank Dorian

headquarters at Seattle, Wash. He resigned from the company's service in 1920.

He now returns to his real business home, and is welcomed with enthusiasm by the entire Columbia organization, as it is felt that he will not only lighten the burden now on the shoulders of Mr. Cox but that his experience will be a valuable acquisition to the Columbia Co.



## Wuebben Record Albums are indestructible

They are manufactured on methods of construction which are protected by the Patent Laws. It is impossible for the records to drop out.

Ask for our illustrated prospectuses and price lists

Wuebben Gesellschaft, m. b. H., Kochstrasse 60, Berlin SW. 68



**COMING!**

**NEW BRUNSWICK RECORDS**

*by*

**AL JOLSON**

*and by these*

**NEW EXCLUSIVE ARTISTS**

**NEW YORK PHILHARMONIC ORCHESTRA**

*(Directed by Willem Mengelberg)*

**WENDELL HALL**

*(The Red-Headed Music Maker)*

**BEN BERNIE**

*(and his Hotel Roosevelt Orchestra)*

**ESTHER WALKER**

*(Famous Singing Comedienne)*

**Revelations in Recording**

*by the new Brunswick  
exclusive electrical method*



# Graves Makes Partners of His Salesmen

Texas Dealer Has Built Effective Sales-Producing Organization by Offering to His Best Salesmen an Interest in the Business

By B. C. Reber

A high-caliber business-producing salesman is worth keeping at any cost, pointed out a leading executive not so long ago. That also was the opinion of J. M. Graves, of Corpus Christi, Tex., who was faced with the loss of his best salesmen. Mr. Graves is a successful Edison phonograph dealer, and he himself is authority for the statement that his prosperity has, in a large measure, been due to his policy of retaining salesmen of outstanding merit—even if he has to take them into the business as partners.

## Opened Store in Poor Location

A few years ago Mr. Graves went into the business of merchandising phonographs and records in the small city of Victoria, Tex. It could hardly be said that he started with a shoestring, for his stock at that time had a valuation of approximately \$10,000. However, it did not seem to be the logical place for his business. One thing after another came up which seemed to keep him down.

He had his eye on Corpus Christi, but the Edison people, whose products he was selling, already had a dealer in that city, so there was nothing to do but keep on with the hope that something might turn up. And it did. A short time later, the dealer at Corpus Christi gave up his dealership and the Edison branch immediately sent word to Mr. Graves, informing him that he could move to the town of his choice if he still wished.

The move was made immediately, and the Phonograph Shop opened up on one of the main streets, offering to the residents of Corpus Christi the best of service in selling and repairing phonographs. In Victoria, however, the business had been so bad that the original stock had deteriorated to \$7,000.

## Selects Experienced Salesman

"When I was in business in Oklahoma," Mr. Graves stated, in speaking of his experiences, "I had a man working for me who I knew was a first-class salesman; so, when I started in to sell phonographs, I sent for him and invited him to work for me in Victoria. He came on down, and we did as much business as could have been expected.

"However, being a man who was ambitious, I saw that he would soon want to go into business for himself. I had spent quite a little time working with this man; in fact, we worked together, and I did not want to lose him. It costs money to break in a new man, and it cuts down your volume of sales until things are

back to normal again. I thought this problem over for quite a while and it finally occurred to me that it wouldn't be a bad idea to give him an interest in the business. By doing this, I could keep him with me, do a bigger business and still retain control.

"I talked the matter over with him and offered him a quarter interest in the business. We discussed matters for a while, and he agreed to

*When J. M. Graves, phonograph dealer of Corpus Christi, Tex., after a hard battle, was just making a success, he was faced by the fact that his best salesman was about to leave. It was then that he decided on his policy of taking into partnership his best men and the wisdom of the move has been proved.*

buy the amount I had offered him, paying cash for it. In this way we were able to go ahead in the same way, only with more sincerity. The man who had formerly been an employe was now a part owner. Naturally, he realized that he was working for himself and that the more effort he put into the business the more he would benefit.

"The business grew and we took on other people. My wife helped in the selling of records and we added another man to the sales force. This second man also proved to be a very good salesman and, with our little force, we were able to push the business ahead in fine shape.

"About this time, however, another problem presented itself. The second salesman was beginning to feel ambitious and wanted to get into some business of his own. He had seen how we were prospering, and, while he had had a hand in making our prosperity possible, he was not sharing in the profits.

"I thought it over again and decided to offer him an interest in the business. I didn't hardly want to give him a quarter interest, as I had the first man, but I felt that if I offered him an eighth he ought to feel very well satisfied.

"One morning I called him into the office and asked him how he would like to join in the business, buying one-eighth as his share in the firm. The value of this share, however, was greater than he could handle at that time. He was eager to get into the business, but he lacked the necessary capital to buy the interest I had offered him. There was one point, however, which helped to swing the whole deal over in good shape: he was a good, reliable man, and I knew that if he was given the opportunity he would make good. On this basis, I offered to sell him the interest and let him pay for it out of his earnings.

"It gave him the opportunity he was seeking, and it enabled me to keep my selling force together, which is the nucleus of every successful business. So I had two partners and myself in the business and we began to put things over in good shape.

"Employees who have money invested in the business take a greater interest in its program, and the sales volume increases accordingly. Little features which will help to cut down expenses or will build up sales are brought out which, otherwise, would never be considered. Then there is the advantage of having a wider range of opinion. Where one man has to think out all his problems alone he is pretty apt to overlook some of the most important points at times. However, with one or more partners helping him, every problem is given careful consideration from all angles.

## When Farmers Buy

"We serve some rural districts and go after them in good shape. When the farmers have a good year they are generally in a buying mood and we take advantage of this opportunity to sell to every one we can. This last season, however, on account of the dry weather, the crops were not as good as the average; so we concentrated our efforts on city trade.

"We do a good record business, in addition to our phonograph sales. This is a department which should never be overlooked for a minute. It helps to carry the business along during periods of depression, for people will feel more inclined to keep their old machines and buy new records than to keep their old records and buy new machines.

The present valuation of the business would inventory at close to \$25,000. This, in a small city where others had failed, is an example that is worthy of consideration.

## Times have changed in the Record Business

Old fashioned, profit-absorbing sales methods are going rapidly into discard

Wanamaker, Lyon & Healy, A. Hospe & Co., Grinnell Bros., Baldwin Piano Co. and a great many other prominent concerns have adjusted their sales methods to meet the changed conditions by adopting

## *The Audak System*

The modern method of demonstrating and selling records  
*Without the Use of Booths*

Dealers place as many as six Audak units in space formerly occupied by one booth. There are Audak models to suit each particular need. Write for full information.

The Audak unit illustrated supplied complete, ready for use upon removal from crate

**AUDAK CO. - 565 Fifth Avenue - NEW YORK, N. Y.**





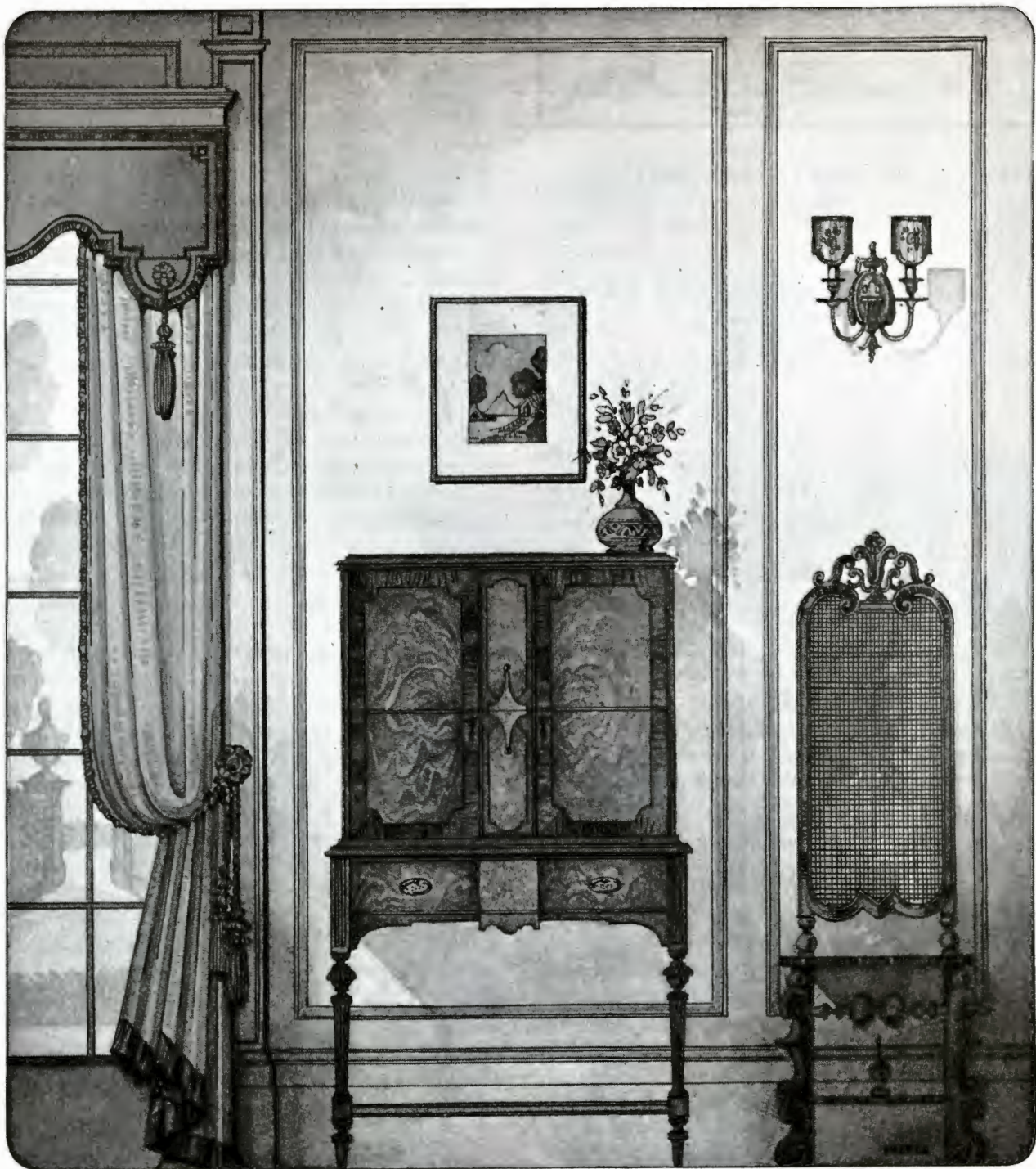

Its performance is equal to its beauty

Musically cultured people prefer Stromberg-Carlson Receivers. Those who appreciate fine violins, grand pianos, boxes at the opera and season tickets to concert courses know what well-played instruments sound like. They wish to appraise the playing of Hoffman, the singing of Homer, the technique of Seidel as accurately by radio as though seated before them. They

prefer a Stromberg-Carlson Receiver because of its faithful tone reproduction. This fidelity of tone is due in large measure to "Rejectivity," an exclusive Stromberg-Carlson feature, made possible by *totally shielding* each radio frequency circuit.

You will attract your finest prospects for radio sales with Stromberg-Carlson Receivers.

No. 602 Art Console Type, illustrated above. American Walnut Cabinet. Built-in Loud Speaker. 6-tube; dual control. Equipped with volt meter. Price \$340 without accessories.



No. 601, Treasure Chest type. 6-tube; dual control. Equipped with voltmeter. Arranged to operate with either cone type or horn Loud Speaker; Solid Mahogany. Price \$210 without accessories.

Prices are for the United States east of the Rockies

Stromberg-Carlson Telephone Manufacturing Co., Rochester, N. Y.

# Stromberg-Carlson





(Registered in the U. S. Patent Office)

**PUBLISHED BY EDWARD LYMAN BILL, Inc.**

President, C. L. Bill; Vice-Presidents, J. B. Spillane, Edward Lyman Bill, Randolph Brown; Treasurer, Raymond Bill; Secretary, E. L. Bill; Assist. Secretary, L. E. Bowers; Asst. Treasurer, Wm. A. Low.

**J. B. SPILLANE, Editor****RAY BILL, B. B. WILSON, BRAID WHITE, Associate Editors****C. R. TIGHE, Assistant Editor****LEE ROBINSON, Business Manager****FRANK L. AVERY, Circulation Manager**

**Trade Representatives:** VINCENT D. WALSH, E. B. MUNCH, VICTOR C. GARDNER, V. E. MOYNAHAN, ROYCE CODY, A. J. NICKLIN

**Western Division:** Republic Building, 209 So. State Street, Chicago, Ill. Telephone, Wabash 5242. LEONARD P. CANTY, Manager.

**Boston:** JOHN H. WILSON, 324 Washington Street

**London, Eng., Office:** 2 Gresham Building, Basinghall St. W. LIONEL STURDY, Mgr.  
The Talking Machine World has regular correspondents located in all of the principal cities throughout America.

Published the 15th of every month at 383 Madison Ave., New York

**SUBSCRIPTION** (including postage): United States, Mexico, \$2.00 per year; Canada, \$3.00; all other countries, \$4.00. Single copies, 25 cents.

**ADVERTISEMENTS:** \$6.50 per inch, single column, per insertion. On yearly contracts for display space a special discount is allowed. Advertising pages, \$172.00.

**REMITTANCES** should be made payable to The Talking Machine World by check or Post Office Money Order.

**NOTICE TO ADVERTISERS**—Advertising copy should reach this office before the first of each month. By following this rule clients will greatly facilitate work at the publication headquarters.

Long Distance Telephones—Numbers 2642-3-4-5-6-7-8 Vanderbilt  
Cable Address: "Elbill," New York

NEW YORK, JANUARY 15, 1926

### Dealers Optimistic Over Outlook for 1926

IT IS conceded that the man best qualified to make fairly accurate predictions regarding business prospects for the immediate future is the man directly on the firing-line—the retail dealer who is charged with maintaining contact with the public and building up distribution. It may be said that his closeness to his immediate public serves to destroy the dealer's perspective, which may or may not be true, but it does not interfere with his keeping in touch with the general situation in his own locality studying the agricultural and industrial prospects, and basing his calculations for the future on conditions as he sees and knows them.

The manufacturer, from his records and the reports of his subordinates can, of course, secure an excellent review of the general situation. His books show the business that has been done with the dealers during the past year and his order file offers some gauge for the business that he may expect to do during the months to come. If stocks are low and advance orders large, he can look forward to a good year. If retailers' stocks are large and advance orders on the books small the outlook is not so promising. It is the opinions of representative retailers after all that afford the best guide to the future. They may not know what is being done, or is going to be done, in the next county, but they do know what is happening and is likely to happen in their own particular district.

The manufacturer and the wholesaler consider the territory or country as a whole. The dealer considers his one particular section, and a grouping of such opinions and predictions is likely to come nearer to an actual casting up of prospects than can be obtained by any other method.

The World this month presents a symposium of reports from retailers in various sections of the country, which should be of particular interest at the moment for they hold bright promise for the months to come. The reports indicate that a substantial volume of business has been experienced in practically all localities, particularly during the last four months of 1925, when sales totals were held in check only by a scarcity of merchandise. The significant fact is that lacking a sufficient number of the new model machines to take care of current demands, many dealers succeeded in

cleaning out stocks of older models, some on a temporary basis pending the arrival of new styles, but the majority on an out-and-out sale to those who were inclined to be satisfied with a combination of old machine and new records.

The survey indicates that dealers generally are entering the New Year with clear decks and the only cloud on the horizon appears to be a question as to how quickly the new products will come through to take care of orders that are not simply in prospect but are actually on the books. Keeping customers quiet while waiting for instruments which have been ordered some time ago is a task that worries the average tradesman, and the dealers are wondering just how soon the necessity for such conciliation will end.

Certainly, reports from the factories to the effect that production is being increased with all possible haste are being received with much satisfaction by dealers, who understand thoroughly that the volume of business they do during 1926 at least will depend largely upon stocks of instruments placed at their disposal by the manufacturers.

The radio situation is also dealt with in the survey in view of its close alliance with the talking machine trade as such, and it is gratifying to learn of a new attitude toward radio by a majority of retailers who see in increased discounts and more sane merchandising methods the stabilization of the industry and with it the possibility for a satisfactory profit for the retailer.

The tendency of the trade in radio appears to be strongly towards the featuring of a limited number of lines and selecting for that purpose those products of proved quality nationally advertised and offered by manufacturers of unquestioned standing. In fact, the checking up of the lines of receivers handled by the various dealers offers a fairly accurate check on the status of the various radio receivers. Several lines may be said to be standard and are handled by the majority of retailers. Others are named here and there. Still others appear to be forgotten in the general rush. This question of careful selection has come from experience covering one, two and in some cases three years. In this survival of the fittest seems to lie the ultimate, complete stabilization of the radio industry.

In all the reports the optimistic note is never missing. That the trade faces a genuine opportunity for re-arousing and capitalizing public interest is generally recognized, and there are some who assert that retailers have before them a future as bright as that which faced the pioneers in the trade a quarter of a century ago. At least there is sufficient promise in what the new lines will produce during the New Year to warrant optimism of the logical kind, based on things that are tangible.

### Better Broadcasting Programs Help Business

THOSE who had the will power to step out of the vortex of the radio market for a brief breathing spell a year or so ago, and then took time to give consideration to what the future had to offer after the immediate excitement was over, agreed, practically unanimously, that although improved and simplified apparatus and better merchandising did serve to keep the market alive indefinitely, the real future, depending upon the maintenance of public interest, lay in the calibre of the broadcasting programs that were offered.

At the outset of the radio craze, while home reception was still considerable of a novelty, and broadcasting stations were few, the question of program quality did not arise to any degree of seriousness, for the fact that music or lectures of any kind were to be heard distinctly appeared to offer sufficient satisfaction to the owner. There were some in the industry, however, who saw that in time the novelty would wear off and that as the quality of the receivers improved, so must be improved the quality of the programs put on the air.

What has been accomplished in this direction is already a matter of record, for there have appeared and are appearing at frequent intervals on radio programs artists of international reputation whose voices under ordinary circumstances would not be heard on the concert stage during the lifetime of the artist by ten per cent as many people as are privileged to hear that same voice in a single concert over the radio.

These contributions to better broadcasting programs, although encouraged by the broadcasters themselves, have been sponsored in practically every case by outside, though closely affiliated interests.



Manufacturers of radio apparatus have seen fit to put thousands of dollars into broadcasting programs by famous artists, and so have the manufacturers of talking machines and records and the makers of other musical instruments. Even those who use the radio for direct advertising have shown a tendency to improve the calibre of their programs and where possible introduce artists of more than local repute.

It is significant that as the programs improve, more artists of standing are willing to cast aside their first prejudices against broadcasting and lend their services, just as many of the same artists eventually came to trust their voices and reputations to the talking machine records. As more of these noted artists become willing to take to the air so much better may we expect radio programs to be.

There is naturally available on current programs, and probably will be available indefinitely, music of the distinctly jazz type and other features designed to appeal to those who desire to give culture a wide berth, but the better programs are proving commercially practical for the reason that they are credited already with arousing greater appreciation for good music on the part of the public at large, and thereby stimulating the sales of those mediums for the production or reproduction of music. Likewise, better programs have brought into the ranks of radio devotees thousands who have desired not simply to hear over the radio, but to hear something worth while for their devotion.

If the improvement made in radio programs during the past few months is to be considered as a criterion, and the promises made by those interested in better entertainment are fulfilled, there may be expected for radio broadcasting a public interest that will be steadfast because it is based on sound principles.

#### *Tribute to Prestige of Phonograph Companies*

THE close alliance that has been developed between large phonograph and radio interests, and particularly the strong position held by three of the leading phonograph companies at the present time, was set forth interestingly and comprehensively in a recent article in the Magazine of Wall Street under the caption, "Phonograph and Radio Industries Pool Their Interests. Both Industries Trying to Co-operate Instead of Fighting Each Other—What It Means."

To those who may have had their confidence in the phonograph industry shaken for some reason or another the article should prove an inspiration, inasmuch as it represents a survey of the entire situation not often gained by the individual in the trade itself and with his perspective, very likely, limited.

Even those who are close to the trade have realized the developments that have taken place during the past year, particularly in the matter of reorganization and the offering of revolutionary products. These are all calculated to insure active merchandising and a substantial market for the months to come, but the outstanding fact is that, basically, the leading manufacturers are in sound financial condition, with substantial assets and every prospect of increasing those assets.

With the radio and the phonograph working in combination there is removed much of that spirit of uncertainty and fear manifested by individuals closely allied with one division or the other. This

phase appears to be the most impressive and important, for it makes possible freedom of movement in the development of a general market without interference.

#### *Important Bills Being Considered by Congress*

THAT new copyright legislation would be presented to the new session of Congress was generally realized for months, for the situation under the present copyright law, in view of developments that have taken place with the entrance of radio, have made absolutely necessary some new Federal statute designed to take care of the new situation and grant the necessary protection both to the creators and to the licensed users of copyrighted works.

As a matter of fact, one of the first bills to be introduced in the new Congress which convened last month was a copyright measure offered by Representative Perkins of New Jersey. It is designed to make a number of radical changes in the existing law as it affects mechanical reproduction of copyrighted compositions, and at the same time to solve the question of the broadcasting by radio of copyrighted music.

The Perkins bill not only gives the copyright owner a full measure of protection but it extends that protection for the full life of the author and for fifty years after his death, limiting copyright protection on mechanical reproductions to fifty years from the date they were first sold or offered for sale.

The bill is naturally regarded largely as a basis upon which to build up an entirely new copyright act. The conferences that have been going on for a year or more among those directly interested in copyright legislation, and the hearings that have been held in Washington on various phases of copyright legislation would indicate that there will be long and more or less excited discussion before a measure is drafted that will prove satisfactory to all interests concerned.

Copyright legislation, particularly since the development of mechanical reproduction, has represented, in a large measure, a compromise designed to keep the conflicting interests quiet rather than satisfied.

It is the expressed hope that any new act, when finally passed, will serve to settle, for some years at least, those disputes which have grown out of the various views of what copyright protection really represents. That protection to the author and composer is necessary and right is admitted, the question at issue being largely as to how far that protection shall go and what rights it shall carry with it.

Also of interest to the trade are the two bills that have been introduced in the House and Senate respectively, both of similar tenor and designed to provide Government agencies, more especially the Department of Commerce, with authority and definite regulations governing radio broadcasting. In view of the great number of new broadcasting stations that have been licensed, or which seek licenses, and the present crowding of the wave bands assigned to such broadcasting, it is realized that some regulation is necessary if the confused condition annoying to the radio listener-in and harmful to the cause of radio itself is to be avoided. Too much Government regulation is naturally undesirable, but even though the air may be free there must be developed some definite regulations to prevent a condition of chaos.

## NATIONAL RECORD ALBUMS SET THE STANDARD

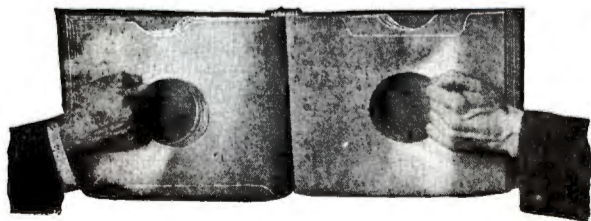

*Strength, Beauty, Value are  
the Outstanding Features*

Furnished in cloth or beautiful brown mission binding

Valuable Phonograph Records Are Safely Kept in National Albums

NATIONAL PUBLISHING CO., 239 S. American Street, PHILADELPHIA, PA.



## Indiana Mfg. & Elec. Co in Important Consolidation

Absorbs Assets of Indiana Radio & Elec. Co.—Indiana Hyperdyne Radio to Be Marketed Under the Trade Name of "Case"

The Indiana Mfg. & Electric Co., Marion, Ind., manufacturer of automobile accessories and Indiana Hyperdyne radio receivers, has announced changes of interest to the trade. The trade name of the company's entire line of products will be changed to "Case," which will be used on all their products.

The Indiana Mfg. & Elec. Co. has been operating in combination with a subsidiary company, the Indiana Radio & Electric Co., in the manufacture and marketing of this line of radio receivers. These two companies have been consolidated, the assets of the Indiana Radio & Electric Co. have been completely absorbed by the manufacturing company and the business will be conducted and owned entirely by the latter company. Officers of the consolidated company are as follows: Arthur E. Case, president and general manager; O. F. Heslar, vice-president and chief engineer; R. J. Spencer, Jr., treasurer.

Plans include the extension of their line of radio receivers and a very much increased manufacturing and advertising program.

## New York Firm Chartered

The Marshall Radio Corp., New York, was recently incorporated at Albany with a capital stock of 200 shares of common stock of no par value. The incorporators are W. A. Sands, J. Newton and S. Schub.

Smith's Music Shop, New York, has been incorporated at Albany with a capital stock of \$10,000. The incorporators are M. Smith, R. Mattor and L. Morrel.

## Dance Records Featured in Columbia Full-Page Ad

Latest Recordings of Nine Leading Dance Aggregations Listed in Attractive Advertisement—Vocal Records Also Stressed

Dance and song, life and laughter featured the full-page advertisement of the Columbia Phonograph Co., New York, which appeared in thirty of the leading newspapers of twenty-eight of the larger cities throughout the country recently. The latest recordings of nine of the leading Columbia dance orchestras were listed, including those of Ted Lewis and His Band, Art Kahn and His Orchestra, Earl Gresh and His Gangplank Orchestra, Ross Gorman and His Earl Carroll Orchestra, California Ramblers, the Cavaliers, Leo Reisman and His Orchestra, Warner's Seven Aces and Paul Specht and His Orchestra. Other records featured were those of Eddie Cantor, the Associated Glee Clubs, Lewis James, Art Gillham (the Whispering Pianist), Kitty O'Connor, the Girl Baritone, Ford & Glenn, the Lullaby Boys of radio fame, and the Singing Sophomores, male quintet. Featured prominently is the slogan "Such records as these make your phonograph worth twice what you paid for it."

Copies of the advertisement for display in windows and in stores were distributed to dealers in advance of the appearance of the advertisements and dealers were urged to effect a tie-up with the advertisement by inserting their own publicity in the same issue. Cuts of couples dancing, similar to the ones used in the full-page ad, were furnished dealers upon request.

Myron M. Studner resigned as vice-president of the Racon Electric Co. in U. S. A. and Canada and the Racon Electric Co., Ltd, in England. He is leaving for a short vacation in the West.

## Northwest Radio Assn. Has Appointed Interference Com.

Trade Assn. Maintains Radio Interference Committee Which Investigates and Remedies Where Possible Outside Troubles

MINNEAPOLIS, MINN., January 7.—The Northwest Radio Trade Assn. some time ago appointed a Radio Interference Committee which investigates complaints of interference received from customers of members of the Association and where possible remedies the trouble. Standard complaint forms have been placed in the members' stores and customers who have been experiencing trouble fill them out and send them to the headquarters of the Association. Experts are sent to the community where the interference is reported and on many occasions the trouble has been eliminated. This committee is in no sense a service department for the repairing or overhauling of sets, but an attempt on the part of the Association to aid dealers and their customers by remedying conditions outside the province of the customer.

## Interest in Okeh Records Is Stimulated by Radio

The General Phonograph Corp., New York, manufacturer of Okeh records, recently received a letter from Marion, N. D., in which the writer stated he had heard Okeh records and artists via radio from Dallas, Tex., and because of his interest would like to have a catalog. It is a long journey from Dallas, Tex., to North Dakota and then to New York, but it is interesting to note that the public demand for records is stirred by hearing the numbers over the radio.

The Whitelaw Furniture Co., Jackson, Tenn., reports an active interest in the Christmas Club plan of purchasing talking machines.

# New Peerless Artcraft Album Now Ready



The new Peerless Artcraft Album, samples of which are now being forwarded to the trade, adds a new note in album quality and attractiveness. It is bound in high-class leather type dressing—gold lettered. The interior and the album leaves are of the best quality brown craft paper blending with the color of the exterior.



The Peerless Artcraft Album is a fitting home for the best in standard, classics and opera selections. Made in both ten and twelve inch sizes it should create a new era in album sales.

*Write for your sample now*

*Exclusive metropolitan distributors for the new beautiful and educational "PICTORIAL RECORDS" for children*

## PEERLESS ALBUM COMPANY

PHIL. RAVIS, President

636-638 BROADWAY, NEW YORK

WALTER S. GRAY CO., Pacific Coast Representative  
San Francisco and Los Angeles

L. W. HOUGH, 146 Mass. Avenue  
Boston, Mass.





# Honest Quaker

Main Springs Repair Materials

## ANNOUNCEMENT

**T**HE wonderful revival of the PHONOGRAPH . . . the introduction of so many splendid improvements in its construction . . . and the realization by practically every successful dealer that a Service Department is as essential and as profitable as their major line . . . has made it possible for us to announce the publication of the finest catalogue on HONEST QUAKER Main Springs and Repair Materials ever compiled by us.

Such features as the display of every Part practically actual size . . . loose leaf arrangement . . . invisible price list so that anyone can be shown our catalogue . . . complete up to the introduction of the revolutionary phonographic equipment . . . are but a few of the good things in the making.

This Complete Service Institution will endeavor during the coming prosperous year to direct its advertising appropriation . . . now greater than ever . . . toward showing Phonograph Dealers concrete ways of making profits on repair work . . . in addition to the value of a Service Department as an entrée in the homes of those who use Phonographs and Records.

*Everybody's*

TALKING MACHINE CO., INC., PHILA., PA.





# How Wunderlich Profits by Radio Service

Kansas City House Has Systematized Its Radio Service So That It Returns a Profit, Builds Good Will and Creates New Business

By J. L. Simpson

In business, especially, theoretical "charts to success" are usually found to be "the bunk" when actually tried out. Only plans and methods which are found to work out in actual practice are worthy of the careful study of retailers in general.

Methods which have worked out in actual practice are of interest to every progressive

be boosters for the Wunderlich radio line; while the principal object of establishing the department has not been to make a profit from this service, rather to build a sound foundation for future business, yet to conduct the service department so that it will return a profit in itself; to secure through satisfied owners of sets introduction to friends, relatives or acquaint-

during the life of the set, I planned to have a service man visit each owner of a set once a month, and upon the same day as that of purchase. For instance, if the set was purchased on the 15th of August, the first visit after the proper installation of the set would fall upon the 15th of September, and so on.

"A complete card index system is maintained in the service department office, showing the date of purchase of each set and all other necessary and valuable data.

"Thus, to-day, the 23rd of December, the service men may ascertain in a brief period of time just what service calls must be made to-morrow, the 24th, and whether it will be a strenuous day, or a fairly easy one. In this work it is essential to maintain a rather perfect system in this regard, and our card index maintains the evenness and perfection of this system.

#### "Free" Service

"Now, we again approach the 'free' angle of our service work. These monthly visits to the owners of sets are, in themselves, free to our customers. The service man calls upon the appointed day, goes over the set rapidly yet carefully, and fills out an inspection report card. The information gained covers all necessary data, condition of all the essential functioning parts of the set, whether or not reception is normal, and the frequency of use, etc., etc. This report is brought back to the service office and filed away for reference.

"If the set is in perfect working condition, the service man, after his work is completed, and the card filled out, leaves the family in peace and harmony, and there is no charge for the visit.

"But suppose inspection reveals the fact that one of the batteries or other parts are 'dead' and beyond further usefulness. The old battery, or whatever part it happens to be, is replaced by a new one which the service man has with him

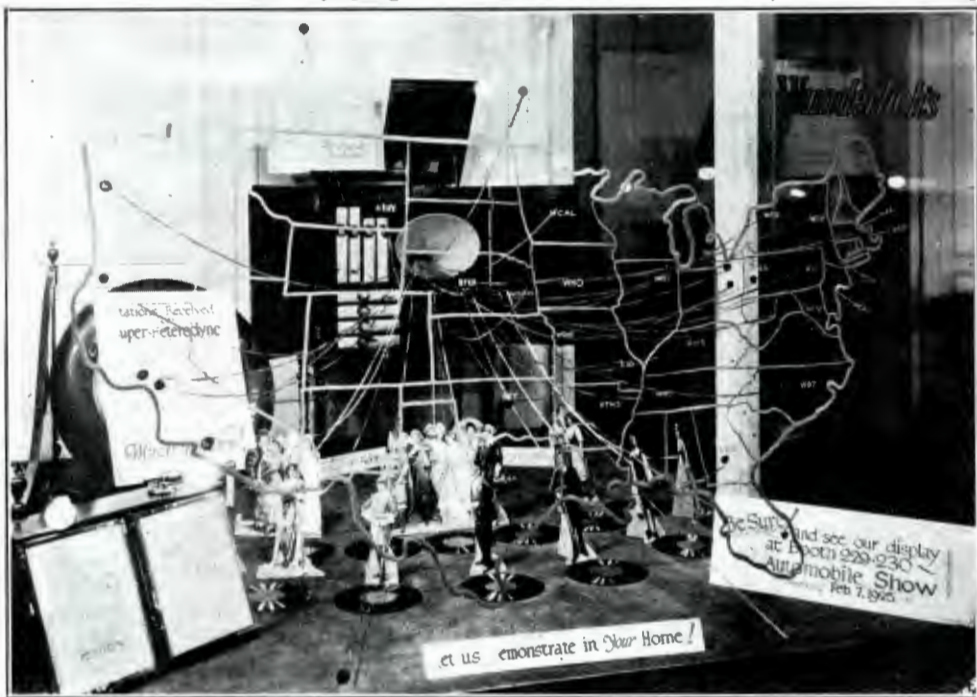

One of the Attractive Radio Windows at Wunderlich's

dealer. B. F. McNeil, manager of the radio department in the Wunderlich music store in Kansas City, is a pioneer in originating methods which work—which actually help sell more radio sets, and whose actual value can be figured in dollars and cents.

Mr. McNeil has established in the Wunderlich Music Store's radio department a servicing system, which is premised upon the idea that there should be a service station for radio, for the same reason that such stations are maintained for automobiles.

#### Why Wunderlich's Feature Service

In this department, radio, the service system planned and brought into existence by Mr. McNeil, occupies a place all its own, with a separate office, complete sets of records, three service men who are kept busy servicing radio sets sold from the Wunderlich store, and a set of small trucks or cars for the use of the men.

The reasons for the establishment of this service department, as explained by Mr. McNeil, are as follows: To maintain contact with the owners of the sets, not for a short period, but during the life of the set; to service the sets so scientifically that they may be nearly 100 per cent efficient during the twelve months of the year, thus insuring satisfied owners who will

ances of these satisfied owners, and thus create an ever-increasing list of "live" prospects, who are predisposed, through genuine evidence, in favor of Wunderlich radio lines, and the accompanying service.

#### How the Plan Works

Now, perhaps of more intense interest to dealers is the plan of the conception and conduct of this service department, and how it has worked out in actual practice.

Mr. McNeil objects strongly to any reference to his carefully planned department as a "free service department." He believes that absolute sincerity in this regard is preferable to what temporary prestige might be gained by tacking the word "free" onto a department which is of sufficient scope and dignity and importance to stand on its own legs, a great feeder department which has transformed the Wunderlich radio department into one of the most extensive and profitable of any in its great music store.

"While, to a certain extent, the word 'free' might be used in connection with this part of our radio business," says Mr. McNeil, "I prefer simply to refer to it as the service department, and let the gratis angles show up for themselves, in our monthly contact with customers.

"To maintain contact with every customer,

in his car, and the part is charged to the owner of the set.

"Or, if no new parts are needed, but the set is functioning poorly, service is given, the necessary service to make the set function properly, and no more. This is not free service, but is charged for at regular time rates.

"So there you have the source of our income

(Continued on page 16)



Wunderlich's Radio Display Room

STARR PIANOS STARR PHONOGRAPHS

GENNETT RECORDS

Represent the Highest Attainment in Musical Worth

The STARR PIANO COMPANY

Established 1872

Richmond, Indiana



# ZENITH

TRADE MARK REG.

## Apologizes

—for its inability to make all deliveries of Zenith radio sets.

MANY who wished to have Zenith radio instruments in their homes by Christmas have been disappointed. The demand for Zenith was too great.

We are now, however, in a position to make *guaranteed deliveries* to all authorized Zenith dealers—of some models within 60 days; of others within 30 days; of others within one week.

We regret exceedingly that any one should have had to wait for his Zenith.

We could, indeed, have forced production, slighted inspections, and sent out a larger number of radio sets bearing the Zenith name.

But—Zenith's reputation has been won on *outstanding* merit. Anything less than the best within Zenith's power to produce would have been a betrayal of confidence.

It is impossible to make a radio instrument possessing Zenith tone-quality, embodying Zenith craftsmanship, unfailingly responsive to demands for Zenith performance, by ordinary rush-production methods.

It is impossible to make Zenith and *sell it at a lower price*. If anything, Zenith prices of the future will be *higher*. For our unswerving aim is to make the finest radio set that can be built; then and then only to affix a price.

Not every dealer handles Zenith. Many we will not *permit* to do so, because of their exaggerated representations, false promises, lack of service. Zenith dealers are carefully selected. They are prepared to render service and to keep Zenith customers satisfied *as long as a Zenith remains in their possession*.

A Zenith Dealer Franchise IS AN ASSET. The solid protective policy of Zenith builds ahead for permanency in Radio retailing and carries with it a reputation in quality and refinement that will add prestige to dealer good will. The Zenith line covers a range in price (from \$100 to \$2,000) sufficient to meet the needs of all buyers.

Certain territories are now available. There may be an opening for a Zenith Dealer Franchise in your locality. Wire for full particulars.

Zenith—the Radio of the Future

*~Costs More~But Does More*

## ZENITH RADIO CORPORATION

310 SOUTH MICHIGAN AVE., CHICAGO



# How Wunderlich, of Kansas City, Makes Systematized Radio Service Pay a Profit

(Continued from page 14)

from the service department proper, accessories and service. From the sale of a single type of batteries the department takes in over \$500 monthly, which helps pay the salaries of men, and upkeep of trucks.

### Profit From Service

"By the way, I may state right here that the department itself shows a profit of about 50 per cent, which is genuinely satisfactory, since it was not inaugurated for profit, but to build business.

"A new source of profit, a by-product, I might term it, has arisen recently, in the matter of rendering service to sets sold by other dealers. Of course, we had no intention of doing any such thing, but the quality of our service has become pretty well known in this territory, and owners of sets have asked us to render the same service as we rendered our regular patrons. Of course we are willing to do this, but in such cases we make a regular charge for the monthly visits, which are in themselves free to our own customers.

"In cases where our patrons may stand in need of a special service trip, this is made as quickly as possible, a blank form or 'telegram' being left with each customer, which he may mail into our service office in case anything goes wrong with the set.

"Now, you have a clear outline of the plan of our service, the details of its workings, and an estimate of the profit made from the department, as a separate unit of our business.

### A Real Business Builder

"But perhaps most important of all are the cumulative benefits arising from the department as a business builder. As I have stated, I did not plan this department primarily as a profit maker, and the fact that we have been able to show a good profit from the department itself has both surprised and pleased me.

"Primarily, my reasons for establishing the department were to maintain permanent contact with our customers, with a view to their future business; to gain the patronage of their friends and relatives by means of the permanent satisfaction we could insure all our customers. In brief, to build new business, using old business as a foundation.

"Nearly every person who bought a set from us had scores of friends, relatives or acquaint-

ances, who called at their homes occasionally, and enjoyed the radio selections. A certain percentage of all these were at least passively interested in the purchase of a radio set, and some of them actively so.

"From the owners they heard favorably of our service and our line of radio merchandise, and were thereby predisposed in favor of Wunderlich radios when they decided to buy.

"We put system into this angle of discovering



Corner of Service Department

new business, by furnishing our customers with blank cards, upon which we urged them to place the names of their friends who might consider the purchase of a set, and offered a small premium in the case of each new customer furnished us in this manner.

"Since the inception of the department, two-thirds of all our new business has come to us from prospects whose names were furnished us by the owners of our sets.

"Now, as to some of the proofs of the value of our service department in increasing our volume of business:

"Since its inauguration our business in the sale of radio merchandise has increased at least 200 per cent, an increase of 100 per cent having been recorded during the past year. To register right up to the minute, so to speak, in straight radio lines alone, during the past week we sold \$2,760 worth of sets, which, combined with the sale of radio-phonographs, which we also handle, would bring the volume up around \$5,000 for the week. Of course, business varies, some weeks more, and some less, but this will give something of an idea of our volume.

"In my opinion, a volume of something like

\$175,000 in straight radio lines, for the year, will be reasonably satisfactory, though if we surpass that I shall not be surprised.

"Just to show the class of our radio trade, I may say that last week's business included sales to Geo. Muehlbach, owner of the Kansas City Blues; Judge Pollock, of the Federal Court, and several more almost as eminent Kansas Citizens."

The entire first floor of the Wunderlich Music Store has just recently been converted to the display of radio sets, radio-phonograph sets and phonographs. Formerly the radio department was situated upon the fourth floor in this store.

Mr. McNeil is also an authority on profit-building radio window displays.

"A grocer may fill his window full of canned goods, and attract customers in that manner," says Mr. McNeil. "But a window filled up with radio sets is a mighty poor sales builder. To be effective, to create sales worth speaking of, a radio display window must be prepared in such a way that it not only interests people, but makes them study, excites their curiosity to such an extent that they must devote more than a glance at the window to figure out its exact significance.

"If a display fails to pull a sale in three days, say, it's a 'dead one,' but if it pulls several sales the first week, then it's worth leaving for a while longer. The window display shown in the photo is typical of the kind I prepare in this store, and this one was a first class business builder, as shown by my records.

"In the foreground of the display we placed one of our radio sets, and extending from each city, or station, from which we had received programs on this radio set, was a ribbon connecting the city in question with our set."

## Joseph A. Sullivan Now Columbia Asst. Ad Manager

Joseph A. Sullivan, who was formerly account executive with the Pratt & Lindsay advertising agency and prior to that was connected with the General Phonograph Corp. as assistant advertising manager, is now with the Columbia Phonograph Co. in the capacity of assistant advertising manager. Mr. Sullivan will relieve J. P. Duffy, advertising manager, of a great deal of routine business and will aid in the preparation of dealer helps and supplement writing. Having been born in the South, Mr. Sullivan is admirably fitted to prepare copy and dealer literature dealing with the Southern old tune catalog of records. Mr. Sullivan matriculated at New York University, where he studied advertising, marketing and merchandising under George Burton Hotchkiss.

## Brunswick Panatrope in Series of Demonstrations

SALT LAKE CITY, UTAH, January 6.—On many occasions during the past month the Brunswick Panatrope has been demonstrated to the music lovers of this city, and never has it failed to draw enthusiastic praise. Daily concerts were given in the warerooms of the Daynes-Beebe Music Co., O'Loughlin's Music Store and Glenn Bros.-Roberts Piano Co. The instrument furnished the entertainment at the meetings of the Kiwanis and Lion Clubs and on several evenings demonstrations were given at the Elks Club. On one occasion, under the auspices of the Utah Music Co., the Panatrope supplied the dance music at Dundee's Ballroom to the Saturday night crowd of dancers. The demonstrations were given by R. F. Perry, of the local branch of the Brunswick Co.

## Paul D. Bodwell Resigns

Paul D. Bodwell, president and general manager of the Deca-Disc Phonograph Co., Waynesboro, Pa., has resigned. His successor has not yet been named.

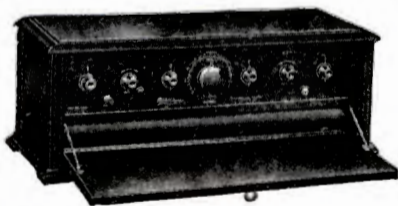

THERMIODYNE—Model TF6—SIX TUBES

Powerful, smooth working instrument, with Three Stages of Thermionic Frequency before Detector, Detector, and Two Stages of Audio Frequency. Master Control. Indoor or outdoor antenna. Walnut finished cabinet with interior compartment for "B" battery.

Price (without accessories) .....\$150  
Rocky Mountain and Coast States ....\$160

### The Famous Master Control

*Thermiodyne*

Excels in Every Essential

- 1 Distance-getting
- 2 Selectivity
- 3 Simplicity of operation

TO sell THERMIODYNE it is only necessary for dealers to demonstrate the outstanding superiority of this Famous Master Control Receiver.

THERMIODYNE demonstration sells THERMIODYNE and THERMIODYNE performance keeps THERMIODYNE sold

A few good trade territories still open. Write us at once for full particulars about a selling franchise for the most sensational receiver on the market. Act quickly.

THERMIODYNE RADIO CORPORATION  
1819 Broadway, New York City Main Plant: Plattsburg, New York  
Canadian Sales Office: Dominion Thermiodyne Radio, Ltd.  
425 Phillips Place, MONTREAL, CANADA





**backing 'em up!**

Cone Speaker

Type H Speaker

Cabinet Speaker

We've been asking you to order just one of the new Brandes speakers—any one. That's because we know you will surely stock up if you hear 'em.

Now we want you to know that you'll sell them if you stock 'em. Millions of Brandes ads (double spreads and single pages in color, in the Sat-

urday Evening Post and other magazines) tell the Brandes story and arouse a buying mood.

And a \$100,000 newspaper campaign will bring in local business that your endorsement can clinch.

Just remember—you bought the Brandes speakers because you heard 'em. Your customers will, too.

# Brandes

EXPERTS IN RADIO ACOUSTICS SINCE 1908





# *Surface!*

—not only all the  
music—  
—but *none* of the  
scratch



COLUMBIA PHONOGRAPH COMPANY  
1819 Broadway New York

**Columbia**  
**NEW**  
**PROCESS** **Records**



# COLUMBIA

The one supreme advance in the phonograph art in twenty years is the development of Columbia Records to today's almost unbelievable perfection.

COLUMBIA PHONOGRAPH COMPANY  
1819 Broadway New York



**Columbia**  
**NEW PROCESS** **Records**





*as in the notes shown above*

— as if you had opened  
the door of a music  
room always closed  
until now.

COLUMBIA PHONOGRAPH COMPANY  
1819 Broadway New York

# COLUMBIA



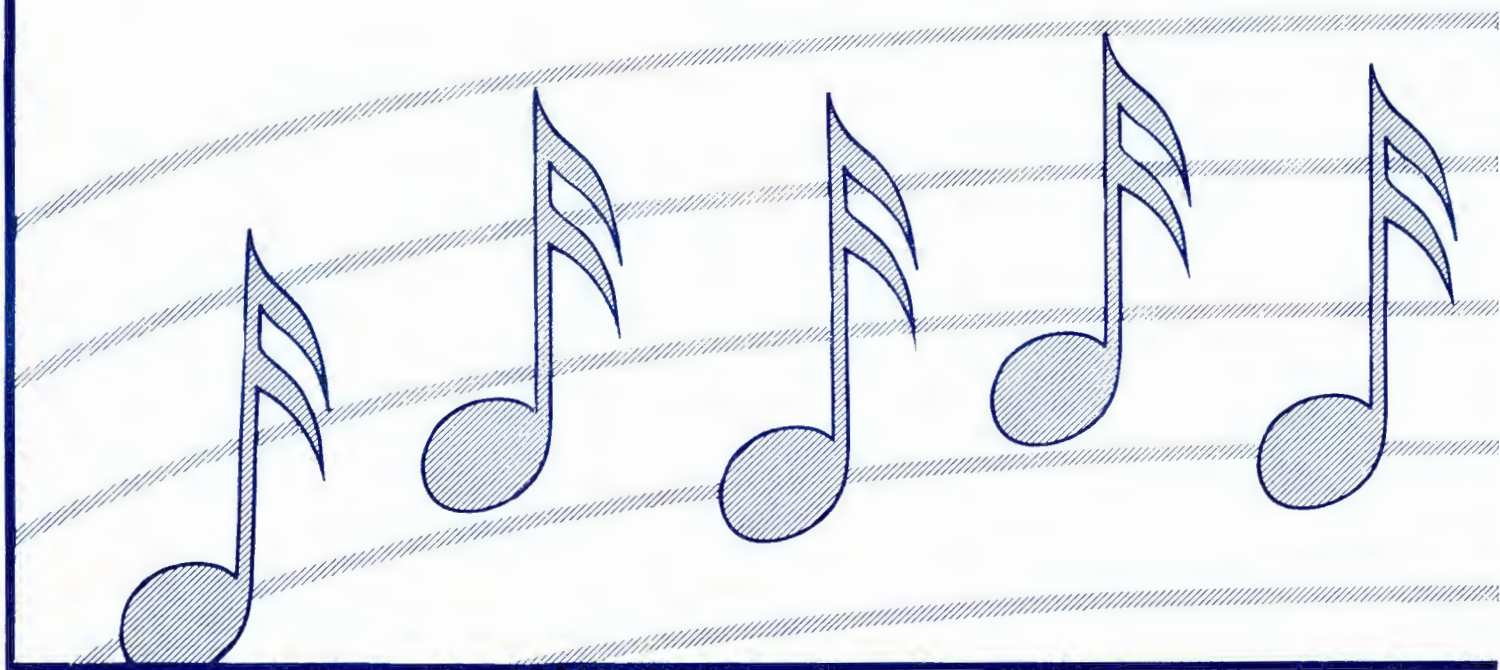

*the difference is as unmistakable*

# **new process**

All the brilliance  
and definition of the  
original rendition —  
and marvelous volume

# **COLUMBIA**



## Col. S. H. Mapes Heads the Radio Center, Inc.

Well-Known Radio Executive Elected President of New Firm With Headquarters in New York City—Wholesalers' Service

Col. S. Herbert Mapes has been elected president of a new project, known as Radio Center, Inc., and space has been acquired in the Bush Terminal Sales Building, 130 West Forty-second street, comprising two entire floors and a por-



Col. S. H. Mapes

tion of a third, and in announcing his plans, Colonel Mapes said:

"For the first time the establishment of a service feature for the radio industry is now under way. It is in the form of a permanent mart in one of New York's most prominent buildings. Receiving sets and all manner of radio products will be demonstrated under actual working conditions the year round. This service is limited entirely to the wholesale trade, save on special occasions when, by special invitations, the public will be admitted."

The Bush Building was selected by Colonel Mapes for Radio Center, Inc., because of the accessibility of its location, as it is a few doors from Forty-second street and Broadway and one of the best spots for an acknowledged business center in New York City for radio reception and excellent broadcasting conditions. This

building is also one of the best-known buyers' service buildings in the world.

The plans of Radio Center, Inc., already include the acquisition of space, with its equipment being already leased. A large number of sound-proof booths are now installed and a reception room, library and assembly hall are to be made available immediately for all trade gatherings in the radio industry.

Col. S. Herbert Mapes is well known throughout the music and radio industries, having numerous important affiliations. He is a cousin of the late Stephen S. Mapes, who at one time controlled most of the piano string business of the country, and has figured prominently in social and sports activities for years. Colonel Mapes owned the thoroughbred show horses, Prince Henry, Follow Me, Jester, Fear Not and Confidence, and is a member of several riding and hunt clubs and was on the Army Polo team in 1917. He is also a member of the Virginians, Sons of the Revolution, Union League Club of New York, Thousand Island Yacht Club and other well-known clubs.

Colonel Mapes served in the United States Army throughout the World War as captain in the Air Service and in the formation of the New York Aerial Police, where he ranked as a lieutenant-colonel. In 1920 he entered radio, conducting the first Radio Fair at the Hotel Imperial in New York that year; afterwards vice-president and Eastern sales manager of the Federal Radio Co. of Buffalo, and a year ago joined the Joseph W. Jones Radio Mfg. Co., Inc., as vice-president and general manager.

## L. B. Casagrande Discusses Portable Outlook for 1926

MILWAUKEE, Wis., January 7.—The Caswell Mfg. Co., of this city, has enjoyed a steadily increasing demand for its portables, according to L. B. Casagrande, vice-president, who stated: "Our 1925 business was very satisfactory as regards volume and we are especially proud of the splendid connections we were able to make for the distribution of our product last year. All of our distributors are going good on our line, and from the present outlook I am satisfied that 1926 will see still further progress on our part. We have the product, policy and price and all we lack is possibly more co-operation in putting over our advertising story."

## N. B. Smith Appointed Columbia St. Louis Mgr.

W. C. Fuhri Announces the Promotion of Norman B. Smith to the Management of St. Louis Branch, Succeeding P. S. Kantner

W. C. Fuhri, vice-president and general sales manager of the Columbia Phonograph Co., Inc., announced this week the appointment of Norman B. Smith as manager of the company's St. Louis branch, succeeding P. S. Kantner, who has resigned from the Columbia organization. This appointment is a well-deserved tribute to Mr. Smith's many years of association with the Columbia organization, and he is ideally qualified to fill the important post of St. Louis branch manager.

Norman B. Smith has been connected with phonograph activities for the past ten years, the greater part of which was spent with the Columbia organization. He was a member of the dealer service division in New York, later being appointed assistant manager of the Cincinnati branch and subsequently being promoted to the position of assistant manager of the Chicago branch. For a period of three years Mr. Smith was associated with the General Phonograph Corp., as manager of the company's New England distributing branch and later as manager of the distributing branch in New York. He rejoined the Columbia organization a few months ago as assistant manager of the New York branch, being promoted from that position to manager of St. Louis. He brings to his new work an exceptional knowledge of all phases of phonograph and record merchandising, for, during his ten years with the industry, Mr. Smith has worked in close co-operation with the dealers, studying their sales problems and gaining an invaluable familiarity with retail merchandising activities.

## F. Weidman Evans Resigns

F. Weidman Evans, for several years manager of the talking machine and radio departments of McManus Bros., Elizabeth, N. J., and Edison vice-president of the Talking Machine & Radio Men, Inc., resigned his position on January 1 to enter another field of activity. His resignation recently tendered to the Association was accepted with considerable regret at the January meeting.

### The RECORD NEEDLE CUTTER

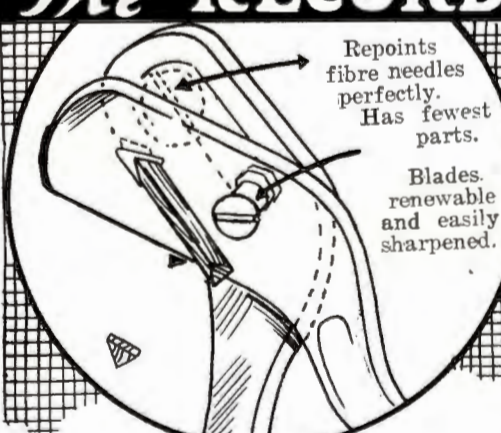

Repoints fibre needles perfectly. Has fewest parts. Blades renewable and easily sharpened.

A guaranteed, nickel-plated, scissors type cutter that gives positive satisfaction. Sell one with every machine. Lists \$1.50. Attractive dealer discount. Write for sample.

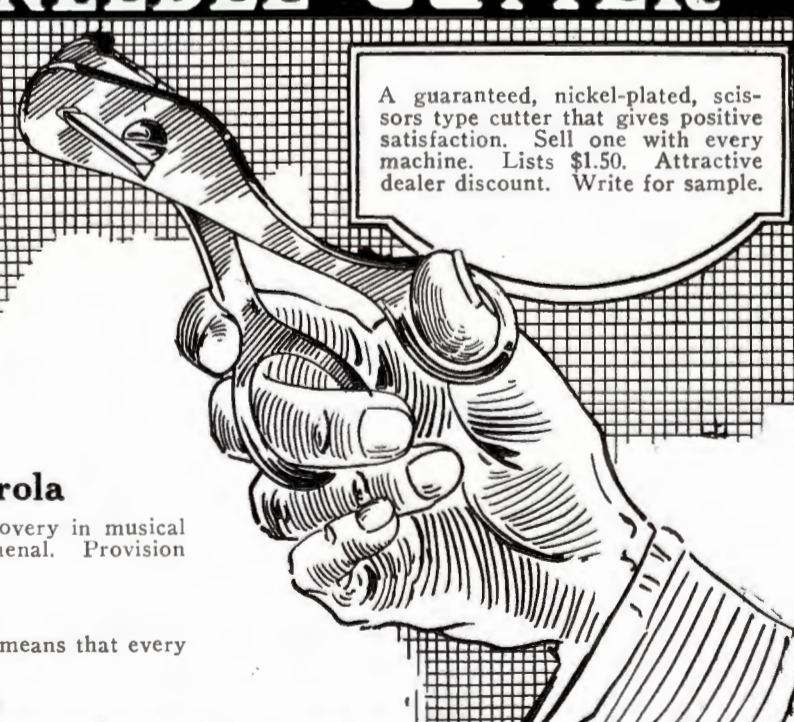

The Orthophonic Victrola

is the most sensational and revolutionary discovery in musical reproduction. Already the sales are phenomenal. Provision has been made for the use of

FIBRE NEEDLES

for the utmost in soft and mellow tone. That means that every dealer should be well supplied with

Record Needle Cutters

The Badger Talking Machine Co.



# Profit Winning Sales Wrinkles

Distributes Invitations for Demonstration to Commuters and Secures Large Attendance—Cash in on School Co-operation—A Collection Idea That Brought Slow Payers to Terms—Texas Dealer Installed New Instrument in Theatre Lobby and "Sold" the Public

A rather clever stunt was put over by the Brunswick Shop in New Rochelle, N. Y., during the recent special presentation of the Panatrophe at its warerooms in that city. Not only were attractive letters sent out inviting the people of that "city of homes" to attend the Panatrophe demonstration held in the auditorium of the High School, but Mr. Wolf of the Brunswick Shop in person visited the railroad station and presented invitations to the army of commuters who were journeying home from New York. In fact nothing was overlooked to make the affair a success, thus emphasizing what can be done when a little effort and originality are combined to a definite end.

### Unusual But Effective Display

Window displays of radio receivers and equipment are more or less common nowadays. It takes a touch of genius to devise something



Strauch Co.'s Exhibit of Radio Speakers

new. The effect obtained in the photograph on this page of the front of the Strauch Piano Co., of Urbana, Ill., is distinctly out of the ordinary. Recently a shipment of Music Master radio products came in to the Strauch store. Apparently, a number of inhabitants of Urbana were waiting for this shipment. What was the quickest way of letting them know that the goods had arrived? An unusual display was decided upon, with the result shown in the illustration. The company completely covered up its windows and entrance, leaving space for customers to come in. The display was directly responsible for considerable business.

### Profits Through Schools

Some time ago there appeared in the columns of The World an article which told of the manner in which Schwartz & Chakrin, Victor dealers of Brooklyn, N. Y., built good-will through co-operation with the public schools of the neighborhood, with added good results in the form of sales of musical instruments and records to teachers and parents of pupils. Another instance of the benefits of this form of making friends and increasing sales volume recently came to light when Public School No. 99, Brooklyn, purchased a Crederza model Orthophonic Victrola from this store and immediately used it to entertain at the meetings of the Mothers' Club, an organization of mothers of pupils, which meets regularly in the school auditorium. Soon after the first meeting at which the Orthophonic was demonstrated there was a notable increase in inquiries and orders for various models of the instrument. Likewise, with the introduction of the Orthophonic, Schwartz & Chakrin were able to secure the use of the school auditoriums for demonstration of the instrument to customers of the store and residents of the neighborhood. Hence it is evident that the policy which has been pursued by this

live establishment in distributing blotters to the school children and giving occasional small gifts of records to the schools is bearing its reward in volume sales. The firm also compiled a list of the residents of the territory served by their store and sent through the mails a letter giving the complete line of musical instruments carried by the establishment, together with a description of the new developments which are part of the new talking machines and records. The Orthophonic Victrola is described and the improvements in records as exemplified by the new electrically recorded discs are mentioned. Similarly the radio line, pianos and other musical instruments are given proper mention in this letter. The results in increased sales in all lines more than justified the money and efforts expended. It might be well for other dealers to take steps to inform their prospects, former and present, of the developments which have taken place in the trade during the past six months or so. There are many who are not aware that the instruments on the market to-day represent tremendous advances over the talking machine or phonograph of the past.

### A "Different" Collection Stunt

Collections and the form and type of letters best suited to bring results from delinquents have been discussed many times in all business circles and publications with many differences of opinion as to what is the best manner of securing the past due. The practice followed by a concern in the Middle West, not a music house—but the problems to be solved by all retail dealers with outstanding accounts are the same—might prove interesting. The establishment after the usual forms of notices of payment due have failed, sends this notice:

I want a "check" of some kind—either a real check or a pencil check in one of the squares below.  
Between you and me, I'd like to know just where I stand—so check up on your bank balance and then drop me "the good news."  
( ) Can't possibly make it fo-day—will send one surely .....  
( ) I'm sending a check, but it's post-dated a few days.  
( ) We don't intend to pay; you'll have to fight for it.

( ) We mailed you one yesterday.  
( ) Here's part of it to show our heart's in the right place.  
( ) Here's all of it—shut up!  
Sorry we got behind—thanks for your patience.  
We'll try to pay each month from now on.

It can be readily seen that every possible answer of the delinquent is anticipated in the above form and it is but necessary for him to check the correct answer. The breeziness of the wording offsets to a considerable degree the insistent demand for the payments that have been overdue and it might prove worthy of consideration and a trial by some dealers.

### Demonstrates in Theatre

The Fox Co., of San Antonio, Tex., has been holding a unique demonstration of the new Orthophonic Victrolas by placing one of the models in the lobby of a local theatre. Selections of a wide range are played and, because of the heavy traffic passing through at all times, a large list of prospects' names have been obtained. One man is in charge and, during the week that the demonstration has been in effect,



Orthophonic in Theatre Lobby

he has secured an average of eight live prospects, all of whom have promised to sign up. However, if only six of these come around, it can readily be seen that the plan is a good one from a merchandising angle. Space is secured at a nominal sum, it being more of a co-operative agreement between the management of the theatre and the officials of the Fox Co. In fact, the selections coming out of the new Victor product draw as much business to the theatre as they do to the dealer. The accompanying photo shows Cleo H. Altheide, salesman in charge, standing beside one of the models in the lobby.

## Sell Pathex Library Reels just like Phonograph Records

**YOU** sell Pathex Library Reels outright just like phonograph records. There are dramas featuring "Doug" Fairbanks, Bessie Love, Charles Ray and others; "Our Gang" Comedies, Harold Lloyd, Will Rogers and many others; Grantland Rice "Sportlights," interesting travel and educational subjects.

Sales of Pathex Library Reels, added to those of Pathex Outfits and raw film, will enable you to build up an ever-increasing, substantial and profitable Pathex business.

Write today for details.



The Camera  
**\$4750**  
(Slightly higher in Far West)

The Projector  
**\$5000**  
(Slightly higher in Far West)

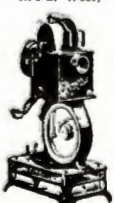

**PATHEX, Inc.,** A Subsidiary of Pathe Exchange, Inc.  
35 West 45th Street, New York

Pathe was developed by Pathe of France, pioneers of the Motion Picture Industry. Pathe, Inc., is a subsidiary of the famous Pathe Exchange, Inc.



# Demonstrating New Records to the Masses

## A New York Retailer Who Believes in Mass Demonstration Has Sold 15,000 of One Record—A Real Opportunity to Increase Sales

Store door playing of records! Does this policy aid the dealer in making sales or does it alienate from him many customers, residents in the vicinity of the store who tire of hearing the same selection repeated hour after hour? Within the past year there was a motion before the New York Board of Aldermen to put this practice under the classification of a misdemeanor, the motion being squelched because of the action of the Talking Machine and Radio Men, Inc., who promised that it would use its influence in having its members use discretion as to the hours when the amplifying apparatus at the door would be used and that a horn with too much power would not be used. Pro and con the question has been discussed, with adherents on both sides, and the logical ending to the matter is that in certain localities there is no other medium which can stimulate the sale of records as can this policy, whereas in other sections it would be regarded as nothing so much as a nuisance.

### Sold 15,000 of One Record

As an illustration: the New York Band Instrument Co., situated on East Fourteenth street, New York, a location which borders on several foreign communities—which has a transient trade of thousands each day, during one year sold approximately 15,000 of one record—a selection issued in a foreign language list, picked out by the manager because of its musical appeal as suitable for attracting passersby. Nor is this instance exceptional. In almost every case where the record played at the door is one with a musical value and with a universal appeal, whether or not the majority of people have heard of it, the sales daily average between seventy-five and a hundred. It is obvious in this instance that the policy of playing records at the store door is a money-maker of the first order and even the most partisan of those advocates of dignity of the trade would not but admit that similarly located he would do the same.

Another achievement of this company which, under the management of William H. Tyler,

during the past five years has become one of if not the leading record selling establishment in New York City, was that during the sale of single-faced Victor records it disposed of some 50,000 within two months. While many dealers availed themselves of the opportunity of disposing of their obsolete stock at the reduced prices and were content to rest there, Mr. Tyler, realizing that recordings by Caruso, McCormack, Kreisler and other world-famed celebri-

*Store door playing of records has its boosters as well as its opponents. However, the experiences of many dealers indicate that this method of bringing new numbers to the attention of the public is profitable if properly carried out. Retailers located in sections where reside many foreign-born find this plan especially worth while.*

ties would sell, and sell at the prices offered in "hot-cake" fashion, ordered thousands upon thousands from jobbers and the result was that the people attracted to the store by the record being played at the door, as well as regular customers, purchased the single-faced recordings by the dozen.

### 200 Per Cent Sales Gain in Year

During the year just past the talking machine division of the New York Band Instrument Co. increased its sales volume 200 per cent over 1924 despite the fact that it was impossible during November and December to secure anywhere near the amount of Orthophonic Victrolas required and despite the fact that the reduced models of Victrolas and the reduced-price sales of records necessitated bringing twice the number of people into the establishment and expending

twice the amount of effort to complete sales.

The reasons for the success of this store would be made plain to anyone spending a half hour or so at the establishment during the busy season. By far the greater percentage of customers are foreign-born, speaking but a smattering of English, and despite the difficulty which often is apparent in making the salesman understand the wants of the customer, the utmost courtesy is always given the buyer, whether he is purchasing a talking machine or whether the purchase is confined to a single record. It is the following of this practice that has caused the foreign-born to patronize this store and bring their friends, and buy the music of their native lands and the better class of music in such quantity that the record sales show a proportion of ninety per cent foreign language and Red Seal records as against ten per cent popular and dance recordings.

### Profitable Tie-Up Opportunities

The appearance of foreign artists in this country is always used as an opportunity for an effective tie-up, and advertisements are inserted in the foreign language papers calling attention to the recordings of the artist. A stock of 25,000 records is carried, with immediate replenishment of "shorts." As it is impossible to handle the record stock from the titles because of the variety of tongues which go to make up the stock, a list of the best sellers in the various languages is posted prominently in the rear of the record department for the benefit of clerks, so that when a customer inquires for a number from the catalog a half dozen or more records of his native music can be handed him for demonstration, a policy which goes far in increasing sales.

## Branson De Cou Uses Victor Orthophonic in Lecture

Branson De Cou, who is well and favorably known in the talking machine industry, delighted a large audience at the Academy of Music in Brooklyn recently when he gave an illustrated lecture—more popularly called "Dream Pictures of the Mediterranean Wonders." He took his audience through Spain, the French Riviera, Rome, Florence, Vienna, the Holy Land, Egypt, Naples, and those Italian cities that emphasize the lure of the Mediterranean. A feature of the lecture was the accompanying music, selected to give "atmosphere" to the lecture, which was interpreted by means of a beautiful Orthophonic Victrola, whose wonderful music filled the hall, and the marvelous Knabe Ampico. These lectures of Mr. De Cou are becoming a national institution not only because of their pictorial value, but because of the novelty of the entire program, which is always informative and educational.

## Okeh Artist Dies as Result of an Automobile Accident

Robert Stephens, a member of McMichen's Home Town Band, of Cartersville, Ga., exclusive Okeh recording artists, died recently, following an accident in an automobile which resulted in his receiving a fractured skull. The McMichen Band is well known to Okeh record fans through its recording of old-time tunes.

The R. B. Radio Co., New York, was recently incorporated at Albany with a capital stock of \$75,000. The incorporators are H. Seiden, A. Rebay and L. Ross.

*The Reason*  
 THE TUBE WITH A SENSIBLE GUARANTEE  
 QUALITY!  
 PERFORMANCE  
 DEPENDABILITY

are the factors which made Supertron the Foremost Independent Tube in America!

The Public buy and enjoy Supertrons because they are assured of satisfaction by a serial numbered guarantee on each tube for their protection—at their own price; the public demand price—two dollars. The best dealers sell Supertrons because they give the most satisfaction; the best profit and a permanent good will. The jobbers who practice their purposes sincerely carry Supertrons to serve their dealers better because Supertron facts are beyond dispute. Backed by a rigid policy; substantial organization and clean merchandising.

All Types \$2.00 Each (Canada, \$2.75)

Branch Offices in Principal Cities Throuth the United States

SUPERTRON MFG. CO., Inc. :: HOBOKEN, N. J.

Export Department, 220 Broadway, New York

**SUPERTRON**  
 A SERIAL NUMBER GUARANTEE



## V A L L E Y F O R G E

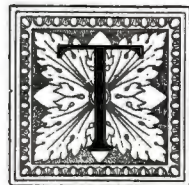

THE new Valley Forge Catalogue has met with tremendous success. Its *Originality*—Its *Completeness*—Its *Index* has solved the greatest problem in the industry—that of ordering the exact part and being sure of getting it promptly.

No Repair Department is complete without it.



REG. U.S. PAT. OFF.

730 MARKET STREET  
PHILADELPHIA, U.S.A.



### Victor Co. Issues First Catalog of Its New Line

Complete Line of Orthophonic Victrolas, Electrolas and the Radiola Combinations Are Described in Attractive Booklet Just Sent Out

The New Victor Line (Orthophonic Victrolas, Electrolas and Radiola Combinations) is the title of the latest catalog issued by the Victor Talking Machine Co., and which has been distributed to the trade. A page is devoted to illustration and description of each of the twelve new models recently announced by the Victor Co., namely the Orthophonic Victrola models, Credenza, Granada, Colony and Consolette; Orthophonic Victrola-Radiola, Alhambra I and II, with five and six tube Radiola installations; Electrola, Cromwell; the Electrola, Tuscany; Orthophonic Victrola-Radiola, Florenza, with six-tube Radiola; Orthophonic Victrola-Radiola, Borgia I, with eight-tube super-heterodyne; Electrola-Radiola, Hyperion, and the Orthophonic Victrola-Electrola-Radiola, Borgia II.

The first page of the booklet contains a general description of what the Orthophonic Victrola is, what it does and similar data regarding the Victrola-Radiola combinations and the Electrola. The last page is devoted to specifications of the twelve models. Altogether, this is a handsome catalog, the illustrations showing the beauty of the instruments and the information briefed so that the reader gets an accurate idea of the size, finish and other advantages of the new instruments in a moment.

Since the introduction of the new Victor models dealers in all parts of the country have been besieged by interested inquirers. Until the new catalog was distributed, the retail merchants were enabled to bring the merits of the instruments to the attention of only those people who were interested enough to enter the store. Some dealers, with commendable enterprise, interested their prospects and patrons through the medium of direct mail and other advertising. The new catalog, however, should prove a most effective sales promotional medium. The dealers now can bring their new products to the direct attention of a large number of people who are most likely to be interested at small expense.

Shortly after the catalog was issued, the following letter, explaining corrections which are made above, was received from the Victor Co.:

"Within a few days we shall begin shipment to wholesalers of limited quantities of a revised edition of the new instrument catalog, and which they, in turn, will supply to their retailing customers, as the quantities they receive will permit. In this revised catalog, the two models of the 'Alhambra' and the two models of the 'Borgia,' illustrated and described therein, will be identified each, respectively, by Roman numerals, as follows:

"Alhambra I—List price, \$350. Orthophonic Victrola, combined with five-tube Radiola.

"Alhambra II—List price, \$425. Orthophonic Victrola, combined with six-tube super-heterodyne.

"Borgia I—List price, \$675. Orthophonic Victrola, combined with eight-tube super-heterodyne.

"Borgia II—List price, \$1,000. Orthophonic Victrola,

combined with Electrola and eight-tube Radiola super-heterodyne.

"This information is supplied to prevent any possible confusion of identification of these instruments through the differences now appearing in the new catalogs you will receive from the wholesaler, and the single copy we enclosed with our trade letter of December 1, accompanying requisition forms."

### Charlot's Revue Hits Are Recorded for Columbia

Jack Buchanan, Beatrice Lillie and Gertrude Lawrence Make Recordings of the Six Song Hits of Show for the Columbia Co.

Ofttimes a patron of the theatre, after hearing some musical selection sung by one of the stars of the show, is so impressed by the rendition by the artist that the appeal of the number is lost when sung by another. There are among record buyers many who have listened to the incomparable trio, Jack Buchanan, Gertrude Lawrence and Beatrice Lillie, the English stars of musical comedy and revues, who last year made Charlot's Revue one of the bright spots of Broadway, and who are this year in Charlot's Revue of 1926 exceeding their triumph of yesterday, and these people will be ready buyers of recordings by these stars. Blasé and hardened newspaper critics enthused like schoolboys at the premiere of this revue and praised highly the song hits and the artists who sang them.

The announcement of the Columbia Phonograph Co., New York, that it was releasing the six song hits of this show sung by the artists who have "put them over" on the stage was well received by the trade and the recordings have proved very popular. These hits, "A Cup of Coffee, a Sandwich and You," "Poor Little Rich Girl," "Susannah's Squeaking Shoes," "Carrie," "Russian Blues" and "Gigolette," sung as solos and duets by Jack Buchanan, who incidentally is at the present time the highest paid musical comedy actor on Broadway, and Miss Lawrence and Miss Lillie, have an undoubted appeal and are different from the usual musical comedy song.

### Now General Sales Manager of Central Radio Labs.

Central Radio Laboratories of Milwaukee, Wis., manufacturers of variable high resistances for radio circuits, announce the appointment of H. E. Osmun as general sales manager as the first step of this company's enlarged sales program for 1926. Mr. Osmun has been assistant sales manager of the Globe Electric Co. of Milwaukee for several years, devoting most of his time to developing the radio receiver sales of that company. Thus his knowledge of the problems confronting set builders will prove of real value in further developing Central Radio Laboratory sales and service facilities for the benefit of the trade.

### So. California Radio Trade Ass'n Advertises

Business of Members Stimulated by Series of Attractive Advertisements in the Leading Newspapers Featuring Radio Sets as Gifts

During the month of December the Radio Trades Association of Southern California ran a series of advertisements in the local newspapers in the interest of its members and the public. Radio as a gift was the point stressed in the advertisements and the appeal of the radio receiver was extremely well described in a paragraph which read: "No other single gift has stored within it such tremendous possibilities as has a radio receiver! When you give radio—you give not simply a beautiful piece of furniture—but you give contact with and access to all that is happening in the world to-day—to-morrow—and forever! Truly—no other gift can even compare to radio! These five things we would have you remember!" Then followed statements regarding the fact that radio was purchasable on an instalment basis; that orders should be given early to allow time for installation and that dealers with a reputation should be patronized.

### Spartan Electric Corp. Made Bosch Distributor

The Spartan Electric Corp. has been appointed wholesale distributor of the radio products of the American Bosch Magneto Corp., Springfield, Mass. L. W. Glazebrook, sales manager of the Bosch radio department, states that the territory allotted to the Spartan Electric Co. includes Greater New York, Long Island and the following counties in New York State: Westchester, Orange, Rockland, Putnam, Ulster and Sullivan.

John W. Weber, Jr., of Brooklyn, is also a Bosch distributor for Long Island and part of New York. Distribution in northern New Jersey will be handled by the Beller Electric Co.

### Panatrope Demonstrated

ALBUQUERQUE, N. M., January 4.—A demonstration of the Brunswick Panatrope was given at the High School Auditorium here recently before a large audience of musicians, newspapermen and prominent citizens. The event was under the auspices of the New Mexico Music Co., local Brunswick dealer.

### C. E. Campbell Co. Chartered

The C. E. Campbell Music Co., Niagara Falls, N. Y., was recently incorporated at Albany, with a capital stock of \$20,000 to make radio sets. The incorporators are C. E. Campbell, C. E. Campbell, Jr., and E. E. Gillick.

## A Square Deal!

Radio Jobbers have learned a lesson. Shamrock's record for *square dealing* during the past year has brought numerous requests for Shamrock territory. Shamrock stands

for *fairness* to you. Shamrock gives *value* to your customers. Shamrock models will lead the field. There are still available—desirable territories. Write today

# SHAMROCK

RADIO SETS

Makers of Famous STANDARD SHAMROCK PARTS

196 Waverly Ave.

Newark, New Jersey



SHAMROCK CONSOLE GRAND  
(One or two dial control)  
Built in loud speaker. Space for A & B batteries. Price (without accessories) ..... \$160  
Other models as low as \$95



# "All-Directional,"\*

## The Feature That Will Sell EVERY Radio Set Owner

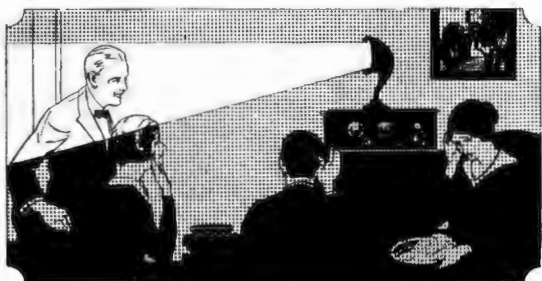

The "One-Direction" speaker lets only those in front hear well.

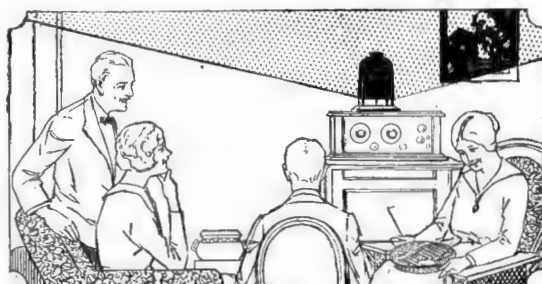

The "All-Direction" N & K Speaker lets everyone in the room hear clearly.

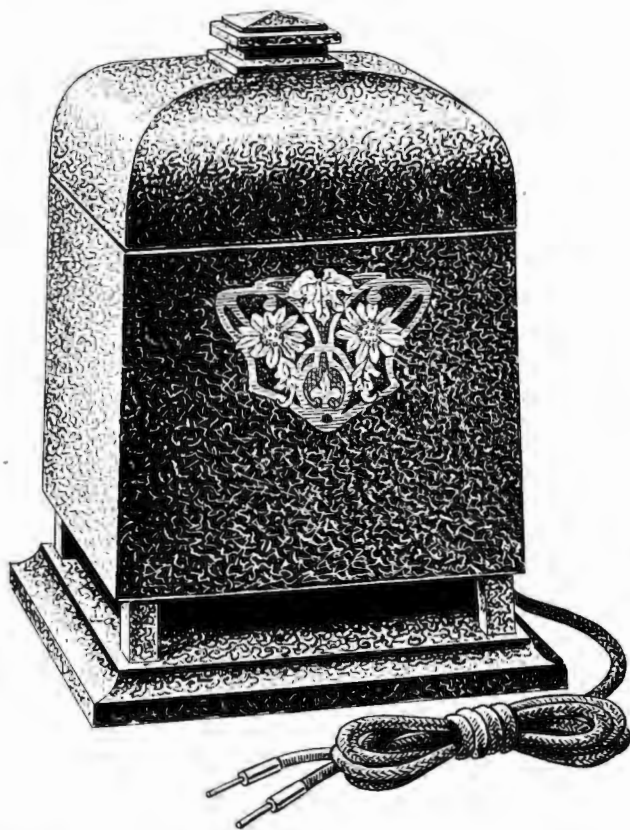

IN some speakers *Tone Quality* is the chief appeal, satisfying the more musically minded.

Some speakers feature *Volume*, and their sales audience is made up of those who want all the sound they possibly can get.

Some speakers appeal merely by *Good Looks*, and depend on artistic appreciation for sales.

The new N & K Model S Imported Loudspeaker has not only *Tone Quality*, *Volume* and *Good Looks*, but it has another feature that appeals to everyone. It is ALL-DIRECTIONAL.\*

Placed *anywhere*—in a corner, at one side, in the center, up on the bookcase, down on the tabourette—this new N & K Speaker allows the broadcasting to be heard distinctly all over the room. No matter where you are, you get the full clearness and distinctness of the broadcasting.

Furthermore, it is *Adjustable*. Variations in local broadcasting conditions or set "hook-up" are overcome instantly at the turn of simple knob.

And on top of all, the price is only \$12.50—within the reach of practically every radio owner.

If you are not yet carrying this speaker, you are missing an unusual profit opportunity. If your jobber is not supplied, order sample direct from us. Use it to demonstrate your sets and you will find that N & K will *sell itself*.

NEUFELDT & KUHNKE DIVISION

Th. Goldschmidt Corp., Dept. T-1, 15 William St., New York, N. Y.

Model S



Imported

# LOUDSPEAKER

ADJUSTABLE

Like all N & K Imported Speakers and Phonograph Units, this Model S Speaker is adjustable instantly to variations in broadcasting conditions and in the construction of receiving sets. 9½ in. high on 6½ in. sq. base. Finished in black burtex, suggesting leather. Packed six to carton.

only  
**\$12.50**

IN CANADA, \$15



# Goldburg's Five-Point Plan an Aid to Sales

Large Concern Practices the Golden Rule in Business Dealings  
With the Result That Sales Volume Has Increased Year After Year

Practice the Golden Rule in the extension of credit and most problems in connection with doing business on the instalment plan will be eliminated or largely minimized. That, in effect, is the plan under which the Goldburg Furniture Co. operates. This concern has five large stores in the city of New York and suburban centers, all of them devoted to the sale of furniture and, what is of particular interest to the trade, all of them operating talking machine departments.

## "The Goldburg Five-Point Plan"

The basis of this concern's credit system, which has been instrumental in building much good will manifested in the growing patronage the firm enjoys, is known as "The Goldburg Five-Point Plan." This provides as follows: If the customer takes sick or is out of work, payments are postponed. If patrons are really unable to make payments the Five-Point Plan emphasizes that there is no need for worry, as nothing need be paid until the patron is again at work and in a position to meet his or her obligations.

The second point is of importance in view of the fact that many of the company's customers are factory workers and other people of very limited circumstances who are unable to make large initial payments and instalments. These people, however, are of the type who religiously meet the weekly or monthly payments. The second point emphasizes the lowness of the initial payment and the small amount that need be paid weekly or monthly, whatever the case may be. Attention is also called to the fact that credit investigation is carried on so that neither employer nor friends will know that the instalment plan has been taken advantage of. The latter is a particularly important point because it is a peculiar characteristic of people in very moderate circumstances that they do not want the "secret" to leak out that they have purchased anything on the time payment basis. The third point, while it bears particularly on the furniture end of the business, also has an effect on the talking machine department, as it

brings people into the store. This is that the firm, because of its size, is able to buy in car-load lots and thus often makes substantial savings which are passed on to the customer.

The fourth point is very important because it is the basis of service which the company extends to its customers. This deals with free

*Goldburg's operate several stores in which talking machines are sold, as well as other merchandise. A large instalment business is done and the policy of the company has been instrumental in materially reducing credit troubles, building good will and consequently increasing the volume of sales.*

repairing. If any product sold by the Goldburg Co. proves to be defective the firm loses no time in making good and repairing the article without cost. Even after the final payment has been made on a talking machine or other article of furniture the Goldburg Co. will send a polisher to the patron's home or a repairman as requested.

"Money back if you're not satisfied," reads the fifth point.

## Service Wins

The five points just outlined indicate the methods which the Goldburg Co. has found so successful in building up a large business, a business that extends further than the confines of the city in which the stores are located. People seldom forget Goldburg's and when they move out of town and it is possible to visit one of the Goldburg stores they do so. Service of the highest order has been responsible for this

very satisfactory condition. Besides the free repairing and service mentioned previously the company does other things in the way of service which customers like. One of these is a system of quick deliveries. When an article is promised for a certain day it gets there on the day stated. Another nice little courtesy which appeals to customers is a letter of thanks when the payments have been completed.

The operation of every branch of this huge business is based on service of some kind. Take as another example the credit department: The method of making payments which is most convenient for the customer rules the company. If the customer prefers to pay weekly in the store he may do so. If on the monthly basis, this can also be arranged. If it is inconvenient to pay at the store, Goldburg's will send a collector, thus relieving the customer of this duty. Payments can also be made by money order or check, and many patrons, especially those who live some miles from the nearest store, avail themselves of this opportunity.

## Making Credit Leniency Pay

Of course, where such leniency is the practice of the credit department the company must be certain that the people who apply for credit will make their best efforts to meet their financial obligations. The character of the individual applying for credit under this plan is of the utmost importance. Indeed, it is the basis on which is determined the credit responsibility of the applicant.

## Making Effort to Improve Distribution Conditions

WASHINGTON, D. C., January 6.—Efforts to improve conditions of distribution, to bring to light the major wastes of marketing and to set up and enforce ethical and economical standards of business practice were brought to a focus at the general meeting of the National Distribution Conference held in Washington in December, under the auspices of the Chamber of Commerce of the United States. A general program of business and trade association activity in the field of distribution was outlined. Steps were proposed, in accordance with the recommendations of Secretary Hoover, looking to the co-ordination of business effort in the assembling of basic information relating to marketing. Machinery for the self-regulation of business was arranged.

In addition the Conference outlined a wide range of activities to be carried on by business men, individually and through their trade organizations, all designed to contribute to the common purpose of putting distribution on a systematic and efficient basis.

The general viewpoint of the Conference was that in the economic scale distribution is quite as important as production or manufacture and should be given as much consideration. As indicated by John W. O'Leary, president of the National Chamber, it regarded the work it had undertaken as the beginning and not the end of a great task.

## M. Nimcowitz Host at Dinner

Morris Nimcowitz, proprietor of the Morris Music Shops, New York, was the host at the annual dinner of the employes of his establishments which was held the latter part of last month at Wimmer & Fein's dining room on East Fordham road. Entertainment was provided by the Clarence Williams Trio, Okeh artists and well known as radio entertainers. Friends of Mr. Nimcowitz were present.

\$2<sup>50</sup>



S-4000  
5-volt  
1/4 Ampere  
Detector  
Amplifier

## Over 1000 New York Dealers Are Making Full Tube Profits

Look over your profits on tube sales! Discouraging isn't it? With competitors all around you cutting prices there's no money in handling ordinary tubes. That's what over 1000 dealers in Greater New York thought—until the Schickerling franchise

was put up to them. Now every one of these dealers is making a real legitimate profit on tubes—a margin that enables them to build up a real tube department and go after tube sales. Let us put the proposition squarely up to you—write.

SCHICKERLING PRODUCTS CORPORATION  
401-407 Mulberry Street, Newark, N. J.  
Philadelphia Office: Jefferson Building, 1015 Chestnut Street

# SCHICKERLING RADIO TUBES

*With the Stabilizing Triangular Plates*



# 12 O'CLOCK AND ALL'S WELL



**Pearsall Service Is  
on the Watch at  
All Times**

A to Z in Radio

**RECEIVERS**

- Zenith
- Adler-Royal
- Sleeper
- Air-Way

**PHONOGRAPHS**

- Adler-Royal
- Caswell Portables

**CABINETS and  
COMBINATIONS**

- Adler-Royal

**SPEAKERS (Horn)**

- Ethovox
- Amplion
- Silvervoice
- Holtzer Cabot
- Saal

**SPEAKERS (Cabinet)**

- Adler-Royal
- Teletone
- P K

**BATTERIES**

- Eveready
- Philco
- Ful-Wave Chargers
- Perryman Tubes
- Philco Socket Power

*Ask any Pearsall dealer, he'll tell you*

*"Desire to Serve,*



*Plus Ability"*

**SILAS E. PEARSALL COMPANY**

10 EAST 39th STREET

WHOLESALE

**INC. DISTRIBUTORS**

ONLY

NEW YORK CITY

BRIGGS



## How Dealers Can Profit by Tying Up With Anniversary of the Boy Scouts of America

Window Displays and Other Definite Ways of Cashing in on the Sixteenth Anniversary of the Existence of the Organization, February 7-13—Music Is an Important Scout Activity

Next month talking machine dealers will have a chance to secure publicity of real value and identify themselves with an organization that the whole country respects, the Boy Scouts of America. From February 7-13, the scouts celebrate by appropriate ceremony the sixteenth anniversary of their incorporation with the cooperation of governors, legislatures, the press, the clergy, educators and prominent citizens of the forty-eight States, and the National Government at Washington. It is a distinct asset to be connected with a national movement of this character, and the wise dealer will take advantage of the occasion to emphasize the close contacts between his line of goods and this rich market.

The very size of the Boy Scouts of America

Mr. Edison Man:—

Never Say

**"KAN'T," say "KENT"**

The KENT No. 1

With "S" Sound Box for playing lateral cut records on the Edison Disc Phonograph has outsold all competition.



Bought for their resale and playing value by thousands of dealers and jobbers for over 10 years.

Write for catalog of complete line



Reg. U. S. Pat. Off.

**F. C. KENT CO.**

Irvington, N. J.

is impressive—nearly 800,000 men and boys—a buying unit of similar interests and similar hobbies. And music is a big hobby. Did you ever know a gang of boys to get together without some sort of tune arising, whether it comes from a jew's-harp or a score of lusty young throats? Scouts are encouraged to bring their musical instruments to camp. Banjos, ukuleles, mandolins and guitars, and saxophones are swapped around in the friendly community of camp life. Most organized camps have phonographs and many of them radios. There is an official Boy Scout Song Book edited by C. C. Birchard & Co., and three official double-faced Boy Scout phonograph records.

Of course, radio is a big hobby with scouts. A questionnaire sent out recently revealed that 95 per cent of them either owned receiving sets, or hoped to.

There is a point here that will be readily appreciated. The Boy Scout is the finest advertisement in the world for the store he patronizes. The clean-cut boy in his trim uniform, and the ideals of trustworthiness, honesty and service that the uniform stands for, make him the ideal representative for your goods. The general public has come to realize that Scouting is not just a game that takes boys into the open for recreation. It is a program that trains boys to be good citizens and teaches them a great many useful activities. Badges are given for proficiency in different subjects, and the scout progresses in rank as he acquires these merit badges.

The subjects that will most interest talking machine dealers are music and bugling. To ob-

tain a merit badge for music a scout must play a standard musical instrument satisfactorily, read music at sight and write a satisfactory essay on the history of American music. The scout who wins the bugler's badge can sound correctly a number of calls, including reveille, retreat and taps.

Is music a necessity or a luxury? That depends upon the interest taken in it by the people at large. And that interest depends largely upon what they were taught when they were young. Boy Scouts are taught to regard it as practically a necessity—to know and love good music. They are taught that a camp is made bright by gay music. They play instruments themselves and enjoy listening to others. Boy Scout bands and orchestras are a popular feature in many councils, and fife and drum corps are the joy of troop rallies.

Now what specific share can music dealers take in the nation-wide publicity of the Boy Scouts of America from February 7-13? Place window displays for one thing—instruments that boys love, and some snappy scout posters, camp photographs, etc. Or you may stage a harmonica contest, always a mirth-provoking and popular feature. If there are enough scout buglers among the boys of your town, a bugling contest at noon in some prominent public place, or in front of your store, will attract interest. Offer a prize of merchandise from your store in some contest of scoutcraft that especially appeals to you—fire-by-friction, water-boiling, first aid race, or any one of the contests that your local scout council is conducting. Identify yourself with the movement. Get in touch with local headquarters and let them know that you like boys, and will be glad to help the scouts. Or write to National Headquarters at 200 Fifth Avenue, New York City, for further information. You will find the time you spend with Boy Scouts the richest investment you ever made.

### Writing Form Letters That Are Producers

Mental Attitude Has Important Bearing on Success in Writing Form Letters—Personal Element an Important Factor

"It is a good thing for the man who writes letters to be reminded occasionally of some of the more elementary characteristics of letters that pull good percentages of returns," says Harrison McJohnston, in an article entitled "When a Form Letter Is Not a Form Letter," appearing in a recent issue of Printers' Ink.

"Being so simple and obvious, these earmarks of good letters are sometimes neglected by the letter writer—or perhaps his experience has not yet taught him to appreciate their full value.

"One of these characteristics is that of personalizing or individualizing the form letter—making it appear to have been written especially to the individual addressed. This is nearly always desirable, but not always, by any means, easy to attain. The woods are so full of form letters and so many people are on the lookout for them—rather, on the lookout against them—that, to-day, almost any letter that is well spaced and well typed is likely to suffer somewhat from a suspicion that it may be a form letter—and therefore to be discounted by the reader, or not read at all.

"To write and prepare a form letter so that it will not be suspected of being a form letter will, as a rule, measurably improve its returns. On this point one of the heads of a large Western advertising agency who has had exceptional success in the use of form letters as a means of ferreting out the very favorable prospects among dealers for handling a line of nationally advertised products recently said:

"There is one thing I always forget when I'm writing a form letter—and that is the fact that it is a form letter. Just because the same letter is to go to many prospective dealers is

no reason why it should not be written exactly as though it were a letter to one particular dealer.

"I have seen many form letters written by advertising copy writers," he said, "which read a great deal like display advertising copy. They lack the personal, individual, intimate touch that gets what you might call the "conversational" attention of the reader. I don't care who he is, no man is ever half so much interested in a "circular" letter as in a letter that was apparently written to him and to him alone—as though the writer were there talking to him face to face.

"I have found few copy writers who are able to write this kind of form letter. But it's a knack that can be learned, and is learned soon enough once a man fully appreciates the effectiveness of the truly personal and individual tone in a form letter."

### Married to Record Music

A unique wedding ceremony was performed in Chicago recently at which the music was supplied by the bride and groom through the medium of phonograph records. Otto Beyer, pianist, and Ruth Olt, soprano, were the happy couple, and before the union of the artists a piano record of Lohengrin's "Wedding March" by Mr. Beyer was played. Then came the solo, "O Promise Me," sung and recorded by Miss Olt. After the ceremony the "Wedding March" record was again played.

### George Sklar Recovered

George Sklar, sales manager of the International Phonograph Co., New York, returned to business the latter part of last month after an absence of six weeks caused by a nervous breakdown. Mr. Sklar is rapidly rounding into form after having lost some forty pounds during his illness.





ELIMINATED  
by This~

# What Does Every Radio Fan Want?

A constant, unvarying, trouble-free current supply. The Majestic A & B Current Supply *really* eliminates both the A & B batteries. Just plug in, on your house current supply (alternating current) and turn "on" the switch. You can then operate your radio continuously 24 hours each day for a week, month or a year if desired. This would not be possible with a battery and charger.

**\$47<sup>50</sup>** Without Tubes

## Majestic A-B Current Supply

No more does your customer have the annoyance of batteries and their ills, chargers, hydrometers, acids, etc. All this is eliminated.



### Used With Any Radio

The Majestic A & B Current Supply can be used with Radio receiving sets using 201A or 199 type tubes. It gives uniformly excellent results on any circuit or combination of circuits.



Model  
WG-10

**\$12<sup>50</sup>**

## Majestic Reproducer

ONE PROFIT RADIO PRODUCTS

*Our Products Are Popularly Priced—Because We Do All the Work That Goes into Them*

There are no parts makers' profits and overhead—or other outside costs to add to the price of Grigsby-Grunow-Hinds Radio Equipment. That's why we are able to sell our merchandise at considerable saving to you, and that's why you, in turn, can meet the trade with attractive prices in any competition.

Our own skilled craftsmen are all we need to rely upon for quality. They work under one great roof and are constantly under our exacting supervision—which insures the very best that it is possible to build. The result is volume and tone unexcelled in the industry.

**WE MAKE THEM—WE KNOW**

Manufactured by

**GRIGSBY --- GRUNOW --- HINDS CO.**  
**4558 Armitage Avenue, Chicago, Illinois**

In Canada: Benjamin Electric Mfg. Co., of Canada, Ltd., Toronto.

### Follow the Reasons:

1. Genuine Roxalin Horn hydraulically pressed.
2. Bases beautifully finished in crystalline lacquer.
3. Exclusive "formed" diaphragm.
4. Adjustable lever volume control.
5. Elimination of all harsh sounds.
6. Permanently perfect reproduction.



# New Field for Radio Sales Open to Trade

Foreign-Born People Are Becoming Interested in Radio to an Extent That Makes It Profitable for Retailers to Bid for Business

During the past year the potential field for radio sales has more than tripled. That this statement is based on fact is indicated by the increase in two classes of sales. First, the farmer has come to realize that radio is an essential to his business. Second, the foreign-born now may be classed as good radio prospects. A year ago the dealer not only made no attempt to sell to foreign-born people but avoided doing so, on the ground that these people, knowing nothing of radio, would require profit-killing service and, because many of them do not even speak the English language, they would not enjoy the programs.

## The Foreign-Born Radio Prospect

Talking machine dealers who cater to this class of people have been reaping a harvest in selling radio. One dealer, who a little more than three months ago installed a radio department, has grossed \$24,000 in radio business, the bulk of the sales being made to Italians, Hebrews, Bohemians, and a sprinkling of other nationalities. Other dealers similarly located also report a large number of radio sales to foreign residents of the community. The dealer must bear in mind that the children of these people speak English and have absorbed the customs of their adopted land. Children influence the parents. Also radio now has reached the point where it is mainly an instrument for the reception of musical programs and foreigners are, for the most part, music lovers.

Another important consideration for the dealer who contemplates going after this business, but who hesitates for fear that the service he must necessarily give customers will make serious inroads into his profits, is that the radio set of to-day, compared to radio of a year or more ago, is practically fool proof.

## Dreazen Sells to Negroes

L. Dreazen, who operates a talking machine store in the heart of the negro section of New York City, has sold many radio sets since he opened a department some months ago. The negro, to even a larger extent than the foreign-born customer, is ignorant of the operation of a radio set. Therefore, in connec-

tion with the sale of radio to this class of trade the service problem presents difficulties which the average dealer does not have to face.

## A Busy Service Man

The radio service man, or whoever is responsible for this work, is kept on the jump continually, according to Mr. Dreazen. "Our men call on some customers every other day to see that the set is working properly," this enter-

*Experiences of dealers who specialize in this market indicate that the foreign-born citizen makes a good radio customer. He makes a large down payment and will pay for service. The negro is also a factor in radio sales not to be overlooked by the retailer who desires to make the most of his opportunity of selling radio. Careful handling of patrons is of vital importance.*

prising dealer pointed out. "It is necessary to show them how the set operates at least three or four times a week and most of them forget the instructions as soon as the service man has left the house. The result is that they fool around with the set and turn off the tubes without turning off the switch, or do something else that will burn out the tubes or ruin the batteries. Then when something goes wrong, as is bound to be the case, we are called upon to repair the damage. Now this means a tremendous service expense, an expense that would be prohibitive if we did not have some way of giving service without endangering our profits."

## Solving a Serious Problem

That is the problem Mr. Dreazen had to solve before his radio sales showed a profit. That he

solved it in a satisfactory manner is proved by the fact that he is still selling radio. In the first place at the time of the sale of a radio set in the contract under the heading "Remarks" is emphasized that no parts are guaranteed. In other words, if something goes wrong with the tubes, batteries, etc., the store is not responsible. Not only is this clause written into the contract but the attention of the customer is called to it, so that there will be no misunderstanding later if trouble develops. That is the first step in Mr. Dreazen's radio selling plan. The second step is the investigation of the purchaser before delivery of the set. This Mr. Dreazen considers of outstanding importance, for the negro, due to his carefree nature, has a habit of leaving town with his belongings without bothering to settle debts. Also in this section there is a large floating population. Negroes come from all parts of the country on more or less extended visits and then leave as suddenly as they came. Of course, the bulk of the negroes who reside in Harlem, as the district is known, are citizens of a fairly substantial type and these are the kind Mr. Dreazen prefers to sell—the reason for the investigation.

## Charging for Service

A charge of one dollar is made for every service call and in addition if new parts or accessories are required due to the mishandling of the set by the customer the usual charge is made for these items. The money coming in through sales made in this way, together with the charge for calls, has practically eliminated all losses through service.

That the radio service problem is not insurmountable has been demonstrated by many dealers, some of whom are actually making this department of the business pay a handsome profit. And since the need for excessive service has been the main reason why retailers have hesitated to go after radio business among the foreign-born people and negroes the slow development of sales to these people is explained. The fact, as the foregoing illustrates in a concrete manner, is that the foreign-born will buy radio sets and service can be made to pay, thus opening an entirely new field to dealers who are determined to build up a profitable radio sales volume.

## Use of Atwater Kent Sets in Sioux City Schools

### Campaign of Local Paper in Connection With Distributor and Dealers Bears Results

SIoux CITY, IA., January 6.—The Atwater Kent radio receiving set received considerable publicity in this city during the pre-Christmas season through a highly successful appeal to all schools located in any part of the Sioux City territory covered regularly by the Sioux City Journal. This campaign was conducted in conjunction with the Noll Electric Co., Atwater Kent distributor, and two of its local dealers. By this arrangement, splendid publicity was secured from the newspaper, which also displayed the Atwater Kent in its show window. The set was awarded for the best 300-word letter on the subject "What Will the Use of Atwater Kent Radio Mean to Our School?" and was presented by the Noll Electric Co., the batteries by the Pelletier Co., Atwater Kent radio speaker and tubes by Davidson Bros., and complete antenna outfit by Charles S. Wilson, district representative for the Noll Co. This campaign did much to start people talking about and buying Atwater Kent radio throughout the entire territory.

## There Is No Substitute for the



Model 11

**BLAIR RECEIVER**  
SIX TUBES  
Resistance-Coupled Amplification

**\$75** The Original and Genuine  
Resistance-Coupled Receiver

Because of its superb tone quality, which is unequalled by any other receiver regardless of price, its great volume and knife-sharp selectivity, the Blair Resistance-Coupled Receiver became instantly popular wherever it was demonstrated and heard.

As a consequence, many and varied have been its imitators, but—there is no substitute for the original. The Blair is the only commercial receiver employing STRAIGHT

Resistance-Coupled Audio. There are no transformers whatsoever in the audio circuit, which accounts for its superb tone. In their efforts to obtain the combination of volume and tone, which characterizes the Blair receiver, its imitators have stepped up one audio stage with a transformer, thereby sacrificing tone in their effort to obtain volume. Consequently, the Blair is the only receiver possessing the pure and mellow tone, for which Resistance-Coupling is noted.

Write or wire us for the name of the nearest Blair representative.

LIST PRICES {East of Rockies—Model 11—\$75; Standish Console, \$125; L'Elegante Console, \$150;  
{West of Rockies—Model 11—\$80; Standish Console, \$135; L'Elegante Console, \$160.

**Blair Radio Laboratories**

368 Sixth Ave.

New York City



# Facts and figures to prove that Eveready Batteries are the most economical



*These Eveready Batteries are the correct size for your set. With average use they will last you a year or longer*

"You" have been one of the many who use 'B' batteries that are too small in capacity for their receivers. That is not economical. It makes you buy 'B' batteries twice as often as necessary. Fit the right size Evereadys to your set and add a 'C' battery,\* if you haven't one, and you'll get maximum service at minimum cost."

The life of your Eveready "B" Battery depends on its capacity in relation to your set and how much you listen in. We know, through a careful investigation, that the average year-round use of a set is two hours a day. Taking that average we have proved over and over that on sets of one to three tubes the No. 772 Eveready "B" Battery used with a "C"

\*Note: In addition to the increased life which an Eveready "B" Battery gives to your "B" batteries, it will add a quality of reception, unobtainable without it.

battery will last a year or longer. On sets of four and five tubes, the larger Heavy Duty Eveready Batteries used with a "C" battery will last eight months or more.

Here is the secret of "B" battery satisfaction and economy:



**EVEREADY**  
Radio Batteries  
*-they last longer*

With sets of from 1 to 3 tubes, use Eveready No. 772.

With sets of 4 or more tubes, use either of the heavy duty batteries, No. 770 or the even longer-lived Eveready Layerbilt No. 486.

We have prepared for your individual use a new booklet, "Choosing and Using the Right Radio Batteries," which we will be glad to send you upon request. This booklet also tells about the proper battery equipment for use with the new power tubes.

Manufactured and guaranteed by  
**NATIONAL CARBON COMPANY, INC.**  
New York San Francisco  
Canadian National Carbon Co. Limited, Toronto, Ontario

EVEREADY HOUR—EVERY TUESDAY AT 9 P. M.  
Entire Standard Time  
For real radio enjoyment, tune in the "Eveready Group" broadcast through stations—

wcaz-New York	wep-Philadelphia	wscw-Cincinnati
wjag-Providence	wad-Dallas	wop-Davenport
wjz-Boston	wca-Pittsburgh	wab-Baltimore
wjz-Boston	wca-Pittsburgh	wab-Baltimore
wjz-Boston	wca-Pittsburgh	wab-Baltimore

Tuesday night means Eveready Hour — 9 P. M., Eastern Standard Time, through the following stations:

WEAF—New York  
WJAR—Providence  
WEEI—Boston  
WTAG—Worcester  
WFI—Philadelphia  
WGR—Buffalo  
WCAE—Pittsburgh  
WSAI—Cincinnati  
WWJ—Detroit  
WOC—Davenport  
WEAR—Cleveland  
WGN—Chicago  
KSD—St. Louis  
WCCO—Minneapolis, St. Paul

THIS year will see the most specific, attention-compelling and convincing advertising ever done on batteries. Actual facts and figures will be used in the national advertising of Eveready Radio Batteries, irrefutable proof that *they do last longer*. There's a mighty appeal to the pocketbook in this campaign. "Fit the large Evereadys, such as No. 772, to one to three tubes, and they will last a year or longer. Use Eveready No. 770 or Eveready Layerbilt No. 486 on four or more tubes, and get at least eight months' service." This campaign combines news, education and selling. Its effect will be tremendous, far exceeding anything ever before accomplished for battery sales by advertising. This year Eveready Radio Batteries take a great step forward. It will pay you to march in the pro-

cession with them. Watch for the advertisement reproduced above. It will appear in the January 9th issue of *The Saturday Evening Post*. Order Eveready Radio Batteries from your jobber.

Manufactured and guaranteed by  
**NATIONAL CARBON COMPANY, INC.**  
New York San Francisco  
Atlanta Chicago Dallas Kansas City Pittsburgh  
Canadian National Carbon Co., Limited, Toronto, Ontario

# EVEREADY

## Radio Batteries

*-they last longer*



## Radio Market Barely Scratched—Four Prospects to Every Owner of a Receiver

Powel Crosley, Jr., President of the Crosley Radio Corp., Points Out That About 5,000,000 Radio Sets Have Been Sold While There Are More Than 25,000,000 Homes in This Country

The year 1926 will be a turning point in the radio industry, according to Powel Crosley, Jr. president of the Crosley Radio Corp.

"Indications point that next year will exceed previous years in the amount of business done, and will witness a decided stabilization of the industry," said Mr. Crosley in a report he recently issued. "If those two facts are accomplished, they will constitute a record for a business practically five years old.

"To attain the first—a record-breaking business in 1926—three factors are necessary: a sufficient number of prospective purchasers, a desire on the part of those prospects to buy, and their financial ability to purchase radio sets and equipment.

"It is safe to say that to-day there are four prospects to every present owner of a radio. It is estimated that there are more than 4,000,000 sets now in use—in fact, this number by the end of the year will be close to 5,000,000. That appears to be a large number, but its apparent size shrinks when it is considered that there are more than 25,000,000 homes in this country. Furthermore there are 18,000,000 automobiles in operation here; about 15,000,000 telephones and approximately 12,000,000 phonographs.

"One huge field of about 5,500,000 prospects has hardly been scratched," said Mr. Crosley. "That is the farm field. It is estimated that out of the 5,950,000 farms in this country, only a little more than 500,000 have radio equipment. There is no question but every farm family can use and wants a radio. The chief reason why more do not have them has been in faulty merchandising methods, which now are being improved.

"The second factor—the desire on the part of prospects to buy—certainly is favorable to a record year's business. As just stated, this large non-radio farm population can be counted among those who want this last word in universal communication. The inhabitants of the small towns and the more urban communities are rapidly becoming enthusiasts. This is being brought about by friends having sets and because of the wide variety of radio entertainment, and the growing practice to broadcast interesting happenings in

the spheres of sport, politics and general life. The automobile industry, with its more than a quarter of a century development, clearly shows by its continuous gains the normal growth of any industry that tends to add pleasurable enjoyment to life.

"Ability to purchase radio outfits is being brought to practically every home in the United States through quantity production of standard sets with the consequent lowering of manufacturing costs being reflected in reduced retail prices, and through the introduction of installment plan purchasing.

"In addition to indications pointing to a tremendous body of potential radio purchasers with a desire and ability to buy, general business conditions are exceedingly favorable for the coming year. Financial and industrial authorities agree on the stability of the present era of prosperity and predict its continuance.

"But besides doing a record volume of business in 1926, the radio industry is likely to accomplish more by bringing into practice systematic merchandising methods. During the past five years the industry has been too busy growing to do anything else, with the result that it has lacked the broad foundation necessary for its future welfare. This has been the history of every infant industry that has met with popular approval from its inception.

"As the demand for radio outfits grew almost spontaneously throughout the nation, the sale of sets was taken up by virtually every type of retail business," said Mr. Crosley. "Experience has proved that all retailers, or their lines of business, were not adapted to handle radio successfully and these 'square pegs' are being eliminated. In place there is being organized through the regular evolution of the industry a chain of successful radio distributors. These men have learned by experience the best methods of bringing radio to the public, and as a result will do much toward making 1926 a banner sales year. They will use proved sales methods to bring the advantage of radio ownership to every home; they will work out and put into practice proper financing methods for the time payment sales; they will provide adequate service facilities;

they will work toward eliminating the peaks and valleys caused by the seasonal demand for radio equipment—in short they will do their part toward completely stabilizing the industry and making 1926 the greatest year radio has known."

## Big Phonograph Companies Amalgamate in Japan

Will Manufacture Radio Sets in Addition to Regular Lines Under the Name of the United States Phonograph Co.

News comes from Japan of the consolidation of the Nipponophone Phonograph Co., of which J. R. Geary is president, and the Tokyo Phonograph Co., main offices of both companies being located in Tokyo. The consolidated companies will hereafter be known as the United Phonograph Co., with a combined capitalization of approximately \$2,300,000, fully paid up. It is understood that in addition to phonographs and records the new company will manufacture radio sets to meet the increased demand for this product in Japan.

Mr. Geary, president of the Nipponophone Co., during his recent visit to the United States, when he was a visitor to The World sanctum, looked into the radio field very thoroughly. Mr. Geary is an American who for many years has made his home in Japan, where he has built up a very important position in the manufacturing world.

## Atwater Kent Bulletin of Window Display Hints

Window displays of a specific mid-Winter appeal are interestingly treated in a recent bulletin issued by the Atwater Kent Mfg. Co., of Philadelphia, Pa., manufacturer of Atwater Kent receiving sets and radio speakers. This bulletin is entitled "The armchair season is here." The importance of featuring an Atwater Kent radio set during the great indoor season is pointed out. A window display suggestion along these lines is presented, together with illustrations and descriptions of some attractive new display cards that have been produced. Many valuable suggestions regarding window displays are given.

## Justin Bros. in New Store

CICERO, ILL., January 6.—Justin Bros. Music House has moved to its new home at 5205-07 West Twenty-fifth street. The opening day ceremonies were observed with appropriate entertainment features, and souvenirs were distributed to those in attendance. The new establishment cost \$80,000 in construction and outfitting costs.

The Rhoades Music Co. has moved its entire stock to Fort Dodge, Ia., from the store at Leon, Ia., which it has occupied for some time past.

## Philpitt Plans Expansion

Ernest S. Philpitt, Victor dealer, who operates six stores in Miami, Tampa and St. Petersburg and other cities in Florida, was a recent visitor to New York and he expressed great optimism over the prospects of business for the new year. He stated that he intends to expand his business and looks forward to having eleven stores before the end of the year.

## G. Westcott Opens Store

SAULT STE. MARIE, MICH., January 6.—A new music store was recently opened at 521 Ashmun street here by George Westcott, one of the best known musical educators in the city. A complete line of musical instruments is carried in stock and plans are being made for an extensive sales campaign.

## Raising the Standard of Radio Products

Dealers have long since known of the high standard of BRACH Radio Products—and radio devotees now insist on BRACH quality.



Safety Demands the Brach Vacuum Lightning Arrester

Safety and satisfaction are assured when you sell anything from BRACH Laboratories.

Lightning Arresters  
Aerial Outfits  
Shock-Proof Radio Plugs  
Extension Cord Connectors  
Pur-A-Tone Audio Couplers  
Fixed Crystals

Grid Leaks  
Brach-Stats  
Crystal Insulators  
Electric Soldering Irons  
Rosin Core Solder  
Solderall



Brach Shock-Proof Radio Plug, Licensed under Patent No. 1,498,196

L. S. BRACH MFG. CO.,

Newark, N. J.



# ATWATER KENT RADIO

## “What kind of company makes it?”

EVERY DAY, as the public gets wiser, do you not hear fewer and fewer customers ask, “What’s the price of that radio?” and more and more customers ask, “What kind of company makes it?”

If you are an Atwater Kent dealer, figuring where you stand at the beginning of this New Year, are you not firmer than ever in your conviction that the stability of your manufacturer is no mean asset?

\* \* \* \* \*

The Atwater Kent dealer knows:

- 1 THAT behind the company with the strongest financial resources of any independent radio manufacturer stands the personal responsibility of a man who for twenty-five years has jealously guarded the quality of every product that bears his name.
- 2 THAT we have built the largest radio factory in the world and are putting on a large addition this winter,\* because we are thinking of tomorrow’s market as well as today’s.
- 3 THAT the merchant is backed by a policy that safeguards his profit, and is not tempted to throw his money away on job lots.
- 4 THAT he is handling the Radio which requires minimum service and is therefore insured against needless worry and expense.
- 5 THAT Atwater Kent owners are satisfied with their receiving sets and radio speakers and are always boosting them in making more sales.

\* This addition covers 153,000 square feet. When it is completed—probably in April—we shall have a fifteen acre factory. We are also using our old Germantown plant, which covers two acres.

6 THAT Atwater Kent is the make the greatest number of people intend to buy—or buy next, if they already have unsatisfactory sets. (Four surveys prove this.)

7 THAT the Atwater Kent sales campaign is supported by an unparalleled advertising campaign, reaching, in magazines and newspapers and on billboards, into every corner of the United States and Canada.

8 THAT the new series of concerts by the Atwater Kent Radio Artists—the world’s best—specially benefit the Atwater Kent merchant, in increased sales.

\* \* \* \* \*

Nineteen Twenty-five was a wonderful Atwater Kent year. We wish to thank every one of you who helped to make it so.

And please keep in mind that more than ever they’ll be asking “What kind of company makes it?” in 1926.

Hear the Atwater Kent Radio Artists every Sunday evening at 9:15 o’clock (Eastern Standard Time) through stations—

WEAF . . . . . New York	WFI } . . . Philadelphia
WJAR . . . . . Providence	WOO } alternating
WEEL . . . . . Boston	WCAE . . . . . Pittsburgh
WCAP . . . . . Washington	WGR . . . . . Buffalo
WSAI . . . . . Cincinnati	WOC . . . . . Davenport
WCCO . . . . . Minn.-St. Paul	WTAG . . . . . Worcester
WEAR . . . . . Cleveland	KSD . . . . . St. Louis
WLIB . . . . . Chicago	WWJ . . . . . Detroit

Send for illustrated booklet of Atwater Kent Radio

ATWATER KENT MANUFACTURING COMPANY  
A. Atwater Kent, President

4725 WISSAHICKON AVENUE • PHILADELPHIA, PENNSYLVANIA



Model L, \$17

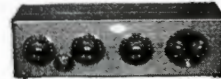

Model 20 Compact, \$80



Radio Speaker Model H, \$22

Prices slightly higher from the Rockies west, and in Canada



# Bringing Back the Backsliding Customer

How a Live Dallas Firm Brought Back Into the Fold a Number of Customers Who Apparently Had Taken Their Patronage Elsewhere

By W. B. Stoddard

What becomes of the customers of yesterday? Patrons who paid their bills, voiced no dissatisfaction with merchandise or service, yet all the same quietly faded out of the picture.

This was the question that came to the mind of Hix Smith, advertising director of Werth Wimberly, Inc., Dallas, Tex., as he glanced over the books of the firm one day. "There must be some way of getting these, or at least a portion of them, back into the fold," he reflected. "I tackled the hardest proposition first—the long inactive accounts. I selected 250 names of ex-patrons, responsible, prompt payers, who had purchased nothing from us for a period of two years. I spent considerable thought in the preparation of a letter, which I tried to make as personal as possible. This letter, with the name carefully filled in, was sent to this list of 250 ex-customers:

Dear Mr. Kennedy:—Do you know why a tramp carries his belongings in a bundle on a stick? It's BECAUSE HE'S LOST HIS GRIP.

When a patron has been a good customer of ours for a long time and, without known cause to us, stops giving us his business, we wonder if we are LOSING OUR GRIP.

Your face used to be more familiar to us than the folks in the family album. We miss your business, and we miss your personality, and we want to register a protest right here about your passing us up. Come in and let us take care of your needs. We need your business and your moral support.

Yours truly,

"This letter brought some ex-customers around, most of them to say that there had been no real intention to slight us, so about a month later we sent to those still outside the fold a second reminder:

Dear Mr. Kennedy:—We wrote a number of our friends last month about losing our grip. The response beats anything we've seen since skirts went up.

The only thing that has kept us from being absolutely happy is the fact that there are a few who have not been in.

Now, we're so encouraged that we are writing you another letter. We are prepared to give you real merchandise and personal service. Come to see us.

Yours very truly,

"Your name is still on our active ledger."

"On consulting our books a week or so after sending out the second letter we were gratified to observe that sixty of these long-vacant ac-

counts had been reopened, so after an interval of two months we fired another broadside at those still impervious to our pleading:

Dear Mr. Kennedy:—We once knew a girl who loved a bass, but she married the tenor—because he was higher toned.

You used to be a real good customer of this shop, and

*Every dealer, if he will go over his books, will find that many of his customers have not made purchases for months. Is the patronage of these people lost? Can the dealer regain their confidence so that they will again become active patrons? The methods used by Hix Smith, described in the accompanying article, prove that the dealer can regain lost trade at comparatively little expense.*

we wonder if you have gone elsewhere because we are not so high toned.

We'll admit we're a bit old fashioned and don't roll our hose, but, honestly, we have the best showing of merchandise obtainable. We want you to come in and reopen your account.

Yours sincerely,

"This straightforward talk brought the best results of all, and after the third letter had a chance to reach the recipients they began to drift in almost every day, many of them with a copy of one of our letters in their hands, saying the combination of 'sense and nonsense' simply stuck in their minds and brought them back.

"The practical results of this letter campaign showed 108 out of 250 so-called 'dead' accounts opened and active again—which I think any merchant who has tried to revive a corpse will say is a pretty high percentage."

The card index kept by this firm is a very

compact and efficient one. On white cards are listed all the dead accounts (i. e., those who had not purchased in two years or over); on pink cards is a list of regular accounts in good standing; while on blue cards is a list of prospects.

One of the most valuable points is the manner in which this list is secured. "The daily newspaper is the best means of securing a list of prospects most likely to become purchasers," he said. "I read the papers each day with this in mind. When I note that a new family has moved to the city—and in a town of this size a person has to be influential in order to have his arrival chronicled—I immediately list them as a prospect, and get out a personal letter. When I see persons commended for activity in any line of endeavor—social, religious, civic, political—I know their trade is worth securing and they get a letter. When any accounts such as these are added to a store they become a real asset. Meanwhile, the regular customer, the back bone of the store, is never neglected. Letters are written at regular intervals, never more than sixty days elapsing between communications. These letters are specific, and call attention to new merchandise in which we think they will be interested. At any rate they know that we are thinking about them all the time, and that in itself gains their good will."

## Phil Baker, Broadway Star, Recording for Columbia

"Bad Boy From a Good Family" Makes His First Columbia Records

Phil Baker, the "Bad Boy From a Good Family," who is featured in the current "Artists and Models" revue on Broadway, has joined the roster of Columbia recording artists and his first releases, "Ann in Her Little Sedan" and "Butter and Egg Man From the West," are scheduled for release this month. Although it was as a master performer on the accordion that Phil Baker first won fame, he is now regarded more as a comedian, with his own special brand of "wise cracks." The Columbia recordings by Mr. Baker show the artist's versatility, for he sings, plays the accordion and discourses to his audience in his own inimitable manner.

## National Referendum on Resale Price Legislation

WASHINGTON, D. C., January 5.—The attitude of 1,400 business organizations throughout the country on the question of resale price legislation is being polled by the Chamber of Commerce of the United States in a referendum submitted to its membership. The result of this nation-wide referendum, which will be concluded in forty-five days, will determine the Chamber's policy toward the whole question of the maintenance of resale prices.

## Large Landay Sales

Landay Bros., Inc., with headquarters in New York, closed a very satisfactory trade in the various stores which they operate. An idea of the general trend of the business of this concern may be estimated from the reports for November, which showed an increase of 77.6 per cent in gross sales of all their stores over November, 1924. The sales for that month were \$453,308, against \$255,232 for the same month a year ago, an increase of \$198,078.

## HARDWARE

for

### RADIO and PHONOGRAPH CABINETS

LID SUPPORTS

BULLET CATCHES

CATCHES

STOP HINGES

CONTINUOUS HINGES

INVISIBLE HINGES

NEEDLE CUPS



## WEBER-KNAPP CO.

JAMESTOWN, N. Y.



# POWELL CROSLEY JR.

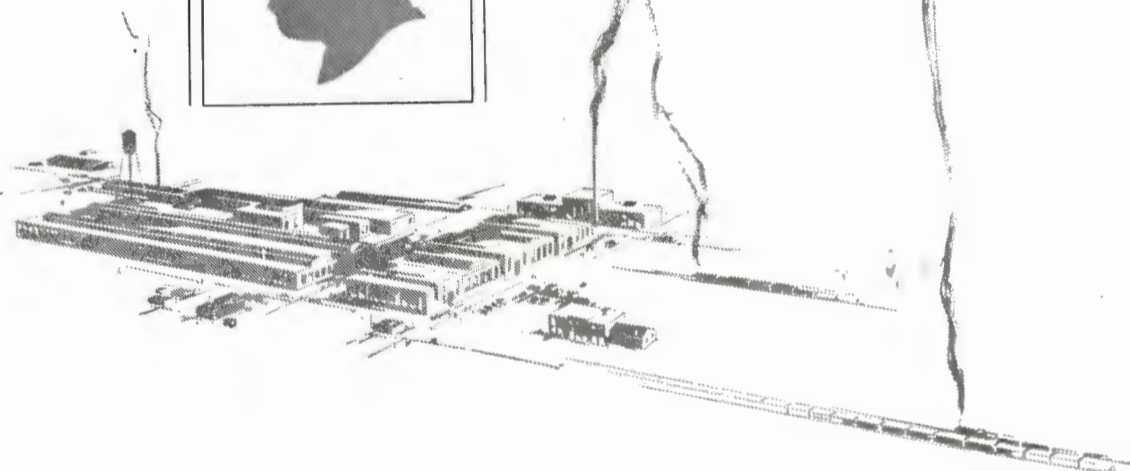

## INDUSTRIALIST *Pioneer Radio Builder*

At a time when products of his manufacturing genius were already known to millions, Powel Crosley, Jr., boldly diverted his energies to the development of radio reception, then scarcely known beyond the laboratory walls.

Pioneering both in engineering trends and manufacturing practices, Mr. Crosley has been a vital factor in making radio and broadcasting as much a part of American life as motion pictures and the motor car.

There is scarcely a milestone in the development of popular radio on which his shadow has not been the first to fall. And his announcement of December 26th concerned a milestone that dwarfed all others in its importance—*four entirely new radio receiving sets:*

- The Crosley 4-29 (4-tube) . . . . . \$29.00
- The Crosley 5-38 (5-tube) . . . . . 38.00
- The Crosley R. F. L.-60 (5-tube) . 60.00
- The Crosley R. F. L.-75 (5-tube) . 75.00

*These are now being demonstrated by Crosley dealers and will be completely described in a forth-coming issue*





## Survey to Secure Vital Data From Radio Owners Launched by Neufeldt & Kuhnke

Radio Fans Are Requested to Answer Fifty Questions Which Will Give Firm Important Information—Work of the Campaign Being Handled by Churchill-Hall, Inc., Advertising Agency

Neufeldt & Kuhnke, makers of the well-known N. & K. reproducers, are making a survey to get first-hand information from radio users. This survey is being conducted by means of personal interviews which follow a questionnaire carefully laid out and tested. There are approximately fifty questions in all which trained interviewers are personally asking owners of radio equipment.

The method of approach in this survey is of particular interest because of the large number of radio surveys to-day which are being conducted among the trade and because of an almost equal number of questionnaires which are being sent by mail to a selected list of users. In using the personal interview the results of the N. & K. survey are certain to be as representative and as unbiased as it is possible to secure.

An intensive study following the questionnaire above mentioned is being made in the New York metropolitan district, and the work will be shortly extended to other sections of the country. It is the purpose of the questionnaire to reflect as clearly as possible the experience of the radio users in connection with the type of equipment used, the make of sets, tubes, loud speakers, head phones, units, etc., and the size of batteries, frequency of charging, etc. Information will also be secured as to the member or members of the family who use the set most, who buy the equipment, and who are most interested in radio. Detailed information is secured concerning the experience with loud speakers and minute comparisons are secured between various types and makes of these reproducers.

The thoroughness with which this work is being done may be judged by the fact that two interviews are secured with each individual approached. The first interview covers the points of general experience and preference, at which time the interviewer leaves an N. & K. Speaker to be tried out. The second interview, occurring from one to several days later, secures the detailed comparison and other pertinent information.

The work on this survey is being handled by

Churchill-Hall, Inc., advertising agents for N. & K. Some of the field work is being done by members of a class in advertising research at Columbia University. This class is directed by E. C. Norris, who is manager of the research department of Churchill-Hall, Inc. Incidentally, work of this type affords the students in such a course a real opportunity to see how actual problems of this sort are handled by a manufacturer and his advertising organization. J. B. Price, sales and advertising manager of the N. & K. organization, addresses the class from time to time in connection with the progress of this work and in order to acquaint them first-hand with the manufacturer's viewpoint on their entire line of products.

Results of this survey are being received at the present time and will continue to come in for some weeks. It is, of course, the purpose of the N. & K. organization to prepare the findings in such form as to be of the greatest help to their jobbers and dealers.

### Werrenrath Scores Big at Atlanta Radio Show

Atwater Kent Sends Great Artist From New York at Request of Mr. Hopkins and Others

The premier attraction of the Atlanta, Ga., Radio Show was the inspiring concert given by Reinald Werrenrath, the distinguished American baritone, on Thursday, December 10, at 8:30 p. m. W. D. V. Hopkins, president of the Hopkins Equipment Co., of Atlanta, local distributor of the Atwater Kent radio, interested Mr. Kent, president of the Atwater Kent Mfg. Co., of Philadelphia, in the Atlanta show to the extent that Mr. Kent made special arrangements to have this renowned artist appear.

Mr. Werrenrath, with Herbert Carrick, his piano accompanist, were met at the railroad station upon their arrival from New York by a special committee from the headquarters of the Atlanta Radio and Electrical Exposition.

The news that Werrenrath was to give a recital in the Assembly Hall traveled like wild-

fire and the hall was crowded long before the concert began. An interesting feature that Mr. Werrenrath introduced was his personal and colorful description of the selections he would sing and a few words about each composer.

To give to the vast radio audience the opportunity to again hear Werrenrath, his recital was broadcast by Atwater Kent through the well-known Atlanta Station WSB. This is one of the many special recitals, given by distinguished artists of the concert and opera stages, arranged and broadcast by Atwater Kent, in addition to the weekly Atwater Kent Sunday evening concerts. Other special recitals by these eminent artists have been arranged and broadcast by Atwater Kent in Montreal, Portland, Los Angeles, San Francisco, Seattle and Dallas.

### Inadequate Turnover Cause of Business Deterioration

J. H. Tregoe, Executive Manager of the National Association of Credit Men, Discusses the Vital Topic of "Slipping" Business

Commenting on a number of old business concerns that have dried up or liquidated recently, J. H. Tregoe, executive manager of the National Association of Credit Men, said to-day that deterioration in business enterprises results from the violation of economic laws that business men so habitually disregard.

"Every now and then we are surprised by the failure of some concern which has gone along for years with apparent success. There was no apprehension of its deterioration," Mr. Tregoe observed. "The question arises, just when did the deterioration begin? There must have been some period in the life of the enterprise when success became impossible and there was nothing ahead eventually but collapse.

"Deterioration in a business enterprise results just as in the human body, from violation of natural laws. Business, as I have frequently pointed out, is not automatic. It is a human instrument and is subject to human control. The laws of success in business are very simple but difficult to put into execution. All too frequently the difficulty of observing them is overlooked because of their very simplicity.

"Without adequate profits a business cannot survive, and every rule that applies to the making of profits must be obeyed or else deterioration results. A proper turnover of merchandise and receivables constitutes the principal hinge on which profits swing. No matter how reputable a concern may be, if these features are not as they should be, then the basis of success is impaired and there may come deterioration that may cause the whole structure to collapse.

"Credit scrutiny is too often directed upon the new order for goods rather than upon the circumstances which, after all, are the guarantee of its safety. Close scrutiny alone will reveal whether or not the rules of profit-making are being lived up to, whether there is soundness or deterioration in the business. It is possible in most concerns to prevent entire collapse by discovering and arresting deterioration before it has proceeded to an irreparable stage.

"If we remain alert and develop a skill that can detect when the rosinness of an enterprise is only the hectic flush that is the sign of an unsound constitution, we need not fear deterioration."

### Discuss Capper-Kelly Bill

"An annual burden of more than \$150,000,000 has been imposed upon the American people by the Supreme Court's interpretation of the laws governing distribution of trade-marked merchandise," said W. H. Crichton Clarke, attorney for the American Fair Trade League, in a statement issued recently, "and this great burden will be removed by the enactment of the Capper-Kelly bill, introduced at the opening of Congress."



## Have You A Genola in Your Store?

It's a great little money maker—a child's phonograph that plays all flat records up to 10-inch size with the clear reproduction of a large machine. It is bright and appealing in appearance and makes a hit with both parents and children.

The Genola stands but 7½ inches high. Then there is The Baby Cabinet, standing 17 inches high and which is a delightful piece of nursery furniture as well as a splendid little talking machine.

Order Samples Today

**THE GENERAL PHONOGRAPH MANUFACTURING CO.**

Elyria, Ohio.



*Now Ready*  
**1926**  
*Catalog*



A New Catalog of Good Luck Products including Repair Parts, Main Springs, Motors, Tone Arms and Sound Boxes, etc. The most complete parts catalog ever issued. Illustrated, indexed and uniquely arranged in a new simplified form making a handy reference book and guide for the Dealer and Repairman.

*Don't miss it.—Send for your copy now.*

## **Superior Phono - Parts Co.**

Offices: 799 BROADWAY, NEW YORK

*Operating a factory devoted exclusively to the manufacture of talking machine Repair Parts—everything old and new.*

FACTORY: Newark, N. J.



# The Greatest Line of Ever Offered to

## **KOMPACT** The Camera-Size Phonograph PLAZA MUSIC COMPANY NEW YORK, U.S.A.

Kompact with its full tone quality and volume equal to that of any of the large size portables on the market, attractive appearance, and low retail price, represents a wonderful sales item of irresistible appeal both as a phonograph and a novelty.

The Smallest REAL  
Phonograph Made

*Comes Ready-to-Play—  
nothing to attach or remove*

Plays Standard Records

Size: 5" x 6" x 7½"

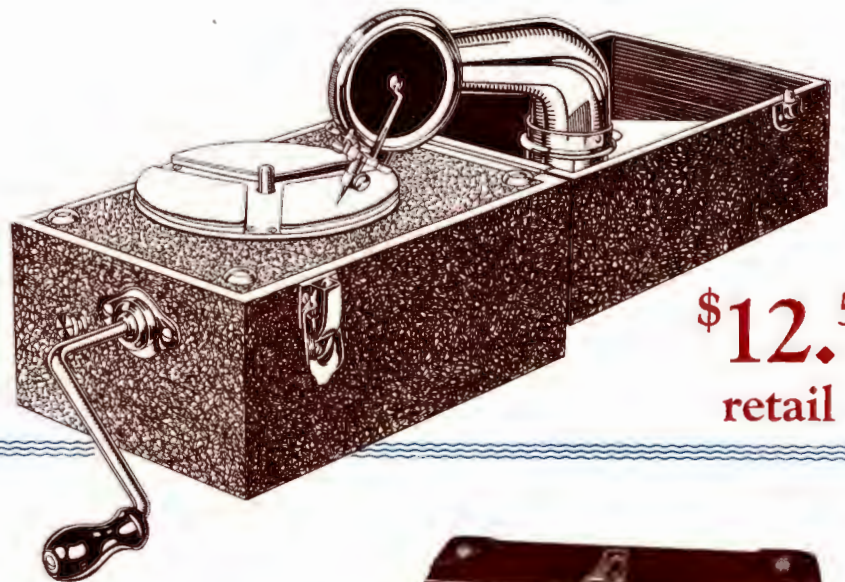

**\$12.50**  
retail!

## *Regal*

Here is a splendid phonograph for those among your customers who do not care to spend more than \$15 for a portable.

Regal has a fine tone quality, plenty of volume, and is sturdily constructed throughout. It is a dandy phonograph—good to look at and good to hear.

**\$15.00**  
retail!



Send Your Sample Order NOW



# PLAZA MUSIC COMPANY



# Portable Phonographs the Music Dealer



## PAL DeLuxe

In smart colors--and  
with 7 points of Superiority

**\$25.00**  
retail!

**Now**—the new DeLuxe Model PAL—smarter in appearance—more beautifully finished in sharkskin fabrikoid, with an embossed cover—but inwardly the same PAL whose superior tone quality has made it the biggest portable in the field.

The new DeLuxe PAL, in smart seal-brown fabrikoid, is available now.

Colors Available in  
February



**10 West 20<sup>th</sup> St., New York.**

FENBERG  
STUDIO



## CAPITALIZE YOUR OPPORTUNITY

### Mr. Victor Dealer

Nothing in life is perfect, therefore we are obliged to pass judgment by comparison. Net results are conclusive and when measuring an industry or a merchant's success, the average net results over a period of time constitute a fair and dependable basis of analysis.

With comparatively few setbacks over a period of twenty years, Victor Dealers have occupied an unusual position, made money, and the net results have been satisfactory. Recently Victor dealers have, by comparison, found the pathway not so smooth. This called for renewed energy, revived salesmanship, and a new product.

The Victor Company have, in the Orthophonic line of Victrolas, both regular and combination, given every Victor Dealer probably the greatest opportunity of his career. It is not that we lack opportunities, but generally that we fail to recognize them or, more seriously, that we neglect them. The Victor Dealer's opportunities at this time carry with them the responsibility to measure up to a standard that will fit him to represent properly a line of Victor instruments ranging in price from \$15.00 to \$1000.00.

Victor Dealers can only capitalize their opportunities by acquiring the knowledge themselves or by employing others with the necessary training to understand and service the Orthophonic Victrolas combined with radio. We believe the Victor factory will give every reasonable opportunity to their distributors and dealers to acquire this knowledge, but the Victor Company is entitled to receive prompt evidence of co-operation to that end.

Sales of pianos ranging from \$500 to \$3500 each are not considered unusual but general, but they are only made possible by the employment of salesmanship combining knowledge and training. So let's stop for a moment, Mr. Victor Dealer, and consider whether the new Victor product coming through the factory this month will find us prepared and competent to fulfill our obligations to the Victor factory. Realizing our own obligation as a Victor Distributor, we have assembled a trained organization, competent to handle the new Victor product and with a knowledge that we will gladly impart to our Victor Dealers.

The new Victor product can and will be sold by dealers competent to do so. Capitalize your opportunity, Mr. Victor Dealer, by preparing yourself in a manner that will not invite into the field others who would be glad to have your opportunity. Victor service hereafter will be a greater factor among Distributors and Dealers, and particularly on the part of Victor Dealers in connection with retail sales.

We welcome the opportunity to fulfill our obligation to our Victor Dealers by helping them in becoming prepared to give proper service.



**Blackman**  
TALKING MACHINE Co.  
28-30 W. 23<sup>RD</sup> ST. NEW YORK N.Y.  
VICTOR WHOLESALE DISTRIBUTORS







# EVERYBODY

**E**VERYBODY wants a Farrand Speaker—the man buying a new receiving set, the fan owning an old one. Everywhere Farrand Speakers are displacing and replacing other speakers. Everywhere Farrand dealers are cashing in on this ever-increasing, every-day demand. Are YOU listed among them? If not, get in touch with your distributor at once and begin reaping profits as you never have before.

FARRAND M'F'G, CO., Inc.  
Thompson Avenue, at Court Street  
LONG ISLAND CITY, NEW YORK

*Farrand  
Speaker*



# *Wants a Farrand!*

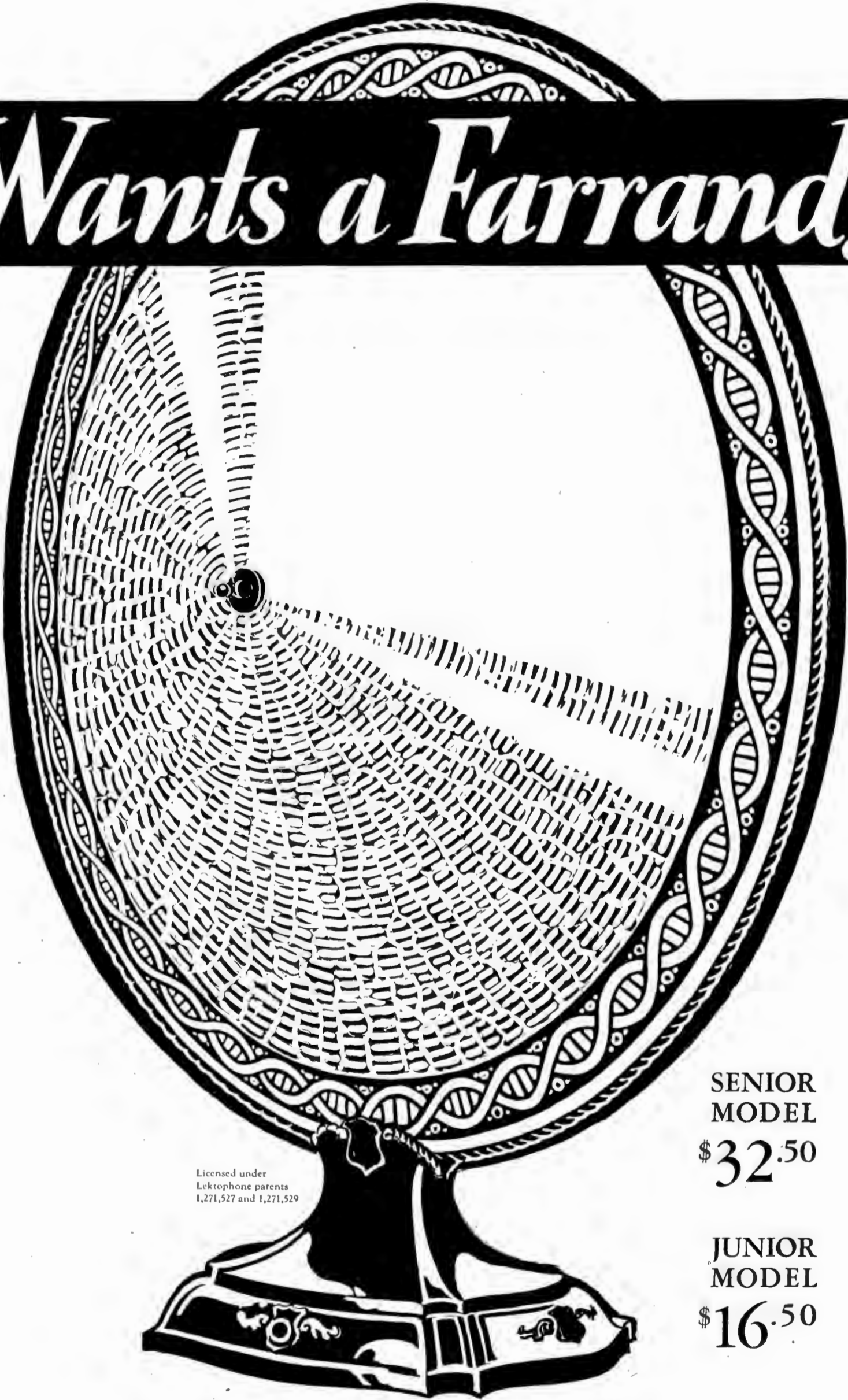

Licensed under  
Lektophone patents  
1,271,527 and 1,271,529

SENIOR  
MODEL  
\$32.50

JUNIOR  
MODEL  
\$16.50



# Elimination of the Radio Trade Problems

Growing Stability of Conditions in the Radio Field Minimizing Profit-Killing Factors Which Dealers Had to Face a Year Ago

By Arthur W. Rhinow

(Arthur W. Rhinow, the writer of this article, is well qualified to express his views on this subject by virtue of his position as publicity manager of the merchandising section of the Kolster division of the Federal Telegraph Co., and his many years' experience in the talking machine field.—The Editor.)

Estimates vary as to the percentage of music dealers in this country to-day handling radio. One thing, however, remains indisputable: The percentage is high and is continuously and rapidly increasing.

Like a vast waste suddenly discovered to contain untold wealth, radio acquired its rudimentary development amid considerable confusion. Be it acknowledged, however, as a stepping stone to permanence and stability that radio has found a haven in the music store and shall probably be anchored there indefinitely.

Figures do not lie when, in spite of the apparent tendency toward the music dealer, we find what are known as electrical and kindred houses doing a growing volume in dollars and cents each year, particularly in the sale of receiving sets. Significance is attached to the fact that it is the firmly established and reputable house that is sharing in this reward. The so-called "fair-weather" dealer is fast fading from the picture and in his place is being built a solid foundation to provide for healthy expansion.

Let us examine more closely this remarkable situation whereby, all rules to the contrary notwithstanding, an industry of immense magnitude actually thrusts itself upon an organization of dealers and proceeds forthwith to revolutionize it. If we can discover why the music dealer in particular has been made the chosen heir, perhaps we can visualize more clearly what the future holds forth to him and to what extent his efforts will be rewarded.

#### Radio Supplies Definite Need

Radio receiving sets to-day are recognized as bearing a growing semblance to the musical instrument. Quality of tone and fidelity to the original rendition, both negligible factors two or three seasons ago, are outstanding features in the current advertising of many manufacturers. Appearance and simplicity of operation likewise demand serious attention now that women represent a large percentage of radio buyers. Insofar as fulfilling a definite need in the home is concerned, the music dealer finds in selling radio an exact parallel to the talking machine. He finds that with radio as with the talking machine he must awaken the desire for entertainment and instruction just as he has

always done in the past in promotion of sales.

Equipped both with the experience and facilities so essential, and usually possessing one of the most attractive stores in town with ample display room and proper surroundings, the music dealer finds himself in a peculiar position to successfully merchandise radio.

#### Well Equipped to Handle Radio

Furthermore, the music dealer knows from experience that no matter how attractive his store, if he is to be successful it is not enough merely that he open the door and expect people

*From the standpoint of merchandising radio the talking machine dealer is in a better position than ever to profit by this branch of his business, according to Mr. Rhinow, of the Federal Tel. Co., who is in a position to speak with authority due to his long connection in the talking machine and radio fields, and his wide knowledge of conditions in retail trade circles. . . .*

to walk in and buy of their own accord. He is accustomed to systematic and intensive house-to-house canvassing and radio moreover requires the bell-ringing method of salesmanship.

Instalment sales are not new to the music dealer. On the contrary, for years he has made a direct bid for business by appealing to the instalment purchaser. He has every facility for making collections, and in many instances has an established connection whereby he can hypothecate his instalment paper.

With radio, the risk due to possible obsolescence is greater than with the talking machine, but if the dealer insists upon a substantial down payment and does not permit the contract to extend over too long a period, he will find a wealth of new business among radio prospects.

#### The Problem of Service

Service. This has been the big bugaboo to the prospective radio dealer. Granted, a novice cannot be expected to repair a receiving set, but neither could a novice be expected to repair a talking machine. Radio requires a certain amount of service. So does a clock need atten-

tion occasionally, and the vacuum cleaner a new part once in a while. A competent radio mechanic is a necessity, but a good man is not difficult to find and can very often pay his own way by making a nominal charge for servicing receiving sets upon which the guarantee has expired.

People are beginning to recognize that radio reception has its limitations and are not prone to be too critical if taught not to expect the impossible of their purchase. True, some dealers with unguarded enthusiasm literally have promised the highly expectant purchaser the earth with a fence around it. Gradual education along these lines supported by organized service on a practical basis will eliminate this difficulty.

#### Possibility of Further Stabilization

Two things remain thus far unaccomplished for complete stabilization of the radio industry. One is the elimination of the "gyp" who continues to prosper in spite of the influence which the legitimate dealer has tried to bring to bear upon the source of supply. The other is the elimination of what is considered as the unfair practice of some manufacturers who "dump" excess merchandise on the market through large retail outlets to be sold at less than the list prices.

A long step in the right direction has been taken by some of the larger manufacturers who maintain a valuable dealer franchise, and who grant dealers not only territorial protection but various guarantees against changes in prices and models.

In the meantime the music dealer is fast recognizing the opportunities which lie before him and will surely emerge a more important factor in his community as a result of his acquisition of radio than ever before.

#### Demonstrates the Panatropo

LITTLE ROCK, ARK., Jan. 7.—A large audience of music lovers attended the recent demonstration of the Brunswick Panatropo at the Hotel Marion, under the auspices of the Hollenberg Music Co., local Brunswick representative. J. H. Bennett and M. C. Schoenly, of the St. Louis office of the Brunswick Co., were in charge of the demonstration. The faithfulness of the reproduction and the volume control greatly impressed the listeners.

Sir Harry Lauder, famous Scotch comedian and Victor artist, recently gave a concert which was broadcast from several British stations. It is understood that he is receiving \$7,500 for a series of three broadcast recitals.

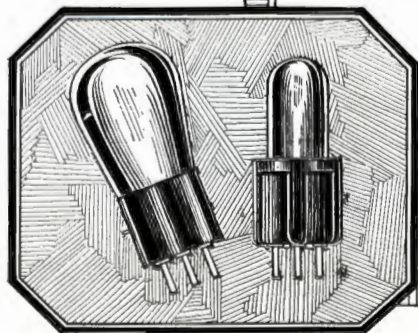

## A New Type of Tube VOLTRON TUBES

AFTER long development we are placing on the market a 5-volt tube with a new filament that is efficient down to 3½ volts.

We want you to test these out and will be

pleased to send you a set of five tubes on your promise to either remit for same or return to us in five days after receipt.

This offer is made only to responsible dealers.

List Price \$2.50

THORNELL-MACLAREN ASSOCIATES 26 Park Place, New York, N. Y.



# RADIOS

## OUT OF THE DARKNESS OF UNCERTAINTY APEX BRINGS ABSOLUTE ASSURANCE OF DEPENDABLE RADIO VALUES

Apex reputation is a wide open book. The reliability—the efficiency—the merit of Apex Radio Receiving Sets is being demonstrated every day—day after day in thousands of homes and every day, every week, every month records a mighty increase in demand. Apex has conclusively proven its value in every phase of operation and upon that proven value is based the preference and the selection of those thousands of radio buyers who want quality beyond question.

No one feature of Apex Radio Receiving Sets has been perfected at the expense

of some other feature. Step by step every feature has been brought to the finest degree of excellence and transformed into one marvelously sensitive instrument that supplies every element to be desired in radio receptivity, combined with rich beauty of appearance.

The few exclusive Apex Dealer Franchises now available will prove of unusual value to dealers who realize the importance of supplying their patrons with radio equipment of proven quality and established reputation. Complete particulars upon request.

### APEX ELECTRIC MFG. COMPANY 1410 W. 59th St. Dept. 117 CHICAGO



Apex Baby Grand Console  
Price \$225



Apex Utility Radio Table  
Price \$75

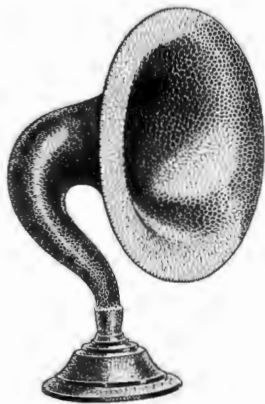

Apex Entertainer, Price \$22.50  
Console Type, Price \$27.50

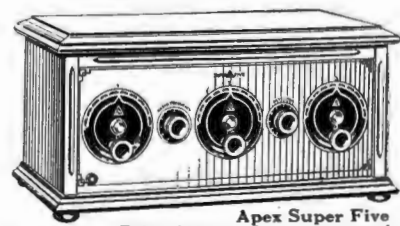

Apex Super Five  
Price \$80—without accessories

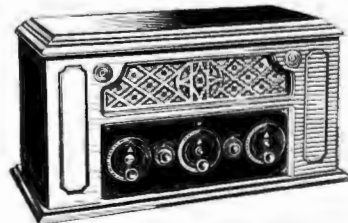

Apex De Luxe Price \$135

Prices West of Rockies, slightly higher.

Canadian prices approximately 40% higher.



# Start the New Year Right on Collections

Firmness Shown During the First Few Months Will Insure the Profits of Holiday Sales — Educate Customers to Pay When Due

To all intents and purposes the holiday business of 1925 is a matter of past record. So far as the talking machine trade was concerned, the volume of business was controlled in no small measure by the ability of dealers to get sufficient goods to meet demands, and in the case of the better known radio receiving sets the same held good. So far as actual sales were concerned, they have been made and closed and dealers are now concerning themselves with maintaining a profitable volume of business during the twelve months of the new year.

Although sales of the closing weeks of 1925 are on the books, in a great majority of cases they will not be officially closed, so far as payment is concerned, for some months to come, just how long depending upon the salesmanship of the dealer, in the selection of customers of proper credit standing, and in the maintenance of terms calculated to make the instalment paper an asset rather than a liability.

## Accounts That Cause Trouble

Credit men of wide experience tell us that the accounts that generally cause most trouble from the collection standpoint are those that are opened during the seasons of holiday buying when there exists a spirit of open handedness and generosity that frequently leads individuals into making purchases that prove more or less of a burden as time goes on and the excitement of Christmas-giving wears out. This has nothing whatever to do with the claims of bankers and others that under the instalment method of selling individuals are inclined to overbuy. It is simply that holiday buyers are more likely to be swayed by the emotion of the moment rather than by cool calculation in the making of purchases and are inclined to cool off as the next year passes by and payments on Christmas purchases still remain to be made.

Experiences of dealers themselves serve in a measure to bear out these statements of credit men, and more than one retailer has found it of paramount importance to give just as much attention to the collection of accounts during the opening months of the new year as he gives to the ways and means for developing and maintaining business.

## How the Dealer Can Protect Himself

Take the case of the talking machine or radio for instance, which is brought into the home for Christmas and provides welcome entertainment. The interest in the new purchase is going to last for a considerable period, and the retailer who capitalizes that interest gets his payments promptly when due during the first few months of the year and works to cut down the balance even beyond the contract figures, where possible, is safeguarding himself against

the inroads that may be made by some new fad or interest.

It is a known fact that the heavier the equity held by the purchaser in an article, whether a musical instrument or something else, the easier it is to make collections on time, for as the equity increases, so increases in direct proportion the amount of money that will be lost by the customer in the event of repossession. Good collecting on holiday accounts during the first few months insures an owner's equity that simplifies materially the problem of the collection department.

The careful watching of credits and of payments, and sharp collecting generally, should be the rule of every retailer who seeks to do an instalment business on a successful and profitable basis whether he handles his own paper or whether he turns it over to a finance company. During most of the year the customer who obligates himself to pay several hundred dollars for an instrument does so without any other emotion than that which develops around the desire to possess the instrument. He does not offer some of the problems presented by the holiday buyer but should be the subject of careful watching regarding collections, nevertheless, for every payment allowed to lag means that much trouble added to the work of collecting.

## Insist on Prompt Payment

An old hand in the instalment business emphasizes particularly the necessity of insisting on prompt payment of instalment moneys due in January and February, basing his contention on the fact that many of the larger department and specialty stores in the metropolitan districts who make a feature of charge accounts seek to stimulate holiday buying by announcing that Christmas purchases will not appear on bills till February 1. It is an easy thing to buy with the idea of paying at a date five or six weeks off, but when these accumulated bills come in, the customer for the moment is likely to be snowed under. The merchant who gets there first and gets his money is going to forestall trouble for the balance of the year.

Methods of collecting instalment accounts, that is, methods that really work successfully, are numerous and varied, and it is probable that a great majority of retailers with any experience have adopted some system that is best calculated to meet the requirements of the business in their own particular localities.

Good collecting, however, cannot depend upon the seasons entirely. While it must be pursued in the early months of the year, when the balance of Christmas funds are available and when bonus money still exists, it is just as essential to follow up accounts carefully during the mid-

dle and end of the year, and particularly when Summer brings the vacation season and the desire to divert available funds into channels of immediate pleasure. By working hard during the first few months of the year building up the owner's equity and keeping accounts fully paid, the retailer enters the Summer with the margin of safety strongly on his side.

## A Costly Error

One outstanding error on the part of many dealers who handle instalment business is the inclination to consider the sale closed at the moment the contract is signed and the instrument delivered, for, even in these enlightened days, there are some who consider the fulfillment of the contract obligation as secondary and a matter of routine. If all retailers doing business on an instalment basis would realize definitely that the sale is not finished until the last payment on the contract has been met and the account closed, there would be far greater effort put into prompt collecting in order to have the sale present that return upon which the dealer bases his calculations for business progress and success.

## Federal Radio Parts Line Catalog Is Sent to Trade

BUFFALO, N. Y., January 6.—The Federal Radio Corp. recently announced a reduction in the price of its line of radio parts, made possible by continued quantity production. The Federal line, which is most complete, is strictly a quality line and has behind it twenty-five years' experience in the engineering and manufacture of sound-transmission equipment. An attractive catalog, illustrating and describing the Federal parts line, has been distributed to the trade.

## Dealers Show Panatropo

WICHITA, KAN., Jan. 6.—The Brunswick Panatropo was demonstrated at the Broadview Hotel here recently by a representative of the Brunswick Co., with the concert being given under the auspices of the P. R. Schul Music Co., and the J. O. Adams Music Co., local Brunswick representatives. The concert made a deep impression on the large audience because of the fidelity of the reproduction.

## Wins Crosley Pedigreed Pup

CINCINNATI, O., January 6.—A pedigreed pup was awarded Otto Glaeser, Jr., of San Antonio, Tex., by the Crosley Radio Corp. as the first prize for a letter on radio reception on a one-tube set during the month of September. Young Glaeser swore, upon his Boy Scout oath, that, within one hour on a one-tube regenerative receiving set, he tuned in forty-two stations.

## Pete Dale at Moulin Rouge

Pete Dale, popular Harmony record artist, is winning a host of new friends and followers by his sterling performances with his seven-stringed ukulele at the Moulin Rouge, Broadway, New York, where he appears nightly.

## Record Corp. Chartered

The Coula Panhellion Records Corp., New York, was recently incorporated at Albany with a capital stock of 100 shares of common stock of no par value. The incorporators are C. Poulos and C. Mayros.

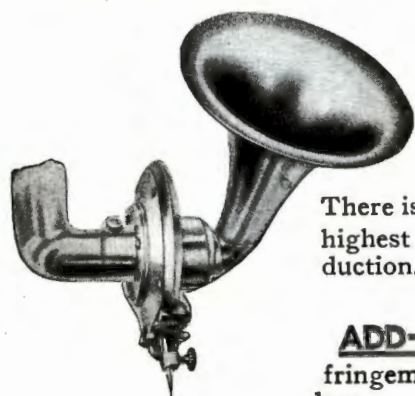

## ADD-A-TONE

*A Revelation In Sound Reproduction*

There is only one **ADD-A-TONE** and it stands for the highest quality of workmanship, design and tone reproduction.

### WARNING

**ADD-A-TONE** patents have been granted. Any infringement will be prosecuted to the full extent of the law.

**UNIQUE REPRODUCTION CO.**  
32 Union Square, N. Y.



**DON'T  
STOP**  
Your Sales Efforts!

When unusual values are offered the public will respond in January as well as in December.

Just because Santa Claus has come and gone is no reason for ceasing to push phonograph sales. Instead of letting up in your sales efforts a strong sales drive right now will bring good results. And here's why. Over a million people, many of them in your locality, received *cash*, in the way of bonuses or gifts, for Christmas. Why not get them to use this cash as a part or complete payment on a Vitanola phonograph.

With such values as these to offer and a little push on the part of your sales force, the job should be easy.



No. 101  
Mahogany or walnut finish; adapted for radio.  
Width, 32"; depth, 21"; height, 33".  
List price, \$75.  
(Discount on dealers' samples 50%)



No. 103  
Mahogany or walnut finish; adapted for radio. Space for record album under tone chamber on right-hand side. (See open view below.) Width, 35"; depth, 23 1/4"; height, 33 1/2".  
List price, \$90.  
(Discount on dealers' samples 50%)



No. 102  
Mahogany or walnut finish; adapted for radio.  
Width, 32"; depth, 21"; height, 33".  
List price, \$80.  
(Discount on dealers' samples 50%)



No. 100  
Mahogany or golden Oak finish; height, 43 1/2"; width, 18"; depth, 20".  
List Price, \$80.  
(Discount on dealers' samples 50%)



No. 103—Open.

**VITANOLA Talking Machine Co.**  
M. C. SCHIFF President  
666 Lake Shore Drive  
LEON C. SAMUELS, Vice-President and Sales Manager  
American Furniture Mart  
Chicago, Ill.



## M. W. Craddock, Mackenzie Corp. General Manager

Appointed to Responsible Post With New York Radio Distributor—Was Formerly Associated With DeForest Radio Co.

M. W. Craddock, for three years associated with the DeForest Radio Co., and for fourteen years a sales executive in the automobile industry, has been appointed general manager of the Mackenzie Radio Corp., radio distributor, with offices at 55 West Thirty-first street, New York. This jobber, although established in its new quarters only a few months, has attained exceptional success and the company's showrooms present a \$10,000 interior decoration display that has been praised enthusiastically by visitors from all parts of the country.

Mr. Craddock is well known in the Eastern radio trade and the sales staff which he has appointed to co-operate with radio dealers is doing an excellent job. The Zenith line is featured by the Mackenzie Radio Corp. as its leader, and during the past few months a large number of the new handsome Zenith Deluxe art models have been sold to prominent dealers in metropolitan territory. Among the other products for which the Mackenzie Radio Corp. is a distributor are the following: Rola loud speakers; Cunningham tubes; Philco power units; Burgess dry batteries; Balkite chargers and other products; Shamrock sets and Acme battery eliminators and loud speakers.

## Effective Atwater Kent Publicity for Windows

Recent Atwater Kent general publicity has taken very interesting form in the shape of a comparison of progress between other days and the present. This advertising copy is well illustrated and describes the progress from the

days of carrying the ice from the ice house in comparison with the present electric refrigerator, the old courier and the telephone in sending messages, the bulky wall clock and the thin pocket timepiece, the old-fashioned fireplace and the modern radiator, the tallow tip candle and the Mazda lamp. In the same way the large radio set is compared with the small Atwater Kent Model 20 compact which can be placed anywhere in the room. As with other publicity this has been produced in giant ad form for display in windows.

## Attachment for Gramophones Invented by a Tasmanian

It is reported by Elmer G. Pauly, American assistant trade commissioner in charge, Melbourne, Australia, that a Tasmanian, Waterworth, has invented an attachment for gramophones which stops any size record, repeats the record automatically and plays a magazine of six records without any attention—playing, stopping and changing each automatically. The inventor has been working on this device for the past eighteen months and will visit Sydney with it shortly in the hope of finding a market.

## Kaufman a Harmony Artist

Irving Kaufman, well-known vocalist, recently joined the roster of artists making Harmony records, which are made by the Columbia Phonograph Co., New York. The first release of this artist couples "The Loneliest Girl in Town" and "Cross My Heart, Mother, I Love You."

## Set Radio Show Date

The 1926 Northwest Radio Show will be held at the Kenwood Armory and Coliseum, Minneapolis, from September 27 to October 2.

## Advice to Dealers on Servicing Orthophonic

"Voice of the Victor" Points Out Necessity of Seeing That Instrument Is in Perfect Playing Condition at All Times

In the December issue of the Voice of the Victor a short article appears which advises dealers to instruct their service department to take special pains to see that the new Orthophonic Victrolas are in perfect condition at all times, either when the instrument is reposing on the floor of the store or when it is finally delivered at the home of the purchaser. It is pointed out that with the new instrument it is more necessary than ever that it be kept in perfect playing condition, for the public has heard so much of its capabilities that to have it out of condition due to some minor adjustment being neglected would do a great deal of harm.

A few of the precautions given dealers are: When the instrument is unpacked have the service man look it over carefully for scratches on the cabinet; have him see that it is properly lubricated and dusted off; have him test the turntable with a good watch; have him see that the sound box is in the proper place and that the door catches and lid supports are in order. Another duty of the service man should be to test the speed of the turntable each morning and see that it is revolving at the proper number of revolutions per minute. This is necessary, as many customers play with the regulator and leave it at some figure far from the correct one.

## James Music Store Moves

James' Music Store has moved to new and larger quarters at 121 North Eighth street, Lebanon, Pa. The opening day was formally observed with entertainment and other features.

All types—including  
Gold Seal High Power  
Tube. \$6.50

Price  
\$2.50



Price  
\$2.50

Insured by exacting  
tests, the matched uniformity  
of Gold Seal Tubes gives supreme  
reception.

## The Radio Sensation of the Year!

**G**OLD SEAL Tube sales have broken all records—setting a new mark of well-deserved success. *Quality* is the reason—quality that results from years of tube making experience and the determination to maintain highest standards. Gold Seal dealers are reaping a profit harvest on Gold Seal popularity. Better join us NOW!

Send today for full details.

GOLD SEAL PRODUCTS CO., 250 Park Ave., New York

# GOLD SEAL Radio Tubes





The  
"Governor"  
magnifies  
his views

"BOYS," said the governor, to the other gears, springs, pinions and shafts, "you're a fine bunch, and we've been working together for a long time—under my leadership."

"Leadership?" questioned the driving shaft, "How come?"

"You heard me! Leadership. You know darn well that the Heineman boys handle me with kid gloves; that they weigh every spring and ball; that my shaft runs true as a die in special phosphor bronze bearings. I control all the rest of you and if I'm off, you're all out of time!"

"Well, can't argue any longer; here comes a record to be played all together now — and come in strong on the Heineman Quality Chorus!"

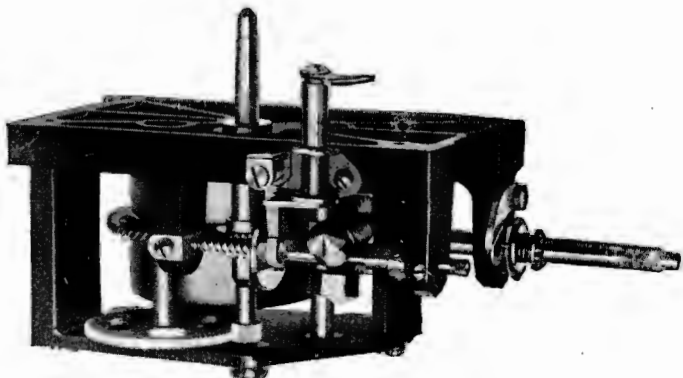

Motor No. 77

*Tom*

The Motor Ad Man

# HEINEMAN *Quality* MOTORS

a product of the

## General Phonograph Corporation

OTTO HEINEMAN, President

25 West 45th Street

New York, N. Y.



### Urges Legislation to Put Curb on Price-Cutting

Samuel J. Bloomingdale, of Bloomingdale Bros., New York, Issues Interesting Statement on Need of Legislation of This Character

In a recent statement on the subject of the need of price maintenance legislation, Samuel J. Bloomingdale, of Bloomingdale Bros., prominent New York department store, says that such legislation would encourage rather than stifle competition as many contend. The statement in part reads:

"The necessity for price maintenance legislation arises from the abuse of price-cutting on trade-marked articles as a bait to the public. Such price cutting is an evil—it is an abuse—it is in a class with false advertising. It gives no advantage to the public because the loss is made up on other goods. While some stores submit to the practice because it is so prevalent, others make it their chief policy and use it to mislead the public in the belief that by cutting the price on a few trade-marked articles, the same policy prevails on all other merchandise in the store. If that were true, then such a store could not exist. The contrary, therefore, must be true. And the fact must be, that what small loss may be sustained at the expense of a few trade-marked articles is more than made up in the price of non-branded articles.

"Why should clean business lend itself to such a practice? Why can it not afford to be honest with the public and let the public decide for itself whether it will buy branded articles at fixed prices or non-branded articles at competitive prices?

"Instead of stifling competition, price maintenance legislation will encourage competition. If such legislation is enacted, no store could then use price-cutting as a bait and as a cloak for the sale of other merchandise. There is a difference between price-cutting and sale

prices. Price-cutting is constant and consistent, and is used for the purpose of misleading and fooling the public, and as a bait, while sale prices are for the purpose of clearing stock or as a result of special merchandising. The former is unfair competition, while the latter is fair competition."

In conclusion, Mr. Bloomingdale said:

"The important benefit to the public from price legislation, and which cannot be overlooked, and which outweighs all fears, is the fact that it will eliminate a fraud now being foisted upon the public by unfair price-cutting, and the use of it as a bait."

### Movie Slides Feature the Orthophonic Victrola

The Manhattan Slide & Film Co., which maintains a motion picture slide service for Victor dealers, has included four new slides featuring the Orthophonic Victrola. This form of advertising is being used by a great many Victor dealers with satisfactory results.

### Columbia Dealer Service

A. H. Purden, dealer service manager of the wholesale division of the Columbia Phonograph Co., New York, is co-operating with dealers in dressing their windows attractively and is visiting various stores installing displays proclaiming the merits of Columbia products.

### M. Grass & Son in New Home

M. Grass & Son, Victor dealers, are now installed in new and larger quarters at 27-29 South Sixtieth street, where a complete line of Victor products, pianos, radio receivers and other musical instruments are carried. The opening ceremonies were held the latter part of last month and appropriate souvenirs were distributed.

### Christmas Party at the General Phonograph Corp.

Otto Heineman, President of the Corporation, Guest of Honor—Okeh Artists Furnish Musical Entertainment at Yuletide Festivities

The employes of the General Phonograph Corp., 25 West Forty-fifth street, New York, held their annual Christmas party on December 21, using the offices on the twelfth floor for the scene of their festivities. The floor was attractively decorated with Christmas coloring and an interesting program was prepared by the committee in charge of the event.

The dance music was furnished by Clarence Williams, popular composer and pianist and an exclusive Okeh artist, assisted by several members of his own organization as well as other prominent Okeh artists. Among the artists who appeared at the Christmas party, in addition to Mr. Williams, were Shelton Brooks, popular composer, pianist and singer, who has toured for many years on the Keith vaudeville circuit; Buddy Christian, banjoist, and Clarence Todd, singer. Dance music and solo numbers were furnished by the artists, who were given an enthusiastic reception by the employes of the organization.

Otto Heineman, president of the General Phonograph Corp., was the guest of honor at the party, but with his usual good fellowship forgot all about the formality of the event and was an active leader in all of the festivities. As December 20 was Mr. Heineman's birthday the party on Monday was a dual event, permitting the employes to celebrate Mr. Heineman's birthday and also the approaching Christmas holidays. The girls at the executive offices as well as the department heads presented Mr. Heineman with handsome birthday remembrances indicative of the esteem and affection in which he is held by every member of his organization.

## EMPIRE UNIVERSAL TONE ARMS AND REPRODUCERS

Excel In Every Important Feature



Empire Radio Phono Tone Arm

It is an acknowledged fact that the tone arm and reproducer are the most vitally important parts of a phonograph.

With no other equipment can you bring out the clearness and sweetness of tone that EMPIRE will accomplish. And it is tone quality and excellence of reproduction that make one phonograph better than another, and make it sell in greater volume.

EMPIRE Tone Arms and Reproducers are made for all types of phonographs, from the portables to the big, handsome cabinet machines and the combination Radio and Phonograph.

Order a sample arm and test it out. It will win you on merit only. Our prices are low and quality second to none.

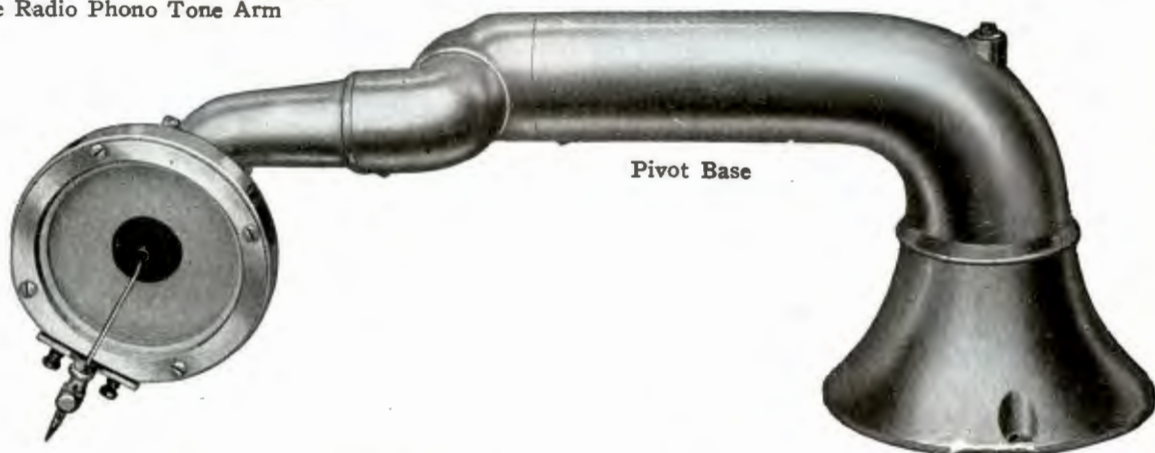

Pivot Base

EMPIRE PHONO PARTS COMPANY 2261 East 14th St., Cleveland, O.

Established in 1914

W. J. McNAMARA, President





## "Let's Take a Chance"

You have heard that said many times, but don't make the mistake of taking too many chances yourselves.

Your radio shipments deserve more reliable protection than they get from pasteboard or corrugated boxes.

The phonograph trade does not believe in taking chances. That is why Atlas Plywood Packing Cases have been standard in the talking machine trade for over twelve years.

Atlas Cases give full protection, are strong and rigid and are quickly assembled. Although they save freight by their extreme lightness, they insure complete protection to the finish of your cabinets and the delicately tuned apparatus within.

Submit your size requirements and we shall be glad to offer suggestions and advice based upon many years of practical experience.

## Atlas Plywood Corp.

PARK SQ. BUILDING

BOSTON, MASS.

*Largest Manufacturers of Box Shook in New England*

### Music Master Line Shown in Salt Lake City Display

Radio Hardware Co. Devotes Two Large Windows to Attractive Presentation of Fifteen Items of Music Master Line

If a dealer were to cover the windows of his store with boards and depend entirely upon the purchase for customers to enter and make purchases, he would be regarded as being not in full possession of his senses, yet the dealer who



Music Master Display of the Radio Hardware Co.

is not taking proper advantage of his display space is in a similar position with the one who would board the windows entirely. The "eye of the store" is a twenty-four-hour-a-day salesman and neglect of this medium of attracting customers through attractive displays is a deliberate throwing away of profits. It is not necessary to go to any elaborate preparations to get the desired effect. Neatness and simplicity in many cases are all that is necessary, as is evidenced by the accompanying photograph of the Radio Hardware Co., of Salt Lake City, Utah, which devoted its two windows to a showing of Music Master receiving sets.

It can be seen that although fifteen different items of the Music Master line are shown artistically there is no effect of crowding. These windows are viewed daily by thousands and the Radio Hardware Co. reports a gratifying result in sales attributed directly to the displays.

### Safety Talks for Children

CINCINNATI, O., January 6.—Station WLW, operated by the Crosley Radio Corp., has inaugurated a series of talks on safety which are being broadcast during the children's hour at 7:30 each Saturday evening. The talks are being given by such authorities as traffic policemen, school superintendents, traffic judges, fathers and children themselves.

The Kincaide Furniture Store, recently opened at 44-46 Billings road, Norfolk Downs, Mass., is carrying a full stock of radio receivers.

### Redi-Mast Aerial Being Introduced to the Trade

Pressed Metal Mfg. Co., of Waukesha, Wis., Is Manufacturer of the New Device—Effective Sales Aid for Dealers' Use

The Pressed Metal Mfg. Co., of Waukesha, Wis., is introducing to the trade at the present time a new type of aerial, known as the Redi-Mast, a product which has met with immense favor wherever it has been shown. The Redi-Mast is furnished complete, ready to install, and is adjustable for all types of roofs, either on houses or apartment dwellings. The aerial consists of a five-foot mast made of sturdy timber with a ferrule and roof lag-screw secured to the bottom, tripod guys of strong steel with patented adjusting devices, and the necessary hardware, which includes an aerial pulley, mast nebs, roof socket and anchor pins.

The tripod guys allow easy adjustment for any location on hip or gable roofs, and in some cases the Redi-Mast has been attached to the side of the building. It will give way slightly in a strong wind, a feature which helps to reduce static. Where single mast installations are desired on apartment buildings or hotels, an outrigger is used which allows for clearance over wide gables and other obstructions. The Redi-Mast is said to be a boon to radio set owners in cities, as it can be easily taken down, moved, and erected again as city dwellers change residences.

The Pressed Metal Mfg. Co., has prepared for dealers an exceptionally fine sales aid in the form of a window or show counter display. It consists of a nickel-plated miniature named "Little Redi", modeled exactly like the Redi-Mast, complete with a green shingled roof and all attachments.

### Make the Deaf Hear

Experiments were made at the American School for the Deaf with a machine which is in the nature of a combination of the phonograph and radio, with head piece and speaking-tube attachments, enabling pupils who never before had heard a sound to hear not only the voices of the speaker but their own voices as well. An eighteen-year-old girl considered totally deaf since four years of age was enabled to hear and speak her own name for the first time.

### New Sterling Voltmeter Is Introduced to Trade

Designed Specifically for Use With Radiola Models 25 and 28—Has Several Attractive New and Outstanding Features

CLEVELAND, O., January 5.—The Sterling Mfg. Co., maker of radio apparatus, recently placed on the market a new filament voltmeter designed specifically for Radiola Models 25 and 28. Through the use of this voltmeter, tubes are operated at the correct voltage, assuring the quality of reception and avoiding the waste of "A" battery energy. One of the outstanding features of the Sterling R. 25-28 filament voltmeters



Sterling Voltmeter in Use

is that when inserted it is unnecessary to give any attention to polarity. The leads from the meter are floated within the case, so that they readily find their centers in the jacks, compensating for any variation on the part of the manufacturer who made the cabinet.

### Bailey's Music, Inc., Opens

SPOKANE, WASH., January 7.—The formal opening of the new establishment, Bailey's Music, Inc., was held recently and more than 2,000 attended. Entertainment was provided by the Fred Hartley Orchestra and local vocalists and a concert was given on the Orthophonic Victrola.

A large number of talking machine and other dealers attended and greatly enjoyed a recent demonstration of the Panatrope made by C. L. Salter, Southeastern representative of the Brunswick Co., at the famous Seminole Hotel, Jacksonville, Fla. The demonstration aroused a lot of enthusiasm, and Mr. Salter promised that ample stocks of the new Panatrope would be in the hands of dealers at an early date.



# ADLER-ROYAL

*Phonograph and Radio*



Model No. 10  
*Combination Phonograph and Radio*



Model 200S  
*Console Radio Speaker*  
\$50



**T**HIS new Console Radio Speaker contains a patented feature, exclusive to Adler-Royal, which enables it to distribute the music or voice throughout the entire room instead of sending it in one direction only.

Comes in combination finish to harmonize with either mahogany or walnut receiver. Ample space for batteries and charger. Complete with vibrating armature type unit with mica diaphragm, cord and plug.

**P**HONOGRAPH and radio are effectively combined in the beautiful Adler-Royal creation here shown. The price of Model 10 (a 5 tube Neutrodyne Radio-Phonograph with Amplion loud speaker unit) is, without accessories . . . \$275.00

**DISTANCE**—Keen sensitivity is a characteristic of Adler-Royal, assuring extremely long-range performance.

**SELECTIVITY**—You can tune in station after station—clear and sharp—with no interference from those stations you do not wish to hear.

**TONE**—The full tone volume and natural tone quality is the result of over a quarter of a century of successful experience in piano and phonograph manufacture.

*Ask us about the Adler-Royal sales and advertising service which will equip you to secure business: it includes window display, newspaper advertising, printed matter, circularizing, etc.*

**ADLER MANUFACTURING CO.**  
881 BROADWAY . . . . . NEW YORK CITY

*Factories: LOUISVILLE, KY.*



## Dallas Dealer's Collection System Keeps Past Due Below the Five Per Cent Mark

Simple and Inexpensive Collection System in Use by the Will A. Watkin Co., Live Dallas, Tex., Dealer, Proves Its Worth by Keeping Delinquent Accounts Down to a Low Figure

A collection system that holds the past due to between 2 and 5 per cent and does not necessitate the employment of any collectors, the entire process being completed by mail, is in use by the Will A. Watkin Co., Dallas, Tex., and has been proved most successful over a long period of years.

There is nothing elaborate about the plan. An applicant for credit is asked for the following information which is listed on a filing card: Name, residence address, mail address, former address, single or married, business or occupation, home telephone, how long in present position, salary, how long in city, do you own your own home, rating, account recommended by, ref-

erences and the amount that the applicant will pay monthly. Information is also secured as to whether any other merchant or establishment is extending credit to the applicant and whether or not the applicant has ever been refused credit and by whom. The applicant's credit limit is also noted. These cards are divided into two classes, city and out-of-town customers, different colored cards being used.

The applicant's credit standing is looked up in the city's credit books and should he not be listed the following letter is sent out to the references given:

"Dear Sir:—Enclosed we hand you a stamped envelope and ask in the strictest confidence if you would consider ..... a safe credit risk for the unsecured

ville, Ark., WIBQ, F. M. Schmidt, Farina, Ill., KFQT, Texas National Guard, Denton, Tex., WAAC, Tulane University, New Orleans, KFDH, University of Arizona, Tucson, Ariz., WGBW, Valley Theatre, Spring Valley, Ill., WBBG, Irvington, Vermilya, Mattapoisett, Mass., WRHF, Washington Radio Hospital Fund, Washington, D.C., and KFKQ, B. H. Woodruff, Conway, Ark.

## Gennett Record Sales for December Show Increase

The New York headquarters of the Starr Piano Co. reports that sales of Gennett records for the past month show a material increase over the volume of sales for the same month of last year despite the fact that the anthracite coal mine strike in Pennsylvania affects greatly this territory, which had previously been one of the best sales sections for Gennett records. The increase over November was great and was confined to no one particular type of record, all showing activity. The Irish recordings were in most demand.

The music department of the Daniels & Fisher Stores Co., Denver, Col., recently opened a small goods department. This is an innovation, as formerly this store had never carried any musical instruments but talking machines and radio receivers.

amount of \$....., payable about \$..... monthly. We attach no responsibility to you in this inquiry and will hold your reply confidential.

Respectfully,

Please reply on the space below.

The usual statement of balance due is sent to customers about the first of each month and should it be necessary to write again before the payment is received a brief businesslike reminder is sent, in the form outlined below:

When we entered into a contract with you we expected, naturally, the prompt fulfillment on your part.

The margin of profit which we allow ourselves demands that the payments be made promptly on the date promised.

We thank you therefore for your check at once.  
Will A. Watkin Co.

Amt. Due: \$.....

In the great majority of cases this letter suffices to bring in the payments from delinquents. Should it fail, however, letters appealing to the customers' sense of justice are sent and, as said before, the percentage of past due is very small considering the large volume of business done each year by the company.

## Twenty-Six Broadcasting Stations Are Eliminated

Eight New Broadcasting Stations Have Been Licensed to Operate

WASHINGTON, D. C., January 5.—The Department of Commerce recently issued an announcement stating that during the month of November twenty-six class A broadcasting stations came off the air and eight new stations were licensed to operate. This makes the total number of broadcasters 553. The list of stations which turned in their licenses were:

WCAZ, Carthage College, Carthage, Ill., KFMV, The L. A. Drake, Battery and Supply Shop, Santa Rosa, Cal., KFRZ, the Electrical Shop, Harrington, Neb., WEBA, the Electrical Shop, Highland, N. J., WNAR, the First Christian Church, Butler, Mo., KFGX, the First Presbyterian Church, Orange, Tex., WKAP, Dutee Wilcox Flint, Inc., Kranston, R. I. WQAC, Gish Radio Service Amarillo, Tex., KFFV, Grace-land College, Lamonie, Iowa, WBBU, Jenks Motor Sales Co., Monmouth, Ill., KRQC, Kidd Bros. Radio Shop, Taft, Cal., KFRX, J. Gordon Klemgard, Pullman, Wash., WDBQ, Morton Radio Supply Co., Salem, N. J. KFIO, North Central High School, Spokane, Wash., WBBA, Plymouth Congregational Church, Newark, Ohio, KFAW, Radio Den, Santa Ana, Calif., KFXV, Radio Shop, Benton-

## R. E. Tongue & Bros. Co., Inc., Adds to Motor Fleet

Rapidly Growing Federal Ortho-sonic Demand Requires Special Delivery Service

To more efficiently serve the Philadelphia and suburban radio trade, R. E. Tongue & Bros. Co., Inc., has added special delivery trucks to



R. E. Tongue & Bros.' Truck

quickly supply the Federal Ortho-sonic radio retailers with Federal sets.

"Trucks are being operated day and night," said R. E. Tongue, Jr., in a recent interview. "Our Federal retailers require quick deliveries of this line, and only by adding more transportation equipment could we promptly serve our retailers to the best advantage."

As exclusive wholesalers of the Federal Ortho-sonic radio receivers, R. E. Tongue & Bros. Co. have enjoyed a very profitable radio business. They have every confidence that the demand for the Federal line will continue unabated in 1926.

## Columbia Recording Takes Prominent Place on Bill

During Christmas week patrons at Warner Bros. motion picture theatre, Broadway, New York, were astounded and greatly pleased to hear a chorus of thousands of voices singing "Adeste Fideles" as one of the features of the program. Consultation of the program gave nothing but the title "Phantom Chorus." The fact of the matter was that the Columbia recording was made by the Associated Glee Clubs and the audience at the Metropolitan Opera House at the convention of music clubs some months ago. The reproduction was amplified by loud speakers and the voices could be heard distinctly through the entire theatre.

The Scott-Kelly Furniture Co., Memphis, Tenn., recently added considerably to the floor space occupied and also completed renovations.

*At Our St. Louis Mill  
we have two million feet of  
dry walnut lumber*

In this large stock we have several items of special lengths and thicknesses that are particularly adapted for radio cabinets.

**THE PICKREL WALNUT CO.**

St. Louis, Missouri

*Exclusive Manufacturers of Walnut Lumber*



# PERRYMAN P RADIO TUBES

*"Distance without Distortion"*



## Here's the Service that helps you sell PERRYMAN Tubes

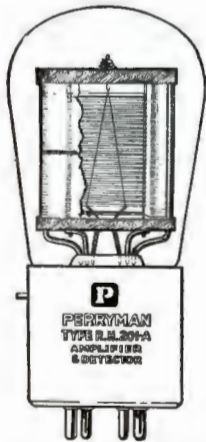

Clear Glass Demonstrating Tube, showing internal construction of Perryman Type R. H. 201-A.

The filament, plate and grid are held in permanent parallel alignment at the point of greatest efficiency by two bridges, top and bottom. You can't shake them apart. Notice the spring catch which holds the filament in position and allows for expansion and contraction with changing heat conditions. You can see at a glance that this tube will deliver the best results obtainable for the longest possible period of time.

Perryman Type R. H. 201-A  
Perryman Type R. H. 199  
(Standard and Miniature Base)  
Perryman Rectifier  
\$2.50 each

Use the sales material we give you free of charge. It is securing a fast turnover wherever it is displayed.

The Perryman Window Display makes them stop, look and come in. The Perryman Counter Display with its clear glass demonstrating tube tells them more at a glance than you could tell them in an hour. It sells them the tubes because it satisfies their common sense.

When they ask your opinion all you have to say is, "We carry these tubes because we think they're mighty good. Put them in your set and try them out. If you don't like them bring them back."

That's fair enough. Isn't it?

Do you wonder that the better dealers and jobbers are handling Perryman Tubes?

*Wholesalers, Dealers and Manufacturers are cordially invited to write us for full information about Perryman Tubes.*

---

# PERRYMAN

LABORATORIES AND PLANT  
NORTH BERGEN, N. J.

# ELECTRIC CO., INC.

SALES AND EXECUTIVE OFFICES  
33 W. 60th ST., N. Y. C.

---



## Demonstration of the New Zenith De Luxe Receiving Set Before a Select Audience

Latest Product of the Zenith Radio Corp. Brought to Attention of Distributors and Press in Special Demonstration in Vanderbilt Hotel, New York—Has Ten Tubes and Built-in Speaker

At the Vanderbilt Hotel, New York, on Friday evening, December 18, there was held an interesting and convincing demonstration of the new Zenith De Luxe receiving set, the latest development in the products of the Zenith Radio Corp., Chicago.

The new Zenith set uses ten tubes, has built-in loud speakers of distinctly high quality and, being elaborately cased, actually lives up to

for ordinary tuning, a supplementary dial being available when particularly fine tuning is desired.

The hotel, being located in the heart of New York, naturally added to the difficulties of proper demonstration, but the new Zenith overcame the difficulties in good shape and offered reception that was impressive for the high quality, particularly in the lower tones and in the reproductions of the consonants in speech, recognized as difficult tests.

During the course of the evening an interesting talk was made by Thomas M. Pletcher, vice-president of the Zenith Radio Corp. and one of the most prominent members of the music industry. Mr. Pletcher, who numbers among his friends dealers from coast to coast, outlined briefly the exceptional co-operation that was being

offered to Zenith dealers by the company in connection with its new product. As a pioneer in the music industry, Mr. Pletcher was in a position to make logical comparisons between the merchandising of radio and music products, and in pointing out the distinctive merits of the Zenith De Luxe line, he gave the members of the press and the jobbers an adequate idea of the Zenith sales policy for 1926.

There were present at the demonstration representatives of the press and local distributors for the Zenith line, including Mrs. L. M. Green and Lloyd L. Spencer, of the Silas E. Pearsall Co.; Herbert Weil, of the Herbert-John Corp., and M. W. Craddock, of the Mackenzie Radio Corp. In addition to Mr. Klugh, who conducted the demonstration, the Zenith Radio Corp. was represented by Wm. J. Gaynor, of the Zenith sales staff; A. G. Linsig, export manager; A. E. Pierce and G. W. Yomans, engineers.



Those Present at First Demonstration of New Zenith Receiver

the term "de luxe" as applied to it. The demonstration was conducted by Paul B. Klugh, of the Zenith Radio Corp., who explained that the new receiver had been so designed as to represent a permanent purchase, in that it was calculated to meet the broadcast receiving requirements of the future as well as of the present. The outstanding features of the set are: first, quality of reception; second, a high degree of selectivity, which had become increasingly necessary with the growth of a number of broadcasting stations, and third, wide range in the matter of wave lengths. The receiver is designed to respond to any wave length from 80 to 600 meters, this wide range being considered particularly desirable in the belief that the Government will lift the restrictions on broadcasting stations in the near future and allow them to use wave lengths of from 100 to 200 meters. A single dial suffices

## Art Gillham's Columbia Records Score in Texas

Famous "Whispering Pianist" Heard by Thousands Through Concerts and Radio Broadcasting in Prominent Cities

SAN ANTONIO, TEX., January 5.—Art Gillham, nationally known as the "Whispering Pianist", who recently signed a five-year contract to make Columbia records exclusively, was a much welcomed visitor to this city, recently, where he gave three public concerts, in addition to two radio programs over WOAI. Probably Mr. Gillham was heard by more than a thousand people at the Fox Co., the King Furniture Co., and the San Antonio Music Co., where, at all three places, he was given a hearty welcome. Mr. Gillham is making a short tour to introduce some of his new pieces, "Let Us Waltz As We Say Goodbye", "Loving Just You", "Since You



Art Gillham

Called Me Sweetheart," and "If You Leave Me I'll Never Cry".

Previous to coming to San Antonio Mr. Gillham gave similar public recitals in Houston and left here to go to Dallas that night, where he had another engagement before leaving the state. That his records are greatly appreciated was ably shown by the hearty applause he received, as well as the many requests for his pieces. Phonograph owners in this state will look forward with keen anticipation to the announcement of his new records and there is every expectation that the sales in these parts will be very good.

The recitals at Houston and San Antonio were under the auspices of J. O. Elliott, local representative for the Columbia Co. While at Dallas, the recital was handled by F. R. Erisman, branch manager.

## Observe 75th Anniversary

F. & R. Lazarus & Co., Columbus, O., have entered into the seventy-fifth year of their existence and elaborate plans are being made to celebrate the diamond anniversary of the concern at various times during the year. A mammoth street carnival was held on New Year's Eve to usher in the jubilee year and on the following night the Lazarus Diamond Jubilee program was broadcast from station WAIU.

## Open Store in Quincy

QUINCY, ILL., January 4.—Crocker & Ewalt have opened a new music store at 111 North Fourth street, this city, handling a full line of pianos, phonographs and radio. Special booths have been installed for demonstrating the various types of instruments and the store has been decorated most attractively.

*Okeh and Truetone*

*Needles*

*sales insurance for*

**1926**

GENERAL PHONOGRAPH CORPORATION

OTTO HEINEMAN, Pres.

25 West 45th Street

New York, N. Y.



# To MAGNAVOX Dealers

Here's an Exclusive Sales Maker for You!

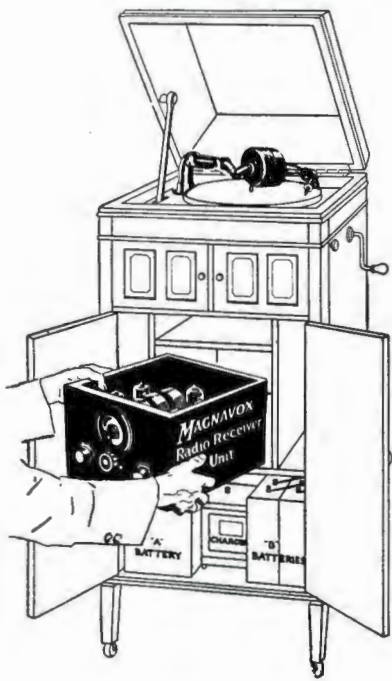

WITH the new Magnavox Radio Receiver Unit, changing the old phonograph into a radio-phonograph combination is the work of only a moment. No mechanical skill is required. No tools, except perhaps a screw driver, are necessary. The illustrations show how easily and simply both console and upright models can be Magnavox Radio equipped.



Merely take out the record shelves, slide in the self-contained Magnavox Receiver Unit, batteries, charger, etc., attach the Magnavox Radio-Phonograph Reproducer, and the work is done.

ROUGHLY estimate the number of phonographs in your territory. Magnavox now offers you a new product which you can sell to every owner.

It's the new Magnavox Single Dial, 5 tube, self-contained Receiver Unit for phonographs which retails for \$75.

Study the illustrations above. These show the ease and simplicity of installation in both console and upright models. Isn't this the most obvious and inexpensive means you have seen for turning your customers' phonographs into combinations?

And in addition you can sell the Magnavox Radio

Phonograph Reproducer at \$10, making two profitable sales in one.

This radio installation will appeal instantly to your customers. It solves the problem of their old phonographs. It makes them up-to-date and modern in every respect; a source of universal home entertainment from both air and record.

Of course we have told enough for you to see the profit-making possibilities. Of course you will want to order a supply and get busy on selling these units at once. Your distributor will work right with you and furnish special literature and other selling helps. Write or wire him today.



Magnavox Perfected Single Dial Control  
(Licensed under Hogan Patent 1,014,002)



MAGNAVOX 75  
Five tube tuned radio frequency set. Built-in Magnavox Loud Speaker; encloses all batteries. Artistic mahogany cabinet, hand rubbed finish. Price, without tubes or batteries, \$200



MAGNAVOX JUNIOR  
Same circuit as Magnavox 75, but not removable from cabinet. A compact, portable set. Price \$85

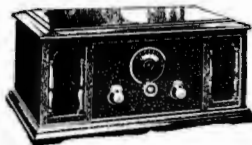

MAGNAVOX 10  
Table model, allowing enclosure of B batteries, operating with external loud speaker. Artistic cabinet finish. Price, without tubes, batteries or loud speaker, \$110



MAGNAVOX 25  
Table model, Magnavox Built-in Loud Speaker, enclosing B batteries, exposed dial panel. Price, without tubes or batteries, \$145



MAGNAVOX M-3 Loud Speaker  
Magnavox Loud Speakers combine all factors essential to perfect reproduction. The M-3 has a 16 inch bell. Price \$25



MAGNAVOX M-20 Cabinet Loud Speaker. Especially adapted for use with Magnavox Model 10 Radio Receiving Set. Price of the M-20 Cabinet Model including cord and plug is \$25

NOTE! If you are not now a Magnavox dealer, but want to get in on this new profit maker, write us at once. If your territory is still open we will make you a mighty interesting proposition by return mail. Don't put this off. Write today!

THE MAGNAVOX COMPANY

OAKLAND, CALIFORNIA

1315 So. Michigan Ave., Chicago



Okeh  
and  
Odeon  
Records

A  
Complete List  
of  
**Okeh**  
and  
**Odeon**  
Distributors

WALTER S. GRAY COMPANY  
926 Midway Place, Los Angeles, Calif.

WALTER S. GRAY COMPANY  
1054 Mission St., San Francisco, Calif.

L. D. HEATER  
469½ Washington St., Portland, Ore.

TEXAS RADIO SALES COMPANY  
411 North Harwood St., Dallas, Texas

JUNIUS HART PIANO HOUSE, LTD.  
123 Carondelet St., New Orleans, La.

CONSOLIDATED TALKING MA-  
CHINE COMPANY  
1121 Nicollet Ave., Minneapolis, Minn.

JAMES K. POLK, INC.  
181 Whitehall St., Atlanta, Ga.

THE ARTOPHONE CORPORATION  
1103 Olive St., St. Louis, Mo.

THE ARTOPHONE CORPORATION  
804 Grand Ave., Kansas City, Mo.

CONSOLIDATED TALKING MA-  
CHINE COMPANY  
227 W. Washington St., Chicago, Ill.

CONSOLIDATED TALKING MA-  
CHINE COMPANY  
2957 Gratiot Ave., Detroit, Mich.

BUEL-LYONS COMPANY  
1231 Superior Ave., Cleveland, Ohio

STERLING ROLL AND RECORD  
COMPANY  
137 W. 4th St., Cincinnati, Ohio

PHONOLA CO., LTD., OF CANADA  
Elmira, Ont., Canada

IROQUOIS SALES CORPORATION  
210 Franklin St., Buffalo, N. Y.

EVERYBODY'S TALKING MACHINE  
COMPANY  
810 Arch St., Philadelphia, Pa.

GENERAL PHONOGRAPH CORPO-  
RATION OF NEW ENGLAND  
126 Summer St., Boston, Mass.

GENERAL PHONOGRAPH CORP.,  
(New York Distributing Division)  
15 W. 18th St., New York City

JAMES K. POLK, INC.,  
811 West Broad St., Richmond, Va.

Okeh  
and  
Odeon  
Records

### Don C. Preston Purchases Store in San Bernardino

Live Dealer Purchases Stock and Fixtures of the Columbia Music Co., and Victor Stock of the Fooshee Furniture Co.

BAKERSFIELD, CAL., January 6.—Don C. Preston, leading music dealer of this city, who also conducts a store in Taft, has further expanded and through the purchase of the Columbia Music Co., San Bernardino, with all its stock and fixtures, together with the entire stock of Victor talking machines and Victor records of the Fooshee Furniture Co., of that city, has assumed a leading position in retail circles in San Bernardino. The Preston establishment in the new territory will be located in the quarters formerly occupied by the Columbia Music Co., at Third and E streets.

John Macdonald is associated with Mr. Preston in the new store and he will act as manager. He has had a wealth of experience in the retailing of musical instruments and opened and managed the Preston establishment in Taft.

The talking machine lines carried in the Preston stores include the Victor, Brunswick, Columbia, Sonora and Emerson.

### German Recorded Good Will Messages Broadcast

Panatrope Method of Reproduction Used in Broadcasting Messages Throughout America—Leading German Statesmen Heard

Voices of Germany's leading statesmen urging "peace on earth" were heard in many parts of the United States in a Christmas greeting by radio from the German Republic to the American people. By means of the Panatrope method of reproduction, the addresses, actually delivered in private and recorded on wax in Berlin, Dec. 9, were broadcast through WRNY, the Radio News Station in the Hotel Roosevelt, and simultaneously through the Westinghouse chain of stations in Pittsburgh, Chicago, Springfield, Mass., and Hastings, Neb.

This was the first time a special program produced in Europe by statesmen, artists and other famous personages had been broadcast in this country. So clearly did the Panatrope reproduce the voices that it was impossible for a listener in to detect that the speakers and singers were not actually before the microphone. Through the Foreign Institute in Stuttgart, arrangements for this new kind of record of an original German broadcast were made by Stanley McClatchie, an American radio engineer living in Germany.

The program included addresses by Dr. Karl Stresemann, Minister of Foreign Affairs of the German Republic; Dr. Paul Loebe, President of the Reichstag; State Secretary Bredow and Dr. Hugo Eckener, pilot of the ZR-3, now the Los Angeles, on her transatlantic flight to America. Clare Dux and Cornelius Bronsgeest, of the Berlin State Opera, sang solos and a duet, and J. Berger, 'cellist, played.

All the speeches were delivered in German and the English translation afterward broadcast by WRNY's announcer.

### Suggests New Records for Demonstrating Orthophonic

One of the cheering results of the introduction of the Orthophonic Victrola with dealers throughout the entire country has been the increase in record sales. Customers who have been astounded by the fidelity of the new instrument see the improvement in records, and while they are unable to secure the Orthophonic at the time, have started to build up their record libraries. The Voice of the Victor, in order to foster in every possible way this demand for records, is selecting each month

## MICA DIAPHRAGMS

Immediate delivery—all sizes  
Send for free samples and prices  
All Mica Products

INTERNATIONAL MICA CO.

Phone Baring 835 PHILADELPHIA, PA. Cable Filatec, Phila.

ten or twelve new records and recommends them to dealers as especially fit for demonstration, as each one has a wide appeal. The December list was as follows:

- 19650-B Winter Song, Victor Male Chorus.  
19753-A I Miss My Swiss, Paul Whiteman and His Orchestra.  
19787-A Cecilia, Jack Smith (the Whispering Baritone).  
19801-A What Do We Care, International Novelty Orchestra.  
19796-A Dinah, The Revelers.  
1116-B Do Not Go, My Love, D'Alvarez.  
6508-A Waltz in E Flat, Bauer.  
1120-A Face to Face, Werrenrath.  
19802-B June Brought the Roses, Victor Salon Orchestra.  
1121-B O How I Miss You Tonight, McCormack.  
6547-B Overture to "Flying Dutchman" (second half), New York Philharmonic Orchestra.

### Many View Amplion Loud Speakers in Exhibitions

Speakers Shown at Zurich, Switzerland, Exposition and Also in Paris—Amplion Corp. Handling the Line in America

Expositions of the latest developments in radio are as popular with the general public of European countries as are the shows which attract



Display of Amplion Loud Speakers

hundreds of thousands of enthusiasts in all the leading cities of this country. The accompanying photographs give an idea of the attractive



Another Amplion Exhibit

manner in which the Amplion loud speakers were shown at the Zurich, Switzerland, exposition and the Paris exhibit. The Swiss exhibit was under the direction of Messrs. Tevelox of Neuchatel, representatives of Alfred Graham & Co., of London, makers of the Amplion loud speakers. The Amplion line of speakers in the United States is handled by the Amplion Corp. of America, New York.

The Music Co., Inc., is now located in its new quarters at 2611 Mission street, San Francisco, Cal., where the Brunswick line is the leader.



# A GREAT DISCOVERY

A new recording process  
used exclusively by  
General Phonograph Corporation  
to record Okeh Records

**Okeh**  
**TRUE TONE**  
**PROCESS**

Dance, Instrumental and Vocal numbers recorded by this new process are reproduced with a superior quality of

tone and detail that music lovers recognize immediately. It is the Okeh Truetone Process.

## A Big Opportunity for Dealers!

Get samples from your nearest Okeh Distributor or write to us direct. Compare records made by the Okeh Truetone Process with all other records.

Back your own judgment in 1926 — a big year for the Dealer selling the new Okeh Truetone records.

# General Phonograph Corporation

OTTO HEINEMAN, Pres.

25 West 45th Street

New York City



### Uses Ray-O-Vac Batteries in Important Speaker Tests

Dr. Lee De Forest Making Exhaustive Tests of His New Radio Loud Speaker Device, the Audalium, in New York Laboratory

The accompanying illustration shows Dr. Lee De Forest in his New York laboratory making a personal test of his latest contribution to the radio art—the Audalium—an entirely new theory and principle in reproduction or loud speaker devices. This is the first picture of this much heralded invention, which not only totally elimi-

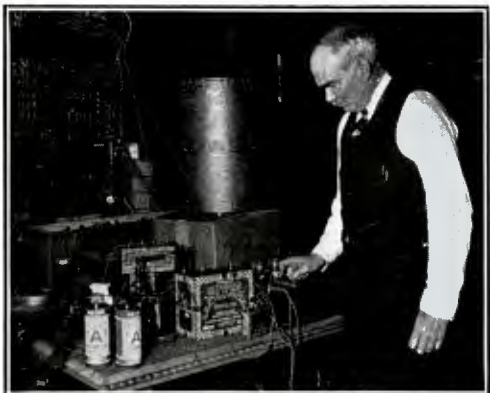

Dr. Lee De Forest in His Laboratory

nates "blasting" but reproduces or amplifies from its entire almost circular surface, without adjustment, the same volume of sound to the auditor whether he is directly behind or in front of the instrument or sixty feet distant. The highest type of low resistance Ray-O-Vac dry batteries are used by the "Wizard of Radio" and his experts in these tests. It is said that perfect reproduction by the loud speaker can only be had where the batteries accessory to the set are of the best grade.

### Music Lover Pays Tribute to Brilliantone Needles

The evils of substitution and its negative effect upon the mind of the purchaser are illustrated in a letter recently received by Harry W. Acton, vice-president and general manager of the Brilliantone Steel Needle Co., New York City, from Harry C. Faber, of Monongah, W. Va. Mr. Faber was formerly connected with the talking machine industry and handled the Victor line in his city. Incidentally Mr. Faber states that he has been a "constant subscriber and a faithful reader" of The Talking Machine World since its birth (this, by the way, was twenty-one years ago). Although not actively engaged in the merchandising of talking machine products, he is still a talking machine enthusiast, has a large collection of records and is also very particular regarding the needle that he uses.

Mr. Faber writes in part:

"The writer is past sixty-one years young and rather hard of hearing. One of my chief pleasures is my Victrola and its library of records and no needle seems to suit the situation. I used to use your Brilliantone needles as your past records will show, but have been unable to locate any since last Spring. I have tried out about everything in the needle line that I could get, but have not been satisfied. About every place that I have made inquiry for them another needle was substituted that was described as far superior to anything on the market. Just anything to make a sale seems to be the order of the day. They never take into consideration that a customer knows the difference between a lie and the truth and they are the losers. We have entirely too great an army of merchants that think lies will help swell their bankroll, but not so with me. When I get bit once that finishes me with the party who bit me."

### New Frederick Branch

The W. F. Frederick Music Co., of Pittsburgh, Pa., has secured a store location in the Schenley Apartments on Forbes street, which will be occupied by the concern in the near future, handling a full stock of musical merchandise of all kinds. The new establishment is one of the best located in the city.

### Discusses Use of Radio in Exchange of Culture

David Sarnoff, Vice-president and General Manager of Radio Corp. of America, in Boston Address, Tells of Fields to Be Developed

BOSTON, MASS., January 5.—The development of a system of super-radio broadcasting that would bring about an exchange of the culture of America with that of Europe, South America and the Orient was predicted recently by David Sarnoff, vice-president and general manager of the Radio Corp. of America, in an address to the Boston Chamber of Commerce.

Mr. Sarnoff said the present development called for a national broadcasting system "ready for any public emergency, with facilities adequate to cover the entire country and to reach across the ocean whenever desired."

He predicted a great step forward in the political education of American people when the masses may listen to debates in Congress, and foresaw the day when the board of education in every metropolitan community would include in its activities a special extension course broadcast from local stations.

He also suggested the possible artistic leadership of radio, when the opera and the stage would draw talent from the broadcasting stations.

The radio industry, he said, has emerged better and stronger from the slump period of last Summer, when the radio art still was in the experimental stage. The business done by the industry in 1925 will aggregate approximately \$350,000,000, he said, and is rapidly approaching \$500,000,000 a year.

The Columbia Stores Co., Denver, Col., distributor of Columbia phonographs and records, reports an excellent volume of sales. The New Process Columbia recordings are responsible in large measure for the tremendous popularity of this line.

### Music Master Corp. Withdraws Models 250 and 50

Distributors and Dealers Protected in Elimination of Models From the Music Master Line—Big Demand for Other Units of Line

PHILADELPHIA, PA., January 7.—Over the signature of H. N. McMenimen, manager of distribution, the Music Master Corp. of this city has issued to its distributors a general bulletin announcing the withdrawal of two models from the line of the Music Master Corp., models 250 and 50 respectively. These two models had been manufactured for the Music Master Corp. by the Ware Radio Corp. in New York City.

The Music Master distributor and dealer has been thoroughly protected in the elimination of these two models as the Music Master Corp. has offered its distributors and dealers full merchandise credit for their stocks on hand. This same bulletin announces that the constantly increasing demand for models 60, 100, 140 and 460 assures a volume of business which will tax factory facilities, as all of these sets are manufactured directly under the control of the Music Master Corp. It is also hinted that the Music Master line may be augmented shortly after the first of the year by a new set which has been perfected in the laboratories of the Music Master Corp.

### New Music Store Opens

A new music store, called the Moorish Corner, has been opened in the Bellaire Building, Cocoa, Fla., by Arthur Salton, who will handle pianos, phonographs and musical accessories. The store is handsomely and uniquely equipped in every sense.

Slight damage was done to the stock of talking machines and pianos in the John Church Co. store, La Salle, Ill.

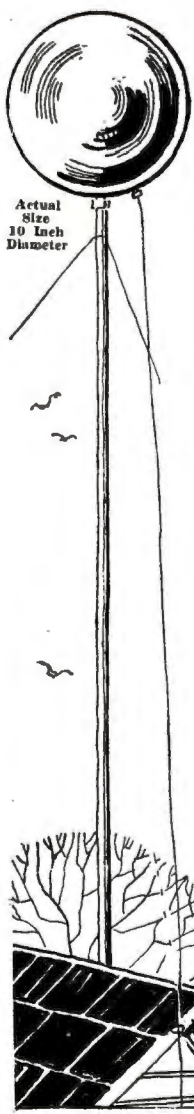

# The Super-Ball Antennae

## Reception You Never Thought Possible

The Super-Ball is the latest development in antennae science. Neat, compact, easily and quickly erected, the Super-Ball is the ideal antennae for the lover of real reception and greater distance. Note Especially — For Apartments, the Super-Ball Antennae can be installed 10 feet apart, eight to ten feet above roof.

PRICE  
**\$10**

### 10 Important Advantages the Super-Ball Makes Possible

1. Increases selectivity
2. Clarifies tone
3. Non-Directional
4. Easy to install
5. Less costly to install
6. Snow and ice cannot collect and stick to it.
7. Will last a lifetime
8. Heat has no effect on its conductivity
9. Cannot corrode
10. Accepts radio frequency signals and rejects a large part of interference from atmospheric or casual electrical disturbance.

Jobbers and Dealers—Write for Information

## Yahr and Lange

National Distributors

207 E. Water St. Milwaukee, Wis.

Established 1872

And Branch at  
241 East Lafayette Ave.,  
DETROIT, MICH.



Running in Vogue,  
 Vanity Fair, House  
 & Garden, Town &  
 Country, Spur, Cos-  
 mopolitan, American  
 Magazine, Literary  
 Digest, Collier's, Na-  
 tional Geographic,  
 Time.  
 Total circulation  
 8,000,000.

Radiola Super-Heterodyne  
 that use no antenna  
 and no batteries



Now radio is as simple as sweep-  
 ing on the light. Just plug in  
 one of our new RCA Radiola  
 sets at the top of a single lamp-  
 and find the music with ease!  
 One great achievement of these new  
 Radiola is their design. You have  
 a fine, compact, unobtrusive volume.  
 With the new Super-Heterodyne and  
 the RCA power transformer, you can  
 get an excellent sound and true  
 reproduction in a portable set. You can  
 get plenty of tone, because you can  
 readily duplicate the volume as well as  
 the quality of tone and music.  
 And for all of this, you need no antenna.  
 In the Radiola 30, and in the RCA  
 Loudspeaker Model 184, is a new  
 device which does away with all  
 noise. On any 60-cycle, 110 volt A.C.  
 lighting circuit, you can now "plug in"  
 the unobtrusive Radiola. It operates  
 silently dependably. And it does what  
 no other battery-powered set can  
 do—it automatically adjusts the  
 volume that gets into your ear. The  
 reason for this volume control is that  
 power lines, a day's radiation that  
 sets up an "induced tone," naturally  
 vary regularly in its just the right  
 volume for your ear.  
 The tone which comes from such a  
 volume control is not only of a high  
 quality but is also of a high degree of  
 uniformity and is not subject to  
 any variation in volume for years of  
 use.

**RCA Radiola**  
 MADE BY THE MAKERS OF RADIOTRONS



**RCA sells  
 the product and the  
 dealer to the public  
 in intensive nation-  
 wide advertising.  
 The RCA Authorized  
 Dealer sign marks the  
 leading radio dealer  
 in every neighborhood**

RADIO CORPORATION  
 OF AMERICA  
 New York Chicago San Francisco



**RCA Radiola**

MADE BY THE MAKERS OF RADIOTRONS





**bring the old set up to date ~**

Any set that uses UV-994 or UV-991-A Radiotrons can be made to give better volume and quality, with one simple change—whether it is a home-made set or a manufactured set.

Simply substitute a new power Radiotron for the last tube. This requires only an inexpensive adapter, and a little extra current. And just ten minutes!

You won't know the old set after the change. No more static and hum, less drifting, and better sound. This power boost—of better tone and finer quality—this tube does it!

**RCA Radiotron**  
MADE BY THE MAKERS OF RADIOLAS



**give your radio set more power with one new Radiotron**

Drive a car uphill beyond its power—and the motor knocks. Drive a radio choker—and the last tube in the set—and you have the power you need for greater volume and finer tone.

The new RCA power tubes add about fifty per cent greater efficiency to any radio set. They cost but \$2.50, and need only an inexpensive adapter and a little extra current! Change the tube of the last audio stage to a new power tube, and any dealer will show you—and in ten minutes you have a new set.

**RCA Radiotron**  
MADE BY THE MAKERS OF RADIOLAS

# more power

*for more*  
**Radiotron sales .....**  
*with the new power Radiotrons*

# RCA Radiotron

MADE BY THE MAKERS OF RADIOLAS

RADIO CORPORATION • OF • AMERICA • NEW YORK • CHICAGO • SAN FRANCISCO





## Stewart-Warner Radioplane Tour Is Highly Successful

Many Accounts Opened and Dealers' Sales Are Increased Through Exploitation Work Done by Sol J. Levy, Radio Sales Manager

The exploitation and promotion campaign, which Sol J. Levy, radio sales manager of the Brooklyn, N. Y., Stewart-Warner Products Service Station, has been waging throughout the territory served by this branch, has brought excellent results. Mr. Levy has covered all of Brooklyn, Long Island, Westchester and Rockland counties in his Stewart-Warner "radioplane," an aeroplane mounted on an automobile chassis, demonstrating the Stewart-Warner radio receiver and distributing literature regarding the company's entire line. This tour had a twofold purpose. The primary reason was the stimulation of trade for the dealer's benefit. To this end Mr. Levy distributed postcards bearing a picture of the "radioplane" and stating that it would "pay to wait until you hear from me before buying a radio, Plane Bill." These cards were self-addressed to the Stewart-Warner headquarters, and carried a space for prospect's name and address. Hundreds of these cards were received by Mr. Levy and turned over by him to the Stewart-Warner dealer in whose vicinity the prospect resided.

The second purpose of the tour was the securing of high-class representation for the Stewart-Warner radio line in sections where the sets were not being sold. The manner in which this purpose was accomplished is interesting. Should the dealer show indifference to the line and reply that his radio stock was complete, Mr. Levy gave concerts on the streets using the Stewart-Warner five-tube set mounted on his plane and distributed literature illustrating and describing the full line. Invariably within a day or two inquiries would be made at the local

store and a request for a further interview with the Stewart-Warner representative would be forthcoming from the dealer. On Long Island alone more than twenty accounts were opened as a result of the tour made by Mr. Levy.

So successful has this exploitation work been that the fame of it has spread throughout the country and many Stewart-Warner stations in different cities have requested a visit of the "Radioplane" to their territories for the stimulation of business. If possible Mr. Levy intends making this tour in the near future.

Another instance of the form of co-operation this branch is giving its dealers is the training of canvassers who makes a house-to-house campaign for the Stewart-Warner dealer who wishes such a sales drive. These men are trained thoroughly and work on a scale of commissions determined by a schedule drawn by Mr. Levy. Several dealers have used these men with unvarying success.

## Panatrope Demonstrations

SPokane, WASH., Jan. 5.—The Brunswick Panatrope was demonstrated to the music lovers of this city in concerts at the auditoriums of the North Central high school and the Lewis and Clark high school. The concerts were given under the combined auspices of the Van Ausdler-Hoffman Music Co., Bailey's and Culbertson's, leading local concerns.

## Wainwright Formal Opening

MARIETTA, O., January 5.—The formal opening of the enlarged store of the Wainwright Music Co., on Putnam street, has been held recently and many patrons and guests of the house were entertained. The concern has added 4,900 square feet of floor space in its annex on the third floor of the Citizens Bank Building, finely equipped.

## Orthophonic Victrola in Demonstration at Concert

J. W. Greene Co. Presents Instrument to Prospective Customers in Joint Concert in Home Setting With Reproducing Piano

TOLEDO, O., January 5.—The Orthophonic Victrola was presented to the patrons of the J. W. Greene Co., Victor dealer of this city, in a con-



A Fine Setting for the Orthophonic

concert in the auditorium of the Greene establishment recently. More than four hundred customers of the store attended and were entertained by the concert, which was given by the greatest artists of the world through the medium of the Orthophonic and a reproducing piano. The instruments were displayed in an attractive home setting as illustrated in the accompanying photograph.

Sam Pickard, formerly in charge of radio extension work at the Kansas State Agricultural College, has been appointed temporary chief of the radio service of the United States Department of Agriculture.



THE SYMBOL OF SERVICE

# CONTINENTAL

"New York's Leading Radio House"



# Radiotrons

Distributors for



Wholesale only

## Tested before sold

A vacuum tube is perhaps one of the most important elements in good radio performance. It is also the most delicate.

All Radiotrons are carefully tested by the maker before they are shipped. It is our duty as an R. C. A. distributor and a reliable jobbing house, to deliver those same tubes in the same condition, 100 per cent perfect.

Here's how we do it.

We test the characteristics of every Radiotron, label the tube tested and then deliver with *special care*. This precaution on our part eliminates the possibility of dealers receiving inoperative tubes, caused by rough handling in shipping.

Reports from our dealers show that this service is successful as well as profitable. Customers prefer Radiotrons with that little blue Continental label "TESTED."

We welcome an opportunity to share this "Radiotron confidence" with other dealers. Write to us or phone Barclay 7320 for your order.

## CONTINENTAL RADIO and ELECTRIC CORPN.

Fifteen Warren Street

New York, U. S. A.





## There Is But One Orthophonic



In all music history nothing ever approached the speedy success of the Orthophonic Victrola. On every hand, it is proclaimed the last word in musical reproduction and so to-day it can be said that perfection itself has been attained.

Because of the enviable and truly exclusive position enjoyed by the Orthophonic Victrola — a new creation for the nation—there will be placed in the market machines to imitate the real product, and claims of “just as good,” “equal to,” “on a par with” will be made to impress and influence the dealer and consumer.

So out of nearly a century's dealing in quality musical merchandise and years of familiarity with the Victor Talking Machine Company's high standards, we earnestly advise you, Mr. Victor Dealer, to *accept no substitutes*.

Into the Orthophonic Victrola have gone the years of knowledge and millions of dollars of resources of the Victor Company, The Western Electric Company and the Bell Laboratories of the American Telephone and Telegraph Company. It is not possible to match these elements either in themselves or in the performance of their product with any lesser skill or finances.

Keep ever present in your mind, Mr. Victor Dealer, that the offer of something “just as good as” the Victor Orthophonic cannot be made in truth.

C. BRUNO & SON, Inc.

351-353 Fourth Avenue

New York

“Victor Distributors to the Dealer Only”



## Two Bills in Congress for Regulation of Radio

Congressman White of Maine and Senator Dill of Washington Introduce Measures Designed to Clear Up Radio Situation

As a result of the recommendation growing out of the Fourth National Radio Conference, held some time ago in Washington, as well as suggestions made by the Department of Commerce, there have been introduced into the present Congress two bills designed to give to Government agencies authority to regulate and supervise radio communication within the United States and police the air in a manner to prevent interference.

The first bill was introduced in the House by Representative Wallace White of Maine and represents a revision of his bill introduced at the last session. It is known as H. R. 5589, and has been referred to the Committee on Merchant Marine and Fisheries. The other bill has been introduced in the Senate by Senator C. C. Dill of Washington and is similar in most respects to the House Bill. It is known as Senate Bill S1754, and has been referred to the Interstate Commerce Commission. A joint conference on the bills is planned for January 18.

Both bills are designed primarily to replace the obsolete Act to regulate radio communication as approved in 1912. In them the Secretary of Commerce is given power to classify licensed radio stations and operators; prescribe the nature of the service rendered by each class and each station; assign wave lengths, etc., to each station, and determine the power that may be used and the time at which it may be operated.

The bill also provides for regulating the character of the broadcasting, establishing zones to be served by the stations, making inspections, and putting in force various regulations deemed necessary.

The bills have been designed to further the interests of the broadcast listeners, as well as the present and future operators of broadcast stations and to eliminate much of the confusion that has developed as a result of the tremendous growth of radio activity. In order to take care of future developments, both bills are designed to cover all forms of transmission by radio, whether messages, signals or pictures, and provide for a radio commission to carry out their provisions.

Senator Howell of Nebraska has also introduced a bill in the Senate reaffirming the use of ether for radio communication to be the inalienable possession of the people of the United States and their Government. He specifies that the use of the ether for terms of two years may be granted through licenses issued by the Secretary of Commerce.

## Hearn's Music Department Has Record December Sales

Herbert D. Berkley, Manager of Radio and Talking Machine Departments, Is Gratified by Month's Volume—Optimistic Over 1926

Herbert D. Berkley, formerly in charge of the talking machine department of Bloomingdale Bros' Department Store, New York, who assumed the management of the talking machine and radio departments of Hearn's Department Store, Fourteenth street, New York, when these departments were taken over by S. L. Schott, Inc., the middle of last November, reports that results for the month of December, the first full month under his direction, were most gratifying. The volume of both talking machine and radio sales was so great an increase over preceding months that comparisons are useless. As a matter of fact the total sales for this month approximate if not exceed those of the eleven preceding months of the year.

The majority of the sales at this store were of the console type higher-priced merchandise. Mr. Berkley is very optimistic over the prospects for the coming year, basing his predictions on the results of last month and taking into consideration that his sales would be greatly increased if it were not for the fact that the Hearn store is not open at night, when a great percentage of Christmas shopping is done in that section.

## Victrolas for Shut-ins

HARRISBURG, PA., January 5.—A few days before Christmas the Harrisburg Telegraph carried a story of a crippled girl whose only wish for Christmas was for a Victrola to satisfy her musical longings. On the morning following, the city editor of the publication received four separate offers of Victrolas, and the remaining three were turned over to deserving cases of invalid shut-ins, thus brightening their holiday. The spirit of Yuletide never dies.

## Springfield Radio Show Has Attractive Exhibits

Haenig Electric Co., Stromberg-Carlson Distributor, Displays Full Line in Most Attractive Fashion at Springfield Exposition

SPRINGFIELD, ILL., January 5.—The Radio Show held here last month was successful, viewed from all angles, and practically all the leading manufacturers were represented either through their



Attractive Stromberg-Carlson Exhibit

own exhibits or by the display of their products by distributors. The attendance at every session of the exposition, which lasted four days, was large and many dealers from the State were among the visitors. The accompanying photograph gives an idea of the attractive manner in which the exhibits were decorated, particularly that of the Haenig Electric Co., Stromberg-Carlson distributor, whose booth is in the foreground.

## Federal Ortho-sonic Volley Ball Competition Winners

General Office Team Wins Trophy This Year After Series of Strenuous Contests

Here are the two Ortho-sonic volley ball teams of the Federal Radio Corp. of Buffalo,



Competitors for the Championship

New York, manufacturer of the Federal Ortho-sonic radio receivers, which are now competing for the Ortho-sonic volley ball trophy. The team kneeling represents the general office and those standing represent the drafting department.

These two teams are playing a series of five games in order to decide the Ortho-sonic volley ball championship and, as an additional inducement, the winning team is given a beautiful silver trophy, presented by L. C. F. Horle, chief engineer of the Federal Radio Corp. (Note: since going to press we have word that the general office team (front row) has won the trophy for this year.) The trophy? Oh, yes, the trophy!—is a cup beautifully engraved and filigreed—ten inches high on an ebony pedestal. It takes three consecutive wins to retain the trophy permanently.

Rappaport & Glanstin, New York, were recently incorporated at Albany to engage in the radio business with a capital stock of \$25,000. The incorporators are M. and S. Rappaport and M. Glanstin, who are both well known to the trade in New York.

# A NEW Radio Product by WESTON Pin-Jack Voltmeter

EVERY sale of this instrument will cut your service costs down, keep your customers sold, mean easy quick profits to you.

Note the illustration—the new Radiola, Victor and Brunswick superheterodyne models are provided with Pin-Jacks for plugging in this new instrument.

No tools, no trouble, no adjustments—just plug-in.

The red mark on the dial at 3 volts enables operation at the proper voltage for the best reception, long-life of tubes, lengthened use of batteries, greater distance, better volume, clarity.

It will be profitable for you to write us for full information.

**WESTON ELECTRICAL INSTRUMENT CORPORATION**

190 Weston Avenue, Newark, N. J.

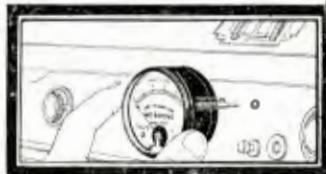

STANDARD THE WORLD OVER  
**WESTON**  
Pioneers since 1888





# PUSH THIS SET! It's Going Big!

## THE THOMPSON MINUET



WHEN you find a product that is a great success, push it hard. That's the way to make the most money in the shortest time.

Put your radio selling efforts where they will do the most good—behind the Thompson Minuet. This is the astounding performer that is one of the very few large sellers of the season.

Perhaps you know some of its history, how it was introduced last September, how it was an immediate triumph because of its perfection of tone, eclipsing anything ever before heard in radio. And how some wisecracs sniffed and said it was all right for locals, but you'd never get distance with it.

Very well. We have letters from owners who get 68 stations in a night. Testimonials, unsolicited, that prove the Minuet is as great a distance-getter as it is a reproducer—second to none and far better than the majority.

Distance plus beautifully perfect quality—the ideal combination in radio—no wonder Thompson dealers in all parts of the country have been wiring us rush repeat orders for immediate shipment of Minuets.

There's no better buy in radio than this Thompson Minuet at \$139 list. Remember that includes the cone speaker too. Remember the Minuet uses dry batteries only and holds them all inside. The greatest success of the year! A sure money-maker for 1926. Write us at once. R. E. Thompson Manufacturing Company, 30 Church Street, New York City.

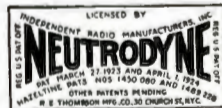
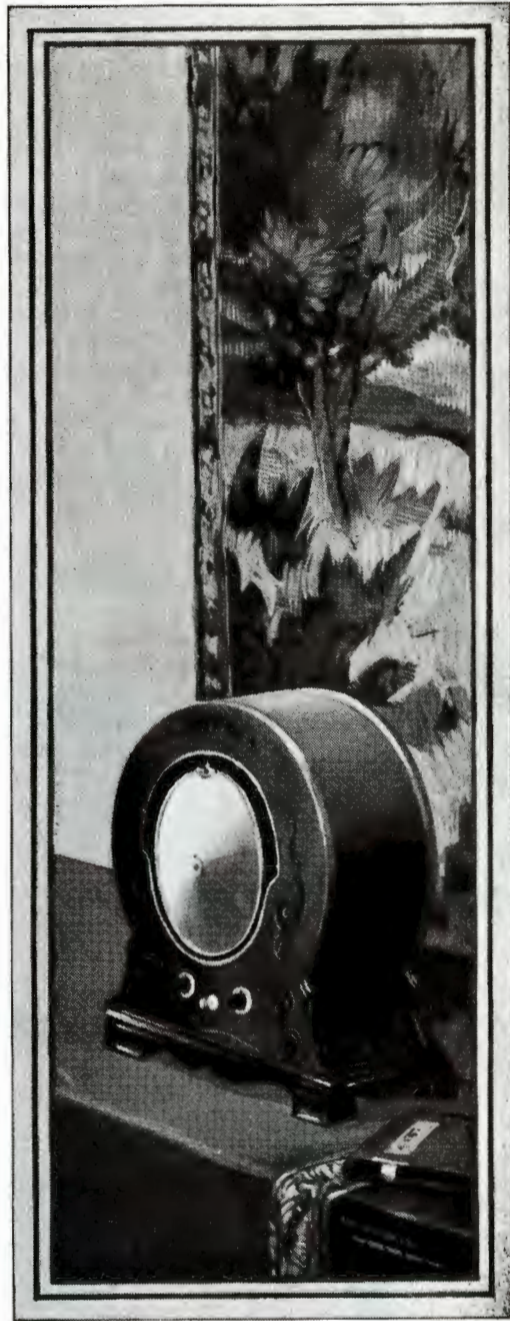

**Thompson Minuet** A 5-tube dry-cell Thompson Receiver combined with improved cone-shaped speaker, enclosed in a newly developed Thompson sound chamber, producing full, natural tones, on low as well as high notes. All batteries are dry cells and are self-contained. If necessary, will operate on a wire around the picture moulding. Size—21½ inches high, 18½ inches wide, 10½ inches deep. List price \$139 (slightly higher west of the Rocky Mountains and in Canada). Other Thompson Receivers, \$89 to \$360 list.

# THOMPSON RADIO

BUILT BY THE MAKERS OF ARMY AND NAVY RADIO APPARATUS USED BY LEADING NATIONS



## Creedman Goes the Limit on Giving His Patrons Service and Finds That It Pays

Live Brooklyn Retailer States That Education of Customers in Operation of Sets Helps to Reduce Service—Prompt Attention to Customers' Demands Results in Increased Good Will

Radio merchandising has developed along lines somewhat differing from the usual business. Experiences of dealers who have made a success of retailing radio prove beyond question that the factor of prime importance in promoting radio business along sound and profitable lines is service. So states S. M. Creedman, proprietor of a successful talking machine and radio establishment in Brooklyn, N. Y., who has built up an unusually large retail radio sales volume, most of which, he points out, is directly due to the policy of his firm of going the limit on service. During the last year, the Creedman store has sold in the neighborhood of 300 sets, an average of six sales each week.

### Service vs. Lines Handled

The lines of radio handled have a great deal to do with service, according to Mr. Creedman. The dealer must select his lines with care. First, he must choose the sets that are most popular and best known in his territory. Second, he must select products of quality—standard, well-built merchandise requiring less service than nondescript sets of unknown antecedents.

Mr. Creedman has rules for giving radio service, which, from long experience, he has found necessary. They are:

Don't keep a customer waiting for service. Send a man out on the job immediately to examine the set and make any necessary adjustments. A set that is out of order for any length of time endangers the good will of the dealer, because it is a constant reminder to the owner of a promise of service that has not been fulfilled.

If examination discloses that the set is at fault mechanically, lose no time in removing it

from the home of the customer. Replace it with a perfect set from stock and then take up the matter with the wholesaler or manufacturer for adjustment. Immediate action here, too, is of supreme importance.

When customers make it a habit to call for service every time something goes wrong with the set (this applies particularly when the operation of the set has been impaired through tinkering), explain that a charge will have to be made for the time of the service man.

Service is expensive, but the peculiar nature of the radio business makes it necessary in order to retain the good will of patrons; therefore, it is cheaper to give service than to fall down in this respect.

### Educating Radio Set Owners

Four experienced service men are constantly on the job at the Creedman store. Mr. Creedman states that because of the size of his radio business and his service policy the services of these men are absolutely necessary. It is during the first two months after the sale that the trouble develops with the radio set, says Mr. Creedman. There are a number of reasons for this. The set is new, the customer usually knows nothing about its installation and very little about its operation, consequently, when something is apparently wrong the first thing the patron thinks about is calling up the store from which the set was purchased. That is where the promise of service at the time of the sale should be kept, not only cheerfully but promptly.

"When we receive a call shortly after the sale has been made our service man visits the home and makes the necessary adjustments,"

said Mr. Creedman. "He then calls the whole family together and explains to them how the set should be hooked up and cautions them against tinkering. He also gives instruction in tuning-in to each member of the family. This seems like a small matter, but I know that this education saves a good deal of time, trouble and cost in servicing. That is one way of reducing the service overhead."

### Service Is Weapon Against Gyps

Mr. Creedman also emphasized the point that the only effective weapon the legitimate dealer has to combat the gyp dealer is by extending a type of service that will build good will. The legitimate dealer can not compete with the gyp on price, but he can beat him at giving service. The gyp and cut-price dealers operate on such a small margin that they can not afford to go to any great lengths in giving free service, therefore, the dealer who handles quality merchandise and not only promises to give service, but gets the reputation of actually doing what he promises, will be effectively using his most powerful weapon against the gyp and cut-price type of merchant.

## Booklet of Sales Aids for R. C. A. Retail Merchants

The Radio Corp. of America has just issued a most interesting booklet of advertising and sales helps for dealers. The booklet describes and illustrates the various show cards and window hangers, display racks, window display layouts, and a great amount of other material that has been prepared by the corporation to aid its distributors in making a strong appeal to the public. A survey of the booklet would indicate that there is material available for practically every purpose, provided the dealer is live enough to take advantage of the opportunity for proper exploitation. Intelligent use of this sales aid will be profitable.



The RIVOLI DE LUXE (with built-in speaker) \$75 List

# Rivoli

**"ALWAYS GOOD COMPANY"**

The Line That Sells—

**THE RIVOLI PLAN**—it is an entirely new idea applied to the selling of radio sets, an idea based upon the firm conviction that the dealer is entitled to a generous slice of profit for his work. If your experience with radio sets has been none too cheerful, all the more reason for tuning in on Rivoli. If you have been quite satisfied heretofore, Rivoli is going to give you a pleasant jolt.

The Rivoli line is complete, with a model for every popular priced range. The Rivoli dealer always has the right thing to offer. The Rivoli line consists of the Console retailing for \$125, the DeLuxe retailing for \$75, the Junior at \$60, and the Rivoli Table at \$50. Then there's the Speaker at \$30.

Radio Industries Corp., 131 Duane Street, New York

a nationally advertised radio line that sells



## Akron-Canton Dealers Experience Demand in All Lines Following Holiday Season

Radios and Records Continue Especially Brisk—B. A. Emerson Dead—Columbia Artists in Local Appearance—General Phonograph & Supply Co. Changes Name—Other News

AKRON-CANTON, O., January 7—With the holiday buying season over, the trade is experiencing the usual after-Christmas lull, but this is not expected to continue long, for radio sales continue brisk and the volume of business generally is expected to hold up well the next few weeks. Talking machine sales are on the increase with the receipt of new models. For the past month record sales have improved and are expected to continue brisk for several weeks, as many of the new releases are proving good sellers.

Radio still is an important factor in music merchandising circles. Compared to a year ago, radio is about 35 per cent ahead, dealers report. Every radio dealer in this district taxed every facility of his organization to get all sets purchased for Christmas installed before the holiday.

Optimism prevails in the Akron-Canton district, which includes some 20 smaller towns hereabouts, and dealers believe business will be entirely satisfactory the first six months of 1926, which it is predicted will be a prosperous period for retail merchandising of all kinds as well as industry in the whole of eastern Ohio.

B. A. Emerson, 57 years old, widely known Akron music merchant, died recently of heart disease. He was head of the B. A. Emerson Music Co., and established the business at 44 East Mill street twelve years ago.

The California Ramblers dance orchestra, Columbia record artists, played a successful two-weeks engagement at Moonlight Ballroom, Canton, O., recently. Talking machine dealers tied up with the appearance of the band and report record sales stimulated.

The General Phonograph & Supply Co., which operates one of the largest manufacturing plants in the city of Elyria, has changed its name to the General Industries Co., it was announced by officials of the company recently.

The branch store of the Home Music Co., on Fourth street, NW, has been discontinued, it is announced. This concern, operating a retail store on North Market avenue, opened a Fourth street store several weeks ago to care for its holiday trade.

Acquisition of the Klein, Heffelman-Zollars Co., large department store, Canton, by the Ross Co., Inc., of New York, will not affect the status of the Alford & Fryar Piano Co., which department, according to Mr. Alford, is operated independently of the department store and is a leased department. The wrong impression has gone out that this concern was included in the transfer of the department store.

The Ackerman Piano Co., one of the oldest music houses in Marion, O., moved the past week to its new building in the rear of its present building. With the completion of the main floor of the new building the talking machine department along with other departments will be enlarged. The Victrola department will be located on the first floor.

The new store of the McCrory Co., Youngstown, will maintain a large talking machine record department.

J. E. MacMullen, well known in music trade circles in eastern Ohio, has joined the sales force of the Grand Piano Co., Akron. B. H. Hite, well known Akron talking machine salesman, also has become identified with the Grand Piano Co.

A much larger stock of talking machines and records will be maintained in the future by the Warner Music Co., which has moved to its new and larger quarters at 16 North Phelps street, Youngstown, O.

It is announced that the well known firm of Alford & Fryar, Canton, has taken on the Starr line of pianos and talking machines, which it will feature.

Six retail music houses of East Liverpool joined with other merchants in carrying out a uniform Christmas decorating scheme which included the placing of two trees in front of each store. Many of the merchants trimmed these as in the home, and the main street of the city presented a pleasing Yuletide appearance, as a result.

### New York Firm Chartered

Stoner & Heath, New York, were recently incorporated at Albany to handle radio and automotive supplies, with a capital stock of \$20,000. The incorporators are P. W. Mack, W. W. Scharp and G. W. Hoehn.

## Okeh Wholesale Division Reports Satisfactory Sales

Ray Wilson, Manager of Distributing Division of General Phonograph Corp., Inc., Reports a Satisfactory Activity in All Lines

Ray Wilson, manager of the Distributing Division of the General Phonograph Corp., Inc., New York, reports a most satisfactory volume of sales for the month of December, comparing favorably with the same month last year and giving indications of a continuance of a heavy demand for some time to come. The large orders were confined to no one class of merchandise or to any one type of record. Okeh records, both popular and foreign, Odeon recordings and album sets, portables—all went to make up the large volume which kept the staff working at high speed throughout the month. That the dealers were correct in gauging their holiday business as looming big has been evidenced by the large orders received.

## MUTUAL Products Will Bring You A Happy and Prosperous New Year



No. 1a tone arm with No. 4 reproducer.

Portable outfit. Made with the popular pivot base and ball bearing swinging elbow.

Samples of illustrated arms may be obtained upon request by responsible concerns.

### OUR LATEST BRASS PORTABLE TONE ARM!



No. 7 Brass arm with No. 2 reproducer.

The most reasonably priced brass arm on the market, that is combined with a scientifically constructed sound box.

Address our Executive Office at

149-151 Lafayette Street

New York City

## MUTUAL PHONO PARTS MFG. CORP.

DISTRIBUTORS

Canadian Acme Screw & Gear, Ltd.	1209 King St., West, Toronto, Can.
Industrias Unidas, S. A.	Balderas 110, Mexico City, Mexico
Targ & Dinner Music Co.	229 W. Randolph St., Chicago, Ill.
Arthur Brand & Co.	1618 Vine St., Cincinnati, Ohio
Shapleigh Hardware Co.	4th St. and Washington Ave., St. Louis, Mo.



# Sitting



World's  
Largest  
Makers of  
Neutrodyne  
Radio

# FREED-



# Pretty

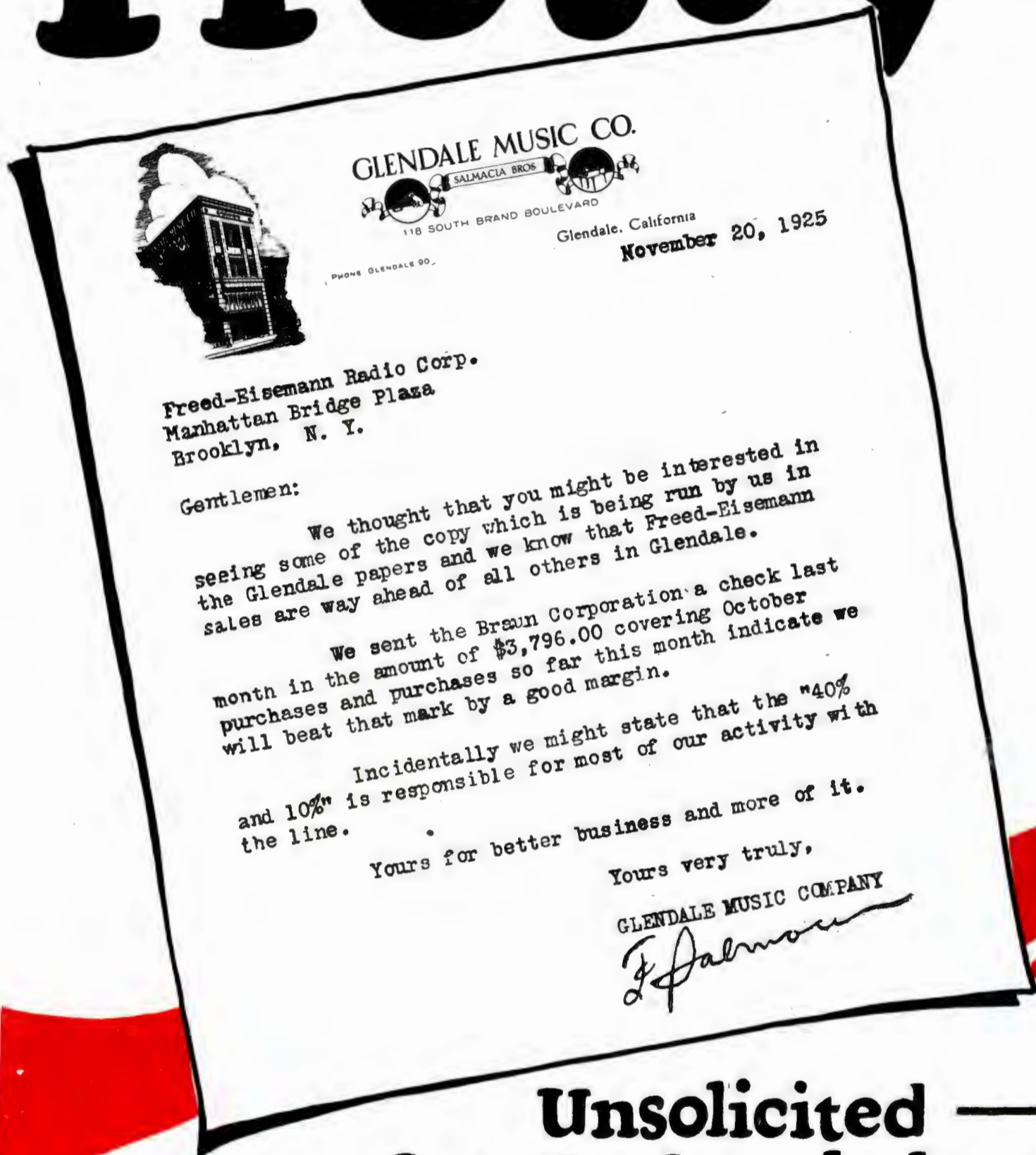

GLENDALE MUSIC CO.

SALMACIA BROS  
118 SOUTH BRAND BOULEVARD

Glendale, California

November 20, 1925



Freed-Eisemann Radio Corp.  
Manhattan Bridge Plaza  
Brooklyn, N. Y.

Gentlemen:

We thought that you might be interested in seeing some of the copy which is being run by us in the Glendale papers and we know that Freed-Eisemann sales are way ahead of all others in Glendale.

We sent the Braun Corporation a check last month in the amount of \$3,796.00 covering October purchases and purchases so far this month indicate we will beat that mark by a good margin.

Incidentally we might state that the "40% and 10%" is responsible for most of our activity with the line.

Yours for better business and more of it.

Yours very truly,

GLENDALE MUSIC COMPANY

*J. Falman*

**Unsolicited —  
It tells the whole story**

# EISEMANN



## Yahr & Lange to Distribute the Super-Ball Antenna

Prominent Milwaukee Institution Appointed National Distributor by Super-Ball Antenna Co.—Features of the New Product

MILWAUKEE, WIS., January 5.—Yahr & Lange, distributors of Sonora phonographs and radio receivers in this city, have been recently appointed national distributors of the Super-Ball antenna by the manufacturers, the Super-Ball Antenna Co., of Green Bay, Wis., and during the past few weeks the prominent Milwaukee jobbing house has instituted a vigorous drive on the new product.

The Super-Ball antenna is one of distinctive appearance, being, as its name might imply, a ball ten inches in diameter, made of metal of excellent electrical conductivity, which is not affected by weather and is rust and corrosion proof. The antenna is easy to install, as it is mounted on the top of a ten-foot pole or conduit, and requires three guy wires. The Super-Ball has met with instant favor wherever it has been shown, and in the city of Green Bay alone it is estimated that over three hundred of the new product are in active service.

The firm of Yahr & Lange, headed by Fred E. Yahr, president, which has made great progress in Wisconsin and upper Michigan in giving prominence to Sonora products and Okeh records, is duplicating the feat in the radio field, handling a number of nationally known products, including Philco storage batteries, Ray-O-Vac batteries, True Blue and Supertron tubes, Brach lighting arresters and aerial outfits and Freidag aerial mast pipe fixtures. In the musical merchandise field the firm is also well represented, carrying Hohner harmonicas, Brilliantone steel needles and Little Tot records. The Detroit office of Yahr & Lange recently moved into new and larger quarters, and the lower half of Michigan is being cared for by a sales force traveling out of this branch under the supervision of H. E. Schultz.

## New York Firm Chartered

The William Voit Co., New York, was recently incorporated at Albany with a capital stock of 200 shares of common of no par value to make musical instruments. The incorporators are F. Fleischauer, F. Mingst, Jr., and M. Greenfield.

## Features Honest Quaker Parts in Window Display

Majestic Distributing Co., Distributor of Repair Parts and Retailer, Arranges a Window Display of Unusual Character

MINNEAPOLIS, MINN., January 6.—The Majestic Distributing Co., of this city, sounded a novel note in a recent window display. In addition to operating a large retail store which does an extensive business in repair work, the Majestic Distributing Co. has a wholesale department which exclusively distributes Honest Quaker main springs and repair parts made by Every-



Effective Window Arranged by the Majestic Dist. Co.

body's Talking Machine Co., Philadelphia, Pa. This concern conceived the unusual idea of devoting its window to a display of the repair parts, also placing in the window a repair bench with a mechanic at work. As mechanical operations of this character never fail to interest the general public, the window drew considerable attention.

As may be seen in the accompanying illustration, this display was characterized as "a general phonograph hospital." Special prices were offered during demonstration week on all repair work. Another cardboard had the suggestion that "it is advisable to have your phono-

graph motor overhauled once each year." It is reported that the display increased the retail repair business of this company considerably, and the success with which this company has met recommends this plan for the consideration of other dealers.

## Walter L. Eckhardt Makes Important Announcement

President of the Music Master Corp., Philadelphia, Sets Rumors at Rest—Discusses Corporation's Finances and Plans

PHILADELPHIA, PA., Jan. 5.—In a statement released for publication here recently, Walter L.

Eckhardt, president of the Music Master Corp., decisively set at rest rumors to the effect that he proposed to retire as active head of the company.

These rumors regarding President Eckhardt's retirement have been persistent in radio trade circles for some little time. According to his statement, these reports are entirely unfounded, and apparently set afloat by those inimical to the interests of Music Master Corp., as well as the entire radio industry.

The Music Master Corp. is well known as

one of the large manufacturers of radio reproducers and radio receivers of the country. Originally, the company featured reproducers almost exclusively, for which it attained nationwide popularity. Last year the company started marketing a complete line of radio receivers. Under the guidance of Mr. Eckhardt, and through energetically progressive sales methods, the concern rapidly advanced in this field.

Briefly summarized, the gist of President Eckhardt's statement follows:

"I do not intend retiring as President of the Music Master Corp. Nothing is further from my thoughts. So long as I have my present faculties and the loyal support of my associates I shall continue as head of this institution.

"I consider it as my life work. Now, in view of these unfounded reports, I am more than ever determined to make the name Music Master synonymous with good radio apparatus and merchandise.

"Rumors to the contrary notwithstanding, Music Master Corp. is financially sound, having assets as of December 1 of over \$1,000,000.00 in excess of all liabilities.

"Distributors and dealers who have loyally cooperated with us may rest assured that they are going to be rewarded next year with a great volume of Music Master business.

"Furthermore, I want to say that our plans for 1926 are sound from a manufacturing and merchandising standpoint. Our present equitable jobber and dealer policy will remain unchanged during the coming year; but I wish to add that we will in the near future have announcements to make of great importance—announcements that will not only gratify our loyal distributors and dealers, but will interest the entire radio industry."

## Weed Music Shop Chartered

The Weed Music Shop, Poughkeepsie, N. Y., was recently incorporated at Albany with a capital stock of \$5,000. The incorporators are C. G. Hoffman, A. E. Kilkenny and M. Robbins, well-known business men.

## FULL LINE of HARDWARE

For Radios and Phonographs

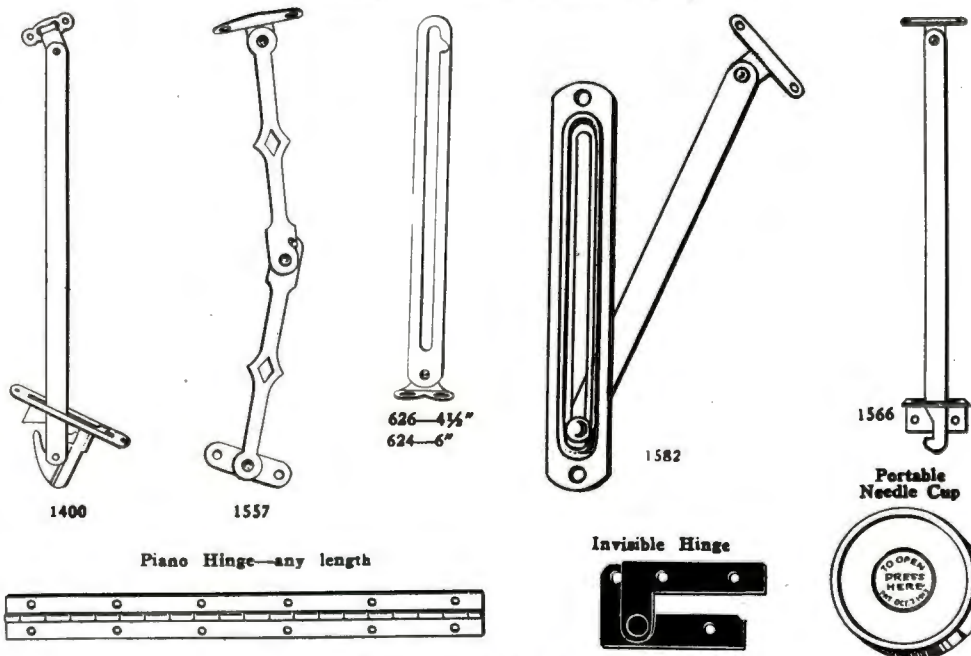

**H. A. GUDEN CO., Inc.**  
87 WALKER STREET  
NEW YORK, N. Y.





The  
**EAGLE**  
*All That is Best in Radio*

# Quality

SHOULD be your first consideration in buying a Radio Set. Quality parts, quality workmanship, quality inspection, quality service.

Eagle is known as the peer of all Neutrodyne (which means the Best in Radio) because everything that enters into the manufacture of the Eagle Radio is of the finest quality procurable.

That is why Eagle Performance is the marvel of Radio Reception.

*Eagle Dealers  
Reap Big Profits*

The steady demand for Eagle Neutrodyne is building up a big volume of profits for Eagle dealers. Most Eagle dealers prefer to demonstrate the Eagle in their customer's homes, knowing that Eagle Performance will prove conclusively to their customers that it is the best Radio set on the market, regardless of Price.

*Your Business Will  
Soar With the Eagle*

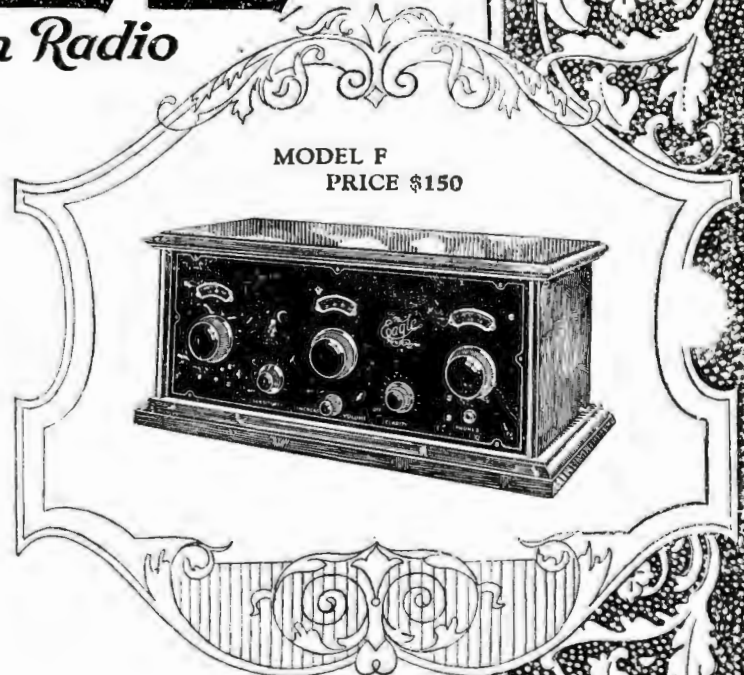

## What's Behind The Panel?



THE EAGLE COIL.

The marvellous efficiency of the Eagle Coil brings in far distant stations while local stations are operating.



**EAGLE RADIO CO.**  
16 Boyden Place, Newark, N. J.

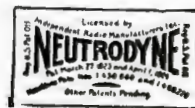



### Sonora Dealers Bring Line to the Fore in Many Ways

Advertising Department of Sonora Co. Receives Photographs From Dealers Showing Wide and Effective Exploitation Activities

The advertising department of the Sonora Phonograph Co., Inc., New York, has received during the past few weeks a series of interesting photographs from various points in this country, as well as abroad, descriptive of sales and advertising ideas utilized by Sonora representatives. The Sonora advertising division is co-operating with its dealer organization in every possible way in profitably using sales and

used by Nicholson's Ltd., Sonora representatives at Perth, Australia; No. 4, a handsome exhibit featured by the Hassler Texas Co., recently appointed a Sonora jobber; No. 5, a timely window display showing Sonora products in the establishment of Rudolph Schmidt, successful Sonora dealer; No. 6, a recent window display prepared by the window dresser of King's Pharmacy, Sonora dealer at Lewiston, Mont.

### Dixie Music Shop Opens

The formal opening of the Dixie Music Shop, 538 Lenox avenue, New York, was held in mid-December, with a very attractive entertainment program, including Clarence Williams

### J. A. Fischer Co.'s First Year a Huge Success

Philadelphia Manufacturer of Repair Parts, Although in Existence About a Year, Has Become a Leader in the Industry

PHILADELPHIA, PA., January 7.—The close of 1925 marked the completion of the first calendar year of the J. A. Fischer Co., of this city, manufacturer of Valley Forge main springs and talking machine repair material. The success of this organization during its first year has been remarkable, but it must be remembered that, although a new organization, its head, J. A. Fischer, is a talking machine man of many years' experience in the repair parts division of the business.

From the very beginning of the organization the line has been added to in accordance with Mr. Fischer's policy of endeavoring to carry a complete line of every part used in the manufacture or repair of the talking machine. One of the newest additions to the line is the Pennant reproducer and tone arm which is manufactured by the J. A. Fischer Co. Mr. Fischer states that, although only recently introduced, the new arm has already met with much success.

A visible example of the growth of this organization is to be found in the large stockroom. When the company was organized, during the early part of the year, this room only gave promises. Now it has been completely equipped with shelves, bins and drawers, in which is to be found a neat and orderly arrangement of the vast number of parts used in talking machine production.

The sales staff is again on the road, and from present indications it would seem that 1926 will prove a banner year for the organization.



Exploiting the Sonora Effectively in Many Parts of the Country

publicity helps and the tremendous popularity of Sonora products in 1925 reflected the importance of this co-operation.

The six illustrations shown herewith portray Sonora activities as follows: No. 1, moving picture celebrities listening to the Sonora; No. 2, the attractive exhibit sponsored by P. C. Peuser at the Scranton Show; No. 3, the delivery truck

Trio and Clarence Williams Blue Five, both Okeh record artists. A large crowd attended the opening ceremonies and many records of these artists were sold. A full line of all musical instruments is carried.

The Carter Brunswick Shop, Ashland, Ky., recently held its formal opening.

### General Corp.'s Wholesale Staff Has Christmas Party

The staff of the Distributing Division of the General Phonograph Corp., Inc., New York, held a most successful Christmas party at the office, 15 West Eighteenth street, on Christmas Eve. The full office and sales staffs were present and although last-minute orders came through they were taken care of without any noticeable interruption to the merriment. A beautiful leather cigar case was presented to Ray Wilson, manager of the department. A set of verses dealing with the personalities and peculiarities of each member of the staff was read off by Mr. Wilson and a copy of the verses was distributed to all present as a reminder of the happy party. Refreshments were served and dancing was the order of the day to the accompaniment of Okeh and Odeon records.

### A Record and Real Estate

When next you play the Victor record, "Carry Me Back to Ol' Virginny," sung by Alma Gluck, sit back and revel in the thought that you helped pay for a twenty-one-room house on Park avenue, New York. For it was from royalties of more than 1,000,000 reproductions of this record that Alma Gluck, in 1919, bought this house, for which she paid \$127,000. This interesting bit of information came out in the real estate news recently, when Miss Gluck, now Mrs. Efram Zimbalist, sold the property at a price of \$300,000. The record was made in 1914, and to this day has large sales.

The Baldwin Music House on North Main street, McPherson, Kan., was recently opened by C. E. White and G. C. Bowen.

No Batteries - No Attachments - All Self Contained

## Make 1926 a Year of P-O-W-E-R!

# ARGUS POWER ELECTRIC RADIO

The only electric radio that works on AC or DC using no outside attachments. Just Plug in the Light Socket—all that is necessary to operate.  
ENTIRELY SELF CONTAINED

NO MORE BATTERIES

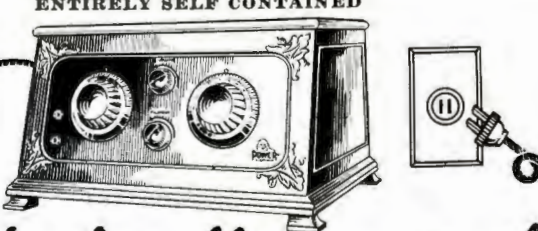

This is all you need

WORKS FROM THE ELECTRIC SOCKET

## NO BATTERIES!

No More Buying A, B, or C Batteries. Economical to operate. Power Electric Radio Receivers—made in 4 different models. Two Console Types, Standard Model and Phonograph Panel.  
Send for Literature, Distributor and Dealer Proposition  
Manufactured by

### ARGUS RADIO CORP.

25 West 18th Street, New York City

Just Plug In. Works on AC or DC Current

**POWER**

FEATURES

- Works on A.C. or D.C.
- Self Contained
- No More Batteries
- No Attachments
- No Rectifying Tubes
- No Trace of Hum
- No Aerial or Ground for Locals
- Loop or Indoor Aerial for Distance
- Various Models
- Ruggedly Constructed
- Life of Tubes Prolonged
- Sensitivity Unexcelled
- 1-10 cent per hour

To the Progressive Radio Merchant "POWER" means—

MORE SALES

LESS RESISTANCE

GREATER PROFIT

Every Set is UNCONDITIONALLY GUARANTEED  
Dealers and Jobbers Franchised

**POWER**



# announcing "The 3" "CHIC"

*honored offspring  
of the Flapper and  
the Master*



"CHIC" is the word! In line and action this bit of impudence has all the verve and dash and style of a petite Parisienne. The poise of a honey-sipping humming bird! The sauciness of a Jenny Wren! The mellow music of an oriole at mating time!

The "Chic" fits as naturally into the Carryola scheme of things as a lightly stepping flapper into the latest tapper's arms. There's a place for her. It lies with those who want, but can't afford, the Flapper or the Master.

The smallest portable made that carries its own records! A genuine Heineman Motor! A tone-arm like the Carryola Master's, only smaller! An exterior of handsome, imitation, patent-leather! An all-over diameter of only 11½ inches! A total weight of but 6½ pounds.

Everywhere that price is a dominating factor—everywhere that extreme compactness and portability are essential, the "Chic" will prove to be just the thing. She fills out the line—gives you a new sales weapon with which to catch business that's been getting away.

LET'S HAVE YOUR  
SAMPLE ORDER NOW

*The CARRYOLA COMPANY of AMERICA*  
647 Clinton Street *Milwaukee, Wisconsin*



## How the Retail Trade and Public Are Protected From Reclaimed Vacuum Tubes

L. L. Manley, of the Radio Corp. of America, Describes How the "Rock Crusher" Grinds the Defective Tubes to Little Bits, Thus Removing All Chance of Their Distribution

Radio vacuum tubes are delicate pieces of mechanism and throughout the entire course of their manufacture and use they must be handled by nimble fingers and with the greatest care. But what a "rough deal" awaits the tube that fails to measure up to proper manufacturing and operating specifications—a stone crusher that grinds every element into tiny, unrecognizable bits.

This so-called "rock crusher" is a rather elaborate apparatus set up in the laboratories of the Service Station of the Radio Corp. of America, and its primary function is to make it impossible for defective tubes or elements of tubes to find their way back into trade through illegitimate channels.

With millions of Radiotrons produced every month, the actual number defective, although representing a very small percentage, is quite large, and would bulk into a fair-sized pile.



The "Rock Crusher"

Grinding Defective Radiotrons Into Little Bits

Should this pile be disposed of by any ordinary means, it might easily be possible for unscrupulous tube manufacturers to pick up large numbers of standard bases, stems, plates and other elements and doctor them up with imitations of the remaining elements of the tubes. Thus, to protect not only the customer but the dealers as well, all defective Radiotrons are completely destroyed.

The "rock crusher" consists of two main elements—an assorting table and the grinding wheel. In the assorting table are a number of holes, each labelled to receive but one type of tube. Pipes underneath the table run from each hole and join in one main pipe below. This main pipe runs through the floor to the story below and into a huge bin. Within the bin is the grinder that might well have graced a New Hampshire granite quarry before it

found a resting-place in a radio laboratory! At the mouth of each individual pipe, directly under the holes in the assorting table is a shutter-counter arrangement which keeps an accurate record of the number of each type of tube "deposited" in the crusher.

Thus when a tube is found defective it is



Defective Tube Assorter

Depositing "Bad" Tubes in the Assorting Table, Where They Are Counted

dropped into the hole specifically for it, it registers on the automatic counter and then drops to the floor below where the "wheels of fate grind slowly, but they grind exceeding fine," and out of the mill there comes an unrecognizable mass of small bits of wire, bakelite and glass dust, and fragments of plates, not the tiniest bit of which can be salvaged or reclaimed for future sale or use.

### Sherman-Clay in Redding

REDDING, CAL., January 2.—A new branch of Sherman, Clay & Co. will be opened here as soon as a suitable location can be obtained by Sydney J. Wilson, who will act as manager. Mr. Wilson has been identified with Sherman, Clay & Co. for the past twenty-five years and has had experience with the largest as well as the outlying stores of the concern. A general line of pianos, phonographs and musical accessories will be handled.

### Manegold Shop Alterations

READING, PA., January 4.—Extensive improvements have been completed recently in the establishment of Manegold's Music Shop, 741 Penn street, this city, making the quarters more attractive for the display merchandise. The first and second floors have been renovated and a new stairway has been installed. Pianos and radio are now shown in an attractive setting on the second floor.

### ILSLEY'S GRAPHITE PHONO SPRING LUBRICANT

Ilsley's Lubricant makes the Motor make good. Is prepared in the proper consistency, will not run out, dry up or become sticky or rancid. Remains in its original form indefinitely.

Put up in 1, 5, 10, 25 and 50-pound cans for dealers. This lubricant is also put up in 4-ounce cans to retail at 25 cents each under the trade name of

### EUREKA NOISELESS TALKING MACHINE LUBRICANT

Write for special proposition to jobbers

ILSLEY-DOUBLEDAY & CO., 229-231 Front St., New York

### Pathex, Inc., Closes Most Successful First Year

Pathex Motion Picture Camera and Projector in Strong Demand During Holidays—Increasing Number of Dealers Now Featuring Product—Look for Busy Year Ahead

The first holiday season for the Pathex motion picture camera and projector manufactured by Pathex, Inc., New York, proved distinctly satisfactory, according to officials of the company, and indicated that although the Winter season does not hold the same interest as Summer for the amateur photographer, the Pathex outfit had a strong appeal at Christmastime, probably for gift-giving purposes, an appeal reflected in a sales volume that actually exceeded expectations.

An increasing number of dealers in various lines have taken on the Pathex and have done well with it, particularly in cases where intelligent effort was used in demonstrations and sales. It has been found that where the dealer took the trouble to show the customer just what the Pathex has accomplished, and can accomplish, the buying interest was quickly aroused; a dealer in a single day during the holiday season having sold fourteen complete outfits as a result of careful demonstrating.

H. C. Brown, general manager of Pathex, Inc., stated that at the outset some doubt was felt regarding the ability of the amateur to produce without practice or experience results that would prove satisfactory and keep him enthusiastic. As a matter of fact, however, the actual results, as proved by the films turned in to headquarters for developing, show that between 80 and 90 per cent of the pictures, and they are taken under varying conditions, are of distinctly satisfactory character. This is considered one of the biggest features in the successful exploitation of the new product.

Several distributors of Pathex products have been appointed West of the Mississippi and others will shortly be announced in the Far West and in the South, the purpose being to give the dealers prompt and efficient service. The bulk of the territory East of the Mississippi and north of Tennessee will continue to be handled from headquarters for a time at least for a number of excellent reasons, chief among them being that this plan enables the executives to maintain first-hand contact with the trade and with the public, an invaluable asset in the formulation of business policies.

There will shortly be launched an extensive campaign of exploitation on Pathex products to carry right through the Spring and Summer and in to the next holiday season, with a view to realizing on every possibility of the trade. There is every indication that the coming months will prove most productive of results, in anticipation of which the company is arranging its facilities to take care of an unprecedented volume of business. The educational work that has been carried on through advertisements in the daily papers and national magazines and through retail outlets is fast acquainting the public with the fact that it is possible for the amateur to take and display motion pictures successfully and at moderate cost, and the effects of this campaign are making themselves felt strongly in the demand.

A tip for this year: Prepare for an active demand for talking machines.

## PHONOGRAPH CASES RADIO CASES Reinforced 3-ply Veneer

The Standard Case for Talking  
Machines and Radio Sets

Let us figure on your requirements

MADE BY  
PLYWOOD CORPORATION, Goldsboro, N. C.

Mills in Va., N. C. and S. C.





## Twin Cities Retailers Plan Increased Activities With Start of the New Year

Dealers and Wholesalers Report Huge Sales Gains Over 1924 and Are Confident Present Year Will See Even Greater Sales Volume, Due to Marketing of New and Improved Instruments

MINNEAPOLIS AND ST. PAUL, January 7.—With a hectic holiday season just passed and the new year under way, Twin City music merchants are in a reflective mood and are making optimistic prophecies for 1926 business.

### Beckwith Co. Closes Busy Year

At the George C. Beckwith Co., Victor headquarters, there is an air of having eaten the canary. All departments have had unusual returns and Manager Bennett radiates enthusiasm for the year just passed and confidence in continued prosperity for 1926. He believes the new Orthophonic will be responsible for a sharply increased business. Dealers say the demand for the Orthophonic is tremendous, with the Crendenza model the favorite by a long way. Announcement of the new model with electric pick-up has been received with enthusiasm and although the demonstration has not been set until January 15, orders have already been sent in for the \$1,000 model. Everything has been cleared out, Mr. Bennett states, except a few portables.

A Victor artist who will be in the public eye and ear the next week or so will be Aileen Stanley, who comes to the Hennepin Orpheum in Minneapolis early in January. Twin City dealers tied up with both the broadcasting of McCormack and Bori, Victor artists, on New Year's night, and featured their records.

The Beckwith Co. has done a phenomenal business with the Music Master radio line and Mr. Coleman, manager of the radio department, has added seven new men to the office and shipping rooms. Two Music Master engineers have been at the Beckwith headquarters since October. Orders have been filled but it necessitated moving the goods day and night and far into the small hours. The December radio business amounted to 25 per cent of the year's total.

### Sonora Sales Increase

Sonora phonographs are in increasing demand, says J. E. Date, manager of the phonograph and radio departments of the Minneapolis Drug Co., Northwest distributor of Sonora phonographs and Magnavox radio. There has been a very pleasing increase in sales of Sonora phonographs and radio equipment during the past year and Mr. Date predicts a continuance of the heavy demand well into 1926.

Foster & Waldo, Minneapolis, recently had a display of Sonora De Luxe phonographs. This was probably one of the greatest exhibitions of period models in the country. The showrooms were crowded with interested prospects and many sales resulted.

### Many Dealers Feature Magnavox

Since the Minneapolis Drug Co. has become exclusive agent for the Magnavox products in the Northwest the company has enjoyed a phenomenal business. Many representative dealers have taken on the line.

Important Twin City dealers who are handling the Magnavox line are the Sonora Shop, Arlington Electric Co., Lehnarts Piano Co., the A. G. Bauer Co., and the Electric Construction Co., of St. Paul, and in Minneapolis, the Foster & Waldo Co., Boutell Bros., Majestic Music Shop, the Gardner Hardware Co. and the Radio Equipment & Supply Co.

There were many visitors to Sonora headquarters the past few weeks, including Leon Golder, Chicago sales manager of the Magnavox Co., and Mr. Parker, field representative. Fred E. Roediger, of the Sonora Co., was also in Minneapolis recently.

### New Adler-Royal Agencies

The Adler-Royal Co. is doing a constantly increasing business through its Northwest distributors, Sprague & Warren. Twenty-five to thirty new accounts have been opened during the past sixty days and that they are all doing well is attested by the repeat orders that come

in. Dyer Bros. and the Emporium are two important St. Paul Adler-Royal accounts that were recently opened.

Both Mr. Sprague and Mr. Warren are on trips through the territory, the former going West and North by way of Crookston and Mr. Warren covering the field in the southern Minnesota territory.

### Record Columbia Holiday Business

Mrs. Helen D. Beggs, Northwest manager for the Columbia Co., has been on a short trip to Milwaukee and Chicago. Her firm did the largest holiday business since the halcyon days of 1919 and the record sales also approached the peak. Columbia 50 cent Harmony records are proving big sellers. Columbia will feature Ted Lewis's first waltz record, "While We Dance Till Dawn," early in January, with a full-page ad in the local papers.

T. G. Rockwell, of Chicago, was in the Twin Cities recently, booking artists for the Columbia Co.

### Close Big Edison Year

The Laurence Lucker Co. closed a satisfactory year with a big holiday business. Edison phonographs were in demand and the company had a most gratifying volume of sales in the DeForest and Crosley radio lines. The record sales were also eminently pleasing.

### Dealers Receive Panatropes

The Brunswick Panatrope continues to hold spellbound many groups of auditors in the various demonstration rooms. On December 14 and 15 the Panatrope was displayed at the Holland Hotel in Duluth, before a large group of northern Minnesota dealers. It was also shown in Superior, Wis., at the Skating and Curling Club. At both demonstrations the many deal-

ers and their staffs, as well as prospective buyers, expressed the greatest enthusiasm. Panatropes are now being delivered to Northwest dealers and several large retail sales have already been made.

### Looks for Better Business

E. G. Hoch, of the Cheney Co., says that while the phonograph business is quiet now he believes that it will soon be better for all lines when public opinion has crystallized as to which of the new methods of reproducing music is the most desirable.

### Receive New DeForest Model

The company has just received a new shipment of the DeForest model W5. This is an innovation both in design and mechanism that gives a most natural reproduction.

### News Brieflets

Steve Murphy, of the Murphy Music Co., St. Cloud, Minnesota, sends word to his Twin City friends that he and Mrs. Murphy are the proud parents of an infant son.

Jack Roden, former Twin City music man, has opened a Brunswick shop in Miami, Fla.

Milton Lowey, for many years with the Laurence Lucker Co. and more recently associated with Foster & Waldo, has been receiving the sympathy of his friends because of his bereavement in the death of his father.

## Unusual Columbia Record

A Columbia recording scheduled for release within the next week or two that is certain to find a wide-selling market is "The Unknown Soldiers' Grave," an old-time tune type song, sung by Al Craven. The selection has unusual bugle effects.

## Changes Firm Name

The Atwater Kent Radio Shop, Syracuse, recently changed its name to the Warren Radio Shop.

# Big Profits in Udell Radio Cabinets



No. 744 Radio Cabinet

One of our newest numbers—a big winner. Handsome and practical. Built-in horn. Priced right!

HERE is illustrated another example of the rare values to be found in all UDELL Cabinets. You can make friends and money by stocking and selling this line now! Also UDELL Player Roll Cabinets and Console Talking Machines.

Write for Catalog



THE UDELL WORKS, Inc.  
28th St. at Barnes Ave., Indianapolis, Ind.



## Milwaukee Retailers and Wholesalers Close the Year With a Rush of Business

All Lines Move as Holiday Shoppers Throng the Stores—Popularity of New Instruments Increasing—Expect to Speed Deliveries of Orthophonic Victrolas—Other Important Trade Activities

MILWAUKEE, Wis., January 8.—December was a very big month in radio, according to reports of Milwaukee jobbers and wholesalers, and the outlook for January is very bright. This has been a very big year for radio in this territory, and it now looks as if the demand would continue in fair volume through February and into March before any decided drop is noted. Record sales have been unusually good during the past month and are expected to continue active. There is a big demand for the new styles of talking machines, but the question of getting deliveries is still of primary importance.

### Yahr & Lange Busy

"There has been a heavy demand for Sonora radio, combinations and loud speakers during the past month," stated Fred E. Yahr, of Yahr & Lange, Sonora wholesalers in Wisconsin and Michigan. "December was the biggest month we ever had in our music department. This was due partly to the development of our Michigan territory as well as to the increased demand for radio."

Yahr & Lange closed out the last of the De Luxe models in Sonora phonographs during December by offering special price concessions, so that the Sonora phonograph can now be obtained only in the combination phonograph and radio instrument. Mr. Yahr announced that his firm has now taken over the national distribution for the new Super-Ball Antenna, which is being manufactured by the Super-Ball Antenna Co., of Green Bay, Wis. This new antenna, which is a metal ball ten inches in diameter, is expected to become a very important accessory in the radio field, according to Mr. Yahr.

### Panatrope Popularity Grows

"January will be a big month for Brunswick dealers, judging from the present outlook," stated Carl Lovejoy, Brunswick representative in this territory. "There has been great interest shown in the new Panatrope, and dealers state that they have no trouble disposing of the instruments as fast as they are received. As deliveries should come through more rapidly during the month of January, the outlook for the month is wonderful."

### Expect Quicker Orthophonic Deliveries

"January should be a very good month for the Orthophonic Victrola," declared Harry Gold-

smith, secretary of the Badger Talking Machine Co., Victor jobber. "Deliveries should come through at a fairly good rate during that month, and dealers are ready to dispose of them as fast as they come. The record business has been exceptionally good during the past month. Our shipments on December 29 were the largest of any day of the year."

### C. D. Weeks Optimistic

"We are very well satisfied with our progress during the past year, and we think that the season is by no means over yet," stated C. D. Weeks, president of the American Radio & Equipment Co. "It looks to me as if January would be as big a month as December, and I believe that buying will continue into February." The American Radio & Equipment Co. has been in existence since last Spring, and has been doing very well in featuring Music Master and Magnavox lines.

### Find Newspaper Ads Profitable

Advantages of newspaper advertising were set forth recently by the Milwaukee Journal in a full-page advertisement, which told of the advertising experiences of three prominent Milwaukee music stores, the Kesselman-O'Driscoll Co., the Noll Piano Co., and the Milwaukee Piano Mfg. Co. The Kesselman-O'Driscoll Co., which carries a full line of musical instruments, including Brunswick, Victor and Edison phonographs, Radiolas and Atwater Kent radio, believes in consistent advertising. The Milwaukee Piano Manufacturing Co., retailer of the Waltham line, attributed its success largely to its newspaper advertising. The Noll Piano Co. used the Journal Roto Art section every Sunday for a period of two and a half years, and stated that "to this powerful medium we attribute our highly gratifying business increase during that time," adding that, based on the cost per sale, this was the most economical form of advertising the store had ever used.

### Julius Andrae & Sons Co. to Expand

The radio department of Julius Andrae & Sons Co., distributors for the Radio Corp. of America, Crosley and Radiodyne, will be enlarged as the result of the reorganization of the firm. The change involves the separation of the automotive division of the firm from the remainder of the organization, and the incorporation of a new firm under the name of the Andrae Auto Supply Co. to handle this division. The new firm will be located at 277 Milwaukee street in a three-story building, which is now being remodeled. This will provide space for the expansion of the radio and other departments of the electrical division of the firm, headed by H. P. Andrae, and located at 354-364 Broadway.

### Little Tots' Records Popular Gifts

Little Tots' records and albums proved a very popular Christmas item in the phonograph and record department of Edmund Gram, Inc., home of the Steinway, according to Miss Dorothy Beards, manager of the department. She stated that these record books solved the gift question for many shoppers who wanted something for little children.

### Lectures Create Interest in Zenith

Interest in the Zenith radio was created last month by the appearance of Capt. Donald MacMillan, of arctic fame, who spoke before a dinner meeting of the Izaak Walton League. Members and their wives gathered for one of the largest dinners of its kind ever given by the organization. Capt. MacMillan gave an illustrated lecture describing his experiences on his recent trip to the Arctic Circle.

### W. L. Miller Resigns

W. L. Miller tendered his resignation as advertising manager of the French Battery Co., effective January 1, after holding this position for about three years. He has several plans for

the future under consideration but for the time being will devote his attention to a Madison, Wis., advertising agency in which he holds an interest.

### Purchase Plant Addition

The Burgess Battery Co., of Madison, Wis., has announced the purchase of the Moline Plow Co. plant No. 2, located at Freeport, Ill. The officials of the battery company state that the plant will be used as a branch of the Madison laboratories, and that about 200 people will be employed when operations get under way.

## Optimism Marks St. Louis Columbia Branch Meeting

Representatives Gather at the Headquarters of the Company in St. Louis for Last Sales Meeting of the Year—Bright Outlook

St. LOUIS, Mo., January 6.—Representatives of the local branch of the Columbia Co., who cover the States of Nebraska, Kansas, Oklahoma, Arkansas, Missouri, Illinois, Indiana, Tennessee, Kentucky and Mississippi, gathered at the headquarters of the company here on December 26 for the last sales meeting of the year. The meeting was presided over by P. S. Kantner, manager of the local branch and director of the Kansas City branch.

The feature of the meeting was the spirit of optimism and enthusiasm of the sales representatives. In this connection, Mr. Kantner said:

"I was very much enthused at the spirit of optimism that prevailed among all of the salesmen for business for the year of 1926. Generally in covering an area of territory this large there are always some pessimistic reports that do not look well for the opening of business for the year, but practically all of the salesmen reported that there were no adverse conditions which had any indication of offering any resistance to progress for the coming year. The unanimous opinion is that the Columbia Co. is on the brink of a year of prosperity. Dealers over the entire territory are very optimistic over the superior merchandise that Columbia is putting out and this plus the general prosperous conditions that exist throughout the entire territory brings about a satisfactory condition."

Mr. Kantner also mentioned that the branch organization is now very complete, paying tribute to the efforts of the members of the sales staff, who have been largely instrumental in bringing about the fine showing of the past year. The organization consists of William B. Oekenden, in charge of the Kansas City branch; Louis Marks, Memphis territory; F. H. Brandt, who covers the Illinois, Indiana, and Missouri territory; George C. Fuhri, in charge of the St. Louis territory, and James Fletcher, who covers Kansas City proper.

A strenuous campaign has been planned with the object of opening new accounts for the first three months of 1926, according to Mr. Kantner, who declared that during this time the Columbia offices are not looking for any great amount of phonograph business, due to the fact that the new Columbia will not appear on the market for some time, and during that time all efforts will be directed toward lining up a list of new accounts.

## Files Bankruptcy Petition

The Hollywood Phonograph Record Co., 6527 Santa Monica boulevard, Hollywood, Cal., has filed a petition in bankruptcy recently, listing its assets at \$26,800 and its liabilities at \$49,012.

## COTTON FLOCKS

Air floated, all injurious foreign matter eliminated for

Record and Radio Manufacturing

THE PECKHAM MFG. CO. 238 South Street  
Newark, N. J.

## Hermann Thorens

Ste. Croix, Switzerland

Manufacturer of Europe's Most  
Celebrated Swiss Phonograph  
Motors

Write for descriptive  
matter and prices on  
portable motor num-  
bers. 36 single-spring  
motor, 24BC and 28BC  
double-spring motor.

L. H. JUNOD & CO.

104 Fifth Ave. New York

Sole Agents for the U. S. A.



This quarter-page advertisement of Landay's ran in the leading New York papers.

**Landay's are Pioneers in all that is BEST in Radio Equipment**

**The Link Between Phonograph and Radio**



**19.50 COMPLETE**

**Selectron**

IN keeping with the progressive policy of the ten great Landay Stores, Landay Bros. announce the introduction of the SELECTRON—the first and only device that permanently and perfectly makes use of your phonograph Tone Chamber as a Radio SPEAKER. The range of tone you can get from your radio receiver by means of this simple appliance—merely turn the dial—and the radio sings from the depths of your phonograph. Turn the dial again—instantly you have the music of the radio. It is so simple that you can not disturb your machine in any way whatsoever. Come into our nearest store and see the wonderful Selectron AT ONCE.

**HEAR IT TODAY**  
At The Nearest LANDAY STORE

**Landay BROS.**

\*LANDAY HALL  
42nd Street & 6th Avenue  
427 Fifth Avenue  
\*23 West 42nd Street \*745 Southern Boulevard  
6th Ave., Bet. 34th & 35th Sts. \*Druggist \*New Haven  
\*New York \*Yonkers \*St. Vernon

**OPEN EVENINGS—TILL 10 P. M.**

# The Progressive Dealer Orders

# SELECTRON!

Makes a Phonograph the best loud speaker in the world—and perpetuates the sale of records besides

—because it sells at sight!

—and allows a liberal dealer profit!

## The One Way to Sell Your Customer Radio and RECORDS

Many of those who want the radio-phonograph combination won't buy them. They want to trade in their old phonograph first—getting a generous allowance for their antiquated machine.

Therefore it has always been difficult to sell these people—because the proper sales-clincher has been absent.

The SELECTRON unites the radio and phonograph without being "just a unit." Its selling value is obvious. Its sale is certain. A twist of the dial and you hear the radio—another twist, and you have record playing. *And you know the importance of making record playing easy.*

No installation! A child can attach it! The Selectron comes below the tone arm. The radio sound does not pass through the tone arm but goes directly to the tone-chamber. You change from radio to record (or vice versa) by merely turning a dial.



# SELECTRON

CORPORATION

Retail Price

# \$19.50

565 Fifth Avenue

New York, N. Y.

Liberal Dealer Profit



## Sales of Expensive Instruments Featured Year-End Business in Cincinnati Field

**Big Volume of Holiday Business Closes Satisfactory Year and Brings Up Sales Volumes—All Lines Moved Briskly and Dealers Look Forward to a Continuation of the Excellent Demand**

CINCINNATI, O., January 8.—With its big volume of holiday sales, December was a wonderful month for the talking machine dealers. The new machines and records had revived public interest in the talking machine to such an extent that they had become the rage once more, and as a consequence the demand was greater than the supply. The feature of the market was a greatly increased demand for the better and more expensive grades of instruments.

According to Otto Grau, head of the Otto Grau Piano Co., 224 West Fourth street, which also has a large suburban store at 4739 Main avenue, Norwood, while the number of talking machines sold only showed a slight increase, there was a considerable increase in the sales total of the holiday season. This, he explained, was because the purchasers almost invariably chose the more expensive instruments. There was a wonderfully large demand for the Orthophonic, he said, and it is unfortunate that he could not make deliveries before Christmas. There was, of course, the usual lull after the holidays, but business is already beginning to get more active, he stated, and he looks for a continued increase in sales.

### Big Demand for Panatrope

"The holiday demand for our new Panatrope was extremely large," said J. E. Henderson, manager of the local branch of the Brunswick-Balke-Collender Co. "There was an enormous demand for our new records. All of our dealers had demonstration Panatropes in advance of Christmas, and a large number of orders were taken for future delivery." Just before Christmas Mr. Henderson went to Ashland, Ky., to attend the opening of the new Carter Brunswick Shop, which is one of the finest stores in the city.

"We did a splendid business in records in 1925, and even in the Summer there was a good demand," said Louis H. Ahaus, owner of the Brunswick Shop, 532 Walnut street. "The Christmas demand for records was greater than ever before, and our stock was reduced almost to the vanishing point. As soon as we are able to get the Panatrope in quantity we will be busy filling the orders that we have taken, through

demonstrations. The new instrument with the new record is going to be a winner."

### Features Okeh Records in Window

The Brunswick Shop, operated in this city by Louis Ahaus, has been attracting considerable attention to Okeh recordings through the medium of well-planned window displays, one of



Effective Okeh Window Display

which is reproduced herewith. The illustration shows how Mr. Ahaus recently featured "Sleepy Time Gal," as recorded by the General Phonograph Corp. on Okeh record 40502. This number has been exceptionally popular throughout local territory, the dealers reporting brisk sales, according to the Sterling Roll & Record Co., local distributor of Okeh records and other talking machine products. As a result of this popularity, many of the dealers handling Okeh records have taken advantage of their window space to "tell the world" they have the record in stock.

### Enjoyed 50 Per Cent Business Gain

Howard L. Chubb, head of the Chubb-Steinberg Co., 17 East Sixth street, expressed himself as satisfied with the past year's business, as the sales showed an increase of 50 per cent over the previous year. "We would have done better, of course, if we had been able to make deliveries of the Orthophonic before Christmas," he explained. "We also sold a great many Sonoras."

A good volume of business was done in 1925 by the Ohio Talking Machine Co., wholesaler,

at 427 West Fourth street, according to A. H. Bates, secretary of the company. Conditions for 1926 are in every way favorable, and with the revived interest in the talking machine which has been created by the new instruments, it should be the best year the trade ever has had, he declared.

### Orthophonic Popular as a Gift

"We had a fine demand for the Orthophonic during the holidays, and we sold quite a number for future delivery," said Geo. P. Gross, head of the Geo. P. Gross Co., 1328 Main street. "There was also a very large demand for records, and this department did well. Radio sold very well during the holidays, and we look for a good volume of sales of radio this year."

"The past year was a wonderful one for us," stated Miss Rose Hellberg, local manager of the Columbia Phonograph Co., 222 West Fourth street. "There is every indication that this year will be still better, for us and for our dealers. True, business was somewhat sluggish in the Summer, but we more than made up for that in Fall and Winter. Our holiday business broke the record of the previous year, both in sales of machines and in sales of records. We are making shipments promptly and our dealers are not handicapped by shortage of stock."

### Brisk Movement of Starr Products

An unusually large holiday business in Starr phonographs and Gennett records was reported by W. M. Purnell, wholesale manager for the Starr Piano Co., 27 West Fourth street. "In the smaller cities and in the towns," he explained, "the upright instruments were in greater demand than the console types. Business is picking up after the usual last-of-the-year lull, and there is every reason to believe that sales will continue to increase through the Winter and until late Spring."

Frank Donovan, formerly with the Pierson Piano Co., Indianapolis, became manager of the talking machine department of Pogue's, a large department store, the middle of December.

The W. G. Woodmansee Piano Co. reports a fine volume of holiday sales of Edison instruments and records. The company is making preparations to move into its fine new home, at 410 Main street.

### Good Holiday Business

"Our holiday business was the largest we ever had," said Ben L. Brown, manager of the Sterling Roll & Record Co., 137 West Fourth street. "The Adler-Royal phonograph went fine and Operadio sold splendidly. The sale of our portables, the Carryola, Flapper and the Chic, were phenomenal."

"The past year's business showed a fine increase and we had a larger holiday business than ever before," said Edw. P. Cooper, an enterprising music dealer at 810 Madison avenue, Covington.

Once more Mr. Cooper is in the Covington limelight, because of his unusual radio service. There was a lot of radio trouble over there a while ago, and he, in co-operation with the newspapers, set out to find and remove it. Finally he found that a large high-tension transformer was leaking and thus affecting the radio receivers for six miles around. As a result of his enterprise Mr. Cooper got a lot of publicity that no amount of money would buy.

### New Broadcasting Policy

CINCINNATI, O., January 6.—A new development in radio broadcasting is to be found in this city, where a Community Broadcasting Committee of the Cincinnati Chamber of Commerce is conducting an interesting series of broadcast concerts, featuring artists and organizations of prominence through Station WSAI, this city. Among those who have appeared, or will appear, on the radio programs are included the Cincinnati Symphony Orchestra, Brace Kerns, soprano; Alma Beck, contralto; Oliver Smith, tenor; Joseph Dito, harpist, and Mieszyslaw Munz, the noted pianist. The programs are about equally divided between popular, semi-popular and classical numbers.

# Okeh Records!!!

## Result of TrueTone Recording!

### A Sound Investment for Sound Business

No records offer a better opportunity to increase your business. This statement is determined by the past achievements of Licensed Okeh Record Dealers. A new Okeh Record License Assures Prosperity for the coming year.

## STERLING ROLL AND RECORD CO.

137 West 4th Street, Cincinnati, Ohio



# Get this point

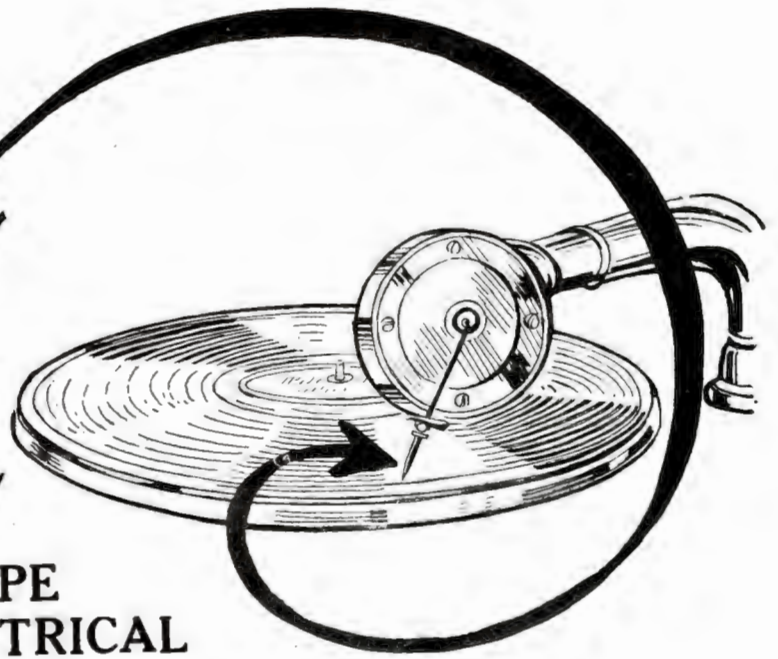

THE "NEW" TYPE  
MACHINES AND ELECTRICAL  
RECORDED RECORDS AT THEIR  
BEST WITH THE *BEST* NEEDLES

—of course—they are!

**BRILLIANTONE—REFLEXO—GILT EDGE**

*The Leaders in the Phonograph Needle Field*

The new type machines have been designed to stimulate business in the trade and have certainly been of tremendous influence in directing public attention to phonographs.

This means that once again the public will be buying records—and that means Needles.

If you have not enjoyed in the past years the experience of building customer good will with the leaders in the Needle field, you should immediately get in touch with us or your jobber and find out why Brilliantone, Reflexo and Gilt Edge outsell every other needle on the market.

These scientifically constructed phonograph needles are the right kind to use on the new *electrical recorded records* especially if your customer is desirous of getting out of the machine the full tonal qualities.

Brilliantone—Reflexo—Gilt Edge have always led the field in quick sales and with the new stimulation in trade during 1926 you should feature these popular brands if you want to make your phonograph department a profitable and popular department with your customers. Let your jobber tell you the entire story or write us direct for details.

## BRILLIANTONE

STEEL NEEDLE CO. of AMERICA, Incorporated

*Selling Agents for W.H. Bagshaw Co., Factories, Lowell, Mass.*

370 SEVENTH AVE., at 31st St., Suite 1214, NEW YORK

*W. H. Bagshaw Co., Export Dept., 44 Whitehall St.  
New York City. Cable Address: "Brillneedl"*

SOLD THROUGH JOBBERS EVERYWHERE



WRITE today to us or your jobber for samples and sales-getting information.





## Richmond Stores Cleaned Out of the New Instruments by the Pre-Holiday Demand

Many Dealers Awaiting Arrival of New Stocks to Take Care of Orders in Hand—Danville Music Co. Chartered—Trade Mourns Death of Houston F. Allen—C. H. Held Promoted

RICHMOND, VA., January 9.—Phonograph dealers in this territory report that they were well pleased at the volume of Christmas business both in machines and records, the volume in most instances being in excess of that for Christmas 1924. Victor dealers say that they would have done considerably more business than they did, but for the fact that it was impossible to get a sufficient number of new Orthophonic Victrolas to meet the demand. All of the new styles moved exceedingly well from the time that they were placed on the market. Because of the difficulty being encountered in getting additional machines, Victor jobbers are going slow in appointing new dealers, being content to retain the

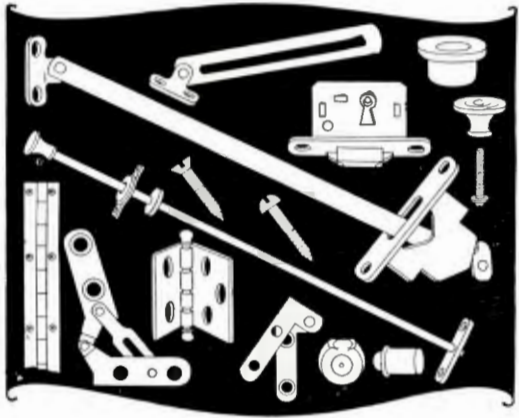

## Rockford Hardware

FROM the complete Rockford Line of Hardware your every need can be supplied to advantage. Over 300 hardware items for pianos, phonograph and radio cabinets. Write for samples of items you use, and catalog.

### National Rock Co., Rockford, Ill.

U. S. A.

Cable Address—Natlock

#### Branch Sales Offices:

Chicago, Ill.	Indianapolis, Ind.
Cincinnati, Ohio	Jamestown, N. Y.
Detroit, Mich.	Los Angeles, Calif.
Evansville, Ind.	Seattle, Wash.
Grand Rapids, Mich.	Milwaukee, Wis.
High Point, N. C.	Sheboygan, Wis.
	St. Louis, Mo.

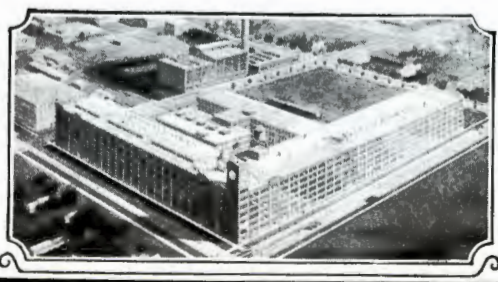

accounts already established. The Biggs Music Co., of this city, it is learned, is negotiating for a Victor connection.

#### Good Demand for Uprights

The James Cowan Co. reports that it is now concentrating on Columbia records. It wholesales Outing portables in this territory as well as Columbia machines. Unlike most dealers, the company is having a very favorable experience with upright models, finding that they are going as well, if not better, with its trade as the consoles. James Cowan, head of the company, says that he believes that there will always be some demand for the uprights as long as they are on the market because of the fact that they take up less space in a home than the consoles.

Talking machine dealers cashed many Christmas savings checks, when this money was released from the banks during the pre-holiday season, and in most instances some of the money was spent in their stores, principally for records.

The James Cowan Co., with a view to keeping abreast of the times, recently added radio. It has taken on the Pathé line.

#### Danville Music Co. Chartered

Of interest to the trade is the news that Danville has a new music company, which plans to sell pianos, organs, radio equipment and phonographs. It was recently chartered under the

name of the Danville Music Co. C. S. Conway, the president, was formerly connected with the Frix Piano & Phonograph Co. of Danville. J. L. Gilliam, likewise associated previously with this company, is also interested in the new firm, being vice-president. The firm has just established itself in a store immediately across the street from the Frix firm.

#### Death of Houston F. Allen

Houston F. Allen, well known to the music trade in this territory, died recently in Norfolk. He was associated with the Levy-Page Co., of Norfolk, which handles the Victor line of phonographs. Besides his widow he is survived by a young son and daughter. Several representatives of the Corley Co. went to Norfolk to attend his funeral, which was held there before the body was taken to Petersburg for burial. They were Frank W. Corley, Fred R. Kessnich and G. W. Greener.

#### Charles H. Held Promoted

Goldberg Bros., Pathé distributors, announce that Charles H. Held, manager of their Baltimore district for the past year or more, has been promoted to superintendent of the phonograph department of the company, with headquarters in Atlanta. In this capacity he will continue to supervise the Baltimore territory as well as the remainder of the Southern States in which the company does business.

The proprietor of the Rackley Piano Co., of Goldsboro, N. C., which handles a general line of musical instruments, including talking machines, dropped dead December 23 and was buried Christmas day. Mr. Rackley was very popular and his untimely passing came as a great shock to his many friends.

## Interest in New Instruments Provides a Fine Start for 1926 in Indianapolis

New Talking Machines Prove of Especial Interest—Radio Trade Plans to Tie Up With "Silent Week"—Wilson-Stewart Music Co. Reorganized—Brunswick Shop Promoting Panatrope Sales

INDIANAPOLIS, IND., January 8.—Local interest is divided equally between radio and the new talking machines that have been brought before the public, the latter especially proving a great stimulator of sales.

#### To Observe "Silent Week"

Reports from radio dealers indicate that the interest has not diminished at all, and that Christmas buying was heavier than in previous years. This condition is especially noted at the Pearson Piano Co., who handle the Erla radio. L. T. Glidden, manager of this department, notes a tendency to buying of a higher priced multiple tube set. During the week of January 21, this store will observe a "silent week" and the fourteen radio salesmen of this store will conduct demonstrations in their respective homes and a special effort will be made to get the foreign stations for the prospective radio buyers. The demonstrations will be conducted in the several parts of the city, with the public invited to attend and listen in. "Such a plan I believe will prove of great value to us in making the Erla radio better known," states Mr. Glidden. "The outlook for 1926 is very promising and I believe we will have the biggest year since we have gone into the radio field."

#### Brighter Outlook Follows Reorganization

W. G. Wilson, manager of the Wilson-Stewart Music Co., is satisfied with the business this store did the past year. Reorganization of this store by the addition of Mr. Stewart instituted new plans that have proved valuable to the new organization. Record sales have shown increased activity after a decided slump last Fall. "Radio sales," states Mr. Wilson, "are moving better than they did the past year, due to the fact that our line is well advertised and the fact that we are able to give prompt service."

#### Big Year-End Demand at Baldwin's

C. P. Herdeman, manager of the talking machine and radio department of the Baldwin Piano Co., has much to say on business done in 1925. In reply to whether or not talking

machine sales had increased, Mr. Erdman said: "Our December record sales were a 'wow.' Our December record business was greater than in any previous year. Talking machine sales were held down because we were unable to get delivery of the new Orthophonic."

It will be recalled that late in the Summer, the Baldwin Piano Co. moved from its old Pennsylvania street location to spacious new quarters in Monument Circle in the heart of the downtown district, which has been of great advantage to them in their record sales.

#### Featuring the Panatrope

W. J. Baker, manager of the Brunswick Shop, exclusive Brunswick dealer, is well pleased with the interest manifested in the new Brunswick Panatrope. "I have found that the phonograph interest is reviving in Indianapolis, and the Panatrope is making a great hit with the public. Each day sees an added number of people who are interested in the new Brunswick. Local newspaper advertising with window displays have aided this store in advertising the new instrument. Our record sales are showing added activity and sales have increased accordingly," states Mr. Baker. "Private demonstrations keep us busy and prospects are very bright." Radio sales are running ahead of their last year's record.

## Marsh Music Co. to Move

HOLLYWOOD, CAL., January 8.—The Marsh Music Co., 5524 Santa Monica boulevard, this city, which, until the first of this year, was known as the Paramount Music Shop, will move to new quarters next door to its present location on February 1. The growth of the business necessitated this move to a larger establishment. The store made known these announcements to its clientèle through an attractive card, which also extended the greetings of the season and an expression of thanks for the patronage extended in the past.



# STEWART-WARNER *Matched-Unit Radio*

## What did 1925 teach you?

**T**HE past year has raised the "Old Harry" with rabid radio price-cutters, manufacturers of "orphan" sets, retailers who scorned service and slipshod radio retailing in general.

If you are sincere and have an abounding faith in the wonderful future of Radio, heed this timely tip.

1926 and many years to come will handsomely reward the man who sells Stewart-Warner Matched-Unit Radio—for many reasons.

Stewart-Warner is in the radio business to stay and to give service! The name, Stewart-Warner, is known the world over to represent the highest quality merchandise, dependable service, and a square deal. Over twelve million people are today satisfied users of Stewart-Warner products. To keep *their* confidence and to win *new* millions, we perfected and built our Matched-Units to give complete radio satisfaction. Our distinct triumph of **MATCHING** our Instrument with our Reproducer, Tubes and Accessories, *all* to work in perfect unison, brings perpetual radio enjoyment for your customers.

Our **NAME** is *right*, our **FACTORY** is *right*, and our **PRODUCT** is *right*.

Our **SALES PROPOSITION** is right! Read and judge for yourself.

Your success means ours. We *must* protect you from unfair competition, to protect ourselves. And we *have*, 100% strong!

For a Stewart-Warner Representative there are *no* bargains—*no* cutting of prices—*no* jobbers and *no* competing representatives in his district. You deal directly with the Stewart-Warner Factory Branch in your district. The Stewart-Warner Distributor positively *will not* sell any of our Matched-Units to any dealer but an authorized Stewart-Warner Representative.

Our national advertising campaign for 1926 will vastly increase our constantly growing demand for Stewart-Warner Matched-Unit Radio.

Some extremely good districts are still open for high-grade, sincere men who appreciate that Stewart-Warner have the Radio and the unusual sales proposition they have been waiting for. Profit, Protection, Prestige and Permanence await you. Don't delay—write today!

Tune in  
**STEWART-WARNER**  
Programs  
Station WBBM  
226 Meters  
TIME SCHEDULE  
OPPOSITE

## Stewart-Warner

SPEEDOMETER CORPORATION

1824 Diversey Parkway - CHICAGO, ILL.

Mon. - 12-3 a.m.  
6-7 p.m.  
Tues. - 9-12 p.m.  
Wed. - 8-10 p.m.  
12-2 a.m.  
Thur. - 8-10 p.m.  
Fri. - 8-10 p.m.  
Sat. - 8-9:30 p.m.  
11-2 a.m.  
Sun. 4-6, 8-10 p.m.  
Chicago Time

Instrument  
plus Reproducer  
plus Tubes plus  
Accessories



Model 300  
\$65.00



Model 325  
\$80.00



Model 305  
\$95.00



Model 505  
Radio Table  
\$22.50



Model 410  
\$65.00

Console Table including Built-in Speaker and Battery Compartment, without Radio.



Model 310  
\$175.00

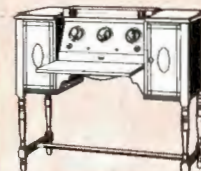

Model 315  
\$285.00

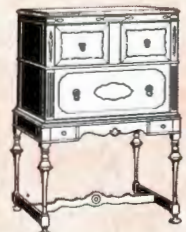

Model 320  
\$450.00



Model 400  
Reproducer  
\$25.00



Model 405  
\$19.50

Radio Tube  
Model S-W  
501-A  
\$2.50



TWELVE MILLION PEOPLE ARE TODAY USING STEWART-WARNER PRODUCTS



## A. Atwater Kent Discusses Present Problems and Future Possibilities of Radio

President of the Atwater Kent Mfg. Co. Describes in a Most Interesting Manner the Growing Part Radio Will Play in Everyday Life in the Future and How Problems Are Being Solved

[Radio, its attainments and its future possibilities, is engrossing the attention of practically everyone connected with the talking machine industry. A. Atwater Kent, president of the Atwater Kent Mfg. Co. of Philadelphia, manufacturer of radio receivers and radio speakers, is recognized as one of the foremost members of the great radio industry. His remarkable and generous contribution to the improvement of broadcast programs through his Sunday evening programs, featuring grand opera stars, also distinguishes him as one of the foremost benefactors of the industry. Probably no other person has delved more deeply into the subject of radio, its manufacture, its scope and its distribution. Therefore, the following statement, prepared especially for The Talking Machine World on the eve of the new year, is of particular interest.—EDITOR.]

To my mind, the outstanding feature of radio in 1925 is the greater and greater part it is taking in our every-day life. Every achievement of the year in radio has contributed to that. So in radio history I believe 1925 will be set down as the year when radio broadcasting began to assume a place in our daily affairs and when it began to take its place as a utility.

### Link-Up of Stations

A contribution to this is the link-up of many broadcasting stations. Nineteen twenty-six will see a still greater link-up, and with little difficulty I can imagine a possible line-up through which nearly half the people who are in the United States could hear a speaker. The greatest possibilities lie therein. If necessary, the President of the United States could rouse the Nation in the event of war. Messages requiring instantaneous transmission could be communicated instantly direct to the homes.

### Improvements in Sets

There has been a great improvement in radio sets. In fact, the radio set has reached the point of precision. I anticipate no revolutionary changes in the set of next year. There will be perfection, of course, and improvement, but the idea that one should not purchase a radio receiving set now because of early anticipated changes is erroneous.

### Better Programs

Broadcasting stations are improving their programs. We should not be impatient. Theirs is a hard job for they have to please all kinds of listeners with all kinds of tastes. I have found,

however, as a result of the Sunday night programs by world-famous artists that I was fortunate enough to be able to arrange, that the American radio public likes good music. A questionnaire I sent out brought a response from 92 per cent that there was not too much classical music on the air. The ultimate development in broadcasting will be to give the people the very best in every line.

### More Radio Sets

The increase in the number of radio receiving sets is in itself a notable thing. It would be difficult to estimate how many more sets there are now than there were at the end of last year, but the number has reached far into the millions. Last Summer it was estimated that there were at least 4,000,000 sets in the United States. The number greatly exceeds that now.

### Radio on the Farm

Two great developments which I believe will take shape in 1926 will be the use of radio on the farm and the use of radio in education. The Secretary of Agriculture has just said: "Radio is already a vital factor in the economic and intellectual life of the farmer. The part it will exert in the future is beyond calculation."

I have been delighted to see that Secretary Jardine has provided increased means in his department for official attention to radio development among farmers. Such a move cannot help but have far-reaching effect. Secretary Jardine has said: "It is easy to foresee millions of dollars added to the value of agriculture through the employment of methods imparted by radio instruction." This is apart from the immediate and practical value to the farmer of receiving daily market quotations by radio, to say nothing of the interesting and helpful programs for the benefit of the housewife.

### Radio in Education

It is very difficult to prophesy the part radio will eventually play in education. To my mind it is sure to take a most important part in the schools, colleges and universities of the country. It will be a gradual development, of course. I do not look for any immediate widespread development in the teaching of any particular sub-

ject. Radio will never take the place of the teacher in the class room, but it will supplement her work; it will bring things of value to her and the time will come when every school-room will have its radio receiving set and the programs will be so varied and classified that it will be possible to tune in on things of special interest almost at any hour of the day.

### Interference Problems

Interference problems are being taken care of and, with the proper support of Secretary Hoover's department, they will be reduced to a minimum. In fact, the whole radio problem is beginning to take shape and when one realizes radio is an industry only a few years old, it is amazing that it has taken such an important place in our national life so soon. There have been no precedents to follow. For that reason it is fortunate that the administration and the guidance of radio into practical channels is in the hands of such an able and level-headed man as Herbert Hoover.

## How Jos. Strauss Co. Won Attention for Zenith Models

Gave Demonstrations in Public Auditorium in Buffalo During Week Before Christmas

BUFFALO, N. Y., January 8.—Placing radio receiving set demonstrations on a par with afternoon musicales was the achievement of the Joseph Strauss Co. of this city, and during the entire week before Christmas demonstrations were held in a public auditorium in Buffalo to which a selected list of friends, prospects and customers were invited. The room in which the concerts were given was attractively decorated with holly wreaths, in keeping with the season, floor lamps and beautiful draperies. The Zenith sets featured in the display were the Super Zenith VIII, the Zenith De Luxe English model, a ten-tube set with five loud speakers, featured in the center of the display, and the Zenith De Luxe English model with ten tubes and three loud speakers, featured on the extreme right.

The Joseph Strauss Co., Zenith dealer of Buffalo, N. Y., mailed to a list of friends, customers and prospects a unique holiday greeting card. It showed two little tots tuning in with the Super Zenith VIII while a "Merry Christmas and Happy New Year" floated from the loud speaker.

## Rudolph Friml Records for Columbia Catalog

The Columbia Phonograph Co., New York, will release the latter part of this month the first recording by Rudolph Friml, the famous composer of some of the best-known musical hits on Broadway during the past couple of years. Mr. Friml's first recording couples the "Song of the Vagabonds," the outstanding musical hit of the "Vagabond King," now playing to capacity audiences on Broadway, and "Chansonette," which was a hit in the Ziegfeld Follies about two years ago. The selections are played as piano solos.

## Starr Piano Co. Output Big

RICHMOND, IND., January 7.—Fred Gennett, secretary of the Starr Piano Co., manufacturer of Starr phonographs and pianos and Gennett records, reports that the past year was the best enjoyed by his company, viewed from the angle of output, as more musical instruments were made than ever before. Mr. Gennett feels that the coming year will see still further expansion, as advance orders received warrant a high feeling of optimism.

Vincent Follmer has been appointed receiver for the Hytone Battery Mfg. Co., Inc., radio batteries, 2420 First avenue, New York. Assets about \$15,000; liabilities not stated.

## Consider Who Sells the A-C Dayton

If any one should know the respective merits of the various radio receivers on the market, it is the jobber, who sooner or later sees all of them.

The A-C DAYTON is not only sold by leading jobbers throughout the country but is universally endorsed by them. They like it because it sells and then stays sold—which means greater profit for all concerned.

Such a receiver deserves investigation, at least. Clip the coupon now and mail to us for full information.

**The A-C Electrical Mfg. Co.**  
DAYTON, OHIO

Makers of Electrical Devices for More Than Twenty Years

Standard Cabinet without accessories, \$115  
(\$120 west of Denver)

Please send me full information on the A-C Dayton line.

Name .....

Address .....

.....

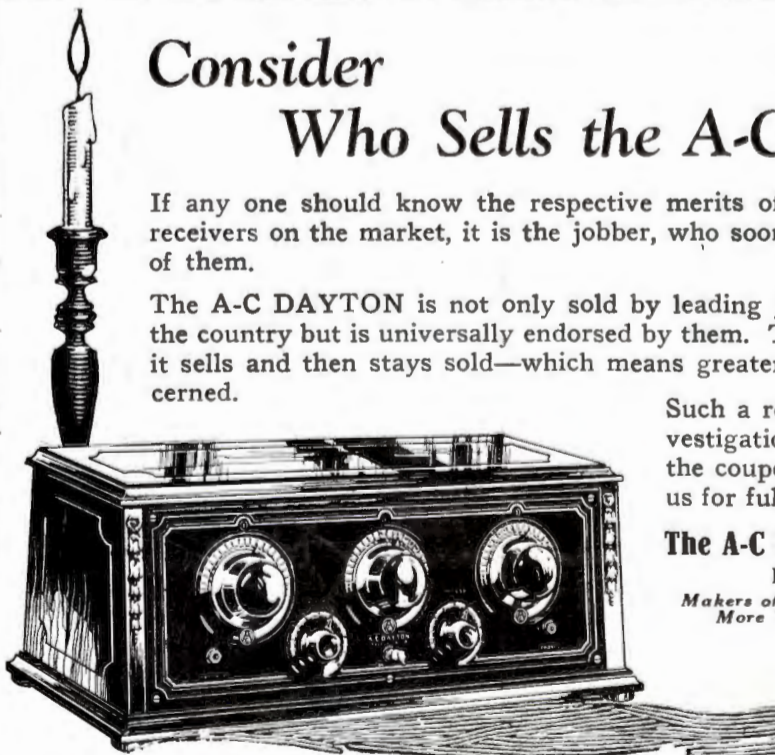

# A-C DAYTON RADIO

for the man who believes his own ears



## Important Activities Feature the Year-End Throughout the Cleveland Territory

Dealers Planning Vigorous 1926 Sales Campaigns—RCA Dealers Co-operate in Putting Over Advertising Campaign—Many New Accounts Opened—Optimism Features Entire Trade

CLEVELAND, O., January 8.—Twenty-five dealers who specialize in RCA sets co-operated with the manufacturer and wholesale distributor, the Erner Electric Co., in a double spread advertisement in the Cleveland Plain Dealer of December 30. The motive of the ad was to call attention to the first of the series of concerts to be broadcast featuring John McCormack and Lucrezia Bori and the Victor Orchestra, and RCA models 25 and 28.

### Dealers Receive Sample Panatropes

All Cleveland Brunswick dealers received sample Panatropes the latter part of the month. The May Co. was the first to run an ad, and the \$600 model was featured. The new machines have met with a very enthusiastic reception not only in Cleveland but also in all territory served from the Cleveland district office. Due to the efforts of Branch Manager L. S. McLeod and District Manager E. S. Germain, a great deal of very effective missionary work has been done since the new machine was announced. This work was in the nature of demonstrations before many prominent clubs and societies. As a result of the numerous exhibitions and recitals, a number of good prospects have been developed for the trade, and now that the instruments are beginning to come through a large volume of business will result. At the salesrooms of the Brunswick Co., an attractive exhibit of the Panatrope and Radiolas has been made. Both Brunswick and Vocalion records sold well during the month and the prospects for 1926 business, according to L. S. McLeod, branch manager, look very good.

### Enjoys Biggest Year

"The best year in the history of the company in dollars and cents." This sums up the opinion of Howard Shartle, president of the Cleveland Talking Machine Co., Victor distributor. Speaking of the outlook for business in 1926, he states that the company's business will only be limited by the factory supply and is confident that the demand for Victor products will be greater in 1926 than in the history of the industry. The Orthophonic has gone over big, and the only difficulty has been in making deliveries. The recent advertisement by the Victor Co. to the public requesting that they be patient a short time longer and explaining the reason for delay in deliveries has helped the situation considerably. The RCA concert on New Year's night, and the appearance in Cleveland of prominent Victor artists all helped to boost the sale of Victor records.

### Buel-Lyons Co. Opens New Accounts

The Adler-Royal line of phonographs and radio enjoyed a good sale during December. The distributor, the Buel-Lyons Co., has opened some good dealer accounts. The Robert L. White Co., one of the oldest established music houses in the downtown section, took on the line and featured it with good success. The Carryola, and Carryola Flapper, portable phonographs, sold unusually well over the holidays. J. A. Blumenthal, special record salesman, has opened a number of new accounts within the past thirty days on Odeon and Okeh records.

### Euclid Music Co. Moves

The Euclid Music Co., whose executive offices have been located at Chester avenue near East Eighteenth street, has moved to the second floor of the company's store on East Ninth street. This gives them a more centralized location.

### Busy Month for Columbia Branch

An exceptionally busy month is reported by Branch Manager Mueller, of the Columbia Co. The branch sold out all its consoles by Christmas and had but a few straight models left in stock. Columbia records are steadily growing in popularity and several large downtown stores have added them and find them ready sellers.

The full-page newspaper advertisements inserted by the Columbia Co. have done much towards boosting record sales, and Columbia dealers have shown their appreciation of the advertising by tying up with it. There is every indication that 1926 will be a big year for Columbia products, exceeding that of 1925.

### Zenith Demand Continues

Zenith models of all sizes have been in good demand and the cabinet models are being featured by some of the large music houses. The ten-tube super Zenith was received by the distributors, the Cleveland Talking Machine Co. and created much interest among the trade.

### Boosting Buying Music on Instalments

Streamers bearing the slogan: "Include music in your instalment purchases" were sent to all members of the Music Merchants' Association of Ohio this month by Rex C. Hyre, secretary. Quite a number of requests for additional supplies were received.

### Closed Big Atwater Kent Year

The preparations made early last Summer by the Cleveland Ignition Co., distributor of the Atwater Kent line, to carry a large stock of the various models, and insistence that dealers also make adequate preparations for the rush season, proved to be good policy, for the company did the largest business in their history in 1925. A last-minute rush cleaned them out of several models, but these were reordered by wire and as a result the trade was enabled to fill all orders. The Sunday night concerts of Atwater Kent have given the line some fine advertising. The Limerick Contest the Cleveland Ignition Co. put on at the radio show developed thousands of live prospects and gave dealers all the

work they could handle. Ray Bechtol predicts that January will be a big business month for Atwater Kent, and bases his prediction on the fact that many people who received dividends and money for Christmas presents will spend the money for sets.

### Dealers Add Freed-Eisemann

The Haas Electric Co., distributor for Freed-Eisemann sets, has added new dealer accounts and has done a large volume of business in 1925. The company moved into larger quarters just in time to handle the rush business and looks forward to a bigger year in 1926.

## Philip K. Murdock Now With Sleeper Radio Corp.

Becomes Foreign Sales Manager of Prominent Radio Manufacturing Concern—Has Had Wide Experience in This Field

Philip K. Murdock, formerly foreign sales manager of the Bryant Electric Co., has been appointed to a similar post with the Sleeper Radio Corp., radio manufacturer of Long Island City, N. Y. Mr. Murdock, who has established his offices in the Woolworth Building, New York City, is well known in the export field. He was an old schoolmate of Gordon C. Sleeper, president of the Sleeper Radio Corp., at Dartmouth College, where he was a gridiron star. He served in the heavy artillery during the World War, his battery winning a Croix de Guerre from the French Government.

## Minnesota Incorporation

Wilfred C. Graham, Inc., has just been organized in Red Wing, Minn., to handle talking machines, pianos and other musical instruments, as well as furniture. The concern has recently been incorporated by Wilfred C. Graham, Simon P. Peterson and Lila I. Garvin.

## Start the New Year Right

with

**Okeh** Records  

THE entirely new recording principle just announced—TRUE TONE PROCESS—applicable either to electric or acoustic recording, and the many selling features of Okeh Records assuring a quick turnover of your record stock, makes an Okeh Dealership exceptionally profitable.

A limited number of franchises are available for Northern Ohio—Write us for details.

THE BUEL-LYONS CO.

WHOLESALE

Phonograph and Radio Products

1231 Superior Ave., N. E.

CLEVELAND



## Trade Activities of Pittsburgh Dealers

Rosenbaum Co. Featuring the Panatrope—W. F. Frederick Co. Opens New Store—W. B. Hamilton, Mellor General Manager

PITTSBURGH, PA., January 9.—The Rosenbaum Co. has installed a new Brunswick Panatrope in its phonograph department. Advertisements were placed in the Pittsburgh newspapers inviting the public to visit the department and listen to the Panatrope. C. R. Parsons, the well-known manager of the department, is making arrangements for a series of demonstrations of the Panatrope before women's clubs, schools and other bodies. At each of the demonstrations an assortment of records is used covering a wide field in the musical world and thus showing the public the advantage of having a Panatrope in the home or school.

### Opens New Music Shop

The W. F. Frederick Piano Co. has leased a large storeroom in the Schenley Apartment Block on Forbes street, where a modern talking machine studio will be installed. The W. F. Frederick Co. has also opened a new music shop in Brownsville, Pa., to replace the shop that was destroyed by fire several months ago. The new store is fitted up in a modern manner in which ample space is devoted to the Victor sales and display department.

### W. B. Hamilton in New Post

W. B. Hamilton is the new general manager of the C. C. Mellor Co., Victor and Brunswick dealer. Mr. Hamilton succeeds the late W. C. Dierks, with whom he was closely associated for more than twenty-five years. Mr. Hamilton stated that the holiday business in the phonograph and record line was brisk and that he was very optimistic concerning the 1926 business.

### In New Post

Miss Hilda Wehrle, who for a number of years was in charge of the Victor record department of the S. Hamilton Co. and later affiliated with the Columbia Music Co., is now associated with the C. C. Mellor Co.'s talking machine department.

### Plans to Move Business

T. E. McCausland, the well known piano and talking machine dealer, who has been located at the corner of Seventh street and Liberty avenue for the past twenty years, is leaving that location on May 1 next. At the present time he



## Hommel is a Helpful Jobber

¶ He maintains close contact with his dealers at all times.

¶ He carries ample stocks of reliable radio apparatus only so that his dealers are assured prompt deliveries.

¶ All user inquiries, resulting from his national advertising, are turned over to his dealers.

¶ A dealer repair and inspection department

is maintained so that all sets needing minor repairs can be fixed up immediately—thus saving the time and trouble of sending them to the factory.

¶ And last, but not least, he issues a complete catalogue of the Radio Sets and Apparatus he carries—known as the "Hommel Encyclopedia of Radio Apparatus" that Hommel dealers find invaluable in ordering and dealing with their customers.

Write to-day for Hommel's Encyclopedia No. 466-W.

WHOLESALE

# LUDWIG HOMMEL & CO

929 PENN AVENUE

PITTSBURGH, PA.

EXCLUSIVELY

has no announcement to make relative to his new location, which, however, will be in the downtown section. A new theatre is to occupy the site now occupied by Mr. McCausland's business.

### Reed Co. Holds Christmas Party

The Reed Radio Co., which operates stores in Pittsburgh, Greensburg, Connellsville, Uniontown and Brownsville, tendered a Christmas dinner and entertainment to the stockholders and sales and office staff in the ballroom of the new White Swan Hotel at Uniontown on the evening of December 30. At the close of the dinner there was informal speaking. A. C. Scott, general manager of the company, acted as toastmaster. Responses were made by R. H. Meyers, of the Brunswick-Balke-Collender Co., who described the new Panatrope, and Leo Reed, president of the company, who related the history of the company and its progress since its inception four years ago and stressed the impor-

tance of the spirit of service to the community in selling and distributing articles that would add to the entertainment and happiness of the persons served by the company. Mr. Reed also announced with regret the retirement of S. V. Burnside, manager of the Pittsburgh branch, who resigned in order to locate in the West for the benefit of his health. He then introduced Mr. Burnside, who briefly expressed his regret in leaving the Reed Co. family. A quintet from the Greensburg store sang several songs. Over 150 persons attended the dinner. The officers of the Reed Radio Co. are: Leo W. Reed, president; James H. Dunn, vice-president and treasurer, and Frank W. Newhall, secretary. These officers, with Allen J. Parke, and Harry B. Gans, comprise the directorate of the company. The Reed Co. is regional distributor for the Atwater Kent radio and the Brunswick machines and records.

### Sees Radio Change in 1926

"In my estimation in the coming year I see great changes in the radio field," says Eugene B. Connolly, acting manager of the Music Master Corp. "There will be an elimination of the smaller competitors. Development of a good alternating current receiving set, doing away with batteries entirely, will mark a big step for greater improvement. Our company has promised some startling things during the year to come. As far as we are concerned the Music Master dealers are taking very favorably to the Music Master franchise and appreciate the value of it."

### Optimistic Over Radio Outlook

H. N. Swartz, manager of the Pittsburgh office of the Eszenbe Co., makes the prediction that 1926 will be a good year for the radio business, especially for the sale of the Atwater Kent, the demand for which is increasing from day to day.

"There was a decided and notable advance toward stabilization of the radio business during the year just closed," says W. K. Thomas, sales manager of Ludwig Hommel & Co. "All I can say for the year 1926 is: if we get the merchandise we will do a big business." This firm represents the Radio Corp. of America, Crosley and Fada.

### Good Brunswick Outlook

K. McInnis, district manager of the Brunswick Co., looks to the coming year with optimism as far as phonographs are concerned. He says: "Due to the new electric reproducing in-

(Continued on page 78)

## Exclusively Wholesale Service in the PITTSBURGH DISTRICT

Atwater Kent Equipment

Pooley Radio Cabinets

French Ray-O-Vac Batteries

Exide Storage Batteries

Balkite Products

Weston Radio Plugs

Brach Antenna Sets

Westinghouse Storage Batteries

**ESENBE COMPANY**



909 Penn Avenue

Telephone: Atlantic 0539

Pittsburgh, Pa.

Catering especially to music dealers





# BRASS AMPLIFYING Speakers



"Use brass wherever possible" is a principle religiously followed by manufacturers of musical instruments since the beginning of that industry. For no other metal is capable of producing such rich, clear and beautiful tones.

The manufacture of Quali-Tone products takes full advantage of this widely recognized principle. In Quali-Tone Loud Speakers the amplifying tube is drawn from circular sheets of musical brass. These circles are worked through a series of more than twenty operations with the most careful annealing between operations in order to prevent fractures that would deteriorate the tube's perfect tone quality.

Rigid maintenance of high standards in both the selection of raw materials and their fabrication insure in the complete Quali-Tone speaker a quality of reproduction that surpasses in resonance and volume the majority of speakers on the market, and is unequaled in accuracy, clarity and sensitiveness.

Each Quali-Tone Speaker contains a Quali-Tone Radio Unit (described below) and operates direct from the radio set, requiring no additional batteries. Quali-Tone Speakers are available in five styles, three of which are shown here. Full details on the Quali-Tone line of Speakers, Radio Units and Tone-Arms furnished on request. Write today.

*A New Adaptation of an old principle.*

**TYPE "E"**  
 Height—11¼ in.  
 Bell or Flare Diameter—7¼ in.  
 Finished in smart looking black crystal.  
 Price .....\$6.50

**TYPE "ES"**  
 Same as type "E"—but finished in beautiful bright crystal gold.  
 Price .....\$7.50

**TYPE "N"**  
 Height—12½ inches.  
 Bell or Flare Diameter—9¼ inches.  
 Finished in rich brown leatherette.  
 Price .....\$10.00

**TYPE "NS"**  
 Same as type "N"—but finished in sparkling crystal gold.  
 Price .....\$11.00



### TYPE "O" CONSOLE

An instrument of rare beauty and utility is this Quali-Tone Console reproducer. Has the same special drawn-brass amplifying tube and radio unit as other Quali-Tone Speakers. The case—the work of master cabinet makers—is of solid walnut and has a finish equal to that of the finest piano or phonograph.  
Price.....\$20.00



### COMBINATION TONE-ARM

This Quali-Tone tone-arm has an interior valve (see arrow-marked disc in photo above) which throws tone from phonograph diaphragm into tone-arm, or shuts off diaphragm entirely and throws tone from radio unit into tone-arm and thence to phonograph tone chamber. Tone-arm is Quali-Tone drawn seamless brass.



### THE QUALI-TONE RADIO UNIT

Adjustable nature permits unusual clarification of tone. Core of laminated type—best silicon steel. Diaphragm of silicon steel. Magnet of large horse-shoe solid type, of tungsten steel. Cord of tinsel construction—white cotton covering protects it from action of dyes, the chief cause of noise. List price \$6.00.

**DURO METAL PRODUCTS CO.,**  
 2649-59 No. Kildare Avenue  
 CHICAGO, ILL.



## Trade Activities of the Pittsburgh Retailers

(Continued from page 76)

strument, the Brunswick Panatrope, I expect the biggest business in our history. The situation now is one of production, the demand far exceeding the supply for the next six months."

### Expects Big Victor Year

Wallace Russell, general manager, Standard Talking Machine Co., states: "If unfilled orders are any indication of business conditions, the Victor trade should have the biggest year in its history in 1926. We have more unfilled orders from dealers on file at the present time than ever before at this time of the year. Victor record business has increased by leaps and bounds since October and dealers are enjoying as good a record business now as ever before."

### Satisfactory Edison Sales

"Business for the last few months of 1925 was quite satisfactory," states A. A. Buehn, of the Buehn Phonograph Co., Edison distributor. "High-grade merchandise appeared to be the best seller." As to the outlook for 1926, Mr. Buehn is of the opinion that as long as the industrial prosperity of the Pittsburgh district continues, other lines of business are bound to be sharers in the same.

### Wintering in Florida

C. L. Dawson, the well-known president of the Dawson Bros. Piano Co., Starr phonograph dealers, accompanied by Mrs. Dawson, is spending the Winter in Florida.

### Takes Over New Plant

The Modernola Co., of Johnstown, Pa., which recently took possession of its new plant in Ferndale, a suburb of Johnstown, following the destruction of the former factory by fire, has received an order from New York for 15,000 machines for markets outside of Johnstown. The management states that the outlook for 1926 business is exceptionally bright.

## Building a Radio Market Among the Foreign-born

PHILADELPHIA, PA., January 4.—The Atwater Kent Mfg. Co., of this city, manufacturer of Atwater Kent radio receiving sets and radio speakers, is stressing the importance of cultivating the foreign-speaking population in this country. A recent dealer bulletin issued by this company calls attention to the fact that few people are more interested in music and entertainment than those hardy foreign-born Americans who constitute so large a portion of the population of the average town or city, and that although they may live thriftily in many ways, music plays an important part in their lives and they spend annually large sums of money for this entertainment.

It is pointed out that ordinary sales methods do not always reach this class of population. They group together and keep to their own language. Their purchasing of an article is oftentimes stimulated by the experience of friends. One Atwater Kent installation in a home of this class is oftentimes the determining factor in many additional sales. Many valuable suggestions are given the dealer in the cultivation of this specialized market.

An attractive music store, the Palace of Music, has been opened at Ferguson avenue and First street, Wood River, Ill., by the Weiss Music & Radio Shop.

## Public Demonstrations of "Pritchard-Roever" Radio

Autophone Mfg. Corp. Plans Enlarged Program Designed to Introduce Its Radio Line to Trade Throughout the Country

The Autophone Mfg. Corp., 324 East Twenty-third street, New York City, the executives of which are pioneers in the talking machine industry, has been giving public demonstrations of the new "Pritchard-Roever" radio receiver. The company so far has confined its activities to Eastern territory, where its console type "Pritchard-Roever" receiver is also being sold in some of the leading stores. The success this instrument has achieved for "Pritchard-Roever" dealers and the favor from consumer owners is the basis of an enlarged program by the Autophone Mfg. Corp. to market the "Pritchard-Roever" radio on a national scale.

The "Pritchard-Roever" receiver is a tuned radio frequency set with resistance coupled amplification carrying a number of exclusive patented features. Its initial success has been won on its tonal quality, reduction of static, selectivity, distance, ease of control, and clarity.

For over twenty years Julius Roever has studied, made laboratory experiments, and placed upon the market reproducing instruments noted for tonal value. This experience was used in carrying out the designs for radio amplification, with the result that a number of music critics and radio engineers have enthused over the quality of the reception through the "Pritchard-Roever" receiver.

The Autophone Mfg. Co., of which William A. Pritchard has been the president and directing head for many years, was originator of "Nickel-in-the-slot" phonograph instruments found in ferry stations, railroad depots and other public places. The "Pritchard-Roever" radio receiver is built for durability. Built of the finest quality parts, cost has never been given a consideration. The receiver is sealed at the factory and where the seal remains untouched is guaranteed.

Those responsible for the "Pritchard-Roever" radio receiver were among the originators of the concealed horn. In the old days, when "Nickel-in-the-slot" phonographs were placed in public places, passers-by often would throw crackers or rubbish down the horn and the manufacturer had to enclose the horn in a case to protect it.

In the "Pritchard-Roever" receiver everything but the panel and tubes are concealed from view. All operations are automatic. The mechanism is factory-sealed. The cabinet is of two-tone walnut, the grain of which is carefully matched. Panels on the cover edge are of genuine rosewood. The wet and dry batteries are placed in compartments on either side of the panel and are covered with a close-fitting top piece. The height of the console cabinet has been designed for the greatest ease in turning the dials, inserting or removing tubes, and for access to batteries. These are the only things that the consumer need touch.

The plans of the Autophone Corp. in marketing the Pritchard-Roever radio receiver will be on a jobber-dealer basis. Both will have exclusive franchises in particular territories. The volume of business in each locality will be set at a minimum amount and the newspaper and periodical advertisements on the part of the manufacturer will be based upon the activity of sales.

The balance of the Autophone Corp.'s pro-

**MICA  
DIAPHRAGMS**

*Absolutely Guaranteed Perfect*  
We get the best India Mica directly.  
We supply the largest Phonograph Manufacturers.

Ask for our quotations and samples before placing your order.

**American Mica Works**  
47 West St. New York

gram for the exploitation of the "Pritchard-Roever" receivers will be carried out on a high standard scale befitting a product of the highest standard. Wm. H. Pritchard, the head of the



Pritchard-Roever Radio Set

Autophone Corp. states the "Pritchard-Roever" product will appeal particularly to talking machine dealers.

## Four New Sets Announced by the Crosley Radio Corp.

Latest Products of Prominent Radio Manufacturer Include Four and Five Tube Sets—Other Features of New Models

CINCINNATI, O., January 8.—Four new radio receiving sets, incorporating many unique improvements, including a "Crescendon," which gives perfect control of volume by simply turning a small knob, and the recently perfected R.F.L. circuit, have just been announced by Powel Crosley, Jr. Three five-tube and one four-tube sets are included in the new models for 1926, which are now in production in the plants of the Crosley Radio Corp.

The sets were enthusiastically received by the Crosley sales representatives from all parts of the country who attended the mid-Winter conference in the home office.

"Our new line of receivers has been designed with the sole purpose of simplifying radio reception and giving greater money value without sacrificing quality of material, despite the addition of more tubes for their operation," said Powel Crosley, Jr., in his closing remarks to the salesmen.

The new receivers are the 4-29, the four-tube set; the 5-38, five tubes; the R.F.L.-60 radio frequency laboratory circuit, and the R.F.L.-75 represents a different style of cabinet. All of the new receivers are enclosed in mahogany cabinets.

Siegfried's Music Store, Lodi, Cal., has moved to new quarters on School street.

**CONSTANTLY INCREASING SALES**

are testifying to the superior quality of our

**COTTON FLOCKS FOR PHONOGRAPH RECORDS**

STEP INTO LINE WITH THE BUYERS OF "QUALITY"

**CLAREMONT WASTE MFG. CO., Claremont, N. H.**



---

---

# SILENT S. S. MOTOR

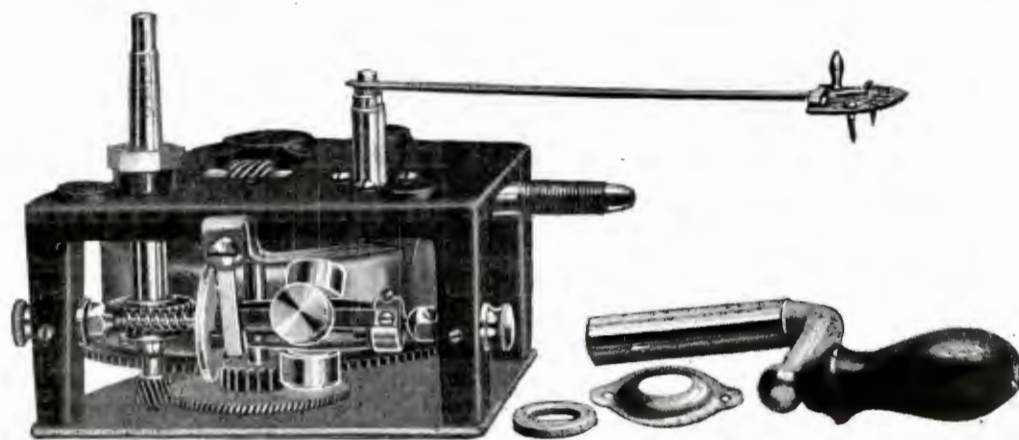

## *Peerless motor equipment used in* **HIGH QUALITY PORTABLES**

**N**O better evidence of satisfaction could be given than that **SILENT S. S. MOTORS** are used in superior quality portables as standard equipment, where dependable, lasting service must be assured.

### The Silent Motor Features

*First*—Only the best materials on the market are used.

*Second*—It is guaranteed to play in excess of two records.

*Third*—It is fool-proof—because regulator is built within motor.

*Fourth*—The true running of governor, rigidity of turntable shaft, are guaranteed through Patents ap-

proved and issued by the United States Government.

*Fifth*—It is absolutely Silent in Wind and Operation.

*Sixth*—Lasting, dependable service is assured through superior construction.

*Seventh*—Millions are in use giving perfect satisfaction.

## THE SILENT MOTOR CORPORATION

321-323-325 DEAN STREET

BROOKLYN, N. Y.

---

---



## Brunswick Co. Supplying Dealers With Material for Complete Panatrope Drive

Every Need of Dealers in Promoting Interest in the Panatrope, Including Advertising, Educational Literature, Etc., Is Embodied in Well Thought Out Sales Promotion Plan

In order to assist Brunswick dealers to properly present the Panatrope in their respective localities, the Brunswick-Balke-Collender Co., Chicago, Ill., has prepared an elaborate sales and publicity campaign, complete in every detail, to arouse public interest in the new instrument and to impart to the dealer and his sales staff a knowledge of the Panatrope so that the demonstration of the instrument will be made in a manner fitting its merits and capabilities.

The campaign, an outline of which has been sent to all Brunswick dealers, anticipates every possible need of the dealer and supplies him with every assistance. A booklet for use by Brunswick retail salespeople gives a detailed explanation of the Panatrope—the meaning of the name, the advance it represents over former models of phonographs and strongly stressed is the fact that the Panatrope synchronizes electrical recording with electrical reproduction. A second booklet gives a complete presentation talk for use by members of the sales force in demonstrating the instrument to either individuals or groups. Contained in this are suggestions which deal with every possible angle of the presentation. From suggested settings in which the Panatrope is shown, to newsy, interesting chats on the suggested list of records to be played, this presentation talk is designed to help the dealer demonstrate the Panatrope in a most impressive manner.

Naturally, the advertising of the Panatrope is given particular attention in the campaign. An attractive folder is included in the material sent dealers and shows copies of the full-page advertisements which are to be used by the Brunswick Co., and advertisements which have been prepared by the company for dealers' use. These prepared ads are of every size from a small card to a full page and include a "teaser" campaign of six small ads. Mats or stereos of these advertisements will be furnished dealers upon request. Other sales aids which have been prepared by the sales promotion department of the Brunswick Co., and which are illustrated and explained in this folder, are newspaper stories for the reading columns of the dealers' local papers; pamphlets, illustrating and describing the different models of the Panatrope for

consumer distribution; mailing card invitations printed on stamped post cards which the Brunswick Co. will supply to dealers with their store name and address imprinted, at a nominal cost.

The question of window displays is solved by two suggested window dressings, illustrated and described in the folder. Each of these windows

## Aftermath of Holiday Demand Keeps Trade in Buffalo Territory Busy Selling

Good Pre-Holiday Business Enjoyed in Western New York Continues Into the New Year—Dealers Preparing for Big 1926 Business—Albert F. Koenig Dies—Plans to Erect Large Store

BUFFALO, N. Y., January 7.—If the volume of business done by talking machine dealers during the early days of January can be taken as an indication, the close of the month will show an increase over the amount of business done in December, several dealers report. There is the usual hangover business after the holidays, many persons investing Christmas money as an initial payment on phonographs and radio, yet there is a new interest in phonographs that has astounded the trade here. Unlike trade conditions of a year ago, prosperity is general and not spotted. Downtown dealers and neighborhood dealers all report an unprecedented activity for early January. Jobbers, however, are somewhat distressed over their inability to secure the desired number of instruments, the two Victor jobbers, Curtis N. Andrews and The Buffalo Talking Machine Co., as well as the Brunswick distributing office here, find the shortage of instruments even more perplexing than early in December, and many dealers have been unable to fill Christmas orders.

### Big December Business

Evans & Eiss, north Buffalo dealers, handling both Brunswick and Victor instruments, have had a remarkable December business, closing out practically their entire line of old Victrolas, and entering the month of January with a volume of trade that promises practically double that of the same month of 1925, according to Mr. Evans. Floyd Barber, of Kenmore, who

can be installed by the dealer for a very small amount and through an arrangement made by the Brunswick Co. with the Dennison Manufacturing Co., the materials will be supplied dealers with full instructions for their use. Two attractive color posters, one featuring the Panatrope, and the other the Panatrope and Radiola, have been sent dealers for use in their windows. These posters, measuring four and a half feet by a foot and a half, finished in vivid colors, are decidedly attractive. Suggestions for other posters and window cards are also included in this sales and publicity campaign, which solves practically all the dealer's problems in making his presentation of the Panatrope an impressive and profitable one.

handles the Victor exclusively, reports similar conditions, while the East Side is enjoying the same volume of business, according to A. W. Erion, of the Erion Piano Co. Neal, Clark & Neal, and Denton, Cottier & Daniels, of the downtown district, are oversold on Victrolas, but find record business lagging.

### Regret Death of Albert F. Koenig

The music trade of Buffalo feels with deep regret the death of Albert F. Koenig, who was in the prime of his business career when he died recently. He operated and owned the Koenig Piano Co., 668 Main street, Buffalo, since 1920.

### Plans to Erect Big Store

A. Victor & Co., furniture and Victor dealers on Main street, have purchased the Majestic Theatre, on Mohawk street, which will be razed in about a year and a modern ten-story furniture house erected on the site. The new store building will cost \$500,000.

### News Gleanings

William H. Daniels, president of Denton, Cottier & Daniels, has been elected a director of the Marine Trust Co., which was recently merged with the Buffalo Trust Co., making the combined institutions one of the strongest of the kind in the country.

The Hoffman Piano Co. has discontinued its Tonawanda branch.

A. Victor & Co. distributed their annual Christmas bonus to employes, the amount totaling \$27,500.

The Radio Service Corp., owned by Samuel Hamilton, is a new radio store at 1223 Niagara street, Buffalo.

## Endicott, N. Y., Store Grows

ENDICOTT, N. Y., January 5.—An enlarged music store has been opened recently by the North Street Music House at Washington avenue and North street, with a full line of musical instruments, including Wurlitzer and Weaver pianos. Victor and Columbia talking machines have been added. The North Street concern is the agent for Martin saxophones and band instruments for Broome County and Oswego and has been doing business in Endicott about two years. The new store will have a complete small goods department, as well as one for sheet music and radio.

## Eastwood Radio Shop Opens

The Eastwood Radio Shop, Syracuse, N. Y., was recently opened for business at 106 Ashdale avenue, with a full line of radio equipment. The Stewart-Warner line is being featured. C. A. Potter is manager of the new store.

A luncheon at the Wm. Penn Hotel in Pittsburgh was recently given by Ludwig Hommel & Co., to visiting dealers in connection with a display of the new art furniture models of Fada radio, manufactured by F. A. D. Andrea, Inc.

Thousands of Record Buyers  
have learned to prefer

**Okeh Records**  
There Is A Reason!

**Okeh**  
TRUE ONE

Recorded by the most satisfactory process, the latest hits, played by famous artists, are so startling true in tone values that they demonstrate to all the noticeable superiority.

Become a licensed Okeh Record Dealer!

**GENERAL PHONOGRAPH CORPORATION**

New York Distributing Division

15 West 18th Street

::

New York City



For Quick Profits ~  
 ~ ~ UNIPOWERS  
 RADIO'S LATEST TRIUMPH

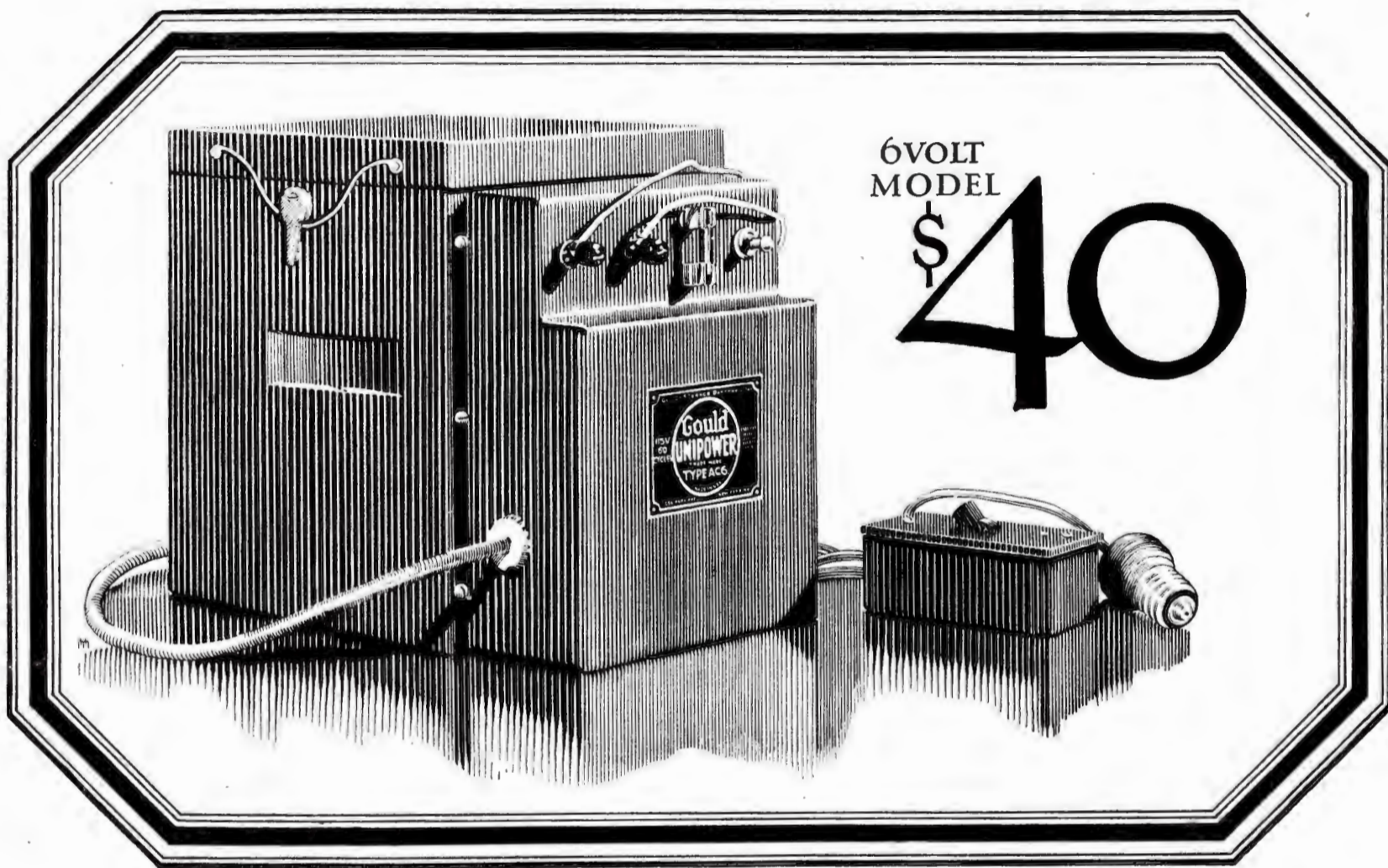

**T**HOUSANDS of dealers report that the national advertising on Unipower is bringing many prospects into their stores for quick, easy sales at substantial profits.

This advertising is telling the millions a proven sales story that makes radio enthusiasts want and buy Unipower.

But to help you reap the greatest benefit from this advertising, we have prepared a "Special Dealer Folder." This folder explains just how you can tie-up your store to this national advertising by means of sales helps that actually help—which we supply FREE.

Unipower is a scientifically designed "A" power unit that automatically converts house lighting current into radio power of the highest quality. It is a single compact unit, enclosed in a beautifully finished gas-tight case that fits comfortably and safely inside most radio cabinets. It is the least expensive "A" power obtainable.

*Send for folder*

Place your order with your jobber immediately and then write for your copy of "How to put Unipower to work for you." It will be mailed promptly. **THE GOULD STORAGE BATTERY CO., Inc.,** 250 Park Avenue, N. Y. Branches: Chicago, Kansas City, San Francisco.

UNIPOWERS is supplied in two models for use with 110-125 volt A. C. only. Standard models are for 60-cycle. [Special models, 25-50 cycle, are available at slightly higher prices.] All are equipped with special Balkite rectifying element. The 4-volt model is for UV-199 tubes or equivalent and retails for \$35; the 6-volt, for UV-201-A tubes or equivalent, retails for \$40. [West of the Rockies, prices are \$37 and \$43.]

**Unipower**  
TRADE MARK

*Off when it's on ~ On when it's off*



# Promoting Sales of the New Instruments

Revision of Policies Necessary to Make Most of Opportunity  
—Demonstration Will Play Vital Part in Selling, Says W. B. White

I think that every clear-sighted merchant, as well as every sincere lover of the phonograph, must welcome the New Year with feelings of no little warmth. The past year has been trying in more senses than one, and not the least in the uncertainty which oppressed so many of us as to the policy of the great interests which stand behind the whole industry. Now, happily, the facts are at length clear. The phonograph business is not only to continue, but to go forward to greater achievements. New machines, new records and (who can doubt?) new and better salesmanship, are to accomplish what every thinker has long wished to see—a more intimate union between public taste and the means of satisfying it.

Let us try to look at the situation clearly. Surprised by the coming of a formidable, mainly because an unexpected, competitor, the phonograph business was compelled to pause, take stock of its situation and acknowledge that the time was come for it to show what it could do. Everyone knew that great advances in the art of recording, and of reproduction too, had been worked out; but there seemed to be little or no call for them. Almost in a moment, however, conditions changed and the call was clearly sounded. It did not find the industry wanting. A short breathing-space, and the world was startled by the emergence of a whole brood of new ideas and new embodiments of those ideas. As fast as they were announced, the public began to snap them up; and to-day we find on all sides that those who a year ago were depressed and anxious are the loudest among those who cry that the phonograph has "come back."

In reality, of course, it has never been away. Let us not quarrel over words, however, but bethink us what lesson to draw from the events of the past year.

## Taste Has Moved Up

And first let us clearly have it in mind that every phonograph now actively in the market is a better machine. It is not that the principles of reproduction are only now being discovered. It is simply that public taste has been a mile behind all the time. Radio has done this much if no more, that it has waked up public taste, given it new standards and made it ready for a new era in the phonographic world, for an age which, in point of grade, of salesmanship and of general prosperity and power bids fair to outdo the best of the so-called "good old days."

## Tone

No one can say in advance what will be the final and standard shape, price or type of popular talking machine. It is probably true that too much emphasis has been laid upon expensive cabinet work and on making machines in the image of beautiful pieces of furniture. Radio cabinets, of course, are all tending in the same direction and doubtless there will always be a demand for beauty of shape as well as efficiency of function. Still, it is permissible to believe that the future of the talking machine is centered in that same tone, which I, for one,

have always insisted was its basis and principle. Whatever else has happened, it is certain that the people are only too happy to possess talking machines and records, with all the musical possibilities of these instruments, so long as the new ideas of musical tone, which the vast musical activities of the last few years have stirred into life, can by them be more or less satisfied.

What then are dealers going to sell? And how are they going to sell it?

It should seem perfectly plain that there is a market for every instrument or transmitter of music which will actually deliver the goods. It should be perfectly plain to every right-thinking merchant that the new records give to every talking machine a new value and that the old belief in the necessity for a tight, restricted "phonograph tone" is now something of the past. It is then surely obvious that thereafter we dealers will be able to offer to the buying public music for which, neither in recording or in reproduction, need any apology be made. This is the big thing to be remembered at this time.

Our 1926 sales policy should then be almost self-indicative. We have better machines and better records, of every make. We can demonstrate better performance, both in volume and in quality. We can put into the American home a library of music, with the means for its reproduction, according to a standard of fidelity hitherto undreamed of. We can, in short, open up the talking machine business all over again, forgetting every mistake that may have been made in the past, cleaning off the whole slate on which was written the record of our old policies and methods; and go forward confidently in the certainty that if we can offer to the public real music, really reproduced, we need fear no competition.

## Nothing Can Take Its Place

For, after all, the talking machine fills a niche in the great structure of western civilized life which nothing else can fill so completely or so fittingly. Music has become a part of civilized life to an extent once hardly imagined. It is not so much that the number of men and women consciously practicing the difficult arts of musical composition and performance has so vastly been increased. It is rather that the listening public has become enormous in its extent, nearly co-terminous with the whole community. We have developed, mainly through the agency of this very talking machine and its records, an immense listening public, and now that the facilities for listening have been so widened by the interposition of radio, we find that this public is demanding of the talking machine musical results more elaborate, more faithful and more diversified than ever. What the public demands the talking machine industry is in a position to give. It is now up to the retailer to do his part.

We shall all need a change of heart in some respects. Easy business of past years has had its natural tendency, making men careless and indifferent, so that they have fallen away from the high and precise standards, which harder conditions always tend to preserve and consolidate. In particular, the basic principle of demonstration had become much more honored in the breach than in the observance, for indeed there seemed to be little need for it. Yet it has always been the foundation of all talking machine salesmanship.

## What Is to Be Demonstrated?

Demonstration means much. It means in truth all of talking machine salesmanship. How much is there in knowing what music to choose, what is the best of each composer's work, what

is the most likely to please the masses of people in each department of musical performance? How much there is in being able to fill any sort of request, in guessing instinctively what a customer means, when the explanation is halting and only half expressed. What a lot there is in handling the machine easily, masterfully and with that appearance of effortless method which only constant study and thorough familiarity can give! How much there is in knowing one's machines, one's library of records, the changes in the published music from week to week, the novelties, the tie-ups between records and visiting musicians, and all the other little niceties which mark the master salesman! These are only small things, perhaps, but it is the small thing which counts in this field, as in most others.

And demonstration, with all the width of its meaning, should be our 1926 watchword. We need not fear that we shall have to work our heads off to gain the public attention. On the other hand, the principal difficulty will be to show to the public that the expectations which have been formed this Winter are not doomed to disappointment, and that in fact the talking machine industry can deliver the musical goods.

That it can do so no one need doubt. Really the future of the business is now, for the time, out of the hands of the manufacturers and in the hands of the dealers. Will these be wise enough to reap the golden harvest which already is spread out before them? If they show only a very moderate amount of wisdom they should have not the least difficulty in harvesting a rich crop.

We face the best year of the talking machine business. Let us go to it!

## M. Rappaport Expanding

M. Rappaport, prominent member of the Talking Machine & Radio Men., Inc., New York, who operates talking machine and radio stores in the Bronx and Woodhaven, L. I., recently took over and incorporated the Goldsmith Music Shop at 1493 First avenue, New York. This store is under the management of Moe Glantzer. Mr. Rappaport is possessed of wide experience in the retail music field, having been a Victor dealer for the past twelve years.

## Panatrope Demonstrated

The Clark Music Co., Syracuse, N. Y., gave a demonstration of the Brunswick Panatrope in its store the latter part of last month. Despite the fact that the evening selected for the event turned out to be a stormy one, the concert was well attended and the audience was most enthusiastic.

## H. P. Rack in New Post

H. P. Rack, who was formerly connected with the Daniels & Fisher Stores Co., Denver, Col., is now a member of the outside sales staff of the Royal Music & Radio Co., of the same city.

## BEL-CANTO PRODUCTS

Superior in Material, Workmanship and Performance. Bel-Canto Adjustable Loud Speakers, with massive, mahogany-finish cabinet, at \$17.50. Goose-Neck Fibre Horns, at \$10.00 and \$15.00. Loud Speaker Units, patented Flexible Reed Tone Chamber. The Bel-Canto Recording Dial, \$2.00. With magnifying glass \$2.50.

**BEL-CANTO RADIO & TEL. EQUIPMENT CO., INC.**  
872 Broadway New York City

Nationally distributed by Baker-Smith Co., Inc.  
Home Office: 715 Call Bldg., San Francisco, Cal.  
Branches in Los Angeles, Cal.; Portland, Ore.;  
Seattle, Wash.; Vancouver, B. C.; Salt Lake City,  
Utah; Denver, Colo.; Chicago, Ill.; Buffalo, N. Y.;  
New York City

## AUTOMATIC LID SUPPORT

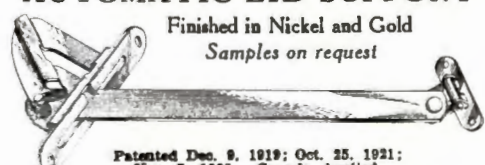

Finished in Nickel and Gold  
Samples on request

Patented Dec. 9, 1919; Oct. 25, 1921;  
Nov. 7, 1922. Canada Applied.

The Most Dependable Lid Support on the Market  
**Star Machine & Novelty Co.,** 8-11 Watassing Avenue  
Bloomfield, N. J.



# Talking Machine Merchants of the Nation Look for Prosperity in 1926

Dealers in Every Section of the Country, Interviewed by The World Correspondents, See a Profitable Year of Business Ahead—Cheery Messages Are Based on Sound Reasoning—New Instruments, General Stability of the Trade and Better Industrial Outlook Favorable Factors

THE new year, 1926, will witness a period of prosperity which has not been equaled in many years, according to the reports of retail dealers supplied to our correspondents in widely separated sections of the country. The year just past closed with a rush of business that in some sections cleaned the stores of merchandise, and many dealers have orders in hand which will absorb all the instruments, specifically the new models of talking machines, as rapidly as they can be obtained from distributors and manufacturers. In past years a shortage in certain popular models was customary at the close of December, but this year the shortage was more pronounced than ever, so pronounced, in fact, that manufacturers will be kept busy for months supplying back orders—an excellent condition insofar as manufacturers and wholesalers are concerned. This also is, in a measure, good for the dealer, as he will get a turnover on his investment practically impossible under ordinary conditions.

The reports of the dealers also emphasize the favorable factors that should make the year 1926 prosperous for the trade. First and foremost, of course, is the interest aroused in the new talking

machines, radio sets and records. Of equal importance is the fact that industrial conditions throughout the country, with the exception of the coal mining districts, never were better. People have more money than ever to spend on talking machines, radio and other musical instruments. Savings banks deposits prove the truth of this assertion.

Radio, which now has become an important and permanent factor in the talking machine field, in 1925 went through a period of stabilization, the full force of which will be felt in the present year. The time of chaos in radio is past; the time of merchandising experiment is past, and this applies with equal force to profitless merchandising brought about by lack of knowledge.

Another condition which will bring about greater prosperity in 1926, insofar as the movement of merchandise is concerned, is the fact that while the trade as a whole is optimistic over the outlook there is a strong feeling among dealers that only through the active promotion of sales—advertising, canvassing, window displays, direct mail, etc.—will the individual retailer be able to make the most of his opportunity.

## New York Dealers Sound Optimistic Note in Predictions of 1926 Business Volume

The talking machine and radio trade in the metropolitan territory, embracing not only New York City but the surrounding territory for a radius of some 200 miles, views the present year with a practically unanimous feeling of optimism and prediction that the end of the year will see a sales volume, in all lines of merchandise carried, that will exceed that of any year for some time past. Reviewing the trend of the trade for the year of 1925, it is easy to ascertain why dealers are prone to feel that 1926 will be bigger and better in every way. There is no doubt that the retail trade, in both the talking machine and radio fields, was disappointing for the first six or eight months of last year. Activity of the buying type was spasmodic and was not widespread but confined to certain sections. The dumping of radio merchandise on the market had the effect of breaking up the morale of the trade and putting the buying public in a most uncertain frame of mind. Some phonographs were being sold, but in nothing like a satisfactory fashion. Records were the only item of stock carried by dealers which sold in a manner that boded for good.

This condition began to change in the late Summer, when sales of talking machines and records at reduced prices were held throughout the country. Despite the extra efforts which had to be expended, dealers were heartened by the crowds that came to their stores, and in September the morale of the trade was strengthened, and with the promises of new instruments soon to be placed in the market the backbone of the trade stiffened. The new process recordings were the first of the new types of merchandise to be introduced, and although there were no special publicity efforts placed behind their record sales started to climb to unprecedented heights, indicating that the public was far from being finished with their talking machines and that, with a quality product on the market, sales would be far more satisfactory. The late Fall saw the introduction of the new types of instruments, and the high hopes of even the most optimistic were exceeded. Orders poured in in such quantities that the dealers were overwhelmed and the close of the year

found them in an enviable situation—business on the books which will take the merchandise which they can secure for months to come. Added to this, they have the knowledge that further additions to their stock in the form of combinations of the new instruments with radio receivers are due in the near future.

The radio situation has also been clarified to a great extent. The receivers manufactured by concerns that have given protection to their dealers and in an indirect way to the public have been selling in satisfactory fashion, and

the sales have been, to a great extent, of the better type of receiver.

This was the situation at the close of 1925, a year which compared favorably with 1924, from the reports of most dealers, despite the fact that the last three or four months of the year were the ones in which real buying activity was manifested. Sales volume for each of these months showed that the demand was on the upgrade, with the peak far from being in sight. This, taken in conjunction with the fact that the economic condition of the people is excellent, with plenty of money to spend, makes it difficult to see how the present-day talking machine or radio receiver can fail of securing its share of attention from the buying public during the year of 1926.

## The Most Prosperous Year in Normal Times Looked for by Philadelphia Trade

PHILADELPHIA, PA., January 8.—Dealers of this city predict the coming year will be the biggest in normal times. Beginning with the manufacturers, already overburdened with orders, and down through the distribution and retail outlets, there is every indication that predictions are to be fulfilled. This confidence in the future has its foundation in actual orders on hand to initiate the new year's business. Dealers have long lists of customers as hangers from the holidays.

Along with the bright outlook in the talking machine industry, its allied industry, the radio trade, is adjusting itself to a newer scope of distribution. Like its ally, it, too, has every indication of a booming year.

A summary of the radio industry in 1925 showed that the business made considerable advance over that of 1924, and that the sales were chiefly confined to popular priced goods and with growing tendency to standard makes. Sound business methods of the manufacturers in co-operation with the dealers will act for the best interest of all concerned.

J. Ralph Wilson, with five stores under his ownership, is looking forward to the best year in trade annals if common sense is used in planning out a business program. He sees in every owner of an old style talking machine a likely purchaser of a new and improved type. Every

citizen also is a prospect for the new machines, in his estimation. Already the files at the Wilson stores are loaded with advance orders. He believes that the manufacturers will have an entire year of rushing operations to meet the nation's needs.

As for the radio end of the business, Mr. Wilson strongly advocates a strong effort by manufacturers in standing back of the dealers. Insofar as the dealers are concerned he believes in promoting the interests and sales of those makers who will give their support to the dealers by healthy merchandising and upright dealing backed by quality of products.

Manifold are the benefits to be reaped by dealers who will plan out a cautious exchange schedule on the old machines to be taken as part payment on the new Orthophonic models, according to the views of the former president of the Philadelphia Victor Dealers' Association, Walter G. Linton, and head of several stores featuring the Victor products. Like his associates he is firmly confident that the next year is to be the biggest in the history of the industry provided the dealers will carefully plan out their exchanges. He believes that if the trade will accept the schedule set forth by the Philadelphia Victor Dealers' Association as a criterion for exchange there will be no financial

(Continued on page 84)



# Trade Stabilization to Be a Factor in Prosperity

losses as result of acceptance of old machines in exchange.

President George C. Davis, of the Philadelphia Victor Dealers' Association, and of the firm of George B. Davis Co., turns to the 1926 outlook with a firm conviction of growth of the talking machine trade to the broadest extent ever attained.

Radio is highly commended as a new year prospect and source of trade revenue by Gerald L. Quimby, head of the Estey radio department, wholesale and retail. Handling standard merchandise, good ethics, etc., in his judgment will make for prosperity in 1926.

It was emphatically announced that the past six months have been the most profitable in the matter of cold dollars and cents ever recorded in his business by H. Royer Smith, head of the firm bearing his name. The scarcity of

goods, he believes, is the best tonic that the trade could apply for the stimulation of business. Record business has been the best in years, showing the generally healthy conditions under which the new year looms.

The Wolf Talking Machine Co. is so enthused with its past successes and with hopes for the continuance of these in the coming year that it has opened a new and larger store and is branching out into radio.

Manager G. T. Wurtele, of the Gimbel Bros. talking machine department, states the coming year is to be the biggest of all insofar as business is concerned. Manager W. P. Saunders, who guides the destiny of the Gimbel Bros. radio department, is highly gratified with 1925 radio sales. He states that radio is fast developing a standardized business, and this is to be more pronounced as the year grows.

the biggest year by at least 50 per cent and already he sees January as a far bigger month than was December.

E. A. Cressey, of the C. C. Harvey Co., inclined to the opinion that more and more the radio business was to be concentrated on the high-grade stuff for he thought that as the public is getting better informed on the subject they are anxious to possess only the best. He thinks that the radio business is going to be good right through the Spring, and he looks for what he calls—speaking stock marketwise—a rising market throughout the year.

Herbert Shoemaker, manager of the Boston headquarters of the Eastern Talking Machine Co., sees every indication of a prosperous 1926, a year that certainly will be better than 1925, which he is not inclined to be overenthusiastic about. "The new instrument," he said, "has been seized by the public in no uncertain manner, and the orders these past few days, and with no cancellations," which Mr. Shoemaker hastens to remark, "have convinced us that many Christmas orders have been held over until January. The fact that general business conditions are good bespeaks a good talking machine business, and I am fully convinced that the year before the retail trade is to be a memorable one."

## New England Trade Leaders Give Sound Reasons for Optimism Over the Outlook

BOSTON, MASS., January 9.—A spirit of optimism pervades the New England trade regarding the outlook for the present year. The many favorable factors in the talking machine, radio and record fields are the basis for this feeling, namely, that 1926 will be both busy and prosperous.

The views of Harry Spencer, manager for New England of the Brunswick Co., are thus expressed: "The year 1925 proved one in which the manufacturers and jobbers got a good chance to clean up their stocks, and this was the first period in the history of the industry that they did it so effectually. We put all of our efforts into getting rid of everything we had on hand and we are thus enabled to make a clean start for 1926, with conditions ahead most bright, brighter in fact than in a long time, and accordingly there is good reason for wishing everyone a happy New Year. The radio combination end of the business is likely to far exceed anything anticipated.

Says William S. Parks, manager of the New England branch of the Columbia Co.: "The year 1925 is gone, and while it has not been a year to be remembered by the phonograph industry as one of special profit, we should not look back upon it too harshly. Most of us have enjoyed mighty good business this past Fall. With the passing of 1925 go several makes of nondescript phonographs and records, general unemployment and many other things which have had an unfavorable influence on the talking machine business. Most of our dealers, speaking, of course, for my own company, have done equally as well as we have in cleaning up their stocks and we are all looking forward with a great deal of confidence to the increased business the New Year and the new Columbia will bring us."

A. M. Hume, head of the music house bearing his name, tells your correspondent that in his mind there is no doubt that the talking machine business has been greatly stimulated by the introduction of the new models, and that while the business for the last few months was justified because of their appearance, it is his belief that this new year of 1926 will see a far more pronounced demand for goods.

Says Manager Shewell, Jr., of the Cheney Sales Corp.: "The year 1925 has been a very successful one; for us it was a pioneer year in the radio business, and at the start we had few accessories, but now we are in possession of a complete line representing nearly all of the nationally advertised items. For 1926 I personally predict that a \$100 set will be a popular-priced line. I also believe that in 1926 the single dial control will be popular with radio fans. So large a business are we looking for in 1926 that we are arranging to enlarge our facilities for carrying on."

At M. Steinert & Sons, Henri Du Questin,

who is in charge of the radio business, spoke enthusiastically of the amount of business done by the company during October, November and December, which he claimed was 40 per cent better than last year. He looks for 1926 to be

## The Merchandising Sky in Cincinnati Is Clear and Big Profits Loom, Say Dealers

CINCINNATI, O., January 6.—Dealers in talking machines and records as well as radio are unanimous in the prediction that 1926 is going to be a good year for the trade in this city and adjacent territory. The members of the wholesale branch of the trade take the same optimistic view, and all expect the sales of the next twelve months to be of record-breaking volume.

The recent improvements in talking machines and records, it is pointed out, will greatly extend the sales possibilities, through making it possible to interest a class of people who are musically too discriminating to be satisfied by the limited range and tonal effects of the former instruments.

Any temporary hardship that dealers may have suffered from the market being disrupted a while before the new instruments and records were available, it is conceded, is more than made up for by the fact that the innovations have taken the talking machine business out of a rut, by increasing the satisfaction given by this form of production. Former types of machines and records, of course, are by no means expected to cease suddenly to be marketable, as they will continue to give satisfaction to a great many people and as they can be purchased at a lower price than the new instruments.

Radio is reported to have been in fair demand the first part of the year, with the usual falling off in sales during warm weather. In the early Fall there was a fair demand and this continued to grow until the approach of the holidays, when the sales increased to a large volume. This business has become so well stabilized that the troubles in connection with it have been removed to a great extent, and therefore talking machine dealers are now finding it very satisfactory and reasonably profitable.

"We see every indication that 1926 will be an excellent year," stated A. H. Bates, secretary of the Ohio Talking Machine Co., wholesaler, at 427 West Fourth street. "Taking everything into consideration, 1925 was a good year for our retailers. For one thing, the price reductions which they were enabled to give gave them a chance to get rid of their old stocks, and this was no small advantage.

"Undoubtedly the new Orthophonic will give every dealer a fine chance to increase his sales this year. While dealers may have been incon-

veniented some in that they could not get enough Orthophonics to supply the demand, this will be more than made up for by the fact that it will increase their sales manifold from now on."

"What are your views of the talking machine business situation in 1925, particularly during the latter part, when the new machines and records were being shown?" When asked the foregoing question, J. E. Henderson, local manager of the Brunswick-Balke-Collender Co., replied that taking everything into consideration the year had been a good one for the company and its dealers.

"With the new instruments, the demand in the last few months has been very gratifying," continued Mr. Henderson. "Orders for the Panatropes have piled up in surprising quantity, and we believe that the demand will exceed the supply for the next three or four months. The acceptance of the Panatropes by the public has been very gratifying. It has met with the approval of all who have heard it, and this indicates that with us 1926 will be one of the greatest years in the history of our business. Our company believed, in view of the depressed condition of the talking machine business in the early part of 1925, that it was necessary to do something to revive the interest of the public in the reproducing instrument. This brought about the introduction of the Brunswick Panatropes, which is purely electrical in its operation, both in reproducing the music and in the operation of the machine. The introduction of the new machine and the new Brunswick records greatly assist the retailer, because they give him many new and excellent things to stress in making a sale, and enable him to get away from his old stereotyped sales-talk."

"While we could have sold more talking machines if we had been able to get the new Orthophonic for delivery, we did very well in 1925," said Howard L. Chubb, head of the Chubb-Steinberg Music Shop, 17 East Sixth street. "As it was, our sales showed an increase of 50 per cent over the previous year. In some cases where the customer wanted the Orthophonic for a Christmas present we gave him an old-type instrument for temporary use, with the understanding that a new one would be

(Continued on page 85)



# Sound Reasons Back of Optimism of Merchants

delivered later. We sell the Sonora also, and there was a good holiday demand for it. I am optimistic as to the future and feel confident that there will be a fine demand for talking machines and records through 1926. Radio has been in good demand, and our holiday sales were considerably larger than in the same season of the previous year."

"Our yearly sales total was kept down by the fact that we could not get Panatropes for de-

livery," explained Louis H. Ahaus, owner of the Brunswick Shop, at 532 Walnut street. "We did a fine business all through the year, and in the holiday season the demand was enormous. With the new instruments coming in, the first part of the year should be better than the corresponding period of last year, and there should be a larger volume of sales of the varied products handled by phonograph dealers until warm weather slows things down."

field, which will be served to the tune of increased business during 1926.

According to Frank H. Frazell, president, Frazell Music House, 1926 with its array of new merchandise will surely step ahead of the year just closed. New Columbia and Sonora phonographs, improved Zenith, Music Master, Sonora and A. C. Dayton receiving sets will keep the public sufficiently interested to entice them to open their purse strings. Industrial conditions are good here; many factories are working at capacity and several are planning additions. Bank deposits are the heaviest on record.

Harry L. Wasserman, proprietor United Music Store, stated that the demand for Victrolas, records and radio for the last quarter of 1925 was excellent. He stated dealers are apt to forget they have an entirely new article to merchandise and must therefore employ methods in keeping with such goods. He looks forward to a banner 1926.

For the Whitney-Blaine-Wildermuth Co., Henry C. Wildermuth, treasurer, stated that trade for the year just ushered out received impetus during the last few months from the new records, machines and radio receivers which will carry them far into the new year. Victrolas, Zenith, Thompson and Atwater Kent products are in the public eye on account of the wide publicity accorded them. He expects to do more business in the coming year than for two or three years past.

## Year of Great Promise Ahead for Trade Is Unanimous Opinion of Toledo Dealers

TOLEDO, O., January 7.—Phonograph and record trade for the early part of the year which just came to a close was not all that could have been desired. The last few months, however, saw a big change for the better, due to the introduction of new machines, records and radios. Holiday sales, while better than last year, did not reach their full swing because of the scarcity of merchandise. With a more plentiful supply of instruments, trade will continue to climb here.

According to Edgar A. Kopf, in charge of the phonograph, record and radio departments of the J. W. Greene Co., general music store, the house lost between eighteen and twenty thousand dollars' worth of holiday business because it was unable to get sufficient Orthophonics, Panatropes and certain widely known radio receivers to care for the demand. Of course, this demand will augment sales in 1926.

Until the advent of the new machines, business for 1925 had shown only nominal activity. With their introduction to groups of musicians, clubs, churches, schools and other selected bodies, interest took a leap forward. In this growth the new recordings played no inconsiderable part. It is the belief of Mr. Kopf that if merchants will talk the new merchandise and do at least the average amount of plugging the industry will come back to more than 75 per cent of what it was three years ago.

Salesmen who were handicapped through lack of machines turned their efforts to radio selling, with the result that more receivers were placed in homes this Fall than in the past two seasons.

During 1926 sufficient phonographs and radios will be turned out to adjust this condition. Mr. Kopf stated the store is getting calls to send machines on approval and permit inspection of the product—just as it did ten years ago when the sale of Victrolas was in its infancy. This is regarded as an excellent sign, for it shows that people are interested in the new models, and no doubt will buy. Nineteen-hundred and twenty-six is going to be a banner year at the J. W. Greene Co., Mr. Kopf predicts.

Fred. N. Goosman, president of the Goosman Piano Co., stated that 1925 phonograph and record sales were about equal to the 1924 volume. Much of the business, however, came towards the end of the year. In the past the house has carried three or four lines of phonographs; starting with the new year the enterprise will confine its efforts to Columbia products. It is believed here that by giving one line full support machine volume will be brought back to a very satisfactory total. Mr. Goosman is looking forward to 1926 as a year of great promise.

Lawson S. Talbert, manager of the Lion Store Music Rooms, Victor and Brunswick dealer, stated that up to the time the Victor cut price was announced in the Summer trade had been of about average proportions. But following that, the house secured sufficient machines to permit aggressive merchandising, which resulted in large sales and an increase for the year. To help this situation along, Orthophonics began to arrive in greater quanti-

ties towards the end of December until now they are coming through in sufficient numbers to allow advertising and salesmanship to be applied. The outside force was increased the first of the year and a thorough job of selling Victrolas and Brunswicks will continue from now on. Record sales are made to climb here by concentrating upon one record each week. Efforts are not scattered. By getting a big play on one number, the others, too, receive additional attention from the public.

D. Wyre, manager of the radio department, is firm in his conviction that radio will continue to be the sensation of the time. Standard, advertised radio lines are dealt in. Both Mr. Talbert and Mr. Wyre assert that each—the talking machine and the radio—has its own

## Trade in Stronger Position Than Ever to Profit, Is Message From Cleveland

CLEVELAND, O., January 9.—Local music stores would have had one of the best Christmases in their history in all probability had they been able to make deliveries on the new type of phonographs. Credit must be given to the manufacturers and wholesalers that no definite date was given when deliveries would commence. The public plainly showed when the new machines were publicly demonstrated that they were keenly interested. Dealers made a determined effort to get rid of the older models of phonographs they had on hand at Christmas. A number cut the price deeply and advertised heavily. That these machines will move there is no doubt, but the trade has come to the conclusion that it will be somewhat of a slow process and sales will have to be pushed. The foreign population is still buying the older type of machine and many are being disposed of in the smaller towns. The public have been told the new models are far superior, they have heard them, and the middle and better class of people are generally waiting for them.

The opinion of the majority of the trade is that the phonograph is a long way from becoming obsolete. The new type of records is responsible for this. A saleswoman at one of the prominent downtown stores that sells as many records as any house in town finds

that many people who purchased radio sets several years ago and quit buying records are now buying them again in as large quantities as before. The largest individual order for records ever received by a Cleveland dealer was received in 1925. It amounted to around \$900.00. In stores where records are pushed it is not uncommon to find people waiting to have the use of a booth. On the other hand, stores that look on the record business as a side line always have empty booths. Portable business is booming. A surprising number of these machines were sold this Christmas, not for immediate use but for the coming vacation season. It seems to be the consensus of opinion among the trade 1925 radio business was good, and the moderate-priced sets sold better than either the very cheap or very high-priced outfits. During the early part of the season a number of dealers featured a trade-in plan in their policy, but as the season has advanced this type of advertising has declined. Many music houses will not accept any kind of a trade-in deal. Advertising in daily newspapers by manufacturers and their jobbers has been heavy all season, and the small dealer has benefited greatly from it. The great majority of the trade feel that the new type of phonograph will mean plenty of business for 1926 not only in the machines but in records also.

## Conditions Are Ripe for Long Period of Prosperity, Is Opinion of Buffalo Trade

BUFFALO, N. Y., January 9.—Talking machines and records reached a place in the trade of Buffalo in 1925 that had not been attained since their inception, according to interviews with several leading dealers of the city. Not since the great volume of business during the post-war days has there been such a demand for talking machines.

Neighborhood stores are evidently getting the greatest volume of record business. All dealers interviewed express enthusiasm over the volume of sales in talking machines, while with one or

two exceptions, downtown stores report record business dull, and the neighborhood store finding it necessary to take on extra help to handle the record trade.

"Talking machine business has come back," said C. H. Heinike, of Denton, Cottier & Daniels. "Since the middle of the Summer we have done a remarkable volume of business in Victrolas and Brunswicks. The last two months of 1925 were the greatest in volume of trade, since we have carried talking machines. The first few

(Continued on page 86)



# Entire Trade Making Plans for Big Business Year

days of January indicate that 1926 is going to be a very good year for the phonograph trade. Improved machines have stimulated interest that has not been greater since the first talking machine was put on the market." Mr. Heinike said that records were moving comparatively slow. Having as their leading lines in radio such sets as Atwater Kent, Fada and Radiola this store is doing a good radio business.

Neal, Clark & Neal, Victor dealers in the downtown section, have closed one of the most active phonograph years since 1920, according to Sales Manager Foster. "We have been finding a good outlet for the old model Victrolas, and have disposed of a greater number of these instruments than we had hoped for," Mr. Foster said. "With the new Orthophonic creating so much interest, we feel very optimistic about 1926 prospects."

"Introduction of the Orthophonic and Panatrope to the public has stimulated a new interest that could not have been conceived a year ago," said Harry G. Russell, manager of the J. N. Adam Co. Music Store. "The reduced prices on the old Victrolas also acted as a stimulus," Mr. Russell said. "I feel especially optimistic about 1926 phonograph business and I think that record business will improve."

C. O. E. Curtis, of the Brunswick Shop, North Main street, said he is waiting patiently for a shipment of the new Panatrope instruments, which have been sold through his sample now on the floor. In the meantime the Brunswick Shop is doing a very good trade in old instruments. The greatest volume of these

sales are made through house-to-house canvassing, Mr. Curtis said. "Buyers entering the store are not interested in the old Brunswick after they have heard the Panatrope," he said. "We have house-to-house salesmen who visit the less critical class of trade. The Radiola maintains its popularity, and we are entering the new year with some nice orders on our books."

Floyd Barber, of Barber & Wilson, reports sales of the old Victor models as fairly good. "We are selling all the Orthophonics we can get, and are even oversold," he said. "December more than doubled profits made during the same month of 1924, considering Victrolas alone. We are doing an excellent record business, Red Seals and popular numbers moving in proportionate volume." Mr. Barber said that 1925 showed a big increase over business done in 1924 and he expects to show a much better figure in 1926.

"If we could get all the machines that we could sell I could give you an idea of what business of the last two months might have been," said A. W. Erion, of the Erion Piano Co., on William street. "However, we have sold any number of old Victrolas and trade-ins, making a nice little profit, but our inability to meet the demand for Orthophonics is rather displeasing though not in the least discouraging, since we know that this trade is going to carry on through the new year. Our record business is very satisfactory, the popular numbers leading in volume of sales. We found it necessary to take on new help to handle the increased volume of record business."

liveries from the manufacturers, will bring us one of the biggest years in our twenty years in business. Our radio department, featuring the Atwater Kent and Radiola lines, shows a healthy increase over last year, and the outlook is bright."

E. H. Chambers, of the Reed, French Piano Co.: "The outlook for 1926 is wonderful. The new Thompson Minuet model featured by us is working out to perfection, and we anticipate big business with this set during the coming year."

A. R. McKinley, Pacific Northwest district manager of the Brunswick-Balke-Collender Co.: "The Panatrope has revolutionized the musical world, and the demand has gone way beyond expectations. If we had 1,000 of these new machines in stock to-day the same would be disposed of immediately. Our record business increased during December, going at least 30 per cent over the previous month, and I look for the same steady increase during the coming months."

G. F. Johnson, G. F. Johnson Piano Co.: "Unquestionably the new talking machines are creating a new interest, and this new interest has also stimulated the record business, and we may reasonably expect a constantly increasing volume of radio business in 1926."

Frank A. Lucas, Seiberling-Lucas Music Co.: "1925 was the biggest year for us since we started in business in 1909, and only lack of deliveries will retard the phonograph business for 1926. We are booking many orders for both the new Brunswick Panatrope and the Orthophonic Victrola machines and our sales volume depends largely on ability to deliver."

Elmer Hunt, manager wholesale, Sherman, Clay & Co., Victor distributors: "Indications are that 1926 will be one of the biggest years in the talking machine history. Our record business is going ahead by leaps and bounds, with all of our dealers optimistic as to what 1926 holds for them."

Charles Soule, Pacific Northwest district manager, Starr Piano Co.: "There is no doubt in my mind but that the phonograph is due to come back in 1926. Our Gennett record business is exceptionally good, and we have never had better prospects for increased business than we have at the present time."

F. L. Hutchinson, manager Victor and Brunswick phonograph departments, Wiley B. Allen Co.: "Our department experienced a most satisfactory year, and we are anticipating a banner year in 1926, with the new Victor Orthophonic and Brunswick Panatrope added to our stock, as we find keen interest among prospective buyers in both machines."

Randall Bargelt, Oregon district manager, Columbia Phonograph Co.: "Our business all over the State has increased tremendously over last year, and I find all dealers most optimistic over the future. All look for one of the biggest years for the phonograph and record industry since the war."

## Favorable Developments in 1925 Brighten the Outlook in the St. Louis Territory

ST. LOUIS, MO., January 7.—The entire trade of this city is looking forward to a prosperous 1926. This optimism is based on many favorable developments of the past year. Improved models of talking machines, better methods of recording, improvements and refinements in radio will all play an important part in better business during the coming months, according to the leading retailers in this territory. It is also significant that while the trade is optimistic there is a general feeling that the full measure of prosperity will only follow most intelligent

and intensive exploitation of the new products.

This territory, in common with other sections of the country, is enjoying a prosperous period; business generally is good. There is no more than the usual unemployment and present indications point to plenty of money to spend on musical instruments and accessories in the next twelve months. Representatives of wholesale houses who cover the trade in this city and the outlying districts are unanimous in their opinion that 1926 will be very satisfactory from the standpoint of sales volume and profits.

## Biggest Business Year in Trade History Looked for by Portland, Ore., Dealers

PORTLAND, ORE., January 4.—Optimism is prevailing among the music dealers of Portland and is the basis of all the following reports of personal interviews from them. All are facing 1926 with the feeling that it will be the biggest business year in their history.

Cliff Neilson, manager of the Victor and radio departments of Sherman, Clay & Co., said: "The phonograph man of to-day is starting out anew, just as those of twenty-five years ago did when the first Victor machine was produced. The Orthophonic Victrola has opened up an entirely new field—in other words, the cultured musical class who appreciate real music, such as we are now ready to give them with the new Orthophonic Victrola. The demand is far beyond our fondest expectations. After the first hearing, customers are completely sold, and contracts are stacking up for those who are willing to wait for their instruments. I personally look for 1926 to be the biggest year in the history of the music industry. A big radio year is also in sight, especially with the arrival of the new Victor and Radiola combinations. The past year has been very satisfactory, and with the organization of the Oregon Radio Trades Association many tangles have been straightened out, with co-operation among local dealers now apparent."

E. B. Hyatt, Hyatt Music Co.: "We have experienced a most satisfactory increase in business over last year, and feel sure that with the arrival of instruments for delivery of the new Orthophonic Victrola and the Brunswick Panatrope the talking machine business has come back into its own and that 1926, with ample de-

## Profits Will Be Determined by Ability to Meet Demand, Opinion in Minneapolis

MINNEAPOLIS, MINN., January 6.—Opinions are drawn up in two camps as to the talking machine trade. It is quite easy to "call the turn" on a dealer's opinion—depending as it does upon whether he has new models to deliver or old stock.

E. R. Dyer, of the Metropolitan Music Co., said his firm could sell dozens of the new machines if they had assurance of being able to fill the orders. Mr. Dyer says that his firm will push radio sales the coming year.

The Foster & Waldo Co. has been unique among music houses during 1925. When other firms were marking time or frankly admitted that things were "pretty slow" R. O. Foster

told a consistent story of tremendous sales. The jobbers with whom he did business confirmed his statements. Of course, this was partly due to the removal sale which the company conducted all Fall. However, Mr. Foster maintains a large share of their success was the result of the company's firm belief in the permanency of the phonograph. They advertised and went after the business hard all Summer, Fall and holiday seasons with entirely satisfactory results. The phonograph business will have a big year if the machines are available, says Mr. Foster, and piano, record and radio sales will show a marked increase in 1926.

(Continued on page 87)



# Low Stocks Mean Busy Days for the Industry

Mr. Hoch, of the Cheney Co., says that undoubtedly the phonograph business is marking time but he is very sanguine as to the prospects for 1926. He believes that all makes will benefit when the final adjustments are made.

At the George C. Beckwith Co. a year of unusual sales is foreseen. In regard to the season just passed it is believed that the new model phonographs will boost sales volumes and that, coupled with the great demand for radio, should spell prosperity to the music trade.

St. Paul merchants state that the radio side of their business in 1925 showed up satisfactorily. Those who handle the new machines,

while admitting that the past situation was not altogether pleasant, are optimistic over the outlook for 1926. They believe the demand will be there if only the goods can be assured.

Several Twin City dealers have only recently taken on radio lines and expect to lean heavily on that for their profits. They believe in pushing the higher priced models, due to the fact that they need less servicing and for the obvious reason of greater profit. All are agreed that the radio business needs many adjustments, principally in the service department, but that it is a field any music dealer is foolish not to cultivate.

were willing to pay several hundreds and even thousands of dollars for a receiving set which would lend grace and charm to home surroundings.

In the final summing up, it is difficult to see, with this section in such an excellent economic condition, and the buying public in a position to expend plenty of money on articles which are not the dire necessities of life, how the talking machine and radio trade can fail to leave the sales figures of 1925 far behind when those of 1926 are totaled and compared.

The Middle West is practically free from labor troubles and disputes, and the army of unemployed has been reduced to a very few. Wages are high and there has been no noticeable increase in living costs, and the public has attained a better scale of living. Savings deposits have increased approximately 6 per cent—tangible evidence that this section is not on a hand-to-mouth basis.

The agricultural districts of the Middle West, which exert perhaps the most powerful influence on trade in this territory, are in better financial condition than for the past several years. Many of the States harvested record-breaking crops, and while the lower prices decreased the income of the farmer about 7 per cent his purchasing power remains high, as is evidenced by his consumption of goods. In this field, of course, retail sales are the reward of hard work.

## Chicago Retail Merchants Are Planning to Meet Strong Demand During New Year

CHICAGO, ILL., January 8.—The year 1925, which opened none too auspiciously for the talking machine dealer, closed with an entirely different aspect. Sales of phonographs at reduced prices during the late Summer months showed that a market remained for cultivation. The Fall, with its introduction of the new types of instruments, preceded by nation-wide publicity, brought with it a rejuvenation which carries over into the new year and far into the future. With the increase in production on the part of manufacturers, dealers in this section expect to continue the present volume of business for many months to come, and in a large number of cases to increase it. One prominent Chicago retail music house, whose business was exceptionally large during the third quarter of 1925, even though it was curtailed by a shortage of instruments, is basing its plans for 1926 on a sales total which will be three times as great as that of the year just closed. While other dealers are not inclined to predict such a figure, they are unanimous in the belief that a wide market exists for talking machines and that business will become increasingly better as the year wears on.

One reason for this feeling lies in the record business, which has been on the upgrade since late Summer. New electrical recordings, placed on the market after considerable research and experiment, won immediate recognition on merit alone, for their advent was not heralded by any undue amount of publicity or advertising. Satisfied customers and word-of-mouth advertising have served to place record sales at the high peak upon which they stand at the present time. Another reason for the belief that the consumer public desires permanently recorded entertainment is pointed out by the dealer in the overwhelmingly large number of portable sales, which have continued throughout the Fall months, and prophesy another banner year in 1926 for the portable phonograph industry.

In radio, where the dealer found many vexing problems a year ago, he finds a comparatively smoother path. Manufacturers who stand back of their products have in large measure taken the place of the itinerant maker of sets, and the service problem has decreased to the point where the dealer has been able to work out some suitable method of handling and servicing radio and still retain a substantial profit. Dealers in this territory state that they have found it best to stock three or four lines of receivers and loud speakers, flanked by standard accessories, and to concentrate advertising and sales effort on the smaller number of lines.

The dealer has gained a much better impression of the manufacturer than was the case a year ago, for he has found that he can obtain co-operation in the way of sales helps, and that, moreover, he is allowed to exploit his own particular territory free from the clash of competition. During the Fall of 1925, the radio sales figure forged ahead of all predictions, and retailers expect to experience a like condition for several months to come. The public, not seeking to such a degree the "ultimate"

receivers as last year, and the consumer, who two years ago would have built his own set, are coming to the dealer and buying sets in which are found tone quality, selectivity and beauty. The music dealer, accustomed to selling these qualities in the phonograph, has become an increasingly powerful factor in the selling of radio receiving apparatus.

The last two weeks of December found many dealers beseeching the manufacturer and distributor for sets, and another surprising fact was revealed when it was found that people

## Business in Richmond Dependent Upon Crop Conditions Throughout the State

RICHMOND, VA., January 9.—Dealers express themselves as optimistic regarding the talking machine outlook for 1926, especially for the next three months. As the year advances, the situation, they say, will be regulated largely by crop conditions. If crops are good, business will go forward. If they are bad, there will be a slowing up. This has been their experience in the past and they expect it to be their experience in the future, so long as this territory continues to be dependent to a very large extent upon agriculture and the prices received by the farmer for his crops.

Increased popularity of the radio during the past year was also a development that attracted wide attention and caused talking machine dealers who were holding aloof from this line to take on radio to meet the demands of their trade.

Record business in 1925 was reported to have been fully 25 per cent better than in the previous year. Song hits as well as new issues of dance numbers enjoyed wide popularity through the year. Collections continued satisfactory and about on a par with those of 1924.

Kenneth Lord, manager of the talking machine department of the Columbia Furniture Co.,

this city, summed up his views as to 1925 business and the outlook for the new year as follows: "With the passing of 1925, we can readily glance back and say that the old year has been a profitable one. Following the usual Summer slump, which really was below normal, the Fall trade proved excellent, far exceeding expectations. With the coming of the new Victrola talking machine interest was revived and it was impossible to begin to meet the demand for these new machines. Scores of machines of another make were also sold in large numbers. The radio business increased in large proportions during 1925, possibly five times greater than in 1924. The outlook for the new year is bright and we are looking for a big year in both Victrola and radio lines."

E. W. Feltner, of the Martin Music Co., said that the past year as a whole was somewhat better with his firm than was 1924 and he predicts a prosperous 1926.

James Cowan, of the James Cowan Co., remarked that he had a satisfactory year in practically all lines handled by his firm. Outing portables were in particularly good demand during the 1925 Summer season and the outlook is excellent.

## Everybody Happy in Kansas City, Mo., With Expectations of Business Betterment

KANSAS CITY, MO., January 7.—This has been a radio Christmas, for there has never been anything like the amount of selling of these instruments as during the past month. The selling began some ninety days ago and has been gradually increasing in intensity as the weeks have gone by. Not only has the number of instruments been larger than ever before, but there has been a big increase in the value of the individual machines sold. The better machines have been the favorites in the selling.

Some of the music houses have not been able to get the necessary machines to supply the demand. Wunderlich's, for instance, was sold out of most of the better machines several days before Christmas, and they thought they had stocked up in sufficient quantity to supply the holi-

day trade. The chief complaint with the trade in other houses has been that they have not been able to get the necessary instruments to supply the demand. This is, of course, the thing which has been the greatest matter of regret with all dealers in Victor machines.

J. W. Jenkins Sons' Music Co. Victor wholesale department reports that they have not been able to supply more than half of the demand for the new machines, but have distributed those which have come to the best advantage possible. In the matter of record sales, this has been a record-breaking Christmas, if the reports of most of the dealers are to be taken at face value. There has been a big demand for all kinds of records. The increase in the interest

(Continued on page 88)



# Strong Retail Demand Expected for All Products

in phonographs of all kinds has been reflected in these sales.

The Columbia Co. is having a big response to their page advertisements in the daily papers. Their new records have had a tremendous sale throughout all the Kansas City territory, the branch office of the Columbia reports. There has been a fine sale of machines, also, partly influenced by the big interest in the Columbia records. Altogether, the Columbia has had a good year in this branch. The outlook for the new year is considered particularly bright.

The Jones Store, which handles the Edison and Sonora machines, had a fine Christmas trade, as they were not bothered about the matter of deliveries. The demand has been heavy for the month, and was quite satisfactory, according to Manager Bowers, of the phonograph department, who looks forward to a busy 1926.

The Brunswick people are looking forward to a great year in 1926. They say that the delay in getting their new instruments has "shot to pieces" the business for some time, but that in spite of that there has been a fair business

in instruments and a fine volume of sales in records.

Manager Standke, of the Star headquarters, is having a very good trade in that line and enjoyed a good business during the holidays. He has built up an exceptionally fine business in records. His location, in the heart of the theatre district, is helping him in this respect, and he expects a banner 1926.

The systematic selling of the Edison phonograph by personal visitation and rendering service which secures good will and leads to references to neighbors and friends who are possible customers is resulting in such large sales that the wholesale Edison representative here is determined to carry on in that way during the next year.

If the general outlook for a good business year has anything to do with the amount of business that is to be transacted during the next year then 1926 will be one of the best. The figures for the year just closed show that, in most things, it was a better year than the one previous, and in many respects it was a record year.

of about 15 per cent over last year. Our record business indicates that people are using their phonographs and if they are using them there is no reason why they shouldn't be buying records. We have also done very well on portables during 1925, and we are going to push them more than ever during 1926."

The Carberry-Parker Co. anticipates a very brisk business in both talking machines and radio as soon as regular deliveries are being made on the lines which they carry, according to W. A. Bye, manager. This store features the Victor line, and the Radiola. The Orthophonic has been received with much enthusiasm, he states, and the instruments on hand have been sold immediately. Mr. Bye added that enough orders were now on file to take up shipments for several months.

The Kaun Music Co., which handles the Columbia, has been very successful in featuring Columbia New Process records, according to J. Weis, who has charge of the department. A very good demand for these records has been built up by Mr. Weis, who states that he now has customers coming there from all parts of the city. "I am looking for a good business in Columbia records during the coming year."

Other retailers interviewed expressed themselves in terms of optimism, pointing out that while there are some conditions in general business that are not as satisfactory as they might be at the present time the favorable factors are so strong that the opinions of betterment are in reality based on the soundest kind of reasoning. It is also worthy of note that dealers generally believe that salesmanship will win in 1926.

## Business in Milwaukee Expected to Take a Sharp Upward Turn During Present Year

MILWAUKEE, WIS., January 7.—The talking machine, radio and record business in Milwaukee stores is expected to take an upward turn during the coming year, and a marked improvement over the past year is anticipated by local dealers. The situation in talking machines has been somewhat peculiar during the past few months since the announcement of the new Victor and Brunswick instruments, due to the fact that these dealers have been unable to get deliveries on their orders. However, dealers who have continued to push the old types of machines, despite the introduction of new models, have been doing a good business in this department.

Radio has been going very big this Fall, and the outlook for the coming year is very bright, dealers state. Buying started off with considerable enthusiasm early in the year, and the holiday trade was excellent. The present outlook indicates that business will continue active through the next two or three months.

The record business has been ahead of last year at a number of stores, while others state that they are very active, although the demand for Christmas numbers was not up to other years.

"I believe that the new combination instruments as well as the straight Orthophonic and Panatropes will revive the talking machine business during the coming year," stated Henry Steussy, vice-president and manager of the Kesselman-O'Driscoll Co., home of the Ampico, and Brunswick, Victor and Edison phonographs, "and we should have a very good year. Our radio department has been progressing very nicely and we are looking forward to a big year ahead in these products."

J. J. Healy, manager of the music department at the Boston Store, states that both records and talking machines have gone ahead of 1924 in 1925, and that all indications point to better business during 1926.

"Our record business has shown an increase over last year since the beginning of June last Spring, and during September, October and November, the increase amounted to approximately 50 per cent over 1924," said Mr. Healy. We have also gone ahead on phonographs. At present, everyone that is interested in a talking machine is asking about the Orthophonic and the Panatropes, but we are still selling the old models in Victrolas and Brunswicks, and the Cheney is also moving very nicely. During the coming year, when we are getting deliveries on new instruments, I see no reason why we should not continue to show a good increase."

"I think that 1926 will be a year of decided

prosperity," declared A. V. Orth, president of the Orth Music Co., which features the Brunswick line and radio, "but we shall proceed very cautiously with our buying until we are able to determine definitely what the public is going to want. Our record business is exceptionally good, and we have been showing an increase

## Favorable Factors for Better Business in 1926 Create Optimism in Pittsburgh

PITTSBURGH, PA., January 8.—Unlooked-for good business featured the closing weeks of 1925 for the talking machine merchants of the Steel City. For the first half of the month there was only a fair volume of business handled and it was most agreeable to note that just about ten days before Christmas there appeared to be a decided upward trend in business, with the result that the talking machine dealers were overwhelmed with orders for high-class instruments for Christmas delivery.

In fact, so pronounced was the demand for the new Orthophonic Victrola and the Brunswick Panatropes that it was impossible for the local dealers to make deliveries on schedule time. In . . . however, augurs well for business in the new year as delayed orders will have a tendency to stimulate new business, some of the leading talking machine dealers assert. Another feature of the holiday business was the large volume of records that were sold. Some of the dealers were handicapped also in this respect, and were unable to secure all of the merchandise they could have disposed of.

On the whole, there is an optimistic tone apparent among the talking machine fraternity as far as business for 1926 is concerned. Excellent industrial conditions are assured for the next twelve months and this prosperity is bound to be reflected in all lines of business in the Steel City.

L. A. Behr, president of the Rosenbaum Co., Victor, Sonora and Brunswick dealer, said: "Prosperity has been with us since the Summer of 1925 and I look for it to continue through 1926 very satisfactorily. Our Christmas business was the largest we ever experienced and the outlook for 1926 certainly is rosy."

Edward M. Lannes, of the Rudolph Wurlitzer Co., Victor dealer, said: "We are confident that the first four months of 1926 will bring the finest business we have ever experienced in Pittsburgh. The new year outlook for trade is very good. Many persons are now buying for

January, February and March delivery. Wage earners are busy paying their debts, and the future is most promising. We are optimists as a result."

Arthur O. Lechner, of the Lechner & Schoenberger Co., is similarly optimistic over the outlook, as are also P. D. Campbell, of Campbell's Store, Columbia dealer, who said: "I believe that our business will continue to gradually increase during 1926, as the basic business of this section—iron and steel—seems to be improving. Another reason for this optimistic attitude is that the shoppers are beginning to realize that prices are stable and that they are as low as they will be for some time. Then, too, the Government's wisdom in reducing taxes—which incidentally ought to be copied by State and city governments—is certainly conducive to greater prosperity."

Burt Hengeveld, sales manager of the S. Hamilton Co., who operates a large talking machine department, declared: "The outlook for 1926 is good and we believe that it will be a better year than 1925. People are getting caught up again and are feeling prosperous."

P. M. Perry, of the W. F. Frederick Piano Co., Victor dealer, said: "We are very optimistic regarding 1926 business prospects. We have shown our confidence in a tangible manner by arranging to open a new branch store in the Oakland district and by making new contracts for additional merchandise. I believe that 1926 will see new records made in the manufacture and sales of talking machines and records."

George S. Schroeder, president of the Schroeder Piano Co., Brunswick and Sonora dealer, commented as follows: "We are firmly convinced that 1926 will be a great business year and we are planning to handle a larger volume of business in talking machines and records than we have ever done before. The general tone of business is strong and dependable."

Theodore Hoffmann, of the J. M. Hoffmann  
(Continued on page 89)



# General Industrial Improvement Favors Trade

Co., Brunswick dealer, is of the opinion that 1926 business will show a marked improvement over that of 1925. He bases his views on the fact that with reduced taxation and a greater volume of money being disbursed in the pay-

rolls by the large industrial establishments of the Pittsburgh district, that the music trade cannot help but share in the general prosperity that is bound to come in a substantial manner during the present year.

new field for the dealers, who are alive to their opportunities, to exploit.

When general business is in good condition the retail talking machine trade has found from long experience that business comes easy. Of course, a great deal depends upon the efforts of individual dealers. No matter how prosperous the times, some merchants have cause to complain, and with good reason. They do not get their share of the business because they make little or no attempt to promote sales. The live wires get to the prospects first and these are the dealers who make the most of a season that is potential for good business. However, there is no doubt that the present year will see big sales volumes rolled up by those dealers who go after sales in an aggressive and thorough manner.

## Los Angeles Retailers Look Forward to a Year of Normalcy Throughout Territory

LOS ANGELES, CAL., January 4.—L. E. Fontron, president of the Music Trades Association of Southern California and secretary-treasurer of the Martin Music Co., reviewing the experiences of 1925 in the phonograph business, stated that one thing which impressed him very much was the remarkable way in which the public responded to the advertisements of talking machines at reduced prices; there had been no difficulty in disposing of entire stocks at bargain prices. What is the answer? Many have declared that the phonograph is passé—as obsolete as the horse and buggy. Would people buy horses and buggies at bargain prices? By no means, yet they rushed after phonographs under the circumstances. Now comes the improved or Orthophonic Victrola; but, alas, the supply was extremely limited, and orders have stacked up, placed by enthusiastic fans, mountain high. He looks forward to a wonderful business revival in 1926 and the opportunity for dealers to make substantial profits.

J. W. Boothe, general manager of the music department of Barker Bros., anticipates fine things for 1926—the beginning of a reincarnation of the phonograph and phonograph-radio business. Sales of Orthophonic Victrolas, Electrolas and Panatropes, singly and in combination with radio, should set new standards of high prices.

R. M. Mattson, of the R. M. Mattson Co., Long Beach, referred to 1925 as a period of struggle in the phonograph business but a great test of endurance in keeping one's head above water. He felt confident over the outlook in 1926 and is enthusiastic regarding the future of the Panatrope. He also looks forward to a still more wonderful development of the electric record, its increase in length of performance and improvement in other respects.

A prominent talking machine distributor declared that 1925 had been a hard year for the wholesaler. He declared 1926 looked like a return to normal times in most respects; but the timidity of the dealer induced by the past experiences, was liable to continue in the direction of not adequately anticipating his wants and ordering stock in advance and is apt to make it additionally difficult for the wholesaler to carry the necessary supplies. He also believed that the time has come for the dealer to take a better view of the rates of discounts which he enjoys—a proper, scientific analysis and check-up would, he believed, reveal that the present margin of gross profit gives the properly managed department a fair and legitimate net return.

P. H. Beck, general sales manager of the Platt Music Co., said that the least said about the phonograph business in 1925 the better, but that the prospects for 1926 especially in respect to the sale of high-priced combination phonograph and radio machines, was exceedingly bright, the incentive to purchasers being twofold, namely, improved talking machine reproduction and radio receiving, whereas, previous to the arrival of the new instruments, the appeal of combination sets was due to the fact that the talking machine cabinet containing the radio receiving set was so attractive in appearance.

F. L. Grannis, general sales manager of the Southern California Music Co., is very optimistic in regard to the future of the Panatrope and improved phonographs. He considers that there are all kinds of wonderful opportunities for selling these higher-priced instruments in fields hitherto untouched, which includes the

scores of clubs, the cafés and roadhouses, resorts and gathering-places. There will be opportunities for the giving of impromptu dances and entertainments with instruments with sufficient volume to take the place of orchestras at all times, which, it is felt, will be taken advantage of more and more, thus creating a practically

## Brightest Outlook in Years Creates a Spirit of Enthusiasm in Salt Lake City

SALT LAKE CITY, UTAH, January 5.—Never before in the history of Salt Lake City and Utah have talking machine dealers looked forward to a new year as they are looking forward to 1926 at this writing. There are two reasons for this view. In the first place, perhaps, it is felt that the two new instruments recently placed on the market by the Victor and Brunswick people are going to arouse greater interest in the phonograph. In the second place, the outlook in this territory, embracing substantial slices of contiguous States as well as Utah, was never quite so good as now. The year that just came to its close proved a wonderful one for the farmers; not only have the crops been unusually large with one or two exceptions, but prices were well above normal for practically everything. All other essential industries have been prospering, too, and at this writing oil has been struck in the State and predictions are that many citizens will be enriched to the extent of millions of dollars.

The entire business world in this section is full of enthusiasm for the future. Bankers, noted for their conservatism, tell your correspondent they can see no "Dark Spots" ahead. Collections are better than normal, for everyone is employed and money is plentiful. Merchants in every line report business as good.

The coming year should see a big advance in radio. Only part of the phonograph and music dealers here is pushing radio at this time, but the Victor people say they will handle the "combinations."

Regarding the business outlook Manager R. W. McMurray, of the Glen Bros.-Roberts Piano Co., said: "Our record business this Christmas was well ahead of last year. The demand for

the Orthophonic Victrola is very encouraging and we expect it will continue greater than the supply. Many orders are booked ahead and they include all models. The phonograph business, including the demand for records, looks as if it is coming back into its own again."

Harry O'Laughlin, of O'Laughlin's, said their radio business had been wonderful, as had the record business. Christmas business was heavy. Mr. O'Laughlin expressed much confidence in 1926 and in the Brunswick Panatrope. He believes Brunswick dealers will do a big business with it.

Mrs. Olin, manager of the Utah Music Co., states radio has been the feature of the last year's business and indications point to a very prosperous 1926.

G. Todd Taylor, of the Daynes-Beebe Music Co., said radio had been selling well, there being a demand for both radio exclusively and in conjunction with the phonograph. Mr. Taylor views the 1926 outlook with optimism based on sound reasons.

Dean R. Daynes, of the Consolidated, and a brother of the company's general manager, said the record business had been very good. This company has lots of orders for new Orthophonic Victrolas they cannot fill at present. Mr. Daynes said the Consolidated Music Co. looked for 1926 to prove a big year, one of the best in the music merchandise history of Utah.

Fred Beesley, Sr., of the Beesley Music Co., lamented the lack of an adequate supply of Victor Orthophonics. Even their samples had to go, people being unwilling to wait. He said they have been enjoying a good record business and he could see "no reason why business should not be 'real good' in 1926."

## Large Retail Outlet for All Lines Is Predicted by Trade In San Francisco

SAN FRANCISCO, CAL., January 5.—L. W. Sturtevant, manager of the radio department, Sherman, Clay & Co., said, regarding trade prospects: "We are particularly optimistic over 1926, as we anticipate a large market for cabinet model radio sets wherein the batteries will be eliminated and power-speaking devices installed, and the public will be more discriminating in its purchases of radio, demanding a set that is mounted in a cabinet and reproduces faithfully. We believe the average radio sales of 1926 will be considerably higher than in 1925. Therefore, the dealer will enjoy a larger volume."

R. M. Bird, Coast manager, wholesale talking machine department, Sherman, Clay & Co., said:

"The developments in the talking machine industry during the year 1925 were, in my opinion, second only to the original inventions of

recording and reproducing sound waves by mechanical means. The public manifested great interest in the Orthophonic Victrola when it was first announced. They simply flocked to every presentation and marveled at its performance. The advance orders booked by dealers were in themselves encouraging—but when customers expressed a willingness to wait until after January 1 for delivery, the complete rejuvenation and comeback of the talking machine was an assured fact. All things being equal and provided there are no unforeseen developments, the year 1926 should be one of the largest years in the history of the talking machine business."

James J. Black, treasurer of the Wiley B. Allen Co. and head of that firm's phonograph activities, who also represents the music dealers in the Radio Trade Association, said: "The de-

(Continued on page 90)



# Business Outlook Brighter Than in Recent Years

velopment of the Orthophonic Victrola and the Brunswick Panatrope has brought renewed interest in talking machines on the part of the public. The talking machine business is again on a basis of stability, whereas, on the other hand, radio at present is not regarded by the music dealers as being an equally stable proposition. There are, on the market, an excessive number of radio sets, good, bad and indifferent, much to the detriment of the radio manufacturer who wishes to feature his line on the highest merchandising plane. Everything, in my opinion, points toward a tremendously in-

creased sale of talking machines and of the new records in 1926."

Jack Bray, manager of the phonograph and radio departments of Kohler & Chase, said: "We always look forward to the best, but, before speaking with authority I think we have to see how the new developments in the talking machine industry strike the public. We are Brunswick dealers. During Christmas sales we had one Brunswick Panatrope and it went too fast, leaving us without any." Mr. Bray added that radio had been a very good seller with Kohler & Chase during the Christmas period.

electric recorded record and buying was thus held down until the dealers' surplus stock could be disposed of. With the advent of the new Orthophonic, demand in the new records was evident. Dealers report record sales running ahead of last year's sales.

C. P. Herdman, manager of the talking machine and radio department of the Baldwin Piano Co., is very well pleased with sales. This store handles the Victor Orthophonic, the Brunswick Panatrope and the Edison.

"The interest in the talking machine has been revived to a tremendous extent," states Mr. Herdman, who looks forward to a busy 1926. L. T. Glidden, manager of the Pearson Piano Co.; W. J. Baker, manager of the Brunswick Shop; W. S. Wilson, manager of the Wilson-Stewart Music Co.; Miss Minnie Springer, manager of the talking machine department of L. S. Ayres, and other leading figures in the local retail trade also expressed the opinion, based on the many favorable indications, that the new year should be prosperous. There is a general feeling that all lines will come in for their share of attention, although the belief is strong that to the dealers who do the most effective sales promotion work will go the biggest rewards in sales. Taken as a whole, the outlook here is better than it has been in several years past.

## Tremendous Public Interest Seen as a Sales Aid by Dealers in Indianapolis

INDIANAPOLIS, IND., January 7.—Much optimism pervades the outlook of the local talking machine dealers for 1926. The local situation is largely the condition of the entire country as regards the talking machine trade—namely that the dealer now has merchandise of tremendous pulling power and growing interest, which will net him a good business in 1926.

Radio sales have been very strong during the Fall and Winter of the past year and should continue their high demand, from reports gathered. A great deal of attention has been given

by local dealers to the proper advertising of their radio goods, with a special view to volume of sales. Sales have therefore not been confined to the Indianapolis territory, but out-State as well. The popularity of the better known sets is attested by the fact that local dealers are unable to secure deliveries.

Record sales have been largely augmented by the interest attracted to the new records issued by the leading talking machine companies. Brought out late in the Summer the general public was not aware of the advantages in the

## Detroit's Rapid Growth and Prosperity Expected to Bring About a Big Demand

DETROIT, MICH., January 8.—Radio and talking machine business had its ups and downs during 1925, although combined the sales were considerably in excess of the previous year. Many sales were held up because of announcements of new models and reports that this and that concern was going to bring out something sensationally new. These reports temporarily caused people to withhold buying, but when the dealers finally offered the new merchandise satisfactory sales resulted.

A great many very expensive sets of combination radio and phonograph consoles were sold during the year and particularly at holiday time. For the first six months of 1925,

radio and talking machine business was slow, and it continued slow until about July when it began to show new life—each month there has been a steady increase and while there are many who will say that December was not up to expectations on talking machines and radio, they figure on the yearly sales that business was very satisfactory.

It must be remembered that if we take the volume of sales for the entire city of Detroit they will show a tremendous increase over the previous year. If we take the individual stores they are not so great in proportion, naturally. Don't forget that Detroit is a much bigger city than it was a year ago—and don't forget also

that there are many more dealers in talking machines and radio than there were a year ago. On every thoroughfare in all sections of the city we find to-day firms who are selling radio and talking machines—and it is only natural that they are all going to get a share of the business.

It is contended by most of our dealers that the business of the future is the combination machine, and it is certainly the most practical. And still we met a dealer just this morning who remarked that he had a nice business last year on talking machines, as the demand for them without radio was surprising.

Detroit dealers look with optimism upon the radio and talking machine possibilities for 1926. In fact, talking machine dealers are now convinced more than ever that the radio has become a definite part of the talking machine industry.

## Baltimore Dealers Have Decks Clear for Profitable Sales Promotion This Year

BALTIMORE, MD., January 8.—The retailers of this city and adjacent communities are exceedingly optimistic regarding the business outlook for 1926. The year which has just come to a close, while it started in an unsatisfactory manner, ended in a rush of business which aided materially in bringing up sales volumes to a point that compares favorably with the sales of the year before.

The slowness at the start of 1925 was largely due to chaotic conditions in the radio industry, and the uncertainty of dealers regarding developments in the phonograph field. The marked features of the developments the latter part of

last year were the announcement and introduction of radically improved talking machines and records—instruments far superior to anything expected. Demonstrations aroused interest to a high pitch, and dealers once again found themselves striving to meet the demand.

Many of the dealers are starting the New Year with floors cleared up of slow moving merchandise. They are starting the New Year with orders on their books for delivery as soon as they can receive instruments. The revival of interest in the talking machine has manifested itself in a sharp upward turn in the demand for records, a very satisfactory condition.

Although at the start of 1925 the radio business was far from satisfactory, the year end also brought improvement in this direction through refinements and improvements in the products of leading manufacturers, thus as far as the radio end of the business is concerned the trade faces the present year with receivers and accessories of a quality which was not thought possible to achieve a year ago.

All in all the outlook for the present year is indeed bright, and the optimism of the retailers is based on the soundest kind of reasoning. The trade, too, feels that to gain a full measure of success from this potential prosperity it is necessary for them to put their best foot forward in effective and consistent sales promotion. In short, while the outlook is bright it is up to the dealer to do his share to cash in on the opportunity.

## New Landay Hall in Newark Is Latest of Large Chain

Entire Five-story Building Given Over to Sale of Musical Instruments—Complete Stock Carried—H. A. Glasser Is Manager

The new Landay Hall at Park Place and Center Market Plaza, Newark, N. J., was formally opened to the public on Monday, January 4, and thousands thronged the five stories and basement of the building, which is devoted en-

tirely to the retailing of musical instruments. The building was practically rebuilt by Landay Bros., and renovations of both the interior and exterior makes the establishment ideal for the display of the highest grade of musical products. From the outside, the outstanding feature is the large space given over to window displays. The interior has been finished to form a setting harmonious with the merchandise for sale.

The first floor of the establishment is given over to a display of different instruments and to the talking machine record demonstration booths. The second floor is occupied by the

piano department and on the third floor a complete stock of talking machines and radio equipment is carried. The basement is given over to player-piano rolls and sheet music. The executive offices and credit department are housed on a mezzanine balcony. Harold A. Glasser, manager of this store, has been in the retail music trade for more than ten years, and for the past couple of years has been connected with Landay Bros. as manager of the Landay store on Broad street, this city. He has a wide knowledge of merchandising and is well-known in trade circles in Newark.



### Condition of Radio Trade Discussed by Dealer Ass'n

Talking Machine & Radio Men, Inc., New York, at January Meeting Discuss Outstanding Selling Evils and Suggest Possible Remedy

A discussion of the merchandising evils of the retail radio trade in the metropolitan territory and possible remedies featured the first meeting of the new year of the Talking Machine & Radio Men, Inc., New York. The discussion opened with a motion by Chester Abelowitz, proprietor of the Brunswick Salon of Fifth Avenue, that a letter be sent to E. E. Bucher, general sales manager of the Radio Corp. of America, thanking him, on behalf of the members of the Association, for the policy of the Radio Corp. in getting rid of the undesirable elements of the radio trade. Other dealers spoke describing their experiences with unfair competition, and several plans were put forth as solutions. Several dealers told how they, by studying their own individual problems, had satisfactorily solved them by carrying no merchandise but that of manufacturers who protected them by maintaining prices and not selling to "gymps." No definite action was taken other than to issue a call for a meeting of the executive committee, at which plans can be made for steps to be taken which will be brought up at the next meeting of the Association for the consideration of the members.

The speaker of the day, Alfred Bloom, president of the Sunbeam Radio Corp., manufacturer of the Akrodyne radio receiver, spoke briefly of the merchandising policies of his company, stating they were: a quality product, price maintenance, as proved by the experience of the past year, and co-operating with dealers by merchandising helps. The advertising program of the company is unusual in that it aims to secure a maximum of word-of-mouth publicity rather than to drive home its message by the printed word. To this end a series of broadcast programs are being given from Station WHN each week and exploitation work to bring the people to the stores of Akrodyne dealers has been started in conjunction with these programs. Co-operation with dealers in local sales campaigns is another feature of the company's policy. A model of the Akrodyne receiver was on display during the meeting.

Irwin Kurtz, president of the Association, reported that many hundreds of telephone calls and written communications had been received following the two broadcast concerts given by the Association from Station WRNY. He paid high praise to E. W. Guttenger, manager of the wholesale department of the Columbia Phonograph Co., New York, for his co-operation in providing artists for the concerts.

The entertainment committee has made all plans for the annual ball, which is to be held at the Hotel Pennsylvania on February 18, and dealers were urged to take posters and tickets, which were available at the meeting, and give them to their customers.

The members were entertained during the meeting by the Silver Masked Tenor of radio fame, who sings with the Goodrich Silvertown Orchestra and who is a Victor artist, who appeared through the courtesy of Irving Berlin, Inc., and sang two of the most popular Berlin hits, "Remember" and "Lullaby Lane."

The next meeting of the Association will be held at the Café Boulevard on February 3. The feature of the meeting will be the display of the products of McPhilbin-Keator Corp., and there will be a talk on its merchandising policies. The lines handled include Kolster and De Forest.

### Temple Music Shop Opened

The Temple Music Shop recently opened at 223 Second Avenue, New York, with a complete stock of talking machines, radio equipment and other musical instruments. S. C. Obsusin and S. Glick are the proprietors.

### Great Increase of Chas. Freshman Co. Business

Gross Sales for 1925 Are Figured Approximately at \$7,500,000—Reasons for Remarkable Success of Fine Radio Organization

Charles Freshman, president of the Charles Freshman Co., Inc., of New York, has announced that the gross sales of his company for 1925 will be approximately \$7,500,000. This figure more than triples the gross sales in 1924, which were \$2,149,327.

The rapid growth of the Freshman Co. is in-



Charles Freshman

dicated by the fact that it is negotiating for additional manufacturing space and is planning a production next year of 3,000 sets a day. Between 2,000 and 2,500 receiving sets a day are now being turned out at its Bronx plant in New York, where 1,100 people are employed, with 56,000 square feet of manufacturing space. The company also occupies 40,000 square feet of the Freshman Building, New York, and 50,000 square feet at its Chicago plant. Although the Bronx plant was occupied only last July, there are six complete production units at work, each with a total capacity of 500 sets a day. An engineering staff, including many former Western Electric engineers, is maintained at the Bronx plant and experiments are constantly being conducted in a well equipped laboratory to improve the Freshman machine. At present the Freshman Co. is manufacturing seven models of receiving sets ranging in price from \$39.50 to \$115.

The remarkable success of the Freshman company is attributable in no small measure to the ability of Charles Freshman, its president. He was born in Chicago and was educated in New York and Chicago public schools and at the City College in New York. The rapid growth of the company since August, 1924, when the first Freshman receiving set was made, is a tribute to Mr. Freshman's extraordinary organizing ability and his thorough knowledge of the mechanical as well as merchandising ends of the radio industry.

### Wanamaker's Features the Priess Cabinet Receivers

Five Custom-built Cabinet Sets Shown in Wanamaker Salon of Heirloom Furniture Model Type—Equipped With Straight 8

A remarkable tribute given to the Priess Straight 8, manufactured by the Priess Radio Corp., 695 Broadway, New York City, was arranged recently by John Wanamaker, one of the country's leading department stores, by a presentation, in the Wanamaker salon, of five custom-built radio cabinets. These were works of art, described as heirloom furniture, of hand-carved models in walnut, Japanese lacquer in gold, green, red and blue, equipped with Priess Straight 8 radio set, floating loud speaker, directional loop, batteries and other equipment, making them self contained. The prices of these antique models range from \$515 to close to \$1,000.

This is only further evidence of the reception accorded the Priess sets, known as the Priess Straight 8. From the trade both William H. Priess, the inventor of the Priess set and head of the company bearing his name, as well as F. Clifford Estey, sales manager of the company, have received hundreds of letters with favorable comment on the efficiency, selectivity and distance-getting qualities of the Priess product.

### Fada Dealers at Rally

About 100 dealers attended the Fada radio rally held by the Siege Co. in Davenport, Ia., recently. Interesting talks were given by R. R. Engleheart, general manager of the company, and L. J. Chatten, Chicago district sales manager for F. A. D. Andrea, Inc. A demonstration of the Fada art furniture models was a feature.

New models soon ready

TRINITY  
SIX

The TRINITY SIX table model has been improved in performance as well as in appearance. A TRINITY SIX console model has been added to the line. Write for details of exclusive dealer franchise.

BEACON RADIO MFG. CO., 323 Berry St., Brooklyn, N. Y.  
(Broadcast Receiver Division)





## From record to radio with the touch of a lever

THERE is a peculiar enchantment in these words "from record to radio" as they ring in millions of ears. Music lovers everywhere pause, dream for a moment of the re-incarnation of the masters of yesterday, and then—the thought that with the "touch of a lever" one can hear living music as it dances merrily through the air. Sonora combines these greatest of modern musical instruments in a single cabinet and at a price that can make the dream a happy realization for almost everyone. There is the Hampden at \$325—a Renaissance period highboy of majestic

dignity in which the wood carver's skill gracefully tempers stateliness with delicacy.

Then there is the Plymouth Highboy at \$275—somewhat different from the Hampden but a true highboy in every sense of the word. Its classic lines proclaim an illustrious origin. Both are masterpieces of cabinet artistry. But greater than this is the realistic reproduction—a golden mellowness that maintains the traditions of Sonora. The radio has that tone which made Sonora synonymous with tone quality in the minds of music devotees.

THE INSTRUMENT OF QUALITY  
**Sonora**  
CLEAR AS A BELL 



### **The Secret of Sonora Tone**

A cross section of the tone chamber or "horn" which is part of every Sonora instrument. This tone chamber frees radio and phonograph from all mechanical noise. In it many plies of wafer-thin seasoned wood are laid at cross grain to each other, neutralizing vibration and eliminating harsh overtones.





**The Sonora Radio Highboy**  
\$200

This season's outstanding achievement in Radio—the Sonora five tube tone quality Radio Receiver, and Sonora Speaker combined in an exquisite Renaissance Period cabinet—space for batteries and charger.

Without Radio Panel - \$120

**The Chatham Radio Phonograph**  
\$225

The Chatham offers the famous Sonora Phonograph and Radio combination at a most attractive price—the graceful console cabinet finds particular favor with those who live in the smaller apartments.

**The Radio Receiver**  
\$90

A remarkable combination of tone quality with distance, volume and exceptional selectivity. Five tube circuit licensed under Government owned Schloemilch & Von Bronk patents.

**Console Speaker**  
\$50

A radio speaker that delights both the eye and the ear—in it is ample space for all batteries and charger—the same Sonora laminated wood tone chamber is built in this speaker that is found in the deLuxe cabinet speaker at \$30 and the Standard Speaker at \$20.

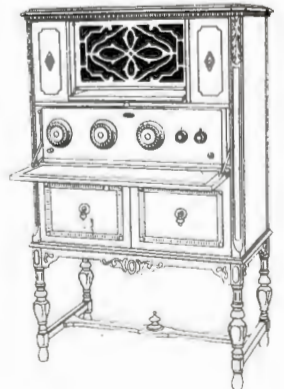
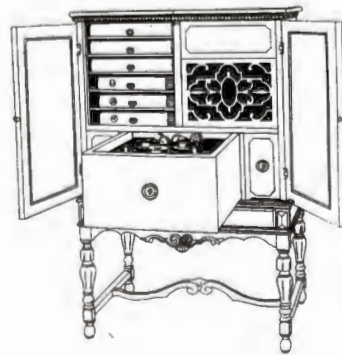
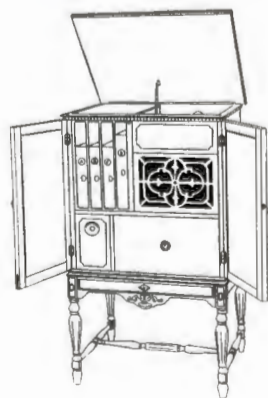
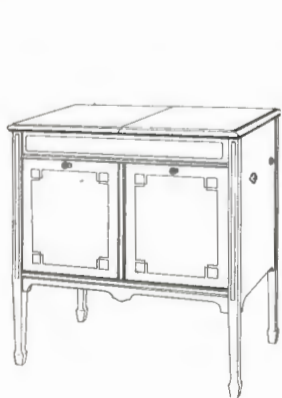



## Big Year-End Sales in Baltimore Field

Largest Demand for Talking Machines and Records in Years—New Instruments Center of Attention—Month's Trade Activities

BALTIMORE, Md., January 7.—Although handicapped in not being able to secure sufficient machines to supply the demand, December business in talking machines and records was one of the best here in years.

This was especially true in regard to the new improved machines just put on the market in the past few months and of which probably only a tenth of the orders booked were delivered. Dealers, however, who had stocks on hand experienced little difficulty in getting rid of practically all makes of machines, both upright and console.

"December business with the Columbia Wholesalers showed an increase of 150 per cent over December, 1924, despite the handicap of not having sufficient products to supply the demand for both machines and records," declared William H. Swartz, vice-president of the company. "The Columbia Wholesalers just closed the banner year in its history and did the largest jobbing business ever done by a jobbing house in this section.

"This tremendous increase in Columbia sales was made entirely through regular dealers, although the number of Columbia dealers in this territory has practically doubled within the past three years.

"Columbia dealers are more optimistic over the outlook for 1926 than for a number of years and are carrying larger stocks of both machines and records. As an example of this, dealers in this territory purchased and distributed 300,000 of the special circulars featuring old-time records.

"I attribute this phenomenal sale of Columbia records to the extensive full-page advertising which the company has been doing in Baltimore, Washington, Richmond and other large cities in this territory. At the end of December we had no machines in stock with the exception of two carloads of uprights received the day before Christmas, too late to be reshipped. The rural trade still prefers the upright type of phonograph, while the city dealers find the consoles are in better demand."

"Give us the goods and we will do the business," said William F. Roberts, manager of E.



## Make 1926 a Record Year!

Columbia New Process Records, carefully manufactured, artistically recorded by nationally known entertainers, and sold with carefully planned advertising material to enable you to profit, will help you to increase your business so that next December you will look back and realize that 1926 was not only a "record" year, but a very profitable one.

*Let Us Show You How!*

# Columbia Wholesalers, Inc.

L. L. Andrews — Wm. H. Swartz

Exclusively Wholesale

205 W. Camden St., Baltimore, Md.

F. Droop & Sons, Victor distributors. "We have just closed the best record year in our history," he said, "and no doubt would have had the same kind of a year in machines had we been able to obtain sufficient of the new Orthophonic Victrolas in time for the Christmas demand."

Practically the same condition exists at the Brunswick agency here, although conditions, if anything, are worse as regards supplying orders booked for the new Panatropé Brunswick machine. "We have not been able to supply 10 per cent of orders already booked," said Charles F. Shaw, manager of the local agency, "and could dispose of several carloads without any difficulty if it were possible to obtain them today. The outlook for 1926 is very encouraging, and the only cloud on the horizon to-day is the inability to obtain merchandise."

Practically all radio dealers have closed one of the most prosperous years in the history of the business despite the large amount of price cutting that has been done throughout the year.

Presenting a varied program ranging from the compositions of the classicist, Rimsky-Korsakoff, to the latest jazz hits, Paul Whiteman and His Concert Orchestra appeared here to-night before an audience that crowded the Lyric. The event marked the first performance of Deems Taylor's "Circus Day," a group of eight short impressionistic selections composed especially for Mr. Whiteman's orchestra.

### Braiterman-Fedder Co.

#### Enjoys Good Business

BALTIMORE, Md., January 6.—The Braiterman-Fedder Co., which was formed during the past year as a talking machine products distributor, has closed an exceptionally satisfactory calendar year. From its very beginning, this concern took on the representation of Valley Forge main springs and talking machine repair material made by the J. A. Fischer Co., of Philadelphia. It has had exceptional success with this line.

William Braiterman, senior partner of the organization, expects even better business throughout 1926. In anticipation of this expectation, the sales department of the organization will shortly be enlarged to the point of having three men cover the Southern territory in addition to the other selling campaigns in progress.

### Bailey and Barnum, Okeh

#### Artists, Score on Broadway

The unique team known as Bailey and Barnum, "The Globe Trotters," and heard as exclusive artists on Okeh records, opened Monday night, January 4, with the "Greenwich Village Follies," New York. This team was a feature of "Lady, Be Good," and now they are duplicating their success in the Follies. "Headin' for Louisville," sung and played by Bailey and Barnum, in white bell-hop attire, is the number that is the hit in the "Greenwich Village Follies," and the team has made this song, coupled with "Tomorrow Mornin'," for the Okeh library.

### Radio Firm Assigns

Brilliantone Radio Products, Inc., 330 West Forty-second street, New York, was recently assigned to Milton Rosenblum, of 300 Sixth avenue. The president and treasurer of the corporation is George Mitchell.

Pennsylvania Maryland Dist. of Columbia Virginia North Carolina Delaware

## Service—Knowledge—Dependability

These three qualities are indispensable to the music dealer in the RADIO WHOLESALER he selects.

### COLUMBIA WHOLESALERS, Inc.

have a staff of experts unequalled in any part of the South, who can solve every radio problem for the music dealer. Advice and help cheerfully given without any obligation.

### CROSLEY - FADA - MAGNAVOX

If you want exclusive franchises protecting you from competition, write immediately to reserve your territory if possible.

BALKITE BURGESS CUNNINGHAM  
TOWER PHILCO BRACH and all accessories

## COLUMBIA WHOLESALERS, INC.

*Exclusively Wholesale*

205 W. Camden St.

Baltimore, Md.



MARWOL  
MARWOL  
MARWOL  
MARWOL  
MA

# The Buy Word for **BIGGER SALES** in **1926** MARWOL RECEIVERS



MARWOL "JEWEL"  
5-Tube Tuned Radio Frequency **\$39.50**



MARWOL "SIX"  
6 - Tube Resistance-Coupled Amplification **\$100**

*The Greatest Line of Profit Makers for the Big Winter Radio Months*

Concentrate your efforts on Marwol, and 1926 will be your banner sales year for the following reasons:

1. Marwol Receivers give superb performance.
2. Marwols are moderately priced —which means a fast-selling line, with quick profits.

Send the coupon below for the Marwol story of sure profits and an outline of our plans to help Marwol dealers make 1926 a profitable radio year.

the fast selling line with **SURE profits**

# MARWOL

A MARVEL for PERFORMANCE

MARWOL RADIO CORPORATION  
546-548 BROADWAY - NEW YORK

**MAIL THIS NOW!**

Marwol Radio Corporation,  
546-548 Broadway, New York  
Send us complete details about your merchandising plans to make 1926 the biggest Radio year for Marwol Dealers.

Name .....

Address .....

City ..... State.....

*Marwol Is Represented by These Leading Concerns:*

In Pennsylvania, New Jersey, Delaware, Maryland, Washington, D. C.  
K. S. Byrd Co.  
221 North 11th St., Philadelphia, Pa.

In Ohio:  
Charles Saenger  
942 Prospect Ave., Cleveland, Ohio.

In Illinois, Indiana, Wisconsin:  
The Barsook Co.  
53 West Jackson Blvd., Chicago, Ill.

In Michigan:  
Dungan Sternfield Radio Sales Co.  
25 No. Dearborn St., Chicago, Ill.

In Minnesota, North Dakota, South Dakota:  
C. L. S. Holmes  
502 Boston Blk., Minneapolis, Minn.

In Nebraska, Kansas, Iowa, Missouri:  
Lane-Meyn & Co.  
Chemical Bldg., St. Louis, Mo.

In Oregon, Washington:  
C. E. Gay  
166 Lowndale St., Portland, Ore.

In Idaho:  
R. T. Carr  
906 Sprague St., Spokane, Wash.

In California:  
Marshank Sales Co.  
926 Insurance Exchange Bldg.,  
Los Angeles, Calif.

In Arkansas, Louisiana, West Mississippi, West Tennessee, Texas, Oklahoma, Colorado:  
C. H. Wallis & Co.  
1409 Syndicate Trust Bldg.  
St. Louis, Mo.



# The Trade in **BOSTON** and **NEW ENGLAND**

JOHN H. WILSON, Manager  
324 WASHINGTON ST., BOSTON, MASS.

## Spirit of Enthusiasm Features the Trade Throughout the New England Territory

Prospects of Increased Deliveries of New Instruments Viewed With Satisfaction by Dealers—Big Year Closed by Most Merchants—Cheney Sales Organization Enlarged—Other News

BOSTON, MASS., January 8.—The new year is upon us; the old one has gone. Just what the year has meant to Boston interests will be found in another part of this issue, so it is not necessary here to repeat either the review or the forecast. But it is of interest that dealers everywhere appear to be possessed of a renewed spirit of enthusiasm which seems especially healthy. The new instruments which have been the center of interest for the last few months should be coming along now in goodly quantities, and prospective buyers will not have to wait for deliveries, which is so often the case with a new product.

### Columbia Closes Big Year

Manager Parks, of the Columbia Co., reports that the Harmony records have proved a phenomenal success and each month the sales have more than doubled those of the preceding month. The New Process records are so smooth, he says, that there is practically no scratch. The company is quick to release hits and it has just issued a remarkable Irish and French catalog and with its complete catalogs for people of other nations, in addition to the listing of Masterworks in its Celebrity Catalog, together with the high quality of its popular-priced records, it is no wonder that the company is adding new accounts each week to its list of Columbia dealers. New England's own Irish entertainer, Shaun O'Nolan, has just approved the test records of six of the recordings that he recently made at the New York laboratory. These records will shortly be released. Twenty-five new dealers now carry the complete Irish catalog.

### Nick Lucas Visits Brunswick Office

Since the appearance here at the Majestic Theatre of "Sweetheart Time" the Brunswick headquarters in Kingston street has been honored with several calls from Nick Lucas, who is one of the Brunswick artists. On December 28 he was given a real Brunswick party at the Majestic and more than 180 dealers and friends attended

the performance. He was given a great ovation. Lucas also paid a visit to Governor Fuller, taking his trusty guitar with him, and he presented the chief executive with several of his Brunswick records autographed. He also has played at several hospitals since being in town and other places, spreading Christmas cheer. In the lobby of the Majestic Theatre there is a display of Lucas's records. The employes of the Brunswick warerooms also invited Lucas to a Christmas tree at the store, this on the day before the holiday, and Harry Spencer mapped out a fine program for the afternoon.

### Thousands Heard the Panatrope

Manager Spencer says of the Panatrope that his house was able to dispose of all of its allotment within four days and that the Brunswick quarters in Kingston street were besieged with visitors during the periods that the new instrument was demonstrated. He reports that fully 75,000 people in New England have heard the Panatrope and that it has been demonstrated most successfully before the Advertising Clubs of New England at the Hotel Bellevue, and at the sales organization conference of the United Drug Company. One interesting piece of news is that the renowned Boston critic—for he's admittedly all of that—Philip Hale, of the Boston Herald, has shown a deep and earnest interest in the Panatrope and has paid several visits to the Kingston street quarters in order to give it close study. In the Boston Herald he wrote most appreciatively of the instrument, using superlatives in speaking of its tonal quality and its unusually wide field of recording, which the instrument covers so satisfactorily.

### Addition to Cheney Sales Staff

Manager Shewell, of the Cheney Sales Corp., has enlarged his selling force by the addition of four new men, all of them hustlers, who should add considerably to the volume of the 1926 Cheney business. J. H. Hayes will travel through western Massachusetts and Connecticut; L. C. Mason will have the northeast part of this State,

including the cities of Lawrence, Haverhill and Lowell; John Grantham will take Boston and vicinity, and J. Girroir will cover Fall River, New Bedford and along the southern part of the State. A fifth man soon to be appointed will devote his time to New Hampshire and Vermont. Manager Shewell, whose Boylston street headquarters are soon to be enlarged, now carries a very large line of radio accessories. Despite business he was able to get away to Philadelphia to spend Christmas with his family.

### Regret Death of Prof. Forrest G. Cheney

The news was learned here with regret of the death at Grand Rapids, Mich., of Professor Forrest G. Cheney, the inventor of the Cheney talking machine, whose death was due to a shock. It was about a year ago that Professor Cheney was a Boston visitor and while calling on Manager Shewell, of the Cheney Corp. here, he had a bad attack, which seemed serious at that time. That was the last visit he paid to Boston.

### Vocalion Hall Is No More

Vocalion Hall at 190 Boylston street is no more. The lease expired at the end of 1925, and as mentioned in a previous issue of The World, it was not feasible to continue at a largely increased rent. A closing out sale, which continued several weeks, resulted in the disposal of a large number of talking machines and the result of the sale was really better than had been anticipated. What goods remained were incorporated into the C. C. Harvey Co.'s line further up Boylston street. Walter Gillis, who has managed Vocalion Hall since giving up his own store, will now take a vacation and probably will start off on a water trip South.

It is quite to the credit of the C. C. Harvey Co., which really maintained Vocalion Hall, that practically everyone connected with the latter store was taken care of following its closing. During the sale a number of the Harvey outside men came in to help out so that they now return to their old association, and others were provided with positions either in the Harvey store or outside employment found for them. Thus everybody was happily provided for.

### Crosley Jobber Holds Dealer Meeting

More than 300 dealers from all over New England were in attendance at a recent meeting at the Hotel Lenox held under the auspices of  
(Continued on page 97)



## Make 1926 a Victor Year



THE Victor trade has started on a new twelve months' period of great business opportunity, with the buying public of the nation eager for the wonderful new Victor products.

Are you prepared to get your full share of business?

LET DITSON SERVICE AID YOU

**Oliver Ditson Co.**  
BOSTON

**Chas. H. Ditson & Co.**  
NEW YORK



FROM OUR NEW ENGLAND HEADQUARTERS—(Continued from page 96)

the Bigelow-Dowse Co., Crosley radio distributor. Walter B. Fulghum, sales manager of the Crosley Radio Corp., was the principal speaker, and he made an interesting address on radio merchandising. Other talks on selling and advertising were given by prominent figures in the trade. The Bigelow-Dowse Co. handles the Crosley line exclusively.

**Defer Southern Trip**

Speaking of the Harvey Co., E. A. Cressey, of the concern, was planning to take Mrs. Cressey South for the benefit of her health when suddenly he was called upon for jury duty, so it may be that his visit to Florence Villa, Fla., where he and Mrs. Cressey were last Winter for a few weeks, may have to be deferred.

**Suffers Fire Loss**

There is considerable local sympathy in the talking machine trade for Fred Peabody, the manager of Peabody's Music Store in Haverhill, which suffered a bad fire on the night of December 31, the fire being one of the worst to visit Haverhill in a number of years. If memory is correct, it is not so long ago that the Peabody Music Co. suffered a similar fate.

**Alexander Steinert Going Abroad**

Alexander Steinert, head of M. Steinert & Sons, of this city, is planning to go to Europe in a few days, his trip to last several weeks. Robert Steinert, his son, who makes his headquarters at 35 Arch street, and Mrs. Steinert, went up into the country for the Winter sports over the New Year's holidays.

**Adds Stromberg-Carlson**

The M. Steinert Co. is meeting with marked success with the DeForest line of radio. A new line which the Steinert house has just linked up with is the Stromberg-Carlson neotrodyne for which there is a wide demand.

**Joe Burke Loses Sister**

Joe Burke, New England manager of the Sonora Co., has the sympathy of his friends in the death of a sister a few days ago, her end coming very suddenly.

**Gets Enlarged Territory**

James A. Frye, traveling representative for the Victor Co. has had his territory in New England enlarged, so that it now includes the cities of Worcester, Fall River, New Bedford and Providence. This keeps Jimmie more on the jump than formerly.

**Plan Visit to Victor Plant**

Herbert Shoemaker, manager for the Eastern



## Successful Men Sell Okeh Records

There are definite reasons why Okeh Records constantly increase Licensed Dealers' profits.

Recorded by a perfected Truetone process the result is unexcelled.

Monthly releases comprise a varied classification of music. Every buyer's whim is best satisfied from your stock of Okeh Records.

We offer you an Okeh Dealer's License.

*Write to-day*

### General Phonograph Corporation of New England

**126 Summer Street, Boston, Mass.**

T. M. Co. here, and Jerome Murphy, of M. Steinert & Sons, are planning a trip to the Camden factory of the Victor Co. the latter part of this month.

**Feature Zenith Radio Line**

Leiter Bros., Syracuse, N. Y., one of the leading music stores in this section, recently added a radio department, and feature the Zenith line of radio receivers. The department was organized in time to share in the large holiday business. The Zenith radio line is enjoying steady popularity in this city.

The Spiderweb Radio Corp., 71 Park place, New York, of which Joseph E. Robin is president, made an assignment on January 2 to Morris D. Kopple.

**Turns Out One Radio Tube  
Every Minute of the Day**

Westinghouse Lamp Co., of Bloomfield, N. J., Has Large and Efficient Organization Devoted to Production of Radio Tubes

One radio tube a minute every minute of the working day is the record set by the largest

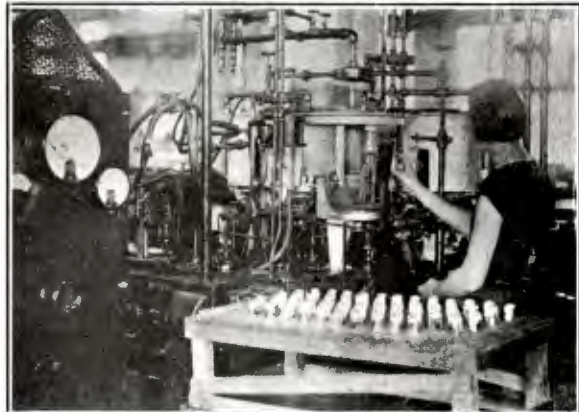

Making a Radio Tube a Minute

radio tube factory in the world, that of the Westinghouse Lamp Co., at Bloomfield, N. J. In particularly busy times the production of RCA and Cunningham tubes in this plant is even greater. The accuracy and dependability of the modern radio tube is due to the unerring automatic machinery on which almost all the work is done, and to the dozens of tests the tube goes through before it is finally wrapped.

**Radio Talks on Banking**

The New York Chapter of the Public Affairs Committee of the American Institute of Banking recently inaugurated a series of addresses on banking broadcast from station WGBS. The talks are being given under the supervision of the American Bankers' Association.

**Standard Music Shop Opened**

A new music store, the Standard Music Shop, has been opened at 209 East Schellenger avenue, Wildwood, N. J.

Ben Fuhr recently opened a new music store at 246 South Fourth street, Brooklyn, N. Y.

"A Dealer is Judged by the Merchandise  
He Sells"

Distributors of the following products:

Thermodyne Receivers  
Superpow-Batteryless  
Trim Loud Speakers  
Silver Voice Loud  
Speaker  
Teletone Loud Speaker  
Astral Loud Speaker  
Sonocorde Loud Speaker  
Eveready Batteries  
Brach Antenna Outfit  
Brach Phone Plugs  
Brach Call Products  
Philco A Batteries  
Philco A & B Socket  
Power  
Valley Chargers  
Valley B—Eliminators  
Battery Cables  
Redi' Mast Antenna Post  
Alco Loops  
Phonograph Units and  
Adapters

Choose your jobber as  
you choose your friend.

A S a man by the company he keeps, a  
jobber by the lines he distributes.

Choose your jobber as you choose your  
friends and keep in good company.

Every manufacturer we represent is re-  
liable, responsible and makes a worthy  
product. Our dealers may sell confi-  
dently, repeatedly and profitably and sure  
of protection.

Franchises that bring dealer prestige, pur-  
chasers and profits.

*Write us today and our  
representative will take  
pleasure in calling.*

CHENEY SALES CORP.

*Radio Distributors*  
376 Boylston Street  
Boston, Mass.

Philadelphia
New York





## Tones which have never come

After twenty-one and more years devoted to the reproducing of sound, the Pritchard-Roever engineers have attained such perfect balance and synchronizing of elements as to reproduce the broadcast sound unmarred, unforced, with utmost purity.

The most distinguished, the most critical music experts have pronounced it as absolutely unique in the fidelity of tonal recreation.

Add to this the wider *range* of tones now made possible for the first time in radio by the Pritchard-Roever, and you have an instrument unequalled by any other radio receiver.

There will always be a demand for the vaudeville class





List  
\$325  
without tubes  
and batteries

THE MARVELOUS NEW

*Pritchard-Roeper*  
RADIO

*through the Radio before !*

of radio, but there are fine homes in every community waiting for radio reception to be raised to the plane of the opera.

There are enough radio dealers and radio jobbers who appreciate the significance of such performance from the sales standpoint to absorb our manufacturing capacity and to require constant enlargement of those facilities.

This is a first announcement. The richest territory is now open. To the right distributors we extend a proposition which will be mutually advantageous and enduring.

**AUTOPHONE MANUFACTURING CORP.**

324 East 23rd Street, New York



## Toledo Retail Dealers Are Clearing Their Decks for New Year Business Campaigns

Holiday Demand for New Instruments So Great That Retailers Suffer From Shortage—Lion Store Closed Tremendously Busy Year—Cable Piano Co. Entertains Employees—Month's News

TOLEDO, O., January 8.—Now that the holiday rush is subsiding, dealers are clearing their desks of an accumulation of business and are making ready for new year drives. The Christmas season was one of the most active in years. Phonographs, records and radios sold up to the last minute.

The most serious handicap, however, to a sales volume of large proportions was a shortage of merchandise. The public had been primed for new machines by the flood of national publicity loosed by the manufacturers of new instruments and were disappointed when they could not get the new phonographs for Christmas. This situation still exists—customers have been promised delivery, but the floors of dealers are practically bare of instruments.

The Lion Store Music Rooms experienced a fine increase in sales for the year just closed. A total of more than 1,400 Victrolas were sold at the 50 per cent price. Early purchases enabled the house to have an accumulation of stock which carried the department through the holidays. But the store is facing the situation of being without goods to offer the public. Manager Lawson S. Talbert is making trips to Cleveland, Chicago and other markets in the hope of finding sufficient Orthophonics to keep sales moving.

The Credenza is played constantly in the department to groups who are much interested in the machine. Then, on Fridays, a special concert is given which embraces a selection of music in the public mind. Gems from the music show "Rose Marie" are enjoying a large sale here. The fox-trot "Who" is pleasing many. Dorothy Kene, Helen Coy and Dorma Baer are new members of the record force.

Radio Manager Doyle Wyre stated radio sets for Christmas gifts and New Year concerts exceeded expectations. Thompson and Atwater Kent sets sold to large proportions.

At the J. W. Greene Co. talking machine and radio sales for December were above the same period of last year, while record sales held their own. The firm, on December 30, held its Christmas contest dinner for the force in Pythian Castle, at which more than fifty prizes were awarded. A. J. Martin was presented with the Orthophonic Victrola for the highest total sales. Ethel W. Keil, office manager and considered of the non-producers, won second

award and J. Harold Beat, of the talking machine division, received the third, the large number of other prizes were given for special services, the most cash on deals and the like.

The United Music Store is making a definite effort to attract and hold the eye through its window displays. For Christmas windows exhibited as appropriate gifts for mother, records; father, a radio; sister, a portable; brother, a banjo, and for the entire family an Orthophonic.

Flightner's Music Store, Columbia dealer, reports trade good, with interest centering on the new records of Art Gillham. In the radio section sets are moving rapidly. The new year concert of McCormack, Bori and others aroused radio enthusiasts to a high pitch, as did the broadcasting from England. The latter in particular emphasized the endless possibilities of the radio and enabled the house to cash in to

### Samples of New Okeh Records Sent Distributors

Recordings Made by New Truetone Process Bear Artistic and Original Label

Okeh distributors received samples recently of the Okeh records made by the new Truetone recording process, perfected recently by the



One of the New Okeh Records

General Phonograph Corp. All records made by this new process have an artistic and original label which has met with the enthusiastic approval of Okeh distributors. The new label is a bright red, instead of the maroon color formerly the background for Okeh labels, and features the new Truetone trade-mark which is the

the extent of closing several profitable deals.

The Cable Piano Co. entertained its force of workers, their wives and sweethearts with a dinner at the new Park Lane Hotel on Saturday, January 2. Manager Leon C. Steele, who is from the South, brought to the occasion much of the old-time Southern hospitality. Twenty-five dollars in gold was presented to A. F. Maag for the largest total December business and a like amount was won by Art Rieneke for getting the highest amount of cash on deals. Upon this occasion the new 16 C Panatropé was shown for the first time to the workers, who were agreeably surprised by its performance. Mr. Steele was the chief speaker of the evening, he outlined policies for the new year. Frank J. Williams is a new member of the sales force.

The Goosman Piano Co., Columbia dealer, is using space in morning editions to popularize Harmony records. A large number of these discs are purchased by downtown workers, sales manager C. E. Colber stated. Fred N. Goosman, president, is in Cleveland on business connected with the coming convention of the Ohio Music Merchants. He heads the carrying charge committee.

distinguishing phase of the product made by the new Okeh recording process. The new label is reproduced herewith in black and white, although this reproduction hardly does justice to the vivid and distinctive color scheme.

### Columbia Wholesale Staff of New York City Dines

Department Heads of the New York Wholesale Division, With Manager Guttenberger, Enjoy Good Time at the Empire Hotel

The members of the sales staff of the New York wholesale department of the Columbia Phonograph Co., Inc., together with the department heads of the division, Frank Walker, of the recording staff of the company, and Comptroller White, of the factory, enjoyed a get-together on Friday night, January 8, the memory of which will long linger with them. E. W. Guttenberger, manager of the wholesale department, was host to the party, which started with dinner at the Empire Hotel and then adjourned to the Martin Beck Theatre, where the popular musical comedy, "Captain Jinks," was viewed as a preliminary to the celebrated Cotton Club, where joy reigned supreme.

While Mr. Guttenberger was the host in the flesh, Louis Sterling, chairman of the board of directors of the Columbia Phonograph Co., Inc., really was responsible for the affair, and thereby hangs a tale. Before Mr. Sterling's departure for Europe, early in November, there was a gathering of Columbia officials at dinner, and in the course of the evening's conversation Mr. Guttenberger ventured an estimate of the amount of Harmony records which his sales staff would sell during December. The figure was so high that expressions of doubt were heard, with the result that Mr. Sterling and Mr. Guttenberger engaged in a bet as to whether or not it could be done. Mr. Guttenberger won by a margin of several thousand, and as his staff was responsible he spent the money on the party mentioned above. To the victors belong the spoils!

### New Branch of Sterling Piano Co. Reports Increase

A. B. Smith, manager of the new branch of the Sterling Piano Co., on Flatbush avenue, Brooklyn, reports that the new location of the store has resulted in many more people visiting the store and greatly stimulated sales in all departments. The talking machine, radio and musical merchandise departments, formerly at the Court street store, are now all located at the new store. The new establishment is one of the most attractive in this section.

## Important Notice

I am no longer associated in any capacity with  
J. A. FISCHER COMPANY, Philadelphia

(Signed) NAT. WITLIN,  
Formerly Sales Mgr. J. A. FISCHER CO.

## Important Notice

I am no longer associated in any capacity with  
J. A. FISCHER COMPANY, Philadelphia

(Signed) EDWARD L. MOBLEY,  
Formerly Service Mgr. J. A. FISCHER CO.



# Air-Way

RADIO RECEIVER

## Music Is Music When You "Hear It The Air-Way"

"I really don't care for the classics," he said apologetically as he tuned out a symphony orchestra and selected some nearby jazzers.

"I shouldn't think you would if that's the best your set can do," answered his musician friend. "The beauty of real music lies in harmonies, modulations, and tones. Come over some evening and I'll play you a program on my Air-Way."

Musicians are quick to appreciate the quality of Air-Way reproduction. It is as sensitive and as true as the ear of a Walter Damrosch. Test the Air-Way in parallel with any other set whatever, on an orchestral or operatic program some evening, then you, too, will hear the difference.

*Write for specifications and data.*

### Air-Way Electric Appliance Corporation

612 Broadway, Toledo, Ohio

Export Department, 220 Broadway, New York, N. Y.

#### List of Distributors

Mr. Ralph Bretzner,  
128 West 42nd Street,  
New York City  
Telephone—Wisconsin 2777

B. H. Smith Sales Company,  
755 Boylston Street,  
Boston, Mass.  
Telephone—Back Bay 7009

Motor Electric Company,  
3320 Broadway,  
Oakland, Calif.

Mr. Frank A. Brady,  
747 Warehouse Street,  
Los Angeles, Calif.

Mr. James M. Sullins,  
Knoxville, Tenn.

Mr. J. D. Palmerlee,  
Armada, Mich.

Mr. Thos. C. Jepson,  
277 Willow Avenue,  
Toronto, 8, Ont., Canada.

The Jackson Sales Company,  
20 E. Jackson Blvd.,  
Chicago, Ill.  
Telephone—Harrison 3744

Mr. C. L. Titus,  
430 U.S. Nat'l Bank Bldg.,  
Denver, Colo.

Mr. H. E. McKenney,  
997 Forest Avenue,  
Portland, Maine.

Mr. C. M. Cutting,  
1217 Bainbridge St.,  
South Richmond, Va.

Electric Power Maintenance Co.,  
1101 Monroe Street,  
Toledo, Ohio.

Mr. J. F. Nutting,  
1001 Flatiron Bldg.,  
Atlanta, Ga.

Wetherbee Bros.,  
1801 Young Street,  
Dallas, Texas.

Shapleigh-Shobe Co.,  
701 A.O.U.W. Bldg.,  
Little Rock, Ark.



\$137.50

Air-Way  
Model 62

This Air-Way model includes a self-contained speaker of truly revolutionary tonal efficiency.



\$197.50

Air-Way  
Model 63

This Air-Way Console model is a amazing value for the price.

\$98.50

Model 61—Everything anybody can want in radio reception.





## Pathe Phono. & Radio Corp. Announces New Models

Three Additions to Line Made, Two Console and One of Upright Type—New Record Demonstrators Also Being Marketed

The Pathé Phonograph & Radio Corp., Brooklyn, N. Y., has announced simultaneously with the New Year the advent of three new popular-priced phonograph models to the Pathé line. The three new models are Colonial, model 24; Windsor, model 28, both of which are the console type, with space for the installation of the radio panel, and model 9, which is an upright. The Pathé Co. has prepared a new booklet giving complete information about these three new phonographs.

The Pathé Co. has also introduced two record demonstrators, known as the Pathé Senior demonstrator and Pathé Junior demonstrator. The Senior demonstrator, particularly designed for use in large stores, has a horn rising thirty-three inches above the machine. This permits

**We are going to PROVE  
Diamond T Radio Re-  
ceivers are a VALUE you  
should give to your trade**

We will send one to you at  
OUR ACTUAL COST of  
labor and materials.



Panel 7x24

**Model S-10—\$49.50 List**

Send check for \$19.80 Only one at this price; no dealer handling Diamond T Sets now can buy at this price.

**This is Sample Price  
Only—\$19.80**

We can't make any profit on these sample machines, in fact we lose money on each one at this price, but we know the quality and performance will get repeat business for us.

All we ask is a fair test.

**GUARANTEE**—If this set does not meet with your approval you may return it in 10 days and we will refund your money.

*We reserve right to refuse orders and return checks.*

**DIAMOND T RADIO  
MANUFACTURERS**

**South Bend, Ind.**

the demonstration to carry over the heads of the listeners and introduces a new note in group demonstration.

The Junior demonstrator is practically the mechanism of the talking machine without the cabinet. The motor and horn are entirely exposed. Both models are produced with either spring or electric motor.

## Stewart-Warner Corp. Starts Publications Department

Shortly before the beginning of the new year, the Stewart-Warner Speedometer Corp., Chicago, manufacturers of radio receivers, reproducers, tubes and accessories, established what is known as the Publications Department, which will prepare and publish three periodicals. They are described as follows: the "News Meter," a Stewart-Warner "Better Accessory" publication which will be directed to the branch offices, salesmen and accessory dealers; "The Announcer," a Stewart-Warner radio publication which will be read by branch office salesmen and dealers handling the Stewart-Warner line of radio products, and "Headquarters Dispatch" an interorganization publication which will go to salesmen, both radio and accessory, and to the service stations throughout the country.

All three publications will be under the direct supervision of B. K. Pratt, manager of the newly created department, who has had extensive newspaper experience with the Chicago Herald & Examiner, Chicago Evening American, Chicago Evening Post, and the Chicago Herald, which discontinued publication some years ago. Under Mr. Pratt's direction, all of the publications will make their semi-monthly appearance in true newspaper style, with cartoons, features and news. Their function will be to serve as a clearing house of ideas for the dealer and salesman alike, and Stewart-Warner dealers will be asked to submit sales ideas, photographs, and other material which will be of interest and help to their fellow merchants. Heretofore, plant instructions to the branch offices have been sent in circular form, such as installation and service information, but the three new publications will be utilized to carry these messages in the future.

## The Arcadian Serenaders Score in Okeh Numbers

St. Louis, Mo., January 6.—The Arcadian Serenaders, in addition to being one of St. Louis' best orchestras, are ardent publicity workers for Okeh records, for which they record. Okeh Night was celebrated recently at the Arcadia ballroom, and prior to the event windows everywhere featured the news that the Arcadian Serenaders would play numbers released by Okeh records. All Okeh dealers received from fifty to 100 complimentary tickets to Arcadia, and every night two selections made by the orchestra for the Okeh library, "Just a Little Bit Bad" and "The Co-ed," may be heard at Arcadia. The enthusiastic response of dancers suggests that they are popular numbers, and St. Louis Okeh dealers are reporting a good sale of this record.

## Fada Dealers at Banquet

The first annual Fada radio dealer banquet was given recently at the St. Paul Hotel by Noyes Bros. and Cutler, Fada distributors in St. Paul and Duluth, Minn. Prof. Jansky, of the University of Minnesota, gave an interesting talk on broadcasting and the developments of radio on the farms of the Northwest.

## New York Firm Chartered

The St. Marks Radio Co., New York, was recently incorporated at Albany, with a capital stock of \$6,000. The incorporators are W. J. Gray and C. Seams.

## Eagle Neutrodyne Trio Is Popular With Radio Fans

The Broadcasting Programs Provided by the Eagle Radio Co., Maker of Eagle Receivers, Have Drawn Many Thousands of Letters

In carrying out its share of contributing broadcasting programs, the Eagle Radio Co., 16 Boyden place, Newark, N. J., manufacturer of the Eagle Neutrodyne receivers, is responsible for the appearance, over WEAJ every Friday evening, of the Eagle Neutrodyne Trio. Since this combination of artists has been giving its program the Eagle Radio Co., as well as the



Lucien Schmidt, Leader of Trio

personnel of the Trio, have received thousands of letters from Eagle and other radio enthusiasts.

The Eagle Neutrodyne Trio are all artists of exceptional ability. The leader is Lucien Schmidt, a remarkable cellist, who has become a national figure in the concert field through the very favorable and extensive publicity his programs have attracted.

## Artophone Corp. Official Optimistic Over Outlook

St. Louis, Mo., January 6.—Herbert L. Schiele, vice-president of the Artophone Corp., distributor of radio equipment, in discussing the company's progress during 1925 and the outlook for the coming year, said: "We look back through 1925 with a great deal of satisfaction as we have greatly enlarged our line of merchandise and added a great number of dealer accounts. The outlook for 1926 is excellent, as we are going ahead by greatly increasing our selling force and taking on additional lines of merchandise."

## Perfect Record Co. Aids Dealers in Window Display

The Perfect Record Co., of Brooklyn, N. Y., has recently prepared for its dealers' use a set of window strips in two colors, each featuring a new record hit.

A set of decalcomanias has also been prepared for use in the window or showcase. The set consists of a reproduction of the record itself in colors and also decalcomanias of Lee Morse and Cliff Edwards (Ukulele Ike), Perfect record artists.

## Fada Employes Get Bonus

A Christmas bonus of 5 per cent was given to all employes of F. A. D. Andrea, Inc., manufacturer of Fada radio. In announcing the bonus Mr. Andrea took occasion to call attention to the tremendous growth of the organization, of which he is president, during the year which has just come to a close.



# The Trade in PHILADELPHIA and LOCALITY

## Quaker City Dealers Awaiting Shipments of the New Instruments to Fill Orders

Unable to Fill Large Number of Orders Taken During the Holidays and Must Await Replenishment of Stocks—Unprecedented Demand for Records Also a Feature of Holiday Buying

PHILADELPHIA, PA., January 9.—With the passing of 1925 the talking machine industry has again become an important factor in the world of musical merchandising. Although the early year was one of disappointment insofar as the trade was concerned, the last half became rosy and bright for the dealers when there came forth the announcements of many new types which were to revolutionize the industry and again place it on a profitable basis as a going enterprise. The only blot on the brighter side of the year was the scarcity of the new Orthophonic, the Panatropé and the newer types to meet the tremendous holiday demands.

Dealers, however, have enough orders on hand to meet all shipments that can be made of the newer types of machines from now on until Springtime, and so there is even a brighter aspect for the new year than that which came with the departure of the old cycle. These orders are holdovers from the holidays, in many cases an advance payment having been made for goods to be delivered as soon as there is sufficient supply forthcoming from the distributors and factories.

### Big Holiday Sales of Records

The sale of records topped any normal holiday season, and although those dealers who were not included in the list of retailers for the standard makes of talking machines, which were the big leaders in gift stocks, they were able to share in the profits of accessory merchandise to excellent advantage through the stimulation brought about by the introduction of the new designs, creating a very broad demand for records.

### Encouraging Victor Announcement

Encouraging to the dealers was the newspaper advertisement recently announcing that the manufacturer of the Orthophonic, the Victor Co., of Camden, N. J., is rapidly increasing production and expects soon to have the situation in hand, and is asking the indulgence of the public pending the speeding up of operations on the new designs. The announcement appeared in all the newspapers throughout the country.

### Making Every Effort to Aid Dealers

Every effort to co-operate with the dealers is being put forth by the Philadelphia Victor Distributors, Inc., 835 Arch street, in meeting its obligations to furnish all available supplies of the new Orthophonic that come into its warehouses, now depleted of machines, shipments being made immediately upon arrival of goods or else sent directly from the Camden headquarters. It is expected that shipments will begin in the early part of January, at that time the Victor factory forces being materially strengthened. Christmas demands completely cleaned up all goods on hand, the record distribution keeping pace with the very satisfactory sales of machines.

### Plan to Move Records

Philadelphia's other distribution house, H. A. Weymann & Son, Inc., 1108 Chestnut street, also hopes to be able to give patrons in the retail trade a better service with the increase in the Victor factory forces, and has sent out an announcement from the wholesale talking machine department which encourages the dealers to look forward to better times in the coming year.

A plan for the trade to dispose of the present surplus stock of records has been sent out this week by the Weymann company to the dealers,

with the following suggestion made relative to the bonus proposition with the sales organization:

Selections in Victor records are now being remade by the improved recording and are being renumbered. They will be added to the Victor record catalog without the regular supplement listing.

It may be of interest to our dealers to devise some plan that will successfully dispose of the present surplus stock of Victor records of the former recordings.

To be helpful in this respect, we have been getting some data on the Victor record sales situation. A bonus proposition, paying 5 cents to the sales people in the record department on every record sold of the former recordings, has been successfully employed in several instances.

In another instance a bonus of 2 cents on all sales made to a customer in excess of two records has accomplished excellent results in increasing the record sales volume. This particular account, in checking up sales slips, noted out of every one hundred sales, sixty sales represented but one record to a customer. The adoption of the bonus system of 2 cents on every record in excess of two sold to each customer, has considerably decreased the percentage of the one and two record sales to a customer.

It is possible our dealers may have suggestions equally as effective or more so. Our object in taking this matter up at this time, when inventories will disclose the amount of stock on hand, which will include some unsalable numbers, is to try if possible, to have our dealers try out the best plan that may be feasible, not only to increase record sales, but to provide some incentive for sales people to dispose of former recordings."

An evidence of the tremendous business in Orthophonics is that given by one dealer's sales record which he placed before Manager Charles W. Bahl, of Weymann & Son, wholesale Victor department, and in which it was shown that forty-four Christmas Day orders were placed which could not be filled with the new models. In order to accommodate the customers the dealer was obliged to give temporary substitutes of other machines than those of the Orthophonic. He cleaned out all models he had on hand in other makes. These will be substituted with the new machines as soon as deliveries can be made. All the sales organization of the Weymann forces will leave this week for their re-

spective territories, W. H. Doerr taking up his duties in the Pennsylvania field, E. J. McCormick covering the coal regions, Larry Urban making the rounds of the dealers in south Jersey, while R. Burrows will go over the city and environs. They will feature on this trip the newest of Victor combinations, along with the Orthophonic, in the Alhambra model, combination radio and talking machine, a sample of this now being on display at headquarters here.

### John Di Stefano Moves

Confidence in the future of the industry is displayed by John Di Stefano, formerly located at 1303 South Thirteenth street, who has just removed to a new home at 1303 Dickinson street, just around the corner. For the past seven years he has been engaged in the piano and Victor retail business at the old address. With the removal to the new location, there has been purchased the property, a two-story structure comprising a store and dwelling.

### Acquires Estey Department

Convinced that the industry is on the verge of the most prosperous period of its history, H. Royer Smith, long engaged in the Victor talking machine retail distribution at Tenth and Walnut streets, has launched into another venture along this same line. Last month he acquired the former talking machine department of the Estey Piano Co. and is now conducting its business in Victor products at the address of the Estey Co., Seventeenth and Walnut streets. The Estey Victor business will be continued in the section of the piano company's store formerly devoted to the phonograph business, and has an entrance on Seventeenth street. It is under the management of Russell Weldy, former associate of the talking machine business of the Huver Co., now disbanded.

### Chose The World as Purchasing Guide

Having learned of the thoroughness with which The Talking Machine World covers the nation's industry, a retail customer and friend of H. Royer Smith in England sent, last month, two American quarters by mail for a special December copy of this publication, so that he might get an insight into the newest offerings on the market, with a view to becoming a pur-

(Continued on page 104)

# RADIO





## All Good—None Better

### PENN PHONOGRAPH CO.

Wholesale Distributor

913 Arch Street
Philadelphia, Pa.



THE TRADE IN PHILADELPHIA AND LOCALITY—(Continued from page 103)

chaser of a modern talking machine and records. In order to assure a prompt response to his request, he made sure that there would be no hold-up over the exchange values in money and so sent two silver quarters. The December Talking Machine World was sent promptly so the Christmas selection might be made by the British patron of the H. Royer Smith Co., and an early reply is anticipated.

**Busy Year-end for Columbia Co.**

The holiday vacation spent at his Brooklyn home with his family was made more enjoyable for Manager A. J. Heath, of the Philadelphia branch of the Columbia Phonograph Co., 40 North Sixth street, by the passing of a very gratifying Christmas season for the products of that nationally known manufacturer. The past year has been marked by the returning patronage of many old-time retail associates of the Columbia that has given added encouragement for the business in the new year. The record sales were so well rounded out that the Columbia Co. made a new high average for these accessories in its Christmas orders. The new Harmony records were particularly in demand. The sales were stimulated by the full-page advertisements which appeared in the local newspaper, the Evening Bulletin, during the holidays. All stocks of machines were practically cleared from the warehouses, but a few odds and ends being holdovers, and these are being disposed of at specially low values to the dealers. With the clearance of old stocks, way is paved for the introduction of the new Columbia phonographs, which are to be marketed within the month and which Manager Heath smilingly states are "all that rumor says them to be in perfection," after inspection of them at the New York headquarters while on his Christmas vacation in that city.

**Gimbel Makes "Clean Sweep"**

To Manager G. T. Wurtele, of the talking machine department of Gimbel Bros., is due the passing of the most successfully conducted campaign for all the makes of talking machines handled by the well-known department store in the closing months of the old year, and with a total sweep of all models of the old styles and all that could be secured in the new makes of the Victor Orthophonic. The past six months witnessed the clearance of all models of the Victor, Brunswick and Sonora carried in the Gimbel stocks, and with them the biggest normal sales that this firm ever enjoyed. Manager



**GUARANTEE PORTABLE**  
**RETAILS FOR \$25.00**

*A Safe Investment*

**SPECIFICATIONS:**

1. Textene Leather Case.
2. Standard Heineman Motor.
3. Plays Two 10" Records.
4. Standard Taper Tone Arm.
5. Specially Loud Reproducer.
6. Device for Carrying Records.
7. Machine Will Play 12" Records.
8. Patented "Non-Spill" Needle Cup.
9. Size 14 1/2" x 11 1/2" x 7 1/4".
10. Weighs 14 1/2 lbs.



**Costs you \$10.50**

**GUARANTEE TALKING MACHINE SUPPLY CO.**

**109 N. Tenth Street** **PHILADELPHIA**

—Write for our latest Main Spring Chart—

Wurtele gives to the Victor Co. the credit for this healthy move in the industry and highly praises that manufacturer for the revival it has brought about in trade circles of the public interest. The combination models he acclaims as having been incentives for the promotion of sales campaigns along with the discounting of old styles. So sure is he of the coming "big times" in the industry that already there has been signed a lucrative order for the January sales, to be featured after inventory is completed. In the new year, Manager Wurtele is planning a complete new policy for the Gimbel talking machine department which will give it the best year in its history. Another Gimbel executive who has been equally assured of the passing of the most active year's business in her department is Mrs. Lucia Carmine, of the record department, who, as head of her divi-

sion, has scored a noteworthy business and who looks forward to bigger things for the future as a result of the new types of machines now on the market.

Manager W. P. Saunders, of the radio department of Gimbel's, has made a record for his department, having doubled his sales and then some over those of 1924.

**Moving to Larger Quarters**

Having for several years been engaged as Victor retailers in the West Philadelphia section, M. Grass & Son are now preparing for the biggest year in business by removal to larger quarters adjoining the old stand. The firm has acquired the adjoining store at 27 South Sixtieth street, removing from the old quarters at 25 South Sixtieth.

**Planning to Feature Radio**

With the new year, the enterprising proprietors of Wolf's Talking Machine Stores, at 1637 Columbia avenue and 5029 Baltimore avenue, Jack Harris and his associates, E. W. Wolf and Ed. Gravell, will introduce in their music stores and Victor retail shops a radio department to feature the Atwater Kent and possibly the Stromberg-Carlson sets, negotiations now being under way for their introduction into the business. The firm has been among the most progressive of local retail Victor dealers, within the past year having taken over and reconstructed a very modern shop, adapted for the neighborhood type of music emporium at the Columbia avenue address.

**Rushed to Meet Demand**

Rushing ahead, with plenty of advance 1926 orders on hand, the Guarantee Talking Machine Supply Co., 109 North Tenth street, is opening up with every indication that the coming year will bring its share of generous trade patronage to its doors. So heavily oversold has been this firm, maker of accessories and the Guarantee portables, that it has been found necessary to have a night schedule of operation in order to render speedier service and to relieve present congestion in orders for both the portable and Guarantee main springs and parts. E. Bauer, who has just returned from a successful season in the Southern States, reports that dealers are well cleaned out of stocks in that section, and this will mean an excellent early 1926 business for the manufacturers and distributors. The embargo on shipments to Florida has been working hardships for the dealers

## The New Victor Line for 1926

<p><b>Orthophonic Victrola</b></p> <p>Credenza Model List Price \$300.00 Granada Model List Price. 150.00 Colony Model List Price... 110.00 Console Model List Price 85.00</p> <p><b>Electrola</b></p> <p>Cromwell Model List Price 450.00 Tuscany Model List Price.. 550.00</p>	<p><b>Orthophonic Victrola-Radiola</b></p> <p>Alhambra Model List Price 350.00 Alhambra Model List Price 425.00 Florenza Model List Price. 550.00 Borgia Model List Price .. 675.00</p> <p><b>Electrola-Radiola</b></p> <p>Hyperion Model List Price 900.00</p>
--	---

**Orthophonic Victrola-Electrola-Radiola**  
Borgia Model List Price...1000.00

*Plan to carry the complete line for the coming year. Do not lose sales through not being able to demonstrate the instrument. Let us help you if situated in our territory.*

**H.A.WEYMANN & SON, INC.**  
1108 Chestnut Street—Philadelphia, Pa.  
*Victor Wholesalers*



handling the Guarantee portables in that section. Mail orders from the Southern resorts in that State have been piling up and, awaiting the opening of rail traffic, will be shipped in considerable volume as a result of the accumulation. William H. Posner, of the firm, anticipates a visit to the Havana dealers coincident with a brief Winter vacation in February.

**Victor Dealers Plan Annual Banquet**

There will be real cause for jubilation among the Victor dealers enrolled in the Philadelphia Victor Dealers' Association when that body meets in mid-February for its annual banquet. President Homer C. Davis, of the Philadelphia Association and of the firm of George B. Davis Co., has called a meeting of the executive board and officers, to be held either in late January or early February, for the purpose of arranging for the annual affair. At that time the date and place will be selected and other details of a program outlined. No date has been set for the meeting of the executive body at this time.

**Big Year for Everybody's**

Almost "Everybody" in the trade has passed along to Everybody's Talking Machine Co., Inc., 810 Arch street, a generous share of the prosperity that has marked the passing of 1925, and as a result of this good will of the industry the firm has scored a tremendous business record in the largest volume of orders for all its products distributed in wholesale throughout the nation and into foreign parts. This firm has won the confidence of the industry, as indicated in its record-breaking sales throughout the past year, by a sound and ethical business practice, as well as by merit of its products manufactured in its plant for the accessory lines and including the Honest Quaker main springs, parts and accessories, put out under that brand. In order to render to its patrons a helpful service in the cataloging of its various parts and repair accessories the Everybody's Talking Machine Co. is about to send out to the nation's dealers and distributors and its foreign clientele the most com-



**Start the New Year with Velvaloid Record Cleaners**

Their Good Will and Advertising Value has been established in nearly every country of the world.

The accepted standard cleaner for records.

Especially beneficial to the new records for Orthophonic and Panatrope models.

Advertises the dealer continually and gives him a prominence in the home, hard to obtain by ordinary methods.

Costs little compared to the profitable results obtained.

Dealers who will send us a copy of the advertising they would like printed on Velvaloids will receive a sample without any obligation to them.

**PHILADELPHIA BADGE CO., Manufacturers**  
942 Market Street Philadelphia, U.S. A.

prehensive compilation of these ever attained since it began the listing of parts in schedule form. A thorough service, with easy reference and reproduction of almost exact size in the various illustrations, is being issued under the new catalog, to be ready for trade distribution by February 5. In order that the cataloging of Everybody's talking machine products may be kept up to date the new catalog will be in loose-leaf form, so that changes or the introduction of new goods may be readily inserted as they are made. F. C. Schuyler, formerly traveler in charge of the Pittsburgh district, has been made manager of the Okeh and Odeon and Adler-Royal division. There was enjoyed a very noteworthy holiday season for both these products in this division, the Christmas sales of the Odeon and Okeh attaining new altitudes and those of the Adler-Royal radio and combination phonographs keeping pace with the records. There were added to the list of Adler-Royal dealers during the December month three new retailers, including M. Krasnoff, 2039 East Orthodox street; Robert H. Knittle, of Port Carbon, Pa., and the New Edison Shop, of Scranton, Pa.

**Takes Over Estey Radio Department**

The radio department of the Estey Piano Co. has been taken over by Gerald L. Quimby, son

of Manager Louis Quimby, of the Philadelphia branch of the Estey Co., and formerly manager of that department while it was under the Estey control. The younger Quimby will continue to feature the RCA, Zenith and other sets formerly sold under the Estey regime. The store floor of the Estey Co., with its central section divided off for this purpose, will be allotted to the sale of the radio, with an entrance from Seventeenth street. The department is on the third floor.

**First Shipments of the Panatrope**

It was with enthusiasm that the trade welcomed the first shipments of the Panatrope, the very latest word in the Brunswick line, which appeared in stores shortly after the New Year. Local headquarters, under Manager E. B. Shiddell, have been besieged with orders for the new electrically operated Brunswick, due to the gratifying reception since the dealers began to show them to their customers. The new machine was readily sold as soon as it appeared in the stores and dealers have a waiting list for future deliveries, with eager customers urging early installations in homes. Another heavy order-bringing device is anticipated with the introduction this month of the combination Panatrope and Radiola, which will be shown here by mid-January. Like all distributing centers for the industry,

(Continued on page 106)

# Start The New Year

by making a RESOLUTION to CAPITALIZE the OPPORTUNITY that is yours in being a Victor Dealer. Merchandise of High Quality at fair prices backed by National Advertising offers every incentive for you to work, and get a big return on your investment during 1926. We are ready to serve every Victor Dealer who should logically buy in Philadelphia.

**Philadelphia Victor Distributors, Inc.**  
835 Arch Street  
Philadelphia, Pa.



**THE TRADE IN PHILADELPHIA AND LOCALITY—(Continued from page 105)**

the Brunswick made a clean sweep of all available stocks of machines, and records coming in with an equally strong demand and making for an excellent Christmas demand. The closing quarter of 1925 was the record-breaking period for the local offices. Most of the larger department stores featured the Brunswick extensively for the Christmas sales, with special concerts and drives on the Panatrope, so that all stocks were cleaned out. The J. H. Troup Music House, of Harrisburg; Hagen Music House, of Reading, Pa., both reported an impressive sales record for the Model P-3, which retails at \$600.

**Will Celebrate First Anniversary Soon**

Though still an infant in years, with its first birthday next month, already the J. A. Fischer Co., 730 Market street, manufacturer of the Valley Forge main springs, parts and accessories, has been making its mark in the trade, as explained in detail on another page in this issue. The firm has extended its business into the Canadian field, having opened up a branch, under R. J. Dearth, at 45 Richmond street, E., Toronto, which is doing very well for the brief time of its opening. Irvin R. Epstan, of the firm, has just returned after visiting the Toronto distributor for ten days, and is enthusiastic over the Canadian outlook.

**Opens Radio Department**

A radio department has been installed in the store of Joseph Heim, Inc., 3800 North Broad street, one of the largest of uptown dealers. There is carried the RCA, Freshman, Atwater Kent and the Fada, along with the Victor talking machines.

**Music Master Set Featured at Dance**

The Music Master radio receiving set model No. 13 made by the Music Master Corp. of this city was featured in a recent "radio dance" conducted by the Poor Richard Club here. Although a local organization, the fame of the Poor Richard Club is nation-wide. It is made up principally of advertising men and is one of the oldest and most exclusive organizations of this character in the country.

Upon taking possession of its new club house the members of the Poor Richard Club decided to stage an affair that would be entirely out of the ordinary. Accordingly, a radio dance was planned entirely without orchestra and with music provided by a Music Master model 13 with two type 460 Music Master reproducers, one placed at each end of the room. The affair was a decided success and the Music Master set

and reproducers lived up to their reputation and name.

**Supplied Dealers With Effective Sales Aid**

H. A. Weymann & Son, Inc., of this city, Victor distributors, recently developed an original idea to combat the marked shortage in Orthophonic Victrolas. It consisted of a Christmas gift certificate attractively engraved, reading as follows:

".....Will deliver as soon as possible to ..... an Orthophonic Victrola ..... model. May it give as much pleasure when it is received as it affords the giver in wishing you a very Merry Christmas and a Happy New Year. ...."

This gift certificate was used effectively by many dealers in tiding over Christmas purchases of Orthophonic Victrolas. The scarcity of this new type of Victrola was as great in Philadelphia as elsewhere and the demand for these instruments as Christmas presents was marked. Customers using the Christmas gift certificate were enabled to make the presentation in effect around Christmas time and thus be assured of the new instrument when additional quantities were received, rather than meanwhile accepting a substitute. As may be readily surmised the benefit was not alone for the customer but was also greatly in favor with the dealer, as many sales which would have been otherwise lost were saved.

**Important Association Meetings Feature the Month in the Portland Territory**

**Interesting and Instructive Addresses Mark Meeting of Oregon Music Trades Association—Oregon Radio Trade Association Elects New Officers—Starr Headquarters Moved—Other News**

PORTLAND, ORE., January 4.—At the December monthly meeting of the Oregon Music Trades Association, held in the Chamber of Commerce Building, with G. F. Johnson, of the G. F. Johnson Piano Co., president, presiding, an interesting talk was made by R. M. Mount, manager of the Portland Better Business Bureau. He was followed by George Thompson, secretary of the Association, who proposed a code of ethics and ordinance for the government of the members, which was adopted unanimously. Over forty members were present.

At the recent meeting of the Oregon Radio Trade Association, held in the same building, the following officers were elected: J. H. Hallock, of Hallock & Watson Radio Corporation, president; H. H. Princehouse, McCormick Music Co., vice-president; G. F. Thompson, Jr., secretary-treasurer. Definite dates were set for Portland's radio show, to be known as the Pacific Northwest Radio Exposition, which will be held September 18-25. This show will follow shortly the two shows to be held in San Francisco and Los Angeles, respectively.

Downtown offices have been opened at 411 Journal Building, Broadway and Yamhill, by the Oregon Music Trades Association and the Oregon Radio Trade Association, with George J. Thompson, executive secretary of both organizations, in charge.

C. D. McKinnon, of the Chicago headquarters

of the Brunswick Co., demonstrated the Brunswick Panatrope at the Hotel Multnomah, in Portland, last month, to over 150 dealers of Oregon and Southwestern Washington, the handsome setting for the occasion being furnished by the Edwards Furniture Co. Mr. McKinnon was introduced to the dealers by M. Davis, who, after thanking them for their large attendance, proceeded to show them what the Panatrope was and could do. The next day A. R. McKinley, Pacific Northwest manager of the company, gave the Portland "Press" a special demonstration and the music critics praised the new instrument very highly in their newspaper reports next day.

The Hyatt Music Co. has moved its east side branch to 1415 Sandy boulevard. Victor, Brunswick, Columbia and Edison phonographs and Atwater Kent and the Radiola lines are carried. C. E. Miller is in charge of the branch, assisted by his wife and Roger Chown.

William Lawton, Pacific Northwest district manager of the Columbia Phonograph Co., spent several days in Portland with Randall Bargelt, Oregon district manager, and reported the Potter Drug Co., of Grand and Morrison streets, as a new Columbia representative. This is one of the largest drug stores in Portland to recently take the Columbia line of merchandise, including the Columbia and Harmony records. Mr. Potter is especially enthusiastic over his new account and anticipates big business. Mr. Lawton reports Columbia record sales materially increased, and is looking forward to a big year in 1926.

The Starr Piano Co., Charles Soule, Pacific Northwest district manager, has moved from its former location at 22 North Tenth street to Fifth and Flanders, where larger quarters have been acquired two blocks from the freight depot, with spur tracks up to their new quarters.

Ivon Johnson, formerly of Schenectady, N. Y., has been appointed technician of the Portland wholesale branch of the Brunswick-Balke-Collender Co. to take the place of F. A. Williams, who has spent the past year in Portland and was transferred to Schenectady to represent the Brunswick Co. in regard to securing equipment for the Panatrope.

H. F. Ebert, formerly of Sherman, Clay & Co., has been appointed outside salesman for the wholesale department of the Brunswick Co. and will cover Oregon and Washington.

**Files Bankruptcy Petition**

David Isenberg recently filed a petition in bankruptcy, listing liabilities of \$219,000. Assets were not given. Mr. Isenberg was president of the Kimberly Phonograph Co., which is now in the hands of trustees.

The Dyersville Music House, Flammang Building, Dyersville, Ia., was recently acquired by William Lappe.

**RADIO DEALER CATALOG**

**—FREE—**

**Our 1926 Catalog**

is being used by thousands of Music Dealers and Furniture Dealers everywhere as a positive guide to more profitable buying of the kind of radio that is in greatest demand today. Our financial strength, responsibility and SAME DAY shipping service will help you to "Grow With Us."

**NATIONALLY RECOGNIZED LINES**

Among the well-known, nationally advertised radio lines handled by us are included those of the following manufacturers whose advertisements appear in this book:



A-C Electrical Co.  
Adler Mfg. Co.  
Apex Elec. Mfg. Co.  
(Apex Dials)  
L. S. Brach Mfg. Co.  
Brandes Products Corp.

Carter Radio Co.  
Electrical Research Laboratories  
(Erie Parts)  
Farnsteel Products Co.  
Farrand Mfg. Co.  
Howard B. Jones

Priess Radio Co.  
Reichmann Co.  
Radio Corp. of America  
(Radiotrons)  
Sterling Mfg. Co.  
Utah Radio Products Co.  
Zenith Radio Corp.

*We are Distributors in Eastern Penna, and Southern New Jersey of*



**TRILLING & MONTAGUE**  
WHOLESALE RADIO MERCHANDISERS

49 No. 7th Street

Philadelphia, Pa.

*"Grow With Us"*



### Gross-Brennan, Inc., Stages Annual Banquet

Members of the New York and Boston Offices Have Jolly Time at First Annual Affair Held at Waldorf-Astoria Hotel, New York

The first annual banquet of Gross-Brennan, Inc., New York, N. Y., Stromberg-Carlson and Glenn L. Martin Co. representatives was held at the Waldorf-Astoria Hotel on Tuesday evening,



Those Present at First Banquet of Gross-Brennan, Inc.

December 29, 1925, being attended by all members of both the New York and Boston offices. The entertainment was furnished by Morton Downey, well known Brunswick artist also featured with the new Florida edition of the Ziegfeld Follies; Edna Beatrice Bloom, of the Wanamaker Auditorium; Evelyn Bennett, spectacular Charleston dancer; Clark and Sheehan, famous radio entertainers.

The toastmaster of the evening was Horace G. Bloom, the first member of the organization, who very creditably filled his part. Both Mr. Gross and Mr. Brennan delivered brief addresses on the growth of the organization, its business principles, and expressed their appreciation of the loyalty of their employes. Each member of the organization responded with a short talk.

The keynote of the banquet seemed to be based on the value of loyalty as a factor of

every successful business. The outstanding manner in which this was evident was reflected in the expressions by everyone round the table which conclusively proved that the signal success of the Stromberg-Carlson line in the Gross-Brennan territory had been largely due to the loyalty of every single member of the organization to the Stromberg-Carlson Co. and its principles.

Dinner was followed by dancing, the music being furnished by Jimmie Caruso's Orchestra. Oscar, the popular manager of the Waldorf-As-

toria, visited the party during the evening and extended his good wishes to all of those present. Those in the photograph are all members of the Gross-Brennan organization.

### Everybody's T. M. Co. Appoints Ad Official

PHILADELPHIA, PA., January 5.—Everybody's Talking Machine Co., manufacturer of Honest Quaker parts and distributor of Okeh and Odeon records, Adler-Royal phonographs and other products, has put the placing of its advertising in the hands of Carlo Votti, prominent Philadelphia advertising expert. Mr. Votti's knowledge and experience, it is felt, will benefit not only the company but the many dealers who feature Everybody's parts as well.

### New York Symphony for Atwater Kent Concert

Notable Organization Under Baton of Walter Damrosch to Be Presented in Radio Concert on January 24—Schumann-Heink on 31st

There is no question but that the series of radio concerts sponsored by A. Atwater Kent, head of the Atwater Kent Mfg. Co., is one of the outstanding features in radio broadcasting. As the series progresses with one great artist following another each Sunday, public interest increases rather than diminishes.

The January Atwater Kent concerts began on Sunday evening, January 3, with Albert Spalding, the famous violinist, whose work is quite new to radio but who gave to his performance for the unseen audience the best of his talent as was evident in the excellent reception of the various numbers.

The month of January has other features of great interest, for on the evening of January 24 Walter Damrosch and the New York Symphony Orchestra, one of the leading musical organizations of the country, will present an elaborate program through station WEA, New York, and some fourteen other associated stations, offering compositions of Beethoven, Tschaiikowsky, Liszt and other famous composers.

The last concert of the month will feature that star of the concert and opera stage, Mme. Ernestine Schumann-Heink, assisted by Florence Hardeman, violinist. Mme. Schumann-Heink will offer a program of some dozen selections.

Not only are Atwater Kent dealers tying up very effectively with the broadcast concerts, but the musical critics of the newspapers, as well as the editors of radio sections, are taking them with proper seriousness, with the result that they are being accorded publicity of the most helpful sort.

# 74547

## "MASTERCRAFT"

(Registered Trade Mark)

Phonographs and Radio Cabinets sold during 1925—

### WHY!!!

Mastercraft Products are unexcelled in—quality and price.

You are missing a big opportunity, if you don't handle the "Mastercraft" line.

There is a Wholesale Distributor near you. If you don't know him—write us.

## THE WOLF MANUFACTURING INDUSTRIES

(Established 1890)

### QUINCY, ILLINOIS

NEW YORK OFFICE—17 West 42nd Street



PLANT N°1

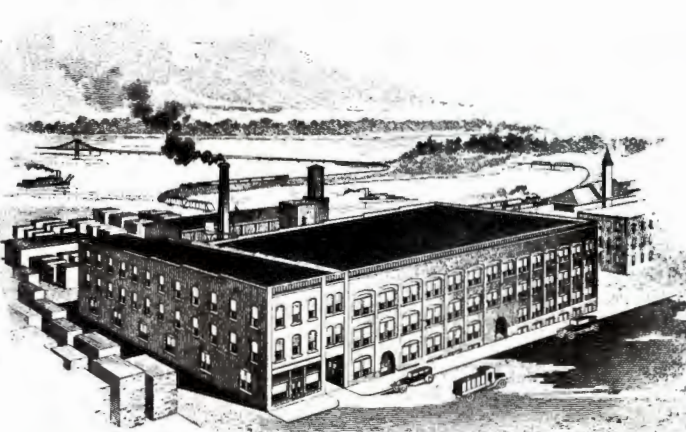

PLANT N°2



USED ON THE FAMOUS  
**MACMILLAN ARCTIC  
 EXPEDITION!**

*What Greater Test for an Outdoor  
 Portable?  
 and yet—Beautiful Enough to Be  
 Used at Home!*

**WATCH**



IN

**1926**

**Read This!**

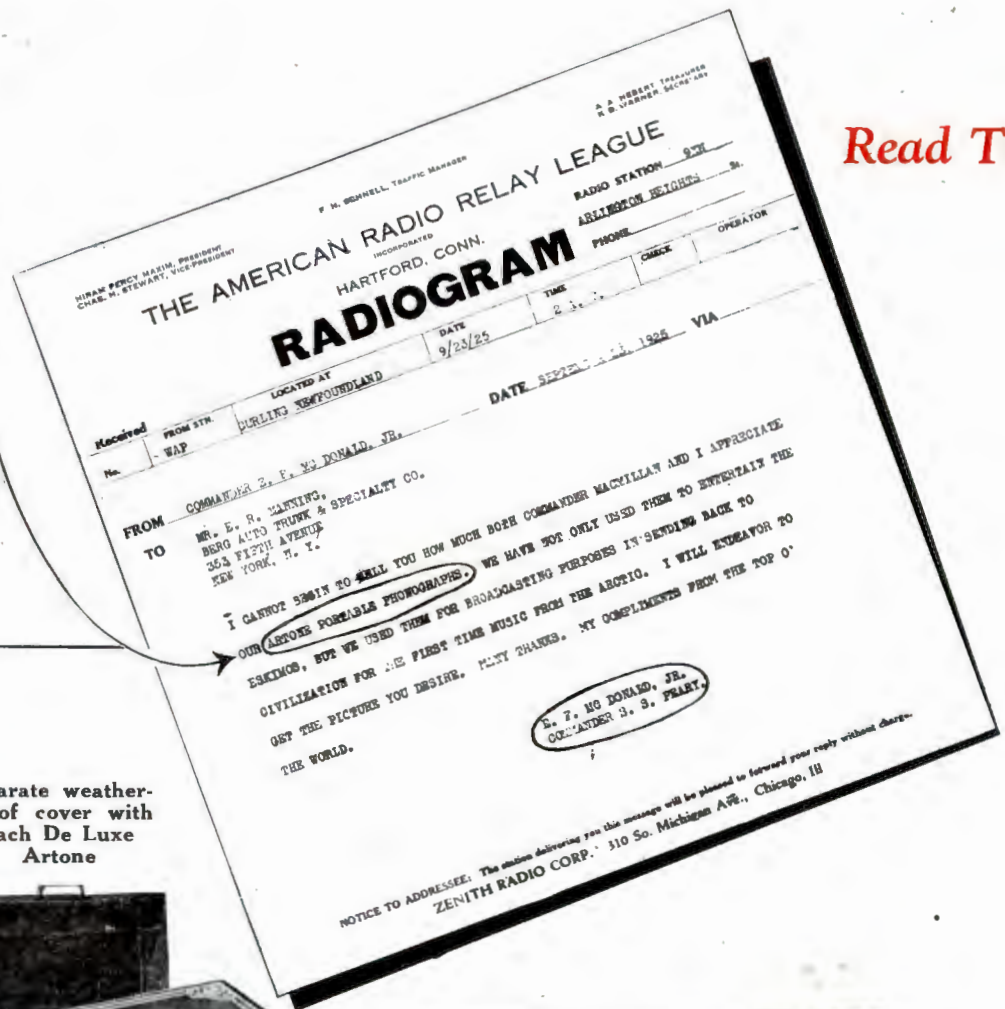

Separate weather-proof cover with each De Luxe Artone



Lined and covered with



Embossed in reproductions of beautiful hand-tooled Leather, various colors



**Artone**  
 No. 2  
 Model  
**\$25**  
 Embossed  
 Top



No. 1 Model

**\$30**

including storm cover

Two of these De Luxe Artone Portables on the MacMillan Arctic Expedition proved they are worth their price!

A richness of tone unequalled in any other portable.

Scientific tone chamber and sounding board added to regular tone column—amplifies and clarifies. (U. S. Pat. Pending.)

**This Popular Model Proclaimed as the  
 Finest \$25 Portable Yet Made**

Lightweight, attractive in appearance and of excellent volume and tone quality.



**New!**

**A Practical Novelty!**  
ENTERTAINMENT and UTILITY COMBINED  
Performance and interior quality identical  
with other Artone Models.



2 in 1—Portable Phonograph and Ladies' Hat Box Combined! Interior is Removable

**BERG Artone**

No. 3 Model

**\$27.50**

(Removable Interior)



Showing Artone and Record Album Removed—Immediately a full size Ladies' Hat Box is available.

**Another!**

Highest Quality Materials only—Silent S. S. Motor—Baxter Tone-Arm—U. S. Plywood Veneer, DuPont Fabrikoid, etc.

Equal in Quality to No. 3 Model—but interior is not removable. Shirred pocket in lid for records. Light weight and attractive.



**BERG Artone**

No. 4 Model

**\$25**

Ample Record and Needle space in each Artone Model

Designed and Manufactured by

**Berg A T & S Co., Inc.**

"DESIGNERS AND MAKERS OF FINE CASES FOR 20 YEARS"

THOMSON AVENUE AND MANLY STREET

LONG ISLAND CITY

NEW YORK

**Dealers:**

Write us for name of nearest Artone Jobber  
Write Today

**Jobbers:**

Good Business for you in 1926. Is your territory still open?  
Write today



## John McCormack and Lucrezia Bori Broadcast in New Radio Concert Series

Famous Artists Give Concert Over Radio on New Year's Evening, Followed by Second Concert, January 14, Under Auspices of Victor Talking Machine Co., First Events in New Series

Nineteen twenty-six shared honors with 1925 by being ushered in with a radio broadcast concert by John McCormack, famous tenor, and Lucrezia Bori, noted soprano of the Metropolitan Opera Company, who first "appeared" on the air New Year's night last year and won such immediate success that the Victor Talking Machine Co. responded to a multitude of requests and offered the same artists on the evening of January 1 this year, through Station WJZ, of the Radio Corp. of America, New York, and a chain of five other stations controlled by that concern, including WGY, Schenectady, WBZ, Springfield, Mass., WRC, Washington, D. C., KDKA, Pittsburgh, Pa., and KYW, Chicago. The artists were assisted by the Victor Concert Orchestra under the baton of Josef Pasternack, which played several selections.

Unusual interest was attached to the performance this year for the reason that the Radio Corp. of America had selected that night for the interchange of broadcast programs with European stations, particularly Station 2LO in London, the program of which was picked up and rebroadcast by the British super-power Station 5XX. The British program, which was picked up by WJZ and rebroadcast direct on its own wave length and also through associated stations, came in with sufficient clarity to keep radio fans glued to their receivers several hours, and when the McCormack concert was presented it was sent out under heavy power in a special effort to reach Europe. That the experiment was successful is evident by the fact that reports were received from practically all parts of the world and as far away as Australia stating that the program in New York had been heard clearly at many distant points.

The McCormack program was made a definite part of the international radio experiment, and during the course of the evening addresses over the radio were made by the Consuls General of Sweden, Japan, France, Poland, and Spain; David Sarnoff, general manager of the Radio Corp. of America, and Kent Cooper, of the Associated Press, who read a number of news despatches.

The Victor program proper was introduced

by Calvin G. Child, a director of the company, who explained the purpose of the concert, stated that it was offered in response to popular appeal, and that it was the first of a series to be given by the Victor Co. during the next couple of months, the details of which would be announced in due time. The official program, which was adhered to strictly by the artists, was as follows:

OVERTURE—"MERRY WIVES OF WINDSOR" (Nicolai)  
(Victor Concert Orchestra—Dir. Josef Pasternack)  
LUOCHI SERENI E CARI.....(Donaudy)  
TO THE CHILDREN.....(Rachmaninoff)  
John McCormack  
BOHEME—Addio.....(Puccini)  
WALTZ.....(Glazunov)  
Lucrezia Bori  
WINE, WOMAN AND SONG—Waltz (Strauss),  
(Victor Concert Orchestra—Dir. Josef Pasternack)  
WHEN YOU AND I WERE YOUNG MAGGIE.....(Butterfield)  
THEN YOU'LL REMEMBER ME (from the "Bohemian Girl").....(Balfe)  
John McCormack  
PATOTERO SENTIMENTAL—Tango.....(Romero-Joues)  
LITTLE DAMOZEL.....(Novello)  
Lucrezia Bori  
BOHEME—O SOAVE FANCIULLA.....(Puccini)  
Bori and McCormack  
TRIUMPHAL MARCH (from "Sigura Porsalfar") (Grieg),  
(Victor Concert Orchestra—Dir. Josef Pasternack)  
JUST A COTTAGE SMALL BY A WATERFALL..(DeSylva-Hanley)  
YOU FORGOT TO REMEMBER.....(Berlin)  
John McCormack

At the conclusion of the public program, Mr. McCormack was induced to offer an encore, singing "Mother, My Dear," and at the close extended greetings for the New Year to the unseen audience in a manner that was characteristic. Both artists were in excellent voice, and the reception of the program was unusually good, due to the fact that WJZ is operating from its new super-power station at Bound Brook, N. J., and probably also to the fact that the artists have profited by the results of their initial appearance before the microphone.

The selections offered by McCormack and Bori and the Victor Concert Orchestra have all been recorded for the Victor catalog, and dealers were urged to tie up with the appearance of these artists over the radio. A great many retailers took full advantage of the opportunity to call attention to the program both through the medium of newspaper advertisements and

window displays, and a goodly percentage saw to it that prospects on their mailing lists were made aware of the coming concert, as well as of the fact that the selections offered were available in the form of Victor records. The results of the concert, which was offered under such unusually favorable circumstances, will be awaited with interest.

David Sarnoff, vice-president and general manager of the Radio Corp. of America, after the international test, expressed himself well pleased with the result, remarking:

"The experiment demonstrated the entire world will in time be able to listen in upon the activity and arts of the world in so far as they are amenable to radio impulse. Of course, it was an experiment; a few rough spots were encountered, but these will be smoothed and eliminated with further experimenting."

### Great Program on January 14

The second radio program in the new Victor series was broadcast on Thursday evening, January 14, through WJZ and a group of other stations utilized for McCormack concerts. The artists in this second concert of the 1926 series were Mme. Frances Alda, noted Metropolitan Opera soprano, Tito Ruffo, baritone of the Metropolitan, and the famous Flonzaley Quartet.

Mme. Alda's program was of the popular sort, and included in addition to Micaela's Aria from "Carmen," "Somewhere a Voice Is Calling," "Daddy," "Bells of St. Mary's," and "Panis Angelicus" by Franck. Mr. Ruffo sang the lively "Largo Al Factotum" from the "Barber of Seville," the prologue from "Pagliacci," the serenade "Lolita" and the "Visione Veneziana"; and the Flonzaley Quartet contributed as their share of the program the playing of Dvorak's quartet in F-major, Mendelssohn's "Canzonetta," Grainger's "Molly on the Shore," and a quartet in A-Minor by Schumann.

## Van Veen Installs Concert Room in Stern Bros.

Van Veen & Co., Inc., New York City, manufacturer of wareroom equipment for the talking machine dealer, has just completed an installation which through the importance of the store and the nature of the equipment is an indication of the progress already being manifested in talking machine circles.

This enterprising institution has just installed in Stern Brothers, large New York department store, a new and modern talking machine department. It consists of a large concert room with twelve individual booths and is attractively finished in antique ivory. A distinguishing feature of this new installation are the high ceilings which allow the occupants the maximum amount of fresh air and incidentally seem to add to the acoustic properties of the room.

This new installation is for the Victrola department of Stern Brothers and is located in a prominent position on the fifth floor adjoining the furniture department. The large concert room is a development in wareroom equipment for the adequate presentation of the new models of the Victor line. It permits frequent group demonstrations of the new instruments and the twelve individual rooms permit the private demonstration of both machines and records.

It is Mr. Van Veen's opinion that as production at the Victor factory catches up with demands it is probable other Victor dealers will rearrange and add to their equipment to display the new line to the best advantage.

### New Binghamton Store

BINGHAMTON, N. Y., January 7.—Arthur P. Gardner and Cecil D. Mastin have opened a new store, called the Music Shoppe, at 80 Court street, where they are handling a full line of pianos, phonographs and miscellaneous small goods. Mr. Gardner has been associated with the local music trade for the past twenty years, having been identified with Barrett Bros.

EXCLUSIVE DISTRIBUTOR

IN

Metropolitan New York, Northern New Jersey  
Brooklyn and Long Island

FOR

The New Federal  
ortho-sonic Line

Musical Products Distributing Co., Inc.

22 West 19th Street

Also

POOLEY-ATWATER KENT

CUNNINGHAM TUBES, RADIO-ART, RED SEAL, WESTERN ELECTRIC

BALKITE, PHILCO

New York City





# A Safe Investment

*Federal stability is assurance against harmful unloading tactics*

Federal *Ortho-sonic* Receivers cost only what good quality is worth. Any economies effected by increased production, or by quantity purchasing, will be passed on to Federal Retailers and Wholesalers in a manner that will not work a hardship on the trade.

There are no structural weaknesses in the *Ortho-sonic* line. Any refinements in construction, any new models produced will be announced to the public without resorting to a wholesale "dumping" program.

Federal is in radio to stay! Federal financial resources are secure! Federal stability is complete! In its dealings with its Wholesalers and Retailers and the public, Federal will always be fair and square. Federal Retailers and Wholesalers need fear no harmful unloading tactics.

The Federal proposition is the most liberal, the most elastic merchandising arrangement ever presented. Discounts allow a margin of profit that

permits you to make money. You are amply protected against excessive competition. You are backed up with an aggressive, powerful advertising campaign, and furnished with complete retail selling helps that will bring business to you.

The Federal *Ortho-sonic* line meets every public demand. Lifelike tone quality, distance-getting ability, precise selectivity, beautiful cabinets, popular prices, a wide range of styles—all these are found in the Federal *Ortho-sonic* line. And the nationally advertised *Ortho-sonic* Tone Test is the most convincing sales demonstration ever prepared for radio retailers.

There are no signed contracts between Federal and its distributors. No "scrap of paper" is needed to strengthen the bonds between Federal and its trade! If you haven't read the details of this unusual proposition that is so ideal from your standpoint, write us.

FEDERAL RADIO CORPORATION, Buffalo, N. Y.

(Division of Federal Telephone and Telegraph Company)  
Operating Broadcast Station WGR at Buffalo

# Federal

*ortho-sonic*

# Radio

"Rivaled only by Reality"



THE INSTRUMENT OF QUALITY  
**Sonora**  
 CLEAR AS A BELL

## RADIO brings in Paris and Budapest!

In all Sonora advertising we have always featured tone quality—but if your customers ask you about distance—well—read what C. A. Reid reports.

C. A. REID PIANO COMPANY  
 238 West Front Street,  
 Plainfield, N. J.

Gentlemen:

The Sonora set was sold to Mr. J. P. Costello, 21 Wilson Avenue, North Plainfield, New Jersey, and on the evening of Friday, November 6, or rather the morning of Saturday, November 7, between 12:30 midnight and 1:00 A. M. he brought in on the loud speaker KFIF in Portland, Oregon, ESP the Paris Telegraph and Telephone Company, Paris, France and the Budapest Post Office, Budapest, Hungary. The call letter as received was HV. However, the station was clearly announced as being the Budapest Post Office, Budapest, Hungary.

We are extremely enthusiastic over your set here solely on account of its wonderful performances. We sell quite a number of prominent makes of radio but this set outstrips all the others in all around performance and its selectivity on small wave lengths is really marvelous. We feel that the Sonora Phonograph Company has a wonderful future before them with this circuit and need have no fear of any radio on the market at the present time.

We have experimented with radios over a year and can unhesitatingly say that this is the outstanding set of all of those which we have experimented with, there being only one exception and that exception sells for \$70.00 more. However, Sonora holds its own with that particular set.

It might be interesting for you to know that we are in close proximity with WJZ's new station at Bound Brook, New Jersey, and we have no trouble whatever in tuning out this new powerful station, although people with other makes of sets are complaining very loudly about hearing nothing else but WJZ when they are broadcasting from Bound Brook.

This truly is a wonderful set and we wish to congratulate you.

Yours very truly,  
 (Signed) C. A. REID,  
 C. A. Reid Piano Company.

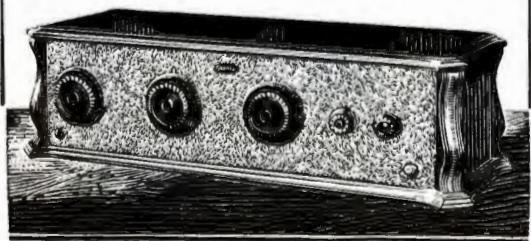

## Last Month of the Year Was the Busiest in 1925 in Detroit Field, Say Retailers

Demand for Combination Talking Machines and Radio Sets Features Year-End Business—Shortage of New Instruments Retards Sales Somewhat—Strong Interest in Columbia Products

DETROIT, MICH., January 6.—December was the banner month of 1925, just as was to be expected, and it is interesting to note what some of our dealers have to report. While we have no way of proving all that we hear we venture to say that 80 per cent of the sales in talking machine stores during the month of December was on combination machines. And it was surprising how the people went for the more expensive models, at \$350 and up—many over \$1,000. Dealers say that in only a few instances did people talk price—it was a matter of which machine would give them the greatest satisfaction—a few dollars more or less was not the issue.

Grinnell Bros. had a banner December month, figuring on the sales of all their retail stores—over forty scattered over Michigan and Ohio. Not only did their stores do well on talking machines but likewise on radio. The Grinnell stores handle the Victor line exclusively.

This company, by the way, is arranging now for its annual sales convention of store managers, which takes place in Detroit later in the month, and at which time all phases of retail business and merchandising are thoroughly gone into and discussed. In addition to the business side, there are a number of entertainment features, among them a banquet for the managers and their wives, and a masked ball for all the Detroit and Windsor store employes.

At the J. L. Hudson Music Store we do know that they enjoyed a great December business—in fact a good business all year, and that their sales leaned mostly towards the combination outfits.

Manager Quinn, of the Brunswick Shop, could have done considerably more in December if he

had been able to get merchandise, but the fact that Brunswick announced a new improved phonograph caused a lot of people to hold back buying. Mr. Quinn says there was no telling where his December sales would have reached had he been able to get the merchandise. As it was, he is well satisfied with business for the year.

Alling's, formerly The Edison Shop, had a corking good December business. It did considerable advertising during December, was open almost every evening, and since adding the Brunswick line this store seems to have a new lease of life. It still continues to handle the Edison line, but with the Brunswick line in addition the store is able to attract a much larger clientele than before. R. B. Alling, general manager of the company, is certainly elated over business during 1925 and says there can be no question as to 1926.

Sam Lind, of the S. E. Lind Co., who specializes in the Adler-Royal line of phonographs and combination outfits, had a corking good year. Business came with a rush early in December and Sam found himself swamped with orders. By getting quick action from the factory he was able to take care of all his customers, and from all reports which have reached him they enjoyed good business, and even since the holidays the Lind Co. has taken some nice orders, showing that dealers handling the Adler line did not have much stock to carry over.

Just a word to say that we have been hearing some very fine reports lately about the "come-back" Columbia is making. As one dealer declared, "Just watch their smoke." We do know that their record business has jumped considerably over previous years and that dealers are now pushing Columbia with splendid results.

## Jazz of Many Nationalities Proves Very Popular With the Music Lovers in Egypt

Richard A. May, American Trade Commissioner, Alexandria, Egypt, Presents an Illuminating Analysis of the Musical Tastes in That Part of the World—American Records Are Popular

"Yes, we have the latest jazz." "Will you have the best American saxophone tunes, the Savoy Band from London, an orchestra of the Montmartre of Paris, the fascinating, fiery melodies of a Venetian trio, a Turkish tango, an Occidental-Oriental production from Athens, or our own popular Oriental Arabic fox-trots?" This is the way the Egyptian phonograph dealer greets one's timid request for a dance record.

Not at all to be unexpected, though, with this wide variety to select from, the American dance productions are far and away in the greatest demand. British orchestration, which copies, in most cases, the American tunes, also is popular, but not so popular as the almost mystical Arabic pieces, which have their own special appeal to large elements in the population.

The Egyptian phonograph record shops report that 40 per cent of their sales are of Arabic songs. Thirty per cent is composed of dance records, most of which are American, while 25 per cent is operatic, practically exclusively Italian. All other types and kinds of productions make up the small remaining 5 per cent.

As already stated, Arabic songs are very important from the point of view of sales and popularity. American song records, many of which are manufactured in England, also are in good demand. But the widest range in languages is found in this category of records. Actually, the ordinary Egyptian record shop carries popular songs in at least ten different languages. These include, besides the Arabic and the English, Turkish, Armenian, Hebrew, French, Italian, German, Russian and Greek. Imagine what linguists the clerks in the Egyptian music shops must be! Among opera and

operetta productions, the Italians are by far the most in demand. French, English and Greek opera and operetta records find a small market.

Of a total import of 18,752 dozen records, valued at L. E. 23,024, during the first eight months of 1925, January to August inclusive, German phonograph records accounted for 13,125 dozens, with a valuation of L. E. 15,992. (L. E. 1 equals approximately \$5 at current exchange.) Unfortunately, the Egyptian Customs Administration only commenced in the current year to compile separate statistics with respect to Egypt's phonograph record imports. The predominance of Germany in the trade is explained by the fact that German manufacturers have specialized in the production of Arabic pieces and now enjoy practically a monopoly of the Arabic repertoire which is so popular.

The United Kingdom ranks second as a supplier of phonograph records to Egypt, being credited with 3,159 dozens, valued at L. E. 4,054, in the first eight months of 1925. Italy and France ship smaller amounts of records to Egypt, while the United States stands fifth on the list, with 556 dozens, valued at L. E. 680, to its credit, or practically the same volume of business as is done by France.

The policy of some American record manufacturers to handle their Egyptian business through London or Continental manufacturing plants or distributing depots and sales offices is, no doubt, responsible, in a large measure, for the seeming backwardness of the United States in the official statistics. As already suggested, American records are among the most popular in Egypt and should continue so with little sales effort on the part of American manufacturers.





*Announcing*  
*The* **Swanson King**  
 P O R T A B L E

*Created especially to include every first-class feature of any portable ever sold—yet priced at the usual popular figure.*

WRITE TO YOUR DISTRIBUTOR FIRST

- |   |  |
|---|--|
| ATLANTA.....James K. Polk, Inc., 181 Whitehall St.  | NEW ORLEANS.....Junius Hart Piano House,<br>123 Carondelet St. |
| CHICAGO..Lyon & Healy, Wabash Ave. and Jackson Blvd.<br>Cheney Talking Machine Co., 24 N. Wabash Ave.<br>Consolidated Talking Machine Co., 227-229 W.<br>Washington St. | NEW YORK CITY.....General Phonograph Corp.,<br>15 W. 18th St.  |
| CINCINNATI.....Sterling Roll & Record Co., 137 W. 4th St.   | PORTLAND, ORE.....L. D. Heater, 357 Ankeny St.                 |
| DETROIT.....Consolidated Talking Machine Co.,<br>2957 Gratiot Ave.  | PUTNAM, CONN. Frank R. Witman Phonograph Supply Co.            |
| KANSAS CITY.....Artophone Corp., 804 Grand Ave.   | RICHMOND, VA...Richmond Hardware Co., 101 S. 14th St.          |
| MINNEAPOLIS.....Consolidated Talking Machine Co.<br>1121 Nicollet Ave.  | SAN FRANCISCO.....L. D. Heater Co., 420 Ninth Ave.             |
|   | ST. LOUIS.....Artophone Corp., 1103 Olive St.                  |

**Consolidated Talking Machine Co.**  
 227-229 West Washington Street . . . CHICAGO

*The*  
**Swanson King**  
 P O R T A B L E







THE *Fletcher* STYLE 30  
REG. TRADE MARK Wgt. 10 Lbs.  
CABINET SPEAKER

## The Fletcher Cabinet Speaker Contains the Famous "Fletcher Unit" ("FULLY PATENTED")

INSURING: Perfect, natural TONE combined with ample Volume and Clarity. Our UNIT eliminates Metallic and Nasal tones, reduces Static and Interference (due to a patented feature of construction). It reproduces Low as well as HIGH notes or ORAL tones with absolute perfection. FIVE YEAR GUARANTEE. Size: 13½ inches long, 9 inches wide, 10 inches deep; solid Walnut or Mahogany. Tone chamber of ½-inch thickness, 5 foot cord attached to unit. Consumer's price, \$30.00. High grade dealers wanted in open territory.

Immediate Deliveries—Write or Wire To-day.

FLETCHER-WICKES CO. (Sole Manufacturers)

116 W. Illinois Avenue

CHICAGO, ILLINOIS

### The Eight Popular Victor Artists Score on Tour

Well-known Figures in Record Field Attracting Big Audiences Everywhere

The Eight Popular Victor Artists under the management of Philip W. Simon, New York, have been attaining exceptional success in a tour inaugurated about two months ago. These



The Eight Popular Victor Artists

Left to right: Carl Mathieu, Monroe Silver, Stanley Baughman, Henry Burr, James Stanley, Billy Murray, Frank Banta and Sam Herman

eight Victor artists have already appeared in a number of the leading Eastern cities and capacity audiences have attended their performances in every city. The artists are directed personally by Harry McClaskey, one of the most popular recording artists in the country, and Mr. Simon's organization has been co-operating with Victor dealers to splendid advantage in every city included in the itinerary.

According to the schedule announced recently by Mr. Simon, the Eight Popular Victor Artists will appear in the month of January in the following cities: January 15, Lansing, Mich.; January 16, Grand Rapids, Mich.; January 18, Battle Creek, Mich.; January 19, Kalamazoo, Mich.; January 20, Terre Haute, Ind.; January 21, Springfield, Ill.; week beginning January 23, Missouri Theatre, St. Louis, Mo.

The members of the Eight Popular Victor Artists are Henry Burr, tenor; Billy Murray, tenor comedian; Monroe Silver, monologist; Frank Banta, pianist; James Stanley, baritone; Carl Mathieu, tenor; Stanley Baughman, bass; Sam Herman, xylophone, and The Peerless Quartet.

The New York office of the Starr Piano Co., manufacturer of Starr phonographs and Gennett records, reports a large demand for the recent release of the pipe organ recording by Milton Charles coupling "Sometime" and "Are You Sorry."

### Columbia Branch Reports Large December Volume

Increases in Gross Volume and in Record Sales—E. W. Guttenberger Attributes Satisfactory Showing to Harmony Records

The wholesale department of the Columbia Phonograph Co., New York, reports business for the month of December as most satisfactory, viewed from every angle, and presents some figures which more than bear out the report. In the first place, despite the fact that November of this year showed a large sales total for the Harmony records, December showed a 400 per cent increase in the sales of these recordings. The entire gross business done by this branch during December showed a 25 per cent increase over the same month of last year, despite the fact that the stock of Columbia phonographs

had been practically depleted during November and the sales during the past month were mainly of Columbia and Harmony recordings. A comparison of record sales for December of this year, as against last year, showed an increase of slightly more than 71 per cent.

E. W. Guttenberger, manager of the branch, attributes the splendid business done to the introduction of Harmony records to the trade. While these recordings have been on the market for a comparatively short time, they have achieved a wide popularity throughout the entire territory served by the New York wholesale headquarters and Mr. Guttenberger reports that not one Columbia dealer who has been approached has refused to order a stock of records. In addition, many large stores which hitherto had not carried Columbia merchandise have added the Harmony records to their stock and have almost all had repeat orders despite the short time the records have been on the shelves. Among the many prominent dealers in metropolitan territory who have become Harmony accounts are: Wanamakers, Gimbel's, Frederick Loeser & Co., Brooklyn department store; E. A. Schweiger, Inc., Brooklyn, N. Y.; G. Schirmer, Inc., New York; Saul Birns' chain of music shops in New York and Brooklyn; Luckey, Platt department store, Poughkeepsie, N. Y.; Goerke's department stores in Newark and Elizabeth, N. J., and the Broad & Market Music Store, Newark. These are a few of the

outstanding accounts that have achieved great success in the marketing of Harmony records.

One of the surprising results of the popularity of Harmony records, and one which puts at rest the misgivings of many dealers, is that these stores, since introducing Harmony recordings, have experienced an increase of sales in their regular records. The Harmony records have brought customers to the stores and the dealer and his sales force have been enabled to demonstrate, with good results, not only the cheaper records but the regular releases. Another feature of the Harmony business is that aside from the record having an appeal, based on its merit as well made and with the best of instrumental and vocal talent, the releases are made every ten days and so the latest song hits are immediately available.

### "Bestone" New Steel Needle Introduced to the Trade

The Wall-Kane Needle Mfg. Co., Brooklyn, N. Y., well known throughout the trade for its Wall-Kane, Jazz, Concert and Petmecky needles, has introduced a new product to the trade at the beginning of the new year. The new needle has been named the "Bestone" and is a steel needle made in loud, extra loud and medium tone. Attractive counter display cards have been prepared containing twenty-four packages, eight of each style. It is expected that the new needle will rapidly take its place in popularity among the other numbers of the Wall-Kane line.

N. Cohen, president and general manager of the Wall-Kane Needle Mfg. Co., accompanied by Mrs. Cohen, will leave this week for a Winter vacation in Florida.

### Important Announcement From the Sleeper Corp.

Gordon C. Sleeper, president of the Sleeper Radio Corp., emphatically denies the truth of various rumors that have been abroad in radio circles to the effect that the Sleeper Corp. was involved in any way in the recent business upheaval centering around the relations of the Ware Radio Corp., of New York, and the Music Master Corp. of Philadelphia. Mr. Sleeper stated that the Sleeper Corp. is an independent organization, its only connection with Music Master being through a contract which it holds with the latter for the manufacture of one model of a Music Master receiver, type 140. Mr. Sleeper further declared that his company is not connected in any way with the Ware Corp.

### Ambassador Shop Chartered

The Ambassador Music Shop, 4112 Forest Park avenue, Baltimore, Md., was recently incorporated with a capital stock of \$10,000.



IT'S A  
**Dymac**  
PRODUCT



Meet the New Member of the DYMAC Family

**CHARLES V. LOGWOOD**  
*Technical Director, Radio Div. Electrical Products Mfg. Co.*

Few men have had as intimate personal connection with the progress of Radio for as long a time as Charles V. Logwood, who, on September 1, 1925, became the Technical Director of our Radio Division.

As far back as 1903 Mr. Logwood was associated with Francis J. McCarty, one of the few engineers of radio telephony of that time. Subsequently, with the Poulsen Wireless Telephone Co. and Canadian Independent Telephone Co., Mr. Logwood was concerned with the establishment of the first three radio broadcasting stations in this country, in California, and with the installations of four prominent Canadian stations.

In 1911, Mr. Logwood invented the rotating ticker later supplanted by the ultra audion patented by Mr. Logwood and Dr. Lee De Forest, jointly. Mr. Logwood independently discovered the audion amplifier which came into commercial use in 1912. Since 1911, Mr. Logwood, in the capacity of assistant to the Chief Engineer and later as Research Engineer of one of the pioneer radio manufacturing concerns of the country, has been instrumental in the development of many interesting circuits.

Mr. Logwood's connection with DYMAC is an additional reason why you can continue to advise your customers that in buying DYMAC they are sure of getting the latest and best in radio.

## Get DYMAC on Display

We've pointed out in earlier issues of this and other publications why the DYMAC Selecto Five receiver is a "marked contribution" to radio reception.

We have likewise informed you about the complete coverage and sales appeal of DYMAC National Advertising.

If you're not already displaying DYMAC, this is a good time to begin. People have Christmas money to spend and are in a radio buying mood. They are reacting most favorably to the common sense of DYMAC national advertising and to the Selecto Five's special features.

The DYMAC Selecto Five, \$75; Loud Speaker, \$8.50, and Type G Headset, \$5.00; make a strong radio trio from the sales standpoint.

### ELECTRICAL PRODUCTS MFG. CO.

Providence, Rhode Island

Export Office: Ad. Auriema, Inc., 116 Broad St., N. Y. City

**DYMAC  
Factory  
Sales  
Agents**

Boston—Hastings Elec. Sales Co.  
Philadelphia—Erllichman Bros.  
Washington—W. Lester Baker  
Cleveland—Factory Sales Co.  
Chicago—E. V. Finson  
Minneapolis—Twin City Radio Sales Co.  
St. Louis—M. Scott Gardner  
Kansas City—Wm. S. Reid Sales Co.  
Omaha—Leonard Kohn

Denver—Schmidt Sales Co.  
Seattle—Fred L. Tomlinson Co.  
San Francisco—Fred L. Tomlinson Co.  
Los Angeles—Fred L. Tomlinson Co.  
Fort Worth—Savage & Schmidt  
Atlanta—Barnes & Co.  
Vancouver, B. C.—John E. T. Yewdall  
Toronto, Can.—Lester Radio Equip. Co.

EVERY **Dymac** PRODUCT  
GUARANTEED FOR ONE YEAR



## George E. Luders Now in Important Columbia Post

Succeeds N. B. Smith as Assistant Manager of New York Wholesale Dept. of Columbia Phono. Co.—Has Wide Experience

Announcement of the appointment of George E. Luders as assistant manager of the wholesale department of the Columbia Phonograph Co., New York, was made during the past week by E. W. Guttenberger, manager of the department. Mr. Luders is well qualified for his new position, having been connected with the New York Columbia wholesale branch for the past five years in various capacities. He was originally dealers' service manager, occupying that position from January, 1920, for a period of six months. He then was transferred to the sales staff and covered the Brooklyn territory until August of the past year when he became special sales representative. Mr. Luders succeeds N. B. Smith as assistant manager, Mr. Smith having been advanced to the managership of the St. Louis branch.

## Cox Co. in New Store

BROWNWOOD, TEX., January 7.—The A. C. Cox Music Co. has recently moved from the King Building on Fisk avenue to a new store on East Baker street, which has been decorated and enlarged. The Cox concern was formerly the Eubanks Music Co., and suffered a heavy fire loss last Fall. The new store will be equipped with the same lines of pianos, phonographs and musical instruments which were carried in the old location.

## Harry P. Bridge's New Post

The Atwater Kent Mfg. Co. of Philadelphia, manufacturer of Atwater Kent radio receiving sets and radio speakers, has announced the resignation of Harry P. Bridge, Jr., formerly in charge of sales promotion. Mr. Bridge has accepted an editorial position with the Keystone Publishing Co. of that city.

An involuntary petition in bankruptcy has been filed against the Manganaro Music & Furniture Co., Quincy, Mass. The concern handles talking machines.

## James K. Polk, Inc., Holds Its Annual Staff Dinner

Prominent Atlanta Wholesaler Entertains Important Guests at Enjoyable Reunion of Its Organization at Christmas Dinner

James K. Polk, Inc., Atlanta, Ga., one of the country's most successful wholesalers of phonograph products, recently held its annual Christmas dinner for the entire staff of the organiza-



Those Present at James K. Polk, Inc., Dinner

tion, as well as its semi-annual sales meeting. The dinner and the meeting were attended by the executives of the company, together with the sales representatives and a number of invited guests, among whom were Ralph S. Peer, general sales manager of the Okeh record division of the General Phonograph Corp.; A. B. Creal, Southern district representative, and L. O. Coulter, assistant sales manager of the Sonora Phonograph Co., and John Casagrande, of the Caswell Mfg. Co., Milwaukee.

The dinner was informal, with P. C. Brockman, general sales manager of the company, officiating as toastmaster. Everyone in attendance at the dinner was invited to give a brief talk, and all of the employees voiced the esteem and affection in which the executives of the company are held by the entire organization. The visiting guests paid a well-deserved tribute to the splendid representation given by James K. Polk, Inc., to the various manufacturers whose products they handle, commenting particularly upon the co-operation accorded the manufacturers by the executives of the company.

Subsequent to the dinner, the various members of the sales organization were invited to confer with the representatives of the manufac-

urers in connection with sales plans for 1926. These meetings served to lay the foundation for an efficient and intensive campaign for the coming year, based on the company's activities in the past four years. James K. Polk, Inc., although only four years old, has already gained the good will of phonograph dealers throughout the Southern territory, and the phenomenal growth of the company is reflected in the fact that in 1923 its sales were 120 per cent greater than 1922; 1924 showed an increase of 60 per cent over 1923, and 1925 an increase of 58 per cent over 1924. The goal for 1926 has been set at \$1,000,000 in sales and, according to the manufacturers who attended the recent dinner, this figure is ultra-conservative, with every indication that the company will far outdistance its goal during the next twelve months.

The tremendous success of the Polk organization may be attributed, in a large measure, to the activities of P. C. Brockman, who, as general sales manager of the company, has been responsible for the



Executives, Sales Personnel and Visitors Attending the Polk Sales Meetings

Standing (from left to right)—Messrs. Porter, Wallace, Butler, Casagrande, Alexander, Peer and Beutell. Seated—H. A. Brockman, James K. Polk and P. C. Brockman.

formation and developments of sales possibilities which have met with the complete satisfaction of the dealers served by the company. Mr. Brockman is assisted by a competent sales organization, including Charles J. Rey, who was recently appointed manager of the Richmond, Va., branch and who was unable to attend the convention because of business activities at Richmond. The products for which James K. Polk, Inc., are representatives include Okeh and Odeon records, Sonora phonographs, Caswell portable phonographs, Honest Quaker main springs and repair materials, Mastercraft phonograph products and Wall-Kane steel needles.

## Amrad Not to Be Merged With Crosley Interests

American Radio & Research Corp., Recently Acquired by Powel Crosley, Jr., Will Operate Independently—H. J. Power President

MEDFORD HILLSIDE, BOSTON, MASS., January 4.—In connection with the recent acquisition of the plant of the American Radio & Research Corp., of this city, by Powel Crosley, Jr., president of the Crosley Radio Corp. of Cincinnati, O., it is announced that the American Radio & Research Corp. will retain its individuality with Harold J. Power continuing as president of Amrad. The operation of the concern will be by the newly-formed corporation of which Mr. Crosley has been elected chairman of the board of directors. Amrad will be operated entirely independently of the other Crosley interests. However, the new organization is to have the advantage of the Crosley buying credit.



### START RIGHT!

Handle Radio Sets Multi-Plug Equipped or Equip Those You Have With Our Type BP Adaptable to Any Set

You can then demonstrate one or a number of sets from one set of batteries as all Multi-Plugs are interchangeable. A plug and socket connection between the batteries and the radio is as essential as a cord and socket on an electric iron, and your customer will want one with the set he buys or for the set he now has. It will pay to stock Jones Multi-Plugs which are nationally advertised and non-competitive. Write today for descriptive folder and prices.

HOWARD B. JONES CHICAGO  
618 S. Canal St.

**Jones**  
**MULTI-PLUG**  
THE STANDARD SET CONNECTOR





*the new*  
**5 ampere Tungar**  
 It charges faster—  
 It sells faster!



**Tell 'em this  
 about Tungar—**

It can't blow out Radiotrons if left hooked to set while charging.

Makes no objectionable noise.

Does not disturb radio reception in neighborhood.

It is complete—charges 2-4-6-volt "A" or 6-12-volt auto batteries, or 24-96-volt "B" batteries in series.

Especially adaptable to permanent installation in cabinet with switch control.

*(East of the Rockies)*

5 ampere Tungar . . . \$28.  
 2 ampere Tungar . . . \$18.

60 cycles—110 volts



Up go your Tungar sales now that the new 5 ampere size is ready to complete your line.

There is a big market for a good battery charger that does a swift, sure job.

Just tell 'em Tungar is a G-E product—trouble-proof, economical, easy to use. Just tell 'em the facts—that is the way to sell them.

*Write for campaign literature*

**Tungar**  
 REG. U.S. PAT. OFF.  
**BATTERY CHARGER**

*Tungar—a registered trademark—is found only on the genuine. Look for it on the name plate.*

**GENERAL ELECTRIC**

GENERAL ELECTRIC COMPANY      MERCHANDISE DEPARTMENT      BRIDGEPORT, CONNECTICUT



# Will You Buck It -or Ride this Wave?

Much more money and much less grief is what hundreds of dealers are reaping this season with Thorola receivers, speakers, and parts. Sold only on the positive basis that it *must outperform*, Thorola radio is doing it by far. "Circuit" talk, more tubes, and price prestige cannot overshadow what Thorola actually *does* in store and home.



You can show the *reasons* why Thorola must excel. Thorola Low-Loss Doughnut Coils with their patented indented wiring, true low-loss construction and other exclusive features go far beyond mere toroid theories in eliminating interference, sharpening selectivity and tuning, adding to volume and distance possibilities.

Thorola actual S. L. F. characteristics keep the efficiency curve from dropping out of sight anywhere in the receiving range — at difficult higher ranges Thorola efficiency is often measurably several times greater!



After hearing the Thorola Islodyne — after trying to show it up in days or weeks of testing — look at its mechanics — note its Bakelite sub-panel — its exquisitely careful hook-up — judge its appearance inside and out — no one has seen or heard anything else like it.

You cannot escape the conclusion that in the Islodyne receiver Thorola has really achieved an advance in design, craftsmanship and performance character heretofore paralleled only in Thorola Loud Speakers.

Thorola Speakers are outselling by far. The strides being made by Thorola receivers are a 1925-26 sensation. Thorola parts give you first call on experimenters' interest. The Thorola line, at Thorola prices and Thorola quick deliveries is carrying over Thorola dealers on a tidal wave of business. It's easier to ride *with* the Thorola line.

REICHMANN COMPANY, 1725-39 West 74th Street, CHICAGO

5-tube Thorola Islodyne Receivers, Walnut Cabinet	\$100	5-tube Thorola Islodyne Console	\$225	Thorola Low-Loss Doughnut Coils (set of 3)	\$12 Each \$4
5-tube Thorola Islodyne Receivers, Thorocco Cabinet	\$85	Thorola Loud Speaker Model 4	\$25	Thorola Low-Loss Straight Line Frequency Condensers	\$5.50 and \$6
5-tube Thorola Islodyne Receivers, Mahogany Cabinet	\$85	Thorola Jr. Loud Speaker	\$15	Thorola Golden Audio Reproducing Transformer	\$4.50



# Thorola

I S L O D Y N E



*From our* **CHICAGO** *HEADQUARTERS*  
 REPUBLIC BLDG., 209 SOUTH STATE ST TELEPHONE WABASH 5242

LEONARD P. CANTY

**Middle West Trade Faces New Year With Optimism as Conditions Continue Good**

All Branches of the Industry Satisfied With Large Year-End Business Volume—New Talking Machines Stimulate Interest in Records—Trade News and Activities of the Month

CHICAGO, ILL., January 8.—The close of the year 1925 found the talking machine dealer of the Middle West, after his summing up the results of the past twelve months, in a better condition than has been the case for several years. The year as a whole was not to be distinguished by its particularly large sales totals, but the increase which came as it drew to a close was one of such proportions as to instill greater confidence and optimism in the heart of the dealer as he stood on the brink of a new year.

Business and financial leaders throughout the Middle West, in speaking of the twelve months which have just passed, are found to be of practically the same opinion, namely, that 1924 marks, not a boom, but a gradual, marked step toward prosperity and stabilization of industry. The Middle West States, as far as the agricultural districts are concerned, are in better shape financially than has been the case for five or six years. Minnesota, North and South Dakota, the States which suffered most from the recent depression, and whose cities and towns were dotted with the closing of banks and business houses, are well on the road to prosperity. Iowa has harvested an exceptionally large crop, and provided the government makes certain adjustments in the near future, will market its products at

a good profit. Wisconsin, relying chiefly upon its dairy products as a basic industry, was not so sorely affected by the depression, and its agricultural regions and cities are enjoying prosperity.

The holiday business in this section was indeed gratifying, and music dealers were among those who enjoyed the benefits. A rough estimate placed the Chicago purchases of radio receiving apparatus for Christmas at five million dollars, on a par with the automobile industry. Musical merchandise, with a large proportion representing the purchase of talking machines and records, was estimated to have brought one million dollars into the hands of the music dealer. With the total of holiday business in the city of Chicago amounting to one hundred million dollars, it is apparent that a gratifying amount of the total was spent for home entertainment in the form of talking machines and radio receivers.

In a number of cases the chief difficulty which confronted the dealer was the securing of talking machines and radio sets for immediate delivery, but with this obstacle removed in the near future, the retailer will find nothing in his path to bar his progress, and his failure or success will depend upon the amount and kind

of effort expended in the promotion of sales.

The widespread publicity given to the talking machine for the past three months has resulted not only in a wealth of orders for the machines themselves, but has crowded the retail record counters with orders; not only for those selections which are enjoying public favor at the present time, but for classical and operatic airs. A visit to one of the leading music stores in Chicago, between Christmas and New Year, found every demonstration booth occupied, about twenty in all, and several customers waiting their turn.

Portable phonographs played one of the principal roles in the holiday shopping program, and, as during the Summer months, the dealer found the small machines to be one of his most valuable lines.

**How Dealers Tied Up With Victor Artists**

The Chicago Talking Machine Co., Victor jobber, in a recent and timely message to Victor dealers in this territory, suggested a number of ways in which they could reap full benefit from the radio concert broadcast by the Victor Talking Machine Co. on New Year's night from Station WJZ, New York City, and which was relayed by KYW Chicago, WBZ Springfield, WGY Schenectady, and WRC Washington, so that practically every locality in the United States was able to "tune in" and obtain the program. Among the suggestions contained in the letters by means of which the dealer could capitalize on the Victor concert broadcast by John McCormack, Lucrezia Bori and the Victor

*(Continued on page 120)*



No. R-16

**EXCELLO**

**Radio Consoles**

Combine highest quality cabinet work with the latest developments in Wall Consoles.

The Console shown here is made of Butt Walnut with matched panels in duo-tone finish. Loud speaker and unit included.

The Excello Line includes all types of cabinets from small table type to Wall Console type illustrated.

*Write for complete catalog sent free on request*

**Excello Products Corporation**

4824 W. 16th St., Cicero, Ill.



FROM OUR CHICAGO HEADQUARTERS—(Continued from page 119)



Kimball Style Y

# KIMBALL PHONOGRAPHS

ALWAYS RELIABLE

You will be amazed at the *new* results and the remarkable sales possibilities of the Kimball.

*Write for particulars.*

## W. W. KIMBALL CO.

Established 1857

Kimball Hall, 306 S. Wabash Ave., Chicago, Illinois

Manufacturers of Phonographs, Pianos, Player Pianos, Reproducing Pianos, Pipe Organs, Distributors of Columbia Records

**KIMBALL PHONOGRAPHS PLAY ALL RECORDS**

Concert Orchestra, were the following: newspaper advertisements; local newspaper stories; a government postcard announcement to be sent to a large list of Victrola and radio set owners; window and store displays of Victor records which were broadcast, with pictures of the artists; using the dealer's store as a receiving station on the evening of the concert for the convenience and entertainment of customers and prospective customers.

Sample advertisements were also prepared, bearing the dealer's name and an invitation to tune in and enjoy the concert, together with a list of the selections to be broadcast. Altogether nothing was left undone to capitalize the value of this concert from a merchandising standpoint.

### Graphic Demonstration of Easy Tuning

Did you ever see a horse tune a radio? Visitors to the Kennedy display at the Chicago



Black Bear Tuning In

radio shows did. They had heard salesmen talk ease of operation. Time after time they had listened to the phrase, "so simple a child can operate it." And then they saw a small, glossy black pony—the kind of pony children instinctively want to fondle—walk up to a Kennedy Model 30 and, without any guidance or

assistance, place its mouth on the Kennedy dials and bring in broadcast programs to delight the amazed crowd of onlookers. Black Bear is the pony's name, and Black Bear seems destined to occupy a place in radio history along with Kennedy—the receivers perfected to the point of simplicity that made this accomplishment possible.

Not only did Black Bear demonstrate the ease of operation and simplicity of the Kennedy, but this wonder horse performed other feats that would be considered difficult for some humans. Solving problems in addition, subtraction and multiplication, counting people in the audience, spelling proper names, identifying colors—these are only some of the seemingly endless stunts with which Black Bear thrilled the crowds.

And in response to the question "What is your favorite radio?" Black Bear showed his horse sense by promptly spelling out K-E-N-N-E-D-Y.

The Kennedy exhibit at the Chicago Radio Show was one of the feature attractions. The new Kennedy Model 30 (the set tuned by Black Bear, the wonder pony) was gorgeously displayed. It was admired by thousands, and Young, Lorish & Richardson, Chicago distributors for Kennedy, report the booking of a large volume of orders for the new receiver.

### Chicago Piano Club's Christmas Party

The Piano Club of Chicago staged a Christmas party at the clubrooms in the Illinois Athletic Club on Monday, December 28, and the function was attended by the largest delegation of members ever assembled, including a large number of out-of-town visitors who were spending the holidays in this city.

After a turkey dinner with cranberry sauce and all the trimmings, the members joined in singing old and new songs and enjoyed an after-

noon of entertainment which was concluded only after Santa Claus, impersonated by William I. Bush, of the Bush & Lane Piano Co., distributed Christmas gifts to everyone present. Santa, with the presentation of each gift, had a special message and brought Christmas greetings from Geo. P. Bent, of Los Angeles, Cal., and a number of other veterans in the trade.

Before the arrival of Santa Claus, entertainment was provided by a number of the club members, including William H. Collins, sales manager of the J. P. Seeburg Piano Co., A. P. Gustafson, superintendent of the player department of the M. Schulz Co., who played the mouth harp and the double guitar; Gene Whelan, of the W. W. Kimball Co., who told stories; Geo. Lufkin, also of the W. W. Kimball Co., who sang a solo, and Ade Duval, who performed some clever tricks with a deck of cards. Harry B. Bibb, secretary of the Piano Club, and Chicago district manager for the Brunswick-Balke-Collender Co., and Fred Michaels also helped to entertain the guests, the former with stories, and the latter with piano numbers.

### New Brunswick Recordings by Paul Ash

Paul Ash and His Orchestra, who have been a phenomenal drawing card at McVicker's Theatre in Chicago since mid-Summer, recently recorded for the Brunswick-Balke-Collender Co. two of his most heartily applauded numbers, "I Do! Do You?" and "Dreaming of To-morrow." "I Do! Do You?" is one of Mr. Ash's own compositions and the composer has injected into his orchestra a full amount of the spirit and dash which has characterized his own personal appearances on the stage.

The success of Paul Ash in Chicago has resulted in his establishing a record run, the longest of any orchestra billed as a feature in a moving picture house. The orchestra presents

(Continued on page 122)

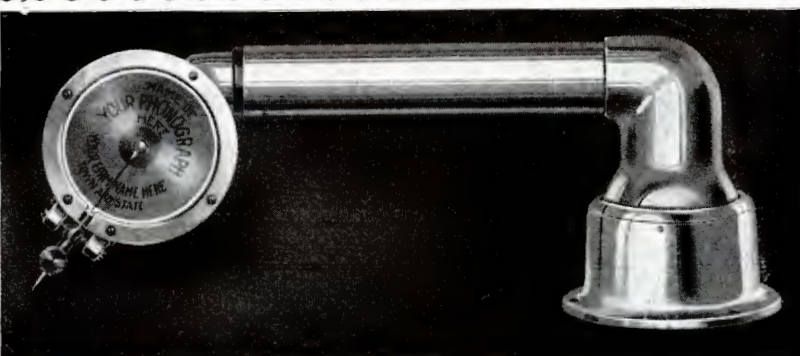

### Scottford Tonearm and Superior Reproducer

Manufactured under patents of Louis K. Scottford. Plays all makes of records. Famous for tone—without the usual metallic sharpness and without the scratch. Standard length 8 1/2 inches center of base to needlepoint—can be made to order longer or shorter. Base opening 2 inches diameter.

Fine quality Nickel and Gold Plate finishes

Supplied to manufacturers of high-grade phonograph cabinets in the United States and all foreign countries  
Samples sent anywhere for trial



### The Superior Spring Balanced Lid Support

A touch of one finger lifts or closes the lid which stops, balanced, at any point desired. Does not warp lid. Noiseless in operation. The simplest spring balance made—and easiest to install. Can be made to fit any type and weight of lid. Furnished complete with escutcheon plate and all necessary screws.

Low quantity Prices quoted on application

**BARNHART BROTHERS & SPINDLER SUPERIOR SPECIALTIES FOR PHONOGRAPHS MONROE & THROOP STS., CHICAGO**



# You Hit the "Bull's-Eye" With



## Utah Superflex

Reg. U. S. Pat. Off.



The Superflex has a tone chamber equal to that of the usual horn type. Stands but 8½ inches high by 6 wide. Finished in a harmonious brown. Weight 3 lbs. Packed 1 in a carton, 12 in a crate.

**\$14**

*No other manufacturer makes such guarantee*

## Utah Standard



Horn is finished in a rich semi-dull black Morocco leather finish; 14-inch bell; weight 11½ lbs. Packed 1 to a carton.

**\$25**



## Utah Phonospeaker



Handsomely finished in black rubber. Furnished with base to rest on turntable of talking machine, or without.

**With Stand**

**\$10**

**Without Stand**

**\$9.50**

## Utah Supreme

Reg. U. S. Pat. Off.

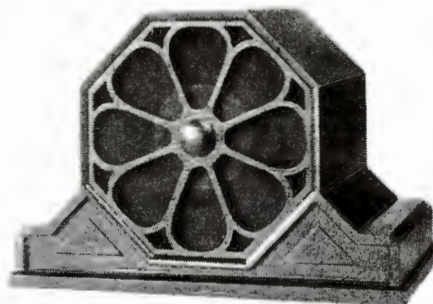

Finished in a soft antique mahogany, designed to please both eye and ear. Measures 10½ x 8 x 7½. Weight 8 lbs. Packed 1 in a carton, 3 in a crate.

**\$25**

**Utah Radio Products Co., 1427 So. Michigan Ave., Chicago**

**WE ARE MANUFACTURERS—NOT ASSEMBLERS**



FROM OUR CHICAGO HEADQUARTERS—(Continued from page 120)

a different act each week in keeping with the season of the year or some other event which is claiming wide attention at the time, such as a "Charleston Week" or "Collegiate Week." In addition to the orchestra, Ash maintains a corps of dancers, several soloists, comedians and specialty dancers.

**The Passing of Prof. Forest Cheney**

The talking machine trade was shocked to learn of the death of Professor Forest Cheney, of the Cheney Talking Machine Co., on Thursday, December 17. Professor Cheney had spent several weeks in Chicago and on the Tuesday night preceding his death entertained a number of friends, and he was apparently in the best of health.

He suffered a stroke on Wednesday morning and twenty-four hours later passed away at the Swedish Covenant Hospital, 2749 Foster avenue, Chicago. His daughter, Elizabeth Cheney, of



The Late Prof. Forest Cheney

Lima, Ohio, arrived at his bedside shortly before his death. The body was taken to the home of his daughter at Lima, Ohio, where services were held, and the burial took place at Jamestown, N. Y., the old home of the Cheney family.

Professor Cheney was born in Jamestown, sixty-two years ago, and in his early life was a well-known professional violinist. About fifteen years ago, while residing in Jamestown, he became interested in the development of the talking machine and obtained patents two years



(Pat. Pend.)  
**CARTER**  
FULL SIZE **75c**  
Any jobber can supply.

## CARTER "Flat" Plug

Here is the plug that was the sensation of the Chicago and New York shows. Fits flush against the panel. Cord instantly connected or disconnected. Cord tips hidden, cord hangs down. Leading manufacturers have adopted it as standard equipment. Can be easily sold to old customers, with console or closed sets.

IN CANADA: Carter Radio Co., Limited, Toronto

Write us for catalog.



later on several of his inventions. In 1915 the Cheney Talking Machine Co. was formed with the controlling stock in the hands of Marshall Field & Co., Chicago. A factory was established in Grand Rapids, Mich., and Professor Cheney made his headquarters at the plant, devoting his time to the further development of the product which bears his name.

In the sudden passing of Forest Cheney the talking machine trade has lost one of its most picturesque figures. Professor Cheney, as he was commonly known, was a remarkable personality. Definite-minded, determined, even self-centered, he was yet a fascination to all who knew him, and the world has already judged favorably the value of his contributions to the theory and practice of phonographic reproduction. He began life as a violinist and all his later work with the phonograph was based upon the ideas which he had conceived and worked out during his days as a professional musician. He was the sort of man who invites criticism and even seems to thrive upon it. He believed in his ideas and in himself. He lived to see those ideas put into practical shape and to build for himself a reputation as a practical acoustician second to none in his line. At the moment of his sudden removal from the scene he was deeply engaged in experimental work which he had determined to complete, despite the warnings which his overstrained body was constantly giving him. He died, in fact, a martyr to his work, for the final apoplexy was undoubtedly caused by the excitement and strain of those last days. Few knew him by more than name, but those who did know him knew him for a remarkable man, for one who, with all his marked individualities of manner and

method, had a definite work to do and lived to do it.

**Super Zenith IX Used by Famous Stars**

Radio has come into its own on the moving picture lots of the Pacific Coast, and between "shots" under the Klieg lights, moving picture actors and actresses are often found setting the dials for their favorite broadcasting station. In the picture reproduced above Laura LaPlante



Film Stars Enjoying the Zenith

and Reginald Denney are shown with their director, William Seiter, resting between scenes being taken for Universal Film Co.'s latest offering, "Skinner's Dress Suit," in the studio and tuning the Super Zenith IX. The model shown is one of many to be found in the plant of the Universal Film Co., Universal City, Cal.

**Charles Kaley Heard on Brunswick Records**

Charles Kaley, soloist with Abe Lyman's Orchestra, Brunswick recording artists now appearing at the College Inn, popular café of the Hotel Sherman, this city, recently became a soloist for Brunswick in two numbers released on records during the month of December. "You Told Me to Go," a selection which has brought Kaley encore after encore every time he has sung it, is Lyman's own composition. On the reverse side of the record is "Hold Me in Your Arms," a song in which Kaley distinguishes himself with that particular style which has led to his national popularity.

**United Cabinet Mfrs. Corp. Chartered**

The United Cabinet Mfrs. Corp., Chicago, Ill., was recently incorporated with a capital stock of \$25,000 to manufacture and deal in phonograph and radio cabinets and all articles incident thereto. The incorporators are Henry C. Forster, Isaac A. Lund and Wilbur C. Perkins.

**H. E. Cohen Entertained by Max Targ**

Harry E. Cohen, special representative of Everybody's Talking Machine Co., Philadelphia, Pa., paid a visit during the first part of December to the Targ & Dinner Music Co., wholesaler of Chicago. While in the city Mr. Cohen was entertained at the home of Max Targ, where, in a specially arranged musicale, several prominent pianists took part. Joseph Raieff, who entertained the guests at the Music Trade Convention at the Drake Hotel last Summer and who records for Duo-Art, was the main attraction. Dr. H. Septow, who recently arrived from Switzerland, where he is prominent in musical circles, played several classical selections on the violin, accompanied by Miss Fish.

(Continued on page 124)

# Make a CLEAN UP!

Turn all damaged, unsalable merchandise into money.

—whatever it be—no matter in what condition—our expert repairmen will rejuvenate it for you.

For your own sake—do it now.

We maintain separate repair departments for PHONOGRAPHS and MUSICAL INSTRUMENTS.

A letter of explanation with each job will facilitate the operation.

## TARG & DINNER MUSIC CO.

"The Wholesale Music Center"

229 West Randolph Street

Chicago, Ill.



New Jewel Attachment for playing the Edison "Re-Creation" records on the new

# Orthophonic Victrola

Weight Lightest That Can Produce Perfect Tone



Showing Jewel Victor Attachment in position for playing Edison and Pathé Records

The patented "NOM-Y-KA" diaphragm almost eliminates all surface sounds and brings forth in a rich pure volume all that was put into the record by the natural voice of the singer or the artistic touch of the instrumentalist.

We also have a special reproducer that can be attached to the old Victor tone arm. It greatly improves the tone and makes a new talking machine out of the old style Victrola. Specially adapted for playing the **ELECTRICALLY RECORDED RECORDS**.

Jewel Needle Equipment for playing lateral cut records on the New Edison. Perfectly balanced for playing the new **ELECTRICALLY RECORDED RECORDS** and brings out the deep bass notes without sacrificing the treble. A real **ORTHOPHONIC** tone.



Showing Jewel Needle Equipment in position for playing Victor and all lateral cut Records on the New Edison Phonograph



## De-Luxe Jewel Cabinet Loud Speaker

This Cabinet Loud Speaker is finished in exact imitation of old ivory, antique bronze, rosewood, ebony or green gold by the "Embossene-Florentine" process. This makes a very beautiful and durable finish, it is not affected by heat or cold; can be washed with soap and water and cannot be scratched except with a very sharp instrument.

*If your jobber does not handle the **JEWEL PRODUCTS** write us direct.*



150-160 Whiting Street, Chicago, Ill.



FROM OUR CHICAGO HEADQUARTERS—(Continued from page 122)

His wife also entertained with interpretations of ballads and European folk songs. In addition to a score of friends, several business associates among the personnel of the Targ & Dinner Music Co. were among the guests.

A. V. Anthony With Concert Master Mfg. Co.

A. V. Anthony, formerly assistant sales manager in the local office of the Pathé Radio & Phonograph Corp., is now sales manager and vice-president of the Concert Master Mfg. Co., of this city, and also sales manager of the Continental Sales Laboratories, a division of that firm. The firm manufactures radio tubes in types 201-A, 199-S and 199, maintaining a factory in Newark, N. J., and sales offices at 179 West Washington street, Chicago, Ill. Mr. Anthony is well known and popular in the music trade, having been associated with the Tay Sales Co., Sonora jobber in Chicago and surrounding territory, and also having made many dealer friends while with the Pathé Radio & Phonograph Corp.

Broadcaster Display at Furniture Show

The Broadcaster Corp., Chicago, manufacturer of talking machines and radio-phonograph combination instruments, is maintaining an attractive display at the Furniture Market, now being held at the American Furniture Mart. Among the products displayed by this firm are the RP2, a console phonograph equipped with the Fada five-tube neutrodyne panel, Model HB Broadcaster highboy phonograph, which is adaptable for radio, radio cabinets and a number of upright and console machines. Several other models on display contain the Fada five-tube neutrodyne radio panel. S. L. Zax, secretary of the Broadcaster Corp., is in charge of the display and has been kept busy demonstrating the instruments to the visiting furniture dealers.

Justin Bros.' Handsome New Store

Rapid growth and development, from a small, unpretentious music shop to a beautiful, spacious establishment, stocked with every variety of musical instrument, marked the opening of the new store of Justin Bros., 5205 West Twenty-fifth street, Chicago, early in December. The firm, headed by Jerry F. Justin, president, and Frank Justin, secretary and treasurer, has made remarkable progress in the retail music business on the southwest side of the city, where twelve years ago they started selling phonographs and sheet music at the same address.

The opening was attended by hundreds of

**We are Direct Factory Distributors**

**100% SATISFACTORY SERVICE!**

A BUSINESS built on giving dealers what they want when they want it! Tremendous stocks always of nationally advertised products assure immediate deliveries... and efficient service that speeds those deliveries along. This business is strictly wholesale... offering adequate protection to our patrons.

Dealers—Send for our latest catalog! Please use your letterhead in writing

**The Harry Alter Co.**  
Wholesale Radio

**Balkite**  
**Premier Electric Company**  
**ERLA**  
**Burgess**  
**Eliminator**  
**BURGESS RADIO BATTERIES**  
**RADION**  
**WALBERT**  
**Parts with a Purpose**  
**Allen-Bradley Co.**  
**ACME**  
for amplification

**DUBILIER**  
Devices  
**REMLER**  
**Howard**  
**SHAMROCK**  
MANUFACTURING COMPANY  
**BRIGHT STAR**  
**Brandes**  
The name to know in Radio  
**ALL-AMERICAN**  
**BENJAMIN**  
MADE IN U.S.A.  
**The Harry Alter Co.**  
Ogden at Carroll Ave., Chicago, Ill.

people, members of the trade and personal friends who packed the store to the doors. The proprietors had arranged a program of continuous entertainment from 2 o'clock in the afternoon until midnight, in which were featured Victor and Brunswick record artists, and a number of vaudeville headliners.

Justin Bros. handle the products of the Victor Talking Machine Co., Brunswick-Balke-Collender Co., Radio Corp. of America, Atwater Kent Mfg. Co., Ludwig & Ludwig, Gulbransen Co. and a number of other piano and musical merchandise lines.

Beautiful Kimball Pipe Organ for Scranton

In the display windows of the W. W. Kimball Co., manufacturer of Kimball phonographs and pianos, there appeared shortly before the holidays a rather large and expensive gift in the

form of a console for a four-manual pipe organ. The instrument, which was presented to the Scranton, Pa., Chamber of Commerce by Col. L. A. Watres, one of the leading bankers of Scranton, was to be installed in the Chamber of Commerce auditorium under the personal direction of Charles M. Courboin, internationally known concert organist, who supervised its construction and who will play the opening recital.

Ambu Radio Features Create Demand

The Ambu Engineering Institute, of this city, manufacturer of the Ambu five-tube radio re-



Ambu Shot Panel

ceiver introduced about six months ago, has found that two features of the set have done much to attract attention and maintain demand. One of these is the "shot" panel, which is manufactured by cutting grooves in a piece of bakelite and shooting hot copper into these grooves in a special pattern which makes all connections automatically when the parts are screwed into place. This method prevents loose wires, leakage, inductance, and several other objectionable features and is said to be permanent. The other feature of the Ambu set is found in the Armstrong "allwave" coils by which the operator may tune in all programs broadcast on any wave length from 40 to 600 meters.

Vitanola Products Attract Attention

The Vitanola Talking Machine Co. is playing host in its offices in the American Furniture Mart from January 4 to 23 during the mid-Winter Market now in progress at the American Furniture Mart. A number of new Vitanola models, including phonographs, combination instruments and radio cabinets, are on display. Among the new products are No. 300, a three-deck mahogany radio cabinet with the loud speaker occupying the entire top section, and a space for batteries and a charger in the bottom compartment, and No. 301, a two-deck radio cabinet finished both in walnut and mahogany with the loud speaker compartment on the left side, the space for the radio panel on the right and room for the batteries in the lower

(Continued on page 126)

**Repair Parts**  
For All and Every Motor That Was Ever Manufactured

We can supply any part. The largest and most complete assortment of repair parts—in the United States—on hand, for old, obsolete and present-day motors. If your order cannot be filled from stock, we will make it up special.

Special prices on main springs, governor springs, micras, repair parts, motors, tone arms, steel needles, etc., in quantity lots.

Expert repairing on all makes of phonographs and motors.

**Consolidated Talking Machine Co.**  
Manufacturers of High Grade Talking Machines, Disc Records, Talking Machine Supplies, Etc.

227-229 W. WASHINGTON ST., CHICAGO, ILL.  
Branches: 5857 Grattet Ave., Detroit, Mich. 1121 Nicollet Ave., Minneapolis, Minn.

INCORPORATED UNDER THE LAWS OF ILLINOIS

SUCCESSORS TO:  
Standard Talking Machine Co.  
United Talking Machine Co.  
Herman Talking Machine Co.  
O'Neill-James Co.  
Arrol Co.

TRADE MARK "CONSOLA"  
CABLE ADDRESS "CONSOLA"





Liberty Sealed 5 Standard,  
Code 6161. Length 20 3/4  
ins., Height 10 1/2 ins.,  
Depth 12 3/8 ins.

Price \$100.00.



Liberty Sealed 5 Console  
DeLuxe, Code 6452. Price  
\$325.00. Length 56 1/2 ins.,  
Height 37 ins., Depth  
23 1/2 ins.



Liberty Sealed Standard  
5 Console, Code 6363.  
Price \$165.00. Length  
30 1/2 ins., Height 38 1/4 ins.,  
Depth 22 1/4 ins.



Liberty Sealed 5 Special,  
Code 6262. Price \$120.00.  
Length 28 3/4 ins., Height  
10 1/2 ins., Depth 12 3/8 ins.



Liberty Cabinet, Code  
64-S With Speaker, Price  
\$35.00. Code 64 Without  
Speaker, Price \$20.00.



Liberty Sealed 5, Code  
5151. Price \$100.00.  
Length 28 3/4 ins., Height  
10 1/2 ins., Depth 12 3/8 ins.

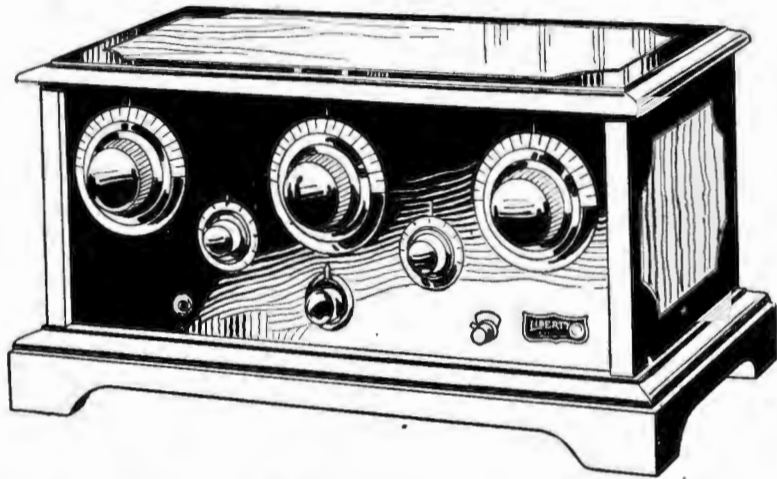

## Guaranteed Performance Not Mere Promises

You can promise the sun, the moon and all the rest of the planetary system, but you couldn't fulfill your promise—you couldn't deliver the goods. A promise is one thing and its fulfillment is another—and radio buyers are aware of the fact. They are skeptical of promises—they have a right to be—they realize that it is an easy matter to elaborate on the merits of any receiving set—and they know, thousands of them from sorrowful experience, that after all is said and done, the value of any radio receiving set can be demonstrated and fully determined only by actual day after day performance in the home and that the only dependable assurance of satisfactory operation is the manufacturer's faith in his product backed by a definite guarantee.

The Liberty Seal supplies a positive assurance of value—of satisfaction—of all the qualities desirable in radio receptivity. It is an absolute safeguard against unsatisfactory selection and is one of the strongest, most convincing arguments ever put in the hands of a dealer.

Every Liberty Sealed Five Receiving Set is sold under an irrevocable guarantee that any defective part or faulty workmanship will be replaced free of charge anytime within 60 days from date of purchase.

Such a guarantee reflects the confidence of the manufacturer in his ability to please the buyer and is a pledge of supremely satisfactory performance.

The Liberty line—the Liberty guarantee—provides dealers with an exceptionally attractive opportunity to procure the most desirable and profitable class of trade. Why not investigate—your name and address on the attached coupon will bring full particulars.

LIBERTY  
TRANSFORMER  
COMPANY

123 N. Sangamon St.,  
Chicago

Kindly send us your propo-  
sition to radio dealers.

**Liberty Transformer Co.**  
123 N. Sangamon St. Chicago, Ill.

NAME .....

ADDRESS .....



FROM OUR CHICAGO HEADQUARTERS—(Continued from page 124)

**"A Truly Wonderful Radio"** The LAKESIDE goes thru the barrage of local stations and successfully brings in distance.



The last word in Radio Sets. A complete five-tube tuned radio frequency receiver designed to meet all needs. Cabinet furnished of selected walnut in two-tone effect with metal panel attractively designed in gold with the latest in knobs and pointers.

Dimensions: Height 10 inches; Length 20 inches; Width 11 inches.

**LIST PRICE; without Tubes or Batteries - - - \$75.00**  
Exceptional Liberal Discounts

**Lakeside Supply Company**  
Radio Sets, Cabinets and Accessories  
73 West Van Buren Street  
Chicago, Illinois

compartment. In addition several new upright phonographs and consoles, the latter adapted for radio installation, finished in mahogany and walnut, are being exhibited. Vitonola executives state that the present Furniture Market has drawn to the exposition building the largest number of buyers in history, and that a keen interest is being displayed in the new Vitonola models.

**Child Film Stars Enjoy Super Zenith IX**

The child stars of the Universal Film Co. are apparently as enthused over radio as are their



Zenith "Entertains" Child Film Stars

elders on the moving picture "lot." In the picture shown above Buster Brown (Arthur Trimble), Mary Jane (Doreen Turner), and Tige, of the Buster Brown Comedies, released through the Universal Film Co., are shown resting between "shots," tuning in the Super Zenith IX at the studio.

**Phonograph Manufacturers' Association to Meet**

The regular monthly meeting of the Phonograph Manufacturers' National Association will take place on Tuesday, January 19, in the Furni-

ture Club, American Furniture Mart, 666 Lake Shore Drive, Chicago, according to an announcement made by the officers of the Association a few days ago. No meeting was held in December because of the approaching Christmas holidays, and the resultant activity on the part of the members in maintaining factory production at top speed. The January meeting will mark the end of the first year in the Association's history, and it is expected that a large number of manufacturers will attend. The meeting will open, as usual, with a dinner at 6 o'clock, followed by the business session, at which a number of matters of interest to the trade in general will be discussed.

**Excel Phono. Co.'s Fine Display**

The Excel Phonograph Mfg. Co., of Chicago, is at the present time maintaining an attractive display at the American Furniture Mart, where the Furniture Market is being held. The display, which is attracting a large number of visiting furniture dealers, includes Model 70, a combination instrument standing fifty inches high; Models 21 and 7, console talking machines adaptable for radio; Model 10, another console phonograph with a space for radio panel; Models 11 and 17, straight consoles, and Models 1 and 2, upright phonographs. With the exception of console Model 17, which is finished in walnut, all of the Excel products shown are finished in mahogany. The display is under the supervision of J. N. Stewart, of the sales-staff, and I. A. Lund, sales manager of the Excel organization.

**Lee Sims Scores in U. S. Music Rolls**

Lee Sims, one of the most popular artists in the radio broadcasting world today, is adding to his achievements and increasing his popularity

through the medium of music rolls. Mr. Sims has been an exclusive recording artist for the United States Music Co. of Chicago for over a year, and during that time has made a number of his hits equally popular on player-pianos. Among the numbers which he has made famous on the air and on U. S. music rolls are "Sweet Georgia Brown," "Sleepy Time Gal," "You Told Me to Go," "No Man's Mama," "Im Gonna Charleston Back to Charleston" and "Then I'll Be Happy."

**New De Luxe Apex Radio Receiver**

A new de luxe type radio receiver was introduced to the trade late in December by the Apex Electric Mfg. Co., maker of Apex radio receiving sets, loud speakers and vernier dials in this city, which is known as the Apex Apartment Grand. It is a five-tube model, employing the tuned radio frequency circuit, and is furnished in a hand carved cabinet of solid burl walnut. The Apartment Grand contains a built-in speaker and battery compartment, stands four feet high, and is thirty inches wide. It is of a



Apex Apartment Grand

particularly handsome design and is already enjoying a fine demand from those who wish to combine an instrument of utility and beauty with their home furnishings.

**Will James Visits Gulbransen Plant**

Will James, manager of the band instrument department of Martin Brothers Piano Co., Springfield, Mo., recently visited Chicago, and while in the city, took the opportunity to visit the plant of the Gulbransen Co., manufacturer of Gulbransen registering pianos. He was keenly interested in the various operations carried out in the manufacture of the Gulbransen instruments, which his progressive firm features in Springfield and surrounding territory.

**Lyon & Healy's Attractive Zenith Window**

Lyon & Healy, the prominent Chicago music house, recently devoted a very attractive window to the display of Zenith radio receiving sets, which the firm recently added to its roster. The Zenith De Luxe Italian model with disappearing doors, two built-in speakers, fretted grill and single dial control, and the Super Zenith IX were shown in attractive setting.

**Important Stewart-Warner Sales Conferences**

Sales conferences, participated in by headquarters executives and sales representatives from all over the United States, are being held at the present time at the Stewart-Warner Speedometer Corp. office in Chicago. At these gatherings, which began on January 4 and will end on the twenty-third of this month, plans for the year 1926 will be discussed, and each representative will be benefited by the close contact with the head office and the information he will receive.

The sales representatives have been divided into three groups, the conferences taking place one after the other, in three day shifts, starting with the Middle West sales staff, the West and Southwest, the South, and the Eastern section

(Continued on page 128)



**So**  
**ATTRACTIVE**  
**ADAPTIVE**  
**and**  
**LOW-PRICED**  
**That**  
**The Largest Retail**  
**Outlets in America**  
**PREFER**  
*this model for their most exacting trade.*

**MODEL "AH" RADIO CABINET**  
Outside Measurements: Height, 46 ins.; Width, 36 ins.; Depth, 18 ins.  
Receiver Compartment: Height 10 1/2 ins.; Width, 33 1/2 ins.; Depth, 12 1/2 ins.

**BROADCASTER CORP.**  
2414 W. Cullerton Street Chicago, Ill.





Okeh  
TRUE TONE

*Okeh Records Greet You With a  
Guarantee for Better Business During 1926*

---

You can tell a good record by its Sound! Some records look as good as Okeh Records but they don't sound as good. That's the test. Have you made it? Hearing an Okeh Record is convincing proof of what is a True Tone recording.

When all is said and done it is the profit making record your business needs. Everywhere there is a multitude of Okeh Record buyers that can be securely counted on.

By becoming a licensed Okeh Record Dealer you can share in this profitable patronage.

Our efficiently organized Service Department will appeal to you.

*Decide to-day to become a Licensed Okeh Dealer*

**Consolidated Talking Machine Co.**

227 W. Washington Street, Chicago, Ill.

BRANCHES:

2957 Gratiot Ave., Detroit, Mich.

1121 Nicollet Ave., Minneapolis, Minn.



FROM OUR CHICAGO HEADQUARTERS—(Continued from page 126)

of the entire United States, in the order named. R. H. Woodford, sales manager of the radio division, George M. McCulloch, advertising manager, and A. B. Dicus, head of the sales quota department, and other of the Stewart-Warner executives are addressing the sales staff, and outlining to them the sales program for the year.

**Represents Apex in New England**

The Apex Electric Mfg. Co., Chicago, manufacturer of Apex radio receiving sets, loud speaker and vernier dials, announced the appointment of D. G. Caywood as its representative in the New England territory. Mr. Caywood, who has been prominent for some time past in the automotive industry in that particular territory, makes his headquarters at 11 Lovell Road, Watertown, Mass., and will cover the entire New England territory, working closely with Apex distributors and dealers.

**Artistic Zenith Display**

Enterprising music houses handling radio equipment are taking advantage of every oppor-



**Booth of the Radebaugh Music Co.**

tunity to bring their lines of merchandise to the attention of the public, and the above picture shows one of the ways in which a music store secured a maximum amount of consumer atten-

tion in a few days. The Radebaugh Music Co., of Columbus, O., occupied a prominent space at the radio show recently held in that city, where it exhibited Zenith receivers. The back of the booth represents a sunburst, topped by window display cards depicting the McMillan Arctic Expedition and the Zenith radio receiving apparatus used by the exploring party. In the display proper are found the Super Zenith IX on the left, the Zenith DeLuxe Spanish model in the center and the Super Zenith VIII on the right.

**Noted Stars at Stewart-Warner Studio**

Several stars in the musical firmament have recently appeared before the microphone at the Stewart-Warner Speedometer Corp. studio WBBM, in Chicago. On the evening of December 25, Kathryn Browne, Chicago Civic Opera contralto, appeared in joint concert with the Imperial Male Quartet, Victor record artists, and duplicated her success of November 20, the date of her previous appearance program at WBBM. On December 29, Wendell Hall, Victor artist, and creator of the popular song hit of two years ago, "It Ain't Gonna Rain No More," entertained his invisible audience with popular selections.

**The Swanson "King" Makes Its Debut**

The Consolidated Talking Machine Co., manufacturer of Swanson portable phonographs, and distributor of Okeh records and Adler-Royal talking machines and radio combinations in this city, recently announced a new addition to the Swanson line. The new portable, known as the Swanson "King," was placed on the market January 1. The "King" is finished in "Leatherode" in black, maroon and brown with an embossed design and a space for the owner's name in the center of the cover. A feature of the new machine is the record filing device, which is also embossed and given an air brush finish in a pleasing combination of colors. The back wall of the record filing case is flexible, permitting the user to remove the records with



**THE ALTO**  
**Automatic Stop**

**For Phonographs.**

Nothing needs to be screwed into the tone arm. Simple in construction. It fits under the turn table. Our customers say it is the most accurate stop they found yet in spite of its low cost.

**ALTO MFG. CO.**, 1647-51 Wolfram Street, CHICAGO  
Canadian Distributor Universal Supply Co., Toronto, Ont.

a minimum of effort. The turntable is finished in colored felt, which will harmonize with the particular color of the exterior, and the quality of the product is further enhanced by a new tone arm and sound box with a completely shielded diaphragm.

**Big Gulbransen Ad Drive to Continue**

The advertising campaign sponsored by the Gulbransen Co., manufacturer of Gulbransen registering pianos, reached its peak in the Fall of 1925, and never before in piano history has a publicity program been conducted on such an extensive scale from the standpoints of size of copy and number of homes reached. Gulbransen is at present entering a new field, the domain of women, and will utilize mediums by means of which women may be appealed to in their own language. A recent survey indicated that 63 per cent of piano purchases are initiated by women and, while magazines like the Saturday Evening Post, American Magazine and Literary Digest are read by women, it was thought by the Gulbransen executives that the indication of feminine influence was outstanding enough to warrant the use of special publications. Consequently, The Ladies Home Journal and The Woman's Home Companion have

*(Continued on page 130)*

## Performance Is What Counts—

The chief point of interest in a phonograph motor is what it will do—because your success and our success depend upon satisfying the ultimate consumer—whose satisfaction is the result of dependable efficient performance.

**PERFORMANCE IS BUILT INTO KRASCO MOTORS**

**MAXIMUM PLAYING CAPACITY**

4 to 10 ten-inch records with one winding.

**SILENT OPERATION**

Elimination of the causes of noise—friction and backlash.

**LONG DEPENDABLE SERVICE**

Quality materials, expert workmanship, thorough test—guarantee years of satisfactory service.



The mark of

**QUALITY  
DEPENDABILITY  
SERVICE**

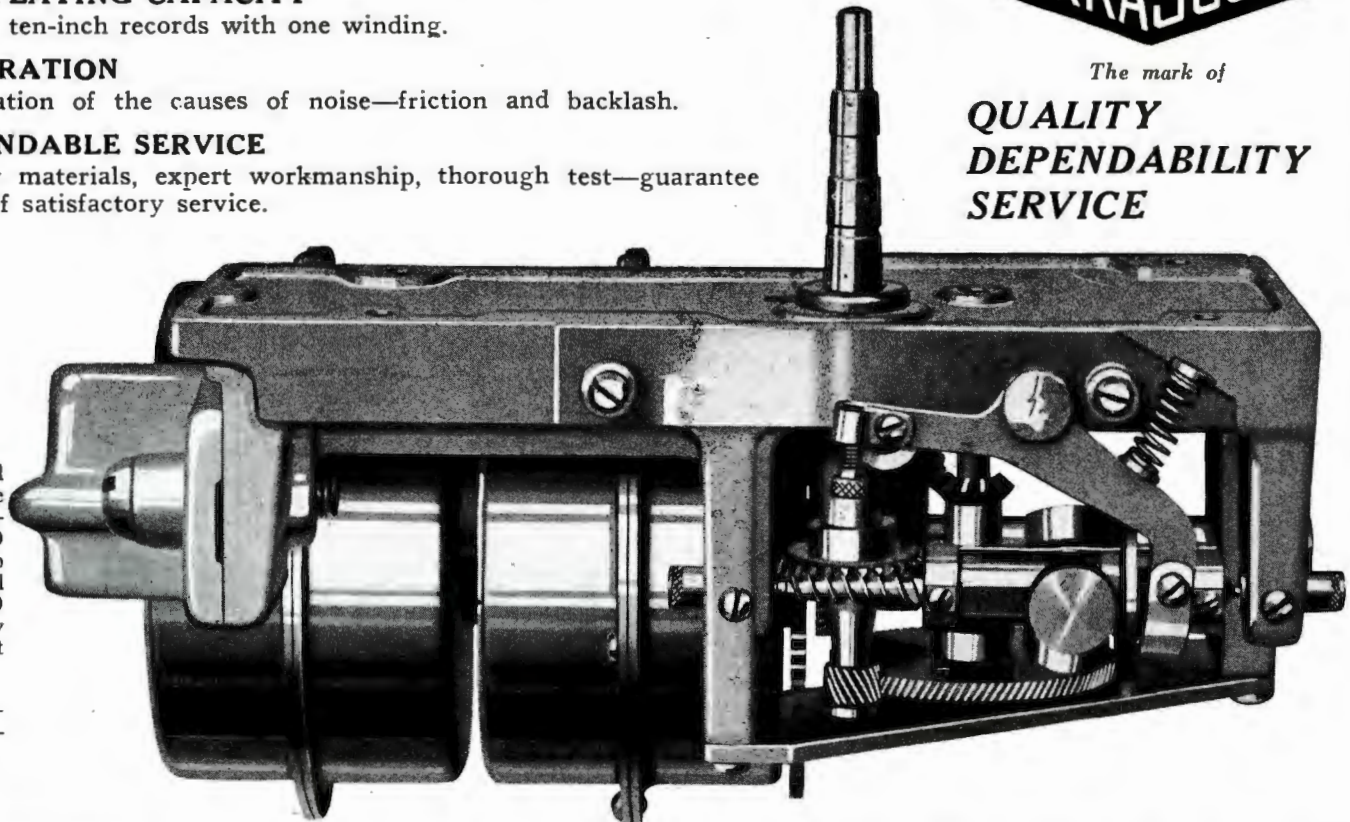

A trial order will demonstrate the efficient performance of KRASCO MOTORS. Keep your sales sold with KRASCO MOTORS -- they cost no more but they're better.

Write for descriptive literature and prices.

**KRASCO PHONOGRAPH MOTOR COMPANY**

**ELKHART, INDIANA, U. S. A.**



# Mohawk Radio

Manufactured by Mohawk Corporation of Illinois  
Independently Organized in 1924

5 tubes - just ONE dial to tune



## Simple Control Sells the Mohawk

WHY waste your time trying to show your customers how to get satisfactory reception with three dials? You don't need to when they can step up to the Mohawk and, with a slight turn of *one* dial, tune stations in and out without any disturbing squeaks or howls.

The Mohawk three-in-line *balanced* condenser has ended the three hand shortage—all you need is one hand. You don't have to be an expert to operate it. Anyone can tune in and get volume and undistorted, life-like reproduction coupled with the Mohawk's beauty of tone and selectivity.

Every woman is instantly attracted by the Mohawk's simplicity of control, and every man realizes a new enjoyment.

But only Mohawk has the *balanced* condenser. An exclusive achievement by Mohawk engineers.

Test the Mohawk and convince yourself.

Write today or ask for free booklet, "Sharper Tuning with One Dial" and list of Mohawk Jobbers.

Manufacturers  
**MOHAWK CORPORATION OF ILLINOIS**  
Independently Organized in 1924  
Chicago, Ill.

Sales Department  
**THE ZINKE COMPANY**  
1323 So. Michigan Ave.  
Chicago, Ill.



Mohawk Radio, "5 tubes, just one dial to tune." [Accessories extra.] \$100.



Mohawk Receiver, Model 100, five tubes, just one dial to tune. Retail price, without accessories, \$100.



Mohawk Consolelette, Model 110, retail price without accessories, \$175.



Mohawk Console, Model 115, retail price without accessories, \$225.



Mohawk No. KU51 Kit. Contains all parts of the famous Mohawk, including cabinet, for assembling. Retail price, \$75.

All the parts of the Mohawk can be had to sell separately. Be sure to have the Mohawk Balanced Condenser—the heart of the Mohawk, it's good for extra sales and profit.



FROM OUR CHICAGO HEADQUARTERS—(Continued from page 128)

been added to the list and the first Gulbransen ad will appear in the former on February 1. The first piece of copy in The Woman's Home Companion will appear in the March issue, which will be on the newsstands February 20.

Another addition to the list is Farm and Fireside, one of the leading national agricultural mediums with a circulation of 1,000,000. Dealers in the South will be given further aid by the addition of the Progressive Farmer, with a circulation of 450,000, and also eight papers of the

bransen advertising will be surpassed in the 1926 campaign. The enlargement of the scope of the Gulbransen publicity campaign is another step toward increasing the strength of connection and the closeness of co-operation between Gulbransen dealers and the manufacturers of the product.

**J. F. Ditzell Tells of Increased Music Interest**

In a recent message to Brunswick dealers John F. Ditzell, manager of record sales for the Brunswick-Balke-Collender Co., literally "hit the nail on the head" when he pointed to the fact that music, as it is interpreted to-day by opera companies, symphony orchestras and other musical organizations, is exciting public interest in music to a greater extent than ever before in the history of the country. His letter, which was directed to all individuals engaged in the selling of Brunswick records, reads as follows:

**TO THOSE WHO SELL BRUNSWICK RECORDS:**

Public interest in music is to-day stronger than in any other period in our history. Grand opera companies in New York, Chicago, Philadelphia and many other cities are enjoying their most successful artistic and financial season. There are more symphony orchestras throughout the country than ever before, and almost without exception they are receiving the loyal and substantial support of local communities.

Light operas, musical comedies, music revues, cabaret shows, in fact, all shows with music, are breaking records for long runs in the larger cities. Such stupendous successes as "Rose Marie," "No, No, Nanette," and "The Student Prince" are being duplicated, and in many instances even surpassed by later shows, such as "Castles in the Air," "Sunny" and "Merry Merry."

This nation-wide interest in music should mean greater interest in Brunswick records. To realize upon this interest it only depends upon the efforts put forth by dealers and sales people in taking advantage of the opportunities to present Brunswick records in the most interesting way.

Within the attached comments covering the records for sale in December and January we have given information that will be interesting to every phonograph owner. It is the purpose of this information to assist you in creating greater Brunswick record sales.

With the season's greetings, we extend to you our heartiest wish for a Happy and Prosperous New Year.

**Big Time at Consolidated Offices**

The Consolidated Talking Machine Co., of this city, and Okeh records, which this firm distributes, jumped into the national limelight on Monday, December 28, when a picture appeared on the first page of a leading Chicago morning newspaper showing Consolidated girl employees enjoying a Christmas party at the of-



**MOTORS For All Types of PHONOGRAPHS**

Quiet Easy Winding—Silent Operation—Quick Pick-up—True Pitch Reproduction—Long Life. Wearing parts protected by air-tight housing. Continuous Automatic Lubrication.

Write for Catalog

United Mfg. & Dist. Co. 9702 Cottage Grove Ave. Chicago

face of the firm. The picture is reproduced herewith, and their smiling faces certainly give proof that the girls enjoyed the frolic arranged for their benefit.

The party was held at noon on December 24, on one of the upper floors of the Consolidated offices and centered around the bar shown in



"A Good Time Was Had by All"

the picture, where coffee and free lunch, with sausage and all of the old-time trimmings, were dispensed. The bar and free lunch stand were constructed of Okeh and Adler-Royal packing boxes and smaller boxes were used for the traditional foot rail.

After the picture appeared in the Chicago newspaper it was released for publication all over the United States by a syndicate news service.

**Geo. W. Davidson's Activities**

George W. Davidson, a well-known figure in retail music trade circles, is now manager of the North Shore Talking Machine Co., Church street, Evanston, Ill. This firm maintains a

(Continued on page 132)



**New Mediums to Tell Gulbransen Story**

Jacobs Religious Group, circulating in North Carolina, South Carolina and Georgia.

Coincident with the picking of new mediums to carry the Gulbransen message to the public the physical appearance of the advertising in 1926 will be altered, and as shown by the advertisements reproduced a finer "atmosphere" is being given the Gulbransen registering piano. The copy is being prepared by the J. Walter Thompson Co., one of the foremost advertising agencies in the world, and Gulbransen executives expect that even the splendid past standards of Gul-

STYLE 21  
Genuine Mahogany or Walnut only.

STYLE 21-B  
Same with both top panels hinged to accommodate Radio Panel.



*Excel*

**Phonographs and Radio-Phonograph Combinations**



STYLE 17  
Genuine Mahogany or Walnut, Phonograph only.

These illustrations show several of the many late models of our line, which have been re-designed, right up to the minute, with especial reference to the Radio-Phonograph Combination, destined to be the standard household unit. Characterized by

**Beauty of Design, Finish and Tonal Quality**

These instruments are produced in all the popular finishes and styles, including Uprights, Consoles and Wall Cabinets, and our facilities enable us to make prompt deliveries and most attractive trade prices. *Catalog and price list mailed on request.*

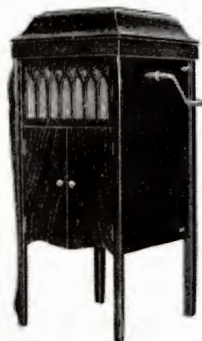

STYLE 1  
Gum Mahogany, Golden or Fumed Oak.

**Excel Phonograph Manufacturing Company**

402-414 West Erie St., Chicago, Illinois

STYLE 2  
Gum Mahogany, Golden or Fumed Oak.





A number  
of leading manufacturers and retailers  
who have heard the new  
Automatic  
**Oro-Phone**  
Reproducer

(Patented August 4th, 1925)  
Other Patents Pend.

in the demonstrating rooms of our factory declare it to be "a new revelation of tonal beauty, strength and clarity."

It will pay *you* to get in touch with us regarding this remarkable new invention.

- For phonograph manufacturers.
- For playing Edison Records on new Victor Orthophonic.
- For playing all records on old style Victor.
- For playing all records on the Edison.

---

Supremacy  
in  
Reproduction

---

**The Oro-Tone Co.**  
1000-1010 George St. Chicago, Ill.



## FROM OUR CHICAGO HEADQUARTERS—(Continued from page 130)

branch store in Winnetka, another North Shore suburb of Chicago, and both establishments handle Victrolas and Victor records, Zenith radio receiving sets, Radio Corporation of America products, Fanstiehl radio receivers, a line of pianos and musical merchandise. Mr. Davidson is particularly well known in Chicago where he has been associated with the retail division of the music trade for over twenty years, occupying the position of secretary and treasurer of Davidson's Talking Machine Shop for seventeen years.

## Stewart-Warner "Air Current Events"

In the month of December the Stewart-Warner Speedometer Corp., manufacturer of Stewart-Warner radio receiving apparatus, this city, augmented the number of Stewart-Warner dealer helps with the addition of a monthly dealer magazine. The publication, under the name "Stewart-Warner Air Current Events," is a twelve-page booklet printed in several blending colors, with a clever front cover illustration.

The complete line of Stewart-Warner matched unit radio apparatus is illustrated in the magazine and the reader also finds information on antenna installation, advance data of WBBM programs broadcast from the Stewart-Warner plant in Chicago, and a list of the principal broadcasting stations in America.

## Colin B. Kennedy Discusses the Radio Developments of the Past and the Outlook

President of the Colin B. Kennedy Corp., Radio Manufacturer, Makes an Interesting Analysis of the Favorable Factors in the Radio Field and Outlines Reasons for Optimism

Colin B. Kennedy, head of the Colin B. Kennedy Corp., St. Louis, Mo., in the following paragraphs analyzes in a most interesting manner radio developments of the year just closed and discusses the outlook:

"The year that has just been brought to a close witnessed no outstanding technical de-

velopment in the radio industry. Engineers in intimate touch with the situation did not expect that there would be any. It seems to me that the public has been greatly misinformed on this subject of technical development and responsibility for it is chargeable to those engaged in the industry. In the battle for commercial supremacy growing out of increased competition extravagant claims and counter claims have been and are being made. The general public, knowing little, and, perhaps, caring less about technical consideration, has been forced to the false conclusion that revolutionary changes are to be expected and that the radio equipment of to-day will be obsoleted by the newer developments of tomorrow. As a matter of fact, nothing like this has occurred or is likely to occur. From an engineering standpoint the radio art is not in that infantile stage of development we are constantly hearing so much about. The radio industry has developed in accordance with a surprisingly few basic principles that existed long before there was any commercial necessity for applying them. These principles are, by their very nature, not subject to change. There has been, of course, and will continue to be progressive mechanical improvements just as is the case with the automobile and other mechanical appliances. As a rule, these changes come so gradually that they are hard to mark.

"If the prospective radio purchaser is delaying his decision for fear of possible improvements, I am sure he is going to have to wait a long time. If one were to apply the same thought with respect to automobiles, for instance, the factories would have to close down. Progress demands changes and improvements, but for all practical purposes the article of yesterday is not greatly inferior to the one of to-day and certainly the benefits of possession in the meantime more than compensate for whatever difference may exist.

"I do not for a moment wish to suggest that present conditions of radio reception are satisfactory. I would, however, like to see the blame for this condition placed where it belongs. I do not believe that either the transmitting or receiving equipment is at fault. On the contrary, I think it speaks well for the efficiency of both that we are able to do as well as we are doing under existing difficulties. I feel it is just a case of too much of a good thing in the matter of broadcasting stations and that we have entirely too many of them for our best interests. I believe I am fairly representing the opinion of our best informed engineers when I say that it is impossible to design receiving equipment to satisfactorily meet present-day demands. On the other hand, if we were given a practical common-sense broadcasting situation, almost any well-designed and well-constructed radio receiver is capable of giving remarkably efficient performance and meeting every reasonable requirement.

"I do not think the public is sufficiently informed in the matter of the present difficult broadcasting situation, as it is a subject that has been touched very lightly in the past. If radio users were cognizant of the facts they would know just why radio reception is growing steadily worse instead of better and would not be so inclined to blame their receiving equipment

(Continued on page 134)

# Balkite

## Radio Power Units

*the ideal power supply for any radio set*



**Balkite**  
Battery Charger

This popular battery charger is entirely noiseless and can be used while the radio set is in operation. Charging rate 2.5 amperes. Operates from 110-120 AC 60 cycle current. Special model for 50 cycles. Also for 25-40 cycles with 1.5 ampere charging rate.

Price \$19.50  
West of Rockies, \$20  
In Canada, \$27.50



**Balkite**  
Trickle Charger

Can be connected to the usual 6-volt battery and left on permanent (or trickle) charge. Automatically charges the "A" battery and supplies "A" current from the light socket.

With small batteries (4-volt and small 6-volt) can be used as an intermittent charger of the usual type. Or it can be used as a trickle charger if a resistance is added.

Charging rate .4 to .5 amperes. Size 5 1/2 x 2 1/4 x 5 inches. Fits in usual dry cell compartment. Operates from 110-120 AC 60 cycle current. Special model for 50 cycles.

Price \$10  
West of Rockies, \$10.50  
In Canada, \$15

Balkite Radio Power Units are the ideal power supply for any radio set. They simplify and improve radio reception. They reduce the amount of attention required by the set. With their use the radio current supply is always exactly what is required for each circuit.

The advantages of the popular Balkite Battery Charger are obvious. Entirely noiseless, it can be used while the set is in operation. The Balkite Trickle Charger converts your "A" battery into a permanent "A" power unit that supplies full "A" current at all times from the light socket.

Balkite "B" eliminates "B" batteries entirely and supplies plate current from the light socket. Balkite "B" for sets of 6 tubes or less. Balkite "B" II for sets of 6 tubes or more.

### Noiseless—No bulbs—Permanent

All Balkite Radio Power Units are entirely noiseless in operation. They have no moving parts, no bulbs, and nothing to adjust, break or get out of order. Each is a permanent piece of equipment with nothing to replace. They require no other attention than the infrequent addition of water. They require no changes or additions to your set. All are fast-moving, trouble free and thoroughly advertised.

Manufactured by

FANSTEEL PRODUCTS COMPANY, Inc.  
North Chicago, Illinois

FANSTEEL  
**Balkite**  
Radio Power Units



**Balkite "B"**

Eliminates "B" batteries. Supplies plate current from the light socket. Operates with either storage battery or dry cell tubes. Keeps "B" circuit always operating at maximum efficiency. Requires no attention other than adding water twice a year.

Will serve any set requiring not more than 20 milliamperes at 90 volts—practically all sets of 5 tubes or less and most 6 tube sets. Occupies about same space as 45 volt dry "B" battery. Operates from 110-120 AC 60 cycle current. Special model for 50 cycles.

Price \$35  
In Canada, \$49.50



**Balkite "B" II**

Same as the new Balkite "B" but will fit any set including those of 8 tubes or more. Operates from 110-120 AC 60 cycle current. Special model for 50 cycles.

Price \$55  
In Canada, \$75

The Gould Unipower is equipped with a special Balkite Radio Power Unit

BALKITE BATTERY CHARGER · BALKITE TRICKLE CHARGER · BALKITE "B" · BALKITE "B" II

ALL BALKITE RADIO POWER UNITS ARE TESTED AND LISTED AS STANDARD BY THE UNDERWRITERS' LABORATORIES



# These Cabinets Will Sell Any Radio Set



Model 35  
Retail Price \$150

You can take any Radio Set in your store, put it in one of these Cabinets, and it will SELL.

Here are three winners without an artistic equal in the field. These models were created by designers, decorators and cabinet workers with lifetime experience here and abroad.

### DESCRIPTION

Materials: Genuine Walnut plywood; real wood inlays; built-in, all wood loud speaker. Finish: New high light, and hand-decorated. Sizes: These radio cabinets accommodate sets 32 inches long and 11 inches high or less.



Model 31  
Retail Price \$135



Model 29  
Retail Price \$120

*Full Particulars on Request*

## UNITED CABINET MANUFACTURERS CORP.

New York Office  
1674 Broadway  
Tel. Circle 9860

Main Office  
1421 S. Michigan Ave.  
Chicago, Ills.



**LEADER PRODUCTS**

FROM OUR CHICAGO HEADQUARTERS—(Continued from page 132)



**Loud Speakers and Units**

The height is 22 inches and the diameter of the bell is 13½ inches

List 18.00

Worth 25.00

**No Metallic or Vibration Distortion**  
The heavy cast aluminum Gooseneck eliminates all metallic and vibration distortion. Leader Speakers combine a wide range of volume with clarity and faithful reproduction of tone.

**Beauty in Design and Finish**  
The graceful lines and the beautiful finish of the Leader appeal to the most fastidious. The bell has a beautiful Mahogany or Walnut finish—the Gooseneck and base are in Wine-Gold—a really handsome Horn.

**A Good Speaker Must Have a Good Unit**  
Without a high-grade reliable Unit a good Speaker is no good. Our Speakers are all equipped with the famous Leader Unit. We not only make our own Horns—we make the Units—we therefore know they are right and we guarantee them.

**Baby Gooseneck Loud Speaker**

Just like the Leader Sr. illustrated and described above—the same graceful lines—the same style heavy cast aluminum gooseneck that rounds out the tone with no metallic or vibration distortion. The same beautiful finish. The only difference is the size—18 in. high, 12 in. Bell. The Baby Gooseneck Loud Speaker is priced lower than any quality Speaker on the market.

List 14.00

**Notice to Jobbers**  
We will send a sample Leader Loud Speaker by Express at our expense to any reliable jobber on approval. We have every confidence in our products. Write for our unusual jobbing discounts.

**The Leader Unit**  
An all around adjustable unit for any horn, console or phonograph. Laminated Core. A strictly high-grade unit—We make it.

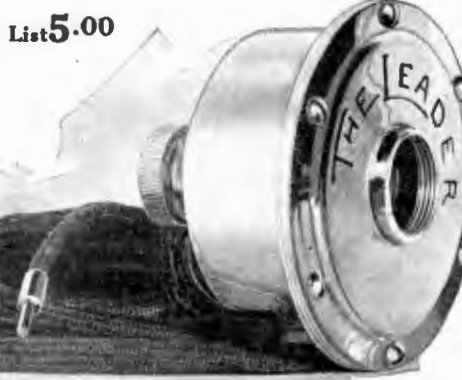

**Victor Radio Corporation**  
4315 No. Western Avenue, CHICAGO

for something that is not the fault of the equipment. The Department of Commerce, under whose jurisdiction radio falls, is fully alive to the situation and is doing its best to bring about a better condition. Its efforts are hampered, however, by the fact that there is little or no legislative authority upon which to act and it is generally understood and hoped that this deficiency will be corrected during the present session of Congress.

"The radio industry made gratifying progress towards commercial stability during the past year. The process has been and is being a somewhat painful one, and I doubt very much if the year has been entirely satisfactory from a profit standpoint to most of the manufacturers. The industry has proved very attractive to the "hit and run" class of manufacturer, jobber and dealer and the older and more legitimate members of the industry who have been inclined to build their businesses more slowly but on a sound foundation have suffered some from the activities of their "fly-by-night" competitors. This condition will adjust itself in time as the buying public becomes more discriminating and I have every confidence that radio will ultimately and shortly take its place as one of the large primary industries of the world. Certainly it is the most remarkable agency that the world has ever known in its capacity for human service."

**Chicago's Piano Row Was Menaced by Fire**

**Old Home of Story & Clark Piano Co. Destroyed by Flames and Adjoining Piano Houses Suffer Losses From Smoke and Water**

CHICAGO, ILL., January 6.—Fire broke out recently in the building at 317 South Wabash avenue, formerly occupied by the Story & Clark Piano Co., which moved out last May, the building itself being gutted by the flames. Immediately adjoining the burned structure are the quarters of six important piano companies and these for a time seemed to be in great danger, but firemen got the blaze under control before it spread to other structures.

The interior decorations in the Adam Schaaf Co. building were destroyed by smoke and water leakage, and the Wade Twitchell Co. suffered serious damage to stock in the basement and on the first, second and third floors of its building, all of which is covered by insurance. Harry Schaaf, of the Adam Schaaf Co., was unable to-day to estimate the damage done, but said that his company was fully protected. The Cable Piano Co., Moist Piano Co. and Julius Bauer & Co. all suffered damage to instruments stored in the basements of their buildings as a result of water leakage.

**Community Radio Programs Are Gaining in Favor**

**Other Cities Show Interest in the Idea Launched by Cincinnati Chamber of Commerce—Oklahoma Governor Seeks Funds for State Station**

CINCINNATI, O., January 6.—The value of community advertising through the medium of radio has made its appeal to three other cities since Cincinnati blazed the way with its series of twenty community radio concerts, the sixth of which was presented on January 4 through Station WSAI. Davenport, Ia., and St. Louis, Mo., have already announced definitely that they would take the air with community programs; San Antonio, Tex., is considering the matter seriously. And Governor M. E. Trapp, of Oklahoma, has set aside a day to be known as "The Voice of Oklahoma Day" in an effort to raise a \$100,000 fund to establish a radio station to advertise his State.

As the pioneer in community radio advertising, Cincinnati is receiving many inquiries from

other cities for information regarding its plan to broadcast twenty "super programs" in its "contribution to the happiness of the world." Edward J. Hoff, chairman of the community broadcasting committee of the Cincinnati Chamber of Commerce, has made the announcement that his committee will be glad to give other cities the benefit of Cincinnati's experience in carrying out this policy.

**New Home for Winter Co.**

PAINESVILLE, O., January 6.—The Winter Piano Co., of Erie, Pa., has leased a store in the McMillan Block on North State street, which will be utilized as a branch music house. Hunter Darling, who will act as local manager, states that the Winter concern plans to locate here permanently and that the quarters will be remodeled in the near future. A large line of instruments is handled.



**A Fortune for You! In This New Radio Set NO BIG INVESTMENT**

Here is the biggest opportunity ever put in your path. Millionaires have been made almost overnight in radio. Yet the NEW AMBU 5-TUBE Set is one of the greatest achievements in Radio today and offers a fortune to those who want to become partners in this great business. So selective is this set that it cut out KYW station, operating one block away, by turning half a point on dial.

**Two Amazing New, Exclusive Features**

The AMBU FIVE has two features not to be found in any other set. The sub-panel is inlaid with copper that has been shot into prepared grooves so that complete assembly of set is simply a matter of screwing parts into place. Connections are automatic and everlasting. 105 points of contact, yet only 4 soldered connections.

The AMBU all-wave coils, three sets of three coils each instantly interchangeable—enable the operator to bring in stations broadcasting on a wave length of from 40 to 550 meters. Ordinary sets do not go below 200 meters.

Hundreds of distributors, dealers in radio, battery shops, tire shops, garages, accessories and phonograph shops are cleaning up big with the AMBU FIVE. Our plan enables you to sell radio without a big investment. All you need is a demonstrator set. We carry the stock for you. You buy at Jobber's prices and sell at a handsome profit.

**Worth \$115, Sells for \$75.00 You Make \$32.00**

The AMBU FIVE, if sold thru Jobbers would retail for \$115 or more. You buy at Jobber's price and sell for \$75.00, make a handsome profit—\$32.00, and undercut all competition. The demand is so great you can make big money at once. Good Territory still open. Don't delay. You will profit by sending coupon.

**Mail Coupon For Plan**

Fill in and mail this free offer coupon at once. Get full details of this amazing NEW AMBU FIVE. If not selling radio now, here is a quick, easy way requiring no big investment by which you can clean up. If already in radio business, AMBU FIVE will double and treble your profits. Get this coupon in the mail today for free facts. No obligation.

**Ambu Engineering Institute**  
Radio Div. 11-A

2632 Prairie Avenue Chicago, Ill.

AMBU ENGINEERING INSTITUTE,  
Radio Div. 11-A, 2632 Prairie Avenue, Chicago, Ill.

Send me, free, complete information and prices and tell me how I can make big money in radio as representative without investment in stock. This does not obligate me.

Name .....  
Address .....  
City ..... State.....  
Business .....

Check here if interested in Radio Training.

**READ**  
Heard KDKA today on 58 meters. I am half a block from WGN and bring in out-of-town stations with the AMBU FIVE without interference.  
R. Peterson.

Ship 10 AMBU FIVES at once. The 2 I had were sold last night and I have many other customers who heard demonstrations and who want the set. AMBU FIVE is the greatest bargain in radio.  
J. McNamara.

**AMBU PLAN MAKES YOUR DEMONSTRATION SET FREE**



# Featuring the **MUSICAL** POSSIBILITIES of the **TALKING MACHINE**

[EDITOR'S NOTE.—This is the fifty-fifth of a series of articles by William Braid White devoted to the various interesting opportunities which prevail in the domain of education for the retailer of talking machines. The subject is one of great interest and we commend these articles to the consideration of all who are devoting attention to the featuring and developing of the musical possibilities of the talking machine.]

## A New Era in Recording

The new methods of recording, which have created so great a sensation throughout the talking machine industry will, of course, demand and obtain an immense amount of public attention and interest during the coming year, and it is well that all who have to do with exploiting the musical possibilities of the talking machine should be acquainted with the special points about which prospective record buyers are most likely to ask questions.

The original and well-tried recording system, of which some account was given in this department last month, as a preliminary to a short description of the microphone and selenium-cell methods which have supplanted it, was purely mechanical. That is to say, it depended upon the immediate impact of sound vibrations upon the recording stylus, which bites into the rotating disk of soft soapy material. Now, everybody who is acquainted with the phenomena of acoustics knows that, although in quality and complexity the energy produced by the playing of instruments or the singing of voices is astonishingly complete, in quantity it is extremely slight, so that only the most delicate apparatus suffices to measure it. In consequence of this limitation upon the mechanical ability of sound energy to perpetuate itself upon a rotating disk, the most elaborate precautions had always to be taken in order to assure that at least the greater part of the aggregate of musical sounds should be recorded. Even with all these precautions there were always gaps. As everyone is now learning, one of the defects was at the lower end of the scale. Another, not so often spoken of, was at the upper end. This does not mean that the very lowest and the very highest were not recorded at all. Records of solo instruments show, for instance, that the very lowest tones of the string contra-bass could be made distinctly audible by themselves and so, too, the highest harmonics of the violin. What is meant, rather, is that, when an aggregate of sounds was being recorded, as, for instance, the performance of a large orchestra, the middle registers obtained an emphasis which tended to throw the whole result out of balance. By long hearing we had become accustomed to this defect, and it took the new recordings to reopen our ears.

### The Sense of Space

Another difficulty was due to the fact that the performance of a large number of instruments depends a great deal for its effect upon the acoustics of space. The size of the room in which the playing takes place has far more than is commonly supposed to do with the ultimate artistic result as presented to the ear. The old recordings, no matter how carefully done, always showed a defect in respect of this matter of spaciousness. The orchestra had to be especially grouped, with the instruments in accustomed positions, simply to obtain anything like a balanced result in the recording; but the effect of the instrumentation was always thereby more or less disturbed. For instance, the string tone of an orchestra never came out well enough under the old system's limitations, because it was impossible, for one thing, to use the needed number of violins, violas, cellos and basses; while for another thing, it was impossible to bring the sounds of all of these into focus, as it

were, with the recording horns at the same time.

The new methods, as has already been explained, change all this. The orchestra may be disposed naturally, and the sounds picked up and relayed, to almost any required extent of amplification. Thus the first thing one notes about an orchestra record of the new type is this sense of "spaciousness" and of what, for want of a better term, may be called "atmosphere." One feels, in listening to an orchestral record as now recorded, as if one were actually sitting in the great hall, looking down, say from a position above the boxes, upon the orchestra, and taking in the sounds in that natural and familiar way. There is a sense of balance, a

sense of "space," a sense that the violins are there en masse, a sense that the whole range of orchestral sound is at one's command. This is what every ear which is in the least sensitive can easily hear; and this is what the salesman, if he be wise, will try to impress upon his customers.

### Slogans and Facts

One manufacturer is advertising "listen to the bass," and the simplification has its uses. It is the presence of that deep ground-swell which so wonderfully supports the performance of the grand orchestra that one first notices. But this should not blind us to the fact that the slogan is designedly simpler than the facts it is intended.

(Continued on page 136)

## USED ALL OVER THE WORLD

*There Is a Reason*

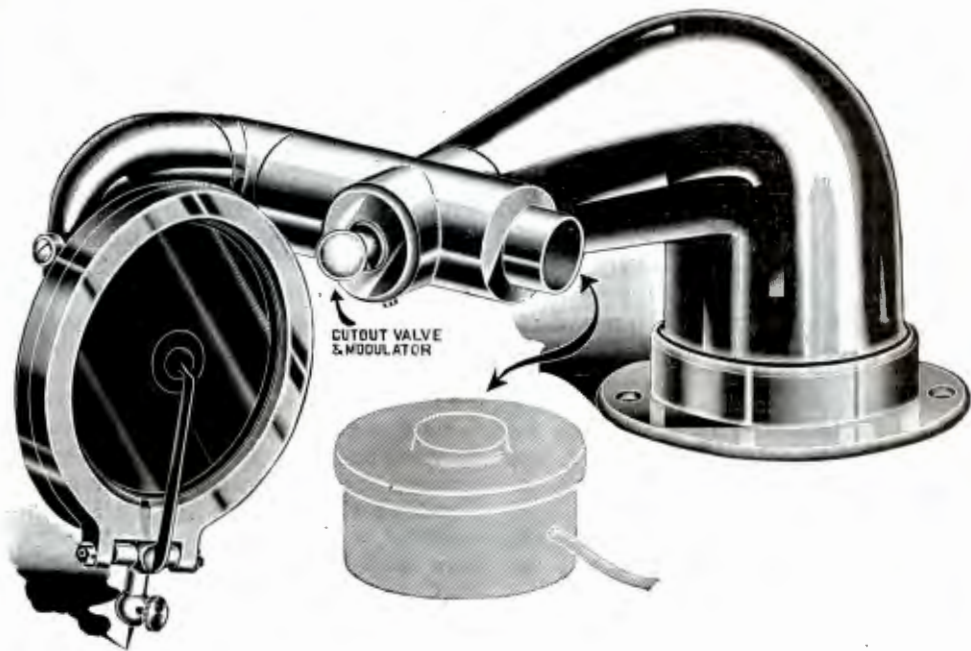

A Blood Tone Arm on your Phonograph assures you the best. The natural tone reproduction insures the sale of your cabinet.

*Dealers Demand Them*

## BLOOD TONE ARM CO.

BAY CITY, MICHIGAN

Sales Office for Chicago District

BLOOD TONE ARM CO., 222 W. Madison St., Chicago



### A New Era in Recording

(Continued from page 135)

to accentuate. In reality it is not only a question of listening to the bass, but to the whole scale. Another manufacturer indeed is pointing this out, and has adopted a scientific name meaning "all the scale." Yet it would not be amiss to point out that this again does not cover all the facts. We are not merely dealing with the extent of the scale. We have also now to consider the fact that the parts are much better balanced, that all the instruments have a chance to make themselves heard in due proportion, and that in fact we are getting a real "phonograph" or sound picture, something neither artificial nor compressed, but spacious, natural and approximately perfect.

It seems that the way to approach all orchestral recording is by the method I have been indicating; that is to say, by making the listener hear the "naturalness," the balance, spaciousness and the filling quality of the performance, as contrasted with a certain meagreness which even the best results of the old system inevitably displayed.

#### What About the Piano?

Solo records do not show so great a disparity for the violin, the cello, the flute, the clarinet and the wind instruments, generally recorded very well indeed when handled by themselves. The piano, however, always did present an almost insoluble problem, which one cannot pretend has been solved yet, although an approach has been more closely made and the future will undoubtedly bring complete perfection. The piano always has been the most difficult of instruments to record, because its tone is extremely evanescent and depends somewhat upon the nature and extent of the enclosed space which contains it. Moreover, the tone of the piano is made up of a mass of feeble and extremely tenuous partial components, which are picked up only in part. Their absence very largely accounts for the peculiar twanginess of the reproduced tone, while the difficulties of space account for the reverberations which make so much trouble in the sustained sounds. Nevertheless, the new piano recordings are much better, and this because they can deal with the piano from a natural and not an artificial standpoint. In showing a customer new piano recordings, the thing to point out is the great improvement in the quality of the tone and its approach to the true quality of the instrument, while emphasis may also be laid upon the fact that the performer may now utilize the pedals freely and feel assured besides that the lowest and the highest notes on the keyboard will alike be adequately recorded.

In choral work the improvement made by the new process is startling. Great bodies of singers are entirely dependent on adequate space for satisfactory placement of the mass of sound, and under old conditions the space question was irrepressible. The new choral numbers

are simply wonderful and ought to awaken enthusiasm among salesmen everywhere.

The solo voice, of course, is not so much affected, save in so far as the piano accompaniments come out much better and there is that saving sense of "atmosphere" which before was always to some extent lacking.

Wonders were worked in the old days by the old system, wonders which to those who knew the difficulties, seemed almost like wizardry. Under new conditions these wonders are already being surpassed. The musical possibilities of the talking machine are to-day limitless. Let us learn how to exploit them. Then success must be ours.

### Polacco and Chamlee Write in Praise of Panatrope

Musical Director of Chicago Civic Opera and Tenor of Metropolitan Opera Pay Tribute to the New Brunswick Panatrope

The Brunswick-Balke-Collender Co., Chicago, Ill., received recently two very interesting letters from Giorgio Polacco, musical director of the Chicago Civic Opera, and Mario Chamlee, popular tenor of the Metropolitan Opera Co., relative to the musical qualities of the Panatrope. Both of these artists are world famous and their enthusiasm regarding the Panatrope is reflected in the following letters:



Mario Chamlee

"The Panatrope has been a revelation to me. The precision and delicacy with which every tone of the artist recording has been preserved and translated again into sound is marvelous. All the tonal beauty of the original rendition is reproduced again for the hearer, without distortion whatever. I am spellbound by this wonderful achievement of science, which, through electrical principles, has at last made it possible for musicians to have their art faithfully recorded, and for music lovers to hear in their own houses their favorite artists, absolutely as perfectly as if they were in their presence. Congratulations to Brunswick on the achievement of the Panatrope, which is a true contribution to the development of musical taste and appreciation."

(Signed) **GIORGIO POLACCO.**

"I have heard the new Panatrope and I wish to express my appreciation of your marvelous achievement. I consider the Panatrope the

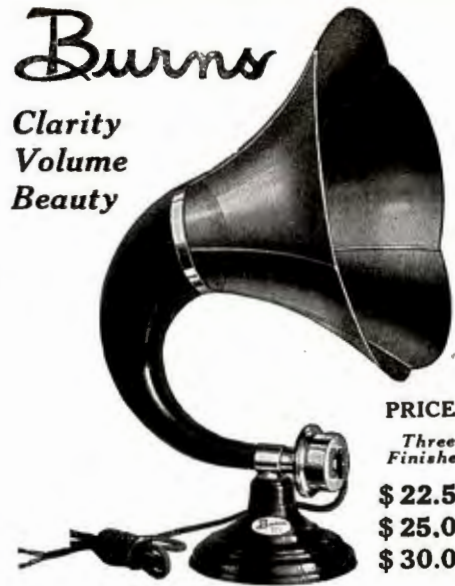

**Burns**  
Clarity  
Volume  
Beauty

PRICES  
Three  
Finishes  
\$ 22.50  
\$ 25.00  
\$ 30.00

#### FOR REAL ENJOYMENT

Use the BURNS Loud Speaker on your receiving set. Produces utmost in volume and clarity of tone. Reaches full range of musical scale—equal to hearing the original production.

At your dealers or direct

**American Electric Company**  
State and 64th Sts., Chicago, U. S. A.

finest sound-reproducing instrument in the world to-day, and its exquisite resonant musical tone was a revelation to me. Panatrope, the entire musical scale, deserves its name, for it truly emulates the beauty and fullness of each and every tone. With my sincere wishes for Panatrope's continued success." (Signed)

MARIO CHAMLEE.

### Brousek's Band of Chicago Exclusive Okeh Artists

W. A. Timm, manager of the foreign language record division of the General Phonograph Corp., New York, closed arrangements recently whereby Brousek's Band, of Chicago, would record exclusively for the Okeh library. This band is not only popular in Chicago, but is a prime favorite with Bohemians throughout the country. The band will specialize on the recording of selections in the Bohemian language best adapted for merchandising in the leading cities, and it is expected that the Okeh records by this band will meet with a very satisfactory sale among Bohemian music lovers throughout the country.

The Nomis Musical Supplies Corp., New York, has been incorporated at Albany, with a capital stock of \$25,000. The incorporators are M. and M. M. Simon and F. Michton.

## Add \$100 to its price, then compare it with others

ONE profit and one selling expense, due to enormous manufacture and the fact that 95% of Erla elements are made by us, make possible a retail price on this beautiful Erla Console \$75 to \$100 less than that of sets of comparable beauty. This console contains the



new-type receiver based on the famous Erla Balloon Circloid coils—greater distance, amazing selectivity, more volume, purer tone. A set fully in keeping with the high standards of the music and talking machine trade. Write for details of the Erla franchise.

The Erla Circloid Five DeLuxe Console, in quartered and matched French walnut. Loud speaker built in. Without accessories, only \$142.50. Standard Console of similar design in two-tone walnut, \$113.50. On Pacific Coast, \$150 and \$119 respectively.

Erla cabinet model in rich two-tone walnut finish, \$69.50. In quartered French walnut, \$77.50. Pacific Coast prices, \$73 and \$82, respectively.



Erla Circloid Five DeLuxe Console

ELECTRIC RESEARCH LABORATORIES, Inc., 2500 Cottage Grove Ave., Chicago, Ill.



### Illinois Music Supply Co. "Good Luck" Parts Jobber

Well-known Chicago Distributor Is Appointed Representative of Superior Phono Parts Co., One of Largest Jobbers in Country

CHICAGO, ILL., January 7.—The Illinois Music Supply Co. was recently appointed distributor of "Good Luck" talking machine repair parts, manufactured by the Superior Phono Parts Co., 799 Broadway, New York City, and Newark, N. J.

The Illinois Music Supply Co. is one of the largest distributing houses in the country. It issues a monthly catalog and price list and includes products of every description, making it a point to be in a position to serve the dealer in practically everything in music.

M. M. Cole, president of the Illinois Music Supply Co., created this distributing organization about five years ago in a small way. Since that time each year it has added greatly to its activities, and is now classed as one of the largest distributors of musical merchandise in the United States.

### Cleveland Phonograph Co. Developing Spring Plans

CLEVELAND, O., January 7.—The Cleveland Phonograph Co., 5300 Harvard avenue, this city, has been quite busy during the new year, developing its plans for the Spring season. Paul Haines, head of the firm, and Art Pressler, of the sales staff, are putting some special emphasis on the "Good Luck" products, manufactured by the Superior Phono Parts Co., of New York City and Newark, N. J. Mr. Pressler is making short trade trips throughout northern Ohio, where he is well known to talking machine merchants. The company prides itself on giving service to dealers in its territory on all repair parts, including main springs, motors, tone arms and smaller items.

### Represents Targ & Dinner Co. on the Pacific Coast

CHICAGO, ILL., January 6.—Max Targ, head of the Targ & Dinner Music Co., of this city, manufacturers' representative, wholesaler and jobber, has announced the appointment of Seth Story as Pacific Coast representative for the company. Mr. Story is a prominent broker who is well known in merchandising circles on the Coast and it is expected that he will develop an active demand for the Targ & Dinner products. The company has recently received many inquiries regarding its line from well-known dealers in the Far West and Mr. Story's appointment will enable these dealers to receive maximum service and co-operation.

### Tie-Up With Artist

St. LOUIS, Mo., January 9.—Cliff Edwards (Ukulele Ike), playing a local theatre of this city, recently tied up his appearance effectively with Pathé dealers. Ukulele Ike is a popular artist upon Pathé records produced by the Pathé Phonograph & Radio Corp. A local ukulele contest put on by the manager of Loew's State Theatre endeavored to find the best ukulele player in St. Louis. In his leisure time Ukulele Ike, himself, visited a number of the dealers and sang a selection of his well-known songs. The result was the sky-rocketing of Pathé record sales and a generally favorable effect on ukulele business as well.

### Buys Bellinger Store

WATERTOWN, N. Y., January 5.—J. M. Schaffer, of Gloversville, has recently purchased the music store of Frederick S. Bellinger, in the Paddock Arcade, this city, and will operate the business in the future.

### United Cabinet Mfrs. Corp. Displays Line

Display at the Furniture Market Contains Two New Model Cabinets, Consoles in Two-tone Walnut—I. A. Lund in Charge

CHICAGO, ILL., January 8.—The United Cabinet Mfrs. Corp., this city, maker of radio cabinets, is displaying its line at the Furniture Market, which is attracting dealers from all over the United States to the mammoth exposition building on Lake Shore drive. Among the cabinets on display are No. 35, an Italian art model, of butt walnut, with a highly decorative inlaid centerpiece on the front panel, and Nos. 29 and 31, period models. Two new popular priced cabinets, shown for the first time, are Nos. 649 and 659, both two-tone walnut consoles. The former will accommodate sets measuring up to nine by twenty-one inches, No. 659 provides for the installation of a panel as large as nine by twenty-nine and one-half inches, and both cabinets are

so constructed as to care for practically all sizes of panels made by radio set manufacturers.

All of the models on exhibition contain a built-in speaker at the top, and a battery and charger compartment in the lower part of the cabinet. I. A. Lund, one of the executives of the United Cabinet Mfrs. Corp., is in charge of the exhibit, which will be maintained throughout the market, which ends on January 23.

### Bill to Protect Trade-Marks

WASHINGTON, D. C., January 6.—A bill designed to protect trade-marks in commerce and to authorize their registration has been introduced in the House of Representatives by Congressman Vestal, of Indiana. This bill was considered in public hearings at a joint meeting of the Senate and House Committees on Patents last January, but failed of passage before the adjournment of the last session of Congress.

The chap who is on the job every minute will enjoy a prosperous 1926.

# OPERADIO

The Original Self-Contained Radio Set

Beauty and Performance  
plus Operadio's  
Unique Convenience



Radio of the very finest quality—simpler, more reliable and powerful than ever before. Radio of mellow, full-throated tone from a cabinet of exquisite beauty and dignity.

Add to this the important factor of convenience—the use of the set wherever wanted—indoors or out. What other radio set today offers such advantages—such sales features?

For with the Operadio the instrument itself may be removed from the cabinet and carried like a suitcase.

No wires or connections—no outside batteries or separate loudspeaker—a 6-tube, self-contained set, which may be taken anywhere or housed in this beautiful cabinet.

Write or wire for Operadio dealer proposition.



The Operadio Corporation  
Dept. V—8 So. Dearborn St., Chicago, Illinois



## Latest Summary of Exports and Imports of "Talkers"

Figures on Exports and Imports of Talking Machines and Records for the Eleven Months Ending November Make Interesting Reading

WASHINGTON, D. C., January 8.—In the summary of exports and imports of the commerce of the United States for the month of November, 1925 (the latest period for which it has been compiled), the following are the figures bearing on talking machines and records:

The dutiable imports of talking machines and parts during November, 1925, amounted in value to \$40,058, as compared with \$42,717 worth which were imported during the same period of 1924. The eleven months' total ending November, 1925, showed importations valued at \$353,485; in same period of 1924, \$386,844.

Talking machines to the number of 8,078, valued at \$207,703, were exported in November, 1925, as compared with 5,431 talking machines valued at \$204,160, sent abroad in the same period of 1924. The eleven months' total showed that we exported 73,101 talking machines, valued at \$2,061,773, as against 67,943 talking machines, valued at \$2,553,232, in 1924.

The total exports of records and supplies for November, 1925, were valued at \$160,095, as compared with \$134,593 in November, 1924. The eleven months ending November, 1925, show records and accessories exported valued at \$1,555,379, as compared with \$1,647,106 in 1924.

The countries to which these instruments were sent during November and their values were as follows: United Kingdom, \$1,070; other Europe, \$19,044; Canada, \$20,334; Central America, \$9,853; Mexico, \$9,832; Cuba, \$10,589; Argentina, \$17,125; Chile, \$14,941; Colombia, \$22,256; Peru, \$4,506; other South America, \$12,431; China, \$1,516; Japan, \$1,502; Philippine Islands, \$5,171; Australia, \$35,761; New Zealand, \$8,946; other countries, \$12,826.

## Proper Direction Needed for Best Business Results

James J. Holland, Sales Manager of Glen Bros.-Roberts Piano Co., Offers Interesting Views on Obligations of Trade Executives

SALT LAKE CITY, UTAH, January 6.—James J. Holland, sales manager of the Glen Bros.-Roberts Piano Co., this city, who has succeeded in building up a very effective sales organization, is firmly of the belief that success in capitalizing opportunities in the retail music field during 1926 will rest largely upon the efforts and ability of the executives to co-operate with members of their organization with a view to maintaining proper interest. In this connection Mr. Holland says:

"There is no question but that we in the music business feel that with the opening of 1926 we are starting on an era of prosperity, partly due to the revival of the phonograph business on account of the new products of the Victor and Brunswick companies and also the way the piano industries are trying, more than ever, to offer the dealers helps and to co-operate in every way with their retailers. So, with all these changes taking place all around us, we can feel ourselves becoming very optimistic, and in our own minds are planning big things ahead.

"There is one thing, however, that all executives should always remember in view of the good things ahead, and that is that the great problem of business is working with people, co-operating in such a way that you have a fighting, loyal organization, all with the same purpose uppermost in their minds, i. e., to get, during 1926, one definite result—good, clean volume.

"All of us have our hobbies, and there are bound to be two or three departments that get slighted and do not receive the attention and co-operation of the higher-ups and, consequently, those departments show no profit. The personnel of those departments is low, and natur-

ally so. The co-operation has first got to come from above, and a real show of interest and a real plan for suggestions will mean the ringing of the bell in that department's cash register every time.

"Take your salesmen, your salesladies, your phonograph department, your piano department, start the ball a-rolling, spread enthusiasm, get suggestions from them, see if you cannot aid the player-roll girl in getting and holding the interest of her customers. Check up on your advertising, wipe off the 'cobwebs' and make your advertising 'snappy.' In other words, my friend, co-operate yourself."

## Interesting Numbers on Late Perfect Records

The Perfect Record Co., Brooklyn, N. Y., has recently produced a number of popular recordings that will undoubtedly provide good record turnovers.

The Deauville Dozen has just recorded two popular numbers. Phil Baker, leading man in "Artists & Models," made his first recording at the Perfect Laboratories recently, entitled "The Big Butter and Egg Man," and "Ann In Her Little Sedan." The Ponce Sisters, Ethel and Dorothea, have recently recorded for the Perfect Record Co. two of their favorite numbers, "That Certain Party" and "There's Nothing On My Mind."

The Radio Franks (Wright and Bessinger) recently recorded "I Wanna Go Where You Go" and "I'm Sitting On Top of the World."

## Radio Exports Increase

The world-wide interest in radio was illustrated in the Department of Commerce figures, showing radio goods worth \$8,936,565 were exported during the first eleven months of 1925, as compared with \$4,950,746 during the same period of 1924.



List Price \$125

## Dealers and Jobbers

write for particulars regarding the

# PHONOGRAND

*The Selling Sensation of the Season*

Here is the opportunity for Quick Sales and Profits. Why waste effort in trying to sell obsolete types of machines when the Phonogrand sells at sight.

The striking design of the Phonogrand has met with wonderful success, its pleasing appearance attracts the eye of the purchaser and at the same time permits the construction of a newly designed tone chamber which produces a tone of great volume and clarity.

## Fuehr & Stemmer Piano Co.

1932-34 Wentworth Ave.

Chicago, Illinois

MUSICAL INSTRUMENT MAKERS FOR 25 YEARS



### Interesting Survey of Talking Machine Trade

Magazine of Wall Street Publishes Comprehensive Article Relative to Developments Made Recently in Industry

An unusually interesting and withal authoritative survey of the existing situation in the talking machine trade as it applies to three of the leading companies, the Brunswick, Columbia and Victor, and in part to the Radio Corp. of America in its affiliations with two of those companies, was presented in the Magazine of Wall Street on January 2, it being emphasized that the talking machine and radio industries were seeking to work together rather than at odds with each other.

The article outlined in considerable detail the various developments that have taken place for the production of new types of records and reproducing instruments, and how the big factors in the radio field had contributed to these new developments. A survey was also made of the financial status of the various companies, particularly as to their tangible assets in relation to outstanding short issued, which indicated that in every case their position was sound.

The article was of a most optimistic tenor, and was designed to give the impression that the immediate future of the talking machine business, both by itself and in its relation to radio, was distinctly bright.

### Ware Radio Corp. Receiver Makes Interesting Statement

Plans for a reorganization of the Ware Radio Corp., of New York City, are being prepared by Stark B. Ferriss, of 165 Broadway, New York, who was appointed temporary receiver and later confirmed as permanent receiver by the bank-

ruptcy court. In a chat with a representative of The World, Mr. Ferriss stated that he would continue the business and was arranging for the sale of the stock of radio sets on hand. New sets are also being manufactured, 200 having been completed under his direction. These will be sold at the best possible terms, together with 2,500 sets which were returned to the Ware Co. by the Music Master Corp.

Mr. Ferriss stated that, in his opinion, the receivership would continue for at least six months and that Paul Ware will be associated with him in the operation of the company in the capacity of consulting engineer.

### Thermiodyne Officers Tender Resignations

M. O. Giles, sales manager of the Thermiodyne Radio Corp., New York, resigned from the organization January 10; his resignation following closely on the withdrawal of Leo Potter, president of the company. Both of these executives are well known in the radio industry, and for many years Mr. Giles was an executive with prominent companies in the talking machine trade. Within a short while Mr. Potter and Mr. Giles will announce their future activities.

### Appointed Export Sales Manager of Perryman Co.

Philip K. Murdock, with headquarters in New York and well known in export circles, has been appointed foreign sales manager of the Perryman Electric Co., manufacturer of Perryman tubes. Mr. Murdock is thoroughly familiar with all details incidental to export sales and the wide interest manifested in Perryman tubes will undoubtedly result in the appointment of export representatives in the leading trade centers throughout the world. The company's plans in this respect are comprehensive.

### Spring Series of Edison Tone Tests Is Launched

Average Audience of 600 Attends Comparison Concerts After Ten Years of Exploitation—Regarded as Annual Feature

Following a very successful Fall season the group of Edison artists conducting tone tests in various sections of the country have started out on their Spring tours. It is significant that although the tone test idea was launched some ten years ago, largely as a temporary novelty, it met with such instant success that it has been carried on year after year as a permanent feature and with the public interest apparently unabated.

According to reports received from field representatives, the tone test audiences during the Fall season averaged 600 persons, and in many localities the comparison concerts are eagerly awaited each year as a definite feature of the local musical season. As a matter of fact, on several occasions Thos. A. Edison, Inc., has received protests from music lovers in certain districts because the tone test program schedule had passed by that particular section.

The retailers have co-operated, and are co-operating, earnestly with the tone test programs, realizing direct sales results from the concerts which have proved most satisfactory.

### Stages Dealer Convention

Fada radio dealers from Missouri, Kansas, Arkansas, Oklahoma, New Mexico and Colorado attended the convention held recently in Kansas City by the Harbison Mfg. Co., Fada distributors. The advantage enjoyed by holders of the Fada radio dealer franchise and the functions performed by the Harbison Co. were outlined by H. B. Harbison, who engaged the large banquet hall of the Coates House for the rally.



\$27.50

Just Hear a  
**QUAM RADIOVOX**  
with the Silver Drumhead  
Diaphragm

DEALERS and JOBBERS.

Let us send you a QUAM RADIOVOX on approval.

MANUFACTURERS — Write us for our special proposition on QUAM RADIOVOX UNITS. Remember your set is no better than its loudspeaker and these units will improve your sets 100%.



\$12.00

**Quam Radio Corporation**

1925 So. Western Ave.

Chicago, Ill.



# Thank



Kolster Eight. Single control. Internal loop. Provisions for external loop or antenna. Built-in reproducer.



Kolster Eight. Single control. Enclosed, rotating loop. Also provision for antenna. Built-in reproducer.



Kolster Six. Dual control for antenna. Built-in reproducer.



Kolster Six, dual control, loud speaker enclosed, space for batteries.



Kolster Six. Dual control for antenna. External reproducer.

*Another Kolster advertisement*



# You, Gentlemen

**I**N the few months since it was announced, Kolster Radio is now being enjoyed in homes everywhere.

We owe much to our dealers and distributors—for their generous welcome—for their splendid cooperation.

Our business principles are sound—our success is based upon the success of our dealers and distributors. We are pleased with their favorable reception.

Kolster Radio is already a known and respected instrument with the public. To them has been addressed a splendid advertising campaign, designed to create sales for Kolster dealers.

Kolster production is well under way and shipments are constantly increasing.

Kolster Radio is a permanent factor in the industry. The value of the Kolster franchise to dealers and distributors will increase with the passing of time.

While representation is widespread, there are communities where the Kolster franchise is still open. We invite interested dealers to communicate with us.

Signed



Alpeeto  
General Manager

## KOLSTER RADIO

*appearing in trade papers*



## J. A. Fischer Co. Announces Important Personnel Changes

Executive Changes Made in the Interest of a Smooth-Running Organization to Take Care of 1926 Demands

PHILADELPHIA, PA., January 9.—J. A. Fischer, president of the J. A. Fischer Co., of this city, maker of Valley Forge main springs and talking machine repair material, has announced at the beginning of the new year several changes in the personnel of the organization.

Mr. Fischer himself has taken personal charge of the service department of the company. As is well known throughout the talking machine industry Mr. Fischer knows the talking machine parts business from A to Z and is intimately familiar with the servicing of these parts, and his personal attention to the service department is destined to insure the acme of parts service to the talking machine dealer.

Irvin R. Epstan, also a member of the firm, has become sales manager and will henceforth personally direct the sales department.

Victor H. Segal has become associated with the company in the capacity of credit counselor and office manager. Mr. Segal is an accountant who has had a wide range of experience in the problems affecting the music industry.

The mechanical staff has been augmented by the engagement of George Williams and Martin H. Krupnick. Mr. Krupnick has been associated with the company in other capacities since its foundation, and Mr. Fischer states that his conscientious work of the past has been instrumental in the growth of the company.

Mr. Fischer when interviewed at the first of the year pointed out that the prosperous conditions in the talking machine industry are being reflected in the steadily increasing business of the company and that the year 1926 has already given indications that it will be a banner year for talking machine business throughout the country.

## Incorporate to Stabilize Radio Show Situation

Radio Exhibition Corp. Chartered in New York — Prominent Figures in Radio Field Comprise the Directorate

The radio industry, as a whole, will be keenly interested in the recent incorporation of the Radio Exhibition Corp. which has received a charter under the laws of the State of New York and which was formed for the purpose of stabilizing the radio show situation to the best interests of the entire industry. The officers of the new association are as follows: chairman of the board, Geo. A. Scoville, vice-president of the Stromberg-Carlson Telephone Mfg. Co.; president, E. B. Mallory, Westinghouse Electric Mfg. Co.; treasurer, R. M. Klein, general manager F. A. D. Andrea, Inc.; secretary, L. W. Staunton, Brandes Products Corp. The board of directors is now being elected and will be announced in the very near future, with the probability that a representative of the Victor Talking Machine Co. or the Brunswick-Balke-Collender Co., or both, will be included on the directorate.

## Wolf Mfg. Industries Close Remarkable Business Year

QUINCY, ILL., January 7.—The Wolf Manufacturing Industries, of this city, closed a remarkably successful year in 1925, and a recent statement by F. A. Wolf, treasurer of the company, indicated that 1926 had started in equally as well. During the twelve months ending December 31, 1925, the Wolf Mfg. Industries shipped 74,527 Mastercraft phonographs and radio cabinets, an amazing volume that emphasizes the magnitude of the company's activities.

In a recent chat with The World, Mr. Wolf stated that the company was still working night and day shifts and that it would be another thirty days before it would be in a position to catch up with orders. Prospects for the coming year are excellent and Mastercraft dealers have advised the company that their sales for 1925 were far beyond all expectations.

## Sales Campaign on "Good Luck" Parts by Burks Co.

LOUISVILLE, KY., January 7.—P. I. Burks Co., of this city, of which Paul Burks is the head, is running a special campaign on "Good Luck" talking machine products, including main springs and repair parts. Recently Mr. Burks stated that the demand for repair materials of all kinds, seemingly indicated that the interest in talking machines now in the homes is being re-aroused, and this is also noted through additional record sales in this territory.

## Columbia Record Releases

The record releases of the Columbia Phonograph Co., New York, scheduled for the thirtieth of this month, include several numbers which are certain of having a wide appeal. Records of the dance variety include "I Wish't I Was in Peoria," coupled with "Pretty Little Baby," played by Ted Lewis and His Orchestra, and "Squeeze Me," and "New Orleans Shuffle," played by the Half Way House Orchestra of New Orleans, which first Columbia recording made such a pronounced hit. The Happiness Boys, Ernest Hare and Billie Jones, contribute a novelty number which is of a high order in "I Wish't I Was in Peoria" and "Hot Coffee"; Ed Smalle of the Singing Sophomores is represented by "Pretty Little Baby" and "Papa De Da Da," two solos of the crooning type, and Ethel Waters, the colored vaudeville headliner, "puts all she's got" in "Shake That Thing" and "No Man's Mama Now."

# This New Filament Voltmeter

is the Final Touch in  
the Successful Merchandising of  
**Radiolas 25 and 28**

*This new filament meter especially designed for Radiola 25 and 28 — saves tubes and insures better reception.*

No Radiola 25-28 is complete without the new Sterling Filament Voltmeter that plugs right into the set to control filament voltage. No R. C. A. dealer can afford to be without it.

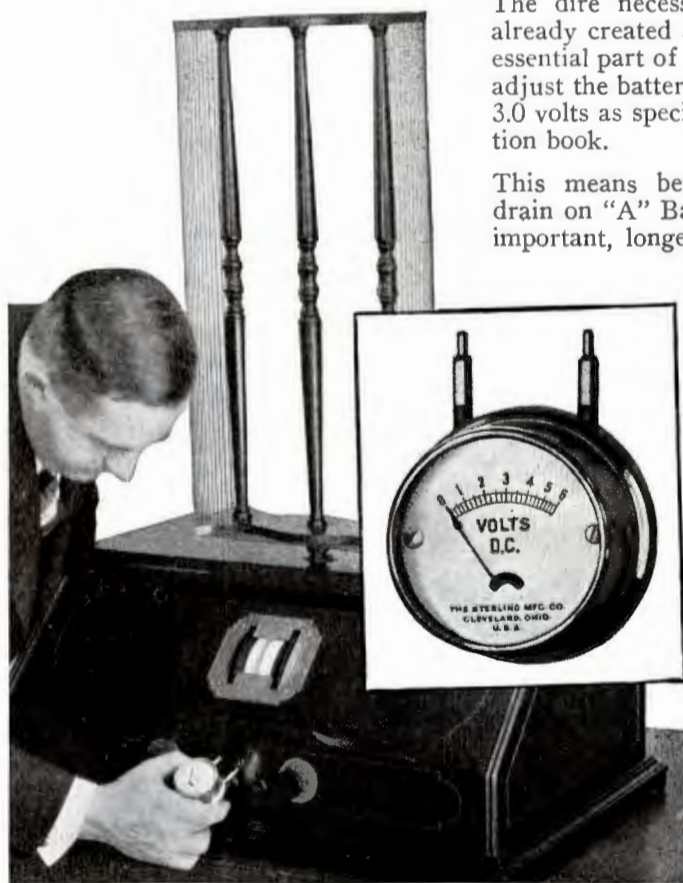

The dire necessity of this device has already created a huge demand. It is an essential part of the set. With it one can adjust the battery setting knob to exactly 3.0 volts as specified in the radio instruction book.

This means better reception and less drain on "A" Battery, and what is more important, longer life to tubes.

The Sterling R25-28 is a high resistance meter, has no cord or leads to fuss with, and is always ready, compact and accurate.

It saves tube life — it gives complete satisfaction to both dealer and customer—it is sold in a handsome maroon case with gold stamped lettering, enhancing its value immensely. All nickel finish, silver etched dial. Ready now!

List Price

**\$7.50**

**The Sterling  
Manufacturing  
Company**

Dept. S

Cleveland, O.

# Sterling

**FILAMENT VOLTMETER**

**R25-28**



# TELETONE CABINET SPEAKER



Ready to Listen, Beautifully finished in Walnut, it stands 15 ins. high and is only 3 1/4 ins. deep.

## Makes Any Radio Receiver Sound Better

TELETONE represents an entirely new principle in sound wave conduction and amplification. Its clear, full-toned resonance, the result of exclusive design and all wood construction, transforms *any* receiving set into an instrument of quality.

Interior of seasoned spruce—the same wood used in the finest violins. Exterior of walnut—beautifully finished and artistic in the extreme.

Compact in form. Handsome in appearance. Amazing in performance. Reproduces clearly every note, either vocal or instrumental, with purity of tone, satisfying volume and freedom from distortion.

### Dealers

Communicate at once with the Teletone distributor located nearest to you and order a sample Teletone. You will reorder many times—and get quick turnover together with good profit.

### Jobbers

Some territory still open. Write today. Attractive discounts. Protection. Free newspaper advertising. Write for sample and jobber's discount. Packed in individual Corrugated Containers. Net Weight—5 lbs. Shipping weight—6 lbs.

### TELETONE Principle

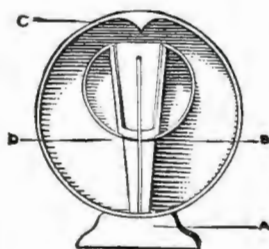

Based on Structure of Throat and Mouth

Note that a sound-wave coming from the sound producing unit "A" (the human vocal chords) is amplified through the orifice "B" (the human larynx) until it reaches the conducting area "C" (the back of the throat), whence it is again conducted to the point of greatest amplification "D" (the correctly formed and opened mouth of the singer.)



## TELETONE DISTRIBUTORS

### BANGOR, ME.

Rice and Miller

### BOSTON, MASS.

Atlantic Radio Co.  
Bigelow and Dowse  
Hub Cycle Auto Supply Co.  
Lewis Electric Supply Co.  
Pettingell-Andrews Co.  
Geo. H. Wahn Co.

### BUFFALO, N. Y.

Iroquois Sales Co.

### CHICAGO, ILL.

New England Mills Co.  
Hudson Ross

### CLEVELAND, OHIO

Cleveland Products Co.  
Cleveland Phonograph Co.

### DETROIT, MICH.

Bice and Archibald

### INDIANAPOLIS, IND.

Pearson Piano Co.

### LOUISVILLE, KY.

Tafel Electric Supply Co.

### MILWAUKEE, WIS.

E. A. Quarfoot  
Tisch Auto Supply Co.

### MINNEAPOLIS, MINN.

R. M. Laird Electric Co.

### NEW HAVEN, CONN.

Hessel and Hoppen

### NEW YORK, N. Y.

Silas E. Pearsall Company  
Royal Eastern Electrical Supply Co.  
Pyramid Motor Equipment Co.  
R. H. McMann

### NEWARK, N. J.

Tri-City Electric Supply Co.

### PHILADELPHIA, PA.

Cheney Sales Corp.

### PORTLAND, ME.

The James Bailey Co.

### RICHMOND, VA.

Tower-Binford Electric & Mfg. Co.

### SAN FRANCISCO, CAL.

Baldwin-Pacific & Co.

### ST. PAUL, MINN.

St. Paul Electric Co.

### ST. LOUIS, MO.

Walsh & Hill

### SYRACUSE, N. Y.

Syracuse Auto Supply Co.

### TOLEDO, OHIO

Toledo Radio Co.

### WASHINGTON, D. C.

H. C. Roberts Electric Supply Co.

# TELETONE CORPORATION

449 W. 42nd Street

New York City



### Mutual Phono Parts Co. to Move During February

Demand for Products So Strong That Larger Facilities Are Necessary—New Home Four Times Larger Than Present Headquarters

The Mutual Phono Parts Co., New York City, manufacturer of Mutual tone arms and sound boxes and phonograph radio loud speaking units, has found the demand for its entire line so strong that on February 1 it will occupy new quarters with about four times the facilities of the present plant. This company has been situated at 149-151 Lafayette street for many years and this location, which at one time was entirely ample, has been for a long period past insufficient for the increased business of the company.

The new location will be at 610-614 Broadway between Bleecker and Houston streets. There will be housed the general offices including the private office of N. Garfinkel and A. P. Frangipane, and also the manufacturing facilities of the plant.

Mr. Frangipane points out that the new quarters will insure exceptionally prompt service. Upon taking possession it is planned to inaugurate a twenty-four-hour service on parts. All orders will be shipped twenty-four hours after they are received.

Mr. Frangipane also announces that several new types of tone arms and reproducers are being produced. This new line has been prepared to meet the demand of all classes of phonograph equipment from the lowest priced talking machine to the highest.

### Kolster Radio Executives Report Excellent Business

SAN FRANCISCO, CAL., January 6.—On their return from the East, this week, Rudolph Spreckels and Ellery Stone, heads of the Federal Telegraph Co., manufacturer of Kolster radio sets, appeared to be very optimistic regarding the outlook for their radio activities. Mr. Stone, who is president of the company, said that the merchandising program is going ahead very satisfactorily. There is big demand, both here and in the East, for the Kolster radio receiving set, manufactured by the Federal, and the corporation is considerably behind in its orders, necessitating capacity production.

### Berg Portable Talking Machine Line Increased

Berg Auto Trunk & Specialty Co. Has Developed Plans to Distribute Artone Portable Through Centrally Located Jobbers

The Berg Auto Trunk & Specialty Co., Thompson avenue and Manly street, Long Island City, N. Y., has added considerably to its sales organization for the new year. Under the new plans now being developed by the company its line of quality and popular priced portable talking machines marketed under the name Artone will be distributed by centrally located jobbing organizations throughout the country. The sales personnel will intensively cover most territory but at all times will work in conjunction with the Artone distributors in the various sections.

The Berg Co.'s Artone line includes a De Luxe model retailing at \$30. This is a square-cornered attractive case with hand-tooled embossed fabrikoid leather. A similar model of the same quality throughout with round corners is made to retail at \$25. The Berg line also includes two models in circular cases made along the lines of a ladies' hat box. In fact, one of these models is made in a manner so that the mechanical equipment can be extracted from the box and used for the other purpose. It makes an attractive outfit, light in weight and easily carried.

All of the Berg products are manufactured under the personal direction of Joseph Berg, who has specialized in case designs and manufacture for over twenty years. Several of the features of the Artone line are the original conceptions of Mr. Berg. He has selected only the high quality of additional equipment including the silent single-spring motors, Baxter tone arms, and U. S. plywood veneers.

E. R. Manning, the general sales manager for the Berg Auto Trunk & Specialty Co., has planned an extensive sales campaign for the Artone distributors and dealers. He will shortly announce the names of sales representatives to cover various sections of the country and the complete arrangements for Artone distribution throughout the 1926 season.

Among the late announcements of the Berg Auto Trunk & Specialty Co. is the addition of a new popular priced model to its line of instruments. The present plans call for a product to retail at \$15, carrying exclusive features.

### Radio Cabinets and Tables

Odd Sizes to Order  
BASE BOARDS  
IN STOCK AND TO ORDER  
Phila. Radio Cabinet Makers  
And Wood Specialists  
28 North 5th Street PHILADELPHIA, PA.

### Clever Zenith Ads of Lee S. Roberts, Inc., Admired

Originally Conceived and Attractively Presented in the Pacific Coast Newspapers

SAN FRANCISCO, CAL., January 5.—One of the most successful and interesting campaigns that has been sponsored by a retail dealer in San Francisco for several years has been appearing

[\$100 to \$2000...on easy payments]



**Short on Claims**      **Long on Proof**

Fishing yarns have given way to radio yarns... for sheer and joyful exaggeration. That's part of the fun. But, when a man buys a radio on all-embracing claims of superiority... that's where the fun stops. Make any radio prove its case... including Zenith. Zenith is short on claims... but long on proof.

Zenith makes no claims except by comparison. Side by side in your home, with any other radio set in the world... Zenith guarantees to get more distance... to bring in more stations... with a finer quality of tone than any other. Don't buy a radio in a store... buy it in your home.



### A Striking Zenith Ad

in the local newspapers over the signature of Lee S. Roberts, Inc. (Chickering Warerooms), 230 Post street. This advertising has featured Zenith radio products and not only has produced direct results far beyond all expectations but has been an important factor in the tremendous success of Lee S. Roberts, Inc., in retail circles.

The Zenith advertising appearing in the newspapers carries the copyright signature of M. E. Harlan, an advertising expert in this city who has collaborated with Lee S. Roberts Inc., in the preparation of the Zenith campaign. One of the advertisements used in the series is reproduced herewith and this copy will give some idea of the originality and effectiveness of the various announcements used in the campaign.

### Miss Alberta Hunter to Record for Okeh Library

The General Phonograph Corp., New York, announced this week that Alberta Hunter will record exclusively for the Okeh library in the future. Miss Hunter is one of the most popular race artists in the country, and in addition to her success as a record artist has appeared on the Keith circuit throughout the country.

The first record by Miss Hunter in the Okeh library, Number 8268, was released recently and is already in active demand by Okeh dealers everywhere. According to the plans of the Okeh advertising department, Miss Hunter will be one of the feature artists in the extensive advertising campaign sponsored by the company in behalf of race artists. During January a full page will appear in the Chicago "Defender," the leading newspaper in the country devoted to the interests of the negro race, and this page will announce Miss Hunter's first two recordings. Okeh dealers are planning to tie up with this advertising effectively and the success of the campaign is already assured.



**RECORDS**

## A word to the wise

It's one thing to sell a man a record once, but, to make him feel that this one was so fine that he must get more—that's a horse of a different garage.

Many dealers find that their customers keep coming back after they have been sold a good record and some

# Okeh and Truetone Needles

Products of the  
**GENERAL PHONOGRAPH CORPORATION**  
25 West 45th Street      OTTO HEINEMAN, President      New York City





SENIOR model  
Red Mahogany, Brown Mahogany, OAK.

## Mr. Dealer

The list price of Outings is their true value (not inflated value). The discount given dealers permits them to make money.

You make quick turnover because of the popularity given Outings through the great many thousands in homes today.

and

## PLUS

All Outings Juniors and Seniors are now equipped with a special tone-arm for playing Edison records (no extra cost).

## OUTING TALKING MACHINE CO., Inc.

MT. KISCO, N. Y.

Export Department

No. 44 Whitehall Street, New York City, N. Y., U. S. A.

Cable Address "OUTING" New York

Canadian Distributors:

R. S. WILLIAMS & SONS CO., LTD., Toronto, Winnipeg, Montreal.

*'One handle handles it'*  
**Outing**  
*'Master of Movable Music'*

Outings are sold in the U. S. A. through distributors only. To our distributors it means protection and co-operation. To dealers it means uniformity of price and more profit.

## THE BABY OUTING

THE BABY FILLS  
THE FAMILY—

Ask Your Jobber.

JUNIOR model

Red Mahogany, Brown Mahogany and Oak Finishes  
Brown, Black and Green Leatherettes





## Paul Ash and Orchestra to Record for Columbia Co.

Announcement That Popular Organization  
Would Record Exclusively for Columbia  
Library Made by J. S. MacDonald

J. S. MacDonald, director of the recording studios of the Columbia Phonograph Co., Inc., New York, announced this week that arrangements had been completed whereby Paul Ash and His Orchestra would record exclusively for



Paul Ash

the Columbia library. This important deal was closed a few weeks ago when Paul Ash was in New York and Columbia dealers who have learned of this latest addition to the Columbia staff of recording artists are keenly enthusiastic regarding the acquisition of this famous director to the Columbia library.

Paul Ash needs no introduction to music lovers throughout the country, for his success as an orchestra director has been nation-wide. He first attracted notice about seven years ago when he was directing the orchestra at the T & D Theatre, Oakland, Cal., where for two years Paul Ash and His Orchestra were a sensation. Subsequently Mr. Ash was appointed musical director at the Grenada Theatre, San Francisco, where he established himself definitely as one of the foremost orchestra directors in the country. The success attained by this theatre attracted the attention of the music and motion picture fraternities the country over,

and the greater measure of the theatre's prestige was attributed to Mr. Ash's individuality and musical capabilities.

After completing four years at the Grenada Theatre, Mr. Ash was appointed orchestra director of McVickers Theatre, Chicago, Ill., owned and controlled by Balaban & Katz-Famous Players, where he immediately became a national figure through the tremendous success of the presentations which he has sponsored. Mr. Ash developed an original and distinctive method of presenting his orchestra which not only has brought capacity audiences to McVickers Theatre but was the subject of newspaper and magazine comment everywhere. Arrangements were recently made whereby Paul Ash and His Orchestra will move on March 1 from McVickers Theatre to the Egyptian Theatre in Chicago, another Balaban & Katz-Famous Players house with a far larger seating capacity and considered one of the finest motion picture houses in the country.

According to the present plans of the Columbia Phonograph Co., Inc., Paul Ash and His Orchestra will be one of the features of the company's advertising and sales campaigns during 1926. The vast following which Paul Ash has developed among music lovers everywhere will undoubtedly be increased materially with the introduction of his Columbia records, and Columbia dealers are planning a tremendous publicity campaign as soon as the Paul Ash records are ready.

## H. Kruse Appointed Brunswick Dealer Service Mgr.

CHICAGO, ILL., January 11.—Harry Kruse, who has been connected for some years past with the Cincinnati, O., branch of the Brunswick-Balke-Collender Co., has been promoted to the management of the dealer service department, with headquarters at the executive offices of the company in this city.

This promotion was earned by Mr. Kruse through his conscientious and effective work among the dealers in the Cincinnati territory. He traveled for the past year as special representative assisting dealers in the promotion of their record business. A part of his work in Chicago will be the development of additional dealer helps and to further promote the long list of co-operative items which the Brunswick Co. offers its dealers.

## Carryola Co. Presents Its Jobbers With Useful Gift

The Carryola Co. of America, Milwaukee, Wis., manufacturer of Carryola portables, presented to its jobbers at Christmastime a very handsome and practical book to be used as a desk pad. The book is bound in artistic green Fabrikoid, bearing the imprint "Lest We Forget" and on the cover is printed in gold letters the recipient's name. The only advertising in the entire book is a gold and blue reproduction of the famous Carryola Master trade-mark, on the inside cover, and the book itself contains several thousand perforated sheets which can be used to splendid advantage the year round on the desk of a busy executive. Don T. Allen, vice-president of the Carryola Co., was responsible for the preparation of this handsome Christmas reminder and he has received enthusiastic letters of thanks from Carryola jobbers throughout the country.

## P. L. Deutsch Sails for Europe on Business Trip

P. L. Deutsch, vice-president of the Brunswick Co., Chicago, Ill., sailed Saturday, January 9, on the S. S. "Leviathan," accompanied by Mrs. Deutsch and their daughter. Mr. Deutsch is going abroad for the purpose of establishing factories and an organization in Great Britain for manufacturing the Panatrope and he will also visit France to commence negotiations for accomplishing the same purpose there. In all probability he will be away several months and his trip abroad will undoubtedly add materially to the international prestige of the Panatrope.

## Columbia New Year's Party

The general staff of the headquarters of the Columbia Phonograph Co., New York, gathered on Saturday afternoon, January 9, in a New Year's Party which was in every sense of the word an immense success. Tribute must be paid to Raymond Barker, assistant cashier, Harry Brown, office manager, and Frank Walker, of the recording staff, the committee in charge of the festivities who handled the details so admirably. In addition to the staff greatly enjoying themselves, many of the Columbia and Harmony artists were entertained and they in turn entertained the assembled members of the staff of the Columbia organization. Refreshments were served and dancing to the strains of the music by one of the leading Columbia recording organizations was indulged in.

*The Wonderful Line of*

# New and Improved FRESHMAN MASTERPIECE

*5 Tube Tuned Radio Frequency Receivers*

Sold direct to selected dealers—one dealer only in towns of less than 25,000 people—specified localities in larger cities.

**NO MORE CUT-THROAT COMPETITION  
NO MORE LOSSES ON INSTALLMENT SALES**

<p><i>Eight distinctive models from \$39.50 to \$115</i></p>	<p><b>Chas. Freshman Co., Inc.</b> Freshman Building New York City 2626 W. Washington Blvd., Chicago</p>	<p><i>Write to either office for complete information</i></p>
--	--	---



# WANTED MANUFACTURERS AGENTS

To Handle Fast Moving Line of  
**25 and 35 Cent Records**

including latest song and dance hits

PROMPT SERVICE AND GOOD PROFITS ASSURED

Address Box 1551, Care Talking Machine World  
383 Madison Avenue, New York, N. Y.

## Bright Outlook for Radio in Music Trade in 1926

R. M. Klein, General Manager of Prominent  
Radio Concern, Comments Upon Success of  
Music Merchants in the Radio Field

R. M. Klein, general manager of F. A. D. Andrea, Inc., well-known manufacturer of radio receivers, is one of those who concede the substantial position established by music merchants in the field of radio retailing. In a recent interview Mr. Klein said, relative to the radio outlook for 1926:

"The outlook for radio business for the coming year is good, if by that we mean taking the industry as a whole. Nineteen-twenty-six will reward those dealers, jobbers and manufacturers that have walked the straight and narrow path of proper merchandising. The market will be larger and more receptive than ever and it will be more than ever a question of 'business for those that deserve it.'

"The bringing of period art furniture into the industry may be regarded as a far step forward and this will be reflected in 1926 sales.

"While many writers wrote hesitatingly of the extent to which the music trade would enter the radio business, there need be no further doubt about it—the radio and musical instruments of other kinds are going to march right along together. Both from the jobber and dealer angle will 1926 see a widening of interest in the music trades in radio. But it should be remembered that in radio, at least, because of the service element and other considerations, the type, or classification of dealer is largely a matter of his business sense and no classification has a real monopoly of outlets at this time. This is good for the music dealers, for competition in other trades put one right on tip-toe more than intra-trade competition. Nineteen-twenty-six will see demonstration and service outstanding requirements from the dealer angle."

## Important Suit Filed

The United States Government is plaintiff in a patent interference suit which opened this week in the Federal District Court at Wilmington, Del. The Government interest is derived from the transfer to the Navy Department by the Alien Property Custodian of the German patent of Alexander Meisner relating to radio audion tubes embodying the "oscillating principle."

Other claimants named as defendants are Lee DeForest, the DeForest Radio Tel. & Tel. Co., the American Tel. & Tel. Co., the Westinghouse Electric & Mfg. Co., Edwin H. Armstrong, General Electric Co. and Irving Langmuir.

## Big Demand for Power Sets

The Argus Radio Corp., New York City, manufacturer of the Power radio receiving set, has entered the New Year with a demand exceeding the supply. Manufacturer and wholesaler alike are stripped of all console models. In order to take care of the demands for this set, which takes its A-C or D-C current from

the house socket, many dealers are specializing on the smaller table models. Ira Greene, president of the company, reports that New England has proved a particularly fertile sales field for the Power set. A. C. Erisman and the Lewis Electrical Supply Co. are wiring for rush shipments almost daily in units of ten or more.

In view of the great popularity of his set and the bright prospects for the coming year, Mr. Greene is making plans for greatly increased production.

## E. M. Smith Appointed Mgr.

E. M. Smith has been appointed manager of the sub-branch of the Columbia Phonograph Co., at Syracuse, N. Y., which, as reported elsewhere, is to be opened on February 1 and will be operated under the direction of the New York wholesale headquarters of which E. W. Guttenberger is manager. Mr. Smith has been connected with the sales staff of the Columbia Phonograph Co., for the past four years covering the up-State territory. With the opening of the Syracuse offices, the Rochester territory has been included in the section covered by this sub-branch.

## Big December Sales for the Charles Freshman Co.

The Chas. Freshman Co., New York, manufacturer of the Freshman Masterpiece receiving sets, report that gross sales for the month of December totaled \$1,793,924.95, the largest volume ever enjoyed in a single month. These sales were made in December despite the fact that dealers anticipated their holiday needs and purchased heavily in November.

## Braydon & Chapman Open New and Enlarged Store

Prominent Dealers in Glens Falls, N. Y., Remodel Building and Now Have Greatly Enlarged Facilities

GLENS FALLS, N. Y., January 7.—An event of real interest in local musical circles was the formal opening of the remodeled and enlarged music store of Braydon & Chapman, held last week, which was attended by several hundred people, who inspected the new quarters and listened to special concerts given in honor of the occasion by George Beaton and His Country Club Orchestra and by several local artists. A number of trade representatives also attended the opening ceremonies, among them B. H. Janssen and A. A. Kidder, of the Janssen Piano Co., New York; A. A. Perry, of the W. D. Andrews Co., Syracuse; C. Lemonoff, of the J. P. Seeburg Piano Co., Chicago, and representatives of the Victor Talking Machine Co. and Edison Phonograph Co.

The improvements include the addition of another story to the main building, the erection of a forty-foot addition in the rear, and a new front which is in keeping with the beauty of the interior has been installed. The first floor is of tile and is one of the largest tile floors in this section. The interior finish is of natural oak and a beautiful textone finish has been placed on the walls, which adds much to the attractiveness of the store. At the rear are several sound-proof booths, in which phonograph records and player rolls may be demonstrated.

A mezzanine floor is devoted to the display of phonographs and to offices.

The next floor is used for the main piano display.

The top floor is devoted to several uses. At the front of the building are two studios for artists who wish to have studios downtown. They open onto a porch which commands a view to the east, north and south. Another large room is used for the display of used pianos. At the rear are rooms for varnishing and for the repair of pianos, phonographs and radio.

## Airo Master in Trouble

A petition in bankruptcy was recently filed on January 11 against the Airo Master Corp., New York, manufacturer of radio equipment.



## "B" POWER SUPPLY UNIT

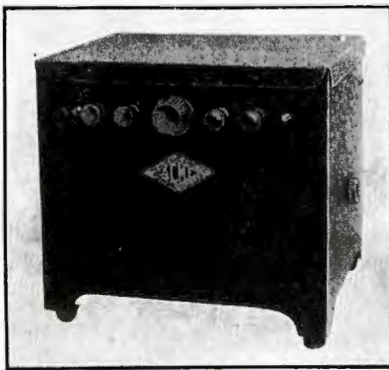

The sensation of the year. No more troublesome "B" batteries to fuss with. The Dealer with vision has long expected an efficient successor to radio batteries.

## NOW IS YOUR OPPORTUNITY TO CASH IN

Guaranteed to Serve

Liberal Discounts With a Rapid Turnover

Write for details

**\$28.50** Complete with Bulb  
East of Rockies

Manufacturers of the ACME radio battery charger.

**THE ACME ELECTRIC & MFG. CO.**

1451 Hamilton Avenue

CLEVELAND, OHIO



## Plaza Music Co. Announces New Sales Plan That Will Be National in Scope

Manufacturer of Portable Phonographs Plans to Feature These Products in a Simultaneous Publicity Campaign and Sales Drive—Distributors to Be Appointed in "Key" Cities

The Plaza Music Co., 10 West Twentieth street, New York City, manufacturer of the Pal and Regal portables and the Kompact camera-size talking machine, recently announced an entirely new sales plan, through which these products of its talking machine department will be distributed on a national scale.

The Plaza Co. has just completed a series of new improvements to its Pal de luxe portable, adding further to the quality of this instrument, without a change in prices. In addition, the Pal is now being offered in various colors of fabricoid leather. Under the sales plans arranged, these products will all be included in a simultaneous publicity campaign and sales drive.

Of unusual importance to both distributors and retailers in the talking machine industry is

the announcement of the Plaza Music Co. that in the future distributors of these products will be appointed in the key cities of the country under a new franchise arrangement.

In speaking of this new departure for national distribution, L. J. Weil, manager of advertising and portable sales promotion for the Plaza Music Co., said: "Since the first creation of the Pal portable and later, with the addition of the Regal and Kompact talking machines to our products, the demands have always been so large as to make impossible the consideration of local or territorial distributors. Our problem has always been to keep production up to a standard that would fill the demands in our sales books.

"With the improvement in our machines,

there have been added new production plans, based upon the installation of much new manufacturing equipment. This will immediately allow a considerable addition to our factory force, and the equipment itself, which is of most modern character, will add greatly to the efficiency of the factory and economy in man and machine power. With this enlarged production, it is now possible, for the first time, to extend the Plaza Music Co.'s distributing activities on these portable products. The quantities of the Pal, Regal and Kompact portables now in production will enable our sales department to arrange nation-wide distribution making possible service and co-operation and frequent deliveries through our distributors."

## International Radio Week Tests Start January 24

American, British and Continental Broadcasting Stations Participating in Tests—Stations Arranging Special Features

On Sunday night, January 24, the first of the series of features arranged for International Radio Week, January 24-31, will take place, when Station 5 XX, Daventry, England, will broadcast in the first test from eleven o'clock to midnight, at which time practically all American broadcasting stations will be silent. This station and seven other British stations will transmit Sunday, Tuesday and one other night at this hour and Continental stations will transmit at the same hour on Monday, January 25; Wednesday, January 27, and Thursday, January 28. The stations participating in these tests are located in Belgium, France, Spain, Norway, Italy, Germany, Czecho-Slovakia, Austria, Switzerland, Russia and Denmark.

Starting on Sunday night, January 24, at ten o'clock, Eastern standard time, American broadcasting stations participating in the tests will broadcast for an hour, during which period foreign radio fans will "listen-in." Special programs are being arranged by a number of stations and special events will be put on by the broadcasters. Canadian, Mexican and Cuban stations are included with those stations in the United States participating during this hour.

A special series of tests for North and South America will be conducted Friday and Saturday, January 29 and 30. On Friday broadcasting stations in the regions observing the various "times" will broadcast simultaneously, e.g., from 11 p.m. to 11:15 Eastern standard time stations will broadcast; 11:15 to 11:30 Central time stations; 11:30 to 11:45 Mountain time stations, and 11:45 to 12 m. Pacific time stations. On Saturday the allocations will be made geographically. From 11 p.m. to 11:15 Canadian stations will operate; 11:15 to 11:30, stations in the Northern part of the United States, and from 11:30 to 11:45, stations in the Southern part of the United States.

## Samuel Eshborn Announces New Sound Box to Trade

Samuel Eshborn, 65 Fifth avenue, New York City, well-known distributor of motors, tone arms and repair parts for talking machines, has announced a new sound box made purposely to fit the old style talking machines. This sound box is said to add to the clearness and volume of electrical recordings when played on obsolete models. The product is being sold to the trade at a very popular price in both nickel plate and gold dressing.

## Hoover Endorses Radio Bill

The White bill to provide for control of the radio industry, which was recently introduced, has been endorsed by Secretary Herbert Hoover and other members of the Department of Commerce.

## Non-Seasonal Always Salable Radio Products

# Sterling

"Right Resistance"

## POCKET METERS

Sterling Pocket Meters as a radio necessity, have always been in demand—used for electrical testing purposes long before the advent of radio. The Sterling line of meters is the most complete line, best known popular priced devices of their kind on the market. Made with exactly the right resistance to give truthful readings and to protect the battery against excessive drain when being tested.

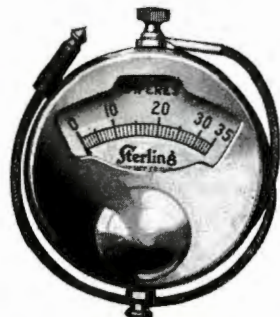

No. 24 Ammeter

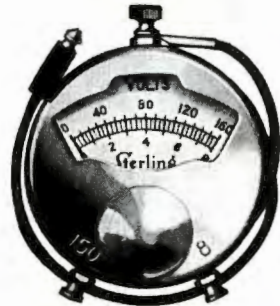

No. 39 Voltmeter

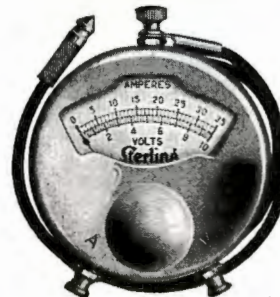

No. 44 Voltammeter

### Sterling Ammeters

For making a test on individual dry cells of the No. 6 size, the Sterling No. 24 Ammeter has been accepted standard for eighteen years. This Ammeter enables the user to determine in a moment the exact strength of the cell he is buying, and to judge when it should be discarded from the circuit. 0-35 ampere scale, 1 ampere division. *List Price—\$1.00*

### Sterling Voltmeters

No. 37—For "B" Storage Batteries—a new meter designed especially for measuring voltage of 24-cell (48-volt) storage batteries when in use or on charge. Also tests up to 3 units of 22½-volt dry batteries connected in series. 0-75 volt 2½v. div. *List Price—\$2.50*

No. 39—Another new Sterling Combination Pocket Meter to measure the maximum "B" Battery voltages now used on receivers. Two spurs and the double scale are provided. 0-160 scale tests up to 48 cells (96 volts) of "B" Storage Battery whether in use or on charge, or as many as 7 units of 22½ "B" dries. The 0-8 scale is for either dry or storage "A" testing. *List Price—\$4.00*

### Sterling Voltammeter

No. 44—Recommended for testing amperage of dry cell "A" Batteries and voltage measurement of both dry cell and storage "A" batteries. 0-35 amp. scale, 1 amp. divisions. 0-10 volt scale, 1/5 volt divisions. *List Price—\$1.50*

No. 45—For testing the amperage of dry cell "A" Batteries and for voltage measurement of "B" Batteries, dry cell and storage. 0-35 amp. scale, 1 amp. divisions. 0-50 volt scale, 1 volt divisions. *List Price—\$3.50*

## The Sterling Mfg. Company

Cleveland, Ohio





(Patented)

CABLE ADDRESS: SAMESHBORN  
5th EDITION A B C CODE

ESTABLISHED 1916

# TRIUMPH

*"As Good As the Name"*

Trade Mark

Creates a SENSATION whenever heard. Plays the new electrically-recorded records with remarkable brilliancy and gives new life to the old-time talking machine.

Send TO-DAY for a sample of this Phonograph Speaker and it will increase your record sales; many of the 8,000,000 owners of talking machines will buy it.

Price \$2.75 each — Nickel Plated

## SAMUEL ESHBORN

*Talking Machine Supplies and Repair Parts*

65 Fifth Ave., New York City

### Daven Radio Corp. Sales Managers Hold Convention

District Managers and Officials of the Company Hold Series of Meetings—Take Motion Pictures of the Sales Staff

The Daven Radio Corp., manufacturer of resistors and other parts for radio products, recently held a district sales managers meeting in its Newark headquarters, 158-60 Summit street, Newark, N. J. During the week's convention W. H. Fresse, president of the Daven Radio Corp., took motion pictures of the sales staff. Among those present were W. H. Fresse, president; W. D. A. Peaslee, assistant to the president; K. R. Moses, sales manager; F. D. Rankins, Boston manager; Fred Garner, Kansas City manager; R. B. Whitley, Cleveland manager; F. E. Wartman, Chicago manager; R. W. Miller, New York City manager; R. N. Brown, manufacturer's sales manager, and G. V. Rockey, advertising manager.

### Victor Announces Special Release of Old-time Tunes

The Victor Talking Machine Co. recently announced the special release of four records by the Henry Ford Old Time Dance Orchestra. Mr. Ford has been making strenuous efforts to revive interest in old-time dances and this orchestra, composed of a tuba, violin, dulcimer and cymbalon, is one of the means which he has adopted toward the end desired. The orchestra is broadcasting over a network of stations connected with WEAJ during the week of January 11-16 and dealers are urged to tie up.

### "Troubador" Five-Tube Set Announced by Sleeper Corp.

A new five tube set, known as the "Troubador," has been announced by the Sleeper Radio Corp., of Long Island City, as an addition to its line of well-known "Scout" and "Serenader" receivers. It is a lower priced set than the latter, retailing for \$65, without accessories. The new "Troubador" is equipped with a simple two-dial control, and is housed in an attractive mahogany cabinet. The "Troubador" is claimed by the Sleeper Radio Corp. to have qualities of selectivity, volume and clarity.

The Weed Music Shop, Poughkeepsie, N. Y., was recently incorporated at Albany with a capital stock of \$5,000. The incorporators are C. G. Hoffman, A. E. Kilkenny and M. Robbins.

### A. J. Engel and M. Levy Join Plaza Sales Staff

Two new members have joined the traveling sales force of the Plaza Music Co., New York. A. J. Engel will cover the Indiana, Ohio and Michigan territory, placing particular emphasis on sales of Pal and Regal portables. Mr. Engel is well known to the trade in that territory. He was formerly associated with the Rudolph Wurlitzer Co., Cincinnati, O., and also traveled for a well-known portable manufacturer.

M. Levy, who was a member of the former

Emerson Phonograph Co. sales staff in the record department, will cover Brooklyn and the metropolitan area for the Plaza Music Co. He will spend most of his time in developing sales in Banner and Domino records.

### Useful Holiday Gift

The Wall-Kane Needle Mfg. Co., Inc., Brooklyn, N. Y., has presented its many friends in the trade with a desk calendar and memo pad. It is expected that this useful remembrance will be cherished by Wall-Kane dealers and distributors throughout the country.

## The Peter Pan Gramophone

*Convenient to Carry—Delightful to hear!*

THE Peter Pan is a light and compact yet truly substantial instrument, which may be conveniently carried anywhere.

It faithfully and clearly reproduces all standard makes of records and is smooth and melodious in operation, far surpassing the average portable instrument in tonal values.

Hundreds of representative dealers, situated throughout the United States, find the Peter Pan a highly profitable instrument to stock.



Write today for complete dealer information and descriptive literature.

MARYSVILLE PRODUCTS COMPANY  
Marysville, Michigan

List Prices  
\$25 LEATHERS  
\$20 IMITATIONS

\* Patented in Foreign Countries  
U. S. Patents Pending



### Many Holiday Good Wishes for Talking Machine World

Greetings Received From All Parts of the Country and From All Branches of the Trade, Manufacturing, Wholesale and Retail

The Talking Machine World acknowledges with thanks and reciprocates the Christmas and New Year's Greetings received from its many friends in the trade, among whom were Henry C. Cox, president, Columbia Phonograph Co., Inc., New York, N. Y.; Eugene F. McDonald, Jr., president, Zenith Radio Corp., Chicago, Ill.; Otto Heineman, president, General Phonograph Corp., New York, N. Y.; Howard J. Shartle, Cleveland Talking Machine Co., Cleveland, O.; Colin B. Kennedy Corp., St. Louis, Mo.; Gulbransen Co., Chicago, Ill.; Pfanstiehl Radio Co., Chicago, Ill.; Buescher Band Instrument Co., Elkhart, Ind.; French Battery Co., Madison, Wis.; Caswell Mfg. Co., Milwaukee, Wis.; Chicago Talking Machine Co., Chicago, Ill.; United States Music Co., Chicago, Ill.; G. F. Ruez, S. W. Goldsmith and H. A. Goldsmith, Badger Talking Machine Co., Milwaukee, Wis.; Philadelphia Victor Distributors, Inc., Philadelphia, Pa.; Arthur W. Rhinow, Federal Telegraph Co., New York, N. Y.; Curtis N. Andrews, Buffalo, N. Y.; Wholesale Radio Equipment Co., New York, N. Y., Newark, N. J. and Buffalo, N. Y.; Triangle Radio Supply Co., Inc., New York, N. Y.; Van Veen & Co., New York, N. Y.; E. A. Kopf, J. W. Greene Co., Toledo, O.; Grinnell Bros. Music House, Detroit, Mich.; Russell E. Hunting, Music Master Corp., Pittsburgh, Pa.; H. Bobker, Supertron Mfg. Co., Hoboken, N. J.; James P. Duffy, Columbia Phonograph Co., Inc., New York, N. Y.; James J. Davin, American Piano Co., New York, N. Y.; Kenneth E. Reed, Pathex, Inc., Boston, Mass.; H. H. Roemer, Zenith Radio Corp., Chicago, Ill.; Henry C. Forster, Utah Radio Products Co., Chicago, Ill.; Walbert Mfg. Co., Chicago, Ill.; H. Emerson Yorke, Brunswick-Balke-Collender Co., Chicago, Ill.; Harry G. Neu, Plaza Music Co., New York, N. Y.; Gross-Brennan, Inc., New York, N. Y.; F. W. Schnirring, Sonora Phonograph Co., Inc., New York, N. Y.; R. E. Thompson Mfg. Co., New York, N. Y.; Carl Knittel, Wolf Mfg. Industries, Quincy, Ill.; Soy Kee & Co., New York, N. Y.; Elmer A. Fearn, Consolidated Talking Machine Co., Chicago, Ill.; E. W. Guttenberger, Columbia Phonograph Co., Inc., New York, N. Y.; E. F. Droop & Sons Co., Wash-

ington, D. C.; Milo E. Westbrooke, National Radio Exposition, Chicago, Ill.; A. B. Cornell, Plainfield, N. J.; Leon Golder, Magnavox Co., Chicago, Ill.; W. D. Montgomery, Fletcher-Wickes Co., Chicago, Ill.; Ralph S. Peer, General Phonograph Corp., New York, N. Y.; A. G. Farquharson, Southern California Music Trades Association, Los Angeles, Cal.; Proctor Brevard, Wave Radio Corp., Detroit, Mich.; Alfred J. Kendrick, Brunswick-Balke-Collender Co., Chicago, Ill.; E. G. Evans, C. Bruno & Son, Inc., New York, N. Y.; Raymond H. Woodford, Stewart-Warner Speedometer Corp., Chicago, Ill.; B. R. Stauffer, Pooley & Co., Philadelphia, Pa.; Ralph H. Meade, Redfield Advertising Agency, New York, N. Y.; Frank F. Paul, United Mfg. & Distributing Co., Chicago, Ill.; B. R. Hassler, Colin B. Kennedy Corp., St. Louis, Mo.; Don H. Leopold, Brunswick-Balke-Collender Co., Chicago, Ill.; Arno Reincke, Reincke-Ellis Co., Chicago, Ill.; Max Targ, Targ & Dinner Music Co., Chicago, Ill.; Walter L. Eckhardt, president, Music Master Corp., Philadelphia, Pa.; J. B. Price, Neufeldt & Kuhnke, New York, N. Y.; Geo. A. Lyons, Brunswick-Balke-Collender Co., New York, N. Y.; H. B. Foster, Perryman Electric Co., New York, N. Y.; W. C. Hutchings, Brunswick-Balke-Collender Co., Chicago, Ill.; Ray Riley, Sonora Phonograph Co., Inc., Chicago, Ill.; Lambert Friedl, Adler Mfg. Co., New York, N. Y.; H. B. Sixsmith, Mickel Bros. Co., Des Moines, Ia.; Joseph C. Roush, Standard Talking Machine Co., Pittsburgh, Pa.; Jack Kapp, Chicago, Ill.; Nat E. Golden, Superior Phono Parts Co., New York, N. Y.; G. Clayton Irwin, Jr., Radio World's Fair, New York, N. Y. and Chicago, Ill.; A. C. Barg, Jewett Radio & Phonograph Co., Pontiac, Mich.; Don T. Allen, Carryola Co. of America, Milwaukee, Wis.; Allan W. Fritzsche, General Phonograph Corp., New York, N. Y.; Robert T. Devlin, Electrical Research Laboratories, Chicago, Ill.; Pierre Boucheron, Radio Corp. of America, New York, N. Y.; Buel-Lyons Co., Cleveland, O.; P. R. Hawley, Girard Phonograph Co., Philadelphia, Pa.; Atwater Kent Mfg. Co., Philadelphia, Pa.; David L. Day, Bacon Banjo Co., Groton, Conn.; Samuel Fingrutd, and Philip Grabuski, Everybody's Talking Machine Co., Philadelphia, Pa.; M. Hohner, Inc., New York, N. Y.; Louis Buehn, Philadelphia Victor Distributors, Philadelphia, Pa.; Orsenigo Co., Inc., New York, N. Y.; Penn Phonograph Co., Philadelphia, Pa.; Bernard D. Colen, Musical Products Distributing Co., New York, N. Y.; Geo. Witney,

**Priess**  
TRADE MARK  
**STRAIGHT 8 EIGHT**  
*It's loop operated!*  
**An 8-tube loop-operated receiver that knows no distance barrier**

Progressive dealers are alive to the liberal discount and full protective dealer policy.

**PRIESS RADIO CORPORATION**  
693 BROADWAY NEW YORK, N. Y.

C. J. Heppe & Son, Philadelphia, Pa.; J. Newcomb Blackman, Blackman Talking Machine Co., New York, N. Y.; H. A. Weymann & Son, Inc., Philadelphia, Pa.; Frank V. Goodman, Sonora Phonograph Co., Inc., New York, N. Y.; M. E. Schecter, Artcraft Industries, New York, N. Y.; Harry A. Beach, Brunswick-Balke-Collender Co., New York, N. Y.; Carl D. Boyd, Chicago, Ill.; Lloyd Spencer, New York, N. Y.; Maurice Landay, Greater City Phonograph Co., New York, N. Y.; Edward B. Lyons, Buel-Lyons Co., Cleveland, O.; Chas. T. Wandres, Radio Corporation of America, New York.

### United Cabinet Mfrs. Corp. Tells of a Year of Progress

W. C. Perkins, president of the United Cabinet Manufacturers Corp., Chicago, Ill., was a recent visitor to New York, making his headquarters at the Eastern offices of the company, 1674 Broadway. Commenting upon the company's activities Mr. Perkins said: "We have just closed a very successful year and are delighted with the reception accorded the various cabinets in our line. We have endeavored to furnish the trade with cabinets that may be merchandised as artistic instruments and our efforts in this direction have been endorsed by manufacturers, jobbers and dealers throughout the country. We have been particularly gratified at the reception accorded our Model 35 cabinet which has won first prize at a number of local radio shows and which is being used by prominent radio manufacturers in the Middle West and East.

"During 1925 we worked to capacity and in the latter part of the year were unable to keep pace with the requirements of our trade. However, we enlarged our facilities recently and with the consummation of several large contracts, we are now in a position to give the trade efficient service in their cabinet orders."

### H. F. Thornell on Trip

H. F. Thornell, of Thornell-MacLaren Associates, exclusive factory representatives for the MacLaren Mfg. Co., which produces the "Domin-Aire," a radio set operating on either AC or DC current, left recently on a ten-day trade trip. Mr. Thornell will visit Baltimore, Washington, Cumberland, Philadelphia, Pittsburgh, Altoona, Harrisburg and Rochester, New York. The MacLaren factory is steadily increasing its production in order to care for the trade needs.

### Nyacco Products in Demand

The New York Album & Card Co., New York City, well known as manufacturer of Nyacco albums, Nyacco and Nyaccoflex radio receiving sets, found a ready market for its five-tube tuned radio frequency receiving set. Production has been taxed to meet the demand.

## WALL-KANE

THE ORIGINAL 10-RECORD NEEDLE PUT UP IN ATTRACTIVE COUNTER DISPLAYS



GIVES YOU 150% PROFIT

Also Jazz, Concert, Petmecky and Best Tone Phonograph Needles

**WALL-KANE NEEDLE MFG. CO., Inc., 3922-14th Ave., Brooklyn, N. Y.**



# IN THE MUSICAL MERCHANDISE FIELD

## William Custer With the Violin Dept. of Vega Co.

**Strong Demand for Vega Co. Violins Causes Expansion of This Department—Vegaphones Selling in Satisfactory Fashion**

BOSTON, MASS., January 8.—The popularity of the violins produced by the Vega Co., of this city, has already caused the expansion of this department. It has been announced that William Custer, well-known violinist of this section of the country, has joined the violin department of the Vega Co.

The demand for the Vegaphone banjo continues strong. An example of its appeal is demonstrated in the experience of Eddie Peabody, well-known orchestra leader. Mr. Peabody has ordered his fourth Vegaphone. The last three months have witnessed exceptionally busy times at the Vega factory, and there has been no cessation in the demand into the new year.

## 70,000 Saxophones Were Produced During the Year

**This Figure Offered by F. A. Buescher, Head of Buescher Band Instrument Co., in Recent Interview, Shows Business Growth**

KANSAS CITY, Mo., January 6.—Seventy thousand saxophones were produced in this country during the past year, according to F. A. Buescher, president of the Buescher Band Instrument Co., Elkhart, Ind., who was here last week attending the meeting of the State Band Association. In an interesting article in the Kansas City Times, in which Mr. Buescher was called the American father of the saxophone, it was stated that these figures will be exceeded next year.

According to Mr. Buescher his company's output of saxophones will exceed 21,000 this year, or nearly 2,000 a month. Next year's production plans call for a larger output, he says, and he believes that this will be generally true of all the band instrument companies.

## King Franchises Awarded

CLEVELAND O., January 5.—L. L. Fox, sales manager of the H. N. White Co., maker of the King line of band instruments, recently announced that the following dealers have secured the King franchise: Chalmers Music Co., Miami, Fla.; Sebring Music Co., Sebring, Fla.; Frank Botefuhr & Son, Pittsburg, Kan.; J. E. Brayles, Shreveport, La.; Tolzien Music Co., Amarillo, Tex.; W. S. Bigelow, Galveston, Tex.; Baker-Nelson Floral Co., Ardmore, Okla.; Bradley Music Co., Corpus Christi, Tex.; Laredo Music & Jewelry Co., Laredo, Tex., and William S. Schoyen, Lemmon, S. D.

## Crocker & Ewalt Store Opens

QUINCY, ILL., January 6.—A new music store, Crocker & Ewalt, has been opened at 111 North Fourth street by Alvin Crocker, well-known musician and former vaudeville star, and Coleman C. Ewalt, Jr. A full line of musical instruments will be carried, with small goods featured.

Rodman Wanamaker, head of the John Wanamaker stores, recently acquired four Stradivari violins, which will be played in concerts in the Wanamaker stores.

## Musical Merchandise Mfrs. Ass'n Ends Its First Year

**Members of Eastern Zone of Merchandise Mfrs. Ass'n, Through President Walter Grover, Report Successful Year of Activity**

The Musical Merchandise Manufacturers' Association, Eastern Zone, which has been organized for the past year, through its president, Walter Grover, reports satisfactory progress for the first year of its existence and a prospect of better accomplishments during 1926. One of the

outstanding achievements of the past year was a closer association with jobbers that culminated in a joint meeting of the Association with the Associated Musical Instrument Dealers of New York on November 24. The two associations will join in presenting two concerts for the purpose of stimulating interest in musical merchandise during the coming year.

## Rules for Band Contests

The National Bureau for the Advancement of Music announces the issuance of the booklet of rules for the 1926 school band contests.

# A Plan for Financing Payment Sales of KING Band Instruments



HAVEN'T you sometimes said "We don't handle band instruments" when some customer inquired about a saxophone, etc., just because of the difficulties in selling on time payments?

With the new plan for financing payment sales which we can now offer to "King" dealers, this obstacle is removed. You can have a small-goods band instrument department without tying up any capital; and what is most attractive, dispose of your leases without sacrificing a cent of profit. The difference between our published cash and payment prices will cover the cost of financing so you receive the full list price.

This financing plan is clearly explained in a folder now ready for distribution. There is no red tape or complicated accounting connected with it, and the plan is available to every dealer selling "King" Instruments. If this plan will be of service to you we'll gladly send one of the folders upon receipt of your request.

If you are interested in this plan and in the exclusive agency for "King" Instruments clip out and mail the coupon below.

**THE H. N. WHITE CO.**  
5215-71 Superior Ave. Cleveland, Ohio  
Manufacturers of  
"KING" BAND INSTRUMENTS

THE H. N. WHITE CO., 5215-71 Superior Ave., Cleveland, O.  
Gentlemen: Kindly send the booklets checked:  
 Plan of Financing Payment Sales.  
 Exclusive Agency for King Instruments.  
 We (do) (do not) handle band instruments.

Name \_\_\_\_\_  
 Address \_\_\_\_\_  
 City \_\_\_\_\_ State \_\_\_\_\_

**SEND COUPON FOR BOOKLETS!**



IN THE MUSICAL MERCHANDISE FIELD—(Continued from page 151)

# HOHNER Harmonicas and Accordions

*THE WORLD'S BEST*



Hohner Harmony Hours, broadcast from WEA F and five other affiliated powerful radio broadcasting stations are again strongly stimulating Hohner Harmonica sales.

Write us for our "Big Business Builders"

**M. HOHNER, Inc.**      114-116 East 16th Street  
New York City



**HOHNER PRODUCTS AWARDED FIRST PRIZE AT THE PANAMA-PACIFIC INTERNATIONAL EXPOSITION SAN FRANCISCO 1915**

### King Dealer Stimulated by Visit to White Plant

Arthur L. Buech, King Dealer, Suggests That All Dealers Make Visit to Factory and Profit From the Knowledge Thus Gained

CLEVELAND, O., January 7.—One of the chief reasons for the success of the H. N. White Co., manufacturer of King band instruments, is the close contact which exists between the company and its dealer organization and the co-operation which is given the dealer. A letter recently received by L. L. Fox, sales manager of the company, from Arthur L. Buech, Milwaukee King dealer, is interesting in that it indicates the manner in which this dealer appreciates the co-operation given him. It also contains some ideas for aiding business which other dealers might find useful. The letter, in part, reads:

It is with great pleasure that the undersigned takes this opportunity of expressing his opinion on a recent visit to your factory. My suggestion to all King dealers would be to make a similar visit—surely they would profit by same.

One of the first important things noticed by the writer was the employes' condition. It seems that all of the individual skilled craftsmen enjoy their work and are a spoke in the wheel of success for the King Band Instrument Co. After asking a few questions, I learned that these conditions existed because the employes are receiv-

ing a living wage. Therefore, I am able to see why King instruments maintain quality and not quantity.

The reading and studying of King literature should be thoroughly made by all dealers. Positively sell yourself on King quality. Surely, you have an "honest-to-goodness" line of instruments to sell.

Building up a mailing list is an essential asset to a music dealer and keeping in constant touch with same at regular intervals.

Daily want advertisements under the headline of musical instruments have also proved to be a winner in sales, especially in disposing of used instruments.

As my letter is getting rather lengthy—let me state, in closing, that the Buech Saxophone Shop, of Milwaukee, is to-day enjoying prosperity through the kind efforts and co-operation of the H. N. White Co.

### New Issue of Leedy "Topics"

INDIANAPOLIS, IND., January 7.—The current issue of Leedy "Drum Topics," issued by the Leedy Mfg. Co. and devoted to the activities of drummers using Leedy products, features, on the cover, a picture of Ben Bernie, the popular orchestra leader, admiring the Leedy drum played by Sammy Fink, drummer in the Bernie Orchestra. In addition to many interesting articles and stories, the issue contains testimonials from many prominent users of Leedy drums.

The Rudolph Wurlitzer Co. reports a most unusual demand for ukuleles during the holiday season, indicating their popularity.

### King Jumbo Sousaphone Used as a Playhouse

Novel Picture Offers Opportunity of Realizing Size of King Sousaphone—This Is the Largest Stock Standard Base Made

HAMMOND, IND., January 7.—Little Miss Raymond need never worry about the housing situation while her daddy plays the King Jumbo



A Musical "Playhouse"

Sousaphone, as she shows in the accompanying photograph. This photo was taken in front of the Parthenon Theatre, where Arthur Raymond plays. The King Jumbo is the largest stock standard bass made.

### Plan School Music Contest

ST. PAUL, MINN., January 8.—Details of the second annual high school music contest are being taken care of by the various district committees for the contests, which will take place the latter part of April and early in May. Finals will be held at the University of Minnesota, May 13-15.

### Opens Retail Department

CHICAGO, ILL., January 7.—The William Frank Co., manufacturer of musical instruments for the past fifteen years, recently opened a retail department at 2035 Clybourn avenue.

## The NEW SUPER-LUDWIG DRUM

Parallel Snare Throw-Off  
Individual Snare Adjustment  
Perfect Snare Control



Patd. Jan. 1924 and Others Pending

### The Sensation of the Drum World

Again Ludwig sets the pace with a new drum—the SUPER-LUDWIG with its many new advanced features.

INDIVIDUAL adjustment of snares, a parallel throw-off of snares and means for securing PERFECT snare control are but a few of the many new improved ideas to be found on this latest creation of Ludwig engineers and craftsmen.

It's a sales leader for the dealer who is on the alert to be up and ahead of the van that will follow.

Send to Us Now for Prices and Discounts

## LUDWIG & LUDWIG

World's Largest Makers of Drums and Drum Accessories

1611 to 1627 No. Lincoln Street, CHICAGO



IN THE MUSICAL MERCHANDISE FIELD—(Continued from page 152)

### Wm. J. Haussler Discusses Growing Hohner Popularity

Vice-president and General Manager of M. Hohner, Inc., Points Out That Ranks of Harmonica Enthusiasts Have Been Increased by 5,000,000 During the Past Year

The extent of growth in the popularity and use of the harmonica was interestingly set forth in a recent statement made by William J. Haussler, vice-president and general manager of M. Hohner, Inc., New York City. Mr. Haussler is recognized as one of the foremost authorities on the merchandising of harmonicas in this country. He is thoroughly conversant with every phase of the situation, and his findings, therefore, are particularly authentic. Incidentally it might be added that it is in no small measure due to Mr. Haussler's untiring zeal in popularizing the harmonica that the following accomplishments were made possible.

During the past year Mr. Haussler pointed out that approximately five million boys and girls were added to the already large number of harmonica enthusiasts in this country which are now estimated to number many millions, showing the instrument's popularity.

The harmonica as a musical instrument is not alone being taken up by the individual but by many institutions and organizations as well. An example of the recognition of the harmonica as an educational musical instrument is to be found in a survey of the public schools of the city of Chicago. In this great metropolis over two hundred schools have harmonica bands or orchestras, and harmonica playing has become part of the curriculum of these schools in musical education. In addition to the educational properties of the harmonica its use as an entertainment feature has also been materially enhanced. Recreation and community centers have enthusiastically adopted the harmonica for various occasions.

In almost every State of the Union teachers and supervisors of music are encouraging the use of the harmonica. Mr. Haussler also calls attention to the fact that the harmonica has received the endorsement of a large number of musical artists.

The old-fashioned haphazard playing of the harmonica has been done away with and it has become a solo instrument and many orchestra arrangements have been made, permitting wonderful harmony from these instruments. Further, the Hohner instruction book on playing of the harmonica has been of great help. This has been further augmented by the bi-weekly lessons given from six large broadcasting stations by William J. Haussler himself. An important feature, when considering the harmonica as a contribution to the appreciation of music, is that it is absolutely accurate. The reeds are firmly fixed and cannot get out of tune. Although a beginner usually starts on simple melodies in his mastery of harmonica playing, it has been ably demonstrated by radio broadcasting and playing of harmonica organizations that the harmonica lends itself admirably to the rendition of classics.

A particularly important note in the present popularity of the harmonica is to be found in the fact that the harmonica has proved time and time again the very beginning of a musical education. Through it there has been generated a thorough appreciation of music and as the pleasure of producing more and more difficult music on the harmonica increases there is also created a desire to play larger musical instruments. Mr. Haussler has found in his experience that many dealers who have sold a customer a harmonica have later sold that same customer other musical instruments.

Even more intensive plans for popularizing the harmonica are being made by M. Hohner, Inc., for 1926. To the widespread activities of the past has been added an extensive billboard campaign.

### Heavy Demand Continues fo Silver Bell Banjos

Continuation of Heavy Orders Into New Year Causes Night Work at Bacon Plant—Outlook for 1926 Exceptionally Good

GROTON, CONN., January 7.—Night work has been the order of the day at the headquarters of the Bacon Banjo Co., of this city. This situation has been caused by the heavy demand for the B & D Silver Bell line. It is interesting to note that the demand carried well over into the new year. Considering the way the year opened, it would seem that 1926 will be a banner year for the Bacon Co.

David L. Day, vice-president and general manager, reports that telegrams for rush shipments are coming in every day and that the orders received are for substantial quantities. The Bacon products have enjoyed growing popularity, as the strong demand proves.

### Leedy Mfg. Co. Holds a Display of Its Products

Exposition of Leedy Drums and Drummers' Supplies at Waldorf Hotel Attracts Many Drummers and Stimulates Trade

TOLEDO, O., January 6.—The Leedy Mfg. Co., Indianapolis, Ind., held a display of its drums and drummers' supplies at the Waldorf Hotel last month which attracted a great deal of attention from local and visiting drummers. Some sixty-five drummers visited the exposition, and several placed orders through local dealers for merchandise seen at the show. Each Leedy dealer was given a day to bring his prospects, and each customer was given special attention. Three new Leedy products were displayed, the Vitraphone, the floating head drum and a new music rack. Sales and Advertising Manager George H. Way was in charge, assisted by Assistant Sales Manager Charles Seibert.

## A Violin Customer!



### Can You Make the Sale?

**T**HE VEGA VIOLIN Outfit has the attractiveness and exceptional value which will make the sale. Every violin is guaranteed to be perfect in every detail and for a period of one year to maintain perfect adjustment. This assures you of a fully satisfied customer.

The Violin is a standard selling instrument, and you as a musical instrument dealer cannot afford to be without this attractive offer. Pleasing in price, appearance, quality and guaranteed by Vega Co., manufacturer of the highest grade musical instruments, the Vega Violin Outfit is a best seller.

*Write for free catalog*

The VEGA Co.

155-6 Columbus Ave.

Boston, Mass.



IN THE MUSICAL MERCHANDISE FIELD—(Continued from page 153)

## Hohner Billboard Campaign Covers Metropolitan Area

One Hundred and Thirty-five Attractive Posters Picture Hohner Harmonica Bringing Happiness to the Hohner Boy

The publicity campaign of M. Hohner, Inc., New York City, maker of Hohner harmonicas, has been so widespread and has made use of so many different means of publicity that it seemed already practically complete. However, recently another medium of publicity was employed, billboards. M. Hohner, Inc., is now conducting probably what is one of the largest outdoor advertising campaigns ever conducted by a musical instrument manufacturer. One hundred and thirty-five billboards, placed in strategic locations in Manhattan, Bronx, Brooklyn, Jersey

overcrowding the poster but in showing just enough to put the message across. The poster reads: "Tune in on Happiness—Play a Hohner Harmonica—Great Music—Great Fun," and at the bottom the free instruction book is offered. It may be mentioned that the preparation of the design in this poster was supervised by Mr. Haussler himself. Last month, during the holiday season, each poster fittingly bore a holly wreath.

M. Hohner, Inc., reports that this campaign is already producing results in increased Hohner harmonica sales in the warerooms of the dealers in the metropolitan territory.

## King Dealers Visit Factory

CLEVELAND, O., January 5.—Recent visitors to the H. N. White Co., manufacturer of King band instruments, included John O'Connor, of



One of the "Eye-arresting" Hohner Billboards

City, etc., completely blanket the metropolitan district. It is hard to estimate how many million people will see these posters during the sixty days for which they are scheduled.

As may be seen from the accompanying photograph, much care has been exercised in the preparation of these posters, which are handsomely lithographed in six colors. The famous Hohner boy is shown. It will be remembered that the model for the Hohner boy was none other than Billy Haussler, son of William J. Haussler, vice-president and general manager of M. Hohner, Inc. Great care was shown in not

the John O'Connor Music Co., Wheeling, W. Va., who was recently awarded the exclusive King franchise, and M. Brinnon, of the Hockett Music Store Co., Bellefontaine, O. Mr. Brinnon stated that his company had built up a splendid school business through its policy of aiding the school authorities in organizing and financing the musical organizations.

## How Texas Dealers Win Sales

The Stapleton Music Co., San Antonio, Tex., in its three years of existence has built up a re-

## "Silver Bell" Banjos

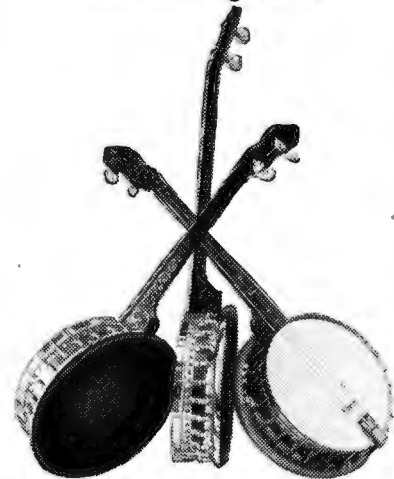

Send for illustrated book of Prominent Orchestra and Professional Players

The Bacon Banjo Co., Inc.  
GROTON CONN.

markable volume of business, due to its policy of supplying the best in musical instruments with a maximum of courtesy. Many of the local bands and orchestras have been equipped by this store.

## Crawford-Rutan Music Co. Moves to Larger Quarters

Topeka, Kan., Concern Finds More Room Necessary to Handle Business of Recently Opened Branch Store

TOPEKA, KAN., January 6.—The Crawford-Rutan Music Co. has moved from its location at 826 Kansas avenue to new and larger quarters at 927 Kansas avenue. The Topeka branch of the company, which has long maintained a successful musical merchandise store in Kansas City, was established here last Fall. Walter Green is the manager.

The new quarters will give the company considerably more room. A stockroom has been partitioned off in the rear of the store. Mr. Green has been teaching music for several years at his home, but he now intends to move his studio to the store. The Crawford-Rutan Co. has met with big success as agent for the Buescher Band Instrument Co.

## White Home From South

CLEVELAND, O., January 5.—H. N. White, of the H. N. White Co., manufacturer of the King line of band instruments, returned to this city from Florida for the holidays. He expects to return South this month.

## Artists Aid Sales

Demonstrations by prominent artists at the store of Frank Holton & Co. have helped considerably to increase sales of musical merchandise and band instruments.

## Organizing Boys' Band

The D. Z. Phillips Music Co., Pueblo, Col., is organizing a boys' band as a means of stimulating business. When the membership reaches thirty-five a second band will be formed.

## Adds Leedy Line

The Union Music Co., of Toledo, O., recently added the Leedy line of drums and drummers' supplies to the merchandise carried in stock.

# BRUNO

THE OLDEST AND  
LARGEST MUSICAL  
MERCHANDISE HOUSE  
IN AMERICA

*Exclusively Wholesale*  
ESTABLISHED 1834

**C. BRUNO & SON, INC.**  
351-53 FOURTH AVE. NEW YORK CITY



IN THE MUSICAL MERCHANDISE FIELD—(Continued from page 154)

**JUST INVENTED  
PLAYS BY ROLLS**

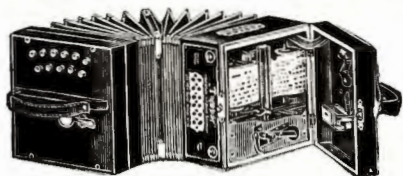

To be played immediately without any knowledge of music. Music for all countries and the late hits. Pamphlets free, postpaid by us.

**Charles Pittle & Co., New Bedford, Mass.**

**Toledo Dealers Doing Well  
With Musical Merchandise**

TOLEDO, O., January 5.—Toledo dealers have been busy selling musical merchandise during the past few weeks. George Terry, manager of the Union Music Co., reports a good demand for band instruments.

The Ignaz Fischer Music House is finding a good sale for Martin band instruments and conducts an active beginners' class under the direction of Walter Dean, giving six free lessons with each instrument. The Lawrence Music Shop is extending its line.

Hohner harmonicas continue to sell exceptionally well in this section, contests and promotion work among the young people contributing a great deal to the increased interest.

Dealers report visits from a number of small goods travelers during the past week or so, including Fred Brenner, of Gretsch & Brenner, Inc., New York; J. R. Frew, of the Ohio Musical Sales Co., Cleveland; Fred Base, of the Fred Gretsch Mfg. Co., Brooklyn, and Lewis Johnson, of Tonk Bros. Co., Chicago.

**Majority of Dealers Now  
Featuring Small Goods**

An outstanding development of the year which has just come to a close is the number of talking machine dealers who are now featuring musical merchandise in an aggressive manner. Many of these dealers have established musical instrument departments, operated as a separate unit of the business and in charge of an experienced merchandiser in this line. Placing the department in charge of a man who understands his stock thoroughly and who can demonstrate what he is trying to sell has been found to be the most efficient and profitable method of selling small goods. In musical merchandise, as in talking machines, the demonstration is the thing that gets the sales message across to the prospect better than all the words in the best salesman's vocabulary.

Because of the small investment involved and the constant demand, musical merchandise has proved a good proposition for the talking machine dealer. Although there are still a number of dealers who do not operate musical merchandise departments this number is rapidly decreasing, and the next year should witness the opening of many new departments, if present indications are any criterion.

**Displays Band Instruments**

READING, PA., January 7.—The letter carriers of this city are engaged in a campaign to raise funds with which to purchase instruments to equip their band. The goal set is \$2,500 and this figure has been nearly reached. The instruments which already have been purchased are on exhibit in the windows of the Grafonola Shop, North Eighth street, near Penn.

R. W. Ryder recently opened a new music store carrying only band instruments and string instruments. It is known as the Melody Shop and is located at Tulsa, Okla.

**Women's Drum Corps Is  
Organized in Portland, Ore.**

**New Unit Equipped With Conn Scout Drums  
—Handzlik Goes to Florida—Important  
Changes in the Band Instrument Field**

PORTLAND, ORE., January 6.—A women's drum corps has been organized in Portland by the Daughters of the Nile. The membership consists of twenty young women of the order, who were equipped with twenty Conn Scout drums by the Conn Portland store, and the new organization is being instructed by Robert M. Brown. This is believed to be the first woman's drum corps ever organized in the Pacific Northwest. Mr. Brown reports that the members are apt pupils and will be able to appear in public early in the Spring, when it is their purpose to equip themselves with attractive uniforms.

R. T. Sherwood, of the Circle Theatre, and Fred K. Trembly, of the Burnside Theatre, both accomplished drummers, have been equipped with Ludwig pedal tympani drums by W. A. McDougall, manager of the small goods department of the Bush & Lane Piano Co. Both of these men are members of the Elks Band of sixty pieces, of which Mr. McDougall is the director.

Leon Handzlik, who has been making Portland his home and was being featured during the past Summer as soloist with the Oregon Journal Park Band, built himself a handsome home in the city. He had just moved into the new residence when he received an offer to go to Palm Beach, Fla., to act as soloist of the Palm Beach Band. He left for Florida, but will return to Portland in the Spring. While here he was connected with the Seiberling, Lucas Music Co. as instructor in the band instrument department, featuring instruction of the Buescher trumpet. During his absence his place at the store will be filled by O. C. Dunning, trumpeter of the Herman Kenin Orchestra of the Hotel Multnomah.

The Conn Portland store was visited during the past week by Leslie W. Brewster, secretary-treasurer of the Conn San Francisco establishment, who spent the time in conference with George Cracknell, the local manager.

Stanley Baylis has returned to the Conn Portland store, which he left several months ago to join the force in the new Sherman, Clay & Co. branch at Salem, Ore.

Vermenia McCauley, of the sheet music department of Sherman, Clay & Co., surprised her friends by slipping quietly away to Salem, Ore., where she was married to David R. Vandenberg, a prominent young lawyer of Klamath Falls, Ore. Her leaving the department was followed by her sister, Maud McCauley, and Nell Harper, who went to Seattle to enter the sheet music department of the Bush & Lane Piano Co., of that city.

**Troup Bros. Equip Band**

HARRISBURG, PA., January 7.—Troup Bros., local representatives of the H. N. White Co., manufacturer of King band instruments, have added another band to their list of King-equipped musical organizations. William Doyle, manager of the musical merchandise and band instrument department of the concern, recently completed the organization of the Steelton, Pa., high school band.

**Awards Four Scholarships**

HAZLETON, PA., January 6.—Landau's Music & Jewelry Store, which recently announced that it would award four scholarships in its boys' band, has selected three fortunate youngsters, who have been supplied with mellophones and will receive a musical education without cost.

**Weaver Piano Co. Features  
King Instrument Display**

**Prominent Music House Has Attractive Showing  
of Instruments in King Line—Window  
Displays Stimulate Sales**

YORK, PA., January 7.—The King line of band instruments, made by the H. N. White Co., Cleveland, O., is featured by the Weaver Piano



Effective Display of Weaver Co. Co., of this city, and the accompanying photograph gives an indication of the attractive manner in which these instruments, together with other items of small goods, were presented to the public through the medium of the window display space. The King saxello is prominently shown in the display.

**Dorfman Leaves Progressive**

Harry Dorfman, who has been connected with the Progressive Musical Instrument Corp. for several years, recently resigned his position from the company. He plans to enter the wholesale musical merchandise business with his own company.

**Every Dealer**

WILL WANT A COPY OF THE

**New Leedy Catalog "N" (NOW)**



NINETY-SIX PAGES—TWO HUNDRED AND FIFTY PHOTOGRAPHS  
—THIRTY-NEW INSTRUMENTS

ALL ABOUT THE NEW **Leedy**  
PROFESSIONAL FLOATING  
HEAD SNARE DRUM

Send a postal for yours to-day—Mailed free

**Leedy Mfg. Co.**  
INDIANAPOLIS, INDIANA



# HAPPENINGS IN THE DOMINION OF CANADA

## Splendid Year-End Sales and Bright Outlook Reported by the Trade in Montreal

New Talking Machines and Records Bring Sharp Revival of Business—C. W. Lindsay Shows Increase of 200 Per Cent in December Business Over Year Previous—Radio in Good Demand

MONTREAL, CAN., January 8.—Practically all talking machine and radio dealers in this city summarize the year 1925 in the same fashion,—a disappointing start which continued for almost the first half of the year and a splendid finish which more than offset the slack early period. October, November and December were the banner months of the year and as the trend was on the upgrade at the end of 1925 the indications point to a continuance of good business for some months to come. The new process records and the new types of phonographs, together with the wonderful publicity which these instruments have received, are given as the reasons why the last few months of the year were such wonderful talking machine months. In radio the results of the year were equally satisfactory, with the tendency on the part of the public to purchase the better type instruments, listing from \$250 upwards. Dealers this past year adopted the policy of carrying but a few lines and concentrating on them rather than scattering their energies and sales efforts for eight, ten or twelve makes of sets.

C. W. Lindsay, Ltd., reports that in the talking machine department business for the last three months of the year was on a par with the corresponding period of 1924 and the radio sales volume showed an increase in December of approximately 200 per cent over the same month of last year and for the year the increase was between 200 and 300 per cent.

Layton Bros., Ltd., report an increase of more than twenty-five per cent in radio sales over the preceding year. The great bulk of the business was done during the latter part of the year although sales were consistently good throughout the year. This firm's Radio Christmas Club resulted in bringing in a great volume of business.

The Hartney Co., Ltd., through its president, I. Sydney Isaacs, reports that for the first five months of the year business was decidedly disappointing but starting in June and continuing throughout the balance of the year the volume of sales far overtopped the figures of 1924. This house, which is one of the leading Victor dealers in the Dominion, secured wonderful results from the sale of Victor single-faced records and discontinued models of instruments.

The Canadian National Carbon Co., Ltd., manufacturer of Eveready batteries, will broadcast from the Northern Electric Station CHYC the first Wednesday of each month. A program of nine numbers inaugurated the series the past month.

Edgar G. Herrmann has been appointed advertising manager of the Victor Talking Ma-

chine Co., of Canada, Ltd. He was previously assistant manager of the Victor Talking Machine Co., at Camden, N. J.

Charles Culross is the only dealer in Montreal featuring the Trinity Six, and is doing some splendid newspaper publicity in the interest of this radio line.

All Victor dealers report a tremendous interest shown towards the new Orthophonic Victor, which astonished all who heard its performance. We understand as a result the Canadian-Victor plant is working full speed ahead, day and night.

## Amended Canadian Copyright Bill to Come Before Parliament at Forthcoming Session

Important Changes in Personnel Take Place With Opening of New Year—F. G. Entwistle to Handle Fada Sales Promotion—Death of William H. Banfield—Other News of the Month

TORONTO, ONT., January 8.—The Canadian Copyright Bill, which was approved in amended form by a special committee of the House of Commons, Ottawa, shortly before Parliament prorogued in June last, will come before Parliament at the forthcoming session. The necessary action in again placing the bill on the order paper of the House is being taken at the request of Leon J. Ladner, Conservative member for Vancouver, South, B. C.

William Henry Banfield, president of W. H. Banfield & Sons, Ltd., this city, died following an attack of pneumonia.

F. G. Entwistle, for many years in charge of a number of large accounts with a leading advertising agency of this city, has accepted a position with the Fada Radio, Ltd., and will henceforth handle sales promotion for that company.

The firm of Electrolax, this city, manufacturer of Bakelite, has changed its name to Bakelite Corp. of Canada, Ltd.

The Canadian Pearson Radio Co., Ltd., has been granted letters patent authorizing them to manufacture radio sets and parts. Capitalization has been fixed at \$40,000. This firm is Canadian distributor of Utah loud speakers.

The radio dealers of St. Thomas, Ont., got together recently and arranged a group page advertisement in the local papers which was productive of splendid business.

Miss Marjorie Braunton, well known in musical circles in London, has assumed charge of the record department at the London, Ont., branch of Mason & Risch, Ltd.

The Q R S Music Co. of Canada, Ltd., Toronto, has been appointed exclusive Canadian distributor for the Frost line of radio accessories,

Stewart-Warner radio sets are being pushed in Montreal by the following music dealers: J. W. Shaw & Co. and Lauzon-Phaneuf, Ltd.

Western Radio, 4841 Sherbrooke street, West, is a new dealer specializing in Thermodyne radio sets.

Wm. Lee Co., Ltd., have been selected as authorized dealers for the Stromberg-Carlson radio sets.

The following well known artists are due to appear in recital shortly in local circles, Mischa Elman, London String Quartet, Isa Kremer.

Donald O. Friend, plant engineer of the Eagle Radio Co., Newark, N. J., recently spent several weeks visiting the trade in Canada, particularly in Quebec, Montreal, and Toronto.

Radio, Ltd., has been appointed exclusive distributor for the Province of Quebec of Freed-Eisemann neotrodyne receivers and plans to feature this line.

including the well-known Musette loud speaker.

Gordon V. Thompson, general manager of Leo Feist, Ltd., Toronto, is now found in the role of inventor to the phonograph and radio trades. His product is called the "Orola," an electro-magnetic device to vibrate the diaphragm of a phonograph reproducer; in other words, this new invention is really an electric needle for the phonograph, employing the phonograph reproducer, tone arm and amplifying chamber, all of which are now the result of years of improvement and development.

The Gold Medal Radio-Phonograph Corp., Ltd., Uxbridge, Ont., has inaugurated a field service division in which a service motor car operates in Toronto. The car carries full equipment in the way of tools, testers, battery testers, etc.

The Barrie Radio & Electric Co., Ltd., Barrie, Ont., has been incorporated recently with a capitalization of \$10,000.

The D-X Engineering & Sales Co. is actively selling the Standardyne, a five-tube receiver.

Mr. Carter, from the Carter Radio Co., Chicago, was a visitor in Toronto recently.

## Winnipeg Trade Activities

WINNIPEG, MAN., January 7.—Brightson True Blue radio tubes, manufactured by Brightson Laboratories, Inc., New York, are represented in Canada by Consolidated Distributors, Ltd.

The Winnipeg Piano Co., Ltd., is still at work making changes in its store in order to accommodate and handle its ever-increasing trade.

Farquhar & Shaw have issued a radio map showing every station in Canada and the United States as a publication feature.

Wood Vallance, Ltd., has been appointed local distributor for King Quality Products, Inc., Buffalo, maker of the King radio receivers, etc.

Canadian Avery Co., Ltd., Regina, is distributing in the Provinces of Alberta and Saskatchewan. Among the lines carried is the Zenith.

Lemery-Denison Electric, Ltd., is a distributor of Canadian General Electric Radiolas for northern Saskatchewan.

J. M. Edgar, Vernon, B. C., has recently been appointed dealer for Fada radio receivers.

Patterson & West, western Canadian distributors for Stewart-Warner radio products, and with headquarters here, are more than pleased with the radio sales for this season.

## Talking Machine Springs and Repair Parts

NONE BETTER IN QUALITY NONE LOWER IN PRICE

THE RENÉ MANUFACTURING CO.  
MONTVALE, NEW JERSEY



# GLEANINGS *from the* WORLD *of* MUSIC

## Sales of Popular Sheet Music at Retail Are Once Again on a Satisfactory Basis

Consistent Demand for Popular Numbers an Encouraging Indication of the Stability of the Sheet Music End of the Business—Demand for Song Numbers Also a Favorable Sign

Popular sheet music has certainly come back into its own. For a period close to a year there has been a most healthy activity in sales. An added spurt in volume commenced in the late Summer, continued through the Fall and completed one of the most active holiday seasons that the popular music industry has ever entertained.

It would appear that popular music sales have at last reached a normal volume, under what can be termed a new era. Sales on individual numbers had, in some seasons past, reached larger totals, but they were probably never so consistent as they are to-day. Never since music has retailed at 30 cents has there been a more diversified call. Catalogs of more than normal length are feeling this new success.

The grand total of sales on entire catalogs probably measure up to the volume that was attained on several individual numbers when sales totals of 1,000,000 or more were achieved.

Another healthy aspect of the present situation is the fact that a fair portion of the additional sales now being attained are due to the demand for numbers in song form. All too many of the popular successes for the past several seasons were based upon the popularity they received as dance successes. The dance numbers still sell, but the old and new fashion song are both also having a good call.

Naturally, this is a better situation for the popular publishing industry, for the reason that the business is not so dependent upon the orchestras for their results. Orchestras still contribute, but the old-fashioned method of having a song sung is being revived and is producing returns. Of course, there has been a change in public taste. Consumers are again calling for songs, and there is doubtless some departure from the typical jazz craze of a couple of seasons ago.

Because the newer demands seemingly are, in no small measure, focused on vocal renditions, the new success of popular sheet music has contributed to the added sale now being attained in popular records. To a great extent, popular records can only reflect the situation in the sheet music field. If the larger volume of popular record sales totals were attained through dance renditions and there arrived an additional call for vocal selections without an appreciable loss to the volume of dance record sales that

industry, too, feels the revival of sales. The history of popular talking machine record sales of the past eight months has, with few exceptions, been almost exact duplicates of the sheet music trend of sales.

Of course, in the talking machine record field,

### "Remember" Has Won an Immediate Success

Number, So Widely Sung, Went Ahead of Publishers' Plans for Its Exploitation

Irving Berlin's latest song, "Remember," has been accepted by many critics as musically his best. Despite the fact that it is hailed as a musical offering of an unusual standard for a pop-



McCrorry Display of "Remember"

ular number, this has in no way lessened its sales. "Remember" seems to be sung in a larger volume than anything Berlin has ever written, considering the period of its life. As a matter of history its popularity was gained much faster than the publishers, Irving Berlin, Inc., originally planned. They had hoped to build it up over a longer period but the public response and the demand created advanced the elaborate period of exploitation by many weeks.

Berlin songs all have some publicity value and for that reason they are frequently displayed by dealers. In the case of "Remember" the number of displays seemingly exceeds that of any of its predecessors. We herewith show

there is always the exception where particular orders have a record following. A number rendered by such an artist may have a wide sale in record form and will be almost unheard of in the sheet music field. This, however, is the exception, because the same artist singing a number that had a title that was more familiar would doubtless create an even greater sale for an individual title.

At any rate, both sheet music and record sales are healthy and they have continued in such a state for a period that marks the present situation as a permanent trend, so both industries look at the situation as most gratifying.

a window display of the J. G. McCrorry Philadelphia store in which the title pages of the number are attractively arranged around a placard announcing "Irving Berlin's Master Song."

### Edward S. Cragin Passes on at the Age of 77

Well-known Figure in Music Field Had Been With the Charles H. Ditson Co. for Over Sixty Years—Popular in the Trade

Edward S. Cragin, of the Charles H. Ditson Co., and one of the best-known figures in the standard publishing business, died at his home on Thursday of last week after an illness of almost two years. Mr. Cragin was seventy-seven years old and for over sixty-two years he was associated with the Charles H. Ditson Co., joining that organization at the age of fifteen.

For the past two years Mr. Cragin had not been very active, although he kept in close touch with the music field. During his many years with the Charles H. Ditson Co. he not only rose to an important position in that organization, but every sphere of music activity felt his influence. His many associates in the music industry and his co-workers in the Ditson house not only regret his passing, but feel distinctly the loss of an unusual personality.

### "Georgia Stockade Blues"

The Edward B. Marks Music Co. has joined the ranks of those issuing funeral ditties. Its offering is called "Georgia Stockade Blues," written by Tom Delaney and said to be based upon the inspiration received through a colored prisoner in a Georgia stockade. Delaney ought to do the number well inasmuch as he is the composer of "Jass-it Blues," "Mournful Blues," "Down Home Blues" and "The Seven Years Itch."

**Three New Song Hits!!!**

*What Can I Say*  
**AFTER I SAY I'M SORRY?**  
Walter Donaldson's  
and Abe Lyman's  
Masterpiece  
FOX Trot Song

**TOO MANY PARTIES  
and  
TOO MANY PALS**  
The Dramatic Ballad  
Sensation  
by BILLY ROSE, MORT DIXON  
and RAY HENDERSON

**PRETTY LITTLE BABY**  
A Fascinating  
FOX Trot Song  
by BEN BERNIE  
PHIL BAKER and  
SID SILVERS

**"You Can't Go Wrong With Any 'FEIST' Song"**



**FIVE RECORD RECORD BREAKERS**

VENETIAN ISLES

THE ROSES BROUGHT ME YOU

TAKE THIS ROSE

WHEN AUTUMN LEAVES ARE FALLING

SOMEBODY'S EYES

ABOVE SONGS FEATURED BY ORCHESTRA AND VAUDEVILLE ACTS FROM COAST TO COAST  
**IRVING BERLIN INC., 1607 BROADWAY, NEW YORK**

**Cleveland Press Drive on Sam Fox "Footloose"**

Newspaper Uses Big Fleet of Trucks in Supplementary Campaign on Popular Number

The Sam Fox Publishing Co., of Cleveland, O., and New York, which sponsored the song "Footloose," in conjunction with the serial story of the same name, which ran in over eight hundred papers throughout the United States, is continuing its exploitation drive on this fox-trot and song despite the fact that the final instalments of the "Footloose" serial have appeared in the newspapers.

Seemingly, "Footloose" has much other value

tensive local advertising drives of this form ever made on a popular number.

**"Don't Wake Me Up" Is Proving a Good Seller**

"I'm Sitting on Top of the World" and "Sleepy Time Gal" Also Among the Feist Good Sellers

"Don't Wake Me Up" (Let Me Dream), one of the newer numbers added to the catalog of Leo Feist, Inc., has already made itself an important addition to that firm's publications. In the coming weeks its popularity should increase.

Of the other new numbers appearing in the Leo Feist catalog "I'm Sitting on Top of the

**William Ackerman Heads Ass'n of Music Men**

Other Officers Include W. Lutze, Vice-president; C. Schloz and T. Heinemann, Secretaries, and H. Trink, Treasurer

At the annual meeting of the Association of Music Men, the organization composed of members of the sales and stock departments of metropolitan standard music publishers, the following officers were elected for the ensuing year: William Ackerman, president; W. Lutze, vice-president; C. Schloz, recording secretary; T. Heinemann, corresponding secretary; H. Trink, treasurer. The board of directors is composed of H.



from a musical standpoint than the mere hook-up with the serial story. Of course, the publicity the number received through the extensive advertising in the columns of the press has given it an introduction that it would not have otherwise procured. The fact, however, that it continues in popularity after the co-operative publicity has been eliminated marks it as unusual.

We herewith show what is described as a fleet of trucks used as part of a supplementary publicity campaign by the Cleveland Press in conjunction with the "Footloose" drive in that city. This was probably one of the most ex-

Featuring the Marks Number "Footloose" World" and "Sleepy Time Gal" are already acknowledged national successes. Despite the fact that we are in the holiday period both of these numbers are having an increasingly large sale.

Among the other new numbers added to the Feist catalog which are already acknowledged successes are "Five Foot Two, Eyes of Blue" (Has Anybody Seen My Gal) and "When I Dream of the Last Waltz With You" and "Teach Me to Smile."

**"Love Bound" Favored**

The Sam Fox Publishing Co., New York and Cleveland, O., which recently released a new fox-trot song called "Love Bound," has arranged an exploitation program on this number through which it is planned to cover the entire country in a very short space of time. Sam Fox, who recently spent some days in New York conferring with the managers of the mechanical reproduction companies and others, found that the new song was looked upon with favor.

**Popular Waltz Recorded**

"Honeymoon Waltz," published by the Triangle Music Publishing Co., was recently recorded by Green Bros.' Marimba Orchestra for Victor records. This number is showing indications of being one of the most popular waltzes of the season and sales by dealers are proving very satisfactory.

C. Schulz, F. Schubert, J. Robinson, W. Froese and R. Banner.

There was a large attendance and the gathering was most enthusiastic. F. Schubert, retiring president, thanked the various committees and the members of the Association for their co-operation. President-elect Ackerman gave a short talk on the possibilities and the future activities of the organization.

**Irving Berlin, Song Writer, and Ellin Mackay Wed**

Irving Berlin, the noted composer and president of the music house bearing his name, Irving Berlin, Inc., recently married Ellin Mackay, daughter of Clarence Mackay of the Postal Telegraph & Cable Co. Despite the unusual publicity that followed this event in the daily papers and the annoyance of curiosity seekers the young couple are very happy.

**Open Niagara Falls Store**

BUFFALO, N. Y., January 7.—Waterson, Berlin & Snyder have opened a branch store at 106 Fall street, Niagara Falls, operating it in connection with the Buffalo store. Murray White-man will manage both stores. Besides sheet music, the store carries small instruments.

The E. B. Guild Music Co., Kansas City, Mo., has moved to new quarters at 1327 Grand avenue.

Just a question which one you like best—  
or to be very safe you can appreciate both of them

**Nothing Seems the Same**  
(Without You)  
Ballad Waltz

**Reaching for the Moon**  
Fox-Trot Ballad

Both Written by

**BENNY DAVIS**  
and  
**JESSE GREER**

Writers of  
**Hits!**

and published by  
"THE HOUSE OF HITS"

**EDWARD B. MARKS MUSIC CO.**  
New York City



## Perkins Copyright Bill Vests Right to Broadcast Music in Copyright Owner

Measure Introduced in the House of Representatives Codifies Copyright Law Thoroughly Covering the Latest Developments in This Field—Details of the Bill

WASHINGTON, D. C., January 6.—The exclusive right to broadcast copyrighted music is vested in the owner of the copyright, under a bill to codify the copyright laws introduced in the House of Representatives by Congressman Perkins, of New Jersey.

The measure provides for copyright of musical compositions, phonographic records, perforated rolls and other contrivances by means of which sounds may be mechanically reproduced, and vests in the copyright holder the exclusive right to copy, print, reprint, publicly produce, reproduce or transmit the copyright work in any form; to vend or otherwise dispose of such work and to authorize its public use in any manner or by any means whatsoever; to arrange or adapt copyright musical work; to communicate the copyright work to the public by means of radio broadcasting, telephoning or any other method for transmitting sounds; or to perform said work publicly, or to make any arrangement or setting of it or of the melody of it in any system of notation or any form of record in which the thought of an author may be recorded and from which it may be read or reproduced.

It is provided that nothing in the act shall

be construed to prohibit the performance of copyright musical works by churches or public schools, provided the performance is given for charitable, religious or educational purposes, unless a fee is charged for admission to the place where the music is so used.

The copyright of any work shall endure for the life of the author and for a period of fifty years after his death; in the case of phonographic records, rolls and other mechanical musical compositions, fifty years from the date the contrivance is first sold, offered for sale or otherwise publicly distributed.

In cases of infringement, restraining injunctions are provided, and the infringing person shall pay such damages to the owner of the right infringed as he may have suffered due to the infringement, as well as all the profits which the infringer shall have made from such infringement, and penalties are provided, the copyright owner having his choice of receiving damages of not less than \$250 nor more than \$5,000 as set by the court, or, in the case of musical compositions, \$100 for the first and \$50 for every subsequent infringing performance, or, in the case of other musical compositions, \$10 for every infringing performance.

## Feist Announces New Plans for Orchestrations

Retail Price to Be 50 and 75 Cents With Discounts to the Dealer Increased

On and after January 2 the retail price of Leo Feist, Inc., orchestrations will be 50 cents net for small orchestra or band and 75 cents net for full orchestrations. The wholesale discount to the trade has been increased, making possible a larger percentage of profit for the dealer.

The initial order price, which has always been a feature of the Feist orchestra sales plan, will be 20 cents for small orchestrations and 30 cents for full ones. This allows the Feist orchestra dealers a standing order at this price with the privilege of reordering in such quantities as the retailer needs at the same price within a period of ten days.

This move on the part of Leo Feist, Inc., was made necessary from the standpoint of good business practice, but at the same time it is a move that will be welcomed by the trade as it will make the orchestration departments more profitable adjuncts.

Leo Feist, Inc., has always been a pioneer in movements for the stabilization of both the wholesale and retail popular music business. The present move is one that should win the approval of every one in the trade, for it is based upon the necessity of having the band and orchestra department more self-supporting.

Most pioneer dealers will remember when orchestrations generally sold for around 55 cents. It was only the advent of the 10-cent stores and the distribution of music in their departments that finally reduced popular orchestrations to a 25-cent price. In those days orchestrations were in more simplified form and were issued for eleven-piece combinations, the cost of printing being approximately 2 cents.

In recent years in order to serve modern musical combinations, orchestrations were issued for sixteen pieces and they became elaborate publications, with solo effects for practically every instrument, extra choruses, and also special introductions. Formerly the music for each instrument was printed on one page. Now it invariably occupies two or more pages. Instead of eleven or sixteen-page orchestration we now generally have thirty-two pages.

Kincaide Furniture Store, Norfolk Downs, Mass., operates a fine department.

The present-day cost of printing orchestrations is generally estimated at 10 cents. From this it can be readily seen that there have been radical changes in methods, sizes and prices.

## "Love Bound" to Be Issued by Sam Fox

New Number by Harry D. Kerr and Carl Rupperto Be Backed by a Big Publicity Campaign

The Sam Fox Publishing Co., of Cleveland and New York, has just made a New Year's announcement of a new song called "Love Bound." This publication is now off the press and the trade has been notified that copies are available.

This seemingly is one of the most important additions in the song line made to the Sam Fox catalog in several seasons. Sam Fox himself made a trip to New York and is spending several weeks lining up mechanical reproduction companies, vaudeville performers, concert artists and other publicity channels in an arrangement for an exploitation drive on an intensive scale.

The Fox organization looks for "Love Bound" to have a spontaneous appeal and is most enthusiastic over its possibilities. The number has words by Harry D. Kerr and music by Carl Rupperto, both well-known writers who have been responsible for successes of the past. "Love Bound" is a fox-trot song which adapts itself readily to a beautiful ballad rendition. The arrangements and orchestrations are by J. S. Zamecnik.

The Fox organization expects "Love Bound" to take its place alongside of such successes as "Nola," "Indian Dawn," "Neapolitan Nights," "Footloose" and other Fox numbers that have achieved great success.

## Popular Berlin Number

"Then I'll Be Happy," the new popular number added to the catalog of Irving Berlin, Inc., and which aroused the enthusiasm of the whole Berlin organization through the results achieved in its try-out period, is to be given special emphasis by the publishers. For the next six or eight weeks the entire Berlin organization will exploit "Then I'll Be Happy" in a most intensive manner.

**You Can't Go Wrong With These FEIST Songs**

**"I'M SITTING ON TOP OF THE WORLD"**  
(Just Rolling Along)  
FOX TROT  
A Great Song by Great Writers!  
Lyric by LEWIS and YOUNG  
Music by RAY HENDERSON

**"FIVE FOOT TWO-EYES OF BLUE, HAS ANYBODY SEEN MY GIRL?"**  
NOVELTY FOX TROT  
Lyric by LEWIS and YOUNG  
Music by RAY HENDERSON

**"TEACH ME TO SMILE"**  
Don Bestor's Best  
FOX TROT  
Lyric by CLOYD GRISWOLD  
Music by DON BESTOR

**"I'M SO DISAPPOINTED IN YOU"**  
A Melodious Waltz Song  
Lyric by GUS KAHN  
Music by WALTER DONALDSON

**"SLEEPY TIME GAL"**  
A Wide Awake FOX TROT SONG!  
Lyric by J.R. ALDEN and RAY EGAN  
Music by ANGE LORENZO and DICK WHITING

**"When I DREAM OF THE LAST WALTZ with YOU"**  
GUS KAHN's and TED FIORITO'S Latest Waltz Hit!

**You Can't Go Wrong With Any FEIST Song**



## A New Year's Announcement of LOVE BOUND

### LOVE BOUND

Song—With Ukulele Arrangement



Words by  
Harry D. Kerr  
Music by  
Carl Rupp

Sam Fox Pub. Co.

Not just another song—  
but a real love melody, one  
with heart appeal and ir-  
resistible charm.

A fox trot song which  
will invoke spontaneous  
approval.

"Love Bound," written  
by Carl Rupp, with lyrics  
by Harry D. Kerr, has all  
the elements of a "hit"  
number.

The whole country will  
be singing and whistling  
"Love Bound."

This great number has  
just been released.

Order a liberal supply of  
copies but give "Love  
Bound" a big window dis-  
play.

**Sam Fox Pub. Co.**  
CLEVELAND NEW YORK

#### ADVANCE ORDER BLANK

SAM FOX PUBLISHING CO.  
Cleveland, O., U. S. A.,  
(New York Office: 158-160 W. 45th St.)  
Gentlemen:

Please send ..... Copies "LOVE  
BOUND" Song @ 16½c Per Copy. (15c  
in Hundred Lots.)

Name .....

Address .....

### "Barber Shop Ballads" Rights Taken by Marks

Company Secures Exclusive Sales Agency for  
Entire Music Trade on Sigmund Spaeth Book

The Edward B. Marks Music Co. has acquired exclusive sales agency for the entire music trade for Sigmund Spaeth's "Barber Shop Ballads." This publication has been given wide publicity through the series of contests held under the auspices of the Keith-Albee Vaudeville Circuit and various newspapers and other organizations. "Barber Shop Ballads," together with "Book of American Negro Spirituals," another publication for which the Marks firm holds the music trade distribution privileges, are important items for the retail store.

At the various conventions of the National Association of Sheet Music Dealers held during the past few years the question of how to get the most out of the sales of musical literature has been before that body. While it is true some of the largest houses carry a complete line of literature and books of every description covering every phase of music knowledge, history, etc., other dealers have overlooked the possibilities not only in the sale of such publications but in the service they can render their customers and the prestige that would be added to their establishments.

Take, for example, the two publications noted above. Both are sold by book stores everywhere. Certainly, they should be found in every retail establishment. Their sale is not only active and thus making it worth while, but it is most fitting that when interested parties want them, or similar publications, they should go to the music store. The retail dealer should not only stock all of the active publications, but he should have available a reference list carrying titles and descriptions as well as prices of everything extant in music literature.

### Feist to Issue Folio of Production Numbers

Leo Feist, Inc., has again evolved an original idea to encourage the sale of groups of songs from musical comedies. It has in preparation on its two shows "Castles in the Air" and "Merry Merry" (which are later to be followed by others) a folio of vocal gems from these musical productions. These include the hit songs of the shows, as well as several others, and the folios invariably contain some six to seven songs.

Doubtless this idea will win the approval of all musical comedy enthusiasts, at least those portions of the audiences which make frequent purchases of the song gems. The new folio will retail at \$1, and is in a form that places in the hands of the customer not only the best song numbers of the show but several other selections that, while appreciated, would hardly be purchased in single copy form.

It is thought that placing the vocal gems of successful musical comedies in these folios will add considerably to the grand total of sales of the music of these productions.

Therefore, there will be more profit for the dealer, publisher and larger royalties for the writers. To the piano player a collection of all the songs, or at least the best songs, from the current offerings all under one cover will be a good purchase. They invariably make one or two purchases of the outstanding successes in each show which at current retail prices totals 70 cents.

The new show, "The Cocoanuts," featuring the Four Marx Brothers, which recently opened in New York City, is hailed as one of the most entertaining attractions of the season. The music, which is by Irving Berlin, is fast gaining popularity and does much to make "The Cocoanuts" one of the most popular shows of several seasons.

### Henry W. Hart Succeeds J. L. Bratton With Schirmer

Widely Known Music Publicity Man to Direct  
Publicity Work of Well-known Publisher

Henry W. Hart has been appointed the successor of John Lilley Bratton in the advertising department of G. Schirmer, Inc. Mr. Bratton becomes American manager of Evans Bros., London publishers.

Henry W. Hart is known to many members of the trade and to all of those in the metro-



Henry W. Hart

politan area where his business life has been spent in publicity work for the music industry. Probably his most important activity in behalf of music propaganda was the opening under his direction of the first "music in the home" page, which appeared in the New York Evening Mail, April, 1916, and which was the forerunner of many similar music departments in daily publications throughout the United States and Canada.

Mr. Hart was the originator of "home music clubs," "noon hour concerts" and similar constructive activities. At one time he was associate editor with the Oliver Ditson Co., and was an executive member of the advertising division of Aeolian Co., as well as former advertising manager for Hardman, Peck & Co.

His experience covers both the artistic and commercial phases of music, in each branch of which he has carried out activities that have given him an important place.

He knows the industry in all of its branches, as he has been a part of it. In publicity work in the cause of music he certainly is the peer of all who have taken part in such activities. There is not the least doubt that as a member of the Schirmer organization, which covers so many fields of publication activities, his efforts and energies in behalf of the music trade in general and music dealers in particular will be an important factor. None is better qualified and he enters his new sphere with an outlook and enthusiasm which should produce constructive and permanent contributions for the general health of Schirmer and the publishing business.

### Arthur Lange Goes With Shapiro, Bernstein & Co.

Louis Bernstein, head of Shapiro, Bernstein & Co., Inc., announced recently the closing of an arrangement whereby Arthur Lange, the well-known arranger, will work exclusively for his concern for a period of two years.

The contract calls for the payment to Mr. Lange of \$25,000 each year, which is undoubtedly the largest salary ever given to a music arranger on an exclusive contract.



### Trade Activities in St. Louis Territory

**Excellent Holiday Business Creates Optimism in Retail Circles—Dealers Suffer From Shortage of Certain Instruments**

ST. LOUIS, Mo., January 8.—The measure of the Christmas talking machine business in St. Louis was the measure of getting the goods. Particularly the new Victors and the Brunswick Panatropes. The dealers sold all that they could get. When they had no more to sell they took orders, delivering other machines for temporary use, pending arrival of the ones ordered.

The radio business was strong throughout the year, growing in volume from month to month except during the Summer slow-down, and for Christmas was very large.

It was such a big year for the Artophone Corp. that as it drew to a close the officers of the firm found it necessary to look around for more room in which to further expand. It had already expanded as much as it could in the building of the Thiebes Music Co. at 1103 Olive street. It was necessary to go elsewhere with its wholesale department. A five-story building on Pine street west of Twelfth street has been chosen and as this is written negotiations have about been completed for a lease.

The Artophone Corp. is increasing its lines of small goods. Herbert Schiele and Ray Layer, vice-presidents of the firm, spent the last week of the month in Chicago making purchases. The department has only been in operation for six months but has been a pronounced success from the first. John Werle, who has not heretofore been in the music business, has been engaged by the Artophone Corp. for the city trade. Herbert Schiele and Ray Layer, who have been looking after this trade, will hereafter devote themselves more to executive work.

The piano department of the Famous-Barr Co. has been definitely discontinued and the entire space formerly occupied by the pianos and talking machines is now occupied by talking machines. Manager H. E. Pelta says the Christmas business was excellent in spite of the scarcity of the new Victors and Brunswicks.

A large business was done at the St. Louis and Kansas City offices of the Columbia Phonograph Co., in December, according to P. S. Kantner, manager.

Although the Columbia Co. has announced to the dealer the fact that there will be a new Columbia phonograph on the market that will be competitive in all respects to other new phonographs that are now appearing, at the same time, according to Mr. Kantner, the Columbia Co. is not going to make a mistake of advertising and announcing the sale of the new Columbia until the merchandise is actually on hand at the various branches.

When the new Columbia is ready for the market we are advised that it will be competitive in every respect and will be something that both the Columbia dealer and the public will be glad to see. The entire stock of the present line of Columbia phonographs has been satisfactorily disposed of at Kansas City and St. Louis and the dealers' stocks are in very good shape.

Mr. Kantner reports that practically all dealers over the territory have had a very favorable Christmas business in spite of the gen-

## The New Improved PET O FONE

MADE IN U. S. A.

### with One Piece Turntable

**TO RETAIL AT \$12**  
Usual Trade Discounts



*Does all a larger phonograph will do. Ready for action in a minute.*



*Weights 4 1/2 lbs. Made in black, red, green or blue fabricoid.*

Pet O Fone is a real portable talking machine. Camera size. Camera shape. New one-piece turntable. Good motor and loud, clear tone. Pet O Fone is an all-year-round seller.

*Distributors and Dealers write:*

**PET O FONE MFG. CO., 557 BROADWAY, NEW YORK**  
Chicago Representatives: Targ & Dinner, 229 West Randolph Street, Chicago, Ill.

eral upheaval of phonograph prices over the territory.

The report on Columbia records throughout the entire territory is one that gives everybody in the Columbia organization a great deal of satisfaction. Sales are simply increasing by leaps and bounds and it is difficult for the different branches to maintain sufficient organization to get the records out to the dealer on time. In other words, business is simply growing faster than the organization, but everyone is busy day and night and gradually catching up so that the service on Columbia records now is as near to 100 per cent as it is possible to get. The Columbia offices are receiving a great many compliments on the service they are giving, particularly on late numbers, and the comments over the territory in general are that Columbia is again assuming first place in getting hits to the dealers on time.

The Harmony record demand at St. Louis and Kansas City is growing very rapidly. Dealers all over the territory are beginning to realize the advantage of meeting the cheaper competition with a superior record at a price that is very acceptable to the public. Practically all Columbia dealers who are now featuring Harmony records are reporting not only increased profits from them but also increased sales on regular Columbia records.

Geo. C. Jell, from the general sales department at the executive office in New York of the Columbia Co., spent a few days in St. Louis calling on the trade, in promoting the Master Works series records of the Columbia catalog. This new Master Works catalog is being received with a great deal of appreciation on the part of the better dealers.

Every one of the Columbia offices as well as the Columbia dealers are looking forward to a very big year in 1926. A general sales meeting was held at the St. Louis office on December 26, for the purpose of formulating plans for the early part of 1926, details of which appear on another page of this issue.

### Irving Kaufman Recording for Banner and Domino

The Plaza Music Co., manufacturer of Banner and Domino records, announces that Irving Kaufman, well-known record artist, will in the future contribute monthly releases to these catalogs. Both the Domino and Banner catalogs are featuring many solo selections in addition to its monthly releases of dance numbers. The acquisition of Irving Kaufman to its contributing artists has met with widespread approval of Banner and Domino dealers as is demonstrated by the sales on his first releases, "Sleepy Time Gal" coupled with "I Wish That I'd Been Satisfied With Mary," and record of "Too Many Parties, Too Many Pals."



Irving Kaufman

The Raven Radio, Inc., manufacturer, of Albany and Cobleskill, N. Y., is in bankruptcy.

**TEST IT.** 

OUR VICTOR

## Record Service

has a reputation for efficiency.  
Suppose you try it.

**E. F. DROOP & SONS CO.**  
1300 G. STREET, WASHINGTON, D. C.  
204-6-8-10 CLAY STREET, BALTIMORE, MD.

## VAN VEEN WAREROOM EQUIPMENT

Quality material—careful workmanship and attractive appearance distinguish Van Veen equipment. Years of experience and specialization enable us to offer quality equipment at attractive prices

*Write for details and catalogue*

**VAN VEEN & COMPANY, Inc.,**

313-315 East 31st Street, New York City  
PHONE LEXINGTON 9956-2163



### Importance of Foreign Market as Radio Outlet

Radio Handled by Representatives for Varied Lines of Merchandise—An Important Market, Says A. Atwater Kent

PHILADELPHIA, PA., January 4.—International test week has drawn more attention to the national aspect of radio and how it reaches the out-of-the-way parts of the world. A. Atwater Kent, president of the Atwater Kent Mfg. Co., of this city, manufacturer of radio receiving sets and radio speakers, has made a recent study of this subject which reveals that the radio set is taking its place with needles and pins, textiles and hardware as a staple article of importation in many lands.

A partial list of Atwater Kent foreign representation well illustrates this fact.

Atwater Kent's representatives in Madras, India, for instance, also conduct a dressmaking and millinery business and sell house furnishings. In Tokio, Japan, they also import Baldwin locomotives, concrete mixers, steam rollers, machine tools, oil engines, electrical supplies, general groceries and hardware. The largest radio importer in Central America also handles cotton goods, champagne, Scotch whiskey and American-packed meats. Similar conditions, revealing radio equipment as a staple article of import, are found in Burma, Australia, Portuguese East Africa, New Zealand, Egypt, China, British East Africa and even in the Fiji Islands.

It is from the owners of sets in these far-away parts of the world, as well as from fans in Continental Europe and North and South America that the results of radio test week will be awaited.

The growing importance of the foreign market as a field for American radio equipment, Mr. Kent believes, is indicated by the fact that exportations for 1925 approximated in value \$8,000,000 as against \$500,000 in 1920.

In Japan, for instance, while the populace is enthusiastic about radio, the government looks at it a bit askance. It is feared the air may open a path for the dissemination of Bolshevist

doctrines by Russia. Sets, therefore, are sealed, so that they may only tune in on certain definite Japanese stations.

In China, the Philippines, South Africa, Turkey, Siam and Asia generally, lack of sufficiently powerful broadcasting stations has been the chief obstacle. There is also, in many of these countries a shortage of local talent to provide programs. Only where their receiving sets are able to tune in on far distant stations can many of the radio owners in these countries enjoy entertainment of any quality, quantity and variety. To what extent they are actually able to do this, the test week of January 24 will demonstrate.

### Now Vice-President Cotter

Effective January 1, Earl R. Cotter for three years associated with the sales promotion department of Sternfield-Godley, Inc., New York advertising agency, became vice-president of the company. This agency is well known in the radio industry, having a number of important accounts among manufacturers and wholesalers as well as several large retail radio accounts. Among the manufacturers whose advertising the agency directs are the Fahnestock Electric Co.; National Electric Novelty Co.; Racon Electric Co.; Barbley's Radio Service; Bruno Radio Corp.; R. B. Radio Co. and the English & Whitman Products Co.

### "Brandes Broadcast" Out

Many splendid letters from wholesalers and retailers, telling of the remarkable results achieved by the Brandes line of loud speakers, were featured in the latest issue of "Brandes Broadcast," the house organ of the Brandes Products Corp. The company was felicitated particularly upon the new Model "H" speaker.

Renovations are being made at the store at 332 Locust street, Columbia, Pa., which when completely remodeled will be occupied by Emery's Music House.



\$100

\$100

The  
Henderson  
TYPE 101A  
Radio Tube

Henderson tubes are being used by discriminating radio enthusiasts throughout the United States, Europe and the Orient.

Guaranteed uniform—50% longer life  
"Best for quality and distance"

Mutual conductance—750  
Amplification constant—9  
Plate impedance—12,000

Standard type—101A—5 volts—1/4 amp.

Dealers wanted everywhere

HENDERSON BROTHERS

Manufacturers of Henderson Receivers  
93 Federal Street Boston, Mass.

## WORLD'S CLASSIFIED ADVERTISING

Any member of the trade may forward to this office a "Situation" advertisement intended for this Department to occupy a space of four lines, agate measure, and it will be inserted free. Replies will also be forwarded without cost. Additional space will be at the rate of 25c. per line. If bold faced type is desired the cost of same will be 25c. per line. Rates for all other classes of advertising on application.

#### FOR SALE

Or will sell an interest to capable manager. Music store. Established 20 years. Centrally located. Good lease. Live little city of 10,000. Fine surrounding country. Only one other music store within 145 miles. Splendid exclusive agencies of pianos, phonographs and radios. Splendid opportunity. Reason for selling. Address "Box 1548," care of The Talking Machine World, 383 Madison Ave., New York.

#### FOR SALE

Going Victrola and music store in suburb of Pittsburgh. Must sell to close estate. Will sacrifice stock and fixtures for \$5,000. Excellent lease. Communicate Wallace Russell, 305 Penn Ave., Pittsburgh, Pa.

#### WILL BUY

What phonograph supplies or accessories you have for sale. Write all information in your first letter to "Box 1545," care of The Talking Machine World, 383 Madison Ave., New York City.

#### NEW YEAR SALE

Various types of main springs, three for \$1. Write for booklet showing sizes, etc. Also main spring for Edison machines, 1 1/2 inches, \$1 each. Order now! Going fast!

PLEASING SOUND PHONOGRAPH CO.  
204 East 113th St. New York City

**POSITION WANTED**—Financial manager, of seasoned experience in radio manufacturing. Can assume entire responsibility in connection with Federal taxes, accounting, time sales payment plans, collections and corporate management. Unqualified references. Address "Box 1547," care of The Talking Machine World, 383 Madison Ave., New York City.

**POSITION WANTED**—Salesman selling musical trade in Middle West desires change. American, 28. Address "Box 1136," City Hall Station, New York City.

**POSITION WANTED**—Victrola service repair man and polisher. Can give best of references, wishing good position. Address "Box 1549," care of The Talking Machine World, 383 Madison Ave., New York, N. Y.

**POSITION WANTED**—Phonograph repair man, inside or outside, repairing motors, looking for good position with leading house. Address "Box 1550," care of The Talking Machine World, 383 Madison Ave., New York, N. Y.

**POSITION WANTED**—Advertising, Sales, Distribution Manager. A prominent advertising manager formerly connected with one of the largest radio manufacturing houses in the country will now consider an offer from radio manufacturers interested in securing his knowledge and experience. Thoroughly familiar with all details of radio advertising, sales and distribution and also well experienced in advertising copy, booklet layout and writing. Address "Box 1544," care of The Talking Machine World, 383 Madison Ave., New York City.

**POSITION WANTED**—Southern Representative. Party available who is thoroughly experienced in all branches of the music industry. Can qualify as branch manager because of past experience, or will consider direct factory connection as traveling representative. Have all essentials necessary to put proposition over successfully. Address "Box 1546," care of The Talking Machine World, 383 Madison Ave., New York City.

### Luncheon to Louis J. Unger

The Brilliantone Steel Needle Co., New York City, sole selling agent for Bagshaw needles, tendered a farewell luncheon to Louis J. Unger at the McAlpin Hotel. Mr. Unger was formerly sales manager of the Brilliantone Co. and left that organization to enter the real estate business for himself.

Mr. Unger's retirement was on the last day of the year and accordingly the luncheon was set on that date. Harry W. Acton, head of the Brilliantone organization, gathered its members together and presided.

Among those present in addition to the honored guest and Mr. Acton were Irving Unger, a brother, Sydney Risser, John Stern and Miss Shaw.

### SPRINGS

<b>VICTOR</b>	
1 1/2"x.022x17', bent each end.....	No. 6543 \$ .57
1 1/2"x.022x18' 6" marine ends.....	No. 3014 .57
1 1/2"x.022x17' bent arbor.....	No. 5362 .56
1 1/2"x.022x13' bent arbor.....	No. 5423 .48
1 1/2"x.022x9' bent arbor.....	No. 5427 .38
1 1/2"x.022x9', bent each end.....	No. 6542 .38
1"x.020x13' 6" marine ends.....	No. 2141 .35
1"x.020x15' marine ends.....	No. 3335 .38
1"x.020x15' bent arbor.....	No. 5394 .39
1"x.020x15', bent at each end.....	No. 6546 .39
<b>COLUMBIA</b>	
1"x.028x16' crimp arbor, new style.....	No. 20009 .61
1"x.028x10' Universal.....	No. 2951 .32
1"x.028x11' Universal.....	No. 2951 .36
1"x.030x11' hook ends.....	No. 1219 .40
1"x11' for motor No. 1.....	No. 1219 .34
<b>HEINEMAN</b>	
1"x.025x12' motors, Nos. 33 & 77.....	.35
1 3/16"x.026x19', also Pathé.....	.70
1 3/16"x.026x17'.....	No. 4 .60
<b>SAAL-SILVERTONE</b>	
1"x.027x10', rectangular hole.....	No. 144 .39
1"x.027x13', rectangular hole.....	No. 145 .45
1"x.027x16', rectangular hole.....	No. 146 .53
Terms, 2% cash with order.	

**TALKING MACHINE SUPPLY CO., PARK RIDGE, N. J.**  
Complete catalogue on request





# EUROPEAN HEADQUARTERS

2 GRESHAM BLDG., BASINGHALL ST., E.C. LONDON



## British Trade Factors Enjoy Big Sales Volume in the Closing Weeks of the Year

Manufacturers Working Day and Night to Supply the Demands of Dealers Who Are Moving Merchandise as Rapidly as It Is Delivered to Them—News Activities of the Month

LONDON, E. C., December 30.—My last two or three reports may have appeared overwhelmingly optimistic in regard to the position of affairs in talking machine circles in this country, but even those reports fail adequately to give a correct impression of the tremendous business done these last few weeks. The trade here has never known such a time and it has been a perfect pleasure to call on manufacturers and dealers, though the time they have been able to give to interested callers has been very small. Despite much augmented staffs, the overwhelming rush of orders, by post, telephone and telegraph, as well as personal calls, made it impossible to cope with, and manufacturers and wholesalers are still working at the highest pressure to fulfill Christmas orders in addition to the abnormally heavy demands for the New Year festivities. The big companies have been literally working day and night and, in fact, to my knowledge the huge factories of the Gramophone Co. at Hayes have only slackened between the hours of two o'clock on Sunday afternoons and seven o'clock on Monday mornings. In years past it has been customary to very much slacken down in the New Year, but this coming year promises such activity as to easily eclipse all previous records, a most satisfactory situation for the trade.

### A New Association

A new association was recently formed by leading importers of pianos, but whose articles of association and policy permit the inclusion, in membership, of importers of Gramophones and records, as well as importers of musical goods generally. Known as "The Association of Importers of Musical Instruments," the announced policy is as follows:

- (a) To work for the abolition or reduction of the McKenna duties.
- (b) To establish to the fullest possible extent friendly relations with the Federation of British Music Industries, and favorably to consider any suggestions for the improvement of trading conditions which may emanate from the aforesaid Federation.
- (c) Generally to safeguard the interests of those engaged in the importation of musical instruments and accessories.

The president of the Association is A. W. Whelpdale, managing director of Messrs. Bluthner & Co., Ltd., the famous pianoforte manufacturers, and the temporary committee includes members of the leading French and German importing houses. At the moment, importers of gramophones, records and parts remain outside the new association, the greater number already being members of the Association of Gramophone and Musical Instrument Manufacturers and Wholesale Dealers, which is affiliated with the Federation of British Music Industries. It is questionable, therefore, if this latter association could adequately look after the interests of those members who largely import, and so it would appear extremely probable that the new association, formed specifically to look after importing interests, would attract members from the Gramophone industry.

### The British Industries Fair

The 1926 British Industries Fair, to be held at the White City from February 15 to 26, promises to be the largest Trade Fair ever held in this country, and reports from the organizers, the Department of Overseas Trade, already show an increase of applications for space over that of all previous years. In the Music Section, which is again being organized by the Federation of British Music Industries, over forty

manufacturers have definitely booked space, and a number of others have indicated their intention of participating. The following members of the Gramophone industry have applied: Boumphrey Arundel & Co., Ltd. (record cabinet makers); Collaro, Ltd. (Collaro Motors); Craies & Stavridi (makers of the well-known Apollo models); the Garrard Engineering Co. (the famous Garrard motor makers); the Johnson Talking Machine Co., Ltd.; the Linguaphone Institute (language records); Perophone, Ltd. (makers of the ubiquitous Pixie Grippa models); Regent Fittings Co. (makers of the Rifanophones); the S. M. T. Gramophone Co.; Smith & Co. (Gramophones) Ltd. (makers of the Itonia models), and the Vocalion Gramophone Co., Ltd.

The Fair has always attracted a considerable number of foreign buyers and this year the Government is all out to encourage visits from abroad, and the Foreign Office has announced that holders of the official invitation cards may have their passports to England visaed without any charge being made.

### "His Master's Voice" in Berlin

The Gramophone Co., Ltd., has always enjoyed an international reputation and its European activities have never been confined to one or two countries. Now comes the news that, in addition to the handsome premises occupied by them in the Leipzigerstrasse, Berlin, a tremendous factory and grounds have been acquired in the West End of Berlin and closely adjacent to the late Kaiser's palace in Potsdam. The factory will be known as Electrola Gesellschaft, and I hope to be able to give further details of this new venture in my next report.

### A Pocket Gramophone

In size about 10½ inches by 5½ by 3 inches, the latest Peter Pan model just introduced here is probably the smallest ever known, and is cer-

tainly the first on this market in the shape of a folding camera. There have been a multiplicity of portable models of novelty dimensions, but the new Peter Pan is unique. It is fitted with a swan-neck tone-arm, which is fitted by a very simple device to a revolving amplifier and reflector. The motor is of fine grade Swiss make as is also an improved method of turntable adjustment. The model is handsomely finished and retailing at the astonishingly low price of £3 5s. A de Luxe grade is also made covered in hide or crocodile, fitted with worm-driven motor, and priced at £4 5s. I understand that the company had a record demand for the new models during the Christmas rush and that they are working at full pressure on the accumulation of unfilled orders, which will carry the firm well into the new year.

### Brief Paragraphs of Interest

The British Legion has received from the His Master's Voice Gramophone Co. a cheque for £1,545 representing the profits up to 30 of June last on the sale of the record of the speech on "Sportsmanship," which the Prince of Wales made last year. The further royalties now accruing will be added to this sum for Poppy Day, 1926.

H. L. Rink, of the Gramophone Co., Ltd., has conducted some thirty gramophone recitals in various parts of England since September last, at which it is calculated there has been an aggregate attendance of over 50,000 people.

Gramophone shares on the market! These reflect the very healthy condition of the leading companies and indicate the activity of the trade generally. Columbia 10s shares now stand at 39/6; the Gramophone Co.'s £1 shares (ordinary) being in the region of 51/9 and 52/-—round which figures they have fluctuated for some weeks.

The outstanding musical recordings of the month have been the Columbia issue of Max Bruch's Concerto in G minor, for violin and orchestra (in six parts) with Albert Sammons as solo artist, and His Master's Voice recording of Tchaikowsky's Symphony No. 4 in F minor, played by the Royal Albert Hall Orchestra, under Sir Landon Ronald (on five double-sided discs.)



**SONGSTER**

**The Pinnacle of Perfection**

Songster means perfect needles—perfect in manufacture, perfect points and perfect tone; in fact, made up to the standard of perfection itself.

**There's money in Songsters**  
—the repeat order needle  
—and your customers will ask for them again and again.

There's a Songster to suit every taste

Ask about our facsimile business cards which are printed with your name and address and inserted in each Songster box. The Songster Collar Needle is the Loudest on Earth.

**Supplied by all the Leading Factors**

**J. STEAD & CO., Ltd., Makers**  
MANOR WORKS SHEFFIELD, ENGLAND

Once a User Always a User



# LATEST PATENTS RELATING TO TALKING MACHINES AND RECORDS

WASHINGTON, D. C., January 7.—Record Repeater for Sound Reproducing Instruments. Rudolph Blash, Chicago, assignor to Edgar S. Byers, Cleveland, O. Patent No. 1,556,667.

This invention relates to a device in the nature of an attachment for a sound reproducing instrument employing records in the form of a disk, its purpose being to produce automatically a repetition of sound from any desired portion of the record.

In the construction of the present device it has been sought to employ parts which are simple and inexpensive to manufacture, and which are certain in their operation as well; and further to so arrange and design the several parts of the device that it may be readily attached in place so as to function with certainty.

Fig. 1 is a perspective view, showing the present device operatively connected with the sound reproducing parts of a talking machine; Fig. 2 is a detail showing one form of roller bracket attached to the sound box; Fig. 3 shows

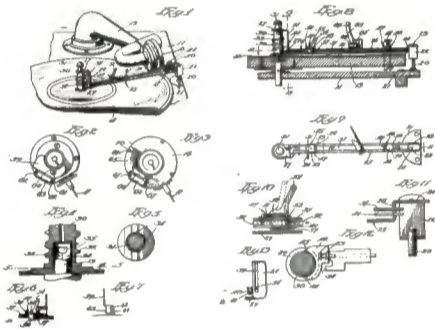

another form of roller bracket secured to a sound box; Fig. 4 is a vertical section through the post in connected relation with the turntable spindle; Fig. 5 is a section taken on line 5—5 of Fig. 4; Fig. 6 is a fragmentary detail showing in side elevation one of the stops in its relation to the roller bracket shown in Fig. 3; Fig. 7 is a side elevation of the roller bracket shown in Fig. 2; Fig. 8 is a transverse view through the turntable showing the repeating attachment arranged operatively thereupon; Fig. 9 is a plan view of the device; Fig. 10 is an enlarged detail in section taken on line 10—10 of Fig. 9; Fig. 11 is an enlarged detail in section taken on line 11—11 of Fig. 9; Fig. 12 is an enlarged detail in plan taken on line 12—12 of Fig. 8, and Fig. 13 is a section taken on line 13—13 of Fig. 8.

Radio and Phonograph Amplifying Resonator. Wm. C. Larson and Charles P. Wegner, Two Harbors, Minn. Patent No. 1,558,189.

This invention relates to radio speakers and phonographs, and the primary object is to provide an improved horn or sound amplifying compartment, so constructed as to first, preserve the delicate overtones or partials and to prevent the damping or smothering thereof by the harsher fundamentals or full notes; second, to reflect back the sound waves into the sound chamber giving additional volume to the overtones; third, the breaking up of prolonged or pronounced reverberations, which often cause, in vocal selections particularly, blurred or jumbled words; fourth, the return of filtered vibrations resulting in the damping of short sound waves which are one of the principal

causes of friction noises; fifth, the creation of a perfect balance in the functioning power of the various parts or segments of the horn resulting in the elimination of discordant vibrations, and, sixth, the giving of a sound of great volume, clear and mellow, resulting from the overlapping columns of sound waves passing to and fro in the horn.

Another prime object of the invention is to provide an improved horn or sound amplifying compartment surrounded by closed air chambers or compartments, the closed air compart-

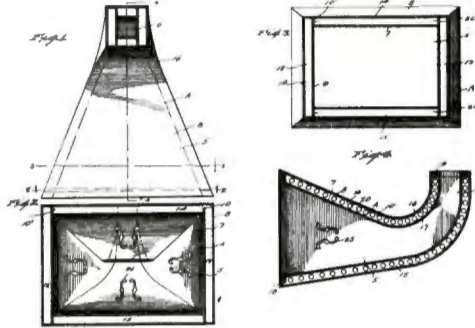

ments or chambers functioning to insure the proper balance of tone, and to preserve the delicate overtones that would otherwise be damped out.

A further object is to provide a horn or sound amplifying compartment having each wall or segment thereof provided with a closed air chamber or compartment, which prevents the leakage of the sound waves from the tone or amplifying compartment or chamber and which can be incorporated with the ordinary types of phonographs and radio speakers.

Fig. 1 is a plan view of the improved horn or sound amplifying member, the throat thereof being shown in section; Fig. 2 is a transverse section through the sound amplifying horn taken on the line 2—2 of Fig. 1 looking in the direction of the arrows; Fig. 3 is a similar section taken on the line 3—3 of Fig. 1 looking in the direction of the arrows; Fig. 4 is a longitudinal section through the improved horn taken on the line 4—4 of Fig. 1.

Phonograph. Herman Rothkirch, New York, N. Y. Patent No. 1,558,048.

This invention relates to phonographs and has for its object to provide such instruments with a tone arm constructed entirely of wood

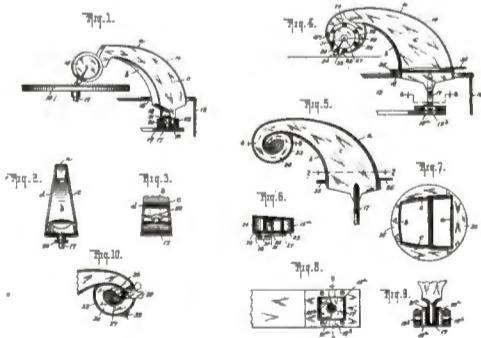

in a novel manner and whereby all objectionable and foreign noises are eliminated from the reproduction of the record. A further object is to provide such a tone arm with a reproducer constructed as an integral part thereof and consisting, excepting as to the diaphragm and needle arm, also entirely of wood.

The present application is, in part, a continuation of another application filed in the United States Patent Office on or about April 7, 1921, Serial No. 459,300.

In the accompanying drawings Fig. 1 is a perspective view of the improved tone arm and so much of a phonograph as is necessary to illustrate the invention; Fig. 2 is an end elevation of the tone arm; Fig. 3 is a fragmentary,

inverted plan view thereof; Fig. 4 is an elevation of the combined tone arm and reproducer, with parts in section; Fig. 5 is a longitudinal section thereof; Fig. 6 is a section on the line 6—6 of Fig. 4; Fig. 7 is a section on the line 7—7 of Fig. 4; Fig. 8 is a similar view on the line 8—8 of Fig. 4; Fig. 9 is a detail section on the line 9—9 of Fig. 8; and, Fig. 10 is a detail section illustrating a sound controlling device which may form a part of the construction.

Record Repeater for Sound Reproducing Instruments. Rudolph Blash, Chicago, Ill., assignor to Edgar S. Byers, Cleveland, O. Patent No. 1,556,668.

This invention relates to a device in the nature of an attachment for a sound reproducing instrument which employs disc records, its purpose being to produce automatically a repetition of sound from any selected portion of the record.

Fig. 1 is a fragmentary plan view of a talking machine, exhibiting the present device in operative relation to the sound reproducing parts; Fig. 2 is a transverse section through the turntable taken on line 2—2 of Fig. 1, exhibiting the device in side elevation; Fig. 3 is a

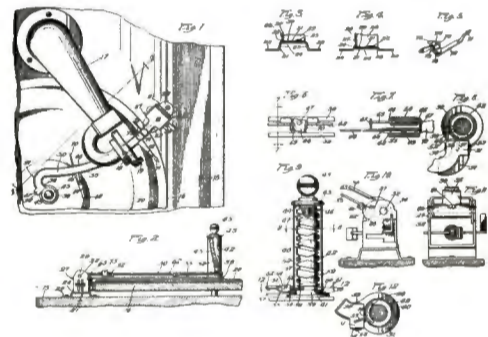

detail in section showing the connection between the base and hinge frame; Fig. 4 is a similar view, exhibiting a base of lower elevation; Fig. 5 is a detail in perspective of the outer stop which co-operates with the needle of the sound box; Fig. 6 is an elevation of the inner stop looking toward the handle end; Fig. 7 is a transverse section through the track bar and associated parts, exhibiting the same stop; Fig. 8 is a horizontal section through the rotatable post, showing the relation of the parts co-operating therewith as they appear at an elevation such as is indicated by the line 8—8 of Fig. 9; Fig. 9 is a side elevation of the rotatable post enclosed within its protective casing, this latter part being exhibited in section; Fig. 10 is a side elevation of the hinge frame, showing the means for frictionally holding the track bar in elevated position; Fig. 11 is a front elevation of the hinge frame; and Fig. 12 is a transverse section through the rotatable post taken on line 12—12 of Fig. 9.

## Salesmanship

S-elling's not just talking  
 A-nd getting folks to buy;  
 L-eading them to want something,  
 E-xplaining how and why.  
 S-alesmanship is more than that,  
 M-ore work and more fun, too:  
 A-dvancing modern methods—  
 N-ew ways, but tried and true—  
 S-ervice given, willingly  
 H-ard work—a cheerful grin—  
 I-t's making friends, for that is what  
 P-uts you in line to win!

—Direct Reflections.

O. E. Carr, who formerly conducted a music store in Hawthorne, Cal., is now located at 204 East Queen street, Inglewood, Cal.

**SOUTHERN  
 VICTOR WHOLESALERS**  
*The Corley Company*  
 RICHMOND VIRGINIA



# Advance RECORD BULLETINS for February, 1926

## Victor Talking Machine Co. LIST FOR DECEMBER 31

- 19765 Mah Lindy Lou.....Philadelphia Male Quartet 10
- Ole Uncle Moon.....Philadelphia Male Quartet 10
- 1925 Safe in the Arms of Jesus.....Henry Burr 10
- Trust and Obey.....Henry Burr 10
- 19829 Devotion (Adapted to the Intermezzo from "Cavalleria Rusticana") (Mascagni), The Mormon Tabernacle Choir 10
- By the Waters of Minnetonka (Lieurance), The Mormon Tabernacle Choir 10
- 19837 The Lightning Express.....Vernon Dalhart 10
- The Letter Edged in Black.....Vernon Dalhart 10
- 19848 Bam, Bam, Bammy Shore.....The Revelers 10
- There Ain't No Flies on Auntie, The Happiness Boys 10
- 35760 The Lost Chord—Pipe Organ, The Organ of the Mormon Tabernacle 12
- Great Is Jehovah (Schubert—Arr. by Parks), Jessie Williams and Mormon Tabernacle Choir 12
- 55288 Die Meistersinger—Prize Song, Tudor Davies and Chorus with Symphony Orch. 12
- Die Meistersinger—Finale of Opera (Disdain Our Masters Not, My Friend) Robt. Bradford and Chorus with Symphony Orch. 12
- 19835 Illinois Loyalty—March, University of Illinois Military Band 10
- Hail to the Orange and Oskee Wow Wow, University of Illinois Military Band 10
- 19842 National Emblem March...Arthur Pryor's Band 10
- "Lights Out" March.....Arthur Pryor's Band 10
- 19764 Imi Au Ia Oe (For Thee I Am Searching), Victor Salon Orch. 10
- Beautiful Kahana.....Victor Salon Orch. 10
- DANCE RECORDS**
- 19850 Five Foot Two, Eyes of Blue—Fox-trot, Art Landry and His Orch. 10
- Don't Wait Too Long—Fox-trot, Art Landry and His Orch. 10
- 19851 You Told Me to Go—Fox-trot, Roger Wolfe Kahn and His Hotel Biltmore Orch. 10
- Spanish Shawl—Fox-trot, Edwin J. McEnelly's Orch. 10
- RED SEAL RECORDS**
- 6550 Kujawiak (Wieniawski).....Cecelia Hansen 12
- Hejre Kati (Hubay, Op. 32, No. 4), Cecelia Hansen 12
- 1123 Damnation of Faust—Mephistopheles' Serenade (Berlioz).....Marcel Journet 10
- Jolie Fille de Perth—Quand la flamme de l'amour (De Flame of Love) (Bizet), Marcel Journet 10
- 1122 Song of the Volga Boatmen—Paraphrase (Arr. by Kreisler).....Fritz Kreisler 10
- Negro Spiritual Melody (Dvorak-Kreisler), Fritz Kreisler 10
- 1127 A Victory Ball—Fantasy—Part 1 (Schelling), Willem Mengelberg and N. Y. Phil. Orch. 10
- A Victory Ball—Fantasy—Part 2 (Schelling), Willem Mengelberg and N. Y. Phil. Orch. 10
- 1128 A Victory Ball—Fantasy—Part 3 (Schelling), Willem Mengelberg and N. Y. Phil. Orch. 10
- A Victory Ball—Fantasy—Part 4 (Schelling), Willem Mengelberg and N. Y. Phil. Orch. 10
- 1124 Melody (Gluck-Spambati)...Sergei Rachmaninoff 10
- Turkish March (Rondo alla Turca) (Mozart), Sergei Rachmaninoff 10
- 1126 Madrigal Espanol (Campero-Huarte)—Spanish, Tito Schipa 10
- La Farfalletta (2) La Girometta (Sibella)—Italian, Tito Schipa 10
- EDUCATIONAL RECORDS**
- 19830 Songs for Children.....Alice Green 10
- 1. Frog and the Mouse. 2. The Tailor and the Mouse. 3. The Frog He Would a-Wooing Go. Songs for Children.....Alice Green 10
- 1. Bow-wow. 2. Song of the Cricket. 3. Good Morning. 4. A True Story. 5. My Pony. 19831 Songs for Children.....Alice Green 10
- 1. The Fiddle Song. 2. Dancing Song. 3. The Bee. 4. The Clock. 5. Who Has Seen the Wind? Songs for Children.....Alice Green 10
- 1. My Old Dan. 2. Honk! Honk! 3. Cradle Song. 4. Soldier Boys. 5. Wing Foo. 6. The Zoo. **FEATURE RECORD**
- 19788 Collegiate.....The Revelers 10
- I'm Gonna Charleston Back to Charleston, The Revelers 10
- LIST FOR JANUARY 8**
- 19856 I "Wanna" Go Where You Go—Do What You Do Then I'll Be Happy.....Jack Smith 10
- Are You Sorry?.....Jack Smith 10
- 19857 Save Your Sorrow (For To-morrow), Gene Austin 10
- Cross My Heart, Mother.....Henry Burr 10
- 19858 The Camel Walk—Fox-trot, Art Landry and His Orch. 10

- Everybody Stomp—Fox-trot, Art Landry and His Orch. 10
- 19859 Clap Hands, Here Comes Charley!—Fox-trot, Jack Shilkret's Orch. 10
- Sugar Plum—Fox-trot, George Olsen and His Music 10
- 19860 A Little Bungalow—Fox-trot, Roger Wolfe Kahn and His Hotel Biltmore Orch. 10
- Lucky Boy—Fox-trot, Roger Wolfe Kahn and His Hotel Biltmore Orch. 10
- FEATURE RECORD**
- 6547 Flying Dutchman—Overture—Part I (Wagner), Willem Mengelberg and N. Y. Phil. Orch. 12
- Flying Dutchman—Overture—Part II (Wagner), Willem Mengelberg and N. Y. Phil. Orch. 12
- LIST FOR JANUARY 15**
- 19863 No Man's Mamma.....Aileen Stanley 10
- Mighty Blue.....Aileen Stanley 10
- 19864 I Wonder Where My Baby Is To-night? Henry Burr-Billy Murray 10
- I Never Knew.....Gene Austin 10
- 19865 That Certain Party.....The Happiness Boys 10
- Why Aren't Yez Eatin' More Oranges?, The Happiness Boys 10
- 19866 Down and Out Blues—Fox-trot, Roger Wolfe Kahn and His Hotel Biltmore Orch. 10
- Swamp Blues—Fox-trot, Art Landry and His Orch. 10
- 19868 Miami (From "Big Boy")—Fox-trot, George Olsen and His Music 10
- Here in My Arms (From "Dearest Enemy")—Medley Fox-trot.....Jack Shilkret's Orch. 10
- 1121 You Forgot to Remember (Berlin), John McCormack 10
- Oh, How I Miss You To-night (Davis-Burke), John McCormack 10
- LIST FOR JANUARY 22**
- 19897 Song of the Vagabonds, Dennis King and Victor Light Opera Co. 10
- Only a Rose.....Carolyn Thomson 10
- 19899 Sleepy Time Gal.....Gene Austin 10
- Five Foot Two, Eyes of Blue.....Gene Austin 10
- 19896 Fond of You—Medley Fox-trot, George Olsen and His Music 10
- Journey's End—Fox-trot, George Olsen and His Music 10
- 19898 Beside a Sil'ry Stream—Fox-trot, Herbert Berger's Coronado Hotel Orch. 10
- Good Night—Fox-trot, Herbert Berger's Coronado Hotel Orch. 10
- FEATURE RECORD**
- 6508 Waltz in E-flat (Durand)—Piano, Harold Bauer 12
- A la Bien Aimee—Waltz (To My Beloved) (Schutt)—Piano.....Harold Bauer 12

## Columbia Phonograph Co.

- CELEBRITY RECORDS**
- 4034-M Barbieri Di Siviglia "Se il mio nome saper" (Would You Know Who Sighs 'Neath Your Window?) (Rossini)—Tenor Solo, Charles Hackett 10
- Tosca "Recondita armonia" (Strange Harmonies) (Puccini)—Tenor Solo, Charles Hackett 10
- 116-M Absent (Metcalfe-Glen)—Mezzo-Soprano Solo, Barbara Maurel 10
- All Through the Night—Mezzo-Soprano Solo, Barbara Maurel 10
- 117-M Because (Guy d'Hardelot)—Tenor Solo, Rafaelo Diaz 10
- How dy do, Mis' Springtime (Guion-Gordon)—Tenor Solo.....Rafaelo Diaz 10
- DANCE MUSIC**
- 517-D Song of the Vagabonds (From "The Vagabond King")—Fox-trot, Leo Reisman and His Orch. 10
- A Cup of Coffee, a Sandwich and You (From "Charlot's Revue of 1926")—Fox-trot, Leo Reisman and His Orch. 10
- 522-D Show Me the Way to Go Home—Fox-trot, with Incidental Singing by the Orchestra, California Ramblers 10
- Then I'll Be Happy—Fox-trot, California Ramblers 10
- 516-D Sleepy Time Gal—Fox-trot, Ross Gorman and His Orch. 10
- I Never Knew—Fox-trot, Ross Gorman and His Orch. 10
- 523-D Clap Hands, Here Comes Charley!—Fox-trot, with Incidental Singing by Johnny Morris, The Georgians 10
- Spanish Shawl—Fox-trot.....The Georgians 10
- 524-D I Love My Baby (My Baby Loves Me)—Fox-trot.....The Little Ramblers 10
- In Your Green Hat—Fox-trot, with Incidental Singing by Arthur Hall, The Little Ramblers 10
- 509-D TNT—Fox-trot, Fletcher Henderson and His Orch. 10
- Carolina Stomp—Fox-trot, Fletcher Henderson and His Orch. 10
- 507-D Miami (From "Big Boy")—Fox-trot, Clyde Doerr's Saxophone Orch. 10
- Someone's Stolen My Sweet, Sweet Baby—Fox-trot.....Clyde Doerr's Saxophone Orch. 10
- 510-D It Must Be Love (From "Merry Merry")—Fox-trot.....Harry Reser's Syncopators 10
- Fond of You (From "Captain Jinks")—Fox-trot.....Harry Reser's Syncopators 10
- 503-D Paddlin' Madelin' Home—Fox-trot, (S. C. Lanin, Dir.) Ipana Troubadours 10
- Say! Who Is That Baby Doll?—Fox-trot, with Incidental Singing by Billy Jones, (S. C. Lanin, Dir.) Ipana Troubadours 10
- 502-D Jacksonville Gal—Fox-trot, The Original Memphis Five 10
- 'Taint Cold—Fox-trot, The Original Memphis Five 10
- 525-D A Little Bungalow (From "The Cocoanuts")—Fox-trot.....W. C. Polla and His Orch. 10
- Lucky Boy (From "The Cocoanuts")—Fox-trot, W. C. Polla and His Orch. 10
- 515-D Sweet Hawaiian Dreams—Waltz, with Incidental Singing by Franklyn Baur, The Xylo-Rimba Orch. 10
- Sunny Smiles of Hawaii—Waltz, with Incidental Singing by Franklyn Baur, The Xylo-Rimba Orch. 10
- VOCAL MUSIC**
- 520-D Let Us Waltz as We Say Good-bye—Tenor Solo.....Tom Burke 10
- Don't Wait Too Long—Tenor Solo.....Tom Burke 10
- 512-D A Cup of Coffee, a Sandwich and You (From "Charlot's Revue of 1926")—Soprano and Tenor Duet, Gertrude Lawrence-Jack Buchanan 10
- Carrie (From "Charlot's Revue of 1926")—Soprano Solo.....Gertrude Lawrence 10
- 513-D Susannah's Squeaking Shoes (From "Charlot's Revue of 1926")—Soprano Solo, Beatrice Lillie 10
- Poor Little Rich Girl (From "Charlot's Revue of 1926")—Soprano Solo, Gertrude Lawrence 10
- 514-D Russian Blues (From "Charlot's Revue of 1926")—Soprano Solo.....Gertrude Lawrence 10
- Gigolette (From "Charlot's Revue of 1926")—Tenor Solo.....Jack Buchanan 10
- 508-D Cross My Heart, Mother—Tenor Solo, Lewis James 10
- Dream Pal—Tenor Solo.....Lewis James 10
- 518-D I Wish That I'd Been Satisfied With Mary—Tenor Solo.....Franklyn Baur 10
- Don't Wake Me Up (Let Me Dream)—Tenor Solo.....Franklyn Baur 10
- 521-D Big Butter and Egg Man—Comedian, Phil Baker 10
- Ann and Her Little Sedan—Comedian, Phil Baker 10
- 506-D Oh, Lovey Be Mine—Vocal.....Ed Smalle 10
- Roll 'Em, Girls—Vocal.....Ed Smalle 10
- 526-D Five Foot Two, Eyes of Blue—Vocal, Frank Harris 10
- What Did I Tell Ya?—Vocal.....Frank Harris 10
- 511-D I Love My Baby—Vocal, "The Ukulele Ace" 10
- Down by the Winegar Woiks—Vocal, Johnny Marvin, "The Ukulele Ace" 10
- INSTRUMENTAL MUSIC**
- 519-D Lonesome—Piano Duet—Fox-trot, with Incidental Singing by Arthur Fields, Alan Moran-Walter Feldkamp 10
- Pretending—Piano Duet—Fox-trot, with Incidental Singing by Arthur Fields, Alan Moran-Walter Feldkamp 10

## Brunswick Records

- 50071 Hérodiane—Vision Fugitive (Fleeting Vision) (Massenet)—Baritone, in French, with Orch., John Charles Thomas 10
- Ballo in Maschera—Eri tu che macchiavi (Masked Ball—Is it Thou?) (Verdi)—Baritone, in Italian, with Orch., John Charles Thomas 10
- 10215 O Dry Those Tears! (Del Riego)—Soprano, with Orch.,.....Edith Mason 10
- Far Off I Hear a Lover's Flute (Eberhart-Cadman)—Soprano, with Orch.,.....Edith Mason 10
- 20041 Pique Dame Overture—Part I (Von Suppé)—Concert Orch., Capitol Grand Orch. (Capitol Theatre, N. Y.) 10
- Pique Dame Overture—Part II (Von Suppé)—Concert Orch., Capitol Grand Orch. (Capitol Theatre, N. Y.) 10
- 10214 Only a Rose, from "The Vagabond King" (Hooker-Friml)—Tenor, with Orch.,.....Mario Chamlee 10
- Here in My Arms, from "Dearest Enemy" (Continued on page 166)

## Song Hits from the Big Show Hits

# "IT MUST BE LOVE"

from "MERRY MERRY"

Lyrics by Harlan Thompson Music by Harry Archer

# "OH YOU!"

from "Florida Girl"

Lyrics by PAUL PORTER and BENJAMIN HAPGOOD BURT Music by MILTON SUSKIND

# "THE LANTERN OF LOVE"

from "Castles In The Air"

Lyrics by RAYMOND W. PECK Music by PERCY WENRICH

"You can't go wrong with any FEIST song"



ADVANCE RECORD BULLETINS FOR FEBRUARY—(Continued from page 165)



- (Hart-Rodgers)—Tenor, with Orch., Mario Chamlee
- 3002 The Rosary (Rogers-Nevin)—Hawaiian Guitar and Piano.....Andy Sannella and Bill Wirges
- Can't Yo' Heah Me Callin' Caroline (Gardner-Roma)—Hawaiian Guitar and Piano, Andy Sannella and Bill Wirges
- 3005 Land of Romance, from "Castles in the Air" (Peck-Wenrich)—Tenor, with Orch., Franklyn Baur
- Lantern of Love, from "Castles in the Air" (Peck-Wenrich)—Tenor and Female Chorus, with Orch.....Franklyn Baur and Female Chorus
- 50070 Liebestraum (A Dream of Love) (Liszt)—Pianoforte Solo.....Leopold Godowsky
- Fantaisie Impromptu (Chopin)—Pianoforte Solo, Leopold Godowsky
- 2993 Drifting Apart (Kahn-Fiorito)—Fox-trot, for Dancing.....Isham Jones' Orch.
- I Want Somebody to Cheer Me Up (Kahn-Fiorito)—Fox-trot, for Dancing.....Isham Jones' Orch.
- 2994 Paddlin' Madelin' Home (Woods)—Fox-trot, for Dancing.....Isham Jones' Orch.
- That Certain Party (Kahn-Donaldson)—Fox-trot, for Dancing.....Isham Jones' Orch.
- 2995 Song of the Vagabonds, from "The Vagabond King" (Hooker-Friml)—Fox-trot, for Dancing, with Elliott Shaw and Male Chorus, Carl Fenton's Orch.
- Here In My Arms, introducing "Bye and Bye," from "Dearest Enemy" (Hart-Rodgers)—Fox-trot, for Dancing, with Vocal Chorus, Carl Fenton's Orch.
- 2996 Lantern of Love, from "Castles in the Air" (Peck-Wenrich)—Fox-trot, for Dancing, with Vocal Chorus.....Harry Archer and His Orch.
- Baby, from "Castles in the Air" (Peck-Wenrich)—Fox-trot, for Dancing, with Vocal Chorus.....Harry Archer and His Orch.
- 2997 Who? from "Sunny" (Harbach-Hammerstein-Kern)—Fox-trot, for Dancing, with Male Trio.....Harry Archer and His Orch.
- Sunny, introducing "D'ye Love Me?" from "Sunny" (Harbach-Hammerstein-Kern)—Fox-trot, for Dancing.....Harry Archer and His Orch.
- 2998 Tea for Two, from "No, No, Nanette" (Caesar-Youmans)—for Dancing, with Vocal Duet, Brunswick Hour Orch.
- Marcheta (Schertzinger)—for Dancing, Brunswick Hour Orch.
- 2999 Just Around the Corner (Singer-Von Tilzer)—Fox-trot, for Dancing, Ernie Golden and His Hotel McAlpin Orch.
- Five Foot Two, Eyes of Blue (Lewis-Young-Henderson)—Fox-trot, for Dancing, Ernie Golden and His Hotel McAlpin Orch.
- 3000 Kentucky's Way of Sayin' Good Mornin' (Kahn-Van Alstyne)—Fox-trot, for Dancing, Harold Leonard and His Waldorf-Astoria Orch.
- Dinah (Lewis-Young-Akst)—Fox-trot, for Dancing, Harold Leonard and His Waldorf-Astoria Orch.
- 3001 What Did I Tell Ya? (De Sylva-Donaldson)—Fox-trot, for Dancing.....The Cotton Pickers
- Fallin' Down (Davis-Robinson)—Fox-trot, for Dancing.....The Cotton Pickers
- 3003 It Must Be Love, from "Merry Merry" (Thompson-Archer)—Fox-trot, for Dancing, Harry Archer and His Orch.
- I Was Blue, from "Merry Merry" (Thompson-Archer)—Fox-trot, for Dancing, Harry Archer and His Orch.
- 3004 I Never Knew (Kahn-Fiorito)—Male Voices, with Piano.....The Merrymakers
- Keep on Croonin' a Tune ((Fain-Weill-McHugh) Male Voices, with Piano.....The Merrymakers
- 3006 Hokey Pokey (Hess-Hall)—Comedian, with Tarapatch, Wendell Hall, "The Red-headed Music Maker"
- Paddlin' Madelin' Home (Woods)—Comedian, with Tarapatch, Wendell Hall, "The Red-headed Music Maker"
- 3007 Kentucky's Way of Sayin' Good Mornin' (Kahn-Van Alstyne)—Comedian, with Orch., Wendell Hall, "The Red-headed Music Maker"
- Show Me the Way to Go Home (King)—Comedian, with Tarapatch, Wendell Hall, "The Red-headed Music Maker"
- 3008 Five Foot Two, Eyes of Blue (Lewis-Young-Henderson)—Comedienne, with Piano Accomp. by Ruhe Bloom.....Esther Walker
- What Did I Tell Ya? (De Sylva-Donaldson)—Comedienne, with Piano Accomp. by Ruhe Bloom.....Esther Walker
- 3009 I Wonder Where My Baby Is To-night? (Kahn-Donaldson)—Vocal Duet, with Piano Accomp. by Frank Banta, The Radio Franks, Wright and Bessinger
- Then I'll Be Happy (Clare-Brown-Friend)—Vocal Duet, with Piano Accomp. by Frank Banta.....The Radio Franks, Wright and Bessinger
- 3010 What Do We Care if It's One o'Clock (Goodwin-Shay-Ash)—Tenor, with Orch.....Frank Munn
- Why Don't You Say So, from "Kid Boots" (Tierney-McCarthy)—Tenor, with Orch., Frank Munn
- 3011 Forever and Ever With You (Davis-Burke)—Fox-trot, for Dancing.....Jack Denny and His Orch.

- Smile a Little Bit (Schenk-Morton-Shevlin)—Fox-trot, for Dancing, with Vocal Chorus, Jack Denny and His Orch.
- 3012 I Would Rather Be Alone in the South (Vause)—Vocal Duet, with Ukulele.....Salt and Pepper
- Roll 'Em, Girls (Heath-Marr-Fletcher)—Vocal Duet, with Ukulele.....Salt and Pepper
- 3013 Miami (Jolson-De Sylva-Conrad)—Comedian, with Orch.....Al Jolson, with Carl Fenton's Orch.
- You Forgot to Remember (Berlin)—Comedian, with Orch.....Al Jolson, with Carl Fenton's Orch.
- 3014 I'm Sitting on Top of the World (Lewis-Young-Henderson)—Comedian, with Orch., Al Jolson, with Carl Fenton's Orch.
- You Flew Away From the Nest (Kalmar-Ruby) Comedian, with Orch., Al Jolson, with Carl Fenton's Orch.
- 3015 My Castle in Spain (Isham Jones)—Fox-trot, for Dancing.....Isham Jones' Orch.
- I Love My Baby (Green-Warren)—Fox-trot, for Dancing.....Isham Jones' Orch.
- 3016 Don't Wake Me Up; Let Me Dream (Gilbert-Wayne-Baer)—Fox-trot, for Dancing, Louis Katzman's Orch.
- You Flew Away From the Nest (Kalmar-Ruby)—Fox-trot, for Dancing.....Louis Katzman's Orch.
- 3018 Someone to Love (Kahn-Fiorito)—Waltz, for Dancing.....Regent Club Orch.
- We'll Meet Again in Normandy (Kahn-Cambria) Waltz, for Dancing.....Regent Club Orch.
- 3022 I'm Sitting on Top of the World (Lewis-Young-Henderson)—Fox-trot, for Dancing, Isham Jones' Orch.
- I Wonder Where My Baby Is To-night? (Kahn-Donaldson)—Fox-trot, for Dancing, with Vocal Duet.....Isham Jones' Orch.
- 3025 Show Me the Way to Go Home (King)—Fox-trot, for Dancing, with Vocal Chorus, The Volunteer Firemen
- Why Aren't Yez Eatin' More Oranges? (Gaskill-Brown)—Fox-trot, for Dancing, with Vocal Chorus.....The Volunteer Firemen
- 2990 Sleepy Time Gal (Alden-Egan-Lorenzo-Whiting)—Voice and Guitar, with Piano.....Nick Lucas
- I Found Somebody to Love (Lucas-Steph)—Voice and Guitar.....Nick Lucas
- 2991 Headin' for Louisville (De Sylva-Meyer)—Fox-trot, for Dancing, with Vocal Chorus, Ben Bernie and His Hotel Roosevelt Orch.
- Lonesomest Girl in Town (Dubin-McHugh-Mills) Fox-trot, for Dancing, with Vocal Chorus, Ben Bernie and His Hotel Roosevelt Orch.
- 2992 Sleepy Time Gal (Alden-Egan-Lorenzo-Whiting)—Fox-trot, for Dancing, with Vocal Chorus, Ben Bernie and His Hotel Roosevelt Orch.
- A Little Bit Bad (Davis-Conley-Eldridge)—Fox-trot, for Dancing, with Vocal Chorus, Ben Bernie and His Hotel Roosevelt Orch.

Edison Disc Records

- ALREADY RELEASED SPECIALS
- 51626 Songs for Little Girls, No. 1 (Hall).
- Songs for Little Girls, No. 2 (Hall).
- 51641 Normandy (Robinson-Little-Britt), Arthur Hall-John Ryan
- Garland of Old Fashioned Roses (Musgrove-Keithley).....Arthur Hall-John Ryan
- 51646 My Sweetie Turned Me Down (Kahn-Donaldson).....The Ponce Sisters—Ethel and Dorothea
- Let's Wander Away (Burnett-Owens), The Ponce Sisters—Ethel and Dorothea
- 51648 Brown Eyes, Why Are You Blue? (Bryan-Meyer).....That Singing Four
- To-morrow Mornin' (Robinson-Little-Britt), That Singing Four
- 51652 The Lonesomest Girl in Town (Dubin-McHugh-Mills).....James Doherty
- Just Around the Corner (Singer-Von Tilzer), Walter Scanlan
- 51653 I Wonder Where My Baby Is To-night (Kahn-Donaldson).....Wright-Bessinger (The Radio Franks)
- I Never Knew (Kahn-Fiorito), Wright-Bessinger (The Radio Franks)
- 80857 Minuet in G (Beethoven), Frederick Kinsley on Midmer-Losh Pipe Organ
- Souvenir (Drdla), Frederick Kinsley on Midmer-Losh Pipe Organ
- 80858 How Firm a Foundation (Keith-Portogallo), Metropolitan Quartet
- Faith of Our Fathers (Faber-Walton), Metropolitan Quartet
- 51660 Show Me the Way to Go Home (King), Billy Jones-Ernest Hare (The Happiness Boys)
- I Would Rather Be Alone in the South (Vause), Billy Jones-Ernest Hare (The Happiness Boys)
- 51649 The Letter Edged in Black—Singing, Violin, Harmonica and Guitar.....Vernon Dalhart and Co.
- The Dream of the Miner's Child (Jenkins)—Singing, Violin, Harmonica and Guitar, Vernon Dalhart and Co.
- 51656 On a Slow Train Thru Arkansas (Bernard)—Violin, Harmonica and Guitar, Al. Bernard (The Boy From Dixie)
- Zeb Turney's Gal (Lamkin-Robinson)—Singing,

- Harmonica, Fiddle and Guitar, Vernon Dalhart and Co.
- 51617 Tranquillo Overture (Pietro)—Accordion Solo, Anthony Monde
- Repasz Band March (Sweeley)—Accordion Solo, Anthony Monde
- 80856 Sweet Blue Bird (Lamb-Olman), Herbert Soman's Salon Orch.
- Garland of Old Fashioned Roses (Musgrove-Keithley).....Herbert Soman's Salon Orch.
- FLASHES
- 51645 How Can You Look So Good (And Still Be So Dog-gone Bad) (Endor)—Fox-trot, Phil Baker's Bad Boys
- Pretty Little Baby (Silvers-Baker-Bernie)—Fox-trot.....Phil Baker's Bad Boys
- 51647 Days of Hearts and Flowers (Mahoney-Tobani-Shilkret)—Fox-trot, with Vocal Chorus by Charles Hart, Mike Speciale and His Hotel Carlton Terrace Orch.
- Dreaming of To-morrow (Davis-Sanders)—Fox-trot, with Vocal Chorus by Charles Hart, Mike Speciale and His Hotel Carlton Terrace Orch.
- 51651 Show Me the Way to Go Home (King)—Fox-trot.....Tennessee Happy Boys
- Paddlin' Madelin' Home (From "Sunny") (Woods)—Fox-trot, with Vocal Chorus by Arthur Hall.....Tennessee Happy Boys
- 51650 Roll 'Em Girls (Roll Your Own) (Heath-Marr-Fletcher)—Fox-trot, with Vocal Chorus by Arthur Hall.....The Florida Four
- Miami (From "Big Boy") (Jolson-De Sylva-Conrad)—Fox-trot, with Vocal Chorus by Vernon Dalhart.....The Florida Four
- 51658 Sleepy Time Gal (Alden-Egan-Lorenzo-Whiting)—Fox-trot, Ernie Golden and His Hotel McAlpin Orch.
- Just a Little Thing Called Rhythm (From "Sunny") (Endor-Ward)—Fox-trot, Ernie Golden and His Hotel McAlpin Orch.
- 51659 Let Us Waltz as We Say Good-bye (Beiner)—Waltz, with Vocal Chorus by Helen Clark and Charles Hart.....Jack Stillman's Orch.
- Close Your Eyes (Yoell-Vincent)—Waltz, Jack Stillman's Orch.
- 51661 Clap Hands! Here Comes Charley! (Rose-MacDonald-Meyer)—Fox-trot, with Vocal Chorus by Hall and Ryan.....Golden Gate Orch.
- Five Foot Two, Eyes of Blue (Lewis-Young-Henderson)—Vocal Chorus by Hall and Ryan, Golden Gate Orch.
- 51654 Let's Wander Away (Ash-Burnett-Owens)—Fox-trot.....Joseph Knecht's Waldorf-Astoria Orch.
- Moonlight in Mandalay—Fox-trot, Joseph Knecht's Waldorf-Astoria Orch.
- TWO CUBAN
- 60052 Ilusion de mi Vida (Villalon), Juan de la Cruz y Bienvenido Leon
- Mi Paloma Blanca (Villalon), Juan de la Cruz y Bienvenido Leon
- 60053 Mi Chiquita (Villalon), Juan de la Cruz y Bienvenido Leon
- Se que vas a Partir (Garay), Juan de la Cruz y Bienvenido Leon

Okeh Records

- POPULAR DANCE RECORDS
- 40511 Bugle Blues (Dunn)—Fox-trot, Barbary Coast Four 10
- Bam, Bam, Bamy Shore (Henderson)—Fox-trot, Barbary Coast Four 10
- 40514 It's the Blues (Intro. Sneakin' Home) (Goldkette-Crozier)—Fox-trot, Tom Brown and His Merry Minstrel Orch. 10
- Forever and Ever With You (Burke)—Fox-trot, Tom Brown and His Merry Minstrel Orch. 10
- 40516 Show Me the Way to Go Home (King)—Fox-trot, V. Lopez and His Hotel Pennsylvania Orch. 10
- Paddlin' Madelin' Home (Woods)—Fox-trot, with Singing Chorus by Bruce Wallace, V. Lopez and His Hotel Pennsylvania Orch. 10
- 40500 Clap Hands! Here Comes Charley (Meyer)—Fox-trot.....Goofus Five 10
- I Wonder Where My Baby Is To-night! (Donaldson)—Fox-trot.....Goofus Five 10
- 40503 Just a Little Bit Bad (Conley)—Fox-trot, with Singing Chorus by Marty Livingston, Arcadian Serenaders 10
- The Co-ed (Conrad-Bernie)—Fox-trot, Arcadian Serenaders 10
- 40504 Everybody Stomp! (Schoebel)—Fox-trot, Jimmie Joy's St. Anthony Hotel Orch. 10
- Hay Foot, Straw Foot (Carroll)—Fox-trot, Jimmie Joy's St. Anthony Hotel Orch. 10
- 40517 You Gotta Know How (Donaldson)—Fox-trot, with Singing Chorus by Marty Livingston, Arcadian Serenaders 10
- Angry (Mecum-Cassard-Brunics)—Fox-trot, Arcadian Serenaders 10
- 40518 The Camel Walk (Smith-Brymn)—Fox-trot, Jack Gardner's Orch. 10
- Hot Aire (Schoebel)—Fox-trot, Jack Gardner's Orch. 10
- POPULAR VOCAL SELECTIONS
- 40506 The Convict and the Rose (Chapin)—Baritone.



ADVANCE RECORD BULLETINS FOR FEBRUARY—(Continued from page 166)

with Fiddle and Guitar Accomp.,  
Vernon Dalhart 10  
Zeb Turney's Gal (Larkin-Robison)—Baritone,  
with Guitar, Fiddle and Harmonica Accomp.,  
Vernon Dalhart 10  
40510 The Life of Tom Watson—Baritone, with Gui-  
tar, Violin and Harmonica Accomp.,  
Vernon Dalhart 10  
The Faded Letter—Baritone, with Guitar, Vio-  
lin and Harmonica Accomp.,  
Vernon Dalhart 10  
40505 I'm Going Back to North Carolina—Singing,  
with Guitar and Harmonica Accomp. by Henry  
Whittier ..... Kelly Harrell 10  
Be at Home Soon To-night, My Dear Boy—Sing-  
ing, with Guitar and Harmonica Accomp. by  
Henry Whittier ..... Kelly Harrell 10  
40507 Brown Eyes, Why Are You Blue? (Bryan-  
Meyer)—Tenor, with Accomp. by Justin Ring  
Trio ..... Bruce Wallace 10  
Mother Me, Tennessee (Sylva-Charig)—Tenor,  
with Accomp. by Justin Ring Trio,  
Bruce Wallace 10  
40513 If I Had a Girl Like You (Rose-Dixon-Hender-  
son)—Baritone, with Taro-Patch Accomp.,  
Richard B. Gilbert 10  
I Need Somebody to Lullaby Me (Coslow-Silver)  
Baritone, with Taro-Patch  
Accomp.,  
Richard B. Gilbert 10  
40519 She Was Just a Sailor's Sweetheart (Burke)—  
Baritone, with Novelty Accomp.,  
Ernest Hare 10  
Hokey Pokey (Diddle-dee-rum) (Hess-Hall)—  
Tenor-Baritone Duet, with Novelty Accomp.,  
Happiness Boys (Billy Jones-Ernest Hare) 10  
40491 The Garden of Eden Was in Ireland (G. Griffin-  
D. J. Sullivan)—Tenor, with Accomp. by Jus-  
tin Ring Trio ..... Gerald Griffin 10  
I'm Always Reaching for the Moon (G. Griffin-  
D. J. Sullivan)—Tenor, with Accomp. by Jus-  
tin Ring Trio ..... Gerald Griffin 10  
40498 The Dream of the Miner's Child (Andrew Jen-  
kins)—Baritone, with Guitar, Harmonica and  
Fiddle Accomp. .... Vernon Dalhart 10  
Mother's Grave (Maggie Andrews)—Baritone,  
with Fiddle, Viola and Guitar Accomp.,  
Vernon Dalhart 10  
40499 June Brought the Roses (Stanley-Openshaw)—  
Tenor, with Accomp. by Justin Ring Trio,  
Bruce Wallace 10  
Summer Nights (Johnson-Bibo-Lyman)—Tenor  
with Accomp. by Justin Ring Trio, with Bird  
and Bell Effects ..... Bruce Wallace 10  
OLD-TIME TUNES RECORDS  
45019 Let Me Call You Sweetheart (Friedman)—  
Waltz ..... Jimmie Wilson's Catfish String Band  
Snow Dear—Two-step,  
Jimmie Wilson's Catfish String Band 10  
45021 When the Whole World Turns You Down (Go  
Back to Your Mother and Home) (DeWitt-  
DeWitt)—Singing, with Guitar Accomp.,  
Charles Nasall 10  
After the War Is Over—Singing, with Guitar  
Accomp. .... Charles Nasall 10  
BAND AND INSTRUMENTAL NOVELTIES  
40470 Seminola (Indian Novelty) (King-Warren)—  
Fox-trot ..... U. S. Naval Academy Band  
From Tropic to Tropic (Alexander)—March,  
U. S. Naval Academy Band 10  
40515 Footloose (Rupp)—Piano Solo ..... Vin James  
Brown Eyes, Why Are You Blue? (Meyer)—  
Piano Solo ..... Vin James 10  
45020 Chicken Reel—Banjo-Clarinet Duet,  
Dr. Claude Watson and L. W. McCreighton 10  
Love My Mama—Banjo-Clarinet Duet,  
Dr. Claude Watson and L. W. McCreighton 10  
40463 Anchors Aweigh (Zimmerman)—March,  
U. S. Naval Academy Band 10  
Before the Mast (Laurendeau)—Nautical Medley  
March ..... U. S. Naval Academy Band 10  
40509 Listen to the Mocking Bird—Harmonica Solo,  
W. W. Macbeth 10  
Carry Me Back to Old Virginny (Bland)—Har-  
monica Solo ..... W. W. Macbeth 10  
45022 Dance in the Light of the Moon—Fox-trot,  
Emmett and Aiken String Band 10  
Alabama Jubilee—Fox-trot,  
McMichen's Home Town Band 10  
45023 When the Redeemed Are Gathering In—Vocal  
Duet, with Violin, Guitar and Harmonica  
Accomp. .... Carson Bros.-Smith 10  
Don't Grieve Over Me—Vocal Solo, with Auto-  
harp, Guitar and Fiddle Accomp.,  
Carson Bros.-Smith 10  
8252 Face to Face (Crosby-Stephens)—Contralto,  
Accomp. by Instrumental Trio ..... Laura Smith  
Take Me Home, Heavenly Father, With Thee  
(Perricone-Dixon)—Contralto, Accomp. by  
Instrumental Trio ..... Laura Smith 10  
8253 Mr. Johnson's Blues (Johnson)—Singing, with  
Piano Accomp. by J. Arnold and Guitar,  
Lonnie Johnson 10  
Falling Rain Blues (Johnson-Johnson)—Singing,  
with Piano Accomp. by J. Arnold and Fiddle,  
Lonnie Johnson 10  
8254 Squeeze Me (Williams-Waller)—Fox-trot, with  
Vocal Chorus by Eva Taylor,  
Clarence Williams Five 10  
Santa Claus Blues (Straight-Kahn)—Vocal Trio,  
with Piano, Guitar and Cornet Accomp.,  
Clarence Williams' Trio 10  
STANDARD AND SACRED VOCALS  
40512 Till the Whole World Knows (Ackley-Ackley)—  
Baritone, Accomp. by Justin Ring Quintet,  
with Chimes ..... Homer A. Rodeheaver 10  
I Shall See the King (Poole-Ackley)—Baritone,  
Accomp. by Justin Ring Quintet, with Bells,  
Homer A. Rodeheaver 10  
RACE RECORDS  
8261 Gut Bucket Blues (Armstrong)—Fox-trot,  
Louis Armstrong and His Hot Five 10  
Yes! I'm in the Barrel (Armstrong)—Fox-  
trot ..... Louis Armstrong and His Hot Five 10  
8262 Alabama Bound (De Sylva-Green-Henderson)—  
Contralto, Accomp. by Harry's Happy Four,  
Sara Martin 10  
Yes, Sir, That's My Baby (Kahn-Donaldson)—  
Contralto, Accomp. by Harry's Happy Four,  
Sara Martin 10  
8251 The Man I Love (Wallace)—Contralto, with  
Piano Accomp. by Hersal Thomas,  
Sippie Wallace 10  
I'm Sorry for It Now (Green)—Contralto, with  
Piano, Clarinet and Banjo Accomp.,  
Sippie Wallace 10  
8257 Grandpa's Spell—Fox-trot,  
Chas. Creath's Jazz-O-Maniacs 10  
Way Down in Lover's Lane—Fox-trot,  
Chas. Creath's Jazz-O-Maniacs 10  
STANDARD EUROPEAN INSTRUMENTALS  
(Odeon Labels)  
3182 Devotion (Becoe)—Orchestra,  
Edith Lorand and Her Orch. 10  
Memories of Sorrento (de Curtis)—Orchestra,  
Edith Lorand and Her Orch. 10  
3183 Waltz Ideals (Murzilli)—Orchestra,  
Mark Weber and His Orch. 10

# "THE ROLL OF HONOR"

Players are bought to play rolls. Hence, if you would stimulate your player trade to the utmost, you must not only direct your efforts equally to the promotion of players and rolls, but—sell the kind of rolls that keep players sold.

U. S. Rolls render constructive service to the player industry. They not only have character—they're both reasonably and uniformly priced.

*"Your player sales can only be as great as you make your roll trade."*

**UNITED STATES MUSIC COMPANY**  
2934-2938 West Lake Street, Chicago 122 Fifth Avenue, New York



**Sell U. S. Rolls—You'll Sell More Players!**

Honeymoon Chimes (Earl)—Orchestra,  
Mark Weber and His Orch. 10  
3184 El Criollo en Paris (Esposito)—Tango Orchestra,  
Mark Weber and His Orch. 10  
Idea (Korla)—Tango Orchestra,  
Mark Weber and His Orch. 10

**Columbia Phonograph Co.**

HARMONY RECORDS  
84-H I Wish't I Was in Peoria—Fox-trot, with In-  
cidental Singing by "Ernie,"  
Ernie Golden and His Hotel McAlpin Orch. 10  
The Monkey Doodle-Do—Fox-trot,  
Fred Rich and His Hotel Astor Orch. 10  
85-H I Wish't I Was in Peoria—Vocal Duet,  
Billy West and Bob Thomas 10  
Roll 'Em, Girls—Vocal Duet,  
Billy West and Bob Thomas 10  
86-H Song of the Vagabonds—Fox-trot,  
Ernie Golden and His Hotel McAlpin Orch. 10  
A Cup of Coffee, a Sandwich and You—Fox-  
trot ..... Carleton Terrace Orch. 10  
87-H You Forgot to Remember—Fox-trot,  
Ernie Golden and His Hotel McAlpin Orch. 10  
Teach Me to Smile—Fox-trot,  
The Manhattan Dance Makers 10  
88-H Get It Fixed—Fox-trot, with Vocal Chorus,  
Dixie Stompers 10  
Florida Stomp—Fox-trot ..... Dixie Stompers 10  
73-H I Love My Baby—Fox-trot ..... University Six 10  
In Your Green Hat—Fox-trot, with Incidental  
Singing by the Orchestra ..... University Six 10  
74-H Show Me the Way to Go Home—Fox-trot,  
with Incidental Singing by the Boys,  
Tommy Christian and His Orch. 10  
That Certain Party—Fox-trot, with Incidental  
Singing by the Boys,  
Tommy Christian and His Orch. 10  
83-H The Loneliest Girl in Town—Fox-trot,  
The Manhattan Dance Makers 10  
Somebody's Eyes—Fox-trot,  
The Manhattan Dance Makers 10  
78-H Kentucky's Way of Sayin' Good Mornin'—  
Fox-trot ..... Carleton Terrace Orch. 10  
Pretty Little Baby—Fox-trot,  
Carleton Terrace Orch. 10  
81-H Lost Hope Waltz—Instrumental Waltz,  
Petite Concert Orch. 10  
Golden Love—Instrumental Waltz,  
Petite Concert Orch. 10  
77-H The Loneliest Girl in Town—Vocal,  
Irving Kaufman 10  
Cross My Heart, Mother (I Love You)—

Vocal ..... Irving Kaufman 10  
82-H I'm Sitting on Top of the World—Vocal,  
Irving Kaufman 10  
Don't Be Afraid to Come Home—Vocal,  
Irving Kaufman 10  
80-H Clap Hands! Here Comes Charley!—Vocal,  
Arthur Fields 10  
No Man's Mama—Vocal ..... Arthur Fields 10  
76-H Give Me Just a Little Bit—Vocal,  
"Crooning" Andy and His Ukulele 10  
Falling for You—Vocal,  
"Crooning" Andy and His Ukulele 10  
72-H Smile a Little Bit—Vocal Duet,  
The Harmony Brothers 10  
I Wish That I'd Been Satisfied With Mary—  
Vocal Duet ..... The Harmony Brothers 10  
75-H I'm Gonna Charleston Back to Charleston—  
Charleston Fox-trot, with Accordion Accomp.,  
Anthony Monde 10  
No Man's Mama—Fox-trot, with Accordion  
Accomp. .... Anthony Monde 10  
79-H Venetian Isles—Waltz, with Steel Guitar  
Novelty ..... Frank Ferera 10  
Honeymoon Waltz—Waltz, with Steel Guitar  
Novelty ..... Frank Ferera 10

**Edison Blue Amberol Records**

5034 Bam, Bam, Bamy Shore—Fox-trot, with Vocal  
Chorus by Arthur Hall,  
Mike Speciale and His Hotel Carlton Terrace Orch.  
5057 Jesse James—Singing, Violin and Guitar,  
Vernon Dalhart and Co.  
5063 Silent Night,  
Frederick Kinsley on Midman-Losh Pipe Organ  
5068 The St. Louis Blues—Hawaiian Guitar Duet,  
Ferera-Paaluhi  
5071 Christmas Morning at Clancy's,  
Steve Porter-Billy Jones and Co.  
5073 Old MacDonald Had a Farm,  
The Sam Patterson Trio  
5074 When the Dear Old Summer Goes—Fox-trot,  
with Vocal Chorus by Arthur Hall,  
Mike Speciale and His Hotel Carlton Terrace Orch.  
5075 I Would Rather Be Alone in the South,  
Billy Jones-Ernest Hare (The Happiness Boys)  
5076 Old Joe Clark—Country Dance of the Southern  
Mountaineers with Singing,  
Fiddlin' Powers and Family  
5077 On a Slow Train Thru Arkansas—Violin, Har-  
monica and Guitar,  
Al. Bernard (The Boy From Dixie)  
5078 The Wreck of the Shenandoah—Singing, Violin  
(Continued on page 168)



ADVANCE RECORD BULLETINS FOR FEBRUARY—(Continued from page 167)

and Guitar .....Vernon Dalhart and Co.
5081 The Convict and the Rose—Singing, Violin and
Guitar .....Vernon Dalhart and Co.
5082 Smilin' Through—Violin Solo.....Herbert Soman
5083 Nobody But Fanny (From "Big Boy")—Fox-
trot .....The Florida Four
5084 Freshie—Fox-trot, with Vocal Chorus,
Golden Gate Orch.

Pathe Phono & Radio Corp.

25163 Remember—Voice and Orch.,
Cliff Edwards (Ukulele Ike) and His Hot Comb.
Someone's Stolen My Sweet, Sweet Baby,
Cliff Edwards (Ukulele Ike) and His Hot Comb.
25164 Keep on Croonin' a Tune—Voice and Orch.,
Cliff Edwards (Ukulele Ike) and His Hot Comb.
Dinah—Voice and Orch.,
Cliff Edwards (Ukulele Ike) and His Hot Comb.
25165 I Wonder Where My Baby Is To-night—Voice
and Guitar .....Miss Lee Morse
My Sugar Babe—Voice and Guitar.....Miss Lee Morse
25166 My Old Kentucky Home—Voice and Guitar,
Miss Lee Morse
Old Folks at Home—Voice and Guitar,
Miss Lee Morse

DANCE RECORDS

36338 Dreaming of To-morrow—Fox-trot..Deauville Dozen
Pep—Fox-trot .....Deauville Dozen
36342 I'm Sitting on Top of the World—Fox-trot,
Lanin's Arcadians
Euccebia—Fox-trot .....Palace Garden Orch.
36343 Five Foot Two, Eyes of Blue—Fox-trot, with
Vocal Chorus by F. Nichols.....Lanin's Arcadians
Lonesome—Fox-trot .....Majestic Dance Orch.
36348 Sleepy Time Gal—Fox-trot,
Bert Dolan's Chateau Orch.
Someone (From "Naughty Riquette")—Fox-trot,
Bert Dolan's Chateau Orch.
36349 Roll 'Em, Girls—Fox-trot, with Vocal Chorus
by Frank Nichols .....Virginia Creepers
Indigo Blues—Fox-trot .....Five Birmingham Babies
36350 Santa Claus Blues—Fox-trot.....Blue Rhythm Orch.
One Week From Now—Fox-trot,
Five Birmingham Babies
36339 I Never Knew—Fox-trot...Hollywood Dance Orch.
Pile of Logs and Stones (Called Home)—Fox-
trot .....Lanin's Arcadians
36340 Whoopee—Fox-trot .....Hollywood Dance Orch.
Dixie Stomp—Fox-trot .....Five Birmingham Babies
36341 Forever—Fox-trot .....Palace Gardens Orch.
It Must Be Love (From "Merry Merry")—Fox-
trot .....Hollywood Dance Orch.
36344 Say, Who Is That Doll?—Fox-trot, with Vocal
Chorus by F. Nichols.....Lanin's Arcadians
I-I-Boy—Fox-trot .....All Star Quartet.
36345 I Wanna Go Where You Go, Do What You Do
Then I'll Be Happy—Fox-trot, with Vocal
Chorus by Jimmy Flynn.....Lenox Dance Orch.
Mammy Chasing Blues—Fox-trot.Lenox Dance Orch.
36346 When I Dream of the Last Waltz With You—
Waltz .....Lenox Dance Orch.
Silvery Moon—Waltz .....Piedmont Dance Orch.
36347 Headin' for Louisville—Fox-trot.....The Red Heads
Nervous Charlie—Fox-trot .....The Red Heads

POPULAR VOCAL RECORDS

32145 I Wanna Go Where You Go, Do What You Do
(Then I'll Be Happy)—Tenor Duet,
Wright-Bessinger (The Radio Franks)
I'm Sitting on Top of the World—Tenor Duet,
Wright-Bessinger (The Radio Franks)
32147 Don't Wait Too Long—Baritone Solo..Tom Morris
Fond of You (From "Captain Jinks")—Baritone
Solo .....Tom Morris
32150 The Convict and the Rose—Tenor Solo,
Vernon Dalhart
The Dream of the Miner's Child—Tenor Solo,
Vernon Dalhart
32148 That Certain Party—Vocal Duet,
The Ponce Sisters—Ethel and Dorothea
There's Nothing on My Mind—Vocal Duet,
The Ponce Sisters—Ethel and Dorothea
32149 Little Rosewood Casket—Tenor Solo,
Vernon Dalhart
Mother's Grave—Tenor Solo .....Vernon Dalhart
32146 Big Butter and Egg Man—Comedian....Phil Baker
Ann in Her Little Sedan—Comedian....Phil Baker

INSTRUMENTAL RECORDS

21160 Stop Flirting—Banjo and Mandolin Duet,
T and T String Harmony Trio
Isabella—Banjo and Mandolin Duet,
T and T String Harmony Trio

JEWISH SELECTIONS

3714 Die Meidlach Fin a Mul—Accomp. by I. J.
Hochman .....Morris Goldstein
Mit a Sistem—Accomp. by I. J. Hochman,
Morris Goldstein
3715 Frauen .....William Schwartz
A Madel Ve Mine Mama.....William Schwartz
3716 Molly Dolly .....Lucy Levine
Ich Hub Im Leib.....Lucy Levine

CUBAN—MEXICAN—PORTO RICAN

6691 "Ella" (Tomas P. Reyre)—Bolero Yucateco,
Jaime Imbernon y Su Orquesta
La Provinciana (Manuel Joves)—Tango,
Jaime Imbernon y Su Orquesta
6692 La Pintura Blanca (Eliseo Grenet)—Danzon,
Jaime Imbernon y Su Orquesta
El Club Del Silencio (Antonio Ma Roman)—
Danzon .....Jaime Imbernon y Su Orquesta
6693 Reflejos Oe I una (Aron Tefel)—Vals,
Jaime Imbernon y Su Orquesta
El Batallon Oe Instruccion (F. Cales)—Himno-
Marcha .....Jaime Imbernon y Su Orquesta

Regal Records

DANCE RECORDS

9962 Song of the Vagabonds (From "The Vagabond
King")—Fox-trot .....Newport Society Orch.
Along Came Love—Fox-trot,
Eddie Peabody and His Band
9963 Good Mornin'—Fox-trot ..Sam Lanin's Dance Orch.
Just Around the Corner—Fox-trot,
Nathan Glantz and His Orch.
9964 What Did I Tell Ya—Fox-trot,
Woodmaste Inn Orch.
Headin' for Louisville—Fox-trot,
Newport Society Orch.
9965 Spanish Shawl—Fox-trot .....Imperial Dance Orch.
Steppin' Fool—Fox-trot .....Perry's Hot Dogs
9966 Who (From "Sunny")—Fox-trot,
Imperial Dance Orch.

A Little Bungalow (From "The Cocoanuts")—
Fox-trot .....Newport Society Orch.
9967 Smile a Little Bit—Fox-trot,
Sam Lanin's Dance Orch.
Nobody's Business—Fox-trot ..Perry's Hot Dogs
9968 That Certain Party—Fox-trot.Newport Society Orch.
Tie Me to Your Apron Strings Again—Fox-trot,
Eddie Peabody and His Band
9969 Down by the Winegar Woiks—Waltz,
Nathan Glantz and His Orch.
Trail of Dreams—Waltz.....Hollywood Dance Orch.
9970 I Love My Baby, My Baby Loves Me—Fox-
trot .....Sam Lanin's Dance Orch.
My Charleston Dancing Man—Fox-trot,
Missouri Jazz Band

EDDIE PEABODY RECORDS

9971 Sweet Man—Jazz, with Fiddle, Clarinet and
Piano Accomp. ....Eddie Peabody
Charleston Mad—Jazz, with Fiddle, Clarinet and
Piano Accomp. ....Eddie Peabody
9972 Show Me the Way to Go Home—Banjo Solo,
with Vocal Accomp. ....Eddie Peabody
I Wonder Where My Baby Is To-night—Banjo
Solo, with Vocal Accomp. ....Eddie Peabody

VOCAL RECORDS

9973 Then I'll Be Happy—Male Duet, with Orch.
Accomp. ....Hall-Ryan
On Saturday Morning—Male Duet, with Orch.
Accomp. ....Hall-Ryan
9974 Sleepy Time Gal—Tenor Solo, with Orch.
Accomp. ....Irving Kaufman
Five Foot Two, Eyes of Blue—Baritone Solo,
with Guitar Accomp. ....Arthur Fields
9975 Freshie—Novelty Trio .....The Serenaders
Keep on Croonin' a Tune—Novelty Trio,
The Serenaders
9976 Keep Your Skirts Down, Mary Ann—Male Duet,
with Piano Accomp. ....Hare-Jones
I Wish't I Was in Peoria—Male Duet, with
Piano Accomp. ....Hare-Jones
9977 Too Many Parties and Too Many Pals—Tenor
Solo, with Orch. Accomp. ....Irving Kaufman
I Wish That I'd Been Satisfied With Mary—
Tenor Solo, with Orch. Accomp. ....Irving Kaufman

VERNON DALHART RECORDS

9978 Dream of the Miner's Child—Tenor Solo, with
Novelty Accomp. ....Vernon Dalhart
Stone Mountain Memorial—Tenor Solo, with
Novelty Accomp. ....Vernon Dalhart
9979 Zeb Turney's Gal—Tenor Solo, Novelty Ac-
comp. ....Vernon Dalhart
Sydney Allen—Tenor Solo, with Novelty Ac-
comp. ....Vernon Dalhart

Vocalion Records

15196 Drifting Apart (Kahn-Fiorito)—Fox-trot, for
Dancing .....Tuxedo Orch.
Whose Who Are You? (Klages-Green-Greer)—
Fox-trot, for Dancing, .....Tuxedo Orch.
15197 Don't Wake Me Up; Let Me Dream (Gilbert-
Wayne-Baer)—Fox-trot, for Dancing,
The Ambassadors, Dir. Louis Katzman
You Flew Away from the Nest (Kalmar-Ruby)
Fox-trot, for Dancing,
The Ambassadors, Dir. Louis Katzman

15198 Lantern of Love, from "Castles in the Air"
(Peck-Wenrich)—Fox-trot, for Dancing, with
Vocal Chorus.....The Vanderbilt Orch.
Baby, from "Castles in the Air" (Peck-Wenrich)—
Fox-trot, for Dancing, with Vocal Chorus,
The Vanderbilt Orch.
15199 Then I'll Be Happy (Clare-Brown-Friend)—
Fox-trot, for Dancing, with Vocal Duet,
Ben Selvin and His Orch.
I Wonder Where My Baby Is To-night? (Kahn-
Donaldson)—Fox-trot, for Dancing,
Ben Selvin and His Orch.

15187 Kentucky's Way of Sayin' Good Mornin' (Kahn-
Van Alystne)—Fox-trot, for Dancing,
The Ambassadors, Dir. Louis Katzman
Just Around the Corner (Singer-Von Tilzer)—
Fox-trot, for Dancing, with Vocal Chorus,
The Ambassadors, Dir. Louis Katzman
15201 What Did I Tell Ya? (DeSylva-Donaldson)—
Fox-trot, for Dancing.....The Tennessee Tooters
Fallin' Down (Davis-Robinson)—Fox-trot, for
Dancing .....The Tennessee Tooters
15202 Headin' for Louisville (DeSylva-Meyer)—Fox-
trot, for Dancing, with Vocal Chorus,
Fleetwood Orch.

Lonesomest Girl in Town (Dubin-McHugh-Mills)
Fox-trot, for Dancing, with Vocal Chorus,
Fleetwood Orch.
15203 Forever and Ever With You (Davis-Burke)—
Fox-trot, for Dancing.....Frivolity Club Orch.
Smile a Little Bit—(Schenk-Morton-Shevlin)—
Fox-trot, for Dancing, with Vocal Chorus,
Frivolity Club Orch.
15204 I Want Somebody to Cheer Me Up (Kahn-Fio-
rito)—Fox-trot, for Dancing,
Fletcher Henderson and His Orch.

Dinah (Lewis-Young-Akst)—Fox-trot, for Danc-
ing.....Fletcher Henderson and His Orch.
15205 Let Me Introduce You to My Rosie (Brown-
Cantor-Santly)—Fox-trot, for Dancing,
Fletcher Henderson and His Orch.
I Want to See a Little More of What I Saw in
Arkansas (Hueston-Edelheit-Oliver-Farrar) —
Fox-trot, for Dancing,
Fletcher Henderson and His Orch.
15206 Someone to Love (Kahn-Fiorito)—Waltz, for
Dancing .....Miami Marimba Band
Dark Hawaiian Eyes (Costello-Hampton)—Waltz,
for Dancing.....Miami Marimba Band
15207 Hawaiian Sweetheart of Mine (Heagney-Cos-
tello)—Hawaiian Players.....Palala's Hawaiians
Sweet Hawaiian Dreams (Parish-Coleman)—Ha-
waiian Players.....Palala's Hawaiians
15208 A Cup of Coffee, a Sandwich and You, from
"Charlot's Revue of 1926" (Rose-Dubin-Mey-
er)—Fox-trot, for Dancing, with Vocal Cho-
rus.....Ben Selvin and His Orch.
Poor Little Rich Girl, from "Charlot's Revue of
1926" (Coward)—Fox-trot, for Dancing,
Ben Selvin and His Orch.

15209 Pensacola (Rose)—Fox-trot, for Dancing,
The Hottentots
Nobody's Rose (Rose)—Fox-trot, for Dancing,
The Hottentots

15210 I Would Rather Be Alone in the South (Vause)
—Tenor and Baritone, with Banjo and Piano,
Billy Jones and Ernest Hare
Why Aren't Yez Eatin' More Oranges? (Gaskill-
Brown)—Tenor and Baritone, with Banjo and
Piano .....Billy Jones and Ernest Hare
21019 A Rose for Every Heart (Eberhart-Cadman)—
Tenor, with Orch.....Colin O'More
Valley of Roses (McDonald-Wood)—Tenor, with
Orch.....Colin O'More
15211 Prancin', Dancin', Yodelin' Man (Bernard)—
Tenor and Yodeler, with Piano Accomp. by Ed
Smalle.....Al Bernard and Frank Kamplain

Yeedle-Deedle Lena (Bernard-Heagney)—Tenor
and Yodeler, with Piano Accomp. by Rube
Bloom.....Al Bernard and Frank Kamplain
15212 I Wonder Where My Baby Is To-night (Kahn-
Donaldson) Tenor, with Guitar and Piano
Accomp. by Eddie Ward.....Chick Endor
Show Me the Way to Go Home (King)—Tenor,
with Guitar and Piano Accomp. by Eddie
Ward .....Chick Endor
15213 Smile a Little Bit (Morton-Shevlin-Schenk)—
Tenor, with Piano.....Irving Kaufman
I Love My Baby (Green-Warren)—Tenor, with
Piano .....Irving Kaufman
15214 Forever and Ever With You (Davis-Burke)—
Vocal Duet, with Piano,
The Radio Franks, Wright and Bessinger

Roll 'Em, Girls (Heath-Marr-Fletcher)—Vocal
Duet, with Piano,
The Radio Franks, Wright and Bessinger

15215 An' I Don't Mean If! (De Leath)—Comedienne,
Rosa Henderson, with The Three Jolly Miners
You Can't Be Like My Last Man Was (Davis-
Hooper)—Comedienne,
Rosa Henderson, with The Three Jolly Miners

13032 Models Fin Libe (Gilrod-Sandler)—Tenor, in
Yiddish, with Orch.....Aaron Lebedeff
Midlach, I Love You Just the Same (Gilrod-
Sandler)—Tenor, in Yiddish, with Orch.,
Aaron Lebedeff

13033 Dort Vie Libe Dort Is Glik (Gilrod-Sandler)—
Tenor, in Yiddish, with Orch.....Aaron Lebedeff
Uggeshikt Oi Tnuim (Rund)—Tenor, in Yid-
dish, with Orch.....Aaron Lebedeff

Perfect Record Co.

11597 Remember—Voice and Orch.,
Cliff Edwards (Ukulele Ike) and His Hot Comb.
Someone's Stolen My Sweet, Sweet Baby,
Cliff Edwards (Ukulele Ike) and His Hot Comb.
11598 Keep on Croonin' a Tune—Voice and Orch.,
Cliff Edwards (Ukulele Ike) and His Hot Comb.
Dinah—Voice and Orch.,
Cliff Edwards (Ukulele Ike) and His Hot Comb.

11599 I Wonder Where My Baby Is To-night—Voice
and Guitar .....Miss Lee Morse
My Sugar Babe—Voice and Guitar.....Miss Lee Morse
11600 My Old Kentucky Home—Voice and Guitar,
Miss Lee Morse
Old Folks at Home—Voice and Guitar,
Miss Lee Morse

14532 8—1=7 (One From Eight Leaves Seven)—Fox-
trot .....Boyd Senter
I'm Taking My Own Sweet Time—Fox-trot,
Boyd Senter

DANCE RECORDS

14519 Dreaming of To-morrow—Fox-trot..Deauville Dozen
Pep—Fox-trot .....Deauville Dozen
14523 I'm Sitting on Top of the World—Fox-trot,
Sam Lanin and His Orch.
Euccebia—Fox-trot .....Golden Gate Orch.
14524 Five Foot Two, Eyes of Blue—Fox-trot, with
Vocal Chorus by Arthur Hall,
Sam Lanin and His Orch.
14529 Lonesome—Fox-trot...Nathan Glantz and His Orch.
Sleepy Time Gal—Fox-trot,
Bert Dolan's Chateau Orch.
Someone (From "Naughty Riquette")—Fox-trot,
Bert Dolan's Chateau Orch.

14530 Roll 'Em, Girls—Fox-trot, with Vocal Chorus by
Arthur Hall .....Lou Gold and His Orch.
Indigo Blues—Fox-trot .....Five Birmingham Babies
14531 Santa Claus Blues—Fox-trot.....Blue Rhythm Orch.
One Week From Now—Fox-trot,
Five Birmingham Babies

14520 I Never Knew—Fox-trot...Mayflower Serenaders
Pile of Logs and Stones (Called Home)—Fox-
trot .....Sam Lanin and His Orch.
14521 Whoopee!—Fox-trot .....Mayflower Serenaders
Dixie Stomp—Fox-trot .....Five Birmingham Babies
14522 Forever—Fox-trot .....Golden Gate Orch.
It Must Be Love (From "Merry Merry")—Fox-
trot .....Mayflower Serenaders
14525 Say, Who Is That Baby Doll?—Fox-trot, with
Vocal Chorus by Arthur Hall,
Sam Lanin and His Orch.

I-I-Boy—Fox-trot .....All Star Quartet
14526 I Wanna Go Where You Go, Do What You Do
(Then I'll Be Happy)—Fox-trot, with Vocal
Chorus by Jimmy Flynn,
Mike Speciale and His Orch.
Mammy Chasing Blues—Fox-trot,
Mike Speciale and His Orch.

14527 When I Dream of the Last Waltz With You
—Waltz .....Mike Speciale and His Orch.
Silvery Moon—Waltz .....Max Terr and His Orch.
14528 Headin' for Louisville—Fox-trot.....The Red Heads
Nervous Charlie—Fox-trot .....The Red Heads

POPULAR VOCAL RECORDS

12224 I Wanna Go Where You Go, Do What You Do
(Then I'll Be Happy)—Tenor Duet,
Wright-Bessinger (The Radio Franks)
I'm Sitting on Top of the World—Tenor Duet,
Wright-Bessinger (The Radio Franks)
12226 Don't Wait Too Long—Baritone Solo..Tom Morris
Fond of You (From "Captain Jinks")—Baritone
Solo .....Tom Morris
12229 The Convict and the Rose—Tenor Solo,
Vernon Dalhart
The Dream of the Miner's Child—Tenor Solo,
Vernon Dalhart
12227 That Certain Party—Vocal Duet,
The Ponce Sisters—Ethel and Dorothea
There's Nothing on My Mind—Vocal Duet,
The Ponce Sisters—Ethel and Dorothea
12228 Little Rosewood Casket—Tenor Solo.Vernon Dalhart
Mother's Grave—Tenor Solo .....Vernon Dalhart
12225 Big Butter and Egg Man—Comedian....Phil Baker
Ann in Her Little Sedan—Comedian....Phil Baker

INSTRUMENTAL

11233 Stop Flirting—Banjo and Mandolin Duet,
T and T String Harmony Trio
Isabella—Banjo and Mandolin Duet,
T and T String Harmony Trio

Domino Records

DANCE RECORDS

3626 I Love My Baby, My Baby Loves Me—Fox-trot,
Sam Lanin's Dance Orch.
Just Around the Corner—Fox-trot,
Majestic Dance Orch.
3627 Song of the Vagabonds (From "The Vagabond
King")—Fox-trot .....Newport Society Orch.
It Must Be You—Fox-trot,
Eddie Peabody and His Band
3628 Good Mornin'—Fox-trot ..Sam Lanin's Dance Orch.
Headin' for Louisville—Fox-trot,
Newport Society Orch.



3629 Who (From "Sunny")—Fox-trot, Missouri Jazz Band  
 Nobody's Business—Fox-trot ... Missouri Jazz Band  
 3630 Smile a Little Bit—Fox-trot, Sam Lanin's Dance Orch.  
 A Little Bungalow (From "The Cocoanuts")—  
 Fox-trot ..... Newport Society Orch.  
 3631 Down by the Winegar Woiks—Waltz, Majestic Dance Orch.  
 For a Girl Like You—Waltz, Imperial Dance Orch.  
 3632 Spanish Shawl—Fox-trot ..... Missouri Jazz Band  
 My Charleston Dancing Man—Fox-trot, Six Black Diamonds  
 3633 That Certain Party—Fox-trot, Newport Society Orch.  
 Steppin' Fool—Fox-trot ..... Six Black Diamonds  
 3634 What Did I Tell Ya—Fox-trot, Lou Gold's Dance Orch.  
 Tie Me to Your Apron Strings Again—Fox-trot, Eddie Peabody and His Band  
 3635 Sweet Man—Jazz Fiddle, with Clarinet and Piano Accomp. .... Eddie Peabody  
 Charleston Mad—Jazz Fiddle, with Clarinet and Piano Accomp. .... Eddie Peabody  
 3636 Show Me the Way to Go Home—Banjo Solo, with Vocal Accomp. .... Eddie Peabody  
 I Wonder Where My Baby Is To-night—Banjo Solo, with Vocal Accomp. .... Eddie Peabody

VOCAL RECORDS

3637 I Wish That I'd Been Satisfied With Mary—  
 Tenor Solo, with Orch. Accomp. .... Irving Kaufman  
 Sleepy Time Gal—Contralto Solo, with Orch. Accomp. .... Henrietta Cross  
 3638 Freshie—Novelty Trio ..... The Collegians  
 Keep on Croonin' a Tune—Novelty Trio, The Collegians  
 3639 Then I'll Be Happy—Male Duet, with Orch. Accomp. .... Hall-Ryan  
 I Wish't I Was in Peoria—Male Duet, with Orch. Accomp. .... Hare-Jones  
 3640 Keep Your Skirts Down, Mary Ann—Male Duet, with Piano Accomp. .... Hare-Jones  
 Five Foot Two, Eyes of Blue—Baritone Solo, with Guitar Accomp. .... Arthur Fields  
 3641 Too Many Parties and Too Many Pals—Tenor Solo, with Orch. Accomp. .... Irving Kaufman  
 On Saturday Morning—Male Duet, with Orch. Accomp. .... Hall-Ryan  
 3642 Dream of the Miner's Child—Tenor Solo, with Novelty Accom. .... Vernon Dalhart  
 Sydney Allen—Tenor Solo, with Novelty Accom. .... Vernon Dalhart  
 3643 Zeb Turney's Gal—Tenor Solo, with Novelty Accom. .... Vernon Dalhart  
 Stone Mountain Memorial—Tenor Solo, with Novelty Accom. .... Vernon Dalhart

Banner Records

DANCE RECORDS

1655 Good Mornin'—Fox-trot ... Sam Lanin's Dance Orch.  
 Headin' for Louisville—Fox-trot, Newport Society Orch.  
 1656 That Certain Party—Fox-trot, Newport Society Orch.  
 Steppin' Fool—Fox-trot ..... Six Black Diamonds  
 1657 Who (From "Sunny")—Fox-trot, Missouri Jazz Band  
 Nobody's Business—Fox-trot ... Missouri Jazz Band  
 1658 Down by the Winegar Woiks—Waltz, Majestic Dance Orch.  
 For a Girl Like You—Waltz, Imperial Dance Orch.  
 1659 I Love My Baby, My Baby Loves Me—Fox-trot, Sam Lanin's Dance Orch.  
 Just Around the Corner—Fox-trot, Majestic Dance Orch.  
 1660 What Did I Tell Ya—Fox-trot, Lou Gold's Dance Orch.  
 Tie Me to Your Apron Strings Again—Fox-trot, Eddie Peabody and His Band  
 1661 Song of the Vagabonds (From "The Vagabond King")—Fox-trot ..... Newport Society Orch.  
 It Must Be You—Fox-trot, Eddie Peabody and His Orch.  
 1662 Spanish Shawl—Fox-trot ..... Missouri Jazz Band  
 My Charleston Dancing Man—Fox-trot, Six Black Diamonds  
 1663 Smile a Little Bit—Fox-trot, Sam Lanin's Dance Orch.  
 A Little Bungalow (From "The Cocoanuts")—  
 Fox-trot ..... Newport Society Orch.  
 1664 Show Me the Way to Go Home—Banjo Solo, with Orch. Accomp. .... Eddie Peabody  
 I Wonder Where My Baby Is To-night—Banjo Solo, with Vocal Accomp. .... Eddie Peabody  
 1665 Sweet Man—Jazz Fiddle, with Clarinet and Piano Accomp. .... Eddie Peabody  
 Charleston Mad—Jazz Fiddle, with Clarinet and Piano Accomp. .... Eddie Peabody

VOCAL RECORDS

1666 Freshie—Novelty Trio ..... The Collegians  
 Keep on Croonin' a Tune—Novelty Trio, The Collegians  
 1667 Then I'll Be Happy—Male Duet, with Orch. Accomp. .... Hare-Ryan  
 I Wish't I Was in Peoria—Male Duet, with Orch. Accomp. .... Hare-Jones  
 1668 Too Many Parties and Too Many Pals—Tenor Solo, with Orch. Accomp. .... Irving Kaufman  
 On Saturday Morning—Male Duet, with Orch. Accomp. .... Hall-Ryan  
 1669 I Wish That I'd Been Satisfied With Mary—  
 Tenor Solo, with Orch. Accomp. .... Irving Kaufman  
 Sleepy Time Gal—Contralto Solo, with Orch. Accomp. .... Henrietta Cross  
 1670 Keep Your Skirts Down, Mary Ann—Male Duet, with Piano Accomp. .... Hare-Jones  
 Five Foot Two, Eyes of Blue—Baritone Solo, with Guitar Accomp. .... Arthur Fields  
 1671 Zeb Turner's Gal—Tenor Solo, with Novelty Accom. .... Vernon Dalhart  
 Stone Mountain Memorial—Tenor Solo, with Novelty Accom. .... Vernon Dalhart  
 1672 Dreams of the Miner's Child—Tenor Solo, with Novelty Accom. .... Vernon Dalhart  
 Sydney Allen—Tenor Solo, with Novelty Accom. .... Vernon Dalhart

U. S. Music Co.

WORD ROLLS

Title	Composer	Played by
The Baby Looks Like Me—Fox-trot	Harold Wansborough	Harold Wansborough
The Black Troop—March with Lyrics	Horace Prell	Horace Prell
Carolina Stomp—Fox-trot	Eubie Jones	Eubie Jones
Charleston Ball (From "Brown Skin Revue")—Fox-trot	Cal Welch	Cal Welch
Don't Wait Too Long—Fox-trot	Lee Sims	Lee Sims
Don't Wake Me Up—Fox-trot	Lee Sims	Lee Sims
Down by the Old Mill Stream—Waltz	Tell Taylor	Tell Taylor
Five Foot Two, Eyes of Blue—Fox-trot	Lee Sims	Lee Sims
Hawaiian Sunset—Waltz Song		

CONSTRUCTIVE ARTICLES IN THIS ISSUE OF THE WORLD

Ready Reference for Salesmen, Dealers and Department Heads

Complete Line of New Phonographs to Be Placed on the Market by the Columbia Co. ....	3
General Phonograph Corp. Using New Recording Principle. ....	3
Balancing the Retail Sales Curve in 1926 .....	4
Thomas A. Edison, Inc., to Market a New Record That Plays Over Twenty Minutes .....	6
J. M. Graves Makes Partners of His Salesmen .....	8
Dealers Optimistic Over the Outlook for 1926 .....	10
Better Broadcasting Programs Help Business .....	10
Tribute to the Prestige of Phonograph Companies .....	11
Important Bills Being Considered by Congress .....	11
How Wunderlich Profits by Radio Service .....	14-16
Profit-Winning Sales Wrinkles ...	19
Business Secured through Schools. .	19
A "Different" Collection Stunt ...	19
Demonstrating New Records to the Masses .....	20
Victor Co. Issues First Catalog of Its New Line .....	22
Goldburg's "Five-Point Plan" Builds Sales .....	24
Making Effort to Improve Distribution Conditions .....	24
How Dealers Can Profit by Tying Up With Anniversary of the Boy Scouts of America .....	26
New Fields for Radio Sales Open to the Trade .....	28
Radio Market Barely Scratched—Four Prospects to Every Owner of a Receiver .....	30
Bringing Back the Backsliding Customer .....	32
Survey to Secure Vital Data From Radio Owners Launched by Neufeldt & Kuhnke .....	34
Inadequate Turnover Cause of Business Deterioration .....	34
Report on Radio Reception Gives Interesting Facts .....	36
Elimination of the Radio Trade Problems .....	38
Starting the New Year Right for Collections .....	40
Advice to Dealers on Servicing the Orthophonic .....	42
Legislation Urged to Put Curb on Price-Cutting .....	43
Dallas Dealer's Collection System Keeps Past Due Below the Five Per Cent Mark .....	46
Demonstration of the New Zenith De Luxe Receiving Set Before a Select Audience .....	48
Two Bills in Congress for Regulation of Radio .....	56
Creedman Goes the Limit on Giving His Patrons Service and Finds That It Pays .....	58
How the Retail Trade and Public Are Protected From Reclaimed Vacuum Tubes .....	66
A. Atwater and Discusses Present Problems and Future Possibilities of Radio .....	74
Brunswick Co. Supplies Dealers With Material for Complete Panatrop Drive .....	80
How the Sales of the New Instruments May Best Be Promoted ..	82
Talking Machine Merchants of the Nation Look for Prosperity in 1926 — (Symposium Covering Widely Separated Sections of the Country) .....	83-90
Spirit of Enthusiasm Favors the Trade Throughout the New England Territory .....	96-97
Quaker City Dealers Awaiting Shipments of the New Instruments to Fill Orders .....	103-106
Famous Artists Again Heard in Concert Over Radio Under Auspices of Victor Talking Machine Co. .	110
Trade in Middle West Faces New Year With Optimism as Satisfactory Conditions Continue. . . .	119-134
Featuring the Musical Possibilities of the Talking Machine .....	135-136
Happenings in the Musical Merchandise Field .....	151-155
News From the Trade in the Dominion of Canada .....	156
Sales of Popular Music at Retail Are Once Again on a Satisfactory Basis .....	157
Perkins Copyright Bill Vests Right to Broadcast Music in Copyright Owner .....	159
Gleanings From the World of Music, .	157-160
News From Our London Headquarters .....	163
Latest Patents Relating to Talking Machines and Records .....	164
Advance Lists of Talking Machine Records for February, 1926. . .	165-169

CORRESPONDENCE FROM LEADING CITIES

Akron-Canton, 59—Minneapolis and St. Paul, 67—Milwaukee, 68—Cincinnati, 70—Indianapolis, 72—Richmond, 72—Cleveland, 75—Pittsburgh, 76-78—Buffalo, 80—Kansas City, 87—Baltimore, 94—Boston, 96-97—Toledo, 100—Philadelphia, 103-106—Detroit, 112—Chicago, 119-134—St. Louis, 161—Canada, 156—News From the World's European Office, 163.

I Love My Baby—Fox-trot ..... Robert Billings  
 I'm "Gonna" Hang Around My Sugar—Fox-trot, Robert Billings  
 In Your Green Hat—Fox-trot ..... Lee Sims  
 Just Around the Corner—Fox-trot, Harold Wansborough  
 Just One More Waltz (With You Sweetheart) ..... Lee Sims  
 A Little Bit Bad—Fox-trot ..... Lee Sims  
 A Little Bungalow (From "The Cocoanuts")—Fox-trot ..... Lee Sims  
 Miami (From "Big Boy")—Fox-trot ..... Robert Billings  
 The National Game—March with Lyrics ..... Horace Prell  
 Paddin' Madelin' Home (From "Sunny")—Fox-trot, Lee Sims  
 Reveresque—A Love Reverie—Waltz  
 Show Me the Way to Go Home—Fox-trot ..... Lee Sims  
 The Sidewalks of New York—Waltz  
 (That's Her—That's Her) What Did I Tell Ya?—Fox-trot ..... Robert Billings  
 'Till the End o' the World With You—Waltz  
 Too Many Parties and Too Many Pals—Waltz  
 Tweedle-Dee Tweedle-Do—Fox-trot ..... Cal Welch  
 When the One You Love Loves You—Waltz  
 Who? (From "Sunny")—Fox-trot ..... Lee Sims

FOREIGN WORD ROLLS

POLISH  
 Chcialo Sie Zosi Jagodek.  
 Jakem Maszerowal ..... Fr. Przybylski  
 Swir, Swir Za Kominem—Mazur.  
 AUTO-ART  
 These Rolls for Reproducing and Expression Player-pianos Using Standardized Tracker Bar  
 INSTRUMENTAL ROLLS—MUSIC ONLY  
 "Juba" Dance ..... Walter Fifielski  
 Love's Caprice (Woods) ..... McNair Ilgenfritz  
 Melodie, Op. 3, No. 3 (Rachmaninoff) ..... Walter Fifielski  
 Novelette (Saint-Saens) ..... Robert Billings  
 The Swan (Saint-Saens) ..... McNair Ilgenfritz  
 LIBRARY EDITION—WORD ROLLS  
 Oh! Dry Those Tears (Del Riego)—Song, McNair Ilgenfritz  
 Rule Britannia (Arne)—Song ..... Robert Billings  
 LIBRARY EDITION—MUSIC ONLY  
 "Juba" (Dett)—Dance ..... Walter Fifielski  
 La Czarine (Ganne)—Mazurka Russe ..... McNair Ilgenfritz  
 Lullaby (Bereceuse from "Jocelyn") (Godard), McNair Ilgenfritz



A B C D E F G H I J K L M N O P Q R S T U V W X Y Z

# INDEX TO ADVERTISERS

A B C D E F G H I J K L M N O P Q R S T U V W X Y Z

**A**

A.-C. Electrical Mfg. Co. .... 74  
 Acme Elec. & Mfg. Co. .... 147  
 Adler Mfg. Co. .... 45  
 Air-Way Elec. Appliance Corp. .... 101  
 Alter & Co., Harry .... 124  
 Alto Mfg. Co. .... 128  
 Ambu Engineering Inst. .... 134  
 American Electric Co. .... 136  
 American Mica Works .... 78  
 Amplion Corp. of America .... 146  
 Apex Elec. Mfg. Co. .... 39  
 Argus Radio Corp. .... 64  
 Atlas Plywood Corp. .... 44  
 Atwater Kent Mfg. Co. .... 31  
 Audak Co. .... 8  
 Autophone Mfg. Co. .... 98, 99

**B**

Bacon Banjo Co. .... 154  
 Badger T. M. Co. .... 18  
 Baltimore Phono. Distributing Co. .... Inside front cover  
 Barnhart Bros. & Spindler .... 120  
 Beacon Radio Mfg. Co. .... 91  
 Bel Canto Radio Tel. & Equip. Co. .... 82  
 Berg Auto Trunk & Specialty Co. .... 108, 109  
 Berlin, Inc., Irving .... 158  
 Blackman Talking Machine Co. .... Insert facing page  
 Blair Radio Labs. .... 28  
 Blood Tone Arm Co. .... 135  
 Brach Mfg. Co., L. S. .... 30  
 Brandes Products Corp. .... 17  
 Brilliantone Steel Needle Co. .... 71  
 Broadcaster Corp. .... 126  
 Bruno & Son, Inc., C. .... 55, 154  
 Brunswick-Balke-Collender Co. .... Front cover, 5, 7  
 Buel-Lyons Co. .... 75

**C**

Carryola Co. of America .... 65  
 Carter Radio Co. .... 122  
 Cheney Sales Co. .... 97  
 Claremont Waste Mfg. Co. .... 78  
 Classified Want Ads. .... 162  
 Columbia Phonograph Co., Inc. .... Insert facing page  
 Columbia Wholesalers, Inc. .... 94  
 Commercial Associates .... Inside front cover  
 Consolidated Talking Machine Co. .... 113, 124, 127  
 Continental Radio & Elec. Corp. .... 54  
 Corley Co. .... 164  
 Crosley Radio Corp. .... 33

**D**

Diamond T Radio Mfrs. .... 102  
 Ditson & Co., Chas. H. .... 96  
 Ditson & Co., Oliver .... 96  
 Doerr-Andrews-Doerr .... Inside front cover  
 Droop & Sons Co., E. F. .... 161  
 Duro Metal Products Co. .... 67

**E**

Eagle Radio Co. .... 63  
 Edison, Inc., Thos. A. .... Back cover  
 Electrical Products Mfg. Co. .... 115  
 Electrical Research Laboratories .... 136  
 Empire Phono. Parts Co. .... 43  
 Esenbe Co. .... 76  
 Eshborn, Samuel .... 149  
 Everybody's Talking Machine Co. .... 13  
 Excel Phonograph Mfg. Co. .... 130  
 Excello Products Co. .... 119

**F**

Fansteel Products Co. .... 132  
 Farrand Mfg. Co. .... 36, 37  
 Federal Radio Corp. .... 111  
 Federal Telegraph Co. .... 140, 141  
 Feist, Leo, Inc. .... 157, 159, 165, 166

Fischer Co., J. A. .... 21  
 Fletcher-Wickes Co. .... 114  
 Fox Pub. Co., Sam .... 160  
 Freed-Eisemann Radio Corp. .... 60, 61  
 Freshman Co., Inc., Chas. .... 146  
 Fuehr & Stemmer Piano Co. .... 138

**G**

General Elec. Co. .... 117  
 General Phonograph Corp.,  
 Inserts facing pages 42 and 50 and pages 48, 50, 144  
 General Phonograph Corp. (New York Distributing  
 Division) .... 80  
 General Phono. Corp. of New England .... 97  
 General Phonograph Mfg. Co. .... 34  
 Gennett Records .... Inside back cover  
 Gibson-Snow Co., Inc. .... Inside front cover  
 Goldschmidt Corp., Th. .... 23  
 Gold Seal Products Co. .... 42  
 Gould Storage Battery Co. .... 81  
 Greater City Phonograph Co. .... Inside front cover  
 Grigsby-Grunow-Hinds Co. .... 27  
 Guarantee T. M. Supply Co. .... 104  
 Guden & Co., H. A. .... 62

**H**

Hassler Texas Co. .... Inside front cover  
 Henderson Bros. .... 162  
 Hohner, M. .... 152  
 Hommel & Co., Ludwig .... 76

**I**

Ilsley, Doubleday & Co. .... 66  
 International Mica Co. .... 50

**J**

Jewel Phonoparts Co. .... 123  
 Jones, Howard B. .... 116  
 Junod & Co., L. .... 68

**K**

Kent Co., F. C. .... 26  
 Kiefer-Stewart Co. .... Inside front cover  
 Kimball Co., W. W. .... 120  
 Kohler Distributing Co. .... Inside front cover  
 Kolster Radio .... 140, 141  
 Krasco Phono. Motor Co. .... 128

**L**

Lakeside Supply Co. .... 126  
 Leedy Mfg. Co. .... 155  
 Liberty Transformer Co. .... 125  
 Long Island Phonograph Co. .... Inside front cover  
 Ludwig & Ludwig .... 152

**M**

Magnavox Co. .... 49  
 Marks Music Co., Edw. B. .... 158  
 Marwol Radio Corp. .... 95  
 Marysville Products Co. .... 149  
 Mohawk Corp. of Ills. .... 129  
 Moore-Bird & Co. .... Inside front cover  
 Musical Products Distr. Co. .... 110  
 Mutual Phono. Parts Mfg. Co. .... 59

**N**

National Carbon Co. .... 29  
 National Lock Co. .... 72  
 National Publishing Co. .... 11  
 Neufeldt & Kuhnke .... 23  
 New England Phono. Dist. Co. .... Inside front cover  
 New York Album & Card Co. .... 4

**O**

Operadio Corp. .... 137  
 Oro-Tone Co. .... 131  
 Outing Talking Machine Co. .... 145

**P**

Pathex, Inc. .... 19  
 Pearsall Co., Silas E. .... 25  
 Peckham Mfg. Co. .... 68  
 Peerless Album Co. .... 12

Penn Phono. Co. .... 103  
 Pennsylvania Phono Dist. Co. .... Inside front cover  
 Perryman Elec. Co. .... 47  
 Pet-O-Fone Mfg. Co. .... 161  
 Philadelphia Badge Co. .... 105  
 Philadelphia Victor Distributors .... 105  
 Pickereel Walnut Co. .... 46  
 Pittle & Co., Chas. .... 155  
 Plaza Music Co. .... Insert facing page 34  
 Plywood Corp. .... 66  
 Polk Co., Inc., James K. .... Inside front cover  
 Pressed Metal Mfg. Co. .... 35  
 Priess Radio Co. .... 150

**Q**

Quam Radio Co. .... 139

**R**

Radio Corp. of America .... 52, 53  
 Radio Industries Corp. .... 58  
 Reichmann Co. .... 118  
 Rene Manufacturing Co. .... 156  
 Richards, Inc., C. A. .... Inside front cover

**S**

Schickerling Products Corp. .... 24  
 Selectron Co. .... 69  
 Shamrock Mfg. Co. .... 22  
 Silent Motor Corp. .... 79  
 Smith Co., C. D. .... Inside front cover  
 Sonora Phonograph Co., Inc.,  
 Inside front cover, 92, 93, 112  
 Star Machine & Novelty Co. .... 82  
 Starr Piano Co. .... 14  
 Stead & Co., Ltd., J. .... 163  
 Sterling Mfg. Co. .... 142, 148  
 Sterling Roll & Record Co. .... 70  
 Stewart-Warner Speedometer Corp. .... 73  
 Strevell-Paterson Hdw. Co. .... Inside front cover  
 Stromberg-Carlson Telephone Mfg. Co. .... 9  
 Superior Phono. Parts Co. .... Insert facing page 34  
 Supertron Mfg. Co. .... 20

**T**

Talking Machine Supply Co. .... 162  
 Targ & Dinner Music Co. .... 122  
 Tay Sales Co. .... Inside front cover  
 Teletone Corp. of America .... 143  
 Thermodyne Radio Corp. .... 16  
 Thompson Mfg. Co., R. E. .... 57  
 Thornell-MacLaren Associates .... 38  
 Triangle Music Pub. Co. .... 188  
 Trilling & Montague .... 106

**U**

Udell Works .... 67  
 Unique Reproduction Co., Inc. .... 40  
 United Cabinet Mfrs. Corp. .... 133  
 United Mfg. & Distr. Co. .... 130  
 United States Music Co. .... 167  
 Utah Radio Products Co. .... 121

**V**

Van Veen & Co., Inc. .... 161  
 Vega Mfg. Co. .... 153  
 Victor Radio Corp. .... 134  
 Vitanola T. M. Co. .... 41

**W**

Wall Kane Needle Mfg. Co. .... 150  
 Weber-Knapp Co. .... 32  
 Weston Elec. Inst. Corp. .... 56  
 Weymann & Son, H. A. .... 104  
 White Co., H. N. .... 151  
 Witlin, N. .... 100  
 Wolf Mfg. Inds. .... 107  
 Wuebben, G. M. B. H. .... 30

**Y**

Yahr & Lange Co. .... 51

**Z**

Zenith Radio Corp. .... 15



# Edison Tonal Supremacy Challenges the Wide World



Where but in the NEW EDISON can you find reproduction as real as the living artist?

**THE** New Edison is the living artist—so clear, so sweet, so true is the Re-Creation of the artist's performance.

Direct comparison between Edison artists and their Edison records—heard by millions of music lovers and critics everywhere—is the test that no phonograph but the New Edison dare present to a discriminating audience.

Edison dealers enjoy the profits derived from this Edison leadership.

THOMAS A. EDISON, Inc.  
ORANGE, N. J.

You don't need a fortune to become an Edison Dealer—ask nearest Edison Jobber

## Jobbers of the New Edison, Edison Records, the Edison Diamond Amberola and Blue Amberol Records

<b>CALIFORNIA</b> San Francisco—Edison Phonograph Distributing Co.	<b>MICHIGAN</b> Detroit—Phonograph Co. of Detroit.	<b>NEW YORK</b> Albany—American Phonograph Co. New York City—J. F. Blackman & Son, (Amberola only). Syracuse—W. D. Andrews Co. (Amberola only).	<b>TEXAS</b> Dallas—Texas-Oklahoma Phonograph Co.
<b>COLORADO</b> Denver—Edison Phonograph Distributing Co.	<b>MINNESOTA</b> Minneapolis—Laurence H. Lucker	<b>OHIO</b> Cleveland—The Phonograph Co.	<b>UTAH</b> Ogden—Proudfit Sporting Goods Co.
<b>GEORGIA</b> Atlanta—Phonographs, Inc.	<b>MISSOURI</b> Kansas City—Edison Phonograph Distributing Co. St. Louis—Silverstone Music Co.	<b>PENNSYLVANIA</b> Philadelphia—Girard Phonograph Co. Pittsburgh—Buehn Phonograph Co. Williamsport—W. A. Myers.	<b>VIRGINIA</b> Richmond—The C. B. Haynes Co., Inc.
<b>ILLINOIS</b> Chicago—Edison Phonograph Distributing Co.	<b>MONTANA</b> Helena—Montana Phonograph Co.	<b>RHODE ISLAND</b> Providence—J. A. Foster Co. (Amberola only).	<b>CANADA</b> St. John—W. H. Thorne & Co., Ltd. Toronto—R. S. Williams & Sons Co., Ltd. Vancouver—Kent Piano Co., Ltd. Winnipeg—R. S. Williams & Sons Co., Ltd. Babson Bros. (Amberola only).
<b>LOUISIANA</b> New Orleans—Diamond Music Co., Inc.	<b>NEW JERSEY</b> Orange—Edison Phonograph Distributing Co.		
<b>MASSACHUSETTS</b> Boston—Pardee-Ellenberger Co., Inc. Iver Johnson Sporting Goods Co. (Amberola only).			





## The New Series Gennett Records at 50c.

**N**OW that the indoor season is here the New Series Gennett Records at 50 cents with their timeliness and quality are an important stimulant in renewing interest in the record as a source of home entertainment.

The Gennett Slogan "First and Best on Gennetts" was never truer than it is today, for up-to-the minute popular dance, vocal and novelty hits are to be had when they are new and at a new price!

Then there are the Gennett standard numbers—without which no dealer's shelves are complete—representing the highest attainment in the art of sound recording.

The new Gennett sales plan eliminates all possibility of dead stock and enables the dealer to have on his shelves selections that are in constant demand, the profits from which are never being jeopardized by left-overs and slow movers.

Every dealer will be interested in this new plan because the Gennett proposition is worth while. Write for further information.

**GENNETT RECORDS**

**Richmond, Indiana**