

*The* **TALKING**  
**MACHINE**  
**WORLD**

*For the  
 makers &  
 sellers of  
 talking  
 machines*

Published Each Month by Edward Lyman Bill, Inc., at 373 Fourth Ave., New York, Aug. 15, 1919



*The best-known trade-mark in the world*

"The Victor talking machine's design, 'His Master's Voice,' has become a household word, and the quaint little fox terrier at attention before the horn is familiar to more Americans than any of the world's great masterpieces"—*Collier's Weekly*.





Chippendale

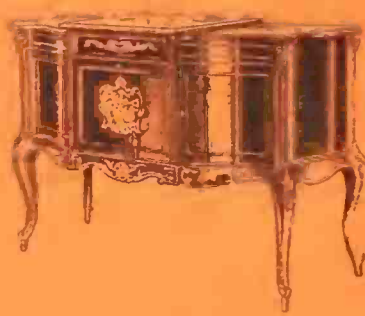

Louis XI



Louis XVI

## Magnificent Models

Not only is the Sonora tone matchless, but the Sonora designs are peerless for beauty. These instruments are unequaled for their many important and exclusive features of construction. Note their superb appearance!

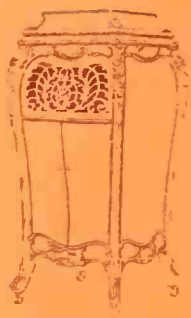

Supreme



Grand



Baby Grand

THE INSTRUMENT OF QUALITY  
**Sonora**  
 CLEAR AS A BELL

The Highest Class Talking Machine in the World

- First to make a cabinet model under \$200
- First to use a tone modifier
- First to employ an automatic stop
- First to use "bulge" cabinet work
- First to have a motor meter
- First to use a wooden tone chamber and an all-wooden tone passage
- First to utilize a feed screw mechanism for the revolving of the turntable for the use of disc records
- First to produce a 30 and 45-minute motor power (which saves frequent winding)
- First to offer a high class portable model
- First to demonstrate that a large business can be done in phonographs on a cash basis.

*The Sonora sells easily for cash, and keeps your bank balances at a high level*

**Sonora Phonograph Sales Company, Inc.**

GEORGE E. BRIGHTSON, President

279 Broadway, Dept. Y, New York City

Toronto: Ryrie Bldg.

Sonora is licensed and operates under BASIC PATENTS of the phonograph industry



Incincible



Elite



Minuet



Jacobean



Colonial



Duncan Phyfe



# The Talking Machine World

Vol. 15. No. 8

New York, August 15, 1919

Price Twenty-five Cents

## TALKERS AND LANGUAGE STUDY

National Educational Association Recognizes the Value of Talking Machines in Aiding the Student to Speak With Proper Accent

At the recent convention of the National Educational Association of the United States, which met at Milwaukee, Professor E. C. Parmenter, of the University of Chicago, spoke on the immense value of the talking machine in teaching the French pronunciation.

He brought forward the fact that by the use of the Dictaphone it was possible for a student to speak a sentence or two in French and then hear what he has said with his own pronunciation. He may in that way more clearly see the faults of his pronunciation.

The value of the talking machine in teaching the proper accent in French he believed was a large one. Educational institutions which could not afford language instructors with a good accent could obtain their accent through the records. He stated, however, that the letter "S" was not distinguishable in the phonographic reproduction.

In a discussion which followed, however, W. H. Willson, manager of the educational department of the Columbia Co., made known the fact that during the past six or seven months great improvements had been made in the recording of the French language and that to-day the "S" was perfectly distinguishable, and that the letter "F," which was even more difficult to record formerly, may now be recorded with perfect clarity.

Among the other representatives of the Columbia Co. present at this convention were J. Milner Dorey and Harry B. Goodwin.

## TALKING MACHINE EXPORTS DECLINE

Exports, Including Records, for Eleven Months Ending May 31, 1919, Total \$4,020,960

Washington, D. C., August 1.—In the summary of exports and imports of the commerce of the United States for the month of May, 1919, (the latest period for which it has been compiled), which has just been issued, the following figures on talking machines and records are presented:

The dutiable imports of talking machines and parts during May, 1919, amounted in value to \$49,190, as compared with \$26,033 worth which were imported during the same month in 1918. The eleven months' total, ending May, 1919, showed importations valued at \$282,318, as compared with \$310,757 worth of talking machines and parts imported during the same period of 1918.

Talking machines to the number of 4,002, valued at \$123,058, were exported in May, 1919, as compared with 9,946 talking machines, valued at \$337,865 sent abroad in the same period of 1918. The eleven months' total showed that we exported 45,186 talking machines, valued at \$1,367,641, as against 88,239 talking machines, valued at \$2,506,617 in 1918, and 69,221 talking machines, valued at \$1,797,028 in 1917.

The total exports of records and supplies for May, 1919, were valued at \$325,748, as compared with \$203,489 in May, 1918. For the eleven months ending May, 1919, records and accessories were exported valued at \$2,653,319 in 1918 and \$1,856,879 in 1917.

## MCCORMACK BUYS LARGE ESTATE

John McCormack, the celebrated tenor and Victor artist, has purchased the Henry L. Stoddard estate, formerly the Stokes Farm, at Darien, Conn. The estate comprises 160 acres and this land is partly in Darien and partly in Noroton. The price is said to be in the neighborhood of \$200,000.

## WHAT FARMERS ARE BUYING NOW

Advertising Man Discusses Talking Machine Trade Among Farmers—Standard Machines and Records Greatly in Demand These Days

In discussing the financial conditions among the farmers of this country and the kind of goods they are buying these days, Herbert S. Cline, advertising manager of A. Livingston & Sons, Bloomington, Ill., points out some very interesting facts regarding the talking machine trade. He also points out the value of advertising which tends to establish the trade-marked name of a product and says that the farmers are calling for machines by name. He says:

"We sell more talking machines to farmers than to city people. And we are fortunate in having a standard make of instrument that is advertised in the farm papers. It has been our experience that our farmer customers are so strongly sold on this machine that they are willing to wait several months to get this particular make (on which there happens to be a shortage), when there are a score of other places in the city where they can get immediate delivery of other makes of machines not so extensively advertised.

"Again, one has only to glance over the mail orders from farmers that we receive every month for records to get an idea as to their taste. Usually the woman in the family has a great deal to say as to the selection of records—and a taste that calls for McCormack, Gallucurci or Caruso is going to call for similar refinement in wearing apparel, accessories and household needs."

## INTERESTING WINDOW DISPLAY

East Liverpool, O., Dealer Features Victor Record in Timely Summer Display

Lewis Bros., Victor dealers of East Liverpool, O., recently featured McCormack's Victor record "When You Look in the Heart of a Rose." The window was arranged by the store manager,

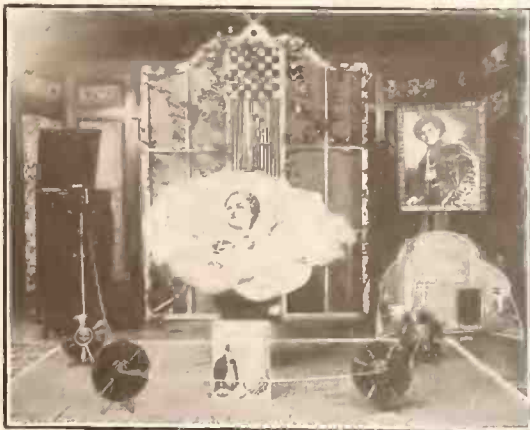

Most Artistic McCormack Window

F. H. Burbick, and in the middle of the display was a beautiful rose with a girl's head in the center. On the left was a large Victrola and on the opposite side a picture of the famous tenor. Around the front of the display were several Victor records of the song with tapes leading the eye to the machine. In the lower right hand corner was a reminder that summer is still here and summer music is in order.

## COLONIAL METAL WORKS CORP.

The Colonial Metal Works Corp., Manhattan, has been incorporated at a capital of \$9,000 to deal in talking machine parts and metal novelties. The incorporators are M. Frideman, I. Lauter and I. Renner, 867 East 179th street, New York.

The Sonora agency has recently been placed with the Greenpoint Talking Machine Co., 638 Manhattan avenue, Brooklyn, N. Y.

## ANENT THE UNPAID BALANCE HABIT

Credit Men Discuss That Particular Evil and Means for Controlling It

The New York Credit Men's Association has just been discussing in its Bulletin what to do with customers who habitually leave balances unpaid week after week or month after month. The feeling is that this is the first sign that an account which heretofore has been profitable and desirable has become risky without apparent reason. So far as the seller can see, there is no change in the customer's income or fixed expenses and the seller's consent to carry a balance is at first readily obtained, but the account grows beyond the former figures to an ever-increasing level and the merchant begins to feel uneasy and wonders what to do. His fear of losing the customer is stronger than the fear of loss of money and so, trusting to luck, the account is allowed to drift along, first up and then down, for weeks and months.

There is just enough of such accounts which eventually pay to mislead the seller into carrying and bothering about the others, which finally are lost. The remedy, of course, is not to let a prompt customer get into the habit of leaving balances. As soon as that habit shows itself, he must be talked with tactfully but firmly and insistently with a view to finding out why the change in the customer's circumstances has taken place. In other words, he must get the facts before him definitely and then have the courage to make the decision.

## HARDWOOD FOR TALKING MACHINES

This Trade Has Established Itself as Largest Factor in Hardwood Panel Business

The important position that has been assumed by the talking machine in the hardwood field is indicated by the following editorial comment which appeared recently in the "Hardwood Record" in connection with a review of market conditions. One paragraph read:

"It is generally estimated that to date only about 4 per cent. of the population has purchased phonographs. The potential proportions of this field are so tremendous that they are incomprehensible at a glance. The phonograph going into these machines, and just as the largest single factor in the hardwood panel business, but the fact must not be lost sight of that there is also a substantial amount of solid wood going into these machines, and just as the growth of the phonograph business has been reflected on the panel business, so it will be reflected on solid hardwood lumber for the legs, corners, tops and other parts."

## CUBAN MUSIC TRADE CONDITIONS

Talking Machines Very Popular—Cheaper Machines Best Sellers—Natives Love Music

The natives of the Island of Cuba are very fond of music of all kinds, says Consul C. S. Williams, Cienfuegos, and the market for American makes of talking machines is excellent, for this seems to be the most popular type of music. In the local retail stores machines are selling at prices ranging from \$5 to \$181, while the most popular models are those retailing at from \$20 to \$30. In order to facilitate negotiations with Cuban firms, American manufacturers should send their correspondence in Spanish and catalogs and all other literature should also be in that language. A list of dealers and importing houses in Cienfuegos, Cuba, may be had from the Bureau of Foreign and Domestic Commerce or by addressing the Talking Machine World. Cuba's trade in talking machines is growing.



# The Importance of Transforming the Sales-room Into a Real Musical Salon :: By Warfield Webb

The man who sells talking machines and records can appeal with profit to the esthetic side of one's nature. The more artistic the effects as applied to the store the greater possibilities are there for sales. In other words, we must combine the beautiful with the musical, and in this way create an environment that makes the whole harmonize, filling the mind with that comforting feeling that adds to our appreciation of music.

Art can be made a real factor in the sales-room. It must not be confined to the booths alone, for the latter are but the complement of the sum total of one's endeavors. If we fail to make the exterior as well as the interior attractive there will be the larger difficulty of arousing that interest which has so much to do with the sale of machines or records. We have to create an atmosphere, that is the whole subject in a few words. If this attribute is lacking our efforts are not going to be nearly so profitable.

There are some stores that have caught this idea and practical tests prove its value. Here is one establishment that has gone a little in advance of most others. Now this particular store has not the advantage of a street display to get the people to buy. It is a department in a large store, and while there are infrequent opportunities for window display and publicity in the dailies, still the larger number of prospects must be brought into the talking machine section by that more pleasing invitation—its sheer attractiveness and the way the goods are displayed.

The idea given prominence here is that this is a music salon and not merely a salesroom for the disposal of machines and records. The effects are obvious when one comes into that part of the store. It is not denoted as a talking machine section, but as a place of restful recreation. It is made to appeal to the more esthetic nature of the visitors. They are given the impression that here one will find rest and comfort and the soothing tones of music will add to this much-sought-after environment. One need not buy because he enters this section, but he can at least find comfort. And how often will this awaken in the mind a keener appreciation of the value of the talking machine as a help to make the home happier!

You are at once robbed of the cold, unpoetic

store, and are given a reminder of the home, of the conservatory, of the music salon. You get away from the businesslike feeling which too often mars the stores that are seeking to make sales for these lines. You are given an easy chair, the little electric fountain plays silently, the large windows are draped with hangings, the floor is carpeted with heavy velvet carpet covering. There is a feeling that this is more than a salesroom in its broadest meaning; it is a salon, and it offers a quiet repose that has its charm, where the mind may be at rest amid the sweet music that floats around.

There is another store with its show windows attractively decorated, and its rugs, flowers and

*The More Artistic the Store the More Possibilities There Are for Resultful Sales*

soft lights charm also. You enter here rather as you would a concert parlor, for the interior is robbed of its industrial glare. You want to linger here because of the contrast from the noisy street, from the whirl and hurry of the busy stores, from the jostle of the crowds. You want to have comfort and to find ease when you are buying machines and records. You prefer to get the atmosphere, so that the instrument purchased will not sound different when the record is played in your own parlor or living room.

If you were the customer in this case you would, just as they, seek out the stores that have come to appreciate the many advantages of this "homy" effect. You do not buy machines or records as you buy dry goods or groceries. You want a different atmosphere, and if this is found it will be only natural for you to give

this place the preference when you make a purchase.

Do you know what a difference there is between hearing a record played in pleasing environment and in an environment that is cold and harsh? You can appreciate the music to a much greater extent when you hear it in suitable surroundings. A fine painting looks far more beautiful in a drawing room than it does amid a large collection when seen in a store that is barren of the proper setting.

You want the customers to feel that you are desirous of making your store distinctive. This same desire should pervade all your endeavors. Make the salesroom a music salon. Do not adopt the idea that just as many sales would be made did you not make this special appeal as a very significant part of your business. You will find that getting away from the sameness and the cold, uninviting showroom will be a material help toward creating this impression that you are desirous of arousing.

If you are not located so that you can augment the art aspect of your store then at least do what is possible with the limited means at your command. One of the stores cited above is not advantageously located, but the proprietor has made the interior effect most pleasing. He has not been lacking in either expense or ideas and the results of this are that he has a show place for the customer's delight. Surely you can do as much as he has done, and without any more ado. He, like the other man noted, realizes that the public believes that there is a great deal of merit in the store that gets away from the stereotyped ideas and that originality and art make a combination that wins out.

## JOINS FORCES OF THE REED CO., INC.

PITTSBURGH, PA., August 8.—The Reed Co., Inc., wholesalers, 237 Fifth Avenue, Pittsburgh, Pa., have secured the services of Henry Hornberger. He will call on the music dealers in the northwestern section of Pennsylvania. Mr. Hornberger is well known through the Pittsburgh district, having formerly been manager of Kauffmann & Baer's talking machine department and also connected with S. Hamilton & Co., of this city.

## THE WAR IS OVER

But a new REVOLUTION will take place  
WHERE ?

At the  
New York Album & Card Co.  
WHY ?

A record album surpassing in quality any book now manufactured will be placed on the market at an attractively low price.

Through unavoidable delay this new album will not be ready until September but—

IT WILL PAY YOU  
TO WAIT

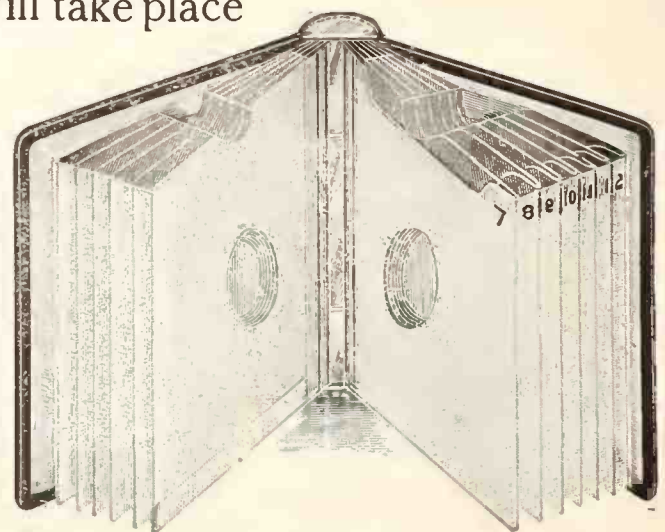
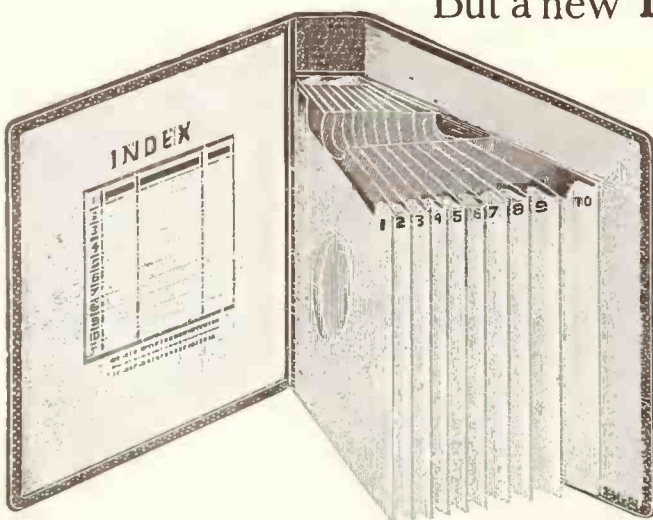

New York Album & Card Co., Inc.

Factory and Executive Offices: 23-25 Lispenard St., New York



Chicago, IL.: CULLEN, MARSH & CO.

21 East Van Buren St., Middle West Rep.

San Francisco, Cal.: WALTER S. GRAY

Chronicle Bldg., Pacific Coast Rep.



Victrola IV, \$25  
Oak



Victrola VIII, \$50  
Oak



Victrola X, \$90  
Mahogany or oak

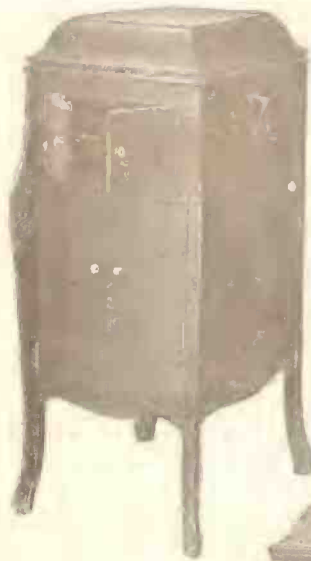

# Victor Supremacy

Supreme as a musical instrument, the Victrola naturally stands supreme as a business proposition.

The success of Victor retailers follows Victor supremacy as a matter of course.

**Victor Talking Machine Co.**  
Camden, N. J., U. S. A.

"Victrola" is the Registered Trade-mark of the Victor Talking Machine Company designating the products of this Company only.

**Warning:** The use of the word Victrola upon or in the promotion or sale of any other Talking Machine or Phonograph products is misleading and illegal.

**Important Notice.** Victor Records and Victor Machines are scientifically co-ordinated and synchronized in the processes of manufacture, and should be used together to secure a perfect reproduction.

Victrola XVI, \$225  
Victrola XVI, electric, \$282.50  
Mahogany or oak



## Victor Wholesalers

Albany, N. Y....Gately-Haire Co., Inc.  
Atlanta, Ga.....Elyea Company  
                          Phillips & Crew Piano Co.  
Baltimore, Md....Cohen & Hughes.  
                          E. F. Droop & Sons Co.  
                          H. R. Eisenbrandt Sons, Inc.  
Bangor, Me.....Andrews Music House Co.  
Birmingham, Ala.Talking Machine Co.  
Boston, Mass....Oliver Ditson Co.  
                          The Eastern Talking Machine  
                          Co.  
                          The M. Steinert & Sons Co.  
Brooklyn, N. Y...American Talking Mch. Co.  
                          G. T. Williams.  
Buffalo, N. Y....W. D. & C. N. Andrews.  
                          Buffalo Talking Machine Co.,  
                          Inc.  
Burlington, Vt...American Phonograph Co.  
Butte, Mont.....Orton Bros.  
Chicago, Ill.....Lyon & Healy.  
                          The Rudolph Wurlitzer Co.  
                          Chicago Talking Machine Co.  
Cincinnati, O....The Rudolph Wurlitzer Co.  
Cleveland, O.....The W. H. Buescher & Sons  
                          Co.  
                          The Collister & Sayle Co.  
                          The Eclipse Musical Co.  
Columbus, O.....The Perry B. Whitsit Co.  
Dallas, Tex.....Sanger Bros.  
Denver, Colo....The Knight-Campbell Music  
                          Co.  
Des Moines, Ia...Mickel Bros. Co.  
Detroit, Mich....Grinnell Bros.

Elmira, N. Y.....Elmira Arms Co.  
El Paso, Tex.....W. G. Walz Co.  
Honolulu, T. H....Bergstrom Music Co., Ltd.  
Houston, Tex....Thos. Goggan & Bro.  
                          The Talking Machine Co., of  
                          Texas.  
Indianapolis, Ind..Stewart Talking Machine Co.  
Jacksonville, Fla..Florida Talking Machine Co.  
Kansas City, Mo..J. W. Jenkins Sons Music Co.  
                          Schmelzer Arms Co.  
Lincoln, Nebr....Ross P. Curtice Co.  
Los Angeles, Cal..Sherman, Clay & Co.  
Memphis, Tenn...O. K. Houck Piano Co.  
Milwaukee, Wis...Badger Talking Machine Co.  
Minneapolis, Minn.Beckwith, O'Neill Co.  
Mobile, Ala.....Wm. H. Reynolds.  
Newark, N. J....Price Talking Machine Co.  
New Haven, Conn.The Horton-Gallo-Creamer  
                          Co.  
New Orleans, La...Philip Werlein, Ltd.  
New York, N. Y...Blackman Talking Mach. Co.  
                          Emanuel Blout.  
                          C. Bruno & Son, Inc.  
                          Charles H. Ditson & Co.  
                          Knickerbocker Talking Ma-  
                          chine Co., Inc.  
                          Landay Bros., Inc.  
                          New York Talking Mach. Co.  
                          Ormes, Inc.  
                          Silas E. Pearsall Co.

Omaha, Nobr.....A. Hospe Co.  
                          Mickel Bros. Co.  
Peoria, Ill.....Putnam-Page Co., Inc.  
Philadelphia, Pa..Louis Buehn Co., Inc.  
                          C. J. Hepe & Son.  
                          The George D. Ornstein Co.  
                          Penn Phonograph Co., Inc.  
                          The Talking Machine Co.  
                          H. A. Weymann & Son, Inc.  
Pittsburgh, Pa....W. F. Frederick Piano Co.  
                          C. C. Mellor Co., Ltd.  
                          Standard Talking Machine Co.  
Portland, Me.....Cressey & Allen, Inc.  
Portland, Ore....Sherman, Clay & Co.  
Providence, R. I...J. Samuels & Bro., Inc.  
Richmond, Va....The Corley Co., Inc.  
                          W. D. Moses & Co.  
Rochester, N. Y...E. J. Chapman.  
                          The Talking Machine Co.  
Salt Lake City, U.Consolidated Music Co.  
                          The John Elliott Clark Co.  
San Antonio, Tex.Thos. Goggan & Bros.  
San Francisco, Cal.Sherman, Clay & Co.  
Seattle, Wash....Sherman, Clay & Co.  
Sioux Falls, S. D..Talking Machine Exchange.  
Spokane, Wash...Sherman, Clay & Co.  
St. Louis, Mo....Koerber-Brenner Music Co.  
St. Paul, Minn...W. J. Dyer & Bro.  
Syracuse, N. Y...W. D. Andrews Co.  
Toledo, O.....The Toledo Talking Ma-  
                          chine Co.  
Washington, D. C.Cohen & Hughes.  
                          E. F. Droop & Sons Co.  
                          Robt. C. Rogers Co.



## AN IMPORTANT ACCESSORY—ALBUMS FOR FILING DISC RECORDS

The enormous demand for "National" Record Albums keeps pace with the ever increasing demand for machines and records, and our output capacity has been enlarged to meet the greater needed supply. Record Albums have proven themselves to be the best and most convenient, as well as economic, method of filing and keeping disc records.



### MAKING THEIR SELECTION

*Illustrating the daily actual usage of the Album, the most convenient and satisfactory record filing system extant.*

### THE ALBUM

*soon pays for itself in time-saving and preserving records. The initial cost is really an investment which comes back fourfold.*

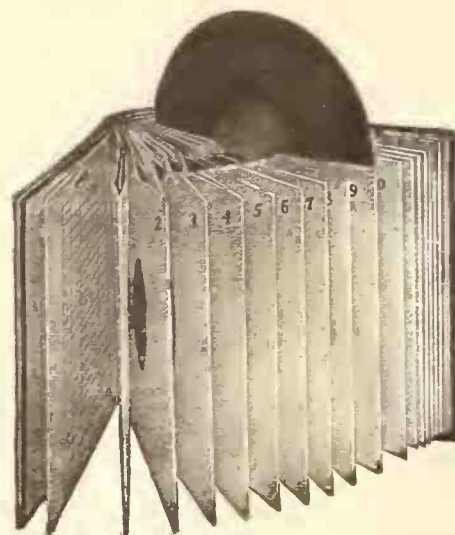

### THE PERFECT PLAN

*The pockets holding the records are substantially made from strong fibre stock, firmly joined together and bound in attractive covers.*

### A PLACE FOR EVERY RECORD AND EVERY RECORD IN ITS PLACE

Albums are an Indispensable Requisite in the talking machine business and wherever records are sold. An accessory that is necessary and worth while. Practical and handy. Save time and records. A profitable adjunct to the business. All owners of machines and records want Albums to file and preserve their records.

We manufacture disc Record Albums containing 12 pockets to fit cabinets of all sizes and styles. We also make Albums containing 17 pockets. With the indexes they are a complete system for filing all disc records.

For durability, finish and artistic design, our Albums are unsurpassed. We have unexcelled manufacturing facilities, and considering quality our prices are the lowest. Write us, giving quantity you may desire, and we will quote prices.

WE MAKE ALBUMS TO CONTAIN VICTOR, COLUMBIA, EDISON, PATHE AND ALL OTHER DISC RECORDS

**NATIONAL PUBLISHING CO. : 239 S. American Street : PHILADELPHIA, PA.**  
**CHICAGO OFFICE: 508 S. Dearborn Street**

### YAWNS MAKE SILVERY VOICES

Miss Edna Bailey, Edison Artist, Has School in Brooklyn to Teach People How to Speak Properly—Yawn Is Fundamental Principle

The blasé habitués of the hotel lobbies and parlors in the Metropolis and the common herd hurrying about their tasks, being borne aloft in speedy elevators in skyscrapers and department stores, have of late been awakened from their preoccupation and thoughts by the silvery voices of page boys and elevator girls announcing their routine phrases in an entirely new and altogether pleasing way. The harsh, irritating voice once so prevalent among this class is rapidly disappearing and New Yorkers live in hope that some day the subway guards and "L" ogres may also fall under the new spell which has for its secret nothing more or less than a yawn. But listen to the story.

Miss Edna Bailey, who makes Edison records when she is not busy teaching people how to talk properly, has one of the most unusual posi-

tions in the city and one of the first things you do when you go to see her is to yawn, which is quite in order. In her work of making over old voices into new ones she always makes the pupil yawn in order to completely relax the muscles of the throat and neck. Then she proceeds with her lessons.

One of her classes was made up of eighteen negro elevator men in a large department store. Another was the staff of page boys from the Hotel McAlpin and her work has been so successful that she is very much in demand to teach her course in every-day speaking.

### CHAS. MARUSAK'S PURCHASE

Charles Marusak, formerly connected with the sales staff of the S. B. Davega Co. and more recently with the Knickerbocker Talking Machine Co., has purchased the business of Matthew Lavine, at Third avenue and Forty-seventh street, New York. Mr. Marusak will handle talking machines and records, as well as sporting goods.

### SOME RECENT INCORPORATIONS

The Belclear Phonograph Corp., Manhattan, has been incorporated at a capital of \$5,000 by Z. D. Benson, E. A. Claffey and F. A. Franke, 154 Nassau street, New York.

The Forer Phonograph Sales Corp. has been incorporated by David Forer, Max Forer and Benjamin Forer. The capital stock is \$7,500 and the address is given as 230 West 107th street, New York.

Articles of incorporation have been filed by the Mocking Bird Phonograph Co., Des Moines, Ia., to manufacture and sell talking machines. A. S. Kirkhart is president and treasurer and the capital stock is \$10,000.

The Fred Myers International Phonograph Co., Manhattan, has been incorporated at a capital of \$200,000 by L. Strauss, H. Roth and J. A. Gilman, 225 Fifth avenue, New York.

### RAHWAY T. M. CO. OPENS STORE

The Rahway Talking Machine Co. has just opened a new store at Rahway, N. J. This concern carries Columbia Grafonolas and is doing a brisk retail trade in those instruments. Ben Saffran, manager of the store at 138 Main street, is planning for a large fall trade and is getting together a large stock of Columbia machines to take care of the holiday rush.



## AUTOMATIC STOPS

The simplest and most efficient Automatic Stop on the market. They give excellent service, are easily installed and are absolutely guaranteed.

Send 50 cents for Sample Stop

**Kirkman Engineering Corporation**  
 237 Lafayette St., New York

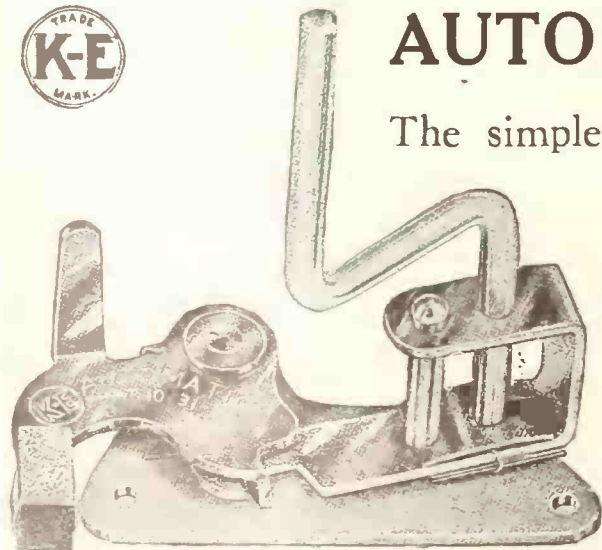

## DIE CASTINGS

In Tin, Zinc, Lead and Aluminum Alloys

**LATROBE DIE & CASTING CO.**  
 LATROBE, PENNA.

NEW YORK OFFICE: 50 CHURCH STREET  
 Phone Cort. 3869





Victrola IV, \$25  
Oak

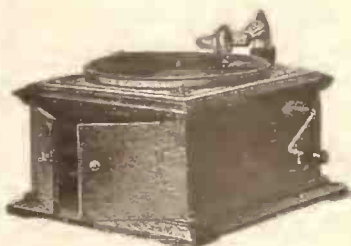

Victrola VI, \$35  
Mahogany or oak

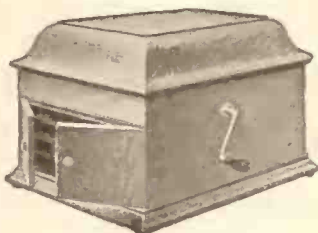

Victrola VIII, \$50  
Oak



Victrola IX, \$60  
Mahogany or oak

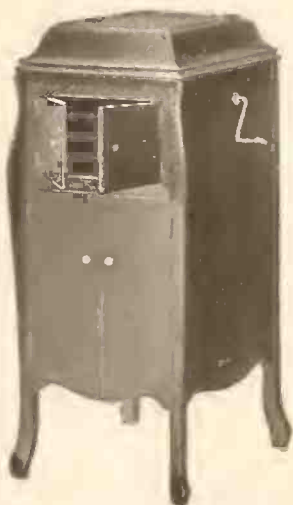

Victrola X, \$90  
Mahogany or oak

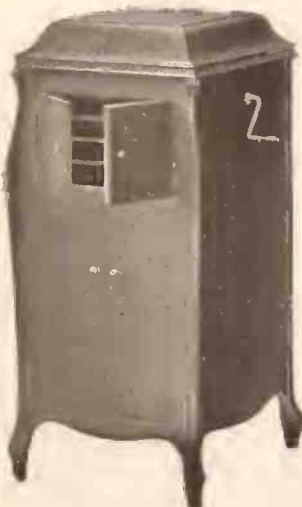

Victrola XI, \$115  
Mahogany or oak

# Victor Supremacy is universally acknowledged

The Victrola has time and time again demonstrated its supremacy in the great things it has actually accomplished.

It is easy for every Victor retailer to reap all the advantages that come with such supremacy.

Victor Talking Machine Co.

Camden, N. J., U. S. A.



Victrola XIV, \$175  
Mahogany or oak



Victrola XVI, \$225  
Victrola XVI, electric, \$282.50  
Mahogany or oak



Victrola XVII, \$275  
Victrola XVII, electric, \$332.50  
Mahogany or oak

"Victrola" is the Registered Trade-mark of the Victor Talking Machine Company designating the products of this Company only.

Warning: The use of the word Victrola upon or in the promotion or sale of any other Talking Machine or Phonograph products is misleading and illegal

Important Notice. Victor Records and Victor Machines are scientifically co-ordinated and synchronized in the processes of manufacture, and should be used together to secure a perfect reproduction.



REG. U.S. PAT. OFF.



*The* **TALKING**  
*For the makers & sellers of talking machines*  
**MACHINE**  
**WORLD**

**PUBLISHED BY EDWARD LYMAN BILL, Inc.**

President and Treasurer, C. L. Bill, 373 Fourth Ave., New York; Vice-President, J. B. Spillane, 373 Fourth Ave., New York; Second Vice-President, Raymond Bill, 373 Fourth Ave., New York; Assistant Treasurer, Wm. A. Low.

**J. B. SPILLANE, Editor**

**RAYMOND BILL, B. B. WILSON, Associate Editors**

**Trade Representatives:** WILSON D. BUSH, C. CHACE, EDWARD LYMAN BILL, V. D. WALSH, E. B. MUNCH, CHAS. A. LEONARD, L. E. BOWERS, A. J. NICKLIN

**Boston:** JOHN H. WILSON, 324 Washington Street

**Chicago Office:** EDWARD VAN HARTINGEN and Associates, Republic Building, 209 South State Street. Telephone, Wabash 5774

**London, Eng., Office:** 2 Gresham Buildings, Basinghall St. W. LIONEL STUROY, Mgr.  
 The Talking Machine World has regular correspondents located in all of the principal cities throughout America.

Published the 15th of every month at 373 Fourth Ave., New York.

**SUBSCRIPTION** (including postage): United States, Mexico, \$2.00 per Year; Canada, \$3.00; all other countries, \$4.00. Single copies, 25 cents.

**ADVERTISEMENTS:** \$4.50 per inch, single column, per insertion. On quarterly or yearly contracts a special discount is allowed. Advertising pages, \$125.00.

**REMITTANCES** should be made payable to Edward Lyman Bill, Inc., by check or Post Office Money Order.

**NOTICE TO ADVERTISERS.**—Advertising copy should reach this office before the first of each month. By following this rule clients will greatly facilitate work at the publication headquarters.

**Long Distance Telephones—Numbers 5982-5983 Madison Sq.**  
**Cable Address: "Elbill," New York.**

**NEW YORK, AUGUST 15, 1919**

THE greatest safeguard for any retail business, whether it be the selling of talking machines or other merchandise of quality, is a staff of competent and contented salespeople, but it is evident that this fact is not appreciated to the extent it should be in many quarters. There appears to be among a certain class of dealers the desire to cut selling expense even below the safety limit—in other words, sacrifice competence in their sales force for the sake of economy. It is the wrong idea.

The customer gets his first impression of a store from the manner in which he is received by the salesman or the saleswoman, and judges the entire character of the store by the character of the person who first approaches him. If the clerk is plainly incompetent, careless or discourteous, his attitude is taken to represent that of the entire store, and likewise the attitude of the proprietor, who is supposed to know the sort of people he is employing. If, on the other hand, the clerk is alert, shows a ready knowledge of records and of machine construction, and gives the impression that he is anxious to give service to the customer that customer is likely to receive such an impression of the store that he will desire to return when further purchases are considered.

The talking machine business, let it be understood, is not a superficial one. The salesman who expects to be successful must possess himself of more than ordinary knowledge of music, and particularly the music offered in record form, and be able to talk intelligently on that subject; to know his stock; to be able to make suggestions that will be considered seriously; to be able to explain the difference between certain records and certain types of machines. This knowledge cannot be gained over night. It takes time and study, and the salesman who is in possession of it is worth money to his employer.

The crux of the matter is that the dealer cannot expect to secure, or hold, the services of a real competent salesman—one who will be a credit to his establishment—for wages that would fail to attract the common laborer of to-day. The extra money that he invests in the salesman later on should bring substantial returns in increased business and a larger clientele. If these results do not show, the trouble is quite likely to be with the individual salesman instead of with the system. The proper thing is to try out a new salesman.

Then, too, the salesman who is kept in one position indefinitely—who receives no encouragement either by word of mouth or more

desirably through an addition to the money in his pay envelope, cannot be expected to be enthusiastic over the business or to take any great interest in it. There is no reason why he should. The trouble is, however, that his discontent cannot very well be hidden, and it is more likely than not to leave an unfavorable impression upon the customer who wonders why the salesman appears to be listless and not inclined to go out of his way to oblige. A little praise and an occasional dollar increase in salary works wonders in keeping the members of the sales force on the alert and anxious to make good. There is something in it for them—something in the future.

In a store of any size the proprietor cannot hope to meet and take care of the requirements of all his customers. He is forced to depend to a greater or less extent on hired assistants. Those assistants represent him to the fullest extent. Their attitude—their actions—are taken to represent his. Their knowledge, or lack of knowledge, reflects the amount of attention given to their training. How important is it, therefore, that in selecting these representatives and developing them the store proprietor proceeds along the right lines, and endeavors to see that his salespeople are really worthy of his representatives.

INCREASED prices in the talking machine field have already made themselves evident, and further increases are to be expected, unless there is a sudden and radical change in the existing situation. It must be admitted that talking machine manufacturers generally have absorbed their full share of increased production costs, and that the advances that have been made heretofore have not in any sense served to cover the larger production costs, to say nothing of the War Excise Taxes. It is a recognized fact that cabinet woods, for instance, are not only difficult to obtain, but are held at prices that in some cases are little short of extortionate. Motors have gone up in price twenty-five per cent. or more within the last few months. Shipping cases have in some instances increased over 200 per cent., and in short every factor entering into machine production, including both labor and materials, has been engaged in a steady upward climb, so far as costs are concerned.

Manufacturers have, for the most part, shown an inclination to be distinctly fair with their distributing forces in the matter of absorbing increased costs, and in making price advances. Jobbers and dealers have in some cases been called upon to sacrifice certain discounts even in the face of diminished turnover and increased overhead. The feeling seems to be that it was a matter of emergency, and that to keep the industry alive and intact throughout the war crisis was in itself a feat worthy of some sacrifice.

By advancing list prices of machines just now manufacturers are, or should be, working in the interests of the distributing forces, as well as themselves, by making it possible for the former to realize a larger net income on a specified business turnover. The main thing is that higher prices must come, the division of the increase being for the moment secondary in importance.

REPORTS to The World from widely separated sections of the country indicate that there has been no slackening business activity during the summer months; the demand for machines and records continues to exceed the supply, and an over-sold condition has prevailed which every dealer hopes will be relieved considerably the coming fall.

A splendid feeling of optimism prevails in all branches of the industry, and everyone is looking forward to a continuance not only of present activities, but a substantial growth in volume, provided—and here's the rub!—that sufficient stock will be forthcoming from the factories to meet the demands of the buying public.

Throughout the trade there seems to be an increased appreciation of the higher priced styles, with a greater call for instruments of special design. Meanwhile the popular priced instruments from \$50 up have more than their usual quota of purchasers, so that there can be no complaint regarding the general trend in the purchasing field.

Dealers who have been moving along somewhat inactively as far as publicity is concerned should now sharpen their pencils and get busy on "copy" that will increase the interest of the public in their establishments. While their stocks may not be as complete as they would like yet dealers must remember that it is time to work not only for to-day but for the future, and this can be



done most effectively by keeping in touch with the public by means of some form of publicity—either artistically prepared announcements by letter or newspaper advertising.

THE renewed recommendation of the Federal Trade Commission to the effect that manufacturers should be permitted by law to fix and maintain resale prices on goods identified by trademark or trade name, as a protection to their intangible property right or good will, created through years of fair dealing, is unquestionably a move in the right direction. The Commission, of course, qualified its recommendation to the extent of providing that both prices and the contracts under which they are to be maintained must be subject to review by a disinterested agency, on the premise that unlimited power to fix and to enforce a resale price may not be made lawful with safety.

Those in the lines of business that have reached their present development largely through the observance of price maintenance, such as the talking machine trade, as well as those who believe on principle that a manufacturer of a trade-marked product, or one having a recognized trade name of standing, should be empowered to protect his business from the inroads of the price cutter, will be interested in the outcome of the Federal Trade Commission recommendation, particularly as that body holds that unrestrained price cutting is not in the public interest. The Commission is broad enough to say that bills now before Congress, such as the Stephens bill, the Kelly bill, etc., may well be made to meet the situation by being amended so as to provide for a review of the terms of resale contracts, or any revision in those contracts, by a disinterested agency.

The majority of modern business men have long been in favor of some form of price maintenance for the protection of articles bearing trade-marks or names that have been given definite standing through years of effort and the expenditure of much money. The only objection seems to have been, with some men, that the unqualified right to maintain prices would give to the manufacturers a power that would tend to create a monopoly were it used improperly. If the recommendations of the Federal Trade Commission are carried out the manufacturer will be protected in his trade-mark or trade name, and, by being subject to control, may not use that power of protection in the wrong direction, and overstep the mark. It would seem that every manufacturer of, or dealer in, a trade-marked article should be earnest and unhesitating in support of the Federal Trade Commission's plan for a price maintenance measure.

PROBABLY every prominent writer on salesmanship takes occasion to emphasize the fact that the salesman who desires to progress in his chosen field should read carefully the various trade and technical publications covering his particular field for the purpose of increasing his knowledge of the product he handles, and the manner in which competitors view it. Broad men of business

on more than one occasion have not only urged that their employes read technical publications, but insisted upon their doing so, and on numerous instances have insured obedience to the order, or request, by themselves subscribing for various trade publications for the use of their employes.

In the face of all this there has come to The World a complaint from a talking machine dealer who inquires why one of his branch managers should receive this publication and thereby become acquainted with various products in the field, the prices of same, and the activities of competing concerns. He appears offended not only with the fact that the employe receives the publication regularly because he is a subscriber, but because admittedly it gives him information that makes him a stronger factor in the industry.

This particular employer, unquestionably, is laboring under the wrong impression. He fails to realize that by gaining, at his own expense, a more thorough and wider knowledge of the talking machine business, its products and those who make them, his branch manager is increasing his efficiency as an employe and thereby proving himself of greater value to the head of the business. If the employer, by failing to recognize this increased efficiency, finds his branch manager discontented and inclined to transfer his allegiance to some other concern more inclined to recognize his ability, then he has no one to blame but himself.

To desire that an employe be kept in ignorance is to desire that he get into a rut and simply become a piece of machinery, unthinking and for that matter incapable of thought. The man who seeks to conduct his business with employes of that stamp cannot hope for continued or permanent success.

DEVELOPMENTS the past month demonstrate most emphatically that no move made in the industry in recent years is having a more far-reaching effect than the action of the Victor Talking Machine Co. in placing records of the great leaders in the musical world—such as Caruso, Farrar, Schumann-Heink, Heifetz, Paderewski, Melba, Elman, McCormack, Alda, Sembrich, Zimbalist, Gluck, and other leading artists of world fame—before the public at a price that makes an appeal to a greatly enlarged clientele.

It marks a step that means much for musical advancement and musical appreciation in America, for it brings into the homes of a great many people too prone to confine their purchases to "popular" records, classic orchestral, instrumental and vocal selections which represent the supreme ability of leaders in their respective fields.

TO make the campaign for music in the home really effective we must naturally first have the home. It is, therefore, meet and proper that dealers in musical instruments take pains to support very practically the present nation-wide "Own Your Own Home" campaign being carried on to solve in a practical way the existing housing problem in the larger cities. Help the cause along.



## Dog Days

*HUMIDITY and temperature have little to do with selling, altho it's good alibi-stuff for the anti-per-spirationist. You'll find Pearsall Service working actively for you in August, for you can't begin too soon to build a Fall stock.*



**SILAS E. PEARSALL COMPANY**

**DISTRIBUTORS**

**WHOLESALE ONLY**

*Victrolas and Victor Records 10 East 39th Street, N. Y.*



# Pointers Regarding the Proper Packing of Talking Machines for Export Shipments

The increase in exports to foreign countries of American-built talking machines has brought up a number of questions, among them that of proper packing for domestic shipments. Talking machines as a rule have always been packed most satisfactorily. As a matter of fact, when the express companies recently started a campaign to influence shippers to give more attention to their packing, citing instances where poor packing had been responsible for heavy losses in certain classes of merchandise, the talking machine manufacturers came out with a clean slate. The express companies had absolutely no basis for complaint regarding their methods.

The ordinary built-up veneer shipping case for the larger models of machines, as used in this country, or the corrugated paper cases for the smaller models are naturally not sufficiently strong to stand the rigors of ocean transportation—the dumping in and out of lighters and barges, the handling by heavy cranes, and the dropping into ships' holds regardless of the fragile character of the contents. Then, too, these lighter packing cases are not in any sense impervious to the effects of dampness to which seagoing ships are subjected.

Those manufacturers and shipping experts who have been engaged in packing talking machines for export have, for some time, advocated substantial cases, built preferably of seven-eighths inch lumber, or at least three-quarter inch lumber strongly cleated and metal strapped, the latter precaution not only to prevent breakage, but to prevent thieves from tampering with the contents.

When the smaller table models of machines are shipped it is suggested that they be packed securely in the ordinary corrugated board containers, and then, where the order is for a sufficient number, packed two, three or four inside a larger, heavily built shipping box.

In the case of pianos and many other articles containing metal parts subjected to rust it is always suggested that the cases be lined with tin, or zinc, to keep out moisture. The average talking machine nowadays, however, is so heavily nickel-plated, even to the exposed parts of the motor, that this precaution is not held necessary in the majority of cases. It is suggested, however, that the motor and other exposed metal parts of the machine be wrapped in several thicknesses of oiled paper with a covering perhaps of cloth, and that the cabinet itself be likewise protected with oiled paper, or the heavy cloth-backed paper frequently used for heavy packing purposes, simply to keep the moist air away from the case.

In packing for export it must be remembered that goods are much more roughly handled than when carried about the United States on freight cars. In hoisting cases into steamship holds they are naturally bumped about considerably, and, unless substantially protected, are liable to be broken open. When heavily strapped with metal they are better able to resist the rough handling, as well as the efforts of dishonest people to tamper with the contents.

At a number of South American ports it is necessary to transfer freight from steamships to lighters to get it ashore, and in some cases the lighters must be run through the surf

to make a landing. Under such conditions packing cases are not subjected to very gentle treatment, and in addition are frequently wet down with spray. It is for protection against this spray, as well as the natural moisture of the sea air, that the protection of metal parts under oiled coverings is urged.

When the machines are fastened securely to cleats in the packing case, as they are in the veneered cases, for domestic shipment there is very little danger of their being jostled about in the case during handling, and becoming damaged. In fastening the machines in the cases, however, it must be remembered that the case in handling may be turned on its side or upside down regardless of any notice to the contrary stenciled on the box. The fastenings, therefore, should be of a character to hold the machine firmly in any position.

The main idea in packing for export is to forestall, by the use of heavy cases and secure fastenings, any possibility of damage in transit. To pack machines as though for the domestic market, marking the case "fragile" and trusting to luck, is the wrong system. Carelessness in this particular will ultimately result in heavy losses.

## TAKES OVER IRVINE MUSIC HOUSE

The Nicholls Music Co. has acquired the store and stock of the Irvine Music House, Macon, Ga., and after extensive improvements has opened as a Victor dealer. Mr. Nicholls has been prominent in musical circles in Macon for years and has many friends in the trade.



Model  
145

**The Brooks Automatic Repeating Phonograph** is justly termed The Wonder Instrument. It has all the good

### Dealers

There are some communities where the Brooks is not represented effectively as yet. Perhaps yours is one of these. There is as much profit and satisfaction in selling the Brooks as there is in owning it.



Model  
165

### The Repeating Device

The Brooks Automatic Repeating and Stop Device is an exclusive Brooks feature. It gives this phonograph a broader scope than any other make and requires no attention beyond setting the needle and turning a little knob.

qualities of other high grade makes, but is completely put in a class by itself by virtue of the inbuilt Repeating Device, which enables the operator to play any make of record, any desired number of times.

There are three Brooks models, of different sizes, all beautifully carved and finished. Each style may be had with electric motor, if desired.



Model  
250

**Brooks**  
The  
Wonder  
Instruments

**Automatic Repeating  
Phonographs**

**BROOKS MANUFACTURING COMPANY, SAGINAW, MICH.**



# Columbia Novelty Record Booklet

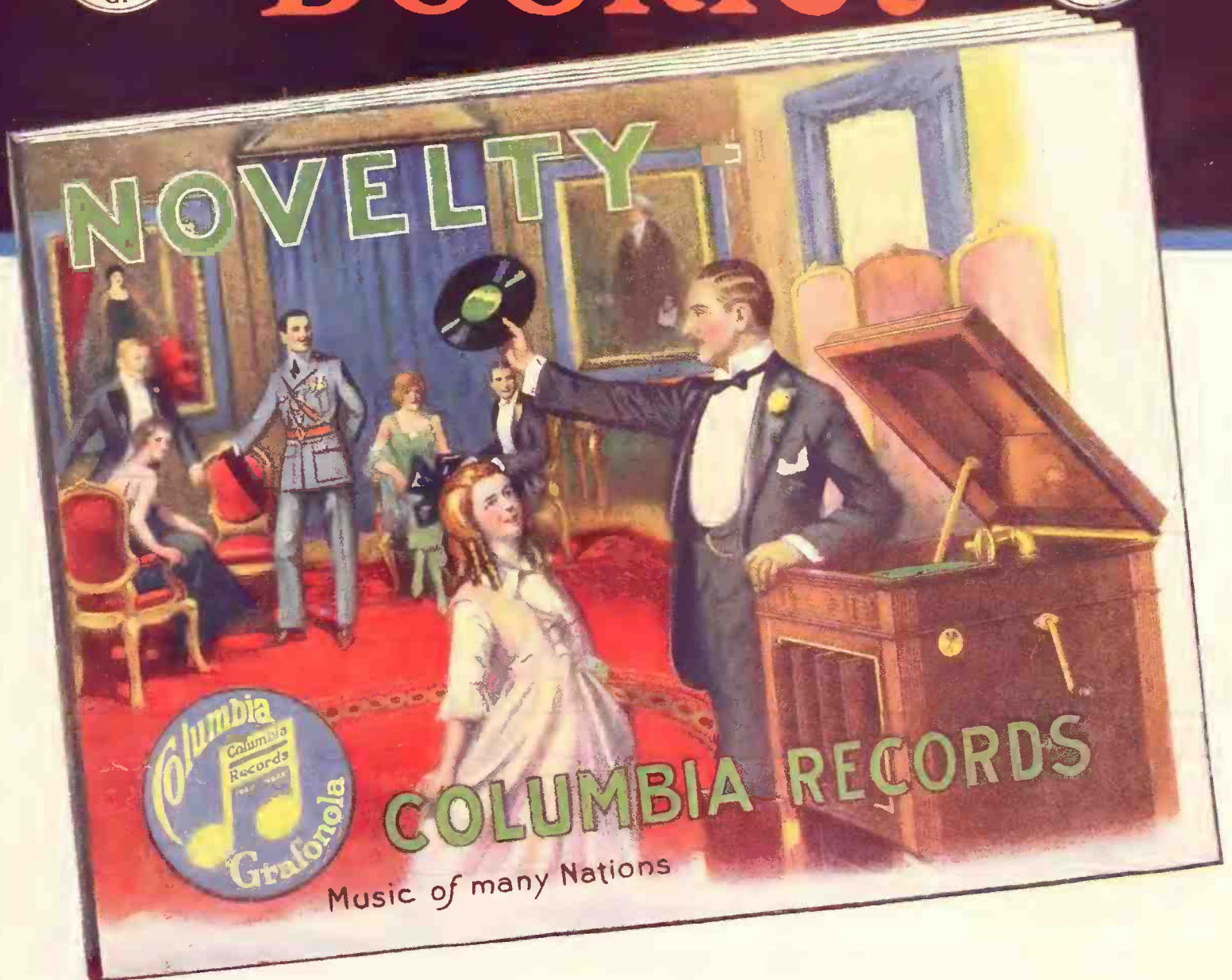

## “Something Different”

COLUMBIA Novelty Records sell. The Columbia Novelty Record Booklet will create a persistent demand for “something novel—something different.” It contains the cream of the instrumental music of many nations. It offers you a unique means

### *To Get New Business*

and to keep all the customers you have. Get a big supply of these booklets and

watch your sales of records grow.

There is always “something different” to be found on Columbia Records. That’s the demand which the Instrumental Novelties have been made to stimulate; and, whether it’s Gypsy, Jewish or Spanish, Turkish or Russian or Hawaiian, a weird old tune or a whistling air, it’s among the Instrumental Novelties listed in this special booklet.

COLUMBIA GRAPHOPHONE COMPANY, New York

London Factory: 102 Clerkenwell Road, E. C.



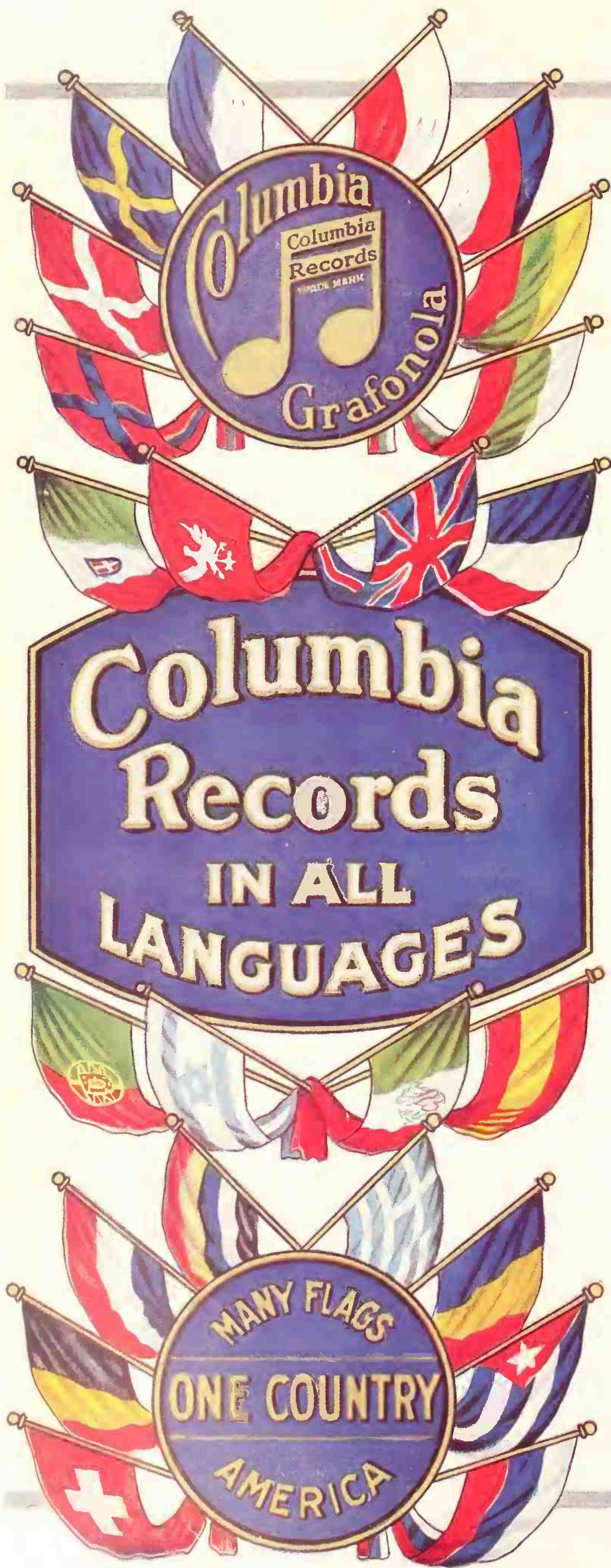

## For Your Window

**P**UT this beautiful decalcomania sign on your window. It makes a striking spot of color, and means to the public that you have Columbia Novelty Records—the music of all the countries these flags represent. All the music of all the world in more than a score of languages is recorded on Columbia Records. Increase your sales of foreign language records by displaying this splendid special sign.

COLUMBIA GRAPHOPHONE CO., New York  
London Factory: 102 Clerkenwell Road, E. C.



**RECORDS FOR THE COLUMBIA CO.**

Mlle. Marguerite Clément, Noted French Linguist, Makes Educational Records

The educational department of the Columbia Co. announces that Mlle. Marguerite Clément, who has been in America representing the French Government in promoting the French



Mlle. Marguerite Clément

language in this country, has recorded several records for them. Mlle. Clément believes that one of the most important factors in promoting the language is the correct pronunciation of it. It is her belief that the accent may most easily be obtained by listening to another who speaks the French language correctly.

In order to further the American's pronunciation she has recorded several records so that the proper accent may be heard and learned. These records, recently released by the Columbia Co., are meeting with a great demand from the educational institutions throughout the country.

**THE MAKING OF FIBRE NEEDLES**

Scientific American Refers to the Great Work of F. D. Hall, Who Introduced the Fibre Needle to the Trade

The achievements of F. D. Hall, president of the B & H Fibre Mfg. Co., Chicago, Ill., inventor and developer of the fibre needle used in talking machines, and now so universally used throughout the world, formed the subject of an extended review in the Scientific American of recent date. The story tells in detail of the many woods with which Mr. Hall had experimented before he found the right one, and describes the intricate processes that the bamboo goes through before becoming a needle.

The hard point of the needle is formed from the enameled cortical surface of the cane. The poles, twenty feet long and two and one-half to three and one-half inches in diameter, carefully selected, are sawn into pieces about an inch long and split in two. Machines split these again into prism-shaped blanks for needles. To force out the sap and replace it with oil and wax in the myriad cells of the cane the bits are put in drip kettles and lowered into vats laden with an oily mixture at 340 deg. F., where they remain forty hours. Then they go into tumbling barrels containing hardwood dust, where they get cooled and polished.

Each needle is inserted by hand into a cutting machine that snips the point into the familiar triangular form at the rate of 30,000 needles a day.

The Sommerhof Co., Erie, Pa., has been incorporated to deal in talking machines by W. A. Somerhof. The capital is \$75,000.

**PATHE PHONOGRAPH FOR TOURS**

Outdoor Model Purchased for Use on Brooklyn Eagle Tours—Machine for Battleship

An outdoor model Pathé phonograph has been purchased by the Brooklyn Eagle as part of the regular equipment for the series of personally conducted tours through the national parks of the country, held under the auspices of that newspaper and known as the Brooklyn Eagle National Park Tours.

A cabinet model Pathé phonograph, together with a library of records, has recently been installed on the U. S. battleship "Michigan" for the entertainment of the crew.

**ENLARGES VICTOR DEPARTMENT**

The Siegling Music House, which has been doing business in Charleston, S. C., for over one hundred years and is said to be the oldest music house in the United States, has recently

remodeled and enlarged its Victor department and added six demonstration booths of attractive design.

**A TACTFUL PAYMENT NOTICE**

Wide-awake Dealer Varies Usual Dun for Money and Makes It Into an Invitation

Instead of the usual notice that a payment is due on an instalment purchase System calls attention to a certain talking machine dealer who sends to his customers an invitation to visit the store and hear the latest records. A list of these records appears on the side of the card bearing the invitation. On the other side of the card the merchant tactfully calls attention to the impending payment, thus:

"Inasmuch as your next payment on your talking machine will be due on July 15 I shall be very happy to have several of these records set aside for your inspection when you visit us that day to make payment on your account."



**FEDERAL ELECTRIC SIGN**

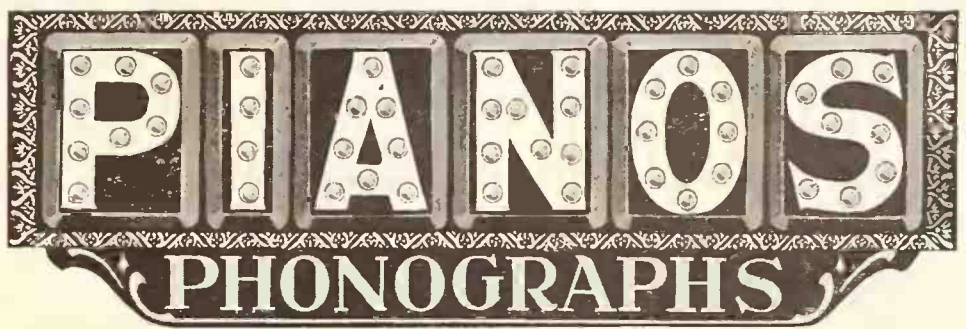

**—12 MONTHS TO PAY**

The first payment brings you the sign—you have the 12 months to make the final payments. Pays for itself many times over—

**—Draws Trade Like A Magnet**

Sparkling at night and glistening in the daytime, it tells the people for blocks in each direction that you are up-to-date and modern. It tells your name and business day and night. It works for you as an energetic salesman, while your competitors are lost in darkness.

The entire sign is made of porcelain enameled steel, brilliant white letters on a blue background. Practically indestructible—will not rust, peel, rot or fade—never needs refinishing. Costs only a few cents a day for electricity—there is no other maintenance expense. An occasional washing keeps it like new.

*Tear off and mail coupon now*



**FEDERAL ELECTRIC COMPANY**

representing

Federal Sign System (Electric), Lake and Desplaines Sts., Chicago, Ill.

Please send me full information on Porcelain-enameled Steel Sign for my business. Explain your 12-months-to-pay Plan

Name ..... City ..... State .....

Street and No. .... Business .....

Store Frontage ..... No. of Floors .....

(T.M.W. 8)





# The Phonograph of Marvelous Tone



*THE slogan heading the full page VITANOLA advertisement scheduled to appear in the SATURDAY EVENING POST, issue of August 23d, is not merely our opinion of the tonal qualities of the VITANOLA, but it is the composite conviction of thousands of dealers and consumers as expressed in numberless unsolicited letters in our files.*

Vitanola Talking  
Machine Co.

508 West 35th Street, Chicago

We invite the co-operation of live dealers, everywhere, in meeting the demand for VITANOLA, the most marvelously toned phonograph of the age. Write for booklet, entitled, "Making a Phonograph Department Pay." Learn about our interesting proposition. Write to-day.

*Exclusive Vitanola Features:*  
Famous Duplex Tone Arm  
Octagonal Reproducer  
Perfected Sound Amplifier  
Improved Tone Modifier

# VITANOLA

Plays ALL Records - Natural as Life



# The Wise Dealer Has Now "Cleaned House" and Is Ready for the Fall Trade Campaign

Now that the summer is nearly over, a summer which, by the way, was like no other in the history of the industry, it is safe to say that every live dealer has used his time well and has taken stock of himself and his business and has found just where he stands. If he has been wise he has done several things. He has taken an inventory, examined his instalment and charge accounts, reorganized the record stock, disposed of the stock of used machines and has put things in shape generally for fall trade, which this year promises to be larger than ever, and needs careful preparation in order to reap the fullest benefits from the golden opportunity. With production difficulties still on the horizon it behooves every dealer to get to work well in advance to pave the way for quick sales in large volume when the holiday rush begins. And when do you have as much time as in the summer?

Take the matter of inventory. It is essential to the talking machine dealer to know where he stands and, while he at all times has some idea of just how the situation is, there is nothing like a thorough inventory to clear up all points and give an exact statement of assets and liabilities. If the results of this housecleaning are good it is a cause for satisfaction. If they are bad it is a warning to get busy and see to it that defects are remedied and steps are taken to prevent the same thing happening again.

The instalment and charge accounts should come in for a careful investigation and consideration, for in a business where the instalment is such an ever-present one it is absolutely essential that the accounts are on a sound financial basis. Each customer's account should be gone over and those who are delinquent or irregular in the matter of payments should be looked after at once. Charge accounts must not be allowed to run too long, for the evils of procrastination, especially in money matters, lead to trouble inevitably. It often requires some little time to straighten out these accounts and this is many times impossible in the busy months. Accounts are allowed to drift along and trouble is ahead. If these accounts are carefully checked up periodically much loss of time and money can be avoided. Many dealers devote their spare time in the summer to this task and have found it to be well worth while.

Then there is the question of the surplus stock of used machines, or, in other words, the number of machines which have been taken in exchange or in part payment for others. In these days it may sound strange to talk of surplus stock when it is hard enough to get instruments of any kind, but the machines which collect around the store in the course of a year make a considerable item, which may, in a way, be called surplus stock. Most of these machines are as good as new internally and with a little repair work, such as polishing, refinishing, a new tone arm here or a touch of varnish there, will make instruments of salable value. And the gratifying part is that these machines seem like money found, for they represent a big return on a relatively small investment. These used machines, especially the smaller models, make excellent instruments for vacation use at seashore, cottage or camp, and appeal to the vacationist, because an expensive, elaborately dressed cabinet is hardly in keeping with the needs of summer conditions. Then, too, it is often possible to sell a used machine to a prospect for summer use and then make another sale of a higher-priced instrument in the fall. And with fall production showing encouraging possibilities, and the greater number of used machines being sold for lack of regular stock

fall trade will come with a rush of activity, which every dealer wants to prepare for.

Records also should come in for a careful inspection, for record sales are steady and continuous, provided you have sufficient stock to supply your customers and do not lose their trade to a competitor through lack of a well-balanced record list. Run through your record files and see if there are any missing numbers. Place your orders well in advance for the numbers you know will be in demand. Devote a little extra energy to move those records which have not had a great sale. Try to turn these

## *Inventory, Instalment, Charge Accounts, Record Stock and Store Changes Are Essential Subjects*

slack numbers into profit, for in summer you can afford to take more time to bring them to the attention of the public.

Reorganize your mailing list. Cut out the dead ones and add those you think might be buyers or prospect getters. A good system is to send out double post-cards to customers and their friends asking if they are interested in receiving the record lists and supplements. If they are interested they will reply on the card.

All these things are more or less incidental to fall trade and while they are concerned most closely with summer itself, yet at the same time they put you on a firm foundation for fall business. When the working parts of your organization are in perfect shape to receive and take care of the fall rush look to your store itself and make it attract that business. You know

the value of an attractive store and if you have neglected that part of your business in the past don't make the mistake of putting it off any longer. Brighten up the interior, have the demonstration booths clean, well-lighted and comfortable, arrange the stock in a way to set off the advantages of each model. Consider your store equipment. Is it modern, is it adequate to take care of your trade, etc.? The many equipment fixtures of to-day have been designed to save the dealer money and to increase his trade. Don't make the mistake of thinking you can't afford new equipment. The truth is you can't afford not to. A penny saved is a penny earned? Fine! But remember, your ship will never come in unless you send one out.

When the interior of your store is put in fine shape there is still one more thing to remember. Your customers will never see that fine interior unless they come in. So the interior of your store must be the final mesh in the web. And here again you are fortunate in being a talking machine dealer, for in what other line are the possibilities for effective display so numerous and have received so much careful attention on the part of recognized experts, artists and designers? Window displays have been worked out for every possible circumstance and condition and you can easily select the ones to fit your location and class of trade. The final touch is an attractive sign, preferably electric, which will attract attention from afar. Such a sign is a business getter that is always on the job seeking out new customers.

Now you are ready for anything. You have taken an inventory and know just how your business stands; your instalment and charge accounts have been aired and renovated; your stock of used machines has been turned into profit; your record stock is in first-class condition; your mailing list is ready to do its work; your store both inside and outside is in the pink of condition; you are ready for fall trade and you may rest assured you will receive your share.

Some of those folks who put forth effort and fall short of success should study the meaning of the word "sustained."

## Pathé Superior Quality

coupled with

## Fischer Superior Service

Makes Dollars for Dealers

*ASK us for Agency proposition NOW*

## THE FISCHER COMPANY

OLDEST PATHÉ JOBBER

CLEVELAND  
943-947 Chestnut Avenue



CINCINNATI  
44-46 Vine Street



Edison Message No. 46

“A new order of things is emerging from the events of the past five years. Whatever may intervene, the ultimate result is going to approach more closely a square deal—for labor, for capital, for the merchant, for the farmer, for everyone. The employer who is not square with his employees, or the employee who is not square with his employer, is going to be out of step with the times.”

*Thomas A. Edison*

**THOMAS A. EDISON, Inc.**  
ORANGE, N. J.



**OVERBOUGHT MARKET CAUSES SLUMP IN SALESMANSHIP**

Indifferent Attitude of Salesmen Developed During War Times—William Maxwell, Vice-president of Thomas A. Edison, Inc., Discusses Present Selling Evils and Sounds a Warning

Market conditions obtaining at present, in which buyers clamor for goods and the arguments of the salesmen are unnecessary, threaten to reduce salesmanship to one of the lost arts. A warning to salesmen against mental stagnation in the present situation is sounded by William Maxwell, vice-president of Thomas A. Edi-

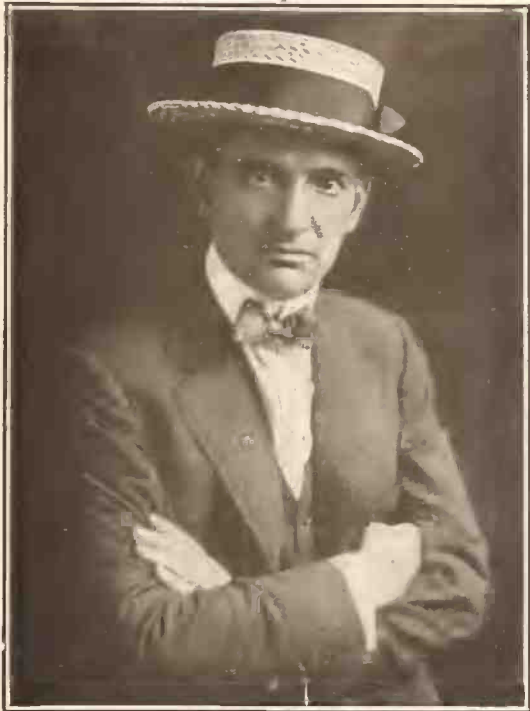

William Maxwell

son, Inc., East Orange, N. J. Mr. Maxwell is recognized as a sales authority, having written several books on the subject. In discussing with the New York Tribune the effect of the war on salesmanship Mr. Maxwell stated that the question involved both psychology and economics.

"For some reason, probably on account of the war," he said, "most of the salesmen in this country are in a mental slump so far as their salesmanship is concerned. I am, and if I didn't realize that fact I should be afraid that I had gone mad. I don't want to be like the lunatic who asserted that he was of sound mind, but that all the rest of the world had gone crazy.

"The war put most lines of business on a basis where the seller could say, 'Take it or leave it.' A seller's market is bad for salesmanship and for business morale generally.

"Salesmanship reached so low an ebb during the war that, following the armistice, it had very little effect in aiding businesses that were prejudicially affected by the end of hostilities. The first period of reaction to the war is now apparently at an end and a great business boom seems to be starting. In other words, we are likely to have a seller's market again for at least another year. By the end of that time salesmanship may have become almost a lost art.

"It is difficult to be a good salesman when you are badly oversold. Our company is over \$6,000,000 behind in its orders and I am devoting most of my time and thought to ways and means

of getting goods. Under ordinary conditions I would be thinking almost entirely about selling and advertising. It is easy to see that I am likely to grow rusty on salesmanship. Multiply my case by the two or three million salesmen and saleswomen in this country and you can readily see what is happening to salesmanship as a science or profession or whatever you want to call it.

"If we salesmen don't keep ourselves in the proper kind of mental training we are likely to wake up some morning and find that our expert services are needed, but that we have ceased to be experts. I feel this so strongly that I am endeavoring to devise a system of cash awards to stimulate self-analysis and self-improvement by the members of our sales and advertising departments. The need of orders to keep your factory wheels turning is the

greatest incentive to salesmanship and when that incentive is removed the sales manager needs to watch himself and his associates to see that mental dry-rot does not set in."

**THE VERSATILE WERREN RATH**

Reinald Werrenrath, the young American baritone, whose Victor records are among the trade's "best sellers," is editing two volumes entitled "One Hundred Modern Scandinavian Songs," for the famous "Musicians' Library," published by the Oliver Ditson Co. of Boston. This volume of Scandinavian songs, after two years of research work, is nearing completion and will be in the hands of the printers shortly.

Another collection which Mr. Werrenrath revised and edited for the Oliver Ditson Co. is the "New Arion," for male chorus, a revision of the well-known "Old Arion." As a composer Mr. Werrenrath is best known for two male choruses, "The Siesta" and "Cavalier's Song," and a number of unpublished songs which he modestly refuses to let appear in print.

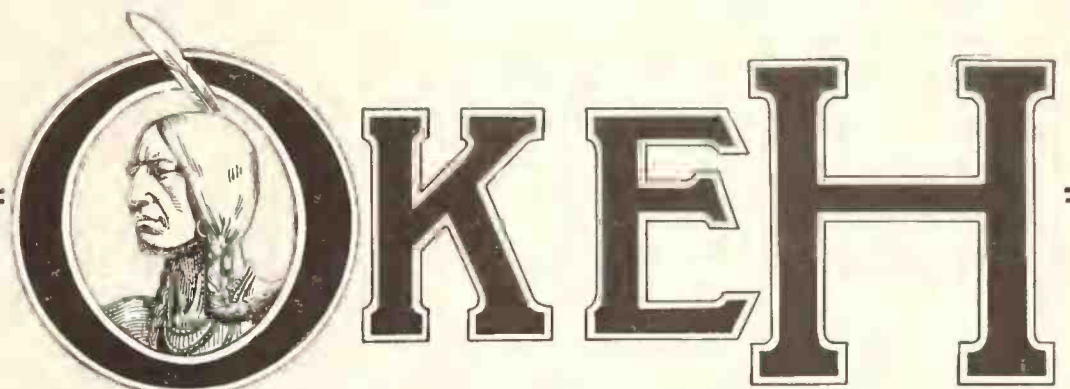

**RECORDS**

**IMMEDIATE DELIVERIES**

OF ALL

**Popular Hits**

Every dealer handling OkeH Records is ready to give efficient service to his patrons and supply them *immediately* with the best sellers of the day.

We are giving our dealers valuable service and co-operation and the "Record of Quality" is winning new friends steadily.

*Do You Know What Our Service Means?*

**THE GARFORD MFG. CO.**  
ELYRIA, OHIO

**Talking Machine CABINETS**

**TO THE TRADE**

All Styles Made to Order  
Lowest Net Prices

**Manufacturers Sales Co.**  
NORRISTOWN, PA.



## Diplomacy Needed by Salesmen or Managers in Handling Customers' Complaints :: By J. S. Fisk

The generosity of the salesman or manager in adjusting a complaint or dispute for a customer must naturally depend, to some extent, upon the fixed policy of the house and the rules and regulations laid down for the guidance of the individual members of the selling force; but it is safe to say that, given a limited freedom of action, there are very few cases where managers or salesmen err in being overgenerous in adjusting settlement.

The instalment sale, of course, carries with it a certain responsibility that the house will naturally recognize. If a talking machine proves unsatisfactory after a few payments, it is policy to satisfy the customer so that the terms of the contract will be carried out regularly and without difficulty.

In the manner of handling the complaint of a cash buyer there may lie the opportunity of creating friends and many actual sales for the house or in bringing about an exactly reverse effect. It may be safe to laugh at the complaint so far as that particular complaint is concerned, but the customer who feels that he has been unjustly treated in a transaction involving a hundred dollars or more is not likely to overlook an opportunity to air his grievance where it will do the most harm to the concern that is believed to be at fault.

A case in point occurred only recently in an Eastern city, where a man of prominence purchased a rather expensive talking machine after careful consideration. After the instrument was delivered the purchaser persisted in claiming that the tone was faulty, because of some imperfection in the reproducer or tone chamber

between the time he left the wareroom and the time it reached his home. The manager himself investigated the case and felt that the complaint was imaginary rather than real. Instead of combating the views of the customer, however, he simply went back to the store and shipped two other instruments to his house, one approximately of the same value, and the other a more expensive one. They were left for the consideration of the purchaser, who selected the more expensive machine of the two. The customer wrote out his check for the difference in the price immediately, and expressed himself as being rather sorry at having caused so much trouble and insisted on taking care of the cartage charges. Incidentally this same purchaser has since been responsible for several subsequent sales amounting to large sums.

In another case the talking machine merchant learned that a fairly well-to-do cash purchaser of an instrument a few days before had met with serious and sudden financial reverses from an unexpected quarter. Being fairly well acquainted with the man, the dealer went to him quietly and offered to take the talking machine back and return in full the purchase price in order that the man might use the money to meet his needs. The purchaser, having other available means, refused the offer, but has since been more active in that particular talking machine merchant's interests than some of the latter's regular salesmen.

At first glance it appears that the merchant in question was foolish in his effort to give back money, but had his offer been accepted he could still have taken back the instrument

and gotten its full value from another purchaser, and would have been out only a few dollars' cartage cost, plus the selling expense. There is no question but that many other people in the town would have heard of the act, and would have made their purchases from him, probably for cash, with the feeling perhaps that the action he had taken in this particular case might be taken in their own cases should occasion warrant. Even should that feeling go abroad, the number of instances where a talking machine would be taken back within a few days after its sale would be so few as to be negligible.

Generosity in the settlement of disputes or in the handling of business generally must of course depend largely upon the particular situation and the sort of people the merchant is dealing with. A generous settlement that would be appreciated by the right sort of purchaser and win his friendship might be looked upon by another sort of man as a sign of weakness and he might endeavor to play upon it accordingly. A safe rule to follow, however, is to be a trifle overliberal rather than under-liberal in cases where there is any doubt. Keeping the customer satisfied and friendly to the house is the main object and that friendship has a real commercial value.

### NEW CAROLINA INCORPORATION

The Curtis Morong Co., Raleigh, N. C., has been incorporated to deal in talking machines. The new concern is incorporated for \$20,000, with the entire amount paid in.

—all you want  
for the asking!

EMERSON hits are going fast these days. But that's to be expected. Emerson advertising is "delivering."

We are delivering, too. It's our special job. Our stock of current Emerson hits is always large enough to take care of our trade. Don't wait till you're out of this or that big hit—watch your stock—and phone us when you run low. *That's business!*

Emerson Record Sales Company, Inc.

Exclusive Metropolitan Distributors

6 West 48th Street, New York City





# Better Dance Music



The simplest way to please your customers, is to give them what they want—and of course they want the needle that produces the best results—that one which by a twist of the wrist will change the volume of tone, from Extra Loud for the Fox Trot, to Soft yet Mellow for the entrancing Waltz. And then—Four Records with the one needle.

*Made in America, by Americans*

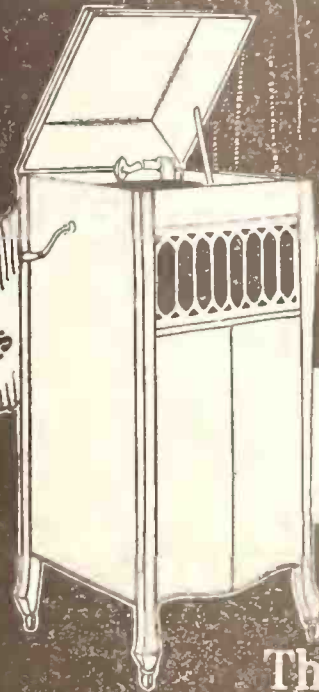

**4c** per package of fifty

The selling price of the Brilliantone Combination Needle is Ten Cents per package of Fifty. Each needle plays four records—two soft tone and two loud tone. It is preferred, and rightly so, wherever used, as the sales which are growing in leaps and bounds, prove

**BRILLIANTONE**  
TWO TONE-FOUR RECORD NEEDLE

**COMBINATION**

*Flat Side, Parallel with the Record, producing Loud Tone*



**BRILLIANTONE**  
TWO TONE-FOUR RECORD NEEDLE

**COMBINATION**

*Flat Side at Right Angles to the Record, producing Soft Tone*



*For Intermediate Tones, Use Intermediate Angles*

**BRILLIANTONE**  
**TWO TONE STEEL COMBINATION FOUR RECORD NEEDLES**

are made of the same superior quality steel, as all other Brilliantone Steel Needles and will therefore withstand the Brilliantone test of

**UNIFORM HARDNESS      UNIFORM POINTS**  
**UNIFORM LENGTH**

**BRILLIANTONE STEEL**  
**NEEDLE CO. OF AMERICA, INCORPORATED**

Suite 655-659 Marbridge Building,

Broadway at 34th St., NEW YORK CITY

Metropolitan District  
EMERSON RECORD SALES CO.  
366 5th Ave., N. Y. City

Chicago District  
WALTER A. CARTER  
57 East Jackson B'ldg.  
Chicago, Ill.

Pacific Coast District  
WALTER S. GRAY  
530 Chronicle Bldg.,  
San Francisco, Cal.

New England District  
EMERSON NEW ENGLAND INC.  
68 Essex Street  
Boston Mass.

MUSICAL MERCHANTS  
DISE SALES CO., Ltd.  
Excelsior Life Bldg.  
Toronto, Canada

CANADA  
BOURGETTE & WOODS  
16 McGill College Ave.,  
Montreal, Canada

Foreign Export: CHIPMAN LTD. 8-10 Bridge St., New York City





**"D'Amor Sull' Ali Rosere," sung by Rosa Ponselle, is one of the purest examples of dramatic vocal melody ever recorded. Columbia 49559.**

**Columbia Graphophone Co.  
NEW YORK**

## TRADE BOARD ASKS PRICE FIXING BY MANUFACTURERS

Federal Trade Commission in Report to Congress Urges Legalizing Resale Price Fixing Under Supervision of Federal Agency—Recent Colgate Decision Has Bearing on This Action

WASHINGTON, August 1.—A renewed recommendation that manufacturers be permitted by law to fix and maintain resale prices, subject to review by a disinterested agency, was made by the Federal Trade Commission recently in a special report to Congress.

Existing laws which have been interpreted by the Supreme Court in the case against Colgate & Co. and in other test cases to prevent the fixing of resale prices should be amended, the commission believes, with a view to removing the present complexity in the business world; to promoting the efficiency of manufacturing and commercial institutions, and to serving the interests of the consuming public.

Under the commission's recommendation, first advanced in a report to Congress last December, manufacturers desiring to fix and maintain resale prices would file with an agency to be designated by Congress descriptions of their articles, contracts of sale, and the price schedules to be maintained. The disinterested agency would be charged with the duty "upon complaint of any dealer or consumer or other party at interest," to review the terms of contracts and prices.

The commission's recommendations, the report said, were based on the following conclusions:

Producers of identified goods—identified by trade-mark or trade practice—should be protected in their intangible property right or good-will, created through years of fair dealing and of sustained quality of merchandise.

The unlimited power both to fix and to enforce and maintain resale prices may not be made lawful with safety.

Unrestrained price cutting is not in the public interest, and tends eventually to impair, if not to destroy, the production and distribution of articles desirable to the public.

"There must be a common ground," the commission's report said, "wherein the rights of producer, purveyor, and consumer may each be fully secured, and equity done to all. The Supreme Court has made it clear that, in the present state of the law, the maintenance of a resale price by the producer is a restraint of trade and is unlawful.

"Such being the judgment of the Supreme Court, the Federal Trade Commission has enforced the law, even though it may have appeared to operate inequitably in some cases. In its enforcement of this rule the commission has been mindful that the cutting of a recognized resale price on well established and identified articles has been at times indulged in for unfair trade purposes. When so unfairly used, such

price cutting is attempted to be cloaked as lawful competition and justified by the Supreme Court decisions.

"Thus, both price maintenance and price cutting under certain conditions are found to be unfair and business men are perplexed.

"It is urged, and the commission believes with reason, that it would be unwise to vest with the manufacturers of articles the right, without check or review, both to fix and compel the maintenance of resale prices. It is true that business practice inclines producers to fix the lowest possible retail price in order to secure the greatest possible sale of their product, but in the commercial organism functioning between the production of an article and its final sale, for actual consumption, both the wholesale and retail merchants are entitled to just compensation for useful service performed.

"It is similarly urged that manufacturers should be protected in their good-will created by years of fair dealing and of sustained quality of merchandise.

"The consuming public does not enjoy benefits by unfair price cutting to compensate it for the injuries following demoralization caused by price cutting. This is for the reason that, in the long run, unrestrained price cutting tends to impair, if not to destroy, the production and distribution of articles desirable to the public."

## W. THOMMEN HEADS PLYMOUTH CO.

First Meeting of Concern Since Merger With Kade Fixture & Showcase Co.

The first meeting of the Plymouth Phonograph Co. since it took over the Kade Fixture & Showcase Co., on June 9, was held recently in Sheboygan, Wis., at the factory. The following were elected directors of the company: William Thommen, J. H. Wheeler, Harry Bolens, J. B. Thiery and Frank McIntyre. After the election these directors met and chose the following officers: President, W. Thommen; vice-president, J. B. Thiery; secretary-treasurer, Frank McIntyre.

## COLUMBIA BRANCH MGR. RETURNS

Capt. E. B. Schidell has recently returned from France, having served with the American artillery for some time on the other side. Capt. Schidell is the proud possessor of the Croix de Guerre, which he won in action. Although formerly manager of the Dallas branch of the Columbia Co., Captain Schidell will now join the sales force of the Cincinnati Columbia branch.

The man who shines at making excuses seldom shines at anything else.

SEND FOR ILLUSTRATED PRICE LIST  
AND FREE SAMPLE

**"GLOBE" TRANSFER NAME PLATES**

DEALERS EVERYWHERE APPLY THEM  
ON PHONOGRAPHS, PIANOS, ETC.

**GLOBE DECALCOMANIE CO.**  
JERSEY CITY, N. J.

## Ward's Khaki Moving Covers



### Distributors

**BRISTOL & BARBER, INC.**  
111 E. 14th St., New York City

**YAHR & LANGE DRUG CO.**  
207-215 E. Water St., Milwaukee, Wis.

**COHEN & HUGHES, INC.,**  
Washington, D. C.

**BECKWITH-O'NEILL CO.**  
Minneapolis, Minn.

**STREVELL-PATERSON HARDWARE CO.**  
Salt Lake City, Utah

**OHIO SALES CO.**  
Beckman Bldg., Cleveland, Ohio

**THE C. E. WARD CO.**  
(Well-Known Lodge Regalia House)  
101 William St., New London, Ohio

Also Manufacturers of Rubberized Covers  
and Dust Covers for the Wareroom

Grade "D" Cover with No. 3 Straps.





- |      |   |  |      |   |  |
|------|---|--|------|---|--|
| 1222 | { | When I Met You (Tenor)   | 1230 | { | I'm Aching for the Sight of You (Vocal Trio)                           |
|      |   | You're Making a Miser of Me (Tenor)                                      |      |   | { For-Get-Me-Not (Tenor)   |
| 1223 | { | Alabama Lullaby (Tenor Duet)   | 1231 | { | Somebody's Waiting for Someone (Tenor)                                 |
|      |   | There Are Just Two I's in Dixie (One Step)                               |      |   | { Friends (Vocal Trio)   |
| 1224 | { | Jazzola (Vocal Quartet)  | 1232 | { | I Ain't-en Got-en No Time to Have the Blues (Vocal Duet)               |
|      |   | Katydid Is the Candy Kid (She's a Rube, by Heck) (Tenor)                 |      |   | { Daa Dee Dum (Vocal Duet)   |
| 1225 | { | Arabian Nights (Vocal Trio)  | 1233 | { | In the Heart of a Fool (Tenor)   |
|      |   | The Gates of Gladness (On the Road to Sunshine Land) (Tenor)             |      |   | { The Woman Thou Gavest Me (Tenor)                                     |
| 1226 | { | Golden Wedding Jubilee (At My Dad and Mammy's) (Vocal Duet)              | 1234 | { | Life and Love (From "The Velvet Lady") (Tenor)                         |
|      |   | Dixie Is Dixie Once More (Vocal Quartet)                                 |      |   | { The Call of the Cosy Little Home (From "Take It from Me") (Baritone) |
| 1227 | { | Kentucky Dream (Tenor Duet)  | 1235 | { | Shake, Rattle and Roll (Baritone)                                      |
|      |   | Western Land (Baritone)  |      |   | { Venus Blues (Baritone)   |
| 1228 | { | Frenchy, Come to Yankee Land (Tenor)                                     | 1236 | { | Western Land (Fox Trot)  |
|      |   | McCarthy, He's a Frenchman Now (Contralto)                               |      |   | { Have You Seen My Stella? (One Step)                                  |
| 1229 | { | Take Your Girlies to the Movies (If You Can't Make Love at Home) (Tenor) | 1237 | { | That Dreamy Dance of Love (Here's to the Waltz) (Waltz)                |
|      |   | Take Me to the Land of Jazz (Baritone)                                   |      |   | { Star of Light (Adrian) (Fox Trot)                                    |

*OkeH Dealers Receive Liberal Discount*



**Otto Heineman Phonograph Supply Co., Inc.**  
 25 West 45th Street New York City, N. Y.

FACTORIES: ELYRIA, O.—NEWARK, N. J.  
 PUTNAM, CONN. SPRINGFIELD, MASS.

Branch Office: Chicago, Ill. San Francisco, Cal. Toronto, Can.





**CABINETS CAUSE OF SHORTAGE**

**Grand Rapids Authorities Cite Cabinet Production as One of the Reasons for Present Furniture Shortage—Many Factories Have Gone Over to Cabinet Making Entirely**

From the great furniture center, Grand Rapids, comes an interesting sidelight on the rapid growth of the talking machine industry and its influence upon the supply of furniture. It is a fact, according to Grand Rapids authorities, that a distinct furniture shortage exists at the present time and one of the most noticeable causes is the tremendous diversion of furniture production activities to the making of cabinets for talking machines.

Grand Rapids factories have contracts for talking machine cabinets aggregating more than \$1,000,000 and in the execution of these contracts more than 1,000 men are employed. Berkey & Gay, the Phoenix, the Macey and the Widdicombs shops have large contracts. The Foote-Reynolds Co. is occupying the Kindel Bed Co. factory, formerly producing furniture exclusively, in the manufacture of talking machines. The School Equipment Co. factory and the Lindner Mfg. Co. plant, recently purchased, and several of the smaller factories are doing the same. It is a modest estimate to place the number of men working on talking machines in Grand Rapids at 1,000. And these are all high-grade men who formerly were producing furniture.

This condition is not confined to Grand Rapids. The Connersville Furniture Co., one of the largest of the Indiana factories, D. L. Conrey Furniture and the Conrey Mfg. companies of Shelbyville have done the same. The Rockford factories also have large contracts. They are making cabinets in Jamestown, in Rochester, in New York and in the South. In the country over it is probable between 4,000 and 5,000 men who used to produce furniture now are producing talking machine cabinets.

When the talking machine was first brought out, and for years thereafter, no special effort was made to popularize it through the artistic appeal. Almost anything in the shape of a box or cabinet to hold the "works" served the purpose.

In the last four or five years, however, the manufacturers have realized the possibilities. The cabinets now are made with the same care that is bestowed on the best furniture. They are brought out in period designs and are finished to be in harmony with the furnishings of the finest homes. The phonograph manufacturers turned to the furniture men to help them out and this demand has been so recent that the furniture industry has not yet had time to adjust itself to the new conditions.

**VEECO MOTORS FOR FOREIGN LANDS**

**Steady Increase of Export Shipments Reported —C. W. Johnson Joins Staff**

The Veeco Co., Boston, Mass., manufacturers of the Veeco electric motor for talking machines, state that the export demand for their product is growing steadily, chiefly as a result of their regular advertising in *The Talking Machine World*, and that recently orders have been filled to be shipped to Holland, England and Australia. Canada also is proving a strong customer.

C. W. Johnson, formerly with the Musical Supply & Equipment Co., Boston, has become connected with the sales department of the Veeco Co., and is making an excellent record in the matter of securing new accounts.

The Montana Phonograph Co., Helena, Mont., is enlarging its record department.

**ELECTRO-PLATING of PHONOGRAPH PARTS AND MUSICAL INSTRUMENTS**  
 Silver, Nickel and Antique Finishes  
 Specializing in GOLD FINISH  
**JOSEPH MUSANTE**  
 125-131 BAXTER ST. Tel. Franklin 3053 NEW YORK

**ALBUMS**

RECORD ALBUM

**BUY DIRECT FROM MANUFACTURER**

**THE BOSTON BOOK CO INC**  
 40-46 W 20th ST NEW YORK

**FOREIGN TRADERS IN CO-OPERATION**

**Old Ideas of Business Secrecy Yield to Policy of Mutual Benefit**

Fear of foreign competition is leading many business firms to overcome their previous dislike for each other and to combine under the Webb-Pomerene Law; while the action of many Government agencies in eliminating competition during the war to facilitate greater production has forcibly impressed all business men with the benefits to be obtained from the mutual interchange of ideas.

Business secrets used to be considered a large part of the stock in trade, to be jealously guarded from all competitors. More recently it has become evident that such secrets were of but small value, in no way comparable to the profits to be obtained from the application of new ideas worked out by one individual to the trade as a whole.

This is specially noticeable in the field of foreign trade. Under the leadership of the National Foreign Trade Council it has been possible to develop a spirit of mutual assistance, which was strikingly evident at the recent Foreign Trade Convention at Chicago. At that gathering of 2,000 of the leading foreign traders of the country a Trade Adviser Service was organized to supply practical information to those desiring it. Seventy business men, each an expert in his own line, together with representatives of the Government trade agencies, were assembled to give out freely to all delegates the information which they had gained from personal experience in foreign markets. That it was a great success may be inferred from the large number of individual conferences arranged between Trade Advisers and delegates. Over 700 such conferences were held. The subjects ranged from the market for spruce in Italy to the need for pins in China.

Co-operation spells increased profits for all.

*Mr. Phonograph Manufacturer and Dealer*

**VEECO**

Electric phonograph motors are the up to the minute energy source for talking machines. Just the same as the automobile has replaced the horse.

It is a step ahead, it is perfection personified. Make your phonograph up to date, do away with the cumbersome cranking, broken springs and running down in the middle of selections. You would not think of buying an automobile if it did not have a starter, would you? Why? Because you want to eliminate the cranking, and this applies absolutely to the phonograph, eliminates the cranking, makes it complete, ideal, and gives you a selling point that is 100 per cent. strong.

An agent of ours in the Middle West writes us that a party to whom he furnished a Veeco motor recently advised him that they "would not take a thousand dollars for it if they could not get another one like it." We have similar letters on file at our office from satisfied owners of the Veeco motor.

The motor runs on any 100-125 volt current. Special motors for other voltages. Furnished mounted on 12 or 12½-inch mahogany board ready to install. Or unmounted without board.

**THE VEECO COMPANY** 248 Boylston St. BOSTON, MASS.

THE ORIGINAL PRODUCERS OF A COMPLETE ELECTRIC DRIVE FOR TALKING MACHINE MANUFACTURERS' USE



# An Instalment Business Presents an Ever-Growing Financial Problem

By Harrison Durant,  
Financial Supervisor Thos. A. Edison, Inc.

It is a well-known custom of the Chinese to pay their physician a fee for every day in the year a "patient" is kept well. There is an excellent thought to be gained from that old idea. If we could always manage to avoid ills rather than seek a method of cure we would be far better off.

The same principle would apply equally well to modern business. A merchant who fails to prepare in advance for the difficulties that are bound to arise is storing up trouble for himself. His lack of foresight will cause him a lot of worry and probably a lot of money. From time to time we have laid considerable emphasis on the necessity for every Edison dealer to calculate in advance just what financial assistance he requires in order to meet the demand of the instalment branch of his phonograph shop—a very important and highly profitable adjunct to his business if properly conducted.

Every instalment sale absorbs a portion of the dealer's working capital. If he is to replace the instrument sold it will be necessary for him to find from some source an amount equal to the difference between that replacement value and the initial payment received from the customer on the instalment contract. An ever-increasing instalment business presents an ever-increasing financial problem, and it should be constantly met in advance. Instalment paper in your safe does not assist in replacing phonographs on your floor. Money can be borrowed at six or eight per cent. per annum. The loss of a two per cent. cash discount on your jobber's bill of goods represents a per annum charge of twenty-four per cent. Don't wait until you are at a loss as to which way to turn in order to finance your instalment sales. Get the habit of borrowing sufficient funds each month to replenish your stock and use the funds so obtained for that purpose only.

Apparently many phonograph dealers find it difficult to make an actual forecast of their requirements. It is really a very simple matter. Make a concise statement of your monthly receipts for the last twelve months, recording the

initial payments, cash sales and instalment payments separately—making sure that you carry forward, under the respective months, the proper number of instalments due on contracts previously made and which are represented by the initial payment already recorded.

If you will add to this partial forecast of next year's monthly receipts the respective total

## Dealers Should Anticipate Financial Requirements So as to Take Advantage of Big Business Ahead

monthly receipts received last year your figure will give you the estimated total cash receipts for the next twelve months, month by month, providing there is no increase or decrease in your sales. It is natural to assume an increase. In this case fix on an arbitrary percentage as your probable increase twenty per cent., fifty per cent., or 100 per cent., whatever sum seems most probable to you—and increase last year's monthly receipts by that amount before adding them to the forecast of the next twelve months. In other words, last year's monthly receipts plus the estimated increase and plus

the instalment payments carried forward will approximately represent your monthly receipts for the next twelve months.

By making this forecast of your next year's business you will be in a position to know on what funds you can absolutely count on each month for the payment of your obligations to your bank, but you can also readily figure what additional assistance over and above those receipts you will require in order to keep your stock up-to-date. It has been my experience that the average merchant who approaches his banker for a loan unsuccessfully is himself entirely to blame for failing to get the accommodation he desires. By not being perfectly familiar with his own business he has been unable to instil into the banker's mind sufficient confidence to grant the extension of credit necessary.

The phonograph business for the next twelve months is going to be especially good. Our production at the factory is greater than at any pre-war period. The Edison dealer who fails to anticipate his financial requirements is going to be unable to take full advantage of the prosperity ahead. He will be unable to take full advantage of all the instalment sale prospects which offer themselves. Sell all the phonographs you possibly can on a strictly cash basis, but, on the other hand, don't lose a sale to a competitor because you cannot afford to sell on long terms.

### DUAL PERSONALITY

She—"So your glee club has formed a baseball team. What are you?"

He—"I sing first tenor and play second base."

## Why Break Records? Just File Them!

That is if you have the wonderful Record filing system which is a feature of

### The Marvelous MAGNOLA



Watching the Music Come Out

This is only one feature of many that will command your interest and attention. Let us send you handsome illustrated catalog and information as to our plans for helping you to make money with MAGNOLA.

### MAGNOLA TALKING MACHINE COMPANY

OTTO SCHULZ, President

General Offices Southern Wholesale Branch  
711 MILWAUKEE AVENUE 1530 CANDLER BLDG.  
CHICAGO ATLANTA, GA.

## ANY STANDARD PHONOGRAPH and THE BLISS REPRODUCER



"A Wonderful Musical Combination."

A Reproducer with a super-sensitive silk diaphragm that eliminates the thin, raucous, ear-straining "Talking Machine" effect.

The "BLISS" Reproducer plays all records with greater volume, less scratch, better tone balance, and a wonderfully human, natural quality. THE MUSIC IS PROJECTED INTO THE ROOM.

The "BLISS," used on any standard Phonograph, will not only help sales of instruments, but will increase your record trade through its extraordinary tone quality.

Send sample order and make your own tests with your favorite demonstration records. Give make and style of tone arm.

## BLISS REPRODUCER, Inc.

80 FIFTH AVENUE  
NEW YORK CITY





Ordinary steel needles stick  
your fingers, don't they?

Try it.

Empty a package in your hand.

Then do the same thing with Torrington  
*Uniform* Needles.

TRADE MARK REGISTERED

You will feel why *Uniform* needles play  
records better.

TRADE MARK REGISTERED

Sharp points scratch—*Uniform* Ball Points  
don't.

TRADE MARK REGISTERED

It's a simple test! Prove it yourself.

***My, How It Rained!***

Day after day it came down. The grouches—for they are always with us, aren't they?—became more grouchy. Perennial optimists let down a bit. Mildew vied with mold to make windows and doors stick.

And if it doesn't rain in your town, the fog comes in, or something else happens to create dampness and tarnish those things which might have looked bright when you bought them.

Isn't it better to have stock finished with a special non-rust process about which you do not need to worry?

That's one of the big advantages of Torrington Uniform Needles. There are other advantages, too, that are even greater.

May we submit our case, you being judge and jury?

Of course you demand proof and we will be satisfied with your verdict after we have submitted the evidence. May we?

Will you write us today?

President

***Uniform in point—length—finish—and quality of steel***

**CONDON & Co., INC., *Sole Agents***

Fifth Avenue Building, New York City

# Uniform Needles



## ROCHESTER A BUSY TRADE CENTER

Dealers in This Thriving Section of New York State Are All Doing a Large Business and Are Most Optimistic Regarding Fall Prospects—Some News of Particular Interest

ROCHESTER, N. Y., August 8.—Expansion seems to be the watchword of the talking machine dealers of Rochester and vicinity. They all report an exceptionally good summer business and many of them are enlarging their departments to take care of the increased demand on their services. Machines and records are coming in better quantities, but there is still a shortage.

The drop in price of the Victor Red Seal records has created a heavy demand for them. As W. J. Smith, of the Talking Machine Co., said: "Rochester has always been a music-loving center, but the demand for Caruso records since the drop in price has been a revelation to me."

The Levis Music Store, of South avenue, has purchased the Victrola department of the Duffy-Powers Co. and now handles the Victor line in addition to the Columbia and Edison.

H. G. Emmons, manager of the Edison Studios, attended the convention of Edison dealers, held recently in New York City. He returned even more optimistic than before and intends to carry a complete line of the new art models. The Edison Studios have also opened a piano department in the store adjoining the Studios, where they are carrying a full line of pianos, players and rolls.

The Music Lovers' Shoppe, exclusive Victor dealer, is making great plans for the new store at 29-31 East avenue. George M. Richter, manager, states that his firm has purchased the three-story building at the above address and when alterations are completed will have one of the finest talking machine stores in the State. He is installing Unico equipment of a modified Louis XVI style, including twenty booths. This store has outgrown the present quarters in three years and expects to move into the new

home shortly before the first of September.

The Reliable Furniture Co. has had considerable difficulty this summer in securing enough Columbia stock to supply the trade.

E. W. Edwards & Son have had to expand their talking machine department, moving it to a larger and better location on the fifth floor. Miss Kathleen Whalen states that both the Brunswick and Victrola are making new friends for the Edwards store every day.

The Balcom Music Co., of East avenue, Aeolian-Vocalion and Columbia dealer, reports a fine summer trade. A. H. Warren says there is a big demand for the period model machines.

The Sibley, Lindsay & Curr Co. has moved its Victrola department, of which F. C. Pfeffer is

manager and buyer, from the third to the fourth floor, where the increased space will make it possible to handle the growing business in a more satisfactory manner.

S. J. Hoffman, Columbia and Victor dealer, of Joseph avenue, says that his sales are only limited by the amount of goods he can obtain. He has a large foreign trade and is very optimistic over its future.

Dealers in Hornell are also making improvements. Tuttle & Rockwell have had to add two sound-proof booths to their talking machine department in order to care for the increase in business they are enjoying. Mrs. L. Clark is manager of this department and reports the sales of Sonoras and Victors as gratifying.

## MUSIC COMMITTEE APPOINTED

Emerson Phonograph Co. Arranges for Notable Body of Men to Pass Upon Its Productions

The Emerson Phonograph Co. has recently established a Music Committee which is to pass on all matters connected with the policies concerning music, artists, selections and other matter in the production of their records. The formation of the committee will allow for more rigid examination of all productions. The interchange of constructive thought, the co-ordination of interest and the fine departmental spirit has resulted in many suggestions of value and new ideas certain to be helpful in the general progress of the company.

The committee is composed of Arthur Bergh, musical director; B. D. Colen, secretary of the company; Arthur H. Cushman, director of sales; Louis Rosenfield, musical supervisor and general sales manager of the Emerson International, Inc.; Charles Wetzels, manager of the production department; Joseph I. Carroll, manager of sales. Mr. Carroll has been appointed chairman of the committee. Victor H. Emerson, president of the company, and H. T. Leeming, vice-president and general manager, are ex-officio advisory members of the committee.

## REAL WELCOME FOR SOLDIERS

Victor Co. Erects Big Signboards Near Camp Dix Announcing Jobs for Soldiers

As a practical means of welcoming returning soldiers home again the Victor Co. erected on the main thoroughfare leading from Camp Dix, the great demobilization center of the East, two big signboards, announcing that jobs were awaiting capable men in the Victor plant at Camden. The various departments in which there were opportunities of employment were listed on these signboards and many soldiers availed themselves of the chance to get work. They needed no introduction to the Victor, for they had been in close contact with it during their sojourn in France.

## TAKES ON THE BRUNSWICK LINE

Thomas Anderson, 717 Manhattan avenue, Brooklyn, N. Y., has just added the Brunswick phonograph, made by the Brunswick-Balke-Clender Co., Chicago, Ill., to his large stock of machines. The agency for the Brunswick was only recently acquired by Mr. Anderson, who says that the many callers to his establishment are deeply interested in this phonograph.

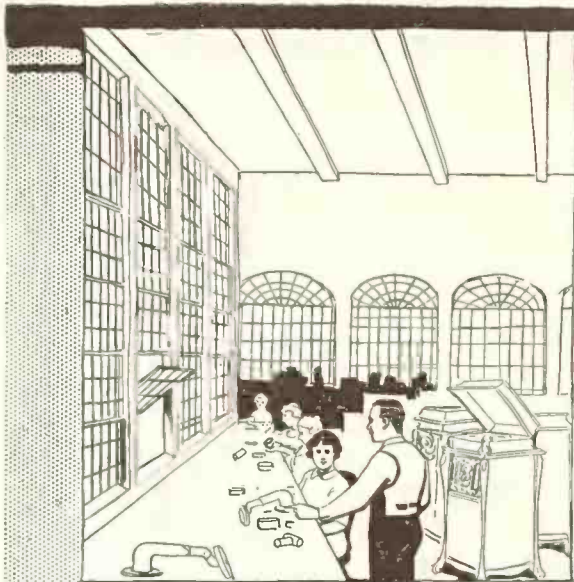

## Quality or Price?

When you buy die-castings of Tone-arms, Reproducers, Turntable Hubs, or Motor Governor discs for your talking machine, which do you consider of the most importance—Quality or Price?

Price is not the chief consideration with us. Our primary aim is to make *better castings*—regardless of price. If our quotations are higher than others, remember this—we ensure a casting that you can put in your product and know it will build up your reputation rather than destroy it.

Our reputation means as much to us as yours does to you—that's why we do not make cheap castings.

Send sample or blue print for quotations.

**"INDIANA"**  
**DIE-CASTING CO.**  
INDIANAPOLIS, . . . U. S. A.

New York Office: Vitus F. Di Lustro, 1003 Tribune Bldg.





This is **IMPORTANT** *only* if you are interested in the Greatest Phonograph Value in the World

The VISTA represents the biggest available sales proposition in its field.

*WRITE US*

**VISTA TALKING MACHINE, Dept. "D"**  
PHONOGRAPH DIVISION  
**THE WISCONSIN CHAIR CO.**  
Port Washington, Wis.



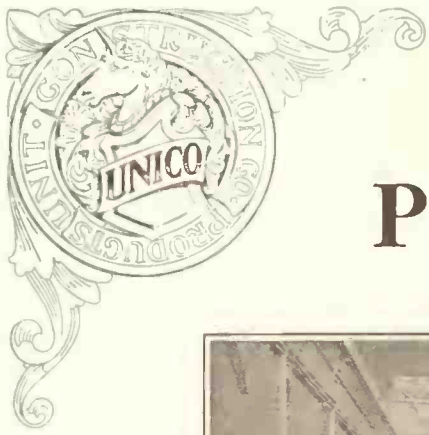

# Make Quality Put Its Best Foot Forward



A TYPICAL INSTALLATION OF UNICO EQUIPMENT

The music store sells to the best homes in the community—homes where quality and art are appreciated.

You cannot completely win the confidence of these people unless the appearance of your store coincides with the quality of your merchandise in its appeal to their good taste.

The quality of Unico Cabinet Work, the art expressed in its design and finish, stand behind your stock as a guarantee of its excellence.

Your customers are bound to appreciate the service given them by Unico Demonstrating Rooms, where they can hear the records and instruments they wish to choose from without distraction, and in an environment suggestive of the home where they are to put their purchases.

Unico Equipment is reasonable in cost, and soon pays for itself by increased sales. As your business grows, more equipment may be added without detriment to the first installation.

*Ten Unico designs are carried in stock for your selection. This is a part of Unico Service which makes it possible to give you prompt delivery so that you can be completely equipped in ample time for the Fall Season.*

*These and many other valuable Unico features are fully covered in our latest booklet, MUSICAL MERCHANDISING—mailed on request.*

*Send to-day the dimensions of your available space. Plans and estimates for a complete department will reach you promptly.*

Address our nearest office

## UNIT CONSTRUCTION COMPANY

Rayburn Clark Smith President

NEW YORK  
299 Madison Ave  
Corner 41st St  
BOSTON  
85 Essex Street

58th Street & Grays Avenue  
PHILADELPHIA

CHICAGO  
Lyon & Healy  
Building  
SAN FRANCISCO  
Holbrook Building





**VICTOR CO. GETS INJUNCTION**

Judge Mayer Grants Permanent Injunction Against Concern Using the Name "Victory Talking Machine Co." in New York City

The Victor Co. has been granted a permanent injunction against the concern which recently started business under the name of the Victory Talking Machine Co., 874 Columbus avenue, New York City. At the hearing before Judge Mayer counsel for the defendant declared that every one was using the word Victory and that defendant should have the same privilege. Judge Mayer ruled that while such a name as Chateau-Thierry might be permissible, the word Victory was not, and granted an injunction restraining the use either of the word Victor or the word Victory as part of any trade name for any business in which talking machine goods were made, advertised or marketed, and likewise restraining the use either of the word Victor or the word Victory as a trade-mark for talking machine goods made by the defendant or for talking machine goods other than the products of the Victor Co., marketed by the defendant.

**FOUND OKEH JOBBERS BUSY**

John Cromelin, General Sales Manager, Returns From Middle Western Trip Full of Enthusiasm Regarding Future Business

John Cromelin, general sales manager of the Otto Heineman Phonograph Supply Co., Inc., 25 West Forty-fifth street, New York, returned Monday from a visit to Minneapolis, Chicago, St. Louis and St. Paul. On this trip he called upon the OkeH jobbers in these cities, and was pleased to learn that general business conditions are excellent and that the jobbers are closing the best year in their history.

Mr. Cromelin found orders for OkeH records were active, with the jobbers looking forward to a very big season. In fact, the majority of the distributors are already placing their fall orders and starting to put their stocks into shape in order to handle a record-breaking trade for the remainder of the year. Wherever he visited Mr. Cromelin was informed that the new OkeH records are proving ready sellers.

Mr. Cromelin states that judging from present indications the most important problem confronting the "independent" phonograph manufacturers is that of securing sufficient supplies, for these manufacturers are finding a market for every machine they are producing. The demand for phonographs is far beyond the supply, and many of the manufacturers are now making arrangements for their "1920" output.

**HANDSOME NEW SONORA SIGN**

Now Apparent to Passersby at Broadway and Ann Streets, New York

When the downtown workers journeyed past the Woolworth Building recently they could not help but notice painters at work on the great Sonora sign at Broadway and Ann street, directly opposite the old Post Office. The French chateau which had been part of the previous



**New Sign Viewed by Millions**  
Sonora sign lost its identity beneath white paint. A new sign of more vivid summer hues, as shown in the attached illustration, now catches the eye of passersby.

**GREENVILLE VICTOR DEALER BUSY**

The J. L. Roark Estate, Greenville, Ky., Victor dealers, are receiving much publicity through the efforts of Manager Oren L. Roark, who is editor of the Record, an independent newspaper of Greenville. Much space is devoted to the display of the Victor line and many useful hints are contained in the sheet which can be used by music lovers to their advantage.

**REJOINS CABLE PIANO CO.**

Wm. Coleman has returned from service and has resumed his former position in the Victrola department of the Cable Piano Co., Atlanta, Ga.

**APPOINTED VISTA DISTRIBUTOR**

A. M. Druckman Becomes Sole Eastern Distributor for Vista Phonograph With Headquarters in New York—Places Large Order

PORT WASHINGTON, Wis., August 1.—A transaction of considerable magnitude has just been announced by the Vista Talking Machine Co. whereby A. M. Druckman, 16 West Thirty-ninth street, New York City, is to represent this line as sole Eastern distributor. The deal, which was closed by O. A. Gressing, sales manager, involves an amount that will run well into six figures, and is, doubtless, one of the largest single phonograph transactions consummated this year.

Mr. Druckman is said to be one of the most successful jobbers of high grade furniture in the East. He maintains well-equipped showrooms at his Thirty-ninth street address, and also has a traveling corps of fifteen men in his territory, besides two men who confine themselves to the Metropolitan district. Mr. Druckman recently returned to New York after a visit to the huge plant of the Vista Co. at Port Washington, Wis., and is more than pleased with the deal closed, also the arrangements he was able to make for immediate and future shipments. Car lots are going forward to him at once, and similar lots will follow weekly until late in the fall.

**NEW EMERSON DISTRIBUTOR**

Hessig-Ellis Drug Co., of Memphis, Tenn., to Cover Arkansas, Tennessee, Louisiana and Mississippi as Emerson Distributors

The Emerson Phonograph Co., Inc., announces that arrangements have just been completed with the Hessig-Ellis Drug Co., of Memphis, Tenn., whereby they will act as distributors for the Emerson records in Arkansas, Tennessee, Louisiana and Mississippi. Mr. Wynn, treasurer of the Hessig-Ellis Drug Co., recently visited the Emerson Co. in order to make a thorough investigation of what the possibilities of the Emerson records were. The investigation proved most satisfactory and resulted in their taking the distribution of Emerson records. At present Hessig-Ellis are making plans to go after the tremendous field which is at present open in the Southern territory, and in order to give satisfactory service they are taking on a larger sales force.

Advertising begins when baby first cries his wants to his mother and ends with an epitaph carved upon a headstone.—Ned Jordan.

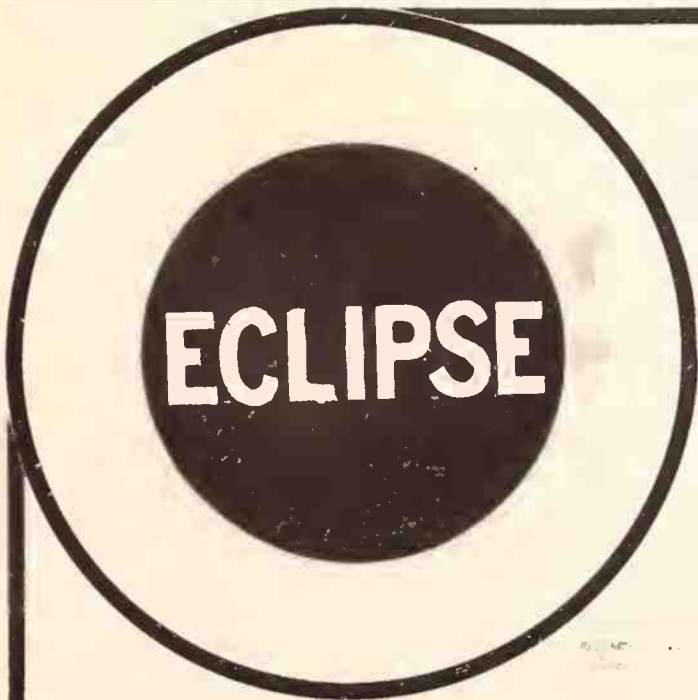

**RISING TO CONDITIONS**

—MEETING THE IMPROVED SITUATION WITH IMPROVED SERVICE WHEREVER POSSIBLE— THAT IS THE SPIRIT BEHIND

**ECLIPSE SERVICE**

EXCLUSIVELY VICTOR

**THE ECLIPSE MUSICAL CO. - CLEVELAND, OHIO**



**SALESMANSHIP NEEDS KNOWLEDGE OF MUSIC HISTORY**

By Henry Purmont Eames, the Well-known Pianist and Composer and Director of the Piano and Orchestra Departments of the Cosmopolitan School of Music, Chicago

The new art of salesmanship, that is to say, the modern methods which aim to advance the cause of music to its proper place among the arts of the civilized world and to popularize all kinds of music in order that every man may have a proper understanding of its relation to his everyday life, is receiving much attention from experts in that line. The task of selling records is no longer simply a matter of giving the customer a few numbers and taking the stipulated price in return. Salesmanship in the music industry is gradually being developed into a greater art and the most successful men are the ones who have recognized



Henry Purmont Eames

the new tendencies and have been quick to broaden their ideas by incorporating the new doctrine advocated by artists and business men in the industry.

The growing popularity of ragtime and jazz music, which has been responsible for much of the increased activity in records of this type, has aroused much discussion and some artists whose ideas have become somewhat narrow in their views, looking at the matter from a purely artistic standpoint rather than from the standpoint of the common people, have done all in their power to discourage this appealing class of music. The antagonism, however, had a good effect. It aroused the industry to action and the result is now an old story. Popular music, ragtime and jazz, has come into its own. Salesmanship has taken on a new aspect as a result and the salesman of today in the record field

is a far different individual from the type so happily out of date.

He recognizes, or should recognize, that there is a very definite relation between ragtime, jazz and art music, and it is his province to make this relation known to his customers in order that they may understand why music is an essential to their homes. In this way sales are increased, satisfied customers are added to the friends of the house and the cause of music generally is raised another notch.

Ragtime, jazz and art music all originated from a single source—the hearts and imaginations of the people, the expressional cravings of the people—the humble mass of humanity, and not from the few so-called intellectuals. It cannot be stressed too much that art is life; life seen and heard through the numberless channels of different personalities. There could be no art music but for the folk songs of the people. What is the origin of ragtime and jazz? It is the same as ninety-nine per cent. of our music, viz., from the crude expressions of the major part of the people, the peasant, the worker and the bearer of burdens.

Our national expression takes its nourishment from the earth and its life blood from the people and when the spirit has transfigured the material now growing up about us, the purity and force of our musical manifestations will be acknowledged just as has been the case in the evolution of all emotional schools. To be ready to accept the crudities and vulgarities of the elemental as art is not at all necessary, but to deny that the vivifying germs of art music are not to be found in America is proof of narrowness of vision and ignorance. America is an intensely musical nation. We must know this and be convinced of it and must spread this doctrine broadcast.

Here is where the talking machine salesman can do his best work. He can explain, to those who seek to discredit "popular" music, the common origin of all kinds of music and by so doing can increase the musical appreciation even of those who profess to see only the esthetic and artistic. All types of music will have their proper share of popularity. To those who scorn the art music, he should explain the common relation of classic and popular and thus help to increase the musical appreciation of that individual. The salesman must think himself a part, and a very important part, of the present nation-wide campaign to advance the cause of

Specialized Manufacturing Production for the Phonograph Trade



"They buy at a place where prices compete, where Quality must always excel."  
One only of the reasons our business is growing. "We serve all our customers well."

NEEDLE CUPS, BRAKES, COVER SUPPORTS, REGULATOR DIALS, etc.

What Is Your Need?

Correspondence invited—  
Orders promptly attended to  
60 Grand Street New York City

music, for he is the one who comes in closest contact with the individual. The advertising campaigns have their great value, speakers from public platforms do wonderful work, but when the average man goes to the store to get the music advocated by the champions of music he comes in closest contact with the salesman who demonstrates the records for him and helps him in the selection of those numbers most suited for his own use. The salesman becomes the final cog in the great machine.

**WARRIOR ENTERS COLUMBIA SERVICE**

Capt. H. B. Haring, who recently served with the American Expeditionary Forces in France, has recently returned to this country. Wishing to enter some line of business which would offer the same opportunities for action that the army did he has connected himself with the Columbia Co. Capt. Haring will be attached to the Baltimore Columbia branch in the sales department.

**MAKE TALKING MACHINE CABINETS**

E. K. Prichett, for some years with the Macey Furniture Co. and the Haskellite Mfg. Co., Grand Rapids, Mich., has organized the E. K. Prichett Furniture Co. to manufacture talking machine cabinets and furniture. The new concern has leased the upper floors of the Nelson-Matter factory and will begin operations soon.

Edward V. Murphy, of Washington, D. C., official reporter of the United States Senate for many years, died at the Homeopathic Hospital at Albany, N. Y., recently. Mr. Murphy was at one time a director of the Columbia Co.

# NYOIL

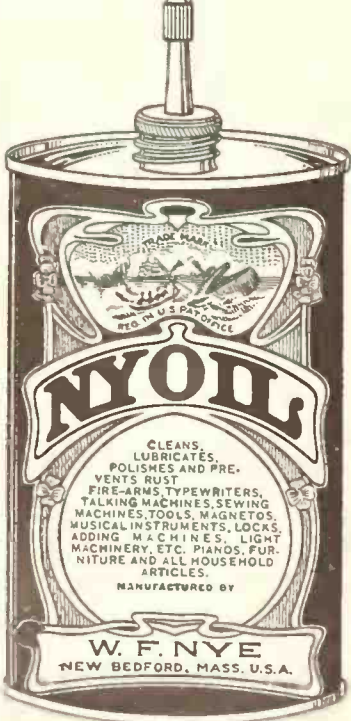

CLEANS, LUBRICATES, POLISHES AND PREVENTS RUST. FIRE-ARMS, TYPEWRITERS, TALKING MACHINES, SEWING MACHINES, TOOLS, MAGNETOS, MUSICAL INSTRUMENTS, LOCKS, ADDING MACHINES, LIGHT MACHINERY, ETC. PIANOS, FURNITURE AND ALL HOUSEHOLD ARTICLES. MANUFACTURED BY W. F. NYE, NEW BEDFORD, MASS., U.S.A.

is the last word in the refining of high-grade oils, for every impurity is taken from it, leaving nothing but what is required to keep machines in perfect condition, being combined of four oils perfectly blended.

Will not Gum, Chill or become rancid; is free from acid. It is colorless and has no sickening smell, being absolutely odorless.

"The finest and most delicate pieces of mechanism do not prove efficient unless properly lubricated. Skill, Genius, Invention and Workmanship must have the proper Oil. Stop and consider this when you have to buy an Oil for household use."

Hundreds of satisfied customers have written us that they would never use anything else for Talking Machines, Graphophones, Phonographs and Sewing Machines  
NYOIL will lubricate the machinery and polish all woodwork

and can be obtained of any "Up-to-date" Talking Machine Dealer in the world, and is manufactured by Wm. F. Nye, who for 50 years has made 80% of all the Watch, Clock and Chronometer Oil that is used in America.

**WM. F. NYE, NEW BEDFORD, MASS., U. S. A.**



NYOIL is put up in the following sizes:

No. 1 Bottle 1 ounce  
No. 4 " 3 ounces  
No. 8 " 8 ounces

NYOIL is put up in the following sizes: No. 16 (Cans) 1 Pint No. 32 " 1 Quart No. 128 " 1 Gallon No. 540 " 5 Gallon		NYOIL is put up in the following sizes: No. 1 Bottle 1 ounce No. 4 " 3 ounces No. 8 " 8 ounces
---	--	---



CLEAR AS A BELL

# SONORA

SEMI-PERMANENT SILVERED

## PHONOGRAPH NEEDLES

*are splendid money-makers for you!*

**Y**OU pay \$1.20 for a counter display holding 6 cards of Sonora needles (see illustration lower right corner). You sell the 6 Sonora cards quickly and easily for \$1.80, making an excellent profit — \$.60.

Sonora Semi-Permanent Silvered Needles are of matchless quality, they're heavily and steadily advertised, they're in great demand and are selling by the millions. They bring repeat customers to your store and these customers are the best kind of prospects to whom to sell phonographs, records, furniture, sheet music, pianos, etc.

*No matter what make of phonograph you sell you need Sonora Semi-Permanent Silvered Needles in stock. Send your order in at once to be nearer the top of the waiting line.*



Striking Poster 22" x 28"



Attractive Two-Color Counter Display Holding Six Needle Packages

*Three Grades*

**LOUD — MEDIUM — SOFT**

Retail price 30c. per card (holding five needles)  
In Canada 40c.

**Sonora Phonograph Sales Company, Inc.**

GEORGE E. BRIGHTSON, President

279 Broadway, Dept. Y., New York  
Toronto: Ryrie Building

*CAUTION! Beware of similarly constructed needles of inferior quality.*



CLEAR AS A BELL

# Sonora

SEMI-PERMANENT SILVERED

# PHONOGRAPH NEEDLES

*Replace steel needles and preserve records*

**T**HE Sonora Semi-Permanent Silvered Needles are entirely different in construction from the ordinary steel needles and their extraordinary merits are evident as soon as they're tried.

These new needles are so remarkably superior that your customers will be enthusiastic about them and will decide to use them exclusively.

The special features of these needles which will appeal to them particularly are:

- 1. Convenience**—They save constant needle changing.
- 2. Greater Economy**—They play 50 to 100 times and give a maximum of service and satisfaction.
- 3. Increasing life of records**—The record-engaging point does not enlarge as it wears (having the same diameter throughout and not being tapered) and always fits the record groove perfectly.

ly, as will be clearly perceived from a study of the photomicrographs at the bottom of this page.

**4. Improved Tone**—The Sonora Semi-Permanent Silvered Needles mellow the tone and eliminate harshness.

**5. Designed for all steel-needle records**—Remember that these needles are for use on ALL MAKES of steel-needle records.

Three Degrees: LOUD—MEDIUM—SOFT  
30 cents per card of 5 40 cents in Canada

**Sonora Phonograph Sales Company, Inc.**

GEORGE E. BRIGHTSON, President  
279 Broadway, Dept. Y., New York  
Toronto: Ryrie Building

**CAUTION!** *Beware of similarly constructed needles of inferior quality*

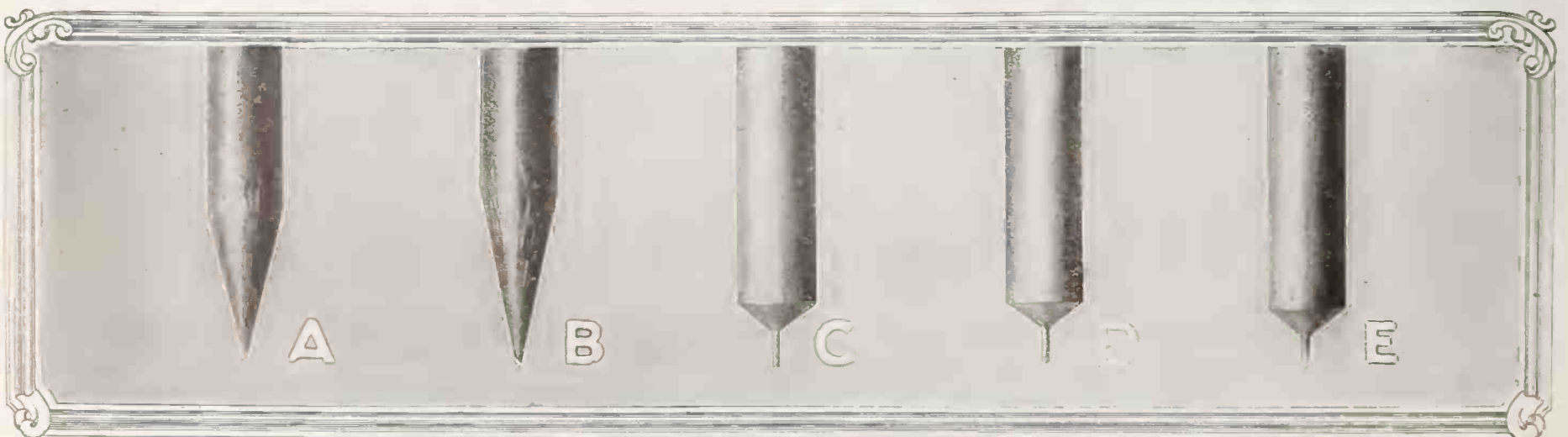
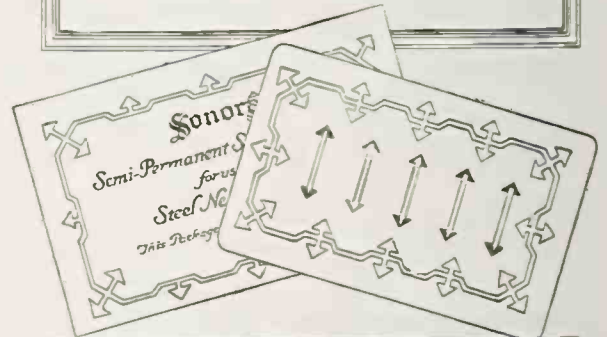
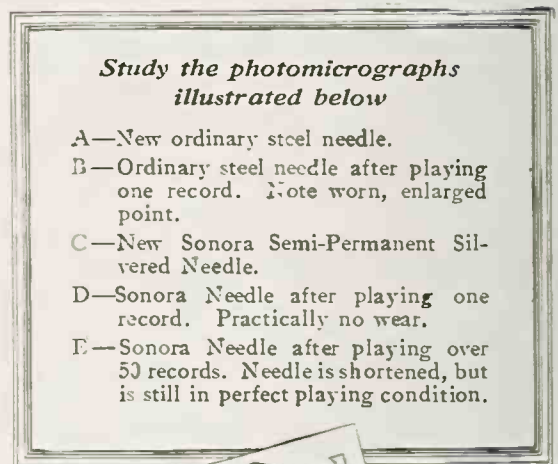



Two novelties this month!—the “Kosovo Waltz” by the Royal Serbian Tambouritza Orchestra, and “Waves of the Marne,” by Olga Bibor’s Gypsy Orchestra. E-4294.



Columbia Graphophone Co.  
NEW YORK

**EDISON PERIOD MODELS PRAISED**

Lady Randolph Churchill Sends Warm Letter of Endorsement to Thos. A. Edison, Inc., Regarding New Edison Period Cabinets

At the Edison Dealers' Convention recently held at the Hotel Commodore, New York City, one of the Edison laboratory staff told an amusing incident which related to the receipt of a letter from Lady Randolph Churchill giving her endorsement of the new Edison period cabinets. Naturally the receipt of such a letter from so distinguished an authority was the source of great satisfaction. Lady Randolph Churchill is a leader of English society and is recognized as possessing not only the best taste in furniture of any woman in England, but also as having the best-furnished house in that country. Her letter reads:

“8 Westbourne street,  
“Hyde Park.  
“May 23d, 1919.

“What an extraordinary man Mr. Edison is. He perfects his phonograph to a point where its realism is astounding. Then he determines to make each Edison phonograph—even the least costly—an attractive piece of furniture. Instead of the usual dentist-like looking cabinet his designers have succeeded in putting the character and feeling of the best periods into his phonograph cases. These graceful and artistic

productions will be hailed with delight by all who can afford them and will cause Mr. Edison's new phonograph to be desired in many houses where less worthy machines have not been welcomed heretofore.

“Jennie Randolph Churchill.”

It was a matter of speculation with the Edison staff why the usual run of phonograph cabinets should suggest to Lady Randolph Churchill the unpleasant thoughts of a dentist's cabinet, because, since whatever their faults, they at least do not look like the wicked little drawers where our American dentists keep their instruments of torture. Someone suggested that possibly dentist's equipments were different in England, but finally one of the laboratory staff

*8 Westbourne Street  
Hyde Park May 23<sup>d</sup> 1919*

*What an extraordinary man Mr. Edison is—  
He perfects his phonograph to a point  
where its realism is astounding. Then he  
determines to make each Edison phonograph  
even the least costly—an attractive piece  
of furniture. Instead of the usual dentist  
like looking cabinet—his designers have  
succeeded in putting the character  
& feeling of the best periods into his  
phonograph cases. These graceful &  
artistic productions will be hailed  
with delight by all who can afford  
them. & will cause Mr. Edison's new  
phonograph to be desired in many houses  
where less worthy machines have not  
been welcomed heretofore.*

*Jennie Randolph Churchill*

**Lady Churchill's Letter**

who has recently had a long session with his dentist decided that what she probably referred to was one of those “X-ray” cabinets, which is a part of the working equipment of the modern dentist.

**1,000 PURITAN BILLBOARDS**

Charles J. Orth, of Milwaukee, Wis., is carrying on an extensive campaign in the interests of the Puritan phonograph. Along the 175 miles of concrete highway in Milwaukee county he has placed 1,000 signboards in yellow and black and these posters are visible from a considerable distance to the thousands of motorists who pass through daily.

**AN EFFECTIVE VICTOR FLOAT**

Rockville, Conn., Dealer Features Victor Dog in Fourth of July Parade—Float One of the Best Features and Is Loudly Applauded

George P. Wendheiser, who has been in the music business in Rockville, Conn., for thirty years, had a very effective Victor float in the

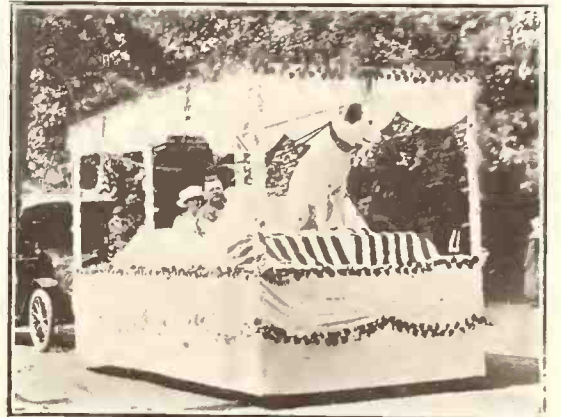

**Victor Dog Figures in National Parade**  
Fourth of July Welcome Home Parade. The float was white trimmed with ivy and roses and a large four-foot model of the Victor dog was placed on the front of the float while a mahogany style 16-A Victrola was placed at the rear. This display attracted much attention and applause and was considered the best float in the parade, which was over a mile long. The George P. Wendheiser store has been one of the progressive music houses of Rockville, handling both the Victor and Edison lines.

**“Does It Play All Records?”**

Certainly MAGNOLA does; and without any extra attachments, too. This is only one feature, albeit a most important one, in the thoroughly up-to-date equipment of the MARVELOUS MAGNOLA.

**MAGNOLA “Built by Tone Specialists”**



Watching the Music Come Out

May we send you our handsome illustrated catalog chock full of information concerning the wonderful construction system of Magnola and the beauties of its musical results, its artistic appearance and its moderate price?

Send your name and let us tell you more!

**MAGNOLA TALKING MACHINE COMPANY**

OTTO SCHULZ, President

General Offices Southern Wholesale Branch  
711 MILWAUKEE AVENUE 1530 CANDLER BLDG.  
CHICAGO ATLANTA, GA.

**LANGUAGE RECORDS**



Progressive Dealers sell  
**LANGUAGE**  
Phone Method  
and ROSENTHAL'S  
Practical Linguistry

The courses are so simply arranged that the demonstration satisfies the prospect. An excellent line for high-class dealers. We especially want to hear from dealers with good store locations.

Write for dealers proposition, booklet and advertising matter.

**THE LANGUAGE PHONE METHOD**  
392 Putnam - 2 West 45th Street, - New York

**WESTERN VENEER PRODUCTS CO.**

3900 CHOUTEAU AVENUE,

ST. LOUIS, MO.

**Largest Manufacturers of 3-ply Water-proof Veneer Phonograph Shipping Cases**

Ask for Prices and Samples



*Mechanically  
Better—Many  
Refinements  
and  
Improvements*



*A Line that is  
already the  
Talk of the  
Phonograph  
World*

## Revives the Art of Reproduction

It is a notable fact that reproducing has not kept up with the improvements in recording.

With the advent of "The Artist" comes a revival of interest in the phonograph as a reproducing instrument.

The general verdict is that "The Artist" marks a new era in phonographs.

Our experts have succeeded in developing a musical instrument that absolutely reproduces ALL the music engraved on the record—not a whisper or a tone is lost. Voices, violins, pianos, bands—ALL render through the new mechanical construction of "The Artist" a beauty and volume of glorious tone that has not hitherto been equaled.

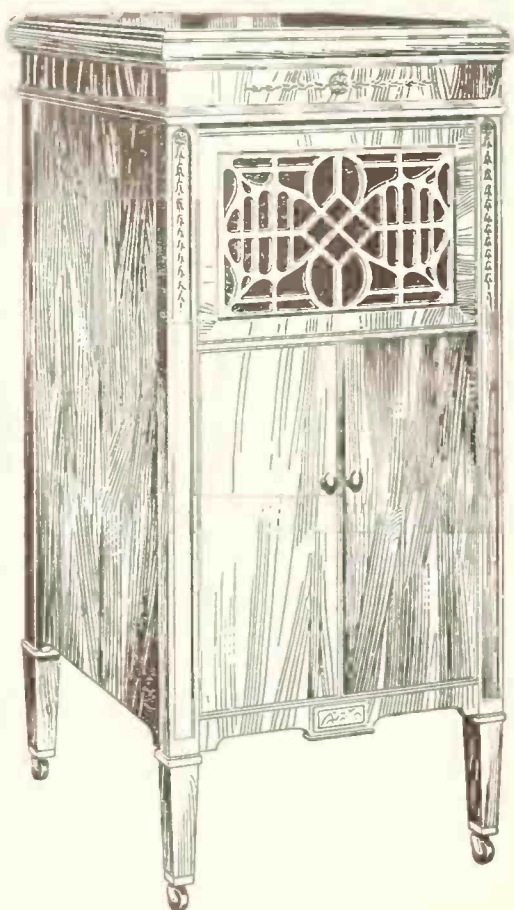

MODEL 2  
Oak or Mahogany  
48x22x23 inches  
Price \$165



MODEL 4—QUEEN ANNE  
Figured Walnut or Mahogany  
50x23x24 inches  
Prices \$290 and \$275

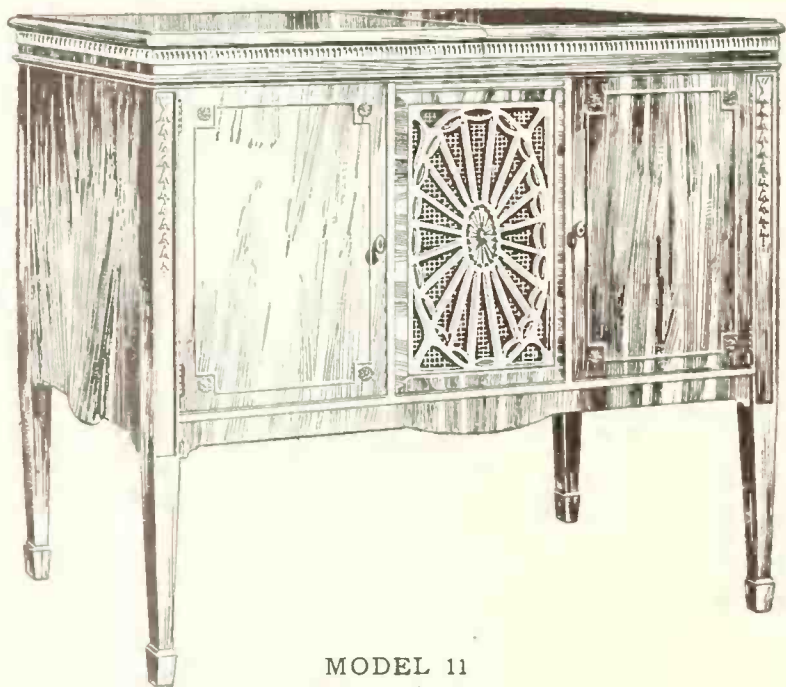

MODEL 11  
42x37x24 inches  
Oak or Mahogany  
Price \$225  
Also in Walnut

There are five beautiful designs in uprights and four Console models.

### PRICES

Upright models: \$110 to \$290.

Console models: \$175 to \$340.

### We Want Dealer Representation

We want dealers in the music trade who have the vision to appreciate the advantages of handling our line. We are interested in placing agencies in only better class stores. Send for our beautifully illustrated catalog and full particulars.

WE GUARANTEE DELIVERIES

We absolutely guarantee to deliver promptly all orders that we accept. Shipments commence in September.

# GRAND RAPIDS PHONOGRAPH COMPANY

Entire 1400 Block Front Ave. N. W.

GRAND RAPIDS, MICHIGAN



# Co-operative Newspaper Advertising Works Advantageously in Canada :: :: By W. B. Stoddard

Just because it is summer and hot and people are away on their vacations is no reason why vigilance in advertising should be relaxed. Indeed, it is the very time that publicity is most needed, in order to do away with that unnecessary "dull season" which some merchants seem to think is the decree of Providence. This is an excellent time to try co-operative advertising and if there is in the town a live newspaper, such as in Vancouver, B. C., any group of merchants who fall in with its plans would find their summer sales increasing. This paper, at the beginning of the summer, went to a dozen of the leading merchants and induced them to take one-twelfth of a page advertising, to run every Saturday for six weeks. Then they announced a painting contest open to all children of Vancouver and vicinity. The idea was that each child should paint the twelve ads (each of which contained a cut of some article carried by the advertiser) and send them into the paper, with the name, address and age written on the margin. Each week a prize of \$3.00 was offered for the best set of colorings. It is easy to realize the valuable publicity this gave the merchants, as all the children in town were coloring them and showing them to proud parents and friends. Each week, too, the four best sets of paintings were exhibited in the newspaper show window, where they were viewed by hundreds of passersby. In order to stimulate interest some of the dealers offered additional prizes. The Canadian Furniture Co., which handles an extensive line of talking machines, offered a very special attraction toward the purchase of a "talker" to the winner of the first prize in the painting contest. Their effective ad read:

**LOOK IN OUR WINDOW BEFORE YOU  
START TO PAINT**  
We have this machine in there, so do not fail to observe the correct color. Come inside, if you wish and ask any questions about it.

A publicity scheme that caused considerable comment was adopted by Fletcher Bros., Ltd., in order to bring their talking machines into the limelight. They installed in their window an automatic machine, which they publicly started one afternoon and then by announcements in the press, and cards in the window, invited estimates as to how long the Victrola

would run. "How Long Will It Play? Come in and get an estimate card. It will cost you nothing." They prepared special cards for the occasion:

**HOW LONG WILL IT PLAY?**  
Answer all questions in order to have your estimate count. My estimate is ..... hours ..... minutes ..... seconds. My address is ..... Street.  
Have you a talking machine?

They offered a first prize of \$20.00, a second of \$10.00 and a third of \$5.00—making them of such substantial value that they set the entire city to talking about it and wondering as to the length of time it would run. On the following day they placed a big card in the window, announcing that the machine had played thirty-six hours, forty-one minutes, thirty seconds, and that the winner, whose name was announced, had estimated thirty-six hours, forty minutes, forty seconds.

Another good example of co-operative publicity was launched by one of the papers of Edmonton, Alta., during the big provincial fair. They took two full pages and divided them into spaces containing twenty-four ads each. Each advertiser placed in the space whatever his fancy dictated, the majority of course confining themselves to a few short phrases with a punch. From eight of the ads one letter each was missing, these letters when discovered forming the word "Bulletin"—the name of the paper. A prize of \$5.00 was offered each day for the first person sending in the ad with the missing letters supplied and the missing letters were shifted from ad to ad each day. Over the top of each page (separate prizes were offered for the letters on pages 1 and 2) was the suggestion of the newspaper: "WIN a Prize and Spend the Money With the Advertisers." This was merely a suggestion and not at all compulsory. It will be readily seen what effective publicity this contest gave the merchants as it was like looking for a needle in the haystack to find the letters and each ad had to be read carefully from beginning to end each time it appeared. Most of the merchants took occasion to change their ad each day, and thus in the course of the week were able to advertise very effectively a number of their lines. One of the firms that took advantage of it to advertise their talking machines was the John-

ston-Walker Co., Ltd. This plan could readily be adopted by a single firm, without the aid of a newspaper—whenever they had an extended ad—such as during a special sale, or at holiday time, when they wished every word in their announcement to be carefully read. Instead of a cash prize for finding the missing word, which in this instance should be the firm name or the word "talking machine," records, needles or other merchandise could be offered, or a special discount on one of the machines.

But regardless of newspaper stunts or other forms of publicity, there is one agency that should never be overlooked, and that is an attractive show window. John Philip Sousa, the band king, is at present touring the Dominion, creating a furor of enthusiasm wherever he goes. Using this as their theme, Eaton & Co., the big store of Winnipeg, recently set forth the "Sousa" window that was responsible for the sale of scores of Victor records. In the background was a brick wall with stone coping and above it a sky of deep blue. Yellow and pink roses almost covered the wall. At one end of the window was a Victrola, with doors open to show the compartments for the records. Multi-colored ribbons ran from the cabinet to a score of Sousa band records set on a mahogany table or arranged in racks on the floor. In the center foreground was a large picture of John Philip Sousa, draped with the American flag and a silver clarinet placed in front of it. Cards at either side of the display read: "In the Eaton Victrola parlors any of the famous Sousa band records will be cheerfully played for you," and "Sousa band records are among the most popular of Victrola music."

## COAST DEALER TAKES OVER STORE

The Saladin Music Store, Santa Maria, Cal., Victor and Columbia distributor, has added a Dodge commercial car to its delivery service. This car is attractively decorated with a reproduction of the Victor dog. The Hawkins Music Store, at Lompoc, has recently been taken over by the Saladin Music Store and will be operated as a branch.

Have you used this summer well to prepare for fall trade?

# PERFORMANCES

—NOT PROMISES

A R E T H E B A S I S O F

# DITSON SERVICE

—VICTOR EXCLUSIVELY

OLIVER DITSON CO.

BOSTON

CHARLES H. DITSON & CO.

NEW YORK



# Steinburn

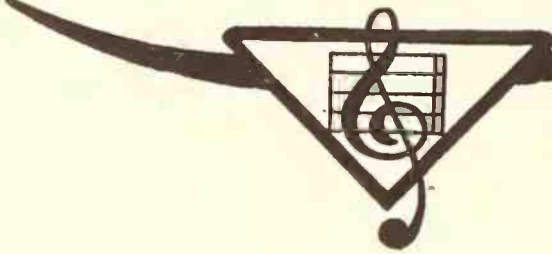

No. 225

**\$250**

36 inches high, 39 inches long, 23½ inches deep. Select genuine mahogany or American walnut veneers. Beautiful console model of Louis XVI period. Motor SDD, extra large double spring noiseless type of the finest possible construction.

Style F6, De Luxe Tone Arm. Plays all makes of disc records. Extra large record compartment in left end. All visible metal parts heavily plated with pure gold, finished in dull satin effect. Turntable covered with richest velvet. Automatic stop included. A De Luxe Masterpiece. Compares in every way with instruments usually selling for \$350.00.

## A Plain Talk to the Trade About the Phonograph Business

You are facing a fall and winter season when you will experience an abnormal demand for phonographs, on one hand, and will find it difficult to get deliveries, on the other.

## The Steinburn Agency is a Franchise of Great Value

The fact that leading dealers in the larger cities are securing exclusive Steinburn agencies is but an indication of their astute appreciation of the unusual value of the Steinburn Franchise.

## Consider Well These Facts

The prices of phonographs are being raised. They **MUST** be raised to meet the increased cost of materials. But the Stein-Burn Corporation, anticipating the condition that now confronts the phonograph industry, prepared for this condition early in 1918. We bought heavily of the various materials we use. Take these hard facts into consideration: Since that time, lumber has advanced from 20% to 100%, shellac has advanced 300%, varnish has advanced 40%, phonograph hardware has advanced

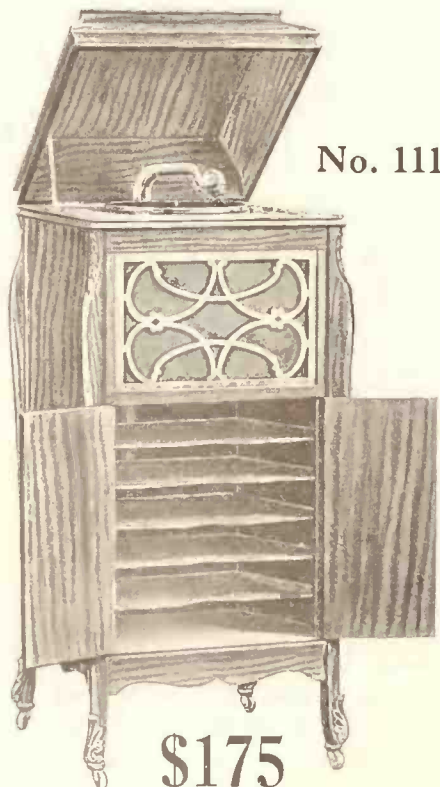

No. 111

**\$175**

51½ inches high; 23 inches wide; 24 inches deep. Choice figured genuine mahogany veneers; select quartered oak, golden or fumed. Motor SC, extra large triple spring noiseless type of the finest possible construction. Style F6, De Luxe tone arm. Plays all makes of disc records. Roomy record compartment with horizontal shelves. Automatic stop included. In quality, appearance and fact like other standard \$225.00 values.

**STEIN-BURN CORPORATION**  
General Offices and Display Rooms for Dealers  
Heyworth Building, Corner Wabash Ave. and Madison St.  
**CHICAGO**



# Steinburn



100%. Even the covering for our turn-tables has advanced 100%.

## But Our Prices Have Not Yet Advanced

You can, even now, contract for your requirements for this important fall and winter season—the greatest potential phonograph selling season ever known—and buy at prices based on our EARLY 1918 COSTS. Obviously this extremely fortunate state of affairs cannot and will not long continue. **THIS IS YOUR UNPARALLELED OPPORTUNITY.**

## Low Prices, Large Discounts, Liberal Terms

With prices SO LOW, even on this spectacular selling market, you can establish retail prices that give the consumer 15% to 25% greater value. Furthermore, we are looking deep into our future relations with you and have established trade discounts that will surely interest you.

And, our terms to responsible, well-rated merchants are most liberal, enabling you to do a far larger volume of business without using your capital.

THE STEINBURN LINE comprises eleven distinctive models, including popular cabinet styles, also period designs in Adam, Chippendale, Queen Anne, Louis XVI, and console models—each predominatingly superior.

They range in retail prices from \$32.50 to \$450.00 list.

(Continued on next page)

**STEIN-BURN CORPORATION**  
General Offices and Display Rooms for Dealers  
Heyworth Building, Corner Wabash Ave. and Madison St.  
**CHICAGO**

No. 211



**\$185**

52½ inches high; 23 inches wide; 24 inches deep. Queen Anne Period, in choice figured mahogany or walnut veneers. Motor SC, extra large triple spring, noiseless type of the finest possible construction. Style F6, De Luxe Tone arm. Plays all makes of disc records. Roomy record compartment with shelves. Automatic stop included. This machine compares favorably with regular \$250.00 models.

No. 210



**\$150**

48 inches high; 21½ inches wide; 22 inches deep. Louis XVI period, in choice figured mahogany or walnut veneers. Motor SAA, extra large double spring, noiseless type, of the finest possible construction. Style 5B, extra large balanced tone arm with grand opera reproducer. Plays all makes of disc records. Roomy record compartment with horizontal shelves. Automatic stop included. Like phonographs usually selling for \$200.00.



# Steinburn



No. 40

**\$175**

50 inches high; 23 inches wide; 24 $\frac{3}{4}$  inches deep. Choice figured genuine mahogany veneers; select quartered oak, golden or fumed. Motor SC, extra large triple spring noiseless type of the finest possible construction. Style F6, De Luxe tone arm. Special precision weight adjustment for all records. Steinburn orchestral reproducer. Plays all makes of disc records. Roomy record compartment with horizontal shelves. Automatic stop included. Other standard makes ask \$225.00 for a machine of this quality.

(Continued from preceding page)

## Steinburn Phonographs Play All Records,

with a patented weight adjustment on tone arm, playing all records perfectly; used on most Steinburn Models.

Quality —unsurpassed and unsurpassable because side-by-side comparisons establish the obvious LEADERSHIP of the Steinburn.

Tone —clear, rich, mellow music without even the slightest foreign vibrations. Steinburn LEADERSHIP is based on scientific improvements exclusively controlled by the STEIN-BURN CORPORATION.

Popularity —assured by a policy of predominating national advertising and a generous campaign of local, practical newspaper advertising featuring our dealers, but paid for by the Stein-Burn Corporation.

Production —on a scale so large that accepted dealers will be assured deliveries.

Guarantee —a 5-year Guarantee Bond with each Steinburn phonograph assuring absolute consumer and dealer satisfaction.

Policy —one dealer in a locality, but he must be awake to the value of LEADERSHIP and able to retain it.

No. 30

**\$150**

48 inches high; 22 $\frac{1}{2}$  inches wide; 24 inches deep. Choice figured genuine mahogany veneers; select quartered oak, golden or fumed. Motor SDD, extra large double spring noiseless type of the finest possible construction. Style 5B, extra large balanced tone arm with grand opera reproducer. Plays all makes of disc records. Roomy record compartment with horizontal shelves. Highly burnished triple plated nickel. Automatic stop included. Equal to any \$175.00 machine on the market.

STEIN-BURN CORPORATION  
General Offices and Display Rooms for Dealers  
Heyworth Building, Corner Wabash Ave. and Madison St.  
CHICAGO



# Steinburn



## Someone Will Secure the Steinburn Agency in Your City

The Stein-Burn organization has been successfully identified with large business interests of Chicago for forty years. For several years past we have been manufacturing phonographs of the better class. Our new policy of selling direct and exclusively to dealers assures the pre-eminence and leadership of the Steinburn phonograph. The securing of this line represents a franchise of unusual value to each dealer accepted.

Someone will secure the Steinburn agency in your city. If interested, let us urge you to send AT ONCE for full particulars, or if possible, to call personally at our General Offices and Display Rooms for the purpose of seeing the Steinburn line and arranging for representation. It might be advisable to wire sample order.

**STEIN-BURN CORPORATION**  
General Offices and Display Rooms for Dealers  
Heyworth Building, Corner Wabash Ave. and Madison St.  
**CHICAGO**

No. 108



\$95

43 inches high; 19 inches wide; 20 inches deep. Choice figured genuine mahogany veneer; select quartered oak, golden or fumed. Motor W2, double spring, long service, precision type with heavy cast frame, improved anti-friction, adjustable bearings; noiseless worm gears. Style PP2, large turnback tone arm with concert reproducer. Roomy record compartment with shelves. A great value that could well have been priced at \$110.00 instead.

No. 105



\$80

43 inches high; 19 inches wide; 20 inches deep. Adam Period. Choice figured genuine mahogany veneer; select quartered oak, golden or fumed. Motor W2, double spring long service type with heavy cast frame; improved anti-friction bearings; noiseless worm gears. Style PP1 brilliant tone arm and reproducer. Plays all records. Roomy record compartment with shelves. Compares with other standard instruments usually listed at \$90.00.





**Sascha Jacobsen's violin fairly talks in  
"Dear Old Pal of Mine." It makes love  
beautifully in Victor Herbert's "Serenade."  
A-2753.**

**Columbia Graphophone Co.  
NEW YORK**

**WINDOW FEATURED PORTABLES**

**Hoffman Piano Co. Has Much Success With  
Sonora Portable Machines**

BUFFALO, N. Y., August 9.—The Sonora shop conducted by the Hoffman Piano Co., 696 Main street, this city, has been featuring recently



**An Attractive Hoffman Window**

Sonora portable phonographs in both its window and newspaper advertising. In the accompanying illustration is reproduced a recent window which attracted a good deal of attention. The portable phonographs are displayed in such a manner as to suggest how they may be used in connection with vacations and summer outings. L. M. Cole, manager of the com-

pany, stated to a representative of The World recently, that this campaign has been most successful and many of these Sonora portable machines have been sold since the summer season started.

**PAULL HAYDEN SHINES AS POET**

**Columbia Man Contributes a Most Interesting  
Bit of Verse in the July Peptimist**

Paull Hayden, of the advertising department of the Columbia Graphophone Co., and who on previous occasions has displayed considerable literary and editorial ability, has contributed the following worth-while poem in the Peptimist for July, under the title of "Beating the Other Man to It":

To-day brought a task to be done;  
I said; "I will do it To-morrow,"  
Another man did it first  
I found to my lasting sorrow,  
"To-morrow I'll get on the job,"  
Another man started to-day;  
I found that the job had been done  
And another had earned the pay.  
I said, "I will start in an hour  
"To find what is really in it,"  
Another man won the prize,  
He started in half a minute.  
I "waited awhile" for Luck,  
I knew I would surely get her;  
I waited—she never came—  
Another man went and met her.  
But now I am P D Q  
When a thing's to be done I do it,  
I'm leaving the rest behind,  
I Beat The Other Man To It.

The Franklin Phonograph Co. is a new Philadelphia corporation.

**TO FINANCE FOREIGN BUYERS**

**Senator Edge's Bill to Foster Trade With Eu-  
ropean Countries Meets With Approval**

WASHINGTON, D. C., August 4.—A comprehensive bill to provide for the financing of foreign purchasers of American goods has been introduced in the Senate by Senator Edge. It proposes to amend the Federal Reserve act, and was drawn after conferences with Secretary Glass and Gov. Harding of the Federal Reserve Board. Mr. Edge also consulted a number of New York financiers.

Provision is made under which corporations may be formed by fewer than five persons to engage principally in international or foreign banking. The objects for which the association is formed must be specified in general terms, and the articles of association forwarded to the Federal Reserve Board. The capital stock must not be less than \$2,000,000.

Authority is given to establish branches or agencies in foreign countries. No business must be transacted in this country, except as approved by the Federal Reserve Board, and as incident to its foreign business. In explaining his bill Senator Edge said:

"In effect this measure provides for the Federal incorporation of one or more concerns to handle the composite commercial-financial business of the American export trade. Not only may such corporations exercise the ordinary banking functions, but they may advance cash to foreign purchasers of American exports on such security, say, as a foreign manufacturing plant or similar collateral.

"For instance, a manufacturing concern in Belgium may wish to buy raw material or other goods from America. Under this bill such an American corporation as it proposes may take a mortgage on this Belgium plant and against it issue debentures, using the money raised on these debentures for payment to the American exporters for their goods.

"As every step of such transaction would be under the supervision of the United States Government, through the Federal Reserve Board, such investments would be thoroughly safeguarded and such debentures should prove an attractive investment to the ever-growing hosts of American investors."

**DENVER MUSIC STORE REOPENS**

The Denver Phonograph Co., Denver, Colo., has again opened for business at 837 Fourteenth street. On July 3, 1918, the proprietors of the store, M. L. Bechtold and M. L. Leve, enlisted in the navy and have just returned and resumed their former work.

**COTTON FLOCKS**

.. FOR ..

**Record Manufacturing**

**THE PECKHAM MFG. CO., 238 South Street  
NEWARK, N. J.**

To the Trade:

Since opening my new business, I have been advised by many friends, who travel all over the country, that they are being repeatedly asked, by the trade, for my new address. I therefore beg to advise you that I am at 3-5 Waverly Place, New York City.

**MAX L. GOLDBERT**





# HEINEMAN



## The Standard of Comparison

The world-wide success attained by **HEINEMAN MOTORS** may be attributed to their mechanical perfection, superior quality, and the fact that they are giving absolute satisfaction under all conditions. The leading phonograph manufacturers prefer the **HEINEMAN MOTOR**, and regard it as the standard of comparison in the phonograph industry.

## The Heineman: **The MOTOR of Quality**

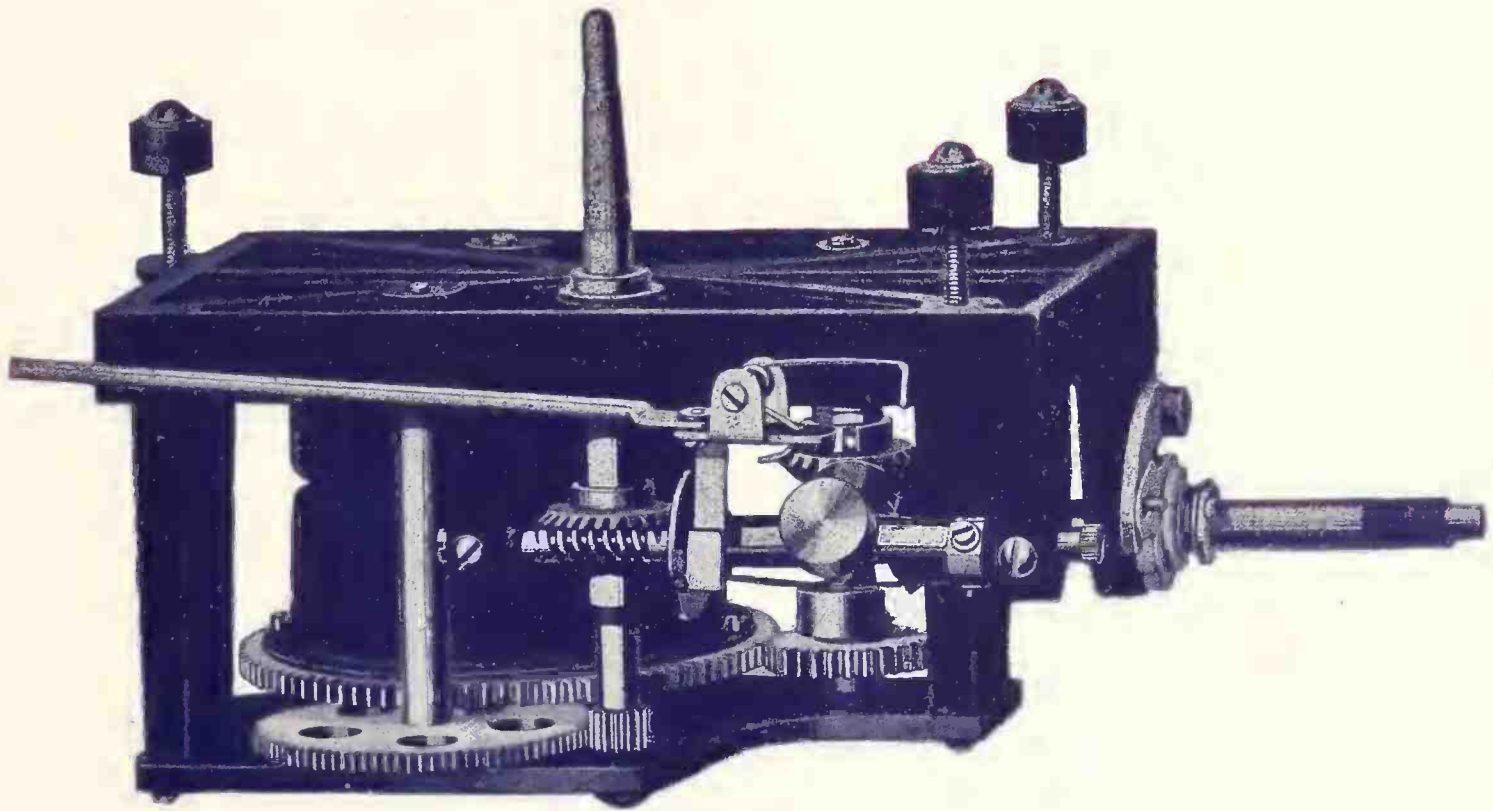

HEINEMAN MOTOR No. 77

*Otto Heineman*  
President

### Otto Heineman Phonograph Supply Co.

INCORPORATED

25 WEST 45th STREET, NEW YORK

FACTORIES: ELYRIA, OHIO, NEWARK, N. J., PUTNAM, CONN.  
SPRINGFIELD, MASS.

BRANCHES: CHICAGO SAN FRANCISCO TORONTO, CAN.







**OKEH**  
**RECORDS**

ORDER NOW

**EIGHTH BULLETIN**

ORDER NOW

- 1209 { The Vamp (One Step)  
      { Shake Your Shoulders (Fox Trot)
- 1210 { Fluffy Ruffles (One Step)  
      { My Dreamy Little Lotus Flower (Fox Trot)
- 1212 { Beaux Esprits (Gay Spirits) (One Step)  
      { Sliding Sid (Fox Trot)
- 1213 { When the Bees Make Honey Down in Sunny  
      { Alabam (Contralto Duet)  
      { It's Nobody's Business But My Own (Baritone)
- 1214 { Lullaby Blues (In the Evening) (Vocal Quartette)  
      { O! Death, Where Is Thy Sting? (Baritone)
- 1215 { Oh, How She Can Sing (Tenor Duet)  
      { Just Another Poor Man Gone Wrong (Tenor)

- 1216 { I'll Say She Does (From "Sinbad") (Baritone)  
      { I Always Think I'm Up in Heaven (When I'm  
      { Down in Dixieland) (From Monte Cristo, Jr.)  
      { (Contralto Duet)
- 1217 { Then You'll Know You're Home (Baritone)  
      { The Return (They Are Here) (Baritone)
- 1218 { My Barney Lies Over the Ocean (Just the Way He  
      { Lied to Me) (Contralto)  
      { Oh! Lawdy (Tenor)
- 1219 { Jazz Baby (Tenor)  
      { You Can't Blame the Girlies At All (Baritone)
- 1220 { When Ireland Comes Into Her Own (Tenor)  
      { Peg Aroon (Tenor)
- 1221 { A Wee Bit of Lace (From "The Royal Vagabond")  
      { (Contralto)  
      { You Don't Know (Tenor)

**Otto Heineman Phonograph Supply Co.**

25 West 45th Street

Incorporated

New York City, N. Y.

FACTORIES: ELYRIA, O.—NEWARK, N. J.  
PUTNAM, CONN.   SPRINGFIELD, MASS.

Branch Offices: Chicago, Ill.   San Francisco, Cal.   Toronto, Can.





# Southern Victor Dealers Hold Convention in Atlanta and Organize an Association

ATLANTA, Ga., August 1.—After more than a year of preparation for the move, the Southern Victor retail dealers met at the Capital City Club in this city on July 16 and formed the organization known as the Southern Victor Dealers' Association. The convention, at which more than seventy-five dealers attended, lasted the entire day, there being a morning and afternoon session, with a luncheon in between given by the Elyea Co., of Atlanta.

The morning session was called together at 10 o'clock by E. N. Upshaw, manager of the Victrola department of the Elyea Co., whose own efforts were largely responsible for bringing about the organization. He introduced Robert F. Maddox, ex-Mayor of Atlanta and president of the Atlanta National Bank and the American Bankers' Association, who delivered an address of welcome and then touched on the present prosperity of the South. He stated that to-day the South is more prosperous than any other section of the country and further that the talking machine future was in proportion even more brilliant. With national prohibition the labor classes would look for some line of amusement other than the cheap barroom. The talking machine as an entertainer, he believed, is unsurpassed and therefore there will be a rapid increase in the demand for talking machines. In closing his address Mr. Maddox showed by actual statistics how the opera talking machine records have educated the public to attend grand opera, and said it would be impossible to have the large attendance during the opera season in Atlanta were it not for the general education that the public received in opera music through the medium of the talking machine.

After a word of appreciation of Mr. Maddox's address was spoken by Mr. Brice, of Parker-Gardner Co., the election of officers was held in order that the important business to be taken up later might be handled as quickly as possible.

#### Election of Officers and Committees

The following officers were elected: F. E. Mahoney, of the Rhodes-Mahoney Furniture Co., Chattanooga, Tenn., president; Benjamin Hammond, of the Clark & Jones Piano Co., Birmingham, Ala., vice-president; Le Roy Webb, of the Le Roy Webb Co., Atlanta, Ga., secretary, and W. H. Cummings, of the Cummings Furniture & Hardware Co., Huntsville, Ala., treasurer. All elections were unanimous.

Mr. Mahoney, as president, then took the chair and gave a brief impromptu address in appreciation of the honor tendered him and stated that the association would prosper and benefit its members in just the proportion in which the members co-operated with one another. He also

asked that all those present use their influence in securing a large membership for the organization.

In order that the organization might proceed along business lines a by-laws committee was appointed, consisting of G. E. Pilgrim, of the Pilgrim-Estes Furniture Co., Gainesville, Ga.; R. G. Brice, of Parker-Gardner Co., Charlotte, N. C., and Benjamin Hammond, of Clark-Jones Piano Co., Birmingham, Ala.

A committee on resolutions, consisting of W. R. Wilson, of A. G. Rhodes & Sons, Charleston, S. C.; H. C. Clemons, of Clemons Bros., Chat-



F. E. Mahoney, President

tanooga, Tenn., and J. R. Brumby, of the Brumby Furniture Co., Marietta, Ga., was appointed. These two committees were asked to report at the afternoon session.

#### An Interesting Open Discussion

The meeting was then thrown open for a short discussion and any one who had anything of interest or any helpful comment that would benefit the association was asked to speak. Among those who gave short addresses were A. R. Boone, of the Talking Machine Co., Birmingham, Ala., who brought forth the fact that at present a great opening for new developments in Victor Red Seal records existed, as the prices of the records were to-day so nominal that they were within the means of anyone who could afford to possess a talking machine. W. M. Edwards, of the Florida Talking Machine Co., and M. B. Robinson, of the Phillips & Crew Co., also spoke. The latter touched on the value of standardizing the amount of interest to be charged for machines

sold on the instalment plan. C. K. Elyea, general manager of the Elyea Co., Victor jobbers, then spoke of the broad co-operation policy of the Victor Co. He was followed by J. D. Salter, of the Cable Piano Co., who dwelt on how the Victor Red Seal records had aroused more interest in the operas given in Atlanta, and how, on the other hand, the operas caused more interest in the records of the great singers. Mrs. Clara Orr, of the Chamberlain-Johnson-DuBose Co., Atlanta; J. H. Holcombe, of C. C. Holcombe, Birmingham; J. B. Shepard, of the J. B. Shepard Co., Savannah, Ga., all spoke on the value of the one-price system, making no reductions for cash, charging a nominal rate of interest on instalments, and not prepaying freight. Dan Orndorff, Knoxville, Tenn.; L. P. Heyman, of Lee Heyman & Co., West Point, Ga.; I. C. Helmy, of the I. C. Helmy Furniture Co., Savannah, Ga.; H. S. Banta, of Newnan, Ga., and L. Lohr, of the Queensboro Music Co., spoke on the general advantages of the association and also enlarged on the previous discussions.

#### Luncheon at Capital City Club

At 12 o'clock the party assembled on the front steps, where the photograph appearing on page 37 was taken. A luncheon was then tendered the association in the grand ballroom of the Capital City Club by the Elyea Co. This luncheon, which consisted of a magnificent repast, with everything from soup to nuts, marked the high point of enjoyment at the convention and served as a relaxation from the morning's hard work.

During the banquet many harmless yet pointed remarks on shipments of talking machines were made by the dealers to the different jobbers present. Finally Mr. Upshaw arose and stated that he shipped out thousands of records the past week and several hundred machines. He then stood back a pace and said: "If there is anyone present who can tell a bigger lie than I, why, let him go to it." This brought hearty laughter from all those who heard his remark and served to appease those bemoaning the fact that they did not have enough goods.

#### E. N. Upshaw Called Upon

Toward the end of the banquet, when everyone was in the most congenial spirit, Mr. Mahoney called on E. N. Upshaw, who gave a most interesting and entertaining address on the past history of the talking machine business. He spoke of the spiral drive machines of the horn type, then of the first Victrola models and of how a contract for a few hundred dollars was

(Continued on page 37)

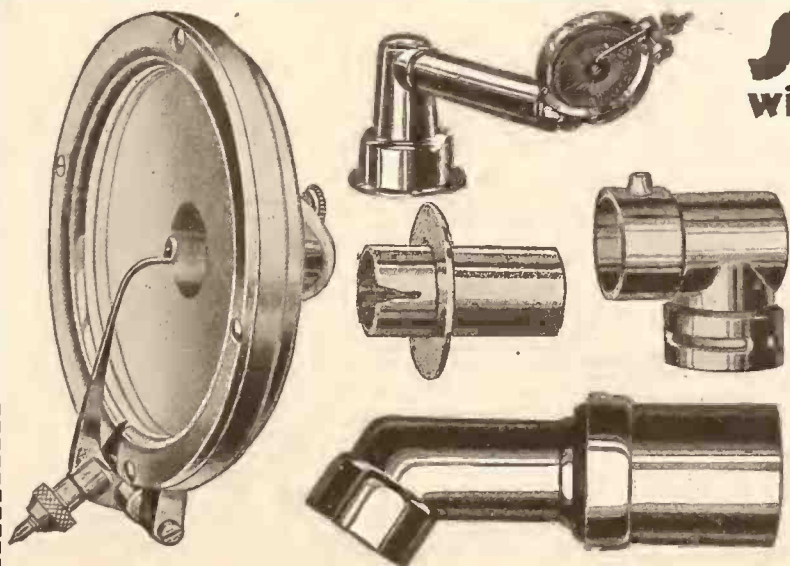

## Superior Die Castings will Cut Your Costs and Increase Your Sales

Tonearm and Reproducer Parts, Attachments, Turntable Hubs, Motor Governor Discs, Knobs, Piano Player Parts—accurately cast in Aluminum, White Brass, White Metal Alloys or Zelco Metal—ready for nickel or gold plating. We employ a large force of die makers especially skilled in this class of work and operate a large battery of die casting machines of our own design and construction with a capacity of 50,000 to 100,000 castings per day.

Write for  
Samples of Work we  
are doing in  
this line



Send us  
your Specifications  
or Models for  
quotations

**Barnhart Brothers & Spindler**  
Monroe and Throop Streets Chicago, Illinois



If you want to cash in on hits shouldn't you get the records before your competitors? Minutes count. Emerson has an enviable record for getting its hits first on the market.

If you wish representation why not write to our Vice-President, Mr. H. T. Leeming.



**Emerson Phonograph Company** <sup>INC.</sup>

NEW YORK  
3 West 35th Street

CHICAGO  
7 East Jackson Blvd.



Barbara Maurel sings "Kathleen Mavourneen" and "Love's Old Sweet Song." Millions will want to hear her. A-6112.

Columbia Graphophone Co.  
NEW YORK



SOUTHERN VICTOR DEALERS ORGANIZE ASSOCIATION—(Continued from Page 35)

considered to be a large order a few years ago. He brought these points out in order that a vivid contrast might be made between those old days and the present era, and said he believed that some day in the future a contrast just as vivid could be made between the business of to-day and the business of the future.

In concluding his address of reminiscence Mr. Upshaw said, "Still, we must not look too much backwards. As a matter of fact, we are in the position of a young man who was making love to his girl and she asked him if she were the only girl he had ever loved, to which he replied, 'No, dearie, I have worked myself up to you.' And, so it is with us Victor men. We have worked ourselves up by gradual stages to our present enviable position, but our work is just commencing, and if we will only take advantage of the prospects which lie spread out before us we will indeed reap a golden harvest."

F. W. Schwoebel's Impressions

F. W. Schwoebel, Southern representative of the Victor Co., was then called upon and remarked that although he had only been with the Victor Talking Machine Co. a short time he was impressed by the high ideals, broad vision and square-deal policy displayed by the company. This was no offhand statement, but was his analysis after becoming familiar with the officers, the growth and the policies of the company, particularly in the last few months.

Frank McGailliard's Interesting Remarks

Frank McGailliard, special representative of the Victor Talking Machine Co., the speaker of the day, gave an interesting talk on the Victor Talking Machine Co. Policies, production, organization, quality and character of the goods and other points of vital interest to the dealer were brought to the attention of the audience. He explained the reasons for the reduction in the price of the Victor Red Seal records and showed that it was only through the

greater production, better contracts with the artists, bigger and more efficient machines and a more liberal policy on the part of the Victor Talking Machine Co. that such a reduction was made possible.

Edward Lyman Bill on Association Value

Edward Lyman Bill, of The Talking Machine World, was then called upon and made a short

worked out by the association to the advantage of all its members. In closing Mr. Bill wished the association a most hearty success and offered the co-operation of The Talking Machine World in furthering the association in any way possible.

With a rousing cheer for Mr. Elyea and Mr. Upshaw the banquet was brought to a close and



Those in Attendance at Convention of Victor Dealers in Atlanta

Standing from left to right on the first row are: William Quinn; Le Roy Webb, secretary; Mrs. Myra Readwell; Benjamin Hammond, vice-president; F. E. Mahoney, president; Mrs. Clara Orr; W. H. Cummings, treasurer; E. N. Upshaw.

address on the value of the association to members. He pointed out that the value of an association lay in the co-operation of its members; that the exchange of merchandising ideas would increase business for all. He also touched on the fact that such vital questions as standardization of prices, the standardization of interest charges and other problems could be

an intermission of a half-hour before the afternoon session ensued.

Afternoon Session

When the afternoon session was called to order the by-laws committee reported and the proposed by-laws were read and unanimously approved by the members of the association.

(Continued on page 39)

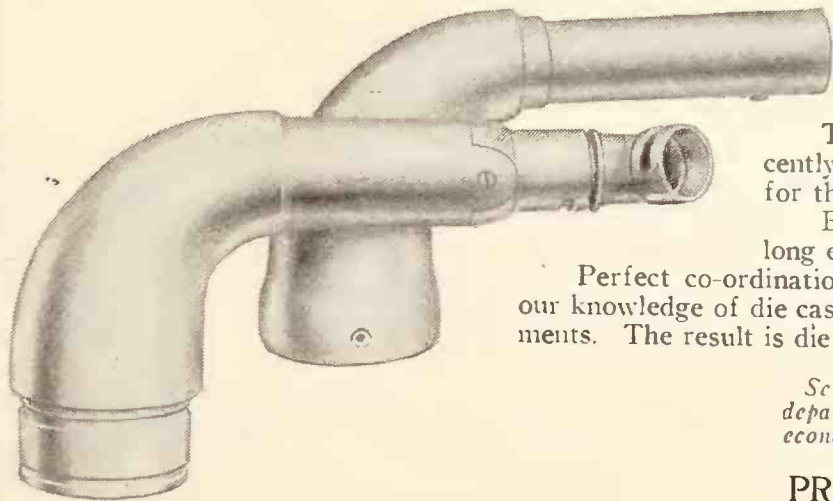

Die Castings for all Purposes

This Company has made many millions of die castings. Orders recently completed were for over 25,000,000 bouchons for hand grenades for the U. S. Government.

Equipment is ample; furthermore it is backed by a personnel of long experience and great skill in the art of die casting.

Perfect co-ordination of this organization with your engineering department combines our knowledge of die casting with your own close study of your manufacturing requirements. The result is die castings that serve their purpose practically 100%.

Send blue prints or models and let our engineering department show you how Precision Castings can serve economically and efficiently.

PRECISION CASTINGS COMPANY, INC.  
SYRACUSE, N. Y. NEW YORK.

Die Casting Plant, Syracuse, N. Y.

Brass, Bronze and Aluminum Foundry, Pontiac, Mich.



**T**HE increase in the sales of GENNETT Lateral Records in the last few months has been simply amazing—to all except their makers and to those who have *heard* these new records.

The sales of these records are increasing in volume so rapidly that our factories, large as they are, cannot keep up with the orders. We are expanding our plant.

The phenomenal volume of sales of GENNETT Records does not surprise us, because we know that we put into these records the same exquisite care that has distinguished the products of the Starr Piano Company for the last fifty years. That care is BOUND to produce sales. We have confidence in our workmanship—and therefore are not surprised at the way orders are pouring in.

Similarly, any person who has heard the new GENNETT Records played on any phonograph is not surprised to learn that they are being ordered by the public in tremendous quantities. To hear one is to understand why their popularity is increasing by leaps and bounds.

Recorded in New York, the birthplace of all the latest musical triumphs, and backed up by the world-wide *prestige* of Starr musical instruments, GENNETT Records are proving to dealers everywhere that perfection of workmanship brings sales whose growing volume is a *certainty!*

**The Starr Piano Company**

Established 1872

Richmond, Indiana



**SOUTHERN VICTOR DEALERS ORGANIZE—(Continued from page 37)**

The resolutions committee then reported, offering the following resolutions to be passed, which were unanimously approved:

"Resolved, By the Southern Victor Dealers' Association, in convention assembled, that we endorse the principle recommended by the Federal Trade Commission in their special report of Congress July 12, 1919, recommending that manufacturers of trade-marked articles be allowed to fix the retail price subject to review by a disinterested agency.

"Resolved, That the Southern Victor Dealers' Association, in convention assembled, extend to The Talking Machine World their heartiest appreciation for the co-operation and support offered through Edward Lyman Bill, whose interesting and instructive talk we all enjoyed.

"Resolved, by the Southern Victor Dealers' Association, in convention assembled, that we extend our sincere thanks to the Victor Talking Machine Co. for the spirit of co-operation they have shown in assisting in the forming of this association, and especially do we appreciate their sending Mr. Gailliard to be with us, and assure them they could not have sent anyone who could have presented the facts in which we are interested in a more pleasing and satisfactory manner.

"Be It Further Resolved, That we commend the patriotic stand which the Victor Talking Machine Co. took in the national crisis and assure them that we are willing to bear with them the hardships resultant therefrom.

"Be It Further Resolved, That we heartily approve of the recent action whereby the retail price of many Red Seal records was reduced and thank the Victor Talking Machine Co. for the excellent method developed by them of handling the reimbursement to the dealers.

"Be It Resolved, That we extend our sincere thanks and heartfelt appreciation to the Elyea Co. for bringing about this first meeting of this association, and assure them of our lasting appreciation of the many courtesies and attentions shown us. We feel that we are indebted to them for one of the greatest things that could happen to the retail Victor business in the South—the formation of this association for the exchange of ideas and the betterment of the business as a whole."

**To Meet Next in Birmingham**

An interesting discussion then followed as to where the next meeting was to be held, and it was finally decided that Birmingham, Ala., should next have the honor of being host to the association. The time of meeting was left to the executive committee, which is composed of the executive officers and B. G. Brice, of the Parke-Gardner Co., Charlotte, N. C.

The adjournment of the meeting then took place. The association on breaking up became the guests of the Elyea Co. on a delightful automobile ride about the environs of Atlanta. This trip was proving most enjoyable when it was broken up by a sudden cloud-burst, but luckily not until the greater part of the tour had been completed.

**List of Conventionists**

Those who attended the meeting were: F. J. Denham and John Denham, Denham Bros. Piano Co., Anniston, Ala.; Benj. Hammond,

Clark-Jones Piano Co.; William C. Quinn and M. E. Williams, of Williams Music House; Irving Bonstein and A. R. Boone, the Talking Machine Co.; Myra Treadwell, Cable-Shelby-Burton Piano Co., Birmingham, Ala.; W. M. Edwards, Florida Talking Machine Co., Jacksonville, Fla.; J. I. Culpepper, Bloodworth Drug Co., Perry, Ala.; M. Flatauer, A. Flatauer, Apalachicola, Fla.; LeRoy Webb, LeRoy Webb & Co.; J. W. Crews, A. F. Joyner, Atlanta Georgian; M. B. Robinson, Phillips & Crew Co.; R. D. Bame, L. M. & R. D. Bame; Mrs. Clara Orr, Chamberlain-Johnson-Dubose & Co., Lawrence Evans and J. B. Salter, the Cable Piano Co.; C. E. Grenath, J. W. Crews, C. L. Elyea, E. M. Upshaw, S. E. Brown, Miss White, Miss Hairston, Ernest Milburn and Roley Nay, the Elyea Co.; P. Lewis, Andalusia, Ala.; J. H. Holcombe, C. C. Holcombe, Birmingham, Ala.; B. J. Shepard, B. J. Shepard Co.; I. C. Helmy and J. H. Strickland, I. C. Helmy Furniture Co., Savannah, Ga.; G. E. Pilgrim, Pilgrim-Estes Furniture Co., Gainesville, Ga.; J. W. Newton, the Toccoa Book Store, Toccoa, Ga.; J. H. King, Bradfield Drug Co., La Grange Co.; H. P. West, F. A. Guttenberger Music Co., Macon, Ga.; O. L. Bradshaw and C. F. Bradshaw, the Bradshaw Music Co., Fitzgerald, Ga.; L. P. Heyman, Lee Heyman & Co., West Point, Ga.; James B. Taylor, Geagle-Taylor Furniture Co., Cordele, Ga.; H. E. Whatley, J. F. Whatley and Mrs. Whatley, H. E. Whatley, Monroe, Ga.; J. D. McCollough, Stockbridge Hardware Co., Stockbridge, Ga.; H. S. Banta, Newnan, Ga.; R. L. Lane, Lane Furniture Co., Bainbridge, Ga.; J. R. Brumby, Brumby Furniture Co., Marietta, Ga.; R. E. Everett, Covington, Ga.; J. R. Northcut, Dorsay Furniture Co., Athens, Ga.; J. E. Humes, Humes Music Co., Columbus, Ga.; B. F. Mann, Vickers & Mann, Brunswick, Ga.; D. M. Yates, Roanoke, Ala.; Frank McGailliard and F. W. Schwoebel, Victor Talking Machine Co., Camden, N. J.; J. B. Gressett, Gressett Music House, Meridian, Miss.; G. E. Murphy, Wilmington Talking Machine Co., Wilmington, N. C.; Chas. E. Lanneau, Seigling Music House, Charleston, S. C.; J. D. Smithdeal, Smithdeal's, Columbia, S. C.; W. C. Lucas, Palmetto Hardware Co., Dillon, S. C.; W. R. Wilson, A. C. Rhodes & Sons, Charleston, S. C.; W. G. Hanks and H. R. Hanks, Hanks Bros., Belton, S. C.; L. Lore, Greensboro Music Co., Greensboro, N. C.; L. Lore, the Raleigh Talking Machine Co., Raleigh, N. C.; R. G. Brice, Parker-Gardner Co., Charlotte, N. C.; F. E. Mahoney, Rhodes-Mahoney Furniture Co., C. H. Clemons, Clemons Bros., Chattanooga, Tenn.; Edw. L. Brotherton, Claude P. Street Piano Co., Nashville, Tenn.; E. T. Sanford, Phonograph and Talking Machine Weekly, New York, N. Y.; W. H. Cummings, Cummings Furniture Hardware Co., Huntsville, Ala., and Edward Lyman Bill, The Talking Machine World, New York City.

**CAFE BECOMES RECORD SHOP**

Bick's Golden Gate Cafe, Quincy, Ill., is being made over into a talking machine shop. F. A. Odell, who will occupy the remodeled building, believes that there are great possibilities for sale in this district, which was once a familiar oasis to travelers.

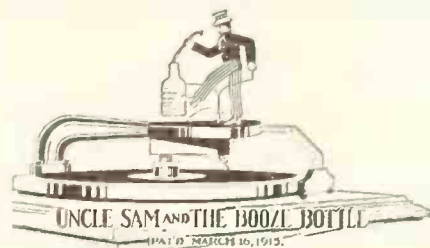

**UNCLE SAM and the BOOZE BOTTLE**

Uncle Sam kicks and fights the "Demon Rum" in the shape of an animated whiskey bottle, with a snake coming out of the neck of the bottle.

The snake and bottle fight back and it makes a great scrap. This is funny, typical and timely, while there is all the talk of War Time Prohibition, Bone Dry Laws, Private Cellar Stocks, etc.

Uncle Sam and the Booze Bottle. Item 100P—Retail \$1.75.



**An Automatic Dancing Dinky Doll for Disc Talking Machines (except Edison)**

Rastus does one hundred different steps while the music is playing. Delights children and amuses the older people, too.

Attractively painted in four colors.

Ragtime Rastus. Item 100 A. Retail \$1.25 After September 1 Retail Price \$1.50

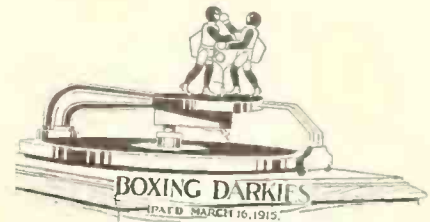

These little Boxers are very realistic and create lots of fun. They do all the different blows and steps knowit. Put on a good lively record and these little figures box away in lively fashion.

Boxing Darkies (Item 100 B) Retail \$1.50. After September 1 Retail Price \$1.75

**SPECIAL COMBINATION TWO TOYS IN ONE**

We pack one dancing platform and the Rastus Dancing figure and the Boxing Darky figures all in one box. This gives the two toys. We recommend this and call it Combination Rastus and Boxers. Item 100 AB. Retail \$1.75. After September 1st retail price \$2.00.

NOTE: These toys fit standard machines (except Edison) and can be put on or taken off in five seconds and do not injure record or mar machine.

NOTE: Owing to steadily increasing cost of manufacture we are obliged to add 25c each to the retail price of our toys on all orders received on and after September 1st.

THE TRADE DISCOUNT from the retail prices will remain the same: In lots of three dozen or more of one kind or assorted, 40% discount; in less than three dozen lots 33 1-3% discount.

**NATIONAL COMPANY**

Mechanical Specialty Manufacturers

171 Oliver Street, Boston, Mass., U. S. A.

**"MAGNET" DECALCOMANIE NAMEPLATES**

**FOR TALKING MACHINE CABINETS ETC.**

Pamphlets with fac-simile illustrations and prices mailed on request.

**SMITH-SCHIFFLIN CO.**  
126 Liberty Street New York City

**DORAN CO.**  
125 MICHIGAN AVE  
DETROIT

**MURTEAU, WILLIAMS & CO. LTD.**  
MONTREAL OTTAWA

**Kunkel Piano Co.**  
BALTIMORE

**THE PHONOGRAPH CO.**  
1240 HURON ROAD (Interway Bldg)  
PROSPECT 2-46 CLEVELAND

**WALTER D. MOSES & CO.**  
Oldest Music House in VA and N.C.  
103 E BROAD STREET  
RICHMOND, VA.

**J. E. STRATFORD**  
AUGUSTA, GA.



# Get in touch with the jobber who operates in your territory

22

- 1—**Senora Phonograph Co.**  
616 MISSION ST.  
SAN FRANCISCO, CAL.  
Washington, California, Oregon,  
Arizona, Nevada, Hawaiian Islands,  
Northern Idaho.
- 2—**Strevell-Paterson  
Hardware Co.**  
SALT LAKE CITY, UTAH  
Entire States of Utah, Colorado,  
Wyoming, New Mexico and Southern  
Idaho.
- 3—**Minneapolis Drug Co.**  
MINNEAPOLIS, MINN.  
States of Montana, North Dakota,  
South Dakota, Minnesota.
- 4—**C. D. Smith Drug Co.**  
ST. JOSEPH, MO.  
Nebraska, Missouri, northern and  
eastern part of Kansas and 5 coun-  
ties of Northeastern Oklahoma.
- 5—**Walthall Music Co.**  
DALLAS, TEXAS  
Western part of Texas.
- 6—**Southwestern Drug  
Co.**  
WICHITA, KANS.  
Southern part of Kansas, Oklahoma  
(except 5 northeastern counties), and  
Texas Panhandle.
- 7—**Southern Drug Co.**  
HOUSTON, TEXAS  
Southeastern part of Texas.
- 8—**Yahr & Lange Drug  
Co.**  
MILWAUKEE, WIS.  
Wisconsin, Upper Michigan.
- 9—**C. J. Van Houten &  
Zoon**  
MARQUETTE BLDG.  
CHICAGO, ILL.  
Illinois, Kentucky and Iowa.
- 10—**Kiefer-Stewart Co.**  
INDIANAPOLIS, IND.  
Entire State of Indiana.
- 11—**Ohio Sales Co.**  
BECKMAN BLDG.  
409 SUPERIOR ST  
CLEVELAND, OHIO  
State of Ohio.
- 12—**Hesseig-Ellis Drug Co.**  
MEMPHIS, TENN.  
Arkansas, Louisiana, Tennessee,  
Mississippi.

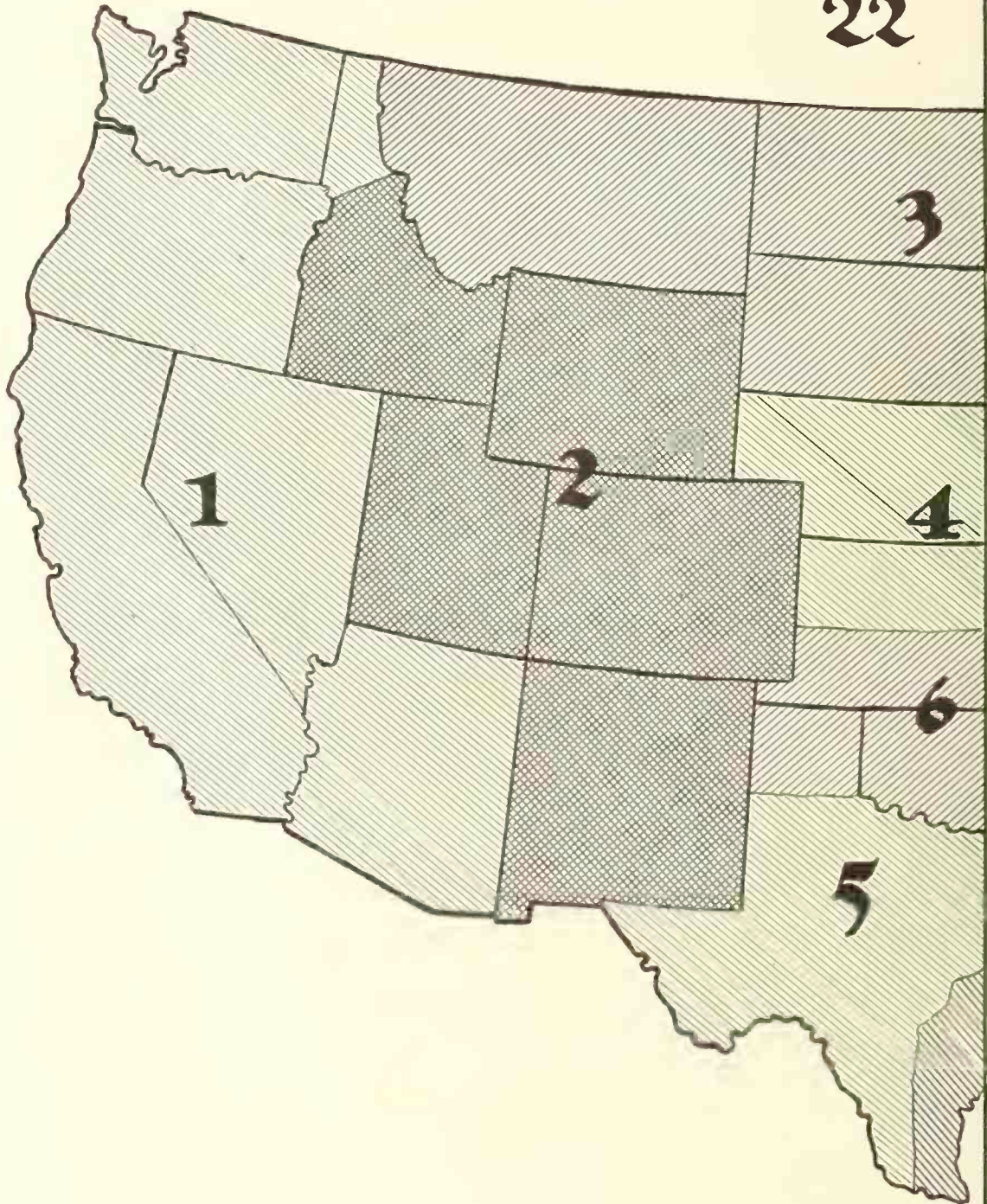

The Highest Class  
Talking Machine  
in the World

THE INSTRUMENT OF QUALITY  
**Sonora**  
CLEAR AS A BELL



A complete line of upright and period models is available at prices from \$50 to \$1000  
The Sonora is the instrument which won the highest score for tone quality at the Panama-Pacific International  
Exposition and sells easily and for cash.



These firms will see to it that you get the best of service

22

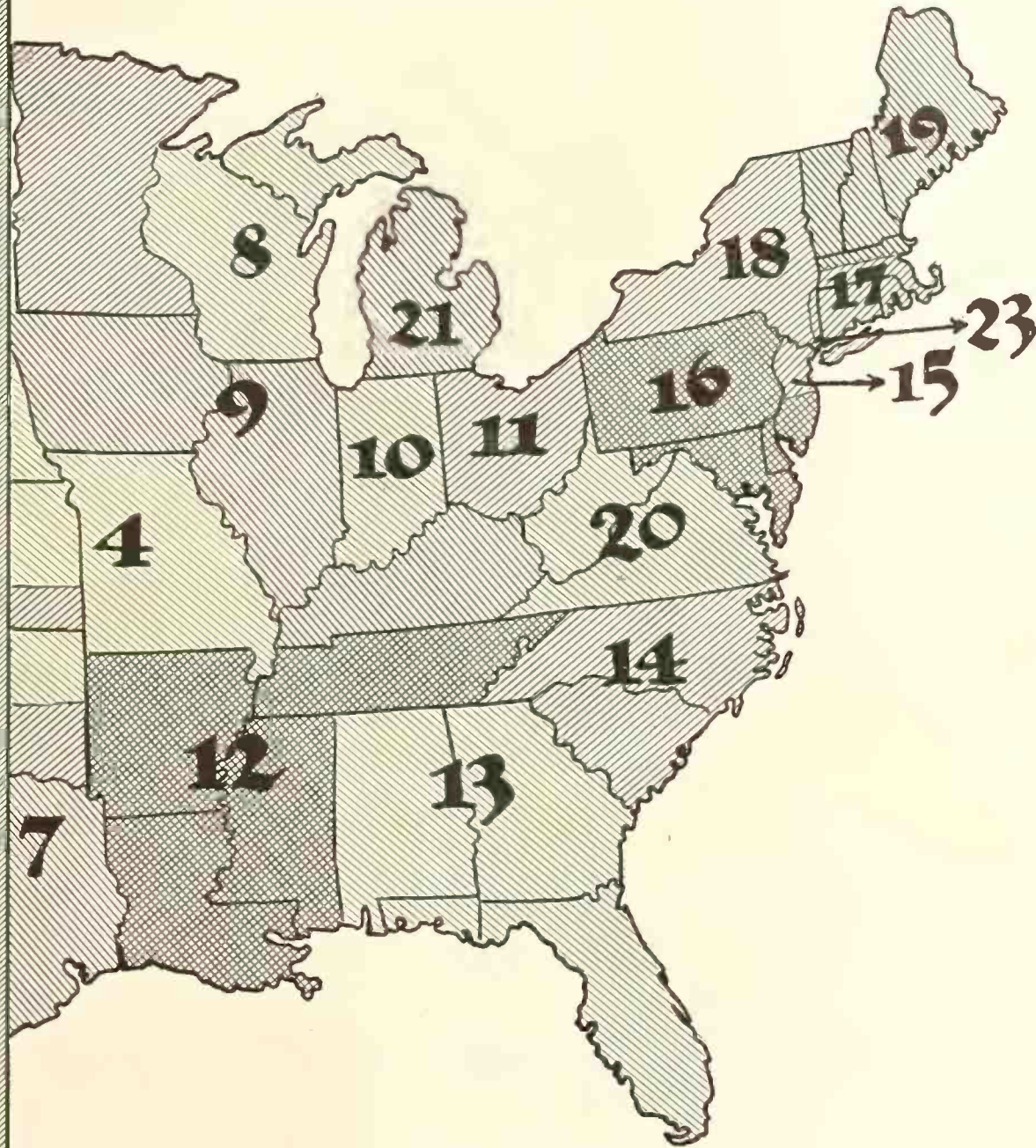

13—Southern Sonora Phonograph Co.

SELMA, ALA.  
Alabama, Georgia and Florida.

14—Rouatree Corporation

RICHMOND, VA.  
North Carolina and South Carolina.

15—Griffith Piano Co.

605 BROAD ST., NEWARK, N. J.  
Northern New Jersey.

16—Smith, Kline & French Co.

PHILADELPHIA, PA.  
State of Pennsylvania, Maryland, Delaware, District of Columbia and New Jersey, south of and including Trenton.

17—Musical Supply & Equipment Co.

221 COLUMBUS AVE.  
BOSTON, MASS.  
Connecticut, Rhode Island and Eastern Massachusetts.

18—Gibson-Snow Co.

SYRACUSE, N. Y.  
State of New York with the exception of towns on Hudson River below Poughkeepsie and excepting Greater New York.

19—W. B. Glynn Distributing Co.

SAXTONS RIVER, VT.  
States of Maine, New Hampshire, Vermont and part of Massachusetts.

20—Hillman & Son Phonograph Co.

WHEELING, W. VA.  
Virginia and West Virginia.

21—C. L. Marshall & Co.

82-84 GRISWOLD ST.  
BUTLER BLDG.  
DETROIT, MICH.  
State of Michigan.

22—I. Montagnes & Co.

RYRIE BLDG.  
TORONTO, CANADA.  
Canada

23—Sonora Phonograph Sales Co., Inc.

279 BROADWAY, NEW YORK  
Distributors for Greater New York.

THE INSTRUMENT OF QUALITY  
**Sonora**  
CLEAR AS A BELL



Semi-Permanent  
Silvered  
NEEDLES

replace steel needles and increase your phonograph records' life  
They play 50 to 100 times, are used on ALL MAKES of steel needle records, are more economical, convenient and give the maximum of satisfaction.  
30c per card of 5—40c in Canada



**REED CO. FORCES VISIT NEW YORK**

District Representatives of Pittsburgh Distributors Combine Business and Pleasure

A meeting of the district representatives of The Reed Co., phonograph and talking machine supply distributors, Pittsburgh, Pa., was held at the Pennsylvania Hotel, New York, over the week end beginning July 4th.

The holiday was spent at Coney Island. On the following day the party, accompanied by W. H. Reed, Jr., president of the Reed Co., Inc., visited the Regina phonograph factory, Rahway, N. J., and the home of the Operaphone record in Long Island City.

The Reed firm has recently taken on the distribution of the New Regina phonograph and all the men were pleased with the new and high class product which the Regina factory is now turning out. Mr. Blumburg, president of the Regina Co., assured the salesmen that they could expect the release of the new instrument by August 15.

Those accompanying Mr. Reed out of Pittsburgh were Jos. P. Miller, representative from the state of Ohio; O. T. Lytle, from Virginia and West Virginia, and Geo. P. Semmer, the Pennsylvania representative.

**ASSOCIATION DUES ARE NOT TAXED**

James T. Coughlin, president of the Talking Machine Men, Inc., New York, has announced that there will be no war tax placed on the dues of the association. Mr. Coughlin made inquiry at Washington and James M. Baker, Deputy Commissioner of Internal Revenue, replied that inasmuch as the Talking Machine Men, Inc., was primarily a business organization, dues should not be subject to war taxation.

The Pierson Co., Rockford, Ill., manufacturer of talking machine accessories, has made application to increase its capital stock to \$100,000.

**THE GRAFONOLA IN PUBLIC SCHOOLS**

The Ontario Association Recommends the Use of Columbia Records

The increasing importance of music in the public schools was manifested at the various sessions of the Ontario Educational Association held in Toronto, a short time ago. The most significant evidence of this increased interest in music in the public schools was a unanimous endorsement of a resolution passed by the Public School Section that the Minister of Education be urged to list the Columbia Grafonola as a school supply and to make it obligatory on every school district in the province to purchase a Grafonola and records for every school in that province. The music supervisors, in a previous session, passed the same resolution.

**IF I WERE A PHOTOGRAPHER?**

Suggested Use of Talking Machine to Help Poor Mortals Camouflage Their Vanity

I. J. Newins, in System, has the following suggestion to make regarding another use of the talking machine by photographers:

"I would have a large mirror at one side of my camera. My subjects could then see pretty well how their pictures would turn out. In their endeavor to see how they look they would lose their self-consciousness and their poses would be more natural. As a result, my pictures would be truer to the reality and my studio would become more popular.

"I might also have a talking machine in my studio. This I would place out of sight. My collection of records would be varied so as to appeal to everyone.

"Then if the mirror failed to take my customer's mind off his posing I would start the talking machine. I am sure the music—I would select a piece I thought would most appeal to him—would attract his attention and perhaps take the strained expression from his face."

**IMPORTANT EXPANSIVE MOVES**

President Phillips, of the Mutual Talking Machine Co., Forms Company to Do Plating Work—Capital Increased to \$50,000—Manhattan Phonograph Co. Business Taken Over

William Phillips, president of the Mutual Talking Machine Co., has recently formed a company to do the plating work for the various companies in which he is interested. The plating plant which has been secured is reputed to be one of the best equipped in the East. The acquisition of this plant will do away with the delays experienced in having the work done by other companies and will provide a service that is prompt and work that is of the highest class.

It has been announced that the capital of the Mutual Talking Machine Co. has been increased from \$15,000 to \$50,000.

Mr. Phillips also announces that, after having carefully investigated the advantages of wooden tone arms in sound reproduction, he has taken over the Manhattan Phonograph Co., of 32 Union Square, this city, manufacturers of wooden tone arms, and will manage the affairs and direct the sales of this company. Mr. Phillips is enthusiastic over the use of the wooden tone arm for the higher quality talking machine and will devote much of his time to its introduction throughout the trade.

**ROARK OFFERS VICTROLA AS PRIZE**

Public welfare work in Muhlenberg, Ky., is enlisting the efforts of many people and many organizations in that city. The J. L. Roark Estate, county distributors for the Victor products, has offered a Victrola and six records to the boy and girl making the best showing for the year.

It never pays to let business matters drift, for too often the current sets in toward the rocks.

The latest, most intelligently constructed lateral record in the world

The only true lateral record on the market without a machine tied to it

**The New Lateral Record**

made by

**THE LIBERTY PHONOGRAPH COMPANY**

Like fine painting or jewelry does not come in bulk

**A**S in masterpieces of art, the superiority of this record is the result of infinite pains and faith in the inherent desire of men and women to have the best that human minds and hands can make.

It is not a record for people who like the cheap, the tawdry, the commonplace—but for those who appreciate and cherish the fine and beautiful things in life.

The output of this record, like the output of the Rolls-Royce car, is limited because master work can not be done in quantity.

We recommend that distributors write us, planning six months in advance to handle The New Lateral Record.

**LIBERTY PHONOGRAPH COMPANY**

Executive Offices: 1836 EUCLID AVENUE, CLEVELAND, OHIO

Laboratory: 16-18 West 39th Street, New York, N. Y.



# The BRUNSWICK

*All Phonographs in One*

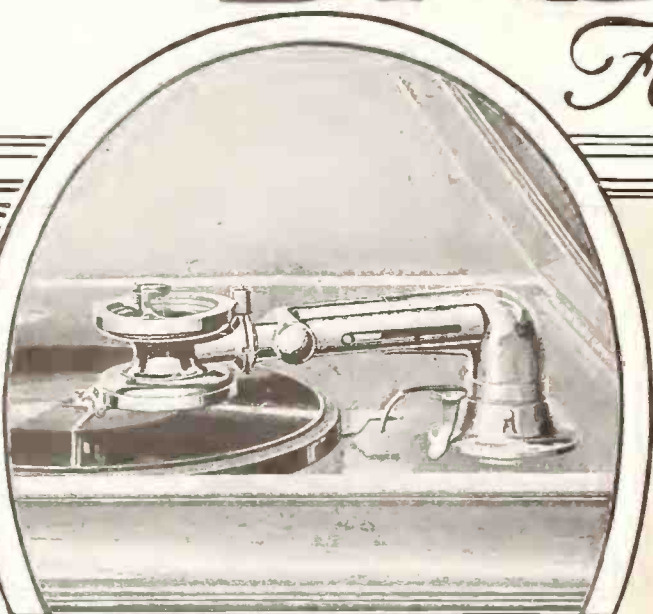

*The Ultona*

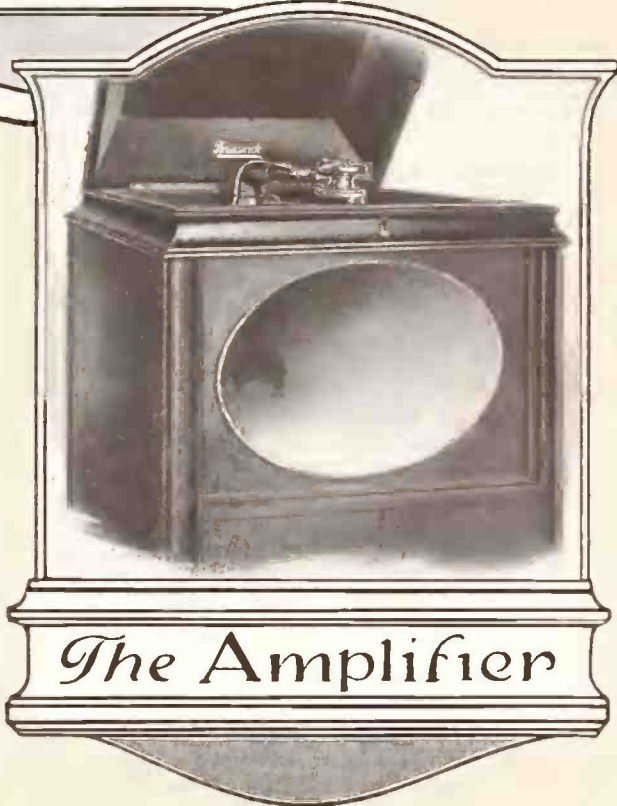

*The Amplifier*

*The Brunswick*  
ALL PHONOGRAPHS IN ONE

TWO radical changes in phonograph building characterize the Brunswick Phonograph. When this super-phonograph made its advent into the world of music it was not as though another instrument had been added to those already on the market. But it marked the launching of a new idea—a radical departure from old-time crudities—and one that had passed the severest hypercritical tests. Is it any wonder the music loving public welcomed it as the crowning achievement of the phonograph industry?

Two outstanding, exclusive features were responsible for this nation-wide ovation. They are the Brunswick Ultona and the Brunswick Amplifier— together comprising the Brunswick Method of Reproduction.

The ULTONA — a scientific creation — makes it possible to play all records on The Brunswick. It is not, as one might suppose, a combination contrivance. It involves a fundamental principle of sound reproduction. Nor is it a complex mechanism. Its very simplicity immediately appeals to the purchaser, for by a very slight turn of the hand it is adapted to any make record, instantly supplying the proper needle, the correct weight and precise diaphragm.

The AMPLIFIER is another improvement of fundamental importance. As its name implies, it *amplifies* the tone, making it richer, sweeter, truer. This vibrant tone chamber, constructed entirely of moulded hollyhock, free from metal, provides the requisite resiliency that unfolds and projects true tone. It is like the sound board of a fine piano or violin and complies with the approved laws of acoustics.

THE BRUNSWICK-BALKE-COLLENDER COMPANY

General Offices: CHICAGO and NEW YORK

Branch Houses in Principal Cities of United States, Mexico and Canada

Manufacturers— Established 1845

Canadian Distributors: Musical Merchandise Sales Co., Excelsior Life Building, Toronto

THE BRUNSWICK - BALKE -



# "SUPERIOR BY COMPARISON!"

*The Unanimous Verdict  
of Dealers Everywhere*

## Exquisite Tones

That Emanate From An Instrument  
of Grace and Beauty

In the Brunswick Phonograph, the House of Brunswick has a super-product. It is the fulfillment of an ideal — to build better regardless of cost.

Ordinarily added improvements such as those described on the opposite page would mean great additional cost if put into the average phonograph. All extra penalties, however, have been spared — something that was possible only to the House of Brunswick because of their previously established nation-wide organization and distributive facilities.

The House of Brunswick had unbounded confidence in the high merit of its product. A confidence that permeates every department — every individual in its massive organization. Behind this was unlimited financial resources.

Then came the question of advertising. It was realized that no better opportunity to merchandise an exceptional article ever presented itself to any organization. An advertising campaign of unusual magnitude was formulated and is now being executed. Dealers already know its helpful influence — the impetus it gives sales and how it makes selling easier.

The Brunswick Phonograph is the newest sensation in the musical instrument world and dealers will do well to capitalize it.

*Plays All Records  
at their Best*



THE BRUNSWICK-BALKE-COLLENDER COMPANY

General Offices: CHICAGO and NEW YORK

Branch Houses in Principal Cities of  
United States, Mexico and Canada

Manufacturers—  
Established 1845

Canadian Distributors: Musical Merchandise  
Sales Co., Excelsior Life Building, Toronto

# COLLENDER COMPANY



# A WORD TO THE WISE IS SUFFICIENT

It is well known that production this Fall will even exceed the high figures already attained. The demand for tone arms and sound boxes will be enormous. We have increased facilities and can handle your orders at the present time. It will pay you to anticipate your Fall needs and send us your order now for



USED BY LEADING TALKING MACHINE MANUFACTURERS

**MUTUAL TALKING MACHINE CO., Inc.**

145 WEST 45th STREET

NEW YORK

## TALKING MACHINES IN LIBRARIES

Music Becoming a Part of the Equipment of Many Public Libraries—Excellent Centers of Education—Dealers Interested in Movement, for It Leads to More and Better Business

The value of our public libraries as educational centers can hardly be overestimated and the possibilities for spreading music and musical ideas from these centers are attracting the attention of men interested in the widespread campaign for a better national appreciation of music. Dealers with an eye to better business have undertaken this work and public libraries to-day are installing talking machines as a part of their regular equipment. The following comment from the Voice of the Victor should be of interest, for it bears directly upon this subject:

To the progressive dealer any proposal for substantially increasing business is met with enthusiasm and hearty co-operation. Often a next-door neighbor is a forgotten customer. Meet him on the street, pass the time of day and he has gone. Meet him at his place of business and you nail him on the spot! So with our next-door neighbor, the public library.

Almost as early as the introduction of Victrolas in schools was the advent of the Victrola in the public library. Dealers reported to the factory sales, scattered to be sure, all over the United States back in 1910 and 1911. An investigation resulted in finding a demand for the Victrola in the library, created directly by two kinds of work which the public library does—the story-hour for children and the public concert for grown-ups. The story-hour is usually a Saturday morning feature combining story-telling for little folk and musical backgrounds for the stories. The public concert is a Sunday afternoon feature of the library's work, stimulating a desire in the general public for wholesome recreation by means of hearing good music.

Both needs the Victrola and Victor records supply well. Our story-tellers, Cora Mel Patten, Sara Cone Bryant, Georgene Faulkner, William Sterling Battis and Sally Hamlin are the most famous in the country. The Victor story-book, "Pan and His Pipes," suggests musical backgrounds and stories on the instruments that delight little children.

The public concert has been utilized for the furthering of a knowledge of music as well as for entertainment. The Victrola Book of the Opera and What We Hear in Music are officially recognized as standard publications for libraries and are the only publications of such nature on the shelves of the Library of Congress, Wash-

ington, and all the great city library systems. These two publications are used as texts for library public concerts, supplemented by special programs for holidays and other occasions outlined in the brochure, A New Correlation, published by the educational department in 1915.

What does the dealer gain by work of this character? Not only the profit from the original sale, but from the point of view of the general public increased interest, increased sales, increased prestige for the dealer, all as the direct result of projecting his record booth into the public concert at no expense to himself.

How to get this business? There are three means of revenue for a public library; appropriation by the library board, cash from book fines and sales of old paper and discarded magazines, and, finally, gifts from private or public-spirited agencies. The latter is most effective. After the dealer has once succeeded in placing the Victrola in the library the cash from book fines will continue to buy records. Later appropriations by the library board will come with unexpected force, especially after the work is thoroughly recognized.

So successful has the Victrola proven to be in library work that there is a latent desire in every library to be the possessor of an instrument. It is most important for the dealer that the instrument his local library acquires should be a Victrola, as it will have an immensely profitable advertising value.

## BOOTHS NAMED FOR PATHE ARTISTS

Pathé Shop in Rochester, N. Y., Uses New Idea for Demonstration Booths

The Pathé Shop, Rochester, N. Y., has installed a number of sound-proof booths and has used a novel idea in connection with them. Each booth is named for some famous Pathé artist, and the twelve new booths bear the names of Muratore, McClaskey, Hoffman, Beck, Norworth, Ganz, Althouse, Campbell, Leginska, Montesante and de Cisneros. A picture of the artist for whom the booth is named appears on each and in this way the customers become better acquainted with the artists whose music they buy and enjoy.

## Motor Troubles?

Of course, we all have them, and 75% of them are due to governor defects. Check it up. The balance can be avoided by the right mechanical construction.

We have solved the problems and the resulting motor satisfaction is at your command.

When you are offered the "BEST Phonograph in the world" ask the salesman if the motor is equipped with the WILLSON SPRING MOTOR GOVERNOR. If it is, buy it, your motor repair worries are over.

Do you want more dope? Write us, we will be glad to tell you all about it.

**WILLSON SALES CO.**

*Phonograph motors and specialties*

Williamsport, Penn.





Headquarters for

**OKEH**

**RECORDS**

**We Fill Orders 98½% Complete All the Time**



**OKEH BUILDING, GRAND RAPIDS**

**Largest Exclusive Phonograph Accessory House in the West**

**We handle every known phonograph accessory at *Right Prices***

**The Okeh Record Distributing Co.**

**Okeh Building, Grand Rapids, Mich.  
99 Fort Street West, Detroit, Mich.**

**FORT WAYNE, IND., AFTER AUGUST 20, 1919**

**EXCLUSIVELY WHOLESALE**





# THE TRADE IN BOSTON AND NEW ENGLAND

JOHN H. WILSON, MANAGER, 324 WASHINGTON STREET, BOSTON, MASS.

BOSTON, MASS., August 6.—A strike on the Boston Elevated Railway system during the latter half of the month put a kink in business and it might have proved very serious to retail trade in particular had it lasted much longer. For a few days business was quite flat and managers of retail establishments realized for the first time how serious a strike on local transportation lines can become. Business people had to get into town and the steam railroads met the situation very creditably, but shoppers, those not absolutely obliged to come to the city, did not care to suffer the inconveniences, which there certainly were, attached to a visit into the business section. There was a decided sigh of relief when the ordeal was over.

But this was not the only strike that the city suffered at the same time, for the waterfront experienced one by which seaboard traffic was held up for several days and quite a few cargoes were not allowed to be unloaded here, but were shunted to other ports. In this case both the wholesale and retail business felt the effects.

Speaking of the elevated, one must not overlook the significance of the increased rate of fare, which about the tenth of July was advanced from eight to ten cents, a fare that entails great hardships to many persons. Meetings of protest have been held in many places and municipal authorities and trade boards have been appealed to by way of remedying the situation. The outcome may be that the State will be compelled to take over the property.

Beyond these perplexing problems, which affect all lines of business alike, the talking machine business has been up to expectations for this time of year. On the whole, July was a good month, dealers all seemed to feel satisfied and with a big fall business staring them in the face it is no wonder that they can take their vacations this summer with a better sense of ease than last year.

### Enjoyed Vacation Period

Manager Warren Batchelder, of the retail warerooms of the Eastern Talking Machine Co., took a week of his vacation the middle of July, spending the time with his family at Marblehead. Ralph W. Longfellow, of these same warerooms, has just returned from his vacation, which was spent at Narragansett Pier, R. I.

### Rejoins Ditson's After Return From Service

One of the latest members of the talking machine craft to return from service is Joseph

Carlson, who has been for a year with the 317th Field Signal Corps. He is back with the Victor department of the Oliver Ditson Co., where Manager Henry Winkelman and all his old associates have had a pleasant welcome for him.

### J. Edward Dunham a Visitor

Among visitors at the headquarters of the Eastern Talking Machine Co. late this month was J. Edward Dunham, Victor traveling representative in Illinois, Indiana and Wisconsin. Mr. Dunham has come East to spend his vacation at his home in Worcester, Mass. G. Hovey Dodge, of the Eastern, paid a visit to the Victor factory in Camden early this month.

### W. J. Hallahan Rejoins Kahn Shop

W. J. Hallahan, who has been in the navy for the past two years, has just been honorably discharged from service, and has returned to his position of assistant manager of Kahn's Music

Shop, 564 Washington street. Mr. Hallahan is being gladly welcomed back into the business after his long absence.

### Rusticating at Manomet Beach

Francis White, manager of the Edison and Victor departments of the C. C. Harvey Co., left the first of the month for his annual vacation, which he is spending with his family at Manomet Beach, down below Plymouth. Miss Anna Heurlin, one of Manager White's saleswomen, has returned from her vacation, which comprised the whole month of July.

### Harvey's "Red Room" Renovated

The Red Room of the talking machine department of the C. C. Harvey Co. has undergone a renovation and is now all ready with its new color scheme and furnishings for the big fall business which the house is expecting. The

(Continued on page 46)

## Steinert Service Serves

### M. STEINERT & SONS CO.

35 ARCH ST.



BOSTON

WHOLESALE HEADQUARTERS

## RECIPROCITY

with our friends is our aim. We believe the dealers who have stood by us in these past trying months should be repaid in terms of Victor merchandise. This is and will continue to be our constant policy.

"New England Service for  
New England Dealers"



TAKE gigantic strides right now in preparing for Fall. The mission of Eastern Service, concentrating in New England, is to make your work *profitable*.

## The Eastern Talking Machine Co.

Victor Wholesalers

85 Essex Street

BOSTON



## THE TRADE IN BOSTON AND NEW ENGLAND—(Continued from page 45)

walls have been painted a brick red, with border of black and gold, while the furnishings are of black and gold. Artistic, thoroughly comfortable and with a flood of daylight, the room is admirably adapted to demonstration purposes.

**To Visit the Coast of Maine**

A. M. Hume, of the A. M. Hume Music House, Victor dealers, is planning to take a part of August away from business and may go down to the coast of Maine. Herman Baker, of this house spent a week the middle of July motoring to several points in Connecticut.

Perley White, of the retail sales force of M. Steinert & Sons Co., has been spending the summer at Portland, Me., having been transferred from the Arch street headquarters to the warerooms in that Maine city for the months of July and August.

**Retire From Talking Machine Field**

After several years of successful handling of the talking machine business Chickering & Sons have decided to give it up, one reason being the difficulty of getting an adequate number of machines and also that the house wants to concentrate its attention on its pianos, as the Chickering line still holds that splendid position which it has enjoyed since the days of its founder. Roy C. Sylvester, manager of the talking machine department, which has carried both the Edison and Victor lines, will start away on his vacation at Bay of Fortune, near Prince Edward's Island, as soon as the affairs of the department are closed. William P. Dockendorf, also of this department, went over to New York upon severing relations, and Herbert Lunn is now with the Vocalion Co. The large stock carried by the Chickering house was eagerly bid for by several large concerns, one of which was in New York.

**Fred E. Mann Again in Trim**

An attack of tonsillitis kept Fred E. Mann, manager of the local wholesale headquarters of the Columbia Graphophone Co., away from his desk for three days the last week in July, but much to the gratification of everyone who knows Mr. Mann, he returned feeling entirely fit.

Kenneth E. Reed, manager of the M. Steinert & Sons Co., wholesale Victor department, started on a ten days' vacation on July 31, going to Cape May, N. J. On the way there he paid a visit to the Victor factory.

**Additions to Hallet & Davis Force**

Manager O. A. Ainslie, of the Pathé, which is carried at the Hallet & Davis warerooms, has now the services of August Geishecker, who is to travel for this line. A new man in the retail department is Mr. Sims, who has come over to

## PERFECTION BALL-BEARING TONE ARMS

### PERFECTION FLEXI-TONE REPRODUCERS

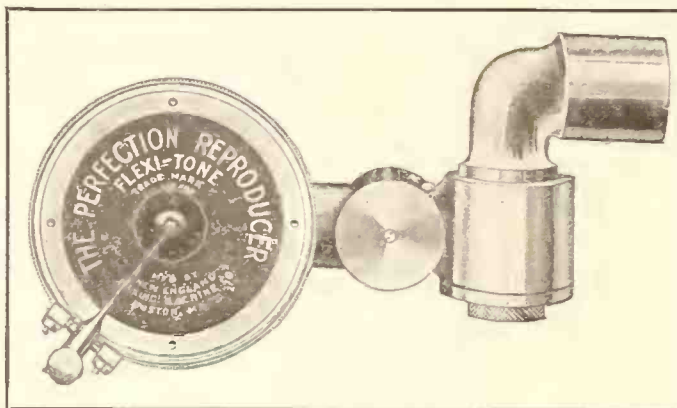

**Manufacturers—**  
**Jobbers—**  
**Dealers—**

The Perfection Flexitone reproducer No. 7 attached to the Perfection ball-bearing tone arm No. 4 plays all lateral cut records on all types of Edison Disc Machines. Made in nickel and 24 carat gold finish, extra fine quality disc.

These reproducers and tone arms are the very finest made, mechanically—reproducing as the records were recorded in the recording room—Clarity of sound with great volume.

*IN STOCK FOR IMMEDIATE SHIPMENT — WRITE FOR QUANTITY PRICES*

Manufactured by

## New England Talking Machine Co.

*The Largest Manufacturers of Phonograph Accessories in the World*

16-18 BEACH STREET

BOSTON, MASS.

*Pacific Coast Distributor: WALTER S. GRAY*

*Chronicle Building, San Francisco, Cal.*

Boston from New York, where he traveled for the Columbia.

**Extensive Wareroom Changes**

The interior of the Kraft, Bates & Spencer, Inc., warerooms, has been undergoing quite an extensive change these past few weeks and the present-day visitor scarcely would recognize the place. With the growth of the business in the Brunswick and Victor lines Harry L. Spencer conceived the idea of putting in a series of booths, and on this the Unit Construction Company has been busily at work. The booths, of which there are four on one side and three on

the other, are finished in old ivory and the walls above the booths are done in rose pink, making a most pleasing combination. Business in the Brunswick line, which the house has carried for about six months, is making great headway. Mr. Spencer, who says he has not had a real vacation in two years, hopes to be able to get away on a fishing trip, probably into Maine, sometime during this month.

**Visiting His Home City**

F. S. Horning, traveling representative for the Victor, is planning to take his vacation during August and will leave here the 8th, going with

— **Oldest and Largest**  
**Manufacturers of Talking**  
**Machine Needles in the**  
**World—There are several reasons**

**W. H. BAGSHAW CO., Lowell, Mass.**



# from Bridgeport to Bangor

Don't forget that New England is a gigantic summer playground, and that dancing was never more popular with summer people than it is today.

Emerson dance hits, rendered by the Emerson Military Band, the Emerson Dance Orchestra, and special combinations of talented musicians, furnish the inspiration wherever dancers get together for an evening's "spree."

Emerson dance hits, being first on the market, give Emerson dealers an exceptional opportunity to cash in. Our proposition is most attractive. May we tell you about it?



## Emerson New England INC.

68 Essex Street, Boston, Mass.

Distributors for Emerson Records, Q R S Player Rolls and Brilliantone Steel Needles Throughout New England.

### THE TRADE IN BOSTON AND NEW ENGLAND—(Continued from page 46)

Mrs. Horning to Camden, N. J., his home city, for a visit.

#### On a Tour of Nova Scotia

Ralph Freeman, secretary of the Victor Co., at Camden, N. J., passed through Boston about the middle of July, en route to Nova Scotia, which, if information is correct, is his home province. He was planning to return to business sometime during the current month. He took his car with him, which means that he had fine driving, as the roads are superb.

The first of the month witnessed the departure of R. W. Alden, of the Vocalion Co.'s sales staff, for Maine, where he is spending his vacation, accompanied by Mrs. Alden.

#### Reports Very Busy Times

Joseph W. Burke, of the Musical Supply & Equipment Co., New England distributors of the Sonora, started on his vacation on July 26, going to Old Point Comfort, Va., where he plans to spend a good deal of his time on the golf links. Mr. Burke said before leaving town that although he has been getting three times the goods he has been having much difficulty in keeping up with the demand. During July shipments in carload lots went through direct from factory to dealers, he said. During the absence of Mr. Burke, R. G. Powers, sales manager, was in charge. The latter plans to start on his vacation the latter part of August.

#### Called on Trade in New England

Herbert W. Shoemaker, manager of the wholesale department of the Eastern Talking Machine Co., spent a week or more late this month on an "acquaintance" trip through his territory, visiting Lowell, Manchester, Haverhill, Lawrence and other New England cities. He made the trip in his automobile.

#### Returns From Trip to Alaska

W. O. Pardee, president of the Pardee-Ellenberger Co., Edison jobbers, returned to his New Haven headquarters the latter part of July, after a five weeks' trip to Alaska, accompanied

by his wife and daughter. A 2,000-mile boat trip from Vancouver, B. C., to Alaska and return was one of the interesting features of Mr. Pardee's trip. Going West, Mr. Pardee traveled by way of Yellowstone Park, and made the return via the Canadian Rockies.

F. H. Silliman, vice-president and manager of the Boston headquarters of the Pardee-Ellenberger Co., reports that dealers appear to

be very enthusiastic about the new Edison lines exhibited at the recent Edison convention, and says also that the demand for goods seems to be tremendous. He is anticipating a shortage of goods that probably will become more marked in the near future.

#### Some Columbia Gleanings

The Uphams Corner branch of the Grafonola  
(Continued on page 48)

SATISFY THE PUBLIC DEMAND FOR

*The Brunswick*  
ALL PHONOGRAPHS IN ONE

EFFICIENT SERVICE FOR NEW ENGLAND DEALERS

KRAFT, BATES & SPENCER, INC.  
156 BOYLSTON ST. BOSTON, MASS.



## THE TRADE IN BOSTON AND NEW ENGLAND—(Continued from page 47)

**CRESSEY & ALLEN**

Portland  
CONN.

COVERS  
New ENGLAND

**CRESSEY & ALLEN**  
VICTOR DISTRIBUTORS  
534 Congress St., Portland, Maine

Co. of New England is having a number of changes made, these including the installation of three booths.

R. F. Bolton, sales manager of the international record department of the Columbia Graphophone Co., New York, was a visitor in Boston for several days late in July.

R. H. Luscomb, of the order department of the Boston headquarters of the Columbia, returned from his vacation the latter part of this month, having spent the two weeks with his family at Hebron, Me.

Will Open on August 15

The Rosen Phonograph Sales Co., of which Harry Rosen is president, expects to be ready for business at its headquarters, 27-28 Court square, about August 15. This company represents the merger of the Phon-O-Musical Sales Co. (retail) and the Phonograph Supply Co. (wholesale). All preparations for the opening are proceeding most favorably.

Return From Service With Uncle Sam

Leo McCarthy, of the Steinert selling staff, returned late this month, after two years' army

service abroad. He was a member of the Fifty-sixth Pioneer Regiment, and in addition to service in France was with the Army of Occupation in Germany. Needless to say, he received a warm welcome back by all his friends and associates in the trade.

Install New Booth Equipment

Eight booths will be included in the new music room of the Remick Song & Gift Shop, 168 Tremont street. This room will be on the second floor and will replace the store's present phonograph department in the rear of the street floor. The Remick Shop carries Columbia Grafonolas and records.

Pleased With Record Situation

Back-number standard records, which have been notably scarce during the past two years, are now coming along fine, according to Kenneth E. Reed, wholesale manager of the M. Steinert & Sons Co.'s Victor department. Moreover, machines are coming through better than has been the case recently and dealers are selling them as fast as they come. The demand is for the high-priced machines, Mr. Reed said.

### FAKERS POSE AS HOUSEHOLDERS

Associated Advertising Clubs of the World Warn Against Fake Sales Advertising

Furs, diamonds, talking machines and many other articles, says a bulletin from the Associated Advertising Clubs of the World, are being sold, by mail or from private houses, by dealers in such articles who pose as private householders forced to dispose of the goods.

"In almost every instance," says the bulletin from the Association, "gross misrepresentations are made as to the value of the articles offered. It is the custom of such advertisers in the talking machine line, for example, to say that the talking machine is 'the \$250 size' or is 'like the regular \$200 instrument'.

"In one recent case a fur dealer in Buffalo was offering furs in an advertisement signed by his wife, in which he said he would sell for \$35 furs worth \$85. The statement of value was untrue. They might have been worth \$35, but were not worth \$85."

The bulletin says the advertising association, which exists for the purpose of making all advertising absolutely truthful, has usually only needed to call the attention of newspapers to the fraudulent character of such advertisements to get them to decline to sell advertising space to such people. In the meantime, the public should beware, and should ascertain whether the seller is in fact a worthy householder or is a merchant.

"The best way to supply our needs is through the usual sources—through the stores of the community. The local storekeeper stands behind the goods he sells, and if anything should go wrong he is right on the job to make good."

## Lansing Khaki Moving Covers

Despite the obstacles that have arisen during the past year have maintained their high standard of

### QUALITY

The Quality of the LANSING cover has given it leadership in the field.

No. 3 Carrying  
Strap Shown in  
Cut



These covers are made of Government Khaki, interlined with heavy felt in Grade A, or cotton in Grade B, fleece lined, quilted and properly manufactured under the personal supervision of E. H. Lansing, the originator of the Talking Machine Cover for protection in moving. Made in two grades.

Write for prices and  
descriptive catalogue

**E. H. LANSING**  
611 Washington St., BOSTON

San Francisco Representative: WALTER S. GRAY  
508 Chronicle Building

Send for Descriptive Circular

*Curry* DEMONSTRATION BOOTHS  
AND RECORD CASES  
IN STOCK OR TO ORDER

"SOUND PROOF"

FRANK B. CURRY  
72-74 Oedham St. Boston, Mass.

**JAQUITH MACHINERY BUREAU, Inc.**  
Designers and Builders of  
**SPECIAL MACHINERY**  
Mechanical and Electrical Devices  
Designed, Developed and Patented  
Correspondence with Talking Machine Industry invited  
77-79 North Washington St., Boston, Mass.

**REPAIRS AND REPAIR PARTS**  
Low Prices and Efficient Work  
Phonograph Supply Co. of New England  
28 School Street, Boston



QUALITY + PROFITS  
 IN  
**CHARMAPHONE PHONOGRAPHS**

TONE, APPEARANCE, CONSTRUCTION AND THE HIGH QUALITY EQUIPMENT MAKE THE  
**CHARMAPHONE LINE**

THE BEST POPULAR-PRICED MACHINES ON THE MARKET.  
 MODERATE PRICE MEANS SALES AND SUBSTANTIAL PROFITS FOR THE DEALER



*Order Today*

*Samples of the  
 CHARMAPHONE  
 and compare them with any high  
 class machine  
 You will surely become a  
 CHARMAPHONE  
 dealer immediately*

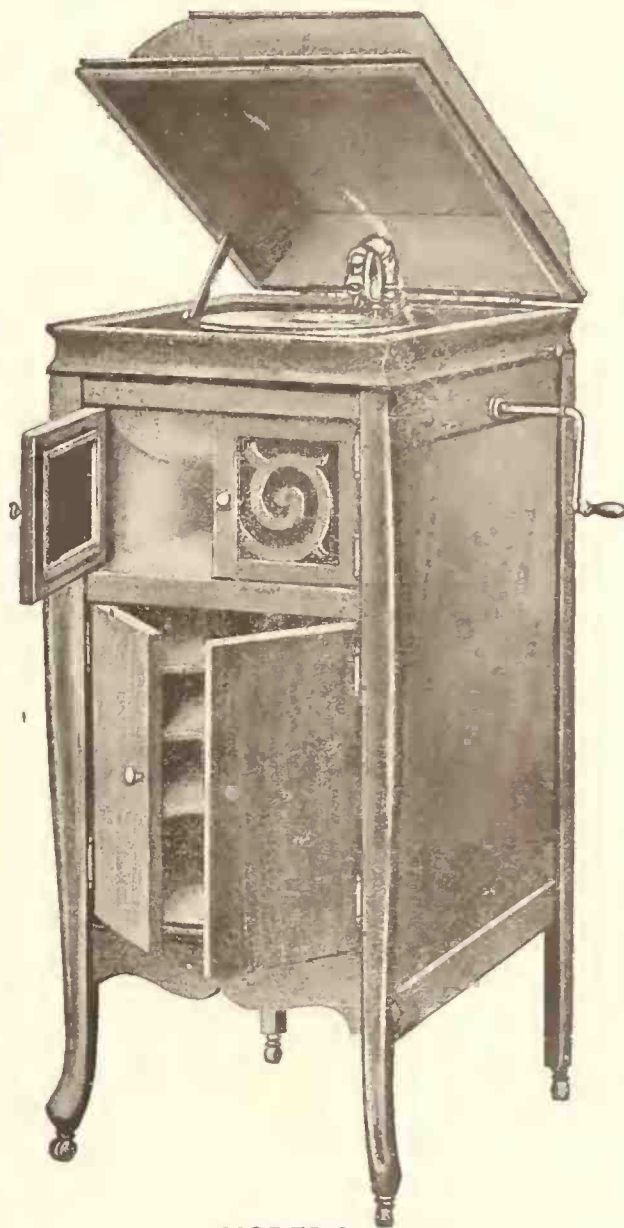

*Good  
 Phonographs*

*will be scarce  
 THIS FALL!  
 Book Your Orders  
 at once*

MODEL 6  
 42 in. high, 18 in. wide, 20 in. deep,  
 Heineman No. 36 motor, Heineman  
 Universal tone-arm and sound-box.  
 Wholesale Price \$37.50  
 Plus war tax  
 F. O. B. Pulaski, N. Y.  
 3% 10 days Net 30 days

MODEL 8  
 44 in. high, 18 in. wide, 20 in. deep,  
 Heineman No. 33 motor, Heineman  
 Universal tone-arm and sound-box,  
 tone modifier, casters.  
 Wholesale Price \$45.00  
 Plus war tax  
 F. O. B. Pulaski, N. Y.  
 3% 10 days Net 30 days

**The Charmaphone Company**

Executive Offices and Showrooms

39-41 West 32nd Street, New York, N. Y.

We manufacture all our phonographs at our factory, Pulaski, N. Y.





**Stracciari sings "The Sunshine of Your Smile!" The success of the song and success of the singer guarantee the success of the record. Columbia 49590.**

**Columbia Graphophone Co.  
NEW YORK**

**CHAS. M. DRESSNER MADE MANAGER**

Former Assistant Manager of Chambers Music Co. Now With Henry B. Pye & Co., New York

Charles M. Dressner, formerly assistant manager of the Chambers Music Co., New York, has taken the position of manager of the talking machine department of Henry B. Pye & Co., Inc., 2918 Third avenue. Mr. Dressner, who was recently released from the navy, is well qualified for his work, having had a wide experience in the talking machine line. Henry B. Pye & Co. handle the Pathé machines and records.

**J. BARLEYCORN DIES IN VANCOUVER**

Flynn Furniture Co. Uses Occasion to Advertise the Brunswick Phonograph

Word has been received from Vancouver, Wash., of the death on July 1 of John XXX Barleycorn, well known in the trade circles of the Coast city. The funeral was largely attended and services were held under the direction of the Flynn Furniture Co., Brunswick dealers of that city. Deceased was borne through the streets on a truck draped in funeral black and a large sign on the side of the truck announced the fact that the Brunswick officiated for all occasions.

The Connecticut Specialty Co., Inc., Meriden, Conn., has taken the agency for the phonograph made by the American Mfg. Co., of Maryland, at the Baltimore factory.

**SONORA IMMORTALIZED IN SONG**

In one of the musical comedies which recently attracted crowds of Broadway theatre-

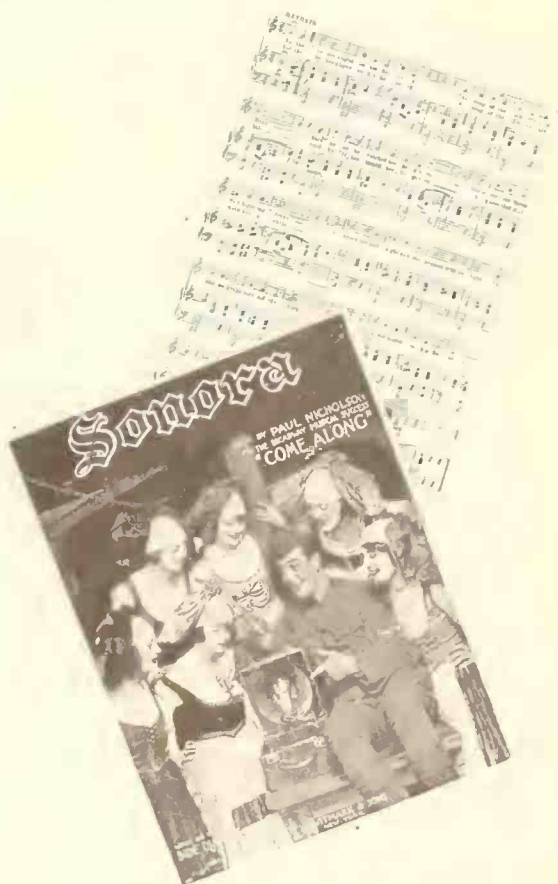

Title Page and Thematic of "Sonora" goes there was a song describing the adventures of a Senior who played the Sonora and

by so doing succeeded in winning the affections of an attractive young Senorita. The words of the song are extremely clever and the music is quite catchy.

Sonora dealers who have shown the song to customers say that on playing the chorus over the customer has been well pleased with the new song, which, incidentally, is a very good piece of advertising matter for the Sonora Phonograph Sales Co. Inc.

**DOMESTIC TRADE GIVEN PREFERENCE**

Modernola Co. Increases Output—Acquires New Factory—Many Foreign Orders—Arranging for New York Representation

JOHNSTOWN, Pa., August 5.—The Modernola Co., of this city, has experienced an unprecedented demand for its talking machine, the "Modernola." A new factory with exceptional facilities for a large output has been recently acquired to take care of the steadily increasing demand. The old factory will also be maintained, and thus the facilities of two large plants will be at the disposal of the firm.

Numerous inquiries have been received from England and the Dominion of Canada, but the demand is so great that foreign business will not be taken care of until the orders in this country have been filled. Two carloads were shipped last week to San Francisco.

D. Hall Wendel was in New York last week arranging for representation of the line in the metropolis. Several large deals are under consideration, the announcement of which will be made at an early date.



Eight Models  
Retailing from \$30  
to \$275

**SONA-TONE**

*"The tone you can't forget"*

The Phonograph that is making Piano and Violin Records Famous. No better constructed and equipped instrument—with a tone not equaled by any. We invite your critical investigation.

Jobbers and Dealers in open territory solicited. Write for catalogue and terms.

*Sona-Tone Steel Needles and Jewels  
are the Best on the Market*

**SONA-TONE PHONOGRAPH, Inc.**  
110 West 40th Street  
New York City

**DISTRIBUTORS AND EXPORTERS**

W. REED WILLIAMS, INC.,  
160 Broadway, New York City.  
HANDELMAATSCHAPPY "TRANSMARINA," INC.,  
62 William Street, New York City.  
WILLIAM A. MURDOCK,  
N.E. Cor. 41st St. and Lancaster Ave., Philadelphia, Pa.

GEORGE A. CALDWELL, 808 Blue Hill Ave.,  
Boston, Mass.  
WILLIAM FISHER & COMPANY,  
200 Broadway, New York City, and San Francisco, California.  
SONA-TONE DISTRIBUTORS CORPORATION,  
322 Livingston Street, Brooklyn, N. Y.

OE VAUSNEY & TAYLOR, 512 Orange St.,  
Newark, N. J.  
VAN WIRT & BROMLEY,  
Fairmont, W. Va.  
SONA-TONE MUSIC COMPANY,  
Glens Falls, N. Y., Hudson Falls, N. Y.





BRANCHES: CHICAGO SAN FRANCISCO TORONTO, CAN.

FACTORIES: ELYRIA, OHIO, NEWARK, N. J., PUTNAM, CONN. SPRINGFIELD, MASS.

25 WEST 45th STREET, NEW YORK

INCORPORATED

# Otto Heineman Phonograph Supply Co.

President

*Otto Heineman*

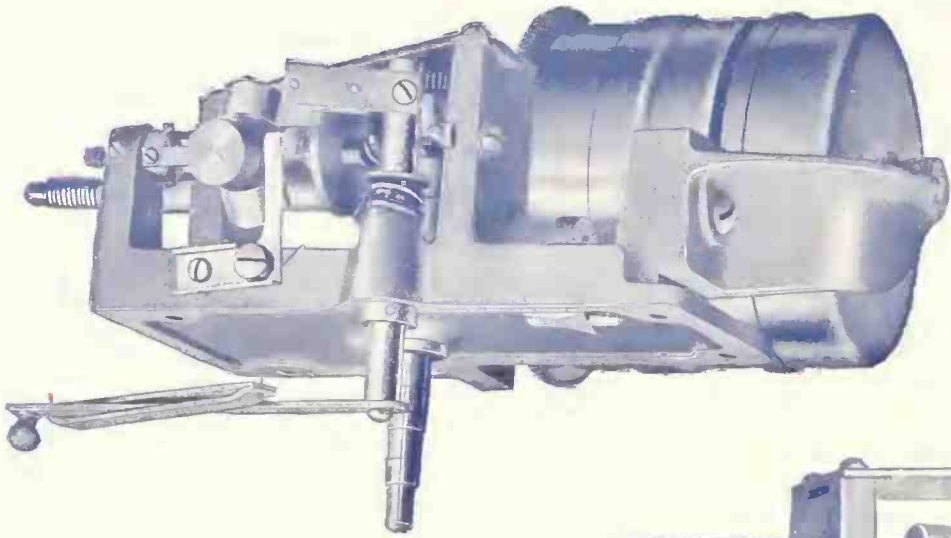

**Triple Spring  
Meisselbach Motor  
No. 17**

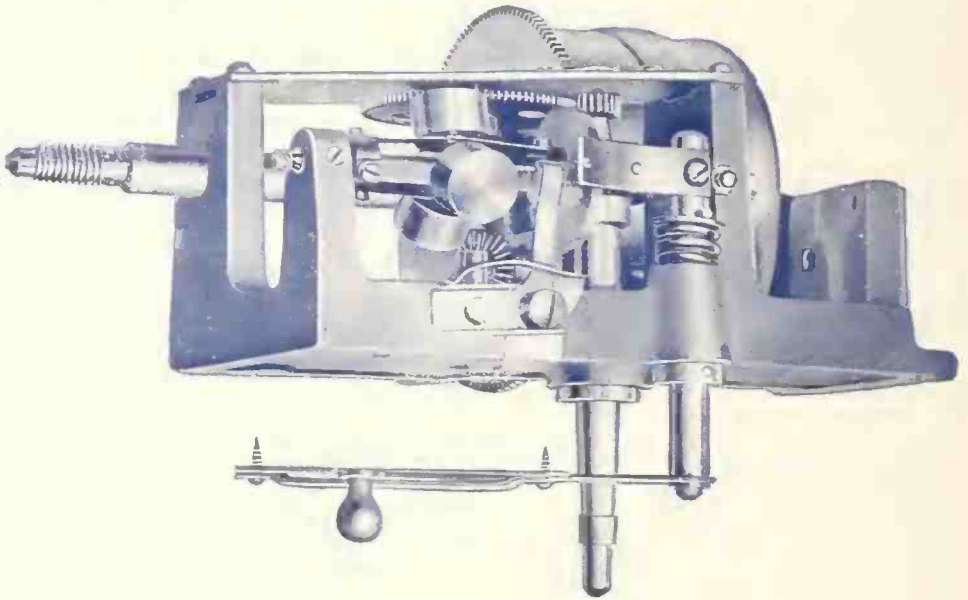

**Double Spring  
Meisselbach Motor  
No. 16**

## The Meisselbach: A Quality Motor

The Successful Phonograph Manufacturer  
Will tell you that he is using MEISSELBACH  
MOTORS because they have stood the test  
of time and service, and represent the best  
in motor production.

# MEISSELBACH





### INCREASED DEMAND PREVAILS IN SAN FRANCISCO TRADE

Summer Business Exceeds Expectations—Hickman With Columbia Co.—City of Paris Department to Open Talking Machine Adjunct—Leading Stores Make Cheery Reports—Other News

Victor department of Sherman, Clay & Co., has returned from his summer vacation. He spent his holidays this summer in Marin County. Miss Mae Springer is again in full charge of the Hale Bros. talking machine department in this city. She has two assistants, Miss Nan Heferman and Mrs. Verdick.

#### New Pathe Agency

Omer Kruschke, Western distributor for Pathe goods, is having unusually good business for the summer months. He recently established an agency with the Pierce Piano House at Eureka, Cal., and with the Rex Drug Co., at Willits. Both these concerns do business in neighboring towns. Mr. Kruschke now has a sample of the "Actuelle," the newest of the Pathe machines.

#### Personal Items

Elmer Hunt, who has been with the Victor department of Sherman, Clay & Co. for many years, has been appointed manager for the wholesale Victor branch at Portland, Ore. E. Cruell, proprietor of the Mission Phonograph Co., this city, together with Mrs. Cruell, has been taking his vacation traveling in the East. He visited several talking machine factories on the trip. E. Johnson, of the E. Johnson Music Co., of Eureka, Cal., is one of the prominent talking machine dealers from up the state to call on the San Francisco jobbers this month.

Walter S. Gray, the "Needle King," has left for a business and pleasure trip to southern California. He will try the fishing at the Catalina Islands and also chase a golf ball some. He is accompanied by Mrs. Gray. L. C. Ackley, a special representative of the Los Angeles branch of the Columbia Co., has been in town for a few days the past week conferring with the company's representatives. The Sonora Phonograph Shop has added four new demonstrating rooms. The executive department of the Stern Talking Machine Co. has been moved to the eleventh floor of the David Hewes Building on Market street.

SAN FRANCISCO, Cal., August 2.—Summer business is holding up in San Francisco and despite the general uncertainty the dealers are not hesitating to prepare for the future. Buying has been stimulated by the raise in the price of Columbia machines and by the cut in the price of Red Seal records. In the one case there was a rush to buy Gratolas before the raise went into effect and in the other it was a rush to stock up on records before the wholesalers were cleaned out. But there will be plenty of records to supply the demand.

#### Art Hickman to Record

Art Hickman, a well-known composer and orchestra director of San Francisco, has signed up with the Columbia Co. for a list of records. He will go East and take his orchestra with him for the purpose of making orchestral records. Mr. Hickman is the composer of "Tears," "You and I," "Rose room Fox-trot," and other popular pieces. He has served in San Francisco as the leader of the St. Francis Hotel orchestra. While in New York he will play an engagement at the Biltmore Hotel.

#### New Departments Opened

The City of Paris, one of the largest department stores of San Francisco, is to open a talking machine department on the fourth floor of the main building about the first of September. There will be several beautifully appointed demonstrating rooms. Another large talking machine department about to be opened is that in the White House in this city. Work has been going on for several weeks getting the department in shape. The former manager of the Emporium Phonograph department, who is the manager of the new department, The Victor goods will be featured. Prosper Reiter is now manager of the Emporium talking machine department.

#### Billy Morton Rests Up

Billy Morton, past master of arranging banquets for the San Francisco talking machine dealers' association, and manager of the retail

The Sonora Phonograph Shop in this city has enjoyed a fine month, the sale of high priced machines being unusually heavy for the vacation season. In June the shop did a business almost twice the volume for the same month a year ago. The Remick Song Shop on Market street has completed its extensive alteration work and the new talking machine department is ready for business. The department is located on the mezzanine floor and the complete line of Columbia machines and records is carried. Bob Adkins, the manager of the shop, says the opening business is most encouraging.

#### Remick Song Shop Expands

The Pacific Coast branch of the Otto Heinemann Phonograph Supply Co. is exhibiting at the San Francisco office the complete line of machines manufactured by the Pacific Phonograph Mfg. Co. of Portland, Ore. This company has made a decided success with its beautiful Stradivara machine. Heinemann parts are used exclusively in the manufacture of the machines. Mr. Gruen, Pacific Coast manager for the Otto Heinemann Co., reports excellent business. He is showing very extensive sample lines, including three novelties in tone arms and reproducers. The moving of the stock department to an extra room has allowed much needed space for the sales department. The wonderful multi-colored bulletin sheets, posters and other advertising literature proves most attractive to jobbers. A special colored slide for throwing advertisements on the screen in movie theatres is a successful novelty which will appeal to individual dealers. The dealer's name is on the slide. Mr. Gruen has just been in Los Angeles calling on the trade.

## Makers of High-Grade Phonographs and Billiard and Pool Tables. Est. 1882

### Our Phonographs Play All Records Correctly



**Number One**  
DIRECTIONS: 17 high, 27 wide. CASE WOODS—Cabinet mahogany, 12 drawers, 12 doors, 12 shelves, 12 compartments. Price \$100.00.

**Number Two**  
DIRECTIONS: 17 high, 27 wide. CASE WOODS—Cabinet mahogany, 12 drawers, 12 doors, 12 shelves, 12 compartments. Price \$100.00.

**Number Three**  
DIRECTIONS: 17 high, 27 wide. CASE WOODS—Cabinet mahogany, 12 drawers, 12 doors, 12 shelves, 12 compartments. Price \$100.00.

**Number Four**  
DIRECTIONS: 17 high, 27 wide. CASE WOODS—Cabinet mahogany, 12 drawers, 12 doors, 12 shelves, 12 compartments. Price \$100.00.

**Number Five**  
DIRECTIONS: 17 high, 27 wide. CASE WOODS—Cabinet mahogany, 12 drawers, 12 doors, 12 shelves, 12 compartments. Price \$100.00.

HIGH QUALITY AT LOW PRICES MAKES US LEADERS IN PHONOGRAPH LINE

The quality of our Cabinet Work, the low price and our long experience in making phonographs places us among the foremost leaders in this industry. We have built a big clientele of satisfied customers throughout the country, and with our knowledge and facilities insure you prompt service.

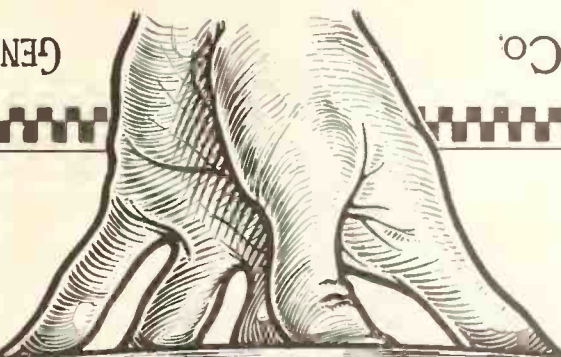

THE BIGGEST JOBBERS COME TO US. We are making machines under various names for the largest jobbers in America. We will do the same for you—Write us.

FOREMOST RETAILERS BUY THRU OUR JOBBERS. We have a jobber in your territory who can keep you supplied with the best line of phonographs at the price made in America, on which you will make a good reasonable profit—Write us.

Also furnish selling helps, such as sales letters, folders, pamphlets, etc. (Have just tripled our capacity by acquiring large factories at North Milwaukee)

GENERAL MANUFACTURING CORPORATION

MILWAUKEE, U. S. A.

RECORDEON PHONOGRAPH CO.

NORTH MILWAUKEE, U. S. A.

To Retail at \$85 to \$200



### MILWAUKEE VACATION TRADE STRONG FEATURE

Reduction in Red Seal Record Prices Stimulates Sales of Better Class Records—Small Machines Demanded for Outings—Future Bright—Some Interesting Developments in the Manufacturing and Retail Fields

MILWAUKEE, Wis., August 8.—The business done by talking machine dealers in this territory this summer is the best in the history of the trade.

Records, both classical and popular, are greatly in demand and the recently reduced Red Seal numbers are moving fast.

The generally improved financial condition of the people in this State accounts for the many sales of summer models to be used during vacation time.

The Co. is planning to remodel a full floor of its big wholesale house for the accommodation of the musical instrument department, due to the enormous increase in Sonora business.

The Badger Talking Machine Co., 135 Second street, Victor jobber, finds little or no relief from the acute shortage that has existed for six to eight months, although the Victor factories have effected considerable improvement in deliveries.

However, as rapidly as demand in deliveries. However, as rapidly as demand in deliveries. However, as rapidly as demand in deliveries.

terment comes business has grown more than enough to discount it. The record situation is probably as bad, the demand being constantly increased by reason of the marketing of thousands of instruments of other makes which depend to a certain extent upon Victor records.

The reduction of prices on the Red Seal record has stimulated an overwhelming demand.

Brunswick business so far this year is greatly in excess of that of any corresponding period in former times in the Wisconsin territory, according to Thomas I. Kidd, manager of the local branch of the Brunswick-Balke-Collender Co.

Local business, likewise, is exceptionally heavy. One of the main Brunswick dealers in the downtown section, the Milwaukee Piano Mfg. Co., moved August 1 to its new and permanent home at 270 West Water street, almost directly across the street from the wholesale house.

The Phonograph Co. of Wisconsin, 49-51 Oneida street, wholesaler of the Edison, reports this year so far as the best in its experience. A shortage of instruments and records is gradually being overcome and it is hoped that before the retail demand sets in with a will the relation between supply and demand will have reached a fairly even status.

The requirements of the company's retail dealers for Edison records is rapidly growing volume of business, President L. C. Parker has introduced numerous innovations.

The Phonograph Co., 207-215 East Water street, distributor of the Sonora in Wisconsin and northern Michigan, has 7,000 to 8,000 instruments on back orders and is somewhat apprehensive over the prospect that it may not be able to take full advantage of the splendid opportunity to do business which existing conditions provide. Assurances have been made,

Another outstanding figure in the Milwaukee industry is the General Mfg. Co. and its allied interest, the Recordon Phonograph Co., recently established at North Milwaukee. This has tripled the capacity, but further expansion already is becoming an urgent necessity.

The General and Recordon companies manufacture a standard line of five instruments under various names for the largest jobbers of the United States.

The situation of local distributors, wholesalers and jobbers at this time is unusual. The factories which they represent are unable to bring that all of them are engaged in the largest output they have ever reached and adding to facilities as rapidly as possible.

Now is the time when the distributors are seeking to fortify themselves and their retailers against the heavy fall and holiday demand, but the current requirements are so broad that so far it has been virtually impossible to make headway on the accumulation of advance stocks.

The Yahr & Lange Co., 207-215 East Water street, distributor of advance stocks.

The Yahr & Lange Co., 207-215 East Water street, distributor of advance stocks.

The Yahr & Lange Co., 207-215 East Water street, distributor of advance stocks.

The Yahr & Lange Co., 207-215 East Water street, distributor of advance stocks.

### PERSONAL SERVICE

The members of our Company are always available and will gladly see you personally or write you at any time we can possibly serve you.

Why not communicate at once with us? EXCLUSIVELY WHOLESALE

### BADGER TALKING-MACHINE CO. MILWAUKEE, WIS. 135 Second Street

VICTOR DISTRIBUTORS

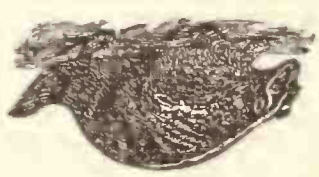

### SPECIAL OFFERS

#### RECORD DELIVERY ENVELOPES

45-lb. Kraft, 2 Buttons, String Fasteners

1-M QUANTITY 10-in.—\$ 9.25 per thousand 12-in.— 11.00 "

5-M QUANTITY 10-in.—\$ 9.00 per thousand 12-in.— 10.75 "

10-M QUANTITY 10-in.—\$ 8.50 per thousand 12-in.— 10.50 "

PATENTED DEC. 11, 1917

#### Talking Machine CABINET

### Sundstrom CONVERTO

F. O. B. NEW YORK



These albums are of the best quality that can be bought. As our stock is limited, we would advise you to place your order at once.

10-in. (12 pockets) \$7.50 per doz. 12-in. (12 pockets) \$8.75 per doz.

#### RECORD ALBUMS

### ELVETONE Phonograph Needles

The Two Best Selling Propositions in the Talking Machine Trade To-day

### The Cabinet & Accessories Company, Inc.

Otto Goldsmith, President  
145 East 34th Street  
Tel. Murray Hill 6470  
NEW YORK CITY



# B & H FIBRE MFG. CO.

33-35 W. Kinzie Street, Chicago

Your real music-lovers will appreciate the needle that lives up to this platform. YOU know B & H Fibre Needles do.

"Spread the gospel."

"No wear on the records, no hiss in the tone."

across?

May we suggest a good terse way of getting the "story"

time you can increase your sales of costlier records. ing the gospel" of Fibre Needle virtues. And at the same get them *all* in the habit, we believe, simply by "spread- these record-saving needles right along. But you can Chances are the majority of your choicest trade DO buy ularly as clockwork from the merchant they patronize. buyers of high-priced records—order Fibre Needles reg- invariably we find that the better class trade—the big There's something wrong somewhere if they don't. For

## Don't Most of Your Best Customers Buy B & H Fibre Needles Regularly?





**"Beautiful Ohio" and "Till We Meet Again," played in waltz time by the Kalaluki Hawaiian Orchestra! You'll run short in waltz time unless you order a lot! A-2743.**

**Columbia Graphophone Co.**  
NEW YORK

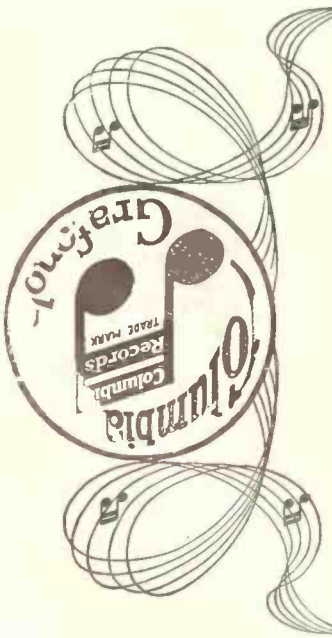

**READY FOR SUBSTANTIAL FALL TRADE IN INDIANAPOLIS**

Wholesalers and Retailers Gradually Getting Into Better Shape for Taking Care of Demands—Indianapolis Talking Machine Co. Takes Charge—Other Trade Changes

INDIANAPOLIS, Ind., July 30.—Summer business in this city is better than it has been in previous years, both the retail talking machine dealers and the distributors report. There is still a shortage of machines and records, but there has been a slight improvement.

E. R. Eskew, manager of the Pathe Shop, is expecting a big business for the Actuelle, a shipment of which he has coming in. The city recreation department is now using eight army and navy model Pathe's sold by Mr. Eskew.

H. E. Whitman, of the Circle Talking Machine Shop, looks for an early start on the fall business this year. July business has been good and the chief worry is figuring on accumulating goods for fall. The Victrola department of the Fuller-Ryde Music Co. is doing a nice summer business.

T. H. Bracken, manager of the Starr Piano Co. store, reports that there has been a marked increase in the record business and the demand for Starr phonographs is greater than the supply. He expects an unusual season this fall.

Mrs. J. E. Fish, manager of the talking machine department of the Pearson Piano Co., while in Chicago last week, visited the talking machine shops and departments of that city. She reports there is a strong demand for the portable machines for canoes and summer cottages. The remodeling of the department will start soon.

George Standke, manager of the Brunswick Shop, continues to have as his chief worry the problem of getting sufficient Brunswick machines on hand. The Brunswicks he is able to get go out as fast as they come in.

A. H. Snyder, manager of the Edison Shop, returned from a vacation in Michigan, to find his sales force making a better record than when he left. Mr. Snyder is anticipating a heavy demand for Edison phonographs and records this fall.

The Indianapolis Talking Machine Co. assumed charge of the Stewart Talking Machine Shop August 1. The remodeling of the shop is about completed. C. R. Anderson, manager of the new company, is highly pleased with the prospects.

W. G. Wilson, manager of the Grafonola Shops, Inc., reports there is no reason to complain about the summer business. Miss G. Wotrhay, of the sales force, has returned from a vacation at the Lakes, and J. L. Peters is forgetting the worries of a talking machine man by spending his vacation at Lake Manitou. The record business has been exceptional at the Carlin Music Co., according to C. A. Nicker-son, manager of the talking machine department. The demand for the small model Columbia's for summer use has been good. Will Carlin has returned from his vacation at Lake Wawasee.

C. P. Herdman, manager of the talking ma-

chine department of the Baldwin Piano Co. store, said that the business had doubled the record of last July. A feature of the business has been the cash sales. Mr. Herdman's salesmen have been successful in closing a large number of deals with customers from the rural districts. Mr. Herdman spent his vacation at Lake Manitou.

At the E. L. Lennox Piano Co. the Columbia record business has been unusually brisk. W. C. Christena, manager of the company, is endeavoring to accumulate a large stock of Columbia machines before the fall buying starts. Miss Minnie Springer, manager of the Victrola department of Taylor's, said that she had never seen summer business hold up as well as it has this summer in spite of the hot weather.

Ralph P. Lancaster, a well-known talking machine salesman, has taken a position with the Sonora department of Charles Mayer & Co. Mr. Lancaster studied tone production and quality at the New England Conservatory of Music. He is an enthusiastic booster of the Sonora. Ernest L. Arthur, manager of the department, said that business is picking up fine and the chief difficulty is getting machines.

The Mooney-Mueller-Ward Co., Pathe distributors, are looking for a big business with Mr. Brown recently.

Ben Brown, manager of the wholesale branch of the Columbia Co., said that business continues to be good, but the demand for machines and records is still greater than the supply. W. A. Willson, manager of the educational department of the company, visited the goods, this week.

Mr. Stewart said that he is looking for a big production of Victor goods, gradually increasing each month to the point where the company will be better able to meet the demands of the dealers. R. H. Zinke, president of the Record Needle & Manufacturing Co., Milwaukee, visited the Stewart Co., which handles his goods, this week.

Mr. Stewart said that he is looking for a big lunch and rest room for the women employees. decorating its entire plant and is installing after Victor artists. The Stewart Co. is receiving for the machines from the dealers. The Stewart Talking Machine Co., wholesale distributor of the Victor line, announces that A. C. Erick, proprietor of the Fayette Shop, of Connorsville, has bought out M. Hassel, former Victor dealer, and will conduct an exclusive Victor shop. George Stewart reports that the Krausgill Piano Co., of Louisville, Ky., since remodeling the store, has one of the most beautiful talking machine departments in the country. The twelve booths are each named after Victor artists. The Stewart Co. is receiving for the machines from the dealers. A large number of orders have been received for the machines from the dealers in their praise. A large number of orders have been recently demonstrating the new machine to dealers and they were all enthusiastic in their praise.

**THE HOUSE OF HOSPE**  
**FOR VICTOR DEALERS**  
**"Out Where the West Begins"**

**FASTEST SERVICE TO OUR RETAILERS**

**SEARCH SERVICE**

**Location—Organization—Stock**  
**Have You Tried Us?**

**A. HOSPE CO.**  
1614 Izard St.  
OMAHA, NEBR.



# The Best Article in the Accessory Line

## Lundstrom

### CONVERTO

PATENTED DEC. 11, 1917

## Talking Machine CABINET

It serves several purposes that all lead to GOOD PROFIT.

(1) It is an accessory easily sold to present owners of small Victrolas, because it displaces the make-shift stand, converts their machines into Cabinet Types and provides a neat, dust-proof record compartment. (2) It revives their interest in records. (3) It sells easily to new purchasers of small Victrolas. (4) It gives the dealer an effective weapon with which to meet the competition of unknown, low-priced cabinet machines.

The Converto has been accepted and handled by the country's foremost Dealers and Distributors.

## THE C. J. LUNDSTROM MFG. CO.

### LITTLE FALLS, N. Y.

Lundstrom "Converto" cabinets are broadly covered by patents. Infringements will be promptly prosecuted.

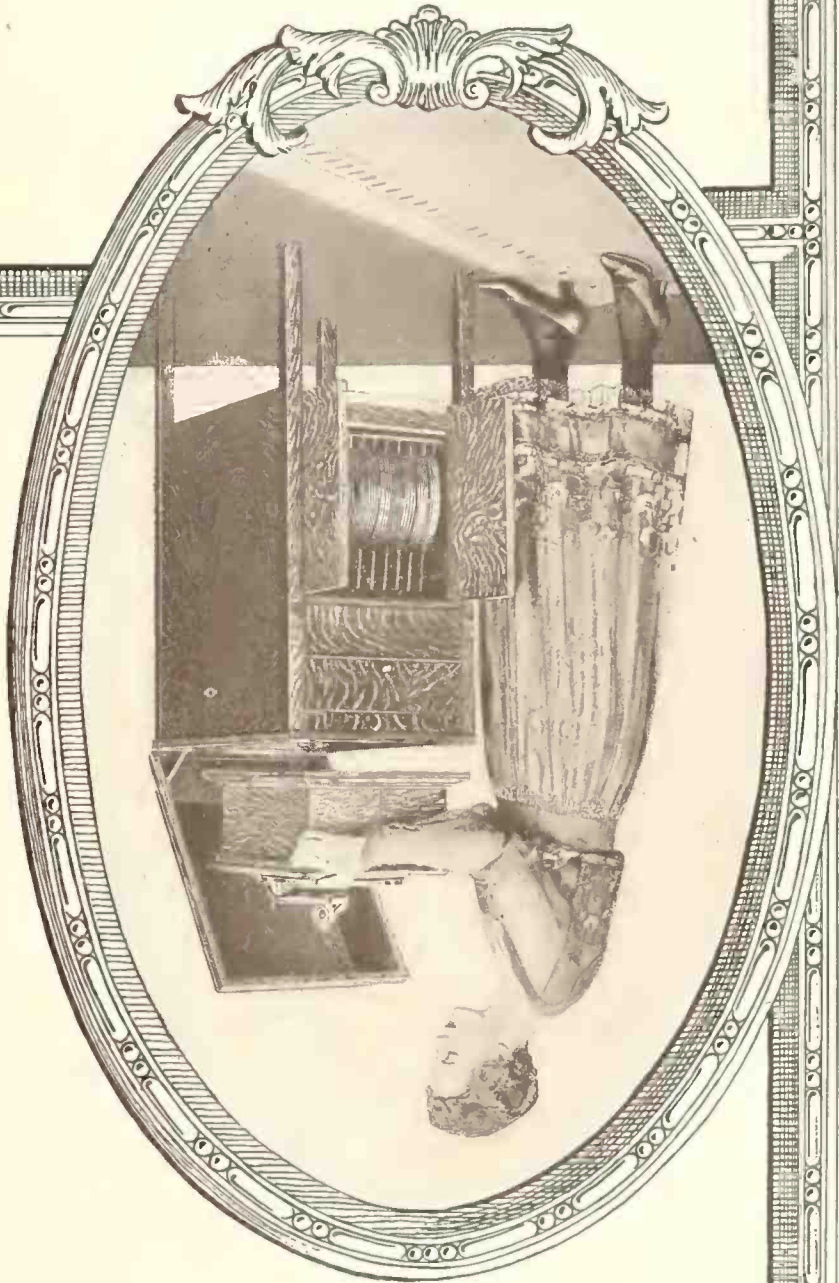

## Converto Distributors

- |   |   |  |   |   |   |   |  |   |  |
|---|---|--|---|---|---|---|--|---|--|
| Atlanta, Ga. .... Phillips & Crew Piano Co. | Baltimore, Md. .... Cohen & Hughes      | Buffalo, N. Y. .... W. D. & C. N. Andrews            | Burlington, Vt. .... American Phonograph Co.        | Butte, Mont. .... Orton Bros.             | Chicago, Ill. .... Lyon & Healy                 | Cincinnati, O. .... The Rudolph Wurlitzer Co. | Cleveland, O. .... The Collier & Sayle Co.   | Columbus, O. .... The Perry B. Whittitt Co. | Dallas, Tex. .... Sanger Bros.                 |
| Des Moines, Ia. .... Mickel Bros.           | El Paso, Tex. .... W. G. Walz Co.       | Houston, Tex. .... The Talking Machine Co. of Texas. | Kansas City, Mo. .... J. W. Jenkins' Sons Music Co. | Memphis, Tenn. .... O. K. Houck Piano Co. | Milwaukee, Wis. .... Badger Talking Machine Co. | Mobile, Ala. .... Reynolds Music House        | Newark, N. J. .... Price Talking Machine Co. | New York, N. Y. .... Emanuel Blout          | The Cabinet & Accessories Co. Inc.             |
| Omaha, Neb. .... Mickel Bros. Co.           | Peoria, Ill. .... Putnam-Page Co., Inc. | Philadelphia, Pa. .... The George D. OrNSTEIN Co.    | Penn Phonograph Co., Inc.                           | H. A. Weymann & Son, Inc.                 | Pittsburgh, Pa. .... W. F. Frederick Piano Co.  | C. C. Mellor Co., Ltd.                        | Standard Talking Machine Co.                 | Portland, Me. .... Cressey & Allen, Inc.    | Providence, R. I. .... J. Samuels & Bro., Inc. |
| Richmond, Va. .... The Corley Co., Inc.     | St. Paul, Minn. .... W. J. Dyer & Bro.  | Syracuse, N. Y. .... W. D. Andrews Co.               | Toledo, O. .... The Toledo Talking Machine Co.      | Washington, D. C. .... Cohen & Hughes     | E. F. Droop & Sons Co.                          |   |  |   |  |



PRINTERS' INK DISCUSSES RECENT VICTOR RECORD MOVE

An Interesting Discussion on the Reduction in Price of Expensive Victor Red Seal Records Which Will Be Read With No Small Degree of Interest in the Trade

The reduction in the price of expensive Victor Red Seal records continues to cause a tremendous amount of comment in trade circles and among manufacturers in general. Printers' Ink in a recent issue discussed the event in a very illuminative way, showing the motives behind the reduction and its benefits as follows:

"Not often these days that a manufacturer reduces his prices 50 per cent. Still, under certain circumstances it is conceivable. If, however, a manufacturer should tell you that he was unable to keep up with his present orders at present prices and then announce a 50 per cent reduction you would certainly dub him an 'idealist.' Blacker term these days, as everyone knows, there is none!

"Well, 'Victor' has gone and done it—has actually reduced the prices of by far the greater portion of its famous library of Red Seal records (in particular those retailing at \$2—or more) a flat 50 per cent. The effect of this price reduction may be imagined from the fact that one can now buy records made by Caruso, Melba, Tetrazzini, Farrar and others in the galaxy of operatic stars at as low a figure as one purchased the latest hit at the Winter Garden. It is unquestionably the biggest development in the talking machine industry since the first operatic record was developed.

"Undoubtedly there is sound business policy behind so sweeping a reduction, and this policy may be surmised from the fact that the records of John McCormack and Alma Gluck at popular prices—'Mother Machree,' for instance, and the 'Little Grey Home in the West'—have all ways had an enormously greater sale and produced a much larger return to the artists than

LYRAPHONE CO. IN NEW HOME

Now Occupying Headquarters in Newark—M. J. Samuels in Europe

The Lyrphone Co. of America, which formerly occupied offices at 12 West Thirty-seventh street, with a plant in Brooklyn, N. Y., has moved from both quarters into its new home 117 Mechanic street, Newark, N. J. M. J. Samuels, president of the above company, will return to this country late this month, after a period of two months spent in European

ROBERT E. RAE RETURNS

Robert E. Rae, of the general sales department of the Columbia Graphophone Co., who has been West for about a week, visiting Cleveland and Detroit, in order to study more closely the Columbia outlook in that region, returned last Saturday. He immediately left for Vineyard Haven, Mass., where he is spending a short vacation with his family.

centers closing contracts with the European artists to record exclusively for his concern.

"These artists have seen this principle demonstrated most effectively within the past few years, and they are now willing to sacrifice immediate returns to the larger returns that will most surely be theirs over a period of years. "The logical effect, from the standpoint of the Victor trade, will be the very great multiplication in sale of Red Seal records. "No dealer, of course, can be compelled under the law to sell the Red Seal records at the reduced prices, but the Victor dealers have been given the privilege of receiving without charge an additional quantity of the records affected by the price reduction up to a point where the value of these records in the dealers' hands will be equivalent to the value of their stocks as of a certain date at the old prices. Needless to say, this adjustment has been made, and the trade is taking wide advantage of its new sales opportunities through local and direct advertising—supplementing, of course, the national announcements of the Victor Co."

certain of the operatic records for which the company has had to pay princely advance fees and exorbitant royalties. "For a long time the Victor Co. has been striving to impress upon famous artists the value of volume in sales, and time and again it has pointed out to them that the artists who have contented themselves with a straight and moderate royalty basis that would permit the company to market their records at not more than \$1 or \$1.50 each have earned far more in this way than they would have earned if they had restricted the volume of sales by exacting advance fees and royalties out of proportion to manufacturing and distributing cost.

THE MASTERKEY  
Dusonto  
TO ALL PHONOGRAPHS  
DISC RECORDS



Dealers in Western Pennsylvania  
Eastern Ohio and West Virginia

The Dusonto is the "Master Key of the Record." It gets the best out of all makes of records. Dealers in this territory are assured of immediate delivery through H. E. GROSS & CO. 819 Reedsdale St., North Side Pittsburgh, Pa.

The Belcanto Company, Inc.  
2007-B Bush Terminal Sales Building  
130-132 West 42nd Street, New York

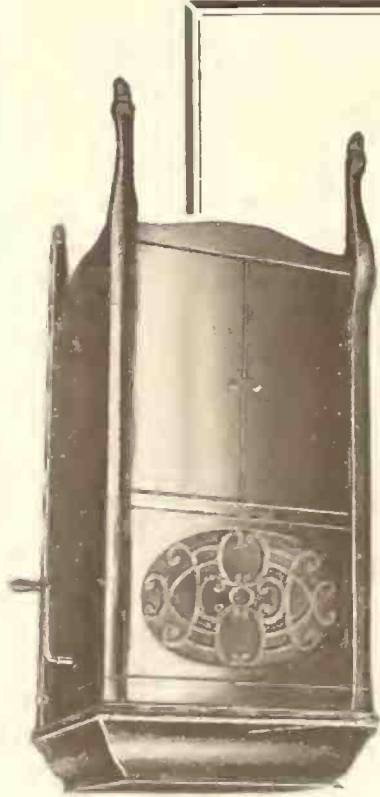

The  
Sommerhof  
Company Inc.

of  
Eric, Pa.

ANNOUNCE to good dealers and distributors that they will be ready to arrange for protected distributing rights for the SOMMERHOF PHONOGRAPH. This will be the opportunity of a lifetime for those who want to handle a COMPETITION PROOF machine.

The SOMMERHOF marks an epoch in phonographs. It is built as a phonograph should be built—correct in design, faultless in finish and mechanically accurate.

And there are no screens to fade or stain, no dusty scroll work, no projecting doors or shutters and the horn is concealed at all times.

The SOMMERHOF controls the tone from the front; the scientific way that eliminates the blasty or choking noise. The SOMMERHOF blends and reinforces the tones of the amplifier and the resultant tone is absolutely smooth and uniform.

A machine that will sell on sight and make it hard to sell the other types to the man who has seen the SOMMERHOF.

All the great features of the SOMMERHOF are right before you and require no proof but inspection and every demonstration is a sale.

Arrange at once for a demonstration and territory rights.



LIST OF THE WINDSOR PHONOGRAPH CABINET PATENTS

48122	50478	50481	50484
49654	50479	50482	1279743
49655	50480	50483	



**THE WINDSOR**  
FURNITURE COMPANY

1420 CARROLL AVE.  
CHICAGO, ILL.

*Write for a catalogue and price-list*

Secure copies of the patents listed below and convince yourself.

We originated the Period Style Phonograph of which all other makes are copies or imitations.

**WE SELL** direct from the factory to the dealer, eliminating the jobber entirely.

**NO JOBBERS' PROFIT**

**MORE RETAILER'S PROFIT**

**THE WINDSOR**  
FURNITURE COMPANY  
1420 CARROLL AVENUE  
CHICAGO, ILLINOIS  
ESTABLISHED 1885,





# The Truth About Talking Machine Needles

No phonograph music is one bit better than the needle it is played with—a poor needle will spoil the charm of the best record made.

## "Tonofone"

Is the Universal Talking Machine Needle Supreme!

Its wonderful elasticum tip is both plastic and elastic—it is cylindrical, of correct diameter and blunt-pointed; therefore it will neither widen with use nor scratch like other needles. That's why each "Tonofone" will play 50 or more standard records without injury.

Its Tones are Marvelously Pure!

"Tonofone" is not a loud needle, but brings out all the tone-value of the record without the scratch. It does not sacrifice the tone quality for the sake of volume.

Its Articulation is Amazingly Clear!

The plastic, elastic point quickly shapes itself to the groove and picks out every one of those wonderful microscopic sound waves, thereby giving a perfect reproduction which no needle of any other construction can do.

Others May Imitate—None Can Duplicate!

"Tonofone" makes the talking machine all but human—makes it sing and talk like the human voice—makes it play instrumental music like the instruments themselves in master hands.

It Makes All Records Better—Makes Good Records Great!

"Tonofone" is not an experiment—it has stood every known test. Musically, mechanically and scientifically it is correct. It has set a new standard in "Phonography."

*If your jobber does not handle "Tonofone," send your order to our nearest distributor.*

## "TONOFONE" DISTRIBUTORS

E. R. GODFREY & SONS CO., Milwaukee, Wis.

MURMANN PHONOGRAPH CO.

1318 Olive St., St. Louis, Mo.

RICHARDS & CONOVER HARDWARE CO.

Kansas City, Mo., and Oklahoma City, Okla.

LYRE-OLA MFG. COMPANY, INC.

8th and Olive Sts., St. Louis, Mo.

M. SELLER & CO.

5th and Pine Sts., Portland, Ore.

HOEFFLER PIANO MFG. CO.

304 W. Water St., Milwaukee, Wis.

BALDWIN-MILLER CO.

304 State Life Bldg., Indianapolis, Ind.

ARMSTRONG FURNITURE CO.

59-61 N. Main St., Memphis, Tenn.

ARTHUR K. KEMPTON

205 Drummond Bldg., Montreal, Canada.

HOME OFFICE AND FACTORY  
110 SO. WABASH AVENUE  
CHICAGO, ILL.  
U. S. A.  
TEL. RANDOLPH 2045

# R. C. WADE CO.

MADE for THE TRADE by

EASTERN AND EXPORT DEPT.  
160 BROADWAY  
NEW YORK CITY  
U. S. A.  
TEL. CORT. 8586

THE REED COMPANY  
237 Fifth Ave., Pittsburgh, Pa.  
WORLD PHONOGRAPH CO.  
736 Tilden St., Chicago, Ill.  
W. A. CARTER  
Cable Building, Chicago, Ill.  
THE OKEH RECORD DISTRIBUTING CO.  
Okeh Building, Grand Rapids, Mich.  
WORLD SALES CORPORATION  
1340 Lawrence St., Denver Colo.  
WALTER S. GRAY,  
Chronicle Building, San Francisco, Cal.  
M. D. SWISHER  
115 S. 10th St., Philadelphia, Pa.  
ASSOCIATED FURNITURE MANUFACTURERS  
1209 Washington St., St. Louis, Mo.  
A. C. McCLURG & CO., Chicago  
ALEXANDER DRUG CO., Oklahoma City, Okla.



TRADE NEWS FROM PHILADELPHIA

(Continued from page 57)

"At Richmond and Indianapolis, Ind., business is very good among the manufacturers, and is limited only by the shortage of labor. George H. Buckley, of the 'Indiana' Die Casting Co., stated that labor conditions in this section are even more of a problem than during the war. He reports the receipt of much business."

"I found a wonderful growth and expansion in the talking machine industry during the past year in Chicago. This city is recognized as one of the leading talking machine manufacturing cities of this country. Business is for the most part in the hands of reliable and business-like houses who are interested in producing lines of quality, and who are co-operating heartily for the advancement of the talking machine industry."

"Not less remarkable than the growth of Chicago, phonographically speaking, is the expansion of the phonograph industry in Grand Rapids. This center at present presents a very fertile field for prospective business, as practically all of the larger furniture companies, of which industry Grand Rapids is the center, are realizing the wonderful opportunities which the talking machine industry presents and are practically all in this business in various degrees. An illustration of what transformation is taking place in this city can be realized by noting that the annual furniture display in this city has practically been turned into a phonograph exhibit."

"The various talking machine and accessory manufacturers of Cleveland are keeping that city quite prominent in the talking machine field. Business is plentiful and labor conditions are improving. On the whole, a very satisfactory and encouraging condition prevails with no let up in business in the so-called dull season. "I believe that the splendid outlook for the coming season can be attributed to the wonderful condition of the public, as is further corroborated by the unprecedented public interest in the stock market. The public indulgence in the stock market is always a reliable barometer with which to judge financial conditions and which shows very favorably indeed at this time."

"It is also hard to overestimate how many of those four or five million sixty dollar bonuses of the soldiers are going into a talking machine. They have realized in their dull and dreary times at camp what a really wonderful diversion the phonograph is and have learned to appreciate the wonderful charms of music most consistently and economically derived through the phonograph. I believe that these conditions will work very favorably for the future of the industry."

SOLD \$250,000 WORTH OF COLUMBIAS

W. C. Thomas, of the Tampa Hardware Co. wholesalers of Columbia Grafonola records, Tampa, Fla., recently addressed the Rotary Club at Tampa. During his address he mentioned the fact that in the past year his company sold more than \$250,000 worth of Columbia goods. He remarked further that the department was constantly growing and the present record might be passed next year.

**ACME-DIE**

**-CASTINGS-**

ALUMINUM-ZINC-TIN LEAD ALLOYS  
 Acme Die-Casting Corp.  
 Boston Rochester Brooklyn N.Y. Detroit Chicago

STIMULATE SUMMER SALES

THE GARFORD MODEL C

The GARFORD Model C Phonograph is designed to assist you in developing a profitable summer business. Its appeal to vacationists is only one of its many sales possibilities.

Retails at \$15



Retails at \$15

THE GARFORD MFG. CO.

ELYRIA, OHIO

Our Dealer Proposition is Unusually Attractive

The GARFORD Model C is a high-class phonograph constructed of quality materials and guaranteed to give absolute satisfaction and excellent service.

NEW JONES-MOTROLA WHOLESALERS  
 Jones-Motrola, Inc., announces that the Eastern Talking Machine Co., of Boston, and the Pardee-Elfenberger Co., of New Haven and Boston, have taken up the wholesaling of their products during the past month. The F. H. Thomas Co., of Boston, Mass., are achieving considerable success with the Jones-Motrola, which they have handled for some time, as may be evidenced by the greatly increased volume of orders which they are sending in.

The United Construction Co. is about to make two important installations of the Unico sound-proof booths. The first of these will be made in the talking machine department of James McCreery & Co., Fifth avenue and Thirty-fourth street, New York, and will consist of three machine salesrooms in Colonial style, which will bring the total Unico booths at the McCreery concern to about fifteen rooms. The other installation will be made at the retail warehouses of M. Welte & Sons, Inc., 667 Fifth avenue, New York City. Here six record-rooms and two machine salesrooms of very handsome Colonial style will be installed. In chatting with 'The World' this month Charles Clement, district sales manager for the Unit Construction Co., who makes his headquarters in New York City, stated that the demand for Unico booths is exceedingly heavy at this time.

The Brunswick Shop, Dallas, Tex., will in the future be known as the Riddle Phonograph Co. and the warehouses will be located at 1205 Elm street. There will be no radical changes in the conduct of the business in the new location.

the present time and that last month was, in fact, the record month, both for his district and for the entire country.



# WANTED: More Philadelphia dealers to make money selling Emerson Records

HERE are 3 reasons why EMERSON RECORDS move fast:

1 HITS. 80% of all records sold are HITS—song hits and dance hits.

Emerson Records are HITS—nothing but HITS.

2. EARLY RELEASES. Naturally the hits that come out first get away to the best selling start. Emerson HITS, as a rule, start rolling up profits for dealers well in advance of competing hits.

3. QUICK DELIVERY. This Company receives Emerson HITS direct from the manufacturer and is prepared to make immediate delivery in Philadelphia territory.

We would like to talk with a few progressive Philadelphia dealers who are open to a first-class proposition.

Phone Spruce 4621, or write:

## Emerson Philadelphia Co.

Parkway Building

BROAD and CHERRY Streets -- PHILADELPHIA, PA.

*Distributors of EMERSON RECORDS*



### THE TRADE IN PHILADELPHIA AND LOCALITY—(Continued from page 56)

#### L. HAMMOND CRABTREE RETURNS

Traveler for International Mica Co. Makes Initial Trip—Finds Prosperity in West

PHILADELPHIA, Pa., August 2.—L. Hammond Crabtree, of the sales department of the International Mica Co., of this city, has returned from a trip in the interest of the company through the Middle West. This was his first

this section.

(Continued on page 58)

On Wednesday, July 23, at the Hotel Adelphi, a dinner was given by all the officials and branch managers of F. A. North & Co., and they all spoke highly of the satisfaction that the Pathe machine was giving their customers. C. S. TAY, of the Pathe Shop, has just returned from a delightful two weeks' vacation spent at Atlantic City.

Paul D. Silver, who for a considerable time has been on the force of the Sonora Co., at the end of last week opened a branch of the Philadelphia store at Wayne, Pa. The Eaken Piano Co., extensive handlers of talking machines at their Fifty-second street store, West Philadelphia, will remove from their present location to 271 South Fifty-second street.

B. B. Todd Purchases Building  
B. B. Todd, who handles talking machines in connection with pianos at 1306 Arch street, has purchased that building and will entirely remodel it, the big business he has been doing in talking machines having required this. Mr. Todd has added Frank Martin, who for a long time was connected with the Goodman store on Girard avenue, to his talking machine sales force.

Louis J. Stouss, in charge of the talking machine department at Bellak's Sons, has just taken to himself a bride, and in consequence is featuring "A Little Bit of Honey" back of his desk.

Write for our prices on albums, Victor and Columbia attachments and automatic stops. Immediate delivery!  
COLE & DUNAS MUSIC CO.  
54 W. Lake St.  
Chicago, Ill.

The large amount of money the QRS Company are spending in advertising is marketing thousands of player rolls. You can have your share of these sales if you let the public know you handle QRS Rolls. Send us your orders. We are ready to give twenty-four hour delivery on all QRS Music Rolls.

# QRS PLAYER ROLLS

## WEYMANN & SON

Wholesale Distributors  
For QRS Rolls

VICTOR WHOLESALERS

MANUFACTURERS of the world renowned WEYMANN KEYSTONE STATE MUSICAL INSTRUMENTS

1108 CHESTNUT ST. Philadelphia  
Established since 1864



THE TRADE IN PHILADELPHIA AND LOCALITY—(Continued from page 55)

Among some of the most recent talking machines in Philadelphia were: W. M. Ed-wards, of the Florida Talking Machine Co., Jacksonville, Fla., and Thomas F. Greene, of the Silas E. Pearsall Co., New York.

Columbia Employees Have Outing  
The employees of the Columbia Co. had a most delightful moonlight picnic (minus the moon) up the Delaware on July 16. The proceeds of this outing were appropriated to the crack baseball team of the Columbia, which is a winner in practically every game it engages.

Mr. Manning, one of the local Columbia officials, who had returned to the offices after an absence of more than nine months on account of illness, was compelled again to go back to the rest cure and will not come out before the 1st of September. H. E. Gardiner made several trips during July among the nearby Columbia retailers, all of whom he found in excellent shape and enthusiastic as to the fall business.

During July the Columbia auditors were at the Philadelphia branch, including H. P. Victor, at 1306 Chestnut street, but they expect to have

The Columbia has set August 15 for the date of their removal to their new building at Sixth and Filbert streets. Much disappointment is expressed by Manager Wilcox in that the local handlers are unable to get sufficient stock to supply their present dealers, much less allow them to take on any new accounts.

North & Co. Featuring Pathé Line  
The F. A. North & Co. have already placed the Pathé machines in all of their eleven branches, with the exception of their main store on the road were called in and all met Mr. Goldstein, who spent considerable time in going over details in regard to records already on the market and those which have been recorded for future production.

In his address Mr. Goldstein outlined the plans and policies of the Emerson International Co., and at the same time gave demonstrations from the various artists on their many foreign catalogs, bringing out to the entire satisfaction of the enthusiastic little group the exceptional merit of the record.

This meeting was the result of the Emerson distributors' demands that the salesmen be especially schooled and equipped with a knowledge of the fine points of the Emerson International records.

Emerson International Salesmen's Meeting  
Mr. Goldstein, of the Emerson International Co., Inc., recently visited the Emerson Philadelphia Co., in this city, in order to address the sales force. Those of the force who were on the road were called in and all met Mr. Goldstein, who spent considerable time in going over details in regard to records already on the market and those which have been recorded for future production.

In his address Mr. Goldstein outlined the plans and policies of the Emerson International Co., and at the same time gave demonstrations from the various artists on their many foreign catalogs, bringing out to the entire satisfaction of the enthusiastic little group the exceptional merit of the record.

This meeting was the result of the Emerson distributors' demands that the salesmen be especially schooled and equipped with a knowledge of the fine points of the Emerson International records.

# The FRANKLIN

## The Phonograph That Satisfies

The aim of the Franklin is to give a more lifelike reproduction of all records than ever before given.

We invite comparative tests as to the tone value of the Franklin.

We will guarantee deliveries on all orders placed before September 1st.

May we not send you a price list or better still, order samples at once.

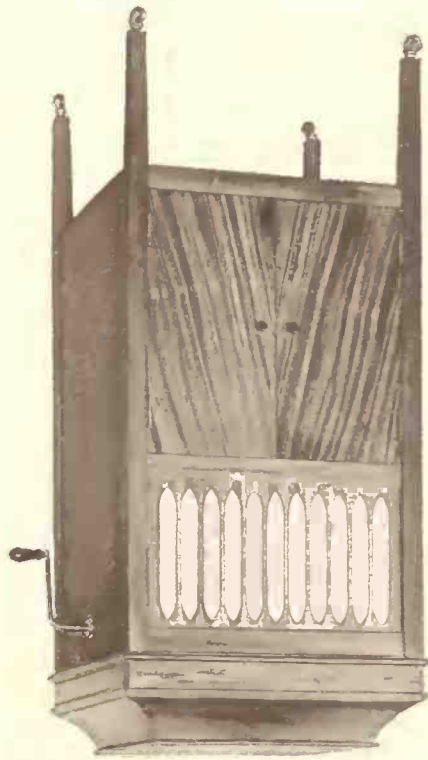

STYLE No. 3—\$110



The Franklin is different.

FRANKLIN PHONOGRAPH COMPANY  
INCORPORATED  
PHILADELPHIA, PA.  
10th & Columbia Ave.

Write for our catalogue "B" on hardware, motors and tone arms.  
COLE & DUNAS MUSIC CO.  
54 W. Lake St.  
Chicago, Ill.

Penn Phonograph Co. Activities  
T. W. Barnhill, of the Penn Phonograph Co., has returned from a two weeks' vacation, which he spent in touring through the New England States, and while the weather was somewhat against him he enjoyed the trip very much. The business of the Penn Co. has been quite satisfactory, in spite of the shortage of goods. The Penn people report that within a few days after the cut to half-price of the Red Seal records by the Victor Co. they were entirely cleaned up on stock of such records which they had on hand and which was considerable.

Among the recent visitors to the Penn offices were Lawrence Seligman, of Seligman & Co., Tamaqua, and P. W. Simon, the well-known dealer of Uniontown, Pa.

H. E. Blake Takes on the Cheney  
Herbert E. Blake says that on the whole he is very well satisfied with the July business on machines and records. Last week he added the Cheney to his representations and now handles the Edison, Cheney, Columbia and the Steger. The Cheney has been housed at the 1102 Walnut street store, while the corner store is given over exclusively to the Edison. The Cheney has been received in every style at the Blake store and Mr. Blake thinks he is going to do a very good business with it. R. N. Rich, of the sales force, is at present on his vacation at Atlantic City. C. J. Levering, Jr., who has been connected with the firm of Blake & Burkart since the firm started, has resigned and has accepted a position with the Phonograph Co., Detroit, Mich. He left for Detroit on last Friday.

Edison Dealers Postpone Meeting  
The Edison dealers in this district decided to do away with their regular monthly meeting in August, and they will hold a general convention of all the Edison dealers in this zone, including Philadelphia, Pennsylvania, New Jersey and Delaware on the second Tuesday in September.



# THE TRADE IN PHILADELPHIA AND LOCALITY

## A Victor Dog in Every Home!

This should be the Slogan of every Victor distributor and dealer. The miniature plaster dog we are making is the best advertisement and Victor propaganda any dealer can give away, sell or use, as a window display.

If you are remodeling your Victor department, what better souvenir can you give away at the re-opening? It is the smallest big thing ever offered the Victor Dealer.

*Write for particulars*



**PENN PHONOGRAPH CO., Inc., 913 Arch St., Philadelphia, Pa.**  
**VICTOR DISTRIBUTORS—Wholesale Only**

PHILADELPHIA, Pa., August 4.—Generally the talking machine business in Philadelphia in the month of July was better than it was either in June or May, and this is surprising considering the much unpleasant weather of the month, but it may be attributed to the fact that machines were put on the market in considerably larger numbers than during the preceding months, giving the dealers a chance to make a better display and the public a better selection. That there is going to be a most active fall business here seems evident to all of the dealers and they are laying plans that they hope to be adequate to handle it. The most striking evidence in this connection is coming from the Wanamaker store, where extensive plans are now under way, to be announced about the 1st of September, whereby this firm will enter the talking machine business on a larger scale than ever before.

Wanamaker Store to Add New Lines

The Wanamaker store, which has been exclusively a Victor store for a great many years, has relinquished its jobbing contract but will continue to handle the Victor line on a retail basis and it will, according to rumor, represent a number of other machines of established reputation. There has been no official announcement made regarding the contemplated changes, but Dame Rumor, with more or less authoritative support, offers a list that is impressive. The entire talking machine department at the Wanamaker store is being rearranged to this end. At present that firm have thirty hearing rooms, but to these will be added ten additional ones, and each of the lines of machines will be given an equal representation. The local Wanamaker department is in the complete charge of A. H. Bates, who is just now busily engaged in working out the details of the new plan which will be incorporated into the Wanamaker talking machine department.

Business with this in-machine department. Changes at Louis Buehn Co. Store

At the Louis Buehn Co., on Arch street, there is also considerable improvement in the office section under way. Portions of the first

floor offices will be removed and Mr. Buehn's private office will be removed to the second floor front. The Buehn store reports an improved business in July. Frank P. Reineck has just returned from a pleasant vacation. (Continued on page 56)

# WORRY-PROOF

Is the way a prominent Victor Dealer described our Victrola and Victor Record service.

Not from the standpoint of supply—but from the point of

FAIR DISTRIBUTION  
 HELPFUL SALES SUGGESTIONS  
 FINANCIAL GUIDANCE  
 CAREFUL METHODS  
 PROMPT SHIPMENTS

We are only serving the Victor dealers of our logical territory—a business practice, which, over a period of twenty years, has merited the confidence and loyalty of a progressive clientele.

# THE LOUIS BUEHN COMPANY

PHILADELPHIA



**EMERSON INTERNATIONAL, Inc., 45 West 34th St.**  
**EXPORT OFFICE: 160 Broadway, NEW YORK, N. Y.**

Catalogs now ready: Polish, Italian, Hebrew-Jewish, Czech-Slovak, Russian-Ruthenian, Spanish-Mexican-Cuban

**9-inch 75c. Play on all machines 10-inch 85c.**

**DOUBLE DISCS — PROMPT DELIVERY**



HR/2

General Manager.

*Henry Fox*

EMERSON PHILADELPHIA CO.

Yours very truly,

"All hail to the EMERSON INTERNATIONAL, whose enthusiasm was infectious. The Philadelphia trade was given their introduction to the Emerson International Record by Mr. Giles. Victor "Red Seal" Record. for 75 and 85¢, and feel it is as good as the believe it possible we could get out a record the Emerson Phonograph Company - they did not wonderful field and opportunity it opens up for more than enthusiastic about the record and the to hear an Emerson International Record has been Frankly, everyone who has been fortunate so far taken a firm hold onto the hearts of the dealers. Operatic selections and Violin solos have entire trade. It's exquisite recording of this kind at the price, is the opinion of the sized the market, in bringing out a record of International Record. That you have revolution- upon the first appearance of the Emerson I wish to extend my heartiest congratulation

My dear Mr. Rosenfield:

Mr. Louis D. Rosenfield,  
 Mgr. Repertoire, Sales & Advertising,  
 Emerson International Co.,  
 New York.

Philadelphia, Pa.  
 BROAD AND CHERRY STREETS  
 PARKWAY BUILDING  
 SPRUCE 4621  
 PHONE

Emerson Records  
 DISTRIBUTORS OF

Emerson Philadelphia Co

AGREEMENTS AND SALES SUBJECT TO STRIKES, ACCIDENTS OR OTHER CAUSES BEYOND OUR CONTROL

July 11, 1919.

BRILLIANTONE  
 NEEDLES

... So say they all!

**EMERSON INTERNATIONAL RECORDS**  
**are "MONEY GETTERS"**



# WORLD PHONOGRAPHS

are always interesting in regard to distinctive and tonally meritorious equipment, and in case of design. The Style 175 shown herewith is covered by design patent. Dealers say it is the best selling "World" they have ever had and that is saying a good deal! Model 175 is made in Adam brown mahogany, walnut and golden oak finishes—height 50 inches, width 21½ inches, depth 22½ inches; motor, multiple spring, constant speed, non-vibrating and mounted free from contact in resonating parts; equipped with "World" patent horn and "World" improved tone arm and sound-box. Price \$175.00, including war tax. For gold trimmings, add \$10.00 to net price.

The only come-backs on "World" phonographs are satisfied customers.

World Phonograph Company

736 Tilden Ave. CHICAGO, ILL.





## TALKING MACHINE WORLD SERVICE

*A department devoted to promoting retail sales — conducted by Robert Gordon.*

SINCE the old game of questions and answers described in our

last issue has helped you to classify your customer, you won't make any mistakes when it comes to the "explanation and demonstration" part of your sale.

First, be sure that your prospect is comfortable. In winter try to get her to remove her wraps, and in summer have a fan in case the booths are warm.

Throughout, be careful to maintain a certain tempo in your talk and in your movements, according to the age and temperament of your customer. If you are dealing with an older person go very slowly. If the prospect is young and of an alert, quick type a slow, plodding demonstration by you tends to make her impatient.

As you wind the machine, talk about the power of the motor and its absolute silence and other good features. While you are putting on the record, describe the sound box, tone arm and reproducer, being careful all the time that she understands what you are talking about. After you have started the machine and closed the top, stand at a distance with your attention directed upon the prospect. Watch her expression and manner carefully.

The moment your customer's eyes begin to wander either to you or about the room stop the machine and explain something about the wonderful quality of tone just demonstrated. If you have been playing a loud record point out the absence of blast. If your selection was a soft one emphasize the fact that your instrument reproduces all the soft tones without a blur. Give the impression that this is a difficult and unusual achievement, just as it is for an artist to sing softly and yet give a full round tone.

Here ask a leading question regarding the tone, and if she does not seem to appreciate the kind of tone you have reproduced change your record to one of exactly opposite type. If you have played a soft record let this next one be a loud military band piece, which always gets the attention of any customer.

When you have taken off the first record open the machine, if it is a cabinet model, and point out the ample space for filing records. This will hold the interest during the interval while you are putting on the second record. Often it is effective to insert a little technical talk at this point about the unique features of your model. Avoid using the same phraseology which your competitors use in describing their machines.

When you have played the second record get your customer to wind the machine herself, drawing her attention to the feel of the spring. Repeat your talk about the unique features as and reproducer, pointing out the unique features as she watches your fingers. Let her move the starting lever. In fact, let her demonstrate the machine to herself. Nothing is so convincing.

By this time your customer will have given you some sign whether or not you are working on the right model. If you feel that this is the design and price she wants that is your time to discuss terms, delivery, etc.

If the indication is that the prospect would prefer either a higher priced or a cheaper model it is best to start your demonstration on this new model, before proceeding to the third record.

In case the machine you want to sell is not on the floor, give your prospect a descriptive catalog of the entire line and explanatory circular about the points of superiority of the particular instrument she has indicated she wants.

Do not give the customer any literature while your demonstration is going on, unless you are trying to sell her something for future delivery. Fix her attention on one thing at a time.

Always have a cloth handy to wipe off the finish after you have touched it. This is not so much to keep the machine clean as for the psychological effect on the customer. She will take her cue from you, and if you give the impression that your instrument is a very valuable piece of furniture, to be treated with consideration and care, she will be impressed without your saying one word.

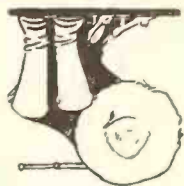

### ILLUSTRATE YOUR RECORDS

THE first principle of effective window display is one thing at a time, and drive it home. Don't try to bring down your game with a bunch of bird-shot; fire off a cannon loaded with just one ball. Some dealers think the more they crowd into their windows the more chances they have of catching sales. Don't use your windows to show everything you've got in stock. Use them to pull people inside. After that you can talk about your other goods.

Give up your whole window to one record, then dramatize that record so that it convinces. By dramatizing I mean this: Take the subject of your record and illustrate it with "stage properties" that will tell its own story.

For example, if you are going to feature "How Ya Gonna Keep Them Down on the Farm, After They've Seen Paree?"—put that record in the center of your window with a sign carrying its name. Then borrow a pair of farmer's boots, old and muddy—a rake, some hay seed and a farmer's straw hat—also some red dancing slippers, a coquettish fan, a powder puff, a pair of long white kid gloves, and a little black mask such as is worn at fancy dress balls. With these "props" you can dress a window that will stop the crowds.

If you want to feature "Good Morning, Judge," borrow enough well-worn, leather bound law books to make a mass of tan color in your window. Against this set your record and finish off with a judge's gavel, pair of horn-trimmed spectacles, some legal-looking papers with red seal attached, and, if you want to be very realistic, an overturned bottle, a "poker hand" and a few chips.

If the opera "Carmen" were given in your town you could put in the "Carmen" records with a yellow Spanish shawl, pair of red slippers, castanets, cigarettes and small dagger if you can borrow one.

For "Monte Cristo, Jr.," your local bank can lend you some empty money sacks, which you can fill with paper, then scatter some real bills and coins on the top of the pile.

You can apply this same principle of "dramatizing" to any record you like, and after you've been at it awhile your windows will begin to pay your rent, and have something left over besides.



Should your prospect be a man who is mechanically inclined, it is well to show him a sample motor, sound box, etc., and explain them in detail.

Throughout your sale be sure to use simple, non-technical language. Don't be tempted to impress your customer with the extent of your knowledge by using long, strange words and expressions. Talk in terms he can understand without effort. Make the climax of your argument bear upon the point you regard as nearest your prospect's heart.

Have your stock classified on the floor in the booths, according to price and design. If you put a cheap machine among your high-priced models your customer is constantly reminded of the high cost of the machine you are demonstrating as compared to the cheap one. Likewise, if you have a handsome period style among your moderate priced models, it acts as a silent competitor, constantly reminding your customer that he is buying an inferior machine.

Don't push the machines around carelessly.

Don't talk while a record is being played.

Don't lounge on the machine.

Don't be too familiar with your customer even if it is a personal friend.

Don't start a mixed discussion on the relative merits of different priced machines. Concentrate on one at a time.

All these suggestions are to help you work out and perfect your sales solicitation. Next month the "closing" comes.



**PATENTS SYNCHRONIZING DEVICE**

W. L. Pollard Assigns Patent on Interesting Invention to the Cable Company

Willard L. Pollard, of Evanston, Ill., has just been granted a patent on a new invention designed to keep a player-piano and a talking machine in synchronism, the patent having been assigned to The Cable Company, Chicago. The basis of Mr. Pollard's invention is a set of two indicators operating together and automatically, one on the player-piano and the other on the talking machine. The indicator on the player-

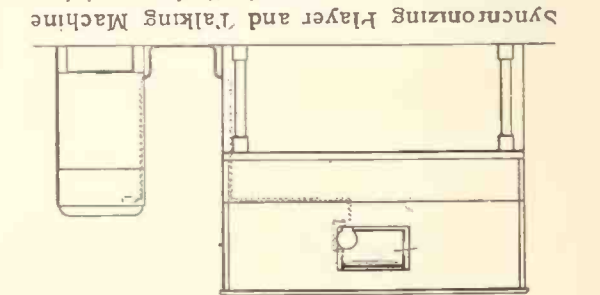

syncronizing Player and Talking Machine piano is controlled automatically by special perforations in the music roll, and special pneumatics, and this indicator in turn controls the indicator on the talking machine to regulate the speed of that instrument in synchrony with the speed of the player-piano. The entire device, although ingenious, is quite simple in operation, and not likely to get out of order easily. The speed adjustments obtained are said to be rapid and accurate.

**COMMERCIAL TRAVELERS MAY VOTE**

Proposed Amendment to State Constitution Would Give Privilege to Salesmen on the Road—Backed by Merchants' Association

Piano travelers who have often been disappointed at not being able to vote at election time, due to the fact that business demanded them on the road, will be interested in the proposed amendment to the State Constitution. The Merchants' Association of New York is advocating an amendment which will permit commercial travelers who are absent from the State on Election Day to cast their votes.

This amendment, as approved by the last two Legislatures, inserts in Article 2 of the State Constitution a new section to be known as Section 1-a, which reads as follows:

1-a. The Legislature may, by general law, provide a manner in which, and the time and place at which, qualified voters who may, on the occurrence of any general election, be unavoidably absent from the State or county of their residence because their duties, occupation or business require them to be elsewhere within the United States, may vote, and for the return and canvass of their votes in the election district in which they respectively reside.

This proposed amendment will have to be submitted to the people for their approval or rejection in the coming general election in November. The National Council of Traveling Salesmen's Association has urged this action to give the proposed amendment its approval and to aid in procuring its adoption at the polls.

**INTERESTING LITERATURE**

The Faultless Caster Co., of Evansville, Ind., has recently issued a very elucidating book entitled, "Faultless—and Why," which explains in detail the mechanical features of the Faultless roller casters and, in a very neat way, emphasizes why it pays to "move the Faultless way."

**WE WANT JOB LOTS OF MOTORS, TONE ARMS, RECORDS, NO QUANTITY TOO LARGE OR TOO SMALL. WHAT HAVE YOU?**  
Commercial Bldg., Lake & Dearborn Sts., CHICAGO, ILL.

**SALESMEN ARE CRANKS ON TONE**

They have tried every needle on the market—but now they are perfectly happy with the perfect needle.

**THE DE LUXE STYLUS**

It plays 100 to 300 Records Three for 30 Cents

They are enthusiastic about it because it does

not scratch or hiss.

It brings out the perfect tone.

Used once always enjoyed.

You can't afford to be without The DE LUXE

**The Duo-Tone Co.**

Manufacturers of Talking Machine Needles

ANSONIA, CONN.

**ATTENDING VICTOR SALES SCHOOL**

At present there are three of the salesmen of the New York Talking Machine Co., of Camden, N. J., taking the regular two weeks' course at the Victor Salesmanship School. They are R. Owens, New York City representative, and Fred. S. Stewart, New England representative. During the two weeks' instructions they will learn many of the fine points in the sale of the machine, the proper use of needles and Red Seal records. In the course on records they will study the composer, the artist and particular attractions of over two hundred and fifty Victor Red Seal records.

Mr. Delano, who is in charge of the course, has had a vast experience in the retail trade, and for this reason the course which he is teaching is chuck full of sales facts that cannot fail to benefit those who attend this important class.

**PHONOGRAPH CASES**

and

**Plywood Cases**

ARE SYNONYMOUS

For 10 years phonographs have travelled in plywood cases and have reached destination in perfect condition.

Our capacity and experience in manufacturing good service and well made cases.

We build cases suitable for export. Let us figure on your requirements.

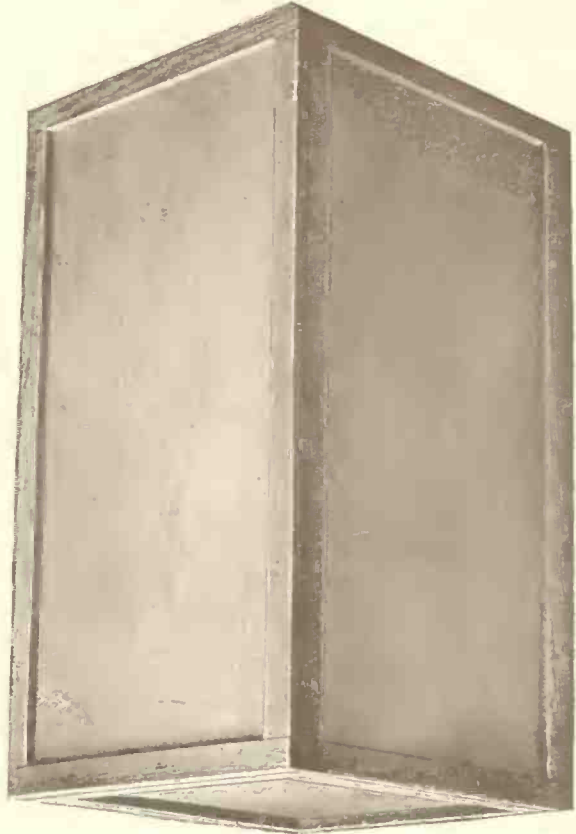

Reinforced 3 ply veneer THE STANDARD CASE for Talking Machine and Records

**PLYWOOD CORPORATION**

GOLDSBORO, N. C.

8 Mills in Va., N. C., and S. C.

New York Office, 103 Park Ave.

Chicago Office, 111 Monroe St.



**PLANNING FOR FUTURE IN DENVER**

**Retailers Maintaining Their Advertising on a Liberal Basis in Preparation for the Fall and Winter Business—Charles E. Wells Music Co. Incorporated—Other News of Interest**

DENVER, COLO., August 1.—The talking machine dealers of this city, although hampered somewhat by a shortage of machines, are maintaining their advertising and are paving the way to future sales. The outlook for an unusually large grain harvest this fall is very bright and a big volume of business is expected by the music dealers in consequence. L. M. Gjerde, manager of the Brunswick-Balke-Collender Co., of this city, says that there is a decided shortage of Brunswicks and all machines in general, but finds in this fact one advantage at least. Since all concerns are behind on deliveries, he says, dealers have looked up the different distributors in their territory in an effort to get machines and members of the trade have in this way become better acquainted. This will

lead to bigger and better business in the future.

The Charles E. Wells Music Co has been incorporated for \$150,000 by Charles E. Wells, F. H. Hunter and L. C. Fetter. Horace P. Wells, son of Charles E. Wells, has returned from France and has joined the staff.

The McKannon Piano Co., Edison dealer, has completed the remodeling of the store. Several demonstration booths have been installed. This store is one of the oldest in this part of the country, having been established by the McKannon brothers in 1889. Previous to this time they had been in business in Burlington, Vt.

The Baldwin Piano Co., which recently took on the Columbia line, has been advertising the Grafonola extensively.

Among the progressive music houses of this city enjoying the summer trade activity are the Knight-Campbell Music Co., Wells Music Co., Darrow Music Co., Cassell Bros. Music Co., Mapel Piano Co., McKannon Piano Co., Baldwin Piano Co., Denver Music Co., Knight-Atmore Co., the Grafonola Store Co. and the Robert D. Sharp Music Co.

**ALBUMS TO COST MORE**

**President of Peerless Album Co. Tells of Reason for Coming Increase in Prices**

Phil A. Ravis, president of the Peerless Album Co., manufacturers of record albums, in speaking of conditions affecting the album trade recently stated that with the present prices of materials it would without doubt be necessary to raise the prices of albums in the near future. The demand for albums is constantly increasing and while the production also has been increased the added cost of materials exceeds any saving that is made by quantity production.

**DUDLEY GEDDES IN THE EAST**

Dudley Geddes, the record expert of the Columbia Graphophone Co.'s Detroit branch, is spending a few days in New York in order to get in close relationship with the home office. Mr. Geddes has visited the executive offices and also the Columbia factory at Bridgeport.

No Attachment Needed  
No Sound Box  
to turn

Can be played on any  
phonograph using  
a steel needle



Model B  
Mahogany  
or Oak

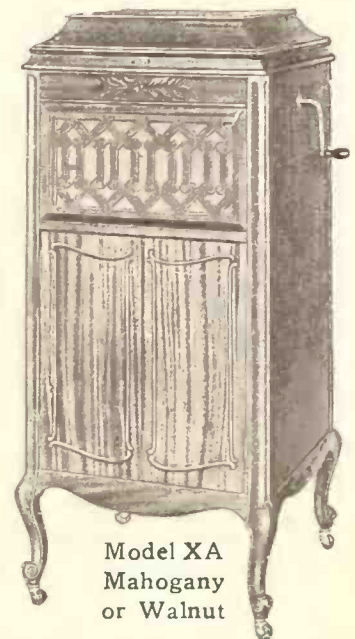

Model XA  
Mahogany  
or Walnut

The Machine  
that Plays  
any Record

The Machine  
that Plays  
any Record

The Empire line shows value in every way. Designs, workmanship, finish — every detail will stand your examination and we are also prepared to make immediate shipments. Empire records can be played on any phonograph using a steel needle — see our list of September records in the record bulletin of this paper.

**WRITE FOR OUR CATALOG AND AGENCY PROPOSITION**

Empire talking machines are unexcelled in quality and are all equipped with high grade motors. There are nine models in the line—prices at retail are from \$35.00 to \$250.00.

**EMPIRE TALKING MACHINE CO.**

John H. Steinmetz, President  
429 South Wabash Avenue, Chicago, Ill.





## Van and Schenck sing "Oh! How She Can Sing." You'll Say: Oh! How They Do Sell! —A-2757.

**Columbia Graphophone Co.  
NEW YORK**

### N. Y. T. M. CO. HOLDS OUTING

Entire Staff of New York Talking Machine Co. Attend Enjoyable Affair at Rye Beach—Athletic Events, Dancing and a Bountiful Shore Dinner Among the Features

The entire force of the New York Talking Machine Co. held its annual summer outing at



The Winning Team

Rye Beach on Saturday, July 26. The party went by buses from the offices of the company, located at 119 West Fortieth street, New York City, to Rye Beach. On arrival there a luncheon was enjoyed by all and the afternoon was taken up by sports of all sorts by those who enjoyed them, while for others theatre tickets were fur-

nished. At six o'clock a shore dinner was served at the Beach Hill Inn.

The athletic meet in the afternoon, which was the main feature of the outing, served to bring forth many "dark horses," which the managers of some of the local athletic clubs might find it well worth their time to look up.

As there seemed to be some discussion between the married and unmarried men the score was tabulated in order to see which showed greater skill. In all the events up to the tug-of-war the single men seemed to show their superiority, with Morey Owens shining out as the star. In the tug-of-war and the fifty-yard swim the married men seemed to bring forth their qualities, with A. D. Geissler, commonly known as A. D. by the boys, showing forth as their star.

But in the ball game, which was the most popular contest of the day, the single men again showed their superior ability over the married men. A handsome loving cup had been offered by A. D. Geissler for the first team to win three games, and as this was the first game a hot contest ensued as to who should possess the cup until the ensuing game next year. The height of interest was reached when Roy Keith cleverly placed a liner and cleaned the bases, bringing in three runs. In order not to embarrass the married men it would suffice to say that the final score was strongly in favor of those unmarried. The married men, however, have threatened at the next annual outing to take the cup away from the single men.

At the shore dinner which followed a spirit of good fellowship and gayness reigned, rousing cheers being given for Mr. Geissler and Mr. Ernst. During and after the dinner there was dancing. Later there was some singing by



The Vanquished

several of the guests. Toward 11 o'clock the buses to take the picnickers home arrived, and, with much protesting by all that such a rollicking good time should be broken up, they were brought back to the city.

### TO HANDLE REGINA CO. ADS

W. A. Schmitt Appointed to the Post of Advertising Manager of the Regina Co.

W. A. Schmitt, formerly vice-president and secretary of the Lobo Macaroni Co., has been appointed advertising manager of the Regina Co., manufacturers of the Reginaophone, and who for over twenty-five years have manufactured musical instruments of various sorts.

It is understood that the Regina Co. will embark on a big publicity campaign in the early fall, some of it of a national character and some in conjunction with the local dealers in territory where the Regina Co. and their products are represented.

### A SNAPPY HOUSE ORGAN

The Stewart Talking Machine Co., well-known Victor distributors, of Indianapolis, Ind., recently started issuing a very snappy house organ newspaper which is published weekly. Among the recent features of this newspaper was an article outlining the real significance of the lowering in price of Red Seal records, an article on the new array of period style Victrolas and a narrative entitled "Bastille Day Celebration and the Victrola 25." The paper is also sprinkled with meaty suggestions on how to sell machines and records.

Our prices on steel needles and sapphire points for Edison and Pathe records will astound you.

**COLE & DUNAS MUSIC CO.**  
54 W. Lake St. Chicago, Ill.

## H. G. NEU & CO. PAPERS

*Manufacturers of*

Neu-lopes  
Record Envelopes  
Wrapping Papers  
Envelopes and Boxes

OR ANY OTHER PHONOGRAPH SPECIALTIES  
IF MADE OF PAPER

*"If It's Made of Paper We Have It"*

H. G. NEU & CO. 108 Worth St., New York



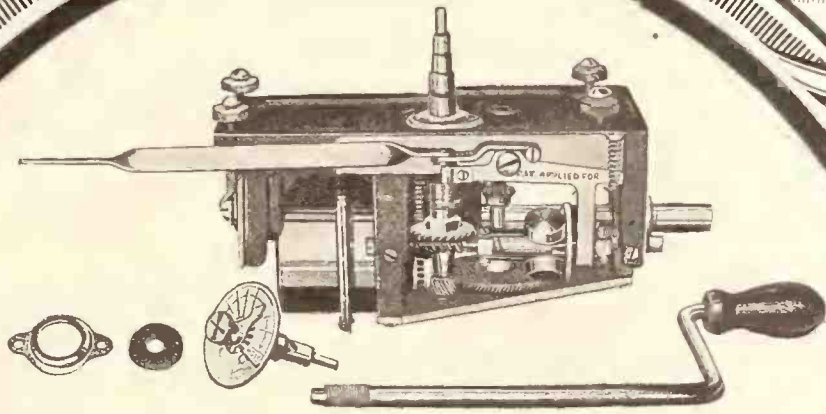

No. 2-A Motor

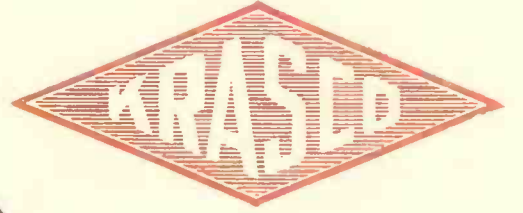

# *Silent Power*

## *The Announcement*

of our increased production of phonograph motors has met with a most flattering response from the trade.

Several years of successful motor construction have given to our product a prestige among phonograph producers that is undeniable.

In our motors is embodied the same excellent workmanship which has been a feature of the tools and machinery so long produced by us.

You should get acquainted with SILENT POWER.

We will send you literature.

Better still, we will send you a few motors for your inspection.

**KRASBERG ENGINEERING AND  
MANUFACTURING CORPORATION  
CHICAGO**

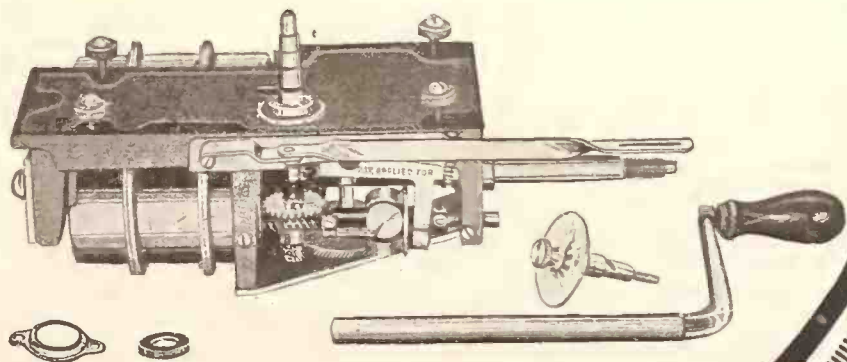

No. 4 Motor





# The Instrumentized, All-Record Player



## Why *Dalion* Sells Better

**THE Auto-File**—exclusive with the *Dalion*. Not only is it the neatest and most compact of record filing devices, but it makes it totally impossible to misfile or misplace records no matter how hurried you may be. By a marvelously simple and ingenious device every record must go back to its individual compartment before another can be taken out.

**Instrumentized Tone Throat.** The triumph of the *Dalion*, embodying the scientific principles of instrument acoustics, applied through the deft skill of hand workers. Their careful, individual shaping of the long-seasoned wood is not factory work but the prideful touch of the real instrument maker.

**Orchestra-Shell Tone Chamber.** All-wood sounding chamber, shaped as scientifically as an orchestra shell, the *Dalion* gets its wonderful resonance and clarity.

**Motors.** Two- and three-spring, according to size of instrument. Long-running, easy-winding and guaranteed against spring breakage.

## A Better Phonograph with a Better Selling Plan

### “Nationalized for Wholesalers” and You

**T**HE discovery that the nationally advertised trademark could be used, has been abused. The nationalized trademark of the *Dalion* will never be used to cut out the wholesaler! It will be used for their benefit—and yours.

Suppose, Mr. Retailer, that all your stock had to come by long distance shipment from factories—what big money you would be compelled to tie up in reserve stock. Let nearby wholesalers carry the reserve—do your business on small shipment turnover.

For self-interest, support your wholesalers, who deserve it because of modern merchandising methods. It's your protection against arbitrary dictation, as well as an assurance of service.

**T**HE *Dalion* wholesaler steps out with a new standard of service—factory trained men to give you co-operation and show you the Merchandising Methods which bring success. Your *Dalion* wholesaler carries a big reserve stock—maintains a service department—is practically a factory branch.

—and behind the wholesaler, directly co-operating with you, is the *Dalion* factory promotion organization. We will back our belief in your success dollar for dollar with you. The details of our retail merchandising plan will prove it. Write for it.

The biggest unit of sale ever possible in almost every home—the greatest money-profit per sale—that's the phonograph business!

Are you interested in it on the basis of an extraordinarily attractive, exclusive agency proposition? Write for details—for figures as to your reasonably possible profits.

Milwaukee Talking Machine Mfg. Co., *Milwaukee*

Prices \$97.50 to \$300.00





**WITLIN JOINS COLLINGS & PRICE**

Former Member of Victor Traveling Staff Joins Newark Concern—Has Extensive Acquaintance With Dealers in the Eastern States

NEWARK, N. J., August 8.—One of the numerous changes resulting in the Victor industry, as a result of recent new distributors' arrangements, is the severance of Ben Witlin from the Victor factory, and his connection with the Collings & Price Co., of this city.

Mr. Witlin has had a wide experience in the traveling department of the Victor Co., having



Ben Witlin

an extensive dealer acquaintance in eastern Pennsylvania, New Jersey and the South, in all sections of which he traveled extensively in the business building department of the Victor Co.

He was more recently resident representative of the Victor traveling department in Philadelphia, where he established an enviable record in co-operative work with the dealers and jobbers.

Numerous testimonials of his value to the industry in the form of personal letters have been sent to Mr. Witlin from well wishers in congratulating him over his new connection.

With the Collings & Price Co., Mr. Witlin will work directly under the heads of the company, forming a close contact with dealers in New Jersey and northeastern Pennsylvania, in which he expects to give a great deal of his time to co-operative business with the dealers.

**A NEW STEPHENSON BULLETIN**

Some New Facts Regarding Stephenson Motor Construction Offered to Trade

Stephenson, Inc., manufacturers of the Stephenson "Precision Made Motor," have just forwarded to the trade a new bulletin known as New Bulletin No. 10, which renews the supply of general descriptive information regarding the Stephenson Motor. An introduction by Frank T. Nutze, vice-president of the company, appears as a "foreword," following which are illustrations and descriptions of the construction, adjustments and the accessories of the motor. The general specifications and a few words in regard to the workmanship itself follow and the bulletin closes with the Stephenson guarantee given below:

"Stephenson products are fully guaranteed. And this guarantee is without time limit. Of course, we do not make the ridiculous claim that our products will not depreciate under years of hard usage, neither do we insure them against abuse, accident or the like. But we do hold ourselves responsible indefinitely for any defect that may manifest itself in material or workmanship. Stephenson products are strictly high grade and honestly made, and our guarantee covers everything such a claim implies."

**TO STIMULATE MAIL ORDERS**

The new Service Bureau inaugurated by the Talking Machine Men Incorporated, the organization composed of talking machine dealers of New York, New Jersey and Connecticut, has recently obtained some coin cards that can be used for mailing purposes. These cards have been used successfully by dealers in kodaks and photo supplies, and it is thought that talking machine dealers can also make use of them by enclosing with their monthly circulars and catalogs. The cards are made to hold a dollar and seventy cents, and thus can be used for the purchase of at least one record by mail.

**TAX ON SALESMEN IN JAMAICA**

The Government of Jamaica has instituted a tax on commercial travelers representing foreign business houses, which has been effective from June 1. Commercial travelers are required to register, reports Consul Charles E. Asbury at Port Antonio, and pay an annual tax of \$48.66. Failure to register and pay the tax involves heavy penalties.

**FALL IN WITH FALL TRADE**

Arrange for your supply of

**UDELL CABINETS**

at the earliest possible moment. You can't have too many—you probably won't have enough of cabinets with this trademark.



TRADE-MARK



NO. 404  
[Vertical Interior]  
For Columbia B or C

Height, 32 in. Width, 17 in. Depth, 17 in. Holds 208 records. Quartered oak front; mahogany front. Average weight, crated, 75 pounds.

[If horizontal shelving is desired, order No. 1404.]

[When felt interior is wanted, order No. 401F.]

**THE UDELL WORKS**

1205 28th Street  
INDIANAPOLIS, :: IND.

**The "VICSONIA" Reproducer**



The ONLY sound box for the PERFECT playing of

**Edison Diamond Disc Records**  
on "VICTROLAS" and "GRAFONOLAS"

Instantly and easily attached or detached. A child can do it.  
No alterations necessary.

*A fine combination of beauty and wonderful tone.  
Always satisfies where others fail.*

**RETAIL PRICE: Nickel, \$7.50, Gold, \$9.00. Order NOW.**

Send check for \$4.50 and we will mail you one N. P. Vicsonia.

Money refunded if not absolutely satisfactory.

**VICSONIA MANUFACTURING CO., Inc.**

313 EAST 134th ST. JAMES W. GREENE, Export Manager NEW YORK, N. Y.  
25 Church St., New York



# Do You Know

## THE Cardinal PHONOGRAPH

TRADE MARK  
APPLIED FOR



Hearth  
\$55.00

Pierre  
\$75.00



Stratford  
\$100.00



Sherwood  
\$150.00



Manor  
\$200.00



*Mr. Dealer--- Meet The CARDINAL  
Take just a moment to get acquainted.*

**H**ERE are instruments stamped with the superlative of excellence. They set a standard in quality, appearance and construction that none yet have reached.

With the wonderful new tone expansion tongue as a big selling point and our liberal sales policy and generous discounts, there is every reason in the world why you should take on the CARDINAL line *and do a big, profitable business right from the start.*

The CARDINAL on your floor and the beautiful posters and big displays that go with it will prove the most effective advertising you can possibly get for your store.

Send us a card with your name and address---if you are at all interested in a proposition that will make money for you and your company.

**THE CARDINAL PHONOGRAPH CO.**  
**Newark, Ohio**

Factories, Zanesville, Ohio, U. S. A.

*Makers of the best in Phonographs---The CARDINAL*

### TELL US THIS, PLEASE---

1. Do you handle phonographs now?
2. Are you selling or have you ever sold more than two makes of phonographs?
3. How many machines (approximately) did you sell in 1918.

**And Get Our Special Offer**



**“How Can You Say Good-Bye?” is an Irving and Jack Kaufman Tenor Duet. You’ll say good-bye to a lot of these records when your customers hear this song. A-2754.**

**Columbia Graphophone Co.  
NEW YORK**



**A PROGRESSIVE BAYSIDE DEALER**

Marcy Riesenburger, who recently bought from Irving Riesenburger, his brother, the Victor shop located in Bayside, L. I., is increasing his business by means of clever publicity. He has not only employed signboards to bring the public’s attention to his Victrola shop, but he has also specialized in publicity in the schools



The Riesenburger Showrooms in Bayside by giving concerts. These concerts, which were absolutely free, and at which programs were distributed bearing the name of his firm, proved to have a big pulling power. Through the programs which the children took home with them his name became familiar with the

families in his locality, and the result has been the increase in both record and Victrola business. The illustration accompanying shows the interior of Mr. Riesenburger’s store. Attention is called to the display of records and to the framed portraits of musical stars.

**J. L. HALL & SONS CHANGE NAME**

The firm of J. L. Hall & Sons, Milton, W. Va., manufacturers of talking machine cabinets, have recently changed their name to the Specialty Manufacturing Co. J. L. Hall is president of the new company, while Virgil L. Hall becomes secretary and treasurer. They will continue to manufacture talking machine cabinets in the white as heretofore.

**PAULL HAYDEN RETURNS**

Paull Hayden, editor of the Columbia Record, recently returned from a two weeks’ vacation spent at Nantucket. Mr. Hayden, who is a tennis enthusiast and a “duck” at aquatic sports, spent most of his time either on the court or in the water. He has returned with a more energetic spirit than ever and expects to turn out some lively issues of the Columbia Record in the next few months.

Miss Lillian Kilpatrick, Marianna, Fla., has been appointed Pathé agent for her county.

**NEW SONORA PERIOD MODEL**

Handsome Creation in Sheraton Design Wins Much Favorable Attention

One of the new Sonora period models which has just been brought before the public eye is the Sheraton model. This instrument is extremely graceful in appearance, making it one of the daintiest of all the Sonora art creations. As the illustration shows it carries a charm because of its simplicity of design, the attractive inlay and the gracefully tapered legs



Sonora Sheraton Model making it quite a favorite with people who are critical and exacting in their tastes.

Following the true Sheraton originals, the construction of this Sonora is based on square lines, without the defects of light shadows made by projecting ornaments. The model is thirty-seven inches high, forty inches in width and twenty-three inches deep. The finish is mahogany with antique gold trimmings. The tone arm, which is of wood, is appropriately carved to match the period design. The record compartment within the cabinet has an envelope filing system with a capacity of sixty records. The motor and tone modifier, automatic stop and other exclusive features of the Sonora are part of this new model.

As the Sonora executive offices described the machine. “Its beauty lies in its purity of design and the perfection of craftsmanship which it reveals.”

**J. F. TESH A VISITOR**

J. F. Tesh, treasurer and manager of the Rominger Furniture Co., Winston-Salem, N. C., last week visited the offices of the Columbia Graphophone Co. Mr. Tesh, who is a progressive Columbia dealer in the South, was accompanied by his wife on his visit to New York. Besides visiting the Columbia offices in the Woolworth Building they also visited the Columbia recording laboratories in the metropolis.

**AUTOMATIC COVER SUPPORT**

**SIMPLE—SUBSTANTIAL  
ECONOMICAL**

No. 1287

**Continuous Hinges  
Automatic Stops**

**“Buy Now, Not Bye and Bye”**

Finished in

- GOLD**
- SILVER**
- NICKEL**
- COPPER**
- BRASS**

Write for New Catalogue

**WEBER-KNAPP CO.  
JAMESTOWN, N. Y.**

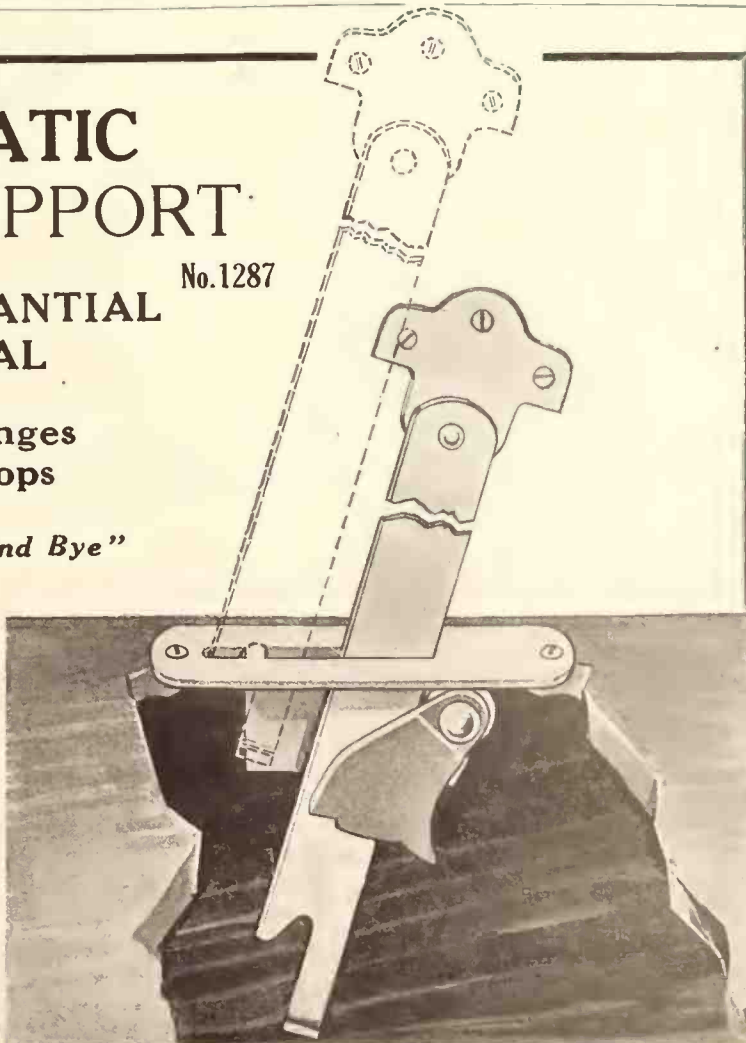





The illustration shown is the store of A. Furer, Stamford, Conn., and is an example of our single construction booths. This outfit was installed complete by our own mechanics and was in use a little over two weeks after time order was given.

Price on application.

**Van Veen**  
"BED SET"

**Booths  
Sectional  
Record Racks  
Record  
Sales Counters**

**How We Serve the Dealer**

Individual service meeting your exact conditions rather than make your business fit our plans.

Send us a plan of your store showing doors, windows, and the position of other fixtures. Our service department will then lay out the installation best fitted for your store.

**Why Van Veen Booths Are Better**

- No. 1. Built of best kiln-dried lumber.
- No. 2. Correctly constructed by skilled craftsmen.
- No. 3. Embody Economy, Simplicity and Efficiency.
- No. 4. Each section is complete in itself, eliminating faulty fitting of numerous small parts that dry out and cause open joints and sound leakage.
- No. 5. High grade glass in large sizes of extra thickness and clearness is a feature, no booths built with less than two-thirds length glass.
- No. 6. Moderate in price and most economical in comparison with any other booths manufactured.
- No. 7. Easily erected, no complicated attachments requiring adjustment.
- No. 8. Handsome in design and high grade cabinet finish.

**Van Veen Booths, Record Racks and Counters Ready for Prompt Shipment**

Write, wire or phone for our representative

**Arthur L. Van Veen & Co., 47 West 34th Street, New York** TELEPHONE GREELEY 4749

**DEMAND AHEAD OF INCREASED SUPPLIES IN TWIN CITIES**

Heavier Shipments of Machines and Records From the Factories Quickly Absorbed by Retailers and the Public—Billboard Advertising for Sonora—Pass Up \$20,000 Order

MINNEAPOLIS and ST. PAUL, MINN., August 6.—The millennium for the talking machine dealers of the Northwest—the time when they can get all the machines they need in their business—has not yet arrived, but otherwise everybody is happy. Business has increased in great strides and although shipments are much heavier than they were a year ago the dealers are worse off than they were then because the demand has far outstripped the efforts of the manufacturers to deliver their products in the northwestern territory. Distributing houses virtually are without stocks as far as machines are concerned. The situation with regard to records is somewhat better, but far from satisfactory.

Jay H. Wheeler, manager of the phonograph department of G. Sommers Co., distributors of the Pathé, reports that he now has about 135,000 records on hand and expects to have more than 200,000 before the big rush begins. The stock of machines is growing but slowly, and

Mr. Wheeler feels that he will be unable to accommodate his customers who are becoming clamorous for their allotment of Pathés. He has received a sample of the Actuelle, and is showing it to visiting dealers who are becoming interested in this novel instrument with its parchment diaphragm.

The Sonora Co. is about to inaugurate a rather extensive billboard advertising plan in Minneapolis in connection with Foster & Waldo. The latter house has been given the exclusive Sonora rights in that city and will push their campaign with characteristic energy.

Sewell D. Andrews, who manages the Sonora department for the Minneapolis Drug Co., which controls the distribution in the northwestern territory, while pleased with the public favor attained by this machine, regrets very much that the factory cannot make greater deliveries out this way, as there is a persistent demand which is gradually extending.

A furniture dealer in one of the thriving towns of Minnesota walked into Beckwith-O'Neill Co.'s headquarters last week and gave an order for \$20,000, half for Victor records and half for Victrolas—that is, he wanted to give the order. It could not be accepted, as the firm is in no position to open new accounts at the present rate of delivery. The house is receiving heavy shipments of Victor records, more than ever before, but the stock is the lowest in the history of the house. Everybody seems to want Victor records. As for machines, they never come to the warehouse at all. Whenever notice is received of the arrival of a carload of Victrolas, a clerk goes down to the freight depot with a marking pot and brush and sends the whole lot to various interior points. In the meantime, E. F. O'Neill has gone off to Lake Vermillion, up on the Canadian border, to fish for pike and bass and has turned his back on the tantalizing talking machine business.

The northwestern headquarters of the Columbia Graphophone Co. removed August 4 to its new location, 18-20-22 North Third street, which is now the largest establishment of its kind in this section of the country. The interior arrangements comprise all the modern devices available and the concern is very nicely housed. One of the features is a model retail store, constructed by the Unit Construction Co., for the benefit of the talking machine dealers of the northwest. It will become a permanent exhibit and is expected to give the small retail dealers all the ideas they may need in equipping and arranging their own stores.

Manager W. L. Sprague reports that he has doubled the Columbia business in this territory, and although very large shipments have been received the orders now on his books and unfilled aggregate \$700,000. Now it's up to the parent house to get busy.

George Mairs, head of the Victrola department of W. J. Dyer & Bro., returned late last month from New York, where he interviewed nearly everybody in authority connected with the Victor Co. He was laden down with promises and assurances when he reached St. Paul and still was under the spell when interviewed by Mr. Correspondent, but at the same time was a little apprehensive that his house would fall far short of accommodating his numerous customers, extending as they do from western Wisconsin to Montana. The Victor demand, he says, is beyond all reason and beyond all control.

Orders for thirty carloads of Brunswick goods are on the desk of E. L. Kern, director of the Brunswick-Balke-Collender Co., in the northwest. Among the orders are ten for carload lots. Then there are more than 100 applica-

**H. J. SMITH LABORATORIES**

*Jewel Manufacturer*

EXECUTIVE OFFICES,  
FINISHING and  
RECORDING  
LABORATORY JEWELS

Plant No. 1  
**833 Broad Street**  
Telephone 2896 Market  
**NEWARK, N. J.**

SAWING  
GRINDING  
ROUGHING  
ROLLING and  
EXPERIMENTAL  
LABORATORY

Plant No. 2  
**54 1/2 Franklin St.**  
**NEWARK, N. J.**

*Manufacturer of*

Phonograph Diamond and Sapphire Reproducing Points—Recording Laboratory Jewels—Rough Diamond—Diamond Powder—Experimental Work. Jewels manufactured for all talking machine records. Consulting Specialist on all experiments relating to any new recording grooves. Recording problems satisfactorily worked out.



tions for permission to open accounts for the sale of Brunswick machines. They can't even be considered.

"July made the best record of the year 1919," said Mr. Kern, "but simply because we received more machines that month. We have taken on only two new accounts in months. The Duluth Glass Block, a big department store has opened a Brunswick line and also the Shiner Furniture Co., of Butte, Montana. Both are doing exceptionally well. The Aeolian-Vocalion is working its way to the front under the able tutelage of the Stone Piano Co., northwestern agents. A roadman who has been working Southern Minnesota is sending in orders continually, while the retail sales in Minneapolis and St. Paul are proving wholly satisfactory.

Mr. and Mrs. Archie Matheis, of Minneapolis, are again on their annual motor tour. Their itinerary includes Oregon and Yellowstone Park, a tour of something like 5,000 miles.

The Peyer Music Co. has given a contract for twelve booths, with record racks and tables for a new store on East Sixth street, St. Paul. This is a Columbia house. The Capital Music Co., recently established at 13 East Seventh street, St. Paul, will be an exclusive Grafonola shop.

Howard, Farwell & Co., recently have added six new demonstration booths to their former battery. A majority of the Minneapolis and St. Paul talking machine dealers will have increased facilities by the first of September.

L. S. Donaldson Co., The Golden Rule, Dayton Drygoods Co., and The Emporium, big department stores, are increasing their talking machine space considerably.

#### A SACRAMENTO WINDOW DISPLAY

Wiley B. Allen Store Increases Record Sales by Effective Window Advertising Displays

SACRAMENTO, CAL., August 5.—Ray Davis, manager of the local branch of the Wiley B. Allen Co., has been paying special attention to the



Wiley B. Allen Co.'s "Dressy" Window art of window dressing and has increased his sales of records and talking machines greatly by this form of advertising. The window display reproduced herewith was designed by Robert P. Raygurt, manager of the talking machine department, who is using all the possibilities for effective display to good advantage.

#### VISITORS AT COLUMBIA OFFICES

Out-of-town Dealers Call at Offices of Columbia Graphophone Co.

Among the many Columbia dealers who visited the executive offices of the Columbia Graphophone Co. this past month were T. Williams, of the Williams Music House, Birmingham, Ala.; Chas. Lonsberg, president of the Lonsberg Book & Music House, Albany, Ga., and Mrs. Florence Perrin, of the Guest Music House, Detroit, Mich.

Mr. Williams was just passing through on his vacation, while Chas. Lonsberg came up to see "the works." While visiting the recording laboratory he had the good fortune to meet Al Jolson.

Mrs. Perrin not only visited the executive offices and recording laboratories, but also visited the factory at Bridgeport. Mrs. Perrin, as might be recalled, won the Columbia record-selling contest a short time ago by her active work in the sales department.

#### MAYER'S SONORA DEPARTMENT

Charles Mayer & Co. Featuring Sonora in Attractive Local Advertising

INDIANAPOLIS, IND., August 8.—Charles Mayer & Co. have one of the most attractive talking



Attractive Sonora Display machine departments in this city and the accompanying illustration shows their Sonora de-

partment and speaks for itself. Ernest L. Arthur, manager of the Sonora department, has been conducting a high-class advertising campaign in the interests of this machine, and the sales campaign is bringing big results.

#### INTRODUCE NEW COVER SUPPORT

Automatic Cover Support & Manufacturing Co. Product Proves Popular in Trade

NEWARK, N. J., July 30.—A new special cover support is now being produced by the Automatic Cover Support & Mfg. Co., of this city, which will be designated as "Style No. 2." "Style No. 1," which they will still continue to manufacture, and which is proving very popular, may be adjusted at any angle. "Style No. 2" must be bent to fit the required angle. A. F. Zega, president of the company, announces that "Style No. 2" can be produced and sold at a lower price than "Style No. 1," and is destined to meet the demands of the manufacturer desiring the more economic cover support.

## LU-FRANC says—

### I'LL TELL THE WORLD

that if brains were money I'd still be no awful rival of Rockefeller; yet from what people tell me, I really must have thought up somethin' pretty durn smart in this monthly envelope service of mine for Victor dealers exclusively.

And on the other hand, as the cop says as he closes up the bracelets, if money were brains, any gink with only enough kale for the price of one glass of this almost nearly near-beer would have gray matter aplenty, to see the good that comes to Victor Dealers who contract for a service like mine.

I'll cut the slang and write a reg'lar letter to all those Victor Dealers who write and ask for information about my proposition. It's well worth your while to know about it. Stamps are only two cents now, and we refund your expenses if we fail to interest you. Could anything be more fair?

I've a real delivery envelope service for the Victor Dealers. Ask your distributor — he knows!

## LU-FRANC SALES SERVICE

1201 Dime Bank Building :: :: DETROIT, MICH.



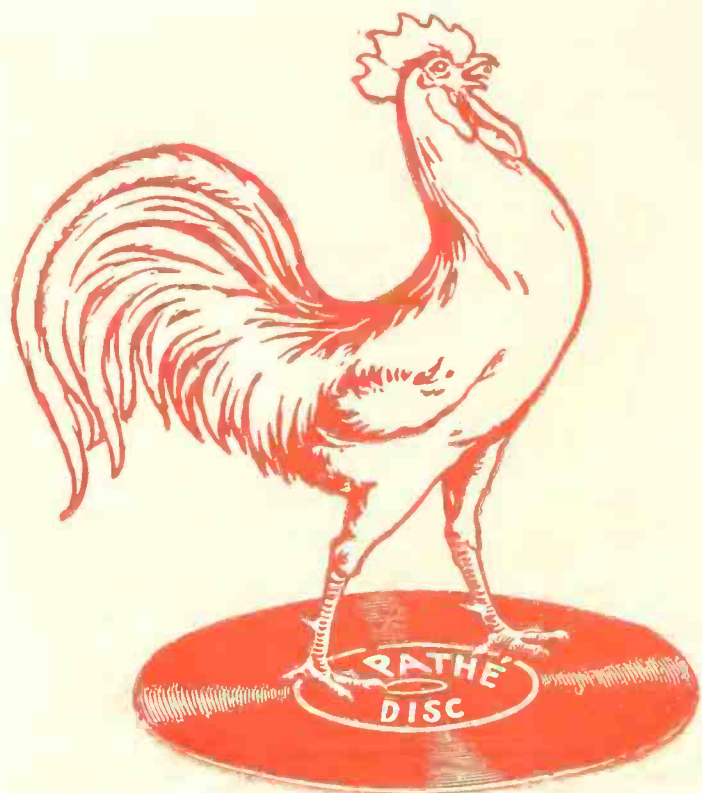

**This trade-mark  
is a symbol  
of supremacy  
in every corner  
of the world.**

**Y**OU don't have to tell people what the Pathé **Red** Rooster on your window stands for. You may stake your reputation as a dealer on this: That they already know it and are entirely familiar with its significance—both as an identification of Pathé phonograph product and as an instantly recognized message of quality flashed daily on ten thousand motion picture screens.

You've got an asset in that red rooster and the Pathé name as big as the world-wide Pathé repertoire—as broad as the claims you can make for Pathé products—and as solid as the business you can build on the exclusive features and **TONE** and quality of both the Pathé and Pathé records.

And it's an asset worth more to you each time we remind the public of what it stands for—as we will with increased force (and frequency) from now on.



**Pathé Frères Phonograph Co.**

E. A. WIDMANN, President

**10-56 Grand Ave., Brooklyn, N. Y.**

And London, Eng.

The Pathé Frères Phonograph Co. of Canada, Ltd., Toronto



**This feature is  
the greatest  
exclusive phono-  
graph selling point  
to-day!**

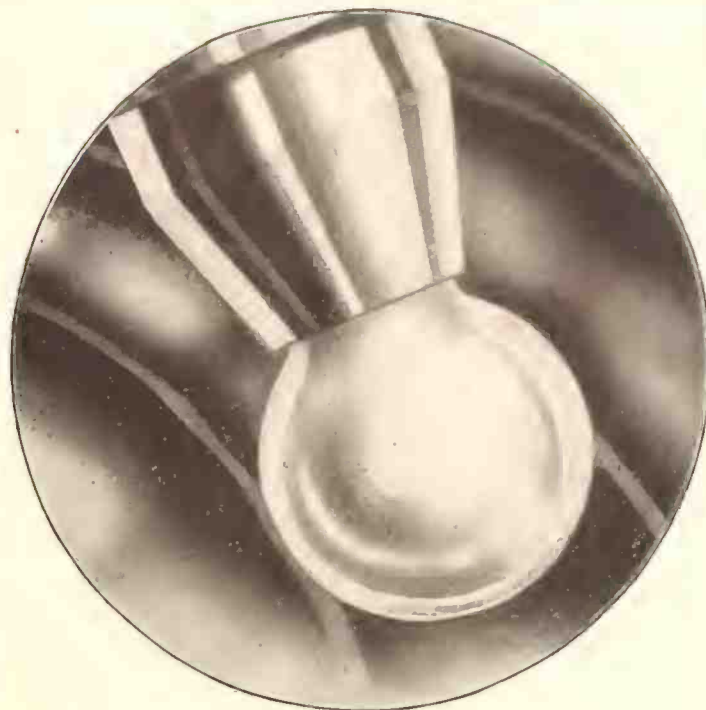

**The Pathé Sapphire Ball**

much enlarged showing how it fits into the half circle of the sound groove, making possible the full reproduction of the delicate "overtones," also showing the microscopically jewel-polished surface that makes possible the Pathé Guarantee below.

**W**E don't need to tell you what sells phonographs: **TONE**, *difference*, exclusiveness—those are the points—and you've got all of them in the **PATHE SAPPHIRE BALL**. You don't have to sell your prospect on comparison of vague, intangible similarities here. The Pathé is different—unmistakably different—convincingly and *demonstrably* different.

There is the point of "no needles to change," for one thing, and elimination of a danger of marring records, for another; the smooth gliding of the sapphire in the sound-grooves; and the matchless purity of **TONE** which that produces; the long life of Pathé Records and the Pathé guarantee—any one point a sales-clincher, and together a combination which is making Pathé product a future in America eclipsing even its leadership abroad.

Remember that "Pathé" is **THE** big proposition in this country. And whether you are tied up with Pathé now or not, you will likely have occasion to be reminded of that prediction with increasing force and frequently from now on!

**We guarantee every Pathé Record to play at least one thousand times with the Pathé Sapphire Ball, without impairment to the unexcelled beauty of tone and without showing any perceptible wear on the record.**

**Pathé Frères Phonograph Co.**

E. A. WIDMANN, President

**10-56 Grand Ave., Brooklyn, N. Y.**



And London, Eng.

The Pathé Frères Phonograph Co. of Canada, Ltd., Toronto



## HEAVY DEMAND FOR RED SEAL RECORDS IN PITTSBURGH

Victor Dealers Cleaning Up as Result of Recent Price Reduction—July Business Generally Breaks Previous Records—Retailers in Various Lines Preparing for Fall

PITTSBURGH, PA., August 5.—The dominant feature of the local talking machine market the past month has been the tremendous sales of the Red Seal records. The price revision announcement made by the Victor Talking Machine Co. is one that has the most cordial and hearty approval of the Victor dealers here and they are now enjoying a very brisk business.

The Victor dealers are unanimous in expressing their commendation of the movement as one that will bring into the homes the good music that so long has been knocking to enter there—but the prices of the Red Seal records hitherto were, in some instances, prohibitive. Now this is swept away and there is no excuse in the opinion of the trade here why the best that the Victor Co. produces should not be in the home. A circular letter is being mailed out to clients by the Standard Talking Machine Co., Victor distributors, explaining this price reduction in detail. The circular letter has ample space for the name and address of the retail Victor dealer and thousands have been sent out the past week with excellent trade-pulling results.

The C. C. Mellor Co., Victor distributor, has given wide newspaper publicity the past few days to a selected list of forty-four Victor records that should be in every home. The Mellor Co. did a very successful business the past few weeks in the Red Seal record division, the demand being very pronounced for the higher-priced records. John Fischer, manager of the Victrola department, has returned to his office after a very pleasant month spent in Canada with his family.

T. T. Evans, assistant manager of the Mellor Victrola department, spent the past week on a business trip to eastern Ohio and West Virginia and found the demand for Victor goods very keen.

George H. Rewbridge, manager of the wholesale Victor department of the W. F. Frederick Piano Co., is highly pleased over the tremendous business that his department has been experiencing in the sale of Red Seal records. He said that the move to reduce prices was a master stroke on the part of the Victor Co. and one that would add to its already powerful prestige and influence.

S. H. Nichols, manager of the Pittsburgh wholesale offices and distributing branch of the Columbia Graphophone Co., said that July business in the Columbia Grafonola and Columbia records was far in excess of the sales made in July, 1918, and pointed out that his department was considerably back in making deliveries, due to the strong demand for machines and records.

Mr. Nichols stated that the service department had been an important factor in expanding the business of the house.

H. Milton Miller, manager of the local offices of the Smith, Kline & French Co., Sonora distributors, stated that the call for Sonora phonographs was far past his ability to satisfy the demand made upon his office.

Gray & Martin, the well-known Jenkins Arcade talking machine dealers, report a brisk sale in the Sonora, Cheney and Mandel machines. Mr. Gray also emphasized the fact that his sales for July were much increased over the same period a year ago. The firm also deals in Emerson records and reports sales as very satisfactory.

J. A. Endres, district sales manager of the Brunswick phonograph, made a business trip through his territory the past week and on his return stated that business was excellent. He pointed out the fact that the success that has followed the introduction of the Brunswick in the Pittsburgh district has been amazing, inasmuch as the demand of the retail trade keeps up at a high pressure and is only limited by the ability to supply phonographs.

H. C. Niles, secretary and treasurer of the Starr Phonograph Co., of Pennsylvania, distributor of Starr phonographs and Gennett records, stated that he was highly pleased with the manner in which the demand for the line was keeping up during the summer months.

A. N. Ansell, manager of the Victrola department of McCreery & Co., returned from a pleasant vacation trip via automobile through some of the garden spots of Pennsylvania and Maryland. He was accompanied by Mrs. Ansell. He left last Sunday night on a business trip to New York and a trip to the Victor plant at Camden, N. J.

H. C. Hornberger, formerly manager of the talking machine department of Kaufmann & Baer Co., is now connected with the World Phonograph Co. here.

John Henk, manager of the Columbia Music

Co., exclusive Columbia dealer, is home from Atlantic City after a vacation outing there. He and his family made the trip in their machine.

Dauler & Close, the leading furniture house, who are handling the Cheney phonograph, report the demand for the Cheney as keeping up at a good rate. The firm has been using newspaper advertising space very liberally in directing the attention of the public to the merits of the Cheney and has sold a large number of machines in the past few months.

H. J. Brennan, manager of the Pittsburgh Pathéphone Co., left for New York last Friday to confer with President Widmann, of Pathé Frères Phonograph Co. Mr. Brennan stated that the outlook for a big season this fall and winter in the Pittsburgh territory for the Pathé phonograph and Pathé records was very bright.

Joseph Hirsch, manager of the Emerson Sales Co., distributors of the Emerson phonograph, says that the Emerson records are attaining a high degree of popularity in this section, and that his office is kept busy filling orders. Mr.

# The Bubble Books

## Irresistible Business Builders

THE Bubble Books are the quickest selling, most profitable novelty in the talking machine field. Lure the children to your store with these enchanting little volumes, and they will take you right into the heart of the family. When a youngster has bought one he always comes for more.

### Cash in on a Million Sales

We are helping you. A smashing advertising campaign in the leading journals of the home, beginning early in the Fall, will bring a live demand right to your counter—the children and their parents.

We will run large space in such dominating magazines as Ladies' Home Journal, Good Housekeeping, Vogue, Vanity Fair, Life, St. Nicholas, Red Book, Harper's, Scribner's, Century, Review of Reviews, John Martin's Book.

NINE BOOKS NOW READY—NEW ISSUES ALMOST EVERY MONTH

Retail \$1.00 each

Write for discounts, terms and circular matter, and order through your regular channels or direct from us—HARPER & BROTHERS, Franklin Square, New York.

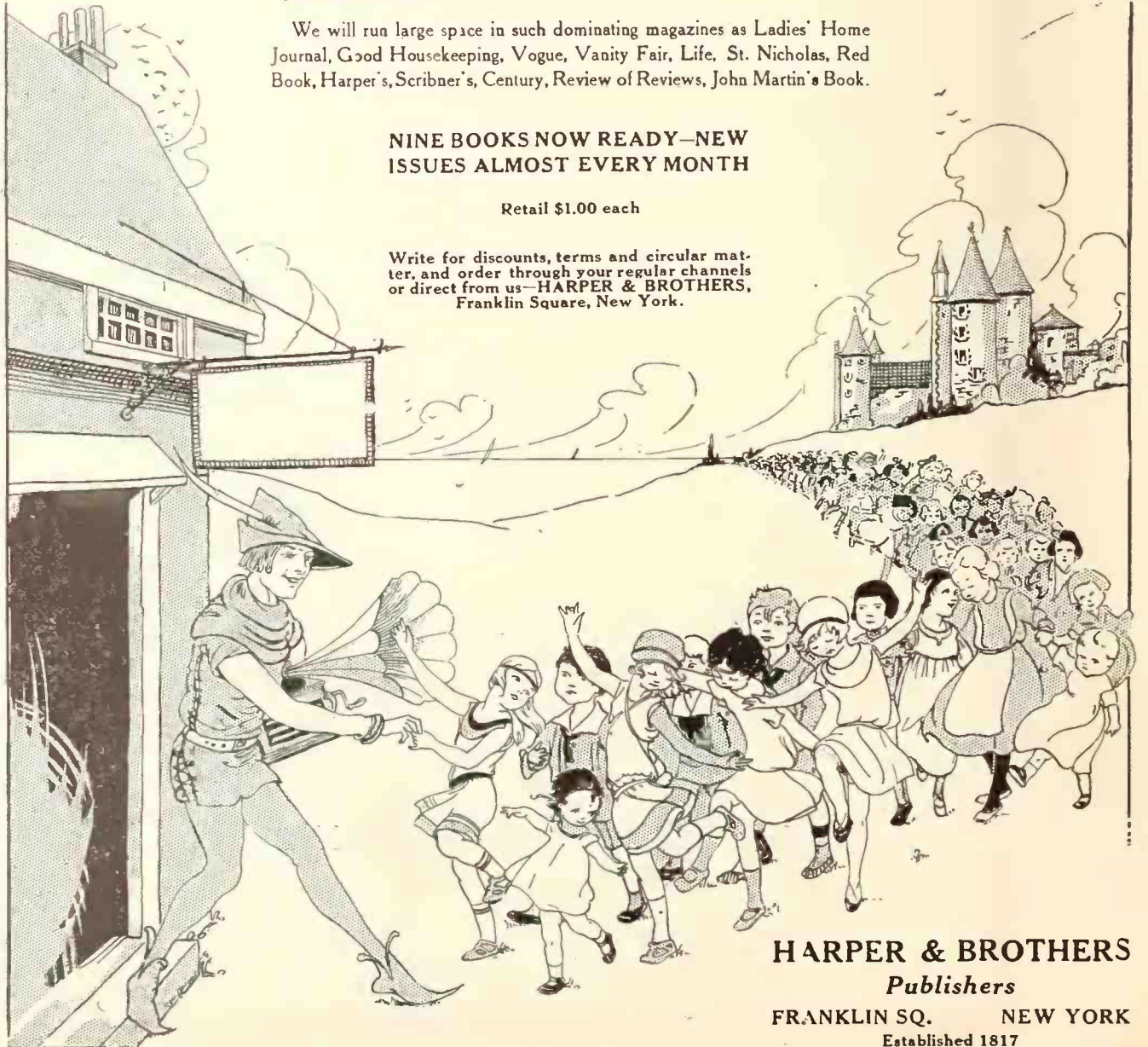

**HARPER & BROTHERS**  
Publishers  
FRANKLIN SQ. NEW YORK  
Established 1817



BEST QUALITY

LOWEST PRICES

**RECORD DELIVERY ENVELOPES**

PLAIN  
1331-33-35 FIFTH AVE.

**The ALDINE CO.**

PRINTED

PITTSBURGH, PA.

Hirsch gives personal attention to his business and is a regular caller on the retail dealers of the Emerson family. Mrs. Hirsch, who is an able co-worker with her husband, is spending several weeks at Atlantic City on a vacation outing.

Hermann Lechner, manager of the talking machine department of Lechner & Schoenberger, is spending his vacation in the East. The firm handles the Victrola, the Edison phonograph and the Columbia Grafonola.

The Buehn Phonograph Co., Edison distributor, is planning a series of tone tests this fall. The first will be a series of twenty-one dates by Marie Tiffany, of the Metropolitan Opera Co., starting September 12. The second will start October 20 and will be by George Wilton Ballard, concert tenor. Mr. Buehn stated that detailed announcements of the local dates and other arrangements would be made later. When the date for the tone test is fixed for Pittsburgh the Buehn Co. plans to have the Edison dealers attend and there may be an informal conference during the day relative to an Edison campaign for local dealers during the fall season.

The Standard Talking Machine Co. had a number of Victor dealers as guests at the St. Clair Country Club last Friday afternoon and evening, when the September list of Victor records was demonstrated. The hosts were J. C. Roush, president of the Standard Co., French Nestor and Wallace Russell. A feature of the event was a chicken and waffle dinner.

The National Phonograph Co., distributor of the Ultraphone, under the management of H. E. Fleishman, reports a marked increase both in the wholesale and retail sales of the Ultraphone. The new Ultraphone Shop in the Jenkins Arcade is very attractively fitted up.

**BUYS INTERESTS OF FIRESTONE CO.**

The Firestone Phonograph Co., 59 East Van Buren street, Chicago, Ill., has been purchased by Nat Kawin, one of the owners and incorporators of the Eastern Phonograph Co., of New York.

**BUILDING ADDITION TO STORE**

Trubin Bros., Red Bank, N. J., are building an addition to their store to take care of the increased trade in the music department, especially in the sale of talking machines.

**FLEXIFILE**  
CHICAGO, U.S.A.

THE PERFECT  
**RECORD FILING SYSTEM**

FOR  
**ALL STYLES OF TALKING MACHINES**  
MANY THOUSANDS IN USE

**DEALERS AND MANUFACTURERS**  
Desirous of supplying their customers with the best possible equipment should

**FURNISH FLEXIFILE**  
It is a pleasure to use FlexiFile, because of its Simplicity, ease of operation, perfect indexing and greater capacity

**INFORM YOURSELF** by writing immediately to

**FLEXIFILE MANUFACTURING CO.**  
115-117 EAST SOUTH WATER STREET  
CHICAGO

**B. BALL RECORDS FOR COLUMBIA**

Authority on American Folk Songs Makes Five Records for Columbia Co.—Has Given Many Historical Lecture-Recitals at Chautauquas

Bentley Ball, well known for his "Song-A-Logue of America," has recently recorded five records for the Columbia Co. Mr. Ball, who is an authority on the history of the American folk songs, has for many seasons been a member of the Chautauqua Tours. During the last two years he has been giving historical lecture-recitals in different schools about the country. Many of Mr. Ball's American folk songs have not been heard outside their original locality. The songs include "Primal America," which deals with the Indians, songs of "The Pioneer," songs of "The Plains" and negro songs of the South.

The Song-A-Logue of America bears a historical significance. Music has always played a part in the history of America, or as Walt Whitman puts it, "I see America go singing to her destiny." The five records which Mr. Ball has recorded for the Columbia Co. cover his entire recital. These records are instructive, unusual and entertaining.

In the near future Mr. Ball will recommence his recitals in the schools, and it is understood that in whatever cities the recitals are given there will be co-operation with the Columbia dealer in that locality.

**VICSONIA CO. INCREASES CAPITAL**

Capital Stock of Corporation Now \$50,000—Wm. J. Sess as President—New Type of Reproducer to Be Ready Shortly

For the purpose of carrying out various plans for the expansion of its business the Vicsonia Mfg. Co., 313 East 134th street, New York, manufacturer of the Vicsonia reproducer, has been reorganized and the capital stock increased from \$5,000 to \$50,000. Under the reorganization William J. Sess becomes president of the company, with David Goldin as vice-president and George Sauger as secretary and treasurer.

The Vicsonia Co., which is enjoying a most substantial demand for Vicsonia reproducers, designed to play Edison records on Victor and Columbia machines, is at present developing another reproducer for the purpose of playing other hill and dale records of what may be termed the needle cut type upon machines designed for lateral cut records. This new reproducer, which is designed to meet a demand that has already made itself evident, will be ready for the market very shortly. The company also has other production plans that will be ready for announcement some time during the next few months.

**TALKING MACHINE STARTS GUN PLAY**

California Man Held on Lunacy Charge After Shooting at Musical Neighbors

LOS ANGELES, CAL., August 4.—Because his neighbors, two discharged soldiers, had a fondness for the songs, "The Rose of No Man's Land" and "Mary, Mary," or had no other records available, and therefore repeated those selections over and over again on a talking machine for several hours each day, Frank Jones, of Sierra Madre, fired seven shots from an automatic pistol into the living room of his neighbor's house, and brought to the soldiers a vivid recollection of their experiences in No Man's Land. After his pistol had been emptied, Jones was overpowered, and detained on a lunacy charge.



**"Unique  
and  
Incomparable"  
Say  
Phono-Grand  
Dealers  
!!Everywhere!!**



That's Why the Demand Keeps

**G-R-O-W-I-N-G!!**

Wise Dealers Know It Is a  
**\$\$ MONEY MAKER \$\$**  
that

**Satisfies Customers**

Phono-Grand is the one big success for public musical entertainment. It combines a Reproducing Piano, Electrically Controlled, with a splendid phonograph.

**!! ALL-IN-ONE !!**

Want Particulars? Write Today.

**J. P. Seeburg Piano Co.**

419 W. Erie St. Chicago, Ill.





Free! Any or all of these leaflets will be sent to you in answer to a request on your business letterhead. There are no secrets about our terms to the trade.

Grey Gull Records are made attractive to you, *not* by unusually large discounts; nor by special concessions of *any* kind. They are made attractive to you because you are certain that *nobody* is buying them on better terms than those published; because they are beautifully recorded and cleanly printed; because they are made by a responsible, strongly financed concern; because you can be sure of getting your monthly quota promptly and regularly, this year, next year, five years from now and twenty years from now. Write us today, at 693 Tremont Street, Boston.





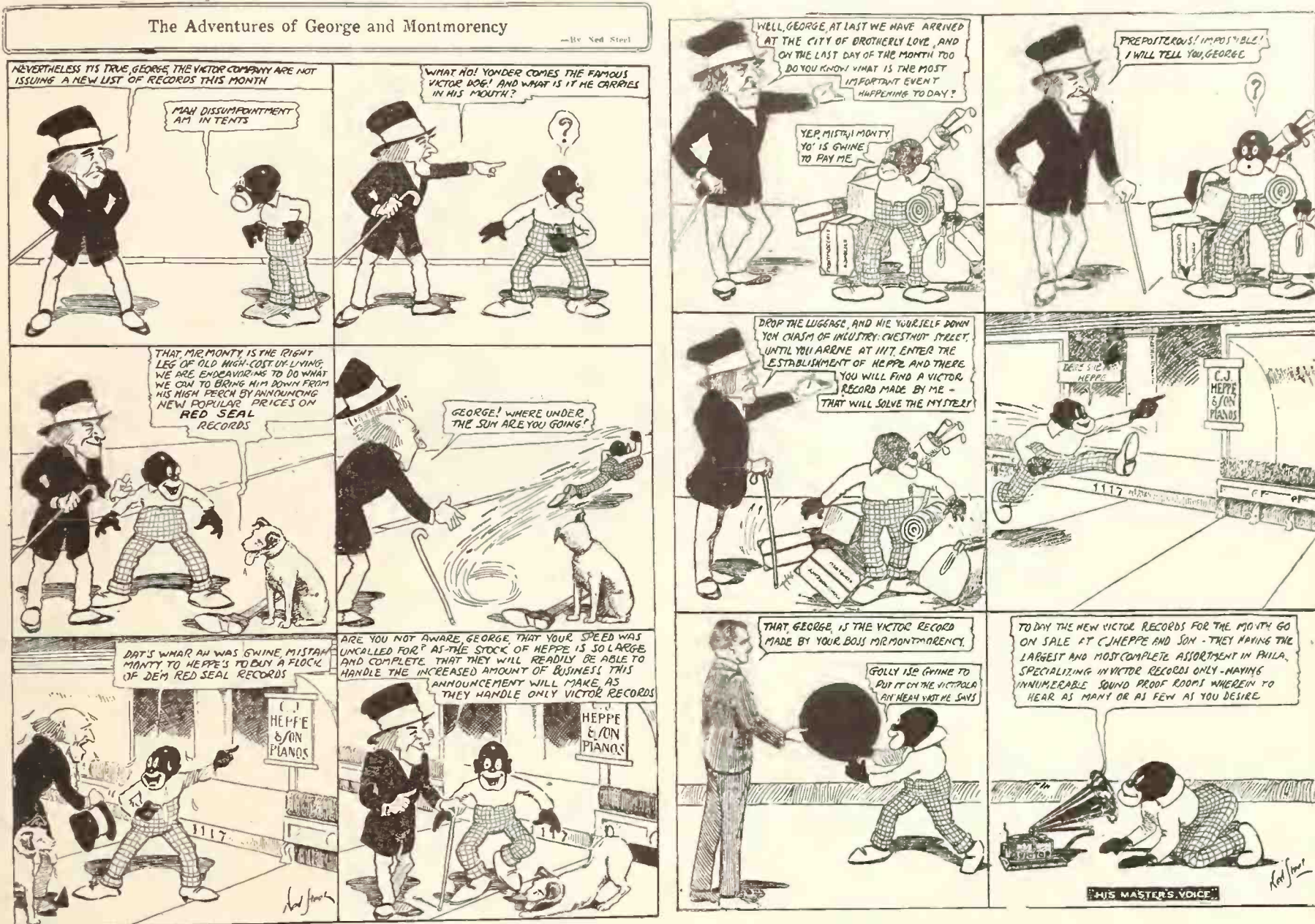

**CLEVER CARTOON ADVERTISING**

C. J. Heppe & Sons Use Familiar Cartoon Series to Advertise Victor Line—The Characters Are Well Known and Attract General Interest—Demonstrates New Trend in Advertising

Novelty in advertising is becoming an art these days and experts are burning midnight oil in search of new ideas. C. J. Heppe & Son,

Philadelphia, are using somewhat unusual methods to feature their Victor talking machine and record department. The familiar cartoon series, "The Adventures of George and Montmorency," by Ned Steel, is made the basis of the clever advertising campaign carried on by Geo. W. Witney, advertising manager. Two of these novel advertisements are reproduced here-with and give an excellent idea of the possibilities of humorous sketches to attract and arouse public

interest. The idea originated in the service department of the advertising staff of the Philadelphia Record and the two characters in the cartoons are familiar to every reader of that paper as well as Philadelphians generally.

The Victor dog brought to life plays a leading part in the adventures and the interest of the reader is held from start to finish. In this way the arguments are brought home in a lasting and effective way.

**What More Can You Ask**

All the features that go to make a talking machine *Profitably Salable* you will find as regular equipment of *Magnola*: "Built by Tone Specialists."



Watching the Music Come Out

Complete description of all these features is to be found in our *handsome illustrated catalog*, which we should like to send you. May we? Ask us to tell you our plans for your benefit!

**MAGNOLA TALKING MACHINE COMPANY**  
 OTTO SCHULZ, President  
 General Offices 711 MILWAUKEE AVENUE CHICAGO  
 Southern Wholesale Branch 1530 CANDLER BLDG. ATLANTA, GA.

**GODFREY DISTRIBUTES VISTA**

Large Milwaukee House Enters Phonograph Field as Exclusive Distributors for the Vista Line in Wisconsin, Iowa and Michigan

MILWAUKEE, Wis., August 9.—E. R. Godfrey & Sons Co., one of the largest wholesale firms in Wisconsin, are now the exclusive distributors for the new Vista phonograph for the States of Wisconsin, Iowa and Michigan, and, though they only entered the field three months ago, report a very large business. The name of Godfrey is known in practically every home in Wisconsin, and it is the aim of this firm to make the Vista as well known. Service has always been a big factor with the house of Godfrey, and it is their intention to give Vista dealers not only perfect service, but co-operation also, and with this determination an entire floor of their large warehouse is devoted to carrying stock, while in their main building a very beautiful department will shortly be installed.

Competent men of years of successful phonograph experience have been secured and very soon an extensive advertising campaign will be begun. Large orders have been placed with the factory, and, though there is a large demand for

Vistas and a much larger one anticipated, the house of Godfrey intend to see that Vista dealers in their territory will have stock.

Plays any make record

THE NEW

**REGINA**  
 DE LUXE

NATURE'S  
 NATURAL TONE®

**PHONOGRAPH**

Made by manufacturers of musical instruments of the highest grade for over a quarter of a century

**A GOOD PROPOSITION!**

—Write for Territory—

**THE REGINA CO.**

47 West 34th Street  
 NEW YORK, N.Y.

209 S. State Street  
 CHICAGO, ILL.

Write for our catalogue "A" on phonographs, records and accessories.

**COLE & DUNAS MUSIC CO.**

54 W. Lake St.

Chicago, Ill.





a  
**HARPONOLA**  
 advertisement  
 by a  
**HARPONOLA**  
 dealer

**The dealer knows**

The machine he stocks is either an asset or a liability to him.

Talking Machine dealers, generally, are pretty wise old owls.

They are quick to buy and buy big when they discover a real machine. And they are generous enough to tell you when your product is really "there."

Here is what one dealer says of the Harponola:—

"The enormous size of our order shows conclusively that we expect to do an enormous business with Harponolas."

"They meet with the approval of the most exacting customer in tone and workmanship."

"Your motors have given us absolutely no trouble and are finely constructed, smooth running and noiseless."

Remember, Harponola Cabinets are made by Mersman-Brandts Brothers.

*Take your cue from this dealer who knows and order your supply before we become over-sold.*

**HARPONOLA COMPANY**

By EDMUND BRANDTS, Sales Manager  
**CELINA, OHIO**

Our OkeH Record proposition is the best in the business for the independent dealer.



**INSTALL FOLDING MACHINE**

Boston Book Co. Equipped With Machine Folding 180,000 Record Containers Daily

The Boston Book Co., New York, the well-known manufacturers of record albums, recently installed a new machine which automatically



Operation of Folding Machines in Plant of Boston Book Co.

folds and glues the record holders. The machine, which was ordered many months ago, was delayed in completion through the war conditions affecting the manufacturer. It was especially

designed and it carries many improvements over any machine of a similar character. It has a capacity of 180,000 record containers per day. The machine practically feeds itself and automatically folds and glues the cardboard inserts into an envelope shape preparatory to their being bound into the record albums.

With the installation of this machine prac-

tically every operation that goes into the making of a record album is made in the New York plant of the company. Herewith is shown a reproduction of the machine in operation.

**NEW MONTANA MUSIC CENTER OPENS**

Great Falls Phonograph Co. Opens Unusual Music Showrooms—Edison Concerts to Be a Feature—Miniature Theatre Built

GREAT FALLS, MONT., August 5.—A very attractive music center has been established in this city by the Great Falls Phonograph Co., at which the Edison phonograph is featured. The new showrooms were opened a short time ago at 506 Central avenue and a concert, at which the celebrated opera star, Marie Rappold, was present, marked the occasion. In the rear of the display rooms is a miniature theatre or recital hall, with a seating capacity of 150 persons, and in this hall many concerts will be held with the advent of cooler weather. This room has a stage on which is placed a Chippendale model Edison, and attractive furnishings make it a very homelike scene.

Allen E. McLean, manager of the Phonograph Shop, is making plans for an elaborate series of concerts this fall and winter, with the purpose of making the people of this city more familiar with the works of the great masters as recorded on the Edison records. These concerts are worked out in detail and one artist and his compositions are to be taken up at each concert. A brief history of the artist and his works will be given and the best-known compositions played. This is a worth-while movement in the cause of the betterment of music and the Grand Falls Phonograph Co. is to be congratulated on its progressive methods.

W. H. Willson, manager of the educational department of the Columbia Co., is at present on a vacation. Mr. Willson expects to spend most of his time riding about in his new Willis-Knight automobile.

The Rosenbaugh-Brown Dry Goods Co., Oklahoma City, Okla., handles talking machines.

**Special on STEEL NEEDLES**

We are contemplating closing a contract for **Thirty Million Needles** Per Month within the near future, and must arrange to sell them, and can quote prices as follows: **For Immediate Delivery**

- 10 thousand lots . . . . . 45c per thousand
- 100 thousand lots . . . . . 43c per thousand
- 500 thousand lots . . . . . 42c per thousand
- 1 million lots . . . . . 39c per thousand
- 5 million lots . . . . . 33c per thousand

**LUCKY "13" PHONOGRAPH CO.**  
 46 East 12th Street, New York

**ALLIED LOYALTY LEAGUE FORMED**

Mrs. Charles H. Ditson, Vice-president of New Organization, to Fight Bolshevism

Mrs. Charles H. Ditson is vice-president of the newly formed Allied Loyalty League, an association organized to fight all evidences of Bolshevik tendencies. It is also an aim of this society to promote good feeling and friendly relations between the United States and the Allies. Members are now being enrolled for a fall campaign, which is planned on a big scale. The headquarters of the league will be at 18 East Forty-first street, New York.

From **\$85** **CULPTONE** To **\$225**



Cabinet Excellence and Tonal Qualities Combine in making the Culptone a Profitable Proposition for the Dealer

Investigate It is paying others Why not You?

*Made up to a Standard Not down to a Price*

**CULP PHONOGRAPH CO.**  
**298 Broadway New York**  
 NOTE NEW ADDRESS





# DEAN



For nearly a quarter of a century this name has stood for the highest quality of Phonograph Steel Needle.

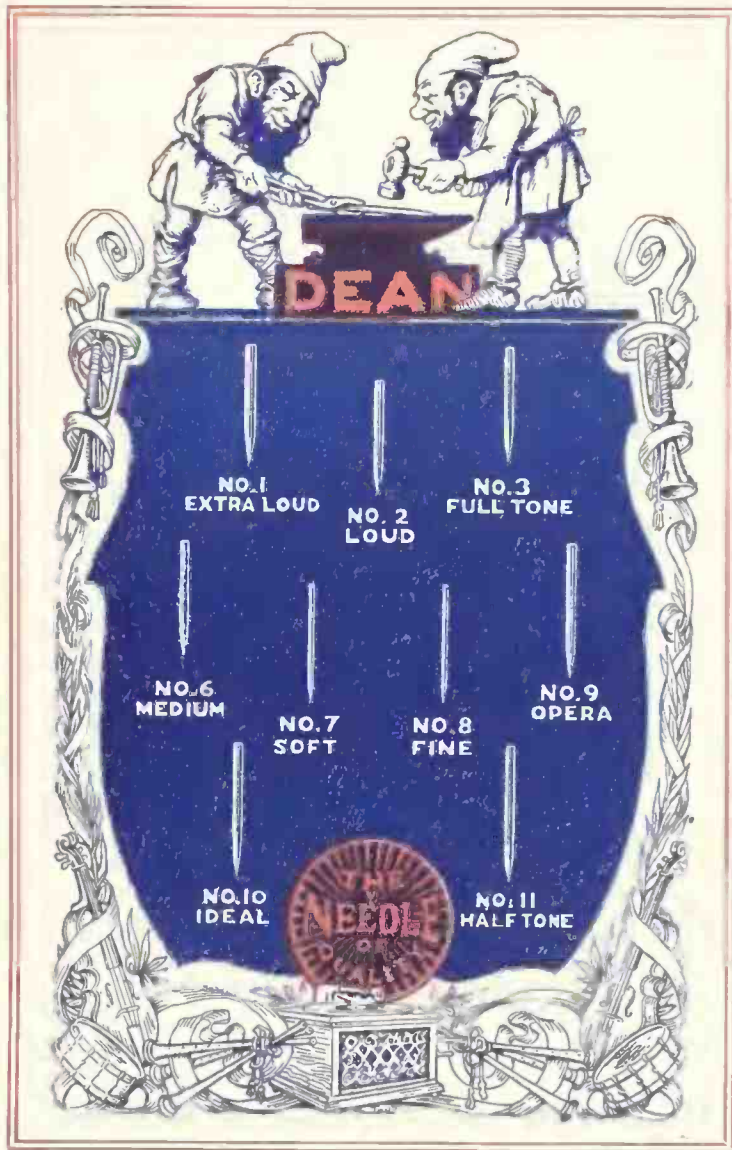

*One Needle with three different tones*  
**LOUD — MEDIUM — SOFT**  
**Petmecky Multitone Steel Needle**

## Petmecky Multitone Steel Needle Plays Ten Records Perfectly

### Three Different Tones

1. For **LOUD TONE** — Play with flattened side facing record.
2. For **MEDIUM TONE** — Play at intermediate angles.
3. For **SOFT TONE** — Play with edge facing record.

**OTTO HEINEMAN PHONOGRAPH SUPPLY CO., Inc.**

25 West 45th Street

New York City, N. Y.

**FACTORIES:** Elyria, Ohio      Newark, N. J.      Putnam, Conn.      Springfield, Mass.  
**BRANCH OFFICES:** Chicago, Ill.      San Francisco, Cal.      Toronto, Ont.



**ATTENTION**

If you are looking for quick service and right prices, get in touch with us on the following lines:

- Q R S Rolls
- Emerson 7 inch Disc Records
- Wall Kane Needles

Complete line always on hand

Write for monthly bulletin, catalog and prices

**Enterprise Music Supply Co.**

145 West 45th St., New York City

MAURICE RICHMOND, Gen'l Mgr.

We are the largest jobbers of sheet music and music books in the U. S.

Save time and money by ordering all your supplies from one house

**A GROWL IN THE DIFFERENTIAL**

A Timely Story Automobically Expressed Which Will Be Read With Interest and Profit by Talking Machine Dealers

"A big Buffalo merchant says, 'My success dates from the time when one morning I bawled out a \$3.00-a-week office-boy without cause or proper explanation, and five minutes after a disgusted, sore office-boy drove my star customer out of one door and he went out another.' If your employes do not like you, they are going to get your customers into that habit some day.

"Now about your automobile. Let's name the two forward wheels of your car 'Speedy Progress' and 'Certain Profits.' The rear driving wheels are 'Customers' and 'Employes,' and the name of the differential is 'Management,' and that of the engine and power is 'Supply' and 'Merchandise-Quality.'

"Funny thing about a differential. It permits one rear wheel to stand still and the other to go ahead, but ye old time Gasolene Hound remembers that you travel in a circle if your rear wheels don't get together. One rear wheel may even go backward and the other forward for a little while, but if they don't get together, perfectly timed, you will make no progress forward. Ever get in a rut? The big difference between a rut and a grave is that the rut is longer.

"No matter how good your care is, you have to travel to the end of that rut. if you don't employ a little brain power to get out. But lay a couple of rails (Improvements) across—give power (Merchandise-Quality) to your vehicle, and out you go on good roads with Progress, Profit, Customers and Employes all happy and going fine, straight ahead, around the corners, up the hills, down the hills, and through all of this never a thought is given to the old differential (if it is working right) but let it go wrong, and the flivver or Rolls-Royce comes to a dead stop or lands you in a ditch.

"It's up to you, Mr. Differential, to keep your business running sweet and clean. By the way, did it ever occur to you that you spend a lot of time growling? A growling differential, even though it does fairly good work, takes the joy out of driving. It's even frequently noticed by the man on the street corner as you pass him.

**DIAMOND POINTS and SAPPHIRES**

In Any Quantity  
**LUCKY 13 PHONOGRAPH CO.**  
 46 East 12th Street, New York

"Your high test motor fuel is Victor Goods—Quality-merchandise—your motor is your store, and may be a Twin-Six or a one-lunger of a vintage of 1903. But what condition is that engine in? Lots of carbon? leaky valves? sooty spark plugs? poor advertising? pardon me, I intended to say ignition, a grabbing clutch? growling gear and general sluggishness?

"While there are mighty few 'dead ones' among the Victor Dealers, there is a cussed tendency in every automobile to slip into a rut, and right now is a fine time to steer a bit the other way, as there is no telling how far you will have to go or what kind of a road trap that rut will take you to.

"Clean up your store, make your improvements, put in your booths, and put a smile into your business that will extend all the way from the consumer to the Factory. Step on it and—Let's go!"

The foregoing constitutes one of the always interesting bulletins recently issued by the Buffalo Talking Machine Co. It is right up to the minute and full of ideas and suggestions that must make an impression.

**ARRANGE TO PROTECT INVENTORS**

International Research Convention Now Meeting in Brussels Agree on International Patent Bureau for the Protection of Inventors

A despatch from Brussels to the New York papers recently says that the members of the patents section of the International Research Convention now meeting there reached an agreement on the establishment of an international patent bureau for the protection of inventors who are now handicapped by costly and widely differing laws of the various countries.

Under the new arrangement none of these laws would be changed so far as native inventors are concerned, but each country would subscribe to an international arrangement protecting foreign inventors. Thus an American inventor would take out a patent in Washington to protect him in the United States and then would apply to the international bureau for protection in every other country. This would do much to obviate the many difficulties experienced in the past.

**CABINETS and TALKING MACHINES for WHOLESALERS, DEALERS, JOBBERS**

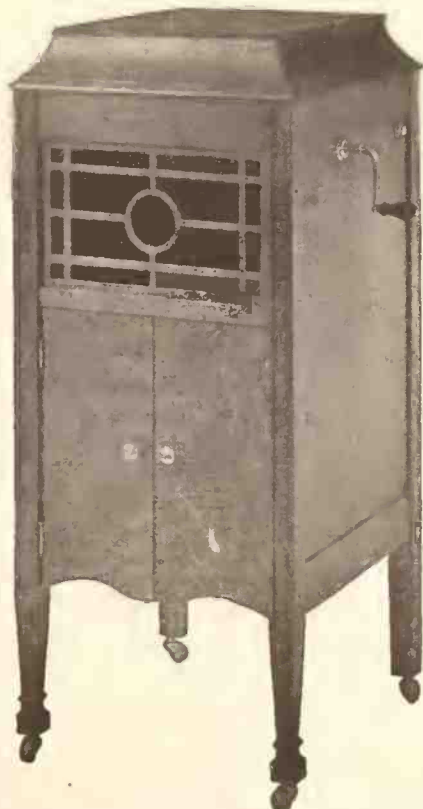

We can supply you with high grade talking machines to suit your every need. While we are cabinet makers we also manufacture complete machines.

We have a large stock prepared ready for shipment to meet the requirements of the trade.

**Prompt Deliveries**

Inquire for Catalog and Price List of

**BEN FERRARA**  
 ONEIDA, NEW YORK



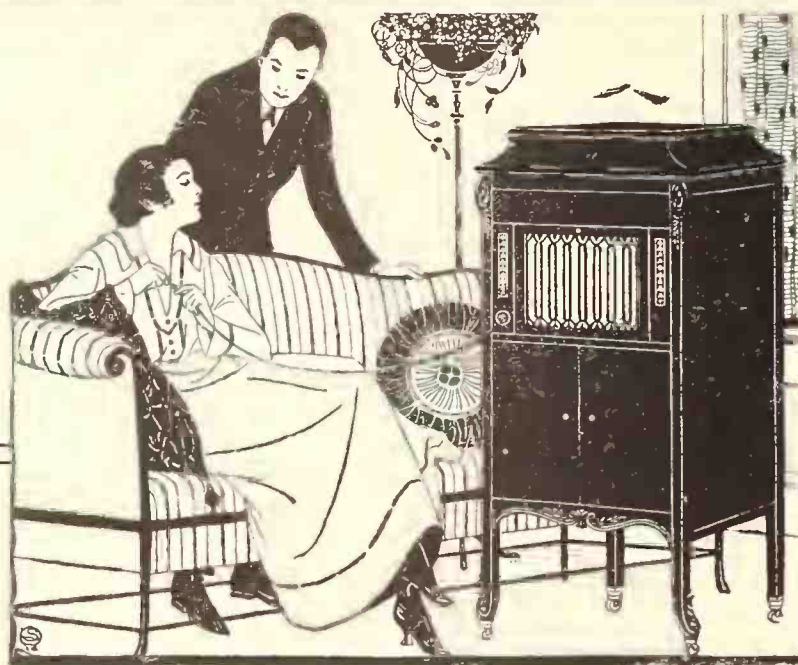

## THE AEOLIAN COMPANY of MISSOURI

*Wholesale distributors for the celebrated*

# AEOLIAN-VOCALION

*and*

## VOCALION RECORDS

**for the Middle West**

**C**OMPLETE dealer service in all branches. Newspaper advertisements are prepared to enable the dealer to tie-up his local publicity with the impressive campaign of Vocalion advertising now being run in the Saturday Evening Post and other mediums.



*Address communications to*

### THE AEOLIAN COMPANY

*1004 Olive Street*

*St. Louis, Mo.*



**LIVE TRADE DEVELOPMENTS IN WHEAT BELT OF KANSAS**

**Kansas City Talking Machine Dealers Feeling the Effect of Farmers' Prosperity—Consignment Business Drops—C. M. Husser Again on Trail of Misleading Advertising**

KANSAS CITY, Mo., August 5.—During the past month the talking machine business has shown quite an unusual summer development in this immediate territory. Dealers declare that the demand for machines of the better quality has been so large that they have had very little opportunity of building up reserve stock to care for the fall and the winter business as has been their custom in past summer seasons. It is estimated by one dealer-jobber that the demand this summer is just twice as large as it was during the summer of 1918.

In the wheat belt of Kansas the business has shown a great deal of activity, especially about the centers of Wichita, Topeka and Salina. The financial condition of the territory directly attributed to the large crops has brought many visitors to the city to make purchases here.

There are fewer firms following the old system of placing machines in the drug stores and

confectionery stores and so forth in the small towns on consignment. This phase of the business has practically passed into oblivion so far as the larger and better established dealers are concerned here. The reason, of course, is obvious. First of all the dealer has not been so overly stocked with machines that he could easily enter into this system of trading or carry it on once he established it. But the chief reason is that the accounts entered into in this fashion did not prove as satisfactory as those handled by more direct business methods through the local sales offices.

George M. Husser, who is well known to the talking machine dealers in this city for his work in past years in cleaning up advertising in this particular field, recently was discharged from the army and has again taken up his work as secretary of the Kansas City Advertising Club and chairman of that organ-

ization's vigilance committee. Mr. Husser was instrumental in making it hot for the few small fly-by-night dealers who one time operated here by stenciling cheap machines with names similar to well-known makes.

Mr. Husser said, "It appears that the advertising has improved since I left for the army, for I have found but few questionable phases in the copy that has come before me of late or that has been called to my attention, and my visits among the dealers have brought forth very few complaints."

Fred Gennett, secretary of the Starr Piano Co., Richmond, Ind., was a recent visitor to the local Starr branch. Mr. Gennett declared that the phonograph business has been extremely good throughout the summer season and that the demand has shown an extremely large increase over the seasons in 1917 and 1918. He reported that he was very favorably impressed with the business done in this territory.

C. V. Bissell, who prior to his entry into the army was manager of the local branch, recently returned from service and immediately took up his former position.

E. S. Hall, of the Hall Music Co., reports that the business has been exceedingly good during the past month. Mr. Hall has been devoting nearly his entire time to the development of a summer talking machine business and has practically confined his advertising to the talking machines rather than to the player-pianos.

Eddie McDonnell, who has been connected with his father, J. C. McDonnell, in the piano and talking machine business at 1217 Grand avenue since his return from the army, left the store for a few weeks to care for the wheat harvest on a farm nearby. He will take up his work again at the store as soon as the harvest has been completed.

C. Mayer, manager of the music department of the Jones Store Co., which is operated by the Werner Industries, Inc., reports that the business has been exceptionally good during the past month in the Victrola department. The Victrola department at the Jones Store Co. was recently remodeled, giving more room to the record department. The partition has been taken away and the record department is now an open store where the sales force is never under the necessity of turning its back on its customers.

O. D. Standke, manager of the Columbia Grafonola Shop, declares that the past month has brought an increased trade to his establishment. Mr. Standke says, "This is the best summer season that I have had in this city: business is not only exceedingly good but is increasing in every department and most especially in the sale of higher priced machines. This has made me exceedingly optimistic in regard to the prospects for fall and winter business. It is my belief that only unforeseen influences can deter the trade to such an extent that the coming season will fail to be the best that the industry has ever had in this territory."

W. R. Berry, who for some time has been manager of the J. C. McDonnell Music Co., recently resigned his position there. Mr. Berry has not announced his future connections, stating, however, that he would continue in the piano and talking machine business.

W. J. Simonson, manager of the Smith, Barnes & Strohber Piano Co.'s branch, declares that the business has been extremely good in the phonograph and talking machine departments. Mr. Simonson has given this department of the business, which is more or less a new one with the company at Kansas City, a great deal of his attention.

Harry Wunderlich, proprietor of the Wunderlich Music Co., recently returned from a fishing trip in Minnesota.

M. M. Blackman, manager of the Phonograph Co., Edison jobbers, reports that the trade has shown a nice increase during the past two months.

Will Chesnut, of the Brunswick Shop, declared that for the first time for two years the summer business at his establishment has kept him busy during the entire season.



## UNIVERSAL TONE ARM





Patented May 13th, 1919

Talking machine manufacturers should anticipate their tone arm needs early to insure prompt delivery. The demand for phonographs this Fall will be very large, and it is the manufacturer who places his order early that will be given the benefit of Empire service. Get in touch with us at once and secure our quantity prices on this splendid equipment.

**WRITE FOR FOLDER AND PRICES**

*We are in position to make immediate deliveries*

## EMPIRE UNIVERSAL ATTACHMENTS

### FOR EDISON PHONOGRAPHS



Makes any disc record playable on the new Edison Disc Phonograph. Write for folder and attractive quantity prices.

Address all inquiries to Chicago Office

## EMPIRE PHONO PARTS COMPANY

Sales Office—429 S. Wabash Ave.—CHICAGO, ILL.  
Factory—1108 W. 9th St.—CLEVELAND, OHIO



# The Bush & Lane Phonograph

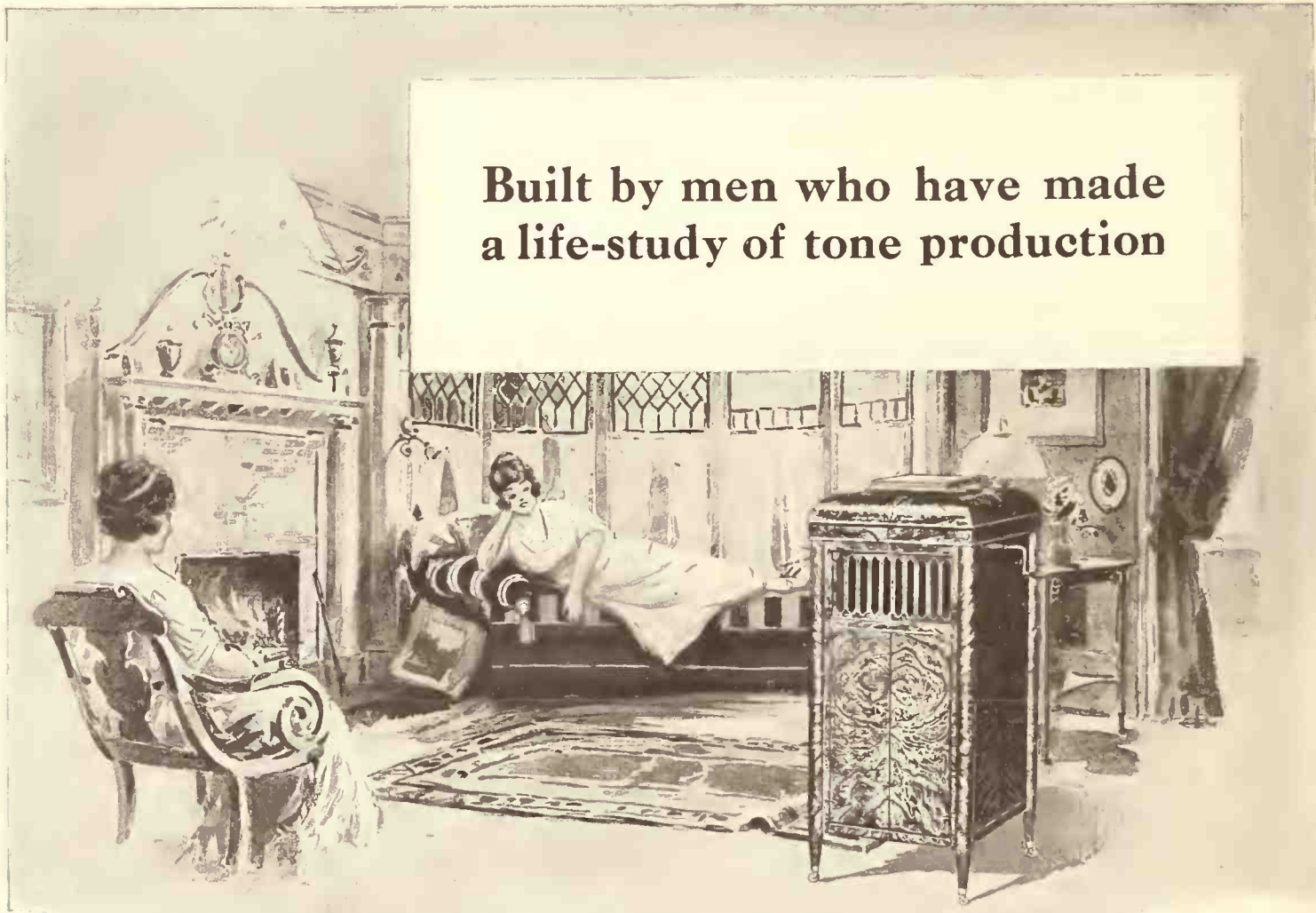

Its superior has yet to be made

**Bush & Lane Piano Company**  
Holland, Michigan



**"The Music of Wedding Chimes" interests more than two million men and women a year in this country. The song will interest nearly as many. A-2749.**

**Columbia Graphophone Co.  
NEW YORK**



**BIRMINGHAM DEALERS INTERESTED IN NEW ASSOCIATION**

Every Victor Dealer of That City Represented at Recent Gathering in Atlanta — Remodeling Operations Under Way in Numerous Establishments in Preparation for Future

BIRMINGHAM, ALA., August 4.—All Birmingham Victor dealers were very much gratified on arriving at the convention of the Southern Victor dealers in Atlanta on July 16 to find that every dealer from the Magic City was represented. Those dealers represented and their representatives were as follows: Cable-Shelby-Burton Piano Co., Mrs. Myra Treadwell; Clark & Jones Piano Co., Benj. Hammond; C. C. Holcombe, J. H. Holcombe; Williams Music House, Wm. H. Quinn and M. E. Williams; Talking Machine Co., A. R. Boone and Irvin Bimstein, and Ernest Milburn, local representative of Messrs. Elyea Company, Atlanta. This large and enthusiastic representation not only saw to it that one of its number was elected to one of the more important executive offices in making Benj. Hammond vice-president of the Association, but likewise made a successful effort to bring the Association to Birmingham in 1920.

Alterations at the C. C. Holcombe store are now nearing completion. The floors are being refinished and a new front installed. Everything will be in splendid condition for the fall season when it opens up.

The Edison and Vocalion shop of F. W. Bromberg has been entirely remodeled. The quarters have been entirely inadequate to the

needs of this growing department. A mezzanine floor has been installed and complete new shelving for the storage of records. Mr. Bromberg contemplates building an entire new front and the installation of two new booths.

The Haverty Furniture Co., Columbia and Pathé dealers, have announced the removal of their store to 1914 Fourth avenue, where the floor space will be just trebled as compared with its present location on First avenue. They announce that much space on the first floor will be given over to one of the finest phonograph parlors in this section.

Miss Thelma Huff, of the Clark & Jones Piano Co. staff, has just returned from a three weeks' vacation spent in Mobile, Pensacola and Norfolk.

Oster Bros. are featuring in their advertising the Vista phonograph. This house handles also the Aeolian-Vocalion and the Columbia lines.

Miss Irene Jenkins, head saleslady for the C. C. Holcombe Co., has just returned from a month's vacation spent mostly in Youngstown, Ohio. Miss Jenkins also visited New York City and spent several days at the Victor factory in Camden.

Williams Music House (Wm. H. Quinn, manager) report a very good business for July. They report Victrolas arriving in greater quantities.

In addition to the Victor line they handle the Columbia and Supertone.

Benj. Hammond, manager of the Victrola department of the Clark & Jones Piano Co., reports the largest sale in high-priced talking machines in July over any other month in the history of the house. Roy Weinberg, who has charge of the Victor records of this house reports a "landslide" on Red Seal records after the reduction of prices which went into effect July 10.

The E. E. Forbes & Sons Co. is remodeling its entire store. Heretofore there have been several floors that the company could not get the exclusive use of. E. E. Forbes has now made arrangements whereby his company will have the entire building to be devoted exclusively to its own needs. The talking machine department will occupy the entire first floor and the three upper floors will be used for piano warerooms. This firm handles the Columbia, Dalion, Stradivara and American.

The Starr Piano Co. (Ira F. Randall, manager) has just completed extensive alterations to its store at 1920 Third avenue. No expense has been spared in beautifying the storeroom and the company can justly boast of having the most beautiful storeroom in this section. The first floor is given over to the talking machine department and player rolls and the upper floors are utilized for the executive offices and piano warerooms. This is a branch store of the Starr Piano Co., Richmond, Ind. They handle the Starr phonographs and Gennett records, both retail and wholesale.

The Birmingham Victor dealers are very grateful to A. R. Boone, of the Talking Machine Co., Birmingham, and E. N. Upshaw, of Messrs. Elyea Co., Atlanta, for their untiring efforts in bringing together the Victor dealers of seven Southern States to form an organization which will do so much good for the individual dealers as the newly-formed Southern Victor Dealers' Association promises to do. The Association is proud to have these two gentlemen among the associate members.

**NOW EXCLUSIVELY VICTOR**

W. D. & C. N. Andrews, Victor wholesalers, of Buffalo, recently announced that they have disposed of their entire Edison Amberola stock, so that the business is now exclusively Victor wholesale.

**ESTABLISHED 1831**

In the Music Business  
Continuously for 88 Years

**Our Age the Best Evidence that We  
Render Satisfactory Service**

**Mellor's**  
**604 Wood St.**

Victrola Wholesalers

PITTSBURGH, PA.

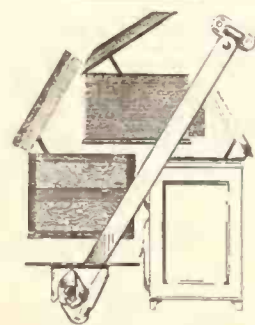

**New Automatic  
Cover Support**

Practical—Inexpensive  
Fool Proof

Made in two different styles

- No. 1 Fit Cover at any angle
- No. 2 Hinge Plate bent to Fit Cover

Samples on Request  
Quantity Discount

**AUTOMATIC COVER SUPPORT MFG. CO.**  
54 JONES STREET  
NEWARK, N. J.





## The Best Talking Machine Needle on the Market

PACKED IN COUNTER SALESMEN

50 Needles to a box and they retail at 10 cents per box.  
60 boxes to a package, \$6.00. This package costs you \$3.90 net.  
Your profit is \$2.10 and your customer gets a needle that will give satisfaction.

### THE FRED. GRETSCH MANUFACTURING COMPANY

60 Broadway

Manufacturers of Musical Instruments

BROOKLYN, N. Y.

Canadian Wholesale Agent, H. A. BEMISTER, 10 Victoria Street, Montreal, Can.  
Western Distributor: WALTER S. GRAY, 530 Chronicle Building, San Francisco, Cal.

## NUMEROUS CHANGES OF IMPORTANCE IN LOS ANGELES

Fitzgerald Music Co. Opens Branch in Long Beach and Incorporates—Columbia Dealers Meet—Various Concerns Enlarge Their Departments—Barker Bros. to Open Branch

LOS ANGELES, CAL., August 4.—July proved a genuine surprise to the talking machine dealers of this city, for, considering that it marks the height of the vacation season, the month produced quite a remarkable volume of business. In fact, some of the department managers report that it stands as the banner month of the year to date. The demand, moreover, was good for both machines and records. Due to the catalog reduction in the price, Victor Red Seal records are piling up a particularly fine lot of business just now, but other record stock is also making a very good showing. The month has also been featured by a number of rather notable improvement programs having been either completed or begun. The telephone strike was settled during the month, and hence the dealers have still another reason for feeling good. It now only remains, in order that the outlook for the fall be made rosy, for the managers to receive assurance that the shortage of stock is soon to be overcome.

### Big Wholesale Business Reported

Speaking from the wholesale point of view, Wm. F. Stidham, local manager of the Columbia Graphophone Co., reports that the sales for the last month from the Los Angeles branch, for southern California and Arizona, proved to be the largest in the history of this branch.

### Fitzgerald Music Co. Starts Branch

The Fitzgerald Music Co., of this city, has opened a branch store in Long Beach, Cal., at 409 American avenue. The formal opening was held on Saturday, July 26. The branch, like the company's main store, represents the Edison

line of phonographs and records, and also carries a stock of pianos and players, of the regular Fitzgerald agencies. L. L. Lawson, formerly connected with the Edison department of the headquarters store, is manager of the branch.

### Store Lease Renewed by Andrews Co.

The Andrews Talking Machine Co., which for some time had been considering moving into the Broadway Department Store and taking over this store's talking machine department to manage on the concession plan, has finally abandoned the idea and decided to remain in its present location at 350 South Broadway. A renewal of lease on the quarters was negotiated during the early part of July for a period of three years. The company represents the Victor and Columbia lines of machines and records. The talking machine section of the Broadway Department Store, which has the Columbia agency, will be continued as heretofore, under the management of Edward R. Darvill.

### Talking Machine Space Is Enlarged

The Lyon-McKinney-Smith Co., furniture dealers, 737-741 South Hill street, completed during July the adding of two more demonstrating rooms to its talking machine department, giving it a total of nine. The department was started less than two years ago, under the management of Howard L. Brown, and has been making steady and rapid expansion. The company has the Columbia, Pathé and Brunswick agencies.

### Fitzgerald Music Co. Incorporates

Articles of incorporation were filed here the early part of July by the Fitzgerald Music Co.

with a capitalization of \$100,000. The incorporators are J. T. Fitzgerald, H. C. Braden and John C. Yuncker. The company has been in existence for about twenty-eight years and has grown to be one of the leading music firms in the city, but it heretofore has been the private undertaking of Mr. Fitzgerald. The house represents the Edison phonograph and a number of piano and player lines.

### Columbia Dealers Hold Monthly Meeting

The regular monthly meeting of Columbia dealers took place in the assembly hall of the Alexandria Hotel on Tuesday, July 22, at 9:30 a. m. The new records for September were demonstrated and played, and then the attending dealers were entertained by the Zoellner Quartet, exclusive Columbia artists. The numbers rendered by the quartet included "Hymnus," by Hartmann; "Serenade," Haydn; "Indian War Dance," Skilton, and "Genius Loci," Thern. The Zoellners have just completed a series of ten concerts in Los Angeles, and will, in the near future, commence a tour of the United States.

### Interested in Red Seal and Symphony

The talking machine department of Hamburger's Department Store reports increased sales of both machines and records and is looking forward to a very extensive fall business. Edward Humphrey, manager of the department, was formerly well known as a tenor on the operatic stage and concert hall, and he, therefore, is giving special and most successful attention to Columbia Symphony and Victor Red Seal record sales.

### Biggest Month's Business of the Year

Manager Harold Jackson, of the talking machine department of the Wiley B. Allen Co., says July, despite its being vacation time, netted his department the biggest volume of sales realized for any month this year, and adds that the increase over the other months is a very substantial one. In consequence Mr. Jackson is wearing one of those smiles of the "won't-come-off" kind. The house represents the Victor, Edison and Brunswick.

### Talking Machine Space To Be Enlarged

The talking machine section of the Broadway Department Store is to be increased to practically double its present size. Work on the addition to the space will be commenced within the next few weeks. D. G. Sunderland, of the department, also reports that he has been obliged, because of a very busy summer season, to increase his staff already, and expects to take on even more help provided the supply of stock he requires is forthcoming. The department is devoted exclusively to the Columbia line of machines and records.

### Barnes Music Co. Is Incorporated

The Barnes Music Co., of 231 South Broadway, heretofore a partnership concern, was recently incorporated with a capital stock of \$150,000. The stock is divided into \$35,000 preferred and \$115,000 common, with a par value of \$10 per share. The officers are George H. Barnes, president; E. W. Elder, vice-president, and A. S. Barnes, secretary and treasurer, and other directors are Earle Osborn and Leslie Elliott. Besides carrying several lines of pianos the company maintains a Columbia and Brunswick talking machine department.

### L. V. Felger Given New Territory

L. V. Felger, of the sales department of the

(Continued on page 90)

Room No. 321

130 Fulton Street

Clifford A. Wolf  
MANUFACTURER OF

Diamond and Sapphire  
Phonograph Points

New York City

Phone, 2812 Cortlandt





# RECORD-LITE

COPYRIGHTED

## Jobbers and Dealers Are Pleased With the New Marketing Method

Many jobbers have written to express their approval of my new method of delivering Record-Lites.

The Lites are now shipped separately to the jobber and fresh batteries sent direct to the dealer. Both jobber and dealer are relieved of battery trouble as all responsibility is assumed at the factory.

New and better methods of manufacture and inspection have made the Record-Lite better than ever. Our new sales plan is building a big consumer demand—are you prepared to supply it?

### Universal and Victrola Record-Lites

Both models have been highly improved. Better materials, better nickel and gold plating. Every Lite carefully inspected and fully guaranteed in every respect.

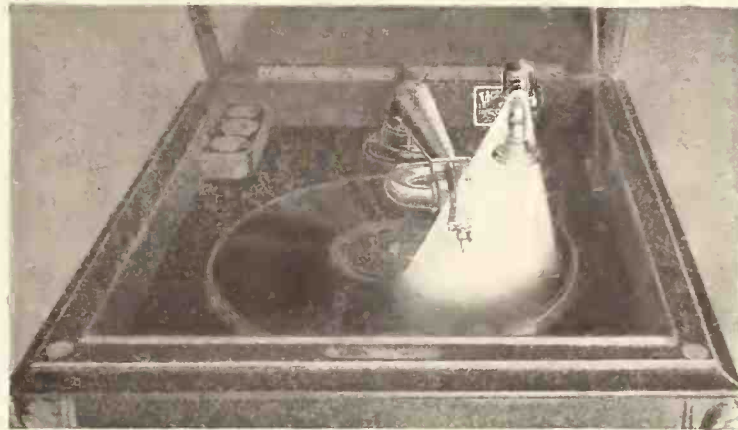

### Record Needle Cutter

The clean shearing stroke of this cutter insures a clear tone from fibre needles. The cutters are made by a special die-casting process to insure close joining and blades are heat treated, hardened, ground and sharpened. Each cutter guaranteed.

#### Order from Your Jobber Now

Lites and cutters are sold by all representative talking machine and accessory jobbers in the United States and Canada.

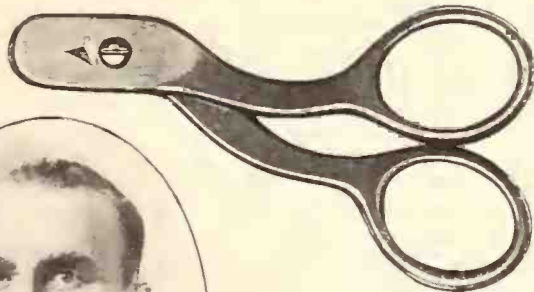

*R. N. Zinke.*

President Milwaukee Association of Music Industries.  
President Wisconsin Association of Music Industries.

## Record Needle & Mfg. Co.

MILWAUKEE,

WISCONSIN

Export Office, 160 Broadway, New York City, U. S. A.

Eastern Representative, Clement Beecroft, 309 W. Susquehanna Ave., Philadelphia. Western Representative, Walter S. Gray, San Francisco, Cal. Canadian Distributors, His Master's Voice Co., Ltd., Toronto, Canada.

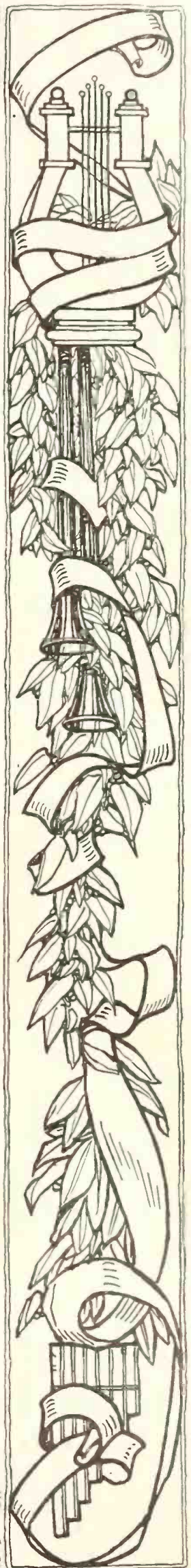





**Bert Williams is at his best in "Everybody Wants A Key To My Cellar" and "It's Nobody's Business But My Own." You'll find these songs will make business for you. A-2750.**

**Columbia Graphophone Co.  
NEW YORK**

### MANY CHANGES IN LOS ANGELES

(Continued from page 88)

Columbia wholesale branch here, who until recently was his company's traveling representative in Arizona, has been appointed, by Manager Wm. F. Stidham, for the California district included in San Luis Obispo, Kern, Santa Barbara and Ventura counties.

#### Will Open Branch Store in San Diego

Barker Bros., some time within the next few weeks, will open a branch store in San Diego, Cal. John W. Boothe, manager of the music department, will leave for the Southern city in a few days to close up on a location and to make the other necessary arrangements. The branch will be stocked with talking machines and records of the regular Barker Bros. agencies, including Victors, Sonoras, Edisons and others, and will also carry a small stock of pianos and players. The firm's other two branches, in Long Beach and Pomona, have been proving so successful that a string of such stores is to be established.

#### Extensive Alterations Under Way

Alterations are well under way in the Columbia department of the Platt Music Co., by which the entire first or basement floor of the building will be devoted exclusively to record business, with the possible exception of one large Grafonola salesroom. This main salesroom will be reached by elevator or down a magnificent marble staircase, and will be known as the "Sunken Grafonola Salons de Luxe." Manager Herman Beck anticipates ample room, under these conditions, to take care of the largely increased sales. The company is also equipping the store throughout with a most complete ventilation system.

#### Association Postpones Meeting

The Music Trades Association of this city, formerly the Retail Talking Machine Dealers' Association, has postponed the meeting scheduled for July to some time in August. The meeting is to take up the question of hiring a secretary and other matters. The postponement was made on account of members of the committee appointed to recommend a man for the secretaryship being absent from the city on vacations.

#### Richardson's, Inc., Receives Art Models

Richardson's, Inc., of 607 West Seventh street, has just received its initial stock of the Columbia Art Models, which includes the Adam, French Gothic and Early English styles.

#### Brief Personal Items of Interest

F. B. Travers, general manager of the San Francisco office of the Sonora Phonograph Co., spent a few days in Los Angeles the first of this month.

C. H. Craigie, of the Edison and Mandel phonograph department of the Wm. L. Glockner Music Co., spent a week's vacation in July in the San Bernardino mountains.

Manager J. W. Boothe, R. E. Daynes and J. H. Montgomery, all of the talking machine department of Barker Bros., spent a two weeks' vacation recently in the Yosemite Valley.

### WORLD AD BRINGS QUICK RESULTS.

Letters Containing Orders in Answer to Ad Reach Portland Concern Before July Issue Is Actually in the Hands of Wax-Wilson Co.

PORTLAND, ORE., August 8.—Does advertising in the Talking Machine World pay? I'll say it does, and so will Monte Wax, head of the Wax-Wilson Co., of this city, manufacturers' agents, who are putting out "Tone Clear," a liquid preparation which is used for cleaning, reviving and preserving records. The Wax-Wilson Co. started advertising in the Talking Machine World in the July issue, after having placed their product before the dealers hitherto only through the medium of local publications. The result is unique in advertising annals. Before the July issue reached Portland, two days before, in fact, the Wax-Wilson Co. received sizable orders from firms in Rhode Island and Connecticut for their preparation. The orders were the first intimation that Mr. Wax had that his advertisement had appeared in Talking Machine World, and it was only because the Eastern dealers had quoted the trade journal in question that he was sure that it had appeared. He had been rather late in forwarding his copy and was afraid that he would have to wait until the August issue for the first publication. These two answers from Rhode Island and Connecticut, however, were only a forerunner of the returns from the initial display in the Talking Machine World and so great has been the call

for "Tone-Clear" in the last month, traceable directly to the single advertisement, that Mr. Wax says it will certainly call for an increased output from the factory.

### HALLET & DAVIS WINDOW DISPLAY

Attractive Window Features Talking Books at Boylston Street Store Warerooms

An unusually attractive window display was that of the Hallet & Davis Piano Co., 146 Boylston street, featuring the talking books and talk-

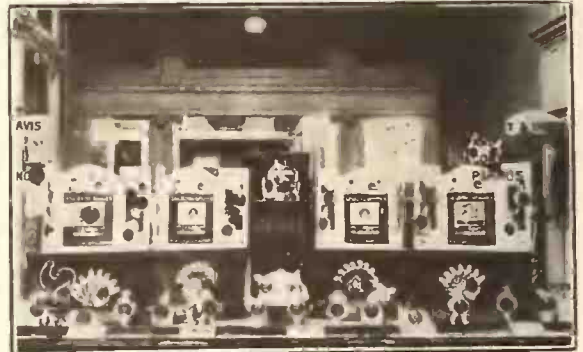

Hallet & Davis' Talking Book Window ing dolls. The Pathé phonograph held the center of the display and around it were many interesting figures and cards illustrating the talking books. The window was arranged in such a way as to attract the interest and attention of the children especially, and the dolls and figures of birds and animals in bright colors made the display one of the most attractive in the city.

## The KENT Master Adapter

MADE UNDER PATENT No. 1,130,298

*It is not an attachment nor a makeshift, but a part of your phonograph.*

*It is simple, neat and durable.*

*It is sturdily and honestly built.*



Position when playing lateral cut record

*It is attractive in appearance and absolutely fool-proof.*

*It is correct in principle and accurate in performance.*

*It is guaranteed.*

**Makes any disc record playable on the NEW EDISON DISC Phonograph**

*Write us for special literature covering the particulars about this ingenious device*

**F. C. KENT CO.**

MULBERRY and CHESTNUT STREETS  
NEWARK, N. J.



## STOCK ACCUMULATION AIM OF ST. LOUISIANS

Despite the Improvements in Shipments From the Factories the Demand Keeps Ahead of Supplies—Demonstrate Pathé Actuelle—General Trade Conditions Most Satisfactory

St. Louis, Mo., August 8.—Talking machine men here are worried about their August business. They are worrying about where the goods are coming from to meet the demand which the fall business forecasts. They sold all the machines that they could get in July and had a rattling good record trade. With the prospect of the August demand exceeding the July demand and the September demand very greatly exceeding the August demand, and so on, in compound ratio to the end of the year, they have something to worry about.

All the distributors and dealers are bending their energies to the accumulation of stocks for the tremendous fall business expected, but the customers don't give them a chance to accumulate anything. They have all that they can do to keep their demonstration machines. They have assurances, to be sure, that the factories will do their best to fill their orders, but even after these assurances have been given proper credit for good faith there is a disconcerting margin of uncertainty.

With the cutting in two of the Victor Red Seal record prices sales of those records leaped tremendously. The buying has not been confined to the most famous selections or the most celebrated voices, but there has been a noticeable increase in the demand for the heavier classics on the Red Seal list.

J. F. Ditzell, manager of the Famous & Barr Co. music salon, thinks the reduction on the Red Seals is the biggest factor for increased business in records since the double-faced records came out about eleven years ago.

The new rapid record service at the Smith-Reis store is doing very well, according to President Val Reis. Customers are finding out that it is just as satisfactory to buy by title as by demonstration. The experiment has been helped along by the Red Seal reduction. Most buyers of the Red Seals know what they want because they have been wanting them a long time, so demonstration is superfluous. Mr. Reis thinks that by the time the fall record business sets in record customers will have been pretty well cured of the demonstration habit.

The four days' demonstration of the Pathé

Actuelle by W. W. Parson at the Hellrung & Grimm store was a complete success. There were between 150 and 200 in attendance, according to Manager Charles L. Staffelbach, and every dealer, he says, ordered machines. All orders are being accepted subject to the factory promise of delivery between August 15 and September 1. Manager Staffelbach has returned from a week's business trip through southern and central Missouri and declares the outlook for fall trade excellent. I. S. Kirby, a Pathé dealer of Unionville, Tenn., was in St. Louis during the past week.

Recent visitors at the Columbia Graphophone Co. were W. T. Wallace, Assumption, Ill.; Ernest M. Stuber, of the E. Wetzmann Co., Memphis, Tenn.; Lee B. Rucker, of the Columbia Shop, Fulton, Ky.; Lloyd L. Parker, Harrisburg, Ill.; C. C. Mendenhall, of the Hannibal Music Co., Hannibal, Mo.; C. E. Bevis, Waltonville, Ill.; M. C. Ellis, of the Martin Hardware and Furniture Co., Martin, Tenn., and A. Backer, of A. Backer & Son, Fulton, Mo.

H. L. Willson, vice-president and general manager of the Columbia Graphophone Co. and R. F. Bolton, sales manager of the International Record Department, all of New York, visited the St. Louis branch recently.

Mr. Tobias, special representative of Arthur L. Van Veen & Co., manufacturers of booths, visited St. Louis recently and with the assistance of C. R. Salmon, city salesman of the Columbia Graphophone Co., sold five fine booths to the Reliable Furniture Co., three to the Kleekamp Bros. Piano Co., and two to the Raigor Art & Music Co.

Miss Sadie Rosenblatt, manager of the talking machine department of the May-Stern Co., is spending her vacation in Yellowstone Park. F. F. Stevenson, of the Columbia Graphophone Co., is visiting the factory and executive offices in New York. B. Valle Grossman, of the Victrola department of the Famous & Barr Co., is to be married August 12 to a Clayton girl.

H. J. Arbuckle, manager of the St. Louis Grafonola Shop, left recently on a month's vacation. He will spend most of the time at his former home, Boston, and will visit the main office there and the branches at Indianapolis, Cincinnati and Philadelphia en route. E. D. Follin, Western supervisor, is in St. Louis and will probably remain until Mr. Arbuckle returns.

Mark Silverstone, president of the Silverstone Music Co., and Myron Goldberg, vice-president, have returned from the Edison dealers' convention at New York and from a stay at Atlantic City. Mr. Silverstone also went to Quincy, Ill., to attend a subdistrict convention of Edison dealers, where he spoke on the outlook for the Edison. Business, he says, is twice as good as it was at this time last year. He attributes part of the Edison demand to the fact that returning soldiers heard it on the transports.

W. F. Taylor, supervisor of the Edison Co., was here during the past week.

No July get-together dinner was given by the Columbia Graphophone Co. on account of the extremely hot weather, but it is planned to have one later in August at the Statler Hotel.

L. McMahon, of the Victor department of the Field-Lippman Piano Co., spent his vacation at St. Joseph, Mo.

**SOSS**  
**INVISIBLE HINGES**

Fine cabinet work has always demanded that hinges be as inconspicuous as possible.

**Soss Hinges are Invisible**

They are therefore ideal for beautiful cabinet work as the preservation of the beauty of unbroken lines in better grade cabinets is thus insured.

The leading manufacturers of the industry use Soss Hinges.

Soss Hinges are so accurately made and so easy to install that they save time and labor, as all mortising can be done by machine.

**SOSS MANUFACTURING CO.**  
GRAND AVE. AND BERGEN ST.  
**BROOKLYN, N.Y.**

## GIVE JOHNNY A JACK KNIFE AND HE'LL WHITTLE



*Give an Owner an Empty Album and He'll Fill It With Records*

EVERY dealer must realize the wide channel for future record business opened by the sale of a record album of quality such as the Peerless Album.

An empty album is a constant and urgent invitation to buy more records.

That is why dealers prefer to sell cabinet type machines equipped with Peerless Albums.

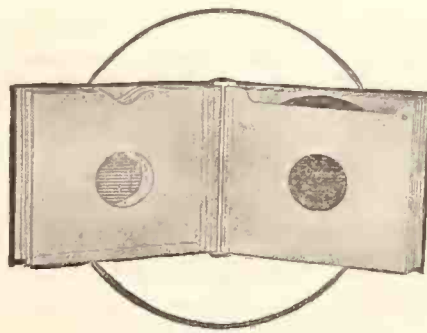

Patented March 3, 1914

**PEERLESS ALBUMS**

**ACCELERATE SALES**

**PEERLESS ALBUM COMPANY** 43-49 Bleecker Street  
NEW YORK

PHIL RAVIS, President

Representatives:

L. W. Hough, Boston Taylor C. White, Portland, Ore. W. H. Carter, Chicago C. W. Kalder, Grand Rapids

We distribute at Wholesale

**THE TOURIST PORTABLE PHONOGRAPH**

A real high grade Phonograph in a convenient, compact form. Retail price \$35.00. Write for illustrated circular.

**COLEMAN MERCANTILE CO.**

4421 Manchester Ave.

St. Louis, Mo.



The most wonderful Talking Machine of the present age at the price  
An Instrument of Supreme Value, Tone and Quality

# Cleartone

SPEAKS FOR ITSELF



No. 250—\$125



No. 150—\$85



No. 100—\$75

The *Cleartone* has become very popular because of its quality, splendid value and the advertising and sales campaign that now stands in back of it. **Dealers!** Watch us grow—write for our agency and grow with us.

### SUNDRY DEPARTMENT

**MOTORS**—No. 1, double-spring, 10-inch turntable, plays 2 10-inch records, \$3.25; No. 6, double-spring 10-inch turntable, plays 3 10-inch records, \$4.00, with 12-inch turntable, \$4.25; No. 8, double-spring, 12-inch turntable, plays 3 10-inch records, castiron frame, \$6.85; No. 9, double-spring, 12-inch turntable, plays 3 10-inch records, castiron frame, bevel gear wind, \$7.85; No. 10, double-spring, 12-inch turntable, plays 4 10-inch records, castiron frame, bevel gear wind, \$9.85; No. 11, double-spring, 12-inch turntable, plays 7 10-inch records, castiron frame, bevel gear wind, \$10.75.

**TONE ARMS AND REPRODUCERS**—Play all records—No. 2, \$1.45 per set; No. 3, \$1.65 per set; No. 4, \$3.75 per set; No. 6, \$3.50 per set; No. 7, \$3.25 per set; No. 8, \$3.15 per set; No. 9, \$2.95 per set; Sonora tone arm with a reproducer to fit.

**MAIN SPRINGS**—No. 00, 5/8 in., 9 ft., 29c; No. 01A, 3/4 in., 10 ft., 49c; No. 01, 7/8 in., 7 ft., 25c; No. 02, 3/4 in., 7 ft., 25c; No. 1, 3/4 in., 9 ft., 39c; No. 2, 13/16 in., 10 ft., 39c; No. 3, 7/8 in., 11 ft., 49c; No. 4, 1 in., 10 ft., 49c; No. 5, 1 in., 11 ft., heavy, 69c; No. 6, 1 1/4 in., 11 ft., 99c; No. 7, 1 in., 25 gauge, 15 ft., 89c. We also carry other size main springs to fit Victor, Columbia and all other motors at nominal prices.

**RECORDS—POPULAR AND GRAMMAVOX**, new 10-inch, double-disc, lateral cut, all instrumental selections 35c. each; 32c. each in 100 lots; Columbia, 10 inch, double-disc, new records, 35c each.

**GOVERNOR SPRINGS**—To fit VICTOR, COLUMBIA and all other motors at moderate prices. Special prices on large quantities to Motor Manufacturers.

**GENUINE DIAMOND POINTS**, for playing Edison records, \$1.95 each.

**SAPPHIRE POINTS**, for playing Edison records, 22c each.

Special prices on sapphire points, balls, and diamonds for quantity buyers.

**SAPPHIRE BALLS**, for playing Pathé records, 22c. each.

**NEEDLES**, steel, 45c. per thousand in 10,000 lot; 42c. per thousand in half million lots.

We also manufacture special machine parts, such as worm gears, stampings, or any screw machine parts for motor; reproducer and part manufacturers.

Special quotations given to quantity buyers in Canada and other export points.

Write for our 84-page catalog, the only one of its kind in America, illustrating 33 different styles of talking machines and over 500 different phonographic parts, also gives description of our efficient Repair Department.



No. 200—\$100

Lucky 13 Phonograph Co., 46 East 12th St., New York



### VICTROLA AND RECORDS USED TO ILLUSTRATE LECTURES

Prove a Feature of Series of Twelve Lectures on "The Teaching of Musical Appreciation" Just Concluded at Columbia University—Much Interest Displayed in Special Course

A very important series of twelve lectures on "The Teaching of Musical Appreciation" has recently been concluded at Teachers' College, Columbia University, New York under the direction of Miss Edith M. Rhett. When the course was started forty students enrolled, which number later jumped to a class of seventy, including representations from twenty-six different states, in addition to Canada and Japan. Practically all of those taking the course were musical supervisors.

The lectures were given to meet the rapidly increasing demand for guidance in presenting music for appreciation, with reference to both the selection and use of material. The lectures covered such topics as

- A. Rhythm—Imitative and metric.
- B. Songs—Rote songs, part songs, folk songs, art songs, types of voices, and the larger forms of opera and oratorio.

C. Instruments—Instruments of the orchestra and instrumental music.

D. Instrumental Forms—Song form with trio, rondo, suite, sonata, symphony.

E. Correlation of music with other subjects in the curriculum.

Musical facts were presented for the successive school grades relating the work to the developing child. No previous knowledge of music was required for admission. The lectures had a two-fold appeal, first to the musically uneducated who wish a simple, non-technical explanation of musical subjects, as a basis for their own listening, as an avenue leading to happiness and recreation, and second, to those who wish practical help in organizing courses designed to lead others to intelligent appreciation of music.

This series of lectures is of special interest to the talking machine industry because of the fact that the lessons were illustrated throughout by the Victrola and Victor records. Furthermore, Miss Edith M. Rhett is, as is well known to the trade, a representative of the Educational Department of the Victor Talking Machine Co. The work she has been doing at Columbia is evidence both of her own standing as an authority on the study of musical appreciation and of the exceedingly broad-visioned spirit behind the educational campaign which the Victor Co. is fostering. Lectures similar to those delivered by Miss Rhett at Columbia have been given in a great many other universities and institutions of learning throughout the country by other representatives of the Educational Department of the Victor Co. Miss Rhett personally has delivered similar lectures at the College of the City of New York and at New York University this summer.

#### EMERSON INTERNATIONAL MOVES

Increase of Business Necessitates Larger Quarters in New York City

Last week the Emerson International, Inc., New York, by means of a neat announcement card sent to the trade, made known the fact that they are moving from their old address at 366 Fifth avenue to new offices at 43-45 West Thirty-fourth street. As Louis D. Rosenfield expressed it, the removal was made necessary in order to obtain larger quarters, business having expanded by leaps and bounds during the past few months. In their new office they hope to be able to handle the demand for Emerson International records which has caused the factory to be running day and night.

#### W. S. GRAY'S ENJOYABLE TRIP

Walter S. Gray, the well-known jobber of phonograph accessories, who makes his headquarters in the Chronicle Building, San Francisco, has just returned from a ten days' trip to Los Angeles and other points in the southern part of the state. It was a combined business and pleasure trip on which Mrs. Gray accompanied him. He indulged in several days of golf and fishing at the Catalina Islands and in writing to The World made the following report about his trip: "Weather hot—business good."

#### OPENS THIRD STORE IN NAPA, CAL.

B. Aldersley, of Napa, Cal., visited San Francisco the last week in July. He is director of the Aldersley Jazz Orchestra and has recently associated himself with A. G. Prouty, also of Napa. Mr. Prouty already has two stores in Napa and is now taking a third one as an addition to the two he already occupies. The extra space will be used for the enlargement of the talking machine business. Mr. Aldersley will manage the talking machine department.

## The Scotford Tonearm and Superior Universal Reproducer

### The Ideal Combination

Plays All Makes of Records as they should be played

Price of Sample Prepaid

Nickel, \$6.25 Gold, \$7.75

Adjusted for Cabinet measuring 8 1/2 inches from center of Tonearm base to center of Turntable shaft

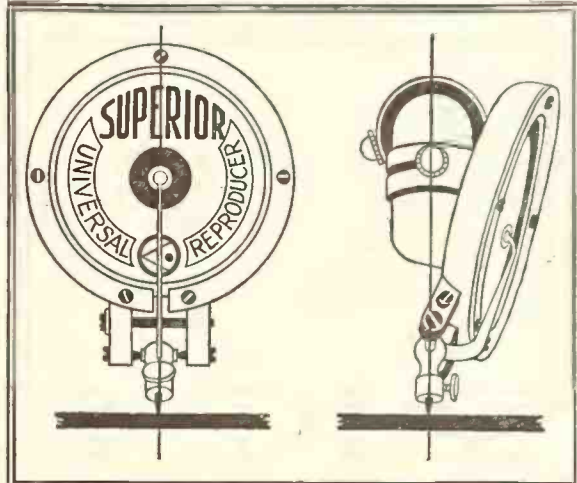

#### Distinctive Features

- ☞ The Reproducer pivots on its axis (as illustrated above), taking the correct angle for all makes of records, and the needle retains same center in both positions.
- ☞ Surface noise is less than with any other reproducer—surface scratchings being reduced to a minimum through perfect proportioning of the stylus construction, and placing the needle in the center of the groove at the correct angle.
- ☞ The split construction of the frame and face ring of the Reproducer, together with the method of pivoting the stylus bar, and perfect insulation—effect a sensitive and free vibration—and prevent a pinched tone resulting at any time from natural contraction or expansion of the metal parts.
- ☞ The reproduction is the mellow, natural quality of tone—absolutely getting away from the usual sharpness and metallic effect so noticeable in most reproducers.
- ☞ Sound waves act upon the same principle as light waves—they travel in a straight line until they meet some obstruction, from which they are deflected at right angles. The right angle turn at the back of the Scotford Tonearm causes less breaking up and confusion of the sound waves than occurs in the curved arm.
- ☞ The connection between the Reproducer and Tonearm is perfectly insulated with a hard rubber bushing. Inside diameter of the Tonearm is correct to accommodate the volume obtained from the latest records.
- ☞ The right-side turn for changing needle is handier than the old style turn-back, and when in position for the Hill-and-Dale records there is no interference with lowering the cabinet cover.
- ☞ The lateral movement at the base is simple, free and permanently satisfactory. Inside there is no obstruction to interfere with passage of the sound waves. There are no loose balls in the bearings, therefore no buzzing noise can occur from the great vibration on high notes.



### Barnhart Brothers & Spindler

Monroe and Throop Streets—Chicago

Manufacturers

of

# PHONOGRAPHS

and

# PHONOGRAPH CABINETS

are invited to write us for samples of Trimmings and Parts such as

- Catches, Sockets,*
- Pulls, Knobs,*
- Escutcheons,*
- Sliding Shoes,*
- Lid Supports,*
- Automatic Stops,*
- Tone Rods,*
- Needle Cups, Etc.*

Our line of such hardware is complete and with our increased facilities we are in a position to give reasonably prompt service to a few more desirable customers.

## GRAND RAPIDS BRASS CO.

GRAND RAPIDS, MICHIGAN



THE CHENEY  
ORCHESTRAL CHAMBERS

The Most Revolutionary Improvement in Phonographs Since Tone Reproduction was Invented. Not only do the flat surfaces insure perfect balance of tone by elimination of the old "megaphone" principle, but every tone is reproduced in its original purity.

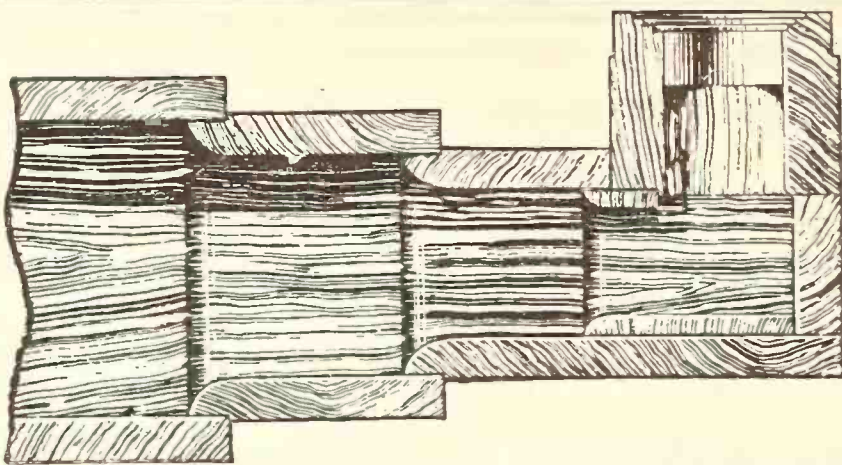

The  
**CHENEY**  
PHONOGRAPH

Distinctive  
Talking Points Make  
Easy Sales

CHENEY Phonographs are distinctive—they employ a method of tone reproduction used by no other phonograph, and the fundamental principles are covered by *basic patents*.

This gives dealers a tremendous selling advantage—for they not only have an instrument superior in cabinet work and in tone reproduction, but they have sales clinching arguments in the exclusive features to which they can point and which are duplicated by no other instrument.

If you have already heard the Cheney play, you know what a revolutionary improvement these exclusive Cheney features are in the reproduction of music. They set the Cheney in a class apart.

The most discriminating music dealers are now selling the Cheney from their floors.

Cheney Talking Machine Company

831 Marshall Field Annex Building  
24 North Wabash Ave., Chicago, Ill.



Style Four  
William and Mary



### IMPORTANT CHANGES IN CINCINNATI FIELD

C. C. Coppin Secures Control of Huss Bros. Phonograph and Piano Mfg. Co.—Columbia Goods More Plentiful in That Territory—Big Spurt in Red Seal Record Business

CINCINNATI, O., August 2.—C. C. Coppin has taken over the interests of Charles W. and William C. Huss in the Huss Bros. Phonograph & Piano Manufacturing Co., the two directors severing their connection with the corporation. The Huss brothers had charge of the production department, while Mr. Coppin, who is a practical phonograph and piano man, looked after the business end of the company. Under the new arrangement Mr. Coppin, who is the president, becomes the head of all departments. "This deal," he said, "will result in the production of better instruments than was originally intended."

It will be good news to many Columbia dealers to know that the Columbia products, both Grafonolas and records, are coming to the local branch in much larger quantities than for many months past. July 22 was the biggest day in volume of sales the local branch has ever had. This came about through two large shipments of Grafonolas being received at the same time, also a carload of old favorite records which they had been out of for some time.

Manager F. F. Dawson, Representatives J. D. Bright and Carl Kraner, together with Mrs. J. D. Bright, spent a week or ten days visiting the executive offices in New York and the factories of the Columbia Graphophone Co. in Bridgeport, Conn. Mr. Dawson made the trip on business matters, while the two representatives made the trip as a part of their summer vacation. Assistant Manager N. B. Smith, with his wife and daughter, will also visit the executive offices of the Columbia Co. early in August.

New dealers that have taken on the Columbia line in this territory are as follows: F. J. Spengler, Lexington, Ky., has opened a large and very attractive art shop in which he will display and sell Columbia Grafonolas and Columbia records exclusively. Frank J. Bader, Newark, Ohio, who will open Bader's Music Shop August 1, will carry exclusively Columbia Grafonolas and records and a line of player-piano rolls, and A. F. Hibbard, for many years a Columbia representative in Athens, Ohio, is opening a fine exclusive shop in Huntington, W. Va., about August 15. Mr. Hibbard has made a wonderful success for himself and the Columbia line in Athens, and is moving to Huntington only because the size of the town limited his scope. Visitors during the past few weeks: J. N.

Immediate delivery of small quantities can be made in the following districts: San Francisco, Calif., Walter F. Gray. Lakeside Supply Co., Chicago, Ill.

## "A Million A Year"

WHAT'S YOUR SHARE OF

# MICA DIAPHRAGMS OF BEAUTY

—Phonographically Speaking—They Talk for Themselves—  
Manufactured for over ten years for the larger consumers by the

### INTERNATIONAL MICA COMPANY

Factory and Sales Dept. { 37th & Brandywine Sts. W. Philadelphia, Pa. Mines, Amelia Co., Va. Executive Dept. { 1228 Filbert St., Philadelphia, Pa.

Send for samples and quotations now and eliminate your diaphragm difficulties

Nixon, of Peebles, Ohio; Mrs. A. M. Katzenmeyer, of the Parlor Drug Store, Blanchester, Ohio; F. J. Spengler and Miss Lucy Trost, of the Spengler Art and Gift Shop, Lexington, Ky.; D. G. Rice, Aurora, Ind., and Paul Burling, of the Samuel Horchow Co., Portsmouth, Ohio.

M. L. Fulcher and Paul Lundy, of Winton & Livingston, booking agents of Columbia artists, have been visiting the Cincinnati territory in the interest of concert tours for Oscar Seagle and Barbara Maurel, Sascha Jacobsen, Charles Harrison, Amparita Farrar and the Columbia Stellar Quartet. About twelve towns have already been booked, and it is probable that five or six more will be added before the season is over.

The disastrous fire which occurred in Ashland, Ky., Friday of last week, almost completely destroyed the store of the Field Furniture Co., Columbia dealers. Fortunately Mr. Field had already formulated plans for a new building which will now be rapidly pushed to completion.

E. B. Shiddell has been added to the local sales force of the Columbia Co. Mr. Shiddell is just back from service, in which he spent nearly two years in France. Prior to this time he was connected with the Columbia Co. in Dallas and Kansas City, Mo. Chas. L. Byars, manager of the Vocalion department of the local Aeolian store, reports a phenomenal business for July. The sale of the larger machines, particularly the art styles, is especially gratifying. He makes special mention of the fact that never in his experience in the music business has he seen the time when people had so much ready cash to buy with, and they all seem to be willing to part with it. The new Vocalion Records are in big demand and are gaining in popularity every day. Mr. Byars predicts the biggest phonograph business in the history of the business for the fall, providing the stock can be had.

Manager Sigman, of Victor section of the Rudolph Wurlitzer Co., yesterday said:

"The Victrola business for the month of July, both wholesale and retail, was very good. This was due to the fact that most Victrolas and records came through from the factory in somewhat larger quantities than they have for some time past. This does not mean, however, that we are anywhere near caught up in our orders, for we are still swamped with orders that will take a long time to be filled.

"The most gratifying event of the month was the reduction in price of the Red Seal records. The very fact that the \$2.00 to \$7.00 Red Seal records were cut in half, practically, will stimulate the record business to such an extent that the future sale of these records should be five or six times greater than in the past. It will not only be noticed by the dealer who always pushed the sale of the Red Seal records, but will also open up the way for the small dealer to handle them who never handled them before."

George E. Kleeman, the Ohio representative of the Crystola Co., is credited with having opened up twenty-five new retail agencies for the Cincinnati house in the State during July.

Manager Oelmann, of the Phonograph Co., Edison jobbers, said the dealers in the Middle West district have placed sufficient orders to gobble up all goods which can be expected for the next three months, this being an evidence of the popularity of the Edison machine.

### GRAFONOLA IN PUBLIC SCHOOLS

Public school authorities are showing an increasing interest in the cause of music in the schools. At the various sessions of the Ontario Educational Association, held some time ago in Toronto, Can., the most significant evidence of this interest was shown in the unanimous endorsement of a resolution passed by the Public School Section that the Minister of Education be urged to list the Columbia Grafonola as school supplies and make it obligatory for every school to have a machine and records for general use.

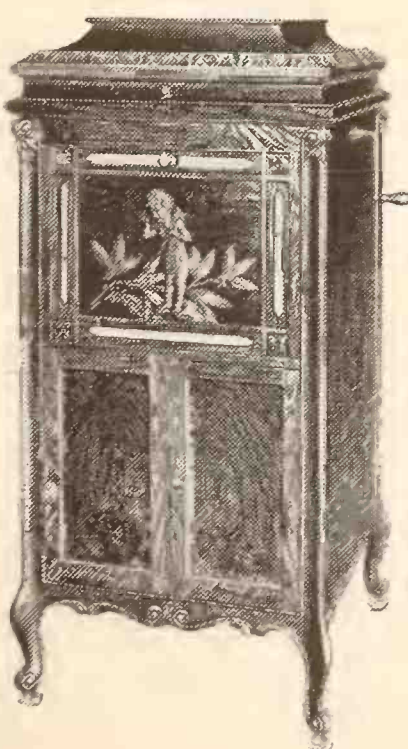

## The Wonderful Tone Production of PHON D'AMOUR

is like the memory of a musician thinking over the performance of a great player. The

## PHON D'AMOUR

plays every record and reproduces them tone true. This tone quality is obtained by the patented Diaphragm and Amplifier, which features are only obtainable in the

## PHON D'AMOUR

THE FRITZSCH PHONOGRAPH CO. N. W. C. Main & Canal  
CINCINNATI, OHIO





## — is the Business that Pays

If your talking machines are giving the satisfaction that is absolutely necessary these days, you'll get repeat business, if NOT you're sure to lose money in more ways than one.

Americans are impatient of men and commodities that work well to-day and not quite so well to-morrow. They admire immensely a talking machine that is as perfect in performance as in appearance.

They DEMAND a motor that makes this possible—a motor that delivers a smooth, unwavering flow of power *invariably* throughout the life of the machine. They demand these things without the annoyance of adjustments and repair.

The Dayton Motor does *more* than that. It will give to your product the reputation and prestige of the highest grade instrument of its class, and the satisfaction that is bound to

come from its use will place you in a position to *dominate* the kind of business that pays.

Makers of the highest grade talking machines are equipping their product with the Dayton Motor. To be Dayton equipped is a sign of the best, whether the machine is to sell for a high, low or medium price.

Dealers who sell Dayton Motor Equipped machines have learned that they stay sold, and the sale that stays is the sale that pays.

Talking Machine Manufacturers and Dealers find in Dayton Motors an unusual value of performance, quality and salability.

If you have not investigated the Dayton Motor and its advantages,—if you have not compared it with other motors, we suggest that you send for a sample from stock and verify these claims.

# The Thomas Manufacturing Company

*Dayton Motors are made in various sizes for a Full Line of Cabinets—from the lowest priced to the Highest Grade Talking Machines.*

Dayton, Ohio, U. S. A.

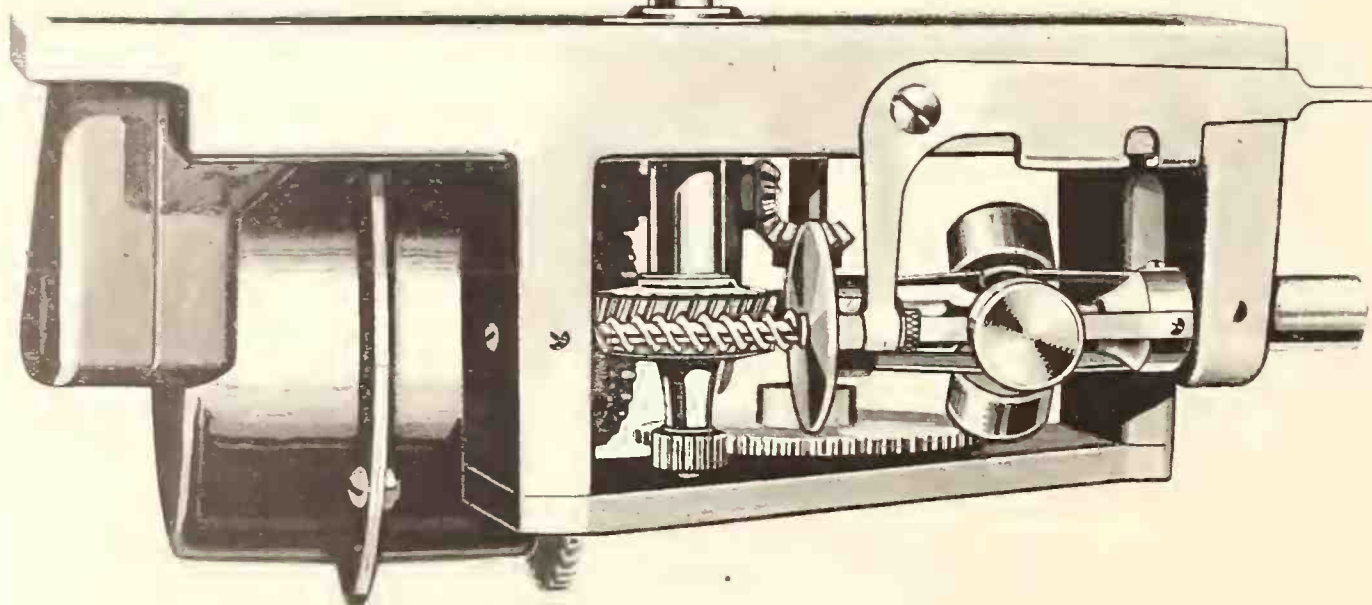

THE DAYTON MOTOR



**IMPORTANT EDISON CHANGES**

Promotions and New Appointments in Various Departments of Thos. A. Edison, Inc., Announced—Advertising Staff Enlarged

Thos. A. Edison, Inc., recently made a number of important announcements regarding staff



Verdi E. B. Fuller

changes as follows: The duties of Verdi E. B. Fuller, who for several years has had charge of Edison tone-test recital work, have been en-



G. L. Roberts

larged to include supervision of the various new forms of dealer co-operation, announced at the recent convention of dealers in New York. Arthur L. Walsh will act as Mr. Fuller's assist-

ant and will have charge of tone-test tours under Mr. Fuller's supervision.

J. A. Shearman, formerly a supervisor in the South of the Edison Co., has been appointed assistant to Thos. J. Leonard, general sales manager.

Lieut. Kenneth A. Moses has been made assistant to F. C. Pullin, manager of the record service department.

P. J. Burns, formerly correspondent in the general offices, has been appointed traveling supervisor; it is understood that he will be assigned to the Dominion of Canada.

C. H. Miller, R. T. Burke and G. L. Roberts have been added to the advertising staff. Mr.



C. H. Miller

Miller, who is a prominent literary man, for many years with Doubleday, Page & Co., has become editor-in-chief of Diamond Points, Along Broadway and the Amberola Monthly. Mr. Burke, who has had extensive editorial experience in the newspaper field, will do general literary work for the Edison advertising department.

Mr. Roberts, who has become assistant to Arthur J. Palmer, advertising manager, was formerly with the Churchill-Hall Advertising Agency and has had extensive practical experience in the advertising game.

The Elizabeth Phonograph Co., New York, has been incorporated to deal in cabinets and furniture. The capital is \$60,000 and the incorporators are P. Kanarek, S. Hechler and R. Flambert, 12 East Forty-second street.

**JOHN McCORMACK'S LIFE STORY**

Career of Noted Irish Tenor Set Forth Most Interestingly in New Volume

"John McCormack—His Own Life Story," is the title of a new volume just published by Small, Maynard & Co., Boston, the new book being devoted entirely to the career of the famous Irish tenor, transcribed by Pierre V. R. Key. The story as presented is distinctly personal in character, and in a large sense represents what might be termed an autobiography, much of the material offered being in McCormack's own words, as set forth by his friend Mr. Key.

The book, in the course of over 400 pages, tells of McCormack's early days in Ireland, of the obstacles he was forced to overcome in order to achieve success, his conquests in the music fields of Europe and America, and many interesting facts regarding the personal characteristics of the singer and of those artists and impresarios with whom he has been associated during his career. In transcribing the story Mr. Key has preserved in it an intimate touch that is distinctly interesting and pleasing.

Although there is little reference to McCormack's experiences in making records, the story of his career should prove of exceeding interest to those talking machine dealers who have enjoyed such a strong demand in McCormack records during the past few years.

The volume is replete with illustrations, chiefly portraits of the singer and the members of his family, and should find many readers among the thousands who consider McCormack as one of their favorite artists. The volume is substantially bound in cloth with decorations and title stamped in gold and is listed at \$3.00 net.

**FRENCH GOODS SHOWN IN NEW YORK**

Industrial Exhibit Opens at Hotel Pennsylvania —Pianos Shown to Buyers

Concerted efforts on the part of French manufacturers in co-operation with the French Government to regain trade lost in this country because of the war began in New York on Thursday with the opening of an exhibition of French products at the Hotel Pennsylvania. This exhibition includes that class of French goods least hurt by the war and pianos are among the articles which were listed on the schedule of manufactures. Maurice Casenave, French High Commissioner to the United States, opened the exhibit at noon and Gaston Liebert, French Consul General in New York, and Marcel Knecht, special representative, were present.



HERE IT IS

The FLETCHER UNIVERSAL TONE ARM and REPRODUCER

Gives Proper Playing Weights for all Records. No Adjustment Screws or Sprisgn.

SAMPLES \$8.00 Specify 8½" or 9½" arm

FLETCHER-WICKES CO., 6 East Lake Street, Chicago, Illinois

THE GEORGE McLAGAN FURNITURE CO., STRATFORD, ONTARIO, EXCLUSIVE CANADIAN AGENTS



# OUR DEALER'S MACHINE REGISTER

## GIVES YOU

# INVALUABLE INFORMATION

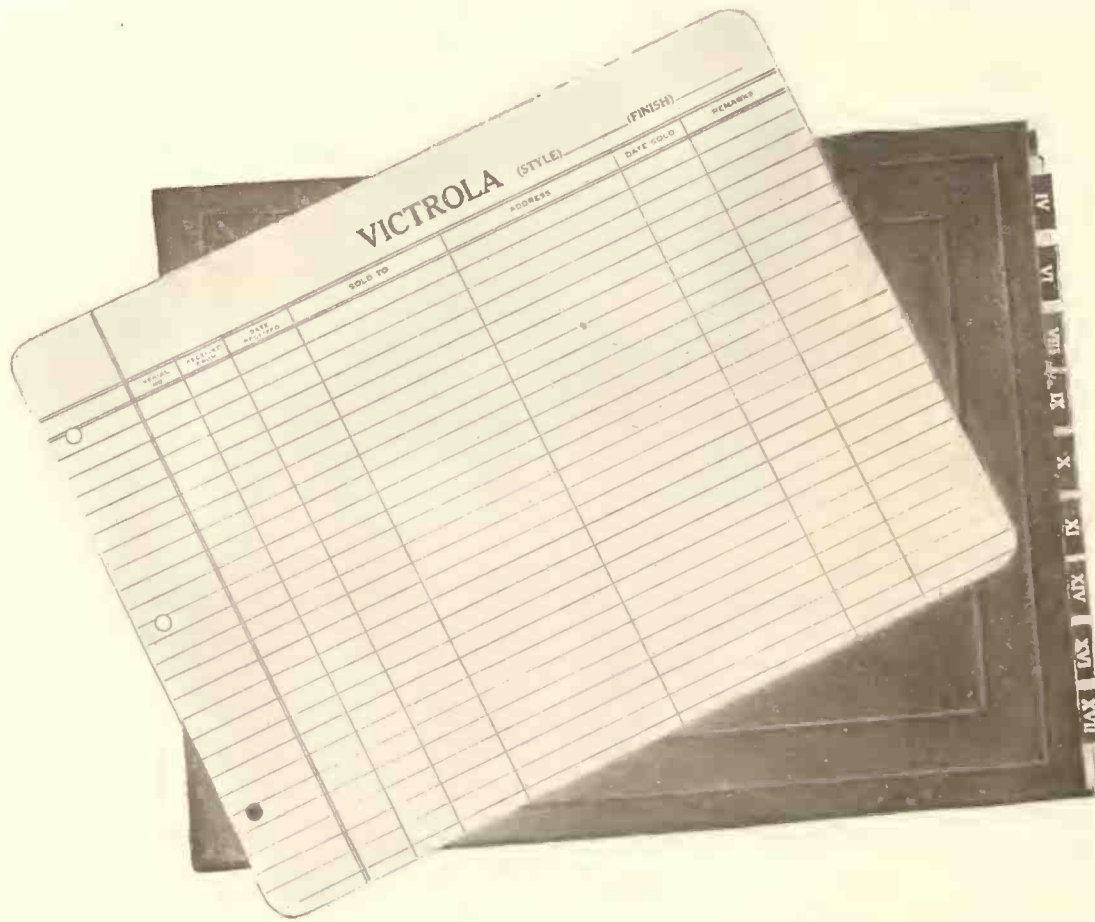

*This loose leaf Machine Register, size 9 x 11<sup>3</sup>/<sub>4</sub>, is bound in a very attractive three ring heavy black canvas binder. The 50 sheets give you complete records on 1250 machines. Nine dividing sheets with rich gold lettered leather index tabs separate the various types of instruments.*

*You can tell at a glance:—The type, finish and serial number of each machine you have in stock. When and from what wholesaler you received it. The name and address of each purchaser together with date of sale and other necessary details. Just what turnover you are getting by type and finish. All data to aid you in determining your requirements and how to intelligently order.*

**PRICE COMPLETE-WITH 50 SHEETS \$ 2.00**  
**ORDER NOW ONLY A LIMITED SUPPLY-PRINTED**

**CHICAGO TALKING MACHINE CO. - NEW YORK TALKING MACHINE CO.**  
 12 N. MICHIGAN AVE. CHICAGO. - 119 W. 40<sup>TH</sup> ST NEW YORK CITY.



# FROM OUR CHICAGO HEADQUARTERS

Edward Van Harlingen  
William Braid White  
A. Snyder

Eugene F. Carey  
Arthur E. Nealy

World Office  
Republic Bldg., 209 South State St., Chicago  
Telephone: Wabash 5774

CHICAGO, ILL., August 11.—Every talking machine manufacturer who exhibited at the Furniture Show just closed at Grand Rapids has learned a valuable lesson which more than repaid him for the time and trouble he expended in exhibiting his goods. Many of the best-known instruments on the market were there, as well as many new aspirants for trade favor. Yet, although so many were shown, the representation was not complete. Some of our best-known machines were not on view.

Some of the manufacturers of talking machines approached by The World representative before the show and questioned as to whether they were going to exhibit replied: "Too much business on hand now. Can't fill the orders. Why should we show our goods and bring more inquiries and more trouble upon ourselves?" There was no reason, of course, if they regarded the show in this light. But manufacturers who could see the benefits to be derived from the show went right to it and had their models on display. Whether they were in favor of putting their lines into furniture stores or not made no difference to them, nor did it make any difference to them whether or not they were tied up with orders. They saw the value of prestige and the possibility of building up their prestige by exhibiting their goods at the show. They knew that the furniture dealers who were on the job are very good prestige builders, because the furniture dealer is the first one who is called on by the newlyweds when the lease is signed and they want furniture. He loads them up with furniture and if he has a talking machine he sells it to them, and if he has not he tells the newlyweds of the good ones he is acquainted with. For this very reason the talking machine manufacturers who exhibited showed that they are really "on the job."

There is going to be another Furniture Show, and it would be well for those who did not exhibit last time to take the advantages offered and get busy. There is also going to be a big music show the first of the year in New York which should not be overlooked by the talking machine manufacturers. They should get on the job right away and make preparations for these big doings if they don't want to be

left by the roadside. They must take advantage of all of these shows and build up a reputation for their instruments and not depend solely upon the amount of business they are doing at present to carry them on in the future, because some day things are going to be less easy, and then the best-known machines only will be sold.

#### Exclusively Victor

Macauley & Nevers, retail talking machine merchants of this city, have become exclusive Victor retailers. Other lines previously handled by the concern have been eliminated and a larger stock of Victor machines and records installed. Extensive alterations have been made in the store, the record racks being removed from the side of the building to the center and additional booths placed where the racks were formerly located. Officials of the company express great satisfaction with the manner in which recent shipments have been coming through. Both the record and talking machine stocks have been increased materially in anticipation of early fall needs.

#### Move to Larger Quarters

Cole & Dunas Music Co., located in the Commercial Building at 54 West Lake street, have removed from their space on the second floor of this building to the third floor, where they will occupy the entire west side of the building. "Larger quarters were required," says Mr. Dunas, "for our stock and assembling departments. The tone-arm assembling department was especially in need of larger quarters, our business in this line having increased greatly within the past few months."

#### Vocalion Travelers

H. B. Levy, manager of the Western division of the Aeolian Vocalion Co., announces that two new travelers have been added to the Western force. They are W. G. Karmann and John T. Schiplett. Mr. Karmann travels in parts of Indiana, Ohio, Kentucky and Michigan; Mr. Schiplett in parts of Michigan, Wisconsin and Illinois. Both of the gentlemen are out at present on the road. According to Mr. Levy both have met with great success in their initial efforts.

"I expect the next sixty days will be the greatest in our history," said Mr. Levy. "Ship-

ments are coming through much faster than they were. I expect to take care of both new and old accounts in August much better than I have in the past. By September even more machines will be coming through. The Aeolian Co. recently announced their new line of instruments and changes in styles, and I have received many words of approbation from dealers who have received the goods. The Aeolian Co. have extended themselves in the design and marketing of these new cabinets, which is strongly indicated by the orders coming into the Western office. The new style 540, which is selling at \$170, seems to be the most popular of all out here. We are not pushing this model any more than any of the rest, but it seemed to put itself to the fore immediately. The Aeolian colored record has also met with great favor throughout the Western territory and dealers have expressed great satisfaction with the Vocalion record advertising service.

#### Booth Equipment Demand Grows

E. E. Morten, formerly in charge of the Chicago office of the Unit Construction Co., has returned to the Philadelphia office of this concern and H. R. Mirick, who formerly traveled the Chicago territory for the Unit Construction Co., has charge of the central branch in the Lyon & Healy building. Mr. Mirick will continue to travel the Western territory, but will spend more time than in the past in the Chicago headquarters. This gentleman has had extensive experience in traveling the talking machine trade of this territory, being formerly connected with the wholesale talking machine department of Lyon & Healy. "Never in the history of the talking machine business have there been more improvements and changes in talking machine stores of the company than in the past few months. The talking machine business has always been rather feverish, dealers having no time to stop selling machines and fix up their departments or, if they had the time, not knowing whether or not the business would continue to increase or decrease. The past few months of shortage in all lines have given the dealers a chance to settle down and improve their stores. They now know that the talking machine business is not transitory, but is destined

(Continued on page 101)

We are glad to announce that we will resume our Original Prices on

## THE "WADE" FIBRE NEEDLE CUTTER

The Wade

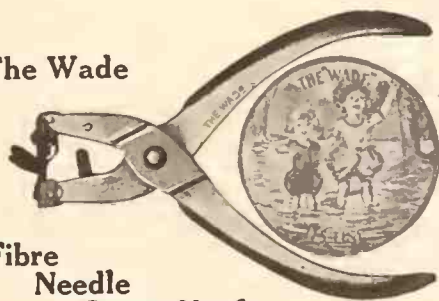

Fibre Needle Cutter No. 1  
Price \$1.50

HURRAH FOR PEACE!

Special attention—  
Read above—

"Not how cheap but how good"

Write for samples and Trade Discounts  
or Order From your Regular Distributor

The Wade

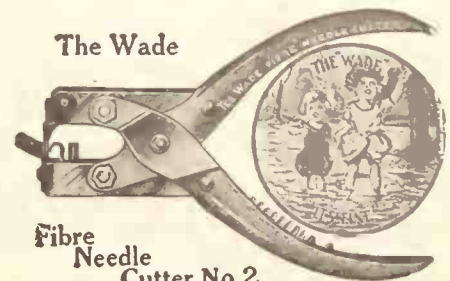

Fibre Needle Cutter No. 2  
Price \$2.00

**WADE & WADE, 3807 Lake Park Ave., Chicago, Ill.**







FROM OUR CHICAGO HEADQUARTERS (Continued from page 99)

to continue in prosperity for a number of years to come. This fact also has convinced them of the necessity for having suitable departments from which to sell their instruments. The average talking machine business of today has doubled or tripled that done a few years ago, but in spite of this fact the average talking machine department has undergone very little improvement."

**Production During Strike**

The recent tie-up of street car and elevated lines in Chicago had no effect on the output of talking machine motors in the Krasberg factory at Lake Shore Drive and Grand avenue. During the week of the strike numerous motor trucks transported the Krasberg workers to and from their homes, mornings and evenings. Full production was maintained and shipments dispatched according to schedule.

The Krasberg employes will enjoy a picnic in August at Schutte's Grove, near Berwyn, Ill. The entire office, sales and factory staffs will be included and a merry time is predicted for all. Numerous prizes will be given for events scheduled at the picnic.

**Public More Discriminating**

F. D. Hall, president of the B. & H. Fibre Manufacturing Co., keeps himself closely in touch with sales of records throughout the country, both of the popular "hit" variety and the more standard classical types. It is this gentleman's business to keep thus informed, as he almost invariably finds the sale of fibre needles varying directly with the demand for the better and more expensive records. Mr. Hall does not deprecate the "hit"; quite the contrary. He believes that it has a definite place, but believes also that a record of this type is not played as often, or over such an extended period of time as are the old-established selections for which the record-purchasing public in most cases pay more money.

Recent observations by Mr. Hall have led him to the belief that classical and standard

record sales are destined to mount steadily during the fall and winter. Many prominent people in musical circles have attributed the increasing appreciation of classical music to the talking machine, and with this increasing appreciation, of course, go larger classical record sales and a desire for better and more enduring means of reproduction. Mr. Hall believes that when a customer pays more for a record he naturally wants to keep it longer, and becomes more discriminating in his selection of needles and the other means of reproduction, even carrying his likes and dislikes as far as to the talking machine itself—perhaps even selling or trading in an instrument which he at first thought entirely satisfactory.

**Comes to Chicago**

The Parlaphone Co., of St. Joseph, Mo., one of the latest entrants in the talking machine industry, will on or about September 1 open a Chicago headquarters at 402-403 McClurg Building, Chicago. This company was recently formed by E. E. Trower, who for many years conducted a retail piano store at Wichita, Kan. J. W. Kelso is secretary. The Chicago office will be in charge of Francis S. Moore, who for many years has been connected with the Cable Piano Co., of Chicago. Mr. Moore is one of the best-known piano salesmen in the city. He is also vice-president of the Parlaphone Co. The Parlaphone will be shown in four models at the Chicago office, and it is expected that the large factory which this company recently built at 1902 South Fourth street, St. Joseph, Mo., will reach a capacity of one hundred a day by September 1.

**Cremona Man Visits**

Among the recent visitors to Chicago was Frank E. Cronan, secretary and treasurer of the Cremona Phonograph Co., of Portland, Ore. Mr. Cronan came to Chicago for the purpose of purchasing hardware, accessories, etc. While here he paid a visit to the Chicago headquarters of The World and told some very inter-

esting facts concerning the talking machine business on the Coast. Mr. Cronan said there is a big demand for talking machines throughout the Northwestern States, and in his opinion the purchasers of talking machines there were paying more cash with orders than anywhere else in the country. The retail trade, especially in Portland, are insisting upon the best grade of instruments that they can get their hands on. In speaking about his company he said the Cremona Co. is controlled by the Wakefield Music Co., of Portland, Ore., of which Mr. C. Guy Wakefield is president. He is also president of the Cremona Co. The Cremona Co. is building its own cabinets and at present has an output of close to fifty a day, which will be gradually increased.

**Change Firm Name**

Announcement was made this week that the Chicago Recording Scale Co. had changed its corporate name to Cherington Mfg. Co. This company has been manufacturing for thirty years spring motors for all purposes. They have recently put on the market a new talking machine motor known as "Ironclad." This is the first motor to be put on the market embodying enclosed gear running in oil. They are also about to place on the market a handsome line of sound boxes and tone arms. It is interesting to note that before this motor was placed before the public it had been put to a test equivalent to ten years' use in the average home. It was run by a special machine continuously for ten weeks twenty-four hours a day. It was figured that in this length of time the motor had run about 100,800 minutes. The average record takes three minutes to play, and so the running time was equivalent to the playing of 33,600 records.

Quite recently the company has revised its method of mounting mainsprings. The new method of putting them in the barrel is such that they cannot stick. This eliminates all the

(Continued on page 102)

**Your Account With Us**



**Will Be an Insurance Policy Against**  
 EMPTY RECORD SHELVES                      LOSS OF CUSTOMERS  
 LOSS OF PROFITS

**Record Dealers Reach the Acme of Wisdom**  
 WHEN THEY STOCK UP WITH POPULAR HITS ON



*No Waiting for Delayed Shipments When You Order From Us*

**MAGNOLA TALKING MACHINE COMPANY**

711 Milwaukee Avenue

OTTO SCHULZ, President

CHICAGO, ILL.



## FROM OUR CHICAGO HEADQUARTERS—(Continued from page 101)

kicks on spring trouble. This spring, by the way, is not lubricated with grease. The manufacturers state that their experience with grease has been that it congeals at low temperature and causes lost power. Therefore the lubricant now being used is dry and will not run from the barrel and cause lost power in cold weather as it adheres to the spring and produces an extremely smooth surface. This lubricating method is not new or untried, as it is the same as was used by this company while manufacturing springs for the well-known "Apollo" motor, which was built for and used by the Melville Clark Piano Co. for many years in the Apollo player-piano.

**New Store Opens**

The Chorister Phonograph Co., of this city, one of the latest entrants in the Chicago trade, has just opened a beautifully furnished sales-room at 335 West Sixty-third street, this city, where it will conduct both a wholesale and a retail business. This company was recently incorporated and the new store will be in charge of Stanley R. Fritz. A full line of complete machines will be on exhibit and they will also carry a complete stock of records and talking machine accessories. The new store is fitted out with the most modern furnishings and demonstration booths and has one of the most attractive talking machine warerooms on the South Side.

**Lakeside Activities**

Bill Fricke, secretary of the Lakeside Supply Co., left on Saturday of this week for a short trip through Ohio. Before leaving Mr. Fricke looked over the sales reports for the month of July and found that the company had practically doubled the business of June, which was the biggest month in their history.

They have recently enlarged their shipping department at their new location, 416 South Dearborn street, and have taken on more room for storing purposes.

Mr. Fricke's brother, Gus, president of the company, is planning a short vacation in Michigan for the purpose of trying out a new motor launch which they recently purchased. Gus plans a visit to Camp Roosevelt, near Muskegon, where his son is stationed, and the two will then go for a cruise along the eastern shore of Lake Michigan for several days. Before leaving Gus was talking about his boat and said that there is going to be a baptism when he gets there, and he is going to christen it "Lakeside." As a protection he says he will take one of the powerful three-spring Lakeside motors along with him to use in case of emergency should the gas engine break down.

**Business and Pleasure**

Samuel S. Schiff, vice-president and general manager of Vitanola Talking Machine Co., left Chicago recently for a tour of the Eastern States. The past few months have been very strenuous for the Vitanola Co., and Mr. Schiff felt it necessary to take a much-needed vaca-

tion. He will pass through Philadelphia, Atlantic City, Washington, New York and Boston, and while his trip is primarily one of pleasure, he will, nevertheless, give his attention to Vitanola dealers in the above-mentioned cities, as the company is doing a very large business there.

G. Edward Lind is spending his vacation at Blue Lake, Fruitvale, Mich. Mr. Lind will return in about two weeks.

**Seasonable Window Suggestions**

Window suggestions of the season are great hobbies with the window dressing departments

attention is that of the Talking Machine Shop, located across the street from Lyon & Healy. In this window the background is taken up with a large painting of the Victor plant. Every building of the Victor Co. is shown, and leading from each building is a ribbon which runs out to the foreground of the window and is attached to a placard, bearing words that tell all about that particular building and what is going on therein. This is one of the cleverest Victor advertisements that has been seen in this neck of the woods for some time and is in itself a



Victrola Display in Window of Lyon & Healy Store, Chicago

of Lyon & Healy. The big double window which faces both Wabash avenue and Jackson boulevard is an ideal show spot and the window dressing department is, it seems, never lacking in ideas to decorate this particular place to suit the occasion. As will be seen in the accompanying illustration, the window is suggestive of outdoors and the Victor talking machine is conspicuously displayed. It is, so to speak, being operated by the "wax woman" and in the foreground may be seen a baby playing with some Victor records. Swinging around the outer edge of the window is a trickling brook, wherein are live fish. In the background is a pergola effect overhung with vines, bowers, etc. These have a waving motion, which is accomplished by means of a concealed blower or electric fan, giving the effect of a genuine breeze. It goes without saying that the window is having the desired effect upon passersby.

Another big Victor window that is attracting

liberal education for those who are desirous of knowing anything about the Victor plant.

**New Emerson Publicity**

Warm weather has seen no let-up in the advertising campaign of the Emerson Phonograph Co. of Chicago. The campaign inaugurated some two months ago is still in full swing and bringing direct results throughout the city and in adjacent territory. Four advertisements appearing in the papers during the latter part of July and the early part of August base their appeal entirely upon the sale of dance selections. Snappy illustrations under such catchy captions as "Who Said Dance?", "Take Your Partner, Lend Your Ear—the Louisiana Five Are Here!", "Let's Dance," and "When Your Feet Get Results" attract the eye of the newspaper-reading public. A little prose poetry a la Walt Mason in the style of the following makes the advertisements highly readable: "Come on, you light

(Continued on page 104)

# TRANSFER NAME-PLATES

We make the Transfer Name-Plates and Trade-Marks for the largest talking machine manufacturers in this country and for dealers in every state.

**YOUR NAME**, Mr. Dealer, on every machine brings the owner back to you for records and his friends to you for a machine.

*Samples, Suggestions and Sketches Furnished Free*

## THE MEYERCORD COMPANY, CHICAGO

Largest Manufacturers of **DECALCOMANIA** Transfer Name-Plates



The Use of the  
**FULTON**  
Practically  
*Ends*  
Motor Trouble

New Illustrations  
and Full Description  
received too late for  
This Issue, but  
Now Ready.  
Write

**THE**

**FULTON**

**“TROUBLE-LESS”**

**MOTOR**

Embracing the  
Greatest  
Spring Motor  
Inventions of a  
Decade

**FULTON BROS.  
MFG. CO.**

Impossible to  
Over-wind.  
No Governor  
Springs to  
Break

WAUKEGAN,

ILL.



# The Oro-Tone

QUALITY FIRST

FOR THE PERFECT REPRODUCTION OF ALL DISC RECORDS ON THE SUPERB EDISON

**DO THIS**— Try the ORO-TONE in comparison with other Edison attachments and be convinced that it is the one perfect attachment for the Edison.

Ask your jobber or  
May we send sample on approval?

Retail Price, Nickel Plated, \$8.50      Highest Grade Gold Plating \$12.50

Mfrs. of highest grade tone arms, reproducers, attachments for phonographs for playing all records. Diamond and Jewel point needles, motors, supplies, etc.



## The Oro-Tone Co.

QUALITY FIRST

Successors to COMBINATION ATTACHMENT CO.

1808-10 IRVING PARK BOULEVARD, CHICAGO, ILL.

### FROM OUR CHICAGO HEADQUARTERS—(Continued from page 102)

fantastic toe—let's go! What'll it be? Let's see! Why, bless my bloomin' sky blue 'lamp,' suppose we fox-trot with the 'Vamp'!"

And here's another: "Clear out the chairs—roll up the rugs—we're going to have some fun! Adjust the needle, now 'crank up'—the evening's just begun. Intermissions are taboo—encores are all the rage; you'll find a lot of inspiration further down the page." And the interested reader looking "further down the page" finds all of the latest Emerson "inspirations" in the form of the latest "hits."

#### New Stein-Burn Traveler

A. P. Miller, who formerly traveled Western Michigan for the Columbia Graphophone Co., has joined the sales force of the Stein-Burn Phonograph Corporation of Chicago and will take charge of the entire state of Michigan, with headquarters in this city.

#### Resume Business

The FlexiFile Mfg. Co., manufacturers of the FlexiFile filing system for talking machines, has moved its general offices from 5 North La Salle street to its plant at 115 East South Water street, Chicago. During the war period the company was obliged to confine its talking machine business to its old customers because of the Government's restrictions on the use of steel. These restrictions are now abated, and the company has perfected mechanical attachments

which enable it to FlexiFile all taking machines. John Hughes, a FlexiFile expert, is in charge of the department that cares for the FlexiFile demand emanating from talking machine trade.

#### In the Furniture Trade

The Furniture Journal, of Chicago, in a recent article about the present great shortage in furniture lines lays most of the responsibility for the present state of affairs to the talking machine trade. It claims that manufacturers of furniture are diverting their facilities to the manufacture of talking machine cabinets, with consequent disastrous results to the former. Evidently the talking machine business offers greater remuneration all around. The article in question, which deals with the present situation in Grand Rapids, the foremost furniture manufacturing city in the world, will be found of great interest to members of the talking machine trade:

"One of the very good reasons for the present shortage in the furniture supply is found in the tremendous diversion of furniture production capacity to the manufacture of phonographs. The Grand Rapids factories alone have phonograph contracts to the amount of between \$1,000,000 and \$1,500,000, employing 1,000 or more hands, and but for these contracts the capacity would all be on furniture. Two large

factories formerly producing furniture have been turned over to phonographs exclusively, and the Berkey & Gay, Macey, Phoenix, Widcomb, Lauzon and several other large factories are working part of their capacity. Outside of Grand Rapids the Connersville Furniture Co. and the Conrey factories at Shelbyville are working exclusively on phonographs, and many factories all over the country have contracts of some sort. It is estimated that between 4,000 and 5,000 furniture workers are employed on phonographs, taking the country as a whole, and with this diversion it is no wonder there is a shortage in the furniture supply. The phonograph undoubtedly has come to stay and will continue to be in demand until every home in the land has its instrument, but at the present rate of production it is only a matter of time when some easing up will be necessary.

### You Ought To Hear It!



Last month we showed the Sterling Reproducer in position for playing bill and dale records. This month you see it in position for playing lateral records.

## "Most Perfect Reproduction I Have Ever Heard!"

—That's what a large Edison dealer exclaimed after an hour's comparison of the Sterling Reproducer with others. It's what they all say. "Never heard Edison records played so quietly and beautifully." "Never heard Victor records played with such a full, natural tone."

Permits immediate change from one kind of record to another No extra elbows. Just a quick, easy turn of reproducer. Especially attractive to Edison owners. They want to play other records.

Order a Sterling on Your Letterhead at Dealer's Price Hear it yourself. Gets the best out of all records. Circular and price list on request.

Guaranteed not for one year only but for all time, against any defect of workmanship or material.

STERLING DEVICES CO. Dept. 100 467 EAST ONTARIO ST., CHICAGO

# Sterling Reproducer and Attachment

## AMBEROLA SERVICE

As the Edison Cylinder products are not controlled by zone system, dealers anywhere can take advantage of LYONS' SERVICE, which is efficient, skilled, and up-to-date.



Contrary to the general impression, the cylinder line IS NOT A THING OF THE PAST. It is absolutely the best value offered the public today.

### J. I. LYONS

17 W. Lake St.

Chicago

### Equip Your Phonographs With Perfect Automatic Brakes

Samples \$1.00 Each Cash with order

State make of tone arm used



Also made with long brake shoe for 1 inch offset

Patented Aug. 28. '17

Simple construction and easily attached. Made in four styles to fit any make of tone arm.

Write for attractive quantity price

PERFECT AUTOMATIC BRAKE CO. Room 400, 425 S. Wabash Ave., Chicago



# The **Blood** Tone Arm And Reproducer

Write for sample, discounts, delivery dates and construction details

Truly clear enunciation!

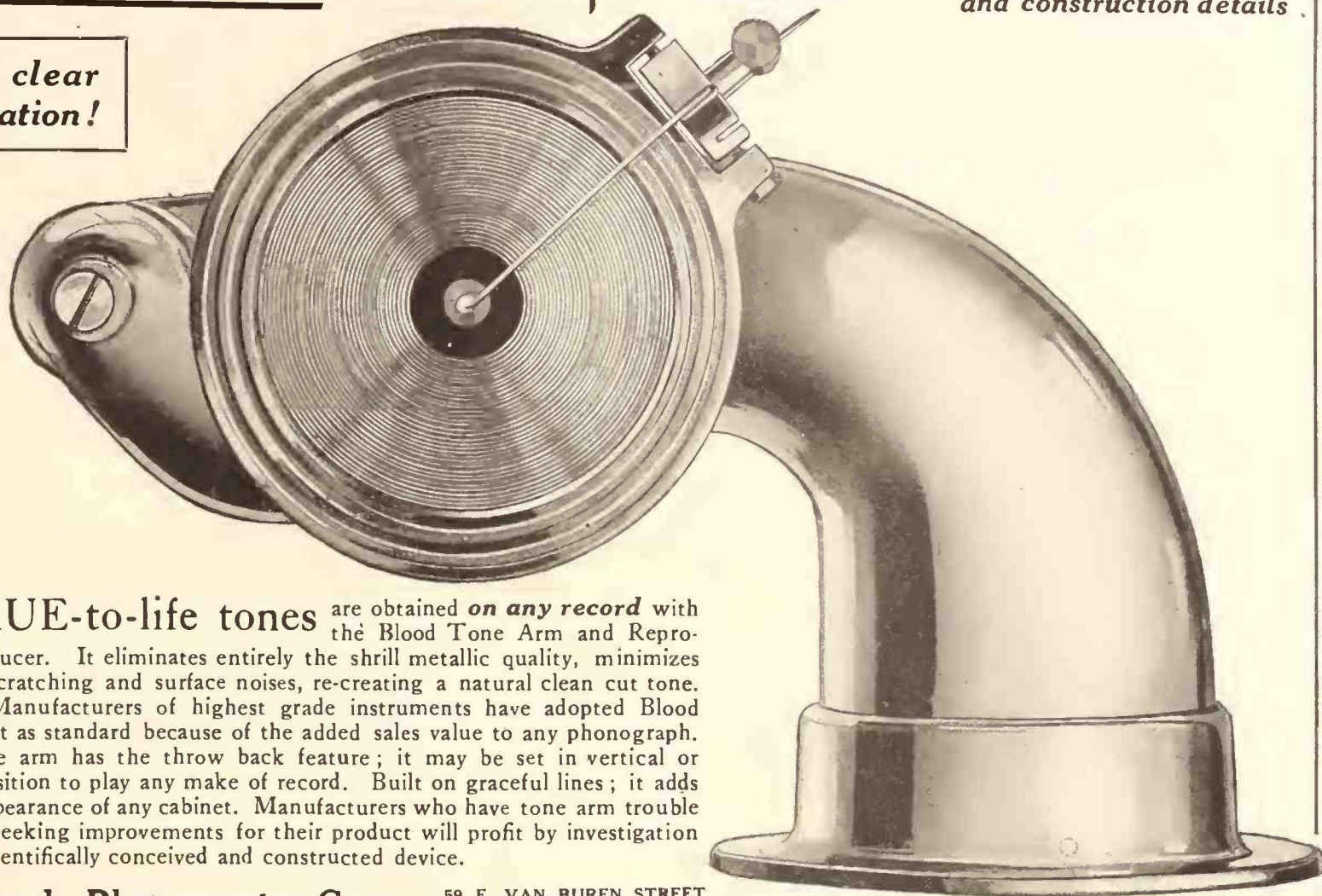

**T**RUE-to-life tones are obtained *on any record* with the Blood Tone Arm and Reproducer. It eliminates entirely the shrill metallic quality, minimizes scratching and surface noises, re-creating a natural clean cut tone. Manufacturers of highest grade instruments have adopted Blood equipment as standard because of the added sales value to any phonograph. This tone arm has the throw back feature; it may be set in vertical or lateral position to play any make of record. Built on graceful lines; it adds to the appearance of any cabinet. Manufacturers who have tone arm trouble or those seeking improvements for their product will profit by investigation of this scientifically conceived and constructed device.

The Jewel Phonoparts Co., 59 E. VAN BUREN STREET CHICAGO, ILL.

## FROM OUR CHICAGO HEADQUARTERS—(Continued from page 104)

This will bring some readjustment to the furniture industry. Manufacturers are also increasing their production capacity to meet the new needs. In this city the Grand Rapids Chair, the Imperial, the Sligh, the Macey, the Johnson, the John Widdicomb and Stow & Davis are building large additions, and when these get into action the diversion to phonographs will be further adjusted. It is only in very recent years that the phonograph has become a work of furniture art. Buyers are now demanding period styles and woods and finishes that will match up with the other furniture in the house."

### Appoint New Distributor

The Emerson Phonograph Co. of Chicago, Ill., have recently secured the Carpenter Paper Co., of Omaha, Neb., as distributors for Emerson records. The announcement is made by F. W. Clement, who also states that C. J. Woodard will assist the Omaha concern in the inauguration of their new line. Mr. Woodard will spend two or three weeks with the Carpenter Paper Co. and hopes to be of material assistance in speeding up the initial preparations and getting things under way in the shortest possible space of time. This is in accordance with the policy of the Emerson Co. in regard to all new distributors. The advice of an experienced record salesman is always put at the disposal of the new concerns.

Mr. Clement also announces that J. A. Tidmarsh has been added to the force of city salesmen. Mr. Tidmarsh will travel the Chicago trade and assist in the downtown office.

### Jobbing Widdicomb Machines

The Baldwin Piano Co. are now jobbing the Widdicomb line of cabinet and period-style talking machines. The Baldwin Piano Co. have for a few months past retailed the Widdicomb instruments, but now a wholesale service is being extended to the company's dealers about the country. The Baldwin Piano Co., in the wholesaling of talking machines, are confining

their efforts mostly to their own previously established piano retailers. W. B. Harrison, in charge of both wholesale and retail talking machine departments of the Baldwin Piano Co., states that the upright cabinet models are going strong at the present time and believes the demand for the "popular types" will increase to immense proportions in the fall.

### Enlarge Department

The Leopold-Kirchman Co., located at 2909 Milwaukee avenue, intend to enlarge their retail talking machine department materially within the next few weeks. New "Unico" record and instrument demonstration booths will be added and the stock both of records and machines increased. The Leopold-Kirchman Co. retail the Victor line of instruments.

### Secure Steger Agency

Roy Hinman, manager of the talking machine department of the Steger Piano Co., announces that the Colorado Bedding Co. has recently been appointed agent for the Steger line of talking machines. The Colorado Bedding Co. is a large wholesale furniture house of Colorado and will market the complete Steger line of upright and period styles in the Colorado territory. The firm recently received its first carload shipment, which included many of the more expensive types. Mr. Hin-

man has this to say of Western talking machine customers: "From Colorado west the people want the best and are willing to pay for it. In that territory I find the better grades going the best."

Mr. Hinman, by the way, has been on the point of leaving for his annual vacation for the past four weeks, but has had some business affair to interfere with his plans on each occasion. He now expects to leave early in August and will spend the vacation in Colorado.

### Market "Medalion" Record

The Baldwin Piano Co., wholesalers and retailers of Columbia and Widdicomb talking machines, announce that they will shortly place upon the market their own record, which will be known as the "Medalion." This will be a lateral-cut record and will come in monthly catalog lists of the latest hits and standard selections. W. B. Harrison, in charge of the talking machine department of the Baldwin Piano Co., states that the "Medalion" will be marketed by Baldwin dealers exclusively.

### New Steger Catalog

Steger & Sons have issued a new and very attractive little catalog descriptive of the Steger line of talking machines. Following four pages of introductory matter there appear

(Continued on page 107)

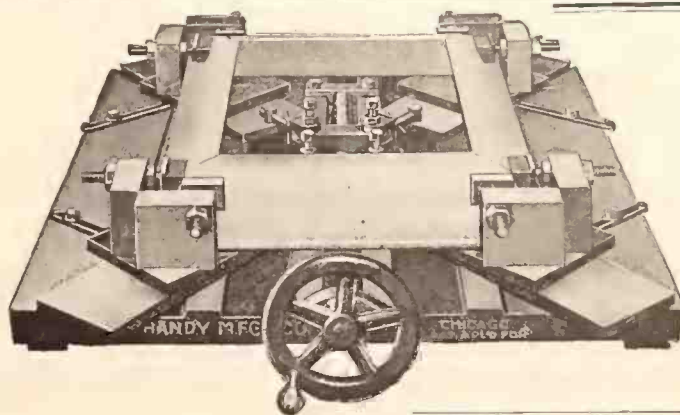

## We illustrate the "Handy" Dome Clamp

Quick action for clamping domes and frames on Talking Machine Cabinets.

Write for Catalogue of clamping machines for Cases and for all purposes

VENEER PRESSES AND CLAMPS

**HANDY MFG. CO.**

27 E. Madison St., Chicago, Ill.



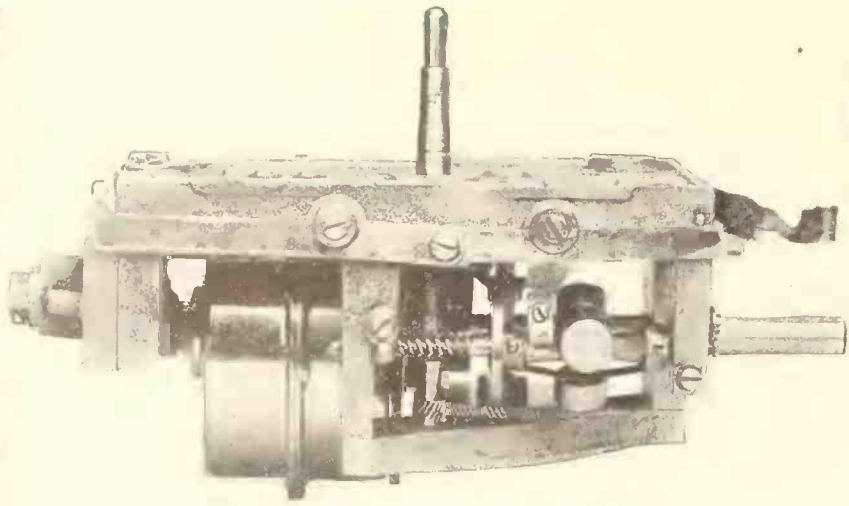

MODEL C MOTOR

All spiral gear, noiseless 18 ft. spring; brass governor disc and bearings; universal joint on winding stem; large diameter worm drive, insuring steady running; balanced governor balls; best trimmings; micrometer governor adjuster.

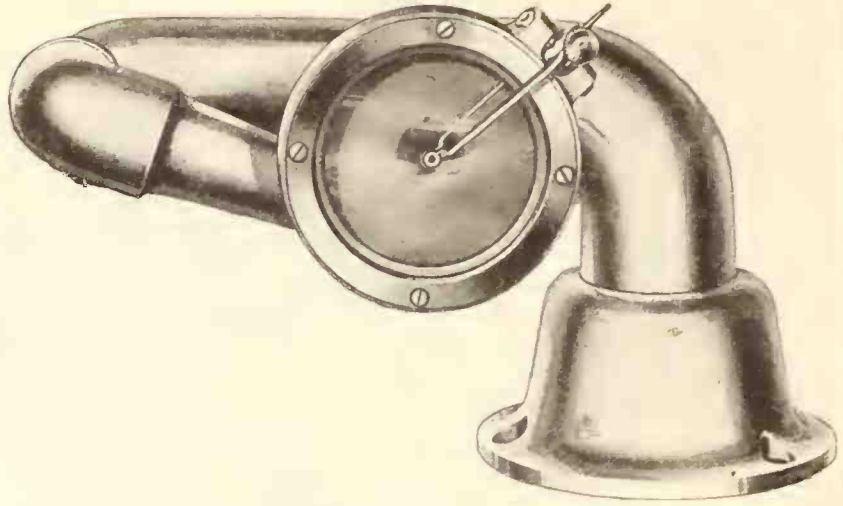

TONE ARM

Universal turn-back tone arm makes changing and adjusting needles easy. Finished in high-grade trimmings.

MANY DEALERS PRAISE THE

"Phoenix: A paragon of excellence and beauty."  
—Webster.

# PHOENIX

"Certainly, Mr. Webster: Plus the finest value obtainable."  
—The Trade.

FOR

Perfect sound reproduction. Big profits and a friend-maker. Reference: "sales."  
No come-backs with motor trouble. Satisfaction both in finish and beauty.

## Why?

Because the equipment is the best obtainable. Cabinet materials are selected from the best qualities. Phoenix plays all records perfectly. Large output provides for

## Immediate Delivery

A dealer with the right phonograph on his floor and with the confidence the PHOENIX always inspires is sure to make money.

## Join the Phoenix Dealers!

We are proud of the reception accorded the Phoenix by our many dealers during the past three years of efforts to satisfy. Your enlistment in the army of Phoenix dealers will add to your reputation and to ours as well.

## PHOENIX PHONOGRAPH CO.

(SAMPLE AND SALES DEPT.)

2504-06 West Van Buren Street, Chicago, Ill.

Telephone West 3629



MODEL "B"  
H—48 inches  
W—19½ inches  
D—22½ inches

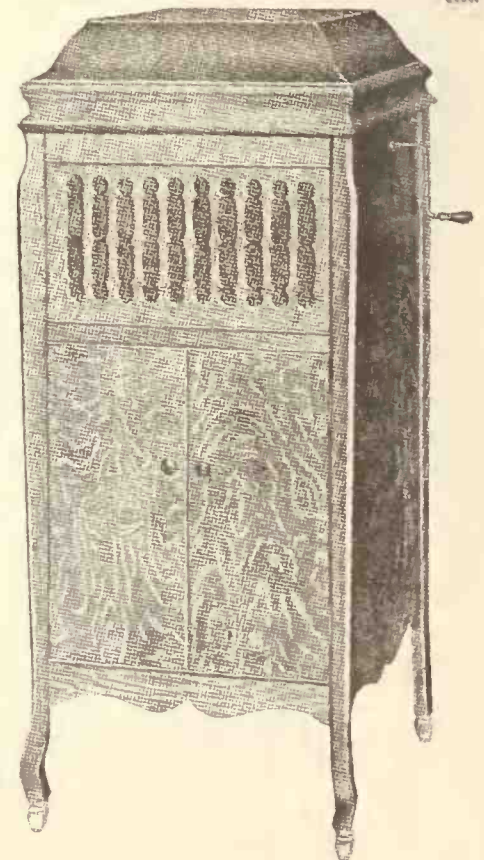

MODEL "C"  
H—50½ inches  
W—22 inches  
D—24 inches



FROM OUR CHICAGO HEADQUARTERS—(Continued from page 105)

half-tone illustrations artistically set off by penciled backgrounds. The three latest Steger models, the "Italian Renaissance," the "Gothic" and the "Adam," are shown, and, according to Roy Hinman, manager of the talking machine department of Steger & Sons, have attracted considerable attention. The cover of the booklet is designed in three colors and pictures a home scene with a talking machine as the center of interest.

**E. H. Stafford Mfg. Co. in Field**

The E. H. Stafford Manufacturing Co., furniture manufacturers of Chicago, have entered the talking machine field and are producing a line of instruments known as the "Stafford." For some time the E. H. Stafford Manufacturing Co. have been making cabinets for the wholesale trade and in this work have earned themselves an enviable reputation for good workmanship. Now that they have gone into the business of selling direct to dealers they are producing a complete machine, extending to dealers the privilege, however, of purchasing the cabinets alone if they so desire. O. R. McElroy, who formerly was connected with the Edison laboratories, has been placed in charge of the production of "Stafford" talking machines. In anticipation of a large fall demand, manufacture has been carried on through the summer months and this concern is unusually well fixed in the matter of available stock. The officials of the E. H. Stafford Manufacturing Co. are: E. H. Stafford, president; E. G. Bentley, vice-president, and E. M. Stafford, secretary and treasurer.

**Six Best Sellers**

The six best sellers in Victor records have been: "Jazz Baby" and "Bring Back Those Wonderful Days"; "Rainbow Division March" and "Spirit of Independence March"; "Oh, Susy, Behave" and "Monte Cristo, Jr.": "Oh, My Dear" and "Somebody's Sweetheart"; "A Rose, a Kiss and You" and "Girl of My Heart"; "Mammy O' Mine" and "When You See Another Sweetie Hangin' Around."

The six best sellers in Columbia records as follows: "I'll Say She Does" and "Just As We Used to Do"; "Friends" and "I'm Going to Climb the Blue Ridge Mountains Back to You"; "Jazz Baby" and "I Ain't Got'en No Time to Have the Blues"; "Just Another Good Man Gone Wrong" and "Yelping Hound Blues"; "Chong" and "Waiting"; "How 'Ya Gonna Keep 'Em Down on the Farm" and "Mammy o' Mine."

The six best sellers in Pathé records: "Chong" and "The Ozark Trail"; "Sweet Hawaiian Moonlight" and "Lullaby Blues"; "Wild

Honey" and "Mammy o' Mine"; "When My Sweetie Comes Back to Me" and "Sweet Hawaiian Moonlight"; "The Alcoholic Blues" and "Lassus Trombone"; "He's Had No Lovin' for a Long, Long Time" and "Behind Your Silken Veil"; "I'll Say She Does" and "Fluffy Ruffles." The six best Okeh sellers: "And That Ain't All" and "By the Camp Fire"; "I'm Forever Blowing Bubbles" and "Red Lantern"; "Beautiful Ohio" and "Tears"; "Mary" and "Beautiful Ohio"; "Till We Meet Again" and "Lonesome"; "Sensation" and "The St. Louis Blues."

The six best sellers in Edison records: "Ma Curly Headed Babby" and "I'se Gwine Back to Dixie"; "Any Place Is Heaven if You Are Near Me" and "Your Voice Came Back to Me"; "Kentucky Dream" and "Someday I'll Make You Glad"; "Better 'Ole" and "Somebody's Sweetheart"; "Jazzie Addie" and "St. Louis Blues"; "All Those in Favor Say Aye" and "Clrong."

The six best Emerson sellers: "Friends" and "Just a Little Place He Can Call His Home"; "The Red Lantern" and "Eyes That Say I

Love You"; "Mammy's Lullaby" and "Hawaiian Moonlight"; "My Cairo Love" and "The Vamp"; "Everybody Wants a Key to My Cellar" and "Golden Wedding Jubilee"; "Beautiful Ohio" and "I'm Forever Blowing Bubbles."

The six best Empire sellers: "Eyes That Say I Love You" and "When I Met You"; "The Alcoholic Blues" and "At the Jazz Band Ball"; "The Irish Regiment" and "General Pershing March"; "Will You Remember" and "Spring Song"; "Kisses" and "My Cairo Love"; "Radetsky" and "High School Cadets."

**Foreign Shipments of Needles**

Dorchester Mapes, secretary and treasurer of the R. C. Wade Co., manufacturers of Tonofone talking machine needles, tells of some recent shipments of Tonofone needles to foreign lands. It would seem from the following list of countries given by Mr. Mapes that the foreign market is an excellent one. Whether or not these same countries are getting the instruments themselves from the United States is rather doubtful. But if they are not, then

(Continued on page 108)

**The "ALL-IN-ONE" Speed INDICATOR and Tester**  
Registering 78 and 80 Revolutions

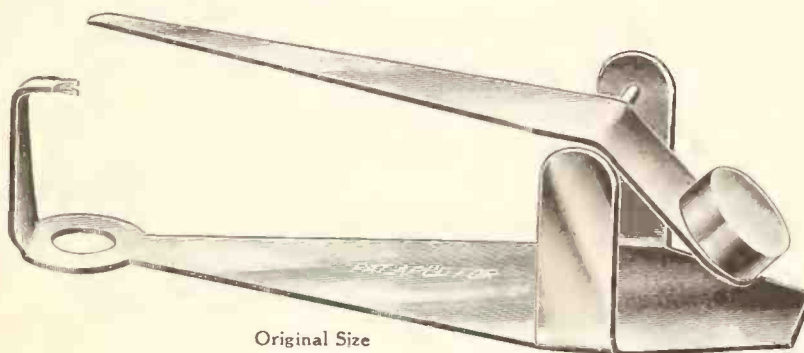

Original Size

VICTOR records are uniformly recorded at a speed of 78 revolutions per minute. All other records made are recorded at a speed of 80 revolutions per minute. To obtain the best results, the instrument upon which the record is played MUST be running at the required speed.

An ever growing demand for a reliable device which will insure the desired results has been met by the

**"ALL-IN-ONE" SPEED INDICATOR**

a reliable instrument, which registers correctly 78 and 80 revolutions of the turntable.

The "ALL IN ONE" is guaranteed in every respect, will never get out of order and is an absolute necessity for EVERY PHONOGRAPH OWNER.

Retail Price, Nickel Plated, \$1.00 each.

**KAUMANN'S & CO.**

21 E. Van Buren Street

--

--

Chicago, Illinois

**SIMPLE—SAFE—and EASILY APPLIED**

AN EFFECTIVE TALKING POINT  
AND A GREAT FEATURE

**THE CHICAGO COVER BALANCE No. 1**

It needs no catch simply because it catches itself. That is, it is self-controlled—and by a mere touch!!

Most of the best known Talking Machines on the market today are equipped with this clever little device because it prevents smashed fingers and broken records. Wise manufacturers know equipment counts. Remember, a satisfied trade causes the dealer to repeat his orders.

Samples sent FREE to Manufacturers

We also manufacture EMPIRE TOP HINGES

Send for our new catalogue just off the press

**Chicago Hinged Cover Support and Balance Company**

2242-44 W. 69th Street

Telephone Prospect 250

CHICAGO, ILLINOIS

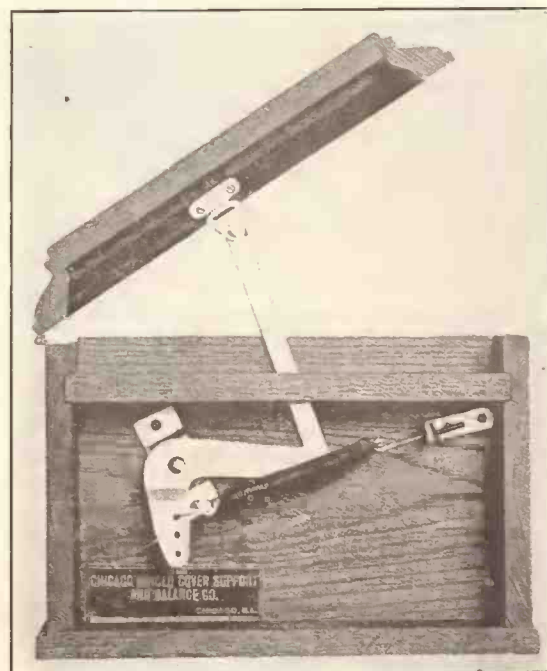

**Perfect Balance No. 1**  
(Patent Applied for)



## FROM OUR CHICAGO HEADQUARTERS—(Continued from page 107)

why not? Here is the list of foreign lands visited by the R. C. Wade Co.'s product: Canada (various provinces), England, France, Sweden, Denmark, Australia, New Zealand, Manila, Japan, China, Siberia, Cuba, Mexico.

**No Orders Till the First of the Year**

L. G. Golder, Chicago wholesale representative of the Sonora phonograph, announces that so many orders have come in within the last thirty days that the Western office will be unable to contract for further deliveries until the first of the year, although the Sonora output has increased considerably within the past few months. Orders have increased with even greater rapidity until the western office finds itself unable to take any more for the time being.

**James L. Abbott Around Again**

James L. Abbott, president of the Chicago Hinge Cover Support & Balance Co., has been unfortunately confined to his house for some time but is now up and about. Mr. Abbott was showing a new hand in his factory how to operate a punch press when the machine crushed his right thumb as far as the first joint. He was then affected by gastritis and has been confined to his house for the past two weeks with this trouble. Now, however, he is up and able to get around.

**Vacationing in Michigan**

S. A. Ribolla, general manager of the Otto Heineman Phonograph Supply Co., of Illinois, is spending two weeks' vacation at the home of Mr. and Mrs. Pilgrim, of the New York Heineman forces, at Grand Beach, Michigan.

**Represents Cover Support**

Charles A. Lewis has been appointed assistant secretary and traveling representative of the Chicago Hinge Cover Support & Balance Co. Mr. Lewis will cover the western territory for this concern.

**Empire T. M. Co. Gets More Space**

The Empire Talking Machine Co. has contracted for the entire fifth floor of the building

at 429 South Wabash avenue. This concern is now located on the fourth floor, which it will have in addition to the new space. The fifth floor will be used for assembling talking machines and for storing stock destined for immediate delivery.

The Empire Talking Machine Co. has secured the Manufacturers' Western Sales Co., of Omaha, Neb., to represent the Empire machines in Nebraska, Montana, Nevada and Colorado. M. H. Levy is president of the Omaha concern and is very enthusiastic over the sale of Empire talking machines. He has already received sample shipments and has placed them on display at Omaha.

A very attractive little flash sign for the advertising of Empire records in retail show windows is now being made up by this company for the use of their dealers. The familiar "Empire Girl" attracts the eye of passers-by. Window banners announcing the new Empire releases each month are also being prepared for dealers.

**Now Jewel Phonoparts Co.**

One of the recent happenings in the Chicago trade was the changing of the corporate name of the Phonoparts to the Jewel Phonoparts. This company has recently been reorganized and has increased its capital stock approximately five-fold.

A. F. Vaughan, one of the new officers of this company, has been made general manager and is now looking after the production end. Mr. Vaughan is well known in the manufacturing business in Chicago, and for many years has looked after the production departments of several of Chicago's largest manufacturing concerns. In the short time during which Mr. Vaughan has been connected with the Jewel Co. he has increased production very largely, and now the various departments are so coordinated that there is very little lost motion in getting out the tone arms and reproducers that this company manufactures. The com-

pany's product, the Blood Tone Arm Reproducer, is given mention throughout the talking machine industries, and, due to Mr. Vaughan's efforts, quite a number of well-known talking machine concerns are now using these parts.

**Discontinue Model Four**

A few months ago the Chicago Hinge Cover Support & Balance Co. placed on the market their cover balance No. 4. This new balance was received with much favor by the trade in the short space of time that it had been on the market. When this company introduced No. 4 they discontinued the old style balance No. 1, but meanwhile the factory experts had got busy and improved balance No. 1 to such an extent that it now does exactly the same work as No. 4. Now, since balance No. 1 costs less than balance No. 4 and does practically the same work, the company has decided to reinstate No. 1 and discontinue No. 4.

**Beg Your Pardon**

The Phoenix Phonograph Co., of this city, makes the announcement this month that in their advertisement which appeared in the July issue of *The World* a mistake in address was made. The correct address of this company is 2504 and 2506 West Van Buren street, Chicago, and not 1504 and 1506, as was printed in the advertisement. When William Cummings, president of the company, noticed the mistake he notified the Post Office and requested the officials to forward all mail to the correct address. Mr. Cummings says that it was several days after publication of *The World* before he noticed the error, but in the meantime quite a number of letters in reply to the advertisement had been returned to the senders. Therefore he takes advantage of *The World's* news columns to make the mistake known to the trade and at the same time asks the dealers who had letters returned to please forward them to the correct address.

**Where Lies Demand?**

The question as to just what priced talking



"Junior"



"Adam"



"Grand"

## For Immediate Delivery!

Complete Phonographs For Immediate Shipment—Very Best Equipment

We are also offering for prompt shipment cabinets not equipped—car load lots only.

**E. H. STAFFORD MFG. CO., 218 S. Wabash, CHICAGO**





STYLE 225

# The STERLING

The machine of No Regrets. A Quality Instrument at a surprisingly Low Price

## OUR MOTTO:

Quality and Workmanship Guaranteed

Mr. Dealer Mr. Jobber

**DON'T PLACE YOUR ORDERS**

until you have investigated our proposition. We can undoubtedly save you money



STYLE 150

**THE STERLING TALKING MACHINE CO., Inc.**

811-13-15-17-19 NORTON STREET

Telephone Haymarket 5412

CHICAGO, ILL.

FROM OUR CHICAGO HEADQUARTERS—(Continued from page 108)

machine is the most popular with the public is one much discussed by talking machine men the country over. There are those who believe the higher-priced types are most in favor and there are those who believe the more moderate-priced instruments are the best. J. D. Keating, president of the Usona Talking Machine Co., is an enthusiastic believer in the latter class. Mr. Keating believes that the most money lies in a machine retailing at approximately one hundred dollars and that many a dealer loses sales of instruments selling at this price by urging one customer with small funds too strongly toward a more expensive purchase.

**Originator of the Console Type**

The Windsor Furniture Co. has received many complimentary letters in praise of its console type of talking machine which has become so popular of late. H. C. Moyer, president of this concern, was the originator of the console type and was the first to see the possibilities of this improved design in cabinets. As in the case with so many modern inventions, the first console cabinet was made by Mr. Moyer without any idea of going into that business in a commercial way. His own words tell the story. He says: "My mother had a machine in her home and one day asked me if I could not make a new cabinet for it so that it would harmonize with the Louis XVI style furniture in her living room. I got working on the idea, and, as a result, we built our first console type, which was the progenitor of this now popular type." The Windsor Furniture Co. was granted a

patent on the console type of machine covering the location of the record file alongside the machine itself in September, 1918. Since that time the demand for console models has greatly increased, and today this is one of the most popular types of artistic cabinets.

**INSTALL NEW EQUIPMENT**

Fulton Bros. Mfg. Co. Now Prepared for Greatly Increased Output

WAUKEGAN, ILL., August 5.—There is much activity around the big plant of the Fulton Bros. Mfg. Co., of this city, these days. The long-delayed shipment of punch presses and other special machinery promised them since the first of the year has finally arrived and is now installed in working order. The installation of this new equipment enables the Fulton Bros. Mfg. Co. to manufacture every piece that goes into their motor, with the exception of the castings. Several new features have been added to the Fulton motor. Among them may be mentioned the new fibre compound for making the gears. This compound, it is said, is the same as was used during the war by the U. S. Government, and will not fray or "mush."

Another new thing that the Fulton Bros. Mfg. Co. has decided upon is to supply each motor with a large instruction sheet, showing a photo diagram of the motor. Each part is numbered and at the bottom of the sheet are printed explanations telling about the part indicated.

**THE MAN ALWAYS "JUST GOING TO"**

He was just going to help a neighbor when he died.

He was just going to pay a note when it went to protest.

He meant to insure his house, but it burned before he got around to it.

He was just going to reduce his debt when his creditors "shut down" on him.

He was just going to stop drinking and dissipating when his health became wrecked.

He was just going to introduce a better system into his business when it went to smash.

He was just going to quit work awhile and take a vacation when nervous prostration came.

He was just going to provide proper protection for his wife and family when his fortune was swept away.

He was just going to call on a customer to close a deal when he found his competitor got there first and secured the order.—Philadelphia Association Bulletin.

**OPEN NEW STORE IN MACOMB**

The Brunswick Shop, Galesburg, Ill., located in the Hill Arcade, has opened a new store in Macomb under the direction of E. L. Fuller. A full line of Brunswick machines is carried.

Bernstein Bros., Athens, Ga., have added a talking machine department to their music store in that city.

**Now is the Time to Order Your Supplies for the Fall Rush!**

We can still take on orders large or small for Motors, Tone Arms, Cabinets, Hardware and Accessories.

We have more than 2000 genuine imported Diamond Points and thousands of Sapphires.

All sizes and grades of Mica Diaphragms.

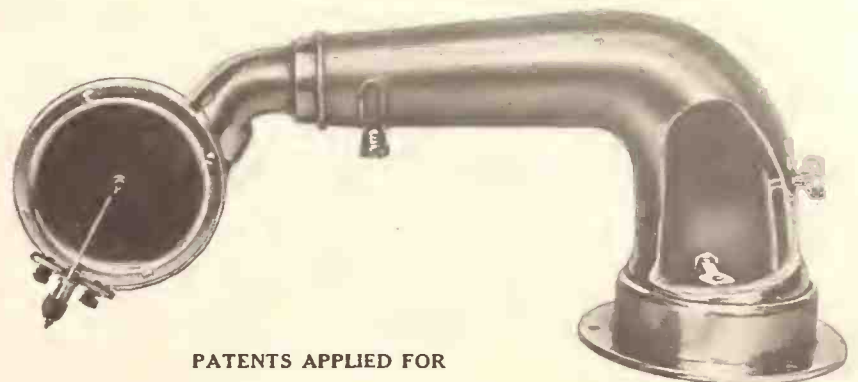

PATENTS APPLIED FOR

**LAKESIDE SUPPLY CO., INC.**

416 SO. DEARBORN STREET

Telephone Harrison 3840

CHICAGO, U. S. A.



FROM OUR CHICAGO HEADQUARTERS—(Continued from page 109)

**COMMONWEALTH CO. ENTERS FIELD**

Electric Light Concern to Handle Pathé and Other Phonographs in Chicago

CHICAGO, ILL., August 5.—That there is every reason to believe that the electrically driven talking machine is coming into its own may be seen from the fact that the big electric light company of Chicago has just entered the talking machine field. A full line of popular-priced electrically driven instruments, such as the Federal Electric phonograph, the Actuelle Electric



Jerauld S. French

and the Pathé Electric, together with a full line of Pathé and Emerson records, will be handled. The Pathé instruments will be supplied by the W. W. Kimball Co., Pathé jobbers, and the Federal instruments are to be supplied by both the Lakeside Supply Co. and the Lorraine Talking



## Repair Parts

**For All and Every Motor That Was Ever Manufactured**

**WE** can supply any part. The largest and most complete assortment of repair parts—in the United States—on hand, for old, obsolete and present-day motors. If your order cannot be filled from stock, we will make it up special.

Special prices on main springs, governor springs, micas, repair parts, motors, tone arms, steel needles, etc., in quantity lots.

Expert repairing on all makes of phonographs and motors.

INCORPORATED UNDER THE LAWS OF ILLINOIS

# Consolidated Talking Machine Co.

SUCCESSORS TO  
Standard Talking Machine Co.  
United Talking Machine Co.  
Harmony Talking Machine Co.  
O'Neill-James Co.  
Aretino Co.



TRADE MARK  
**"CONSOLA"**  
CABLE ADDRESS  
"CONSOLA"

High Grade Talking Machines, Disc Records, Talking Machine Supplies, Etc.

227-229 West Washington Street, CHICAGO, ILL.

Machine Co., the latter instruments to be equipped with the Johnson electric motor manufactured in this city.

Jerauld S. French will manage the new department. Mr. French is a young man, who, while a newcomer to the trade of Chicago, has long been acquainted with the talking machine. During his thirteen months in Paris as a member of the United States army ambulance service with the French army he had a splendid oppor-

tunity to become familiar with the possibilities of the talking machine. The designs of the Federal line are very attractive, and the instruments will be equipped with gold-plated hardware. They will retail at \$150.

The Pathé line, which the Commonwealth Edison Co. will handle, is distributed by the W. W. Kimball Co., and the deal was handled by A. J. Cullen, manager of their wholesale department.

# "IRONCLAD" ENCLOSED MOTORS

"SILENT AS A SHADOW"

"Not a kick in a carload"

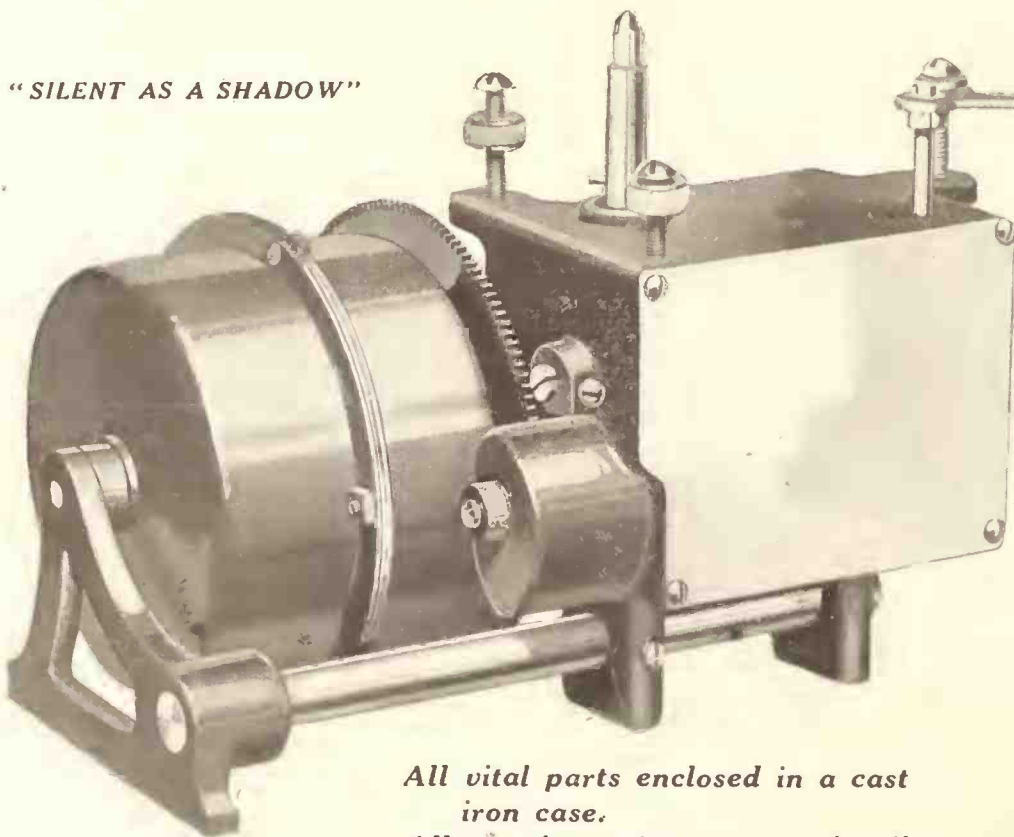

*All vital parts enclosed in a cast iron case.  
All wearing points operate in oil.*

There are no bevel gears in the IRONCLAD Enclosed Motor.

It has many other attractive features.

Investigate and then insist that the IRONCLAD be installed in "the machine of your choice,"—your customers will appreciate it.

*Catalog on request.*

**CHERINGTON MFG. CO.**

SALES OFFICE

108 WEST LAKE STREET  
CHICAGO

*Factory, Waukegan, Ill.*

**MORE POWER**

**Six Sizes. Plays 4 to 14 Records**



# ONE OF THE FINEST PHONOGRAPHS

We Might Say *The Finest*  
We Say *One of the Finest*  
Because——

Our phenomenal success in the past year permits us to make this statement and prove every word of it.

If we were to substitute a word for the name Hiawatha that word would be quality.

Our tremendous increase in business is due to quality.

We are now enlarging our present plant, which will mean an increased production — in fact double our present output — this proves conclusively that the keynote of our success is due entirely to our quality phonographs.

Mr. Dealer: You should handle one of the finest phonographs and let Hiawatha quality be your trade mark.

Your initial order for one Hiawatha will enable you to do so

*Our policy is just as fair as our claim.*

## HIAWATHA PHONOGRAPH COMPANY

MANUFACTURERS

209 S. State Street, Chicago, Ill.

FACTORY: GENEVA, ILLINOIS

HIAWATHA  
PHONOGRAPHS

Listen to this simple story  
to this song of *Hiawatha*  
LONGFELLOW





FROM OUR CHICAGO HEADQUARTERS—(Continued from page 110)

REAL CO-OPERATIVE ADVERTISING

Stein-Burn Corp. Perfect Plan for Carrying on Initial Advertising Campaign in Local Territory for All New Representatives

CHICAGO, ILL., August 4.—The Stein-Burn Corp., of this city, manufacturers of the Steinburn

a new agency is established, and the campaign which has been carefully developed is one of very considerable size.

The advertisements appear in large four-column size, three-column size and two-column size, giving a very practical assortment of sizes to meet the requirements of each merchant. In every case the local dealer's name and address

**Steinburn**

Your Neighbors will Marvel at Your Steinburn  
—and it will give you pleasure to hear their exclamations of approval over its rare beauty.  
—and then when you play it you will all agree it is the perfect phonograph.

Come and see the Steinburn—hear it play your favorite records—and let us tell you how very easy it is for you to have one in your home, too.

(Dealers Name and Address)

**Steinburn**

The "Dancing" Phonograph  
especially preferred for schools, clubs, lodges and homes where dancing is to be enjoyed.

The tone modulator on the Steinburn can be regulated from double the tone volume of ordinary phonographs to the finest pianissimo.

The Steinburn reproduces every sound as originally played. For dancing it is divine.

Let us demonstrate the Steinburn in a large room or auditorium for you. That's the test.

(Dealers Name and Address)

Reproduction of Two of the Most Striking Steinburn Newspaper Ads, Reduced in Size phonograph, have developed through its advertising department a local co-operate advertising plan of unusual interest. Under the plan the corporation pays the entire cost of an initial advertising campaign in every territory where appears at the bottom of the advertisement and he is linked with the national advertising movement. Unlike some advertising that has from time to time been developed by manufacturers

STEEL MOTOR BOARD SUPPORT

THESE IN  
**HUNDRED THOUSAND LOTS**  
FOR 7/10'S OF ONE CENT EACH

OTHER  
**TALKING MACHINE HARDWARE**  
AT SIMILAR PRICES

LET US QUOTE ON YOUR REQUIREMENTS

**Acme Engineering & Mfg. Co.**  
1622 FULTON STREET CHICAGO, ILL.  
TELEPHONE WEST 1164

the Steinburn phonograph newspaper copy is entirely written from the viewpoint of the local merchant. The corporation manufacturing the Steinburn phonographs is never mentioned and all of the text is strong merchandising "copy," written so as to not only build prestige for the dealer and the line, but to actually draw into his store the prospective phonograph buyers reached by the newspaper.

In addition to the careful attention to the text the advertisements are illustrated in a very effective manner, with attractive drawings, reproduced in cut form so that they show up particularly well when printed in newspapers. By this kind of advertising Steinburn dealers will undoubtedly benefit greatly.

**USONA**

Hold a conference with yourself! Decide whether or not you are getting and selling as many \$100.00 machines as you might. Remember you can't sell them all high priced models. Here's your chance to install a wonderful BIG money maker that will show immediate results.

★ **USONA** ★

47 inches  
19 by 19 inches  
Heineman  
No. 33 Motor  
Heineman  
No. 11 Tone  
Arm and No. 2  
Sound Box



Model AX  
PRICE \$100.00

There are four USONA models, the retail prices range from \$100 to \$200. Every USONA is guaranteed. They play all records.

A trial order is subject to return if not perfectly satisfactory. Get your sample now and arrange to handle the USONA exclusively in your town. \$41.50 including 5% war tax will bring you a sample of the USONA model AX; we will talk about the regular wholesale price on future orders after you are satisfied with the instrument. Let us get acquainted. We will both profit by the acquaintance. The above offer is made for prompt acceptance. We know you will represent our line when you see sample.

**Usona Talking Machine Co.**  
1977-79 Ogden Avenue :: Chicago, Illinois  
Phone Seeley 674



The increasing distribution of THE WIDDICOMB makes an agency for it more valuable each day.

# Have You Improved Your Opportunity?

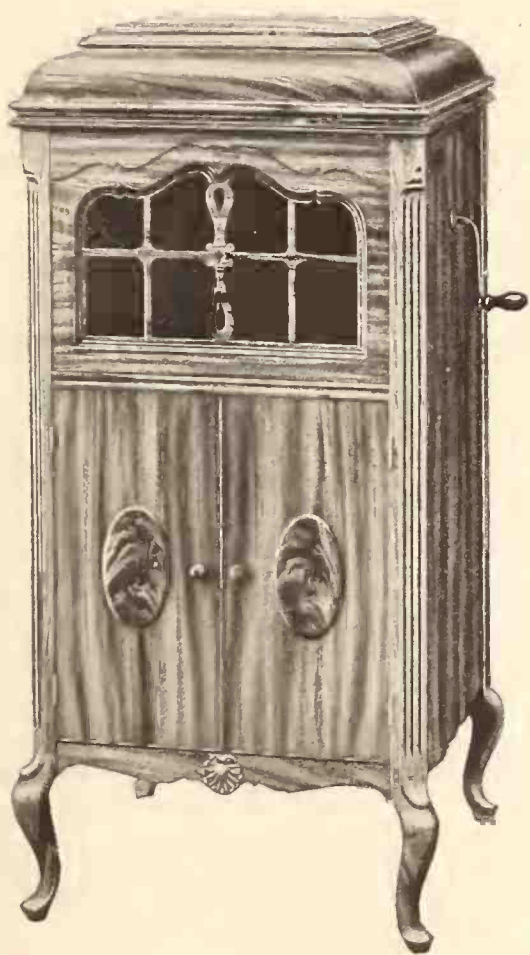

Queen Anne. 48x22x24. \$185.  
Widdicomb No. 6.

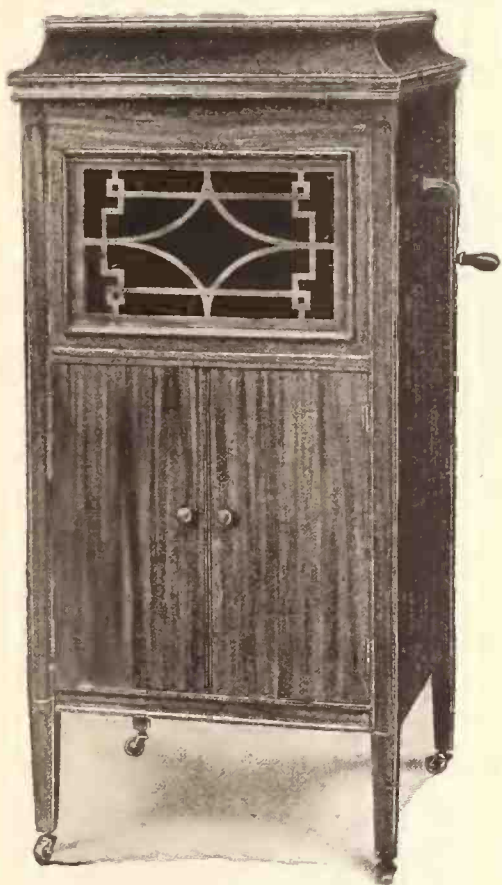

Sheraton. 47x22x23. \$150.  
Widdicomb No. 5.

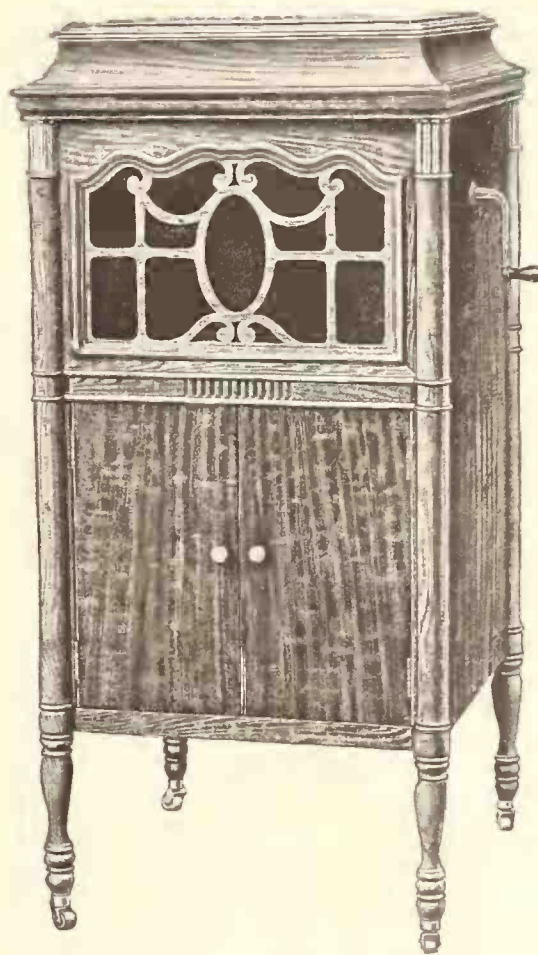

Sheraton. 49x23x25. \$210.  
Widdicomb No. 8.

*PHONOGRAPH DIVISION*

## THE WIDDICOMB FURNITURE CO.

Grand Rapids, Michigan



FROM OUR CHICAGO HEADQUARTERS—(Continued from page 112)

## THE NEEDLE QUESTION

By DORCHESTER MAPES  
SECRETARY AND TREASURER, R. C. WADE CO.

[While there is no question but that the importance of the talking machine needle is generally recognized, there is some question as to whether it is recognized as widely as it should be, not only by those who sell, but those who use talking machine records. There have, during the past few years, been placed upon the market a great variety of needles, many of practical design, others somewhat freakish, and the success of these new needles has been varied. Naturally the members of the trade who have given thought to the subject are committed to the desirability of one special form of needle or another. The accompanying article by Dorchester Mapes sets forth one view of the needle question, and is from the pen of a man who has had wide experience in needle production. The World will welcome the views of other members of the trade on this same needle question, feeling that the subject is one well worthy of discussion.—Editor.]

It is a vital question—this needle question—because, admittedly, no talking machine or record is or can be one bit better than the needle with which it is played. In fact, from the very beginning, one of the great problems has been to produce a needle which shall prove to be the right and potent medium between the record—that infinitely delicate “storage battery” of sound impulse—and the phonograph proper, through the sound box, with its magical mechanism and wondrous diaphragm.

Too little study, it would seem, has in the past been given this really crucial question. Be that as it may, we must admit that—though the record be the finest and the phonograph proper be perfect in every detail—if the needle be not right, the rendition must be a disappointment.

The solution of any problem is dependent first, upon a clear understanding of the question itself, and second, upon some one or more relative axioms and—manifestly—the greater number of self-evident truths brought to bear upon the given question the more direct will be the reckoning and the more obvious the conclusion.

If we can conceive what the perfect needle should be and do—and what not—and the why and wherefore of it all—shall we not have gone far toward solving the whole question?

Disclaiming all thought of anything more than a very general and superficial description—the record-groove (the walls of which form those wonderful microscopic sound-recording waves) is a spiral trench pressed or moulded into the face of the record. This trench or groove is (if right) an exact counterpart of the original groove in the pattern or matrix, made therein by the vibrations of the tool or needle of the recording mechanism—which vibrations, in turn, are caused by the sound waves or impulses set in motion by the original rendition.

In the lateral cut record the trench is of approximately uniform depth while its walls (in their spiral course) describe myriads of transverse, lateral waves corresponding with the lateral vibrations of the recording needle. In making the vertical cut record, however, the recording needle vibrates up and down, hence the waves are up and down (“hill and dale”) and the trench or groove correspondingly shallow or deep.

Throw a stone into a pool of placid water and watch the surface—first comes the splash and then the multiplying wave circles, ever growing wider but fainter, until not a ripple is left and all again is quiet. In this we see exactly how a single tone, like the stroke of a bell, creates a series of sound waves in the air. Now throw a handful of stones, big and little, into the water and we will get a faint

idea of what band or orchestral music does in creating sound waves. Each stone and each tone from each instrument makes its own series of waves, crossing and recrossing each other, each series a myriad—yet all in perfect rhythm.

It is the art of record making to catch and perpetuate in material form these wondrous mystic waves—an art which seems well-nigh perfected. And now we come to the part that the needle must play in the re-rendition of all these stored-up sounds.

The perfect needle—the ideal needle—must pick out and transmit to the sound box every one of those recorded vibrations—from the biggest wave to the tiniest ripple; so that each may give back its true tone value, neither too loud nor too soft—each without flaw or blemish, hiss or scratch—and all without clang or confusion. And here let us pause to reflect, pause to realize that many faults commonly charged against the needle are due, primarily, to the faulty construction of some other part. Yet we must not

forget that the inferior needle frequently intensifies such faults, whereas the good needle, according to its degree of goodness, nullifies many of them.

But how can a needle be made to do all this—what must its physical properties be if it is to approach the degree of perfection aimed at? Manifestly it must be materially, mechanically and, withal, musically correct. Preferably it should be of two-piece construction, because the only purpose of the shank or stem is to act as a holder for the tip or point which is the stylus proper and to carry the vibrations to the reproducer, the sound-box, so called. If it does more than that it multiplies the difficulty.

On the other hand, the function of the stylus proper is so multipotent and so delicate that it must be made of exactly the right material, treated in exactly the right way and formed and measured with the extreme of accuracy possible in mechanics. It will, of course, have a tone of its own, but that tone must be musically pure and infinitely flexible and responsive, else it will conflict and discord with the very tones it seeks to reproduce. Evidently then, material suited to one of these parts is ill suited to the other, yet there must be a perfect union of the two.

The stylus proper must not be hard and harsh, else it will not shape itself to the groove, but will injure the record and give forth rasping, grating sounds. It must not be tapered and sharp, because, while sharp, it will dig down into the bottom of the groove (hence the scratch) and the instant the sharp point is worn the least bit what is left will be wider than the groove, and will then ride on top and straddle two or more grooves at a time. Furthermore, if such a point is a trifle soft it will not play through even one record, while if too hard it will continue to scratch and cut—we have seen needles so sharp and highly tempered as to cut glass, like a diamond.

Our ideal needle point must be pliable, not brash and brittle, because a tense, brittle needle (even if right in other respects) intensifies all the tones and high notes become veritable shrieks. Again, the stylus proper must be cylindrical in form, of correct diameter and blunt pointed. It must be plastic, that is to say, of such consistency that, on being applied to a record in motion, it will quickly conform to the shape of the groove. It must be just hard enough so that the point will retain that same shape, as it wears down in length, yet just soft enough to ensure against cutting the record, which means that the record (which is made of abrasive material) should wear the needle—the needle must not appreciably wear the record.

Last of all and most important, the ideal stylus must be elastic and resilient, else it cannot possibly follow the undulations of the groove and get all the tones. There is exactly the same difference between such a needle and a stiff, rigid needle, as between a wheel fitted with a pneumatic tire and one with a hard steel rim, traveling at a high rate of speed over a rough stone pavement. The former travels softly and smoothly, while the latter does not even hit all the stones but makes an awful clatter and injures itself and the roadway.

Since the beginning of time there has been, perhaps, no greater force for bringing about a higher and nobler civilization than music, and in all that time nothing has done more for the development of musical taste among all classes of people than the modern talking machine. We may never have the perfect, the ideal needle, but it is well worth trying for and whoever contributes to its development is surely doing a good work.

## EMPIRE UNIVERSAL ATTACHMENTS for EDISON PHONOGRAPHS



Showing the attachment connected to Edison Tone Arm set in correct position to play Victor, Columbia, and any lateral cut record.

Write for  
Descriptive Folder  
and  
Attractive  
Quantity Prices



This shows the attachment in the proper position for playing the Pathé and any hill and dale cut record.

**The Empire Phono Parts Co.**

Sales Office

429 So. Wabash Avenue  
CHICAGO, ILL.

Factory

CLEVELAND, OHIO

Write for our catalogue “B” on  
hardware, motors and tone arms.

COLE & DUNAS MUSIC CO.

54 W. Lake St.

Chicago, Ill.

Die Cast Tone Arms, Reproducers  
and Attachments in any Quantity

PARKER WHITE-METAL & MACHINE CO.

ERIE, PENNSYLVANIA



# Happenings in Dominion of Canada

## INCREASED TALKING MACHINE PRODUCTION IN CANADA

Several New Manufacturers Enter the Field in and About Toronto, While Established Concerns Expand Facilities—Music Industries Interested in Coming Canadian National Exhibition

TORONTO, ONT., August 2.—Piano Cases and Phonographs, Ltd., Brantford, is the name of the new company incorporated under Dominion charter resulting from a reorganization of the Brantford Piano Case Co., Ltd., makers of the Brant-Ola phonograph. The new concern has an authorized capital stock of \$100,000. Gilbert Brereton is president, and the management is now in the hands of James A. Scace, for nine years secretary-treasurer of the P. H. Secord & Sons Construction Co., Ltd., a prominent contracting firm in Brantford, whose chief worry is how to produce enough goods to meet the business offering. His plans, however, include provision for extending their business.

To permit of the production of cabinets in larger quantities Canadian Symphonola Co., Ltd., of this city, have decided to increase their capital stock from \$50,000 to \$150,000 and have also made a number of factory alterations and improvements. The millroom has been enlarged and the dry kiln, which was formerly in the main factory, is being removed to a separate building. Mr. Long, president of the Canadian Symphonola Co., Ltd., in conversation with our correspondent, predicted that the coming autumn would see the usual scramble for goods greatly intensified and his advice is to order early.

A solid brick addition, forty by one hundred feet, is being erected at the cabinet plant at Elmira, Ont., of the Phonola Co., of Canada, Ltd. President A. B. Pollock expects to occupy the new building within two months and a material increase in the output of cabinets will at once be possible.

Harold W. Vetter, formerly manager of the Victrola department of Heintzman & Co., Ltd., and previous to which he was connected with that company's Victrola department at Toronto, has joined W. M. Knapp.

"Going out as fast as they come in," remarked Mr. E. van Gelder, referring to receipts and deliveries of the Sonora, of which line of phonographs I. Montagnes & Co., Toronto, are the exclusive Canadian distributors. The Sonora semi-permanent needles is a line that the firm enthuse over, and for which they are receiving many orders and inquiries.

Curtiss Aeroplanes & Motors, Limited, Toronto, are manufacturing and placing on the market the Curtiss Aeronola, designed and built complete in one of the largest factories in Canada devoted to the production of talking machines. Under the same management and organization were built Curtiss aeroplanes for the Allied Governments. A comprehensive advertising campaign to place the Curtiss Aeronola before the public is now under way.

L. L. Merrill, western representative of the Starr Co. of Canada, and whose home address is Regina, visited the firm's headquarters at London recently. In speaking of trade in the territory looked after by him, Mr. Merrill commented upon the western people being much larger purchasers of oak cases than in the east. The durability of the oak case appeals to the practical buyer. Gennett lateral cut records Mr. Merrill considered the greatest development of the present year in the talking machine trade.

The Geo. McLagan Furniture Co., Ltd., Stratford, Ont., have been appointed selling agents for the Fletcher reproducer, manufactured by the Fletcher Wickes Co., of Chicago. It is used on all McLagan instruments.

The Musical Merchandise Sales Co., Canadian distributors of the Brunswick phonograph, have secured the sole agency for the new spear-point Brilliantone needle, also the regular

Brilliantone needles, in the provinces of Ontario and Western Canada.

In anticipation of Sousa's Band touring Canada this summer, the distributors of "His Master's Voice" lines are directing their retailers' attention to the list of "His Master's Voice" recordings by the band of Lieut. John Philip Sousa, U. S. N. R. F. The dealers are offered valuable selling helps in getting public attention to these records at the psychological time, that is, when the band is touring the country.

Brunswick dealers will now identify themselves by a novel new electric sign in their window which is an attention compeller, because of the colored lights in the background which are constantly moving behind an attractively colored slide, showing a young couple looking in at the old folks listening to a Brunswick. The wording on the slide reads: "We are certainly glad we bought them a Brunswick."

The employes of the Columbia Graphophone Co. held their annual picnic recently at Victoria Park, Niagara Falls. The entire plant closed for the day and everyone boarded the early morning boat for the Falls. James P. Bradt, general manager, was on hand all day and was an active participant in all the affairs of his employes. A. E. London, assistant manager, and J. E. Errock, plant superintendent, aided in running off the various athletic events which featured the outing. E. J. Casson, who handles the firm's transactions with His Majesty's Customs department, was master of ceremonies and kept things going at top speed. Each member of the organization was tagged with a pair of grand opera labels pasted together, making a most appropriate badge for the occasion. Many prizes were distributed to the winners of the contests and a happy crowd returned in the evening, making plans for next year.

Music is a necessity on the steamship as well as in the home. The boats "Kingston," "Toronto," "Rochester," "Montreal," "Quebec," "Saguenay" and "Syracuse," all boats of the Canada Steamship fleet, will now have Brunswicks on them. A Brunswick has also been placed in the Manoir Richelieu Hotel, at Murray Bay, Que. The Musical Merchandise Sales Co., sole Canadian distributor of the Brunswick, is being congratulated on placing these Brunswicks on all the Canada Steamship boats.

Frank H. Whetsel, who recently received his discharge from the army after three years' service, is now connected with the Victor department of the National Piano Co., Ltd. He was for several years manager of the Bell Piano Co.'s Victrola department and is thoroughly conversant with "His Master's Voice" lines.

Large crowds attended the formal opening of J. Kellestine's store at Owen Sound recently. In addition to a number of selections by the

New Edison phonograph J. C. MacKay, the Edison representative for Ontario, gave two solos, which were well rendered.

H. Gittleston, of U. S. Picture & Portrait Co., St. John's, N. F., which firm has handled Columbia lines for many years, visited Canadian headquarters of the Columbia Graphophone Co. recently. Mr. Gittleston's farm near St. John's was used by Hawker from which to make his memorable "hop-off" in his Sopwith plane.

During the period of April 15 to June 20 the J. M. Greene Music Co., of Peterborough, in conjunction with their branches at Kingston, Bellevue and Lindsay, launched an Edison sales contest. The branch manager who secured the largest amount of net business was given a trip to the Edison Dealers' Convention at New York. The various branches joined enthusiastically in the competition and Wesley Mason, manager of the Lindsay branch, won the laurels of victory.

From a music industries standpoint the 1920 Canadian National Exhibition, beginning August 23, will be unusually interesting. As usual, the Manufacturers' Building will be the rendezvous for piano men, while the phonograph representation promises to exceed in numbers and quality the exhibits of previous years. The exhibition management reports that it has been impossible to give all applicants space in buildings, but a number have been placed in the Horticultural Building, the east wing of which has been given up to them. This space will, of course, accommodate part of the talking machine firms wishing to exhibit and others will doubtless be accommodated with tent privileges, as in previous years. Unusual interest centers in the expected visit of the Prince of Wales.

Emile Berliner, of Washington, D. C., president of the Berliner Gramophone Co., Ltd., Montreal, stopped over in Toronto for a day on his way West recently. Being the inventor of the Gramophone and for many years active in the reproduction of sound industry, in which he has still extensive financial interests, it is natural that phonographic development in Canada should have a keen interest for Mr. Berliner. While in this city he visited "His Master's Voice," Ltd.

The employes of the Starr Co., of Canada, distributors of Starr phonographs and Gennett records, turned out in full force on their first annual picnic day at Grand Bend.

## FRENCH CANADIANS GOOD BUYERS

Talking Machine Houses of Quebec Find Profit in Musical Desires of That Element—Planning for Big Fair in Montreal

MONTREAL, QUE., August 6.—Albert Bienjonnetti, manager of B. G. Valiquette's music department, this city, believes there is a big trade among French-Canadians if properly handled.

Music plays a great part in the life of French-Canadians and the Province of Quebec is a good field for business for the music industries of Canada and a most excellent one for talking machines and record selling, provided manufac-

(Continued on page 117)

## Talking Machine Supplies and Repair Parts

**SPRINGS, SOUND BOX PARTS, NEEDLES**

**THE RENÉ MANUFACTURING CO.**  
MONTVALE, NEW JERSEY



# When You Buy The Mandel

**You Buy a Musical Instrument That Will Satisfy  
The Most Critical Prospective Phonograph Owner**

The MANDEL line comes direct from the MANDEL factories, where every part of the machine is made—not merely assembled—but built from the “ground up”—by one maker. There is no divided responsibility for the proper performance of the MANDEL. Each machine that leaves our factory is destined to give its ultimate purchaser the satisfaction, pleasure and service he has a right to expect. That is our guarantee. Only a manufacturer *can* give such a guarantee.

The MANDEL line of talking machines not only pleases the eye with its beautifully designed and finished cabinets, but delights the ear by its faithful reproductions of the world's best records. The MANDEL motor—the pulsating heart of the phonograph—is a thoroughly efficient power plant which performs its work quietly and smoothly. Each unit in the mechanism of the MANDEL is made accurately and with precision. And the result is *a good phonograph*—the kind you can safely guarantee to every purchaser.

## **More Than 3000 Dealers Are Now Successfully Selling Mandels**

Leading dealers in furniture and pianos, drug stores and jewelry stores are adding to their profits by selling MANDEL Phonographs. Every home is a prospect. Every live and aggressive dealer can make more money with this line. The dealer's sales are limited by his own energy and his ability to get the business.

### **WHAT WE OFFER THE DEALER**

A high-grade line of talking machines—low retail prices—liberal discounts—liberal terms—factory service—guarantee of satisfaction.

*Your territory may be available—write at once for  
our co-operative selling proposition.*

## **Mandel Manufacturing Co.**

501-511 SOUTH LAFLIN ST.

CHICAGO, ILL.



## **Just Out!**

Our new pictorial portfolio, illustrating the complete line of MANDEL Phonographs is just off the press. This beautiful work of art, together with our confidential dealers' proposition, will be mailed upon application to all recognized dealers.

**WRITE TODAY**



**HAPPENINGS IN CANADIAN TRADE**  
(Continued from page 115)

turers go about it in the right way. French-Canadians are willing to pay the price for a "talker," but they want quality and service. They are most particular people and when they can't get what they want they very seldom accept a substitute. For this reason any first-class talking machine, backed with a peerless reputation and a well-organized service, will find a buyer in the French-Canadian patron. It is of importance that it be advertised in good French literature and this seems to be hard to get from manufacturers.

The French-Canadians who own talking machines are good record buyers. While they will listen to the amazing melody of a rag-time or dance record their collection is usually composed of records of a more serious character.

Montreal is at last to have a fair. So says ex-Mayor Villeneuve. The first effort along this line will be a Cartier Centenary Fair, which is an effort to raise \$150,000, necessary to complete the beautiful monument that is in place at the foot of Mount Royal on Park avenue. A very handsome fairground has been laid out on Fletchers Field, with beautiful booths erected for the use of the merchants of Montreal and vicinity to display their wares.

Mr. Brennand, manager of Layton Bros.' phonograph department, arranged through Mr. Villeneuve for permission to erect a marquee on the grounds in which to give Edison and Columbia concerts. Lawrence Sky, the talented Russian violinist from Toronto, has been contracted for and will make tone-tests with the various instruments on exhibit there. This is the first time that this sort of tone-tests have been done in a fair in Montreal and Layton Bros. look forward to a profitable advertising campaign through their effort. Messrs. Gilbert and Frank Layton will assist Mr. Brennand in carrying out the work of giving concerts. It is expected that the fair will run from August 9 to 25, inclusive.

Frieda Hempel, the Metropolitan star and Edison artiste, was an interested visitor at the warerooms of Layton Bros. one afternoon during the last week of July. She was on her way to the West, where she purposes doing some mountain climbing in our Canadian Rockies. She expressed herself as delighted with the phonograph salon which Layton Bros. have almost ready for their opening.

A particularly gratifying announcement to

"His Master's Voice" dealers throughout the country is that carrying to them particulars of the revision in prices of Red Seal records. The Berliner Gramophone Co., Ltd., of this city, announced these price reductions in prominent advertisements in the newspapers, so that the public was immediately apprised of the changes.

Brown's Talking Machine Shop reports wonderful business for July in the sale of "His Master's Voice" products. S. H. Brown, the congenial proprietor, will shortly take his vacation and accompanied by a friend will make for the wilds on a camping expedition.

On August 1 the prices on all Columbia Grafonola models advanced 10 per cent.

J. T. Lemieux has been made manager of the phonograph department of H. P. Labelle, Ltd. The Perfection Phonograph Co. have registered in Montreal.

Henry Hamlet has been placed in charge of the phonograph department of J. W. Shaw & Co.

George H. Drennand, manager of the phonograph department of Layton Bros., has returned from New York, where he acquired first-hand knowledge of a number of new features, which he intends introducing to the public very shortly.

Messrs. Armitage, Frank, Gilbert and George Layton, of Layton Bros., were recent visitors to the Edison factory in Orange, N. J., and the Columbia plant in Bridgeport, Conn.

A. Ramsperger, for a number of years in charge of the phonograph section of J. W. Shaw & Co., is now filling a similar position with the Brunswick Shop.

**THOMAS MFG. CO. STILL EXPANDING**

Arrangements Now Under Way Will Increase Output Practically Fifty Per Cent.

DAYTON, O., August 5.—It is intimated through reliable channels that the Thomas Mfg. Co., manufacturers of "Dayton" phonograph motors, sound boxes and tone arms, is negotiating for additional factory space in Dayton that will permit of an increase of almost fifty per cent. of their capacity. The Thomas company has been seriously crowded for space for the past six months. Conditions have made it impossible to obtain additional space until the present time, as the requirements of the Thomas Co. were for space of a very special character to properly house their skilled workmen and intricate machinery.

**WALTER S. GRAY'S**

**JOBBER'S BULLETIN OF PHONOGRAPH ACCESSORIES**

*The best of everything my policy and the best of service my practice.*

Albums; Attachments for Edison Machines to play all records; All in One and plays all attachments to play all Records on Columbia and Victor Machines; Corrugated and Wooden Packing Boards; Diaphragms-Mica; Edison Diamond Points; Edison Sapphire Points; Fibre Needle Cutters; Harmonicas; Lansing Khaki Covers; Literature Hangers; Easels and Monthly Supplement Displayers; Monthly Supplement Envelopes; Needles, Steel and Semi-Permanent; Pathé Sapphire Balls; Ready Files; Record Cleaning Brushes, Printed and Unprinted; Record-Lites; Record Stock Envelopes for all sizes Victor, Columbia, Pathé; Reproducers; Record Delivery Envelopes, 11½x11½ and 13½x13½; Seals and Stickers for Envelopes and Packages; Sticker Moisteners; Violin Strings.

**WALTER S. GRAY**

508-529-530 Chronicle Building  
SAN FRANCISCO

A member of the Thomas organization in a chat with The World said: "It was thought that the extensive additions that were made last year would take care of the increased demands on the business for several years to come, but the phenomenal increase in their business has made more space immediately necessary. The additional factory space now contemplated will place the Thomas Co. among the largest concerns in Dayton, and will give employment to several hundred more operatives skilled in the production of fine machinery, for which the city of Dayton is justly famous. The Thomas Co.'s principal product is the 'Dayton' phonograph motor, which has met with unprecedented success in the last eighteen months. The officers of the company are extremely optimistic over the future outlook for their motors and other phonograph accessories which are now being used by some of the largest and best-known manufacturers of talking machines in the country."

**LAUZON OUTPUT TO BE DOUBLED**

Michigan Phonograph Co. to Enlarge Grand Rapids Factory—Exhibit at Furniture Show Attracted Much Favorable Attention

GRAND RAPIDS, MICH., August 8.—The Lauzon talking machine exhibited at the furniture ex-



Lauzon Models in Michigan Phon. Co. Store inhibition here last month attracted much favorable attention. The Michigan Phonograph Co., which manufactures this machine, had its exhibit on the main floor of the store at Monroe and Pearl streets, and Geo. M. Cook, president of the concern, said that the sales even in the first week of the exhibition broke all previous records. The Michigan Phonograph Co. has leased additional space near the present factory and it is expected that by fall the output will be doubled.

**TO OPEN BRANCH STORE**

Paul B. Silver, of the Sonora Shop, Philadelphia, Pa., will open a branch of this store at Wayne, Pa.

The Pathé is now carried in all of the eleven branch stores of F. A. North & Co., North Philadelphia, Pa.

**RAMOSOLA PHONOGRAPHS**

*The Talking Machine With a Soul*

Best on Earth. We Prove it by Perfectly Playing All Makes Of Disc Records.

Richmond Made Perfectly Adjusted Machine of Universal Proclivities.

We Have Profited by The Mistakes of Others. The Proof of Our Profit—Look What Happened

To The Blind Typewriter So Will it be with the One School Machine and The So-called Universal.

Thirteen Models. Write for Trade Discounts. We also Job the Quality Line of Motors, Tone Arms and Records

We mean OkeH Records, Heineman Motors, Meisselbach Tone Arms, Cleartone Needles.

**Ramos-Eubank Phonograph Mfg. Co.**

*The South's First Phonograph Manufacturers*

P.O.Box 1354 104 N. 7th Street Richmond, Va.





## DEALERS OF DETROIT LOOK FOR ENORMOUS FALL TRADE

The Only Fear Is That Strike Activities on the Railroads Will Interfere With Shipments of Stock, Which Are Most Necessary to Meet Demands—Grinnell Expansion—News of the Month

DETROIT, MICH., August 8.—We find that most talking machine dealers are taking regular vacations this summer in view of conditions shaping themselves back to normal again. In going the rounds we see many of the old familiar faces in the selling end now that the war is over. For instance, at the Edison Shop we find Peter Sweeney, who served ten months in France with the American artillery, and who saw considerable action. George Middleton is back at the Brunswick Shop after being in service nearly a year and is practically in full charge.

The latest strike activities with railroad employes is by no means pleasant news to talking machine dealers and jobbers. Shipments have been none too good for the past nine months, but dealers had hopes that there would be a great improvement during August and September so that they would be well stocked for the heavy fall and holiday business. Now, with strikes among the railroad men, it means further hampering of shipments and many dealers are somewhat discouraged. Dealers are confident that they will see the biggest fall business on record if only they can secure the merchandise. And this applies to every dealer, no matter whose goods are handled, just as long as they are nationally advertised.

Wallace Brown, proprietor of the Brunswick Shop, who has been touring in the East, is expected back, not later than August 10. He will then start at once to lay out his fall campaign of advertising. Mr. Brown says business is more than double what it was last year for the first seven months, and he expects to more than triple business in the fall.

R. B. Alling, of The Phonograph Co. of Detroit, Edison jobbers, is back from a month's vacation in the Northwest.

A. A. Grinnell and C. H. Grinnell, of Grinnell Bros., attended the recent convention of Victor jobbers at Atlantic City. Incidentally, they held conferences with Victor officials and are confident that they will get larger shipments from now on to take care of their increasing orders.

In connection with the 100th anniversary of the Michigan Drug Co., an exhibition will be held this month at the Arcadia Auditorium. The hall is to be divided into booths and in them will be displays of the various products handled. Every druggist and every person interested will be given invitations. Among the exhibits will be one devoted to the Pathé phonograph and Pathé records, which are jobbed in Michigan through Williams, Davis, Brooks & Hinchman Sons, a subsidiary of the Michigan Drug Co.

Ed. Andrew, manager of the J. L. Hudson talking machine department, will take a two weeks' vacation in August. He reports very good summer business, particularly in Sonora machines.

Grinnell Bros. now have retail stores in Grand Rapids and Toledo, which increase their total circuit to twenty-eight—the largest chain of stores in the country for the territory covered. There have been rumors of additional stores being opened during the coming year, but this is very indefinite. Officials of the company say they have no such plans in mind.

A retail store specializing in Okeh records has just been established at 97 West Fort street, Detroit. This is the second Michigan Okeh store to be opened, the first being opened many months ago in Grand Rapids.

An exclusive Brunswick Shop has been opened in Flint, Mich., at 125 East Kearsley street.

The Grosse Pointe Furniture Co., live Edison dealers, will move early in the fall to new and larger quarters on Jefferson avenue.

## ILSLEY'S GRAPHITE PHONO SPRING LUBRICANT

Ilseley's Lubricant makes the Motor make good  
Is prepared in the proper consistency, will not run out, dry up, or become sticky or rancid. Remains in its original form indefinitely.  
Put up in 1, 5, 10, 25 and 50-pound cans for dealers.

This lubricant is also put up in 4-ounce cans to retail at 25 cents each under the trade name of

## EUREKA NOISELESS TALKING MACHINE LUBRICANT

Write for special proposition to jobbers.

ILSLEY-DOUBLEDAY & CO., 229-231 Front St., New York

## POUND SPEAKS AT T. M. M. LUNCHEON

Noted Speaker Outlines Situation in the Resale and Tax Questions—Sees No Immediate Relief in Sight—Meeting at the Hotel McAlpin Well Attended—Many Out-of-Town Dealers Present at Meeting—Want More Red Seal Records

The July meeting of the Talking Machine Men, Inc., made up of dealers from New York, New Jersey and Connecticut, was held at the Hotel McAlpin, New York City, on Wednesday, July 16, at noon. George W. Pound, counsel and general manager of the Music Industries Chamber of Commerce, was the guest of honor. Following the plan inaugurated some time ago the meeting was preceded by a luncheon, at which a goodly number attended in spite of the bad weather. Music was furnished by the All-Star Trio and several vocal numbers were sung by Messrs. Field and Devine.

President J. T. Coughlin, following the luncheon, introduced Mr. Pound in a few well-chosen words, outlining the great work done by this champion of the cause of music. For more than an hour Mr. Pound held the interest of his hearers as he outlined once more the fight which he waged at Washington to save music and to establish it in its rightful place as one of life's necessities. In speaking of the recent Colgate decision he said that this case has been given more prominence than it really deserves, for it is by no means a final solution or ruling on the question of resale price maintenance. This matter is still in an unsettled condition, he said, and the Federal Trade Commission has chosen a middle course.

In discussing the fight against the tax on musical instruments Mr. Pound declared that it had now been carried into the enemy's camp and that bills will soon be introduced in Congress by the very men who once were bitter opponents of the cause of music to have the tax removed. He sees no immediate relief in sight from the present tax, but declared that Congress is opposed to the tax generally and will repeal the luxury tax affecting things outside the music trade. If it is found possible to include any other items besides those now covered by this luxury tax musical instruments will be the first to be placed on the free list. In closing his talk he made an earnest plea for co-operation to raise the music industry to its rightful high plane among the other industries of the world.

The routine business was transacted after Mr. Pound's speech and the names of several new members were brought up and referred to the membership committee. President Coughlin said that he had sent a telegram to the Victor Co. asking that the dealers be supplied with more Red Seal records, as the reduction in price caused a depletion of stock among the dealers.

At the meeting the following resolution was unanimously adopted:

"Whereas, on July 10, 1919, the Victor Talking Machine Co., through widespread publicity, announced a tremendous reduction in the price of Red Seal records, thus giving an added impetus and new stimulus to the talking machine industry and the cause of music generally,

"Therefore, be it resolved that the Talking Machine Men, Inc., extend to the Victor Talking Machine Co. its heartiest thanks and congratulations for their far-reaching action and benefit to the trade at large, and

"Furthermore, that the secretary be, and is hereby, instructed to send a copy of this resolution to the Victor Talking Machine Co. and the trade press."

## Automatic Change of Weight



(Patent Applied for)

### An Exclusive Feature of Parr Central Universal Tone Arm

The Parr Central Universal Tone Arm marks a new departure in tone-arm construction and removes the principal objection heretofore existing in universal arms. The weight to play either vertical or lateral cut records is automatically and accurately changed. This is a very novel and important improvement in tone-arm construction and should appeal to those who have wanted a tone arm that would not require the makeshift arrangements for doing what this tone arm does automatically. The first scientifically constructed universal tone arm, and the only one having this very important improvement.

#### OTHER IMPORTANT FEATURES

Length of tone arm required should be specified when ordering.

Needle change is facilitated by rotating sound box, which returns to normal position.

Needle always takes same position in playing any type of record, setting in direct center.

Supplied with either mica or Vibratone diaphragm, but the latter is recommended if superior tone quality and volume are desired.

#### OTHER PARR PRODUCTS:

Magnetic Reproducer Vibratone Diaphragm

**PARR MANUFACTURING CORP.**

Main Offices: 100-108 West 23rd St., NEW YORK

Factories: New York City—Latrobe, Pa.





*Certainly!*

*Larger Profits*

will be placed in your cash drawer by the sale of the Playerpiano Phonograph. Certainly, you are interested in this innovation!

**T**HIS instrument brings to the home a high priced Phonograph, as well as a Playerpiano, for only a few dollars more than the cost of a Playerpiano alone. Double value is an attractive selling point.

**H**OW many possible customers are there in your territory who have not purchased either a Playerpiano or a Phonograph, merely because they cannot decide which to buy? Think of this new field of business open to your store. If you are not selling Playerpianos, introduce this instrument—it is proving a wonderful seller and bringing a much larger profit than from the sale of the Phonograph alone.

**W**E are using the Meisselbach Phonograph, one of the best Phonographs manufactured. The Playerpiano case acts as the sounding board for the Phonograph and magnifies the full rich tone quality of the instrument.

*The Standard Phonograph can only be secured with Playerpianos equipped with Standard Player Actions.*

Write immediately for further details and prices.

Standard Pneumatic Action Co.  
638-652 West 52nd Street  
New York City



*The Player Piano Phonograph plays Victor, Columbia or Edison Records*



# Featuring the Musical Possibilities of the Talking Machine

:: :: :: ::

## By William Braid White

[NOTE.—This is the twenty-ninth of a series of articles on the general subject of the musical possibilities of the talking machine. The aim of the series is to develop these possibilities from all angles, thus opening up fields for sales expansion oftentimes neglected wholly or in part.—Editor.]

### HOLD UP THE STANDARD

The man who sells the talking machine is certainly the man who, better than anyone else, should understand the feelings of the people from whom he buys. He certainly should know what the people are asking for in a talking machine, and if he does not guide aright their ideas and build up the sort of demand amongst them which best suits the interests of the whole trade he has himself specifically to blame.

In all the articles I have written on the general subject of the musical possibilities of the talking machine, the governing idea has been that the dealer and his salesmen have in their hands the future of the trade and that they can make it a permanent industry and a permanent element in the life of the American people if they choose to handle it intelligently, but not at all otherwise. I have therefore undertaken to open up many less traveled paths and to explore, for the dealer's benefit, many hitherto unrecognized facts concerning the present and future possibilities of the talking machine. In so doing, I have sometimes worked away from ordinary lines of direction, but the result has never, I think, been unfruitful.

#### Our Point of View

This talking-machine we sell, how do we regard it? To a good many retailers, I doubt not, the talking machine is neither more nor less than a well-demanded, easy-selling article which need not be understood or cared for in its internal aspects by anybody outside the factory in which it is made. This view of the talking machine has, of course, encouraged the building and selling of machines which ought not to have been sold by anyone to anyone else. Still, one of the finest characteristics of this trade is that it was built up on the very best and on that very best has always flourished. The machines which did the pioneer work were the best their makers could turn out; and the original standard has never been lowered. Little by little the original conception of the talking machine has been broadened, until today we find that it is not so much a "speech" as a "song" reproducer, not so much a "talker" as a "singer" and a "player." Little by little the talking machine has become the great musical instrument of the masses. To-day its position in that respect is pretty nearly unquestioned.

Let the musicians who are too narrow-minded to see differently complain as they will! Others quite as eminent believe in the talking machine and make use of it. The men and women who can appreciate what the machine is doing for the musical education of the masses are for it. And the masses seem to be decidedly for it too.

#### Building for Permanency

But one thing is sure. It is impossible to build up any permanent specialty trade on a mere fad or on a basis of misunderstanding. Fads pass one by one and are forgotten. Genuine conviction of the desirability of any article on the part of the public generally leads always to a permanent foundation for the industry concerned in making and selling it. If we intend that the talking machine shall be part of the future life of the American people permanently, if we intend to make it not a fly-by-night matter but a solid trade built on a permanent foundation, we must begin from now on to handle it with a respect commensurate with its real importance. We must begin selling "music" and not furniture.

Every one of the great manufacturers has

recognized this fact and has tried in every possible way to stimulate the understanding of the retailers in the same direction. When there were only a few machines and consequently only a few dealers, relatively speaking, it was much easier than it is now to treat the talking machine on a uniformly high-grade level. Today, however, the situation has altered in every way. The number of available makes of machines has increased many-fold and the number of dealers has increased in proportion. But along with this great expansion has come a perceptible loosening of the bands of what might almost be called discipline, which a few years ago was so striking an element in the success of this industry. That feeling of pride and of confidence, that knowledge that here was

a new and splendid thing opened up to humanity, that determination to maintain the splendid standard of musical bigness and importance, all these were elements for success of which the talking machine trade cannot afford to lose one now.

#### "Music"

Whatever else we do, let us never forget that it is the music the talking machine gives that makes it what it is and that provides the substratum for its popularity and our prosperity. The moment we begin to neglect this side of the machine, that moment we are beginning, though imperceptibly, to loosen our hold upon the public mind.

That is why it is so important to insist, and insist constantly, that the dealer give more and



Japanese Lacquer—Style H



William and Mary Period—Style D

## LAUZON Phonographs

THERE ARE SO MANY phonographs on the Market that conscientious dealers find it difficult to choose the make they can best depend upon to bring them steady profits and the lasting good will of their customers.

It is with existing conditions in mind that "LAUZON" phonographs are manufactured. They afford a secure foundation for the building of a big profitable business.

"LAUZON" motors and mechanical equipment are of the very highest class—the most expensive made.

"LAUZON" cabinets are in themselves works of art. The Period styles harmonize perfectly with the better types of period furniture.

9 Models—\$90 to \$400

### The Michigan Phonograph Company

Phonograph Division of the Lauzon Furniture Company

705 Ashton Building Factory, Monroe Ave. and Sixth St.

Grand Rapids, Michigan



more attention as time goes on and the number of machines constantly multiplies, to developing the musical side of his store to the utmost. If days of ruinous competition should ever come, which we all hope may never be so, the dealer who will survive will be the dealer who has been able to work up for himself a reputation as a seller of music in talking machines rather than as a storekeeper from whom talking machines may be bought. The future of our industry lies in encouraging the sale of high-priced goods and the best records. It does emphatically not lie in pushing cheap machines and jazz records. But how is this class of trade to be maintained under the growing stress of competition from a multitude of machines of all sizes and prices sold by a multitude of men who are not unanimous in seeing that quality trade is the trade to seek? Obviously it can only be done by refusing from now onwards to sell anything but "music" to one's customers, and by declining absolutely to treat either machines or records as mere articles of temporary popularity.

**Maintainers of Standards**

In a word, the future of the talking machine industry, as I see it, will lie in the hands of those dealers who will insist on maintaining the highest standards, who will look for the best tone and the finest reproduction, who will work up for themselves reputations as reliable authorities on everything which pertains to machines and records. It lies with those who will study tone and reproduction, who will not sell a machine unsatisfactory on these points, who will study the needle question and the sound box question and the tone arm question and the motor question, who will come to well-founded conclusions and insist upon machines which satisfy those conclusions, who will train their clerks to sell machines as musical instruments and records as music, who will be music merchants and not household goods merchants.

The fundamental elements of construction are probably settled. It is more than probable foundation of the machine with to considerable modification as Certainly we may look for many improvements. Certainly, however, it puts itself on a level of mere merchandising, progress will be slow, and finally will be brought to a stop if we allow the talking machine to be sold to the public in a manner and on a basis not sufficiently "interesting," as we may call it, not sufficiently "exciting," if we cease to demand and secure and advertise and sell genuine improvement

year by year, we shall knock the trade into a cocked hat yet. Shall we be so foolish?

This is no time for self-satisfaction or for the feeling that everything is for the best in the best of all possible worlds. Far from it. This is a time for reflection, for thought, for improvement and for an earnest determination to sell the talking machine as the greatest of musical instruments. It is indeed the time for every dealer to know that the musical secrets of the talking machine must be explored from end to end by those who have the job of maintaining and developing our great industry, and that the manufacturers will devote themselves to improvement in the proportion wherein the dealers back them up.

**TO SHOW L'ARTISTE IN NEW YORK**

E. C. Howard to Supervise Exhibit at the Hotel Pennsylvania Beginning August 15

The L'Artiste line of phonographs is to be exhibited at the Pennsylvania Hotel, New York City, from August 15 to September 1. This exhibit, which will comprise the full line of attractive models in period designs, will be under the personal supervision of E. C. Howard, originator of the L'Artiste phonograph, and sales manager of the Grand Rapids Phonograph Co., which produces this machine.

Mr. Howard will be assisted by P. Kaufman, Eastern representative of the Grand Rapids Phonograph Co. This exhibit will enable the Eastern dealer to become familiar with this exceptional line of talking machines which has recently been produced in Grand Rapids.

**KNITTEL PLANT TO DOUBLE OUTPUT**

The Knittel Showcase Co., Quincy, Ill., now manufacturing talking machines, is planning to double its output and has taken over the output of the Wolf Co., which makes cabinets in that city. The Wolf Co. will also enlarge its plant to increase the production of cabinets.

**MILWAUKEE PLANT WILL ENLARGE**

Manufacturing Space of Milwaukee Talking Machine Co. to Be Increased by 100,000 Square Feet—Plant Ready September 1

MILWAUKEE, Wis., August 4.—The remarkable success of one of the newer but fast-growing talking machine concerns in the country, namely, the Milwaukee Talking Machine Co., 416-418 Fourth street, is manifested once more by the announcement that it will increase its manufacturing space by more than 100,000 square feet by September 1. The factory has twice been enlarged during the last six months and the latest expansion will more than double its capacity.

The seven-story light manufacturing building, at 241-245 East Water street, formerly the home of the Benj. Young Saddlery Co., was taken over July 15 and is now undergoing remodeling and re-equipment for talking machine manufacture. The work is expected to be completed during the latter part of August. The East Water street factory, then, will become the main works and offices, the present factory on Fourth street being retained as a branch works.

In four years the company has grown to be one of the largest manufacturers of talking machines in the world, barring only a few of the older and larger concerns in the East. Credit for its rapid and substantial growth is due to its principal owners, Clem F. Romadka, president, and Stanley Roth, secretary and treasurer. The business now covers not only the entire United States and Canada, but foreign countries as well.

The Dalion is manufactured in five styles, which sell at a range from \$105 to \$325. The entire machine is built by the company in its own plants.

William H. Shire, special representative of the Emerson Phonograph Co., has left for a trip through the Texas territory.

**Take Advantage**

of the

**Summer Months**

Suggest to your customers how they may return from their vacations at the mountains or seashore with the accomplishment of another language acquired, at the same time providing excellent pastime for the long summer evenings.

Sell them the

**CORTINA  
Phone-Method**

It means profits on records, machines and text books.

Send for full information. Advertising matter and window displays.

**The Cortina Academy**  
12 East 46th Street :: New York

*Built for People Who Want the Best*

**LAWSON**

**UNIVERSAL  
PHONOGRAPHS**

PLAY ALL DISC RECORDS BETTER

WITH THE

**LAWSON PATENTED WOOD TONE-ARM**



*Lawson  
Distinctive  
Styles  
Win  
Admiration  
Everywhere*



**Backed Up By**

40 years experience in manufacturing Musical Instruments. Also a "Gold Bond Guarantee."

Phonographs that are Good.  
Phonographs that sell Good.  
Phonographs that stay Good.

SOLD DIRECT TO DEALER AT JOBBER'S PRICES

**LAWSON PIANO CO.**

Executive Offices  
372 East 149th St.

NEW YORK

Factory  
2572 Park Ave.



# Arme TONE ARMS Arme REPRODUCERS Arme PHONOGRAPH MOTORS

Are the supreme combination of mechanical engineering science and the art of true and natural tone reproduction

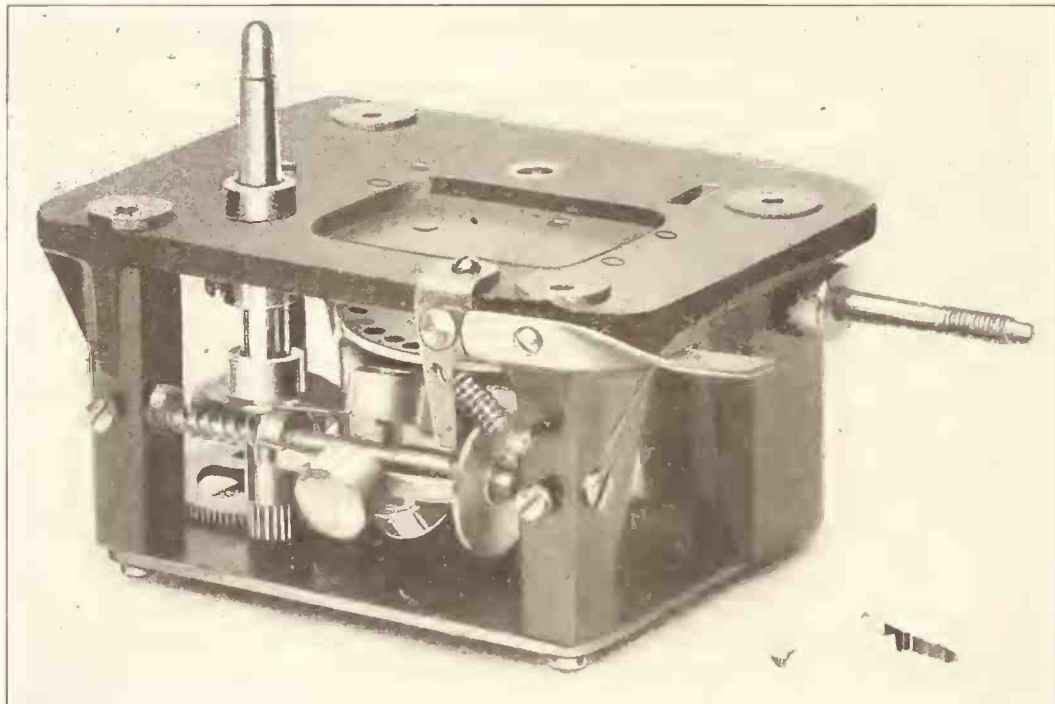

**MODEL A**  
Single spring steel plate motor.

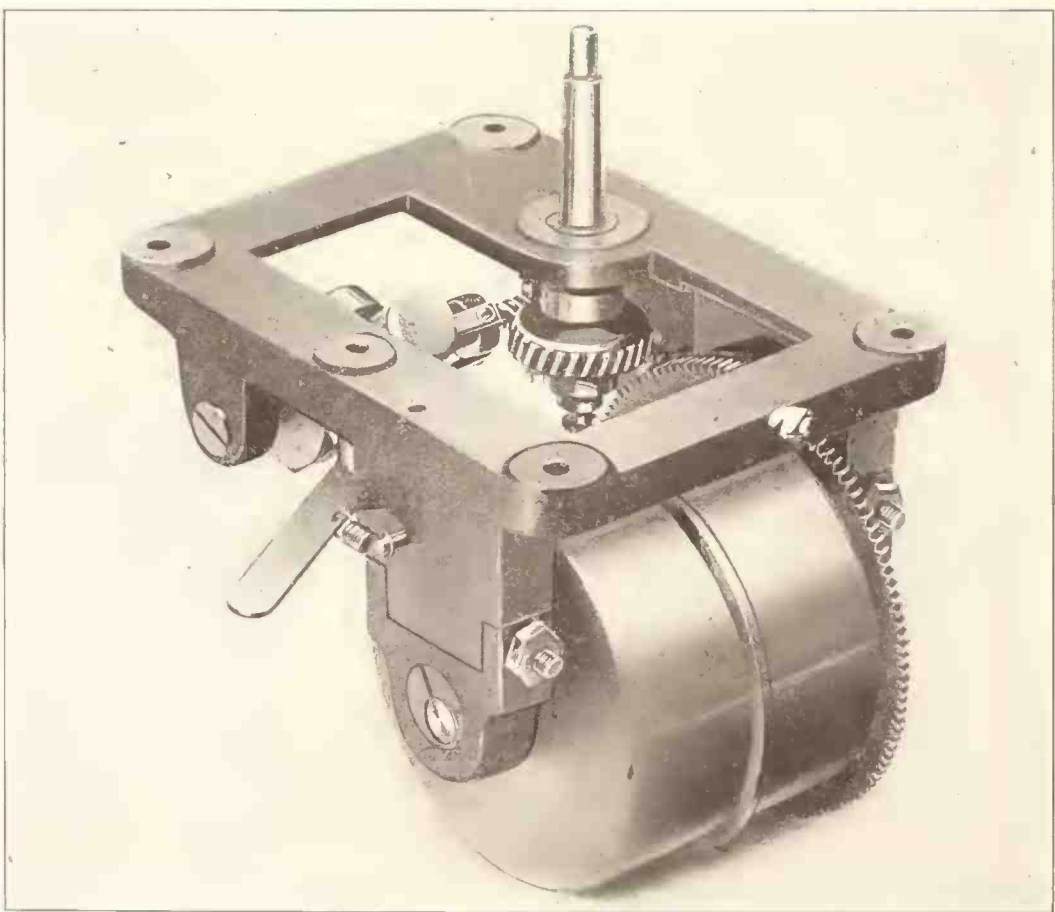

**MODEL B**  
Model B1 is a single spring, cast iron frame motor easily wound, smooth running and absolutely silent. It is fully equipped with adjustable brass bushings and can be accurately regulated. This motor is recommended for medium priced instruments and guaranteed to be high-class and satisfactory in every particular. Length of run approximately 14 minutes.

Model B2 is the same construction as Model B1 except that it is wound with double spring. Length of run approximately 19 minutes.



**MODEL C**  
Model C is a double spring, cast iron frame motor which is guaranteed to supply all the requirements of the highest type instruments. This motor is constructed from the best materials obtainable and all parts are made by expert precision tool makers. It is considered equally efficient to any high-grade motor on the market. Length of run approximately 35 minutes. All motors to fit either wooden or metal cases. Large quantities of these motors can be supplied promptly at attractive figures. We can also furnish special motors to fair specifications.

## Arme Phonograph Corp.

Chicago  
431 South Dearborn St.  
Tel. Harrison 8021

Makers of phonograph specialties for the trade. Anything made to your specification

New York City  
46 Murray St.  
Tel. Barclay 7633  
7634



## THE TALKING MACHINE THE NEW HOSPITAL INSTRUMENT

American Red Cross Recognizes Value of Talking Machine as Aid to Medical Work as Well as for Entertainment Purposes in the Army Hospitals—Keeps Up Campaign for Record Supplies

The quiet of night enveloped an army hospital. Suddenly from out one of the long low buildings appeared four figures. They moved cautiously toward a nearby ward. Two remained outside, sentinels. Two entered. A single shaft of moonlight fell across the table in the aisle, between the rows of sleeping men. The raiders advanced, seized two boxes from the table, made a hurried exit and the party disappeared into their ward.

The next morning there was much excitement in the ward visited by the strangers. The talking machine was gone. An excited search proved fruitless. The whereabouts of the instrument was not discovered until there came the sound of a melody from the adjoining ward, and the searchers realized that they had been victims of a raiding party.

Such an event is not unusual in army hospitals where phonographs and talking machines are scarce. For these instruments have been officially adopted as a part of the hospital equipment and are serving to entertain, to keep up morale and thus to hasten the recovery of hundreds of American youths injured on the battlefields during the world war. And the foregoing anecdote proves the appreciation of the new hospital instrument by the patients.

Appreciating that even the most inveterate music lover will tire of the same tunes repeated day after day and will long for harmonies and other melodies a Phonograph Record Recruiting Corps was organized by the American Red Cross. Its purpose is to collect records that have passed into the disfavor of their owners either by virtue of age or taste and to secure as many new discs as possible.

In practically every ward of the great army hospitals the Red Cross itself or through its agencies has placed a talking machine or phonograph. Not content with giving the instrument the association is endeavoring to keep the patients supplied with records by this corps recently mobilized.

Co-operating with the corps are the directors in the hospitals. They assemble the records, as books, in a circulating library, so that new discs are taken to each ward two or three times a week.

At first the machines were placed in the wards of patients who were far ahead on the road to recovery. Many of the men who have been wounded have been in the hospitals for months, some more than a year. Day by day, month by month, they have lain in bed, at first eager for something to do, gradually relapsing into a don't-care attitude toward life. To these men the music proved a great boon.

There was one boy suffering from a weak heart. He was unable to leave his bed for months. A talking machine was taken to the ward and he had a violin, so he amused himself for hours playing the fiddle to the accompaniment of the machine's reproduction.

This boy was but one of hundreds, even thousands, whose spirits have been brightened by the talking machine. The boys who suffer from the amputation of a leg or arm and must remain in bed for weeks, pass the hours playing these machines. And the thought and fears of the future that would otherwise come to torture idle brains are banished by melody.

When a man first learns that he is blind he experiences a fear of getting about. Because of this and the fact that his sense of hearing is daily becoming more acute the music of the talking machine is of great value during that period when he is unable to be active.

But it is among the shell-shocked and insane that the talking machine has worked most surprisingly. At first brain and nerve specialists in charge of such wards hesitated, fearing that a tune which would please one patient would excite another and on the whole be injurious. The venture was made and resulted most suc-

cessfully. That abandonment of self, that abnormal indifference to surroundings which is a general feature of psychiatric patients, has been decreased through the agency of the talking machine.

Music is generally accredited as a remedy

for the "blues" and has again proved its efficiency in this role in the tubercular hospitals. These are filled with men, otherwise normal, longing to be near their home and loved ones. They are restless during the irksome days, resentful of their malady that presses about them on every side. But a merry tune on a talking machine and the most gloomy and optimistic will forget his troubles and join the circle that surrounds the newest instrument in hospital equipment.

### CONTROL TWIN INDUSTRIES

E. A. Heaney and W. H. Schwab Looking After Affairs of General Manufacturing Corp. and of Recordeon Phonograph Co. With Success

MILWAUKEE, WIS., August 5.—The General Manufacturing Corp., whose plant is located at Buffum and Keefe avenues, this city, and the Recordeon Phonograph Co., North Milwaukee, are twin industries controlled by E. A. Heaney and W. H. Schwab, who are particularly fitted for the positions they respectively occupy in

the industries mentioned. Mr. Heaney was one of the first men in the West to go in for talking machine manufacturing. W. H. Schwab is a practical manufacturer with years of experience, who supervises both plants.

The Recordeon plant has long been devoted to wood-working, and was bought on June 16 last. A few days later it was started at the manufacture of talking machines. This was made possible because with the plant were bought nine carloads of fine hard lumber. Mr. Heaney has entire charge of the marketing of the product of both plants.



## Is Your Record Business Growing?

OkeH Dealers are in a position to expand and increase their record business month after month, for the new OkeH monthly supplements contain the records that are in active demand everywhere.

Our OkeH record stocks are complete, and we can give you efficient, practical co-operation in selling this popular hill and dale record.

OkeH Dealers Receive Liberal Discounts



OkeH Jobbers

INCORPORATED UNDER THE LAWS OF ILLINOIS

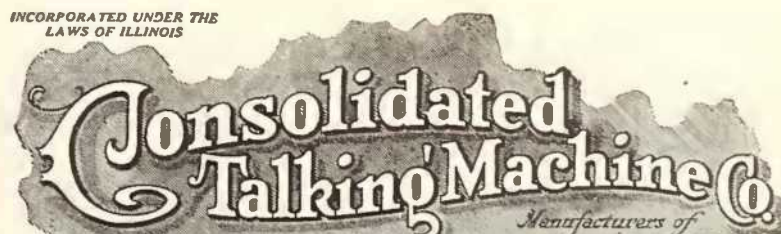

SUCCESSORS TO Standard Talking Machine Co. United Talking Machine Co. Harmony Talking Machine Co. O'Neill-James Co. Aratino Co.

High Grade Talking Machines, Disc Records, Talking Machine Supplies, Etc.



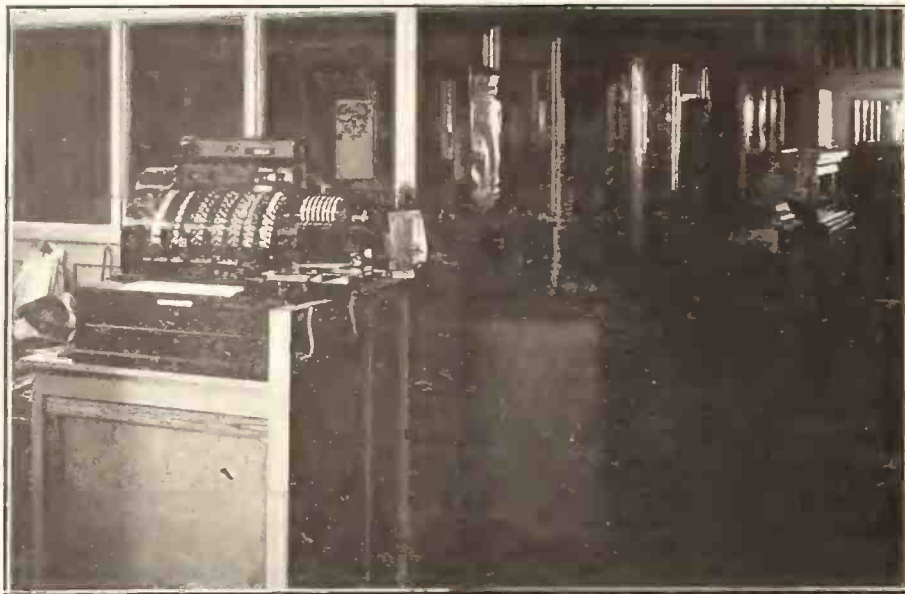

## Efficient Merchandising shows on the cash register

Every Victor dealer naturally wants to sell all the machines and records possible, and to make as big a proportion of profit therefrom as is justified.

To increase sales turnover, and at the same time keep overhead at a minimum, is the chief aim of every dealer. But to attain real success in this line is difficult, and requires a thorough utilization of the principles of efficient merchandising.

Efficient merchandising! The words suggest an unsolvable acrostic puzzle. When studied purely from the theory end perhaps that is just what it is—but when put before you in practical concrete form, merchandising efficiency is the answer to business prosperity.

*Eclipse Victor Service* proposes to do that very thing, i. e., to provide you with the opportunity not to abstractly visualize, but to actually see with your own eyes efficient merchandising in operation, as applied to the retail Victor business.

# ECLIPSE





## What We Plan to do for You

Our plans for the coming year are ambitious. We are pleased to mention at this time the following:

1. The Unit Construction Company will make an installation at our wholesale headquarters which will not only be original but also practical and artistic, and will give us a complete dealer's equipment, or in other words, a model Victor shop.
2. Another feature will be our *NEW KIND* of Service Department, organized for the exclusive use of our dealers. This department will be in charge of a thoroughly experienced Victor man who will work out practical ideas for each dealer and personally assist him to develop his Victor department to the highest point of efficiency possible— This to include merchandising ideas, sales talks, arrangement of departments, window trims and mechanical instructions and many other valuable helps.
3. In addition to the above, we will have our usual road force covering the Cleveland territory.

Surely the kind of service that will be offered to Victor dealers through the Eclipse institution will prove a wonderful boom to retail Victor business.

**ECLIPSE MUSICAL CO.**

VICTOR WHOLESALERS

CLEVELAND, OHIO

**S E R V I C E**



PREPARING FOR A STRONG CAMPAIGN

Record Needle & Mfg. Co. Establish Agencies in the East and on Pacific Coast as Well as Foreign Office—Sales Corps on Road Soon

MILWAUKEE, Wis., August 7.—The Record Needle & Mfg. Co., of this city, are preparing for an extensive campaign on their two principal specialties, the Record-Lite and the Record Needle-Cutter. President R. H. Zinke, who has just returned from the East, announces that the company have established a foreign office at 160 Broadway, New York, in charge of S. Apisell, who will push the Record specialties through twenty-four agencies situated in as many different world-centres. The company has also appointed Clement E. Beecroft, 309 West Susquehanna Avenue, Philadelphia, as general eastern agent. The Pacific Coast territory will be taken care of by Walter S. Gray, 508 Chronicle Building, San Francisco. The Central States territory is still open, but arrangements for this territory will probably be made within the next week or two. In all

probability it will be covered from a branch office in Chicago. "His Master's Voice, Ltd.," of Toronto, Canada, has taken over the representation of the Record Needle & Mfg. Co.'s specialties for the entire Dominion.

By the first of October, states Mr. Zinke, his company will have on the road twenty-five missionary men visiting the dealers and turning over the orders taken to the nearest jobber. The Victor jobbers are protected on the Victor Record-Lite—that model adapted specially to the Victor machine. The Universal Record-Lite, which fits all machines, is sold to any good, responsible dealer.

The company have established a new system of distribution on the Record-Lite. They will practically carry stock for the jobber. That is, they will see that the jobber's stock is kept at the minimum, and they will make direct shipments so that dealers will always be sure of getting fresh batteries and so on.

During his Eastern trip Mr. Zinke attended the convention of the National Association of Talking Machine Jobbers, at Atlantic City, and also called on jobbers in Eastern points.

# FAULTLESS

## PIVOT BEARING

# CASTERS

Casters that roll easily across the floor—and smoothly. No chatter—no unsteadiness.

Simple construction—no complicated parts to get out of order, nothing to retard easy movement. Strong—plenty of metal in required places to resist strains.

Silent—neat appearing—a real necessity to YOUR talking machine, these FAULTLESS CASTERS.



Full Size—C.65

Made with leather, fibre, felt, steel and lignum-vitae wheels. A word from you puts all our caster experience at your service and brings you a copy of Faultless Catalog "G".

**FAULTLESS  
CASTER COMPANY**  
EVANSVILLE, INDIANA

"Move the FAULTLESS Way"

Eastern Sales Office:  
Geo. Mittleman, 487 Broadway, N. Y.

### ATTRACTIVE ART POSTERS

Issued by the Columbia Co. for the Use of Its Dealers Win High Praise From Critical Members of the Trade—Two Good Examples

The Columbia Co. in its dealers' service department for September is issuing an extremely attractive art poster of Barbara Maurel. This exquisite poster is the work of the famous



The Maurel Poster

portrait artist Verrees and is to be used as a window display in advertising the records of Barbara Maurel.

Another window display which the Columbia



Columbia Poster on The Dance

Co. is issuing for September is a lively poster bringing home the adaptability of the Columbia Grafonola as a reproducer of dance music for the home.

**DECALCOMANIA**

Name Plates for Talking Machines, Pianos, etc.  
High Class Workmanship  
Write us for further information  
National Decalcomania Co.  
220-230 N. 60th St., Philadelphia, Pa.



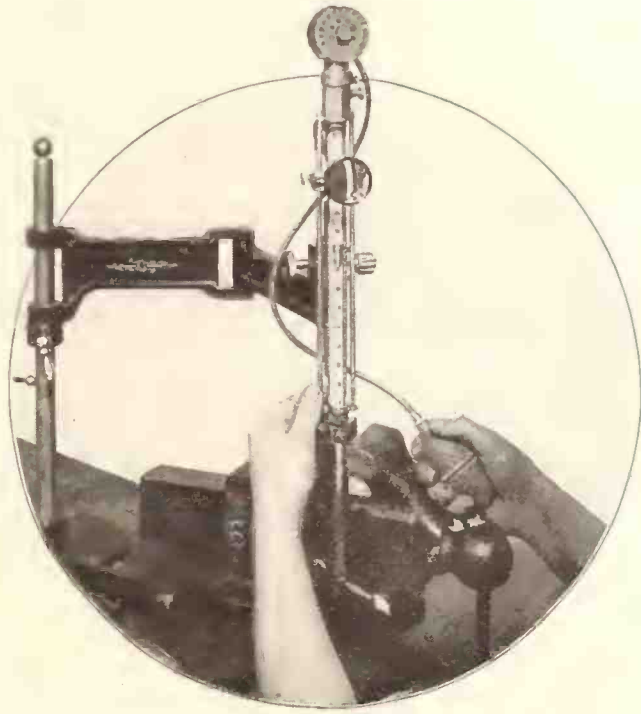

## *Rigid Inspection*

Raw materials entering into the manufacture of the Stephenson Precision-Made Motor are as rigidly inspected as the finished product . . . all metals are tested by the Scleroscope — a delicate laboratory instrument used to determine the degree of hardness of metals. And raw materials not coming up to specification are quickly rejected.

Rigid inspection from Receiving Room to Shipping Department keeps the Stephenson Motor a Precision-Made Motor.

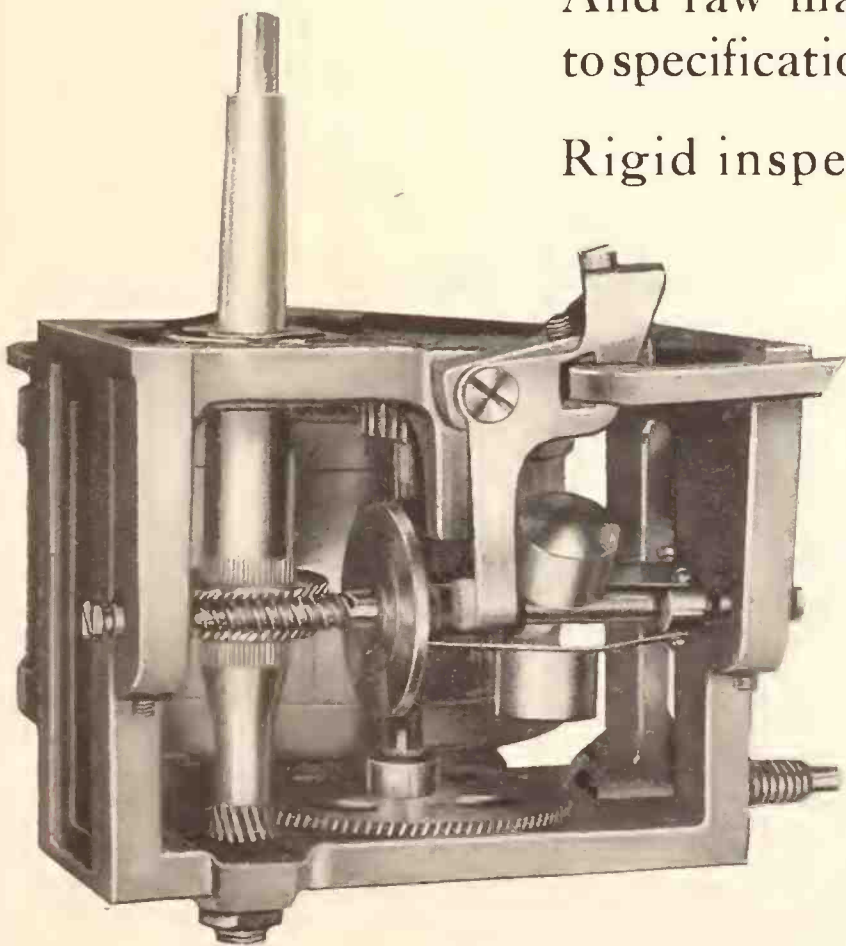

*STEPHENSON*  
INCORPORATED  
One West Thirty-fourth Street  
New York City



## MUSIC SUBSTITUTE FOR FAMOUS FIZZES IN NEW ORLEANS

Columbia Dealer Occupies Former Joy Water Parlor—Improved Conditions in Machine and Record Supplies—Good Music Shares Favor With Jazz in Louisiana—General News

NEW ORLEANS, LA., August 6.—Music as a substitute for the foamy gin fizz and the appetizing cocktail! This is the newest idea that is buzzing in the New Orleans offices of the Columbia Graphophone Co. It already has reached the experimental stage, and evidences are not lacking that the Grafonola soon will bloom on a number of corners which were wont to beckon to the thirsty before July 1.

The gin fizzes, cocktails and frappes of the Crescent City have gained fame reaching from coast to coast. The passing of these famous New Orleans "institutions" has resulted in the passing too of about 25 per cent. of the local cafes.

It is on some of the one-time gay corners, now vacated, that William F. Standke, manager here for the Columbia, has his eye. The initial experiment is under way at a corner of Tulane and Claiborne avenues. The new dealer shop is owned by H. Perloff, furniture merchant. In charge is A. D. Abramson, who resigned as traveling salesman for the Columbia, covering Louisiana and Southern Arkansas, to take the position. The new shop is reported to be proving a profitable dealer location. Mr. Standke intimates there are "more to come."

A rapidly improving condition as to the record supply and a slower but surely improving condition in supply of machines, coupled with an unprecedented demand by dealers and the public for both machines and records, comprises the gist of the situation in New Orleans and tributary territory, as reported this week by the trade.

J. D. Moore, manager of the talking machine wholesale department of Philip Werlein, Ltd., Victor distributors, emphasized the fact that dealers have come to understand, through the advertising of the Victor Co., that the manufacturers are doing their utmost to catch up with the demand. Under normal conditions in this territory, he said, the supply would be nearly keeping pace with the demand. But conditions have changed. July and August,

once rated dull months here in the talking machine field, this year are outranking the liveliest months of other seasons.

The Victor distributors just now are carrying on a special campaign aimed to inculcate in the dealers the idea of building the business on a permanent foundation. Mr. Moore said the campaign, carried on by correspondence as well as by the traveling salesmen, already is having a notable effect. He explained the situation as follows:

"New Orleans is known as the home of jazz. There is a great demand in this section of the South for jazz music. Several factors enter into this demand. The people here know and understand the negro, so what more natural than jazz music as a diversion, even among true music lovers who have cultivated a taste for the classics? Again, the negroes themselves are great buyers of the jazz records.

"But when the situation is analyzed, it will be found there is an inherent, widespread liking for the best music in New Orleans and vicinity. We are telling our dealers it will pay them in the end to take advantage of this liking and help cultivate it. The new owner of a talking machine who is fed up on jazz at the start is much more apt to tire of his machine than the one who buys some of the best selections at the outset. So, we tell the dealer, never let the new machine buyer leave the store without taking with him at least a few Red Seal records. The man who starts out by buying some selections that he never will tire of in the long run will prove to be your best customer. Treat good music as your stock in trade—jazz as merely supplementary."

Mr. Moore said the reduction on Red Seal records which went into effect July 10 boosted the sales instantly and heavily. The wholesale stock was cleaned out in three days. The Maison Blanche department store sold \$600 worth of Red Seal records in a day.

Otto Wilkin, of the talking machine department of the Maison Blanche, said there has

been a big demand for machines, and this in a season in former years regarded as dull. He said the big department store is finding its new plan of long terms is working out well, and that losses are very small. These terms are 10 per cent. down and 10 per cent. a month. Under this plan 3 per cent. is added to the amount due after the initial payment. Mr. Wilkins said that Brunswick sales are showing a healthy increase.

E. W. Wilson, Jr., manager of the Collins Piano Co., dealers in Victor and Brunswick products, spoke enthusiastically of sales and credit conditions. Money is so plentiful, he said, that the terms now average six months.

The Diamond Disc Co., Inc., Edison jobbers, has had no phonographs in stock for the past four months, reported Adolph Schreiber, secretary-treasurer, the machines being shipped out to fill orders as rapidly as they arrived from the factory. They now are about 1,000 phonographs behind in their orders. Mr. Schreiber said that shipments from the factory are improving, however, and by September 1 or soon thereafter they hope to be able to fill all orders without delay. The Diamond Disc has not favored its retail department in New Orleans; the latter has had to stand on its own bottom, with the result that most of its recent orders have been taken with future delivery stipulations.

Speaking of the enormous demand for ragtime and jazz selections, he said: "One sure way to create sales in this section is to have the word 'blues' in the title."

The Diamond Disc Co. will hold a convention here August 28 of Edison dealers in the territory. About seventy-five dealers are expected to attend. An Edison factory representative will make addresses. About September 15, under the auspices of the Diamond Disc Co., a tone-test recital will be given here by Julia Heinrich, soprano, formerly of the Metropolitan Grand Opera Co.

D. H. Holmes Co., retailers and wholesale distributors of the Aeolian-Vocalion, recently have been pushing sales of records by an extensive use of newspaper space. R. E. Ching, manager of the music department of D. H. Holmes Co., reported this advertising has been markedly successful in pulling power. He said there is a moderate improvement in the supply of machines, and that the situation as to records is almost satisfactory. Since taking the Aeolian-Vocalion agency about two years ago, D. H. Holmes Co. has established about forty dealers in Louisiana and Southern Mississippi, and reports that territory sales are flourishing.

The L. Grunewald Co., retailer of the Columbia and Starr, announces it is experiencing an unprecedented run in Columbia jazz records. This week it sold 500 records of "Another Good Man Gone Wrong" in less than four days. The Grunewald house was fortunate in being heavily stocked in machines before the shortage became acute. It reports that the Starr is constantly gaining in popularity, and that buyers invariably express warm satisfaction with it.

Edgar Newman, head of the Maison Blanche talking machine department, is enjoying a four months' vacation in Alaska and Canada. He will return about October 1.

Miss E. Delery, assistant manager of the Werlein offices for the wholesale distribution of Victor, leaves August 9 to spend a vacation in New York. She will spend some time at the Victor factory.

L. M. Willis, traveling representative of the Unit Construction Co. of Philadelphia, builders of the Unico booths, is scheduled to arrive in New Orleans August 7.

W. F. Standke, Columbia manager, is planning a trip to Kansas City and other Middle West cities about August 15. He remarked that had it not been for the ocean shipping tie-up, due to the seamen's strike, the agency would have been able to fill nearly all July orders from dealers.

A. C. Clapperton, formerly in the United States aviation service, is an addition to the Columbia office force, filling the position of correspondent and credit manager.

**Run down!**  
This would not have happened if there had been a **MOTROLA** attached

**A Real Achievement in Winding** — ZIP — touch the button and the phonograph is wound electrically.

Does not mar or deface the most expensive cabinet.  
**QUICKLY AND EASILY ATTACHED BY ANYONE**

Any phonograph dealer will demonstrate the MOTROLA, or write us for the name of our dealer in your city.

**JONES-MOTROLA, INC.**  
29 W. 35th St., New York. 57 E. Jackson Blvd., Chicago.

DEALERS—We have a wonderful proposition to offer you—write us

### NOTICE

This advertisement will be read by over 500,000 people in August.

### The MOTROLA

offers you Mr. Dealer a

**Big Profit**

### ORDER TODAY

from your jobber or write us for particulars.

**JONES-MOTROLA, Inc.** NEW YORK. CHICAGO. LOS ANGELES.

:: 29 West 35th Street  
:: 57 E. Jackson Blvd.  
:: 1967 No. Bronson Ave.



# ATLAS PACKING CASES

## Make Your Responsibility Our Responsibility

**Y**OU must be responsible to your dealers for the condition of your shipments on arrival—a defective packing case not only means financial loss but dissatisfaction to your trade and damage to your reputation as a careful manufacturer.

Insurance against the possibility of damage and dissatisfaction is available and may be had only by placing your packing case responsibilities with reputable and careful packing case manufacturers.

Remember the packing case is all that protects the high quality instrument you manufacture while it is in transit.

“Atlas” 3-ply veneer cases are *quality* cases manufactured in enormous quantities for the highest class trade. “Atlas” cases are made of 3-ply birch and hard maple veneer with clear spruce battens—a remarkable combination—insuring both beauty and strength.

These four thoroughly organized factories are equipped to furnish you with “Atlas” packing cases in any quantity. “Atlas” cases are uniformly of high quality.

Why not make us responsible for your *important* packing case needs?

Nelson & Hall Company  
Richford Manufacturing Co.

Blair Veneer Company  
Veneer Products Company

*Exclusive Selling Agents*

**ATLAS SALES  
CORPORATION  
RICHFORD, VERMONT**

*Chicago Office*  
327 South Lasalle St., Webster Bldg.

“ATLAS”  
PACKING  
CASES



Carry  
the  
Weight  
  
Save  
Freight



### "KNICKERBOCKER STREET" A WONDROUS THOROUGHFARE

One of the Features of the Attractive New Quarters of the Knickerbocker Talking Machine Co., New York—Progressive Victor Merchandising Exemplified for Benefit of Dealers

On April first of this year the then existing firm of I. Davega, Jr., sold out their retail business, changing their name to the Knickerbocker Talking Machine Co., for the wholesaling of Victor merchandise exclusively. This change enabled them to give their entire attention to the problems of the Victor dealers whom they supplied.

They realize that, although Victor merchandising at the present time is scarce, the future holds forth the prospects of obtaining plenty of merchandise and therefore formed an organization along big lines in order to give the maximum amount of service to the Victor dealer in his merchandising problem. An organization of men, experts in this field, was formed to

act in an advisory capacity in the matter of advertising, window display, circularizing and general good merchandising.

The headquarters of the Knickerbocker Talking Machine Co., at 130 to 140 West 124th street, are most attractive and are an inspiration in themselves towards progressive Victor merchandising. These headquarters were equipped by the Unit Construction Co., of Philadel-

phia, Pa., whose work is to be seen in the warerooms of hundreds of progressive Victor dealers throughout the country. Taking the elevator to the first floor, the visitor enters "Knickerbocker street," a real model street patterned after the old English design, with paved walks, brown stone store front and old English street lamps. Mirrors are located at the end of the street which tend to give one the impression of a long vista. The show windows are constructed in the very latest designs with prism glass at the top to permit the full street lighting benefits. These windows, five in number, have Victor products on display, constituting helpful suggestions to the visiting dealer in the matter of window display. A billboard has been constructed at the end of the street, which is illuminated by electric reflector lights and which billboard is painted with a Victor ad. Quaint lamps give all the illumination that is required and the



A View of "Knickerbocker Street"

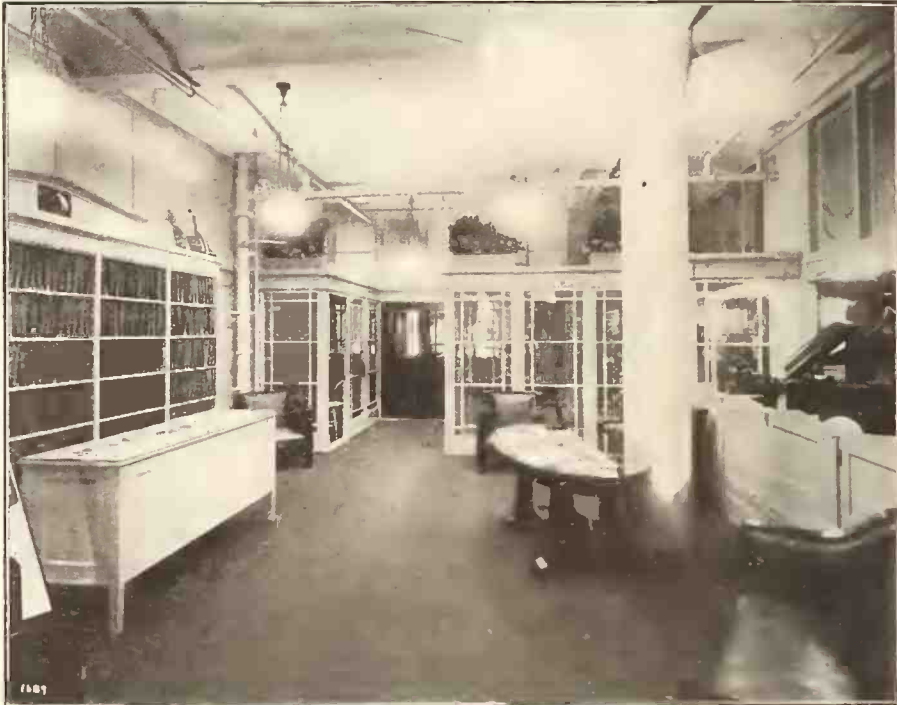

The Reception Room for Dealers

dise at the present time is scarce, the future holds forth the prospects of obtaining plenty of merchandise and therefore formed an organization along big lines in order to give the maximum amount of service to the Victor dealer in his merchandising problem. An organization of men, experts in this field, was formed to

phia, Pa., whose work is to be seen in the warerooms of hundreds of progressive Victor dealers throughout the country.

Taking the elevator to the first floor, the visitor enters "Knickerbocker street," a real model street patterned after the old English design, with paved walks, brown stone store

front and marooned draperies over and around the show windows add a becoming touch of brightness and color.

The executive offices are also situated on this floor and are richly furnished. The Unico partitions of all glass allow a maximum of light.

# THE STODART PHONOGRAPH

is made by the makers of the Stodart Piano, an all American product, and has made for itself the same splendid reputation borne by the Stodart Piano for nearly a century.

The STODART PHONOGRAPH is equipped to play any record. Its tone is rich and mellow, and has what critics declare to be the most perfect reproducing device ever conceived.

It is made in Mahogany in artistic models, beautifully finished, in every range of price.

*Orders for Fall should be placed NOW to assure deliveries.*



**STODART PHONOGRAPH COMPANY**  
INCORPORATED  
119 WEST 42nd STREET, NEW YORK



A handsomely appointed model Victor retail store is also found on Knickerbocker street and a Victor retailer visiting these modern warerooms may carry back with him many valuable ideas of distinct benefit to him in his own warerooms. Two Unico demonstrating rooms are installed, one for demonstrating the different types of Victrolas and the other for demonstrating records.

At the rear of this floor is found a concert hall where it is intended to bring Victor retailers together each month to hear the new releases,

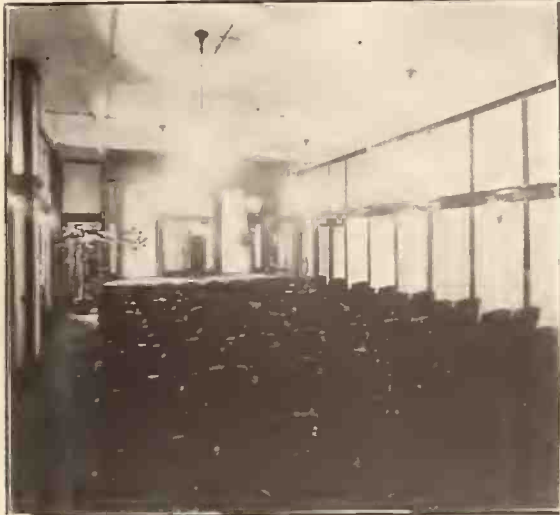

Partial View of Concert Hall

and to exchange ideas in merchandising. The Knickerbocker Co. will endeavor to have acknowledged leaders in the Victor industry give other retailers the benefit of their experience. The color scheme of the concert hall is old rose, mahogany and ivory, and there is an attractively set stage. The walls are decorated by pictures of famous Victor artists.

On this same floor is the Knickerbocker model Victor repair shop, maintained to instruct retailers or their employes in the repair of the Victrolas, although the Knickerbocker Talking Machine Co. also does repair work for the retailer.

Adjacent to this room is the Victor advertising

room, containing printed matter, exterior and interior signs, Victor dogs of all sizes, and general display fixtures, in fact, everything necessary to a Victor retailer in this important end of the business.

On the next floor is found the model wholesale department wherein are stored Victor records, Victor parts, advertising matter, sundries and Victrolas. The shipping department and billing department are also on this floor, which is equipped throughout with the most modern steel files, and is efficiently laid out so that orders may be filled with facility.

In the record filing department provision has been made to stock a half million records. The Victor dealer visiting this department is impressed with the facilities at hand to provide him with the service he desires.

Four delivery trucks are maintained, which at the same time advertise the Victor product as they go through the streets.

Many Victor retailers have already availed themselves of the cordial invitation extended by the Knickerbocker Talking Machine Co., to visit their new headquarters.

**PRESIDENTIAL CAMPAIGN RECORDS**

Nation's Forum to Feature Speeches by Candidates on New Records—National Campaign Committees of Both Parties—Plan Nation-wide Publicity Work—Big Campaign Feature

The talking machine is to play an important part in the coming Presidential campaign, under the plan arranged by the Nation's Forum in conjunction with the national committees of both the Democratic and Republican parties, and the campaign will be carried into the homes of the 2,000,000 talking machine owners in every part of the country. Presidential candidates and noted speakers are to record a series of addresses on specially made records designed for volume and clarity of tone.

Beginning September 1 the Columbia Co. will release these records at the rate of two a month,

one Republican and the other Democratic. On the reverse side of the record will be appropriate campaign songs or other selections. The first release will be records by United States Attorney General A. Mitchell Palmer for the Democratic party and Henry Cabot Lodge, leader in the Senate, for the Republican party.

Unusual publicity, national in scope, will feature these records and dealers will benefit by the opportunities for unusual window displays and also by the historical and biographical literature furnished with each release. Each dealer will be identified in a bi-partisan way with the affairs of his community.

The national committees of both parties will send letters to their State, Congressional, city, county, township and ward organizations and clubs pointing out the political value of the records and furnishing the names and addresses of dealers who handle them. Records will be featured in the weekly and monthly publications of both parties, and so far as possible the tone of campaign literature distributed everywhere throughout the struggle will call attention to the records and where they may be obtained. Dealers will be granted permission to circularize political meetings in the interest of their sale—something that could not under ordinary circumstances be secured at any price.

The retail price of these records, which will carry a gold label with the autographed signature of the speaker, will be \$3 each.

**WILLIAM C. GUTHRIE RETURNS**

William C. Guthrie, formerly of the editorial department of the Columbia Graphophone Co., has recently returned from overseas. Mr. Guthrie, who spent eleven months in the service on the other side in the Evacuation Ambulance Co. No. 9, received his discharge shortly before leaving France and has been traveling around France with the Beacon Male Quartet. This quartet has played in many of the principal American concentration camps, and at St. Nazaire, Le Mans, Brest and Paris.

**GUARANTEED**

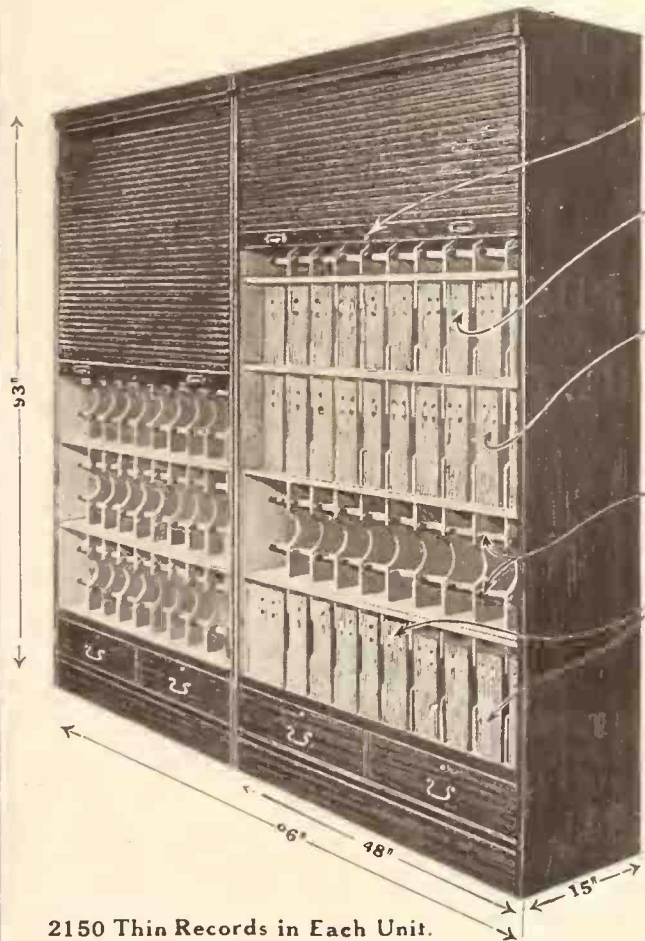

Locking Roll Top Prevents Dust and Theft.

350 10" Records on each shelf. Filed in Sales System Covers and Index Guides.

350 10" or 12" Records on this shelf.

Soft Flat Supporting Springs Prevents Warping (Patented).

10 and 12" Records Filed on same shelf. Held Flush at the front by Patented Adjuster.

2150 Thin Records in Each Unit.  
4300 Records in These 2 Units Illustrated.

WRITE FOR CATALOGUE

**Ogden Sectional Cabinet Co., Inc.**  
LYNCHBURG, VA.

**File Your Records So You Can Sell Them**

This System pays for itself in six months.  
Automatically Re-orders All "Sold Out" Records.  
Every Record Located Instantly as Simple as 1-2-3.

PRICES, Models No. 2150 D. D. and L. C.  
(PATHE MODELS SPECIAL)

OAK	{	Locking Wood Roll Curtain . . . . .	\$70.00
		Spanish Leather Roll Curtain . . . . .	60.00
BIRCH MAHOG.	{	Locking Wood Roll Curtain . . . . .	75.00
		Spanish Leather Roll Curtain . . . . .	65.00

Sectional Models Fit Any Size Stock and Help You Grow.

**Prices Models No. 2 and 62**

(CAP. 300 10 and 12" RECORDS)

Sections . . . . .	Oak \$6.00, Mah. \$6.25
Base . . . . .	Oak 5.00, Mah. 5.25
Top . . . . .	Oak 2.50, Mah. 2.75
Roll Curtain for complete Unit,	3.00

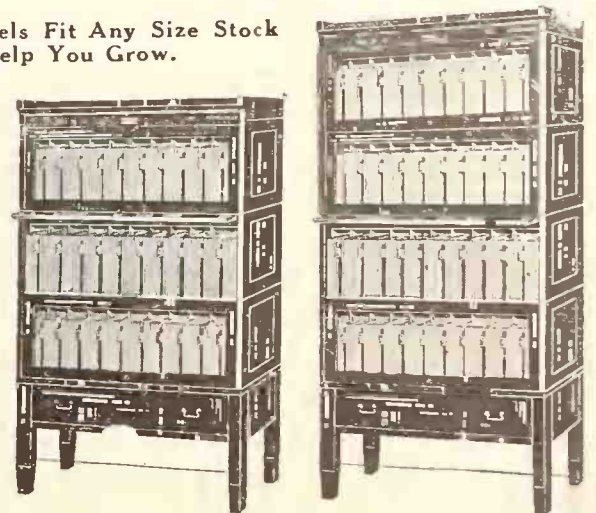

The Ogden Sales System Is Equivalent to an Extra Clerk and Increases Sales. Prices \$2.25 to \$9.75 a Section.



*Get In On This*

# Big Edison Diamond Amberola Campaign

*NEW* Edison Diamond Amberola dealers are offered a co-operative plan of advertising by which arrangement they are required to furnish but one-third of the cost.

If you are not an Amberola dealer—and wish to know more about the merits of the attractive Amberola line, the profits possible from its sale and the proposed Advertising Campaign, write to this office.

---

**THOMAS A. EDISON, Inc.**

*Amberola Department*

ORANGE, N. J.



**WITH HEINEMAN IN CHICAGO**

**H. L. Coombs Becomes Assistant Sales Manager—Has Had Wide Experience in the Record Field—Is Popular and Capable**

The Otto Heineman Phonograph Supply Co., Inc., of Chicago, Ill., announces this week the appointment of H. L. Coombs as assistant sales manager of the company, with headquarters at the executive offices in Chicago.

Mr. Coombs is one of the best-known members of the record industry and until recently



H. L. Coombs

was general sales manager of the New York Recording Laboratories, manufacturers of Paramount records, resigning this position to become associated with the Otto Heineman Phonograph Supply Co., of Illinois. Prior to that he was branch manager for the Emerson Phonograph Co., Boston, Mass., and he is therefore thoroughly acquainted with every detail of record merchandising.

According to his present plans Mr. Coombs will specialize on the development of Okeh record business throughout the Middle West, and his intimate familiarity with every phase of the business will enable him to give invaluable co-operation and service to the Okeh clientele.

**WILLOUGHBY-STILLMAN**

Miss Lois Willoughby, a newspaper writer of this city, formerly of Chicago, was married to Edwin B. Stillman, son of Mrs. Orville Stillman, of Westerly, R. I., Saturday afternoon, July 26, in her home, 296 Manhattan avenue, by the Rev. Dr. Frank Crane. Mr. Stillman was graduated from the Harvard Law School in 1909. He and his bride will make their home in New York. Mr. Stillman is the Edison dealer in Westerly and his father was one of the first Edison dealers in this country. Miss Willoughby is the press representative of Frieda Hempel.

**LATHAM REJOINS BRILLIANTONE CO.**

Eugene Latham, who was on the sales staff of the Brilliantone Steel Needle Co. previous to his enlistment in the U. S. service, is now once more with the Brilliantone Steel Needle Co. Mr. Latham, who has been in the talking machine field for many years, has a host of friends throughout the trade and is anxious to meet them all again at his earliest opportunity. He will give his attention to export and special work in the interest of the Brilliantone Steel Needle Co.

**WHERE SALESMEN MAY GET ORDERS**

Julius Burnstine, talking machine and piano dealer, at 127 North Tenth street, Philadelphia, desires to announce to salesmen and representatives of manufacturers generally that all the buying for his branch stores in Beverly and Riverside, N. J., is done through his headquarters in Philadelphia.

**VISITS NEW YORK BY AIRPLANE**

**A. H. Curry, of Texas-Oklahoma Co., Pays Flying Visit to Edison Laboratories**

"Going up in the air" was a thriller planned by A. H. Curry, president of the Texas-Oklahoma Phonograph Co., of Dallas, Tex., as a feature of his recent personally conducted visit to the Edison laboratories and New York. Urgent business at home had forced him to miss the annual Edison Dealers' Convention in June, so he made a special trip to the Edison laboratories to confer directly with departmental managers and to obtain first hand the many original business ideas and new plans promulgated at the convention.

The trip by airplane was arranged by Harrison Durant, of Thomas A. Edison, Inc., and the flight was made in an army plane from the Mineola Field, on Long Island.

Mr. Curry is 100 per cent. enthusiastic about Texas and its business possibilities and opportunities for the highest prosperity during the coming year.

**MOVES TO NEW QUARTERS**

The Recordion Co., Inc., manufacturers of a home recorder to be attached on talking machines, have moved their executive offices from 110 West Thirty-fourth street to 256 Broadway, New York City.

**TALKING MACHINE MEN TO MEET**

**Luncheon and Business Meeting to Be Held at Hotel Pennsylvania on August 20**

The Service Bureau of the Talking Machine Men, Inc., has planned an unusually good program for their next meeting and luncheon, which will be held at the Hotel Pennsylvania at 12.30 p. m. on August 20. Edward Lyman Bill, of The Talking Machine World, will speak at this meeting on "Co-operation Within the Organization." John Steele, who records exclusively for the Victor Co. and is one of the features of this year's "Follies," will also speak. The All-Star Trio, composed of Messrs. Wadsworth, Green and Arden, will furnish musical entertainment during the luncheon. Joseph C. Smith, of the J. C. Smith orchestra, will also be present. The meeting promises to be of great benefit to the dealers and members of the organization, and the good work that the new service bureau is doing and the new ideas which are carried out from time to time have done much to help dealers in talking machines to better the standards of their business, both within their own organizations and in co-operation with others.

The Ramona Trading & Mfg. Co., Wilmington, Del., has been incorporated to manufacture talking machines and other musical instruments with a capital stock of \$100,000.



# NEEDED

ON EVERY

## Victrola and Grafonola

No. 10 FOR VICTOR PRICE 35c

No. 20 FOR COLUMBIA PRICE 25c

### The *Cleanrite* RECORD BRUSH

TRADE MARK RECORD BRUSH

## MOST EFFECTIVE RECORD CLEANER ON THE MARKET



BRUSH IN OPERATION

Saves Records

and Labor of Cleaning

It does the work automatically and once attached requires no further attention

Every Dealer Should Carry Them

Circular and Price List Mailed on Request

Manufactured by

# Blackman

TALKING MACHINE Co.

81 Reade Street Near Church St. New York

Victor Distributors



# PLA-RITE NEEDLES

*PLA-RITE IS THE NAME*

*PLA-RITE THEY DO*

NUF

SED

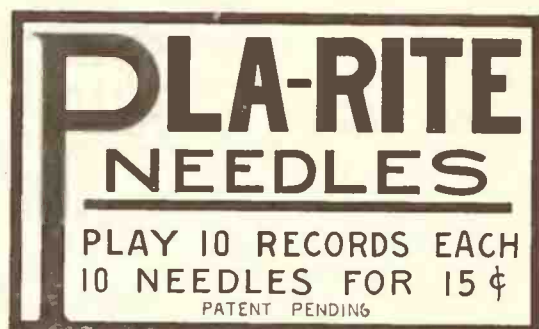

*COST TO DEALER, 9c.*

*RETAIL AT 15c.*

---

*WILL SHIP IN LOTS OF 100 PACKAGES OR MORE*

---

## PLA-RITE MFG. WORKS

GALESBURG, ILLINOIS



REMODELING IN BUFFALO

W. D. & C. N. Andrews Make Some Important Changes in Their Business Building

BUFFALO, N. Y., August 4.—W. D. & C. N. Andrews, Victor wholesalers, have completed some very important changes in the appearance of the large business building which they own in providing a direct entrance to the upstairs

very ideally located. It is directly across the street from Denton, Cottier & Daniels, the oldest and largest music house between New York and Chicago; it is nearly opposite to Shea's Theatre and is midway between the Soldiers' and Sailors' Monument and the McKinley Monument, two blocks from the leading hotels, the Iroquois and the Lafayette, and only one short block off Main street.

All the suburban trolleys north and east start



New Home of W. D. & C. N. Andrews in Buffalo

offices. Previous to the change just effected there was, in fact, no entrance to the offices in the front of the building. The tenants all used to enter through the entrance on the side and rear. The other changes which are being effected in the building are rapidly going forward, the sum being spent on this work involving about \$40,000.

The members of the Andrews Co. are feeling very pleased with their new home, which, in addition to being spacious and handsome, is

nearly in front of the building and the trolleys south and west start within two blocks. All of this, of course, renders the Andrews headquarters particularly accessible to in and out-of-town Victor dealers.

A meeting of the stockholders of the Columbia Co. is called for August 19 to act on the plan to increase the present stock issue from 150,000 shares to 1,500,000 shares without par value.

NOW THE CARDINAL PHONOGRAPH CO.

Reorganization of Newark, O., Concern Opens Way for Increased Machine Production—New Catalog Soon Ready for Distribution

NEWARK, O., August 5.—The Cardinal Phonograph Co., of this city, capitalized at \$250,000 and representing the reorganization formerly known as the Art Cabinet Co., is preparing to increase materially the production of talking machines, under the name "Cardinal." It is stated that the rearrangement of the factory of the company in Zanesville, O., has made possible the production of 500 machines per month.

The president of the Cardinal Phonograph Co. is George Hayden, Sr., who has large interests in big business enterprises in Ohio. George Hayden, Jr., who has had wide experience in the manufacturing field, is secretary and general manager of the company, while the treasurer is R. H. Patterson. E. A. Querinjean, formerly of Cincinnati and New York, is manager of the sales and advertising departments of the company, and is already planning a strong campaign of advertising and sales service for the benefit of dealers.

The Cardinal Phonograph Co. has ready for distribution an attractive new catalog illustrating and describing five of the company's machines, ranging in price from \$55 for a table model to \$200 for an attractive cabinet model. Considerable space is given to a description of the Cardinal phonograph and its various special features.

WORKING AT FULL CAPACITY

PORT WASHINGTON, WIS., August 5.—The Vista Phonograph Co., of this city, which is one of the companies affiliated with the great Wisconsin Chair Co., is running at full capacity and turning out a substantial quantity of talking machines weekly, according to reports. Otto A. Gressing, sales manager of the company, is now on a Southern trip.

VICTOR RECORD SUPREMACY

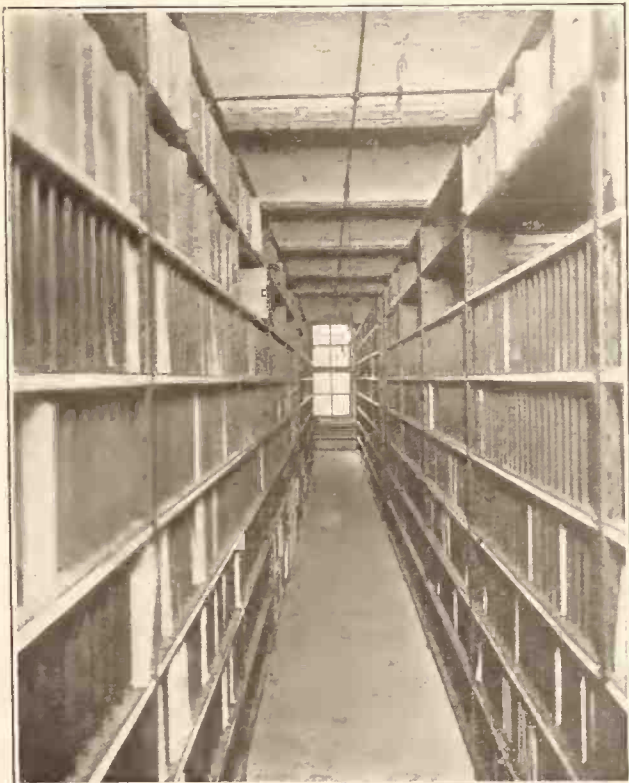

Altho the enormous demand for Victor records has reduced our stock we have just completed newly constructed record shelving with a capacity of stocking over 500,000 records in every language. : : : : :

AT YOUR SERVICE

KNICKERBOCKER TALKING MACHINE CO.

Exclusively Victor Wholesalers

138-140 West 124th Street

New York City

VICTOR RECORDS IN ALL LANGUAGES







**MEETING OF COLUMBIA RETAILERS HELD IN BALTIMORE**

In Addition to Enjoying Business Discussions Retailers Are Also Entertained by Columbia Artists —Elmer J. Walz Takes Up New Duties With Cohen & Hughes—General News

BALTIMORE, MD., August 8.—While business held its own in the talking machine trade during July this month finds the distributors being besieged for goods in final preparations for the big fall and winter business that is bound to come. While there has been a slight increase in the receipts of machines by the various companies the arrivals are insufficient to meet the demand of the trade. There has been a slight increase in shipments of records by the various manufacturers to this city, which included many needed numbers for the old stock.

A most interesting and instructive sales meeting was held recently by the Columbia Co. at the Southern Hotel. Several of the Columbia stars were on hand and furnished the entertaining feature after the business of the evening was disposed of. Marjorie Pringle, Charles W. Harrison and Louise Lockwood, the latter the piano accompanist, made a fine impression. Miss Pringle, especially, captured the dealers and it is safe to say that when her numbers appear on the record list she will have a fine hustling set of men and women to aid in their sale.

In his address to the dealers W. S. Parks, the local manager, stated that the company had delivered at least 50 per cent. more product than in the same period of 1918. He recited various incidents due to the war condition that are now happily past and then dwelt on the needle situation. He spoke of how the International records were being handled for the dealers' benefits. He dwelt at some length on the advertising plans of the company and how the dealers benefit through these plans, which cover newspapers and magazines. He made a strong plea for better-looking stores and more efficient organizations on the part of Columbia dealers. Among the out-of-town dealers who attended the gathering were Henry F. Searle, Winchester, Va.; R. L. McDowell, H. C. Grove, Inc., Washington, D. C.; M. Phillips, Washington, D. C.; E. H. Hurwitz, Globe Furniture Co., Annapolis, Md., and A. Clifton Powell, Urbana, Va.

Elmer J. Walz, who for fifteen years was with the Victor Co. and who had been appointed general manager of the wholesale business of Cohen & Hughes, Victor distributors, arrived in Baltimore on the first of the month and assumed his new duties. This is Mr. Walz's first visit to Baltimore, but he made a hurried survey of the situation soon after his arrival here and he feels sure that he is going to be very much at home in the city of his adoption.

The new headquarters of the National Piano Co., Pathé distributors, is rapidly getting into shape. The first floor has been completed with its many booths and the upper floors will be all finished before the middle of this month. The company has just received several models of the new Actuelle and W. W. Parsons, of the Pathé Co., dropped into town during the first part of the month. He has visited numberless cities and in the West he says the demand for talking machines is simply phenomenal. The farmers are demanding high-priced instruments and this, he believes, is going to be a wonderful season for business. Jesse Rosenstein, of the National Co., is looking forward to real business and believes it is going to be one of the best seasons.

The Kranz-Fink Talking Machine Co. has placed new booths on the first floor of its building.

A. B. Creel, who was the Washington, Rich-

mond and Norfolk representative on the road for the Columbia headquarters, has been made manager of the New Orleans branch of the Columbia Co. A. M. Calis has been appointed salesman for the Columbia in southern West Virginia and western North Carolina. Captain

**THOMAS A. EDISON TAKES VACATION**

In Camp in Adirondacks With Henry Ford and John Burroughs

"Now I am going camping for a couple of weeks with those two wild children of nature, Henry Ford and John Burroughs," said Thomas A. Edison, as he left the Edison laboratories for his annual outing trip in the woods, a custom of several years' standing.

Mr. Edison, Mr. Ford, H. D. Firestone and the latter's son met John Burroughs, the eminent naturalist, at Albany, N. Y., on August 4,

H. B. Haring, who saw service with the A. E. F., has joined the Columbia forces here and is looking after Baltimore and Eastern Shore dealers. He succeeded Lyman Bryan.

The Music Dealers' Association of Baltimore, Inc., will very likely make their September meeting of especial interest to the talking machine men. To this end there is a movement on foot to bring some of the leaders of the industry to Baltimore to speak to the members and their friends.

and the following day left for the Adirondack Mountains. Mr. Firestone's Albany representative was host at a dinner given to them in Albany and at which former Governor Glynn, Mayor Watt, of Albany, and President Winchester, of the Albany Chamber of Commerce, also were guests.

W. H. Meadowcroft, private secretary to Mr. Edison, is spending a month's vacation at his bungalow at Lovett's Field, South Portland.

A new talking machine department has been installed in the McCuneo furniture store in El Centro, Cal.



**CLEANS  
REVIVES  
PRESERVES**

**MAKES OLD RECORDS PLAY LIKE NEW**

**Something New: A Liquid Cleaner**

TONE-CLEAR IMPROVES AND LENGTHENS THE LIFE OF ANY RECORD AND REDUCES THE CHANCE OF DAMAGE TO THEM BY 90%

TONE-CLEAR WILL MAKE MONEY AND FRIENDS FOR ANY JOBBER OR DEALER

It is easy to sell, simple to use and is absolutely fool-proof. Use it sparingly. One bottle will clean 250 or more records. It is a 100% article with a 100% guarantee.

Tone-Clear has been subjected to the most severe tests and proves our every claim for it. We guarantee it without reserve. Our list of customers already includes many of the largest jobbers and dealers in the United States. Be the first to introduce Tone-Clear in your territory.

**Beware of Imitations**

**Ask for and Demand Tone-Clear Only**  
*The Crowning Feature of Phonograph Accessories*

SEND US YOUR ORDER FOR A SAMPLE GROSS. YOU WILL BE MORE THAN REPAYED FOR THE POSITIVE RESULTS TO BE OBTAINED. Owing to the many inquiries regarding TONE-CLEAR, we have had to decline sending free samples; however we will cheerfully send circulars and details of this wonderful liquid upon receipt of your request, or a bottle of TONE-CLEAR prepaid upon receipt of the regular retail price—50c.

\$48.00 per GROSS, LESS 10% or \$4.00 per DOZEN  
Jobbers write for special discount

**WAX-WILSON COMPANY**

*Exclusive Selling and Distributing Agents for U. S. and Canada*

201-5-6 FENTON BLDG. PORTLAND, OREGON



**NICHOLSON**  
Talking Machine  
**RECORD CABINETS**  
the kind that talk  
**VALUES and SALES**  
**K. NICHOLSON FURNITURE CO.,** Chase City Virginia  
*Record Cabinets, Sect. Bookcases and Ladies' Desks*



# Crystal Edge MICA Diaphragms

THE STANDARD OF QUALITY AND SERVICE

PHONOGRAPH APPLIANCE CO.

109-113 West Broadway, New York

## APPRECIATION OF GOOD MUSIC EVIDENT IN PORTLAND

Reduction in Price Stimulates Red Seal Record Sales on Pacific Coast—Liberal Advertising Has Excellent Effect—What Various Concerns Report Anent Conditions in the Trade

PORTLAND, ORE., August 8.—The reduction in prices of the Red Seal records has created an immense demand for them. A full-page advertisement of the G. F. Johnson Piano Co., giving both numbers and names of the records that were reduced in price, brought an astonishing response—crowds of people awaiting the opening of the doors of the store on the following morning. All the dealers report increases in the demand for Red Seal records. While this was not unexpected, very few dealers were prepared for the unusual call which immediately followed the announcement. A large shipment of Cheney machines has just been received.

Miss Bertha Serr, manager of the record department of the Wiley B. Allen Co., who has done much to increase the love of good music among her regular customers and has always been well supplied with the very best Victor records, was very well prepared to serve Wiley B. Allen's patrons with most of the Red Seal records called for.

A handsome display of Sonoras is seen in the windows of the Bush & Lane Piano Co. A new electric Sonora sign attracts a great deal of attention. James Loder, manager of the department, has returned from the country.

Miss Madeline Larson, manager of the talking machine department of the Meier & Frank Co., says the sales of Edison machines have greatly increased. A new saleslady, Miss Madeline Kribs, has been engaged for the record department. Miss Kribs comes from Tacoma, where she was in the record department of Rhodes Bros.

Tone-Clear, the new liquid for restoring and reviving phonograph records, is meeting with extraordinary success. The Wax-Wilson Co., who are the sole selling and distributing agents of Tone-Clear, are rushed with orders. Three hundred gross were sent to San Francisco and Portland and other dealers are being supplied with the article as fast as possible. A new factory site is being looked for, as the present

location is not large enough to meet the needs of the manufacturers.

M. W. Davis, manager of the talking machine department of Edwards Furniture Co., has made this department one of the most important sections of the store, and certainly one of the most attractive in this city.

After being connected with the Columbia Graphophone Co. for eight years L. P. Older, one of its most efficient employes, has resigned and will hereafter be traveling representative for the M. B. Smith Co., which handles the Aeolian-Vocalion and the Puritan. Before traveling for the company Mr. Older will spend several months in the factory studying the business. He left Portland for Omaha on the 16th of July, where he will remain a week or two in the executive office. Mr. Older's friends wish him success in his new venture.

The Columbia Dictaphone offices and the office of L. D. Heater, of the Columbia Graphophone Co., have been moved from the Grafonola Shop on upper Washington street to the Spaulding Building, where a suite of five rooms gives ample accommodation for the increased volume of business.

The big Columbia advertisements, which appear in all the daily papers, are creating an interest in the Grafonola and Columbia records. Window decorations are becoming more frequent and more elaborate in the Columbia dealers' establishments. Some of the demonstrations are very striking and in excellent taste.

W. A. Hodecker, manager of the Seiberling & Lucas talking machine department, is well pleased with the good business done during the summer. Every day they have sold from one to five Victrolas and could sell more if they could get the stock.

Phonographs made of reed or wicker are attracting considerable attention in the phonograph department of Oregon Eilers Music House. The instruments of both large and small

types are equipped with electric motors. They have attracted a great deal of attention as they are particularly well adapted to the furnishing of summer homes.

The Brunswick phonograph is selling particularly well in Clarke County, and the dealers are very well satisfied with results.

The Pathé talking machine had an attractive and interesting jazz ad in the Portland papers on July 16. Jazz music was specially advertised, a list of popular music of the jazz variety being published.

A wave of Pathé popularity has struck Montana, Northern Idaho, Eastern Oregon and Washington. M. Seller & Co., North Pacific distributors, announce that their business in this section has grown to such an extent as to

## Phonograph Repair Parts Motors, Tone-Arms, Sound-Boxes, and Accessories

### Main Springs

No. 1— $\frac{5}{8}$ x8x.022	Each	\$0.30
No. 2— $\frac{5}{8}$ x11x.020	"	.30
No. 11— $\frac{5}{8}$ x11x.023	"	.39
No. 12— $\frac{5}{8}$ x9x.023	"	.35
No. 7— $\frac{3}{4}$ x10x.025, H. No. 2, 6, Mark, Sw.	"	.29
No. 14— $\frac{3}{4}$ square hole	"	.41
No. 17—1x18x.026, Sonora, Meisselbach, Thomas	"	.65
No. 20—1x11x.027, Sonora, Meisselbach, Thomas	"	.60
No. 26—1 3/16x18x.027, Heineman No. 44	"	.75
No. 41—2x16x.025, Edison, Meisselbach	"	1.75
No. 3— $\frac{5}{8}$ x11x.020, Edison, Gem	"	.30
No. 30—1", Edison, Std.	"	.53
No. 34—1 1/4", Edison, Home	"	.65
No. 25—1 1/16x21x.030, Edison	"	1.15
No. 35—1 1/2", Edison-100	"	1.55
No. 36—1 9/16x16x.024, Edison	"	1.45
No. 6— $\frac{3}{4}$ x9x.022, Col. No. 5, Tr. Fl. Melo.	"	.27
No. 23—1"x8, Col. Harm.	"	.43
No. 19—1x10x.025, with loop or hole	"	.39
No. 18—1x11x.025, Col. II No. 3, 7	"	.53
No. 24—1x11x.025, Hook Ends	"	.53
No. 16—1x11x.022, Victor	"	.48
No. 21—1", Victor, N. S. with clip, short	"	.58
No. 22—1", Victor, N. S. with clip, long	"	.63
No. 31—1 1/4", Victor, Marine Ends	"	.65
No. 32—1 1/4", Victor, New Style with clip, short	"	.60
No. 33—1 1/4", Victor, New Style with clip, long	"	.65

### Governor Springs

For Victor, 1 1/2c each; per 100	\$1.00
For Victor—Bend Ends, 1 3/4c each; per 100	1.25
For Col. 1 1/2c each; per 100	1.00
For Hein. Meis. Thom., etc., 1 1/2c each; per 100	1.00
Governor Screws, Col., 1c each; per 100	.75
Governor Screws, Victor, 1c each; per 100	.75

### Sound Boxes

Sound Box, Victor	Each	\$3.75
Needle Arm Exh.	"	.49
Diaphragm Mica Exh.	"	.13
Diaphragm Mica No. 2 Sound Box	"	.18
Rubber Backs Exh.	"	.39
Thumb-Needle Screw, Vic. or Col., 1 1/2c each; Per 100	1.00	
Sound Box, Columbia	Each	2.75
Needle Arm for Columbia	"	.41
Diaphragm Mica for Columbia	"	.23
Diaphragm Mica for Columbia, 1 1/2"	"	.13
Sound Box, Sonora	Each	1.75
Needle Arm for Sonora	"	.35
Diaphragm, Mica, 1 31/32	"	.18
Diaphragm, Comp., 1 31/32	"	.05

### Tone Arms

Baby T. A. & S. B.	Each	\$0.85
No. 1—T. A. & S. B., Universal	"	1.90
No. 3—T. A. & S. B., Goose Neck and Universal	"	3.75
No. 5—T. A. & S. B., Universal	"	2.75
No. 6—T. A. & S. B., Goose Neck and Universal	"	4.50

### Motors

Single $\frac{3}{4}$ Spr. 10" T.T. Top Reg.	Each	\$2.25
Single Cast Iron Frame, 10" T.T.	"	3.50
Double Spr. 12" T.T. Dial Reg.	"	5.25
Double Spr. Sw. Nickel Plated, 12" T.T.	"	6.25

### Attachments, Felts, Sapph. Points, Etc.

Attachment to play Edison or Pathe Rec. on Vic.	Each	.25
Attachment to play Edison or Pathe Rec. on Col.	"	.25
Attachment, Permanent for Victor	"	1.15
Attachment to play Vic. or Col. Rec. on Edison	"	1.75
10" T.T. Felts	"	.10
12" T.T. Felts	"	.15
Sapphire Points for Pathe Records	"	.27
Sapphire Points for Edison Records	"	.27
Diamond Points for Edison Records	"	2.25
Needle Cups for 1 1/4" hole	"	.03
Needle Cups with cover for 1 1/4" hole	"	.04
Automatic Lid Support	"	.45
Automatic Stop	"	.60

### Records

Columbia 10" Records, 100 selections to pick from	37 1/2c each; Per 100	\$35.00
Imperial and Rex Sapphire 10" Records, 200 selections to pick from	25c each; Per 100	22.00

Terms: Net Cash, F.O.B. N. Y.

Catalogue on request

**Manhattan Phonograph Co.**  
75 East Fourth St. New York, N. Y.

# THE BELL HOOD

Is the Fastest Selling Phonograph Needle Because—

The hood resonator clarifies the vibrations, resulting in best tonal effects. This is the one needle that makes the phonograph human. Everything bell-shape causes the best vibrating forces. Vibrations, when reproduced by Bell Hood Needles, travel through the bell sounding board.

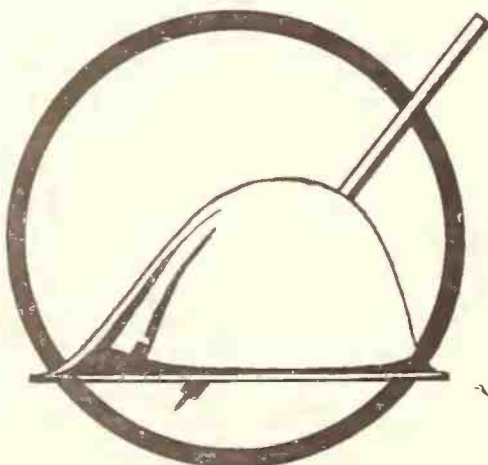

The Sounding Board Bell Produces the Best Result

Advantages of the Bell Hood Needle

Plays 50 to 100 Records—Eliminates Scratching—Purifies and Humanizes the Tone.

Retails one package of 3 Needles for 25c. Dealers' prices, \$15.00 for 100 packages.

**New England Musical Instrument Trading Co.**

PHILIP JACOBSON, PROP.

Exclusive World Distributors

127 East 23rd Street

Jobbers of a Complete Line of Musical Instruments and the Famous NEMITCO Brand of Violin Strings

NEW YORK

Representative for Dominion of Canada  
ARTHUR K. KEMPTON  
Suite 205, Drummond Bldg., Montreal, Quebec.

Sole Representative for the State of Pennsylvania  
NON-LEAKABLE PEN & NOVELTY CO.,  
Abbott Building, Philadelphia, Pa.

Pat. Sept. 24, 1912

Semi-Permanent Point Needle

The following are some of the distributors of the Bell Hood Semi-Permanent Point Needle:

#### NEW YORK CITY

Winterroth & Co., 141 West 42d St., and all their seven branches.

Union Talking Machine Co., Ave. B and Second St.

Charmaphone Co., 39 W. 32d St.

European Phonograph Co., 170 Ave. A.

James Cavalaro, 5 East 14th St.

J. Klein, 28th St. and Second Ave.

Webster Music Store, 2561 Webster Ave.

L. Gendel, 544 W. 207th St.

Wallace Liberty, 25 E. Fordham Road.

C. Rubino, 596 8th Ave.

Conrad Schmidt, 44 W. 125th St.

Electric Shop, 895 Broadway, Brooklyn, N. Y.

B. E. Peebles, Adams, Mass.

A. Mussal, East Orange, N. J.

J. Blum, New Brunswick, N. J.

Geo. Cook, Ticonderoga, N. Y.

M. Steinert & Sons (in all their branches).

J. Gaynor & Co., College Point and Flushing, L. I.

Westchester Music Store, 761 Westchester Ave., Bronx, N. Y.

Ph. Pravder, Inc., New Rochelle, N. Y.

Newark Music Shop, Newark, N. J.

Behrend's Music Store, Newark, N. J.



necessitate their carrying a complete stock of machines at their Spokane branch for distribution throughout this territory. All Pathé business, however, is still transacted at their Portland house—the Spokane branch simply carrying a stock and shipping the machines on instruction from Portland. This will give dealers throughout this territory exceptional service and enable them to replenish their Pathé stock promptly.

The talking machine department of Powers Furniture store is selling more Victors and Brunswicks than ever before. The summer trade has been excellent. Wheeler Dodds, manager of the department, having put in his order far ahead, has on hand a good supply of Brunswicks. Red Seal records are selling rapidly and in large numbers.

In the Meier & Frank talking machine department are found many buyers of portable machines. While small machines have always been in big demand during vacation time, there has never been anything approaching the demand of the present season. The Victrola Outfit for \$33.50 is a style that is very popular and the Grafonola outfit for \$41.00 is another portable style in big demand.

Miss Genevieve McCormick, daughter of S. J. McCormick, is assisting her father in the Columbia Grafonola Shop during part of her summer vacation.

Miss M. E. Johnson, of the Columbia Grafonola Shop, is spending her vacation at the beach at Seaside, Oregon.

The sudden death of Genevieve, the nine-year-old daughter of E. B. Hyatt, of the Hyatt Talking Machine Co., was a great shock to the friends of Mr. Hyatt and family. Genevieve was an attractive child of unusual promise. She was injured on Saturday, July 12, and died the following day. The funeral on Tuesday was largely attended and the floral offerings many and exceedingly handsome.

Midsummer musical matinees are being given in Recital Hall of Oregon Eilers Music House. Invitations are extended to these informal affairs, which are given on Tuesdays, Wednesdays and Thursdays. These recitals are proving very popular with music lovers in this city.

A. R. McKinley, local manager of the Brunswick Phonograph Co., is having trouble in supplying dealers with machines. The local house are now selling more than they can get. The new factory which has just been opened in the East will relieve the situation and the output will be doubled in the next sixty days.

E. W. Barlow, vice-president and manager of the Pacific Phonograph Mfg. Co., says that they have purchased the right to manufacture the patented features of the Stradivara and also to use their trade name. They are at present putting out fifty machines a day and will increase the output 50 per cent. this fall, perhaps more than that by January 1, according to plans now under consideration.

Frank E. Conan, secretary of the Wakefield Music Co., left for the East for the purpose of selecting phonograph hardware and to see about the manufacturing of carved cabinet styles for the new Cremona phonograph. He will visit Chicago, Jaynesville, Wis.; Holland, Mich., and Grand Rapids in an effort to secure the desired styles.

Mrs. Olga Moreland, who for years has been prominent in the Columbia Graphophone Co., is rejoicing over the return of her son, Albert J. Moreland, from France. He was with the 148th Field Artillery and was one and a half years in France and five and a half months in Germany.

Difficulty in obtaining shipments of sheet music and records from the East apparently is ended, according to Taylor C. White, of the Remick Song and Gift Shop.

# The ACME of Perfection

in tone reproduction is attained in the ACME soundbox, because of its scientifically correct diaphragm construction which produces the real scientific sound waves.

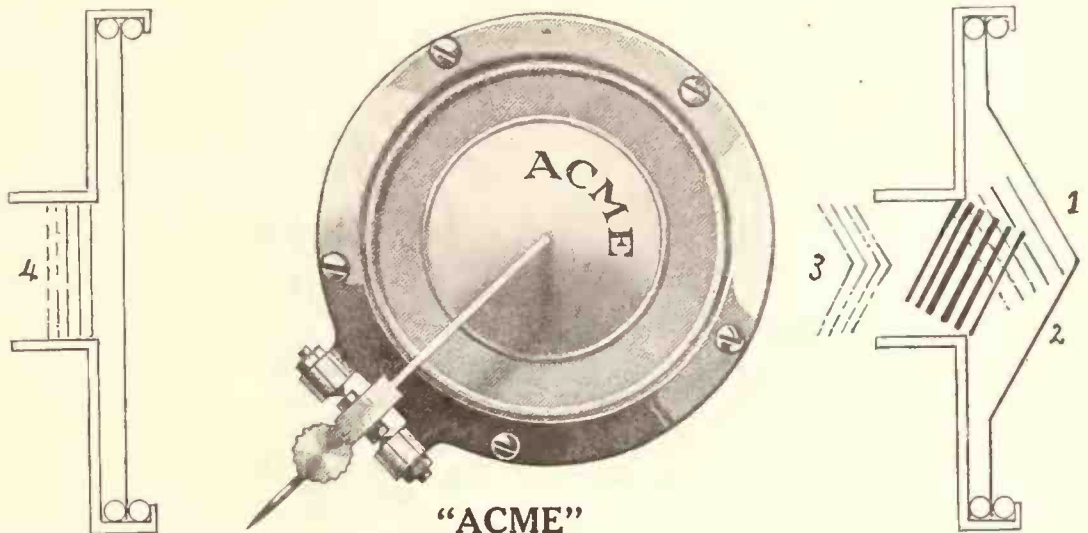

This illustration shows the short tone waves of the ordinary soundbox as used on most phonographs.

**"ACME"**  
**The Tone Magnificent**

Nature's tone wave as produced by the ACME reproducer and approximately six times longer than tone waves of the ordinary soundboxes.

The result is an unmuffled NATURAL TONE of immense volume and an entire absence of that tin can, metallic tone of mica diaphragms. Made in Nickel and Gold to fit Victor, Columbia and Sonora.

## SPECIAL ATTACHMENTS to play Victor and Columbia Records on EDISON Machines

Try an ACME reproducer for yourself. If not delighted you may return it. The price is right.

## TALKING MACHINE MANUFACTURERS

Let us make your Sound Boxes for you  
Any type of reproducer made to your specification  
We manufacture a complete line of Sound Boxes  
with Mica or Composition diaphragms

## Acme PHONOGRAPH CORPORATION

New York City :  
46 Murray Street  
Tel. Barclay 7633  
Tel. Barclay 7634

Chicago :  
431 S. Dearborn St.  
Tel. Harrison 8021

### WHAT HAVE YOU TO SELL ?

We purchase in any quantity, anything you have for sale in the talking machine industry. The larger the quantity the better we like it. We can use cabinets, motors, tone arms, reproducers, springs, tabulators, micas, machine screws, wood screws, etc., etc., in job lots, or regular merchandise if the price is satisfactory. Get in touch with us on anything you have to sell.  
**LUCKY 13 PHONOGRAPH CO.**  
46 East 12th Street, New York





**Columbia dance records are up to date. So are the organizations which make them.**

**Columbia Graphophone Co.  
NEW YORK**

## DROP IN CANADIAN CURRENCY HURTS BUFFALO TRADE

The Charging of Exchange on Canadian Money Serves in Measure to Discourage Purchasers From Across the Border—Trade Interested in "Own Your Home Campaign"—Recent Happenings

BUFFALO, N. Y., August 8.—This city is seeing wonderful developments in the talking machine trade these days. It is predicted that this advancement will be still greater as soon as stock conditions improve. Citizens and visitors alike comment most favorably on the fine facilities and artistic interiors of some of this city's retail talking machine stores. Other improvements along this line are under way and will soon be completed. One local jobbing firm has developed its talking machine trade to such an extent that a new business block was needed to meet its requirements. When all improvements are made to this building it will take its place among the finest structures in the heart of Buffalo's business district. These and other improvements in the trade prove that the leaders in the business are only keeping pace with the public's demand for high-class talking machines and records.

Canadian customers have always been active purchasers of records in the local talking machine stores. Just now, however, a complication has arisen in regard to the circulation of Canadian money at local business places. The reason is that the banks of Buffalo have decided to charge exchange on all Dominion money. For many years Canadian coin passed current on the frontier, but the Canadian dollar is now worth only ninety-five cents in American money at local stores. The rate of discount on Dominion coins less than a dollar is much heavier than on larger sums. This is to enable Buffalo merchants to do their part in checking the inflow of fractional Canadian silver. At the local talking machine stores customers are demanding American money exclusively and are wary of coins with the King's

picture on them. It is said the lowered buying power of the Canadian dollar will for a time keep customers from that country from stores on this side of the border.

Foreign workmen and negroes living at Lackawanna, a Buffalo suburb, where the Lackawanna steel plant is located, are drawing big money these days and, despite the H. C. L., seem to have plenty of money to pay for first-class talking machines and records. Local merchants give a number of instances where these workmen tender satisfactory checks to cover the cost of their purchases at the talking machine stores.

Most of the Victor dealers have not been content with merely announcing the reduction of the price of Victor Red Seal records. They have been receiving fine results by giving this line extra window display and newspaper advertising.

Kuhn Bros., located at Elmwood avenue and Utica street, Columbia dealers, announce that Harold E. Kuhn, a member of the concern, recently returned from France. For a time he was a prominent member of a military band at the front and later was a dispatch bearer. Frank W. Kuhn is the other active member of the firm. For years they played in Kuhn's orchestra, a well-known local organization established by their father.

C. A. Ford, assistant manager of the Robert L. Loud Music Co., has returned from a fishing trip to Canada.

The main floor of the store of Victor & Co., who handle the Pathéphone, is being extensively remodeled. When the improvements are completed they will have some of the handsomest and most up-to-date display rooms in the State.

The suite of offices will be twice as large as formerly and this will be accomplished without curtailing the main floor display space. A big horseshoe balcony of rich mahogany will be the most attractive feature of this new arrangement.

The Buffalo Chamber of Commerce is planning an "Own Your Home" campaign. Local talking machine dealers believe the drive will considerably increase the talking machine and record trade in this city.

Portable talking machines and records have commanded a ready sale among local vacationists. There has been a heavy rush of tourists to Buffalo on account of peace times. Many of the visitors, who visit Niagara Falls or nearby lake and river resorts, buy records at the stores here. The purchasers also include thousands of Buffalonians, who missed their vacations during the war and are flocking to the summer resorts. It is expected that the tourists' trade will be especially heavy in August.

J. F. Huber, of Denton, Cottier & Daniels, has returned from an auto trip with his family to the White Mountains. Vacationists from this store include George Webb and A. Simonds.

Nearly all the downtown talking machine stores are closed all day Saturdays in July and August. Five days of concentrated selling is therefore the rule during the remainder of the week.

OkeH record dealers in the Buffalo territory are appreciating the monthly trade bulletins which they are receiving through the jobbers. These bulletins supplement the OkeH catalogs, advance notices and other advertising matter.

"Ready for Business" is the latest slogan which W. D. & C. N. Andrews, talking machine jobbers, are using in their palatial new business home at Court and Pearl streets. A beautiful new entrance has been built in the new building. Features of the entrance are marble floors



**WE ARE LOCATED AT OUR  
NEW HEADQUARTERS**

**WE HANDLE EXCLUSIVELY  
VICTOR PRODUCTS  
AND ACCESSORIES**

**WE ARE WHOLESALE ONLY  
WE SOLICIT YOUR BUSINESS  
GIVE US A TRIAL ORDER**

**W. D. & C. N. ANDREWS**  
COURT and PEARL STREETS      BUFFALO, N. Y.



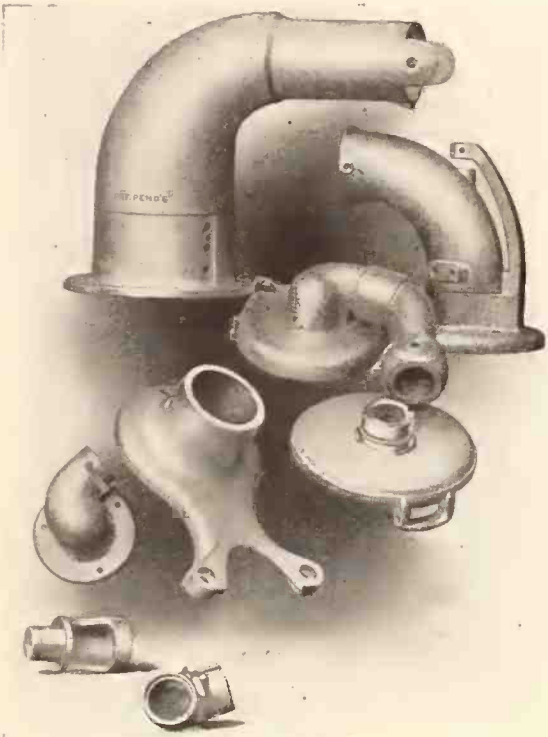

# DOEHLER DIE-CASTINGS

are produced by the leading and largest concern of its kind in the world; by an organization whose sole and undivided efforts are devoted to the manufacture of Die-Castings exclusively.

Doehler Die-Castings are produced from virgin metals of our own alloying, and as a result of formulas especially developed for their use all talking machine parts of our manufacture are readily plated in Nickel or Gold in a most satisfactory manner by the usual electroplating methods.

Our resources and facilities enable us to offer to die-casting users the advantage of a Quality Product, an unflinching Service at an attractive Price.

## DOEHLER DIE-CASTING CO.

MAIN OFFICE AND EASTERN PLANT  
BROOKLYN, N.Y.

WESTERN PLANT  
TOLEDO, OHIO.

SALES OFFICES IN ALL PRINCIPAL CITIES

and marble sides and rich woodwork of quartered oak. A new sign carrying the firm's name as well as the famous Victor advertising appears on the Court and Pearl street sides of the building.

### INCORPORATED FOR \$750,000

The Universal Phonograph Co., Seattle, Wash., has been incorporated with a capital stock of \$750,000. The incorporators are C. B. McCoy, H. J. Farrar and D. P. Witherbee.

Time to be thinking about holiday stock. Don't you think so?

### L. M. COLE IN NEW YORK

Well-known Buffalo Man Visits Metropolis on Important Business

L. M. Cole, manager of the Hoffman Piano Co., of Buffalo, was a visitor in New York this week. Mr. Cole made the trip to the metropolis on important business and upon his return stopped off to visit many New York State dealers. He stated to a representative of The World that the distribution of Okeh records has become more widespread than ever, and that the sales of the dealers who are handling them are constantly on the increase.

### ALBUS T. M. CO. IN NEW QUARTERS

The Albus Talking Machine Co., Louisville, Ky., is now installed in its new quarters in the Doyle Building, at 514 East Market street. The new location has double the floor space available in the former store and a good business is expected the coming year. Plans are now under construction for a new store on West Market street which will be under the direction of L. B. Judd. In addition to Columbia Grafonolas and records, a large stock of Q R S music rolls is carried by this concern and the demand for these rolls has grown to substantial proportions.

## The Wooden Tone- Arm

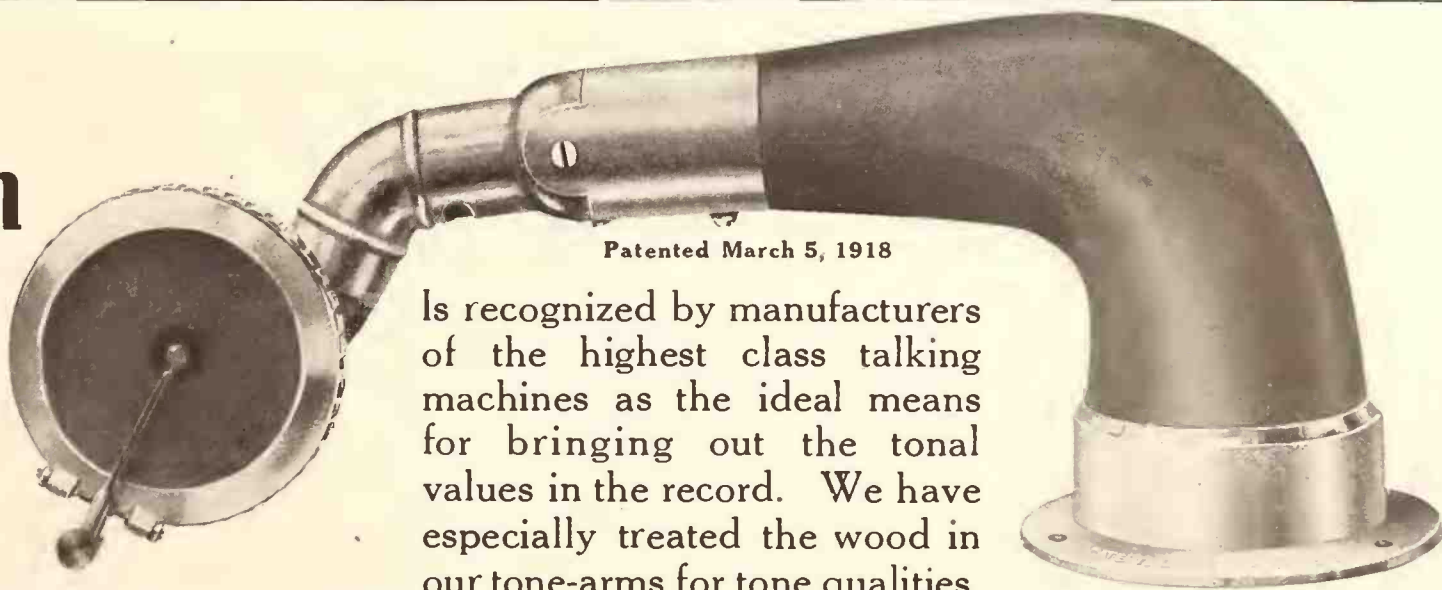

Is recognized by manufacturers of the highest class talking machines as the ideal means for bringing out the tonal values in the record. We have especially treated the wood in our tone-arms for tone qualities.

Exclusive Territory Can Be Had—Address

The wooden tone-arm is a strong selling point in talking machine sales. Can be had in all finishes. Sample \$6.

## MANHATTAN PHONO PARTS CO., Inc.

145 West 45th Street

New York City



**BRIGHTSON PURCHASES NEW ESTATE**

President of the Sonora Phonograph Sales Co. Has Magnificent Home, Which Is Ideally Located at Oyster Bay in Long Island

Geo. E. Brightson, president of the Sonora Phonograph Sales Co., Inc., New York, recently purchased a large estate adjoining the property which he has had for several years at Oyster Bay. This property, in connection with his previous holdings, gives him title to between forty and fifty acres of land on a peninsula called Central Island, opposite Sagamore Hill, which comprises between four hundred and five hundred acres. His estate is most charmingly private, the region being accessible by only one road.



The Home of Geo. E. Brightson at Oyster Bay, L. I.

The house, which is located on an elevation of several hundred feet, has a commanding view,

which can hardly be equaled the entire length of the sound. There is a view of Portchester, Greenwich, Stamford and Norwalk on one side, with a full view of Cold Spring Harbor on the other, and Oyster Bay on the third, the whole making a magnificent panorama. Mr. Brightson's home, the illustration of which gives only a poor idea, is an imposing structure of stone

and is one of the many points of interest in that Long Island town, famous as the home of the late ex-President Roosevelt

**GREAT INTEREST IN SALESMANSHIP**

Half a Million Soldiers and Sailors Have Read William Maxwell's Books on Salesmanship—Edison Co. Offers Bonus to Dealers

That there is a huge interest among soldiers, sailors and marines in the subject of salesmanship is evidenced by the royalty statements just received by William Maxwell, vice-president of Thomas A. Edison, Inc., covering his three books on salesmanship, viz., "If I Were Twenty-one," "The Training of a Salesman" and "Salesmanship." These statements cover the period beginning with the armistice and extending to August 1. They show greatly increased sales to the A. L. A. and Y. M. C. A. since the armistice, indicating that so soon as the soldiers realized that the war was over they began to ask for books which would be helpful to them in civilian life and that the subject of salesmanship is one which has engaged the interest of a large number. Several thousand copies of these books have been purchased for the army during the past few months and it is estimated that the books in question have been read by at least 500,000 young men—in other words, that there are 500,000 ex-soldiers who would like to become salesmen. Out of this huge number it should certainly be possible to pick some exceptional men.

The Edison Co., still further to promote the employment of soldier-salesmen, is offering a bonus to dealers, which enables a dealer to make the experiment of hiring and training a man at practically no cost to himself. This stimulating offer should bring about most satisfactory results.

**INCORPORATED**

The Masterphone Phonograph Co., East Liverpool, O., has been incorporated at a capital of \$15,000 by S. T. Herbert, E. L. Bradford, F. P. Geiger, J. V. Hughes, John Stamm and R. J. Thompson.

**ENTER TALKING MACHINE FIELD**

Perfection Talking Machine Co. to Market the "Oranola" Very Shortly

A new entry into the ranks of phonograph manufacturers is the Perfection Talking Machine Co., Inc., 129 DeGraw street, Brooklyn, N. Y., who announce their plans to market a talking machine called the "Oranola." The manufacturers of the machine are a firm of cabinet makers who have had over thirty years' experience in manufacturing of cabinets for talking machines and other purposes.

According to the officers of the company, in the new product the horn is constructed first

and a cabinet built around it on lines that make for greatest harmony. It is announced the cabinets will be constructed under certain patents now pending, and which it is thought will prove of great value to the trade.

The firm at the present time will make but one model, a floor cabinet machine, but it is their intention to manufacture several higher-priced models in time for the holiday trade. They will confine themselves to machines of the better sort.

The Aaron Co., Connellsville, Pa., has purchased the retail Victor shop formerly conducted by C. M. Hyatt and propose developing this business in a big way.

Remember—

**ALBANY**

*"for capital service"*

ON

**RED SEAL RECORDS**

*This Map Shows Our Exceptional Shipping Facilities*



*Seven Railroads  
Two Barge Canals  
One River*

FROM US TO YOU

**THE GATELY-HAIRE CO., Inc.**

*Victor Distributors*

121 N. PEARL ST.

JOHN L. GATELY, Pres.

ALBANY, N. Y.



# Prices on the New WILSONIAN will advance September 1st

All orders received before  
September 1st will be filled at  
the old prices shown below.

Since the new Wilsonian made its initial bow, the price of labor and materials has been advancing steadily. But even in spite of rising costs the old price has been maintained. Now, however, in order to keep up that high standard of quality which so quickly popularized the new Wilsonian, it has become necessary to advance the price on all models.

It is a satisfaction during these uncertain times to know that you can depend upon the maintenance of high quality standard. The Wilson trade-mark is *your* guarantee that the sterling quality of the new Wilsonian will *never* be lowered.



Here are the old and the new prices:

	Old	New
WILSONIAN III . .	<b>\$ 90.00</b>	<b>\$100.00</b>
43 in. high, 18 in. wide, 20 <sup>3</sup> / <sub>4</sub> in. deep. Mahogany, Golden and Fumed Oak.		
WILSONIAN IV . .	<b>110.00</b>	<b>125.00</b>
45 in. high, 20 <sup>1</sup> / <sub>4</sub> in. wide, 21 <sup>1</sup> / <sub>4</sub> in. deep. Mahogany, Golden and Fumed Oak.		
WILSONIAN V . . .	<b>135.00</b>	<b>150.00</b>
47 in. high, 21 <sup>1</sup> / <sub>4</sub> in. wide, 22 <sup>1</sup> / <sub>4</sub> in. deep. Mahogany, Golden and Fumed Oak.		
WILSONIAN VI . .	<b>160.00</b>	<b>175.00</b>
49 in. high, 22 <sup>1</sup> / <sub>4</sub> in. wide, 23 <sup>1</sup> / <sub>4</sub> in. deep. Mahogany, Golden and Fumed Oak.		

Remember the new prices are effective September 1st. Take advantage of the old prices NOW. Write or wire your order at once.





# IMPORTANT NOTICE

## TO THE AMERICAN TRADE

**The Sterno Manufacturing Company**  
19 CITY ROAD . . . . . LONDON, E. C. ENGLAND

Manufacturers of the world known COMPACTOPHONE—the most complete portable gramophone extant—beg to announce the conclusion of arrangements for the EXCLUSIVE SELLING RIGHTS IN THE UNITED STATES OF THE

**High Grade Motors** <sup>Manufactured</sup> **By** **Mermod Freres** <sup>St. Croix</sup> <sup>Switzerland</sup>

### WONDERFUL MECHANISM

These motors represent the acme of workmanship and quality. Each part is made to the finest gauge limits and assembled to run with the precision of a watch—silent and true. Messrs. Mermod Freres is an old established Swiss manufacturer. Back of their motors are years of hard practical experience. The experimental stage was left behind a decade or more ago. Reliability and quality is therefore assured.

### DIFFERENT MODELS

Mermod Freres motors comprise several types—single and double spring worm and pinion-gear drive, the very latest and scientific method of construction.

### CONSULT US

Before placing your orders elsewhere consult us as to prices and terms of trading. We are out for quick shipments and prompt delivery direct from the factory to the buyer.

### SPECIAL TERMS TO JOBBERS

Within the near future it is proposed to establish  
**A CENTRAL DISTRIBUTING DEPOT IN NEW YORK**  
Meanwhile trade enquiries should be directed to

**THE STERNO MANUFACTURING CO.**  
19 CITY ROAD . . . . . LONDON, E. C. ENGLAND



**EDISON'S MESSAGE APPROVED BY EDITORIAL WRITERS**

Many Newspapers Throughout the Country Comment Approvingly on Views Concerning Labor and the Square Deal as Expressed by Mr. Edison's Message to Recent Dealers' Convention

The words of optimism and sound common sense contained in Mr. Edison's message to the Dealers' Convention recently held in New York have created a profound impression on the press of the country. He has been quoted editorially in the great newspapers all across this broad continent. In speaking of the message the Boston Post said:

"Thomas A. Edison has provided a cure for radicalism. He declares the square deal is fatal to the cult, and reasoning men must agree that there is real virtue in his conclusion that, as our Government is founded on the idea of giving everybody a fair show, therefore our Government is only to adhere to the principles established by its founders to eliminate the demagogues and stiff-neck reactionaries from any prominence whatever in our public life.

"There is a new order of things," the famous

inventor said, 'and the ultimate result is going to approach more closely a square deal for labor, for capital, for the merchant, for the farmer, for everyone.'

"This is simply saying that all which is necessary is a realization that all men have rights which must be considered and protected, to assure harmony in their dealings one with another. The 'magician' is absolutely correct in his position, for there is really no room for any other kind of life here, where right must and will triumph. The great electrician is also consistent in advising others to do in their dealings with their fellow men what he has always done."

The Zanesville, Ohio, Signal, in an editorial, makes this comment:

"A square deal is fatal to radicalism.' This is a good epigram from Thomas A. Edison, who turns his ability from U-boat destruction to reconstruction. Doubtless a few fools will not know when they are well treated. Just as a rule a square deal embitters nobody. It sounds as self-evident as the axioms of geometry or the first proposition that the shortest distance between two points is a straight line. But all great truths are obvious. Edison never discovered the electric lights or the phonograph until he had traveled a road of thought and came upon them lying before him plainly across the road and he just reached out and picked them up. Perhaps this square deal is the same thing. Everyone who is fair kills a radical before he is born. Justice stopped the greatest war in history."

The Keene (N. H.) Sentinel said editorially: "We have come to expect from Thomas A. Edison a great deal more than wonderful inventions, for, unlike many men of genius in the inventive line, he has a wealth of common sense and an ability to see things as they are in real life. It is for this reason that much attention will be paid to remarks he recently made regarding radicalism, in which he declared that the square deal was fatal to radicalism and that no social revolution can be expected in this country because the Government is founded upon the idea of giving everyone a fair show.

"The veteran inventor sees a new order emerging from the events of the past few years, the ultimate result of which will be betterment all around, for labor, for capital, for the merchant, the farmer and the consumer. In spite of the possibility that radicalism may master a following and that progress may be opposed by some who are unable to keep up with the times, Mr. Edison sees in the end a just basis for relations."

In quoting the message the Middletown, Ohio, Journal said:

"When we see or hear the name of Thomas A. Edison at once we think of electric lights, phonographs and other marvelous inventions.

"In connection with anything the great inventor says or does our minds never would develop a thought which borders on philosophy, and yet at a recent banquet in New York Mr. Edison's statement is a gem, especially just at this critical period in the world's history."

**E. M. HARVEY MADE MANAGER**

Earl M. Harvey has been appointed to take charge of the talking machine department of the Lindsay & Morgan Co., Savannah, Ga., preparatory to an expansion in this department, it was announced recently. Mr. Harvey is an expert in this line, having been manager of the Florida Talking Machine Co., at Jacksonville.

**THOMAS F. GREEN BUYS ESTATE**

Thomas F. Green, general manager of the Silas E. Pearsall Co., New York, Victor distributors, and owner of a handsome estate at Kensington, L. I., has purchased the property adjoining his estate in that suburb.

**NEW COMPANY BUYS MUSIC HOUSE**

Talking Machine Concern Takes Over Business of Dahlberg Music Co. and Incorporates

The Montgomery Talking Machine Co., Montgomery, Ala., which has taken over the business of the Dahlberg Music Co., on Dexter avenue, has filed papers of incorporation with the probate court. It is capitalized at \$12,000. It is understood that W. I. Dahlberg has gone with the Federal Government in the Internal Revenue Department.

The agent of the new company is W. M. Hood, of Birmingham, Ala. The stockholders are E. B. Burton, Roy McCullough and W. M. Hood, all of that city.

B. B. Burton is the president, Roy McCullough is secretary and W. M. Hood is treasurer. All three are members of the board of directors.

Not by standin' still, my friends,  
Not blind economizin',—  
Big business and dividends  
Are made by advertisin'.

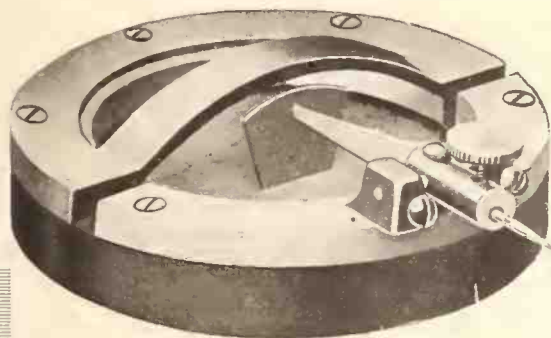

**THE ELLIS Reproducer**

"Humanizes" all standard makes of talking machines or phonographs using disc records.

The trade once thought the retail price too high but the same dealers who once talked this way are pouring in a steady stream of readers.

The ELLIS not only is good but it has made good.

It's a great revivifier of machines that have fallen into disuse. That means more record sales.

We help the dealers sell the Ellis. Let us send you a set of the attractive convincing literature we supply our dealers for distribution to their trade.

The retail price of the Ellis Reproducer is \$10 (nickel); \$12 gold plated.

**J. H. ELLIS**

Patentee and Manufacturer

410 JEFFERSON STREET

MILWAUKEE

WISCONSIN



**What Sells a Phonograph?**

We know this much. Simple beauty and rich finish undoubtedly account for a big share of Singer popularity. Phonographs are seen first.

Then they are heard. The sound makes the final impression. Unexpected clearness, great volume and mellowness are produced from the Singer Tone Chamber. Your trade is delighted—convinced.

The outward appearance of the Singer cabinet can be materially changed by substitutions of various scroll designs and legs. We have adopted the policy of making such changes without extra charge in orders of 100 or more.

Singer cabinets are sold at figures which make an attractive proposition to jobbers selling under their own trade names. Let us quote.

**SINGER TALKING MACHINE CO.**

579 MARKET STREET

MILWAUKEE

WISCONSIN



# QUALITY LEADERS IN THE CABINET FIELD



Style 71.—Mahogany, Golden Oak, Fumed Oak, Weathered Oak. Height 33 3/4 in. Top 17 1/2 x 17 1/2 in. Holds 168 12-in. Records. For Victrolas IV-A and VI-A; Columbia No. 25 and No. 35.



Style 24.—Mahogany, Golden Oak, Fumed Oak, Weathered Oak. Mahogany has Mahogany front door; Oak has Quartered Oak front door. Height 33 in. Top 17 x 17 in. Holds 168 12-inch Records. For Victrolas IV-A and VI-A; Columbia No. 15, No. 25, No. 35.



Style 72.—Golden Oak, Fumed Oak, Weathered Oak. Height 34 in. Top 16 1/4 x 20 in. Holds 180 12-in. Records. Made specially for Victrola VIII-A. Top has countersunk holes to accommodate rubber humpers on machine.



Style 86.—Mahogany, Golden Oak, Fumed Oak, Weathered Oak. Height 30 in. Top 19 1/8 x 22 3/8 in. Holds 96 12-in. Records. For Victrola IX-A; Columbia No. 50; Pathé No. 50.



Style 79.—Mahogany, Golden Oak, Fumed Oak, Weathered Oak. Height 34 in. Top 19 1/4 x 22 3/4 in. Holds 96 12-in. and 96 14-in. Records. For Victrola IX-A; Columbia No. 50; Pathé No. 50.



Style 32.—Mahogany, Golden Oak, Fumed Oak, Weathered Oak. Height 30 in. Top 24 x 20 in. Holds 126 12-in. Records. For Victrolas VIII-A and IX-A; Columbia No. 50; Pathé No. 50, and smaller machines.

**The Geo. A. Long  
Cabinet Company**  
HANOVER, PA.

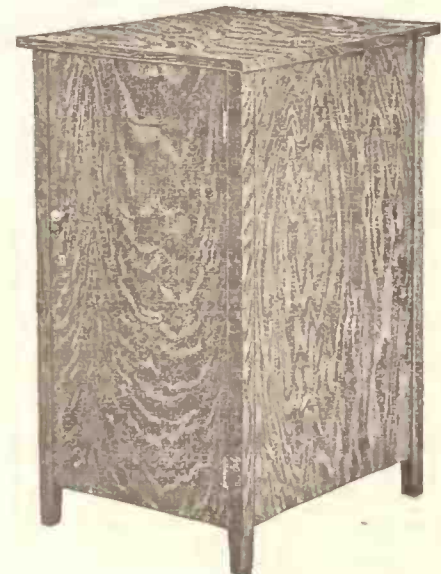

Style 76.—Mahogany, Golden Oak, Fumed Oak, Weathered Oak. Mahogany has Mahogany front door; Oak has Quartered Oak front door. Height 34 in. Top 19 1/8 x 22 3/8 in. Holds 96 12-in. and 96 14-in. Records. For Victrola IX-A; Columbia No. 50; Pathé No. 50.

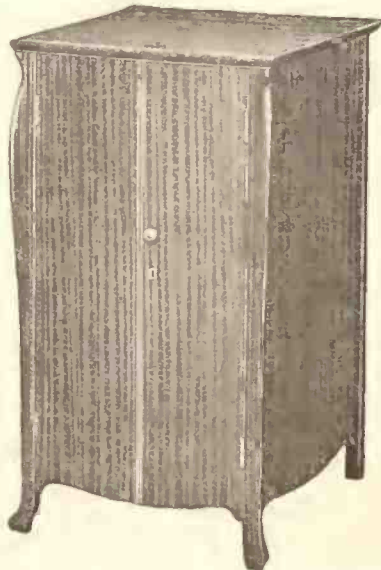

Style 77.—Mahogany, Golden Oak, Fumed Oak, Weathered Oak. Height 34 in. Top 19 1/8 x 22 3/8 in. Holds 96 12-in. and 96 14-in. Records. For Victrola IX-A; Columbia No. 50; Pathé No. 50.



Style 77.—Shows cabinet equipped with top moulding to be used only in connection with Victrola IX-A.

*Prompt deliveries on all orders. Write for Illustrated Catalog of complete line*



# Gleanings From the World of Music

## A BRIGHT FUTURE FOR MUSIC OF THE HIGHER CLASS

Reduction of Red Seal Records Should Lead to a Greater Demand for Good Numbers Sung by Artists of Repute—Music Publishers Giving Heed to the Demand in That Field

The recent reduction of the wholesale and retail prices of Red Seal records by operatic and concert stars has already added greatly to the sale of such works, and this demand will without doubt increase from month to month. The consequences of this demand will force these artists and the record companies to record more and more works, as the sales will justify enlarging that department of their catalogs.

This will increase the interest in standard numbers and will give them such publicity that the publishers will be encouraged to enlarge their advertising appropriations and increase their end of the publicity on such issues.

One of the biggest results of this reduction in the price of the recordings of concert artists and standard numbers will be the increased interest in music of the better grade. There is no doubt that over a period of years it will have a tremendous effect in elevating the musical taste of the average sheet music buyer as well as of the record purchasers themselves.

Already the standard publishers are meeting this move enthusiastically, and they intend to capitalize this additional publicity for their numbers. Their co-operation can only add to the demand to which the move itself gave impetus.

In addition to the publishers of standard music, the houses which in the past have confined themselves to strictly popular works have, during the past season, shown a tendency to open catalogs, the numbers of which are of the better grade. The success of a few houses in this field last season has forced other houses to see the value of publishing standard numbers, and during the coming season many more of the popular houses will issue such works.

Several writers during the past season seem to have felt the public's demand for works of the better sort, and both the lyrics and melodies of last season's issues are of a better grade than formerly. Many of the numbers that are to receive big publicity during the coming fall are of this type, mostly ballads, to be sure, but with lyrics and melodies which should meet with the approval of the musical critics.

The move then, as a whole, means more than the reduction of the price of the works of artists already catalogued. It means that the publishers of such numbers will take new heart, and that the whole field of the publishing and recording of standard works is to undergo a change which, if it does not make such works actual competitors of popular numbers in point of sales, will certainly be greatly felt and will add to the profits of the live dealer. This is

not to be confined to this one season alone, when the reduction of the price itself will be the bait to increase the sales, but with the added interest which will be created this season, and with the publishers and the various recording companies giving more attention to the popularizing of such works, such catalogs will have bigger sales each season.

This does not mean that there will not still be a demand for novelty numbers and the popular jazz; it will be many, many seasons before the demand for such works will be greatly curtailed. As far as the coming season is concerned, when popular numbers are taken into consideration, we are to have a lot of jazz and the craze for this type of song has hardly reached its height—although it may this season. Certainly as far as the song-writers and the publishers are concerned, they intend that we should get our fill.

### Men Who Make Popular Songs

No. 5—Joseph McCarthy

Joe McCarthy probably has written as many songs of great popularity and large sales records as any one song-writer of the present era. For years he confined himself to what are known as popular numbers, but during the last two seasons he has branched out and has written both scores and interpolated numbers for musical productions, and has demonstrated that he can do this successfully.

Last season he had much to do with the musical success "Oh Look" and gave the music lovers of the country that wonderful song, "I'm Always Chasing Rainbows." Another good



Joseph McCarthy

number found in that show was "Typical, Topical Tunes." It is understood during the coming season he will be co-author of several musical shows and it is already rumored that at least one of them has unusually pretty and catchy music. In this season's "Ziegfeld's Follies" he has a ballad entitled "In My Baby's Arms." It is understood this number is to be released to the profession shortly and as it demonstrated in the production that it is a number that is destined to have great popu-

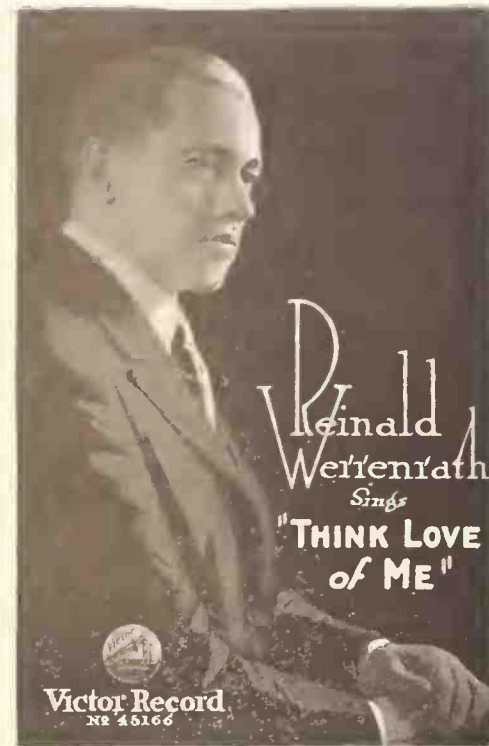

Released on

**VICTOR**  
SEPTEMBER LIST

### The Big Song of the Year

This is the Big Song of the year. Nearly 40 of the greatest concert singers will program "Think, Love, Of Me" all season before hundreds of thousands of music lovers. This record by so favorite a singer as Werrenrath of this popular high class ballad success should be one of the big sellers on the September list.

SPECIAL ADVERTISING MATTER BEING  
DISTRIBUTED TO VICTOR  
DISTRIBUTORS

**SAM FOX PUB. CO.**  
CLEVELAND, O., U. S. A.

larity its success under such conditions is assured.

Among some of the older songs most easily remembered of which he is the author are: "I Want to Go to Tokio." "There's a Little Spark of Love Still Burning." "If We Can't Be the Same Old Sweethearts." "Sweet Cider Time." "That's How I Need You." "I'm On My Way to Mandalay," and "When You're Playing the Game of Love." One of the most successful of all, one that he himself thought was the greatest work that he ever turned out, was "Norway." Shortly after he had written that song he had the following to say:

"Song-writing is surely a gift. Songs are inspired—not built. Thousands of persons can rhyme but not one in ten thousand has the 'knack' of writing popular song hits. Of course I love all my songs—but I love 'Norway' most of all. I really lived this song. I had just met with a painful accident. Doctors were at my bedside. The instant the anesthetic was administered I chanced to look in the doorway. There stood a girl who was very dear to me. She smilingly waved her handkerchief

(Continued on page 148)

Everyone SINGS **FIFER SONGS** Everyone SELLS

### WONDERLOVE

Waltz—Serenade

a high-class waltz song by Harry D. Kerr and H. Joseph Tandler, of Los Angeles Symphony Orchestra. "I've Got a Little Home in the Country," the natural hit, a lyric and a melody that young and old cannot resist.

"When You're Lonely"—(Won't you come back to me) a syncopated ballad. It prompts a tear and tickles the toe at the same time. Featuring Ruth Clifford—Movie Star.

"Clovertime"—A tingling tantalizing tempo.

"The Only Sweetheart I Ever Had"—a sweet and expressive "mother" song.

"The Busted Blues"—A razzzy-jazzy funny no money blues.

"Just for a Place in Your Heart"—A popular-priced waltz song of the better sort.

**C. ARTHUR FIFER MUSIC CO., Inc.**  
Quincy, Ill., U. S. A.



## GLEANINGS FROM WORLD OF MUSIC

(Continued from page 147)

and kept repeating 'Good-bye, Good-bye.' It seemed as though I had visited a strange country where beautiful lights played brilliantly, I saw the midnight sun. Then I awoke. I really thought I had been to Norway."

## SHEET MUSIC SALE WILL GUIDE RECORD DEMAND

How One Victor Wholesaler Provides for Retailers' Estimates Regarding the Probable Salability of the New Record Bulletins—An Important and Valuable Factor

That a study of the sheet music market can prove of real value to the talking machine wholesaler and retailer in offering a guide as to the salability of records bearing popular selections of the day is indicated by the bulletin gotten out each month by the Stewart Talking Machine Co., Indianapolis, Victor wholesalers, in which retailers are advised regarding the special qualities of the new records. In offering the information to the dealer the Stewart Co. relies upon a study of the sheet music trade, as is indicated by the following comments offered by the company and covering the September list of the Victor Co.

"Coming events cast their shadows before"—and there's always a certain amount of satisfaction in looking at the shadow and trying to estimate the size and shape of the object that makes it.

This is no more than an estimate of what the September list will be like. We have not yet heard the records. Following our regular custom, however, we have begun the study of this list from the sheet music standpoint and have canvassed our musical friends for opinions as to how the numbers will go in record form. Sheet music stores have contributed to this article with their testimony as to how the songs have sold in sheet music—a consideration that is of great importance in judging the success of a record.

The September list embraces practically all the good-selling numbers in the music stores to-day. All the sheet music people are extremely enthusiastic over it.

18566—On the "A" side of this record is "My Swanee Home." It's a new one on the sheet music stores; no information could be obtained regarding it. "The Alabama Lullaby," its companion piece, is having a wonderful sale. It is on the same order as "Beautiful Ohio," appealing to folks who enjoy that kind of music. It is a ten-cent piece of music.

18588—This record carries two of the choice numbers from the 1919 "Follies." The price of each piece of sheet music is thirty-five cents, and both are excellent sellers. One store reports that they are the two best-selling pieces of music they have. "A Pretty Girl Is Like a

Melody" goes perhaps a little bit better than the other.

18589—"Anything Is Nice if It Comes From Dixie Land" is on the same line as "Everything Is Peaches Down in Georgia." and other fervent Dixieland expressions. It is a ten-cent piece of music, as is its opposite, "Eyes That Say I Love You." Both are selling well, but nothing to equal the songs carried on 18588.

18590—"You're Still an Old Sweetheart of Mine" is the only one on this record concerning which they could inform us. It was featured last week at the Circle Theatre, Indianapolis, and has been greeted everywhere as a fine number. "The Gates of Gladness" is not yet known by the music stores.

18591—The record is by Henry Burr. On that fact must rest its chief claim to popularity. In sheet music form neither number is going exceptionally. "In the Heart of a Fool" is compared musically with "The Curse of an Aching Heart."

The manner in which the new songs are com-

### WITH STODART PHONOGRAPH CO.

G. H. Beverly Appointed General Manager With Offices at 119 West Forty-second street, New York—Well Known and Esteemed

Geo. H. Beverly, who is well known throughout the piano and talking machine industry,



George H. Beverly

has been appointed general manager of the Stodart Phonograph Co., whose headquarters are now located at 119 West Forty-second street, New York. The Stodart Phonograph Co. was

pared with songs of the same type formerly offered in record form, and therefore familiar to the dealer, adds much to the value of the Stewart Co.'s estimate of the record's salability. Moreover, the opinions appear to be frank, and if the song in sheet music form has not proven a great success the retailer is so advised.

By following the Stewart Co.'s plan of keeping in touch with sheet music sales retailers can acquaint themselves with the possibilities of the new records without waiting for the issuance of any information or bulletin by the wholesaler.

It sometimes happens that a certain number, particularly an instrumental number which has not proven successful in sheet music form simply cleans up as a record, due chiefly to the fact that it may be adapted particularly for orchestral rather than piano rendition and is played by artists of recognized standing. The retailer who is familiar with the popularity of the recording artist should have little difficulty in judging these matters.

formed a short time ago to manufacture the Stodart phonograph. The demand for these machines has become so pronounced that it was deemed advisable to move the headquarters of the company to as central a location as possible in New York City, so that they would be convenient for members of the industry while visiting the metropolis. Mr. Beverly has had many years' experience in the merchandising of musical instruments and is highly esteemed in the trade. He comes to the Stodart Phonograph Co. with a very wide knowledge of the requirements of dealers throughout the country.

### SINGER TALKING MACHINE CO. GROWS

Milwaukee Cabinet Manufacturer Finds Big Demand for His Products of All Kinds

The thriving condition of the cabinet-making industry has made it necessary for the Singer Talking Machine Co., of Milwaukee, to enlarge its manufacturing facilities. Recently this concern moved into new and much larger quarters and with the improved manufacturing conditions it is expected that it will be possible to more than double the output in a short time. The high quality of the Singer products is assuring a continued trade and the steady increase of orders has justified the new expansion.

### TO TOUR EASTERN CANADA

Carolina Lazzari, a favorite Edison artist and leading contralto of the Metropolitan Opera Co.; her manager, Anthony Larney; Verdi E. R. Fuller, director of sales promotion for Thomas A. Edison, Inc., and Mrs. Fuller will tour eastern Canada and Maine during the latter part of August. They expect to make the entire trip by auto and will visit numerous historic places of old Canada.

*The Corley Company*

VICTOR WHOLESALERS

RICHMOND - VIRGINIA



# Read!

E. F. Bitner, Treas & Gen Manager.

Leo Feist, President.

LOCAL & LONG DISTANCE TELEPHONE. With Private Connections to all Departments.

7200  
7201  
7202  
7203  
7204  
7205  
DRYANT



PUBLISHER

## Leo Feist INC.

NEW YORK

231-235 WEST 40<sup>TH</sup> STREET.  
FEIST BUILDING

You can't go wrong with any Feist Song.  
CABLE ADDRESS "FEISTEL"

To Record Manufacturers and Dealers:  
To Roll Manufacturers and Dealers:  
To the Trade in General:

You probably know that "Feist" created the thought of simultaneously advertising "Feist" Sheet Music, YOUR records and YOUR Rolls. This definitely helpful co-operation will be greatly extended in the coming year. I cannot, in this public manner, give you the full details, but I can say that the entire campaign means an expenditure of close to a quarter of a million dollars.

As an indication of its extent, let me mention \$100,000 worth of full pages in practically all the leading magazines during the months of September, October, and November. These will concentrate on the following four songs:

- "Sand Dunes" ----- Song, Fox-trot
- "The Vamp" ----- Song, Novelty, Biggest Dance Hit Since (Poor Butterfly).
- "Lullaby Blues" ----- Song, Waltz Blues
- "My Baby's Arms" ----- Song Hit of Ziegfeld's Follies, 1919

This full page advertising will appear in:

- Ladies Home Journal
- Delineator
- Good Housekeeping
- McCall's
- Pictorial Review

- American Magazine
- McClure's
- Red Book
- Everybody's
- Cosmopolitan

- Woman's Home Companion
- Hearst's
- Vogue
- Metropolitan
- Theatre Magazine

64 Million Readers! Just think what that means to you! Each advertisement will strongly feature these important ideas:

- Get the Music for your piano!
- Get the Records for your talking machine!
- Get the Rolls for your player-piano!

The live manufacturer can therefore reap for himself his share of the results of this big expenditure by featuring, in his own advertising and display matter, the same titles we are advertising so heavily.

If the four Feist-featured numbers are already in your catalog, put on your thinking cap, and oash in on this tip by doing "something unusual" as we are trying so hard to do.

We are boosting your game--boost ours!

Boostingly yours,  
LEO FEIST, Inc.  
By *E. F. Bitner*  
General Manager.

EFB/AH



# Song Lovers! Four New Song Hits

## Accepted by Everybody Everywhere!



**"The Vamp"**  
By Byron Gay

Vamp and sing a-long, Keep a-do-log it,  
Vamp and sing a song, Dont you ru-in it,  
Do a nif-ty step with lots of  
"pup" And watch your rep - u - ta - tion,  
Do a "Bum-ble Bee" buzz a-round a bit.

© Leo. Feist, Inc.

Sh-h-h! B-b-beware of "The Vamp!" After capturing every song center in the West, it is spreading its spell all over the country! "The Vamp" has been appointed the most wonderful song ever written for modern American dancing. Its rhythm is alive! Its melody is bewitching! Its lyric has a chuckle in every line.

A reward is offered to any one who can frown or keep his feet still when the band plays or the singer sings "The Vamp." It's a wonderful dance song—get it before it gets you.



**"My Baby's Arms"**  
By Harry Tierney and Joseph McCarthy  
Staged by Ned Wayburn

My ba - by's arms —  
Hold all my charms, — My ba-by's  
eyes of blue, Just seem to  
thrill me, And fill me with a new sen-sa-tion,  
My ba - by's smile, —

© Leo. Feist, Inc.

If you could hear New York audiences applaud this song at Ziegfeld's Follies and call for encore after encore—you would realize—it's a HIT! And if you could travel from New York to California and stop at all the theatres, restaurants and other song centers between—you would know how fast this hit is spreading.

A sweet, wholesome melody, and cute, lovable words—"My Baby's Arms" is a song you'll love—a song that will make you happier, make the world sunnier. Try it out—buy it today.



**"Sand Dunes"**  
By Byron Gay

Fair - est of flow'rs Is my  
sweet des - sert rose, — And hap - py  
were all the hours, When o'er  
hills of sand we would roam, —  
No clouds or show'rs in this

© Leo. Feist, Inc.

Somewhere down in everybody's heart is a love for oriental song—the weird rum-tum of the tom-tom—the mysterious luring chords of far-east music. That is why "Sand Dunes" is a sensational hit.

With the lights turned low at the end of the day, "Sand Dunes" is soothing comforting, fascinating, good. With the lights ablaze and jazz bands jazzing, "Sand Dunes" is a wonderful dance number, a fox-trot that makes feet step lightly, faces laugh brightly. "Sand Dunes" is a great song—get it.



**"Lullaby Blues"**  
By Al. M. Kendall, J. Russel Robinson  
and Theodore Morse

In the eve - ning, The la - zy South-ern  
moon, In the eve - ning, peeps in the cab - in'  
room, As the soft shad-ows creep, ba-by falls a -  
sleep, While dear Mam-my coos him the "Lul - la - by  
Blues" In the eve - ning, her lit - tle hon - ey

© Leo. Feist, Inc.

The only lullaby ever written to keep folks awake!—"Lullaby Blues." It's a dreamy, soothing tune that makes you feel good, smile and hum and sing and dance. It is a waltz melody truly beautiful that gets right on to your mind and into your heart and stays there.

And as to the words, just recall the songs with which your Mother rocked you to sleep—those are the words, the sentiment of "Lullaby Blues." Try it yourself—get the complete song wherever good music is sold.

### You'll Sing, You'll Dance, You'll Love these Hits from Song Headquarters

THEY have thrilled audiences. They have enthused dancers. They have won the recognition of singers, orchestras and jazz bands—of record makers and player-roll producers. They are truly the new song-hits of the day—the songs that folks will sing, whistle, dance and hum through Fall twilights and Winter nights. You'll fairly love them—their beautiful melodies—their wonderful lyrics.

#### Other Beautiful Feist Songs You'll Enjoy:

- "Thank God You're Here, Mother Mine"
- "A Girl in Chateau-Thierry"
- "Dreaming of a Sweet Tomorrow"
- "Sweet Love Dreams"
- "Persian Moon"
- "Bluin' the Blues"
- "In the Land of Lullaby"
- "Your Heart is Calling Mine"
- "Keep All Your Love for Me"
- "Sweetie Mine"—by Al Jolson
- "Star of the East"
- "Give Me All of You"
- "Sing Me Love's Lullaby"
- "Radiance in Your Eyes"

#### INSTRUMENTAL NUMBERS

- "Aloma"
- "Syria"
- "Djer Kiss"
- "Bells of Bagdad"
- "Klondyke Blues"
- "Laughing Blues"
- "Orange Blossom Rag"

Take this page to your piano and try out these four songs now.

Get them wherever good music is sold, or we will supply you direct at 40c a copy, postpaid. Band or orchestra, 25c each.

Get These Two Big Song Hits—  
"By the Camp Fire" and  
"When You Look in the Heart of a Rose."

LEO FEIST, Inc.  
Feist Building New York City

Get a Record for your Talking Machine



Sand Dunes

Get a Roll for your Player Piano



You can't go wrong with any Feist Song

Whenever wherever Music is played Ask to hear these Feist Songs

One of the full page ads that will tell 64,000,000 people to get these four songs for their pianos, TALKING MACHINES and player pianos.

Nothing Less than full Pages  
September - October - November



One of our big full page ads

## *A Quarter of a Million Dollars to Put Across Four New Song Hits!*

### **Greatest Single Publicity Campaign in Music History**

**T**HE announcement of this campaign has astounded the music world—it has been received with enthusiasm everywhere. Dealers, record and player roll makers, artists—all are preparing to get behind it, to cash in on it, to share in the success it will achieve.

How about you? Will you boost these four wonderful songs—will you back up a wonderful advertising campaign that will sell these four songs to 64,000,000 people through full pages in America's fifteen best magazines in September, October and November?

This advertising is an investment for *you*, Mr. Dealer—its success means business and profits in your pocket. Get behind it—stock the songs—co-operate—boost—"you can't go wrong."

# *Furthermore—*

**A**SIDE from the big campaign described above—in addition to this big investment—Leo Feist is running a special campaign in the Saturday Evening Post for four new popular songs so good, so instantaneously successful, that they deserve publicity all their own. On the next page we reproduce a full page ad from this campaign which will appear in the September 13th issue of the Saturday Evening Post. Its power is apparent. Its success is obvious. The opportunity it offers you is unquestionably great. Cash in on it.

**LEO FEIST, Inc., Feist Bldg., New York**

over!  
Another Great Investment for you!



This full page ad in Saturday Evening Post

# Signal Song Successes

You can't go wrong with any Feist Song

## I Know What It Means To Be Lonesome

By KENDIS, BROCKMAN and VINCENT

CHORUS

I know what it means to be lone - some, I know how it feels to be blue, I know what it means to long in my dreams, for some one, for some - one, I've sighed and I've cried since we part - ed, there's

© Leo. Feist, Inc. New York

Great company for a lonesome piano or a lonesome heart is this "Lonesome" song There never was a sweeter, prettier melody. Nor a sentiment more human. You'll love its memory-awakening, heart-warming charm. Get it today for your piano, phonograph or player-piano.

## JERRY

Words by DANNIE O'NEIL

Music by BILLY BASKETTE

CHORUS

Jer-ry, wild as an-y huc-kle - ber-ry, cheeks as red as an-y cher-ry and eyes of true blue, Jer-ry, tell me why you are con-tra - ry. You know you promised when you war-ra war-ri-or in the war, a war-ri - or yes in-deed you war-ra

© Leo. Feist, Inc. New York

You don't have to be Irish to love this song—though if you are, of course, you'll love it more. A sweet little love ballad with a rare captivating Irish tune and frank true-blue Irish words. Try it—buy it—today.

## I Am Always Building Castles In The Air

Words by TED GARTON

Music by A. FRED PHILLIPS

CHORUS

I am al-ways build-ing pret-ty cas-tles in the air, Sun-shine ev-ry-where, ros-es al-ways bloom-ing, But then the clouds come back and soon the shad-ows gath-er there, hid-ing all my cas-tles in the air.

© Leo. Feist, Inc. New York

You ARE building castles in the air if you think your piano is up-to-date without a copy of this pretty new song-hit—everybody everywhere is singing and dancing "Castles in the Air."

## Ragging The Chopsticks

Words by ARCHIE GOTTLER

Music by ARCHIE GOTTLER and ABE FRANKL

First you play this strain, try it once a-gain, And you'll find you have a sweet re-frain, Then it goes like this, and it goes like that, If you fol-low me you won't go flat, Now comes "chopsticks, ragtime chopsticks" with two fingers just like fiddlesticks, Tick, tick, tick, tick, Like a clock tick, It's an eas-y trick.

© Leo. Feist, Inc. New York

You've heard "Chopsticks" dozens of times—the way every kid plays it. But you never heard it ragged and sung and enjoyed until this new song-hit spread itself over the country. "Ragging the Chopsticks" is a hit! Get it today.

Whenever you go where music is played ask to hear these Four Feist Hits:—

- "Jerry"
- "Castles In the Air"
- "Ragging the Chopsticks"
- "I Know What It Means to Be Lonesome"

HELLO, Music lovers! Here are four messages for you from Song Headquarters! Sh--h-h-- they're in code—you'll have to take them to your piano and decipher them on the key-board with your melody finger. You'll know then that they're messages of joy 'cause they're SONGS—great songs—wonderful new hits just out but already loved and played and danced from the finest jazz palace on Broadway to the humble piano in Home, Sweet Home. These four songs are the biggest instantaneous successes in years—get the complete sheet music today for your piano, a record for your phonograph or a roll for your player piano.

### Music On Sale Now

at all music and department stores or at any Woolworth, Kresge, Kress McCrory or Kraft Store.

### Other Big Feist Song Hits:—

- "Anything Is Nice If It Comes From Dixieland"
- "Alabama Lullaby"
- "Friends"
- "Das Dee Dum"
- "At The High Brown Babies' Ball"
- "Hawaiian Lullaby"
- "Jazzola"
- "Good-Bye Wild Women"
- "Johnny's In Town"
- "In the Old Sweet Way"
- "Moonlight Down In Dixie"
- "Salvation Lassie of Mine"
- "The Rose of No Man's Land"

15c a copy, any 7 for \$1.00, postpaid. Band or orchestra, 25c each. Male or mixed voices, 15c each.

Ask Your Dealer for a copy of Feist's new booklet "Songs for Song Lovers"—in it you'll find a Song for every occasion. If not at your dealer's, send us his name with a 2c stamp and we will supply you direct.

LEO FEIST, Inc., Feist Bldg., New York  
CANADA: 195 YONGE ST., TORONTO, ONT.

Get a Record for your Phonograph



I Am Always Building CASTLES IN THE AIR

Get a Roll for your Player Piano

Your Customers read the Saturday Evening Post—they'll read this ad—want these songs—on September 13th. Be ready for them.



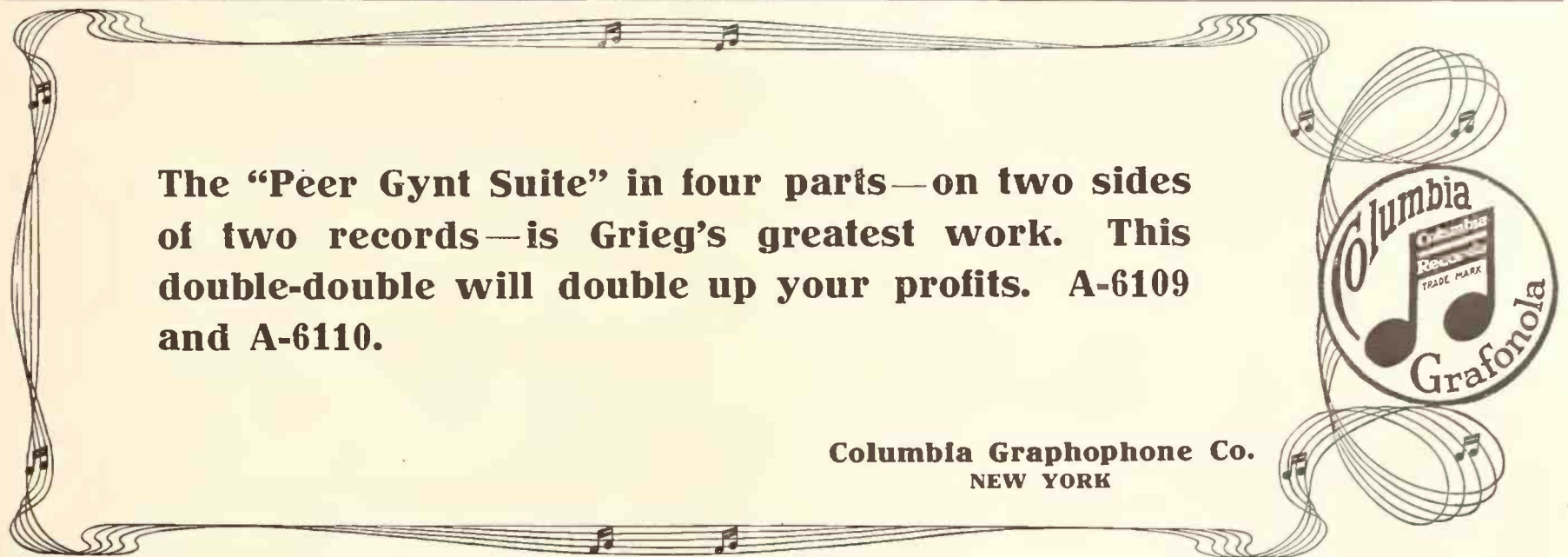

The "Peer Gynt Suite" in four parts—on two sides of two records—is Grieg's greatest work. This double-double will double up your profits. A-6109 and A-6110.

Columbia Graphophone Co.  
NEW YORK

**W. F. STANDKE TO MAKE CHANGE**

Columbia Co. Branch Manager in New Orleans Resigns to Join His Brother in Retail Columbia Business in Kansas City

NEW ORLEANS, LA., August 9.—W. F. Standke, who has been manager of the New Orleans branch of the Columbia Graphophone Co. since 1912, will give up that position this month to enter the retail Columbia business in Kansas City. He expects to leave New Orleans about August 20.

Early this year his brother, O. D. Standke, purchased the retail Columbia store in Kansas City operated as "The Grafonola Shop." This deal is understood to have been consummated largely upon the advice and with the assistance of W. F. Standke, and the latter has just decided to join his brother in the business, both being convinced of splendid possibilities in the retail field of Kansas City.

Mr. Standke has been a Columbia branch manager since 1906, having been stationed in Memphis and Denver before taking his present position here. While still a young man he probably can claim to be one of the oldest Columbia men in point of continuous service, having been connected with the company since 1903. For every day since January 1, 1903, he has drawn pay from the Columbia Co. During the seven years he has been in New Orleans the branch has grown to one of considerable importance, now occupying space of 15,000 square feet at 517-25 Canal street. The branch during the past three years has been doing a jobbing business, exclusively supplying Columbia dealers

in Louisiana, Mississippi and sections of Alabama, Arkansas, Florida and Texas. Mr. Standke said to-day that leading merchants of New Orleans and tributary territory are numbered among Columbia dealers, and he foresees excellent business ahead for the New Orleans branch and dealers in this section. He attributes his success here to the fact that he has given constant personal attention to the problems of the Columbia dealers.

Mr. Standke intimated a progressive and experienced Columbia man will be selected from one of the Southern branches of the Columbia to succeed him as New Orleans branch manager.

**EDISON OFFICIALS RETURN**

Thomas J. Leonard and Robert Michie Enjoyed Vacation Period

Thomas Leonard, sales manager, and Robert Michie, manager of the order and service department of Thomas A. Edison, Inc., have recently returned to the Edison laboratories after their annual vacation. Mr. Leonard and family spent the past month at Bradley Beach, N. J., where he had an opportunity to enjoy to the fullest his favorite sports, swimming, motoring and crabbing. Recently Mr. Leonard was one of the guests at the annual jollification given by Governor William N. Runyon, of New Jersey, at Sea Girt, his summer home, for prominent State members of both the Republican and Democratic parties.

Mr. Michie and family toured the East. They visited Savannah, Ga., Washington, Baltimore and Bangor, Me.

**GETS PRIZE FOR CLEVER SLOGAN**

Mary V. Coddington, Manager of Victrola Department of L. S. Ayres & Co., Indianapolis, Offers Best Reasons Why Advertising Men Should Meet in That City Next Year

INDIANAPOLIS, IND., August 11.—As is generally known, Indianapolis is making a very strong bid to secure the 1920 convention of the Associated Advertising Clubs of the World and a fund of \$50,000 to carry out the plans is now being raised.

It remained for a member of the talking machine trade, however, and a lady at that, to win the silver cup offered as prize for the best reason why the advertising men should select this city as their next meeting place. The prize winner was Miss Mary V. Coddington, manager of the Victrola department of L. S. Ayres & Co., the big department store, and her reasons for the selection of Indianapolis as the convention city were as follows:

"Indianapolis should have the 1920 convention of the Associated Advertising Clubs of the World because more advertising men can get here in less time and at less cost and get more after they come than in any other city on the Western Hemisphere."

Miss Coddington's sister, Miss Clara B. Coddington, received special mention in the same contest.

Tom Griffith, sales manager of the Udell Works, who can claim kinship with the talking machine trade because his company manufactures cabinets, is the chairman of the program committee in the convention campaign.

**NEEDLE CUPS, TONE ARMS, MEISSELBACH MOTORS**

Ask for our prices, lowest prices to quantity users. Ask for samples.

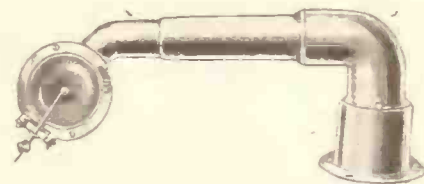

Immediate deliveries of this universal tone arm equipped with extra loud and clear sound box. Samples \$4.25. Ask for quantity prices.

**MAIN SPRINGS**

Following sizes in stock. Any other sizes to order.

1" x 0.20 x 13', for Victor, with oval hole, each.....	0.50
1" x 0.28 x 10', for Columbia.....	each 0.50; per 100.....45.00
7/8" x 0.23 x 10', each.....	0.38
3/4" x 0.22 x 10', Columbia, oval hole.....	0.35
3/4" x 0.25 x 9', oval hole, each.....	0.30
5/8" x 0.22 x 8', each.....	0.27

**MICA DIAPHRAGMS**

1-23/32", Victor Ex. Box, with or without center bole.....	Each 0.15
1 1/8", for new Victor No. 2, very best, with or without center hole..	Each 0.18
1-31/32", for Sonora and all standard soundboxes.....	Each 0.20
2-3/16", for Columbia No. 6, very best.....	Each 0.25
2-9/16", for Pathé or Brunswick.....	Each 0.45

**SAPPHIRE NEEDLES**

Pathé, very best, loud tone genuine sapphire.....	Each 0.27
Pathé, soft tone.....	Each 0.27
Edison, very best, loud tone.....	Each 0.27
Edison, very best, medium tone.....	Each 0.27

**SUNDRIES**

Attachment for Victor Arm.....	Each 0.25
Attachment for Victor Arm, permanent.....	Each 1.15
Kent Attachment for Edison Arm, nickel or gold plated.....	Each 1.75
Kent Attachment for Edison with Sound Box, nickel or gold plated....	2.75
Attachment for Columbia Arm.....	Each 0.25
Green turntable felt, 10" cut.....	Each 0.10
Green turntable felt, 12".....	Each 0.15
Governor springs, for Columbia motor.....	Each 2c; per 100 1.00
Governor springs, for Victor motor.....	Each 2c; per 100 1.00
Motor, double spring Meisselbach No. 12, complete.....	12.50
Motor, single spring, with 10" T. T., each.....	2.25
Tone Arms, style P with mica box, each.....	4.25
Soundbox, "M," fit Victor tone arm.....	1.00
Columbia bevel pinion, No. 12333.....	Each 90c; per doz. 9.00
Columbia driving shaft, No. 11778.....	Each 60c; per doz. 6.60
Stylus Bar (needle arm) for Victor Exhibition Sound Box, complete, Each.....	0.35

**FAVORITE PHONOGRAPH ACCESSORIES COMPANY, 1506 DeKalb Ave., BROOKLYN, N. Y.**



## ANNUAL OUTING OF THE TALKING MACHINE MEN, INC.

One of the Most Enjoyable Reunions of This Organization Held on August 13 at Beach Hill Inn, Rye Beach, N. Y.—Program Called for Action All the Time

The annual outing of the Talking Machine Men, Inc., the organization composed of talking machine dealers of New York, New Jersey and Connecticut, was held on Wednesday of this week, August 13, at Beach Hill Inn, Rye Beach, N. Y. One of the largest gatherings that ever attended an affair of this kind was on hand,



Committee in Charge of the Outing

and the majority of the members and their guests left Washington square in a number of sight-seeing buses. In addition there was a large number of private cars making the trip, starting shortly after 9 o'clock in the morning.

Every one who attended the outing was given a cane with a pennant attached, the pennant carrying the insignia of the association. In addition larger pennants with the same design decorated the various autos and buses. Each individual who attended the affair had a tag attached to the lapel of his coat carrying his name and the firm with which he was connected.

There was no price marked on the tags, however. This was to encourage members who were not acquainted to introduce themselves with little or no trouble.

Upon the arrival at Beach Hill Inn a light luncheon was served, after which a five-inning ball game, between teams of dealers on one side and employes on the other, was played. A series of races then followed, including a 100-yard dash, fat man's race, a 50-yard dash for the ladies and a three-legged race for the dealers only.

On the large spacious dance floor of the Beach Hill Inn numerous couples enjoyed dancing throughout the afternoon, music being furnished by an especially peppery jazz band. Each individual who attended the affair was given a ticket with eight perforated cards, which entitled them to the bus ride, the luncheon, the various games, bathing, boating, fishing, dinner and the theatre. The different attractions were efficiently handled and the committee in charge of the day's activities was roundly congratulated upon the way it conducted the entertainment. Late in the evening a very elaborate dinner was served, the diner having his choice of a shore or a chicken dinner. As the menu of both items was quite inviting many of those who had taken part in the various sports and who had substantial appetites were in a quandary as to just which of the offerings they should choose. However, none were left unsatisfied. Following the dinner there was more dancing, jazz and more jazz.

In the evening those who desired attended the theatre, where both vaudeville and moving picture entertainment was programmed, after which the gathering, following the effects of the strenuous activities of the day, welcomed the announcement of the return of the buses and cars. The outing was without doubt the most

**\$25.**  
**THE COMPLETE OUTFIT.**  
**RETAIL**

**MAKE YOUR OWN Records**  
on your own  
**PHONOGRAPH AT HOME.**

The greatest amusement you have ever had. Phonograph the voices of your family and friends, and play them instantly. No process to learn, no failures; attaches and detaches to your phonograph in an instant—manufactured by

**Audion Phonograph Co., Boonton, N. J.**

successful ever held in the history of the organization and the attendance was beyond the expectation of the most optimistic member of the committee on arrangements. The committee in charge of the affair was J. J. Davin, A. Galuchie, J. Hunt, Cass Riddle, Sol Lazarus, J. T. Coughlin and E. Leins.

### ADAPTED TO THE CHRISTMAS IDEA

How Talking Books Are Peculiarly Adapted to Make a Strong Appeal During the Holidays

The Talking Book Corp., publishers of "talking" books, "talking" figures and "talking" animals, have announced a set of new issues for Christmas.

These attractive "talking" books are peculiarly adapted to the Christmas idea, as they combine a semi-flexible phonograph disc on which songs, recitations, verses, sleigh bells, etc., are reproduced, with pictures in full color and printed stories for the children to read, all forming a complete volume, the book, phonograph record, pictures and all being put on the talking machine.

The corporation is making the most of the opportunity for Christmas goods which their unique products afford by adapting the best of the time-honored, beloved Christmas stories to "talking" book form. The illustrations in full colors for these are setting new standards in excellence as to design and printing.

One of the most popular numbers issued today is the time-honored "Mother Goose Book," with "Peter Pringle," "Old King Cole," "Little Bo Peep" and real nursery rhymes and songs. Another is the beautiful bird book, "Twilight and Dawn in Birdland." This book, illustrated by the famous artist, Willy Pogany, reproduces the various types of song-birds.

### Let Us Make Your Cabinets And Install Your Motors



We know how to build Cabinets, and to construct the horn that will produce a loud tone, yet it comes from the bell of the horn perfectly soft and mellow. Hook the selling force into our Secret of Cabinet building and watch both ends grow.

Write us your wants at once.

**PARAGON MFG. CO., Inc.**  
**HICKORY, N. C.**

## Hill and Dale Record Dealers:-

Double your Record market by having the A.R.L. Attachment put on the VICTOR TALKING MACHINE in your Home Territory

IT MAKES THE VICTROLA A UNIVERSAL MACHINE

Without removing or changing the Sound Box

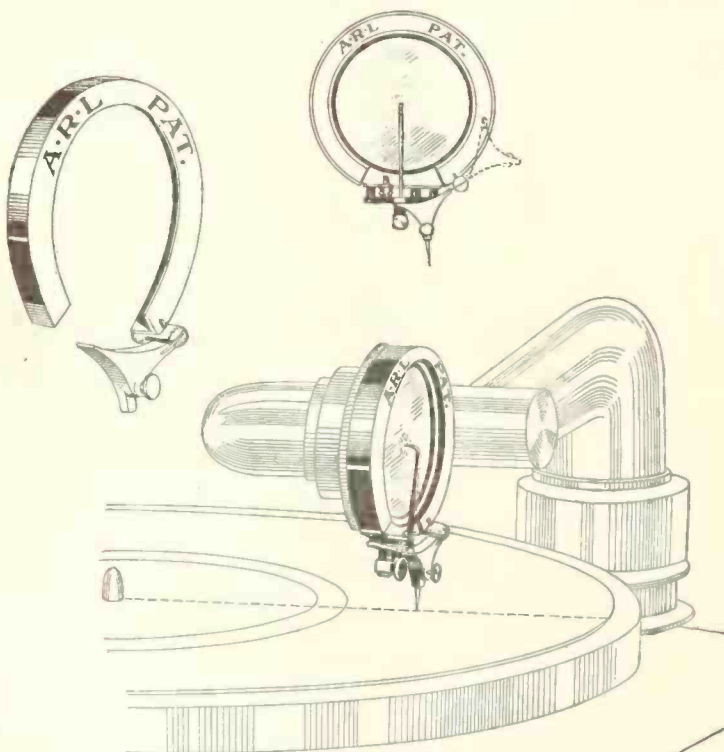

Showing the position of the A. R. L. attachment when Victor is playing Hill and Dale record. Note that the sound box is in the regular position, and needle on direct line with center. It is scientifically and mechanically correct. Either steel or sapphire needles may be used.

So simple a child can attach and operate it.

Remains permanently upon the machine.

Mechanically and scientifically correct.

Plays all types of records in the ONE NATURAL position of the Victor sound box with equal beauty of reproduction.

Protected by patent.

Attachments for Victor Exhibition Box now ready for delivery.

Retails, \$2.00

American Recording Laboratories  
Department 7

56 West 45th Street, New York





Introducing the  
**Tablatone**

(Pat. applied for)

*A wonderful phonograph built in an artistic library table.*

*Musical : Useful : Artistic*

*A phonograph with distinctly original features, finished on all four sides.*

Electrically or spring operated.  
(Batteries furnished with the machine)

DIMENSIONS

4 ft. long, 2 ft. 8 in. high, 2 ft. 1½ in. wide

List Price, \$170

*Dealers: Write for Trade Discount and Exclusive Territory*

**DeRivas & Harris Mfg. Co.**

135th St. and Willow Ave.

New York



## CLEVELAND TRADE PLANNING FOR BIG FALL BUSINESS

Coming of H. J. Shartle Welcomed—Eclipse Activity—Making the Show Window Pay—Records That Are Most Popular—Fischer Co. Renovations—Interesting News Budget

CLEVELAND, O., August 8.—With the midsummer monthly gathering of the members of the Talking Machine Dealers' Association of Northern Ohio over and dealers settled back for fall trade, business conditions promise well in this city. The excessively hot and depressing weather during the latter half of July affected trade, as have the early closing rules of practically all of the best stores. Most of the big department stores and retail furniture emporiums handling talking machines and their accessories close Saturdays at noon. Some of the biggest concerns close all of Saturday and open on Monday. This is true of the May Co. and others handling large stocks of musical instruments. The early closing rule holds good until September 1.

Just now the city is undergoing a spasm caused by the high prices of food and almost every business man is adding his mite to the various movements to try and cut down food prices.

Cleveland's July building record was the banner one in its history, so there is plenty of work for mechanics. Conditions generally speaking in this city are good.

The local trade will welcome the coming of Howard J. Shartle, who is to take service with the Buescher concern about September 1. It is reported he will acquire an interest in the recently organized concern and be general manager. His long service with the Victor Talking Machine Co. will give him prestige with the Cleveland house, which handles Victors.

Cleveland did not have a failure in the talking machine business during the first half of the year. This was also true of the piano and player-piano business. The Caldwell Piano Co. was the only big concern to retire.

The Brunswick phonograph is making an enviable record in this territory, probably because of the push behind the local branch store of the Brunswick-Balke-Collender Co. With talk of a new record to be put forward by this firm the future of the Brunswick phonograph seems doubly assured.

The May Co. has added a fine line of instruments to its musical department, the stock of talking machines, player-pianos and player rolls being the largest the firm ever carried at this season of the year.

The Eclipse Musical Co.'s retail store reports a splendid business in July. Charles K. Bennett, manager of the wholesale and distributing department for this section of Ohio, says that indications for August business never were

brighter, with the prospects of increased stock from the Victor factory. Mr. Bennett is nothing if not optimistic in looking at the talking machine business.

The G. M. Ott Piano Mfg. Co., which recently announced its intention of increasing its capacity for assembling pianos, player-pianos and turning out talking machines, will go ahead with expansion plans this fall. Mr. Ott is well known to the Cleveland trade and has made a success of a venture of which several dealers were very skeptical when he started out on "his own hook," after giving up a good job.

The Caldwell Piano Co.'s big retail store at East Ninth street and Prospect avenue is still an attractive place for talking machines. The Wurlitzer Co., when it took over this store several weeks ago, added to the attractiveness of the ground floor and window display of talking machines and player-pianos.

The Muehlhauser Bros. Piano Co. is offering some attractive bargains in Cheney talking machines. This firm also handles the highest type of Corona machines manufactured.

Cleveland dealers are much interested in the Kelley bill introduced in Congress. They think that the measure affords more protection than the Stephens bill because the new measure provides for the enforcement of the provision regarding resale prices for instruments.

Cleveland dealers were much interested in the article appearing in The Talking Machine World for July entitled "Making the Show Window an Instrument of Profit and Prestige." Dealers in this city have gone about the limit in window space for attractive advertising. Among the firms which make a specialty of this class of advertising are the Harmony Music Shoppe Co., the Wolfe Music Co., Buescher's, the Eclipse Musical Co., the B. Dreher's Sons Co., the Robert L. White Music Co., the Phonograph Record Co., the Starr Piano Co., A. L. Maresh Piano Co., and many furniture stores which carry large side lines in talking machines. These stores are going deeper every month into the talking machine and record business and using considerable daily newspaper space in advertising various makes of machines. Better machines at higher prices are being sold than were offered a year ago, furniture retailers realizing that the talking machine is no longer a mere "catch-penny" instrument for drawing trade in other lines.

Jerome Kern, composer of "She's a Good Fellow," the New York musical hit of this title,

has made a killing with the Cleveland public, but with the coming of prohibition he scored another big success in a song intended to be more particular in a pleasing way, and found popularity in "The First Rose of Summer." This song, reproduced in a Pathé record, is making a big hit here. The Fischer Co., 25 Taylor Arcade, dealers in Pathé talking machines and records, are doing wonders with the record. The Fischer concern has one of the best retail stores in the city, in a much-sought locality downtown.

Other Pathé records now selling well are "Ballyho Bay" and "Take Your Girl to the Movies," by Patricola; "Oh, Lady, Stop Rolling Your Eyes," by Arthur Fields; "You're Making a Miser of Me," by Henry Burr.

Other good sellers are:

Vocalion—"I See My Mother," by Marie Sundelius and Guillo Crimi; "Bells of Bagdad Fox Trot," by the Aeolian dance orchestra; "Arabian Knights One Step."

Victor—"Orpheus Ballet," by Philadelphia orchestra; "Any Place Is Heaven, If You Are Near Me," by Charles Harrison; "When I Found the Way to Your Heart," by the same author; and "The Star-Spangled Banner," by John McCormack.

Columbia—"Mary Ann," by Waldorf-Astoria dance orchestra; "Out of the East," by Fuller's orchestra; "I'll Think of You," by Jockers Brothers; "Muslin Rag," by Prince's band.

Starr—"Friends Medley," and "Fluffy Ruffles," by Green Brothers Xylophone orchestra; "The Two Doctors" and "My Uncle's Farm," by Golden and Hughes; "The Little Whistler," by Sybil Sanderson Fagan.

Edison—"Father O'Flynn," by Arthur Middleton; "My Redeemer and My Lord," by Marie Tiffany; "I've Gwine Back to Dixie," by Maggie Teyte and Lyric quartet; "There's a Wideness in God's Mercy," by May E. Wright.

The Collister & Sayle Co., Victor dealer, is making a splendid window attraction out of records and the Victor trade-mark artificial dogs. The firm is calling attention in a novel way to what the end of the war did in cutting the price of records one-half and scores of the most popular records are displayed advantageously in a large window.

The Wurlitzer Co., which recently moved from Huron road into new six-story quarters in the Euclid building, near the Hotel Statler, is now running in fine order, with a greatly increased stock and much better facilities for displaying instruments of all kinds.

Since its reorganization and a change of name Buescher's has done a big business in talking machines, particularly the Victor make. This store is one of the most attractive to the eye.

## WE HAVE WHAT YOU WANT IN TONE ARMS AND SOUND BOXES

**A Large Tone Arm**—8 $\frac{3}{4}$  inches centre to centre—height 4 $\frac{1}{8}$ ".

**A Small Tone Arm**—8 $\frac{1}{4}$  inches centre to centre—height 3 $\frac{5}{8}$ ".

Both tone-arms scientifically constructed for perfect sound reproduction and finely finished in our own plating plant. They play all makes of records.

**In Sound Boxes.** We have the special No. 3 Hub Cushion Sound Box. A Sound Box of wonderful tonal quality.

Write us for prices and further information

## SUPREME PHONO PARTS CO., Inc.

145 West 45th Street

New York City



Harry L. Feiss, a talking machine sales manager, of Cincinnati, was a visitor in Cleveland, this week.

Charles J. Higgins, of Pittsburgh, was mixing among local dealers a few days during the first week of August.

"Pittsburgh dealers in talking machines are very hopeful," he said. "They now have one of the best organizations in the country in the Talking Machine Dealers' Association of Pittsburgh, whose closing meeting for the summer was held, attended by more than 100 dealers, about the middle of June, at "The Pine," a suburban resort.

W. W. Parsons, Pathé special representative; Charles J. Womeldorf, manager for the Toledo Talking Machine Co.; George W. Hunter, of Dayton, O.; E. G. King, of Williamsburg, O.; and A. R. Polasky, Georgetown, O., were among the out-of-town visitors recently in Cleveland.

A. R. Grinnell, of Grinnell Brothers, Detroit, took a flyer through Cleveland last week.

B. W. Smith, L. N. Bloom and M. R. Kreusch, Clevelanders who attended the second Edison Travelers' Convention in New York recently, say they derived much benefit and got many good ideas out of the gathering.

The Bing Furniture Co., a big downtown concern, is featuring high-class talking machines in its ground floor display stock. Cleveland's talking machine dealers let down somewhat on their daily newspaper advertising during July, but are again coming back into print. Schmidt Brothers, 2063 East Fourth street, report a big July trade.

The Columbia Graphophone Co. and the Cheney Phonograph Sales Co. are preparing for an unusual August and September run of business. The Cheney concern, which distributes Cheney talking machines, is still holding an enviable record for a new concern.

The Phonograph Co., 1240 Huron road, reports prospects for splendid fall sales.

The Western Reserve Music Co., 6311 Euclid avenue, takes its name from Cleveland's big university and the title has made a hit with students and other patrons of the institution.

R. J. Jamieson, manager of the Fischer Co., has been hard at work on plans whereby this concern will greatly enlarge its distribution facilities in Ohio and adjacent territory. The warehouse equipment at 44-46 Vine street has been increased and many new dealers have been lined up for future trade. When the present plans are put into operation the Fischer Co. will have the reputation of being one of the fastest-growing jobbing houses in this section of the country.

**PAYS QUITE A TRIBUTE**

Gomprecht & Benesch, of Baltimore, Write the Manufacturers of the Harponola

CELINA, O., August 1.—The plant of the Harponola Co. in this city is very busy these days with the volume of business received for their product. Edmund Brandts, sales manager of the company, has received many complimentary letters from Harponola dealers throughout the country. Gomprecht & Benesch, Baltimore, Md., who handle the Harponola in a big way, have just written Mr. Brandts as follows:

"We have tried out your product and find that it meets with the approval of the most exacting customer both in tone and workmanship. Your motors have given us absolutely no trouble, and are finely constructed, smooth running and noiseless. Our only desire is that you will be equipped to make large and prompt shipments of future orders."

John Spillane, of the Blackman Talking Machine Co., New York, recently visited Atlantic City, where he attended the national convention of the Elks.

The Smith-Reis Piano Co., St. Louis, Mo., has added a quick service department for talking machines and records.



# Operaphone

**SEPTEMBER, 1919**

POPULAR SONGS OF THE DAY

21117	I'm Forever Blowing Bubbles (Kenbrovin-Kellette).....Lewis James & Charles Hart	
	Hearts (MacDonald-King).....Lewis James	
21118	A Rose, A Kiss and You (Arthur).....Robert Bruce	
	You're Making a Miser of Me (Dubin-Ball).....Henry Burr	
21119	Sipping Cider Thru a Straw (Morgan-David).....Collins & Harlan	
	Katydid Is the Candy Kid (Freeman).....Byron G. Harlan	
21120	Ragging the Chopsticks (Gottler-Frankl).....Arthur Fields	
	Oh, You Women (Green-Step).....Arthur Fields	

HAWAIIAN SELECTIONS

61105	Sweet Lei Lehua.....Louise & Ferera Hawaiian Guitars	
	Whistling and Singing by Irene Greenus	
	Stephanie Gavotte (Czibulka).....Louise & Ferera Waikiki Orchestra	

STANDARD VOCAL SELECTIONS

41105	The Dear Little Shamrock (Cherry).....Charles Hart	
	I'll Sing Thee Songs of Araby (Clay).....Millie Leon	

DANCE SELECTIONS

31113	You Don't Need the Wine to Have a Wonderful Time, from "Ziegfeld Follies of 1919" (Rogers-Arst).....One Step, Castleton's Dance Orchestra	
	Will o' Wisp, from "A Lonely Romeo" (Smith-Franklin-Spencer), Intro, "Candy Jag".....Medley Fox Trot, Castleton's Dance Orchestra	
31114	Down by the Meadow Brook (Wendling).....Waltz, Castleton's Dance Orchestra	
	The Red Lantern (Fisher), Intro, "I Found the End of the Rainbow," Medley Fox Trot.....Castleton's Dance Orchestra	
31115	Missouri Blues (Brown) Fox Trot.....Jazzazza Jazz Band	
	Lassus Trombone (Fillmore) Dne Step.....Jazzazza Jazz Band	

INSTRUMENTAL SELECTIONS

51113	Bullets and Bayonets (Sousa) March.....Operaphone Military Band	
	The Nightingale and the Frogs (Eilenberg) Characteristic.....Operaphone Concert Band	
51114	Fauns and Wood-nymphs (Dnlvas) Danse Pastorale.....Operaphone Concert Orchestra	
	Starlight (Johnson) A Serenade.....Operaphone Concert Orchestra	

SACRED SELECTIONS

71101	Sweet Hour of Prayer (Bradbury).....Maude Gordon	
	Lead Me, Saviour (Davis).....Stanley Mackey	

RECORDS

OPERAPHONE CO. INC., LONG ISLAND CITY, N. Y.

**24 NEW TITLES EVERY MONTH**

**Operaphone Records Play on All Talking Machines Without Attachments**

**ALL THE LATEST POPULAR HITS—THE VERY NEWEST SNAPPY DANCE RECORDS**

*Write for Your Nearest Distributor*

**OPERAPHONE CO., Inc., Long Island City, N. Y.**



# *You Ought to Know*

In case you are contemplating expanding the sphere of your business to include departments devoted to Pianos, Player-Pianos, Musical Merchandise or Sheet Music, that you'll find news and comments about them all in



ESTABLISHED 1876

The oldest and leading music trade weekly, which covers every branch of the industry.

## **It Contains**

*instructive and educational articles. Hints on salesmanship and advertising. Editorials that are timely and authoritative. Facts about the new things in the trade. Trade happenings in all parts of the United States.*

***“Review the Music Trade With Us”***

*Send your \$2 now for a full year's subscription to*

**THE MUSIC TRADE REVIEW**  
373 FOURTH AVENUE NEW YORK



## REPAIRS

TALKING MACHINE TROUBLES AND HOW TO REMEDY THEM

Conducted by Andrew H. Dodin

[This department of The Talking Machine World is designed for the service of all classes of our readers, including those who make, and those who sell, talking machines. Andrew H. Dodin, who conducts this department, has a wide and enviable reputation as a repairer of talking machines and conducts an exclusive talking machine repair shop at 176 Sixth avenue, New York. Tell him your troubles through The World and he will help you if possible. The service is free.—Editor.]

### SUPPLIES OF STEEL SPRINGS

Richmond, Va., July 19, 1919.

Editor Talking Machine World.

As I conduct quite an extensive repair shop for phonographs, kindly advise me regarding the name of manufacturers of springs.—Manly B. Ramos.

Answer—I feel sure that the Schwartz-Hermann Steel Works, Inc., 55 Liberty street, New York, will be able to supply you with any size and amount of steel springs you may require to meet your needs.

### Wants Concert Phonograph

85b Cato Road, Clapham,  
London, Eng., July 28, 1919.

A. H. Dodin, New York.

I am a buyer of Edison Concert phonographs and shall be glad to hear from you where you can obtain them in perfect condition, either new or second hand. Any job line in Edison goods interests me, but in records, disc or cylinder, I only buy grand opera and instrumental and nothing in damaged condition.—J. de Toro.

Answer—I do not know personally of anyone who has on hand Edison Concert phonographs, either new or second hand. I am publishing your letter in this column with the hope that some of my readers may be able to be of service to you.

### ANNOUNCE THE TABLATONE

DeRivas & Harris Mfg. Co. Making Talking Machine in Library Table—Superior Workmanship Throughout Is a Feature

The DeRivas & Harris Mfg. Co., 135th street and Willow avenue, New York, announce this month the "Tablatone," a phonograph which is built into an artistic library table in such a manner that the top of the table does not have to be disturbed in order to play the machine. The design is of the Queen Anne period and the cabinet work is of the highest quality, a dull finish being used. The machine is finished on all four sides so that it may be used as a library table in the centre of the room. In one side of the "Tablatone" are two doors which open out one containing the tone arm and turn table and the other a compartment for the filing of records. The machine is operated by electricity through the use of batteries which are furnished with it, or may be wound by hand if desired.

The DeRivas & Harris Mfg. Co. have been manufacturing pianos and player-pianos for many years and have entered into the manufacture of talking machines with the same progressive spirit which has always marked the success of their piano manufacturing enterprise.

### CAPITAL IS \$100,000

The Collings & Price Co., Newark, N. J., has been incorporated with capital stock of \$100,000, to do a jobbing business in Victrolas. This company succeeds the Price Talking Machine Co.

The New York Metal Parts Service Co., of New York, has been incorporated with capital stock of \$6,000.

The J. Goldsmith & Son Co., Memphis, Tenn., Brunswick dealer, is building an addition to its store and expects to be ready by September 1.

### ROEMER MADE VITANOLA JOBBER

Roemer Furniture Co. to Take Charge of Vitanola Distribution in New York City

The Roemer Furniture Co., 332-334 Eighth avenue, New York, has been appointed wholesale distributor and sales representative of the Vitanola Talking Machine Co. for the Metropolitan district. M. M. Roemer heads the new organization and is well known in local trade circles.

### VISITED COLUMBIA HEADQUARTERS

Recent visitors to the Columbia headquarters in New York were the members of the sales force of the Chicago branch and representatives from the Cleveland and Buffalo branches. The purpose was to have an interchange of sales views with George W. Hopkins, general manager. Those present were: C. L. Morey, E. O. Zeckle, A. T. Boland, M. M. Marrin, F. G. Cook, A. J. Tucker, R. M. Walley and F. S. Binger. William Kennedy, of Cleveland, and F. K. Peace, of Buffalo.

### OFFICERS OF DULCITONE CO.

The officers of the Dulcitone Phonograph Co., recently organized in South Haven, Mich., are as follows: President, T. L. Powell; vice-president and treasurer, R. G. Brier; secretary, J. L. Barron.

### INCREASE CAPITAL STOCK

The Pierson Co., of Rockford, Ill., manufacturers of talking machine accessories, have increased their capital stock from \$25,000 to \$100,000.

The Lucky 13 Phonograph Co., 46 East Twelfth street, New York, report an unusually active condition of business these days, every specialty which they handle being in demand.

# REVOLUTION! OPPORTUNITY!

The announcement last month of **The Copper Process Company of New York** has been received by the trade as one of the greatest revolutionary improvements towards the absolute perfection of the tone of talking machines.

The new Copper Process used in our manufacture of tone arms produces a natural tone, full and mellow.

Our process of manufacture permits perfect centering of needle point with center line of tone arm, unusual graceful lines, unbreakable structure, better and permanent plating.

The adoption of our Copper Process Tone Arm will give strong selling points for you and your dealers.

Our new process of manufacture can be adapted to any design which you care to submit.

*Write for particulars.*

## COPPER PROCESS COMPANY

19 West 44th Street

New York, N. Y.



**NEW TONOFONE DISTRIBUTOR**

W. L. Weaver, Dallas, Tex., Planning a Strong Campaign on Tonofones and Needles

CHICAGO, ILL., August 12.—The latest addition to the constantly growing family of Tonofone and needle distributors is W. L. Weaver, Sumpster Building, Dallas, Tex. Mr. Weaver, who is regarded as a real live wire in the Lone Star State, is now making elaborate plans for a vigorous campaign during the coming Texas State Fair in October. This fair is the biggest annual affair in the Southwest and is always attended by thousands of progressive retail merchants of Texas and surrounding States.

**CAPT. KINGWILL HOME FROM FRANCE**

Former Member of The World Staff in Chicago Saw Long Service in Battle Lines

Captain H. Scott Kingwill, formerly assistant manager of the Chicago office of The Talking Machine World and The Music Trade Review, returned recently from France, where he saw active service for over a year with the Fifty-eighth Infantry of the Fourth, or Regular, Army Division, and spent over 100 days in the front battle line. Although he had some hair-breadth escapes, Captain Kingwill returned without a scratch. His division for a time formed a part of the Army of Occupation in Coblenz, Germany.

Captain Kingwill won a commission as first lieutenant at the Officers' Training Camp at Fort Sheridan, Ill., and was promoted to captain for his good work in France.

**BANQUET NOT SUBJECT TO TAX**

President James T. Coughlin Secures Ruling in Favor of the Talking Machine Men, Inc.

Owing to the fact that a number of artists who make records furnished entertainment at the recent annual banquet of the Talking Machine Men, Inc., an effort was made by certain Government officials to impose an amusement tax of 10 per cent. under the War Revenue act upon the gross amount realized at the banquet. James T. Coughlin, president of the Talking Machine Men, Inc., immediately took up the question with Washington and was advised by James M. Baker, Deputy Commissioner of Internal Revenue, that the sections of the Revenue act referring to a tax on amusements did not apply to the association's banquet in that it was primarily a business organization.

**APPOINTED DISTRIBUTORS**

The C. E. Ward Co., of New London, O., announce that they have appointed the Reed Co., 237 Fifth avenue, Pittsburgh, Pa., distributors for the moving covers which they manufacture.

**MUSIC THAT CURES ALL HUMAN ILLS**

H. I. Phillips, of New York Globe, Offers Interesting List of Selections as Cures for Those Who Suffer Ills That Human Flesh Is Heir To

H. I. Phillips, who conducts "The Globe Trotter" column in the New York Globe, has his own ideas regarding the curative value of

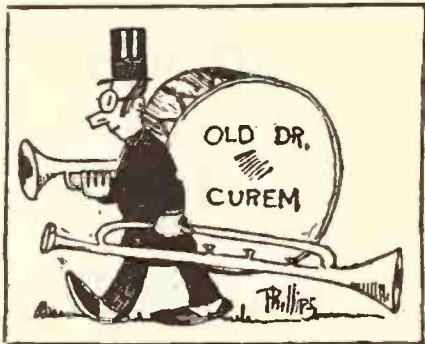

The Modern Medico-Musico-Psycho Sawbones music, as the following matter clipped from his column recently indicates:

**DOCTOR, BRING ON YOUR JAZZ BAND**

Miss Maud Ilsen, director of hospital music for the Red Cross and professor of musicotherapy at Columbia, says music is one of the greatest cures for the ailing. Her prescription follows:

- INSOMNIA**
- "Spinning Maiden" .....Raff
- "Ave Maria" (violin) .....Schubert
- "Mammy's Song" .....Ware
- "Serenade" .....Schubert
- "Reverie" .....Schutt
- HYSTERIA**
- "Barcarolle" ("Tales of Hoffman")
- "Moonlight Sonata" (first movement).....Beethoven
- "To a Wild Rose" .....Macdowell
- NEURASTHENIA**
- "Melody in F" .....Rubinstein
- "Meditation" from "Thais".....Massenet
- "Spinning Song," "Spring Song,".....Mendelssohn
- March from "Mignon" .....Poldini
- "Love's Joy" .....Kreisler
- "Hungarian Dance" .....Brahms
- "The Lass With the Delicate Air".....Arne
- "Song of the Brook" .....Burleigh
- "Jocelyn Lullaby" .....Godard
- "Fairy Lullaby" (op. 37, No. 3).....Mrs. Beach

May we not offer a few of our own suggestions merely by way of boosting the idea?

- SLEEPING SICKNESS**
- Any jazz music by any jazz orchestra.
- Piano practice by the young lady across the way.
- Street organs.
- Any circus band.
- HOUSEMAID'S KNEE**
- "Father's Old Malacca Cane,".....Larrome
- "Oh, How I Hate to Get Up in the Morning".....Berlin
- "The March on Stilts" .....Schultze
- 2.75 HEADACHES**
- "The Old Oaken Bucket" .....Welles
- "Last Night Was the End of the World".....Hoffman
- "When the Sands of the Desert Grow Cold".....Smith
- "Please Go Way an' Let Me Sleep".....Anonymous
- CHILLS**
- "Jimmy, Do the Shimmy".....Remick
- "That Mysterious Rag" .....Smathers
- FALLING HAIR**
- "The Coming Out" .....Grieg
- "Just a Word of Sympathy" .....Remick
- "Pretty Baby" .....Remick
- "Silver Threads Among the Gold,".....Anonymous
- "Good-by, Forever" .....Tosti
- FALLEN ARCHES**
- "Tramp, Tramp, Tramp, the Boys Are Marching,"
- "Chiropodists' Barcarolle" .....Anonymous
- "The Subway Glide" .....Anonymous
- ALCOHOLISM**
- "Coming Thru' the Rye" .....Anonymous
- "Drink to Me Only With Thine Eyes".....Anonymous
- LA GRIPPE**
- "That Little Old Red Shawl".....Anonymous

**CHAS. H. YATES**

311 Laughlin Bldg. Los Angeles, Cal.

Manufacturers' Distributors of High Grade Phonograph Trade Accessories.

Complete Stock Prompt Deliveries

Exclusive Pacific Coast distributor for the

**JONES-MOTROLA**

**MANY TONE-TESTS THIS SEASON**

Host of Prominent Edison Artists to Appear in Tone-tests This Fall and Winter

The 1919 tone-test season will be the greatest yet projected, according to the predictions of Verdi E. B. Fuller, director of sales promotion, and Arthur Walsh, manager of the recital department of Thomas A. Edison, Inc.

"More than 1,400 concerts have already been booked for all sections of the United States and Canada and the demands of our dealers call for at least 75 per cent. more bookings for the season which will start in September and continue until Christmas time," said Mr. Fuller.

"Our recital department is flooded with orders for at least three times as many concerts as we can fill. Daily we receive many letters from owners of Edison phonographs requesting that certain artists be sent to their towns this season. It seems that the ending of the war has brought an exceedingly great demand for music and somehow has caused what might be termed as a revival of the general love of music in every American home."

"We have ordered more than 40,000 stereotypes for use in part of our publicity for this concert work," said Mr. Walsh. "We are finding that we could book every artist for at least three times as long on tone-test tours as we have contracted for their efforts in that character of service."

Among those who will appear in Edison tone-test concerts this fall are: Marie Rappold and Marie Tiffany, of the Metropolitan Opera Co.; Alice Verlet, of the Paris Opera, Cyrena Van Gordon, of the Chicago Opera Co., and the following well-known concert artists: Ida Gardner, Marie Morrissey, Amy Ellerman, Julia Heinrich, Betsy Lane Shepherd, Vernon Dalhart, Leola Lucey, Hardy Williamson, Glen Ellison, the Sokoloff Trio, the Fleming Sisters Trio, Lucille Collette, Odette le Fontenay, Claire Lillian Peteler, Sibyl Sanderson Fagan and George Wilton Ballard.

Business is booming and there is a great demand for goods in the Ohio district, according to L. N. Bloom, of the Phonograph Co. of Cleveland, an Edison jobber, who was at the Edison laboratories recently.

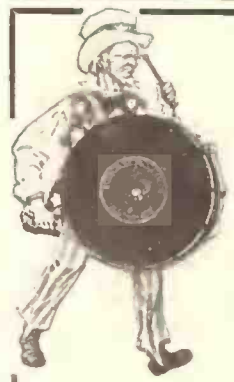

**What does this mean to you?**

The shrewdest buyers in the country are stocking Talking Books and sending big re-orders, because they SELL.

**A Few Famous Judges of Merchandise**

—who are selling Talking Books and taking profits.

- JOHN WANAMAKER  
Philadelphia, New York
- MARSHALL FIELD  
Chicago, Ill.
- J. L. HUDSON CO.  
Detroit, Mich.
- LASALLE & KOCH  
Toledo, Ohio
- HALLET & DAVIS  
Boston, Mass.

- R. H. MACY & CO.  
New York City
- SCRUGGS, VANDER-  
VOORT & BARNEY  
St. Louis, Mo.
- JOSEPH HORNE & CO.  
Pittsburgh, Pa.
- LORD & TAYLOR  
New York City
- H. & S. POGUE & CO.  
Cincinnati, O.

**They advertise your store —**

the kids bring their mothers, and you can sell other records also.

**No dead stock**—Mocking Bird, Parrot, Lion, Mother Goose, etc., always standard, year after year.

**No breakage**—semi-flexible records stand rough treatment without damage.

**We'll make up a trial** shipment of best sellers for any amount you say. Discount 1/3 off and over, according to quantity.

**TALKING BOOKS**



**TALKING BOOK CORP.**

1 West 34th St., N. Y. C.  
608 S. Dearborn St.,  
Chicago  
Ohio Talking Book Co.  
27 Taylor Arcade, Cleve-  
land, Ohio

**EXPORT DISTRIBUTORS**

Emerson Internat'l, Inc.  
160 Broadway, N. Y. C.



**SOME RECENT PATHE LITERATURE**

Interesting Folder Bearing Upon the "Actuelle" Just Sent Out—New Phonograph Catalog Also Issued—Outing of Pathé Employes

A four-page folder announcing the "Actuelle" was sent out by the Pathé Freres Phonograph Co. during the first week of the month. The radical difference in the reproduction of sound by the Actuelle has been previously published in *The World*. This folder photographically and verbally portrays this revolutionary development in the talking machine field.

Other pieces of interesting and attractive literature have also recently been issued from Pathé headquarters. An eight-page folder in colors entitled "Aloha Pathé Hawaiian Records" is devoted to a classification of the large number of Pathé Hawaiian records, and an interesting article on Hawaiian music. Space is left on the last page of the folder for the dealer's imprint.

A new sixteen-page catalog has also been published describing Pathé phonographs. The volume is handsomely illustrated with reproductions of the various instruments constituting the line, including both Console and upright types, a number of them in period designs. Two table models and one outing model are also shown. The models are fully described and the catalog also contains an article on the advantages of a Pathé sapphire ball and an article on Pathé phonographs in general.

A set of twenty handsome photographic reproductions of Pathé artists, size 11 inches by 14 inches, has also been issued, which has been enthusiastically received and highly commented upon.

On Saturday, August 9, the Pathé Frères Welfare Association held a clambake and outing at Wetzel's, College Point, L. I. The large Pathé plant was closed at that date with full pay allowed for all employes. The party left the factory at nine-thirty sharp and journeyed to College Point, where all entered heartily into the games of the day, which included

*A Wonderful Success!*

**The "Best" semi-permanent Stylus**

NO SCRATCH NO HISS

**Plays 100 to 300 Records**

Cranks on Tone, who have used every needle, are now perfectly satisfied with The Best Stylus.

Write now for free samples, attractive discounts and descriptive circulars which we furnish for your mailing list.

**The Ansonia Needle Co.**

Ansonia ❖ ❖ Conn.

two baseball games, bowling contests, swimming races, dashes for the ladies and a fat man's race. An excellent opportunity was provided for one-steppers, fox-trotters and waltzers to dance to the jazziest jazz band that ever jazzed. Excellence in the various events was well rewarded by prizes.

The menu of the clambake was one that made those participating wish that the affair was weekly rather than annually. A home-made breakfast was also served immediately upon arriving at College Point.

**TO EQUIP LANDAY BROS. STORE**

NEWARK, N. J., August 12.—Arrangements have been made by Landay Bros. with the Unit Construction Co., of Philadelphia, for the installation of a series of Unico demonstration rooms in the Landay warerooms in this city. The rooms are to be finished in the Adam period, and when finished will be one of the most attractive installed by the Unit Construction Co. Work is now under way on this important installation.

**ASK FOR OUR No. 22 MOTOR**

**THE BEST SMALL, DOUBLE SPRING, WORM DRIVEN MOTOR ON THE MARKET**

**READ THE SPECIFICATIONS**  
And Send for Sample at Once

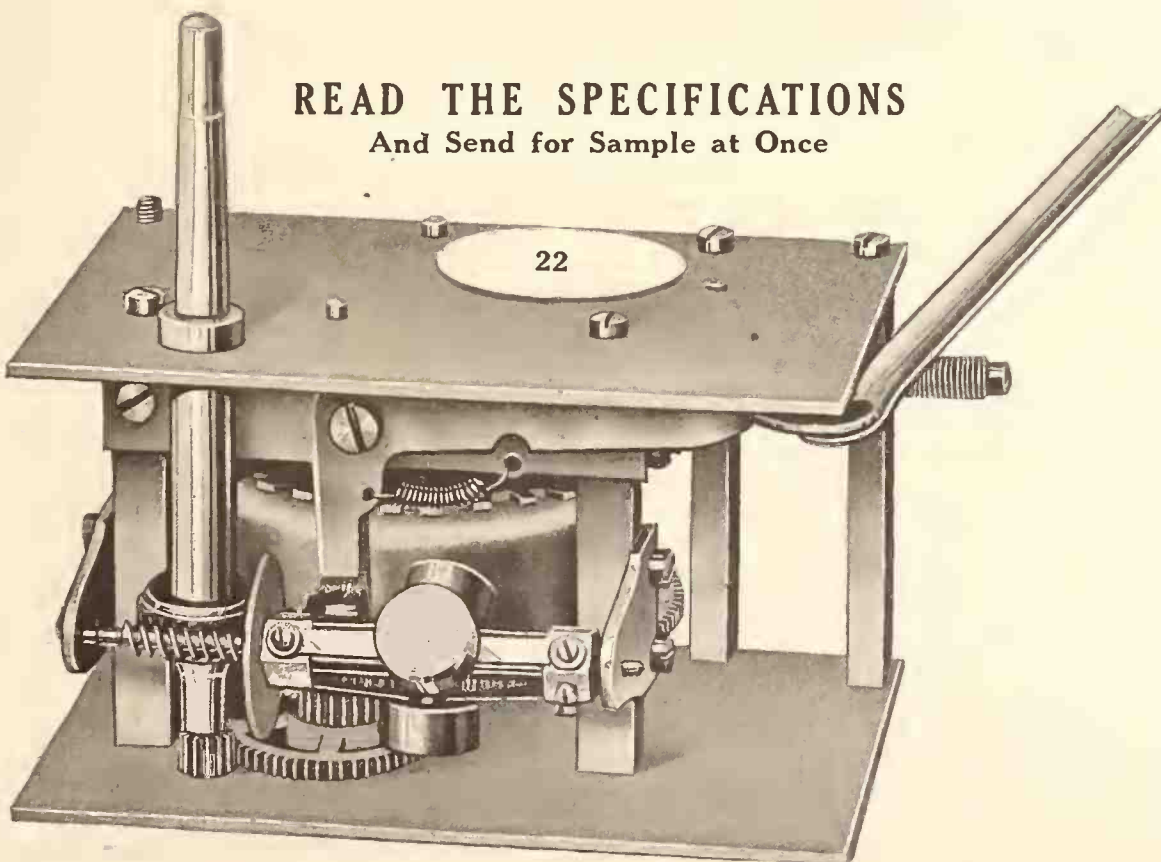

**ECONOMICAL,  
EFFICIENT,  
DURABLE and COMPACT**

**GUARANTEED UNQUALIFIEDLY  
IN EVERY DETAIL**

**SPECIFICATIONS**

*Double Spring, Motor Playing Three 10-inch Records without Rewinding.*

Double Spring. Worm Drive. Fibre Gear.

Furnished complete, with graduated or plain regulator, winding key of desired size, turntable stop, working either outside or under turntable, fibre-back escutcheon, washers, screws, felts, also stamped 10-inch or 12-inch turntable, covered with all-wool felt. Also with cast-iron turntables, nickel plated through and through

**BUTTERFLY PHONOGRAPH MOTOR CORPORATION**  
243 WEST 17th STREET, NEW YORK CITY



## NEW PLYMOUTH CO. PLANT READY

Factory in Plymouth, Wis., Recently Taken Over by That Concern Entirely Remodeled and Equipped to Produce Phonographs—Those in Charge of Company's Destinies

PLYMOUTH, WIS., August 5.—The Western representative of The Talking Machine World had the pleasure this week of calling at the plant of The Plymouth Phonograph Co. This corporation, which was recently formed with a capital stock of \$500,000, has taken over the plant of the C. F. Kade Fixture & Showcase Co., which for some months has been largely occupied in the manufacture of talking machine cabinets. The plant has been entirely remodeled and adapted for the production of complete machines. It comprises a three-story structure with 35,000 square feet of space available, exclusive of dry-kiln and power plant. W. H. Thommen, the president of the Plymouth Phonograph Co., resigned from the Wisconsin Chair Co., of Port Washington, Wis., with whom he had been connected for thirty years,

to form the new corporation. He was in charge of the various talking machine activities of the great Port Washington concern and has a list of patents in this line to his credit. Mr. Thommen is a master of recognized distinction and a graduate of L'Ecole des Beaux Arts, in Paris, and of the Munich Polytechnic School.

The vice-president of the company is J. P. Thierry, the well-known piano and talking machine merchant of Milwaukee. F. D. McIntyre,

a young man prominent in Plymouth business circles, is secretary and treasurer, as well as manager of the purchasing department. The directors include the above, together with H. W. Bolens, brother of A. D. Bolens, and president of the Gibson Mfg. Co., of Port Washington, a man of great prominence in Wisconsin affairs, and Herman Wheeler, a Plymouth capitalist.

The company is devoting itself for the present to the manufacture of complete machines for jobbers, but about the first of the year will be ready for the market with a high-grade machine containing a number of distinctive features of Mr. Thommen's own invention.

## PERFECTION TALKING MACHINE CO., Inc.

200 FIFTH AVENUE, NEW YORK CITY

MANUFACTURERS OF

THE  
ORANOLA

THE PERFECT TALKING MACHINE

We take pleasure in announcing our product will be ready for delivery in September.  
We are prepared to make exclusive contracts with dealers.

## Stoffer &amp; Stackhouse Co., Inc.

BOURBON, IND.



Direct Factory Distributors for

The OkeH Record plays perfectly with either the Steel Needle or with the Sapphire Ball.

The OkeH Record is the only Record on the Market that plays thus—with either the Steel Needle or the Sapphire Ball.

The OkeH Record is the hill and dale type, but is the hill and dale type that plays perfect.

The OkeH Record is guaranteed to play perfectly, guaranteed to play from beginning to end of any selection without slipping or jumping.

The OkeH Record is guaranteed against any scratching or squeaking.

The OkeH is guaranteed (if handled with care) to play a thousand times, and when played a thousand times still be in good shape and play perfectly.

The OkeH Record Library comprises the very latest hits, such as "Beautiful Ohio," "Till We Meet Again," "Ja-Da," etc., both in Song and Instrumental. To hear the OkeH Record means satisfaction to the most critical musical ear.

Let us ship you at once on approval a small sample shipment of the very latest and best numbers. If satisfactory, retain same and order more—if not satisfied with same return at our expense. If you have not received an OkeH Record catalog, write us and we will forward you a general catalog and latest supplements.

OkeH Records are all ten-inch double-faced records; all retailing at 85c. Very liberal profits for the dealer.

Write us at once for Catalogs, also a small sample order of the Record that is leading all others—the OkeH.

## A TIMELY NOVELTY

BOSTON, MASS., August 4.—A new talking machine novelty has been presented by the National Co., of this city, entitled, "Uncle Sam and the Booze Bottle." Other novelties brought out in the past by this firm and pertaining distinctly to the affairs of the time were "Uncle Sam and the Mexican" and "Uncle Sam and

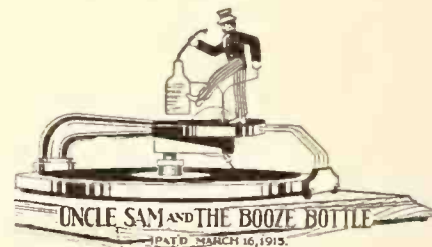

One of the Season's "Hits"

Kaiser Bill." Both these former novelties proved exceedingly popular. "Rag Time Rastus" and the "Boxing Darkies" continue strong in popularity, both in the home and the dealer's show window, where they have attracted crowds.

In the novelty "Uncle Sam and the Booze Bottle," "Demon Rum," represented by a whiskey bottle, is well punished by our national character. Both the bottle and the snake, which issues from it, fight back to the accompaniment of the record selected, which gives much amusement to the spectator.

## ROTTEN STONE

We are the only miners and manufacturers in this country of Rotten Stone for use in Phonograph Record making. Our product is now in use by practically every record manufacturer in this country. We are also headquarters for all other minerals for record making and everything we handle is made especially for this purpose and absolutely guaranteed. Expert advice given upon any formula.

## KEYSTONE MINERALS CO.

41 Union Square, New York City

## GEIER &amp; BLUHM

Manufacturers of

Mechanical and Scientific Instruments

Establ. 1906

Troy, N. Y.

U. S. A.



# WORLD'S CLASSIFIED ADVERTISING

Any member of the trade may forward to this office a "Situation" advertisement intended for this Department to occupy a space of four lines, agate measure, and it will be inserted free. Replies will also be forwarded without cost. Additional space will be at the rate of 25c. per line. If bold faced type is desired the cost of same will be 25c. per line.

## SALES EXECUTIVE

Five years directing sales of Victor line, desires new connection as Manager of Progressive Victor Store. Able to Organize, Inspire and Direct a Sales Force; at present managing successful Victor Shop. Thoroughly experienced in Collection and Advertising detail—only high-grade association desired. Address Progressive, care The Talking Machine World, 373 Fourth Ave., New York City.

WANT a live wire to sell an excellent line of talking machines and records in Western Pennsylvania and West Virginia, a man in Philadelphia, another in New England and another in Metropolitan district. A. M. Druckman, 16 West 39th St., New York.

YOUNG man with business ability, several years' experience in the talking machine line, wishes to connect with a partner, about two thousand dollars. Have splendid opportunity to explain. For full particulars address "Box 676," care The Talking Machine World, 373 Fourth Ave., New York.

SALES MANAGER—Must have had the best of connections, and wide experience and acquaintance with phonographic trade. To qualify for executive position handling sales department of phonograph company now being organized. Will take the best obtainable. Address "Box 678," care The Talking Machine World, 373 Fourth Ave., New York City.

EXECUTIVE — Thoroughly familiar with manufacturing and selling phonographs. To be production manager in charge of organization in New York offices. Extensive executive experience in trade absolutely necessary. Will take only the highest of qualifications. Address "Box 679," care The Talking Machine World, 373 Fourth Ave., New York City.

MR. MANUFACTURER—A sales manager with sufficient energy and initiative to keep your factory working up to capacity desires a connection with you on September 1. Married man, thirty-six years old, with fourteen years' successful experience in the phonograph business. At present connected with one of the leading phonograph factories. Address "A. U. 7," care The Talking Machine World, 209 South State St., Chicago, Ill.

SITUATION WANTED—Would like position with reliable concern building, or desiring to build, a high-grade phonograph. Am thirty-six years old, temperate and had about fourteen years in the construction of the phonograph. Also have several good inventions which I would gladly turn over to the right parties. Address "Box 624," care The Talking Machine World, 373 Fourth Ave., New York.

SALESMEN WANTED—Road men with A-1 references, widely acquainted among Western piano, music and furniture houses. Have high grade, well advertised phonograph proposition on side line basis. Give age, detailed experience and reference in first letter. Address "Box 648," care The Talking Machine World, 373 Fourth Ave., New York.

I WANT A MAN between 25 and 30 years old with the ability to produce business as the wholesale sales representative of a reputable concern making a thoroughly high grade product. The man I want will write me a letter (in confidence of course), telling me everything about his selling experience, etc. Possibly he is not a college man, but is a hustler. Address "Box 670," care The Talking Machine World, 373 Fourth Ave., New York City.

POSITION WANTED—By lady in either Victor, Columbia, Edison or Brunswick lines. Am capable of taking charge of department. Can furnish best of references. Address "Box 671," care The Talking Machine World, 373 Fourth Ave., New York, N. Y.

WILL buy a Victor store and license in any town not far from New York. Will deal promptly and pay cash. Address "Box 672," care The Talking Machine World, 373 Fourth Ave., New York.

SITUATION WANTED—Young man (30 years), desires position as manager for live talking machine dealer. Before entering service, July, 1917, was in talking machine business for several years and am capable of handling all lines of the business. Address "Box 673," care The Talking Machine World, 373 Fourth Ave., New York.

WANTED—Position as superintendent of phonograph cabinet factory, understand all branches of the business. Would like to locate in or about Denver, Colo. Address "Box 674," care The Talking Machine World, 373 Fourth Ave., New York.

SALESMAN WANTED who handles a line of furniture, to carry a side line of popular priced phonographs. Samples are four photos, with price quotations and descriptions thereon. See our ad in this issue. Charnaphone Co., 39-41 West 32nd St., New York.

VICTOR TALKING MACHINE SALESMAN DESIRES POSITION in New York. Six years' experience with largest wholesale and retail house in New England. Just out of the service. "Box 675," care The Talking Machine World, 373 Fourth Ave., New York.

SITUATION WANTED—Young man with three years' experience, wholesale and supplies. Would like position preferably as Chicago City salesman. Address J. O. 17, Talking Machine World, 209 South State St., Chicago, Ill.

WANTED—Several young men (married men preferred), as Edison Phonograph salesmen, on Main Line. Men who can show results and are active. Mostly outside work. Best of chances for improvement to the right parties. State salary expected and experience in first letter. Territory to cover—northwestern part of Ohio. Address "Box K," care The Talking Machine World, 373 Fourth Ave., New York.

SITUATION WANTED—Young man 33 years of age just returned from service wishes position as foreman. Seven years' experience in motor and assembling department, also have had charge of same. Best of reference as to character and mechanical ability. Address "Box 665," care The Talking Machine World, 373 Fourth Ave., New York.

WANTED—Position as foreman or repair man. Twelve years' experience. Take complete charge. Address "J. U. 30," care Talking Machine World, 209 South State St., Chicago, Ill.

EXPERIENCED talking machine salesman with large following, covering Chicago and surrounding territory, is open for a good line. Address J. N. 20, The Talking Machine World, 209 South State St., Chicago, Ill.

WANTED POSITION—Sales manager, assistant manager, or production supervisor for Western phonograph company, Chicago preferred. Eight years' experience. Best references. Address J. U. 16, care The Talking Machine World, 209 South State St., Chicago, Ill.

SITUATION WANTED—An all around talking machine man with a practical knowledge to take charge of manufacturing plant desires position with a reliable firm in the Middle West. Best references. Address "Box 669," care The Talking Machine World, 373 Fourth Ave., New York.

POSITION WANTED—Talking machine man, many years in trade, wide acquaintance, desires to represent line of talking machines or accessories in the East. Address "Box 668," care The Talking Machine World, 373 Fourth Ave., New York.

SITUATION WANTED—Man (thirty-eight), married, five years' experience with Columbia, Victor and Brunswick, desires a position as manager of talking machine department. Can furnish best of reference. Address "Box 651," care The Talking Machine World, 373 Fourth Ave., New York.

POSITION WANTED by ex-Victrola traveler, capable of taking charge of and increasing sales of your talking machine department. Married, man of character and energy; only a salary and commission, or straight commission basis considered. Address "Box 652," care The Talking Machine World, 373 Fourth Ave., New York, N. Y.

SALESMAN WANTED—Phonograph salesman wanted to take on a complete line of phonograph accessories. Every dealer a customer. Address "J. N. 4," care The Talking Machine World, 209 South State St., Chicago, Ill.

POSITION DESIRED by first-class varnisher, rubber and polisher, as foreman with concern making cabinets. Can furnish first-class reference, both from piano and cabinet shops. Understand assembling of all kinds of motors. Address "Box 653," care The Talking Machine World, 373 Fourth Ave., New York.

SALESMAN—Experienced live-wire man. One who can take charge of phonograph department, desires connection with retail concern either in an executive or sales capacity. Best references. Address "Box 656," care The Talking Machine World, 373 Fourth Ave., New York.

SITUATION WANTED by Victrola salesman for New York City vicinity. References. Address "Box 657," care The Talking Machine World, 373 Fourth Ave., New York, N. Y.

WE want a man who understands plating and pressing records and the making of recording wax and mixing of record material. Write giving references and experience. Don't waste your time trying to flourish. Address "Box 658," care The Talking Machine World, 373 Fourth Ave., New York.

WANTED—A retail inside Victrola and Victor record salesman, who is acquainted with the city of Brooklyn. Man with experience and high-class reference need only apply. Address "Box 659," care The Talking Machine World, 373 Fourth Ave., New York.

WANTED—A live wire manager for an exclusive phonograph department, state experience and salary expected in first letter. A. B. Smith Piano Co., 190 South Main St., Akron, O.

## FOR SALE

Retail Business

Victor and Columbia Agencies—Sales \$100,000 a year—Located in one of the leading cities of the West.

Stock is well balanced and in perfect condition.

Fixtures are the best including complete battery of "Unico" demonstrating rooms.

Wonderful opportunity for a live wire to greatly increase the sales of this successful business.

Stock and Fixtures will inventory approximately \$25,000.

Address inquiries to "Box S 30," care The Talking Machine World, 373 Fourth Ave., New York, N. Y.

## PHONOGRAPH CABINETS

Large cabinet factory is ready to supply manufacturer with 100 to 150 cabinets per week. Will make them to your design. Address "Phonograph Cabinets," care The Talking Machine World, 373 Fourth Ave., New York City.

## FOR SALE

For immediate sale, complete set of jigs, punches and dies, fixtures and special tools for a simple and substantially constructed phonograph motor, with one, two and three spring barrels, together with a substantial quantity of finished and partly finished parts and castings. For particulars, inquire "Box 677," care The Talking Machine World, 373 Fourth Ave., New York City.

## PATENT RIGHTS FOR SALE

A new type talking machine. Would enable any company to put a machine on the market which would be a radical improvement and which would differ from any existing type. In execution it surpasses any known instrument. It is not a "freak" and to construct would not be more expensive than present popular phonographs. Write for particulars. Address "Box 680," care The Talking Machine World, 373 Fourth Ave., New York.

WANTED—Phonograph accessories salesman to call on manufacturers. Not less than \$5,000 a year to right man. Gentile only. Address "M. A. 3," care The Talking Machine World, 209 South State St., Chicago, Ill.

WANTED—Five live wire salesmen to handle our phonographs, state experience. A. B. Smith Piano Co., 190 South Main St., Akron, O.

SITUATION WANTED—An American thoroughly conversant with the export trade wants to represent a reliable talking machine manufacturer to develop an export business. Address "Box 640," care The Talking Machine World, 373 Fourth Ave., New York.

SITUATION WANTED—Ten years' experience in talking machine line, motor repairer, wood finisher, polisher, shipping clerk, etc., desires steady position in New York. Address "Box 641," care The Talking Machine World, 373 Fourth Ave., New York.

WANTED—Position in phonograph factory as foreman in mill and cabinet room. Fifteen years' experience in Eastern factory. Address "A. P. 11," care The Talking Machine World, 209 South State St., Chicago, Ill.

(Continued on page 164)



TALKING MACHINE WORLD CLASSIFIED ADVERTISING—(Continued from page 163)

I am interested in complete new or second-hand equipment for making lateral cut 10" records, with a capacity of 500 records daily. Also wish to know of any young man who would be willing to come to Havana, Cuba, to take charge of my record plant. Will make him a good proposition providing he is well acquainted with recording, galvanoplatin, pressing, mixing, etc. Address "Cuban Manufacturer," care of TALKING MACHINE WORLD, 373 Fourth Avenue, New York City.

WILL represent firms of East, manufacturing supplies and accessories suitable to phonograph and piano stores on the Pacific Coast. Address "N. A.," care Columbia Graphophone Co., 745 South Broadway, Los Angeles, Cal.

SITUATION WANTED—By man (33) expert mechanic in all branches of manufacturing and repairing of talking machines. Take complete charge of plant. Twelve years' experience as working foreman and manager. Understand every point of the business, am at present at liberty to connect with some reliable firm. Address "Box 642," care The Talking Machine World, 373 Fourth Ave., New York.

POSITION WANTED—Young married man, with years of experience, to take charge of phonograph department. Preferably the Brunswick. Am a live wire and can produce the business. At present located, reason for changing, to better myself. Good references. Address "Box 643," care The Talking Machine World, 373 Fourth Ave., New York.

SITUATION WANTED—Am open for a good proposition from some reliable piano or talking machine man, either as traveling salesman or the right proposition in handling on consignment (latter preferred). Results guaranteed. Address "Box 644," care The Talking Machine World, 373 Fourth Ave., New York.

**TAG DAY FOR GRAFONOLA**

School Children in Kensington, Kan., Raise Funds for Purchase of Machine

An unusual purchase of a Columbia Grafonola was recently reported at Kensington, Kan., when a Tag Day was appointed in order to raise sufficient funds with which to purchase it, the machine to be installed in one of the local schools.

The school children wanted a Grafonola and in order to raise the funds necessary for its purchase a Tag Day was designated. On the day chosen the school children went about selling tags for ten cents each, which were appropriately marked to show that the person wearing it had donated funds to be used toward the purchase of the Grafonola for the school.

**The FULTON**

We are now offering to dealers our New Improved Maestola Phonograph, Mahogany, 14x14x7 1/2". Motor plays 4 10" Records with one winding. 12" Turn Table, Dial Regulator. Price \$6.00 each and Sample \$6.50.

CASH WITH ORDER

Best American Steel Phonograph Needles **TRUE TONE or CLEAR TONE**

200 to a metal box, or 100 to a package, 55c

Per thousand, 50c in lots of 100,000

Phonograph parts and accessories, as Motors, Tone Arms, Sound Boxes, Cabinets, and Cabinet Hardware. Repair parts for all makes.

Records—Standard make, Lateral Cut, at \$40.00 per 100.

**FULTON TALKING MACHINE CO.**  
640 Broadway New York, N. Y.

MR. DEALER—Increase your sales 100 to 500%. Use Harely's Follow-up-letters and how to get owners' names and prospects. Sample letter heads and envelopes that get the business. By one who succeeded. Any Talking Machine or Edison Disc. Which? \$1 set, worth \$25. Will make you hundreds. Address: J. H. Miskimen, Glendive, Montana.

**WANTED—SPOT CASH PAID**

Any amount of records in all languages. Talking Machines, horn or hornless. Parts of all makes, record cabinets, etc.

VICTORIA RECORD EXCHANGE  
2104 Third Avenue New York  
Phone Harlem 7848

**BUSINESS OPPORTUNITY**

WANTED—Distributors and agents for State territories by manufacturer of latest designed and most up-to-date phonograph on market. Applicants must be financially able to handle territory and push same. A good-paying proposition for live, active men. Address "M. S. 2," care The Talking Machine World, 209 South State St., Chicago, Ill.

**INTERNATIONAL MOTOR**

is the silent running motor, built in Canada, on the right principles, best of material and correct workmanship. It is not a cheap imitation but a high-class production, manufactured by

INTERNATIONAL MACHINE & MFG. CO., LTD.  
111 Adelaide St. W. Toronto, Canada

**State Your Wants in  
The Talking Machine  
World and Get Results**

**SELENIUM CELLS**

Made by entirely new process. Highly sensitive and quick-acting. Suitable for all experiments. From \$5 up. Send for catalogue.

Selenium Laboratories, Good Ground, L. I.

**SEEKS AD MEN'S CONVENTION**

Indianapolis Carrying on a Strong Campaign to Secure 1920 Convention of the Associated Advertising Clubs of the World

INDIANAPOLIS, IND., August 4.—This city has already started a strong campaign with a view to securing the 1920 convention of the Associated Advertising Clubs of the World and is leaving no stone unturned to convince the advertising men, and particularly those in charge of the convention arrangements, of the desirability of Indianapolis as a convention city, and a special booklet setting forth some of the city's facilities for entertaining visitors.

Tom Griffith, sales manager of the Udel Works, one of the city's leading industries, who, in his former position as advertising manager of

Patents, Drawings, Patterns, Models.

**MULTIPLE RECORD MACHINES**

For Sale or License at Reasonable Prices

U. S. Patent No. 1028707, playing 50 double face disc records

U. S. Patent No. 978014, playing 35 cylinder records

COMMUNICATE WITH

**GEORGE W. SAYWELL**  
702 Engineers Bldg. Cleveland, Ohio

**"WHAT ARE YOU SHORT?"**

Get in touch with us. We have everything in the phonograph line. Needles, Tone Arms, Motors, Cabinets, all kinds of accessories and repair parts. We specialize on Main Springs, Bettertone phonographs. Let us do your repairs.

PLEASING SOUND PHONOGRAPH CO.,  
204-206 East 113th St., New York.

**WANTED**

Any amount of Victor and Columbia Foreign Records.

PLAZA MUSIC CO.,  
424 North Main St. Los Angeles, Calif.

**WANT TO BUY.**

The highest spot cash prices for any quantity, single or double motors, parts talking machines and records.

N. Y. PHONOGRAPH EXCHANGE,  
101 Orchard Street New York, N. Y.

**FOR SALE**

Phonograph records, Victor, Columbia, Emerson (Brand New). A very fine assortment of vocal and instrumental selections. Particulars given upon request.

I. DECKINGER  
3064 Albany-Crescent Ave.,  
New York, N. Y.

**WILL BUY PHONOGRAPHS**

I am a retail dealer, who is interested in handling a good, showy phonograph which retails from \$9.00 to \$14.00. If you have a table model in this class, please let me hear from you. Address "X. Y. M.," care The Talking Machine World, 373 Fourth Ave., New York.

the concern, took a more than passing interest in advertising matters generally, and in the affairs of the Associated Advertising Clubs, is one of the active workers in the convention campaign. He has been made chairman of the program committee.

Indianapolis recently entertained close to 50,000 Shriners in their annual session and is now starting a campaign to raise \$50,000 to see that the advertising men's convention is handled properly.

\$25.  
THE COMPLETE OUTFIT. RETAIL

**MAKE Your OWN Records**  
on your own PHONOGRAPH AT HOME.

The greatest amusement you have ever had. Phonograph the voices of your family and friends, and play them instantly. No process to learn, no failures; attaches and detaches to your phonograph in an instant—manufactured by

**Audion Phonograph Co., Boonton, N. J.**



# FROM OUR EUROPEAN HEADQUARTERS

2 GRESHAM BUILDING, BASINGHALL STREET E. C., LONDON, W. LIONEL STURDY, MANAGER.

**Importations From Germany and Austria Much Discussed by the Trade—Strong Prejudice Against Trading With These Countries—An Analysis of the Situation—Why a Fight Should Be Made for British Trade—Wm. Manson Honored by Zonophone Factors—Presented With Grand Piano—Zonophone and Gramophone Men Visit Factories—Winner Record Staff Celebrate—American Methods Depicted by Louis Sterling—News of Month**

LONDON, E. C., ENG., August 1.—In and around British gramophone trade circles the question most under discussion and review at the present time concerns the general attitude likely to be adopted with regard to the probable descent upon this market of German and Austrian manufacturers. The peace treaty has been signed and ratified at least by some of the late belligerent powers. The word "enemy" is no longer a permissible term to use, "friendly" relationship having been re-established by treaty. That, in plain language, sums up the legal aspect of the position, and though the nations will not be disposed to forgive or forget the Central Powers' terrible crime of 1914 and succeeding years, with its avalanche of bloodshed and world-ruin, the fact remains that according to a specific clause in the Treaty of Peace the principle of ordinary relationship is now officially recognized. German mentality we must recognize as still somewhat of a corkscrew type, and we must accordingly be on our guard against it. Our quarrel with her has wrought wounds of a depth that will take a long, long while to heal. But, having recognized the facts, I do not feel justified in thrusting down the throats of my readers any personal opinions that may in

any way help to fan and develop feelings of perpetual hatred. Common sense must now come into the reckoning, and it is perhaps that spirit which has prompted the subject of this article, having special connection with the current opinion in trade circles.

Let it be at once admitted that a good deal of prejudice exists against a revival of trade with the Central Powers. The British market is now partially independent of much that Germany alone provided, and that section of the music trade known as the small goods branch has boldly adopted an all-or-nothing policy by issuing a manifesto declaring their allegiance to the principle of no trading with Germany. This is subscribed to by eight leading firms, comprising a good majority of such houses. A campaign is being conducted among retail and other trades who are asked to adopt a definite line of action by signing a declaration that . . . "The scheme meets with our hearty approval . . . shall have our strong support," and avowing that "It is certainly our intention not to handle goods of German or doubtful origin," etc. The "doubtful origin" in the sense of its context would seem to mean—of doubtful German origin, which evidently takes account of possible attempts at trading through neutral sources. As I have previously remarked, German mentality is, on occasions, of a corkscrew type! However, let be. Every retailer concerned is free to take what action he thinks best.

My inquiries lead me to conclude that this "never again" movement does not altogether interpret the feelings of the gramophone trade, albeit a strong disinclination is uppermost against trading with the Central Powers. It is felt that every effort should be made to pre-

vent by all legitimate means anything like the pre-war German monopoly of the British market. We have managed for five years without German gramophones and records, and a good many in the trade are of opinion that we can, mainly at any rate, continue to so manage for another five years, or for all time. Let us see. Close upon a year has elapsed since the armistice. Within a few days of November 11, 1918, the Ministry of Munitions began to suspend war work. The 6,000 and odd controlled engineering establishments were gradually relieved of their obligations. Capacity for the manufacture of gramophones, accessories and parts was abundant. Leading men of the gramophone trade at once got busy. Notwithstanding the most persistent efforts little success was achieved. In short, the present number of British manufacturers of, for instance, gramophone motors, can be counted on one's hand. Of those but two or three have succeeded in producing a motor comparable with the continental makes. Output, too, is exceedingly low. Take tone arms; manufacture has been proceeding even during the war. Have we yet produced a respectable article or at a reasonable price? Has any effort been made along the lines of improvement so often represented to the makers? To these questions there is only one answer—a plain no! Even common civility is at a discount. Over and over again have I had to listen to the complaints of those whose patriotic preference has brought them to humility. So often have they been told in brusque terseness—That's the article we sell; take it or leave it!

I hold no brief for German, Swiss or any  
(Continued on page 166)



"His Master's Voice"

Copyright

**This intensely human picture stands for all that is best in music**

—it is the "His Master's Voice" trade-mark, and it brings to you, no matter where you are, the very best music of every kind, sung and played by the world's greatest artists—the greatest singers, pianists, violinists, orchestras and bands—all enshrined in the unequalled "His Master's Voice" records

## 'His Master's Voice'

—the trade-mark that is recognized throughout the world as the HALL-MARK OF QUALITY

### Branches

**DENMARK:** Skandinavisk Grammophon-Aktieselskab, Frilhavne 4, Copenhagen.

**FRANCE:** Cie. Française du Gramophone, 115 Boulevard Richard Lenoir, Place de la République, Paris.

**SPAIN:** Compañía del Gramófono, 56-58 Balmes, Barcelona.

**SWEDEN:** Skandinaviska Grammophon-Aktiebolaget, Drottning Gatan No. 47, Stockholm.

**RUSSIA:** The Gramophone Co., Ltd., 45, Nevsky Prospect, Petrograd (Petersburg); No. 1 Solyanka, Solyanoi Dvor, Moscow; 9, Golovinsky Prospect, Tiflis; Nowy-Swiat 30, Warsaw; 11 Michailovskaya Ulitsa, Baku.

**INDIA:** The Gramophone Co., Ltd., 139, Ballaghatta Road, Calcutta; 7, Bell Lane, Fort, Bombay.

### Great Britain :

**The Gramophone Company, Ltd.**

**HAYES - MIDDLESEX - ENGLAND**

### Agencies

**AUSTRALIA:** S. Hoffnung & Co., Ltd., Sole Concessionaries of The Gramophone Company, Limited, 163, Pitt Street, Sydney.

**NEW ZEALAND:** Gramophonium, Ltd., 118-120 Victoria Street, Wellington.

**SOUTH AFRICA:** Darter & Sons, Post Box 174, Capetown; Mackay Bros., Post Box 251, Johannesburg; Mackay Bros. & McMahon, Post Box 419, Durban; Ivan H. Haarburger, Post Box 105, Bloemfontein; Franz Moeller, Post Box 108, East London; B. J. Ewins & Co., Post Box 88, Queens-town; Handel House, Kimberley; Laurence & Cope, Post Box 132, Buluwayo; The Argus Co., Salisbury.

**EAST AFRICA:** Bayley & Co., Lourenso Marques.

**HOLLAND:** American Import Co., 22a, Amsterd Veerkade, The Hague.

**ITALY:** A. Bossi & Co., Via Orefici 2, Milan.

**EGYPT (Also for the Soudan, Greece and the Ottoman Empire):** K. Fr. Vogel, Post Box 414, Alexandria.



EDISON BELL

**WINNER**  
 TRADE MARK  
**GRAMOPHONE RECORDS**

 CABLE  
 "PHONOKINO,  
 LONDON"

**ARE THE GREATEST VALUE FOR MONEY PRODUCED IN GREAT BRITAIN**

TEN INCH

DOUBLE SIDED

NEEDLE CUT

**PLAY ON ALL GRAMOPHONES**
**Catalogue contains 4000 Titles by the Premier Artistes, Instrumentalists, Orchestras and Bands of the British Empire**

DEALERS PREPARED TO DO BUSINESS ARE INVITED TO COMMUNICATE WITH

**Proprietors and Manufacturers, J. E. HOUGH, Ltd., 62 Glengall Road, London, S. E. 15, England**
**FROM OUR LONDON HEADQUARTERS—(Continued from page 165)**

other manufactures, far from it, but I do hold that our manufacturers have had sufficient time to put their works in order, to revise their demeanor, to relegate to the limbo of the past that objectionable take-it-or-leave-it attitude, to give us better goods and to sell those goods as cheaply as possible consistent with a fair profit, in contradistinction to the present selling principle of get as much as you can. Look both ways is a good motto. Let us then face the facts. If the British market is catered as at present by British manufacturers, then, and I say it advisedly, British trade buyers and the British public will be forced into the old trade clutches of the continental merchants! One important difference between their method of trading and that of the average British merchant is their provision of goods that we want, not "That's the article we sell; take it or leave it!"

We all intend heartily to fight for British trade, but, again, the British manufacturer must collaborate. The trade, fortunately, retains some measure of faith, yet, that he will. It must be soon, the sands of time are running low. The signatures on the Peace Treaty are scarcely dry, but already we hear rumors of German commercial movements. There are plenty of trading loopholes, of which they will not be slow to take advantage. What are we—what is the British manufacturer—going to do about it?

Will Carl Lindström Reinstate British Market?

With the ratification of the Peace Treaty Dame Rumor is, of course, busy. That is, perhaps, to be expected. I am not going to chronicle all that is being said, because most of it is sheer nonsense and nothing else. British firms who have contracted for large supplies of motors, tone arms, sound boxes, etc., from home sources and from Swiss or other foreign centers are naturally prone to give more

credence than is deserved to the insidious statements that German manufacturers will again descend upon our market. One rumor is rather more persistent than others and it is to the effect that the Carl Lindström people have already appointed an agent for England. At the time of writing this agent, whoever he may be, is thought to have reached Holland on his way to consult with the Lindström directorate, which firm, by the way, is said to be interested in a big German combination of some eleven manufacturers.

Now, what is the position? It is, firstly, that the British public will not buy German gramophones if others are available at equal values, or even a little higher. Also, although the Government is taking overmuch time about it we are promised an anti-dumping bill that should effectually prevent any great flood of German gramophones or parts reaching us for many a long day. Again, the economic conditions in Germany are even worse than with us. Labor and materials are certainly equally costly, and new goods could not be manufactured and exported to England, the tariff duty also considered, at anything like competitive prices. Look, too, at the German financial position. The mark is worth to-day approximately fourpence, against the normal exchange rate of one shilling. It is scarcely likely that the German manufacturer could stand the loss and still less likely that their Government could carry it, when around its neck is a floating debt of \$18,000,000,000, with an annual bill of more than \$5,000,000,000.

Wm. Manson Honored by Zonophone Factors

In celebration of Mr. Manson's acceptance of the sales managership of the Gramophone Co., Ltd. (he retains, by the way, supervision of the Zonophone interests), Mr. and Mrs. Manson were "dined" on the evening of July 14 at Frascati's, London, at the instance of the Brit-

ish Zonophone Co.'s London and provincial factors. Mr. Alfred Clarke, managing director of the Gramophone Co., occupied the chair. About nineteen factors attended, some with their wives (a plural perversion), many having traveled long distances specially for the occasion, as witness, Thos. Edens Osborne, of Belfast; J. O'Neill, Dublin; J. Robertson, Glasgow, etc.

As representative of The Talking Machine World and other trade newspapers, I have attended most trade functions of a similar kind, but seldom have I witnessed such a spontaneous feeling of good fellowship among a body of commercial rivals or such a genuinely—almost affectionate—attitude towards one man, outwardly bound by ties of commerce only, as on this occasion. And the deserved object of it all was our genial friend, Wm. Manson, an unassuming gentleman of large sympathies, who, by these virtues, combined with the exercise of tact and ability throughout the trying period of the past five years, had won the hearts of his company's wholesale patrons.

Well over sixty persons sat down to the usual excellent repast one expects at Frascati's, and that over the chairman read numerous telegrams and letters of congratulation from factors and other friends of Mr. Manson's unavoidably absent.

After a few introductory words, Mr. Clarke then called upon "The Invincible Nineteen," as the factors were humorously described on the Zonophone toast list (July 14 supplement), each in turn to toast "Our Guest" in a three-minute-limit speech. Emphasis was placed by most of the "Invincibles" upon their trade link with Mr. Manson, being subversive to the personal element of friendship, though, as Howard Buck remarked, "Mr. Manson had been promoted to the position just simply because he deserved it." In recounting the various business virtues of their guest, valuing each to the company, some

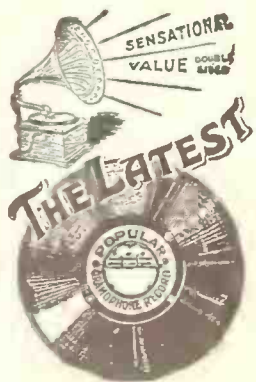

# YE "POPULAR" RECORDS

 Double-Sided  
 Superb Needle Cut  
 "Lateral"

**LONDON'S LEADING VALUE!!!**
**"OUR POINTS"**  
 SET OUT BELOW )

**Have Attracted Keen Overseas Houses**

 from SCANDINAVIA to PATAGONIA  
 AND THE PRINCIPAL  
 EAST and WEST MARKETS of the WORLD

**REMEMBER** You Can Have CLOSE QUOTATIONS  
 For 5,000 Lots and up "Your Selection" or a Sample 1,000,  
 made up with "One Example" of Every Catalogued Pairing.

 Address: **SOUND RECORDING CO., Ltd.** CABLES "Grammavox"  
 EXPORT DEPT., 18-19 Swallow Street London  
 Piccadilly, London, England "QUOTATIONS CABLED FREE"

**POINTS**

- ➔ Repertoire Approx 2,000 Titles—Covering
- ➔ Superb Selection, Bands and Orchestras
- ➔ Lightning Shipments
- ➔ Packing by Experts
- ➔ **Rock Quotations "Always"**
- ➔ F. O. B. London
- ➔ We attend to all Insurances "if Requested" to Buyers A/c
- ➔ Our Shipping Services, **this Side FREE**



# APOLLO GRAMOPHONES

Apollo  
Portable  
with  
Sound  
Reflector



Every type of instrument with Horn, Hornless, Table Grand, Pedestal and Portable.

**FINEST BRITISH WORKMANSHIP**

**Motors, Tone Arms, Sound Boxes and Accessories**

**AGENCIES OPEN FOR CERTAIN FOREIGN MARKETS**

*Write for lists and full particulars to the makers*

**CRAIES & STAVRIDIS, 4 BUNHILL ROW, LONDON, E.C.1.**

**FROM OUR LONDON HEADQUARTERS—(Continued from page 166)**

at £1,000, others at £2,000 per annum, H. J. Cullum (Lockwood) caused a deal of laughter when at £5,000 the chairman's wand of office was raised ominously. Other factors spoke appreciatively of the good treatment they had received at the hands of Mr. Manson, dwelling upon the excellent Zonophone delivery of records throughout the war period, and, like Oliver Twist, begged for more!

On behalf of the Zono factors Mr. Cullum now asked the chairman to present to Mr. Manson a "Mignon" grand piano. This piano, of a beautifully sweet tone, was played upon during the evening for the first time. It was cased in rosewood and represented a fine example of the product of the house of Chappell. In making the presentation, feeling assured that it would give Mr. and Mrs. Manson the greatest possible pleasure, the chairman took the opportunity of saying a few words as managing director of the Gramophone Co., Ltd. Mr. Manson had been selected for the position vacated by Mr. Ricketts, because they were satisfied he was the man for it. This gathering had confirmed him in that opinion and that meant a great deal. Paying tribute to the successful manner in which Mr. Manson had handled the Zonophone business the chairman mentioned that during the last eight years there had been no change, except one, in the list of Zonophone factors. A happy and a united family, truly!

Cheer upon cheer greeted Mr. Manson as he rose to reply. When it ceased silence reigned for a few long seconds. Deeply moved by this demonstration of sincere regard the lion of the evening obviously spoke from his heart—he doubted his ability to express all he felt, and, in thanking them for the great honor conferred upon him and his dear wife the loyalty and good wishes they had expressed he knew that all would understand what was in his heart to say. Next called upon, Mrs. Manson, better

known professionally as Miss Mabel Manson, made a most charming little speech. She captured the hearts of her audience by addressing them as her very dear pals, thanked them from the bottom of her heart for their great honor to her husband, of whom she was the happy and proud wife.

Speeches of thanks to and from the chairman and the committee (Messrs. Howard Buck, H. J. Cullum and Robert Willis) who so ably organized the whole affair, terminated a very useful and happy ceremony. During the evening Miss Mabel Manson, Ernest Pike, Harry Fay and other well-known artistes contributed choice morceaux from their repertoire.

#### Factories at Hayes Visited

Of the presence in London of so many good and true Zonophone and Gramophone men advantage was taken by the company to afford them a sight of the wonderful Hayes factories, which are in full swing, producing enormous quantities of instruments and records in musically pleasant contrast to the war-time production of shell cases, fuses, primers, ammunition cases, aeroplane parts, etc. Among those who accepted the company's invitation were R. J. Appleton (Leeds), Howard Buck (London), H. J. Cullum (London), A. Hindley (Nottingham), W. A. Johnson and Mrs. Johnson (Birmingham, Liverpool and London), B. Newton (Newcastle), J. O'Neill (Dublin), Thos. Edens Osborne (Belfast), E. C. Paskell (Birmingham), J. Richardson and R. Geddes (Manchester and Liverpool), J. Robertson (Glasgow), Mr. and Mrs. Lewis (Glasgow), Mr. and Mrs. Swaine Stoddart (Bradford), G. Wallis (London) and R. Willis (London and Glasgow). The press was represented by Mr. Alferi (music), R. Poulter (Talking Machine News) and W. Lionel Sturdy (Talking Machine World and Music Trade Review). Altogether, quite a large party foregathered at Paddington on the morning of

the day following the banquet. Arrived at Hayes the visitors in sections of three parties were conducted throughout the three huge works known as machine factory, cabinet factory, record factory. In the first our guide carefully explained each process of manufacture of the motors and, indeed, every metal part of the instrument, as we passed from shop to shop. Great interest was evinced in the series of huge machines on the ground floor busily stamping, punching or pressing, as the case may be. Turn tables, parts of sound boxes and motors, tone arms, etc., were here seen taking recognizable shape from discs or pieces of metal having no resemblance to the finished article. The automatic shop, next visited, at first glance presented to the visitors' gaze a forest of belting. Closer inspection revealed its connection with row upon row of wonderful human-like machines, accomplishing their work in the production of motor parts and other instrument essentials without the slightest apparent attention. The mill and drill, assembling, the foundry and other shops were in turn the object of keen enthusiasm on the part of all.

The manufacturing side of record production was next revealed. Through the huge power house, past the voracious furnaces, where fuel was simply gobbled without a thought on the stokers' part of the threatened six-shillings-a-ton coal increase, we reached the record factory. A new house for the making of record material is in course of construction. The sifting of the foreign elements from shellac by the magnetic process, the machines devoted to the mixing of the various ingredients in the composition of Zonophone records, the rolling mills which "blanket" and cut the material ready for the pressers—five rollers were on the job day and night—the pressing and finishing touches to the completed article, caused the visitors to

*(Continued on page 168)*

## Millions of Your "Boys" in France Heard the Scots Guards' and Hon. Artillery Company's Bands

When they come home it will be one of the pleasant memories of the "Great Adventure."

They will want to forget the "horrors of war" and recreate those rare occasions of happiness.

Then they will ask you, Mr. Dealer, for Gramophone Records of these two famous Bands.

Anticipate their wishes. The pleasure will be mutual.

A large selection by these two world-famed Bands and hundreds of Orchestral, Instrumental and Vocal pieces can be obtained on

### GUARDSMAN RECORDS

10 AND 12 INCH LATERAL CUT

1 New Inn Yard, London, E. C. Write for Catalogs and prices to **INVICTA RECORD CO., Ltd.** Cables: Duarrab, London



# TRADE IN G.T. BRITAIN

## S. & B. WOLFF

15 PAPER STREET

LONDON, E. C.

ENGLAND

ARE OPEN TO REPRESENT  
MANUFACTURERS OF GRAMOPHONES  
AND ACCESSORIES

ON COMMISSION OR SOLE SALES BASIS

BANKERS BARCLAYS COLEMAN ST.  
CITY

CABLES "CYCLONETTE" LONDON

### FROM OUR LONDON HEADQUARTERS—(Continued from page 167)

exclaim enthusiastically as process after process was revealed to them. The system of testing the records, their careful examination, disclosed the almost impossibility of a faulty disc leaving the factory. The manufacture of the copper matrix, its backing and various other operations in connection therewith and finally a peep into the company's fine laboratory, where all materials are tested and analyzed before use, completed our round of this truly amazing plant.

Next in order came the cabinet factory, where is produced in big quantities daily the various models which, outwardly, will carry the quality symbol of British workmanship from the village of Hayes to the great distributing centers throughout the Kingdom.

A fine luncheon was spread in the company's famous oak-paneled boardroom, and speeches of welcome and of congratulation passed host and guests. After a few felicitous words from Alfred Clark, Wm. Manson referred to the probable advent of "the gentle-tongued foreigner with his wiles" and averred that they had demonstrated "Britain's ability to supply Britain's needs" in gramophones and records, of course. Hayes can take care of that, we know as a result of our visit. It was mentioned by Mr. Clark that an additional six-story building would be erected as soon as possible, enabling them to double the output of records. Mr. Cul-

lum made an appropriate reply of thanks and congratulation on behalf of the visitors. It was a red-letter day for Zonophone factors. All departed with the knowledge that behind their business they had the support of the finest organization of its kind in Europe. The return journey to town gave me an opportunity of appreciating how vastly impressed and delighted they were with all they had seen.

The Winner Record Staff Celebrate July 4

Perhaps the above caption should read: "... celebrate on July 4." If the choice was by deliberate intention—there's no telling—it at least was a happy coincident. Anyway, my American readers must take it as a compliment that they did not altogether monopolize the great day for festival purpose. It was shared by all the employes of Messrs J. E. Hough, Ltd., of Edison-Bell and Winner renown, for a summer outing to Walton-on-Thames. Leaving Richmond Pier by 9.30 the party, to the number of 500 odd, arrived at their destination after a delightful "voyage" of about three hours' duration. Two large river steamers were specially chartered for the occasion. Old Father Thames reflected a sunlit demeanor, the scenery en passant being much admired by those members of the party who, be it whispered, were not otherwise engaged. Much to the pleasure of all, Mr. and Mrs. Hough were of the party.

After a stroll through the pretty riverside town Mr. Hough's big family began to respond to wiles of Little Mary. They were accommodated at two centers, the Angler's Hotel and the Working Man's Club. Very democratic, to be sure. But the hospitality of mine hosts rose nobly to the occasion and in each case their larders proved equal to the great strain put upon them. A sumptuous meal was followed by a few words from the "dear gov'nor," who, with Mrs. Hough, presided over the midday feast. He took the opportunity of thanking his staff and the trade generally for their extreme kindness and happy remembrance on two recent oc-

casions, i. e., his marriage and his seventieth birthday anniversary. What might be thought a good omen was mentioned by Mr. Hough, that the day peace was signed marked the close of the tenth year of the company's existence. Though legally true, so far as the registration of J. E. Hough, Ltd., is concerned, readers will, of course, know that Mr. Hough has been in the business since its inception. Continuing, Mr. Hough expressed his great pleasure as he glanced around to see so many of the old familiar faces, of many who had loyally stuck to him through thick and thin. So much loyalty had been demonstrated between them that there was no reason whatever to fear the troubles which affected other industries consequent upon the disturbing relations between capital and labor. A spontaneously hearty cheer reflected the opinion of his employes as Mr. Hough sat down.

Some enjoyable sports were indulged in after lunch, and about six o'clock the happy excursionists embarked for home. During the journey Mr. Hough distributed a number of valuable silver prizes, to say nothing of chocolates, cigarettes, cigars, etc.

The latter part of the day unfortunately went into liquidation, but, notwithstanding all voted it the best outing ever. A word of congratulation is due to Mr. Charles Lawreen, who, by his personal supervision of all the arrangements, contributed so much to the day's success. The whole party, too, will not soon forget the generosity of their employer, who, I understand, made himself responsible for the costs of this most enjoyable outing—further proof of his generosity.

Victory and Peace Zonophone Records

Most companies have commemorated the symbol of peace by the issue of appropriate titles, but special mention should be made of the Zonophone program. Jazz, rags, two-steps and other examples of the terpsichorean art have been issued in endless variety and number, too pro-

**J. Stead & Co., Ltd.**

Manor Needle Works

SHEFFIELD, ENGLAND

MANUFACTURERS OF

Talking Machine

**Main Springs**

Best Prices—Best Quality  
Inquiries Solicited



# GRAMOPHONES

Complete—Fittings—Sundries—Repair  
Parts—Needles

*Special Lines and Quotations for Export Trade*

## THE BRITISH POLYPHON CO.

Glasgow, Scotland  
27 Jamaica St.

1, 2 and 3 NEWMAN STREET  
LONDON, W. 1, ENGLAND

FROM OUR LONDON HEADQUARTERS—(Continued from page 168)

lific for detailed mention. The enormous Zono record output of dancing selections is lamentably short of the demand, which is almost insatiable just now. With this class of record the great peace is being celebrated all over the Kingdom. The trade—Zonophone and generally—is in consequence enjoying a remarkable prosperity. Perhaps the more pertinent Victory records published on Zonos are No. 1833, "Victory Overture," parts one and two a rousing and inspiring morceau; also the grand peace record, No. 1896, part one, "Arrival of the Troops in London," part two, "The Royal Review," which in a previous issue I described as the best of its kind ever issued. It is really a most remarkable presentation of joyous acclamation by a typical London crowd welcoming home the boys. Everything, just as it actually happens, is faithfully produced with a fidelity beyond compare. Another appropriate number is 1809, "When the Bells of Peace Are Ringing" and "All the World Will Be Jealous of Me," both exceedingly well sung by Herbert Payne, with chorus. Though it is true to say that all Zonos are good, these records are especially so and should therefore be heavily stocked by all home and oversea dealers.

### Miscellaneous Notes of Trade Interest

The mails between England and America still take an inordinate length of time, which partly accounts for the statement in my June issue report that Mr. A. Balcombe had sailed for New York. At the last minute his plans were changed, and I understand it is now his hope, if not his intention, to get away some time early in September.

The Johnson Talking Machine Co. (1919) of Liverpool and Birmingham announce the opening of a London depot at 244 Tottenham Court Rd., where they will carry full stocks of Zonophone and Columbia goods, motors, tone-arms, and other parts and accessories.

Another firm for which London has an attraction is G. A. Bryan, Ltd., of Croydon. This firm has equipped a splendidly commodious warehouse of some 30,000 square feet, located on Southwark street. While not difficult of access to north of the Thames dealers it is very centrally situated and more easily get-at-able for dealers on the south side. Complete and prompt service will, however, attract the suffrage of all live dealers, and with that in mind Messrs. Bryan have stocked fully to the last button, as it were. They specialize Winner records, Columbia goods, and carry a complete range of motors, sound boxes, horns, tone-arms, springs, needles, and a-hundred-an'-one other necessary parts and accessories.

Mr. E. Somerfeld, I learn, has accepted the position of manager to Messrs. Luyton & Co., who are giving up the cycle accessories branch of their business with a view to confining their future trade solely to goods gramophonie. Good!

The Association of Gramophone and Musical

Instrument Manufacturers and Wholesale Dealers has been registered as a limited company. Pressure on space this month compels me to hold over comment until next issue.

A recent visitor to London was an old friend, Thos. Edens Osborne, the Belfast factor. He speaks well of Irish trade prospects, the only complaint being inability to get Edison goods. And he is not the only one, Mr. Edison! The "Decca" Aloft—Aerial Trip to New York

The manufacturers of the portable "Decca" gramophone, Messrs. Barnett Samuel & Sons, Ltd., this city, have achieved a scoop in getting one of their famous little instruments aboard the R-34. It proved a delightful passenger, and as Lieut. Shotter says in his diary: "Our gramophone has been a godsend to us. I saw four of the younger members of the crew dancing a sort of rag just now." In order not to impair his chance of accomplishing the great voyage the captain of the R-34 was forced to consider every ounce weight, and only at the last moment was room found for the "Decca"—one of the most compact portable gramophones on the market, by the way. Immediately on receipt of a wire that it had been taken aboard, Messrs. B. S. & S. conceived a big advertising campaign in the daily press and other journals. The advertisement copy pictured R-34, with the telegram of advice, previously mentioned, announcing the fact of the "Decca" being on board, a few choice words including the very appropriate slogan, "They shall have music wherever they go," with an illustration of the instruments. The whole, being imposed upon a marine view, formed a decidedly attractive advertisement, which must result in a larger demand than ever for the famous "Decca."

### False Reports About the British Polyphon Co.

Reports having been circulated by malicious persons that in the above business alien interests still exist, a reward of £100 is offered by Robert Willis, the sole proprietor, for information that will enable him to take legal proceedings. The facts are that the pre-war German business known as the New Polyphon Co. was wound up by the Board of Trade, from whom Mr. Willis purchased it on January 1, 1917. As Mr. Willis further states in a public warning: "Before completing the purchase I had to furnish guarantees to the Board of Trade as to my bonafides as a British subject. I am sole proprietor and nobody else is interested in this business, either directly or indirectly. Moreover, the staff is entirely British."

That should effectually squash any more statements to the contrary; it is twenty-two carat.

### "His Master's Voice" Instrument Production

After a long period the issue of His Master's Voice new instrument catalogue, as reported in this section last month, has met with a wonderful welcome from the trade. The company's new sales manager, Wm. Manson, tells

me that huge orders have been placed for the various models, which, by the way, are throughout all-British. "Changing over from war work," said Mr. Manson, "is a more complicated process than is generally imagined. We have been at it day and night for the past few months, and I am happy to say that all our instruments are now equipped with fittings made in the 'His Master's Voice' factories. The chief task was the manufacture of the motor. We are now producing single, double and triple spring mechanism of first grade quality in conformity with the 'His Master's Voice' standard. Delivery will commence in August." Welcome news, indeed, to "His Master's Voice" agents!

### Topical "Guardsmen" Records

A feature of the latest Guardsman list is the evident care shown in the class of titles offered. The buyers of this record embrace a variety of musical tastes, for the items represented offer a very wide choice. I notice that Jack Charman, who before the war was a prolific record maker, is again to the fore, being a contributor of two comic numbers on record 917. Messrs. Francis & Farrington are down for no less than six duets (three records), and Tom White offers two well-played concertina solos—"Destiny Waltz" and "Consolation Waltz." "One Day Nearer Home" and "That Little White Cottage of Mine," two popular songs by A. J. Meredith (tenor); "For You Alone," by W. G. Ellis (tenor), and "Little Mother of Mine," by Miss Margaret Eaton (contralto) should all prove good sellers. The foregoing are all ten-inch doubles. There are two double twelve-inch records bearing four topical numbers, some from the Revues, played by the Chevron Dance Orchestra.

### British House Wants American Representation

With the removal of import and export restrictions on gramophone goods a speeding-up of trade between America and Great Britain is anticipated. Several American firms have already made arrangements for representation here. In this regard Messrs. S. & B. Wolff, 15 Paper street, London, E. C. 1., announce elsewhere in this section that they are open to represent first-class wholesale American houses. With convenient showrooms in the heart of London and being well acquainted with the large buyers in English gramophone trade, Messrs. Wolff are well equipped to take care of

(Continued on page 170)

## Horn, Hornless and Table-Grand GRAMOPHONES

FOR

## EXPORT

Please State Your Requirements

REX GRAMOPHONE CO. 2 Elizabeth Place  
Rivington Street, LONDON, E.C. 2, England  
Cable Address "Lyrecodisc, London"





# Soaring

with a burst of silver melody surpassing  
"Sound of vernal showers on the twinkling grass.  
Rain awakened flowers—all that ever was  
Joyous and clear and fresh  
—there is all the transcendent purity of the Singer in the  
Blue wrought into "Songster tone."

## SONGSTER NEEDLES

are a Sheffield product of best steel tapered to a very fine point. It's this sensitive point that gives such wonderful definition and volume to the reproduction. People will be asking for "Songster"—and the waxed wrapping sealed round each box is your guarantee that they get undeteriorated quality every time. Just here is your chance to get in line with the demand and build up profitable sales on "Songster" reputation.

Drop a card to-day—it brings you a free  
sample box and list of Price Quotations.

**A. Waite & Co. Ltd.**  
15-17 Figtree Lane  
SHEFFIELD

### FROM OUR LONDON HEADQUARTERS—(Continued from page 169)

American interests this side. Both partners have been in the trade many years and from my knowledge of them I think they are in a position satisfactorily to handle any business with which they may be entrusted.

#### Louis Sterling's Interesting Address

At the ninth British Music Convention held at Birmingham, July 20-23, the greater part of the time was devoted to a discussion upon the establishment of a Federated Board of the Musical Industries of Great Britain, somewhat on the lines of the United States Musical Industry Chamber of Commerce. A most useful discussion resulted in the passing of a resolution that the Federation should be started in the autumn. That of most interest to my readers was a paper entitled, "Gramophone Conditions in America," read by Louis Sterling (Columbia) at the sectional meeting of the gramophone and small goods manufacturers, over which presided M. E. Ricketts. Mr. Sterling said:

"The gramophone shop in the United States has become as fixed an institution as their public buildings. The gramophone store is as high-grade an establishment as the most expensive jewelry store or piano store—in choice of position, in furnishing and in character. In New York and the larger cities the rents for exclusive gramophone stores run as high as £10,000 a year, and in New York alone there are at least twenty-five such exclusive stores at rentals from £3,000 to £10,000 per year. The gramophone is not a side line as it is here. Every piano dealer who handles gramophones either has a separate store or department which in itself is as big or bigger than the average music store here. Every such dealer has at least six demonstration booths where records can be tried over, and this number ranges between that and eighty booths. Lyon and Healy, of Chicago, have some sixty or seventy booths. And this is such a feature of the gramophone stores that there are manufacturers who ex-

clusively devote their factories to the construction of these booths. These booths are one of the most remarkable things about the American gramophone store. No dealer would think of playing over records in the store—you retire to the booth, and so the dealer's assistants can be selling records to several customers at once. The idea is only beginning to be adopted in this country, but is proving just the same success. The right idea is to display the gramophone and demonstrate the records in a setting which suggests harmony.

"The shops are furnished in luxurious styles. They are more like reception rooms or halls than mere places of trade. They are tastefully decorated and comfortably furnished. Everything is conceived with the idea of making the visitor feel welcome. He is, of course, but the American dealer does not say so in as many words. He tries to suggest it, in very subtle ways, but effectively.

"Pictures of artists hang on the walls, a soft carpet covers the floor and inviting chairs simply ask to be sat in. Small tables bearing printed matter and lists are scattered about, always within handy reach of a seat. Record display racks carry a selection of newest records,

#### STARTS IN THE WHOLESALE FIELD

Max L. Goldbert, who has been identified with the talking machine industry for several years, has recently started in business, wholesale merchandising talking machines and records on a large scale, at 3-5 Waverly Place, New York. He has acquired a distributing depot of several thousand square feet where a large number of machines and records may be stored at all times, in order that he may give the best service possible to dealers. He states, as usual, he is open to purchase any size stocks of phonograph product, or factory outputs, for which he will pay cash.

and other racks arranged in screen fashion display the latest artistic posters. Although the dealer is quite anxious for you to be comfortable in his store he is clever enough to surround you with little things that will make selling suggestions to you and help you to make up your mind to buy something or several somethings. Silent salesmen, he calls them. In New York dealers have spent from £5,000 to £20,000 to produce these luxurious effects and with store rents ranging from £1,000 a year upwards you will see that the gramophone business in America is indeed on a very high plane and on a very extensive scale."

Continuing Mr. Sterling told of the demand for machines of the higher grades in the American market, and of the vast amount of money spent by manufacturers and dealers in advertising. He also made reference to the development of the period types of machines at prices ranging from \$500 to \$5,000. He reviewed in detail various selling methods with which he comes in contact, and in the discussion that followed the reading of his paper offers some interesting suggestions for the consideration of British gramophone dealers.

#### Columbia Secures "Monsieur Beaucaire."

The triumph of Andre Messager's delightful music in "Monsieur Beaucaire," for the production of which English music lovers owe a debt of gratitude to Gilbert Miller, is a sure and certain sign that there is as great an appreciation of light opera to-day as there ever was. It is for us, too, a matter for general congratulation that so far as records of the production are concerned the Columbia Co. (who have secured the exclusive rights) regard this higher type of musical production as of even greater importance than the most successful revues, and consequently are lavishing upon it the same expedition of issue, the same completeness and an even greater attention to detail.

"Monsieur Beaucaire" introduces to British music an established favorite in the person of Miss Maggie Teyte, fresh from her operatic triumphs in America: Marion Green, possessing a baritone voice of unexampled brilliance and power, and such popular British artists as Robert Parker, John Clarke and Alice Moffat—in all a cast of vocal excellence far beyond the average.

#### Burke's Four New Records

The Columbia Co. announce four new records by Thomas Burke, this making a total of six now available. The sensation caused by Burke's Covent Garden debut has resulted in an enormous demand for his records and the latest four have been urgently called for by those who were impressed by the first issues. They give the great tenor in the principal airs "La Donna e Mobile" and "Questa o Quella" from "Rigoletto" (which Burke has sung at Covent Garden), "M'Appari" from "Martha" and "Chiudo gli oochi" from "Manon."

#### NO CONNECTION WITH THE CONCERN

Newark, N. J., July 30, 1919.

The Talking Machine World, New York.

Gentlemen: Our attention has been called to the article in your issue of July 15, 1919, regarding proceedings of the Federal Trade Commission against the Boston Piano & Music Co., of Iowa City, Ia., regarding practices in the sale of talking machines and records known as Masterphone machines and records.

This is the first information we had of the use of our trade mark MASTERPHONE by any other concern and we would be obliged if you would make public the fact that the Boston Piano & Music Co. has no connection whatever with the Masterphone Corp., of New York and Newark, which makes and sells the attachment for talking machines known as the Masterphone. Very truly yours,

THE MASTERPHONE CORP.,

By W. J. Burckett, President.

W. E. Henry, special representative of the foreign record department of the Columbia Co., has returned from a Pacific Coast visit.

**GOLD PLATING** of **Tone Arms, Sound Boxes and Phonograph Parts**  
**OUR SPECIALTY**

PRICES QUOTED ON REQUEST

**Cliff Manufacturing Works, Inc.** 20-22 JACOB STREET  
NEW YORK CITY



# LATEST PATENTS RELATING TO TALKING MACHINES AND RECORDS

WASHINGTON, D. C., August 8.—PHONOGRAPH ATTACHMENT—Arthur G. Remhilt, Philadelphia, Pa. Patent No. 1,304,513.

This invention relates to phonograph attachments, and one object is to provide certain novel means for guiding a thread across the needle or stylus in order to secure improved results in the reproduction of the record. A further object is to provide a device adapted to be carried by the casing retaining the diaphragm, said device being detachable and serving to mount a plurality of winding elements adapted to carry a thread along opposite sides of the needle and across the edge thereof.

Figure 1 is a view in side elevation showing means for mounting reels or spools for the thread so that the latter shall pass across the needle.

Fig. 2 is a perspective view of the ring member in which the spools are mounted.

Fig. 3 is a perspective view of the device for guiding the thread across the needle.

Fig. 4 is a perspective view of the needle or stylus, the shank portion of which passes

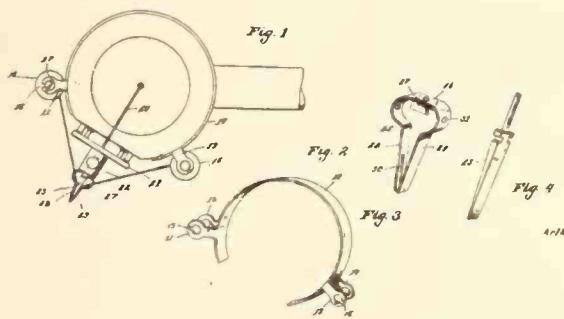

through the central portion of the device appearing in Fig. 3.

PHONOGRAPH OR TALKING MACHINE—John P. Constable, West Orange, N. J. Patent No. 1,304,158.

In the improved device the sound conveyer forming a part of the phonograph or talking machine is preferably so mounted at the large or exit end that the whole conveyer and the reproducer connected thereto move about a substantially horizontal axis to permit disengagement of the reproducer from the record. During the reproduction of a record the sound conveyer and the reproducer move laterally of the record, this lateral movement being preferably obtained by mechanical feeding means. The said means are rendered inoperative by the same adjustment of the sound conveyer which causes the reproducer to be moved out of engagement with the record. One of the objects of the invention is to provide in a machine of the class described improved means for mounting the sound conveyer and for disengaging the reproducer from the record and rendering the mechanical feeding means inoperative. Other

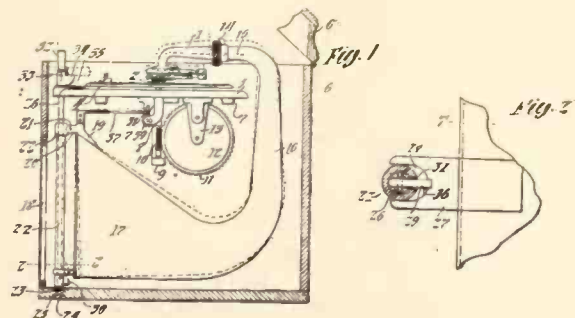

objects of the invention will be more fully described in the following specification and appended claims.

Figure 1 represents a view partly in elevation and partly in section of a phonograph or talking machine embodying the preferred form of the invention, and Fig. 2 represents a section taken on the line 2-2 of Fig. 1.

PHONOGRAPH—Leo J. O'Riley, Grand Rapids, Mich. Patent No. 1,303,951. This invention relates to improvements in phonographs. The

main objects are; First, to provide an improved phonograph by which all tones are very accurately reproduced. Second, to provide an improved phonograph in which the tones produced are of great carrying power and at the same time without harshness or mechanical sound. Third, to provide an improved horn for phonographs.

Figure 1 is a vertical central section on a line corresponding to line 1-1 of Fig. 2 of a

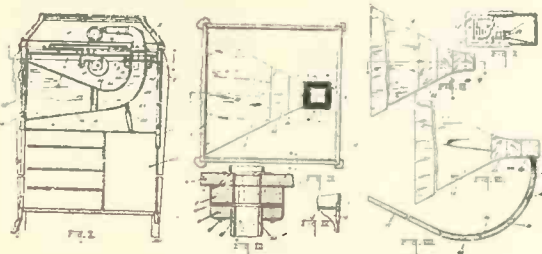

structure embodying the features of the invention, the tone arm, record and parts of the motor being shown in full lines and more or less conventionally.

Fig. 2 is a horizontal section on a line corresponding to line 2-2 of Fig. 1.

Fig. 3 is an enlarged detail vertical section through the motor board and the end of the horn on a line corresponding to line 3-3 of Figs. 1 and 2.

Fig. 4 is a detail section on a line corresponding to line 4-4 of Fig. 2, showing details of the sounding board.

Fig. 5 is a detail front elevation showing the sound opening and the relation of the mouth of the horn thereto.

Fig. 6 is a detail plan view of the horn as it would appear extended or straight, showing the arrangement of the top wall parts.

Fig. 7 is a detail bottom view of the horn as it would appear extended or straight, showing the arrangement of the bottom wall parts.

Fig. 8 is a detail longitudinal section through the top wall of the completed horn on a line corresponding to line 8-8 of Fig. 6.

CENTRAL MECHANISM FOR PHONOGRAPHIC APPARATUS. Frank D. Lewis, West Orange, N. J., assignor to Pathé Frères Phonograph Co., Brooklyn, N. Y. Patent No. 1,303,927.

This invention relates to control mechanism for phonographic apparatus and includes repeat mechanism which can be applied to a phonograph alone, or control mechanism in accordance with the invention may be utilized for simultaneously actuating a phonograph so as to cause reproduction of a portion of the record to be repeated, and also for controlling the operation, as by starting and stopping the same, of means adapted to display visible characters or symbols corresponding to the sound reproduced from a phonograph record.

In the drawings forming part of this specification, Figure 1 is a plan view of a phonograph and display apparatus equipped with one

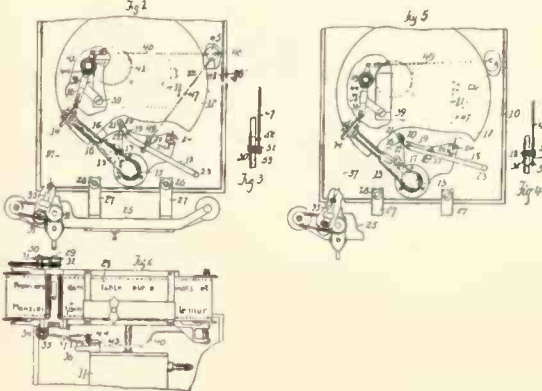

form of control means in accordance with the invention. Fig. 2 is a front view thereof. Fig. 3 is a sectional detail view showing operating parts in one position. Fig. 4 is a view similar to Fig. 3, but showing the operating parts in a different position, and Fig. 5 is a plan

view similar to Fig. 1 with parts broken away and showing the operating parts in another position from that of Fig. 1.

STYLUS GUIDING DEVICE.—Harry Horn, Brooklyn, N. Y. Patent No. 1,303,900.

It is well recognized that there is a great deal of breakage in phonograph records, owing to carelessness or inexperience in placing the stylus in tracking relation to the record, the breakage being due to the fact, mainly, that the reproducer and tone arm are allowed to drop on the edge of the record with such force that the record is either seriously scratched or broken. In either event the loss is a very substantial one, yet, so far as applicant is aware, no means of the type herein under consideration has been devised to obviate the breakage or injury adverted to.

The present invention overcomes the disadvantages specified. Speaking generally, the invention, from a structural standpoint, embodies a member, preferably mounted on the top of the phonograph cabinet, adapted to co-operate with the stylus and record in such manner that when the stylus is placed thereon it may be moved laterally into tracking position on the record in such manner as to preclude all danger of scratching or breaking the record.

Referring to the drawings, Fig. 1 shows a phonograph in perspective with the device of this invention mounted on the cabinet; and Fig. 2 shows a fragmentary section of a phonograph, with the devices of this invention

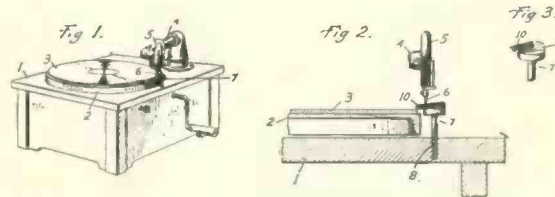

shown in co-operative relation with the stylus and reproducer; and Fig. 3 shows a fragmentary perspective view of the device of this invention.

TONE-MODIFIER.—Harold Edward White, Putney, London, Eng., assignor to the Aeolian Co., New York. Patent No. 1,304,005.

This invention relates to sound reproducing instruments, the chief object being to enable the volume of sound emitted by the instrument to be varied and controlled in a more reliable and effective manner than has heretofore been possible.

According to the invention a pneumatic or hydraulic sound modifying appliance for the gramophone or similar sound reproducing instrument is provided and adapted to be controlled so as to vary the volume of sound emitted by the instrument. The sound modifying appliance preferably comprises a flexible chamber situated at some point between the sound box and the mouth of the instrument and adapted to be expanded or contracted at the will of the operator by pneumatic or hydraulic means so as to vary the opening for the passage of the sound.

Alternatively the sound modifying appliance may be of any other suitable type, for example, it may comprise a valve, plug, disc or other obturating device, arranged between the sound

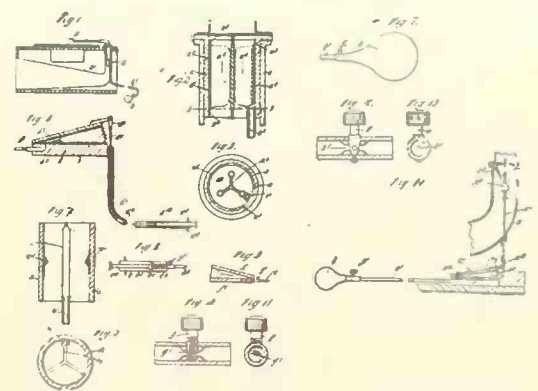

box and the mouth of the instrument and operatively connected with a flexible bulb, bellows, air container or other pneumatic or hydraulic pressure producing means so as to be actuated by the air or liquid pressure produced thereby, such flexible bulb or other means



being controlled by the operator or by the driving mechanism of the gramophone, phonograph or other sound reproducing instrument.

Figure 1 is a sectional elevation of the recording instrument in the form of a gramophone showing the improved sound modifying device applied thereto. Fig. 2 is a sectional elevation of one form of the improved sound modifying appliance. Fig. 3 is a cross sectional view thereof taken on the line 3-3 of Fig. 2. Fig. 4 is a sectional elevation of a modified form of the sound modifying appliance, and Fig. 5 is a cross sectional view thereof. Figs. 6 to 9 inclusive show various forms of pressure producing means employed with the appliance. Figs. 10 to 13 inclusive are detail views of valves adapted to control or sustain the action of the sound modifying appliance. Fig. 14 is a sectional elevation of a portion of a horn for use with the reproducing instrument showing a further modification in the improved sound modifying appliance applied thereto.

**SELF-OPERATING TALKING MACHINE.**—Garrett W. Woodward, Chicago, Ill., assignor to J. Herbert Benjamin, same place. Patent No. 1,306,241.

This invention relates to improvements in talking machines of the type wherein provision is made for automatically playing in succession a plurality of records without requiring any action on the part of the operator; and the primary objects are to provide improvements in machines of this type to the end that the mechanism may be simplified and rendered less expensive; that the space occupied by the mechanism and records may be reduced to the minimum, particularly with a view to providing a machine of such size that it will be especially desirable for household use; and to provide for the replaying of any record, and by a simple manipulation so condition the machine that it may be played in the usual way; and other objects as will be understood from the following description.

Referring to the accompanying drawings, Figure 1 is a view in side elevation, with certain parts broken away, of a cabinet talking machine constructed in accordance with the invention, the parts illustrated being shown in the positions they assume while playing one of the records. Fig. 2 is an enlarged elevational view of the operating mechanism shown in Fig. 1, certain parts being broken away and viewing the record-feeding devices at the irregular line 2-2 on Fig. 4. Fig. 3 is a section

one of the intermediate positions of the feeding disks. Fig. 7 is a plan view of the disk of Fig. 6. Fig. 8 is a view in elevation, partly sectional, of the feeding-disk of Figs. 6 and 7, together with its supporting and operating mechanism, the disk being shown in the position it assumes when in record-feeding position, a portion of a record being shown by dotted lines, in a position preparatory to feeding, and by full lines in the act of dropping from the feeding means to the turn-table of the talking machine mechanism. Fig. 9 is a view in side elevation of the lower end of the upper section of the spindle supporting and driving the record-feed disk. Fig. 10 is a similar view of the upper end of the other section of this spindle. Fig. 11 is a view in side elevation of a portion of the mechanism for raising and lowering the tone arm and swinging it out of the path of movement of the records in the feeding of the same to the turntable. Fig. 12 is a section taken at the line 12-12 on Fig. 11 and viewed in the direction of the arrows. Fig. 13 is a view in elevation of a cam device forming a part of the mechanism of Figs. 11 and 12, and Fig. 14 a modification of the intermittent driving mechanism of Fig. 4.

**TONE REGULATOR FOR PHONOGRAPHS.**—Charles H. Smith, Chicago, Ill., assignor to Smith, Barnes & Strohber Co., same place. Patent No. 1,306,196.

This invention relates to tone regulators for phonographs and the object of the invention is to provide efficient means whereby the volume of sound issuing from the machine may be regulated in accordance with the wishes of the user.

Figure 1 is a perspective of the upper portion of a phonograph equipped with the inven-

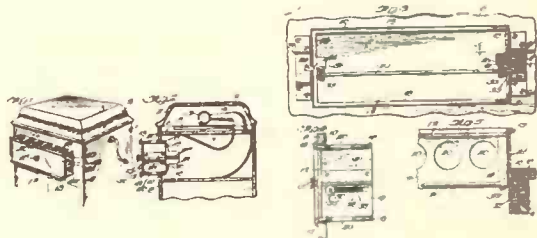

tion. The regulator is here shown pulled forward approximately to the limit. Fig. 2 is a vertical section, taken from front to rear, of the parts shown in Fig. 1. Fig. 3 is an elevation drawn to an increased scale, showing more particularly the guiding means and the equalizing mechanism by which the two ends of the regulator are compelled always to move equal amounts. The view is partly in section but is chiefly in elevation, looking toward the left in Fig. 4. Fig. 4 is a sectional elevation of the tone regulator and a portion of the front of the phonograph adjacent thereto, the plane of section being from front to rear. Fig. 5 is a plan section on the line 5-5, Fig. 3.

**PHONOGRAPH ARM AND HORN ATTACHMENT.**—George A. Hoover, Salisaw, Okla. Patent No. 1,306,182.

This invention relates to improvements in phonograph arm and horn attachments.

It relates particularly to the type of phonograph having a casing in which a horn is

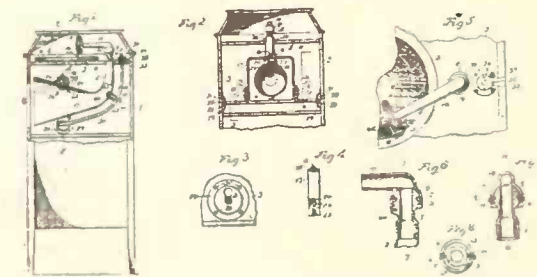

wanted and in which the reproducer arm is pivoted on the horn so as to swing vertically and laterally.

Figure 1 is a view partly in vertical section and partly in side elevation of the improvement in phonograph arm and horn attachments, shown mounted in a casing of an ordinary type. Fig. 2 is a vertical sectional view on the line 2-2 of Fig. 1, the record table being removed. Fig. 3 is an enlarged cross section on the line 3-3

of Fig. 2. Fig. 4 is an enlarged vertical sectional view on the line 4-4 of Fig. 2. Fig. 5 is an enlarged view partly in plan, partly in horizontal section and partly broken away, showing the reproducer arm, a part of a record and a part of the casing and parts connected therewith. Fig. 6 is a vertical section on the line 6-6 of Fig. 7. Fig. 7 is a vertical section on the line 7-7 of Fig. 6. Fig. 8 is a cross section on the line 8-8 of Fig. 7.

**SUPPORT FOR HINGED MEMBERS.**—Jacob F. Larsen, Chicago, Ill., assignor of one-half to James Dziadaszek, same place. Patent No. 1,306,853.

This invention relates to certain improvements in means for supporting hinged members, especially the lids or covers of phonographs, graphophones, desks, trunks, boxes, pianos, trap doors and the like, when raised or turned on their hinges, to any desired elevation or angle, in such a manner that the supporting action or operation of the device will be automatic and of such a character as to securely hold the members in their tilted or raised position without accidental lowering or falling of the same, yet so that by the proper manipulation of the cover or member and by applying slight downward pressure thereto it can be easily lowered or closed, in which position it will remain until again lifted.

The principal object of the invention is to provide a support of the above-named general character, which shall be extremely simple and inexpensive in construction, strong, durable, and effective in operation, and has means whereby the tension of a spring may be adjusted and regulated so that it may be efficiently used in connection with hinged members of varying weights and dimensions.

A further object is to provide a support for hinged members, the parts of which shall be so made and arranged that they can be readily applied or attached to the article and its cover or hinged member, and when in use will be concealed or protected, when the cover or member is closed. Numerous other objects and advantages of the invention will be disclosed in the subjoined description and explanation.

Figure 1 is a fragmental vertical sectional view of a portion of a casing with a support for the lid thereof embodying the invention applied thereto, and illustrating the lid or hinged member in its lowered or closed position. Fig. 2 is a vertical sectional view taken on line 2-2 of Fig. 1, looking in the direction indicated by the arrows. Fig. 3 is a similar view to that shown in Fig. 1, but illustrating the lid or

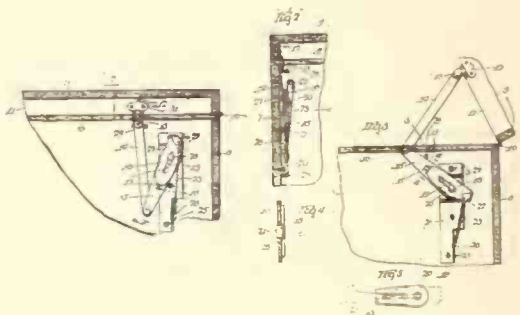

hinged member in a raised position, and also showing the positions the parts of the support will occupy under such conditions.

Fig. 4 is an enlarged cross sectional view of the compound lever of the support, and Fig. 5 is a slightly enlarged face view of a portion of said lever.

The Pleasing Sound Phonograph Co., 204-206 East 113th street, New York, is a new entry into the talking machine field and will sell talking machines, cabinets, parts and accessories. The two members of the firm are I. Pascal and L. Silverman.

## LESLEY'S PATCHING VARNISH

dries in 10 seconds, flows without showing the lap. With it damaged varnish can be repaired invisibly. New price 1 pt. \$1; 1 qt. \$1.90. Complete repair outfit \$3.50. F.O.B. Indianapolis, Ind. LESLEY'S CHEMICAL COMPANY, Indianapolis, Ind.

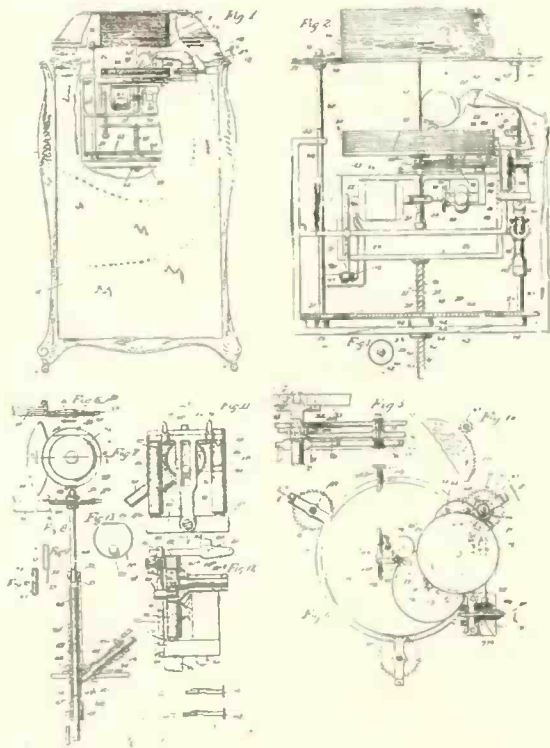

taken at the line 3-3 on Fig. 2 and viewed in the direction of the arrows. Fig. 4 is a plan section taken at the line 4-4 on Fig. 2 and viewed in the direction of the arrows. Fig. 5 is an enlarged broken view taken at the line 5-5 on Fig. 4 and viewed in the direction of the arrows. Fig. 6 is a diagrammatic view of one of the similar record-feeding disks, showing a single record thereon, this view illustrating



ADVANCE RECORD BULLETINS FOR SEPT., 1919

VICTOR TALKING MACHINE CO.

- POPULAR SONGS
18566 My Swanee Home. Vivian Holt-Lillian Rosedale 10
18588 A Pretty Girl Is Like a Melody. John Steel 10
18589 Anything Is Nice If It Comes from Dixie-land. American Quartet 10
18590 You're Still An Old Sweetheart of Mine. Elizabeth Spencer-Henry Burr 10
18591 In the Heart of a Fool. Henry Burr 10
18592 Take Your Girlie to the Movies. Billy Murray 10
18593 I Ain't Got 'en No Time to Have the Blues. Billy Murray-Ed Smalle 10
18562 Peter Gink. One-step. Six Brown Brothers 10
18563 Ruspana. One-step. Six Brown Brothers 10
18564 Fidgety Feet. One-step. Original Dixieland Jazz Band 10
18594 Tell Me. Fox-trot. Joseph C. Smith's Orchestra 10
45166 Smilin' Through. Reinald Werrenrath 10
45167 Think Love of Me. Reinald Werrenrath 10
45167 Chinese Lullaby. Olive Kline 10
18587 Mrs. Rastus Johnson's Joy Ride (Comic Monologue). Ralph Bingham 10
RED SEAL RECORDS
74595 Yohrzeit (Kadish) (In Memoriam). Silberstein-Rhea Silberta 12
88612 La Campa di San Giusto (The Chimes of San Giusto). Drovetti-Arona 12
64816 For You a Rose. Cobb-Edwards 10
74595 La Traviata—Ah, fors'è lui (The One of Whom I Dreamed). Giuseppe Verdi 12
64770 Turkish March (From "Ruins of Athens"). Beethoven 10
87303 Hard Times, Come Again No More. Stephen C. Foster 10
64817 Beautiful Ohio. Mary Earl 10
64818 The First Rose of Summer. Caldwell-Kern 10
74593 Scheherazade—Festival at Bagdad. Rimsky-Korsakow 12
87302 Sun of My Soul. Keble-Ritter 10

COLUMBIA GRAPHOPHONE CO.

- 49559 Il Trovatore. D'Amor Sull' Ali Rosee (Love Fly on Rosy Pinions). Rosa Ponselle 12
49590 The Sunshine of Your Smile. Riccardo Stracciari 12
A6112 Kathleen Mavourneen. Barbara Maurel 12
Love's Old Sweet Song. Barbara Maurel 12
A2753 Dear Old Pal of Mine. (Violinist) Sascha Jacobsen 10
Serenade. (Violinist) Sascha Jacobsen 10
NEW RECORDING OF COMPLETE PEER GYNT SUITE
A6109 Peer Gynt Suite—Morning, Part I. Columbia Symphony Orchestra 12
Peer Gynt Suite—Ase's Death, Part II. Columbia Symphony Orchestra 12
A6110 Peer Gynt Suite—Anitra's Dance, Part III. Columbia Symphony Orchestra 12
Peer Gynt Suite—In the Hall of the Mountain King, Part IV. Columbia Symphony Orchestra 12
NOVELTY RECORD FOR SEPTEMBER
E4294 Kossovo Waltz. Royal Serbian Tambouritz Orchestra 10
Waves of the Marne Waltz. Olga Bibor's Gypsy Orchestra 10
THE POPULARS
A2748 You're Making a Miser of Me. Henry Burr 10
Some Day You'll Be Sorry That You're Glad. Irving and Jack Kaufman 10
A2755 My Swanee Home. Sterling Trio 10
My Sugar-Coated Chocolate Boy. Campbell and Burr 10
A2756 Take Your Girlie to the Movies (If You Can't Make Love at Home). Irving Kaufman 10
Pig Latin Love. Arthur Fields 10
A2757 Oh! How She Can Sing. Van and Schenck 10
And That Ain't All. Billy Murray 10
THE DANCE RECORDS
A2751 One and Two and Three and Four, Rock-a-Bye. Medley one-step. Intro. (1) "For Johnny and Me." (2) "The Boys Who Won't Come Home." Waldorf-Astoria Dance Orchestra 10
"Monte Cristo, Jr." Medley fox-trot. Intro. (1) "Flutter on By, My Broadway Butterfly." (2) "Sahara (We'll Soon Be Dry Like You)." (3) "Monte Cristo." Waldorf-Astoria Dance Orchestra 10
A2758 The Vamp. One-step. Waldorf-Astoria Singing Orchestra 10
Behind Your Silken Veil. Medley Fox-trot. Intro. "What Would We Do Without the Girls." The Happy Six 10
A2759 Ting-Ling Toy. (Fox-trot). Columbia Saxophone Sextet 10
Where the Lanterns Glow. Medley one-step. Intro. (1) "My Golden Rose." (2) "Everybody Calls Me Honey." Columbia Saxophone Sextet 10
AUGUST MID-MONTH LIST
POPULAR HITS
A2754 My Little Sunshine. Charles Harrison 10
How Can You Say Good-Bye. Irving and Jack Kaufman 10
A2749 The Music of Wedding Chimes. Peerless Quartet 10
Dear Old Sue. Henry Burr 10
Giulio Crimi and Rimini Giacomo 10

- A2743 Beautiful Ohio. Waltz. Kalaluki Hawaiian Orchestra 10
Till We Meet Again. Waltz. Kalaluki Hawaiian Orchestra 10
A2750 Everybody Wants a Key to My Cellar. Bert Williams 10
It's Nobody's Business But My Own. Bert Williams 10
DANCES
A2752 I'll Say She Does. Fox-trot. From "Sinbad." Intro. "N" Everything. Sweatman's Original Jazz Band 10
Lucille. Fox-trot. Sweatman's Original Jazz Band 10
A6111 Kiss Me Again. Waltz. Columbia Orchestra 12
Life and Love Waltz. Intro. "Come Be My Wife." Columbia Orchestra 12
BENTLEY BALL RECORDINGS FOR EDUCATIONAL DEPARTMENT
Song-a-Logue of America (American Folk Songs) Recordings by Bentley Ball
A3083 Tribal Prayer (Omaha Indian Song). Love Call (Iroquois Indian Song). Bentley Ball 10
Hiawatha's Departure. My Bark Canoe (Ojibway Indian Songs). Bentley Ball 10
A3085 Jesse James (Cowboy Song). Bentley Ball 10
The Dying Cowboy (Cowboy Song). Bentley Ball 10
A3086 Go Down Moses (Negro Spiritual). Bentley Ball 10
O Graveyard (Old Slave Song) and Peter, Go Ring Dem Bells (Negro Spiritual). Bentley Ball 10

EDISON RE-CREATIONS

- 80419 Air For G String (Bach-Wilhelmj). Violin. Joel Belov 10
Menuet in G (Beethoven); and Largo—Xerxes (Handel). Violin. Joel Belov 10
80489 Calm As the Night (Bohm). Soprano, Betsy Lane Shepherd 10
Home, Sweet Home (Bishop). Soprano, Betsy Lane Shepherd 10
50543 Don't Cry, Frenchy, Don't Cry (Donaldson). Tenor. George Wilton Ballard 10
Don't Forget the Salvation Army (My Doughnut Girl) (Brown-Frisch). Baritone, Arthur Fields and Male Chorus 10
50545 Everybody Wants a Key to My Cellar (Rose-Basket-Pollack). Al Bernard 10
Turkestan (Stern). Male voices. Premier Quartet 10
50549 Mary (Frey). Fox-trot. Tuxedo Dance Orchestra 10
Tears (Henry). Fox-trot. Tuxedo Dance Orchestra 10
50555 Frenchy, Come to Yankee Land (Ehrlich-Conrad). Tenor. Billy Murray and Male Chorus 10
Jazzolla (Robinson-Morre). Male voices, Premier Quartet 10
50556 Call of the Cosy Little Home—Take It from Me (Johnstone). Soprano and tenor, Leola Lucey and Charles Hart 10
You're Still An Old Sweetheart of Mine (Whitting). Mixed voices. Metropolitan Quartet 10
50558 I Want to Hold You in My Arms (Robinson), Al Bernard and Ernest Hare 10
Oh! Lawdy (Something's Done Got Between Ebenezer and Me) (Creamer-Layton). Ada Jones 10
50567 In My Daddy's Arms (Owens). Fox-trot, for dancing. Lenzberg's Riverside Orchestra 10
Razzle-Dazzle (Lenzberg). One-step, for dancing, Lenzberg's Riverside Orchestra 10
50568 Eyes That Say I Love You (Fisher). Contralto and tenor. Helen Clark and George Wilton Ballard 10
When the Bees Make Honey (Down in Sunny Alabam') (Donaldson). Tenor and baritone, Irving and Jack Kaufman 10

EDISON AMBEROL RECORDS

- SPECIALS
3802 Egyptland (Casey). Fox-trot, for dancing, Green Bros. Novelty Orchestra 10
3804 Kentucky Dream (Henry-Onivas). Soprano and tenor. Leola Lucey and Charles Hart 10
3806 In My Daddy's Arms (Owens). Fox-trot, for dancing. Lenzberg's Riverside Orchestra 10
3812 I'm Not Jealous (But I Don't Just Like It) (Nelson-Mayo). Soprano and tenor, Rachel Grant and Billy Murray 10
3814 Wait and See (You'll Want Me Back) (McCarron-Morgan). Tenor. Charles Hart 10
3815 When I Met You (Klickmann). Contralto and tenor. Helen Clark and George Wilton Ballard 10
3816 Royal Vagabond (Goetzl-Cohan) (Selection) Peerless Quartet 10
ROYAL PURPLE RECORDS
29034 Evviva la Francia (France I Salute Thee)—Daughter of the Regiment (Donizetti). Soprano, in Italian. Frieda Hempel 10
29035 Cortigiani—Rigoletto (Verdi). Baritone, in Italian. Mario Laurenti 10
REGULAR LIST
3803 Chan Chan Gavotte (Chandler). Edison Concert Band 10
3805 Tenth Regiment March (Hall). Conway's Band 10
3807 By the Babbling Brook (Ring-Hager). Whistling and Singing. Sihyl Sanderson Fagan and Lewis James 10
3808 Me-Ow (Kaufman). Tenor. Irving Kaufman 10
3809 Think, Love, of Me (Gray). Soprano. Gladys Rice 10
3810 Ruspana (Earl). One-step. Tuxedo Dance Orchestra 10
3811 Lola—Italian Serenade (Friedmann). Conway's Band 10
3813 In Heavenly Love Abiding (Arranged by Holden). Mixed voices. Metropolitan Quartet 10
3817 That Soothing Serenade (De Costa). Soprano. Betty Barrett 10
3818 How Sandy Proposed (Boone) Ada Jones and Len Spencer 10
3819 My Golden Rose (Logan). Tenor. Lewis James 10
3820 Witches (Tierney). Tenor. George Wilton Ballard 10
3821 Memories of You in Dear Hawaii (Mac-Meekin). Lyric Male Quartet 10
3822 When You Hold Me in Your Arms (Klickmann). Contralto and tenor, Helen Clark and George Wilton Ballard 10

AEOLIAN CO.

- OPERATIC SELECTIONS
50007 Il Trovatore—Ah, si ben mio (The vows we fondly plighted) (Verdi). Tenor, in Italian. Vocalion orch. accomp. Giulio Crimi 10
54024 Louise—Dupis le jour (Ever since the day) (Charpentier). Soprano, in French. Vocalion orch. accomp. Marie Sundelius 12
50006 Gioconda—O girdo di quest'anima (Oh cry of this soul) (Ponchelli). Tenor and baritone duet, in Italian. Vocalion orch. accomp.,

- STANDARD SELECTIONS
30030 Loch Lomond (Old Scotch Air). Soprano, Vocalion orch. accomp. May Peterson 10
22029 When Shadows Gather (Marshall). Tenor, Vocalion orch. accomp. Colin O'More 10
The Garden of Your Heart (Dorel). Tenor, Vocalion orch. accomp. Colin O'More 10
12168 Maria Mari (di Capua). Baritone, in Italian. Vocalion orch. accomp. Fernando Guarneri 10
Bolero d'Amore (False). Baritone, in Italian. Vocalion orch. accomp. Fernando Guarneri 10
12169 Day by Day (Smith). Tenor, orch. accomp., Arthur Burns 10
Hearts (Adapted to Drigo's Serenade). Tenor, orch. accomp. Arthur Burns 10
INSTRUMENTAL SELECTIONS
32011 Allegro Appassionata (Rubenstein). Cello, piano accomp. Maurice Dambois 10
Larghetto (Handel). Cello, piano accomp., Maurice Dambois 10
22030 Barcarolle—Tales of Hoffman (Offenbach). Violin, piano accomp. Maximilian Pilzer 10
Orientale (Cui). Violin, piano accomp., Maximilian Pilzer 10
HAWAIIAN SELECTIONS
12170 Minnehaha Waltz (Waijiala). Kalani Hawaiians 10
Karwi Waltz (David Kaiwi). Kalani Hawaiians 10
POPULAR SELECTIONS
12171 Yearning (Neil Moret). Orch. accomp., Sterling Trio 10
Grany (Gilbert-Belledna). Orch. accomp., Henry Burr 10
12172 I Found You (Gilbert-Friedland). Tenor, orch. accomp. Samuel Ash 10
First Rose of Summer (From "She's a Good Fellow" (J. Kern) Tenor, orch. accomp., Samuel Ash 10
12173 Hawaiian Smiles (Mary Earl). Orch. accomp., Charles Hart and Shaw Elliot 10
Hawaiian Lullaby (Bridges). Orch. accomp., Charles Hart and Shaw Elliot 10
12174 The Woman Thou Gavest Me (Piantadosi). Orch. accomp. Arthur Fields 10
Ragging the Chopsticks (Frankl-Gotler). Two piano accomp. Arthur Fields 10
12175 When I'm Gone You'll Soon Forget (Austin Keith). Orch. accomp. Peerless Quartet 10
Our Yesterdays (Leslie). Orch. accomp., Henry Burr 10
12176 Take Your Girlie to the Movies (If You Can't Make Love at Home) (Wendling). Orch. accomp. Billy Murray 10
Gimme This, Gimme That (Gilbert-Sullivan-Vincent). Orch. accomp. Billy Murray 10
12177 Himalaya (Henry Onivas). Orch. accomp., Premier American Quartet 10
In Cleopatra's Land (Forster). Orch. accomp., Premier American Quartet 10
DANCE SELECTIONS
12178 Ting Ling Toy—Fox-trot (Mary Earl) Played by Aeolian Dance Orchestra 10
Tell Me—Fox-trot (Lee S. Roberts) Played by Aeolian Dance Orchestra 10
12179 Frisco's Kitchen Stove Rag (Get the wood, burn it up)—Fox-trot (Reisner-Morgan) Played by Dahney's Band 10
Squealing Pig Blues—Fox-trot (Pinkard) Played by Dabney's Band 10

PATHE FRERES PHONOGRAPH CO.

- POPULAR SUPPLEMENT NO. 24 VOCAL RECORDS
22163 You Don't Need the Wine to Have a Wonderful Time (From "Ziegfeld Follies of 1919"). Eddie Cantor 10
Oh! The Last Rose of Summer (From "Ziegfeld Follies of 1919"). Eddie Cantor 10
22148 Daddy Long Legs. Henry Burr 10
I Know What It Means to Be Lonesome, Lewis James 10
22160 Oo-Sole-Mi. Miss Patricola 10
You Can't Get Lovin' Where There Ain't Any Love. Miss Patricola 10
22159 Yearning. Sterling Trio 10
Hearts. Lewis James 10
22161 Tulip Time (From "Ziegfeld Follies of 1919") (Vocal obligato by Sylvia Swan). Henry Burr 10
Mandy (From "Ziegfeld Follies of 1919"). Invincible Four 10
22162 Dreamy Alabama. Lewis James and Charles Hart 10
Tell Me Why. Lewis James 10
22155 Oh, You Women. Arthur Fields 10
Laughing Water! Ha, Ha, Ha! Invincible Four 10
22156 Ragging the Chopsticks (Archie Gotler at the piano) Arthur Fields 10
And He'd Say Oo-La-La! Wee, Wee! Billy Murray 10
22157 Gimme This, Gimme This, Gimme That (From "Oh, What a Girl!") Billy Murray 10
Sipping Cider Thru a Straw. Collins and Harlan 10
22158 Sweet Kisses. Acme Male Quartet 10
Hawaiian Lullaby. Lewis James and Charles Hart 10
DANCE RECORDS
NICHOLAS ORLANDO'S ORCHESTRA
22165 You Don't Need the Wine to Have a Wonderful Time (From "Ziegfeld Follies of 1919"), (Vocal refrain by Arthur Fields.) One-step.. 10
Hindu Rose. One-step. 10
22166 Honeymoon (Vocal refrain by Harry McClaskey). Waltz. 10
Will o' Wisp (from "A Lonely Romeo"). Fox-trot. 10
22168 Castles in Spain. One-step. 10
Jerry. Fox-trot. 10
LIEUT. JIM EUROPE'S "HELL FIGHTER" BAND
22167 The Dancing Deacon. Fox-trot. 10
Clarinet Marmalade. One-step. 10
GREEN BROTHERS' XYLOPHONE ORCHESTRA
22164 Shake Your Shoulders. Fox-trot. 10
The Vamp. One-step. 10
FASCINATING HAWAIIAN NOVELTIES
22149 Yearning. Hotel Biltmore Hawaiian Orchestra 10
Sweet Hawaiian Moonlight. Hotel Biltmore Hawaiian Orchestra 10

Regular September Pathé List

- OPERATIC AND STANDARD VOCAL RECORDS
59076 The Two Grenadiers (Les Deux Grenadiers) (Schumann). Baritone, in French, Gustave Huberdeau 12
Elegie (Massenet). Baritone, in French. Violin obligato. Gustave Huberdeau 12
27020 At Dawning (Cadman). Tenor. Paul Althouse 10
Where My Caravan Has Rested (Lohr). Tenor, Paul Althouse 10
60076 Cradle Song (Vannah). Contralto, Kathleen Howard 12
Happy Days (Strelezki). Contralto, Kathleen Howard 12
25030 A Southern Song (Ronald). Soprano, Grace Hoffman 10
(Continued on page 175)



# Some Leading Jobbers of Talking Machines in America

1856 **WURLITZER** 1916

**VICTOR**  
DISTRIBUTORS  
VICTORS EXCLUSIVELY

*We make a specialty of getting the order out on time—every time.*

**The Rudolph Wurlitzer Co.**  
CINCINNATI AND CHICAGO

*Two points of supply; order from the nearer*

**TEST IT.** 

OUR VICTOR

**Record Service**

has a reputation for efficiency.  
Suppose you try it.

**E. F. DROOP & SONS CO.**  
1300 G. STREET, WASHINGTON, D. C.  
231 N. HOWARD STREET, BALTIMORE, MD.



**W. J. DYER & BRO.**  
DYER B'LD'G, ST. PAUL, MINN.  
NORTHWESTERN DISTRIBUTORS  
OF THE

 **VICTOR**  
Machines, Records and Supplies

Shipped Promptly to all  
Points in the Northwest



Where Dealers May Secure

**COLUMBIA**

Product

**STARR Phonographs and GENNETT Records**  
Complete Stock and REAL Service

**Crafts-Starr**  
PHONOGRAPH CO.  
Factory Distributors  
218-220 NORTH SECOND STREET, RICHMOND, VIRGINIA  
Write for Dealers' Proposition;

**Mickel Bros. Co.**

Omaha, Nebraska  
Des Moines, Iowa

**Victor Distributors**

Ready, Full Stocks, and Prompt Deliveries  
from Convenient Shipping Centers  
all over the United States.

**William Volker & Co.,** Kansas City, Mo.; Houston, Tex., and Denver, Col.

**Pathé** 

DISTRIBUTORS  
Complete Pathephone and Pathe Record Stocks.  
The best proposition for the progressive dealer.

**Sherman, Clay & Co.**

San Francisco, Los Angeles, Portland, Seattle, Spokane  
PACIFIC COAST DISTRIBUTORS OF  
VICTOR PRODUCTS

- Distributors**
- Atlanta, Ga., Columbia Graphophone Co., 63 N. Pryor St.
  - Baltimore, Md., Columbia Graphophone Co., 16 South Howard St.
  - Boston, Columbia Graphophone Co., 137 Federal St.
  - Buffalo, N. Y., Columbia Graphophone Co., 736 Main St.
  - Chicago, Ill., Columbia Graphophone Co., 14 N. Michigan Ave.
  - Cincinnati, O., Columbia Graphophone Co., 427-429 W. Fourth Ave.
  - Cleveland, O., Columbia Graphophone Co., 1376 Euclid Ave.
  - Dallas, Tex., Columbia Graphophone Co., 1011 Elm St.
  - Denver, Colo., Columbia Stores Co., 1608 Glenarm Place.
  - Detroit, Mich., Columbia Graphophone Co., 401 Woodward Ave.
  - Indianapolis, Ind., Columbia Graphophone Co., 207-217 W. Washington St.
  - Kansas City, Mo., Columbia Graphophone Co., 1017 McGee St.
  - Los Angeles, Cal., Columbia Graphophone Co., 745 S. Broadway.
  - Minneapolis, Minn., Columbia Graphophone Co., 412-414 Nicollet Ave.
  - New Haven, Conn., Columbia Graphophone Co., 206 Meadow St.
  - New Orleans, La., Columbia Graphophone Co., 517-525 Canal St.
  - New York City, Columbia Graphophone Co., 55 Warren St.
  - Omaha, Neb., Schmoller & Mueller Piano Co., 1311 Farnum St.
  - Philadelphia, Pa., Columbia Graphophone Co., 210 N. Broad St.
  - Pittsburgh, Columbia Graphophone Co., 632-640 Duquesne Way.
  - Portland, Me., Columbia Graphophone Co., 43 Exchange St.
  - Salt Lake City, Utah, Columbia Stores Co., 221 South West Temple.
  - San Francisco, Cal., Columbia Graphophone Co., 130-150 Sutter St.
  - Seattle, Wash., Columbia Graphophone Co., 911 Western Ave.
  - Spokane, Wash., Columbia Stores Co., 161 South St.
  - St. Louis, Mo., Columbia Graphophone Co., 1127 Pine St.
  - Tampa, Fla., Tampa Hardware Co.

**Southern Victor Dealers**  
Largest Stock VICTROLAS and RECORDS.  
Prompt Shipment and Low Freight Rates.

**WALTER D. MOSES & CO.**  
Oldest Music House in Virginia or North Carolina.  
RICHMOND, VA.

**The PERRY B. WHITSIT CO.**  
Distributors of  
Victrolas and Victor Records  
COLUMBUS, OHIO

**OLIVER DITSON COMPANY**  
Largest VICTOR Talking Machine Distributors East of Chicago.  
Creators of "The Fastest Victor Service." Let us tell you more about our service.  
**BOSTON**

Have You Noted the Growth of This Department?  
Special Rates for Jobbers' Directory on Application

During the past six months this Jobbers' Directory has grown steadily in importance. It affords progressive jobbers an opportunity to keep their names before the dealers consistently and regularly, and provides representation in the Jobbers' Directory of the publication which is the recognized authority of the industry.

Join the progressive jobbers on this page next month.

**Pathé** 

"The Quality Phonograph"  
PLAYS ALL MAKES OF RECORDS

Dealers in southeastern territory write for full information. Our representative will be pleased to call without any obligation to you.

**THE JOHN A. FUTCH COMPANY,** Distributors  
Jacksonville, Florida

Headquarters for Canada:  
Columbia Graphophone Co., 54-56 Wellington St., West, Toronto, Ont.

Executive Office  
**COLUMBIA GRAPHOPHONE CO.**  
Woolworth Building New York

**Victor Exclusively**  
EASTERN TALKING MACHINE CO.  
177 Tremont Street, Boston  
VICTOR DISTRIBUTORS



ADVANCE RECORD BULLETINS FOR SEPTEMBER—(Continued from page 173)

- Flower Rain (Schneider). Soprano, Grace Hoffman 10
- 40172 For All Eternity (Mascheroni). Baritone, Bernard Stonehill 12
- Thy Sentinel Am I (Oxenford-Watson). Baritone, Bernard Stonehill 12
- FAMOUS NEAPOLITAN FAVORITES
- 22132 Q Sole Mio! (Capurro-Di Capua). Tenor, in Italian. Accompaniment by Sherbos Neapolitan Orchestra. Roberto Rotondo 10
- Maria Mari! (Russo-Di Capua). Tenor, in Italian. Roberto Rotondo 10
- FAVORITE GOSPEL HYMNS FERVENTLY RENDERED
- 22133 I Am Praying for You (Sankey). Tenor, organ accomp. Earle F. Wilde 10
- Lead Me, Saviour (Davis). Tenor, organ accomp. Earle F. Wilde 10
- NEW INSTRUMENTAL RECORDS
- 40175 Scarf Dance (Chaminade). Great Lakes String Quartet 12
- Spanish Dance (Albeniz). Great Lakes String Quartet 12
- 22129 Valse Erica (Wiedoeft). Saxophone solo, Rudy Wiedoeft 10
- Silver Threads Among the Gold (Rexford-Danks). Saxophone solo. Rudy Wiedoeft 10
- 22136 Scotch Hot (Whitlock). Bell solo, Billy Whitlock 10
- Comical Coons (Grimshaw). Banjo solo, Thomas Malin 10
- NEW BAND AND ORCHESTRAL RECORDS
- 40173 Raymond Overture (Thomas). Part I, Patrick Conway's Band 12
- Raymond Overture (Thomas). Part II, Patrick Conway's Band 12
- 22134 Kirmanshah (Claypoole). Intermezzo, Pathé Concert Orchestra 10
- Starlight (Johnson). Serenade, Pathé Concert Orchestra 10

EMPIRE TALKING MACHINE CO.

POPULAR SONGS

- 21117 I'm Forever Blowing Bubbles (Kenbrovin-Kellette). Orch. accomp., Lewis James and Charles Hart 10
- Hearts (MacDonald-King). Tenor, orch. accomp. Lewis James 10
- 21118 A Rose, a Kiss, and You (Arthur). Tenor, orch. accomp. Robert Bruce 10
- You're Making a Miser of Me (Dubin-Ball). Tenor, orch. accomp. Henry Burr 10
- 21119 Sipping Cider Thru a Straw (Morgan-David). Orch. accomp. Collins and Harlan 10
- Katydid Is the Candy Kid (Freeman). Tenor, accordion accomp. Byron G. Harlan 10
- 21120 Ragging the Chopsticks (Gottler-Frank). Baritone, Archie Gottler at the piano, Arthur Fields 10
- Oh, You Women (Green-Step). Baritone, orch. accomp. Arthur Fields 10

DANCE SELECTIONS

- 31113 You Don't Need the Wine to Have a Wonderful Time (From "Ziegfeld Follies of 1919") (Rogers-Arst. One-step. Empire Dance Orchestra 10
- Will O'Wisp (From "A Lonely Romeo") (Smith-Franklin-Spencer). Intro. "Candy Jag." Medley fox-trot. Empire Dance Orchestra 10
- 31114 Down by the Meadow Brook (Wendling). Waltz. Empire Dance Orchestra 10
- The Red Lantern (Fisher). Intro. "I Found the End of the Rainbow." Medley fox-trot. Empire Dance Orchestra 10
- 31115 Missouri Blues (Brown). Fox-trot. Empire Jazz Band 10
- Lassus Trombone (Fillmore). One-step. Empire Jazz Band 10

STANDARD VOCAL SELECTIONS

- 41105 The Dear Little Shamrock (Cherry). Tenor, orch. accomp. Charles Hart 10
- I'll Sing These Songs of Araby (Clay). Soprano, orch. accomp. Millie Leon 10

"The Music Without the Blur!"

This ideal of talking machine manufacture is attained more nearly than by any other, in the construction of the

MARVELOUS MAGNOLA "Built by Tone Specialists"

"Magnola's Tone Deflector eliminates the scratch"



Watching the Music Come Out

We want to show you how to make money with MAGNOLA; and how MAGNOLA is the best buy on the Talking Machine Market to-day. Send us your name and let us send you some real Talker Tips.

MAGNOLA TALKING MACHINE COMPANY

OTTO SCHULZ, President
General Offices Southern Wholesale Branch
711 MILWAUKEE AVENUE CHICAGO 1530 CANDLER BLDG. ATLANTA, GA.

INSTRUMENTAL SELECTIONS

- 51113 Bullets and Bayonets (Souza). March. Empire Military Band 10
- The Nightingale and the Frogs (Eilenberg). Characteristic. Empire Concert Band 10
- 51114 Fauns and Woodnymphs (Onivas). Danse Pastorale. Empire Concert Orchestra 10
- Starlight (Johnson). A serenade, Empire Concert Orchestra 10

HAWAIIAN SELECTIONS

- 61105 Sweet Lei-Lehua (Whistling and singing by Irene Greenus). Louise and Ferera Hawaiian Guitars 10
- Stephanie Gavotte (Czibulka). Louise and Ferera Waikiki Orchestra 10

SACRED SELECTIONS

- 71101 Sweet Hour of Prayer (Bradbury). Contralto, organ accomp. Maude Gordon 10
- Lead Me, Saviour (Davis). Tenor, organ accomp. Stanley Mackey 10

GENNETT LATERAL RECORDS

- 14003 The Rosary (Nevin). Violin with piano accomp. Helen Ware 10
- Ave Maria (Schubert). Violin with piano accomp. Helen Ware 10
- 2501 The Forge in the Forest (Michaelis). Descriptive. Vincent's Band 10
- In the Clock Store (Orth). Descriptive Fantasy. Vincent's Band 10
- 2502 The Red Lantern (Fisher). Fox-trot, Coney Island Jazz Orchestra 10
- Medley Fox-trot (Hickman-Black). Green Bros. Xylophone Orchestra 10
- 4538 Daddy Long Legs (Fleeson-Von Tilzer). Tenor, orch. accomp. Billy DeRex 10
- My Sugar-Coated Chocolate Boy (Mahoney-Loos). Vocal Duet with orch. accomp. Campbell-Burr 10
- 4539 The Vamp (Gay). One-step, Green Bros. Xylophone Orchestra 10
- Just Leave It to Me (Tracey-Pinkard). Fox-trot. Reisenweber's Orchestra 10
- 4540 Cohen at the Telephone. Geo. Thompson 10
- Cohen Telephones the Garage. Geo. Thompson 10
- 4541 And He'd Say Oo-La-La! Wee-Wee (Ruby-Jessel). Tenor, orch. accomp. Billy Murray 10
- Dixie Is Dixie Once More (Tracey-Pinkard). Premier American Quartet 10
- 4542 I Ain't Got-en No Time to Have the Blues (Von Tilzer-Sterling). Tenor, orch. accomp. Irving and Jack Kaufman 10
- Take Your Girlie to the Movies (Leslie-Kalmer-Wending). Tenor, orch. accomp. Billy Murray 10
- 4543 Western Land (Gay). One-step, Reisenweber's Orchestra 10
- Take It From Me (Anderson). Medley. Johnson's Orchestra 10
- 4544 Everybody Wants a Key to My Cellar (Rose-Baskette-Pollack). Tenor, orch. accomp. Al. Bernard 10
- Bluin' the Blues (Mitchell-Ragas). Tenor, Al. Bernard with Kansas Jazz Boys 10

OKEH RECORDS

- 1122 When I Met You (Armstrong-Klickmann). Tenor, with orch. Sam Ash 10
- You're Making a Miser of Me (Ball-Dubin). Tenor, with orch. Henry Burr 10
- 1223 Alabama Lullaby (De Voll). Tenor duet, with orch. James and Hart 10
- There Are Just Two I's in Dixie (Herscher). One-step, instrumental, singing chorus. Okeh Dance Orchestra 10
- 1224 Jazzola (Kendall-Robinson-Morse). Vocal quartet, with orch. Premier American Quartet 10
- Katydid is the Candy Kid (She's a Rube, by Heck) (Freeman). Tenor, with orch. Byron G. Harlan 10
- 1225 Arabian Nights (Reynolds-David-Hewitt). Vocal trio, with orch. Shamrock Trio 10
- The Gates of Gladness (On the Road to Sunshine Land) (Brennan-Cunningham-Rule). Tenor, with orch. Harvey Hindermyer 10
- 1226 Golden Wedding Jubilee (At My Dad and Mammy's) (Green-Kaufman-Step). Vocal duet with orch. Kaufman Brothers 10
- Dixie Is Dixie Once More (Tracey-Pinkard). Vocal Quartet, with Orchestra. Premier American Quartet 10
- 1227 Kentucky Dream (Warren-Henry-Onivas). Tenor Duet, with Orchestra. Lewis James and Charles Hart 10
- Western Land (Gay). Baritone, with Orchestra. Joseph Phillips 10
- 1228 Frenchy. Come to Yankee Land (Ehrlich-Conrad). Tenor, with Orchestra. Irving Kaufman 10
- McCarthy, He's a Frenchman Now (Clarke-Baskette-Glogau). Contralto, with Orchestra. Fannie Watson (of Watson Sisters) 10
- 1229 Take Your Girlies to the Movies (If You Can't Make Love at Home) (Leslie-Kalmar-Wending). Tenor, With Xylophone Orchestra. Irving Kaufman 10
- Take Me to the Land of Jazz (Leslie-Kalmar-Wending). Baritone, with Xylophone Orchestra. Bert Harvey 10
- 1230 I'm Aching for the Sight of You (Rose-Meyer). Vocal Trio, with Orchestra. Sterling Trio 10
- For-Get-Me-Not (Kendis-Brockman). Tenor, with Orchestra. Sam Ash 10
- 1231 Somebody's Waiting for Someone (Sterling-Von Tilzer). Tenor, with Orchestra. Henry Burr 10
- Friends (Johnson-Meyer-Santly). Vocal Trio, with Orchestra. Sterling Trio 10
- 1232 I Ain't Got-en No Time to Have the Blues (Sterling-Von Tilzer). Vocal Duet, with Orchestra. Collins and Harlan 10

- Daa Dee Dum (Vincent-Platau). Vocal Duet, with Xylophone Orchestra. Kaufman Brothers 10
- 1233 In the Heart of a Fool (Freedman-Squires). Tenor, with Orchestra. Henry Burr 10
- The Woman Thou Gavest Me (Piantadosi). Tenor, with Orchestra. Sam Ash 10
- 1234 Life and Love (From "The Velvet Lady") (Blossom-Herbert). Tenor, with Orchestra. George Lambert 10
- The Call of the Cozy Little Home (From "Take It from Me") (Johnstone-Anderson). Baritone, with Orchestra. Joseph Phillips 10
- 1235 Shake, Rattle and Roll (Bernard). Baritone, with Xylophone Orchestra. Al Bernard 10
- Venus Blues (Bernard-Robinson). Baritone, with Xylophone Orchestra. Al Bernard 10
- 1236 Western Land (Gay). Fox-Trot. Xylophone Orchestra. Novelty Effects. Green Brothers 10
- Have You Seen My Stella? (Costello-Joy-Hays). One-Step, Xylophone Orchestra. Novelty Effects. Green Brothers 10
- 1237 That Dreamy Dance of Love (Here's to the Waltz) (Hays). Waltz, Instrumental. Okeh Dance Orchestra 10
- Star of Light (Adrian). Fox-Trot, Xylophone Orchestra. Green Brothers 10
- 1209 The Vamp (Gay). One-step, Xylophone Orch., Green Brothers 10
- Shake Your Shoulders (Green). Fox-trot, Xylophone Orchestra. Green Brothers 10
- 1210 Fluffy Ruffles (Green). One-step, Xylophone Orchestra. Green Brothers 10
- My Dreamy Little Lotus Flower (Olman). Fox-trot, Instrumental. Van Eps Quartet 10

(Continued on page 176)

Why WALL-KANE Needles are Superior

The highest grade steel needle of American manufacture, and playing only one record, is put through a complicated, scientific, chemical process, by which the point of the needle is greatly improved. The popular explanation of the method is as follows:

An ordinary steel needle is made of wire, which consists of long, parallel running grains on the inside. This wire is inserted in automatic machines, which automatically cut off the steel needles.

The friction of the revolving record grooves will gradually flatten out the point of the needle, so that more and more grain of the steel will reach the record grooves. The WALL-KANE needle will eliminate the grain of the steel coming into contact with the grooves by a process which is accomplished as follows:

The steel needle is first dipped into a chemical solution which will take out most of the charcoal, making a closer unit of the needle.

Then the needles are dipped in several solutions, which place three different coatings on the top of the point, so that an entirely separate unit is created on the point, very much smoother and 25 to 30 per cent. softer than an ordinary steel needle's point.

More than three thousand revolutions are required to take off these three coatings by the friction of the point with the record. The playing surface of more than ten records do not amount to 3000 revolutions—that is why WALL-KANE needles will play at least ten records perfectly, and will make less surface noise, and by the distribution of the solution into the grooves of the record, the record itself will be greatly benefited, and its life prolonged.

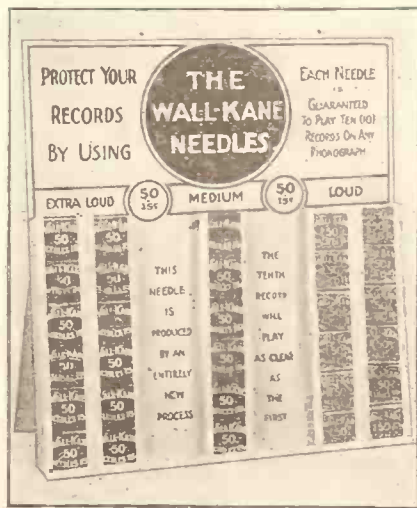

BEWARE OF IMITATIONS

This handsome colored metal enameled display stand holds 60 packages, 24 extra loud, 24 loud and 12 medium packages and costs the dealer \$4.60. (\$4.90 in the Far West) and retails for \$9.

JOBGING TERRITORIES OPEN

Progressive Phonographic Supply Co., Inc. 145 West 45th Street, New York

REPAIRS

All Makes of Talking Machines Repaired Promptly and Efficiently

ANDREW H. DODIN

176 Sixth Avenue New York TELEPHONE, CHELSEA 8437



ADVANCE RECORD BULLETINS FOR SEPTEMBER—(Continued from page 175)

- 1212 Beaux Esprits (Gay Spirits) (Tompkins). One-step, Xylophone Orchestra..... Green Brothers Sliding Sid (Losch). Fox-trot, Instrumental, Okeh Dance Band
- 1213 When the Bees Make Honey Down in Sunny Alabama (Lewis-Young-Donaldson). Contralto Duet with Orchestra..... Watson Sisters It's Nobody's Business But My Own (Skidmore-Walker). Baritone with Orchestra..... Arthur Collins
- 1214 Lullaby Blues (In the Evening) (Kendall-Robson). Vocal Quartet with Orchestra, Premier-American Quartet
- O! Death, Where Is Thy Sting? (Stout). Baritone with Orchestra..... Arthur Collins
- 1215 Oh, How She Can Sing! (Van and Schenck-Yellen). Tenor Duet with Orchestra, Billy Murray and Ed. Smalle
- Just Another Poor Man Gone Wrong (Sterling-H. Von Tilzer). Tenor with Orchestra, Billy Murray
- 1216 I'll Say She Does (From "Sinbad") (De Sylva-Kahn-Jolson). Baritone with Orchestra, Arthur Fields
- I Always Think I'm Up in Heaven (When I'm Down in Dixie Land) (From "Monte Cristo, Jr.") (Lewis-Young-Abrahams). Contralto Duet with Orchestra..... Watson Sisters
- 1217 Then You'll Know You're Home (Johnstone-Winne). Baritone with Orchestra, Joseph Phillips
- The Return (They Are Here) (Price-Bergh). Baritone with Orchestra..... Royal Dadmun
- 1218 My Barney Lies Over the Ocean (Just the Way He Lied to Me) (Lewis-Young-Grant). Contralto with Orchestra..... Ada Jones
- Oh! Lawdy (Something's Done Got Between Ebecanezer and Me) (Layton-Creamer). Tenor with Orchestra..... Billy Murray
- 1219 Jazz Baby (Merrill-Jerome). Tenor with Orchestra..... Billy Murray
- You Can't Blame the Girls at All (Gerber-Silver). Baritone with Orchestra..... Arthur Fields
- 1220 When Ireland Comes Into Her Own (Branen-Stanley). Contra-Tenor with Orchestra, Will Oakland
- Peg Aroon (Costello-Solman). Contra-Tenor with Orchestra..... Will Oakland
- 1221 A Wee Bit of Lace (From "The Royal Vagabond") (Cohan-Tierney). Contralto with Orchestra..... Ruth Lenox
- You Don't Know (Callahan-Roberts). Tenor with Orchestra..... Sam Ash
- 1173 That Tumble Down Shack in Athlone (Pascoe, Carlo, Sanders). Vocal Trio with Orch., Sterling Trio
- My Old Grand-dad's Flute (Wilson-Emerson). Tenor, with Orch..... Henry Burr
- 1174 By the Babbling Brook (Hager). Tenor-Bird Obligato, with Orch., Henry Burr and Sybil Sanderson Fagan
- The Little Whistler (Ring-Hager). Whistling Novelty, with Orch..... Sybil Sanderson Fagan
- 1175 Castilian Echoes (Siegel). Mandolin Solo, Ukulele Accomp. .... Samuel Siegel and Marie Caveny
- Valse Caprice (Siegel). Mandolin Solo, Ukulele Accomp. .... Samuel Siegel and Marie Caveny
- 1176 I'd Love To (from "Listen Lester") (Cort-Stoddard-Orlob). Vocal Duet, with Orch., Helen Clark and Joe Phillips
- Waiting (From "Listen Lester") (Cort-Stoddard-Orlob). Baritone, with Orch..... Joe Phillips
- 1177 Prelude (Rachmaninoff). Piano Solo..... Paul Eisler
- (a) Albumleaf (Cesar Cui), (b) Papillon (Butterfly) (Ed. Grieg). Piano Solo..... Paul Eisler
- 1178 Valse Poudree (Intermezzo) (Popy-Roberts). Instrumental Quartet..... Park Quartet
- Serenade Chaminade (Chaminade). Instrumental Quartet..... Park Quartet
- 1179 Looking This Way (Sacred Duet) (Van De Venter). Vocal Duet, with Orch..... Miller and Wheeler
- One Sweetly Solemn Thought (Sacred Duet) (Cary-Ambrose). Vocal Duet, with Orch., Meyers and Gillette
- 1180 Jesus, Savior, Pilot Me (Sacred Duet) (Gould)—Calvary (Hymn) (Rodney). Vocal Duet, with Orch..... Meyers and Gillette
- 1181 Love, Here Is My Heart (Ross-Silesu). Tenor, with Orch..... George Lambert
- Sing, Smile, Slumber (Hugo-Gounod). Soprano, with Orch..... Grace Kerns
- 1182 My Old Kentucky Home (Foster). Contralto, with Orch..... Marie Morrissey
- Drink to Me Only With Thine Eyes (Jonson). Tenor, with Orch..... George Lambert
- 1183 Mighty Lak' a Rose (Stanton-Nevin). Contralto, with Orch..... Marie Morrissey
- The Rosary (Rogers-Nevin). Tenor, with Orch., George Lambert
- 1186 Liberty Bell Ring On (Gillespie-Brown). Baritone, with Orch..... Royal Dadmun
- Good-bye Shot and Shell (Spero and Peck). Baritone, with Orch..... Royal Dadmun
- 1190 Caliope (Betancourt). One-step, Instrumental, Mata's Blue and White Marimba Band
- Carmela Waltz (Valle). Waltz, Instrumental, Mata's Blue and White Marimba Band
- 1191 The Minstrel Boy (Moore). Tenor, with Orch., Charles Hart
- On the Road to Mandalay (Speaks-Kipling). Baritone with Orch..... Joe Phillips

- 4160 Kentucky Dream. Waltz..... Lyric Dance Band
  - Oh, Susie Behave. One-step..... Lyric Dance Band
  - 4161 My Dreamy Little Lotus Flower. Fox-trot, Lyric Dance Orchestra
  - Ruspana. One-step..... Lyric Dance Orchestra
  - 4162 Love Is Love. Fox-trot..... Lyric Dance Orchestra
  - Mammy's Lullaby. Waltz..... Lyric Dance Orchestra
  - 4163 Everybody Shimmies Now. One-step, Lyric Dance Orchestra
  - How Ya Gonna Keep 'Em Down on the Farm. One-step..... Lyric Dance Orchestra
- BAND RECORDS**
- 4164 Boston Commandery March
- HAWAIIAN**
- 4158 Hawaiian Hula Medley. Fox-trot, Kalawao Hawaiian Orchestra
  - Aloha Land. Waltz..... Kalawao Hawaiian Orchestra
  - 4159 Kamawe. One-step..... Kalawao Hawaiian Orchestra
  - Hilena Waltz..... Kalawao Hawaiian Orchestra
  - 4165 Hawaiian Dreams..... Kalawao Hawaiian Orchestra
  - Southern Blues..... Kalawao Hawaiian Orchestra
- POPULAR HITS**
- 5140 Dear Old Pal of Mine..... Henry Burr
  - The Return..... Royal Dadmun
  - 5141 The Americans Come..... Royal Dadmun
  - Madelon..... Arthur Fields
  - 5142 How Ya Gonna Keep 'Em Down on the Farm, Byron G. Harlan
  - I Ain't Gott'n No Time..... Collins and Harlan
  - 5144 Monte Cristo..... Irving Kaufman
  - Singapore..... Arthur Fields
  - 5145 By the Camp Fire..... Peerless Quartet
  - I'm Forever Blowing Bubbles..... Campbell and Burr
  - 5146 Mammy O'Mine..... Sterling Trio
  - When You Look in the Heart of a Rose. Henry Burr
  - 5147 Jazz Baby..... Arthur Fields
  - Breeze..... Fields and Kaufman

EMERSON PHONOGRAPH CO.

NEW GOLD SEAL RECORDS

- 9209 You Didn't Want Me When You Had Me. So Why Do You Want Me Now (Russell-Grossman-Bennett). Baritone solo, orch. accomp., Song, accomp. by xylophone and piano, Ragging the Chopsticks (Gottler-Frankl). Novelty Arthur Fields
- 9213 Breeze, Blow My Baby Back To Me (MacDonald-Goodwin-Hanley). Baritone duet, orch. accomp..... The Two Kauffields
- Baby. (Kahn-Van Alstyne). Baritone solo, orch. accomp..... Arthur Fields
- 9207 Oo-La-La! Wee! Wee! (Ruby-Jessel). Character solo, orch. accomp..... Billy Murray
- 9207 Thipping Thider Thru a Thraw (Morgan-David) Character duet, orch. acc., Arthur Collins and Byron G. Harlan
- 9214 Hawaiian Lullaby. (Terrise-Bridges). Tenor and baritone duet, orch. accomp., Charles Hart and Elliot Shaw
- Every Tear Is a Smile In An Irishman's Heart. (Sullivan-Sanders-Carlo). Tenor solo, orch. accomp..... Henry Burr
- 9206 Daa Dee Dum. (Vincent-Flatow). Male trio, orch. accomp..... The Three Kauffields
- Tell Me Why. (Coburn-Rose). Baritone solo, orch. accomp..... Arthur Fields
- 9208 Lonesome—That's All. (Roberts-Bradley). Tenor solo, orch. accomp..... Henry Burr
- Her Danny. (Byers-Schonberg). Tenor solo, orch. accomp..... Reed Miller
- 9215 The Music of Wedding Chimes. (Leslie-Wendling). Tenor solo, orch. accomp., Charles Hart
- When It's Sweet Patootie Time. (Leslie-Wendling). Character song, orch. accomp., Eddie Nelson
- 9216 Oh! The Woman in Room 13. (Lewis-Young-Donaldson). Character song, orch. accomp..... The Two Kauffields
- When the Preacher Makes You Mine. (Lewis-Young-Donaldson). Baritone solo, orch. accomp..... Eddie Nelson
- 9210 You Oughta Go An' See the Wimmin' Swimmin'. (Ehrlich-Conrad). Character solo, orch. accomp..... Billy Murray
- Save Your Money, John. (Copeland-Rogers). Baritone solo, orch. accomp..... Arthur Collins
- 9212 Soldiers of Erin. (Kearney-Herbert). Tenor solo, orch. accomp..... Shaum McClaskey
- When Ireland Comes Into Her Own. (Stanley-Branen). Baritone solo, orch. accomp., Padric O'Brien

LATEST DANCE AND BAND HITS

- 9211 Yearning. (Neil Moret). Fox-trot, Emerson Military Band
- Dreamy Amazon. (Gilbert-MacBoyle-Vincent). Waltz..... Emerson Dance Orchestra
- 1034 Tell Me, Tell Me Why. (Max Kortlander). Fox-trot..... Emerson Military Band
- Mammy O' Mine. Medley Intro. "Idol" and "Longing." (Pinkard-Rose-Seymour and Pike). Fox-trot..... Emerson Military Band
- 1037 Tulip Time, from "Ziegfeld's Follies of 1919." (Buck-Stamper). Fox-trot, Emerson Dance Orchestra
- Greased Lightning. (George Hamilton Green). One-step, xylophone solo, orch. accomp., George Hamilton Green
- 1036 Coo Coo. (Joseph Smith). Fox-trot, Emerson Dance Orchestra
- Castle Valse Classique. (Ford T. Dabney). Waltz, xylophone solo, orch. accomp., George Hamilton Green
- 1038 Chinese Chop Sticks. (Stanley Crawford). Fox-trot. Banjo, piano and saxophone, Van Eps Banta Trio
- Song of Omar. (Leo Edwards). Fox-trot. Banjo, piano and saxophone, Van Eps Banta Trio
- 1031 Don't Forget the Salvation Army. Medley, Intro. "One and Two and Three and Four," and "Frenchy, Come to Yankee Land." (Brown-Frisch-Creamer and Layton-Ehrlich-Conrad). One-step..... Emerson Dance Orchestra
- In the Shadow of the Desert Palm. (Will. E. Dumage). Fox-trot. Emerson Dance Orchestra

STANDARD SELECTIONS

- 1035 Mother Machree. (Young-Olcott-Ball). Tenor solo, orch. accomp..... Walter Scanlon
- Little Grey Home in the West. (D. Eardley Wilmot-Hermann Lohr). Tenor solo, orch. accomp..... Walter Scanlon
- 1039 Nearer My God to Thee. (Sarah F. Adams-Lowell Mason). Male quartet..... Shannon Four
- Onward, Christian Soldiers. (S. Baring Gould-Arthur Sullivan). Male quartet..... Shannon Four
- 1040 Old Black Joe. (Foster). Male quartet, Rialto Quartet
- My Old Kentucky Home. (Stephen Foster). Male quartet..... Rialto Quartet
- 1041 Gypsy Love Song. From "The Fortune Teller." (Victor Herbert). Baritone solo, orch. accomp.

- Gypsy John. (Melville-Clay). Baritone solo, orch. accomp..... Lane Rogers 10
- 1032 Boston Commandery March. (T. M. Carter, March..... Bergh's Concert Band 10
- American Republic March. (H. H. Thiele, March..... Bergh's Concert Band 10

EMERSON PHONOGRAPH CO.

THE NEW SEVEN-INCH RECORDS

- 7520 You're Making a Miser of Me (Dublin-Ball). Tenor solo, orch. accomp..... William Sloane
  - Just a Little Place He Can Call His Home (Arthur Fields). Baritone solo, orch. accomp., D. (Bud) Bernie
  - 7521 Jazzola (Kendall-Robinson-Morse). Male quartet, orch. accomp..... Emerson Quartet
  - Ze Yankee Boys Have Made a Wild French Baby Out of Me (Gold-West). Character solo, orch. accomp..... D. (Bud) Bernie
  - 7522 Lonsome—That's All (Hoberts-Bradley). Tenor solo, orch. accomp..... Robert Rice
  - Sometime It Will Be Love Time, Sometime—Somewhere (Arthur-Walker). Tenor solo, piano and violin accomp..... William Robinson
  - 7523 In the Heart of a Fool (Freedman-Squires). Tenor solo, orch. accomp..... George Gordon
  - My Little Sunshine (Jones-Conrad). Male trio, orch. accomp..... Sterling Trio
  - 7524 Longing (Seymour-Pike). Tenor solo, orch. accomp..... Robert Rice
  - When Ireland Comes Into Her Own (Stanley-Branen). Baritone solo, orch. accomp., D. (Bud) Bernie
  - 7526 Some Sunny Day (Jackson-Donaldson). Tenor solo, orch. accomp..... William Sloane
  - Every Tear Is a Smile, In An Irishman's Heart (Sullivan-Sanders-Carlo). Tenor solo, orch. accomp..... Robert Rice
  - 7526 Some Day You'll Be Sorry That You're Glad (Wells-Conrad). Baritone and tenor duet, orch. accomp..... Sanford and Sanford
  - You Oughta Go an' See the Wimmin' Swimmin' (Ehrlich-Conrad). Character song, orch. accomp..... Jack Tracey
  - 9 7527 The Call of the Cosy Little Home (Johnstone-Anderson). Tenor solo, orch. accomp., Robert Rice
  - Tears Tell The Story to Me (Carl and Frank Wilson). Tenor solo, orch. accomp..... George Gordon
- LATEST DANCE AND BAND HITS**
- 7528 Behind Your Silken Veil (Coburn-Rose-Burnett). Fox-trot..... Emerson Dance Orchestra
  - Daffodil Waltz (Gerald Arthur). Waltz, Emerson Xylo-Phiends
  - 7529 Chong, Medley. Intro. "Anything Is Nice" (Frey-Clarke-Meyer-Ager). Fox-trot, banjo, piano and saxophone..... Van Eps Banta Trio
  - Sabres and Spurs (Lieut. John Philip Sousa). March..... Emerson Military Band
  - 7530 The Alcoholic Blues. Some Blues (Al. Von Tilzer). Fox-trot..... Emerson Military Band
  - New Trix (Eugene Platzman). Fox-trot, Emerson Military Band
  - 7531 Waiting. Intro. "Oh! You Sweet Stuff" (Cort-Stoddard-Orlob). Fox-trot, Emerson Military Band
  - Hop-a-Long (John L. Herman). One-step, Emerson Military Band
  - 7532 You're the One That I Want (Hugh Frey). One-step, banjo, piano and saxophone, Van Eps Banta Trio
  - Gypsy Girl (Oliver Wallace). Fox-trot, Emerson Xylo-Phiends
  - 523 Irish Jigs. Accordion duet..... Phil and Dan Boudoni
  - Irish Reels. Accordion duet..... Phil and Dan Boudini

EMERSON INTERNATIONAL, INC.

NINE-INCH DOUBLE RECORD

- 02004 "Celeste Aida"—Aida (Verdi). Tenor.... S. Berini
- "Vesti La Giubba"—Pagliacci (Leoncavallo). Tenor..... S. Berini
- 02003 "Una Furtive Lagrima"—Elisir d'Amore (Donizetti). Tenor..... S. Berini
- "M' Appari"—Martha (Flotow). Tenor, S. Berini
- 02008 "Mia Sposa Sara Le Mia Bandiera" (Rotoli) (My Bride Is My Flag). Tenor..... S. Berini
- "Pecche"—(Why?) (Pennino). Tenor.... S. Berini
- 02009 "La Serenata" (The Serenade) (Tosti). Tenor, S. Berini
- "Vorrei Morire"—(A Desire to Die) (Tosti). Tenor..... S. Berini
- 02002 "Vecchia Zimarra"—(Rustic Coat Song). La Boheme (Puccini). Basso-contante..... Enzo Bozano
- "Mignon"—Berceuse (Thomas). Basso-contante, Enzo Bozano
- 02010 "Largo Al Factotum"—Barbiere di Siviglia (Rossini). Baritone..... Millo Picco
- "Dio Possente"—Faust (Gounod). Baritone, Millo Picco
- 02011 "Prologo"—Pagliacci (Leoncavallo) Baritone, Millo Picco
- "Solenne in Quest 'Ora"—Duet from "Forza del Destino" (Verdi). Baritone-Tenor Millo Picco-S. Berini
- 02012 "Il Balen del suo Sorriso"—Travatore (Verdi) Baritone..... Millo Picco
- "Eri tu che Macchiavi quell 'Anima"—Ballo in Maschera (Verdi) Baritone..... Millo Picco
- 02013 "Di Provenza il mar il suol"—Traviati (Verdi) Baritone..... Millo Picco
- "Ah, Mimi tu piu non torni"—La Boheme (Puccini) Duet, Baritone and Tenor, Millo Picco-S. Berini
- 02023 "Wedding Dance"—March..... Russian-Jewish Orchestra
- Zion March, "The Hope of Israel"—Symphonico..... Russian-Jewish Orchestra
- 1634 "La Paloma"—Danza, Soprano..... Mme. Maria Grever
- "Fingida"—Danza, Soprano..... Mme. Maria Grever
- 1633 "La Golondrina"—Popular Song, Soprano, Mme. Maria Grever
- "Perjura"—Danza, Soprano..... Mme. Maria Grever
- 02001 "Medley of Slavic Airs," Violinist..... Milán Lusk
- "Kubelik Serenade" (Drdla), Violinist..... Milán Lusk
- 10-Inch Double Records
- 02036 "Lakme"—Bell Song, Coloratura Soprano..... Eva Léoni
- "Rigoletto"—Caro Nome, Coloratura Soprano, Eva Léoni
- 02005 "Traumeriei" (Schumann), Violinist..... Milán Lusk
- "Souvenir" (Drdla), Violinist..... Milán Lusk
- 02006 "Humoresque" (Dvorak), Violinist..... Milán Lusk
- "Meditation"—Thais (Massenet), Violinist, Milán Lusk
- 02007 "Spanish Dance"—Romanza Andaluza (Sarasate), Violinist..... Milán Lusk
- "Valse Bluette"—Air de Ballet (Drigo), Violinist..... Milán Lusk

**NEEDLES**  
WE MANUFACTURE  
Diamond needles for Edison  
Sapphire needles for Edison  
Sapphire needles for Pathe  
in stock ready for delivery  
MERMOD & CO., 874 Broadway, N. Y.



# The important thing is—

Your store, your name, your prestige —are featured in the T. M. W. Service ads, as well as the merchandise you carry.

John Wanamaker knows how to advertise, and this is the principle on which he has made his success.

Hitch this Service to your store, and you'll make an equal success in your own community.

You want to do more business. *Better advertising* will do it for you. Subscribe to this Service and you'll get advertisements for your newspapers and merchandising ideas for your store that will bring you new business in car load lots!

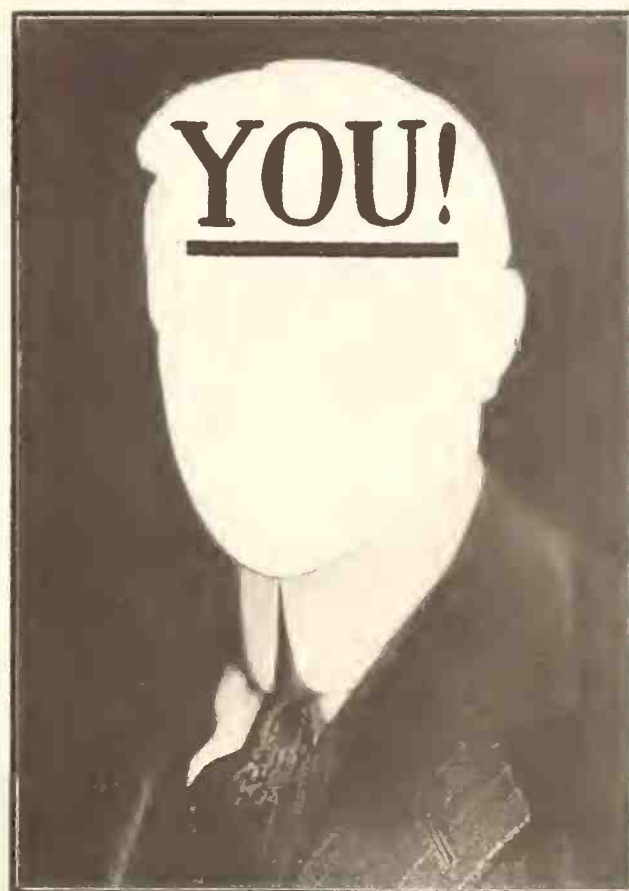

### Going, Going,—Gone!

In one city of over 1,000,000 a big store with an advertising manager has taken the Service. A live wire in a town of less than 5,000 has subscribed and there are many other subscribers in between, proving that the Service is what we claim for it—invaluable to any progressive merchant, and adapted to the big store as well as the little one.

*Mail the Coupon!*

# The Talking Machine World Service

## Brings you the following material every month—

**17** advertisements every month are mailed to you, to be put in your newspapers. They are unmistakably YOUR ads, featuring your institution, written by the same men who write some of the best ads you see in the national magazines. Experts whose yearly earnings are more than \$52,000. Get these men to work for you and you can do twice as much advertising because you get back the money you spend and more besides.

**17** cuts every month drawn by such well-known artists as Arthur Finley and Olga Thomas of "Vogue"; Herman Palmer, a regular contributor to "Judge"; Frederick T. Chapin, who illustrates the Franklin Automobile and Arrow Collar advertisements; Charles Baskerville, Jr., of "Scribner's"; and other artists of the same class—207 cuts per year. These cuts alone are worth more than the Service costs. Your advertising will build up your prestige. You'll see the difference in SALES.

**2** or more window display plans every month that will stop the crowds and make them look. Put them in your windows and you'll make your windows pay your rent.

**2** or more merchandising ideas every month that produce business for you. Ideas are the seeds of success. These will bear fruit in dollars and cents.

**2** or more form letters every month written by a specialist who regularly receives \$100 for a single letter—because his letters produce the business. Send them out and they'll produce business for you!

### Tell us your troubles

Special advice and personal service by mail to solve individual problems about which you write us.

### The Cost—

of all this is about ¼ the cost of an office boy, because we are selling it to the live dealers all over the United States, thereby dividing the expense into small units.

The money you spend on one ad that doesn't pay would cover the cost of this Service for a whole year.

And it is exclusive to you in your territory. We only sell to one dealer in each locality. But remember, it is first come, first served.

Send us the coupon and we will mail you a sample of one man's complete service for your inspection.

### COUPON

THE TALKING MACHINE WORLD SERVICE

373 Fourth Ave., New York

Send full information about your Service with specimens of the cuts, form letters, advertisements, etc., etc. Tell me how much it costs per month under your syndicate plan.

The population of my territory is.....

I handle the following make or makes.....

Firm Name .....

By .....

Street and Number.....

City and State.....

# MAIL THIS COUPON TODAY

## It may mean doubling your profits



# Index of Advertisers

<b>A</b>						
Acme Die Casting Corp.	58	Goldbert, Max L.	34	Parr Mfg. Co.	118	
Acme Engineering & Mfg. Co.	112	Gramophone Co., Ltd.	165	Pathé Frères Phonograph Co.	76, 77	
Acme Phonograph Corp.	112, 122, 139	Grand Rapids Brass Co.	93	Pearsall Co., Silas E.	9	
Aeolian Co.	84	Grand Rapids Phonograph Co.	28	Peckham Mfg. Co.	34	
Aldine Co.	79	Gray, Walter S.	117	Peerless Album Co.	91	
American Recording Laboratories	154	Gretsch Mfg. Co., Fred	88	Penn Phonograph Co.	55	
Andrews, W. D. & C. N.	140	Grey Gull Records	80	Perfect Automatic Brake Co.	104	
Ansonia Needle Corp.	161	Griffith Piano Co.	41	Perfection Talking Machine Co., Inc.	162	
Atlas Sales Corp.	129	<b>H</b>			Phoenix Phonograph Co.	106
Audion Phonograph Co.	154, 164	Handy Mfg. Co.	105	Phonograph Appliance Co.	138	
Automatic Cover Support & Mfg. Co.	87	Harper Bros.	78	Phonograph Supply Co. of New England	48	
<b>B</b>		Harponola Co.	82	Pla-Rite Mfg. Works	134	
B & H Fibre Mfg. Co.	64	Heineman Phonograph Supply Co.	Inserts facing pages 18, 34, 50, 66 and 82	Plywood Corporation	51	
Badger Talking Machine Co.	65	Hessig-Ellis Drug Co.	40	Precision Castings Co.	37	
Bagshaw Co., W. H.	46	Hiawatha Phonograph Co.	111	Progressive Phonograph Supply Co.	175	
Barnhardt Bros. & Spindler	35, 93	Hillman & Son Phonograph Co.	41	<b>R</b>		
Belcanto Co., Inc.	61	Hospe, A., Co.	63	Ramos-Eubank Phonograph Mfg. Co.	117	
Blackman Talking Machine Co.	133	Hough, J. E., Ltd.	166	Recordeon Phonograph Co.	66	
Bliss Reproducer, Inc.	20	<b>I</b>			Record Needle & Mfg. Co.	89
Boston Book Co., Inc.	19	Illinois Record Service	51	Regina Co.	81	
Brilliantone Steel Needle Co.	17	Isley-Doubleday & Co.	118	Rene Manufacturing Co., The	115	
British Polyphon Co.	169	Indiana Die Casting Co.	22	Rex Gramophone Co.	169	
Brooks Mfg. Co.	10	International Mica Co.	95	Rishell Phonograph Co.	136	
Brunswick-Balke-Collender Co.	Insert following page 42	Invicta Record Co., Ltd.	167	Rountree Corporation	41	
Buehn Co., Louis	55	<b>J</b>			Saywell, Geo. W.	164
Bush & Lane Piano Co.	86	Jaquith Machinery Bureau Inc.	48	Seeburg, J. P., Piano Co.	79	
Butterfly Phonograph Motor Corp.	161	Jewel Phonoparts Co.	105	Selenium Laboratories	164	
<b>C</b>		Jones-Motrola, Inc.	128	Sherman, Clay & Co.	174	
Cabinet & Accessories Sales Co.	65	<b>K</b>			Singer Talking Machine Co.	145
Cardinal Phonograph Co.	72	Kaumanns & Co.	107	Smith Drug Co., C. D.	40	
Charmaphone Co.	49	Kent Co., F. C.	90	Smith, Klina & French Co.	41	
Cheney Phonograph Co.	94	Keystone Minerals Co.	162	Smith Laboratories, H. J.	74	
Cherington Mfg. Co.	110	Kiefer-Stewart Co.	40	Smith-Schiffin Co.	39	
Chicago Hinged Cover-Support & Balance Co.	107	Kirkman Engineering Corp.	6	Sommerhof Co., Inc.	61	
Chicago Talking Machine Co.	98	Knickerbocker Talking Machine Co.	135	Sona-Tone Phonograph, Inc.	50	
Classified (Want) Ads.	163, 164	Kraft, Bates & Spencer, Inc.	47	Sonora Phonograph Sales Co., Inc., Inside Cover, 40, 41, and insert following page 26	91	
Cliff Manufacturing Works, Inc.	170	Krasberg Engineering & Manufacturing Corp.	69	Soss Manufacturing Co.	166	
Cole & Dunas Music Co.	56, 57, 68, 81, 114, 133	<b>L</b>			Sound Recording Co., Ltd.	40
Coleman Mercantile Co.	91	Lakeside Supply Co., Inc.	109	Southern Drug Co.	41	
Columbia Graphophone Co.	18, 27, 34, 37, 50, 63, 68, 73, 87, 90, 140, 153, 174, and insert following page 10	Language Phone Method	27	Southern Sonora Phonograph Co.	41	
Condon & Co., Inc.	21	Lansing, E. H.	48	Southwestern Drug Co.	40	
Consolidated Talking Machine Co.	110, 123	Latrobe Die & Casting Co.	6	Stafford E. H., Mfg. Co.	108	
Copper Process Co.	159	Lawson Piano Co.	121	Standard Pneumatic Action Co.	119	
Corley Co.	148	Lesley's	172	Standard Talking Machine Co.	174	
Cortina Academy	121	Liberty Phonograph Co.	42	Starr Piano Co.	38	
Crafts-Starr Phonograph Co.	174	Long Cabinet Co., Geo.	146	Stead, J., & Co., Ltd.	168	
Craies & Stavridi	167	Lorentzen, H. K.	26	Stein-Burn Corp.	30, 31, 32, 33	
Cressey & Allen	48	Lucky 13 Phonograph Co.	82, 83, 92, 139	Steinert, M., & Sons Co.	45	
Culp Phonograph Co.	82	Lundstrom Mfg. Co., C. J.	62	Stephenson, Inc.	127	
Curry, Frank B.	48	Lu-Franc Sales Service Co.	75	Sterling Devices Co.	104	
<b>D</b>		Lyon & Healy	100	Sterling Talking Machine Co., Inc.	109	
DeRivas & Harris Mfg. Co.	155	Lyons, J. I.	104	Sterno Manufacturing Co.	144	
Ditson Co., Oliver	29	<b>M</b>			Stodart Phonograph Co.	130
Dodin, Andrew H.	175	Magnolia Talking Machine Co.	20, 27, 81, 101, 175, 178	Stoffer & Stackhouse, Inc.	162	
Doehler Die-Casting Co.	141	Mandel Mfg. Co., Inc.	116	Strevell-Paterson Hardware Co.	40	
Droop & Sons Co., E. F.	174	Manhattan Phonograph Co.	138	Supreme Phono Parts, Inc.	156	
Duo-Tone Co.	51	Manhattan Phono Parts Co., Inc.	141	<b>T</b>		
Dyer & Bro., W. J.	174	Manufacturers Sales Co.	15	Talking Book Corp.	160	
<b>E</b>		Marshall & Co., C. L.	41	Talking Machine World Dealer Service	177	
Eastern Talking Machine Co.	45, 174	Mellor's	87	Thomas Mfg. Co.	96	
Eclipse Musical Co.	25, 124, 125	Mermod & Co.	176	<b>U</b>		
Edison, Inc., Thos. A.	Back Cover, 14, 132	Meyercord Co.	102	Udell Works	71	
Ellis, J. H.	145	Michigan Phonograph Co.	120	Unit Construction Co.	24	
Emerson International, Inc.	54	Mickel Bros. Co.	174	Usona Talking Machine Co.	112	
Emerson New England, Inc.	47	Milwaukee Talking Machine Mfg. Co.	70	<b>V</b>		
Emerson Philadelphia Co.	57	Minneapolis Drug Co.	40	Van Houten, C. J., & Zoon	40	
Emerson Phonograph Co.	36	Montagues, I., & Co.	41	Van Veen & Co., Arthur L.	74	
Emerson Record Sales Co.	16	Moses & Co., Walter D.	174	Veeco Co.	19	
Empire Phono Parts Co.	85, 114	Musante, Joseph	19	Viconia Mfg. Co., Inc.	71	
Empire Talking Machine Co.	67	Music Trade Review	158	Victor Talking Machine Co.	Front Cover, 5, 7	
Enterprise Music Supply Co.	83	Musical Supply & Equipment Co.	41	Vitanola Talking Machine Co.	12	
<b>F</b>		Mutual Talking Machine Co., Inc.	43	Volker & Co., W.	174	
Faultless Caster Co.	126	<b>N</b>			<b>W</b>	
Favorite Phonograph Accessories Co.	153	National Decalcomania Co.	126	Wade, R. C.	59	
Federal Sign System	11	National Publishing Co.	6	Wade & Wade	99	
Feist, Leo, Inc.	149, 150, 151, 152	National Co.	39	Waite, A., & Co., Ltd.	170	
Ferrara, Ben	83	Neu, H. G., & Co.	68	Walthall Music Co.	40	
Fifer, C. Arthur, Music Co., Inc.	147	New England Musical Instrument Trading Co.	138	Ward Co., C. E.	18	
Fischer Co.	13	New England Talking Machine Co.	46	Wax-Wilson Company	137	
Fletcher-Wickes Co.	97	New York Album & Card Co.	4	Weber-Knapp Co.	73	
FlexiFile Manufacturing Co.	99	New York Recording Laboratories, Inc., Inside Back Cover	69	Western Veneer Products Co.	27	
Fox, Sam, Pub. Co.	147	New York Talking Machine Co.	69	Weymann & Son, H. A.	57	
Franklin Phonograph Co.	56	Nicholson, K., Furniture Co.	137	Whitsit Co., Perry B.	174	
Fritzsche Co.	95	Nye, William F.	26	Widdicomb Furniture Co.	113	
Fulton Bros. Mfg. Co.	103	<b>O</b>			Wilson, Thomas E., & Co.	143
Fulton Talking Machine Co.	164	Ogden Sectional Cabinet Co., Inc.	131	Willson Sales Co.	43	
Futch Co., John A.	174	Ohio Sales Co.	40	Windsor Furniture Co.	60	
<b>G</b>		OkeH Record Dist. Co.	44	Wolf, Clifford A.	88	
Garford Mfg. Co.	15, 58	Oliver Ditson Co.	174	Wolff, S. & B.	168	
Gately-Haire Co., Inc.	142	Operaphone Co., Inc.	157	World Phonograph Co.	53	
General Manufacturing Corp.	66	Oro-Tone Co.	104	Wurlitzer Co., Rudolph	174	
Gibson Snow Co.	41	<b>P</b>			<b>Y</b>	
Gier & Bluhm	162	Paragon Mfg. Co., Inc.	154	Yahr & Lange Drug Co.	40	
Globe Decalcomanie Co.	18	Parker White Metal & Machine Co.	114	Yates, Chas. H.	160	
Glynn, W. B., Distributing Co.	41					



REG. U.S. PAT. OFF.

# Paramount Records

The Popular All-Hit Records are Now

## Lateral Cut

You can play them on any phonograph. No attachments necessary (except Edison). All records are double-face—made by well-known artists. List prices 85c., \$1.00 and \$1.25. Good discounts.

### Some Popular Records Now Ready

Aloma—Fox-Trot . . . . J. C. Beck's Orch.	} 33003	Souvenir of Switzerland . . . . Capodiferro	} 50025
Rainy Day Blues—One-Step, Master Saxophone Sextet		Aloha Oe . . . . . Capodiferro	
I'm Always Chasing Rainbows—Med- ley . . . . . J. C. Beck's Orch.	} 33002	Llewellyn Waltz . . . . . Rudy Weidoeft	} 50026
Egyptland—Fox-Trot, J. C. Beck's Orch.		Saxophobia . . . . . Rudy Weidoeft	
Ragging the Scale—Fox-Trot, Van Eps Trio	} 33004	Stars and Stripes Forever . . Rogers Band	} 33001
Havanola—Fox-Trot . . . . Van Eps Trio		Boston Commandery—March, Rogers Band	
Ja-Da . . . . . Arthur Fields	} 33011	Where Is My Wandering Boy To- night? . . . . . Peerless Quartet	} 33010
Kisses . . . . . Chas. Hart and Helen Clark		Rock of Ages, M. Richardson and Marion Cox	
Salvation Lassie of Mine, Marion Evelyn Cox and Chas. Hart	} 33009	Largo (Handel) . . . . . Arthur Gramm	} 33005
Hush-a-Bye, Ma Baby . . . . . Henry Burr		Meditation (Thais) . . . . . Arthur Gramm	

Order These Today and get our Complete List of Late Lateral Cut Paramount Records.

**The New York Recording Laboratories**  
**PORT WASHINGTON** **WISCONSIN**



# THE NEW EDISON



Substantiated  
 Claims  
 Prove the  
 Worth of the  
 New Edison

**JOBBER OF THE NEW EDISON, EDISON RE-CREATIONS,  
 THE NEW EDISON DIAMOND AMBEROLA AND BLUE AMBEROL RECORDS**

**CALIFORNIA**  
 Los Angeles—Edison Phonographs, Ltd.  
 San Francisco—Edison Phonographs, Ltd.  
**COLORADO**  
 Denver—Denver Dry Goods Co.  
**CONNECTICUT**  
 New Haven—Pardee-Ellenberger Co., Inc.  
**GEORGIA**  
 Atlanta—Phonographs, Inc.  
**ILLINOIS**  
 Chicago—The Phonograph Co.  
 James I. Lyons. (Amberola only.)  
**INDIANA**  
 Indianapolis—Kipp Phonograph Co.  
**IOWA**  
 Des Moines—Harger & Blish.  
 Sioux City—Harger & Blish.

**LOUISIANA**  
 New Orleans—Diamond Music Co., Inc.  
**MASSACHUSETTS**  
 Boston—Pardee-Ellenberger Co.  
**MICHIGAN**  
 Detroit—Phonograph Co., of Detroit.  
**MINNESOTA**  
 Minneapolis—Laurence H. Lucker.  
**MISSOURI**  
 Kansas City—The Phonograph Co. of Kansas City.  
 St. Louis—Silverstone Music Co.  
**MONTANA**  
 Helena—Montana Phonograph Co.  
**NEBRASKA**  
 Omaha—Shultz Bros.  
**NEW JERSEY**  
 Paterson—James K. O'Dea (Amberola only.)  
**NEW YORK**  
 Albany—American Phonograph Co.

New York—The Phonograph Corp. of Manhattan.  
 Syracuse—Frank E. Bolway & Son, Inc.  
 W. D. Andrews Co. (Amberola only.)  
 Buffalo—W. D. & C. N. Andrews Co. (Amberola only.)  
**OHIO**  
 Cincinnati—The Phonograph Co.  
 Cleveland—The Phonograph Co.  
**OREGON**  
 Portland—Edison Phonographs, Ltd.  
**PENNSYLVANIA**  
 Philadelphia—Girard Phonograph Co.  
 Pittsburgh—Buehn Phonograph Co.  
 Williamsport—W. A. Myers.  
**RHODE ISLAND**  
 Providence—J. A. Foster Co. (Amberola only.)  
**TEXAS**  
 Dallas—Texas-Oklahoma Phonograph Co.

**UTAH**  
 Ogden—Proudt Sporting Goods Co.  
**VIRGINIA**  
 Richmond—The C. B. Haynes Co., Inc.  
**WISCONSIN**  
 Milwaukee—The Phonograph Co. of Milwaukee.  
**CANADA**  
 Montreal—R. S. Williams & Sons Co., Ltd.  
 St. John—W. H. Thorne & Co., Ltd.  
 Toronto—R. S. Williams & Sons Co., Ltd.  
 Vancouver—Kent Piano Co., Ltd.  
 Winnipeg—R. S. Williams & Sons Co., Ltd.  
 Calgary—R. S. Williams & Sons Co., Ltd.