

WBKB
CHICAGO'S PIONEER
TELEVISION
STATION



Looking Ahead With **TELEVISION**



Today, the American family sits entranced at the new wonder of television which enables them to **see** as well as **hear** the rich, full drama of life's pageant . . . sports, current events, entertainment, and information. Through this new channel of communications they discover the greatest treasury of enlightenment and education that has ever before been given to free men. To the families of Chicagoland . . . who for the past 32 years have looked to Balaban and Katz for the highest standards of family entertainment . . . **WBKB**, B & K's Television Theatre, dedicates this album.

Compliments of:

BALABAN & KATZ

C

H



Mr. John Balaban shapes the policies of **WBKB** and the vast Balaban and Katz organization.

32 YEARS LEADERSHIP

Entertainment has been our business for several decades and service our privilege for the millions of Chicagoans who patronize Balaban & Katz theaters.

We launched into television upward of eight years ago when we acquired **WBKB** because we regarded television to be entertainment, although we knew we had an uphill journey ahead of us, and we dedicated ourselves to present the same quality of entertainment, the same superior service to television audiences as our theater audiences have enjoyed.

And this promise we propose to fulfill to the utmost.

JOHN BALABAN

LUC

SORROWFUL JONES

50¢ TO 12¢ STAGE

ANDREWS SISTERS

BOB SLEMAN'S SANDWICH SHOP

CARRYING ON THE BALABAN and



JOHN H. MITCHELL, General Manager

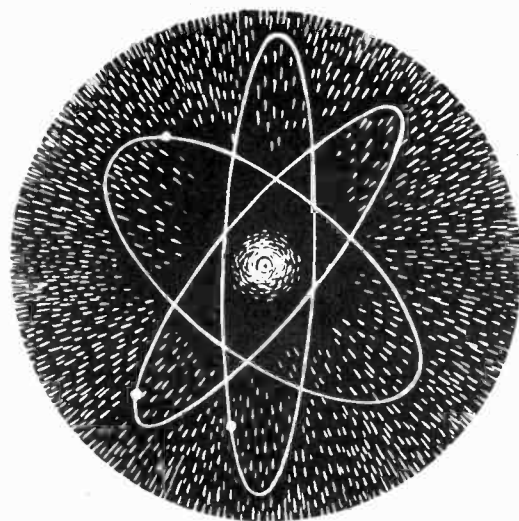

Mr. Mitchell brings to the new video industry 18 years experience in show business gained as a Balaban and Katz theatre executive. Under his competent and far-sighted leadership this team of men from all walks of life, representing a total of 35 years experience in the entertainment field, work hand in hand to offer Chicagoland audiences the utmost in television enjoyment.

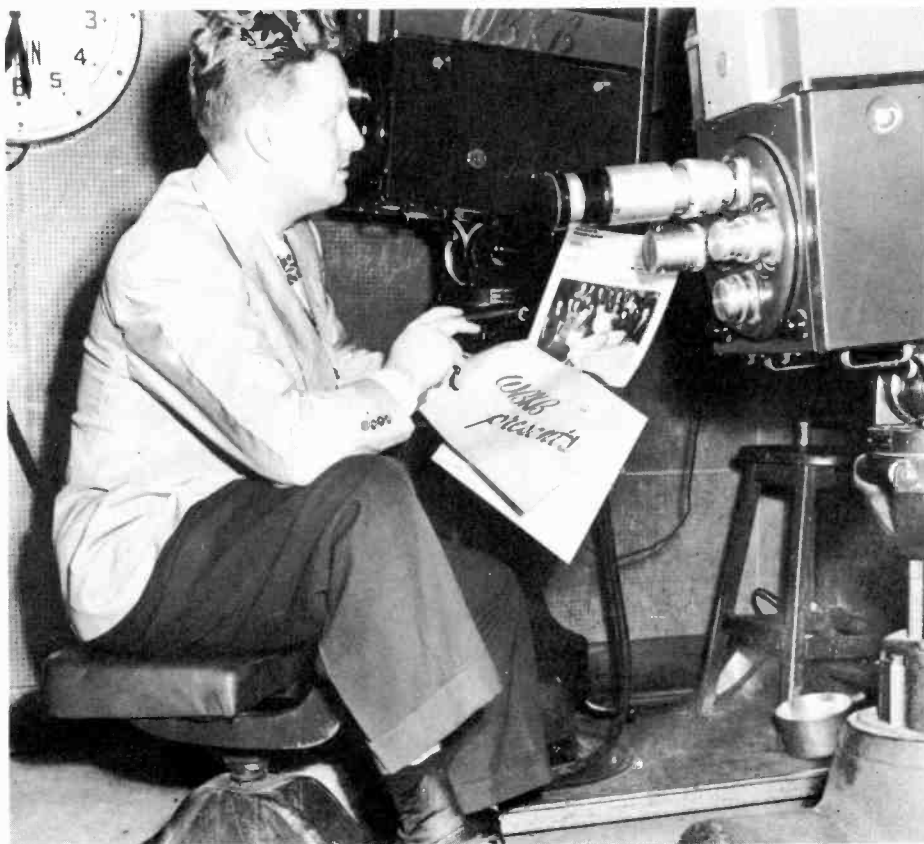
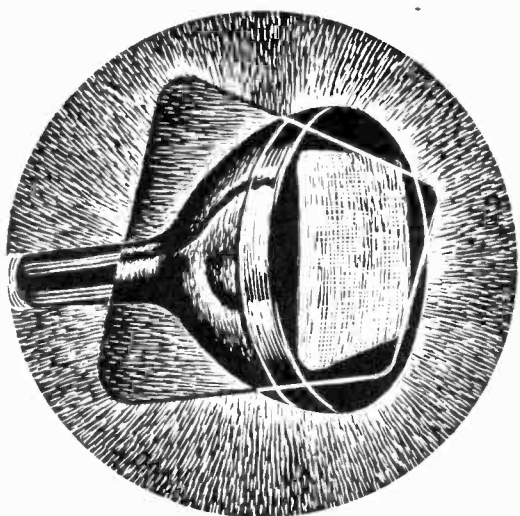

STERLING QUINLAN, Program Manager

KATZ TRADITION OF LEADERSHIP



HARRY BIRCH, Chief Cameraman



WILLIAM KUSACK, Chief Engineer



WILLIAM RYAN, Production Manager



WARREN JONES, Director of Talent

WBKB's HOME EXPRESSES THE



The minute you step off the elevator into the 12th floor studios and offices of **WBKB** in the State Lake Building, you are made to feel thoroughly at home. Chicago's pioneer **TV** station has finished a complete renovation project of approximately \$15,000, resulting in one of the most modern and lovely television stations in the country as you can see on these pages.

Here in **WBKB's** compact and beautifully appointed Little Theatre visitors, agency personnel and clients can view **WBKB** programs on the 20-inch screen in air conditioned comfort. The theatre seats 40 persons.

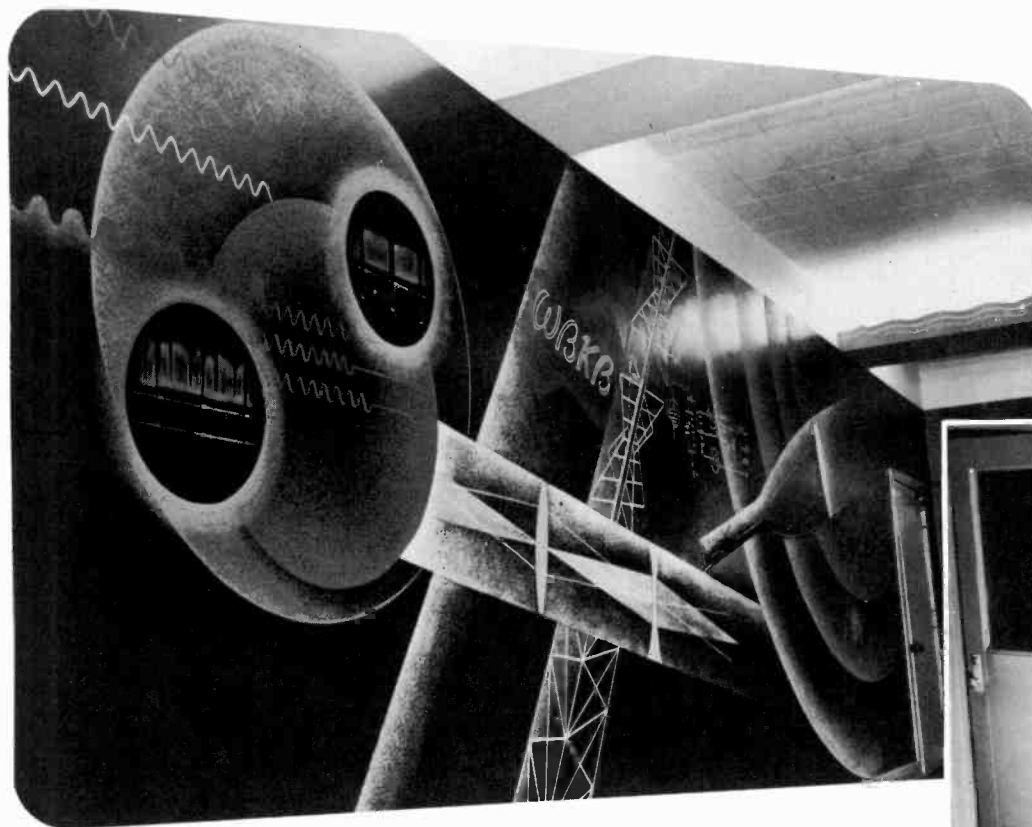

Looking down the entrance hallway to the **WBKB** "Little Theatre", visitors view this beautiful mural depicting the engineers concept of sending a picture through **WBKB's** antenna system to receivers in the home.

In pleasant, air-conditioned surroundings such as these, **WBKB's** staff carries on their duties.



OUTMOST IN TELEVISION DESIGN

This is famed studio "G" from which the B and K Television Theatre presents their larger production programs involving elaborate sets and special effects. As many as 13 sets at one time have been erected in this huge studio.



Hundreds of calls daily from Chicagoans are handled by **WBKB's** busy switchboard operator, Lillian Noble. Queries of all sorts dealing with television are answered courteously and promptly.



The **WBKB** "brainchild", the Multiscope, is the nerve center of Studio "B" which contains, in addition, two 16 mm RCA film projectors, two 35 mm RCA projectors as well as slide projector.

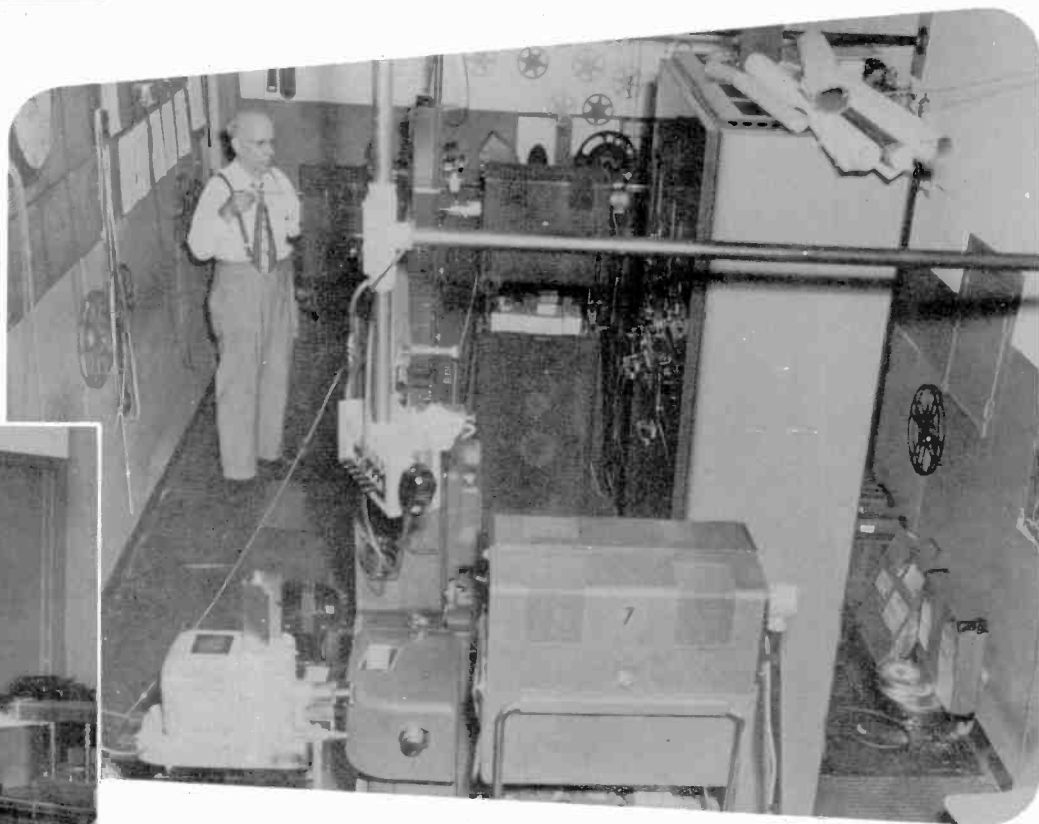

These are the main executive offices of Chicago's pioneer **TV** station.



THE MIDWEST'S PIONEER TV

for bringing you

first

baseball game ever to be televised from Wrigley Field, home of the Chicago Cubs.



first

interstate telecast of boxing matches direct from ringside at Michigan City, Indiana.

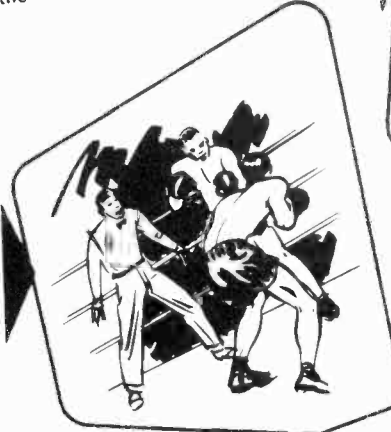

first

official remote broadcast of any consequence, the Shriner's parade televised from in front the Sheraton Hotel.



first

inter-city relay golf tournament telecast from atop the roof of Tam O'Shanter Country Club.

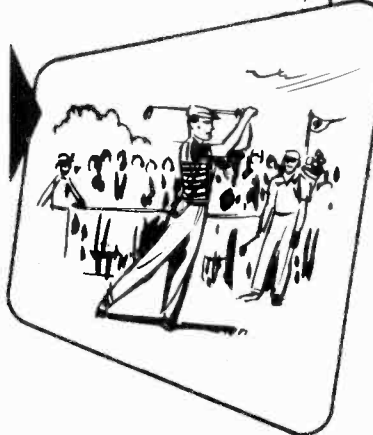

first

Football game relayed from Dyche Stadium, Evanston.

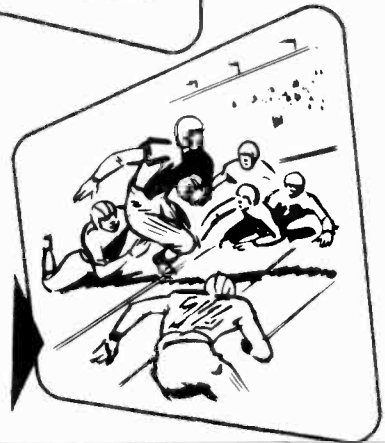

STATION IS NOTED

the

first

inter-state relay from South Bend, Indiana with the telecast of Notre Dame Football game.

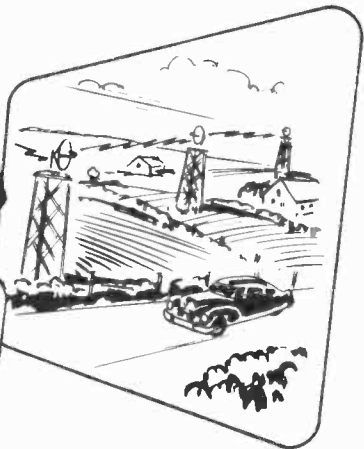

first

full length drama ever to be televised in its entirety and complete with costume and setting.



first

television account of the impressive midnight Mass from Holy Name Cathedral.

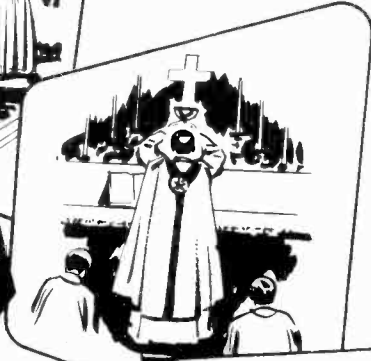

first

Easter Sunrise service telecast from Cook County Hospital.



first

concert to be televised in Chicago direct from Grant Park bandshell.

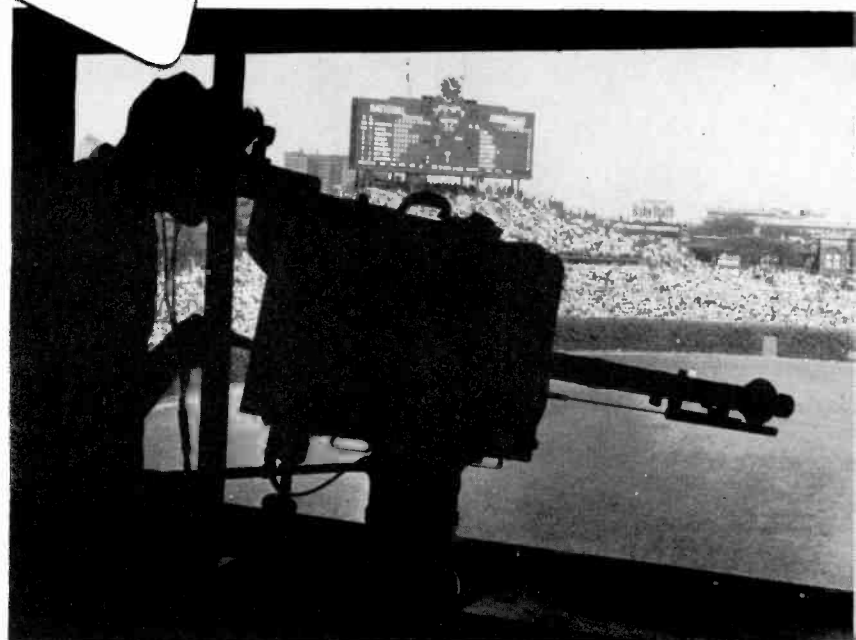
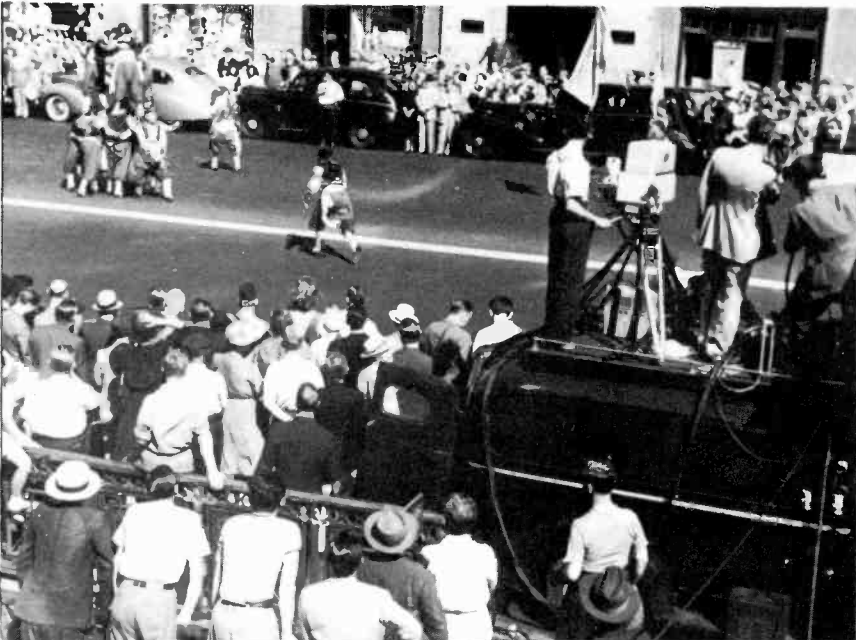



ON THE ROAD FORWARD,

MILESTONES



Long remembered by Chicagoland television audiences is **WBKB's** presentation of the Ring Lardner laugh-riot, "June Moon" one of the first full length plays ever to be televised. Recognize Joe Wilson (then an actor) on the left?



Famous celebrities such as Sally Rand never considered a visit to Chicago complete without "guesting" at **B & K W9XBK**, now **WBKB**.



Election night 1948 was a memorable evening for more than its unexpected outcome. It marked **WBKB's** much-lauded coverage of the vote returns in cooperation with the Sun-Times.



Long before **WBKB's** offices, studios or transmitter were anywhere near completion, their first TV camera was tested.



One of the first public service series telecast by **B & K** dealt with the art of ceramics under the auspices of the Chicago Art Institute.

WBKB GLANCES BACK

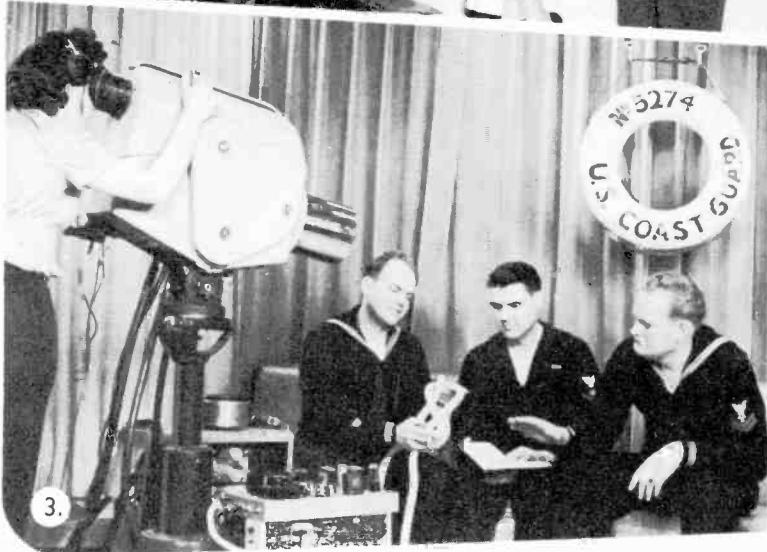

1 An early model camera used by **WBKB** "moves in" on the actors during this experimental commercial comedy skit show.

2 Even in the early days as now, **WBKB** grabbed off top stars for special interviews. Here Billy Gilbert, movie star, making an appearance at the Chicago Theatre takes time off for a **TV** chat.

3 Ingenuity is second nature with **WBKB**'s skilled technicians. Here in use on this Coast Guard show is the station's second television camera, re-designed and rebuilt by **WBKB** engineers.

4 The old time melodrama comes into its own on the newest medium — television. Bill Vance starred in this early chiller, a **WBKB** production.



Glamorous Gloria Swanson, now star of her own television show, made one of her first video appearances before a **WBKB** camera.

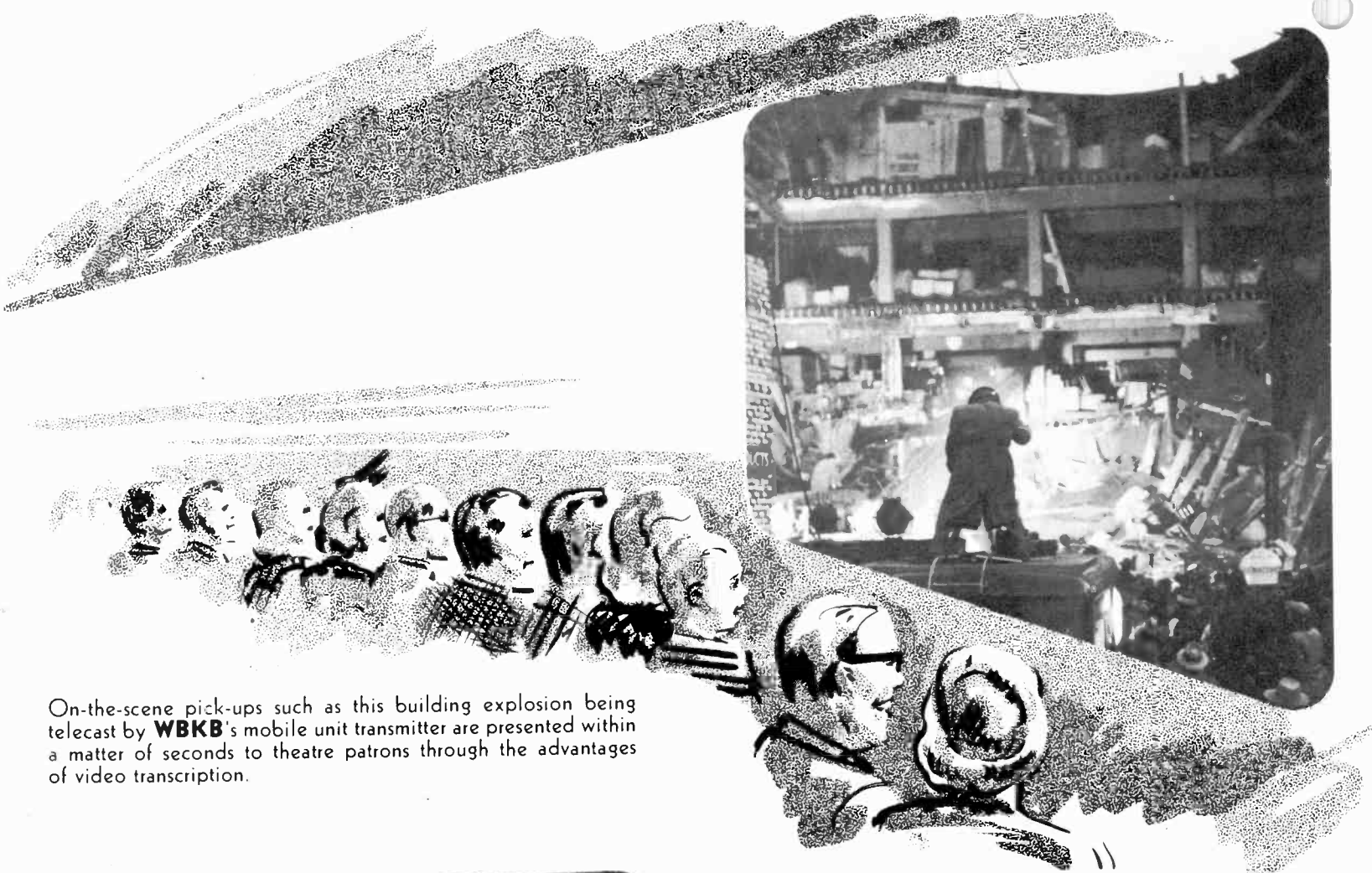

On-the-scene pick-ups such as this building explosion being telecast by **WBKB**'s mobile unit transmitter are presented within a matter of seconds to theatre patrons through the advantages of video transcription.



"The picture is flashed on this tube from **WBKB** and and photographed by our special camera", explains Carl Maurer, Paramount development engineer to Helen Glait. Operating an Ackley camera, Maurer focuses on the kinescope tube where the image appears.



Threading the camera is an exacting job as demonstrated to B and K installation engineers by Mr. Maurer. This specially designed Ackley camera contains the unique Paramount electronic shutter developed for this use. The camera alone is valued at \$11,000.

THEATRE TELEVISION — Another Balaban and Katz Triumph

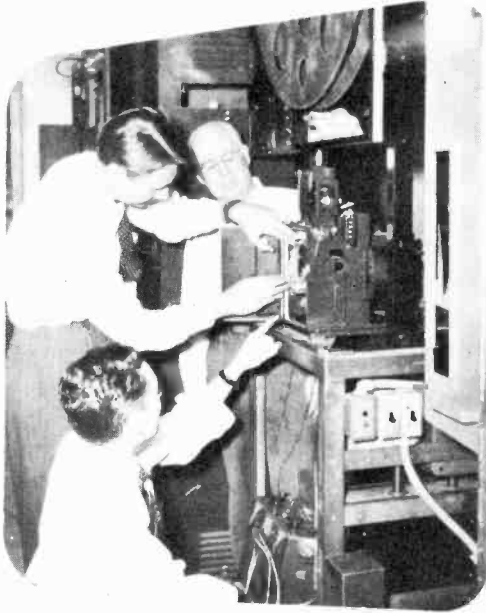

As the television image is photographed, the film leaves the Ackley camera on its long trip through the video transcription system. Here, I. F. Jacobsen, B & K engineer, starts the ribbon of film on the first of **four separate processing operations.**

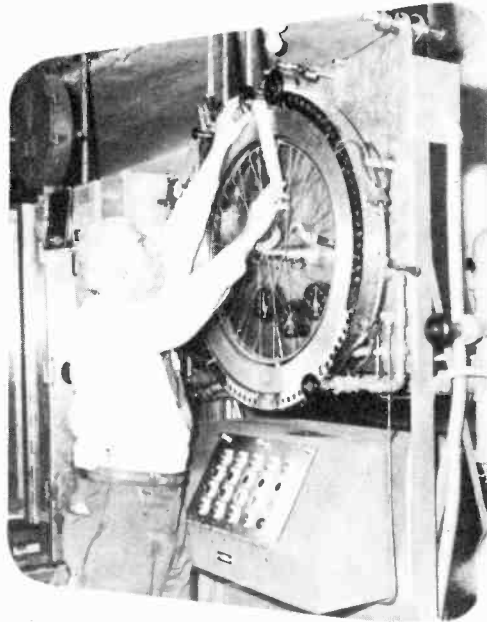

In just **ten seconds** after being developed, the finished film is dried by jets of hot air on this drying cylinder which resembles a bicycle wheel. Robert Burns, Balaban and Katz engineer, makes certain the threading is started properly.

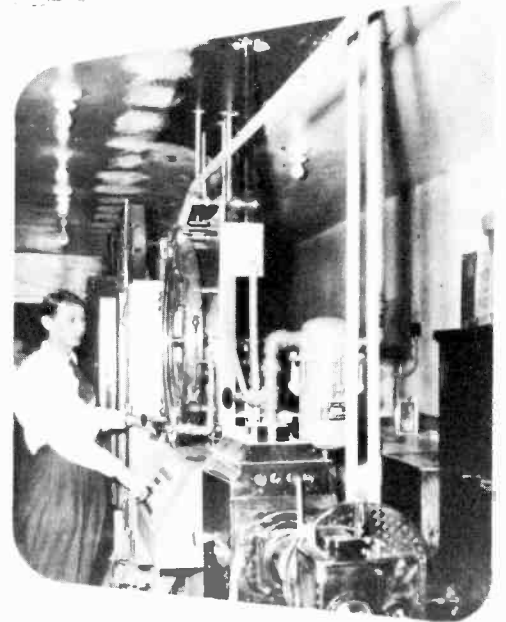

The film is now ready to continue its unbroken trip to the projection room of the B & K Chicago Theatre, a distance of 20 yards from the point of video-transcribing. Speed of the operation is here carefully regulated as it heads for the projection room and ultimately the huge Chicago Theatre screen.

45 seconds later! Still untouched by human hands after four stages of processing and drying, the finished high quality 35 mm sight-and-sound print is fed into the projection machine which flashes it onto the giant Chicago Theatre screen. Thus, by the miracle of theatre television, patrons see news history in the making!

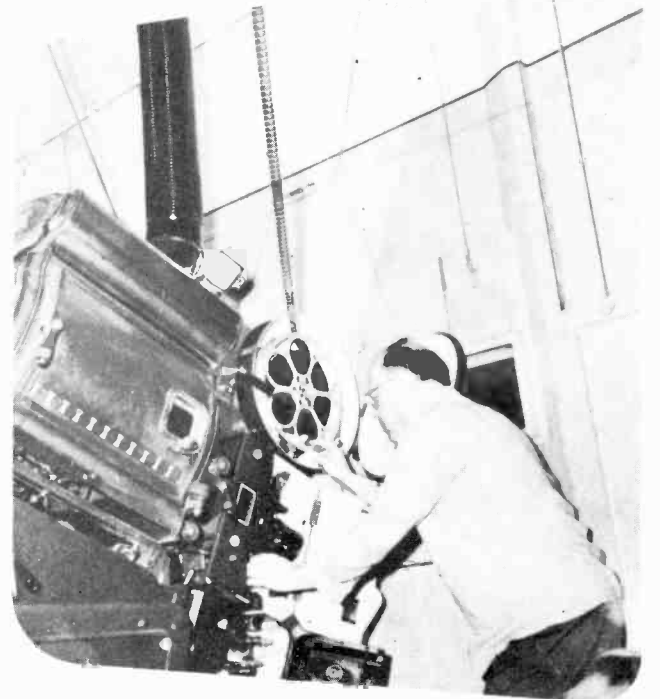

Constantly striving to remain in the front ranks of television progress, **WBKB** is the first television station to introduce the amazing video transcription development to the midwest. By means of this sensational \$65,000 invention, scenes picked up by **WBKB** cameras are flashed on the immense screen of the Chicago Theatre in just 45 seconds, enabling patrons to witness events as they actually happen and are telecast by **WBKB**.

WBKB PUBLIC



During National Dog Week, an event of considerable activity on the part of Chicagoland dog fanciers, **WBKB**'s canine representative, "Mac" a collie who appeared often at the B and K Television Theatre, strolled over to the Mayor's office, accepted His Honor's Proclamation and delivered it to the **WBKB** studios. All leading highlights of Dog Week celebration were sent into Chicago television homes by **WBKB**.

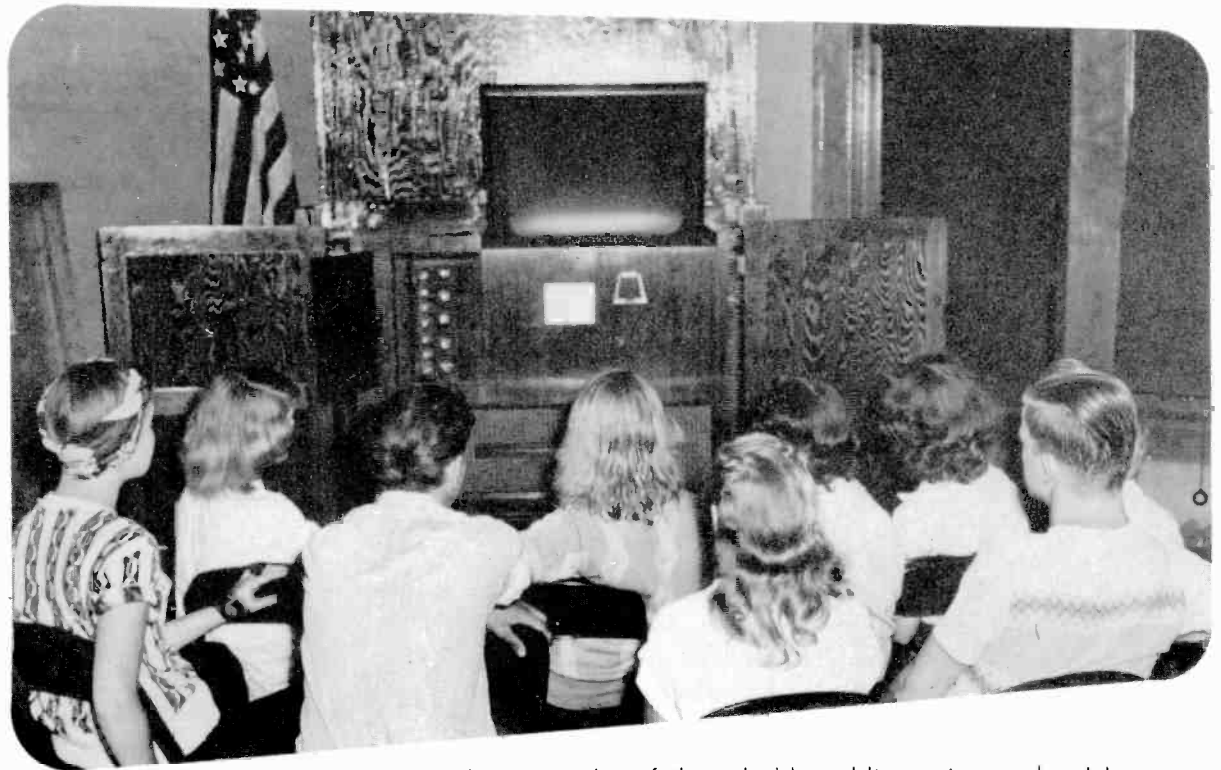

One of the most outstanding examples of the valuable public service rendered by **WBKB** is the installation of television receivers in nine fieldhouses in Chicago public parks. The station, in cooperation with that other public-spirited organization, the Chicago Cubs, placed the **TV** sets for the benefit of the people of this area. While primarily for the entertainment of the younger folks, these sets make available the joy of watching programs as well as hearing them to thousands of folks in all walks of life.



SERVICE WBKB



Russ Davis, amiable **WBKB** announcer, has a most profitable way with a cause, especially if it is a worthy one. As the Television Theatre's ambassador of public service, Russ has collected an estimated \$13,000. from kind-hearted Chicagoans on his various programs. In the last three years, Russ and **WBKB** have raised \$800 for the Shriner's Hospital Fund; \$2,200 for the Sun-Times Charities; \$900 for crippled youth, Paul Nelson; \$1,000 Christmas-time fund for Illinois Disabled Vets; \$1,000 for the Illinois Crippled Children's Hospital. In addition, Russ has spread a good deal of cheer with such humane acts as "surprise showers" of cards from listeners to deserving, unfortunate folks.



The Treasury Bond Show under the supervision of Milton Wolf brings before the **WBKB** television cameras the best of talent in a well rounded production which is a weekly feature of the B & K Television Theatre. Utilizing the full facilities of the station's staff, the program is a presentation of the United States Treasury Department on behalf of United States Savings Bond sales. So very popular with Chicagoland audiences is this fine public service feature, **WBKB** maintains it on their schedule of regular telecasts.

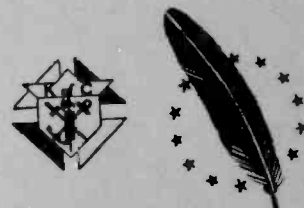

WBKB

CHICAGO'S PIONEER
TELEVISION
STATION

TOPS

CHICAGOLAND IN TV ENTERTAINMENT

Children love the thrilling adventure serials shown on **WBKB**. Here John Dunham describes the aerial exploits of Ace Drummond to one of the young cadets who watch **WBKB**'s popular Saturday morning serial program called "Movies For Kids". Many other equally exciting juvenile programs keep the eyes of Chicago's younger set glued to channel 4. Among them are "Wranglers Club" starring genial Texas Bruce Roberts and the best of western pictures; "Lucky Pup" and "Mr. I Magination" seen on **WBKB** on Sunday afternoons.

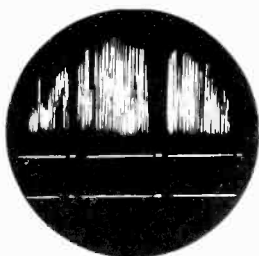

Considered a definite threat to the laurels of that ace performer Arthur Godfrey, **WBKB**'s "Curbstone Cutup", Ernie Simon is the zaniest man-on-the-street you'll ever meet. His hail-fellow greeting and clowning with passersby is a sure traffic stopper for busy Chicagoans who take part in his daily telecasts from beneath the marquee of the B & K State Lake Theatre on famous State Street. Ernie is just another stellar attraction of **WBKB**, your Television Theatre.



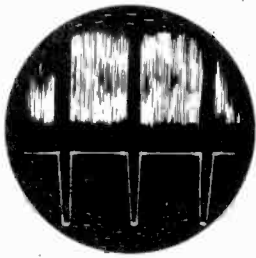

What is your favorite hobby? All Chicago television fans know that **WBKB's** weekly program, "Hobby Parade" is a meeting place for hobby lovers from far and wide. Phil Lewis shown in the center here is not only principal of one of Chicago's large high schools, but he is known as the hobby expert of television. Dinny Burns, his pretty assistant, holds one of the decorative candles made on a recent "Hobby Parade" program, while Marshall Goldberg, star of the Chicago Cardinals football team, looks on.



Don and Vera Ward relieve dad of the chore of reading the funnies with their daily offering before the **WBKB** Television camera of "Comic Capers". All the most widely-read comic strips which appear in the Chicago Sun-Times including "Steve Canyon", "Joe Palooka", "Dixie Dugan" and others are read by Don and Vera as they give realistic interpretation to the comic characters. As a special part of the program, Don's puppet rabbit "Boo" performs tricks of his own to the intense delight of the youngsters in the studio and those watching at home.

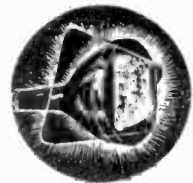

Drama has always been emphasized on Chicago's oldest television station. **WBKB**, for years, presented outstanding dramatic productions of its own. Full length versions of Skylark, June Moon, Papa Is All and many other hit plays were seen on **WBKB** when television was in its infancy. Now channel 4 presents the leading dramatic shows of **CBS**. Here Lilli Palmer and Fredric March rehearse a lively scene from the **CBS** production of "Ford Theater", while Rex Harrison, Miss Palmer's actor husband looks on. Other great **CBS** dramatic hits seen on **WBKB** include: Studio One, Suspense, Silver Theater, Man Against Crime and Front Page.

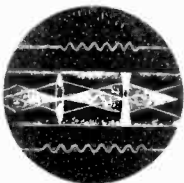



Douglas Edwards, newscaster on the "CBS Television News" series aired by **WBKB** was the first major radio newscaster to switch to **TV**.



One of the spectacular dance routines you see when the "Toast of The Town" **CBS** show goes before the cameras as viewed on Channel 4.

In The Midwest More and



Here's the permanent cast of "Mama", the **CBS-WBKB** series (about 1950) starring Peggy Wood, third from left in back row.

The **CBS-TV** camera catches Arthur Godfrey in a jovial mood over the fact that he now can be seen by his Chicagoarea fans on **WBKB**.



"Yoo hoo . . . is anybody". Now the 17-year-old radio family dramatic serial, "The Goldbergs," is viewed by Chicagoans via **WBKB**.

Among the most beautiful singers in show business, Gigi Durston of the "Sonny Kendis Show" is right at home before the **TV** camera.





Fred Waring directs his orchestra and choir on the **WBKB-CBS TV** network's "Fred Waring Show".

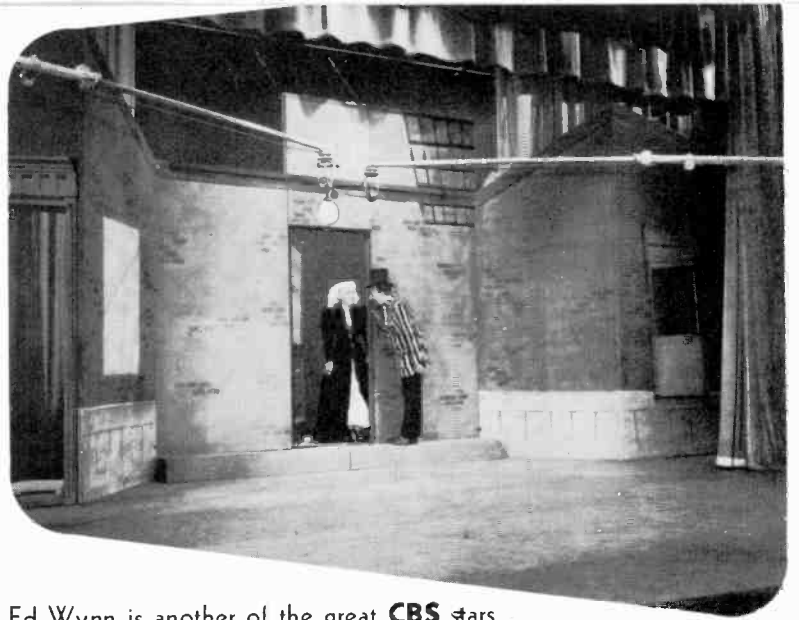

Ed Wynn is another of the great **CBS** stars to be seen weekly on **WBKB**. Here, Gertrude Niesen gives Ed a sultry greeting.

More Watch Channel Four



Zany Ernie Simon — **WBKB**'s sure cure for the blues. Once seen, never forgotten!

Typical of the ultimate in television dramatic fare is one of many splendid productions seen on the **WBKB-CBS** presentation of "Studio One".



Foodini and Pinhead are the principal characters on the **CBS-WBKB** Television fun-show "Lucky Pup".

A production point in "Silver Theater", **CBS** dramatic hit is discussed by emcee Conrad Nagel, Burgess Meredith and producer Frank K. Telford.



••• ITS WBKB ••• WITH THE NEW ••• STARTLING APPROACH

The midwest's pioneer television station leaves nothing to chance in assuring their viewers pictures and stories on news events as quickly as they develop. WBKB maintains a 24 hour daily service with both Acme Photo Service and the Chicago Sun Times on pictures of major world and local news stories.

Also, through the world wide facilities of the far-flung agencies that make up the United Press, late bulletins come ticking into the WBKB newsroom in a steady stream. This coverage is further augmented by hourly liaison with the Chicago Sun Times for extensive reporting of the local and state-wide scene.

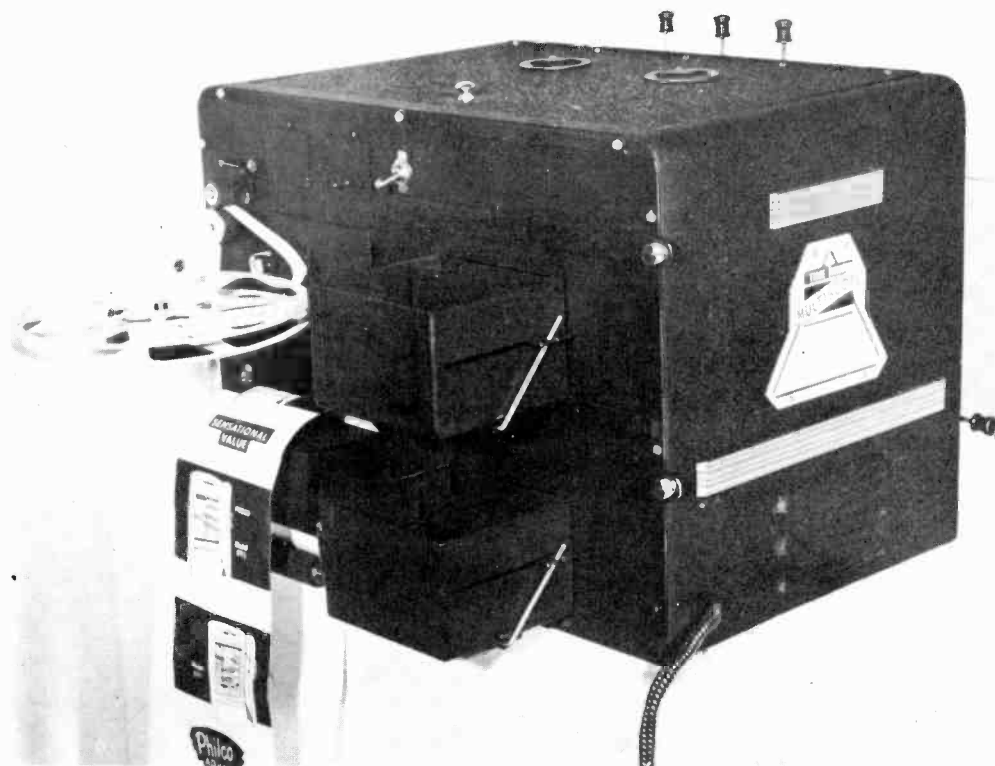

Multiscope is the miracle machine developed by **WBKB** and presented to Midwest audiences for the first time over Chicago's oldest television station. With this amazing device, Chicagoland viewers are kept constantly up-to-date on the correct Western Union time; the latest weather forecast including temperature, humidity, barometric pressure and wind velocity as all the while latest worldwide and local United Press tape flashes across the screen, just as it is received in the **WBKB** Newsroom. In effect, Multiscope makes every home a city desk.

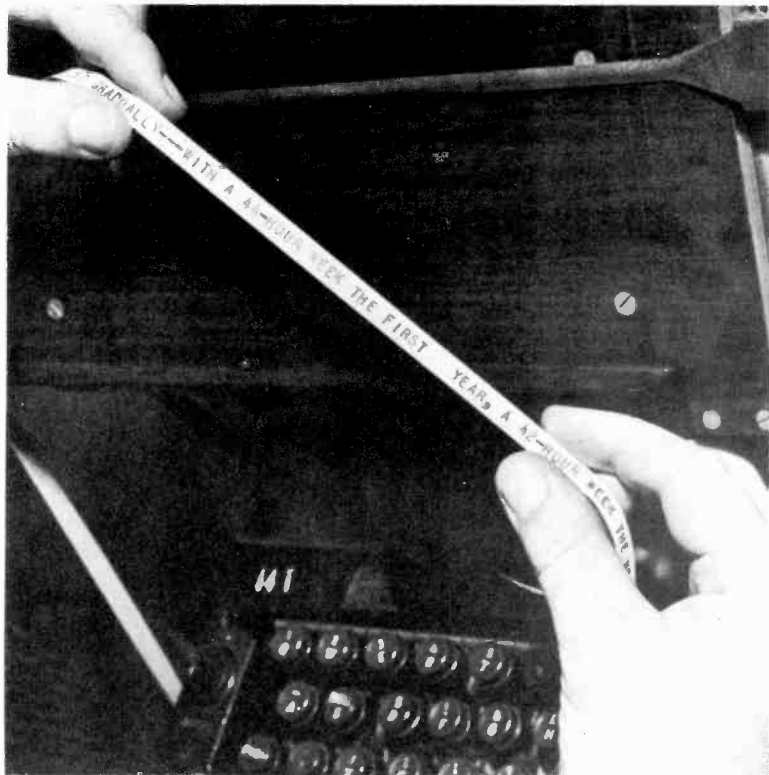

This is Multiscope in action! Onto the screens of Chicagoland television sets is sent pictures similar to the above during the 49 hours every week that Multiscope is in operation at the Television Theatre.

Without editing or alteration, the special ticker tape is taken directly from the United Press News machine in the **WBKB** Newsroom to the lens of the Multiscope, eventually to roll past your **TV** screen.

TO NEWS COVERAGE..... ITS WBKB..... WITH THE NEW.....



The Television Theatre's capable News Editor, Ulmer Turner is no newcomer to television. Measured by years of experience, Mr. Turner is Chicago's senior kilocycle columnist. As head of **WBKB's** greatly enlarged news and special events operation, he draws upon a colorful and seasoned background as radio editor of the old Chicago Herald and Examiner, Herald American and Chicago Sun; as a roving writer for International News Service and broadcast commentator for the Hearst papers in Chicago. Mr. Turner has traveled widely and as a hobby and adjunct to his commentary-press work, maintains probably the most complete privately owned shortwave listening post in the country. It consists of 24 separate receivers attuned to all world capitals.

Many of the top news stories of the day come from the busy, bustling Sun - Times Newsroom with its trained staff of news people.

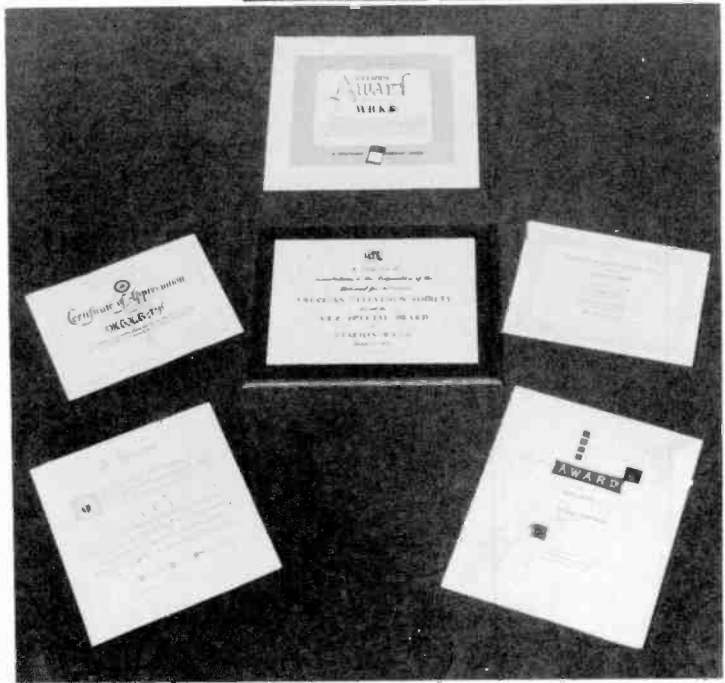

For outstanding achievements in television programming, public service, and technical advancement, **WBKB** has been honored with numerous awards of recognition. Only a few of them are shown.

First in Sports Telecasting —

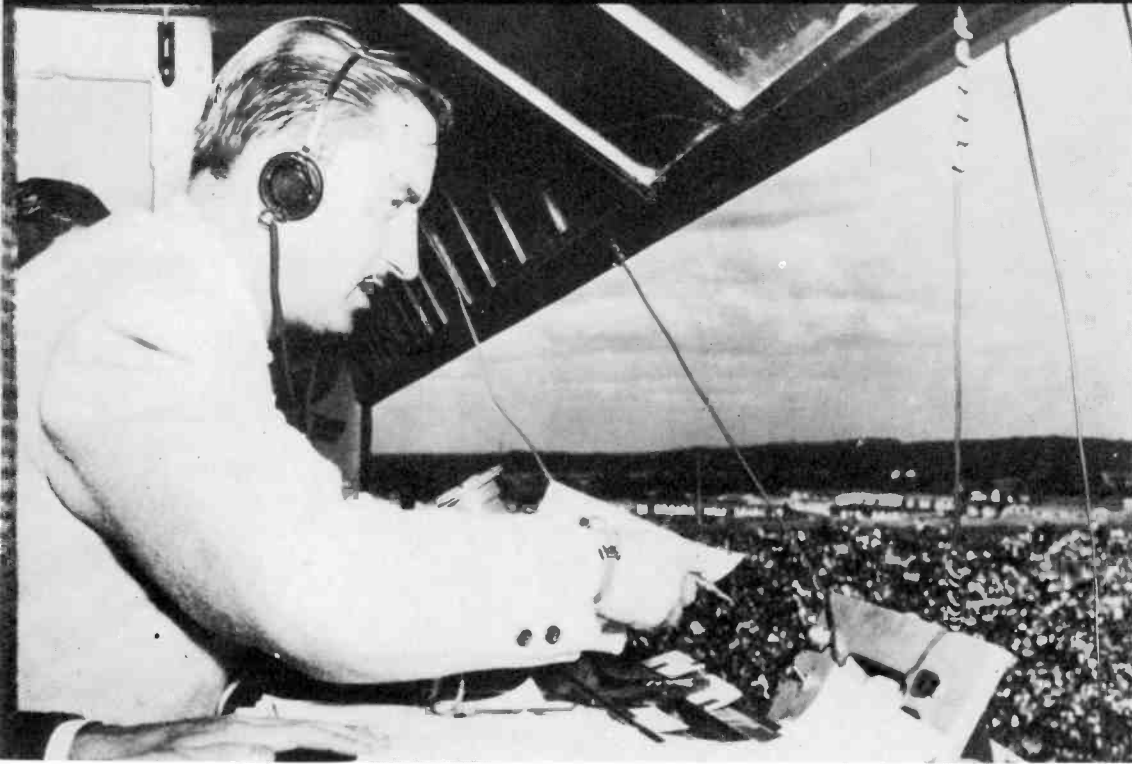

One of the country's top television sports-casters, popular Joe Wilson has earned an immense following as a result of his interesting and factual reporting of major sports events on Channel Four. His advent into radio occurred quite by accident when he was given a chance to voice his opinion of a hockey game in his native Minneapolis during an intermission while visiting his friend, the announcer. And Joe's been at it ever since. Thanks to a splendid background in sports work assisting Harry Wismer on the ABC network, Joe possesses a keen insight of sporting activities in all fields. Chicagoland televiewers know him best for his play-by-play reporting of the Chicago Cub baseball games, as well as on-the-scene telecasts of football games, hockey matches, boxing bouts, basketball, harness racing, golf and midget racing.

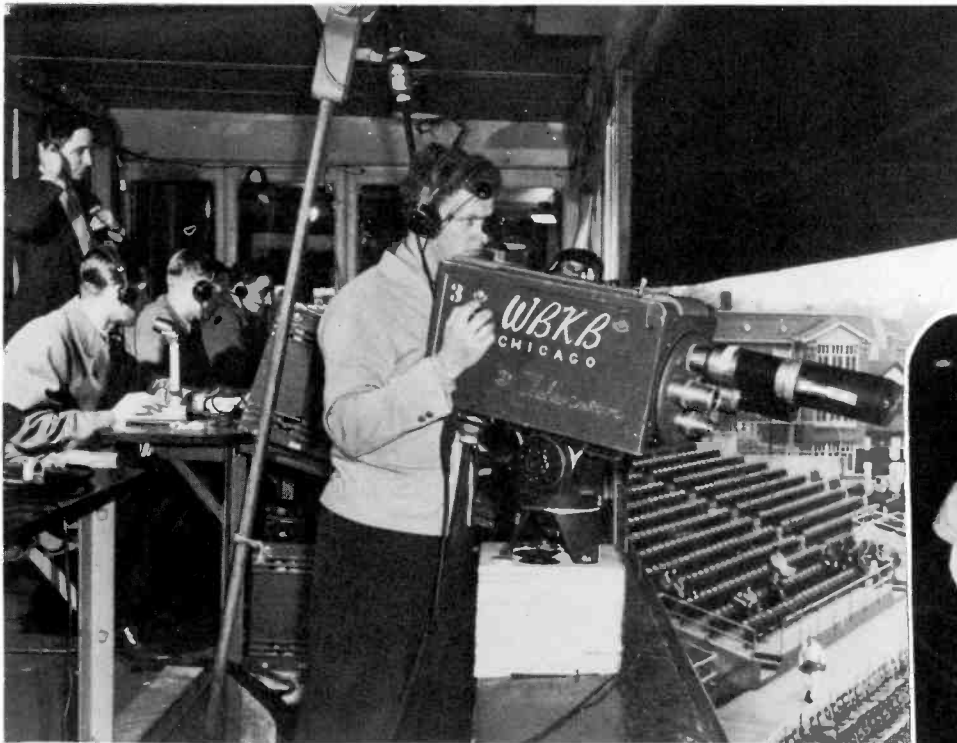
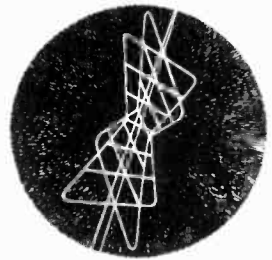

"Play Ball", shouts the ump and Art Kamb focuses one of the three large **WBKB** television cameras set up at vantage points in Wrigley field to bring baseball fans every bit of thrilling play.



Hockey fills a definite niche in sports reporting and as such **WBKB** considers it a "must" in rounding out their schedule of events. With Joe Wilson at the mike, games of the Chicago Blackhawks have been a regular seasonal feature of the mid-west's pioneer **TV** station.

WBKB Still Leads the Field



Football hungry midwest sports fans look to Channel Four first for complete coverage of leading midwest contests. **WBKB's** cameras and Joe Wilson bring to viewers top home games of Notre Dame, Illinois and Northwestern.



To Chicago wrestling fans, Russ Davis is almost as well known as Gorgeous George or the Masked Marvel. His inimitably funny comments make the wrestling matches from Midway something telefans simply can't miss.



Mixing it up, local amateur boxers perform before the B & K Television Theatre cameras at the Madison-Cicero Arena. **WBKB** was the first Chicago station to televise boxing, a forerunner of their present day coverage.



No powder puffs here! There's action galore when the gals take over the diamond. You never miss a second of it thanks to **WBKB** and Russ Davis' reporting of the Girl's Baseball Games from Admiral Stadium in Des Plaines, Illinois.

A WBKB TELECAST



1 While the program is still in the "idea" stage, **WBKB** department heads confer to work out details of dialogue, settings, camera operation and time of scheduling for closest cooperation among Staff members.



2 Next step is placing the program in the right "time slot" or **WBKB's** immense schedule board which tells at a glance the day, time and number of weeks each program is telecast.



5 Working out a bit of "business" for the cameras the actors, having dispensed with their script, are memorizing lines and matching them with action. Simultaneously, last minute adjustments are made on the near-ready set.



6 With seconds to go, a quick touch-up is given Miss Leonard's lips by make-up technician Adele Bowers as Director Joe Simon anxiously looks on.

COMES TO LIFE

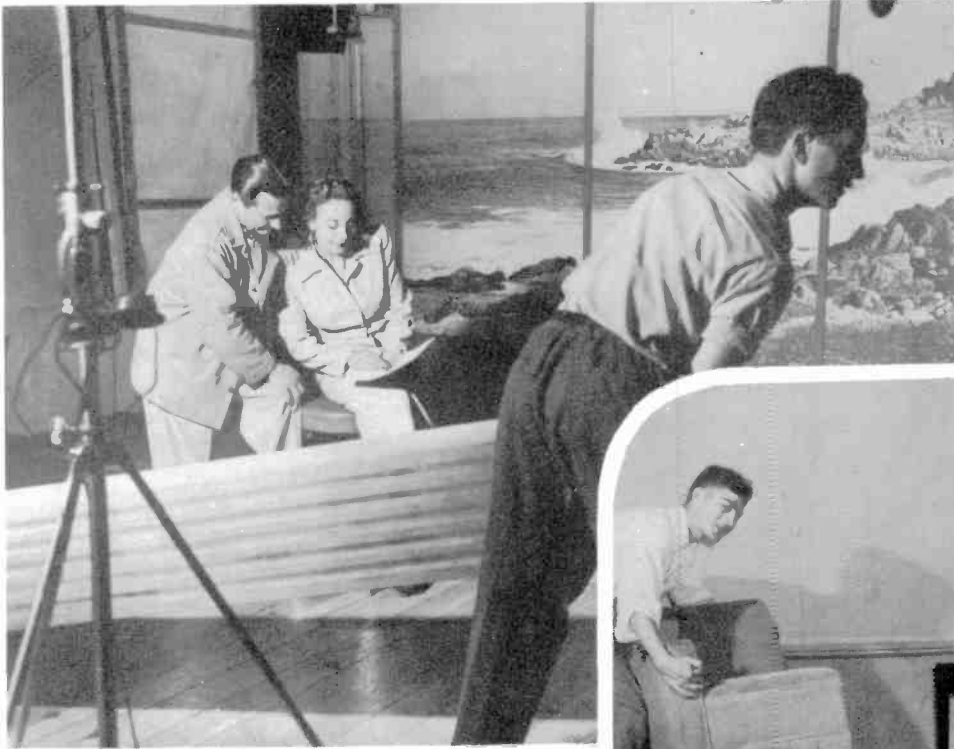

3

Hours before camera time, work gets underway. Unmindful of the activities of Bill Taylor and the rest of the Studio Crew, leading players Art Hern and Sheryl Leonard give the script a first "read through".



4

As Mr. Hern and Miss Leonard get down to the business of actual rehearsal, the setting around them takes form. Prop man Red Leahy makes certain that Phil Ruskin places that chair in the right spot.



7

As the camera moves in for the final embrace, viewers are given this scene just as it is enacted in **WBKB's** Studio G. Many hours of painstaking work have been put forth to make the performance flawless.

8

"Yes, there's no business like show business", choruses the cast and crew as they relax after the show. Much personal satisfaction is gained by **WBKB** artists in presenting television productions that are top quality.





1. **WBKB's** Film Director, Al Rhone selects all the film features you see via Channel Four. **WBKB's** film offerings maintain the same high standards of family entertainment associated with B & K's 32 years leadership.
2. In capturing the necessary realism for which **WBKB** sets are famous, long hours of painstaking work are put in by expert set designers.
3. So listenable is the musical background when viewing your favorite **TV** station, you probably aren't even aware of its enjoyment. Howard Dennewitz, **WBKB** Music Librarian, "hand picks" each musical portion for your listening pleasure.
4. The unique distinction of being the only feminine television camera operators in the country belongs to Esther Rojewski and Rachel Stewart, who came to **WBKB** during the war and stayed.
5. Television programs of Chicago's pioneer **TV** station run such a wide course of variety "prop" men are kept busy filling demands for anything from a birthday cake to a world globe.

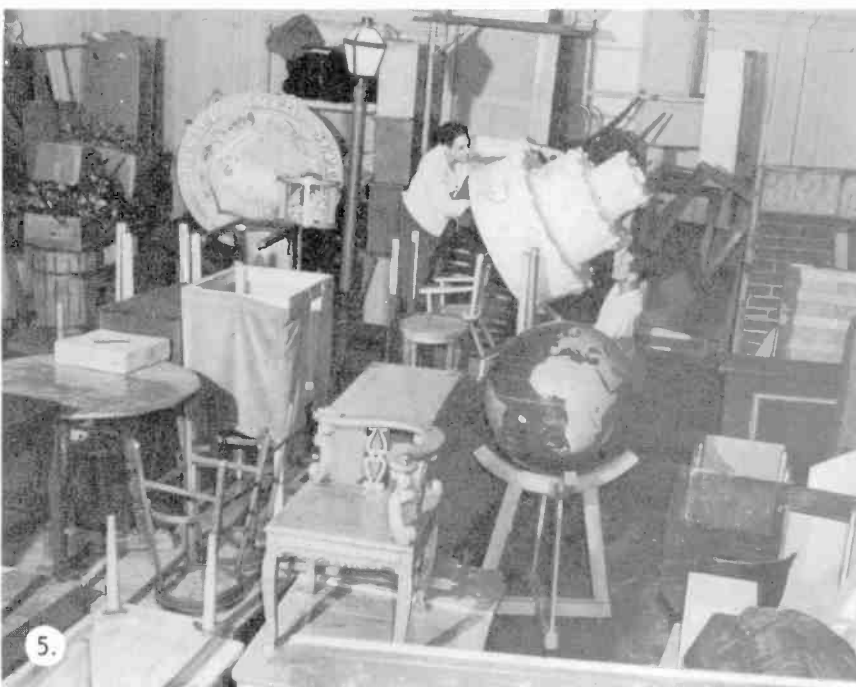

BEHIND THE SCENES

5. This fellow lends voice to many of **WBKB's** presentations via Channel Four. His name is John Dunham, one of the B & K Television Theatre's announcing staff.

7. A full time art department is kept hustling to fill the insatiable appetite of the **WBKB** Multiscope. Here Ken Ponte, Art Director, puts finishing touches on a strip of sketches for use on one of the many commercially sponsored programs.

8. "Come right just a bit more". Two of **WBKB's** skilled lighting engineers make exacting adjustments in "setting up" their light pattern. It's careful attention to details like this that brings **WBKB's** programs into your homes so clearly.

9. From his control booth, **WBKB** Director John Alexander calls instructions to camera crew, engineers and announcers over a special inter-studio hook-up which connects his mike with head phones worn by crew members.

10. Since each of the five color pigmentations in the human skin reflect light differently, proper make-up is necessary. Artists appearing before **WBKB's** cameras take extreme pains in applying the proper shading.

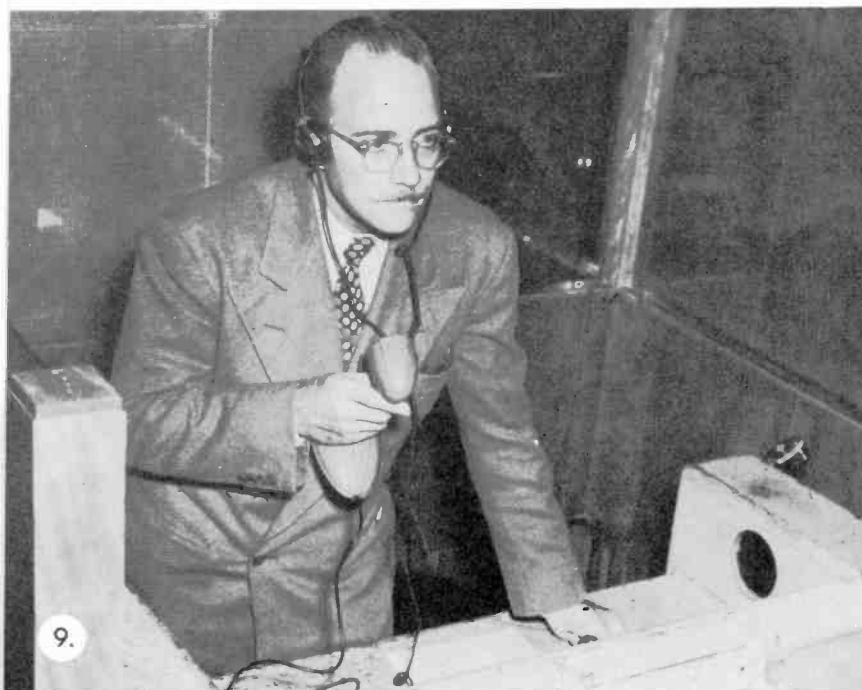
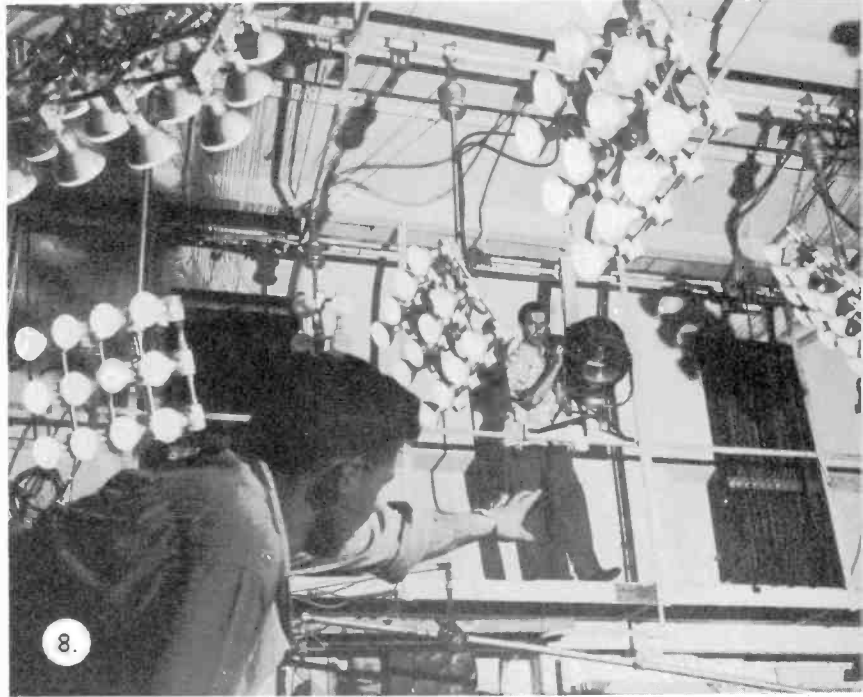

ON WBKB'S AIR STAGE

WBKB'S GROWTH IS MARKED BY 1941 — REPORT ON YESTERDAY

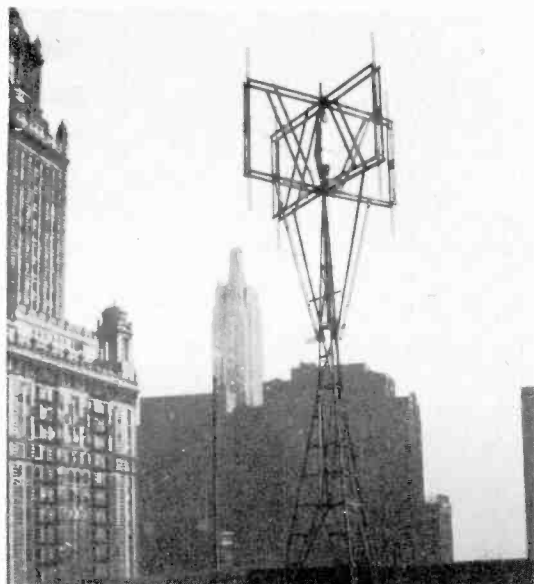

Looming into the skies all of 25 feet, this was the tower atop the State Lake Building over which **WBKB**'s first video signal was transmitted.

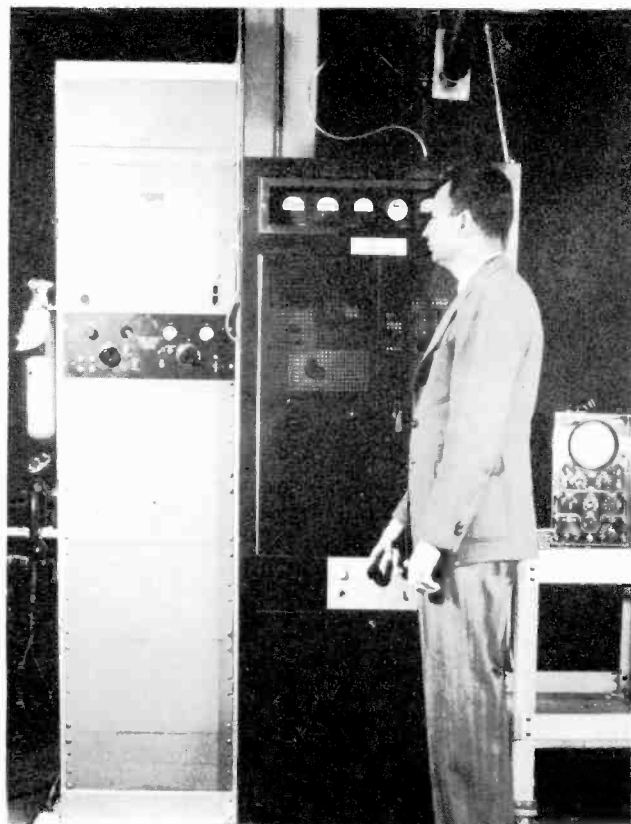
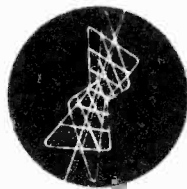

Back in 1941 this comparatively simple one-panel affair was the midwest pioneer station's first transmitter with an output of 100 watts.

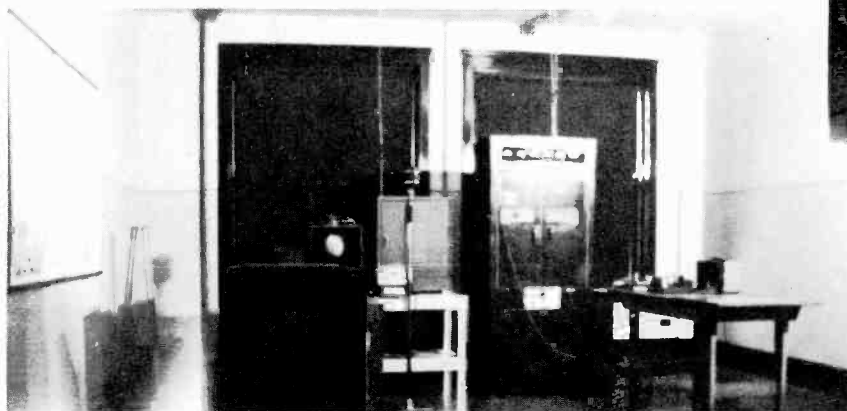

This was IT! From this small room containing studios, transmitter, control room and offices has grown the mighty **WBKB** of today.

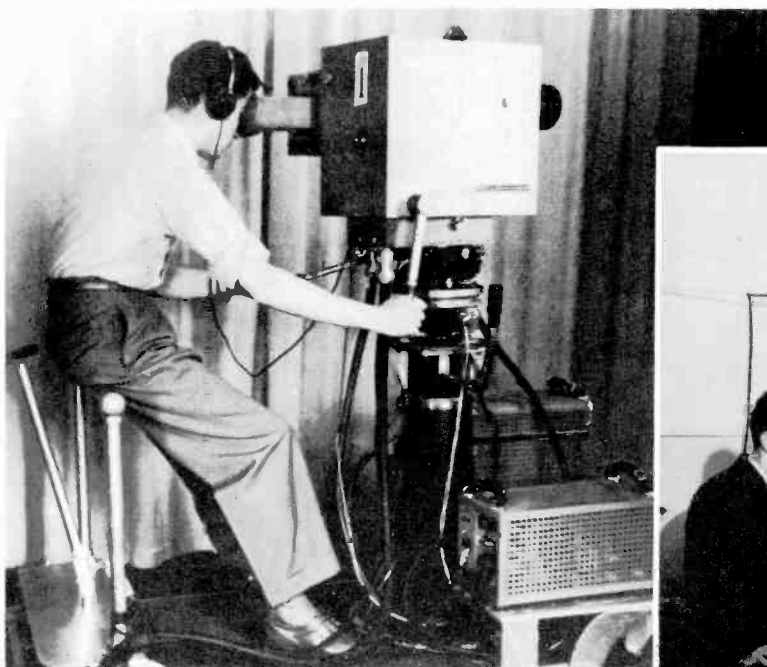

A look at history is this view of the first **WBKB** iconoscope type television camera. Compare this photo with the camera shown on the opposite page.

The B and K Television Theatre was transmitting programs from this early control room when there were less than 100 TV receivers in this area. To make sure the signal was being seen, **WBKB** engineers would call owners of sets whose phone numbers they knew by heart.

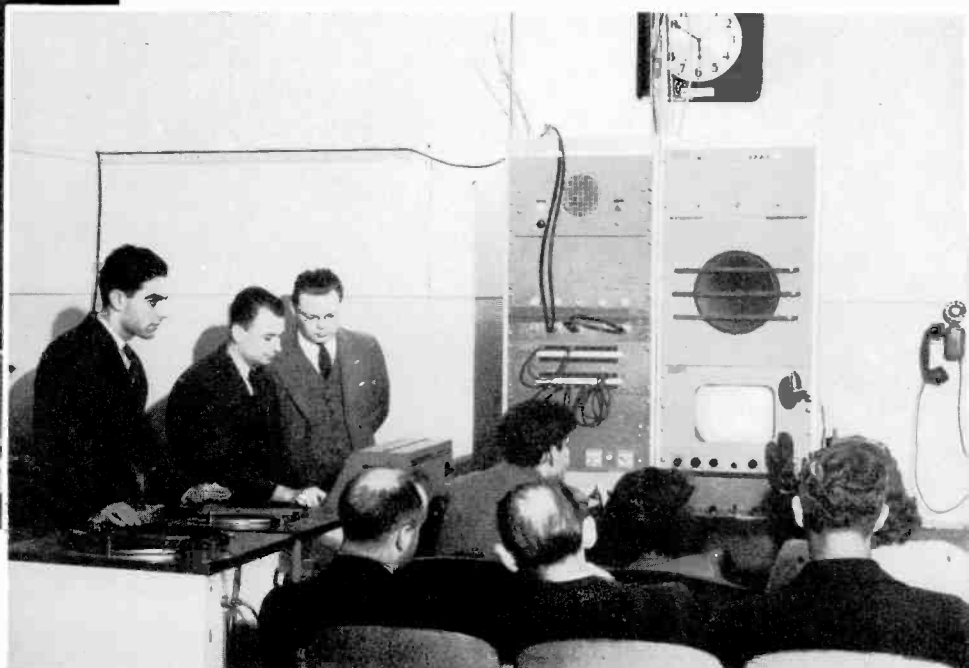

SPECTACULAR TECHNICAL ADVANCE

MEMO FOR TOMORROW



700 feet above street level, the highest point in Chicago, **WBKB's** new \$250,000. transmitter tower gives midwest viewers, for a radius of 42 miles, the clearest signal in the area.



The last word in engineering design is embodied in the **WBKB** five thousand watt RCA television transmitter housed in their control room beneath the tower.

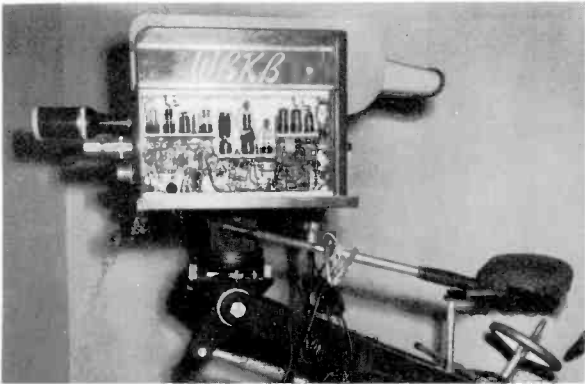

This is the type of camera utilized by Chicago's first **TV** station at the present time. **WBKB** owns 16 of these cameras, each of which is valued at \$14,000.00!

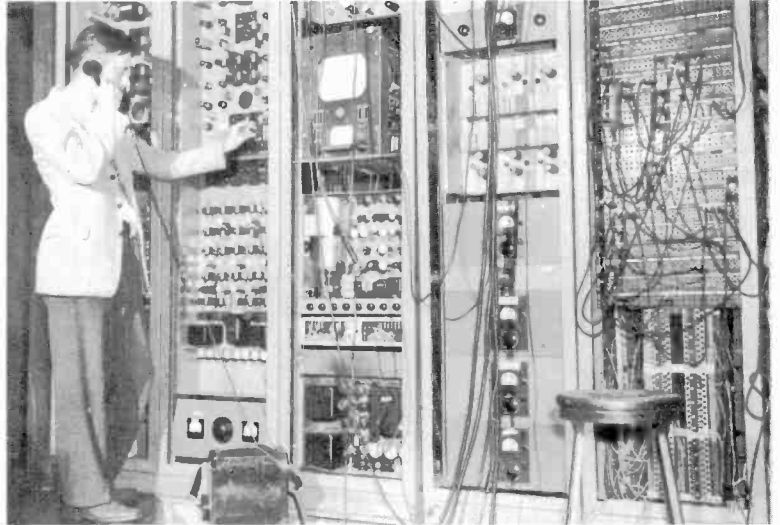

Unless the picture received here in the Television Theatre's Master Control Room is bright and clear, the technician in charge will delay transmission into your homes until it returns to a good, quality image.



In order to bring you the best in television reception on Channel Four, this laboratory-workshop is maintained by **WBKB** for periodic check-up on equipment to keep it in tip-top condition.



A "shading" engineer operates controls on the monitor system connected with the camera. Behind him, the director switches to whichever camera view best suits the action.



... "by
remote
pick-up"

The present remote unit is an efficient studio and transmitter on wheels ready, at a moment's notice, to originate telecasts from almost any point outside **WBKB's** studios.

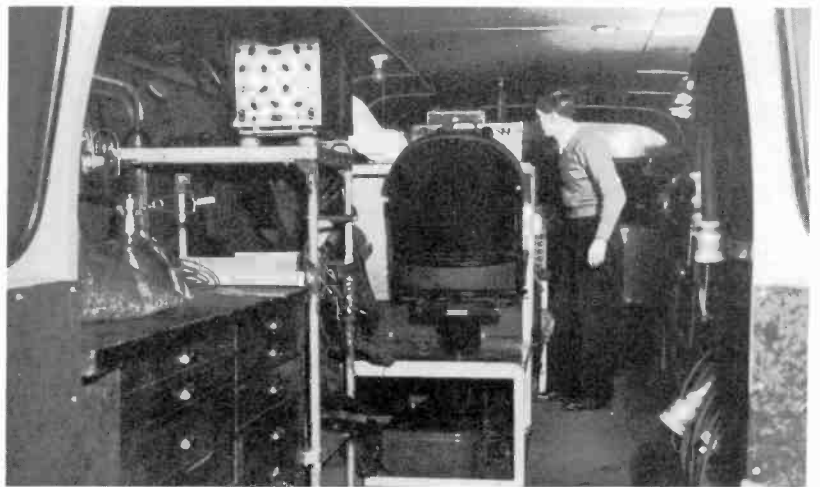

Well planned and compact, the interior of **WBKB's** remote unit contains all necessary equipment for on-the-spot originations.

Can you imagine trying to work in this? It's **WBKB's** first remote truck built in 1941, a maze of wires and equipment jammed into a small space.



As the scene unfolds before the eyes of Remote Director Bill Balaban the signal is flashed miles away to . . .

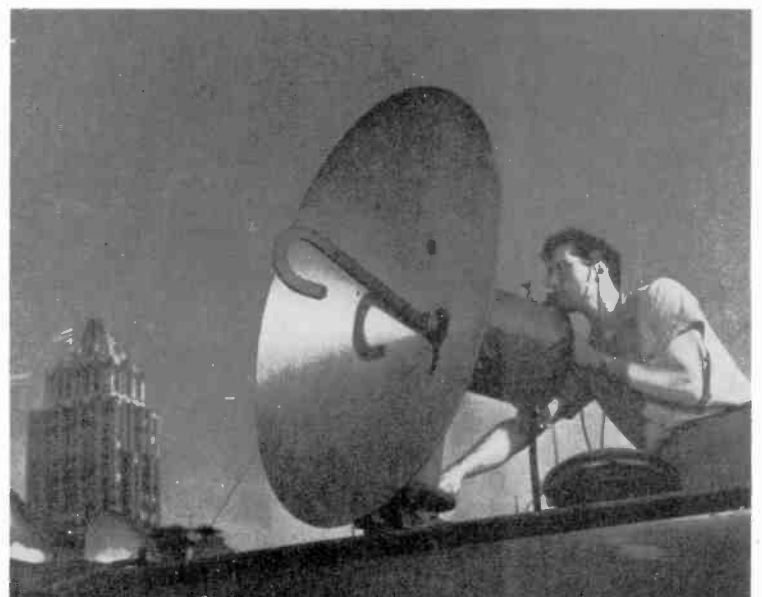

. . . this huge reflector "dish" on the roof of **WBKB's** studios in the State-Lake Building which is being adjusted to catch the wave.

STAFF MEMBERS

LEE ATWOOD, Sales Representative



RICHARD SHAPIRO,
Engineer in Charge of Maintenance
and Remote Operations



MILTON FRIEDLAND,
Managerial Secretary

JACK FLATLEY,
Sales Representative



MATT VIERACKER, Comptroller of **WBKB**



CHARLES BUZZARD,
Engineer in Charge of Studio
Operations



JAMES BROWN, Sales Representative

Teletips -- Helpful

DIAGRAM OF A TELEVISION SYSTEM: FOR SENDING---

-AND RECEIVING

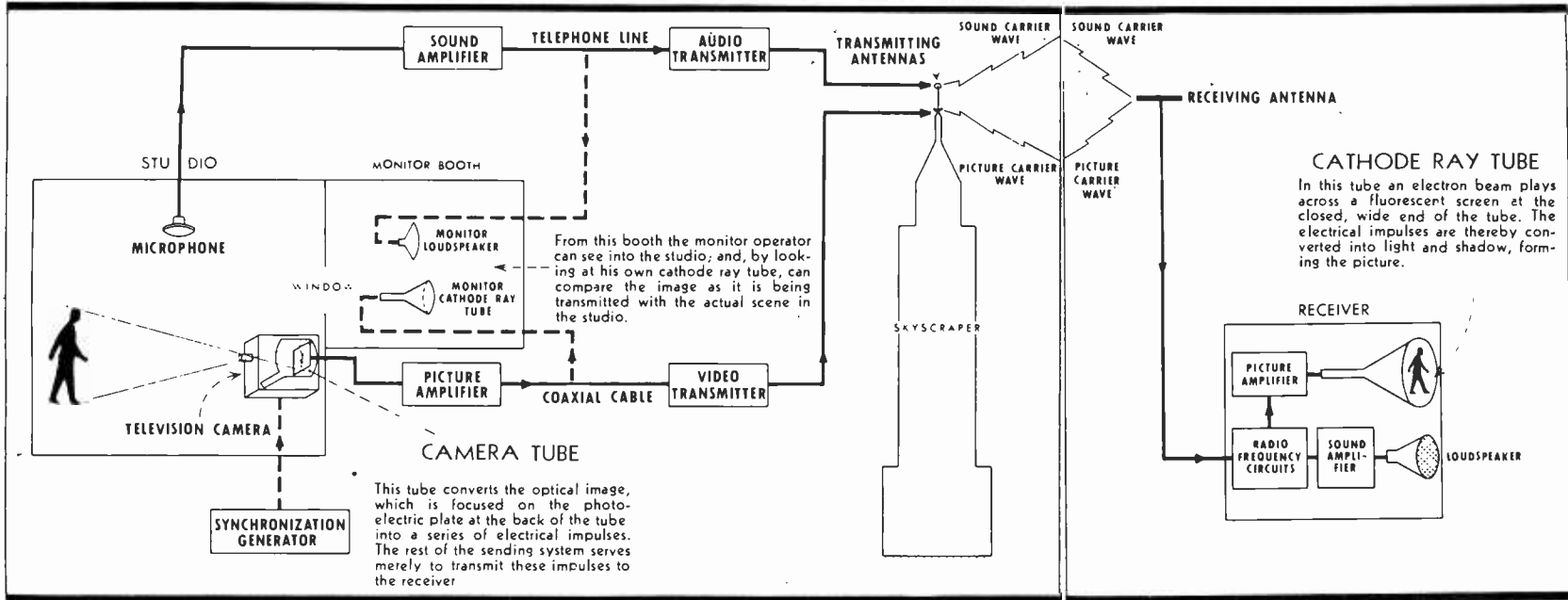

When the television cameraman focuses the image in his camera, this image falls upon a highly sensitive plate in the camera tube which is called a mosaic, a pattern made up of a number of tiny electric eyes each of which is light sensitive. The picture falls upon these electric eyes in such a manner as to form a pattern of millions of tiny spots of different degrees of light and dark. At the opposite end of the camera tube a tiny "gun" shoots minute charges of negative electricity against this mosaic and at the point where there is strong light, each little dot accumulates a strong charge of electricity with the lighter dots having weaker charges and the black portions no charge at all.

The beam of electrons from the gun moves across the mosaic image in a steady stream, sweeping from left to right in a straight line and discharging each little dot in turn and causing a current of electricity to flow from the plate, the current varying in intensity depending upon

the amount of light on each individual spot. The electron gun is "aimed" by means of a set of deflecting coils which keep it moving in orderly left-to-right sweeps, moving to the next line below after each trip across the image. This is called "scanning" and there are 525 of these "scanning" lines in each picture. The signal current which the millions of tiny electrical charges have created is carried by wires to the transmitter where it is superimposed upon a "carrier" wave which transmits it through the air to your receiver. Along with the signal current and the carrier wave are transmitted other electrical impulses which "line-up" or synchronize your set to act in harmony with the camera.

As the current reaches the television receiving set it goes through a similar process as in the camera with the exception that the process is reversed. As the electrical impulses enter the controls of the set, one by one in the same order they were transmitted from the camera,

they activate another electron "gun" which beams the stream of electrons against a sensitive plate in the cathode tube which is the viewing scope of the set and the "window" upon which you see the program. (See sketch on opposite page.)

Since the image focused on the television camera is most generally moving, you must see several picture images a second or the picture will appear to stand still. When you watch a movie, you actually see 24 separate pictures or "frames" a second which is the minimum necessary to create smoothness. In television, the movement is much smoother due to the fact that 30 frames a second are transmitted. It has to be 30 frames because television power lines are geared to 60 cycles a second. So, in television you see 30 separate pictures every second composed of 525 lines each. By multiplying these two numbers you can get some idea as to the number of impulses hitting your television screen every second.

The room should not be too dark. This causes too great a contrast between the brightness of the television picture and the surrounding darkness and the eyes have to work harder to adjust themselves to this contrast. Keep a dim light on.

Don't sit too close to your set. The viewer should sit as directly in front of the screen as possible and the screen should be at eye level. For sets with 10 or 12 inch screens, the best distance is six to eight feet away.

The television picture should be tuned in as clear as possible without becoming too bright. A darker image results in less eye-strain to one in which there is excessive glare.

There is one chief reason why television sets will never sell anywhere as low as radios. That fact is that the average television set has 400 different parts and is the equivalent of about five radio sets. The TV set's chassis uses about 10 times as much steel as a radio, the **VIEWING TUBE** represents 10 pounds of glass that a radio doesn't have; there are about 26 or 27 receiver tubes compared with about six for radio; a television set has about 80 resistors against radio's six and it requires about 10 times as many condensers.

According to Dr. Courtney Pitt, Vice-President in Charge of Finance, Philco Corporation, television set production will hit three million annually by 1950. Also, by the end of 1950 there will be over 6,000,000 TV sets in daily use.

Within the next four years the television industry will spend \$5,000,000,000 in building and equipping stations and producing receivers.

In addition to the 1,200,000 TV sets already in use, there is a potential market of approximately 14,000,000 receivers.

A survey reveals that the average television receiver uses only 75 cents worth of electricity monthly.

As of September, 1949 there were more than 78 Television stations in operation; 38 construction permits granted and 351 applications still awaiting action. There are 18 cities linked by a television network extending from the Atlantic seaboard to the Mississippi River.

Information for You

In order that you may enjoy the best television picture on your set, we show here how various types of interference disturb the image. Ready identification enables you to best help a trained **TV** technician remedy the difficulty.

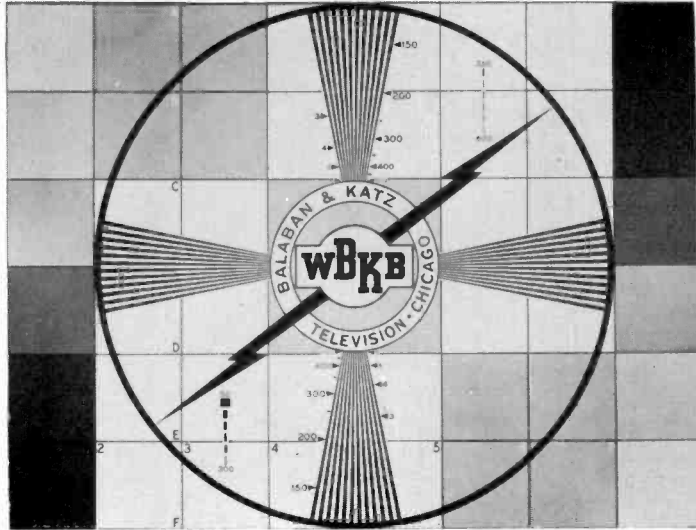

This is how the picture should look when your set and antenna are properly adjusted.

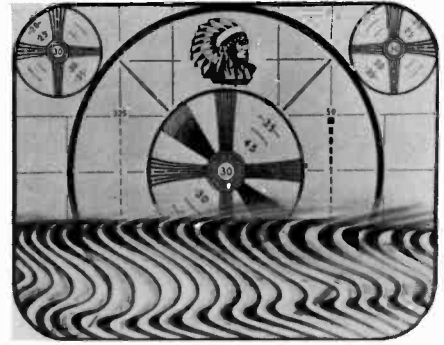

ELECTRONIC MEDICAL EQUIPMENT INTERFERENCE

Many electronic medical machines act as short wave transmitters emitting a signal that causes the above pattern when picked up by your set. Try to locate the doctor's office or hospital in your neighborhood from where you think the signal is originating. Solicit their cooperation in placing the proper filters and shields on the equipment so that your television reception won't be interrupted.

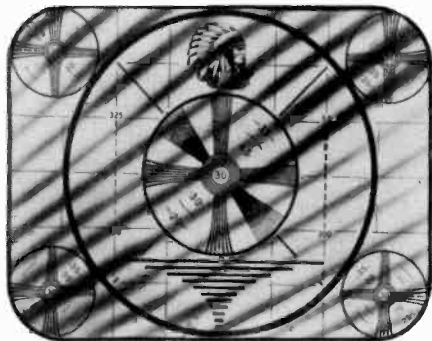

SHORT WAVE INTERFERENCE

This is usually due to faulty transmission of a short-wave amateur station in your immediate vicinity. Try to locate the owner of the station and he'll gladly adjust his equipment to eliminate the interference to your receiver. When you have exhausted all attempts to locate your man, you might, as a last resort, contact your local Federal Communications Inspector for assistance.

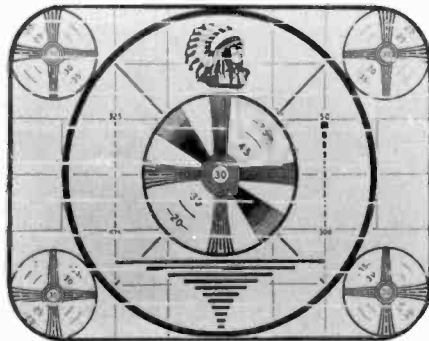

MOTOR IGNITION INTERFERENCE

This is usually the indication of a weak signal or a lack of maximum efficiency in your antenna location or transmission line (lead in). By moving the position of the antenna and transmission line this condition can usually be cleared up and all-around reception improved.

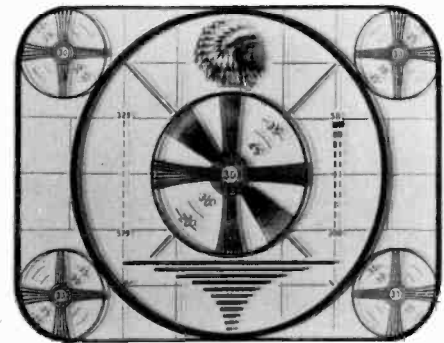

GHOSTS OR MULTIPLE IMAGES

This condition is caused by the receiving, on your set, of two or more impulses from the transmitting station to which tuned. The first and most clear image is the direct signal and the "ghost" or identical image is caused by identical impulses usually reflected from buildings and picked up a fraction of a second later than the first. This condition can often times be corrected by moving your antenna a few feet, sideways or up and down, or rotating it a few degrees.

(Photos courtesy Admiral Radio)

Some of the types of **TV** antenna now in use. The further away the receiving set from the transmitter, the more complicated the design.

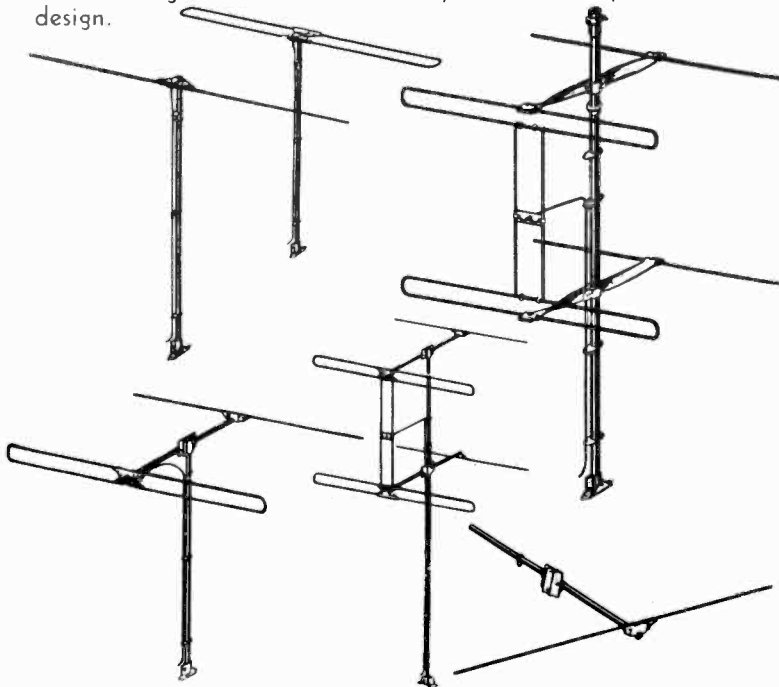

How a cathode ray picture tube works . . .

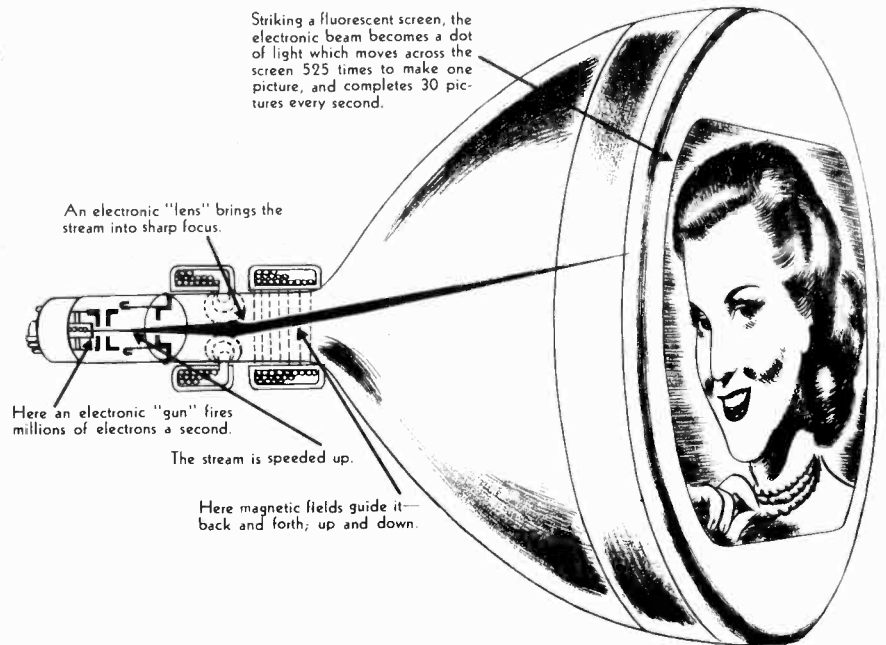



Guest Register

You want to enjoy the best things with your friends. So that you may keep a record of those people who will drop in to watch television programs with you, this page is devoted to that purpose. Here's happy viewing to you and your pals . .

NAME

DATE

PROGRAM SEEN

DX LOG

Day after day, television set owners report getting programs from stations thousands of miles away. A family watching a baseball game in Chicago may suddenly see the game fade away and be replaced by a rodeo in Texas, or vice versa. When this happens on your set, more than likely the set is okay. This phenomena is most prevalent during the summer season, generally from May to September and is due to two causes:

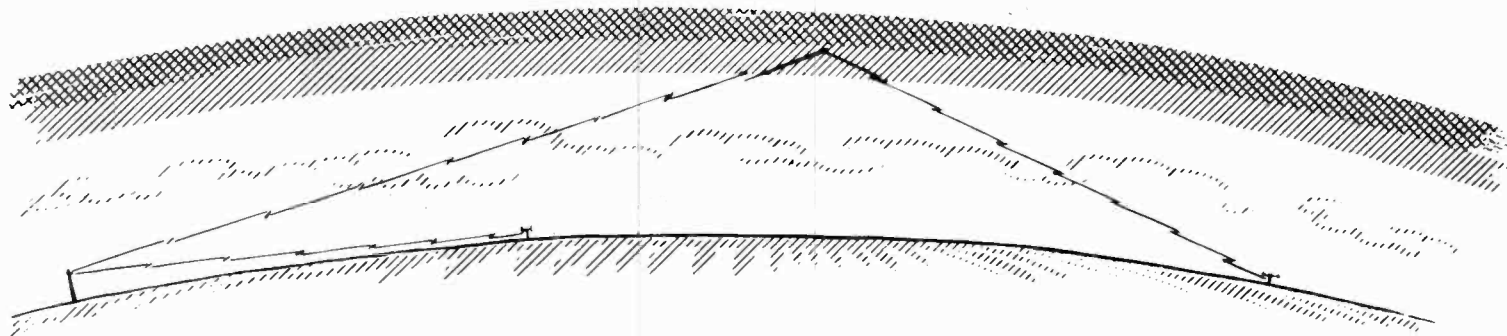

TEMPERATURE INVERSION: wherein layers of air above the earth's surface gradually cooling off after sundown have a tendency to refract or bend the wave depending upon the density of the particular layer through which the wave is passing. As the signal strikes each succeeding strata of air, it is bent and eventually directed downward to the earth's surface where it is picked up at a distant point.

SUN SPOT CYCLES: effect layers of gaseous substances above the earth's surface to the extent of their retaining an electrical charge. This enables them to act as a reflector, turning the television wave back down toward the earth. In the hope it will be of interest to you in your enjoyment of the wonders of **TV**, this page is devoted to a record of your "**DX**" or distance television reception.

DATE	STATION	LOCATION	PROGRAM SEEN
------	---------	----------	--------------

CHICAGO'S CLEAREST PICTURE
FROM CHICAGO'S HIGHEST POINT

