

RADIO'S *Complete* MAGAZINE

# RADIO & TELEVISION

**MARCH OF RADIO**

Department



**RADIO CONSTRUCTION**

Department



**AMATEUR RADIO**

Department

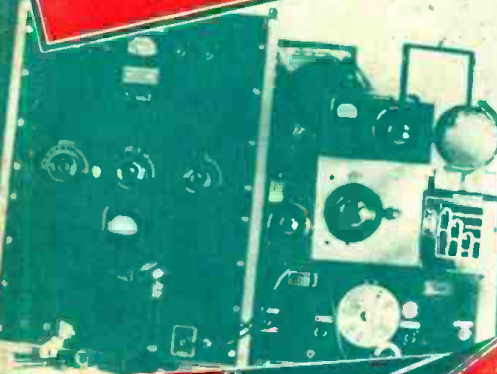

**RADIO HOOK-UPS**

Department



**TELEVISION NEWS**

Department



**RADIO PATENTS**

Department

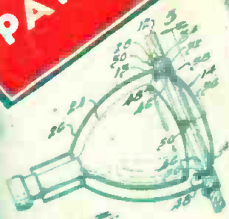

**RADIO KINKS**

Department

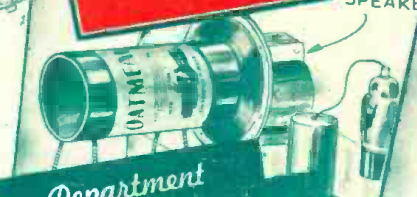

**ELECTRICAL EXPERIMENTS**

Department

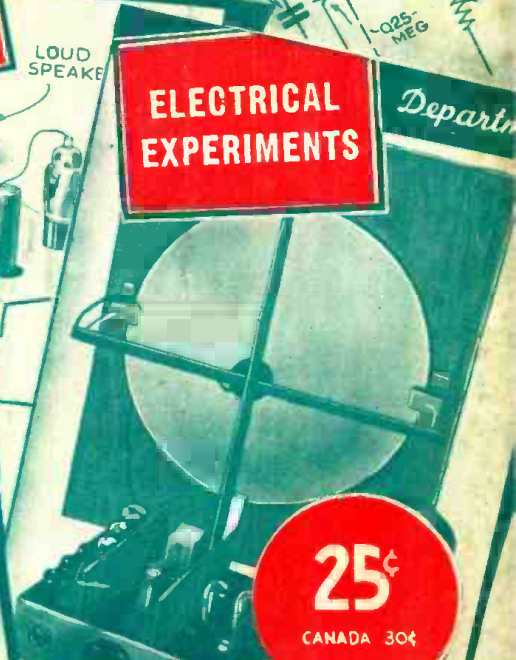

**RADIO BEGINNER**

Department

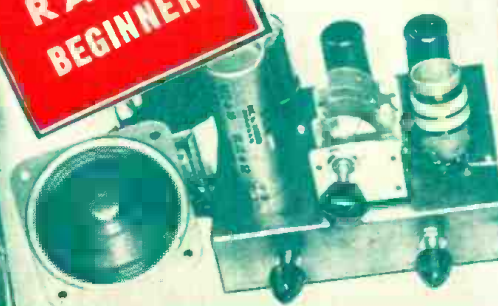

**25¢**

CANADA 30¢

**HUGO GERNSBACK**  
EDITOR

**AMATEUR & EXPERIMENTAL RADIO**

**APR.**

**CONSTRUCTIVE RADIO ARTICLES**

**1941**

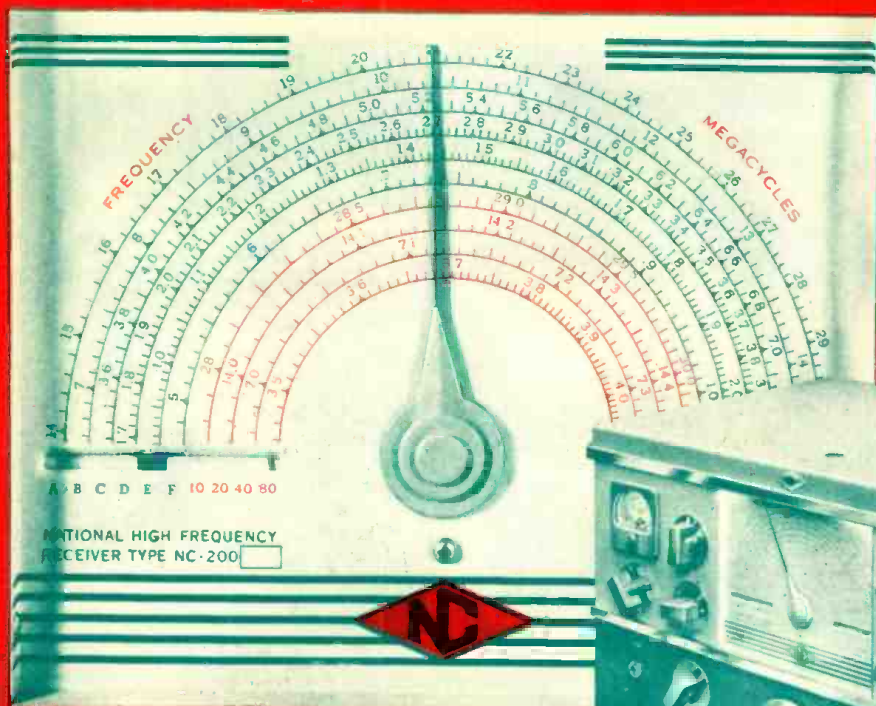

**NC-200 DIAL**  
( $\frac{2}{3}$  Actual Size)



## TEN RANGES

The NC-200 has ten calibrated coil ranges, as shown on the dial above. Six of these ranges provide continuous coverage from 490 KC to 30 MC. The remaining four ranges cover the 10, 20, 40 and 80 meter amateur bands, each band being spread out over the major portion of the dial scale. Each bandspread range is independent of the other ranges. Its calibration is fixed, it is tuned by the main tuning control, and its frequency is read by the big sweep pointer on the dial. And as a final assurance of logging free from errors, automatic indicators are always in view opposite each end of the scale in use.

## OTHER FEATURES OF THE NC-200

- Sensitivity better than one microvolt
- Signal-to-noise ratio better than 30 db at 10 meters
- Stability 3 parts in 10,000 for 20 volt line fluctuation
- Series valve noise limiter
- Low drift temperature compensation
- Wide range crystal filter
- Eight watts undistorted output
- Amateur net price only \$147.50 with speaker in cabinet to match.

**NATIONAL COMPANY, INC.**  
MALDEN, MASS., U.S.A.

J. E. Smith, Pres.  
National Radio  
Institute  
Est. 25 Years

# I WILL TRAIN YOU TO START A SPARE TIME OR FULL TIME RADIO SERVICE BUSINESS WITHOUT CAPITAL

I Trained  
These  
Men

I Trained  
These  
Men

**N. R. I. MEN  
WORK IN THESE  
BRANCHES, TOO**

## These Men Have SPARE TIME BUSINESSES



"I repaired many Radio sets when I was on my tenth lesson. I really don't see how you can give so much for such a small amount of money. I made \$600 in a year and a half, and I have made an average of \$10 to \$20 a week—just spare time."  
**JOHN JERRY**  
1529 Arapahoe St., Room 17, Denver, Colo.



"I am now making from \$10 to \$25 a week in spare time while still holding my regular job as a machinist. I owe my success to N.R.I."  
**WM. F. RUPP**  
611 Green Street, Bridgeport, Pa.



"I am doing spare time Radio work, and I am averaging from \$700 to \$850 a year. Those extra dollars mean so much—the difference between just barely getting by and living comfortably."  
**JOHN WASHKO**  
97 New Cranberry, Hazleton, Penna.

## These Men Have FULL TIME BUSINESSES



"For the last two years I have been in business for myself making between \$200 to \$300 a month. Business has steadily increased. I have N.R.I. to thank for my start in this field."  
**ALBIE J. FROEHNER**  
300 W. Texas Ave., Goose Creek, Texas



"Before taking your Course I earned about 17 1/2 cents an hour as a truck driver. When I had completed 20 lessons I started service work, about \$3,000 in Radio. I have made own shop."  
**KARL KELLY**  
409 W. Calhoun St., Magnolia, Ark.



"I am making between \$50 and \$60 a week after all expenses are paid, and I care of, thanks to N.R.I."  
**H. W. SPANGLER**  
126 1/2 S. Gay St., Knoxville, Tenn.



(Above) Broadcasting Stations employ operators, installers, maintenance men and Radio Technicians in other capacities and pay well.



(Above) Radio Jobbers and Dealers employ installers and service men at good pay.



(Above) Loud Speaker Systems are another field for Radio Technicians.



(Left) Police, Aviation and Commercial Radio are newer fields for which we give the required knowledge of Radio.

## DRAFT REGISTRANTS!

Hundreds of men who know Radio when they enter military service are going to win specialist ratings in the Army, Navy and Marine Corps. These ratings pay up to 6 times a private's or seaman's base pay, in addition to carrying extra rank and prestige! If you ARE NOT called, you are getting into Radio when the Government is pouring millions into the Radio industry to buy Defense equipment, on top of boom civilian Radio business. Whether you enroll or wait for conscription—IT'S SMART TO LEARN RADIO—NOW!

## SAMPLE LESSON FREE

I want to prove our Course gives practical, money-making information, that it is easy to understand—what you need to master Radio. My sample lesson text, "Radio Receiver Troubles—Their Cause and Remedy," covers a long list of Radio receiver troubles in A.C., D.C., battery, universal, auto, T.R.F., superheterodyne, all-wave, and other types of sets. And a cross reference system gives you the probable cause and a quick way to locate and remedy these set troubles. A special section is devoted to receiver check-up, alignment, balancing, neutralizing, testing.

You can get this lesson Free by mailing the coupon.

**Mail Now**

The world-wide use of Radio has made many opportunities to have a spare time or full time Radio service business of your own. Over 28,000,000 homes have over 40,000,000 Radios. There are more Radios than telephones. Every year millions of these Radios go out of date and are replaced. There's an opportunity to earn good commissions selling new sets. Millions more need new tubes, servicing. I will train you at home in your spare time to sell, install, fix all types of Radios; to start your own Radio service business and build it up on money you make in your spare time while learning. You don't have to give up your present job, or spend a lot of money going away to school to become a Radio Technician.

## BEGINNERS QUICKLY LEARN TO EARN \$5 TO \$10 A WEEK EXTRA IN SPARE TIME

I start sending Extra Money Job Sheets the day a student enrolls—start showing how to do Radio repair jobs. Throughout the Course I send additional plans and directions for doing increasingly complicated, better paying jobs. That's why many students make \$5 to \$10 a week extra in spare time; why many start building their own Radio service businesses while learning.

## I TRAIN YOU FOR GOOD JOBS TOO MANY PAY \$30, \$40, \$50 A WEEK

Anyone can tune a Radio set, but few can service one. That's why many qualified Radio Technicians make such good money installing, fixing, selling home and auto Radio Sets, operating and maintaining Broadcast, Police, Aviation, Commercial Radio stations; selling, installing, servicing

Loudspeaker systems. That's why many open their own Radio sales and repair businesses and make \$30, \$40, \$50 a week. Why others hold their regular jobs and make \$5 to \$10 a week extra fixing Radios in spare time.

## HOW I GIVE YOU PRACTICAL EXPERIENCE

I send you special Radio equipment; show you how to conduct experiments, build circuits illustrating important principles used in modern Radio receivers, broadcast stations and loudspeaker installations. You work out, with your own hands, many of the principles you study in our lesson texts. YOU ALSO GET A PROFESSIONAL ALL-WAVE, SET SERVICING INSTRUMENT.

## YOU LEARN TELEVISION, "F-M", ELECTRONICS

The N. R. I. Course is up-to-date. You are taught how to install, adjust, service Television receivers and antennas. You learn about Frequency Modulation transmitters and receivers; you learn the principles of electronic control equipment, such as photoelectric counters, safety devices, electric burglar alarms, etc.

## FIND OUT HOW I TRAIN YOU AT HOME

Act Today. Mail the coupon now and I will send my book, "Rich Rewards in Radio," and a Sample Lesson free. Find out what Radio offers; what opportunities are coming in Television. Read the details of my Course in Radio and Television; read more than 100 letters from men I have trained; what they are doing, earning. Read my Money Back Agreement. MAIL COUPON BELOW in an envelope or paste on a postcard—NOW.

**J. E. SMITH, President**  
National Radio Institute, Dept. 1DB3  
Washington, D. C.

## GOOD FOR BOTH 64 PAGE BOOK FREE SAMPLE LESSON

J. E. SMITH, President, National Radio Institute  
Dept. 1DB3, Washington, D. C.

Without obligating me, mail your Sample Lesson and 64-page Book FREE. I am particularly interested in the branch of Radio checked below. (No salesman will call. Write plainly.)

- Radio Service Business of My Own
- Service Technician for Radio Stores and Factories
- Spare Time Radio Servicing
- Auto Radio Technician
- Operating Aviation Radio Stations
- Operating Broadcasting Stations
- Army, Navy Radio Jobs
- Operating Police Radio Stations
- Operating Ship and Harbor Radio

(If you have not decided which branch you prefer—mail coupon for facts to help you decide.)

Name .....

Address .....

City ..... State ..... 14 X 1



# RADIO & TELEVISION

*The Popular Radio Magazine*

April — 1941  
Vol. XI No. 12

HUGO GERNSBACK, Editor  
H. WINFIELD SECOR, Manag. Editor  
ROBERT EICHBERG, Television and Digest Editor

## *In May Issue*

A Simple Signal Tracer  
A Universal Antenna Tuner for the Ham—Herman Yellin, W2AJL  
Recording on Acetate Discs—A. A. Schmitt  
The "Musicaster"—H. G. Cisin  
A Fixed-Frequency "Booster Amplifier" for Television—Thornton Chew  
A Simple 100-Watt Exciter or Transmitter—Harry D. Hooton, W8KPX  
How Superhets Work

## *In This Issue*

### GENERAL FEATURES

Guest Editorials — "What Amateurs Can Do" ..... 709

#### MARCH OF RADIO

FCC Observes Television Progress ..... 710  
CBS Demonstrates "Live" Pick-Up in Color Television ..... 711  
F-M Continues Progress ..... 712  
How Bats Fly in the Dark ..... 713

#### INTERNATIONAL RADIO REVIEW

Two-Tube Battery "Reflex" Receiver ..... 715  
Interference Reduction Systems ..... 716  
Automatic Control of Television Brightness ..... 716  
Short-Wave "Signal Booster"—Charles Leutz ..... 718  
A High-Fidelity Phono Amplifier—Milton T. Putnam ..... 724  
Interference Phenomena in Television Reception — Thornton Chew ..... 741

### RADIO CONSTRUCTION

Building a Short-Wave "Signal Booster"—Charles Leutz ..... 718  
A Modern "Hi-Fi" Amplifier—John T. Wilcox, W2CLS ..... 722  
A High-Fidelity Phono Amplifier—Milton T. Putnam ..... 724  
Converting "Little Nipper" for Battery Tubes—Lee Garrison ..... 728

#### Certified Circuits



When you see this seal on a set it is a guarantee that it has been tested and certified in our laboratories, as well as privately in different parts of the country. Only constructional—experimental sets are certified.

You need not hesitate to spend money on parts because the set and circuit are bona fide.

This is the only magazine that renders such a service.

Further Notes on a "Compact" Kilowatt Transmitter—Larry LeKashman, W2IOP ..... 736  
"Pull-Swing" Transmitter and Receiver—R. Muniz, E.E., Donald & Warren Oestreicher ..... 738  
Spotting Airplanes with a Super-Sensitive Sound Detector ..... 752  
"Band-Switch 3" T.R.F. for the Radio Beginner—L. M. Dezettel, W9SFV ..... 758

### AMATEUR RADIO

"CQ"—Larry LeKashman, W2IOP ..... 732  
Plaque Award for Best Ham Station Photo ..... 735  
"Compact" Kilowatt Transmitter—Larry LeKashman, W2IOP ..... 736  
A New "Pull-Swing" F-M System for Amateurs—R. Muniz, E.E., Donald & Warren Oestreicher ..... 738  
Relays and Magnetic Controllers for Hams & Experimenters ..... 760

### NEW FEATURES

Television News ..... 741  
Applied Radio—"Frequency Modulation Principles"—F. L. Sprayberry ..... 744  
Radio Hook-Ups ..... 750  
Experimental Radio—Super-Sound Detector ..... 752  
Question Box ..... 755  
Radio Beginner ..... 758  
Electrical Experiments ..... 760  
Radio Patents ..... 762

### TELEVISION NEWS

FCC Observes Television Progress ..... 710  
CBS Demonstrates "Live" Pick-Up in Color Television ..... 711  
Where to Place the Antenna for Best Television Reception — Thornton Chew ..... 741  
Television Patents ..... 762

### MISCELLANEOUS

What Do YOU Think? ..... 707  
How NYA Girls Learn Radio ..... 714  
Can YOU Answer These Radio Questions? ..... 716  
Inexpensive Test Instruments for the Experimenter—Wm. J. Vette ..... 731  
"CQ"—Larry LeKashman, W2IOP ..... 732  
Plaque Award for Best Ham Station Photo ..... 735  
Principles of Frequency Modulation—F. L. Sprayberry ..... 744  
Radio Hook-Ups ..... 750  
Experimental Radio—Super Sound Detector for Locating Airplanes ..... 752  
Question Box ..... 755  
Radio Beginner—3 Tube Receiver ..... 758  
Electrical Experiments ..... 760  
Radio Patents ..... 762  
New Radio Apparatus ..... 763  
Book Review ..... 740

Cover Composition by Hugo Gernsback and Thomas D. Pentz

RADIO & TELEVISION—Published monthly on the tenth of the month. Entered as second-class matter Feb. 15, 1938, at the post office at Springfield, Mass., under the act of March 3, 1879. Trademarks and copyrights by permission of H. Gernsback. Text and illustrations are copyright and may not be reproduced without permission. Subscription price \$2.50 a year in the United States (in foreign countries, 75c additional per year to cover postage; Canada 50c additional). Make all subscription checks payable to Popular Book Corporation.

Published by Popular Book Corporation, Publication Office—29 Worthington St., Springfield, Mass., Editorial and Executive Offices—20 Vesey St., New York, N. Y. HUGO GERNSBACK, President; EMIL GROSSMAN, Director of Advertising. European Agents: Atlas Publishing and Distributing Co., Ltd., 18 Bride Lane, Fleet St., London, England; Brentano's—London and Paris. Australian Agents: McGill's Agency, 179 Elizabeth St., Melbourne.

Copyright 1941 by H. Gernsback

# What Do YOU Think?

## Liked 3-Tube Construction Article

**Editor:**  
I am a beginner in radio and enjoy reading RADIO & TELEVISION. In your April 1940 issue I was impressed with an item written by H. G. Cisin on "Tips for Radio Beginners." I built the three-tube battery set with little difficulty, and the reception I accomplished with a 5" P.M. speaker is more than I expected. I think many others had the benefit of Mr. Cisin's ideas.

I am looking forward to finding more helpful information in your future issues.

CHARLIE ROMANO,  
Northfield, B. C., Canada.

## He Finds Everything in R.&T.

**Editor:**  
I think you have a very good publication, because I have found everything from the simplest circuit to the most complex in it. It's good to be able to pick up your magazine and get an idea of how *Television* and *Frequency Modulation* are progressing. Although amateur radio is off the air here, it is still of interest to a beginner, like myself, and I'm beginning to understand a little about transmitters and all the amateur jargon.

D. CRONER,  
Vulcan, Alberta,  
Box 528,  
Canada.

## He'll Subscribe for 3 Years

**Editor:**  
To tell you the truth, the magazine is a "dandy." In fact, I think that it is one of the best radio magazines on the market today, but I am now in the California National Guard and going away for a year's training. I probably won't find much time in which to read the magazine, but I will buy it at the newsstands while on maneuvers.

When my year's training is up, I only hope that you will have me back in your ranks as a steady customer, because I am going to subscribe to it for at least three years. RADIO & TELEVISION can't be beat.

EDDIE DARBY,  
Oakland, Calif.

## One-Tuber Works Fine

**Editor:**  
I am a constant reader of your magazine and I have built one of your one-tube receivers and it works fine. I have heard KC4USA, CE1AO, CO8MP, CO2GL, KA7LZ, VK2ME and several others.

I agree with Charles Mourmouris, that you should have a picture contest for SWL's.

I am a 100% SWL and will QSL for anyone with any kind of a card.

VERNON LEE GIBBS,  
Route 5, Lexington, Ky.

## Of Interest to SWL's

**Editor:**  
I have read your magazine for exactly nine months and I appreciate it a great deal. I started sending out SWL cards about a month ago. I get my complete lists from your magazine. I find that not all listed in your SWL column send out cards.

I have joined a club for the SWL swappers and I believe that we have a good plan.

All members of the club keep track of their cards sent out and received. We send these lists into the head office. We publish a bulletin every two months that contains the names and QRA's of those who have answered 100%. This enables every member to get 100% verification of his cards. Please include the contents of this letter in your magazine and thus a great many SWLers can get in touch with me to join our club, the SWLR. I QSL 100%.

Thanks a million.

CLYDE MOSS, JR.,  
586 Lynn Street,  
Chillicothe, Ohio.

## He Likes Our Circuits

**Editor:**  
I like RADIO & TELEVISION magazine—especially the three- and four-tube receiver and the phono-oscillator circuits. I should like to see more of these circuits in future issues.

I am wondering if you couldn't include, in some future issue, diagrams for obtaining a power-supply for D.C. circuits, by making use of some rectifier tube.

LEWIS ORLOWSKI,  
856 Nott Street,  
Schenectady, N. Y.

(Continued on page 767)

# WHY NOT START NOW!

Waiting and wishing will never prepare you for a promising career in the Army, Navy or Commercial communications field. Find out today how you can easily learn RADIO CODE with the Candler System without leaving your own home. Expert radio operators are in demand. The Communications Reserve of the U. S. Navy is enlisting 5400 radio operators. The Candler System is a SPECIALIZED TRAINING backed by over a quarter century of success. Candler System was selected by the U. S. Naval Reserve in the ninth district for training radio operators.

## Get All the Facts!

Write today for the New Candler Book of Facts. It's FREE! It tells you the whole interesting story of how you can build a career. Send for it today. A postal will do, and there's no obligation.



**CANDLER SYSTEM CO.**

Dept. S-4,  
ASHEVILLE, N. C., U. S. A.

# RADIO ENGINEERING

DEGREE IN 2 1/2 YEARS

Complete Radio Engineering Course in 2 1/2 years. Bachelor of Science Degree. Radio (television, talking pictures and the vast electronic field) offers unusual opportunities for trained radio engineers. Courses also in Civil, Electrical, Mechanical, Chemical, Aeronautical Engineering, Business Administration and Accounting. Tuition, living costs low. World famous for technical 2 1/2 year courses. Special preparatory department for those who lack required high school work. Students from all parts of the world. Enter June, September, January, March. 58th year. Write for catalog.

2442 COLLEGE AVE., ANGOLA, IND.

# TRI-STATE COLLEGE

# LEARN RADIO TELEVISION

500 LICENSED graduates placed in past 7 years in shipping, broadcasting, aviation, police, etc.; we also teach radio servicing and repairing; new beginners' class now forming; 60-page catalog free; oldest, largest and best equipped.

**MASS. RADIO SCHOOL**  
18 BOYLSTON ST., BOSTON, Mass., Est. 1899

## AMATEUR RADIO LICENSES

Study for your licenses the "rhythm" way, the A.R.I. way. Acquire code proficiency in from 3 1/2 to 8 weeks. Theory taught in understandable, non technical language. Classroom courses in New York, home study courses for outside students. Write for list of calls of hundreds of licensed students now on the air.

**AMERICAN RADIO INSTITUTE**  
1123 BROADWAY, NEW YORK, N. Y.

# RADIO ENGINEERING

broadcasting, aviation and police radio, servicing, marine radio telegraphy and telephony, Morse telegraphy and railway accounting taught thoroughly. 48 weeks' Engineering course equivalent to 3 years of college radio work. All expenses low. Catalog free. School established 1874. Dodge's Institute, Turner St., Valparaiso, Ind.

## RADIO AND ELECTRONIC DICTIONARY Containing 3,800 Definitions . . . . .

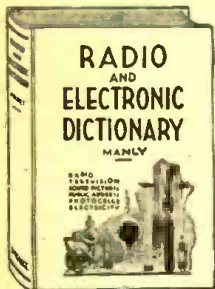

THIS RADIO AND ELECTRONIC DICTIONARY, written by Harold P. Manly, explains the meaning of 3,800 words used in radio, electronics and other closely allied fields. It includes new terms used in radio transmission, sound pictures, television, public address, aviation radio, navigation and industrial control, photoelectricity, photocell application, telephotography, etc. This dictionary permits learning every new expression whether you hear it or read it. Alphabetically arranged for quick reference. 550 illustrations augment definitions in the text.

The book is recommended for students, instructors, engineers, service men, experimenters, salesmen and everyone in any way associated with radio. ONLY \$2.50

BOOK OF ITS KIND—HANDY—EASY TO USE—AND TIMELY. THE RADIO AND ELECTRONIC DICTIONARY is new, authentic and printed in a single volume of 300 pages, size 6 x 9 inches. The book weighs two pounds, and bound in durable cloth. SHIPPED ANYWHERE \$2.50 IN U. S. A. POSTPAID . . . . . Price

Mail remittance by check or money order to  
**RADIO PUBLICATIONS**  
44 VESEY STREET NEW YORK, N. Y.

## RADIO TECHNOLOGY

RCA Institutes offer an intensive course of high standard embracing all phases of Radio and Television. Practical training with modern equipment at New York and Chicago schools. Also specialized courses in Aviation Communications, Radio Servicing and Commercial Operating. Catalog Dept. RT-41.

**RCA INSTITUTES, INC.**  
A Radio Corporation of America Service  
75 Varick St., New York, 1154 Merchandise Mart, Chicago

## RADIO-TELEVISION

Oldest, largest Radio-Television school in West trains you for good pay job. Complete instruction including Radio Construction and Service, Broadcast Operating, Sound, Talking Pictures, Television, Public Address, etc. Flexible plan to meet specific needs of those with or without jobs. Transportation allowed to L.A. Barn room and board while learning. Request Free Catalog.

**NATIONAL SCHOOLS** Dept. 4-RT  
Los Angeles



*Radio City, New York, world center of broadcasting, where several thousands of radio's 400,000 workers are employed*

# Your Radio Helps Employ 400,000 People!

**A**S YOU LISTEN to the radio, do you ever stop to think of the thousands of people employed because you own a radio set—because you are listening? The radio industry employs directly 400,000 persons, and indirectly hundreds of thousands of others. From the research laboratory to the song on the air, the employees of radio are at your beck and call. They earn their living in jobs which only two decades ago did not exist.

*An Endless Procession of Workers*  
 Long before the radio set "went on the air" in your home it helped to give employment to an army of workers from lumbermen to cabinetmakers, from the miners who mined the copper and iron, to the electrical engineers who designed the circuits that perform the magic. And, of course, there are those who fashion the metal

chassis; those who make the plastics and the vacuum tubes.

Radio employment is an endless procession—as endless as the production belts that constantly carry new instruments to the public, or the research that constantly plans improved instruments for the future. There are factory workers, salesmen, advertising men, artists, printers, wholesalers, retailers, and many others who work in radio because people in the United States have installed 50,000,000 radios in their homes and automobiles, and will want 10,000,000 more radios this year.

*The People Behind the Programs*  
 Each broadcast program has its actors, but behind every voice or song you hear, behind every comedian, opera and drama, are the program planners, script writers, technicians, announcers, sound-effects men, control oper-

ators, and thousands of clerical helpers. Broadcasters alone employ many thousands of men and women in 850 stations, while radio-telegraph stations ashore and afloat, aircraft and police radio, add greatly to the roster of radio and to the payrolls of America.

*New Gateways of Employment*  
 Constantly developing new products and services through research, radio is ever widening the gateway of employment. Television holds the promise of another new industry developed by American enterprise, to create employment and raise the American standard of living.

Through the purchase of a radio you did your bit as an employer of people unseen, and that role is always yours as long as you own a radio—while it works for you it enables others to work, too.



**RADIO CORPORATION OF AMERICA**  
 RADIO CITY, N. Y.  
 RCA Manufacturing Co., Inc. • Radiomarine Corporation of America • RCA Laboratories  
 National Broadcasting Company, Inc. • R. C. A. Communications, Inc. • RCA Institutes, Inc.

# RADIO & TELEVISION

## Readers' Editorials

### What Amateurs Can Do

#### RADIO IN DEFENSE

● RADIO can aid materially in our defense against "fifth columnists," the spore taking root in this country. Insignificant as it may seem—why not an army of selected amateurs and radio men, armed with special monitoring equipment, whose sole job will be tracing suspicious "bootleg" signals to their source, investigate the real motives for their (operator's) actions, and report their findings to the proper authorities?

ANTHONY GUIDE,  
15 Wolcott Street,  
Malden, Mass.

#### GOOD OPERATING PRACTICE

● MANY amateur radio operators, both young and old, look upon the amateur regulations with disgust and think of them only as a set of rules which should not be applied frequently. Just how many amateurs do you hear on the air today who have unmodulated carriers, who fail to sign their call when throwing off the carrier, or who let some visitor (especially when working "break-in") in the shack, sign their call when they themselves should sign the call letters of the specific station? These certain types of amateurs are too numerous to mention. If you do not believe this statement to be true, just listen in on the 160 meter amateur band some afternoon, and try to count the number of amateur stations that have these faults. It is true that an amateur might not be in a position to improve his modulation, or get rid of a harmonic, but the least he can do is to *abide by the regulations* which are in his power to control—such as using a dummy antenna when testing, or testing with a modulated carrier. We must think of the *Federal Communications Commission* as our employer, who grants us certain rights or privileges, but who in turn expects the best that he can get out of us. If we abide by the Federal Communications Commission regulations, we might be able to get an extension in frequency of our amateur bands—or better yet, get a few *new* bands.

In order to improve our amateur standing in the eyes of the Commission, let us look over the amateur regulations, but don't only read them, *put them to use*, and I am sure that the radio amateur will be recognized as a *radio operator*, and not frowned at as just "hams." Please remember, fellows, that you took an oath to abide by these amateur regulations. *See to it* that this oath remains unbroken.

JOHN FITZPATRICK, W2NPL,  
18 First Street,  
Port Reading, N. J.

#### PLEASE QSL!

● HOW often I have heard this simple but age-old request and given it myself. Yet how often we fall down on our promises. One of the chief values of Ham radio is the fraternity it offers with all types of boys and girls, and surely no O.M. or Y.L. is old! Amateur Radio was what Ponce de Leon was unknowingly searching for in his fountain of perpetual youth!

But what fun is radio, if there is no one you can think of who will hear you, slap on his carrier, call your name, know your

habits, your likes and dislikes, and treat you like an old friend? What better way of cultivating such a friendship than beginning with a QSL? You've begun your friendship with a QSO—now bind it with a "veri."

Not only do I want QSL's from my DX contacts, but from my neighbor as well. It affords a wealth of information concerning the particular Ham and Ham radio. See what big dividends can be reaped from a one-cent stamp and thirty seconds time? It perpetuates the memory of you and your signal in the minds of fellow Hams, and more than likely they will give you a call next time you're on.

I don't know who sent the first QSL; who started this fad of papering the shack with "veris"—colorful, exciting and reminiscent of happy hours—but praise be his name! Let's erect a statue of him in the town square!!

ROBERT HARRISON,  
Obion, Tenn.

#### HAMS FOR AIR DEFENSE

● WE all know that the Ham is always ready to do all that he can to help out in any emergency that may come up at any time. Just at present there is a wonderful opportunity to help out the army in its new defense program. They should form an organization of all operators to

aid in the air defense warning system. This could easily be done by having an operator, with a portable set, at all lookout stations to send information to the army base, and at other posts along the courses taken by the planes. In this way all stations and bases at the same time, will know at once just where the planes are heading, and not have to depend on the telephone, which only lets the army bases know where they are. If there are not enough operators to go to all the different stations, have short-wave listeners take over some of the stations, so that they will know the course that the planes are taking, and they can be on the lookout for them and be prepared to warn the bases, by telephone, that they are in their location.

LESTER F. CHESSMAN,  
4 Pleasant Street,  
Dorchester, Mass.

#### RADIO AND A FUTURE WORLD

● OF the thousands of cards I have received from amateurs and short-wave listeners throughout the world, none has left such a vivid impression on my mind as a five-word phrase contained in the SWL card of Niccola Cannata, well-known Chicago experimenter and listener. "*Worldwide Friendship Is My Aim.*" Contained in this simple, homely phrase is the amazing reason for the fact that within our own lifetime, amateur and experimental radio has risen from nothing to a position of universal dignity, with a background of ethics, cooperation and fair play.

What is it that has made this hobby such a notable contribution to contemporary twentieth century life? The central idea to the short wave listener and the amateur is the means of communication with others on equal terms, of finding friendship, adventure and prestige, while seated at his own fireside. In picking his human

(Continued on page 768)

## FCC Observes Television Progress

Members of the Federal Communications Commission, accompanied by members of the National Television Standards Committee, saw virtually all major television developments in the East during a two-day trip of NBC, CBS, Du Mont, Bell Laboratories and Scophony. If you had been a member of the FCC, the following is what you would have seen:

At 10:30 on a Friday morning the tour commenced in the Du Mont Labs. Mr. Du Mont believes that the future of television will be better established through the use of fewer frame frequencies, his demonstration was largely concerned with a presentation of this principle. The first part of the demonstration was of some amateur motion pictures, one film being taken at 24 frames (which is roughly the present television standard frame frequency) and another reel taken at 16 frames (15 frames being the Du Mont proposed standard). The company engineer who gave the talk accompanying the picture showing stated that there was no noticeable flicker introduced at the lower frame frequency. While this was perfectly true of slow moving objects or those at some distance though moving perpendicular to the camera, some observers commented on the fact that there was noticeable jerkiness

when objects close to the camera moved across its plane.

In the demonstration of the Du Mont receiver using the longer persistence screen which this company advocates, the subjects televised were principally stationary objects, so it was impossible to determine what effect rapid motion such as is sometimes encountered in a television play—and always in a sporting event—would have had. The image shown was on the 20-inch tube and its size apparently impressed most observers favorably.

The next stop on the television tour was at NBC, where a new developmental type of home receiver was shown. In this receiver the projector tube working at 28,000 volts threw excellent images on a translucent screen measuring 13½ x 18 inches! The receivers used were standard TRK 120's (the standard 12 inch cathode-ray type) changed only in that the screen was installed, the 12-inch tube replaced with a small projection tube and projection lens, and a higher voltage power-pack substituted for the 7,000 volt one usually employed. An ingenious system makes it unnecessary to use any heavy filtering on the high voltage power pack. Observers were impressed by the size, brilliance, and con-

trast range of the pictures, which included subjects of various types from maps and charts to fast moving dance acts. The images approximated home motion pictures in size, apparent detail and brilliance, and observers were enthusiastic. One interesting feature of the demonstration was a pick-up from an army camp 68 miles away, the transmission being conducted by radio relay.

Following a buffet lunch, the tour next went to the New Yorker Theater, where motion picture screen size television had been installed by RCA. So sensational was the excellence of the pictures that even the hard-boiled newspapermen present broke into spontaneous applause. The screen was 15 x 18 feet in size, apparently as brilliant as standard theater movies, and with all the detail and contrast range that one could desire. The projection tube was operated at approximately 60,000 volts. As a special demonstration, an image picked up in Radio City was relayed around a loop of approximately 100 miles and received in the theater with very little loss of contrast and detail. This is important in that it demonstrated the possibility of using television for important news coverage to remote points.

Bell Labs. and Scophony progress was described before; CBS on the next page.

Upper left, RCA theatre installation; upper right, close-up of projector. Lower left, layout of television relay; lower right, large screen home receiver.

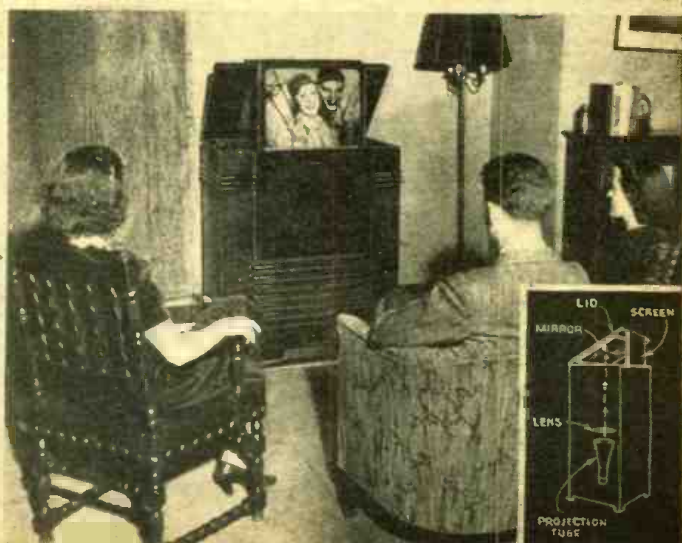
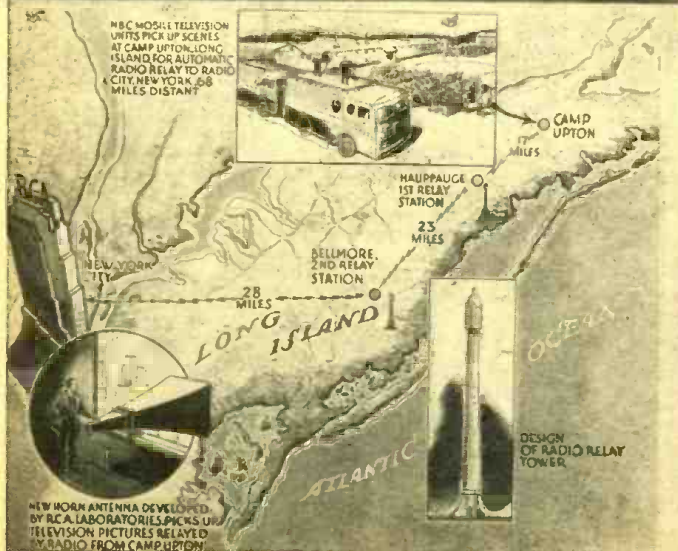
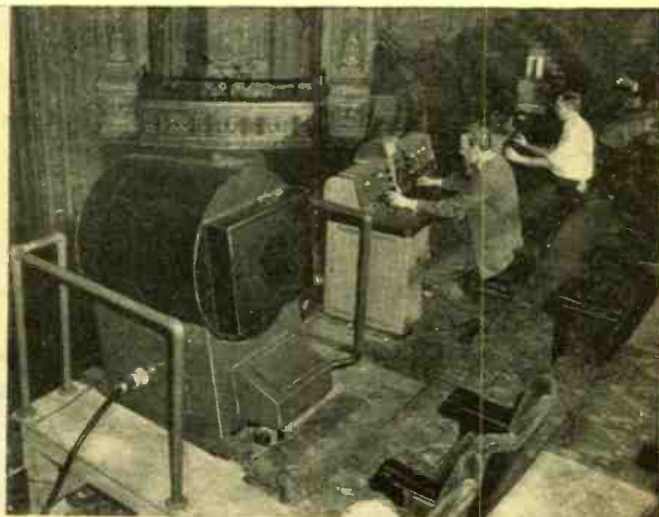
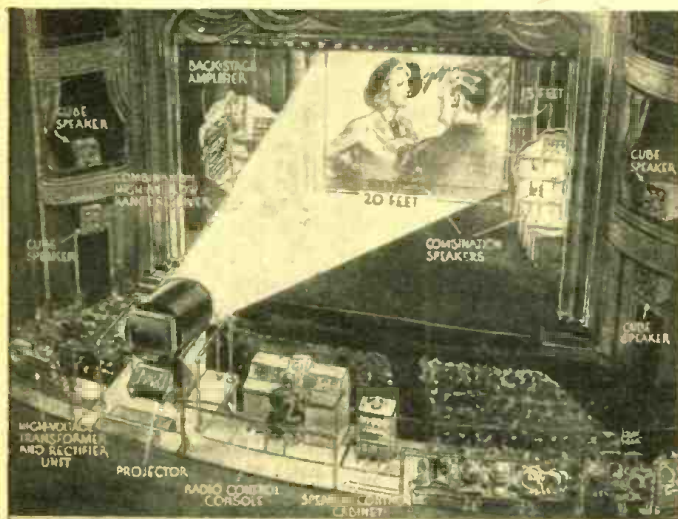



CBS MAKES LIVE PICK-UP IN COLOR TELEVISION

The first public showing of color television in which the program material consisted of direct pick-ups using the CBS system designed by Dr. Peter C. Goldmark, the company's chief television engineer, was made for the New York convention of the Institute of Radio Engineers. The transmitter was located on the fifth floor of the CBS building and the images were trans-

mitted by co-axial cable across the street to the basement of another Columbia building. Three receivers were used—a special large table model with a built-in Goldmark color wheel, a standard console model with the wheel installed as an accessory, and a standard black and white model. A 9-inch C.-R. tube was used in each set.

As standard black-and-white pick-ups generally require illumination of 800 to 1200 foot-candles on the subject, some television engineers believed that so much heat would be generated in providing enough light for color television that actors would find it unbearable. Nevertheless, it was stated by persons in charge of the demonstration that the illumination used for the color transmission ranged only from 110 to 200 foot-candles. This was explained as being made possible by the use of an orthicon tube. Specially sensitive orthicons, to require even less light, are in the process of development, according to CBS informants.

The specially designed and constructed table model receiver incorporates two important features not previously demonstrated to the public. The first of these is a method of synchronizing the color disk in the receiver with the color disk in the studio by the synchronizing impulses ordinarily transmitted. This means it is no longer necessary to rely upon 60-cycle current for synchronizing the disks, and permits reception of color pictures when a receiver and transmitter operate from different power supplies.

This receiver also has a simple method of phasing the color disk so that the colors shown at the receiver can be "locked" to the colors being picked up. The viewer at home has only to push a button on the cabinet's side until the picture appears in

its proper colors, then release the button. The colors remain properly synchronized with those of the original scenes.

During the demonstration, a new system of low intensity fluorescent lighting was used. These lights eliminate most of the glare from the eyes of the person in front of the camera and are "cold light" so that no discomfort is experienced. They

were developed in the Columbia Broadcasting System television laboratories.

The demonstration showed substantial progress along new fronts such as: direct pick-up itself; synchronization of color disks; phasing of color disks, and new lighting methods for color television.

Among the material televised was a test chart, maps and globes of the world, fabrics, sheer stockings, confetti, a pair of gloves (1 green and 1 lavender glove were worn by the model—the fact that they did not match could not be observed on the black and white image tube), an ink chart, an experiment in dyeing, a magician's trick in which silks changed colors as they were drawn through the performer's hand, a kitchen scene with a salad being mixed, and a girl's head. Various color effects were introduced on the latter.

In conclusion Dr. Goldmark stated: "The results, thus far, in all phases of color television are most encouraging and it would appear that an answer has been found to every fundamental problem. From now on, I think, we can progress steadily, even if we have nothing more than straightforward engineering effort looking toward commercial application. Today color television is in the laboratory, but with the co-operation of the industry, I do not think it will be there long."



"Engineers'-eye view" of CBS studio during a color television program. This shows rear of apparatus. Insert is front view of equipment, as seen by person being televised.



Upper left—the color filter drum which forms the heart of the CBS television scanner. Upper right—the drum in position around the orthicon. Lower left—control bench. Center—the amplifier rack, with CR tube for monitoring programs. Lower right—the film scanner for color television. Note: The receiver looks just like any black and white receiver from the outside, but inside there is a color filter wheel about twice the diameter of the viewing screen. This was described in a previous issue of RADIO & TELEVISION.

NEW F.M. STATION FOR ARMSTRONG

Three more licenses for frequency modulation broadcast stations were granted March 5th by the F.C.C., making 42 such awards to date. Major Edwin H. Armstrong is authorized to erect at Alpine, N. J., a Class D F.M. broadcast station operating

on 43,100 kc. It should reach a population of 12,200,000. The Stromberg-Carlson Telephone Manufacturing Co., Rochester, N. Y., received a grant to operate on 45,100 kc. A new Chicago F.M. station will be operated by the Moody Bible Institute on 47,500 kc.

## F-M Continues Progress Ashore, Afloat, and Commercially

Three additional F-M stations have recently been authorized, making the total about 30 okayed by the FCC for full commercial service. CBS has received a construction permit for a 46.7 mc. station to be located in Chicago. Station WJJD of the same city has received a like permit for 44.7 mc. The third permit is to Westinghouse, which will operate on 44.5 mc.

In Syracuse, New York, the Central New York Broadcasting Corp. will operate an F-M station on 46.3 mc. The Commission waived certain technical requirements to expedite the operation of this and other stations. It also announced certain modifications in the New York and Philadelphia areas. For example, WCAU in Philadelphia will operate on 46.9 mc. instead of

46.7 and CBS will operate on 46.7 instead of 48.8 mc. The call letters have been changed accordingly.

At the same time, General Electric announces a new F-M station monitor which acts as a center-frequency monitor, modulation monitor, high-fidelity audio monitor and flasher-type modulation-limit indicator.

This company also has installed F-M radio equipment for two-way communication between United States quarantine tugs and Quarantine Administration Headquarters at the Customs House, Boston, Mass. The tugs go out five miles to inspect all vessels entering the port of Boston and the F-M equipment will permit them to communicate with the Custom House when returning to shore to check records. The

radio equipment in each vessel consists of a 25-watt F-M transmitter and a receiver. This is shown in one picture with Dr. J. M. Chisholm, Quarantine Officer, U.S. Public Health Service, Boston, Mass., talking from a tug to Quarantine Administrative Headquarters. The other illustration shows Dr. R. E. Bodet, Senior Surgical Medical Officer in charge of U.S. Quarantine Station, Boston, Mass., talking to the tug over Headquarters equipment. The antenna is on the 20th floor of Headquarters building. Tests have shown that the two-way transmissions are noise-free for distances up to 30 miles—six times the distance they will normally be required to cover. The ship picture is at the left, headquarters at right, below.

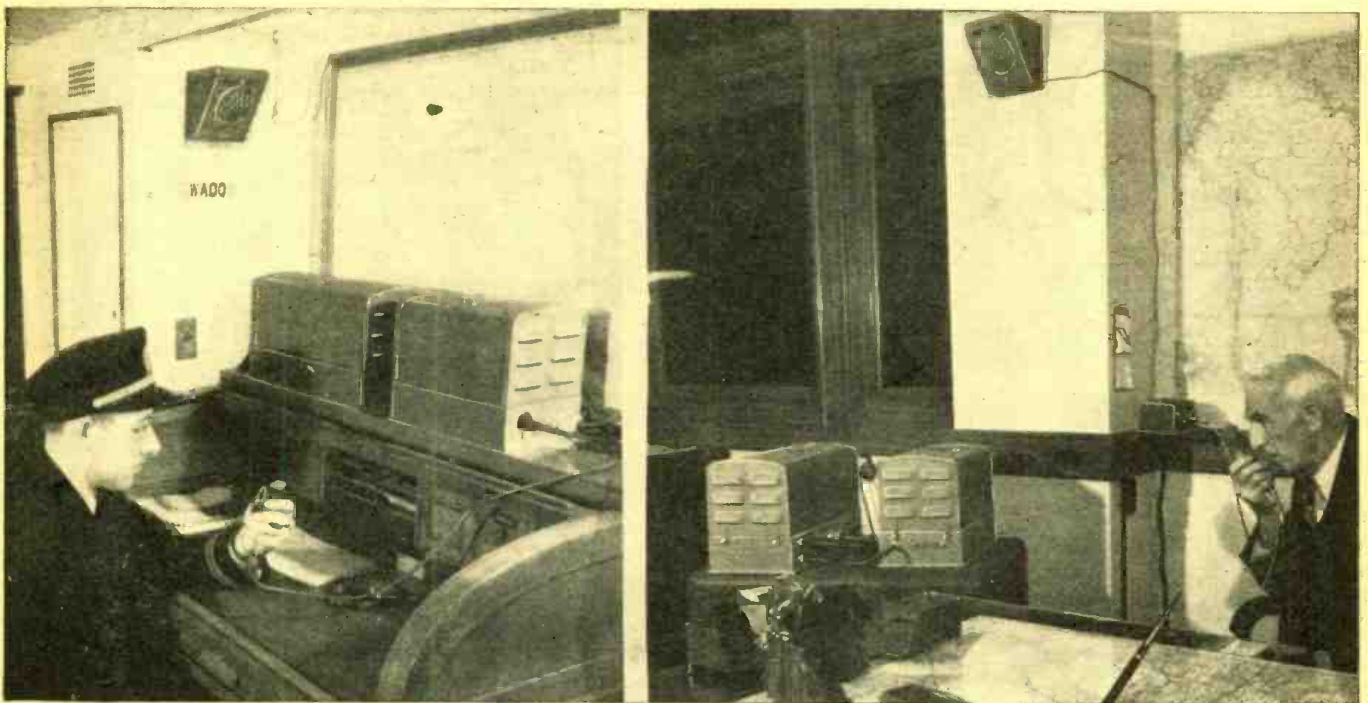

### BRITISH STATIONS KEEPING COOL UNDER FIRE

If ever a country at war kept its head and went along in its usual way despite the fact that enemy bombs were wrecking its cities, that nation is Great Britain. Very calmly Air Marshal Sir Philip Joubert told listeners why in certain parts of the country good reception had to be sacrificed.

"You may have had difficulty," he said, "in getting the news on nights when there have been air-raids. The reason for this is that a broadcasting station is a very good navigational help to anybody flying towards it. To avoid giving this help to the Germans, we, at the outbreak of war established a system which confused the transmissions from the navigational point of view. This system, I'm sorry to say, is apt to spoil reception in this country at certain places, but the Royal Air Force must accept the responsibility. Remember that in Germany they stop broadcasting altogether at certain hours, in order to avoid giving us any navigational help . . . this trouble is not due to BBC inefficiency, but to a wise precaution that has to be taken."

It is significant that not only German stations go off the air when the R.A.F. is

carrying out its nightly attacks, but that stations in adjacent countries under Nazi domination or influence are also shut down. There is, in fact, a *radio curfew* over the greater part of the continent of Europe.

The accuracy of Air Marshal Sir Philip Joubert's statement was conclusively proved only five days after his broadcast, when Deutschlandsender, the German long-wave station, broadcast a statement to the effect that special war conditions had made it necessary to close down certain German stations "rather early" in the evening hours. Then followed the names of twenty-eight transmitters—Berlin, Bremen, Danzig, Munich, Vienna, Prague and Warsaw among them—that closed down at 18.15 GMT. Deutschlandsender, it was said, would normally continue transmission until 20.15 GMT. but "German listeners in the entire Reich territory can hear Breslau until midnight (GMT) with certainty."

On the evening of the announcements, Deutschlandsender suddenly closed down at 17.30 GMT, and Breslau was off the air for an hour and a half in the middle of the evening.

### RED HOT DEBUNKING

If you have a short-wave receiver capable of picking up Australia, you can get some news broadcasts which have been termed even more pungent than those originating in Germany. The stations are VLQ5 on 30.99 meters at 7:20 a.m., E.S.T., and VLQ7 on 25.25 meters at 7:20 a.m., P.S.T. Their evening transmission times are VLQ7 at 4:55 p.m., E.S.T., and 9:55 p.m., P.S.T.

Australia feels that its special function is to represent and interpret the British Commonwealth of Nations to the countries of the Western Pacific. The programs are intended to strengthen and extend existing bonds of interest and friendship between the United States and its fellow democracy in the southwestern Pacific.

### FCC TO SETTLE TELLY

In latter January a television report was made to the FCC and a further hearing was scheduled for March 20th, at which time it is hoped that standards will be definitely established and television given the "go ahead" signal.

## WBBQ Goes Off the Air as FCC Cracks Down

Radio listeners around the area of Hubbell, W. Va., were annoyed by the programs of WBBQ. Alleged entertainment from this station interfered with regular broadcasters and with amateur transmissions throughout the area. Knowing that no station had been assigned the call letters WBBQ, field inspectors of the FCC, acting in cooperation with the local United States Marshal, tracked down the illegal station. They found a young man operating a 25-watt transmitter with a vertical steel radiator and promptly arrested him, charging him with violations of sections 301 and 318 of the Communications Act. The illustration at the right shows how an FCC inspector's car is equipped to locate sources of radio interference and illegal stations.



## Problems of All Sorts Taken From the FCC Mail File

Federal Communications Commissioners have received a letter from a doctor inquiring as to whether or not there are any requirements that broadcast program continuities regarding food be submitted to medical authorities before transmission. The FCC replies that while it has no such regulations, it will consider complaints regarding specific broadcast material. Other complaints can be referred to the National Association of Broadcasters and, more specifically, to the Federal Trade Commission,

which is the government agency authorized to consider alleged misrepresentations in interstate commerce.

A New York company asks whether or not a station may charge extra for broadcasting a program over FM at the same time it is on the standard waves. The Commission has no authority to decide what charges radio stations may make.

A sharp note from the Commission warned the master of a ship which put out to sea without radio equipment, that he was

violating the safety provisions of the Communications Act.

From Wisconsin, a law firm wrote to ask FCC aid in obtaining a copy of a telegram to be used as an exhibit in a divorce case. The Commission suggests that the only action which the lawyers can take is to subpoena the wire through the local courts in the regular way, as the Communications Act treats all personal messages as confidential.

And so the world wags on!

## How Bats Fly in the Dark by Using Supersonic Sound Waves

That bats make use of supersonic sound to enable them to fly through pitch-dark caves without striking obstacles is the theory of Robert Galambos and Donald R. Griffin of the Harvard Biological Laboratories. Using super-sensitive high frequency sound detectors developed by Professor G. W. Pierce, they found the bats' cries to be loudest at 50,000 cycles per second (the average human ear cannot hear much above 20,000 cycles).

The cries emitted during the apparently silent flight sound like machine-gun fire when translated to lower frequency sounds which the human ear can hear. In normal flight the bat utters about 25 cries per second, but when it approaches an obstruction, it raises the rate to about 50 per second. Flying bats which do not vary the number of cries almost always collide with wires or walls in a room.

To prove that the sound is what enables the bat to guide himself as it is reflected from obstructions, scientists covered the bats' ears to prevent their hearing, or their mouths to prevent the sounds from being uttered. Animals thus handicapped batted blindly into walls and wires. On the other hand, bats with their eyes covered could fly just as well as those who could see. Persons who are fond of animals will be glad to know that the bats were not injured in the least by these experiments. This problem has awaited solution many years.

A study of bats' flying has been recorded as early as 1793, in which year an Italian scientist found that blinded bats could fly perfectly. About five years later a Swiss

scientist discovered that deafened bats could no longer fly in the dark. Ladies who are timid of bats can now be assured that any bat who is not hard of hearing will be able

to avoid bumping into her, and if a bat should be so clumsy as to alight in her hair, it will be even more eager to get away than she will to have it out.



Bat, held before supersonic sound detector, is found to "broadcast" his own "beam".



Top left—Miss Frances Koenig at the blackboard during lecture in radio theory at the NYA All-Girls' Radio Club, Brenham, Texas. Lower left—Miss Sadie Simonds of Forth Worth, Texas, looks on, Miss Carol Rodesney of Huntsville, Texas, practices sending and receiving code on a practice set. Top right—Miss Fannie Raye Massey, of Dallas, Texas, "receiving" at the Brenham, Texas, NYA Girls' Center. Lower right—Miss Massey repairing an audio oscillator.

# How NYA Girls Learn Radio

● **BREHAM**, in east central Texas, is a city of 6,000 population, not unlike many other southwestern communities. But Brenham has a unique place in radio—it is the home of what is believed to be the first *all girls'* radio communications club in the world, established as part of the nationwide radio project of the *National Youth Administration*.

The 25 young women of the Brenham radio club (call W5JNA) not only transmit and receive code messages, but they wield a soldering iron with as much dexterity as the average woman handles a curling iron. They tear down and put together receivers and transmitters with as much ease as they do the family wash.

Texas, however, is not the only southwestern state in which the NYA employs young women on radio projects. Both Oklahoma and Kansas have their fair share of young women employed in radio work, doing everything young men do and doing it equally well. In Topeka and Tonkawa, in Shawnee and San Antonio, NYA girls are giving a demonstration that they can be just as good "hams" as the next man.

But back to Brenham for a moment. The idea of forming an all girls' NYA radio club originated with Robert R. Burton, radio engineer in the Washington office of the National Youth Administration. J. C. Kellam, State Youth Administrator for Texas, took up the idea with the result that the

project was established on October 1, 1940, under the supervision of Kathryn Porter.

Miss Porter virtually grew up in a radio control room, choosing to work at the controls rather than appearing before a microphone. She was operating her own "rig" while a student at the University of San Antonio. Although only 19 years old, she has had her commercial operating license for about a year and a half. Prior to going to work for the National Youth Administration she was control room engineer at KCMO, the Kansas City Journal station, and was production manager and engineer at Station KVIC in Victoria, Texas.

The transmitter used by the Brenham girls' club is a 6L6 oscillator and an 807 amplifier with an output of 50 watts. The antenna is a 66 foot Y-matched doublet, center-fed with a twisted pair. The rig operates in the 40 meter band, at 7,202 kilocycles. Other equipment includes a Halli-crafter receiver and a telegraph key, and for practicing receiving and sending, an Instructograph and an audio oscillator with built-in speaker.

In Oklahoma the NYA in January established a project at Tonkawa which will provide 200 youth with basic technical experience in all phases of radio construction and communications. While this new project is getting under way, 24 youth, 17 boys and 7 girls, who received their radio experience on a project at Shawnee, will be busy estab-

lishing a "state-wide" NYA network, which it is planned to place in operation in the near future.

The NYA in Kansas has already laid the ground work for an extensive radio project with two transmitters, one fixed and one portable, ready to go on the air and receivers installed at 25 resident projects throughout the state. Through the cooperation of radio dealers this organization in Kansas has developed a very worthwhile program for providing radio reception facilities for public institutions and welfare agencies. Under this arrangement the radio dealers turn over to the NYA old receiving sets acquired by trade-in on new models. These sets are then repaired and issued to charitable and to welfare institutions.

In Texas, 28 short wave radio stations are already operated on National Youth Administration projects and 24 more transmitters are proposed. All told, more than 400 boys and girls are engaged in NYA radio communications, construction and service work in the Lone Star State.

Each unit at which a transmitter is operating averages about 15 youth. Thus far, since the first NYA station went on the air from the Ranger Boys' Center, under license W51VA, in March, 1940, fifteen young men have found jobs in private employment as a result of their work experience in constructing and maintaining short-wave transmitters.

## British P. E. Cell Circuits Perform Variety of Functions

● A NUMBER of circuits for photo electric cell operation are described in *Electronics and Television and Short-Wave World*. In Fig. 1, a simple 2-stage A.C. operated photo amplifier relay, the bias is obtained by the rectifying action of the grid itself which tends to keep the plate potential constant and independent of large fluctuations between the grid and cathode. The impedance of condenser C1 acts as a load

for the P.E. cell, the condenser being charged to a definite negative potential on 1/2 cycle and discharged through the cell on the other half. The amount the condenser is discharged by the P.E. cell determines the working potential on the grid of the buffer tube. Condenser C1 may be adjusted to any desired value depending upon the sensitivity of the relay.

Three variations are shown in Figs. 2,

3 and 4. These circuits will respond to a pulse of light having a duration as short as 1/60 of a second or one-half cycle of A.C. Briefly their operation may be explained as follows: On the negative half of the cycle the cathode of the 6F5 goes negative with respect to the grid and passes current to the grid while the tube is dark. During a period of several cycles C1 receives a charge equal to the peak value of the A.C. voltage applied between the grid and cathode. Added to the instantaneous A.C. voltage, this reduces the plate current of the output tube to zero. When light strikes the P.E. cell, first an instantaneous drop appears across the load R1, and second the P.E. cell current into C1 opposes the current fed into this same condenser from the amplifier grid, balancing the potential across C1 at some negative value between zero and the A.C. peak voltage between the grid and cathode. The potential across C2 is obtained similarly by a balance between the charging grid current and the discharging buffer tube current. In Figs. 2 and 3 a flash of light causes an instantaneous drop across R1 and triggers the circuit. In Fig. 4, due to the current drawn by the buffer tube, there is a slight amount of potential across C2 which is slowly increased through R3 during several cycles. Thus a pulse of output current has sufficient duration to operate even a slow relay though the light pulse may be extremely brief. The only difference between Fig. 2 and Fig. 3 is that, in the latter, heater voltage is supplied by means of transformers. This affords a far more efficient circuit and one that is thoroughly flexible.

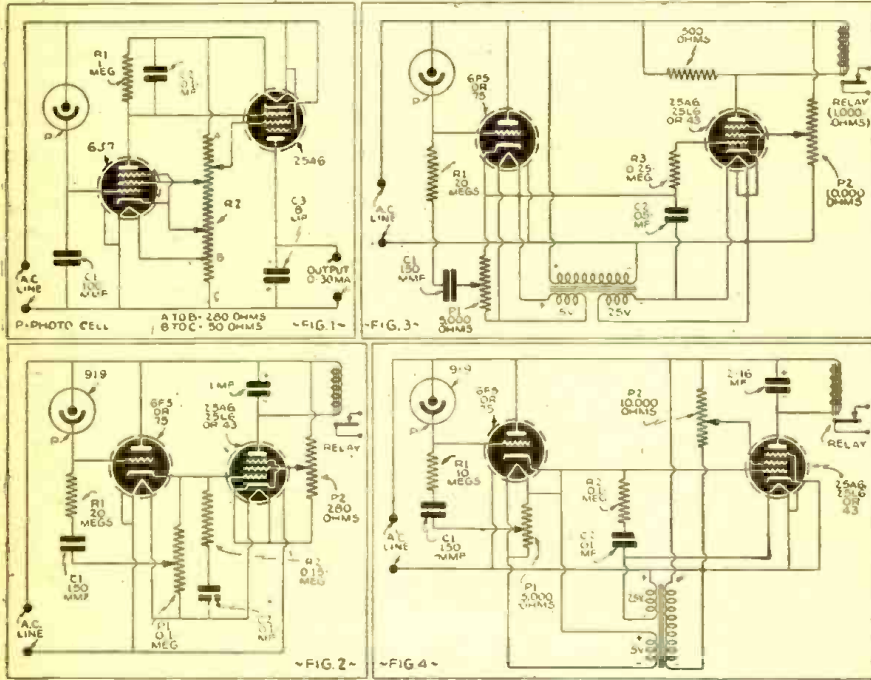

## 2-Tube Reflex Uses 7½ Volts "B" and Flashlight "A" Batteries

● A 2-TUBE reflex that affords a stage of radio, detector, and a stage of audio and uses but 7½ volts of "B" battery was recently described in the *Australasian Radio World*. The set uses two type 49 tubes and the circuit is extremely simple. The signal is fed from the antenna to the R.F. stage and through it to the second tube, which is a tuned regenerative detector; from there it is fed back to the first stage, which also functions as audio amplifier. The only batteries required are 2 volts for the "A" battery and 10½ for the "B" and "C," 7½ being used in the plate circuits. This great

economy in dry battery cost and weight makes the set virtually ideal for portable use. The materials required are one 4-prong socket and one 6-prong socket for the detector and antenna coils, respectively, and two 5-prong sockets for the tubes. Variable condensers C1, C2 and C3 are 140 mmf. each and are provided with trimmers. C4, 5 and 6 are mica condensers having capacities of .001, .0005, and .00015 mf., respectively. R1 is a 3 meg. grid-leak and R2 15 ohm filament rheostat. T1 is a 1 to 5 ratio audio transformer; L1 is a set of 4-prong plug-in coils and L2 a set of 6-

prong plug-in coils. RFC is a radio frequency choke of about 30 microhenries.

Very few points are necessary to watch in wiring this apparatus. One is to experiment with the primary and tickler windings. Since commercially-made coils vary, it will sometimes be found that using the primary as tickler and vice versa will improve results. It may also be necessary to reverse connections to any or all of the windings.

The constructor must also make sure that the control grid is employed as screen-grid in the R.F.-A.F. stage, while wiring of the detector tube is standard.

In tuning, C1 acts as a vernier control as it tunes more broadly than C2. If C1 fails to cover the entire range of C2, the value of the former may be increased to 350 mmf. and a few turns removed from the secondary winding of L1 (the 4-prong plug-in coil). While best results are obtained with a 5 to 1 ratio audio transformer, others may be employed at some sacrifice of volume or quality.

The set was designed for use with a 75-foot antenna and the constructor suggests that if a shorter aerial is used, volume can be increased by connecting the antenna directly to the grid of the R.F. tube through a 100 mmf. nidget condenser, in which case about 1/3 of the turns are removed from the secondary of L1.

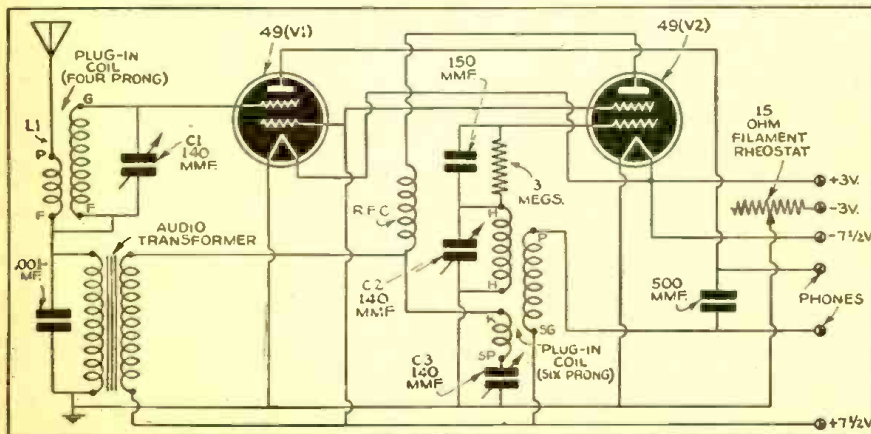

## Interference Reduction Systems Improved by British

● THE Comte de Monge, a noted radio inventor, has devised an ingenious system of balancing out interference which is described in *Wireless World* of Great Britain. This system is shown in Fig. 1. In this A is an ordinary single wire antenna and B is a second wire running parallel to it about two inches away from it for half its length. By adjusting the variable resistance R, two points of balance will be found in the voltage fed to the grid of the next tube in the receiver. The first point of balance is a neutralization of the wanted signal; the second point is due to neutralization of the interference voltage. If the signal-to-noise ratio in the two antennas is different, these points of balance will not coincide. Thus, by adjusting R to the second point, a considerable improvement of signal-to-noise ratio is possible, although complete interference suppression cannot be secured.

Writing in the magazine, R. I. Kinross points out several disadvantages in the de Monge system and suggests a simpler means which is usable on long-wave and medium-wave reception (the broadcast band). His circuit is shown in Fig. 2. While the de Monge system cannot be easily added to a receiver already built, the Kinross circuit can be thus employed. By adjusting the

value of "C," the interference voltage from A and B can be neutralized out at one setting, while the signal is neutralized at an entirely different setting. Both these points of neutralization are established in the primary of the transformer "T." The improved signal is fed into the antenna and ground terminals of the receiver through the secondary winding of "T" which is tapped to match the input impedance of the receiver.

In designing the transformer, care must be taken to keep the setting of "C" constant on all wavelengths in the broadcast band, and to make the efficiency as high as possible. The first is achieved by keeping the leakage inductance of the primary at a low level, and the second by using a high permeability core. In addition to suppressing interference, improved intelligibility of speech or code is had when interference would otherwise drown out the signal.

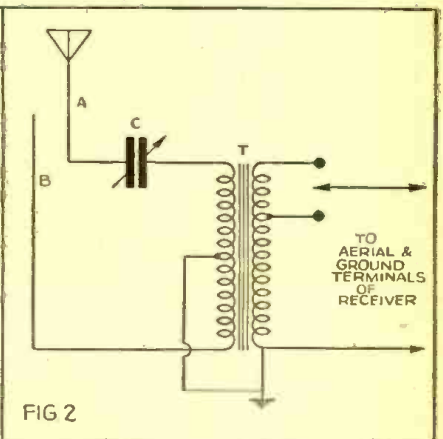
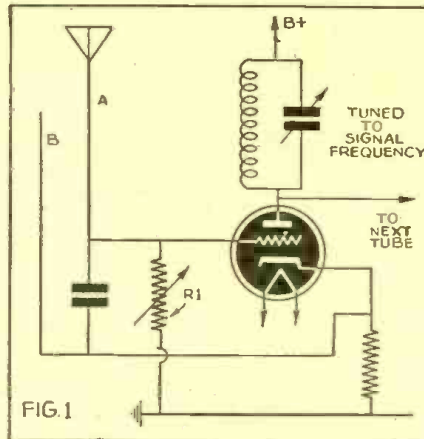

### OUR TELEVISION GOOD

● RECENT refugees from France, Germany and England, interviewed by the R. & T. television editor, expressed their amazement at the quality and steadiness of American television images. Those from the former countries state that far more publicity was given to television transmissions in these places than actual achievement warranted, while those from England state that the 441 line American standard gives vastly superior images to Britain's 405 line pictures. They also commented favorably on the extreme steadiness of American transmissions. The French and Germans state that there were virtually no regularly scheduled programs in their countries before the war. All agree that America is the last stronghold of television, at least until the war is over, and hope that it will be permitted to advance, in order that the art may not be handicapped irremediably.

We often wonder what some of the foreign "lookers-in" would say if they could see the fine color television images which CBS and others have broadcast in the U. S.

### AUTOMATIC CONTROL OF TELEVISION BRIGHTNESS

● WHEN television reception is being witnessed in a darkened room and somebody turns on the lights, it is necessary to re-adjust the brightness and contrast controls so that the picture can still be seen under the new lighting conditions. A further adjustment must be made when the room light is switched off again. A new system has been designed by British engineers to perform this readjustment task automatically.

As shown in the diagram from *Electronics and Television & Short Wave World* of Britain, a photo cell, P, is mounted on the front panel of the television receiver where light which falls upon the screen of the viewing tube from varying room light will also strike the active surface in the photo-cell. As the resistance of the cell is changed, due to alterations in room lighting, the resultant output of the cell is used to vary the biasing voltage of one of the amplifiers, through which the video signals pass. This controls the gain, and therefore automatically varies the brilliance of the

image to compensate for any changes in room lighting. The photo cell thus finds one more useful role.

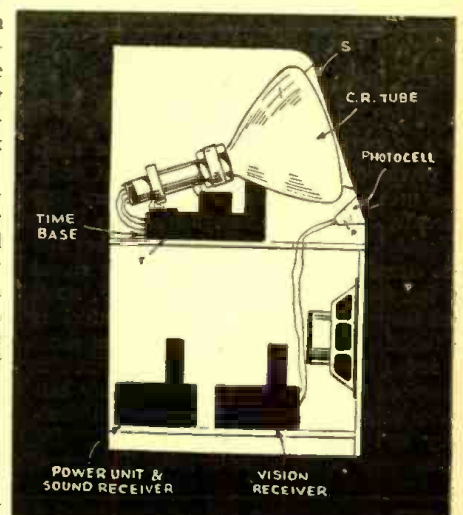

## Can YOU Answer These Radio Questions?

1. What is the name of the special image pick-up tube used in the recent color television demonstration by CBS? (See page 711)
2. What is the purpose of a short-wave Signal Booster and where is it connected with respect to the ordinary receiver? (See page 718)
3. What is the purpose of degeneration in an audio amplifier? (See page 726)
4. Name one of the undesirable effects that auto ignition causes in television reception. (See page 741)
5. How can the range of a voltmeter be increased? (See page 731)
6. Why should the complete radio transmitter be grounded? (See page 736)
7. What is the purpose of the parabolic reflector used in connection with a super-sensitive sound detector to be used for spotting airplanes? (See page 752)
8. How can the hand-pass circuit in an F-M system be adjusted? (See page 739)
9. What is a "set" relay, and how is it used? (See page 760)
10. How is relative signal strength judged and evaluated? (See page 755)

**THERE'S MORE DRAMA** and excitement packed into amateur reception when your communications receiver is a Hallicrafters. Back of Hallicrafters precision engineering is long experience, and it is this that accounts for the finer, broader, more accurate and dependable reception amateur owners enjoy. Lafayette Radio offers a complete line of latest Hallicrafters models. Time payments make owning one easy. Send for **FREE** catalog today, or visit branch nearest you.

*Hallicrafters*

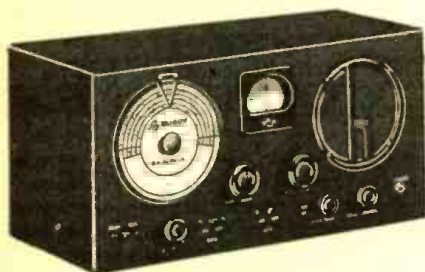

**MODEL S-19R**

Efficient superheterodyne circuit employs 6 tubes, of which two are double-purpose types, providing 8 tube performance. Complete tuning range of the receiver from 545 kc. to 44 mc. in 4 tuning bands. Electrical band spread on each band. Broadcast band coverage, beat frequency oscillator, automatic volume control switch, built-in speaker and a separate band spread dial. Designed for operation from any 110-120 volt 50-60 cycles a.c. line. Antenna connections provided for both doublet and Marconi type antennas. Cabinet beautifully finished - 17 1/2" x 8" x 8 1/2".

**\$29<sup>50</sup>**

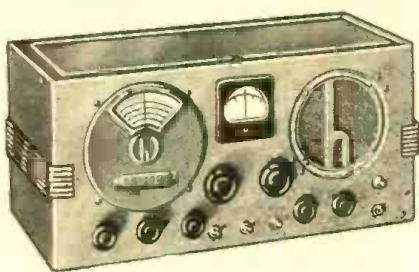

**MODEL S-20R**

New improved 9 tube model. Covers the complete range from 545 kc. to 44 mc. in four bands. Employs a stage of pre-selection on each band for added sensitivity and selectivity. Controls: r.f. gain, audio gain, tone control, a.v.c. switch, BFO switch, band switch, main tuning control, separate band spread control, and "stand-by" switch. Built-in speaker. Circuit features electrical band spread, automatic noise limiter, r.f. amplifier. Designed for 110 volts 50/60 cycles a.c. operation, (plug and jack provided for batteries or vibrapack operation). Steel cabinet measures 18 1/4" x 9 3/8" x 8 1/2".

**\$49<sup>50</sup>**

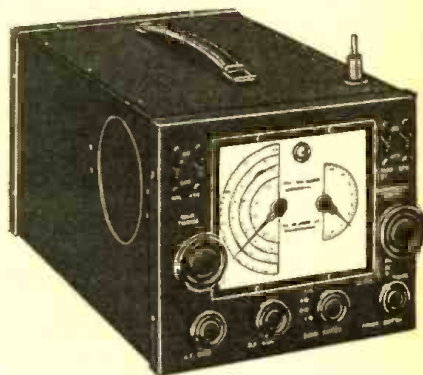

**MODEL S-29**

Precision-built communications receiver in portable form. Operates on either 110 volts AC or DC or from self-contained batteries. Self-contained telescopic antenna. Receiver covers four complete bands: 11.26 mc. to 1490 kc. Employs an r.f. stage on all bands, incorporates an automatic noise limiter; electrical band spread. Built-in speaker. Controls include: main tuning —band spread—r.f. gain—A.f. gain—band switch—power switch—a.v.c. "off-on" switch —BFO "off-on" switch—ANL "off-on" switch —send-receive—standby switch. Dimensions: 7" high, 8 1/2" wide, 13 1/4" deep.

**\$59<sup>50</sup>**

*Lafayette*

100 SIXTH AVE., NEW YORK

901 W. JACKSON BLVD., CHICAGO

265 PEACHTREE ST., ATLANTA

boston • newark, n. j. • bronx, n. y. • jamaica, l. i.

**THE WORLD'S LARGEST RADIO SUPPLY HOUSE**

for April, 1941

Please Mention This Magazine When Writing Advertisers

717

# How to Construct a Short-Wave "Signal Booster"

Charles R. Leutz

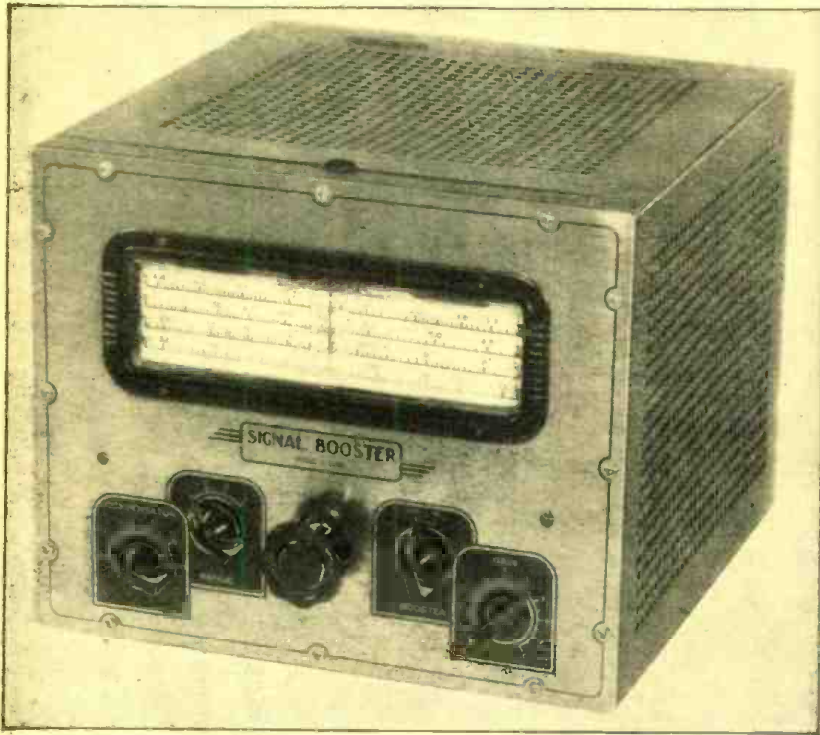

This article describes the construction of an efficient pre-amplifier. It is easy to build this pre-amplifier as it is available in kit form. Complete diagram and construction data are included herewith, for the benefit of experimenters in general, as well as set-builders who prefer to follow kit instructions.

• MODERN super-heterodyne radio receiver circuits include at least one stage of tuned radio frequency amplification at the signal frequency and preceding the mixer tube. Special designs call for two and even three stages of T.R.F. at this point.

The advantages of one or more stages of T.R.F. ahead of a straight super-heterodyne circuit have been known for many years. Years ago this T.R.F. addition could not be effectively applied, due to the fact that tubes then available were unsatisfactory as tuned radio frequency amplifiers, especially on the higher frequencies. Now

Photo above shows the finished signal booster, while diagram below shows its simple construction.

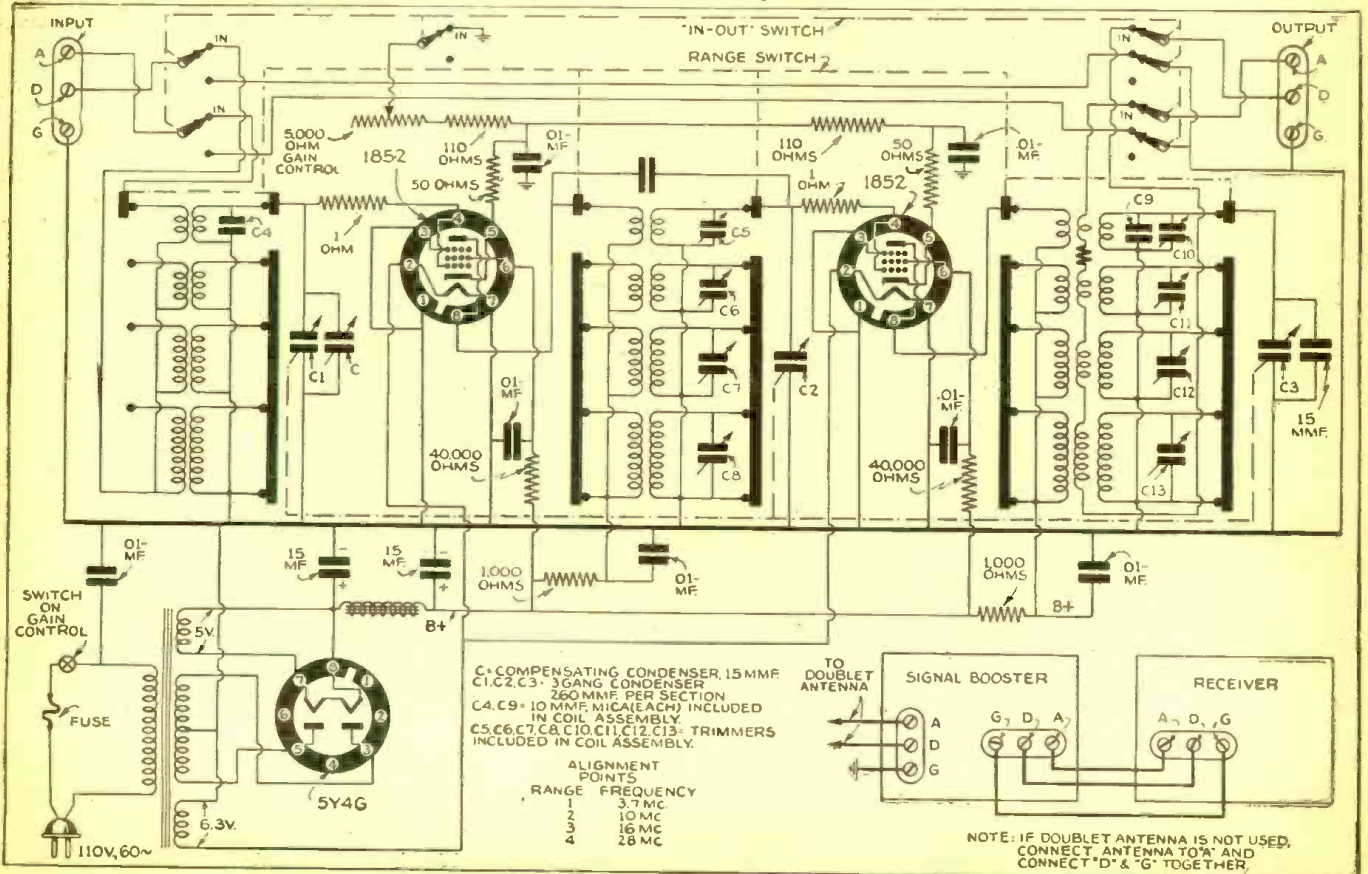



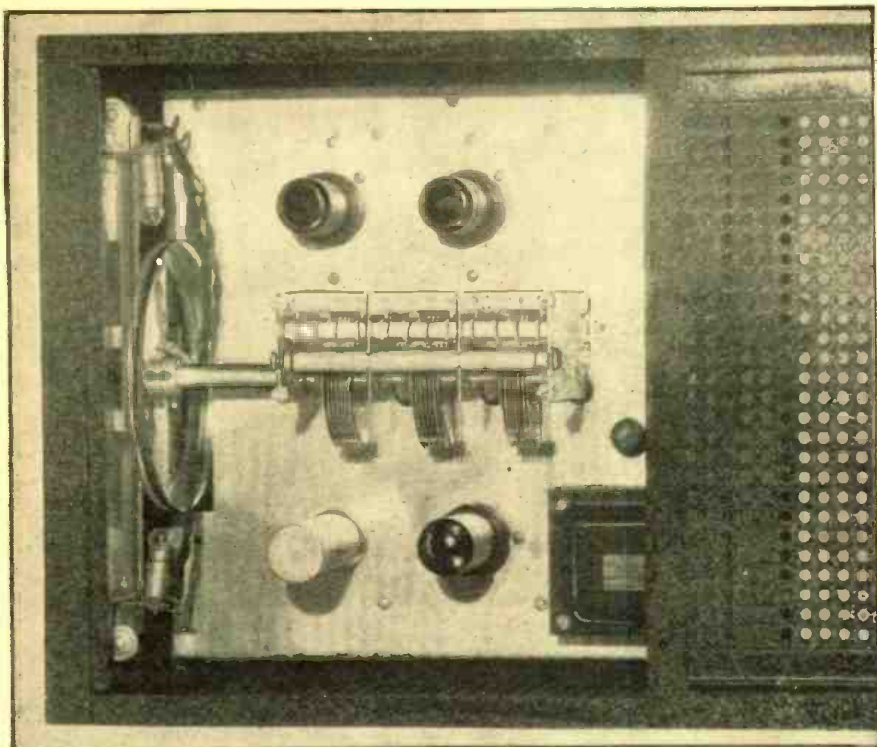

Top view of the pre-amplifier with cover of cabinet swung back.

that efficient T.R.F. amplifier tubes are available, the application is applied to all good receiver designs where cost is not a first consideration.

The addition of one or more stages of T.R.F. to existing receivers permits improving the *signal-to-noise* ratio, the sensitivity and probably most important, also provides a more favorable image ratio. The last mentioned feature is a most desirable addition if the existing receiver does not have a T.R.F. stage or if the T.R.F. stage included is inefficient. A signal booster can of course also be used with a T.R.F. receiver or with a regenerative short wave receiver, to obtain the improvements available, mentioned above.

The Meissner *signal booster* to be described in this article is ordinarily marketed as a completely constructed and wired instrument ready for operation. For the benefit of radio experimenters, the manufacturer has given permission to publish the design details of this modern instrument.

#### Two Stages of T.R.F. Boost Signals

The signal booster consists essentially of two stages of *tuned radio frequency amplification*, with provision for antenna input and for a matched output to standard receiver antenna circuits. To make the instrument most useful, it has been designed for a wide frequency coverage, viz. 1.6 to 31 megacycles, in four bands.

The R.F. transformers used to cover the above mentioned range are machine wound and accurately adjusted using precision measuring instruments, in order to secure accurate tracking and also so that the frequency coverage will indicate properly on the calibrated scale. In view of this it is a very difficult proposition to duplicate the coils by hand and not suggested, accordingly the winding data is omitted. If desired, standard R.F. transformers can be used for one or two stages experimentally, for example for a broadcast band booster using the

circuit described. However, in the case of requirements calling for complete short wave coverage, the manufacturer's tuning unit can be secured at a reasonable cost; considerably less than it would cost to duplicate one by hand. The tuning unit consists of the four point multiple switch, the twelve R.F. transformers and eight trimmer condensers, all assembled, wired and pre-aligned, ready for wiring into a booster circuit. This unit is tuned by a three-gang 260 mmf. variable condenser.

#### 4-Band Switch Tunes in Signals

The accompanying schematic wiring diagram is complete in every detail and clearly shows the special four-band switch together with the associated R.F. transformers, tuning condenser and trimmers. For each of the four bands, the three R.F. transformers are different, the first transformer is the antenna or doublet input, the second transformer a high gain interstage and the last transformer an output unit. *The latter has an output winding of proper characteristics to match the input circuit of standard receivers.* As all the transformers and the associated gang condenser are designed to track accurately, the output circuit delivers maximum possible energy to the associated receiver over the entire frequency range, the main purpose being to over-ride the tube or circuit noises which may be generated within the receiver. Accordingly, in tuning in a weak distant signal using the signal booster, the over-all response is similar to that obtained when tuning to a strong local signal on a receiver alone. Under these conditions the signal is clear and strong and *background noise at a minimum.*

By designing the circuit for the 6AC7/1852 "television" tube for the R.F. amplifier stages, excellent gain is obtained even at the highest frequencies, together with good circuit stability and a low noise factor.

This useful instrument is not difficult to build. Accompanying drawings give full

## HOW TO SAVE ON EVERYTHING IN RADIO

Just off the press! ALLIED'S new Spring Catalog—cramped with smashing values from cover to cover; ALLIED offers you everything new in Radio, real savings and fast service. Dealer, Serviceman, Soundman, Builder, or Amateur—whatever your interest in Radio, you'll find the new ALLIED Catalog a necessity! Send for your FREE copy today. Keep it handy for speedy reference!

### NEW RADIO SETS

See them all—1941's Radio Hit! Models for every purpose. Every one a Champion—new "Personal" three-way Portables; latest Recorders; Phono-Combinations; Plastic Sets; World-wide Models; new FM-AM receivers; Auto and Farm Radios; Amateur Sets—all at lowest prices that spell Real Savings and Profits for you!

### VALUES IN P. A.

25 New Sound Systems! For every Public Address application—7 to 75 watts. Widest selection; finest features, Easy Payment Plan and 15 Day Trial. Complete P.A. accessory listings for every purpose. Dollar for dollar you get more when you buy 1941 KNIGHT Sound Equipment. Send for your FREE catalog now!

### FOR THE BUILDER

If you build your own, you can count on ALLIED for the latest low-cost kits and for help in building any type of radio circuit. Complete listings of the latest Builders' and experimenters' supplies. New diagrams. Complete Ham Gear for the Amateur. ALLIED is Headquarters for Radio Builders! For Radio Amateurs!

### 15,000 RADIO PARTS

The biggest selection of quality parts in all radio. Every leading make—complete listings for every radio replacement and servicing requirement. Parts, tools, test equipment, books, etc. You need this reliable Guide to Everything in Radio at the lowest prices! Don't be without it! Don't wait! Mail coupon TODAY!

## ALLIED RADIO

833 W. Jackson Blvd., Dept. 3-D-1  
Chicago, Illinois

Send me your FREE 180-Page 1941 Spring Catalog.

Name .....

Address .....

City ..... State .....



dimensional details of the chassis and front panel. It will be noted that a standard chassis is not suitable for the design, first because of the 4" depth required and secondly due to the fact that one side of the chassis must be removable in order to complete internal connections.

### Construction Details

After providing the chassis and panel, assembly is started by mounting the power transformer and the tube sockets, noting that the two ceramic sockets are for the R.F. amplifiers. Next mount the electrolytic filter condenser above the chassis and the filter choke underneath the chassis and also mount the fuse extractor post. On the rear of the chassis mount the two 3 terminal connection posts. On the front of the chassis mount the compensator condenser (a 15 mmf. variable) to the extreme left position and the volume control-switch to the extreme right position.

Two 4 terminal tie lugs are mounted underneath the chassis, to the left of the R.F. sockets and two 3 terminal tie lugs are mounted to the right of the R.F. sockets. The above tie lugs accommodate all the small fixed condensers and resistors with the exception of the one .01 mf. condenser connected at the power transformer primary. One side of the small resistors or fixed condensers should be connected directly to the indicated socket terminals or ground where possible, using the tie lugs for the "live" anchors. The R.F. leads should be kept to minimum lengths and the R.F. leads separated as far as possible.

The parts installed so far can now be wired, including the line cord and making sure all connections are well soldered and

as indicated in the schematic diagram.

The next step involves placing the three gang condenser in position followed by mounting the dial assembly. When the gang condenser is fully meshed, the dial pointer should be at the extreme right or low frequency end of the scales.

The R.F. transformer-switch assembly can now be placed into position, the front end being held into place with the shaft bushing and the rear end held with the bracket provided. The connections to the above assembly are then made, including connections to the gang condenser stators, as indicated in the wiring diagram.

The antenna switch is placed into position, also fastening the front end to the chassis with the shaft bushing and the rear end to the back of the chassis with screws and spacers. The switch is then wired.

To this stage, the assembly and wiring has been confined to the chassis. The front panel is held to the chassis using four dowel spacers together with screws and nuts. With the front panel in place, the dial assembly can be completed by adding the escutcheon and wiring the dial lights. This completes the assembly and tests for operation and alignment should be made before inserting the unit into a cabinet.

Provided a high resistance or vacuum tube voltmeter is available, a preliminary check can be made by inserting the tubes, connecting the power and measuring the voltages at the R.F. tube sockets. The plate voltage should be about 260 to 300 volts and the screen voltage about half that amount. The control grid voltage will vary depending upon the Gain Control adjustment, same giving minimum reading with

the gain adjustment full on clockwise.

### Testing the Booster

Final tests and adjustments are made with the signal booster connected to the receiver. If a doublet aerial is used, same is connected to posts A and D on the booster input terminals and a ground connected to G. Assuming the associated receiver also has provisions for doublet input, the booster output terminals A, D and G, are connected to corresponding terminals on the receiver input. However, if the receiver is only arranged for a single aerial, then a wire is run from booster output terminal A to receiver antenna post. Posts D and G on the booster output terminal are connected together and to the ground post on the receiver input.

When the booster is to be operated from an ordinary aerial, the aerial is connected to A on the booster input. Posts D and G on the booster input are connected together and to ground. The inter-connections from booster to receiver are the same as previously indicated. Best results will be obtained when the booster is located immediately to the left of the receiver input connections, so that the connecting leads between the two units will be at minimum length. A piece of low-loss concentric cable, such as Amphenol No. 72-12 is ideal for the inter-connections "A" and "D".

Turning the Booster Switch to the "Out" position now connects the aerial directly to the receiver without any booster action. The desired signal can now be tuned in on the receiver alone and assume the signal frequency involved is 8 megacycles; then the Booster Switch can be turned to the "In" position, the booster Range Switch

Details of chassis, etc., of the signal booster.

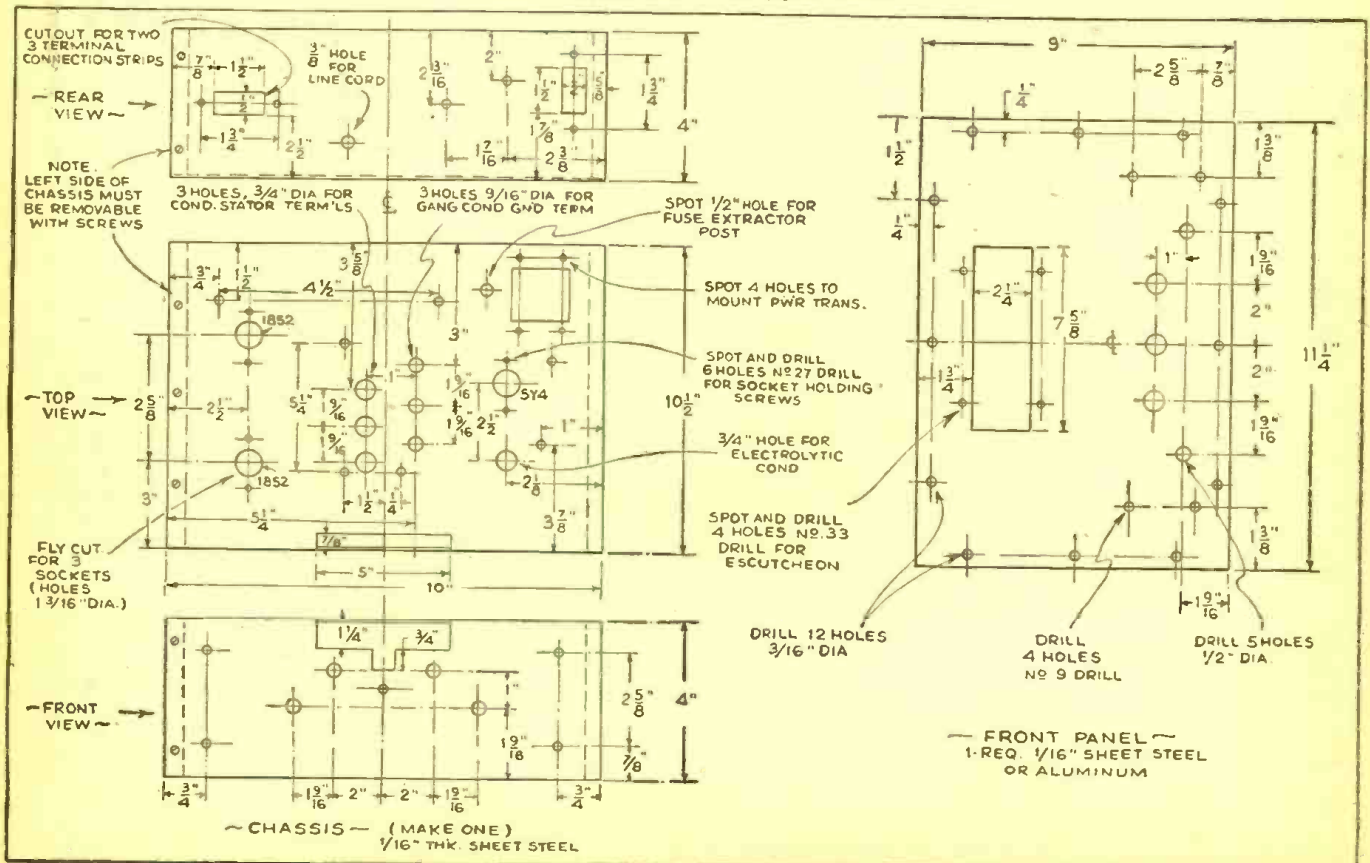

turned to band 2 and the booster dial tuned to 8 megacycles or to the desired signal. With the booster action in operation, the booster gain control should be adjusted as high as possible and the receiver gain retarded correspondingly, in order to obtain the most favorable *signal-to-noise* ratio. The booster "In-Out" switch controlling the aerial does not turn the booster tube filaments off, so that the booster is always ready for immediate operation.

In some instances, it may be found that a signal received on the receiver alone, disappears when the booster is connected into circuit. In that case the signal being received was an image and disappeared when the booster was switched in, as the added tuned R.F. stages discriminate against images. Therefore it is always important that the receiver and booster both be tuned to the true signal frequency for true maximum results.

The *gain control* on the booster permits variation of amplification right up to the oscillating point. This is important because the input and output loads on the booster vary, according to the types of aeri- als and receivers used, and no one fixed adjustment of booster gain could possibly be suitable for all conditions.

#### Use on T.R.F. and Regenerative Sets

When using the booster with a T.R.F. set or with a *regenerative* receiver, it is important that both the booster and receiver be tuned closely as possible to the signal frequency, so that the booster gain can be advanced substantially without the booster circuit oscillating.

Alignment can be checked by either using a signal generator or on received signals. Each of the four bands must be aligned. If a signal generator is available the alignment points are as follows: for range 1 (3.7 mc.); range 2 (10 mc.); range 3 (16 mc.) and range 4 (28 mc.). If received signals are used for alignment, the same should be selected approaching the above values. With the received signal coming in steadily, first adjust the booster *compensator* condenser and then adjust the trimmers on the R.F. and output transformer for the range position involved. These trimmers are adjusted for maximum response, at the same time keeping the receiver gain control at a minimum, in order that corresponding changes in signal strength are readily discernible.

While a *signal booster* substantially improves the DX reception possible, using only an ordinary aerial and average receiver, greatly improved results will be obtained by erecting the *best possible* aerial, preferably of the *doublet* type. By erecting two doublets at right angles to each other, each with separate low-loss co-axial cable lead-in, a switch can be provided to connect to either one of the two doublets. Depending upon the direction of arrival of the desired signal, one of the doublets will invariably collect more signal strength than the other and give a better *signal-to-local noise ratio*.

#### List of Parts

- 1—Cabinet, 11¼" long, 9" high and 11¼" deep, No. 9781
- 1—Front panel, etched dial markings, 11¼" x 9" x 1/16", No. 9779
- 1—Chassis, (as per detail drawing, No. 9657)
- 1—Power transformer, primary 110 volt 60 cycle A.C. secondaries, 6.3 volt fil., 5 volt fil. and 350-0-350 volt, No. 19255

## Get this new QSO INDEX

for only 25¢  
with purchase of  
any BUD product from

your jobber during March and April

"When did I last work W8VCC?"  
... "What was my last report from W9TLQ?" ... "What frequency is W8CTI?"

Now, for the first time, you can get the answers to these and other questions with the helpful new QSO Index! There's a card for every station you

work, alphabetically arranged for easy reference. Saves tedious time spent in looking up call letters in your log.

The regular price of the QSO Index, based on quantity production, is 75 cents. But during March and April you may obtain yours for only 25 cents with the purchase of any BUD merchandise at your jobber.

Your jobber has a wide range of BUD radio parts, scientifically designed to give you maximum performance at minimum cost. Or consult your latest BUD Catalog.

# BUD RADIO, INC.

CLEVELAND, OHIO

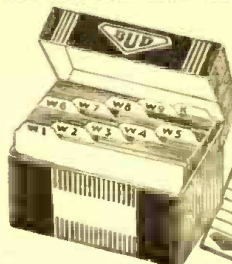

75¢

Attractively lithographed steel cabinet—10 buff bristol index cards—100 printed station cards (3"x5") with spaces for all important information.

## Whatever YOU WANT In A HEADSET



You'll find in a Cannon-Ball Guaranteed Headset: Sensitivity. Clarity of tone. Dependable performance. Quality at fair price. Folder T-22 illustrates complete line. Write Headset Headquarters.

Scientifically Built Heavy bar magnets greatly increase their efficiency.

C. F. CANNON COMPANY  
SPRINGWATER, N. Y.

## BUILD THE BROWNING AUTODYNE CONVERTER AND PRE-SELECTOR

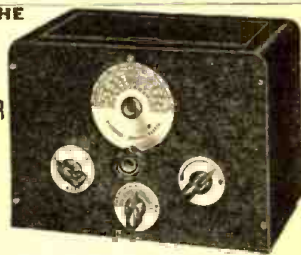

Make any receiver a short-wave set, tuning from 5 to 185 meters. (less 1852 tube) \$16.50  
Available in kit form  
Laboratory wired and tested, \$19.80 (less 1852 tube)  
Cabinet: Black or Grey crackle finish.  
BROWNING LABORATORIES, INC.  
750 MAIN STREET WINCHESTER, MASS.

Still a BEST SELLER!  
RADIO AMATEUR COURSE  
See Page 759

- 1—Filter choke, 20 hy., 20 mil. No. 19256
- 1—Filter electrolytic condenser, 15-15 mfd., 450 volt No. 16124
- 7—.01 mf., 400 volt paper condensers. No. 14110
- 1—Compensator variable condenser. 15 mmf. No. 17150
- Following ¼ watt resistors, 2—110 ohm, 2—one ohm, 2—1000 ohm, 2—50 ohm, 2—40,000 ohm
- 1—5000 ohm gain control with A.C. switch. No. 19514
- 1—3-gang, 260 mmf. variable condenser. No. 17151
- 1—Shield for gang condenser. No. 9783
- 1—Special switch, 2-gang, 4-position. No. 19494
- 1—4-band, R.F. transformer assembly, with special switch and trimmers, wired and pre-aligned. No. 9782
- 1—Moulded Octal socket. No. 9349
- 2—Ceramic Octal sockets. No. 8437
- 1—Line cord and plug. No. 12434
- 1—Tuning knob. No. 25-8225
- 4—Bar knobs. No. 25-8222
- 1—Dial mechanism. No. 19322
- 1—4-band calibrated scale dial. No. 19513
- 1—Dial escutcheon. No. 19516
- 2—Dial lights. No. 19262
- 2—3-terminal connection blocks each marked "A," "D" and "G." No. 16738
- 1—Littelfuse fuse extractor post and ½ ampere fuse

#### MISCELLANEOUS HARDWARE

- 4—Wood dowel spacers, ¼" O. D. x ½" I. D. x 11/16" long
- 25 feet push back connection wire
- 2—4-terminal tie lugs and 2 3-terminal tie lugs
- 4—Rubber feet for cabinet
- 1—Rubber grommet for line cord
- 12—No. 8 rd. hd. drive screws ¾" long for front panel
- 7—No. 6 rd. hd. drive screws, ¼" long for removable chassis side
- 4—No. 6 32 x 1" rd. hd. mach. screws with nuts and lock washer, for front panel
- 4—No. 2 56 x ¾" rd. hd. mach. screws, nuts and lock washers for dial escutcheon
- 3—No. 8 32 x ¾" rd. hd. mach. screws, nuts and lock washers for gang condenser
- 14—No. 6 32 x ¾" rd. hd. mach. screws, nuts and lock washers for sockets, filter choke and ties

#### TUBES

- 2—RCA 6AC7/1852 R.F. amplifiers
  - 1—RCA 5Y4G or 5Z4 rectifier
- Manufacturers' numbers given in the list of parts are those of the Meissner Manufacturing Co. Substitutes, if identical in electrical characteristics and quality may of course be used.

# A Modern "Hi-Fi" Amplifier

John T. Wilcox, W2CLS\*

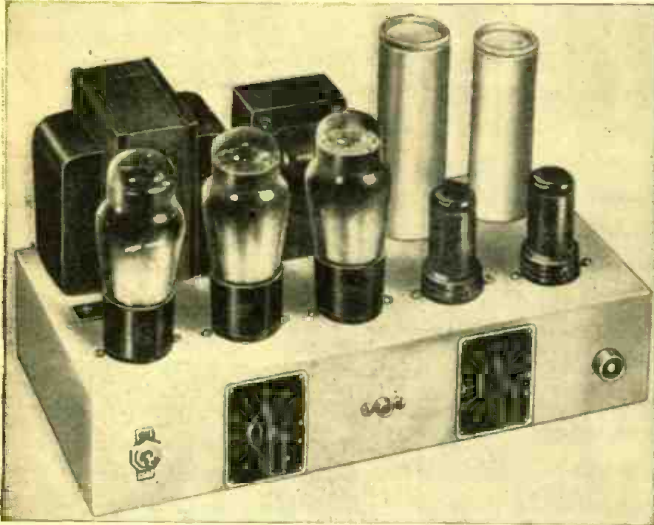

This very excellent audio amplifier can be used with phono pick-up, a microphone, radio tuner, etc. It has a wide frequency response—from 25 to 15,000 cycles. The final stage is of the "push-pull" type—the phase inverter is self-balancing, with very good regulation. The amplifier has a measured output of 12 watts, with very low distortion.

The complete high-fidelity audio amplifier is shown at the left, with the controls and switches mounted on the chassis. Standard parts are used and it is easy to wire.

● HERE is an amplifier that is well suited to present-day needs, it has an extremely wide band response and a very low distortion level. The measured range of this amplifier extends from 25 to 15,000 cycles. It is down 1½ d.b. at 25 cycles and up 1 d.b. at 15,000 cycles, measured in the low-gain channel, tone control off.

This makes an ideal amplifier for frequency and amplitude modulation reception, P.A. work, recording and other special applications such as measurement work, etc. Other features are compactness (chassis

size only 6" x 12" x 2½") and low cost to construct and ease of construction.

Controls are provided to fade from the high-gain channel to the low-gain channel, and also a very gradual change tone-control. A switch to change impedances quickly is provided, which eliminates soldering and resoldering speaker plugs.

The circuit line-up is as follows: a 6SJ7 is used as a high-gain pre-amplifier; a 6SC7 is used as a phase-inverter, this is a dual triode tube (the low gain input also feeds this tube); a pair of 6V6G tubes are the final push-pull amplifiers. The rectifier

is the old reliable 80. The phase inverter circuit is self-balancing and has very good regulation, which accounts for an output of 12 watts measured, with very low distortion.

The circuit as shown should need no further explanation to wire, even to a novice, as the socket terminals which are the main cause of confusion are clearly marked. Any one who can handle a few simple tools and a soldering iron can easily build this amplifier and derive a lot of pleasure out of the time spent.

The parts are so laid out that the leads are very short and when wiring in the various resistors and condensers, the extra length of wire should be cut off. Keep all the parts flat to the chassis. This will make a very neat wiring job and helps in re-checking any parts or wiring.

The hum-level of the amplifier is very low, and a bottom metal plate with felt feet is included with the complete kit, to preclude the possibility of stray A.C. fields from inducing hum.

Any good P.M. speaker or separately

\*Engineer, Lafayette Radio Corporation.

Wiring diagram for the amplifier, also top view of chassis layout.

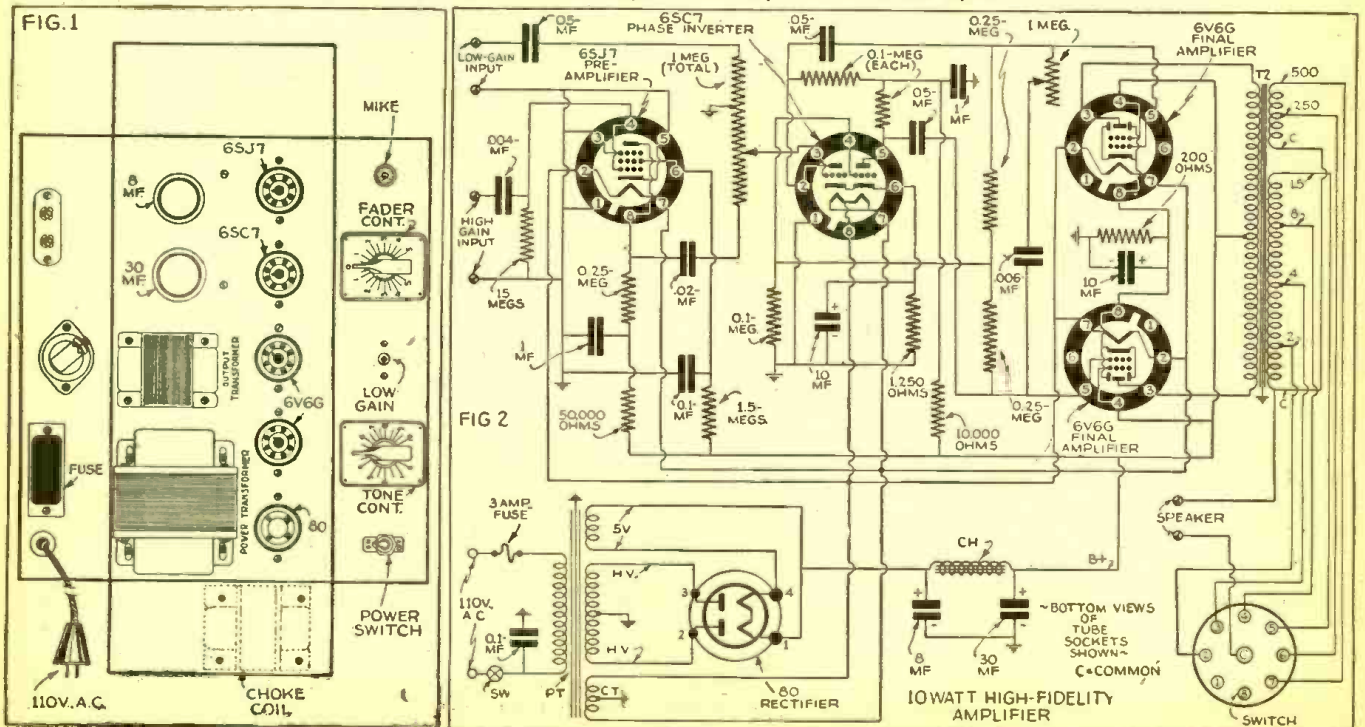

excited speaker can be used with the amplifier. It should, however, have a very good frequency response curve. Buy the best you can afford as this amplifier will do justice to even the best of speakers. A P.M. speaker is preferred because some A.C. type speakers may produce hum. A 5 or 6 inch P.M. speaker can be used as a tweeter (high frequency response) as shown in Figure No. 4. However, it is recommended that a special P.M. tweeter speaker be obtained for the best results.

A tweeter is not needed to note the difference between this amplifier and the usual run of amplifiers. The difference is really amazing on any good single speaker.

The low-gain channel is used for phono pickups, also frequency and amplitude modulation tuners, and the high-gain channel is used for mike input. Any high impedance mike can be used with good results.

The various types of recorders can be connected as shown in Figures Nos. 5, 6, 7.

Adjust the series resistor on the crystal cutters while making a few test records until best results are obtained; after it is once adjusted it can be left set. This resistor varies the response and while it is not too critical it should be adjusted to give a good high frequency response.

### Parts List

#### 10-12 Watt Hi-Fi Lafayette Amplifier

- 1—Power transformer; K1460
  - 1—Filter choke; K1578
  - 4—Octal sockets; K13050
  - 1—Speaker switch; K11510
  - 1—Amphenol mike plug; K13359
  - 1—Special chassis (punched) with bottom plate
  - 1—Line cord and plug; K13285
  - 1—1 megohm fader; K9004
  - 1—1 megohm tone control; K9129
  - 1—Terminal strip; K13145
  - 2—Knobs; K13053
  - 1—Crowe dial scale; 437
  - 1—Crowe dial scale; 439
  - 1—Toggle switch; K12836
  - 1—On-off plate for above; K12818
  - 1—Fuse holder; K12325
  - 1—Phono plug and socket; K13311
  - 1—Special output transformer
  - 1—Special 15 megohm resistor, 1/2 watt
  - 1—1.5 megohm resistor, 1/2 watt; K4248
  - 3—0.25 megohm resistors, 1/2 watt; K4285
  - 3—0.1 megohm resistors, 1/2 watt; K4281
  - 1—0.05 megohm resistor; K4277
  - 1—1250 ohm resistor; K4257
  - 1—10,000 ohm resistor; K4269
  - 1—200 ohm resistor, 10 watts; K4439
  - 1—0.004 mf. condenser; K2634
  - 1—0.02 mf. condenser; K3188
  - 3—0.05 mf. condensers; K3189
  - 2—0.1 mf. condensers; K3182
  - 2—1.0 mf. condensers; K3172
  - 1—0.006 mf. condenser; K3186
  - 1—10.0 mf. condenser; K3381
  - 1—8.0 mf. filter condenser; K492
  - 1—30.0 mf. filter condenser; K2766
- Hardware assortment including wire and solder  
 Diagram and instruction sheet
- 1—4-prong socket; K13057
  - 1—Amphenol mike socket; K13361
  - 1—3 ampere fuse; K12381

### TUBES

- 1—6S17
- 1—6SC7
- 2—6V6G
- 1—80

**Building a "Home" Diathermy Machine**  
 by  
**Ricardo Muniz, E.E., and S. Morton Decker**  
 in next issue

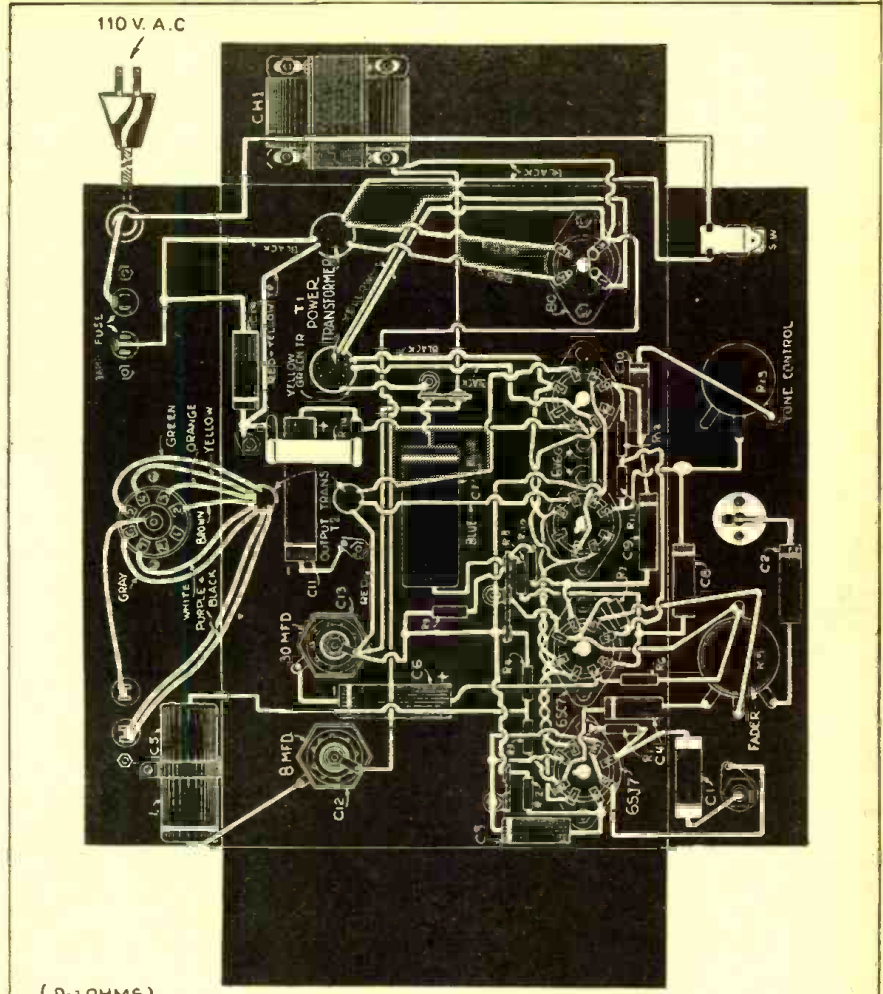

(Ω - OHMS)

### - LEGEND -

R1 - 15 MEG	R8 - 0.1-MEG	C1 - .004-MF	C8 - .05-MF
R2 - 1.5 MEG	R9 - 10,000 Ω	C2 - .05-MF	C9 - .05-MF
R3 - .25-MEG	R10 - 0.1-MEG	C3 - 0.1-MF	C10 - .006-MF
R4 - 50,000 Ω	R11 - 0.25-MEG	C4 - .02-MF	C11 - 10MF
R5 - 1 MEG	R12 - 0.25-MEG	C5 - 1 MF	C12 - 8 MF
R6 - 1,250 Ω	R13 - 1 MEG	C6 - 10 MF	C13 - 30 MF
R7 - .1 MEG	R14 - 200 Ω	C7 - 1 MF	C14 - 0.1-MF

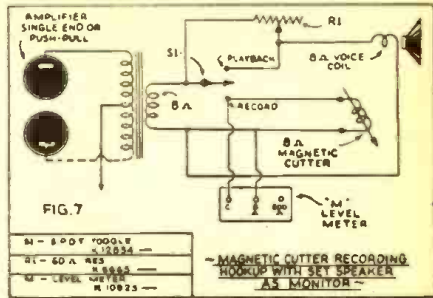
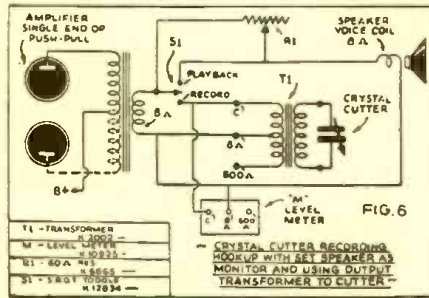
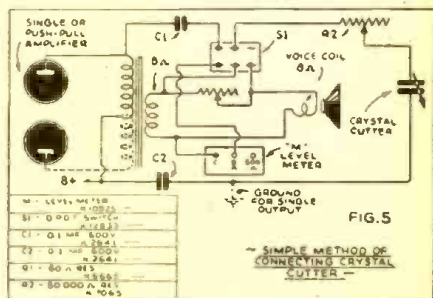
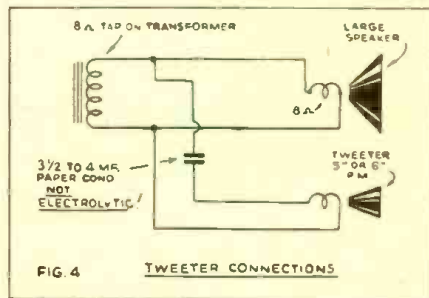

In the drawing above, the wiring diagram of the "high fidelity" audio amplifier is shown, together with picture diagram. This amplifier has been carefully tested in the laboratory, and the results of course depend a great deal upon the quality of the loudspeaker used with it. Either a high-fidelity loudspeaker should be used, or else a tweeter should be used in conjunction with an average range, good quality speaker.

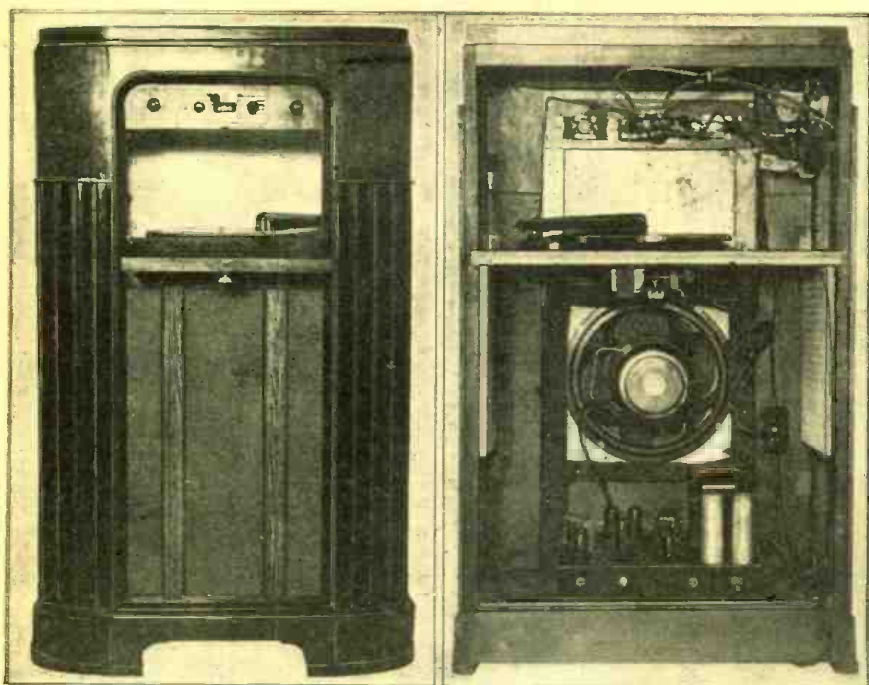

This high-fidelity audio amplifier can be built at very moderate cost. It has been tried out thoroughly by the engineers in a radio broadcast station, measurements having been made as to the quality of the reproduction with suitable measuring instruments. Not only is this amplifier useful for microphone or phonograph pickup, but it may also be employed in connection with a radio tuning unit.

Left—front and rear views of the cabinet containing phono turntable, loudspeaker and the high quality audio amplifier here described. The amplifier is seen at the bottom of the cabinet and a radio tuning unit is mounted in the top of the cabinet.

Milton T. Putnam

Chief Engineer, Station WDWS, Champaign, Illinois

# High-Fidelity Phono Amplifier

● THE amplifier and combination described was designed and built first of all because high-fidelity reproduction of phonograph records was desired. In view of this fact, most of the lower-priced commercial combinations, which could be purchased for anywhere near the construction cost of this amplifier, offered very little satisfaction, as far as high fidelity goes. Almost any kind of a radio-record player would cost a great deal more than the type we have constructed here, and by no means compare in quality of reproduction. I do not intend to imply, however, that there are not any number of good combination assemblies on the market, but only that for those who care to construct their own amplifier and tuner assembly, they can do far better from the standpoint of high fidelity, dollar for dollar, with the equipment we are about to describe. Most of the lower priced commercial units have single-ended output, with a pentode used for high gain, and thus add considerable distortion, not to mention the use of a five or six inch speaker. The layman can see that this makes for poorer reproduction.

### Pickup and Speaker

Probably the most expensive units in our entire amplifier and associated equipment are the speaker and pickup. As you can readily see, it is important that, first of all, you should choose a decent pickup and lastly that the speaker should be parallel in quality. The choice of these should be made dependent upon the result you expect and, of course, the amount of money you care to spend. There are any number of good pickups on the market at very rea-

sonable prices which may be equalized with the circuits given here to produce excellent quality. These range in price from \$3.00 to \$5.00. The speaker used in the original was a twelve inch model, and it is advisable

to use at least a ten inch unit if you wish to get reproduction of the lower bass notes. A satisfactory speaker may be purchased from any one of the leading radio supply houses, ranging in price from \$4.00 to

Top and bottom views of the Hi-Fi audio amplifier are shown below.

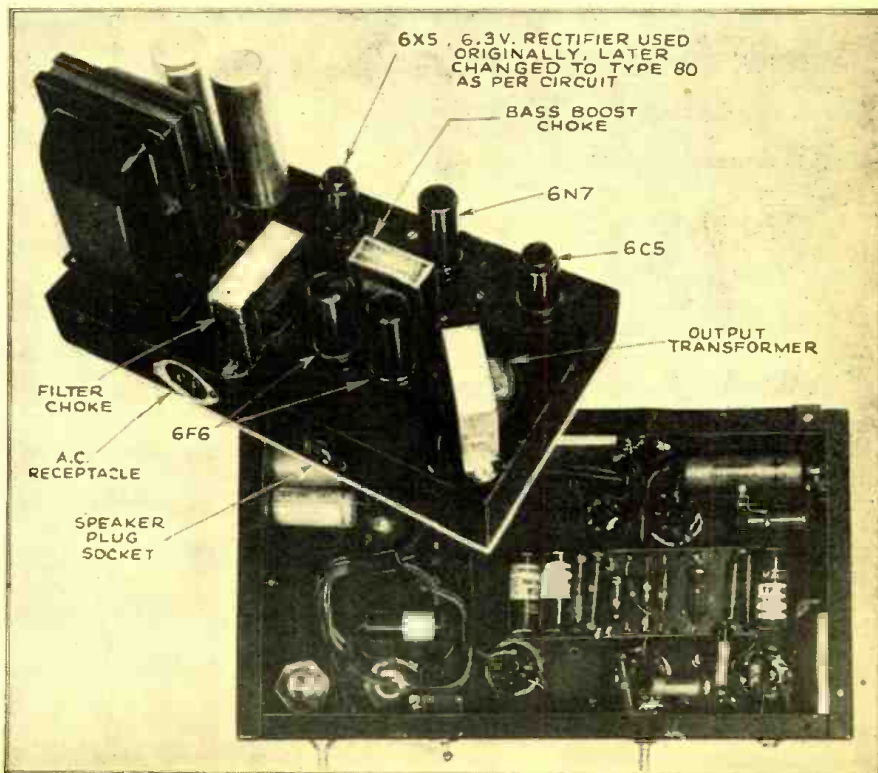

\$6.00, and up. It need not be of the permanent magnet type, except for convenience. As a matter of fact, it would be considerably cheaper to buy an electrodynamic and add filter to the power supply circuit by using its field as a choke.

### "Phase Inverter" Used

Ordinarily the other important factor which limits frequency response of an amplifier, outside of its fundamental design and circuit components, is the use of transformers throughout the circuit. In this particular case, we have used only one transformer in the entire audio line-up, this being facilitated by the use of the *phase inverter* circuit. With the use of a special bass and/or hi-frequency *lift* circuit, the response remains substantially flat over a range of the audio spectrum greater than that recorded on the average phonograph records. We will later go into more detail on the normal frequency response of the average crystal pickup, and how it may be equalized for other response characteristics. Also the use of the phase inverter circuit and the bass and hi-lift equalizer circuit will be discussed and explained more fully.

**Tuner:** As for the tuner, well, that again depends upon what you may expect or desire in the way of radio reception. You have any number of choices there, and I have made no attempt to go into detail on construction or choice of a tuner. In this case, I happened to have access to one of the four tube "A.C.-D.C. orphans," which worked out very well for size. By eliminating the output stage entirely, the overall distortion is decreased and the frequency response is improved. One thing in favor of the smaller, super-het "fidgets," used as a tuner, is that probably they will not have over one I.F. stage and though their gain may be less, the frequency response may be considerably better, due to the use of less tuned circuits. Incidentally, if you do desire better audio frequency response from the tuner and do not mind losing considerable gain, the resonance curve of the I.F. stage may be flattened with the proper value of resistors connected across the I.F. transformer. In the case of those who desire a receiver to have a great deal of selectivity and sensitivity, the above suggestions are very irrelevant, since it is impossible to have a high-fidelity receiver with a great deal of selectivity and gain. High fidelity depends upon the flatness of the response curve of any given tuned circuit, and a receiver which has a great deal of selectivity and gain is required to have a very narrow, and sharp resonance curve. The method of connecting the tuner to the amplifier is shown clearly in the diagram.

### P.A. and Other Applications

Many of you who happen to want a good amplifier for one purpose or another, may desire to use it in conjunction with a *portable record player*, or perhaps connect a *pre-amplifier* to it and have a high quality P.A. system capable of ten to twelve watts output. You might even connect a crystal microphone in place of the pickup; however, it will not drive the 6F6 grids to full output. There are any number of applications for the amplifier. You may use the same circuit for a modulator in your "ham"

rig, simply by changing the output transformer to match the class "C" load impedance.

The tube line-up is straight-forward. The input tube is a 6C5 which has a high-transconductance and a comparatively high amplification factor, which makes it excellent as an amplifier in this particular application where the signal voltage may be fairly high from the pickup. Actually the voltage peaks generated across one megohm grid resistor from full output of the pickup may reach fifteen volts or more during loud passages in recordings. This danger of overloading in the grid circuit is partially eliminated in the equalizing circuit for the pickup, and by using a volume control in the first stage.

The 6N7 was chosen for the *phase inverter* since two triodes were required for the balance circuit, as explained later on.

The 6F6's are triode connected, class AB<sup>2</sup>, capable of approximately ten watts output with very low distortion, ranging from three to four per cent. It is generally accepted that we hear nothing less than eight to ten per cent distortion. The plate-to-plate load impedance under these operating characteristics is 10,000 ohms, and the cathode bias resistor is approximately 750 ohms, with 300 to 350 volts on the plate.

There has been a lot said in favor of and also against *phase inverter* circuits replacing inter-stage transformers. Any engineer will concede, first of all, that phase inverter circuits are cheaper than an average trans-

## To Simplify Resistor Replacements ...

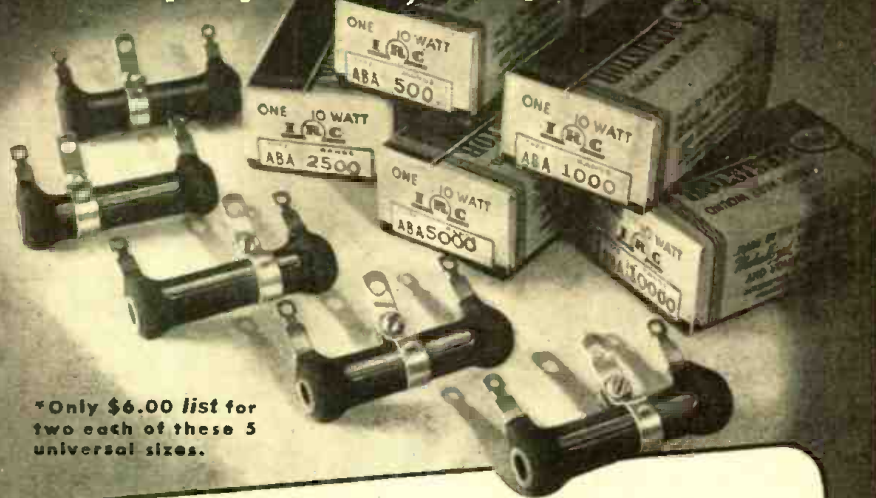

\*Only \$6.00 list for two each of these 5 universal sizes.

## Use Adjustable 10-Watt Resistors for the Hard-to-Stock Sizes!



### CLIMATE-PROOFED

IRC Power Wire Wound Resistors are made in a complete range from 5 to 200 watts—all standard types having the famous IRC "Climate-Proofed" Cement Coating to guard against the most common cause of power resistor failure.

Sure you try to stock frequently used resistor values in half, one and two watt sizes, but it's difficult to have them all on hand at all times, and it's tough to hold up a job while you wait for the one you need.

Stock a couple each of the IRC type ABA adjustable ten watt resistors, 500 - 1000 - 2500 - 5000 - 10,000 ohms,\* each of them adjustable by moving the slider for any resistance value up to the maximum.

These five units will handle any wattage requirements up to 10 watts and any resistance value from 50 ohms to 10,000 ohms. Use the low range units for high wattage-low resistance requirements because in all cases the wattage rating is based upon the full length of the resistor.

IRC Type ABA 10-watt Adjustable Resistors are made in all popular ranges from one ohm to ten thousand ohms and list at 60¢ each.



## POWER WIRE WOUND

# RESISTORS

INTERNATIONAL RESISTANCE CO., 401 N. Broad St., Philadelphia, Pa.

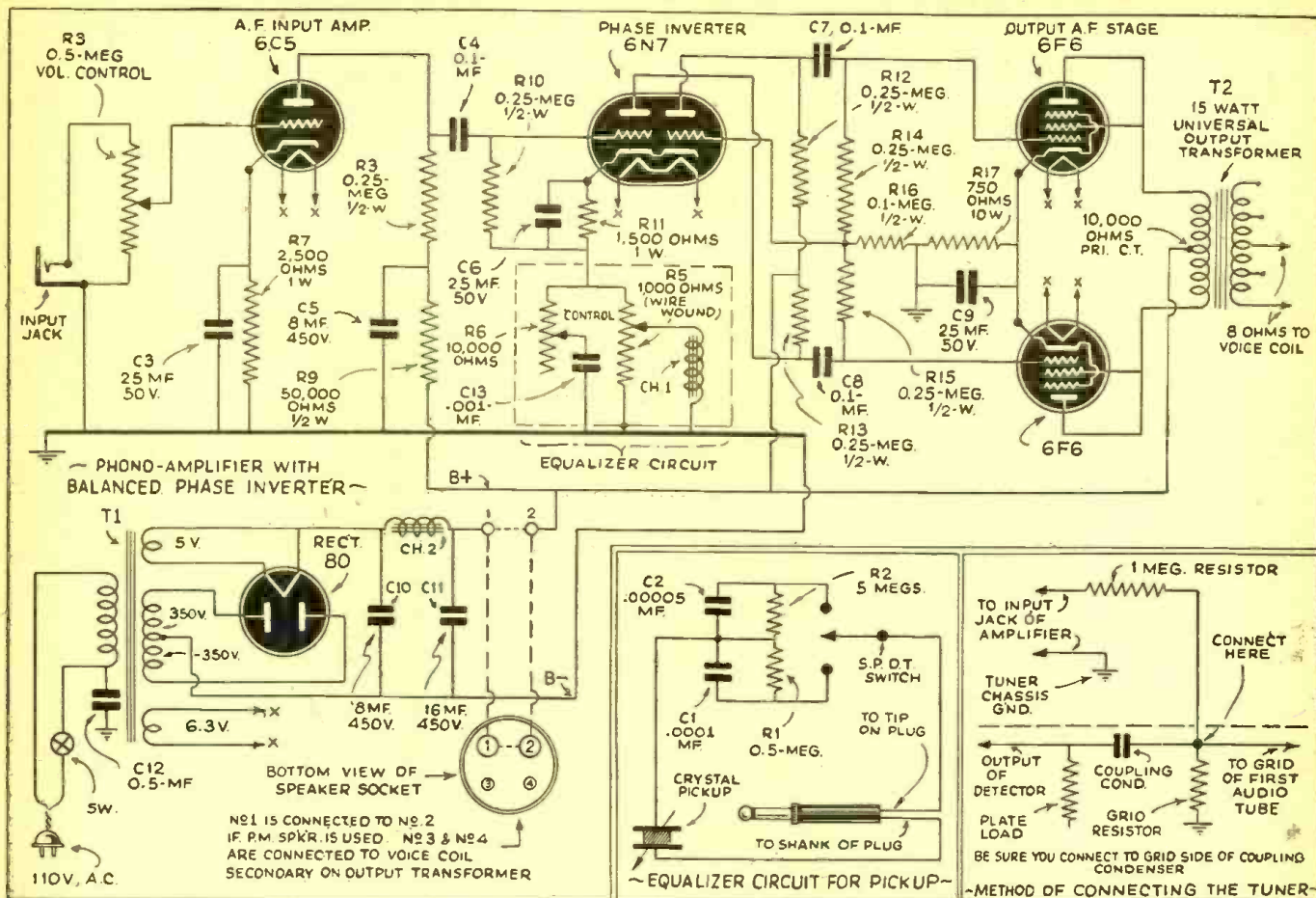

Diagram of the high-fidelity audio amplifier here described by Mr. Putnam. The cost of building the amplifier is very moderate.

former, and very much cheaper than a transformer which will give *high-fidelity* frequency response. Of course, there is the argument of instability and difficulty in balancing the grid drive to the following push-pull stage; however, in recent circuit designs most of these difficulties have been overcome. In this circuit, shown here, using both triode sections of the 6N7 operating 180 degrees out of phase, we have a *self-balancing phase inverter*. The usual difficulty in these circuits is that of obtaining the same amount of grid drive on each of the output tubes; however, with the values used here for grid resistors and plate loading resistors, you will experience no difficulty in getting the circuit to work with excellent results. To allay most criticism from the engineers, I had better explain that I do not imply that the grid drive on both of the output tubes is **EXACTLY** equal; however, with the values of resistance ordinarily used, the ratio of signal voltage on one 6F6 grid to the other is approximately 1.1 to 1, or less. A ten per cent unbalance in the pushpull output stage is easily tolerated.

Incidentally, for those who may appreciate inverse feedback, degeneration, negative regeneration, or whatever you may please to call it this amplifier has it, since part of the output of one triode section of the 6N7 is fed back 180 degrees out of phase to its own grid. I might add, for those who are not familiar with the far-flung attributes of degeneration, that briefly it stabilizes the amplifier, decreases phase and frequency distortion, reduces the noise

generated in the amplifier, and makes the amplifier independent of electrode voltages and tube constants, i.e., slight differences to be encountered in tubes of the same type from the same manufacturer, but perhaps slightly different in electrode characteristics. Actually, there is a small amount of gain lost in any degenerative circuit, this being a function of the voltage fed back and the original gain of the amplifier. The actual amount of inverse feedback in the circuit is comparatively small. This degeneration is one explanation for the difference in signal potential on the grids of the two 6F6's.

The *bass* and *high lift* circuit in the grid and cathode return of the 6N7 was designed by Wayne Batteau, one of our engineers here at the station, and we have used it with excellent results in the audio equipment here at WDWS. The effectiveness of either circuit depends upon the settings of the potentiometers connected across the inductance and the resistance in series with the capacity. To increase the "lows," you turn R5 to greater resistance, and to increase the "highs" you must decrease the value of R6.

#### Pickup Equalizer Circuit

Now we will consider the equalizer circuit in the pickup itself. It is characteristic of any crystal pickup to have a rising bass response, i.e., it has greater output on the *lower* range of frequencies. The equalizer circuit, or tone control, shown here, for the pickup will tend to flatten the response curve of the device and extend

its response range to 6,000-7,000-8,000 cycles per second, depending upon the particular pickup you are working with. It is generally accepted information that the average popular-priced phonograph records are recorded in the range extending from about 70 to 6,000 or 6,500 cycles per second. Some of the better classical recordings extend into a slightly higher audio range. Usually it is true that the higher fidelity the reproducing equipment, the more audible surface noise and record "scratch" becomes. If, however, there is no "scratch" at all to be heard through the speaker, it is a pretty good indication that the amplifier is definitely *deficient* in the higher tonal range. Again it is a matter of choice and taste and presents no small problem around a radio station. Good engineering practice says that the response from the turn-tables should be substantially flat, even to 9,000-10,000 cycles per second, but the public in general says, "No, too much scratch." It is still a matter of taste.

#### Circuits All Tested

In concluding, I would like to assure you who are about to construct this complete assembly, or any part of it, that it is simple to build, the circuits are tried and tested, and the results will be excellent if constructed properly. All of the claims made herein have been verified with measurements taken with equipment here at the station. The distortion measurements were taken with the RCA 69B, direct-reading distortion meter at 400-1,000 and 5,000 cycles per second. All readings indicated less than



four per cent overall distortion. Frequency response measured with the RCA beat frequency oscillator and Weston meters showed the amplifier flat within plus or minus 2DB, from 50 to 7,500 cycles per second, dropping off slightly to 9,000 cycles per second.

As we are primarily interested in reproduction of sound, a great deal of time will not be spent describing the cabinet. There are many possible arrangements for this assembly, such as a portable record player in a case, with the speaker and amplifier in a large cabinet. It is important to keep in mind the fact that a large cabinet is necessary if the speaker is expected to reproduce the lower bass notes. At least it should have a large baffle. In the case of the writer, I purchased the cabinet shown here for \$1.50 and lined it with Celotex to reduce cabinet resonance or "boom."

The A.C.-D.C. tuner is connected through an old car radio dial by flexible shafts and mounted out of sight in the top of the cabinet. The shelf was put in to facilitate the mounting of the turn-table.

This is only one idea, and I am sure you will have better ones for a cabinet or arrangements to suit your own particular application.

### Parts List

#### I.R.C. (Resistors)

- R1—5 megohm, ½ watt
- R2—5 megohm, ½ watt
- R7—2,500 ohms, 1 watt
- R8—250,000 ohms, ½ watt
- R9—50,000 ohms, ½ watt
- R10—.25 megohm, ½ watt
- R11—1,500 ohms, 1 watt
- R12—250,000 ohms
- R13—250,000 ohms
- R14—250,000 ohms, ½ watt
- R15—250,000 ohms, ½ watt
- R16—100,000 ohms
- R17—750 ohms, 10 watts

#### STANCOR (Transformers and Chokes)

- T1—700 volt, center tap, 70 mills sec. with 5 volt at 3 amps. and 6.3 at 2.5 amp. filament winding, type P6011

T2—Type A3852, universal output transformer connected for 10,000 ohm primary 8 ohm voice coil

- CH1—Type 1707, 10 henry choke
- CH2—Type C1708, 9 henry choke, 85 mills

#### CENTRALAB (Volume Controls)

- R3—Standard midget radiohm, 500,000 ohms, taper No. 1 with switch
- R5—Wire wound radiohm, 1,000 ohms, part No. VF129
- R6—Same as R5

#### MALLORY (Condensers)

- C1—.0001 mf. mica condenser
- C2—.00005 mf. mica condenser
- C3—25 mf., 50 volts, type 14, electrolytic condenser
- C4—.1 mf., paper tubular, type TP
- C5—8 mf., 450 volts, type 61, electrolytic condenser
- C6—25 mf., 50 volts, type 14, electrolytic condenser
- C7—.1 mf., paper tubular, type TP
- C8—.1 mf., paper tubular, type TP
- C9—25 mf., 50 volts, type 14, electrolytic condenser
- C10—8 mf., 450 volts, type 61, electrolytic condenser
- C11—16 mf., 450 volts, type 64
- C12—.5 mf., type TP, tubular paper
- C13—.001 mf., paper tubular condenser

#### AMPHENOL (Sockets)

- 4—Octal sockets
- 2—4 prong sockets
- 1—No. B483, male type plug and receptacle
- 1—No. B1625 plug

#### RAYTHEON (Tubes)

- 1—6C5
- 1—6N7
- 2—6F6
- 1—Type 80

#### MISCELLANEOUS

- 1—Carter closed-circuit phone jack and plug
- 1—7x13 crackle-finish chassis
- 1—12 inch dynamic speaker, either permo-dynamic or electro-dynamic, such as Utah model 12P, or any 12 inch electro-dynamic speaker (with 1,000 ohm field)
- ½ dozen terminal strips for mounting of parts
- 25 ft. cloth covered push back hook up wire
- 4-wire cable for connecting speaker, if electro-dynamic is used
- Switch 1, single pole, double-throw switch, rotary type
- Nut, bolt and washer assortment

## Have You VAC?

● THE handsome 9" x 12" VAC Certificates are still available and will grace any DXer's wall. To be eligible for this DX honor, a phone QSL is needed from each of the 6 continents, Asia, Africa, Europe, Australia, North America and South

America (Java and Philippines count as Asia). Send in these six QSL's with 25c for handling and costs; after checking, the QSL's will be returned with certificate. Address V.A.C. Editor, RADIO & TELEVISION, 20 Vesey St., New York, N. Y.

# FREE!



## Lafayette's BIG 196 PAGE Radio Catalog

HERE'S A REGULAR ENCYCLOPEDIA of nationally advertised parts, radio sets, components, and equipment. Lists and describes everything a radio serviceman, builder or experimenter could ever want.

Complete radios and phonograph combinations, both AM and FM . . . PA systems and parts . . . A full line of ham transmitting and receiving equipment . . . Thousands of hard-to-get parts . . . Test instruments . . . Tools . . . Special equipment . . . and lots of other items—all at Lafayette's famous rock-bottom prices.

don't put it off—

MAIL THE COUPON NOW

for your copy of

LAFAYETTE'S BIG FREE CATALOG

use the coupon below



## Lafayette Radio

20  
ANNIVERSARY

NEW YORK, N. Y.  
100 Sixth Ave.  
CHICAGO, ILL.  
901 W. Jackson Blvd.  
ATLANTA, GA.  
265 Peachtree Street  
BOSTON, MASS.  
BRONX, N. Y.  
NEWARK, N. J.  
JAMAICA, L. I.

Lafayette Radio Corp. Dept. 4D-1  
100 Sixth Ave., New York, N. Y. or  
901 W. Jackson Blvd., Chicago, Ill.

★ Rush Free Catalog.

Name.....  
Address.....  
City..... State.....

**VAC**  
VERIFIED ALL CONTINENTS  
**RADIO & TELEVISION**  
MAGAZINE

This is to certify that  
*Frank Bordon*  
is admitted to Membership in the VAC CLUB,  
having submitted adequate proof of his reception  
of Radio Phone Signals from each of the six continents.

*Joe Miller*

# Converting "Little Nipper" for Battery Tubes

Lee Garrison

Mr. Garrison, in the accompanying article, explains how he converted the "Little Nipper" 110-volt model receiver of the 9TX-30 series, so that it could be operated on batteries, using the new miniature type 1S4 tubes.

● THIS set was built for use by a friend who lives out in the mountains, a short distance from me. She wanted a set that would be inexpensive to operate, one that would "get" the stations and separate them satisfactorily.

I first built the set, using the "Three Tubes equal six in this superhet" circuit. While it worked good, the results did not satisfy me. There was too much rewinding of the oscillator coil, and as I wanted to keep the expense down and use everything in the set that it was possible to use, I discarded the circuit.

I found the answer to my problems in the new miniature tubes. The new miniature tubes more nearly duplicate the style of construction of the single ended tubes used in the electrical version.

While I did not use any specific diagram

for this set, there are three commercial sets which contribute to the building of the finished product: RCA's new portable, Emerson DU 379 and a Montgomery Ward and Company radio.

After the set has been rebuilt, a slight re-adjustment of the tuning condensers and intermediate transformers, and the set is ready to go.

After you have drilled out the sockets which are in the set, cut four pieces of heavy tin to fit over them and drill a five-eighths inch hole in the center of each. After you place the miniature sockets in the holes in the tin, solder the tin pieces over the original socket holes. This is necessary, as the miniature sockets would just fall right through the holes for the original sockets.

Just a word about these sockets, they are

so small and are not to be handled like the larger sockets, they won't stand it. My soldering iron slipped and I knocked off two of the prongs on one of mine and had to use a new socket. Don't have gobs of solder on your iron, or you'll have all of the prongs soldered together. How well my kid brother knows that now.

These sockets are so small and dainty looking that they would make dandy ornaments for the YL's or ex-YL's wearing apparel. A word to the wise is sufficient. Hi!

Another thing you will notice in the diagram is that the bias resistor, instead of being grounded, is returned to the "A" minus lead. This is necessary, as it keeps the "B" battery from discharging through the electrolytic condenser. Instead of putting the switch in the "A" plus lead I put it in the negative lead, to break the "A" minus and the "B" minus at the same time.

### Loop and Oscillator Circuits

I used the resistors and condensers specified in the RCA miniature portable, except

Wiring diagram for low-voltage battery tubes as used by the author in re-wiring the "Little Nipper."

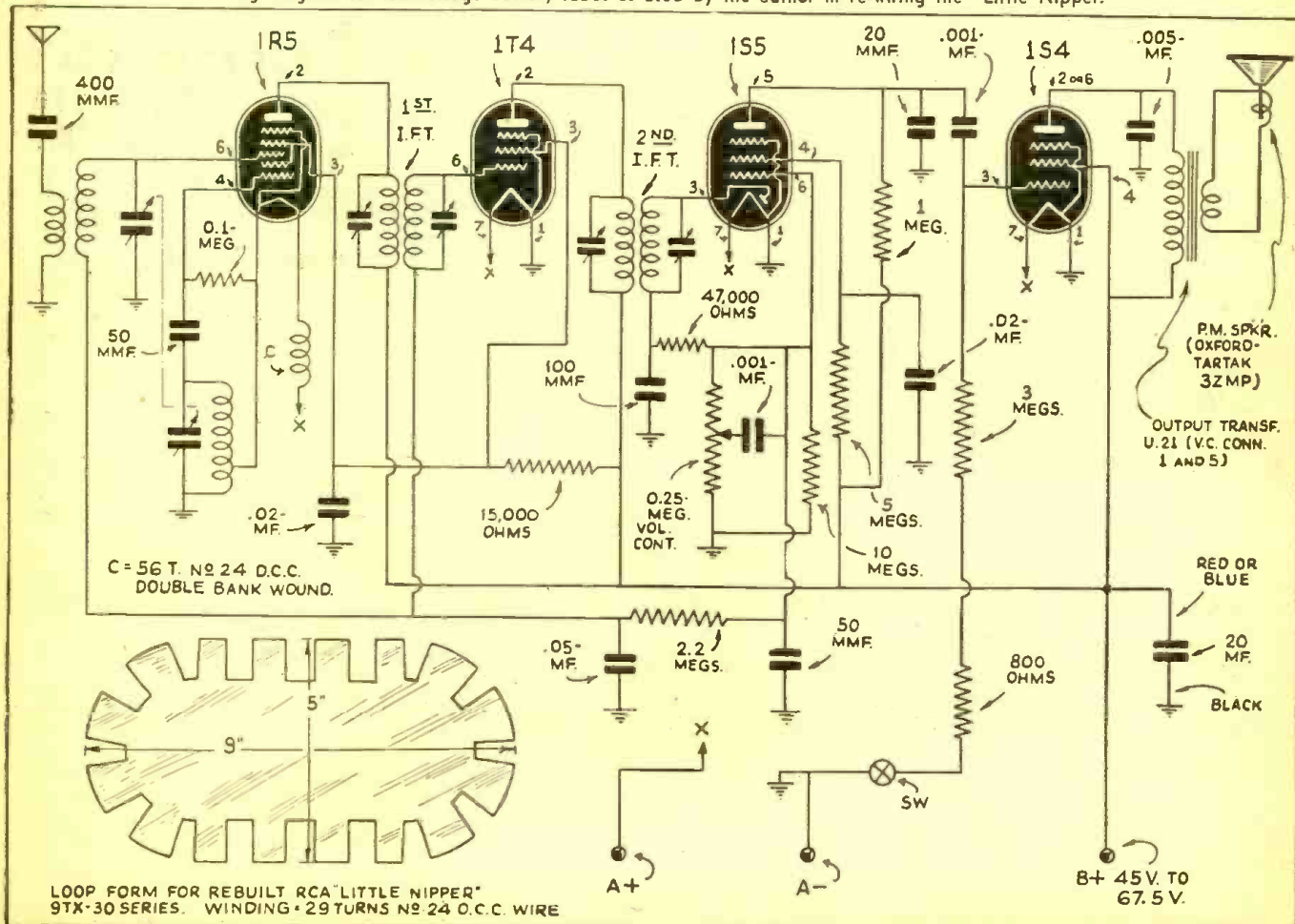

where noted; the oscillator circuit of the Emerson DU 379 and the loop antenna from the mail order portable (Montgomery Ward and Co.)

I have tried several different styles of loops, but this one seems to work the best. It is the easiest to make and the least tricky of them all.

Now, this loop is not needed, but as long as you have to buy the No. 24 double cotton covered wire to wind the choke coil, you might as well have a loop out of what is left. You can wind three loops and several choke coils out of a quarter pound of this wire, so why waste it.

This set gives excellent results with the "B" voltage as low as 35 volts (38 volts no load).

At 35 volts, the total cathode current is between 5½ mills (ma.) and 6 mills current drain. At 67½ volts, the current drain on the "B" supply is between 8 and 9 mills.

At 4 P.M., P.S.T., KSL, at Salt Lake City comes through with excellent volume. After dark, it gets practically all the stations that the set did before it was converted to battery operation.

Antenna May Be Used

In metropolitan areas, the antenna can be anywhere from 15 to 25 feet long. In the country a longer antenna is to be preferred; about 50 feet would be right.

If it is desired to use this set as a portable, the loop can be used.

If the loop is used, connect the inner side of the winding to the tuning condenser and the outer end to the A.V.C. line. This loop works the best connected in that way.

The best way to make the loop form is to make a rectangle on heavy cardboard, according to the dimensions given. It may take just a little extra work to make the form, but the results justifies the extra effort.

If this set is to be used as a portable, the information below may interest the builders of this little set. It compares the finished set with four other miniature port-

**COMPLETE RADIO COURSE \$1.95**  
**POSTPAID**

*"I am well pleased with the Radio Course. I am at present doing part time radio service work for a radio store."*  
 S. T. Alexander, Elroy, Wis.

**PLACED ME IN MY RADIO JOB**  
 "The R.T.I. Course reprint is a complete education in radio servicing. It put me in my present job at a well known radio shop." James P. McIntyre, Houston, Tex.

**VERY MUCH SATISFIED**  
 "I am very well pleased with the Radio Course purchased from you a few weeks ago." M. F. Anderson, Denver, Colo.

**HELPS ANY SERVICEMAN**  
 "The R.T.I. Course is worthy of space on any radioman's shelf. He can get the value of the cost in an hour's reading." Wm. C. Mitchell of Parchman, Miss., goes on in his letter to compare this course to resident training costing over \$300.00.

**WELL SATISFIED**  
 "I am so satisfied with your Radio Technical Institute Course, that I have to congratulate you. . . . This course is worth its price by several times." J. M. Ocasio, New York, N. Y.

**AMAZING REDUCED PRICE**  
 Exact reprint of the regular \$39.00 Radio Technical Institute course is offered for only \$1.95, the full price. This is the latest radio course complete in every way and exactly the same as the much higher priced original lessons. Become a radio expert almost for nothing. Act today while the offer lasts.

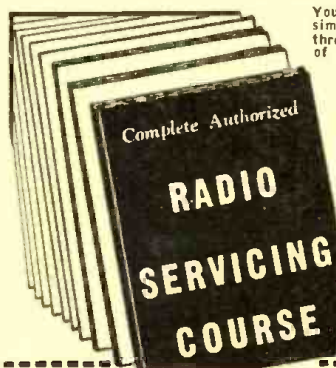

You quickly learn radio with this simplified training. You really get three courses in one: (1) Elements of Radio and Electricity, (2) Practical Radio Servicing, and (3) Advanced Training.

**LIMITED OFFER**  
 No-risk free-trial given. Write to us today while this offer is in effect. Limited quantity of courses printed to sell at the reduced price.

**FOR HOME-STUDY**  
 Get ahead in Radio with this practical training. The lessons are clear, interesting, easy to understand and use. Final exam and diploma available after course is finished. Look the course over without any risk.

**10 DAYS FREE EXAMINATION**

**SUPREME PUBLICATIONS, Room 736, 3727 W. 13th St., Chicago, Ill.**  
 Ship the complete course on approval without any obligation to buy. I may keep the course for 10 days. If, for any reason, I am not pleased, you guarantee to refund my money.  
 I will pay \$1.95 and postage to the mailman.  
 I am sending \$1.95, the full price, ship postpaid.  
 Name: \_\_\_\_\_  
 Address: \_\_\_\_\_

ables on the market. It is a comparison between the weight of the sets named, their cubic inch displacement, with that of the RCA Little Nipper, converted for battery operation:

RCA BI-10, 94.5 cubic inches: weight 4.5 pounds.

Emerson DU 379, 110 cubic inches: weight 5 pounds.

**BEGINNERS!**  
**LEARN RADIO CONSTRUCTION..**  
 by building your own electric short wave receiver. We furnish kit of all parts for **\$3.25** only . . . . .  
**NOT A TOY**  
**but A REAL RADIO SET**

Model 3TE

Uses type 76G tube as regenerative detector, type 76G tube as audio amplifier and type 76G tube as rectifier. No ballast tube is used, as the line cord does the same work without giving the appearance of an extra tube. Operates from any 110 volt AC or DC house lighting current. Covers the shortwave bands from 8½ to 200 meter with four plug in coils, supplied with kit. For those who desire broadcast reception, we will supply a set of two coils for \$.95 extra. Kit includes all parts mounted on a black crackle finish metal cabinet, ready to wire. Instruction sheet included with all kits. (Kits do not include tubes or broadcast coils).  
 If tubes are desired add \$1.50 for three tubes. Wired and tested, complete and ready to use including **\$6.50** type 76G tubes, less earphones, \$1.95 extra. Battery operated models at same prices. When ordering specify if electric or battery operated model is desired.

**ACME S-W RADIO COMPANY**  
 98 Park Place, Dept. 441, New York City

**Simplest WAY TO REPLACE BALLASTS**  
**4 STANDARD TYPES** of Amperite Regulators replace over 200 types of AC-DC Ballast Tubes now in use. . . . Has patented automatic starting resistor.  
 List \$1.00  
**WRITE FOR REPLACEMENT CHART "S"**  
 Amperite Co. 561 Broadway, N. Y. C.

**AMPERITE**

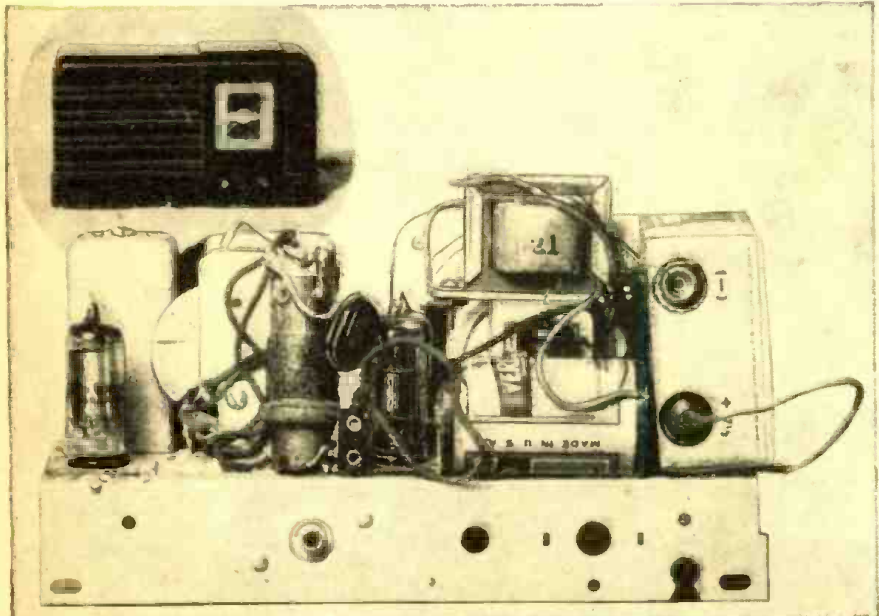

Appearance of the re-vamped Little Nipper for operation on batteries is shown above, as well as appearance of the front of the set.

## T WIRELESS TRANS-CASTER

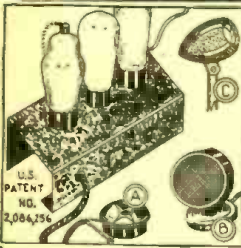

### HUNDREDS

of practical applications. Will broadcast voice or music from any room or floor in home, office or store in same building WITHOUT CONNECTING WIRES! Operate from any lighting socket. Transmit your favorite recordings thru any radio without connection between radio and phonograph. Your radio becomes a Public Address or Inter-communication system with a Trans-caster.

Home broadcasting without wires. Great fun for parties, additions. Use as a detective device to listen to secret conversations. A few other uses include wireless nursemaid, pipe line tracer, mind reader, trick ventriloquist, bingo announcer, talking dog, etc. Impossible to enumerate many other uses in this limited space.

**TRANSCASTERS** are available in FIVE models, all completely wired, laboratory tested and ready to use. All fully guaranteed as to materials and workmanship and also against damage in transit.

**STANDARD MODEL** Excellent beginner's outfit. Permits use of earphone or small mag. speaker as microphone or any high impedance magnetic or crystal pickup record player. **POWERFUL**, not to be confused with one-tube toy-type outfits. Priced amazingly low. Works from a.c. or d.c. Price, complete with 3 tubes, ready to use (see Mike) ..... **\$2.95**

Earphone Mike (Fig. A) ..... 95c additional

**DE LUXE MODEL TRANSCASTER-TRANSMITTER** Powerful, high-gain device engineered so that it will transmit high-fidelity music without connection wires to remote radio set. No sacrifice of quality or power. Operates from a.c. or d.c. Same frequency range as Senior Model, but greater db amplification. Price (less tubes and mike) ..... **\$4.95**

Set of 4 Matched Tubes for Deluxe Model ..... \$1.95

**ACCESSORIES**—Earphone Mike (Type A) 95c; Dynamic Mike (Type B) \$2.25; High Fidelity Crystal Mike (\$25 List) Special Only \$3.95.

**H. G. CISIN, Chief Engineer**  
**ALLIED ENGINEERING INSTITUTE**  
 Dept. S-74  
 85 Warren St., New York, N. Y.

## SHORT WAVE CONVERTERS for CAR RADIOS



Can be attached to any car radio.

**MODEL 600-A** covers 49-31.25-20.18 and 16 meter bands. Designed for American and Foreign short wave broadcast. Distance range 3,000 to 10,000 miles. List Price ..... \$24.95

**MODEL 900** long wave covers 135 to 110 KC. Receives gov. weather reports, etc. List Price ..... \$24.95

**POLICE UNITS**  
**MODEL 100 100-A** with fixed condensers, covers 1600 to 2600 kilocycles. List Price ..... \$42.50

**MODEL 800** Super Sensitive police converter with fixed condenser. Covers 1500 to 2600 kc. Two metal tubes, exceptional distance range. List Price ..... \$45.95

**MODEL 200-A** with variable condenser, covers 1550 to 6000 kilocycles. List Price ..... \$17.95

**MODEL 500-A** with variable condenser and (lit) coated dial covers 1600 to 8000 kc. Very sensitive, has two metal tubes. Exceptional distance range. List Price \$21.95

Jobsbers and Dealers Wanted

**ABC RADIO LABORATORIES** 3334 N. New Jersey St., Dept. RT-4, Indianapolis, Ind., U.S.A.



### NEW! 1941 MODEL 1 POCKET RADIO!

NO TUBES NO BATTERIES NO PLUG-IN

**DURABLE PLASTIC CABINETS**

**DUAL BANDS—MAGICTENNA—MICRODIAL.** Fits your pocket or purse—4 1/2 x 6 1/2. Small as cigarette package. Receives standard & some short wave. **PATENTED POWER RECTIFIER** NO TUBES. **BATTERIES.** Hi-ratio easy tuning slide "MICRODIAL." **M. L. OF ILL. SAYS: "MIDGET RADIO WORKS FINE!"** **ONE YEAR SERVICE GUARANTEE!** Sent complete ready to listen with instructions & tiny photo for use in homes, offices, hotels, in bed, etc. **SIMPLE TO OPERATE—NO ELECTRICITY NEEDED!** **SEND NO MONEY!** Pay postman only \$2.00 plus postage charges on arrival or send \$2.00 (Check, M.O., Cash) and yours will be sent postpaid. **A MOST UNUSUAL VALUE!** **ORDER NOW!** **FREE! PLUG IN "MAGICTENNA" ELIMINATES OUTSIDE WIRES!** **MIDGET RADIO CO., Dept. RT-4, Kearney, Neb.**

## RECORDING ACCESSORIES

All rec. acc. from one source of supply. Four types of rec. blanks in usual sizes. Cutting and play-back needles, etc. New QSL rec. blank for amateurs, 1941 cat. Just off the press. Everything for professional, home or experimental recording.

**NATIONAL RECORDING SUPPLY CO.**  
 1065 VINE ST. HOLLYWOOD, CAL.

Philco Transitone, 200 cubic inches: weight 5 pounds.

Tom Thumb, 412.5 cubic inches: weight 5 pounds.

Rebuilt RCA, Little Nipper, 9TX-31, 186 cubic inches: weight 4.5 pounds.

If the local grocery store scales are correct, and I believe them to be, the Little Nipper is second in weight to none and only third in cubic inch displacement.

### Best Battery to Use

If you use this set as a portable, the Eveready No. 467 portable "B" battery can be used in conjunction with a size "D" flashlight cell. All batteries in the cabinet. As a house set, the standard 45 volt Eveready layerbuilt "B" battery should be used in conjunction with a larger "A" battery. You can understand the above better since the No. 467 "B" battery lasts only 40 hours and a flashlight about two to three hours. The larger batteries last longer and are more economical to use, since weight is of no object in a house radio.

To rebuild this set you strip the chassis of everything but the intermediate transformers, volume control, don't touch the A.V.C. line, leave it as it is, tuning condensers and coils. There is an .01 mf. condenser connected between the oscillator section of the tuning condenser and the grid of the tube, remove it and connect the tuning condenser direct to the coil. Leave the phono input as it is, you can use it for playing records through this radio. Save all of the condensers, with the exception of the .25 mf. tubular condenser and one or two others.

All you need to buy is tubes, sockets, speaker with output transformer, batteries and a few condensers and resistors. This set can be built for about \$12, according to what you pay for the RCA Little Nipper secondhand, which should not be much; probably \$3 or \$4; mine cost me \$2.50.

The 1R5 is placed in the socket which is over the socket hole of the 12SA7, the 1T4 in the socket which is over the socket hole of the 12SK7, the 1S5 in the socket which is over the socket hole of the 12SQ7 and the 1S4 is placed directly behind the speaker, a five-eighths inch hole being drilled there for its socket. By placing the tubes thus, you will not need to lengthen the existing I.F. leads nor the leads from the tuning condensers.

I specified four pieces of tin, but you will only need three with the miniature

sockets placed in holes drilled in them, as the hole for the output pentode is drilled in the chassis behind the speaker. The speaker goes in the same place as the original one did.

I do not think anyone who has had experience in building radios or who can read a diagram, should have any trouble with this one.

There is nothing specified which is not needed.

### Parts List

**NEW ENGLAND RADIOCRAFTERS**  
 1—Kit of "C" type coil forms (5—no less than this amount sold)  
 1—Bottle of polystyrene #PQD coil dope for choke and loop

**RCA**  
 1—Little Nipper, 9TX-30 series (secondhand)

**I.R.C. (Resistors)**  
 1—15,000 ohm, 1/2 watt resistor  
 1—100,000 ohm, 1/2 watt resistor  
 1—10 meg. ohm, 1/2 watt resistor  
 1—3 meg. ohm, 1/2 watt resistor  
 1—5 meg. ohm, 1/2 watt resistor  
 1—1 meg. ohm, 1/2 watt resistor  
 1—800 ohm, 1/2 watt resistor

**AEROVOX (Condensers)**  
 1—20 mmf. mica midget condenser  
 1—.005 mf., 200 volt condenser  
 2—.001 mf., 200 volt condenser  
 1—.0001 mf., mica midget condenser

**OXFORD-TARTAR RADIO CORP.**  
 1—3ZMP PM speaker  
 1—U21 output transformer (voice coil leads 1 and 5, for 800 ohm plate load)

**AMPHENOL**  
 4—Sockets for miniature tubes (ISR type)

**BELDEN WIRE CO.**  
 1/4 pound #24 D.C.C. for loop and choke coil

**SYLVANIA (Tubes)**  
 1—1R5  
 1—1T4  
 1—1S5  
 1—1S4

**EVEREADY BATTERY CORP.**  
 1—Minimax #467 or 1 standard size layerbuilt "B" battery  
 1—Size "D" flashlight cell or 1—#6 dry cell

**MISCELLANEOUS**  
 Choke coil—56 turns #24 D.C.C. double bank wound on 3/4 inch form, length of winding 3/4 inch; approximate 35 microhenries inductance (for winding of double bank windings, see Ghirardi's Radio Physics Course at local library).  
 Loop—29 turns on #24 D.C.C. wound on form (see drawing for size and shape of loop). One complete turn of wire for antenna and ground winding, wound on outside of loop.

The inside of the loop goes to the tuning condenser, and the outside goes to the A.V.C. line (yellow wire on RCA Nipper). No connection between the antenna winding and the secondary of the loop.

4—Fahnestock clips, which may be obtained from an old "B" battery; while these clips are not needed, they aid in removing the loop and allow one to use either loop or original coil in the set at will.

## Automatic Time Switch

This simple but efficient unit may be used around the Ham shack to turn on or off radio sets or other electrically operated devices. A cheese box was cut down for the base and an alarm clock mounted on its top. The spring is an old hack-saw blade and should be sanded to make better contact. A small bakelite strip was used to insulate the switch from the clock. The metal square designated as (A) is shown in a front view; it's used to keep the alarm handle from completing a circle and turning the switch back on. If silent operation is desired the alarm bell must be removed. To turn the switch on, the alarm handle must be reversed.—Robert W. Pipher.

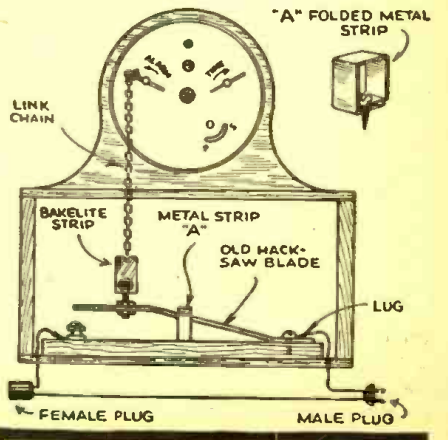

# Inexpensive Test Instruments for the Experimenter

William J. Vette

● UNLIKE the serviceman who, once established in a business can buy expensive testing equipment and charge it up as an investment which will be returned several times over, the experimenter must count his pennies which will be spent for radio materials; seldom does he have enough to spend for the parts he needs, let alone for test equipment.

Possibly more of us would own adequate equipment, were it not for the fact that such equipment costs quite a little. Some of us have perhaps a meter or two, and anything outside the range of this meager equipment must be met with only a good guess to go by.

For experimental purposes, the elaborate multi-range equipment is not absolutely necessary, I have found in my own work. I have found, over quite a period of time, that a means of checking D.C. voltages of all ranges, and some way of determining resistance values were all I absolutely had to have, though occasionally I had need of an A.C. voltmeter. Since I seldom had need for a meter for checking current values, especially in the lower ranges, I concluded that this feature, heart of the cost of most test instruments, was a luxury I could better be without than afford.

I found that it was not only simple, but easy and inexpensive to provide myself with an instrument capable of performing all the functions I absolutely needed. I was able to take a very low priced voltmeter of very low range, and not only increase its testing range many times, but also to put it to work, in conjunction with a simple formula, to determine resistance values.

### Increasing Range of Voltmeter

My meter equipment is the result of the fact that the range of any voltmeter can be extended almost without limit, by merely using external series resistors. Knowing this, it is a simple matter to provide oneself with a voltmeter of low range, at very little cost. While these conversion facts and formulae may be applied to any D.C. voltmeter the experimenter may have, or have access to, my own experiments have been based on the meter which sells for the lowest price of all: the Readrite models 55 and 95. Since these were the meters used by the writer, the resistance readings given at the end of this article are for the meters of this line most suited for use with these formulae.

While these meters are not the most accurate to be had, they are adequate for most experimental purposes, and are as well adapted to service work in many cases. Besides being a vital adjunct to the experimental bench, the meter system described here is ideal for use by the serviceman just getting started, and without sufficient funds for more elaborate equipment right at first. If more precision is desired or needed, the formulae here are as well adapted for use with more expensive and accurate meter equipment, if your pocket-book can stand it, or if a better meter is easily available to you.

It is best to select a meter having a fairly low maximum scale, and this scale will be used for reading voltages within its range. While the ideal arrangement is had with a meter reading to, say, 5 or 10 volts, meters reaching as high as 25 volts or more may be used. My own meter has a basic scale

of 0-5 volts, and is extended by four extra ranges, to 20, 50, 150 and 500 volts, as these are the particular ranges I find most useful.

### Value of Multiplier Resistance

In order to find the correct series resistor needed for each range, it is necessary that you know the internal resistance of your meter. If this does not appear somewhere on the meter itself, you may often find the values in various radio catalogs, and if not there, write to the makers of your meter. It is for those who must buy the cheapest that the resistance values of the Readrite meters are given.

The formula is simple, and doesn't involve any complicated or difficult calculations. The resistance for external application to your meter is found as follows:

$$R_1 = R \frac{E_1 - E}{E}$$

in which  $R_1$  is the desired resistance,  $R$  the internal resistance of the meter,  $E$  the present maximum scale reading, and  $E_1$  the new maximum desired to read.

The resistors used to extend the range should be as accurate as possible, although they needn't be held to any closer tolerance than the meter in use.

It will, of course, be necessary to multiply the scale reading with a figure corresponding to the ratio of the scale to the new range; for example, if a meter with range of 10 volts has been extended to read 50 volts, all readings will be multiplied by 5 in order to get the correct voltage values.

The multiplier resistors may be connected to a rotary switch for range selection, or, at less cost, may be connected to small tip jacks, with a small plug used for selection.

### Using a Voltmeter for Resistance Measurements

An ohmmeter, highly accurate, and calling for use of a very simple calculation, is

at the disposal of all who possess an ordinary D.C. voltmeter and a source of D.C. voltage. A resistor of known and fairly accurate value will be needed, and while the calculation of resistances by this method is not quite so handy as reading them on the scale of an ohmmeter, it is a lot cheaper, and, unless the ohmmeter is an especially good one, more accurate, even to reading fractional values, which is a quantity many ohmmeters leave to the imagination.

The calculation involves merely the reading of a voltage across a resistor of known value compared with a reading across the unknown resistor, which is in series with the known value, and across the same supply, which is selected to be within the range of the meter in use. The formula is:

$$R_x = \frac{R E_1}{E}$$

where  $R_x$  is the unknown value,  $R$  the known,  $E$  the voltage reading across the known resistor, and  $E_1$  the reading across the unit under test.

For example, suppose you have a known value of resistance equal to 1000 ohms, giving a reading, when in series with the unknown value, of 100 volts. Then suppose the unknown resistor gives a reading of 10 volts. Applying the above formula to this gives a value of 100 ohms to the unknown resistor.

Internal resistance of Readrite Model 55 and 95 voltmeters (D.C.) for use in conversion to multi-scale meters.

Volts range	Resistance (ohms)
0-1	18
0-3	135
0-5	310
0-10	1475
0-25	1625
0-15	2700

Another 0-25 voltmeter is made by this company, with a much higher resistance, 7720 ohms.

Diagrams herewith show how to increase the range of a voltmeter and method of measuring resistance.

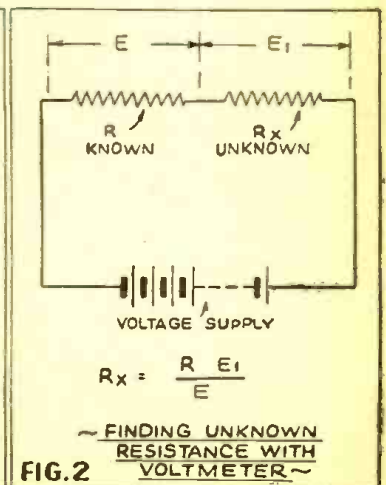
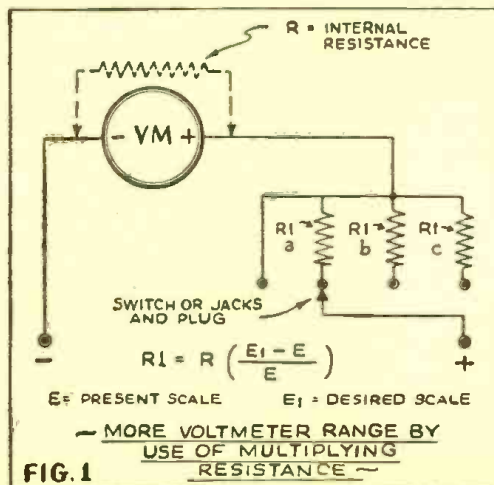

## Your Inquiries Invited

We have the world's largest stock of all makes and models of communications receivers. Write us for technical bulletins or other information about receivers or other equipment.

**YOU GET** specialized personal service of genuine value that you can't get from other jobbers.

**YOU GET** 6% terms which I finance myself so you will have less cost—no red tape—quicker delivery. Write for terms.

**YOU GET** best trade-in for your receiver. Describe it and I will tell you its trade-in value. Pay the balance on my 6% terms.

**YOU GET** ten day free trial—you don't buy unless you are satisfied.

We have a complete stock of all transmitters, kits, tubes, parts, etc. We assemble, wire, and test kits if you wish. **WRITE ME FOR ANY EQUIPMENT IN ANY CATALOG OR AD. I GUARANTEE YOU CAN'T BUY FOR LESS OR ON BETTER TERMS ELSEWHERE.**

All orders and inquiries personally attended to by Bob Henry, W9ARA; active amateur for 17 years; graduate E. E. of M. I. T.; owner of Henry Radio Shop selling amateur supplies exclusively for 13 years. You can reach me by letter, telexgram, phone, or visit nearly 24 hours a day and 365 days a year. Write for any information. Your inquiries invited.

### HENRY RADIO SHOP

BOB HENRY, W9ARA BUTLER, MISSOURI

## FASTEST WAY TO LEARN CODE

Easy, Fascinating, LEARN by EAR To Be a GOOD OP.

The New All Electric Master Teleplex Code Teaching Machine is exactly what thousands are looking for. No experience needed. Ideal for beginners — steps up WPM for ALL Ops. There is no guess work with Master Teleplex, because it records your sending in visible dots and dashes. You SEE and HEAR exactly how you are making your signals. You learn code the way you'll be using it—by SOUND. That's why practically every school teaching code uses TELEPLEX. Complete course included at no extra charge. Used by many schools for teaching code. Low cost; easy terms. **MONEY BACK GUARANTEE.** Send now for booklet S4, no obligation. Postcard will do.



### TELEPLEX COMPANY

67-69 Park Place, New York

In Canada write:

CANADIAN ELECTRONIC INST., TORONTO, ONT.

PRECISION CRYSTAL CONTROL FOR ALL AMATEUR BANDS

**BLILEY CRYSTALS** Now \$3.35 UP  
BLILEY ELECTRIC CO., ERIE, PA.

# "CQ"

Larry LeKashman, W2IOP

● IN line with the new QSL spirit Thornton Lyford has formed a new club to be known as the Radio Card Swapper's League. For full particulars SWL's are cordially invited to write to Thornton Lyford at 260 Woodlawn Avenue, Hubbard Woods, Illinois.

Speaking of Illinois, the University of Illinois is planning a Radio Interference Conference to be held in Urbana, Saturday, May 10th. The purpose of the conference is to inform radio service men, radio amateurs, public service interference trouble-shooters and radio engineers of the sources of radio interference and their correction. It is hoped through this conference to clear up many misunderstandings which have caused much friction in the industry.

Some of the topics to be discussed by outstanding engineers are generation of combination frequencies in a non-linear element, diathermy interference, receiver design to minimize strong signal interference, panel discussion on interference between radio amateurs and the broadcast listeners, the adjustment of transmitters to reduce spurious emissions, reduction of appliance interference and other kindred topics.

Our old friend, W9BRD, has just sent out a special QSL card for the QSL party. On the back of each card there is printed the following:

"The exchange of confirmation cards of contact between radio stations or between listeners and radio stations has always been a great tradition of radio. The amateur who refuses to verify communication with his station gains no friends and may lose many by not so doing, since the majority of active amateurs derive a vast amount of pleasure

from this phase of their hobby. Your QSL file is a good yard-stick with which to measure the efficiency as well as the activity of your station. This is a much more authentic and colorful proof of contact than a mere log. How many states have you verified separately on each of the ham bands? A station boasting of a confirmed WAS on three or four bands has made no slight accomplishment even if its real DX is limited. There is a wide assortment of objectives to be attained in which the QSL plays an indispensable part. Do you need cards? Ask for other samples of cards by an active ham, W9BRD."

It is a worthwhile reminder that QSLing is by no means extinct—as so many amateurs would have us believe.

W9BRD's letters are worth reproducing in their entirety. Starting with a description of his latest creation, Egbert, as portrayed in the cartoon illustrated, Rod goes on to say (with slight censorship here and there)—

Egbert is the typical Ham. The striking resemblance to an owl is possibly due to Egbert's first year of hamming, when he exhausted all the midnight oil and had to DX in the dark. Egbert did pick up an XYL somehow and now they are both kinda sorry. But she's getting used to it. Egbert is exceedingly pro-ARRL, by the way, and takes part in all ARRL activities. He might even be an A-1 op if his rig would only hold together long enough to let him get used to it. Egbert's time is divided pretty evenly between all phases of radio and bringing home the family bacon.

Well, now that I got that plug in, let's see if I have any dope to bring to light here.

W9BRD's Brain Child, "Egbert—The Typical Ham."



ARRL party scores are scarce up to now. I haven't had too much time to hunt up the boys on 80, but I sent out about a half dozen or so messages to 3BES, 1TS, etc., and when they bring response then I can give you more info. Or maybe you have taken care of that yourself. Anyhow, W9FS had over 400 QSO's in 60 sections, I hear. 3DGM had 355 in 59 for 41,000 some points. 8NDS had 334 in 56 for 40,000. Those are the high scores I've heard from. Poor 9BRD got only 290 in 56 for 35,000. But, needless to say, he is very determined to do better with his 75 watts next time, drat it. Maybe I need a strong second harmonic and another receiver, I dunno.

My input is gonna stay below 100 watts, though, and I don't see how I can put up any better skywires, so I'll just have to brush up on my operating. 3BES suggested I throw out my homemade super and get an HRO or NC-101X. 4DWB and numerous others advised me to QRO. 9ELC told me to quit using the gutterspout for an antenna. Perhaps the best idea comes from 9VES who suggests a new operator.

At any rate, look out for me next month in the 1.7 mc. WAS affair, as I am going to wind a 160 meter final coil and feed about 50 watts into my 40 meter zepp tuned against ground. The last time I wound a final coil for 160 it wouldn't work on 160 but FB on 80, so I threw away my old 80 meter coil. This time I'm going to use small enough wire to fit enough turns on the form, doggone it.

The BBC has a new BC station smack in the middle of 40 meters with an indescribably loud signal when conditions are right for G. Covers about 40 kc. on my pile. How long is this going to continue? It's bad enough that we have XE and CM fones splattering all over our best CW band, but any more of these super-powered European BC (broadcast) jobs are going to ruin it utterly. The effect, of course, will be worse in winter than in summer, and will increase during this part of the sunspot cycle. Will 40 meters be-

come as deserted at night as the low end of 20, since the fones chased out the CV? The signal that G station was pouring in here the other night wouldn't have been touched by our puny heterodynes, even by a sig from W1AW. A local SWL who gets a whack out of foreign BC reception recently told me to quit interfering with his reception from the new 41 meter BC band stations (our 40 meter band) and said he would even go as far as the FCC if neces-

sary. I'm not worried about that, but Larry, if too many people start thinking likewise, GB 40 meters.

Local dope from local dopes: 9KIO is on with a new transmitter using parallel T20's final, 125 watts. 9BUD is working out neutralizing difficulties with his new 100 watt parallel 6L6G's final. 9FWR, physically disabled, challenges any and all to games of checkers on 7210 kc. 9VES was grinding away in ARRL QSO party



Super Pro

SERIES  
200

for the Tough jobs!

THE illustration above shows "Bob" and "Mabel" Beebe operating W7HXU, one of their two fine amateur stations. "Bob" has his own station, W71GM, at his place of business. Both stations use "Super-Pro" receivers. Here is what "Bob" writes: "We have, beyond doubt, the world's worst receiving location, bar none, including three 26,000 volt transmission lines exactly 35 feet from the transmitter, and when the old-timers saw what we were blundering into, we were assured that 'It could not be done,' and actually were out looking for a new home with suitable reception when someone suggested Hammarlund 'Super-Pro.' The 'Super-Pro' changed the situation completely and when the band is open, Mabel works 'em."

YES—for the tough jobs you'll find the "Super-Pro" can't be beat. It is built for 24-hour a day service under practically all conditions. To enjoy really fine reception, use a "Super-Pro." Your local jobber will be glad to arrange a demonstration. See him today. For complete technical information including curves and diagrams, mail coupon below.

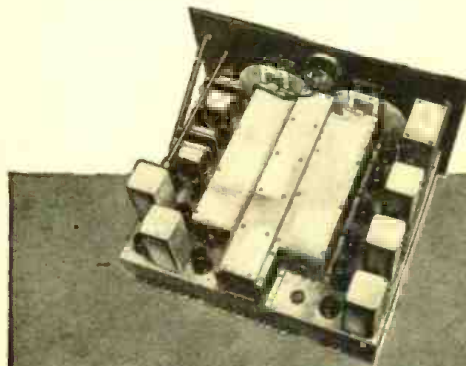

HAMMARLUND MFG. CO., Inc.  
424 West 33rd St., New York City  
Please send 16 page "Sp" booklet.

Name ..... RT-4  
Address .....  
City ..... State .....

HAMMARLUND

EXPORT OFFICE: 100 VARICK STREET, NEW YORK CITY

CABLE—ARLAB

**PAR-METAL  
PICTURE YOUR RIG  
IN A  
CABINET LIKE THIS!**

Par-Metal Cabinet Racks are handsomely finished, modern in design and streamlined for eye appeal—but their beauty goes deeper than that. You'll find that all Par-Metal Parts are easy to assemble because they are so accurately machined—and they can be interchanged almost at will. It's things like that that really make Par-Metal Products worthy of your investigation.

**CATALOG 40** describes and illustrates our De Luxe and Standard Lines. Everything you'll need to build from a simple chassis to a KW job or a complete Sound System. Get a copy from your jobber or from us direct.



**PAR - METAL  
PRODUCTS CORP.**

3262 49th St.,  
LONG ISLAND CITY, N. Y.  
EXPORT DEPT.:  
100 Varick St.,  
NEW YORK, N. Y.

**PAR-METAL**

**TRANSFER YOUR 1940 MAGAZINES INTO A  
"JIFFY"**

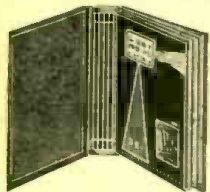

**Magazine Binder**

Sturdily built and covered with black fabricoid. Has two stamped metal ends with 12 spring wire separators. Magazines can be inserted and removed in a jiffy. No fuss—no lost time—no labor.

- No. 00. 15" x 11 1/4", with 3-inch back for Life, etc. **\$2.00**
- No. 0. 13" x 10", with 3-inch back for Electronics, etc. **\$1.75**
- No. 1. 12 1/2" x 9 1/2", with 2-inch back for Radio-Craft, R. & T., Radio News, etc. **\$1.50**
- No. 2. 10 1/2" x 7 1/2", with 3-inch back for QST, Radio, Popular Mechanics, etc. **\$1.25**
- No. 3. 8 1/2" x 6 1/4", with 3-inch back for Reader's Digest, etc. **\$1.00**

**GOLD SHIELD PRODUCTS**

Dept. RT-441, 350 Greenwich Street, New York City

**EVERYTHING  
IN RADIO**



**B.A.**  
HAS IT?

This big book serves your entire needs. It includes sets, parts and supplies, public address, amateur equipment, test-ers, kits, fluorescent lighting. Nationally known favorites at lowest possible prices. Write today for your copy of this

**BIG FREE CATALOG**

**BURSTEIN-APPLEBEE COMPANY**

1012-14 McGEE STREET, KANSAS CITY, MISSOURI

Do YOU want to be a Government radio operator?  
Additional operators are needed NOW.



Why not learn to be an operator quickly and easily with the Ayers Automatic Code Machine all electric, 50,000 words practice tapes available, low monthly rental.

TAPES FOR MAC AUTOS, RECORDING SLIPS AND RECORDING INKS

Write AYERS AUTOMATIC CODE MACHINES  
711 Boylston St., Boston, Mass.

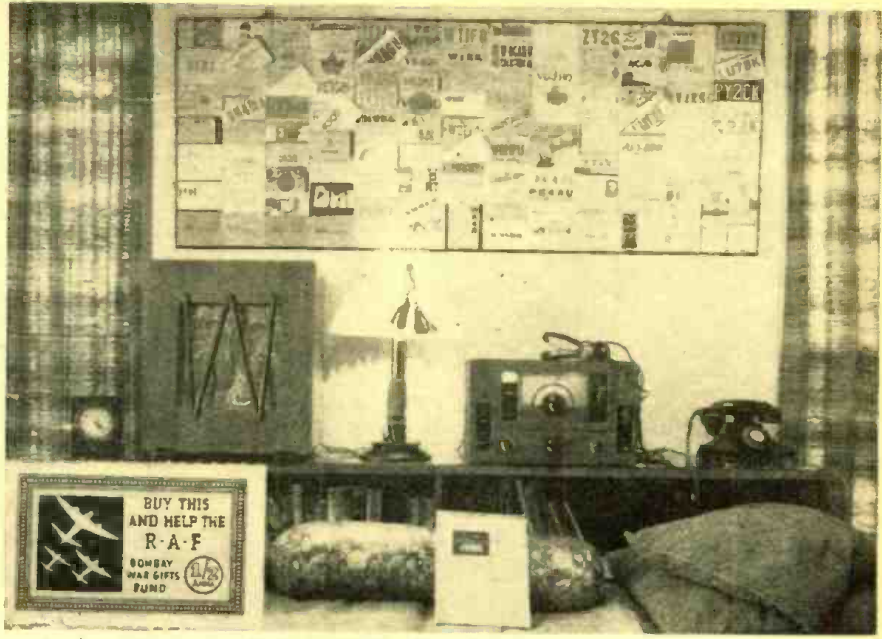

Bombay SWL Post of D. R. D. Wadia. Note R.A.F. war sticker in lower left corner.

without his raisin filter! 9ZTN has one, though, and is back on with 200 watts, eco, 7 mc.; also in the ARRL party for a while. 9MUX was pounding away in party with the regular bunch, 9TH, GY, PKW. 9SG holds forth on 7005 kc. CW while 9SGA hits ten fone from same QTH. Chicagoans on ten fone, 9HVS, FXB, GV, IJX, IHI, YUC, VZW, JN, AI. 9AI, by the way, works out like a kw. on both 10 and 20 with nothing over 50 watts, an 8JK on 10, and keeps the CW from getting too rusty on 40 meters. 9UJR has a little ten fone going, along with the 200 watt 40 CW rig. 9QEE has a half kw. and now minus key, clicks on 14 mc. Local signals, on the whole, sound much better since 9BRD got rid of his clicks, parasitics, harmonics, etc., by correctly neutralizing his final. Conditions on 160 are better than ever for this time of year, but the BCL's are as crabby as always. 9IDH blew part of his 7 mc. rig so is QRM'ing on 80 now with a 6L6. 9TTJ continues to shove traffic vigorously on 80. The 160 CV gang continues to go strong, led by 9ZBG, ABZ, CMZ and GRB. Coast-to-coast evening contacts on that band are reported frequently, with QRP, too. The party next month should be hot.

Miscellaneous: The Chess Wireless Association invites all radio chess fiends to join in. Sundays on 7280 kc. in the afternoons and most evenings on 3640. 9NCS, JRI, HMO, VDY, 3EEW and 9BRD can be heard regularly mentally QRM'ing each other.

The YLRL announces a 40 meter QSO party in conjunction with FTS (Forty Traffic System) Feb. 1-2, 8-9. You OM's who wanna meet some snappy and cute YL ops better sign up with FTS quick, as the two organizations have conjunctional parties frequently; drop request for appointment to Nils Michaelson, W2LSD, if you are interested in 7 mc. traffic work and have a rock between 7200 and 7250 kc. 40 meter traffic handling is an art and a science in itself with erratic skip to combat. Messages for destinations a hundred miles away frequently take journeys of a thousand miles or more and to do so without

too much loss of time requires snappy opping. No, you can't join the YLRL!

8QYK, one of the smoothest fists in Michigan, got married and is now working for the Gov't. 6PH misses his ZS QSO's and runs 200/800 w. on 40 from Salinas. He says Bolinas may have KPH, but Salinas has 6PH . . . (College cheer.) 9EYH, one of the middle west's crack ops, still is off the air. How Wally could resist an ORS Party, Sweepstakes and ARRL Party in succession is a mystery to me. W5IGO, Oklahoma's best YL op, now has ECO. This has effectively broken up the stag line around 7220 kc., but has simply moved it elsewhere around the band. K6QUJ gets more calls per CQ than any 7 mc. station (even 5IGO) and he keeps 'em short. Several PY's and LU's are occasionally heard boring in on CW on 40, as well as the usual XE and CM. Judging from the signal strength of Euro fones, K6's and South American fones, 7 mc. would be the ideal DX band right now. Darn Hitler, anyhow! One thing has been proved, though, removing DX does cut down QRM considerably by eliminating all those rock-crushing "CQ DX's" we used to hear. But I'll take my DX, QRM and all. Add BL's: HRK2 on 7100 kc.

One country now on the air is K5AX in Panama proper.

W1CH swings a mean bug for a 20 meter 'phone man. Why don't some of those boys get wise to themselves with W1AW sending out code practice just outside the high end of the band? W9ELC is going to build a new rig which won't be laughed at so much, he sez. Just so nobody laughs at the signal it's OK, and just so there aren't too many exposed hot spots. 9CRK, an 80 meter traffic fiend who has 9EYH's final now, said he is going to K6 with the army. W9ENH, a real OP, has 30 watts on 160 CW and knocks off anything he hears. W9GFF was batting off the ARRL contacts on 7 mc. W9LPS, W9MSS and W9KYX are charter members of the Stan-cor IOP club on 160 fone. KYX also knocks off 7 mc. DX. 9MCM had trouble with his modulator and joined the 7 mc. gang.



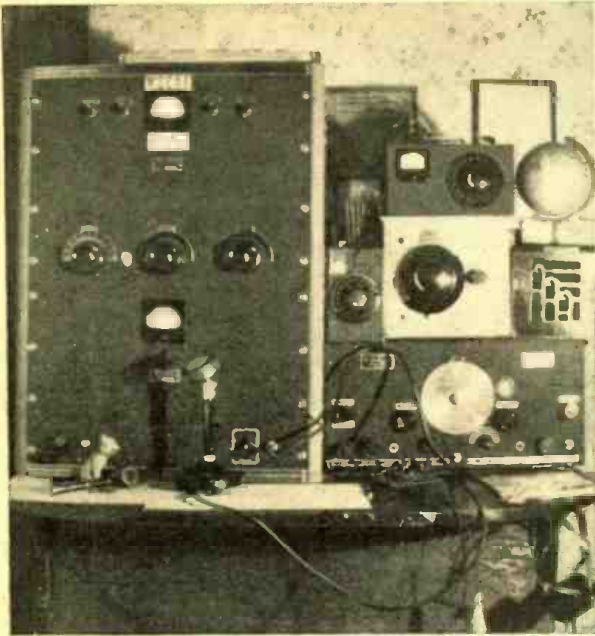

Photos herewith show Eugene M. Gillespie, operator of amateur station W2EAF, located at Mt. Vernon, N. Y. A Thordarson transmitter line-up is used; the receiver is a Hallicrafter "Sky Challenger". Antenna is Premax "rotary beam," atop a 35-foot steel pole.

## "Honor" Plaque Awarded To Eugene M. Gillespie, W2EAF

For Best HAM Station Photo

**Editor:**

The transmitter is a Thordarson; tube line-up is 6J7, 6F5 driving a 6F6, which in turn drives a pair of 6L6's in Class B. Plate modulation is used. The RF section of the transmitter is 6L6 crystal oscillator, 6L6 doubler-buffer and a TZ-40 in the final stage. The output is 125 watts on CW and 100 watts on phone.

Operation is mostly on the 20 meter CW and phone band. A Turner crystal mike (VT-73) is used at this station. I am using a Hallicrafter "Sky Challenger." You will also note a frequency

monitor and a combination "modulation" and "field strength" meter in the picture.

The antenna is a two-element rotary beam (Premax elements) controlled from the operating table.

A total of about 50 countries have been "worked," on both CW and phone, mostly on 20 meters. The transmitter is designed for operation in the 5 to 160 meter bands.

Have been in the Ham "game" since 1912.

EUGENE M. GILLESPIE, W2EAF,  
21 No. 7th Avenue,  
Mt. Vernon, N. Y.

Here is the new "Award of Honor" Plaque which measures 5" x 7" in size. It is handsomely executed in colors on metal, and is framed, ready to hang on the wall. The name of the winner will be suitably inscribed.

**Note These Important Rules**

Attach a brief description not longer than 300 words, describing the general line-up of the apparatus employed, the size, type and number of tubes, the type of circuit used, name of commercial transmitter—if not home-made, watts rating of the station, whether for c.w. or phone or both, etc., also name of receiver.

State briefly the number of continents worked, the total number of stations logged or contacted, and other features of general interest. Mention the type of aerial system and what type of break-in relay system, if any.

Important—Enclose a good photograph of yourself, if your likeness does not appear in the picture!

You do not have to be a reader of RADIO & TELEVISION in order to enter the contest.

Address all photos and station descriptions to Editor, Ham Station Photo Contest, c/o RADIO & TELEVISION, 20 Vesey Street, New York, N. Y.



# New EFFICIENCY

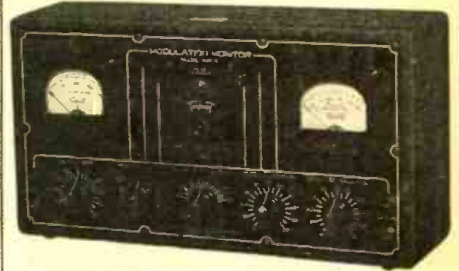

**TRIPLET MODEL 1696-A**

You've solved your problem of getting maximum efficiency from your transmitter when you invest in a Model 1696-A Modulation Monitor . . . A new monitor with improved shielding—just the unit for 10-meter bands. Plug it into your AC line—make simple coupling to the transmitter output and the monitor shows:

- Carrier Reference Level • Per Cent of Modulation • Instantaneous Neon Flasher (no inertia) indicates when per cent of modulation has exceeded your predetermined setting. Setting can be from 40 to 120 per cent. Helps comply with FCC regulations. Has two RED • DOT Lifetime Guaranteed Triplet Instruments. Modernistic metal case. 14½"x7½"x4½", with black suede electro enamel finish. . . . Black and white panel.

Model 1696-A . . . Amateur Net Price . . . **\$34.84**

Also available as a rack panel mounting unit.

FOR MORE INFORMATION  
WRITE SECTION 284 HARMON AVENUE

**THE TRIPLET ELECTRICAL INSTRUMENT CO.**  
Bluffton, Ohio

## NEW 1941 PATENTED JEWEL MOVEMENT

# DE LUXE GENUINE VIBROPLEX

World's Finest Semi-Automatic Key

The smartest looking, smoothest action, easiest to operate "Bug" Vibroplex has ever produced. Has Patented Jewel Movement found only in De Luxe Vibroplex Keys. Precision construction including DIE CUT contact and main spring. Highly polished chromium base and machine parts, colorful red switch knob, finger and thumb pieces and green silk cord and wedge. Large contacts. An outstanding key in smartness, signal quality, speed and ease of operation, users say. Vibroplex keys give quality performance—insist on Vibroplex. Three De Luxe Vibroplexes . . . Lightning Bug, Original and Blue Itacer. The finest semi-automatic keys money can buy. Each is equipped with Patented Jewel Movement. Place your order NOW! Money order or registered mail. Write for catalog of Vibroplex keys priced from \$9.95 to \$19.50.

Send for Free Catalog  
**THE VIBROPLEX CO., INC.**

832 Broadway New York, N. Y.

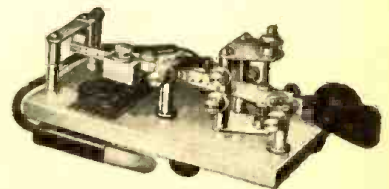

## USED Correspondence Courses

COMPLETE HOME-STUDY COURSES and educational books, slightly used. Sold, rented, exchanged. All subjects. Money-back guarantee. Cash paid for used courses. Full details and illustrated 72-page bargain catalog FREE. Write today!

NELSON COMPANY, 500 Sherman, Dept. D-210, Chicago

Further Notes on the

# "Compact Kilowatt" Transmitter

Larry LeKashman, W2IOP

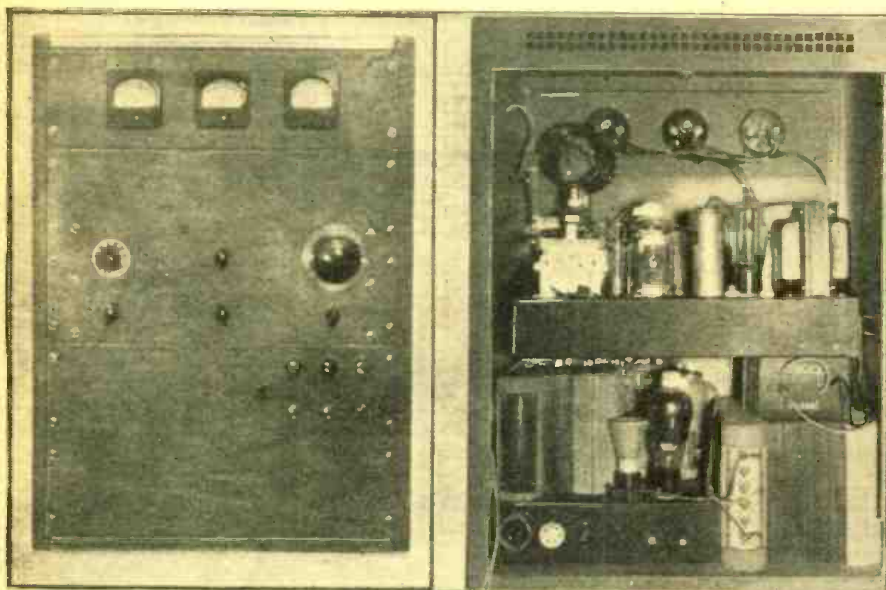

Front and rear views of the Compact Kilowatt transmitter, the revised version of which is here described by Mr. LeKashman.

[Photos by Harold Lerino

was possible to *over-drive* the 813s by over 700%!

The physical layout of the transmitter is well illustrated in the accompanying photographs and the mechanical chassis layout. It is essential that these plans be adhered to, if maximum results are to be obtained with these high-power beam-power pentodes. It should be pointed out that the neutralizing condensers used to remove the last trace of oscillation are not standard items obtainable from the shelf. They are Bud 1930 condensers which have the rotating plug cut down to 1/3 its original size, in order to reduce the minimum capacity. To clarify the situation, the accompanying sketch shows the operation performed. Under no circumstances should an attempt be made to neutralize the 813 with a 6L6 or similar voltage-neutralizing condensers. Home-made condensers with a low enough minimum capacity are easily made, but more than likely their physical dimensions will exceed the limitations in this compact transmitter. For break-in operation, *hash-filters* were put on the 866s, but frankly the new shielded type rectifiers are more effective and will prove a worth-while investment.

AS promised two issues ago, we are presenting herewith the final solution to the technical and mechanical problems that arose in the "Compact Kilowatt." The short-comings of the transmitter, in a broad sense, were lack of excitation on the higher frequencies, parasitic oscillation on the lower frequencies and as a by-product of both these faults, inability of the transmitter to operate with all stages on the same frequency.

It would seem logical enough from the first study of the problem that all the oscillation, both parasitic and R.F. could be traced to the mechanical layout. On the drafting board the first design seemed fundamentally sound but it was not until many hours of research that its faults became apparent. Naturally the construction of a kilowatt transmitter in a 29" rack would involve numerous problems which one might not normally encounter. Working from the design of two months ago we attempted to remove the oscillation by neutralizing the 813s. This, of course, if it worked, would have been the simplest solution of the entire problem. The inter-electrode capacity of this tube is such that for correct neutralization they must be fully shielded. This meant, at once, a mechanical change. The characteristics of the tubes as released by the manufacturers were based on the fully shielded operation, which is extremely important in screen-grid tubes of this nature. The mechanical changes made were—*dropping the tubes below the chassis and completely isolating the input and output circuits*. It was necessary to remove the band-switching assembly in the grid circuit of the 813s, since there was not sufficient room to do a good job of shield-

ing. The Bud type OCL coils, with link completely collapsed, were used in place of the band-switching assembly. The fact that the link was almost entirely removed for normal operation was another point in making the band-switching unit impractical. As further assistance in the control of excitation to the final amplifier, a variable poten-

**Numerous improvements in the circuit for the "Compact Kilowatt" transmitter described in the January issue of this magazine are here outlined by the author. Many helpful suggestions are also included, which the Ham beginner will find valuable. This transmitter was used in the A.R.R.L. QSO party; it performed with very gratifying results. 375 contacts on three bands in 17 hours, proved that it could really "step out and go places."**

tiometer was placed in the cathode circuit of the 807. These complex excitation controls have all proved desirable, if not essential, since the 813 is such an easy tube to "over-drive," under correct operating conditions. The Meissner *Signal-Shifter* was capable of supplying sufficient excitation to the 813 on all bands, when a tuned grid was used. This system was not adopted because it made no provisions for doubling. Using the *Signal-Shifter* into the 807, it

Except for the *tube line-up* and the physical dimensions for the transmitter, there is little in common between the previous and the current edition of the "Compact Kilowatt." The filament transformer which is one of Kenyon's variable input type, has proved excellent in making possible critical control of filament voltage on the 813s. When one has forty-four odd dollars invested in tubes, it is best to be careful in observing the ratings. By varying the input types on the Kenyon 312, it is possible to obtain the exact voltage on the 813 under varying line-load conditions. Completely "debugged" this transmitter makes an excellent *all-band* job, with no "ands," "ifs" or "buts" attached to its operation.

Needless to say, the transmitter should be completely *grounded* in order to protect the operator against any possible failure of high voltage components, as well as to provide maximum effectiveness of the shielding.

The transmitter as described holds its tuning extremely well over considerable frequency-spread, which is extremely helpful for all types of operating.

We might call your attention to the fact that the proximity of the Simpson Meter to the R.F. amplifier in no way affected its operation. While this might be considered an achievement for Simpson products, we do advise careful by-passing of the meter contacts.

The transmitter, exactly as pictured, was used in the ARRL QSO and operated and performed with gratifying results. 375 contacts on three bands in 17 hours amply proved that the transmitter is *really* working! Not yet tried on phone; look forward to the cathode modulator for 813s and other high-power pentodes.

### Compact Kilowatt Parts List

**RCA RADIOTRON (Tubes)**  
807 2-813's 2-866's

**JAMES MILLEN MFG. CO.**  
1-10008 tuning knob  
2-37001 safety plugs  
4-36001 safety caps  
2-33004 sockets  
1-33005 socket  
1-33008 socket  
1-77083 hash filter  
3-34100 RCF  
1-34150 RFC  
Type 31001 standoffs

**IRC (Resistors)**  
All resistors as indicated on circuit  
1/2 watt, type BT 1/2  
10 watt, type ABA  
100 watt, type HAA

**PAR-METAL (Panels & Chassis)**  
1-MG 3003 meter panel  
2-G3605 front panels  
1-DL 2613 rack  
2-B4536 chassis  
2-SB713 chassis brackets

**KENYON**  
1-T385 813 fil. trans.

**E. F. JOHNSON**  
813 sockets

**BUD**  
OCL Grid Coils  
3-JL16985 pilot lights  
1-OCS 3 band-switching unit  
1-SH278 shield  
1-SH293 shield  
2-NC1929 neut. cond.

**BARKER & WILLIAMSON (Coils)**  
1-HDV base assembly  
Type HDVL coils

**CARDWELL (Condensers)**  
1-XG 110 XD, C4  
1-EU140AD  
1-ZU100AS

**SIMPSON (Meters)**  
Model 27 illuminated meters  
0-25 ma.  
0-150 ma., M2  
0-750 ma., M3

**GUARDIAN**  
1-Model X-100 overload relay-RY1

**CORNELL-DUBILIER (Condensers)**  
(All condensers as indicated on circuit) .01 by-pass may be paper  
C1-(HV supply) TQ 30020  
C2-TLA 6040  
C3-TLA 6040

**STANCOR (Transformers & Chokes)**  
**THOROBREDS**  
1-T8005 plate trans., T1  
1-C2313 choke, CH1  
1-P8023 HV fil., T2  
**STANDARD LINE**  
1-P4081 6L6 plate, HV only, T3  
1-P6289 fil. windings only, T4  
1-C1421 choke, CH2

**AMPHENOL**  
Plugs

Revamped diagram of the transmitter here described, as well as chassis layout.

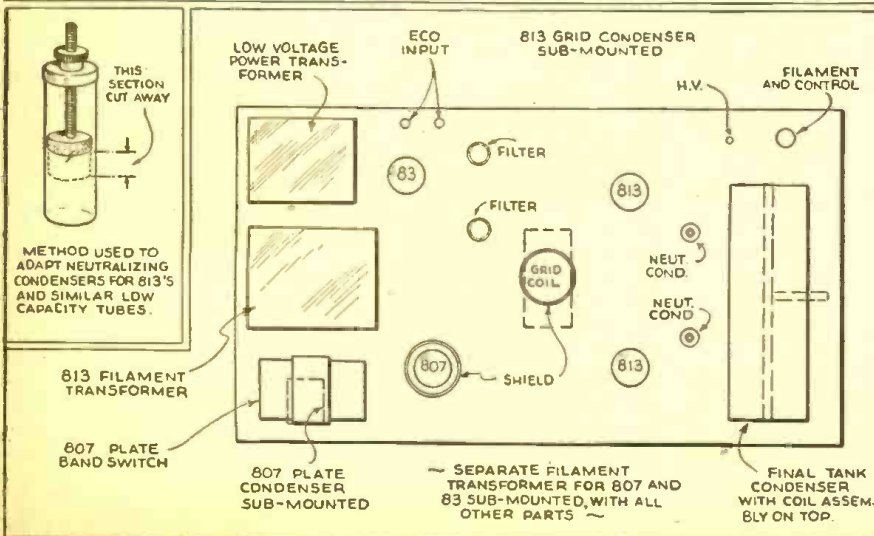
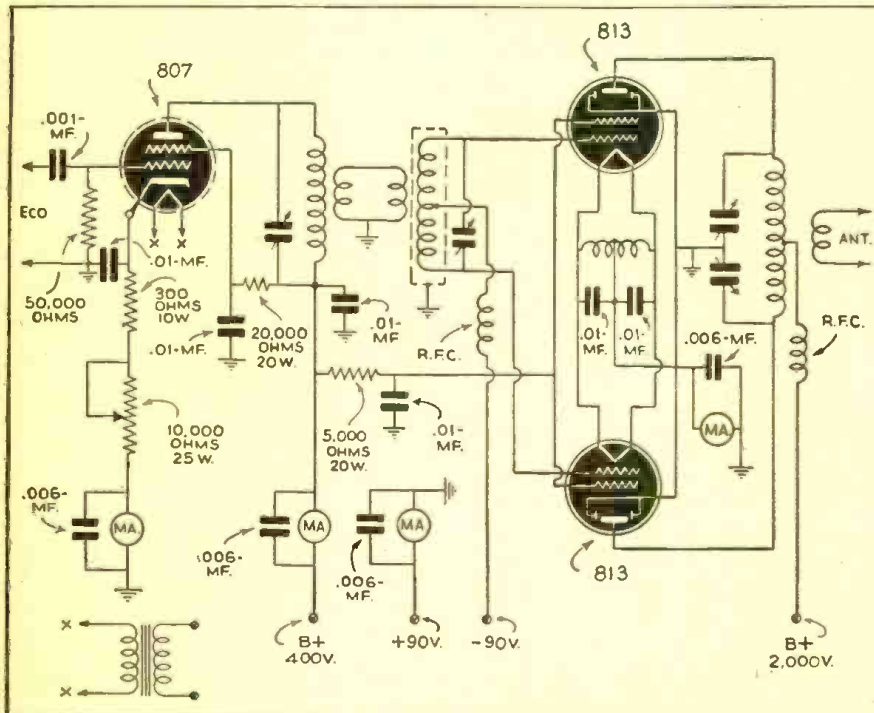

## RADIO made EASY

with Ghirardi's BIG  
**1-Volume Radio Training Course**

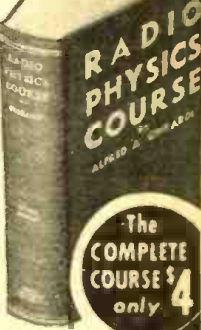

Fit yourself, at home in spare time, for a good-paying Radio job. Yes, you can do it—with Ghirardi to help you, as he has helped thousands of others who got their basic training in Radio from his world-famous Radio Physics Course. It's easy this way, because Ghirardi has a genius for making it all vividly clear and easy to understand. You need no "background" to prepare you for this intensive course of technical training—not even a knowledge of math! Ghirardi will "see you through" any elementary Electricity right through Radio, Sound, Television, Cathode-Ray Tubes, etc., etc. It's all explained simply, completely—in this one big 972-page book that costs you only \$4.

**USED BY U. S. ARMY and NAVY**  
Because of its excellence, Radio Physics course has the rare honor of being used as the training text in the radio courses conducted by the U. S. Army schools and students, and is used by more radio schools and students than any other radio text in the world! Here's what you will learn all about:

**36 Volumes in 1—972 pp.—\$08 illus.**

1. Radio Broadcasting Systems
2. Sound, Speech, Music
3. Electron Theory; Elec. Current
4. Elec. Batteries
5. Elec. Circuits; Ohm's Law; Resistance
6. Magnetism
7. Electromagnetism
8. Electromagnetic Induction
9. Inductance
10. Capacitance; Condensers
11. A. C. Circuits
12. Filters
13. Measuring Instruments
14. Radio Waves
15. Broadcastink
16. Receiving
17. Vacuum Tube Principles
18. Vacuum Tube Characteristics
19. Vacuum Tube Construction
20. Vacuum Tube Detector and Amplifier Action
21. Radio Frequency Amplification
22. "Superhete"
23. R.F. Amplifiers; Tuning Coils
24. Audio Amplifiers
25. Speakers
26. Battery-Operated Receivers
27. Power-Supply Units
28. Elec. Receivers
29. Automobile and Aircraft Radio
30. Phone Pickups; Sound Systems
31. Short-Wave
32. Photoelectric Cells; Cathode-Ray Tubes
33. Television
34. Antennas and Grounds
35. Testing; Servicing
36. Sound Motion Pictures

Review Questions send for this great 856 Self-Test It—5 DAY TRIAL—MAIL NOW!

**RADIO & TECHNICAL PUBLISHING CO.**  
45 Astor Place, New York, Dept. R&T-41  
Here is my \$4.00 (84.00) Send my copy of Ghirardi's RADIO PHYSICS COURSE postpaid, with your 5-Day Money-Back Guarantee.

NAME \_\_\_\_\_  
ADDRESS \_\_\_\_\_  
CITY \_\_\_\_\_ STATE \_\_\_\_\_  
 Send me free illustrated descriptive literature.  
**...MONEY BACK IF NOT SATISFIED!**

## ★ PERSONAL SERVICE

By *Bill Harrison*

## RECEIVERS

### AMATEUR EQUIPMENT

Fastest service—lowest prices—  
most liberal trade-in allowances—  
easiest time payment terms—in the  
country!

It will pay you to write to me about any Radio Apparatus you need. I guarantee you complete satisfaction and my personal attention.

73,  
Bill Harrison, W2AVA  
\*Send stamp for my latest list of  
**NEW AND RECONDITIONED RECEIVERS**

## HARRISON RADIO CO.

12 WEST BROADWAY - NEW YORK CITY

## EASY TO LEARN CODE

It is easy to learn or increase speed with an Instructograph Code Teacher. Affords the quickest and most practical method yet developed. Available, takes from beginner's alphabet to typical messages on all subjects. Speed range 5 to 40 WPM. Always ready—no O.P.M.

**MACHINES FOR RENT OR SALE**  
The Instructograph Code Teacher literally takes the place of an operator-instructor and enables anyone to learn and master code without further assistance. Thousands have used and endorse the Instructograph System. Write today for full particulars and convenient payment and rental plans.

**INSTRUCTOGRAPH COMPANY**  
Dept. RT, 4701 Sheridan Rd., Chicago, Ill.  
Representatives for Canada  
Radio College of Canada, 54 Bloor St. West, Toronto.

# A "Pull-Swing" Frequency Modulation System for the Amateur

Part 3—Power Supplies

Ricardo Muniz\* ; Donald Oestreicher\*\* ; Warren Oestreicher\*\*\*

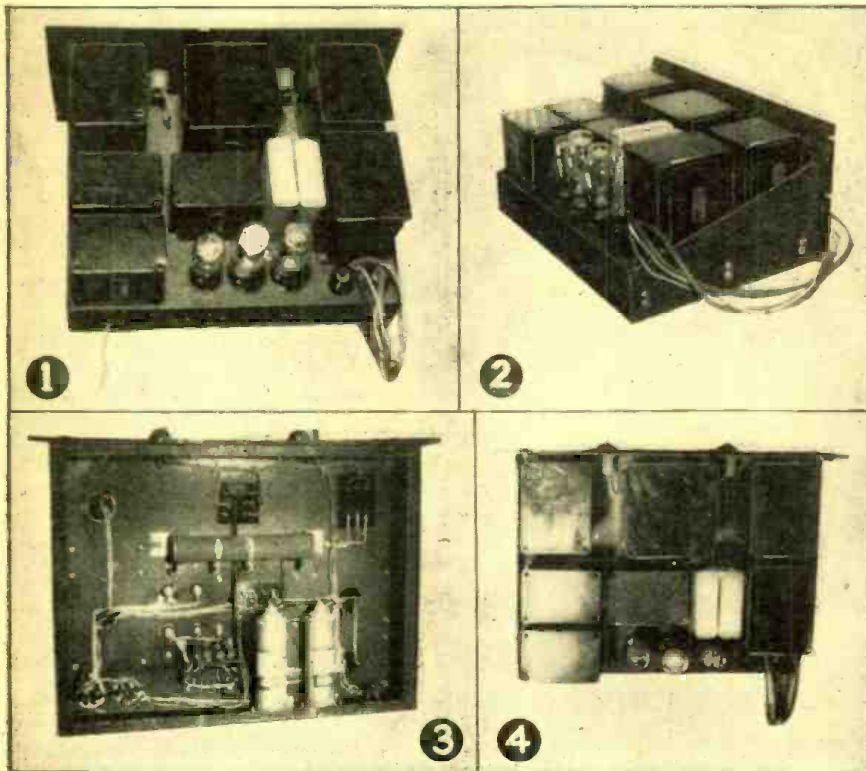

1—Top view of power supply, showing tubes and connector plugs. 2—General view of power supply, showing general arrangement. 3—Bottom view of power-supply, illustrating mounting of parts. 4—Top view of power supply, showing tubes and connector plugs.

**Power Supplies:** In designing a power supply for use with the frequency modulation transmitter the authors considered it advisable not only to make a power supply applicable to this unit, but to make a dependable, sturdy supply which could be used wherever voltages in the order of 200 to 600 are needed.

The evolved unit is a supply which will give 250 volts at 250 ma. and 500 volts at 350 ma. or (by use of the primary taps), 350 volts at 250 ma. and 600 volts at 350 ma. It is readily apparent that these voltages and currents can be used to supply all but the final stages of any medium power transmitter. The oscillator and buffer stages can be run from the 600 volt supply, and all audio equipment from the low voltage section. At the same time this unit completely satisfies the needs of the R.&T.-F.M. transmitter.

**Design Factors:** In a power supply of this type where heavy currents at high voltages are encountered, there will be found strong fields about all of the transformers and filter chokes. In laying out the chassis, therefore, care must be taken that the power transformers are so placed that their fields will not induce ripple in the windings of the filter chokes. As one can see by referring

to the layout diagram, the transformer's axes are at right-angles to the axes of the choke windings (the condition for minimum mutual inductance). The layout used was decided upon only after careful consideration of theoretical and practical (space) factors. It is inadvisable, in a unit designed to supply equipment having a large number of tubes, to incorporate filament voltages on the power-supply chassis. (The heavy filament currents would cause excessive IR drop in long leads to the equipment in use.) Provision has been made for 110 volt A.C. leads in the power cable to supply filament transformers on the equipment chassis. A six-wire cable and male and female six contact plugs (Amphenol) in the low voltage supply, and a four-wire cable and plugs in the high voltage supply, are used to carry all voltages to the equipment chassis. This method was used in order that there should be no exposed high voltage contacts.

**Voltages Available for F.M. Unit:** To properly operate the F.M. unit, the construction of which was described in last month's article, the following voltages are needed: For the audio system, 350 volts; control oscillator, 100 volts (screen and plate); master oscillator, 200 to 350 volts; limiter, 200 volts. The intermediary voltages are obtained from a 5,000 ohm 100-

watt bleeder on the low voltage supply. If modulation causes reaction on the master oscillator amplitude it may be necessary to take the plate voltage for this tube from a tap on the 600 volt supply.

**Additional Construction Data for F.M. Unit:** It was found that the electron-coupled oscillator is more stable when the following grid coil is used: Eight turns, one inch long, No. 18 bare tinned wire, tap three-quarters of a turn from ground (on Amphenol miniature form). The larger sized wire does not heat as much as the small wire that was previously specified and, therefore, frequency drift during the warm-up period is greatly minimized.

Three toggle switches (S.P.S.T.) have been added, one in each of the plate supply leads of the three oscillators in order to facilitate adjustment. They have been mounted on the back of the chassis since they are only used during initial adjustment.

It was found that better control of balance with less reaction on oscillator frequency was had if the capacitance of each section of the balancing condenser were reduced to about twenty micro-micro-farads. This may be done by removing all but two stator plates on each side of the balancing condenser.

**Adjustment for Operation of F.M. Audio System:** The audio system differs in no way from a conventional audio amplifier either in adjustment or operation, except for the fact that the amplification is proportional to the audio frequency. This exception, however, need not be rigidly adhered to, so long as the highs (5,000 cycles) are between fifteen and thirty db.; above the lows (100 cycles) with approximate linearity between. A method for obtaining this type of response was described in the preceding article.

**Oscillator Adjustments:** The control oscillators are tuned with the balancing condenser set for equal capacitance in each section. The control oscillators are left in operation and their signals are found at 14.83 and 14.79 megacycles on an A.M. receiver. The receiver dial is then set to a point midway between these frequencies and the control oscillators are turned off. The master oscillator is then turned on and adjusted by means of the 100 mmf. condenser roughly to the receiver dial setting and exactly centered from the front panel by the 10 mmf. band-spread condenser. The plate circuit is then tuned. Since the "Q" of tuned circuits at 28 megacycles is usually low—therefore, the dip in plate current at resonance may not be noticeable, a tenth-watt neon bulb will prove a valuable tuning indicator. With the band-pass adjustment knob set for low coupling the limiter is tuned, first the grid circuit and then the plate circuit, as a conventional doubler. The signal is then found on an F.M. receiver at

\*Radio Instructor, Brooklyn Tech. H. S., Eng. WYNE.  
\*\*Student, Electrical Eng., Brooklyn Polytech., W2LOE.  
\*\*\*Student, Electrical Eng., Cooper Union, Night.

59.25 megacycles and the control oscillators are turned on. An oscilloscope is connected to the output of the receiver. An audio oscillator is connected to the input of the F.M. unit and adjusted to about 200 cycles. If the wave-form viewed in the 'scope contains appreciable harmonics, the following adjustments must be made: 1. The balancing condenser should be shifted slightly from the center position. 2. Since this will change the center band frequency, the master oscillator is retuned by means of the band-spread condenser. 3. If the wave-form viewed in the scope is worse than before, the balancing condenser must be adjusted in the opposite direction. If the wave-form is improved, further adjustment should be made in the same direction. If the receiver does not appear to have sufficient output the audio gain of the F.M. unit may be turned up and usually an optimum setting of this control for minimum distortion will be easily found. The next step is the tuning of the band-pass circuit. The M-type curve desired is obtained by over-coupling, therefore, adjust the coupling knob for increased coupling. The introduction of the metal of the movable coil into the field of the fixed coil will detune both slightly. Readjustment should, therefore, be made. The audio oscillator frequency should be increased to 5,000 cycles. The wave-form may now be viewed in the 'scope and if it appears incorrect increase the coupling of band-pass circuit.

A more reliable, although more difficult means of adjusting the band-pass circuit is as follows: The saw-tooth wave-form obtained from the oscilloscope horizontal deflection circuit may be introduced into the F.M. audio system. This will cause a linear frequency swing over the complete band. If a broadly tuned detector (a single tube will do) is then coupled to the limiter output and the detector's output is fed to the vertical deflection terminals of the 'scope, a curve will be traced representing the characteristics of the band-pass circuit. Adjustments may then be made quite easily. (The saw-tooth voltage is obtained through a .1 mfd. condenser tied to the horizontal deflection plate of the cathode ray tube, and the circuit in the 'scope is not broken.) Care must be taken to provide adequate shielding in all external leads since their lengths may be sufficient to introduce appreciable radio frequency voltages to the measuring equipment.

When the above adjustments have been made, and they should not prove difficult, a microphone may be connected to the input and the unit is ready for operation.

In all of the above adjustments the authors used a Hallicrafters model S-27 high frequency F.M.-A.M. receiver. It proved to be the most practical receiver we have yet seen for this service since A.M. and F.M. adjustments are made by simply turning a switch, and the quality of reproduction leaves no doubt as to where any distortion may be found. It will certainly not be in the receiver.

Of interest is the fact that the band width of this transmitter may be readily varied. The authors used crystals ground 10 kc. apart, thus halving the band width, and little change was noticed.

In the next article, we expect to describe an amplifier which will give about

(TURN THE PAGE)



## 12 WATT UNIVERSAL TRANSMITTER

For Portable and Emergency Service



The ideal portable unit for emergency services. Circuit changes from 115 volt A.C. to 6 volt D.C. are accomplished by merely inserting the proper power plug—no changes in wiring are necessary. Designed for phone and CW operation on all amateur bands from 160 to 10 meters. Nominal power input for phone operation is 12 watts when operated from a battery supply. Higher inputs may be obtained when operated on A.C. Doubling may be accomplished in either the crystal oscillator or final amplifier stage. An antenna matching network provides coupling to all type radiators. High gain audio system gives full modulation when using a crystal mike.

Kit including all parts, except accessories, available from your local Thordarson distributor. Ask for kit T-22K13. List Price \$72.50. Fully described in bulletin SD464—FREE.

500 WEST HURON ST.

**THORDARSON**

CHICAGO, ILLINOIS

ELEC. MFG. CO.

TRANSFORMER SPECIALISTS SINCE 1895

## LAST CHANCE

that you will have to buy

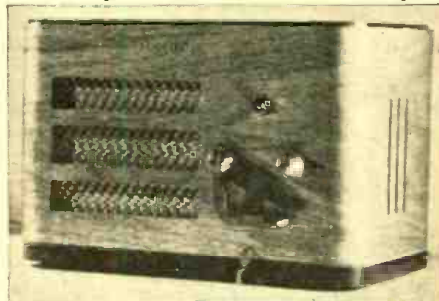

**Crosley CHATTABOX**  
INTERCOMMUNICATION SYS- \$19<sup>95</sup>  
TEM OF TWO UNITS FOR  
LIST PRICE—\$59.50 A PAIR

Complete two-way wireless loud speaking system. Perfect performance. Plug into any 110 volt house socket A.C. or D.C. Equipped with Call-Listen-Talk switch and volume control.

No installation charges. Modulated carrier signal travels over the electric light lines.

IDEAL FOR OFFICES, STORES, FACTORIES, SCHOOLS, LIBRARIES, HOMES AND WHEREVER INTERCOMMUNICATION IS DESIRED. EXCELLENT SPEECH CHARACTERISTICS.

Each unit is housed in beautiful 2 tone veneered cabinet with grilled speaker front.

This Coupon is worth \$2.00 if mailed to us with order BEFORE MAY 15th.

Name .....  
Address .....  
City .....

**KORROL MFG. CO.**

350 GREENWICH ST. (DEPT. RT-441)  
NEW YORK CITY

## BRAZILIAN AMATEURS JOIN HANDS

● BRAZILIAN radio amateurs have now joined hands with those of brother "hams" in thirty-six other countries of the world by their recent election to membership in the International Amateur Radio Union, according to a statement by Kenneth B. Warner, secretary of the Union, in announcing the affiliation of the *Liga de Amadores Brasileiros de Radio Emissoao*.

In Brazil there are about 1,000 amateur operators, all of whom belong to the L.A.B.R.E. Due to present international conditions amateurs in that country are not allowed to contact stations in foreign countries actively at war, so the emphasis is on domestic communication. Numerous groups of amateurs form weather-reporting nets and emergency communications reserves, and learn military operating procedure as well, patterned after similar groups in the United States. Brazilian amateurs have an official organ to keep each other posted on radio happenings, called "QTC"; in radio parlance this reads, "I have a message for you," appropriately enough.

## MODERN PARTS for MODERN CIRCUITS

THAT HAVE BEEN

"Designed for Application"

CATALOG UPON REQUEST

JAMES MILLEN



MFG. CO. INC.  
MALDEN, MASS.

## EXPERT PHOTOGRAPHY MADE EASY

Successful photography as a career, for sparetime earnings or as a hobby—made easy through N.Y.I. Training! Personal coaching by leading photographers. Fascinating field. Splendid opportunities. Commercial, News, Portrait, Motion Picture, Advertising and Color Photography. Personal Attendance and Home Study Courses. Booklet FREE! N. Y. INSTITUTE OF PHOTOGRAPHY, Dept. 11, 10 West 33 St., New York, N. Y. (31st Year)

50 watts of frequency modulated power in the 112 mc. band (118.5 mc.). The amplifier will be readily adaptable to conventional A.M. service. Subsequently, too, will be described a combination frequency deviation indicator and monitor for this F.M. transmitter.

**Acknowledgments:** The authors wish to express their gratitude to *Hallcrafters, Inc.*, for their generous cooperation and to all the other companies whose splendid response in the interests of modern research made this series of articles possible.

### Parts List for Pull-Swing Set

#### KENYON TRANSFORMER CORP.

- T1—Plate power transformer—pri. tap., 450-350-0 at 250 ma.; T-655
- T2—Plate power transformer—750-600-0; 300 ma., T-656
- T3—Fil. transformer. See text; 2.5 V., 10 A.; 2.5 V., 7 A.; 5 V., 4 A.; T-364
- L1—Swinging choke (to carry 300 ma.) 6-19 hy.; T-510
- L2—Filter choke, 11 hy., 300 ma.; T-166
- L3—Filter choke, 10 hy., 250 ma.; T-151
- L4—Filter choke, 10 hy., 250 ma.; T-151

#### INTERNATIONAL RESISTOR CO.

- R1, R2, R3, R4—50 ohm, 10 watt (wire-wound); AB
- R5—Bleeder resistor, 50,000 ohms, 100 w. fixed; HAA
- R6—Bleeder and stabilizer resistor, 5,000 ohms, tapped; HAA

#### PAR-METAL PRODUCTS CO.

- 1—8 3/4" x 19" steel rack panel; 3604
- 1—13" x 17" x 3" steel chassis and bottom plate; 15281
- 1—13" type angle-bracket set; SB-713

#### BUD RADIO, INC.

- P1—"Jumbo" type pilot-light, candelabra base; JL1698S
- P2—"Jumbo" type pilot-light, candelabra base; JL1698S

#### AMERICAN PHENOLIC CO. (Amphenol)

- 2—6-prong bakelite sockets; S-6
- 3—4-prong bakelite sockets; S-4
- 2—6-prong "male" cable connectors; PM-6
- 1—Socket punch; LD-1

#### NATIONAL-UNION (Tubes)

- 1—Type 83v.
- 2—Type 83

#### KESTER SOLDER

- 1—Roll "radio type" rosin core solder

#### CORNELL-DUBILIER (Condensers)

- C1—4 mf., 600 V., Dykonol paper; TLA-6040
- C2—4 mf., 600 V., Dykonol paper; TLA-6040
- C3—8 mf., 1000 V., paper type; T-10080
- C4—8 mf., 1000 V., paper type; T-10080

#### INSULINE CORP. OF AMERICA

- SW1—S.P.S.T. toggle switch; 1281
- SW2—S.P.S.T. toggle switch; 1281
- Hardware, nut and bolt assortment, etc.; 5252

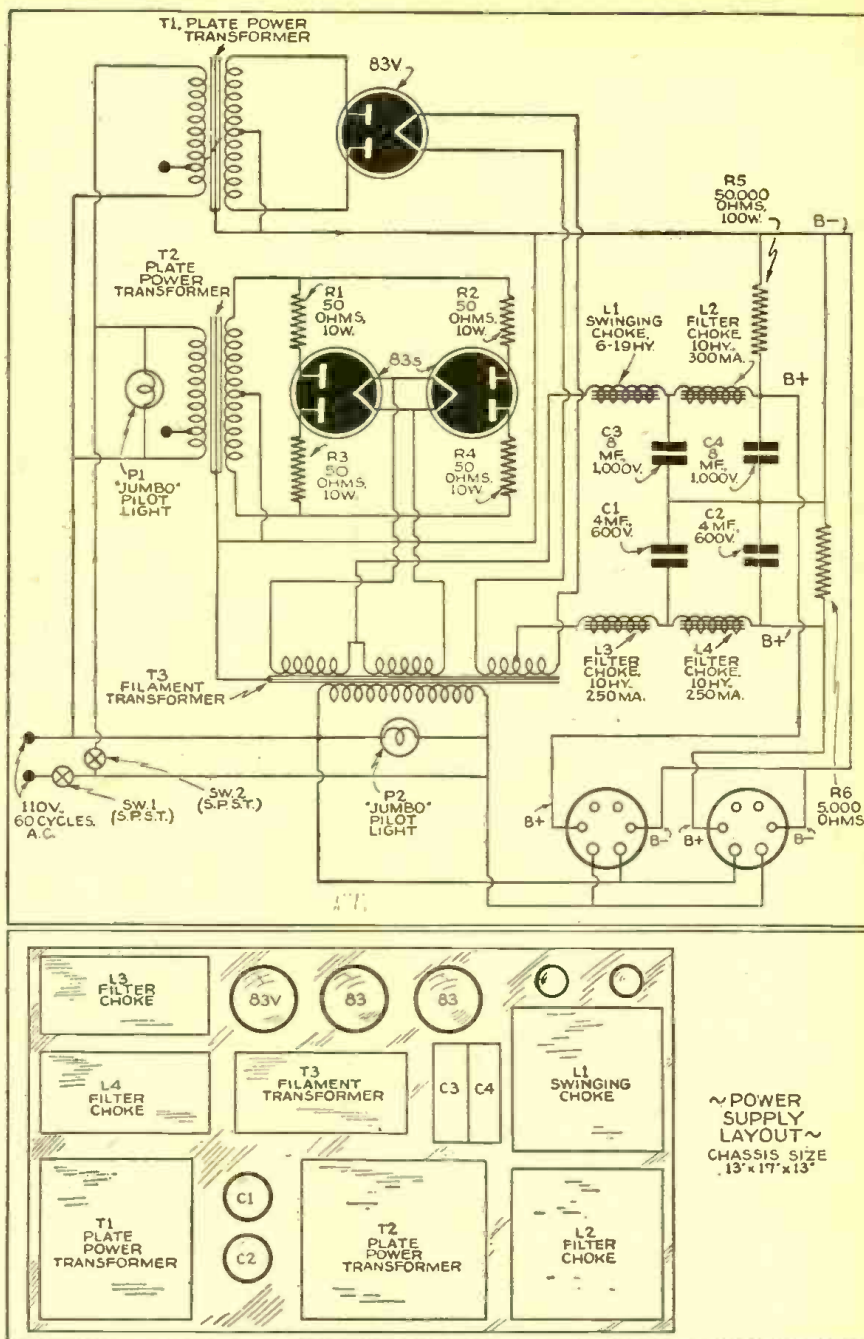

The drawings above show plan view of the power-supply and also a schematic diagram of this unit.

## BOOK REVIEW

The final chapter deals with the future of radio broadcasting, including opportunities in television.

**PLAYING WITH LIGHTNING**, by Dr. K. B. McEachron in collaboration with Kenneth G. Patrick. Cloth covers, size 6 x 8 1/2 inches, 232 pages, illustrated. Published by Random House, New York, N. Y.

This unusual volume deals with man's experiments with lightning—both natural and artificial. Many years ago electrical engineers decided that they must know more about lightning, for otherwise the high voltage transmission lines would be constantly out of order. Due to lightning bolts smashing insulators and causing other disturbances, such as high transient currents or surges which would wreak all kinds of havoc on sub-stations and generating apparatus.

This book is written in popular style, and anyone interested in such questions as—*what is the voltage of an average lightning flash?* and *How long does it exist?*—will find the answers in this book. Some of the chapter titles are—*How Much? How Fast? How Long?—Men Make Lightning—How Quick Is a Flash?—The Lightning Stroke—Skyscrapers and Lightning Rods—Freezing*

*Lightning on Film—The Thunder Storm—Lightning Rods.*

**THE RISE OF MODERN PHYSICS**, by Henry Crew. Cloth covers, size 5 x 7 1/2 inches, 434 pages, illustrated. Published by Williams & Wilkins Co., Baltimore, Md.

Every radio and electrical student is, by a common token, also interested in physics. This book will prove very interesting as it is written in a smooth, easy style and the origin of the electrical and similar branches of physics is discussed. In the forefront of the book we find a very interesting treatment of the early Greek and Roman science, Arabian physics, and physics in the middle ages. Next the author takes up the birth of American physics and modern optics and then progresses to early discoveries in the field of electricity and magnetism. This is followed by the discovery of the nature of heat and the nature of matter in general. Radio and electrical students will find particularly interesting the sections dealing with Volta, Oersted, Hertz and other well-known scientific investigators.

The origin of modern electrical units forms a fine chapter. This is followed by—*The Rise of Modern Spectroscopy, Relativity, etc.*, followed by a valuable bibliography and a thorough index.

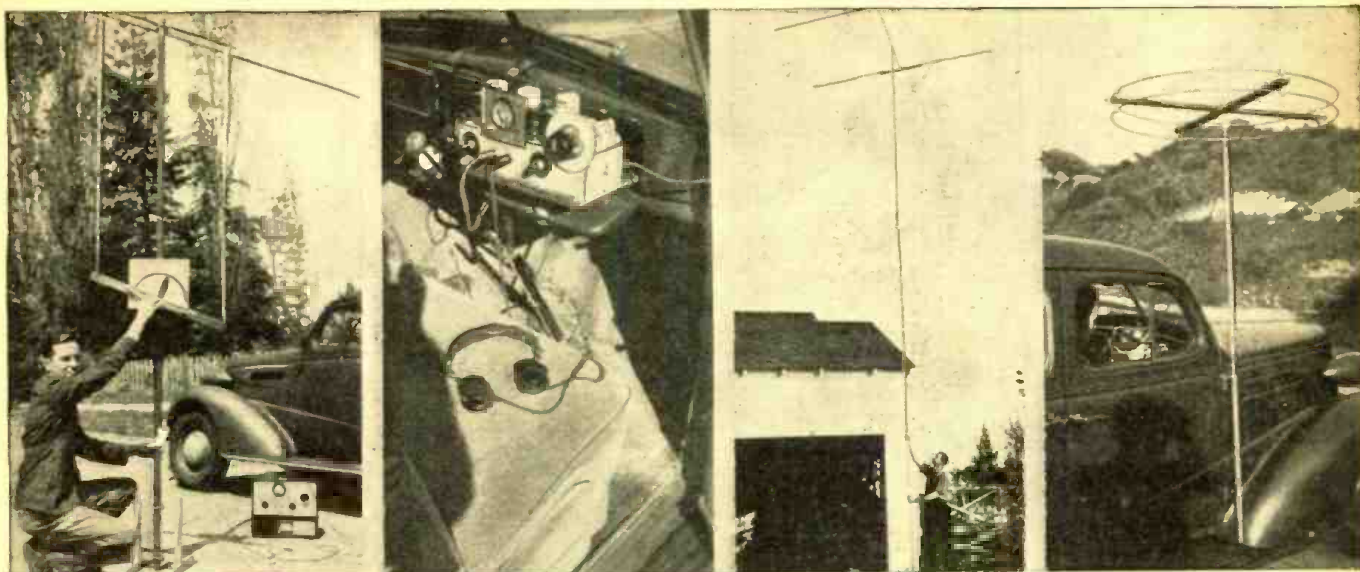

Left to right: 1—Dipole antenna calibrated in degrees of polarization off horizontal, and field strength meter. This combination was used in auto-ignition interference tests and "carrier-wave" polarization measurements. 2—Signal strength meter used in locating diathermy interference, and other mobile explorations of "carrier-wave" propagation. 3—30-foot, telescoping mast supporting dipole reflector antenna. It can be moved about and held by one man. 4—Mobile equipment consisting of Reinartz antenna and signal strength meter, used in locating source of diathermy interference.

## Interference Phenomena in

# Television Reception

● IT is an obvious truth that the most exact calculations on the part of the design engineer, and the finest work on the part of the production engineer will be lost value unless the television receiver is equally well applied in public use.

Good television reception is undoubtedly dependent upon the antenna design and installation method. Only by acquaintance with the peculiar relationships between the carrier wave and the several forms of interference, is the television engineer able to so design the antenna system that adequate and "pure" signal input to the receiver is obtained.

The three major types of interference, in the order of the frequency of their appearance, are automobile ignition systems, diathermy, and reflected signals. For the present, at least, auto ignition interference presents the greatest problem.

When, in the course of establishing standards of television transmission, the question of polarization of the carrier wave arose, so little was known of noise propagation characteristics within the ultra-high frequency portion of the radio spectrum that horizontal polarization was decided upon merely because the committee "believed" it had more favorable noise characteristics. The findings of subsequent research have supported this conclusion.

### Auto Ignition Noise

In a series of tests recently, the average automobile ignition noise level, using a vertically polarized antenna was found to be as much as 25% greater than when using a horizontally polarized antenna.

The tests were made under a variety of conditions using a field strength meter and a dipole antenna mechanically arranged to provide an instant change to any angle of polarization.

### Thornton Chew

**This article will be of interest to every student of television—whether he is an experimenter or a service man. Test reports are given with diagrams, showing the effect of placing the television receiving antenna at different angles.**

It was also observed that ignition noise pickup, like other radiations, is sharply reduced from the end directions of a dipole. This again is a point in favor of horizontal carrier polarization, since in the case of the commonly used horizontal dipole antenna the noise pickup will be bi-directional rather than non-directional as with the vertical dipole.

Quantitative tests show that ignition noise has a sharply critical nuisance-value versus distance characteristic.

To the average television viewer streaks of interference passing through the picture are not unbearable since most of the picture information is still conveyed. But interference strong enough to destroy synchronization renders the receiver completely useless throughout its duration. The average auto ignition noise will have sufficient magnitude to destroy synchronization of a visual signal, having a field strength of one millivolt per meter, within a radius of 150 feet from the antenna. With a signal field strength of 100 microvolts per meter, the critical distance moves out to about 400 feet.

### Moving Antenna Often Helps

It can readily be seen how important the length of a city lot may be in the place-

ment of a television antenna. Quite often a receiver may be freed of frequent breaks in synchronization by moving the antenna from the front to the back of the lot. The signal strength will, for practical purposes, remain constant, while the increased distance between noise source and antenna will result in a relatively large attenuation of interference. Even a considerable increase of lead-in length, to the point of minimum modulation voltage requirements, may be tolerated since a well-balanced transmission line will discriminate equally against signal and noise, and the rapid rise of signal-to-noise ratio in the antenna will more than offset the loss of surplus picture-tube modulation capabilities.

If this critical distance of separation between ignition noise source and antenna may be accomplished in vertical direction, a still more favorable signal to noise ratio will be obtained since signal voltage developed in the antenna will rise while the noise level is reduced.

### A Freak Case

A good example of this is shown by a receiver located about six miles from the Don Lee television transmitter, W6XAO, in a business district congested with automobile traffic. The measured field strength was approximately 500 microvolts per meter. The antenna was roughly 125 feet above street level and 200 feet of low-loss twisted-pair transmission line was brought down through an air shaft. With this installation, a picture completely free of blemishes from ignition interference was obtained, although a constant stream of automobiles passed within less than 100 feet of the receiver location.

A more complete knowledge of auto ignition interference characteristics would undoubtedly be of great value, but after con-

# GEOPHYSICAL PROSPECTING OUTFITS



## BLUE PRINTS and INSTRUCTIONS

For Building the Following Treasure Finders and Prospecting Outfits

- Folder No. 1. The "Radiofactor Pilot"—consists of a 2-tube transmitter and 3-tube receiver. Principle: radiated Wave from transmitter loop is reflected back to receiver loop. Emits visual and aural signals. Tubes used: two 1A5G—two 1N5G—one 1H5G.
- Folder No. 2. The "Harmonic Frequency Locator"—Transmitter radiates low frequency wave to receiver, tuned to one of Harmonics of transmitter. Using regenerative circuit. Emits aural signals. Tubes used: one 1G6G—one 1N5G.
- Folder No. 3. The "Beat-Note Indicator"—Two oscillators so adjusted as to produce beat-note. Emits visual and aural signals. Tubes used: Three type '30.
- Folder No. 4. The "Radio-Balance Surveyor"—a modulated transmitter and very sensitive loop receiver. Principle: Balanced loop. Emits visual and aural signals. By triangulation depth of objects in ground can be established. Tubes used: Seven type '30.
- Folder No. 5. The "Variable Inductance Monitor"—a single tube oscillator generating fixed modulated signals and receiver employing two stages R.F. amplification. Works on the inductance principle. Emits aural signals. Tubes used: six type '30.
- Folder No. 6. The "Hughes Inductance-Balance Explorer"—a single tube Hartley oscillator transmitter and sensitive 3-tube receiver. Principle: Wheatstone bridge. Emits aural signals. Tubes used: two type '30—one type '32—one type '33.
- Folder No. 7. The "Radiodyne Prospector"—a completely shielded instrument. Principle: Balanced loop. Transmitter, receiver and batteries enclosed in steel box. Very large field of radiation and depth of penetration. Emits aural signals. Tubes used: two 1N5G—one 1G4G—one 1H5G—one 1Q5—one 1G4.

With any one of the modern geophysical methods described in the Blue-Print patterns. Radio outfits and instruments can be constructed to locate metal and ore deposits (prospecting); finding lost or buried treasures; metal war relics; sea and land mines and "duds"; mineral deposits; subterranean water veins; oil deposits (under certain circumstances); buried gas and water pipes; tools or other metallic objects sunken in water, etc., etc.

Each set of blueprints and Instructions enclosed in heavy envelope (9 1/2" x 12 1/2"). Blueprints 22" x 34"; eight-page illustrated 8 1/2" x 11" folder of Instructions and construction data. **50¢** Add 5¢ for postage

The complete set of seven folders. **\$3.00** Shipping weight 2 lbs. (add 25¢ for shipping anywhere in U.S.A.)

## TECHNIFAX

1917 S. STATE ST. RT-441 CHICAGO, ILL.

TECHNIFAX 1917 So. State, Chicago, Ill.

Enclosed herewith \$..... for which mail to address below:  
 Treasure Finder No. 1, 2, 3, 4, 5, 6, 7.  
 Complete set of seven folders.

NAME .....

ADDRESS .....

CITY ..... STATE .....

RT-441

considerable observation, it is my opinion that the only complete solution of the problem lies in cooperation with automobile manufacturers, with a view to eliminating this type of interference at the source.

### Diathermy Apparatus Frequent Offender

Diathermy is probably the most irritating form of interference. Being of sustained magnitude for several minutes at a time, it thoroughly destroys picture information for large portions of the program, and the impulse of the viewer is to turn from the receiver in disgust. It is poor tribute to the rationality of our self-government, that the so completely regulated radio-television communications art should suffer interference from its offspring, completely unregulated by any Federal agency.

Diathermy radiations are not sharply limited as to polarization. However, from nearly one hundred recorded observations, it appears that most of this type of interference approaches vertical polarization.

Design characteristics account for the considerable variation in magnitude and form of diathermy interference. Apparatus having poorly filtered plate voltage supplies cause black-out of part of the raster. Strong interference causes a shift of vertical synchronization control from the desired synchronization pulse to the negative peak of this A.C. modulation. The same apparatus with well filtered plate voltage supplies would not affect vertical synchronization and much picture information would remain.

Poor or complete lack of line filtering permits radiation through power supply lines acting as long wire, aperiodic radia-

tors. One manufacturer of diathermy equipment stated that only the highest priced of three models incorporated line filtering. When it is remembered that many diathermy machines boast of 500 watt ratings with no more shielding than a wooden cabinet, the extent of interference is not surprising.

However, these sources of interference are relatively limited in number. Explanation of the problem to the diathermy owner may elicit permission to re-tune, shield and install line filtering in the offending apparatus. When the interference is strong and frequent, the attempt to obtain such permission is well worth while. It remains to locate the apparatus.

In connection with diathermy interference problems of the Don Lee Broadcasting System, a rapid method of locating the point of origin of diathermy interference was developed. The equipment used consisted of an automobile carrying a Reinartz circular antenna, provided with means of rotation, and a portable receiver incorporating a "signal strength" meter. The field pattern of this antenna is characterized by its heart shape, the null point being very narrow and deep.

### Locating Interference

The method is to first determine the general direction of the source using the antenna null point. About three readings at spaced intervals are necessary to obviate possibility of error due to reflected signals. The previously used system of taking frequent cross-bearings with the directional antenna, resulted in considerable delay since it was necessary to stop for each

The diagrams here reproduced are the result of actual field tests made by the author, in picking up television signals in California from a local station.

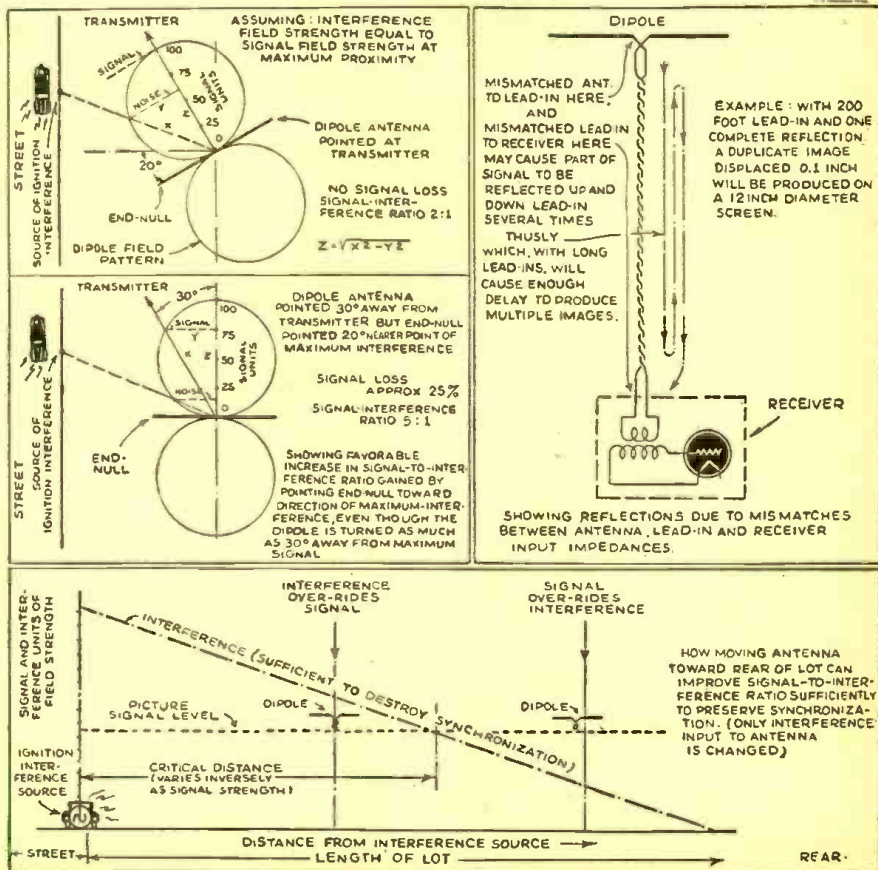



bearing and false clues were obtained from numerous reflected waves. It is therefore advisable to switch the receiver to a non-directional antenna, after the general direction is established and to base subsequent conclusions upon the signal magnitude. This permits of rapid driving with no stops necessary.

A course following the direction indicated is maintained until a rise and fall of signal strength is observed. When a point of maximum signal along this line of travel has been determined, the course is retraced to that point and a new course, 90 degrees from the first, is pursued until a point of maximum signal strength along this line is obtained—thereby providing, in effect, *cross-bearings*.

Standing waves will be observed to cause rapid fluctuation of signal strength until the point of origin is approached within a few hundred feet, at which time the field of electro-magnetic induction establishes control and the standing wave effect disappears.

This method will determine the point of origin to within 100 feet and it then but remains to look for a physician's sign, or make a few inquiries.

### Carrier Wave Reflections

The problem of interference from *carrier wave reflections* can only be solved by a receiving antenna installation technique, based upon a thorough knowledge of the behavior of such reflections. In general, reflections can be considered lateral in direction, although occasional reflection interference from aircraft has been observed.

Radio waves travel about 75,000 times faster than the spot on a 12 inch picture tube scanning at the 441 line 30 frame rate. Thus the displacement of the secondary image upon the raster will be 1/75,000th part of the difference between the length of direct and reflected wave travel. Phase differences between the two waves and their side-band components may cause reinforcements or cancellations, which distort half-tone values and frequently produce *negative images*.

Special care must be taken to determine the presence of short delay reflections. These cause only blurring and loss of vertical picture detail and therefore are likely to be overlooked, while the sub-standard picture is blamed upon poor video frequency band-pass of the receiver.

### Poor Impedance Matching May Cause Trouble

It should be noted here that many multi-image effects are *not* due to *carrier wave reflections*. When the transmission line length is in the order of 100 feet or more, poor *impedance-matching* between receiver, transmission line, and antenna may cause signal reflections from receiver to antenna and back again to the receiver, sufficient to seriously impair the picture quality.

Repetition of vertical lines may result from undamped oscillation, set up in poorly designed or defective high frequency compensation circuits by shock excitation.

A sharply directional antenna is necessary where the angle of arrival between direct and reflected waves is less than 45 degrees. Orienting this antenna 10 degrees off maximum, away from the reflected

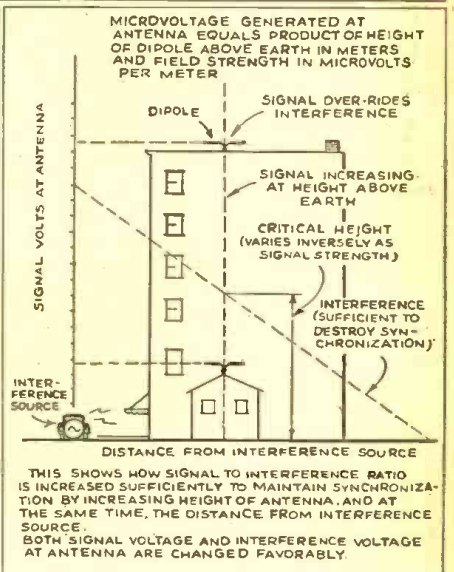
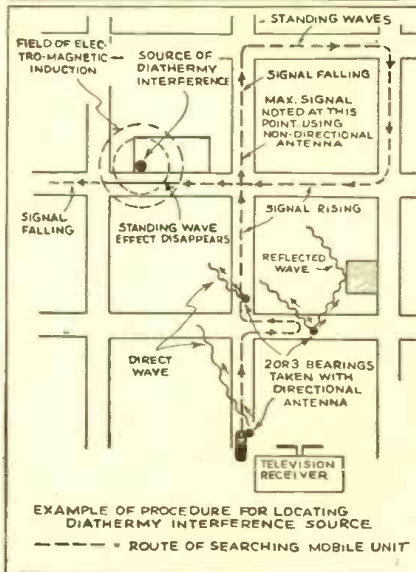
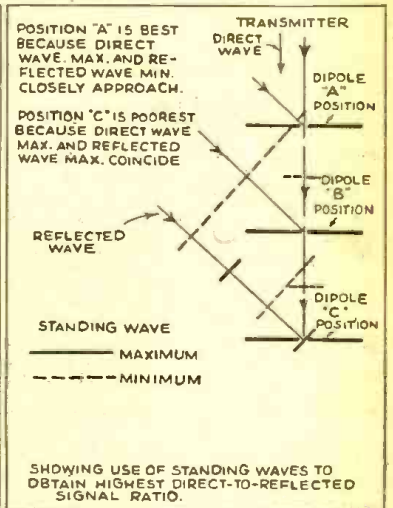
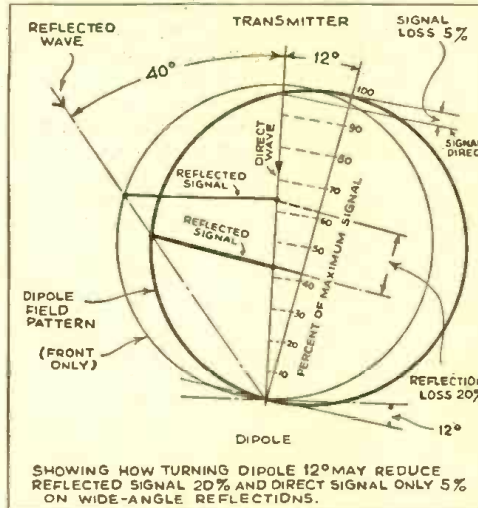
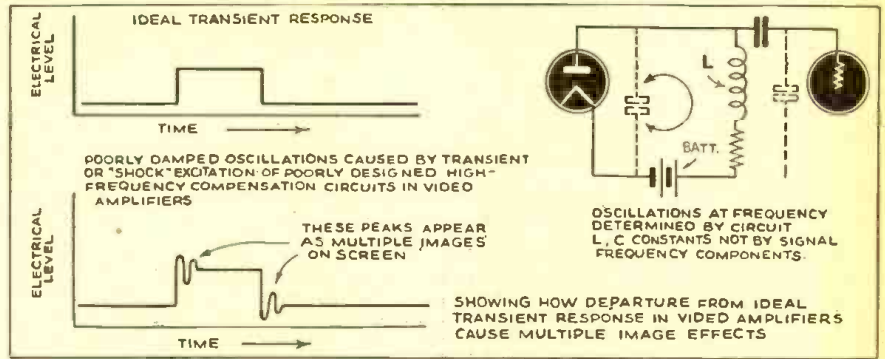

Diagrams herewith show effects of interference with received television signal, and the reason why it is important to choose carefully the final location for the television antenna.

standing wave maximum to minimum is most frequently encountered.

Standing wave phenomena is very helpful where the angle between direct and reflected signal is greater than 30 degrees. Phase relationship between direct and reflected standing waves varies for each half-wavelength. Thus at a given point, the direct signal may be maximum, while the reflected signal is minimum. At a point several half-wavelengths removed, direct and reflected maximums may coincide. The obvious solution is to locate the antenna position at a point where the direct signal is maximum and the reflected signal is minimum. About a five to four ratio of

standing wave maximum to minimum is most frequently encountered.

Evidence points to possible *twists of polarization* of reflected waves, but observations to date are inconclusive. If this be true, antennas polarized accordingly will offer another means of discrimination between direct and reflected signals.

In conclusion, may I urge that those vitally interested in the television art do not permit slipshod use of their art in the field. No invention of science has been measured against more exacting standards of performance, and only an unrelenting insistence upon peak performance can place television in its rightfully high place in public service.

Principles of

# Frequency Modulation

Part 2—Concluded

F. L. Sprayberry\*

● OBVIOUSLY, if we use 1000 cycles instead of 100 cycles, the deviation frequency will become 10 times as great. Similarly if we use 10,000 cycles our deviation will be 100 times as great. Since we desire to have every deviation in frequency of the carrier correspond to an equivalent audio amplitude and have a faithful proportion between the two—this matter of deviation being determined by frequency introduces a serious problem.

In the foregoing, we have chosen 100 cycles as the modulation frequency for the sake of our example, and we have found that this has been involved in finding the corresponding frequency deviation to be 52.3 cycles. For reasons which we are about to study, we desire to have a maximum fre-

and 30 for  $\theta$  we have—

$$fm = \frac{25}{.01745 \times 30}$$

$$fm = .523$$

$$fm = 47.75 \text{ cycles}$$

Whereas 100 cycles of A.F. will produce a deviation of 52.3 cycles of the 200 kc. carrier, 47.75 cycles A.F. will produce 25 cycles deviation of the 200 kc. carrier.

This being so, we see that if we desire 25 cycles deviation of the carrier for every audio frequency of the same amplitude, we must supply the balanced modulator screens with 10 volts at 47.75 cycles, 1 volt at 477.5 cycles and .1 volt at 4775 cycles

will amplify all energy inversely proportional to its frequency. The amplifier circuit is shown in Fig. 11 and its characteristic output response is shown in Fig. 12. The usual flat characteristic is shown in a dash line for comparison.

The amplifier is a 4 stage unit, using a self-balancing phase inverter and the values of parts are chosen to give it the desired characteristic. Note that the output grids are shunted with .1 mfd. condensers and have 200,000 ohm resistors in series with them. This part of the circuit alone will very much reduce the voltage of high frequencies.

The amplifier uses a transformer coupled push-pull type input with an R.F. filter in each lead. The R.F. filter is, of course, typical of any audio amplifier used near a transmitting circuit. A single triode input tube V1 using a cathode loaded circuit also called a "cathode-follower" circuit feeds energy through a resistance network to another triode (V2) grid. The 75,000 ohm series element of this network is shunted by a condenser in series with a switch so that a larger portion of high frequencies may pass this point in the circuit when desired. It is possible in this way to emphasize the high frequencies and the action is called "pre-emphasis" of the high frequencies. The same can be done in amplitude modulation but the transmitters for amplitude modulation are not equipped to make use of additional high frequencies at an equivalent FM transmitter cost and in addition having operating channel limitations placed upon them. Thus, while pre-emphasis is not new, it has importance in this type of transmission.

Tube V3 is simply a monitor for indicating the voice level during operation. Tubes V4 and V5 are amplifier and phase inverter respectively, while V6 and V7 are push-pull output tubes. This type of amplifier having characteristics as given in Fig. 12 must be used with the Armstrong modulation system. The output terminals of this amplifier connect to the input screen terminals of V3 and V4 of Fig. 8.

(End of Part 2)

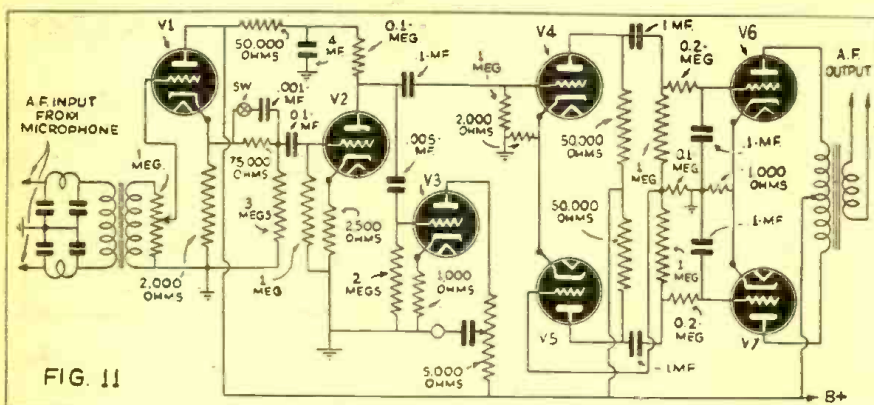

FIG. 11

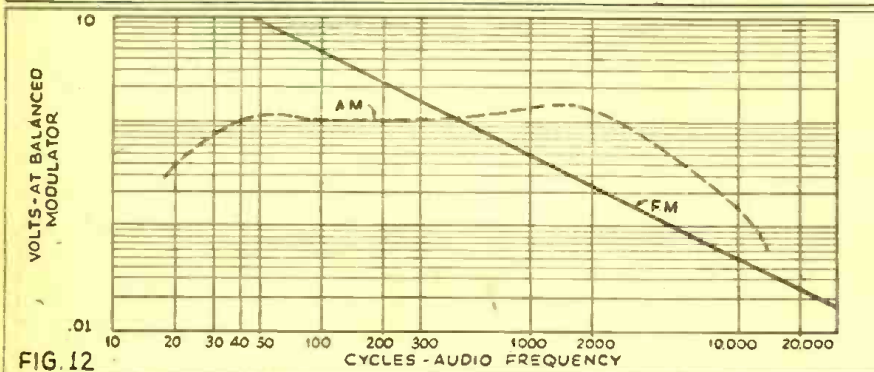

FIG. 12

Circuit of input A.F. amplifier designed to be continuously frequency selective; so as to amplify all energy inversely proportional to its frequency. Response curve of amplifier is also shown.

quency deviation of 25 cycles. Now, we must find what modulation frequency (audio) will give exactly this deviation if we retain the maximum phase shift of 30°. To find this value for fm, we simply invert the formula—

$F = .01745fm\theta$  to solve for fm as follows—

$$fm = \frac{F}{.01745\theta}$$

or the audio voltage must vary inversely as the audio frequency. If we did not do this at the transmitter, a 1000 cycle signal would produce 10 times the output of a 100 cycle signal at the receiver. This figure of 10 volts is purely arbitrary and is used only in illustration. The actual voltage must be adjusted so that a peak phase shift does not exceed 30° each side of zero phase.

To correct this undesirable effect, we design the input A.F. amplifier so that it will be continuously frequency selective and

It is up to YOU—  
Mr. Reader of "R. & T.!"

Do you want more on  
Principles of  
Frequency Modulation?

A Post Card will do.

Just say frequency modulation  
and indicate more or less.

The Editors

\*President, Sprayberry Academy of Radio.

F-M PRINCIPLES—Part 3

WE have chosen a reference deviation frequency of 25 cycles in the foregoing but in accordance with our earlier studies we know that this must ultimately be expanded by frequency multiplication to around 75 or 100 kc. Since a deviation of the final carrier of 75 kc. is considered satisfactory, let us see what is involved in the multiplier circuits. To multiply 25 cycles until it is 75,000 cycles it must be multiplied 3000 times. Let us look at an actual multiplier circuit as in Fig. 13.

The 200 kc. signal with a maximum deviation of 25 cycles enters tube V1 in Fig. 13 and is simply amplified. It is further amplified by V2 which feeds the grids of V3 and V4 in phase opposition. The plates of V3 and V4, however, are in parallel so that they receive a plate current pulse for each positive grid pulse in each tube. Being biased at cut-off or beyond, these tubes V3 and V4 produce two plate pulses for each grid cycle and in this way the frequency is doubled effectively. The common plate load for V3 and V4 is tuned to 400 kc. Accordingly, the frequency deviation has been doubled, becoming 50 cycles instead of 25. For example, as the 200 kc. carrier momentarily rises to 200,025 cycles on deviation peaks and this frequency is doubled, we have  $2 \times 200,025$  or 400,050 cycles, in which we may observe that the 25 cycle deviation has now reached 50 cycles. Tube V5 then amplifies the 400 kc. signal and feeds it to another frequency doubler of the same type, raising the carrier to  $2 \times 400$  kc. or 800 kc. and the deviation to  $2 \times 50$  or 100 cycles.

Tube V8 is simply an 800 kc. amplifier but V9 is a doubler stage of the bias type. In this stage the grid is biased beyond cut-off so that plate current may flow in the tube only during a small fraction of the R.F. cycle. The plate circuit is then tuned to 1600 kc. and while energy is only supplied to it once every two cycles, its own "energy storage" or pendulum effect makes it produce a cycle in between each one which is forced in it. The carrier is now 1600 kc. while the deviation is 200 cycles.

Stages V10, V11 and V12 are similar types of doubler-amplifier stages raising the carrier frequency to 12,800 kc. and the maximum deviation to 1600 cycles. It should be apparent that we cannot continue this direct multiplication process if we desire a 75 kc. deviation and a carrier of not more than say 50 mc. Two more doublings of 12.8 mc. would produce a carrier of 51.2 mc. with a deviation of only 6400 cycles. We have gone beyond our carrier goal but have not nearly reached our desired frequency deviation.

We, therefore, must resort to heterodyning or beating the 12.8 mc. carrier with another carrier having no frequency deviation so that we may have a relatively low frequency with this same deviation. This particular multiplier circuit makes use of another frequency of 11.9 mc. as in Fig. 13, which is introduced into the mixer grid of a 6L7 tube with the 12.8 mc. fed to its oscillator grid. The tube is identified as V13 and its plate load is tuned to 900 kc. as this would be the "difference-beat" produced by the demodulating action of this tube.

Now as the 12.8 mc. carrier advances to 12,801.6 kc. on maximum positive deviation

# 10 BEST RADIO BOOKS 10¢ ea.

RADIO FANS EVERYWHERE—these fine ten cent text books give you an excellent foundation for the study of RADIO. They are clearly written, profusely illustrated and contain over 15,000 words in each book. You'll be

amazed at the wealth of information contained in these handy books. Excellent for reference—ideal for every technical library. **YOUR MONEY BACK** if you are not satisfied. **PROMPT SHIPMENTS**



No. 1  
**HOW TO BUILD FOUR DOERLE SHORT WAVE SETS**

Thousands of radio fans have built the famous DOERLE Short Wave Radio Receivers. So insistent has been the demand for these receivers, as well as construction details, that this book has been specially published. Contains EVERYTHING that has ever been printed on these famous receivers.

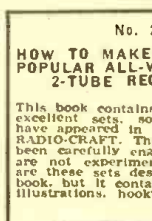

No. 2  
**HOW TO MAKE THE MOST POPULAR ALL-WAVE 1- and 2-TUBE RECEIVERS**

This book contains a number of excellent sets some of which have appeared in past issues of RADIO-CRAFT. These sets have been carefully engineered. They are not experiments. Not only are these sets described in this book, but it contains all of the illustrations, hookups, etc.



No. 3  
**ALTERNATING CURRENT FOR BEGINNERS**

This book gives the beginner a foothold in electricity and Radio. Electric circuits are explained. Ohm's Law, one of the fundamental laws of radio, is explained; the generation of alternating current; sine waves; the units—volts, amperes, and watts are explained; Condensers, transformers, A.C. instruments, motors and generators.

No. 4  
**ALL ABOUT AERIALS**

This book explains the theory underlying the various types of aerials; the inverted "L," the Doublet, the Double Doublet, etc. It explains noise-free reception; how low-impedance transmission lines work; why transposed lead-ins are used. It gives in detail the construction of aerials suitable for long-wave broadcast receivers, for short-wave receivers and for all-wave receivers.



No. 5  
**BEGINNERS' RADIO DICTIONARY**

Are you puzzled by radio language? Can you define Frequency? Kilovolt? Tetraode? Screen grid? Baffle? Anode? Triode? Pole? Ionization? Joule's Law? Harmonic? Gravity Cell? If you cannot define these very common radio words and dozens of other, more technical terms used in all radio magazines and instruction books, you need this book in your library.

No. 6  
**HOW TO HAVE FUN WITH RADIO**

Stunts for parties, practical jokes, scientific experiments and other amusements which can be done with your radio set are explained in this fascinating volume. It tells how to make a newspaper talk—how to produce silent music for dances—how to make visible music—how to make a "silent radio" unit, usable by the deafened—how to make toys which dance to radio music, etc., etc.

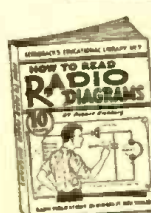

No. 7  
**HOW TO READ RADIO DIAGRAMS**

All of the symbols commonly used in radio diagrams are presented in this book, together with pictures of the apparatus they represent and explanations giving an easy method to memorize them. This book by Robert Eleberg, the well-known radio writer and member of the editorial staff of RADIO-CRAFT Magazine, also contains two dozen picture-wiring diagrams of radio sets that you can build.

No. 8  
**RADIO FOR BEGINNERS**

Hugo Gernsback, the internationally famous radio pioneer, author and editor, whose famous magazines, RADIO AND TELEVISION and RADIO-CRAFT are read by millions, scores another triumph with this new book. Any beginner who reads it will get a thorough ground work in radio theory, clearly explained in simple language, and through the use of many illustrations. Analogies are used to make the mysteries of radio clear.



No. 9  
**SIMPLE ELECTRICAL EXPERIMENTS**

Over 100 interesting and practical electrical experiments are described in this book, covering every branch of electricity—from simple experiments with magnets to high frequency "stunts." All of the experiments described can be carried out with simple apparatus, most of which can be found about the home.

No. 10  
**TELEVISION**

Every one is asking the question "How does television work?" This book explains all of the different systems of television from the simplest to the most complex. It describes in A-B-C style just how the image is scanned, how the scene is picked up by the television camera and broadcast to your home, etc. Various types of television systems are described.



BOOKS ARE ALL UNIFORM

Every book in the GERNSBACK EDUCATIONAL LIBRARY has 32 pages—with illustrations varying from 30 to 66 in number. Each title volume contains over 15,000 words. Positively radio's greatest book buy! If you do not think these books worth the price asked, return them in 24 hours and your money will be instantly refunded.

RADIO PUBLICATIONS • 20 VESEY STREET • NEW YORK, N. Y.

RADIO PUBLICATIONS, Dept. RT-4-41  
20 VESEY STREET, NEW YORK, N. Y.  
Gentlemen: Please read immediately, POSTPAID, the book numbers circled below, I am enclosing ..... cents—each book being 10c.

1 2 3 4 5 6 7 8 9 10  
NEW NEW

Send FREE listing of 48 new 10c publications.

Name ..... Address .....

City ..... State .....

Remit by check or money order—register letter if you send cash or unused U. S. postage stamps.

**MAIL COUPON TODAY!**

its beat with 11.9 mc. will be 12,801.6—11,900.0 kc. or 901.6 kc. Thus, we find that the same frequency deviation, namely 1600 cycles, is found in the 900 kc. beat as was originally found on the 12.8 mc. carrier.

Incidentally, the 11.9 mc. signal is obtained by using a 5.95 mc. crystal controlled oscillator (V14) and doubling its output frequency. Continuing from the 900 kc. output of V13, we come to V16—another frequency doubler. The action is often roughly compared to that of a single cylinder 4 cycle engine in which only every other "stroke" is a power stroke while the "fly-wheel action" supplies the additional intake stroke. A radio tank circuit is, therefore, often referred to as having fly-wheel action although it is actually reciprocating as a pendulum rather than a continuous motion as a fly-wheel.

In the plate of V18, we therefore, have 1800 kc. and for reasons given above we also have  $2 \times 1600$  or 3200 cycles deviation. Following are listed the final frequency considerations.

Tube	Carrier Output	Cycles Deviation	Type
V16	1.8 mc.	3200	doubler
V17	3.6 mc.	6400	doubler
V18	7.2 mc.	12,800	doubler
V19	21.6 mc.	38,400	tripler
V20	43.2 mc.	76,800	doubler

Operation of the tripler stage V19 is similar to that of the doubler except that its plate circuit is tuned to three times the frequency supplied to the grid. Hence, the plate tank circuit produces two additional cycles between each grid pulse by "fly-wheel" or "pendulum" action.

The tubes in Fig. 13 may all be power amplifiers so that we can increase power in addition to multiplying. We may thus start with from 1 to 5 watts at V16 and

obtain 1 KW. at V20. From the plate of V20 energy is fed to a vertical dipole antenna.

Note that all of the plate and grid tank circuits are resistance padded so that they will respond to the increasing frequency deviation. They are broadly tuned in the same manner as receiver circuits.

### Motor Controlled Reactance Tube Modulator

Among the reactance tube types of frequency modulated oscillators for F-M transmission there is a motor frequency controlled type in present use, which may become important in this field in the future.

Because of our previous detailed study of the reactance control tube and circuit, we can discuss this circuit as presented in Fig. 14 much more freely.

The oscillator circuit is of the push-pull or, as we more commonly say, back-to-back Hartley type. It is identified by the connection to its main tank inductance which is connected to the plates of tubes V1 and V2. The oscillator plates (V1 and V2) are series fed through this coil while the grids are shunt coupled to it by means of the regular grid coupling condensers.

The tank circuit is primarily tuned by means of a relatively large two-section fixed condenser and a relatively small two-section variable condenser (correction condensers) which, as you will notice, is motor driven through a reduction gear train indicated by the dotted line. In parallel with each oscillator plate is a plate of one of the reactance-operated tubes (V3 and V4).

In this study it may have occurred to you that since it is possible to make a tube exhibit certain inductive properties by control of the phase between its plate current and voltage, it may also be possible to make a tube exhibit capacitive properties by an equivalent means. This is what the react-

ance control tubes accomplish in this circuit.

To make a tube exhibit certain capacitive properties it is only necessary to make its A.C. plate voltage lag its A.C. plate current component by as near  $90^\circ$  as possible. As you will recall, the voltage across a perfect condenser lags the current flow through it by  $90^\circ$ .

A phase-shifting network shown supplied with R.F. energy through inductive coupling to the oscillator delivers a voltage to one grid (V3) approximately  $90^\circ$  leading the A.C. plate voltage applied by the oscillator. To the other tube V4 (since the grids are supplied in phase), it is a lagging voltage but as the instantaneous R.F. plate voltage is now minimum the current in the other tube is the dominant influence in the circuit. The net A.C. plate-to-plate current therefore leads the A.C. plate voltage by approximately  $90^\circ$  and the effect on the tuned circuit is that of a condenser whose reactance approximates the plate to plate A.C. impedance of the reactance control tubes V3 and V4.

Far from being a low frequency oscillator the circuit of tubes V1 and V2 operates at about 5425 KC. or 5.425 mc. By using such a high frequency we only need to change the capacity reactance of tubes V3 and V4 .46 of 1% in order to change the frequency 12.5 KC. (this is the deviation frequency). Since this is the maximum amount of capacity change caused by tubes V3 and V4, it is obvious that the reactance control tubes form but a very small part of the entire tank capacity.

This fundamental oscillator frequency of 5.425 mc. with a frequency deviation of 12.5 KC needs only to be doubled three times (multiplied by 8 as  $2 \times 2 \times 2 = 8$ ) to bring it to the desired final output carrier frequency of 43.4 mc. on which we have a deviation frequency of 100 kc. (12.5

Fig. 13—Multiplier circuit described in the text.

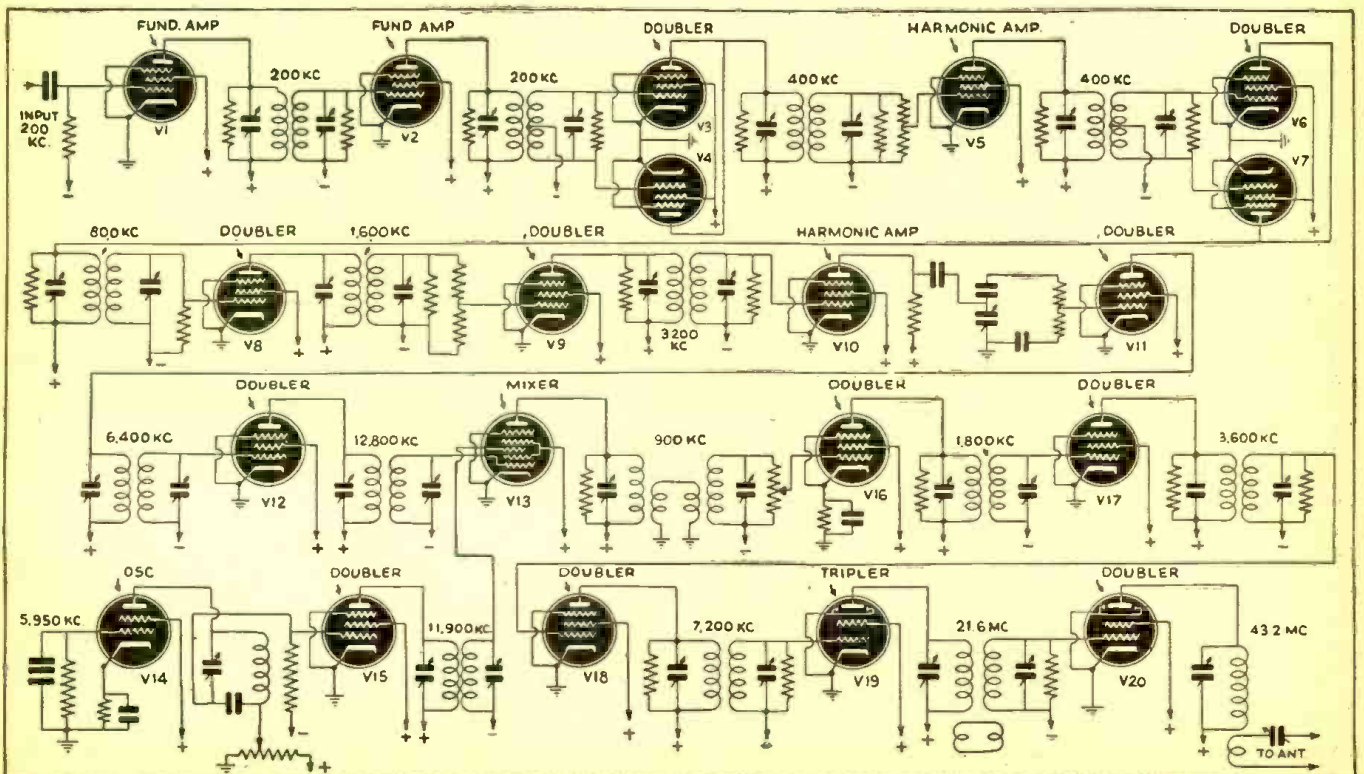

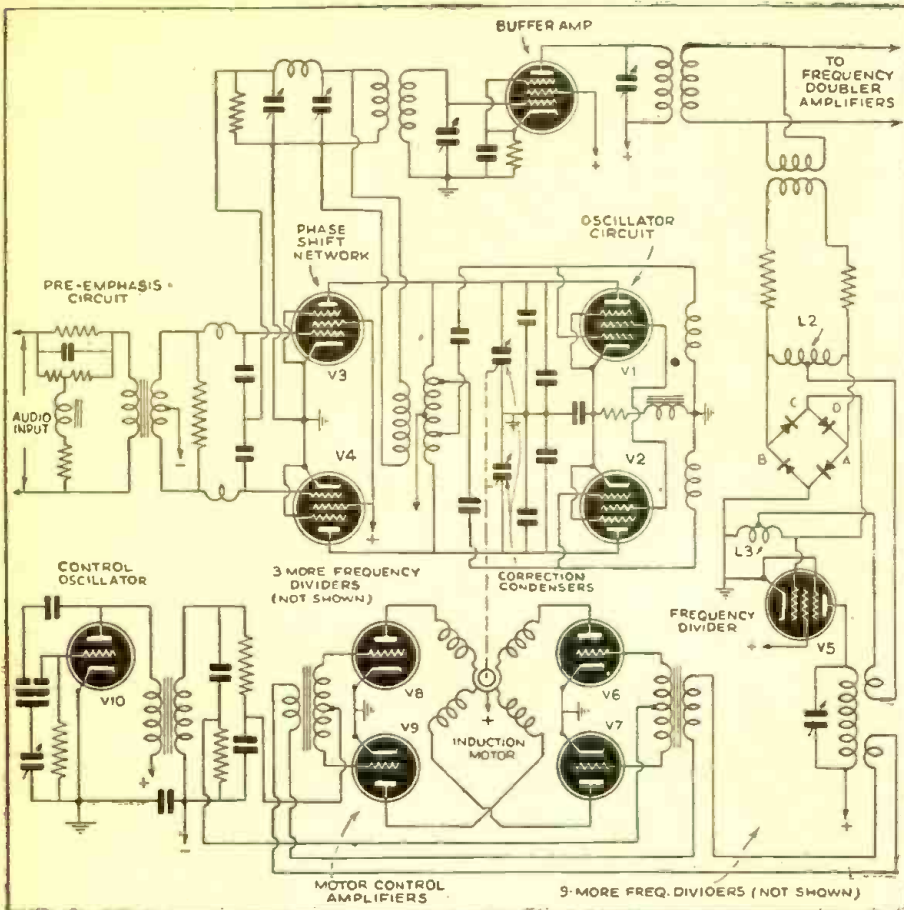

Note in this circuit, Fig. 14, that from the same source that supplies the phase-shifting network, a buffer amplifier is fed, which isolates the oscillator and its reactance control from the following circuits.

kc.  $\times 8 = 100$  kc.) each side of the radiated carrier.

The A.F. as usual entering the grids of the reactance tubes V3 and V4 varies the amount of capacity which these tubes can exhibit, bringing about frequency changes in the carrier proportional to the A.F. voltage impressed. This capacity reactance tube circuit has the advantage that the frequency deviation of the carrier is proportional to the A.F. voltage only—the audio frequency not affecting it as in the Armstrong system.

Since the reactive tubes in this circuit also exhibit variable resistance properties tending to vary the load on the oscillator and hence produces a certain amount of amplitude modulation, this, of course, is not wanted. For this reason other provisions of the circuit are needed to overcome this. This action is effectively compensated by the introduction of a cathode load in the oscillator producing degeneration enough to compensate for amplitude modulation to a satisfactory degree. Note the iron core inductance with a series resistance in the common cathode to ground circuit of the oscillator tubes V1 and V2.

The most serious problem with this type of circuit is the one of frequency control of the carrier. Note in the circuit Fig. 14, that from the same source that supplies the phase-shifting network, a buffer amplifier is fed. This buffer effectively isolates the oscillator and its reactance control from the following circuits. The output of this buffer feeds the frequency doublers and power amplifiers as well as a frequency control circuit to be described later. As mentioned, there are three doubler stages following the

buffer and enough additional fundamental frequency amplification to acquire any output power which may be desired. The one described here has a power output of 1 KW.

The frequency control circuit consists of ten frequency dividers, each dividing its input frequency in half. Thus the ten stages divide the carrier frequency by 1024. One of these ten similar stages is shown in Fig. 14. It consists of an R.F. transformer coupling into a special bridge circuit which is in turn coupled to a tube input (V5). Note that the control circuit rectifier resembles a bridge rectifier and is of the copper oxide type with two of its elements reversed from the conventional bridge rectifier wiring.

The input frequency (5.425 mc. from the buffer) alone causes no output action of the amplifier V5 because the input bridge circuit is balanced. Thus for a half cycle of the basic oscillator frequency (5.425 mc.) introduced into the bridge at point A, it will become more positive than ground and B, equally more negative. Let us say A is at +10 volts while B is at -10 volts. The bridge circuit elements to C being equal, whether current flows through this branch or the ground branch the potential of C will remain fixed or at ground.

A regenerative action of V5 however, with its plate circuit tuned to  $\frac{1}{2}$  the input frequency to the bridge feeds this frequency back to the bridge input (taps of L2 and L3). It feeds points A and B of the bridge in-phase—that is, both positive or negative at the same time and this influence varies point C in the same phase as the feedback connections to the taps of coils L2 and L3.

## Home Recorder FREE!

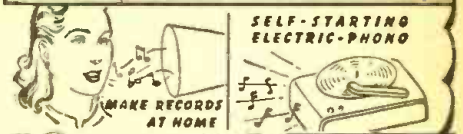

**15 TUBE MIDWEST RADIO-PHONO COMBINATION**

Put this Radio-Phono Chassis in Your Present Cabinet...  
**FACTORY-TO-YOU SAVES UP TO 50%**

Thrilling World-Wide Foreign News DIRECT!

UP \$25 TRADE-IN (On many models up to 18 tubes)

ENJOY listening to fine recordings on electric phonograph—delight in amazing ocean-spanning radio. Make records on Home Recorder (sent FREE for a limited time). Big FREE catalog pictures beautiful 1941 Factory-To-You radio chassis and console values—from 6 to 18 tubes—up to 5 Bands—including Automatic Record-Changing Automatic Record-Phonographs; Home Recorder, etc. Liberal Trade-In! Write today.

ONLY \$22.50 COMPLETE RADIO-PHONO CHASSIS and SPEAKER

MIDWEST RADIO CORPORATION DEPT. 14-KK CINCINNATI, OHIO



## ELEMENTARY MATHEMATICS

EASY — SIMPLIFIED — PRACTICAL

HERE is a book for the business man, the technician and craftsman explaining and answering every operation and meaning with interpreting illustrations and examples. It is the key to a simple understanding of many perplexing problems in daily life. In clear, positive and definite language, the author popularizes and clarifies every subject and helps the reader to overcome any apparent difficulty in the study of mathematics. A real home study-course in mathematics for the student or the man who wants to achieve proficiency or desires to brush-up on his knowledge.

Entire Chapter on Special Mathematics for the Radio Technician

### CONTENTS OF BOOK

- CHAPTER I. Arithmetic—Addition—Subtraction—Multiplication—Division.
- CHAPTER II. Factoring and Cancellation—Fractions—Decimals—Percentages—Ratio and Proportion.
- CHAPTER III. The Metric System.
- CHAPTER IV. How to Measure Surfaces and Capacity (Geometry).
- CHAPTER V. Powers and Involution—Roots and Evolution.
- CHAPTER VI. Mathematics for the Manual and Technical Craftsman—Thermometer conversions—Graphs or Curve Plotting—Logarithms—Use of the Slide Rule.
- CHAPTER VII. Special Mathematics for the Radio Technician.
- CHAPTER VIII. Commercial Calculations—Interests—Discounts—Short Cut Arithmetic.
- CHAPTER IX. Weights and Measures—Useful Tables.

\*Elementary Mathematics can be carried readily in your pocket. Send Stamps, Cash or Money Order.

## TECHNIFAX

1917 S. State St. RT-441 Chicago, Ill.



## WARSHIP MODEL PRINTS

- \$6—10,000 ton U.S. Navy 37" Cruiser. Model Blueprints . . . \$3.15 (Complete Kit, all fittings . . . \$28.00; Hull Kit . . . \$7.75)
- 54—U.S. Destroyer; 39" exact model; Blueprints . . . \$1.60 (Hull constr. Kit \$5.60; complete Kit \$33.50)
- 53—"Constitution" (Old Ironsides 28" Model. Blueprints) . . . \$2.20 (Complete Kit \$35.00; Hull Kit \$6.50)
- 57—"Rob't. E. Lee"—Mississippi River Steamboat; 28" long. Blueprints . . . \$2.60 (Complete Kit \$22.00; Hull Kit \$8.50)
- 52—"Clermont"—first steamboat (blueprints) . . . \$1.10 (Complete Kit for 18" Model—\$7.00 prepaid)

## DATAPRINT CO.

Box 322, Ramsey, New Jersey

**Social Security name Plate**

SOCIAL SECURITY ACT  
NUMBER 000-000-000  
NAME JOHN DOE

**Only 35¢**

Bronze Plate with your Name & Number on it and This GENUINE LEATHER BILLFOLD without Extra Charge.



For the nominal amount of 35c we will send you the following values:

1. One duo-tone imperishably etched Bronze Name Plate, size 3x1 1/2 inches with your Social Security number and name permanently stamped upon it.
2. One Genuine Leather Billfold, size 8 1/2 x 3 inches in natural brown color, with four compartments, as per illustration above.

This Pocketbook is our free present to you. Absolutely no strings of any kind. We make you this gift because we expect you to do us a favor by showing your name plate to your friends, to interest them in ordering one for themselves. That's all. Help us and you will profit yourself.

**ACT NOW!** Mail the coupon below and enclose 35c in coins. The bronze name plate and the Leather Billfold will be forwarded to you at once.

PREMIUM DISTRIBUTING SERVICE  
Wrigley Bldg., Chicago, Dept. RT-441

Enclosed find 35c for which mail to the address below, my Social Security Bronze Plate and the Genuine Leather Billfold without extra cost, as per your offer.

My Social Security Number is .....

NAME .....

ADDRESS .....

CITY ..... STATE .....

**300 WAYS TO MAKE MONEY**

**10c PER COPY**

**Cash In!**

68 PAGES  
MAIL ORDER PLANS  
TESTED MONEY MAKERS  
BUSINESS SECRETS  
SUCCESS SCHEMES

MARVEL BOOK OF THE YEAR!  
40,000 WORDS in TEXT!

In "CASH IN" you get ALL the real money-makers—dozens of profitable tested mail order plans, confidential business secrets, dozens of practical tested formulas, successful tested schemes—actual experiences of men who have started on a shoestring—with less than \$10 capital.

**25 CENTS**

SOLD ON A MONEY-BACK GUARANTEE

Buyers of This Book Tell Us—  
"Biggest value I've yet to see. Book is worth at least a dollar." S. Buda, Brooklyn, N. Y.  
"Your book is as good if not better than others selling at \$1.00." George Brunet, Montreal, Can.  
"CASH IN is the best value I have yet to see in the mail order field." Lawrence Fox, Brooklyn, N. Y.  
"CASH IN" contains only tested ideas covering every type of full- or spare-time enterprise—it's a "masterpiece" in business ventures.

BOOK CONTAINS NO ADVERTISING  
10c a copy postpaid. Send U.S. stamps or coin.

**NATIONAL PLANS INSTITUTE**  
246-T Fifth Ave., N.Y.C.

During the other half cycle of the input the potential of A and B are both reversed but since C is midway between them in potential it is unchanged by this process. During 1/2 of the R.F. input cycle a current through one bridge section due to this R.F. is in phase with the voltage at C, while during the second half cycle, another modulator section is in phase with C which now is completing its first half cycle. In this way the 5.425 mc. carrier has accurate control over the divided frequency at all times. Ten circuits of this kind will divide the 5.425 mc. carrier by 1024, producing approximately 5300 cycles output which is a frequency low enough to act on a motor so as to give mechanical control as explained further on.

A crystal controlled oscillator (with tube V10) operating at approximately 84 kc. is likewise fed into a smaller series of frequency dividers four stages dividing it by 16, and producing also 5300 cycles approximately. This latter frequency is held to better than 1 cycle accuracy due to the crystal action.

The two 5300 cycle frequencies are fed each to a special double push-pull amplifier (tubes V6, V7, V8 and V9) loaded with a frequency correction motor, of the non-synchronous induction type. Note that the control oscillator feeds all four grids of V6, V7, V8 and V9 in phase by reason of the grid return feed, while the reduced carrier component feeds the grids in opposite phase by pairs. For example, V6 and V9 will be in phase while V7 and V8 will be in phase but displaced 180 degrees from V6 and V9.

With the two frequencies exactly in synchronism the field of this motor will simply be one of changing intensity but of fixed direction. However, if one frequency exceeds the other, the motor fields will change phase continuously and a rotating magnetic field will be produced in the motor. This will, of course, rotate the armature. The magnetic field will rotate at the frequency of the beat between the two 5300 cycle (approx.) frequencies and this motor will rotate the correction condenser plates of the oscillator through a reduction gear train.

If the component from the transmitter carrier is higher than that of the crystal controlled oscillator V10, the rotating magnetic field will rotate in such a direction as to turn the oscillator tuning condensers more in-mesh lowering the oscillator frequency. If the carrier frequency component is too low the reverse rotation will result. Thus the carrier is automatically kept within 1000 cycles by this mechanical means. With the frequency corrected the motor field will naturally cease rotation.

Frequency changes due to modulation of the oscillator, of course, produce rapidly, reversing rotating fields up to nearly 200 revolutions per second reversing at A.F. but the mass of the motor armature is far too great to follow these instantaneous fields. It will only follow the cumulative effect of a great number of such instantaneous fields

which, of course, would correspond to the carrier.

With this apparatus all conditions of transmission can be well within the Federal Communications Commission requirements. The fidelity and noise level achievements are as usual characteristic of this type of transmission.

F-M Quiz

1. What relationship between audio volts and carrier cycles deviation is most desirable in F-M transmitters?
2. In what essential way must we operate a vacuum tube to make it exhibit inductive properties?
3. What is the chief disadvantage of the resistance component in the "reactance tube" type of modulator?
4. In the Armstrong modulator system, do the two waves which in combination form the ultimate carrier have the same frequency?
5. What two basic factors determine the frequency deviation in the Armstrong modulator?
6. Does the audio output of the voice amplifier for the Armstrong modulator depend in any way upon the audio frequency?
7. For what reason are practically all of the tuned circuits in the frequency multiplier circuits loaded with shunt resistors?
8. How is the frequency which actually drives the motor in Fig. 14 derived?
9. Why can no system of frequency modulation as described in this lesson be crystal-controlled but the Armstrong system?
10. By what factor do we increase a frequency deviation if we multiply the frequency itself by 3000?

**Electroplate BRUSH**

COMPLETE PLATING KITS

FOR Industrial plants, repair shops, radio shops, mechanics, craftsmen and home use.

For repairing, replating or plating—nickel, cadmium and other finishes.

Radio and electrical shops can now silver plate electrical connections on radios, testing instruments, sound systems, etc. (Silver plated connections do not require cleaning and have better conductance than any other metal.)

Worn spots on horns, saxophones and other instruments can be replated without disassembling.

Covered by U.S. & Foreign Pat.

**ALL KITS GUARANTEED**

Silver kits .....\$2.50 and up  
Nickel or cadmium .....\$2.00 and up  
(\$2.00 kit illustrated)

Send for catalog folder and other information

**RAPID ELECTROPLATING PROCESS, INC.**  
1414 S. WABASH AVE. Dept. R-2 CHICAGO, ILL.

**NEXT MONTH—**

A simple Signal-Tracer for the Set-Builder and Radio Beginner.

Also the "Musicaster" by H. G. Cisin, M.E.

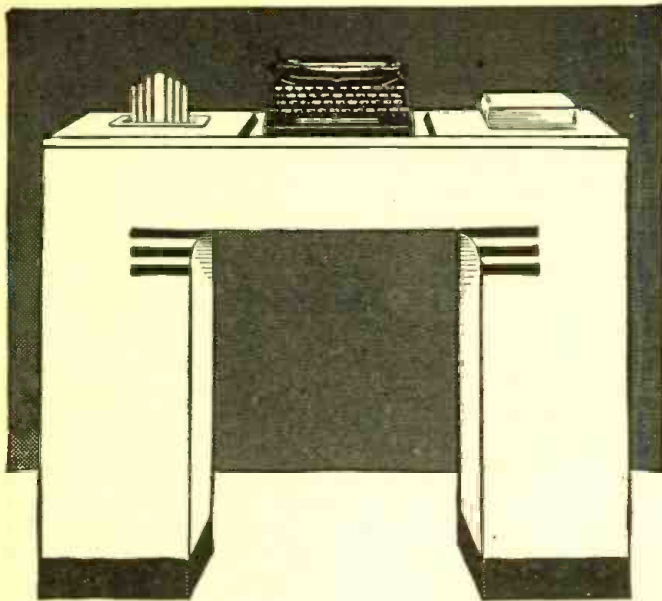

**THIS  
BEAUTIFUL DESK  
for only \$1.00 EXTRA**

**WITH ANY  
REMINGTON  
PORTABLE TYPEWRITER**

*The*  
**COMBINATION**  
FOR AS LITTLE AS  
**10¢ A DAY**

How easy it is to pay for this combination of desk and Remington Deluxe Noiseless Portable Typewriter! Just imagine, a small good will deposit with terms as low as 10c a day to get this combination at once! You will never miss 10c a day. Yet this small sum can actually make you immediately the possessor of this amazing office at home combination. You assume no obligations by sending the coupon.

A beautiful desk in a neutral blue-green which will fit into the decorations of any home—trimmed in black and silver—and made of sturdy fibre board—is now available for only one dollar (\$1.00 extra) to purchasers of a Remington Noiseless Portable Typewriter. The desk is so light that it can be moved anywhere without trouble—it is so strong that it will hold six hundred (600) pounds. With this combination of desk and Noiseless Deluxe Portable Typewriter, you will have a miniature office at home. Learn the complete details of this offer. Mail the coupon today.

**THESE TWO EXTRA FOR YOU**

**LEARN TYPING FREE**

To help you even further, you get free with this special offer a 32-page booklet, prepared by experts, to teach you quickly how to typewrite by the touch method. When you buy a Noiseless you get this free Remington Rand gift that increases the pleasure of using your Remington Noiseless Deluxe Portable. Remember, the touch typing book is sent free while this offer holds.



**SPECIAL CARRYING CASE**

The Remington Deluxe Noiseless Portable is light in weight, easily carried about. With this offer Remington supplies a sturdy, beautiful carrying case which rivals in beauty and utility the most attractive luggage you can buy.



**MONEY BACK GUARANTEE**  
The Remington Noiseless Portable Typewriter is sold on a trial basis with a money back guarantee. If, after ten days trial, you do not wish to keep the typewriter, we will take it back, paying all shipping charges. You risk nothing in buying a Remington Portable Typewriter on terms as low as 10c a day.



**SPECIFICATIONS**

ALL ESSENTIAL FEATURES of large standard office machines appear in the Noiseless Portable—standard 4-row keyboard; back spacer; margin stops and margin release; double shift key and shift lock; two color ribbon and automatic ribbon reverse; variable line spacer; paper fingers; makes as many as seven carbons; takes paper 9.5" wide; writes lines 8.2" wide. There are also extra features like the card writing attachment, black key cards and white letters, touch regulator, rubber cushioned feet. These make typing on a Remington Deluxe Noiseless Portable a distinct pleasure. Thousands of families now using the Remington Deluxe Noiseless Portable know from experience how wonderful it is!

**MAIL  
COUPON  
NOW!**

Remington Rand Inc., Dept. 300-4  
465 Washington St., Buffalo, N. Y.

Tell me, without obligation, how to get a Free Trial of a new Remington Deluxe Noiseless Portable, including Carrying Case and Free 32-page Typing Instruction Booklet on terms as low as 10c a day. Send Catalogue.

Name.....  
Address.....  
City..... State.....

Please Mention This Magazine When Writing Advertisers

# SPEED Up Your Work!

Learn to Type  
without  
A Typewriter



Master the Touch System—Quickly—  
Accurately Get the "Feel" of Typing  
Before Investing Your Money

Now, you don't have to own a typewriter to learn how to type. The ingenious, patented "Tuch-Rite" board gives you all the practice you need for speedy, accurate typing. It teaches you the touch system—the real, professional way universally used in business. You may have been a "hunt-and-peck" typist for the longest time or you may never have used a typewriter before—it doesn't matter, because the "Tuch-Rite" teacher will soon permit you to master it. "Tuch-Rite" is a scientific substitute for a typewriter. It is a life-size counterpart of a standard keyboard, which is real as to size, position, and "feel". Each key has a depression in the 1/4" thick board, in which the black plastic buttons slide. Printed under each key is a number which indicates the finger of each hand which strikes it—simple as A B C.

"Tuch-Rite" is highly recommended by the Principal of Horace Mann School; Director, Bureau of College Research, Columbia College; American Foundation for the Blind; Professor of Experimental Education, New York University; Director of Scarborough School, Scarborough-on-Hudson.

An 8-page illustrated book of instructions will show you how best to use the "Tuch-Rite" teacher. **\$2.00**  
Weight 3 lbs. Add postage

## GOLD SHIELD PRODUCTS

350 Greenwich Street Dept. RT-441 New York, N. Y.



# FLIGHT THE PICTORIAL FLYING REVIEW

Brings you all the phases of world aviation and aeronautics in a non-technical yet educational manner—exciting articles which catch your breath, yet give you the fundamentals of flying and ALL related subjects.

FLIGHT keeps you abreast of all the major developments as fast as they appear anywhere. Now, when planes and flying are of vital importance to all, you just can't do without this highly absorbing yet instructive publication. You must be "in the know."

Partial Contents of the April Issue: The Flying Tank. Huro Gernback. The R.A.F. Wellington Bomber—with Sectional Views. Question Box. How Anti-Aircraft Predictors Work. Full Details of the Famous "Hurricane" Fighter. How English Fight Mass Bombing Attacks by Nazis. New Aerial Tactics. Airplane Cannon vs. Machine Guns. The New Nazi "Bombers" and "Fighters."

Attractive three-color cover, numerous illustrations. **15c** a copy

Subscription price \$1.50 a year, Canada and foreign \$2.00.

FLIGHT MAGAZINE, 20-T Vesey St., New York, N.Y.

# Diagrams of Interest

This is a new department. If you have a new Hook-Up, send it along; a pencil diagram will do. Be sure to include a brief description.

All diagrams and descriptions accepted and published will be paid for at regular space rates. Diagrams may be for receivers, adapters, amplifiers, etc. Send them to Hook-Up Editor, RADIO & TELEVISION, 20 Vesey St., New York City.

## 10-WATT HIGH FIDELITY AUDIO AMPLIFIER

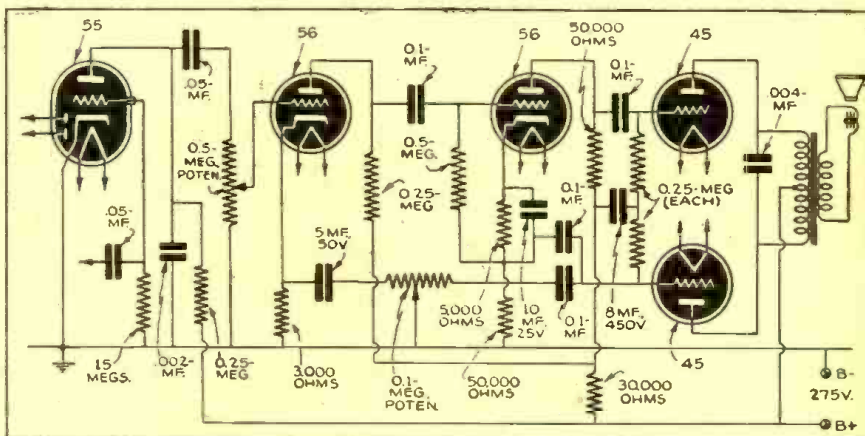

A 15 megohm resistor is used in the grid circuit of the 55 to increase its sensitivity to weak signals. Resistance-capacity coupling is employed and also single tube phase-inverter. All resistors one watt, condensers 600 volt. The "pot." connected to cathode of first 56 tube is a "high-fidelity" control. Circuit contributed by R. T. Stephens, W9CPC, Davenport, Iowa.

## EASY-TO-BUILD TUBE TESTER

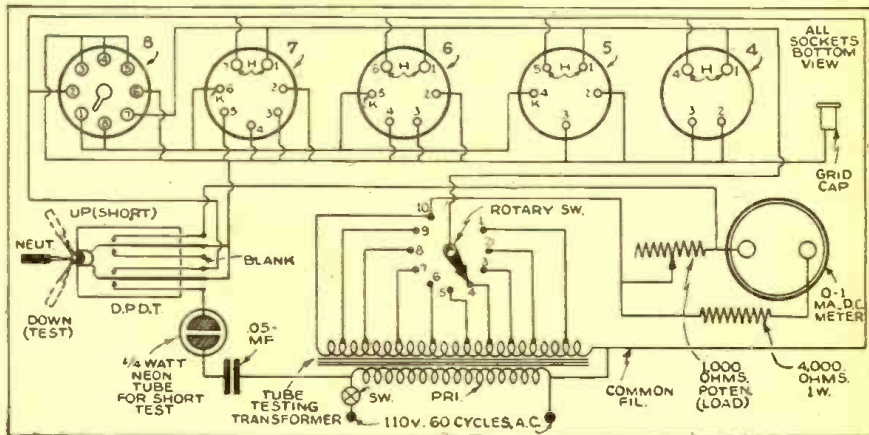

The sensitive short-tester checks leakage between cathode and filament, where it is most apt to occur. The meter is fitted with a new scale, calibrated to read half BAD-GOOD. The Neon bulb will show a pale color if a tube is "shorted."—Robert Boehler, La Grange, Ill.

## WHAT'S WRONG WITH THIS DIAGRAM?

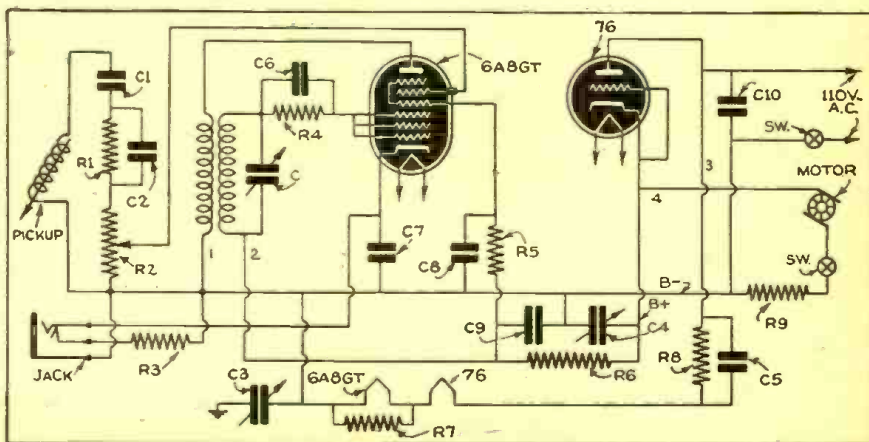

Study this diagram at least three minutes before turning to the answer on page 768.



# to the Radio Experimenter

## CODE-PRACTICE SET

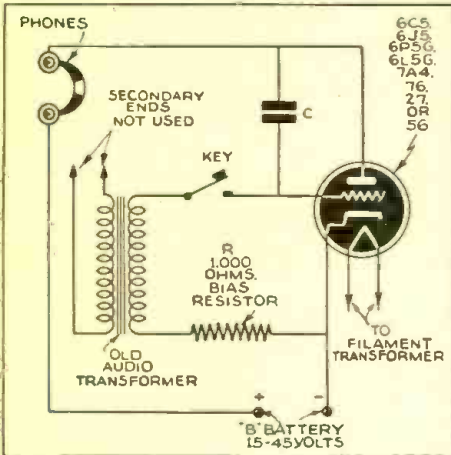

This code-practice circuit oscillates easily. The plate voltage may be as low as 15; tone can be changed by varying capacity of C, using values between .0005 and .002 mf. No key clicks!—John Sasuga, Los Angeles, Calif.

## HIGH-PASS AUDIO FILTER

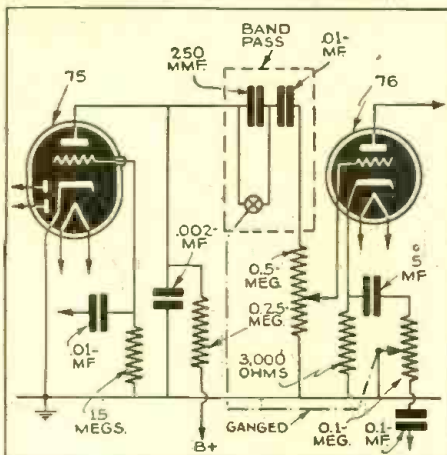

With the switch "on"—normal tone results; with switch "off" only high frequency notes pass. Makes speech easier to understand, with less hum and background noise, especially when QRM is present.—R. T. Stephens, W9CPC, Davenport, Iowa.

## PHONO AMPLIFIER

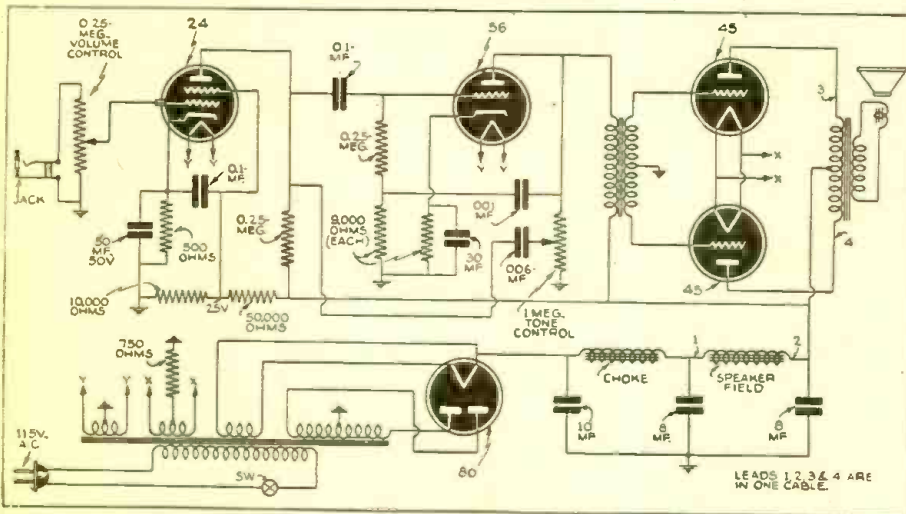

William W. Hutchinson contributes this audio amplifier hook-up, which he has used mostly for phono work. The negative feed-back improves the tone qualities very remarkably; an 8 inch Magnavox speaker was used. Two hundred volts was used on the plates by the contributor, due to the 75 volt drop caused by the speaker field (unusually high resistance in this case).

## 3-TUBE "T.R.F." A.C.-D.C. RECEIVER

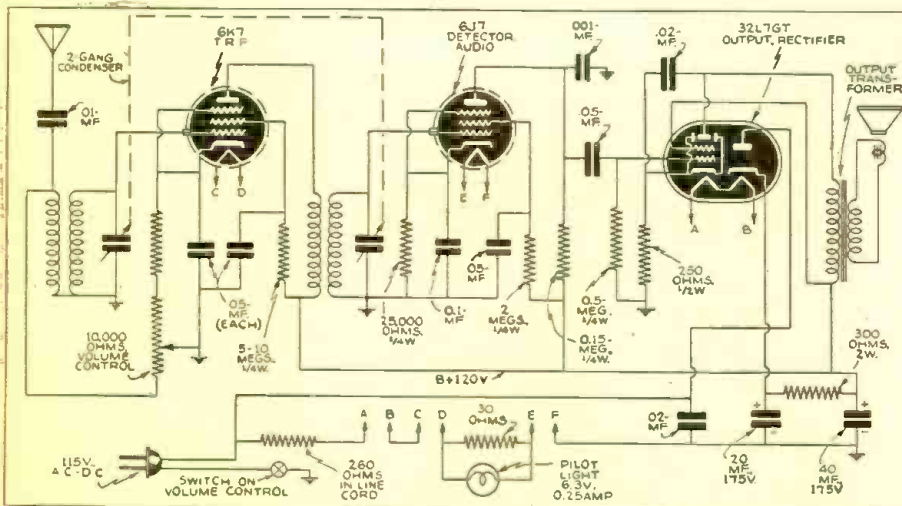

This circuit, contributed by Winslow Williams, 74 So. Elliott Place, Brooklyn, New York, of a 3-tube T.R.F. receiver, makes use of the 32L7-GT tube. A 6K7 is used as an R.F. amplifier and a 6J7 as a biased detector, resistance-coupled to the output stage. The author states that he has built this circuit at a very low cost, and that it gives surprisingly fine results. It has good tone, selectivity and sensitivity, the power output being about 1 watt. Use "good" Antenna and R.F. coils, the author stresses.

# FREE! ONE or ALL of these books

THE publishers of RADIO & TELEVISION give you the opportunity to add three outstanding books to your technical radio library. They make the offer even more attractive by giving these books to you absolutely FREE. A subscription to RADIO & TELEVISION for seven months at the cost of One Dollar gives you a choice of either of the three books shown in this advertisement. For Two Dollars you receive RADIO & TELEVISION for fourteen months and you receive any two books absolutely FREE. To get all three books FREE, enter your subscription for twenty-one months for only Three Dollars.

ANOTHER SAVING FOR YOU—THE PUBLISHERS PAY POSTAGE ON THE BOOK OR BOOKS YOU CHOOSE. All of the books contain numerous photographic illustrations and diagrams and have stiff, flexible covers.

### ABC OF TELEVISION

Contains latest material on television developments. It covers theory of scanning; simple television receiver; how the eye sees; the photo-electric cell; neon lamps; need for broad channel width in transmission signals; cathode ray tube and television receivers; Farnsworth transmission; and other important features.

### SHORT WAVE GUIDE

Covers hundreds of short-wave questions and answers; illustrates popular short-wave kinks; gives explicit instructions for building simple short-wave receivers; instruction on the best type of antenna installation; diagram and construction details for building transmitters.

### S. W. RADIO QUIZ BOOK

This book covers questions and answers on transmitters, ultra short-wave receivers, practical kinks, wrinkles and novel winding data; novel hook-ups for experimenters; how to "hook-up" converters, noise silencers, beaters, modulators, power supplies, antennas, pre-oscillators, 5-meter receivers, selectors.

**RADIO AND TELEVISION,**  
20 Vesey Street, New York, N. Y. R&T-4-41

Gentlemen: Enclosed you will find my remittance of \$..... for which enter my subscription to RADIO AND TELEVISION as checked below; also send me, postpaid, the book or books which I have marked below.

ABC OF TELEVISION  
 S. W. RADIO QUIZ BOOK AND KINKS  
 SHORT WAVE GUIDE

7 months—\$1.00—choice of any one of three (3) books. (Canadian and foreign—\$1.30)  
 14 months—\$2.00—choice of any two (2) of the three (3) books. (Canadian and foreign—\$2.60)  
 21 months—\$3.00—all three books. (Canadian and foreign—\$3.90)

If you are a subscriber now, we will extend your present subscription.

New subscriber       Old subscriber

Name .....

Address .....

City .....

State .....

Send your remittance by check or money order. If you send cash or unused U.S. postage stamps, please be sure to register your letter for your own protection.

Please turn to page 757 for full details on another FREE book given with subscriptions.

# Detecting Approach of Airplanes with Sensitive Sound Amplifier

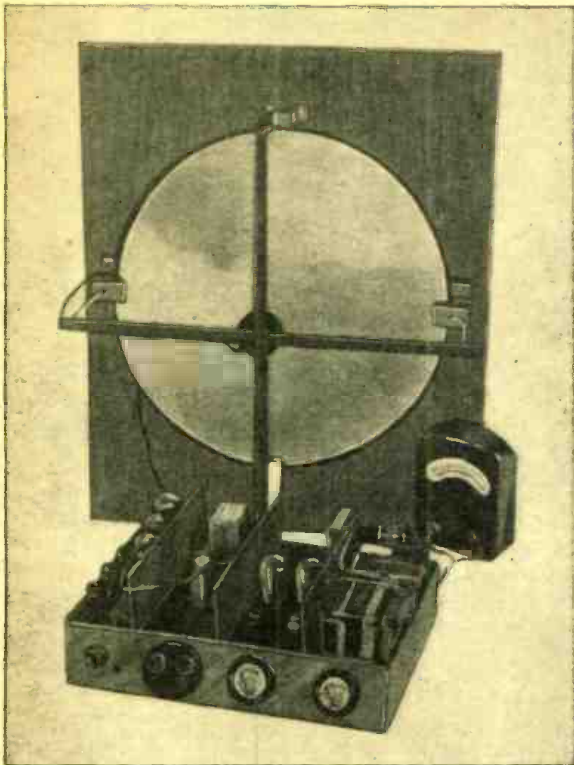

The complete sound-detecting apparatus, including the parabolic reflector which focuses the sound onto the microphone. The amplifier and A.C. voltmeter are also shown.

Experimenters everywhere will be interested in this sensitive sound detector, which was designed in England for detecting the approach of aircraft. Not only is the apparatus interesting from this angle, but there are many other applications of such a "super-sensitive" sound detector. A method of laying out the parabolic reflector which focuses the sound on to the microphone, is given in detail.

● ONE of the most urgent needs at the present time is the development of apparatus that will accurately locate hostile aircraft invisible either by reason of darkness or cloud.

Aural methods, of course, are liable to error due to factors over which we have no control, but properly applied it appears that they will render useful service in assisting roof "spotters" to obtain an idea of direction and distance of aircraft more easily and quickly than with the unaided ear.

The following is an account of a number of experiments which were made to assist roof spotters of a large building, and the

result has justified the inclusion of the apparatus described as a permanent feature of the warning system.

Various types of directional microphones are available, but the area of pickup is much too wide for accurate sound direction finding. Of the methods tried in order to increase the ratio of desired to undesired sound, the one now to be described provides excellent discrimination and a large magnification. The first experiments carried out made use of a 10 ft. exponential horn with the microphone located at the throat. The angle of coverage appeared to be about 25° which, although it enabled one to ascertain the location of aircraft, was very

cumbersome, heavy and inaccurate.

The final apparatus makes use of a parabolic reflector with a microphone at the focus point followed by a high-gain amplifier, telephones and an A.C. rectifier-type voltmeter. Fig. 1 shows a schematic arrangement of the apparatus. The choice of a parabolic reflector was due to experience of its use in film studios, where it is employed to pick up the voices of the leading actors in a crowd scene.

Before describing the apparatus in detail it will be useful to outline the method of projecting a parabolic curve. It can be described by a point which moves in a plane so that its distance from a given point,

Fig. 1 shows schematic diagram of the sound locating device. Fig. 2 illustrates one method of laying out the parabolic reflector curve.

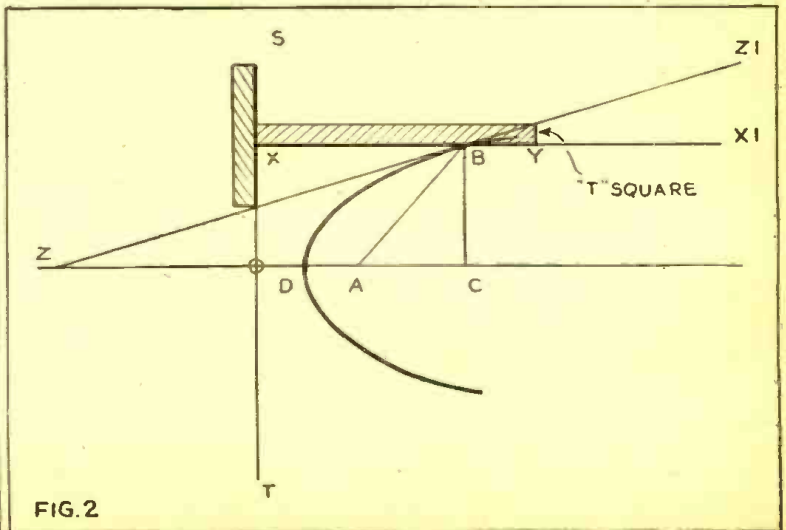
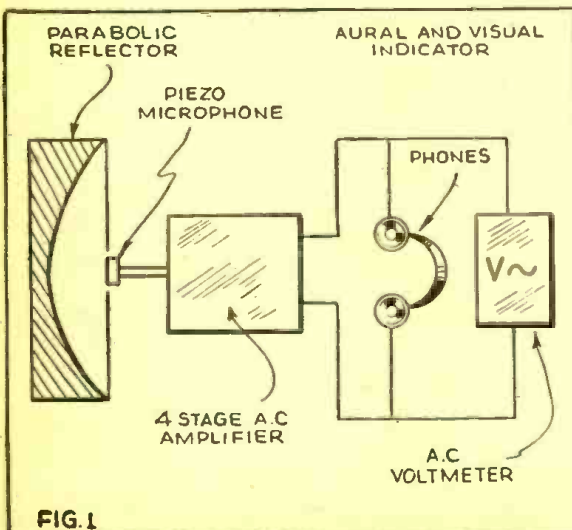

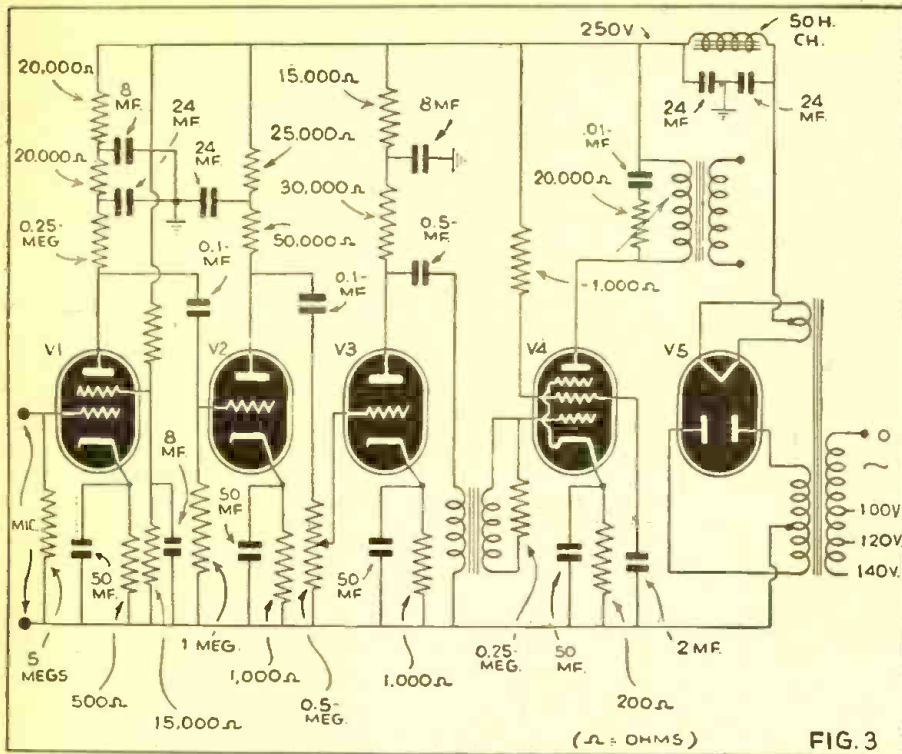

Diagram of the special amplifier used with the airplane sound detector.

which is termed the focus, is the same as its distance from a line termed the directrix.

In order to plot a parabola the following method can be adopted. Pin a sheet of drawing paper to a drawing board and place a pin at any point chosen as the focus A (Fig. 2). With the aid of a "T" square, set it so that the side XY is at right angles to the side of the board ST. To the pin at A fasten a length of thread and fasten the other end of the thread to the extreme edge of the "T" square at Y, the length of thread being equal to the length of the side XY. By means of a pencil press the thread up against the edge of the "T" square so that it makes contact at B, sliding the "T" square along the edge ST, and maintaining contact between the pencil and "T" square. Thus one half of the parabola will be drawn, and by inversion the other half can be traced. Thus point A is the focus and the line OX is termed the directrix from which it can be seen that the length  $AB = BX = OC$ .

The point D is known as the vertex of the parabola and let it be assumed that  $OD = DA = a$ .

Therefore  $(AB)^2 = (AC)^2 + (BC)^2 -$   
Pythagoras' theorem.

Also  $(AC)^2 = (x-a)^2$  and  $(BC)^2 = y^2$

Also  $BX = OC = (x+a)$

Therefore  $(x+a)^2 = (x-a)^2 + y^2$   
 $y^2 = 4ax$

It will be seen that the lines AB and  $BX^1$  produce equal angles with the tangent ZZ<sup>1</sup>. Thus if, for example, a beam of light radiated from the focus A falls on the internal mirrored surface B, it will always be reflected parallel to the axis OC, because the optical reflection of the angle of incidence ZBA is equal to the angle of reflection Z<sup>1</sup>BX<sup>1</sup>.

It is assumed that the focus point A is of zero size and all the radiated light will, therefore, travel in parallel paths similar to a searchlight beam. The reverse of the

above operates in a similar manner, that is all light picked up by the parabolic mirror is reflected and concentrated on the point A.

As light obeys these laws, sound radiations will follow the same laws approximately. Therefore, a 24 in. parabolic mirror was used in the initial experiments, the focus point A being 12 in. from the vertex. At this point a microphone was suspended and held rigidly in position. The degree of magnification obtainable is in proportion to the ratios of the areas of the mirror and the microphone, and, therefore, it is desirable to use the smallest microphone possible, provided that it has a good response in the bass register. For the early experiments various types of Reisz and other carbon microphones were used, but the final instrument is fitted with a small piezo crystal microphone. The one used is rugged and has a silent background.

The output from the microphone is taken via a screened cable to a four-stage high-gain A.C. mains operated amplifier. The requirements here are (a) a very low background noise level, (b) high stage gain, (c) means of measuring output signal level. The amplifier follows conventional lines in design, and no special components are necessary; Fig. 3 gives the circuit, but values of the components can vary considerably without affecting the performance of the apparatus, provided that a good low frequency response is maintained. Very adequate smoothing must be provided so that if an A.C. voltmeter is placed across the headphone's terminals no reading should be obtained with zero input. The intervalve transformer may pick up stray hum voltages, and it may be necessary to orientate it for minimum hum level. The output transformer must have a ratio suitable for use with headphones. In the final amplifier Ericsson 120 ohm phones were used so that the transformer ratio was calculated to be

**Astonish YOUR FRIENDS!**

Pass 500,000 Vts. Thru the Body! Light Lamps, etc.

NEW! 5-ft. Spark Oudin Coil, Condenser & 4 k.w., 40 k.v. Transf. data. .... net 75c

**DATAPRINTS**

Drawings & Construction Data Show You How

**20c Each in Order for 10 TESLA-LOUDIN HI-FREQ. COILS**  
(Data and Drawings only; no parts included)

- 36" Sp'k Tesla-Oudin Coil.....40c (1 K.W. Exc. Trf. Data, included FREE!)
- 8" Sp'k Tesla-Oudin Coil.....40c (1/2 K.W. Exc. Trf. Data included FREE!)
- 3" Sp'k Oudin; 110 Vt. "Kick Coil" type.....40c
- 3" Sp'k Tesla Works on Ford Sp'k Coil.....40c
- 1" Sp'k Violetta Hi-Freq. Coil.....40c

FREE with order for \$1.00 or more—"20 Tricks with Hi-Freq. Coils" (40c separate)

**TELEPHONE—Records on Steel Wire 40c**

**20 ELECTRIC PARTY AND LODGE TRICKS! Loads of Fun!**

How to Do 'em!.....40c  
New Electric Oro & Pipe.....40c  
Locator.....40c

**Solenoid & Magnet Data—Get Our List!**

**20 Telephone Hook-ups—Build Your Own... 40c**

**RADIO CONTROL FOR MODEL BOATS, PLANES**  
Data 40c  
Photophone; Data 40c

**S-W DIATHERMY (Artificial Fever)**

Dataprint giving Constructional data for Small, Medium and Large size App. (All 3)...40c

"MIND READING" Radio Act .....40c

"Fry Eggs" on cake of Ice! Data 40c

**LOOK at these DATAPRINTS !! 40c Each.** See Special Prices below

- 20 A.C. Problems and their Solutions. Welding Trans. 2 K.W. Rerouting Armatures.
- 1/2 Meter Transm. & Rec. Water Wheels
- 5 Meter Superhet. Water Turbines
- 100 Mechanical Movements. Wheatstone Bridge.
- 20 Motor Hook-ups. Photo-cell and Relay Data
- Electric "Inductor" Organ 20 Simple Bell Circuits.

Special Prices: 4 prints \$1.00; 10 for \$2.00; 40c each, single orders. Get New List 100A

**The DATAPRINT Co.**  
Lock Box 322A RAMSEY, N. J.

**LAST CALL at this LOW PRICE. Short-Wave fans need this WORLD-TIME CLOCK**

*The Only Clock for Universal Use Throughout the Entire World!*

**A REGULAR CLOCK**  
with A.M. and P.M. divided dial

**A WORLD-TIME CLOCK**  
Instantly indicating time in all 24 zones

**INTERNATIONAL CLOCK**  
with A.M. and P.M. 24 hour dial

Indispensable for Short Wave Fans.

Electric (for A.C. 110-120 volts, 60 cycles) **\$5.95**  
Spring Model **\$4.95**

P.P. prepaid in U.S.A.  
Remit by check or money order; register letter if you send cash or unused U. S. postage stamps.

**GOLD SHIELD PRODUCTS**  
350 Greenwich St., Dept. RT-441, New York City

$$\sqrt{\text{tube optimum load}} = \sqrt{7000}$$

$$\frac{\text{Headphone resistance}}{120} = 7 \text{ to } 1 \text{ approximately.}$$

As the ear is very insensitive to small sound level changes an A.C. voltmeter is also connected across the output on a suitable range. This shows the slightest change in output level before it can be appreciated by the ear.

It was found on completing the apparatus that although the microphone was accurately located at the focal point of the mirror, the low-frequency response of the mirror-microphone unit using a carbon microphone was inadequate. A piezo (crystal) microphone was obtained, and in the final instrument a 36-in. diameter reflector was used. Not only did the magnification increase considerably, but the angle of discrimination decreased also.

The parabolic reflector can be constructed in various ways, but it was found that one made from plaster of Paris was the easiest to make. A rectangular box, 36 in. square with a depth of 10 in. was made from 1 in. deal. A full-scale drawing of a parabolic curve was produced, from which a section of wood 1 in. thick, having the same contour was made. The box was partly filled with plaster of Paris, and then slowly rotated on a turntable. The parabolic contour board was carefully lowered into the box and the plaster was moulded into shape as it was rotated. After it had set, it was

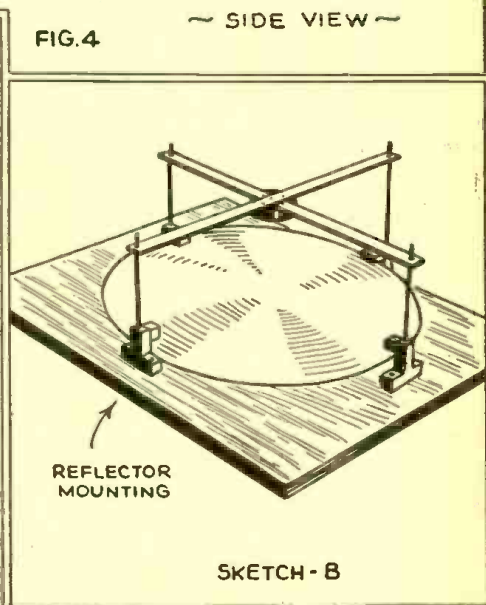
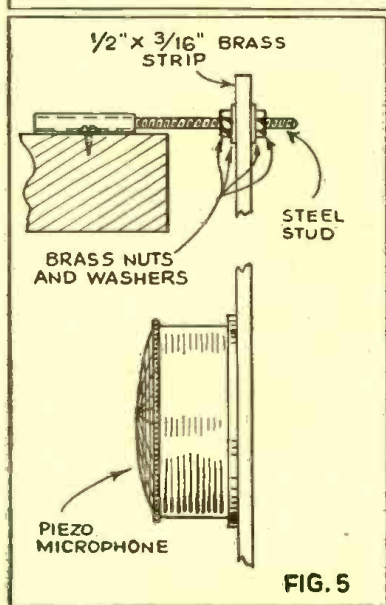
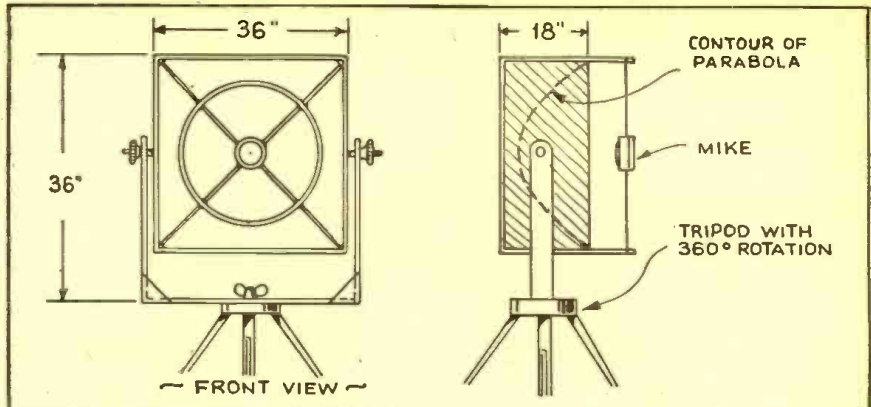

Fig. 4 shows front and side views of the parabolic reflector and its mount. Fig. 5—one method of mounting the mike. Another sketch shows the mike adjustably mounted over the parabolic reflector.

sand-papered smooth and finally sprayed with a cellulose paint. This gives a very hard and weatherproof surface. The center of gravity of the box was then found, and it was then mounted on a rigid tripod in a U-shaped arm (Fig. 4) with swinging adjustments so that it could be rotated and elevated at any desirable angle. The micro-

phone is attached to two brass rods, which are mounted diagonally across the cabinet; by means of 2BA studding it can be accurately set to the focal point (Fig. 5). The screened lead from the microphone is taken along one of the arms and led to the amplifier, which can be located in the vicinity.

The microphone unit was placed as high as possible, and clear of any obstacles that would reflect sound waves. A map of London was located below the tripod so that the location of enemy aircraft can be noted, and by means of a pointer attached to the rotating turret the direction of flight can also be ascertained. In addition a protractor was mounted on the side of the cabinet so that the angle of elevation can be read off.

The method of operation is relatively simple, and can be readily mastered by an inexperienced operator. The microphone unit, having been mounted at a suitable location, can be checked by pointing it at a source of sound, for instance, a clock some 10 to 15 feet away, and the unit rotated until the tick can be heard in the 'phones. Then by referring to the A.C. voltmeter, more accurate positioning of the microphone can be made. Speech conversations can be picked up from up to 100 feet away, suitable adjustment of the volume control being made.—Courtesy of *Electronics and Television & Short-Wave World*.

**GREATEST SLIDE RULE VALUES EVER OFFERED**

10 inch enameled slide rule, made of kiln dried seasoned hardwood, has auxiliary removable magnifier with pins to fit (curved) runner. This rule has inch, millimeter, sine log and tangent scales. Packed in individual carrying case. This rule is equal in performance to a \$10.00 rule. Our special price, P.P. prepaid anywhere ..... **\$1.00**

LAWRENCE 10-inch white enameled slide rule with clear glass magnifier in Black Case. Price includes 36-page instruction book, prepaid... **60c**

8" Slide Rule ..... **25c**

Illustrated Book of Instructions ..... **10c**

Secret Code slide rule, with 16-page book... 2 for 50c ..... **30c**

Postage Prepaid

**GOLD SHIELD PRODUCTS**

Dept. RT-441 350 Greenwich St. New York

**SHORT WAVE COIL DATA BOOK**

COMPLETE COIL DATA AND CIRCUITS FOR ALL TYPES OF RECEIVERS AND TRANSMITTERS

Price 25 Cents

RADIO PUBLICATIONS

FOR RECEIVERS AND TRANSMITTERS

## DON'T FAIL TO GET THIS

### SHORT WAVE COIL DATA BOOK

Every experimenter knows that the difference between a good and a poor radio set is usually found in the construction of short-wave coils. Coil winding information is vitally important and in the new coil book all "dope" appears. There're illustrations which give instructions on how to wind coils, dimensions, sizes of wire, curves and how to plot them. Every experimenter needs this book—it also contains complete data on all types of receiving coils, together with many suitable circuits using these coils. Also complete data on various types of transmitting coils with many transmitting circuits such as exciters and amplifiers using the various coils described.

**Contents Briefly Outlined**

S-W Tuning Inductance Charts • Coil Data for T. R. F. Receivers • One Tube Oscillodyne • Two Tube Bandspreeder • The Mono-Coil • 2-Tube Old Reliable • 2-Tube Globe Trotter • 2 Winding Coils—10-500 Meters • Dyerle 3-Tube "Signal Gripper" Electrified • 3-Tube Bandspreeder for the Home • General Coverage Coils on Ribbed Forms • Coil Data for Superhet or S-W Converter • Ultra S-W Coils • Switch Coils for S-W Superhets • Experimental Coils • S-W Antenna Tuner • Most Popular S-W Tuning Circuits • Self-Supporting Transmitting Circuits Employing Coils Described • All Band Antenna Tuner for Transmitting • Plug-in Coils for Exciters • Frequency-Wavelength Conversion Chart.

**PRICE 25c PREPAID**

For a copy of this handy book send 25c in U.S. Coin or stamps to

**RADIO PUBLICATIONS**

20 VESEY STREET NEW YORK, N. Y.

Edited by Herman Yellin, W2AJL

**6 Volt Amplifier**

**?** I would like to build the small 6 volt amplifier shown on page 393 of the November issue, but wish to use a crystal mike instead of a carbon microphone as shown.—J. Godin, La Sarre, Canada.

**A.** Shown herewith is a 6J7 preamplifier for use with the amplifier mentioned. The 500,000 ohm volume control feeds into the grid of the tube lettered "55" on the diagram, but which should have been an "85"; the microphone transformer shown on the original diagram is not used. The bias cell is the tiny 1½ volt type, made especially for this purpose by Mallory. It must not be shorted, as it is not designed for any current drain.

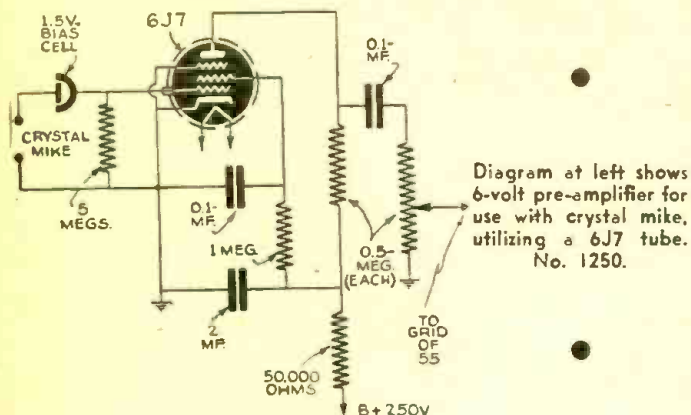

Diagram at left shows 6-volt pre-amplifier for use with crystal mike, utilizing a 6J7 tube. No. 1250.

**Set Howls on One Band**

**?** What causes squeals and howls to appear when tuning in stations on the 5.3 to 15.7 mc. band on my receiver?—J. J. Meier, Bethlehem, Pa.

**A.** Since the squeals occur on one band only, the receiver is obviously oscillating in the R.F. section. If changing the R.F. tube and realigning the set does not help, try re-dressing the leads. Insertion of RC filters, consisting of a 2000 ohm resistor in series with the B plus lead to the R.F. stage, by-passed by a 0.1 mf. condenser, may help. In extreme cases it may be necessary to lower the gain of the stage, by cutting down on the screen-grid voltage or increasing the amount of bias.

**Judging Signal Strength**

**?** I was greatly interested in your answer in the November issue, dealing with information ament Verification Cards. I would like to know how to judge signal strength.—G. Boycoman, Brooklyn, N. Y.

**A.** It is not necessary, in reporting to a station on its signal strength, to give the absolute signal strength, since this would necessitate the use of accurate and expensive measuring instruments. Comparative and approximate strengths are sufficient and can be estimated in several ways. If a magic eye or cathode-ray tuning indicator is used, the amount of closing of the shadow angle is indicative of the signal strength. If an R.F. gain control is used, this control should always be in the same position when making measurements. An excellent device is the so-called "R" meter, used on the better short-wave communications type receivers. Lacking either of these two methods, you can always give the strength of the signals relative to some other station, or employ the system used by amateurs and other communications services for reporting on signal strength.

The scale used to express strength or legibility of signals as adopted at the last International Telecommunication Convention follows:—

<i>Strength</i>	<i>Legibility</i>
QSA 1—scarcely perceptible.	QRK 2—readable now and then
QSA 2—weak	QRK 3—readable, but with difficulty
QSA 3—fairly good	QRK 4—readable
QSA 4—good	QRK 5—perfectly readable
QSA 5—very good	
QRK 1—unreadable	

for April, 1941

**Push-Pull Amplifier**

**?** How many watts of audio can be obtained from the push-pull 2A3 amplifier, shown on page 303 of the September issue?—K. L. Francis, Kansas City, Mo.

**A.** This amplifier will deliver 10 watts without any distortion and employs the newly developed self-balancing type of phase inverter, for procuring the two out-of-phase voltages necessary for feeding the push-pull output stage. In building this amplifier, keep the 6J7 input tubes as far as possible from the power-supply and output tubes. Keep all leads in the input circuit as short as possible, using shielded wire for any grid leads over one inch long.

**Audio Frequency Hook-Up Query**

**?** Referring to the diagram shown on page 239 of the August issue, a 1H5-GT is coupled by means of a center-tapped audio choke to two 1Q5-GT tubes. Is this conducive to good tone quality and where can the choke be obtained?—R. H. Trimble, San Bernardino, Calif.

**A.** The center-tapped choke is used to obtain two out-of-phase voltages to apply to the push-pull audio stage. This is employed in preference to using an additional tube as a phase-inverter, or else using a heavy audio transformer. The tapped choke will give quite good tone quality and can be obtained from any of the various transformer manufacturers or your local dealer.

**Adding Audio Stage to 1-Tube Set**

**?** I have built the 1-tube "Pigmy" receiver described in the June issue, and would like to build a small additional unit to amplify the signal to operate a speaker. Please show such a diagram.—J. Schoenhaut, Brooklyn, N. Y.

**A.** A single stage 117L7GT amplifier is shown above. This can be connected to the original Pigmy receiver through a 4-prong plug and cable, or if desired it can be built into a somewhat larger container, with the detector shown previously. Use shielded wire for the lead from the upper phone jack to the 25,000 ohm resistor and .05 mf. condenser. Note that the rectifier section of the 117L7 is not used, the rectifier section of the detector tube furnishing sufficient power to operate the audio tube. The 10,000 ohm resistor R-3 should be replaced with a 5000 ohm unit, and an 8 mf. 250 volt filter condenser is added to the rectifier cathode. As mentioned in the original article, the tuning condenser is a midget 140 mmf. unit, used in conjunction with two winding plug-in coils, thus affording "all-wave" coverage.

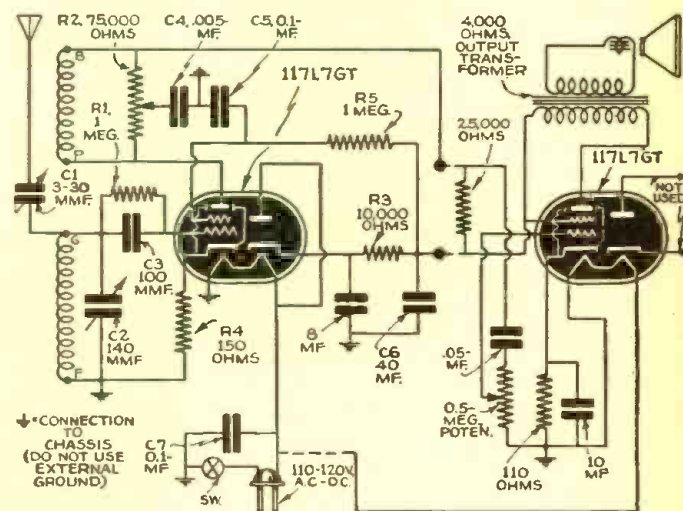

Diagram above shows how to add an audio stage to the one-tube Pigmy receiver. No. 1251.

Queries to be answered by mail (not on this page) should be accompanied by fee of 25c (stamps, coin or money order). Where schematic diagram is necessary, our fee is 50c up to 5 tubes; for 5 to 8 tubes fee is 75c; over 8 tubes, fee is \$1.00. No picture diagrams can be supplied.

## The Cover Kink First Prize Winner

### Improvised Baffle

When testing a radio set outside of its cabinet, an empty twenty-ounce oatmeal box, with both ends removed, makes a very effective baffle for four or five inch speakers. Four two-inch screws may be used as legs. It is important that the end of the container next to the speaker does not quite touch it. The tone and quality of the set is reproduced as though it were in its cabinet.—*David Spencer.*

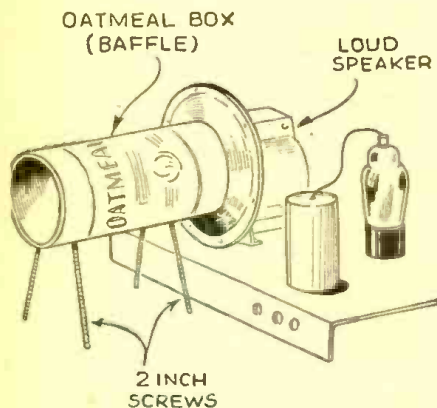

### Power Plugs

Here is my idea for a power supply plug which I arranged for use with my short wave receiver. I took an old burnt out metal tube, a 6K7 for example, removed the grid cap and enlarged the hole for the wire leads or cable. I pried open the 4 clamps holding the base on the tube and cleaned up the inside. The metal shell and base remained. I then put the leads through the hole in the top of the tube and soldered them to the prongs. I put the base back on and poured wax in the top hole to secure the wires in place. The plug may be painted if desired.—*Bob Murphy.*

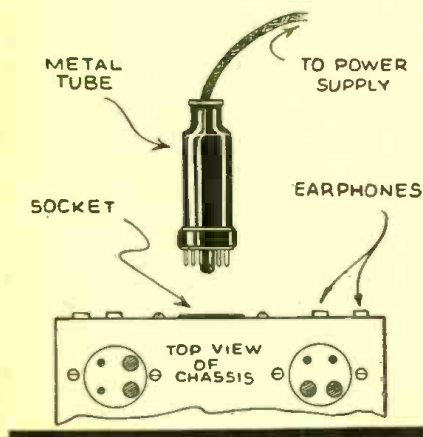

### Nut Locator

The accompanying sketch shows a simple trick which I have often found useful in placing a nut or washer on a screw in an awkward corner of a radio cabinet. A piece of adhesive or other tape is placed over the end of one finger and the washer

PIECE OF ADH  
FRICTION  
TAPE



NUT WILL  
STICK TO TAPE

or nut pressed against the tape. In this way you can readily place a nut in many locations, where it would be impossible otherwise.—*Russell Minks.*

### Coil Winder

I have found this coil winder very useful in my radio laboratory. The base is a piece of wood of medium size. Part G is not movable and one of the wooden or metal cones C is mounted on a rod fitted in a hole in the block G. The upright F is movable and is held tight to the base with a screw and nut. A slot A in the base

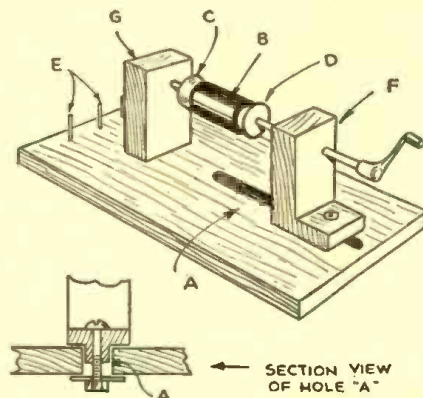

permits F to be moved back and forth to accommodate different size coil forms B. A second cone D clamps the coil form rigidly. The hole in G for the shaft supporting C, should not be drilled all the way through, and in this way and with little grease on the shaft the coil and the two cones will rotate when the handle is turned. The nails E prove handy to hold spools of wire when winding coils.—*Isaac Stempnitzky.*

### Circuit Tester

Here's a handy unit for making continuity tests where current is not available. I took a flashlight and placed the bulb at one end of the wires and the battery at the other, and on this principle I constructed this small test set.

I found two old flashlight cases and

using a few radio phone tips, I made this device as shown. With this device continuity tests can be made where current is not available, for tracing out wires in switch boxes, etc. It also can be used on "trouble" calls.

In operating it, one fellow can take a unit to one end, as on a three-way switch circuit, and the other person one unit on the other end. If the person is alone he can plug in phone tip cords and clip on alligator clips to the circuit to be traced, then proceed to the other end of the circuit; by placing the wires into phone tip jacks or by touching them, the bulb will light if on right wires.—*Homer L. Davidson.*

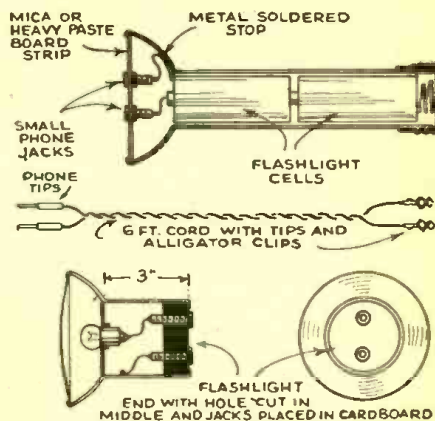

### Volume Control Repairs

Like many experimenters I have "hundreds" of bad volume controls laying around. These may be repaired by using a mixture of lubricating oil and some graphite scraped from a lead pencil with a knife. This is applied to the carbon resistance strip inside the control. The resistance of the control may be made nearly anything you wish, by applying the mixture in different variations. After the control has been turned back and forth a number of times to spread and pack the mixture evenly, the control may be put back together. This will come in handy when building sets or repairing sets with bad volume controls.—*Wayne Furnell.*

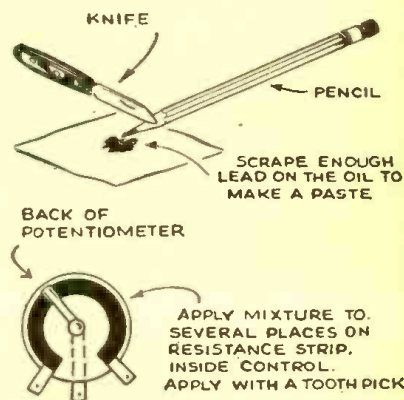

## RADIO KINKS

use to you, besides indicating what is wanted. Send a typewritten or ink description with sketch of favorite to the Kink Editor

published on these pages will win their senders 8 months' subscription to RADIO & TELEVISION. The best kink published each month will win a 2 years' subscription. Read these kinks; they will be of real

# THE FINEST RADIO BOOK FREE WE EVER OFFERED :- the 1940-41 Radio-Television Reference Annual With \$1.00 subscription to RADIO & TELEVISION

WITH our compliments, we want to send a copy of the 1940 RADIO-TELEVISION REFERENCE ANNUAL to you FREE. If you will simply take advantage of RADIO & TELEVISION magazine's special subscription offer NOW. This offer is being made for a limited time only.

The 1940 RADIO-TELEVISION REFERENCE ANNUAL has 68 pages, large size 8½ x 11½, with over 170 illustrations. The contents of this book has never appeared before in handy book form. Its pages cover practically every branch of radio sound, public address, servicing, television, construction articles for advanced radio men and technicians, time and money-saving kinks, wrinkles, useful circuit information, "ham" transmitters and receivers, and a host of other data.

The Annuals have always been regarded as a standard reference work for every practical branch of radio operation and service. This 1940 edition ably sustains this reputation. Every radio man wants a copy of this valuable book. Just as this book will be of unquestionable value to you, so, too, will every monthly issue of RADIO & TELEVISION. This magazine brings you big value every month. It keeps you intelligently informed about new developments in radio and television. You want the news, want it fully but concisely, want it first—that is why you should read RADIO & TELEVISION regularly.

This very special offer is made for just one purpose—we want you as a regular subscriber. The Annual, whose contents appears at the right, is not sold, but a copy is FREE to you if you subscribe now.

**SAME SIZE AS  
RADIO & TELEVISION**

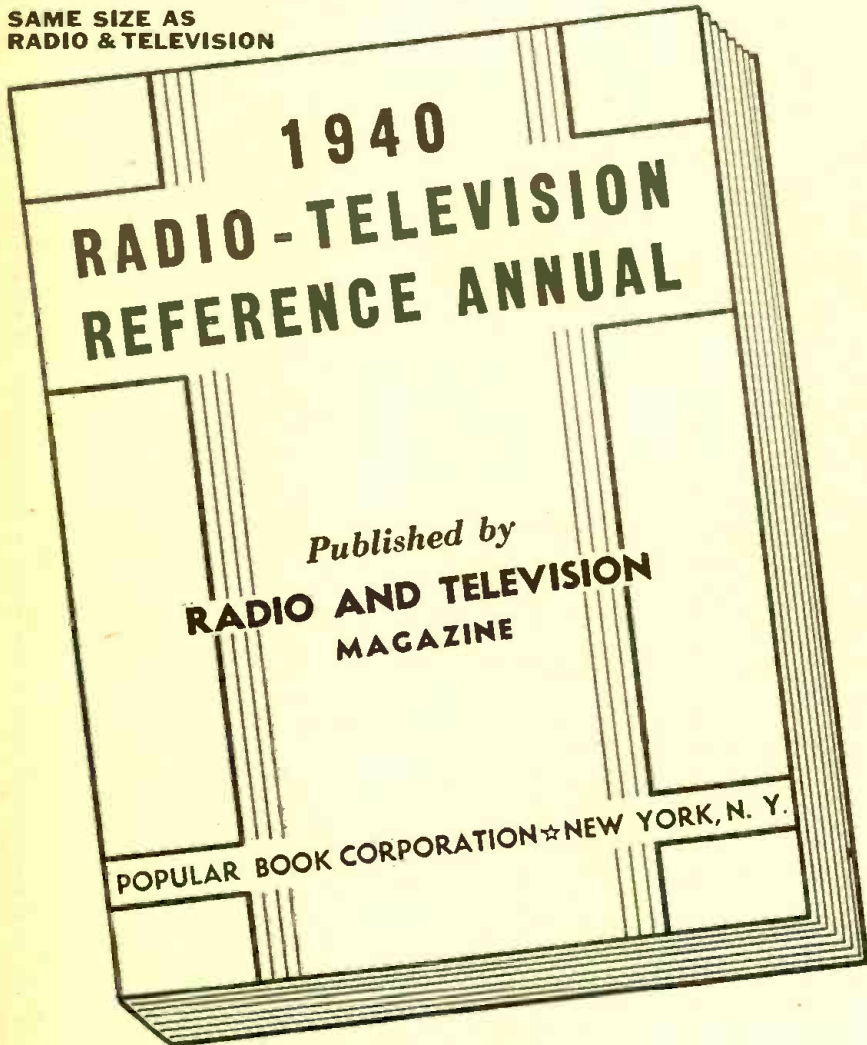

**THIS COUPON BRINGS YOU THE ANNUAL**

**RADIO & TELEVISION • 20 VESEY STREET • NEW YORK, N. Y.**

Gentlemen: Enclosed you will find One Dollar for which enter my subscription to RADIO & TELEVISION Magazine for Eight Months. Send me ABSOLUTELY FREE and POSTPAID, my copy of 1940 RADIO-TELEVISION REFERENCE ANNUAL.

This is a new order  Extend My Present Subscription

NAME ..... ADDRESS .....

CITY ..... STATE .....

**DON'T DELAY — MAIL TODAY!** RT-4-41

Please Mention This Magazine When Writing Advertisers

**Read the summary of contents  
in this FREE BOOK!**

THE 1940 RADIO-TELEVISION REFERENCE ANNUAL contains a collection of the best and most important articles. Covering as they do nearly every branch of radio, they form a handy reference works. In addition, many time and labor-saving kinks, circuits and wrinkles, tried and tested by practicing Servicemen, experimenters and radio fans have been included. This book cannot be bought anywhere at any price. Yet it is yours by merely subscribing. Use the convenient coupon below.

**BEGINNER'S SIMPLE INEXPENSIVE  
CONSTRUCTION ARTICLES**

Beginner's Breadboard Special - a 1-Tube High-Gain All-Wave Receiver—Wiring Pointers for Radio Beginners—A Watch Charm Size 1-Tube Set—Beginner's Simple Volt-Milliammeter—Making a 1-Tube Broadcast Loop Receiver—A.C.-D.C. Power Supply for Battery Portables—A 1-Tube Short-Waver with Band Coil Switching.

**MORE ADVANCED SET CONSTRUCTION**

The "High-Seas 4" Broadcast Lamp Radio—How to Build a 6-Tube 1-4 Volt Short-Wave Superhet for the "Ham" or Short-Wave Fan—Build the "Lunch Box 5" Super Set - a Broadcast Battery Portable—How to Build a Plug-Together 8 Tube Broadcast Set—The "5-in-4" All-Wave Radio for A.C. Operation—An Easily-Built 3-Tube Midget Broadcast Superheterodyne Receiver.

**THE SERVICEMEN'S SECTION**

Bass Tone Control—Simplified Variable Selectivity—Practical Servicing Pointers—Servicing Universal A.C.-D.C. Receivers—Killing the "Intermittent" Bug—A Service Shop A.C. to D.C. Power Supply—Sideline Money for Servicemen—Adding A.V.C. to any Screen-Grid T.R.F. Receiver—Iron Particles in Speaker Air Gap.

**TEST INSTRUMENTS**

A Useful Neon Lamp Tester—An Inexpensive Output Meter—Making Milliammeter Multipliers—Home-Made Frequency Modulator—The Busy Servicemen's V.T. Volt-Meter.

**PUBLIC ADDRESS AND AMPLIFIERS**

Build this Combination A.C.-D.C. Radio and Inter-Communicator—Speaker Placement in P.A. Work—The Design and Construction of an Inexpensive All-Push-Pull 10-Watt Amplifier—Obscure Sources of Hum in High-Gain Amplifiers—How to Build a High-Fidelity 5-Watt Versatile Amplifier.

**"HAM" SECTION**

Ultra-High Frequency Antennas—The Beginner's Low-Cost Xmitter—Modulator Meter—Phone Monitor—The Beginner's "Ham" Receiver—2½ Meter Acorn Transceiver.

**TELEVISION**

How to Build a 441 Line T.R.F. Television Receiver—Useful Notes on Television Antennas.

**MISCELLANEOUS**

Simple Photo-Cell Relay Set Up—Making a Burglar Alarm—How to Build A.C.-D.C. Capacity Relay—How to Make a Modern Radio Treasure Locator.

**USEFUL KINKS, CIRCUITS AND WRINKLES**

Making a Flexible Coupler—Two-Timing Chime—A Simple Portable Aerial—An Improvised Non-Slip Screw-Driver. NOTE: The book contains numerous other useful Kinks, Circuits and Wrinkles, not listed here.

(approximately)

**45 ARTICLES**

(approximately)

**170 ILLUSTRATIONS**

**68 BIG PAGES**

**RADIO & TELEVISION  
20 VESEY STREET  
NEW YORK, N. Y.**

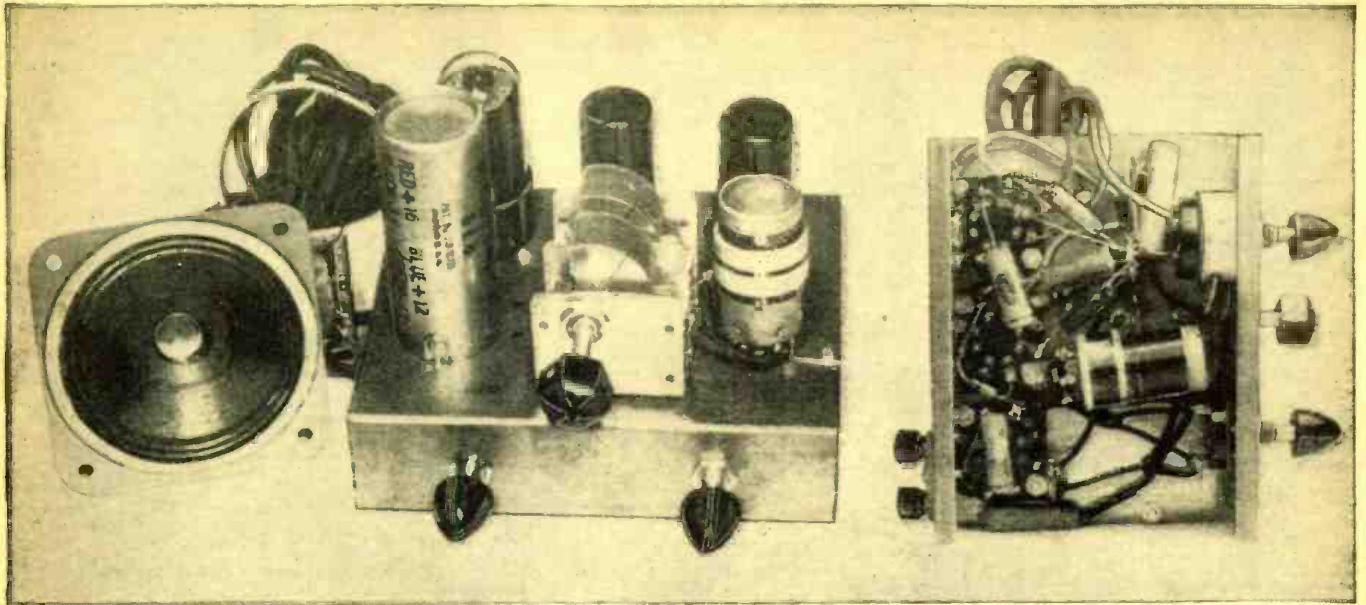

Two views of the T.R.F. receiver are shown above.

# The "Bandswitch 3" TRF

L. M. Dezettel, W9SFW\*

● FOR the experimenter who wants to build an inexpensive TRF set to listen to the local hams on 160 meters as well as the broadcast band, the "Bandswitch 3" is an ideal construction project. It makes use of three of the latest type tubes and is easily built.

The design of this kit is based on the simple *tuned - radio - frequency* circuit. Tapped antenna and R.F. coils are used with a double-pole, single-throw switch for changing bands. With the switch open the entire broadcast band is covered, and with the switch closed the frequency coverage is about 1400 kc. to 3500 kc., where many police, amateur and airport stations can be heard.

The sensitivity on the broadcast band is so great that the volume control could not be set at maximum volume without overloading the speaker, except on the low power stations. Although the *short-wave* band section does not have the sensitivity of a good superhet—police, amateur and airport stations were heard up to 200 miles distant.

An attempt was made to build the set onto as small a chassis as practical. This, together with the 3½ inch speaker, makes it possible for those of you who are a little adept at cabinet making, to build a compact modern receiver for the home.

For the sake of economy and versatility, operation is on 110-125 volts A.C. or D.C. The use of 150 ma. heater tubes keeps total power consumption down to about 25 watts.

A little about the circuit: A 12SK7 tube serves as R.F. amplifier. Volume control is accomplished by a combination of varying the bias and shunting the antenna in the

**The beginner in radio set-building will find this article a very interesting one, as it describes a very effective receiver built on the T.R.F. principle. No aligning of I.F. stages is necessary and the whole construction is a simple, straight - forward job. Loudspeaker operation is obtained with but three tubes.**

R.F. stage. A 12SJ7 tube functions as a power type detector. These two tubes are of the new single-ended type and have higher gain, as well as doing a better job of shielding, than their older counterparts with the grid cap at the top. The antenna and R.F. coils are tuned simultaneously with a two-gang 365 minf. variable condenser. The condenser has trimmers on both sides of it for easy accessibility.

A 70L7GT tube combines the functions of power amplifier and power-supply rectifier. This tube is capable of nearly two watts of audio output. A four-section filter condenser takes care of by-passing the 12SJ7 and 70L7GT tube cathodes and filtering the D.C.

Now, what do you say we build one of these sets: The chassis measures 6" x 4¾" x 1½". This chassis can be obtained already formed and punched, ready for mounting. If you prefer you can make your own chassis from electralloy, aluminum or cold rolled steel. The pictures show the general layout, which should be followed closely when mounting the parts. The *antenna* coil

is mounted above the chassis and the R.F. coil below it. The mounting bracket on the R.F. coil was intended for vertical mounting, so it will be necessary to put a squared "S" shaped crimp in it to mount it horizontal to the chassis. Be careful when mounting the speaker plug, that the terminals do not touch those of the 70L7GT tube socket.

Wiring should be done slowly and *carefully*. There is really very little to it, but a reasonable amount of care is necessary to prevent excessive regeneration. Keep all leads as *short* as possible and close to the chassis. This applies particularly to those connections which are made to the grid and plate contacts on the sockets. Notice that there is only one connection to the chassis itself—one side of a .1 mf. 200 volt condenser, which acts as an isolating condenser so that the chassis does *not* become part of the power circuit. The other side of the condenser is connected to the common negative in the circuit. This arrangement permits you to use an *external* ground connected directly to the chassis, although an external ground is not necessary. Isolating the chassis eliminates the hazards of accidental shock or blowing of house fuses. An isolating condenser is also used in the antenna circuit to prevent "fireworks" in case your antenna should come free and accidentally touch the ground or a pipe that is grounded.

No special equipment is required for adjustment. The primaries of the antenna and R.F. coils are adjustable by sliding them up and down on the secondaries. The positioning of the primaries and the adjusting of the trimmers on the condensers are the only adjustments necessary.

\*Engineer, Allied Radio Corp.



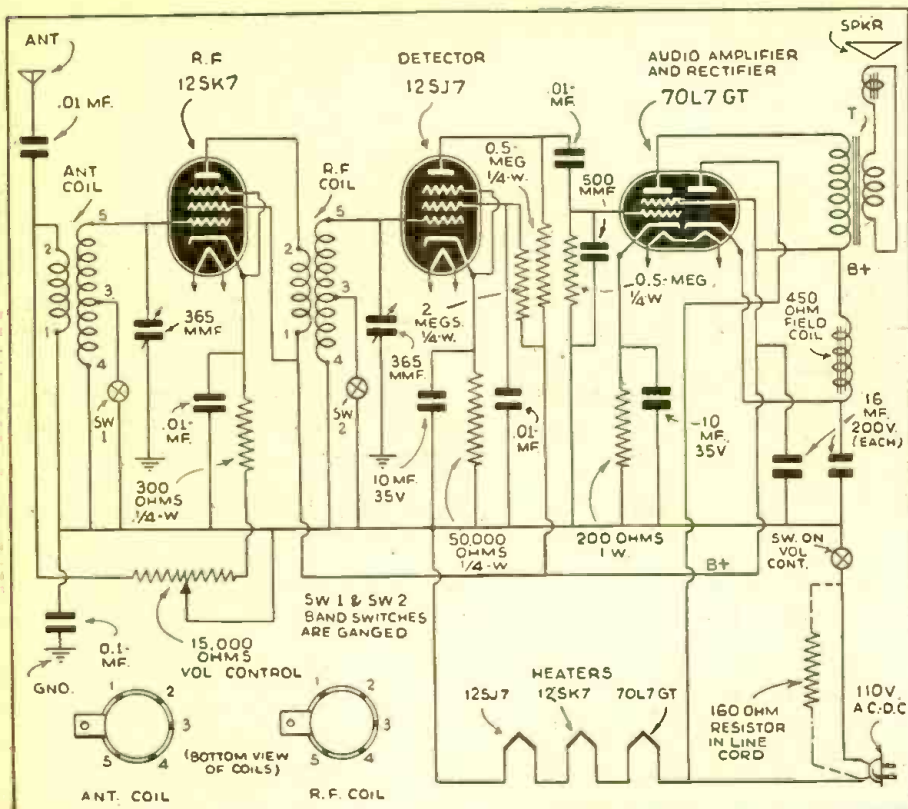

Wiring diagram of the T.R.F. receiver.

We begin by plugging the line plug into a 110 volt A.C. or D.C. outlet. Turning the volume control to the right turns on the set, as the "on-off" switch is on the volume control. Connect an antenna and allow a minute for the tubes to warm up. With the band-switch in the *broadcast* position, you should hear stations immediately. Some oscillation, indicated by squealing sounds, will occur with the volume control on full. Slide the primary of the R.F. coil to the other end of the secondary—the end on which the terminals are located. This will eliminate or substantially reduce the oscillation. A perfectly built and adjusted job *should not oscillate at all*. However, a little oscillation occurring when the volume control is full on, will not hurt and will disappear when the volume control is turned down slightly. Even at slightly reduced volume, the signal strength is much too great for comfort.

With the receiver switched to *receive* on the *short-wave* band, local 160 meter amateur phone stations will come in at about one-half scale. Tune in the highest frequency station you can hear. Now turn each of the trimmers on the sides of the gang condenser for loudest signal. This adjustment can also be made with the switch in the broadcast band position. Next slide the antenna coil primary down on the secondary. There will be a place about half-way down, where a happy compromise between signal strength and selectivity is obtained. The exact position is a matter of antenna length used and your personal preference. Loudest signal response is heard with the antenna primary at the top. Best selectivity, with the primary at the bottom.

Even if a cabinet is not used, a speaker baffle cut from an 8" square piece of plywood will improve the tone considerably. You will be surprised at the fine reproduc-

tion quality and sensitivity of the set.

### "Bandswitch 3" Parts List

- 1—4 prong socket, wafer
- 3—Octal sockets, wafer

- 1—Antenna coil and R.F. coil, tapped for S.W., Miller #20-T
- 4—.01 mfd. 400 volt condensers, Knight
- 1—.1 mfd. 200 volt condenser, Knight
- 1—4 section filter condenser, Knight
- 1—15,000 ohm potentiometer, Utah-Carter
- 1—Switch for potentiometer
- 1—Dual tuning condenser, 365 mmfd. per section, Knight
- 1—300 ohm, 1/4 watt resistor, Knight
- 1—50,000 ohm, 1/4 watt resistor, Knight
- 1—2 megohm, 1/4 watt resistor, Knight
- 2—1/2 megohm, 1/4 watt resistors, Knight
- 1—200 ohm, 1 watt resistor, Knight
- 1—160 ohm line cord, c or d ohm
- 1—Bandswitch D.P.S.T., Centralab #144
- 2—Small knobs
- 1—Large knob
- 1—4-prong plug
- 1—Ant.-Gnd. connector, Eby
- 1—Chassis, Knight
- 1—.0005 mfd. mica condenser, Knight
- 2—2 terminal wiring tie-points
- Miscellaneous wire and hardware
- (Knight—trade name of Allied parts.)

### Accessories

- 1—Tube, type 12SK7
- 1—Tube, type 12SJ7
- 1—Tube, type 70L7GT
- (RCA or other good make)
- 1—Speaker
- 1—Transformer

If you like this article and want to see more like it—tell the Editors.

Also tell us what other articles of a "constructional" nature you would like to see published.

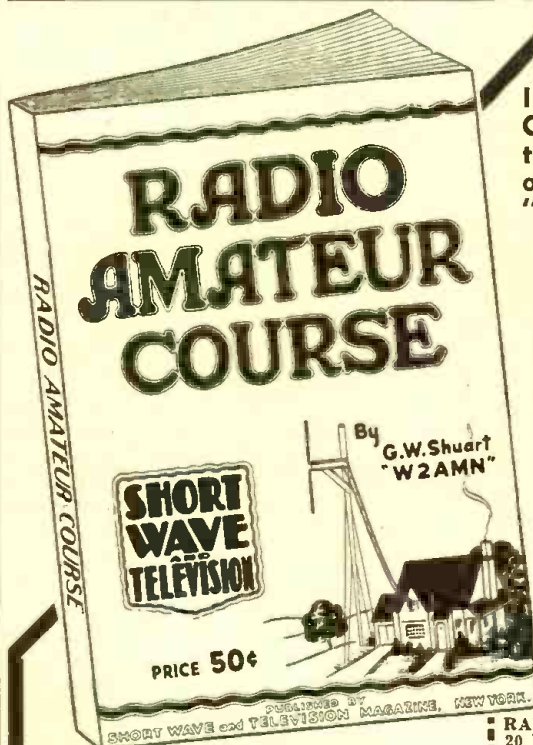

### Your Money Back—

If the **RADIO AMATEUR COURSE** does not represent the greatest book value ever offered to the radio "fans" for **50c**

To convince you that there isn't a better book buy today, the publishers of the **RADIO AMATEUR COURSE** make the sensational offer of a money-back guarantee on such a low-priced book. Stop in at any of the many dealers handling this book and examine it. See for yourself if the **RADIO AMATEUR COURSE** isn't just the book you've always wanted.

Printed on the finest coated paper—well illustrated attractive 4-color cover—complete with radio information you must have. It contains a step-by-step program for obtaining a short-wave radio education.

Written by **George W. Shuart, W2AMN**, foremost short-wave authority

**148 PAGES**  
6 1/4 x 9 1/2 INCHES  
**OVER 150 RADIO DIAGRAMS**  
**and TECHNICAL PHOTOGRAPHS**

**RADIO AND TELEVISION**  
20 Vesey Street New York, N. Y.

**RADIO AND TELEVISION**  
20 Vesey Street, New York, N. Y.

Gentlemen: I enclose herewith my remittance of Fifty Cents (50c) for which please send me **POST-PAID**, my copy of the **RADIO AMATEUR COURSE**. (Remit by check or money order; register letter if you send cash or unused U. S. Postage stamps.)

Name .....

Address .....

City ..... State ..... R&T-4-41

# Relays and Magnetic Controllers for Radio Experimenters

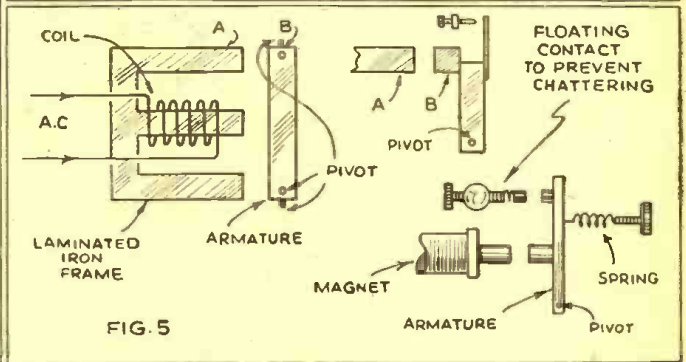
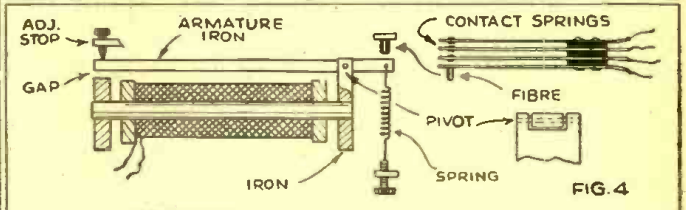
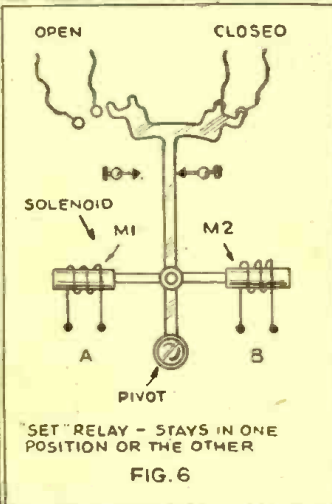
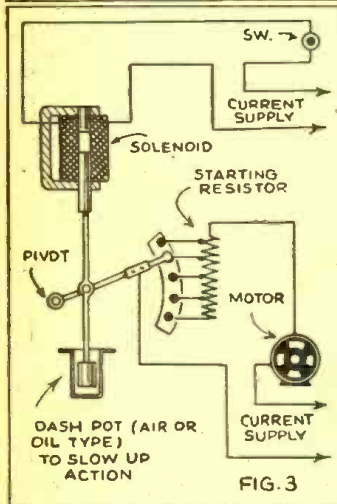
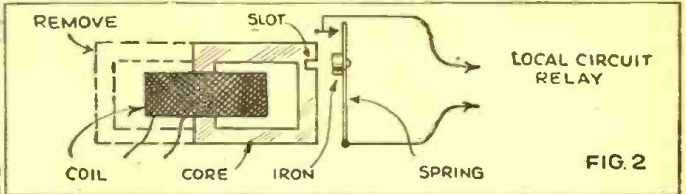
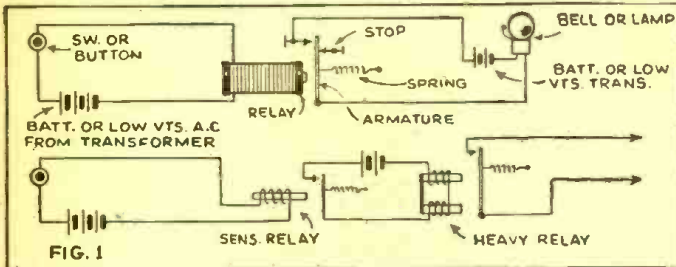

The radio and electrical experimenter will find the designs suggested useful about the shop and laboratory. Very good relays can be constructed from old electric bells and telegraph apparatus. Old audio-frequency transformers can be revamped to make surprisingly good relays.

● THE radio and electrical experimenter frequently finds it necessary to use a relay of some type, whether it be for controlling a distant motor, or performing some other important function about the station or laboratory.

In Fig. 1 the use of a relay for controlling a signal bell or lamp is shown; also how a sensitive relay may be used to close the circuit of a secondary heavy-current relay. The sensitive relay usually has a high resistance, which means that the magnets are wound with fine insulated copper wire, the current requirement being a fraction of an ampere. In consequence a few batteries will operate such a sensitive relay over a circuit several hundred feet long or more. A common resistance value for such relays is 300 ohms.

Where a heavy current, such as that for controlling a motor or other apparatus, is to be switched on and off—then a more sturdy relay with heavier (silver) contacts is used. Such a relay may be constructed from an old electric bell or a telegraph sounder. Where relays are to be operated on A.C. the iron core should be laminated or built up of sheet iron strips.

The relay may be caused to close a circuit when a current is passed through the coils, or in some cases the reverse action may be desired—i.e., when the armature is attracted by the magnets, it breaks the local circuit.

A sensitive relay that may be made from

an old audio frequency transformer is shown in Fig. 2. Here half of the iron core is cut away as shown, and either the primary or secondary coil of the transformer is used as the relay winding. The armature spring, of steel or brass, has a soft iron button riveted on to it as shown; this button is mounted so as to come opposite a slot cut almost—but not quite—through the iron core with a hacksaw. The slot should be about 3/32 inch wide and may be cut easily by putting two or three blades on the hacksaw frame, and cutting the slot at one operation with the compound blade.

This relay will be found very sensitive and, with proper adjustment screws on the armature, it can be regulated so as to have a high degree of sensitivity. It may be used in connection with photo cells and for other purposes.

A solenoid or suction type magnet, shown in Fig. 3, is very useful for radio and electrical experimenters, the one shown at Fig. 3 being used to pull up the arm of a motor-starting rheostat. In order that the arm shall not be jerked up instantly but moved slowly, a dashpot is attached to the arm. This delays the upward motion so that the motor is started slowly, as it should be. These dashpots may be of the oil or air type, and consist of a close-fitting piston, in a brass or other metal cylinder, closed at the lower end. The degree of delay caused by the dashpot may be varied by drilling a hole through the piston, and fit-

ting a screw near this hole, so as to cut off more or less of the opening as the screw is adjusted. For direct current, the solenoid magnet may be made with a wrought iron or mild steel core or yoke; for alternating current the core and yoke should be laminated, or made up of soft iron (or transformer steel) strips.

For battery operation (6 to 8 volts) the solenoid may be wound with fairly heavy wire, about No. 16 to 18, depending upon the size of the coil. For 110 volt D.C. operation, the coil will have to be wound with much finer wire, or about No. 28 to 30, depending upon the size of the coil. If the magnet coil should heat up a little too much, some extra resistance such as a 110 volt lamp, of suitable size, may be connected in series with the magnet. For 110 volt, 60-cycle A.C. operation, the coil can be wound with heavier wire, or about No. 24, for average size coils.

In Fig. 4 a very good design of relay is shown; here the armature has a powerful action and the short end of the armature closes the contact springs in the manner apparent from the drawing. A relay of this type can easily be made by the experimenter, and as indicated there is an iron piece at each end, secured to the core, with a slot cut in one of these end strips. The armature is pivoted by means of a nail in this slot, as per drawing. An adjustment nut and a spring permit of varying tension on the armature, the back motion of which is con-

# SUPER SPECIALS

trolled by an adjustable stop-screw. Any number of contact springs can be mounted in a position like that illustrated and operated by the armature. The coil winding may have fine wire on it, if it is to be used on a fairly long circuit, but if a strong pull is desired, and a fair amount of current is available to operate the relay, it may be wound with heavier wire, say about No. 18 or 20.

One method of constructing an A.C. relay is shown in Fig. 5. To make this an old audio frequency transformer core may be utilized. A section of the iron core may be employed as the armature, arranging it on pivots so that it can move.

For A.C. operation, where the armature is liable to vibrate or chatter, a very good idea is shown in the drawing, whereby a "floating" contact may be mounted on the end of the stationary contact screw (or it may be mounted on the armature). In some cases experience has shown that an ordinary telegraph relay will work very well when operated on low voltage A.C. from a step-down transformer. The trick in this case is to adjust the magnets so as to leave an extra large air gap between the poles of the magnets and the armature. In any event, for A.C. operation, the floating contact will be found a life-saver and is very desirable.

A "set" relay, see Fig. 6, is one in which the armature stays where it is moved by one magnet or the other; for many cases such as radio control of model boats, etc., such a relay will find many applications. By means of solenoids or ordinary tractive magnets, the arm A is moved to one side or the other and the contact shoe or spring caused to open and close the respective circuits in the manner apparent from the diagram. The contact springs carried on the arm A, may be of any intricate pattern worked out by the experimenter for such cases, and instead of these springs closing the circuits, the end of the arm A may simply push against a fiber block on a set of contact springs, like those found on jack type switches. In the case of a model boat, such a relay switch is very desirable, in order that one radio impulse may excite solenoid M1, for instance, and cause a solenoid-operated device to pull the boat's rudder, let us say to port. The second impulse transmitted from shore would operate the arm A, in the opposite direction, and energize the magnet or solenoid pulling the rudder in the opposite direction—or to starboard.—H. W. S.

All of the attractive items listed here are brand new. ALL are in PERFECT WORKING ORDER. In many cases, the parts alone total more than the price we are asking. 100% satisfaction guaranteed or your money refunded. ORDER FROM THIS PAGE. Use the convenient coupon below. Include sufficient extra remittance for parcel post charges, else order shipped express, collect. Any excess will be refunded. C.O.D. shipments require 20% deposit. If full remittance accompanies order, deduct 2% discount. Send money order, certified check, new U. S. stamps. No C.O.D. to foreign countries.

ORDER TODAY LIMITED QUANTITIES PROMPT SHIPMENTS ASSURED

## VARIABLE SPEED UNIVERSAL MOTOR

FOR 110 VOLTS, A.C. OR D.C.

Made for Dictation machines by American Gramophone Co. Used, but in excellent condition. Special lever control permits variable speeds up to 3000 r.p.m. Shaft extends from both sides of motor. Measures 7 1/2" x 3 1/4" diam. Overall: Shp. Wt. 6 3/4 lbs.



ITEM NO. 11  
YOUR PRICE \$1.55

## 2-WAY LAMP

Ornamental dual purpose lamp. Can be used as a table or vanity lamp in one position. By turning swivel base it becomes a bracket lamp which may be mounted on wall.



Holder in base is provided for this. Handsome design. Base made of pressed glass, polished wood and plated metal stand. Comes with round shade colorfully decorated with ribbon design, or more elaborate fluted shade with flower design. Height of lamp 12 1/2"; shade 8". Complete with cord. Shipping wt. 2 lbs.

ITEM (Plain Shade) NO. 120 98c

ITEM (Fluted Shade) NO. 121. YOUR PRICE \$1.05

## BENNETT LABORATORY BALANCE

A compact laboratory balance made of finest quality tested materials. Extreme sensitivity (to 2-100ths gram or 2-7ths grain). Weighs to one decimal pt. further

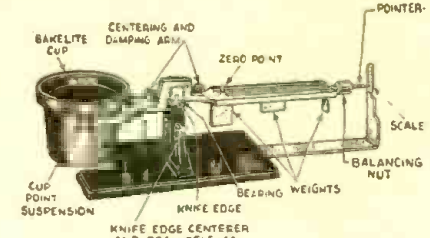

than usual low priced counter scale. Will handle up to 100 grams (about 4 oz.). Bakelite pan; tool steel knife edge; skate bearing for long life and accuracy. Ideal for photographic work and lab use. Handsome streamline design. Graduated either in metric or apothecary system. Shipping wt. 2 lbs.

ITEM NO. 122  
YOUR PRICE \$7.20

## 100 POWER TELESCOPE LENS KIT

Make your own high powered 6 ft. telescope! Now you can thrill to a closeup view of the worlds out in space. See the rings around Saturn, the mountains of the moon! Kit contains 3" diam., 7 1/2" focal length, Frensch and polished objective lens and 2 astronomical eye-pieces. magnification 50x and 100x. Complete kit with full instructions.



ITEM NO. 123  
YOUR PRICE \$1.95

## AMAZING BLACK LIGHT!!

Powerful 300-Watt Ultra-Violet Bulb



The best and most practical source of ultra-violet light for general experimental and entertainment use. Makes all fluorescent substances brilliantly luminescent. No transformers of any kind needed. Fits any standard lamp socket. Made with special filter glass permitting only ultra-violet rays to come through. Brings out beautiful opalescent hues in various types of materials. Swell for amateur parties, plays, etc., to obtain unique lighting effects. Bulb only. Size of bulb.

Shp. Wt. 1 lb.  
ITEM NO. 87  
YOUR PRICE \$2.00

## ULTRA MAGNET

LIFTS MORE THAN 20 TIMES ITS OWN WEIGHT

LITTLE GIANT MAGNET. Lifts 5 lbs. easily. Weighs 1 oz. Made of ALNICO new high-magnetic steel. Complete with keeper. World's most powerful magnet ever made. The experimenter and hobbyist will find hundreds of excellent uses for this high quality permanent magnet. Measures 1 1/2" x 1 1/2". Shp. Wt. 3/4 lbs.



ITEM NO. 86  
YOUR PRICE \$1.00

5 LBS

## ELECTRIC TURNTABLE

A sturdy electric turntable, ideal for eye-catching window displays. MUST for alert retailers. Frame made of 16 gauge steel, 16 in. steel turntable makes three revolutions per minute. Turntable supports load of 200 lbs. Ballbearing construction. Rich black enamel finish. Operates on 110 v. A.C. Current cost only 1/2c a day. Size: 5 1/4" high, base 8" square. Shipping wt. 14 lbs.



ITEM NO. 124  
YOUR PRICE \$8.95

## NEW ELECTRIC MOTOR-SAW

Now you can have all the fun of fine, fast jig saw work without any of its difficulty. Simply steer the lightning-fast blade and see it seemingly melt its magic way through wood, plastics and building board. 7200 STROKES per MINUTE! Average cutting speed 1 foot per minute through 1/2" medium hard wood. Works 3 times faster than any free-hand saw. Operates on 50-60 cycle 110 v. Alternating Current. Screw adjusts blade stroke from 1/4" to 5/16". On-On Switch built in handle. Complete with 6 ft. power cord and 3 saw blades.

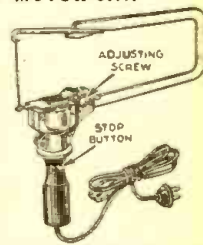

ITEM NO. 97  
YOUR PRICE \$4.85

## ELECTRIC HUMIDIFIER FOUNTAIN

Adds healthful moisture to the air in winter. Evaporates as much as a pint of water in 24 hours. Fountain is 14" in diam. Sprays 9 streams of water 5" above fountain head. Made of spun aluminum. Comes in five colors: Bronze, chrome, copper, red, green. No water connections required. Just plug into 110 volt, 60 cycle A.C. outlet. Current consumption few cents a month. Complete with base switch and 8 ft. power cord. Shipping wt. 9 lbs. List price \$14.95. Only a limited supply on hand.

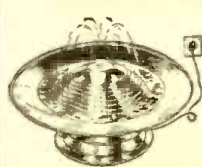

ITEM NO. 125  
YOUR PRICE \$4.95

## ELECTRICAL ARTICLES WANTED!

● IF you enjoy this department be sure to send us a description of your favorite piece of electrical apparatus. We want articles on simple electric motors and methods of using them, electric meter test set-ups, high frequency furnaces, home-made battery chargers, home-made measuring instruments and bridges, etc. All articles accepted and published will be paid for at regular space rates. Be sure the photos are sharp and clear.—The Editors

## New Catalog

JUST OUT  
A POSTAL CARD BRINGS IT TO YOU  
SEND FOR IT TODAY

HUDSON SPECIALTIES CO., 40 West Broadway, N. Y. C.

IT'S EASY TO ORDER—CLIP COUPON—MAIL NOW ORDER FROM THIS PAGE.

HUDSON SPECIALTIES CO., 40 West Broadway, Dept. RT-441, New York, N. Y.

I have circled below the numbers of the items I'm ordering. My full remittance of \$..... (include shipping charges) is enclosed.

OR my deposit of \$..... is enclosed (20% required), ship order C.O.D. for balance. No C.O.D. order for less than \$2.00. (New U. S. stamps, check or money order accepted.)

Circle Item No. wanted: 11, 86, 87, 97, 120, 121, 122, 123, 124, 125

Name..... Address.....

City..... State.....

Send remittance by check, stamps or money order; register letter if you send cash or stamps.

## A Spot or Floodlamp you will be proud to own



In beautiful black crackle finish with **UNIVERSAL BRACKET** that may be moved and locked in any position desired. Complete as illustrated, ready to plug into A.C. or D.C. house current. Includes tripod, bulb and rubber cord. Total weight 12 lbs. **\$5.50** When ordering specify whether spot or floodlamp is desired.

### Separate Units

**Spotlamp**, black crackle finish, fitted with Westinghouse frosted bulb, 6 ft. rubber cord with plug for A.C.-D.C. house current. Wt. 7 lbs. **\$3.00**

**Floodlamp**, black crackle finish, fitted with No. 1 G.E. Floodlamp, 6 ft. rubber cord with plug for A.C.-D.C. house current. Wt. 7 lbs. **\$3.00**

**Tripod**, 4½ ft. high with bronze fittings. Weight 6 lbs. **\$1.65**

**Adjustable Tripod**, made of selected straight grained hardwood fitted with sturdy clamps, large thumb nuts and solid metal prongs. Adjustable from 44" to 84". Standard head screw to fit any camera. Weight 6 lbs. **\$3.00**

All prices quoted FOB, New York.

### GOLD SHIELD PRODUCTS

Dept. RT-441

350 Greenwich St. New York

## Inventions Wanted Patented or Unpatented

We have been successfully selling inventions, patented and unpatented, since 1924. Write us, if you have a practical, useful idea for sale.

**CHARTERED INSTITUTE  
OF AMERICAN INVENTORS**

Dept. 109 Barrister Building, Washington, D.C.

## PATENTS — TRADE MARKS

Booklet concerning Inventions & Patents

Form "Evidence of Conception" with instructions for use and "Schedule of Government and Attorneys Fees"—Free

**LANCASTER, ALLWINE & ROMMEL**

Registered Patent Attorneys

436 Bowen Bldg. Washington, D. C.

### (Cover Feature)

## TELEVISION APPARATUS

2,224,287—issued to Vern W. Busch, Rushton, Michigan.

● THIS invention includes the provision of television apparatus having non-shatterable means, through which the audience may view the pictures on the end of the cathode ray tube; pleasing in appearance and readily adaptable to changes in design, enabling it to be readily blended into various design features of a television cabinet.

This invention also provides a protective transparency for the large end of the cathode ray tube, so constructed as to impart to it a maximum degree of inherent rigidity.

This apparatus introduces air directly to the cathode tube upon implosion thereof, to thereby neutralize the effects of the implosion, with a minimum disadvantage to both the audience and the television apparatus contained within the cabinet.

The transparency is mounted for movement toward and away from the cathode

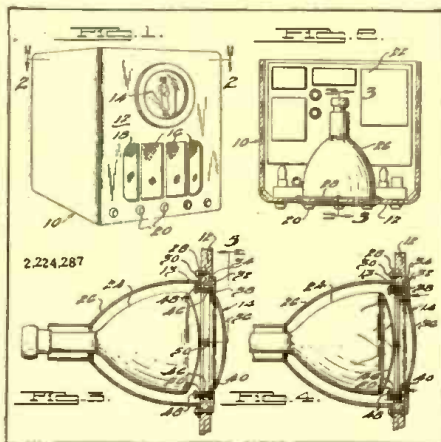

Non-shattering transparent "safety" screen for use with television tubes.

tube by resilient means. The transparency through which the audience views the large end of the cathode tube is of a lens-like character and partially corrects any distortion of the image on the end of the cathode tube.

## PICTURE TRANSMISSION

2,226,436—Issued to Donald K. Lippincott, Larkspur, Calif.

● AMONG the other objects of my invention are: to provide a scanning system which may be applied with any type of scanning mechanism, whether cathode ray, oscillating mirror, or scanning disk, and with either beam scanning (the so-called flying spot) or image scanning. Further: to provide a scanning system wherein synchronizing pulses are automatically generated without the use of additional equipment; to provide a system wherein the entire picture transmission is accomplished on a single wave, the positive portions of the wave carrying the picture, while the negative portions accomplish the synchronizing. And to provide a scanning system wherein variations in scanning speed, over the various portions of the picture field, do not result in departures from the true illumination level as long as the transmitting and receiving scanning apparatus travel at the same velocity.

An additional object of the invention is to provide a scanning system, whereby either square front waves or waves resulting from the removal of certain definite frequencies from such square-front waves, may be generated without the use of filters or other auxiliary apparatus.

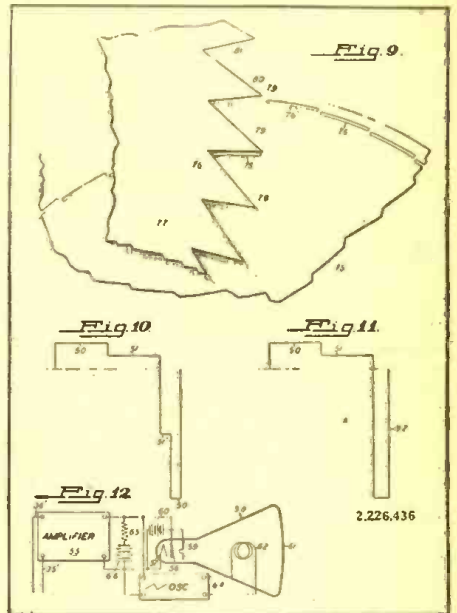

A scanning method applicable to cathode ray, oscillating mirror or scanning disc television systems.

## FILM PROJECTOR FOR TELEVISION

2,227,054—Issued to Alda V. Bedford, Collingswood, N. J.

● IN the present invention provision is made whereby intermittent movement of the film is entirely unnecessary, and the film may be moved through the television scanning device in a continuous and uniform manner. In order that an image of the separate frames of the continuously moving film may be projected upon the mosaic or light responsive electrode of the television transmitting tube, some means must be provided for creating a stationary image. In the present invention a mirror is used, the mirror being oscillated in synchronism with the operation of the scanning device and in accordance with the movement of the film.

A still further purpose is the provision of means for the operation and optical adjustments of the scanning device and compensating for changes in the physical dimensions of the film.

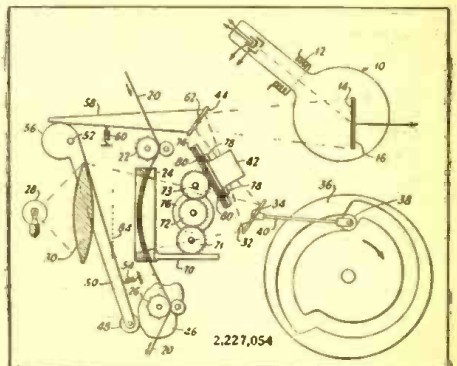

Intermittent movement of the film in television is not necessary with this device.

## New Radio Apparatus

### New Deluxe Victrola Home-Recorder and Table Model Set

• A DELUXE Victrola, incorporating home-recording facilities, housed in an 18th century design cabinet in Chippendale style, has been announced by RCA. Also introduced was a powerful, but compact, table model RCA Victrola.

The deluxe instrument, Mr. Mills said, is substantially the DeLuxe Victrola V-301, with the addition of home recording facilities. It has the same handsome cabinet and the same operating features.

The new instrument provides a deluxe home recording instrument at reasonable cost. In addition to conventional home recording, this model also provides for re-recording, for mixing music or speech with either radio programs or recorded music, or it may be used as a public address system. The new instrument is identified as Model VHR-307 and may be had in either mahogany or walnut.

The new "table model," V-101, is a 5-tube (plus rectifier tube and ballast) instrument delivering 5 watts of power through an audio system especially designed for record reproduction. Its distinctive cabinet allows for playing 10- and 12-inch records with the lid closed.

It has the newest type of molded tone arm and an efficient crystal pickup. Two-point tone control and a highly efficient 6-inch loudspeaker are among its many features. Convenient radio reception is provided by a built-in loop antenna, while provision is made for connecting an outside antenna for distant reception. Its selective superheterodyne circuit has magnetite core I-F transformer for increased sensitivity.



New Victrola Home-Recorder



RCA Table Model Phono-Radio Set

### Company Changes Name

• GOAT RADIO TUBE PARTS, INC., recently announced a change in their corporate name to Goat Metal Stampings, Inc. This company has recently reorganized their plant in expanded quarters; they will continue to supply their well-known line of tube shields, etc.

## COMMERCIAL NOTICES 10¢ A WORD

Under this heading only advertisements of a commercial nature are accepted. Remittance of 10¢ per word should accompany all orders. Copy should reach us not later than the 10th of the month for the second following month's issue.

CORRESPONDENCE COURSES	MOTION PICTURES	PATENT ATTORNEYS
USED CORRESPONDENCE COURSES and Educational Books Bought, Sold or Rented. Catalog Free. Vernon Exchange, Summerville, Ga.	GENERA FILMS FOR MOVIE CAMERAS. Save 50%. Two films "The End," 10¢. (Size 7) Bargain circulars. Fromaders, Davenport, Iowa.	INVENTORS — PROTECT YOUR rights before disclosing your invention to anyone. Form "Evidence of Conception"; "Schedule of Government and Attorneys' Fees" and instructions sent free. Lancaster, Allwine & Rommel, 436 Bowen Building, Washington, D. C.
INSTRUCTION	MOTORS	PRINTING
\$15.00 STEAM ENGINEERING Course—8 vols. \$4.50; Radio and Electrical text-book bargains—get list. Life of Napoleon. 3 de luxe volumes \$3.00. \$10.00 New Cyclopedia of Science. 1300 pp. \$4.50; Hopkins' "Experimental Science," 2 vols. \$3.50. Harry Ackerson, Box 322, Ramsey, N. J.	RECONDITIONED MOTORS, 1/50 HP, AC-DC, Nickel \$1.50; 1/30 HP, black \$2.50. Fully guaranteed. F.O.B. New York. Wonderful value limited quantity. Act Promptly! Gold Shield Products, Dept. 441, 350 Greenwich St., New York City.	PRINTING: 500 STATEMENTS; \$1.00, 500 letterheads with envelopes, \$3.00. Postpaid. Add 10% west of Rockies. Hargett, 3648 Kosciusko, St. Louis, Mo.
		RADIO
		QUESTION? ABOUT RADIO? Write William D. Hayes, Box 1433-G, Oakland, California.

## FOR SALE (NON COMMERCIAL) 3¢ A WORD

Under this heading we accept advertisements only when goods are offered for sale without profit. Remittance of 3¢ per word should accompany all orders. Copy should reach us not later than the 10th of the month for the second following month's issue.

RECONDITIONED GUARANTEED communications receivers cheap. Free trial. Terms. Hallcrafters, Nationals, Hammarlunds, RMES, RCAs, Howards and all other makes and models at lowest prices. Write for free list, W9AltA, Butler, Missouri.	DON'T BUY A RECEIVER UNTIL you get my free list of reconditioned, guaranteed receivers! Practically all models at money saving prices. Trade-ins. Time Payments. Send for list, W2AVA, 12 West Broadway, New York.	microphones. Thordarson equipped. Motor, Audak D-36-E pickup. Cases, cabinets. George Beggs, 5321 Wayne Avenue, Phila., Penna.
RIMCO DYNALYZER (SIGNAL Tracer), ATR Auto Radio "A" Battery Eliminator, Readrite tube tester Model 432A, at reduced prices. Samuel W. Sweeney, 1221 Brook Rd., East Milton, Mass.	150 WATT, 160 PHONE TRANSMITTER. Operating condition. Make offer. A. E. Varnes, Ritzville, Wash.	FOR SALE—TRIPLET PROFESSIONAL all-wave all-purpose tester. Same as new. Any reasonable offer considered. Clyde Dearinger, 103 W. Main St., Greenfield, Ind.
	6L6 AMPLIFIER, SIX CHANNELS, bass, treble controls. Two Jensen, two Chnoudagraph 12" speakers. Amperite	1939 CODE MACHINE. WILL SELL or trade. Chas. Benjamin, 1016 East 23rd Ave., North Kansas City, Missouri.

## BARTER AND EXCHANGE — 1¢ A WORD

NO ADVERTISEMENT TO EXCEED 35 WORDS, INCLUDING NAME AND ADDRESS

Space in this department is intended solely for the benefit of our readers, who wish to BUY or EXCHANGE anything in the Radio, Television and Photographic fields for Radio, Photographic and other merchandise; therefore we charge only 1¢ a word. Each word in a name and address is counted. Remittance should accompany order.

Only one advertisement can be accepted from any reader in any one issue.

Copy should reach us not later than the 10th of the month for the second following month's issue.

We cannot accept responsibility for any statements made by the readers.

All dealings MUST be above board. Remember you are using the U. S. Postal Laws, and therefore you are bound by the U. S. Postal Laws. Describe anything you offer accurately and without exaggeration. Treat your fellow men the way you wish to be treated. We welcome suggestions that will help to make this department interesting and helpful to our readers.

Copy should reach us not later than the 10th of the month for the second following month's issue.

WANT UNCANCELLED HONG KONG Walker Z. Scott stamp. Name what you require new radio parts. W. R. Carroll, 3057 E. 95th St., Seattle, Wash.

HAVE NEW HALLCRAFTERS Super Defiant, complete, value \$85.00; three half acre Lots near Seattle, Wash., value \$250.00. Want Home Movie equipment. Reflex Camera, Home Recorder outfit. Thrill Box, H. Coote, Riverbank, Calif.

WILL ACCEPT ANYTHING OF value. Send list. Have meters, tubes, checkers, receivers, adapters, generators, magazines, handbooks, speakers, transformers, pickups, xtals, buzzers, tools, motors, .22 Winchester, .41 Mauser, trombone, miscellaneous. Notices write—Roby, 6305 Kenwood, Chicago.

WANTED: HQ120N, RME NATIONAL or Hallcrafters communications receiver, also interested in late models of all test equipment. Cash or trade. W. C. Jensen, 330 Aberdeen St., Rochester, N. Y.

HAVE 500 .22 long cartridges, belt moneychanger, leather travel kit, Bullard first aid kit, electric razor, generator current regulator, 1937 Ford ring-pinion gears. Need frequency monitor. Rider's Manuals, typewriter. O. Link, High Bridge, Wisconsin.

WANT SKY BUDDY OR SIMILAR receiver and 6V. Vibrapack. Receiver must be 6V. portable type. Have 6 volt DeVry 16 mm. projector, 700 feet of Art Film, value \$40.00. Kenneth Walker, La Cynne, Kansas.

WILL TRADE NEW 32 volt input, 110 volt output, 500 watt converter, for canoe or hunting and fishing equipment, or what have you. Jack Carter, 2115 Birchwood Ave., Chicago, Ill.

WILL SWAP JOHNSON TWIN OUTBOARD Motor for phone transmitter. F. T. Blanchard, Gunnison, Miss.

MEISSNER TUNING UNIT—5 band—Philco Signal Generator Octal tubes, transformers, lots of good components; want record player, good portable. E. R. Morgan, 112-10 Farmers Blvd., St. Albans, Long Island.

WANTED: BACK ISSUES OF Radio Craft, Short Wave Craft, Science & Invention, Experimenter, Electrical Experimenter, Modern Electric, Practical Electric, Popular Electricity, and Television News. Have RCA Wireless Record Player, Emerson Portable Radio, Univex 8 mm. projector, etc., to exchange, or will pay cash. M. F. Bustlin, Box 237, Wayland, Mass.

WANT SKY BUDDY S19R receiver. T. DeBruce, 2960 E. 72nd St., Cleveland, Ohio.

HAVE DEMONSTRATOR PHILCO 2 volt octal tubes, 1C7G, 1D5G, etc., tube tester, 6 volt Vibrapacks, many others. Want transmitting meters, condensers, transformers, coils, mikes, Stancor or Utah kits, oscilloscopes. send list. Herman Zachry, Ashdown, Ark.

HAVE PHILCO 4-BAND ALL-WAVE, 4-tube S-W, 2-tube S-W converter. All good condition. Want test equipment, servicing books, Scott-14, similar all-wave receiver. Holstein, 246 E. 148th, New York City.

HAVE ALL-STAR, JR. 4-5-6 TUBE Meissner kits, midjet b.c. receivers, magazines and hundreds of fine radio parts. Want: stamps, radio parts, V.O.M. meter or useful articles. Jno. Kasperaki, Baldwin Court, E. Hempstead, N. Y.

WANTED: AMATEUR TRANSMITTER, amateur equipment. Have complete Lionel electric train, chemical apparatus, miscellaneous. Foster Park, 900 School Street, Columbia, Tenn.

WILL GIVE ALL THE FOLLOWING: small toolmaker's surface plate, battery charger with bulb, and trickle charger; for a Superior Multi-tester or similar in good condition. Joseph Marsh, 34 Hartwell St., New Brunswick, N. J.

TRADE: WIRELESS PUSHBUTTON tuner, crystal record player, coil oscillator, 6F6-6L6 CW transmitter, vibrator power supply, 3 watt amplifier. Need: enlarger, drill, typewriter, printing press, photo equipment and supplies, 2748 Meade, Detroit, Mich.

WANTED: MIDWEST RT-16 1934 model, good condition or not, want this RT-16 for parts. State your price. Cash will be paid. Theo. LaForest, 83 Columbia, Adams, Mass.

WANTED GOOD 8 MM. CAMERA and projector. Have a Wurlitzer 12 record coin operated music machine—model 412, which has a 15 watt amplifier, Jack Buck, 56 Morton Ave., West Hempstead, L. I.

HAVE SUPREME 2" MODEL 530 oscilloscope, 5" Cathode-ray tube, FB-7 with 40 meter handspread coils. Want good Xtal mike, typewriter or what have you? John C. Cram, Upper Sandusky, Ohio.

8 MM. MOVIES, RECTIFYING AND transmitting parts, tubes, back issues of Radio & Television wanted. Have high value stamps, speakers, mikes, etc. My list for yours. M. McDonald, 271 Pearl St., Cambridge, Mass.

SWAP: 1 INCH OSCILLOSCOPE, 3 band, 4 tube short-wave converter and 2 band midjet for late model tube tester, Radio News-1940 and signal generator. Eugene Sontos, 33 Hinckman Ave., Dover, N. J.

### SWL EXCHANGE

This department is for the benefit of all short wave listeners who wish to exchange SWL cards. Remittance of 1¢ a word for each word in the name and address should accompany order.

UNITED STATES  
PAUL ANKERMAN, 404 Lima Street, Wapakoneta, Ohio.  
O. BARNESON, Box 6332, Los Angeles, Calif.

RICHARD DURNIN, 10 Mount Air Ave., Waynesboro, Penna.  
VICTOR FELTON, 1119 S. Mich. Ave., Welston, Ohio.

HOWARD FREEZE, 1005 East Druid Road, Clearwater, Florida.  
FOSTER PARK, 900 School Street, Columbia, Tennessee.  
W. J. SAUNDERS, Jr., 145 U Street, N.W., Washington, D. C.  
STEVE SIDOR, 228 Nutt Road, Phoenixville, Pa.

The Finest Radio Book We Ever Offered

Free with Subscriptions.

See page 757.

**FREE CATALOGS and INFORMATION**

By carefully reading the advertising columns, you will find many offers to furnish literature containing valuable technical information that will help you in your work. Use this list freely.

Firm	Business	Offer	No.	Cost	Adv. Page
ABC Radio Laboratories	Set Mfr.	Information		Free	730
Acme S-W Radio Co.	Kit Mfr.	Circular		Free	729
Allied Engineering Institute	Kit Mfr.	Circulars		Free	730
Allied Radio Corp.	Mail Order	180-Page 1941 Spring Catalog		Free	719
American Radio Institute	Radio School	Booklet		Free	707
Amperite Co.	Parts Mfr.	Replacement Chart	"S"	Free	729
Ayers Automatic Code Machines	Code Machines	Information		Free	734
Bliley Electric Co.	Parts Mfr.	Circular	D-2	Free	732
		Engineering Bulletin	E-6	10c	
		Bulletin	E-7	Free	
		Circular	A-7	Free	
Browning Laboratories	Kit & Parts Mfr.	Information		Free	721
Bud Radio, Inc.	Parts Mfr.	Catalog		Free	721
Burstein-Applebee Co.	Mail Order	1941 Catalog	57	Free	734
Candler System Co.	Code Course	Book of Facts		Free	707
Cannon, C. F., Co.	Parts Mfr.	Folder	T-22	Free	721
Chartered Institute of American Inventors	Inventors Organization	Booklet		Free	762
Dodge's Institute	Radio School	Catalog		Free	707
Gold Shield Products	Mail Order	Catalog		Free	734, 750, 753, 754, 762
Hallicrafters, Inc.	Set Mfr.	Literature		Free	B.C.
Hammarlund Mfg. Co.	Set & Parts Mfr.	16-Page "SP" Booklet		Free	733
Harrison Radio Co.	Mail Order	Information—List		Free	737
Henry Radio Shop	Mail Order	Information		Free	732
Hudson Specialties Co.	Mail Order	Catalog		Free	761
International Resistance Co.	Parts Mfr.	Catalog		Free	725
Instructograph Company	Code Machine	Information		Free	737
Lafayette Radio Corp.	Mail Order	196-Page Catalog		Free	717, 727
Lancaster, Allwine & Rommel	Patent Attorneys	Booklet		Free	762
Mass. Radio School	Radio School	60-Page Catalog		Free	707
Midget Radio Co.	Set Mfr.	Information		Free	730
Midwest Radio Corp.	Set Mfr.	1941 Catalog		Free	747
Millen, J., Mfg. Co., Inc.	Parts Mfr.	Catalog		Free	739
National Company, Inc.	Set & Parts Mfr.	Literature		Free	1.F.C.
National Radio Institute	Radio School	64-Page Book		Free	705
National Recording Supply Co.	Parts Mfr.	1941 Catalog		Free	730
National Schools	Radio School	Catalog		Free	707
Nelson Co.	Used Courses	72-Page Catalog		Free	735
N. Y. Institute of Photography	Photography School	Booklet		Free	739
Par-Metal Products Corp.	Parts Mfr.	Catalog	40	Free	734
Radio & Technical Publ. Co.	Radio Textbooks	Circulars on each book		Free	737
Radolek Company	Mail Order	Radio Profit Guide		Free	767
Rapid Electroplating Process, Inc.	Electroplating Kits	Catalog Folder		Free	748
RCA Institutes, Inc.	Radio School	Catalog		Free	707
Remington Rand, Inc.	Typewriter Mfr.	Catalog		Free	749
Sprayberry Acad. of Radio	Radio School	52-Page Book		Free	1.B.C.
Supreme Publications	Publisher	Information		Free	729
Teleplex Co.	Code Machines	Booklet	S-4	Free	732
Thordarson Electric Mfg. Co.	Parts Mfr.	Bulletin	SD-464	Free	739
Triplett Electrical Inst. Co.	Parts Mfr.	Catalog		Free	735
Tri-State College	Radio School	Catalog		Free	707
Vibroplex Co., Inc.	Radio Keys	Catalog		Free	735

If you wish to buy, sell or exchange anything in Radio or allied fields, RADIO & TELEVISION'S classified ads will bring results. See Page 763.

**Allied Introduces New Tube Line**

● A NEW line of Knight radio tubes is currently being featured by Allied Radio Corporation. Built to exacting standards and specifications, these new tubes have created a stir. First, because of the adherence to strict standards in the manufacture of these tubes, engineers have been able to develop high quality, superior performance, and long-life dependability. Each tube carries a replacement guarantee covering any electrical or mechanical defect for a period of six months from the date of purchase. In addition, all tubes are



R.C.A. licensed and incorporate the latest developments in vacuum tube design and characteristics. The line of radio tubes offers a wide selection of the latest type tubes in all-glass, all-metal, octal base glass, miniature, and GT octal base types. All tubes are supplied in factory-sealed cartons.

**New 5-Scale Dial**

● THE type ACN dial illustrated is a new National item. Here, for the first time, is a dial that will fill a long-felt need of individuals in constructing home-built units such as electron-coupled oscillators, UHF Receivers, etc.—its five-range scale can be calibrated by hand. To facilitate accurate calibration and reading, a 0 to 100 division linear range is provided and the transparent lucite pointer has a black etched hairline. A bezel holds the dial scale and its transparent lucite window in place. Two extra dial scales are supplied with each ACN Dial for use in case calibration is changed or original scale is spoiled. The same 5 to 1 ratio Velvet Vernier Drive that has been famous for many years in Type A and N dials is employed in this new item. The large black HRK knob is similar to that used on the NC-200 Receiver.

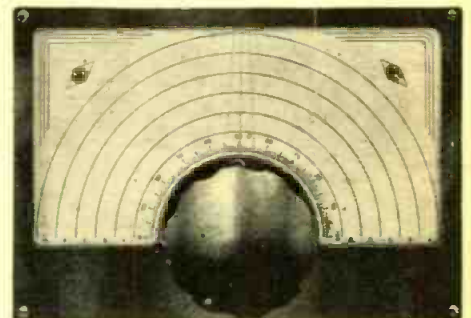

An insulated coupling permits the assembly to be used in conjunction with a 180-degree rotation capacitor having a 1/4 inch diameter rotor shaft. The dial frame measures 5 by 7 1/4 inches.

**New Line of Relays**

● A NUMBER of relays interesting to Hams and radio experimenters in general have been developed by the Standard Electrical Products Co. These relays include break-in and change-over types, as well as radio frequency relays, etc. One of the new relays featured by this company is of the miniature type, and the A.C. models of these relays are said to be free from hum and A.C. chatter.

The break-in relays are of the type commonly known as push-to-talk type, the operator merely pressing a push-button while transmitting and releasing it when receiving. The armatures have ball bearing pivots and large silver contacts are fitted on the relay. The radio frequency relays of the RB series are especially insulated for frequencies up to 15 megacycles, while the RM series are specially insulated for frequencies up to 60 megacycles. The A.C. coils on the R.F. relays consume 4 watts and the D.C. coils 2 watts. In the group of miniature relays it is interesting to note that one type has a coil of 5,000 ohms resistance, and it will pick up at 2 ma. and drop out at 1 ma. These relays are designed for vacuum tube plate circuits and general control applications.

(Continued on page 766)



### W47P GETS LAST MINUTE CHECK

The new 3 kilowatt frequency modulation transmitter for Pittsburgh's F-M station, W47P, is seen here receiving a last minute inspection at the G.E. Laboratories from C. A. Priest (left) of the radio transmitter engineering department and W. R. David of the transmitter sales department. The transmitter will be shipped to WWSW.

The complete unit comprises a 250 watt exciter (the left rack) and a 3 kilowatt amplifier (right). Priest's hand is on the attenuator which controls audio input. The station will broadcast on 44.7 mc. to cover an area of 8400 square miles with a potential audience of 2,100,000 persons.

### NEW INTERNATIONAL STATION ON COAST

Station KGEI is being converted from 20 kw. to 50 kw. to carry non-commercial American programs from the heart of San Francisco to Latin America, Asia, the Antipodes and South Africa. The station broadcasts from 4 to 9:15 A.M., and from 10 P.M. to 12:15 A.M., P.S.T. daily on 9.67 mc. or 31.02 meters. Its programs are beamed to Alaska, Hawaii, Philippines, China, Japan, Netherlands East Indies, French Indo-China, Australia, New Zealand and South Africa, and it is the only United States station heard in the Orient, according to a statement from G.E.

### INTERNATIONAL LISTENING

A report from the BBC says that now more than 400 persons are engaged in its headquarters listening to and transcribing what the Axis powers say of themselves and the rest of the world over the air. In view of the increased German and Italian comment on the American attitude toward the war, summaries of such broadcasts are transmitted nightly from BBC at 7:45 P.M. E.S.T. The British stations are also broadcasting programs dealing with the Empire's war progress. These broadcasts give radio listeners the opportunity of getting the best information "direct from the feed box."

### DON LEE MAKES IMPROVEMENTS

Station KHJ, which recently moved to new half-million dollar quarters in Hollywood, has one of the most elaborate studio plants in the United States. The layout includes a central plant comprising lobby, three luxurious auditorium studios, one production studio, and executive sales offices. There is also a two-story annex, housing production, news, publicity, merchandising, and engineering offices. On the second floor of this building are six one-man studios for commentators, etc. A third building contains the \$100,000 Don Lee music library.

The Don Lee network, incidentally, comprises 33 stations and is the largest regional network in the United States. Nearly 200 persons are employed in the technical and production departments of KHJ, which was founded April 13, 1922, and came under Don Lee management some five years later. The network is still completing its new \$100,000 television station, and the 300 foot steel tower is already up.



### New Microphone Has "Paracoustic" Reflector Baffle

• A NEW aeropressure microphone whose directional characteristics may be changed at will by the use of a new "paracoustic" reflector baffle attachment, has been announced by the RCA Manufacturing Company. The microphone is ideal for all types of public address applications, as well as for amateur radio-telephone transmitters.

Characterized by outstanding modern design and unusual ruggedness of construction, the microphone is designed primarily to withstand the wind and weather conditions found in outdoor applications. It is equally well suited for indoor use, especially under conditions demanding low cost and ability to withstand rough usage. Frequency response covers the full usable range—60 to 10,000 cycles, with exceptionally high sensitivity.

The microphone is of the bullet-shaped type, with the "live" end protected by a grill. Housed in an attractive black and chrome plastic case, the unit is supplied with an adjustable mounting and adaptor for any type microphone stand.

The "paracoustic" baffle changes the directional characteristics of the microphone. With the concave face of the circular, dish-shaped baffle toward the grille, the directional characteristics become sharpened, and feedback is reduced. When the baffle is reversed, so that the convex face is toward the grille, the opposite directional effect is obtained. Without the baffle, the microphone becomes a normal pressure microphone.

The "paracoustic" reflector fits over the "live" end of the microphone and is held in place by an inconspicuous thumb-screw.

The microphone is available in both low impedance (250 ohms) and high impedance (40,000 ohms) models. It employs a new type of plastic diaphragm to assure maximum ruggedness and is equipped with a 30-foot cable.

### CORRECTION

In the article on Television Receiver appearing on page 530 of January issue note following corrections: There should be one each .25 mf., 600 volt condensers from R80 to R81 to ground. In sweep circuit diagrams the Cathode Resistor R69 in the 6N7 tube circuit and R51, where connected together, should go to ground.

### In Next Issue

•  
**Portable Receiver A.C.-D.C.  
and Battery**

**The TRF 7, with  
lots of zip!**

**A Receiver for the  
Set Constructor  
by STANLEY WEBER**

## NEW RADIO CATALOGS

### New Howard Catalog

• HOWARD announces three new free catalogs. Illustrated is the 490 Technical Manual. In addition to full charts and schematics on the Howard 14-Tube Professional Receiver, several pages are devoted to the art of receiver measurements. A good technical book for amateurs, servicemen and sound engineers. The other catalogs are Folder 103, containing recording discs and needles; and Folder 104, complete line of Communication Receivers and Accessories.

### Recording Catalog

• THE National Recording Supply Company of Hollywood, Cal., has just issued its annual catalog of recording accessories. Newest single item is a small coated blank made especially for amateurs in the form of a patented National QSL disc. Recent developments indicate that many ama-

teurs now possess recording equipment and, instead of the old-time postcard, now use a disc to record other amateurs' voices and send them through the mails.

The Hollywood company, the staff of which represents many years of recording sales and service, has specialized in grouping complete recording accessory lines under one roof at a single source. Its items also include recording albums, crystal pickups, marking inks, mailing envelopes and the like.

### New Chart Presents RCA Tube Characteristics

• COMPLETE information on the characteristics, classification, and socket connections of RCA receiving tubes is included in the new edition of the RCA Receiving Tube Characteristics Chart now being supplied through RCA tube distributors.

The chart, published in 14-page booklet form, is invaluable for jobbers, servicemen, engineers, radio amateurs, and others in constant need of complete information on radio tubes. The chart is printed in easily legible, large-size type.

The first two pages are given over to classifying RCA tubes according to their cathode voltages and their functions. It assists the tube user in identifying type numbers and choosing the proper tube type for a given application.

The following nine pages make up the characteristics chart. Complete information is given as to dimensions, socket connections, cathode type and rating, use, plate supply, grid bias, screen supply, screen current, plate current, A-C plate resistance, transconductance, amplification factor, load and power output.

On the last two pages are shown bottom views of socket connections for 116 types of tubes. Ask for booklet No. 1275-B.

# Lowest Priced Publications for Experimenters

10 FOR 50c

Here is a large number of radio, short-wave, and mechanical "how-to-make-it" designs. Each is a special publication originated by masters in their respective fields. For the low price of 50 CENTS, you buy TEN complete pamphlets with photographic reproductions, complete mechanical layout, and full description to make it possible for anyone to build the project in question.

PLEASE ORDER EACH PROJECT BY ITS PUBLICATION NUMBER, and use the special coupon below. We accept money-orders, cash, checks or new U. S. stamps. (No foreign stamps.) If you send cash or stamps, register your letter. Money refunded if you are not satisfied. ANY TWENTY-FOUR PUBLICATIONS FOR ONE DOLLAR.

## SHORT-WAVE RECEIVER PUBLICATIONS

- HOW TO MAKE THE "OSCILLODYNE" 1-TUBE WONDER SET. No. 101
- HOW TO MAKE THE "19" TWINPLEX (ONE TUBE PERFORMS AS TWO) RECEIVER. No. 102
- HOW TO MAKE THE WIZARD 1-TUBE 50-WATT TRANSMITTER. No. 103
- HOW TO MAKE THE IMPROVED 3-TUBE DOERLE SET FOR BATTERY OPERATION. No. 104
- HOW TO MAKE THE "GO-GET-EM 2" RECEIVER FOR THE BEGINNER. No. 105
- HOW TO MAKE THE 1-TUBE ALL-ELECTRIC OSCILLODYNE. No. 106
- HOW TO MAKE THE 2 TO 5 METER TWO-TUBE LOUDSPEAKER SET. No. 107
- HOW TO MAKE THE 3-TUBE BATTERY SHORT-WAVE RECEIVER. No. 108
- THE BRIEF-CASE SHORT-WAVE RECEIVER AND HOW TO BUILD IT. No. 109
- HOW TO BUILD THE POCKET SHORT-WAVE RECEIVER. No. 110
- HOW TO BUILD THE CIGAR-BOX 1-TUBE "CATCH ALL" RECEIVER. No. 111
- HOW TO BUILD THE "DUAL-WAVE" SHORT-WAVE BATTERY RECEIVER. No. 112
- HOW TO BUILD THE 1-TUBE "53" TWINPLEX RECEIVER. No. 113
- HOW TO BUILD THE PORTABLE NINIDYNE SHORT-WAVE BATTERY SET. No. 114
- HOW TO BUILD THE HAM-BAND "PEE-WEE" 2-TUBER. No. 115
- HOW TO BUILD THE DUO-AMPLIDYNE. No. 116
- HOW TO BUILD THE "MONO-COIL 2." No. 117

## RADIO BROADCAST RECEIVER AND SPECIAL RADIO PUBLICATIONS

- HOW TO MAKE THE A.C.-D.C. "CASH BOX" RECEIVER. No. 118
- HOW TO MAKE BEGINNER'S 2-TUBE ALL-WAVE SET. No. 119
- HOW TO BUILD THE "RADIO-LAMP" 4-TUBE TABLE RECEIVER. No. 120
- HOW TO BUILD A SUPER-SENSITIVE ALL-WAVE CRYSTAL SET. No. 121
- HOW TO BUILD THE 2-TUBE "PENTODE PORTABLE" BROADCAST SET. No. 122
- HOW TO BUILD THE RADIO "TREASURE" FINDER. No. 123
- HOW TO BUILD THE GERNSBACK ONE-TUBE PENTODE LOUDSPEAKER SET. No. 124
- HOW TO BUILD THE WORLD'S SMALLEST ONE TUBE BATTERY RADIO. No. 125
- HOW TO BUILD A 6-TUBE BATTERY ALL-WAVE "FARM PORTABLE" SET. No. 126
- HOW TO MAKE AN A.C.-D.C. ONE-TUBE "DEAF AID." No. 127
- HOW TO BUILD A PIANOTRON. No. 128
- HOW TO BUILD THE ONE-DOLLAR RADIO. No. 129
- HOW TO MAKE A VARIABLE-TONE CODE PRACTICE SET. No. 130

## MECHANICAL PROJECTS PUBLICATIONS

- HOW TO MAKE A SOUTH SEA OUTRIGGER CANOE. No. 131
- HOW TO BUILD A PEE-WEE AUTOMOBILE. No. 132
- HOW TO BUILD A DUAL-CONTROL GLIDER. No. 133
- HOW TO BUILD A HOUSEBOAT ON PONTTOONS. No. 134
- HOW TO MAKE A BAND SAW FROM OLD AUTO PARTS. No. 135
- HOW TO BUILD A REAL LATHE FOR \$5.00. No. 136
- HOW TO BUILD A SAIL CATBOAT. No. 137
- HOW TO BUILD A SIMPLE PORTABLE REFRIGERATOR. No. 138
- HOW TO BUILD A XYLOPHONE. No. 139
- HOW TO BUILD THE ROWMOBILE. No. 140
- HOW TO BUILD LARGE TESLA AND ODIN COILS GIVING 18-INCH SPARKS. No. 141
- HOW TO MAKE AN ARC WELDER. No. 142
- HOW TO USE AN A.C. ARC WELDER. No. 143
- HOW TO MAKE YOUR OWN MICROSCOPE. No. 144
- HOW TO MAKE A WIMSHURST ELECTROSTATIC MACHINE. No. 145
- HOW TO MAKE A POWER DRILL PRESS FROM SCRAP PARTS. No. 146
- HOW TO BUILD A GOOD LATHE FOR \$1.00. No. 147
- HOW TO MAKE AND EXPERIMENT WITH AN ELECTROPHOROUS. No. 148
- HOW TO MAKE AN ELECTRIC ARC WELDER FROM AN AUTOMOBILE GENERATOR. No. 149

## RADIO PUBLICATIONS • 20 Vesey Street • New York, N.Y.

RADIO PUBLICATIONS, 20 Vesey Street, New York, N.Y. R&T-4-41

I enclose \$..... for the publications listed by number, at right, at the rate of 50c FOR ANY TEN PUBLICATIONS, NO ORDER FOR LESS THAN 50c ACCEPTED. \$1.00 for 24 publications. These publications are to be sent to me postpaid. I have placed a circle around each number which I want.

Name ..... Address .....  
 City ..... State .....

# 6 COPIES OF R & T FOR 50c

For a limited time only, and as long as they last, we will send you six back numbers of RADIO & TELEVISION assorted, your choice, for 50 cents.

The usual price for six copies would be \$1.50, and most publishers charge a higher price for back numbers over one year old.

We can supply only the following back numbers: Sept., 1931; Sept., 1934; Aug., Oct., 1935; 1936—all issues except Apr., May and Oct.; 1937—all issues except Feb. and Aug.; 1938—all issues except March and Nov.; 1939—all issues except Jan., March and April;

1940—all issues except Jan. and April; 1941—all issues to date.

If you do not specify copies, we will send assorted numbers to fill your order. Note, we cannot exchange the copies for ones that have been sent to you.

Every copy of RADIO & TELEVISION contains information which you should have. Here is a chance to get those copies.

As only a small supply of back numbers is on hand, this offer will be withdrawn as soon as they have been sold.

We accept U. S. stamps, U. S. coin, or money order. Rush your order today.

RADIO & TELEVISION 4-41  
 20 Vesey Street, New York, N. Y.

Gentlemen: I enclose herewith 50c (Foreign: Add 25c for postage), for which you are to send me six back numbers of RADIO & TELEVISION as follows:

Name .....  
 Address .....  
 City ..... State .....

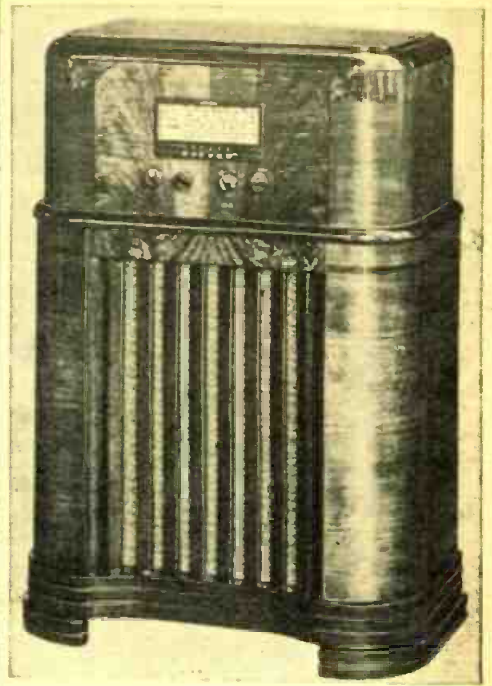

## New Howard 12-Tube Receiver

HERE'S the new Howard 12-tube console, tuned 3 band from 540 kc. to 22 mc. (555 to 13 meters). Model 718-C has six push-buttons, 12" Jensen speaker and 10 watts beam power output.

Exceptional distance on both the broadcast and short wave bands are made possible by two iron core I.F. stages and a stage of tuned radio frequency on the broadcast band. The built-in loop antenna can be used for all ordinary reception, but there are connections for an outside antenna when exceptional distance is desired.

A unique tone control system permits the user to have the exact response desired. One tone control brings out the bass, and a separate tone control amplifies the treble tones. These can be mixed until the exact tonal response is achieved to suit the program. Set is housed in an attractive modernistic walnut cabinet, with butt walnut center panel and trim.

## New Television Receiver

THE new Gilfillan Bros. Model G12 television receiver has the following characteristics:

The receiver utilizes a total of twenty-eight tubes plus the picture tube, which is an R.C.A. 12AP4. The "mask opening" for this picture tube is 8 by 10 2/3 inches. The receiver incorporates the broadcast band, manually tuned, and also the selection of four broadcast stations by push-button. Provision is made for the selection of any one of four television channels, which is the total number presently anticipated in any one area. Volume and tone controls are provided for the sound side and their equivalent contrast and brilliance controls are also available on the panel for the adjustment of the picture.

Nine other controls which may need adjustment at the time the television receiver is installed are accessible through a cut-out at the bottom of the protective screen in the rear of the cabinet.

The G12 television receiver is Underwriters' approved and has special magnetic shielding and electrical filtering of the power supply—this latter requirement due to the fact that some areas on the West Coast are supplied with fifty cycles as against the more commonly available sixty.

## New Hallicrafters FM-AM Tuner

THE Hallicrafters Model S-31 FM-AM Tuner offers special advantages to those who already possess high-fidelity audio equipment, providing full facilities for FM, and for broadcast reception of unusual quality, without the necessity for duplication of audio equipment. Its undistorted output of 130 milliwatts is ample for any standard amplifier, including those in existing broadcast receivers.

The S-31 provides a dual I.F. system, the 4.3 mc. FM channel utilizing 1852 and 1853 tubes in its two 4.3 mc. stages, a 6SJ7 limiter and 6H6 discriminator. The 455 kc. AM channel includes a single 6SK7 with special band-pass input circuit, and a 6SR7 which serves as detector and A.V.C. and its triode section as the output stage for both AM and FM channels and also for phono. A



6SK7 T.R.F. stage and 6SA7 converter provide the R.F. input to both channels.

The two tuning ranges are 540 to 1650 kc. and 40 to 51 mc. These are selected by a panel switch which also automatically selects the appropriate I.F. channel. Terminals are provided for standard and doublet antennas, and for phono input. The two scales on the "slide-rule" dial are fully calibrated in kc. and mc. Other controls include a radio-phono switch, A.F. gain, tone control, and

"S"-meter adjustment. This meter, mounted on the panel beside the tuning dial, serves as a conventional tuning and signal strength meter for AM reception and as a carrier-centering indicator for FM tuning.

Outputs of 500 and 5000 ohms are provided, plus a headphone jack for monitoring purposes. The panel is the standard rack-mounting type, 19" x 8 3/4" and suitable for rack or cabinet mounting.



Newest rack mounting model S-31 Hallicrafter FM-AM receiver.

## What Do YOU Think?

(Continued from page 707)

### He Wants SWL Magazine

Editor:

There are so many short wave listeners in the United States that are enjoying their hobby, while studying to become an amateur, that I think they would like a national organization such as the amateur's A.R.R.L. and have their own magazine like Q.S.T. Why doesn't some radio magazine editor try this out and see how it goes over? I would suggest that it contain articles on sets and operating of receivers and other helpful data that would be valuable for them. Also have some award for the best looking SWL shack. How about it, you SWL's out there, write in and maybe we might succeed.

CHARLES GRETEN,  
755 Monahala Ave.,  
Zanesville, Ohio.

### SWL Reports Should Be Answered

Editor:

I have heard much about the QSL cards and SWL reports, and I would like to say something.

First of all, my name is Juan R. Saborio, T.I.S.J.R.S., Alajuela, Costa Rica. (I am now studying electrical engineering at Clemson College, S. C.)

In Costa Rica I used to read your magazine which one of my friends received. I am now a regular reader of RADIO & TELEVISION.

I think (and so do most of my friends of the air in Central and South America) that an SWL report is always to be answered. Most of the radio amateurs I know used to send their QSL card, but there are radio amateurs that never send a card. I

think that all these problems will be solved if a radio Ham answers the reports; they are always useful and bring the satisfaction that the set has been working well.

I have some QSL cards that I'll be glad to exchange.

JUAN R. SABORIO,  
P.O. Box 1404,  
Clemson College, S. C.

### Constructive Criticism

Editor:

My criticisms start at the front with the cover. The covers used to be paintings and were so good that I framed some of them and hung them in my listening post; they are, in my opinion, "works of art." They would be a lot better than a page of small photographs.

Your monthly "editorials" are still good and hope they continue so.

The receiver diagrams you print are all right, but 7 tube "super-bloopers" are out of the average experimenter's class. So why not print a few 2, 3, 4 tube TRF and Super. jobs? Let's have less high-fidelity amplifiers for F-M and more 3 and 4 tubers.

The "Kink" department could stand a little shakeup. Everybody who submits a kink that is published should receive a 6 mo. subscription to R&T. The best kink should be worth \$10 and second best \$5, while the third ranking one should be a year's subscription.

I would also like to see a diagram for a code practice oscillator employing a 4 1/2 volt "C" battery and a tone control.

GLENWOOD HALL,  
P.O. Box 285,  
Desloge, Missouri.

**FREE!**  
**RADOLEK'S**  
NEW 1941  
RADIO  
PROFIT  
GUIDE



**Bargains / Galore Like These.**  
**PORTABLE RECORDER and Play Back Combination \$19.75**

A complete self-contained Portable Recorder and Electric Phonograph. Nothing else to buy. Consists of combination record cutter and playback pickup, constant speed 78 RPM motor with weighted turntable, built in 3 tube amplifier complete with tubes, volume control, PM dynamic speaker, crystal microphone and desk stand. Entire unit housed in alligator grain fabricoid covered case, size 13" x 13" x 7". Uses standard acetate discs and needles. For 110 volt 60 cycle AC operation.



**BASIC RECORDER \$7.25**



Same combination recording and playback chassis as used in above unit. For build-your-own recorders or for use in conjunction with radio receiver. Includes combination cutting head and playback pickup with feed mechanism, constant speed 78 RPM motor with 8 1/2" weighted turntable and needle cup installed on 3/4" leatherette covered mounting board ready to use with your own microphone and recording amplifier. Mounting space required 12 1/2" x 12 1/2" depth, 3" below board and 3 1/2" above board. For 110 volt 60 cycle AC operation.

**PROFESSIONAL TYPE 10" RECORDING DISCS**  
*only 19¢*



Made by foremost manufacturer. Proven equal or superior to any discs of this type regardless of cost. These blanks have very slight imperfections but guaranteed to make perfect recordings or your money back. Coated on both sides - heavy metal base - non-inflammable. Big savings!

6" Discs - 10¢; 8" - 14¢; 10" - 19¢; 1¢ less in 25 lots. Send no money - shipped C.O.D. plus postage

**EVERYTHING NEW IN RADIO AT BARGAIN PRICES!**



Shows hundreds and hundreds of up-to-the-minute radio parts, sets, accessories, ham gear, electric appliances and supplies. Indispensable to every amateur, experimenter, set builder, sound engineer and service man. Keep up with radio and all its phases - send for the big FREE Radolek Profit Guide now! DON'T WAIT - SAVE MONEY AT RADOLEK

**SEND TODAY! PASTE ON A POST CARD**

**RADOLEK CO., Dept. T-53**  
601 W. Randolph St., Chicago, Ill.

Send FREE Catalog.  
 Ship PORTABLE RECORDER C.O.D. \$19.75 Plus Postage.  
 Ship BASIC RECORDER C.O.D. \$7.25 Plus Postage.  
 Ship \_\_\_\_\_ Discs. Size \_\_\_\_\_ inches. C.O.D. Plus Postage.

Name \_\_\_\_\_  
Address \_\_\_\_\_

Index to Advertisers

<b>A</b>	
ABC Radio Laboratories	730
Acme S-W Radio Co.	729
Allied Engineering Institute	730
Allied Radio Corporation	719
American Radio Institute	707
Amperite Co.	729
Ayers Automatic Code Machines	734
<b>B</b>	
Barter & Exchange Ads	763
Bliley Electric Co.	732
Browning Laboratories	721
Bud Radio, Inc.	721
Burstein-Applebee Co.	734
<b>C</b>	
Candler System Co.	707
Cannon, C. F. Co.	721
Chartered Institute of American Inventors	762
Commercial Notices	763
<b>D</b>	
Dataprint Company	747, 753
Dodge's Institute	707
<b>F</b>	
Flight Magazine	750
For Sale Ads	763
<b>G</b>	
Gold Shield Products	734, 750, 753, 754, 762
<b>H</b>	
Halicrafters, Inc.	Back Cover
Hannmarlund Manufacturing Co., Inc.	733
Harrison Radio Co.	737
Henry Radio Shop	732
Hudson Specialties Company	761
<b>I</b>	
Instructograph Company	737
International Resistance Co.	735
<b>K</b>	
Korrol Mfg. Co.	739
<b>L</b>	
Lafayette Radio Corp.	717, 727
Lancaster, Allwine & Rommel	762
<b>M</b>	
Mass. Radio School	707
Midget Radio Co.	730
Midwest Radio Corporation	747
Millen, James, Mfg. Co., Inc.	739
<b>N</b>	
National Company, Inc.	Inside Front Cover
National Plans Institute	748
National Radio Institute	705
National Recording Supply Co.	730
National Schools	707
Nelson Co.	735
N. Y. Institute of Photography	739
<b>P</b>	
Par-Metal Products Corp.	734
Premium Distributing Service	748
<b>R</b>	
Radio Amateur Course	759
Radio & Technical Publ. Co.	737
Radio Corporation of America	708
Radio Publications	707, 745, 754, 766
Radio-Television Reference Annual	757
Radolek Company	767
Rapid Electroplating Process, Inc.	748
RCA Institutes, Inc.	707
Remington Rand, Inc.	749
<b>S</b>	
Sprayberry Academy of Radio	Inside Back Cover
Supreme Publications	729
<b>T</b>	
Technifax	742, 747
Teleplex Co.	732
Thordarson Electric Mfg. Co.	739
Triplet Electrical Instrument Co.	735
Tri-State College	707
<b>V</b>	
Vibroplex Co., Inc.	735

(While every precaution is taken to insure accuracy, we cannot guarantee against the possibility of an occasional change or omission in the preparation of this index.)

What the Amateurs Can Do  
(EDITORIALS)

(Continued from page 709)

contacts out of the air, the *short-wave experimenter* is not seen by them. He is not known by the company he keeps, the church he attends nor by the clothes he wears, but by the signals he sends out and the honest reports he sends in. He is in a *new* world, whose qualifications for success are entirely within his own grasp. A good home-made transmitter or receiver, carefully built from the data given in the pages of RADIO & TELEVISION gives him more prestige than a commercially manufactured one.

The nations on earth may well take a lesson—many lessons—from the *short-wave* listener and amateur radio operator—lessons in WORLDWIDE FRIENDSHIP. I like to see these idealistic men and boys, and yes, women too, working toward international peace and friendship—and they are doing it, too. You know, it's rather bewildering to find that the fellow your home-town propaganda expert is trying to teach you to *hate*, is a "brother radio experimenter," faced with the same problems of life as yourself and that HIS kids just had chickenpox too!

DR. PHILIP WEINTRAUB,  
W9SZW-W9TMQ,  
3860 Harrison St.,  
Chicago, Illinois.

TELEVISION TUBE OF THE FUTURE

● IN the future, television pictures will be obtained with a tube having a screen only one inch in diameter, or smaller.

The tube's screen will be coated with a chemical, which instead of fluorescing, will vary in opacity as the strength of the electron beam varies.

The tube will have receptacles for lights, which will shine through behind the chemical screen, and as the screen varies in opacity, will shine through. In this way pictures will be obtained which will compare favorably with the present system of home movies.

The projecting system will use a set of

lenses, such as are used in the present-day home movie projectors.

The low voltages necessary to operate it will mean smaller sets, and smaller sets mean portability.

We, more than any other country, have

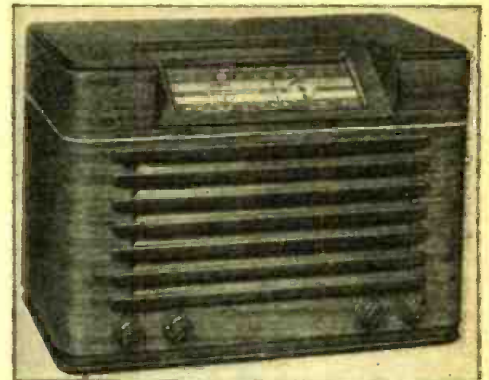

Prize—The Pilot Clipper—Model T-122 receiver, covering the "broadcast" band and also the 15 to 53 meter short-wave band.

the necessary engineering ability and ingenuity to develop this; so Television Industry, why not get busy and develop the chemical screen, one that varies in opacity as the electron beam varies in strength, instead of using the present fluorescent screen?

LEE GARRISON,  
Radio Service,  
Falls City, Oregon.

(The Editor's reason for selecting Mr. Anthony Guide's guest editorial this month as the prize winner, is that Mr. Guide pointed out one of the most important angles that should be carefully checked in every case where radio transmissions are to be investigated. In other words, Mr. Guide points out a very important job which our radio amateurs can and should do; undoubtedly the F.C.C. or other government agency, will sooner or later take advantage of this suggestion.)

ANSWERS TO PUZZLE DIAGRAM  
ON PAGE 750

The diagram shows a phono oscillator and the following errors occur in the hook-up as shown:

1. There should be no condenser C1 in series with pick-up.
2. Bypass condenser C2 is superfluous.
3. Leads 1 and 2 are transposed, so that no plate voltage is applied to the plate of the 6A8GT.
4. Condenser C3 and C4 are ordinary fixed bypass condensers and not variable, as indicated by the arrows.
5. Bypass condenser C5 is superfluous.
6. Resistor R9 is not needed.
7. The motor lead wire 4 should connect to the 110 volt wire 3, and not to the cathode of the 76 tube, as it would not derive sufficient current to operate it.
8. Resistor R7 is not required.
9. The grid of the 76 tube should be connected to the plate and not to the cathode.
10. One grid too many is shown in the 6A8GT.

A Few of the Features in April  
RADIO-CRAFT

- Fluorescent Lighting—Latest Sideline for Servicemen—Part III, Installation Design
- 2 Radio Service Data Sheets
- Sound Engineering—No. 16
- Modern Microphone Technique—Part III, The Microphone in Action
- Build Your Own Experimental Electronic Organ
- Signal-Tracing Amplifier — An Effective Radio Servicing Tool
- Modernize Your Tester to Check High-Voltage-Heater Tubes
- An Englishman's Home-Built Television Black-Spotter
- Theater Screen-Size Television
- How To Make a Reliable Marine Radio Direction Finder

# FULL EQUIPMENT

## Included WITH

# SPRAYBERRY RADIO TRAINING!

*Experience Easily Acquired at Home!*

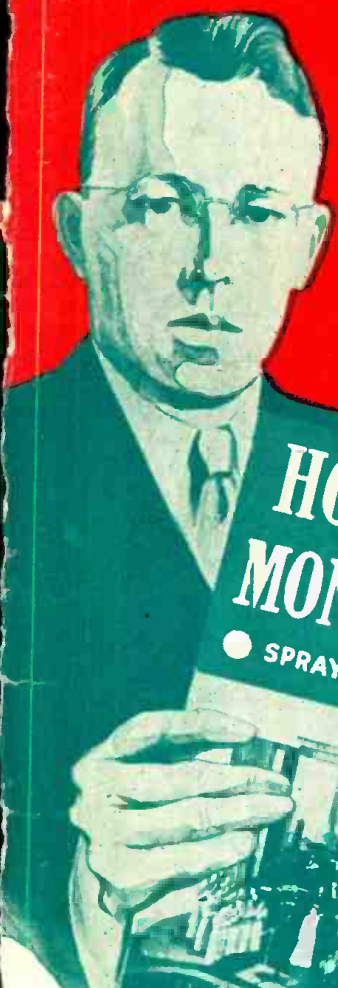

**HOW TO MAKE MONEY IN RADIO**  
 SPRAYBERRY ACADEMY OF RADIO



**146 RADIO PARTS**



**OVER 100 EXPERIMENTS**

*plus Many Other Special Features*

**ALL DESIGNED TO HELP YOU MAKE FAST PROGRESS!**

SPRAYBERRY Training starts right at the beginning of Radio... unfolds each subject in a simplified, logical, understandable style. You easily learn Television Frequency Modulation, Signal Tracing, Mobile Radio (Auto-Tank), Aviation Radio Electronics, Facsimile Radio, Radio Set Repair and Installation Work. You learn quickly in your spare hours... **AT HOME OR AT CAMP.**

**Training Prepares You for a Business of Your Own... Or Good Radio Jobs at Excellent Pay!**

The great, fascinating and progressive field of Radio and Television offers many opportunities to the man who wants to get ahead. There is good money to be made. My Training is designed to give you quick access to these opportunities. SPRAYBERRY Methods are thorough and practical. Your Training will not interfere with your present work.

**You Get Professional Test Equipment plus Experimental Outfits!**

... Includes 146 RADIO PARTS for building a complete Receiver, RADIO TOOLS and a modern TESTER-ANALYZER. You also receive 8 BIG SHIPMENTS OF RADIO EQUIPMENT for conducting actual experiments with your own hands. I show you how to create Radio defects... how to correct them. This practical "beforehand" experience will come in handy again and again when you are called on to do actual Radio repair work later on.

**RADIO TOOLS**



**TESTER-ANALYZER**



**READ WHAT THESE FELLOWS SAY ABOUT THE NEW PRACTICAL SPRAYBERRY TRAINING**



**"GROSSED BETWEEN \$150 AND \$200"**

"Since finishing your training I've started in the Radio repair business. I have about all the work I can take care of. I have grossed between \$150 and \$200 in the last few months in my spare time. I think your Course is 'tops'!"  
 W. Francis Waseka, Fountain City, Wisconsin.

**"SALARY HAS INCREASED"**

"Your Radio training has made it possible for me to make more money. My salary has increased from \$10.00 to around \$50.00 per week. I now have about all the Radio repair work I can handle."  
 Asa Smith, P. O. Box 524, Fort Leavenworth, Ky.



**"MADE AS MUCH AS \$8 A DAY"**

"The Instruments you have sent me helped me in solving Radio problems. I am building up my business by using all your methods. have made as much as \$8 in one day. L. R. Lanole, 316 Dudley Street, Providence, R. I.



**EARN WHILE YOU LEARN**

My BUSINESS BUILDERS show you how to put your equipment to actual use in handling money-making Radio Service jobs shortly after you begin training.

**Learn More About the SPRAYBERRY Method And How Easy It Is to Start**

The complete details of my fundamental Course and Advanced Training Course... all features are fully described in my new, valuable 32 page FREE Book. Send for your copy. No obligation.

**No Previous Experience Needed**

It makes no difference what your education has been. I can fit you quickly for a good-paying Radio job. I make it easy for you to grasp Radio principles and remember them. Your success is my full responsibility.

All Equipment Becomes Your Personal Property

**Cash In on Radio's Rich Opportunities**

No matter if you desire to BE YOUR OWN BOSS in your own business or hand down a good job in Radio, my Training will give you the useful information and knowledge to win success. Days of delay mean precious time wasted. Start training for a money-making Radio career—right now.

**REMEMBER —THE SPRAYBERRY COURSE IS SOLD UNDER A MONEY-BACK AGREEMENT**

**DON'T DELAY! ACT NOW**

SPRAYBERRY ACADEMY OF RADIO

F. L. Sprayberry, Pres.  
 445-D University Place, N. W.  
 Washington, D. C.

Please send my FREE copy of "HOW TO MAKE MONEY IN RADIO"

Name ..... Age .....

Address .....

City ..... State .....

Tear off this coupon, mail in envelope or paste on penny postcard.

**RUSH THIS COUPON for BIG FREE BOOK**  
 GIVING COMPLETE FACTS

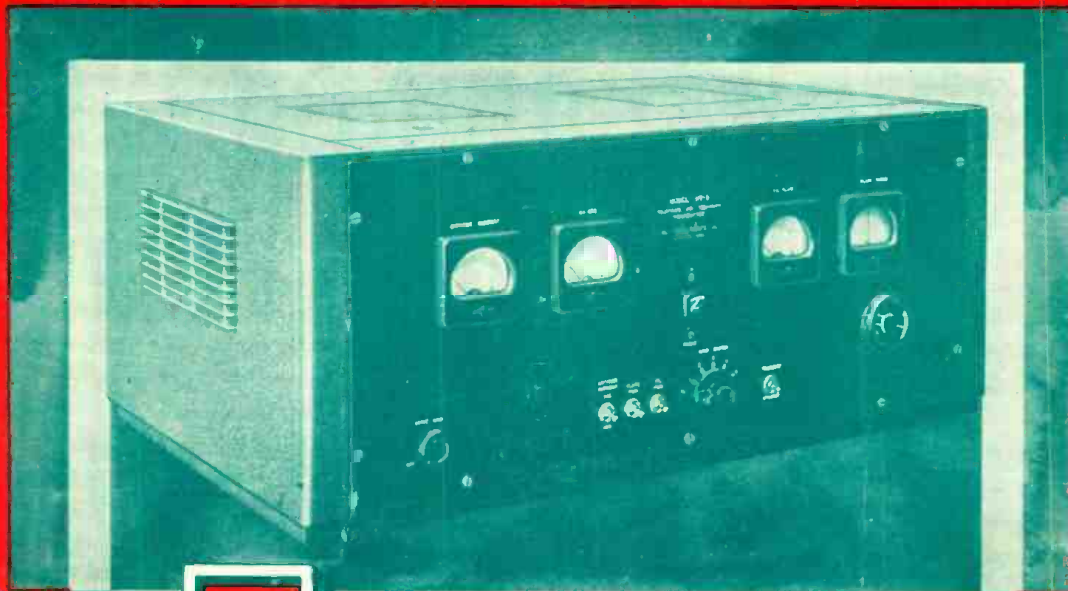

**5**

## Frequency Phone & CW

**100 WATTS ON C. W.  
75 WATTS ON PHONE**

**M**ODEL HT-9—a 5-frequency phone and CW unit, rated at 100 watts on CW and 75 watts on phone (carrier output). Coils available for all bands from 1.7 to 30 mc. Exciter coils for 5 bands can be plugged in, pretuned, and left in the transmitter. 14 tubes. Operates on 110 volts, 50-60 cycles A.C.

Model HT-6 (illustrated below) gives you exacting transmitter performance. Gives an output of 25 watts on most bands. Frequency range is 1.7 mc. to 60 mc. Coils for any 3 bands may be plugged in, pretuned and then control switched at will. 8 tubes. Operates on 110 volts, 50-60 cycles A.C.

the **hallicrafters** co.

CHICAGO, U. S. A.

USED BY 33 GOVERNMENTS • SOLD IN 89 COUNTRIES

