

SERVICE

VOL. 23

THE TECHNICAL JOURNAL OF THE TELEVISION-RADIO TRADE

JULY
1954

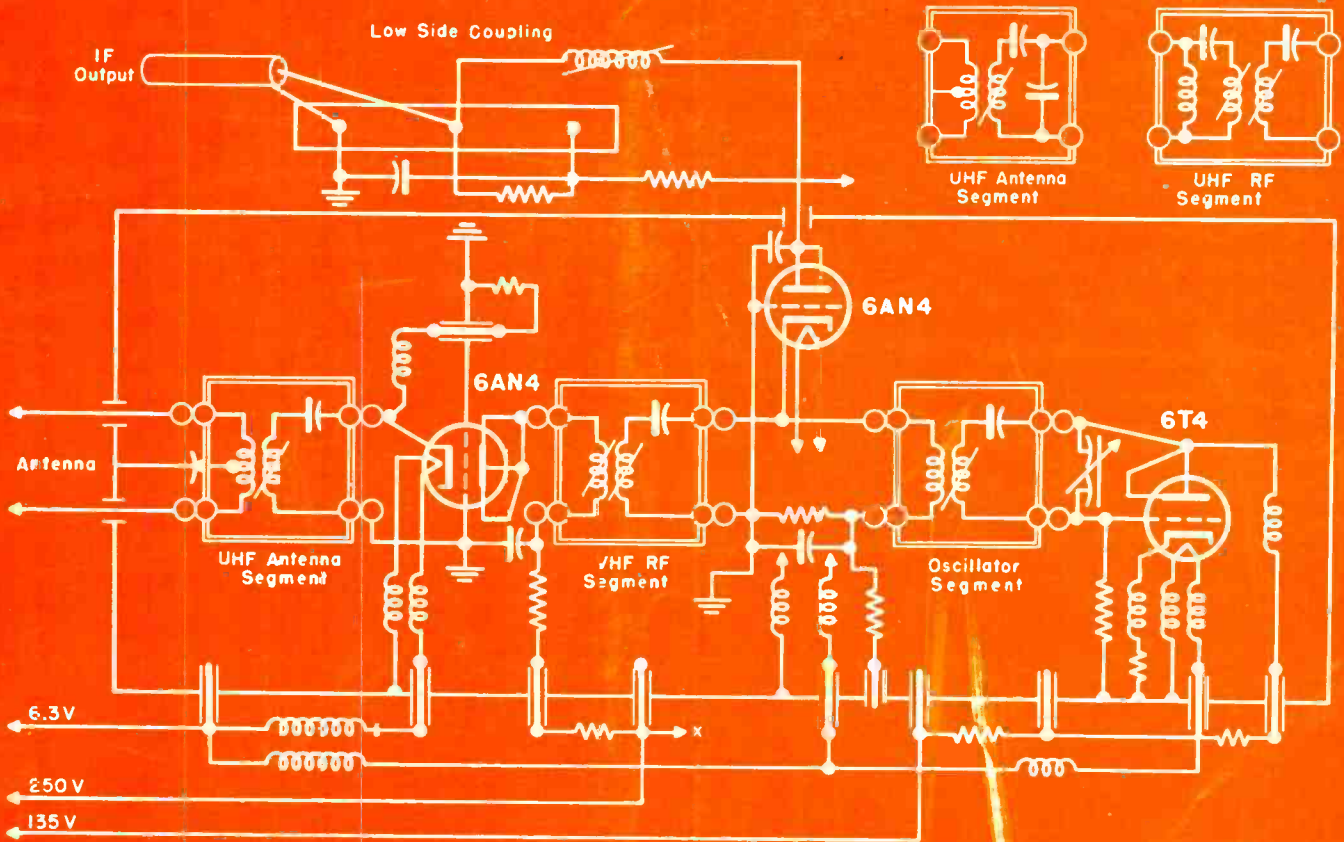

12-position turret tuner or channels 2 to 83 with 6AN4
 rf amp, vhf/uhf 6AN4 mixer and 6T4 as an oscillator.
 [See circuit analysis, this issue]

PEARSON RADIO-TV
 3062 E 65 ST
 CLEVELAND 27, OHIO
 2-59
 SU 5 3-5-54 GR



**Leading
Manufacturers
use RADIART
VIBRATORS
in their ORIGINAL Equipment**

**because of their
DEPENDABILITY
and QUALITY**

**you get the same quality and
dependability in RADIART Replacement
Vibrators ... *the complete line!***



THE RADIART CORP.
CLEVELAND 13, OHIO

VIBRATORS - TV ANTENNAS - AUTO AERIALS - ROTORS - POWER SUPPLIES

New
**UHF & VHF
 LEAD-IN**

Thousands of separately sealed tiny cells, filled with inert gas, make this waterproof cable stable and efficient electrically.

ADVANTAGES:

- 1 Lowest losses at UHF and VHF frequencies.
- 2 Great abrasion resistance and mechanical strength.
- 3 No time-consuming end seal required; easy to install.
- 4 No internal moisture to cause signal loss.
- 5 No kinking when used with antenna rotors.
- 6 Resistant to snow, ice, rain, and wind.
- 7 Resistant to ultraviolet rays from the sun.
- 8 Uses Belden Weldohm conductor for long conductor life.
- 9 Can be clamped tightly in stand-off insulators without crushing. No special fittings required.
- 10 Conductor spacing is constant even when the lead-in is transposed.
- 11 No stripping problem for attaching the conductor.

...Cuts
SIGNAL LOSS

This heavy wall of brown virgin polyethylene protects the cable against mechanical abuse and damage from ultraviolet sun rays.

This completely new 300-ohm line results from the development of a new cellular plastic core where each separate cell is filled with an inert gas to make an efficient cable with the lowest possible losses at both UHF and VHF frequencies. With this absolutely waterproof cable, no sealing of the ends is necessary. Celluline cable can be fixed in stand-off insulators without crushing. The thick outer wall of polyethylene serves to protect the cable from abrasion and sun damage.

By fusing *only* virgin polyethylene, the wall can be made smooth—absolutely free from rough spots—to prevent the adherence of dust and other impurities which would increase the losses.

The copper-covered steel strands, which make up the conductors, assure 49% greater resistance to breaking from flexing or stretching than any all-copper conductor.

8275 CELLULINE[®]
 TRANSMISSION LINE

by **Belden**
 WIREMAKER FOR INDUSTRY

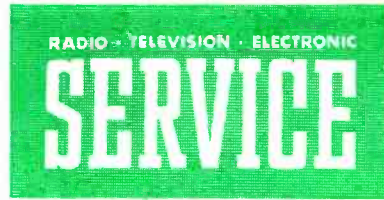

LEWIS WINNER
Editor

B. BLOCK
F. WALEN
Assistant Editors

Including SERVICE—A Monthly Digest of Radio and Allied Maintenance; RADIO MERCHANDISING and TELEVISION MERCHANDISING. Registered U. S. Patent Office.

Association News	45
Audio Installation and Service (Wireless Microphone System Design-Installation Notes). By Ken Stewart and Paul Edwards	24
Audio-Video Coax Cable Applications. By O. Lowenschuss and J. M. Sienkiewicz	29
Bias Circuitry in Hi-Fi Amps. By Mark Vino	38
Color TV Developments (CRTSA Report: G.E. R-Y/B-Y Chassis.) By L. A. Bassett and Jack Hawthorne	26
High Masts and Towers (Solo/Team Installations . . . Tower Repair). By Jack Darr	34
Multiple Loudspeaker Installations. By Jesse Dines	28
Ser.-Cuits (12-Position Channel 2-83 Turret Tuner: Cover Diagram). By M. W. Percy	40
Service . . . The National Scene	19
Service Engineering (Communication Receiver Crystal Filter IF Stage Alignment). By Thomas K. Beamer	46
Servicing Helps (Peak-to-Peak Measurements). By T. L. Gilford	35
Ten Years Ago	45
The NCTA Community-TV Symposium (Highlights of Talks by Sen. Edwin Johnson and Walter Brown on Trends and Cable Radiation). By Wyn Martin	23
Tube News (Stacked-Element Ceramic Tubes). By E. A. Teverson	48
UHF/VHF Antenna Digest (Tying Hi/Lo-Band Antennas to Single Line). By Sam Schlussel	36
Views and News. By Lewis Winner	17

CIRCUITS

Anchor TV 900 (Cover)	40
Amplifier Stage Altered to Cathode-Driven Output	29
Automatic Bias-Control Circuit	38
Driving-Amplifier Plate Circuit Modified to Reduce Output Resistance	29
G.E. 15CL100 Color Chassis Block Diagram	27
Identical Speaker Matching Circuitry	28
Low-Level Heater Line (for Amps) Supplied Via DC Cathode Current	38
Matching Layout for Four Speakers With Different Characteristics	28
Preamp Output Stage	29

COVER

12-Position Channel 2-83 Turret Tuner (Anchor TV 900)	40
---	----

Index to Advertisers

63

Manufacturers

Catalogs and Bulletins	44
Instruments	60, 61
Jots and Flashes	63
News	56
New Parts . . . Tools	59
On Book Row	15
Personnel	33
Rep Talk	32
TV Parts . . . Antennas . . . Accessories	62



Entire Contents Copyright 1954, Bryan Davis Publishing Co., Inc.



Published monthly by Bryan Davis Publishing Co., Inc.

52 Vanderbilt Avenue, New York 17, N. Y.

Telephone MUrray Hill 4-0170

Bryan S. Davis, Pres. F. Walen, Sec. John Iraci, Adv. Mgr. A. Goebel, Cir. Mgr.

Mid-West Mgr.: Stuart J. Osten, 333 N. Michigan Ave., Chicago 1, Ill. Tel.: DEarborn 2-3507
East-Central Rep.: James C. Munn, 2253 Delaware Dr., Cleveland 6, O. Tel.: ERievview 1-1728
Pacific Coast Rep.: Brand & Brand, 1052 W. 6th St., Los Angeles 17, Cal. Tel.: MADison 6-1371

Entered as second-class matter June 14, 1932, at the Post Office at New York, N. Y., under the Act of March 3, 1879. Subscription price: \$2.00 per year in the U. S. A. and Canada; 25 cents per copy. \$3.00 per year in foreign countries; 35 cents per copy.

NEW



completely assembled

6 and 12 Volt

DC POWER SUPPLY

At a comparable KIT PRICE

Only \$39⁹⁵ net

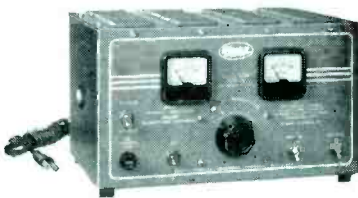

MODEL D-612

UNMATCHED . . .

FOR TESTING AND SERVICING

0 to 8, 0 to 16v. completely variable
0 to 10 amps. at 12 v. continuous

This unbeatable combination of performance and dependability makes the D-612 an invaluable aid to you for testing and service work. AND . . . it's backed by Electro's recognized reputation of high quality products.

CHECK!
COMPARE THESE FEATURES

- Operates all auto radios. For relays, phone circuits, low voltage devices, electroplating and battery charging.
- Less than 5% ripple over rated ranges.
- Patented EPL conduction cooling.
- Withstands high overloads.
- Same top quality as other EPL models.

Write for details or see your nearest parts jobber!

↓

ELECTRO PRODUCTS LABORATORIES
4501-Sa N. Ravenswood Ave., Chicago 40, Ill.
RUSH FREE BULLETIN DC-123

Name _____

Street _____

City _____ Zone _____ State _____

Canada: Atlas Radio Corp., Ltd., Toronto

SUPER-PERFORMANCE

...THAT COSTS NO MORE!

MAKE THE SCREEN TEST!

- Measure the space between reflector elements of any other big screen antenna.
- Note that the TRI-KING has closer spacing between reflector elements for improved performance. The TRI-KING's element spacing is the proven maximum for a full 1/10 wave length.

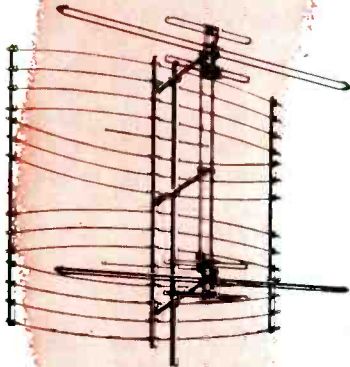

**SUPER
TRI-KING
Model
TK1800**

WIND TUNNEL TESTED to exacting aircraft standards. Test results prove that a full size TRI-KING antenna can withstand 30% higher wind velocities than any other large screen antenna.

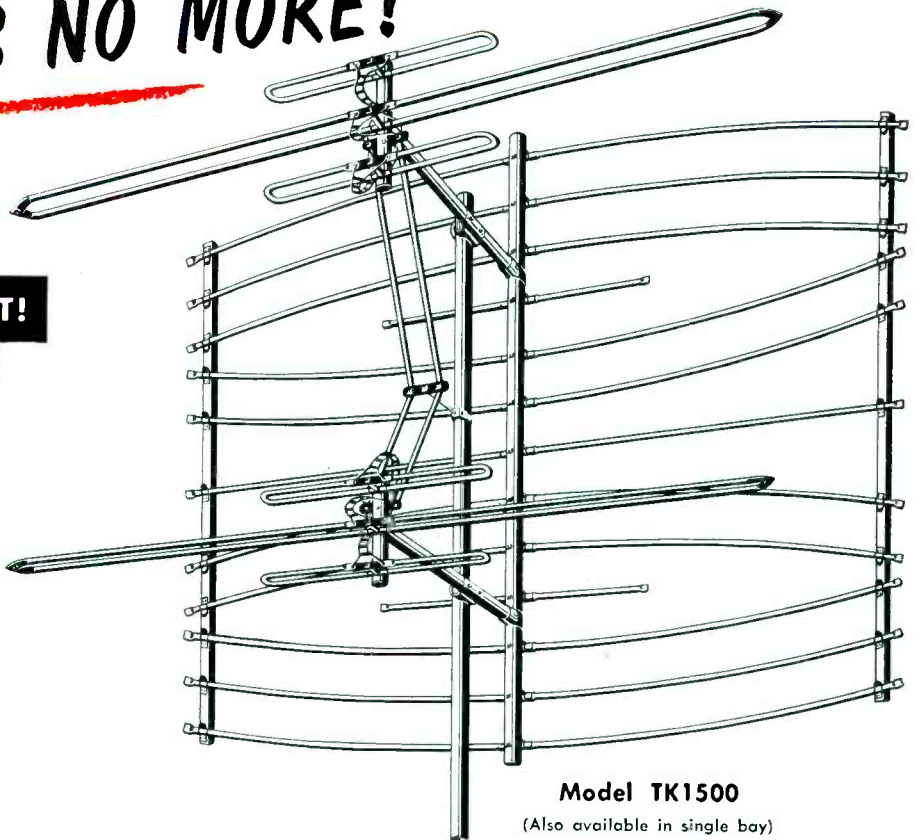

Model TK1500
(Also available in single bay)

CLEAR BEAM'S **TRI-KING**

Patent Applied For

POSITIVE GHOST REJECTION! Clear Beam proudly announces the new TRI-KING, combining for the first time a Radar-type reflector screen with the improved TRI-KING dipole assembly. A real champion with many Clear Beam features including rugged, quality construction and Quik-Rig assembly that outsells all other big screen antennas. Sold on a money back guarantee.

WRITE FOR COMPLETE INFORMATION TODAY

Clear Beam Antenna Corp.



100 PROSPECT AVENUE • BURBANK, CALIFORNIA
THornwall 2-4886 • Victoria 9-2141

ORDER NOW - IMMEDIATE DELIVERY!

CLEAR BEAM PRICES

Model TRI-KING	List Price
TK1500	\$44.50
Super TK1800	\$52.95

WAREHOUSES IN: San Francisco • Portland • Seattle • Chicago • Kansas City • Detroit • Dallas • Baltimore

Mr. Dealer...

NEWCOMB puts you into the HI-FI PROFIT PICTURE!



At last you can sell high fidelity components at a full profit! Newcomb, nationally advertised and famous for quality leadership in sound since 1937, now offers two completely new amplifiers for radio, TV and record dealers to sell competitively at full profit. Just look at all the advantages you'll enjoy under Newcomb's new sales plan:

FULL PROFIT TO YOU—Your selling price will be exactly the same as the Audiophile Net Price listed by distributors.

EASY TO SELL—Newcomb's new D-Series Amplifiers

answer a great need in the high fidelity field. They're engineered for top quality, dependable sound reproduction; designed for eye appeal and easy installation; and priced for easy sale.

NATIONALLY ADVERTISED—Newcomb Amplifiers are advertised in High Fidelity, Saturday Review, Time, The New Yorker, Schwann's and The New York Times Magazine. What's more, you'll get newspaper mats, radio spots, counter card, window banners and booklets for use in promoting these new units to your customers.

AVAILABLE NOW
FOR SALE
TO YOUR
CUSTOMERS:



D-12
AMPLIFIER
ONLY \$99⁵⁰
AUDIOPHILE
NET

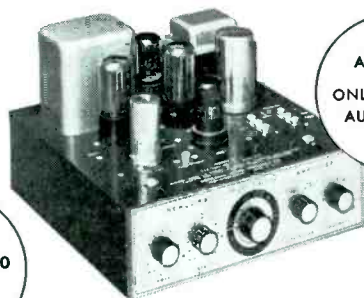

D-10
AMPLIFIER
ONLY \$69⁵⁰
AUDIOPHILE
NET

MODEL D-12
12 watts at less than 1% distortion • 20-20,000 cycles ± 1 db • selects up to 36 different recording curves • new rumble filter and input selector • large potted output transformer doubly protected against humidity by cellulose acetate insulation • advanced design wide range separate bass and treble tone controls • built-in matched and fully compensated magnetic pickup pre-amplifier •

6 inputs • microphone input • tape input • new tape output jack • "loudness" control • "loudness" compensation switch • "Adjusta-Panel" easy installation feature • removable "gold" anodized panel plate • "petite" non-glare pilot • hum balance control • hum 80 db below 12 watts • output impedances 8 and 16 ohms • tubes: 2-12AX7, 2-6V6GT, 1-5Y3 • U/L approved.

MODEL D-10
10 watts at less than 1% distortion • 20-20,000 cycles ± 1 db • six position recording curve selector • built-in rumble filter • input selector • built-in matched and fully compensated magnetic pickup pre-amplifier • 6 inputs • microphone input • tape input • new, easier-to-operate "interlocked" tone circuit • bass tone control • treble tone control • "loudness" control • "Adjusta-Panel" easy installation feature • potted output transformer doubly protected against humidity by cellulose acetate insulation • removable "gold" anodized panel plate • "petite" non-glare pilot • hum balance control • hum 75 db below 10 watts • output impedances 8 and 16 ohms • tubes: 1-6SC7, 1-12AX7, 2-6V6GT, 1-6AX5GT • U/L approved

Mail this coupon NOW for full details

Newcomb Audio Products Co. Dept. E-7
6824 Lexington Ave., Hollywood 38, Calif.

Please send me full details on the new Newcomb D-10 and D-12 High Fidelity Amplifiers, and how I can sell these units profitably. Please include the name of my nearest Newcomb distributor.

Company Name _____

Address _____

City _____ Zone _____ State _____

My Name _____

My Preferred Distributor is _____



NEWCOMB

True High Fidelity Since 1937

HIGH FIDELITY AMPLIFIERS • TUNERS • REMOTE CONTROL UNITS

When the profile of the Cadillac looked like this



It was understandable that the profile of a V.O.M. might look like this



But this is the profile of today's Cadillac



And, if you buy a V.O.M. that is truly of today it will have a profile like this



STREAMLINING signifies the difference!

In cars, streamlining symbolizes the tremendous advances in automotive engineering and performance. In fine test equipment, too, streamlining signifies the difference.

The flush switches, dials and jacks of the Smoothie make it easy to slip in your pocket, carrying case or tool kit, eliminate snag hazards on your bench.

But even more—the streamlining expresses externally the advanced internal design which makes the Triplet Model 630 as superior to the obsolete knobby bumpy-faced testers as the Cadillac of today is to the Cadillac of fifty years ago. These internal design features include such developments as selector switch of molded construction, completely enclosed; elimination of harness wiring, etc. Your most frequently used tester—your V.O.M.—should be the best—the one of which many thousands are in use in laboratories today—the Smoothie, Triplet Model 630 Volt-Ohm-Mil-Ammeter, \$39.50 net. Ask your parts jobber or write Triplet Electrical Instrument Company, Bluffton, Ohio.

Only Triplet offers you a ten day free trial on all test equipment.

the SMOOTHIE

the only streamlined V.O.M. with a smooth face

TRIPLET

630

Volt-Ohm-Mil-Ammeter



Free! HEAVY-DUTY TOP-QUALITY PLIERS KIT

with 10 CBS-Hytron Pliers Kit Stamps

LIMITED OFFER

From July 1 through August 31 . . . Your CBS-Hytron distributor will give you 1 Pliers Kit Stamp with your purchase of 25 CBS-Hytron receiving tubes.





A
\$10⁰⁰
LIST VALUE

PICK UP THESE FINE IMPORTED TOOLS. Examine the beautiful finish of their drop-forged tool steel. Try their comfortable handle grips. Feel the precise balance . . . the powerful leverage. Go ahead! Cut some eight-penny nails. Like cutting cheese, wasn't it? And not a trace of a nick in the tough, carefully matched jaws.

You will be proud to own these husky, quality pliers. Tested . . . guaranteed . . . they can take it. And did you notice that two are unique? Nothing else just like them . . . they are "musts" for your tool kit. Yes sir, this free Pliers Kit (packed in an attractive, handy plastic case) is an offer you cannot afford to miss!

 **The 6½-Inch Diagonals** are husky, box-joint, fully polished side cutters with precisely matched jaws. Size is right: Compact, but big enough . . . with comfortable, full-fashioned, full-polished handles . . . to do repeated, tough cutting jobs with ease.

 **The 8-Inch Long-Nose** is unique. Extra-long (2¾ inches), spring-tempered jaws combine with extra-long, knurled handles for powerful leverage. Hand-honed cutting knives. Beautifully chrome-plated.

 **The 6-Inch All-Purpose** is also unique. Combines: Flat and round nose. Jaws shaped for positive gripping. Two wire strippers. Two side cutters. Finish of handles is gun-metal; jaws are fully polished. This tool has everything.



Get This Pliers Kit Stamp Book . . .

and stamps from your CBS-Hytron distributor: One Pliers Kit Stamp for 25 CBS-Hytron receiving tubes. Each Stamp is imprinted with your CBS-Hytron distributor's code number. Redeem your Stamps with him. This offer is valid only in areas where such offers are legal . . . and it is limited: July 1 through August 31. Don't miss it. Be sure to get your free CBS-Hytron Pliers Kit. See it at your CBS-Hytron distributor's . . . today!

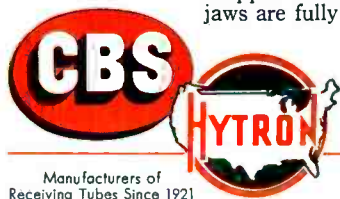

CBS-HYTRON Main Office: Danvers, Mass.

Manufacturers of Receiving Tubes Since 1921

A Division of Columbia Broadcasting System, Inc.

A member of the CBS family: CBS Radio • CBS Television • Columbia Records, Inc. • CBS Laboratories • CBS-Columbia • CBS International • and CBS-Hytron

RECEIVING • TRANSMITTING • SPECIAL-PURPOSE • TV PICTURE TUBES • CRYSTAL DIODES AND TRANSISTORS

Can You afford to take a Chance

ON ANYTHING LESS THAN BUSS QUALITY IN FUSES?

Hardly!

Dependable electrical protection . . . isn't that what you rightly expect of a fuse? For you rely on the fuse alone to safeguard your equipment when there is trouble in the circuit — and just as important, a fuse should never give a "false alarm" by blowing needlessly.

To make sure of proper operation under all service conditions, every BUSS fuse normally used by the Electronic Industries is tested in a sensitive electronic device that rejects any fuse that is not properly constructed, correctly calibrated and right in all physical dimensions.

And there's no need to sacrifice quality on any type of fuse, for BUSS offers a complete line of fuses to the Electronic Industries: — standard type, dual-element (slow blowing), renewable and one-time types . . . in sizes from 1/500 ampere up.

And in sales and service — your customer doesn't question quality when you furnish BUSS fuses. The BUSS trademark and the BUSS reputation for 'trouble-free' fuses have been firmly established over the past 39 years by the millions and millions of installations for home, farm, and industry. So be doubly safe — protect your profits and your reputation — standardize on genuine BUSS fuses.

For more information mail this Coupon



FUSETRON

TRUSTWORTHY NAMES IN
ELECTRICAL PROTECTION

BUSS

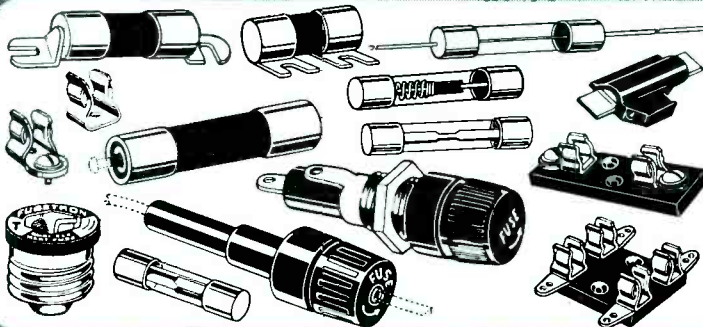

BUSSMANN Mfg. Co.
(Division of McGraw Electric Co.)
University at Jefferson, St. Louis 7, Mo.

Please send me bulletin SFB containing facts on
BUSS small dimension fuses and fuse holders.

Name _____

Title _____

Company _____

Address _____

City & Zone _____ State _____ S-753

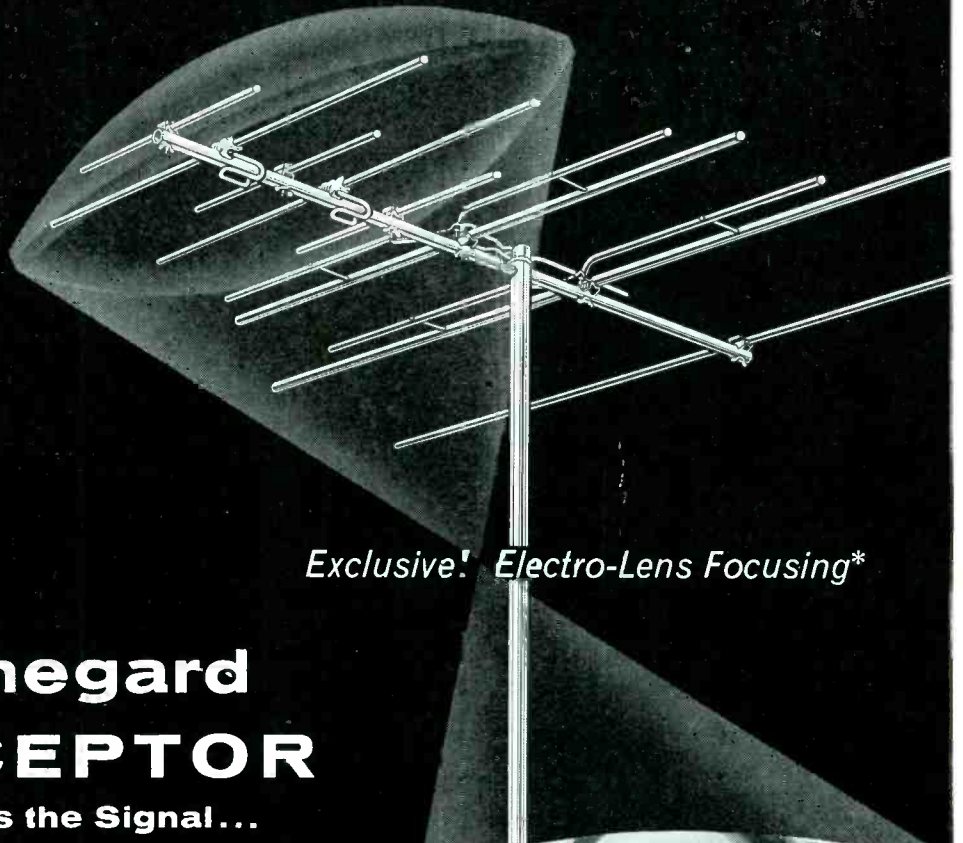

*Exclusive! Electro-Lens Focusing**

New Winegard INTERCEPTOR

**Grabs and Boosts the Signal...
Focuses It...like a Lens**

• Completely new in appearance. Completely new in electrical design. Sensational in results! The new INTERCEPTOR antenna now combines the famous Winegard Multi-Resonant Dipole with the most sensational electronic design of the decade... *Electro-Lens Focusing*.* This exclusive Winegard feature literally grabs the signal out of the air and focuses it on the driven element the same as an ordinary lens focuses light. The result... a picture gloriously brilliant... sharp and clear. A picture up until now unobtainable!

• Never before has one antenna incorporated so many outstanding and exclusive features. The INTERCEPTOR gives highest possible gain and still maintains rejection from the back and sides that really shuts out co-channel interference. Its *Electro-Lens Focusing* makes it an ideal fringe area antenna without the bulk required by present fringe antennas. Small, light-weight and compact, the INTERCEPTOR's neat appearance will be appreciated by owners of the finest homes.

Attention: Servicemen! You will notice we show no charts trying to establish fabulous claims. We suggest you order a Winegard INTERCEPTOR today. If your regular jobber does not have it, please contact us. Test it for yourself. The INTERCEPTOR is its own best salesman!

- A Winegard Exclusive... *Electro-Lens Focusing*.
- All channels (2-13).
- Light, rigid, quick to assemble, easy to install.
- Low wind resistance.
- Designed for color reception.

For complete information on the Winegard INTERCEPTOR VHF antenna with exclusive *Electro-Lens Focusing*, send for Bulletin No. L-4.



WINEGARD COMPANY

3000 Scotten Boulevard, Burlington, Iowa

*Patent Pending

NEXT MOVE'S UP TO YOU!



CHEMICALS

...Everything You Need!



G-C PLI-O-BOND CEMENT
No. 43-2 2 oz. List \$0.65



G-C ELECTRONIC CONTACT CLEANER
No. 210-2 2 oz. List \$0.55



G-C RUBBER-TO-METAL & PHONO DRIVE CEMENT
No. 35-2 2 oz. List \$0.65



G-C VINYLITE CEMENT
No. 58-2 2 oz. List \$0.65



G-C RADIO-TV SERVICE CEMENT
No. 30-2 2 oz. List \$0.65



G-C TV HIGH VOLTAGE CORONA DOPE
No. 47-2 2 oz. List \$1.20



G-C TELEVISION TUBE KOAT
No. 49-2 2 oz. List \$0.95



G-C MAG-NETIK RECORD-ING HEAD CLEANER
No. 53-2 2 oz. List \$1.60



G-C ELECTRICAL & RESISTOR CEMENT
No. 27-2 2 oz. List \$0.65



G-C PLASTIC CEMENT
No. 32-2A 2 oz. List \$0.65



G-C DE-OX-ID
No. 19-2 2 oz. List \$1.60



G-C RADIO SERVICE SOLVENT
No. 31-2 2 oz. List \$0.55

90 CHEMICALS FOR... BETTER TV-RADIO SERVICING

With the largest, most complete line of quality chemicals in the industry, G-C is the name you should remember whenever you need cement, solvent, cleaners, lubricants and all the rest. Yes, with close to a hundred different G-C Chemicals now available—everything you need—the next move's up to you!

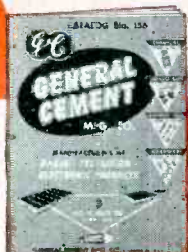

FREE CATALOG . . .
big, 64-page illustrated
G-C Catalog No. 156.
Get it at your jobber . . .
or send postcard direct.



GENERAL CEMENT MFG. CO.
901 TAYLOR AVENUE, ROCKFORD, ILLINOIS

New service-aids to solve servicing puzzles

WALSCO

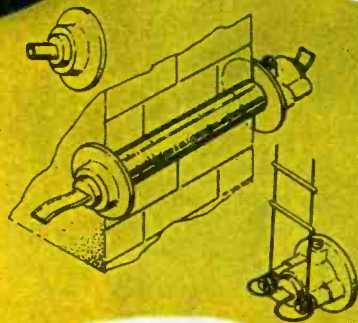

Walsco Universal Feed-Thru Bushing
Fits all standard types of coaxial, tubular and twin-lead wires. Can be terminated to open line, enabling you to bring 300 ohm twin lead through wall and into room. The bushing fits walls up to 14" thick. Dealer net \$1.17 (Cat. no. 1551)

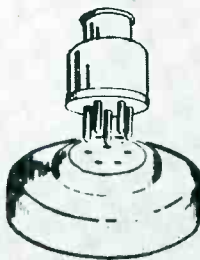

Walsco TV Lead-In and Rotor Receptacles
Used effectively as wall outlets for any type of lead-in or rotor cable. They also fit over and fasten to the inside flange of feed-thru. Matching plugs included.
2 prong (Cat. no. 1552) \$.63 dealer net
5 prong (Cat. no. 1553) \$.90 dealer net

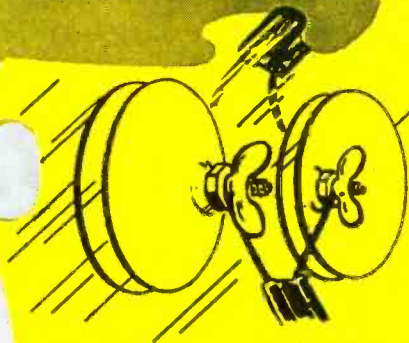

Walsco Window-Thru Bushing
A new, simple way to bring lead wires into the home without drilling holes, etc. Used effectively on both VHF and UHF. Walsco supplies the adhesive to cement capacitor discs to window pane. A quick, easy, weatherproof installation.
Dealer net \$.59 (Cat. no. 1555)



Walsco Electronic Chemicals in Spray Cans
Just spray it on! "Instant-spray" cans cut chemical application time in half. No messy applicators. Can't leak, break, spill or evaporate... it's air-tight. Insist on WALSCO chemical spray cans containing — Contactene, Tubecoat, Anti-Corona Lacquer, and Wrinkle Varnish.



WALSCO counter displays featuring chemicals in spray cans are at jobbers everywhere.



WALSCO
ELECTRONICS CORPORATION

3602 Crenshaw Boulevard, Los Angeles 36, California

Canadian Factory Distributor:

ATLAS RADIO CORP., Ltd., 560 King St., West, Toronto 2-B

Export Distributor:

AD AURIEMA, Inc., 89 Broad St., New York 4, N.Y.

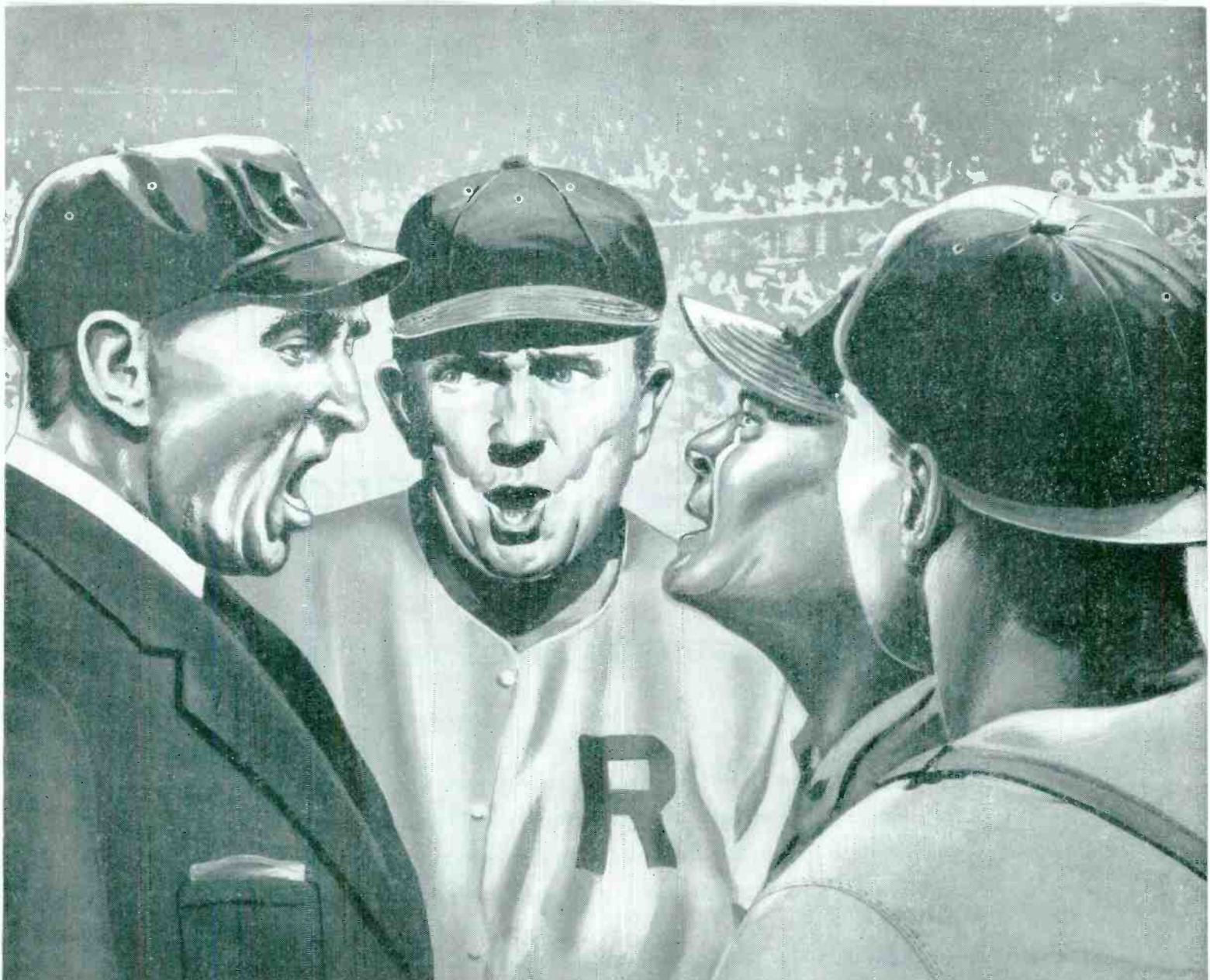

avoid "RHUBARBS"

The key to successful servicing is a satisfied customer. In television servicing, customer satisfaction is assured only when your highly technical knowledge is employed with components that meet or exceed performance expectations. Taking chances with components of questionable quality leads eventually to "rhubarbs" with dissatisfied customers. Nothing can be more harmful to the future of your television servicing business.

Always back up your quality work with dependable component parts. You can depend on Du Mont quality picture tubes to do more for your service.



Replacement Sales, Cathode Ray Tube Division
Allen B. Du Mont Laboratories, Inc., Clifton, N. J.

PIONEER IN BIG PICTURE TUBES • ORIGINATOR OF THE FAMOUS BENT-GUN AND SELFOCUS •
LEADER IN HIGH RESOLUTION • MAJOR SUPPLIER TO MOST FINE TELEVISION RECEIVER MANUFACTURERS

*Trade-ma

Naturally

I'm building my Electronics
On **DELCO** and

UNITED MOTORS SERVICE

DIVISIONS OF GENERAL MOTORS CORPORATION

It pays to deal with names you know—names that through years of service have won national respect for dependability and business integrity. Through these great names you can build a better electronics business on a solid foundation that offers many exclusive advantages to the industry.

ONE SOURCE

- Delco offers special application parts as well as complete coverage of the most important universal parts groups.

ONE POLICY

- A single sales policy for all electronics parts eliminates the confusion of dealing with many manufacturers.

ONE BILLING OPERATION

- Means fewer records to keep, fewer purchase orders; cuts bookkeeping time and costs to a minimum.

READY-MADE MARKET

- In addition to universal replacement parts, Delco is the sole source for original equipment replacement parts on all Delco radios.

TECHNICAL ASSISTANCE

- Current bulletins and field schools play an important part in keeping the industry well posted on new developments.

DISTRIBUTION

- United Motors Service maintains 21 strategically located warehouses to assure ample supply of all parts.

QUALITY

- You are assured of uniformity of parts, built to high standards of production and to exacting specifications.

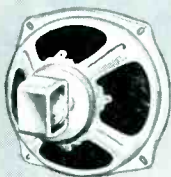

SPEAKERS

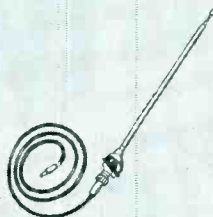

AUTO RADIO AERIALS



VIBRATORS



CONTROLS

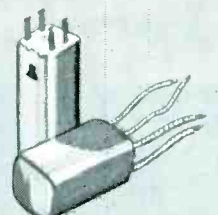

COILS

Business



A GENERAL MOTORS PRODUCT   A UNITED MOTORS LINE

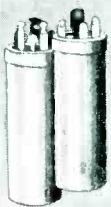

CAPACITORS



RECEIVING TUBES

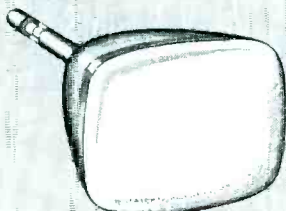

PICTURE TUBES

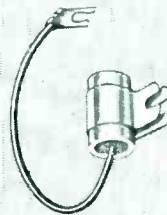

CONDENSERS

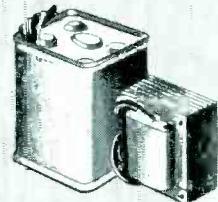

TRANSFORMERS

without equal **FOR PERFORMANCE!**

Telrex 4-BAY "CONICAL-V-BEAMS"®

The finest long distance array
ever produced . . . for the ultimate
in fringe area reception

Guaranteed to outperform
any antenna or combination
of cut-to-frequency antenna.

When used with Telrex Duo-Band
splines, the 8X-TV comprises the
finest in reception on channels 2 to
83. This famous Telrex antenna has
proven unequalled for performance
for distances up to 200 miles. When
you check the facts on antenna,
you'll agree that Telrex is
BEST BY EVERY TEST!

Every genuine Telrex antenna
features rugged all-aluminum,
all-weather construction

Over 60 different models for every installation
need, near or far, are included in the new Telrex
catalog. Ask for your copy, today!

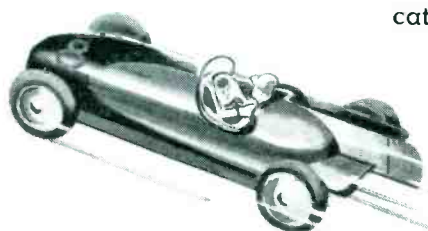
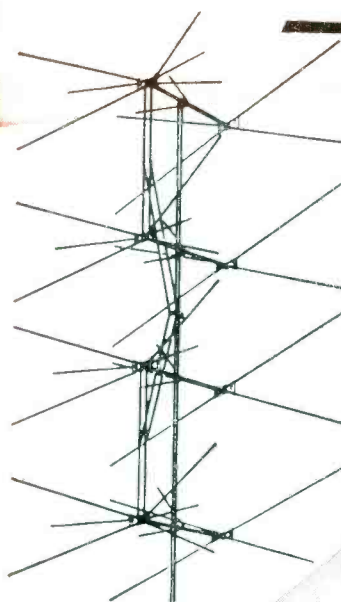

"Conical-V-Beams" are produced under U. S. Patent No. 23,346, Canadian Patent No. 500,436 and British Patent No. 691,485 — other patents pending. Sold only through authorized distributors.



**ASBURY PARK 4
NEW JERSEY**

MAKERS OF THE FAMOUS "BEAMED POWER" COMMUNICATION ROTARIES

On Book Row

RIDER'S TELEVISION MANUAL . . . VOLUME 13: Factory-prepared, factory-authorized servicing information on TV receivers manufactured in the period from September '53 to May '54. Lists makes and models of over 65 manufacturers, and also contains servicing information on color TV chassis. Includes replacement parts listing, and cumulative index, listing all items covered in previous volumes.—2300 pages, 8½ x 11", bound in binder, priced at \$24.00; John F. Rider Publisher, Inc., 480 Canal St., New York 13, N. Y.

* * *

TELEVISION RECEIVER SERVICING, VOL. I . . . BY E. A. W. SPREADBURY: Volume covers time-base circuits in TV receivers. Chapters review: blank screen symptoms; obtaining a raster; applying a signal; synchronization; examining interlace quality; the synchronized time-base; *hv* boost; picture shift; tube circuits; fly-wheel sync circuits; *dc* restoration; and use of instruments.—310 pages, 8¾" x 5½"; Iliffe and Sons, Ltd., Dorset House, Stamford St., London, England.

* * *

HOW TO LOCATE AND ELIMINATE RADIO AND TV INTERFERENCE. . . BY FRED D. ROWE: A practical book covering all types of devices causing interfering signals, how to locate them and exactly what to do to correct the difficulties. Some of the topics detailed are: antennas and interference; basic interference sources and sounds; locating the source; power-line interference and filters; and eliminating interference at the TV receiver.—122 pages, 5½" x 8½", paper bound, priced at \$1.80; John F. Rider Publisher, Inc.

* * *

INTRODUCTORY CIRCUIT THEORY . . . BY ERNST A. GUILLEMIN: An excellent text covering methods of steady-state and transient circuit analysis, as well as basic concepts essential to synthesis procedures. Author deals with the importance of network topology as a means of determining an appropriate set of variables; he covers the significance and usefulness of the principle of duality, and complex frequency, and discusses the concept of the impedance function.—550 pages, priced at \$8.50; John Wiley and Sons, Inc., 440 Fourth Ave., New York 16, N. Y.

* * *

TECHNICIAN'S GUIDE TO TV PICTURE TUBES . . . BY IRA REMER: An informative manual with basic information on picture tubes and accessories. Detailed are recognition of faults occurring in picture tubes, their correction where possible; rejuvenation equipment and handling of similar devices; details surrounding the optical accessories used with picture tubes; and replacement questions surrounding picture tubes, sweep accessories, and other related devices. The color picture tube is also discussed.—160 pages, 5½" x 8½", paper bound, priced at \$2.40; John F. Rider Publisher, Inc.

* * *

SUCCESSFUL SERVICE MANAGEMENT: One of the most useful trilogies on business practices, merchandising, and technical data ever published. Contains all of the information needed to set up and organize an efficient service business. . . Included in the business practices section is such material as accounting for the Service shop and preparation of Federal income tax returns. Under merchandising are included a discussion of the value of advertising and promotion, as well as specific *how-to-do-it* material on advertising, direct mail, window and store displays, and other means to increase service business. . . The technical data section includes material on troubleshooting with a 'scope, alignment techniques, *uhf* servicing, and service tips. Profusely illustrated.—318 pages, loose leaf; Available through authorized General Electric tube distributors as part of a management program.

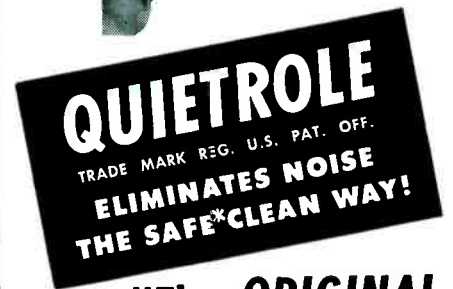

**"The ORIGINAL
NON-INFLAMMABLE
NON-CONDUCTIVE
LUBRICANT CLEANER"**

Available in
2 oz., 4 oz., 8 oz.



QUIETROLE . . . the original and most reliable lubricant cleaner quiets noisy television and radio controls, switches* and other moving parts. Why take less . . . avoid imitations . . . order QUIETROLE, developed after years of research.

**NO GUM! NO GOO!
NO GRIME!**

Carried by recognized jobs . . . everywhere!

*Unequaled for TV front end switches. Contains no "thinner".



manufactured by
**QUIETROLE
COMPANY**
Spartanburg, South Carolina

GET OFF THE SPOT



AND
INTO
THE
SPOTLIGHT



WITH THE



BONDED ELECTRONIC TECHNICIAN PROGRAM

Once you gain the confidence of customers, you're on your way to increased volume and profits. The Raytheon *Bonded* Electronic Technician program is designed to help you do just that. The Raytheon Registered Bond Certificate, the Raytheon Creed Display Decal and Identification Cards, featuring your bonded status and the fine Raytheon "Code of Ethics", inspire customer confidence. And a recent survey proved that wherever Raytheon Bonded Technicians took full advantage of their Bonded status — used it to inspire customer confidence — business improved *by at least ten per cent.*

Ask your Raytheon Tube Distributor if you can qualify for this important sales advantage. If you can, the bond is yours *at no cost to you* — it is *Raytheon's investment in your future.*



RAYTHEON MANUFACTURING COMPANY

Receiving Tube Division
Newton, Mass., Chicago, Ill., Atlanta, Ga., Los Angeles, Cal.

RAYTHEON MAKES ALL THESE:

RECEIVING AND PICTURE TUBES • RELIABLE SUBMINIATURE AND MINIATURE TUBES • SEMICONDUCTOR DIODES AND TRANSISTORS • NUCLEONIC TUBES • MICROWAVE TUBES



Excellence in Electronics



As Lively and Progressive As Ever*

To MOST OF US, even the hardened old timers, TV and radio are truly miracles of the electronic world. And, as many have often viewed, TV is probably humanity's greatest blessing. Even in the halls of Congress, TV has been applauded as one of the great inventions of the ages; having restored the home to its rightful place as the center of family pleasure and entertainment. Indeed, any medium that makes home more than a place to eat and sleep, is certainly precious to our welfare and life generally.

With so gleaming and beaming a horizon, we still have apostles of doom wandering about, tossing morbid statements and figures around.

Of course, no one denies that problems do not obtain; there are many roads that still have cracks, potholes and ruts, making driving difficult. We know that incompetence, indifference to ethical standards, and the race for the dollar, has created ill will and blemished many a record. We know, too, that because of these conditions, it has often been difficult to avoid sharp waves of friction and confusion. It has become necessary to display keen resourcefulness and courage to forge ahead. Industry has met that challenge, perhaps not everywhere in every community and city, but in the majority of towns, villages and urban areas throughout the country.

This has been an enormous job, but it has been and is being done, thanks to planned thinking, sparked by alert associations. The consumer has become aware of those who have chosen to follow the forthright trail prescribed by association groups. They have found that those who have banded together for a common cause are not only completely reliable, but capable of performing an installation, a service call or a maintenance assignment with more know-how, and in a completely professional manner.

Often, it has been said that folks are becoming less and less interested in keeping their receivers in good operating condition. And to compound the problem, we have been told that the seasons continue as threats to good business. As we have noted on several occasions, seasons have actually been found to be stimulants. To illustrate, whereas years ago practically everyone raced to the seashore or mountain resorts for relief during the summer months, today, thanks to air conditioning, millions are staying home and tuning in. It has been reported that this summer over a million families will keep cooler at home. Eight years ago, there were only about 15,000 air conditioners in operation. Today, the nation has been sold on the comforts of conditioning, and not only for the small homes, but in apartment houses as well. Several alert service shops in the east have found that the conditioned home represents a fertile market for repair and maintenance. They uncovered this golden fact

through a consistent mail and personal-contact campaign to owners of conditioners, working through dealers and distributors. In several coordinated deals, letters have been sent out by freezer dealers to consumers recommending the services of an approved radio, TV and phono shop. Letters have been followed up by mail from the service shop, and phone calls have supplemented the written notices. While the season is young, shop owners have been rubbing hands with glee, for the results have been described as outstanding.

In community TV¹, many Service Men have also found gilded opportunities. There'll always be communities, or even sections of communities, that do not now receive nor ever will receive satisfactory TV signals, either from the station in the community or from those in neighboring areas. The potential market for this service is truly vast, and as the records show, it can be operated profitably even in rural communities.

Earlier, it was said that there are too many bearers of gloom still strolling about. If these weary folks would take a look at the record and study the reasons for the dismal conditions they complain about, they would shed their cloaks of misery and begin a crusade that would rouse instead of bury.

Few have realized that the cause of the bulk of drop-outs in small business has been due to general incompetence. According to a survey conducted by a government agency, over 50% of the troubles has been caused by a lack of skill and a lack of knowledge of the industry.

Realistic Service Men have always fared well because they have studied and analyzed the prospects and problems facing their industry, not only as individuals, but as members of their community and their lively associations. They are not isolationists as many have tagged them. Folks in town have learned to respect their judgment and their skill. They have been alerted to the fact that it takes more than a flashlight and screwdriver to repair a modern receiver, be it radio or TV, or phono.

Manufacturers also have been lending a valued assist counseling consumers on what one must do today to keep equipment in order. Pitching in, via TV stations across the country, one tube manufacturer has begun to show a lively spot film telling viewers that: Television receivers have more than 500 different parts, and a good Service Man must know what each one does, where each one is located, and which one is causing the trouble in more than 150 different makes of sets now available. All this, the film continues, requires months of intensive schooling and plenty of practical experience in repairing sets; an investment of thousands of dollars for test equipment, and another big investment in tubes, parts and trucks. Quick, economical TV repairs, call for professional skill, technical knowledge, and honest workmanship.

The conscientious shop owner has always been able to render such service, as advertised. He has always followed the rigid code, and as result, he has found that there's plenty of bounce in servicing today; for the industry is as lively and progressive as ever.—L.W.

* From talks delivered by *yo ed* before the annual all-industry banquet of the Radio-Television Servicemen's Association of Pittsburgh, and the annual outing of the Radio and TV Service Men's Association of Luzerne County, Wilkes Barre, Pa. See page 45, this issue.

¹See page 23, this issue, *NCTA Symposium* report.

The BACKSTOP

STOPS co-channel and adjacent-channel interference caused by rear signal pick-up!

- Highest front-to-back ratio ever built into an antenna
- No rear pick-up; eliminates "venetian blinds"!
- Largest screen area: 70 square feet!
- Very high all-channel gain. Incorporates basic Champion design, including Tri-Pole, with additional elements!
- Completely preassembled!

Table of Front-to-Back Ratios (Relative Voltage)

Channels	Front-to-Back Ratios
2	9:1
3	10:1
4	11:1
5	20:1
6	18:1

Only Low Band channels shown, since co-channel interference is not encountered on High Band channels.

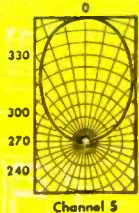

IMPORTANT . . . don't be misled by polar patterns representing relative POWER. Remember, power is the square of voltage. All Channel Master polar patterns are presented in relative VOLTAGE.

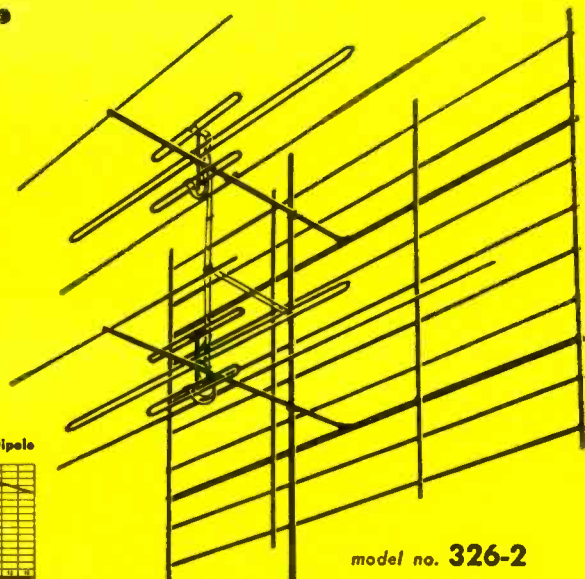
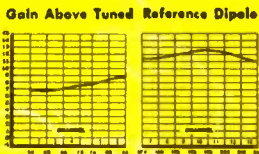

model no. 326-2

VHF-UHF antenna

\$63⁹⁰ list

2 radical new antennas by CHANNEL MASTER

The most beautiful antenna ever made! The only indoor antenna featuring powerful outdoor design principles — Bow-Tie and Screen.

Wonder Bow

VHF-UHF indoor antenna

DESIGNED FOR POWER!

On **UHF**: For primary and secondary areas. In many cases, performance is equal to actual outdoor installations. Good directivity on all channels.

On **VHF**: Ideal in areas of strong VHF signals.

STYLED FOR BEAUTY!

Designed by a well-known industrial designer, the WONDER BOW is proof that indoor antennas can be beautiful as well as powerful. Wins customer approval on beauty alone!

The first gain figures ever to be published for an indoor antenna!

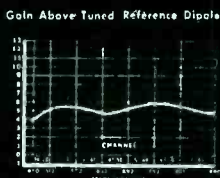

Gold and black
model no. 416

Silver and black
model no. 417

\$83⁵ list



CHANNEL MASTER CORP. ALLENVILLE, N. C.

The World's Largest Manufacturer of TV Antennas

Write for complete technical literature.

Copyright 1954, Channel Master Corp.

*Pat. No. D-171560

SERVICE... The National Scene

HEALTHY INDUSTRY CLIMB FORECAST FOR FALL-WINTER--A solid rise in business should prevail during the next six months, RETMA's set division chairman predicted recently. His optimism was based on the news that authoritative statistics on production and sales had enabled set makers to judge their output wisely and avoid the creation of dangerously high inventories. The radio-electronic-TV industry accordingly, he said, has been able to enter the second half of the year with balanced inventories. . . . These views were also shared by the association's prexy, who announced during an annual report meeting that we are now on a sounder basis than a year ago because of the lower-level inventory conditions. Commenting on color, he said that while the market has been slow in developing, there are indications that it will now gain momentum and we can look forward to a steadily growing interest in color equipment. . . . Enthusiasm for the future was also voiced by the chairman of the board of a leading tube and set manufacturer during an annual stockholders meeting. He felt that not only would the radio and TV industry continue to grow, but that opportunities in commercial and industrial electronics would spiral, too. He invisioned a volume of more than a billion dollars in seven years or so, and a continuing rise. In his opinion, there are really no limits as to what electronics can do for industry. Electronifying in industry is just beginning, he said.

UHF-ONLY ASKED FOR AREAS WHERE 14-83 BANDS PREDOMINATE--A proposal that intermixed stations in 10 key markets switch over to v or y operation only, depending on the predominance of high or low-band channels in those areas, was filed in Washington recently. Cities included in the plan were: San Francisco (presently with 3 v and 1 u stations); Miami (1 v and 2 u); Louisville (2 v and 1 u); Portland, Me., (1 v, 2 u); Boston (2 v, 1 u); St. Louis (1 v, 3 u); Oklahoma City (2 v, 2 u); Dayton (2 v, 1 u); Pittsburgh (1 v, 2 u); and Milwaukee (1 v, 2 u). . . . The brief also revealed estimated number of total and uhf sets in these areas: San Francisco-70,000 u (840,000 total); Miami-120,000 u (240,000 t); Louisville-82,000 u (370,000 t); Portland-70,000 u (90,000 t); Boston-105,000 u (1,400,000 t); St. Louis-215,000 u (620,000 t); Oklahoma City-83,000 u (260,000 t); Dayton-32,000 u (637,000 t); Pittsburgh-250,000 u (943,000 t); and Milwaukee-218,000 u (668,000 t). . . . Substantial quantities of the so-called u-sets were described as being actually converted veryhigh chassis. . . . In a letter accompanying the proposal, it was noted that the change to all v or u might eliminate almost 50 per cent of the problems in one stroke, without serious dislocation.

UHF A SUCCESS, OPERATOR TELLS SENATE COMMITTEE--There's 95% conversion in Columbus, Ga., probably the only city in the country where it costs more to buy time on a uhf rather than a vhf station, and everyone is very happy with the situation. So testified a representative of WDAK-TV (Columbus) channel 28, before the Washington sub-committee investigating the ultrahighs. Committee members were told that the station's worst problem is Madison Ave., headquarters of many key ad agencies in New York City, where the impression seems to be that there are no useful uhf stations. Senators learned that there were at least nine other uhf stations now doing very well, and it would not be long before others joined the success parade.

CONVERT-A-SET CONTEST LAUNCHED IN ST. LOUIS--A uhf convert-a-set contest, expected to promote about 70,000 conversions over a three-month period, has been launched over WTVI in East St. Louis. Viewers are being asked to submit the names of five friends whom they believe will convert to uhf, and in addition write a 15-word essay on why they like the station. Prizes being offered include an air-conditioned home, convertible, air conditioners, refrigerators, stoves, diamond rings, piano, and even some lessons. . . . Over 150 daily and weekly newspapers, in a 25-county area served by the telecaster, and billboards, taxicabs and radio too are being used to promote the conversion drive. . . . Names of conversion prospects will be sent to dealers and Service Men.

SERVICE... The National Scene

SUBSTANTIAL PRODUCTION OF 19" COLOR SETS SEEN FOR THIRD-FOURTH QUARTERS--Promised delivery of large-screen picture tubes for color chassis has prompted a number of manufacturers to announce that they'll soon have quite a few chassis on the market. . . . Reporting on tube sizes, a representative of one company said that their large-screen version would be closest in size to the popular 21" b-w tube and provide 205 square inches of picture-screen area. The production capacity of the plant offering these tubes is 10,000 a month, and it was said, demand may make this rate necessary by late September. It was also predicted that industry would produce between 50,000 and 60,000 large-screen color tubes this year.

SINGLE-GUN COLOR-CHASSIS DEVELOPMENTS STIRRING--Within the next few weeks, licensees of one lab in the East will attend the showing of new color models using single-gun tubes featuring built-in radiation suppression. While chassis displayed will be bench models, it is felt that it will be possible to use them as practical prototypes for production purposes.

BIG PUSH FOR TWO-STEP HI-FI DISTRIBUTION PLANS UNDERWAY--Unique merchandising programs, which it is felt will stimulate sales of hi-fi gear through Service Men, are now being readied for the field. Plans revolve about rebates and special models for the market. . . . In one approach, conceived by a Pacific coast manufacturer, two chassis have been exclusively designed for the program. Models will be available to bonafide audio Service Men at a special discount. These sales will be entered separately and reported on a special form to the manufacturer, who will reimburse the distributor to provide a profit on each shop or dealer sale. . . . In another plan, prepared by a Chicago speaker manufacturer, shops or dealers will also be able to buy equipment at a discount, and distributors who have been designated as hi-fi wholesalers, will get an additional discount on all verified sales.

ULTRAHIGH BOOSTER SOUGHT FOR WATERBURY, CONN.--Permission to install an experimental uhf-TV station booster in the Waterbury, Conn., area, was filed recently with the Commission. The booster, with 10 watts of power, would it was said serve to retransmit programs of WATR-TV (channel 53).

COMPLETE PRINTED-CIRCUIT TV CHASSIS BEING READIED FOR MARKET--A 26-tube cascode, 41-mc receiver, using nine printed-circuit sections (plus a standard tube-transformer unit) has been developed on the Pacific coast, and will soon be marketed under brand names. Receiver will contain four stages of if, and an aluminized picture tube. The pc sections have been designed for plug-in so that they can be removed quickly in case of trouble. Receivers will be offered in 21, 24 and 27-inch models.

TEXAS SERVICE ASSOCIATION PLANS THREE-DAY MEETING IN AUGUST--The 2nd annual electronics fair and clinic, conducted by the Texas Electronics Association, will be held in Fort Worth on August 27, 28, 29, in the Grand Ballroom of the Hotel Adolphus. . . . Scheduled talks will cover transistors, public relations and advertising, uhf receivers and antennas, test equipment and color receivers.

AWARDS TO TELECASTERS FOR FRIENDLY HELP--The valued technical and promotional assistance supplied by TV stations to Service Men has been applauded on a number of occasions. In recognition of this outstanding service, one antenna manufacturer has announced the establishment of a TV engineer's award. . . . A short time ago, the chief engineer of WDTV in Pittsburgh received the first of these awards. . . . In late September, it has been reported, a plaque will be presented to another TV broadcaster for his friendly help to those in servicing.--L.W.

WARD Antenna Rama

A DYNAMIC NEW CONCEPT

in the Manufacture and Marketing of TV Antennas,
Auto Radio Aerials and Accessories

LENGTH OF EXPERIENCE

Ward electronic engineers have pioneered many important advances in TV and Radio communications — advances which have set the pattern for others.

DEPTH OF PRICES

Whatever the budget may indicate, Ward offers the right answer with TV antennas, auto radio aerials and accessories at the right price . . . profitable for you, too.

BREADTH OF LINE

The new Ward line includes TV antennas, auto radio aerials, and accessories . . . engineered and styled for complete customer satisfaction.

HEIGHT OF QUALITY

Every TV and radio product which proudly bears the Ward name represents the finest material money can buy.

RANGE OF MODELS

That Ward dealers may best serve their patrons, Ward offers a wide selection of antennas and accessories to meet every need.

LET SAM
WORK
FOR YOU!



SALES PROMOTION

Eye catching displays, mailing pieces, catalog sheets.

ADVERTISING

National advertising plus local cooperation for you.

MERCHANDISING

Actual sales leads plus products and prices that make selling easy for Ward dealers.

WARD PRODUCTS CORP.

DIVISION OF THE GABRIEL COMPANY
1148 Euclid Ave., Cleveland 15, Ohio
Canadian Distributor: ATLAS RADIO CO., LTD., TORONTO, CANADA



ALLIANCE first with AUTOMATIC GARAGE DOOR OPERATOR

THAT'S PRICED LOW FOR THE MASS MARKET



\$179⁹⁵

OFF-SEASON PROFITS FOR TV DEALERS



AMAZING LOW PRICE!

The first dependable fool proof garage door operator, fully guaranteed at a price all can afford! A real convenience—a protective necessity that saves work—simply push a button!

THE ELECTRONIC

LIFT-*Alliance*-DOR

OPENS • CLOSES • LOCKS GARAGE DOORS

Automatically. A RADIO-CONTROLLED "NATURAL" FOR RADIO AND TV SERVICE DEALERS AND INSTALLERS!

More than 15,000,000 homes are prospects!

Fast—Easy Installation—Alliance Lift-A-Dor Is a Packaged, Quality, Low Priced Unit. Fits Nearly All Overhead Doors
—Takes Only Ordinary Tools and 'Know How' To Install.

AVOID SEASONAL SLUMPS WITH THE ELECTRONIC ALLIANCE LIFT-A-DOR!

TV DEMONSTRATIONS!

Alliance TV spots like those making Alliance Tenna-Rotor famous, will show and demonstrate Lift-A-Dor to millions of TV viewers.

Newspapers—magazines—point-of-sale displays pre-sell!

WRITE THE FACTORY FOR FACTS!

A radio impulse transmitter in car, operated by push-button on dash is pre-tuned to receiver in garage which raises or lowers door automatically—locks, unlocks and turns on light. Installation takes no digging—no outdoor wiring, no special tools. Write for catalog and complete information.

THE ALLIANCE MANUFACTURING CO. • ALLIANCE, OHIO

Makers of the Famous Alliance Tenna-Rotor



The NCTA Community-TV Symposium

by WYN MARTIN

SMALL TOWNS and small communities of this great country of ours represent the very heart and soul of America, and what is good for them is good for this nation.

So observed Senator Edwin C. Johnson in presenting his views on the dynamic impact of TV's new dimension, *Community TV*, at the annual NCTA* meeting in New York, a few weeks ago. Now, he said, it has become possible to bring the magic of TV to thousands of areas, which would be blacked out because of economic and geographic problems.

Declaring that the potential market for community TV can only be described by the super word—vast, the Senator said that systems can operate profitably in communities with as few as 5,000 people; and in this country there are more than 2,500 such cities and towns. Noting that it is doubtful that half or even three-fourths of these 2,500 communities will ever have television stations of their own, or receive satisfactory service from nearby cities, he said: "Here is a vast market of millions of people who will demand the blessings of good television entertainment in their own homes, once they learn that there is no technical reason against having it."

Even today, community TV is not exactly an infant industry. For there are now more than 300 separate systems in operation serving some 275,000 households, reaching a volume of service which no longer can be ignored, conference members were told.

Reviewing some of the technical and legal problems that do obtain today in community service, the Senator said that such a service is premised upon picking up signals of operating stations and relaying those signals to sub-

scribers through closed circuits. Thus one of the burning questions has been what rights have community operators to those signals, or what are the proprietary rights of the originating station or the network in the programs delivered to subscribers?

The function and role of the community pickup is to strengthen signals of the originating station for distant areas where otherwise the reception would not be satisfactory.

A station's programs are free, it was said, waiting for and available to anyone with a receiver to tune in on them and view them; actually stations are anxious that more and more people buy receivers and tune in their programs, since they use the number of listeners they serve to attract advertising. Thus a community TV's function, explained the Senator, is one of providing a technical service which results merely in an extension and expansion of the coverage of the station and thus is helpful to the station and at the same time serves the public interest.

Therefore, he pointed out, such a service is neither a broadcast nor a common carrier operation and, thus it should not be subject to regulation by the Commission, or by a state utility agency in the case of a solely intra-state operation. Certainly, operators were told, they are not engaged in broadcasting nor in interstate communications for hire, but were simply furnishing a purely local antenna service. And as such, systems were no more a common carrier than a hotel

with one master antenna, which serves its many rooms.

One of the outstanding developments of the community operation, continued Senator Johnson, is the friendly and cooperative relations with the TV broadcast industry. So far as he knew, only one station licensee has sought to deny the pickup of his programs. This cordial relationship is understandable, he said, when it is realized that operators provide the station with an additional audience and market not ordinarily reached by his signal. He noted that most licensees with whom he has talked feel that community systems constitute a very desirable adjunct to their business.

Radiation from Community TV Cable

IN ANOTHER revealing conference report, *Walter N. Brown** discussed the problems arising from radiation or leakage of signals via community TV cable systems. Radiation from many systems has been strong enough to encourage non-subscribers to erect antennas near the cable lines and operate their receivers from signals radiated by the cable system. And in areas where there is direct signal available from TV stations, radiation from cable systems has been found to cause *ghosts*, black bars, or other types of interference.

Reviewing the general nature of the problem, Brown said that in an ideal system the entire system and the sets connected to it would be perfectly shielded. Thus the only entry of signals would be through the antennas, and the signals traveling inside the systems would be confined by an im-

(Continued on page 50)

Above, left: NCTA proxy Martin Malarkey, Jr., (right) discussing coax cables with Amphenol field engineer at meeting. Right: Senator Edwin C. Johnson who delivered key address at conference.

*Consultant, U. S. Wire and Cable Corp.

*National Community TV Association.



AUDIO

INSTALLATION AND SERVICE

Hi-Fi - Phono - Tape - P A
Amplifiers - Speakers

by **KEN STEWART**

and **PAUL EDWARDS**

ON THE LECTURE platform, in the athletic stadium, before a night-club audience, on stage or in the pulpit, many have objected to being anchored before a fixed mike stand or entwined with reels of lead feeding to a more flexible breast, lapel or hand mike. It has often been felt that the ideal approach to this situation would obtain in a lineless lightweight mike with which one could roam about.

In one effort to meet this requirement, a stick microphone featuring use of a non-licensed or FM induction system, has been evolved¹.

In developing the wireless technique, it was found that the stick-type mike could be so designed that it would be self-contained, readily handled from one person to another, or placed in a microphone stand and used conventionally. Thus performers would not have to dress themselves in the microphone. And having no interconnecting cables, the unit would not be subject to wear and tear and require less main-

tenance. The concealment factor was felt to be a minor point.

Frequency modulation was chosen because it was found to assure a constant overall gain, notwithstanding the varying coupling between transmitter and pickup element. In addition, the desire to obtain an effective signal-to-noise performance, with a transmitter of limited power, dictated the use of an FM system.

One of the key items in a system of this type is the antenna for the transmitter. It was found that within practical limits the size of the antenna would not affect the performance of an induction system. Studies have disclosed that any antenna can be reduced to an equivalent magnetic dipole, the only effect of size variation appearing in the change of power required to produce the desired

¹Shure Vagabond Model 88 Wireless Microphone System.

²National Scene, SERVICE; October, 1953.

field strength. An effective solution appeared in a ferrite-core inductor 3" long, weighing 2 ounces.

The transmitter, using five sub-miniatures, operates from a 30-volt hearing-aid battery and a 1.3-v mercury cell. The circuit, divided into two parts, has a two-tube audio and three-tube rf section.

Two tetrode voltage amps were cascaded in the audio portion; this served to provide a gain of 55 db at 1000 cycles. For the desired degree of modulation, a miniature *vc* was included between the two stages. During tests it was found that motorboating occurred at low frequencies when the amp was connected to the reactance modulator, due to modulation of the plate supply voltage. This was eliminated by adding a decoupling filter in the first audio stage and restricting the *lf* response of the audio amp.

An 80 microsecond preemphasis, in the transmitter, and corresponding

(Continued on page 52)

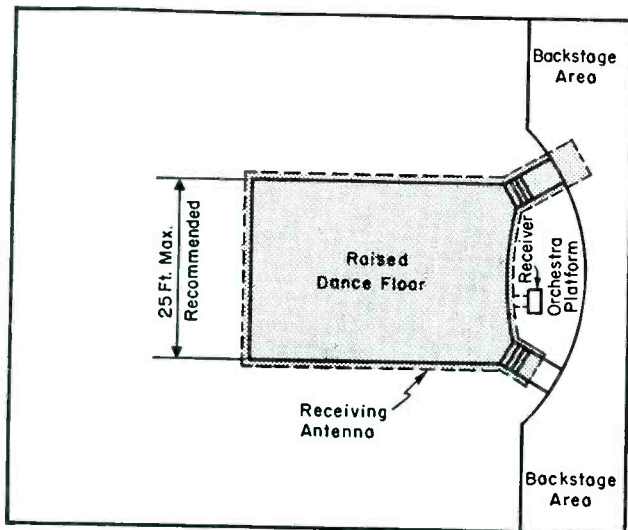

Above: Typical night-club installation. Primary area of coverage (dance floor) is indicated by heavy outline. Dotted line indicates loop antenna stapled to edge of raised dance floor. Loop need not be enlarged to enclose entire stage and stairways, but merely to secure coverage over area needed.

‡Based, in part, on a report prepared by **Thomas W. Phinney**, Shure Brothers, Inc. presented at Sept., '53 NEC meeting in Chicago, and published in March-April, '54 transactions of IRE Professional Group on Audio.

Below: Wireless mike receiving antenna layouts. Loop A will pick up more noise than loop B because the enclosed area is larger. The signal pickup will be about equal for A and B. Loops C and D have equal enclosed areas and hence will pick up about the same amount of noise. However, loop C will pick up more signal than loop D because the transmitter cannot be taken as far away from the receiving antenna wire within loop C as it can within loop D.

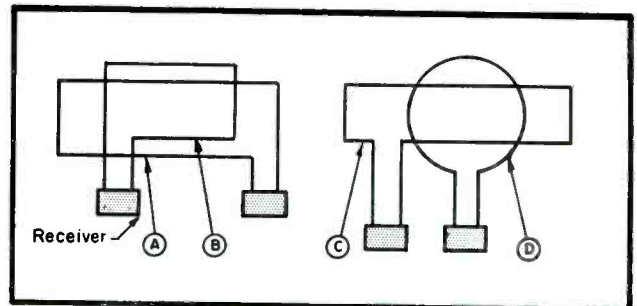

Audio: Turntable Mats ... Tri-Speaker Systems ... Ceramic Cartridges ...



A 3-way speaker system employing combination woofer-mid-range and tweeter reproducers together with an inductance-capacitance type dividing network, housed within a balanced double-port bass chamber. The woofer section of the speaker is said to employ a heavy duty diaphragm capable of large low frequency excursion without acoustic break-up. The mid-range section provides two separate concentric horn radiators. The tweeter is comprised of a driver unit employing a lightweight phenolic diaphragm, Alnico V gold dot magnet, and reciprocating flare wide angle horn. A balance control is provided in the network tweeter circuit to permit adjustment of tonal quality. (Companion with Diffusicone 8 and Model 4401 Tweeter System; University Loudspeakers, Inc., 80 S. Kensico Ave., White Plains, N. Y.)

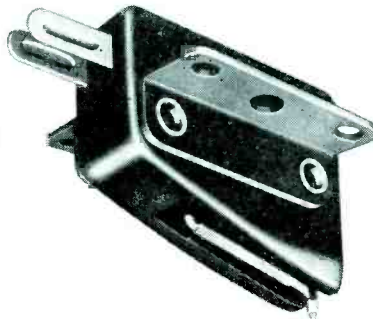

Cartridge with ceramic element, said to have a 30 to 15,000 cps response on RCA 12-6-51V test record. Output is .70 volt, nominal, on test record at 1,000 cps. Cartridge said to fit all standard tone arms, both manual and record changer type, with RETMA standard 1/2" mounting centers, and plug-in head types. One replaceable stylus is furnished, with diamond or sapphire tip; one-mil tip radius for slow speed recordings or three-mil tip for 78. (Model 51-1-J; Astatic Corp., Connecticut, C.)

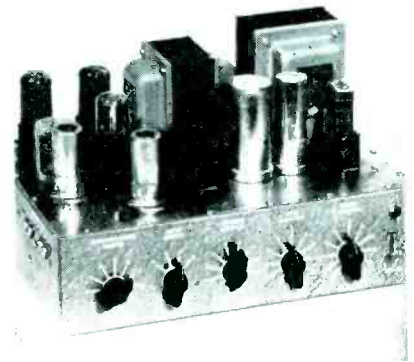

A 10-watt amplifier, available in kit form. Also made up in kit form are Williamson type all triode amplifier delivering 16.5 watts, and an auditorium amplifier delivering 40-55 wats. A preamp featuring a record equalizer and tone control is also provided as a kit. Kits include all necessary transformers, chokes, sectional chassis and complete instructions for assembly, including photographs, drawings and decals. (Models HF 12, 18 and 40; Triad Transformer Corp., 4055 Redwood Ave. Venice, Calif.)

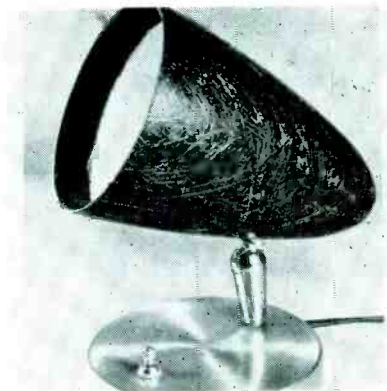

Portable extension speaker, with acoustic fiberglass cone. Has a 4-in-1 switch that turns on either TV set speaker or extension or both. (Floritone models 100 and 200; Sootins, Inc., 321 N.W. 3d Ave., Miami 36, Fla.)

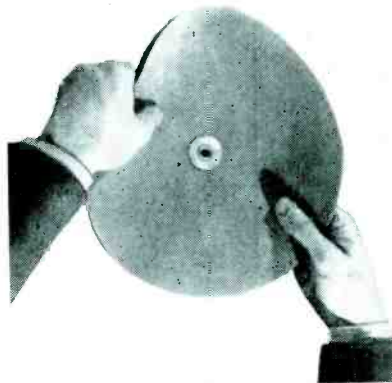

Poured foam-rubber turntable mat, 1/4" thick and 9 3/4" in diameter. Has a felt back, metal grommet (designed to prevent central core from grabbing spindle), and a 45-rpm wide spindle adaptor. (Disc-O-Foam; Disc-O-Foam Sales Corp., 164 Duane St., N. Y. 13, N. Y.)



Portable magnetic tape recorder-playback with built-in amplifier. May be regulated by visual or auditory controls. (Model M-33; Magnecord.)

Right: Wireless mike football stadium installation. Conventional closed loop receiving antenna is not used here. Instead, an open wire is run the length of the field, along the sidelines. In the installation shown, the wire is broken at the middle and the two ends brought to the two outside antenna terminals in the receiver. The center antenna terminal of the receiver is connected to the ground strap. The far ends of the two antenna wires are connected to pipes driven into the ground, which completes the antenna circuit. Such a ground connection may not always be necessary although somewhat better performance can be expected when it is used. With an open wire receiving antenna of this type, the transmitter of the system must remain fairly close to the wire. Also, the amount of noise picked up by the system will be greater than it would be if the shaded area were enclosed in a normal receiving loop antenna. Whether or not this higher noise level will be acceptable will depend upon local conditions and the use which is made of the signal from the receiver, i.e., stadium public address use will tolerate higher noise levels than radio broadcasting.

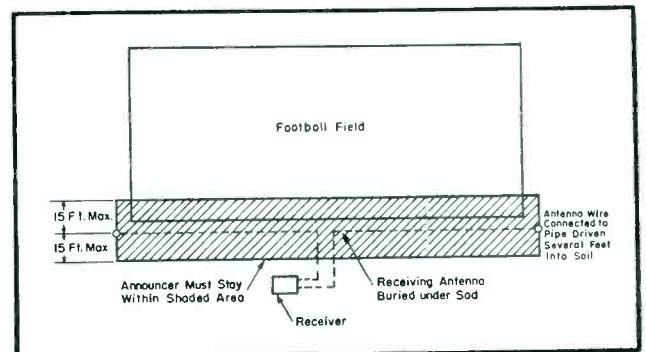

COLOR TV developments

by **L. A. BASSETT** and **JACK HAWTHORNE**

Radio and TV Department, General Electric Company

GENERALLY SPEAKING, color TV receivers are high-quality monochrome sets to which have been added the necessary circuits to detect and reconstruct the original red, green and blue voltages generated by the studio cameras. These color voltages, together with the monochrome *picture detail* voltages, are then applied to the respective red, green and blue guns of *tri-color* picture tubes to reproduce the original colored scene.

RF Tuner

In the G.E. model 15CL100 the tuner unit is quite similar, physically and electrically, to previous G.E. *rf* tuners.

The tuner unit consists of a low-noise, grounded grid preamp $\frac{1}{2}$ 6BK7A, a high-gain 6AK5 pentode *rf* amplifier, and a 6U8 converter-oscillator combination. The oscillator operates nominally at 41.25 mc above the audio carrier on each channel.

The *if* output of the converter is low-impedance coupled into the *if* amplifier section, and *agc* voltage is applied to the second *rf* stage to control its gain.

The fundamental differences between this tuner and an ordinary monochrome tuner are:

(1) The oscillator circuits are designed with a slightly narrower fine tuning range and better drift characteristics for greater frequency stability. These factors are important in a color receiver since excursions of the oscillator too far off proper frequency may cause excessive 920-*kc* beat interference, or going in the other direction, will cause a loss of color information.

(2) The limits allowed for *tilt* or *saddle-back* of the *rf* response are restricted to the tolerances indicated in Fig. 2. As will be noted, the *rf* curves of the color tuner on each channel are almost *ideal* curves. This is required to provide reasonably flat response

across the portion of the passband which contains the color-conveying sidebands.

Servicewise, the only special consideration required is that of the alignment tolerances mentioned.

The IF System

In many respects, the *if* system is quite similar to the *if* systems found in high quality intercarrier-type monochrome receivers. Primarily, the system consists of four stagger-tuned pentode amplifiers, the last of which feeds two detector circuits rather than just one, as in monochrome practice.

The output of the tuner unit is low impedance coupled into the bottom end of the first *if* grid tank circuit and the input capacity of the first 6BA6 *if* tube. In this form of *bottom coupling*, the degree of coupling between the converter plate tank circuit, consisting of an iron-core unit and the converter output capacity, and the *if* input tank circuit is controlled by the magnitude of the theoretical common impedance, *Z*, between the coaxial inner conductor and ground. In this case, the impedance is represented by the capacity of the coax line and three traps. This system is often referred to as *trap coupling*. The traps are used for accompanying audio and adjacent channel audio and video carrier attenuation. Their effect, together with the passband characteristics of the following stages, provide attenuation figures of approximately 80 db at 38 mc, and 52 db at 47.25 mc.

The tank circuits and three bifilar coupling transformers, are stagger-tuned in a conventional manner. As

mentioned previously, the fourth *if* amplifier (6CB6) feeds two detector circuits. The first to be considered is the *chroma* detector. The response of this detector, together with the preceding stages, is shown in Fig. 3. Here, it will be noted, we find a response curve which would be considered entirely unsuitable for a monochrome receiver. However, at this point, we desire only to obtain chroma information which is centered about a subcarrier frequency of approximately 3.58 mc and an audio *if* signal at 4.5 mc. The chroma subcarrier, in terms of intermediate frequencies, falls at approximately 42.2 mc. As noted in this waveform, a *chroma* shelf is built into the chroma detector response, centered at this frequency. The accompanying audio carrier, 41.25 mc, is down only 25 db at this point, and hence, the chroma detector output becomes a convenient source of 4.5 mc information.

Coupled into the chroma detector is the *Y* or monochrome detector. This detector is tuned to the center of the *if* passband at approximately 44.15 mc. The response of this detector, together with the responses of all the preceding tank circuits, is also shown in Fig. 3. This response is similar to a conventional monochrome *if* curve, except that it is perhaps a bit wider than usual and that the accompanying audio attenuation is much greater, i.e., 80 db. This is permissible since the audio carrier has already been obtained from the chroma detector assembly.

The output of the *Y* detector consists of the usual video *brightness detail* information as well as composite

Part III of CRTSA Color Symposium Report†:
The G.E. R-Y/B-Y Color Chassis

sync. The polarity of the detector output is *positive white*.

A word of caution regarding *if* alignment. Naturally, an attempt should always be made to follow closely the manufacturers' specifications for receiver alignment. However, it is of even greater importance in color TV *if* systems. This may be seen if we consider the example of an *if* system which is poorly aligned or if the fine tuning control of the tuner were improperly adjusted. In the case of the *Y* signal, either of these troubles would cause the usual monochrome symptoms of *smear* or 4.5-mc crystallization effects. Additionally, if color programs were being viewed, an excessive 4.5-mc signal level at the *Y* detector would cause harsh 920-*kc* beats to appear. This would be caused by a heterodyne action between the 4.5-mc signal and 3.58-mc chroma sideband information.

Similarly, other undesirable effects would be noted in the chroma detector output under the foregoing maladjusted conditions. Just as in the *Y* channel, excessive 4.5-mc signal level at the chroma detector would cause 920-*kc* beat effects, while going in the opposite direction we might find the chroma *if* information falling off of the chroma *shelf*, down into the 41.25-mc trap. In this case, we would lose chroma information altogether. It, therefore, becomes obvious that, when aligning such an *if* system, one should follow the prescribed procedure as closely as possible to achieve the desired results. Actually, this particular *if* system may easily be aligned by anyone already familiar with such procedures. The fact that two detectors must be aligned requires only a few more minutes time than would be required for most four-stage systems.

The first three stages of the *if* system are controlled by *agc* voltage derived from an *agc* keyer tube. These tubes are 6BA6s and have been chosen because of their excellent linearity characteristics under conditions of high applied *agc* bias. This is an important consideration in a color receiver, since non-linearity in the *if* system might impair the receiver's ability to display truly *saturated* color information and, in extreme cases, may actually cause erroneous *hue* information. One must bear this in mind when troubleshooting *agc* diffi-

(Continued on page 30)

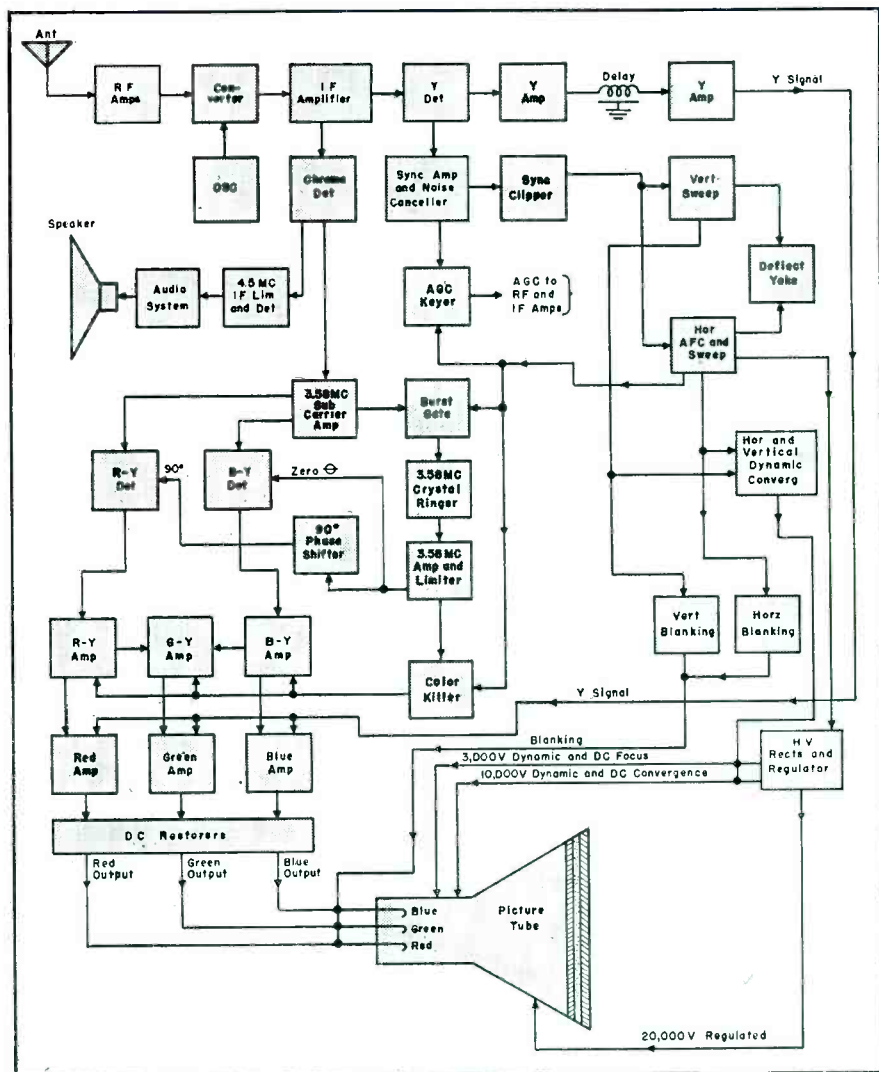

Fig. 1 (above). Block diagram of the G. E. color receiver; model 15CL100.

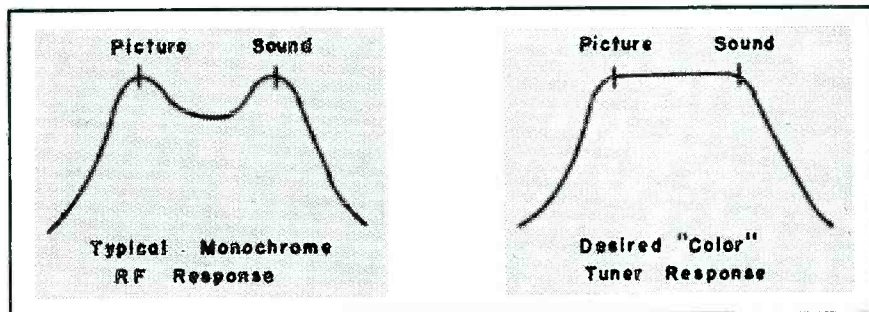
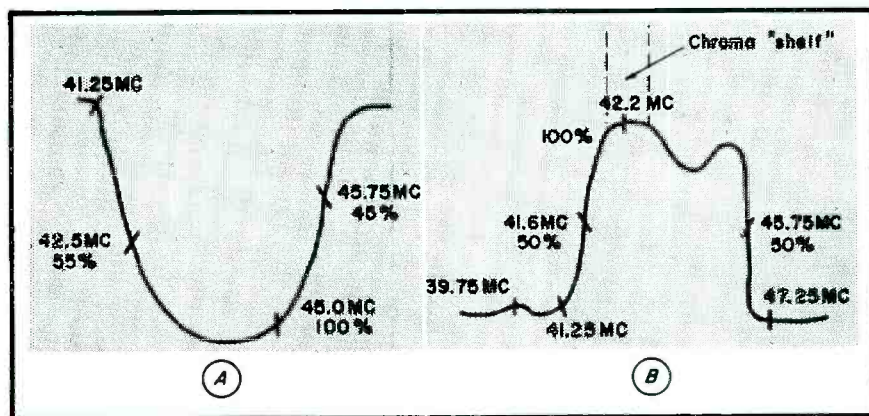

Fig. 2 (above). Waveforms of b-w rf response and desired tuner response.

Fig. 3 (below). *Y* *if* channel response (A) and chroma *if* channel response



†At the CRTSA Color TV Symposium, Fred Miller of General Electric discussed sub-carrier sync and matrixing circuitry in the G. E. chassis.

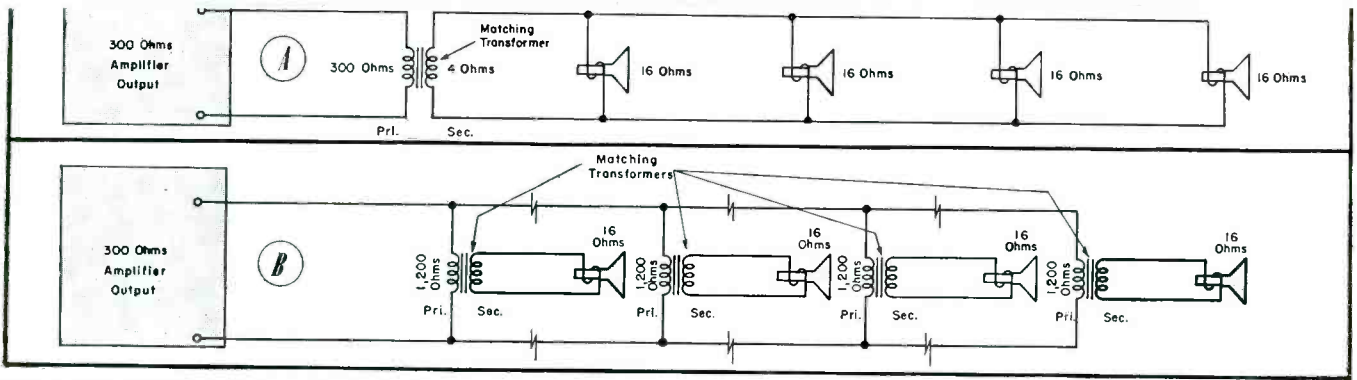

Fig. 1. Two methods used to match identical speakers to an amplifier; when they are placed relatively close to each other (A), and far apart from each other (B). When four speakers (close-together), 16 ohms each, are to be matched to a 300-ohm amplifier, only one matching transformer is needed with primary of 300 ohms to match amplifier and secondary of 16/4, or 4 ohms. When four, separated speakers, 16 ohms each, are to be matched, four matching transformers are required, each with primary impedance of 300×4 , or 1200 ohms, and 16-ohm secondary.

Multiple LOUDSPEAKER Installations

by **JESSE DINES**, Educational Director, Ram Electronic Sales Co.

SPEAKERS CAN BE CONNECTED so that they are relatively close to the amplifier (as in an intercom system in a business office), or, on the other hand, so that they are at quite a distance from the amplifier, as in a very large auditorium. In the former case, it is necessary to use only one *mt**; in the latter, however, a separate *mt* must be used with each speaker to keep the losses of the lines (interconnecting the speakers) at a minimum.

Parts (a) and (b) of Fig. 1 illustrate the foregoing two cases, respec-

tively, with typical examples in which four 16-ohm speakers are used. In (a), the impedance of the amplifier output is 300 ohms and the *mt* primary, therefore, is equal to it; the secondary impedance is calculated by formula: $R(\text{total}) = R(\text{of 1 resistor})/\text{Number of resistors}$; for more than two parallel resistors equal in value. However, in (b), the primary impedance of each *mt* must be 1,200 ohms—so that four in parallel will equal 300 ohms; the secondary impedance of each trans-

former is equal to the impedance of the speaker and, therefore, 16 ohms, in this case.

On occasion, it is necessary to connect two or more speakers with different impedance ratings to an amplifier. Although it would be most convenient to connect them directly, it is necessary that each differently-rated speaker be connected to a separate *mt*. A typical problem, shown in Fig. 2, indicates that four speakers with dif-

*Matching transformer.

(Continued on page 30)

Fig. 2 (below). Method used to match four different speakers to an amplifier and determine the primary impedances of the matching transformers. In solving this problem, the plot shown in Fig. 3 (below, right) for voltage versus power for commonly-encountered speaker impedance values, should be used. Here we find that $Z = 240$ ohms, $P = 10$ W total power dissipation and $E = 50$ V; $Z_A = E^2/P_A = (50)^2/1 = 2500$ ohms; $Z_B = E^2/P_B = (50)^2/2 = 1250$ ohms; $Z_C = E^2/P_C = (50)^2/3 = 833$ ohms; $Z_D = E^2/P_D = (50)^2/4 = 625$ ohms.

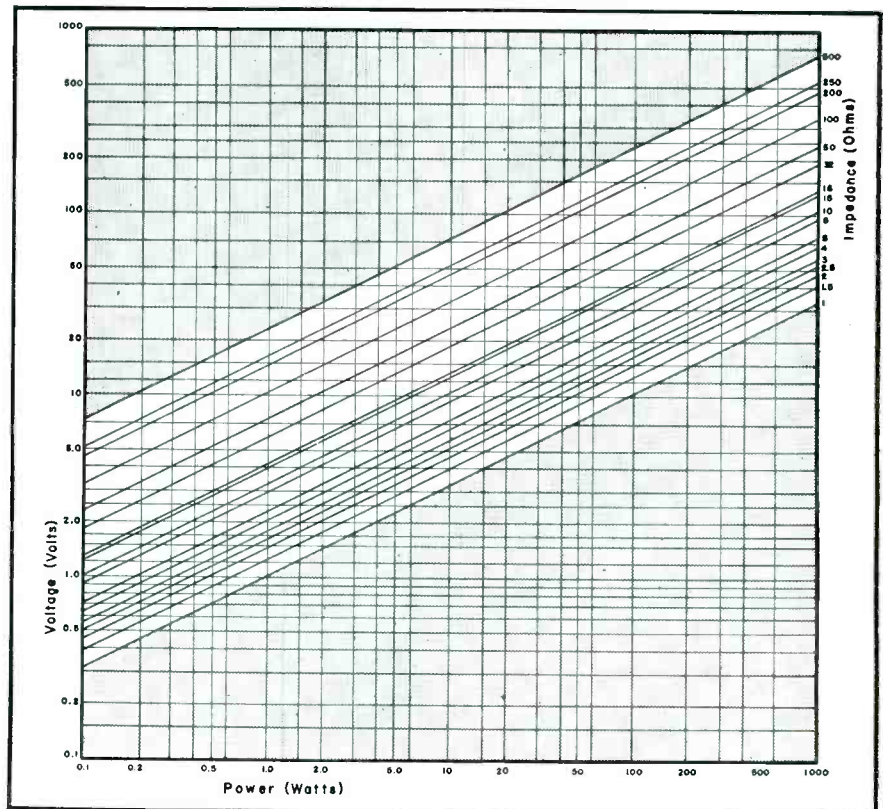
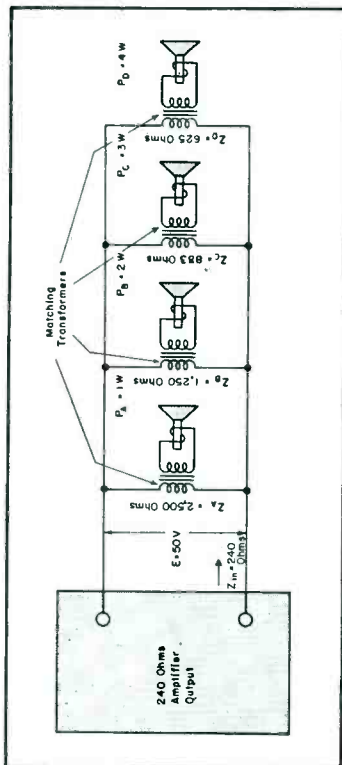

Audio-Video COAX CABLE Applications

by O. LOWENSCHUSS and J. M. SIENKIEWICZ

THE AVAILABLE RANGE of coax cable capacitance, C_0 , is normally small. Thus, to use this cable the final driving stage must be altered to obtain a lower output impedance. This can be accomplished by one of two methods. In the first approach a plate-coupled final amplifier stage can be converted into a cathode-coupled stage; Fig. 1. A conventional plate-coupled amplifier can be modified by removing the cathode bypass capacitor, if any, and connecting the coax cable to the cathode. The second method is to alter the existing plate circuit of the amplifier stage by tapping down on the load resistor or inserting a small resistor in series with the existing plate load resistor, as shown in Fig. 2. The output resistance of the stage is now less than R_2 . One should select the value of R_2 that will give a value of the output resistance required to allow the necessary cable length for a selected coax cable.

It will be noted that both methods trade output impedance for gain; if very low output impedance is required, the gain is materially reduced. If there

is no gain to spare, an additional cathode follower, similar to that described earlier¹, can be constructed.

Typical Example

Let us now apply the principles described to a practical problem, using the circuit shown in Fig. 3 which is representative of the output stage of a commercial variable-reluctance equalizer preamplifier. Since the cathode resistor is bypassed, the output resistance of the triode output stage is nearly equal to 80,000 ohms, which is its plate resistance as shown in the tube manual. The graph, shown in Fig. 4 reveals that not more than 16' of RG-59/U coax cable can be used without causing excessive distortion. Suppose this preamp were to be located in the projection booth of a movie theater, and connected to the power amplifier, mounted near the screen, through a 150-foot RG-59/U coax cable. Reference to Fig. 4 shows that the output

(Continued on page 30)

¹SERVICE; June, 1953.

Fig. 4. Chart designed to permit determination of maximum coax cable length versus effective resistance at 20 kc, allowing 1 db drop only. The 13.5 ± 2.6 mmfd-per-foot cables include RG7/U, RG22/U, RG62/U and RG71/U. In the 28 ± 5.6 mmfd-per-foot category are RG8/U, RG10/U, RG17/U, RG18/U, RG19/U, RG20/U, RG29/U, RG34/U, RG35/U, RG117/U, and RG118/U.

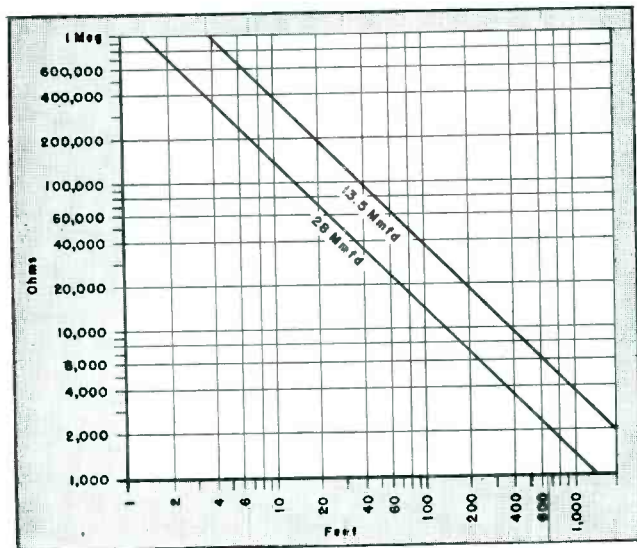
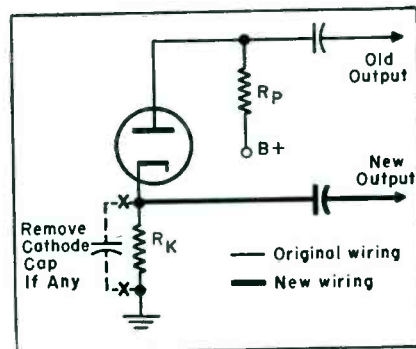
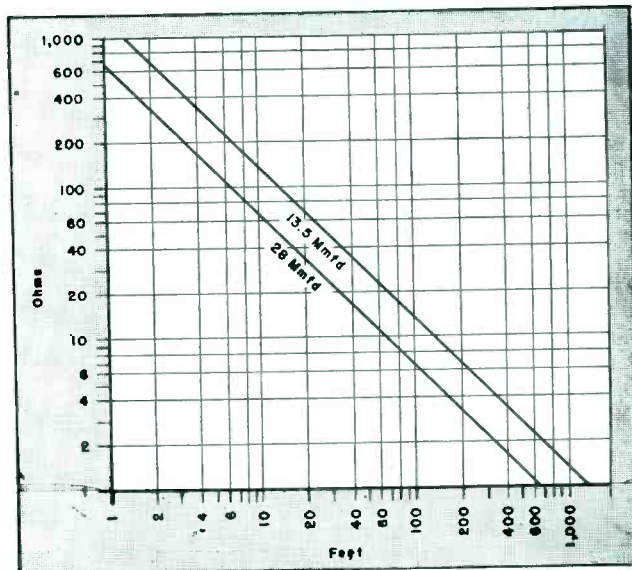
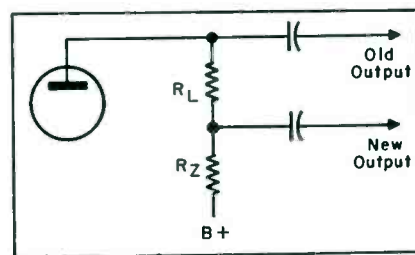

Fig. 5. Coax chart designed to permit evaluation of maximum cable length versus effective resistance at 4.5 mc, allowing 1 db drop only. Same types of cables detailed in Fig. 4 were used in preparing this plot.



(Above)

Fig. 1. Amplifier stage altered to a cathode-driven output stage to lower output resistance.



(Above)

Fig. 2. Plate circuit of a driving amplifier stage altered to reduce output resistance.

(Below)

Fig. 3. Output stage of a typical preamp.

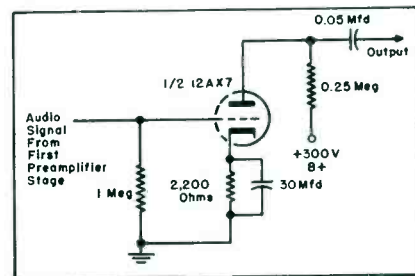

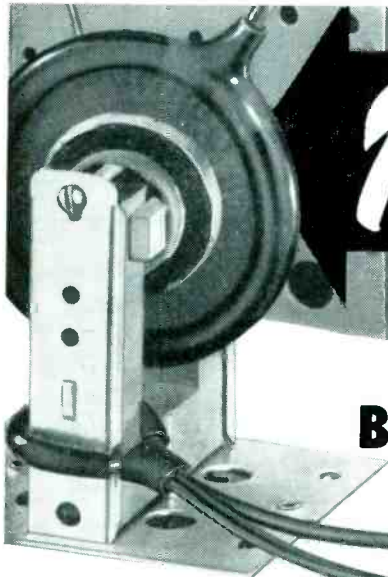

"Better than Originals!"

THIS IS Plaskoil

THE NEW PLASTIC-COATED
H. V. COIL WITH
**4-WAY
BETTER PROTECTION!**

NO INCREASE IN PRICE
FOR THIS PREMIUM FEATURE

FB414, FB415—Above, specific replacements for over 100 Emerson TV Models and Chassis.

More PLASKOIL units now available

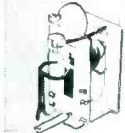

FB412—Specific replacement for 83 Airline, Raytheon, and Truetone models.

FB410—Multi-purpose flyback with AGC winding and universal mounting.

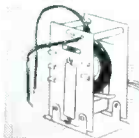

FB401—Widely used G.E. Type replacement flyback.



FB404—Direct-Drive replacement flyback for RCA, Capehart, Emerson, etc.



RF800—Horizontal Width-Linearity Coil with AGC winding.



Halldorson

QUALITY Transformers SINCE 1913

Only HALLDORSON Gives You PLASKOIL!

Loudspeakers

(Continued from page 28)

ferent power ratings (1, 2, 3, and 4 watts) are connected to a 240-ohm amplifier. The primary impedance of each *mt* must be calculated separately by using the $P = E^2/R$ formula. However, before this is done, the voltage across the primaries of the *mts* (which are all in parallel and therefore have the same voltage) must first be found. This voltage can be found through the use of the foregoing formula where E (across the *mt* primaries) = \sqrt{Z} (to-

tal) $\times P$ (total). The total impedance equals Z_{in} , or 2 ohms; the total power equals $1 + 2 + 3 + 4$ or 10 watts. Therefore $E = \sqrt{240 \times 10}$ or approximately 50 v. A good way to check the correctness of the impedance calculations is to substitute them in the following formula: $R = 1/R_1 + 1/R_2 + 1/R_3$. The answer should be 240 ohms.

For guidance, full use should be made of the chart shown in Fig. 3 (p. 28); a plot of voltage versus power, for commonly-encountered speaker impedance values. This graph may be used in place of the $I = E/R$ and $P = E^2/R$

equations. Its application is easily demonstrated by using the earlier example where voltage was calculated to be approximately 50. Looking at the horizontal axis of the graph where $P = 10$ watts, and at the impedance line of 240 ohms (between the 200 and 250-ohm bars) and then studying the left of the chart, where the vertical voltage axis obtains, you will find that $E = 50$ volts.

Coax Cables

(Continued from page 29)

resistance for this cable length should not exceed 8000 ohms.

The output resistance can be lowered by any of three methods:

(1) An additional cathode follower can be included on a preamp chassis.

(2) The cathode resistor can be removed and the final stage operated as a cathode follower. If this is done, and the load resistor is shorted, the output resistance will be about 600 ohms, but the gain will be reduced by about 30 db.

(3) The load resistor can be replaced by a voltage divider of about 100,000 and 8,000 ohms, with the output taken across the 8,000-ohm resistor. In this case, the gain will be reduced by about 24 db.

Coax cable transmission lines, when applied properly, allow one to locate portable and permanent chassis at any convenient point about the home, shop, or on the job. Signal transmission with an absolute minimum of distortion and loss of power can be achieved. Space requirements are also reduced, since chassis can be located in any unused area available.

Piping of music and video programs about the home, restaurants, or elsewhere can be achieved inexpensively and without signal deterioration.

Color TV

(Continued from page 27)

culties, particularly with respect to gassy *if* tubes.

The Y Channel

The Y section of the receiver is similar to the video amplifier found in a monochrome model. However, in this case, the video or *brightness detail* information is fed to the red, green and blue adders instead of directly to the picture tube. This section consists of the 6U8 Y cathode follower and 6U8 amplifiers.

The cathode follower is included to provide a convenient low impedance source of video information, whose

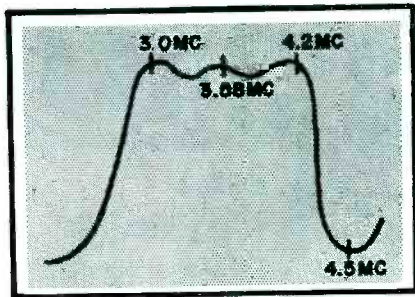

Fig. 4. Chroma channel response.

level may be varied without effecting changes in the tuning or the Q of associated compensating networks or traps. The video signal is obtained from a cathode potentiometer and fed to the first Y amplifier. The cathode pot is ganged with a gain pot in the chroma channel for operating convenience.

The Y channel includes two traps tuned to 4.5 and 3.58 mc, respectively. These frequencies would produce undesirable interference in the picture if allowed to pass through the Y channel. The only unusual component found in the Y channel is a delay line; the chroma or picture color component voltages are delayed approximately .8 microsecond. Consequently, the line was designed to provide a Y delay of similar duration.

The video output voltage from the 6U8 is fed simultaneously to the red, green and blue adders. These adders are resistor networks. Here the Y signal is added to each of the *color difference* signals $R-Y$, $G-Y$ and $B-Y$ to form the red, green and blue components of the picture. The relative gains of the following red, green and blue amplifiers are adjusted so that the picture tube guns are driven with the correct amount of video to provide a black and white picture in the absence of color information.

Chroma Channel

As mentioned earlier, the chroma detector output primarily consists of 3.58 mc and related sideband information as well as 4.5-mc intercarrier sound *if* signal.

Chroma information consists of the *burst* signal and chroma sidebands of 3.58 mc, which are amplitude modulated to convey color saturation and phase modulated to convey *hue*. This signal is fed to a bandpass amplifier. Allied circuitry are aligned to produce response shown in Fig. 4. A 4.5-mc trap is included to reject the sound carrier, which would otherwise produce 920-kc beat effects in the picture. (Should 920-kc beat effects ever cause difficulty, it is easy to determine whether the chroma or Y channel

(Continued on page 54)

LOOK TO THE LITTLE INDIAN  FOR
THE **BIGGEST** VALUE IN
MOLDED PAPER TUBULAR CAPACITORS

the Sangamo

Telechief®



The Telechief will outlive all other tubulars! Major manufacturers' test and stamp of approval prove that

Telechiefs have longer life. They have a final insulation resistance value 10 to 15 times greater than any other paper tubular—because they're molded in HUMIDITITE!



The Telechief outperforms all other molded paper tubulars in moisture resistance... in high temperature operation... in holding its rated capacity under all conditions.



EXTRA VALUE AT NO EXTRA COST! This amazing new capacitor—that meets specifications so tough that no previously existing paper tubular could approach them—is a *premium* tubular at the price of an ordinary one. See your Sangamo Distributor today!

Those who know  choose Sangamo

SANGAMO ELECTRIC COMPANY

MARION, ILLINOIS

SC 54-11

THE *American* IDEA

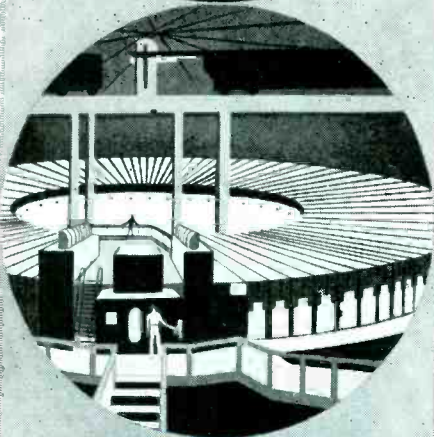

"To find and follow the better way"... Gigantic offspring of the cyclotron, the Bevatron—world's greatest magnet—can send masses of protons hurtling around its 135'-diameter race track at almost the speed of light. "Idea", to penetrate deep into the atomic nucleus, where lie secrets of matter and energy.

With us, the "American Idea" is, by directed effort and applied know-how, to continue to lead in bringing you electronic products of the highest quality.

Complete line of "Full Vision" Microphones
D33 Broadcast
D-22 Public Address

Replacement Phonograph Cartridges

INSIST ON AMERICAN FOR QUALITY
Send for FREE Catalog 47

American microphone co.
370 South Fair Oaks Ave. • Pasadena, 1, Calif.

Rep Talk

EDWARD MILLER, formerly with the Sandia Corp., has been appointed branch manager for the Kittleson Co., Los Angeles, in the Albuquerque, N. M., office at 210 Cagua Dr., NE. Company has been named rep for New London Instrument Co., in California, Arizona, New Mexico and Nevada. . . . *George Davis Sales Co., Los Angeles*, is now rep for the Hallcrafters Co., for communications and industrial radio-telephone equipment, and for Don Good Inc., in southern California and Arizona. . . . The Los Angeles chapter of the Reps has changed the format of its monthly meetings, and will alternate between noon and evening meetings. . . . *William Tauber* has been added to the sales staff of Land-C-Air Sales Co., 42 Oak Ave., Tuckahoe N. Y., and will cover upstate New York jobbers. . . . *Hagerty-Scott Co.*, 10116 Puritan Ave., Detroit, Mich. is now rep for Buxton Industries, in the state of Michigan. . . . For the northwest territory, including Washington, Oregon, Montana and Idaho, Hi-Lo TV Antenna Corp. has named *Frank Wedel Co.*, 3215 Western Ave., Seattle 1, Wash. . . . *Paul Nief Associates* (New England area); *Custom Sound and Vision, Ltd.* (eastern Canada); and *Dick Hyde Co.* (Inter-mountain and Rocky mountain territories), have been appointed reps for Berlant Associates. . . . *Fred I. Tourtelot Co.*, 407 S. Dearborn St., Chicago, Ill., is now rep for Cal-Tronics Corp., in northern Illinois, northern Indiana, and southwest Michigan. . . . *Brach Manufacturing Corp.* has named *Robert Harris* as rep for the New York state territory, except metropolitan New York City. . . . *Louis D. Cohen*, 2630 S.W. 22nd Terr., Miami, Fla. (Cuba and Puerto Rico); *Gene Piety*, 2030 Home Rule St., Honolulu, Hawaii (Hawaii); and *Roger Minthorne*, 7521 N.E. Glison St., Portland 16, Ore. (Washington, Oregon, Idaho, Alaska and British Columbia), have been named reps for iE Manufacturing. . . . *Burt F. Homsher*, 2018 Jessie Ave., Ft. Wayne, Ind. (Indiana), and *William M. Linz*, 7115 N. Mobile Ave., Chicago, Ill. (Illinois), have been appointed wholesale distributor reps for the Astron Corp.

Newly-elected board of governors of The Reps (seated, left to right): M. K. Smith, Atlanta; Leroy Beier, Chicago; Russ Diethert, Chicago (subsequently elected chairman); and R. W. Ferris, Kansas City. Standing, left to right: B. C. Landis, New York; Walter T. Hannigan, Boston; W. S. Trinkle, Philadelphia; and Mose C. Bramum, Dallas. Ninth board member, Norman B. Neeley of Los Angeles, was not present for the photograph.



PHALO



Radio Television & Communication Wires & Cables

RADIO - TELEVISION WIRE

300 OHM LEAD

TRANSMISSION LINE CABLES

MICROPHONE CABLES

INTERCOMMUNICATING & PUBLIC ADDRESS CABLES

INDOOR AERIAL WIRE

ROTOR CABLES

CORD, CORD SETS & POWER SUPPLY CORDS

PHALOTel
PHALOTran
PHALON
PHALOCora
PHALOlord

Quality Products for Quality Results!

Complete catalog on request!

PHALO **Plastics Corp.**
25-3 Foster St.,
Worcester, Mass.

PERSONNEL

ALLEN J. DUSAULT has been appointed sales manager for the transistor division of CBS-Hytron, Danvers, Mass.



Allen J. Dusault



Herbert Jacobs

HERBERT JACOBS has been named general manager of Jerrold Electronics Corp., Philadelphia, Pa.

RALPH L. WEBER, secretary, is now executive vice president; BURT ANDERSON, vice president in charge of sales, and FRED R. COOPER, vice president in charge of engineering, for the Gramer Transformer Corp., Chicago, Ill.



Ralph L. Weber



Marshall L. Remund

MARSHALL L. REMUND has become jobber sales manager of Jensen Industries, Inc., 329 S. Wood St., Chicago, Ill.

JOSEPH ROCHE is now publications manager for the service department of CBS-Columbia, 3400 47th Ave., Long Island City 1, N. Y. ROCHE previously held a similar position with Allen B. DuMont Labs, Inc. . . . DANIEL NEWMAN is now assistant director of service.

DONALD H. ROGERS, formerly chief engineer of Blonder-Tongue Labs, has joined the engineering department of Jerrold.

THOMAS C. SOBY has been appointed advertising and sales promotion manager of the Allen D. Cardwell Electronics Productions Corp., Plainville, Conn.

PETER BUTTACAVOLI, technical supervisor of the Teleset service department, has been appointed manager of field technical services of the Allen B. DuMont Labs, Inc., Clifton, N. J.

EDMUND L. BATAILLE has been named sales manager of The Winslow Co., Inc., Newark 5, N. J.

WILLIAM EDWARDS, formerly associated with Utah Radio Products and Crescent Industries, has joined the staff of Oxford Electric Corp., Chicago, Ill., as a sales engineer.

JAMES R. BUTLER has been appointed director of advertising and sales promotion for Magnecord, Inc., Chicago, Ill. Butler was formerly with Raytheon Manufacturing Co.

ATR INTRODUCES

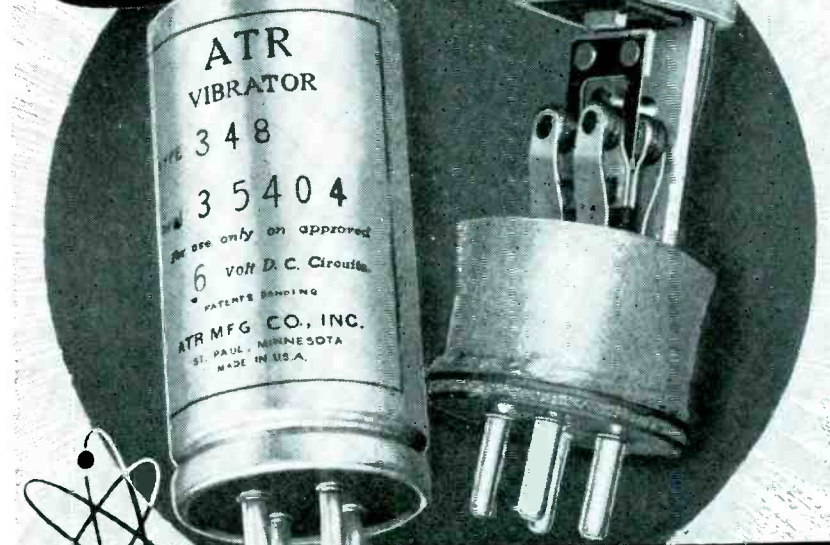

The World's Finest Communication VIBRATORS

featuring:

- CERAMIC STACK SPACERS
- 1/4" DIAMETER POWER CONTACTS
- DRIVER-TYPE COIL CONSTRUCTION
- SPECIAL REED HINGE and WIRING
- POWER CAPABILITY UP TO 15 AMPERES

A COMPLETE LINE OF REPLACEMENT

ATR VIBRATORS

FOR AUTOMOTIVE, HOUSEHOLD and TWO-WAY COMMUNICATION SETS

ATR VIBRATORS are proven units of the highest quality, engineered to perfection. They are backed by more than 23 years of vibrator design and research, development and manufacturing. ATR pioneered in the vibrator field.



FREE - Just off the Press!
1954 ATR VIBRATOR MASTER MANUAL

See your jobber or write factory today for complete information



AMERICAN TELEVISION & RADIO Co.

Quality Products Since 1931

SAINT PAUL 1, MINNESOTA - U. S. A.

High Masts and Towers

by JACK DARR



Survey truck with antenna which can be raised up to 70 feet to receive and test signal strength and other data recorded on test receiver shown on ground. (Courtesy RCA)

IT HAS BEEN FOUND that one man can install even fairly high towers on flat roofs. Peaked roofs almost always require two or more men. On flat roofs, the following installation method has been used. Two sections of a tower should be assembled and bolted to the base. Guy wires can then be fastened to the top of this section, temporarily pushed up into place. The lengths of the guy wires needed for this section can then be determined. The tower can then be lowered, the two back guys fastened, and the top 12' of the tower bolted in place with the top guys fastened and looped around the tower, to keep them out of the way. The whole tower can then be pushed up, and, holding to the front guy, temporarily guyed in place. It can then be guyed, plumbed, and the top guys tightened. The mast section holding the antennas can be installed while it remains still on the roof. The antennas can then be installed by climbing the tower and dropping them

into place on the mast; finally the leadin can be run down the sides.

If roof conditions permit, *solo* installations of this type may be made on the shorter masts. Two guys on one side should be measured, fastened temporarily into place, and the mast then raised, and held by the other guy wire while it is fastened. The two-man job would be much faster, of course.

If an antenna should fall down, either due to strong winds or some mechanical failure, repair is possible. Spare parts for most popular makes are available at distributors; the soft aluminum used for the antenna elements can be straightened out. If the elements are broken then replacement will be necessary. In an emergency one must become very resourceful. When the main boom on one antenna broke recently, repair was effected by sawing a piece of thin-wall tubing down the center, making two half-cylinders. These were then bolted through the boom.

The quality of workmanship is extremely important in tower-mast work. Taller masts and towers are much more difficult to erect and maintain than the smaller types. Therefore, every bit of material and *workmanship* which goes into an installation must be evaluated carefully. The omission of even such a small item as a soldering lug or a standoff insulator may cause one to spend an unhappy and unprofitable half-day, lowering and re-raising an extremely tall tower, to replace a broken leadin wire. On those *Long-John* type yagis, the point of leadin attachment is around four or five feet from the mast. It has been found that usually at least two standoffs should be used between the antenna and the mast; if the leadin is firmly fastened here, the likelihood of wind flexing and breakage will be greatly reduced.

When installing open-wire line down the mast and the side of the house, one should use standoffs at least every ten feet. This type of line should be pulled and held taut. Although most of it is

(Continued on page 49)

Dual leadin wires from a dual antenna installation anchored to wall with woodscrew standoffs. A small hole bored in the wall with masonry bit can be plugged with wooden dowel, and standoff screwed into wood.

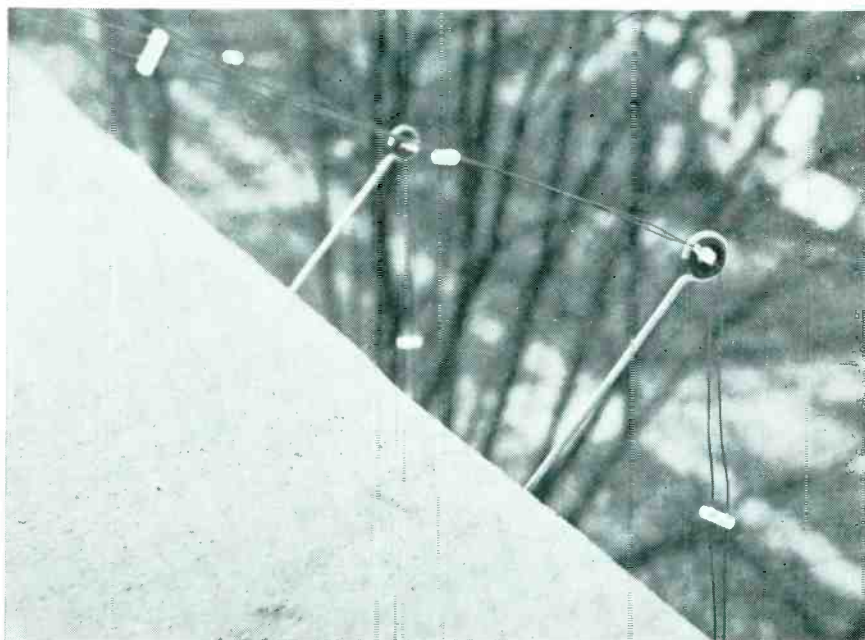

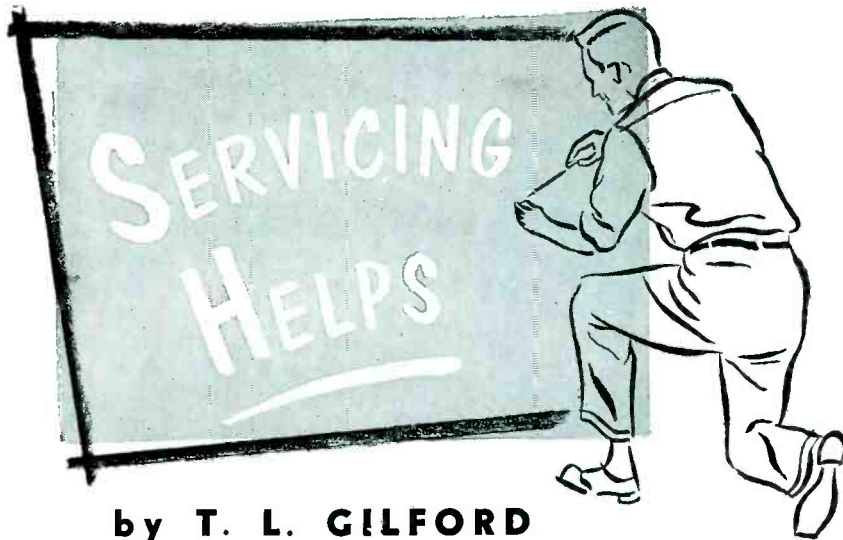

by T. L. GILFORD

Peak-to-Peak Measurements ‡

MOST TV MANUFACTURERS include waveforms at all test points on schematics. Peak-to-peak values are offered along with these waveforms to indicate their amplitude. This information is very helpful since it is often possible to view the proper waveshape on 'scope and yet the receiver could be defective because the waveform amplitude is insufficient.

Peak-to-peak measurements are invaluable when servicing gated *agc* and gated sync separator circuits, and there are many different types in use today. Color receivers employ as many as five and six separate gated circuits and they too demand equipment that make it possible to determine pulse amplitude.

Just how does one measure peak-to-peak voltages? A 'scope calibrator or a *vtvm* especially designed for the job must be used. A conventional *ac* voltmeter can't be used because it serves to measure voltages of a sine wave nature only.

Typical Waveforms

Let us now study a few typical waveforms and their values. In Fig. 1a we have a sine wave which measures 117v on an *ac* meter, but it is 328v from one peak to the other. This relationship always holds between the peak value and the *rms* potential in a sine wave; the peak-to-peak value is 2.8 times the *rms* reading.

When a waveform of a different nature, such as one finds in a TV receiver, is encountered, this relationship does not hold. If, for example, a waveform like the one shown in b is in question, a reading with an *ac* meter would be very misleading. This waveform is similar to the plate waveform

on gated *agc* tubes and measures 300 v peak-to-peak. An *ac* meter which measures the average voltage, would measure in the vicinity of 10 v.

The composite video waveform shown in c cannot be measured without a peak-to-peak instrument. Here the *dc* level varies with background illumination and any reading on either an *ac* or *dc* device cannot be evaluated.

Thus it becomes quite evident that some type of peak-reading device should be used to expedite servicing of any tricky circuits.

Different Types Available

Peak-to-peak measurement circuits are available in some *vtvms*, the circuit being similar to that shown in d. The measured waveform is applied here to capacitor C_1 which charges to peak value through the diode. During pulse intervals, capacitor C_1 discharges slightly through R_1 . As long as R_1 and C_1 have a time constant of at least ten times the period of the applied waveform, the capacitor will stay charged at very near its peak value. To read the peak value in the opposite polarity, the diode can be reversed.

System Limitations

Normally, when this method is used, the input capacity is quite high and the *vtvm* will load tuned circuits. Also, one will find that high frequencies suffer and do not register when measuring the composite waveform. Usually we are interested in reading amplitudes when viewing a waveform on a 'scope,

‡From an exclusive report prepared by Ron Tinsley, Service Instruments Company.

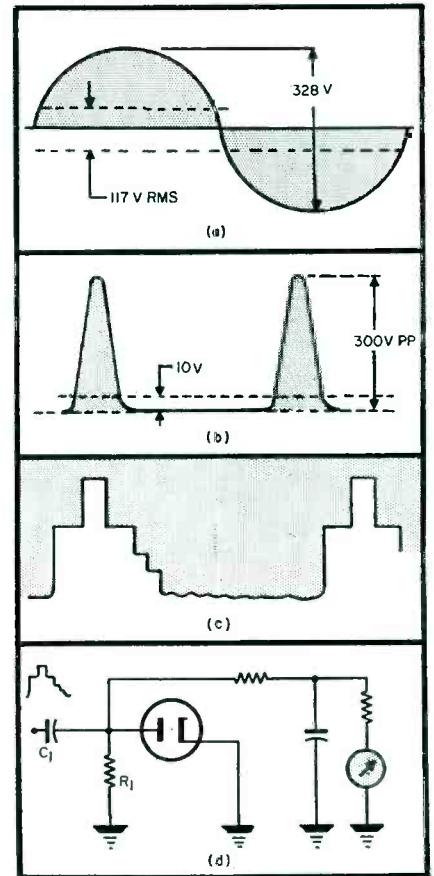

Fig. 1. In a is a typical sine-wave waveform with both *ac* meter and peak-to-peak values shown. Waveform in b appears on plate of a gated *agc* tube. A composite video waveform is shown in c. In d we have a peak-to-peak measurement circuit included in some *vtvm* instruments.

and one does not mean much without the other. If a *vtvm* is used, it becomes necessary to change from the 'scope to the *vtvm*, and so on. Certainly *vtvm* peak-reading devices have their place in home service, etc., but they do have the foregoing limitations.

Another instrument that can do a very accurate job and is very practical is a 'scope voltage calibrator which squares the 60-cycle line voltage and calibrates it. The unknown waveform is applied to the 'scope and then the calibrated voltage is adjusted to fill the same space on the 'scope. In

(Continued on page 55)

Peak-to-peak comparison meter which provides a calibrated sine wave that is compared in amplitude to an unknown waveform.

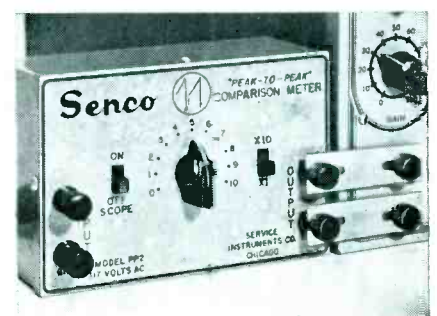

Techniques for Tying Separate Bands to Single Line

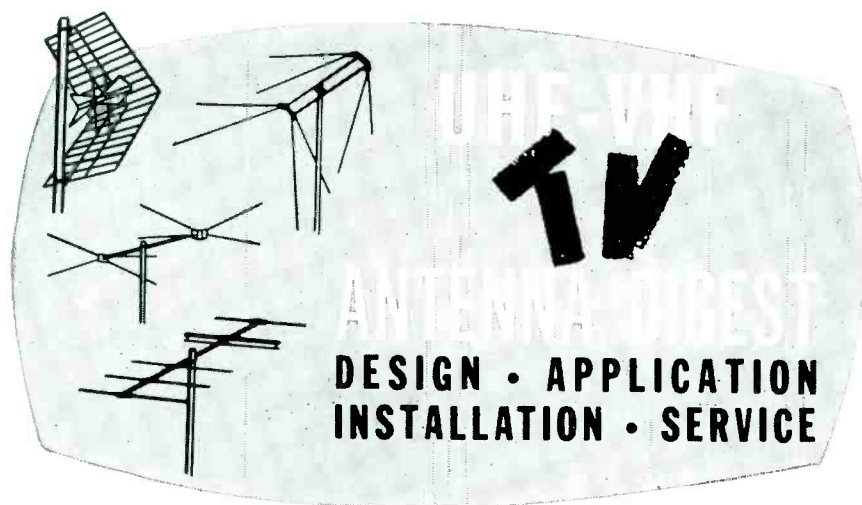

by **SAM SCHLUSSEL**, Channel Master Corp.

INTERACTION FILTERS, analyzed last month, were described as filter networks which permit antennas operating on different bands to be combined into a single transmission line.

It was pointed out that two basic types of circuits can be employed in devices of this type: Parallel-resonant circuits and high-pass and low-pass filter circuits. The report also disclosed that parallel-resonant circuits have inherent shortcomings:

(1) Leads must be cut to a specific length to obtain efficient operation on *vlf*; otherwise, an impedance mismatch results.

(2) This type of circuit is not efficient on *uhf* because it cannot be designed with sufficient bandwidth.

Interaction filters employing high and low-pass circuits have been found to overcome both of these difficulties and accordingly it is this type of cir-

cuit that is being used in a number of current filters.

There are three basic types of interaction filters presently available, each designed to cover specific installation situations. They are:

(1) Filters combining one high band and one low band *vlf* antenna.

(2) Filters combining one *uhf* with one *vlf* antenna.

(3) Filters combining one *uhf* antenna with one high-band and one low-band *vlf* antenna.

VHF and UHF Filters

One unit can be made to combine a *vlf* high-band and a *vlf* low-band antenna by designing the cut-off frequency at approximately 125 mc¹.

In such a filter, the low-pass section will pass all frequencies below 125 mc, and the high-pass section will pass all

frequencies above 125 mc. (One must remember that the low band ends at 88 mc, and the high band begins at 174 mc.)

Then we have the *vlf-uhf* filter which has been found to have the advantage of unlimited bandwidth, and does not require any specific lead lengths.

One can also use the high- and low-pass filter as a highly efficient unit to combine a *uhf* and *vlf* antenna into one leadin. This can be done by designing the cutoff frequency to be somewhere between 216 mc (the end of the *vlf* band) and 470 mc (the beginning of the *uhf* band).²

In areas where all three TV bands are received, and where separate antennas are required for each band, both of the foregoing types of filters can be combined into one unit joining all three antennas to a single transmission line.³

Although these filters have been in general use for some time, to our knowledge no detailed discussion of the installation techniques required for all three types has ever been offered. Many are for the first time encountering the problem of tying together antennas, operating on different bands, into a single transmission line system.

It is recommended that, to eliminate the possibility of interaction between high and low-band *vlf* antennas, they be spaced at least one-quarter wavelength apart on the low band. The *vlf* hi/lo-band filter can be used to

¹Channel Master *Tenna-Tie* is representative of this type of filter.

²Channel Master *Ultra-Tie*; cutoff frequency is 325 mc.

³This type of filter, such as Channel Master *Triple-Tie*, combines one *vlf* low-band antenna, one *vlf* high-band antenna, and one *uhf* antenna into a single transmission-line system.

(Continued on page 54)

Left to right: At left is a vhf interaction filter. In center, an interaction filter for combining one vhf and one uhf antenna. At right is an interaction filter for combining up to two vhf antennas with one uhf antenna.

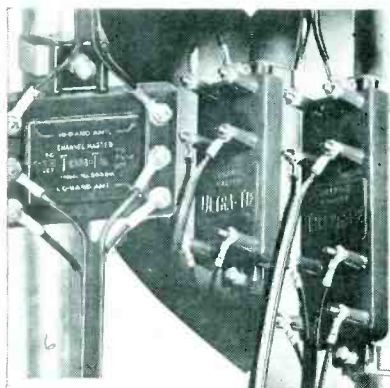

A vhf yagi and uhf bow-tie joined with an interaction filter and used with single transmission line.

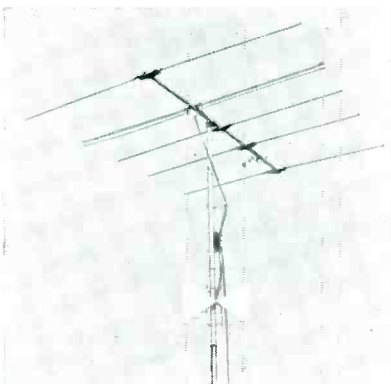

A high-band vhf and low-band vhf yagi tied to an interaction filter for use with a single lead.

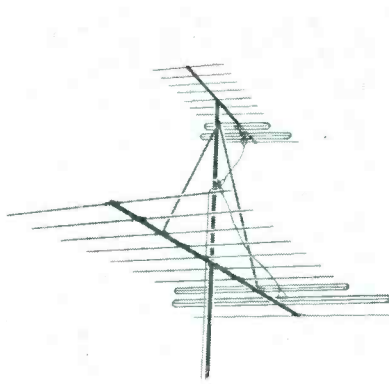

Antennas, Converters and Towers for UHF and VHF

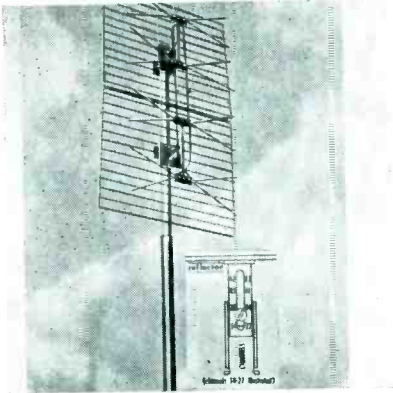

UHF fringe antenna featuring a calibrated slide between dipole and grid reflector (inset photo) that is said to permit one to regulate distance between bowtie dipoles and grid reflectors. The uhf channel numbers are shown at each calibration, indicating fractional wavelength distance between dipole and reflector that will peak a particular point in the uhf band. (Model 4-Bow; JFD Manufacturing Co., Inc., 6101-16th Ave., Brooklyn 4, N. Y.)



All-channel uhf converter which can be installed behind, on either side, on top of, and, in the case of certain table models, below TV set. Dial and switch are positioned on top. Switch is of the button type. Converter provides continuous type tuning. (Model 66; General Instrument Corp.)



Self supporting tower, 3' tall, that it is said will receive any size mast. Shown with tower, displayed at recent Parts Show in Chicago, are Roy A. Lake, vice-president and general manager, and W. R. Jontz, president of Jontz. (Model 300; Jontz Manufacturing Co., 1101 E. McKinley Ave., Mishawaka, Ind.)

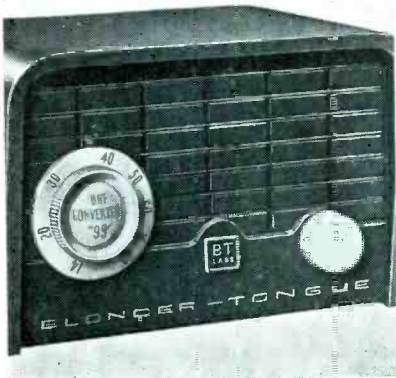

Uhf converter for class A signal areas, with tuned input which tracks with oscillator, eliminating spurious response and suppressing radiation. Oscillator circuit is said to be thermally compensated for drift-free operation. Has 6T4 tube, crystal diode mixer, and selenium rectifier. (Model 99; Blonder-Tongue Laboratories, Inc., 526 North Ave., Westfield, N. J.)

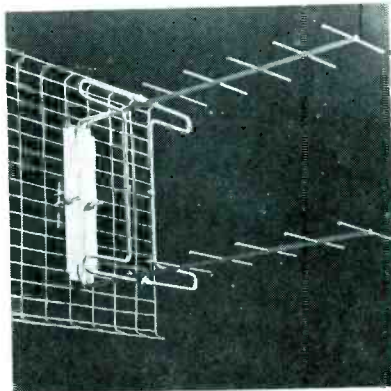

Broad band uhf antenna utilizing stacked folded dipoles as driven elements with five directors for each dipole, backed by a screen. Constructed of solid aluminum elements and cadmium-plated screen. Terminals use air spacing. (Model U-204 Ultra Telecon; Teletenna Co., 1033 Indiana Ave., LaPorte, Ind.)



Uhf converter with two control knobs; one for selector-power and the other for high-ratio tuning of slide-rule tuning dial. Has two-cavity coax tuner, which covers the uhf band continuously, and preselection. Available in either mahogany or blond finish. (Model LCU-A; Granco Products, Inc., 36-17 20th Ave., Long Island City 5; N. Y.)

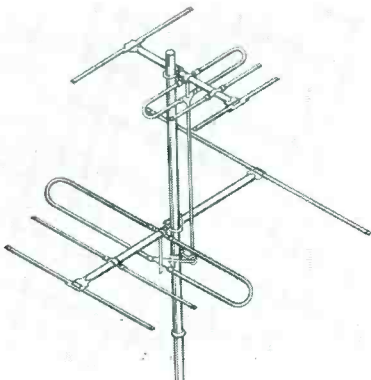

(Left)
Separately orienting broad-band yagi designed for twelve vhf channels. Comes pre-assembled. Also available as separate arrays. (Model RM-218, and models RS-206 (10-band) and RS-713 (hi-band); Radelco Manufacturing Co.)

(Right)
Dual corner uhf reflector, with all-metal insulators. Dipole is supported directly by mast; reflector is constructed entirely of horizontal elements. Antenna mounts in front of mast. Has half-wave dipole spacing. (Model US-152; Radelco.)

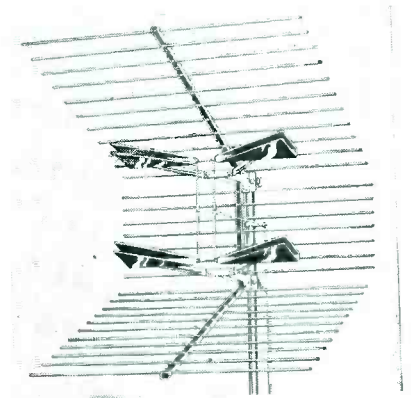

BIAS Circuitry in Hi-Fi Amps

Cathode-Biasing Systems Used to Provide DC Heater Current . . .

Faulty Bias Symptoms and Cures

by **MARK VINO**

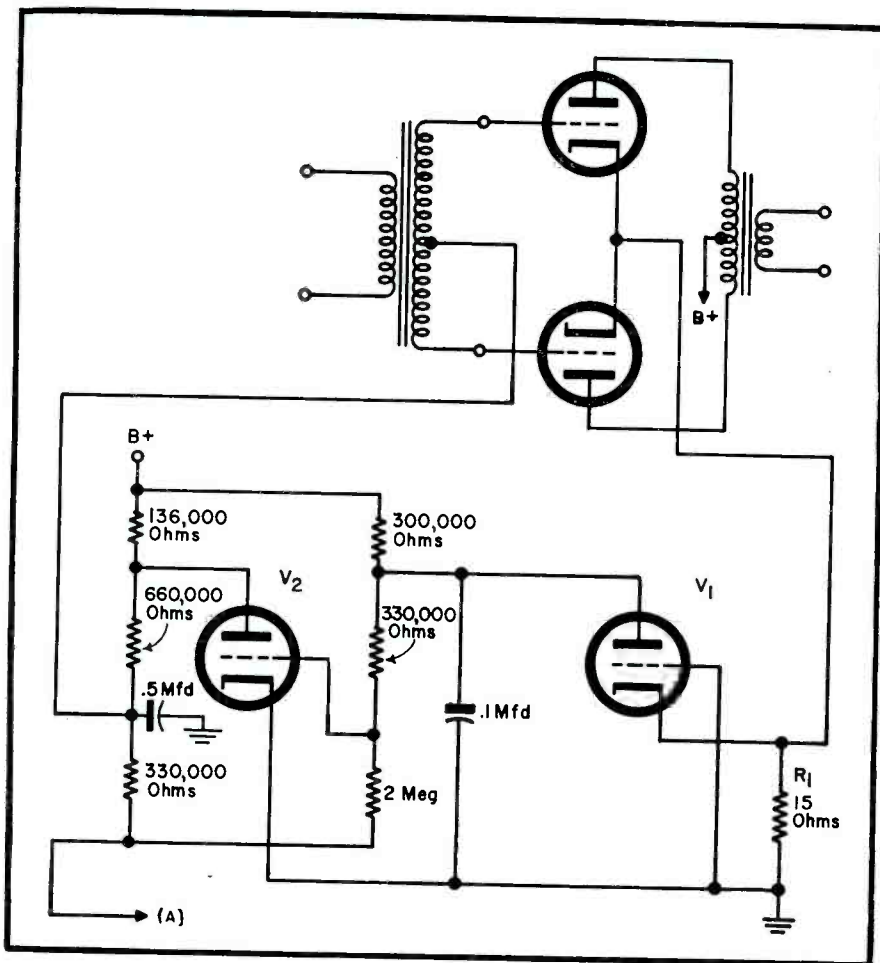
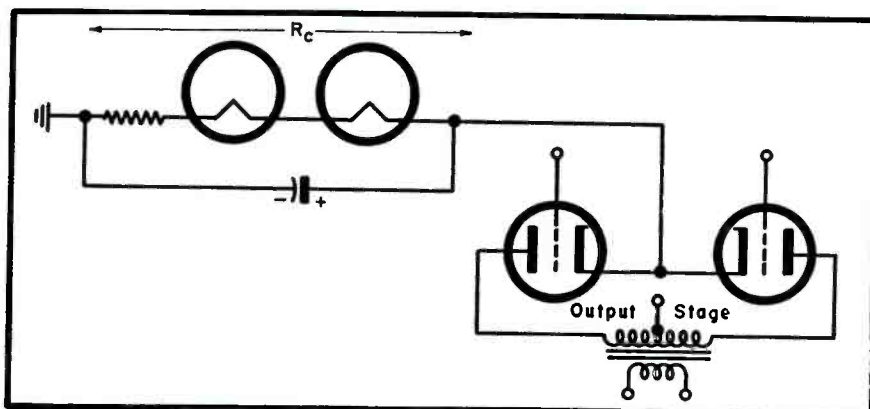

Fig. 1. Basic circuit providing automatic bias control. In the Brook amplifier, push-pull cathode followers are inserted between the input transformer and output stage. The A lead is connected to plate of separate rectifier.

Fig. 2. Low-level heaters supplied with dc cathode current, eliminating hum from heater-to-cathode leakage in the tube.



IT IS POSSIBLE to bias an amplifier with an automatic control system. One such circuit for output stages has appeared in recent years¹; it operates from a separate voltage source, as in fixed-bias circuits, but it varies the bias voltage to provide optimum operation at different power levels. The circuit¹ shown in Fig 1, provides class A operation up to about 5 watts, after which there is a gradual transition to class AB₂, at 30 watts. The bias voltage on the output stage is dependent on the plate current flow through V₂, which in turn is controlled by the amplitude of the output signal current through R₁. (The voltage drop across R₁ is injected as a signal between grid and cathode of V₁.)

Direct-Coupled Bias

In direct-coupled circuits the plate voltage of one stage is applied directly to the following grid. This must be counterbalanced by a slightly higher positive voltage between cathode and the grid return, leaving the final grid potential negative with respect to cathode. A common application of this principle is in the first voltage amplifier and cathode-loaded phase-splitter of the Williamson amplifier.

Cathode Bias Circuits to Provide DC Heater Current

The current flowing in the cathode-bias resistor of a pair of output tubes is often about 150 mils; the value of current needed for most 12-volt heaters and certain 6-volt heaters. One can take advantage of this by inserting the heaters of the lowest level stages (preamps low-level voltage amplifiers, etc.), in series with the output stage cathode line, as illustrated in Fig. 2.

The problem of hum pickup from these heaters is thereby eliminated, since the heaters are being operated on *dc* instead of *ac*. The *dc* source of heater current is absolutely free, as the output cathode current has to flow whether or not it is used for heaters, and one saves all or part of the price of a high-wattage cathode resistor.

The circuit of Fig. 2 sometimes comes in handy when installing a pre-
(Continued on page 57)

¹Used in the Brook amplifier.



A first PERFORMANCE

Introducing the longest line of replacement loud speakers with the lowest inventory requirement.

The highest performance in replacement loud speakers at the lowest cost.

THE NEW Viking Replacement Speakers by JENSEN.

Completely redesigned for all today's requirements, the new Viking speakers are completely streamlined both for stocking, selling and performance. Viking is the most complete line for radio, TV, replacement and general purpose applications—there are 13 models including 3 ovals

BUT

because of the ingenuity of the Jensen design, you need only one universally applicable model in each speaker size. Your inventory requirements are lower than for any other speaker line—your stock investment is cut to the bone.

And the Viking speakers are universal. The new Viking design is the most compact, has the least depth of all the replacement speakers. They'll fit into even the most crowded sets. And with the most compact design Viking has introduced greatly improved efficiency, heavier magnets, truly permanent alignment, at no increase in price in all models 6" and smaller.

Free with all sizes from 3" to 6" Viking speakers new free, easy-mount combination transformer and chassis mount bracket.

Jensen

MANUFACTURING COMPANY

Division of The Muter Company

6601 South Laramie Avenue • Chicago 38, Illinois

In Canada: COPPER WIRE PRODUCTS, LTD., Licensee

SER-CUITS

[See Front Cover]

12-Position Channel 2-to-83 Turret Tuner With RF Amp and Tube Mixer †

THE ADVENT of commercial *uhf* TV broadcasting introduced numerous problems, particularly in the design of a tuner which could operate over the wide range of 50 to 900 mc for low and high-band use.

Recently, a solution was found in a 3-tube unit¹ featuring a novel turret switch. In the circuit, a 6T4 is used in the local oscillator, which functions on the fundamental and above signal frequency on all channels, an important factor, since allocations are based on this standard to lessen interference problems.

The oscillator is of the ultra-audion type; found to be very stable at all frequencies. Voltage requirements were not found to be critical; B+ varies from 10 ma on channel 2 to 28 ma on channel 83. Optimized injection is said to be assured with link coupling fed in at the cathode of the mixer, using a 6AN4 mixer-amplifier tube to

achieve conversion gain, rather than loss, found to be the case with crystals.

The *rf* amplifier employs another 6AN4, connected in a grounded-grid circuit, resulting in a gain of 6 db at channel 83. The *vhf* performance of this tube has been found to be equal to cascode type front ends currently used in *vhf* tuners.

In the past, it was opined, that the cross-modulation characteristics of the 6AN4, when used in grounded-grid circuitry, would prove to be very poor. However during a test in a tube plant lab, it was found that the cross-modulation factor of the tube was better than in crystal-type tuners. One does not deny that it is possible to obtain lower noise factors in crystal-type tuners with the use of selected crystals; but it has been found that many of the absolute noise measurements are purely academic and can not be taken at

their face value. Many other factors such as impedance match, tracking and tuner insertion loss etc., must be considered.

A maximum of twelve channels can be inserted into the turret assembly of the tuner. Grouping is optional in accordance with local requirements. The channel segments, consisting of a set of three which fit into the oscillator, *rf* and antenna section of the tuner, contain the proper lumped *l-c* combinations, pretuned to a specific channel frequency. The antenna segment contains L_{40} and C_{40} which are series resonant with the input of the *rf* amplifier and are coupled through L_{41} to the antenna. The *rf* segment contains a double-tuned transformer (L_{21} , L_{20} and C_{20}) which couples the output of the *rf* amplifier to the input of the mixer. The oscillator segment contains the frequency-determining resonant circuit, L_{20} and C_{20} , and inductor L_{21} , which primarily serves as the local oscillator feed (link coupling) to the mixer.

The difference between the *vhf rf* and the *uhf rf* segments are merely in the method used to reduce the tube loading of the resonant circuits involved. Because of the large frequency range required for complete coverage of the present TV spectrum, it was found necessary to incorporate both inductors and capacitors in the segments. By changing the values of these inductances and capacitances mounted on the segments, full coverage was found possible and complete control of bandwidth, gain etc., was maintained. Thus each channel could be optimized and no wide-range compromises made.

Physically the turret assembly, on which the segments mount, consists of

(Continued on page 42)

Circuit of Anchor TV-900 12-position turret tuner capable of receiving any channel from 2 to 83. Unit features *rf* amplification plus a tube mixer operating in the veryhigh and ultrahigh bands. (See Cover.)

¹Anchor Radio model TV-900.

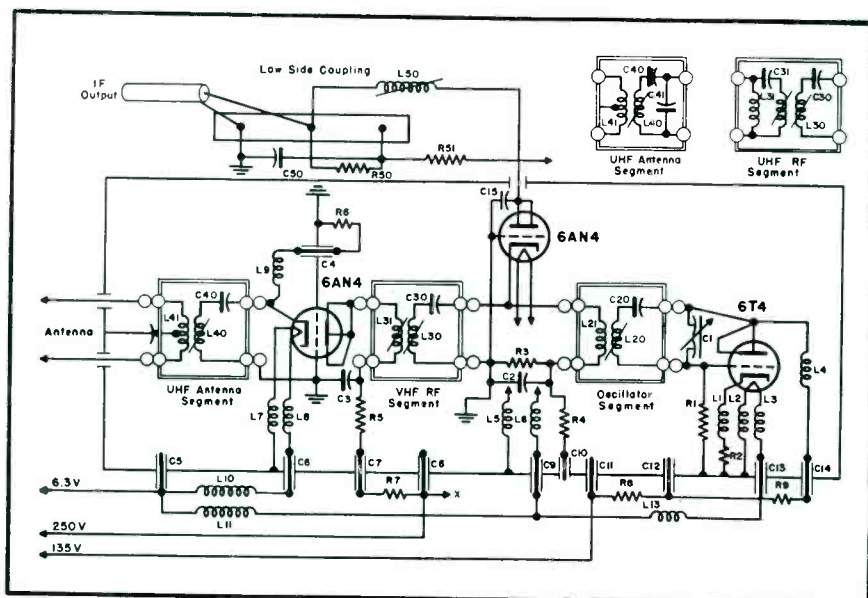

†From exclusive information supplied by William Claps, chief electronics engineer, Anchor Radio Corp.

NOW AT LAST...

A Reliable, General-Purpose 5" OSCILLOSCOPE

Priced
at Only \$12750



The NEW **PRECISION** MODEL **ES-520**

The new ES-520 is **PRECISION**-engineered in response to long and growing demand for a reliable, factory-made, general purpose 'scope at a price within reach of all to whom initial investment is of extreme importance.

The ES-520 conforms to every **PRECISION** standard of quality, workmanship and performance. It is a completely factory-engineered, factory-wired and factory-calibrated instrument... ready to go to work for you the moment you take it out of its carton!

SPECIFICATIONS

- ★ Push-Pull vertical drive. 20 millivolts per inch sensitivity.
- ★ 3-Step, frequency-compensated, vertical input attenuator.
- ★ Vertical frequency response 20 cycles to 500 KC within 2 DB
- ★ 1 volt, peak-to-peak, built-in vertical voltage calibrator.
- ★ Excellent vertical square wave response from 20 cycles to 50 KC.
- ★ Push-pull horizontal drive. 50 millivolts per inch.
- ★ 'H' frequency response 20 cps to 200 KC within 3 DB (at full gain).
- ★ Internal linear sweep 10 cycles to 30 KC. Neg. and pos. sweep sync.
- ★ Tube Complement: 12AU7 'V' cathode follower and amplifier, 6C4 phase-splitter, 12A27 push-pull 'V' drive. 6AB4 'H' amplifier, 12A27 push-pull 'H' drive. 12AU7 sweep oscillator. 6X4 rectifier, 1V2 high potential rectifier, NE-51 calibration regulator, 5U1 CR tube.
- ★ Built-in 60 cycle sine-sweep phasing control.
- ★ Beam modulation input terminal at front of panel.
- ★ All 4 deflection plates directly accessible at rear.
- ★ Filter-type, removable calibrated graph-screen.
- ★ Etched, anodized, heavy gauge aluminum panel.

SERIES ES-520: In black ripple finished, rugged steel cabinet, 8¼ x 14½ x 16½". Complete with all tubes, including 5U1 CR tube. Comprehensive instruction manual. Code: Quest. Shipping weight: 30 lbs. Net Price: \$127.50.

... and STILL THE LEADER IN ITS FIELD
for performance, versatility and value —
the popular **PRECISION**



ES-500A HIGH SENSITIVITY WIDE-RANGE 5" OSCILLOSCOPE

The famous ES-500A incorporates advanced engineering features and refinements so necessary to meet the more critical needs of modern electronic circuit analysis, AM, FM and TV.

SERIES ES-500A: in louvered, black ripple-finished, heavy gauge steel case, 8¼ x 14½ x 18". Complete with removable light shield, calibrating mask and detailed instruction manual. Net Price: \$173.70



PRECISION Apparatus Company, Inc.
92-27 HORACE HARDING BLVD., ELMHURST 6, N. Y.

Export Division: 458 Broadway, New York 13, U.S.A. Cables: Morhanex
Canada: Atlas Radio Corp., Ltd., 560 King Street W., Toronto 2B

there is
a correct
CORNELL-DUBILIER

REPLACEMENT*
VIBRATOR

for every
original equipment
vibrator made

all you need is C-D

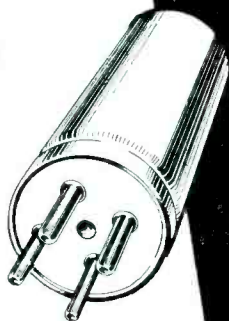

*ask your distributor for your "C-D VIBRATOR GUIDE"



CONSISTENTLY DEPENDABLE

CORNELL-DUBILIER

SOUTH PLAINFIELD, NEW JERSEY



ROTORS • CAPACITORS • VIBRATORS • ANTENNAS • CONVERTERS

(Continued from page 40)

two separate turret sections, mechanically coupled together but electrically shielded from one another by means of a metal partition which form two complete cavities within the tuner housing. The front cavity houses the oscillator turret in which the oscillator segments are placed. The back cavity contains the amplifier turret on which the *rf* and antenna segments are installed. The metal partition separating these two cavities tends to reduce oscillator radiation to a minimum. To further aid in controlling oscillator radiation, a multiple section power

lead filter system was included; C_{12} , R_8 , C_{13} , R_9 and C_{14} .

The fine tuning capacitor, C_1 , consists of two cylindrical plates connected to the grid and plate leads from the 6T4 and a gold-coated mica plate which is moved to and away from the cylindrical plates to change the capacity between the oscillator grid and plate circuitry. Mechanically this is accomplished by means of a cam mounted outside of the tuner housing and rotated with the fine tuning shaft.

The TV signal, be it *vhf* or *uhf* is coupled by L_{41} to L_{40} , which is pre-tuned with C_{40} , and the input imped-

ance of the *rf* amplifier, to a specific channel frequency. Since the input of the grounded-grid amplifier is on the order of 100 ohms, the loading effect of the tube is controlled by the size of C_{40} . The smaller the capacity, the less the loading effect. Beginning with channel 14, the loading effect is further reduced by the addition of C_{41} . The self bias and plate current is fed through L_6 with R_6 and C_4 cathode-bias resistor and bypass capacitor. The *rf* amplifier is thus shunt fed.

No *agc* connection is provided, mainly because of the difficulty in obtaining an *rf* ground at the grid of the amplifier over the complete frequency range. However, in this type of tuner, overloading, which normally occurs without *agc*, first shows up in the mixer due to the gain of the amplifier. Now, when the signal level approaches the oscillator-injection level, the output of the mixer will no longer increase proportionally to the signal increase. Distortion of the signal is further minimized because of the low input impedance of the grounded-grid amplifier in normal operation and due too to the fact, that this input impedance changes only slightly with grid current flow caused by strong signals.

Thus, due to the linearity of the *rf* amplifier operating at a 1.3-*v* bias with 200 *v* at the plate, plus the minimized clipping effect in the grounded-grid amplifier and mixer, *agc* was not found necessary. During actual field tests it was found impossible to overload the tuner.

The output of the amplifier on channels 2 to 13, requires no reduction in tube loading and the plate circuit is simply tuned by L_{21} . To reduce tube loading on channels 14 through 83, a shunt-fed system was incorporated; *uhf* *rf* segment L_{31} , C_{31} and the tube are resonant and $B+$ is fed to the tube through a choke. A two-section *rc* filter (C_5 , R_5 , C_7 , R_7 and C_8) is used in plate supply to the amplifier. Its function is to reduce the plate voltage to 200 and eliminate resonant lead effects from the amplifier, thus effecting complete isolation of the amplifier.

The mixer-input circuit consists of L_{30} and C_{30} , which are resonant and coupled to L_{31} . This arrangement was found to assure the required double-hump response and a bandwidth of 6 to 8 mc. Control of the bandwidth is accomplished primarily by the coupling between L_{30} and L_{31} , and the loaded Q of the mixer circuit. The complete resonant circuit is C_{30} , L_{30} and L_{21} , with mixer loading across L_{21} . Here we find that L_{21} controls mixer loading at the lower frequencies, while C_{30} becomes effective over the higher fre-

quency range; L_{21} also provides injection to the mixer. The amount is optimized by the amount of coupling with the oscillator coil L_{20} . R_3 and C_2 , the cathode resistor and bypass capacitor for the mixer, together with the plate circuit resistors, R_{50} and R_{51} , establish the characteristics of the 6AN4 as a mixer.

The plate circuit of the mixer is tuned to the *if*. In the schematic low-side coupling is shown. However, on the tuner, this *if* transformer assembly is mounted as a separate unit, which facilitates variations without affecting the tuner circuitry.

From the Service Man's viewpoint, the tuner provides an extension of *vlf* practices into the *uhf* range. If it becomes necessary to change the oscillator tube and it is desired to trim the oscillator, a hole provided in the center of the fine tuning cam permits access to the oscillator slug. Thus the oscillator segment can be quickly retuned on any channel from 2 to 83, in the same manner as on a *vlf* tuner.

Actually the only field adjustments provided are the *if* transformer and the oscillator segment. There are no provisions for other adjustments nor are they required in field service. In this tuner, three tuned circuits plus the *rf* amplifier are effective; this has been found not only to improve performance, but aid in minimizing the radiation problem.

The entire construction of this tuner has been based on control of radiation, with a view of bringing them below FCC standards.

Summarizing, the tuner features separate oscillator and *rf* cavities, no solid metal shaft extending through the tuner, and power distribution on the top side of the chassis with feed-through capacitors to the various sections of the tuner circuitry; eleven of the feed-through capacitors are used in the filter networks. All *rf* ground returns of the mixer and amplifier stages are floating. This was accomplished with specially shaped metal pieces that form the connecting pattern and by-pass systems all at once.

This particular type of wiring method was necessary to achieve electronic duplication of chassis in production. On the other hand it also provided a *cold* chassis, of extreme importance in combating radiation problems. Not only did this eliminate the need for solder bonding of any of the structural metal parts, but it also allowed the chassis to be mounted on top of the turret assembly with the use of spring clips. This approach provided a one-plane tuner chassis, quickly removable for service, with all connection and components fully accessible.

3 SHURE CRYSTAL PICKUP CARTRIDGES replace the 192

cartridges you are most likely to encounter
in your service work!

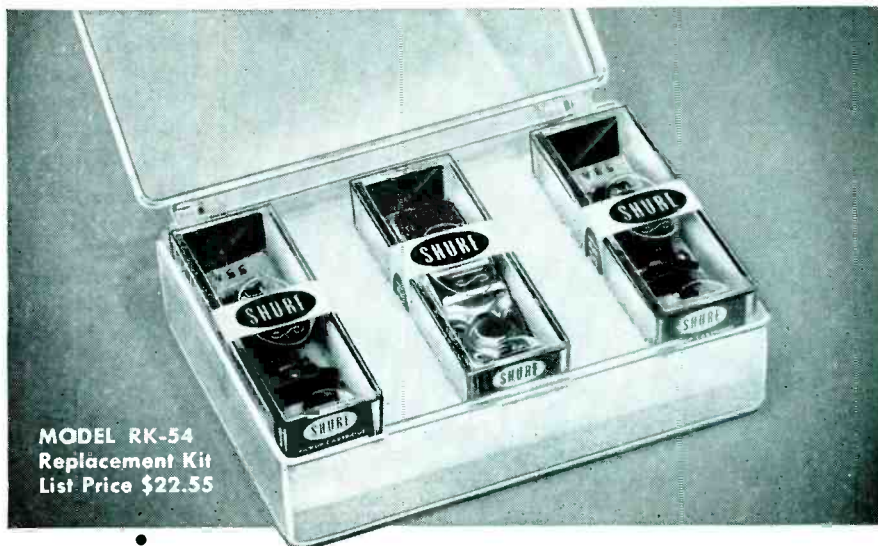

MODEL RK-54
Replacement Kit
List Price \$22.55

-
- TECHNICAL DATA AND REPLACEMENT CHART IS ENCLOSED.
- Lists 192 Crystal Cartridges manufactured by
- five leading cartridge manufacturers.
-

Lowest investment for broadest coverage! The RK-54 is beyond all doubt the *most practical* Replacement Kit on the market! Proof? Simply this—you get the broadest coverage at the lowest investment—only \$22.55 list! Think of it—3 Crystal Cartridges replace 192 of those specific Cartridges most likely to be in need of replacement! Two of the Cartridges consistently have been “best sellers” in the Shure line—as established by actual sales to Servicemen! The Cartridges are: Model W22AB, 3-Speed, 2-Needle Cartridge—Model W26B, All-Purpose, Single-Needle Cartridge—Model W78, 78 RPM, Dual-Volt, Dual-Weight Cartridge. Model W78 is the new, versatile Cartridge that replaces 149 other Cartridges! This Cartridge alone will become a sensation overnight! Order a Replacement Kit from your Distributor today—once you have worked with this practical kit you will find that these three Cartridges are dependable replacements—will make your service work faster, easier and more profitable!



TRANSPARENT PLASTIC BOX IS FREE!
This Handy Box is 5" long, 3½" wide,
1¼" deep.

SHURE — The Mark of Quality

TUNG-SOL TUBE QUALITY PAYS OFF IN SALES!



Black and White Picture Tubes

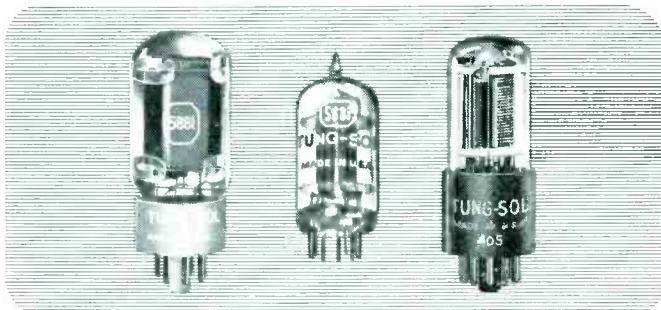

Special Purpose Tubes

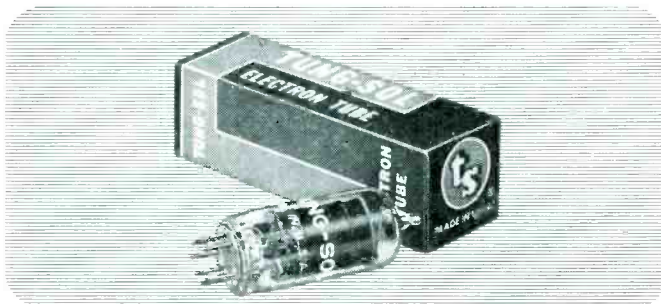

Radio and TV Receiving Tubes

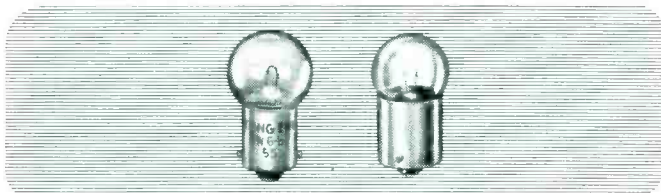

Dial Lamps

The performance quality of Tung-Sol Tubes will keep customers convinced that you're the best serviceman in the business. Tung-Sol Tubes meet highest set manufacturers' specs—protect you against call-backs. Tell your supplier you'd rather have Tung-Sol.

TUNG-SOL ELECTRIC INC., Newark 4, N. J.

Sales Offices: Atlanta, Chicago, Columbus, Culver City (Los Angeles), Dallas, Denver, Detroit, Newark, Seattle

TUNG-SOL® *dependable*
ELECTRON TUBES

Catalogs and Bulletins

P. R. MALLORY AND Co., INC., Distributor Division, P. O. Box 1558, Indianapolis, Ind., has published a 61-page standard stock catalog, 554, describing batteries, capacitors, controls, resistors, rectifier stacks, switches, vibrators, mobile and ac-operated power supplies, TV components and equipment, and test equipment.

* * *

MUELLER ELECTRIC Co., 1583 E. 31st St., Cleveland 14, Ohio, has released an 8-page catalog, 150, detailing battery and test clips, insulators for clips, antenna-clamp stand-off insulators and battery charging jumpers. . . .

* * *

INTERNATIONAL RESISTANCE Co., 401 N. Broad St., Philadelphia 8, Pa., has prepared catalog data bulletin G-1, on type *mw* high-voltage resistors. . . . Catalog data bulletin F-1, detailing data on 43 types of *mp* high-frequency resistors, and bulletin N-1, on type *IN* series germanium diodes, are also available.

* * *

JAN HARDWARE MANUFACTURING Co., 75 N. 11th St., Brooklyn 11, N. Y., has released a 6-page data chart, listing stock magnetic shields and bezel combinations which fit most standard picture tubes. Also described are *hw* insulated couplings, panel bearings, jack covers, shaft locks, bushing extenders and shock testers.

* * *

RECOTON CORP., 147 W. 22nd St., New York 11, N. Y., has issued a revised *Simplified Reference Guide*, containing information on replacement needles. A replacement needle chart and manufacturers' cross index are included.

* * *

UNITED TRANSFORMER CORP., 150 Varick St., New York 13, N. Y., has published a 26-page catalog, A, describing its line of transformers. Detailed are: linear standard audio types; output transformers; compact audio units; hermetically-sealed components; variable inductors; inter-stage and line filters, and audio amplifiers, in kit form, featuring *pc* chassis.

* * *

TECHNICAL APPLIANCE CORP., Sherburne, N. Y., has announced publication of localized catalogs, arranged to include only those antennas and accessories that are specifically designed for the area served by a Service Man.

* * *

TRIAD TRANSFORMER CORP., 4055 Redwood Ave., Venice, Calif., has issued a 28-page catalog, TR-54, listing more than 500 transformers, as well as 11 new amplifier kits for hi-fi, plus hermetically-sealed power components, an instrument power supply, filament chokes, and power and audio transformers.

* * *

HALLDORSON TRANSFORMER Co., 4500 Ravenswood Ave., Chicago 40, Ill., has published catalog 22 which features an expanded line of transformers, with special emphasis on TV components. Both specific and multi-purpose replacements for popular TV models and chassis are described and illustrated. Catalog also contains comprehensive range of power and audio transformers, reactors, and varivolts.

* * *

CHANNEL MASTER CORP., Ellenville, N. Y., has announced publication of a 20-page loose-leaf general catalog which illustrates and describes more than 125 different items, including both *vhf* and *uhf* antennas, masting, towers, mounts, interaction filters, and general accessories. Most of the antenna information is supplemented by technical data, including gain curves and horizontal polar patterns.

Associations

RTSA, Pittsburgh

JOHN F. COCHRAN has been reelected president of the Radio and Television Servicemen's Association of Pittsburgh, Inc.

Others elected include: *Philip J. Polito*, first vice president; *J. A. Shafer*, second vice president; *E. A. Roberts*, treasurer; *Tom Ging*, secretary; and *Bert Brezenger*, program and publicity chairman.

At an all-industry banquet of the group in the Elks Club, *Dan Creata*, RCA Service Company vice prexy and *ye editor* were honored guests. Dan reviewed the prospects of color TV, while *ye ed* presented a report on trends in industry.

Those at the dinner included the chief engineers and managers of local TV stations, component and set distributors, and members of RTSA.

Bert Brezenger served as toastmaster.

* * *

RTG, L. I.

THE GUILD NEWS, published by the Radio Television Guild of Long Island, continues to sparkle with timely photo-reports on service aids, association activities and color TV. Current issue describes working color demonstrations staged recently before the group using RCA color set and Telechrome Chromalyzer.

Discussed also are techniques to be used in renewing an old cabinet with flocking material, and improving flyback checkers. A quiz, entitled *How do you rate with your customers*, was another featured item in the *News*.

* * *

IRTSA, Wisconsin

VERNON TOWNSEND has been elected president of the Indian-head Radio-TV Servicemen's Association, Eau Claire, Wis. Other elected officers include: *Earl Kratch*, vice president; *C. W. Stiemke*, secretary, and *Upton St. Clair*, treasurer.

Nominations and elections followed the annual banquet meeting at the Empire Cafe, Chippewa Falls.

* * *

RSA, Luzerne County, Pa.

THE EIGHTH ANNUAL clambake of the Radio Servicemen's Association of Luzerne County, Wilkes-Barre, Pa., was recently held at Lily Lake.

Among those at the outing were *Fred Schmidt*, *Milan Krupa*, *Joseph Czapracki*, *Maurice Rader*, *Bert Brezenger*, *Leon Helk*, *William Landsberg*, *William Deardorf*, *Max Leibowitz*, *John Wheaton* and *O. Capetelli*, representing RSA, FRSA, PRSA, MRSA, LRSA, ARTT, RTSEA, ESFETA, ARTSNY and RTG, from Luzerne County, Pittsburgh, Harrisburg, Scranton, Williamsport, Altoona, Chambersburg, New York City and Long Island.

Ye ed was guest speaker.

TEN YEARS AGO

TUBE supplies for consumers were reported to be on the increase for the remainder of the year, due to increased production, stockpiles of military types and backlog cutbacks. . . . Results of a magazine survey among receiver owners revealed that 65% of those interviewed planned to buy a radio after the war; 57% of this group chose radio-phonograph combinations, 22% chose a table model, 21% a console and 3% selected TV. . . . Ralph S. Mueller described the evolution of the clip. . . . Front cover featured circuit of a high-fidelity audio system of a 12-tube AM/FM receiver (Zenith 12H689) with 6-position push-button tone control. . . . *Dan Fairbanks*, formerly with IRC, was named jobber sales manager for Cornell-Dubilier Electric Corp. . . . Illinois Condenser Co. added another floor to its facilities at their plant at 1160 N. Howe St., Chicago. *Jerome J. Kurland* joined the company as chemical engineer.

TUNG-SOL TECHNICAL DATA PAYS OFF IN SERVICE!

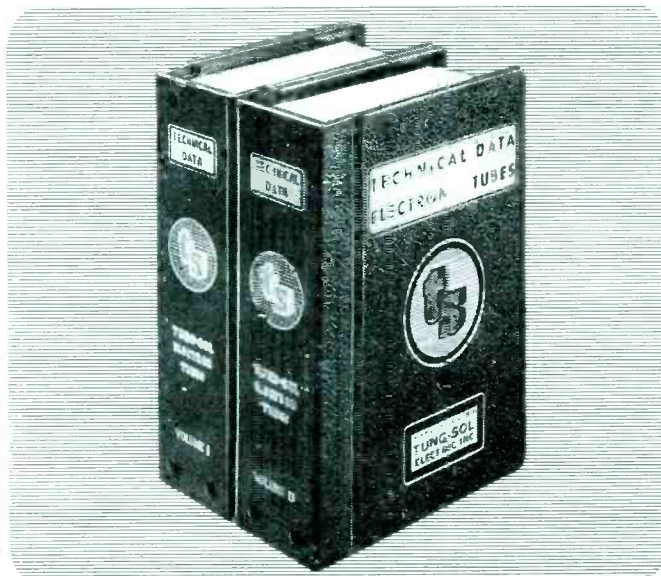

T-58 700 pages—500 tube types



NEW! 1954 Edition! T-70 160 pages of data on CR tubes, receiving and special tubes, diode lamps



T-31 300 blueprint base diagrams for 1100 tube types

Here's the most practical set of tube reference books in the industry—all the information you need for everyday jobs! They're easy to read—easy to use (always lie flat when open.) You'll get work done faster with Tung-Sol Technical Data Books. Ask your tube supplier about them.



TUNG-SOL makes All-Glass Sealed Beam Lamps, Miniature Lamps, Signal Flashers, Picture Tubes, Radio, TV and Special Purpose Electron Tubes and Semiconductor Products

TUNG-SOL® easy reference TECHNICAL DATA

SERVICE, JULY, 1954 • 45

The TARZIAN TUNER

UV 13

All Channel
Combination UHF-VHF

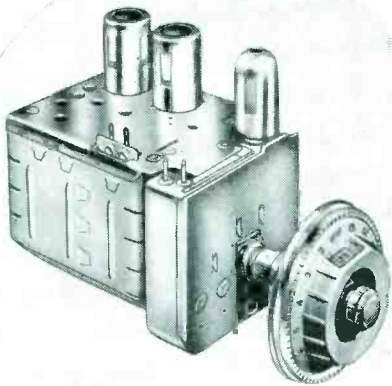

- A compact, combination tuner (the world's smallest) for covering the entire UHF-VHF bands.
- Straight line electrical sequence of compartmented circuits.
- Simple, coaxial tuning.
- Stage shielded.
- **OVERALL PERFORMANCE MAKES ANY SET A BETTER SET.**

Write for folder covering complete description and performance data.



SARKES TARZIAN, Inc.
Tuner Division
Bloomington, Indiana

Service Engineering

field and shop notes

by **THOMAS K. BEAMER**

THE CRYSTAL filter in a communication-type receiver is used as a *series-resonant circuit*. The crystal is ground to the intermediate frequency, and when switched into the circuit, allows only the exact-frequency signal to pass. In effect, it is a very steep-sided bandpass filter; so sharp that it usually distorts voice transmissions. Because of this needle-point characteristic the *if* stages must be precisely tuned to the exact frequency; otherwise very poor results will be obtained. There are several techniques that can be used to align the *if* stages.

Instrument Setup for Alignment

One of the simplest is to set a signal generator to the exact crystal frequency, using the crystal itself as a standard. Both the receiver and signal generator must be warmed up for at least a half-hour, before beginning the alignment, to avoid the effects of temperature drift. The crystal should be left in the receiver. (This method applies only to those sets which use the plug-in type of crystal; if the crystal is concealed in a can, another approach must be used.) The crystal must be removed from its socket and the signal generator output lead connected to one pin. The hot lead of an *ac vtvm* should be connected to the other, connecting the grounds of the two instruments together, although this is not too essential. The *vtvm* should now be set to its lowest scale, 3 *v* or so, and the signal generator's attenuator set to approximately the output needed for alignment; this should be about half-scale on its lowest range. If the attenuator is frequency-sensitive, this setting should not be disturbed. It may cause a change in frequency if moved. Next, the signal-generator should be tuned to the approximate frequency (*kc*) of the crystal, 455, 456, or whatever it is, and tuned very slowly until a reading is noted upon the meter. This reading need not be large; anything that will give a readable deflection will be sufficient. When the signal generator is peaked upon the crystal frequency, it should be disconnected from the crystal, connected to the set, and the alignment can be begun. The signal generator is now tuned to the exact frequency of the crystal. The crystal can be left out of the circuit entirely until the *if* stages have been aligned, or replaced

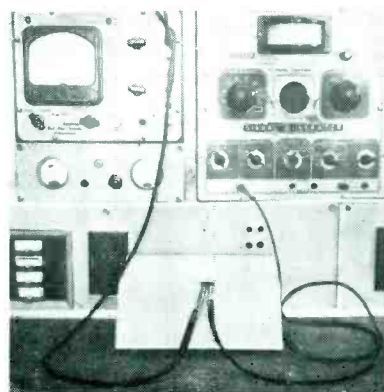

Setting signal-generator to exact frequency of crystal. One lead of generator is connected to crystal; one lead to *ac-vtvm*. Signal generator is tuned for maximum deflection on *vtvm*; it is then on exact frequency of crystal.

Alignment of Communication

Receiver Crystal-Filter IF Stages*

in the set. One must be sure, however, that the crystal is switched out of the circuit until the transformers have all been aligned, and you are ready to check the crystal alignment. One will find that this part of the procedure can be performed best with a 'scope; an output meter can be used, if necessary.

Using an output meter, one should note the reading on the meter and switch the crystal into the circuit. A drop in the indicated output should result, but not to zero. The drop is due to the excessive steepness of the sides of the curve and is quite normal. The crystal-phasing control can be tuned to make up part of the drop. With a 'scope, an FM signal can be fed in, swept around the *if* frequency, and the presence of a single response curve noted. If the *if* stages are not aligned to the exact frequency of the crystal, two curves will be seen, one usually smaller than the other. Varying the frequency of the signal generator will show which one is the crystal's response; it will remain stationary, while the curve of the *ifs* will move back and forth across the screen. The signal generator dial should be moved until both curves coincide; then the crystal can be switched out of the circuit and the *if* trimmers readjusted. One should now recheck to see that both curves coincide when the crystal is switched back in.

With the sets using a fixed crystal (permanently mounted in one of the *if* cans), the signal generator should be tuned until its curve rests atop the curve of the crystal. Then the crystal can be switched out and the *if* stages aligned. One should then check for best coincidence after alignment is completed.

With the sets using variable-selectivity *ifs*, one should align at a specified bandwidth setting. If this setting is not specified, alignment should be at the narrowest bandwidth, using the 'scope; then one can check for curve distortion when the bandwidth control is operated. Some sets used a tertiary winding in the middle of the *if* strip, switched in and out to vary bandwidth. These should be checked very carefully for correct alignment of the tertiary trimmer to avoid possible curve distortion and regeneration.

General Procedure

The common broadcast-band practice of using a *vum* on the *avc* buss as an alignment indicator, or the *if* probe of a signal tracer, a favorite method with many, often leads to

(Continued on page 51)



*Based on a report prepared for SERVICE by Jack Darr.

Rear view of communications receiver with cover removed. Note neat construction and arrangement of the parts. (Halcrafters.)



for COMMUNITY
TV SYSTEMS
Quality Cables
and Connectors
by

AMPHENOL

BECAUSE of the long lengths of cable that must be used and the multiplicity of connections that must be made, the complete quality of these components is extremely important in Community TV Systems. That is why leading equipment manufacturers and system designers have long insisted upon the incorporation of AMPHENOL cable and connectors in Community TV Systems. They know that they can rely upon the *quality* and the *performance* of AMPHENOL components.

Sweep Testing One of the quality checks that AMPHENOL makes on cable for Community TV Systems is sweep testing of the cable used in long lengths in an installation. Under sweep testing procedures each reel of 21-125, 21-007 (RG-11/U) and Triaxial 21-529 is tested for each VHF channel, 2 to 13. The customer is then furnished with a notarized affidavit stating that the sweep test has been performed and that the attenuation of the cable does not vary more than 5% from the nominal values throughout the VHF spectrum (50 mc to 90 mc, 170 mc to 220 mc).

Specify **AMPHENOL** **to be sure**

AMERICAN PHENOLIC CORPORATION
CHICAGO, 50

TUBE News

by E. A. TEVERSON

THE ABILITY OF TUBES to operate satisfactorily under wide variations of temperature, vibration conditions and shock has always been considered as a principal feature, particularly for industrial and military applications. On many occasions, it has been found that extreme temperatures and severe vibration were the basic causes of tube failures.

A number of avenues of development have been followed to produce rugged tubes that would stand up under all types of adverse conditions.

Realizing that rapid strides in electronics pointed toward the future need for tubes not only with unique high-performance properties, but also capable of unprecedented mass-production should a national emergency arise, engineers of one manufacturer¹ suggested to the Navy² that a special research project be set up to develop tubes that would meet such specs.

The government approved the plan and a few weeks ago the results of

the study were announced. It was found that a new type of rugged tube could be made by using a ceramic envelope or cap, instead of the usual glass bulb, with the elements *stacked* one atop the other in the assembly process. In addition, ceramic spacers could be employed instead of mica.

In describing the tube at a conference in N. Y. City, Dr. Bennett S. Ellefson, director of research for Sylvania, said that sealing is done with a *bell-jar system*; a glass dome under which the stacked parts are placed, air-evacuated, and the tube envelope sealed over the stacked parts.

Commenting on the tube's ruggedness, and ability to withstand shock and vibration without deterioration of performance, Dr. Ellefson said that contributing to this ruggedness was the substitution of ceramic spacers for

mica spacers. In extreme operating conditions, it was said, mica has a tendency to spall and flake under vibration and shock, causing mechanical tube failure.

Whereas a feature of the new development was the ceramic envelope, the stacked structure of the tube was described as lending itself to the use of either a glass or ceramic envelope, depending upon the ultimate application.

The complete mount of the tube is assembled on two small pins. First a plate, a spacer ceramic, a grid, a spacer ceramic, a cathode, a spacer ceramic, and so on until the top is reached. When the stack is completed, the small pins are then electrically riveted.

The ceramic material used for the envelope and stem is aluminum oxide. Sealing the envelope and stem together is a single-step process. No mica is used in the mount, and it can, therefore, be placed on a ceramic stem and

¹Sylvania. ²Bureau of Ships.

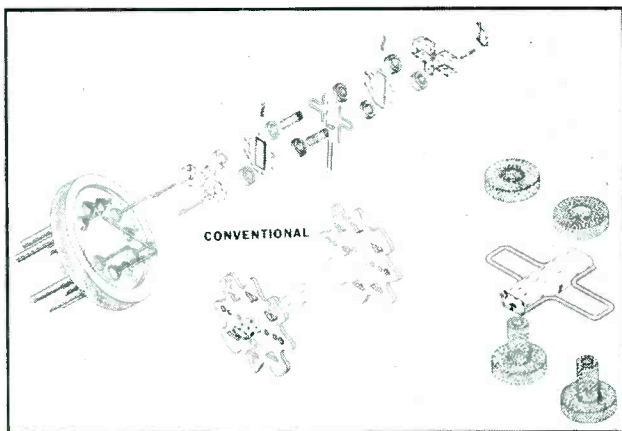

(Right)

Stacked tube assembly, center, showing a mount on which the tube components have been stacked by automatic production methods. Finished tube is at the right. (Sylvania)

Left: Exploded view of the ceramic tube's stem and mount; in progression on two small pins are stacked a plate, spacer ceramic, grid, spacer ceramic, cathode, spacer ceramic, and so on until the top is reached. Drawing at right shows the difference between the cathode support assembly of a conventional vacuum tube, left, and that of a stacked tube. Wire loops of the cathode fit over the rivet insulator posts, and the two ceramic washers at the top then are lodged above the loops.

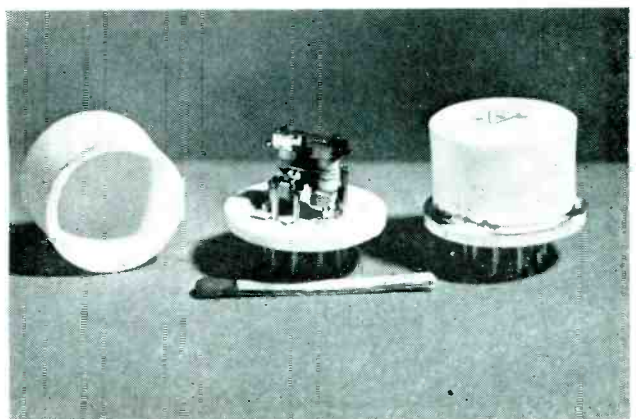

Ceramic Envelope Tube

sealed in a ceramic envelope under temperatures of about 950° C.

Aside from sealing the tube, this process also provides a high *baking-out* temperature which it has been found sealing glasses could not withstand. Thus, it was pointed out, the finished tubes have less gas to begin with, and, therefore, have a longer gas-free life.

The ceramic envelope has been found to be extremely rugged under widely fluctuating temperature conditions; it has been removed from liquid nitrogen at -195° C and immersed in boiling water at +100° C, a range of almost 300° C, without fracture.

The tube can be strapped directly to the equipment chassis, or it can be socketed. Lead wires can also be soldered directly to the pins.

New Element Designs

The stacking construction has made it necessary to adapt new designs for the elements. To illustrate, the grid is tightly stretched across a metal frame, like a harp, and gold brazed onto the metal. Ceramic spacers hold the structure tightly in place. Similarly the cathode is supported by a metal looped assembly with the element spot welded onto its support.

While the tube was developed especially for the military, it was emphasized that the ceramic-stacked technique could well be used to produce a new family of tubes for industrial and radio and TV equipment for the home.

Presently, a number of stacked tubes with 6J6 characteristics are being made for experimental and field study.

High Masts-Towers

(Continued from page 34)

very well insulated, excessive swaying and vibration can eventually cause crystallization and breakage of the solid conductors. Some makers of this line have special spring-loaded stand-offs which take up any slack in the line. One should stand-off this line over metal gutters and other objects. Over the eaves, a 7" standoff on the roof itself, and one on the wall below the gutter, will usually keep it in position. For an unusually deep wall, one can bore or punch a small hole in the heavy lip of the gutter, and use a 7" machine screw type standoff, with two nuts, one on either side of the metal, to hold it in place. The stiffness of

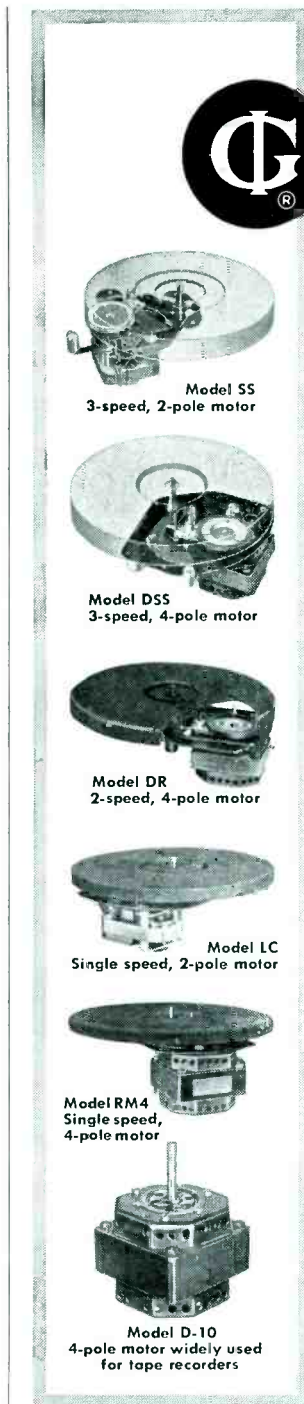

The Complete Line of Quality Phonomotors

- FOR PORTABLE PHONOS
- FOR HI-FI UNITS
- FOR COMBINATIONS
- FOR RECORD CHANGERS
- FOR TAPE RECORDERS
- FOR REPLACEMENT USE
- FOR EVERY PHONO APPLICATION

Whatever your phonomotor or tape recorder requirements, you'll find the *exact* answer in the famous *Smooth Power* line of single-speed, dual-speed and three-speed motors. Illustrated at the left are just a few of the many different types from which to choose.

Each of these advanced design motors incorporates General Industries' exclusive engineering and construction features which assure trouble-free performance and long-lasting dependability.

Complete information, including dimensions, specifications and quantity quotations, furnished promptly upon request. Write to:

THE GENERAL INDUSTRIES CO.

DEPARTMENT MF • ELYRIA, OHIO

this type line will usually keep a clearance-loop in place without this precaution. When handling, this line will sometimes become bent or twisted. It can be straightened by holding one of the bars and pulling the line between thumb and fingers of the other hand. All kinks, bends, and twists should be pulled out of the line as it is installed. To avoid trouble with this line, it should be left in the container until ready for use. It can be pulled out as needed. If the line is of the insulated type, the enamel must be scraped off very carefully from the ends, before any joints or connections are made.

If it becomes necessary to splice open-wire line, the small polystyrene *splicing-blocks* which hold the four ends in place with two set-screws, are very useful; they introduce little loss into the line.

Fringe tower and mast jobs require a great deal of intelligent planning and execution if they are to be at all profitable. By setting up a well-planned system, a small crew can erect tall towers in a short time. Whether one can make a substantial profit out of this activity depends almost entirely upon how well the job is done, and how well it stays done.



SHE WANTS
FINE FURNITURE

HE WANTS
TECHNICAL EXCELLENCE

YOU SATISFY BOTH WITH

Manfredi

HI-FI SPEAKER ENCLOSURES

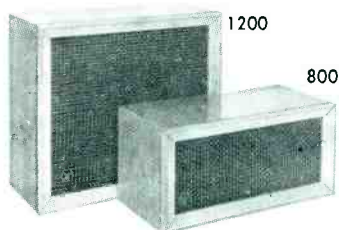

HUMMINGBIRD — Model 800 for 8" speaker; 1200 for 12" speaker. Compact without loss of performance... excellent tonal fidelity.

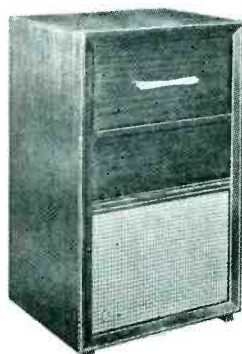

FLAMINGO — Model 2000 — Universal cabinet and speaker enclosure... maintains high acoustical integrity. Houses complete hi-fi system... finest woods and veneers. 36 1/8" x 22 1/4" x 18 1/2" deep.

You protect your own reputation when you sell a Manfredi cabinet or enclosure—the woods stand up... performance stands out! This excellence has been the mark of Manfredi craftsmen for over a quarter-century. Write for illustrated brochure.

Manfredi

WOOD PRODUCTS CORP.

226 New York Ave., Huntington, L. I., N. Y.

Community TV

(Continued from page 23)

permeable shield and dissipated inside the cable in terminating and isolation resistors, and in the input circuits of amplifiers and receivers.

In a practical cable system, though, it was noted, the shielding is permeable, and minute fractions of the signal carried within the system leak out at various and sundry points.

There are a great many different sources or causes of radiation, some being related to system design and others a consequence of defective workmanship, materials or maintenance, or of the ravages of time, Brown emphasized.

In a commentary on signal levels and radiation, the cable specialist said that since all system leaks involve radiation of some fraction or percentage of the total signal carried internally by the system, the level at which the system operates has a direct effect on the strength and nuisance value of the radiated signal. In different types of systems, it was noted the maximum levels range from 30 db above one millivolt per channel to 66 db and higher; the higher levels permit use of fewer amplifier stations, longer runs, and cables of higher loss. However, it was emphasized the savings achieved by use of higher levels must be balanced against the cost of the increased attention which must be given to radiation problems both at the time of installation and during maintenance of operation. It has been found that types of cable and shielding or maintenance methods producing negligible radiation in a system operating at 40 db can produce serious interference and stealing¹ problems when used in a similar system operating at 60 db. Noting specific sources of radiation, Brown listed receiving antennas, which may radiate local oscillator harmonics or other signals originating in the equipment to which they are connected; splitters, tapoffs and other accessories; cable connectors and cable splices.

Cable connectors were described as a very important and often unsuspected source of leakage in systems which have been in operation for a year or more. Such leakage may vary widely with humidity and temperature and may either disappear or be aggravated when the connector is manipulated.

Noting that the TV signal from the amp fitting flows through the outer shield walls of the connector and then into the cable braid, Brown said that even a very small resistance in the

¹Many have used induction field probes and multi-element yagis pointed at cable, with element tips almost touching to pick up community TV signals.

The COMPLETE line



Paging & Talk-Back Speakers

DR Double-Reentrant Projectors



ALNICO-V-PLUS Driver Units

Dual Speakers

for EVERY

Public Address need!



Tweeters

FULL-GRIP, VELVET-ACTION Mike Stands

WRITE NOW for FREE Catalog 553



ATLAS SOUND CORP.

1442 39th St., Brooklyn 18, N. Y.
In Canada: Atlas Radio Corp., Ltd., Toronto, Ont.

outer shield connection can cause serious radiation; with an amplifier running at 1/2 output, a connector resistance of 0.075 ohm will develop a voltage of 1000 microvolts applied between the amplifier case and the braid of the cable, with no perceptible change in the signal inside the cable. Thus, conferees were told that because of the wide variation of contact resistance with temperature, humidity, and handling, troubles of this sort frequently elude accurate diagnosis.

It was also reported that small solderless coax connectors tend to loosen from temperature cycling and develop contact resistance between two sections of the connector. Solderless connectors, which have been sealed with waterproof compound, disconnected, and then reconnected, frequently develop very high contact resistance between two parts due to some of the compound becoming lodged in the joint, it was said. Deterioration of the joint between the cable braid and the connector was cited as another source of contact resistance. This trouble was described as resulting from loss of clamping ferrule pressure or moisture entry and attendant corrosion.

Braided coax cable was held probably responsible for some 75% of the

Service Engineering

(Continued from page 47)

radiation from community antenna systems, although it receives credit for about 99% of the radiation. Semi-flexible coax cables with continuous tubular metallic outer conductors, it has been found, do not produce any measurable radiation.

Cable-Radiation Cure Proposals

Five ways to reduce cable radiation were proposed:

Single braided cable should be replaced with a double braided cable; by far the most expensive solution, this approach should not be undertaken hastily.

All single braided cable running above some intermediate level, say 30 db, should be replaced with double braided cable.

Signal levels in the cable should be reduced; this usually requires insertion of additional intermediate amplifiers which may, however, be highly desirable for other reasons.

The entire line, including coax cables and messenger, can be covered with a single sheath of highly conducting metallic foil, preferably aluminum. Strips of household freezer foil, applied lengthwise to the line in 50' or greater lengths and overlapped one foot at joints and bound tightly have been found to cut radiation as much or more than installation of double-shielded double-jacketed cable. The wrapping, it was noted, can be applied selectively and on short notice to combat stealing or to satisfy radiation complaints. It was found that there is a serious practical disadvantage of aluminum foil wrapping; the permanence of the shielding effect depends on the permanence of the bonds at the ends of the lengthwise pieces of foil and upon the wrapping not becoming broken. (No paint of sufficiently high conductivity to provide economical cable shielding has been found, and it appears unlikely that such a paint can be developed.)

[Next Month: System Amps and Cables]

trouble in *comm* sets. The trouble seems to be due to a reradiation of an *if* signal from the unshielded portion of the probes themselves, which cause the *if* stages to spill over. The *old-fashioned* output meter across the speaker will probably give the best results as a general alignment indicator. One should be sure that the noise limiter is switched out of the circuit when aligning, as some very peculiar curves can be obtained when the set is aligned with this in the circuit.

Recalibration

Recalibration of multi-band receivers is quite different from the practice followed with broadcast chassis, with no padder and only one trimmer. Tracking is another problem frequently encountered; the set may be right at both ends of the band, but severely out of calibration in the center. This is often caused by the oscillator trimmer set on the image instead of the fundamental.

The *rf* and antenna-stage alignment will also affect sensitivity of these sets; most of them incorporate at least one stage of tuned *rf* amplification, sometimes two, with both trimmer and padder adjustments for each band, making very accurate adjustments important.

Trimmer adjustments are usually mounted adjacent to the coils tuned by them, and are accessible through holes in the bottom cover of the set, which must be in place during alignment. Trimmers and padders are seldom labelled and it is a good idea to identify them with numbers on the bottom plate, at each access hole, to speed the process. It might be helpful to note the frequency at which each is adjusted, also: C-10, B 8 mc which would mean C-10, band B. These are generally arranged in rows, so that

all the trimmers or padders for one band will be in the same row. It might also be a good idea to draw a line between the rows, designating one as band, B, C, etc., to avoid confusion. In some sets, low-frequency padding adjustments are made from the top of the chassis, while the high-frequency trimmers are tuned from beneath; in others all adjustments are made from the bottom.

On *comm* models it is conventional practice to begin alignment with the highest-frequency band, working down to the lowest. When adjusting oscillator trimmers, especially on the bands above 10 mc or so, one must be sure that the oscillator trimmer is not set on the *image frequency*, the beat-note generated about twice the *if* frequency away from the correct setting. To check for this, the output of the signal generator should be increased and tuned to a point twice the *if* down the dial. The image heard there will be much weaker than the signal. Oscillators in most sets work above the received signal.

If the dial is off, quite a bit, it is sometimes easier to *walk* the signal down the dial to the correct point than to try to adjust to it after setting the dial. The signal on the set should be tuned, noting which way it must be moved; i.e., up or down the dial. If it must be moved up to a higher frequency, the trimmer must be *loosened* to leave less capacity in the circuit. The trimmer should be turned just a bit, and the dial moved until the signal is tuned in. The trimmer and dial should be moved alternately until the signal is heard at the correct place on the dial. This operation is not as difficult as it sounds, and is actually speedier than trying to locate the correct signal by turning the trimmer, since most of the trimmers

(Continued on page 55)

RETMA MEDAL OF HONOR WINNER

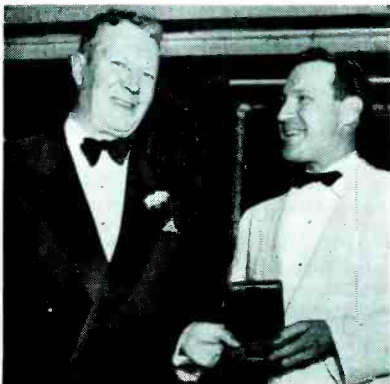

(Left)

Robert C. Sprague, left, chairman of the board of Sprague Electric, receiving the RETMA Medal of Honor from Glenn McDaniel, RETMA president, during annual association meeting in Chicago. Sprague, third to receive the medal in the association's history, was honored for his contributions to the progress of the electronics industry.

(Right)

Incoming president of Radio's Old Timers, Charley Golenpaul (right) presenting outgoing president Ray Triplett, who has rounded out his 50th anniversary as a radio-electronic equipment manufacturer, with a testimonial plaque, which mounts gold-plated Triplett tube tester of the '29 vintage, during the recent Parts Show in Chicago.

OLD TIMER PREXYS MEET



YOU CAN WIN A NEW FORD!

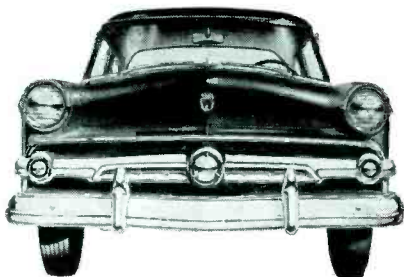

Nothing to buy! Nothing to sell!

**Just Illustrate and Explain
a New Application for
International Rectifier Corporation
Selenium Diodes**

50 PRIZES

Grand Prize

**New Ford V-8 Mainliner Tudor Sedan
and 49 other
valuable prizes**

INTERNATIONAL RECTIFIER CORP.
PORATION'S Selenium Diode Ap-
plication Contest is open to every-
one! Here's all you have to do —
pick up an official entry blank
from your favorite parts distrib-
utor. Illustrate and explain a new
practical application for Interna-
tional Rectifier Selenium Diodes.
Have the entry blank counter-
signed by your distributor's sales-
man and then forward it to us
before January 1, 1955. Rules and
regulations for this contest are
included in the entry blank along
with helpful hints on selenium
diode applications.

**JUDGES—Dr. Lee de Forest—United
Engineering Labs., Los Angeles, California,
J. T. Cataldo, F. W. Parrish—International
Rectifier Corp.**

SAMPLE ENTRY ↓

—APPLICATION—

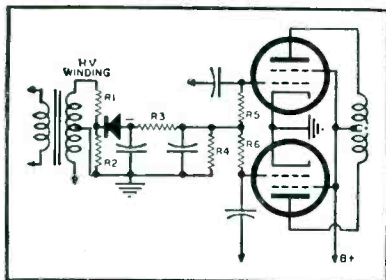

—EXPLANATION—

Typical application for providing fixed bias for push-pull stage of an audio system using International Rectifier Corp. Selenium Diode in conjunction with a voltage divider and filter network... etc., etc.

**DON'T DELAY! ENTRY BLANKS ARE
AVAILABLE FROM YOUR
PARTS DISTRIBUTOR**

CONTEST ENDS JANUARY 1ST, 1955

**INTERNATIONAL RECTIFIER CORP.
EL SEGUNDO, CALIFORNIA**

Audio

(Continued from page 24)

deemphasis in the receiver, provides an effective signal-to-noise ratio. The problem of obtaining sufficient audio gain together with the necessary pre-emphasis, system designers found could be solved by providing an omnidirectional ceramic microphone cartridge, with a response which very closely approximated the desired pre-emphasis curve.

In the *rf* section of the transmitter a self-controlled oscillator, reactance modulator and a *rf* amp were included.

The use of any sort of *afc* in the transmitter was found to be impractical due to the complex circuitry and the minute space available; thus it was necessary to design an oscillator-modulator circuit with sufficient frequency stability. This has been achieved by a modulator grid-bias circuit, with the bias derived from a self-rectified voltage developed by oscillator and amp grids. As the plate and filament batteries weaken, it was noted that the transconductance of the reactance modulator tends to be reduced, causing the carrier frequency to shift. However, the circuit has been so designed that the *dc* grid bias of the modulator is changed in such a fashion that its transconductance variation is substantially reduced.

The complete transmitter, excluding the antenna and tubes, occupies a volume of about one cubic inch. Here there are eight capacitors, eleven resistors, a volume control, five subminiature tube sockets, and a powdered iron core oscillator coil, a cylinder 1" in diameter and 1.3" long. Two printed circuit plates form the basic structure of this chassis.

In the receiver, a superhet, there's a pentode, tuned *rf* amp with a bandwidth of 150 kc; a pentode mixer with a separate triode oscillator is used. A pentode reactance modulator provides

afc. In a wide-band *if* amp there are two pentode amp stages, two cascaded triode limiters and a Foster-Seeley discriminator; output of the discriminator is fed through a gated, cathode follower triode to the audio output terminals of the receiver. In a carrier-operated squelch circuit, there is a triode *dc* amp.

A double-target tuning eye, controlled by the outputs of the discriminator and the first limiter, has been included to aid tuning. With this eye, it is possible to tune both the oscillator and antenna circuits of the transmitter. A 3-position switch on the receiver shifts the frequency of the oscillator in 50-*kc* steps to provide three operating channels. These can be used when more than one system might be operated simultaneously in the same area or when strong interference is experienced on any one channel. In view of the *rf* amp's 150-*kc* bandwidth, no retuning of the receiver is required.

Installation Notes

Usually, the receiving antenna for this system will consist of a copper wire installed in the form of a loop surrounding the operating area. The effectiveness of such a receiving loop will vary with the shape and area of the loop. The amount of noise picked up by the loop (in a given location) will be proportional to its enclosed area, while the amount of signal picked up from the transmitter will decrease rapidly as the distance between the transmitter and the closest part of the loop is increased.

A length of copper wire of any convenient size can be tacked or taped around the operating area. Ordinary magnet wire or bell wire has been found satisfactory, the gauge being determined by mechanical considerations. The wire can be placed under the floor, tacked around the baseboard or platform edge or around the ceiling.

Faster, Easier, more PROFITABLE Operation

Get into the MASTER habit!

Brings you the product data of the industry in one handy book — all products vital to your daily sales and service operations. In the customer's home, across the counter or on the bench, you'll value the MASTER'S thoroughly complete descriptions, specs, illustrations and prices . . . all systematically organized in 18 big sections. Over 1300 pages of unabridged catalog data direct from the manufacturers. Keeps you abreast of all latest electronic products. Increase your sales and speed-up your buying — the MASTER way.

As **\$1.95** at your parts distributor. Publisher's price **\$6.50**.

**OFFICIAL BUYING GUIDE OF
ELECTRONICS-TV-
RADIO INDUSTRY**

- 1370 pages
- 8" x 11" — 5 lbs.
- Over 8,000 illus.

Just a few of the more than 85,000 items included:

Tubes — Transmitters
Test Equip. — Receivers
Transformers
Capacitors — Antennas
Resistors — Wire & Cable
Coils & Relays
Recording & PA
Hardware & Tools

Eliminates
Small
Catalogs and
Loose
Literature

**Get your MASTER now from leading parts distributors or write to:
United Catalog Publishers, Inc., 110 Lafayette St., N. Y. 13**

sewed around the edge of a carpet, etc. However, at all times the enclosed area must be kept as small as possible. The wire does not have to be insulated; however, it should not be shorted to any pipes or electrical conduits.

The optimum shape and connection of the receiving antenna are determined by experiment after the system is placed in operation. It is best that a temporary installation be set up until the best shape is determined.

After one decides on installation of the loop antenna, a location for the receiver must be determined; two ends of the loop antenna must be connected to the receiver antenna terminals. The receiver should be placed as close to the loop as possible, and located where it is readily accessible and where connections to a power line and *pa* system, etc., can be conveniently made.

If the loop must be located at a distance from the receiver, connection between the receiver and loop can be made by running parallel wires about 2" apart from the ends of the loop to the receiver location. This distance must be kept as small as possible. In some installations, TV twin-lead can be used for this purpose.

The voltage output and sensitivity of the system depends upon the output connection and setting of the transmitter gain control. In the receiver, there is provision for a microphone-level and phono-level outputs.

Typical Installations

In a night-club installation, the primary area of coverage desired is the dance floor. The loop antenna wire should be stapled to the edge of the raised dance floor, and in addition, the upper runway and stair enclosed by the antenna wire. This will enable the *mc* to use the microphone from the wing of the stage as he walks on stage.

Good performance can be achieved in the enclosed area and extending 10'-15' beyond the dance floor, outside the loop. The point of particular interest in this installation is the extension of the loop area to cover the runway and stair where operation of the microphone might be desired.

* * *

HERBERT A. BERNREUTER

Herbert A. Bernreuter, vice president and general manager of the Simpson Electric Co., 5200 W. Kinzie St., Chicago, Ill., died recently.

He was a director of Bach-Simpson Ltd., and held many patents in the electrical and electronic fields.

more servicemen prefer
STANCOR
REPLACEMENT TRANSFORMERS
than all other brands combined*

because they like the . . .

- ease of installation
- completeness of the Stancor line
- availability of accurate replacement information
- rugged, breakdown-proof construction
- quick delivery from distributor's stock



* Brand Name Surveys, Chicago, Illinois; brand preference survey of electronic replacement components, May, 1954. Answered by servicemen from all over the U.S.

FREE NEW STANCOR GENERAL CATALOG listing over 500 transformers for TV, radio, high fidelity, communications and other electronic applications. Available from your local Stancor distributor or by writing Standard Division, Chicago Standard Transformer Corporation.

Stancor transformers are listed in Photofact Folders and Counterfacts



CHICAGO STANDARD TRANSFORMER CORPORATION

3588 ELSTON AVENUE • CHICAGO 18, ILLINOIS

EXPORT SALES: Roburn Agencies, Inc. 431 Greenwich Street, New York 13, N. Y.

FTR DIODE SELF-SERVICE DISPENSERS

A packaging program featuring self-service dispensers designed for germanium diodes, has been introduced by Federal Telephone and Radio Co., 100 Kingsland Rd., Clifton, N. J. Three packages and two types of dispensers have been created. Available are: Single diodes in cellophane-wrapped packages, either individually or in 50-unit cartons, and five and ten unit packs of single crystal-stabilized diodes in reusable, clear plastic cases with hinged, snap-lock covers. Wall dispensers contain 50 of one diode type in individual packages; and counter dispenser accommodates single packs, as well as the plastic cases with a choice of five or ten diodes to a container.



Vidaire

FIL-TEST

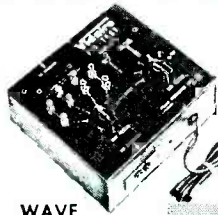

WAVE TRAP METER

Accurately Determines Line Filter or Antenna Wave Trap

Within Seconds.

- Eliminates installing individual filters or wave traps
- Eliminates hours of troubleshooting TVI.
- Reduces service man's inventory of filters and traps.

Vidaire

FIL-TRAN WAVE TRAPS

- Reduces effects of interfering signals
- High Q coils used for high efficiency
- Removes most picture sound interference from amateur radio, foreign broadcasts, drabbing, etc.



5 Models
15 to 160 MC

LINE FILTER



4 MODELS AVAILABLE

Vidaire

- Reduces, eliminates effects of interfering signals thru line of TV or radio
- Completely shielded, prevents stray signal pickup
- Low pass filter — no tuning adjustments necessary

Vidaire

KINE-TEST

- Accurately determines if picture tube is bad
- Simultaneously checks filament voltage, bias voltage, first anode voltage, video signal at picture tube socket



Vidaire Electronics MFG CO.
EXECUTIVE OFFICES and PLANT

576 WEST MERRICK RD. LYNBROOK, N.Y.

FREE MAIL THIS COUPON

Please Send FREE

- Latest catalog
- TV INTERFERENCE AND ITS REMEDIES

NAME _____

ADDRESS _____

CITY _____

STATE _____

Color TV

(Continued from page 31)

traps are at fault, since the chroma may be turned off with a customer-operated chroma control.

This particular receiver is of the *R-Y/B-Y* type, as opposed to an *I-Q* receiver. The sync detectors are made to detect along the *R-Y* and *B-Y* vectors, rather than along *I* and *Q* vectors. In this case, the *R-Y* and *B-Y* signals are treated with equal bandwidth, being approximately the same as the bandwidth required for the *Q* channel alone. This may be noted from Fig. 4 (p. 31), wherein the bandwidth of the chroma channel is shown to be ± 600 kc referred to 3.58 mc. It has been determined by numerous observers that widening the bandwidth of the chroma channel adds little, if anything to the ultimate color picture quality. (One must bear in mind that the *Y* signals essentially provide all picture detail information and that only limited detail is required in the reproduction of the chroma portion of the picture.)

In the process of bandpass limiting in the chroma channel, the chroma signals become unavoidably delayed, as would any signal which is passed through a low-pass filter or other band-limiting device. With the actual bandwidth employed, this delay becomes approximately .8 microsecond. It is for this reason that a similar delay is incorporated in the *Y* channel to assure simultaneous arrival of both signal components at the adders. One distinct advantage of an *R-Y, B-Y* equal bandwidth receiver is the fact that only one delay line is required rather than two, as would be the case in an *I-Q* receiver which treats both pieces of chroma information with unequal bandwidth.

As indicated, chroma signal output is taken from the chroma cathode follower. Here again, it is necessary to obtain an adjustable level, low-impedance output. This requirement is established by the following sync color detectors.

It has been found necessary to shut off the chroma channel during the horizontal retrace interval to prevent erroneous operation of the *dc* restorers in the grid circuits of the picture tube. To prevent this difficulty, a negative-polarity horizontal blanking pulse is fed to the grid of the chroma cathode follower.

The chroma channel actually supplies two output signals. The first is the adjustable level chroma signal which is fed to the synchronous detectors, as mentioned. The other signal is also a composite chroma signal which is fed to the burst gate.

[To Be Continued]

The NEW 60 SUPER 60

TV ANTENNA

UNCONDITIONALLY

GUARANTEED for

100 MILES ON VHF
60 MILES ON UHF

BOTH COLOR AND

BLACK & WHITE \$36⁷⁵

ON

ALL CHANNELS 2-83
IN ALL DIRECTIONS

WITHOUT A

ROTORMOTOR OF ANY KIND

ALL CHANNEL ANTENNA CORP.

47-39 49th STREET, WOODSIDE 77, N. Y.

EXETER 2-1336

TV Antennas

(Continued from page 36)

combine single channel and broad-band yagis. Consequently, it is a popular device not only in two-channel areas, but also in areas capable of receiving many channels, particularly fringe areas. In such locations, it is not uncommon to find a filter combining broad-band yagis for both the high band and the low band.

In areas where both *uhf* and *vlf* channels can be received, Service Men often have a choice of installing an all-channel *vlf-uhf* antenna or separate antennas for each band. It is frequently more desirable for one to use separate antennas for each band because there then is the opportunity to select antennas peaked for the channels involved; in addition one also has the opportunity of orienting the antennas separately.

Two different interaction filters are available for these situations, as noted. One type² combines a single *uhf* antenna with a single *vlf* antenna. It makes no difference what type of antennas are joined; these can be yagis, or broad-band types.

In many cases *uhf* stations have gone on the air in those areas where separate yagis had previously been

used to receive high and low-band channels. Here again Service Men have found that an interaction filter³ can be used to join all three antennas to a single transmission line; *uhf*, high-band *vhf*, and low-band *vhf*.

Interaction filters operating on *uhf* require particular attention on the part of the Service Man. For example, even in filters employing high and low-pass circuits it is desirable to maintain specific lead-lengths. Not only does this help to maintain the impedance over the enormous frequency spread involved, but maintaining the recommended lead-lengths assures one of proper minimum spacing between his antennas.

Some of the interaction filters designed for *uhf* operation employ free space stand-off terminals. This is a desirable feature which helps prevent picture dimout due to shorts caused by rain or snow. It is recommended that Service Men select such filters that are sealed in electrical wax, protecting the surface from dirt and moisture. On *vhf* interaction filters ordinary flat ribbon transmission line is satisfactory, but in the *vhf-uhf* types the use of quality *uhf* transmission line is recommended throughout.

It is no mystery why interaction filters have become a standard accessory with most installation men. They permit the use of up to three antennas with but a single transmission line, and they eliminate switching and prevent interaction. And properly designed filters can accomplish this with no signal loss.

Servicing Helps

(Continued from page 35)

other words, the known waveform is substituted for the unknown.

Some 'scope manufacturers have recognized the need for peak-to-peak readings and have added this feature to their 'scopes. A system employed identical to the calibrator is used, except that the sine wave is not squared but merely calibrated. This results in a practical approach that is easy to apply and accurate enough for service work.

Peak-to-Peak Meter

A similar design principle has been included in a recently developed peak-to-peak comparison meter*. The unit can be connected to any 'scope permanently with two mounting brackets or two separate leads. When the equip-

*Senco model PP2; Service Instruments Co.

**EVERY
SERVICEMAN
NEEDS THIS
VOLTAGE
ADJUSTOR**

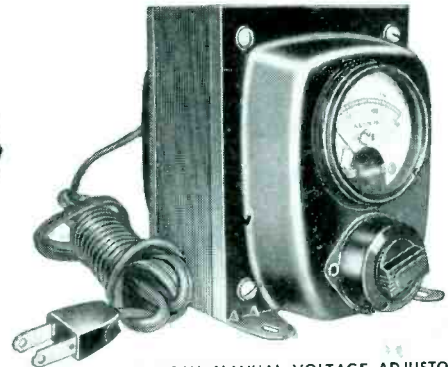

T-8394M MANUAL VOLTAGE ADJUSTOR

Where low voltage is affecting TV reception, the service man can detect the condition at once with a T-8394M Acme Electric Voltage Adjustor. And by a simple demonstration he can sell a Voltage Adjustor to the TV set owner. Sales are easy to make because demonstration while servicing a set quickly convinces its owner that the voltage regulation is essential to good TV reception.

How To Use The T-8394M VOLTAGE ADJUSTOR on Service Calls

With the tap switch set at 115 volts, the meter reading will show incoming line voltage. Thus it can be instantly determined if line voltage is lower than normal required for good TV set performance.

The T-8394M Voltage Adjustor can also be used to reproduce the operating condition about which the customer complains by turning tap switch to the voltage which simulates such condition. For example, customer complains that evening program pictures flicker and shrink. When service man calls next day all operation appears normal — voltage tests out properly. But, by adjusting voltage to 97 volts the condition about which the complaint was made is reproduced. This indicates low voltage condition during evening that can be corrected with a T-8394M Voltage Adjustor.

Not A Gadget — A High Quality Unit You'll Be Proud To Use

The T-8394M Voltage Adjustor can be installed instantly, no tools needed. Just plug into most convenient outlet. Then plug television cord into secondary receptacle on Voltage Adjustor.

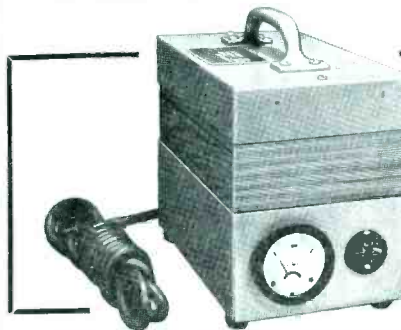

FOR COMPLETELY AUTOMATIC VOLTAGE CONTROL

Regardless of line voltage supply, the Automatic Voltrol corrects voltage fluctuation over a range from 95 to 130 volts. The voltmeter supplied indicates secondary voltage while unit is in operation. A built-in relay automatically disconnects circuit when set is turned off.

Acme Electric
TRANSFORMERS

ACME ELECTRIC CORPORATION
MAIN PLANT: 477 WATER STREET • CUBA, N. Y.
West Coast Engineering Laboratories:
1375 West Jefferson Boulevard. • Los Angeles, California
In Canada: Acme Electric Corp. Ltd.
50 North Line Road • Toronto, Ontario

ment is turned off, the input can be connected straight-through and the 'scope functions as though the unit were not attached. When the meter is turned on, a calibrated sine wave appears; this is compared in amplitude to the unknown waveform.

Import of 'Scope

Substantial time can be saved when one learns to use their 'scope properly. Waveform amplitude is as fundamental as a 6-volt battery and becomes more important as circuits become more complicated.

Service Engineering

(Continued from page 51)

are very, very sharp and it is difficult to hit the proper signal.

Frequency coverage varies with individual models, of course, but the average set will reach at least 18 mc, and some of the larger sets will go as high as 50 mc; usually in the amateur FM band. Frequencies around 20-25 mc are not out of the ordinary. The correct setting of the oscillator on these models demands an extremely accurate source of signal.

look for the
Howard W. Sams
"BOOK TREE"

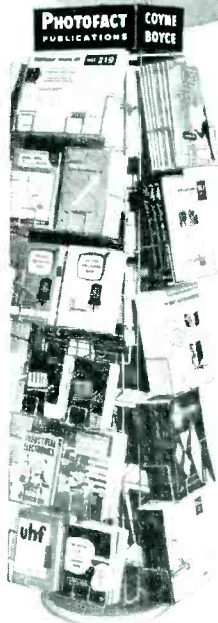

at your
PARTS
DISTRIBUTOR

Make it a habit to "browse" at the Howard W. Sams "Book Tree". You'll find it at your Parts Distributor. It's loaded with the time-saving, profit-building books you want and need. Keep ahead with these timely, practical publications that help you learn more and earn more daily.

LOOK FOR THESE TITLES:
Television Books

"Telecasting Operations".....	\$7.95
"Photofact Television Course".....	3.00
"TV Servicing Short-Cuts".....	1.50
"TV Test Instruments".....	3.00
"UHF Converters".....	1.00
"UHF Antennas".....	1.50
"Television Antennas".....	2.00
"Servicing TV in the Customer's Home".....	1.50
"Making Money in TV Servicing".....	1.25
"TV Tube Location Guide" Vols. 4, 3, 2, each.....	2.00
"TV Tube Location Guide" Vol. 1.....	1.50

Audio Publications

"Recording & Reproduction of Sound".....	\$7.95
"Audio Amplifiers" Vols. 4, 3, 2, each.....	3.95

Record Changer Manuals

"Automatic Changer Manual" Vols. 5, 4, 3, each.....	\$3.00
"Automatic Changer Manual" Vol. 2.....	4.95

Handy Service Guides

"Radio Receiver Tube Replacement Guide".....	\$1.25
"AM-FM Servicing Short-Cuts".....	1.50
"Dial Cord Stringing Guide" Vols. 4, 3, 2, 1, each.....	1.00

Auto Radio Service Manuals

"Auto Radio Manual" Vols. 3, 2, each.....	\$3.00
"Auto Radio Manual" Vol. 1.....	4.95

Communications Receivers

"Communications Receivers" Vols. 2, 1, each.....	\$3.00
--	--------

Coyne and Boyce Books

"Coyne TV Servicing Cyclopedias".....	\$5.95
"Coyne Transistors".....	1.50
"Coyne Practical TV Servicing".....	4.25
"Coyne Latest Test Instruments".....	3.25
"Coyne TV & Radio Handbook".....	2.75
"Coyne Industrial Electronics".....	3.75
"Boyce Video Handbook".....	5.95
"Boyce Radio Handbook".....	4.95

See these and dozens of other
invaluable books on the
Howard W. Sams "Book Tree"!

HOWARD W. SAMS & CO., INC.
Indianapolis 5, Indiana

Look for these books—
order them at your Parts Distributor

NEWS

CBS-HYTRON KITS

A pliers kit, available free with the purchase of CBS-Hytron receiving tubes, from July 1 through August 31, has been announced by CBS-Hytron, Danvers, Mass.

Kit consists of a set of three pliers in a plastic carrying case. Pliers are 6½" diagonal, a box-joint side-cutter with matched jaws; 8" long-nose, that is chrome-plated and has hand-honed cutting knives; and 6" all-purpose, which combines flat and round nose, two wire strippers, and two side cutters.

An improved tube-and-tool caddy, that features a scuff-proof, soil-resistant vinyl plastic covering; heavy-duty metal corner reinforcements; more space for GT tubes (holds 68 GT tubes, 210 tubes in all); one-inch deeper tool compartments; roomier door pocket for flashlight, manuals, etc.; 10" x 12" test mirror mounted inside the cover, has also been announced.

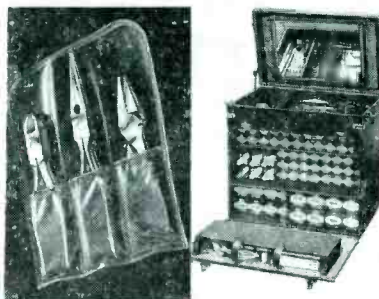

**INTERNATIONAL RECTIFIER SELENIUM
DIODE APPLICATION CONTEST**

A nationwide contest, for new applications of selenium diodes, has been announced by the International Rectifier Corp., 1521 E. Grand Ave., El Segundo, Calif.

A Ford V-8 Tudor Mainliner sedan will be awarded to the contestant submitting the most useful and practical new application. In addition, 50 secondary prizes totaling \$1500 will be awarded. The contest has no special requirements for participation and any and all persons are urged to compete. Deadline for all entries is January 1, 1955.

Dr. Lee deForest, United Engineering Laboratories, Los Angeles, will be a consultant to final selection of the winning entry along with contest judges J. T. Cataldo, assistant general manager, and F. W. Parrish, design engineer.

TARZIAN SELENIUM SALVAGE DRIVE

A selenium rectifier salvage campaign, designed to alleviate an acute shortage of selenium throughout the country, has been announced by Sarkes Tarzian Inc., Rectifier Division, 415 N. College Ave., Bloomington, Ind.

Company will pay, in the form of credit against future purchases, for burned out or defective out-of-warranty rectifiers, regardless of make. Call types wanted include 1" or 1.25" (models 65 through 150), and 1.5"—1.6"—2" (models 250 through 500).

**Mueller
MAKES THE CLIPS!
ALL TYPES—ALL SIZES
at jobbers everywhere**

Wee-Pee-Wee Clips

Pee-Wee Clips

Alligator Clips

Crocodile Clips
Shown in typical flexible insulator

Needle Clips

Test Clips

SAMPLE BOARD

**SEND FOR FREE CLIP &
INSULATOR SAMPLES!**

Pick from illustrations above.

5 INSULATOR COLORS now available for easy lead identification. Black, Red, White, Blue and Yellow. Samples furnished on request.

NEW CATALOG No. y573
ON REQUEST



Ask about handy, low cost display and selection board, for department heads, jobbers, etc.

Mueller Electric Co.

1573Y EAST 31st STREET • CLEVELAND 14, OHIO

**JENSEN MOVES TO CHICAGO
SUBURB**

Jensen Industries, Inc., has moved both factory and office headquarters from Chicago to 7333 W. Harrison, Forest Park, Ill.

Facilities at Forest Park are all on one floor and provide double the floor space of all three floors in the old building.

**SYLVANIA DISTRIBUTOR-DEALER
PROMOTION**

A 3-month promotion, which will make available to distributors and dealers an aluminum TV set carrier, *Classy Chassis*, for transporting TV sets, has been announced by Sylvania Electric Products Inc., New York, N. Y.

TV set carrier is of all aluminum construction and weighs 13½ pounds, including ball-bearing rubber wheels.

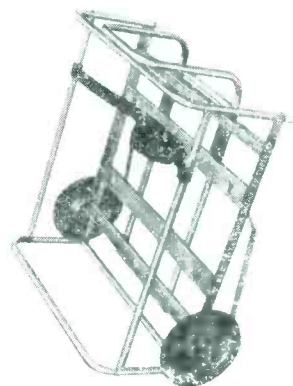

Hi-Fi Amp Bias Circuitry

(Continued from page 38)

amp into a system whose heater supply was not designed for low-level stages, and where the preamp introduces hum derived from heater-to-cathode coupling in the preamp tube. If the output tubes draw 150 mils of current, as do 6L6s, for example, the preamp filament can be connected into the output cathode circuit, rather than to the heater winding of the power transformer. The preamp tube itself, of course, must have a 150-mil heater; 6SC7s or 6SL7s must be replaced by 12SC7s or 12SL7s. Certain tubes designed especially for preamp use, such as the 12AY7, can be operated with either a 6.3 v, .3 a heater supply, or a 12.6 v, .15 a supply, depending on whether the two heater sections are connected in parallel or in series.

When a tube filament forms part of the cathode bias resistance, the original cathode resistor must be changed to one of lower value. The new value may be calculated by Ohm's law, where E = the original cathode-to-ground voltage minus 12.6 (the voltage used up by the tube heater), and I = .15 amp. It may also be checked experimentally; when the cathode-to-

ground voltage of the new circuit is the same as it was previously (assuming no original defects) R is of the correct value.

Symptoms of Faulty Bias

Incorrect bias voltage increases the distortion level of an amplifier by a large factor. This is especially true for high-amplitude signals, which cause the amplifier to overload and the sound to become mushy.

Too negative a bias will distort the sound but not damage the tubes. A bias voltage which is too little negative, on the other hand, or actually positive, will cause surplus current to flow and will quickly destroy the tube, possibly with internal fireworks. A fairly common occurrence, especially with output tubes, is to find that a replacement for a defective tube soon goes bad itself. Insufficient negative bias must be suspected.

Correction

In the fixed-bias power supply circuit (Fig. 4, June, 1954), the ground in the heater-return circuit of the rectifier was inadvertently omitted.

Mr. Serviceman

OXFORD'S

NEW

REAR DECK SPEAKERS

mean **MORE PROFITABLE**

AUTO RADIO WORK for YOU!



Model
RD-69
6" x 9"
\$13.40

Suggested list price:

Preferred for
Original
Equipment —
Proven for
Replacement



Model
RD-57
5" x 7"
\$12.15

Suggested list price:

Sold Through Recognized Jobbers Only!

**OXFORD
ELECTRIC
CORPORATION**



3911 SOUTH MICHIGAN AVENUE
CHICAGO 15, ILLINOIS

EXPORT — ROBURN AGENCIES, NEW YORK CITY
IN CANADA — ATLAS RADIO CORP. LTD., TORONTO

Heathkit TEST EQUIPMENT

BUILD YOUR OWN — INCREASE KNOWLEDGE — SAVE MONEY — BUY DIRECT FROM MANUFACTURER . . . Top quality instruments in kit form featuring latest design and circuit developments. Completely detailed step-by-step construction manual — clear pictorials — complete schematics. All sheet metal work punched, formed and finished. Low kit prices include tubes, chassis, cabinet and all necessary constructional components.

Kits for the school — service shop — industrial laboratory — hobbyist, etc.

Write for free catalog for further information.



NEW MULTIMETER KIT
\$26.50



SIGNAL TRACER KIT
\$23.50



NEW SCOPE KIT
\$59.50



CONDENSER CHECKER KIT
\$19.50



VACUUM TUBE VOLTMETER KIT
\$24.50



TUBE CHECKER KIT
\$29.50



SIGNAL GEN. KIT
\$19.50



GRID DIP METER KIT
\$19.50

HEATH COMPANY
BENTON HARBOR 11,
MICHIGAN

NEW RCP AC-DC MULTITESTER

IMPROVED... ALL MOLDED

Unequaled
in Appearance
and Performance
by any other
in its class

Now within an all molded panel and case RCP has built a multitester based upon the successful tradition of its famous Model 447, whose acceptance has been proven through the sale of 100,000 prototypes. The Model 480 provides greater multitester value than ever before at a far lower price. Here is a must for every laboratory, shop and serviceman's kit... truly universal in design. Its smart looking appearance is only equalled by its quality of performance.

3" square meter with 800 microampere D'Arsonval movement gives 1000 ohms per volt sensitivity on DC. Battery for ohmmeter circuit is readily removable and replaceable without soldering or unsoldering. Special spring contact clips make replacement immediately and easily. Excellent rectifier characteristics and quality control of components in a very large production result in an unusually low price.



Model 480
An Exceptional Value at... **\$14.85**

Size 7" x 4 3/4" x 2 1/2", Weight 20 oz. Shipping Weight 34 oz. Complete with battery, ready to operate

RANGES

DC Voltmeter	0-5-50-250-500-1000 volts.
AC Voltmeter	0-10-100-500-1000 volts.
Output Voltmeter	0-10-100-500-1000 volts.
DC Milliammeter	1-10-100-1000 milliamperes.
Ohmmeter	0-10,000 ohms—100,000 ohms—1 megohm and 10 megohms external.
Decibel Meter	—8 to 55 Decibels.

RADIO CITY PRODUCTS CO.
EASTON
PENNSYLVANIA

See your local parts distributor, or write Dept. S-7 for RCP catalog.

2-STEP AMP DISTRIBUTION-PLAN



Hi-fi 10-watt amplifier, featuring a 6 position record crossover selector, now being marketed through a two-step distribution program. Has an interlocked tone circuit, built-in rumble filter and a tape output jack from which one can make own tape recordings while listening. Includes compensated magnetic pickup preamp. Circuit incorporates stabilized inverse feedback. Output impedances are 8 and 16 ohms. Tubes: one 6SC7, one 12AX7, two 6V6GTs and one 6AX5GT. (Model D-10; Newcomb Audio.)

ALIGNMENT TOOL DISPLAY



Alignment tool stand displaying 49 of the most popular alignment tools. Display requires 21" x 15" of space. (General Cement Mfg. Co., 919 Taylor Avenue, Rockford, Ill.)

ROTATING BOOK SELLER



Revolving book merchandiser which stocks up to 500 Rider books and displays as many as 66 different titles.

RADELCO

LIGHTNING ARRESTOR FITS FLAT, OVAL, ROUND AND OPEN CABLES!

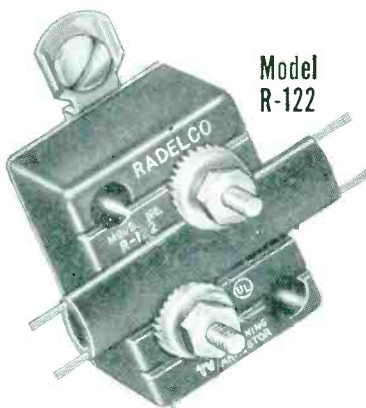

IT'S NEW! IT'S BETTER!
The only Underwriters Listed UHF-VHF Lightning Arrestor selling at 90c list.

ORDER FROM
YOUR NEAREST
PARTS JOBBER

LIST PRICE
90c

GI ACQUIRES CANADIAN SUBSIDIARY

Formation of General Instrument—F. W. Sickles of Canada, Ltd., which has purchased Watt Electronic Products, Ltd., with a plant in Kitchener, Ont., near Toronto, has been announced.

Edgar Messing, vice president of F. W. Sickles division, will be responsible for initiating and coordinating Canadian activities. Hugh T. Watt, former president of Watt Electronics, will remain in charge of this operation.



Hugh T. Watt



Edgar Messing

* * *

GRAMER BUYS HALLDORSON

Gramer Transformer Corp., 2734 North Pulaski, Chicago, has purchased the Halldorson Transformer Co., 4500 North Ravenswood, Chicago.

No basic personnel changes are contemplated in the Halldorson organization.

Tools . . . Parts . . .

MULTICORE SOLDER SERVICE PAK

A line of 5-core non-corrosive Erisin-flux solder in a *service pak* that features a wooden spool, is now available from the Multicore Sales Corp., 164 Duane St., New York 13, N. Y.

Solders are available with 60% tin/40% lead (red pak), 50% tin/50% lead (yellow), and 40% tin/60% lead (green). Gauges and alloys are printed on each pak.

Solder has a thin wall 5-core construction that is said to assure flux continuity and prevent dry joints. Flux is a high-grade water-white rosin, homogeneously activated, that is claimed to be non-corrosive even after a long exposure to humidity.



C-D MINIATURE MICA CAPACITOR

A midget mica capacitor, hi-Q type, in the form of an encapsulated unit, *Super Micadon*, (capacitor section is separately processed in its entirety and then inserted and sealed into a premolded case) has been developed by the Cornell-Dubilier Electric Corp., South Plainfield, N. J. Two sizes are available: *5A*, 51/64" x 15/32" x 7/32", and *1A*, 53/64" square x 9/32".

Units, designed with flat, clinched wire leads are said to feature a temperature range of from -55° C to +130° C, and capacitance range up to 20,000 mmfd at 300 *dcv.*

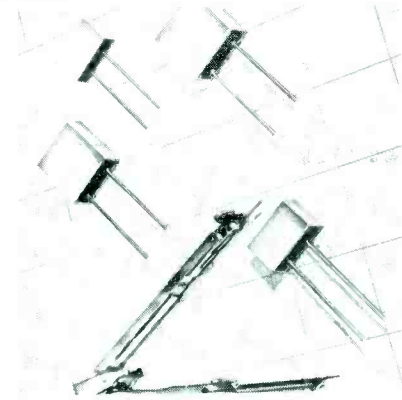

SIMPSON COLOR PROBE AND BOOSTER AMPLIFIER

A color adapter cable, *Chromatic Probe*, and *booster amplifier*, for alignment and adjustment of color TV sets, for use with either the 480 *Genoscope* or 479 AM-FM signal generator, has been developed by the Simpson Electric Co., 5200 W. Kinzie St., Chicago 44, Ill.

Accessories convert monochrome sweep marker systems into chromatic systems. Probe increases b-w TV test applications for either model. Booster amplifier serves to check certain low-gain video amplifiers in color TV chassis and may be required for other tests also, in case a low-gain scope is being used.



Presenting the New Vidaire

EXTENSION SPEAKER

MODEL ES-200

- Brings the TV or Radio sound right to the viewer or listener.
- Either speaker may be switched on or off.
- Volume control for adjusting sound level.



Vidaire ELECTRONICS MFG. CO.
LYNBROOK, NEW YORK



Available Through Parts Distributors From Coast To Coast

Snyder
PHILADELPHIA

AUTO RADIO ANTENNAS

THE ONLY COMPLETE LINE



SNYDER

SNYDER MFG. CO., PHILADELPHIA 40, U. S. A.
BELLEVUE TUBE MILL, INC., PHILADELPHIA
SNYDER ANTENN-GINEERS LTD., TORONTO 14
WORLD EXPORT: ROBRUN/AGENCIES, INC., N. Y.

NEW SUPER POST TOWERS for TELEVISION ANTENNAS in FRINGE AREAS

Available
in Heights
from 33 ft.
to 100 ft.

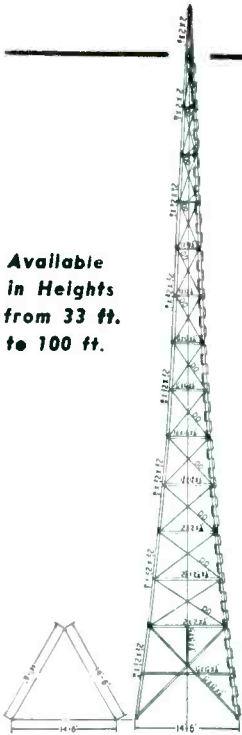

TOWERS OF STRENGTH TO LAST A LIFETIME

Self-supporting tower built up of galvanized steel sections. No guy wires necessary. Easy to erect. Safe and resistant to high wind. Available in heights 33 ft., 47 ft., 60 ft., 73 ft., 87 ft., and 100 ft. with bases in proportion.

FRINGE AREA TV BUYERS MUST HAVE SPECIALLY BUILT TOWERS FOR CLEAR RECEPTION

Tower and the TV set go hand in hand as a package sale to rural TV buyers. Provides an extra sale and profit to dealers. An excellent fast selling accessory for jobbers and dealers.

TERRITORIES OPEN FOR JOBBER DEALER FRANCHISE

Write for complete structural details, packing, prices, discounts, and territorial assignment.

MANUFACTURED BY

AERMOTOR CO.

DEPT. 6407, 2500 ROOSEVELT ROAD • CHICAGO 8, ILL.
BUILDERS OF STEEL TOWERS SINCE 1888

Coming Events

Western Electronic Show

Pan-Pacific Auditorium, Los Angeles, Calif.
August 25, 26 and 27, 1954

Hi-Fi Show:

International Sight-Sound Exposition
Palmer House, Chicago, Ill.

Sept. 30, Oct. 1 and 2, 1954

National Electronics Conference

Hotel Sherman, Chicago, Ill.

October 4, 5 and 6, 1954

WHEN YOU CHANGE YOUR ADDRESS

Be sure to notify the Subscription Department of SERVICE at 52 Vanderbilt Avenue, New York 17, N. Y., giving the old as well as the new address, and do this at least four weeks in advance. The Post Office Department does not forward magazines unless you pay additional postage, and we cannot duplicate copies mailed to the old address. We ask your cooperation.

SNYDER DUAL REAR-DECK AUTO- RADIO ANTENNA

A dual rear deck auto-radio antenna kit, is now available from the Snyder Manufacturing Co., Philadelphia 40 Pa.

Two styles are featured: a swivel, and ball and socket. The former, RD-8 and the RD-8B, has a matched impedance hi-Q transformer for country and low-signal area reception. Ball and socket, RD-9 and the RD-9B have a matched impedance hi-Q transformer.

Kits include 2 antenna staffs, 22' hi-Q coax harness consisting of a 15' length (rear deck to radio), a 7' length T-connector lead (antenna to antenna) and one M/P plug adapter, plus five body cable clips for mounting cable on car. Coax cable harness is a shielded hi-Q cable which interconnects dual antennas to car radio and abolishes splicing and taping.

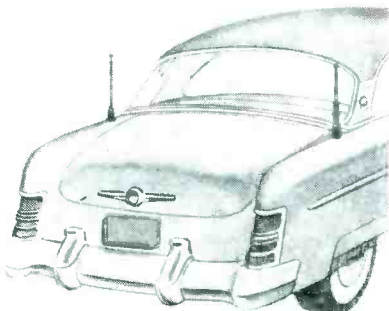

HICKOK UNIVERSAL NOISE GENERATOR

A noise generator, 755, for measurement of noise factor, has been introduced by The Hickok Electrical Instrument Co., 10521 Dupont Ave., Cleveland 8, Ohio.

Unit contains two indicating meters and is divided into a vtvm section and a generator noise section. In the voltmeter section, meter readings are provided for 0-1, .5, 1 and 5 v, zero center. In the output section, db-meter output readings include 300, 75 and 50 ohms.

Instrument features built-in stand-by position for noise output, and noise diodes built into probe whereby the output noise is connected directly to receiver input. A uhf head with 100-1000 mc is available.

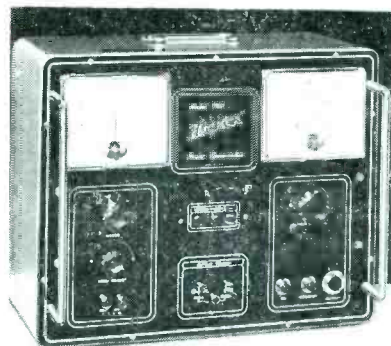

EICO VTVM AND PROBE

A peak-to-peak vtvm, 232, in kit or wired form, is now available from Electronic Instrument Co., Inc., 84 Withers St., Brooklyn 11, N. Y.

Specifications include: dc voltmeter—ranges 0-1.5, 5, 15, 50, 150, 500, 1500 v; ac voltmeter—ranges rms reading of sine waves same as dc; peak-to-peak reading of sine and complex waves 0-4, 14, 42, 140, 420, 1400, 4200 v; separate scale for 0-1.5 v rms and corresponding 0-4 v p-p ranges; frequency response 30 cps to 3 mc; ohmmeter readings 0-1000 megohms in 7 ranges.

A high-voltage probe, HVP-2, designed for use with any vtvm or 20,000-ohms/volt multimeters for measurements up to 30,000 v, is also available.

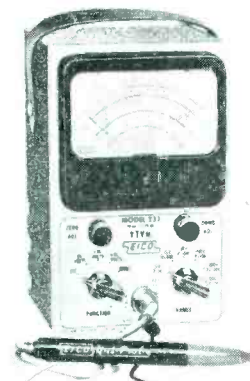

Instrument

GRANCO UHF SIGNAL GENERATOR

A *uhf* signal-gain generator, *SU-200*, that features coax tuning elements; continuous tuning over entire *uhf* band; calibration in both frequency and channel designations; balanced detector meter circuit and gain control has been announced by Granco Products, Inc., 36-17 20th Ave., Long Island City 5, N. Y.

Frequency range is 440 to 910 mc, with an accuracy said to be $\pm 2\%$, indicated by a single direct-reading scale. Instrument measures gain, tracking, calibration, accuracy and range of *uhf* tuners, converters, antennas, strips, boosters and receivers. Can act as a signal power source for various types of measuring equipment, such as *uhf* bridges and slotted lines.



* * *

WESTON SWEEP GENERATOR

A sweep generator, model 984, designed for troubleshooting of sound and video *if* circuits, associated trap circuits, TV tuners, video amplifiers and all-purpose visual alignment has been announced by Weston Electrical Instrument Corp., 614 Frelinghuysen Ave., Newark, N. J. *RF* output: frequency-modulated signal, TV channels 2 to 13; complete FM coverage available by means of two preset selector positions. Frequencies are fundamentals of oscillator frequency. *If* video output: Frequency modulated signals ranging to 50 mc, continuous tuning. Sweep width: Full 10-mc on all channels. Output voltage (*rms*) is 0.1 volt; sweep is linear.



SYLVANIA VTVM

A vacuum-tube-voltmeter, 302 *Poly-meter*, featuring a subminiature vacuum-tube *rf* probe, peak-to-peak scale, 7" meter movement, lighted scale, patented linearity circuit, input impedance of 17 megohms, shielded *ac* and *rf* leads, and screw-on connectors, has been announced by Sylvania Electric Products Inc., 1221 W. 3rd St., Williamsport, Pa.

Instrument reads peak-to-peak voltages from 200 mv to 2,800 v, *dc* voltages from 200 mv to 2,800 v, *dc* voltages, \pm polarity from 50 mv to 1,000 v, *ac* voltages from 50 mv to 1,000 v, *rf* voltages from 100 mv to 300 v in the band of 10 kc to 300 mc, resistance from .5 ohm to 1,000 megohms and db from -20 to +61.4. *DC* voltage range may be extended to 30,000 v by using a 30-kv *dc* voltage multiplier probe, model 225.



* * *

EMC TUBE-TESTER

A tube-tester, 208, that checks octal, loctal, miniature and noval base tubes for tube quality as well as shorts, leakages, continuity or opens between any two elements of the tube, has been introduced by Electronics Measurements Corporation, 280 Lafayette Street, N. Y. 12

Incorporated is a visual line voltage check. Individual sockets are furnished for each tube type and elements are numbered according to pin number in RETMA base numbering systems.

Another feature enables tester to match and check *hi-fi* tubes, such as 1614, KT66, and 5881. A picture tube adaptor is also available.

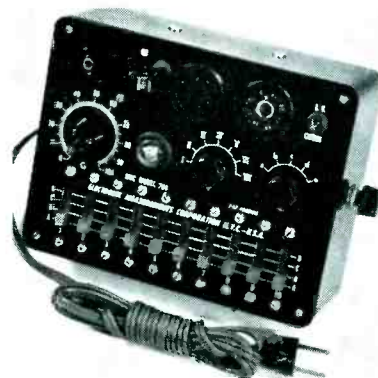

4 NEW RIDER BOOKS RELEASED IN JUNE!

ADVANCED TELEVISION SERVICING TECHNIQUES

Written by the RETMA (Radio Electronic Television Manufacturers' Association) Pilot Training School Teaching Staff.

A completely new approach to books for TV service technicians. Written by experts who are teaching every day. The contents have been tried and proven to be the finest ever written. Completely practical. A step-by-step approach to how to service every section of a TV receiver with every kind of test equipment—by resistance measurement, by voltage measurement, by means of the scope. It explains the uses of test equipment of all kinds in connection with TV receiver servicing, such as sweep generators—signal generators—vacuum tube voltmeters—scopes, ohmmeters! Approx. 175 (8 1/2 x 11") pages. Soft cover.

Only \$3.60

ATTENTION TEACHERS: The main book above and a Laboratory Manual for use with it, as well as the Teacher's Guide also are available. Write for details.

SPECIALIZED AUTO RADIO MANUALS

VOL. 4-A covers Chrysler, DeSoto, Dodge, Dodge Trucks, Plymouth. 160 (8 1/2 x 11") pages. Soft cover. . . . Only 3.00
Cover 5 years' production (1950 thru 1954) of factory installed car radios. Identical data from other sources is just not available! Each volume contains: Parts List, Schematics, Tube Layout, Voltages, Trimmer Location, Chassis Views, Chassis Pictures, Dial Stringing, and complete installation and removal information.

VOL. 1-A covers Ford, Lincoln, Mercury. 208 (8 1/2 x 11") pages. Soft cover. Only \$3.00
VOL. 2-A covers Buick . . . Cadillac . . . Oldsmobile. 200 (8 1/2 x 11") pages. Soft cover Only 3.00

VOL. 3-A covers Chevrolet, Pontiac, GMC Trucks, Chevrolet Trucks. 128 (8 1/2 x 11") pages. Soft cover. . . . Only 1.80

COLOR TV DICTIONARY

by J. R. JOHNSON

First complete explanation of new color TV terms with their definitions that everyone—service technicians, students, engineers, amateurs—interested in color television must be familiar with. This is more than a dictionary! Over 50 illustrations. 72 (5 1/2 x 8 1/2") pages, soft cover. . . . Only \$1.25

R-C & R-L TIME CONSTANT

edited by ALEXANDER SCHURE, Ph.D., Ed.D.

First in a series of review books written expressly for the student who is studying electronics or the technician who has studied electronics and wishes to understand Time Constant (R-C and R-L) more clearly. It supplements the contents of courses in textbooks which are on a technical institute level. Covers practical applications of Time Constant and how it affects circuit operation. 52 (5 1/2 x 8 1/2") pages. Soft cover. . . . Only \$1.90

Write for information on all RIDER books. Buy these books now from your jobber . . . bookstore . . . If not available from these sources, write to:

JOHN F. RIDER PUBLISHER, INC.
480 Canal Street, New York 13, N. Y.

KESTER

Since the most important single step in Radio-Television Servicing is soldering . . . it's just plain good sense to use the best — KESTER SOLDER . . . Key Name in Solder for More Than 50 Years.

KESTER SOLDER COMPANY
4248 Wrightwood Avenue • Chicago 39, Illinois
Newark 5, New Jersey • Brantford, Canada

SOLDER

TV Parts . . . Accessories

VIDAIRE LINE FILTERS

Line filters, *LF 1-4* (low-pass devices designed to pass all frequencies below 10 kc and attenuate all frequencies above) are now available from Vidaire Electronics Manufacturing Co., Lynbrook, N. Y.

Most TV interference entering the receiver through the line is said to be reduced or eliminated by utilizing one or more of the filters, which are shielded to prevent stray pickup of signals.

A vertical retrace line eliminator, *Elim-A-Trace* designed to blank vertical retrace lines, is also available.

Models *LF-2* and *TE-3* (illustrated) are intended for subchassis mounting.



* * *

MERIT-PHILCO REPLACEMENT TRANSFORMERS

Seven *hr* horizontal deflection transformers, *HVO-15* through *HVO-21*, designed as exact replacements for Philco units, are now available from the Merit Coil and Transformer Corp., 4427 North Clark St., Chicago 40, Ill.

Transformers are said to cover 90 per cent of all Philco chassis and models produced prior to and during '53. Mounting bracket of these models is an exact replica of the Philco units that they replace.

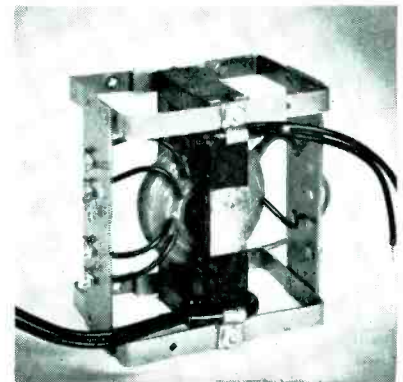

THE NEW MODEL TV-11

TUBE TESTER

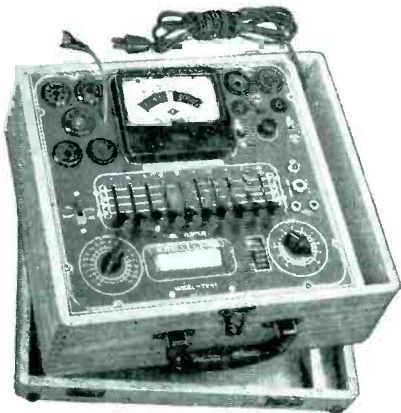

- Uses the new self-cleaning Lever Action Switches for individual element testing.
- Because all elements are numbered according to pin number in the RMA base numbering system, the user can instantly identify which element is under test. Tubes having tapped filaments and tubes with filaments terminating in more than one pin are truly tested with the Model TV-11 as any of the pins may be placed in the neutral position when necessary.
- Uses no combination type sockets. Instead individual sockets are used for each type of tube. Thus it is impossible to damage a tube by inserting it in the wrong socket.
- Free-moving, built-in roll chart provides complete data for all tubes.
- Phono jack on front panel for plugging in either phones or external amplifier detects microphonic tubes or noise due to faulty elements and loose external connections.

EXTRA SERVICE—The Model TV-11 may be used as an extremely sensitive Condenser Leakage Checker. A relaxation type oscillator incorporated in this model will detect leakages even when the frequency is one per minute.

Operates on 105-130 Volt 60 Cycles A.C. Hand rubbed oak cabinet complete with portable cover.

\$47⁵⁰

**SHIPPED ON APPROVAL
NO MONEY WITH ORDER — NO C. O. D.**

Try it for 10 days before you buy. If completely satisfied send \$11.50 and pay balance at rate of \$6.00 per month for 6 months.—No Interest or Carrying Charges Added. If not completely satisfied, return to us, no explanation necessary.

MOSS ELECTRONIC DISTRIBUTING CO., INC.
Dept. D-48, 3849 Tenth Ave., New York 34, N. Y.

Please rush one Model TV-11. I agree to pay \$11.50 within 10 days after receipt and \$6.00 per month thereafter.

NAME
ADDRESS
CITY ZONE STATE

ADVERTISERS IN SERVICE

JULY, 1954

	Page
Acme Electric Corp.	55
Aermotor Co.	60
All Channel Antenna Corp.	54
Alliance Mfg. Co.	22
American Microphone Co.	32
American Phenolic Corp.	47
American Television & Radio Co.	33
Atlas Sound Corp.	50
Belden Mfg. Co.	1
Bussmann Mfg. Co.	7
Buxton Industries, Inc.	63
CBS-Hytron (Div. Columbia Broadcasting System)	6
Channel Master Corp.	18
Chicago Standard Transformer Corp.	53
Clear Beam TV Antennas	3
Cornell-Dubilier Radiart	42
Crosley Div. AVCO Mfg. Corp.	64
Allen B. DuMont Laboratories, Inc.	11
Electro Products Laboratories	2
General Cement Mfg. Co.	9
The General Industries Co.	49
Halldorson Transformer Co.	30
The Heath Co.	57
International Rectifier Corp.	52
Jensen Mfg. Co., Inc.	39
Kester Solder Co.	62
P. R. Mallory & Co., Inc. Inside Back Cover	
Manfredi Wood Products Corp.	50
Moss Electronic Dist. Co., Inc.	62
Mueller Electric Co.	56
Newcomb Audio Products Co.	4
Oxford Electric Corp.	57
Phalo Plastics Corp.	32
Precision Apparatus Co., Inc.	41
Quietrole Co.	15
Rad-EI-Co Mfg. Co.	58
The Radiart Corp. Inside Front Cover	
Radio City Products Co., Inc.	58
Radio Corporation of America. Back Cover	
Raytheon Mfg. Co.	16
John F. Rider Publisher, Inc.	61
Sangamo Electric Co.	31
Howard W. Sams & Co., Inc.	56
Shure Brothers, Inc.	43
Snyder Mfg. Co.	59
Sarkes Tarzian, Inc., Tuner Div.	46
Telrex, Inc.	14
Triplett Electrical Instrument Co.	5
Tung-Sol Electric, Inc.	44, 45
United Catalog Publishers	52
United Motors Service Div. (General Motors Corp.)	12, 13
Vidaire Electronics Mfg. Co.	54, 61
Walsco Electronics Corp.	10
The Ward Products Corp. Div. The Gabriel Co.	21
Winegard Co.	8

JOTS AND FLASHES

A SUBSTANTIAL INCREASE in portable radio popularity during the first quarter of this year has been reported by Ray V. Buzid, G.E. radio sales manager. Industry retail sales figures, he said, show that the portable radio has bettered its share of total sales by about 31 per cent during the first part of this year compared with a similar period in '53. . . . Dr. Allen B. DuMont, president of Allen B. DuMont Laboratories, Inc., was recently named *Father of the Year* in the field of Science by the Boys' Clubs of America. . . . Manufacturers were urged to tap the nearly 4½-billion dollars in sales that lie outside the radio and TV set fields by *Burton Browns*, in a recent address before the N.Y. chapter of *The Repts.* Today, he said, there are some 1,339 specific applications of electronic equipment by such industries as the airlines, ceramic manufacturers, chemical manufacturers, construction contractors, cosmetic manufacturers, food processors, glass manufacturers, plastics, railroads, petroleum, and others. . . . *Queens Evening Trade School*, 47th Ave., and 37th St., Long Island City 1, N.Y., is offering free courses in radio and TV service. Classes meet two nights a week, from 7-9 P.M. Registration for all classes will be held Sept. 13-14, from 7-9 P.M., in the school auditorium. . . . The '54 annual convention of the *Audio Engineering Society*, to be held at the Hotel New Yorker, is scheduled for October 13-17. . . . G. E. has announced it is ready to supply color TV systems for closed circuit use in education, business and industry. System is composed of color camera, camera control console together with a remote control unit for controlling all elements of focusing, angulation, and lens selection, a rack-mounted power supply providing a regulated source of dc power, and a receiver. . . . State and city officials, civic and business leaders of Indianapolis recently joined in formally dedicating the new home of *Howard W. Sams and Co., Inc.*, at *Sams Park*, 34th and Sutherland Ave., Indianapolis, Ind. . . . '54 *NEDA* battery index is now available. Single copies are free, and larger quantities are available at \$5.75 per hundred, by writing to 228 N. La-Salle St., Chicago 1, Ill. . . . Radio Receptor, Inc., New York City, has changed the name of its *selectron* and *germanium* division to *semi-conductor* division. *Jerome R. Meltzer* has been appointed assistant sales manager of the division's distributor sales department. . . . All radio receivers (eight-tube sets) for the '55 Lincoln and Mercury models will be manufactured by the Radio Communication division of *Bendix Aviation Corp.* . . . An internal house organ, *Sales Symphony*, published by *Phalo Plastics Corp.*, received the premiere award in the Creative Awards Competition held recently by the National Advertising Agency Network. . . . 1500 Service Men attended Raytheon's *Service Saver* and *Bonded Electronic Technician* meetings held recently throughout the northwest. Over 600 attended meetings held in Ohio and western Pennsylvania, and 500 were at meetings held in New England. . . . A new single-story plant annex of *Granco Products, Inc.*, 36-17 20th Ave., Long Island City, N.Y., was opened recently. Structure is equipped with latest machinery, assembly lines and test positions to provide for more than twice the previous production capacity of *uhf* converters and instruments.

THE BIG 3 of SALES SUCCESS WITH BUXTON POWER-VUE ANTENNAS

We give the trade

1. WHAT THEY WANT
2. WHAT THEY CAN SELL
— PROFITABLY
3. WHAT PERFORMS BEST
IN THEIR AREAS

FOR EXAMPLE:

COBRA* CONE (Conicals)

PROVED UNIVERSALLY HIGH GAIN for practically all areas. WINNING UNQUESTIONED APPROVAL wherever used. . . . An EXCLUSIVE KEY FEATURE: Quick-Lock "2 BOLT" COBRA HEAD (Greater element separation achieves longer, cleaner, clearer signal.) Other important features, too.

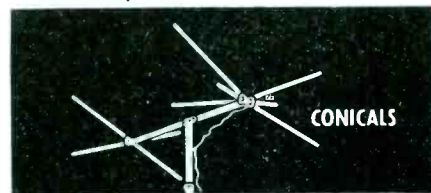

NO. 3cc POWER-VUE COBRA CONE
(An outstanding sales number)

The PLAIN FACTS about BUXTON POWER-VUE YAGIS

1. MAINTAINED HIGH GAIN via correct design.
2. APPROVED PHYSICAL STRENGTH Aluminum alloys, Steel Support brackets, non-break insulators.
3. "E-Z UP" ASSEMBLY. Either pre-assembled Snap-Out, or One-Piece, Elements.

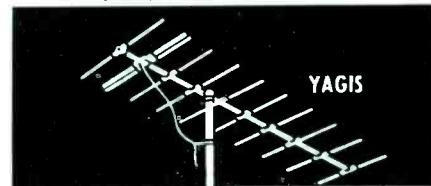

A FULL LINE OF YAGI TYPES

Broad Band, Delta Match, etc.

BUXTON ALSO BUILDS: Power-Vue Straight Dipoles, Arrows, V Stacks, Diamondbacks, Folded Dipoles and Fringe Area Antennas. And Accessories. *A Buxton Name

SOLD NATIONALLY THROUGH JOBBERS

BUXTON INDUSTRIES, INC. S-1
88 North Fair Oaks Ave., Pasadena, California

PLEASE SEND INFORMATION AS CHECKED:
 FULL INFORMATION & PRICES.
 Name & Address of NEAREST JOBBER

Name _____
 Street _____
 City _____ Zone _____ State _____

A look inside will show you why—

CROSLEY SUPER-V IS A SERVICE MAN'S DREAM

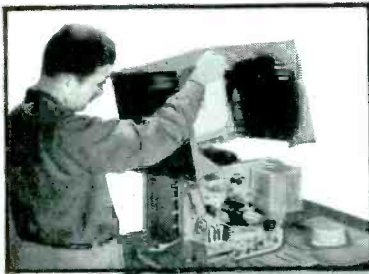

- Bonnet-type cabinet lifts right off
- No more chassis tugging
- Every tube accessible at rear

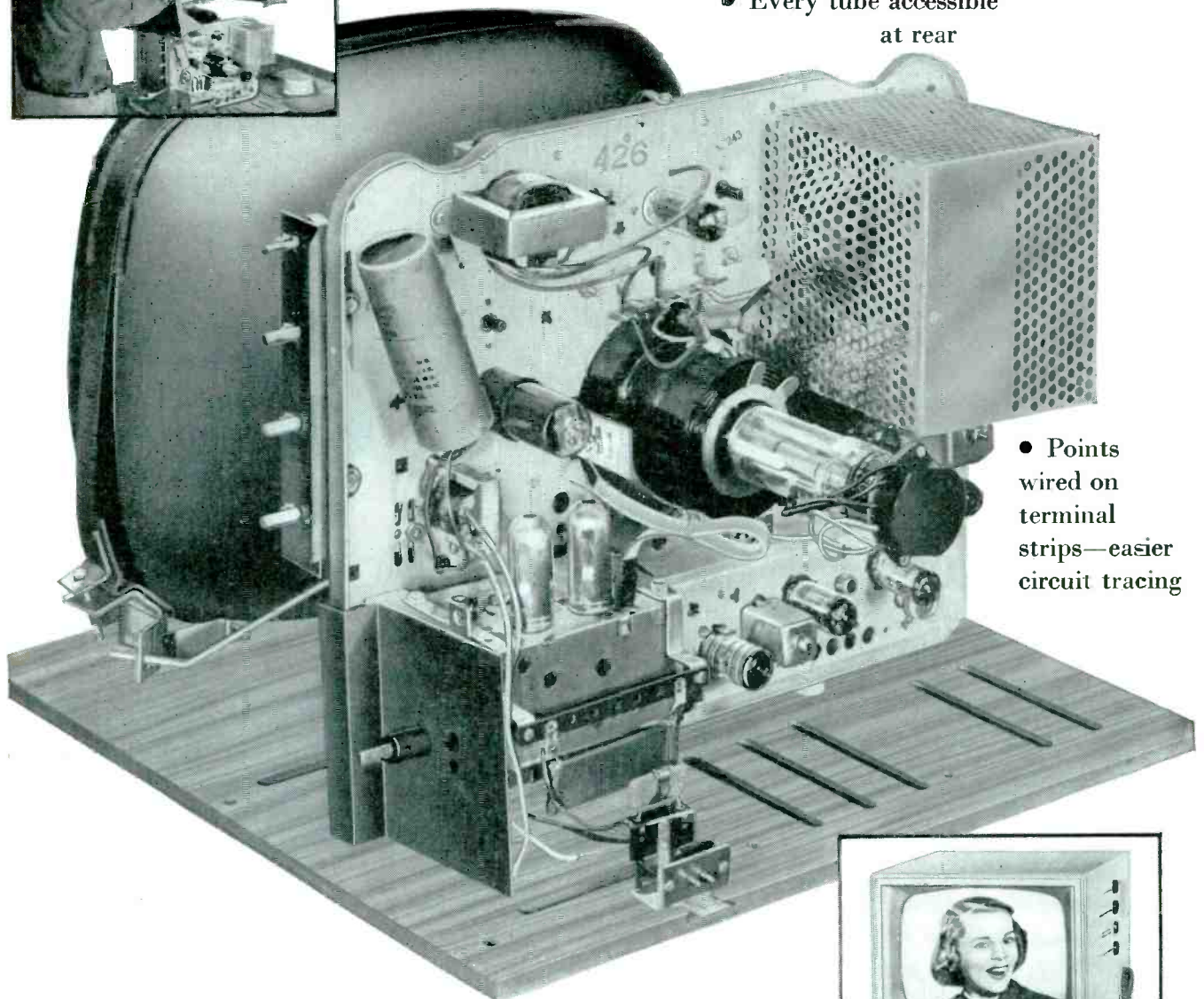

- Points wired on terminal strips—easier circuit tracing



Everything about this exciting new TV set was planned and built with you in mind! Crosley's own revolutionary vertical circuit makes checkups simpler than ever. Changing a tube takes only a few minutes (they're all at the back

in easy reach) and more complicated service requires only the loosening of 6 screws; lifting the entire cabinet off. Men who've serviced the Super-V call it the greatest forward step in TV chassis design.

Crosley
Division



Cincinnati
25, Ohio

**Do a Lot...
With
a Little**



*Cover 75% of Your Replacement Needs
with Just 6 Mallory Vibrators*

You don't need a large inventory when you rely on Mallory Vibrators for your replacement work. A selection of just six Mallory Vibrators gives you coverage of 75% of your jobs.

And you can use Mallory Vibrators with complete confidence that their performance will satisfy you . . . and your customers. Mallory not only made the first commercial vibrator but supplies more to set makers than all other manufacturers combined.

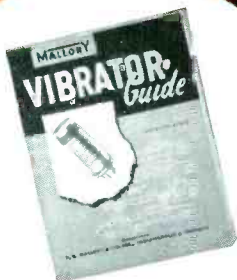

Do It Faster...

You speed selection of the right Vibrator for any job when you use the current Mallory Vibrator Guide. It's your complete cross-reference and service guide. See your Mallory Distributor about this handy book . . . or write P.O. Box 1558, Indianapolis 6, Indiana.

P. R. MALLORY & CO. Inc.
MALLORY

CAPACITORS • CONTROLS • VIBRATORS • SWITCHES • RESISTORS
RECTIFIERS • POWER SUPPLIES • FILTERS • MERCURY BATTERIES
APPROVED PRECISION PRODUCTS

P. R. MALLORY & CO. Inc., INDIANAPOLIS 6, INDIANA

They look alike...



...but what a difference!

These RCA types today give you ...

LONGER LIFE



SUPERIOR PERFORMANCE



AT NO EXTRA COST



Here are 3 more examples of how regular RCA receiving tubes are constantly being improved to meet the changing requirements of radio and television applications. These RCA types provide you with the superior performance usually claimed for higher priced specialty designed types.

RCA-6J6 features pure tungsten heaters for improved life . . . uses a special cathode material to help maintain characteristics throughout the life of the tube. Each tube mount is adjusted to provide increased uni-

formity of characteristics of each triode unit.

RCA-6CB6 uses a No. 2 grid of improved design, resulting in lower grid operating temperature and longer tube life. Special controls on materials and processing improve uniformity of plate cutoff and reduce variations in characteristics when heater voltage fluctuates.

RCA-6AU6 uses a double helical heater, resulting in an extremely low hum level. Inverted pinched cathode reduces possible motion of tube ele-

ments thus minimizing microphonics.

The superior performance of *regular* RCA receiving tubes—at *regular* prices—eliminates unnecessary call-backs, assures you of greater customer satisfaction, results in increased profits for you.



When you sell a receiving tube, your reputation and profit depend on its *performance* and *reliability*. So, you can't afford to buy anything less than the best in receiving tubes . . . and the best are RCA.



RADIO CORPORATION of AMERICA
ELECTRON TUBES

HARRISON, N. J.