

SERVICE

AUGUST
1942

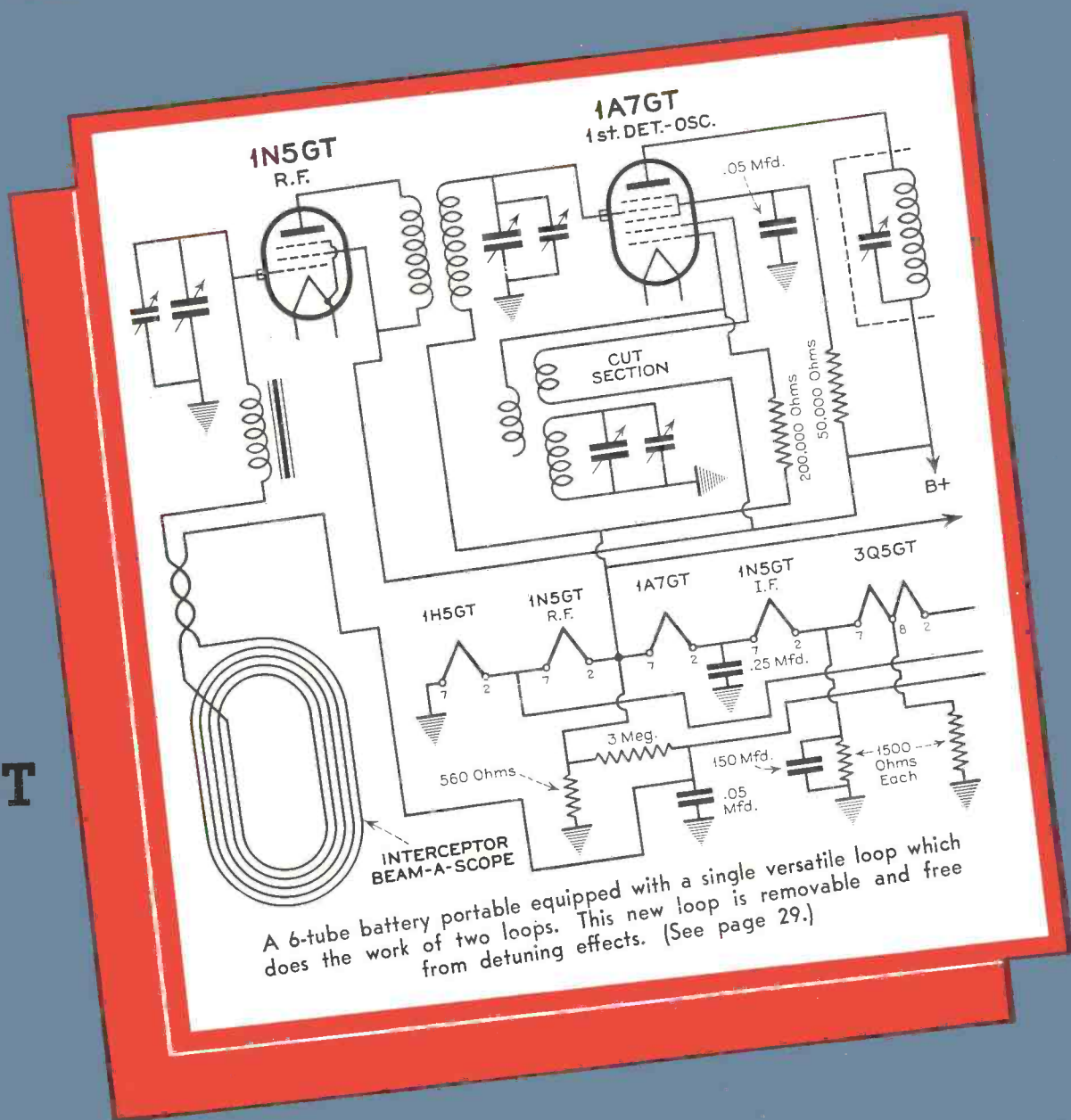

A 6-tube battery portable equipped with a single versatile loop which does the work of two loops. This new loop is removable and free from detuning effects. (See page 29.)

Announcing

The Book You've Waited For

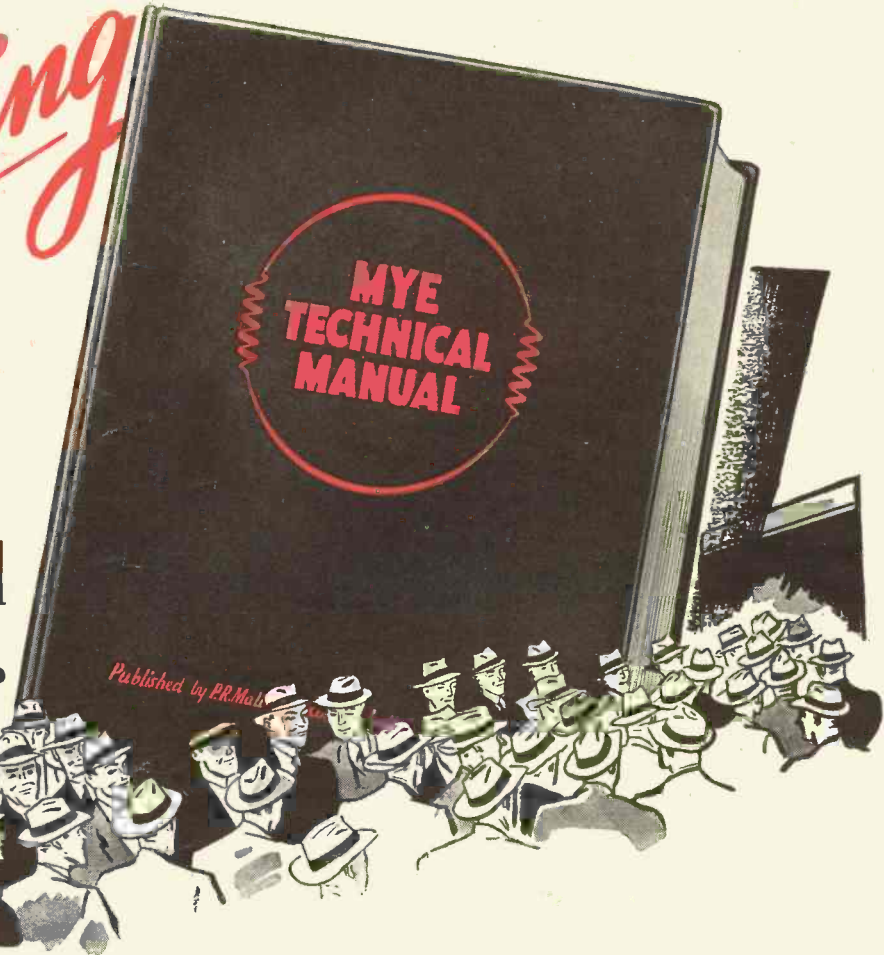

When 300 radio servicemen who are known to be outstanding write letters offering to buy a book before it's even printed, chances are it's a good book. And then, if military radio engineers decide to use many hundreds of copies to train the men in America's fighting forces . . . you *know* it's a good book.

That, briefly, is part of the story behind this new MYE TECHNICAL MANUAL. Just glance over this list of chapter headings, and you'll know why you want a copy.

- | | |
|---|--|
| 1 Loud Speakers and Their Use | 6 Automatic Tuning—operation and adjustment |
| 2 Superheterodyne First Detectors and Oscillators | 7 Frequency Modulation |
| 3 Half-Wave and Voltage Doubler Power Supplies | 8 Television—suggestions for the post-war boom |
| 4 Vibrator and Vibrator Power Supplies | 9 Capacitors—how to overcome war-time shortages |
| 5 Phono-Radio Service Data | 10 Practical Radio Noise Suppression |
| | 11 Vacuum Tube Voltmeters |
| | 12 Useful Servicing Information |
| | 13 Receiving Tube Characteristics—of all American tube types |

Here's a suggestion. If you want to reserve a copy of this 392-page book, bound beautifully in hard cloth . . . go around to your Mallory Distributor today. The supply of manuals for civilian distribution, at the price of \$2.00, is limited. Order your copy now! Your Mallory Distributor has it!

P. R. MALLORY & CO., Inc.
INDIANAPOLIS, INDIANA

Cable—PELMALLO

P. R. MALLORY & CO., Inc.

MALLORY

Approved Precision Products

The image shows several Mallory electronic components: a vacuum tube, a capacitor, a transformer, and a box of Mallory products. The box is red and white with the Mallory logo and text.



At Listening Ease
WITH METAL TUBES

Metal radio tubes afford listening ease to so many radio users that there are over 80,000,000 in the nation's radios. When the war is over

we will again make and recommend metal tubes for civilian use. Our entire production of metal tubes is now being used in the war effort.

Handle Ken-Rad Radio Tubes and Be Sure of Satisfied Customers.

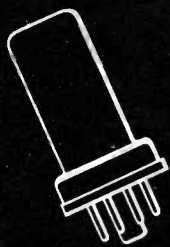

KEN-RAD

Metal Radio Tubes

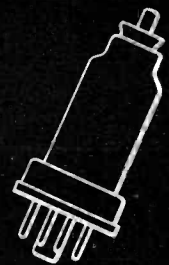

KEN-RAD TUBE & LAMP CORPORATION, Owensboro, Kentucky

SERVICE, AUGUST, 1942 • 1

EDITORIAL

CONFERENCES of industry committees on replacement parts and officialdom have been frequent of late. The decisions, unfortunately, have not been whistling through, as everyone had hoped. But it's a tough problem to solve . . . getting material and manufacturing facilities . . . even though the quantities are small. Allocation of metals for restricted quantities, the use of selected manufacturing facilities and standardization, are the rays of hope that may eventually solve the problem. Proper distribution of stockpiles of parts, of which there are many in some instances, may also help in the solution. Unfortunately these stockpiles do not prevail in all of the popular units needed, and, in many instances, it is *these* parts that are essential towards the servicing of most of the principal sets. The various government agencies are aware of these facts, and particularly the facts that radio is so vital a commodity today. We know that they will do all humanly possible and see to it that the situation gets action . . . the kind of action that will help to . . . Keep 'em Working!

WHAT are you doing that's new or different to handle servicing business under wartime conditions? All of us are interested in and working for the general betterment of radio servicing. So why not inform us of your methods? Possibly others can use these ideas. We'll be grateful . . . and so will they!

THE newcomer in Servicing should take heed and prepare himself or herself . . . with a thorough schooling or training. For Servicing is not the simple matter many would have you believe. Servicing is quite a job. Receivers today are complicated mechanisms. You can't guess . . . you must know. And you certainly can only know, if you have trained yourself thoroughly. There are a flock of recognized schools and courses that offer that background, and there are many good books and articles that should be read, too. Service the right way . . . the professional way . . . by training . . . not guessing!

SERVICE

A Monthly Digest of Radio and Allied Maintenance

Reg. U.S. Patent Office

Vol. 11. No. 8

August, 1942

ROBERT G. HERZOG,

Editor (On Leave)

ALFRED A. GHIRARDI,

Advisory Editor

Modernization. By R. G. Chrouch	21
Ser-cuits. By Henry Howard	13
Solving Problems of Replacement in Power Supplies. By M. E. Heller	6
Tricks of Trade for Wartime Servicing. By Alfred A. Ghirardi	8
Unique Voltage Regulator. By Francis C. Wolven	15
Vibrator Problems Today. By R. M. Ellis	5
Case Histories	
Airline 62-77, 77, 95	17
Airline 62-135	22
Automatic P 57, P 58	19
DeWald 633	20
Fada 5F60T	22
Fada "KA" 60	22
General Electric 106	19
General Electric 106	20
General Electric H-116	22
General Motors 211	22
Grunow 871 (Chas 8E)	22
Grunow 871 (Chas 8 E)	22
Majestic 500	22
Midwest 18-35	22
Philco 47-762, Code 121	16
Philco 42-718, Code 121	17
Philco 42-1019, 42-1011, Code 121	17
Philco 42-1004, Code 121	19
Philco 96	19
Philco 39-40	20
Philco 118, Code 121	22
Philco 37-623	22
Philco 1942 Record Changer Replacement Spindle Kit	26
Philco 37-690	31
Pilot 31.8 (Rainbow)	22
RCA Q 16 E (RC 561 C)	17
RCA 222	20
RCA U-9	20
RCA Q-17	21
RCA 26 BP	21
RCA 46 X 3 (1940 Model)	22
Silver-Marshall 30	22
Sonora Record Player	19
Stromberg Carlson 410 H	17
Westinghouse 473-Y	22
Circuits	
Silvertone 57 RL 391	13
Silvertone 57 RL 390	14
Silvertone 57 RL 385	14
Cover Diagram	
Versatile Loop Receiver	29
Index to Advertisers	
32	
Manufacturers	
New Products	25
Catalogs, Bulletins	30
Jots and Flashes	32

Copyright, 1942, Bryan Davis Publishing Co., Inc.



Bryan S. Davis, Pres.
F. Walen, Secretary



Paul S. Weil, General Manager
A. Goebel, Circulation Manager

Published monthly by Bryan Davis Publishing Co., Inc.
19 East 47th Street, New York City. Telephone PLaza 3-0483

Entered as second-class matter June 14, 1932, at the Post Office at New York, N. Y., under the Act of March 3, 1879. Subscription price: \$2.00 per year in the United States of America and Canada; 25 cents per copy. \$3.00 per year in foreign countries; 35 cents per copy.

Meissner RADIO KITS

ARE DOING THEIR DUTY
WITH THE ARMY SIGNAL CORPS!

... For Faster Radio Training

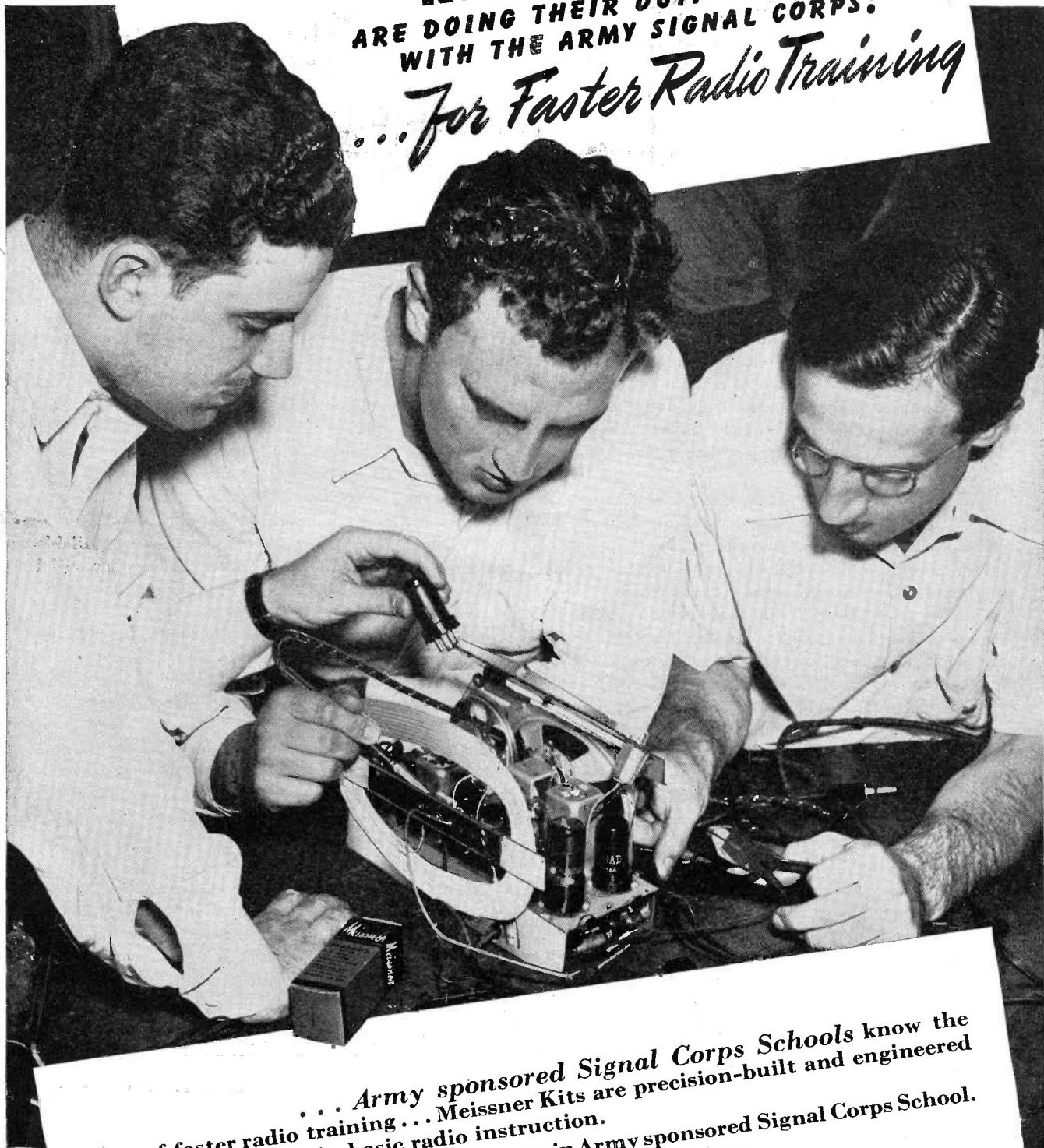

... Army sponsored Signal Corps Schools know the value of faster radio training ... Meissner Kits are precision-built and engineered to give better results in basic radio instruction.
Illustration of actual Radio Kit instruction in Army sponsored Signal Corps School.
See your nearest Meissner Distributor

Meissner
MT. CARMEL, ILLINOIS
"PRECISION-BUILT PRODUCTS"

RESISTORS for REPLACEMENTS



The Army, the Navy, the Air Force have first call on all the radio parts and equipment that can be made today. Their requirements are *vital*. Maximum dependability, stability and accuracy are essential under all of the severe conditions of war. That is why IRC resistors are specified, and why IRC is producing resistors 24 hours a day, 7 days a week.

This explains the increasing difficulties service men are experiencing in securing dependable resistors for repair and maintenance of home radio sets.

Realizing the importance of maintaining and servicing home radio sets, IRC is making available for servicemen large stocks of the same dependable resistors the armed forces are using (but in ranges and tolerances not called for on war orders) and are offering the following suggestions to enable servicemen to obtain greatest possible use of resistors in these times.

1/2-, 1-, and 2-watt Resistors

The resistors in home and automobile sets are almost invariably of the so-called "Preferred Number" or "RMA" standard resistance values and are color-coded accordingly.

Jobbers have, in the past, carried in stock the 1/2-, 1-, and 2-watt resistors only in "nominal" or round figure ranges such as 1,000, 5,000, 10,000 and 25,000 ohms, etc.

Now, however, many jobbers are stocking the IRC resistors in RMA ranges. These resistors are being furnished by the factory from stocks originally accumulated for the set makers before the manufacture of home sets was discontinued. They are of exactly the same quality previously used in the finest radio sets, but as they are not the ranges and tolerances required for military equipment, they can be supplied without interfering with the all-out war program.

A defective resistor in a set can always be replaced satisfactorily by a new resistor within

20% of the color-coded resistance value of the original unit.

In rare cases, where close tolerance units are used as original equipment, they are usually identified by a gold or bronze band for 5%, or a silver band for 10% tolerance. If a close-tolerance unit is required for replacement, two resistors, one higher and one lower than the required range, may be used in series or in parallel when matched for their combination resistance value.

If a 2-watt resistor is required and none is available from the jobber, two 1-watt units in series or in parallel will do the trick. Similarly two 1/2-watt units can be used instead of one 1-watt. Any low-wattage unit can, of course, be replaced satisfactorily by any higher-wattage unit of the same range.

Power Wire Wound Resistors

All wire wound resistors above the 2-watt size are becoming scarce because they are made of critical materials which must be conserved for war requirements. Fortunately, however, they are seldom required for service work except in A.C.-D.C. sets. Also, they are seldom used at their full rating.

If a wire wound resistor of the required wattage rating is not available, a combination of any types of lower-wattage units, either in series or parallel, may be substituted. In combining resistors for this purpose, the wattage rating is cumulative based on the number and rating of the resistors used.

Substitutions

It is daily becoming more necessary to make substitutions in many civilian industries to conserve the critical materials needed for winning the war. The substitutions suggested above will not affect the quality of replacement jobs. We hope that these suggestions may help to keep the home sets of the country operating.



INTERNATIONAL RESISTANCE COMPANY

401 NORTH BROAD STREET, PHILADELPHIA, PA.

VIBRATOR PROBLEMS TODAY*

By R. M. ELLIS

P. R. Mallory & Co., Inc.

A VIBRATOR is not a "brute-force" device. Its life is very largely controlled by the operating conditions. If the conditions are favorable long life will be secured—if the operating conditions are bad, vibrator life may be very unsatisfactory. Let us therefore examine the factors which make for long vibrator life.

It is not generally known that temperature has a considerable influence on vibrator life. Within reasonable limits, the cooler a vibrator operates, the longer it will run. It has been determined by thermocouple tests that a vibrator attains its maximum operating temperature after about three hours of continuous operation. If at that time the vibrator is turned off and allowed to cool before being re-operated, a much longer life will be secured than if the vibrator is allowed to operate continuously. This emphasizes the importance of shutting off the car radio when the car is out of service, even for short periods of time.

Consideration of operating temperature should be given when installing a receiver in an automobile. For the sake of both the condensers and the vibrators always choose the coolest possible location for the set.

Not all automobile receivers have been built with proper ventilation. If your records on any particular model set show consistent short vibrator life, check the ambient temperature. This should not exceed 50° to 60° centigrade for best vibrator life. If the ambient temperature runs higher than this, give careful consideration to the possibility of adding a few ventilating slots in the receiver housing—it may work wonders.

Long vibrator life results from proper circuit constants and from light loading. Let us analyze these factors separately.

The successful functioning of a modern vibrator is due to its use in a tuned circuit so that the voltage and/or current is at or near zero when the contact points make and break. If proper circuit tuning is not achieved the life of a vibrator may be very short.

The circuit tuning is performed by the buffer condenser in combination with the inductance of the transformer winding across which it is connected. The buffer condenser is usually connected to the high voltage secondary winding for 6 volt equipment because the large number of secondary turns permit the employment of a condenser of small capacity. If economic and space considerations were disregarded the buffer could be connected to the primary, altho a very large capacitor would be required.

From this information it will be seen that proper vibrator life requires the use of a power transformer, operating at a reasonable flux density so that core saturation does not occur, plus the correct value of buffer condenser. Since the buffer condenser tunes the circuit, variations in value are permissible only within narrow limits. Incorrect values of buffer capacity may originate from the following causes:

1) *Incorrect initial design.* This is very unlikely in the product of any reputable manufacturer since all major radio manufacturers have their transformer designs approved by their vibrator supplier.

2) *Change of transformer design in production.* This is just a possibility, but it can happen that a change in the grade of transformer iron will alter the inductance of the transformer so that the previously selected value of buffer capacity will no longer be correct.

3) *Carelessness on the part of a Service Man in making a replacement.* Here is one factor that will occur with regularity. Because the receiver will operate with the incorrect value of buffer capacitor, the fault will not be recognized until it is discovered by the continuous record of short vibrator life.

4) *Change in vibrator frequency.* If the replacement vibrator has a radically different frequency than the original equipment vibrator, a different value of buffer condenser is required. Happily, most all vibrators now available operate at or near the frequency of 115 cycles, so that trouble from this source is now rare.

The correct value of buffer condenser

can easily be determined by connecting an oscilloscope across the primary winding so that the wave form can be observed, and then adjusting the value of the buffer condenser for about 90% closure.

Vibrator life varies considerably with the primary load current. If the load is light the life will be long. If the load is heavy the life will be shorter. Consequently any change which will reduce the current drain of the receiver will result in greater vibrator economy.

An examination of some receivers show that they are capable of delivering an audio output far in excess of the actual requirements. Like extra horsepower in an automobile, extra audio output is nice to have when you need it. But when replacement vibrators are difficult to secure it is worthy of giving some thought about reducing power output to decrease the burden on the vibrator. The burden can be lightened either by substituting a smaller output tube, or by increasing the value of the cathode bias resistor on the power output stage.

It is rather universal practice to make repairs only when the set stops operating, and then to fix only the part that has failed. Under existing conditions, repair procedure should be given more serious consideration.

Now is the time to keep life records on tube and vibrator replacements. Some are doing that. Be sure that your records are for each individual set; and make use of these records. When you find that any one particular receiver requires more vibrator replacements than the average, check into that receiver and find out why it is hard on vibrators. Such conditions do not just happen—there is a reason for it.

A new procedure** for servicing vibrator operated receivers, has been developed by Mallory engineers. Briefly the procedure is as follows.

When the set comes in the shop in an inoperative condition and the fuse is blown, proceed in the following way.

Connect a 0-20 reading d-c ammeter in series with the hot "A" lead to the receiver. Connect a 0-10 voltmeter between the hot "A" lead and the receiver

(Continued on page 16)

*From a paper presented at the APCO Conference, in St. Louis, Mo., July, 1942.

**1942 Mallory Vibrator Guide for further data.

SOLVING PROBLEMS OF REPLACEMENT

In Power Supplies

By MARK GLASER

IN a great many a-c/d-c sets the rectifier tube takes a beating on a-c operation. The principal reason for this is the large value of the first filter condenser as commonly used. A large charging current flows from the source of a-c (the power line in this case) through the rectifier and first filter condenser as soon as the rectifier tube warms up. This current is shown by the arrows in Fig. 1. The regular "B" supply current to plates and screens also starts at the same time. After the first filter condenser is fully charged, current flows only when the rectifier voltage exceeds the condenser voltage. Also, the higher the current drain, the longer the period of charging.

Surge Resistance

When the value of C_1 in Fig. 1 exceeds 30 mfd. or so, the charging current becomes excessive and a protective resistor, sometimes called a surge resistor, must be inserted at "X" to limit the peak rectifier current. High capacities in a-c/d-c sets are necessary because it increases the d-c output; no filter chokes are used and, also, because of rather low load resistance. Note the typical resistance-capacity filter in Fig. 1. Many sets have the protection of a surge resistance but, sometimes, the value is insufficient to afford full protection. Because of competition, engineers were forced to squeeze out every milliwatt. Insertion of a resistor where

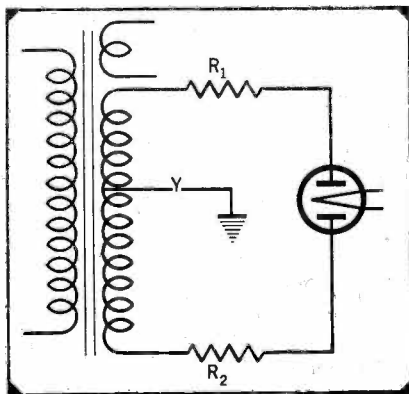

Fig. 2. In replacing power transformers, resistors in the plate leads or a single resistor, placed at "Y", can be used.

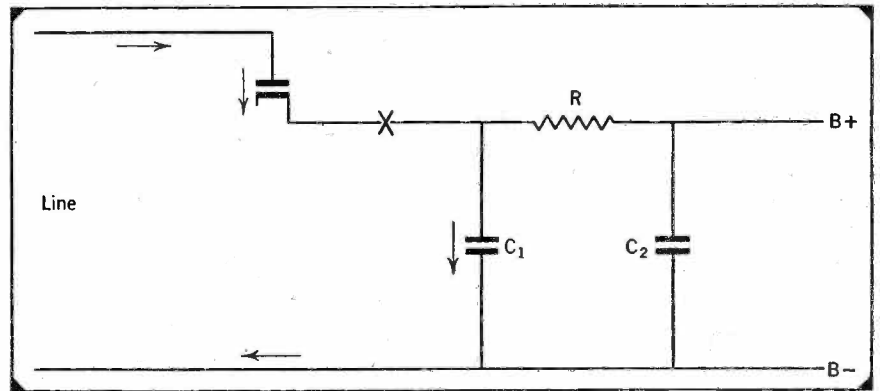

Fig. 1. A diagrammatic explanation of a typical surge resistance circuit.

none is present or increasing the value of a doubtful one will go a long way toward providing increased rectifier life, increased condenser life and somewhat better filtering. The resistor acts a bit like an input filter choke. The disadvantages include slightly lowered power output due to decreased plate voltage and somewhat lower sensitivity, neither of which are obvious. In a rare case, a high-loss oscillator may quit oscillating.

Rectifier Substitutions

The 35 volt, 150 ma, 35Z5 and 35L6 are more readily available than the older 25Z5 and 25L6. Hence, there will be cases where substitution will be necessary to keep going. By shunting the filament of either 35 volt tube with a 10 watt wire-wound resistor of approximately 230 ohms (35 divided by 0.150), the 35 volt tube may be inserted. A bit of extra profit may come along, too. Don't forget to change the socket marking to correspond to the new tube though.

Resistor Aids

Similar changes may be made with 6.3 volt tubes where an 80 ohm, 5 or 10 watt resistor should be substituted. The reverse process of substituting 300 ma tubes for 150 ma tubes cannot be used, of course. Where brown bead Mazda pilot lamps as No. 40 burn out frequently, they should be replaced with the blue bead types 46 and 44 250 ma lamps. Burnouts will not be

as frequent and rectifier filaments will run cooler.

A-C Receivers

The replacing of power transformers is becoming a problem. It's always safer to use a larger than a smaller transformer, of course. If the filament windings are not too heavily overloaded, a smaller transformer may frequently be used by lowering the demand of the "B" supply so that the va rating of the transformer is not exceeded. This is easily accomplished by inserting a resistor in series with the rectifier or high voltage center tap, similar to the surge resistor in a-c/d-c sets. The size and rating of the resistor will depend upon the individual case but it isn't necessary to figure it to the second decimal place. Filament windings are

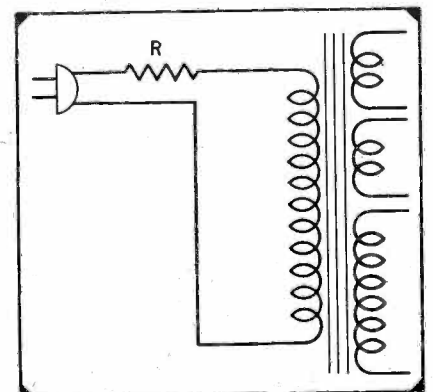

Fig. 3. The use of a primary resistor can be helpful in maintaining correct "B" voltage.

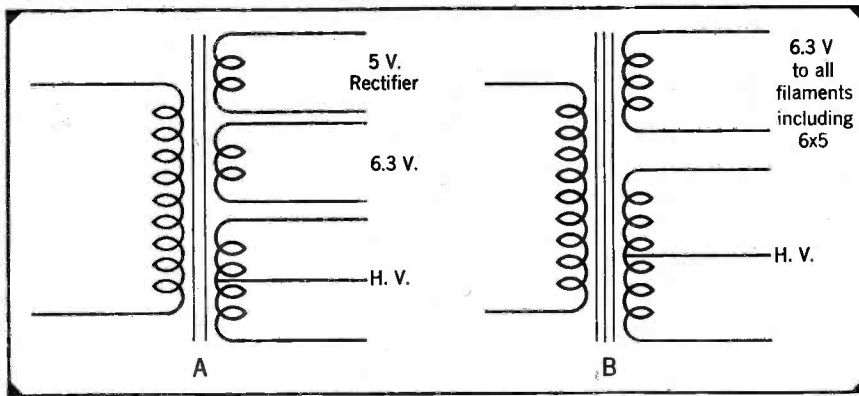

Fig. 4. How to substitute two-filament winding transformers with a single filament winding transformer.

wound on the outside of the coil and so have better cooling than the secondary (high voltage) winding. A full wave rectifier requires a resistor in each plate lead as shown in Fig. 2 or a single resistor in the center-tap lead inserted at "Y" in the diagram.

Primary Winding Resistors

When a transformer has correct filament voltage and excessive plate voltage, either method may be used to cut the "B" voltage to a safe value. If all voltages are high, a primary resistor should be used as illustrated in Fig. 3. If the filament voltages are too high and the "B" is satisfactory, the primary resistor is still the most reasonable solution.

Dual Filament Winding Transformer

Power transformers having two filament windings with one serving for the rectifier may be replaced with a transformer having a single filament winding provided the rectifier tube is of the indirectly heated type and built for the voltage and current to be handled. The 6X5 is the most common of this group. In Fig. 4, this point is illustrated.

Electrostatic Shield Transformers

Where a transformer is replacing one that originally had an electrostatic shield, it is important to connect condensers across the line and to the chassis, as shown in Fig. 5. These condensers run from .01 to .1 mfd. and their function is to eliminate tunable hum that rides in on station carriers. A good ground is also of material aid in reducing tunable hum.

Electrolytic Alternatives

If it becomes difficult to obtain high-voltage electrolytics for replacement purposes, try to dig up some old type paper high voltage sections. Since these will be of rather low capacity compared to electrolytics, a choke will be found quite necessary for good filtering. In a pinch, the primary of an

output transformer will serve as a filter choke, provided that it is of suitable current-carrying capacity. In the case of voltage doubler circuits, defective electrolytics should be replaced with individual tubular type condensers which are more readily available than the original condenser pack.

Hum Bucking Circuits

In hum bucking, we have another phase of power supply material control. Hum bucking consists of introducing at some point in the audio amplifier a voltage in magnitude and of opposite phase to every hum frequency present. These frequencies are usually 60 cycles accompanied by many harmonics. In most cases some trick giving partial hum bucking is used for reasons of both economy and, at present, necessity. The most universal stunt is to use a hum bucking coil wound around the field coil of the speaker and connected in series with the voice coil. Another scheme makes use of a copper slug, or shading ring around the field coil, this being particularly effective against audio frequency ripple generated in the battery circuit of automobile sets. Receivers of the a-c/d-c type, using a half-wave rectifier which generates a 60-cycle ripple, have a greater hum problem. In small receivers the speaker doesn't reproduce bass notes, so not much of the funda-

mental hum gets through. The p-m type speakers have one disadvantage in that a number of these hum reducing methods cannot be employed.

Hum neutralization may be accomplished through the introduction of anti-hum voltages, by means of an autotransformer and trimmer condenser at the first audio frequency grid. The trimmer condenser usually has a capacity of from two to thirty mmfd. Another method of delivering anti-hum voltage to the power tube cathode can be accomplished by placing a 150-ohm resistance in series with a cathode and the ground, in addition to the 20,000-ohm resistance connected in series with the same cathode and the biasing cathode resistance.

The hum output from a given filter is proportional to the load current or conversely, larger filter components are required for a given amount of hum voltage as the load increases since more stored energy is demanded. This energy comes from the charge in the condensers and the magnetic field of the chokes, if there is any. A push-pull output stage can take a great deal more ripple than a single-ended stage because the hum is neutralized by the bucking action in the primary of the output transformer.

The elimination of audio transformers and chokes and the use of inverter stages for push-pull have almost allowed us to forget about magnetic fields in relation to hum. One exception to this is the high-gain audio amplifier where the heater leads must be watched for magnetic as well as static effects.

Radio frequency stages cannot amplify hum, but they can modulate the program that hum frequency may be even worse. The hum on the carrier is minimized by using an electrostatic shield in the power transformer and by-passing one of both sides of the a-c to the ground. In replacing an output transformer, the phasing must be watched since considerable hum maybe introduced by reversing a winding.

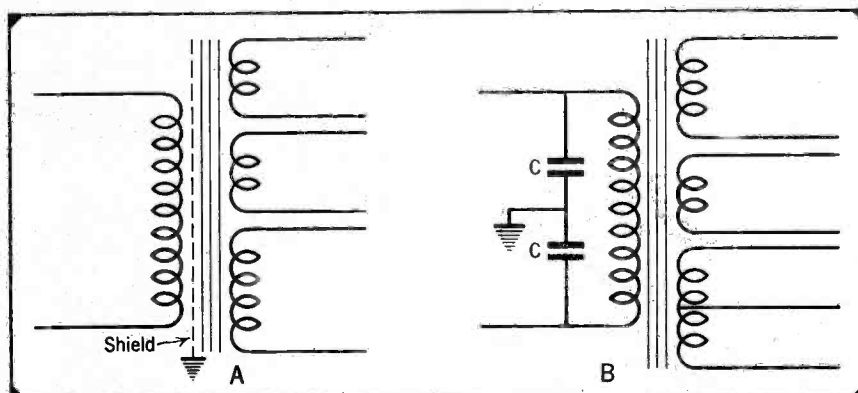

Fig. 5. Eliminating tunable hum with by-pass condensers, when replacing electrostatically shielded transformer.

TRICKS OF THE TRADE

For War-time Servicing

By **ALFRED A. GHIRARDI**

Advisory Editor

"KEEP 'em playing" is the patriotic slogan that has gone over with a bang in the radio servicing industry during the past few months. In spite of the difficulty of keeping trained Service Men and obtaining deliveries on many important replacement parts and supplies, service shops the country over have done an admirable job of keeping the nation's fifty-five million radio receivers operating. So efficiently has it been done that comparatively few civilians are even aware of the handicaps under which radio Service Men have been working.

There is a growing realization of the need for ingenuity and resourcefulness in these new conditions. The times call for REPAIRmen as well as REPLACEMENTmen in service work. We need the return of the fellow who isn't stumped by lack of a particular part; who can, when necessary, sit down and think out a perfectly satisfactory way of doing without the new part, even if it means repairing or rebuilding the faulty one. No one can foretell today what will be happening sixty days from now, but we do know that a great many past practices and techniques followed by radio Service Men will have to be modified or discarded until the emer-

gency is over. Then, too, the many new men who have recently come into the servicing industry to replace those now in the armed forces, will have to develop nimble fingers and nimble brains to cope with the demands that will be made on them.

This, and the next few articles of this series, will present parts-servicing ideas that should be helpful, in these trying days, to both experienced and new Service Men.

Servicing Noisy Volume or Tone Controls and Switch Contacts

There is no doubt that the best policy in service work is to replace faulty volume or tone controls; very seldom do they hold up for any considerable length of time after being cleaned or repaired. However, when a correct replacement is not available, the control must be repaired as well as possible to obtain further use from it.

Noisy carbon controls can be "touched up" by applying carbon to the worn, noisy spots. For this purpose, "Carbon X," a special compound made by the General Cement Manufacturing Company, is useful and easily applied. It comes in convenient small bottles as illustrated in Fig. 1. Some Service Men fill in these worn spots with carbon from an ordinary soft lead pencil,

but this is a highly unsatisfactory method, suitable only as a temporary makeshift.

Handy combination cleaners and lubricants for noisy wire-wound volume controls (also for all air-exposed switch contacts in radio equipment) are available. One of these, sold under the trade name "Grafoline," can be applied easily with an ordinary matchstick, as illustrated in Fig. 2. "Energine" and "Carbona," the popular home cleaning fluids, are also excellent cleaners for contacts. Powdered graphite mixed thoroughly with white uncarbolated vaseline (obtainable at any drug store) can be used as a home-made lubricant to be applied after thorough cleaning.

Another excellent cleaning and lubricating solution can be made of two ounces of "Carbona" and one-half level teaspoonful of white uncarbolated vaseline. Shake well and let it stand overnight. Apply the mixture with a stiff toothbrush to the contacts to be cleaned. Then wipe over the contact with clean fingers. Very often an amazing improvement in noisy contacts or volume or tone controls results from simple cleaning and lubricating with such solutions.

The illustration in Fig. 3 shows how a separate cleaner and lubricant are

Fig. 1. "Carbon-X," a special liquid for "touching up" the resistance elements of moving carbon-type volume or tone controls, at worn, noisy spots.

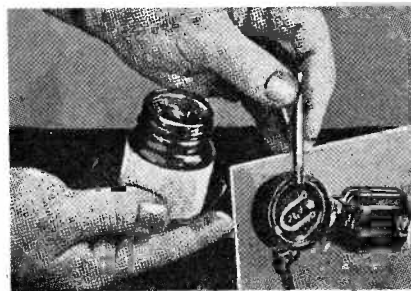

(Photos courtesy General Cement Mfg. Co.)

Fig. 2 (above). The method of applying "Grafoline" cleaner and lubricant to noisy wire-wound control.

Fig. 3. Applying a contact cleaner and a contact lubricant to the band switches of an all-wave receiver. This simple operation eliminates noisy scratches.

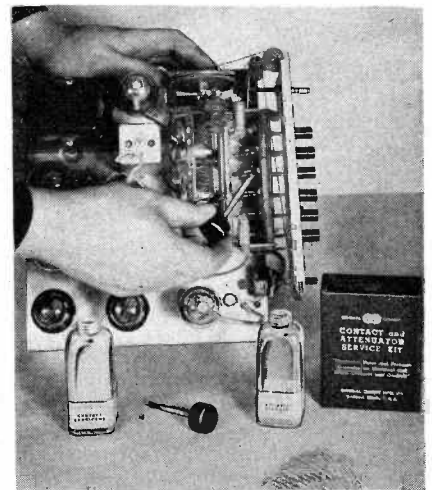

Score a Dividend for Substitution!



Sometimes Necessity is an ideal mother for invention—and in developing the new Mallory Wood Neck* Dry Electrolytic Condenser, Necessity has done herself proud. Mallory engineers have found a thoroughly satisfactory replacement for aluminum threaded neck condensers of either the wet or dry electrolytic type.

They are designed for the emergency but we predict they will be popular long afterwards.

Using an absolute minimum of raw materials vital for war production, these new Mallory Condensers employ an impregnated cardboard tube container and threaded wooden neck. Ingeniously providing the same mounting convenience as the aluminum can condensers they replace, they are handsome, trouble free and long-lived. You can use Mallory Wood Neck* Condensers with confidence—and recommend them enthusiastically.

Free—from your Mallory Distributor—a chart showing how to select and use Wood Neck* Condensers to replace wet and dry aluminum can units.

You can depend on Mallory and Mallory Distributors to help you lick the problems that war imposes . . . and meet the challenge to "keep 'em listening" with receiving sets in good repair.

*Patent Applied For

P. R. MALLORY & CO., Inc.
INDIANAPOLIS INDIANA
Cable Address—PELMALLO

P. R. MALLORY & CO., Inc.

MALLORY

Approved Precision Products

NATIONAL UNION *De Luxe* AMPLIFIER

15 Watts Output . . . Less than 3% Distortion . . .
at rated output . . .

Patented Circuit . . . Permits Extreme Compactness

W15A-

Amplifier includes set of 5 N U
Loktal Tubes.

W15A-C-

Portable Case Only — Imitation
Leather (space for Amplifier
W15A, Two 8" P.M. Speakers,
Microphone and Cable).

W15A-CS-

Portable Case with
2—8" P.M. Speakers.



The Patented Circuit Provides . . .

SMOOTH AND FLEXIBLE CONTROL OF BOTH VOLUME LEVEL AND TONE GRADATIONS OVER A WIDE RANGE . . . TWO MIKE INPUTS AND ONE PHONOGRAPH INPUT MAY BE SEPARATELY CONTROLLED OR MIXED FOR SIMULTANEOUS OPERATION . . . CONTINUOUSLY VARIABLE SEPARATE BASS AND TREBLE TONE CONTROLS . . . EASILY ACCESSIBLE FUSE . . . HOUSED IN COMPACT ATTRACTIVE GREEN CRACKLE FINISHED CABINET WITH PLASTIC IVORY KNOBS AND CARRYING HANDLE.

SPECIFICATIONS

Rated Output: 15 Watts.

Peak Power Output: 25 Watts.

Distortion: Less than 3% at Rated Output

Tone Controls: 1—Bass Boost Control.
1—Treble Tone Control

Frequency Range: ± 1 Db from 50 to 10,000 cycles

Input Circuits: Two high impedance microphones
One high impedance phonograph

Output Circuits: Variable Impedance Output Two
Speaker Sockets. Each Socket
has Combination Voice Coil and
110 V A C Terminals

Output Impedances: 4-8-16-500 Ohms

Power Considerations: 110-117 Volts 60 Cycle
A.C.

Power Consumption: 50 Watts.

Circuit: Special Patented Output and Bass Control
Circuits.

Tubes: National Union Loktal 2-7N7—2-7CS—1-7Z4

Size: Extremely Compact 8⁵/₈ x 5⁵/₈ x 5⁵/₈

Weight: 12 Pounds

Ask Your N. U. Distributor or Write

NATIONAL UNION RADIO CORP.

57 STATE STREET, NEWARK, NEW JERSEY

applied to the band-switch of an all-wave receiver.

Replacing Volume or Tone Controls in "Orphan" or "Private-Brand" Receivers

A "private-brand," "loft," or "orphan" receiver often requires a new volume or tone control and no replacement information or schematic diagram is available. To make a correct replacement in such receivers, the Service Man must consider the following important factors: 1. Physical size of the control. . . . 2. Shaft diameter. . . . 3. Shaft length. . . . 4. Location of control in circuit . . . 5. Total resistance of control . . . 6. Maximum current control carries. . . . 7. Type of control used (carbon or wire-wound) . . . 8. Taper of the control (if any).

The physical size of the replacement control may or may not have to be the same as the original, depending on the space available. The replacement must, however, be small enough to fit into the available space, but large enough to carry the necessary current.

The shaft diameter and length should be such that the unit works satisfactorily when installed. Many replacement controls have shafts which can be cut or broken off easily, or to which shaft length can be added if necessary.

The total resistance of the control can be measured by an ohmmeter. If the original control has an open, the total value can be arrived at by measuring the value of resistance on each side of the open; then adding the two values.

The maximum current to be carried by the control can be measured by inserting a d-c milliammeter in series with the control with the set turned on. If the control is open, a fixed resistor of equal value may be substituted temporarily. The wattage the resistor must dissipate may then be found by multiplying the square of the current in *amperes* by the resistance of the control.

Controls below about 10,000 ohms are usually of the wire-wound type. Carbon controls are used when values above this approximate value are needed.

Carbon type volume controls which have abrupt tapers generally give "noise" trouble sooner than those having more gradual tapers. Practically all volume controls designed for audio grid use have a taper which is gradual over the first 65% rotation and much steeper thereafter; but some tapers have a much more abrupt change at the 65% rotation position than do others. When selecting the proper control for audio grid replacement work, try to choose a unit having a taper which does not provide too sharp a change at this point.

Locating Breaks in Line-Cord Resistors

In view of the shortage of line-cord resistance of the type so prevalent in

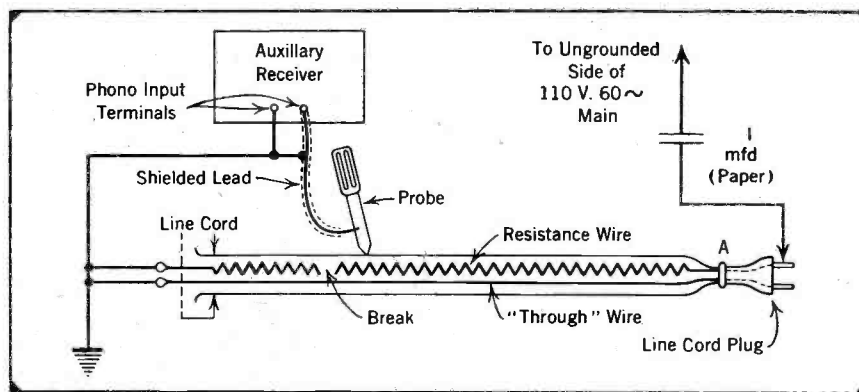

Fig. 4. Circuit for locating break in line-cord resistance.

older a-c/d-c sets, the repair of these essential components may frequently be necessary if the set is to be put back into service quickly. The job is often a very simple one, three-quarters done if the break can be located easily and accurately.

A clever method of doing this, without damaging the protective outer covering of the line cord in any way, is described in a recent issue of *Wireless World* (the English Service Men's magazine). It is illustrated in Fig. 4. The "through wire" in the cord is grounded, as is one end of the broken resistance wire. The other end is connected to a source of a-c (such as the ungrounded side of a 110-volt a-c lighting circuit) through an isolating paper-type condenser of about 0.1 mfd. A shielded lead from the grid side of the phono pickup terminals of an auxiliary radio receiver is connected to the blade of an insulated screwdriver, or to the metal tip of a "trimmer" tool.

To locate the break, the screwdriver blade is slid along the line cord from the end A; a loud power line hum is continuously heard from the radio set. The moment the blade passes the break, the hum drops nearly to inaudibility, depending on the efficiency of the grounding and screening arrangements. The position of the break can be found to a small fraction of an inch. To repair the break, the outer protective covering of the line cord can be slit at this point, gaining access to the resistance wire inside.

Of course, other quick, effective methods for locating such breaks in line-cord resistors suggest themselves. For example, one terminal of an ohmmeter can be connected to one end of the resistance wire and the other terminal connected to an ordinary large darning needle. The needle may then be stuck into the line cord at short intervals along its length, making contact with the resistance wire inside each time and progressing toward the other end. The ohmmeter indication will tell when the break has been passed. Breaks

in battery connection leads may also be located quickly by these tests.

Repairing R-F Transformers

Broadcast r-f transformer primaries, if found to be faulty, can be repaired with reasonable ease. Fortunately, this part of the r-f transformer (which fails most often) has only a minor influence on the "tracking" of the tuned receiver circuits.

Service Men generally hesitate to tackle the repair of an r-f transformer because of the fine wire involved. However, fine wire can be easily handled if reasonable care is taken. To remove the enamel and fabric insulation from the wire, use a piece of No. 00 sandpaper, folded and cut as illustrated in Fig. 5. Hold the sandpaper between the thumb and forefinger, and strip off the insulation by running the wire between the folded halves. Too much pressure on the paper breaks the wire, but a few tries on the wire of a discarded coil will quickly indicate the proper pressure to be used. Be sure to clean the wire well, or a good soldered connection to the terminal lug cannot be made.

Repairing I-F Coils

As with broadcast band r-f coils, one or two turns on the i-f coils are not critical. If breaks can be located and repaired without losing more than a few turns, receiver performance is not affected noticeably. In making repairs on litz-wound coils, it should be remembered that each and every one of the many strands must be carefully cleaned and that they must all be soldered to the terminal; otherwise, noise and reduced gain results.

The spacing between the windings of the i-f transformer is important to both the selectivity and gain of the stage in which it functions. It is, therefore, important in making replacements or repairs in such windings, that they be returned to exactly the same position which they previously occupied.

Replacing Condensers

One of the chief difficulties in replac-

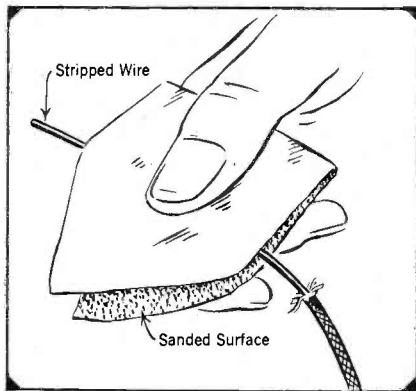

Fig. 5. Sandpaper slip for cleaning insulation off fine wire.

ing condensers in some more recent radio receivers is, when the service sheets and parts list for the receiver are not available, to identify their electrical characteristics (capacity, working voltage, capacity tolerance, whether of the inductive or non-inductive type, whether of the foil-paper or electrolytic type). Many wax and oil-filled foil-paper condensers closely resemble, in their external appearance, dry electrolytic condensers; the Service Man should determine the original construction of the faulty condenser before attempting to replace it.

One method of quickly distinguishing electrolytic condensers from other types is by a leakage current test. If the leakage through the condenser is of the order of *milliamperes*, it is an electrolytic. If the leakage is of the order of *microamperes*, it is a tinfoil-paper (wax or oil-impregnated) condenser.

Dial Drive Repairs

Dial drive repairs involve practically all labor and very little material. The *direct* drive, the *friction* and *planetary* drive, the *cable* or *cord* drive, and the *V-belt* drive are the four most common types. Troubles in direct-drive arrangements usually consist of condenser bearings which need lubrication, dial knob or wheel rubbing against some other

part, loose set-screw on knob, etc. Such difficulties are easily remedied.

Troubles in friction and planetary drives are usually due to slippage caused by worn parts. If the friction drive and the wheel are symmetrical, a remedy can often be effected by simply reversing either or both. If there is a friction adjustment, this may clear up the trouble. If there is such an adjustment, it is often possible, by a little ingenuity, to increase the pressure on the small drive wheel on the disc. A rough drive can often be cured by inspecting the drive and wheel carefully and dressing down the rough spots with a thin ignition-point file. A spot of light oil on the main spindle bearing frequently helps.

Cable and cord type drives are most popular in recent models of home receivers. The cables are made of phosphor bronze, specially woven linen, silk, Fibreglass and other special materials. The most common troubles with cable and cord drives are those due to excessive wear or slippage. Of course, a cable or cord that is worn excessively must be replaced. Try to use a replacement made of the same material as the original. Slippage can also be caused by a cable or cord which has stretched so much that the tension spring, normally provided for taking up the stretch, is unable to do so. In some such instances, the cable or cord must be shortened. Others are best remedied by shortening the spring, or doing both.

Slippage can also be caused by excess friction in the tuning condenser bearings. Cleaning and proper lubrication are the remedies.

Mild cases of slipping drives can be remedied quite often by the simple application of a compound designed to increase the friction between the cord and the drives. A nickel's worth of rosin (procurable in any music shop, paint store or pharmacy), dissolved in about four ounces of rubbing alcohol makes an excellent such solution for applying to the cord or belt with a small paint

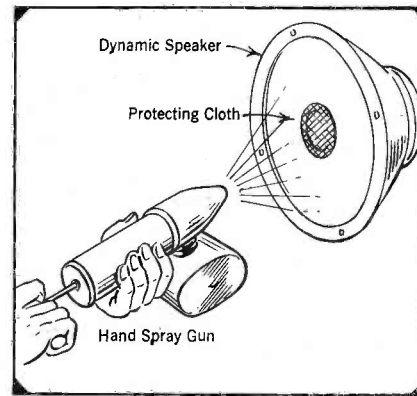

Fig. 7. Applying a coat of thinned lacquer with a hand spray gun for stiffening "softened" speaker cones.

brush; it penetrates easily and also causes the cord to shrink slightly. Such compounds are also obtainable in handy stick form. The illustration in Fig. 6 shows a stick of cord dressing being applied to the slippery dial cord of a receiver.

Troubles with belt drives usually involve the replacement of the belt or the application of a friction-increasing compound such as that just described. When replacement is necessary, be sure to use the proper size of belt; this eliminates the countless trials and tribulations encountered when attempting to "make the next size do."

When a scale and pointer is employed, pointer wobble can be caused if the slide which carries the pointer, fits too loosely on its guide rail. The remedy is to reduce the amount of play—but carefully, so the pointer does not stick anywhere during its travel.

Speaker Cone Repairs

Service shops report that reduction of volume, "thin" reproduction, and rattling due to "soft" speaker cones are again becoming very widespread—mostly among receivers of recent issue. To remedy "soft" cones, spray several times with thinned, clear lacquer, using a spray gun. A hand sprayer is satisfactory. This can be done without removing the cone from the speaker, by covering the center opening of dynamics with a cloth pad, as shown in Fig. 7; the results are better, however, if the cone is first removed and both sides are sprayed evenly. Do not use more lacquer than the cone material readily absorbs, and wipe off any excess before it sets. Allow at least 10 hours drying time before attempting to center the cone or use the speaker. This treatment is also effective on old types of dynamics constructed of doped cloth, such as the early Victors and Philcos, which have softened due to vibration and humidity. When this defect appears, the simple lacquer treatment makes cone replacement unnecessary.

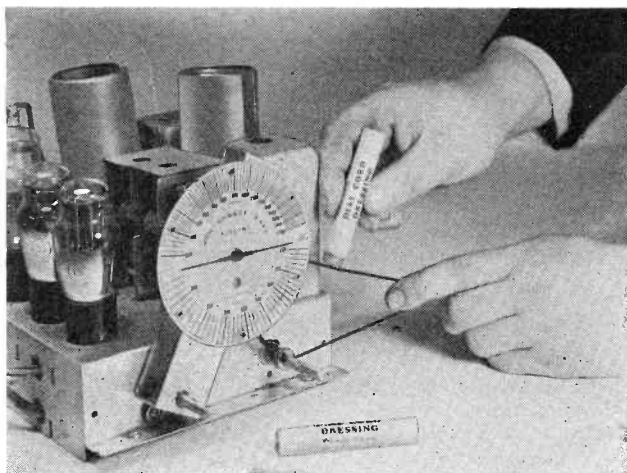

Fig. 6. Remedying a slipping dial cord by applying a stick of dial cord dressing to it. (Courtesy General Cement Mfg. Co.)

SER-CUITS!

By HENRY HOWARD

THE series of Silvertone sets (Sears, Roebuck), models 7189, 7905 and 7188, have many unique circuit features that are particularly interesting now. The first is an ac-dc personal portable—model 7189—a typical 4-tube and rectifier job using a 67½ volt "B" battery and two 1.5 volt "A" batteries. On battery operation, the filaments are run in parallel while on the line, they are switched to a series connection. Note the method of switching in Fig. 1.

Series filament arrangements are con-

siderably more complicated than parallel connection but, for economical considerations due largely to rectifier limitations and voltage regulation, must be used in line operation. Resistors must be used in parallel with filaments on the negative side of the series to by-pass the plate current: the filaments

drawing only 50 mils; 10 mils of plate current represent a 20% overload passing through the most negative tube. In this receiver, a 1,000 ohm shunt is used across the 1S5 which also has a 55 ohm series resistor in the circuit. The first three filaments are shunted by 1,700 ohms. A 2,200 ohm filament voltage dropping resistor and the 3S4 filament act as a series filter element while a 30 mfd. condenser connected across the above mentioned 1,700 ohms acts as the shunt element of a second filter section to reduce the ripple volt-

Fig. 3. Silvertone 57RL391 (Model 7188) 5-tube receiver with permeability tuning. Antenna transformer has an interrupted primary.

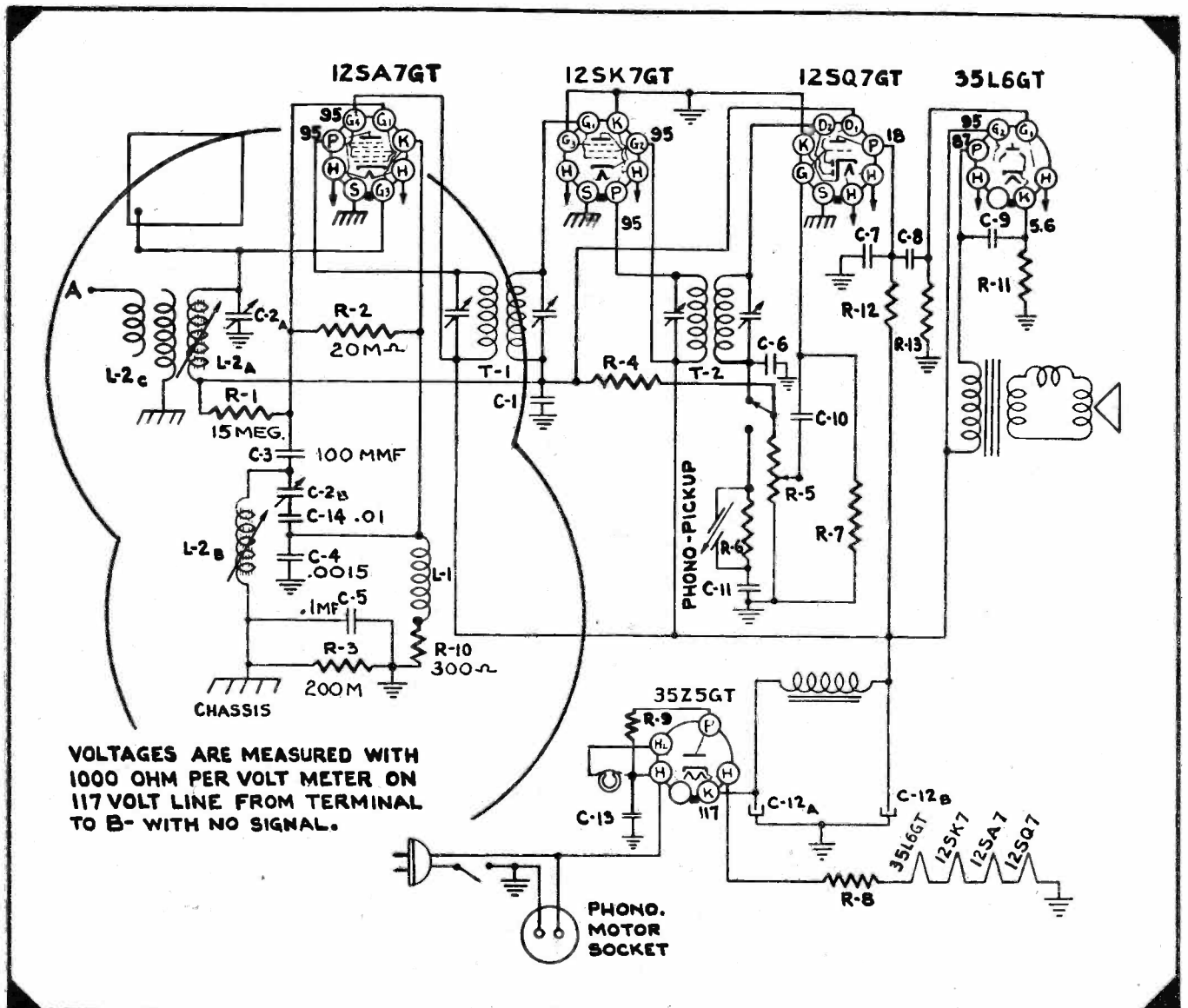

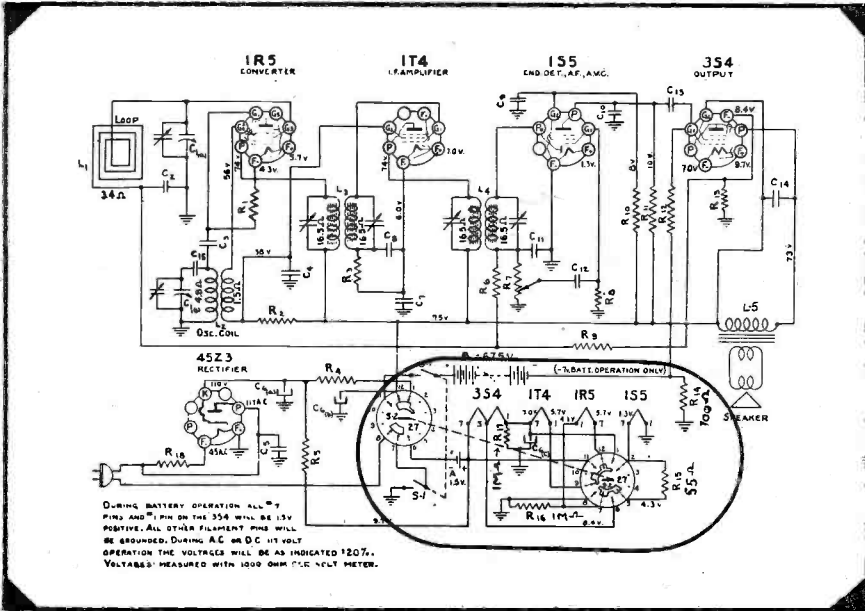

Fig. 1. Silvertone, Model 57RL390 (7189), an a-c/d-c portable, in which filaments are run in parallel, while on the line they are switched to a series connection.

able condenser is fully closed. The output meter is connected across the voice coil (0.42 volts equals 50 milliwatts). The signal generator ground is connected to the chassis through about 0.1 mfd. and the volume control is turned on full.

Alignment

For the i-f—455 kc—connect the signal generator to the signal grid of the converter through 0.1 mfd.; turn the dial to the high frequency end and tune the four trimmers. To set the oscillator, turn the dial to 1,600, set the signal generator to 1,600 and adjust the oscillator trimmer. To set the antenna trimmer, tune the set and generator to 1,400; use a standard loop or single turn on the generator loosely coupled to the set and adjust the antenna trimmer. The entire procedure should be repeated, step-by-step, to insure perfect tracking and optimum performance. The signal generator output should always be kept at the lowest

(Continued on page 27)

age on the sensitive tube filaments. The power tube can stand more ripple as it is not followed by further amplification.

Fig. 2. Silvertone, Model 57RL385 (7905), 6-tube, 5-band a-c with magnetite cone oscillator coils and i-f transformers.

Some personal sets are tricky to service as they are all more or less involved. The alignment procedure should be followed strictly as every bit of gain is required for good performance in any miniature set. First, the pointer is set at 540 kc when the vari-

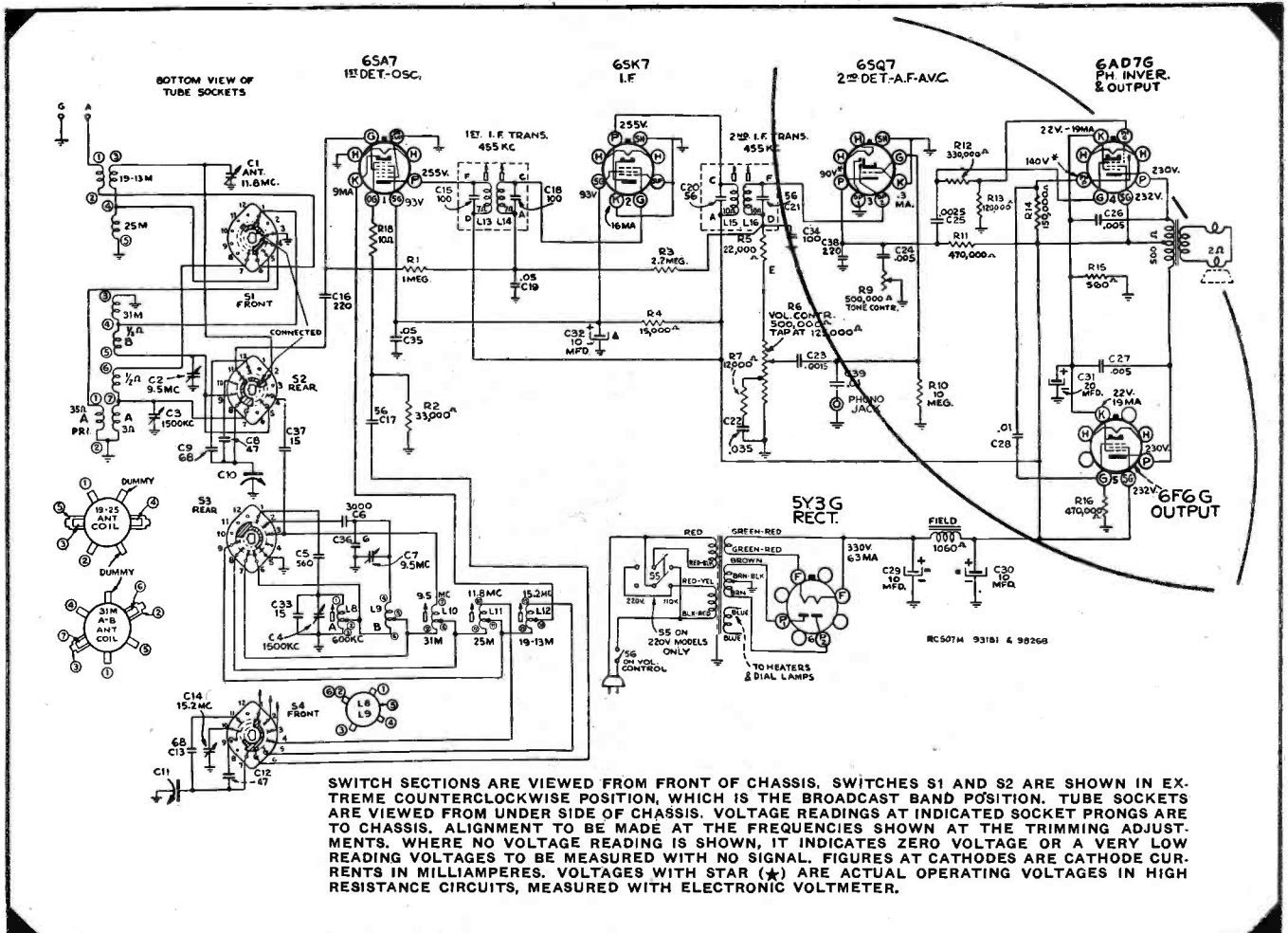

A UNIQUE VOLTAGE REGULATOR

By FRANCIS C. WOLVEN

IN THE flurry of gain-per-stage measurement and signal-tracing in the last few years, some Service Men have forgotten that it is necessary to repair a set as well as to diagnose the trouble. While I am an ardent signal tracer myself and try to be as well versed in radio theory as time and money will permit, it seems to me that radio service could well be improved by an infusion of careful workmanship and common sense.

Soldering Iron Difficulties

For some time, I spent my time burning a-c cords, service manuals and my knuckles on my trusty soldering iron. It never heated rapidly unless left alone; then it could be depended upon to burn up unless connected and disconnected at regular intervals. It would fall off its stand almost at will and burn craters in the bench. It was never hot enough to solder to the chassis when necessary. All in all, it consumed more time and attention than the set under test.

Intermittent Sets

Fading and intermittent sets were annoying, too. After many hours of waiting, the trouble would often be nothing more than a tube which developed gas; cathode leakage; or thermo-intermittent opens or shorts which would show up only after prolonged heating.

Another source of trouble was the set, often an old-timer using '26s, which showed a wide discrepancy in sensitivity in the shop as compared to the sensitivity obtained in the home. Experiment proved that five or ten volts on the line over or under the rated 115 made all the difference in the world.

Voltage Regulator Needed

Obviously, a good voltage regulator is just as important as an oscillograph—maybe more so, since the oscillograph is usually used on only part of the sets which require repair.

Desirable Features

One rainy afternoon, I listed the features wanted in an adequate voltage regulator as follows: (1) Two or more channels—one for the set; one for the iron; and a third one, optional, for test instrument. (2) Provision for regulation from about 90 volts to about 130. (3) Means for metering any channel

plus tell-tale lights to indicate whether a given channel is operating above or below normal line voltage. (4) Means for enclosing the iron safely, insulating it so as to save current. (5) Some sort of indicator to show temperature of the soldering iron.

The result is shown in the accompanying photographs. Two channels are available, each adjustable in steps of five volts to twenty-five volts above or below normal line voltage. A meter is provided plus a switch to cut in on any channel, or to connect directly to the a-c line. Red and green pilot lights are provided to indicate normal or sub-normal voltages as well as those in excess of normal. A shockproof fuse is replaceable from the front of the panel. Multiple outlets connect the channels to the front of the panel and space has been left for a third channel where this becomes necessary. Last, and best of all, the soldering iron is safely enclosed and well insulated. A meter on the front panel gives accurate indications of the iron temperature.

Construction

Construction is simple. A standard 7 by 19-inch rack panel is used to match my other equipment, all of which is mounted, rack and panel style in steel cabinets. The framework is strap and angle-iron. In making corner joints in the latter, four small bolts are better than one large one if rigidity is wanted. The transformers are units which were

salvaged after burned high-voltage secondaries were removed. The five-volt windings were then added. Switches are of the best quality and give snappy action; have given no trouble with arcing or burning.

Iron Holder

Of special interest is the iron holder which is also made of salvaged material. The mounting ring is taken from a meter which gave just one incorrect reading too many. The body is an old RCA tube shield. The lining is the case of an old wet electrolytic condenser. The top is cut from the condenser (which must be a sliding fit over the barrel of the iron) and the electrodes, liner, etc., removed. The condenser can is then put about half way through the top of the tube shield and the inside of the shield is packed with a mixture of fire clay and water glass. Care should be used to keep this clay-water glass cement out of the inside of the ex-tube shield. It is formed into a truncated cone-shape, tapering from the opening in the condenser shell to the opening of the tube shield. (See photo.) This serves to guide the iron into place.

The temperature indicators are thermocouples. I made a quantity of them by cutting three-inch lengths of No. 22 nichrome wire and four-inch lengths of No. 22 copper. The extra inch of copper was wound in a tight even layer at the extreme end of a length of nichrome. This end is then welded in an electric arc. The arc is formed between the wire to be welded and a block of carbon with power supplied from the 115-volt a-c lines applied through a couple of old heavy-duty A-eliminator chokes.

It will be necessary to connect a number of thermocouples in series unless a very good meter is used as an indicator. Any comparatively sensitive voltmeter of very low range can be used. Thermocouples are connected just like batteries, copper to nichrome, and the joints made secure with acid solder. Wash them in running water to remove the acid. Then they are mounted firmly in a ring of cement around the exposed end of the condenser case surrounding the hottest part of the iron.

I found that the spacers supplied with universal replacement field coils very handy to use as forms for keeping the

Top and bottom views of the voltage regulator unit.

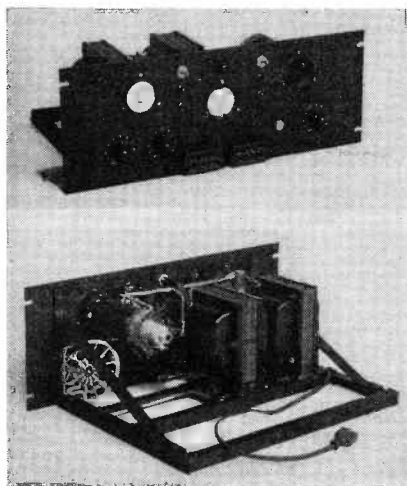

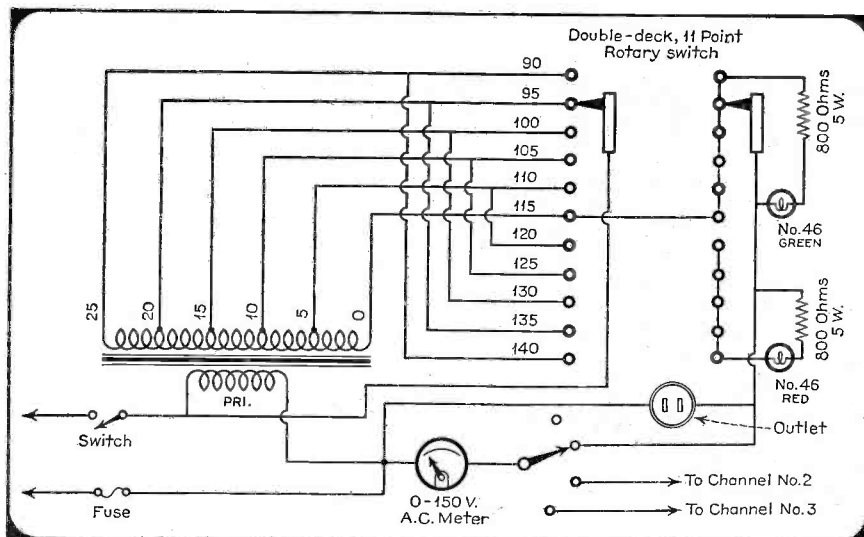

Circuit diagram of the voltage regulator.

cement within bounds. After all the cement is in place, the holder should be kept in a warm place for two or three days and then baked in a slow oven (300°). While baking, gradually increase the temperature unless steaming is noticed, in which case the baking should be retarded until the cement is dry. When completed and mounted, cut in enough thermocouples to give a mid-scale reading on the meter when the iron is at proper temperature. Considerable lag will be noticed, but this will do no harm and can be allowed for in use.

Wiring

Wiring is done with good hookup wire and is cabled and laced for appearance and ruggedness. Examination of the circuit will show that the secondary of each transformer is wound to 25 volts, and that phase changing is used rather than single winding of 50 volts overall. This was done in order to enable the transformer to carry heavy loads in case it might be necessary. The red-green indicators also work on the phase-changing circuit since it was felt that this would eliminate complications which other methods might entail. The result is a unit of rugged simplicity which may be safely used to check a flatiron as well as radio if the rotary switches are not used too much and loads of 800 or 1,000 watts are not permitted to remain connected for more than an hour or so.

Results

Concerning results, the humidity in the instrument cabinet is at a new low, the iron is never overheated and always ready. I keep it running all day with the regulator set at about 95 volts un-

less the work requires a higher setting. With a 115-watt iron and an applied voltage of 130, I have successfully soldered the commutator of a 1/2-hp motor without a single rough joint. Of course, this represents an extreme case, seldom met in practice. But it is a great comfort to know the extra heat is there and a still greater comfort to read iron temperature on a meter. Most gassy tubes and similar troubles will show up in a few minutes once the voltage goes over 120. It is things like this which make me feel that we should make our shops more practical. All the instruments in the world cannot help much if we persist in making things inconvenient for ourselves.

VIBRATOR PROBLEMS

(Continued from page 5)

chassis. Be sure the ammeter is poled properly in the circuit. Install a new fuse and vibrator in the receiver and turn on the set. Read the meter.

The service manual of the receiver will give you the rated input current at some fixed potential, usually 6.3 volts. If the measured input current exceeds this rating by more than one ampere after the tubes become heated, *there is something wrong with the set.*

If the set were allowed to continue operation under excessive input current conditions, the vibrator will gradually reach a temperature which would cause the contact arms to lose their temper. Under these conditions the contact arms will warp and shift to a position where the vibrator contacts will remain permanently closed. This causes a dead short which will blow the fuse.

If the current reading of the ammeter is excessive, turn off the set at once to

prevent damage to the vibrator, and check for trouble from one of the following sources.

(a) Replace the rectifier tube with one known to be good to see whether the input current is reduced to normal.

(b) Check the secondary buffer condenser, or condensers for shorts, and replace if necessary with units having the same capacity.

(c) Check by-pass condensers, especially those in screen circuits, for shorts or high leakage.

(d) If hash by-pass condensers are used across the elements of the 0Z4, these should be checked.

(e) If a hash by-pass condenser is used between the "B—" circuit and ground, it should be checked.

(f) Check the filter condensers for short circuits or high leakage.

(g) Check for a short or leakage, the coupling condenser between the grid of the power tube and the plate of the preceding tube.

(h) Check tubes for shorts. Output tubes especially are likely to develop shorts. Also check the bias voltage of the power tubes. Low bias voltage will cause abnormally high plate current, resulting in short vibrator life.

When it is certain that the receiver is in proper operating condition, the original vibrator should be reinserted in the set. If the "B" voltage is at least 90% of the B voltage obtained with the new vibrator, and if the old vibrator operates smoothly, it should be left in the set because it is capable of giving more service.

If, when examining a vibrator mechanism you find the springs have turned blue, the points have a burned look, the rubber sound insulation is charred, and possibly even the solder melted where the lead attachment is made, heavy overloading is indicated. There is no known manufacturing defect which will cause the trouble. The vibrator has been handling so much current that the IR losses have heated it to destruction. In all such cases, there is definitely something wrong with the set.

PHILCO 42-762, CODE 121

Speaker change: Beginning with chassis marked run 3, the speaker of this model was changed from a permanent-magnet type to electro-dynamic type. The voice coil of the electrodynamic speaker is connected in the same manner as that of the p-m speaker. The field coil of the electro speaker is connected to the (+) positive and (—) negative wiring of the 6-volt storage battery.

Buy United States War Savings Bonds and Stamps every payday.

CASE HISTORIES



PHILCO 42-718, CODE 121

Speaker change: Beginning with run 2, the speaker (35) was changed from Philco Part No. 36-520-4 to Part No. 36-1576. The new speaker is a p-m type and the wiring is different from that shown on the diagram for speaker Part No. 36-1520-4. The wiring for the new speaker is shown in the accompanying illustration. The speaker output transformer (34) is also removed when the new speaker is installed. The voice coil in the new speaker takes the place of the output transformer.

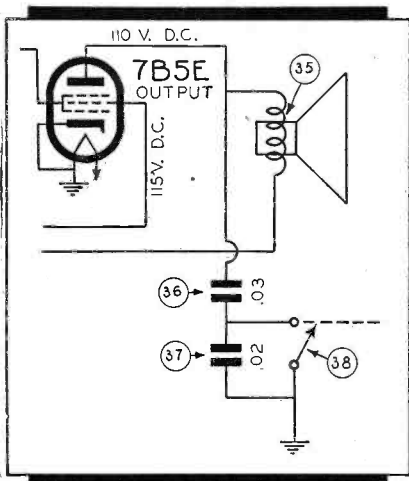

PHILCO 42-1019, 42-1011, CODE 121

Production changes: Beginning with later production of Model 42-1010 and the first production of Model 42-1011, a 10-mfd condenser was connected in series with the oscillator compensator (5B). This condenser improves the padding of oscillator compensator (5B) on 15 mc.

Hum reduction: To reduce hum, electrolytic condenser (32)-(32A) 9-9 mfd, 475 volts, was changed to 8-24 mfd, 475 volts. The 8-mfd section is connected in the circuit position (32) and the 24-mfd section in position (32A) across the rectifier output. Chassis with this change are marked run 4. In some receivers prior to this change an 18-mfd condenser was connected in parallel with (32A).

To accomplish a further reduction in hum remove the 0.01 condenser, which is connected from the center tap of the volume control to the terminal on the wiring panel right below it. Also, remove the 10-meg resistor which is wired to this terminal and to the second terminal of the bias resistor (82).

Remove the wire which formerly connected the resistor and condenser to the No. 3 terminal of the 7C6 tube socket. Connect the center terminal of the volume control to the dummy No. 4 terminal of the 7A4 tube socket. Connect the second terminal of the resistor (82) to the dummy No. 3 terminal of the 7A4 tube socket. Both of these leads must be dressed close to the chassis sub base.

Connect the 0.01-mfd condenser from the No. 3 terminal of the 7C6 tube to the No. 4 terminal of the 7A4 tube. Connect the 10-meg resistor from the No. 3 terminal of the 7C6 tube to the No. 3 terminal of the 7A4 tube.

To prevent oscillation a 0.2 mfd, 400-volt condenser was connected in the circuit at the lug of the terminal panel where resistors (33), (39) and (44) are connected. Ground one side of the condenser. Chassis with this change are marked run 3.

Beginning with chassis marked run 5, the 375-mmfd mica condenser (16) was changed to 350 mmfd. This change made to improve oscillator performance.

RCA Q16E (RC561C)

Service data: Model Q16E is similar to Model Q16, except that it has an electromagnetic speaker, as shown in accompanying sketch.

AIRLINE 62-77, 77, 95

Inoperative or erratic on low frequency end of dial: Cause—moisture absorption, etc., in oscillator coil. Remove composite oscillator and first i-f coil ticated on the right front of chassis (facing front of chassis with chassis inverted. Connect 6-volt storage battery across grounding lug and bus wire that goes to 700 to 1150-mmfd, 600-kc padding condenser. Allow resultant heat to boil out all air bubbles and permit old wax to run out of coil. While still hot

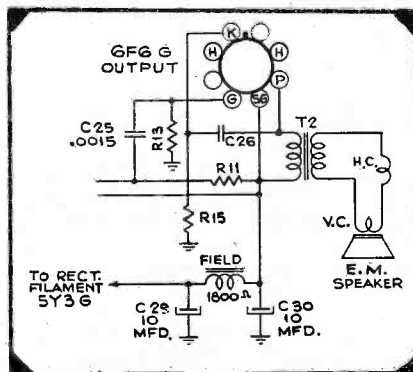

either dip or paint on i-f coil dope. Check to see if 34 i-f tube draws its positive filament supply through choke L1. If so connect as per schematic on Montgomery Ward page 4-18 in Rider's Volume IV. In extreme cases remove jumper lead between 32 detector-oscillator screen and 34 i-f screen. Install 0.05-mfd paper condenser from 34 screen to ground and run an extra battery cable lead to the B battery plus 67½-volt post for 34 screen supply. Remove 67½-volt cable marker from original wire and install on new wire. Connect new wire to plus 67½-volt tap on B battery and old 67½-volt wire to plus 45-volt tap. Oscillator works better with 45 volts on 32 screen, whereas signal will be distorted at low volume levels on strong stations if 34 i-f is operated with 45 volts on screen.

D. C. Sprong.

STROMBERG-CARLSON 410-H

Noisy While Tuning: A scratchy sound which occurs as the dial pointer moves across short-wave scale may be eliminated by replacing bronze cable with one of silk or rayon. Lubrication of the runner on which dial pointer moves will also help. The condenser rotor contacts, of course, should also be thoroughly cleaned and connected to ground by means of suitable pigtails.

Willard Moody.

PHILCO 39-55RX, 39-116RX

Skipping stations on mystery control: Cause, armature of stepping relay hitting pole piece before ratchet gear rotates a sufficient amount for holding latch to engage next tooth. Remove same from stepper unit. Loosen two screws on top of stepper relay and push fulcrum for armature toward front of set just far enough to cause proper operation. If moved too far forward inertia will carry ratchet gear and rotating assembly far enough past when dialing "Soft" to cause holding pawl to release and permit switch to drop back one or more stations from one previously dialed.

If impossible to eliminate one trouble without introducing the other, remove stepper assembly. Disassemble stepper assembly until cam that releases holding pawl can be removed. File or grind a notch in the curved portion that first touches holding pawl. Reassemble and it will then be found possible to adjust fulcrum so that proper operation can be obtained.

D. C. Sprong.

TO EXECUTIVES:

NOW YOU CAN HELP

Even More...

**New Treasury Ruling Permits Purchases
UP TO \$100,000, in any Calendar Year, of
Series F and G WAR BONDS!**



The Treasury's decision to increase the limitations on the F and G Bonds resulted from numerous requests by purchasers who asked the opportunity to put more money into the war program.

This is not a new Bond issue and not a new series of War Bonds. Thousands of individuals, corporations, labor unions, and other organizations have this year already purchased \$50,000 of Series F and G Bonds, the old limit. Under the new regulations, however, these Bond holders will be permitted to make additional purchases of \$50,000 in the remaining months of the year. The new limitation on holdings of \$100,000 in any one calendar year in either Series F or G, or in both series combined, is on the cost price, not on the maturity value.

Series F and G Bonds are intended primarily for larger investors and may be registered in the names of fiduciaries, corporations, labor unions and other groups, as well as in the names of individuals.

The Series F Bond is a 12-year appreciation Bond, issued on a discount basis at 74 percent of maturity value. If held to maturity, 12 years from the date of issue, the Bond draws interest equivalent to 2.53 percent a year; computed on the purchase price, compounded semiannually.

The Series G Bond is a 12-year current income Bond issued at par, and draws interest of 2.5 percent a year, paid semiannually by Treasury check.

Don't delay—your "fighting dollars" are needed *now*. Your bank or post office has full details.

Save With . . .



War Savings Bonds

This space is a contribution to America's All-Out War Program by **SERVICE**

PHILCO 42-1004, CODE 121

Production changes: To improve the operating performance of the rectifier circuit, the wiring of rectifier tube 50Y6GT socket was changed as follows:

Remove the bare wire between contacts 2 and 3. Connect a wire from contact 3 of the socket to the lug of the filament resistor (43) to which condenser (40) is already attached. This change was incorporated in all chassis marked run 2. Sets prior to run 2 do not have this wiring change.

Beginning with chassis marked run 3, 0.01-mfd condenser (36) was changed to 0.006 mfd, 400 volts. This change was made to improve the tone quality of the phonograph.

SONORA RECORD PLAYER

Gradual Decrease in Output from the Pickup: This unit is wired with cotton-insulated shielded wire. Instead of "pig-tailing" the shielding at the ends of each wire and grounding the pigtail, the grounding was done directly to the body of the wire. Damp weather often causes leakage from shield to wire and cuts the output of the pickup. Replace the wire and solder to the ends.

Francis C. Wolven

PHILCO 96

Set inoperative after a very short operating period: The push-pull input transformer in this model often develops a fault that necessitates the replacement of the unit. In this latest case, it caused the set to go dead after a few minutes of operation. It was found that a 5,000-ohm short circuit of the plate winding to the chassis was reducing the plate voltage. The short would not be disclosed by the customary ohmmeter test, using a low voltage. However, with the transformer disconnected entirely from the receiver circuits and about 300 volts connected to the casing of the transformer and its plate winding through a voltmeter of suitable range and sensitivity, the defect was readily disclosed. A new transformer cured this phase of the job.

Another fault, also encountered in these sets, is shorting of the pilot light wires to the chassis; this removes the bias from the output tubes and cause a disagreeable distortion and will increase the plate current drain of the output tubes.

If trouble is experienced with oscillation, and the shielding cover of the screen grid tubes is in place, make sure that a good ground connection is made to the set. Curiously, freedom from oscillation seems to depend to a great

★ ★ ★
TO MAKE MORE MONEY—
... SPOT TROUBLE QUICKER

LET THIS BIG HANDBOOK SPEED UP YOUR TROUBLESHOOTING AND MAKE MORE MONEY IN WARTIME SERVICING

A. A. GHIRARDI'S
New, Revised and Enlarged
Radio Troubleshooter's HANDBOOK



A. A. GHIRARDI
Leading authority on radio servicing and radio instruction, is the author of the Radio Troubleshooter's Handbook. So clear, complete and understandable are his various books that they have been adopted as standard by the leading government and civilian radio schools.

CONTENTS
(Partial List of 65 Sections)
Time-saving trouble "case histories" for 4607 receivers and record changers. * Battery Replacement charts. * 1-1/2 "peaks" of 20,173 superhets. * Condenser Replacement chart. * Socket diagrams and operating characteristics of 970 tubes. * Grid-bias resistors for 297 tubes. * Volume and tone control circuits. * How to modernize old receivers.
Nowhere else will you find all the vital factory-checked information this single big Handbook contains.

Cut Repair Time and INCREASE YOUR SERVICING PROFITS
Complete in one big 710-page volume.
NOW only \$5.00

Never before have minutes meant money in service work the way they do now! To speed up your troubleshooting—get this great big handbook of working service data and keep it at your elbow. It's boiled down to essentials—indexed for split-second reference. Saves you precious hours of work.
YOU TOO CAN MAKE MORE MONEY! C. P. Lauzon, of Burlington, Vt., writes: "The information I received from p. 397 and on, paid for the book." H. Johnson, of Chicago, writes: "The arrangement of the data is perfect. The Handbook paid for itself the very first day." R. W. Wheeler, of Towanda, Kansas, writes: "Your Handbook has saved me enough time in a day to more than pay for itself. It's a gold mine of servicing information."

OTHER GHIRARDI RADIO BOOKS

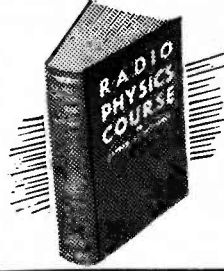

RADIO PHYSICS COURSE,
A complete course in basic radio fundamentals in one volume, 972 pp., 508 illus. Used as basic text by U. S. Signal Corps and civilian radio schools.

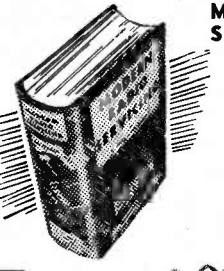

MODERN RADIO SERVICING,
Practical How - To - Do - It home - study course in radio repair work and use of test instruments. 1300 pp., 706 illus. —only \$5.00.
Special Money-Saving Combination — Modern Radio Servicing and Radio Troubleshooter's Handbook—only \$9.50 if ordered together.

SPECIAL MONEY SAVING OFFER
Includes Sound and Electricity—only \$5.00.

GOING TO JOIN UP?
Get set for better pay—quick promotion—more interesting duty. Use Ghirardi's quick home-study books. Here's what Ch. Instructor F. S. Bailey of Radio Operator's School in Brownsville, Texas, says of Radio Physics Course: "We find your book by far the best of 20 or more we have tried."

5-DAY TRIAL OFFER
See all 3 Ghirardi books at your local distributors. Or you may order direct, with the privilege—it not fully satisfied—of returning them within 5 days and receiving your money back. (Foreign prices are 50c. higher on each book.)

RADIO & TECHNICAL PUBLISHING CO. 45 ASTOR PLACE • NEW YORK CITY

extent upon having this ground wire attached to the set.

If the dial cord has been replaced, because of breakage, check the tuning condenser gang for mechanical inertia, lubricating if necessary.

Willard Moody.

GENERAL ELECTRIC 106

Receiver does not shut off when the off button is pressed: It is probable, in cases where this trouble is experienced, that the switch is not being opened because the bracket on which it is mounted does not permit the switch to be pressed tightly against the horizon-

tal member which engages or presses against it. To correct the trouble, loosen the screws of the switch bracket located at the right side of the chassis and move it farther to the left toward the shut-off arm. This will insure the application of adequate pressure for correct operation of the switch.

Willard Moody.

AUTOMATIC P57, P58

Faulty avc: Faulty avc action in these models may be due to an open or excessive resistance in the 1A7G grid return lead. One such instance showed up an isolating resistor with 5 megohms

"TEST TO DESTRUCTION"

Standard Electro-Voice engineering practise includes orders for "Test to Destruction" during manufacture and assembly. At frequent intervals, microphones are taken from our production lines and abused until they are completely demolished.

Throughout the procedure, Electro-Voice engineers carefully examine and analyze the resulting changes in level and response. This is but one of a series of tests that are perfecting a line of rugged microphones for dependable service under the strains and shocks of military service.

ELECTRO-VOICE MFG. CO., Inc.
1239 SOUTH BEND AVENUE SOUTH BEND, INDIANA
Export Office: 100 VARICK STREET, NEW YORK, N. Y.



STANCOR TRANSFORMERS

First Choice of Servicemen!



STANDARD TRANSFORMER

• CORPORATION •
1500 NORTH HALSTED STREET . . . CHICAGO

Back Copies Available

A few copies of back issues of SERVICE are available if you need them to complete your files.

Just let us know what issues you require and enclose 25c for each copy requested back to January, 1941, or 50c for each copy prior to that date.

SERVICE, 19 East 47th Street, New York City

when it should have been 1 megohm.
Willard Moody.

PHILCO 39-40

Intermittent Oscillation: Cause—poor grounding contact from low side of tertiary winding on second i-f transformer (No. 23). Remove transformer from chassis and disassemble from shield can by unscrewing small discs around trimmer screws and sliding coils out through bottom of shield, after removing grid clip. Carefully clean of all impregnating wax from lug connected to top adjusting screw nut. Check carefully for cold soldered connections and reassemble. Also make certain that tertiary winding is not shorted where turns cross to soldering lugs. Carefully realign.

Oscillation upon adjusting i-f trimmers to resonance: Cause and cure same as above.

D. C. Sprong.

RCA 222

To improve bass response: By-pass screen of 2B7 first audio tube with 8-mfd electrolytic. By-pass cathode-bias resistor (R20) with 10-mfd or larger, 25-volt electrolytic. Change 0.02-mfd coupling condenser (C33) to 0.05-mfd, 600-volt tubular.

D. C. Sprong.

GENERAL ELECTRIC G 105

Mechanical and electrical noise while tuning: Carbon tetrachloride applied with a brush and wiped off with a linen rag will ably clean the motor rim contacts. These are all subject to corrosion over a period of time. Noisy electrical tuning, mechanical in nature, can be eliminated by lubricating the rods on which slide the moving members immediately behind the dial.

If a crystal phonograph is connected to the set, a shielded wire from the arm of a double-pole double-throw switch should be run to the volume control. The insulated wire is connected to the high side and the shielding to the low. The shielding should be taped as far as the switch. This prevents possible noise occurrence when the shielding touches the chassis. The other pole of the switch is used to break the plate return lead to the oscillator section of the 6A8-G, which effectively mutes the set during phonograph reproduction.

Willard Moody.

RCA U-9

Distortion on phonograph operation: If the tone of the phonograph does not seem to be normal, check the position of the tone arm, which is mounted on a
(Continued on page 22)

MODERNIZATION

By R. G. CHROUCH

SINCE AUTO-RADIO sets are increasing in price and are becoming more and more scarce, a greater demand for used sets is evident. Modernization is definitely a paying business and will become more so in the near future. Take the PT6 Ford-Philco, for example. These sets were built for top aerials and aren't so hot on whips. Change the antenna coil to a universal iron-core auto-radio type. Adjust carefully and pickup trouble is overcome with a good condition to pep. While you are at it change the type 39 r-f and i-f tubes to metal type 6SK7s. New sockets and new 400-ohm cathode resistors are easily installed. These sets then become practically as sensitive as the latest models. They are well built and will give good service after this alteration. Several customers have told me that these sets in their cars will bring in stations that they just can't get on the receivers in their home.

Oh, yes, of course, it's necessary to carefully realign, and while you are doing this don't overlook checking the buffer condenser for leakage. It is also best to remove the old antenna lead and install a bayonet socket in the slot provided for the old lead, thus completely adapting the set to the whip antenna.

The 1934 model had the speaker in the case. Early 1935 models, however, provide a cut-out for a speaker in the case, although these were used as ear level jobs. I like to put the speaker in the case as it makes installation easier.

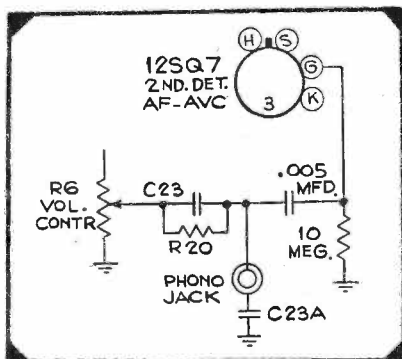

RCA Q17

Distortion on 110-volt d-c operation: Distortion at all volume levels when Model Q17 is operated on 110-volt d-c supply is caused by incorrect bias on the 12SQ7 control grid. This condition can be eliminated by changing to the circuit shown in accompanying sketch.

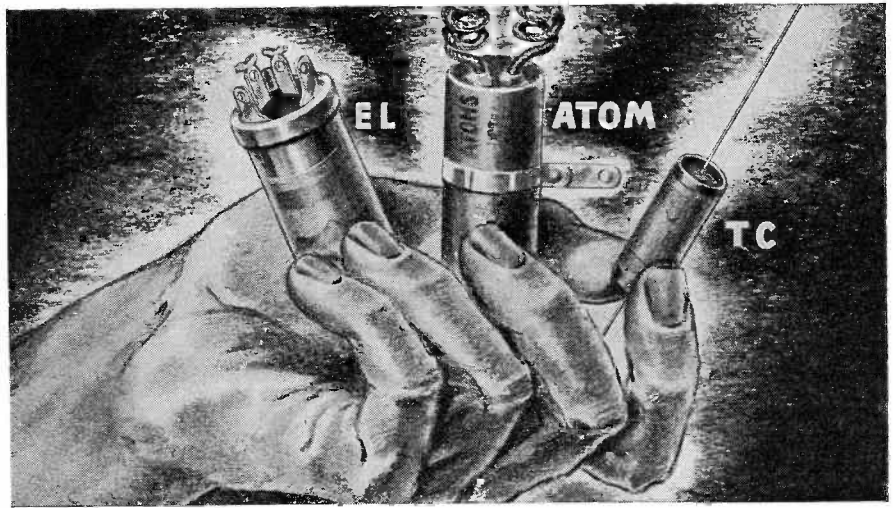

TODAY'S CONDENSER PROBLEMS WERE SOLVED YEARS AGO!

No matter how many condenser types war restrictions may make it impossible to supply... you're still in business as far as condenser replacements are concerned as long as you can continue to get Sprague Atom Midget Dries, Sprague EL prong-base Electrolytics, and Sprague TC Paper Tubulars.

Long ago, Atoms proved that they were the truly universal condensers—just the thing to replace any cardboard or can-type unit up to their rated values, and regardless of size. For higher voltages and wet condenser replacements, use EL's. For all tubular by-pass needs, use Sprague TC's—the most famous units of their kind in the history of Radio, and still the most dependable. These three types enable you to handle practically any condenser replacement job!

Practically all of Sprague's greatly enlarged facilities are devoted to war work, have been for a long time past, and will be until Victory is won. Although present jobber stocks of the above condenser types are largely complete, it is obvious that further production for civilian use must depend upon authorization from those in charge of the allotment of manufacturing facilities and critical materials.

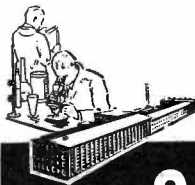

SPRAGUE PRODUCTS COMPANY

North Adams, Mass.

RCA 26BP

Alignment: The r-f detector and oscillator adjustments in Model 26BP are easily accessible when the chassis is mounted in the cabinet. Consequently

the regular dial may be used for reference during alignment. In the event that only the chassis is brought in for service, the accompanying full-size dial reproduction can be used as a substitute for the regular dial.

55 60 70 80 100 120 140 160

CASE HISTORIES

(Continued from page 20)

rubber bushing. If the tone arm has a tilt to it, naturally the needle will not hit the record properly. The result will be excessive scratching and distortion.
Willard Moody.

WESTINGHOUSE 473-Y

Record fails to stop: When the record player fails to stop at the end of a record, it means that the trip lever adjustment, located beneath the turn table, is not set properly. This trip lever is so mounted that it can be slid around over a short space, by loosening the wood screw holding the bracket to the wooden motor board. The adjustment is made by experiment, to the left tending to make the record stop before playing through, and the opposite, if moved to the right.
Willard Moody.

GENERAL ELECTRIC H-116

Oscillation squeals and intermittent reception: These troubles may be the result of a defective 6SQ7, which frequently may not show up in a tube tester.
Willard Moody.

RCA 46X3 (1940 Model)

Modulation hum after heating up: If this hum is not due to a defective 50L6-GT, it may be caused by the 0.05-mfd condenser lead touching the 12SA7 oscillator grid leak near the tube socket. This shorts the grid to the rectifier tube's heater and causes modulation of the oscillator at 60 cycles. The hum will be noticed more than a station is tuned in and will not be so bad off resonance. Ordinarily, one would look for an open line condenser or poor filter. For best guarantee against reoccurrence use spaghetti over the connection.
Willard Moody.

FADA 5F60-T

Open heater circuit: Like many a-c/d-c sets, this one may require attention at the line plug at the end of the resistor cord. Very frequently a new cord will usually be near the plug. By skinning back some of the insulation and reconnecting the fine resistance wire carefully (installing a plug of the standard type) trouble from this source will usually be eliminated.
Willard Moody.

AIRLINE 62-135

Oscillation: This set will oscillate if aligned over-correctly. To obtain best results, align with oscilloscope; try to obtain smooth curve free from the ragged spots that indicate a tendency to oscillate.
Francis C. Wolven.

PILOT 31, 81 (RAINBOW)

Loud hum with low plate voltages, no bias on 47 tube: Due to open 500,000-ohm resistor in 47 bias divider circuit; replace.
Francis C. Wolven.

GENERAL MOTORS 211

Low volume and distortion: Open 250,000-ohm $\frac{1}{2}$ w detector plate resistor; replace.
Francis C. Wolven.

SILVER MARSHALL 30

Loose or broken dial cords: The dial cord is a constant offender on this model. To replace remove shield over r-f stages, loosen screws holding tuning condenser and remove dial assembly. Clean out and tin the slots in the winding drums. Use ordinary dial cord for replacement, cut longer than the original and wrap $\frac{1}{4}$ inch of each end tightly with fine bare copper wire. Use rosin and alcohol flux and solder the dial cords into the slots. Cords fastened in this way never work loose. After the cord is installed, get a small coil spring of moderate tension and plenty of stretch and hook it around the hub of the dial, fastening the ends to the cord, one on each side of the tension screw. Use a good grade of fine grease at all bearings, since the dial and tuning condenser must run perfectly free. A very little friction compound on the cord where it passes over the idlers helps. This will keep the idlers turning and prevent wear and jumping. Due to the fact that all parts are die-cast warping sometimes occurs in the drum dial bearing. This bearing should run perfectly free, and if it binds even a little, it should be worked true with emery powder and oil before any repairs are made. Need it be said—and remove the emery before reassembling.
Francis C. Wolven.

MIDWEST 18-35

Low volume: Leakage in 0.05-mfd, 400-volt by-pass condensers inside i-f cans resulting in burned-out 5,000-ohm, $\frac{1}{4}$ -watt decoupling resistors. These condensers seldom short but develop a very high leakage causing the resistors to overheat and the set to lose volume. If one fails, replace them all.
Francis C. Wolven.

GRUNOW 871 (Chas. 8E)

Crackling and popping even with volume control off: Cause defective push-pull audio input transformer. To make test short plate prong of 605 first audio tube to chassis momentarily. If noise immediately clears up or primary of transformer "opens" the trouble is in transformer.
D. C. Sprong.

FADA "KA" 60

Intermittent fading and cutting off: Considerable cutting off and fading as well as oscillation can be traced to cathode, screen and plate by-pass condenser in the little rectangular cans. These run a little too hot due to the close proximity of the r-f tubes and lose their wax as a result. Had one case which kept bouncing back with the complaint of "fading," although several hours run failed to produce this condition in the shop. Finally the line voltage was advanced to 130 volts and five tubes developed secondary emission. The owner happened to be on one of these rural lines where the voltage wanders around 130 to 135 volts. A voltage regulator cured the trouble. Voltages somewhat in excess of normal are to be recommended as a means of testing any similar condition on any case of this kind.
Francis C. Wolven.

PHILCO 118, CODE 121

Cutting off with great loss of sensitivity, broadening and shadow in tuning meter, etc.: Loss of sensitivity may be found to be confined to one stage, r-f, i-f or mixer. Usually due to intermittent open in one or more of the avc by-pass condensers. These are small 0.05-mfd tubulars. As a rule they are installed with the leads stretched very tight, which is the chief cause of their failure.
Francis C. Wolven.

GRUNOW 871 (Chas. 8E)

Inoperative short-wave trimmers: Quite a number of these sets have one or more trimmers unconnected when shipped from the factory. Connecting them and carefully realigning greatly improves performance.
D. C. Sprong.

MAJESTIC 500

Poor selectivity: Replace second i-f transformer with double tuned duplicate replacement unit and carefully realign. Improves both selectivity and sensitivity.
D. C. Sprong.

PHILCO 37-623

Inoperative on short-wave bands or all bands in extreme cases: Cause is leaky insulation on oscillator section of range switch. Cure by replacing said section of range switch. In some cases replacing 1C7G detector-oscillator tube restores operation temporarily, but usual trouble reoccurs. "Mushy" tone: Cause is open output transformer primary. Replace with new transformer.
D. C. Sprong.

LOW PRICE MIDGETS

Low sensitivity: Midgets and other "price" sets give a great deal of trouble, especially in damp weather with the common complaint of low sensitivity.
(Continued on page 31)

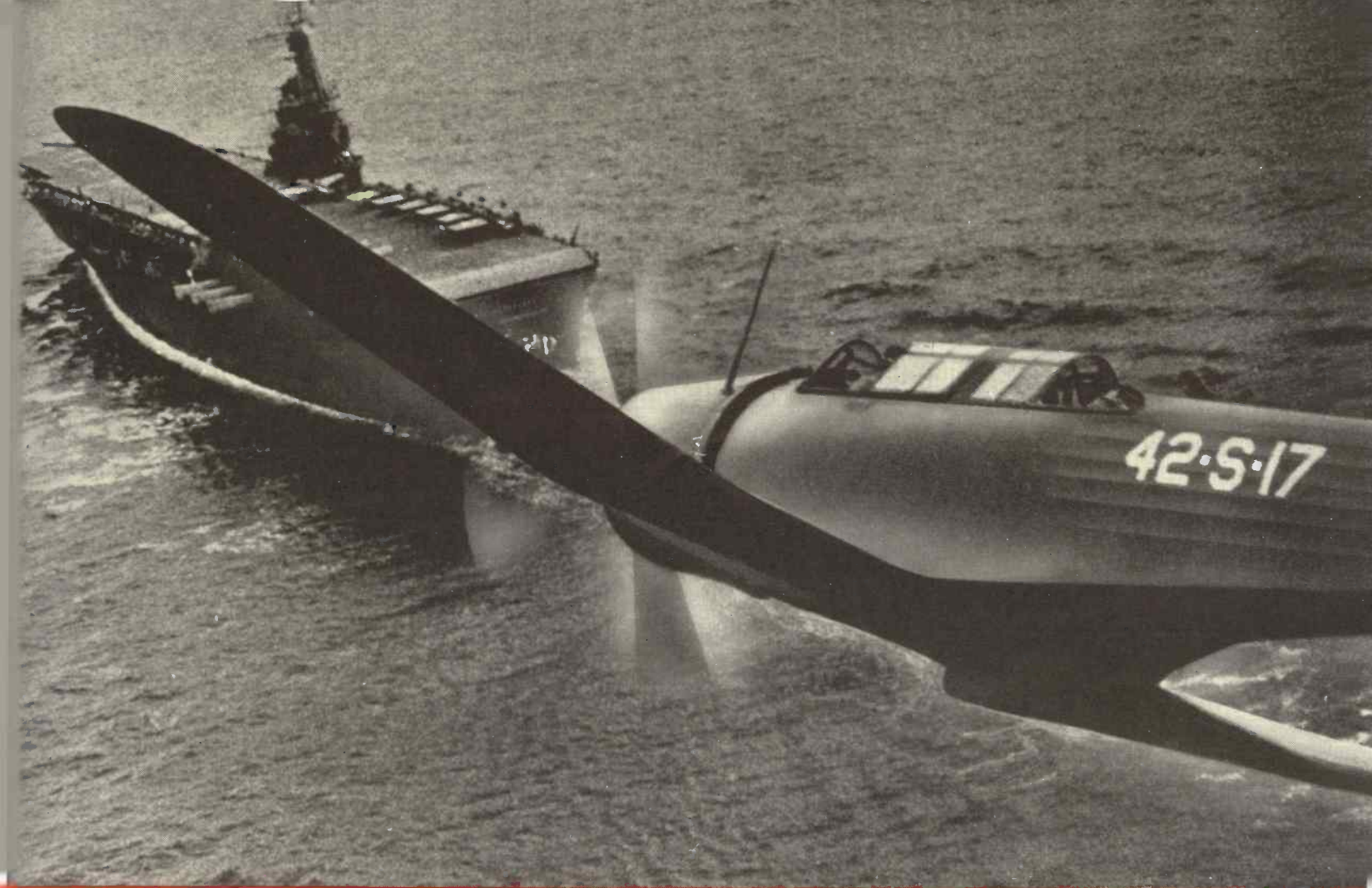

DESIGNED FOR SPECIFIC APPLICATIONS

The bulk of U.T.C. production is on special units constructed to precise customers' requirements. It is naturally impossible to describe all of these thousands of designs as they become available. Many of them are unique.

In most cases, today, a major design factor is the conservation of material, or provision of substitutes for critical materials. All in all, it is significant that the difficult transformer jobs find their way to U.T.C.

MAY WE ASSIST YOU IN YOUR PROBLEM?

U.S. NAVY OFFICIAL PHOTO

UNITED TRANSFORMER CO.

150 VARICK STREET



NEW YORK, N. Y.

EXPORT DIVISION: 100 VARICK STREET NEW YORK, N. Y. CABLES: "ARLAB"



Geared to the Wartime Needs of Radio Service

SERVICE—19 E. 47th St., N. Y. C.

Please enter annual subscription (12 issues) for each of the undersigned for which payment is enclosed at the rate of \$1.00 each; foreign \$2.00. (This rate applies only on 4 or more subscriptions when occupations are given.)

Name

Address

City-State

Occupation

Title (Service Mgr., etc.)

Employed by

State whether Employer is a Service Organization, Dealer, Jobber or Manufacturer

Name

Address

City-State

Occupation

Title (Service Mgr., etc.)

Employed by

State whether Employer is a Service Organization, Dealer, Jobber or Manufacturer

Name

Address

City-State

Occupation

Title (Service Mgr., etc.)

Employed by

State whether Employer is a Service Organization, Dealer, Jobber or Manufacturer

Name

Address

City-State

Occupation

Title (Service Mgr., etc.)

Employed by

State whether Employer is a Service Organization, Dealer, Jobber or Manufacturer

—When Exact Duplicates are Unavailable

Data prepared by a group of leading receiver design engineers discussing various circuits and procedure necessary for making component substitutions.

—When even Substitutes are Unavailable

Articles by Editor Herzog and engineers from parts companies and laboratories dealing with repairs of components and accessories.

—When Industrial Electronic Service is Required

Technical discussions by Alfred A. Ghirardi and other engineers who specialize in electronic development—for industry, for control, for protective use.

—When the latest Data on Circuits are Needed

Henry Howard's circuit analyses each month with diagrams and parts values.

—Sound—Case Histories—Shop Notes



Remember that until further notice the Group Rate (**\$1.00 Yearly instead of the regular \$2.00 Yearly**) is still in effect.

NEW PRODUCTS

Additional information and prices of the products described below may be obtained, without obligation, from the respective manufacturers.

SAV-A SHAFT VOLUME CONTROLS

A unique series of volume controls featuring a new development . . . "Sav-a-Shaft" . . . that affords utilization of the shaft from the defective control is announced by National Union Radio Corp., 57 State Street, Newark, N. J. No cutting, filing or special knob is necessary regardless of whether the knob requires a flat, split knurl or other special shaft-end. Other features include the availability of ten types with correct tapers and taps that are said to handle 95% of most service work. Each control is complete with switch operating only when lug is released. All controls are of the midget type.

* * *

PORTABLE VOLT-OHM-AMMETER

A new portable volt-ohm-ammeter, known as Model 625-T, has been produced by the Triplett Electrical Instrument Co., Bluffton, Ohio. The instrument affords measurements of 12 a-c/d-c voltage ranges to 5,000; six d-c ranges, including microamperes, milliamperes and amperes; and three resistance ranges. Sensitivity is 10,000 ohms per volt d-c.

Complete insulation for high voltage testing is provided by attractive black molded case and panel. Case size is 6 inches by 5½ inches by 2½ inches.

Instrument has extra-long readable scales, with contrasting colors for a-c and d-c markings.

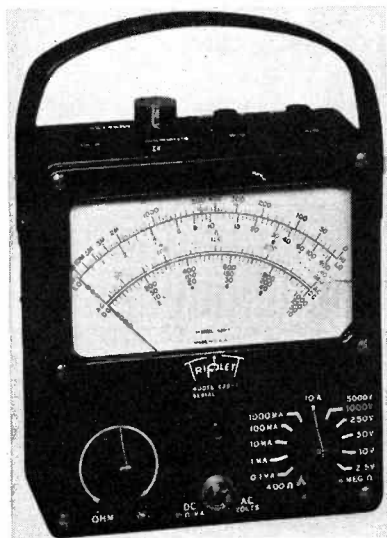

* * *

WALSCO STAPLE DRIVER

A new improved model of the outstanding WalSCO Staple Driver has been developed by the Walter L. Schott Company, Los Angeles, Calif.

The new model staple driver is now made with hardened steel inserts which is

said to prevent all possibility of jamming and clogging its automatic staple magazine.

The device quickly sets staples into otherwise inaccessible places, and even into hard surfaces such as brick, plaster walls, or hard wood.



* * *

HEAVY-DUTY 50-WATT POWER RHEOSTAT

A 50-watt heavy duty power rheostat has been developed by Clarostat Manufacturing Co., Inc., 285-7 N. 6th St., Brooklyn, N. Y.

This new 50-watt rheostat, like the 25-watt unit, introduced some time ago, has selected resistance wire wound on an insulated metal core which distributes the heat at intermediate rotational settings. The resistance element is firmly imbedded in a ceramic housing with an inorganic cement, resulting in a solid thermal mass. A graphited-copper contact shoe rides the collector ring and the winding, assuring two positive sliding contacts. Contact pressure is provided by a helical spring, concentrically mounted about shaft whose action is evenly distributed by use of a tripod-type contact carrier. The contact is insulated from the metal shaft by a center ceramic insulator, thus providing a "dead" shaft and mounting bushing. Available in any resistance value up to and including 10,000 ohms.

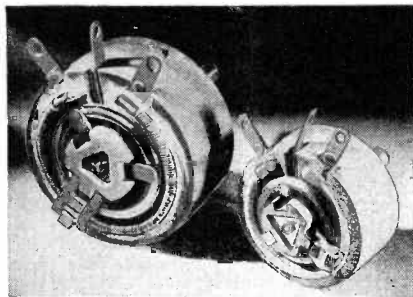

* * *

THE RCP MULTITESTER

Many features are included in the RCP No. 423 volt-ohm milliammeter, that are effective in production line tests and commercial laboratory measurements.

The instrument, developed by Radio City Products Co., 127 W. 26th St., New York City, has 3-inch-square meter with a movement of 395 microamperes or a sensitivity of 2,500 ohms per volt. Other features include an ohmmeter range of 10 megohms, each shunt and multiplier individually calibrated, while all multipliers are individually matched in pairs so that the overall accuracy is said to be within 1%. A suppressor type copper oxide rectifier is used for a-c measurements and cabled

or harnessed type construction is used throughout.

This instrument—and others—are described in Bulletin No. 126, available upon application.



* * *

ELECTRONIC LIMIT BRIDGE

An Electric Limit Bridge is now being made by Radio City Products Co., 127 W. 26th St., New York City.

The dial of the device, known as Model 670, is calibrated from zero center to ten per cent deviation on either side. With each main division on the dial indicating one-half of one percent, fractional divisions showing deviations of one-tenth of one percent can be read quickly, and approvals or rejections promptly determined. Comparison is made against a predetermined internal standard of any arbitrary value selected. While this is supplied as part of the bridge, provision is also made for using any other value of resistance desired by switching to "External Standard" and connecting the new standard value to the corresponding terminals.

Component resistors are said to be accurate to one one-tenth of one percent and the indicating meter is a 4½-inch galvanometer having a sensitivity of 25-0-25 microamperes.

The unit is battery operated and completely self-contained in a handsome, natural finish solid oak carrying case. Model 670 is described in Bulletin 126 free on request.



KEEP A BALANCED TUBE STOCK ALWAYS ON HAND



Win Customer Goodwill
With Quick Service

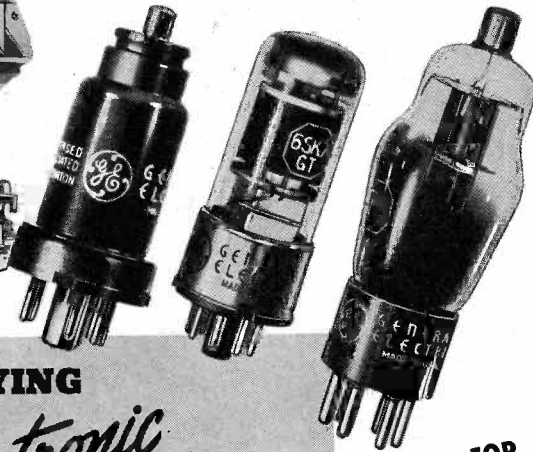

KEEP 'EM PLAYING

WITH



Electronic
**RADIO
TUBES**

FAMOUS FOR
LONG LIFE AND
FINE RECEPTION

GENERAL ELECTRIC

PHILCO 1942 RECORD CHANGER REPLACEMENT SPINDLE KIT

Because of material shortage it is not possible to supply the early type spindle with the large bushing as used on recorder changes Model 35-1258. A replacement kit is available making it possible to substitute the spindle and other associated parts as used in the later changers. The following is the installation procedure. Service bulletin 402 gives the reference numbers.

Remove positioning bracket from the cam gear mounting bracket (No. 32A) and replace screw. Remove old spindle assembly. Remove two screws that hold bracket No. 32A to the U bracket. Unhook the spring from the U bracket to cam lever.

Remove solenoid bracket by drilling out the four rivets that hold it in place at base plate. Mount new U bracket to base plate.

Screw eccentric washer on U bracket and replace screws holding bracket No. 32A to the U bracket. Replace spring to U bracket and cam lever.

Mount new spindle assembly (Part No. 318-2839) with pin in slot in U bracket.

Locate clutch lever fork between washers on spindle assembly. Replace solenoid bracket and solenoid core bracket screws. Adjust changer for correct performance.

Spindle Kit for Standard Changers (Kit No. 45-2963):

- 1 (218-1400) U bracket.
- 1 (318-2839) spindle assembly.
- 1 (318-2838) turntable.
- 4 (W-136) rd. hd. steel machine screws.
- 4 (W-661) steel hex nuts.
- 4 (W-223) Shakeproof lockwashers.
- 1 (217-1406) fibre washer.
- 1 (217-1407) curved washer.
- 1 (218-1252) lockwasher.
- 1 (218-1504) nut.

Spindle Kit for Deluxe Changers (Kit No. 45-2964):

- 1 (218-1400) U bracket.
- 1 (35-2606) spindle.
- 1 (35-2611) turntable.
- 1 (218-1403) spring.
- 1 (218-1406) washer.
- 1 (218-1405) washer.
- 1 (218-1401) clutch.
- 1 (218-1500) sleeve.
- 1 (218-1501) pin.
- 4 (W-136) rd. hd. steel machine screws.
- 4 (W-661) steel hex nuts.
- 4 (W-223) Shakeproof lockwashers.
- 1 (217-1406) fibre washer.
- 1 (217-1407) curved washer.
- 1 (218-1525) lockwasher.
- 1 (218-1504) nut.



Old Man Centralab
reminds you to always "specify
Centralab" when ordering parts.



**FIXED
RESISTORS**



**CERAMIC
CAPACITORS**



**VOLUME
CONTROLS**



**WAVE CHANGE
SWITCHES**



**TOGGLE
SWITCHES**

Centralab

DIVISION OF GLOBE UNION INC.
MILWAUKEE, WIS.

BUSY?

CHECK AUDIO FREQUENCY
FASTER, MORE ACCURATELY

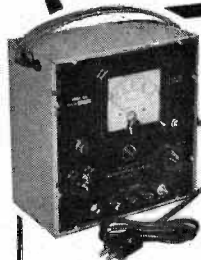

RCP MODEL 666
Complete, only
\$35.50

**New RCP Vacuum
Tube Voltmeter
Covers Entire Audio
Frequency Range**

NOW—make quick, accurate measurements throughout the ENTIRE audio frequency range, including the ultra-high audio frequencies. RCP's new vacuum tube voltmeter eliminates errors due to line voltage fluctuation, simplifies and speeds up the job these days when seconds count. Use it anywhere—on regular AC line, or with external batteries; it's fully equipped with connections and throw-over switch for either supply. Here are more features you've always wanted:

4 1/2" rectangular meter with movement of 0-200 microamperes — ranges 0-3-6-30-150 volts — constant input impedance resistance 16 megohms — tubes used 6K6GT, 6X5GT, 6H6 and voltage regulator VR105-30—hand-some grey finish steel case with sturdy leather strap handle.

For typical RCP stamina, convenience and economy, Model 666 is a standout honey-for-the-money. GET YOURS NOW—and you'll wonder how you ever managed without it! Available promptly on high priority orders.

Write today for FREE RCP Catalog No. 126.

Radio City Products Company

INC.

127 WEST 26th STREET NEW YORK CITY

SER-CUITS

(Continued from page 14)

possible level to prevent a-v-c action from apparently flattening the resonance curve. The chassis must be removed from the case in order to align the i-f and oscillator. The loop must remain connected. Also, the batteries and chassis must be in place in the cabinet while aligning the loop so the tuning won't change after assembly. A loop checker is very handy to check this.

Model 7905 is a 6-tube, 5 band a-c job with magnetite core oscillator coils and i-f transformers, tapped power transformer for 110 or 220 volts and push-pull output equivalent to a pair of 6F6s. A 6AD7G combination triode-pentode is used for phase inversion and power output, the pentode section matching that of a 6F6G, (see Fig. 2). The volume control is tapped for aural compensation.

Automatic phonograph model 7188 is a 5-tuber with permeability tuning. Note the antenna plate and input transformer in Fig. 3. The transformer has an interrupted primary, the capacity between the coils completing the circuit. This permits both capacity and magnetic coupling simultaneously. The oscillator circuit is also unusual, a separate cathode tickler being used. The grid coil is tuned by a moving core. A 300 ohm resistor is added to the tickler to flatten the voltage frequency characteristic. Note that the chassis is connected to a ground post through a parallel circuit consisting of a 0.1 mfd. and 0.2 meg.

TEST EQUIPMENT

Maurice Leffler, 1674 Bryant Ave., New York City, now employed by the Signal Corps, has the following test equipment which he would like to sell: 1 new Hickok oscillograph RFO-5, 1 new Hickok 177X signal generator with crystal, 1 Hickok 510X tube and set tester, 1 new Stancor auto power pack and other miscellaneous equipment. If interested communicate direct with Mr. Leffler.

NATIONAL UNION HOLDS RALLY

National Union Radio Corp., Newark, N. J., held an impressive production rally on August 6th. Representatives of the Army and Navy escorted by National Union executives made an inspection of the factories. At the rally for employes, National Union President Muldowny, as Master of Ceremonies, introduced the distinguished visitors, including several heroes of the battle of the Java Sea. Winners of the recent slogan contest received their awards in war bonds from the Deputy-Mayor of the City. Over 2,000 employes attended.

NAVY ASKS FOR ENGINEERS

An activity of the United States Navy is in need of civil junior, assistant and associate radio engineers; assistant and associate physicists and physicists for laboratory research and development work in conjunction with the war effort

It Shouldn't be Repaired But It MUST BE!

What if the set **IS** ten or twelve years old, if it goes dead you still **have to** fix it. Even your customer might admit "it's ready for a new one" —if a new one could be bought!

Mr. and Mrs. America are depending on their radios more than ever—and depending on you to keep 'em playing. The only way you can handle your share of this tremendous volume is to work more efficiently—use your Rider Manuals more regularly. Stop spending valuable time trying to "guess out" servicing data—look it up in one of your thirteen volumes of Rider Manuals. If you don't have all thirteen—better order today.

RIDER MANUALS

Volumes XIII to VII.....\$11.00 each
Volumes VI to III.....\$8.25 each
Abridged Volumes I to V.....\$12.50
Automatic Record Changers
and Recorders 6.00

FOR EARLY PUBLICATION

Inside the Vacuum Tube—complete elementary explanation of fundamentals of vacuum tubes.

JOHN F. RIDER PUBLISHER, Inc.

404 Fourth Ave., New York City

EXPORT DIVISION:

Rocke-International Elec. Corporation
100 Varick Street, New York City
Cable: ARLAB

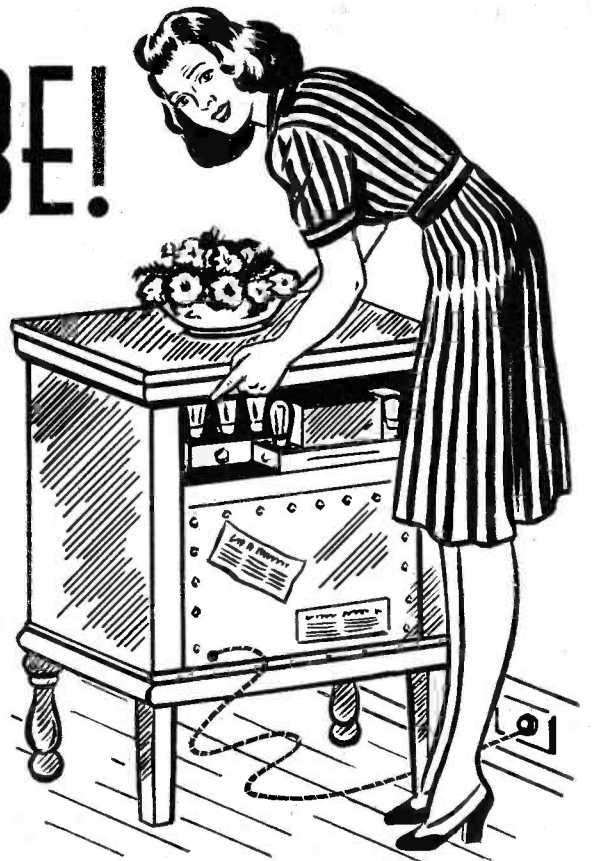

OTHER RIDER BOOKS YOU NEED

The Cathode Ray Tube at Work.....\$3.00
Frequency Modulation..... 1.50
Servicing by Signal Tracing..... 3.00
Meter at Work..... 1.50
Oscillator at Work..... 2.00
Vacuum Tube Voltmeters..... 2.00
AFC Systems..... 1.25
HOUR-A-DAY-WITH-RIDER SERIES—on "Alternating Currents in Radio Receivers"—on "Resonance and Alignment"—on "Automatic Volume Control"—on "DC Voltage Distribution".....90¢ each

JUST OUT!

A-C CALCULATION CHARTS—Two to five times as fast as a slide rule—and more fool-proof. All direct reading—operative over a frequency range of from 10 cycles to 1000 megacycles. 160 Pages—2 colors—9½ x 12 in.\$7.50

**YOU NEED RIDER MANUALS
TO "CARRY ON"**

program. Salaries range from \$2,000 to \$3,800 per annum. For further information and application for employment form write the Director, U. S. Navy Radio and Sound Laboratory, San Diego, California.

PLASTIC ALTERNATES FOR RUBBER

A semi-plastic material, made from polyvinyl alcohol, has been pressed into service to release large quantities of rubber heretofore required to operate intricate machines used to build RCA radio tubes.

Time-honored custom has made rubber tubing standard for the flexible

hoses needed to feed the fires with gas to moving burners from a fixed source. In addition, moulded rubber sections of almost pure gum have long been used as connectors between valves, traps, pumps and gauges in evacuating lines. A material known as "resistoflex," highly resistant to the many solvents that depreciated the rubber, has been placed in use by RCA to replace these rubber parts other than hoses. Washers, spacers, rollers and other machine parts have also been made of moulded or laminated "resistoflex" sheet stock, and machined to required dimensions, sometimes being frozen solid in liquid air.

Radio Amateurs!
Radio Servicemen!
Radio Engineers!

Be a **RADAR** Specialist with the United States Navy . .

Here is your opportunity to serve your country and advance yourself at the same time. The U. S. Navy needs 5,000 picked men to install, operate, maintain and repair RADAR equipment—the secret ultra high frequency apparatus used to locate airplanes. If you are an Amateur, Serviceman or Engineer YOU may be eligible.

You go into the Navy as a Petty Officer with food, quarters, uniforms, medical and dental care supplied *plus* pay of from \$60.00 to \$106.00 monthly. After the

successful completion of eight months technical training you are eligible to immediate promotion to the rank of Chief Radioman with pay up to \$175.00 monthly the first year and up to \$200.00 per month thereafter—with opportunities to remain in the service permanently.

Go to your nearest Navy Recruiting Station TODAY (generally in your local post office) and find out how YOU can take advantage of your technical knowledge. **THE NAVY NEEDS YOU!**



UNITED STATES NAVY
Ask at Your Local Post Office

Dual DANDEES

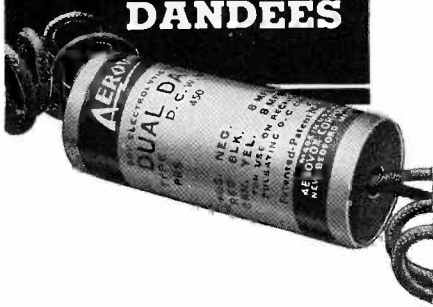

- Two electrolytic sections in minimum space and mighty easy on your pocket-book—that's the story of Dual Dandees. Type PRS-A is a concentrically-wound dual-section job. Three leads (one common). Center mounting strap. Type PRS-B has two separate dual sections and four leads permitting use of either section and either common positive or common negative connections. PRS-A in 25 to 450 v. 3-8 to 20-20 mfd. PRS-B in 150 to 450 v. 8-8 to 20-20 mfd.

Ask Our Jobber . . .

Ask him to show you these Dual Dandees. Ask for other handy electrolytics or other type condensers. Ask for latest Aerovox catalog—or write us direct.



WHEN YOU CHANGE YOUR ADDRESS

Be sure to notify the Subscription Department of SERVICE at 19 E. Forty-seventh St., New York City, giving the old as well as the new address, and do this at least four weeks in advance. The Post Office Department does not forward magazines unless you pay additional postage, and we cannot duplicate copies mailed to the old address. We ask your cooperation.

VERSATILE LOOP RECEIVER

(See Front Cover)

THE General Electric model LB-673 6 tube battery-line portable loop which does the work of two loops in competitive models. We refer to the many designs described in these columns which have a built-in fixed loop and a second plug-in loop for difficult locations. G.E. calls this new type of removable loop an Interceptor Beam-a-Scope. Basically, it is a low impedance loop aerial of about 15 turns having a five or six-foot high capacity. low impedance flexible cable permanently attached which permits removing the loop from the back of the cabinet and placing it at a remote point—such as the window of a car or train.

The action of the low impedance loop may be considered similar to an auto-transformer in which the loop antenna is the primary while the loop and high-Q grid coil in series act as the secondary. The loop being at the low potential side of the circuit and being connected through a low impedance cable, is remarkably free from detuning effects so that no compensation is necessary when the loop is removed from the cabinet. Two suction cups are attached to the hinges of the Beam-a-Scope for temporary fastening to a window. Two slide rails permit easy insertion of the loop in the back of the cabinet and the flexible cable easily wraps around the suction cups. This receiver also has a genuine TRF stage with a 3-gang condenser.

ELECTROLYTIC TERMINALS

ON CERTAIN types of multiple-section electrolytics, the terminals are identified by small markings (triangle, half-round, or square). The marks are either cut-outs or moldings in the base. Corresponding marks are shown adjacent to the electrolytic symbols in the schematic diagrams.

RCA Service Note



Send for FREE Ohmite Stock-Unit Catalog No. 18. Very handy for quick reference.



The extras built into Ohmite Resistance Units make them electrically and physically fit for the toughest service. Ohmite units, for instance, were on the planes that bombed Tokyo. They're widely used in ships and tanks, too—in communications and electronic equipment—in research and production—in training centers and industrial plants. It's well worth remembering, when you build original equipment or make vital replacements—today and tomorrow.

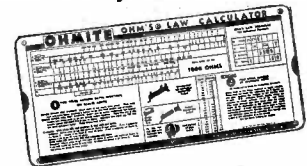

Send 10c for handy Ohmite Ohm's Law Calculator. Helps you figure ohms, watts, volts, amperes—quickly, easily.

OHMITE MANUFACTURING COMPANY
4878 Flournoy Street, Chicago, U. S. A.



THERE'S A
STANCOR
TRANSFORMER
For Every Practical Application!



STANDARD TRANSFORMER

• CORPORATION •

1500 NORTH HALSTED STREET . . . CHICAGO

CATALOGS, BULLETINS ETC.



Copies of the catalogs and bulletins discussed below may be obtained directly from the respective manufacturers mentioned. Write for them today!

GHIRARDI BOOK DISPLAY

An improved "silent salesman" display for Ghirardi books, titled, "Train Yourself—Help Your Country—Learn Radio Quickly!" has been prepared by the Radio and Technical Publishing Co., 45 Astor Place, N. Y.

Features of the display are a convenient reading rack below the three Ghirardi's books. The books themselves are safely attached to the display by silk covered wire cords and, when standing in place, tilt slightly into the display for improved visibility.

These silent salesmen are available to all jobbers stocking Radio and Technical Publishing Co.'s books.

* * *

TUNG-SOL ISSUES "V" PUBLICATIONS

In an effort to improve organization morale, speed production and aid the war effort, the Tung-Sol Lamp Works, Inc., Newark, N. J., are issuing organization organs, entitled, "Life at Tung-Sol." H. F. Cook is editor and art director.

* * *

SOUND HELPS RAILROADS

During the past 60 days, a variety of sound installations are reported to have been installed in railroads, according to George Ewald of RCA.

The Illinois Central is using sound to direct operations in one of its most important classification yards, and has installed complete radio and paging facilities on its new "Panama Limited." The Michigan Central, and Chicago-Northwestern Railroad have also installed sound systems,

while the Pennsylvania is putting special sound equipment in 40 coaches.

Among other sound installations completed during the period, Mr. Ewald listed a "military" mobile public address system placed at the Tank Destroyer School in Texas. This unit is mounted on a trailer which can be moved to any part of the camp where it may be needed for both instruction and entertainment.

* * *

OFFICIALS INSPECT NEW NATIONAL UNION PLANT

With Major Kenneth D. Johnson of Washington representing the Signal Corps of the United States Army as the guest of honor, officials of the National Union Radio Corporation recently made an inspection tour of the new National Union plant now nearing completion at Lansdale.

Officials in the party, in addition to Major Johnson, were S. W. Muldowny, president of National Union; Henry A. Hutchins, in charge of construction of the new plant; O. H. Brewster, director of engineering; E. O. Sandstrom, assistant treasurer; Elwood Schafer, manager of the cathode ray tube division; Clifford Hughes, plant manager; Harold Butterfield, purchasing agent, and J. A. Clancey, traffic manager.

* * *

H. C. L. JOHNSON PROMOTED

H. C. L. Johnson has been named advertising manager of Hygrade Sylvania radio tube division. Until recently, P. S. Ellison, now advertising and sales promo-



tion director, had been manager of both renewal tube sales and advertising, and Mr. Johnson had been assistant advertising manager of the division.

Mr. Johnson was formerly advertising manager of Thordarson Electric Manufacturing Company of Chicago. He has been with Hygrade Sylvania for almost five years. Mr. Johnson is a member of the New York Sales Executives Club, Advertising Club of New York and treasurer of the Northwestern University Club of New York.

* * *



BURTON BROWNE RECEIVES NAVY CITATION

For his work in originating and placing a national advertising campaign for the Radar division of the Navy, Burton Browne, of Burton Browne, Inc., Chicago, Ill., has been awarded a Navy Proclamation of Gratitude. The citation was presented to Mr. Browne by Commander Philip R. Weaver, U. S. N. More than twenty-five publications are co-operating in the Dadar enlistment campaign.

RADIO CLUB HONORS LOU ALEXANDER

The Radio Club of America recently elected Louis Alexander of Aerovox a Fellow of the Radio Club of America.

* * *

RMA ELECTS BALCOM TO EXECUTIVE POST

M. F. Balcom, vice president and general manager of the radio tube division, Hygrade Sylvania Corporation, was elected vice president and director of the Radio Manufacturers Association and chairman of the radio tube division, succeeding Roy Burlaw of the KenRad Radio Tube Company, Owensboro, Ky., at the recent meeting in Chicago.

THANKS

TO YOU, MISTER SERVICEMAN

From the first SUPREME instrument, and through the fourteen years since, the acceptance, loyalty and co-operation of servicemen everywhere are largely responsible for the excellence of SUPREME instruments today—and our ability to produce them in quantity for our armed forces. If you could not get the new equipment you wanted this year, just remember that it is now doing duty for us in some spot on the globe and represents part of your contribution to Victory.

Many Jobbers still have SUPREME Instruments in Stock. Tell us the instrument you want. We'll do our best to get it for you.

SUPREME

INSTRUMENTS CORP.
GREENWOOD, MISSISSIPPI, U. S. A.

RADIO TECHNICIANS WIREMEN COIL WINDERS ASSEMBLERS

An outstanding opportunity for Radio Technicians, Wiremen, Coil Winders and Assemblers with experience on aircraft receivers, transmitters, and electronic equipment in an organization with large war orders as well as post war plans. Plant located in the east.

Write giving full personal history, experience and present salary; personal interview will be arranged later. We do not desire applications from men in key defense positions. Box 8, SERVICE, 19 E. 47 St., New York.

BUY WAR SAVINGS BONDS & STAMPS

Victory is in the air WITH POLYMET

We are now supplying the Army and Navy contractors with POLYMET Condensers. Uncle Sam comes first with us. However, expansion of our facilities enables us to fill regular requirements with very little delay.

POLYMET CONDENSER CO.
699 E. 135th St.
NEW YORK, N. Y.

SERVICEMEN!
Get This Handy New
RADIO CHEMICAL LABORATORY



SAVES TIME—MONEY—TROUBLE

Repair Old Parts with Chemicals
A real professional outfit! Contains every essential radio chemical and cement—everything you need for instant service on speakers, coils, contacts dials, volume controls, cabinets, etc. Permanent indexed rack for easy use on bench or wall. Every efficient radio man should have this complete Laboratory.

Contains 20 Most Needed Radio Cements and Chemicals
Twenty large 2 oz. bottles contain cements, solvents, contact cleaners, non-slip dial chemicals, lubricants, insulating varnish, cabinet stains, glue, liquidop, grafoline, etc., etc. Use it a week and you'll wonder how you ever got along without it. Get one today! Dealer net cost only \$4.90 with FREE RACK.

Order from Your Radio Jobber

Brushes Attached to Caps



GENERAL CEMENT MFG. CO.
Rockford, Illinois, U.S.A.

(Continued from page 22)

The sets are usually off peak, tune broadly, and yet no amount of alignment will make them work decently. The usual voltage analysis will not disclose the trouble, but current analysis or voltage measurement with a 10,000 or 20,000-ohm-per-volt meter will tell the story. High plate current will be found in the r-f and i-f stages, and a very sensitive meter will show a positive voltage on their grids and through the entire avc network. To test, remove the grid clips from all tubes controlled by the avc circuit and check the voltage between the grid clip and ground. In extreme cases, almost the entire plate voltage will show on the meter. This is, of course, nothing but leakage, usually in the i-f coils, but sometimes the r-f, and the only remedy is replacement.

In these and other sets with cut oscillator plates and no low-frequency paddler, it is sometimes advantageous to change the i-f to obtain better tracking. I have found the following method to be most satisfactory. First, check the tuning of the r-f and antenna coils at the low-frequency end of the dial and correct, if necessary. Next, tune the r-f and antenna coils to some convenient frequency, any 550 or 600 kc. Then turn on the set in question and pick up the signal of its oscillator on another set or frequency meter, to determine the frequency to which it is tuned. Subtract the known frequency of the r-f and antenna coils from the frequency of the oscillator and you have the correct i-f. Slight h-f adjustments will be needed at 1,500, but these are minor in comparison. *Francis C. Wolven.*

PHILCO 37-690

Rumble and crackling with bass control set to maximum and with volume control off: Cause is defective bass amplifier audio choke (No. 104 on schematic). After replacing new unit but before bolting down, rotate unit with volume control off and base control full on for position of minimum hum. Occasionally a position different from original mounting will effect a decided decrease in hum. *Noisy, pilot lamps flickering:* May be traced to loose contacts between soldering lugs and pins on 10-contact plug that connects tuner chassis to power supply and audio unit. To check for this trouble, disassemble plug and inspect riveted connections between soldering lugs and contact pins. To cure, remove base of plug from cable, sandpaper riveted ends of pins to lugs with a hot iron. Reassemble.

D. C. Sprong.

Radio Men: Your country needs you! Get in touch with the Army or Navy recruiting station nearest your home for full details.

The name is new
... the Purpose is not Changed

AS of July 30, 1942, the Hygrade Sylvania Corporation became Sylvania Electric Products Inc.

Needless to say, the change is one in name only.

There is no change in the high quality of our products, no turning from our purpose to bring forth the finest lighting and radio equipment our skill and experience can create.

And that means we will continue to provide you with an incomparable line of radio tubes, backed by all the technical assistance and promotional help you need to do a first-rate selling job.



SYLVANIA

ELECTRIC PRODUCTS INC.

formerly

HYGRADE SYLVANIA CORPORATION

Emporium, Pa.

Also makers of Incandescent Lamps, Fluorescent Lamps and Fixtures



★ They can take an awful beating, those Clarostat Greenohms (green-colored cement-coated power resistors) now found in communication transmitters, aircraft and police radio, high-grade instruments, electronic assemblies, and in many industrial applications. Even when overloaded red hot, they won't burn out, flake, peel, crack. ★ From 5 to 200 watts fixed; 10 to 200 watts adjustable. Popular resistance values. ★ Insist on Greenohms!



RADIART
for
VIBRATORS
AERIALS
VIPOWERS

THE RADIART CORP.
CLEVELAND, OHIO

JOTS & FLASHES

Frank Murphy now covering Chicago territory traveling out of the Clarostat plant in Brooklyn. All Chicago correspondence now being handled at the plant because production is paramount problem. . . . John L. Bossert, sales engineer for Ward-Leonard for 17 years, died on July 9th. . . . Newell B. Parsons, retired vice-president of Belden Mfg. Co., passed away on July 15th. . . . Estimated by FM Broadcasters, Inc., that 500,000 frequency modulated sets now in use in the United States. . . . Write to General Electric, Bridgeport, for a copy of new bulletin on circuit control switches for industrial applications. . . . Philco supplying war time identification cards to R. M. S. members now in armed services. Swell idea. . . . Write to Littelfuse, 4757 Ravenswood, Chicago, for a copy of a new folder on Beryllium fuse clips and screw terminals. . . . Stamps and bonds daily. . . . A purchasing must for every Service Man. . . . New York Transformer Co. now located at 26 Waverly Place, that city. . . . How's the scrap collection coming along? . . . Don't slacken your efforts. . . . Rubber and metal are vital for war production. . . . Hope you've been reading KenRad's advertisements . . . an outstanding series . . . quoting from July 31st issue of Printers' Ink—"Radio repair men getting scarcer. Now takes two or three days to get a radio repaired. Break is that work is now done mostly by proprietor, consequently a more expert job is being done." . . . How about it, boys? . . . Vic Mucher, Clarostat s. m., "yacht-clubbing" for relaxation these hectic days. . . . Radio Club of America has elected Louis Alexander, veteran Aerovox salesman, as a Fellow. . . . Congratulations, Lou. . . . Several letters from readers ask why test equipment manufacturers don't give them more data on proper maintenance and repair. . . . Instruments must last for duration of war at least and advice is badly needed. . . . NOTE: NRPDA name will not be changed to NEDA. . . . Some confusion relative to corporate name. . . . Another new plant, the third, for Cornell-Dubilier at Providence, R. I. . . . Will process raw materials for the older two factories. . . . Hygrade Sylvania stockholders vote to change corporate name to Sylvania Electric Products, Inc., as of July 30th. . . . Regret death of Mrs. J. M. Devoe, editor of *Sylvania Radio Tube News*. . . . a distinct loss to the industry. . . . A new catalog on machine tool accessories offered by Ideal Communitator Dresser Co., Sycamore, Ill. . . . Ralph C. Stuart appointed manager of production at five plants of the Lamp Division of Westinghouse.

P. S. W.



Readrite
RANGER
MODEL 432-A

The Outstanding Tube Tester Value . . . Checks all type tubes including Loctals, Bantam Jr., 1.4 volt. Miniatures, Gaseous Rectifier, Ballast, High Voltage Series, etc. Filament Voltages from 1.1 to 110 volts. Direct Reading GOOD-BAD Meter Scale. Professional-appearing case with accessory compartment large enough for carrying Model 739 AC-DC Pocket Volt-Ohm-Milliammeter, thereby giving the serviceman complete testing facilities for calls in the field. . . . Model 432-A with compartment, Dealer Net Price . . . \$20.73. Model 432-A in case less compartment . . . \$19.65. Model 739. Dealer Net Price . . . \$10.89.

WRITE FOR CATALOG—Section 817 College Drive

READRITE METER WORKS, Bluffton, Ohio

Index to Advertisers

	Page
Aerovox Corp.	29
Centralab	26
Clarostat Mfg. Co., Inc.	32
Electro-Voice Mfg. Co., Inc.	20
General Electric	26
General Cement Mfg. Co.	31
International Resistance Co.	4
Ken-Rad Tube & Lamp Corp.	1
Mallory & Co., Inc. P. R. Inside Front Cover, 9	3
Meissner Mfg. Co.	10
National Union Radio Corp.	29
Ohmite Mfg. Co.	31
Polymet Condenser Co.	32
Radiart Corp.	26
Radio City Products Co., Inc.	19
Radio & Technical Publishing Co.	32
Readrite Meter Works.	27
Rider Publisher, Inc., John F.	21
Solar Mfg. Corp.	20, 29
Sprague Products Co.	30
Standard Transformer Corp.	31
Supreme Instruments Corp.	Back Cover
Sylvania Electric Products Inc.	Back Cover
Triplett Elec. Instr. Co.	23
United Transformer Co.	Inside Front Cover
Yaxley Mfg. Division.	23

SOLAR **VICTORY** CONDENSERS HELP SAVE ALUMINUM!

To help our nation in this time of need . . .
so that aluminum can be spared for the
most vital applications . . . Solar designs
incorporate **MINIMUM** practical quantities
of this essential metal . . .



Wet electrolytic condensers—and screw-base aluminum cans—**are SCARCE!** War restrictions make it impossible for any condenser manufacturer to obtain the necessary screw-base aluminum cans in sufficient quantity for all replacement purposes.

To immediately offset this handicap, Solar presents two effective and economical types as practical substitutes, available promptly from your Solar distributor.

ALUMINUM-SAVER TYPE DY

Zinc containers; excellent moisture protection. Convenient "twist-prong" mounting. Hermetically sealed and properly vented. Available in a wide range of single and multiple capacity units at all voltages.

ALUMINUM-SAVER TYPE DH

Processed cardboard containers. Provided with both mounting strap and mounting feet, for horizontal or upright mounting. Available in a wide range of single and multiple capacity units at all voltages.

Write for Literature

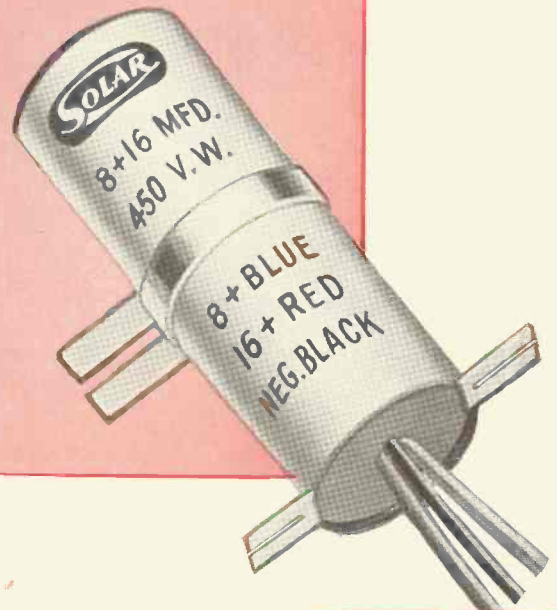

SOLAR

MANUFACTURING CORPORATION, BAYONNE, N. J.

MICA • PAPER • ELECTROLYTIC CAPACITORS

TRIPLETT

Thin-Line INSTRUMENTS

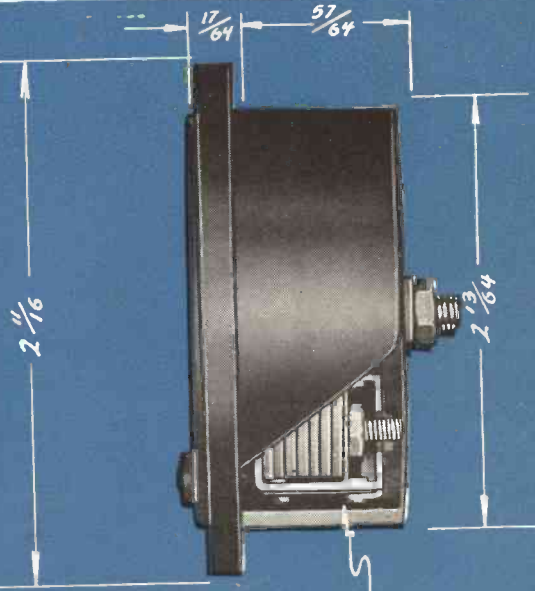
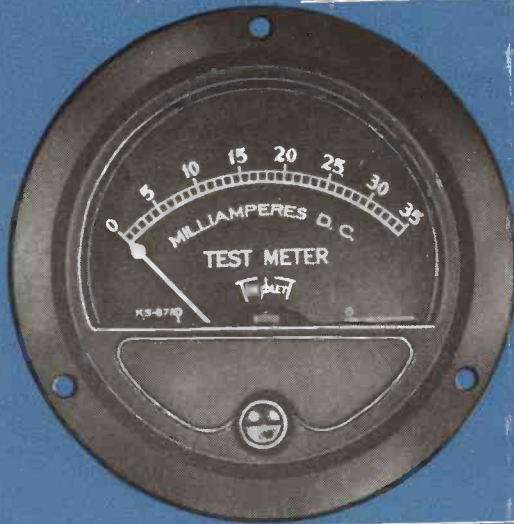

NOTE - THIN MOLDED CASE WITH FULL SIZE TRIPLETT MECHANISM.

FULL SIZE TRIPLETT MECHANISM.

TRIPLETT
Thin-Line

INSTRUMENT "S P E C S"

- Minimum case depth.
- Full standard size rigid mechanism . . . no projecting base.
- Wider shroud strengthens face: focuses attention on scale.
- Simplified zero adjustment.
- Sapphire or equivalent jewels. All component parts finely made and of superior quality.
- Balanced Bridge Support.
- Metal Bridges at both ends.
- Separate Scale Mounting.
- Doubly Supported Core.

Also available in metal case

NOTE: When space is at a premium and for all installations where space is efficiently used, Triplet Thin-Line Instruments set a new standard of precision performance in "condensed" space. For full details write for Triplet Thin-Line Bulletin to The Triplet Electrical Instrument Co., Bluffton, Ohio.

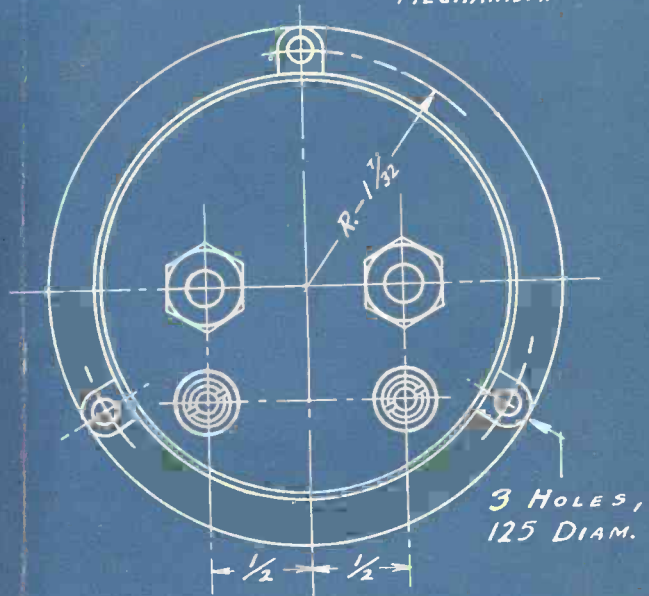

DIMENSIONS OVERALL WITH STUDS & NUTS. ORDER. 0221-T
K.S. 8789

THE TRIPLETT ELECTRICAL INSTRUMENT CO.
BLUFFTON, OHIO, U.S.A.

DRAWN H.A. 4-29-42
CHECKED W.F. 5-16-42
APPROVED J.O. 5/16/42

5417X