

SERVICE

A Monthly Digest of

RADIO

and Allied Maintenance

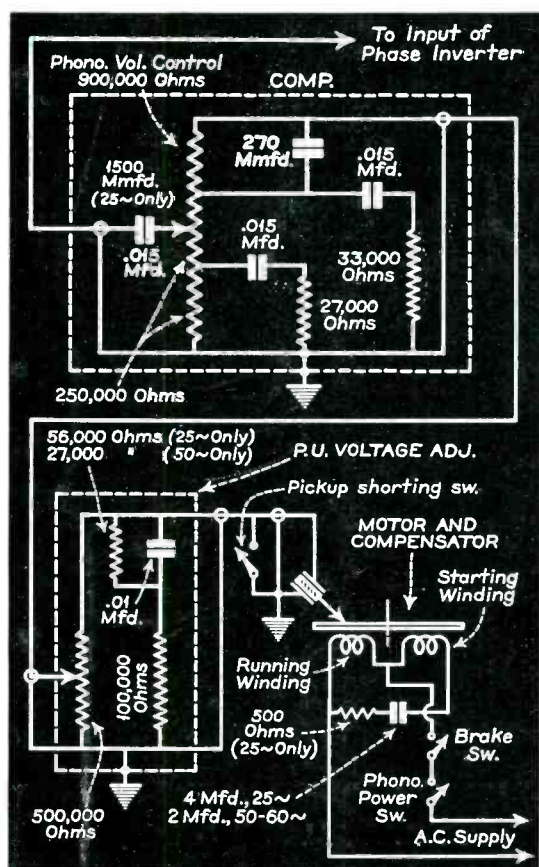

PER COPY
25 CENTS

NOVEMBER
1937

Crystal Pickup Circuit
(See page 696)

ARE YOU AN OLD TIMER?



DO YOU REMEMBER . . .

WHEN

Chicago broadcasting stations were silent Monday nights so that listeners could hear D.X.?

WHEN

Superheterodynes used a 30 K.C.I.F. and had a filament rheostat for each tube?

WHEN

Gassy detector tubes were preferred because they were more sensitive, and over 22½ volts of "B" battery would make them turn blue?

If you do, you will remember that then, as now, Yaxley Precision Radio Products were preferred by discriminating radio men. Yaxley has always led the march of radio progress by providing dependable easy-to-use radio apparatus.

From the Yaxley Air Cooled Rheostats never equalled by any other manufacturer which controlled the tiny outputs of early battery tubes to the modern Yaxley SILENT Volume Control which smoothly controls the giant output of beam power tubes, that which was once a distinct company and is now the Yaxley Manufacturing Division of P. R. Mallory & Co., Inc., presents a story of constant research and constant progress to produce the finest products of modern engineering.

On the basis of past experience and *present performance* leading radio service men depend on Mallory-Yaxley Precision Radio Products. They demand the best . . .

and they get the best in Mallory Replacement Condensers and Vibrators. They demand the best . . . and they get the best in Yaxley Volume Controls.

So—if you're an *old timer*, or a *newcomer*, in the radio servicing field you'll find it to your advantage to advance your interests with Mallory-Yaxley Precision Radio Replacement Parts. After all, they cost no more—and the longer you use them the more readily you'll agree that they actually *cost less in the long run*.



ONE Book Gives ALL the Right "Dope" on Over 12,000 Different Radios

You'll find the Mallory-Yaxley Radio Service Encyclopedia the biggest help a serviceman ever had. Ask your Mallory-Yaxley distributor about a copy *now!*



MALLORY CONDENSERS · YAXLEY VOLUME CONTROLS · MALLORY VIBRATORS

Use

P. R. MALLORY & CO. Inc.
MALLORY
REPLACEMENT
CONDENSERS . . . VIBRATORS

P. R. MALLORY & CO., Inc.
INDIANAPOLIS INDIANA
Cable Address—PELMALLO

Use

YAXLEY
REPLACEMENT
VOLUME CONTROLS



NOT in years has there been such a heavy demand for wire in connection with the Serviceman's business. You have noticed it—we have noticed it.

With Public Address going like a prairie blaze and Radio a seething hotbed of activity which promises to be sustained, you will be needing **GOOD WIRE.**

CORWICO Wires are scientifically produced to do their job 100%. Antenna Systems, P-A Cables, Hook-up Wires—made by engineers for engineers. Use CORWICO on your next contract.



No. 14 — (illustrated above) — \$6.75 list

FOR broadcast and shortwave frequencies, designed to eliminate "man-made" static and afford better reception. 2 to 6 sets can be operated at the same time with an additional lower transformer for each added unit. Other "Noise-Master" units available. WRITE FOR INFORMATION.

NOISE-MASTER • ALL-WAVE ANTENNA •

Eliminates "Man-Made" Static on Broadcast as Well as on Shortwave Bands

LICENSED by Amy, Aceves & King, engineered with traditional CORWICO care, this masterly aerial system fits every set and every location. Filters out nuisance noises caused by electrical devices. Improves reception generally—widely endorsed by Service men.

CORWICO Wire Catalog available to Service men.

Distribution is exclusively through jobbers.



CORNISH WIRE CO., Inc.
30 CHURCH STREET NEW YORK CITY

SERVICE

A Monthly Digest of Radio and Allied Maintenance
Reg. U. S. Patent Office. Member, Audit Bureau of Circulations

EDITORS

NOVEMBER, 1937

Ray D. Rettenmeyer

W. W. Waltz

VOL. 6, NO. 11

EDITORIAL CONTENTS

FEATURES

Interpretation of Vacuum Tube Characteristics
By R. M. Purinton..... 669

Modern Theater Servicing
By "Sound Track"..... 673

Let's Look at Service Equipment
By Bernard H. Porter..... 676

*Volume Control Installation
By W. H. Fritz..... 690

*Equipment for High-Power Outdoor
Installations
By W. L. Rothenberger..... 704

ANTENNA 666

ASSOCIATION NEWS 698

AUTO RADIO

*Volume Control Installation
By W. H. Fritz..... 690

GENERAL DATA

*G. E. F-62, F-65, F-66..... 680

*Technical Features of 1938 Sparton Radio
Receivers 681

*Stewart-Warner R-188..... 682

*Belmont 588 684

*RCA 87EY..... 688

HIGHLIGHTS710-716

MANUFACTURERS712-714-716

ON THE JOB

Gulbransen 40 and 40a..... 661

Sparton 617 Chassis..... 661

Silver Marshall 724-AC..... 696

A-c, d-c Sets 702

SOUND SERVICE

Modern Theater Servicing
By "Sound Track"..... 673

*Equipment for High-Power Outdoor
Installations
By W. L. Rothenberger..... 704

TEST EQUIPMENT

Let's Look at Service Equipment
By Bernard H. Porter..... 676

* Indicates that a circuit accompanies the text.

BRYAN S. DAVIS
President

JAS. A. WALKER
Secretary

Chicago Office—608 S. Dearborn St.—C. O. Stimpson, Mgr.
Telephone: Wabash 1903

Published Monthly by the

Bryan Davis Publishing Co., Inc.

19 East 47th Street

New York City

Telephone: Plaza 3-0483



Wellington, New Zealand—Tearo Book Depot.
Melbourne, Australia—McGill's Agency.

SANFORD R. COWAN
Manager

PAUL S. WEIL
Advertising Manager

A. B. CARLSEN
Circulation Manager

Entered as second-class matter June 14, 1932, at the Post Office at New York, N. Y., under the Act of March 3, 1879. Subscription price \$2.00 per year in the United States of America and Canada; 25 cents per copy. \$3.00 per year in foreign countries; 35 cents per copy.

25,000 OHMS PER VOLT

**TRIPLETT
De LUXE
SET TESTER**

Entirely New

Modern Design
for Quick
Accurate Set
Testing



Model
1601
\$45³³
In Metal
Case

- D.C. Volts at 25,000 Ohms per Volt. A.C. Volts at 1,000 Ohms per Volt. Reads to 2,000 Volts A.C. and D.C. in 6 Ranges
- Resistance Measurements to 20 Megohms.
- Condenser Tester to 30 Mfds.
- 50 Microamperes to 20 Amperes in 9 Ranges.
- Free Point Tester.
- Incorporates Exclusive Plug-in Type Copper Oxide Rectifier.
- New Single Zero Adjustment for Ohmmeter.
- All A.C. Operated—No Batteries Used.
- Large 4-inch square instrument with open dial is regularly supplied with front illumination.

Triplet's new De Luxe Set Tester incorporates the very latest features. Ultra high class and professional appearance. Durable etched panel—natural silver background with sunken black lettering. Control knobs and other fittings are finished in red. The exclusive plug-in type copper oxide rectifier is the approved, most accurate method for recti-

fication, with the newly added advantage of easy replacement due to accidental damage or overloading. Replaces as easily as removing an ordinary fuse. In leatherette case, as shown, \$49.33

Other De Luxe Items:

MODEL 1690 OSCILLOSCOPE—With 2-in. Screen—Exclusive Triplet turret type tube mounting. Linear Sweep 15 to 20,000 Cycles—complete with tubes and instructions—in Metal Case\$47.00
(Three-inch Oscilloscope also available in larger case. Slight additional cost.)

MODEL 1630—Outstanding Signal Generator for extreme accuracy—zero leakage—100 K.C. to 30 M.C. in six ranges—complete—in Metal Case.....\$45.00

MODEL 1631—Same as 1630 but in addition incorporates electronic frequency modulation—in Metal Case.....\$55.00

MODEL 1670—Vibrator Tester—completely tests all vibrators under actual performance conditions—in Metal Case..\$24.00

All DeLuxe Testers in two case styles: Sturdy metal with black wrinkle finish, 14½" x 7¾" x 4½". Leatherette covered case has removable cover and compartment for accessories, size 15½" x 12" x 6¾".

**TRIPLETT'S NEW
DE LUXE LINE OF
RADIO TESTERS
SETS A
"NEW HIGH"
IN ACCURACY
APPEARANCE and
PRACTICABILITY**

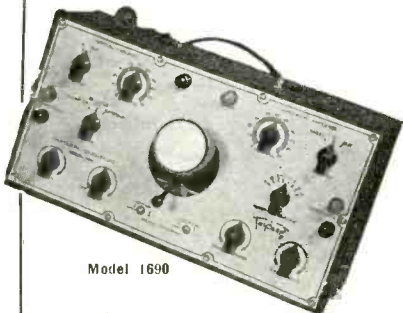

Model 1690



THE TRIPLETT ELECTRICAL INSTRUMENT CO.
1711 Harmon Ave., Bluffton, Ohio

Please send me more information on Model 1601;
 Model 1690; Model 1630; Model 1631; Model 1670.
 I am also interested in.....

Name.....
Address.....
City..... State.....

THE ANTENNA . . .

MOVIE THEATERS

FOR QUITE A WHILE we have been considering the idea of publishing some material on servicing theater sound equipment. More and more, of late, we have become convinced that here is a field in which the Service Man can do himself some good—as well as a lot of harm if the approach to the problem is not carefully handled—and it is especially true now that so very many theaters are without any connections for service on their equipment. There are, it is true, several organizations in, or soon to be in, the field looking to pick up this business. Each Service Man must decide for himself whether or not he wants to tackle it.

Let us say, from the start, that it is a field full of headaches. We know whereof we speak, based on quite a few years of experience in hearing some hair-tearing theater manager shout into a telephone, "All I know is, it don't work. Get the hell out of bed and come down here and fix it!" Invariably, such a call will come about the time one figures that he is due for a good night's sleep. But all you can do is laugh or swear (that'll depend upon how lousy you feel at that particular moment) and get down and fix the damn thing. Chances are you'll find that someone forgot to pull a switch or something equally as foolish, but if it is really trouble, boy, you're in for it!

We have an article on this subject this month; according to plans, it is the first of a series. We'd like to point out that the articles are being written by a man who is, at the present time, the chief sound engineer for one of the largest and best-known theaters in the country. For several reasons, we can't use his name, but you may rest assured that the dope he puts into these articles is the last word on what and what not to do. It'll be interesting to hear from those of you who have had any experience with theater work.

• • •

REMODELING SETS

WE HAVE quite a few letters on hand, as a result of our editorial last month regarding the Forum (which, incidentally, won't appear this month because of lack of space). Many of these letters either comment on or re-

quest information on modernizing old receivers. This is a subject worth some attention, so let's look over the situation and see what can be made of it.

In the first place, consider that when you undertake a remodeling job, in nine cases out of ten you'll practically have to redesign at least a part of the old receiver. Can you charge enough for the job to make it worth the amount of time you will necessarily have to put on this redesign? In other words, let us say that here is a job which will require, chiefly, new audio stages. (Such a job may not be a typical revamping one, but it will serve to illustrate our point). Suppose that the materials and actual working time figure out to \$15. Now, how long did it take you to make your preliminary inspection and decide that new audio would be necessary; add, too, the time you spent looking up part prices. Figure all this in, add your profit and you'll have quite a bit more than the actual labor and materials come to. Chances are, you'll arrive at a figure that will be high enough to result in losing the job.

So what?

So, here's where you sell a set! That is the practical answer to most remodeling jobs which come to you. When you figure out the cost for a typical remodeling job (not forgetting your time for planning what to do and how to do it) it probably adds up to the point where the sale of a new set is indicated—and you have a swell talking point. After all, a rebuilt job can never be as satisfactory as a new one. It won't sound as well, nor will it look as good as a new job fresh from the distributor—and, don't forget that if you are smart, you will be as cagy as hell on guaranteeing the results of a remodeling.

Another point worth considering is that every time the old set goes hay-wire, you will be expected to furnish free service because you were the guy that "fixed" it, and anything that goes wrong is automatically your fault.

There are plenty of other reasons for avoiding these revamp jobs, but these which we have pointed out ought to be sufficient to indicate the dangers.

Anyhow, you want to sell sets if possible—and here are live prospects coming in through your front door!

• SERVICE FOR

ELECTRO-ACOUSTIC SOUND SYSTEMS

Every Job Sells Another One!

NO SATURATION IN THIS MARKET HERE'S HALF A MILLION PROSPECTS

290,000 STORES AND MARKETS • 80,000 LARGE INDUSTRIES • 50,000 CHURCHES • 33,000 COAL AND MATERIAL YARDS • 25,000 HIGH SCHOOLS • 22,000 THEATRES AND HOTELS—are going to be busy this winter. They're going to need Electro-Acoustic Sound Equipment—the modern necessity wherever people must hear. They have the money to pay for it.



You have a right to expect perfect performance in the sound equipment you sell. Electro-Acoustic Systems give it to you because they're carefully engineered and built of the highest quality materials in the finest plant in the industry. They're built by people who "know how"—backed by twenty-six years of experience and leadership in this field. That's why the "Electro-Acoustic" label is your customer's guarantee of a perfect installation.



THE LINE IS COMPLETE

Electro-Acoustic is the line with which you can get your share of this mighty untouched market.

It's the line with systems, amplifiers, power stages, microphones, baffles and all accessories for every permanent and portable installation requirement.

It's the line that features advanced design—matchless flexibility—modern appearance—perfect performance.

Complete systems from \$53.00 up, with adequate discounts to qualified distributors and dealers.



ELECTRO - ACOUSTIC SYSTEMS ARE FULLY LICENSED

MAGNAVOX SPEAKERS



An outstanding new line of Magnavox Speakers for every application of sound distribution. The latest in radio replacement models too. All types and sizes—electro-dynamics and permanent magnet dynamics—5" to 15"—distinctively labeled and packaged. Built to satisfy every requirement of high fidelity voice and music reproduction.

MAIL THIS COUPON

ELECTRO-ACOUSTIC PRODUCTS COMPANY
Dept. S, Fort Wayne, Indiana

Please send me catalog on Electro-Acoustic Sound Systems and the name of my nearest distributor. I am also interested in receiving complete information on
 Electro-Acoustic Portable System. Electro-Acoustic Amplifiers.
 Magnavox "EA Special" Speakers.

Name
 Address
 City State

ELECTRO-ACOUSTIC
SUBSIDIARY OF THE MAGNAVOX COMPANY

PRODUCTS COMPANY
FORT WAYNE, INDIANA

QUIET

**SILENT
SPIRAL
CONNECTOR**

PATENTS APPLIED FOR



**5-FINGER KNEE
ACTION ELEMENT
CONTACT**



Metallized TYPE
VOLUME CONTROLS



IRC HAS SPARED NO EXPENSE SO THAT YOU CAN BE SURE

Study the design of IRC Metallized Controls. Note in particular the precision construction of the 5-Finger "Knee Action" Silent Element Contact and the new Silent Spiral Connector.

Each of these exclusive features means thousands of dollars in research by IRC engineers. Each means additional manufacturing expense—yet IRC Controls cost you no more than ordinary controls having neither of these noise-eliminating features.

It is "plus" values such as these that have made IRC resistance products famous the world over. By giving you the greatest value for your money, by doubly insuring you against customer complaints, we protect our reputation by helping you protect yours. That is good business for both of us!

Silent Spiral Connector available on IRC Special Replacement Controls listing at \$1.50 and up . . . designated in Guide with prefix "J".

5-Finger "Knee Action" Silent Element Contact supplied on all IRC Controls.

INTERNATIONAL RESISTANCE COMPANY

401 NORTH BROAD STREET, PHILADELPHIA, PA

Factories or Licensees in Canada, England, France, Germany, Italy, Denmark and Australia

**MAKERS OF RESISTANCE UNITS OF MORE TYPES, IN MORE SHAPES, FOR
MORE APPLICATIONS THAN ANY OTHER MANUFACTURER IN THE WORLD**

SERVICE

A Monthly Digest of Radio and Allied Maintenance

FOR NOVEMBER, 1937

INTERPRETATION OF VACUUM TUBE CHARACTERISTICS

By R. M. PURINTON

A SATISFACTORY working knowledge of vacuum tube characteristics can be gained from any one of the many available characteristic charts which show base diagrams, dimensions, characteristics under conditions of voltage common to a majority of receivers, and sometimes capacitance values for the tubes. The charts form an important part of every Service Man's library of information. To the Service Man looking for complete information or the engineer designing electronic equipment, the data chart is of limited value. On the other hand, complete characteristic curves provide no useful information unless a clear interpretation of their meaning can be made. In most texts, the authors take it for granted that the reader knows what certain degrees of steepness or curvature mean in terms of performance. Clear explanation might waste the engineer's time but it would make the entire subject more useful to the Service Man and amateur.

In the chart and in the published characteristics on radio tubes only those characteristics which apply under one or two voltage conditions can be given. In the characteristic curves, however,

everything one could want to know about a tube will be found. It will be shown later that two tubes which seem to be alike, according to the values on the chart, are dissimilar in operation with one distinctly superior to the other. A study of tube characteristic curves may turn out to be a boresome task for some, and an unforeseen pleasure for others. Any addition to one's store of knowledge of the fundamentals is worth while.

To demonstrate the utility of curves as a means of comparison, the plate "families" for the 6C5 and the more recent 6J5 are shown in Fig. 1. The plate "family" is the most common form of presentation of characteristics to be found. The data or "points" through which each curve is drawn are taken by holding the grid-bias voltage constant and noting the plate current as the plate voltage is raised from zero, or the voltage where plate current starts up to a value which produces as much plate current as the tube will ever pass in service. For receiving tubes, it is usual to show the rise in plate current with rising plate voltage for zero bias and for values of negative bias down to

negative control-grid voltages which limit the plate current to a small amount at the highest plate voltage the tube will ever have impressed on it as an instantaneous peak. Thus, in Fig. 1 for the 6J5, the upper limit of plate current at zero control-grid bias is about 25 milliamperes reached at a plate voltage of approximately 185 v. The plate current could be made to go higher but it is not necessary to show higher values since higher instantaneous plate current will not be drawn in any normal use. It will be noted that with the control-grid set to -30 volts, plate current does not start to flow until the plate voltage is 450 v. This potential is the upper limit of instantaneous plate voltage so the measurements are stopped at that point. Continuing with reference to the solid curves for the 6J5, it will be noted that as the negative grid-bias values are made more negative, it takes more plate voltage to start the flow of plate current. Thus, for a bias of -16 volts, 250 volts must be applied to the plate before current starts. Putting it another way: -16 volts is the "cut-off" point for a plate potential of 250 volts. Since Class B audio tubes are operated

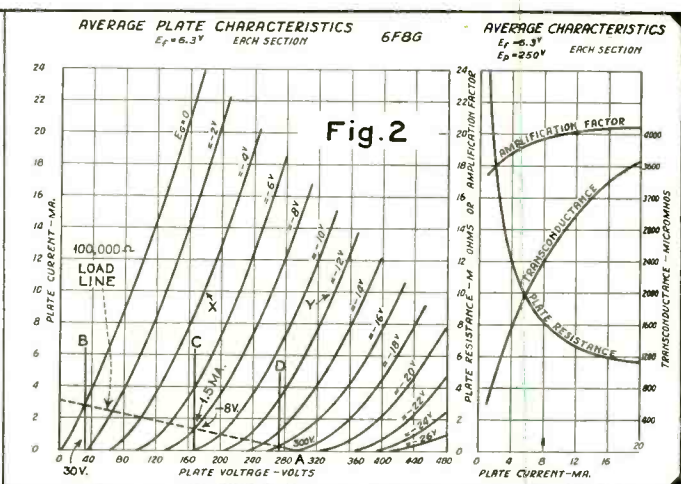
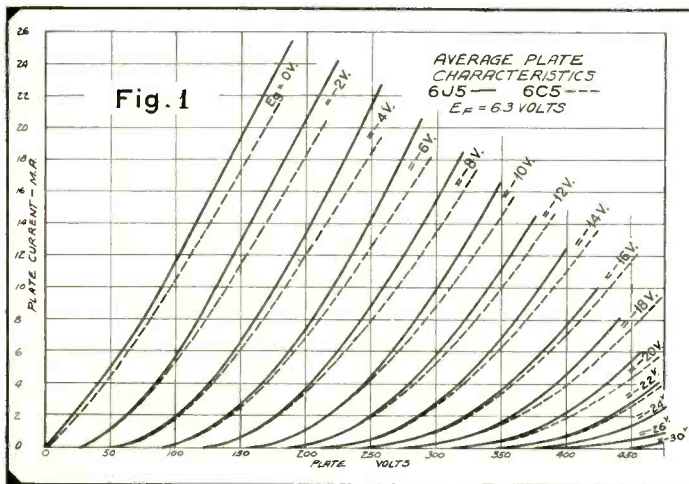

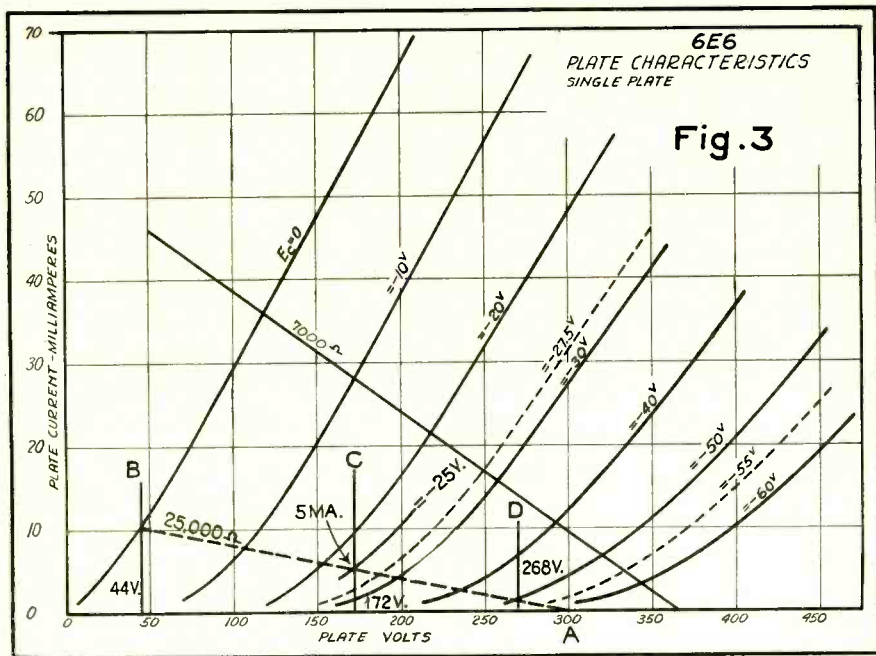

at or near "cut-off," the plate family will tell the designer what the "cut-off" bias should be for whatever voltage the power supply happens to deliver. In triode tubes, it is desirable that the "cut-off" be sharp at normal working voltages. From 250 volts down, the 6J5 characteristics for "cut-off" are quite good. The long, gradual arc at the foot of each of the higher bias curves in the lower right corner of Fig. 1 would not be desirable at lower bias voltages. A good oscillator must have sharp "cut-off," and the 6J5 is a good oscillator.

The explanation of the 6J5 curves in Fig. 1 could include some other factors, but those of major importance have been covered. Returning to the comparison between the 6J5 and the older 6C5, characteristics of which are shown in dotted curves in Fig. 1, it will be noted that for each value of grid-bias voltage, plate current starts for each tube at the same voltage. However, as the plate voltage increases, the plate current in the 6J5 climbs at a faster rate than in the 6C5. The two tubes have the same amplification factor. Therefore, the difference between them indicates that the 6J5 must have the lower plate resistance of the two. The amplification factor of a tube divided by the plate resistance gives the tube's mutual conductance in micromhos. Since both tubes have the same amplification factor, the 6J5 with its lower plate resistance has the higher mutual conductance. For most purposes, the lower plate resistance and higher mutual conductance make it a better tube for general use.

The plate "family" of the 6F8G (one triode section) in Fig. 2 has been utilized to show some additional information. For one thing, one can determine the amplification factor of the tube by sim-

ply noting what change in plate voltage is required to maintain the plate current constant with a change in grid bias voltage. Measurements should be made near the center of the group of plate curves. Take 10 milliamperes as a convenient plate current to be maintained as the constant. At point X, it will be noted that the plate current is 10 milliamperes with a grid bias of -4 volts and a plate potential of 180 volts. Moving to the right along the 10 milliamperere line to point Y it will be noted that the plate current has been maintained but that the negative grid bias is now -12 volts and the plate potential is 340 volts. The grid bias has been changed by 8 volts and the plate voltage by 160 volts to maintain the plate current constant. Thus it has been necessary to change the plate voltage twenty times as much as the change in grid bias, showing that the amplification factor of the tube is 20.

Another useful determination which

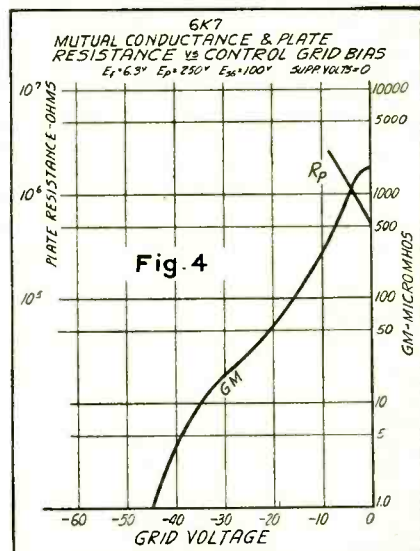

can be reached through graphical work with the plate "family" is shown at the lower part of this group of curves in Fig. 2. The data chart does not tell what the grid bias should be for operation of the 6F8G in resistance-coupled circuits. It does say that the plate resistance is approximately 7700 ohms. With that value of plate resistance, a plate load resistor having a value of 100,000 ohms would be satisfactory for straight voltage amplification. Assume a plate supply voltage of 300 v. With resistance coupling there is no inductance in the plate circuit to produce instantaneous peak-signal voltages higher than the supply voltage so it can be expected that the instantaneous peak plate-signal voltage on the positive side will not be greater than the 300 volts supplied. Also, this peak positive voltage at the plate can be realized only when there is minimum plate current (point where the signal voltage on the grid is most negative). Accordingly, a load line representing 100,000 ohms is drawn on the plate "family" with one end placed at point A where the plate voltage is 300 v. and the plate current is zero. The slope or angle of the load line with respect to the base line is determined by simple calculation: Under Ohm's Law, $I = E/R$. The value of R has been chosen as 100,000 ohms. The value of E is the supply voltage, 300 v. Substituting these figures into Ohm's Law, $I = 300/100,000$ or .003 ampere (3 milliamperes). Therefore, the load line, to represent 100,000 ohms, should connect the point where the voltage is 300 and the current zero with the point where the voltage is zero and the current is 3 milliamperes. In a Class A amplifier, grid current is not permitted so the load line is cut where it meets the plate current curve for zero grid bias by the vertical line B. This line, B, intersects the base line at 30 volts and establishes 30 volts as the lowest instantaneous plate voltage to be reached. If the highest instantaneous voltage is the supply value, 300 volts, and the lowest is 30

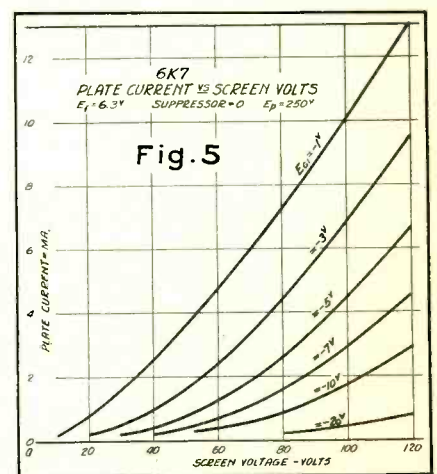

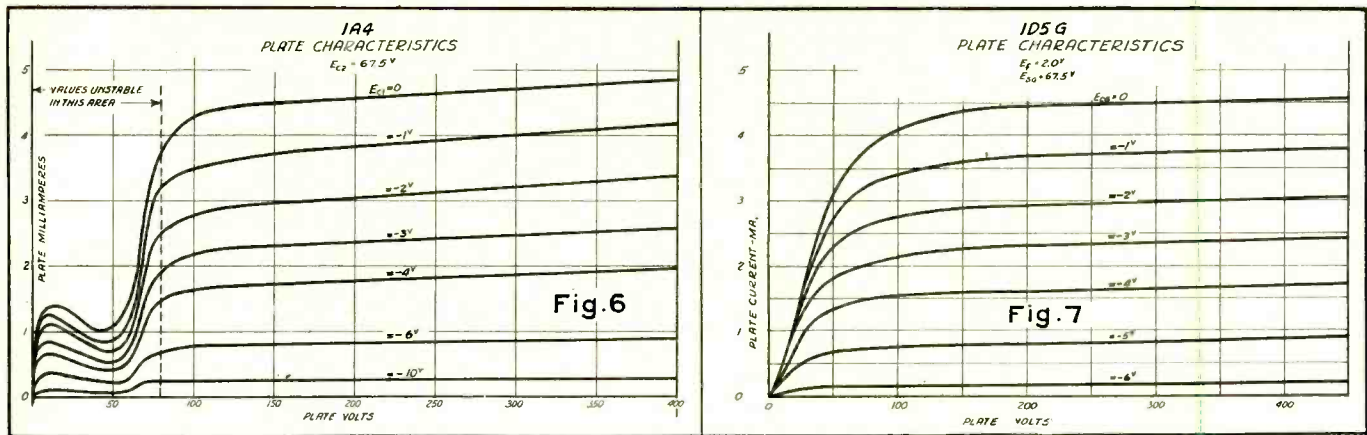

volts, then the average instantaneous plate voltage should be midway between the two or 165 volts. The line C drawn up from the base line at 165 volts establishes the correct operating point where it intersects the load line. Note that this new point lies on the plate current curve for a grid bias of -8 volts and that the vertical height of the operating point corresponds to a plate current of 1.5 ma. Using Ohm's Law again to determine what value the cathode resistor should have, $R = E/I$ or $R = 8/.0015 = 5333$ ohms. A 5000 ohm resistor would be satisfactory. If both sections of the 6F8G are used similarly and their cathodes are tied together, the cathode biasing resistor should be half that for a single section or 2500 ohms. The load line is not a mysterious factor at all. Drawn between the points of extreme signal-voltage fluctuation in the plate circuit, it represents the instantaneous values of plate current and plate voltage present at the tube plate as the signal changes the instantaneous control grid voltage above or below the fixed grid bias voltage.

In Fig. 3, another problem in deter-

mining proper operating conditions is presented. Type 6E6 is used primarily as an output tube, but its power capabilities and high plate current recommend it as a driver tube where voltage gain is not important. With 300 volts as the plate supply voltage and 25,000 ohms selected as the load resistor, the 25,000 ohm load line is drawn in. Here the line was started at the 300 volt, zero plate-current point and for convenience was drawn through the 50 volt, 10 milliamper point. By Ohm's Law this gives the load line a slope equivalent to 25,000 ohms since for a change in plate voltage of 250 the current rise is 10 milliamperes ($R = E/I = 250/.010 = 25,000$). The intersection of the load line with the zero grid-bias plate-current curve is shown by the vertical line B, which cuts the base line at 44 volts. Thus 44 volts is established as the minimum swing of the instantaneous plate voltage. Half way between this minimum of 44 volts and the maximum of supply voltage is the operating point, 172 volts. The vertical line, C, erected at this point intersects the load line about midway between the plate-current

curve for a bias of -20 volts and the curve for a bias of -30 volts. A plate-current curve for a grid bias of -25 volts would pass through or very close to the operating point and therefore -25 volts is established as the operating bias voltage. The height of the operating point above the base line is equivalent to a plate current of approximately 5 milliamperes. Using Ohm's Law, it is determined that the cathode bias resistance for a single section of the 6E6 would be 5000 ohms. However, this tube has a common cathode and since it would be used as a push-pull driver in most cases, the cathode resistor should be 2500 ohms theoretically. In practice, it may be necessary to lower this value to 2000 ohms because it is appreciable compared with the plate load resistor.

In both Fig. 2 and Fig. 3, a vertical line D will be noted. This vertical line which passes through the intersection of the load line with the plate-current curve representing twice the operating bias voltage (-16 volts in Fig. 1 and -50 volts in Fig. 2) establishes the actual upper limit of the plate-voltage swing during amplification of a signal which has a peak voltage equal to the bias. The crest-to-crest signal-output voltage will be approximately the plate voltage at D minus the plate voltage at B. The peak signal-output voltage will be half this value (middle to one crest), and the r-m-s signal at the plate will be 0.7 of the peak-signal voltage.

This method of determining proper operating conditions for new plate voltages not covered by published figures is easy to carry out. It must be understood that it provides approximate results and that final adjustment of bias with an oscillograph to check wave form, or, lacking the oscillograph, an ear test should be made. The method gives a very close approximation to the values suggested for a few types on which resistance coupling information is given.

Fig. 4 shows how the mutual conductance of the 6K7, or type 78, varies when the control-grid bias is changed.

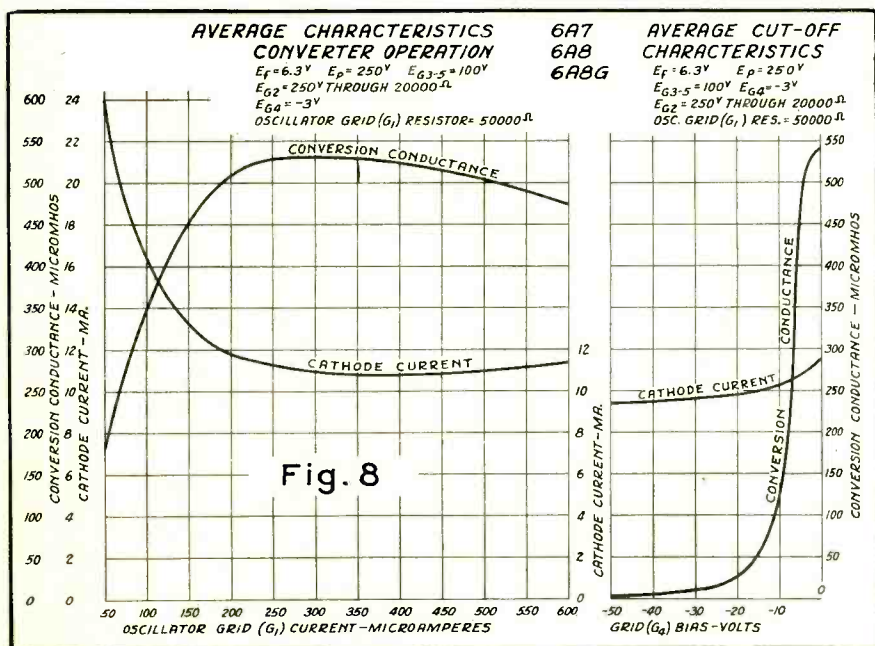

This tube is of the variable-mu type developed to reduce cross modulation and consequently the control grid must be made quite negative to reduce the mutual conductance or gain of the stage using it. The shape of the mutual conductance or G_m curve is followed in the design of volume controls. One factor of interest to the Service Man is the flattening of the curve as zero bias is approached. Actually, a tube of this type should never be operated with less than approximately -1.5 volts bias if the full mutual conductance is to be realized. A lower value of bias will generally cause instability and, by permitting the total cathode current to rise above the normal, will bring up the "rush" noise level of the receiver.

Fig. 5 is shown to illustrate the effect of the screen-grid voltage on plate current in tubes similar to the 6K7. The Service Man will find this kind of information valuable in determining proper cathode-bias resistance values for r-f or i-f stages where the screen voltage furnished within the receiver under test or repair is not the screen voltage specified under the limited ratings on the usual data chart. In screen-grid tubes of all types, the screen voltage and the control-grid bias determine the plate current for all values of plate voltage higher than the screen voltage.

Figs. 6 and 7 should be studied together. They illustrate (in Fig. 6), the effect of secondary emission in the tetrode 1A4, and (in Fig. 7) the elimination of this effect in the pentode 1D5G.

In data chart ratings, the two tubes appear to be similar. The plate "families" for each tube show them to be quite different in the region where the plate voltage is equal to or less than the screen voltage. The addition of the suppressor grid in the 1D5G raises the effective gain of the tube and provides better performance. Some receivers, designed for the tetrode 1A4, will not take a pentode 1A4 without developing oscillation trouble induced by the higher gain of the improved tube. Consequently, manufacturers are now beginning to mark the 1A4 with a suffix letter T to indicate tetrode construction or with a suffix P to indicate that the tube has a suppressor grid.

Fig. 8 shows interesting relationships for the 6A7 mixer tube. To determine whether or not a tube of this type—6A7, 6A8 or 6A8G, is working at maximum conversion conductance, the grid leak connection to the cathode of the tube should be opened and the grid-leak current read on a microammeter or 0.1 milliammeter while the receiver is tuned completely over each band. If the meter is inserted between the cathode end of the grid leak and cathode, it will not interfere with the operation of the oscillator. Note that the figures given are for a 50,000-ohm grid leak. Some receivers use a 25,000-ohm grid leak and these should show considerably higher values of current than will be found where the leak has a resistance of 50,000 ohms.

The curves showing average cut-off

characteristics for the 6A7 illustrate the sharp cut-off characteristic of the signal control grid. Most receivers having one r-f stage operate the 6A7 with fixed bias and apply the a-v-c voltage only to the r-f and i-f amplifier tubes.

Fig. 9 shows the output power and distortion characteristics of the 6L6 and 6L6G type tubes. While the curves explain themselves clearly, the information they present could not be given in understandable form without some reference. In audio work, particularly, curves offer a comprehensive view of interrelated data which would mean very little if considered alone.

Another complete story is told by the curves, in Fig. 10, which represent the effect of a straight resistance as compared with the ballast action of the new NB tube for voltage regulation in battery-operated receivers. The curves, shown for operation with a 3-volt "A" pack, indicate that a straight resistance will limit the initial voltage of 3.1 to 2.4 volts on the tube filaments, whereas the NB regulator permits the tube voltage to reach 2.25 volts. At the end of battery life with the battery-terminal voltage at approximately 2.0 v, the straight resistance drops the filament voltage to approximately 1.53 v. while the NB regulator delivers 1.65 volts to the filaments. Since modern two-volt tubes will work down to approximately 1.6 volts, the NB regulator saves the filaments from over-voltage at the start and permits the battery to be completely used at the end of life.

Fig. 10 tells a story in an easy-to-understand way. The multiple curves published for vacuum tubes may have looked complicated, but they, too, are simple and will give up much useful information to the Service Man who will study them.

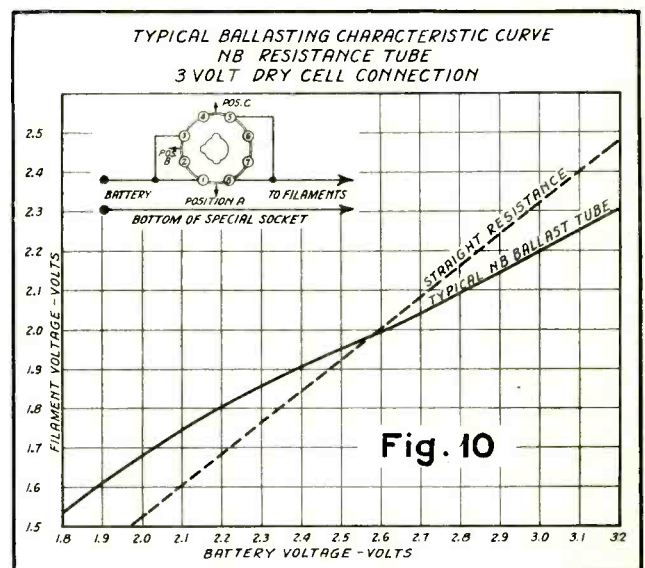
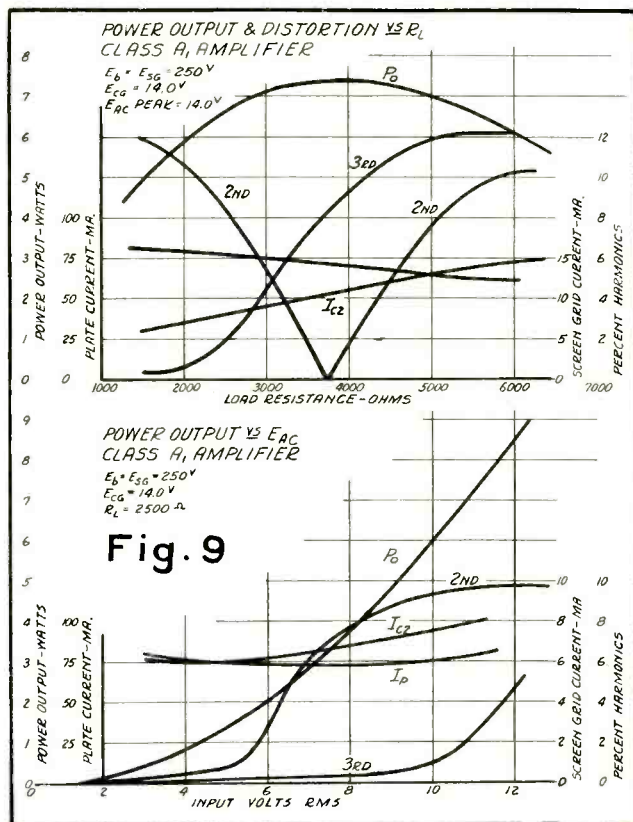

MODERN THEATER SERVICING

By "SOUND TRACK"

THE THEATRE FIELD for sales and service of sound equipment includes 16,000 working theatres in the United States, and three separate classes of apparatus. The most important of these, economically, is the installation used for talking pictures. The other two are: indoor sound apparatus that reinforces stage shows and various forms of prize-giving; and outdoor public address systems associated with theatre advertising, either at the marquee or in a sound truck.

The entire range of theatre business is now open to the enterprise of every Service Man. This was not true in the past. At one time the great majority of talking picture systems were made available to the theatre only under contracts which vested all service and replacement business in the manufacturer of the apparatus. These conditions no longer obtain anywhere in the United States. Regardless of the make of talking picture equipment used, all theatres today are free to buy service and spare parts wherever they think they can do best. And they can always obtain special sound parts from the manufacturer of their installation, regardless of who does the servicing or whether sound parts of other make are also used from time to time. Thus any Service Man may repair a movie amplifier with a condenser taken from his own stock, and if he finds he also needs a socket of special mechanical construction, there will be no difficulty about buying it from the amplifier's maker. Further discussion of these details will follow in its proper place.

TYPES OF EQUIPMENT USED

The actual work of servicing and repairing talking picture installations presents no enormous technical difficulties. Fundamentally, the apparatus is nothing but a public-address system with a photoelectric cell as the input source instead of a phonograph pickup or a microphone. The overall gain is generally in the order of 90 db, and output ratings range from less than one watt, in some cases, to nearly 100 watts. Frequency range in modern installations is from 40 to 8,000 cycles or better, with multiple-speaker arrangements for handling high and low frequencies separately. Systems of earlier design reproduce all frequencies through a

single speaker or speaker set, and cover only from 55 to 6,000 cycles, or less. The harmonic content of a good theatre amplifier is low, generally less than that to which the Service Man has been accustomed in other sound work. Arrangements that are peculiar to talking picture apparatus alone, as distinct from all other sound equipments, will be found only in the mechanical and optical systems associated with the photoelectric cell, and are described and diagrammed hereafter with particular attention even to small details.

Indoor theatre sound equipment (as distinct from the motion picture sound) is not called a public address system, but a sound reinforcing system. Its presence is not intended to be too obvious to the audience, even when they see the microphone. The best reinforcing system is the one that most nearly creates the illusion of natural sound, unaided by mechanical devices. Such illusion is achieved only through careful attention to auditorium acoustics, another special subject.

Outdoor public-address systems as used in theatre advertising are standard equipment of the type found in any outdoor sound work. They are often tied in very closely with visual advertising; for example, by concealing a loud speaker behind the lips of the cardboard cut-out of an actor or actress which is mounted in front of the theatre to attract attention. Careful inspection of the details of a theatre's outdoor advertising will help the Service Man sell or rent his apparatus. He should be able to suggest ways, consistent with normal advertising arrangements, in which sound will prove an attractive factor.

Public address, outdoor and indoor, offers a highly practical entrance wedge to all theatre business.

SALES RESISTANCE

There is no intention of indicating here that theatre work is easy to get. It is very much worth having; as will be shown, theatre business of every kind pays extremely well in comparison with the same activities in other fields. But it is hard to get. There are a number of strong obstacles in the way of selling sound, and particularly the most profitable branch of sound, service. They can of course be overcome, but the job isn't simple.

One handicap is that many theatre men feel they have been "burned" in the past in the matter of sound servicing. In the opinion of the writer the feeling is unwarranted, but it is there and should be understood. The history of it goes back to those same compulsory service contracts of the past. In order to get equipment of good quality theatres were compelled, or thought themselves compelled, to pay from twenty to forty dollars a week for service, and to buy all supplies from a single source at prices set by the seller. Actually the contracts were not rigidly enforced, and in the end were abandoned entirely, but a bitter taste was left in many mouths and a large number of theatres are working today with very haphazard sound maintenance instead of the adequate servicing they know they ought to have for their own protection. Those theatres offer the Service Man his best opportunity, but they require an extremely diplomatic sales approach. Some practical suggestions are given later in this article.

COMPETITION

A second handicap is competition. The theatre may already be receiving sound service from one of four sources: (a) from the manufacturer's service engineer, in accordance with a short-term, voluntary contract subject to cancellation; (b) from the projection operator or operators—this arrangement is sometimes coupled with emergency resort to the manufacturer's service department at a one-call rate of \$35.00 per day or fraction thereof; (c) from a central servicing organization maintained by a chain of theatres for its own use; (d) from another Service Man.

Manufacturer service is still extensively used, but is only a slight shadow of what it was. Traveling and overhead costs make it more expensive than the use of a local Service Man who knows his business.

Projectionist service is not thoroughly accepted and is in general of indifferent quality. Almost all projectionists can change a burned out tube or clean a volume control, but some can do no more than that. They relied for years on compulsory service visits, and never learned any more about sound. Some, however, are comparatively com-

petent, and not a few could probably give the average Service Man pointers about amplifiers, particularly theatre amplifiers. But the competent men often decline to service sound on the ground that it isn't their job. That precedent was established years ago during the period of compulsory manufacturer servicing; the projectionists' unions accepted the arrangement, and today generally hold that their members are not responsible for sound servicing. At present there are two cities in the United States in which the unions themselves provide sound service to union theatres; in all other communities theatre service work is free from union restriction and substantially free from competition of projectionists. Non-union projectionists also are able, or at least expected, to go no more than just so far, and then call for help.

Self-servicing organizations are maintained by a few theatre chains. They are not as numerous as they were in the past. In the case of a large chain they involved about the same high overhead costs and high traveling costs that make manufacturer service comparatively expensive. A small, compact chain, however, can use self-service, and the Service Man who gives satisfaction to one member of such a chain can logically expect to extend his activities to the group as a whole.

Competition by another Service Man is the least likely to be encountered at the present time.

All of this competition is less formidable than it may seem to be from reading a few paragraphs intended to emphasize the Service Man's possible difficulties. Still, he will do well to find out before he approaches a theatre what form of competition, if any, he will have to meet. The indirect approach, either through public address or through one of the other ways to be mentioned later, may prove valuable. It provides a contact with the management which makes possible asking a casual question about sound servicing, and how it is taken care of, without arousing sales resistance. Not only the competitive angle, but any touchiness the manager may have on the subject, are readily uncovered, and an intelligent sales campaign can be planned according to the circumstances as found.

ATTITUDE OF THE PROJECTIONIST

Existing competition, if any, and possible resentment toward sound on the part of the management, are the major obstacles in the way of obtaining theatre work. Actually doing the work, after it has been obtained, involves two further difficulties. The most important lies in the relations between the

Service Man and the projection operator.

The projection room, and everything in it, is the latter's job. To intrude in such a way as to convey the idea that the projectionist is incompetent never helped anyone. The proper attitude, and in most cases the correct one according to actual facts, is that of course the projectionist is competent so far as can be expected of him. But there are reasonable limits to his abilities in matters of sound, and that's what a Service Man is for. He is not there to supersede the projectionist, but only to advise and help in connection with certain specialized apparatus.

An important point with the projectionist is overtime, for which he is generally paid if any repair, maintenance or replacement work has to be done out of theatre hours. The Service Man, as an employee of the theatre, has a certain duty to keep down costs, but excessive zeal in limiting overtime is not too advisable. An unscrupulous projectionist can always create occasions for overtime work; if the man is honest and conscientious a little laxity now and then about letting a job stretch into the beginning of another hour is only common sense.

The majority of projectionists are union men, and as such are theoretically entitled to bar from the projection room anyone who is not a member of the same union. Except in the two cities referred to, that is hardly ever done, but it can be done if a Service Man sees fit to make himself objectionable. Union regulations and sensibilities can be enforced, in union houses, regardless of the wishes of the theatre owner. One vital regulation is that—in theory—the visiting Service Man merely ad-

vises. The actual work, down to handling test leads or lifting a screwdriver, is done by union projectionists only. In his first visits to a union theatre the Service Man should never do the slightest work with his own hands except as specific permission is asked and given. The common formula runs something like this: "We'll have to loosen that bolt; want me to do it or would you rather do it yourself?" In extreme cases, as said, the projectionist insists on applying test prods, the Service Man pointing out where they shall be applied. Naturally, these formalities seldom last long. After a few visits have established confidence and friendly relations, the Service Man peels to his undershirt and goes to work with the rest of the boys. It is none the less necessary to be careful at first.

Another point the union decides is, how many men are to be present for each individual job. Thus in most jurisdictions repairing an amplifier needs one man, changing a sound head (the part that contains the photoelectric cell) two men, and so on. That is, union projectionists, in addition to the Service Man who in theory only directs the work. The Service Man should never dispute or even question these arrangements. In a union theatre they are none of his business. If the manager thinks there are too many men on a given job, that's for him to settle with the union.

LOCAL ORDINANCES

A minor hindrance in service work is sometimes presented by legal ordinances. Projectionists are usually licensed, and local regulations commonly provide that only licensed men shall be permitted in the projection room during show time. This is because of the film fire hazard. It is a regulation seldom enforced, but always a weapon that will protect even a non-union projectionist against any Service Man so ill-advised as to make himself objectionable to that gentleman. Other local regulations, also primarily directed against the fire danger, prohibit smoking in the projection room, use of open flames for soldering, open wiring, unapproved equipment, and so on. Few of these are very extensively enforced, but the Service Man who undertakes theatre work should prepare himself for any question that may ever arise concerning them. That is easily done by writing to, or calling on, the local authorities.

These obstacles have been stressed here intentionally, for no branch of show business is any bed of roses. But show business, the fourth largest industry in the country, almost always offers greater rewards than any other for the same type of work.

The opportunities it extends to the

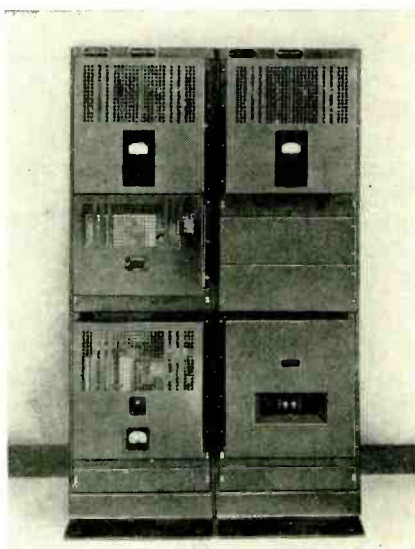

An amplifier rack used in large theaters. This rack is usually mounted at the rear of the room out of the way of the projection machines.

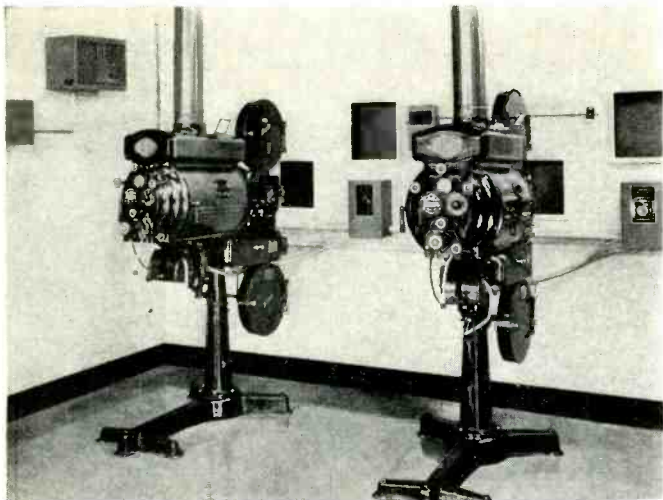

The projection room in a small theater. Notice the amplifier mounted on the wall at the left.

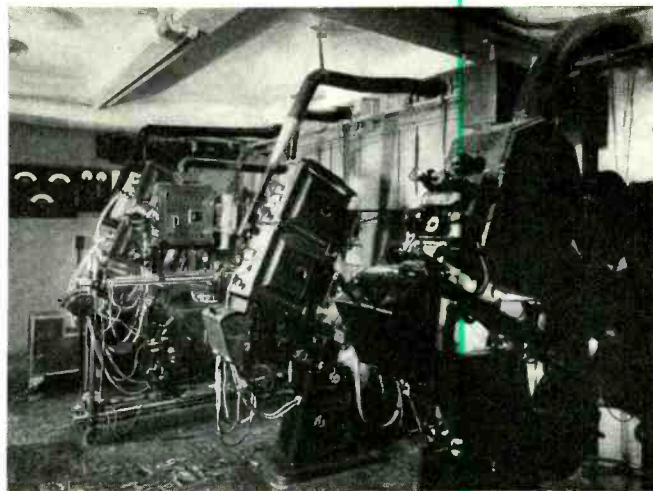

The large theater has an impressive-looking projection room. Sound equipment not shown in this illustration.

Service Man are distinctly attractive. Theatre equipment is commonly more highly priced than similar apparatus (amplifiers, speakers and so on) used for other purposes. Theatre service is usually better paid. Three classes of equipment are used, each of which offers the Service Man the triple opportunities of maintenance, repair and sales, while two of the three also provide a chance for rentals.

SALES APPROACH

There is a variety of possible sales approaches, simple and direct, or round-about and elaborate. If any theatre is known to have definitely bad sound, or to have had serious sound breakdowns, a direct sales visit may be indicated. Or if the Service Man is at all acquainted with the manager or with the situation at the theatre in question, direct approach should be worth considering as probably the surest as well as the fastest method. And mere cold canvassing, of course, usually yields a certain percentage of results.

A very simple indirect approach can be found in those theatres in which the manager for his purposes maintains a degree of personal contact with his patrons—asks them as they leave how they liked the show, and so on. It is easy enough to build up a small acquaintance in that case, to feel out the situation, and let talk about the show develop into talk about sound. But many managers seclude themselves in their offices and can be seen only by appointment.

Several methods of indirect attack are provided by the importance of theatre advertising. Entertainment is an intangible commodity. The buyer never sees it until after he has paid for it. If radios had to be sold on that basis they would need a great deal of very intensive advertising. That is just what a theatre needs, and the manager is in-

initely more interested in his advertising than in his sound.

Careful attention to his advertising, especially his important, exceptional efforts, may reveal some way to tie in public address. If the public-address angle is so original and striking that it must compel public attention a rental, at the very least, should be easy to obtain, inasmuch as commanding public notice is the most important part of the showman's business.

Still another approach is provided by the cost of theatre advertising, which drives showmen to ways and means of getting a certain percentage of it at someone else's cost. They are extremely shrewd and ingenious at what is known as the "tie-up"—which means either splitting costs with another merchant, or, preferably, letting the latter bear the whole expense while the showman contributes only a lobby display or some mention in the theatre itself. The Service Man, who has more than one axe to grind in this case, can propose as a tie-up, loan of a public-address system for some exceptional occasion. He will be repaid in the form of advertising, and at the same time will have fired the opening gun in his campaign for that theatre's sound business. The loan can easily lead to a suggestion of future rentals, and so on.

The necessary contact having been made, the possibilities in that theatre's business can be examined in detail. Aside from sales of equipment at a good price, servicing arrangements of some sort will usually be most attractive.

SERVICE REQUIREMENTS

The idea of periodic servicing as a necessary adjunct to sound equipment is one with which all theatre men are familiar, and which most theatre men accept as unavoidable even if disagreeable. The basic reason for the industry's acceptance of servicing as a

necessity lies in two other peculiarities of the business.

First, a theatre sells nothing tangible, only illusion, an emotional thing easily destroyed by disagreeable sound quality. Every showman will maintain that his patrons are not analytical, but merely form semi-conscious associations and impressions that lead them to stay away from a theatre where sound (or anything else) is disagreeable. Therefore it is worth while for him to undertake a reasonable expense that will keep his sound quality as high as possible.

Secondly, a theatre sells time,—entertainment over a certain number of minutes. Every new minute, hour and day is a separate part of the theatre's only stock in trade. Tomorrow can't make good for an hour lost today—tomorrow is another day. An hour lost through sound breakdown is lost forever. The refunds or rain checks can never be made good; the seats that weren't sold during the breakdown can never be sold again. Therefore the show must go on at any cost, including the cost of periodic servicing and the very best quality replacement parts, or of emergency amplifying channels, which are quite common.

Service work offers two advantages, a steady and reliable income in return for a minimum of time, and close contact with the theatre in all matters pertaining to its purchase of any sound parts or equipment.

Normal service arrangements provide for between two and four regular inspection visits per month. These take from an hour to two hours each. They are used to make any small adjustments that were not within the skill of the projection staff, and to look for signs of developing trouble. If the trouble is at all imminent it is never allowed to appear; it is cured in advance.

(Continued on page 709)

THIS

or

THIS

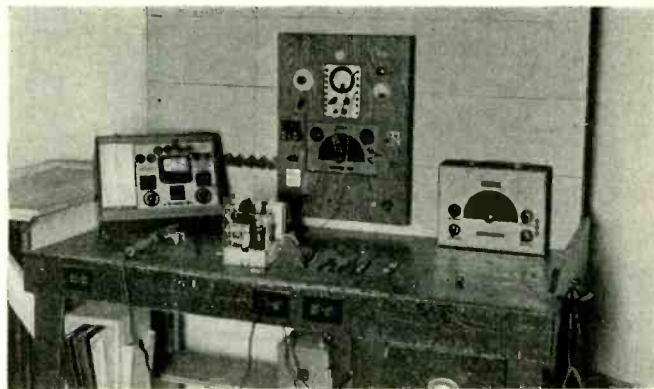
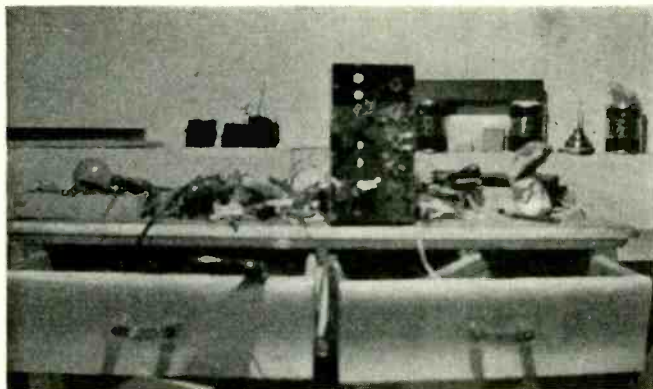

LET'S LOOK AT SERVICE EQUIPMENT

By BERNARD H. PORTER

THE ART of reconditioning radios, like other technical professions in a scientifically-minded age, is becoming increasingly involved. It is agreed, at the outset, that a man without proper tools in so complex a business as radio servicing, is entirely at loss. Indeed, it is common knowledge that he who possesses thorough training, backed by long experience and aided by superior all-purpose equipment is most apt to succeed, while others utilizing inferior facilities in an unguided and deficient manner find progress slow. In brief, he who prospers, keeps up with new developments by adjusting and augmenting his test devices to meet the requirements. And kindly note that the progressive Service Men are making the extra investments in new equipment with a view to meeting manufacturers' developments and increasing their own long-range profits.

Manufacturers annually introduce changes in design and operation that mean varied and complicated refinements over their previous models. First it's automatic volume control, then automatic frequency adjustment, followed by a selectivity operation and remote control of the same mechanical variety. Last year with the aid of dealers and Service Men, the radio manufacturers added 8,000,000 new receivers to the 28,000,000 already in use. This year, with the same cooperation, they hope to find 10,000,000 more buyers, and are even confident that the following year can absorb that quantity plus several thousand. Such merchandising calls for either more and more gadgets, or less

and less of the same. Some claim it is no secret that we are on the eve of a revolution in both broadcasting and receiving techniques, with the result that the new era will be introducing receiver models having little or no resemblance to the knob and box designs we know at present.

By way of keeping pace with increasing improvements, the instrument makers have assumed the task of providing the corresponding test devices. Undoubtedly this latter group find the manufacturer's trail toward originality somewhat involved at times, for they, too, like the set producer, must engage on lengthy and costly experimental work, including design and field tests before any type of instrument can be introduced safely. In fact, the three groups, radio manufacturers, makers of test apparatus, and set reconditioners, are all faced with the new-developments problem in order to satiate the perfection-conscious public. With increased cooperation between all parties involved the future should be easier going.

We have seen that Service Engineers are responsible to their public for an ability to cope with the newest refinements of the radio manufacturer. The latter, in turn, owe it to themselves to see that every detail of technical, general engineering, and design data—in preference to being guarded jealously—is passed on to the active Service Man. The next question is: "What test instruments are now necessary for the average run of service work?" To answer this properly the writer has queried sev-

eral of the prominent Service Men, editors, and manufacturer's representatives attending the recent N. R. P. M. Trade Show in New York and presents herewith a resume of the findings.

ANALYZER PLUG

The first operation concerns the free point analyzing of receiver circuits: a test so elementary as to be assumed. A standard analyzer plug, of which there are many available varieties, does the trick. In this connection, however, attention should be drawn to those modern methods of free point testing as introduced by some manufacturers, wherein reference to instruction books and complicated tube charts is eliminated. For reducing the possibilities of embarrassing error and actually making socket analysis a routine, series type jackets are so arranged with respect to the sockets that stencil cards fit over them to give at a glance the internal arrangement of any given tube under test. In any case, whatever tester is purchased, it should have ample provision for future changes in tube design and so not become obsolete as new types are offered.

TEST OSCILLATOR

The signal generator can not be dispensed with and failure to possess one puts the service shop at a serious disadvantage. Time was when Service Men peaked the trimmers of t-r-f sets at 1400 kc by tuning in a local station. The ear served as the output meter. Today the human hearing organ is rightly accused of giving logarithmic indications rather than linear reproduction

and the output meter is being discarded because of its inability to align high-fidelity and variable-selectivity super-heterodynes. In their place the r-f oscillator is not only necessary, but it should be modulable with a sine wave, audio signal; it must be wobblable over a narrow frequency band, and should possess a range of at least 150 to 20,000 kc. Some models cover a frequency range of 90 to 25,000 kc by means of over-lapping bands for the fundamentals, give direct frequency reading with modulation on-off service via an appropriate sine-wave voltage either externally or internally, are switch operated from the front panel, and offer condenser or leakage tests up to 100 megohms. Such an instrument covers all r-f and i-f points of automobile, battery, and a-c receivers.

Service Men having an eye for future expansion, will desire a panel jack on the oscillator to permit use of an external modulating frequency voltage such as a beat oscillator. For later oscillograph operation, a single-circuit jack across the tuning capacitor facilitates the connection of a frequency modulator. Those generators possessing internal amplitude modulation may be operated as heterodyne frequency meters for checking the frequency of unknown stations. Headphones are merely plugged in the modulation jack and the switch placed at the unmodulated position. The variable attenuator circuit coupled with a tapered potentiometer or toggle switch provides a high ratio of r-f voltage change in the output. (Table I.) A minimum range of the high position overlaps the maximum range of the low position giving a continuous variation over the entire scale. The dial calibration of most generators is accurate to plus or minus 3 percent, or greater than that of the average receiver control. Greater accuracy, as calibrated to plus or minus 1/2 of 1 percent at the factory for an additional fee, is probably not necessary for the average shop, one manufacturer's representative remarked.

Some concerns offer a signal generator of somewhat greater flexibility and

DO YOU KNOW just what instruments are considered to be absolutely indispensable in radio servicing?

THE FULL USES
to which these instruments can be put?

IS YOUR cathode-ray oscilloscope used for service work to the extent which its abilities demand.

OR IS IT USED CHIEFLY
to dress up the shop and impress the customers?

having a range of 100 to 22,000 kc on fundamentals and 100 to 105,000 kc on harmonics. Variable and calibrated audio frequencies on direct reading, are given in the bands 24-400, 400-5,000, and 5,000-10,000 cycles. Thus audio amplifiers can be checked for fidelity with closely-known, bandsread selected frequencies where a choice of frequency is required. The a-f values can be taken independently of the radio frequencies, i. e., the audio is not confined to modulation, but is in reality an individual audio oscillator.

For the selection of the signal generator, the consensus of opinion recommended those types that are adaptable readily for the cathode-ray oscillograph, such a policy to include the shop's expansion toward the most modernized service. An oscillator like the electronic-sweep design and having the majority of features just discussed would serve the Service Man admirably, particularly as no separate frequency modulator is needed.

VOLT-OHM-DECIBEL-MILLIAMMETER

Of the numerous makes of volt-ohm-milliammeters, it pays to purchase the best that a reliable manufacturer has to offer. Long range accuracy and high

sensitivity under changing electrical, climatic, and work conditions are to be desired. While most instruments provide voltage, current, and resistance values directly, there is much to be gained from additional a-c and decibel scales. Should an inductance range and a capacity gradation also be included in the same instrument, its versatility is increased, though oddly enough, many Service Men seem wary of a single device that will perform too many operations even if these functions are closely related in their electrical principles. The usual specifications, more or less standardized for this type of tester, are given in Table II.

The a-c feature eliminates all the restrictions of a d-c measuring device and permits the measurement of reactive components. For example, capacities from 0.01 to as high as 50 mfd can be read with accuracy in the lower range and nearly so in the higher limits. The inductance range, if used, is usually 5-1000 henries with about 2 percent accuracy for values in excess of 10 henries. Thus in the case of a choke coil, or the like, the inductance may be determined either in a loaded or unloaded state, i. e., direct current may be passed through the coil and measurement made of the speaker field or B-supply choke directly in the receiver. Within limits, it is said these devices draw small currents and accordingly can be used as a vacuum-tube voltmeter in ranges up to 750 volts per 10 mc.

Strong, moisture-proof containers, long scales, and very legible markings to permit close reading are preferred.

TUBE TESTER

In fabricating the numerous tube analyzers and multiple combinations thereof, the manufacturers have contended vigorously with one another. The results range obviously from good.

Table I

Range, kc.	Switch at Low Position		Switch at High Position, Maximum Volts
	Minimum Less Than	Maximum	
90- 200	1 Microvolt	2 Millivolts	0.2
200- 400	1 Microvolt	2 Millivolts	0.2
400- 800	1 Microvolt	2 Millivolts	0.2
800- 1500	1 Microvolt	2 Millivolts	0.2
1500- 3100	5 Microvolts	1 Millivolt	0.1
3100- 6800	10 Microvolts	1 Millivolt	0.1
6800-14000	20 Microvolts	1 Millivolt	0.1
14000-25000	40 Microvolts	1 Millivolt	0.1

R-f output voltages of a popular, battery-operated, test oscillator having an internal amplitude modulator.

Table II

Six d-c voltage ranges at 20,000 ohms per volt:
 0-5, 0-10, 0-50, 0-150, 0-500, 0-1500 volts.

Six a-c voltage ranges at 1000 ohms per volt:
 0-2.5, 0-10, 0-50, 0-150, 0-500, 0-1500 volts.

Six d-c current ranges:
 0-100 microamperes, 0-1, 0-10, 0-50, 0-150, 0-500 ma.

Three resistance ranges:
 Low ohms0-4000 ohms (35 center).
 Medium ohms0-400,000 ohms.
 High ohms0-40 megohms.
 (self contained supply)

Six decibel ranges from -12 to -59 db:
 0, 12, 26, 36, 46, 56 db.

Six output ranges:
 0-2.5, 0-10, 0-50, 0-150, 0-500, 0-1500 volts.
 (Large scale: 4½", D'Arsonval movement 2 percent accuracy, ohms compensator, leatherette case with removable cover or panel model, tool compartment, batteries, and test leads. \$27-\$40.)

bad, to indifferent. In some respects the competition has benefited the Service Man: the prices at least have kept within reasonable limits. With the rivalry, however, of producing devices of the same function under different names, multi-colored panels with irrelevant patterns in bas-relief and other decorative furbelows of no good purpose have been applied to catch the eye, though at the considerable cost of good taste. The effect, while striving for modernism, is reminiscent of the atrocities of Mid-Victorian architecture and unfortunately for the makers bespeaks externally of a possible lack of quality on the inside. Symmetry in layout is now reduced to geometrical exactitude as a means of impressing the novice repair man, the handy boy who fixes his own, and any or all customers entering a shop. Convenience of use is rarely considered.

The recommendation in regard to the tube tester or its combination in a set analyzer is to purchase the best that an "old-line" firm has to offer. Expect of it the accurate measurement of all essential tests minus any abilities to determine an excess of functions rarely used. Moreover, be certain that it is equipped with extra jack and plug leads, and provides periodically the new charts of latest changes in design, thus permitting continued use when other testers are obsolete. The non-obsolescence factor, as proved by time, is not to be overlooked. Of the good-bad indicating features in such devices, those providing for the customers' benefit output signals in colored lights and stethoscopic facilities for hearing the detrimental effects of loose connections and intermittent shorts, are said to have increased sales value for the shop.

CATHODE-RAY OSCILLOSCOPE AND WOBBLER

Up to this point we have considered the four essential devices as thought necessary for the run of service work.

When considering the remaining instruments there has not been a complete agreement among the various individuals queried. These manufacturers, for example, whose production does not include the oscilloscope, term it unnecessary in the average shop. Out of a possible 50,000 Service Men in the country, less than 3000 know how to use one correctly, they say. In spite of wide publicity and distribution of information on the subject of oscillographic test methods, this same group claimed Service Men bought them only to place on their shelves as a means of impressing clients and establishing the shop's credit or facilities with tube and part suppliers when the time comes for re-stocking. On the other hand, the concerns who do fabricate the oscillograph admitted the turn-over is not yet as high as it should be. Finally, the independent Service Man, having a small but growing business, seems only to have arrived at the stage of being impressed. Perhaps the price of a sure quality instrument is an obstacle. Naturally, the more technically minded men, a minority group, have long since used the visual possibilities of the cathode-ray as a necessary adjunct to modern servicing.

In view of these opinions it should be stated, all comments to the contrary, that the future of the servicing industry will be centered around the oscilloscope. With the production of increasingly complicated circuits of the high-fidelity receivers and automatic-frequency-control sets, those unacquainted with the servicing techniques via oscillographic methods will gradually find themselves entirely at loss as time passes. Briefly, a visual record of what is occurring in a given receiver supplies more information than any other type of reconditioning, provided the user has the knowledge to interpret the wave-forms seen.

As an indication of the versatility of such an instrument, one editor in close contact with Service Men in different

parts of the country, reports that the oscilloscope is being used to align r-f and i-f stages of superheterodyne receivers, measure capacity and inductance, test overall audio fidelity, localize distortion in a-f amplifiers, test overall receiver sensitivity, localize audio distortion, and check on intermittent reception. The last test, on intermittency, usually the most difficult problem of the service profession, can be located by feeding in the appropriate signal and viewing the output, stage by stage. Auto vibrators can be tested either when in position, or, later, on the bench. Other applications include hum, hysteresis, phase, amplifiers, and transmitters. Each of these tests and measurements are made more accurately and in less time than by any other method.

The most important aid to the oscillograph, as we have seen, is the modulated oscillator that sweeps a band of frequencies across the desired frequency at a given rate of speed. By following the recommendations above on the oscillograph, one has the necessary associated equipment for the oscillograph, particularly so if the generator also supplies audio frequencies. The sine-wave output allows easier comparison on the oscilloscope. If the recommendation for associated devices is not followed, the wobblator will be necessary.

As in previous instances, it pays in the end to buy the latest models. Too, a little extra on the price from the older concerns who have pioneered and developed the cathode-ray tube and oscillographic parts from the start, pays finally. Second-hand equipment has the double disadvantage of being outmoded and of questionable accuracy. Some concerns offer an oscilloscope kit thereby permitting the home construction of professional equipment at a partial saving in cost.

VACUUM-TUBE VOLTMETER

The electronic type, or vacuum-tube voltmeter of infinite impedance is the final instrument regarded by some as essential to the Service Man's shop.

The present standardized characteristics of this device are as follows:

Measures voltages over a wide range of frequencies, with practically infinite resistance in ohms per volt.

Measures from 0.1 to 16 volts in the ranges 0-1.2, 0-3, 0-6, 0-8, 0-12, 0-16.

Measures all a-v-c circuits without upsetting circuit conditions as all ranges have an input impedance equal to that of the tube, no resistance networks being used in the input circuit.

Measures gain-per-stage, in combination with a test oscillator, most efficiently.

Neon regulator bulbs are used to keep line fluctuations out of the meter circuit and to hold the plate and grid potentials constant. Usually the input

(Continued on page 699)

Consistent Leadership by

AMPERITE

achieves another new development...

THE ACOUSTIC COMPENSATOR (Pat. Pend.)

An exclusive Amperite feature, available in new Models RBHk (High Impedance) and RBMk (200 ohms)



PUSH UP TO INCREASE HIGHS
PUSH DOWN TO INCREASE LOWS

3 IMPORTANT USES

1. The Acoustic Compensator enables you to lower or raise the response of the microphone by the mere flip of the finger. Not a volume control—operation is similar in principle to the sliding panels in broadcast studios.
2. Makes the Velocity immediately adjustable to close talking or distant pickup.
3. Immediately adjustable to any room condition... or any type of job or occasion.

Increasing the quality, without increasing the price, is the keynote of the Amperite sales policy. In the new Amperite Velocity, with the Acoustic Compensator, the P.A. Industry has the last word in microphone perfection at a competitive price.

MODELS RBHk, RBMk, with acoustic compensator. Frequency range 40 to 11,000 CPS. Output, -65 db. Complete with switch, cable connector and 25' of cable. **\$42.00 LIST**

MODELS RBHn, RBMn, without acoustic compensator **\$42.00 LIST**

NEW! AMPERITE CONTACT MICROPHONE

A contact mike without distortion. Ideal for use on all string instruments. Flatters an ordinary fiddle by giving it the volume and depth of a "Strad"; makes a small piano sound like a "Grand". Unusual high output—can be used on radio sets.

No string changes, no drilling. Attached without tools. Operates with either high or low gain amplifiers. Frequency response, 40 to 9000 cps. Output, -40 db. 25' of cable.

MODEL KTH (Hi-imp); KTL (200 ohms).....\$22.00 LIST
KTH or KTL with foot-operated volume control...\$30.00 LIST

NEW! AMPERITE "HAND-I-MIKE"

The smallest velocity made... but has an output equal to larger types, -68 db. Frequency range 60 to 7500 cps. Excellent for close talking, and can be used as hand, desk, or stand microphone. Unusually rugged. Size of head, 1" x 3/4" x 2 3/4".

MODELS HDH (Hi-imp); HDL (200 oms); with switch, **\$22.00 LIST**

AN EXCELLENT VELOCITY AT \$22.00 LIST

P.A. Men, you do not have to sacrifice quality on a "low-cost" job. This fine velocity, built to Amperite standards, is excellent for both speech and music. Gives flat response without peaks over entire audible range. Reduces feedback. Frequency range 60 to 7500 cps. Output, -68 db. Unusually rugged, not affected by temperature, pressure or humidity. Triple shielded, fitted with shock absorber and swivel bracket.

MODEL RAH (Hi-imp.) with 12' of cable; MODEL RAL (200 ohms) with 8' of cable.....**ONLY \$22.00 LIST**

BROADCASTING STUDIOS, please note :

New Output, -56 db.

The new Amperite Studio Velocity, model SR80n, has -56 db. output, highest in studio velocities available today. The SR80n is now accepted as the finest microphone for studio and recording: (Two weeks' free trial to established studios). Frequency range 40 to 15000 CPS. Triple shielded, fitted with switch (optional), cable connector, and 25' of cable. MODEL SR80Hn (Hi-imp.); SR80n (200 ohms).....\$80.00 LIST

SALES AIDS FOR THE P.A. MAN

Amperite offers the following co-operation to P.A. Men

1. FREE: Window Decal advertising your Sound Service. Size 5 1/4 x 9 1/4, finished in 4 striking colors.
2. FREE: Window Display, 11x17.
3. Special Sound Equipment Letterheads. Samples and prices on request.

Write for these valuable sales helps, and new Illustrated Bulletins, today!



AMPERITE CO. 561 BROADWAY, N. Y. U. S. A. CABLE ADDRESS ALKEM. NEW YORK



VELOCITY AMPERITE MICROPHONES

General Data . . .

G. E. F-63, F-65, F-66

THESE MODELS ARE SIX-TUBE super-heterodynes employing the circuit shown in Fig. 1. Two bands cover the frequency range from 540 to 1750 kc and from 2.2 to 7.0 mc. A tuning ratio of 8 to 1 is provided. The average power consumption is 70 watts.

The Model F-63 is a long table model with a 6½-inch speaker. The Models F-65 and F-66 are consoles with 8- and 12-inch speakers, respectively.

Two and a half watts of undistorted output are available from all models with a maximum of 5 watts. Electrodynamic speakers with a voice-coil impedance of 5.5 ohms (at 400 cycles) are used.

Tube types, functions and the various voltages encountered on the socket prongs are lettered on the diagram (Fig. 1). These voltages were measured with a 1000-ohm-per-volt voltmeter, with the dial at 530 kc and no signal input. The line voltage was 120 volts during the measurements.

ALIGNMENT PROCEDURE

An output indicating device should be connected across the primary of the speaker transformer or across the voice coil. The various r-f and i-f trimmers

should be adjusted for a maximum indication on the device. The wave-trap trimmer (C-2) should be adjusted for minimum output.

Throughout the alignment procedure the volume control on the receiver should be on full and, as the stages are brought into alignment, the signal generator output should be kept low by means of the attenuator provided. The

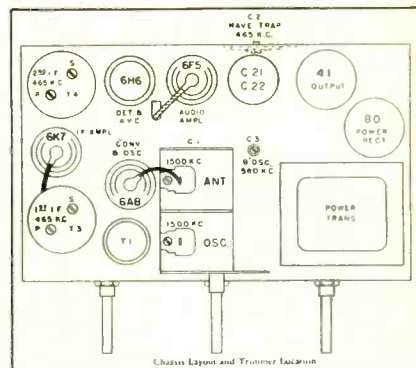

Fig. 2. Chassis layout and trimmer location.

G. E. F-63, F-65, F-66 ALIGNMENT OPERATIONS

Generator Connection	Dummy	Generator Frequency	Band Switch	Dial	Trimmer	Peak
I-F ALIGNMENT						
6K7 Grid	0.05 mfd	465 kc	Band B	Open	C-10, C-9	Second i-f
6A8 Grid	0.05 mfd	465 kc	Band B	Open	C-7, C-6	First i-f
Antenna	250 mmfd 400 ohms	465 kc	Band B	Open	C-2	Wave trap
R-F ALIGNMENT						
Antenna	250 mmfd & 400 ohms	1500 kc	Band B	1500 kc ¹	Gang cond trimmers	Osc and ant
Antenna	250 mmfd & 400 ohms	580 kc	Band B	580 kc	C-3	Padder
Antenna	250 mmfd & 400 ohms	1500 kc	Band B	1500 kc ¹	Gang cond trimmers	Repeat

Adjust dial pointer to first line at left end of tuning scale with the plates fully meshed.

Check the output at various points on the dial for the C band. There are no adjustments on this band.

¹Tune receiver to signal.

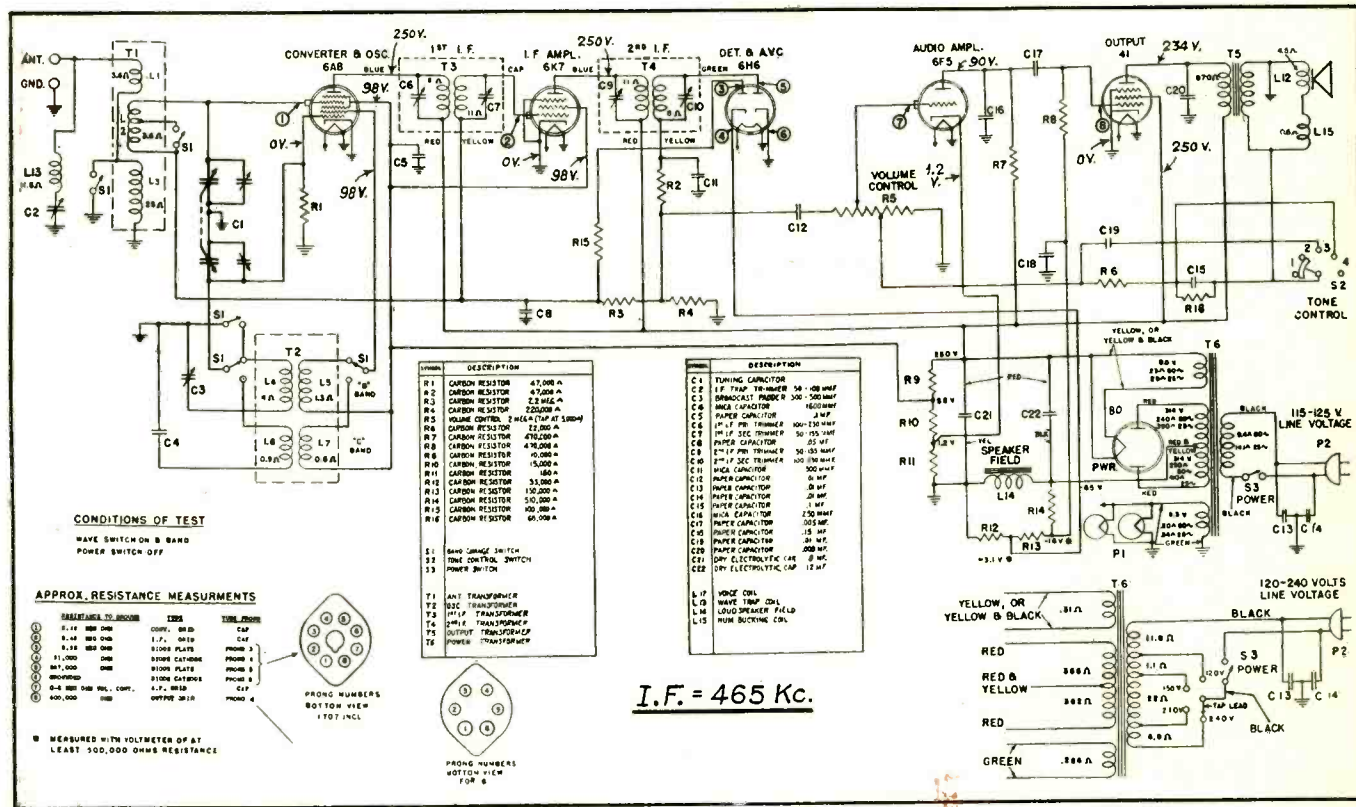

Fig. 1. G.E. F-63, F-65, F-66 circuit diagram.

Technical Features of 1938 Sparton Radio Receivers ...																							
Model No.	518	558-B	558-C	568	528-2	588-2	538	628	668	678	608	608-B	638-B	688-6	768	778	968	1068	1078	1268	1288-P	1568	
Cabinet *	T	T	T†	Ce	T	Ce	T	T	Ce	Ce	T	T	T	Ce	Ce	Ce	Ce	Ce	Ce	Ce	Ce	Ce	
Bands	2		2			3			3			1	2		3		3		3		3		
Range (Kc.)	535-1730 5850-18,900		535-1730 5850-18,900			535-17,000			535-17,000			535-1710		540-1650 5758-18,100		540-16,500		540-18,500		540-18,500		540-18,500	
I.F. Peak	456		456			456			456			456		456		456		456		456		456	
Power Supply	A.C.		A.C.			A.C.			A.C.			A.C.-D.C.		6V.		A.C.		A.C.		A.C.		A.C.	
Drain (Watts)	60		60			60			60			50		65		90		85		110		155	
Speaker	6"	-	6"	8"	6"	6"	6"	8"	10"	10"	5"	8"	8"	10"	10"	10"	10"	10"	10"	12"	12"	12"	
Field Res.	1500		1500			1500			1500			500		1000		1000		1000		600		-	
Tone Control °	1 Meg.		1 Meg.			1 Meg.			1 Meg.			500,000s		1 Meg.		500,000s		500,000s		1 Meg.		-	
Volume Control °	500,000		500,000			500,000			500,000			500,000s		250,000		250,000		250,000		1 Meg. †		-	
Wave Trap	Yes		Yes			Yes			Yes			Yes		Yes		Yes		Yes		Yes		Yes	
Doublet Conn.	/																						
Selectronne	/																						
Tuning Eye	/																						
R.F.	/																						
1st. Det.	/																						
Osc.	/																						
AFC Control	/																						
I.F.	/																						
AFC Discrim.	/																						
2nd. Det., AVC, 1st. Aud.	/																						
2nd. Aud.	/																						
Output	/																						
Rectifier	/																						
Expander	/																						
Expander Amp.	/																						
Ballast	/																						
	6A8G		6A8G			6A8G			6A8G			6A8G		1C7G		6A8G		6A8G		6A8G		6A8G	
	6K7G		6K7G			6K7G			6K7G			6K7G		6K7G		6K7G		6K7G		6K7G		6K7G	
	6Q7G		6Q7G			6Q7G			6Q7G			6Q7G		6Q7G		6Q7G		6Q7G		6Q7G		6Q7G	
	6F6G		6F6G			6F6G			6F6G			25L6G		6F6G		6F6G		6V6G		(2) 45		(2) 2A3	
	5Y3G		5Y3G			5Y3G			5Y3G			25Z6G		5Y3		5Y3		5Y3G		5Y3G		5Y3G	
	/		/			/			/			/		/		/		/		/		/	
	/		/			/			/			/		/		/		/		/		/	
	/		/			/			/			/		/		/		/		/		/	
	/		/			/			/			/		/		/		/		/		/	
	/		/			/			/			/		/		/		/		/		/	
	/		/			/			/			/		/		/		/		/		/	
	/		/			/			/			/		/		/		/		/		/	
	/		/			/			/			/		/		/		/		/		/	
	/		/			/			/			/		/		/		/		/		/	
	/		/			/			/			/		/		/		/		/		/	
	/		/			/			/			/		/		/		/		/		/	
	/		/			/			/			/		/		/		/		/		/	
	/		/			/			/			/		/		/		/		/		/	
	/		/			/			/			/		/		/		/		/		/	
	/		/			/			/			/		/		/		/		/		/	
	/		/			/			/			/		/		/		/		/		/	
	/		/			/			/			/		/		/		/		/		/	
	/		/			/			/			/		/		/		/		/		/	
	/		/			/			/			/		/		/		/		/		/	
	/		/			/			/			/		/		/		/		/		/	
	/		/			/			/			/		/		/		/		/		/	
	/		/			/			/			/		/		/		/		/		/	
	/		/			/			/			/		/		/		/		/		/	
	/		/			/			/			/		/		/		/		/		/	
	/		/			/			/			/		/		/		/		/		/	
	/		/			/			/			/		/		/		/		/		/	
	/		/			/			/			/		/		/		/		/		/	
	/		/			/			/			/		/		/		/		/		/	
	/		/			/			/			/		/		/		/		/		/	
	/		/			/			/			/		/		/		/		/		/	
	/		/			/			/			/		/		/		/		/		/	
	/		/			/			/			/		/		/		/		/		/	
	/		/			/			/			/		/		/		/		/		/	
	/		/			/			/			/		/		/		/		/		/	
	/		/			/			/			/		/		/		/		/		/	
	/		/			/			/			/		/		/		/		/		/	
	/		/			/			/			/		/		/		/		/		/	
	/		/			/			/			/		/		/		/		/		/	
	/		/			/			/			/		/		/		/		/		/	
	/		/			/			/			/		/		/		/		/		/	
	/		/			/			/			/		/		/		/		/		/	
	/		/			/			/			/		/		/		/		/		/	
	/		/			/			/			/		/		/		/		/		/	
	/		/			/			/			/		/		/		/		/		/	
	/		/			/			/			/		/		/		/		/		/	
	/		/			/			/			/		/		/		/		/		/	
	/		/			/			/			/		/		/		/		/		/	
	/		/			/			/			/		/		/		/		/		/	
	/		/			/			/			/		/		/		/		/		/	
	/		/			/			/			/		/		/		/		/		/	
	/		/			/			/			/		/		/		/		/		/	
	/		/			/			/			/		/		/		/		/		/	
	/		/			/			/			/		/		/		/		/		/	
	/		/			/			/			/		/		/		/		/		/	
	/		/			/			/			/		/		/		/		/		/	
	/		/			/			/			/		/		/		/		/		/	
	/		/			/			/			/		/		/		/		/		/	
	/		/			/			/			/		/		/		/		/		/	
	/		/			/			/			/		/		/		/		/		/	
	/		/			/			/			/		/		/		/		/		/	
	/		/			/			/			/		/		/		/		/		/	
	/		/			/			/			/		/		/		/		/		/	
	/		/			/			/			/		/		/		/		/		/	
	/		/			/			/			/		/		/		/		/		/	
	/		/			/			/			/		/		/		/		/		/	
	/		/			/			/			/		/		/		/		/		/	
	/		/			/			/			/		/		/		/		/		/	
	/		/			/			/			/		/		/		/		/		/	
	/		/			/			/			/		/		/		/		/		/	
	/		/			/			/			/		/		/		/		/		/	
	/		/			/			/			/		/		/		/		/		/	
	/		/			/			/			/		/		/		/		/		/	
	/		/			/			/			/		/		/		/		/		/	
	/		/			/			/			/		/		/		/		/		/	
	/		/			/			/			/		/		/		/		/		/	
	/		/			/			/			/		/		/		/		/		/	
	/		/			/			/			/		/		/		/		/		/	
	/		/			/			/			/		/		/		/		/		/	
	/		/			/			/			/		/		/		/		/		/	
	/		/			/			/			/		/		/		/		/		/	
	/		/			/			/			/		/		/		/		/		/	
	/		/			/			/			/		/		/		/		/		/	
	/		/			/			/			/		/									

PIONEERS

IN THE DEVELOPMENT OF AUTO-RADIO TUBES

RAYTHEON pioneered the first outstanding tube developments that made home-like reception in auto-radios possible! Since then, Raytheon auto set tubes have been noted for their maximum life under adverse conditions — for their noiseless reception under extreme sensitivity! Raytheons, too, are especially designed and constructed for maximum life over the wide range of voltages in an automobile battery—to work efficiently in close proximity to each other—to withstand the jarring and pounding received on the roughest of roads.

It is almost impossible to find a modern auto-radio not using the latest Raytheon development—the OZ4 rectifier! This fact is a universal tribute to Raytheon engineering. These are the reasons why more auto-radio manufacturers use Raytheon than any other tube —and why almost all servicemen use them as replacements.

RAYTHEON

445 Lake Shore Drive, Chicago, Ill. 420 Lexington Ave., New York, N.Y.
55 Chapel Street, Newton, Mass. 555 Howard St., San Francisco, Cal.
415 Peachtree Street, N. E., Atlanta, Ga.

FOR BETTER RECEPTION

VOLUME VIII—JUST OFF THE PRESS



The Extra Features make VOL. VIII RIDER MANUAL An Even Greater Value . . .

In the manufacture of receiving sets—in the publishing business—yes, even in the servicing of radio sets, it's the extra services which put some businesses far above and away out in front of competition.

Today's radio sets are far more complicated than those of three years ago, especially in the construction outside of the radio circuit itself. Such things as motorized tuning, automatic frequency control and other standard improvements require information you must have if you are to be in a position to deliver the "extra" services which will get you the better—the more profitable business of your neighborhood.

So—this year with each copy of Volume VIII Rider Manual—with its 1650 pages full of circuit information on the sets of over a hundred manufacturers—there is supplied at no additional cost a section entitled "How It Works." This supplement is devoted to explanations of the electrical operations of the more complicated 1938 receivers and instruments.

Other needed information supplied by the Manual covers the installation and servicing of intercommunica-

tion systems, electronic musical instruments, and new P. A. amplifiers of all types.

To make all the facts of Volume VIII instantly available, the Index of about 118 pages covers all the information in all 8 volumes of Rider Manual.

And all this extra information is yours at no increase in price over last year's volume! Check your Rider Volumes and order any missing numbers today!

1. EXTRA PAGES—1650 pages of complete servicing data on 1937-38 home and auto receivers. Complete because everything is included that more than 100 manufacturers gave us. For **COMPLETENESS** and **COVERAGE**—there's none better than Rider's Volume VIII.

2. EXTRA SUPPLEMENT—"How It Works"—A 64-page special section of Rider's Volume VIII devoted to explanations of the electrical operations of the more complicated 1938 receivers and instruments . . . Principles and theory you need for profitable servicing.

3. EXTRA FACTS—Installation and servicing instructions for many types of intercommunication systems will be found in Rider's Volume VIII . . . Also servicing data on the electronic musical instruments (has never appeared in any other manual) . . . New Public Address Amplifiers of all types are included.

JOHN F. RIDER, Publisher
1440 BROADWAY
NEW YORK CITY

YOU NEED ALL 8
Rider
MANUALS

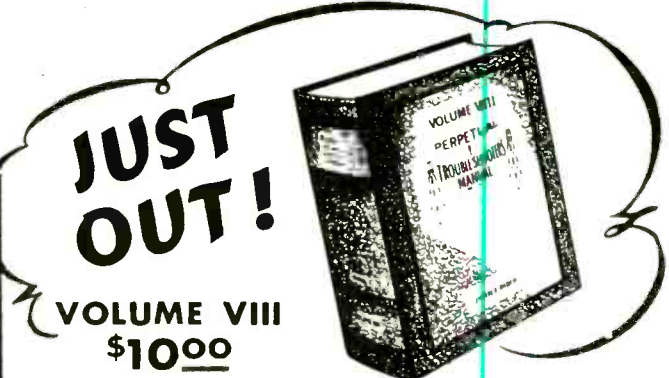

GENERAL DATA—continued

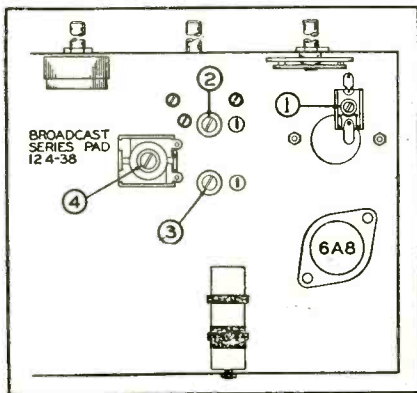

Underside of Belmont 588 chassis.

nmfd condenser and a 20-ohm resistor connected in series with each other and in series with the external signal generator. Dummy 3 used on the short-

BELMONT 588 ALIGNMENT OPERATIONS

Signal Generator Connection	Dummy	Signal Generator Frequency	Band Switch Setting	Dial Setting	Trimmer
6K7 Grid	No. 1	465 kc	Brdcst	1720 kc	Output i-f
6A8 Grid	No. 1	465 kc	Brdcst	1720 kc	Input i-f
<i>Repeat the i-f alignment.</i>					
Antenna	No. 3	6 mc	S-W	6 mc	On osc section of gang cond
Antenna	No. 3	6 mc	S-W	6 mc	No. 1
Antenna	No. 2	1720 kc	Brdcst	Open	No. 3
Antenna	No. 2	1400 kc	Brdcst	1400 kc ¹	No. 2
Antenna	No. 2	600 kc	Brdcst	600 kc ¹	No. 4 ²

Repeat the 1720 kc and 1400 kc adjustments. Check the sensitivity at 1400 kc, 1000 kc and 600 kc.

¹Tune receiver to signal.
²Rock the gang condenser through this adjustment.

wave band consists of a 0.1-mfd condenser and a 400-ohm resistor connected in series with each other and the external signal generator.

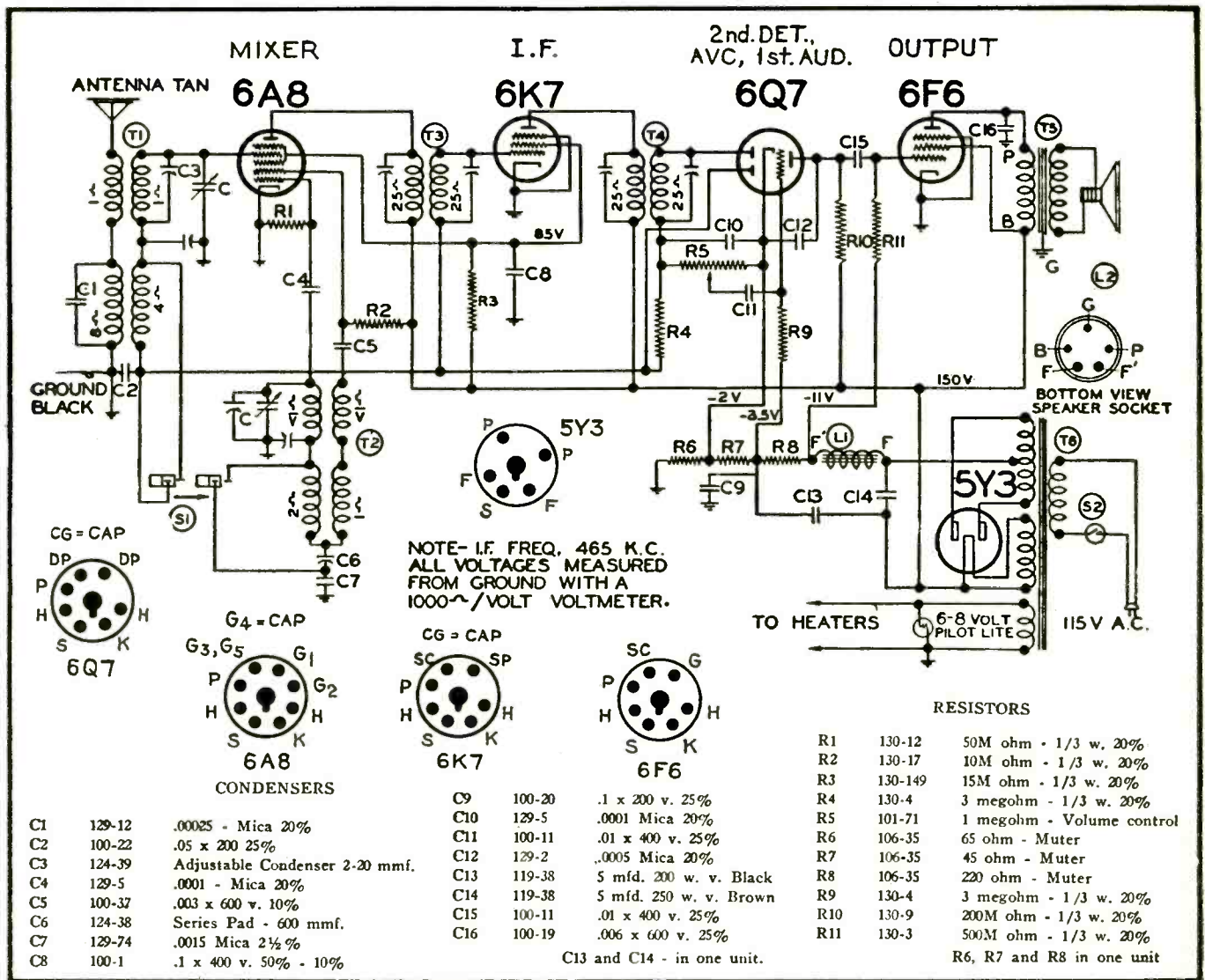

Belmont 588 schematic.

CAMPBELL'S

329 ADAMS AVENUE

SCRANTON, PA.

August, 7, 1937

Scranton Radio Supply Co.
809 Mulberry Street
Scranton, Pa.

Dear Mr. Mack:

May I take this opportunity to express to you my sincere appreciation for my outstanding success with Centralab products.

We consider quality of parts a major essential in rendering efficient radio service; we obtain this by using Centralab at no greater cost.

I have been, and am, consistently one hundred percent Centralab, and as I am conservative in my expressions, and having used hundreds of Centralab controls, resistors and switches, I highly recommend the use of Centralab products to other radio service men.

Yours sincerely,

J. Campbell
RADIONEER



MR. J. F. CAMPBELL
Radiioneer of Scranton, Pa.

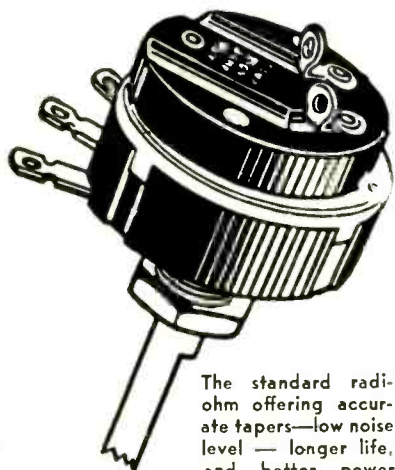

The standard radio control offering accurate tapers—low noise level — longer life, and better power dissipation.

Servicemen . . . jobbers . . . experimenters . . . manufacturers . . . all voice a preference for the smooth, certain, satisfactory service that Centralab Controls offer. For "100%" satisfaction specify Centralab!

CENTRALAB—Division of Globe-Union Inc., Milwaukee, Wisc.

Centralab

BRITISH CENTRALAB, LTD.
Canterbury Rd., Kilburn, London N.W.6, England

FRENCH CENTRALAB CO.
118 Avenue Ledru-Rollin, Paris XI, France

'100%
Centralab'

*- thanks Scranton
Radio Supply Co.
for sending
this on!*

GENERAL DATA—continued

RCA 87EY, 87X, 87Y

THESE RECEIVERS EMPLOY a conventional 3-band, a-c, d-c superheterodyne circuit as shown in Fig. 1. The Model 87EY is an armchair model and the Model 87Y is a console, each employ a 12-inch permanent-magnet-dynamic speaker. The Model 87X is a chest-type table model employing a 6-inch permanent-magnet-dynamic speaker.

The tuning range from 530 to 22,000 kc is provided in 3-bands. A maximum power output of 3 watts is available from the Models 87EY and 87Y; from the 87X, 2.8 watts. The total power consumption on a-c is 55 watts. The impedance of the speaker voice coil at 400 cycles is 2.2 ohms.

Features of design include magnetite-core adjustments for i-f transformers

RCA 87 EY, 87X, 87Y ALIGNMENT OPERATIONS

Signal Generator Connection	Dummy Antenna	Signal Generator Frequency	Range Switch	Dial Setting	Adjustment	Circuit
I-F ALIGNMENT						
6K7 I-F Grid	0.001 mfd	460 kc	A Left	No signal	L8, L9	Second i-f
6A8 Det Grid	0.001 mfd	460 kc	A	550-1750 kc Same	L6, L7	First i-f
R-F ADJUSTMENT						
Antenna	300 ohms	20,000 kc	C Right	20,000 kc	C27	C osc
<i>Use the minimum capacity peak if two peaks can be found.</i>						
<i>After this adjustment check for the image signal by shifting the receiver dial to 19,080 kc.</i>						
Antenna	300 ohms	6000 kc	B Center	6000 kc	C30	B osc
<i>Use the minimum capacity peak if two peaks can be found.</i>						
Antenna	300 ohms	6000 kc	B	6000 kc	C8	B ant
Antenna	200 mmfd	600 kc	A Left	600 kc	L15	A L-F osc
Antenna	200 mmfd	1500 kc	A	1500 kc	C32	A H-F osc
Antenna	200 mmfd	600 kc	A	600 kc	L15	A L-F osc
Antenna	200 mmfd	1500 kc	A	1500 kc	C32	A H-F osc

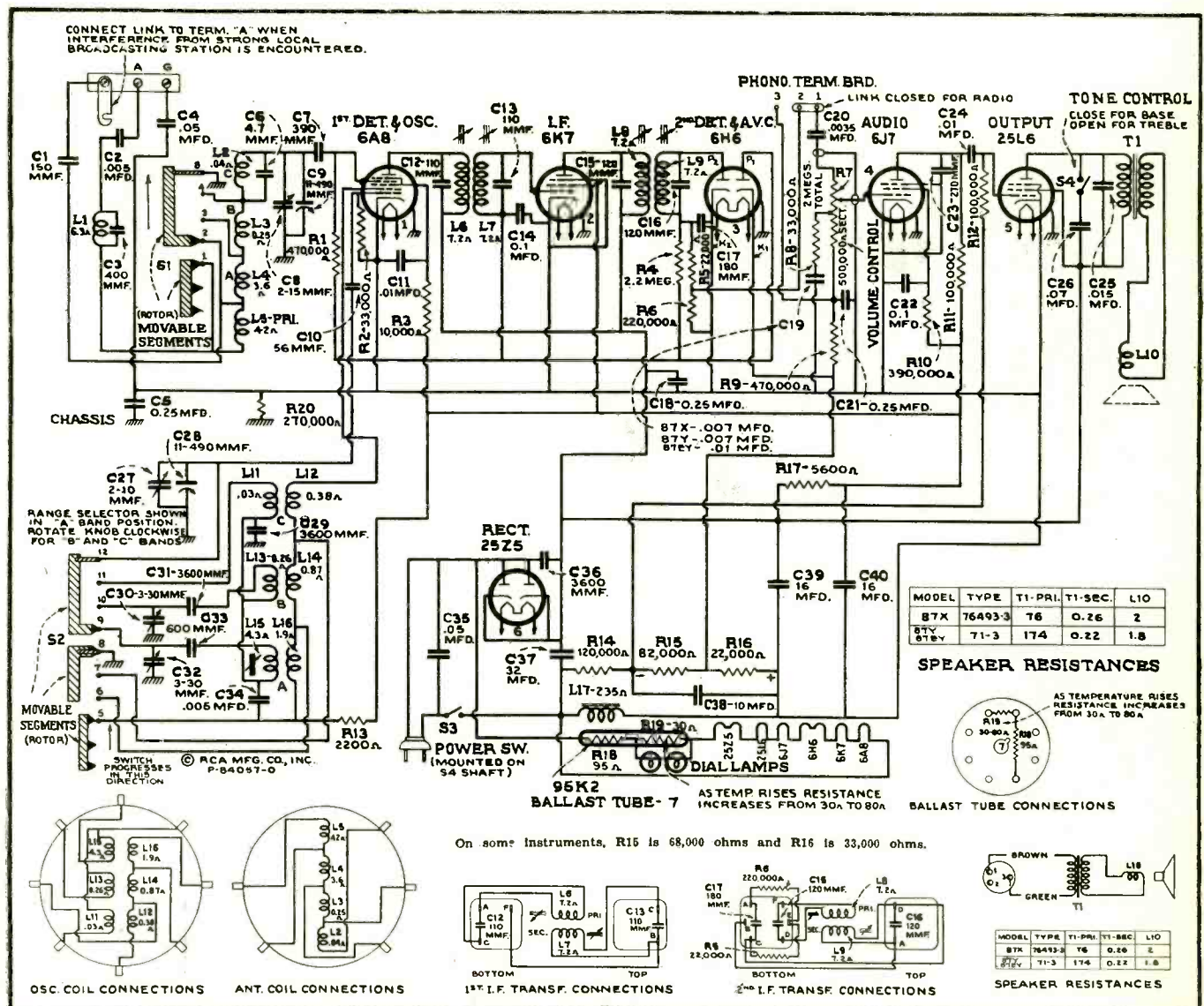

Fig. 1. RCA 87EY, 87X, 87Y circuit diagram.

GENERAL DATA—continued

and low frequency A-oscillator tracking; cumulative-wound antenna transformer for high signal-to-noise ratio; antenna wave-trap; full avc; phonograph terminal board; aural-compensated audio volume control; dust-proof permanent-

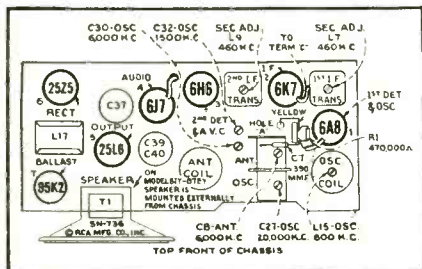

Fig. 2. RCA 87EY tube and trimmer locations.

magnet-dynamic speaker and a 20 to 1 ratio sunburst dial with band indicator and short-wave stations listed by name.

Caution: Avoid contact of grid caps, tuning condenser or other receiver component parts to external ground.

The various diagrams shown contain such information as will be needed to isolate causes for defective operation if such develops. The ratings of the resistors, capacitors, coils, etc., are indicated adjacent to the symbols signifying these parts on the diagrams. The coils, transformer windings, and reactors are rated in terms of d-c resistance to permit continuity checks.

LEAD DRESS

- (1) Dress power cord away from audio circuits.
- (2) Keep filament leads away from C24.
- (3) Keep bus lead from terminal 8 or S1-S2 to ground lance as short as possible.
- (4) Bus lead from terminal 12 of S1-S2 to C27-C28 thence to C10 should be $4\frac{5}{8}$ inches long.
- (5) Bus lead from terminal 4 of S1-S2 to L2-L3 should be $2\frac{1}{2}$ inches long.
- (6) Bus lead from L2 to C8-C9 should be $3\frac{3}{8}$ inches long and dressed over bus lead from antenna coil to range switch.
- (7) Bus lead from terminal 7 of S1-S2 to L12-L14 should be $2\frac{3}{4}$ inches long.
- (8) Keep bus lead from terminal E of second i-f transformer to terminal 2 on phono board as short as possible.
- (9) Keep leads of C10, C29, and C34 as short as possible. When replacing bus leads, use only wire having same diameter as original.

ALIGNMENT PROCEDURE

Calibrate the tuning dial by adjusting main dial pointer to the low-frequency (end) calibration mark on dial with the gang tuning-condenser plates in full-

(Continued on page 697)

ANNOUNCING

THE MOST SENSATIONAL P. A.
SALES PLAN EVER CONCEIVED

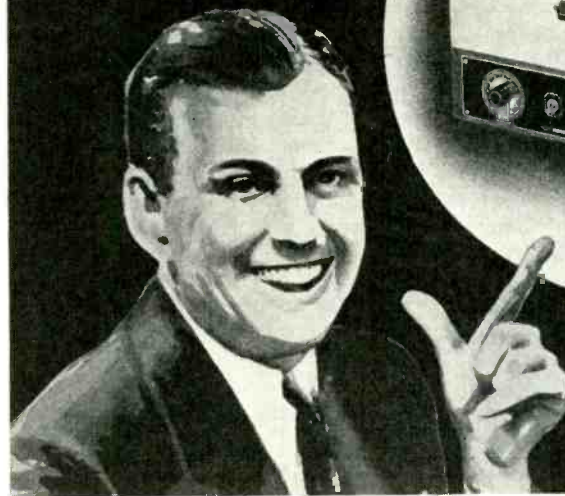

EXCLUSIVELY
FOR THE
SOUND
SPECIALIST

Transformer Corporation of America is extremely happy to announce formation of the CLARION INSTITUTE OF SOUND ENGINEERS — a nation-wide organization, designed to give the sound man a "BREAK" at last.

Here is just a sample of what C.I.S.E. is offering members:

1. C.I.S.E. enables you to buy sound equipment DIRECT FROM THE FACTORY.

2. As the official C.I.S.E. man in your territory, you enjoy a selected market. Only one C.I.S.E. representative will be appointed to a territory.

3. C.I.S.E. representative can enjoy the vast engineering and research facilities of the TRANSFORMER CORPORATION OF AMERICA free of charge.

4. An extensive advertising campaign —both trade paper and direct-mail,

will help sell a larger percentage of prospects called on.

5. C.I.S.E. enables you to sell sound the way it should be sold, the way it must be sold—with the sound specialist the BIG profit-maker. C.I.S.E. is the PROVEN METHOD of meeting competition in sound today.

6. As a recognized member of this MODERN ORGANIZATION, you can OUTSELL THE ENTIRE FIELD. But, membership is filling rapidly. Remember, only one representative to a territory. It may as well be YOU.

MAIL CONVENIENT COUPON IMMEDIATELY!

TRANSFORMER CORPORATION OF AMERICA

C.I.S.E.

CLARION INSTITUTE
OF SOUND ENGINEERS
69 WOOSTER ST., N.Y.C.

CLARION INSTITUTE OF SOUND ENGINEERS
69 WOOSTER STREET, NEW YORK CITY

Please send me an application form immediately. I want to belong. This, in no way obligates me, of course. S-11

Name

Address

City State

Auto-Radio . . .

VOLUME CONTROL INSTALLATION

By W. H. FRITZ*

EVERY MANUFACTURER of replacement radio parts dreams of a perfect replacement unit—a transformer, condenser, resistor, switch, vibrator, or volume control so designed that it will take the place of any similar defective original unit. The perfect replacement unit would be so designed that both physical dimensions and electrical characteristics of the original unit would be met. It is absurd to even dream of this ideal single replacement unit. Physical dimensions and electrical characteristics vary so widely, even in receivers made during the same year by the same manufacturer, that different replacement units in a given classification are required. It is of course possible to analyze the entire field of replacement requirements for volume controls, for example, and by standardizing on a definite number of resistance values, resistance tapers, and shaft dimensions, it is possible to offer a group of ten or fifteen controls to handle two or three thousand different radio receiver models. In this way the ideal replacement is approached, but like a desert mirage, is never reached. At best, a group of replacement controls is required to replace volume controls in a typical group of assorted radio receivers.

Auto receiver volume controls are an excellent example of a special group of units that have proved difficult to replace with anything but exact duplicates in the past. To show why this has been the case, we shall enumerate some of the peculiarities of this particular group.

METHODS OF CONTROL

In the first place, auto radio receivers are usually controlled from a re-

*Centralab.

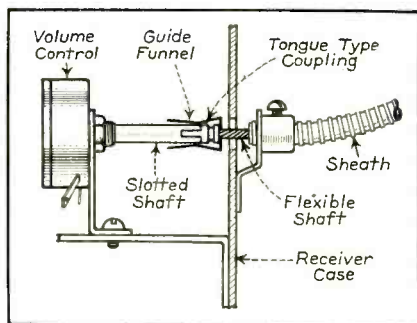

Fig. 1. Assembly of control and coupling.

mote position. The receiver proper is mounted on the bulkhead between the instrument panel and the motor compartment, while the control head is situated on the steering column, under the instrument panel, or in the instrument panel. Flexible shafts couple the volume control and tuning knobs to their respective shafts in the receiver chassis. To facilitate installation, semi-rigid, easily separable coupling devices are used on the volume control and variable tuning condenser. The usual type of coupling used with volume control shafts consists

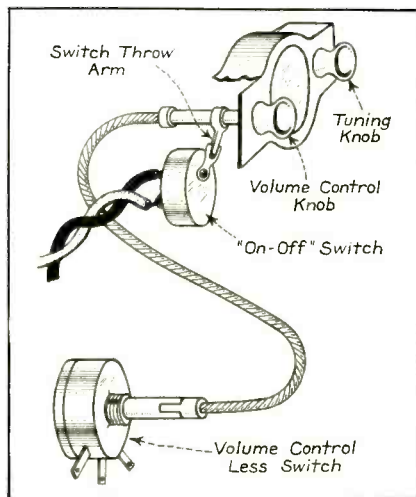

Fig. 2. The remotely-controlled switch.

of a slotted shaft on the volume control in which is fitted a tongue-shaped coupling that is in turn staked on the flexible control shaft. Fig. 1 shows a typical method of assembling these parts. Note that a guide funnel is slipped over the slotted shaft so that the flexible shafts can be attached without removing the receiver cover. This method, with slight variations, is universally used with auto receiver volume controls.

THE "ON-OFF" SWITCH

In the earliest types of auto receivers, it was almost universal practice to mount the "on-off" switch on the volume control, adjusted to turn off the radio when the volume control knob was in the most counter-clockwise position. In modern receivers, for the purpose of eliminating interference the "on-off" switch is located in the remote

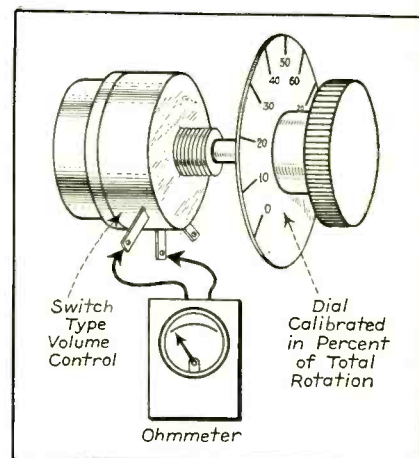

Fig. 3. Test setup for controls and switches.

control head, while the volume control remains in the receiver box. It is desirable to have the receiver turned off when the volume control knob is turned to its most counter-clockwise position, so to accomplish this, a switch throw arm is included on the volume control shaft in the remote control head. The arm is so positioned in relation to the switch throw lever that the switch is actuated when the knob is rotated to the counter-clockwise end of rotation. The mechanical layout of this arrangement is pictorially shown in Fig. 2. With an arrangement like this, accurate synchronization between the switch and volume control action is very essential, for the switch must throw "on" and "off" exactly like it would if it were mounted directly on the control.

Consider, for a moment, the relation between switch action and rotation in a conventional switch-type volume control. Fig. 3 shows a test set-up for checking this relationship. Here a switch-type volume control is rotated by a pointer knob that expresses the degrees clockwise rotation of the resistance contact button as a percentage of the total degrees rotation. For example, if a control has a total rotation of 300 degrees and the contact button happens to be set at 120 degrees from the counter-clockwise position, the dial would read "40% rotation." If we check the resistance between the left and center terminals as shown, and plot the resistance measured as a function of the control rotation, we arrive at a curve similar to that illustrated in Fig. 4. This illustrates the popular semi-log taper universally used in modern audio-grid types of volume control. It is of course necessary that receiver volume be reduced to the minimum value before the switch turns the set off. This means that the resistance curve should remain flat and be very nearly zero in that portion of rotation required to throw the switch. In Fig. 5 the percent of rotation

6 REASONS WHY SUPREME



Model 546 3" Cathode Ray Oscilloscope
\$6.50 down—\$5.95 for 10 months. Cash Price \$59.95

VISUAL SERVICING will increase YOUR profits!



Model 581 Signal Generator
\$6.00 down—\$5.44 for 10 months on S.I.C. terms. Cash Price \$54.95

ALL visual servicing is not alike! That's why you should demand proof of its accuracy and profit-making ability—before you buy! Shown here are six profitable short-cuts that not only allow you to do service work *more quickly*, but *more efficiently*! They are only a few of the many dozens of uses to which you can place your Supreme Model 581 Signal Generator and your Supreme Model 546 3" Cathode Ray Oscilloscope—the perfect instrument combination for Visual Servicing because they were *both designed to work together!*

Check the features of the Supreme 581 Signal Generator and Frequency Modulator: Razor-Edge *Shadow Tuning*—Giant 340 degree dial—38 to 1 knob to condenser ratio—actual 8 feet long scale length—125 KC to 60 MC on 8 bands—can be used as (1) Unmodulated RF oscillator (2) 400 cycle—30% amplitude modulated RF oscillator (3) 24 KC fixed band width frequency modulated RF oscillator (for visual alignment) (4) Externally amplitude modulated RF oscillator (5) Fixed 400 cycle AF oscillator (6) Variable 60 to 10,000 cycle AF oscillator (7) Power supply frequency time base for scope.

Check the features of the Model 546: 3" Cathode Ray Oscilloscope:—(1) Lowest price complete 3" tube scope (2) 0 to 90,000 cycle linear vertical and horizontal gain controlled amplifiers (3) 15 to 30,000 cycle saw toothed linear time base (4) "Snap Lock" Synchronization circuit (5) Internal or external synchronization circuit (6) All controls including "Spot Centerers" on panel (7) D.C. or A.C. signal can be fed direct to deflecting plates.

For the utmost in high precision, low cost, latest design and complete satisfaction, see SUPREME before you buy!

Combination Offer! Model 546 3" Oscilloscope, Plus Model 581 Signal Generator, Only \$11.50 down—\$9.48 per month for 12 months.

Sold on Supreme S.I.C. Terms—the world's easiest installment terms!

SUPREME INSTRUMENTS CORP.
Greenwood, Miss., U. S. A.

Export Dept., Associated Exporters Co., 145 W. 45th St., New York City • Cable Address: Lopreh, New York

HERE ARE THE 6 REASONS!

- 1. Visual Alignment—**

Only by using this type equipment can R. F. and I. F. circuits on modern, high fidelity receivers be properly aligned.
- 2. Audio Response—**

Only by using this type equipment can over-all audio response and "stage-by-stage" analysis measurements be made quickly and accurately in both receivers and P.A. or theater amplifiers.
- 3. Hum Check—**

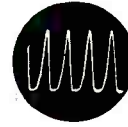
Only by using this type equipment can objectionable hum be quickly traced and eliminated.
- 4. A.F. Amplifier Overload—**

Only by using this type equipment can audio frequency distortion caused by overload or phase shift be located and corrected.
- 5. I.F. Amplifier Overload—**

Only by using this type equipment can I.F. overload with resulting A.F. signal distortion be found and removed.
- 6. Demodulator Distortion—**

Only by using this type equipment can Demodulator Output Waveforms be checked and distortion or possible presence of R.F. be located.

required to throw the switch is indicated by the dimension "A." If this flat portion on the resistance strip did not exist, minimum volume could not be reached, for the switch would throw "off" before the minimum audible level was reached. Auto receiver controls similar to the one illustrated in Fig. 3 must be supplied with a resistance strip that has a flat portion with no resistance change over 15% rotation at the counter-clockwise end of rotation. This is the same type of resistance element that is used in standard switch-type controls.

CONTROL AND SWITCH ACTION

To permit ready synchronization of control and switch action, when the two are separated, plain auto radio controls are supplied with a "slip clutch." A shaft and contact button assembly of this type are roughly sketched in Fig. 5. As noted, the shaft will rotate after the contact button has stopped, if additional torque is supplied. The torque required to rotate the shaft against the friction of the clutch is of the order of ten or twelve inch-pounds. This torque

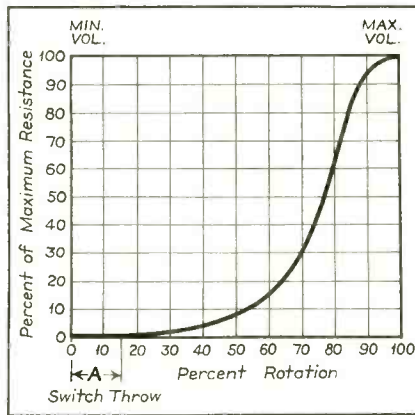

Fig. 4. Calibration curve.

requirement is high enough to give the knob a positive "stop" feel when the button comes to rest, but is not so great that the knob and shaft cannot be rotated beyond the normal limiting stop. A friction drive of this type eliminates difficulties in lining up switch and control action. If the slip-clutch were not used, the control shaft slot would have to be carefully located, or a set screw

positioning arrangement could be used. Either of these arrangements is costly and increases the difficulty of assembly. The separation of the switch from the control necessitates the friction clutch assembly and special resistor elements.

TAPPED CONTROLS

Another factor in deciding whether or not a universal replacement for auto radios can be designed is whether or not the original control incorporates a tone compensation tap on the resistance element. Many late model receivers include this feature. Schematically, most tone compensating volume control circuits are similar to Fig. 6. A tap, D, is located on the resistance element, usually at about 50 per cent of the total rotation. The resistance between the tap and ground, or between D and A in Fig. 6, is usually between 20 and 30 per cent of the total resistance measured between A and C. The effect of the resistor-condenser network between tap D and ground is a flattening out of the audio-frequency response curve. Low-fre-

IMPROVED UP-TO-THE-MINUTE 1937-38 TUBE TESTER



READRITE METER WORKS
1117 College Dr.
Bluffton, Ohio

Please send me more information on Model 430 Model 431

Name
Address
City State

Model 430
DEALER PRICE
\$19.80

Only
\$1980
for this TUBE TESTER

Positively Checks All Type Radio Tubes According to Latest Recommendations of Tube Engineers.

- Has Line Voltage Adjustment
- Has Leakage and Short Test
- Uses Triplett Direct Reading Instrument (GOOD-BAD) Scale

Five flush type sockets provide for all tubes. The tester operation is very simple and indicates condition of the tube for dealer and customer on Direct Reading (GOOD-BAD) colored scale of Triplett instrument. Will also test for inter-element shorts and leakages. Complete in attractive, sturdy, quartered-oak case. Sloping etched panel of silver and black. Suitable for portable or counter use.

Model 431 same as 430 except has Readrite (GOOD-BAD) Meter

Dealer Price \$15.90
See Your Jobber Write for Catalog

A MODIFIED EMISSION TYPE TESTER . . APPROVED CIRCUIT

AUTO-RADIO—continued

quency response is made more apparent by reducing the response to medium and high audio frequencies at low volume. Provision for this feature should be made in designing a universal auto replacement control.

SHAFT CONSIDERATIONS

The final special feature found in auto volume controls is the shaft design. As pointed out previously, the shaft must be so designed that it is readily detachable from the flexible remote control shaft and yet offer a positive method of transmitting torque, or rotational force. Usually this is accomplished by slotting the volume control shaft and providing a tongue-shaped coupling on the end of the flexible shaft to fit the slot. Occasionally the process is reversed in that the flexible shaft coupling is slotted and the volume control shaft is tongue-shaped; the net result is the same in either case. The shaft on a universal replacement control must

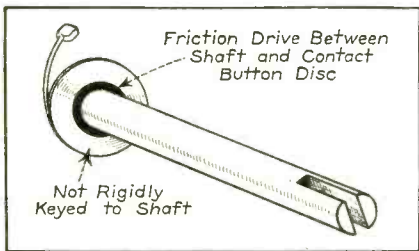

Fig. 5. Shaft detail.

be designed to accommodate either type of flexible shaft fitting.

Most auto receivers are designed with a minimum of waste space. A glimpse inside any late model will be most convincing in this regard. Because of space requirements, most auto receivers now use midget type volume controls. In many cases only a midget will replace the original, for while there is only about one-half inch difference in diameter between standard and midget size controls, receivers are built around the smaller units and only a midget replacement will fit the space provided. The physical dimensions of a universal replacement should be small enough to agree with all original controls now supplied to auto radio manufacturers.

To sum up, a satisfactory universal auto replacement control must have satisfactory electrical characteristics and be designed mechanically so that original controls can be replaced with a minimum of effort. This means that plain controls should be equipped with a slip-clutch shaft and both plain and

21

MODELS

OF Peri-

Dynamic

REPRODUCERS

- Every centralized sound job seems to require specially designed speakers and cabinets—but here is a complete line, the only complete line, already prepared by Jensen; for schools, hotels, hospitals, auditoriums and like uses.
- Speaker sizes range from 8 to 18 inches.
- For wall installation—Flush, Semi-Flush and Surface Mounting Styles.
- For Stage and Floor—Beautiful Cabinets, Imperial Models and more simple designs.
- Some models for voice reproduction only—many models incorporate *Bass Reflex*.
- Prices range from \$12.90 to \$310.00 complete with speakers.

Illustrating a Few of the 21 Models

MODEL 400C
With 12" Speaker; Surface or Floor Mounting; with Bass Reflex

MODEL 3000
With 8" Speaker; Surface or Desk Mounting

MODEL 2000
With 8" Speaker; Flush Mounting

MODEL 1001
For 8" Speaker; Semi-Flush Mounting

MODEL KM-10
For 10" Speaker Kit Model with Bass Reflex

MODEL D
With Dual Speakers and Bass Reflex

JENSEN RADIO MANUFACTURING CO.
6601 So. Laramie Avenue, Chicago, Ill. S-1137

... Please send new 8-page Catalogue describing 21 Jensen Peri-Dynamic Reproducers.

Name

Address

City State



It's the No. 1 CRYSTAL MICROPHONE

"Ultra" Wide-Range Response with High Output Level and Extra-Dependability.

There's nothing to compare with ULTRA 700A. It gives you remarkably accurate "ultra" wide-range response from 30 to 10,000 cycles, with a high output level. It gives you exclusive built-in features that insure more dependable service. It gives you the finest performance available today in general-purpose crystal microphones, at a cost far below its performance level.

Just try Shure ULTRA 700A. Find out for yourself why it has been adopted as standard equipment by eminent sound engineers and nationally-known sound-equipment manufacturers.

Model 700A. Swivel-Type. List Price, complete with 7 ft. cable..... **\$25**

Also available in Grille-Type and Spherical Models.



TRY the ZEPHYR—now!

Improved wide-range response gives finer, more faithful reproduction—makes records sound better. "Balanced-Tracking" reduces record wear—makes records last longer. High output level (3 volts at 1000 cycles).

Model 99B. Shure Zephyr Crystal Pickup. List Price..... **\$12**

Specially designed Arm Rest available at 50c list additional.

Get the Facts from Your Jobber, or Write for Bulletin 1445.

Shure patents pending. Licensed under patents of the Brush Development Company.



AUTO RADIO—continued

switch-type units should have a shaft readily adaptable to special flexible shaft fittings. Finally, the physical overall size of the replacement must satisfy the space requirements. Fig. 7 shows a photograph of a replacement control that is said to fulfill all of the requirements listed above.

There should be little difficulty found in installing ordinary switch type controls. The special type of assembly illustrated in Fig. 2 does warrant further discussion, however. In installing a control of this type, first cut off the replacement control shaft and insert to conform to the original shaft dimen-

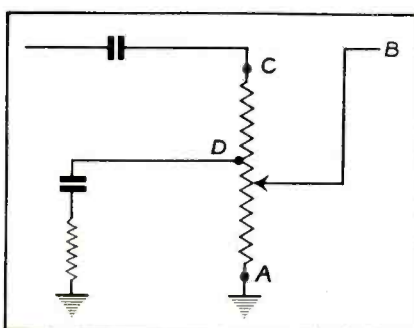

Fig. 6. Tone compensated volume control.

sions. Mount the replacement in the receiver chassis and solder the wires to their respective terminals. If the original circuit includes a tone compensation network, connect the wire from this circuit to the resistance tap. If no tone compensation is included, this terminal is disregarded—it can be cut off, if care is used. Then the flexible shaft fitting should be slid into position, so that rotation of the volume control knob rotates the volume control itself. Next, the volume control knob should

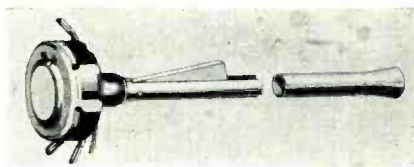

Fig. 7. A modern auto-radio control.

be rotated to the extreme clockwise position. To be sure that the volume control is in the most clockwise position, rotate the knob slightly beyond the point where rotation of the volume control contact button stops. Then rotate the volume control knob to the counterclockwise end of rotation, where the switch throws "off." The control is now properly synchronized with the switch action.

NEW BIRNBACH Self-Selling WIRE ASSORTMENT DISPLAY

It's a sensation! Birnbach leads again with this self-selling display. Attractive metal spools, including Pushback, Hookup, Colored Rubber, Leadin, Fixture, Lamp Wire, etc. To resell at 39c.



MAGNET WIRE ASSORTMENT

On metal spools. Even sizes from 14 to 40, inclusive. Double Cotton, Plain Enamel, Double Silk. To resell at 25c. each.

FREE Multicolored DISPLAY

One display given with each initial order for 100 spools. Display made of reinforced steel, mahogany crackle finish with attractive 3-color display. Your jobber can supply you, or write to us direct. Dept. S-10.

NEW FREE CATALOG.
Just off the press. Send for your copy.

BIRNBACH RADIO CO.
145 HUDSON ST. BIRCO NEW YORK, N. Y.

CINAUDAGRAPH

Speaker

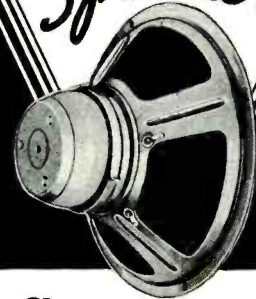

CINAUDAGRAPH Magic Magnet Speakers

—extensively utilized by all leading radio receiver and P. A. equipment manufacturers—are available in a complete range of sizes from 5½ to 18 inches, to meet your every radio requirement.

If you demand utmost dependability and fidelity of reproduction from your equipment—in-sist on Cinaudagraph P. M. speakers. Carried in stock by all progressive distributors. Free descriptive literature on request.



**CINAUDAGRAPH
CORPORATION**
Speaker Division • Stamford, Conn.

Get the "Inside Story" before you buy any instrument!



WESTON Model 775 Serviset, which consists of Model 772 (20,000 ohms-per-volt) Analyzer—and Model 773 Tube Checker.

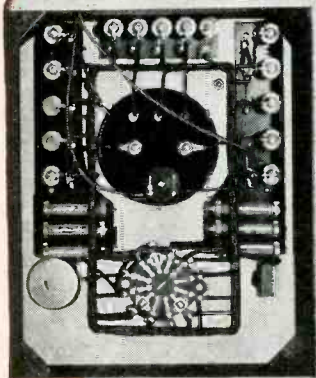

An inside view of the Serviset...above, Model 772...below, Model 773.

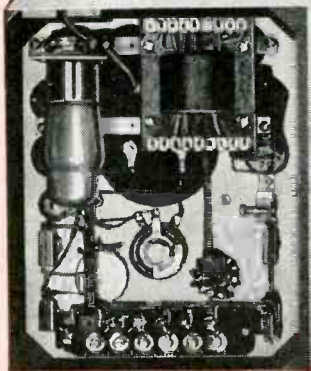

Buy instruments as you would buy a radio set. See what's inside! Examine the quality of every single part. Carefully inspect the workmanship. Check the fundamental design. These are the factors which determine the accuracy, dependability and service life of an instrument . . . and should be your guide when buying any test equipment.

After checking the inside of the two WESTONS shown above in the combination case . . . instruments also sold singly . . . remember that these instruments give you the following outstanding operating features:

**MODEL 772
Analyzer**

All AC readings on single AC are Simplified, easy reading scale . Decibel readings for sound measurement . Current ranges for auto testing . New rectifier circuit . Improved accuracy . Improved temperature coefficient . Big 50 microampere WESTON meter . . .

**MODEL 773
Tube Checker**

Individual emission test, each element . Individual short test, each element . Noise test, each element . Cathode leakage test . Short test while tubes are hot . Tubes tested under proper load . Wired for changing filaments . Flexible switching arrangement defeats obsolescence.

Send coupon for complete details

WESTON
Radio Instruments

WESTON ELECTRICAL INSTRUMENT CORPORATION
604 Frelinghuysen Avenue, Newark, N. J.

Send full data on all Radio Instruments

Name _____

Address _____

City _____ State _____

The pendulum swings again for **1938 CARS**

AGAIN CROWE LEADS with new Panel Mounting Kits for 1938 cars! Official styling! Attractive escutcheons! Softly illuminated dials! Colored knobs! All blending with instrument panel of car. Airplane and drum-type dials. Crowe Interchangeable Controls and Shafts make auto radios adaptable to any car. Re-installation simply by changing Panel Mounting Kit. Get complete details!

ASK FOR SUPPLEMENT 204 AND BULLETIN 202

PHILCO DEALERS!

Crowe-Philco program increases sale of Philco auto radios. Stock Crowe Panel Mounting Kits. Ask for Supplement 204 and Bulletin 201!

CROWE ANNOUNCES NEW PANEL MOUNTING KITS
CROWE CUSTOM-BUILT

Manufacturers! Crowe Method of Distribution reduces inventory—improves service—standardizes prices—simplifies selling—stabilizes profits. Write for details.

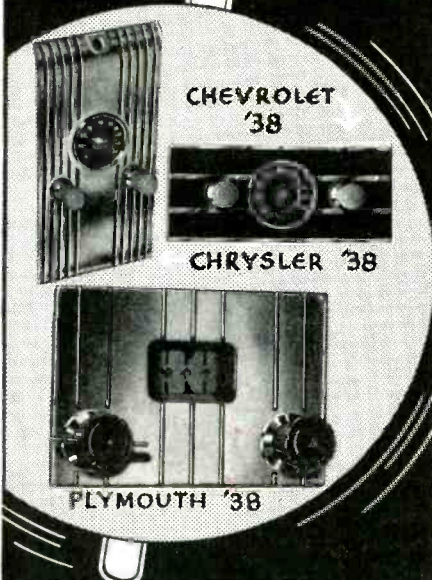

CROWE NAME PLATE & MFG. CO.
1775 Grace Street
CHICAGO, ILL.

CRYSTAL PICKUP

(See Front Cover)

THE CIRCUIT DIAGRAM shown on the front cover is that of the phonograph unit incorporated in the RCA Victor Model U-107 receiver. The receiver itself is a ten-tube, three-band, a-c operated superheterodyne. The audio system, into which the phonograph unit works, employs a phase-inverting voltage amplifier to drive push-pull 6F6's; the phase inverter tube is a 6N7. Tone control is accomplished in the plate circuits of the power-amplifier tubes.

The phonograph unit is provided with an automatic record changer which, in the Model U-107, handles eight 10-inch or seven 12-inch records. As indicated by various symbols on the front-cover diagram, the radio-phonograph is available for operation, at various voltages, on frequencies of 25, 50, or 60 cycles. Since different supply frequencies would affect the speed of the phonograph motor, provision is made to compensate for this (in manufacture) by the use of a resistance-capacity network in the motor circuit.

As will be seen on the cover diagram, the pickup is of the crystal type, feeding through voltage-adjusting and compensating networks directly into the phase inverter (assuming, of course, that the radio-phonograph switch is in the "phonograph" position). The purpose of the network is two-fold—it permits adjustment of the output voltage of the crystal pickup to a value which will insure against overloading the input of the phase inverter regardless of how much the user may advance the phonograph volume control. Aural compensation of the pickup output is accomplished by means of the network of resistances and condensers which are shunted across the pickup. These resistance-capacity compensators tend to maintain low-frequency response when the phonograph is operated at low volume. It is interesting to note that the supply-line frequency governs the choice of values of some of the components of the voltage-adjusting and compensating networks, i.e., the low-frequency response is further curtailed when the set is operated on 25 cycles.

To allow for possible reduced output of the pickup with age, an adjustment is described which should be of interest. It is necessary to use a 1000-ohm-per-volt, rectifier-type a-c voltmeter; one with a 0-10 volt range is recommended. Either an 84519-A or an 84505-B RCA Victor frequency record is to be used. The green wire is disconnected from terminal 1 of the phonograph-terminal board and a 1-megohm resistor is connected between the green lead and terminal 1. The voltmeter is connected



TACO ANTENNA SYSTEMS and make many Extra Dollars

- Equip any set, anywhere, any owner, with a TACO Antenna System. Presto! Ideal results. Broadcast and short-wave. Minimized background noise.
- All because TACO (Licensed under A. A. K., Inc., Patents) represents most advanced engineering by specialists.
- Factory assembled, wired, soldered. New low-loss transformers. A model for every pocketbook.
- Also a Master Antenna System for private dwellings, providing any number of radio set outlets. Same job used for apartment houses, hotels, hospitals, etc.

New DATA: Ask your local TACO jobber or write us direct for technical details and merchandising ideas.



TECHNICAL APPLIANCE CORP.
17 East 16th St., New York City
In CANADA: 414 Bay St., TORONTO

across the loudspeaker voice coil. The "Phonograph Volume" and "Power-Tone" controls are turned to the extreme clockwise positions, and the "Phono-Volume" (radio) control is set in the extreme counter-clockwise position. Then adjust the "Pickup Voltage Adjuster" (mounted under the right-hand end of the motor-board) until either of the above mentioned frequency records gives a reading of 6.8 volts on the meter using the 400-cycle section of the record. Following this adjustment, the 1-megohm resistor is disconnected from between the green wire and terminal 1, and the green wire is restored to terminal 1.

Silver Marshall 724-AC

Positive bias on one 45: Heavy plate current, overheating of bias resistor, etc. Due to shorted 0.1 mfd. coupling condenser to plate side of 1-to-1 audio transformer used to secure push-pull action. Common troubles are: shorted plate and screen bypasses, worn or noisy volume control. If unstable, bypass line to chassis and set may be opened wide with no oscillation at any setting.

Francis Wolven

mesh position; then adjust the small (vernier) pointer to "0." These are friction adjustments.

The locations of the aligning adjustments are indicated in Figs. 2 and 3. The adjustments should be made for a maximum indication on the output meter.

A sensitive output meter should be connected across the voice coil or across the primary of the speaker transformer. In making adjustments the signal-generator output should be reduced to a minimum consistent with a reasonable deflection of the output meter. The receiver volume control should be turned to its maximum position clockwise (full on) through the entire alignment procedure. The alignment operations are given in the accompanying table. The resistor or condenser listed under dummy antenna should be connected in series with the signal-generator-output lead and the position on the receiver chassis indicated under signal-generator connection.

The voltages indicated in Fig. 3 were taken with the receiver in operation on a 115-volt, 60-cycle supply. Except for the heater voltages, these values will be approximately 10% less when the receiver operates from a 115 volt d-c supply. The receiver volume control was on full and the antenna and ground terminals were connected together during the measurements.

Two voltage values are shown for some readings. The value shown in parentheses with the asterisk indicates operating conditions without voltmeter loading. The other value (generally lower) is the voltage measured with a 1000-ohm-per-volt voltmeter and differs from the value shown in the parentheses because of the additional loading of the voltmeter through the high series circuit resistance.

Voltage values should hold within plus or minus 20% of those given when the receiver is in normal operating condition at the rated line voltage.

PHONOGRAPH ATTACHMENT

A terminal board is provided for connecting a phonograph into the audio amplifying circuit. RCA Victor Models R-93, R-93-A, R-93-S, R-93-2, or R-94 record players should be connected as follows: Remove link between terminals 1 and 2 on terminal board. Connect green wire in radio-record switch cable to terminal 1, yellow to terminal 2, and shield extension to terminal 3. Tape unused red and blue leads separately. Connect a 2-conductor twisted cable between the record player binding posts and the screw terminals on radio-record switch. When employing the R-93-S, the 0.1 mfd capacitor contained in the R-93-S should be shorted out.

NEW OPPORTUNITIES for a BIGGER and BETTER SERVICE BUSINESS

NATIONAL UNION RADIO TUBES

- A Complete Line
- Highest Quality
- Thoroughly Guaranteed



NATIONAL UNION CONDENSERS

A Complete Line of Electrolytics and Papers

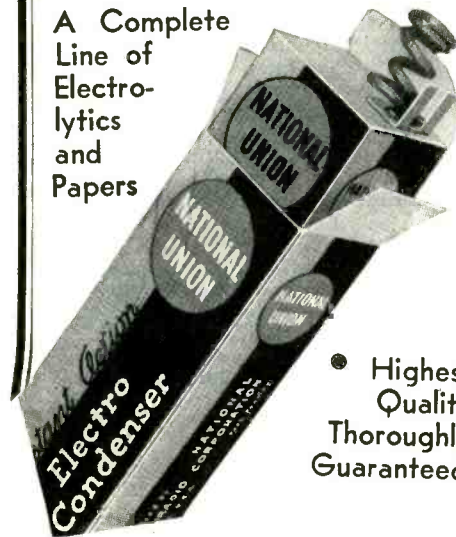

- Highest Quality Thoroughly Guaranteed

. . . PLUS FREE EQUIPMENT

Now National Union deals can be worked out with both N. U. Radio Tubes and N. U. Condensers. This is wonderful news for the service engineer who wants more and better equipment. Your condenser purchases combined with your tube purchases makes it easier and quicker to own the kind of equipment you want.

National Union has constantly put the latest advances in scientific equipment as well as modern selling aids within reach of the service dealer.

The National Union deal calls for a dealer deposit which is rebated when the purchase of the required amount of tubes and condensers has been made. Thousands of completed deals. Every dealer should investigate. Just ask your jobber.

NATIONAL UNION THE ROAD TO BETTER BUSINESS

1. Full guarantee on highest quality radio tubes.
2. Cut price business not solicited.
3. Price Protection.
4. N. U. jobber stocks are complete...No hunting for odd types.
5. Timely business building aids.

National Union Radio Corporation,
570 Lexington Ave., New York City.

I am interested in obtaining complete information on your proposition.

Name

Address

City..... State..... S 1137

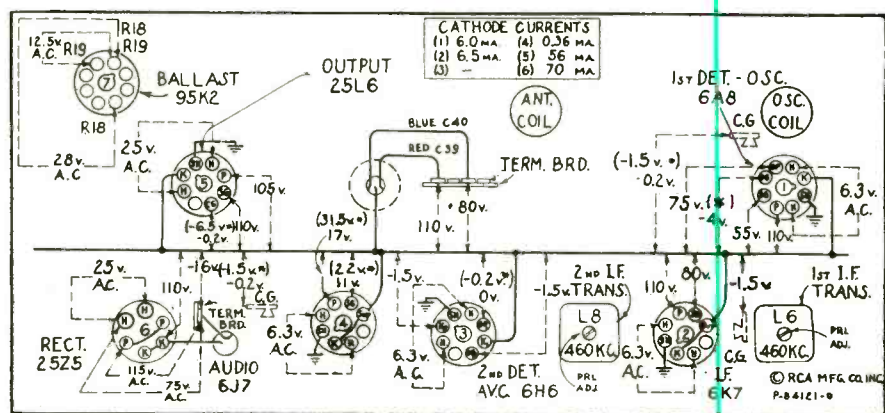

BOTTOM VIEW - REAR OF CHASSIS
Fig. 3. RCA 87EY voltages, etc.

ASSOCIATION NEWS . . .

PRMSA FLASHES

Proud Papa! Word comes that Morrie Green has a bouncing little lady in the family . . . and swears that he's not going to let this advent interfere with his social, business and association duties.

Dave Krantz is having quite a time with the distributors. They tell him one thing and do the opposite.

When Bill Hoos, Jr., runs short for something to say at those big meetings, he tells them about our great and glorious PRMSA.

What became of the "Charter"—Ask Mr. Groff.

A surprise meeting was called September 28th in the auditorium of the Philadelphia Inquirer Building by the RCA-Victor Engineers. The auditorium was filled to capacity, as everyone from far and near broke away from their bench and came out to learn a few new tricks.

Warren Kimball, who recently returned from South America with some new stories and a mustache, gave us an instructive demonstration on the adjustment of a-f-c circuits in the 1938 RCA-Victor sets.

Warren was followed by Mert Brisbin, who enlightened us on the subject of "commercial sound." He brought with him an array of sound equipment which, under his magic touch, did everything but sit up and bark. He demonstrated the new expansion and compression amplifier, aptly termed "compander."

Judging from appearances, Little Schmitt must take the cake for being PRMSA's expert alignment artist. Armed with an insulated screwdriver and a flashlight, he merely walks inside a console and presto, the job is done in short order!

Our portly Treasurer, Stan Myers, surely knows how to make an accurate, but very brief, report on the financial condition of the Association. "Boys, we have \$\$\$\$ in the Treasury."

From reliable sources it was learned that Jess Ehly has forsaken the radio service game (either by request or ?) and is now busily engaged in the art of pipe-bending. Jess sniffs SO-2 like a veteran.

From time to time, various cases have come to our attention where men have made the statement to their customers that they are members of PRMSA when they are not. We feel this is unfair to the association and the members. If you men would honestly like to enjoy the prestige of our association, come in, make application, and become one of us.

The November meeting was scheduled for the 16th instead of November 2nd. Technical lecture was planned, and some important business was to be transacted.

More later—maybe!!!

CLEVELAND IRSM

Members of Cleveland Chapter, IRSM, one of the first to pledge allegiance to RSA and having applied for an RSA Charter, are now a duly accredited unit on word just received from Joe Marty of the Chicago office.

In reviewing our activities of the past two months we find that Floyd Wenger of Triplett Elec. was on deck with the latest from their factory including the "Howitzer" type Oscilloscope. Come again,

Floyd, you're always welcome. John Oros, ex-IRSM member and the head chambermaid for Arnold Wholesale Corp., representing Zenith in this area, enlightened us on what's new in Zenith. Harry Hill, another ex, came to bat for the M. & M. Co., local Grunow and Motorola agent, and was most ably backed by Mr. Dale Andrews and Mr. Tim Alexander, fresh from the Motorola factory, who put on a bang up demo on push-button tuning. Last but not least came another ex, Tony Dorazil of the Cleve. Distb. Co. with Sparton's version of "Button-button, who's got the button?" All these meetings were well attended, showing that even we Clevelanders are willing to admit that we don't know everything.

In retrieving notes from our waste basket we see that:

John Yost, RCA Service Engineer with Mook Elec., local RCA distb., is fresh back from Camden, having spent a hectic twelve days there on a lecture course on new developments in the radio field.

Lee Evans, former service mgr. for Strong, Carlisle & Hammond Co., local Philco Distb. and well known to Service Men in this area, has just opened the Allied Sales Co. in Chagrin Falls, O. Lots of luck, Lee.

Bill Hochman, loyal IRSM member and formerly service mgr. for Frankelite Elec. Co., distributors of Crosley here, now operating the Hochman Parts Distb. Co. in Cleveland. Atta boy, Bill.

The first thing we know, we'll have more parts houses than Service Men and what does that add up to?

*L. Vangunten,
Official Observer,
Cleve. Chapter, RSA.*

ART-BRITISH COLUMBIA

A meeting of the ART was held in the D. V. A. Hall, Homer Street, Tuesday, September 14th. Thirty-eight members were present. Minutes of the previous meeting were read and passed on a motion of Mr. Hurst and Mr. Tait.

Treasurer reported a bank balance of \$236.44. On a motion of Mr. Stoneberg and Mr. Brown the report was accepted.

Secretary's correspondence was read and ordered filed on a motion of Mr. Paine and Mr. McMillan.

The Examination Board stated that an examination will be held in October. All Associate Members not having passed their exam yet should get in touch with Mr. Bernie.

Report was given by Mr. Lennox and Mr. Brown on the recent Convention stating that a handsome profit and wide publicity had been gained from it.

It was proposed by Mr. Alder that debates be held at the meetings. This was acted upon and Messrs. Tait, Alder, Hurst and Winstone were elected to stage the first debate.

Mr. Tait suggested that all members be phoned the day before a meeting, with a view to getting a better attendance.

Mr. Marriott informed the members that he had been asked by the Vancouver Electrical Association if our Association would send a delegate to attend their meeting to support a request of theirs that the B. C. Electric be approached and asked to cut out

free tube testing. Mr. Lennox ruled that their request should have been made to the Secretary, stating their full cause for a complaint, in which case the matter would be brought before the members. No action was taken at this time.

Convention Committee Report

Our convention is over—there is no need to say again that it was a great success—largely due to the splendid way you turned out. Based on past experience we budgeted on a basis of attendance of 40 to 50, but when a hundred turned up the first day and even more on the last day, the Committee's enthusiasm was reflected in the spirit of the whole gathering. And incidentally a very handsome cash profit was realized, a full report of which was presented at the general meeting, September 14th. It is impossible to list all out-of-town points from which delegates came—but among the more distant were: Long Beach, Cal., Spokane, Seattle, Tacoma, Kamloops, Penticton and speakers from Toronto.

The technical lectures were so well received that an extra session to present two of the speakers a second time had to be arranged.

All in all, it is clear we are entering a new era in the service business and far from the Convention being the peak of ART activities it shall be only the first step to bigger things and more concrete results.

As Chairman I want to thank the Committee members for their fine work and co-operation; they were a fine bunch of fellows to work with and I know the entire Association appreciates their efforts.

M. J. Lennox, Chairman.

RADIO SERVICEMEN OF AMERICA, INC.

Announcement of the formation of Radio Servicemen of America, brought a large number of applications for membership from existing local groups of Service Men including such outstanding groups as Cleveland, Chicago, Binghamton, Denver and Duluth. During the first week of its existence they made inquiry to join and receive Local Charters from Radio Servicemen of America.

These men represent only a small percentage of the Service Men in the country who are now favorably considering affiliation with the Radio Servicemen of America. The work of contacting the various groups and individuals is going ahead rapidly, but due to the magnitude of the task there are many who have not been contacted. Any group or individual who has not been contacted is invited to write RSA, Room 1533, 304 S. Dearborn Street, Chicago, for application blank and information on how to become a member. Where a number of Service Men are formed in a group, such groups are invited to inquire concerning Charters for their local groups.

The Board of Directors of RSA is indeed glad to know that its efforts are receiving such widespread support all over the country and pledges itself to continuation of its plans to create and maintain a national Service Men's organization of, by and for radio Service Men.

LET'S LOOK AT SERVICE EQUIPMENT

(Continued from page 678)

capacity is kept at a minimum by bringing the tube through the top panel so that the grid lead is an inch or more from any grounded surface. Operation is directly from a 105-130 volt, 40-60 cycle a-c line.

SERVICE LABORATORIES

If any other type of instrument is introduced or required, it will have to be an additional one to those mentioned. Obviously extra equipment may be useful for special measurements and may be included in a combination unit whose major functions we have considered here as the prime role of a separate device. With the proper knowledge an expert job can be accomplished with the essentials as given.

The final suggestion in regard to the purchasing of service equipment pertains to the gradual development of a service laboratory. An increasing amount of servicing is being done in the shop with less and less in the client's home. Usually the installation of a new tube, or aerial, the adjustments or repairs of a minor sort constitute the service activities that can be carried out effectively there. Such a situation permits a minimum of portable devices and allows the permanent mounting of all instruments in a really fine and business-like manner at the back of the shop's bench. As pointed out in the September issue of this publication ("Complete Service Laboratories," page 526-527), tidy equipment layouts pay for themselves, conserve shop space, simplify operations, and protect individual instruments from accident. Separate parts may be purchased as the budget permits and later mounted in the shop panels or similarly installed in automobile trailers for rural work.

COSTS

A budget of three hundred dollars should cover amply the price of all instruments mentioned, such a figure to include first quality throughout. With the use of kits, home-assembled or made parts, second-hand instruments, and the like, this quotation may be reduced considerably. Tube manufacturers and parts suppliers also have purchase plans whereby test equipment is provided in exchange for a monthly sales quota of the concern's products. In order, however, that there be no later question about the initial quality and accuracy of the equipment obtained, it is preferable to make purchases direct from the makers. Oddly enough this will be found the cheapest and easiest way in the end. To assist in the matter, manufacturers have a four-point payment

TRY *Knight* ELECTROLYTIC CONDENSERS

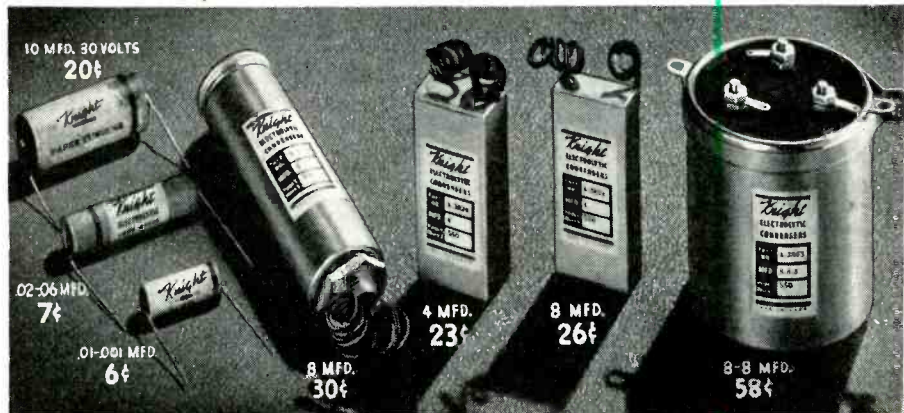

They Cost Less—Earn More AND HUNDREDS OF SERVICE MEN SAY THEY'RE BETTER

CHECK THESE AMAZING PRICES!

CARDBOARD

550 Volts D.C. Peak

8 MFD (No. B3826)	38¢
8-8 MFD (No. B3832)	60¢
8 MFD Bantam Size (No. B3816)	38¢
8-8 MFD Bantam Size (No. B3819)	60¢
8-16 MFD (No. B2738)	90¢

METAL

8 MFD (No. 3853)	42¢
8-8 MFD (No. B3858)	72¢
5-15 MFD (No. B3862)	88¢

CARTRIDGE

8 MFD (No. B3799)	33¢
8-8 MFD (No. B3796)	48¢
10-10 MFD (No. B3794)	28¢

BUILD YOUR OWN



Build an excellent Volt-Ohm-Milliammeter at low cost! Use the KNIGHT Foundation Meter Kit shown on page 34 of ALLIED'S catalog.

Have you made this great discovery? You get standard quality at a great saving in KNIGHT SERVICE PARTS! Note these amazing prices on KNIGHT Dry Electrolytic Condensers—savings up to nearly half!—Yet servicemen everywhere report unequalled satisfaction. Similar savings are yours on many different items if you buy KNIGHT (ALLIED'S own brand) — condensers, carbon resistors, volume controls, etc.—all in your ALLIED catalog. All dependable, reliable, carrying the regular R.M.A. guarantee. Different only in their low prices, made possible by ALLIED'S volume and low distribution costs —Start now to make extra profits by using KNIGHT service parts. Let KNIGHT condensers prove KNIGHT values — send coupon today.

SEND THIS COUPON FOR TRIAL ORDER NOW!

ALLIED RADIO CORP. Dept. 19-L8
833 W. Jackson Blvd., Chicago, Ill.

Enclosed please find Check Money order for—
KNIGHT Condensers, as specified in order enclosed.

Your Name

Address

City State

ALLIED
RADIO CORPORATION
833 W. JACKSON BLVD. CHICAGO

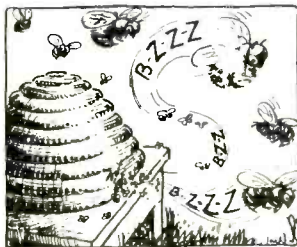

HUM IS EXPECTED

around bee hives, but should not be tolerated in audio design.

Kenyon Hum Bucking Transformers are priced as low as \$2.40.

Catalogs describing the various Kenyon audio and power components obtainable from your local dealer.

KENYON TRANSFORMER CO., Inc.

840 Barry St., New York, N. Y.

The World's Fastest Selling Line of DRY ELECTROLYTIC CAPACITORS

WHEN you order C-D electrolytics you KNOW that, whether it be an "8 mike" or a "16 mike," it will be absolutely the best obtainable in the industry.

If you could step behind the scenes at the Cornell-Dubilier plant and witness the careful selection and inspection of raw materials, the extreme precautions taken by C-D engineers to insure positive sealing, (C-D dry electrolytics are triply sealed), against corrosion and humidity, and the endless test and inspection of the finished electrolytic, you would understand why these condensers are the world's fastest selling line of electrolytics.

Be sure you say "C-D" when ordering your dry electrolytics. Send for complete technical data, Today!

**CORNELL-DUBILIER
ELECTRIC CORPORATION**
1026 Hamilton Blvd., So. Plainfield, N. J.

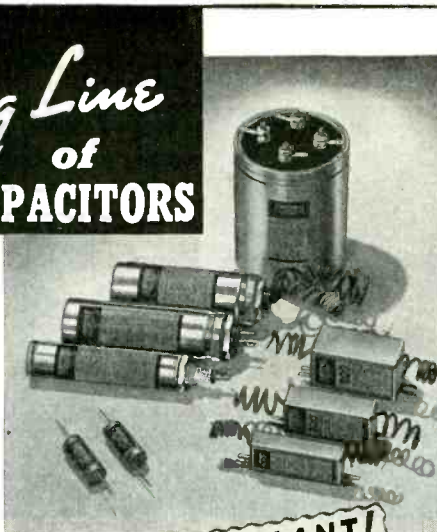

**MOST IMPORTANT!
C-D ELECTROLYTICS
are UNCONDITIONALLY
GUARANTEED AGAINST
INTERNAL CORROSION**
The most STARTLING, SWEEPING,
condenser GUARANTEE EVER
WRITTEN, and a dramatic example
of C.D. engineering ability.



**CORNELL-DUBILIER
ELECTRIC CORPORATION**
South Plainfield, New Jersey

Now! BALLAST REPLACEMENT

made
**AMAZINGLY
SIMPLE**

- Servicemen, with only 4 standard types of Amperite AC-DC Regulators you can replace 90% (over 100 types) of AC-DC Ballast Tubes now in use! Consult your jobber.
- Amperite Regulators are equipped with a patented Automatic Starting Resistor to prevent untimely burnouts and save pilot lights.
- New Low Price on Amperite AC-DC Regulators: \$1.00 LIST

Amperite Replacements
for 2V Battery Set ballasts
\$1.25 list

**AMPERITE
Company**
561 BROADWAY
NEW YORK



WRITE
FOR
CHART
A R

AMPERITE
AUTOMATIC REGULATORS



Do You
Know all
About

AUTOMATIC DIAL TUNING

New Radio Developments Create
A Demand For More Highly Trained Men
You need more than a pair of pliers and a screwdriver to repair the complex troubles that the new receivers can develop. Years of actual service experience went into the planning of this complete course for professional Servicemen. Start anytime—take up to 3 years to complete.

ADVANCED TRAINING IN RADIO SERVICE AND PUBLIC ADDRESS

Terms As Low As \$5.00 Monthly

WRITE TODAY FOR OUR
FREE BOOKLET

"THE KEY TO
SUCCESSFUL SERVICING"



If you are anxious to make more money in the Service field read this interesting book—and benefit by it as so many others have done. A post card mailed today is all you need.

RADIO SERVICE INSTITUTE

SUBSIDIARY OF CREI
Dept. S-11, 3308 14th St., N. W., Washington, D. C.

plan of which the following is typical:

(1) Select the test equipment needed to modernize the shop.

(2) Make application and deposit a down payment according to the following table:

Price	Down Payment	Monthly Payment	Months to Pay
\$50	\$10.00	\$4.68	10
75	10.00	6.08	12
100	10.00	8.25	12
125	12.50	10.26	12
150	15.00	12.25	12

(3) Immediately place the equipment purchased to work, simplifying service problems and increasing the shop's earning capacity.

(4) Make the small monthly payments and in a short time the instruments will be free of all encumbrances.

ODDS AND ENDS

In closing this survey on equipment, the writer's attention has been directed by various parties to several useful but smaller items for the service shop. In addition to the usual tools, soldering irons, racks, and drawers, many spoke of file cabinets, one for clients' names and addresses, the other for servicing tips.

A radio jack, so-called and shown at the N. R. P. M. Show for the first time, attracted considerable attention. Consisting of various length dowels adjustable to different size bases, the jack provides a simple yet sturdy support for a receiver chassis on the work bench.

A third item of interest is known as the "Prod-Lite," an ingenious device used by many Service Men in repair work as a means of illumination. An extremely small lamp and socket is adjusted conveniently to any desired position on a test prod. It is furnished complete with focusing type bulb, flexible cord, flashlight battery, case, and switch cover.

Finally, the miscellaneous articles included a portable typewriter, files or bindings for back numbers of service publications, tube racks, and volumes for a technical library.

TECHNICAL QUALIFICATIONS

Throughout this survey, editors, Service Men, and manufacturers stressed repeatedly that instruments without technical knowledge were of little account, if any. By way of a fitting conclusion we might re-emphasize this phase of the subject, now thought by many to be somewhat over-written, though one gathers not yet absorbed fully by all.

The mere possession of tangible test devices may or may not suggest an equal understanding of their efficient operation. Intensive training, coupled by long experience under capable supervision in the preferred preparation for a business of one's own. Such a background alone cultivates the analytical ability that en-

MASTER of all it surveys—

AN ALL-SERVICE TUBE AND SET TESTER

- for general radio servicing
- for auto radio servicing
- for public address systems, sound equipment and transmitters

THIS great addition to the impressive list of sensational Simpson developments has been named the "Test Master" because it offers complete mastery of every condition that can arise in every branch of radio servicing—in the store or on the job—now, or in years to come.

No other instrument, selling at any price, covers so much ground—yet its price is lower than that of instruments that do not approach its range, its accuracy, its stamina, its beauty of design and finish. Here, briefly, are some of the features it brings to you:

A tube tester of improved design—based on R. M. A. standards, employing double switching of filament terminals (which eliminates obsolescence) for testing special types such as 5X4 G, 5Y4 G, 6A5G, 6P7, etc., without adaptors or special sockets. It provides screen fluorescence and angle test for "magic eye" tubes; hot cathode

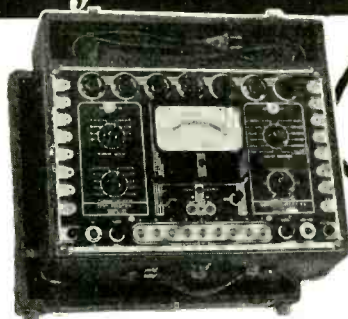

the **NEW Simpson**
"TEST MASTER"

MODEL 440

No other tester, selling at any price, provides as many tests and ranges!

Yet the dealer's net price is only **\$59.00**

leakage neon test and "high sensitivity" neon short check—individual tests for each electrode in tube. Cathodes, diodes, battery types and gaseous rectifiers are tested under proper load. Even "noise test" pinjacks are provided for ear phone connection. Impressive "good" and "bad" scale is provided as well as percentage scale for comparing or matching tubes. It is a tube tester that tells the whole story to you and your customer in your terms and his terms. Tube charts in loose leaf form are readily accessible in the cover. Supplementary cards are easily added

A set tester of tremendous scope—As a set tester the Model 440 has six A.C. and D.C. voltage ranges at 1,000 ohms per volt — 0-7.5-30-150 - 300 - 750 - 1500. All A.C. ranges are available for output measurements. Three ranges cover resistance from 1 ohm to 100,000,000 ohms. Scales are 1,000 ohms (30 ohms center); 100,000 ohms (1,000 ohms center); 100,000,000 ohms (1,000,000 ohms center). Four milliamperes ranges are provided — 0 - 3 - 15 - 75 - 300. There are six decibel ranges of —12 to —58. D.C. current range of 0 - 15 amperes is incorporated for auto work. Capacity range is 0 - 30 microfarads. Meter leakage test for all condensers including electrolytics is provided.

There is truly nothing that you can ask for, or find in any instrument that is not covered by the Model 440 at the moderate price of \$59.00. It is sold on deferred payments. Write today for complete description.



without adaptors or special sockets. It provides screen fluorescence and angle test for "magic eye" tubes; hot cathode

Model 220 "Roto-Ranger" Tube and Set Tester—a great tester with the convenient Simpson Roto-Ranger feature which provides separate resistance scales of 100 — 100,000 — 100,000,000 ohms — separate D.C. scales of 8 — 300 — 1,000 volts. **\$62.75**
Net price
(Sold on Terms)

SIMPSON ELECTRIC CO., 5218 W. KINZIE STREET, CHICAGO, ILL.

SIMPSON Instruments that *STAY accurate*
ASK YOUR JOBBER

Model 201 and 202 "Roto-Ranger" Volt-Ohm-Milliammeter with twelve independent scales covering all ranges for general servicing. Net price Model 201 (for D.C. only) **\$32.50**
Price Model 202 (A.C. - D.C. type) **\$35.75**
(Sold on Terms)

MORE SALES—GREATER PROFITS

REPLACEMENT VIBRATORS



For **AUTO and FARM RADIOS**

- Longer Life
- Improved Performance
- Precision Construction
- Lower Prices

Write for your **FREE** copy of the *ATR Vibrator Guide*

Backed by more than six years of experience in Vibrator Design and research, development and manufacturing.

DC - AC INVERTERS



AC CURRENT ANYWHERE!
In CARS .. On FARMS .. In DC DISTRICTS

- Interference-Free All-Wave Radio Operation.
- Improved Long Life ATR Vibrators of new design and construction having dual arms and using eight $\frac{1}{4}$ " diameter tungsten contacts assuring increased long life and reliable service.
- Four Point Voltage Regulators make possible the correct output voltage for minimum to maximum loads and also help compensate for input voltages which are lower or higher than normal.
- 32 Different Types for DC Input voltages ranging from 6 to 220 volts and having AC Output voltages of both 110 and 220 volts.

Ideally suitable for operating standard 110 or 220-volt AC radios, public address systems, electrical testing equipment, etc.

Write or Wire for Additional Information. Sold by Leading Jobbers Everywhere.

AMERICAN TELEVISION & RADIO CO.

ST. PAUL, MINNESOTA, U. S. A.

Cable Address: "LIKEX" New York

For
**HIGH-VOLTAGE
Jobs**



Inexpensive, handy, oil-filled capacitors. Compactness due to HYVOL—the super-dielectric oil.

Same size and mounting as usual electrolytic. 1½" dia. Either 2¾" or 4½" tall.

Grounded can. May be insulated with insulator washer.

.5 to 4 mfd. 600, 1000 and 1500 v. D.C. working.

HyVOL HIGH-VOLTAGE CAPACITORS

For those big P-A jobs or wherever higher voltages must be handled safely, dependably, economically, you will find these HYVOL units just the thing. Also available in larger round-can units and in rectangular units.



So it's AEROVOX again! Whether you need a low-voltage by-pass electrolytic or a high-voltage oil-filled unit, you can get it in the AEROVOX brand.

Ask

New catalog lists the largest selection yet offered. Ask your jobber or write us.



ables the Service Engineer to separate causes and effects, particularly if this period of apprenticeship has bred a wholehearted interest in conclusive facts in preference to superficial diagnoses and deficient techniques.

Receiver design changes; so too must one's qualifications progress with the industry. Mathematics, electrical principles, alternating current theory, salesmanship, business fundamentals, and accounting represent the prime subjects. However, it is not sufficient to know these alone. Coupled with them must be a field knowledge of the circuits and characteristics of present receivers along with an apprehension of their corresponding ills and cures. One must also comprehend the older types that continue in use, thus embracing all basic problems that will sooner or later become a part of future developments. Electrical principles and electricity remain unchanged; it is solely the manner of their application that alters without apparent warning to those in the industry. Thus in addition to radio school attendance, or completion of a correspondence course of instruction, the prominent Service Engineers resort to continual home study supplemented by monthly reading of the major service journals. This they gladly do, knowing well the future profits depend upon it. Thereby every independent service shop becomes comparable to a branch factory of the original radio makers, for it is not only equipped with the necessary instruments, but also staffed by a competent personnel.

Backed by sentiments freely expressed at the N. R. P. M. Trade Show, we give reassurance, finally, that the service and related industries offer as bright a prospect for the future as ever they did in any time in their comparatively young history. The imminent years embrace the servicing of home receivers, auto-sets, public-address systems, and television equipment. With the aid of modern service instruments, the trained and experienced Service Men will establish, without difficulty, a sound financial independency for themselves.

A-C, D-C Sets

Low volume, noise: Low volume, hum distortion, fading and similar complaints in a-c, d-c sets are often due to positive bias on the 43. If positive bias remains with the detector plate grounded, it is due to secondary emission and the tube should be replaced. High values of grid resistor and high line voltages aggravate the trouble. Keep the voltage across the 43 heater down to 22 or 23 volts to avoid this.

Francis C. Wolven

new "PRECISION" D.C. VOLT-OHM- MILLIAMMETER

SERIES 830

Specifications

★ Five D.C. voltage ranges at 1000 ohms per volt: 0-10; 0-100; 0-250; 0-500; 0-1000 volts.

★ Four D.C. current ranges; 0-1; 0-10; 0-100; 0-250 MA.

★ Two resistance ranges: Low ohms (shunt method) 0 to 500 ohms. High ohms 0-300,000 ohms.

★ Ohmmeter ranges are powered by self contained supply.



SMALL . . . COMPACT . . . LOW IN
PRICE . . . ACCURATE . . . POPULAR

Furnished with self contained battery. Net Price

\$10.95

Precision Apparatus Corp.
821 EAST NEW YORK AVE., BROOKLYN, N. Y.

SALES

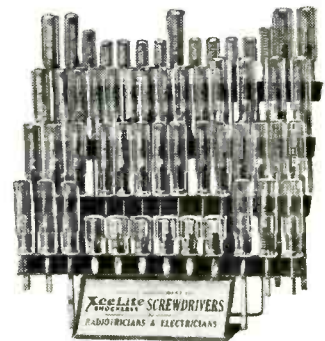

QUICK—EASY XCELITE Screw Drivers

Xcelite Screw Drivers—for eleven years the industry's quality product—is now furnished in three attractive display assortments. The famous Xcelite handle—beautiful, transparent, breakproof and shockproof—is known throughout the industry. Made in all popular sizes. Use them. . . . Display them. . . . Sell them. Order from your jobber or write for special descriptive circular.

PARK METALWARE CO., Inc.
Orchard Park, N. Y., U. S. A.

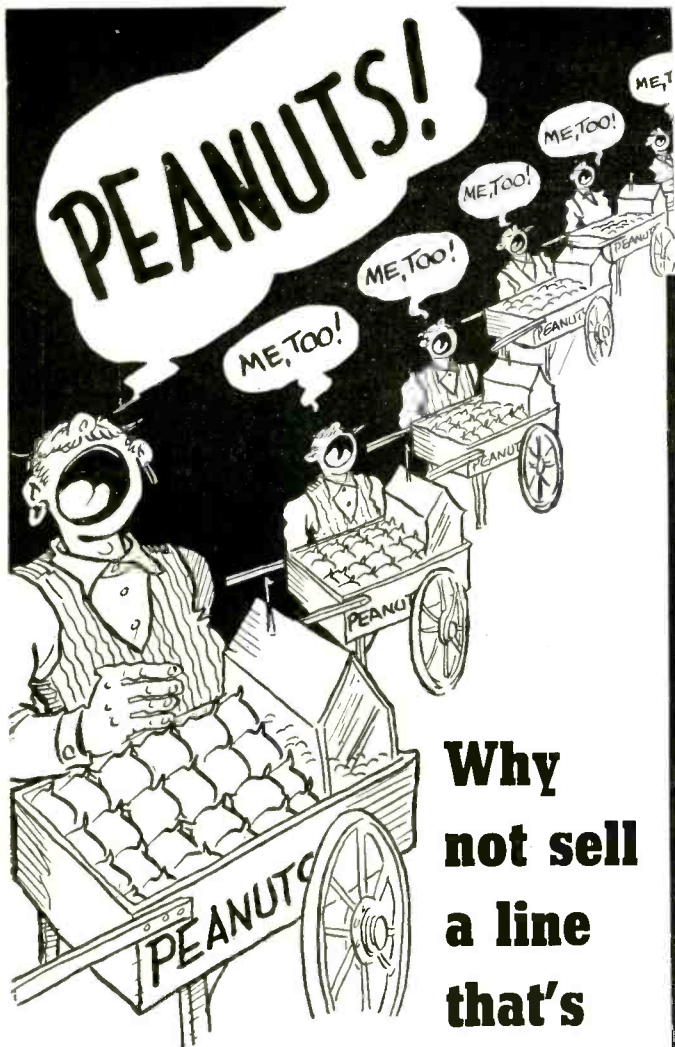

**Why
not sell
a line
that's**

DIFFERENT

That's STANCOR: the COMPLETE, COMPACT, COMPETITIVE line. It's COMPLETE because it covers the greatest range of transformer requirements with the fewest types . . . COMPACT because "dead-wood" has been eliminated . . . COMPETITIVE because it's COMPLETE, COMPACT and so conservatively priced. • It's different because a stable price policy protects everyone who buys or sells it • It's different because it is supported by active field merchandising that makes it the "livest" line on anybody's shelf • Get the full story on the STANCOR line. It's Different.

**S T A N D A R D
T R A N S F O R M E R
C O R P O R A T I O N**
850 BLACKHAWK ST. • CHICAGO, ILL.

SOMETHING NEW UNDER THE SUN



A COMPLETE TUBE COMPLEMENT BOOK

• Of course there have been tube complement books before. But when you find one as full of helpful information as is the big, 200-page Sylvania Tube Complement Book—that's something new.

Take a look at this list of features:

1. Tube complement listings for 10,386 models.
2. Listings for 259 companies.
3. Most complete compilation of i-f peaks available today.
4. Contains helpful articles on tube selling, etc.
5. Largest compilation of trade names ever made—560 names.

That's all we have room to mention here. But there are many more features—all designed to be of help to you.

Where "under the sun" can you find a book as complete as this one? And the price is only a quarter!

See your jobber, or rush the coupon and 25c. to us right away. You'll get your copy of the Sylvania Tube Complement Book in a few days.

S Y L V A N I A

SET-TESTED RADIO TUBES

Also makers of famous Hygrade Lamp Bulbs

HYGRADE SYLVANIA CORPORATION, Emporium, Pa. S-117

Enclosed please find 25c. Send me my copy of your new Tube Complement Book right away.

Name

Address

City State

Dealer
 Amateur

Service Man
 Experimenter

Sound Service . . .

EQUIPMENT FOR HIGH-POWER OUTDOOR INSTALLATIONS

By W. L. ROTHENBERGER*

HIGH-POWERED outdoor sound installations have always been a problem for the average p-a man, because this type of installation usually requires a complicated variety of equipment such as faders, input panels, preamplifiers, speaker-matching transformers, speaker field-supply units, a multiplicity of speakers, and various other items in addition to the main power amplifiers, which, for high-power output, are generally large and expensive.

The situation, however, has changed almost over-night through the recent introduction of new equipment that is specifically designed and coordinated for p-a work. The new equipment is simple, extremely flexible, and readily adapted for small or large, indoor or outdoor installations.

ELECTRIC MIXING AND REMOTE CONTROL VOLTAGE AMPLIFIER

Of these developments, probably the most important is the new remote electric mixing system. Large p-a installations require several input channels, with provision for fading from one input to another, and for mixing two or more inputs. This is usually accomplished by means of high-level or low-level mixing circuits, with faders, mixers and pads connected directly in the signal circuits. The new electric mixing system is radically different because there are no controls in any signal circuit. Each input is fed into a separate input amplifying unit, and these are fed into a master amplifying unit. Mixing is accomplished electrically (not electronically) in the master amplifying tube. Mixing and volume are controlled by regulating the bias voltage (and consequently the gain) of each input unit and of the master unit. Fading is accomplished by reducing the gain of one input unit and increasing the gain of another unit. As the controls are in the d-c bias circuit, remote controls can be used at any desired distance from the amplifier, without signal loss, distortion, cross-talk, hum or noise pickup, and no necessity for shielded control cables.

It is unnecessary for the operator to sit backstage or in a distant control room where it is impossible to judge the reproduction as the audience actual-

ly hears it. With this system, the controls can be located in the audience, so that the operator is really part of the audience and can therefore make adjustments intelligently for the most satisfactory results.

Two input units, a master unit, and a compander unit are mounted on the voltage amplifier, which has space for two additional input units. The compander unit provides adjustable volume compression for microphone operation, and expansion for phonograph reproduction, and in itself is a notable contribution to successful sound installations.

50-WATT POWER AMPLIFIERS

The second development is a compact 50-watt power amplifier utilizing beam-power tubes in parallel-push-pull (with low plate and screen voltages for long tube life). These amplifiers in-

corporate phase inversion and reversed feedback, and have output terminals for matching various speaker loads. One, two, three, or four of these 50-watt amplifiers may be operated from one voltage amplifier, thereby providing the necessary flexibility for present requirements and future expansions of any installation.

The third development is the new high-power high-efficiency permanent-field dynamic directional loudspeakers, available in 60-watt and 100-watt continuous-power-handling capacity. These speakers require no field-supply units. The simplicity of using two 100-watt speakers instead of twenty 10-watt units is immediately evident.

REQUIREMENTS FOR TYPICAL ATHLETIC FIELD INSTALLATION

To illustrate the simplicity and flexibility of the new sound equipment, we

TABLE 1
GENERAL POWER REQUIREMENTS
FOR SOUND INSTALLATIONS

The following data serves as an approximate guide for power requirements. Deviations may be necessary in specific installations.

APPLICATION	6 Watts	12 Watts	24 Watts	50 Watts	200 Watts
AIRPORTS				★	★
ALL OPEN AIR APPLICATIONS WHERE HIGH POWER IS REQUIRED					★
AMUSEMENT PARKS			★	★	
ARMORIES				★	
ATHLETIC FIELDS				★	★
AUCTION ROOMS	★				
AUDITORIUMS			★		
AUDITORIUMS (LARGE)				★	
BALL PARKS				★	★
BALLYHOO SYSTEMS	★				
BATHING BEACHES					★
BEER GARDENS		★			
BEER GARDENS (SMALL)	★				
BOWLING ALLEYS		★			
BOWLING ALLEYS (SMALL)	★				
BUS STATIONS		★	★		
BUS STATIONS (SMALL)	★				
CEMETERIES				★	
CHURCHES			★		
CHURCHES (SMALL)		★			
CONVENTIONS				★	
COUNTRY CLUBS			★		
COUNTER DEMONSTRATORS	★				
DANCE HALLS			★		
DANCE STUDIOS			★		
DEPT. STORES			★		
DEPT. STORES (SMALL)		★			
DRUG STORES	★				
FAIRS AND EXPOSITIONS					★
HOTEL BALLROOMS			★		
INDUSTRIAL PLANTS				★	
LUNCH ROOMS	★	★	★		
LODGE ROOMS			★		
MASS MEETINGS					★
NIGHT CLUBS		★	★		
ORCHESTRAS			★		
RACE TRACKS				★	
RAILROAD STATIONS		★	★		
RAILROAD STATIONS (SMALL)	★				
RESTAURANTS		★			
RESTAURANTS (SMALL)	★				
SHIPS				★	★
SKATING RINKS			★	★	
SOUND TRUCKS		★			
SPORTS ARENAS				★	
STADIUMS				★	★
S. S. PIERS			★		
TRAFFIC CONTROL		★	★		
WEIGHING STATIONS	★				
WINDOW DEMONSTRATORS	★				

*Commercial Sound Section, RCA Mfg. Co., Inc.

IF YOU CAN ANSWER "YES" TO THESE QUESTIONS

1. Have you an established radio service business?
2. Is your location free from interference with already established Tung-Sol agents?
3. Have you the necessary technical knowledge and equipment to service radio?
4. Is three months' supply a sufficient tube stock?
5. Will you agree to make a monthly stock report on standard forms provided by the wholesaler?
6. Will you regularly use display and advertising material furnished by us?
7. Will you maintain Tung-Sol established retail prices?
8. Have you sufficient capital to meet your obligations promptly when due?

If you can answer "Yes" to these questions, Tung-Sol has a Consignment Plan that will show you better and quicker tube profit than you ever thought possible.

Look the questions over—and if your answers are "Yes" —WRITE TODAY for name of your nearest wholesaler. Please Address Dept. D.

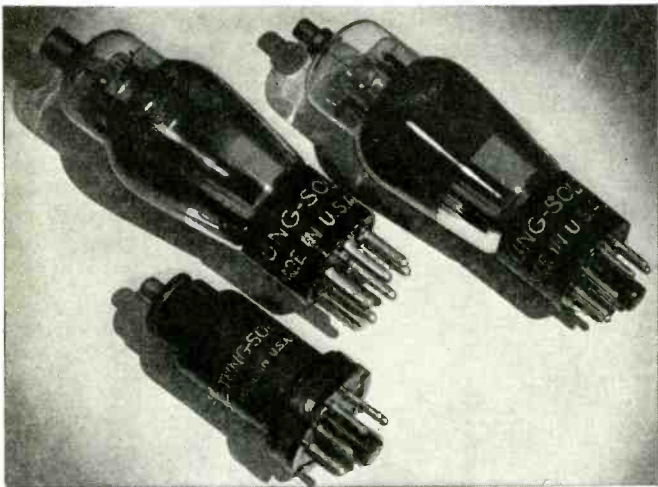

SALES OFFICES:

Atlanta • Boston
 Charlotte • Chicago
 Dallas • Detroit
 Kansas City • Los Angeles • New York

TUNG-SOL
 Tone-flow Radio Tubes

TUNG-SOL LAMP WORKS, INC.
 Radio Tube Division -
 General Office: Newark, N. J.

Now

REDUCED PRICES BRING BRUSH MIKES within everyone's reach

A price reduction of approximately 20% on two popular Brush microphones—Types BR2S reduced from \$37.50 to \$29.50; Type B-1 reduced from \$32.50 to \$26.50—give you another advantage in using and recommending Brush mikes.

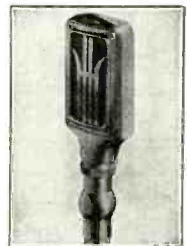

B-1, now \$26.50

This reduction is made possible by the constantly increasing number of users who, accustomed to quality sound equipment, prefer these brush mikes that are so FREE FROM hum pickup, frequency discrimination on long lines, and response peaks causing feedback.



BR2S, now \$29.50

BRUSH MONEY-MAKERS FOR THE SERVICE MEN

The "Hushatone" (pillow speaker) primarily for personal radios but adaptable to any type of receiver. List price only \$5.00.

Headphones—Type A—comes in three styles—double phone \$9, single phone \$5, and lorgnette handle type \$6.50. Type B—recently announced ultra light weight metal phones. Same style and prices as Type A.

The **B r u s h**
 DEVELOPMENT COMPANY

3326 Perkins Ave., Cleveland, Ohio

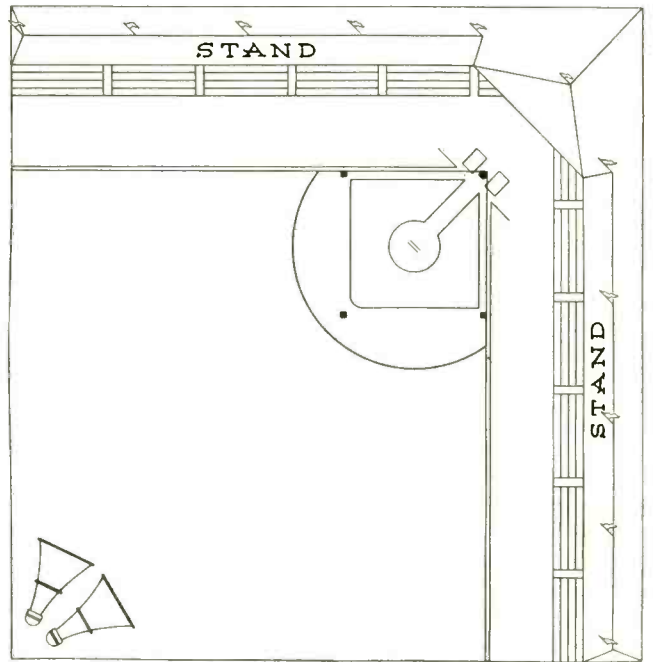
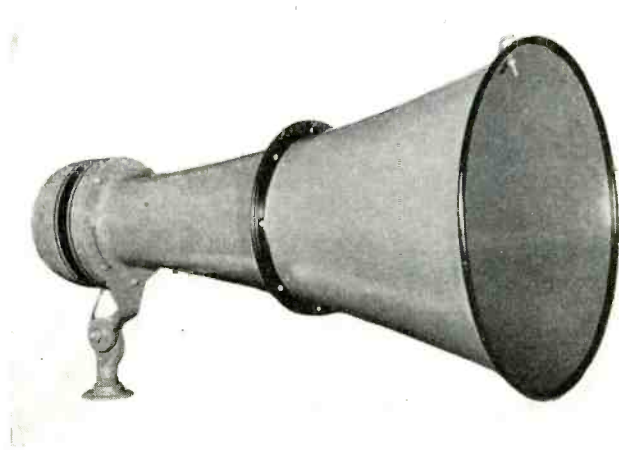

High-power speakers for outdoor use, and (right) Fig. 1, showing location for best sound distribution.

will consider a typical installation in an athletic field or baseball park. The location of loudspeakers is shown in Fig. 1.

The requirements of such an installation are rather severe. Each requirement must be considered carefully, and completely satisfied.

(1) *Power Requirements.* There must be adequate power to over-ride the noise level, and carry to all parts of the stands. Calculations and extensive experience with such installations indicate that, with high-efficiency speakers, an output of 100 watts is entirely adequate for the average-size field. For extremely large fields, a 3-db boost, or 200-watts output, is desirable.

(2) *Sound Distribution.* The sound must be distributed uniformly to all sections of the stands. By mounting the speakers in the far corner, as shown in Fig. 1, the distance to all sections of both stands is practically equal, ensuring uniform intensity when the coverage angle of the speakers is correct. The horizontal angle to be covered is 90 degrees. Two of the high-power permanent-field loudspeakers, which have a nominal distribution angle of 60

degrees, will provide the required coverage. The speakers should be mounted high, and, generally, the center axis should point to the ground in front of the stands.

(3) *Continued Operation.* The equipment should be arranged in units or sectionalized so that failure of one unit will not throw out the entire system. This operating safety factor is obtained by employing two independent power-amplifier sections, and four independent input units on the voltage amplifier. For the same reason, the speakers are not connected in series, but are independent of each other, and are connected to separate amplifiers.

(4) *Reproduction Quality.* The sound reproduction must be clear for voice, and pleasing for music. The specified amplifier equipment has an over-all response that is practically flat from 50 to 10,000 cycles. The speakers have ex-

cellent response, with no peaks in the frequency range from 100 to 7000 cycles. A music-speech switch and a tone control are provided on the amplifiers to facilitate any desired tone adjustment.

(5) *Weather-Proof Loudspeakers.* The loudspeakers must be completely weather-proof. The high-power speakers previously described have moulded resin diaphragms and heavy metal weather-proof-finished bells. The speakers are designed for outdoor use, and have been tested under the most adverse climatic conditions.

(6) *Sufficient Input Channels.* There must be a sufficient number of input channels to provide for phonograph pickup at several points, for radio or other input. There are four separate input channels on the voltage amplifier, which is more than sufficient for the majority of in-

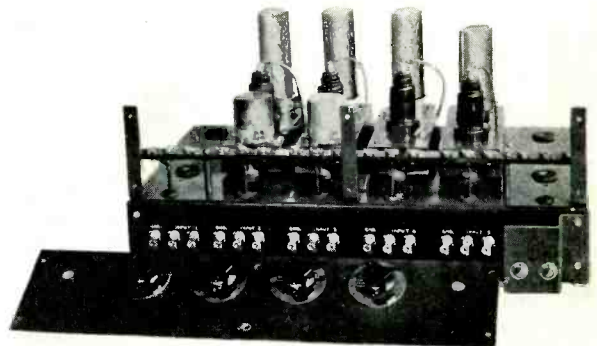
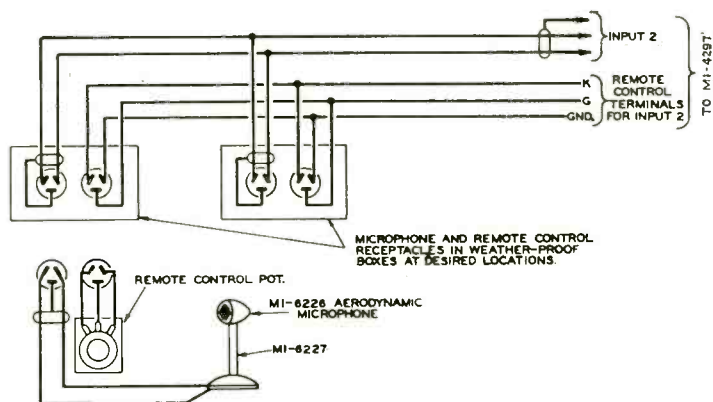

Fig. 2. Volume controls at microphone locations, and (right) the voltage amplifier showing the input terminals.

ALWAYS REPLACE
with

Utah

"No Hum"- "No Buzz"
TRANSFORMERS

**THEY BRING OUT
THE BEST IN ANY
RADIO**



■ No need for you to gamble on improved performance when replacing transformers. UTAH transformers bring out the best in any radio—the result of 16 years' experience in the design of radio parts. Thin laminations minimize eddy current losses and prevent overheating. Properly sized and shaped cores provide the most efficient magnetic field. Complete impregnation assures long life under any atmospheric condition. Insist on UTAH transformers. Your jobber has the complete line.

**WHEN YOU FIND
SPEAKER TROUBLE**

■ Remember that putting new parts in old speakers is risking business. Even at the factory each part must be carefully matched and balanced. It's a delicate job and requires special equipment. A new UTAH speaker brings a new thrill to set owners—more credit to you and more profit, too. Your jobber has the correctly engineered UTAH speaker for every set.



UTAH RADIO PRODUCTS CO.

CHICAGO, U. S. A.

TORONTO

BUENOS AIRES

ONTARIO, CANADA

(UCOA RADIO PRODUCTS CO.)

"16 YEARS OF LEADERSHIP"

RADIO'S *Fairest* DEAL
RADIO'S *Finest* TUBE!



**The ARCTURUS
EQUIPMENT DEAL**
Is Making Radio History!

Year after year ARCTURUS has led the way in tube engineering design and research . . .

Now ARCTURUS again pioneers by offering the fairest, easiest equipment deal in the history of radio.

The ARCTURUS offer includes a wide variety of highest quality standard equipment—tube and set testers, oscilloscopes, portable typewriters, etc. It gives you IMMEDIATE DELIVERY with only a small down payment . . . tube requirements are surprisingly low . . . ARCTURUS quality and ARCTURUS Dealer Helps actually help you sell. You profit two ways!

AND REMEMBER: You buy tubes at STANDARD LIST PRICES, less standard discounts. We haven't added one cent extra! Nothing could be fairer! You simply cannot lose . . . Write for details.

**Modern Service Demands
Modern Equipment . . .**

Let ARCTURUS help make yours
the best equipped shop in town!



ARCTURUS RADIO TUBE CO., Newark, N. J.

ARCTURUS

**INDEPENDENT TUBES FOR DEALERS WHO
DO THEIR OWN INDEPENDENT THINKING**

Radiojac

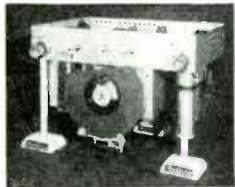
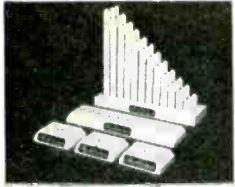

The Ideal Tool
to Support
Your Radio
Chassis

Patent pending

\$1.60

net to
Servicemen

Benchstand with
36 Hardwood Rods,
from 1½" to 8",
1 large Base,
3 small Bases.

- From a handy benchstand you can readily select any length of support. Simply insert the needed rods into respective bases, and presto—you have a substantial support.
- RADIOJAC is the only device which will actually support any chassis regardless of size, age or weight.
- RADIOJAC is set up without loss of time, without screwing or clamping.
- The support is rigid, due to a patented spring-tight fit between rod and base.
- The chassis is free to be turned back and forth without interfering with speaker leads, etc.
- RADIOJAC requires very little bench space—only 2½" x 9".
- RADIOJAC is low in price.

If your Distributor cannot supply you,
write us direct.

COOKS MFG. COMPANY
274 Mile Sq. Rd., Yonkers, N. Y.

SOUND SERVICE—continued

stallations, but additional input channels may be added if desired, or whenever necessary.

(7) *Microphone and Remote Control Outlets.* Outlet receptacles for microphones and remote volume controls are arranged and connected as shown in Fig. 2, so that microphones may be plugged in and volume controlled from any desired point. Five outlets are shown in the layout diagrams, but any required quantity may be installed. The location of the outlets will depend on the various uses for which the field is employed. One should be installed in back of the catcher's box for the umpire's announcements; one in the press box, manager's office, etc.

If the field is used for football, or pageants, a line of outlets for microphones and remote controls (all connected in parallel to one input) should be provided along both sides of the field, and by using 50- or 100-foot cables on the microphone and control, it will be possible to cover events on all sections of the field. A remote control outlet is placed alongside every microphone outlet. The announcer plugs in his mike and little control unit and is complete master of the entire system. When the

roar of the crowd threatens to drown out his announcements, he simply turns up the control so that his voice overrides the roar.

(8) *Phonograph and Radio Input.* An automatic turntable is located adjacent to the amplifying equipment and connections may be made to an input channel for radio pickup.

(9) *Monitor and Office Speakers.* A monitor speaker is located at the amplifying equipment, and additional speakers of the same type may be installed in the offices of various officials, etc. Since the average-size room requires only a fraction of a watt, several of these speakers may be connected to suitable output terminals on the power amplifiers without appreciably decreasing the main power output. (Use the 5000-ohm taps on speaker, and connect to the 30- or 60-ohm taps on the amplifier.)

(10) *Microphones.* The successful operation of any sound system depends upon the correct choice of microphones for particular applications. Microphones are classified in two general groups, pressure-operated (diaphragm-type), which includes inductor, dynamic, carbon, magnetic, condenser, and crystal; and velocity ("ribbon") type.

The pressure-operated type is recommended for outdoor applications and close talking.

The velocity type is preferable for indoor applications, wide-angle pickup, distance pickup, and reduction of feedback problems.

For the athletic field application, pressure-type microphones are recommended for announcements, and velocity-type are recommended for band pickup.

(11) *Wiring. Speaker cables.* The impedance of the 60- and 100-watt speakers is 15 ohms; to avoid appreciable power loss, the total resistance of the connecting cables between each speaker and the amplifier must be kept below 2 ohms by using wire of adequate size. With 2000 feet of wire connecting to one speaker, the wire size should be No. 10 or heavier. Speakers must be connected in phase so that the diaphragms move in and out together.

Microphone cables. The cables between the microphone outlets and the amplifier should be No. 16, 18, or 19 two-wire twisted lead-covered cable.

Remote control cable. Leads from the amplifier to the remote control should be No. 18 rubber-and-braid covered wire.

All cables should be run in compliance with local and national codes.

THE Eyes HAVE IT!

Write for
Descriptive
Literature

**Solar
Capacitor
Analyzer**

Your eyes and the MAGIC TUBE...
see all, know all, quick as a wink!

SOLAR MFG. CORP.
599-601 Broadway New York, N. Y.



RADIO FABRIC BELTS

More than half a million modern radio sets now in use are equipped with Woven Fabric radio dial belts. . . . Every one of these, sooner or later, will require replacement and this replacement will be repeated again and again.

The Fibre Board Display Kit illustrated contains 300 assorted radio dial belts exactly the same as originally used on Zenith, Emerson, Grunow, Sparton, Crosley, R.C.A., Fada, Stromberg-Carlson, Detrola, Silvertone (Sears, Roebuck), Airline (Montgomery Ward), and every other popular radio set manufactured.

The attractive kit will last a lifetime and should be prominently displayed by every jobber and distributor. Send for complete detailed schedule.

J. F. D. MANUFACTURING CO.
4107 Ft. Hamilton Pkway, Brooklyn, N. Y.

Gulbransen 40 and 40A

Instability: "Popping" on stations, unstable tuning meter action. Due to grid emission in 35 1st r-f or i-f tubes, or may be due to very high value of a-v-c plate resistor. In this model, all carbon resistors are subject to rise in value.

Francis Wolven

THEATRE SERVICING

(Continued from page 675)

that the Service Man be available as quickly as possible in case of emergency. The theatre should know where to reach him by telephone at all times and particularly on Saturday nights, holiday nights and other occasions when a breakdown is most expensive. If he is inconvenienced that is his own fault—it is his business so to use his routine visits that emergencies don't occur. An emergency call is answered with the utmost promptness—airplanes have often been used. If the Service Man is at a distance, diagnosis can be attempted, and remedies suggested, by telephone. Telephone servicing, even if successful, is followed by a personal visit at the earliest practicable moment.

The compulsory service charges of some years ago ran, as has been said, from \$20 a week for the smaller theatre to \$40 a week for very large ones. The same charges per month would be approximately in line with present conditions. But this question also will be discussed in greater detail hereafter.

If, as often happens, the theatre is one of a chain, successful work will bring the Service Man additional contracts almost automatically, and multiply not only his direct monthly income, but also his "inside" market for theatre sales.

(To be continued)

Sparton 617 Chassis

Intermittent operation with audio end ok and i-f section cutting out: All voltages normal. Due to shorted i-f trimmer. Replace the mica but keep it thin as thick mica will not peak. Set tends to motorboat when aligning at 18 mc unless signal input is kept low.

Francis Wolven



E. C. Cahill, RCA Service Manager (left), and W. L. Rothenberger, Manager of the RCA Commercial Sound Section, with some of the public-address and other equipment which is explained and demonstrated in the "Technaural" lecture meetings.

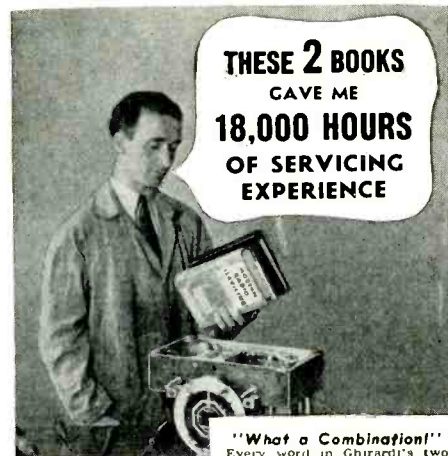

**THESE 2 BOOKS
GAVE ME
18,000 HOURS
OF SERVICING
EXPERIENCE**

"What a Combination!"

Every word in Ghirardi's two big servicing books brings you the results of thousands of hours of tried and tested servicing experiences and knowledge of others—to save your own time.

Handy Time-Saver

For example, the big "loose-leaf" DATA BOOK gives you the "Case Histories" of 1,500 receivers—the biggest collection in the world! Every one of them means anywhere from 10 minutes to 10 hours saved on a job. And then there's a list of superhet receiver I.F.'s (over 6,000 of them!) for alignment work. You'll also get Auto-Radio Installation and servicing data for all cars and loads of shop & job data in this quick and reference book that has a regular Supplement Sheet Service to keep it always up-to-the minute.

The Companion volume, MODERN RADIO SERVICING, is laid out to explain fully every aspect of modern servicing practice—all about test instruments, quick trouble-shooting methods, repair methods, etc. etc.—written in Ghirardi's famous "Easy-to-Understand Style" with loads of diagrams and illustrations (1708 of them!).

Order the books NOW—and tomorrow you'll have complete command of your profession within your grasp. Fill out the coupon below and mail it. You don't risk a single penny! Sent Postpaid Anywhere!

**MODERN RADIO
"Servicing"
RADIO FIELD
SERVICE DATA BOOK**

"1800 PAGES", 813 ILLUS.

Both Books for \$6



ORDER NOW! MONEY-BACK GUARANTEE

Radio & Tech. Publ. Co.
Dept. S-117,
45 Astor Pl. N.Y.
 Here's \$6 for MODERN RADIO SERVICING and RADIO FIELD SERVICE DATA (including the Jan. and June '37 Supplements to Data Book) postpaid. Send free literature

NAME _____
ADDRESS _____

SERVICE

with the
"SPEED TWINS"

GHIRARDI'S
TROUBLE-SHOOTER
GADGETS



Take you straight to the trouble in any radio set. How do they work?—just take up your Gadget; pick out the card marked for the

Trouble Symptom you find in the sick receiver; flip the card around—and there you'll see both the exact TESTS to make and the REMEDIES. One for HOME and one for AUTO radios. Spot over 850 different troubles! Sent postpaid anywhere on 5-day TRIAL basis.

\$1
RADIO & TECHNICAL PUBL. CO.
Dept. S-117 45 Astor Place, New York a Pair

HIGHLIGHTS . . .

RIDER MANUAL VOL. VIII

Anticipating the growing importance of mechanical knowledge in servicing automatic frequency control and motorized tuning, etc., the new 1600-page Volume VIII Rider Manual contains an additional supplementary 64-page section "How It Works" in which mechanical features are clearly and adequately covered.

In addition to the usual complete service data on a maximum coverage of 1938 American receivers Volume VIII also contains valuable information on p-a systems, electronic musical instruments, intercommunicating systems and other instruments which require servicing.

The completely revised Index—120 pages in itself—now covers all eight Rider Manuals. It enables a Manual user to locate quickly schematics, alignment data, voltage readings, mechanical adjustment of dial or drive—in fact everything covered on every page in every one of the Manuals.

In spite of the additional pages and new features in Rider Manual Volume VIII—there is no increase in price over last year's volume. Published by John F. Rider, 1440 Broadway, New York City.—SERVICE.

G.E. RADIO TUBE RETAILING PLAN

To enable dealers to go into the radio tube business with little investment on their part, Charles T. Wandres, General Electric tube sales manager, has announced a complete merchandising program which includes a comprehensive line of tubes, advertising, sales promotion aids, and service equipment, all offered on an attractive deal.

A deluxe Merchandiser which sets up a complete tube department in a small space has been made available to dealers. This sturdily constructed, all-metal cabinet, especially designed to accommodate a tube checker on top, constitutes a highly effective selling device for the tube dealer. Among its other features are the eye-level, double-faced, four-color sign which draws attention by offering a "Free Tube Test," four compartments with a maximum capacity of 324 tubes, three removable shelves, a handy sliding drawer-shelf which holds tubes to be tested, and an attractive and durable blue crackle finish.

Both the cabinet and a tube checker may be obtained by the dealer at greatly reduced prices by placing an order for a small number of tubes. The Merchandiser then costs him only half the regular price, and he may secure not only a tube checker but also other test equipment at a saving of approximately 75 per cent of the list price.

This test equipment, states Mr. Wandres, is a precision line of great dependability and thus more profitable to the tube dealer. He points out that efficient tube checkers weed out more defective tubes while dependable set analyzers eliminate wasted time in trouble-shooting.

As further service aids, G-E tube dealers are offered free with a small order for tubes, both the Service Notes for 1930-35 General Electric Radio Receivers, attractively bound, and a combination insulated screwdriver and socket wrench, that the Service Man can conveniently clip into his pocket, fountain pen style.—SERVICE.

JOHNSON BUYS DAY-RAD

D. E. Johnson, formerly president of the Day-Rad Company, and who, for the past two years has been sales manager of Bendix Day-Rad, has purchased the Day-rad division from the Bendix organization.

Mr. Johnson was in Chicago recently to check inventory, and to supervise the movement of equipment and apparatus to Dayton, where he will manufacture a complete line of test instruments and units, using the former trade name, Day-Rad. His new company, known as the Dayton Radio Corporation, will begin operation at once.—SERVICE.

RADIO AND ELECTRICAL SHOW

The Radio Electric Service Co., 7th and Arch Streets, Philadelphia, Pa., has announced a two-day exhibit of the products of a number of manufacturers of radio and electrical equipment. Open house, to which all are invited, is scheduled for December 1 and 2; the hours, 8:30 a. m. to 10:30 p. m.—SERVICE.

NATIONAL UNION CATALOG

The new line of electrolytic and paper condensers, recently announced by the National Union Radio Corp., 570 Lexington Ave., New York City, is described in a catalog just released by that organization. The catalog also describes National Union tubes, photo cells, etc.

Also just released is a convenient radio log book which is available through National Union distributors at low cost. The book has space on the rear cover for the name and address of the Service Dealer.—SERVICE.

TOBE DEUTSCHMANN APPOINTEE

The Rowe Radio Research Laboratory Company, 1103 Bryn Mawr Avenue, Chicago, Ill., has been appointed technical sales representative of the Tube Deutschmann Corp., Canton, Mass., for the Chicago area.—SERVICE.

SHURE ZEPHYR WINS AWARD

The Zephyr Crystal pickup of Shure Brothers, 225 West Huron Street, Chicago, Ill., was given an award in the recent Modern Plastics competition.—SERVICE.

U. S. L. NAMES DISTRIBUTORS

Royal Eastern Electric Supply Co., 16 West 22nd Street, New York City, has been appointed distributor by the United Scientific Laboratories, New York, for the new Electro Call line of inter-communicating systems.

Sager Electric Supply Co., Boston, will serve the Boston territory for Electro Call.—SERVICE.

SUPREME INSTRUMENT FOLDER

A bulletin illustrating and describing the line of test instruments manufactured has been issued by Supreme Instruments Corp., Greenwood, Miss. Copies may be obtained by writing to the company.—SERVICE.

ANTENNA SYSTEM MANUAL

A new Master Antenna System Manual just issued may be had from the local Taco jobber or by writing the Technical Appliance Corp., 17 East 16th St., New York City. This latest edition covers the profit-making possibilities of the master antenna system as applied not only to apartment houses and other large buildings, but also to individual dwellings wherein many radio set outlets are required. It deals with the theory, installation and operation of such a system, as well as the survey of buildings and estimating.—SERVICE.

RAYTHEON PROMOTES TWO

Promotions have just been announced by the Raytheon Production Corporation, in which Art Akeroyd, Ohio representative, was transferred to the position of manager of the New York office, and assistant to Earl S. Dietrich, manager of Distributor Sales.

Carl M. Lundquist of Raytheon's Chicago office has been promoted to the position of District Sales Manager in the Cleveland territory.—SERVICE.

PRECISION APPARATUS CATALOG

A new catalog sheet, Number 38, describing the Precision series of test equipment, is available by writing to Precision Apparatus Corp., 821 East New York Avenue, Brooklyn, N. Y.—SERVICE.

TRIPLETT BULLETINS

New price sheets, 45-I and 45-T, have been released by The Triplett Electrical Instrument Co., Bluffton, Ohio.—SERVICE.

MOSS-THALHEIMER

Announcement has been made of the marriage of Arthur Moss, secretary-treasurer of the Radio Parts Manufacturers National Trade Show, and Miss Marjorie Thalheimer on October 14.—SERVICE.

STANDARD TRANSFORMER TO BUILD

The Standard Transformer Corp., 850 Blackhawk Street, Chicago, Ill., has acquired property at Halstead and Blackhawk Streets, to which location the plant will be moved in February, 1938.—SERVICE.

ARCTURUS CHICAGO OFFICE IN NEW LOCATION

Resale Division Manager Jack Geartner of the Arcturus Radio Tube Company, Newark, N. J., announces removal of the Arcturus Chicago office to new and larger quarters in Room 14112A Merchandise Mart. In addition to providing the greater space necessitated by expanding business in this territory, the new office is easily accessible via fast transit lines from all parts of the city.

Wm. J. Johnston, better known as "Bill," is in charge of the Chicago office with F. P. Benson, R. S. Diethert and E. Englerth assisting.—SERVICE.

(Continued on page 716)

A COMPLETE **NEW** LINE FOR SALES AND PROFITS

GENERAL
ELECTRIC
PRE-TESTED
METAL
TUBES

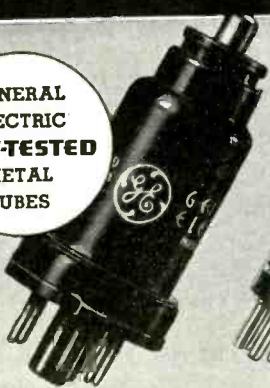

GENERAL
ELECTRIC
PRE-TESTED
GLASS
TUBES



FOR CUSTOMER SATISFACTION
Use G-E RADIO TUBES

Memo to:

Dealers and Servicemen

Ask your G-E Radio Distributor for details of the G-E Radio Tube Merchandising Plan, or write to Radio Tube Sales Section, General Electric Company, Bridgeport, Conn.



**GENERAL
ELECTRIC**

APPLIANCE AND MERCHANDISE DEPARTMENT
GENERAL ELECTRIC COMPANY, BRIDGEPORT, CONN.

New manual contains most extensive listings.

Standard and exact-duplicate types for every job.

Exact-duplicates insured to fit mechanically and electrically.

Each unit guaranteed for satisfactory performance.

Nearest CLAROSTAT jobber stocks these replacements.

You'll save time, labor, money and come-backs with CLAROSTAT.

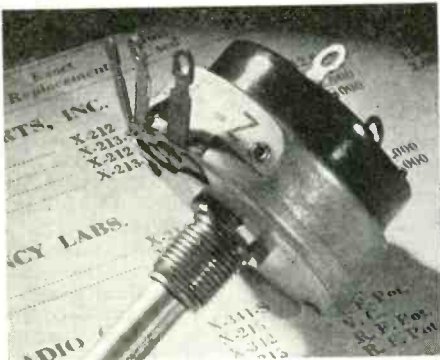

Correct!

That's the story of CLAROSTAT Exact-Duplicate Controls and Ballasts for any standard set. These replacements are *correct*—mechanically and electrically.

Free MANUAL: Just issued. Over 200 pages. Handy pocket size. Most extensive listings and other practical data. Yours for the asking.

CLAROSTAT *Manufacturing Co. Inc.*



285-287 NORTH SIXTH STREET
BROOKLYN, NEW YORK, U.S.A.

• OFFICES IN PRINCIPAL CITIES •

FOR THE FIRST TIME!

A ONE-WATT
Precision
**VITREOUS
RESISTOR**



RITEOHM 71

OHMITE VITREOUS ENAMEL advantages in compact, 1 watt, 1% accurate, precision resistors. OHMITE opens a new field with this achievement—time-proven vitreous enamel now made available to protect the accuracy of small, close-tolerance resistors for meter multipliers, test sets, laboratory equipment and other applications. Bulletin 108 lists the many stock values of the new RITEOHM 71.

OHMITE

MANUFACTURING COMPANY

4827 Flournoy Street

Chicago, U. S. A.

Haldorson *Vacuum Sealed* Transformers

- Impervious to Moisture
- Choice of Leading Service Experts
- Construction and Shell Assemblies Make Possible Universal Mounting.

Use Haldorson Transformers for trouble-free service work. Vacuum Sealed means impervious to moisture, an impregnation that does not crack, flake off or open up even in tropical climates.



The **NEW**
VARI-VOLT

Have you obtained your
**FREE VARI-VOLT
TRANSFORMER**

Makes your test bench voltage exactly what you want it. Improve your test work . . . find troubles quickly with over voltage judiciously applied. 0 to 256 V. in one-volt steps, 0 to 128 V. in half-volt steps.



The Haldorson Company, 4500 Ravenswood Ave., Chicago, Ill. S-1137

Please send me

- New Catalog on Haldorson Vacuum Sealed Transformers.
 Information on how I can obtain Vari-Volt Transformer Free.

Name

Address

City State.....

THE MANUFACTURERS . . .

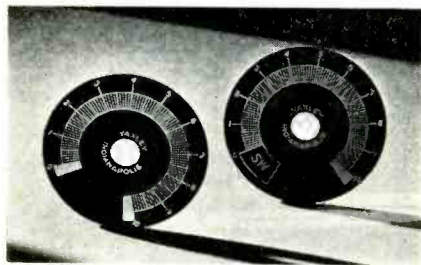

YAXLEY MATCHED DIAL PLATES

These dial plates are marked in 100 divisions of the active rotation, and are calibrated numerically from 1 to 10. The rotation covered by the terminals and the switch short out is clearly marked so that it is easy to set the plates in their proper position on the panel. The new Yaxley matched dial plates are $2\frac{3}{4}$ " in diameter and finished with polished aluminum markings against a satin black background.

If the control is of the linear type, a setting of "5" on the matched dial plate indicates that one-half of the resistance is in the circuit. A setting of "1" indicates that one-tenth of the resistance is in the circuit, etc. When a matched dial plate is used with a tapered control in the proper circuit, the calibration is in proportion to the audible intensity of the signal—thus a setting of "5" would indicate 50 percent volume as heard by the ear.

Matched dial plates, made by P. R. Mallory & Co., Inc., Indianapolis, Ind., are available from Mallory-Yaxley, distributors.—SERVICE.

CROWE ANNOUNCES NEW KITS

The Crowe Name Plate & Mfg. Co., Chicago, is bringing to completion its line of panel mounting kits for 1938 auto radios, and now announces the availability of this new line for use on the new automobiles for the coming year.

These new Auto Radio Panel Mounting Kits embody such features of design as softly illuminated dials, interchangeable controls and shafts permitting use on any car or re-installation in any car simply by changing only the panel mounting kit. The color treatment of the knobs harmonizes with the instrument panel of the car, as does the design of the kit itself. The entire job conforms to the official styling of the car manufacturer.

Complete details regarding the new line of Crowe panel mounting kits are available to anyone on request to the manufacturer.—SERVICE.

"PLUGGIN" CONDENSERS

A departure from conventional design in electrolytic condensers is the Tobe "Pluggin" condenser, a newly patented product constructed with a UX 4-prong tube base. With this new unit it is possible to make quick changes. The unit is completely sealed and protected against moisture and high temperatures in a non-corrosive aluminum container. Further information may be obtained from Tobe Deutschmann Corporation, Canton, Mass.—SERVICE.

Illustrating the wave-expanding feature of the new Du Mont Oscillograph.

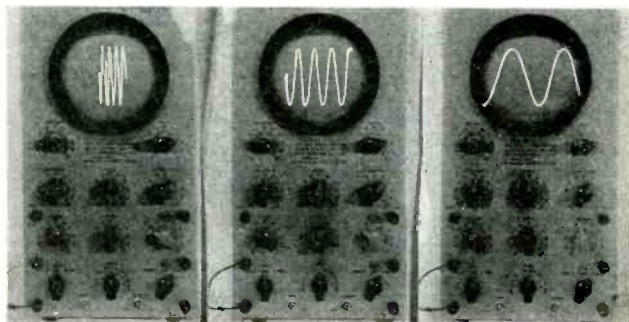

DOUBLE-TUNED TRANSFORMERS

A new line of standard i-f double-tuned transformers has recently been placed on the market by the Meissner Mfg. Company. They are known as the Wide Range line. The unusual feature of these transformers is said to be the wide range that the transformers can be tuned to. A Service Man can, with only four standard wide-range transformers, tune to any i-f required from 121 to 650 kc without skip. They are available in either air core or iron core. 1500 kc and 3000 kc units are also available for the amateur.

Further details may be obtained by writing to the manufacturer at Mt. Carmel, Ill.—SERVICE.

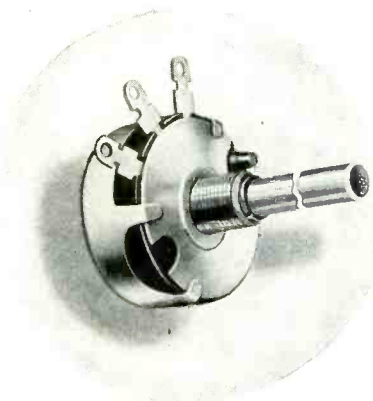

IRC POWER CONTROL

A new IRC metallized-type power control, capable of carrying 2 watts, for plate-circuit tone control and other similar applications, has recently been announced. It is known as the IRC Type CP control. It incorporates all of the well-known features and characteristics of the Type C control, including the metallized-type resistance element permanently bonded to a moisture-proof bakelite base, 5-finger contact, etc. Rapid heat conduction from element to cover and shaft assembly is obtained by an arrangement of a copper heat-conducting plate. This is said to make possible the conservative 2-watt rating as compared to the $\frac{1}{2}$ -watt rating of standard IRC Type C controls. The size is the same as that of the latter, being small for a power control of this rating.

Complete specifications and samples will be sent upon requests addressed to the International Resistance Co., 401 N. Broad St., Philadelphia, Pa.—SERVICE.

WAVE-EXPANDING OSCILLOGRAPH

A wave-expanding feature, incorporated in a new DuMont 5-inch, all-purpose oscillograph, permits the spreading of a small portion of a wave for detailed study. It also allows expansion of waves of much higher frequency than the fundamental frequency of the sweep. Million-cycle waves are said to be observed with good detail, and the return trace eliminator permits the waves to appear only on the forward linear portion of the sweep.

Complete information may be secured from the Allen B. Du Mont Laboratories, Upper Montclair, N. J.—SERVICE.

WAX AND OIL CAPACITORS IN SERVICE WORK

There is no difficulty in identifying a capacitor which is plainly marked by either the condenser or set manufacturer. However, should this means of identification be lacking, it then becomes the Service Man's job to find out the electrical characteristics of the unit itself, namely, capacity, working voltage, capacity tolerance, whether section is inductive or non-inductive, whether process of assembly is wax, oil or electrolytic. According to William M. Bailey, Chief Engineer of the Cornell-Dubilier Electric Corp., many wax and oil units closely resemble electrolytic condensers in external appearance. The Service Man should make absolutely sure which are electrolytic and which are wax or oil impregnated units before attempting to make any definite replacement. This can easily be accomplished by checking the leakage through the capacitor. If the leakage is in the order of milliamperes, it is of the electrolytic type. If in the order of microamperes, it is paper (wax and oil).

In analyzing the faulty unit, the Service Man should test for open circuits, short circuits, or, should the capacitor be of a dual nature, shorts between sections. Other tests that should be made are shorts to

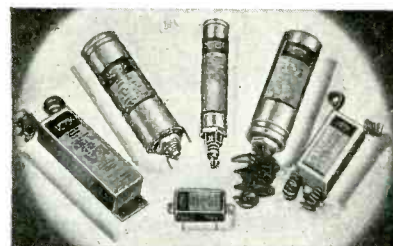

All but two are electrolytics. How can they be distinguished?

• SERVICE FOR



RED,
BLUE,
OR BLACK
CRACKLE
FINISH

MODERN 12 WATT P. A. SYSTEM In a Choice of Colors

A compact and powerful system that combines modern beauty to reliable performance! Improved in every respect! Here are a few of the many superior features: Ultra wide range crystal microphone—heavy duty permanent magnet twin speakers—beam power output tubes—equally suitable for permanent or temporary installations—entire system is encased in one unit for easy portability—easy to operate and service—streamlined appearance—choice of colors. Write for complete details and specifications.

DEALERS

Write for details and information on Bell's complete line of P. A. Equipment and Inter-Office communicating Systems.

MANUFACTURED UNDER LICENSE
ARRANGEMENT WITH E. R. P. I.

BELL Sound Systems, Inc.
61-62 East Goodale St.
Columbus, Ohio

Export Offices: 308 W. Washington Street, Chicago, Ill.

STATEMENT OF THE OWNERSHIP, MANAGEMENT, CIRCULATION, ETC., REQUIRED BY THE ACTS OF CONGRESS OF AUGUST 24, 1912, AND MARCH 3, 1933

Of SERVICE—A Monthly Digest of Radio and Allied maintenance published monthly at New York, N. Y., for Oct. 1, 1937.
County of New York, } ss.:
State of New York, }

Before me, a Notary Public, in and for the State and County aforesaid, personally appeared Bryan S. Davis, who, having been duly sworn according to law, deposes and says that he is the Business Manager of the SERVICE—A Monthly Digest of Radio and Allied Maintenance, and that the following is, to the best of his knowledge and belief, a true statement of the ownership, management, (and if a daily paper, the circulation), etc., of the aforesaid publication for the date shown in the above caption, required by the Act of August 24, 1912, as amended by the Act of March 3, 1933, embodied in section 537, Postal Laws and Regulations, printed on the reverse of this form, to wit:

1. That the names and addresses of the publisher, editor, managing editor, and business manager are: Publisher, Bryan Davis Publishing Co., Inc., 19 East 47th Street, New York, N. Y.; Editors, W. W. Waltz, Tottenville, S. I., N. Y., and Ray D. Rettenmeyer, Brooklyn, N. Y.; Managing Editor, None; Business Manager, Bryan S. Davis, Ghent, N. Y.

2. That the owners are: Bryan Davis Publishing Co., Inc., 19 E. 47th St., New York; B. S. Davis, Ghent, N. Y.; J. C. Munn, Union City, Pa.; J. A. Walker, Richmond Hill, L. I., N. Y.; A. B. Goodenough, New Rochelle, N. Y.

3. That the known bondholders, mortgagees, and other security holders owning or holding 1 per cent or more of total amount of bonds, mortgages, or other securities are: None.

4. That the two paragraphs next above, giving the names of the owners, stockholders and security holders, if any, contain not only the list of stockholders and security holders as they appear upon the books of the company, but also, in cases where the stockholder or security holder appears upon the books of the company as trustee or in any other fiduciary relation, the name of the person or corporation for whom such trustee is acting, is given; also that the said two paragraphs contain statements embracing affiant's full knowledge and belief as to the circumstances and conditions under which stockholders and security holders who do not appear upon the books of the company as trustees, hold stock, and securities in a capacity other than that of a bona fide owner; and this affiant has no reason to believe that any other person, association, or corporation has any interest direct or indirect in the said stock, bonds, or other securities than as so stated by him.

(Signed) BRYAN S. DAVIS, Business Manager.

Sworn to and subscribed before me, this 5th day of October, 1937.
(Seal) J. A. WALKER, Notary Public.

Queens Co. Clk's No. 2034; Reg. No. 5634. New York Co. Clk's No. 433, Reg. No. 9-W-299. My commission expires March 30, 1939.

Quiet, Insulated, and Reliable RESISTORS

CONTINENTAL CARBON

bakelite Insulated resistors are impervious to moisture, conveniently small and noiseless in high gain circuits. They are recommended for use in compact amplifiers and radios.

M3, 2"x13/16"....3 Watt, \$.30
M1, 1"x9/32"....1 Watt, .20
M1/2, 3/8"x7/32"....1/2 Watt, .17



CONTINENTAL CARBON

ceramic Insulated resistors have withstood the tests of time in actual service. Where space permits, ceramic Insulated resistors are recommended for the utmost in stability and long life. In close tolerance applications, these resistors are the choice of leading test instrument manufacturers of precision equipment and meters.

H5, 3"x9/16"....5 Watt, \$.50
E2, 2"x3/8"....3 Watt, .30
D2, 1 3/4"x1/4"....1 Watt, .20
G4, 1"x1/4"....1/2 Watt, .17

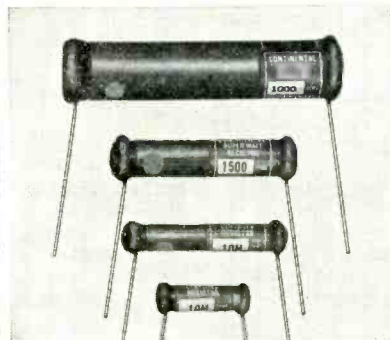

Send for Bulletins 104B, 105, 103A, and 101A.

CONTINENTAL CARBON Inc.

13912 Lorain Avenue

Also Toronto, Canada

Cleveland, Ohio

FLASHING SIGNALS! EAR PHONE! NOISE TEST!

FLASHES a brilliant red signal for a bad tube—amber signal for a weak tube—and green signal for a good tube. Signals are translucent ivory until you press the button. The customer listens to the noise test through a permanently attached earphone. Shorted or leaky tubes cause intense glow, spreading lengthwise in long glass cylinder. Makes test of grid control. Fast and simple to operate.

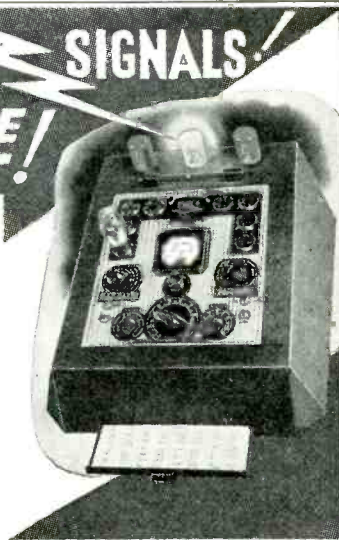

Crystalline Metal Case

Lustrous Chrome Panel—Steel Slide for Chart.

NET PRICE TO DEALERS \$54.00

ON DEMONSTRATION AT YOUR JOBBER'S

THE RADIOTECHNIC LABORATORY
1330 SHERMAN AVE., EVANSTON, ILL.

A Complete Line of
Tube Test Equipment

SEE
YOUR
JOBBER

RADIOTECHNIC

MANUFACTURERS—continued

ground, high-voltage terminal leakage, and over loading due to some high transient setting up a peak voltage, when the peak voltage is applied before the heaters have come up to full values of current.

In the replacing of wax or oil impregnated paper capacitors as they are known today to the trade, the Service Man is concerned with capacity, working voltage, test voltage, capacity tolerance, inductive or non-inductive sections, power factor, size and price.

The actual capacity marking should be carefully checked by the Service Man before final replacement is made in the set. After locating and repairing the trouble, the Service Man can check against the rating of the new capacitor, if the capacitor is one where the value is at all critical. This applies especially to the smaller type condensers which are used in oscillator circuits. If the capacities are not of the proper value, the oscillator will not operate as originally intended by the set manufacturer.

When selecting the proper working voltage at which the units are to be operated, take care to select a capacitor whose rated peak voltage will take care of any high peak voltages due to line surges and other faults beyond the control of the usual operation of radio receiving equipment.

The choice of inductive or non-inductive sections for replacement work can easily and quickly be chosen by investigating the unit that has failed in service. A non-inductive section is wound with an extending margin of foil on either side of the paper or dielectric. The inductive type of winding appears with paper extending beyond the foil, with tabs as connectors.

Capacitors today are available in many styles, shapes and containers. The particular type is a consideration usually dictated by the space and mounting room available in the radio receiver.

In the servicing of multi-band receivers today, the Service Man will notice that the original manufacturer had to devise various engineering schemes to properly by-pass the radio-frequency current at widely different frequencies. In many cases, special capacitor construction was required, such as in the shape of the unit, the casing or mounting, and the length, width and size of the leads. Usually in replacing such a unit which has failed, it is necessary to use an exact duplicate replacement type in every respect, in order to have the set function properly over all the bands. Otherwise the units may be satisfactory on three or four bands, and may be entirely unsatisfactory on the fifth or ultra-high-frequency band. This is due to the lead length being large enough to resonate with the capacitor, setting up a resonant circuit not desired on that particular band. At the ultra-high frequencies, one can readily see where an addition of one-half or three-quarters of an inch will make an entirely different picture in the circuit and the receiver will not operate properly under those conditions.—SERVICE.

RCA TELEVISION TUBES AVAILABLE

Two cathode-ray tubes suitable for television reception are being made available to radio amateurs, educational institutions, laboratories and others interested in experimental television by the RCA Manufacturing Company. Some television equip-

ment has been sold to the National Broadcasting Company and to the Columbia Broadcasting System, but this is the first television apparatus offered for general sale by RCA in the United States.

In its announcement RCA emphasized that placing the tubes on the market for the convenience of experimenters should not be construed in any way as an announcement by RCA of commercial television apparatus for use by the general public. The tubes, known as "Kinescopes," are being made available as a result of inquiries by amateurs, experimenters, laboratories, and schools for cathode-ray tubes suitable for television reception.

The tubes are both of the electromagnetic-deflection type and employ viewing screens on which the picture appears clearly, with a yellowish hue. They are known as RCA-1800 and RCA-1801, the former being a nine-inch tube and the latter a five-inch tube.

The "Kinescopes" each employ an electron gun and a fluorescent screen assembled within a vacuum tube. The negative electrode delivers a stream of electrons varying in intensity with the strength of the signals received. By means of magnetic deflection coils, this beam is made to scan the fluorescent screen which then emits light in proportion to the beam intensity. The beam can be made to trace a pattern of 441 lines, 30 times a second, giving picture definition substantially equivalent to a good photographic enlargement.

The tubes will permit experimenters to build receivers to pick up experimental television transmissions. At the present time experimenters will be restricted necessarily to the areas within some 50 miles of experimental stations, since television transmissions are practically limited to line of sight distances.—SERVICE.

CABINET REPAIR KIT

A repair kit suitable for filling and refinishing nicks and scratches in radio cabinets is available from the General Cement Mfg. Co., Rockford, Ill. The kit comes complete in a leatherette finish box and contains six shellac sticks in light and dark shades, alcohol lamp with alcohol, spatula, steel wool, sandpaper and polishing cloth.—SERVICE.

CATHODE-RAY OSCILLOGRAPH

The Model RFO-4 cathode-ray oscillograph, shown in the accompanying illustration, has a self-contained electronic frequency modulator which simplifies connections and permits selectivity measurements. It has a variable width sweep from 0-30 kc. This modulator permits visual alignment at 665 kc or any harmonic thereof to 5 megacycles, without the use of an external oscillator. With an external oscillator it produces an audio-frequency output continuously variable from 0 to 15 kc. Also permits visual development of audio-frequency response curve.

Among the other features of this instrument are: return trace eliminator (simplifies alignment of a-f and r-f circuits); horizontal amplifier for sweep expansion; high sensitivity horizontal and vertical amplifiers (0.2 volt per inch); trapezoidal pat-

terns permit percent modulation measurements; calibrated screen; cathode-ray tube rotation adjustable by means of flexible mounting.

Complete information may be secured from the maker, *The Hickok Electrical Instrument Co.*, 10514 Dupont Ave., Cleveland, Ohio.—SERVICE.

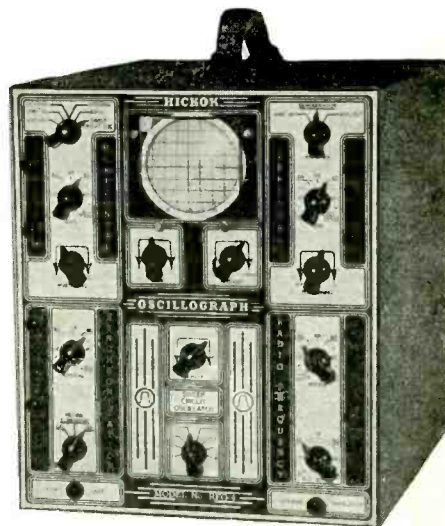

CORNELL-DUBILIER INTRODUCES UNIVERSAL MOUNTING

Mechanical difficulties in mounting high-voltage filter capacitors are said to be entirely eliminated with the universal mounting brackets introduced by the Cornell-Dubilier Electric Corporation. As the illustration shows, mounting in all positions is easily accomplished. Impregnated and filled with Dykanol in hermetically sealed non-corrosive containers, the C-D type TJ-U high-voltage filter capacitors can be mounted in any position without altering or affecting the electrical characteristics of the unit, according to the manufacturer. The universal mounting brackets are supplied at no extra cost with each C-D type TJ-U filter capacitor. For catalog listing of these new capacitors, write to the Cornell-Dubilier Electric Corporation, South Plainfield, New Jersey.—SERVICE.

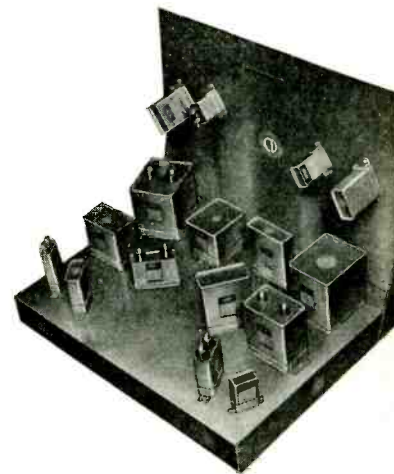

• SERVICE FOR

DON'T MISS . . . Ward's
announcement of new models
in December **SERVICE**

"A NEW ERA IN ANTENNAE"

WARD
PRODUCTS CORP.



FUNCTIONAL DESIGN

"V" Series Velocity Microphones

The smooth trim lines and screen housing are more than just style. They contribute to the top performance that typifies the "V" Series. No side-wall reflection. No resonance.

Priced from \$25 to \$75 list.
Write for catalog. See your jobber.

ELECTRO-VOICE MFG. CO.

332 E. Colfax Avenue, South Bend, Ind.
Export Office: 100 Varick Street, New York City

A REAL OPPORTUNITY SERVICE SALESMEN

Centrally located national distributor parts and public address equipment, requires local representatives to solicit orders from dealers and servicemen. Excellent opportunity for live wires. Must be familiar with local service trade. Liberal commissions. This is a real proposition for go-getters. Write full details, training, experience and background in trade.

BOX 150, c/o SERVICE, 19E. 47th St., New York, N. Y.

SAVE \$1.00!!!

- The Group Subscription Plan for *Service* enables a group of service men, dealers or jobbers to subscribe at one-half the usual yearly rate.
- The regular individual rate is \$2.00 a year. In groups of 4 or more, the subscription rate is \$1.00 a year. (In foreign countries, \$2.00.)
- Each subscriber should print his name and address clearly and state his occupation—whether a dealer, jobber, independent service man, service organization, etc.

Remember this Group Plan when *Your*
Subscription Expires

(See page 649, October issue)

MULTI TAP

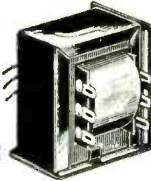

Available with lugs (as shown) or with covered wire leads.

Be prepared to replace faulty transformers on your first call!

Six MULTI-TAP Transformers belong in every emergency kit—one output, one input and four sizes of power transformers. With this assortment you can service practically all sets from 4 to 12 tubes.

For example, output MULTI-TAP No. 1337, shown above, serves many purposes: Although the primary is untapped, it matches almost any single tube or push-pull output stage. For push-pull operation, correct primary matching is obtained when 71A, 4S, 50 or 43 type tubes are used. For single tube output using the total primary, correct matching is obtained with the 33, 47, 41, 42, or 2A5 tubes. One-half of the primary can be used to match a single 48 tube.



The secondary is tapped to accomplish with the least number of terminals a most uniform range of load impedances from 1 to 30 ohms.

MOISTURE PROOFED All coils are vacuum-baked to extract every last trace of moisture, and then impregnated with special 9X Moisture-Proofing Compound, forced into windings under tremendous pressure. This is essential in humid seacoast climate or where hot days followed by cool nights causes condensation on the coils. Ask your jobber or write for FREE Bulletin, Form 41.



**GENERAL
TRANSFORMER CORP.**

1266 W. Van Buren St., Chicago

I wonder if she's
got a Radio..
that needs fixin'



Ward Leonard Replacement Parts help the service man build up a reputation for good work. Ward Leonard Parts are dependable, because they are made right, conservatively rated and tested. The service man who uses them, therefore doesn't lose his job profit or customer good will making good for parts failure.

WARD LEONARD ELECTRIC COMPANY

36 SOUTH STREET, MOUNT VERNON, N. Y.

Please send me service man's price sheets No. 507A.

Name

Address

City..... State.....

Jobber's Name

MANUFACTURERS—continued

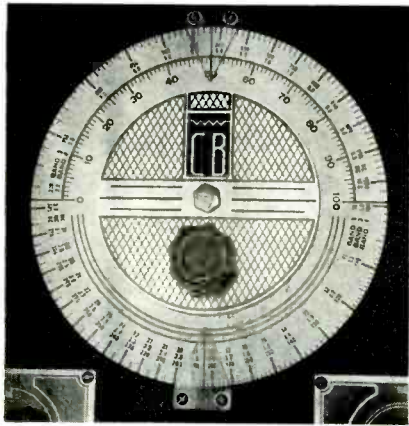

CLOUGH-BRENGLE SIGNAL GENERATOR

Featured by a dial which, it is claimed, makes for exceptional ease in operation, the Clough-Brengle Model 110 signal generator has been announced. As may be seen from the illustration, the dial has unified calibration, one set beneath the other for all of the five bands provided by the generator.

Further details may be obtained from Clough-Brengle, 2815 West 19th Street, Chicago, Ill.—SERVICE.

PRECISION RESISTORS

Ohmite Manufacturing Company announces the new Riteohm "71," a vitreous enameled 1 percent accurate, precision resistor of 1 watt rating. Riteohms are said to be ideal for use as voltmeter multipliers, in laboratory equipment, radio and electrical test sets and in many similar applications.

The Riteohm "71" is single-layer wound with special alloy wire, on a ceramic tube. The ends of the wire are mechanically locked and brazed to the copper lugs providing permanent connection. Easily soldered tinned copper wire leads make installation convenient. The resistor is covered with special Ohmite vitreous enamel, which rigidly holds, insulates and protects the space-wound wire.

Because of their small size, single-layer construction and relatively few turns, the resistors have low inductance and distributed capacity. They are very conveniently used in many kinds of circuits.

Bulletin 108 describing the Riteohm "71" and other precision resistors may be had from the Ohmite Manufacturing Company, 4827 W. Flournoy Street, Chicago, Illinois.—SERVICE.

PHILCO OFFERS PLIERS

An unusual free offer for Service Men has just been announced by Philco—free Kraeuter pliers and cutters with orders for Philco Identified Resistor Kits.

The offer is good for November only, according to instructions sent out by Robert F. Herr, Manager of Philco's Parts and Service Division. Until November 15, Philco is including one of these high-priced tools with each resistor kit sent from the factory, the dealer selecting the tool desired. The Resistor Kit carries part No. 45-1248.—SERVICE.

EQUIPMENT CARRYING CASE

A recent idea in professional service kits, of sturdy wood construction covered with imitation leather and providing space for a complete line-up of parts, tools, tubes, etc., has just been added to the long list of dealer helps featured by the Arcturus Radio Tube Company of Newark, N. J.

The kit is 22 inches long, by approximately 10 inches high and 8 inches deep. One large compartment at the bottom provides ample space for miscellaneous test equipment, tubes, tools and parts. A removable tray at the top makes a handy way of keeping small parts and tools.

Besides opening at the top, the side of the kit is hinged, thus providing ready access to all of the contents.

The kit has metal corner pieces to guard against possible damage and is also equipped with a carrying handle. The fact that it is constructed of 5/16-inch wood with leatherette covering gives ample evidence of its durability.

The new Kit is made available to Arcturus tube users at a very low cost and is obtainable through authorized Arcturus distributors.—SERVICE.

TURNER MICROPHONE

The Turner Company, Cedar Rapids, Iowa, has announced a crystal microphone, model T-9, which features a new cartridge unit said to be shock-proof and suitable for either voice or music. Further details may be obtained from the manufacturer.—SERVICE.

HIGHLIGHTS—continued

SYLVANIA TUBE COMPLEMENT BOOK

Hygrade Sylvania Corporation has recently published a pocket-size Tube Complement book of 165 pages, said to be a complete compilation of tube complements and intermediate frequencies. More than a year has been required to assemble and complete the information. Included in the book are tube complements for 10,386 radio receivers, from early sets to many of the 1938 models, intermediate frequencies for these sets, information on tube replacements in approximately 75,000 sockets, trade names of 560 sets with names of the manufacturers, names and business addresses of 144 set manufacturers now in business and many helpful technical articles for Service Men. The book will be merchandised through Sylvania tube jobbers at a price approximating the cost of printing.—SERVICE.

SOLAR CATALOG

It was announced last month that Solar was making available a line of high-voltage condensers for use in power packs, transmitters, etc.

For the benefit of Service Men, transmitter engineers, and Solar Distributors, a catalog describing the complete line of Transoil, Transmica, and Solarex high-voltage condensers, has been made available by the Solar Mfg. Corp., 599-601 Broadway, New York City. A copy may be obtained by writing to Solar and asking for Catalog Number 2.—SERVICE.



NEW AMPERITE SALES HELPS

The Amperite Co., 561 Broadway, New York, has just announced a new series of sales helps available to the trade. Featured is an attractive window decalcomania in color. Another sales attracting display features the world-famed orchestra leader, Cab Calloway, at an Amperite Velocity Microphone. This display measures 11x17 inches, mounted on heavy cardboard, easel backed. A series of three new letterhead designs in two colors to be imprinted with name, address and phone number has found a ready response. These are available to the sound and servicing trade, filling a long needed requirement from a business standpoint. For further information please write direct to Amperite Company.—SERVICE.

DUBILIER ANNIVERSARY

Twenty-five years ago the Dubilier Electric Company started to turn out a product for which, at that time, the demand could not have been excessive—condensers for radio use. In commemoration of the anniversary of that event, the English company bearing his name presented William Dubilier with an illuminated scroll.

The American company (now the Cornell-Dubilier Corporation) is even older than its English contemporary, having been founded in 1910.—SERVICE.

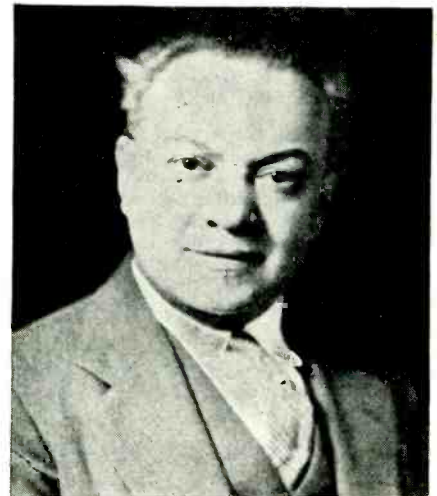

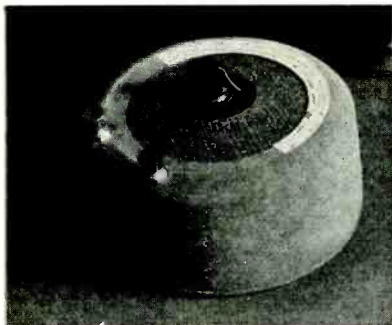

Attractive Model T. B. U. 1700, Size 6 1/2" Diameter, 3" high

TECHNICIANS

Install custom built inter-communication systems with Talk-Bak* Units.

New Technical and Sales Pamphlet

gives complete information regarding all known inter-communication systems. Method of connecting different Talk-Bak* Units and full detail information on what they will accomplish. Write for it and be sure to include your distributor's name.

Wright-DeCoster Distributors are always anxious to cooperate.

WRIGHT-DeCOSTER, Inc.

Export Dept.: M. Simons & Son Co., New York. Cable Address: "Simontrice"
 Canadian Wm. F. Kelly Co., 1207 Bay St., Toronto, Ontario
 Representatives: Taylor & Pearson, Ltd., Edmonton, Alberta *Copyrighted.

2253 University Avenue, St. Paul, Minn.

UNIVERSAL DUPLICATE THORDARSON

SPOT

REPLACEMENT TRANSFORMERS

that Replacement Transformer in a flash with Thordarson Replacement Encyclopedia No. 243. FREE at your Parts distributor, or 15c postpaid from factory.

for 99.8% of all radio receivers listed in Ryders 7 volumes. NOW!! Perfect matching, plus Thordarson quality for long life, trouble free, service.

THORDARSON ELECTRIC MFG. CO.
 500 W. HURON ST., CHICAGO, ILL.
Demand 'Power by Thordarson'

Curtis

Electrolytic CONDENSERS

Their high Quality is demonstrated by Unusual Dependability and Outstanding Performance in millions of installations.

Write for complete catalog.

CURTIS CONDENSER CORPORATION

3088 WEST 106TH ST. CLEVELAND, OHIO

Patent No. 1,950,352

RADIO AMATEUR CALL BOOK

is the only publication listing all radio amateurs throughout the entire world. It also includes a complete list of High Frequency Commercial Stations, International Abbreviations and "Q" Signals, High Frequency Press and Weather Schedules, "Q", "R" and "T" Signals, U.S. Radio Inspection Districts, International Prefixes.

Every radio amateur should have a copy of this valuable book. Always up-to-date, published quarterly, single copies \$1.25, annual subscription \$4.

RADIO AMATEUR CALL BOOK, Inc.
 612 So. Dearborn Street Chicago, Illinois

INDEX TO ADVERTISERS

<p>A</p> <p>Aerovox Corp. 702 Allied Radio Corp. 699 American Tel. & Radio Co. 701 Amperite Co. 679, 700 Areturus Radio Tube Co. 707</p> <p>B</p> <p>Bell Sound Systems, Inc. 713 Birnbach Radio Co. 694 Box 150, SERVICE 715 Brush Development Co., The 705 Burstein-Applebee Co. 718</p> <p>C</p> <p>Centralab 687 Cinaudagraph Corp. 694 Clarion Inst. of Sound Engineers 689 Clarostat Mfg. Co., Inc. 711 Continental Carbon, Inc. 713 Cooks Mfg. Co. 708 Cornell-Dubilier Electric Corp. 700 Cornish Wire Co., Inc. 663 Crowe Name Plate & Mfg. Co. 696 Curtis Condenser Corp. 717</p> <p>E</p> <p>Electro-Acoustic Products Co. 667 Electro-Voice Mfg. Co. 715</p> <p>G</p> <p>General Electric Co. 711 General Transformer Corp. 715</p>	<p>H</p> <p>Haldorson Co., The 711 Hygrade-Sylvania Corp. 703</p> <p>I</p> <p>International Resistance Co. 668</p> <p>J</p> <p>J. F. D. Mfg. Co. 709 Jensen Radio Mfg. Co. 693</p> <p>K</p> <p>Ken-Rad Tube & Lamp Corp., Inc. 718 Kenyon Transformer Co., Inc. 699 Kraeuter & Co. 718</p> <p>M</p> <p>Mallory & Co., Inc., P. R. Second Cover Meissner Mfg. Co. 718 Million Radio & Tel. Labs. 718</p> <p>N</p> <p>National Union Radio Corp. 697</p> <p>O</p> <p>Ohmite Mfg. Co. 711 Operadio Mfg. Co. 718</p> <p>P</p> <p>Park Metalware Co., Inc. 702 Precision Apparatus Co. 702</p>	<p>R</p> <p>RCA Mfg. Co., Inc. Fourth Cover Racon Elec. Co., Inc. 718 Radio Amateur Call Book 717 Radio & Technical Pub. Co. 709 Radio Service Inst. 700 Radiotechnic Lab., The 713 Raytheon Production Corp. 695 Readrite Meter Works. 692 Rider, John F., Publisher 685</p> <p>S</p> <p>Shure Brothers 694 Simpson Electric Co. 701 Solar Mfg. Corp. 708, Third Cover Standard Transformer Corp. 703 Supreme Instruments Corp. 691</p> <p>T</p> <p>Technical Appliance Corp. 696 Thordarson Elec. Mfg. Co. 717 Triplett Elec. Inst. Co. 665 Triumph Manufacturing Co. 709 Tung-Sol Lamp Works, Inc. 705</p> <p>U</p> <p>Universal Microphone Co., Ltd. 718 Utah Radio Products Co. 707</p> <p>W</p> <p>Ward Leonard Elec. Co. 715 Ward Products Corp. 715 Weston Elec. Inst. Corp. 695 Wright-DeCoster, Inc. 717</p> <p>Y</p> <p>Yaxley Manufacturing Division Second Cover</p>
---	---	---

MODEL 108 8-15 WATT PORTABLE UNIT

Ideal where a low priced portable unit is required. Complete with Model 813 Amplifier, veleton microphone with combination hand and banquet stand, ten inch Electrodynamic speaker and tubes.

Send for Catalog 12
Address Dept. S10



OPERADIO

MANUFACTURING COMPANY

ST. CHARLES, ILLINOIS

Export Division: 145 West 45th Street, New York City

MILLION ALL-WAVE OSCILLATOR



A.C., D.C.
6 BANDS—100-
25,000 K.C.
SEPARATE
AUDIO
LINE FILTERS

19.95
NET

Write for literature on
our complete line of test
instruments.

MILLION RADIO AND TELEVISION LABORATORIES

671 W. OHIO STREET

CHICAGO, ILL.

"ASK ANY MECHANIC"

he'll tell you

IF IT'S QUALITY
YOU'RE
LOOKING FOR,
REMEMBER
THE NAME
KRAEUTER



That's because Krauter Pliers do the job quicker and better. As, for example, the diagonal cutting pliers 4601 shown here, made especially for close cutting and precisely fitted for exact work.



KRAEUTER & CO., Newark, N. J.

(Pronounced KROY-TER)

Manufacturers of Highest Quality Pliers and Tools Since 1860

SATISFY CUSTOMERS

Ken-Rad Radio Tubes

Always carry dependable
Ken-Rad Tubes. Advanced
Engineering. Precision
manufacture. Good reputa-
tion.

KEN-RAD TUBE & LAMP CORPORATION, OWENSBORO, KY.

NEW UNIVERSAL DYNAMIC MICROPHONE

100% Satisfaction

or

100% Refund

Self energizing. Not affected by heat or climate. An amazing sound development. Impedances 33 or 50 or 200 or 500 ohms; also high impedance direct to grid. Frequency response 40-8000 C. P. S. Output —58 db.

Microphone Division

UNIVERSAL MICROPHONE CO., LTD.

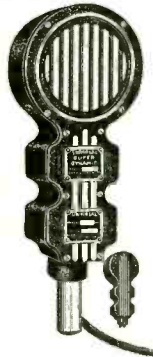

List \$44.50
with 25 ft. cable

424 Warren Lane

Inglewood, Calif., U. S. A.

RACON P. M. Units



An efficient permanent magnet horn unit requiring no outside excitation. Aluminum nickel steel magnets are used to supply maximum flux density in the air gap. Cast bronze case, completely enclosed, making Unit water tight.

15 ohm impedance at 1000 cycles. Continuous operating capacity 10 watts.

Peak load capacity 30 watts.

RACON'S catalog S-11 describes the complete line of Horns, Electro-dynamic Units and Acoustical Sound Projectors.

RACON ELECTRIC CO., INC.

52 EAST 19th STREET

NEW YORK CITY

THE NEW

Meissner

WIDE RANGE I.F. TRANSFORMERS

will solve 90% of your I.f.
replacement problems.

Only four transformers needed to take care of any frequency from 121 KC to 653 KC. Especially designed to eliminate carrying large quantities of exact duplicates. All transformers double tuned.

Air Core List Price \$1.25
Iron Core (Genuine Ferrocart) List Price \$2.00
FREE—Write to departmant G-2 for complete 32-page coil catalog.

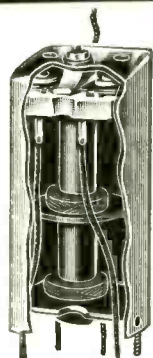

MEISSNER MFG. COMPANY
MT. CARMEL ILL.

RADIO IN ITS ENTIRETY!



"B-A" serves the trade with every need in radio. Complete 160-page catalog of radio receivers, public address systems, parts, supplies and equipment is now available. You will find your favorite nationally known lines represented in this big book. Orders will be shipped the same day as received.



BURSTEIN-APPLEBEE CO. 1012-14 MCGEE ST. KANSAS CITY, MO.

UP-TO-DATE CATALOG AVAILABLE



TRANSOIL

for transmitting

HIGHEST QUALITY OIL CAPACITORS

*Ask for new complete
Transmitting Catalog
describing*

TRANSOIL—SOLAREX—TRANSMICA

SOLAR MFG. CORP., 599-601 BROADWAY, NEW YORK, N. Y.

RCA offers: OUTSTANDING ANTENNAS.

**FOR EVERY TYPE
OF SERVICE!**

**Give exceptionally high perform-
ance . . . at unusually low price!**

NO MATTER how difficult your installation problems, RCA can help you with its complete line of low-priced, highest quality antennas.

Scientifically designed by RCA engineers—thoroughly tested by radio listeners throughout the country—these outstanding RCA Antennas offer many exclusive features! Features which make quicker sales, bigger profits!

Every RCA Antenna is sturdily constructed—*complete* in itself. No soldering. No time-wasting servicing required. Every RCA installation saves you time. Makes you money!

RCA Antennas operate efficiently on both long and short wave stations. RCA's unique construction greatly reduces noise caused by electrical interferences. You'll boost your profits if you push this exceptional 1938 line of RCA Antenna Systems now!

300 million RCA Tubes have been bought by radio users... in tubes, as in radio sets, it pays to go RCA ALL THE WAY!

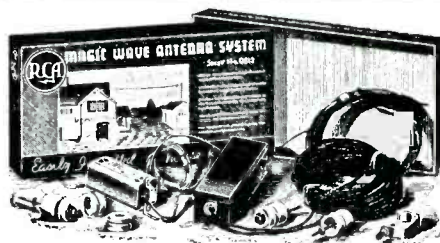

RCA Magic Wave Antenna System—This antenna is assembled and soldered at the factory. Kit contains one antenna coupling transformer, one receiving coupling transformer, 60-foot antenna wire, 45-foot transmission line, 5-foot ground wire, 2 strain and 3 nail-on knob porcelain insulators, one ground clamp. Stock No. 9812. List price \$6.95.

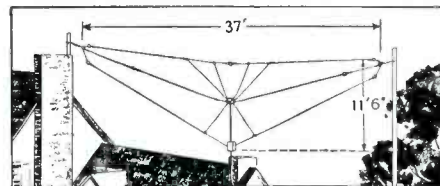

RCA Spider-Web Antenna—This antenna is the trans-oceanic communication type. Stock No. 9685. List price \$8.95. Its frequency coverage can be increased to 70,000 kilocycles by adding RCA High Frequency "D" Band Kit—Stock No. 9689. List price \$1.50.



RCA 395 Antenna System—Comes completely assembled and soldered. Kit contains two 20-foot antenna wire coils, two strain insulators, one 45-foot transmission line, one junction box, one receiver coupling unit, two coupling unit links, two nail-on knob insulators, one ground clamp and one instruction sheet. Stock No. 395. List price \$3.95.



Parts

FOR PROFIT

RCA MFG. CO., INC., CAMDEN, N. J.
A SERVICE OF THE RADIO CORP. OF AMERICA