

VOLUME XIX

PERPETUAL

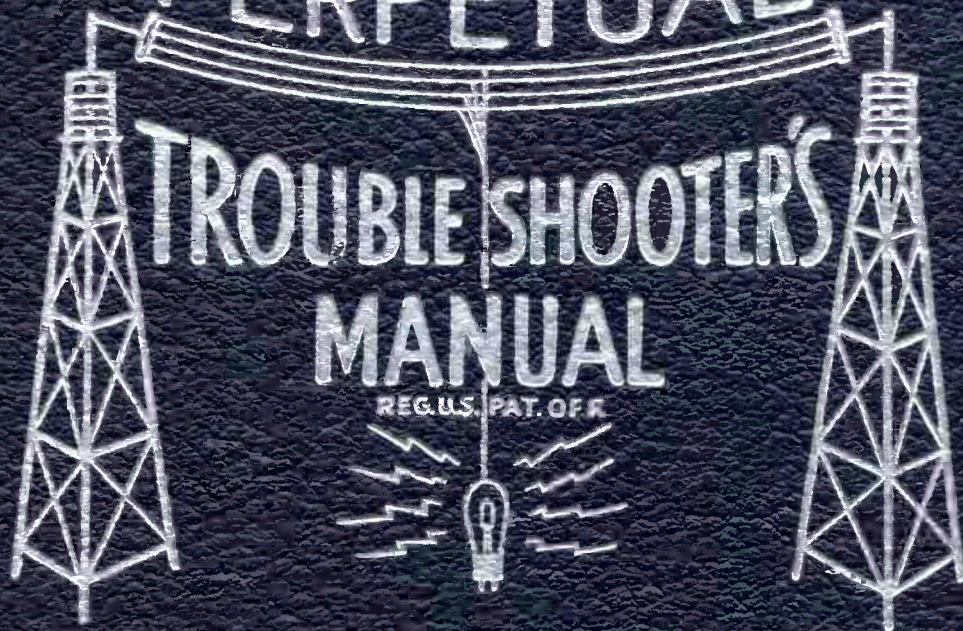

JOHN F. RIDER

WARWICK MFG. CORP.

MODELS X132,
YX132 Series

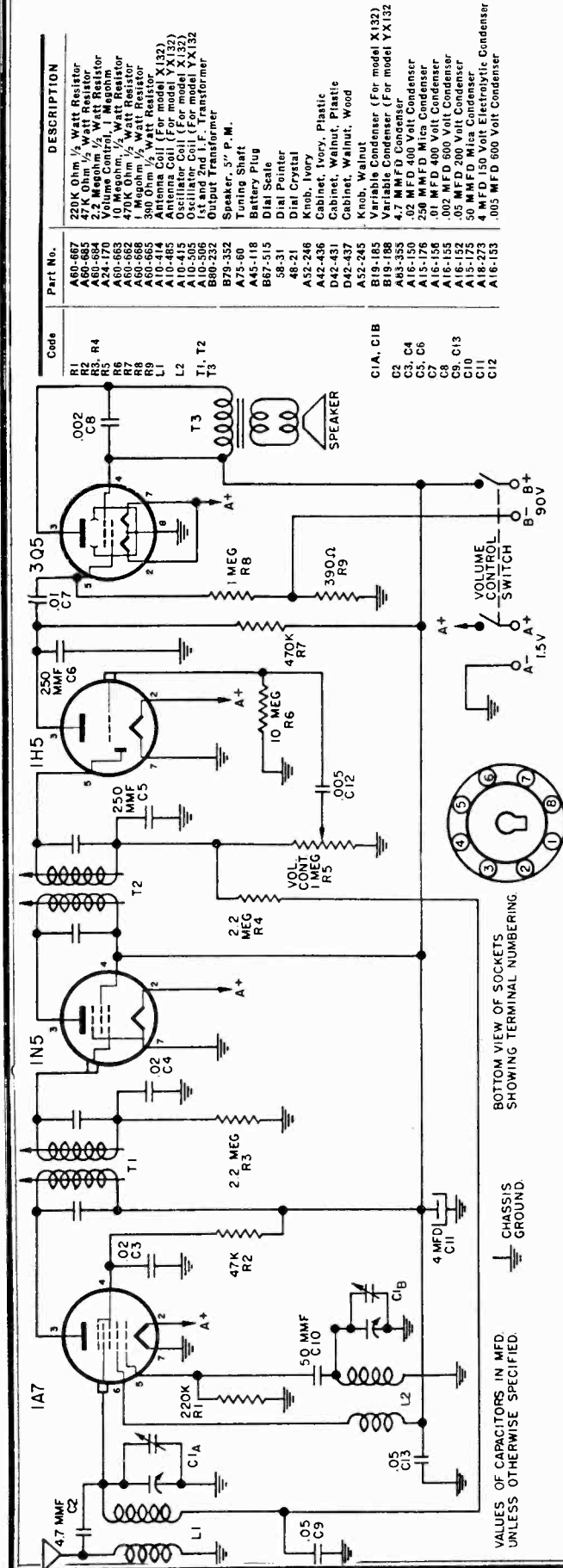

Part No.	DESCRIPTION
A60-687	220K Ohm 1/2 Watt Resistor
A60-688	2.2 Megohm 1/2 Watt Resistor
A24-170	Volume Control, 1 M Megohm
A60-683	10 Megohm 1/2 Watt Resistor
A60-684	100K Ohm 1/2 Watt Resistor
A60-685	300 Ohm 1/2 Watt Resistor
A10-414	Antenna Coil (For model X132)
A10-485	Antenna Coil (For model YX132)
A10-505	Oscillator Coil (For model X132)
A10-506	1st and 2nd I. F. Transformer
B90-232	Output Transformer
B75-352	Speaker, 5" P. M.
A75-90	Tuning Shaft
A45-118	Battery Plug
B87-515	Dial Scale
58-31	Dial Pointer
48-21	Dial Crystal
A52-248	Knob, Ivory
D42-436	Cabinet, Ivory, Plastic
D42-431	Cabinet, Walnut, Plastic
D42-437	Cabinet, Walnut, Wood
A52-245	Knob, Walnut
B19-185	Variable Condenser (For model X132)
B19-186	Variable Condenser (For model YX132)
A15-150	4 MFD 400 Volt Capacitor
A15-151	.02 MFD 400 Volt Capacitor
A15-176	250 MMFD Mica Condenser
A16-156	.01 MFD 400 Volt Capacitor
A16-155	.007 MFD 600 Volt Capacitor
A16-152	.05 MFD 200 Volt Capacitor
A13-175	50 MMFD Mica Condenser
A16-252	4 MMFD 150 Volt Electrolytic Capacitor
A16-153	.002 MFD 800 Volt Capacitor

This receiver has been designed to operate on a self-contained battery containing both the "B" battery (90 Volts) and the "A" battery (1 1/2 Volts) such as General #60B61.

The battery cable coming from the receiver has been made long enough so that it may be used with larger batteries placed outside of the cabinet. Any one of the following batteries can be used with this receiver when they are placed on the outside of the cabinet: Eveready No. 748, General No. 60DL-11 L, Burgess No. 17G-D60, Ray-O-Vac No. AB 82.

This model is a 4-Tube Superheterodyne radio receiver designed to cover a frequency range of from 540 kilocycles to 1725 kilocycles (K.C.). The tubes used are —
 1A7 GT—Osc. Converter
 1N5 GT—I. F. Amplifier
 1H5 GT—AVC Det. Audio Amplifier
 3Q5 GT—Power Output

ALIGNMENT PROCEDURE

With an output meter connected across the voice coil of the speaker, the output meter reading for 50 milliwatts is .4 volts using a signal which is modulated 30% at 400 c.p.s. Follow through the procedure as outlined below for proper alignment.

Connect the signal generator to the grid cap of the 1A7 GT Tube through a .1 MFD. Condenser. Connect the ground lead of the generator to the chassis. Adjust the signal generator to 455 K.C. and set the variable condenser of the receiver to minimum capacity (fully opened). With the volume control full on and minimum output from the signal generator adjust the two trimmers on the first and second I.F. transformers for maximum output.

Now connect the signal generator to the antenna connection of the receiver through a .00025 condenser. Adjust the signal generator frequency to 1725 K.C. and set the variable condenser to minimum capacity (fully opened), and adjust the oscillator trimmer (C1B) for maximum output. Set signal generator to 1500 K.C. and tune receiver to signal. Adjust the antenna trimmer (C1A) on the variable condenser for maximum output.

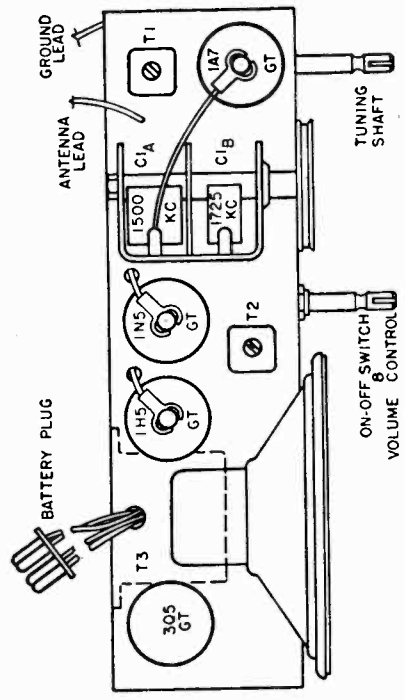

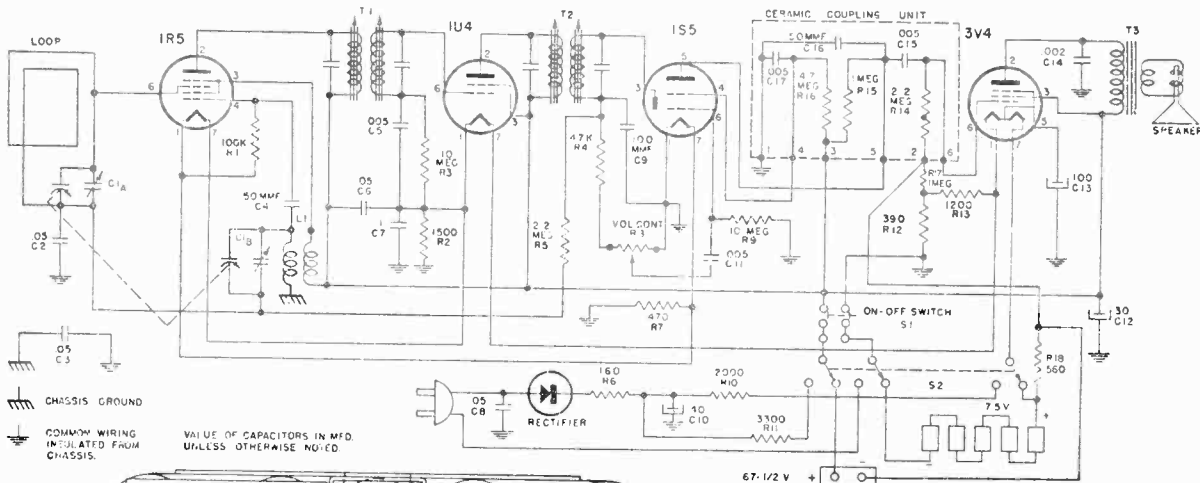

PARTS LIST

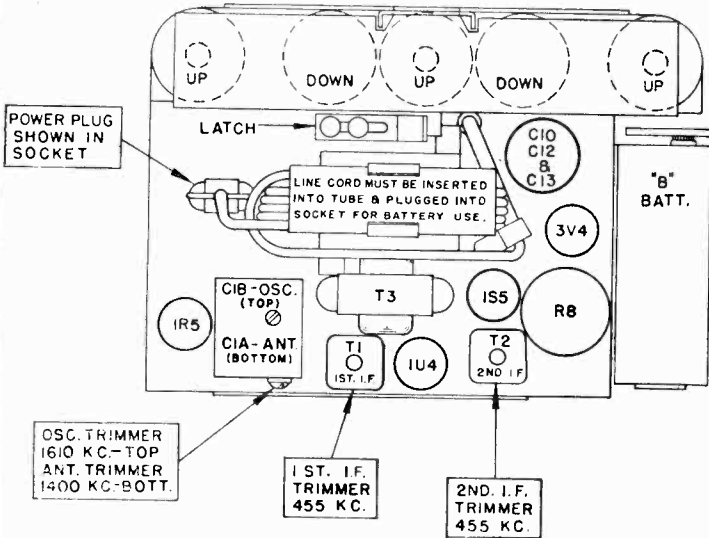

Fig. 1. Tube, Trimmer and Battery Locations

CODE NO.	PART NO.	DESCRIPTION
C1A, C1B	B19-197	Variable condenser
C2, C6	A16-152	.05 MFD 200 volt condenser
C3	A16-189	.50 MFD 400 volt condenser
C4	A16-175	50 MMF mica condenser
C5, C11	A16-153	.005 MFD 500 volt condenser
C7	A16-157	.1 MFD 200 volt condenser
C8	A16-172	.05 MFD 400 volt condenser
C9	A15-188	100 MMF mica condenser
C10, 12, 13	A18-290	40-30 MFD 150 volt, 100 MFD 10 volt, electrolytic
C14	A16-182	.002 MFD 200 volt condenser
C15, 16, 17	A17-180	.005 MMF, .005 MFD, 50 MMF. See note below.
R1	A60-671	1500 ohm 1/2 watt 20% resistor
R2	A60-680	100K ohm 1/2 watt 20% resistor
R3, R9	A60-663	10 megohm 1/2 watt 10% resistor
R4	A60-685	47K ohm 1/2 watt 20% resistor
R5	A60-684	2.2 megohm 1/2 watt 20% resistor
R6	A60-725	160 ohm 5 watt 10% resistor
R7	A60-722	470 ohm 1/2 watt 10% resistor
R8, S1	A24-178	Volume control, with switch
R10	A60-757	2000 ohm 10 watt 10% resistor
R11	A60-724	3300 ohm 1 watt 10% resistor
R12	A60-665	390 ohm 1/2 watt 10% resistor
R13	A60-756	1200 ohm 1/2 watt 10% resistor
R14, 15, 16	A17-100	2.2 megohm, 1 megohm, 4.7 megohm. See note below.
NOTE: C15, C16, C17, R14, R15, R16 are contained in the Ceramic Coupling Unit Port		
No. A17-100		
R17	A60-688	1 megohm, 1/2 watt 20% resistor
R18	A60-758	560 ohm 1/2 watt 10% resistor
L1	A10-514	Oscillator coil
T1, T2	C10-475	1st and 2nd I.F. transformer
T3	B80-245	Output transformer
S2	A69-182	Switch, AC-DC, battery
	S84-242	Bracket, "A" battery retainer
	S84-278	Cover, front, grey (with loop)
	S84-281	Cover, front, maroon (with loop)
	S84-128	Cover, rear, grey
	S84-169	Cover, rear, maroon
	D21-108	End-cap, for handle
	A83-421	Clip, I.F. transformer mounting
	B83-442	Handle, rubber, grey
	A83-494	Handle, rubber, black
	S84-243	Hub and pointer assembly
	C52-216	Knob, tuning, grey
	A52-229	Knob, tuning, maroon
	B52-217	Knob, volume control, grey
	A52-232	Knob, volume control, maroon
	A83-568	Rectifier, selenium
	B79-364	Speaker, 4" P.M.
	A76-49	Terminal, for "B" battery

ALIGNMENT PROCEDURE

(See schematic diagram.)

The following alignment procedure is for use only by competent servicemen having the proper equipment.

The alignment should be made with volume control fully on, and the output from the signal generator as low as possible, to prevent A.V.C. action from interfering with correct alignment.

With the output meter connected across the voice coil of the speaker; the output meter reading for 50 milliwatts is .4 volts using a signal which is modulated 400 c.p.s.

Adjust all trimmers for maximum output. Repeat alignment procedure given below as a final check.

For alignment points refer to Figure No. 1.

CAUTION: This is an A.C.-D.C. receiver and if alignment is made with the receiver connected to 117 volts A.C. or D.C., it is necessary to isolate the signal generator or the receiver from the line by use of a transformer, or place a .2 M.F.D. condenser in both test leads of the Signal Generator.

Position of Variable	Generator Frequency	Dummy Ant. Mid.	Generator Connections	Trimmer Adjustment	Trimmer Function
Fully open	455 KC	.1	*1R5 Grid (Stator of C1A)	T2	Output I.F.
Fully open	455 KC	.1	*1R5 Grid (Stator of C1A)	T1	Input I.F.
Fully open	1600 KC	.1	*1R5 Grid (Stator of C1A)	C1B	Oscillator
Tune in signal from generator	1400 KC	—	Loosely coupled to loop	C1A	Antenna

*Connect ground lead of signal generator to common negative.

- 1R5—Mixer, Oscillator
- 1U4—I.F. Amplifier
- 1S5—Detector and 1st Audio
- 3V4—Power output

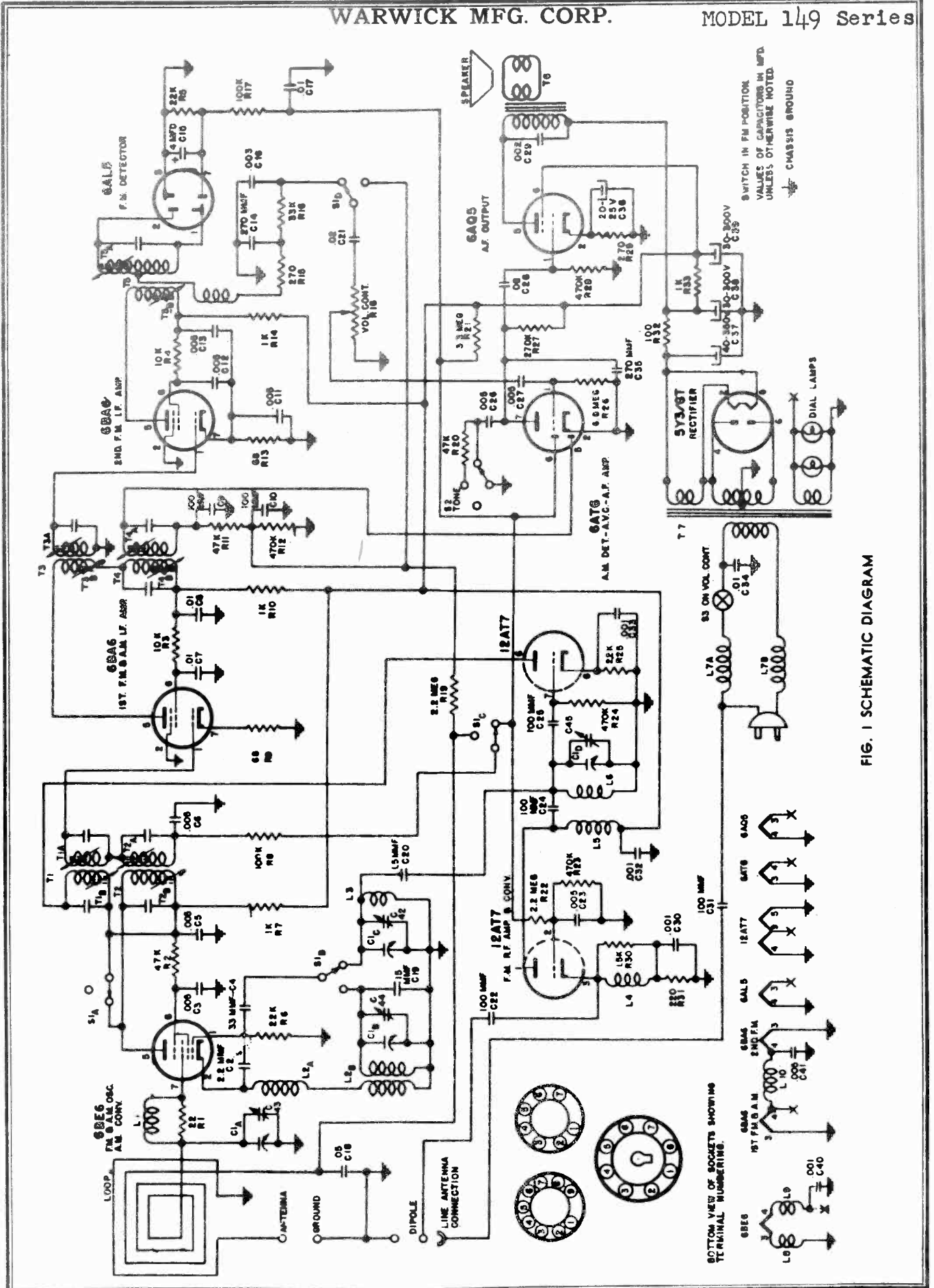

SWITCH IN FM POSITION
VALUES OF CAPACITORS IN MFD
UNLESS OTHERWISE NOTED
CHASSIS GROUND

FIG. 1 SCHEMATIC DIAGRAM

SPECIFICATIONS

Power Supply..... 105-125 volts 60 cycle AC only.
 Power Consumption..... 65 Watts
 Frequency Range FM..... 88 to 108 MC.
 Frequency Range AM..... 540 to 1600 KC.
 I.F. Frequency FM..... 10.7 MC.
 I.F. Frequency AM..... 455 KC.
 Band width, FM, Ratio Detector..... 330 KC.
 Band width, FM, 1st I.F..... 280 KC.
 Band width, FM, Converter..... 220 KC.
 Speaker..... 6 $\frac{1}{4}$ " P.M.

The tubes used are as follows:

12AT7 FM RF Amplifier, Converter
 6BE6 FM Osc, Am Osc, Converter
 6BA6 FM-AM, 1st I.F. Amplifier
 6BA6 FM-AM, 2nd I.F. Amplifier
 6AL5 FM Detector
 6AT6 AM Detector, AVC, Audio
 6AQ5 Power Output
 5Y3 Power Rectifier
 No. 47 Pilot Lights (2)

SERVICE NOTES

INSTALLATION

This receiver is shipped from the factory complete with a built-in loop antenna for standard AM broadcast reception. A power-line antenna is used for the reception of FM stations. These antennas will be satisfactory for good reception under normal conditions. Terminals are provided at the back of the radio for connecting external AM and FM antennas, wherever this is found to be desirable as explained below.

When the receiver is to be used under difficult conditions, such as in buildings constructed mainly of steel, or those with steel lath, or, when large buildings, mountains or other objects are between the receiver and the station to be received, it may be necessary to use an external dipole antenna. Remember too, FM reception is limited as to distance and when used outside the primary service area of the transmitter, an outside antenna is very necessary.

The type of dipole to be used depends upon the signal strength of the station in that particular area, as well as conditions of reception as outlined above. There are three types of FM dipole antenna available, the single dipole, the folded dipole, and the non-directional dipole. When the stations to be received are in one general direction, a reflector may be added to either of the first two types to increase their efficiency.

GENERAL

Due to the high frequencies at which FM signals are received the service man must use great care when servicing these sets. Extreme caution must be used regarding the moving of component parts in the R.F. and oscillator circuits of the receiver as those circuits can be detuned in this manner.

If it becomes necessary to replace components such as resistors and condensers they must be replaced with parts of the same size, type, voltage rating and tolerance as called for in the parts list.

When installing new parts they should be placed in the same position as the original, and the leads should be cut to the same length.

ALIGNMENT NOTES

This receiver has been thoroughly inspected and tested at the factory, using the most modern test equipment available, such as FM sweep generators and oscilloscopes. All R.F. and I.F. circuits have been accurately adjusted at the factory and no attempt should be made to realign these circuits unless it is absolutely necessary.

CAUTION: If realignment is necessary be sure the proper test equipment is available, as listed below, before proceeding with the alignment procedure as given

EQUIPMENT USED FOR ALIGNMENT

Vacuum tube voltmeter.
 AM Signal generator
 FM Sweep generator.
 Oscilloscope.
 Insulated screw driver.
 Dummy antenna:
 .1 MFD condenser
 .00025 MFD mica condenser
 150 ohm resistor (2)
 Output meter.

ALIGNMENT PROCEDURE

STEPS	RECEIVER DIAL SETTING	BAND SWITCH POSITION	SIGNAL GENERATOR FREQUENCY	DUMMY ANTENNA	SIGNAL GENERATOR CONNECTIONS	OUTPUT INDICATOR	TRIMMER ADJUSTMENT	TRIMMER FUNCTION	REMARKS
1	Minimum capacity	AM	455 KC 400 cycle AM	.1 MFD	High side—grid of AM converter tube (6BE6) Low side—chassis	Output Meter across voice coil	T4A, T4B T7A, T7B	AM I.F.	Adjust for maximum output
2	"	"	1600 KC 400 cycle AM	"	"	"	C44	AM Oscillator	"
3	1400 KC	"	1400 KC 400 cycle AM	.00025 MFD	High side—One ant. terminal Low side—Other ant. terminal	"	C43	AM Antenna	"
4	Any position where there is no station interference.	FM	10.7 MC unmodulated .1 volt output.	.1 MFD	High side—grid of 2nd I.F. amplifier tube (6BA6) Low side—chassis	Connect V.T.V.M. to plate of Ratio Detector tube, pin 7 (6AL5)	T58	Ratio detector primary	Adjust for maximum negative voltage, about -3 volts
5	"	"	10.7 MC 400 cycle 30% Modulation. (See note A)	"	"	Connect scope to audio take-off point (across C16)	T5A	Ratio detector secondary	Adjust for a balanced pattern on scope. See Fig. 2
6	"	"	"	"	High side—grid of 1st I.F. amplifier tube (6BA6) Low side—chassis	"	T3A T3B	FM 2nd I.F.	Adjust for maximum gain and best pattern on scope. See Fig. 2
7	"	"	"	"	High side—grid (pin 7) of FM converter tube (12A17) Low side—chassis	"	T1A T1B	FM 1st I.F.	"
8	108.5 MC	"	108.5 MC 400 cycle 30% modulation (22.5 KC deviation)	300 ohms in high side	High side—ant. terminal Low side—chassis	Connect output meter across voice coil	C42	FM oscillator	Adjust for maximum output
9	105 MC	"	105 MC 400 cycle 30% modulation (22.5 KC deviation)	"	"	"	C46	FM R.F.	"

NOTE A: When aligning the FM I.F. circuits, keep the out put from the signal generator as low as possible.

FIGURE 2

VOLTAGE CHART

	PIN 1	PIN 2	PIN 3	PIN 4	PIN 5	PIN 6	PIN 7	PIN 8	PIN 9
6BE6 FM & AM OSC AM CONV	0	0	0	0	6	155	125	0	
12A77 FM RF AMP & CONV	170	0	1.5	0	0	155	0	1	6 AC
6BA6 1st IF AM & FM	0	0	0	0	6	150	100	0	
6BA6 2nd IF AM & FM	0	0	0	0	6	155	110	1	
6AL5 FM DETECTOR	0	0	6	0	0	0	0	0	
6AT6 AM DETECTOR, AVC, AUDIO	-5	0	0	6	0	0	0	60	
6AQ5 POWER OUTPUT	0	7.5	6	0	215	170	0	0	
5Y3 POWER RECTIFIER	235	235	230	230	230	230	235	235	

All voltage readings are taken from tube pin to chassis.
 All measurements are made with no signal, using a 20,000 ohm per volt meter.
 AC input voltage must be maintained at 117 volts for accurate readings.
 AC voltages shown are at 1000 ohms per volt.

RESISTANCE CHART

	PIN 1	PIN 2	PIN 3	PIN 4	PIN 5	PIN 6	PIN 7	PIN 8	PIN 9
6BE6 FM & AM OSC AM CONV	22K	1.5	.5	3.5M	3.5M	2.5M			
12A77 FM RF AMP & CONV	3.3M	500K	250	0	0	3.5M	500K	2K	0
6BA6 1st IF AM & FM	200K	0	0	0	3.5M	3.5M	70		
6BA6 2nd IF AM & FM	0	0	0	0	3.5M	3.5M	70		
6AL5 FM DETECTOR	OPEN	OPEN	0	0	0	0	22K		
6AT6 AM DETECTOR, AVC, AUDIO	7M	0	0	0	500K	120K	3.5M		
6AQ5 POWER OUTPUT	470K	300	0	0	3.5M	3.5M	0		
5Y3 POWER RECTIFIER	3.5M	0	0	0	0	3.5M			

All voltages shown are approximate.
 All resistance readings are taken from tube pin to chassis.
 Due to manufacturing tolerance on component parts, resistance readings may vary as much as 20%.
 All readings are shown in ohms unless otherwise noted.

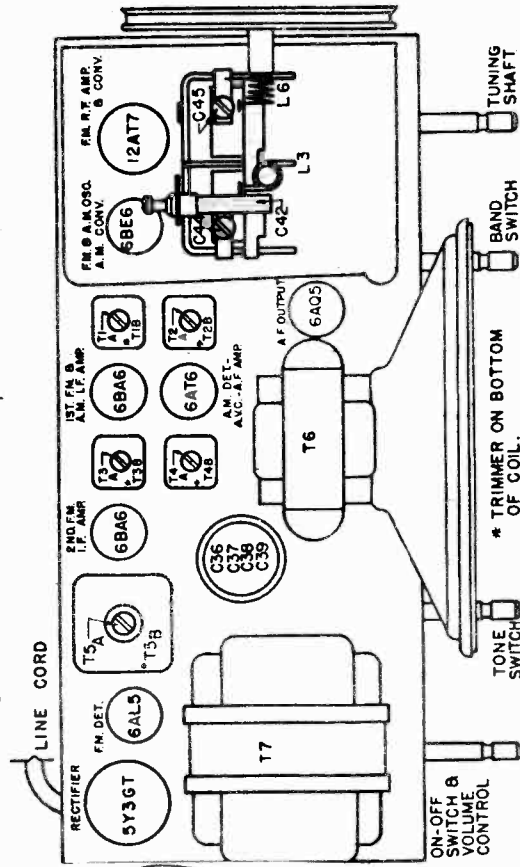

FIG. 3 TUBE AND TRIMMER LOCATIONS

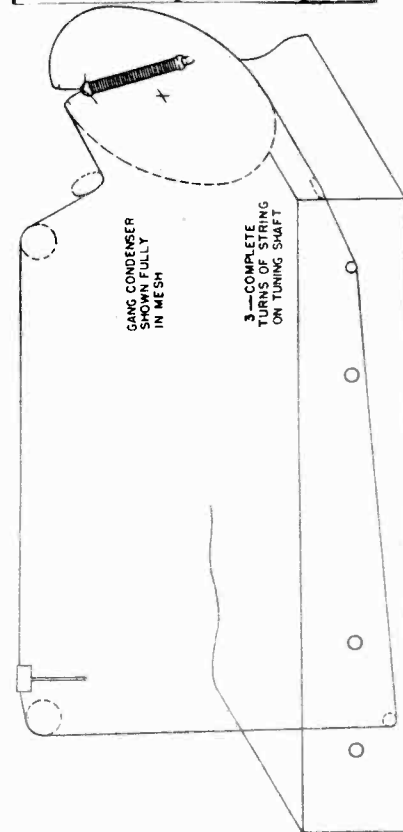

FIG. 4 DIAL CORD STRINGING

PARTS LIST

Schematic Diagram Reference	Part No.	Description	Schematic Diagram Reference	Part No.	Description
C1A, C1B } C1C, C1D }	C19-200	Variable Condenser	R27	A60-747	270 K ohms, 1/2 watt, 20%
C2	A83-376	2.2 MMF, gimmick	R29	A60-754	270 ohms, 1/2 watt, 10%
C3, C5, C6 } C23, C41 }	A16-177	.005 MFD ceramic (Centralab NO. DAO48 or equiv.)	R30	A10-516	See L4
C4	A15-210	33 M.MF ceramic, 20%, (Erie Style "A" NI400)	R31	A60-753	220 ohms, 1/2 watt, 10%
C7, C8, C34	A16-192	.01-400 volts, paper tubular	R32	A60-755	100 ohms, 1 watt, 10%
C9, C10, R11	A17-101	100 MMF, 100 MMF, 47K ohms (Diode filter unit, Herlec FO6-001)	R33	A60-763	1 K ohms, 4 watts, 10%
C11, C12, C13	A17-102	3 x .005 MFD Herlec B34-005	R34	A60-667	220 K ohms 1/2 watt 20%
C14, C35	A15-208	270 MMF ceramic, 20%, (Erie Style "K" or equiv.)	L1	A33-231	Choke, wound on R1, 22 ohms
C15	A18-292	4 MFD—50 volt electrolytic	L2A, L2B	A10-515	Oscillator coil, AM
C16	A16-180	.003-200 volts, paper tubular	L3	A10-517	Oscillator coil, FM
C17	A16-165	.01-200 volts, paper tubular	L4	A10-516	Antenna coil, FM, wound on R30, 1.5 K ohms
C18	A16-197	.05-200 volts, paper tubular	L5	A33-233	Plate choke, FM RF
C19	A15-209	15 MMF ceramic, 10%, (Erie Style "A" or equiv.)	L6	A10-518	RF coil, FM
C20	A15-206	1.5 MMF ceramic, 33%, (Erie Style "A" or equiv.)	L7A, L7B	A33-230	Line choke
C21, C28	A16-196	.02-400 volts, paper tubular	L8, L9	A33-232	FM oscillator filament choke
C22, C24	A15-196	100 MMF 20% Ceramic Condenser	L10	A33-227	Filament choke
C25, C31	A16-199	(Erie Style K or Equiv.)	S1A, S1B	A69-183	Band switch
C26, C27	A16-198	.005-400 volts, paper tubular	S1C, S1D	A26-125	Band switch
C29	A16-195	.001 MMF ceramic (Centralab NO. BC20A or equiv.)	S2	A26-125	Tone control
C30, C32 } C33, C40 }	A18-291	20-25 volts, 40-350 volts electrolytic	S3	B24-181	ON-OFF SWITCH, on volume control
C36, C37 } C38, C39 }	A20-146	30-300 volts, 30-300 volts	T1	A10-519	1st I.F., FM
C42	A33-231	FM oscillator trimmer	T2	A10-521	1st I.F., AM
R1	A60-759	See L1.	T3	A10-520	2nd I.F., FM
R2	A60-760	4.7 K ohms, 1/2 watt, 10%	T4	A10-522	2nd I.F., AM
R3, R4	A60-744	10 K ohms, 1/2 watt, 10%	T5	SC10-492	Ratio detector, FM
R5, R6	A60-744	22 K ohms, 1/2 watt, 10%	T6	A80-247	Output transformer
R7, R10, R14	A60-675	1 K ohms, 1/2 watt, 20%	T7	C80-246	Power transformer
R8, R17	A60-727	100 K ohms, 1/2 watt, 20%	A23-153	A23-153	Line cord and plug
R9, R13	A60-742	68 ohms, 1/2 watt, 10%	B79-351	B79-351	Speaker, 6 1/4", P.M.
R11, C9, C10	A17-101	47 K ohms, 100 MMF, 100 MMF (Diode filter unit, Herlec FO6-001)	B79-342	B79-342	Speaker, 6 1/4", P.M. Alternate
R12, R23 } R24, R28 }	A60-731	470 K ohms, 1/2 watt, 20%	B79-341	B79-341	Speaker, 6 1/4", P.M. Alternate
R15	A60-723	270 ohms, 1/2 watt, 20%	SC84-292	SC84-292	Beet and loop
R16	A60-748	33 K ohms, 1/2 watt, 10%	D42-379	D42-379	Cabinet, walnut
R18	B24-181	Volume control and switch S3	A42-401	A42-401	Cabinet, ivory
R19, R22	A60-726	2.2 Megohms, 1/2 watt, 20%	C67-537	C67-537	Dial scale, glass
R20	A60-730	47 K ohms, 1/2 watt, 20%	A52-284	A52-284	Knob, FM-AM, walnut
R21	A60-761	3.3 Megohms, 1/2 watt, 20%	A52-285	A52-285	Knob, FM-AM, ivory
R25	A60-714	2.2 K ohms, 1/2 watt, 10%	A52-250	A52-250	Knob, ON-OFF-VOL, ivory
R26	A60-762	6.8 Megohms, 1/2 watt, 20%	A52-253	A52-253	Knob, ON-OFF-VOL, walnut
			A52-249	A52-249	Knob, TONE 1-2-3, ivory
			A52-254	A52-254	Knob, TONE 1-2-3, walnut
			A52-248	A52-248	Knob, TUNING, ivory
			A52-255	A52-255	Knob, Walnut
			A58-65	A58-65	Pointer, slide type
			A83-292	A83-292	Retainer, dial scale, RH
			A83-293	A83-293	Retainer, dial scale, LH
			A87-31	A87-31	Socket, pilot light
			A70-122	A70-122	Spring, string tension
			A51-105	A51-105	String, pointer travel, 42"

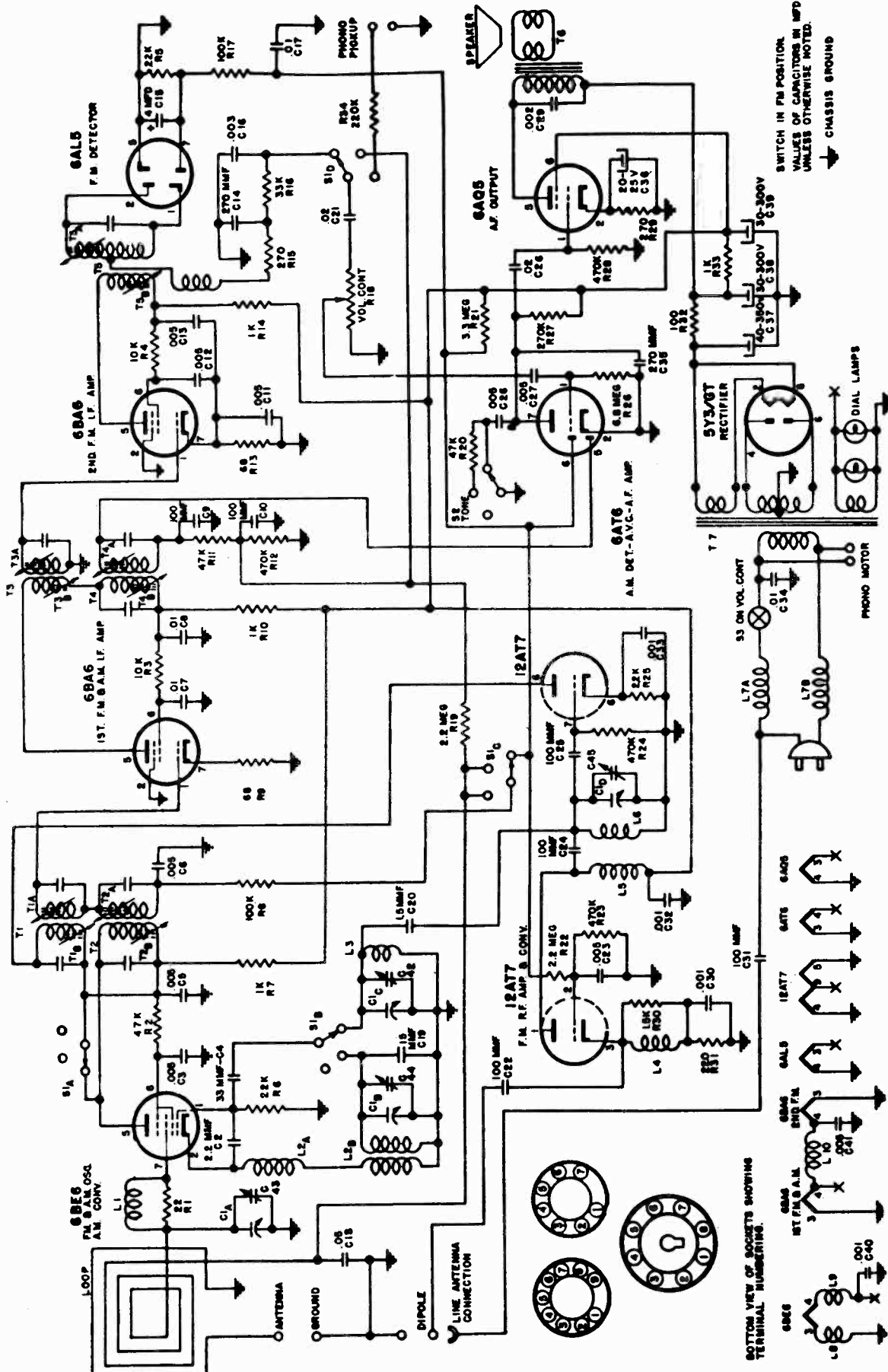

FIG. 1 SCHEMATIC DIAGRAM

SPECIFICATIONS

Power Supply.....105-125 volts 60 cycle AC only.
 Power Consumption.....65 Watts
 Frequency Range FM.....88 to 108 MC.
 Frequency Range AM.....540 to 1600 KC.
 I.F. Frequency FM.....10.7 MC.
 I.F. Frequency AM.....455 KC.
 Band width, FM, Ratio Detector.....330 KC.
 Band width, FM, 1st I.F.....280 KC.
 Band width, FM, Converter.....220 KC.
 Speaker6 $\frac{1}{4}$ " P.M.

The tubes used are as follows:

12AT7 FM RF Amplifier, Converter
 6BE6 FM Osc, Am Osc, Converter
 6BA6 FM-AM, 1st I.F. Amplifier
 6BA6 FM-AM, 2nd I.F. Amplifier
 6AL5 FM Detector
 6AT6 AM Detector, AVC, Audio
 6AQ5 Power Output
 5Y3 Power Rectifier
 No. 47 Pilot Lights (2)

SERVICE NOTES

INSTALLATION

This receiver is shipped from the factory complete with a built-in loop antenna for standard AM broadcast reception. A power-line antenna is used for the reception of FM stations. These antennas will be satisfactory for good reception under normal conditions. Terminals are provided at the back of the radio for connecting external AM and FM antennas, wherever this is found to be desirable as explained below.

When the receiver is to be used under difficult conditions, such as in buildings constructed mainly of steel, or those with steel lath, or, when large buildings, mountains or other objects are between the receiver and the station to be received, it may be necessary to use an external dipole antenna. Remember too, FM reception is limited as to distance and when used outside the primary service area of the transmitter, an outside antenna is very necessary.

The type of dipole to be used depends upon the signal strength of the station in that particular area, as well as conditions of reception as outlined above. There are three types of FM dipole antenna available, the single dipole, the folded dipole, and the non-directional dipole. When the stations to be received are in one general direction, a reflector may be added to either of the first two types to increase their efficiency.

GENERAL

Due to the high frequencies at which FM signals are received the service man must use great care when servicing these sets. Extreme caution must be used regarding the moving of component parts in the R.F. and oscillator circuits of the receiver as those circuits can be detuned in this manner.

If it becomes necessary to replace components such as resistors and condensers they must be replaced with parts of the same size, type, voltage rating and tolerance as called for in the parts list.

When installing new parts they should be placed in the same position as the original, and the leads should be cut to the same length.

ALIGNMENT NOTES

This receiver has been thoroughly inspected and tested at the factory, using the most modern test equipment available, such as FM sweep generators and oscilloscopes. All R.F. and I.F. circuits have been accurately adjusted at the factory and no attempt should be made to realign these circuits unless it is absolutely necessary.

CAUTION: If realignment is necessary be sure the proper test equipment is available, as listed below, before proceeding with the alignment procedure as given

EQUIPMENT USED FOR ALIGNMENT

Vacuum tube voltmeter.
 AM Signal generator
 FM Sweep generator.
 Oscilloscope.
 Insulated screw driver.
 Dummy antenna:
 .1 MFD condenser
 .00025 MFD mica condenser
 150 ohm resistor (2)
 Output meter.

ALIGNMENT PROCEDURE

STEPS	RECEIVER DIAL SETTING	BAND SWITCH POSITION	SIGNAL GENERATOR FREQUENCY	DUMMY ANTENNA	SIGNAL GENERATOR CONNECTIONS	OUTPUT INDICATOR	TRIMMER ADJUSTMENT	TRIMMER FUNCTION	REMARKS
1	Minimum capacity	AM	455 KC 400 cycle AM	.1 MFD	High side—grid of AM converter tube (6BE6) Low side—chassis	Output Meter across voice coil	T4A, T4B T2A, T2B	AM I.F.	Adjust for maximum output
2	"	"	1600 KC 400 cycle AM	"	"	"	C44	AM Oscillator	"
3	1400 KC Any position where there is no station interference.	"	1400 KC 400 cycle AM	.00025 MFD	High side—One ant. terminal Low side—Other ant. terminal	"	C43	AM Antenna	"
4	"	FM	10.7 MC unmodulated .1 volt output.	.1 MFD	High side—grid of 2nd I.F. amplifier tube (6BA6) Low side—chassis	Connect V.T.V.M. to plate of Ratio Detector tube, pin 7 (6AL5)	T5B	Ratio detector primary	Adjust for maximum negative voltage, about -5 volts
5	"	"	10.7 MC 400 cycle 30% Modulation. (See note A)	"	"	Connect scope to audio take-off point (across C16)	T5A	Ratio detector secondary	Adjust for a balanced pattern on scope. See Fig. 2
6	"	"	"	"	High side—grid of 1st I.F. amplifier tube (6BA6) Low side—chassis	"	T3A T3B	FM 2nd I.F.	Adjust for maximum gain and best pattern on scope. See Fig. 2
7	"	"	"	"	High side—grid (pin 7) of FM converter tube (12AT7) Low side—chassis	"	T1A T1B	FM 1st I.F.	"
8	108.5 MC	"	108.5 MC 400 cycle 30% modulation. (22.5 KC deviation)	300 ohms in high side	High side—ent. terminal Low side—chassis	Connect output meter across voice coil	C42	FM oscillator	Adjust for maximum output
9	105 MC	"	105 MC 400 cycle 30% modulation. (22.5 KC deviation)	"	"	"	C45	FM R.F.	"



NOTE A: When aligning the FM I.F. circuits, keep the output from the signal generator as low as possible.

FIGURE 2

RESISTANCE CHART

	PIN 1	PIN 2	PIN 3	PIN 4	PIN 5	PIN 6	PIN 7	PIN 8	PIN 9
6BE6 FM & AM OSC AM CONV	22K	1.5	.5	3.5M	3.5M	2.5M			
12AT7 FM RF AMP & CONV	3.3M	500K	250	0	0	3.5M	500K	2K	0
6BA6 1st IF AM & FM	200K	0	0	0	3.5M	3.5M	70		
6BA6 2nd IF AM & FM	0	0	0	0	3.5M	3.5M	70		
6AL5 FM DETECTOR	OPEN	OPEN	0	0	0	0	22K		
6AT6 AM DETECTOR, AVC, AUDIO	7M	0	0	0	500K	120K	3.5M		
6AQ5 POWER OUTPUT	470K	300	0	0	3.5M	3.5M	0		
5Y3 POWER RECTIFIER	3.5M				0	0	3.5M		

All voltages shown are approximate.
All resistance readings are taken from tube pin to chassis.
Due to manufacturing tolerance on component parts, resistance readings may vary as much as 20%.
All readings are shown in ohms unless otherwise noted.

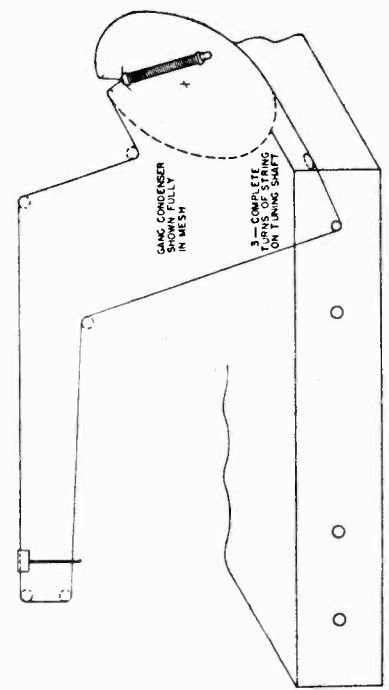

FIG. 4 DIAL CORD STRINGING

AC input voltage must be maintained at 117 volts for accurate readings.
AC voltages shown are at 1000 ohms per volt.

VOLTAGE CHART

	PIN 1	PIN 2	PIN 3	PIN 4	PIN 5	PIN 6	PIN 7	PIN 8	PIN 9
6BE6 FM & AM OSC AM CONV	0	0	0	6	155	125	0		
12AT7 FM RF AMP & CONV	170	0	1.5	0	0	155	0	1	6 AC
6BA6 1st IF AM & FM	0	0	0	6	150	100	0		
6BA6 2nd IF AM & FM	0	0	0	6	155	110	1		
6AL5 FM DETECTOR	0	0	6	0	0	0	0		
6AT6 AM DETECTOR, AVC, AUDIO	-5	0	0	6	0	0	60		
6AQ5 POWER OUTPUT	0	7.5	6	0	215	170	0		
5Y3 POWER RECTIFIER	235			230 AC			230 AC		235

All voltage readings are taken from tube pin to chassis.
All measurements are made with no signal, using a 20,000 ohm per volt meter.

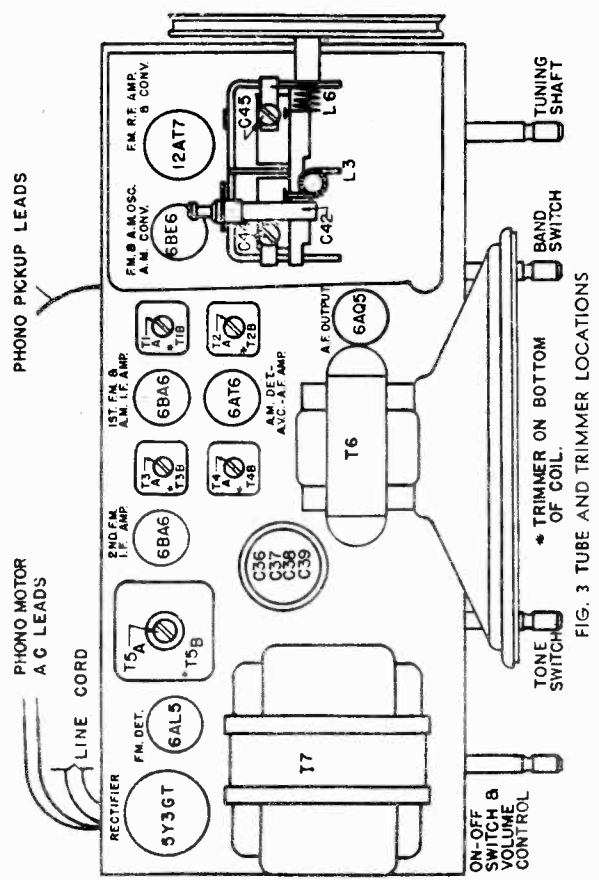
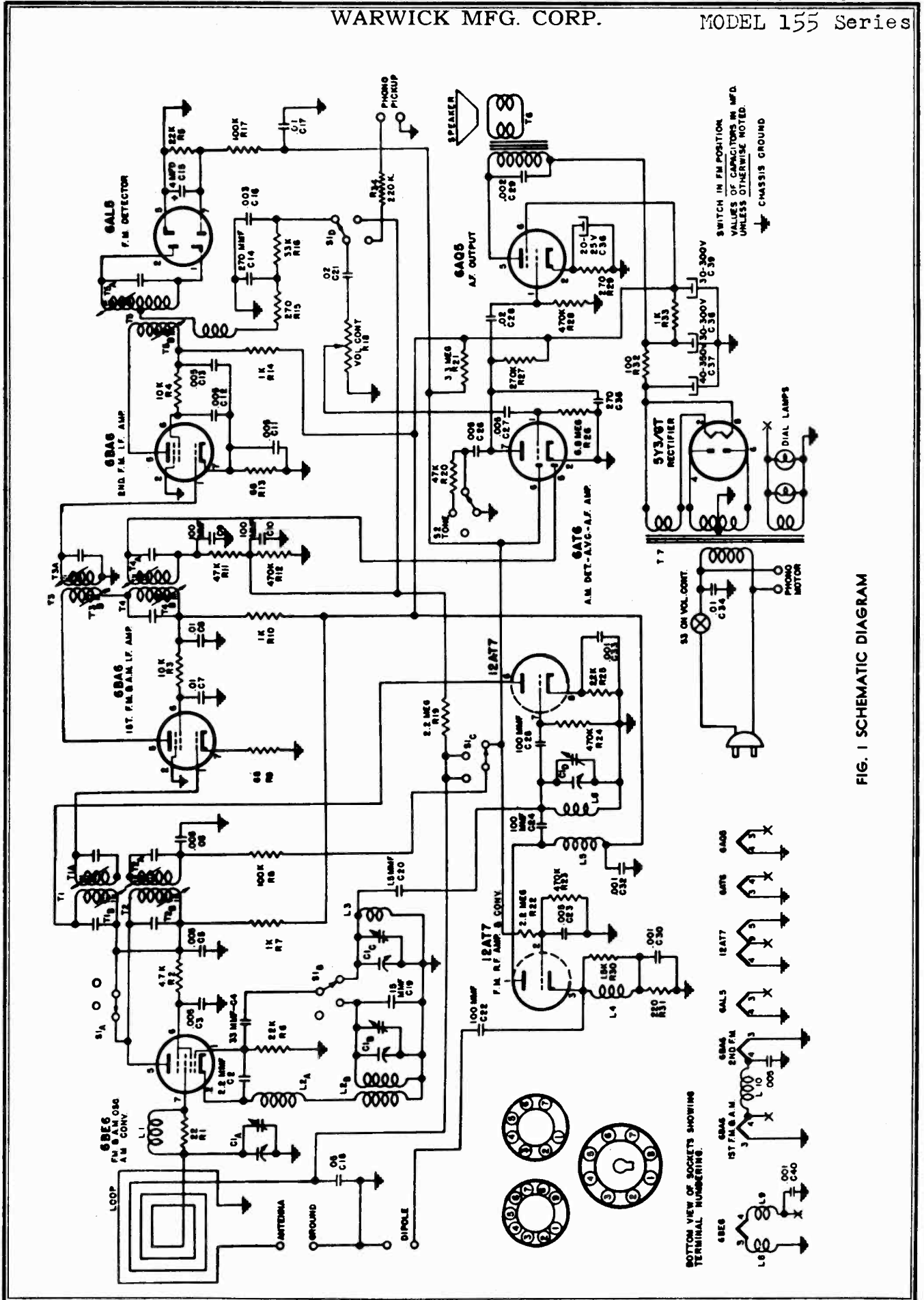

FIG. 3 TUBE AND TRIMMER LOCATIONS

PARTS LIST

Schematic Diagram Reference	Part No.	Description	Schematic Diagram Reference	Part No.	Description
C1A, C1B } C1C, C1D }	C19-200	Variable Condenser	R27	A60-747	270 K ohms, 1/2 watt, 20%
C2	A83-376	2.2 MMF, gimmick	R29	A60-754	270 ohms, 1/2 watt, 10%
C3, C5, C6 } C23, C41 }	A16-177	.005 MFD ceramic (Centralab NO. DAO48 or equiv.)	R30	A10-516	See L4
C4	A15-210	33 MMF ceramic, 20%, (Erie Style "A" NI400)	R31	A60-753	220 ohms, 1/2 watt, 10%
C7, C8, C34	A16-192	.01-400 volts, paper tubular	R32	A60-755	100 ohms, 1 watt, 10%
C9, C10, R11	A17-101	100 MMF, 100 MMF, 47K ohms (Diode filter unit, Herlec F06-001)	R33	A60-763	1 K ohms, 4 watts, 10%
C11, C12, C13	A17-102	3 x .005 MFD Herlec 834-005	R34	A60-667	220 K ohms 1/2 watt 20%
C14, C35	A15-208	270 MMF ceramic, 20%, (Erie Style "K" or equiv.)	L1	A33-231	Choke, wound on RI, 22 ohms
C15	A18-292	4 MFD—50 volt electrolytic	L2A, L2B	A10-515	Oscillator coil, AM
C16	A16-180	.003-200 volts, paper tubular	L3	A10-517	Oscillator coil, FM
C17	A16-185	.01-200 volts, paper tubular	L4	A10-516	Antenna coil, FM, wound on R30, 1.5 K ohms
C18	A16-197	.05-200 volts, paper tubular	L5	A33-233	Plate choke, FM RF
C19	A15-209	15 MMF ceramic, 10%, (Erie Style "A" or equiv.)	L6	A10-518	RF coil, FM
C20	A15-206	1.5 MMF ceramic, 33%, (Erie Style "A" or equiv.)	L7A, L7B	A33-230	Line choke
C21, C28	A16-196	.02-400 volts, paper tubular	L8, L9	A33-232	FM oscillator filament choke
C22, C24	A15-196	100 MMF 20% Ceramic Condenser (Erie Style K or Equiv.)	L10	A33-227	Filament choke
C25, C31	A16-199	.005-400 volts, paper tubular	S1A, S1B	A69-184	Band switch
C26, C27	A16-198	.002-600 volts, paper tubular	S1C, S1D	A26-125	Tone control
C29	A16-195	.001 MMF ceramic (Centralab NO. BC20A or equiv.)	S2	B24-181	ON-OFF SWITCH, on volume control
C30, C32 } C33, C40 }	A18-291	20-25 volts, 40-350 volts 30-300 volts, electrolytic	S3	A10-519	1st I.F., FM
C36, C37 } C38, C39 }	A20-146	FM oscillator trimmer	T1	A10-521	1st I.F., AM
C42	A33-231	See L1.	T2	A10-520	2nd I.F., FM
R1	A60-759	4.7 K ohms, 1/2 watt, 10%	T3	A10-522	2nd I.F., AM
R2	A60-760	10 K ohms, 1/2 watt, 10%	T4	SC10-492	Ratio detector, FM
R3, R4	A60-744	22 K ohms, 1/2 watt, 10%	T5	A80-247	Output transformer
R5, R6	A60-675	1 K ohms, 1/2 watt, 20%	T6	C80-246	Power transformer
R7, R10, R14	A60-727	100 K ohms, 1/2 watt, 20%	T7	A23-153	Line cord and plug
R8, R17	A60-742	68 ohms, 1/2 watt, 10%		B79-351	Speaker, 6 1/4", P.M.
R9, R13	A17-101	47 K ohms, 100 MMF, 100 MMF (Diode filter unit, Herlec F06-001)		B79-342	Speaker, 6 1/4", P.M. Alternate
R11, C9, C10	A60-731	470 K ohms, 1/2 watt, 20%		S84-299	Back and loop
R12, R23 } R24, R28 }	A60-723	270 ohms, 1/2 watt, 20%		C67-539	Dial scale, glass
R15	A60-748	33 K ohms, 1/2 watt, 10%		A52-260	Knob, TONE 1-2-3
R16	B24-181	Volume control and switch S3		A52-261	Knob, ON-OFF-VOL
R18	A60-726	2.2 Megohms, 1/2 watt, 20%		A52-263	Knob, TUNING
R19, R22	A60-730	47 K ohms, 1/2 watt, 20%		A52-286	Knob, FM-AM-PH
R20	A60-761	3.3 Megohms, 1/2 watt, 20%		A58-53	Pointer, slide type
R21	A60-714	2.2 K ohms, 1/2 watt, 10%		A83-429	Retainer, dial scale
R25	A60-762	6.8 Megohms, 1/2 watt, 20%		A70-122	Spring, string tension
R26				A87-29	Socket, pilot light
				A51-105	String, pointer travel
				B59-16	Record changer, General Instrument No. 205



SWITCH IN FM POSITION
VALUES OF CAPACITORS IN MFD.
UNLESS OTHERWISE NOTED.
CHASSIS GROUND

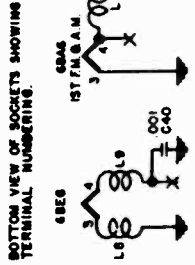

FIG. 1 SCHEMATIC DIAGRAM

SPECIFICATIONS

Power Supply.....105-125 volts 60 cycle AC only.
 Power Consumption.....65 Watts
 Frequency Range FM.....88 to 108 MC.
 Frequency Range AM.....540 to 1600 KC.
 I.F. Frequency FM.....10.7 MC.
 I.F. Frequency AM.....455 KC.
 Band width, FM, Ratio Detector.....330 KC.
 Band width, FM, 1st I.F.....280 KC.
 Band width, FM, Converter.....220 KC.
 Speaker.....6 $\frac{1}{4}$ " P.M.

The tubes used are as follows:

12AT7 FM RF Amplifier, Converter
 6BE6 FM Osc, Am Osc, Converter
 6BA6 FM-AM, 1st I.F. Amplifier
 6BA6 FM-AM, 2nd I.F. Amplifier
 6AL5 FM Detector
 6AT6 AM Detector, AVC, Audio
 6AQ5 Power Output
 5Y3 Power Rectifier
 No. 47 Pilot Lights (2)

SERVICE NOTES

INSTALLATION

This receiver is shipped from the factory complete with a built-in loop antenna for standard AM broadcast reception. A power-line antenna is used for the reception of FM stations. These antennas will be satisfactory for good reception under normal conditions. Terminals are provided at the back of the radio for connecting external AM and FM antennas, wherever this is found to be desirable as explained below.

When the receiver is to be used under difficult conditions, such as in buildings constructed mainly of steel, or those with steel lath, or, when large buildings, mountains or other objects are between the receiver and the station to be received, it may be necessary to use an external dipole antenna. Remember too, FM reception is limited as to distance and when used outside the primary service area of the transmitter, an outside antenna is very necessary.

The type of dipole to be used depends upon the signal strength of the station in that particular area, as well as conditions of reception as outlined above. There are three types of FM dipole antenna available, the single dipole, the folded dipole, and the non-directional dipole. When the stations to be received are in one general direction, a reflector may be added to either of the first two types to increase their efficiency.

GENERAL

Due to the high frequencies at which FM signals are received the service man must use great care when servicing these sets. Extreme caution must be used regarding the moving of component parts in the R.F. and oscillator circuits of the receiver as those circuits can be detuned in this manner.

If it becomes necessary to replace components such as resistors and condensers they must be replaced with parts of the same size, type, voltage rating and tolerance as called for in the parts list.

When installing new parts they should be placed in the same position as the original, and the leads should be cut to the same length.

ALIGNMENT NOTES

This receiver has been thoroughly inspected and tested at the factory, using the most modern test equipment available, such as FM sweep generators and oscilloscopes. All R.F. and I.F. circuits have been accurately adjusted at the factory and no attempt should be made to realign these circuits unless it is absolutely necessary.

CAUTION: If realignment is necessary be sure the proper test equipment is available, as listed below, before proceeding with the alignment procedure as given on page 5.

EQUIPMENT USED FOR ALIGNMENT

Vacuum tube voltmeter.
 AM Signal generator
 FM Sweep generator.
 Oscilloscope.
 Insulated screw driver.
 Dummy antenna:
 .1 MFD condenser
 .00025 MFD mica condenser
 150 ohm resistor (2)
 Output meter.

ALIGNMENT PROCEDURE

STEPS	RECEIVER DIAL SETTING	BAND SWITCH POSITION	SIGNAL GENERATOR FREQUENCY	DUMMY ANTENNA	SIGNAL GENERATOR CONNECTIONS	OUTPUT INDICATOR	TRIMMER ADJUSTMENT	TRIMMER FUNCTION	REMARKS
1	Minimum capacity	AM	455 KC 400 cycle AM	.1 MFD	High side—grid of AM converter tube (6BE6) Low side—chassis	Output Meter across voice coil	T4A, T4B T7A, T7B	AM I.F.	Adjust for maximum output
2	"	"	1600 KC 400 cycle AM	"	"	"	C44	AM Oscillator	"
3	1400 KC	"	1400 KC 400 cycle AM	.00025 MFD	High side—One ant. terminal Low side—Other ant. terminal	"	C43	AM Antenna	"
4	Any position where there is no station interference.	FM	107 MC unmodulated .1 volt output.	.1 MFD	High side—grid of 2nd I.F. amplifier tube (6BA6) Low side—chassis	Connect V.T.V.M. to plate of Ratio Detector tube, pin 7 (6AL5)	T5B	Ratio detector primary	Adjust for maximum negative voltage, about -5 volts
5	"	"	107 MC 400 cycle 30% Modulation. (See note A)	"	"	Connect scope to audio take-off point (across C16)	T8A	Ratio detector secondary	Adjust for a balanced pattern on scope. See Fig. 2
6	"	"	"	"	High side—grid of 1st I.F. amplifier tube (6BA6) Low side—chassis	"	T3A T3B	FM 2nd I.F.	Adjust for maximum gain and best pattern on scope. See Fig. 2
7	"	"	"	"	High side—grid (pin 7) of FM converter tube (12AT7) Low side—chassis	"	T1A T1B	FM 1st I.F.	"
8	108.5 MC	"	108.5 MC 400 cycle 30% modulation (22.5 KC deviation)	300 ohms in high side	High side—ant. terminal Low side—chassis	Connect output meter across voice coil	C42	FM oscillator	Adjust for maximum output
9	105 MC	"	105 MC 400 cycle 30% modulation (22.5 KC deviation)	"	"	"	C45	FM R.F.	"

NOTE A: When aligning the FM I.F. circuits, keep the output from the signal generator as low as possible.

FIGURE 2

RESISTANCE CHART

	PIN 1	PIN 2	PIN 3	PIN 4	PIN 5	PIN 6	PIN 7	PIN 8	PIN 9
6BE6 FM & AM OSC AM CONV	22K	1.5	.5	3.5M	3.5M	2.5M			
12AT7 FM RF AMP & CONV	3.3M	500K	250	0	0	3.5M	500K	2K	0
6BA6 1st IF AM & FM	200K	0	0	0	3.5M	3.5M	70		
6BA6 2nd IF AM & FM	0	0	0	0	3.5M	3.5M	70		
6AL5 FM DETECTOR	OPEN	OPEN	0	0	0	0	22K		
6AT6 AM DETECTOR, AVC, AUDIO	7M	0	0	0	500K	120K	3.5M		
6AQ5 POWER OUTPUT	470K	300	0	0	3.5M	3.5M	0		
5Y3 POWER RECTIFIER								0	3.5M

All voltages shown are approximate.
 All resistance readings are taken from tube pin to chassis.
 Due to manufacturing tolerance on component parts, resistance readings may vary as much as 20%.
 All readings are shown in ohms unless otherwise noted.

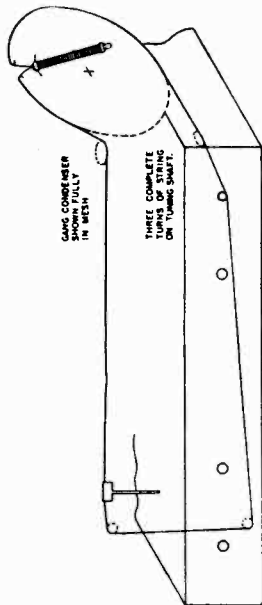

FIG. 4 DIAL CORD STRINGING

VOLTAGE CHART

	PIN 1	PIN 2	PIN 3	PIN 4	PIN 5	PIN 6	PIN 7	PIN 8	PIN 9
6BE6 FM & AM OSC AM CONV	0	0	0	6	AC	155	125	0	
12AT7 FM RF AMP & CONV	170	0	1.5	0	0	155	0	1	6 AC
6BA6 1st IF AM & FM	0	0	0	6	150	100	0		
6BA6 2nd IF AM & FM	0	0	0	6	155	110	1		
6AL5 FM DETECTOR	0	0	6	0	0	0	0		
6AT6 AM DETECTOR, AVC, AUDIO	-5	0	0	6	0	0	60		
6AQ5 POWER OUTPUT	0	7.5	6	0	215	170	0		
5Y3 POWER RECTIFIER								230 AC	235 AC

All voltage readings are taken from tube pin to chassis.
 All measurements are made with no signal, using a 20,000 ohm per volt meter.
 AC input voltage must be maintained at 117 volts for accurate readings.
 AC voltages shown are at 1000 ohms per volt.

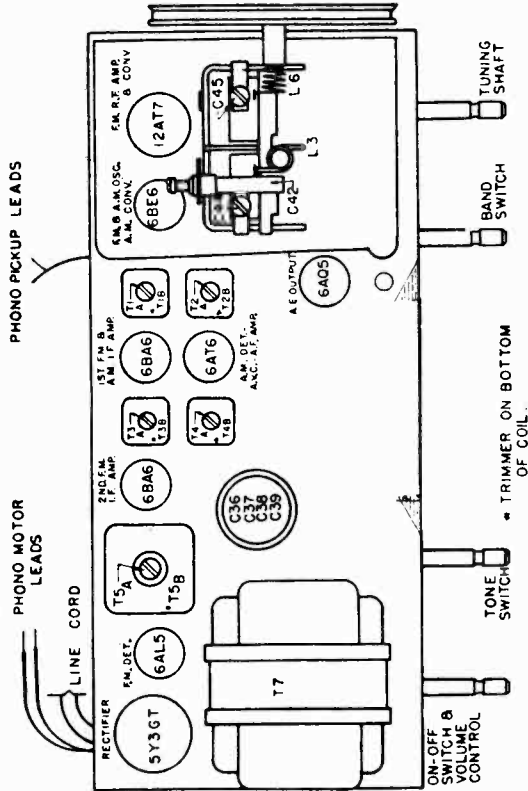
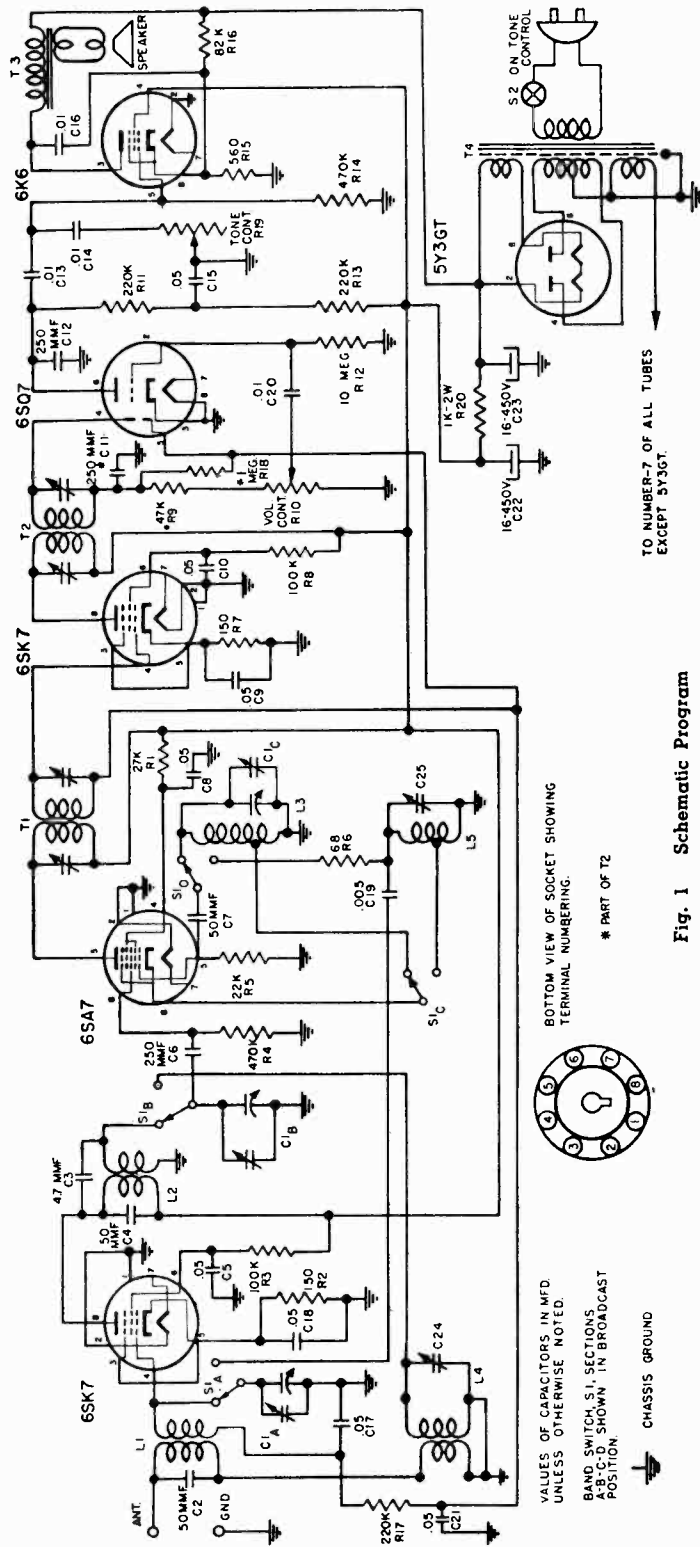

FIG. 3 TUBE AND TRIMMER LOCATIONS

PARTS LIST

Schematic Diagram Reference	Part No.	Description	Schematic Diagram Reference	Part No.	Description
C1A, C1B } C1C, C1D }	C19-200	Variable Condenser	R27	A60-747	270 K ohms, 1/2 watt, 20%
C2	A83-376	2.2 MMF, gimmick	R29	A60-754	270 ohms, 1/2 watt, 10%
C3, C5, C6 } C23, C41 }	A16-177	.005 MFD ceramic (Centralab NO. DAO48 or equiv.)	R30	A10-516	See L4
C4	A15-210	33 MMF ceramic, 20%, (Erie Style "A" N1400)	R31	A60-753	220 ohms, 1/2 watt, 10%
C7, C8, C34	A16-192	.01-400 volts, paper tubular	R32	A60-755	100 ohms, 1 watt, 10%
C9, C10, R11	A17-101	100 MMF, 100 MMF, 47K ohms (Diode filter unit, Herlec F06-001)	R33	A60-763	1 K ohms, 4 watts, 10%
C11, C12, C13	A17-102	3 x .005 MFD Herlec B34-005	R34	A60-667	220 K ohms 1/2 watt 20%
C14, C35	A15-208	270 MMF ceramic, 20%, (Erie Style "K" or equiv.)	L1	A33-231	Choke, wound on R1, 22 ohms
C15	A18-292	4 MFD—50 volt electrolytic	L2A, L2B	A10-515	Oscillator coil, AM
C16	A16-180	.003-200 volts, paper tubular	L3	A10-517	Oscillator coil, FM
C17	A16-165	.01-200 volts, paper tubular	L4	A10-516	Antenna coil, FM, wound on R30, 1.5 K ohms
C18	A16-197	.05-200 volts, paper tubular	L5	A33-233	Plate choke, FM RF
C19	A15-209	15 MMF ceramic, 10%, (Erie Style "A" or equiv.)	L6	A10-518	RF coil, FM
C20	A15-206	1.5 MMF ceramic, 33%, (Erie Style "A" or equiv.)	L8, L9	A33-232	FM oscillator filament choke
C21, C28	A16-196	.02-400 volts, paper tubular	L10	A33-227	Filament choke
C22, C24	A15-196	100 MMF 20% Ceramic Condenser (Erie Style K or Equiv.)	S1A, S1B	A69-184	Band switch
C25, C26	A16-199	.005-400 volts, paper tubular	S2	A26-125	Tone control
C27	A16-198	.002-600 volts, paper tubular	S3	B24-181	ON-OFF SWITCH, on volume control
C29	A16-195	.001 MMF ceramic (Centralab NO. BC20A or equiv.)	T1	A10-519	1st I.F., FM
C30, C32 } C33, C40 }	A18-291	20-25 volts, 40-350 volts 30-300 volts, 30-300 volts electrolytic	T2	A10-521	1st I.F., AM
C36, C37 } C38, C39 }	A20-146	FM oscillator trimmer	T3	A10-520	2nd I.F., FM
C42	A33-231	See L1.	T4	A10-522	2nd I.F., AM
R1	A60-759	4.7 K ohms, 1/2 watt, 10%	T5	SC10-492	Ratio detector, FM
R2	A60-760	10 K ohms, 1/2 watt, 10%	T6	A80-247	Output transformer
R3, R4	A60-744	22 K ohms, 1/2 watt, 10%	T7	C80-246	Power transformer
R5, R6	A60-675	1 K ohms, 1/2 watt, 20%	S84-302	S84-302	Antenna assembly, AM loop
R7, R10, R14	A60-727	100 K ohms, 1/2 watt, 20%	S882-53	S882-53	Antenna assembly, FM dipole
R8, R17	A60-742	68 ohms, 1/2 watt, 10%	C67-539	C67-539	Dial scale, glass
R9, R13	A17-101	47 K ohms, 100 MMF, 100 MMF (Diode filter unit, Herlec F06-001)	A52-203	A52-203	Knob, TUNING
R11, C9, C10	A60-731	470 K ohms, 1/2 watt, 20%	A52-236	A52-236	Knob, TONE 1-2-3
R12, R23 } R24, R28 }	A60-723	270 ohms, 1/2 watt, 20%	A52-237	A52-237	Knob, ON-OFF-YOL
R15	A60-748	33 K ohms, 1/2 watt, 10%	A52-288	A52-288	Knob, FM-AM-PH
R16	B24-181	Volume control and switch S3	23-153	23-153	Line cord and plug
R18	A60-726	2.2 Megohms, 1/2 watt, 20%	A58-68	A58-68	Pointer, slide type
R19, R22	A60-730	47 K ohms, 1/2 watt, 20%	C83-429	C83-429	Retainer, dial scale
R20	A60-761	3.3 Megohms, 1/2 watt, 20%	A87-29	A87-29	Socket, pilot light
R21	A60-714	2.2 K ohms, 1/2 watt, 10%	C79-358	C79-358	Speaker, 10" P.M.
R25	A60-762	6.8 Megohms, 1/2 watt, 20%	A59-22	A59-22	Record changer, Webster No. 50-1



VALUES OF CAPACITORS IN MFD UNLESS OTHERWISE NOTED.
BAND SWITCH S1, SECTIONS A-B-C-D SHOWN IN BROADCAST POSITION

CHASSIS GROUND

TO NUMBER-7 OF ALL TUBES EXCEPT 5Y3GT.

Fig. 1 Schematic Program

CODE	PART NO.	DESCRIPTION	CODE	PART NO.	DESCRIPTION	CODE	PART NO.	DESCRIPTION
C1A, C1B	B19-186	Variable Condenser	R2, R7	A60-686	150 ohm 1/2 watt resistor	R1	A84-41	Dial drive shaft assembly
C2, C4, C7	A15-175	50 MMFD Mica condenser	R3, R8	A60-671	100K ohm 1/2 watt resistor	R2	B79-341	Speaker, 6 1/4" P. M.
C3	A83-355	4.7 MMFD condenser	R4, R14	A60-662	470K ohm 1/2 watt resistor	R3	B79-342	Alternate Speaker, 6 1/4" P. M.
C5, C8, C10, C15	A16-158	.05 MMFD 400 volt condenser	R5	A60-659	22K ohm 1/2 watt resistor	R4	B83-453	Cabinet back
C6, C12	A15-176	250 MMFD Mica condenser	R6	A60-733	68 ohm 1/2 watt resistor	R5	B83-325	Baffle speaker
C8, C17, C18, C21	A16-152	.05 MMFD 200 Volt condenser	R7	A60-689	220K ohm 1/2 watt resistor	R6	D42-379	Cabinet, mahogany
C13, C14, C20	A16-156	.01 MFD 400 Volt condenser	R8, R10, R11, R13, R17	A60-687	220K ohm 1/2 watt resistor	R7	A42-401	Cabinet, Ivory
C16	A16-168	.01 MFD 1000 Volt condenser	R12	A60-683	10 megohm 1/2 watt resistor	R8	A52-197	Knob, Ivory
C19	A15-181	16 MMFD Mica condenser	R15	A60-701	560 ohm 1 watt resistor	R9	A52-191	Knob, Ivory
C22	A18-279	16 MMFD 450 Volt electrolytic condenser	R16	A60-700	82K ohm 1 watt resistor	R10	A83-65	Dial pointer
C23	A18-274	16 MMFD 450 Volt Electrolytic condenser	R19	A26-124	Tone control, 2 megohm, with switch	R11	A83-292	Dial glass retainer, right
C24	A20-143	Condensens trimmer	R20	A10-688	100 ohm 1 watt resistor	R12	A83-293	Dial glass retainer, left
C25	A20-143	S.W. Oscillator trimmer	R21	A10-689	100 ohm 1 watt resistor	R13	B79-376	Band switch
R1	A60-692	27K ohm 1 watt resistor	R22	B10-452	B.C. Oscillator coil	R14	B79-351	Alternate Speaker, 6 1/4" P. M.
			R23	B10-446	B.C. Antenna coil			
			R24	A10-482	S.W. Antenna coil			
			R25	B10-412	1st I.F. Transformer			
			R26	A80-222	2nd I.F. Transformer			
			R27	C80-223	Power Transformer			

DESCRIPTION

Model 11901 is a 6 tube (including rectifier) superhetrodyne radio receiver designed for operation on 50-60 cycle 105-125 volt, AC current.

The tubes used are:

- | | |
|---------------------|----------------------|
| 6SK7 R.F. Amplifier | 6SQ7 Det, AVC, audio |
| 6SA7 Mixer, Osc. | 6K6GT Power Output |
| 6SK7 I.F. Amplifier | 5Y3GT Rectifier |

This receiver covers the standard broadcast frequency range from 535 to 1725 kilocycles (K.C.) and the shortwave frequency range from 6 to 18.2 Megacycles (MC).

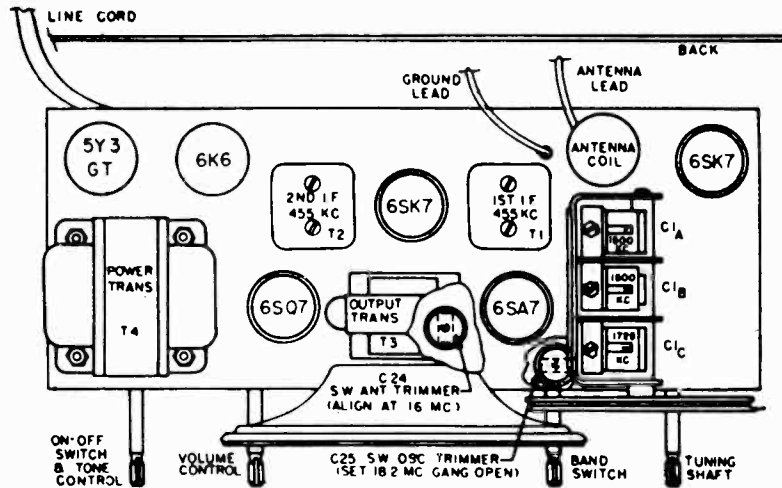

Fig. 2 Tube Positions and Alignment Points

ALIGNMENT PROCEDURE

The following alignment procedure is for use only by competent servicemen having the proper equipment.

With an output meter connected across the voice coil of the speaker, the output meter reading for 1/2 watt is 1.25 volts, using a signal which is modulated 400 C.P.S. Follow through the procedure as outlined below for proper alignment.

The alignment should be made with volume control fully on, and the output from the signal generator as low as possible, for accurate alignment.

Position of Variable	Band Switch Position	Generator Frequency	Dummy Ant.	Generator Connections	Trimmer Adjustment	Trimmer Function
Fully open	BC	455 KC	.1 MFD.	6SA7 Grid (stator of C1B)	T1 T2	I. F.
Fully open	BC	1725 KC	.00025 MFD.	Ant. lead	C1C	BC Osc.
Tune in signal from generator	BC	1500 KC	.00025 MFD.	Ant. lead	C1B	R. F.
Tune in signal from generator	BC	1500 KC	.00025 MFD.	Ant. lead	C1A	BC Ant.
Fully open	SW	18.2 MC	400 ohms	Ant. lead	C25	SW Osc.
Tune in signal from generator	SW	16 MC	400 ohms	Ant. lead	C24	SW Ant.

GROUND lead of generator should be attached to the chassis for all adjustments

C24 and C25 are located under the chassis

For alignment points refer to Figure 2

Repeat alignment procedure as a final check

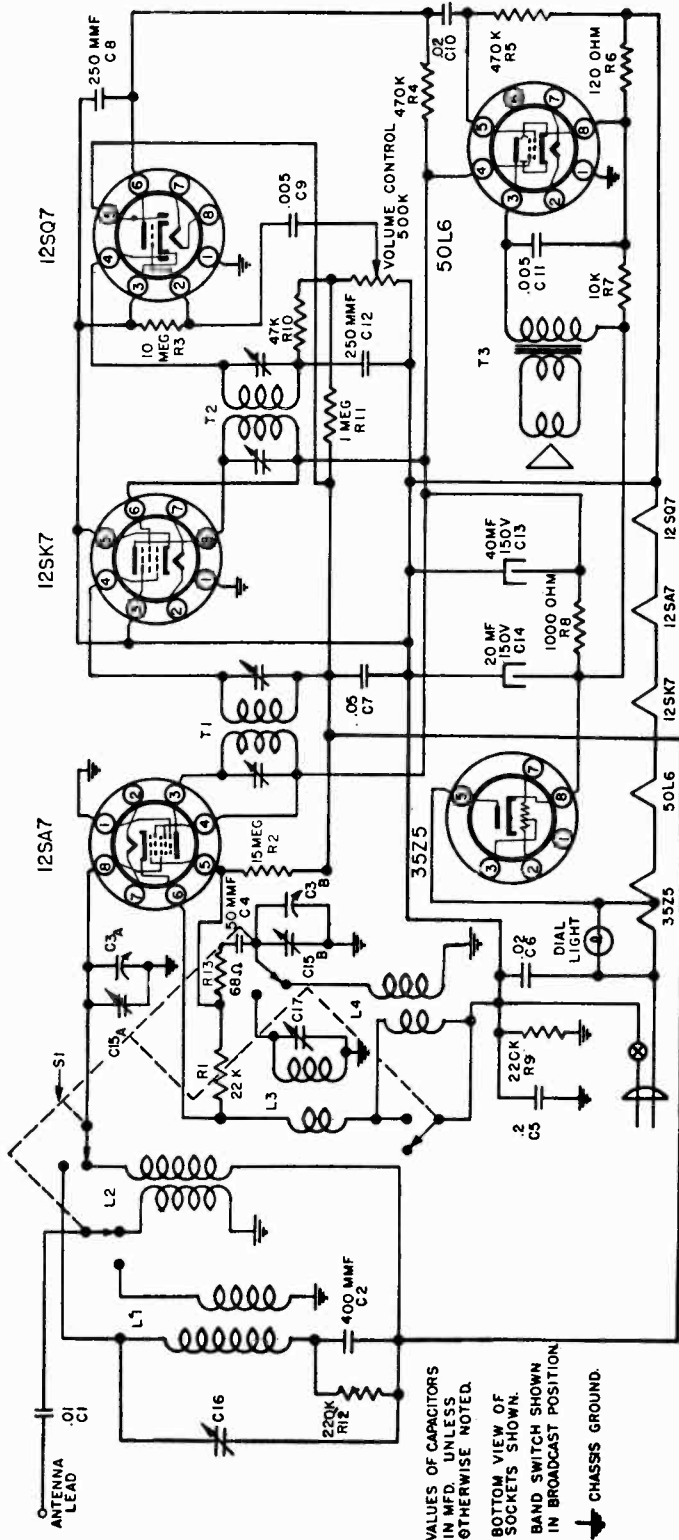

VALUES OF CAPACITORS
IN MFD. UNLESS
OTHERWISE NOTED.
BOTTOM VIEW OF
SOCKETS SHOWN.
BAND SWITCH SHOWN
IN BROADCAST POSITION.
→ CHASSIS GROUND.

PARTS LIST

CODE	PART NO.	DESCRIPTION	CODE	PART NO.	DESCRIPTION	CODE	PART NO.	DESCRIPTION
C1	A16-156	.01 MFD 400 volt condenser	R2	A60-664	15 megohm 1/2 watt resistor	A71-22	Cover for volume control	
C2	B19-180	400 MMF mica condenser	R3	A60-663	10 megohm 1/2 watt resistor	A75-52	Dial drive shaft	
C3A, C3B	A15-175	Variable capacitor	R4	A60-658	10K ohm 1/2 watt resistor	A24-164	Volume control and switch	
C4	A16-154	.2 MFD 400 volt condenser	R5	A60-658	10K ohm 1/2 watt resistor	B79-340	5" x 3" speaker with output transformer	
C5	A16-151	.02 MFD 400 volt condenser	R6	A60-658	10K ohm 1/2 watt resistor	D83-452	Cabinet back	
C6	A16-151	.02 MFD 400 volt condenser	R7	A60-658	10K ohm 1/2 watt resistor	D42-376	Cabinet, Mahogany	
C7	A16-152	.05 MFD 200 volt condenser	R8	A60-660	220K ohm 1/2 watt resistor	A42-398	Cabinet, Ivory	
C8	A16-153	.250 MMF mica condenser	R9, R12	A60-660	220K ohm 1/2 watt resistor	B67-504	Dial scale	
C9	A16-153	.250 MMF mica condenser	R10	A60-665	47K ohm 1/2 watt resistor	A52-181	Dial pointer	
C10	A16-150	.02 MFD 400 volt condenser	R11	A60-733	1 megohm 1/2 watt resistor	A32-193	Knobs, Mahogany	
C11	A18-280	40 MFD 150 volt electrolytic condenser	R13	B10-433	84 ohm 1/2 watt resistor	A32-233	Knobs, Ivory	
C12	A18-272	20 MFD 150 volt electrolytic condenser	T1	B10-434	2nd I.F. transformer	A38-46	Dial pointer	
C13	A18-272	20 MFD 150 volt electrolytic condenser	T2	A10-483	Output transformer (part of speaker)	A83-279	Dial scale retainer, left	
C14	A18-272	20 MFD 150 volt electrolytic condenser	T3	A10-483	S.W. antenna coil	A83-280	Dial scale retainer, right	
C15A	A18-272	B.C. antenna trimmer (on variable condenser)	L1	A10-483	S.W. antenna coil	A69-177	Band switch	
C15B	A20-143	B.C. oscillator trimmer (on variable condenser)	L2	A10-483	S.W. antenna coil			
C16	A20-143	S.W. antenna trimmer condenser	L3	A10-411	B.C. oscillator coil			
C17	A20-143	S.W. antenna trimmer condenser	L4	A10-411	B.C. oscillator coil			
R1	A60-659	22K ohm 1/2 watt resistor						

DESCRIPTION

Model 12001 is a 5 tube (including rectifier) super-heterodyne radio receiver designed for use on 105-125 volt A.C., 60 cycle, or 117 volt D.C. current.

The tubes are:—

- 1—12SA7 Oscillator, converter
- 1—12SK7 I.F. Amplifier
- 1—12SQ7 AVC, Detector, 1st audio
- 1—50L6GT Power Output
- 1—35Z5GT Rectifier

This receiver covers the standard broadcast frequency range of 535 to 1725 K.C. (560 to 174 meters), and the Short Wave frequency range of 9 to 18.2 Mega-cycles (33 to 16.5 meters).

ALIGNMENT PROCEDURE

The following alignment procedure is for use only by competent servicemen having the proper equipment.

The alignment should be made with volume control full on and the output from the signal generator as low as possible to prevent AVC action from interfering with correct alignment.

With the output meter connected across the voice coil of the speaker, the output meter reading for 50 milliwatts is .4 volts, using a signal which is modulated 400 c.p.s.

Adjust all trimmers for maximum output. Repeat alignment procedure as a final check.

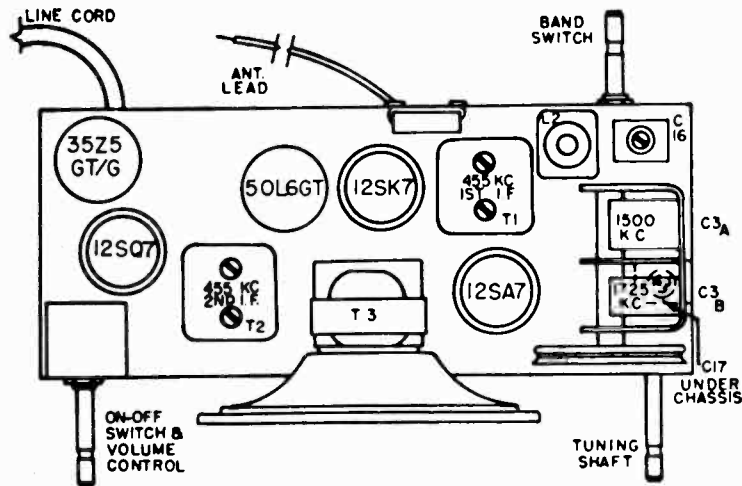

ALIGNMENT PROCEDURE—Continued

CAUTION: This is an AC-DC receiver and when aligning the set it is necessary to isolate the signal generator or the receiver from the line by use of a transformer, or place a .2 MFD condenser in both test leads of the signal generator.

Before proceeding with actual alignment the dial pointer must be set to the proper position. With the variable condenser fully open the dial pointer should read 1725 K.C.

Position of Variable	Band Switch Position	Generator Frequency	Dummy Ant.	Generator Connections	Trimmer Adjustment	Trimmer Function
Fully open	B. C.	455 KC	.1 MFD	* 12SA7 Grid (Stator of C3A)	T1 - T2	I. F.
Fully open	B. C.	1725 KC	.00025 MFD	* Ant. lead	** C3B	B. C. Oscillator
Tune in signal from generator	B. C.	1400 KC	.00025 MFD	* Ant. lead	** C3A	B. C. Antenna
16 MC	S. W.	16 MC	400 ohms	* Ant. lead	C17	S. W. Oscillator
16 MC	S. W.	16 MC	400 ohms	* Ant. lead	C16	S. W. Antenna

* Connect ground lead of signal generator to "Common B."

** C3A, C3B, are located on variable condenser

NOTE: The above procedure must be followed in exact sequence for proper alignment.

MODEL 12110

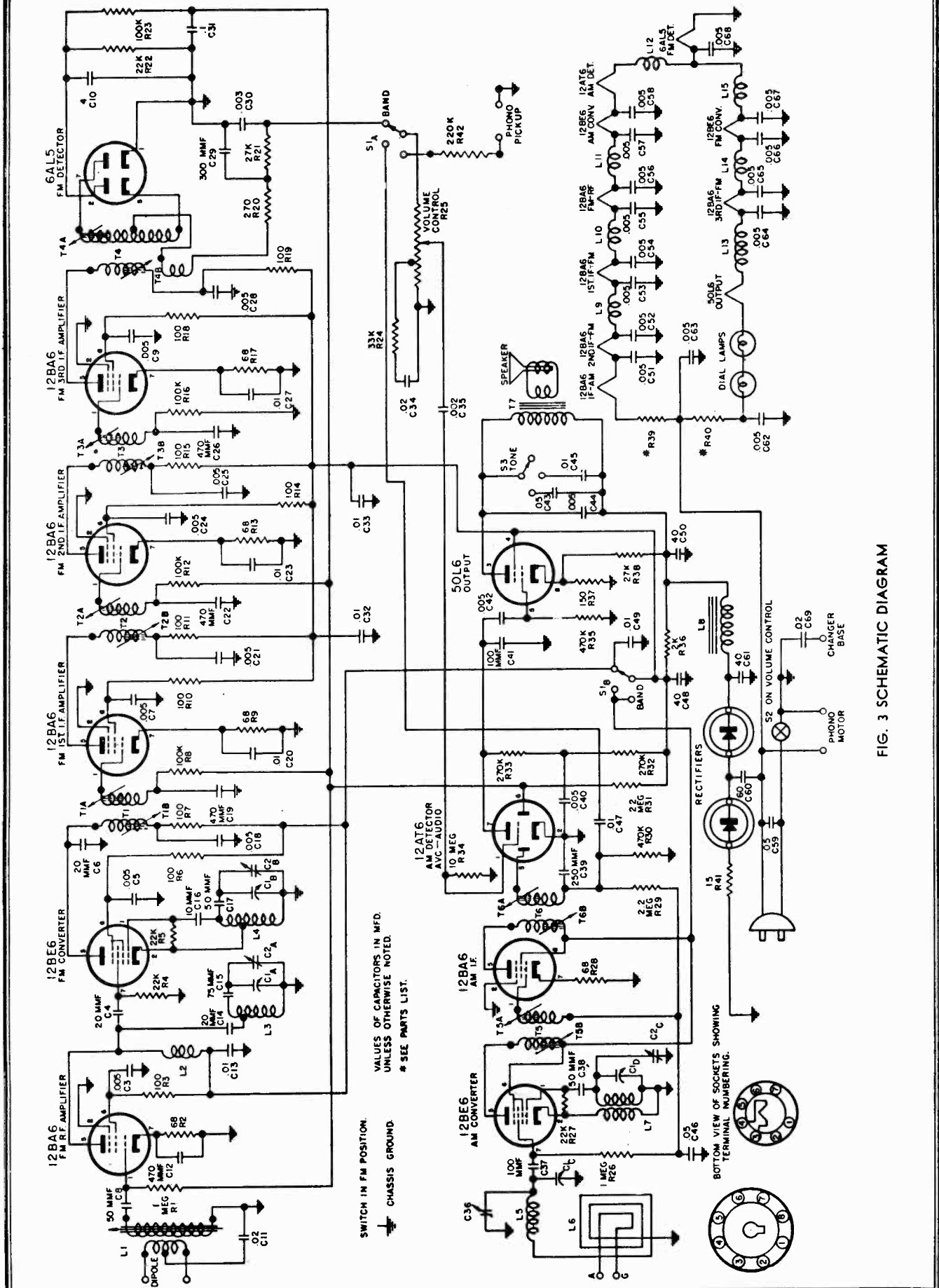

FIG. 3 SCHEMATIC DIAGRAM

SPECIFICATIONS

Power Supply.....117 volts AC 60 cycle
 Power Consumption.....95 Watts
 Frequency Range FM.....88 to 108 MC.
 Frequency Range AM.....540 to 1600 KC.
 I.F. frequency FM.....10.7 MC.
 I.F. frequency AM.....455 KC.
 Band width, FM, Ratio detector.....360 KC.
 Band width, FM, 2nd I.F.....280 KC.
 Band width, FM, 1st I.F.....240 KC.
 Band width, FM, Converter.....180 KC.
 Tubes.....10
 Rectifiers.....Selenium, 150 ma.
 Speaker.....10" P.M.

The tubes used are as follows:
 12BA6 FM, R.F. Amplifier
 12BE6 FM, Converter
 12BA6 FM, 1st I.F. Amplifier
 12BA6 FM, 2nd I.F. Amplifier
 12BA6 FM, 3rd I.F. Amplifier
 6AL5 FM, Ratio detector
 12BE6 AM, Converter
 12BA6 AM, I.F. Amplifier
 12AT6 AM, Detector-AVC-1st audio
 50L6GT Power output
 A83-463 Selenium rectifier (2)
 No. 47 Pilot lights (2)

SERVICE NOTES

INSTALLATION

The loop antenna provided with the receiver will prove adequate for the reception of all AM stations under normal operating conditions. The flexible folded dipole antenna will be adequate for the reception of powerful or near-by FM stations except when the set is used in a building constructed mainly of steel or where FM reception is otherwise difficult. When the radio is used with the inside antenna as provided, it is suggested that you try placing the set in different locations in the room. FM reception especially will vary greatly according to the location of the antenna within the room.

When it is desired to receive FM stations outside of the primary service area, or if the receiver is being used under difficult conditions, the use of an outside dipole antenna is recommended. There are three types of such aerials, namely single dipole, the folded dipole, and the non-directional dipole. To increase the "pick-up" or sensitivity, a reflector may be used with either of the first two types. The proper type of antenna as well as its location are determined by the terrain and distance from the station to be received, the direction, etc. Your local service man will advise you of the proper antenna installation, for your particular area. Two terminals are provided on the back of the set for connecting the outside dipole antenna leads.

FM reception is very directional, and even when using the FM antenna furnished with the receiver, reception can sometimes be very much improved by turning the receiver in a different direction. Be careful not to place the radio close to large metal objects as this might tend to cause reflections or otherwise interfere with good reception.

CAUTION: Always disconnect the line cord before removing the back for tube replacement, etc.

GENERAL

Due to the high frequencies at which FM signals are received the service man must use great care when servicing these sets. Extreme caution must be used regarding the moving of component parts in the R.F. and oscillator circuits of the receiver as those circuits can be detuned in this manner.

If it becomes necessary to replace components such as resistors and condensers they must be replaced with parts of the same size, type, voltage rating and tolerance as called for in the parts list.

When installing new parts they should be placed in the same position as the original, and the leads should be cut to the same length.

ALIGNMENT NOTES

This receiver has been thoroughly inspected and tested at the factory, using the most modern test equipment available, such as FM sweep generators and Oscilloscopes. All I.F. circuit adjustments have been sealed at the factory and no attempt should be made to realign these circuits unless it is absolutely necessary.

CAUTION: If realignment is necessary be sure the proper test equipment is available, as listed below, before proceeding with the alignment procedure as given on page 5. This receiver employs the "double peak" type of I.F. circuits, and can not be satisfactorily aligned with conventional AM equipment. Visual alignment procedures must be used.

EQUIPMENT USED FOR ALIGNMENT

AM Signal generator
 FM Sweep generator.
 Oscilloscope.
 Vacuum tube voltmeter.
 Insulated screw driver.
 Dummy antenna:
 .1 MFD condenser
 .00025 MFD mica condenser
 150 ohm resistor (2)
 Output meter.

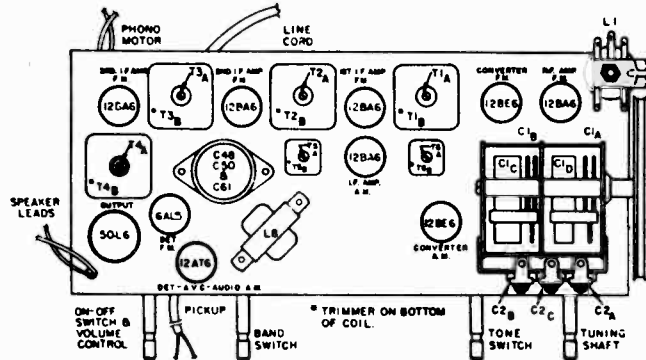

FIG. 1 TUBE AND TRIMMER LOCATIONS

VOLTAGE CHART								RESISTANCE CHART									
TUBE No.	PIN 1	PIN 2	PIN 3	PIN 4	PIN 5	PIN 6	PIN 7	PIN 8	TUBE No.	PIN 1	PIN 2	PIN 3	PIN 4	PIN 5	PIN 6	PIN 7	PIN 8
12BE6 AM—Converter	—6	0	29ac	17ac	100	100	0		12BE6 AM—Converter	20K	1	27	18	25K	25K	3 meg.	
12BA6 AM—I.F. Amp.	0	0	75ac	63ac	100	100	1		12BA6 AM—I.F. Amp.	2 meg.	0	70	62	25K	25K	70	
12AT6 AM—Det.-AVC-Audio	0	0	17ac	6ac	0	0	30		12AT6 AM—Det.-AVC-Audio	10 meg.	0	18	5	470K	120K	540K	
12BA6 FM—R.F. Amp.	0	0	29ac	39ac	100	95	1		12BA6 FM—R.F. Amp.	1 meg.	0	27	40	25K	25K	70	
12BE6 FM—Converter	0	0	6ac	18ac	95	95	0		12BE6 FM—Converter	20K	0	5	18	25K	25K	22K	
12BA6 FM—1st I.F. Amp.	0	0	39ac	50ac	95	95	1		12BA6 FM—1st I.F. Amp.	220K	0	40	50	25K	25K	70	
12BA6 FM—2nd I.F. Amp.	0	0	50ac	63ac	95	95	1		12BA6 FM—2nd I.F. Amp.	220K	0	50	62	25K	25K	70	
12BA6 FM—3rd I.F. Amp.	0	0	18ac	31ac	95	95	1		12BA6 FM—3rd I.F. Amp.	100K	0	18	28	25K	25K	70	
6AL5 FM—Ratio detector	0	—3	0	6ac	—4	0	0		6AL5 FM—Ratio Detector	0	25K	0	5	750K	0	750K	
50L6GT Power output	0	31ac	225	100	0	30	80ac	6.5	50L6GT Power output	0	28	25K	25K	450K	250K	70	150

All voltage readings are taken from tube pin to chassis.
 All measurements are made with no signal, using a 20,000 ohm per volt meter.
 AC input voltage must be maintained at 117 volts for accurate readings.
 AC voltages shown are at 1000 ohms per volt.
 All voltages shown are approximate.

All resistance readings are taken from tube pin to chassis.
 Due to manufacturing tolerance on component parts, resistance readings may vary as much as 20%.
 All readings are shown in ohms unless otherwise noted.

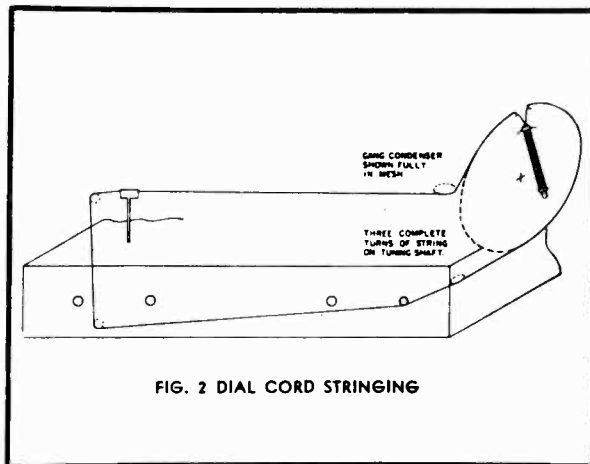

FIG. 2 DIAL CORD STRINGING

ALIGNMENT PROCEDURE

STEPS	RECEIVER DIAL SETTING	BAND SWITCH POSITION	SIGNAL GENERATOR FREQUENCY	DUMMY ANTENNA	SIGNAL GENERATOR CONNECTIONS	OUTPUT INDICATOR	TRIMMER ADJUSTMENT	TRIMMER FUNCTION	REMARKS
1	Minimum capacity	AM	455 KC 400 cycle AM	.1 MFD	High side—Grid of AM converter tube (12BE6) Low side—Chassis	Output Meter across voice coil	T5A, T5B T6A, T6B	AM I.F.	Adjust for maximum output
2	"	"	1600 KC 400 cycle AM	.00025 MFD	"	"	C2C	AM Oscillator	Adjust for maximum output
3	1400 KC Any position where there is no station interference.	"	1400 KC 400 cycle AM	"	High side—One ant. terminal Low side—Other ant. terminal	"	C36 (on back)	AM Antenna	Adjust for maximum output
4	"	FM	10.7 MC unmodulated .1 volt output.	.1 MFD	High side—Grid of 3rd I.F. amplifier tube (12BA6) Low side—Chassis	Connect V.T.V.M. to plate of Ratio detector tube, pin 2 (6AL5)	T4B	Ratio detector primary	Adjust for maximum negative voltage, about -5 volts
5	"	"	10.7 MC 400 cycle 30% Modulation. (See note A)	"	"	Connect scope to audio take off point (across C30)	T4A	Ratio detector secondary	Adjust for a balanced pattern on scope. See Fig. 4.
6	"	"	"	"	High side—Grid of 2nd I.F. amplifier tube (12BA6) Low side—Chassis	Connect scope across 100K ohm grid return resistor of 3rd I.F. (R16)	T3A, T3B	FM 3rd I.F.	Adjust for maximum gain and best pattern on scope. See Fig. 5 (See note "B" below)
7	"	"	"	"	High side—Grid of 1st I.F. amplifier tube (12BA6) Low side—Chassis	"	T2A, T2B	FM 2nd I.F.	Adjust for maximum gain and best pattern on scope. See Fig. 6.
8	"	"	"	"	High side—Plate of FM R.F. tube, pin 5 (12BA6) Low side—Chassis	"	T1A, T2B	FM 1st I.F.	Adjust for maximum gain and best pattern on scope. See Fig. 7.
9	109 MC	"	109 MC 400 cycle 30% modulation. (22.5 KC Deviation)	150 ohms in each lead.	High side—One ant. terminal Low side—Other ant. terminal	Connect output meter across voice coil	C2B	FM Oscillator	Adjust for maximum output (remove AVC ground)
10	103 MC	"	103 MC 400 cycle 30% modulation. (22.5 KC Deviation)	"	"	"	C2A	FM R.F.	Adjust for maximum output
11	100 MC	"	100 MC 400 cycle 30% modulation. (22.5 KC Deviation)	"	"	"	L1	FM Antenna	Adjust for maximum output

NOTE A: When aligning the FM I.F. circuits, keep the out put from the signal generator as low as possible.

NOTE B: The AVC circuit must be grounded to the chassis when aligning the FM I.F. circuits.

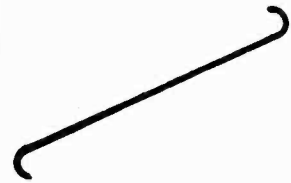

FIGURE 4

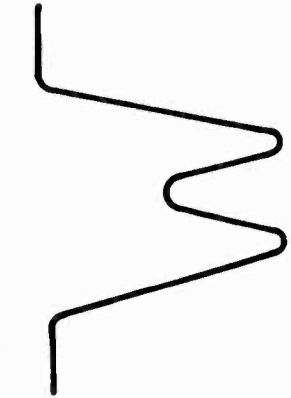

FIGURE 5

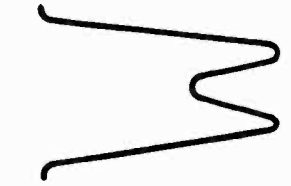

FIGURE 6



FIGURE 7

Schematic Diagram Reference	Part No.	Description	Schematic Diagram Reference	Part No.	Description
C1A, C1B	C19-191	Variable Capacitor	R4, R5, R22	A60-744	22 K Ohm Resistor 10% 1/2 Watt
C1C, C1D	A20-144	FM—R.F. Trimmer FM—Oscillator Trimmer AM—Oscillator Trimmer	R7	A60-727	100 K Ohm 20% 1/2 Watt
C2A	A16-177	005 MFD Ceramic Capacitor (Centralab No. DA048 or Equiv.)	R8, R12, R16	A60-727	100 K Ohm 20% 1/2 Watt
C2B			R23	A60-727	100 K Ohm 20% 1/2 Watt
C3, C5, C7, C9, C18, C21, C23, C24, C25, C28, C40, C51, C52, C53, C54, C55, C56, C57, C58, C62, C64, C65, C66, C67, C68			R20	A60-733	Special Compensating Resistor (Order from MFG.)
C4, C14	A15-198	20 MMF 20% Ceramic Capacitor (Erie Style "A" or Equiv.)	R21	A60-733	Special Compensating Resistor (Order from MFG.)
C6	A15-193	20 MMF 20% Ceramic Capacitor (Erie Style K or Equiv.)	R22, R33	A60-733	Special Compensating Resistor (Order from MFG.)
C8, C17	A15-194	50 MMF 10% Ceramic Capacitor (Erie Style K or Equiv.)	R30, R35	A60-733	Special Compensating Resistor (Order from MFG.)
C10	A18-273	4 MFD 150 Volt Elec. Capacitor	R32, R33	A60-733	Special Compensating Resistor (Order from MFG.)
C34, C69	A16-150	.02 MFD 400 Volt Tubular Capacitor	R34	A60-733	Special Compensating Resistor (Order from MFG.)
C12, C19	A15-200	470 MMF 20% Mica Capacitor	R36	A60-733	Special Compensating Resistor (Order from MFG.)
C22, C26	A16-165	.01 MFD 200 V Tubular Capacitor	R37	A60-733	Special Compensating Resistor (Order from MFG.)
C13, C32, C33	A15-195	75 MMF 10% Ceramic Capacitor (Erie Style K or Equiv.)	R38	A60-733	Special Compensating Resistor (Order from MFG.)
C47, C49	A15-197	10 MMF 10% Ceramic Capacitor (Erie Style A or Equiv.)	R39	A60-733	Special Compensating Resistor (Order from MFG.)
C15	A16-163	.01 MFD 120 V Molded Paper Capacitor	R40	A60-733	Special Compensating Resistor (Order from MFG.)
C16	A16-153	.005 MFD 600 Volt Tubular Capacitor			
C20, C23, C27	A15-199	300 MMF 20% Mica Capacitor	R41	A60-667	15 Ohm — Glassohm 10% 3 Watt Resistor
C42, C44	A16-180	.003 MFD 200 V Molded Paper Capacitor	R42	S810-488	220K Ohm Resistor 20% 1/2 Watt
C31	A16-157	.1 MFD 200 V Tubular Capacitor	L1	B10-489	Antenna Coil, FM
C35	A16-178	.002 MFD 200 V Molded Paper Capacitor	L3	B10-489	R. F. Coil, F.M.
C36	A20-139	AM Antenna Trimmer	L4	B10-490	Oscillator Coil, F. M.
C37	A15-190	100 MMF 20% Mica Capacitor	L5	A10-504	Antenna Loading Coil
C38	A15-191	50 MMF 20% Mica Capacitor	L6	S84-166	Loop Antenna Assembly
C39	A15-176	250 MMF 20% Mica Capacitor	L7	B10-491	Oscillator Coil, A. M.
C41	A15-196	100 MMF 20% Ceramic Capacitor (Erie Style K or Equiv.)	L8	A33-225	Filter Choke
C46	A16-158	.05 MFD 400 V Tubular Capacitor	L2, L9, L10	A33-226	Filament Choke, 11 mh.
C67, C43, C59	A16-156	.01 MFD 400 V Tubular Capacitor	L11, L12, L14	A33-227	Filament Choke
C45	A18-284	40 MFD 150 Volt Electrolytic Capacitor	L13	A69-178	Switch, FM-AM-PHONO
C48			L14		Switch, ON-OFF. (on volume control)
C50			S1A, S1B	A26-125	Tone Control
C61	A18-285	40 MFD 300 Volt Electrolytic Capacitor	S3	SA10-493	1st I. F. Transformer, F. M.
C60	A18-285	60 MFD 150 Volt Electrolytic Capacitor	S2	SC10-494	2nd & 3rd I. F. Transformer, F.M.
R1, R26	A60-668	1 Megohm Resistor 20% 1/2 Watt	T1	SC10-492	Radio detector transformer, F.M.
R2, R13, R17, R28, R9	A60-742	68 Ohm Resistor 10% 1/2 Watt	T2, T3	A10-499	1st I. F. transformer, A. M.
R3, R6, R7, R10, R19, R11, R14, R15, R18	A60-743	100 Ohm Resistor 20% 1/2 Watt	T4	A10-500	2nd I. F. transformer, A. M.
			T5	B39-285	Output Transformer
			T6	AZ3-153	Drum, for Variable Capacitor
			T7	A83-463	Selenium rectifier, 150 ma.
				A75-63	Tuning shaft
				C79-358	Speaker, 10" P.M.
				A21-111	Cover, for Compensating Resistors
				S882-53	FM Antenna Assembly, Dipole
				C67-503	Dial Scale
				C83-471	Retainer, Dial Scale
				B83-482	Dial Diffusing Plate
				A58-68	Dial Pointer
				A52-203	Knob, Tuning
				A52-236	Knob, Tone
				A52-237	Knob, ON-OFF VOLUME
				A52-238	Knob, PH-AM-FM

NOTE: Model 12110M uses a Webster Record Changer No. 50-1

SPECIFICATIONS

Power Supply.....	117 volts AC-DC
Power Consumption.....	55 Watts
Frequency Range FM.....	88 to 108 MC.
Frequency Range AM.....	540 to 1600 KC.
I.F. frequency FM.....	10.7 MC.
I.F. frequency AM.....	455 KC.
Band width, FM, Ratio detector.....	360 KC.
Band width, FM, 2nd I.F.....	280 KC.
Band width, FM, 1st I.F.....	240 KC.
Band width, FM, Converter.....	180 KC.
Tubes.....	10
Rectifier.....	Selenium, 150 ma.
Speaker.....	6" P.M.

The tubes used are as follows:

12BA6	FM, R.F. Amplifier
12BE6	FM, Converter
12BA6	FM, 1st I.F. Amplifier
12BA6	FM, 2nd I.F. Amplifier
12BA6	FM, 3rd I.F. Amplifier
6AL5	FM, Ratio detector
12BE6	AM, Converter
12BA6	AM, I.F. Amplifier
12AT6	AM, Detector-AVC-1st audio
50L6GT	Power output
A83-463	Selenium rectifier
No. 47	Pilot lights (2)

GENERAL SERVICE INFORMATION

INSTALLATION

This receiver is shipped from the factory complete with a flexible, folded dipole antenna. This antenna will be satisfactory for good reception under normal conditions. It should be connected to the two (2) dipole terminals on the back of the cabinet, and then extended to its full length. Since FM signals are directional, reception may be sometimes improved by rotating the extended sections of the flexible antenna in different directions.

This antenna is also used in conjunction with the AM antenna coil for standard AM broadcast reception, and therefore must be connected as described above for reception of standard broadcast stations.

When the receiver is to be used under difficult conditions, such as in buildings constructed mainly of steel, or those with steel lath, or, when large buildings, mountains or other objects are between the receiver and the station to be received, it may be necessary to use an external dipole antenna. Remember too, FM reception is limited as to distance and when used outside the primary service area of the transmitter, an outside antenna is very necessary.

The type of dipole to be used depends upon the signal strength of the station in that particular area, as well as conditions of reception as outlined above. There are three types of FM dipole antenna available, the single dipole, the folded dipole, and the non-directional dipole. When the stations to be received are in one general direction, a reflector may be added to either of the first two types to increase their efficiency.

GENERAL

Due to the high frequencies at which FM signals are received the service man must use great care when servicing these sets. Extreme caution must be used regarding the moving of component parts in the R.F. and oscillator circuits of the receiver as those circuits can be detuned in this manner.

If it becomes necessary to replace components such as resistors and condensers they must be replaced with parts of the same size, type, voltage rating and tolerance as called for in the parts list.

When installing new parts they should be placed in the same position as the original, and the leads should be cut to the same length.

ALIGNMENT NOTES

This receiver has been thoroughly inspected and tested at the factory, using the most modern test equipment available, such as FM sweep generators and Oscilloscopes. All I.F. circuit adjustments have been sealed at the factory and no attempt should be made to realign these circuits unless it is absolutely necessary.

CAUTION: If realignment is necessary be sure the proper test equipment is available, as listed below, before proceeding with the alignment procedure as given on page 5. This receiver employs the "double peak" type of I.F. circuits, and can not be satisfactorily aligned with conventional AM equipment. Visual alignment procedures must be used.

EQUIPMENT USED FOR ALIGNMENT

Vacuum tube voltmeter.

AM Signal generator

FM Sweep generator.

Oscilloscope.

Insulated screw driver.

Dummy antenna:

.1 MFD condenser

.00025 MFD mica condenser

150 ohm resistor (2)

Output meter.

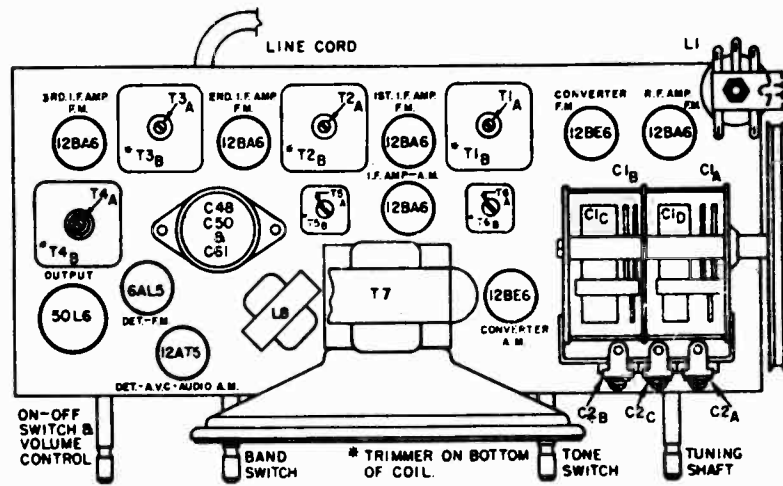

FIG. 1 TUBE AND TRIMMER LOCATIONS

VOLTAGE CHART									RESISTANCE CHART								
TUBE No.	PIN 1	PIN 2	PIN 3	PIN 4	PIN 5	PIN 6	PIN 7	PIN 8	TUBE No.	PIN 1	PIN 2	PIN 3	PIN 4	PIN 5	PIN 6	PIN 7	PIN 8
12BE6 AM—Converter	—6	0	29ac	17ac	100	100	0		12BE6 AM—Converter	20K	1	27	18	25K	25K	3 meg.	
12BA6 AM—I.F. Amp.	0	0	75ac	63ac	100	100	1		12BA6 AM—I.F. Amp.	2 meg.	0	70	62	25K	25K	70	
12AT6 AM—Det.-A.V.C-Audio	0	0	17ac	6ac	0	0	30		12AT6 AM—Det.-A.V.C-Audio	10 meg.	0	18	5	470K	120K	540K	
12BA6 FM—R.F. Amp.	0	0	29ac	39ac	100	95	1		12BA6 FM—R.F. Amp.	1 meg.	0	27	40	25K	25K	70	
12BE6 FM—Converter	0	0	6ac	18ac	95	95	0		12BE6 FM—Converter	20K	0	5	18	25K	25K	22K	
12BA6 FM—1st I.F. Amp.	0	0	39ac	50ac	95	95	1		12BA6 FM—1st I.F. Amp.	220K	0	40	50	25K	25K	70	
12BA6 FM—2nd I.F. Amp.	0	0	50ac	63ac	95	95	1		12BA6 FM—2nd I.F. Amp.	220K	0	50	62	25K	25K	70	
12BA6 FM—3rd I.F. Amp.	0	0	18ac	31ac	95	95	1		12BA6 FM—3rd I.F. Amp.	100K	0	18	28	25K	25K	70	
6AL5 FM—Ratio detector	0	—3	0	6ac	—4	0	0		6AL5 FM—Ratio Detector	0	25K	0	5	750K	0	750K	
50L6GT Power output	0	31ac	85	95	0	30	80ac	6.5	50L6GT Power output	0	28	25K	25K	450K	250K	70	150

All voltage readings are taken from tube pin to chassis.
 All measurements are made with no signal, using a 20,000 ohm per volt meter.
 AC input voltage must be maintained at 117 volts for accurate readings.
 AC voltages shown are at 1000 ohms per volt.
 All voltages shown are approximate.

All resistance readings are taken from tube pin to chassis.
 Due to manufacturing tolerance on component parts, resistance readings may vary as much as 20%.
 All readings are shown in ohms unless otherwise noted.

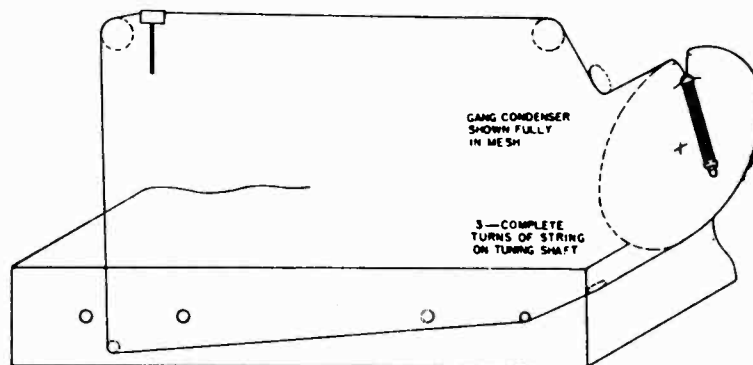

FIG. 2 DIAL CORD STRINGING

ALIGNMENT PROCEDURE

STEPS	RECEIVER DIAL SETTING	BAND SWITCH POSITION	SIGNAL GENERATOR FREQUENCY	DUMMY ANTENNA	SIGNAL GENERATOR CONNECTIONS	OUTPUT INDICATOR	TRIMMER ADJUSTMENT	TRIMMER FUNCTION	REMARKS
1	Minimum capacity	AM	455 KC 400 cycle AM	.1 MFD	High side—Grid of AM converter tube (12BE6) Low side—Chassis	Output Meter across voice coil	T5A, T5B T6A, T6B	AM I.F.	Adjust for maximum output
2	"	"	1600 KC 400 cycle AM	0.025 MFD	"	"	C2C	AM Oscillator	Adjust for maximum output
3	1400 KC	"	1400 KC 400 cycle AM	"	High side—One ant. terminal Low side—Other ant. terminal	"	C36 (on back)	AM Antenna	Adjust for maximum output
4	Any position where there is no station interference.	FM	10.7 MC unmodulated .1 volt output.	.1 MFD	High side—Grid of 3rd I.F. amplifier tube (12BA6) Low side—Chassis	Connect V.T.V.M. to plate of Ratio detector tube, pin 2 (6AL5)	T4B	Ratio detector primary	Adjust for maximum negative voltage, about -5 volts
5	"	"	10.7 MC 400 cycle 30% Modulation. (See note A)	"	"	Connect scope to audio rate off point (across C30)	T4A	Ratio detector secondary	Adjust for a balanced pattern on scope. See Fig. 4.
6	"	"	"	"	High side—Grid of 2nd I.F. amplifier tube (12BA6) Low side—Chassis	Connect scope across 100K ohm grid return resistor of 3rd I.F. (R16)	T3A, T3B	FM 3rd I.F.	Adjust for maximum gain and best pattern on scope. See Fig. 5 (See note "B" below)
7	"	"	"	"	High side—Grid of 1st I.F. amplifier tube (12BA6) Low side—Chassis	"	T2A, T2B	FM 2nd I.F.	Adjust for maximum gain and best pattern on scope. See Fig. 6
8	"	"	"	"	High side—Plate of FM R.F. tube, pin 5 (12BA6) Low side—Chassis	"	T1A, T2B	FM 1st I.F.	Adjust for maximum gain and best pattern on scope. See Fig. 7.
9	109 MC	"	109 MC 400 cycle 30% modulation. (22.5 KC Deviation)	150 ohms in each lead.	High side—One ant. terminal Low side—Other ant. terminal	Connect output meter across voice coil	C2B	FM Oscillator	Adjust for maximum output (remove AVC ground)
10	103 MC	"	103 MC 400 cycle 30% modulation. (22.5 KC Deviation)	"	"	"	C2A	FM R.F.	Adjust for maximum output
11	100 MC	"	100 MC 400 cycle 30% modulation. (22.5 KC Deviation)	"	"	"	L1	FM Antenna	Adjust for maximum output

NOTE A: When aligning the FM I.F. circuits, keep the output from the signal generator as low as possible.

NOTE B: The AVC circuit must be grounded to the chassis when aligning the FM I.F. circuits.

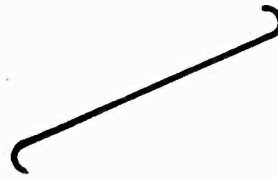

FIGURE 4

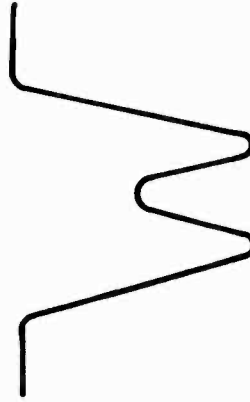

FIGURE 5

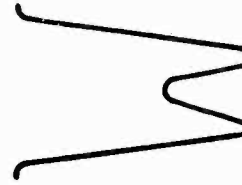

FIGURE 6

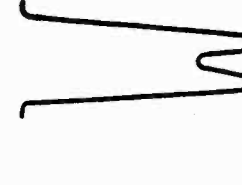

FIGURE 7

PARTS LIST

Schematic Diagram Reference	Part No.	Description	Schematic Diagram Reference	Part No.	Description
C1A, C1B	C19-191	Variable Condenser	R8, R12, R16	A60-727	100 K Ohm 20% 1/2 Watt
C1C, C1D	A20-144	FM—R.F. Trimmer	R20	A60-723	270 Ohm 20% 1/2 Watt Resistor
C2A		FM—Oscillator Trimmer	R21	A60-745	27 K Ohm 10% 1/2 Watt Resistor
C2B		AM—Oscillator Trimmer	R24	A60-748	33 K Ohm 10% 1/2 Watt Resistor
C2C		AM—Oscillator Trimmer	R25	B24-173	Volume Control with Switch
C3, C5, C7	A16-177	.05 MFD Ceramic Condenser (Centralab No. DA048 or Equiv.)	R29, R31	A60-726	2.2 Megohm 20% 1/2 Watt
C9, C18, C21, C28			R30, R35	A60-747	270K Ohm 20% 1/2 Watt
C24, C25, C28			R32, R33	A60-728	10 Megohm 20% 1/2 Watt
C40, C51, C52			R34	A60-755	100 Ohm 1 Watt 10% Resistor
C53, C54, C55			R36	A60-741	150 Ohm 10% 1 Watt Resistor
C56, C57, C58			R37	A60-751	12K Ohm 10% 1 Watt Resistor
C62, C23, C64			R38	A60-734	Special Compensating Resistor (Order from Mfg.)
C65, C66, C67	C68	.05 MFD Ceramic Condenser (Centralab No. DA048 or Equiv.)	R39	A60-734	Special Compensating Resistor (Order from Mfg.)
C4, C14			R40	A60-735	Special Compensating Resistor (Order from Mfg.)
C6	A15-198	20 MMF 20% Ceramic Condenser (Erie Style "A" or Equiv.)	R41	A60-738	15 Ohm — Glassohm 10% 3 Watt Resistor
C8, C17	A15-193	20 MMF 20% Ceramic Condenser (Erie Style K or Equiv.)	L1	S810-488	Antenna Coil, FM
	A15-194	50 MMF 10% Ceramic Condenser (Erie Style K or Equiv.)	L3	B10-489	R. F. Coil, F.M.
C10	A18-273	4 MFD 150 Volt Elec. Condenser (Erie Style K or Equiv.)	L4	B10-490	Oscillator Coil, F. M.
C34	A16-150	.02 MFD 400 Volt Tubular Condenser	L5	A10-507	Antenna Coil, A. M.
C12, C19	A15-200	4-70 MMF 20% Mica Condenser	L7	B10-491	Oscillator Coil, A. M.
C22, C26	A16-165	.01 MFD 200 V Tubular Condenser	L8	A33-225	Filter Choke
C32, C33	A15-195	75 MMF 10% Ceramic Condenser (Erie Style K or Equiv.)	L2, L9, L10	A33-226	Filament Choke, 11 mh.
C47, C49	A15-197	10 MMF 10% Ceramic Condenser (Erie Style A or Equiv.)	L11, L12, L14	A33-227	Filament Choke
C15	A16-163	.01 MFD 120 V Molded Paper Condenser	L13	A69-181	Switch, FM —A.M.
C20, C23, C27	A16-153	.005 MFD 600 Volt Tubular Condenser	S2	A26-125	Switch, ON-OFF, (on volume control)
	C42, C44	A15-199	.003 MFD 200 V Mica Condenser	S3	A10-493
C29	A16-180	.003 MFD 200 V Molded Paper Condenser	T1	SC10-494	1st I. F. Transformer, F. M.
C30	A16-157	.01 MFD 200 V Tubular Condenser	T2, T3	SC10-492	2nd & 3rd I. F. Transformer, F.M.
C31	A16-178	.002 MFD 250 V Molded Paper Condenser	T4	A10-499	Radio detector transformer, F.M.
C35	A20-139	AM Antenna Trimmer	T5	A10-500	1st I. F. transformer, A. M.
C36	A15-190	100 MMF 2-5% Mica Condenser	T6	A80-234	2nd I. F. transformer, A. M.
C37	A15-191	50 MMF 20% Mica Condenser	T7	A80-234	Output transformer
C11, C38	A15-176	250 MMF 20% Mica Condenser		B39-285	Drum, for variable condenser
C37	A15-196	100 MMF 20% Ceramic Condenser (Erie Style K or Equiv.)		A23-151	Line cord
C46	A16-158	.05 MFD 450 V Tubular Condenser		A83-463	Selenium rectifier, 150 ma.
C69, C43, C59	A16-156	.01 MFD 400 V Tubular Condenser		A75-63	Tuning shaft
C45	A18-284	40 MFD 150 Volt Electrolytic Condenser		B79-354	Speaker, 6/4" P. M.
C43		40 MFD 300 Volt Electrolytic Condenser		A21-111	Cover, for compensating resistors
C61		40 MFD 300 Volt Electrolytic Condenser		S882-49	F. M. antenna assembly, Dipole
R1, R26	A60-688	1 Megohm Resistor 20% 1/2 Watt		883-325	Speaker baffle
R2, R13, R17, R28, R9	A60-742	68 Ohm Resistor 10% 1/2 Watt		A42-401	Cabinet, Ivory
R3, R6, R7, R10, R19, R11	A60-743	100 Ohm Resistor 20% 1/2 Watt		D42-379	Cabinet, Walnut
R14, R15, R18	A60-744	22 K Ohm Resistor 10% 1/2 Watt		C67-511	Dial Scale
R4, R5, R22				A98-4	Grille Cloth
R27				A52-191	Knob, Ivory
				A52-187	Knob, Walnut
				A83-292	Retainer, dial scale, right
				A83-293	Retainer, dial scale, left
				C83-502	Cabinet back
				B83-503	Dial diffusing plate
				A58-65	Dial pointer

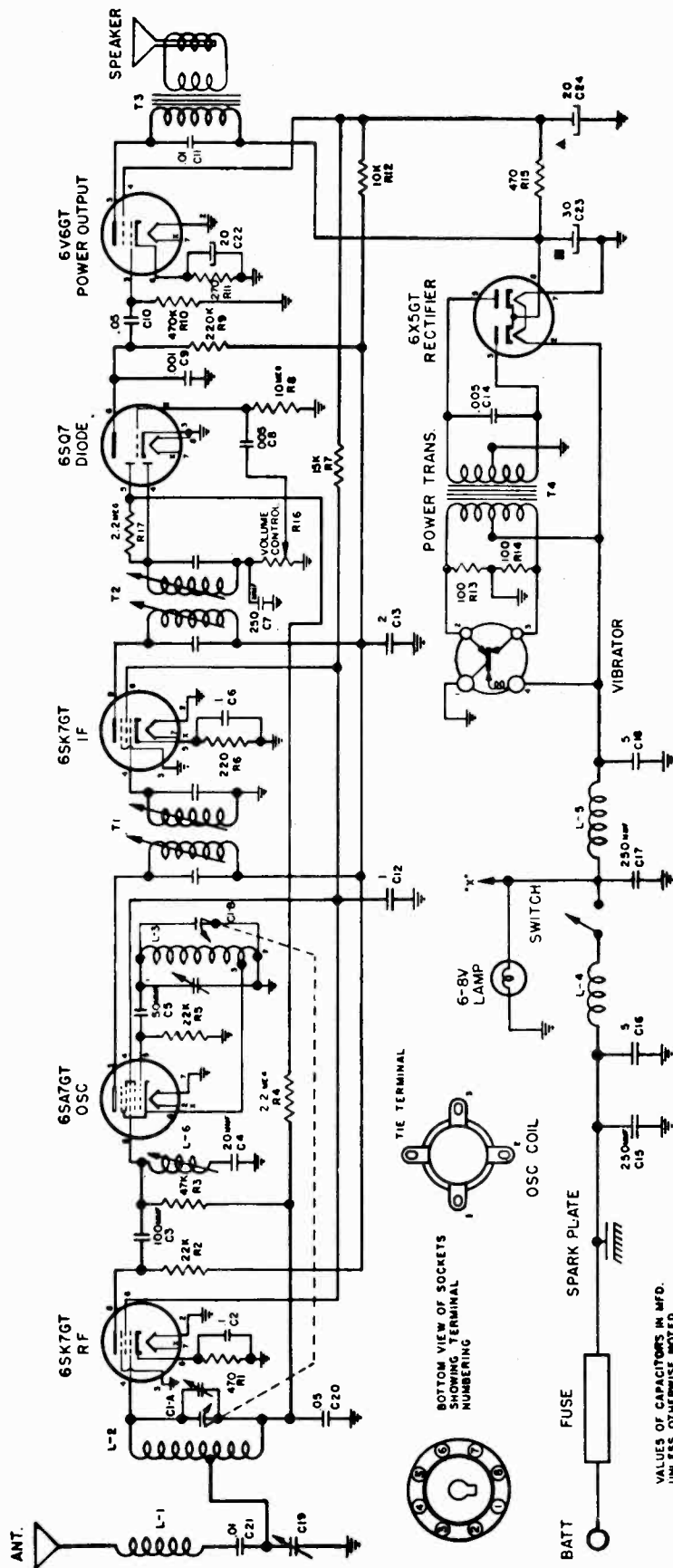

Fig. 3 Schematic Diagram

INSTALLATION

This radio comes to you complete with all hardware necessary for mounting, and also with a distributor suppressor, ammeter condenser and generator condenser. By referring to Figures 1 and 2, and following the instructions outlined below, you will find that it is very simple to install.

First determine where the receiver is to be mounted by holding it with the hands in the approximate location in the car. Using the front mounting bracket as a template, mark and drill two $\frac{5}{8}$ " holes in the instrument panel flange. Now secure the mounting bracket to the radio receiver with the screws provided, and then mount the front of the radio to the instrument panel, using the bolts, lock washers and nuts provided for this purpose. The back of the radio is supported by means of the rear mounting strap. The mounting strap should be formed to the correct angles, as illustrated in Figure 2, so that it can then be fastened to the fire wall. After marking and center-punching the fire wall at the correct location, drill with a $\frac{3}{8}$ " drill. The mounting strap is then secured to the radio and fastened to the fire wall of the car with the $\frac{1}{4}$ " bolt, lock washer and nut furnished with the receiver.

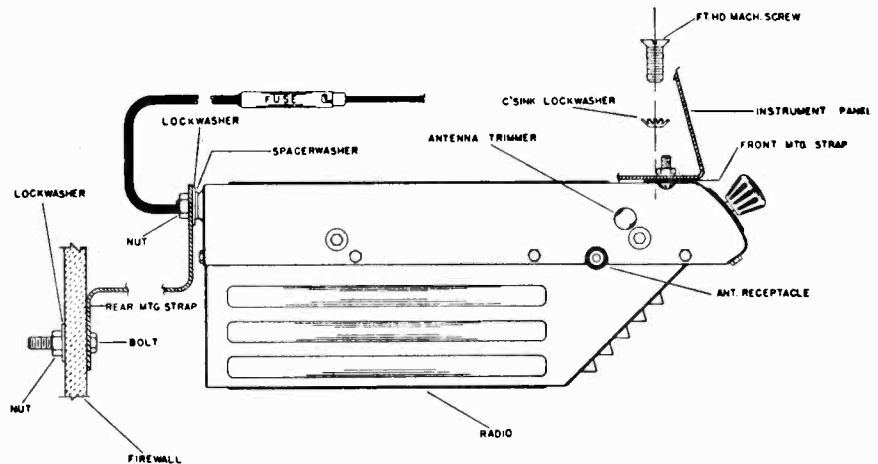

Fig. 2 Side View, Showing Mounting

CONNECTING THE RADIO

The antenna cable should be connected to the radio by inserting the jack into the socket provided on the side of the radio. Connect the battery cable to the hot side of the ammeter behind the instrument panel. The fuse should then be inserted into the cable receptor.

FINAL ADJUSTMENTS

The input circuit has been especially designed to be used with a low capacity antenna, of the fish pole or whip type.

To adjust the antenna trimmer condenser, carefully tune the receiver to a weak station at approximately 600 kilocycles (K.C.). Remove the snap button covering the antenna trimmer (See Figure 2) and adjust the trimmer for maximum volume. A small screw driver will be needed for this purpose.

ACCESSORIES FURNISHED FOR INSTALLATION

All of the parts that are needed for installing this receiver are furnished in the Mounting Parts Kit, part No. S84-192, and the Suppression and Misc. Parts Kit, part No. S84-230, as listed below. Also supplied are the rear mounting strap, part No. B31-134, and the front mounting plate, part No. A31-138.

NOTE: For shipping, the two control knobs have been removed from the tuning and volume control shafts. To install the knobs, line up the flat side of the knob spring, (inside knob) with the flat side of the control shaft and push the knob forward until it stops.

S84-192 MOUNTING PARTS KIT

- | | |
|----------------------------------|-------------------------------|
| 1 $\frac{1}{4}$ " Bolt | 2 External Tooth Lock Washers |
| 2 $\frac{1}{4}$ " Lock Washers | 2 Internal Tooth Lock Washers |
| 2 $\frac{1}{4}$ " Hexagon Nuts | 2 10-32 Hexagon Nuts |
| 2 10-32 x $\frac{5}{8}$ " Screws | |

S84-230 SUPPRESSION KIT & MISC. PARTS

- | | |
|----------------------------|--|
| 1 S84-233 "A" lead assem. | 1 S84-193 Suppression Kit consisting of: |
| 1 A43-10 Fuse | 2 .5 MFD Condensers |
| 2 A52-256 Control knobs | 1 Distributor Suppressor |
| 1 A81-13 Sleeve (for fuse) | 20" Wire Braid |

ELIMINATING MOTOR NOISE

IMPORTANT: Special care should be taken when mounting the radio to make sure all paint, grease, rust, etc., is removed from all three mounting points. A good electrical contact at these points will aid materially in eliminating motor noise.

GENERATOR CONDENSER

The generator condenser must be connected to the battery terminal of the generator in all cases. If your car is equipped with a generator using an automatic regulator, make sure the condenser IS NOT fastened to the field winding terminal. If in doubt, your local car dealer can advise you as to where the car manufacturer recommends connecting it.

DISTRIBUTOR SUPPRESSOR

Remove the coil to distributor high tension lead from the distributor. Cut the lead two inches from the end, and screw the distributor resistor on to the coil lead, then screw the short length into the resistor and plug the cable into the distributor cap.

AMMETER CONDENSER

A .5 MFD bypass condenser is furnished for attaching to the ammeter. This should be connected to either side of the ammeter with the ground lug fastened to a good ground nearby. In most cases the use of this condenser, the distributor suppressor, and the generator condenser, will eliminate all objectionable ignition interference.

ELECTRICAL ACCESSORIES

In some cases, it may be found that car accessories such as electric heaters, lighters, automatic relays, or gauges, may cause interference while in operation. Proper procedure in such cases is to try another by-pass condenser from ground to the suspected accessory until the source of the interference is found. The condenser then should be permanently mounted in this location.

HIGH AND LOW TENSION LEADS

In many cases the low tension battery leads, etc., are grouped together with the high tension wires. These leads will very often pick up motor noise and feed it into the

receiver through the battery circuit. In cases such as these it will be necessary to separate the low tension from the high tension wires and run them through another hole if they run from the engine compartment up to the instrument panel. This condition is particularly true on the V-8 Ford, as the battery and primary leads run through a special tube which also houses the high tension leads. Shield and ground these leads.

IGNITION COILS

In cars where the ignition coil is located on the back side of the instrument panel it is often necessary to use an additional condenser. It must be installed from the battery side of the ignition coil to the closest ground on the instrument panel.

Short leads are very important. Where coils are mounted either on the instrument panel or in the driver's compartment, it may be necessary to shield the high tension lead from the coil to the distributor.

WHEEL STATIC

Wheel Static is a form of interference caused by the rotation of the front wheels of the car, and it is, of course, only noticed when the car is in motion. If this form of interference is present it can be eliminated by installing wheel static collector springs between the inner hub cap and the spindle shaft.

BONDING OF FIRE WALL TUBES

Bonding the steering column to the fire wall with a short braid may also be effective. Clean the paint from the steering column at the fire wall where the column enters the motor compartment, and solder on a short piece of braid. Ground the end of the braid to the fire wall.

In some cases it may be necessary to ground the tubes and rods coming through the fire wall in order to reduce the interference. Clean them with emery cloth and spot-solder the braid, fastening the end under a convenient screw. A 1/4" piece of wire braid 20 inches long is furnished in the suppression kit assembly for this purpose.

ALIGNMENT PROCEDURE

- Volume control—Maximum, all adjustments.
 No signal applied to antenna.
 Power input—6.3 volts.
 Connect dummy antenna in series with output lead of signal generator.
 Connect output meter across voice coil.
 Connect ground lead of signal generator to chassis.
 Repeat alignment procedure as a final check.
- The following equipment is necessary for proper alignment:
 Signal generator that will provide the test frequencies as listed.
 Non-metallic screwdriver.
 Output meter.
 Dummy antennas—.1 MFD., .00025 MFD.
 For alignment points refer to Figures 4 and 5.

Dial Setting	Generator Frequency	Dummy Ant.	Generator Connections	Trimmer Reference	Trimmer Adjustment	Trimmer Function
Fully Open	455 KC	.1 MFD.	6SA7 Grid	T2	Maximum	Output I.F.
Fully Open	455 KC	.1 MFD.	6SA7 Grid	T1	Maximum	Input I.F.
Fully Open	455 KC	.00025 MFD.	Ant. lead	L6	Minimum	Wave trap
Fully Open	1600 KC	.00025 MFD.	Ant. lead	C1B	Maximum	Oscillator
Tune in signal from generator	1400 KC	.00025 MFD.	Ant. lead	C1A	Maximum	Antenna

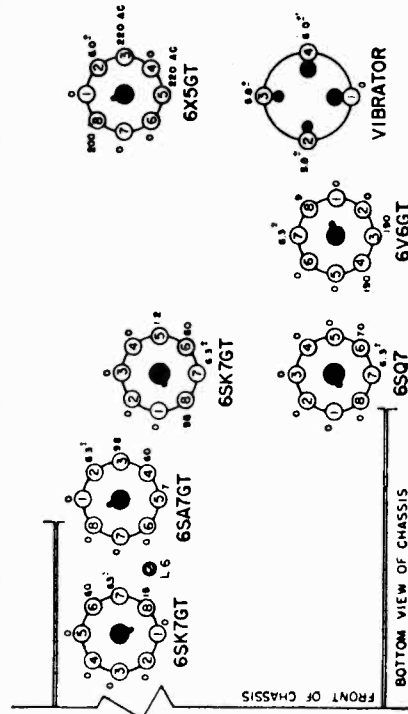

Fig. 4 Socket Voltages

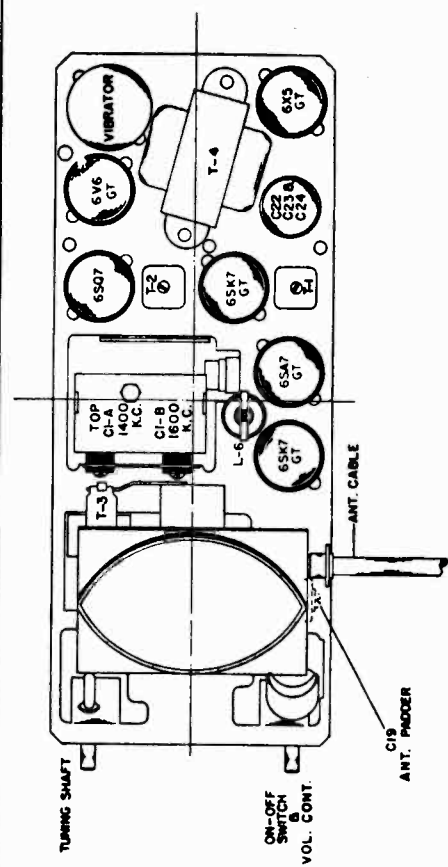

Fig. 5 Tube and Trimmer Locations

CONDENSERS

Schematic Diagram Reference	Part No.	Description
C1A, C1B	B19-196	Variable Condenser
C2, C6, C12	A16-187	.1 MFD. 400 Volt Condenser
C3	A15-196	100 MMFD Ceramic Condenser
C4	A15-202	20 MMFD Ceramic Condenser
C5	A15-204	50 MMFD Ceramic Condenser
C7, C15, C17	A15-176	250 MMFD Mica Condenser
C8	A16-190	.005 MFD. 600 Volt Condenser
C9	A16-195	.001 MFD. Ceramic Condenser
C10	A16-193	.05 MFD. 600 Volt Condenser
C11, C21	A16-192	.01 MFD. 400 Volt Condenser
C13	A16-188	.2 MFD. 400 Volt Condenser
C14	A16-185	.005 MFD. 1600 Volt Oil Filled Condenser
C16, C18	A16-184	.5 MFD. 100 Volt Condenser
C19	A20-145	Trimmer Condenser
C20	A16-189	.05 MFD. 400 Volt Condenser
C22	A18-289	{ 20 MFD 25 Volt Electrolytic Condenser } { 30 MFD 350 Volt Electrolytic Condenser } { 20 MFD. 350 Volt Electrolytic Condenser }
C23		
C24		

RESISTORS

R1	A60-722	470 Ohm 1/2 Watt 20% Resistor
R13, R14	A60-752	100 Ohm 1/2 Watt 10% Resistor
R2, R5	A60-744	22K Ohm 1/2 Watt 10% Resistor
R3	A60-685	47K Ohm 1/2 Watt 20% Resistor
R4, R17	A60-726	2.2 Megohm 1/2 Watt 20% Resistor
R6	A60-753	220 Ohm 1/2 Watt 10% Resistor
R7	A60-716	15K Ohm 1 Watt 10% Resistor
R8	A60-728	10 Megohm 1/2 Watt 20% Resistor
R9	A60-667	220K Ohm 1/2 Watt 20% Resistor
R10	A60-731	470K Ohm 1/2 Watt 20% Resistor
R11	A60-754	270 Ohm 1 Watt 10% Resistor
R12	A60-698	10K Ohm 1 Watt 10% Resistor
R15	A60-694	470 Ohm 1 Watt 10% Resistor
R16	A24-177	Volume Control, 500,000 Ohms, with Switch

COILS

L1	A10-513	Antenna Loading Coil
L2	B10-511	Antenna Coil
L3	A10-512	Oscillator Coil
L4	A33-229	Choke, "A" Line
L5	A33-228	Choke, Vibrator Mesh
L6	A10-510	I.F. Trap Coil
T1	A10-508	1st I.F. Transformer
T2	A10-509	2nd I.F. Transformer

TRANSFORMERS

T3	B80-242	Output Transformer (Part of Speaker)
T4	B80-243	Power Transformer

DIAL PARTS

A11-303	Bracket, Dial Scale
A11-304	Bracket, String Guide
A72-29	Bushing, Tuning Shaft Bearing
A70-130	Clip, Spring, for Tuning Shaft
B48-44	Dial Crystal
A58-55	Dial Pointer
B67-525	Dial Scale
A28-101	Gasket for Speaker
A52-256	Knob
A89-10	Pilot Light, Type G.E. No. 422
A65-37	Rivet, Shoulder, for String Guide Bracket
A75-68	Shaft, Tuning
A75-67	Shaft, for Dial Pointer
A70-132	Spring, for Pilot Light Socket
A70-133	Spring, String Tension, Pointer Drive, and Tuning

MISCELLANEOUS

A83-421	Clip, I.F. Transformer Mounting
A83-517	Clip, Oscillator Coil Mounting
A43-10	Fuse, 15 Amp.
A47-112	Grommet, Rubber (for Mounting Speaker and Variable Condenser)
B31-134	Mounting Strap, Rear
A31-138	Mounting Plate, Front
S84-192	Mounting Parts Kit
A87-38	Receptacle, Antenna Cable
B79-362	Speaker, 4" P.M. (includes Output Transformer)
S84-193	Suppression Kit Assembly
A34-105	Vibrator
A83-519	Wiper, Grounding, for Case Covers

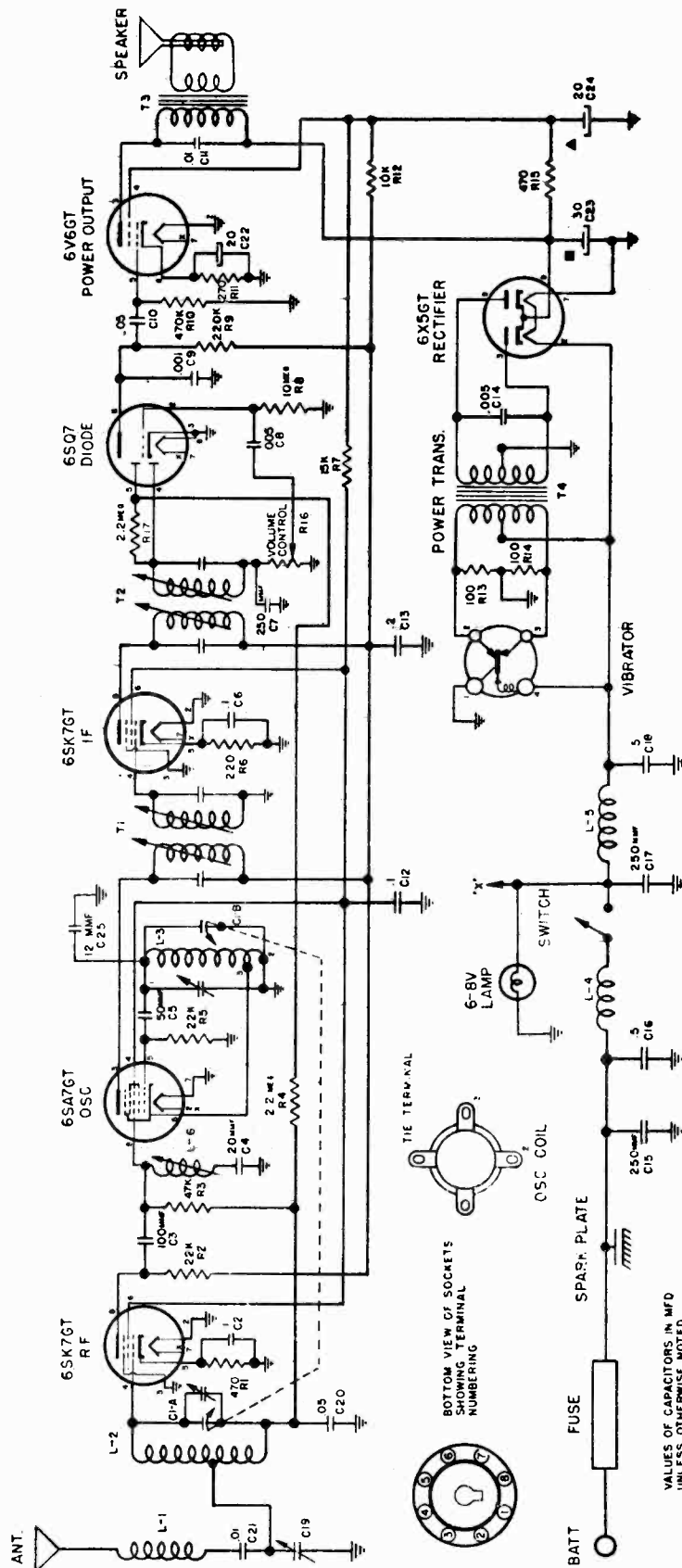

Fig. 3 Schematic Diagram

INSTALLATION

This radio comes to you complete with all hardware necessary for mounting, and also with a distributor suppressor, ammeter condenser and generator condenser. By referring to Figures 1 and 2, and following the instructions outlined below, you will find that it is very simple to install.

First determine where the receiver is to be mounted by holding it with the hands in the approximate location in the car. Using the front mounting bracket as a template, mark and drill two $\frac{5}{8}$ " holes in the instrument panel flange. Now secure the mounting bracket to the radio receiver with the screws provided, and then mount the front of the radio to the instrument panel, using the bolts, lock washers and nuts provided for this purpose. The back of the radio is supported by means of the rear mounting strap.

The mounting strap should be formed to the correct angles, as illustrated in Figure 2, so that it can then be fastened to the fire wall. After marking and center-punching the fire wall at the correct location, drill with a $\frac{3}{8}$ " drill. The mounting strap is then secured to the radio and fastened to the fire wall of the car with the $\frac{1}{4}$ " bolt, lock washer and nut furnished with the receiver.

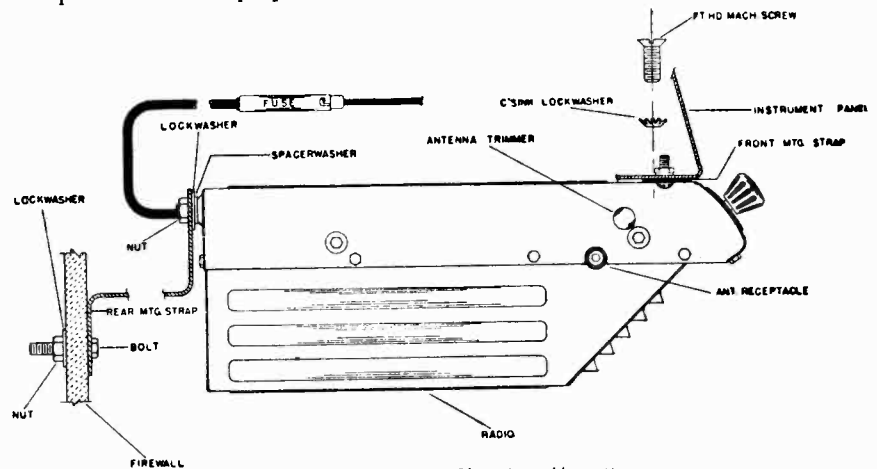

Fig. 2 Side View, Showing Mounting

CONNECTING THE RADIO

The antenna cable should be connected to the radio by inserting the jack into the socket provided on the side of the radio. Connect the battery cable to the hot side of the ammeter behind the instrument panel. The fuse should then be inserted into the cable receptor.

FINAL ADJUSTMENTS

The input circuit has been especially designed to be used with a low capacity antenna, of the fish pole or whip type.

To adjust the antenna trimmer condenser, carefully tune the receiver to a weak station at approximately 600 kilocycles (K.C.). Remove the snap button covering the antenna trimmer (See Figure 2) and adjust the trimmer for maximum volume. A small screw driver will be needed for this purpose.

ACCESSORIES FURNISHED FOR INSTALLATION

All of the parts that are needed for installing this receiver are furnished in the Mounting Parts Kit, part No. S84-192, and the Suppression and Misc. Parts Kit, part No. S84-230, as listed below. Also supplied are the rear mounting strap, part No. B31-134, and the front mounting plate, part No. A31-138.

NOTE: For shipping, the two control knobs have been removed from the tuning and volume control shafts. To install the knobs, line up the flat side of the knob spring, (inside knob) with the flat side of the control shaft and push the knob forward until it stops.

S84-192 MOUNTING PARTS KIT

- | | |
|----------------------------------|-------------------------------|
| 1 $\frac{1}{4}$ " Bolt | 2 External Tooth Lock Washers |
| 2 $\frac{1}{4}$ " Lock Washers | 2 Internal Tooth Lock Washers |
| 2 $\frac{1}{4}$ " Hexagon Nuts | 2 10-32 Hexagon Nuts |
| 2 10-32 x $\frac{5}{8}$ " Screws | 1 Washer Spacer |
| 2 10-32 x $\frac{3}{8}$ " Screws | |

S84-230 SUPPRESSION KIT & MISC. PARTS

- | | |
|----------------------------|--|
| 1 S84-233 "A" lead assem. | 1 S84-193 Suppression Kit consisting of: |
| 1 A43-10 Fuse | 2 .5 MFD Condensers |
| 2 A52-256 Control knobs | 1 Distributor Suppressor |
| 1 A81-13 Sleeve (for fuse) | 20" Wire Braid |

ELIMINATING MOTOR NOISE

IMPORTANT: Special care should be taken when mounting the radio to make sure all paint, grease, rust, etc., is removed from all three mounting points. A good electrical contact at these points will aid materially in eliminating motor noise.

GENERATOR CONDENSER

The generator condenser must be connected to the battery terminal of the generator in all cases. If your car is equipped with a generator using an automatic regulator, make sure the condenser IS NOT fastened to the field winding terminal. If in doubt, your local car dealer can advise you as to where the car manufacturer recommends connecting it.

DISTRIBUTOR SUPPRESSOR

Remove the coil to distributor high tension lead from the distributor. Cut the lead two inches from the end, and screw the distributor resistor on to the coil lead, then screw the short length into the resistor and plug the cable into the distributor cap.

AMMETER CONDENSER

A .5 MFD bypass condenser is furnished for attaching to the ammeter. This should be connected to either side of the ammeter with the ground lug fastened to a good ground nearby. In most cases the use of this condenser, the distributor suppressor, and the generator condenser, will eliminate all objectionable ignition interference.

ELECTRICAL ACCESSORIES

In some cases, it may be found that car accessories such as electric heaters, lighters, automatic relays, or gauges, may cause interference while in operation. Proper procedure in such cases is to try another by-pass condenser from ground to the suspected accessory until the source of the interference is found. The condenser then should be permanently mounted in this location.

HIGH AND LOW TENSION LEADS

In many cases the low tension battery leads, etc., are grouped together with the high tension wires. These leads will very often pick up motor noise and feed it into the

receiver through the battery circuit. In cases such as these it will be necessary to separate the low tension from the high tension wires and run them through another hole if they run from the engine compartment up to the instrument panel. This condition is particularly true on the V-8 Ford, as the battery and primary leads run through a special tube which also houses the high tension leads. Shield and ground these leads.

IGNITION COILS

In cars where the ignition coil is located on the back side of the instrument panel it is often necessary to use an additional condenser. It must be installed from the battery side of the ignition coil to the closest ground on the instrument panel.

Short leads are very important. Where coils are mounted either on the instrument panel or in the driver's compartment, it may be necessary to shield the high tension lead from the coil to the distributor.

WHEEL STATIC

Wheel Static is a form of interference caused by the rotation of the front wheels of the car, and it is, of course, only noticed when the car is in motion. If this form of interference is present it can be eliminated by installing wheel static collector springs between the inner hub cap and the spindle shaft.

BONDING OF FIRE WALL TUBES

Bonding the steering column to the fire wall with a short braid may also be effective. Clean the paint from the steering column at the fire wall where the column enters the motor compartment, and solder on a short piece of braid. Ground the end of the braid to the fire wall.

In some cases it may be necessary to ground the tubes and rods coming through the fire wall in order to reduce the interference. Clean them with emery cloth and spot-solder the braid, fastening the end under a convenient screw. A 1/4" piece of wire braid 20 inches long is furnished in the suppression kit assembly for this purpose.

MODEL 14515

WARWICK MFG. CORP.

ALIGNMENT PROCEDURE

Volume control—Maximum, all adjustments.
 No signal applied to antenna.
 Power input—6.3 volts.
 Connect dummy antenna in series with output lead of signal generator.
 Connect output meter across voice coil.
 Connect ground lead of signal generator to chassis.
 Repeat alignment procedure as a final check.

The following equipment is necessary for proper alignment:
 Signal generator that will provide the test frequencies as listed.
 Non-metallic screwdriver.
 Output meter.
 Dummy antennas—.1 MFD., .00025 MFD.
 For alignment points refer to Figures 4 and 5.

Dial Setting	Generator Frequency	Dummy Ant.	Generator Connections	Trimmer Reference	Trimmer Adjustment	Trimmer Function
Fully Open	455 KC	.1 MFD.	6SA7 Grid	T2	Maximum	Output I.F.
Fully Open	455 KC	.1 MFD.	6SA7 Grid	T1	Maximum	Input I.F.
Fully Open	455 KC	.00025 MFD.	Ant. lead	L6	Minimum	Wave trap
Fully Open	1600 KC	.00025 MFD.	Ant. lead	C1B	Maximum	Oscillator
Tune in signal from generator	1400 KC	.00025 MFD.	Ant. lead	C1A	Maximum	Antenna

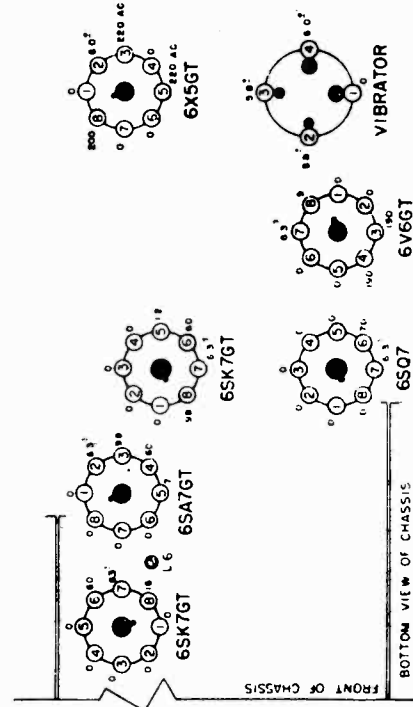

Fig 4 Socket Voltages

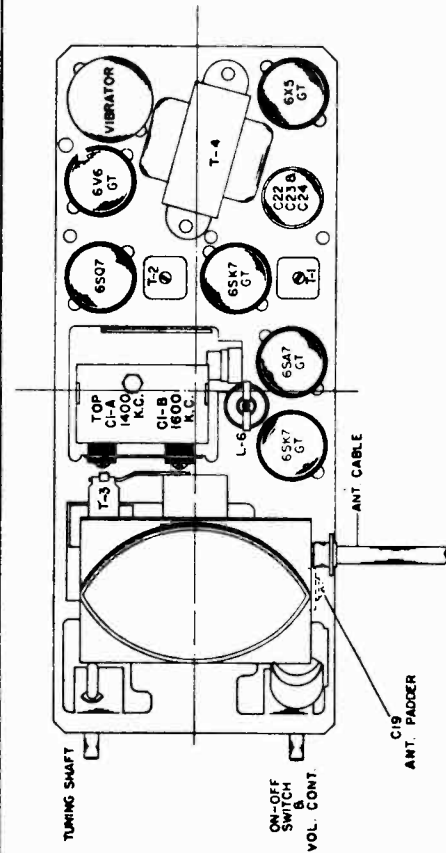

Fig. 5 Tube and Trimmer Locations

CONDENSERS

Schematic Diagram Reference	Part No.	Description	
C1A, C1B	B19-196	Variable Condenser	
C2, C6, C12	A16-187	.1 MFD. 400 Volt Condenser	
C3	A15-196	100 MMFD Ceramic Condenser	
C4	A15-202	20 MMFD Ceramic Condenser	
C5	A15-204	50 MMFD Ceramic Condenser	
C7, C15, C17	A15-176	250 MMFD Mica Condenser	
C8	A16-190	.005 MFD. 600 Volt Condenser	
C9	A16-195	.001 MFD. Ceramic Condenser	
C10	A16-193	.05 MFD. 600 Volt Condenser	
C11, C21	A16-192	.01 MFD. 400 Volt Condenser	
C13	A16-188	.2 MFD. 400 Volt Condenser	
C14	A16-185	.005 MFD. 1600 Volt Oil Filled Condenser	
C16, C18	A16-184	.5 MFD. 100 Volt Condenser	
C19	A20-145	Trimmer Condenser	
C20	A16-189	.05 MFD. 400 Volt Condenser	
C22	A18-289	20 MFD 25 Volt Electrolytic Condenser	
C23			30 MFD 350 Volt Electrolytic Condenser
C24			20 MFD. 350 Volt Electrolytic Condenser
C25	A15-205	12 MMFD ceramic condenser, temp. comp.	

RESISTORS

R1	A60-722	470 Ohm 1/2 Watt 20% Resistor
R13, R14	A60-752	100 Ohm 1/2 Watt 10% Resistor
R2, R5	A60-744	22K Ohm 1/2 Watt 10% Resistor
R3	A60-685	47K Ohm 1/2 Watt 20% Resistor
R4, R17	A60-726	2.2 Megohm 1/2 Watt 20% Resistor
R6	A60-753	220 Ohm 1/2 Watt 10% Resistor
R7	A60-716	15K Ohm 1 Watt 10% Resistor
R8	A60-728	10 Megohm 1/2 Watt 20% Resistor
R9	A60-667	220K Ohm 1/2 Watt 20% Resistor
R10	A60-731	470K Ohm 1/2 Watt 20% Resistor
R11	A60-754	270 Ohm 1 Watt 10% Resistor
R12	A60-698	10K Ohm 1 Watt 10% Resistor
R15	A60-694	470 Ohm 1 Watt 10% Resistor
R16	A24-177	Volume Control, 500,000 Ohms, with Switch

COILS

L1	A10-513	Antenna Loading Coil
L2	B10-511	Antenna Coil
L3	A10-512	Oscillator Coil
L4	A33-229	Choke, "A" Line
L5	A33-228	Choke, Vibrator Mesh
L6	A10-510	I.F. Trap Coil
T1	A10-508	1st I.F. Transformer
T2	A10-509	2nd I.F. Transformer

TRANSFORMERS

T3	B80-242	Output Transformer (Part of Speaker, not furnished separately)
T4	B80-243	Power Transformer

DIAL PARTS

A11-303	Bracket, Dial Scale
B11-328	Bracket, String Guide
A72-29	Bushing, Tuning Shaft Bearing
A70-130	Clip, Spring, for Tuning Shaft
B48-44	Dial Crystal
A58-55	Dial Pointer
B67-525	Dial Scale
A28-101	Gasket for Speaker
A52-256	Knob
A11-329	Link, String Guide
A89-10	Pilot Light, Type G. E. No. 422
A65-37	Rivet, Shoulder, for Dial Pointer Stringing
A65-41	Rivet, Shoulder, for String Guide Brkt. and Link
A65-12	Rivet, Shoulder, for Dial Drive Stringing
A75-70	Shaft, Tuning
A75-67	Shaft, for Dial Pointer
A70-132	Spring, for Pilot Light Socket
A70-133	Spring, Dial Drive String Tension
A70-142	Spring, Pointer Drive String Tension

MISCELLANEOUS

S84-233	"A" Lead Assembly
A83-421	Clip, I.F. Transformer Mounting
A83-517	Clip, Oscillator Coil Mounting
A43-10	Fuse, 15 Amp.
A47-112	Grommet, Rubber (for Mounting Speaker and Variable Condenser)
B31-134	Mounting Strap, Rear
A31-138	Mounting Plate, Front
S84-192	Mounting Parts Kit
A87-38	Receptacle, Antenna Cable
B79-362	Speaker, 4" P.M. (includes Output Transformer)
S84-193	Suppression Kit Assembly
A34-105	Vibrator
A83-519	Wiper, Grounding, for Case Covers

MODELS 4800,
4802

WATTERSON RADIO MFG. CORP.

Use an unmodulated signal and tune for minimum noise in all FM adjustments.

FM Alignment:

MODEL 4800
AM/FM

1. Connect a signal generator to the FM ant. terminals. Using a 21.75 Mc. signal, tune the IF slug adjustment for minimum noise making sure slug is at the tuning point nearest top of can. There is another tuning point with the slug screwed farther down into the coil which produces unwanted coupling.

2. With a 150 ohm resistor in each lead, connect a high frequency generator to the FM ant. Terminals. Set ant. trimmer to maximum capacity. Use enough signal to give a definite dip in noise but do not block the receiver. Set the osc. section to track from 87.5 Mc. to 108.5 Mc. by trimming on the high end and adjusting the osc. coil spacing on the low end. Check each of these adjustments several times. Next, with the generator set at 103 Mc. Tune in this signal on the receiver. While rocking the dial slightly, tune the ant. trimmer for minimum noise. Use an insulated screw driver on all RF adjustments.

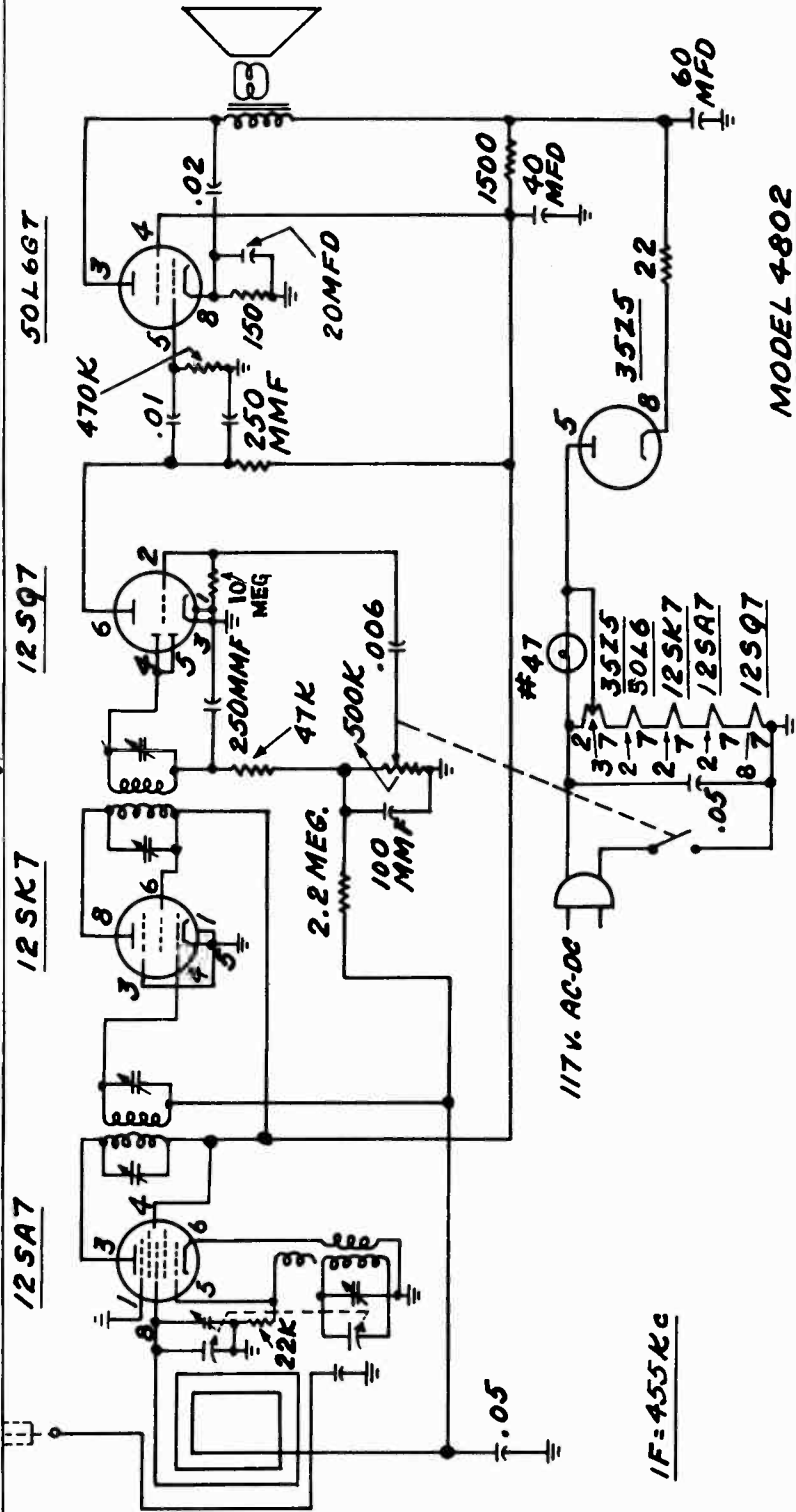

MODEL 4802

IF = 455 Kc

SHORT WAVE BAND

5.75 to 18.3
Megacycles

This band is calibrated in both megacycles and meters. The principal international short wave stations will be found in the 16, 19, 25, 31 and 49 meter bands.

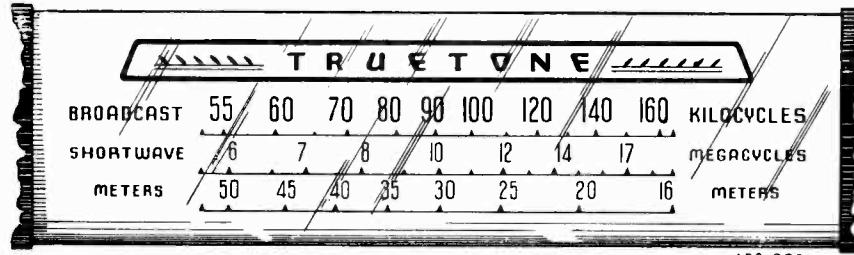

A86-2274

BROADCAST BAND

540 to 1600

← Kilocycles

This band is calibrated in channel numbers. Add a zero to the dial number to get the kilocycle number.

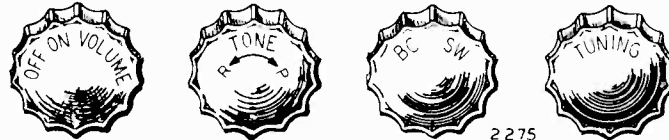

ON-OFF SWITCH AND VOLUME CONTROL

Turn radio on by turning knob to the right. A click will be heard—wait 30 seconds for tubes to heat. Continuing to turn the knob to the right will increase the volume.

TUNING KNOB

Turn until desired station is heard. Then slowly rotate back and forth until signal is clearest and strongest. If signal is too strong, reduce it by means of the volume control, not by using the tuning knob.

TONE CONTROL AND PHONO-RADIO SWITCH

PHONO-RADIO SWITCH—For radio reception, turn knob completely to the left. A click will be heard, if the knob was in the phono position. For phonograph reproduction, turn knob completely to the right. (See page 2 for Record Player Connections). A click will be heard, if the knob was in the radio position.

TONE CONTROL—When knob is turned to the right, a brilliant tone is obtained and when turned to the left, a deep bass effect is produced. Do not turn knob past the stop position when adjusting the tone or the position of the Phono-Radio Switch will be changed as explained above.

BAND SWITCH

This knob has two positions. The position to the left provides reception on the standard Broadcast Band. The position to the right switches the tuning to the Short Wave Band.

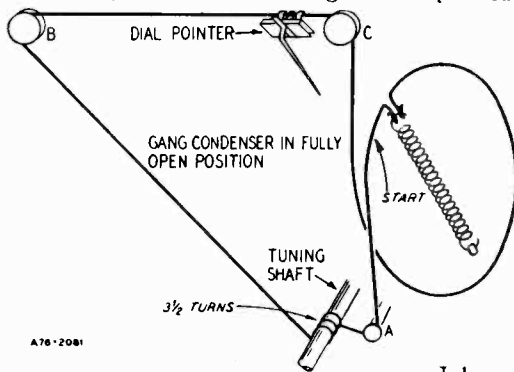

A76-2081

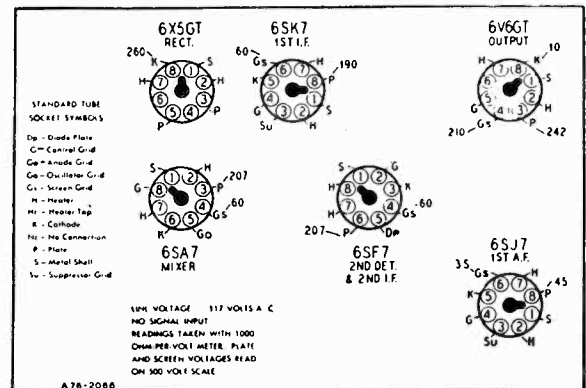

DRIVE CORD REPLACEMENT

The drive cord should be replaced as shown on the accompanying illustration using a new 10X66 drive cord assembly for the purpose. After the cord has been installed, stretch the tension spring and fasten the free end of the cord to it.

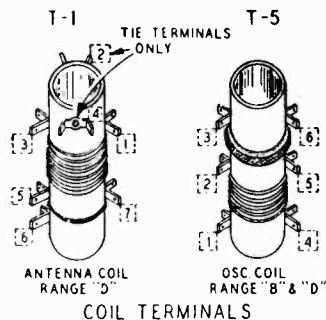

A86-2262

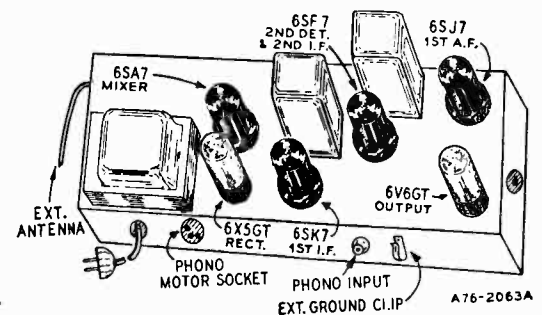

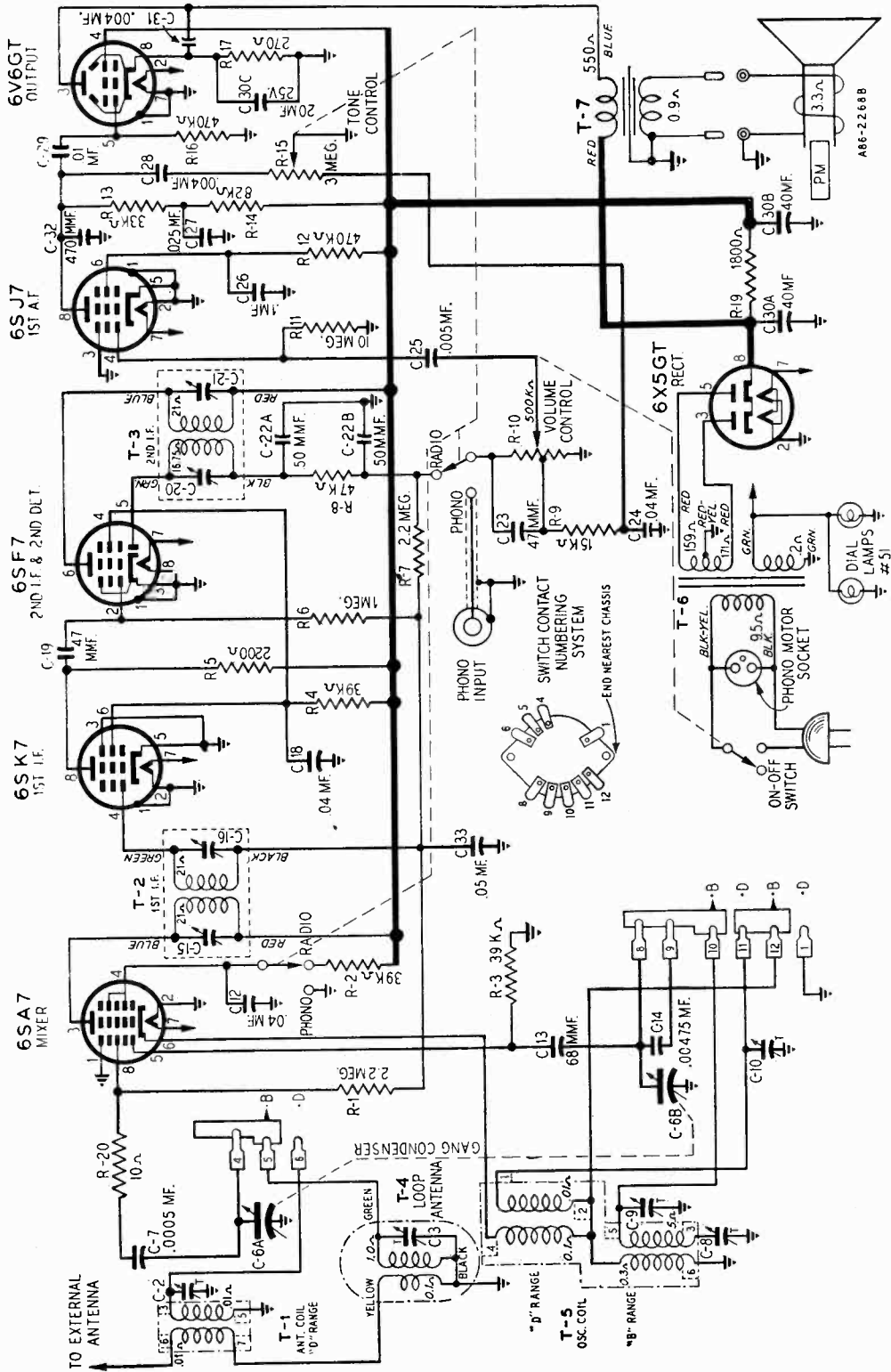

WESTERN AUTO SUPPLY CO.

MODEL D1835B

ALIGNMENT PROCEDURE

Volume Control—Maximum All Adjustments.
Connect Radio Chassis to Ground Post of Signal Generator with a Short Heavy Lead.
Allow Chassis and Signal Generator to "Heat Up" for several minutes.

The following equipment is required for aligning:
An All Wave Signal Generator which will provide accurately calibrated signal at the test frequencies as listed.
Output Indicating Meter—Non-Metallic Screwdriver.
Dummy Antennas—.1 mf., 50 mmf., and 400 ohms.

	SIGNAL GENERATOR FREQUENCY SETTING	CONNECTION AT RADIO	DUMMY ANTENNA	BAND SWITCH SETTING	CONDENSER SETTING	ADJUST TRIMMERS TO MAXIMUM
I.F.	455 KC	Grid of 6SA7 Pin 8	.1 mf.	B Range	Turn Rotor to Full Open	1st I.F. (C15) & (C16) 2nd I.F. (C20) & (C21)
RANGE B	1620 KC	Antenna Lead	50 mmf.	B Range	Turn Rotor to Full Open	Oscillator Range B (C9)
	1400 KC	Antenna Lead	50 mmf.	B Range	Tune Rotor to Max. Output	Ant. Range B (C3)
	600 KC	Antenna Lead	50 mmf.	B Range	Tune Rotor to Max. Output	600 KC (C8) See Note B
Repeat above steps at 1620 and 600 KC until readjusting the oscillator Range B Trimmer (C9) causes no further improvement in output.						
RANGE D	18.3 MC	Antenna Lead	400 Ohm	D Range	Turn Rotor to Full Open	Oscillator Range D (C10)
	16 MC	Antenna Lead	400 Ohm	D Range	Tune Rotor to Max. Output	Ant. Range D (C2) Rock Rotor—See Note B
LOOP RANGE B	Reassemble chassis in cabinet.					
	1400 KC	Antenna Lead	50 mmf.	B Range	Tune Rotor to Max. Output	Ant. Range B (C3) See Note A

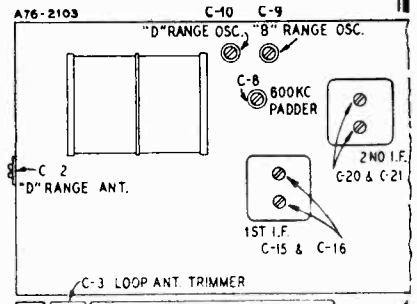

NOTE A—Set pointer at the 1400 KC mark on the dial scale. Attach pointer to drive cord.

NOTE B—Turn rotor back and forth and adjust the trimmer until peak of greatest intensity is obtained.

The dial lamp socket assemblies may be disengaged from the cabinet mounting by squeezing together and pulling away from the cabinet mounting, the spring bracket to which the dial lamp socket is mounted. Take care not to bend or damage the large drive pulley on the gang condenser while doing this.

When replacing the chassis in the cabinet it will be necessary to tune in a station of a known frequency and move the dial pointer until that frequency is indicated on the dial and then attach the pointer to the dial string. Take care not to scuff or cut the dial string or bend the pointer during this operation.

SPECIFICATIONS

Power Consumption	45 Watts (At 117 volts AC)
Power Output	4 Watts Maximum 2.3 Watt 10% Harmonics
Selectivity	40KC Broad at 1000 times Signal
Intermediate Frequency	455 KC
Speaker	12" PM Dynamic
Tuning Frequency Range	B Range 540 to 1600 KC D Range 5.75 to 18.3 MC

Sensitivity (For .05 watt output—External Antenna).
B Range 9 Microvolts Average
D Range 20 Microvolts Average

REMOVAL OF CHASSIS FROM CABINET

Before removing the chassis from the cabinet it will be necessary to detach the dial pointer from the dial string. To do this, spread the tabs on the pointer and pull the dial string off the pointer.

REPLACEMENT PARTS LIST

NOTICE: There is a model number label on the chassis. This label identifies the radio as to chassis, dial and issue letter. When ordering parts or writing, give ALL information appearing on this label.

C-27	D64253	.225 mf	400 V	Tubular
C-28	D66402	.004 mf	400 V	Tubular
C-29	D66103	.01 mf	400 V	Tubular
C-30A	45X346	40 mf	450 V	3 Section Electrolytic
C-30B		40 mf	450 V	
C-30C		20 mf	25 V	
C-31	H66402	.004	800 V	Tubular
C-32	47X467	470 mmf		Moulded
C-33	B66503	.05 mf	200 V	Tubular

MISCELLANEOUS

12A486	12" P.M. Speaker
3A303	Tube Socket—Octal (8 prong) Moulded
3A304	Phono Motor Socket
3A305	Phono Socket—Single Pin Tip
10A689	Knob (Tuning)
10A690	Knob (Off-On Volume)
10A687	Knob (SW-BC)
10A688	Knob (Tone—R.P.)
2A372	Band Change Switch
13X328	Line Cord and Plug Assembly No. 856 Console Cabinet

TRANSFORMERS AND COILS

T-1	9A1917	"D" Range Antenna Coil Assembly
T-2	9A1814	1st I-F Coil Assembly
T-3	9A1815	2nd I-F Coil Assembly
T-4	26A474	"B" Range Loop Antenna
T-5	9A1918	Oscillator Coil Assembly
T-6	53X282	Power Transformer
T-7	51X134	Output Transformer

CAPACITORS

C-2	17A164	5-50 mmf	Trimmer
C-3	17A235	2-24 mmf	Trimmer
C-6A, C-6B	14A184	Gang Condenser with Drive Pulley	
C-7	B66501	.0005 mf	200 V Tubular
C-8	17A155	350-430 mmf	Trimmer
C-9, C-10	17A109	2.5-35 mmf	Dual Trimmer
C-12, C-18	D66403	.04 mf	400 V Tubular
C-13	47X466	68 mmf	Moulded
C-14	46X289	.00475 mf	180 V Tubular
C-15, C-16	Part of T-2 (1st I-F Coil Assembly)		
C-19, C-23	47X463	47 mmf	Moulded
C-20, C-21	Part of T-3 (2nd I-F Coil Assembly)		
C-22A, C-22B	47X112	50-50 mmf	Dual Mica
C-24	D64403	.04 mf	400 V Tubular
C-25	D66502	.005 mf	400 V Tubular
C-26	D67104	.10 mf	400 V Tubular

RESISTORS

B85225	R-1, R-7	2.2 megohms	0.5 W	Carbon
B84393	R-2, R-4	39 K ohms	1.0 W	Carbon
B84393	R-3	39 K ohms	0.5 W	Carbon
B84222	R-5	2200 ohms	0.5 W	Carbon
B85105	R-6	1 megohm	0.5 W	Carbon
B85473	R-8	47 K ohms	0.5 W	Carbon
B84153	R-9	15 K ohms	0.5 W	Carbon
36X358	R-10	500 K ohms	Volume Control and Line Switch	
B85106	R-11	10 megohms	0.5 W	Carbon
B85474	R-12, R-16	470 K ohms	0.5 W	Carbon
B84333	R-13	33 K ohms	0.5 W	Carbon
B84823	R-14	82 K ohms	0.5 W	Carbon
40X276	R-15	3.0 megohms	Tone Control & Radio Phono Switch	
C84271	R-17	270 ohms	1.0 W	Carbon
D84182	R-19	1800 ohms	2.0 W	Carbon
B85100	R-20	10 ohms	0.5 W	Carbon

DIAL AND DRIVE ASSEMBLY

6X21	Rubber Grommet	} Mtg. Gang Condenser {
20X329	Cond. Cushion Stud	
25X1489	Pulley Bracket (Right)	
25X1490	Pulley Bracket (Left)	
26X485	Drive Shaft	
19X192	"C" Washer	
25X1491	Pointer Bracket	
15X229	Pointer	
10X66	Drive Cord Assembly	
28X113	Drive Cord Tension Spring	
30X517	Dial Clamp	
4X915	Escutcheon, Dial (Right)	
4X916	Escutcheon, Dial (Left)	
4X931	Escutcheon Insert	
58X694	Dial Glass	
7A200	Pilot Light Socket Assembly	
7A32	Pilot Light Bulb No. 51	

MODEL D1840

WESTERN AUTO SUPPLY CO.

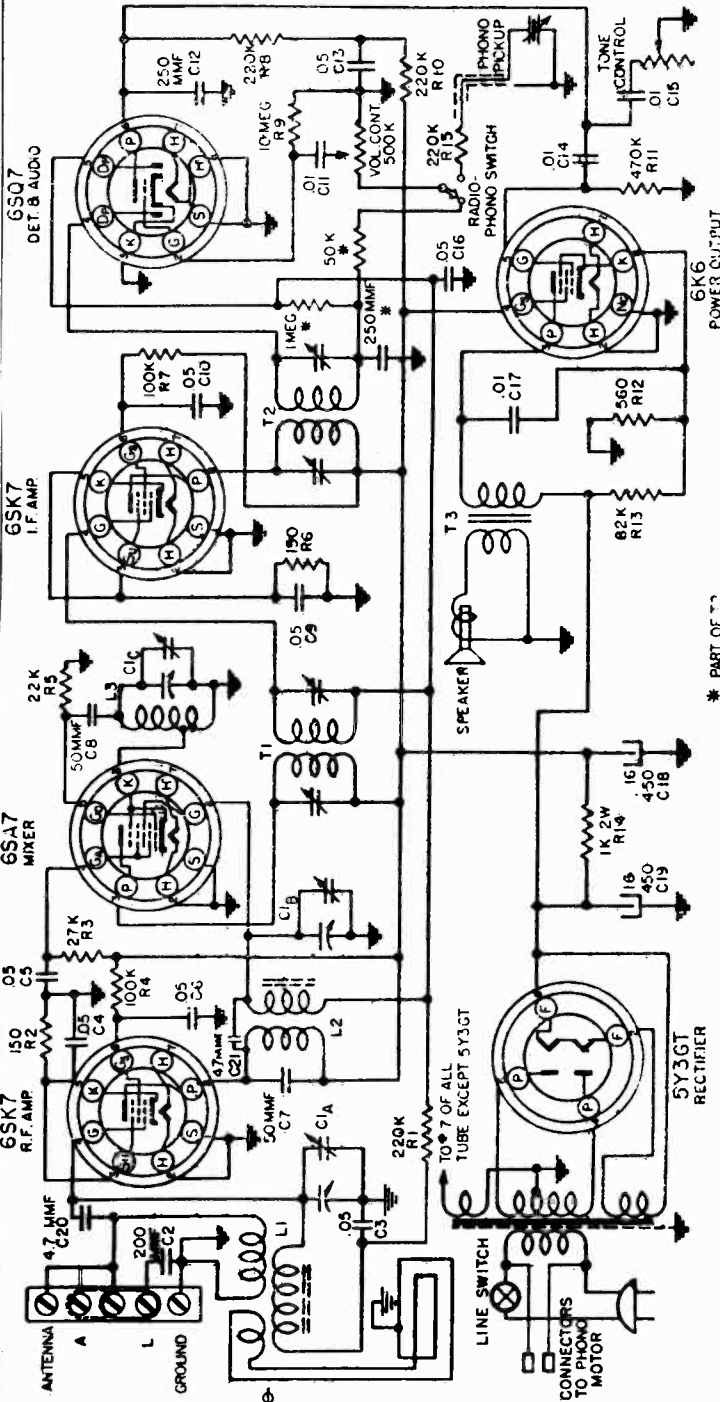

TUBE COMPLEMENT

The tube complement of this receiver consists of the following:

- 1—6SK7—R.F. Amplifier
- 1—6SA7—Mixer—OSC.
- 1—6SK7—I.F. Amplifier
- 1—6SQ7—Det. AVC—Audio
- 1—6K6—Power Output
- 1—5Y3—Rectifier

SOCKET VOLTAGES

All voltages are measured with a 1000 ohm per volt meter on the 150 volt scale, with no signal. To obtain an accurate voltage check the A.C. line voltage must be 117 volts. Where no voltage is shown the voltage is 0 or cannot be read with this type of voltmeter.

SERVICE NOTES

Voltages taken from the different points of the circuit to the chassis are measured with volume control in maximum position, all tubes in their sockets and with a volt meter having a resistance of 1000 ohms per volt, using the 150 volt scale. These voltages are clearly indicated on the voltage chart. (Fig. 2).

All voltages should be measured with an A.C. line voltage of 117 volts.

To check for open bypass condensers, shunt each condenser with another one having the same capacity and voltage rating which is known to be good until the defective unit is located.

ALIGNING INSTRUCTIONS

Never attempt any adjustments on this receiver unless it becomes necessary to replace a coil or transformer, or the adjustments have been tampered

with in the field. Always make certain that other circuit components, such as tubes, condensers, resistors, etc., are normal before proceeding with realignment.

If realignment is necessary follow the instructions given under the heading "ALIGNMENT PROCEDURE" on the next page. After realignment has been completed repeat the procedure as a final check.

REMOVING CHASSIS FROM CABINET

The dial pointer must be removed from the pointer rail assembly, and cabinet before the chassis can be taken from the cabinet. This can be done by detaching the dial cord from the pointer and sliding the pointer to the right (viewed from the rear of the cabinet) as far as it will go. The dial pointer can now be removed from the cabinet.

The chassis can now be removed in the conventional manner by taking out the four chassis mounting bolts after disconnecting the speaker and phono leads.

ALIGNMENT PROCEDURE

Volume control—Maximum: all adjustments.
 Tone Control—Treble: Full Clockwise Rotation.
 Connect ground lead of signal generator to radio chassis.
 Connect dummy antenna in series with output lead of signal generator.
 Connect output meter across voice coil of speaker.

The following equipment is necessary for proper alignment
 Signal generator that will provide the test frequencies as listed.
 Output meter.
 Non-metallic screwdriver.
 Dummy antennas—.1 mfd., .00025 mfd.

Position of Variable	Generator Frequency	Dummy Ant. mfd.	Generator Connections	Trimmer Adjustment	Trimmer Function
Minimum Capacity (Fully Opened)	455 K.C.	.1	6SA7 Grid (Stator of C1B)	T1 T2	I. F.
Minimum Capacity (Fully Opened)	1725 K.C.	.00025	*Ant. Terminal on Loop	C1C	Osc.
Tune in signal From Generator	1500 K.C.	.00025	*Ant. Terminal on Loop	C1B	R. F.
Tune in signal From Generator	1500 K.C.	.00025	*Ant. Terminal on Loop	C1A	Ant.

*Be sure coupling link is in correct position for external antenna operation. See illustration below (Fig. 4).

With an output meter connected across the voice coil of the speaker, the output meter reading for 1/2 watt is 1.25 volts using a signal which is modulated 400 c.p.s.

Repeat the above alignment procedure as a final check.

ANTENNA and GROUND CONNECTIONS

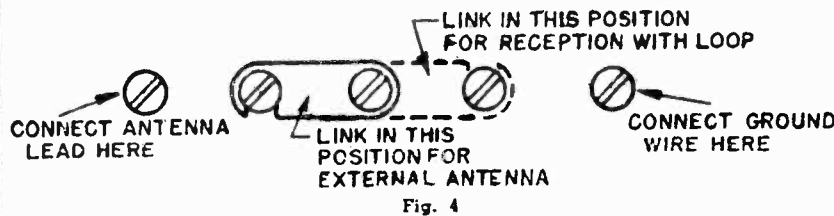

Fig. 4

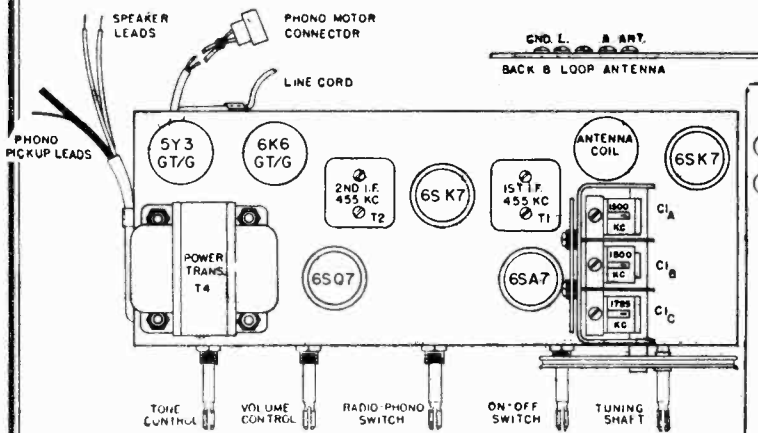
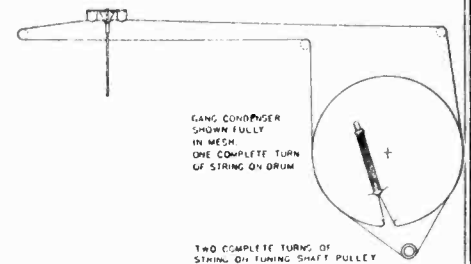

Fig. 1 Chassis, Top View

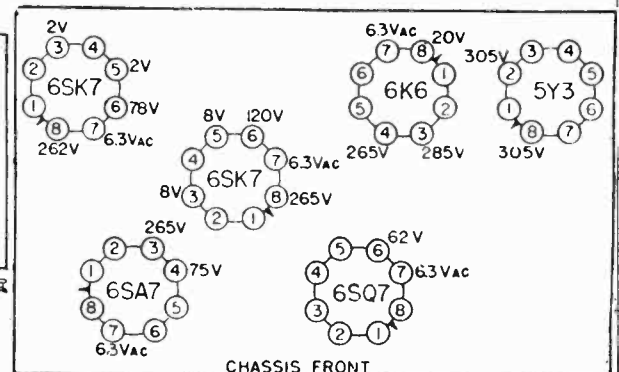

Fig. 2 Chassis, Bottom View

MODEL D1840

WESTERN AUTO SUPPLY CO.

CONDENSERS

Circuit Reference	Part No.	Description
C1A, C1B, C1C	B19-186	Variable condenser
C2	B15-189	200 MMF Mica condenser (on loop).....
C3, C4, C9, C16	A16-152	.05 MFD 200 volt condenser.....
C5, C6, C10, C13	A16-158	.05 MFD 400 volt condenser.....
C7, C8	A15-175	50 MMF mica condenser.....
C11, C14, C15	A16-156	.01 MFD 400 volt condenser.....
C12	A15-176	250 MMF mica condenser.....
C17	A16-168	.01 MFD 1000 volt condenser.....
C18	A18-279	16 MFD 450 volt electrolytic condenser.....
C19	A18-274	16 MFD 450 volt electrolytic condenser.....
C20, C21	A83-355	4.7 MMF condenser

RESISTORS

R1, R8, R10, R15	A60-667	220K ohm ½ watt resistor.....
R2, R6	A60-686	150 ohm ½ watt resistor.....
R3	A60-692	27K ohm 1 watt resistor.....
R4, R7	A60-671	100K ohm ½ watt resistor.....
R5	A60-659	22K ohm ½ watt resistor.....
R9	A60-663	10 megohm ½ watt resistor.....
R11	A60-662	470K ohm ½ watt resistor.....
R12	A60-701	560 ohm 1 watt resistor.....
R13	A60-700	82K ohm 1 watt resistor.....
R14	A60-699	1000 ohm 2 watt resistor.....

COILS

L1	C10-459	Antenna coil
L2	B10-452	R. F. coil
L3	B10-446	Oscillator coil
T1	B10-412	1st I.F. transformer
T2	B10-444	2nd I.F. transformer

MISCELLANEOUS

T3	A80-222	Output transformer
T4	C80-223	Power transformer
	A69-169	Switch, on-off
	A26-123	Tone control
	A24-169	Volume control
	A84-41	Dial drive shaft and pulley assembly.....
	B79-359	Speaker, 10" P. M.
	S84-204	Loop antenna and Back assembly.....
	C67-520	Dial scale
	A52-203	Knob, (tuning)
	A52-207	Knob, (tone)
	A52-208	Knob, (volume)
	A52-209	Knob, (on-off)
	A52-242	Knob, (radio-phono)
	B58-70	Dial pointer
	A83-532	Retainer, dial scale, right
	A83-533	Retainer, dial scale, left
	A69-180	Switch, radio-phono

ELECTRICAL SPECIFICATIONS

- Power Supply**.....105 to 125 volts, AC, 60-cycles; Chassis only 122 watts. With phono operation 150 watts.
- Frequency Range**...Broadcast Band—535 to 1620 kc. FM Band—88 to 108 mc.
- Intermediate Freq.**..AM-455 kc; FM-10.7 mc.
- Selectivity**.....AM-48 kc. broad at 1000 times signal, measured at 1000 kc. I.F. FM-180 kc. broad at 2 times down. I.F. FM-320 kc. broad at 10 times down.
- AM Sensitivity**.....(For .5 watt output with external antenna)—3 microvolts average.
- FM Sensitivity**.....(For .5 watt output)—10 microvolts average.
- Power Output**.....8 watts. 10% distortion. 10 watts maximum.

- Loud Speaker**.....12" electrodynamic. Voice coil impedance 3.2 ohms, 400 cycles.
- Tube and Lamp Complement**.....6BA6, FM—AM R.F. stage. 12AT7, FM—AM oscillator and mixer. 6BA6, FM—AM—1st I.F. 6BA6, FM—2nd I.F. 6AL5, FM—ratio detector. 6AT6, AM detector. A. F. AMP. and A.V.C. 6SN7, Push-Pull. Driver and phase-inverter. 5U4G, rectifier. 6V6, output. 6V6, output. T-44 dial lamp (2 used).
- Automatic changer**..Oak 6666 with P-93 Cartridge.

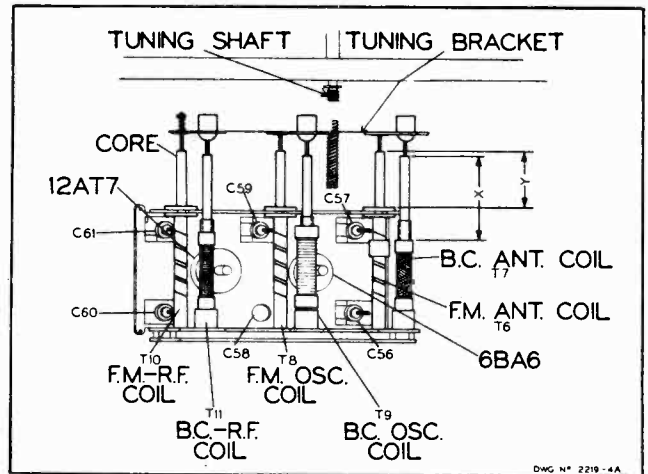
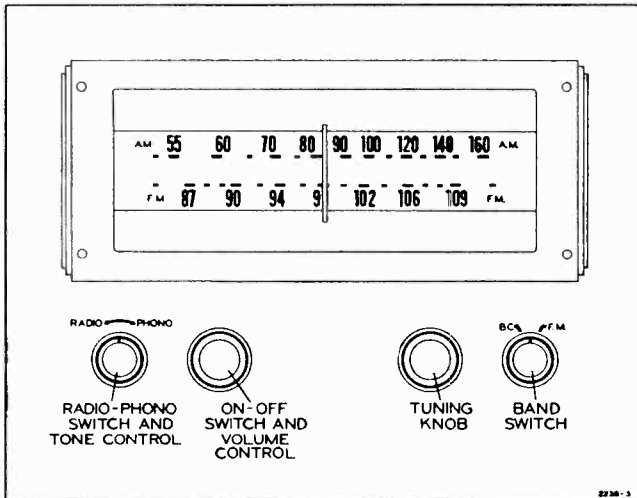

TUNER ADJUSTMENT

With tuner all the way out, dimension "X" should be 1 1/2 inches. "Y" should be 1-1/32 inches. "X" is from the end of the slug to edge of the coil winding. Check these dimensions before R.F. alignment is attempted of either the AM or FM Band. No slug adjustment should be necessary since the slugs are properly set at the factory.

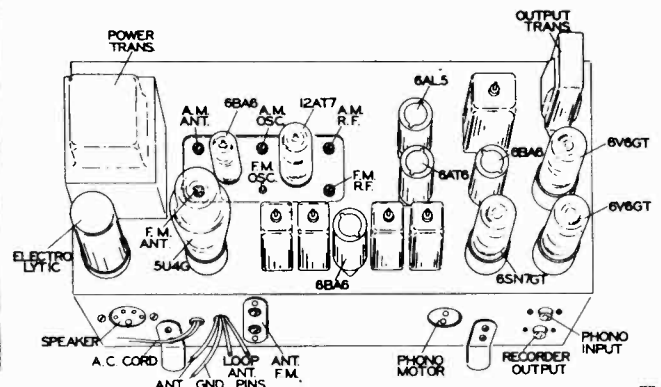
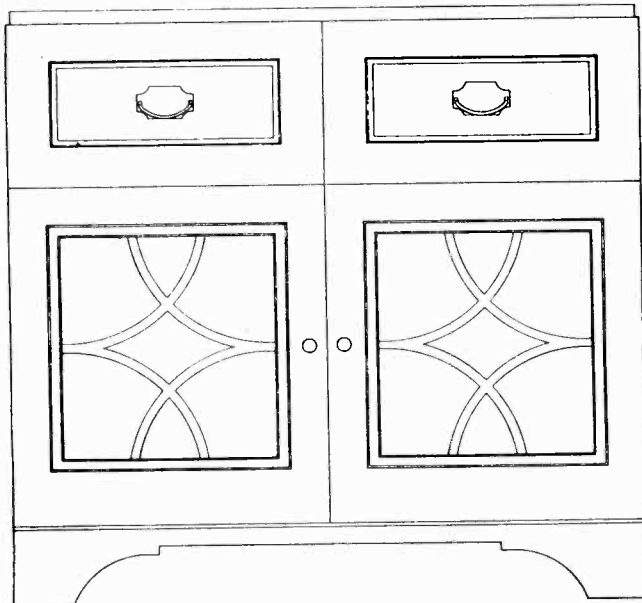

Chassis — top view

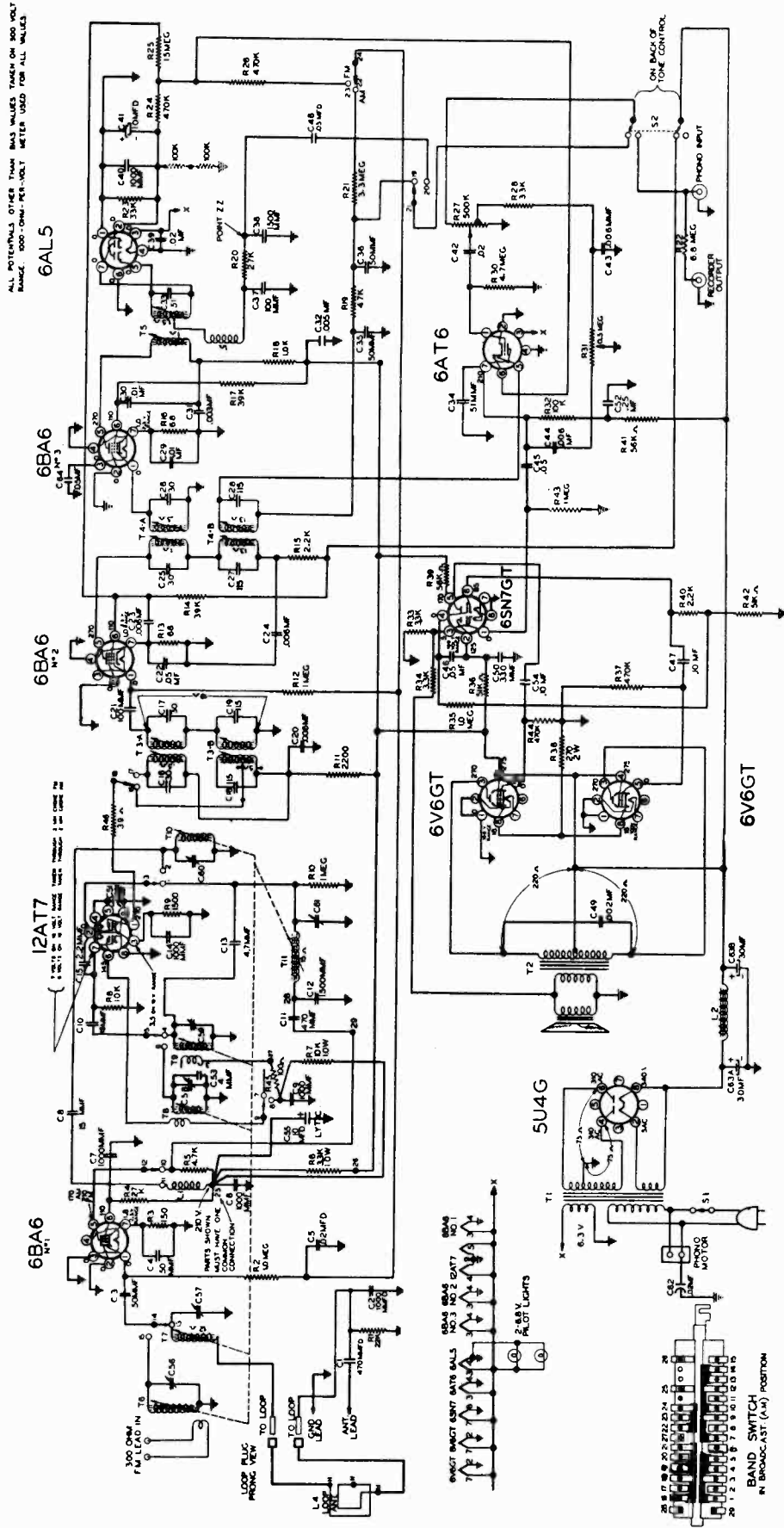

NOTE: Two 100K ohm resistors in series from Pin No. 2 of the 6AL5 to ground are connected as shown only when aligning the FM I. F.
 Refer to FM I. F. alignment procedure.

NOTE: B.C. Oscillator Coil T9 and number 7 terminal of slide switch should be connected together.

NOTE: Resistor R22 removed; with shielded wire from recorder output jack to radio side of radio-phonos switch S2 added.

ALIGNMENT PROCEDURE

Broadcast Band Section I.F. and R.F.

The alignment procedure below includes the sensitivities at the inputs of various stages. All signal input values are based on an output of 1/2 watt. This may be measured by disconnecting the speaker voice coil and substituting a 3.2-ohm resistor across the secondary winding of the output transformer. A reading of 1.3 volts AC across this resistor will be approximately equivalent to a 1/2-watt output with the speaker con-

nected. The volume control must be set at maximum. The tone control must be set for maximum treble.

The signal source must be an accurately calibrated signal generator capable of supplying the frequencies designated, modulated 30% with a 400-cycle audio signal. A 400 cycle audio signal is required for the audio measurement. Variations in sensitivities of plus or minus 25% are usually permissible.

A M - I . F . ALIGNMENT

Band Switch in AM Position. Tune Set to 1400 Kc. Dummy Antenna .1 Mfd.

SIGNAL GENERATOR FREQUENCY	CONNECTION TO RADIO	ADJUSTMENTS TO BE MADE	ADJUST FOR
455 Kc. Use 1000 microvolts	Pin No. 1 of 6BA6 No. 2 and ground	Primary and Secondary of T4B AM windings See I. F. view	Maximum output Should be 1/2 watt.
455 Kc. Use 30 microvolts	Pin No. 2 of 12AT7 and ground	Primary and Secondary of T3B AM windings See I. F. view	Maximum output Should be 1/2 watt.
400 cycles. Use 28 millivolts	Hot end of volume control and ground	None	Maximum output Should be 1/2 watt.

BROADCAST BAND - R . F . ALIGNMENT

Check pointer so that it coincides with the right hand marker to the extreme right when iron cores are all the way out.

For adjustment, see dial mechanism illustration.

SIGNAL GENERATOR FREQ.	CONNECTION TO RADIO	DUMMY ANTENNA	ADJUST
1620 Kc. Use 3 microvolts	AM Antenna and Ground	200 mmf.	C59, C57, C61. For maximum, 1/2 watt

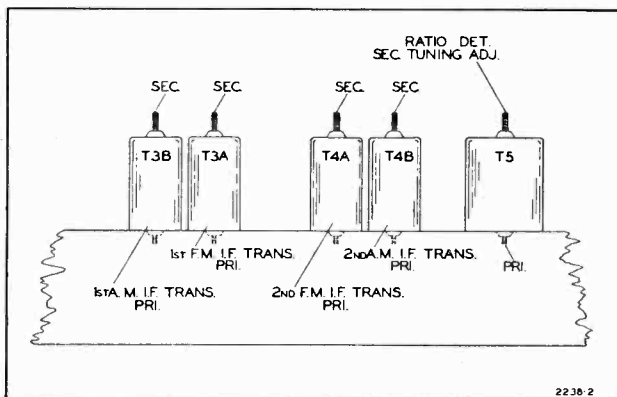

I. F. VIEW

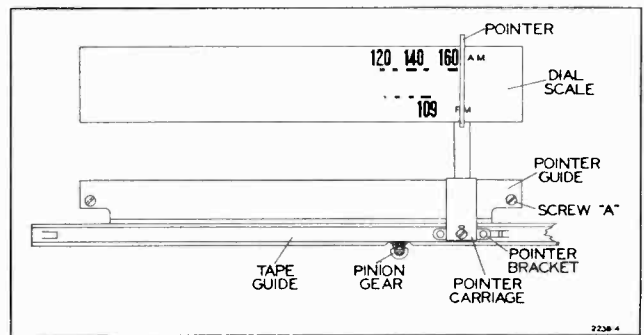

DIAL ADJUSTMENT VIEW

Loosen screw "A" so that teeth of tape can be properly meshed with pinion gear to give proper pointer travel.

ALIGNMENT PROCEDURE

FM Band Section I.F. and R.F.

A non-metallic alignment tool must be used.

IMPORTANT— No alignment of the FM section of this radio should be attempted unless you are positive that the circuits are in need of adjustment and you have the necessary equipment.

All components used in this radio

are extremely stable and the tuned circuits should require no adjustment over a long period of time.

NOTE— The following alignment is based on the use of the new Simpson vacuum tube voltmeter which has a "floating ground". In other

words, the meter, when used as a vacuum tube volt-meter, can have both the positive and negative sides connected to points above ground and still give true readings.

A standard AM signal generator is required.

FM - I. F. ALIGNMENT

Band Switch in FM Position. Dummy Antenna .1 Mfd.

SIGNAL GENERATOR FREQUENCY	CONNECTION TO RADIO	VACUUM TUBE VOLT METER CONNECTION TO RADIO	ADJUSTMENT TO BE MADE	ADJUST FOR
10.7 Mc. Use about .1 volt	Pin No. 1 of 6BA6 No. 3 and ground	Pin No. 2 of 6AL5 and ground	Primary of T5	Resonance should be about 3 volts
10.7 Mc. Use about .1 volt	Pin No. 1 of 6BA6 No. 3 and ground	See note "A"	Secondary of T5	Resonance should be about 3 volts
10.7 Mc. Use about 3300 microvolts	Pin No. 1 of 6BA6 No. 2 and ground	Pin No. 2 of 6AL5 and ground	Primary and Secondary of T4A 10.7 m.c. windings See I.F. view	Zero. Use zero center scale See note "B"
10.7 Mc. Use about 200 microvolts	Pin No. 2 of 12AT7 and ground	Pin No. 2 of 6AL5 and ground	Primary and Secondary of 10.7 m.c. windings of T3A See I.F. view	Resonance should be about 3 volts

NOTES ON FM — I. F. ALIGNMENT

NOTE "A" Connect two resistors, 100K OHMS each, from Pin No. 2 of 6AL5 to ground. These resistors must be matched within 5%. Connect as shown in dotted lines on schematic diagram. Connect vacuum tube voltmeter between the mid-

point of the resistors and point zz.

NOTE "B" If T5 has been tampered with, it is possible that no crossover point will be found at first. Careful adjustment of both primary and secondary is necessary.

GENERAL: Input signals should be adjusted to give approximately 3 volts. The ratio detector is operating at reasonable level at this point and will give the truest indication of correct alignment with the procedure specified.

FM - R. F. ALIGNMENT

Check pointer so that it coincides with the right hand marker to the extreme right when iron cores are all the way out.

For adjustment, see dial mechanism illustration.

SIGNAL GENERATOR FREQUENCY	CONNECTION TO RADIO	DUMMY ANTENNA	ADJUST	VACUUM TUBE VOLT METER CONNECTION TO RADIO	ADJUST TO
100 Mc. Use about 10 microvolts	FM Antenna Terminals See note	300 ohms	C58 Osc. C60 R. F. C56 Ant.	Pin No. 2 of 6AL5 and Ground	Resonance about 3 volts

NOTE: If a signal generator with the above fundamental frequency is not available, it is sometimes possible to use harmonics. Use extreme care in picking harmonics. An alternate procedure is to use a local station carrier of known frequency to align the FM Band and to use the vacuum tube volt-meter

as above for resonance indication. A weak carrier, however, will not produce 3 volts.

NOTE: Connect 300 ohms in series with hot side of generator and connect to one screw. Connect cold side of generator to other screw.

ELECTRICAL SPECIFICATIONS

Power Consumption—
117 volts AC 60 watts normal
85 watts phono operating

Power Output—
4.5 watts maximum
2.5 watts 10% distortion

Speaker—8" PM dynamic

Frequency Ranges—
Broadcast 540-1600 KC
Frequency Modulation 88-108 MC

Intermediate Frequency—
AM 455 KC — FM 10.7 MC

Selectivity — AM — 45 KC broad
at 1000 times signal, measured
at 1000 KC

I.F. FM—200 KC broad at 2 times
down

I.F. FM—950 KC broad at 200
times down

AM Sensitivity—(For .5 watt output
with external antenna)
10 microvolts average

FM Sensitivity—(For .5 watt output)
100 microvolts average

REMOVAL OF CHASSIS FROM CABINET

Before removing the chassis from the cabinet it will be necessary to detach the dial pointer from the dial string. To do this, spread the tabs on the pointer and pull the dial string off the pointer.

The dial lamp socket assembly may be disengaged from the cabinet mounting by squeezing together and pulling away from the cabinet mounting, the spring bracket to which the dial lamp socket is mounted. Take care not to bend or damage the large drive pulley on the gang condenser while doing this.

When replacing the chassis in the cabinet it will be necessary to tune in a station of a known frequency and move the dial pointer until that frequency is indicated on the dial and then attach the pointer to the dial string. Take care not to scuff or cut the dial string or bend the pointer during this operation.

DRIVE CORD REPLACEMENT

Replacement of the drive cord may be accomplished as shown in the illustration. For this purpose use the new drive cord assembly listed in the Replacement Parts List. Turn the gang condenser until the plates are fully meshed. Then install the string as shown, winding three turns clockwise around the tuning shaft with the turns progressing away from the chassis. After the cord is installed, rotate the tuning shaft several times in order to take up any slack in the cord.

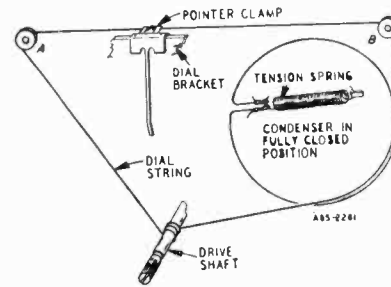

TUBE SOCKET VOLTAGES

Socket voltages are shown on the Bottom Socket diagram at the tube socket terminals. All voltages are between the socket terminal and chassis ground. Plate, screen and cathode voltages were taken with a 1000 ohm-per-volt meter with a 300 volt scale used for plate and screen voltages. Audio grid voltages were read with a vacuum tube volt-meter. Conditions of measurement are:

- Line voltage117 Volts AC
- Signal InputNone
- A Variation of $\pm 10\%$ is usually permissible.

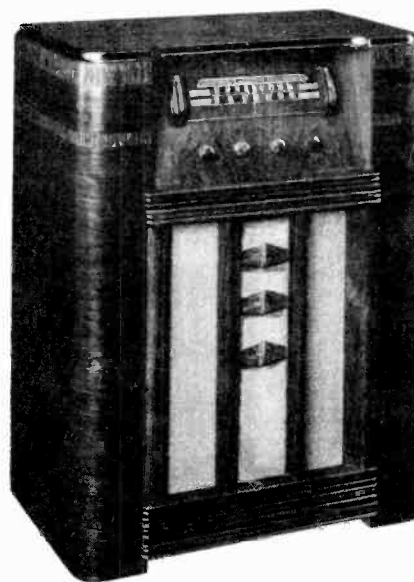
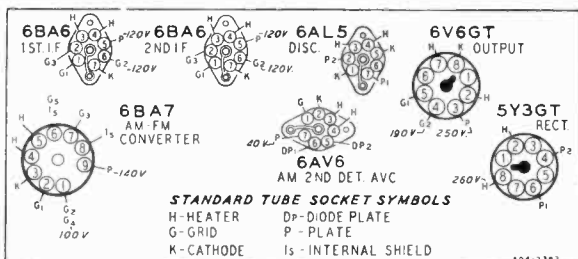

WESTERN AUTO SUPPLY CO.

MODEL D1946

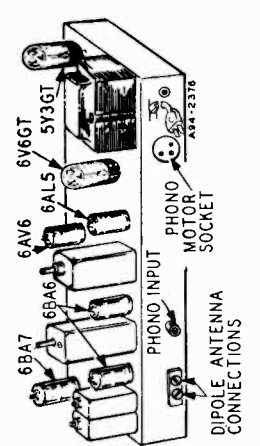
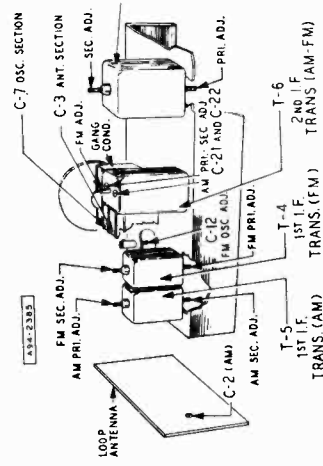
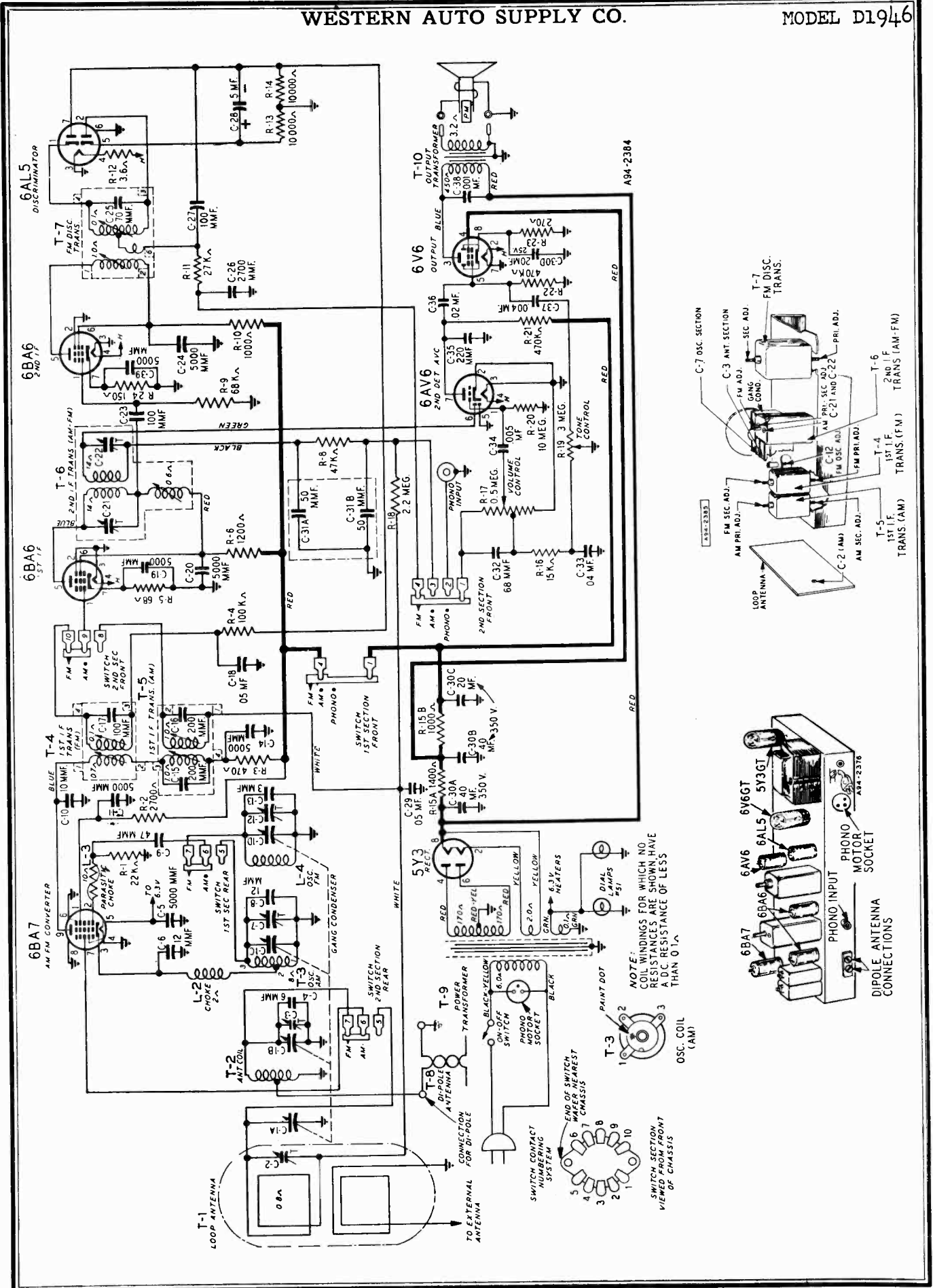

A94-2384

A94-2376

MODEL D1946

WESTERN AUTO SUPPLY CO.

ALIGNMENT PROCEDURES

AM STAGES

Volume Control Maximum all Adjustments.

Connect Radio Chassis to Ground Post of Signal Generator with a Short Heavy Lead.

Allow Chassis and Signal Generator to "Heat Up" for Several Minutes.

The following is required for aligning:

An All Wave Signal Generator Which Will Provide an Accurately Calibrated Signal at the Test Frequencies as Listed.

Output Indicating Meter, Non-Metallic Screwdriver, Dummy Antennas — .1 mf, and 50 mmf.

SIGNAL GENERATOR					
FREQUENCY SETTING	CONNECTION AT RADIO	GROUND CONNECTION	DUMMY ANTENNA	GANG CONDENSER SETTING	ADJUST TUNING SLUGS AND TRIMMERS
455 KC	Control Grid 1st 6BA6 Pin No. 1	Chassis Base	.1 mf	Turn Rotor to Full Open	2nd I.F. C-21 & C-22
455 KC	Control Grid 6BA7 Pin No. 7 1st Def.	Same as above	.1 mf	Turn Rotor to Full Open	1st I.F. Pri. & Sec.
1620 KC	Control Grid 6BA7 Pin No. 7	Same as above	.1 mf	Turn Rotor to Full Open	Oscillator C-7
1400 KC	External Antenna Lead	Same as above	50 mmf	Turn Dial to 1400 KC. See Note A	Antenna C-2

NOTE A—Set pointer at the 1400 KC mark on the dial scale. Attach pointer to drive cord.

FM STAGES

Allow chassis and signal generator to warm up for several minutes.

The following equipment is required for aligning:

An accurately calibrated signal generator providing unmodulated signals at the test frequencies listed below.

Non-metallic screwdriver.

Dummy Antennas and I-F Loading Resistor—2500 mmf, 300 ohms and a 3300 ohm .5 watt resistor with short leads.

Zero center scale DC vacuum tube voltmeter having a range of approximately 3 volts.

(If a zero center scale meter is not available, a standard scale vacuum tube voltmeter may be used by reversing the meter connections for negative readings.)

SIGNAL GENERATOR						
	FREQUENCY SETTING	CONNECTION AT RADIO	DUMMY ANTENNA	BAND SWITCH SETTING	CONDENSER SETTING	ADJUSTMENT FOR MAX. METER DEFLECTION
Discriminator	10.7 MC	6BA6 2nd I-F Pin 1 & Chassis	2500 mmf	FM	Rotor Fully Open	Disc. Pri. Note A
	10.7 MC	Same as above	2500 mmf	FM	Rotor Fully Open	Disc. Sec. Note B
	10.7 MC	Same as above	2500 mmf	FM	Rotor Fully Open	Disc. Pri. Note A
	10.7 MC	Same as above	2500 mmf	FM	Rotor Fully Open	Disc. Sec. Note B
I-F	10.7 MC Note E	6BA6 1st I-F Pin 1 & Chassis	2500 mmf	FM	Rotor Fully Open	2nd I-F Note C
Discriminator	10.7 MC	6BA6 2nd I-F Pin 1 & Chassis	2500 mmf	FM	Rotor Fully Open	Disc. Pri. Note A
I-F	10.7 MC	Antenna and Chassis	2500 mmf	FM	Rotor Fully Open	1st. I-F Pri. and Sec. and Note C
	10.7 MC	Antenna and Chassis Solder a 3300 ohm resistor across terminals 3 and 4 of 1st. I-F trans.	2500 mmf	FM	Rotor Fully Open	1st. I-F Pri. Note C
	10.7 MC	Antenna and Chassis Note D	2500 mmf	FM	Rotor Fully Open	1st. I-F Sec. Note C

RECHECK I-F ADJUSTMENTS IN ORDER GIVEN

Oscillator	108.4 Note F	Disconnect built-in dipole antenna and connect generator to dipole terminals with resistor in series.	300 ohms	FM	Rotor Fully Open	Osc. C-12
Antenna	104.5	Same as above	300 ohms	FM	Tune rotor for max. AVC voltage	Ant. C-3

RECHECK ANTENNA & OSC. ADJUSTMENTS IN ORDER GIVEN

FM ALIGNMENT NOTES

NOTE A—The zero center scale DC vacuum tube voltmeter is to be connected between chassis ground and the AVC line. A signal of .1 volt must be fed into the receiver for this adjustment.

Note output voltage on the zero center DC vacuum tube voltmeter.

NOTE B—Disconnect zero center DC vacuum tube voltmeter from AVC and connect it to the audio takeoff point at the 27 K ohm resistor (R-11) and its junction with the terminal strip. Adjust for zero voltage indication.

NOTE C—Connect zero center DC vacuum tube voltmeter as in Note A. Adjust input to give same output on the zero center DC vacuum tube voltmeter as in Note A.

NOTE D—Unsolder 3300 ohm resistor from terminals 3 and 4 of 1st I-F transformer and resolder across terminals 1 and 2.

NOTE E—2nd I-F Trimmers (AM) must be aligned before attempting to adjust 2nd I-F (FM) tuning slug.

NOTE F—Remove the 3300 ohm load resistor before attempting to check the antenna and oscillator adjustments.

REPLACEMENT PARTS LIST

NOTICE: There is a Model Number label on the chassis. This label identifies the radio as to chassis, dial and issue letter. When ordering parts or writing, give ALL information appearing on this label.

MISCELLANEOUS

12A477	8" PM Speaker
2A373	Band Change Switch
3A303	Molded Octal Tube Socket
3A304	Phono Motor Jack
3A305	Phono Input Jack
3A426	Miniature Tube Socket
3A443	Miniature Tube Socket (For AM-FM Converter Tube).....
10A691	Knob (Tuning)
10A692	Knob (Off-On Volume)
10A693	Knob (Tone)
10A694	Knob (AM-FM Phono)
13X546	Line Cord and Plug
30X547	Line Cord Clamp

		Ohms	Watts	
R-6	B84122	1200	.5	Carbon.....
R-8	B85473	47 K	.5	Carbon.....
R-9	B85683	68 K	.5	Carbon.....
R-10	B84102	1000	.5	Carbon.....
R-11	B84273	27 K	.5	Carbon.....
R-12	43X233	3.6	.5	Wire Wound....
R-13	B84103	10K	.5	Carbon.....
R-14				
R-15A	43X224	1000	6.0	Wire Wound....
R-15B		1400	4.0	
R-16	B84153	15 K	.5	Carbon.....
R-17	36X371	.5 meg	.5	Volume Control.
R-18	B85225	2.2 meg.	.5	Carbon.....
R-19	40X284	3 meg.	.5	Tone Control....
R-20	B85106	10 meg.	.5	Carbon.....
R-21	B85474	470 K	.5	Carbon.....
R-22				
R-23	B84271	270	.5	Carbon.....
R-24	B84151	150	.5	Carbon.....

CAPACITORS

C-1A, C-1B	14A204	Gang Condenser Assembly	Part of T-1 (Loop Antenna Assembly)							
C-1C, C-1D										
C-2	47X521	6 mmf	Ceramic.....							
C-3										
C-7										
C-4										
C-5	47X507	5000 mmf	Silvered Ceramic..							
C-11										
C-14										
C-19										
C-20										
C-24										
C-39										
C-6						47X522	12 mmf	Ceramic.....		
C-8										
C-9						47X517	47 mmf	Ceramic.....		
C-10										
C-12	17A255	1-8 mmf	Trimmer.....							
C-13										
C-15	47X547	3 mmf	Ceramic.....							
C-16										
C-17	B66503	.05 mf	200 V	Tubular.....						
C-18										
C-21	47X497	100 mmf	Ceramic.....							
C-22										
C-23	47X492	2700 mmf	Molded.....							
C-25										
C-26	47X526	100 mmf	Molded.....							
C-27										
C-28	45X361	5 mf	100 V	Dry Electrolytic...						
C-30A										
C-30B	45X359	40 mf	350 V	Dry Electrolytic...						
C-30C										
C-30D	47X112	50-50 mmf	Dual Mica.....							
C-31A										
C-31B	47X471	68 mmf	Molded.....							
C-32										
C-33	B66403	.04 mf	200 V	Tubular.....						
C-34										
C-35	D66502	.005 mf	400 V	Tubular.....						
C-36										
C-37	47X468	220 mmf	Ceramic.....							
C-38										
	D66203	.02 mf	400 V	Tubular.....						
	B66402	.004 mf	200 V	Tubular.....						
	H66102	.001 mf	800 V	Tubular.....						

TRANSFORMERS AND COILS

L-2	35A1	Insulated Choke
L-3	9A1940	Parasitic Choke Assembly
L-4	9A2021	Oscillator Coil Assembly (FM)
T-1	9A1972	"B" Range Loop Antenna Assembly
T-2	9A1956	Antenna Coil Assembly
T-3	9A1997	Oscillator Coil (AM)
T-4	9A1932	1st I.F. Transformer (FM)
T-5	9A1998	1st I.F. Transformer (AM)
T-6	9A1999	2nd I.F. Transformer (AM-FM)
T-7	9A1970	Discriminator Coil Assembly
T-8	9A2003	Dipole Antenna Assembly
T-9	53X290	Power Transformer
T-10	51X134	Output Transformer

DIAL AND DRIVE ASSEMBLY

15X229	Pointer
6X21	Rubber Grommet
20X260	Condenser Cushion Stud } Mtg. Gang Condenser
58X717	Dial
28X113	Drive Cord Tension Spring
26X507	Drive Shaft
19X192	"C" Washer (For drive shaft)
10X66	Drive Cord Assembly
7A215	Pilot Light Socket Assembly
7A32	No. 51 Pilot Light
25X1491	Pointer Bracket
4X915	Escutcheon (Right)
4X916	Escutcheon (Left)
30X517	Dial Clamp
25X1571	Idler Bracket
4X931	Escutcheon Inserts

RESISTORS

		Ohms	Watts	
R-1	B84223	22 K	.5	Carbon.....
R-2	B83272	2700	.5	Carbon.....
R-3	B84471	470	.5	Carbon.....
R-4	B85104	100 K	.5	Carbon.....
R-5	B83680	68	.5	Carbon.....

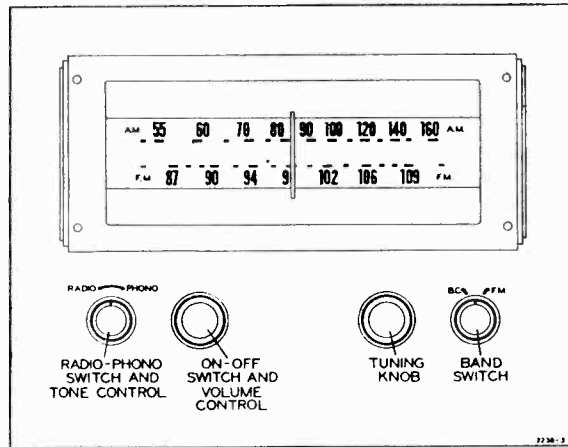
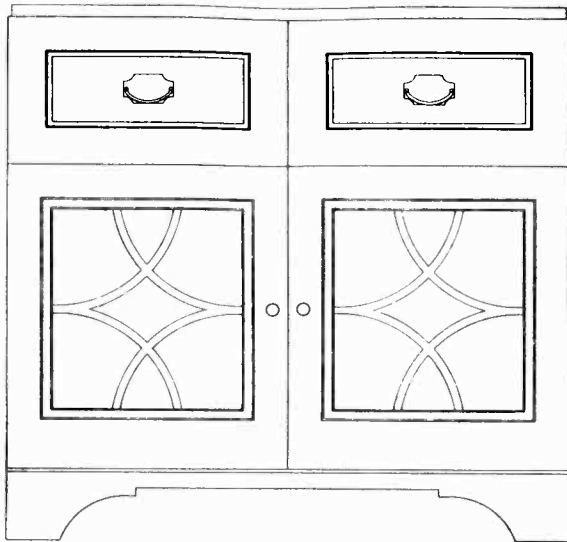

ELECTRICAL SPECIFICATIONS

- Power Supply**.....105 to 125 volts, AC, 60-cycles; Chassis only 122 watts. With phono operation 150 watts.
- Frequency Range**...Broadcast Band—535 to 1620 kc. FM Band—88 to 108 mc.
- Intermediate Freq.**...AM-455 kc; FM-10.7 mc.
- Selectivity**.....AM-48 kc. broad at 1000 times signal, measured at 1000 kc. I.F. FM-180 kc. broad at 2 times down. I.F. FM-320 kc. broad at 10 times down.
- AM Sensitivity**.....(For .5 watt output with external antenna)—3 microvolts average.
- FM Sensitivity**.....(For .5 watt output)—10 microvolts average.
- Power Output**.....8 watts. 10% distortion. 10 watts maximum.

- Loud Speaker**.....12" electrodynamic. Voice coil impedance 3.2 ohms, 400 cycles.
- Tube and Lamp Complement**.....6BA6, FM—AM R.F. stage. 12AT7, FM—AM oscillator and mixer. 6BA6, FM—AM—1st I.F. 6BA6, FM—2nd I.F. 6AL5, FM—ratio detector. 6AT6, AM detector. A. F. AMP. and A.V.C. 6SN7, Push-Pull. Driver and phase-inverter. 5U4G, rectifier. 6V6, output. 6V6, output. T-44 dial lamp (2 used).

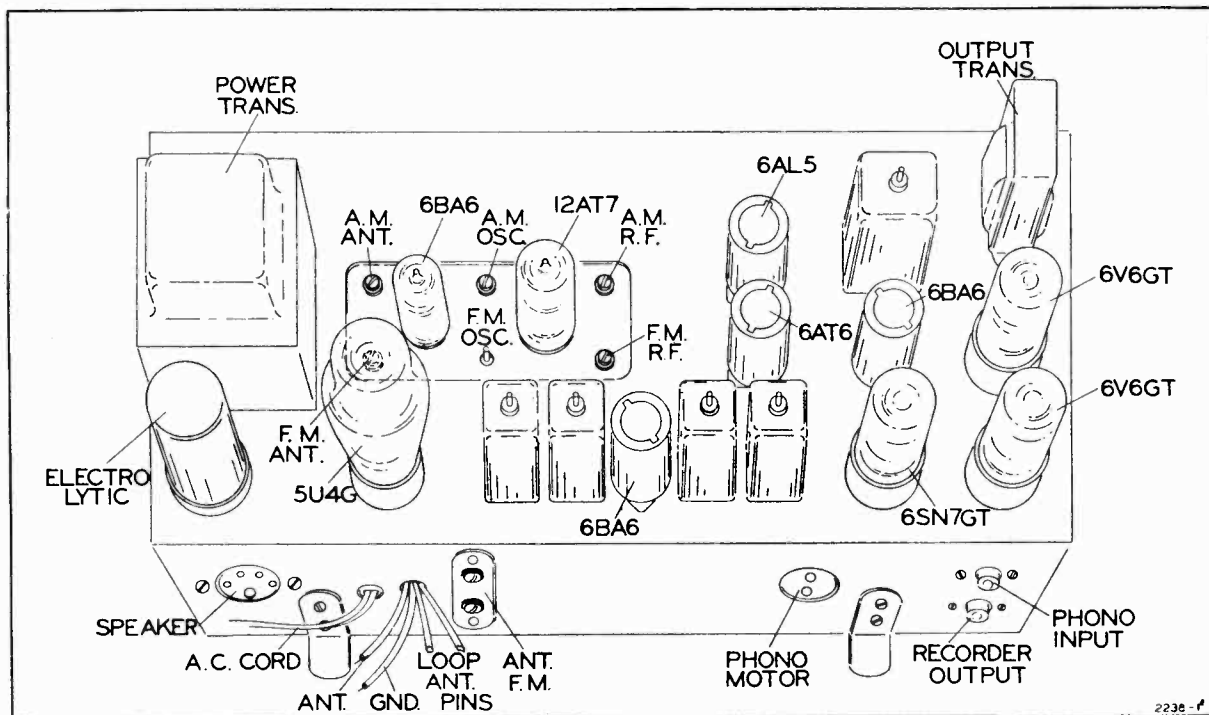

Chassis — top view

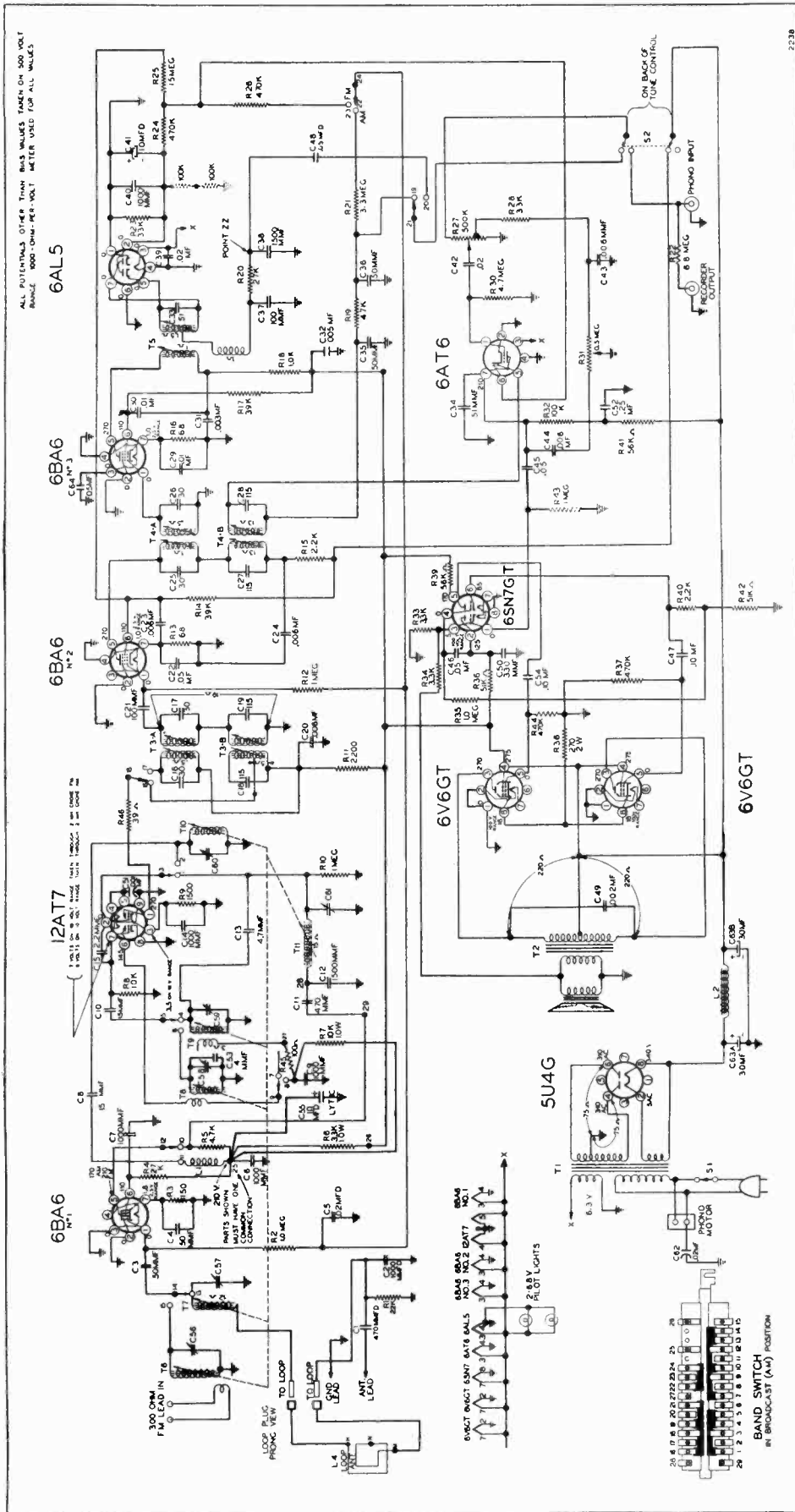

NOTE: Two 100K ohm resistors in series from Pin No. 2 of the 6AL5 to ground are connected as shown only when aligning the FM I. F. Refer to FM I. F. alignment procedure.

NOTE: B.C. Oscillator Coil T9 and number 7 terminal of slide switch should be connected together.

NOTE: A 3.3 ohm resistor C-9B1-1069 is connected between Pin 3 of 6AL5 and the filament line (X) in some productions.

ALIGNMENT PROCEDURE

Broadcast Band Section I.F. and R.F.

The alignment procedure below includes the sensitivities at the inputs of various stages. All signal input values are based on an output of 1/2 watt. This may be measured by disconnecting the speaker voice coil and substituting a 3.2-ohm resistor across the secondary winding of the output transformer. A reading of 1.3 volts AC across this resistor will be approximately equivalent to a 1/2-watt output with the speaker con-

nected. The volume control must be set at maximum. The tone control must be set for maximum treble.

The signal source must be an accurately calibrated signal generator capable of supplying the frequencies designated, modulated 30% with a 400-cycle audio signal. A 400 cycle audio signal is required for the audio measurement. Variations in sensitivities of plus or minus 25% are usually permissible.

AM-I.F. ALIGNMENT

Band Switch in AM Position. Tune Set to 1400 Kc. Dummy Antenna .1 Mfd.

SIGNAL GENERATOR FREQUENCY	CONNECTION TO RADIO	ADJUSTMENTS TO BE MADE	ADJUST FOR
455 Kc. Use 1000 microvolts	Pin No. 1 of 6BA6 No. 2 and ground	Primary and Secondary of T4B AM windings See I.F. view	Maximum output Should be 1/2 watt.
455 Kc. Use 30 microvolts	Pin No. 2 of 12AT7 and ground	Primary and Secondary of T3B AM windings See I.F. view	Maximum output Should be 1/2 watt.
400 cycles. Use 28 millivolts	Hot end of volume control and ground	None	Maximum output Should be 1/2 watt.

BROADCAST BAND-R.F. ALIGNMENT

*Check pointer so that it coincides with the right hand marker to the extreme right when iron cores are all the way out.
For adjustment, see dial mechanism illustration.*

SIGNAL GENERATOR FREQ.	CONNECTION TO RADIO	DUMMY ANTENNA	ADJUST
1620 Kc. Use 3 microvolts	AM Antenna and Ground	200 mmf.	C59, C57, C61. For maximum, 1/2 watt

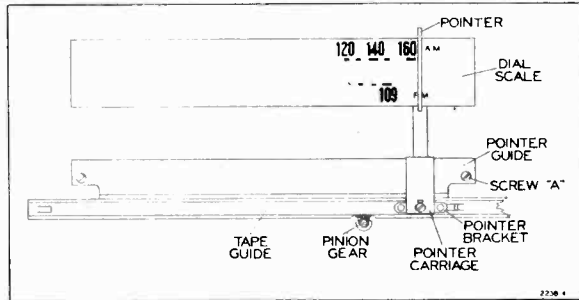
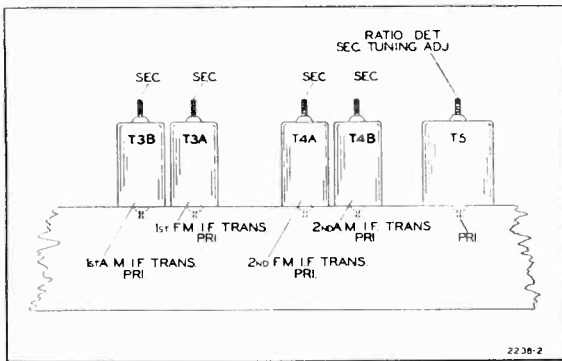

Loosen screw "A" so that teeth of tape can be properly meshed with pinion gear to give proper pointer travel.

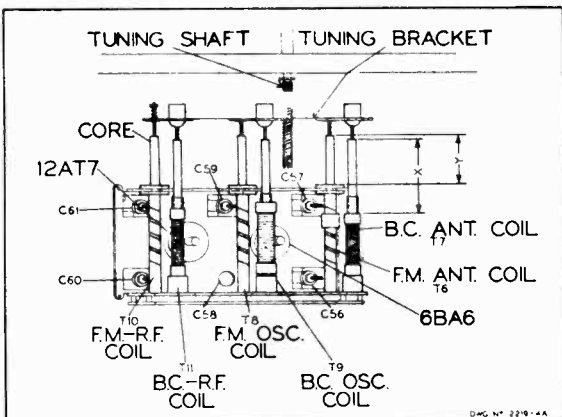

With tuner all the way out, dimension "X" should be 1 1/2 inches. "Y" should be 1-1/32 inches. "X" is from the end of the slug to edge of the coil winding. Check these dimensions before R.F. alignment is attempted of either the AM or FM Band. No slug adjustment should be necessary since the slugs are properly set at the factory.

ALIGNMENT PROCEDURE

FM Band Section I.F. and R.F.

A non-metallic alignment tool must be used.

IMPORTANT— No alignment of the FM section of this radio should be attempted unless you are positive that the circuits are in need of adjustment and you have the necessary equipment.
All components used in this radio

are extremely stable and the tuned circuits should require no adjustment over a long period of time.

NOTE— The following alignment is based on the use of the new Simpson vacuum tube voltmeter which has a "floating ground". In other

words, the meter, when used as a vacuum tube volt-meter, can have both the positive and negative sides connected to points above ground and still give true readings.

A standard AM signal generator is required.

FM - I. F. ALIGNMENT

Band Switch in FM Position. Dummy Antenna .1 Mfd.

SIGNAL GENERATOR FREQUENCY	CONNECTION TO RADIO	VACUUM TUBE VOLT METER CONNECTION TO RADIO	ADJUSTMENT TO BE MADE	ADJUST FOR
10.7 Mc. Use about .1 volt	Pin No. 1 of 6BA6 No. 3 and ground	Pin No. 2 of 6AL5 and ground	Primary of T5	Resonance should be about 3 volts
10.7 Mc. Use about .1 volt	Pin No. 1 of 6BA6 No. 3 and ground	See note "A"	Secondary of T5	Zero. Use zero center scale See note "B"
10.7 Mc. Use about 3300 microvolts	Pin No. 1 of 6BA6 No. 2 and ground	Pin No. 2 of 6AL5 and ground	Primary and Secondary of T4A 10.7 m.c. windings See I.F. view	Resonance should be about 3 volts
10.7 Mc. Use about 200 microvolts	Pin No. 2 of 12AT7 and ground	Pin No. 2 of 6AL5 and ground	Primary and Secondary of 10.7 m.c. windings of T3A See I.F. view	Resonance should be about 3 volts

NOTES ON FM — I. F. ALIGNMENT

NOTE "A" Connect two resistors, 100K OHMS each, from Pin No. 2 of 6AL5 to ground. These resistors must be matched within 5%. Connect as shown in dotted lines on schematic diagram. Connect vacuum tube voltmeter between the mid-

point of the resistors and point zz.

NOTE "B" If T5 has been tampered with, it is possible that no crossover point will be found at first. Careful adjustment of both primary and secondary is necessary.

GENERAL: Input signals should be adjusted to give approximately 3 volts. The ratio detector is operating at reasonable level at this point and will give the truest indication of correct alignment with the procedure specified.

FM - R. F. ALIGNMENT

*Check pointer so that it coincides with the right hand marker to the extreme right when iron cores are all the way out.
For adjustment, see dial mechanism illustration.*

SIGNAL GENERATOR FREQUENCY	CONNECTION TO RADIO	DUMMY ANTENNA	ADJUST	VACUUM TUBE VOLT METER CONNECTION TO RADIO	ADJUST TO
100 Mc. Use about 10 microvolts	FM Antenna Terminals See note	300 ohms	C58 Osc. C60 R. F. C56 Ant.	Pin No. 2 of 6AL5 and Ground	Resonance about 3 volts

NOTE: If a signal generator with the above fundamental frequency is not available, it is sometimes possible to use harmonics. Use extreme care in picking harmonics. An alternate procedure is to use a local station carrier of known frequency to align the FM Band and to use the vacuum tube volt-meter

as above for resonance indication. A weak carrier, however, will not produce 3 volts.

NOTE: Connect 300 ohms in series with hot side of generator and connect to one screw. Connect cold side of generator to other screw.

MODEL D1950

WESTERN AUTO SUPPLY CO.

REPLACEMENT PARTS LIST

Ref. No.	Part No.	Description	Qty. Used
TUNER PARTS			
Condensers			
C58	A-8H-15444	Trimmer, FM oscillator	1
C56, 57, 59, 61	A-2M-12618	Trimmer plate, large	4
C60	A-5M-14368	Trimmer plate, small	1
C59, C61	A-5M-12615	Locator, for trimmer plates	5
C56, 57, 60	B-6M-12616-S-2	Silvered mica film	2
C1, C11	A-6M-12616	Clear mica film	3
C2	A-3C-12617	Spacer, for trimmer plates	5
C6, 7, 9, 14, 51	C-8G-11732	470 mmf, ceramic	2
C12	C-8G-13695	1000 mmf, ceramic	1
C10, C8	C-8G-13201	1000 mmf, ceramic	5
C3, C4	C-8G-11731	1500 mmf, ceramic	1
C13	C-8G-13017	15 mmf, ceramic	1
C15	C-8G-11484	50 mmf, ceramic	2
C53	A-8G-12495-6	4.7 mmf, ceramic	1
C5	A-8G-12495-4	2.2 mmf, ceramic	1
	C-8G-15859	4 mmf, ceramic	1
	C-8D-11304	.02 x 200 volts, paper	1
Resistors			
R4	C-9B2-79	27K ohms, 1 watt	1
R1	C-9B1-21	22K ohms, 1/2 watt	1
R3	C-9B1-52	150 ohms, 1/2 watt	1
R5	C-9B1-17	4700 ohms, 1/2 watt	1
R8	C-9B1-19	10K ohms, 1/2 watt	1
R21	C-9B1-31	1 megohm, 1/2 watt	2
R20	C-9B1-34	3.3 megohms, 1/2 watt	1
R45	C-9B1-50	100 ohms, 1/2 watt	1
R46	C-9B1-45	39 ohms, 1/2 watt	1
R9	C-9B1-64	1500 ohms, 1/2 watt	1
R6	C-9B2-6	3000 ohms, 1 watt	1
R7	C-9B2-74	10K ohms, 1 watt	1
Coils			
T8	B-13D-13027-1	F.M. oscillator coil	1
T6	B-51A-13056	Core for F.M. oscillator coil	1
T10	B-13E-13028	FM antenna coil	1
T9	B-51A-13058	Core for FM antenna coil	1
T7	B-13C-13029	FM R.F. coil	1
T11	B-51A-13057	Core for FM R.F. coil	1
	A-13D-15704	B.C. oscillator coil	1
	B-51A-12722	Core for B.C. oscillator coil	1
	B-13E-13031	B.C. Antenna coil	1
	B-13C-13032	B.C. R.F. coil	1
	B-51A-12723	Core for B.C. ant. and R.F. coil	2
Miscellaneous			
B-20B-15628		Slide switch	1
A-15B-12997		7-prong min., tube socket	1
A-15B-13430		9-prong min., tube socket	1
B-3A-15415		Lead screw	1
A-3J-2309		Pinion gear	1
A-49A-14439		Drive spring	2
A-49A-13228		Tension spring	1
A-49A-12394		Spiral spring, for slugs	3
B-2J-13006		Rack tape with teeth and pointer bracket	1
Coils			
B-13A-15680		Input I.F. transformer, 455 kc.	1
B-13B-15681		Output I.F. transformer, 455 kc.	1
B-13A-15682		Input I.F. transformer, 10.7 megohms	1
B-13B-15683		Second I.F. transformer, 10.7 megohms	1
B-13M-15684		Ratio detector, 10.7 megs.	1
C-13E-15687		Loop antenna assembly	1
Transformers			
B-12A-13038-1		Power transformer, 105-125 volts, 50-60 cycles, primary	1
B-12C-13042-1		Output transformer, for speaker	1
Speaker			
B-18B-13043-1		Electrodynamic speaker, 12-inch, less output transformer	1
Miscellaneous			
C-30A-15686		Dial scale	1
B-30B-13943		Dial glass	1
2G-13696		Escutcheon	1
56D2-12463		Screws for escutcheon	4
B-5B-13737-37		Knob, mahogany—small with dot	2
A-15B-11538		Speaker socket	1
A-19B-12468		Phono-motor socket	1
A-19B-11044		Recorder socket	1
A-19B-12170		Phono input socket	1
B-14M-11479		AC line cord	1
32K10-14306		10-32 x 1 inch, chassis mounting screws	4
B-5B-13738-37		Knob, mahogany—large, without dot	2
B-5B-13737-14		Knob, walnut—small, with dot	2
B-5B-13738-14		Knob, walnut—large, without dot	2
A-3A-15630		Shaft for band switch	1
A-43D-12934		"U" speed clip	1
A-55C-12935		Ball bearing	1
B-47A-13801		Pilot lite assembly	1
A-46A-11739		Pilot lite bulb, 6-8 volts	2
A-2H-10974		Tube shield	4
A-15C-13174		7-prong, min., tube socket	4
A-15B-10440		8-prong, octal socket	4
A-7B-13050		FM dipole socket	1
Condensers			
B-2D-15416		Guide for rack tape	1
B-2D-15649		Pointer carriage	1
A-5M-13741		Pointer	1
32F4SE-11488		4-40 x 1/8" screw for pointer 2	2
MAIN CHASSIS PARTS			
Condensers			
C63A, C63B	B-8C-11629	Electrolytic filter condenser, 30—30 x 450 volts	1
C52	C-8D-13439	.25 mfd x 400 volts	1
C54, C47	C-8D-10760	.1 mfd x 400 volts	2
C31	C-8D-11013	.003 x 600 volts	2
C44, 43, 24, 23, 20	C-8D-10785	.006 x 600 volts	5
C29, C30	C-8D-10761	.01 x 400 volts	2
C46, C45	C-8D-10813	.05 x 400 volts	2
C49	C-8D-10789	.002 x 600 volts	2
C48, C22	C-8D-10770	.05 x 200 volts	2
C64	C-8D-15860	.05 x 200 volts	1
C41	A-8C-13132	Electrolytic, 10 mfd x 50 volts	1
C62	C-8J-11321	.02 x 600 volts, molded case	1
C35	A-8G-13962	.005 x 500 volts, ceramic	1
C21	C-8G-11734	100 mmf, ceramic	1
C38	C-8G-13059	1500 mmf, ceramic	1
C34	C-8G-13060	51 mmf, ceramic	1
C40	C-8G-13201	1000 mmf, ceramic	1
C50	C-8F-11741	330 mmf, ceramic	1
C37	C-8F3-225	100 mmf, mica	1
C39, C42	C-8D-11304	.02 x 200 volts, paper	2
C35, C36	A-8F-13047	Mica condenser, 50 mmf, dual	1
C55	A-8C-12154	Electrolytic, 10 mfd, 450 volts	1
Resistors			
R27, S1	A-10A-13114	Volume control and switch, 500K ohms	1
R31, S2	A-11A-15645	Tone control and phono radio switch	1
R22	C-9B1-36	6.8 megohms, 1/2 watt	1
R44, R37	C-9B1-94	100K ohms, 1/2 watt	1
R41, R39	C-9B1-83	470K ohms, 1/2 watt	2
R33, R34	C-9B1-68	56K ohms, 1/2 watt	2
R30	C-9B1-35	3300 ohms, 1/2 watt	2
R23, R28	C-9B1-80	4.7 megohms, 1/2 watt	1
R20	C-9B1-79	35K ohms, 1/2 watt	2
R13, R16	C-9B1-48	27K ohms, 1/2 watt	1
R14, R17	C-9B2-81	68 ohms, 1/2 watt	2
R24, R26	C-9B1-29	39K ohms, 1 watt	2
R25	C-9B1-302	470K ohms, 1/2 watt	2
R19	C-9B1-23	15 megohms, 1/2 watt	1
R40	C-9B1-31	47K ohms, 1/2 watt	1
R12, R43, R35	C-9B1-31	1 megohm, 1/2 watt	3
R36, R42	C-9B1-200	2200 ohms, 1/2 watt	1
R38	C-9B4-55	51K ohms, 1/2 watt	2
R8	C-9B1-13	270 ohms, 2 watts	1
R11, R15	C-9B2-15	1000 ohms, 1/2 watt	1
	C-9B1-1069	2200 ohms, 1 watt	2
		3.3 ohms, 1/2 watt	1

WESTERN AUTO SUPPLY CO.

MODEL D2690,
1st Type

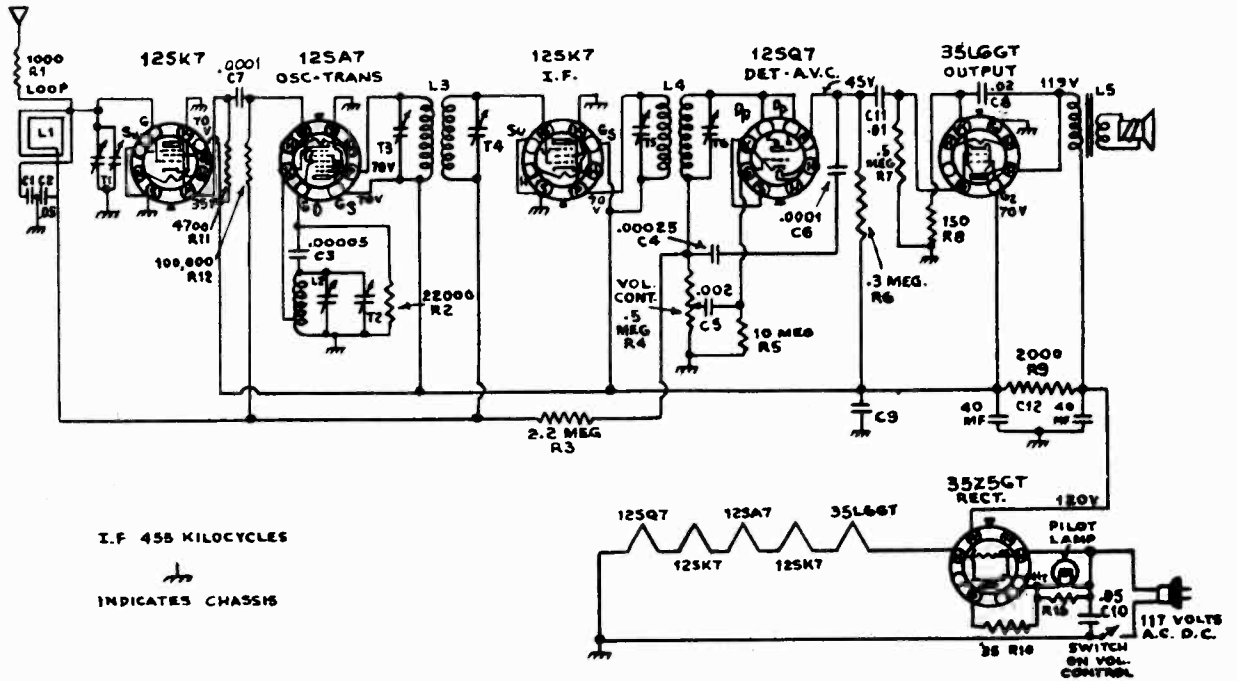

ALIGNMENT PROCEDURE

- Output meter connections.....Across primary output transformer
- Connection of generator ground.....Chassis
- Generator modulation.....App. 30% @ 400 cycles
- Position of volume control.....Fully Clockwise

POSITION OF DIAL POINTER	GENERATOR FREQUENCY	GENERATOR CONNECTION	TRIMMERS ADJUSTED	TRIMMER FUNCTION
540 kc	455 kc	12SA7GT	T3, T4, T5, T6	I. F.
1500 kc	1500 kc	* * *	T2, T1	Osc., R. F.

See Note Below

IMPORTANT ALIGNMENT NOTES

It is advisable to repeat the entire alignment procedure in the original order to insure greater accuracy.

Always keep the output from the test oscillator at its lowest possible value. As the sensitivity is increased by alignment, the generator output should be reduced correspondingly.

***Run a wire from the output terminal of the generator near the receiver. However, no connection is made between the signal generator and the receiver.

MODEL D2690,
2nd Type

WESTERN AUTO SUPPLY CO.

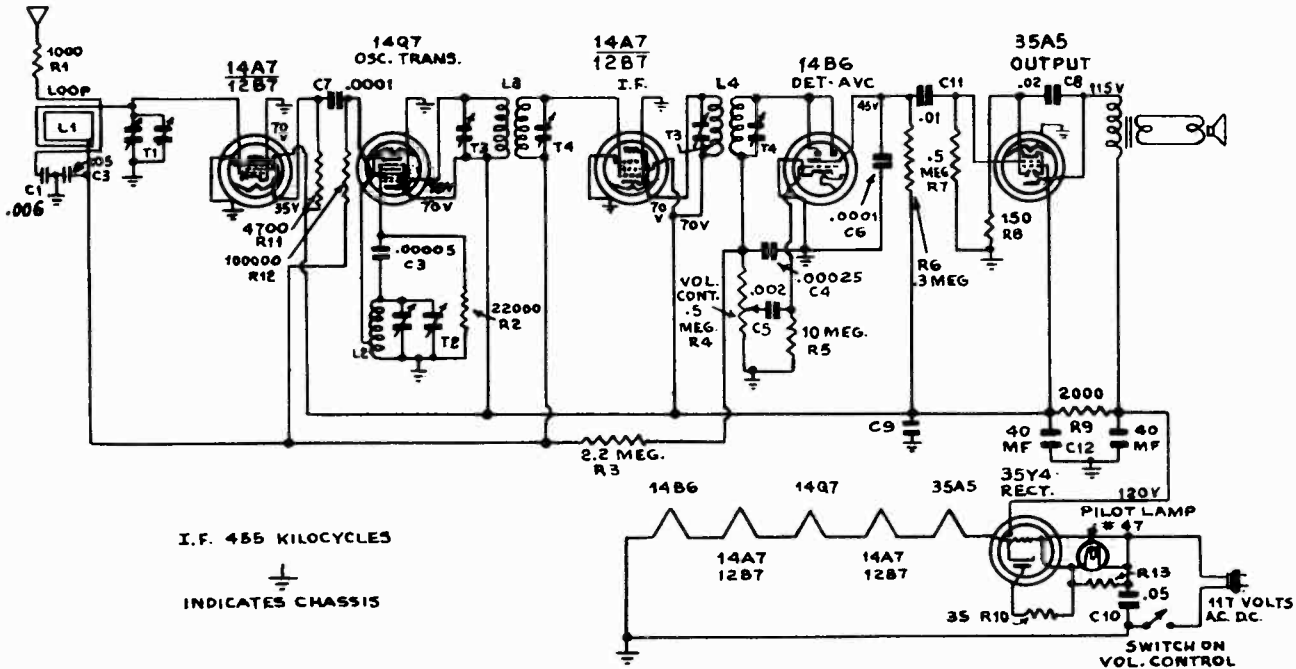

ALIGNMENT PROCEDURE

- Output meter connections.....Across primary output transformer
- Connection of generator ground.....Chassis
- Generator modulation.....App. 30% @ 400 cycles
- Position of volume control.....Fully Clockwise

POSITION OF DIAL POINTER	GENERATOR FREQUENCY	GENERATOR CONNECTION	TRIMMERS ADJUSTED	TRIMMER FUNCTION
540 kc	455 kc	14Q7	T3, T4, T5, T6	I. F.
1500 kc	1500 kc	* * *	T2, T1	Osc., R. F.

See Note Below

IMPORTANT ALIGNMENT NOTES

It is advisable to repeat the entire alignment procedure in the original order to insure greater accuracy.

Always keep the output from the test oscillator at its lowest possible value. As the sensitivity is increased by alignment, the generator output should be reduced correspondingly.

***Run a wire from the output terminal of the generator near the receiver. However, no connection is made between the signal generator and the receiver.

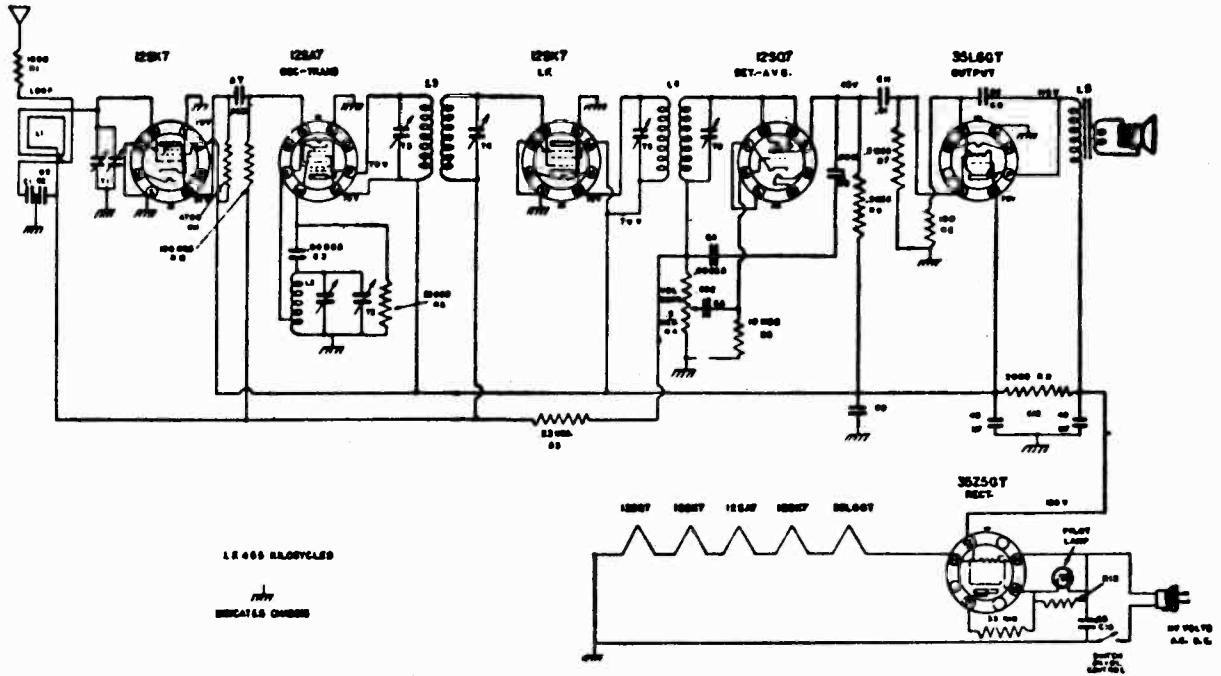

ALIGNMENT PROCEDURE

- Output meter connections.....Across primary output transformer
- Connection of generator ground.....Chassis
- Generator modulation.....App. 30% @ 400 cycles
- Position of volume control.....Fully Clockwise

POSITION OF DIAL POINTER	GENERATOR FREQUENCY	GENERATOR CONNECTION	TRIMMERS ADJUSTED	TRIMMER FUNCTION
540 kc	455 kc	12SA7GT	T3, T4, T5, T6	I. F.
1500 kc	1500 kc	* * *	T2, T1	Osc., R. F.

See Note Below

IMPORTANT ALIGNMENT NOTES

It is advisable to repeat the entire alignment procedure in the original order to insure greater accuracy.

Always keep the output from the test oscillator at its lowest possible value. As the sensitivity is increased by alignment, the generator output should be reduced correspondingly.

***Run a wire from the output terminal of the generator near the receiver. However, no connection is made between the signal generator and the receiver.

MODEL D2718B

WESTERN AUTO SUPPLY CO.

BROADCAST AND SHORT WAVE RADIO WITH BUILT-IN LOOP AERIAL

7 TUBE AC-DC (Including Rectifier) 2 BANDS

SHORT WAVE BAND

6 to 18 Megacycles

This band is calibrated in megacycles. The 16, 19, 25, 31 and 49 meter bands, in which the principal international short wave broadcasts will be heard, are located in this band.

These bands will be found on the dial as follows:

- 16 Meter Band... 17.7—17.9 MC
- 19 Meter Band... 15.1—15.3 MC
- 25 Meter Band... 11.7—11.9 MC
- 31 Meter Band... 9.5— 9.7 MC
- 49 Meter Band... 6— 6.2 MC

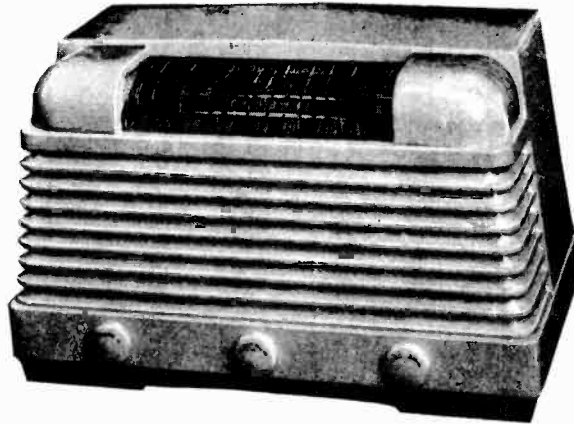

BROADCAST BAND

540 to 1600 Kilocycles

This band is calibrated in channel numbers. Add a zero to the dial number to get the kilocycle number.

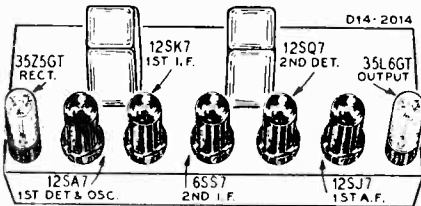

CHECK YOUR LINE VOLTAGE

Unless otherwise marked, this radio must be operated on a power supply of 105-125 volts AC, 50 to 60 cycles only, or 105-125 volts DC.

REPLACEMENT PARTS LIST

MISCELLANEOUS

- 12A464 4" x 6" P.M. Speaker, Complete with Mtg. Bracket.....
- 3A303 Tube socket—Octal (8 prong) Molded.....
- 2A206 Band change switch.....
- 10A601 Knob—Tuning } For Ivory Cabinet {
- 10A602 Knob—Volume } {
- 10A603 Knob—Band } {
- 10A604 Knob—Tuning } For Brown Cabinet {
- 10A605 Knob—Volume } {
- 10A606 Knob—Band } {
- 13X546 Line Cord and Plug Assembly.....
- 55X292 Cabinet, Ivory Plastic.....
- 55X296 Cabinet, Brown Plastic.....
- 28X292 Snap Button (Mtg. Antenna to cabinet).....
- 6X53 Rubber Bumpers (Mtd. to bottom of cabinet).....

TRANSFORMERS AND COILS

- T-1 9A1443 "D" Range Antenna Coil Assembly.....
- T-2 26A451 "B" Band Loop Antenna Assembly.....
- T-2 26A452 "B" Band Loop Antenna Assembly.....
- T-3 9A1444 "D" Range Oscillator Coil Assembly.....
- T-4 9A1442 "B" Band Oscillator Coil Assembly.....
- T-5 9A1793 1st I-F Coil Assembly.....
- T-6 9A1794 2nd I-F Coil Assembly.....
- T-7 51X118 Output Transformer.....

CAPACITORS

- C-1 B67102 .001 mf 200 V Tubular.....
- C-2 17A152 2-25 mmf Trimmer strip.....
- C-3A 14A148 Gang Condenser Assembly.....
- C-3B 46X289 .00475 mf 180 V Tubular.....
- C-4 17A174 2-25 mmf Trimmer.....
- C-5 Part of C-3 (Gang Condenser Assembly)
- C-6 47X463 47 mmf Molded.....
- C-7 47X466 68 mmf Molded.....
- C-8 17A234 300-450 mmf Trimmer.....
- C-9 47X466 68 mmf Molded.....
- C-10 17A234 300-450 mmf Trimmer.....
- C-11 B66104 .1 mf 200 V Tubular.....
- C-12 B66403 .04 mf 200 V Tubular.....
- C-13 B66403 .04 mf 200 V Tubular.....
- C-15 B66403 .04 mf 200 V Tubular.....
- C-22 B66403 .04 mf 200 V Tubular.....

- C-13 } Part of T-5 (1st I-F Coil Assembly)
- C-14 }
- C-17 }
- C-18 } Part of T-6 (2nd I-F Coil Assembly)
- C-19 47X476 100 mmf Molded.....
- C-20 B66502 .005 mf 200 V Tubular.....
- C-25 B66103 .01 mf 200 V Tubular.....
- C-26 B67253 .025 mf 200 V Tubular.....
- C-27A 50 mf 150 V } Dry Electrolytic
- C-27B 50 mf 150 V }
- C-27C 20 mf 25 V }
- C-29 D67204 2 mf 400 V Tubular.....
- C-30 D67104 .1 mf 400 V Tubular.....
- C-31 17A123 1.5-12 mmf Trimmer.....

RESISTORS

- R-1 B84393 39K 0.5 Carbon.....
- R-2 B84472 4700 0.5 Carbon.....
- R-3 B85473 47K 0.5 Carbon.....
- R-4 B84332 3300 0.5 Carbon.....
- R-6 B85104 100K 0.5 Carbon.....
- R-7 B85225 2.2 meg 0.5 Carbon.....
- R-8 B85475 4.7 meg 0.5 Carbon.....
- R-9 36X309 .5 meg Volume control and switch.....
- R-10 B84153 15K 0.5 Carbon.....
- R-11 B85474 470K 0.5 Carbon.....
- R-12 B84333 33K 0.5 Carbon.....
- R-13 B84823 82K 0.5 Carbon.....
- R-15 B84181 180 0.5 Carbon.....
- R-16 B85224 220K 0.5 Carbon.....
- R-18 B84270 27 0.5 Carbon.....
- R-19 C85152 1500 1.0 Carbon.....

DIAL AND DRIVE ASSEMBLY

- 20X329 Cond. Cushion Stud, (Mtg. Gang Cond.).....
- 6X21 Rubber Grammet, (Mtg. Gang Cond.).....
- 26A450 Dial Bracket Assembly.....
- 25A1044 Diffuser and Clamp Assembly.....
- 58X671 Dial (for Ivory Cabinet).....
- 30X532 Dial Clamps.....
- 15X236 Pointer.....
- 25X580 Drive Shaft Bracket.....
- 26X465 Drive Shaft.....
- 19X192 "C" Washer (for drive shaft).....
- 24X564 Drive Shaft Spool.....
- 10X51 Drive Cord Assembly.....
- 28X113 Drive Cord Tension Spring.....
- 7A185 Pilot Light Socket Assembly.....
- 7A103 No. 47 Pilot Light Bulb.....
- 17X96 Celluloid Crystal.....

WESTERN AUTO SUPPLY CO.

MODEL D2718B

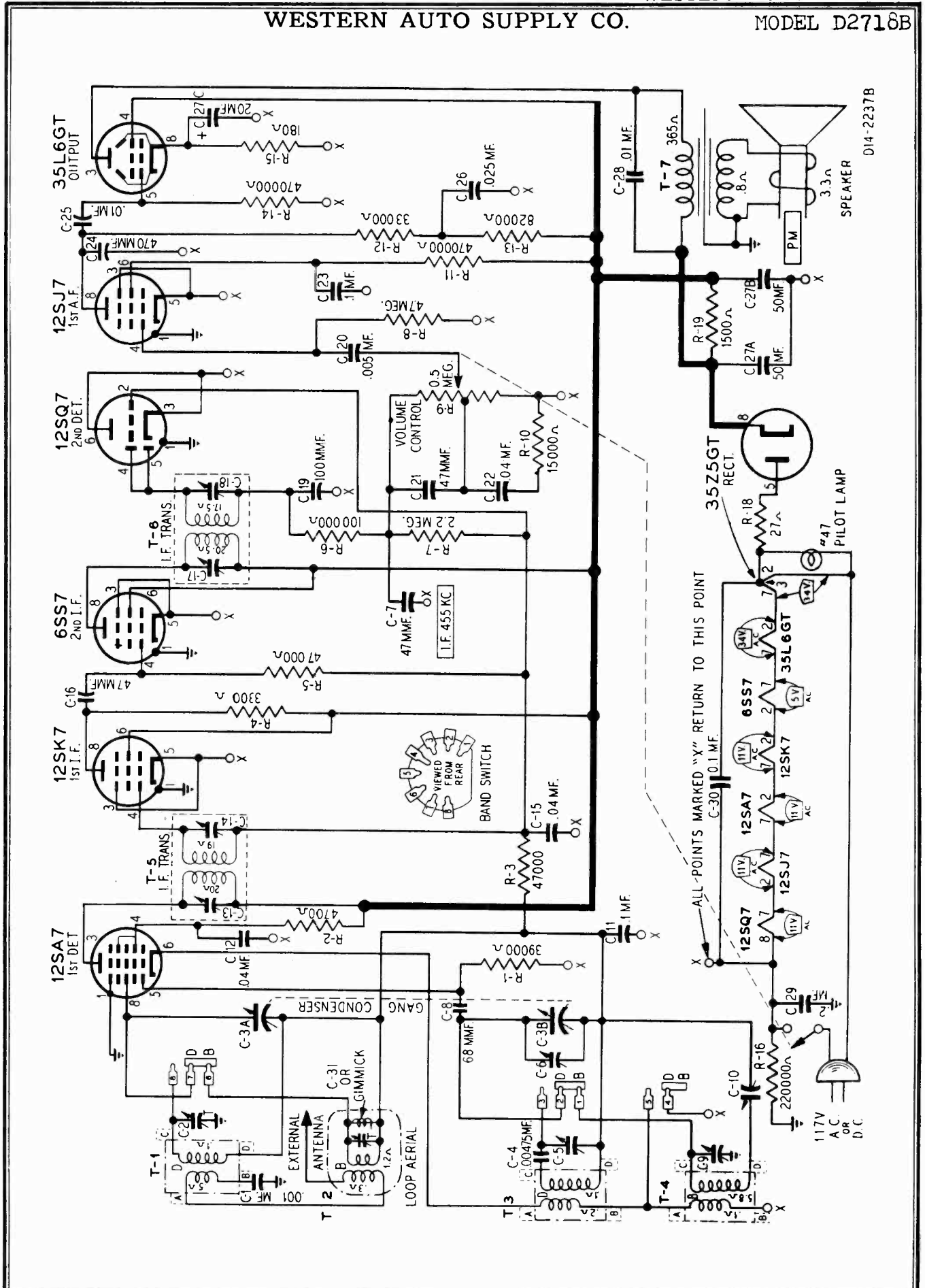

D14-2237B

ALIGNMENT PROCEDURE

Volume Control—Maximum All Adjustments. Signal Generator which will provide an accurately calibrated signal at test frequencies as listed.
 Allow Chassis and Signal Generator to "Heat Up" for several minutes. Output indicating Meter; Non-Metallic Screw-driver.
 The equipment in column at right is required for aligning:
 Dummy Antennas—.1 mf., 50 mmf., and 400 ohm.

FREQUENCY SETTING	SIGNAL GENERATOR ANTENNA CONNECTION	GROUND CONNECTION	DUMMY ANTENNA CONNECTION	RAND SWITCH SETTING	CONDENSER SETTING	ADJUST TRIMMERS TO MAXIMUM (See Trimmer Illustration)
1. F. 435 KC	Signal Grid Ant. Connect at Stator of Large Gang Section.	Point "X"	.1 mf.	B Range	Turn Rotor to Fully Open Position	1st I.F. (C13) & (C14) 2nd I.F. (C17) & (C18)
RANGE B 1600 KC	External Antenna Clip	Point "X"	50 mmf.	B Range	Turn Rotor to Fully Open Position	Oscillator Range B (C9) See Note A
1400 KC	External Antenna Clip	Point "X"	50 mmf.	B Range	Turn Rotor to Max. Output. Set pointer to 1400 KC. See Note C	Antenna Range B (C-31)
Note D	External Antenna Clip	Point "X"	50 mmf.	B Range	Turn Rotor to Max. Output and Rock	600 KC Padder (C10) Rock Rotor See Note B
600 KC	External Antenna Clip	Point "X"	50 mmf.	B Range	Repeat above oscillator adjustments at 1600 and 600 KC until readjusting the oscillator Range B Trimmer (C9) causes no further improvement of output.	
RANGE D 18.3 MC	External Antenna Clip	Point "X"	400 Ohm	D Range	Turn Rotor to Fully Open Position	Oscillator Range D (C5)
17 MC	External Antenna Clip	Point "X"	400 Ohm	D Range	Turn Rotor to Max. Output	Ant. Range D (C2)
Loop Range 1400 KC	Reassemble chassis in cabinet				Turn Rotor to Max. Output	Ant. Range B (C-31)
Note D	External Antenna Clip	Point "X"	50 mmf.	B Range		

DRIVE CORD REPLACEMENT

Use a new 10X51 drive cord assembly or a piece of new cord 45" long for this installation. Turn the large drive pulley counterclockwise until the gang condenser is in the fully open position, then fasten one end of the new drive cord to one end of the tension spring. Hook the other end of the tension spring over the tab on the drive pulley, pass the drive cord through the slot in the drive pulley rim and wind it 1/2 turn counterclockwise around the top of the drive pulley. Wind 2 turns around the drive shaft spool with the turns progressing towards the chassis. Continue with the cord around idler studs A, B and C as shown in the illustration. Wind the cord 3/4 turn counterclockwise around the large drive pulley, pass it through the slot in the pulley rim and fasten the end to the tension spring. Rotate the tuning shaft several turns to take up any slack in the drive cord, then attach the dial pointer to the cord.

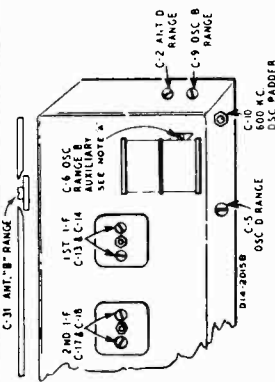
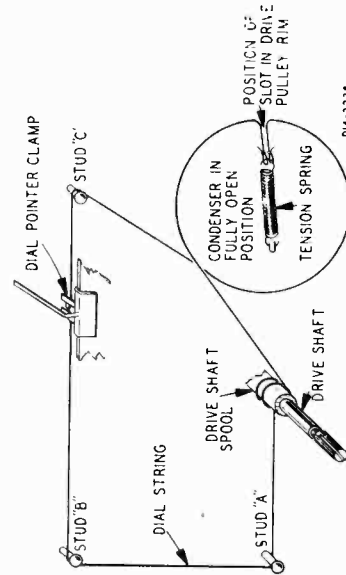

ALIGNMENT NOTES

NOTE A—Adjust Oscillator Range B (C9) trimmer on side of chassis. Oscillator Range B (C6) auxiliary trimmer on gang condenser is adjusted at factory and ordinarily need not be readjusted in the field.

NOTE B—Turn the rotor back and forth and adjust the trimmer until the peak of greatest intensity is obtained.

NOTE C—Attach pointer to drive cord and position at 1400 KC mark on dial scale.

NOTE D—Some receivers have a "gimmick" capacity formed by twisting two wires together on the loop antenna in place of the Antenna Range B Trimmer, C-31. When aligning receivers having the "gimmick" capacity, proceed as instructed in the Alignment Procedure Table but omit the steps at 1400 KC involving C-31.

The "gimmick" capacity is set at the factory and normally will not require adjustments when realigning the receiver. Adjustment is obtained by twisting or untwisting the wires.

On receivers having the "gimmick" the dial pointer should be set at 1600 KC rather than as instructed in Note C.

On receivers having neither a trimmer or a "gimmick", the dial pointer should also be set at 1600 KC.

SPECIFICATIONS

Power Consumption.....	42 Watts
	(At 117 volts AC)
Power Output.....	9 Watt Maximum
	1.5 Watt 10% Harmonics
Selectivity.....	49KC Broad at 1000 times Signal
Intermediate Frequency.....	455 KC
Speaker.....	4"x6" oval PM Dynamic
Tuning Frequency Range	
B Range.....	.540 to 1600 KC
D Range.....	.6000 to 18,000 KC
Sensitivity (For .05 watt output—External Antenna).	
B range.....	9 Microvolts Average
D Range.....	30 Microvolts Average

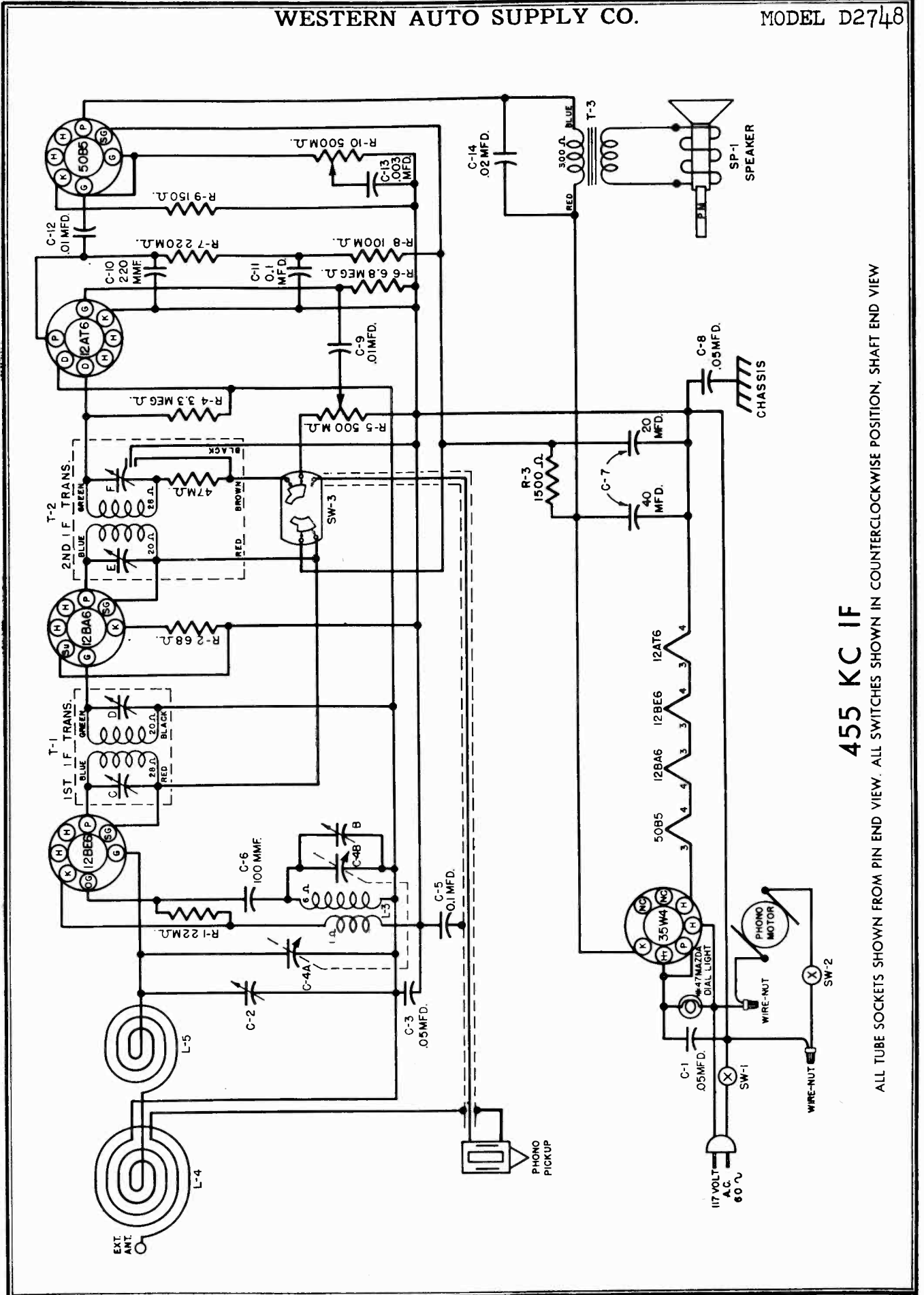

455 KC IF

ALL TUBE SOCKETS SHOWN FROM PIN END VIEW. ALL SWITCHES SHOWN IN COUNTERCLOCKWISE POSITION, SHAFT END VIEW

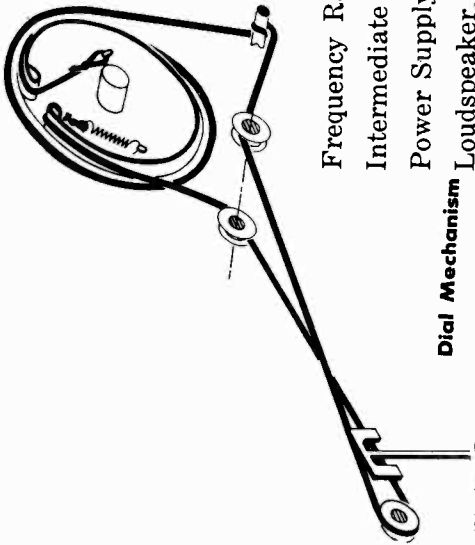

Frequency Range..... 540-1600 kc.
 Intermediate Frequency..... 455 kc.
 Power Supply..... 117 volts AC, 60 cycle
 Loudspeaker..... 5x7 elliptical type PM

Dial Mechanism

TUBE COMPLEMENT

- 1—12BE6 Converter tube
- 1—50B5 Power Output tube V.C. Impedance..... 3.2 ohms at 400 cycles
- 1—12BA6 IF Amplifier tube
- 1—35W4 Rectifier tube
- Power Output (Undistorted)..... .8 watt
- 1—12AT6 Detector—AVC—First Audio tube
- Power Output (Maximum)..... 1.5 watts
- Tuning Drive Ratio..... 7 to 1

ALIGNMENT PROCEDURE

The following equipment is necessary to properly align this chassis:

1. A signal generator which will provide an accurately calibrated signal at the frequencies listed.
2. An output meter.
3. A non-metallic screwdriver.
4. Dummy antenna: — .1 mfd. — RMA loop.

NOTE: Intermediate Frequency and Oscillator adjustments may be made with the loop disconnected provided a resistor of 10,000 to 50,000 ohms is substituted to close the 12BE6 grid circuit. The loop alignment must be done with the loop and chassis mounted in operating position in the cabinet. A single turn loosely coupled to loop may be substituted for RMA loop.

* Loop trimmer accessible through back of cabinet.

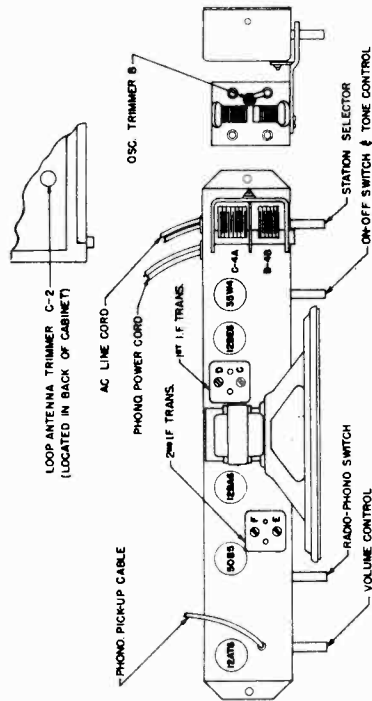

Tube Layout

GENERATOR	CONNECTION AT RADIO	DUMMY ANTENNA	DIAL	TO TUNE TRIMMERS	REMARKS
IF 455 kc.	12BE6 grid	.1 mfd.	HF end	IF trimmers C D E F	Tune to max.
1620 kc.	12BE6 grid	RMA loop	HF end	Osc. trimmer B	Set limit of band
1400 kc.	Through loop*	RMA loop	1400 kc.	Ant. trimmer C-2	Tune to max.

SOCKET VOLTAGES

TUBE	POSITION	1	2	3	4	5	6	7
12BE6	Converter	-5	0	24 AC	12 AC	88	88	0
12BA6	I.F. Amplifier	0	0	24 AC	35 AC	88	88	0.7
12AT6	2nd DET.—1st AF—AVC	0	0	12 AC	0	0	0	12
50B5	Power Output	0	5	85 AC	85 AC	115	88	0
35W4	Rectifier	0	0	85 AC	117 AC	112 AC	112 AC	122

NOTE: All DC voltages measured with a 1000 ohm-per-volt meter from ON-OFF switch (—B) to socket contact indicated. All AC voltages are measured from ON-OFF switch (—B) to socket contact indicated. All voltages are positive DC unless otherwise marked. Volume Control full on. No signal input. Line voltage 117 volts AC.

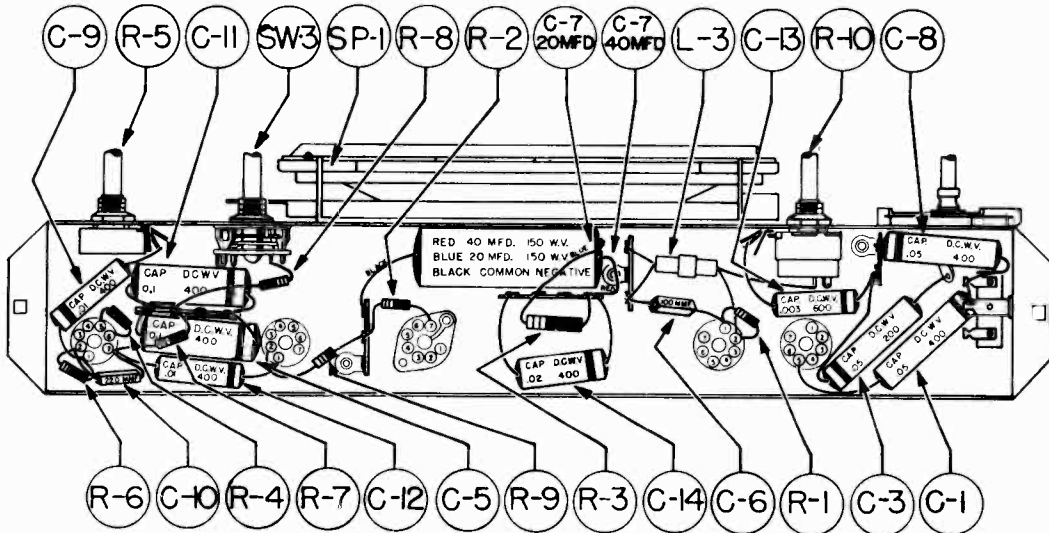
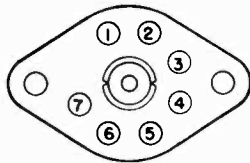

Parts Layout—Chassis Model 7156

SERVICE PARTS LIST

Symbol	Part No.	Description	Symbol	Part No.	Description
C-3	BD210503	Capacitor, Paper, .05 mfd., 200 v.	SW-3	B-51576-2	Switch, Radio-Phono
C-9, C-12	BD410103	Capacitor, Paper, .01 mfd., 400 v.	A-51787	A-51787	Spring, for Dial Cable
C-5, C-11	BD410104	Capacitor, Paper, 0.1 mfd., 400 v.	A-54122	A-54122	Button, Plug
C-14	BD410203	Capacitor, Paper, .02 mfd., 400 v.	R-5	B-54466-2	Control, Volume, 500,000 ohm
C-1, C-8	BD410503	Capacitor, Paper, .05 mfd., 400 v.	T-2	B-56718-1	Transformer Assembly, 2nd IF
C-13	BD610302	Capacitor, Paper, .003 mfd., 600 v.	T-1	B-56722-1	Transformer Assembly, 1st IF
C-6	BM74A101	Capacitor, Mica, 100 mmf.	B-57262-6	B-57262-6	Cord, AC Phono.
C-10	BM74A221	Capacitor, Mica, 220 mmf.	R-10	B-57841-1	Control, Tone & Switch, 500,000 ohm
R-2	BR16B680	Resistor, 68 ohm, 1/2 w.	B-57842	B-57842	Coil Assembly, Oscillator
R-9	BR16C151	Resistor, 150 ohm, 1/2 w.	SP-1	C-57843	Speaker, 5x7 PM
R-8	BR17B104	Resistor, 100,000 ohm, 1/2 w.	B-57848-1	B-57848-1	Shaft, Tuning Drive
R-1	BR17B223	Resistor, 22,000 ohm, 1/2 w.	B-57857-1	B-57857-1	Pointer, Dial
R-7	BR17B224	Resistor, 220,000 ohm, 1/2 w.	B-57858-1	B-57858-1	Strip Assembly, Light Diffusing
R-4	BR17B335	Resistor, 3.3 megohm, 1/2 w.	C-4	C-57859-1	Capacitor, Variable
R-6	BR17B685	Resistor, 6.8 megohm, 1/2 w.	A-57891	A-57891	Sheet, Operating and Service
R-3	BR17E152	Resistor, 1500 ohm, 1 w.	L-4 & L-5	D-57870	Coil Assembly, Loop
A-2163	A-2163	Cable, Drive	C-57872-1	C-57872-1	Knob
A-6158	A-6158	Lamp, Pilot, No. 47 Mazda, 6.3 v.	E-57873-1	E-57873-1	Cabinet
A-6182-1	A-6182-1	Socket, Dial Light	A-57878	A-57878	Clip, Gang Mounting
C-7	B-9564-1	Cap., Electro., 40-20 mfd., 150 v.	C-2	B-57879-1	Capacitor Assembly, Trimmer
A-51163	A-51163	Clip, Spring	C-57862-1	C-57862-1	Crystal and Indicator, Dial
B-51427-5	B-51427-5	Grommet (large)	B-58069-1	B-58069-1	Cord, AC Power
B-51427-8	B-51427-8	Grommet (small)			

MODELS D2806,
D2807

WESTERN AUTO SUPPLY CO.

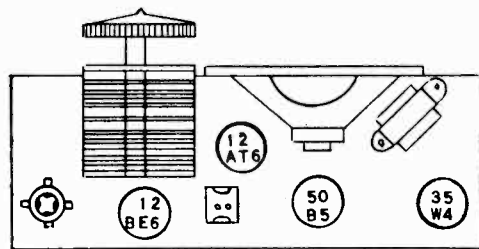

Remove back to replace tubes

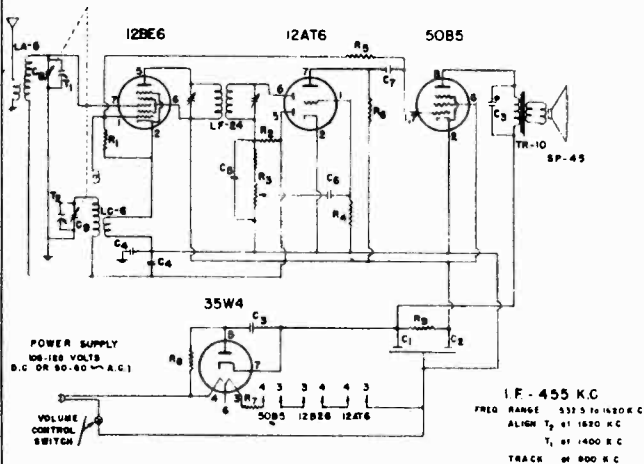

CHASSIS SERIES "AC"

ELECTRICAL SPECIFICATIONS

- Power Supply** 105-125 Volts D.C. or 50-60 Cycles A.C. 30 Watts
- Frequency Range** 532.5 to 1620 kc.
- Intermediate Freq.** 455 kc.
- Tuning** Two gang capacitor
- Speaker** 4 inch PM 3.5 ohm voice coil impedance
- Power Output** 1 watt undistorted
1.5 watt maximum
- Sensitivity** 800 Microvolts at 50 milli-watts Output
- Selectivity** 120 kc broad at 1000 times signal at 1000 kc.

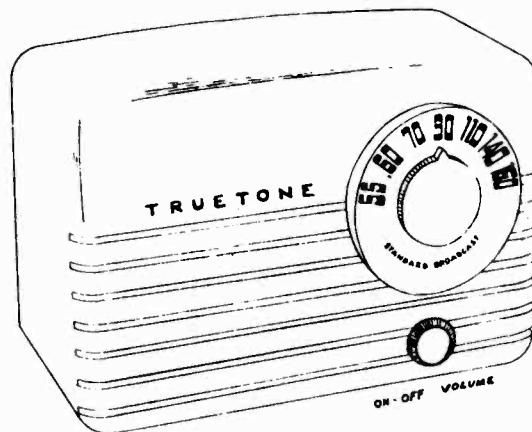

REPLACEMENT PARTS LIST

Ref. No.	Part No.	Description
CAPACITORS		
C1, C2	CE-15	2 x 40 mfd V. Elect
C3	CP203-1	.02 mfd 400V paper cond.
C4	CP503-4	.05 mfd 200V paper cond.
C5	CM151-1	.00015 mfd 500V paper cond.
C6	CP202-2	.002 mfd 400V paper cond.
C7	CP502-3	.005 mfd 200V paper cond.
C8, C9	CV-14	Variable Condenser (2 gang)
RESISTORS		
R1	RC183-2	18,000 ohms 1/2W 10%
R2	RC475-1	4.7 megohms 1/2W 20%
R3	VC-11	2 meg. vol. cont., 100 K Stop
R4	RC106-1	10 megohms 1/2W 20%
R5	RC334-1	330,000 ohms 1/2W 20%
R6	RC224-1	220,000 ohms 1/2W 20%
R7	RC390-4	39 ohms 1W 20%
R8	RC180-1	18 ohms 1/2W 20%
R9	RC222-4	2200 ohms 1W 20%
COILS & TRANSFORMERS		
LA-5		Antenna Coil
LC-6		Oscillator Coil
LF-24		IF Transformer
TR-10		Output Transformer
MISCELLANEOUS		
CB-106		Cabinet (specify Ivory or Walnut)
KN-20		Knob
KN-21		Pointer Knob
SP-45		4" PM Speaker

ALIGNMENT PROCEDURE

- Output meter across 3.5 ohm output load.
- Volume control at maximum for all adjustments.
- Align for maximum output. Reduce input as needed to keep output near 0.4 volts.

SIGNAL GENERATOR				SETTING TUNER	ADJUST TRIMMERS TO MAXIMUM OUTPUT (in order shown)
Frequency	Coupling Factor	Connection to Receiver	Ground Connection		
455 kc	.1 mfd	12BE6 Grid	B—	Rotor full open (Plates out of mesh)	Input and output trimmers on IF cans
1620 kc	.1 mfd	12BE6 Grid	B—	Rotor full open (Plates out of mesh)	Oscillator trimmer T2
1400 kc	.75 muf	Hank	B—	1400 kc	Antenna trimmer T1

• John F. Rider

WESTERN AUTO SUPPLY CO.

MODELS D2819A,
D2819B, D2819C,
D2819D, D2819E

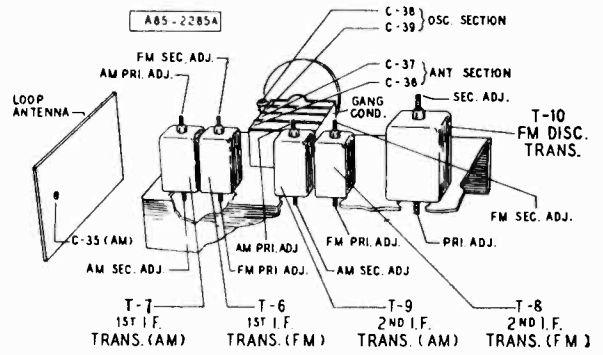
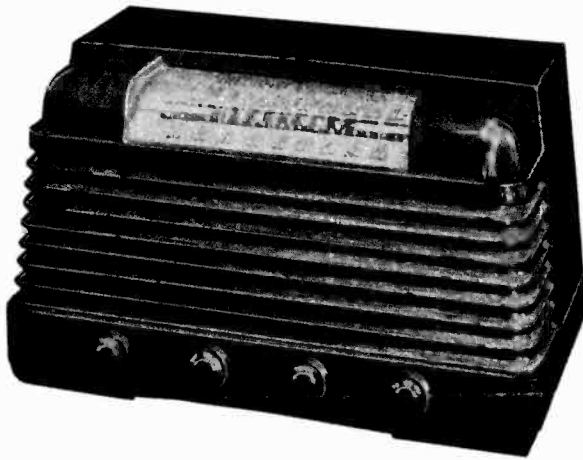

DRIVE CORD REPLACEMENT

Replacement of the drive cord may be accomplished as shown in the illustration. For this purpose use the new drive cord assembly listed in the Replacement Parts List. Turn the gang condenser until the plates are fully meshed. Then install the string as shown, winding three turns clockwise around the tuning shaft with the turns progressing away from the chassis. After the cord is installed, rotate the tuning shaft several times in order to take up any slack in the cord.

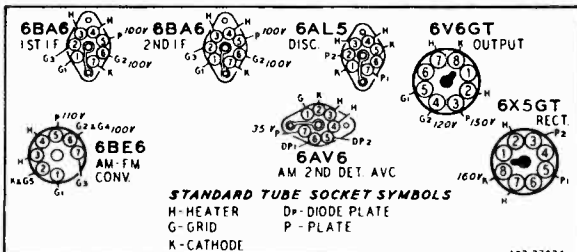
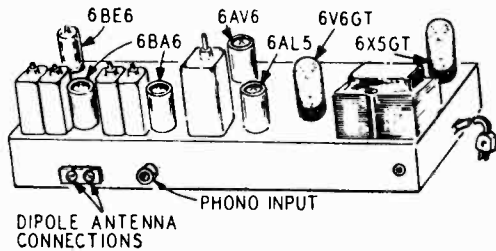
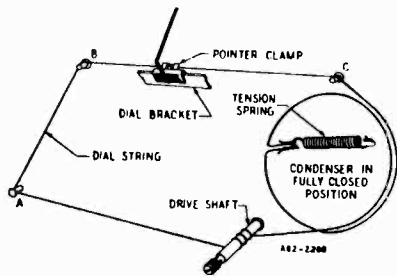

RECORD PLAYER AND TELEVISION SOUND CONNECTIONS

For models not equipped with built-in record player, a socket marked PHONO is provided on the back of the chassis for connections to an external record player or automatic record changer. When it is desired to play records through the radio, insert the connector on the cable of any standard record player into this socket. Turn the phono-radio switch to the phone position and use the volume control to adjust the sound level.

When television programs become available in your community, the audio amplifier and speaker of this radio may be used in conjunction with a Television Picture Receiver and sound converter to reproduce the sound portion of the television programs. Simply insert the connector on the cable of the Television Converter into the socket marked PHONO and operate the receiver in the same manner as described in the foregoing paragraph.

TUBE SOCKET VOLTAGES

Socket voltages are shown on the Bottom Socket diagram at the tube socket terminals. All voltages are between the socket terminal and chassis ground. Plate, screen and cathode voltages were taken with a 1000 ohm-per-volt meter with a 300 volt scale used for plate and screen voltages. Audio grid voltages were read with a vacuum tube volt-meter. Conditions of measurement are:

- Line voltage117 Volts AC
- Signal InputNone
- A Variation of $\pm 10\%$ is usually permissible.

MODEL D2819A

WESTERN AUTO SUPPLY CO.

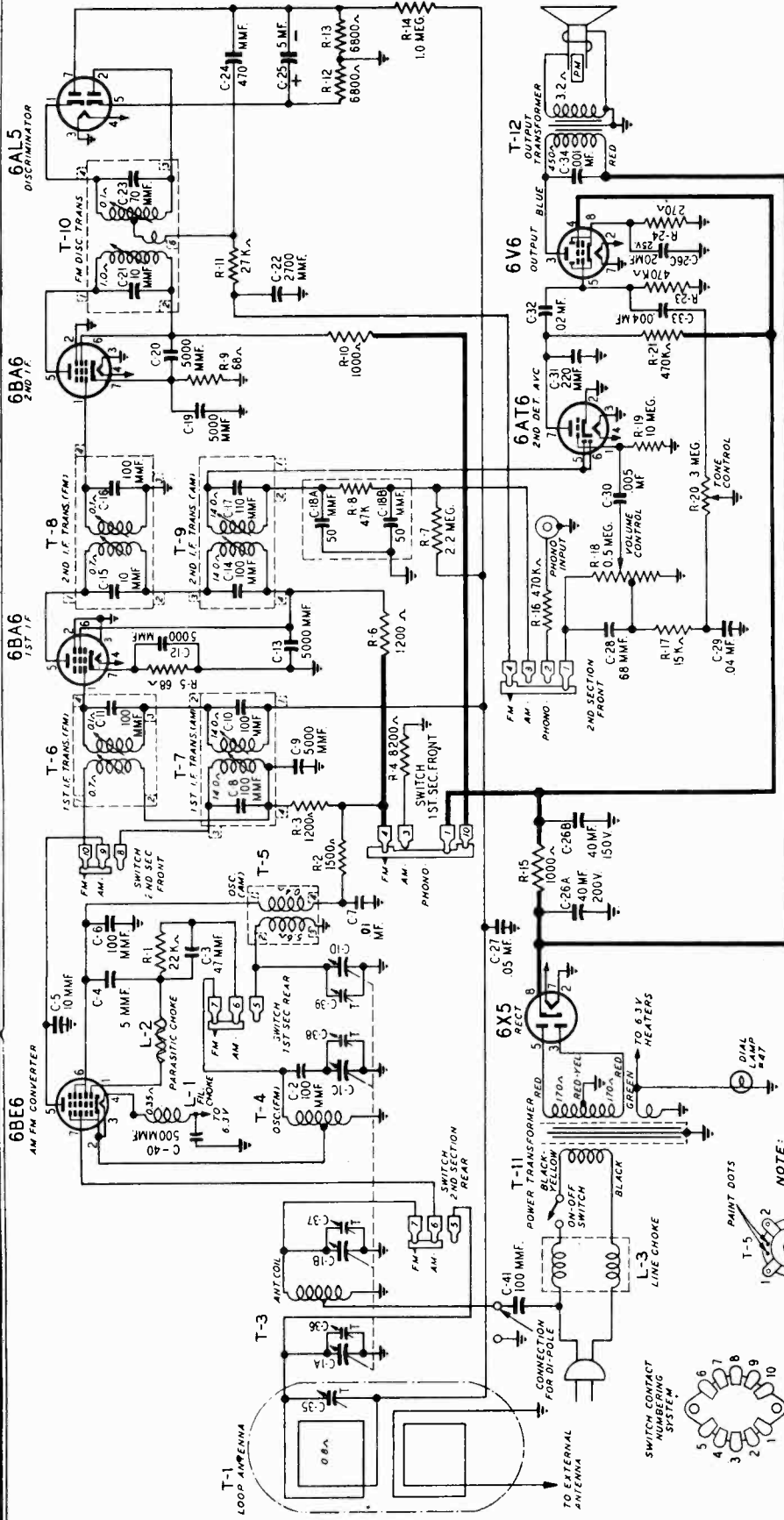

ELECTRICAL SPECIFICATIONS

- Power Consumption—
117 volts AC—35 watts
- Power Output—
1.5 watts maximum
.9 watts 10% distortion
Speaker—4 x 6 inch oval PM dynamic
- Frequency Ranges—
Broadcast 540-1600 KC
Frequency modulation 88-108 MC
- Intermediate Frequency—
AM 455 KC — FM 10.7 MC
- Selectivity — AM — 60 KC broad
at 1000 times signal, measured
at 1000 KC
I.F. FM—200 KC broad at 2 times
down
I.F. FM—800 KC broad at 200
times down
- AM Sensitivity—(For .5 watt output
with external antenna)
40 microvolts average
- FM Sensitivity—(For .5 watt output)
300 microvolts average

NOTE:
COIL WINDINGS FOR WHICH NO
RESISTANCES ARE SHOWN HAVE
A DC RESISTANCE OF LESS
THAN 0.1 Ω.

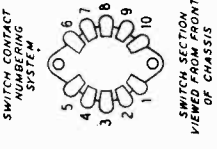
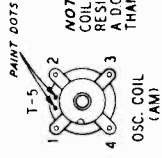

WESTERN AUTO SUPPLY CO.

MODELS D2819B,
D2819C

SUPPLEMENTARY SERVICE DATA

TRUETONE MODEL D2819B

Model "B" chassis differ from the model "A" chassis as follows:

PARTS LIST ADDITION:

L-4 9A1882 Choke

SCHEMATIC DIAGRAM CHANGE:

6BE6

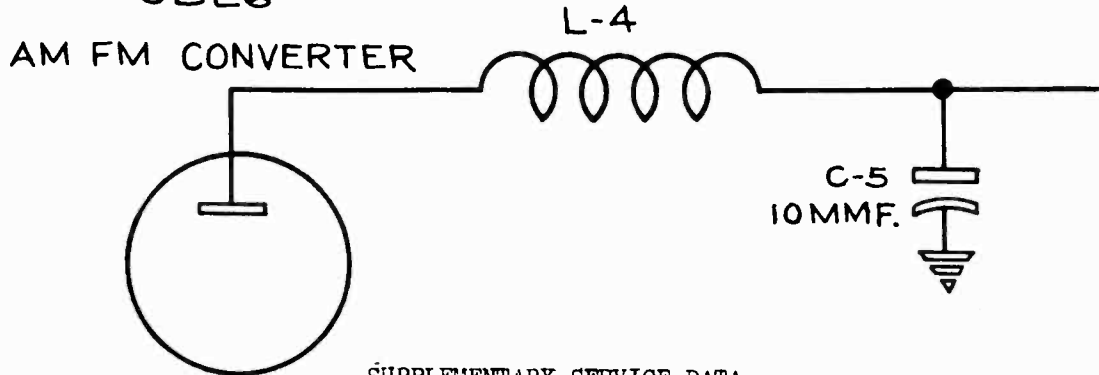

SUPPLEMENTARY SERVICE DATA

TRUETONE MODEL D2819C

A choke has been added to the circuit to eliminate parasitic oscillation on the FM Band.

PARTS LIST ADDITION

<u>Ref. #</u>	<u>Part #</u>	<u>Description</u>
L-5	9A1967	Parasitic Choke

The circuit connection of L-5 is shown in the partial schematic below.

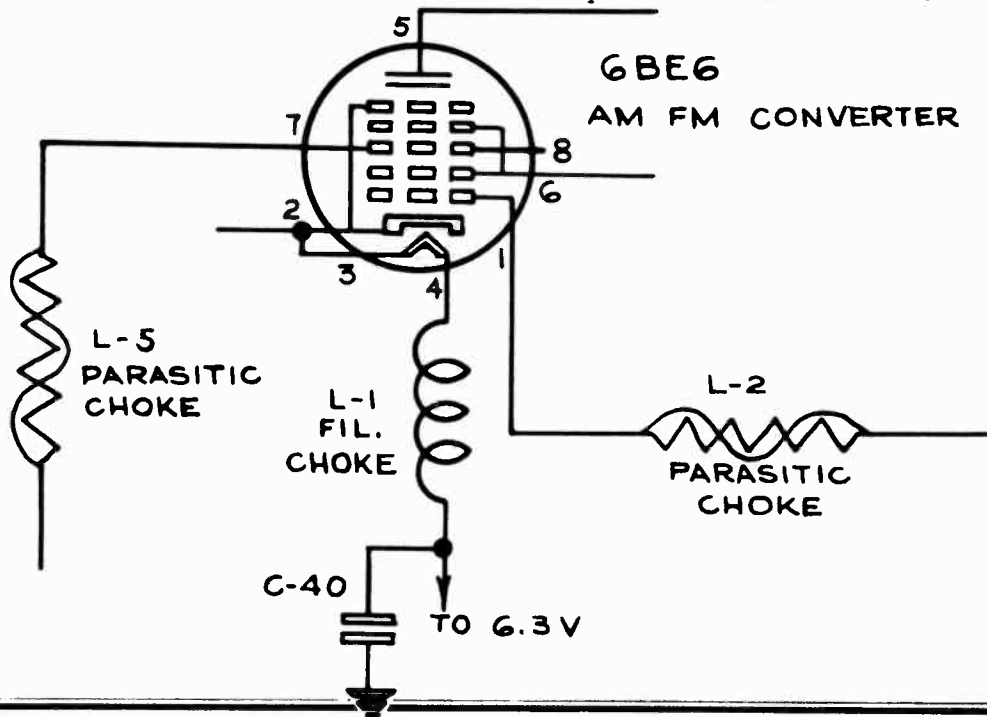

MODEL D2819C

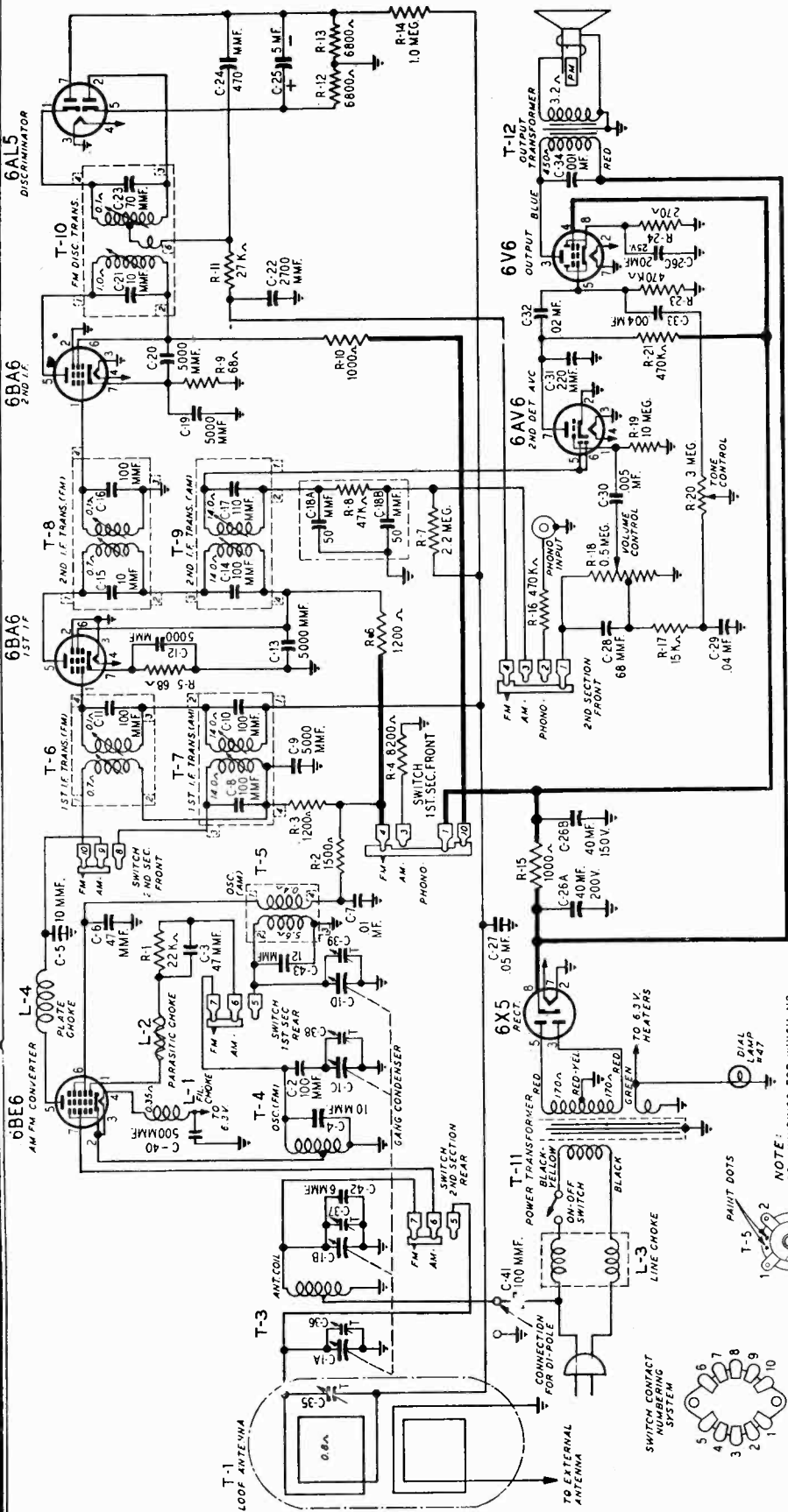

Intermediate Frequency—
AM 455 KC — FM 10.7 MC

Selectivity — AM — 60 KC broad
at 1000 times signal, measured
at 1000 KC

I.F. FM—200 KC broad at 2 times
down

I.F. FM—800 KC broad at 200
times down

AM Sensitivity—(For .5 watt output
with external antenna)
40 microvolts average

FM Sensitivity—(For .5 watt output)
300 microvolts average

ELECTRICAL SPECIFICATIONS

Power Consumption—
117 volts AC—35 watts

Power Output—
1.5 watts maximum
.9 watts 10% distortion

Speaker—4 x 6 inch oval PM dynamic

Frequency Ranges—
Broadcast 540-1600 KC
Frequency modulation 88-108 MC

NOTE:
COIL WINDINGS FOR WHICH NO
RESISTANCES ARE SHOWN HAVE
A DC RESISTANCE OF LESS
THAN 0.1 Ω.

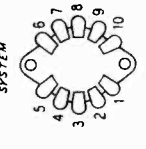
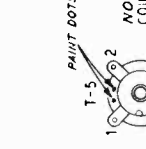

WESTERN AUTO SUPPLY CO.

MODELS D2819D,
D2819E

SUPPLEMENTARY SERVICE DATA

TRUETONE MODEL D2819D

Model "D" receivers differ from the model "C" receivers by the change in value of resistors R-12 and R-13 from 6800 ohms to 15,000 ohms.

The new part number and description follows:

R-12, R-13 B84153 15,000 ohms 0.5 W

SCHEMATIC DIAGRAM CHANGE:

The wires on lugs 1 and 4 of "SWITCH 1ST SEC. FRONT" view have been interchanged. This change is shown on the partial schematic below.

SUPPLEMENTARY SERVICE DATA

TRUETONE MODEL D2819E

SCHEMATIC DIAGRAM CHANGE

The wires on lugs 1 and 4 of "SWITCH 1st SEC. FRONT" view has been interchanged. This change is shown on the partial schematic below.

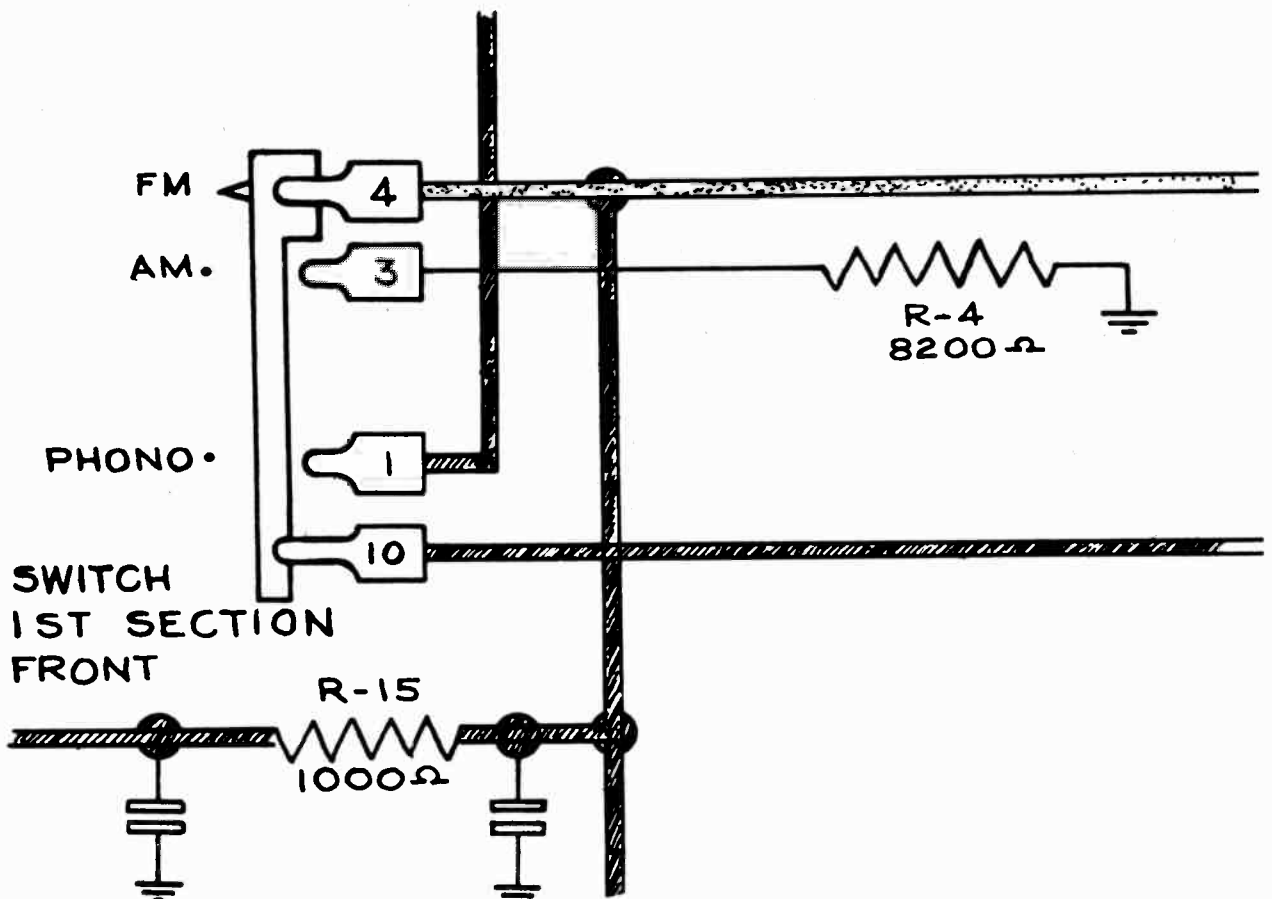

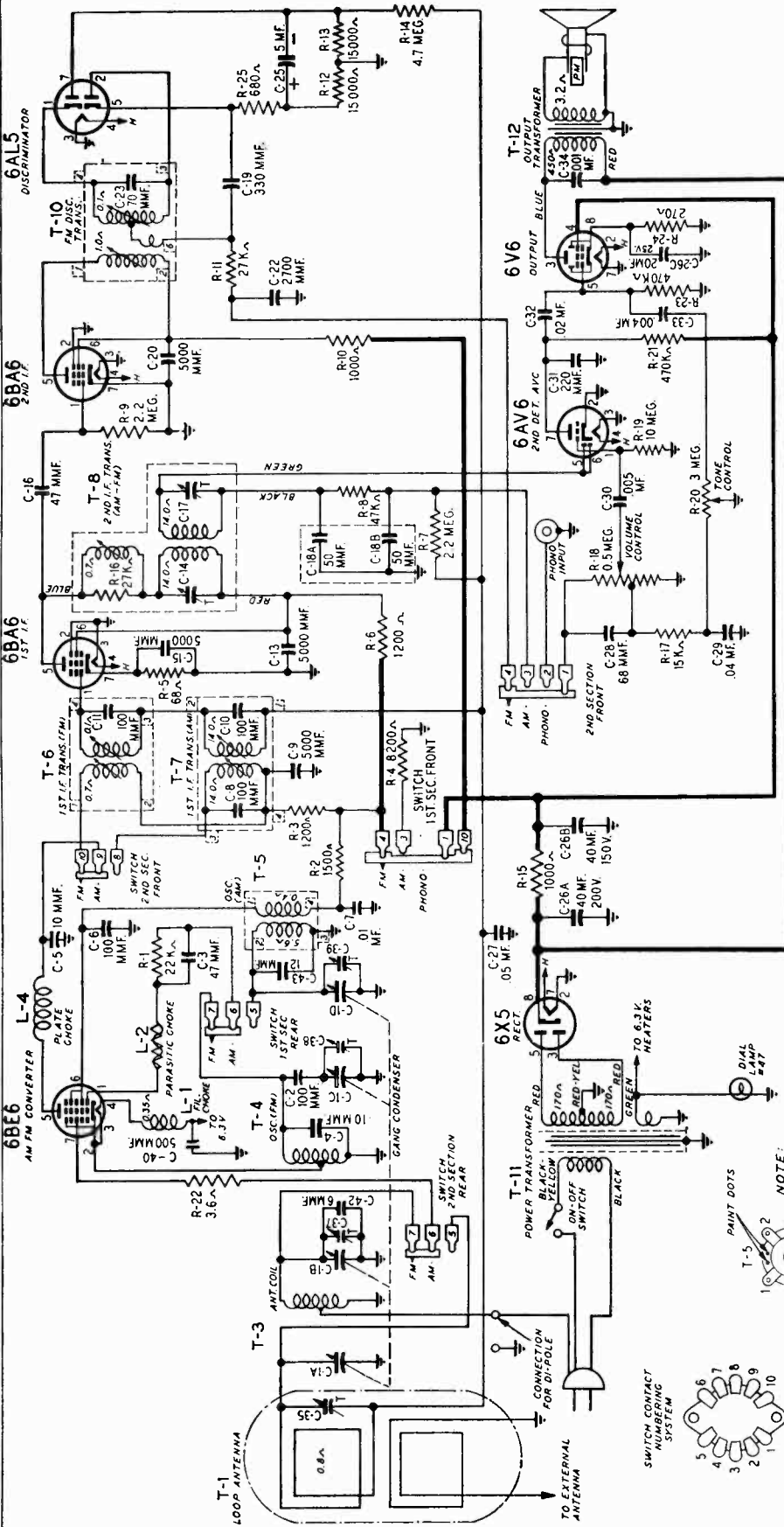

ELECTRICAL SPECIFICATIONS

- Power Consumption—117 volts AC—35 watts
- Power Output—1.5 watts maximum
.9 watts 10% distortion
- Speaker—4 x 6 inch oval PM dynamic AM Sensitivity—(For .5 watt output with external antenna) 60 microvolts average
- Frequency Ranges—Broadcast 540-1600 KC
Frequency modulation 88-108 MC
- Intermediate Frequency—AM 455 KC — FM 10.7 MC
- Selectivity — AM — 60 KC broad at 1000 times signal, measured at 1000 KC
I.F. FM—200 KC broad at 2 times down
I.F. FM—700 KC broad at 200 times down

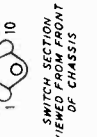
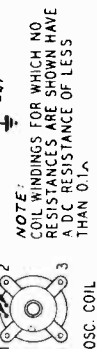

WESTERN AUTO SUPPLY CO.

MODELS D2819A,
D2819B, D2819C,
D2819D

ALIGNMENT PROCEDURES
AM STAGES

Volume Control Maximum all Adjustments.

Connect Radio Chassis to Ground Post of Signal Generator with a Short Heavy Lead.

Allow Chassis and Signal Generator to "Heat Up" for Several Minutes.

The following is required for aligning:

An All Wave Signal Generator Which Will Provide an Accurately Calibrated Signal at the Test Frequencies as Listed.

Output Indicating Meter, Non-Metallic Screwdriver, Dummy Antennas — .1 mf, and 50 mmf.

SIGNAL GENERATOR					
FREQUENCY SETTING	CONNECTION AT RADIO	GROUND CONNECTION	DUMMY ANTENNA	GANG CONDENSER SETTING	ADJUST TUNING SLUGS (I-F ONLY) TRIMMERS (OSC. & ANT.)
455 KC	Control Grid 1st 6BA6 Pin No. 1	Chassis Base	.1 mf	Turn Rotor to Full Open	2nd I.F. Pri. & Sec.
455 KC	Control Grid 6BE6 Pin No. 7 1st Det.	Same as above	.1 mf	Turn Rotor to Full Open	1st I.F. Pri. & Sec.
1620 KC	Control Grid 6BE6 Pin No. 7	Same as above	.1 mf	Turn Rotor to Full Open	Oscillator C-39
1400 KC	External Antenna Lead	Same as above	50 mmf	Turn Dial to 1400 KC. See Note A	Antenna C-35

NOTE A—Attach pointer to drive cord and position at 1400 KC mark on dial scale.

FM STAGES

Allow chassis and signal generator to warm up for several minutes. The following equipment is required for aligning:

An accurately calibrated signal generator providing unmodulated signals at the test frequencies listed below.

Non-metallic screwdriver.

Dummy Antennas and I-F Loading Resistor—.01 mf, 300 ohms and 100 K ohms.

Zero center scale DC vacuum tube voltmeter having a range of approximately 3 volts.

(If a zero center scale meter is not available, a standard scale vacuum tube voltmeter may be used by reversing the meter connections for negative readings.)

	SIGNAL GENERATOR			BAND SWITCH SETTING	CONDENSER SETTING	ADJUSTMENT FOR MAX. METER DEFLECTION
	FREQUENCY SETTING	CONNECTION AT RADIO	DUMMY ANTENNA			
Discriminator		6BA6 2nd I-F				Disc. Pri. Note A
	10.7 MC	Pin 1 & Chassis	.01 mf	FM	Rotor to Full Open	
	10.7 MC	Same as above	.01 mf	FM	Same as above	Disc. Sec. Note B
	10.7 MC	Same as above	.01 mf	FM	Same as above	Disc. Pri. Note A
I-F	10.7 MC	Same as above	.01 mf	FM	Same as above	Disc. Sec. Note B
	10.7 MC	6BA6 1st IF Pin 1 & Chassis	.01 mf	FM	Same as above	2nd I-F Pri. 2nd I-F Sec. Note C
	10.7 MC	Unsolder lead from Pin 7 to band switch. Insert 100K ohm resistor between Pin 7 & Ground and feed signal into Pin 7 of 6BE6	.01 mf	FM	Same as above	1st I-F Pri. Note C
	10.7 MC	Same as above	.01 mf	FM	Same as above	1st I-F Sec. Note C
RECHECK I-F ADJUSTMENTS IN ORDER GIVEN						
Ant. & Osc.	108.5	Disconnect built-in line antenna and connect generator to dipole terminals with resistor in series.	300 ohms	FM	Rotor to Full Open	Osc. C-38
	Note D	Same as above	300 ohms	FM	Tune rotor for max. AVC voltage	Ant. C-37
	104.5	Same as above	300 ohms	FM	Tune rotor for max. AVC voltage	Ant. C-37

RECHECK ANTENNA & OSC. ADJUSTMENTS IN ORDER GIVEN

FM ALIGNMENT NOTES

NOTE A—The zero center scale DC vacuum tube voltmeter is to be connected between chassis ground and the A.V.C. line at the 27 K. ohm resistor (R-11) and its junction with terminal strip. A signal of .1 volt must be fed into the receiver for this adjustment.

Note output voltage on the zero center DC vacuum tube voltmeter.

NOTE B—Disconnect zero center DC vacuum tube voltmeter from A.V.C. and connect it to the audio takeoff point at

the 1 megohm resistor (R-14) and its junction with the terminal strip. Adjust for zero voltage indication.

NOTE C—Connect zero center DC vacuum tube voltmeter as in Note A. Adjust input to give same output on the zero center DC vacuum tube voltmeter as in Note A.

NOTE D—Remove the 100 K ohm load resistor and solder the lead from pin 7 of 6BE6 tube to the band switch before attempting to check the antenna and oscillator coil adjustments.

ALIGNMENT PROCEDURES AM STAGES

Volume Control Maximum all Adjustments.

Connect Radio Chassis to Ground Post of Signal Generator with a Short Heavy Lead.

Allow Chassis and Signal Generator to "Heat Up" for Several Minutes.

The following is required for aligning:

An All Wave Signal Generator Which Will Provide an Accurately Calibrated Signal at the Test Frequencies as Listed.

Output Indicating Meter, Non-Metallic Screwdriver, Dummy Antennas — .1 mf, and 50 mmf.

SIGNAL GENERATOR					
FREQUENCY SETTING	CONNECTION AT RADIO	GROUND CONNECTION	DUMMY ANTENNA	GANG CONDENSER SETTING	ADJUST TUNING SLUGS AND TRIMMERS
455 KC	Control Grid 1st 6BA6 Pin No. 1	Chassis Base	.1 mf	Turn Rotor to Full Open	2nd I.F. C-14 & C-17
455 KC	Control Grid 6BE6 Pin No. 7 1st Det.	Same as above	.1 mf	Turn Rotor to Full Open	1st I.F. Pri. & Sec.
1620 KC	Control Grid 6BE6 Pin No. 7	Same as above	.1 mf	Turn Rotor to Full Open	Oscillator C-39
1400 KC	External Antenna Clip	Same as above	50 mmf	Turn Dial to 1400 KC. See Note A	Antenna C-35

NOTE A—Attach pointer to drive cord and position at 1400 KC mark on dial scale.

FM STAGES

Allow chassis and signal generator to warm up for several minutes. The following equipment is required for aligning:

An accurately calibrated signal generator providing unmodulated signals at the test frequencies listed below.

Non-metallic screwdriver.

Dummy Antennas and I-F Loading Resistor—.01 mf, 300 ohms and 100 K ohms.

Zero center scale DC vacuum tube voltmeter having a range of approximately 3 volts.

(If a zero center scale meter is not available, a standard scale vacuum tube voltmeter may be used by reversing the meter connections for negative readings.)

SIGNAL GENERATOR						
DISCRIMINATOR	FREQUENCY SETTING	CONNECTION AT RADIO	DUMMY ANTENNA	BAND SWITCH SETTING	CONDENSER SETTING	ADJUSTMENT FOR MAX. METER DEFLECTION
Discriminator	10.7 MC	6BA6 2nd I-F Pin 1 & Chassis	.01 mf	FM	Rotor to Full Open	Disc. Pri. Note A
	10.7 MC	Same as above	.01 mf	FM	Same as above	Disc. Sec. Note B
	10.7 MC	Same as above	.01 mf	FM	Same as above	Disc. Pri. Note A
	10.7 MC	Same as above	.01 mf	FM	Same as above	Disc. Sec. Note B
I-F	10.7 MC Note E	6BA6 1st IF Pin 1 & Chassis	.01 mf	FM	Same as above	2nd I-F Note C
	10.7 MC	Unsolder lead from Pin 7 to band switch. Insert 100K ohm resistor between Pin 7 & Ground and feed signal into Pin 7 of 6BE6	.01 mf	FM	Same as above	1st I-F Pri. Note C
	10.7 MC	Same as above	.01 mf	FM	Same as above	1st I-F Sec. Note C
RECHECK I-F ADJUSTMENTS IN ORDER GIVEN						
Ant. & Osc.	108.5 Note D	Disconnect built-in line antenna and connect generator to dipole terminals with resistor in series.	300 ohms	FM	Rotor to Full Open	Osc. C-38
	104.5	Same as above	300 ohms	FM	Tune rotor for max. AVC voltage	Ant. C-37

RECHECK ANTENNA & OSC. ADJUSTMENTS IN ORDER GIVEN

FM ALIGNMENT NOTES

NOTE A—The zero center scale DC vacuum tube voltmeter is to be connected between chassis ground and the A.V.C. line at the 27 K. ohm resistor (R-11) and its junction with terminal strip. A signal of .1 volt must be fed into the receiver for this adjustment.

Note output voltage on the zero center DC vacuum tube voltmeter.

NOTE B—Disconnect zero center DC vacuum tube voltmeter from A.V.C. and connect it to the audio takeoff point at the 4.7 megohm resistor (R-14) and its junction with the

terminal strip. Adjust for zero voltage indication.

NOTE C—Connect zero center DC vacuum tube voltmeter as in Note A. Adjust input to give same output on the zero center DC vacuum tube voltmeter as in Note A.

NOTE D—Remove the 100 K ohm load resistor and solder the lead from pin 7 of 6BE6 tube to the band switch before attempting to check the antenna and oscillator adjustments.

NOTE E—2nd I-F trimmers (AM) must be aligned before attempting to adjust 2nd I-F (FM) tuning slug.

REPLACEMENT PARTS LIST

NOTICE: There is a Model Number label on the chassis. This label identifies the radio as to chassis, dial and issue letter. When ordering parts or writing, give ALL information appearing on this label.

MISCELLANEOUS

12A478	Speaker, 4" x 6" PM with Output Transformer.....
2A374	Band Change Switch
3A303	Molded Octal Tube Socket
3A304	Phono Socket - Single Pin
3A427	Tube Socket, Miniature (For AM-FM Converter Tube)....
3A312	Tube Socket, Miniature
32X221	Tube Shield, Miniature
10A639	Knob, Tuning
10A640	Knob (Off-On-Volume)
10A641	Knob (Tone)
10A642	Knob (AM-FM-Phono)
13X546	Line Cord and Plug
76X1	Resistor-Capacitor Combination
55X318	Plastic Cabinet

CAPACITORS

C-1A, C-1B } C-1C, C-1D }	14A198	Gang Condenser Assembly
C-6, C-41	47X476	100 mmf Molded
C-3	47X517	47 mmf Ceramic
C-4	47X513	5 mmf Ceramic
C-5	47X512	10 mmf Ceramic
C-2	47X511	100 mmf Ceramic
C-9	47X507	5000 mmf Silvered Mica
C-12, C-13 } C-19, C-20 }		
C-8, C-10		
C-7	D66103	.01 mf 400 V Tubular
C-11		Part of T-6 (1st I-F Trans. FM)
C-14, C-17		Part of T-9 (2nd I-F Trans. AM)
C-15, C-16		Part of T-8 (2nd I-F Trans. FM)
C-18A, C-18B		Part of 76X1 Resistor-Capacitor Combination
C-21, C-23		Part of T-10 Discriminator Coil Assem.
C-22	47X492	2700 mmf Molded
C-24	47X510	470 mmf Silvered Mica
C-25	45X361	5 mf 100 V Dry Electrolytic
C-26A } C-26B } C-26C }	45X360	40 mf 200 V
		40 mf 150 V
		20 mf 25 V
C-27	B66503	.05 mf 200 V Tubular
C-28	47X471	68 mm Molded
C-29	B66403	.04 mf 200 V Tubular
C-30	D66502	.005 mf 400 V Tubular
C-31	47X468	220 mmf Ceramic
C-32	D66203	.02 mf 400 V Tubular
C-33	B66402	.004 mf 200 V Tubular
C-34	H66102	.001 mf 800 V Tubular
C-35	17A123	1.5-12 mmf Trimmer
C-36, C-37, } C-39 }		Part of C-1 Gang Condenser
C-38	17A247	3-12 mmf Trimmer
C-40	47X508	500 mmf Ceramic

RESISTORS

		Ohms	Watts	
R-1	B84223	22 K	0.5	Carbon
R-2	B84152	1500	0.5	Carbon
R-3, R-6	B84122	1200	0.5	Carbon
R-4	D84822	8200	2.0	Carbon
R-5, R-9	B83680	68	0.5	Carbon
R-7	B85225	2.2 meg	0.5	Carbon
R-8		47 K		Part of 76X1 Resistor— Capacitor Combination
R-10	B85102	1000	0.5	Carbon
R-11	B84273	27 K	0.5	Carbon
R-12, R-13	B84682	6800	0.5	Carbon
R-14	B85105	1 meg	0.5	Carbon
R-15	D84102	1000	2.0	Carbon
R-16, R-21, } R-23 }	B85474	470 K	0.5	Carbon
R-17	B84153	15 K	0.5	Carbon
R-18	36X347	.5 meg		Volume Control & Switch
R-19	B85106	10 meg	0.5	Carbon
R-20	40X254	3 meg		Tone Control
R-24	B84271	270	0.5	Carbon

TRANSFORMERS AND COILS

L-1	9A1882	Filament Choke Assembly
L-2	9A1940	Parasitic Choke Assembly
L-3	9A1930	Line Choke Assembly
T-1	9A1931	"B" Range Loop Antenna Assembly.....
T-3	9A1937	Antenna Coil Assembly
T-4	9A1938	Oscillator Coil Assembly (FM)
T-5	9A1929	Oscillator Coil Assembly (AM)
T-6	9A1932	1st I.F. Transformer (FM)
T-7	9A1934	1st I.F. Transformer (AM)
T-8	9A1933	2nd I.F. Transformer (FM)
T-9	9A1935	2nd I.F. Transformer (AM)
T-10	9A1936	Discriminator Coil Assembly
T-11	53X291	Power Transformer
T-12		Output Transformer (See Miscellaneous).....

DIAL AND DRIVE ASSEMBLY

15X236	Pointer	
6X21 } 20X260 }	Rubber Grommet } Condenser Cushion Stud }	Mtg. } Gang } Condenser
10X68	Drive Cord Assembly	
19X192	"C" Washer	
26X506	Drive Shaft	
58X698	Dial Scale	
17X96	Dial Crystal	
7A103	No. 47 Pilot Light	
7A216	Pilot Light Socket Assembly	
25X1573	Dial Bracket	
25A1044	Diffuser and Clamp Assembly	
28X113	Drive Cord Tension Spring	

REPLACEMENT PARTS LIST

NOTICE: There is a Model Number label on the chassis. This label identifies the radio as to chassis, dial and issue letter. When ordering parts or writing, give ALL information appearing on this label.

MISCELLANEOUS

12A478	Speaker, 4" x 6" PM with Output Transformer.....
2A374	Band Change Switch
3A303	Molded Octal Tube Socket
3A305	Phono Socket - Single Pin
3A427	Tube Socket, Miniature (For AM-FM Converter Tube)....
3A426	Tube Socket, Miniature
32X386	Tube Shield, Miniature
10A683	Knob, Tuning
10A684	Knob (Off-On-Volume)
10A685	Knob (Tone)
10A686	Knob (AM-FM-Phono)
13X546	Line Cord and Plug
76X1	Resistor-Capacitor Combination
55X318	Plastic Cabinet

CAPACITORS

C-1A, C-1B } C-1C, C-1D }	14A204	Gang Condenser Assembly
C-2	47X511	100 mmf Ceramic
C-3	47X517	47 mmf Ceramic
C-4	47X523	10 mmf Ceramic
C-5	47X512	10 mmf Ceramic
C-6	47X463	47 mmf Ceramic
C-9		
C-12, C-13 } C-19, C-20 }	47X507	5000 mmf Silvered Ceramic.....
C-8, C-10		Part of T-7 (1st I-F Trans. AM)
C-7	D66103	.01 mf 400 V Tubular
C-11		Part of T-6 (1st I-F Trans. FM)
C-14, C-17		Part of T-9 (2nd I-F Trans. AM)
C-15, C-16		Part of T-8 (2nd I-F Trans. FM)
C-18A, C-18B		Part of 76X1 Resistor-Capacitor Combination
C-21, C-23		Part of T-10 Discriminator Coil Assem.
C-22	47X492	2700 mmf Molded
C-24	47X510	470 mmf Silvered Mico
C-25	45X361	5 mf 100 V Dry Electrolytic
C-26A } C-26B } C-27C }		40 mf 200 V
	45X360	40 mf 150 V Dry Electrolytic
		20 mf 25 V
C-27	B66503	.05 mf 200 V Tubular
C-28	47X471	68 mmf Molded
C-29	B66403	.04 mf 200 V Tubular
C-30	D66502	.005 mf 400 V Tubular
C-31	47X468	220 mmf Ceramic
C-32	D66203	.02 mf 400 V Tubular
C-33	B66402	.004 mf 200 V Tubular
C-34	H66102	.001 mf 800 V Tubular
C-35	17A256	2-24 mmf Trimmer
C-36, C-37, } C-39 }		Part of C-1 Gang Condenser
C-38	26A489	1-8 mmf Trimmer Assy.....
C-40	47X508	500 mmf Ceramic
C-41	47X476	100 mmf Molded
C-42	47X521	6 mmf Ceramic
C-43	47X522	12 mmf Ceramic

RESISTORS

		Ohms	Watts	
R-1	B84223	22 K	0.5	Carbon
R-2	B84152	1500	0.5	Carbon
R-3, R-6	B84122	1200	0.5	Carbon
R-4	D84822	8200	2.0	Carbon
R-5, R-9	B83680	63	0.5	Carbon
R-7	B85225	2.2 meg	0.5	Carbon
R-8		47 K		Part of 76X1 Resistor- Capacitor Combination
R-10	B84102	1000	0.5	Carbon
R-11	B84273	27 K	0.5	Carbon
R-12, R-13	B84682	6800	0.5	Carbon
R-14	B85105	1 meg	0.5	Carbon
R-15	D84102	1000	2.0	Carbon
R-16, R-21, } R-23 }	B35474	470 K	0.5	Carbon
R-17	B84153	15 K	0.5	Carbon
R-18	36X347	.5 meg		Volume Control & Switch
R-19	B85106	10 meg	0.5	Carbon
R-20	40X287	3 meg		Tone Control
R-24	B84271	270	0.5	Carbon

TRANSFORMERS AND COILS

L-1 } L-4 }	9A1882	Choke Assembly
L-2	9A1940	Parasitic Choke Assembly
L-3	9A1930	Line Choke Assembly
T-1	9A1931	"B" Range Loop Antenna Assembly
T-3	9A1956	Antenna Coil Assembly
T-4	9A1938	Oscillator Coil Assembly (FM)
T-5	9A1929	Oscillator Coil Assembly (AM)
T-6	9A1932	1st I.F. Transformer (FM)
T-7	9A1934	1st I.F. Transformer (AM)
T-8	9A1933	2nd I.F. Transformer (FM)
T-9	9A1935	2nd I.F. Transformer (AM)
T-10	9A1936	Discriminator Coil Assembly
T-11	53X291	Power Transformer
T-12		Output Transformer (See Miscellaneous)

DIAL AND DRIVE ASSEMBLY

15X236	Pointer
6X21 } 20X260 }	Rubber Grommet } Condenser Cushion Stud } Mtg. Gang Condenser
10X58	Drive Cord Assembly
19X192	"C" Washer
26X506	Drive Shaft
58X698	Dial Scale
17X96	Dial Crystal
7A103	No. 47 Pilot Light
7A216	Pilot Light Socket Assembly
25X1573	Dial Bracket
25A1044	Diffuser and Clamp Assembly
28X113	Drive Cord Tension Spring

REPLACEMENT PARTS LIST

NOTICE: There is a model number label on the chassis. This label identifies the radio as to chassis, dial and issue letter. When ordering parts or writing, give ALL information on this label.

MISCELLANEOUS

12A478	Speaker, 4" x 6" PM with Output Transformer.....
2A374	Band Change Switch
3A303	Molded Octal Tube Socket
3A305	Phono Socket - Single Pin
3A427	Tube Socket, Miniature (For AM-FM Converter Tube)..
3A426	Tube Socket, Miniature
10A683	Knob, Tuning
10A684	Knob (Off-On-Volume)
10A685	Knob (Tone)
10A686	Knob (AM-FM-Phono)
13X612	Line Cord and Plug
55X318	Plastic Cabinet

CAPACITORS

C-1A, C-1B } C-1C, C-1D }	14A204	Gang Condenser Assembly
C-2	47X511	100 mmf Ceramic
C-3	47X517	47 mmf Ceramic
C-4	47X523	10 mmf Ceramic
C-5	47X512	10 mmf Ceramic
C-6	47X476	100 mmf Ceramic
C-7	D66103	.01 mf 400 V Tubular
C-8 } C-10 }	Part of T-7 (1st I.F. Trans. AM)	
C-9 } C-13 } C-15 } C-20 }	47X507	5000 mmf Silvered Ceramic
C-11	Part of T-6 (1st I.F. Trans. FM)	
C-14 } C-17 }	Part of T-8 (2nd I.F. Trans. AM-FM)	
C-16	47X463	47 mmf Ceramic
C-18A } C-18B }	47X112	50-50 mmf Dual Mica
C-19	47X529	330 mmf Silvered Ceramic
C-22	47X492	2700 mmf Molded
C-23	Part of T-10 (Discriminator Coil Assembly)	
C-25	45X361	5 mf 100 V Dry Electrolytic
C-26A } C-26B }	45X360	40 mf 200 V Dry Electrolytic
C-26C }		20 mf 25 V
C-27	B66503	.05 mf 200 V Tubular
C-28	47X471	68 mmf Molded
C-29	B66403	.04 mf 200 V Tubular
C-30	D66502	.005 mf 400 V Tubular
C-31	47X468	220 mmf Ceramic
C-32	D66203	.02 mf 400 V Tubular
C-33	B66402	.004 mf 200 V Tubular
C-34	H66102	.001 mf 800 V Tubular
C-35	17A256	2-24 mmf Trimmer
C-37 } C-39 }	Part of C-1 Gang Condenser	
C-38	26A489	1-8 mmf Trimmer Assy.....
C-40	47X508	500 mmf Ceramic
C-42	47X521	6 mmf Ceramic
C-43	47X522	12 mmf Ceramic

RESISTORS

		Ohms	Watts	
R-1	B84223	22 K	0.5	Carbon
R-2	B84152	1500	0.5	Carbon
R-3, R-6	B84122	1200	0.5	Carbon
R-4	D84822	8200	2.0	Carbon
R-5	B83680	68	0.5	Carbon
R-7 } R-9 }	B85225	2.2 meg	0.5	Carbon
R-8	B85473	47 K	0.5	Carbon
R-10	B84102	1000	0.5	Carbon
R-11	B84273	27 K	0.5	Carbon
R-12 } R-13 } R-17 }	B84153	15 K	0.5	Carbon
R-14	B85475	4.7 meg.	0.5	Carbon
R-15	D84102	1000	2.0	Carbon
R-16	Part of T-8 (2nd I-F Trans. AM-FM)			
R-18	36X347	.5 meg		Volume Control & Switch.
R-19	B85106	10 meg	0.5	Carbon
R-20	40X287	3 meg		Tone Control
R-21 } R-23 }	B85474	470 K	0.5	Carbon
R-22	43X233	3.6	0.5	Wire Wound
R-24	B84271	270	0.5	Carbon
R-25	B84681	680	0.5	Carbon

TRANSFORMERS AND COILS

L-1 } L-4 }	9A1882	Choke Assembly
L-2	9A1940	Parasitic Choke Assembly
T-1	9A1931	"B" Range Loop Antenna Assembly.....
T-3	9A1956	Antenna Coil Assembly
T-4	9A1938	Oscillator Coil Assembly (FM)
T-5	9A1929	Oscillator Coil Assembly (AM)
T-6	9A1932	1st I.F. Transformer (FM)
T-7	9A1934	1st I.F. Transformer (AM)
T-8	9A1973	2nd I.F. Transformer (AM-FM)
T-10	9A1970	Discriminator Coil Assembly
T-11	53X291	Power Transformer
T-12	Output Transformer (See Miscellaneous).....	

DIAL AND DRIVE ASSEMBLY

15X236	Pointer
6X21 } 20X260 }	Rubber Grommet } Mtg. Condenser Cushion Stud } Gang Condenser
10X68	Drive Cord Assembly
19X192	"C" Washer
26X506	Drive Shaft
58X698	Dial Scale
17X96	Dial Crystal
7A103	No. 47 Pilot Light
7A216	Pilot Light Socket Assembly
25X1573	Dial Bracket
25A1044	Diffuser and Clamp Assembly
28X113	Drive Cord Tension Spring

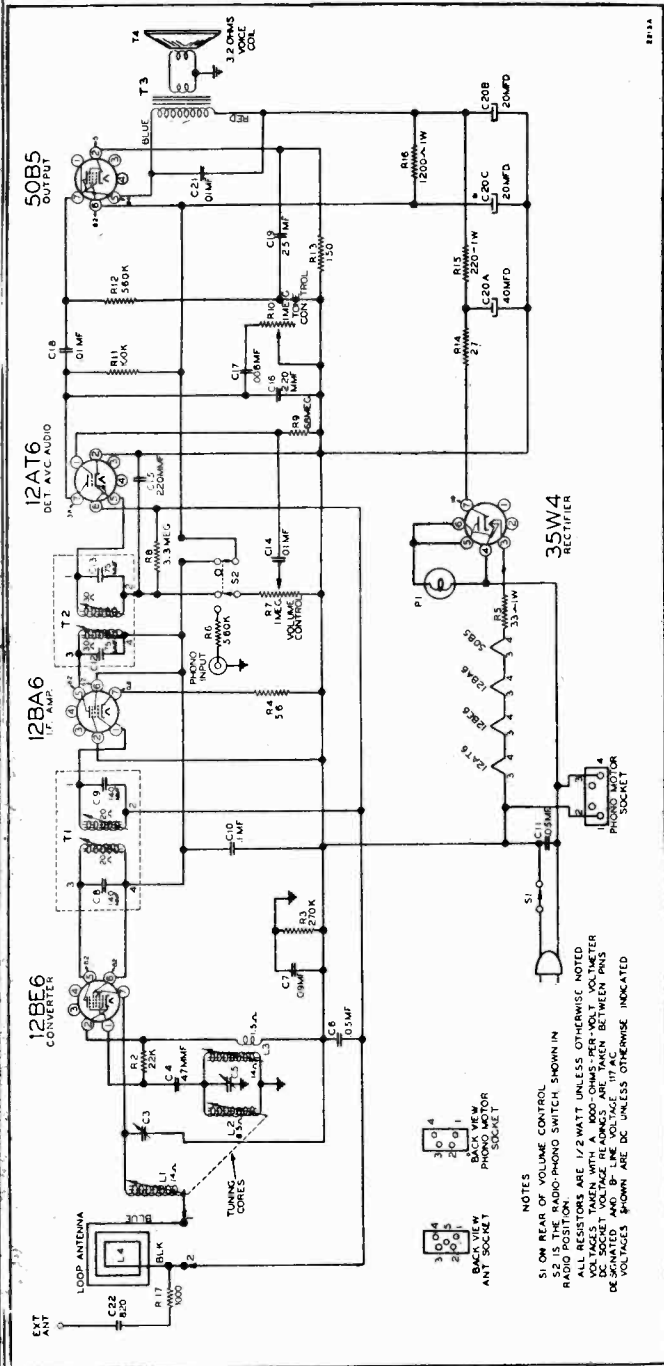

On some sets a 100M ohm resistor is in series with the high side of volume control. On some sets R5 is eliminated.

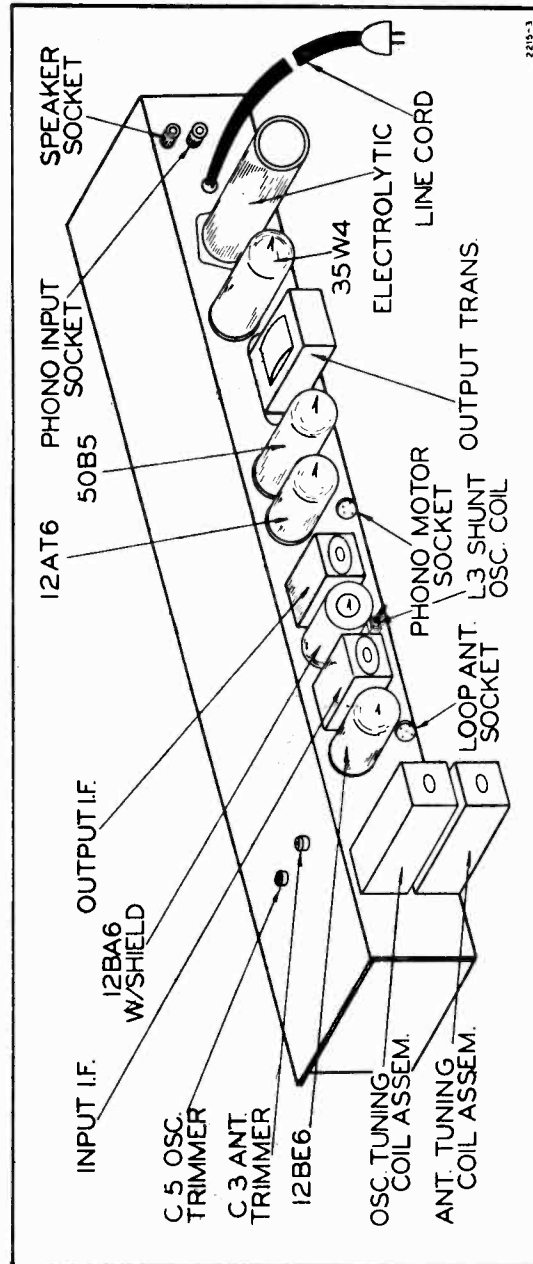

SIGNAL GENERATOR			TUNER SETTING	ADJUST FOR MAXIMUM OUTPUT	INPUT FOR 50 MILLIWATT OUTPUT
Frequency	Coupling Capacitor	Connection to Radio			
455 kc.	.1 mf.	12BE6, Pin 7	Iron cores all the way out	Cores in output and input I.F. cans	28 microvolts
1620 kc.	.1 mf.	12BE6, Pin 7	Iron cores all the way out	Oscillator trimmer C5	—
535 kc.	200 mmf	External antenna clip	Iron cores all the way in	Shunt osc. coil L3	11 microvolts
1620 kc.	200 mmf	External antenna clip	1620 kc.	Antenna trimmer C3*	8 microvolts
1400 kc.	200 mmf	External antenna clip	1400 kc.	Adjust position of ant. core (see coil illustration view)	8 microvolts
400 cycles	.1 mf.	12AT6, Pin 1	—	—	.03 volts

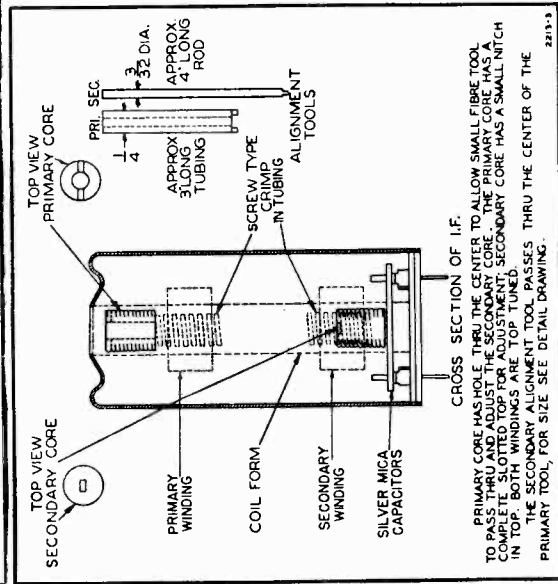
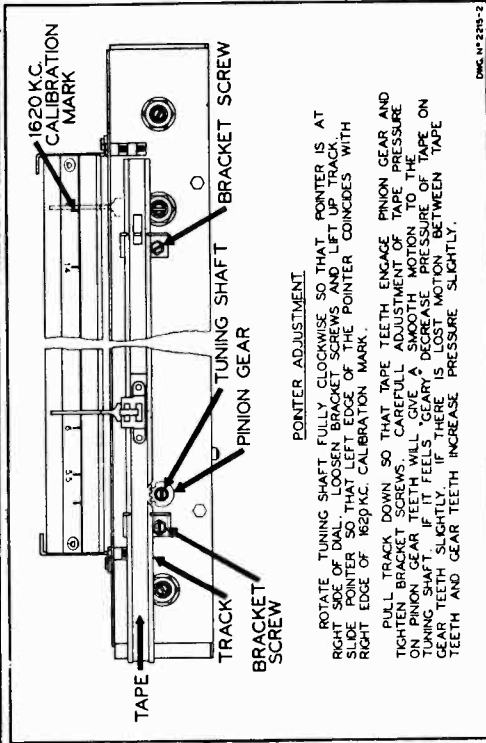

Tube Complement....12BE6, converter
 12BA6, I.F. amplifier.
 12AT6, detector, AVC, audio amplifier.
 50B5, output amplifier.
 35W4, rectifier.
 Pilot lite, 6-8 volts, T-47.

Ref. No. Part No. Description Qty. Used In Set Ref. No. Part No. Description

COILS AND TRANSFORMERS

T1, C8, 9	B-13A-13071	Input I.F. coil	1	C20A, B, C	A-8C-10077	40 mf; 20 mf; 20 mf; 150 volts
T2, C12, 13	B-13B-13072	Output I.F. coil	1		or	Electrolytic filter condenser
L4	C-13E-13305-1	Loop antenna assembly	1		A-8C-10937	40 mf; 20 mf; 20 mf; 150 volts
L3	B-13D-12371	Osc. shunt coil assembly	1		A-2M-12618	Electrolytic filter condenser
L2	A-23D-12667	Osc. tuning coil	1	C3, 5	A-6M-12616	Trimmer plate
L1	A-13E-12668	Antenna tuning coil	1		A-2M-14054	Insulator for trimmer
T3	B-12C-12356	Output transformer for speaker	1	C3	A-6M-14203	Trimmer plate
						Insulator for trimmer (laminated)

SPEAKER

T4	B-18A-13369	4" x 6", P.M. speaker, less output transformer	1	C10	C-8D-10771	.1 mf x 200 volts, 20%
				C14, 18, 21	C-8D-10761	.01 mf x 400 volts, 20%
				C11	C-8D-10813	.05 mf x 400 volts, 20%
				C6	C-8D-10770	.05 mf x 200 volts, 20%
				C7	C-8D-11251	.89 mf x 400 volts, 10%
				C17	C-8D-12243	.006 mf x 600 volts, 10%
				C19	A-8C-11678	Electrolytic condenser, 25 mf x 25 volts

PHONO PARTS

D-21HF-12439		Record changer, Detroita 650	1			
L70		Crystal cartridge,	1			

DIAL AND TUNING PARTS

B-30A-13408		Dial scale	1	C15, C16	C-8G-11733	220 mmf x 500 volts, 20%
B-5B-13391-60		Knob	4	C22	C-8F3-124	820 mmf x 300 volts, 10%, mica
A-2G-13404		Pointer	1	C4	C-8G-12198	47 mmf, 10%, ceramic
B-2J-13292		Rack tape, with teeth and pointer bracket	1			

A-200-13288		Tuning shaft assembly	1			
B-6B-13407		Diffuser	1			
B-2M-7758		Snap-pin rivets to fasten diffuser	4	R7, S1	A-10A-12654	Volume (1 megohm) control and switch
A-47A-13468		Pilot lite and bracket assembly	1	R10	A-11B-12659	Tone control, 1 megohm
A-46A-10793		Pilot lite bulb, 6-8 volt, type T-47	1	R3	C-9B1-91	270K ohms, 1/2 watt, 10%
				R4	C-9B1-47	56 ohms, 1/2 watt, 10%
				R14	C-9B1-43	27 ohms, 1/2 watt, 10%
5C-13400		Escutcheon	1	R5	C-9B2-44	33 ohms, 1 watt, 10%
				R11	C-9B1-86	100K ohms, 1/2 watt, 10%
				R13	C-9B1-52	150 ohms, 1/2 watt, 10%
A-15C-10717		Miniature 7 prong tube socket	5	R15	C-9B2-54	220 ohms, 1 watt, 10%
B-15B-10076		Mounting plate for lyric	1	R16	C-9B2-63	1200 ohms, 1 watt, 10%
A-19B-12644		Phono motor socket	1	R2	C-9B1-78	22K ohms, 1/2 watt, 10%
A-19B-12645		Loop antenna socket	1	R17	C-9B1-62	1000 ohms, 1/2 watt, 10%
A-19B-12170		Speaker socket	1	R6, R12	C-9B1-95	560K ohms, 1/2 watt, 10%
A-19B-11044		Pick-up socket	1	R8	C-9B1-34	3.3 megohms, 1/2 watt, 20%
A-23A-10344		Line cord lock	1	R9	C-9B1-36	6.8 megohms, 1/2 watt, 20%
A-20A-12653		Radio-phonon switch	1			

MISCELLANEOUS

A-15C-10717		Miniature 7 prong tube socket	5			
B-15B-10076		Mounting plate for lyric	1			
A-19B-12644		Phono motor socket	1			
A-19B-12645		Loop antenna socket	1			
A-19B-12170		Speaker socket	1			
A-19B-11044		Pick-up socket	1			
A-23A-10344		Line cord lock	1			
A-20A-12653		Radio-phonon switch	1			

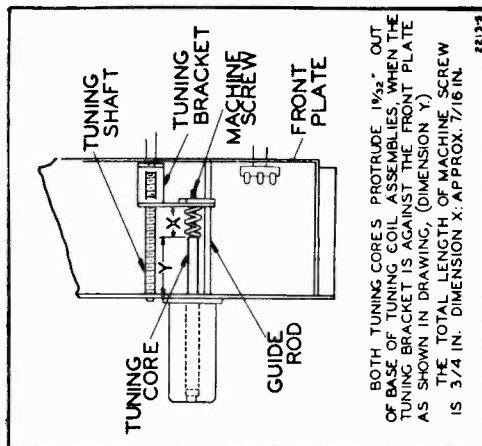

BOTH TUNING CORES PROTRUDE 1/32" OUT OF BASE OF TUNING COIL ASSEMBLIES. WHEN THE TUNING BRACKET IS AGAINST THE FRONT PLATE AS SHOWN IN DRAWING, (DIMENSION Y) THE TOTAL LENGTH OF MACHINE SCREW IS 3/4 IN. DIMENSION X: APPROX. 7/16 IN.

28125

WESTERN AUTO SUPPLY CO.

MODELS D2906,
D2907

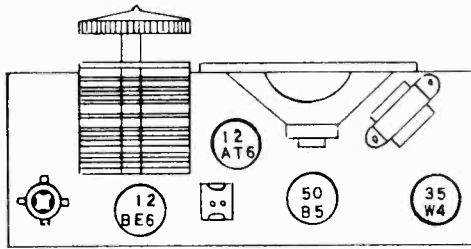

Remove back to replace tubes

ELECTRICAL SPECIFICATIONS

- Power Supply** 105-125 Volts D.C. or 50-60 Cycles A.C. 30 Watts
- Frequency Range** 532.5 to 1620 kc.
- Intermediate Freq.**..... 455 kc.
- Tuning** Two gang capacitor
- Speaker** 4 inch PM 3.5 ohm voice coil impedance
- Power Output** 1 watt undistorted
1.5 watt maximum
- Sensitivity** 800 Microvolts at 50 milli-watts Output
- Selectivity** 120 kc broad at 1000 times signal at 1000 kc.

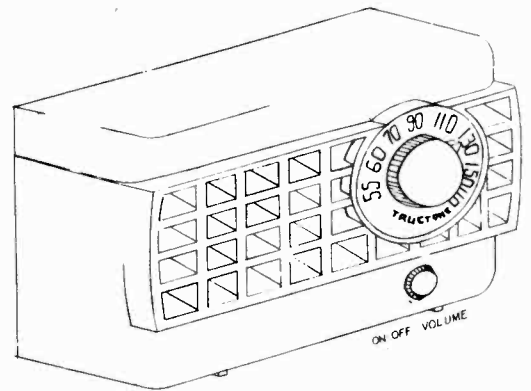

REPLACEMENT PARTS LIST

Ref. No.	Part No.	Description
CAPACITORS		
C1, C2	CE-15	2 x 40 mfd V. Elect
C3	CP203-1	.02 mfd 400V paper cond.
C4	CP503-4	.05 mfd 200V paper cond.
C5	CM151-1	.00015 mfd 500V paper cond.
C6	CP202-2	.002 mfd 400V paper cond.
C7	CP502-3	.005 mfd 200V paper cond.
C8, C9	CV-14	Variable Condenser (2 gang)
RESISTORS		
R1	RC183-2	18,000 ohms 1/2 W 10%
R2	RC475-1	4.7 megohms 1/2 W 20%
R3	VC-11	2 meg. vol. cont., 100 K Stop
R4	RC106-1	10 megohms 1/2 W 20%
R5	RC334-1	330,000 ohms 1/2 W 20%
R6	RC224-1	220,000 ohms 1/2 W 20%
R7	RC390-4	39 ohms 1W 20%
R8	RC180-1	18 ohms 1/2 W 20%
R9	RC222-4	2200 ohms 1W 20%
COILS & TRANSFORMERS		
LA-5		Antenna Coil
LC-6		Oscillator Coil
LF-24		I.F. Transformer
TR-10		Output Transformer
MISCELLANEOUS		
CB-106		Cabinet (specify Ivory or Walnut)
KN-20		Knob
KN-21		Pointer Knob
SP-45		4" PM Speaker

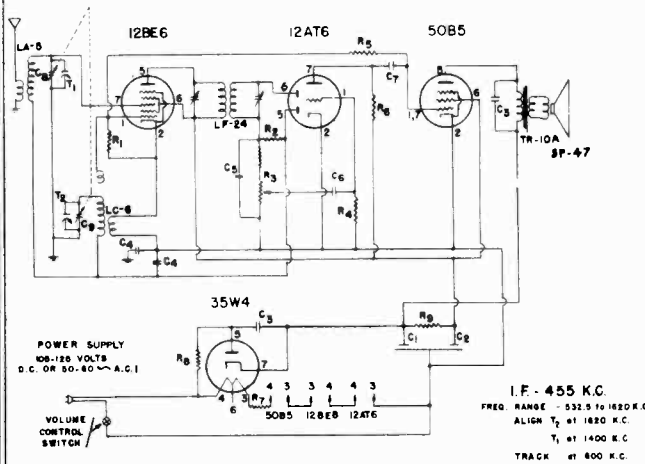

CHASSIS SERIES "AG"

ALIGNMENT PROCEDURE

- Output meter across 3.5 ohm output load.
- Volume control at maximum for all adjustments.
- Align for maximum output. Reduce input as needed to keep output near 0.4 volts.

SIGNAL GENERATOR				SETTING TUNER	ADJUST TRIMMERS TO MAXIMUM OUTPUT (in order shown)
Frequency	Coupling Factor	Connection to Receiver	Ground Connection		
455 kc	.1 mfd	12BE6 Grid	B—	Rotor full open (Plates out of mesh)	Input and output trimmers on IF cans
1620 kc	.1 mfd	12BE6 Grid	B—	Rotor full open (Plates out of mesh)	Oscillator trimmer T2
1400 kc	.75 mmf	Hunk	B—	1400 kc	Antenna trimmer T1

© John F. Rider

MODEL D2910

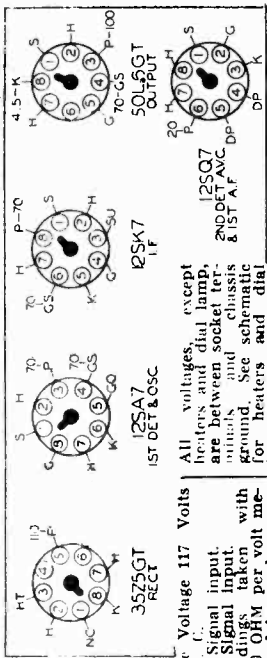

Line Voltage 117 Volts
A.C.
No Signal input.
No Signal input with
1000 OHM per volt me-
ter. Plate and screen
voltage read on 500
volt scale.

All voltages, except
heaters and dial lamp,
are between socket ter-
minals and chassis
ground. See schematic
for heaters and dial
lamp voltages.

F. W. Mc2910 81X

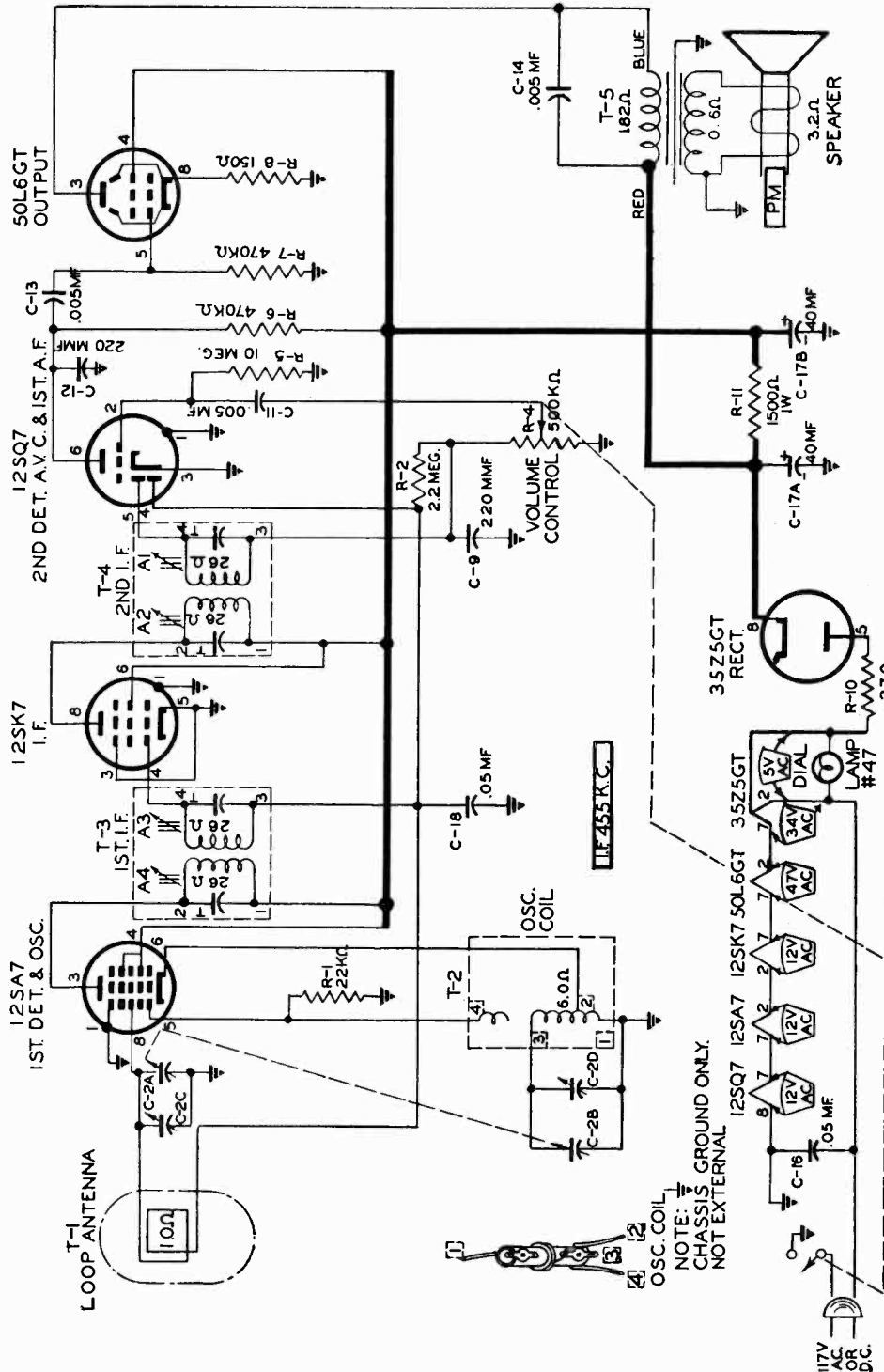

NOTE:
OSC. COIL
CHASSIS GROUND ONLY.
NOT EXTERNAL

WESTERN AUTO SUPPLY CO.

MODEL D2910

SPECIFICATIONS

5 Tube Superheterodyne, including Rectifier Tube
 Tuning Frequency Range _____ 540 to 1600 KC
 Power Consumption _____ 30 watts (At 117 volts AC)
 Power Output...1.5 watt maximum, 9 watt (10% distortion)
 Intermediate Frequency _____ 455 KC
 Speaker _____ 5" PM Dynamic

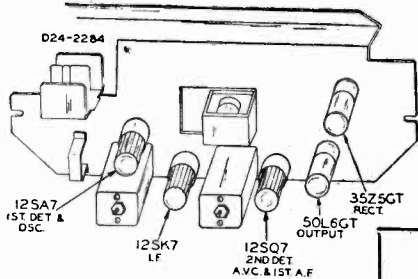

CHECK YOUR LINE VOLTAGE

Unless otherwise marked, this radio must be operated on a power supply of 105-125 volts AC, 50 to 60 cycles only, or 105-125 volts DC.

ALIGNMENT PROCEDURE

Volume Control—Maximum All Adjustments.
 Allow Chassis and Signal Generator to "Heat Up" for several Minutes.
 The equipment in column at right is required for aligning:

Signal Generator which will provide an accurately calibrated signal at the test frequencies as listed.
 Output Indicating Meter: Non-Metallic Screwdriver.
 Dummy Antennas—.1 mf., 50 mmf.
 Blocking Condenser—.1 mf.

FREQUENCY SETTING	SIGNAL GENERATOR ANTENNA CONNECTION	GROUND CONNECTION	DUMMY ANTENNA	GANG CONDENSER SETTING	ADJUST TRIMMERS TO MAXIMUM (See Trimmer Illustration)
455 K C	Control Grid 12SK7—I. F. Prong No. 4	Chassis Base Through .1 mf. Condenser	.1 mf.	Turn Rotor to full open	2nd I. F. A2 & A1
455 K C	Control Grid 12SA7—1st Det. Prong No. 8	Same As Above	.1 mf.	Turn Rotor to full open	1st I. F. A4 & A3
1620 KC	Control Grid 12SA7—1st Det. Prong No. 8	Same As Above	.1 mf.	Turn Rotor to full open	Oscillator (C-2D)
1400 KC	Reassemble chassis in cabinet See Note B	Same As Above	50 mmf. Set pointer to 1400 KC. See Note A		Antenna (C-2C)

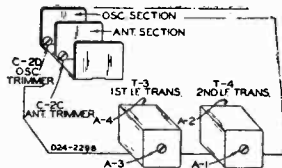

NOTE—Attach pointer to drive cord and position at 1400 KC mark on dial scale.

NOTE B—Wind 2 turn loop of heavy enameled wire 6" diameter connect to signal generator. Place loop of wire 6" from loop on set and in the same plane.

DRIVE CORD REPLACEMENT

Turn the large drive pulley to the fully closed position. Use a new 10x66 drive cord assembly or a piece of cord 43 inches long and fasten one end to the tension spring and fasten the other end of the spring to the drive pulley. Install the cord as shown in the illustration. Wind 2 3/4 turns counterclockwise around the tuning shaft with the turns progressing toward the front of the chassis. After string is installed, stretch the tension spring and fasten free end of cord to spring.

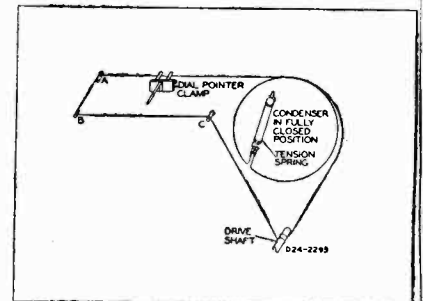

Replacement Parts List

MISCELLANEOUS

- 2A479 5" PM Speaker
- 3A435 Molded Octal Tube Socket
- 55X321 Cabinet, Plastic
- 14x411 Grille Cloth
- 10A297 Knob
- 13x328 Line Cord and Plug Assembly
- T-1 9A1943 Loop Antenna Assembly
- T-2 9A1914 Oscillator Coil Assembly
- T-3 X-1295 1st I-F Trans. Assembly
- T-4 X-1296 2nd I-F Trans. Assembly
- T-5 X-507 Output Transformer

CAPACITATORS

- C-2A, C-2B
- C-2C, C-2D—14A199 Gang Condenser Assembly
- C-9, C-12 47x468 220 mmfd
- C-11, C13 B66502 .005 mf 200 V Tubular
- C-14 D66502 .005 mf 400 V Tubular
- C-16 D66503 .05 mf 400 V Tubular
- C-17A 45x363 50 mf 150 V Dry
- C-17B lytic Con.
- C-18 B66503 .05 mf. 200 V Tubular

RESISTORS

- R-1 P84223 22K 0.5 Carbon
- R-2 B85225 2.2 meg 0.5 Carbon

- R-4 36x373 500K Volume Control & Switch
- R-5 B85106 10 meg. 0.5 Carbon
- R-6, R-7 B84474 470K 0.5 Carbon
- R-8 B83151 150 0.5 Carbon
- R-10 B83270 27 0.5 Carbon
- R-11 C85152 1500 1.0 Carbon

DIAL AND DRIVE ASSEMBLY

- 15x242 Pointer
- 26x508 Drive Shaft
- 19x192 "C" Washer doz
- 10x66 Drive Cord Assembly
- 28x113 Drive Cord Tension Spring doz.
- 7A217 Pilot Light Socket Assembly
- 7A103 No. 47 Pilot Light
- 58x791 Dial Glass

TUBE COMPLEMENT

The tube complement of this receiver consists of the following:

- 1—6SK7—R.F. Amplifier
- 1—6SA7—Mixer—OSC.
- 1—6SK7—I.F. Amplifier
- 1—6SQ7—Det. AVC—Audio
- 1—6K6—Power Output
- 1—5Y3—Rectifier

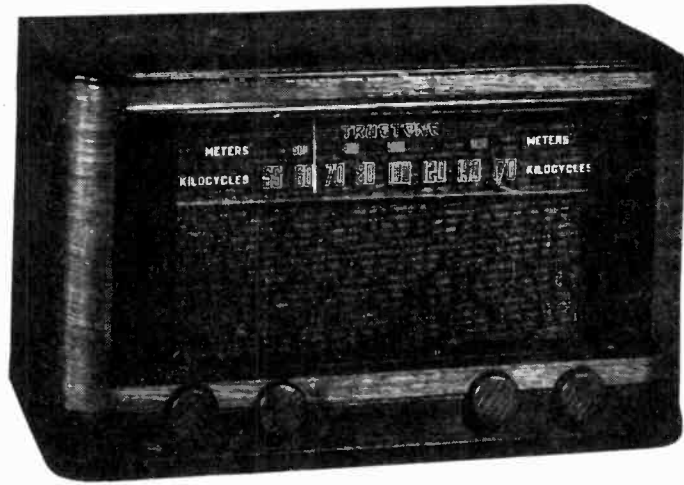

POWER SUPPLY

This receiver is designed to operate from a power source of 117 volts A.C. 60 cycle current

Frequency - Range 535-1725 KC

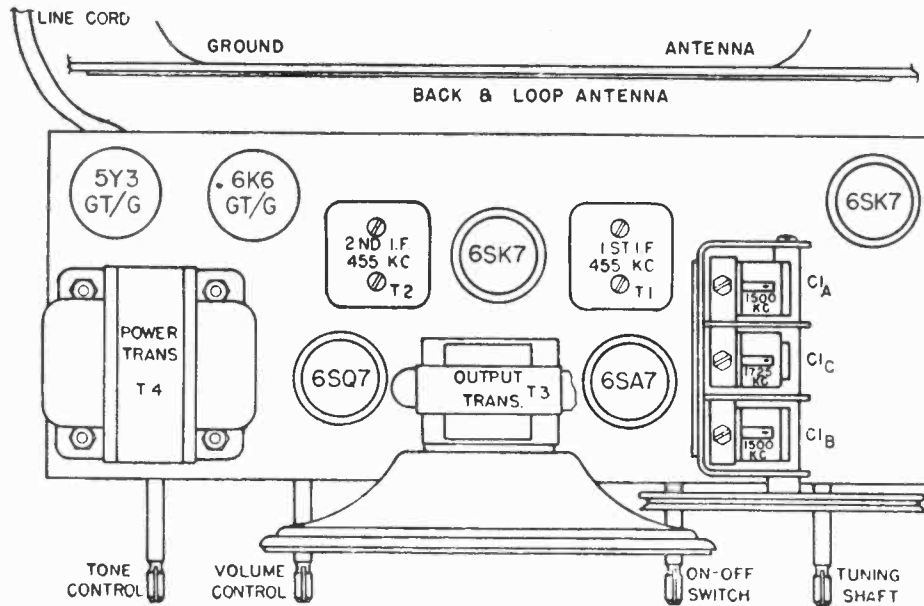

Fig 1 Chassis, Top View

SERVICE NOTES

Voltages taken from the different points of the circuit to the chassis are measured with volume control in maximum position, all tubes in their sockets and with a volt meter having a resistance of 1000 ohms per volt, using the 150 volt scale. These voltages are clearly indicated on the voltage chart. (Fig. 2).

All voltages should be measured with an A.C. line voltage of 117 volts.

To check for open by-pass condensers, shunt each condenser with another one having the same capacity and voltage rating which is known to be good until the defective unit is located.

ALIGNING INSTRUCTIONS

Never attempt any adjustments on this receiver unless it becomes necessary to replace a coil or transformer, or the adjustments have been tampered with in the field. Always make certain that other circuit components, such as tubes, condensers, resistors, etc., are normal before proceeding with realignment.

If realignment is necessary follow the instructions given under the heading "ALIGNMENT PROCEDURE" on the next page. After realignment has been completed repeat the procedure as a final check.

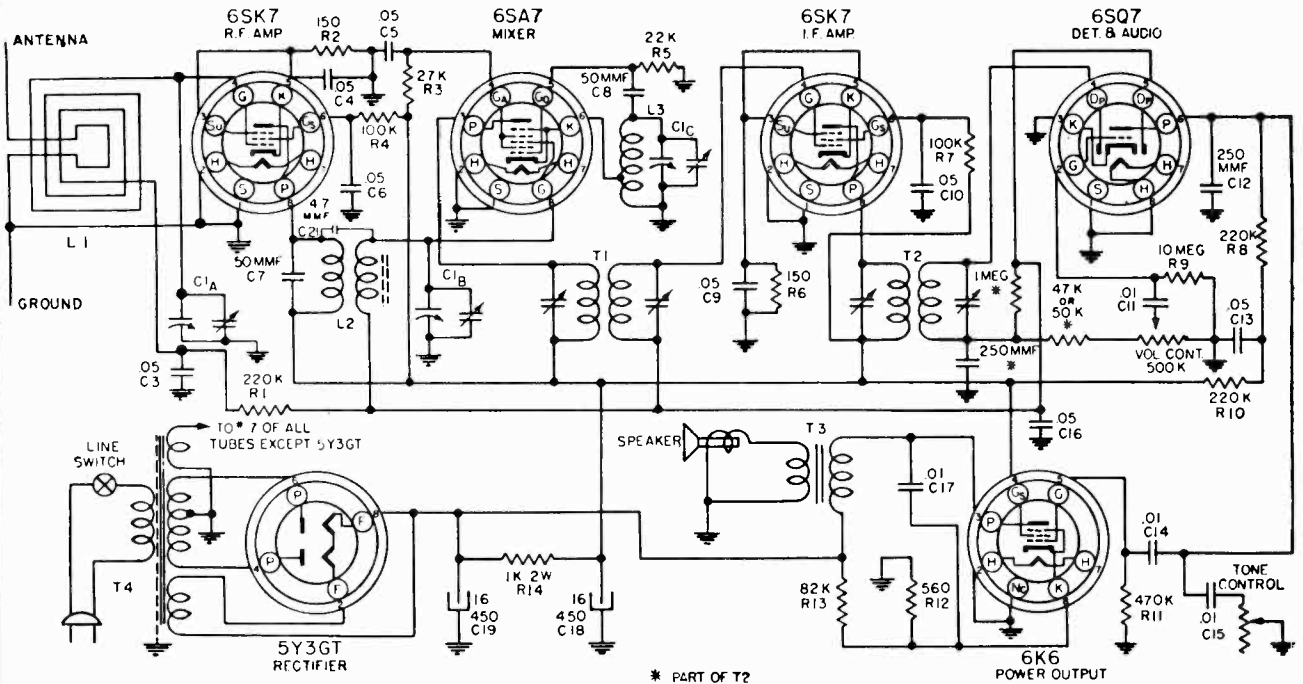

Fig. 3 Schematic Diagram
ALIGNMENT PROCEDURE

- Volume control—Maximum: all adjustments.
- Tone Control—Treble: Full Clockwise Rotation.
- Connect dummy antenna in series with output lead of signal generator.
- Connect output meter across voice coil of speaker.

- The following equipment is necessary for proper alignment:
- Signal generator that will provide the test frequencies as listed.
 - Output meter.
 - Non-metallic screwdriver.
 - Dummy antennas—.1 mfd., .00025 mfd.

Position of Variable	Generator Frequency	Dummy Ant. mfd.	Generator Connections	Trimmer Adjustment	Trimmer Function
Minimum Capacity (Fully Opened)	455 K.C.	.1	High side to 6SA7 grid Low side to chassis	T1 T2	I. F.
Minimum Capacity (Fully Opened)	1725 K.C.	.00025	High side to ant. lead Low side to ground lead	C1C	Osc.
Tune in signal From Generator	1500 K.C.	.00025	High side to ant. lead Low side to ground lead	C1B	R. F.
Tune in signal from Generator	1500 K.C.	.00025	High side to ant. lead Low side to ground lead	C1A	Ant.

Repeat the above alignment procedure as a final check.

With an output meter connected across the voice coil of the speaker, the output meter reading for 1/2 watt is 1.25 volts using a signal which is modulated 400 c.p.s.

PARTS LIST

CONDENSERS

Circuit Reference	Part No.	Description
C1A, C1B, C1C	B19-186	Variable condenser
C3, C4, C9, C16	A16-152	.05 MFD 200 volt condenser L2
C5, C6, C10, C13	A16-158	.05 MFD 400 volt condenser L3
C7, C8	A15-175	50 MMF mica condenser T1
C11, C14, C15	A16-156	.01 MD 400 volt condenser T2
C12	A15-176	250 MMF mica condenser
C17	A16-168	.01 MFD 1000 volt condenser
C18	A18-279	16 MFD 450 volt electrolytic condenser T3
C19	A18-274	16 MFD 450 volt electrolytic condenser T4
C21	A83-355	4.7 MMF condenser

RESISTORS

R1, R8, R10	A60-667	220K ohm 1/2 watt resistor
R2, R6	A60-686	150 ohm 1/2 watt resistor
R3	A60-692	27K ohm 1 watt resistor
R4, R7	A60-671	100K ohm 1/2 watt resistor
R5	A60-659	22K ohm 1/2 watt resistor
R9	A60-663	10 megohm 1/2 watt resistor
R11	A60-662	470K ohm 1/2 watt resistor
R12	A60-701	560 ohm 1 watt resistor
R13	A60-700	82K ohm 1 watt resistor
R14	A60-699	1000 ohm 2 watt resistor

COILS

R. F. coil	B10-452
Oscillator coil	A10-446
1st I.F. transformer	B10-412
2nd I.F. transformer	B10-444

MISCELLANEOUS

Output transformer	A80-222
Power transformer	C80-223
On-Off Switch	A69-169
Tone Control	A26-123
Volume Control	A24-169
Dial drive shaft and pulley assembly	A84-41
6 1/4" P.M. Speaker	B79-341
Baffle Board and Grille Cloth	C83-323
Wood cabinet	D42-400
Dial glass	C67-493
Knob	A52-193
Dial pointer	A58-60
Loop antenna	C82-59
Cabinet back	D83-602

SOCKET VOLTAGES

All voltages are measured with a 1000 ohm per volt meter on the 150 volt scale, with no signal. To obtain an accurate voltage check the A.C. line voltage must be 117 volts. Where no voltage is shown the voltage is 0 or cannot be read with this type of voltmeter.

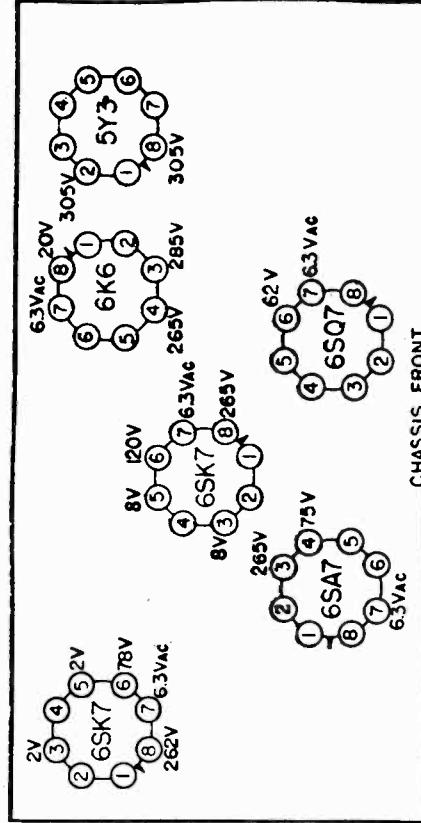
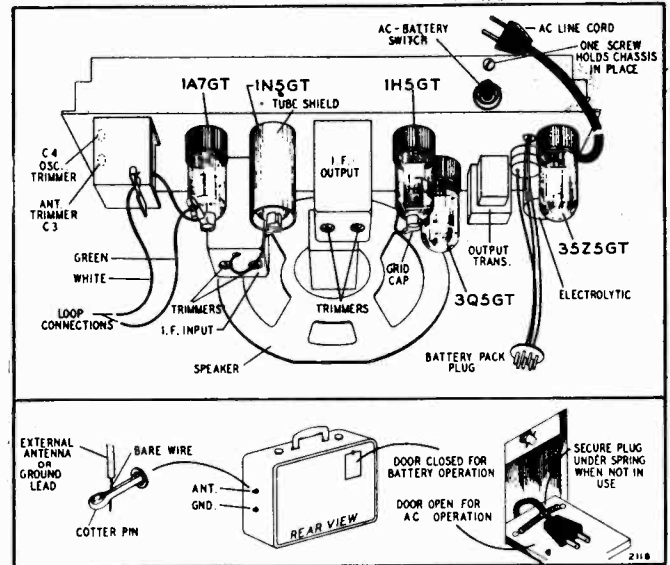
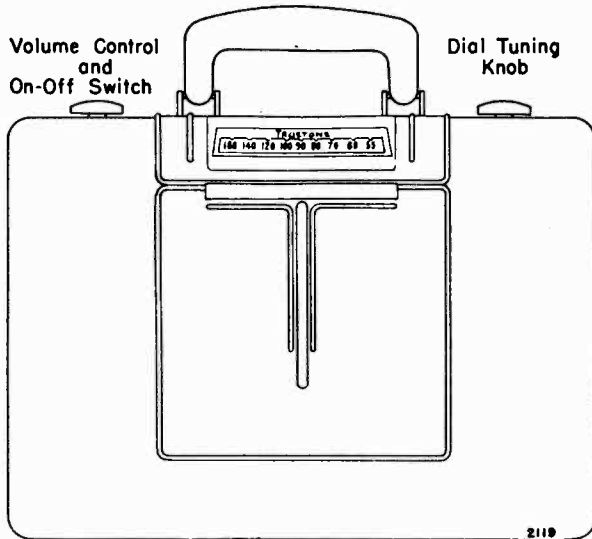

Fig. 2—Chassis, Bottom View



Chassis View

LINE VOLTAGE

If the set is to be operated from a house receptacle, the voltage, unless otherwise indicated, must be 105-125-volt DC (direct current) or 105-125-volt, 50-60 cycle AC (alternating current). If you are in doubt as to the voltage of the power supply, consult your local power company.

BATTERY PACK

The battery pack used with this radio must contain a 7½-volt "A" battery and a 90-volt "B" battery. Use Wizard Battery Pack No. B6460 or No. B6470.

PILOT LIGHT

If the pilot lamp burns out, the set should not be operated on AC or DC power until a new lamp has been installed. Failure to heed this caution may result in a burned-out 35Z5GT tube.

ELECTRICAL SPECIFICATIONS

Power Supply	105 to 125 volts DC or 50-60 cycle AC, 29 watts.
	Battery: A—7½ volts, 50 ma.
	B—90 volts, 11 ma.
Frequency Range	530 to 1650 kc.
Intermediate Freq.	455 kc.
Tuning	Two-gang capacitor
Antenna	Built-in loop. Provisions also for external antenna and ground.
Speaker	5-inch; P.M.; voice coil impedance 3.2 ohms.
Power Output	150 milliwatts undistorted. 250 milliwatts maximum.
Sensitivity	30 microvolts average for 50-milliwatt output.
Selectivity	43 kc broad at 1000 times signal at 1000 kc.

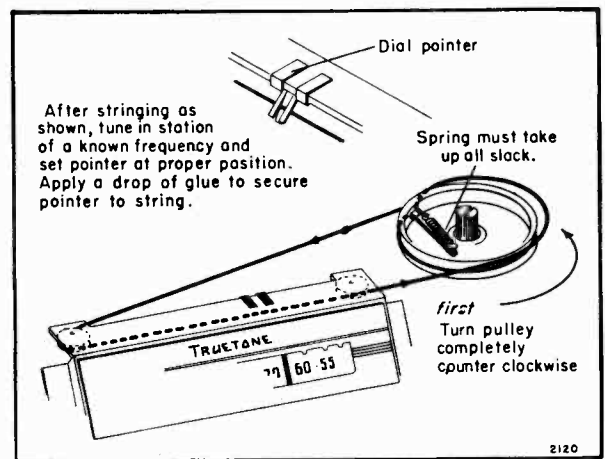

Replacement of Dial Pointer Drive Cord

3Q5GT
OUTPUT

1H5GT
2ND DET
1ST AUDIO
A.V.C.

1N5GT
I.F. AMP.

1A7GT
CONVERTER

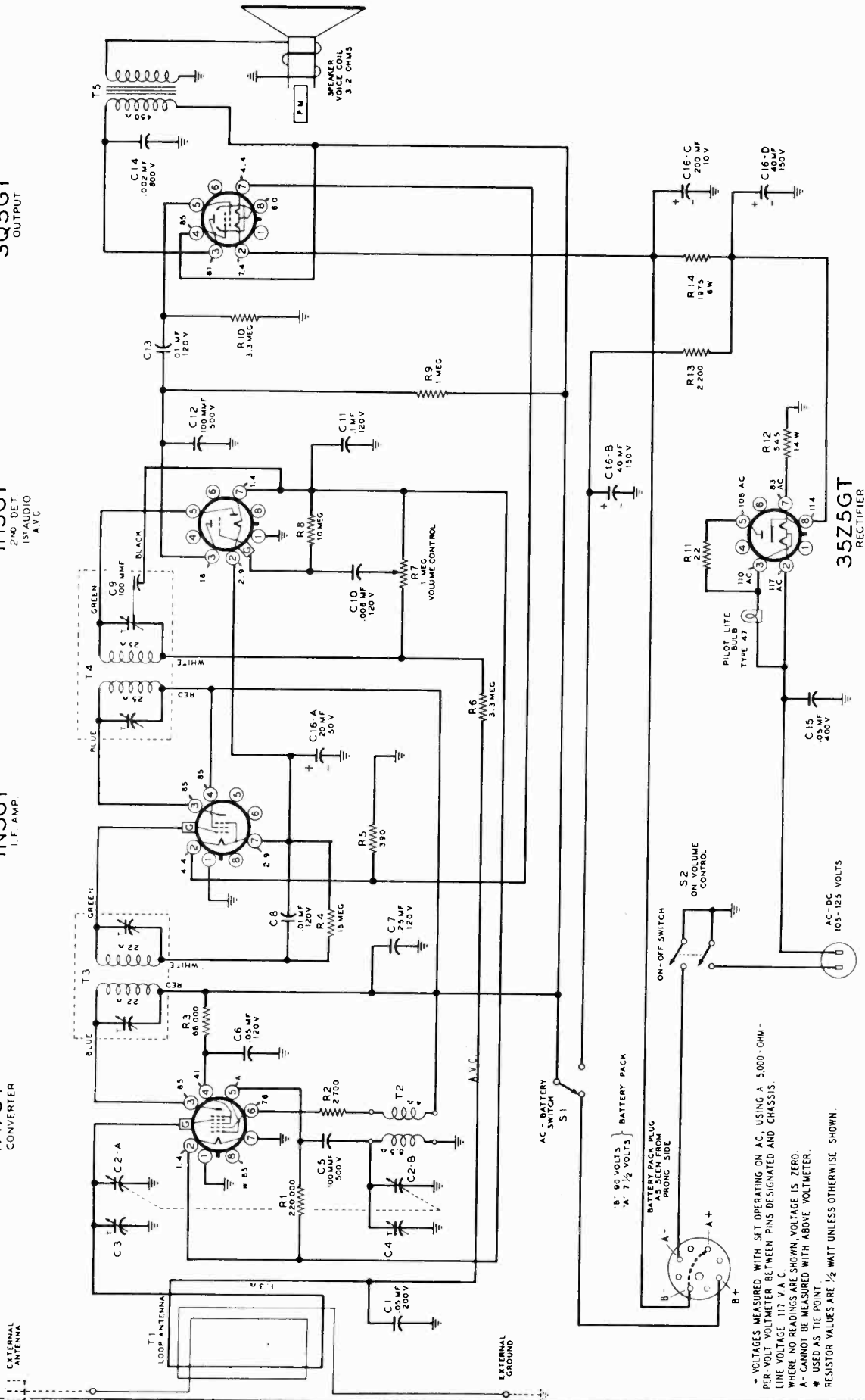

* VOLTAGES MEASURED WITH SET OPERATING ON AC. USING A 5,000-OHM-
PER-VOLT VOLTMETER BETWEEN PINS DESIGNATED AND CHASSIS.
LINE VOLTAGE 117 V A.C.
WHERE NO READINGS ARE SHOWN VOLTAGE IS ZERO.
A- CANNOT BE MEASURED WITH ABOVE VOLTMETER.
* USED AS TIE POINT
RESISTOR VALUES ARE 1/2 WATT UNLESS OTHERWISE SHOWN.

ALIGNMENT PROCEDURE

- Output meter across 3.2-ohm output load.
- Volume control at maximum for all adjustments.
- Align for maximum output. Reduce input as needed to keep output near 0.4 volts.

SIGNAL GENERATOR				SETTING TUNER	ADJUST TRIMMERS TO MAXIMUM OUTPUT (in order shown)
Frequency	Coupling Capacitor	Connection to Radio	Ground Connection		
455 kc	.1 mf	1A7GT grid cap*	Chassis	Rotor full open (plates out of mesh)	Input and output trimmers on IF cans
1650 kc	.1 mf	1A7GT grid cap*	Chassis	Rotor full open (plates out of mesh)	Oscillator trimmer C4
1400 kc†	200 mmf	External antenna clip	External ground clip	1400 kc	Antenna trimmer C3

* If loop is not connected when making this adjustment, substitute a 1-megohm resistor across the loop leads.

† For this adjustment chassis should be remounted in cabinet and loop connected. Antenna trimmer can be reached through a hole in the side of the cabinet.

REPLACEMENT PARTS LIST

Ref. No.	Part No.	Description	Ref. No.	Part No.	Description
CAPACITORS			COILS AND TRANSFORMERS		
C1	1009	.05 mf, 200 volts, 25%	T1	B-13E-10184	Loop antenna assembly
C2-A, C2-B, B-8A-10246		Two-gang, including antenna and oscillator trimmers. Range of gang: 14-452 mmf (ant) and 10-198 mmf (osc)	T2	A-13D-10239	Oscillator coil
C3, C4			T3	108201	Input I.F. coil complete in can. Range of trimmers: 53-97 mmf each
C5, C12	1295	100 mmf, 20%, mica	T4, C9	108200	Output I.F. coil complete in can. Range of trimmers: 39-71 mmf each
C6	100128	.05 mf, 120 volts, 25%	T5	105119C	Output transformer
C7	100135	.25 mf, 120 volts, 25%	MISCELLANEOUS		
C8, C13	100127	.01 mf, 120 volts, 25%	114241B		Speaker, 5-inch P.M.
C9		Approx. 100 mmf. Part of I.F. can.	B-14A-10145		Battery cable assembly
C10	100134	.006 mf, 120 volts, 25%	121171		Tube socket, octal
C11	100133	.1 mf, 120 volts, 25%	S1	A-20F-10247	Line-battery switch
C14	10025	.002 mf, 600 volts, 25%	107363		Line cord and plug
C15	10013	.05 mf, 400 volts, 25%	115396B		Tube shield
C16-A, -B, -C, -D	119123	Electrolytic; 20 mf x 50 volts, 40 mf x 150 volts, 200 mf x 10 volts, 40 mf x 150 volts	112922		Dial pointer
RESISTORS*			B-53A-11340		Drive cord for dial pointer
R1	C-9B1-27	220,000 ohms, 1/2 watt, 20%	120197		Spring for drive cord
R2	C-9B1-67	2700 ohms, 1/2 watt, 10%	B-6D-10244		Dial scale
R3	C-9B1-84	68,000 ohms, 1/2 watt, 10%	112925		Diffuser
R4	C-9B1-302	15 megohms, 1/2 watt, 20%	A-2M-7758		Snap-in rivets (4 for diffuser, 2 for dial scale)
R5	C-9B1-57	390 ohms, 1/2 watt, 10%	107249		Dial lamp, 6-8 volts, type T-47
R6, R10	C-9B1-34	3.3 megohms, 1/2 watt, 20%	107362		Socket assembly for dial lamp
R7, S2	101252	Volume control (1 megohm) and on-off switch	112910		Escutcheon for dial
R8	C-9B1-37	10 megohms, 1/2 watt, 20%	128634		Escutcheon for grille
R9	C-9B1-31	1 megohm, 1/2 watt, 20%	128645-8		Knob, tuning
R11	C-9B1-42	22 ohms, 1/2 watt, 10%	128647-8		Knob, volume
R12	130343	545 ohms, 14 watts, 5%			
R13	C-9B1-66	2200 ohms, 1/2 watt, 10%			
R14	130344	1975 ohms, 6 watts, 5%			

MODELS D3630,
D3630N
POWER SUPPLY

WESTERN AUTO SUPPLY CO.

This receiver is designed to operate on either a Battery Pack; or any AC (Alternating Current) power supply line of 105 to 125 volts, 50 to 60 cycles; or DC (Direct Current) power supply line of 105 to 125 volts.

BATTERY

Any one of the following battery packs may be used in this portable radio: Western Auto Supply Wizard B6460 or B6470, Ensign AB50, Ensign AB49, General 60A-6F6-5, General 60B-6F6-5, Burgess F6A60, Burgess G6M60, Eveready 754, Ray-O-Vac AB878 or Ray-O-Vac AB994. For best results, use Western Auto Supply Wizard B6460 (Standard) or B6470 (Deluxe) battery packs for replacement.

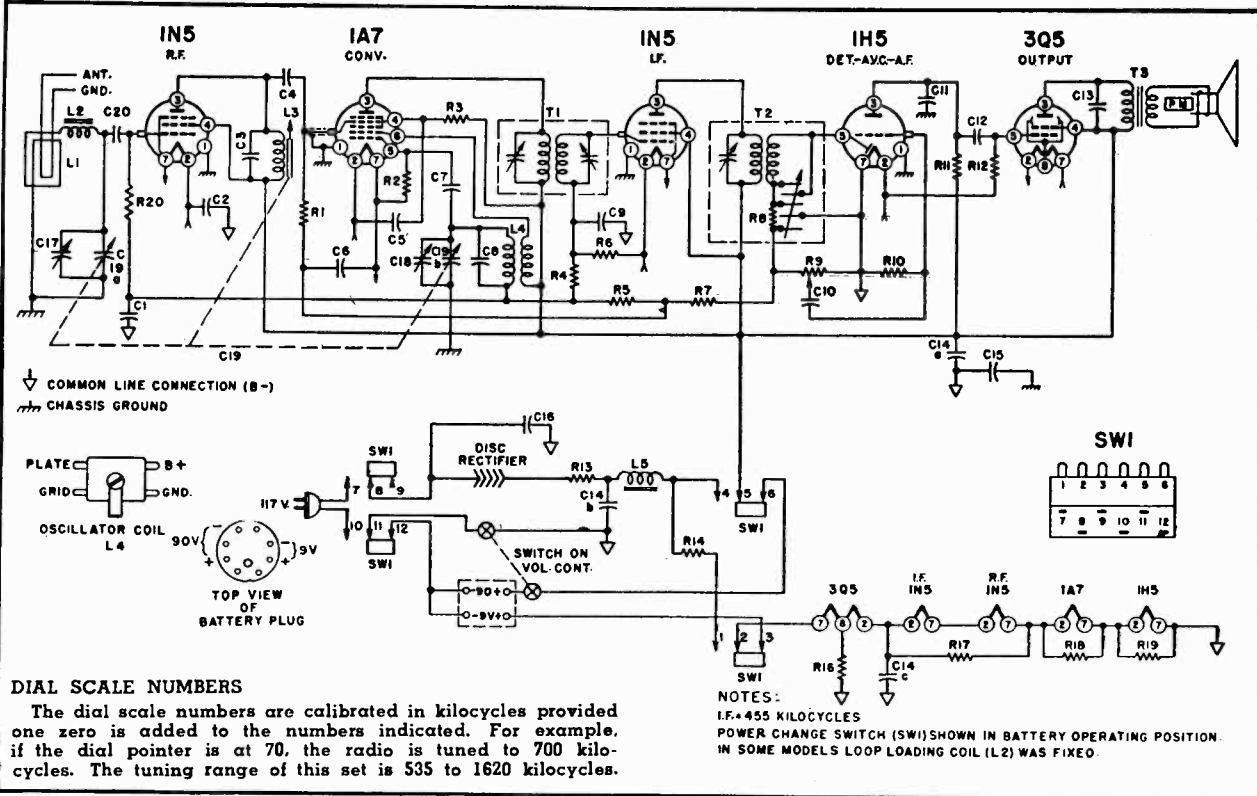

DIAL SCALE NUMBERS

The dial scale numbers are calibrated in kilocycles provided one zero is added to the numbers indicated. For example, if the dial pointer is at 70, the radio is tuned to 700 kilocycles. The tuning range of this set is 535 to 1620 kilocycles.

VOLTAGE CHART

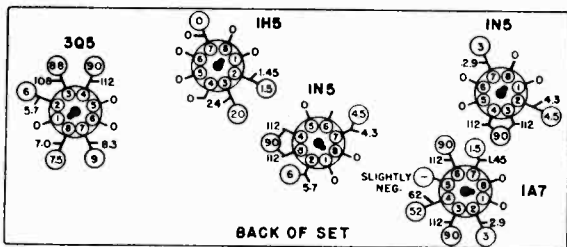

VOLTAGE DATA

1. Voltage readings circled (O) are for Battery Operation.
2. All readings made between Tube Socket Terminals and Pin No. 7 on the IH5.
3. A.C. Voltages measured on a 117 Volt A.C. line.
4. Battery Voltages measured with a fresh battery.
5. Dial turned to low frequency end, no signal.
6. All Voltages measured with a 1000 ohm-per-volt meter.

REPLACEMENT PARTS

CONDENSERS			RESISTORS			COILS and TRANSFORMERS			
Symbol	Description	Part No.	Symbol	Description	Part No.	Symbol	Description	Part No.	
C1	.05 Mfd., 200 Volt, Paper	64B1-32	R4, R5	4.7 Megohms, 1/4 Watt, Carbon	60B2-475	T2	2nd I.F. Transformer	72B10-2	
C2	.25 Mfd., 200 Volt, Paper	64B1-28	R6	4.7 Megohms, 1/4 Watt, Carbon	60B2-475	T3	Transformer, Output	*	
C3	.00042 Mfd., Mica	65B1-13	R7	3.3 Megohms, 1/4 Watt, Carbon	60B2-335		* When ordering, specify all numbers on the speaker and transformer.		
C4, C11	.00025 Mfd., Mica	65B5-22	R8	47,000 Ohms, 1/2 Watt, Carbon	60B8-473		Switch, Power Change	77A6	
C5, C6, C9, C10, C12	.01 Mfd., 400 Volt, Paper	64B1-25	R9	1 Megohm Volume Control	75B1-10C		Switch, Power Change	77A10	
C7	.00005 Mfd., Mica	65B5-11	R10	15 Megohms, 1/4 Watt, Carbon	60B2-156		Switch, Power Change	77A10	
C8	.00015 Mfd., Mica	65B5-3	R11, R20	1 Megohm, 1/4 Watt, Carbon	60B2-105				
C13	.002 Mfd., 600 Volt, Paper	64B1-14	R12	2.2 Megohms, 1/4 Watt, Carbon	60B2-225				
C14a	50 Mfd., 150 Volt } Elect.	67C7-42	R13	68 Ohms, Wire Wound, 1 Watt	60B28-4				
C14b	30 Mfd., 150 Volt } Cond.		R14	2.275 Ohms, Wire Wound, 5 Watt	61A3-6				
C14c	100 Mfd., 25 Volt } Cond.		R16	1,500 Ohms, 1/2 Watt, Carbon	60B8-152				
C15	2 Mfd., 400 Volt, Paper	64A2-1	R17	560 Ohms, 1/2 Watt, Carbon	60B8-561				
C16	.05 Mfd., 400 Volt, Paper	64B1-22	R18	220 Ohms, 1/2 Watt, Carbon	60B8-221				
C17	Antenna Trimmer	66A12-5	R19	120 Ohms, 1/2 Watt, Carbon	60B8-121				
C18	Oscillator Trimmer (Part of Gang)								
C19 { C19a } C19b {	Condenser, Gang	68B4	COILS and TRANSFORMERS						
C20	.00025 Mfd., Mica	65B7-22	L2	{ Coil, Loop Loading, (fixed) AA114 { Coil, Loop Loading, (variable) AA115 { Iron Slug for plate coil 71B1-3 { Coil, Plate AB100-5 Oscillator Coil 69A7 Choke Filter 74A5 1st I.F. Transformer 72B9-2					
R1	100,000 Ohms, 1/2 Watt, Carbon	60B8-104	MISCELLANEOUS						
R2	220,000 Ohms, 1/2 Watt, Carbon	60B8-224				Description	Part No.		
R3	47,000 Ohms, 1/2 Watt, Carbon	60B8-473				Dial Background	21A18-2		
						Dial Cord, 12"	50A1-3		
						Dial Cord Tension Spring	19A1-2		
						Escutcheon and Dial Scale	23C14		
						Knob, Tuning	33A14-6		
						Knob, Volume	33A14-5		
						Plug, Battery (9 prong)	88A3-3		
						Pointer, Cream Tenite	25A15-1		
						Rectifier, Selenium	93A1-2		
						Speaker and Output Transformer	78B6		
						Tube Shields	87A8		

WESTERN AUTO SUPPLY CO.

MODELS D3630,
D3630N

1. Be sure both set and signal generator are thoroughly warmed up before starting alignment.
2. Make alignment, using a battery whenever possible.
3. Disconnect Loop Antenna leads from clips on set and remove chassis from cabinet.
4. Connect a 50,000 ohm carbon resistor across the two clips from which the Loop Antenna was removed.
5. Connect Output Meter across the Voice Coil.
6. Connect a fresh battery to the set.
7. Turn receiver Volume Control full on.

Step	Dummy Antenna Used in Series with Signal Generator	Connect High Side Signal Generator to	Signal Generator Frequency	Gang Condenser Setting	Trimmer Description and Designation	Type of Adjustment
1	.00025 Mfd. when using A.C. .1 Mfd. when using Battery	Grid Cap 1A7	455 K.C.	Any point where it does not affect Signal	2nd I.F. (A), (B). 1st I.F. (C), (D).	Maximum Deflection. Then repeat
2	.00025 Mfd. when using A.C. .1 Mfd. when using Battery	Grid Cap 1N5	1620 K.C.	Rotor full open (Plates out of mesh)	Oscillator Trimmer (G)	Maximum Deflection.
3	.00025 Mfd. when using A.C. .1 Mfd. when using Battery	Grid Cap 1N5	1400 K.C.	Tune in Generator Signal	R.F. Slug (H)	Maximum Deflection.
4	Replace Set in Cabinet					
5	.00025 Mfd.	Antenna and Ground Leads*	1400 K.C.	Tune in Generator Signal	Antenna Trimmer (F)	Maximum Deflection.
6	Disregard the next two steps if the set being aligned is a model with a fixed loop loading coil (L2).					
7	.00025 Mfd.	Antenna and Ground Leads	600 K.C.	Tune in Generator Signal	Loop Loading Coil Slug (E)	Maximum Deflection.
8	.00025 Mfd.	Antenna and Ground Leads	1400 K.C.	Tune in Generator Signal	Reset Antenna Trimmer (F)	Maximum Deflection.

Seal adjusting screw on the loop loading coil with any quick drying cement.

REPLACING R.F. TUNING SLUG

If the R.F. Tuning Slug has to be changed, use the following procedure. Set the gang condenser to the point where the plates are fully meshed. Screw the slug adjusting screw about halfway down. Place the slug in the coil in such a position that the top of the slug is flush with the top of the Coil. Solder the slug wire to the adjusting screw. Be sure that the position of the slug does not change during the soldering and that the slug wire is straight. Proceed to re-align the set as shown in the chart.

TUBE AND TRIMMER LAYOUT

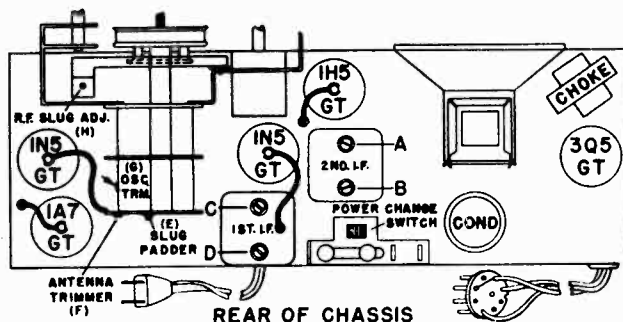

DIAL CORD STRINGING

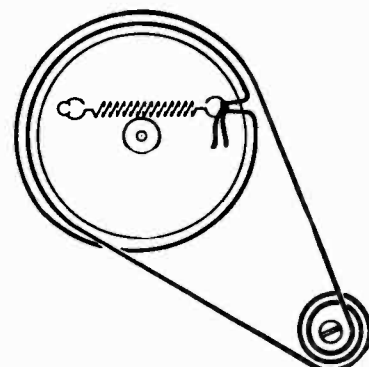

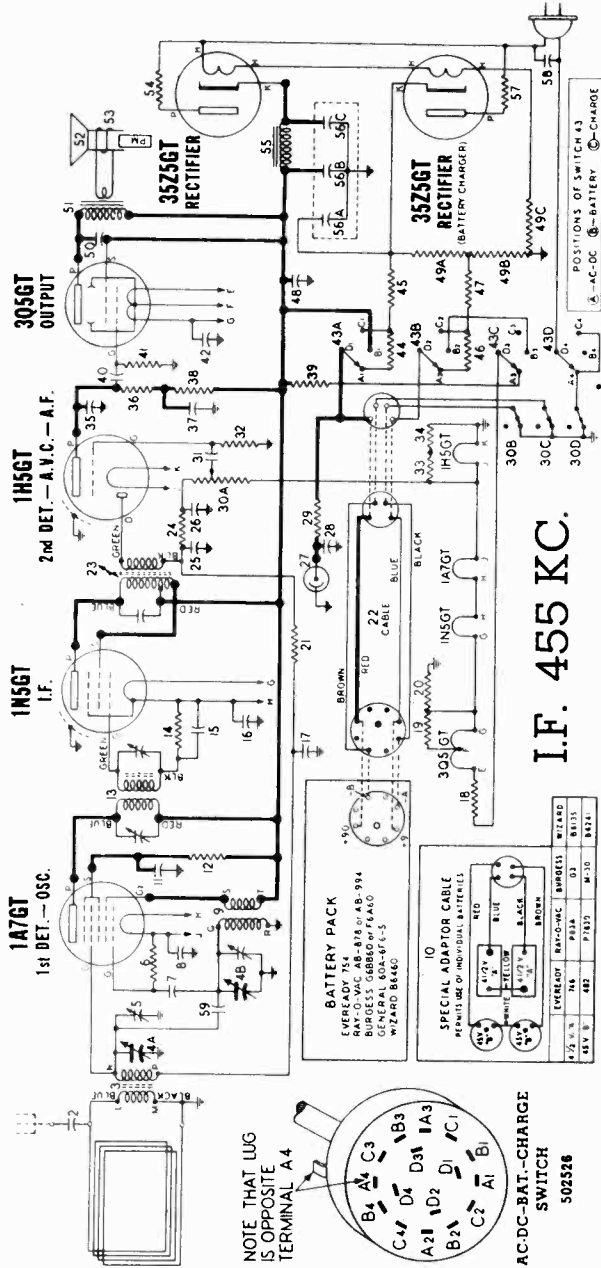

I.F. 455 KC.

SOCKET VOLTAGES

Measured with voltmeter having sensitivity c/1000 ohms per volt except where indicated by (*):
 VOLUME ON FULL WITH NO SIGNAL
 "AC-DC-BAT.-CHARGE" SWITCH IN "AC-DC" POSITION
 DIAL TUNED TO 540 KC.

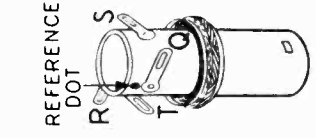
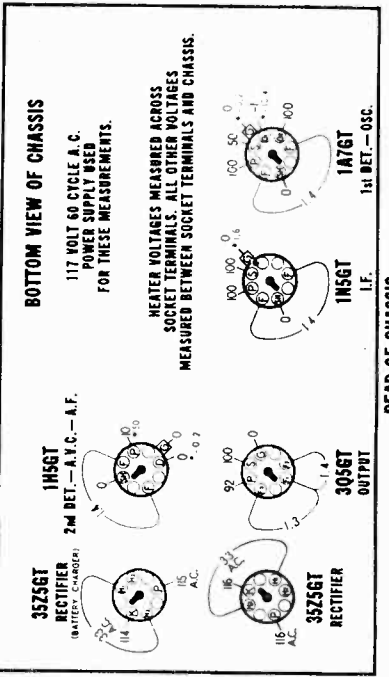

ANTENNA COIL
502499

OSC. COIL
502498

PARTS LIST

DIA-GRAM NO.	PART NO.	DESCRIPTION
2	502150	Condenser—.004 Mfd. 600 volt.
4-A, B	502494	Condenser—variable gang.
5	119132	Condenser—trimmer, 2 to 15 Mmfd.
7	502159	Condenser—mica 50 Mmfd. 500 volt.
8	502153	Condenser—.05 Mid. 200 volt.
11	502547	Condenser—electrolytic 4 Mfd. 150 volt.
16	502153	Condenser—.05 Mid. 200 volt.
17	502153	Condenser—.05 Mid. 200 volt.
25	502153	Condenser—.05 Mfd. 500 volt.
26	502153	Condenser—mica 30 Mmfd. 500 volt.
31	502156	Condenser—.004 Mfd. 100 volt.
35	502160	Condenser—mica 110 Mfd. 500 volt.
37	502155	Condenser—.1 Mfd. 200 volt.
40	502151	Condenser—.01 Mid. 200 volt.
42	502527	Condenser—electrolytic 50 Mfd. 25 volt.
48	502155	Condenser—.1 Mfd. 200 volt.
50	502453	Condenser—.002 Mid. 400 volt.
56-A, B, C	500714	Condenser—electrolytic A—20 Mfd. 150 volt. B—20 Mfd. 200 volt. C—20 Mfd. 200 volt.
58	502153	Condenser—.05 Mid. 200 volt.
59	502411	Condenser—2 Mmfd. 500 volt.
6	502133	Resistor—carbon 220,000 ohms 1/4 watt.
12	502466	Resistor—carbon 33,000 ohms 1/4 watt.
14	502136	Resistor—carbon 10 Meg. 1/4 watt.
18	502455	Resistor—carbon 27 ohms 1/4 watt.
19	502457	Resistor—carbon 330 ohms 1/4 watt.
20	502458	Resistor—carbon 430 ohms 1/4 watt.
21	502269	Resistor—carbon 3.3 Meg. 1/4 watt.
22	502132	Resistor—carbon 100,000 ohms 1/4 watt.
24	502595	Volume control 1 1/2 Meg. 1/4 watt.
30-A, B, C, D	502269	Volume control 1 1/2 Meg. 1/4 watt.
32	502456	Resistor—carbon 220,000 ohms 1/4 watt.
33, 34	502268	Resistor—carbon 1 Meg. 1/4 watt.
36	502134	Resistor—carbon 470,000 ohms 1/4 watt.
39	500712	Resistor—wire wound 180 ohms 5 watt.
41	502135	Resistor—carbon 2.2 Meg. 1/4 watt.
44	502266	Resistor—carbon 15,000 ohms 1/4 watt.
45	502459	Resistor—carbon 6800 ohms 1/4 watt.
46	502457	Resistor—carbon 330 ohms 1/4 watt.
47	502455	Resistor—carbon 27 ohms 1/4 watt.
49-A, B, C	500715	Resistor—wire wound A—1460 ohms 10 watt B—155 ohms 1 watt C—310 ohms 10 watt
54	502454	Resistor—wire wound 47 ohms 1 watt.
57	502454	Resistor—wire wound 47 ohms 1 watt.

DESCRIPTION

- 10 500746 Cable—for use with indiv. batteries.
 - 27 500733 Cable—for use with battery pack.
 - 27 500733 Neon indicator lamp.
 - 43-A, B, C, D. 502526 Speaker—AC-DC "BAT.-CHARGE".
 - 52 502491 Cone & voice coil for R-502491 speaker.
 - 53 502491 Speaker—P.M. dynamic (8 inch).
- MISCELLANEOUS PARTS**
- 160026 Base for mtg. electrolytic condenser.
 - 112745 Clip—coil mtg.
 - 117057 Card—dial drive (28" required) per lit.
 - 502780 Escutcheon plate.
 - 502784 Knob volume or tuning.
 - 502785 Knob AC-DC "BAT.-CHARGE".
 - 502547 Plug for battery cable (fits chassis).
 - 502786 Retainer for tuning shaft.
 - 81145 Ring for dial.
 - 117087 Ring for dial.
 - 75484 Screw—No. 8x3/4" for mtg. chassis.
 - 502524 Shield—tuning control.
 - 117716 Shield—tube.
 - 116680 Socket—social battery.
 - 500681 Socket for battery cable.
 - 161384 Spring—dial cord tension.
 - 502533 Terminal strip for antenna.
 - 111456 Washer—spring washer for tuning shaft.
 - 502534 Washer—felt for knobs.

COILS AND TRANSFORMERS

- 1 502493 Coil—antenna coupling.
- 9 502493 Transformer—1st I.F.
- 13 502493 Transformer—2nd I.F.
- 23 502902 Trans.—output for A-502491 speaker.
- 51 502492 Trans.—output for R-502491 speaker.
- 55 502528 Filter choke.

OTHER ELECTRICAL PARTS

- 10 500746 Cable—for use with indiv. batteries.
- 27 500733 Cable—for use with battery pack.
- 27 500733 Neon indicator lamp.
- 43-A, B, C, D. 502526 Speaker—AC-DC "BAT.-CHARGE".
- 52 502491 Cone & voice coil for R-502491 speaker.
- 53 502491 Speaker—P.M. dynamic (8 inch).

Lettered terminals in illustrations correspond to similarly lettered terminals on the circuit diagram.

ANTENNA COIL
502499

OSC. COIL
502498

WESTERN AUTO SUPPLY CO.

MODEL D3635

ALIGNMENT PROCEDURE

- Slide chassis partially out of cabinet by removing staples at each side of wood shelf and pulling entire shelf back about 2 inches. Do not disturb connections to loop antenna.
- Connect an output meter across the voice coil of the speaker or between the plate of the 3Q5GT output tube and chassis through a .1 mfd. condenser.
- Connect the ground lead of the signal generator to chassis through a .25 mfd. condenser.
- Set the volume control in the maximum position and use a weak signal from the generator.
- Set "AC-DC—BAT.—CHARGE" Switch in "AC-DC" position.

DUMMY ANT. IN SERIES WITH SIGNAL GENERATOR	CONNECT HIGH SIDE OF SIG. GENERATOR TO	SIGNAL GENERATOR FREQUENCY	RECEIVER DIAL SETTING	TRIMMER NUMBER	TRIMMER DESCRIPTION	TYPE OF ADJUSTMENT
300 MMFD. Condenser	Grid Cap of 1A7GT Tube	455 KC.	Any Point Where It Does Not Affect Signal	1	2nd I.F.	Loosen lock nut. Adjust screw for maximum output.
				2-3	1st I.F.	Adjust for maximum output. Re-check 1, 2 and 3 for maximum output and tighten lock nut on 1.
300 MMFD. Condenser	Center Terminal on Antenna Terminal Strip at bottom of cabinet.	1500 KC.	1500 KC. (Slide set into cabinet and replace pointer to set dial.)	4	Broadcast Oscillator (Shunt)	Adjust trimmer for maximum output.
300 MMFD. Condenser	Center Terminal on Antenna Terminal Strip at bottom of cabinet.	1500 KC.	Tune to 1500 KC. Generator Signal	5	Broadcast Antenna	Adjust for maximum output. Slide chassis all the way into cabinet when making this adjustment.

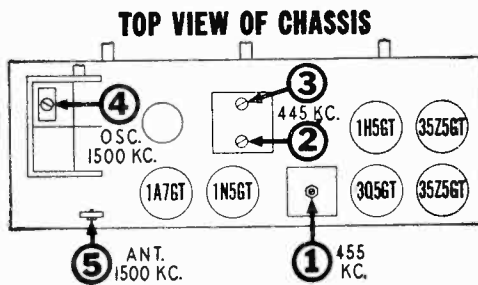

INDICATOR LAMP

The flashing neon lamp on the dial face indicates condition of batteries. This lamp is included in an oscillating (R-C) circuit which is designed to oscillate at approximately 3 pulses per second when batteries are in a fully charged condition. As the battery voltage decreases with use, number of pulses per second decreases.

This lamp will only show the true condition of the batteries when the Selector Switch is in the "Battery" position. Lamp flashes more rapidly during charging or "AC-DC" operation.

When battery voltage is low (approximately 72 volts) the lamp flashes more slowly (about once per second). The set should not be operated from battery power after this point is reached and batteries should be recharged immediately. Charge for at least twice the time they were used and as soon as possible after they are run down. As batteries age it is necessary to charge for a longer period. For longest battery life, charge immediately after using.

- IMPORTANT:**
- Completely dead batteries cannot be recharged.
 - When set is connected to a DC line, check for correct polarity by operating it before attempting to charge the batteries.
 - Batteries will be discharged if ON-OFF switch is left ON when power cord is not connected to wall outlet.

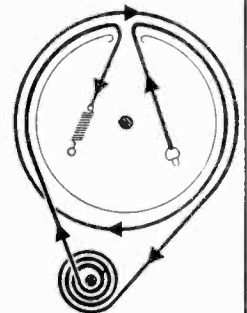

DIAL DRIVE CORD ARRANGEMENT

To string dial cord, set gang condenser to fully meshed position and use following parts:

- 114955 Clip on end of cord
- 117057 Cord (28 inches)
- 119087 Ring for dial cord
- 161384 Tension Spring

CHARGING CIRCUIT

The battery charging circuit consists of a 35Z5GT rectifier and a suitable resistor voltage dividing network. This circuit provides a very low charging current when the receiver is operated on AC-DC and is just enough to maintain the batteries but will not charge them. A separate charging position is provided for the regular charging operation. A charging rate of approximately 1/3 the discharge rate is used to give best results.

APPROXIMATE STAGE GAIN DATA

Be sure R.F. and I.F. stages are accurately aligned before measuring gain. R.F. gains can be measured with a "channel" type instrument containing a tuned and calibrated R.F. amplifier. A vacuum tube voltmeter may be used for audio gain measurements.

- For all gain measurements connect signal generator as shown. Use 600 KC. signal with 400 cycle modulation (use nearby frequency if local station interferes).
- For R.F. and I.F. measurements connect negative terminal of a 1 1/2-volt battery to A.V.C. lead and positive terminal to chassis. This provides a definite operating point.
- Be sure radio is carefully tuned to generator signal (use weak signal for sharp tuning).
- When using a "channel" type instrument carefully tune it for maximum output at desired frequency before making measurements.

The R.F. and I.F. stage gains shown below are less than under normal operating conditions due to the use of 1 1/2 volts fixed bias in order to establish a definite operating point. Therefore, these values are not intended to indicate the full capability of a stage.

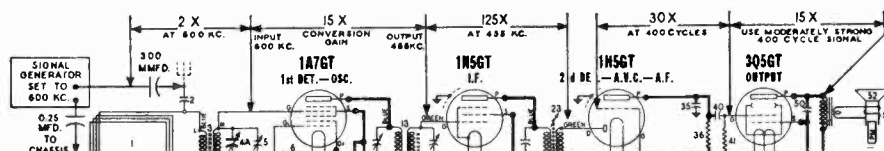

Differences in tube characteristics, tolerance of parts, adjustment of tuned circuits, and variations of line voltage will influence stage gain. Accuracy of measurements is dependent upon careful tuning of receiver to generator signal and experience in using your test equipment. These factors may create considerable variation in gain measurements.

CHARGING THE BATTERY

The specially developed electronic circuit used for charging the battery will produce best results if battery deterioration has not progressed too far. Check the battery frequently as described in the previous section. To use the built-in charger proceed as follows:

1. Plug the power cord into wall outlet.
2. Turn Selector Switch to "AC-DC" position and turn On-Off Switch to "ON" position.
3. Make sure that radio operates properly before attempting to use the charger. This is especially important when the radio power cord is connected to a D.C. (Direct Current) power supply. After you are sure the radio operates properly, turn the Selector Switch to the "CHARGE" position.
4. Allow the set to operate in this manner and charge the battery for at least twice as many hours as battery was previously used.
5. After charging is completed be sure to turn the radio On-Off Switch to the "OFF" position. If this switch is left on and the power cord is disconnected from the wall outlet, the battery will discharge.

If the receiver is equipped with individual "A" and "B" batteries instead of a single unit battery pack, the built-in charging circuits will recharge all four batteries.

THE DIAL SCALE is calibrated to cover frequencies between 540 Kc and 1600 Kc. Add a zero to dial number to obtain the frequency in kilocycles (Kc). Examples: When pointer is set to 90, radio is tuned to 900 Kc. See your newspaper for frequencies of local stations.

The bottom compartment of the cabinet provides adequate space to accommodate a single unit battery pack (or individual "A" and "B" batteries if desired). Any of the following single unit type battery packs may be used as a suitable power supply for this receiver.

WIZARD B6460
EVEREADY 754
GENERAL 60A-6F6-5
RAY-O-VAC AB-878 or AB-994
BURGESS G6BB60 or F6A60

Place the battery in the bottom compartment of the cabinet and wedge a piece of corrugated paperboard between the battery and the wall of the cabinet (see Fig. 1). The paperboard serves to hold the battery in a fixed position.

After the battery is installed in the cabinet it must be connected to the cable extending from the rear of the radio chassis. This cable is equipped with a special plug that will fit the receptacle in any of the single unit battery packs whose type numbers are listed above.

Where it is desired to use individual "A" and "B" batteries instead of the single unit battery pack, it will be necessary to obtain a special adapter cable (part 500746) in order to connect the separate batteries to the radio. Four batteries (two 4½ volt "A" batteries and two 45 volt "B" batteries) would be required for this type of installation. The following batteries will satisfactorily fit in the space provided:

INSTALLATION

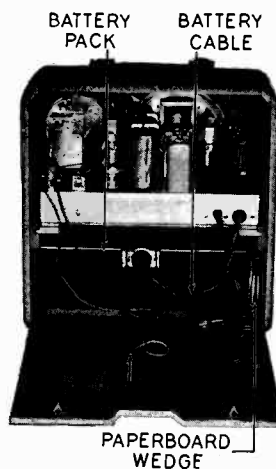

FIG. 1

4½ Volt "A" Battery
(2 required)

Wizard B6135
 Ray-O-Vac P83A
 Eveready 746
 Burgess G3

45 Volt "B" Battery
(2 required)

Wizard B6241
 Ray-O-Vac P7830
 Eveready 482
 Burgess M-30

CONNECTING RADIO TO ELECTRIC POWER SUPPLY: The rubber covered power cord and plug, which is coiled up and placed inside the cabinet when the radio is battery operated, must be connected to an electric power outlet if you wish to operate the radio from the power

line. The power cord must also be connected to the electric power outlet when using the special battery charger in this receiver.

IMPORTANT: Before connecting the power cord to the electric power outlet, close the back of the cabinet. Do not handle the metal chassis or attempt to remove tubes after the power cord is connected.

When connecting the radio to the electric power outlet be sure that outlet will supply the proper current and voltage. This radio may be connected to either 50 or 60 cycle Alternating Current (A.C.) at 105 to 125 volts or Direct Current (D.C.) at 105 to 125 volts. If in doubt as to the voltage and type of current which is supplied by an electric power outlet, call local power company.

If a Direct Current power supply is used and the radio does not operate after it has been turned on for approximately one minute, reverse plug connection at wall outlet.

REPLACEMENT PARTS LIST

Ref. No.	Part No.	Description
C1	1694	Variable
C2, C14		Paper, .05 MFD 200 volts
C3		Paper, .2 MFD 200 volts
C4, C8		Mica or ceramic, 100 MMFD
C5, C13		Paper, .005 MFD 200 volts
C6, C7, C15		Paper, .02 MFD 200 volts
C9, C12		Paper, .001 MFD 200 volts
C10, C11		Paper, .1 MFD 200 volts
C16 A.B.C.	2075	Electrolytic

RESISTORS

R1	100,000 ohms, 1/4 watt
R2	8200 ohms, 1/4 watt
R3	470,000 ohms, 1/4 watt
R4	3.3 meg ohms, 1/4 watt
R5	10 meg ohms, 1/4 watt
R6	Control, volume, DFST Switch, 1 meg ohm
R7	4.7 meg ohms, 1/4 watt
R8	330,000 ohms, 1/4 watt
R9	2.2 meg ohms, 1/4 watt
R10	270 ohms, 1/4 watt
R11	820 ohms, 1/4 watt
R12	33 ohms, 1 watt
R13	Filter and Filament, dropping

RESISTORS

L2	3371	Input IF Transformer
L3	3335	Output IF Transformer
T1	1337	Output transformer
L1	28190	Loop

COILS AND TRANSFORMERS

28197	Oscillator coil
MISCELLANEOUS	
5588	Cord, Line (Polarized)
39164	Knobs
5899	Loud Speaker 4"
472	Cabinet
18132	Wafer, Switch—Battery A.C.

TUBE LOCATION

FOR BATTERY OPERATION PLUG LINE CORD IN THIS RECEPTACLE AS SHOWN BY DOTTED OUTLINE OF PLUG.
FOR 105-125 VOLT A.C. OR D.C. OPERATION, REMOVE THIS PLUG FROM SOCKET AND PLUG INTO ELECTRIC OUTLET.

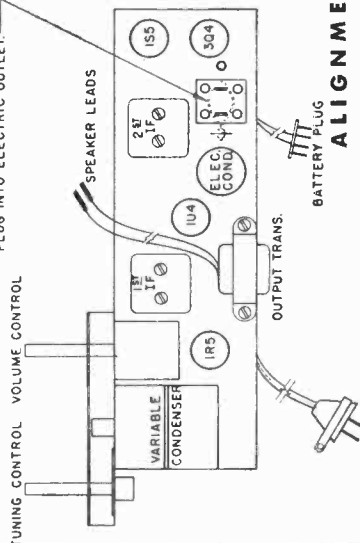

DIAL STRINGING DIAGRAM

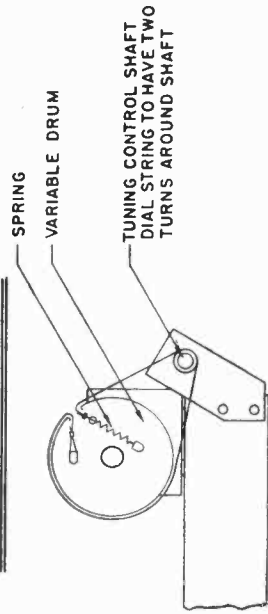

ALIGNMENT PROCEDURE

- Output Meter across 3.2 ohm output load
- Volume control at maximum
- Connect ground post of signal generator to chassis
- Align for maximum output. Reduce input as needed to keep output near 0.05 watts

SIGNAL GENERATOR

Frequency	Connection to Radio	Dummy Antenna	Tuner Setting
455 KC	Center of antenna section of Gang	0.2 mf	Any
1500 KC	**	**	Set pointer at second dot from end. On dial pan
15000 KC	**	**	Set pointer at second dot from end. On dial pan

Adjust for Maximum Output (in order shown)
Trimmers on I.F. Can
Oscillator Trimmer on Gang
R.F. Trimmer on Gang

** Run a wire from Output Terminal of the Generator near the Receiver. However, no connection is made between the signal generator and the Receiver.

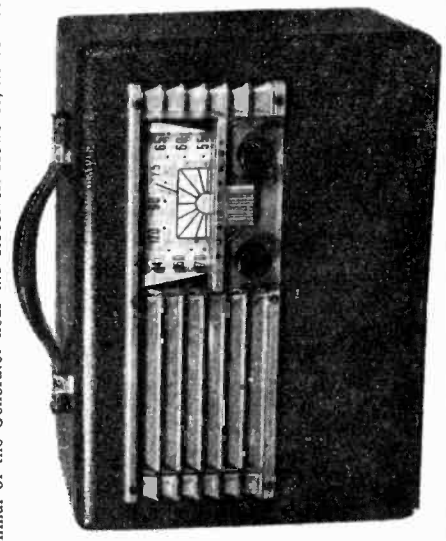

TECHNICAL DATA

Tuning Range	540-1600	Sensitivity (For 0.05 Watt Output)	300 Microvolts per Meter Average
Intermediate Frequency	455 KC	Power Output (in voice coil):	.130 Watts
Power Consumption	15 Watts	Undistorted	.300 Watts
Selectivity	A.C.A. 12-1	Maximum	

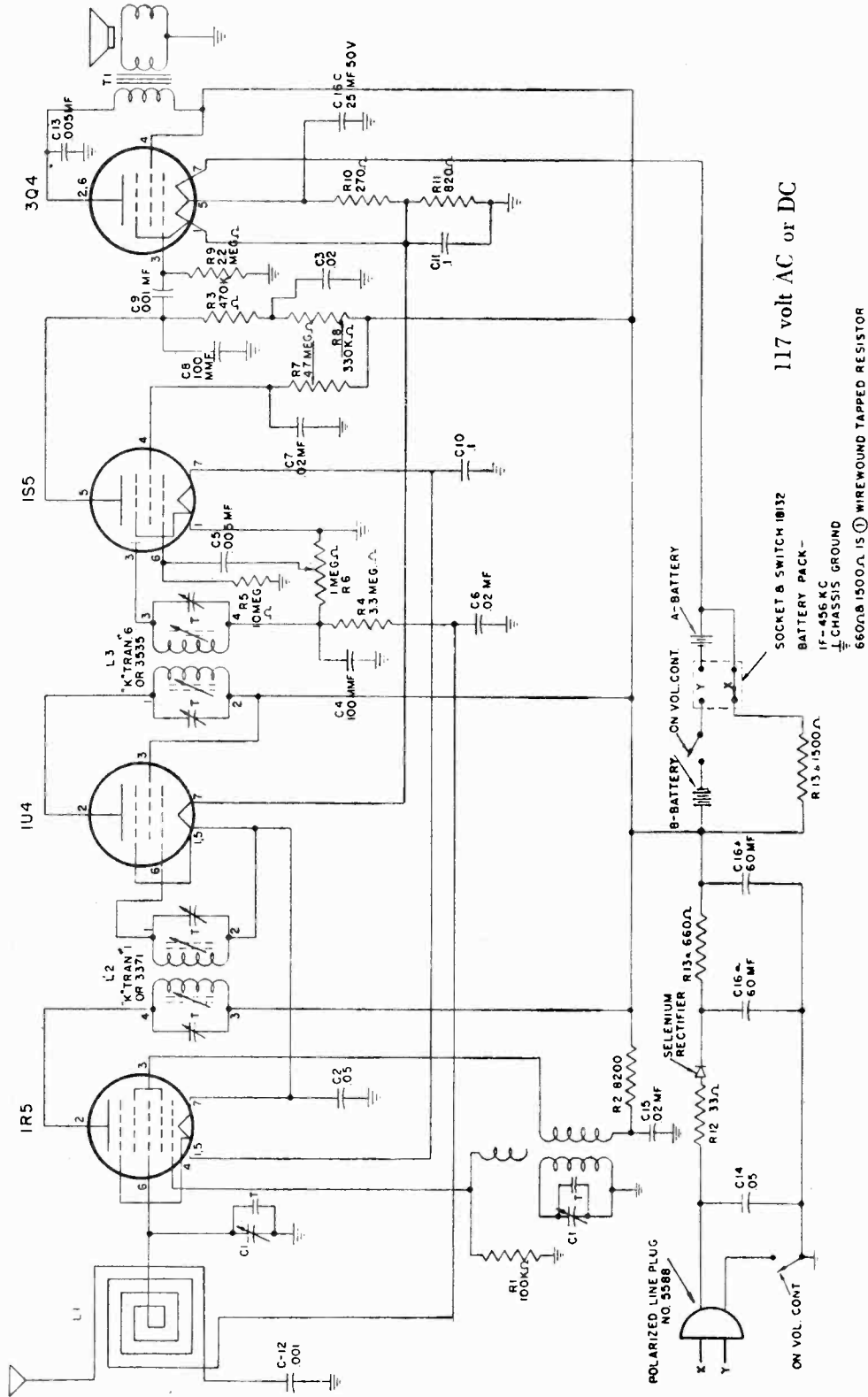

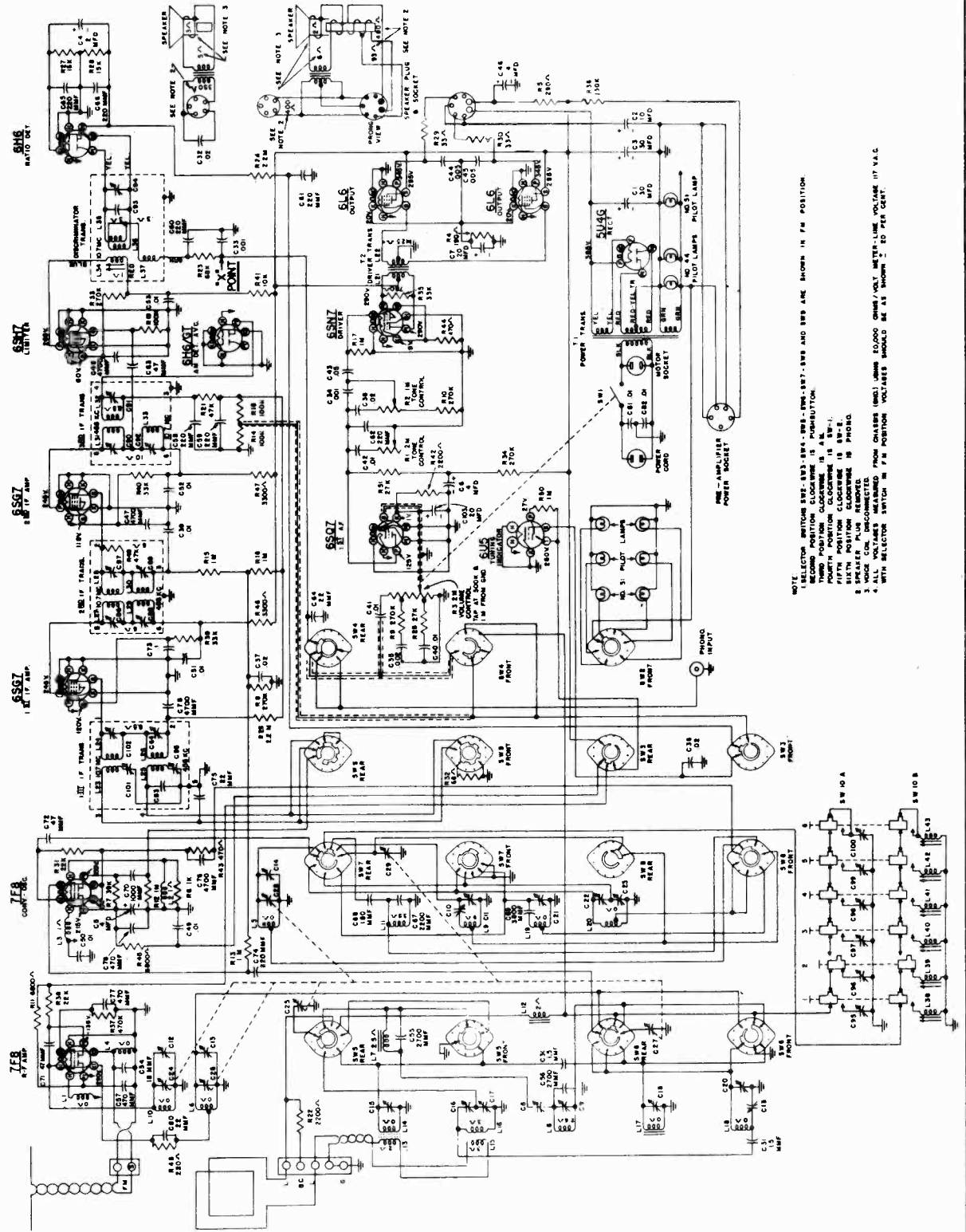

NOTE: SELECTOR SWITCHES SW2, SW3, SW4, SW5, SW6, SW7, SW8 AND SW9 ARE SHOWN IN FM POSITION.
 SECOND POSITION CLOSURE IS PUSH-BUTTON.
 THIRD POSITION CLOSURE IS A B-L.
 FIFTH POSITION CLOSURE IS SW-E.
 SIXTH POSITION CLOSURE IS PHONO.
 SEVENTH POSITION CLOSURE IS PHONO.
 3. VOICE COIL DISCONNECTED.
 4. ALL VOLTAGES MEASURED FROM CHASSIS (WELL) UNLESS OTHERWISE SPECIFIED. LINE VOLTAGE IS V.A.C.
 WITH SELECTOR SWITCH IN FM POSITION VOLTAGES SHOULD BE AS SHOWN ± 20 PER CENT.

MODEL H-169

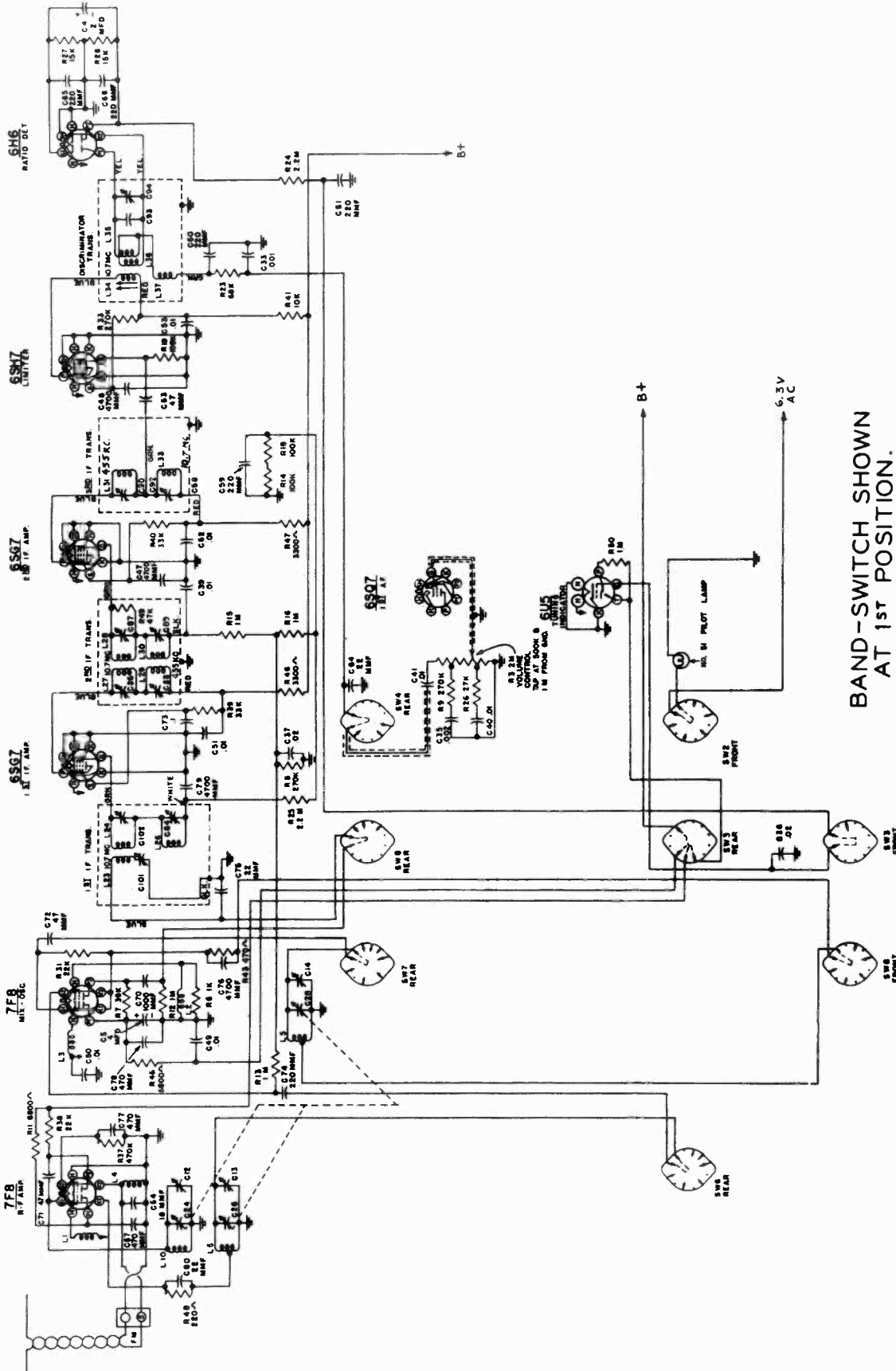

BAND-SWITCH SHOWN AT 1ST POSITION. F M BAND 88-108 MC

CLARI-SKEMATIX

Registered Trademark

WESTINGHOUSE ELECTRIC CORP.

MODEL H-169

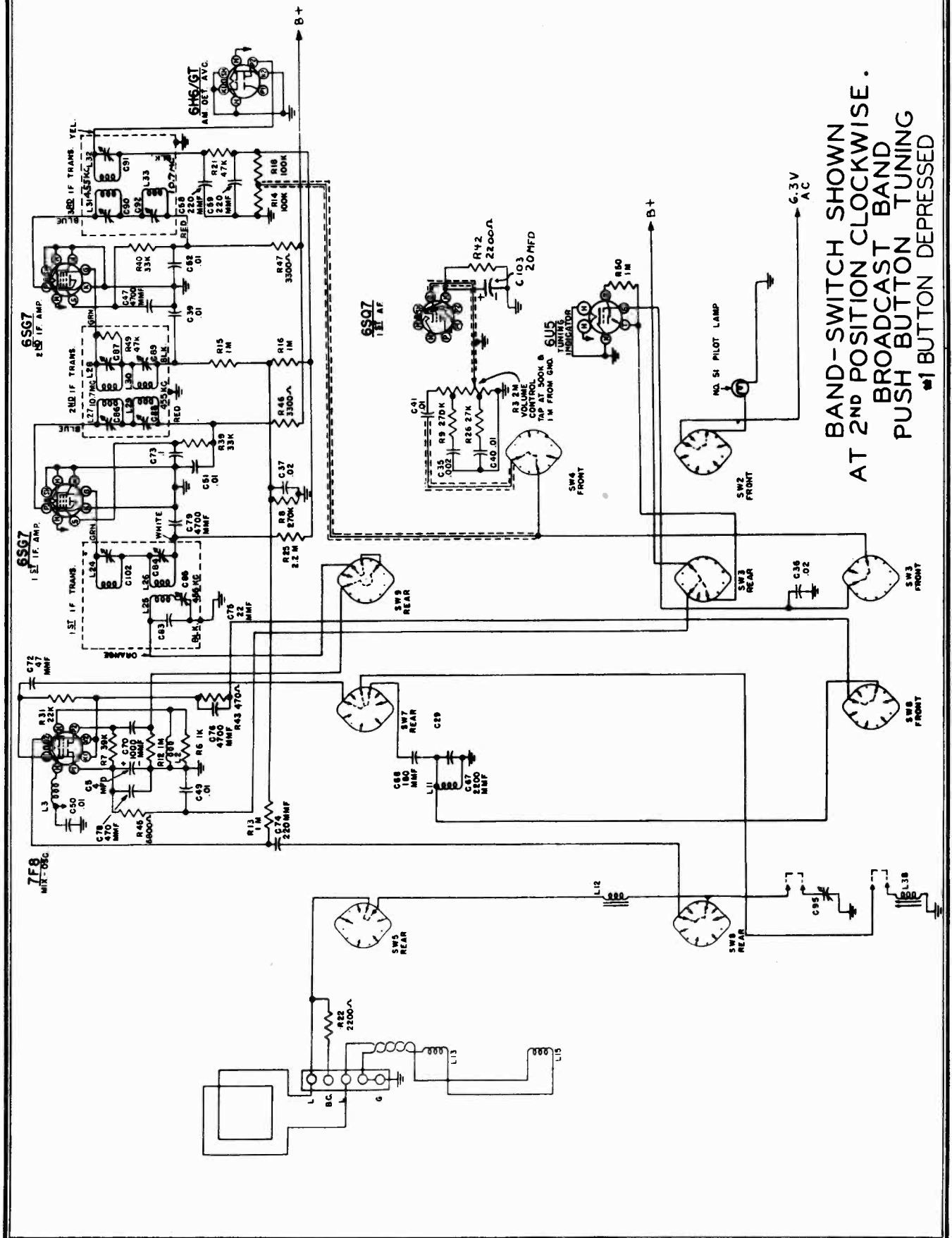

BAND-SWITCH SHOWN
AT 2ND POSITION CLOCKWISE.
BROADCAST BAND
PUSH BUTTON TUNING
#1 BUTTON DEPRESSED

CLARI-SKEMATIX

Registered Trademark

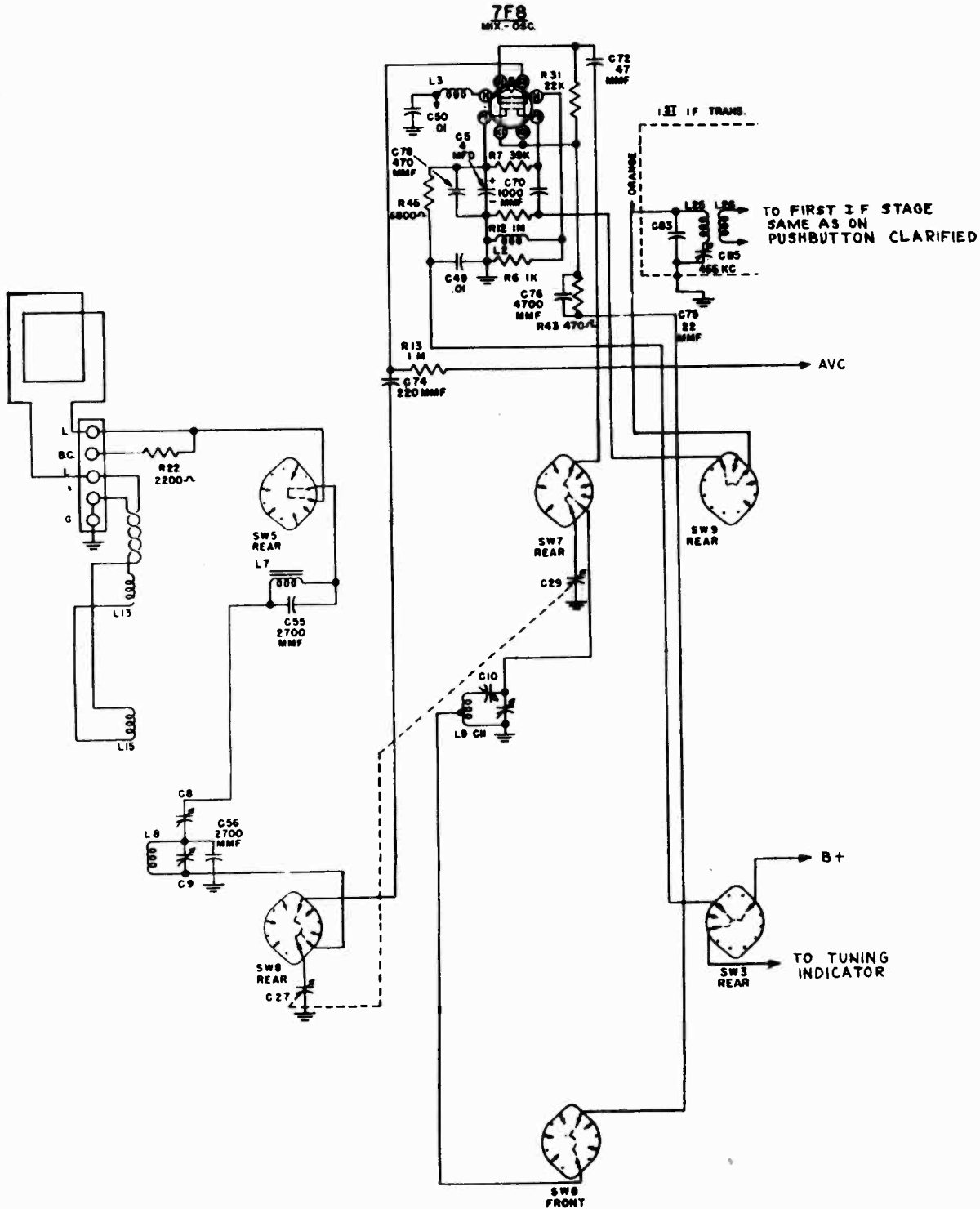

BAND-SWITCH SHOWN
 AT 3RD POSITION CLOCKWISE
 BROADCAST BAND
 MANUAL TUNING
 540- 1615 KC

CLARI-SKEMATIX

Registered Trademark

WESTINGHOUSE ELECTRIC CORP.

MODEL H-169

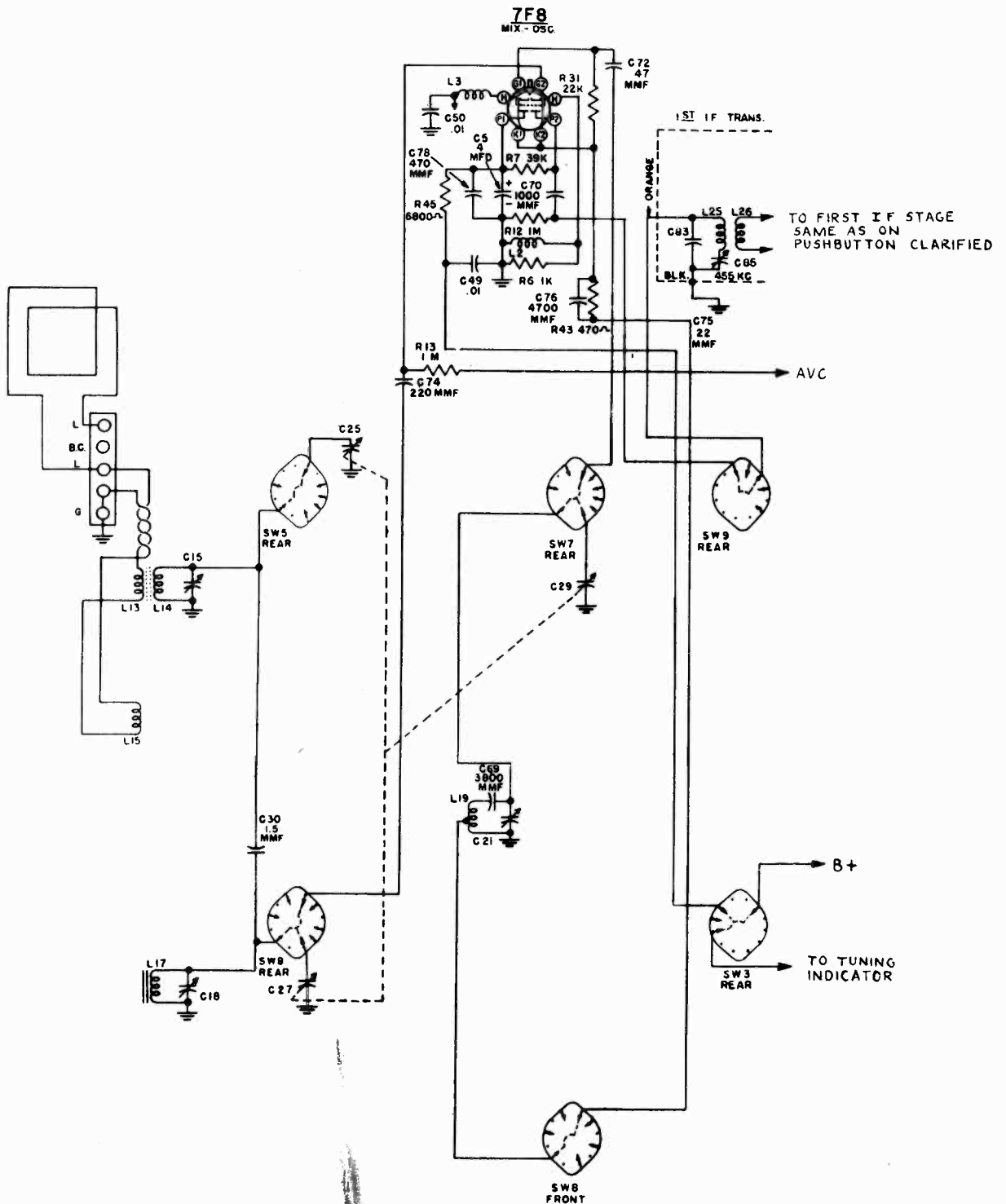

BAND-SWITCH SHOWN
AT 4TH POSITION CLOCKWISE.
SHORT WAVE -1BAND
5-10 MC

CLARI-SKEMATIX

Registered Trademark

PAGE 19-6 WESTINGHOUSE

WESTINGHOUSE ELECTRIC CORP.

MODEL H-169

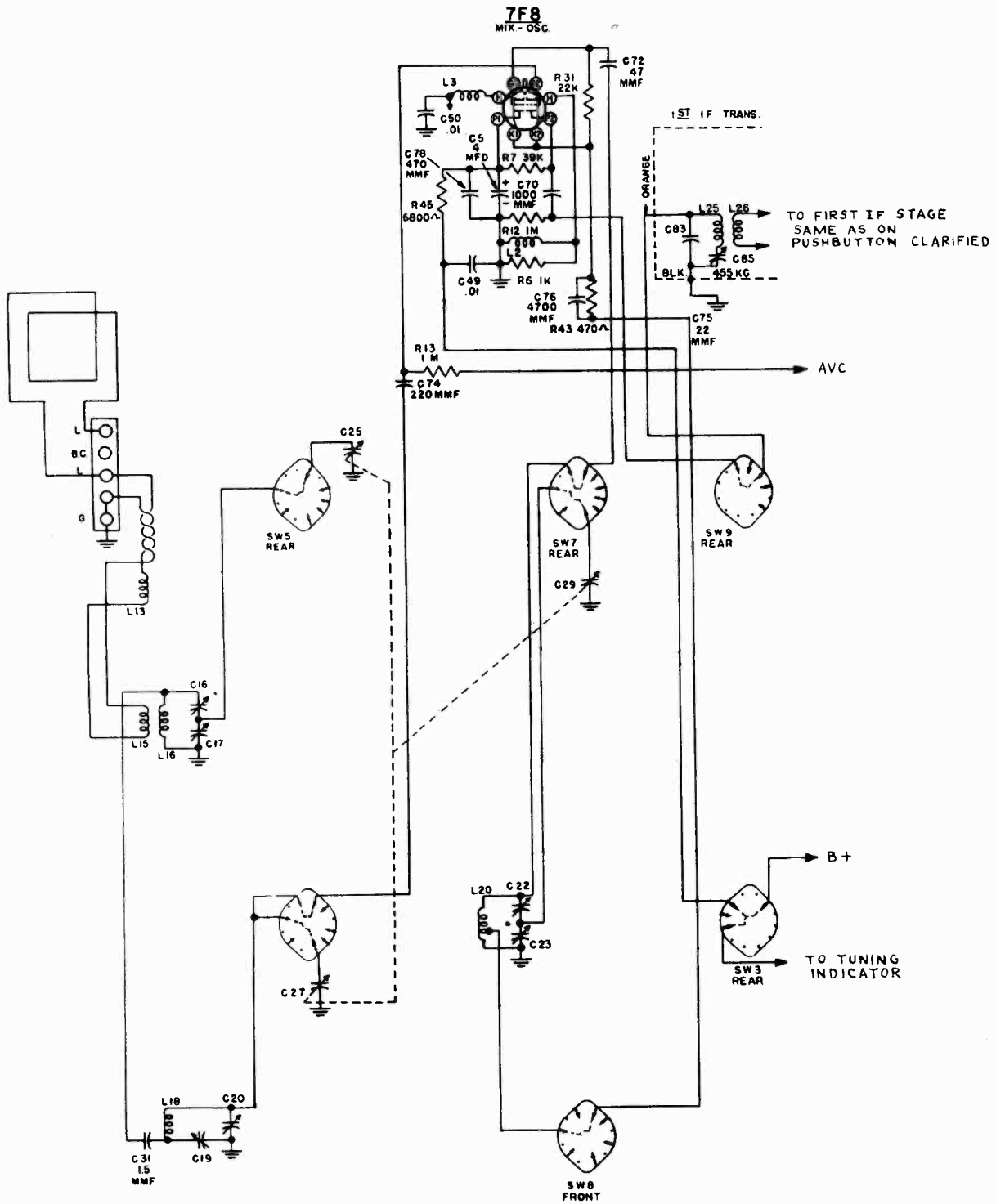

BAND-SWITCH SHOWN
AT 5TH POSITION CLOCKWISE .
SHORT WAVE 2ND BAND
12 - 20 MC

**ALIGNMENT PROCEDURE
BROADCAST AND SHORT WAVE BANDS**

Connect an output meter across the speaker voice coil.

With the volume control set for maximum output and the signal from the generator attenuated to avoid A.V.C. action, proceed as follows:

Step	Connect Signal Generator to —	Signal Generator Frequency	Radio Dial Setting	Adjust
1.	Set selector switch to "AM"			
2.	Pin #4 on 6SG7, 2nd I-F amplifier tube through a 0.1 mfd capacitor	455 kc	550 kc	455 kc secondary and primary trimmers of 3rd I-F for max. output.
3.	Pin #4 on 6SG7, 1st I-F amplifier tube through a 0.1 mfd capacitor	455 kc	550 kc	455 kc secondary and primary trimmers of 2nd I-F for max. output.
4.	Pin #1 on 7F8, converter tube through a 0.1 mfd capacitor	455 kc	550 kc	455 kc secondary and primary trimmers of 1st I-F for max. output.
5.	Converter section of gang (C27) through a 0.1 mfd capacitor	455 kc	550 kc	Carefully "peak" all 455 kc I-F transformers for max. output.
6.	B.C. antenna terminal through a 200 mmf capacitor	1500 kc	1500 kc	B.C. oscillator trimmer (C11) for max. output.
7.	Radiated signal (no actual connection)	1400 kc	1400 kc	B.C. converter (C9) and antenna (C8) trimmers for max. output.
8.	B.C. antenna terminal through a 200 mmf capacitor	600 kc	600 kc	B.C. oscillator padder (C10) for max. output. Rock gang while aligning padder.
9.	Recheck steps 6, 7, and 8.			
10.	Set selector switch to "SW-1"			
11.	Short wave antenna terminal through a 400 ohm resistor (center terminal marked "L")	9 mc	9 mc	Short Wave #1 oscillator trimmer (C21) for max. output.*
12.	Short wave antenna terminal through a 400 ohm resistor (center terminal marked "L")	9 mc	9 mc	Short Wave #1 converter (C18) and antenna (C15) trimmers for max. output. Rock gang while adjusting trimmers.
13.	Set selector switch to "SW-2"			
14.	Short wave antenna terminal through a 400 ohm resistor (center terminal marked "L")	18 mc	18 mc	Short Wave #2 oscillator trimmer (C23) for max. output.*

FREQUENCY RANGES:

Standard Broadcast 540 to 1615 kc.
 Short Wave 1 5 to 10 mc.
 Short Wave 2 12 to 20 mc.
 Frequency Modulation 88 to 108 mc.

TUBE COMPLEMENT:

1 7F8 R-F Amp.
 1 7F8 Conv.-Osc.
 2 6SG7 1st and 2nd I-F Amp.
 1 6SH7 Limiter (FM)
 1 6H6 Ratio Det. (FM)
 1 6H6 or 6H6GT Det. and AVC (AM)
 1 6SQ7 A-F Amp.
 1 6SN7 or 6SN7GT Driver
 2 6L6 or 6L6GA Power Output Amp.
 1 6U5 Tuning Indicator
 1 5U4G Rectifier
 1 6SC7 Phono. Pre-Amp.

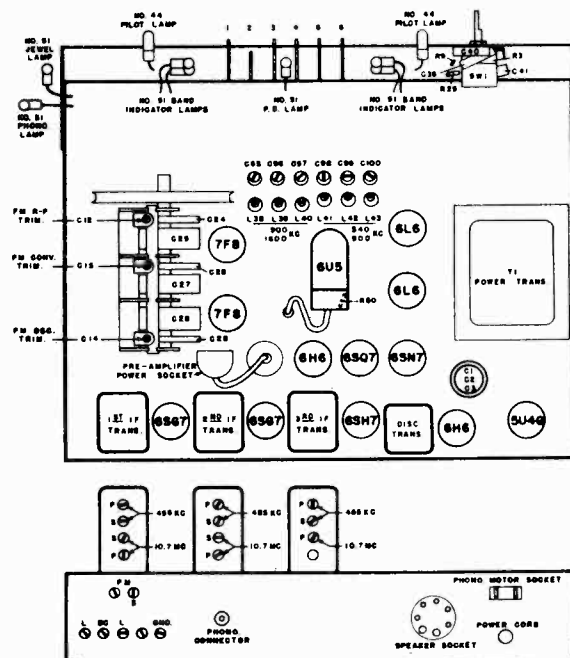

WESTINGHOUSE ELECTRIC CORP.

MODEL H-169

PUSH BUTTONS

Push buttons 1 to 3 are designed to receive stations from 900 to 1600 kc; push buttons 4 to 6 receive stations from 540 to 900 kc.

Refer to Fig. 3 for adjustor locations, and then proceed as follows:

1. Turn on radio and allow it to warm for five minutes.
2. Set the selector on AM, and tune in the desired station of the highest frequency (900 to 1600 kc).
3. Re-set the selector to PUSH BUTTONS and depress No. 1 push button (right button viewed from the front).
4. Adjust C95 for maximum receiver output (either a station or static will be heard depending on the setting of L38). Now adjust L38 until the desired station is heard. It may be necessary to re-adjust C95 at intervals to maintain receiver sensitivity.
5. Make a final adjustment of L38 for correct tuning and C95 for maximum output.
6. Return the selector to AM to make certain that the push button has been set on the desired station.
7. Adjust the remaining push buttons in the same manner.

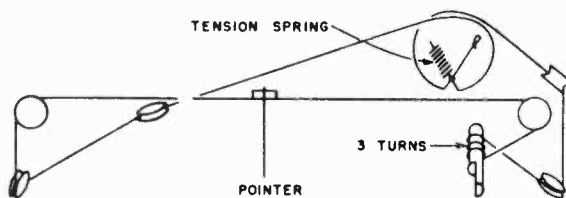

BROADCAST AND SHORT WAVE BANDS

Step	Connect Signal Generator to —	Signal Generator Frequency	Radio Dial Setting	Adjust
15.	Short wave antenna terminal through a 400 ohm resistor (center terminal marked "L")	18 mc	18 mc	Short Wave #2 converter (C20) and antenna (C17) trimmers for max. output.
16.	Short wave antenna terminal through a 400 ohm resistor (center terminal marked "L")	12 mc	12 mc	Short Wave #2 oscillator padder (C22) to receive 12 mc signal.
17.	Short wave antenna terminal through a 400 ohm resistor (center terminal marked "L")	12 mc	12 mc	Short Wave #2 converter (C19) and antenna (C16) padders for max. output.
18.	Repeat steps 14, 15, 16 and 17 until calibration and tracking is correct.			
FM BAND				
Do not align the 10.7 mc I-F circuits until all 455 kc I-F adjustments have been completed.				
1.	Set selector switch to "FM"			
2.	Connect a vacuum tube voltmeter between point X (see Figs. 1 and 2) and ground (chassis).			
3.	Pin #4 on 6SH7 limiter tube through a .001 mfd capacitor	UNMODULATED 10.7 mc	88 mc	Secondary of discriminator transformer (C94) for zero voltage.
4.	Re-connect the vacuum tube voltmeter to pin #3 on the 6H6 ratio detector tube.			
5.	Pin #4 on 6SH7 limiter tube through a .001 mfd capacitor	UNMODULATED 10.7 mc	88 mc	Primary of discriminator transformer (L34) for max. voltage.
6.	Pin #4 on 6SG7 2nd I-F tube through a .001 mfd capacitor	UNMODULATED 10.7 mc	88 mc	10.7 mc. pri. of 3rd I-F trans. for max. voltage.
7.	Pin #4 on 6SG7 1st I-F tube through a .001 mfd capacitor	UNMODULATED 10.7 mc	88 mc	10.7 mc. pri. and sec. of 2nd I-F trans. for max. voltage.
8.	Pin #1 of 7F8 converter tube through a .001 mfd capacitor	UNMODULATED 10.7 mc	88 mc	10.7 mc. pri. and sec. of 1st I-F trans. for max. voltage.
9.	Pin #1 of 7F8 converter tube through a .001 mfd capacitor	UNMODULATED 10.7 mc	88 mc	Recheck all 10.7 mc. I-F adjustments and discriminator primary (L34) adjustment.
10.	Re-connect the vacuum tube voltmeter to point X.			
11.	Stator of FM tuning capacitor (C26) through a .001 mfd capacitor	UNMODULATED 10.7 mc	88 mc	Secondary of discriminator trans. (C94) for zero voltage.
12.	Re-connect the vacuum tube voltmeter to pin #3 on the 6H6 ratio detector.			
13.	FM antenna terminals through a 72 ohm resistor (low side of generator to "S" terminal)	UNMODULATED 105 mc	105 mc	FM oscillator trimmer (C14) for max. voltage.
14.	FM antenna terminals through a 72 ohm resistor (low side of generator to "S" terminal)	UNMODULATED 105 mc	105 mc	FM converter (C13) and R-F (C12) trimmers for max. voltage.
15.	Re-check steps 13 and 14.			

Part No.	Description	Part No.	Description
V-4777-1	Antenna Assembly, FM dipole	RCM30B222M	Capacitor, 2200 mmf mica (C67)
V-5104	Background, dial	RCM20C181J	Capacitor, 180 mmf mica (C68)
V-5224	Bearing, ball, for speaker turntable	RCM30B382J	Capacitor, 3800 mmf mica (C69)
V-5223	Bearing, sleeve, for speaker turntable	R5CC26ZY102M	Capacitor, 1000 mmf ceramic (C70)
V-3507	Bracket and Clip Assembly, for tuning eye	R2CC26PJ470K	Capacitor, 47 mmf ceramic (C71, C72)
V-4893	Bumper, recessed, for doors	RCP10W4104A	Capacitor, 0.1 mfd 400 v. (C73)
V-5225	Bumper, speaker turntable	R2CC36SL221M	Capacitor, 220 mmf ceramic (C74)
V-5189	Button, hole plug	R2CC21PJ220K	Capacitor, 22 mmf ceramic (C75)
V-5191	Cable and Socket, for eye tube	R5CC36ZY472M	Capacitor, 4700 mmf ceramic (C76)
V-4931	Cable, output for pre-amplifier	R5CC21ZY471M	Capacitor, 470 mmf ceramic (C77, C78)
V-4965-1	Cable, phono input	R5CC35ZY472M	Capacitor, 4700 mmf ceramic (C79)
V-4930	Cable, power for pre-amplifier	RCM20B220K	Capacitor, 22 mmf mica (C80)
V-5115	Capacitor, electrolytic 30-10-30 mfd 450 v. (C1, C2, C3)	V-4634	Capacitor, dual line filter (C81, C82)
V-5311	Capacitor, electrolytic 2 mfd 450 v. (C4)	V-5064-1	Catch, bullet (mahogany)
V-4885	Capacitor, electrolytic 4 mfd 450 v. (C5, C6, C46)	V-5064-2	Catch, bullet (blonde)
V-3236	Capacitor, electrolytic cartridge, 20 mfd 25 v. (C7, C93)	V-4638	Choke, filament, R-F amplifier tube (L1)
V-5159	Capacitor, trimmer, B.C. antenna (C8)	V-4886	Choke, filament, converter tube (L2, L3)
V-5208	Capacitor, trimmer, B.C. converter (C9)	V-5261	Choke, FM antenna input (L4)
V-5143	Capacitor, trimmer, 2-gang (C10, C11)	V-4763	Clamp, dial
V-3713-1	Capacitor, ceramic variable, F.M. (C12, C13, C14)	V-5139	Coil, FM oscillator (L5)
V-5219	Capacitor, trimmer, SW1 and SW2 antenna (C15, C16, C17)	V-5140	Coil, FM converter (L6)
V-5220	Capacitor, trimmer, SW1 and SW2 converter (C18, C19, C20)	V-5129	Coil, BC antenna (L7)
V-5221	Capacitor, trimmer, SW1 and SW2 oscillator (C21, C22, C23)	V-5149	Coil, BC converter (L8)
V-3296	Capacitor, variable 3-gang (C24, C25, C26, C27, C28, C29)	V-5127	Coil, BC oscillator (L9)
V-5362	Capacitor, 1.5 mmf (C30, C31)	V-5140	Coil, FM antenna (L10)
RCP10W6102M	Capacitor, .001 mfd 600 v. (C33, C34)	V-3313	Coil, oscillator cathode (L11)
RCP10W6202M	Capacitor, .002 mfd 600 v. (C35)	V-5128	Coil, push button converter (L12)
RCP10W4203A	Capacitor, .02 mfd 400 v. (C36, C37, C38)	V-5125	Coil, SW1 antenna (L13, L14)
RCP10W4103A	Capacitor, .01 mfd 400 v. (C39, C40, C41, C42)	V-5147	Coil, SW2 antenna (L15, L16)
RCP10W4503A	Capacitor, .05 mfd 400 v. (C43)	V-5126	Coil, SW1 converter (L17)
RCP10W6502A	Capacitor, .005 mfd 600 v. (C44, C45)	V-5148	Coil, SW2 converter (L18)
RCM30B472M	Capacitor, 4700 mmf mica (C47, C48)	V-5124	Coil, SW1 and SW2 oscillator (L19, L20)
RCM30B103M	Capacitor, .01 mfd mica (C49, C50, C51, C52, C53)	V-3254S	Connector, phono
RCM20B180K	Capacitor, 18 mmf mica (C54)	V-5130	Control, tone, dual 2.0 megohms (R1) and 1.0 megohms (R2)
RCM30B292H	Capacitor, 2700 mmf mica (C55, C56)	V-5111	Control, volume 2.0 megohms (R3) and switch (SW1)
RCM20B471M	Capacitor, 470 mmf mica (C57)	V-4304-12	Cord Assembly, dial drive
RCM20B221M	Capacitor, 220 mmf mica (C58, C59, C60, C61, C62)	V-3239	Cord, power A-C
RCM20B470M	Capacitor, 47 mmf mica (C63)	V-4966-1	Cord, record changer power
RCM20B220M	Capacitor, 22 mmf mica (C64)	V-4525-3	Cushion, chassis mounting
RCM20B221K	Capacitor, 220 mmf mica (C65,	V-5109	Dial Background, rivet assembly
		V-5112	Dial, glass
		V-5171	Escutcheon, push button
		V-4902	Glide, furniture
		V-5060-1	Grille Cloth Assembly, speaker box (mahogany)
		V-5060-2	Grille Cloth Assembly, speaker box (blonde)
		V-5059-1	Grille Cloth, top (mahogany)
		V-5074	Grille Cloth, top (blonde)
		V-5123	Grille, metal, speaker
		V-3345S-4	Grommet, variable capacitor mounting
		V-5067-1	Hinge, center, split door (mahogany)
		V-5067-2	Hinge, center, split door (blonde)
		V-5363-1	Hinge, lower left hand (mahogany)

WESTINGHOUSE ELECTRIC CORP.

MODEL H-169

Part No.	Description	Part No.	Description
V-5170	Retainer, molding for V-5169	V-5363-2	Hinge, lower right hand (mahogany)
V-5188	Rosette, brass	V-5363-3	Hinge, lower left hand (blonde)
V-5173	Screw, #2-56, for front glass plate	V-5363-4	Hinge, lower right hand (blonde)
V-3429-8	Screw, #10-32 Hex Head, chassis mounting	V-5179-1	Jewel, pilot light
V-5187-1	Screw, mounting, for front glass plate	V-5155-1	Knob, band (mahogany)
V-5110	Shaft, tuning	V-5155-2	Knob, band (blonde)
V-3344S-2	Sleeve, spacer, variable capacitor mounting	V-4362-4	Knob, tone, front (mahogany)
V-3353-5	Slide Mechanism, left hand	V-4362-5	Knob, tone, front (blonde)
V-3353-6	Slide Mechanism, right hand	V-5028-2	Knob, tone, rear
V-3393-4	Socket, A-C power, phono	V-5095-1	Knob, volume and tuning (mahogany)
V-5117-2	Socket Assembly, tube (7F8)	V-5095-2	Knob, volume and tuning (blonde)
V-4933	Socket, molded octal, for pre-amplifier	No. 44	Lamp, pilot light
V-4195	Socket, molded octal tube (6L6)	No. 51	Lamp, pilot light
V-3275S	Socket, molded octal tube (5U4G)	V-3283-4	Loop Assembly
V-3246	Socket, octal tube (wafer)	V-5169	Molding, bronze strip, front
V-5181	Socket, pilot light, jewel	V-5365-1	Molding, plastic, for lower doors (mahogany)
V-5237	Socket, pilot light, phono	V-5365-2	Molding, plastic, for lower doors (blonde)
V-5183	Socket, pilot light, push buttons	V-5205	Nut, speed, for front glass plate
V-5180-3	Socket, pilot light, (SW1, SW2, BC, FM)	V-5236	Plate, anchor, 1½" x 1½"
V-5192	Socket, 7 contact for speaker	V-5158-1	Plate Assembly, front glass (mahogany)
V-5193	Socket, tuning eye (plus R50)	V-5158-2	Plate Assembly, front glass (blonde)
V-5182	Sockets, pilot light, edge lights	V-5229	Plate, bottom, for speaker turntable
V-5354	Spacer, Neoprene, for speaker turntable	V-5230	Plate, mounting, for speaker turntable
V-5160	Speaker, 12" Electro-Dynamic	V-5231	Plate, top, for speaker turntable
V-5161	Speaker, 5" x 7" P.M. (plus C32)	V-5133	Pointer
V-3248S	Spring, dial drive	V-5062	Pull, door, lower (mahogany)
V-3258S	Spring, knob	V-5305	Pull, door, lower (blonde)
V-5233	Spring, speaker turntable	V-5061	Pull, door, upper (mahogany)
V-5065-1	Strike, bullet catch (mahogany)	V-5306	Pull, door, upper (blonde)
V-5065-2	Strike, bullet catch (blonde)	V-3166S	Pulley, 7/16 dia.
V-5168-1	Strip, felt, 5/16" x 15" (mahogany)	V-5166-1	Push button
V-5168-2	Strip, felt, 5/16" x 15" (blonde)	V-5232	Race, bearing, for speaker turntable
V-5234	Stud, bearing, for speaker turntable	V-5203	Reflector, dial
V-3167S-1	Stud, pulley, threaded	V-5134	Resistor, 190 ohms 4 w. (R4)
V-5235	Stud, threaded, for speaker turntable	V-5340	Resistor, 290 ohms 2.3 w. (R5)
V-3261-3	Switch, push button (SW10A, SW10B)	RC10AE102M	Resistor, 1000 ohms 1/4 w. (R6)
V-5135	Switch, selector, (SW2, SW3, SW4, SW5, SW6, SW7, SW8, SW9)	RC20AE393K	Resistor, 39K ½ w. (R7)
V-5152	Tab, AM and SW1	RC10AE274M	Resistor, 270K 1/4 w. (R8, R9, R10)
V-5185	Tab, FM and SW2	RC20AE682K	Resistor, 6800 ohms ½ w. (R11)
V-5174	Tab, station	RC10AE105M	Resistor, 1.0 megohm 1/4 w. (R12, R13, R15, R16, R17)
V-3482	Teenut, for speaker box	RC10AE104K	Resistor, 100K 1/4 w. (R14, R18, R19)
V-5144	Terminal Board, ANT-GND	RC10AE273K	Resistor, 27K 1/4 w. (R20)
V-3417	Terminal Board, FM antenna	RC10AE473M	Resistor, 47K 1/4 w. (R21)
V-5136	Transformer, driver (L21, L22)	RC10AE222M	Resistor, 2200 ohms 1/4 w. (R22)
V-5373	Transformer, 1st I-F (C83, C84, C85, C101, C102, L23, L24, L25, L26)	RC10AE683M	Resistor, 68K 1/4 w. (R23)
V-5374	Transformer, 2nd I-F (C86, C87, C88, C89, R49, L27, L28, L29, L30)	RC10AE225M	Resistor, 2.2 megohms 1/4 w. (R24, R25)
V-5375	Transformer, 3rd I-F (C90, C91, C92, L31, L32, L33)	RC10AE273M	Resistor, 27K 1/4 w. (R26)
V-5212	Transformer, discriminator (C93, C94, L34, L35, L36, L37)	RC10AE153J	Resistor, 15K 1/4 w. (R27, R28)
V-5137	Transformer, power	RC20AE330K	Resistor, 33 ohms ½ w. (R29, R30)
V-3274S	Tube Holder	RC10AE223K	Resistor, 22K 1/4 w. (R31)
V-3317	Tuner, push button	RC10AE680M	Resistor, 68 ohms 1/4 w. (R32)
V-5222	Turntable Assembly, for speaker box	RC10AE274K	Resistor, 270K 1/4 w. (R33, R34)
V-3506S-1	Washer, chassis mounting, Neoprene	RC20AE333M	Resistor, 33K ½ w. (R35)
V-3752S	Washer, felt, for knobs	RC10AE154K	Resistor, 150K 1/4 w. (R36)
V-3267S-3	Washer, flat, chassis mounting	RC10AE474M	Resistor, 470K 1/4 w. (R37)
V-3267S-10	Washer, flat, record changer mounting	RC40AE223K	Resistor, 22K 2 w. (R38)
V-3215S	Washer, spring, for tuning shaft	RC30AE333K	Resistor, 33K 1 w. (R39, R40)
V-5175	Windows, station tab	RC20AE103K	Resistor, 10K ½ w. (R41)
		RC10AE222K	Resistor, 2200 ohms 1/4 w. (R42)
		RC20AE471K	Resistor, 470 ohms ½ w. (R43, R44)
		RC40AE682K	Resistor, 6800 ohms 2 w. (R45)
		RC30AE332K	Resistor, 3300 ohms 1 w. (R46, R47)
		RC10AE221K	Resistor, 220 ohms ½ w. (R48)

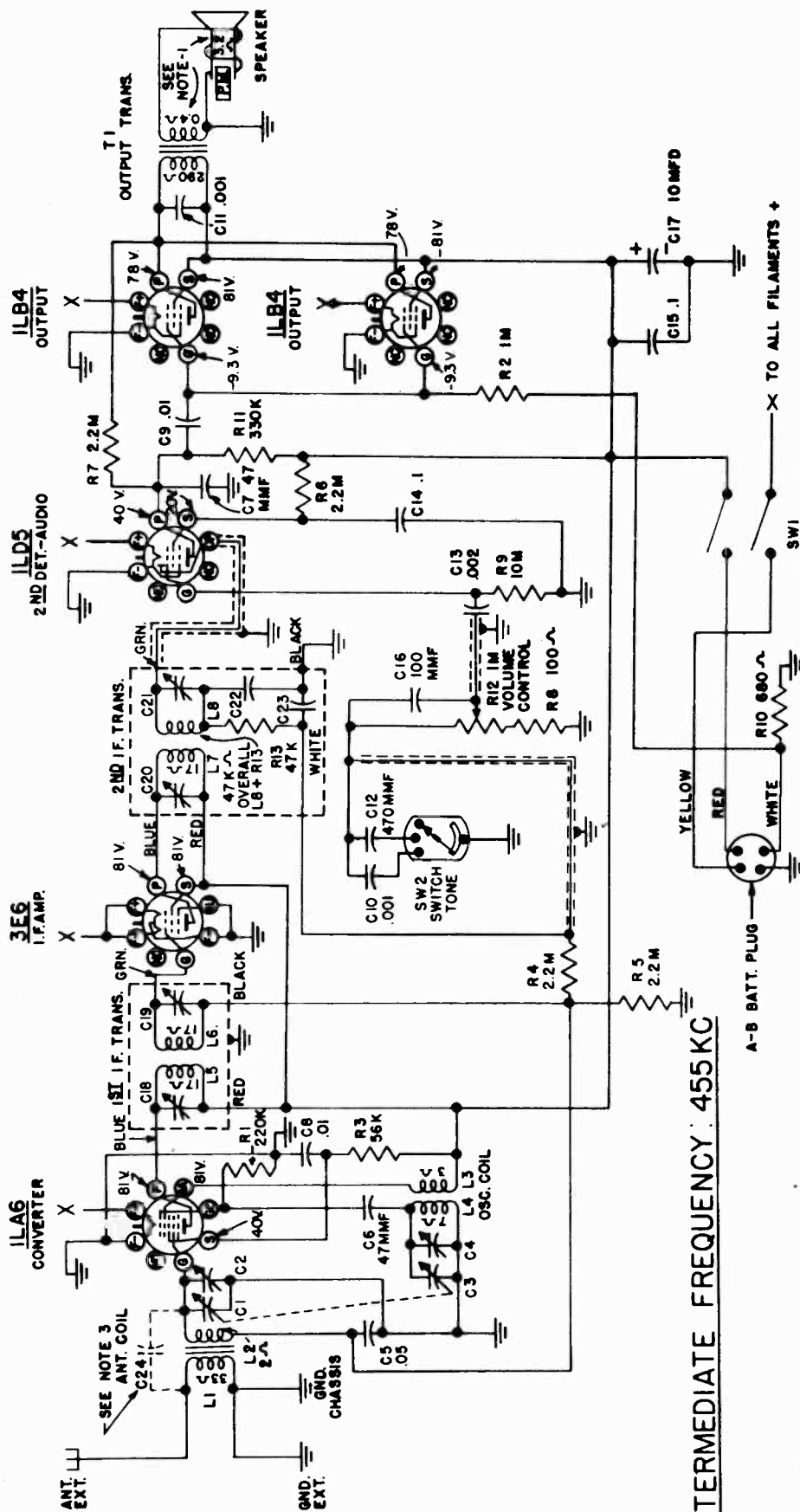

INTERMEDIATE FREQUENCY: 455 KC

- NOTE -
1. VOICE COIL DISCONNECTED.
 2. ALL VOLTAGES MEASURED FROM CHASSIS (GND) USING 20,000 OHMS/VOLT METER. READINGS SHOULD APPROXIMATE THE VALUES SHOWN WITHIN 20 PERCENT.
 3. NOT USED ON ALL CHASSIS.

FREQUENCY RANGE:

Standard Broadcast and Police 550 to 1700 kc

POWER OUTPUT:

Undistorted 140 milliwatts
 Maximum 350 milliwatts

POWER SUPPLY:

1 Westinghouse V-3594 "AB" Battery Pack
 (1 1/2 v. "A" and 90 v. "B")

CURRENT CONSUMPTION:

"A" Section of "AB" Battery 260 ma.
 "B" Section of "AB" Battery 16 ma.

LOUDSPEAKER:

Size and Type 5 1/4" P. M.
 Voice Coil Impedance 3.2 ohms

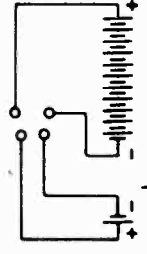

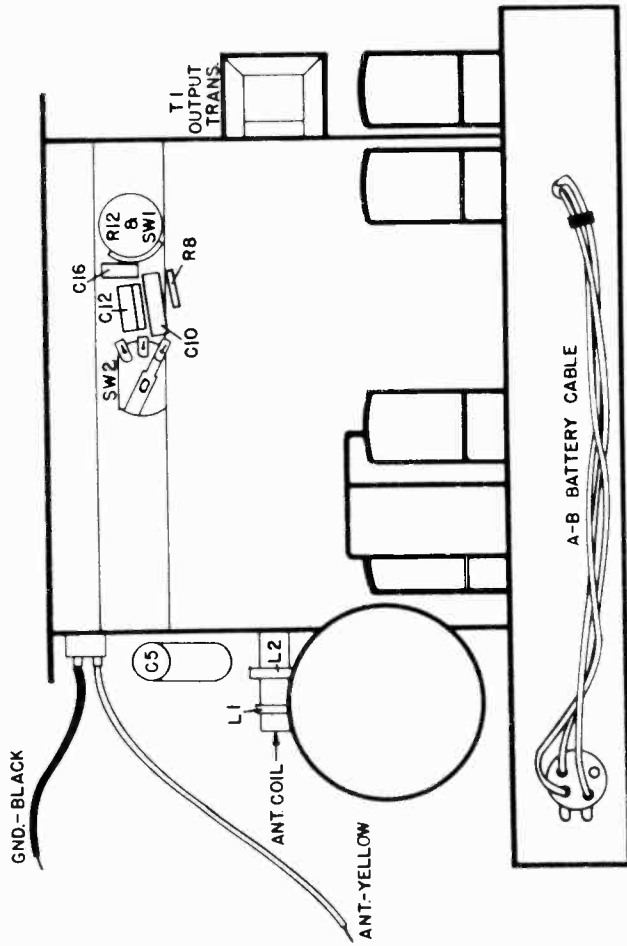
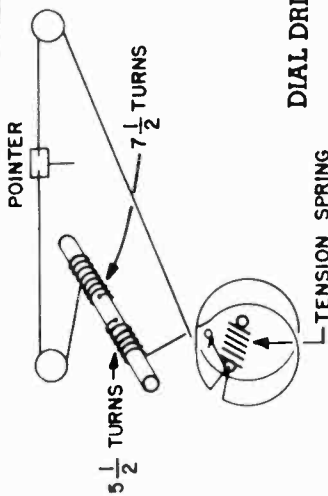
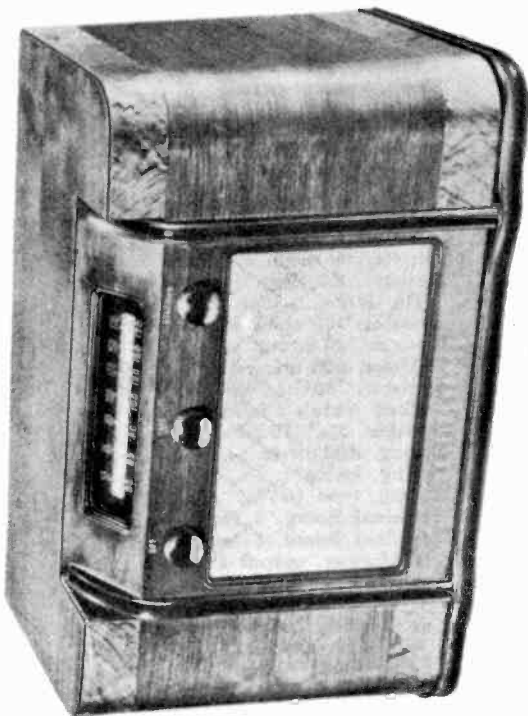

REAR VIEW OF CHASSIS

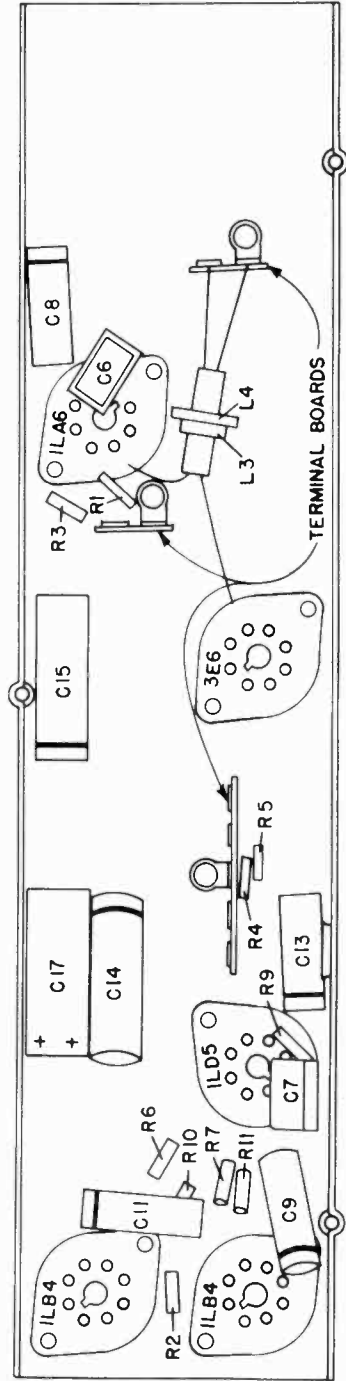

BOTTOM VIEW OF CHASSIS

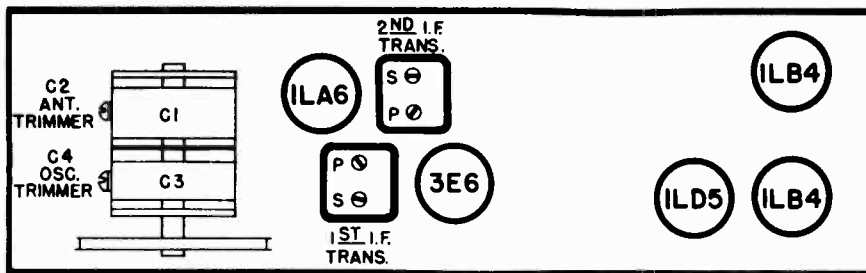

CHASSIS LAYOUT

ALIGNMENT

Before beginning alignment, make certain that the dial pointer aligns with the dot on the extreme high-frequency end of the dial when the tuning capacitor is set for minimum capacity.

Connect an output meter across the speaker voice coil.

While making the following adjustments, keep the volume control set for maximum output and the signal generator output attenuated to avoid A. V. C. action.

Step	Connect Signal Generator to—	Signal Generator Frequency	Radio Dial Setting	Adjust
1	3E6 control grid through 0.1 mfd capacitor	455 kc	550 kc	Secondary and Primary trimmers of 2nd I-F trans. for max. output.
2	1LA6 control grid through 0.1 mfd capacitor	455 kc	550 kc	Secondary and Primary trimmers of 1st I-F trans. for max. output.
3	Antenna terminal through 200 mmf capacitor	455 kc	550 kc	"Peak" all I-F trimmers.
4	Antenna terminal through 200 mmf capacitor	1500 kc	1500 kc	Oscillator trimmer for max. output.
5	Antenna terminal through 200 mmf capacitor	1500 kc	1500 kc	Antenna trimmer for max. output.

PARTS LIST FOR MODEL H-178

When ordering parts specify model number of set in addition to part number and description of part.

Part No.	Description	Part No.	Description
V-3603	Background, dial	V-3489S-1	Foot, rubber
V-3593	Baffle, speaker	V-3592-2	Grille Cloth
V-3594	Battery, "A-B"	V-3268	Grommet, variable condenser mounting
V-3550	Bracket, dial mounting	V-3331-1	Knob, volume-switch
V-3551	Bracket, pulley stud assembly	V-3331-3	Knob, tone
V-3600	Bracket, speaker mounting	V-3331-2	Knob, tuning
V-3555	Bracket, tuning shaft mounting	V-3585	Plug, battery cable
V-3580	Bracket, variable capacitor	V-3558	Pointer Assembly
V-1147-1	Cabinet	V-3166S	Pulley, 7/16" dia.
V-5324	Cable Assembly, battery	RC10AE224M	Resistor, 220K 1/4 w. (R1)
V-3569	Capacitor, variable 2 gang (C1, C2, C3, C4)	RC10AE105M	Resistor, 1.0 meg. 1/4 w. (R2)
RCP10W2503A	Capacitor, .05 mfd 200 v. (C5)	RC10AE563M	Resistor, 56K 1/4 w. (R3)
RCM20A470K	Capacitor, 47 mmf mica (C6, C7)	RC10AE225M	Resistor, 2.2 meg. 1/4 w. (R4, R5, R6, R7)
RCP10W4103A	Capacitor, .01 mfd 400 v. (C8, C9)	RC10AE101M	Resistor, 100 ohms 1/4 w. (R8)
RCP10W6102K	Capacitor, .001 mfd 600 v. (C10, C11)	RC10AE106M	Resistor, 10.0 meg. 1/4 w. (R9)
RCM20A471K	Capacitor, 470 mmf mica (C12)	RC10AE681K	Resistor, 680 ohms 1/4 w. (R10)
RCP10W6202A	Capacitor, .002 mfd 600 v. (C13)	RC10AE334M	Resistor, 330K 1/4 W. (R11)
RCP10W2104A	Capacitor, 0.1 mfd 200 v. (C14, C15)	V-3573	Socket, loktal, miniature tube
RCM20A101M	Capacitor, 100 mmf mica (C16)	V-3601	Speaker, 5 1/4" P. M.
V-3581	Capacitor, electrolytic, tubular 10 mfd 150 v. (C17)	V-3248S	Spring, dial drive
V-3562	Clamp, dial	V-3258S	Spring, knobs
V-3567	Coil, antenna (L1, L2, C24)	V-3563	Switch, tone (SW2)
V-3582	Coil, oscillator (L3, L4)	V-3574	Terminal Board, 2 lugs
V-3564	Control, volume, 2 meg. (R12) with switch (SW1)	V-3575	Terminal Board, 5 lugs
V-4157S-66	Cord, dial drive	V-3576	Transformer, output (T1)
V-3596	Decal, OFF	V-3577	Transformer, 1st I-F (L5, L6, C18, C19)
V-3662	Decal, STATIONS	V-3578	Transformer, 2nd I-F (L7, L8, C20, C21, C22, C23, R13)
V-3660	Decal, TONE	V-3556	Tuning Shaft Assembly
V-3665	Decal, WESTINGHOUSE	V-3752S	Washer, felt
V-3559	Dial, glass	V-3267S-4	Washer, flat, chassis mounting
		V-3237	Washer, cup, variable capacitor Mounting

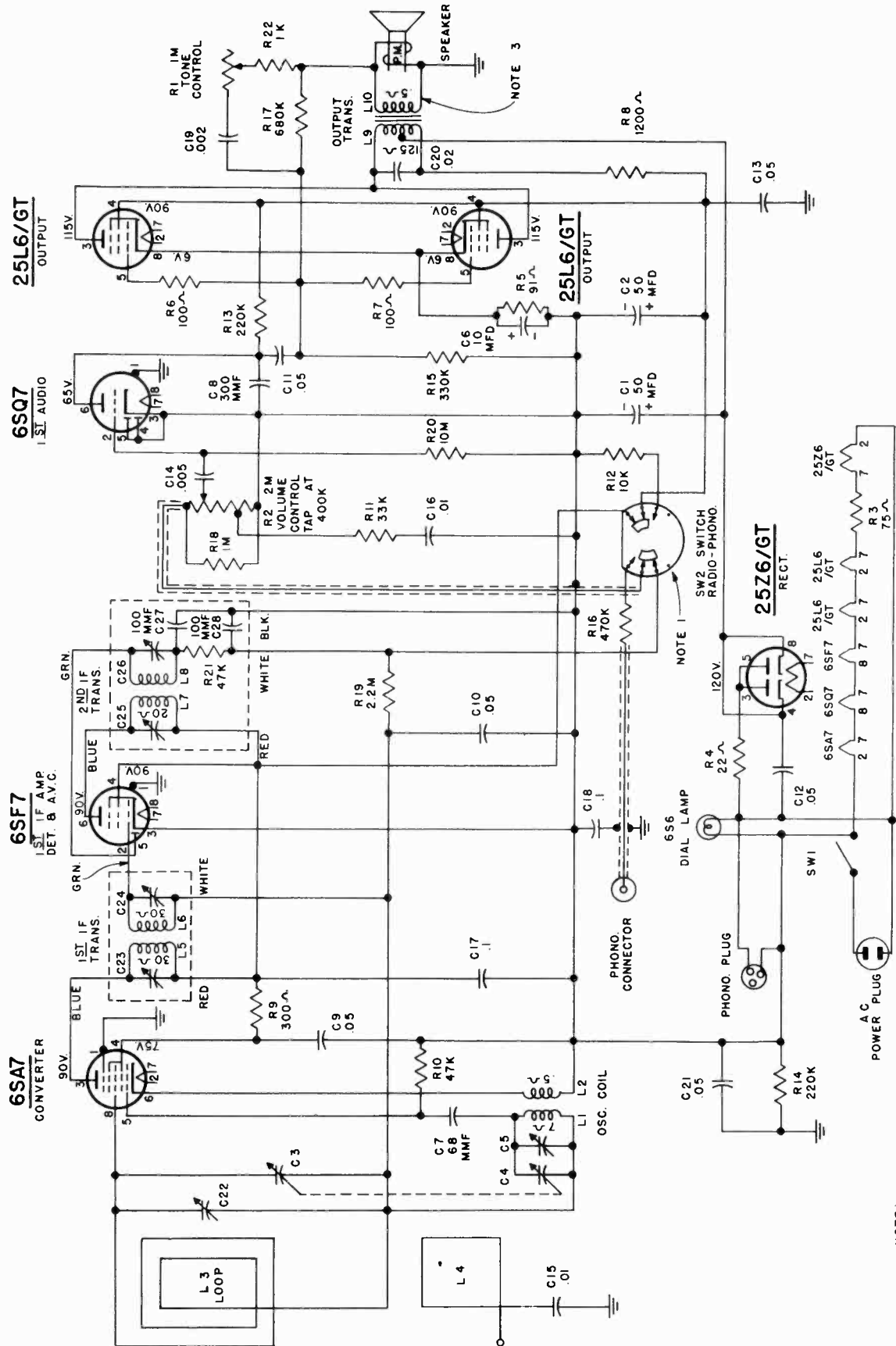

NOTE:
 1. SELECTOR SWITCH (SW2) IS SHOWN IN BROADCAST POSITION.
 2. SECOND POSITION CLOCKWISE IS PHONO.
 3. ALL VOLTAGES MEASURED FROM CIRCUIT (GND.) USING A 20,000 OHM/VOLT METER - LINE VOLTAGE 117 V.A.C. VOLTAGES SHOULD BE AS SHOWN ± 20%.

MODELS H-183,
H-183A

WESTINGHOUSE ELECTRIC CORP.



ALIGNMENT

The use of an isolation transformer in the power line is recommended.

Connect an output meter across the speaker voice coil.

While making the following adjustments, keep the volume control set for maximum output and the signal generator output attenuated to avoid A. V. C. action.

Step	Connect Signal Generator to—	Signal Generator Frequency	Radio Dial Setting	Adjust
1	Pin No. 2 of 6SF7 tube through a 200 mmf capacitor	455 kc	540 kc	Secondary and primary of 2nd I-F transformer for maximum output.
2	Stator of tuning capacitor (C3) through a 200 mmf capacitor	455 kc	540 kc	Secondary and primary of 1st I-F transformer for maximum output.
3	Recheck 1st and 2nd I-F transformers.			
4	Antenna terminal through a 200 mmf capacitor	1615 kc	1615 kc	Oscillator trimmer (C5) for maximum output.
5	Radiated signal (no actual connection)	1400 kc	1400 kc	Antenna trimmer (C22) for maximum output.

FREQUENCY RANGE540 to 1615 kc. **POWER OUTPUT:**
INTERMEDIATE FREQUENCY455 kc. Undistorted2 watts
 Maximum2.5 watts

TUBE COMPLEMENT:
 1 6SA7Converter
 1 6SF71st I-F Amp, Det., and AVC
 1 6SQ71st Audio
 2 25L6GTOutput
 1 25Z6GTRectifier

LOUDSPEAKER 10" PM
OPERATING VOLTAGES (radio section only):
 105 to 120 volts, 50-60 cycles or 105 to 120 volts, D.C.

PILOT LAMPWestinghouse No. 6S6 120 v., .05 amp. **POWER CONSUMPTION (radio section)**35 watts

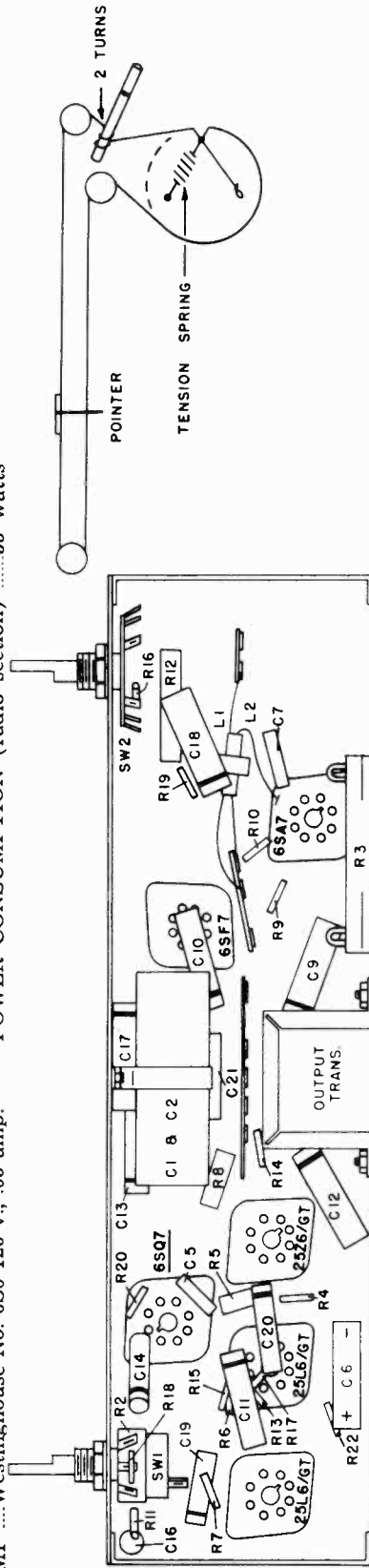

WESTINGHOUSE ELECTRIC CORP.

MODELS H-183,
H-183A

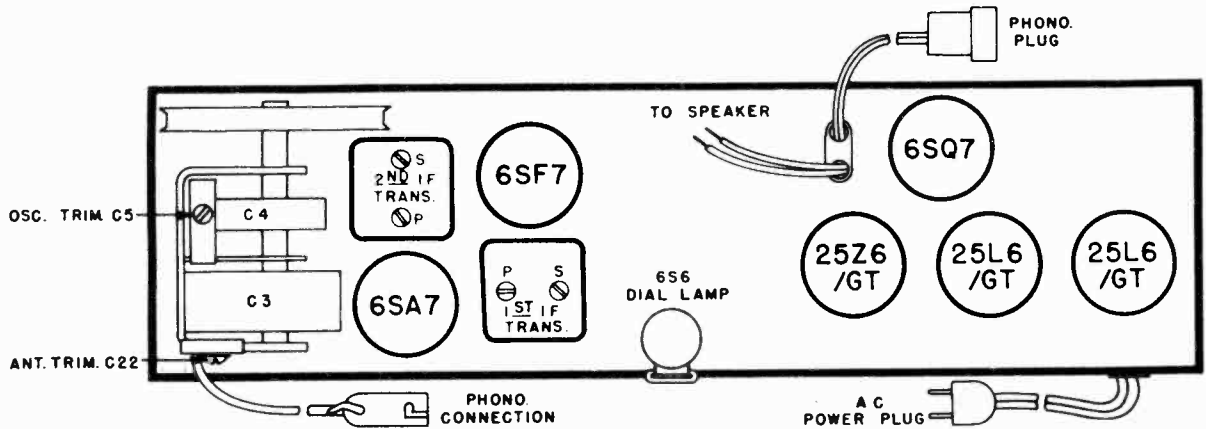

Part No.	Description	Part No.	Description
V-3166S	Pulley, 7/16 dia.	V-5580	Bracket, dial lamp
V-3321	Rail, pointer	V-5584	Cable and Socket, phono power
V-4994	Resistor, 75 ohms 2 w. (R3)	V-5593	Capacitor, electrolytic 50-50 mfd (C1, C2)
RC20AE220M	Resistor, 22 ohms 1/2 w. (R4)	V-5586	Capacitor, variable 2-gang (C3, C4, C5)
RC30AE910J	Resistor, 91 ohms 1 w. (R5)	V-5621	Capacitor, electrolytic cartridge 10 mfd (C6)
RC10AE101M	Resistor, 100 ohms 1/4 w. (R6, R7)	RCM20A680M	Capacitor, 68 mmf mica (C7)
RC40AE122K	Resistor, 1200 ohms 2 w. (R8)	RCM20A301M	Capacitor, 300 mmf mica (C8)
RC10AE332M	Resistor, 3300 ohms 1/4 w. (R9)	RCP10W4503A	Capacitor, .05 mfd 400 v. (C9, C10, C11, C12, C13)
RC10AE473M	Resistor, 47,000 ohms 1/4 w. (R10)	RCP10W6502A	Capacitor, .005 mfd 600 v. (C14)
RC10AE333M	Resistor, 33,000 ohms 1/4 w. (R11)	RCP10W4103A	Capacitor, .01 mfd 400 v. (C15, C16)
RC40AE103M	Resistor, 10,000 ohms 2 w. (R12)	RCP10W4104A	Capacitor, .1 mfd 400 v. (C17, C18)
RC10AE224M	Resistor, 220,000 ohms 1/4 w. (R13, R14)	RCP10W4202A	Capacitor, .002 mfd 400 v. (C19)
RC10AE334M	Resistor, 330,000 ohms 1/4 w. (R15)	RCP10W4203A	Capacitor, .02 mfd 400 v. (C20)
RC10AE474M	Resistor, 470,000 ohms 1/4 w. (R16)	V-5618-1	Capacitor, .05 mfd 400 v. (C21)
RC10AE684M	Resistor, 680,000 ohms 1/4 w. (R17)	V-4992	Capacitor, trimmer, antenna (C22)
RC10AE105M	Resistor, 1 megohm 1/4 w. (R18)	V-5627-1	Catch, bullet
RC10AE225M	Resistor, 2.2 megohms 1/4 w. (R19)	V-5622	Clip, dial mounting
RC10AE106M	Resistor, 10M 1/4 w. (R20)	V-3473	Coil, oscillator (L1, L2)
RC10AE102M	Resistor, 1000 ohms 1/4 w. (R22)	V-5585	Connector, phono, female
V-3322	Shaft, tuning	V-3303	Control, tone (R1)
V-5620	Shield, light	V-5617	Control, volume (R2) and switch (SW1)
V-3344-1	Sleeve, spacer	V-4304-15	Cord Assembly, dial drive
V-5631-1	Slide Mechanism, left hand	V-3663	Decal, radio-phono
V-5631-2	Slide Mechanism, right hand	V-3662	Decal, stations
V-5619-1	Socket, dial lamp	V-3660	Decal, tone
V-3163	Socket, octal No. 1 ground	V-3661	Decal, volume
V-3246S	Socket, octal tube	V-5567	Dial, plastic
V-5571	Speaker, 10" P. M.	V-5569	Escutcheon
V-3248S	Spring, dial drive	V-5629	Glide, furniture
V-3258S	Spring, knob	V-5625-1	Grille Cloth
V-5628-1	Strike, bullet catch	V-3766	Grommet, fibre
V-3301	Switch, radio-phono (SW2)	V-3345-7	Grommet, phono mounting (H-183)
V-3482	Teenut, phono mounting (H-183)	V-5630-1	Hinge, door
V-3328	Transformer, 1st I-F (C23, C24, L5, L6)	V-3667-6	Knob, radio-phono
V-3329	Transformer, 2nd I-F (R21, C25, C26, C27, C28, L7, L8)	V-3262-5	Knob, tone and band
V-5430	Transformer, output (L9, L10)	V-3667-5	Knob, volume
V-3668S	Washer, felt (knobs)	No. 6S6	Lamp, dial
V-3267S-10	Washer, flat (record changer mounting for H-183A)	V-5583	Loop, antenna
V-3267S-4	Washer, flat (chassis and record changer mounting for H-183 and chassis mounting for H-183A)	V-5632-1	Nameplate
		V-3712S	Needle, phono
		V-3366-2	Pin, escutcheon-nameplate mounting
		V-5577	Pointer, dial
		V-5626-1	Pull, door

MODEL H-188

WESTINGHOUSE ELECTRIC CORP.

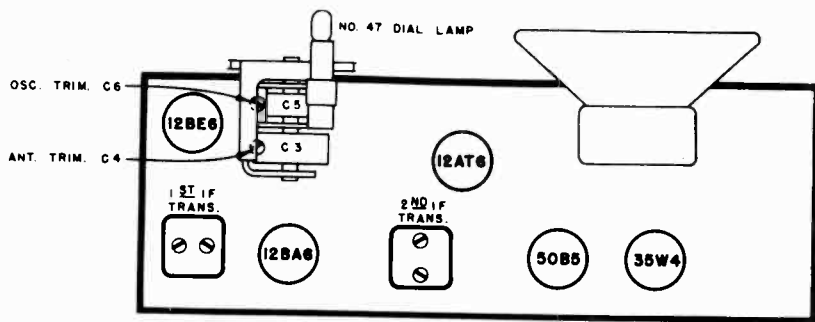

CHASSIS NO. V-2133

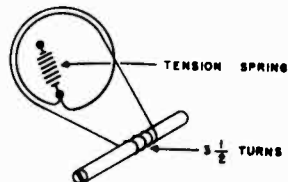

Step	Connect Signal Generator to —	Signal Generator Frequency	Radio Dial Setting	Adjust
1.	Stator of antenna tuning capacitor (C3) through a 0.1 mfd capacitor	455 kc	minimum capacity	Trimmers in 1st and 2nd I-F trans. for max. output
<p>NOTE: If the I-F transformers are badly mis-aligned, it may be impossible to obtain sufficient output using the above system. In this event, it will be necessary to align each transformer separately. Start with the last I-F transformer and work forward, connecting the signal generator to the control grid of the tube preceding the transformer under alignment.</p>				
2.	Recheck Step 1 adjustments.			
3.	Radiated signal (no actual connection)	1615 kc	minimum capacity	Osc. trimmer (C6) for max. output
4.	Radiated signal (no actual connection)	1400 kc	tune to signal	Ant. trimmer (C4) for max. output (rock-in adjustment)

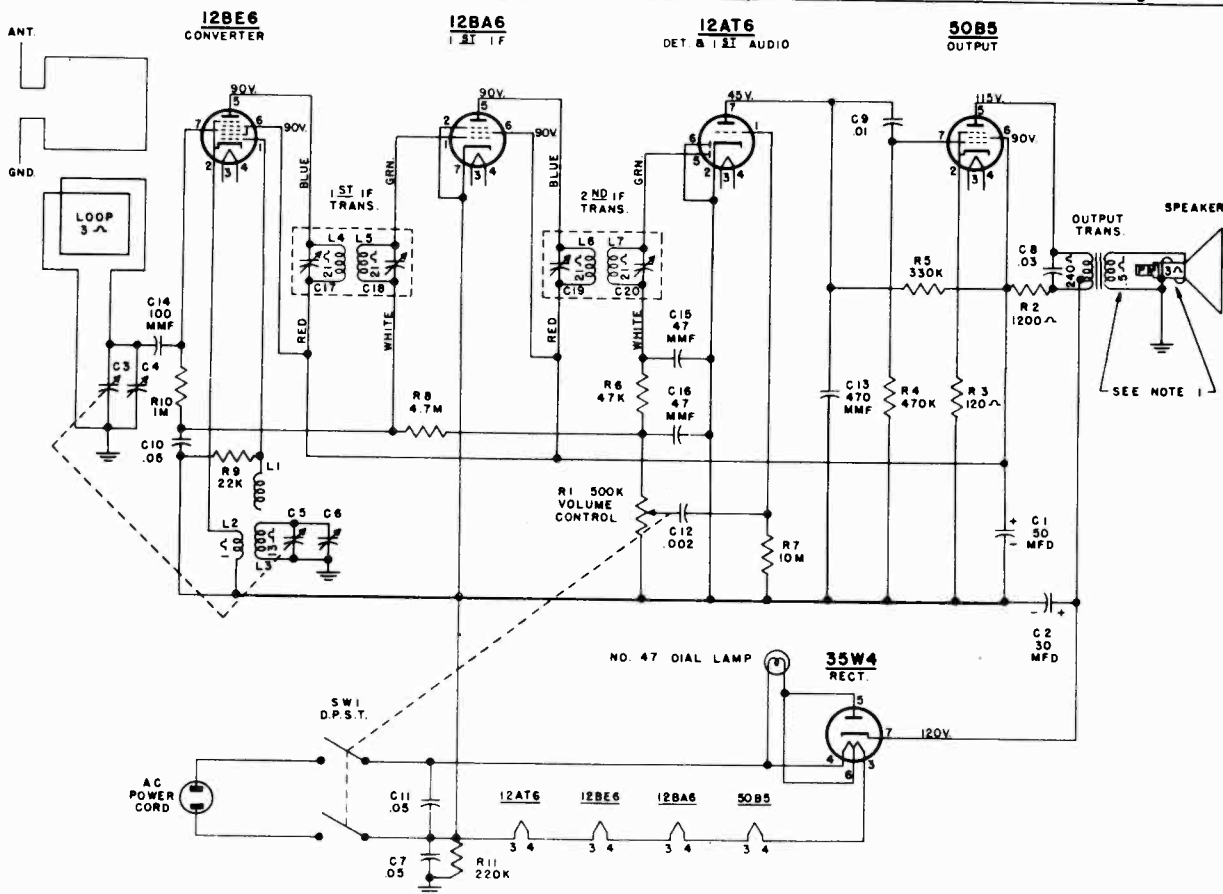

NOTE:
 1. VOICE COIL DISCONNECTED.
 2. ALL VOLTAGES MEASURED FROM CIRCUIT (GND.) USING 20,000 OHM/VOLT METER—LINE VOLTAGE 117 V.A.C. VOLTAGES SHOULD BE AS SHOWN ± 20 PER CENT.

CHASSIS NO. V-2133



ALIGNMENT

It is recommended that the chassis be isolated from the power line by means of an isolation transformer.

Connect an output meter across the speaker voice coil.

While making the following adjustments, keep the volume control set for maximum output and the signal generator attenuated to avoid AVC action.

SPECIFICATIONS

V-5778-1	Baffle and Grille Cloth Assembly	
**V-1160-1	Cabinet	
V-4044	Capacitor, electrolytic	
	50 mfd 150 v. (C1)	
	30 mfd 150 v. (C2)	
V-5819	Capacitor, variable, 2 gang	
	Tuner, antenna (C3)	
	Trimmer, antenna (C4)	
	Tuner, oscillator (C5)	
	Trimmer, oscillator (C6)	
V-5618-1	Capacitor, .05 resonant 400 v. (C7)	
RCP10W4303A	Capacitor, .03 mfd 400 v. (C8)	
RCP10W4103A	Capacitor, .01 mfd 400 v. (C9)	
RCP10W4503A	Capacitor, .05 mfd 400 v. (C10, C11)	
RCP10W6202A	Capacitor, .002 mfd 600 v. (C12)	
RCM20A471M	Capacitor, 470 mmf mica (C13)	
RCM20A101M	Capacitor, 100 mmf mica (C14)	
RCM20A470M	Capacitor, 47 mmf mica (C15, C16)	
V-5851	Coil, oscillator (L1, L2, L3)	
V-5833	Control, volume, variable resistor 500K (R1) and switch D.P.S.T. (SW1)	
V-4304-18	Cord, dial drive	
V-5679-1	Cover, back	
V-5777	Dial	
V-5784	Disc, pointer	
V-5785-1	Hub, pointer	
V-5780-1	Knob	
No. 47	Lamp, pilot light	
RC30AE122K	Resistor, 1200 ohms 1 w. (R2)	FREQUENCY RANGE: 540 to 1600 kc.
RC20AE121K	Resistor, 120 ohms ½ w. (R3)	
RC20AE474M	Resistor, 470,000 ohms ½ w. (R4)	INTERMEDIATE FREQUENCY: 455 kc.
RC20AE334M	Resistor, 330,000 ohms ½ w. (R5)	
RC20AE473M	Resistor, 47,000 ohms ½ w. (R6)	TUBE COMPLEMENT:
RC20AE106M	Resistor, 10 megohms ½ w. (R7)	1 12BE6 Converter
RC20AE475M	Resistor, 47 megohms ½ w. (R8)	1 12BA6 I-F Amp.
RC20AE223M	Resistor, 22,000 ohms ½ w. (R9)	1 12AT6 Det., AVC, and 1st Audio
RC20AE105M	Resistor, 1 megohm ½ w. (R10)	1 50B5 Output Amp.
RC20AE224M	Resistor, 220,000 ohms ½ w. (R11)	1 35W4 Rectifier
V-4053	Socket, dial light	
V-5852-2	Socket, miniature wafer	
V-5852-1	Socket, miniature wafer (shielded)	PILOT LAMP: Westinghouse No. 47, 6.3 v., 0.15 a.
**V-5682	Speaker, 5" P.M.	POWER OUTPUT:
V-4057	Spring, dial drive	Undistorted 0.8 watts
V-5685	Transformer, 1st I-F (L4, L5, C17, C18)	Maximum 1.3 watts
V-5686	Transformer, 2nd I-F (L6, L7, C19, C20)	
V-5775-1	Transformer, output	LOUDSPEAKER: 5" P.M.
V-5421-3	Washer, felt, knob	OPERATING VOLTAGE: 105 to 120 volts 50-60 cycles A-C or D-C
V-5776	Window, dial	POWER CONSUMPTION: 35 watts at 117 volts

MODELS H-190,
H-191, H-191A

WESTINGHOUSE ELECTRIC CORP.

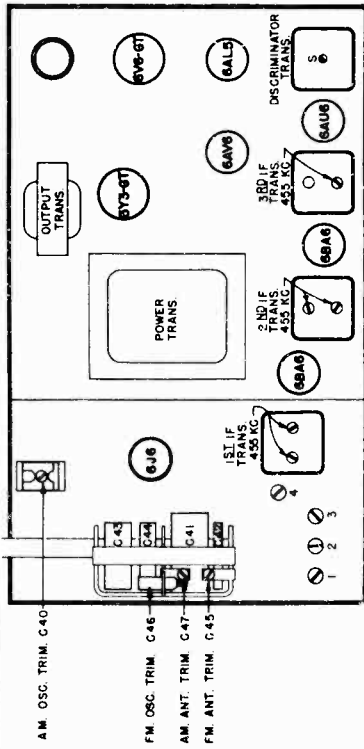

— TOP VIEW

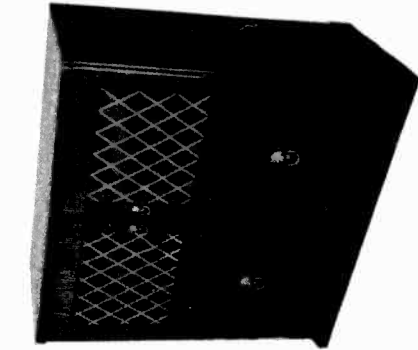
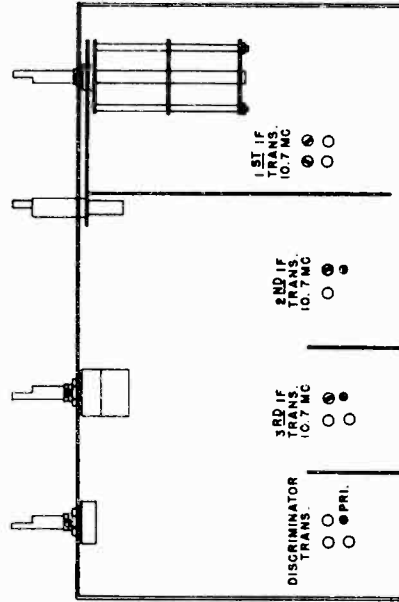

H-191 & H-191A

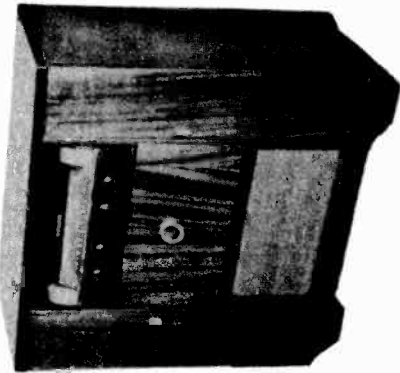

H-190

SPECIFICATIONS

FREQUENCY RANGES:

Standard Broadcast 540 - 1600 kc.
Frequency Modulation 88 - 108 mc.

INTERMEDIATE FREQUENCIES:

Amplitude Modulation 455 kc.
Frequency Modulation 10.7 mc.

TUBE COMPLEMENT:

- 1 6J6 Osc. - Converter
- 2 6BA6 1st and 2nd I-F Amp.
- 1 6AU6 Limiter (FM)
- 1 6AV6 Det. (AM) and 1st A-F Amp.
- 1 6AL5 Ratio Det. (FM)
- 1 6V6GT Output Amp.
- 1 5Y3GT Rectifier

PILOT LAMPS:

...2 Westinghouse No. 44, 6.3 v., 0.25 amp.

POWER OUTPUT:

Undistorted 3.5 watts
Maximum 5 watts

LOUDSPEAKER:

H-190 8" P.M.
H-191 and H-191A 10" P.M.

OPERATING VOLTAGE:

..... 105 to 120 volts, 60 cycles A-C

POWER CONSUMPTION 150 watts

WESTINGHOUSE ELECTRIC CORP.

MODELS H-190,
H-191, H-191A

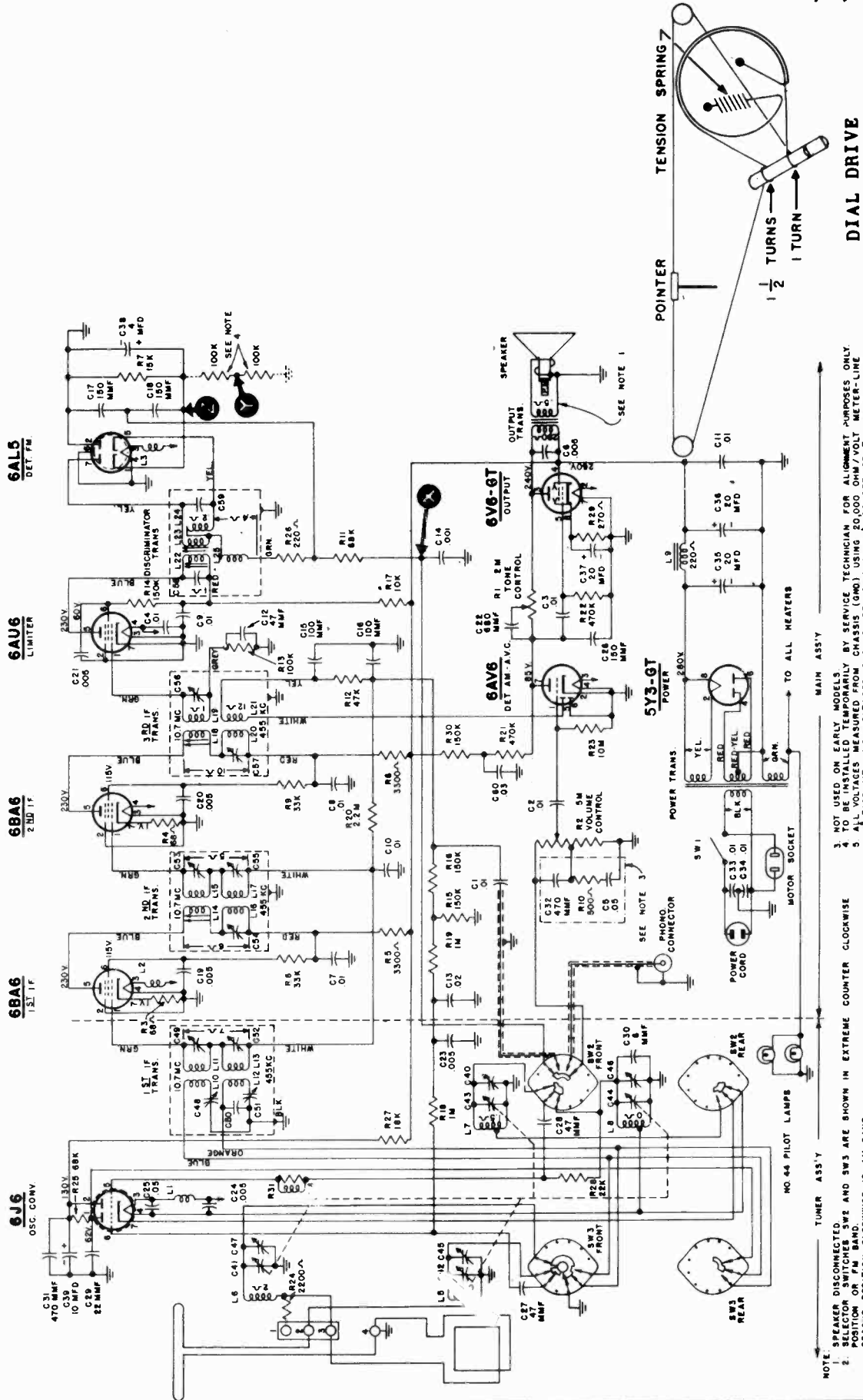

3. NOT USED ON EARLY MODELS
 4 TO BE INSTALLED TEMPORARILY BY SERVICE TECHNICIAN FOR ALIGNMENT PURPOSES ONLY
 5 ALL VOLTAGES MEASURED FROM CHASSIS (GND) USING 20,000 OHM/VOLT METER-LINE
 VOLTAGE 117 V.A.C. VOLTAGES SHOULD BE AS SHOWN ± 20 PER CENT.

CHASSIS NO. V-2134

MODELS H-190,
H-191, H-191A

WESTINGHOUSE ELECTRIC CORP.

ALIGNMENT
BROADCAST BAND

Completely mesh the tuning capacitor plates and set the dial pointer to the end mark on the dial scale.

Connect an output meter across the speaker voice coil.

While making the following adjustments, keep the volume control set for maximum output, the tone control set for maximum treble, and the signal generator output attenuated to avoid A.V.C. action.

Step	Connect Signal Generator to —	Signal Generator Frequency	Radio Dial Setting	Adjust
1	Set the band switch to AM.			
2	Stator of tuning capacitor (C41) through a 0.1 mfd capacitor	455 kc	maximum capacity	455 kc. pri. of 3rd I-F trans., sec. and pri. of 2nd I-F trans., and sec. and pri. of 1st I-F trans. for max. output
<p><i>NOTE: If the I-F transformers are badly mis-aligned, it may be impossible to obtain sufficient output using the above system. In this event, it will be necessary to align each transformer separately. Start with the last I-F transformer and work forward, connecting the signal generator to the control grid of the tube preceding the transformer under alignment.</i></p>				
3	Radiated signal (no actual connection)	1600 kc	1600 kc	AM osc. trimmer (C40) for max. output
4	Radiated signal (no actual connection)	1400 kc	tune to signal	AM ant. trimmer (C47) for max. output (rock-in adjustment)

FM BAND

Do not align the 10.7 mc. I-F circuits until all 455 kc. I-F adjustments have been completed.

1	Set the band switch to FM.			
2	Connect two 100,000 ohm resistors (the resistances must be equal within 5 percent) between pin #1 of the 6AL5 tube and ground as shown in Fig. 4.			
3	Connect a V.T.V.M. between points "X" and "Y" (see Fig. 4).			
4	Pin #1 of the 6BA6, 1st I-F amp. through a .001 mfd mica capacitor	10.7 mc	maximum capacity	Sec. of discriminator trans. for zero voltage (the voltage will go positive on one side of the correct setting and negative on the other side)
5	Connect the V.T.V.M. between point "Z" and ground.			
6	Pin #1 of the 6BA6, 1st I-F amp. through a .001 mfd mica capacitor	10.7 mc	maximum capacity	Pri. of discriminator trans., 10.7 mc. sec. and pri. of 3rd I-F trans., and 10.7 mc. sec. and pri. of 2nd I-F trans. for max. voltage
7	Using the same sig. generator and V.T.V.M. connections as in Step 6, adjust the sig. generator output until the V.T.V.M. indicates 4 volts. Use this sig. generator setting to perform Step 9.			
8	Reconnect the V.T.V.M. between points "X" and "Y".			
9	Pin #1 of the 6BA6, 1st I-F amp. through a .001 mfd mica capacitor	10.7 mc	maximum capacity	Sec. of discriminator trans. for zero voltage. The voltage will change polarity as the sec. is tuned through resonance — tune carefully for exact zero
10	Remove the two 100,000 ohm resistors which were inserted in Step 2.			
11	Reconnect the V.T.V.M. between point "Z" and ground.			
12	Pin #1 of the 6BA6, 1st I-F amp. through a .001 mfd mica capacitor	10.7 mc	maximum capacity	Recheck pri. of discriminator trans. for max. voltage
13	Stator of FM tuning capacitor (C42) through a .01 mfd mica capacitor	10.7 mc	maximum capacity	Sec. and pri. of 10.7 mc. 1st I-F trans. for max. voltage
14	Ant. terminal #2 through a 300 ohm resistor	108 mc	108 mc	FM osc. trimmer (C46) for max. voltage*
15	Ant. terminal #2 through a 300 ohm resistor	105 mc	tune to signal	FM ant. trimmer (C45) for max. voltage (rock-in adjustment)**

*After adjusting the oscillator trimmer at 108 mc., check dial calibration by tuning the receiver to an 88 mc. signal from the generator. If the dial pointer indicates 88 mc., no further oscillator adjustments are necessary. If the pointer is on the high frequency side of 88 mc., slightly expand the length of the oscillator coil (L8); if the pointer is on the low frequency side of 88 mc., slightly compress the oscillator coil. Re-adjust the oscillator trimmer at 108 mc., and again check the calibration. Repeat this process until calibration is correct.

**After adjusting the antenna trimmer at 105 mc., check tracking by tuning to a 90 mc. signal from the generator and re-adjusting the antenna trimmer for max. output. If the peak setting is the same at 90 mc. as it was at 105 mc., no further adjustments are necessary. If the trimmer capacitance must be increased to obtain max. output at 90 mc., slightly compress the antenna coil (L5); if the capacitance must be decreased, slightly expand the coil. Re-adjust the antenna trimmer at 105 mc., and again check the tracking. Repeat this process until tracking is correct.

WESTINGHOUSE ELECTRIC CORP.

MODELS H-190,
H-191, H-191A

Part No.	Description	Part No.	Description	Part No.	Description
V-5803	Coil, antenna loading (L6)	RC10AE225M	Resistor, 2.2 megohms K w. (R20)	RC10AE225M	Resistor, 2.2 megohms K w. (R20)
V-5804	Coil, oscillator (L7)	RC10AE474K	Resistor, 470,000 ohms K w. (R21, R22)	RC10AE474K	Resistor, 470,000 ohms K w. (R21, R22)
V-4674	Coil, FM antenna (L5)	RC10AE106M	Resistor, 10 megohms K w. (R23)	RC10AE106M	Resistor, 10 megohms K w. (R23)
V-6076	Coil, FM oscillator (L8)	RC10AE222M	Resistor, 2200 ohms K w. (R24)	RC10AE222M	Resistor, 2200 ohms K w. (R24)
V-3254S	Connector, phono	RC20AE683K	Resistor, 68,000 ohms K w. (R25)	RC20AE683K	Resistor, 68,000 ohms K w. (R25)
V-5790	Control, tone, 2 megohms (R1)	RC10AE221M	Resistor, 220 ohms K w. (R26)	RC10AE221M	Resistor, 220 ohms K w. (R26)
V-5791	Control, volume-off-on, .5 megohms (R2) and switch (SW1)	RC30AE183K	Resistor, 18,000 ohms 1 w. (R27)	RC30AE183K	Resistor, 18,000 ohms 1 w. (R27)
V-4304-17	Cord, dial drive	RC10AE223K	Resistor, 22,000 ohms K w. (R28)	RC10AE223K	Resistor, 22,000 ohms K w. (R28)
V-70	Crystal Cartridge (Shure P-93) (H-190)	RC30AE271K	Resistor, 270 ohms 1 w. (R29)	RC30AE271K	Resistor, 270 ohms 1 w. (R29)
V-7689	Crystal Cartridge (Shure P-30) (H-191) and H-191A)	V-4169-1	Shield Base, miniature tube (6J6)	V-4169-1	Shield Base, miniature tube (6J6)
V-4690	Decal, band	V-4169-2	Shield, miniature tube (6J6)	V-4169-2	Shield, miniature tube (6J6)
V-4691	Decal, tone	V-5795-1	Socket, dial light	V-5795-1	Socket, dial light
V-4692	Decal, tuning	V-4292S-2	Socket, miniature molded (6J6)	V-4292S-2	Socket, miniature molded (6J6)
V-4693	Decal, volume	V-5670	Socket, miniature wafer (4)	V-5670	Socket, miniature wafer (4)
V-4474	Dial, Westinghouse (H-190)	V-5673	Socket, miniature wafer (unshielded) (6AV6)	V-5673	Socket, miniature wafer (unshielded) (6AV6)
V-5820	Dial, Westinghouse (H-190)	V-3275S	Socket, molded octal tube (5Y3G)	V-3275S	Socket, molded octal tube (5Y3G)
V-5998-1	Grille Cloth, speaker (H-190)	V-4195	Socket, molded octal tube (6V6)	V-4195	Socket, molded octal tube (6V6)
V-5363-1	Hinge, L.H.	V-5405	Socket, molded power (phono A-C)	V-5405	Socket, molded power (phono A-C)
V-5363-2	Hinge, R.H.	V-5981	Speaker, 8" P.M. (H-190)	V-5981	Speaker, 8" P.M. (H-190)
V-3667-7	Knob Assembly, band switch	V-5571	Speaker, 10" P.M. (H-191 and H-191A)	V-5571	Speaker, 10" P.M. (H-191 and H-191A)
V-3667-5	Knob Assembly, tone-volume- tuning	V-3248S	Spring, dial drive	V-3248S	Spring, dial drive
No. 44	Lamp, pilot light	V-3258S	Spring, knob	V-3258S	Spring, knob
V-5859	Molding, decals	V-4491-5	Strip, dial	V-4491-5	Strip, dial
V-7682	Motorboard (H-190)	V-6017-2	Support and Grille Cloth Assembly, L.H. Door (H-191 and H-191A)	V-6017-2	Support and Grille Cloth Assembly, L.H. Door (H-191 and H-191A)
V-4696	Nameplate, Westinghouse-FM (H-191 and H-191A)	V-5980	Support and Grille Cloth Assembly, R.H. Door (H-191 and H-191A)	V-5980	Support and Grille Cloth Assembly, R.H. Door (H-191 and H-191A)
V-3712	Needle, phono (H-190)	V-5878-1	Support and Grille Cloth Assembly, speaker (H-191 and H-191A)	V-5878-1	Support and Grille Cloth Assembly, speaker (H-191 and H-191A)
V-7690	Needle, phono (H-191 and H-191A)	V-5806	Switch, selector	V-5806	Switch, selector
V-5793	Painter, dial	V-4627	Transformer, 1st I-F (C48, C49, C50, C51, C52, L10, L11, L12, L13)	V-4627	Transformer, 1st I-F (C48, C49, C50, C51, C52, L10, L11, L12, L13)
V-6000-1	Pull, door, phono (H-190)	V-4628	Transformer, 2nd I-F (C53, C54, C55, L14, L15, L16, L17)	V-4628	Transformer, 2nd I-F (C53, C54, C55, L14, L15, L16, L17)
V-5877-2	Pull, door, phono (H-191 and H-191A)	V-4629	Transformer, 3rd I-F (C56, C57, L18, L19, L20, L21)	V-4629	Transformer, 3rd I-F (C56, C57, L18, L19, L20, L21)
V-5999-1	Pull, door, record compartment (H-190)	V-5796	Transformer, discriminator (C58, C59, L22, L23, L24, L25)	V-5796	Transformer, discriminator (C58, C59, L22, L23, L24, L25)
V-5877-1	Pull, door, record compartment (H-191 and H-191A)	V-5798	Transformer, audio output	V-5798	Transformer, audio output
V-4886-3	Reactor, R-F (L1, L2, L3)	V-5797	Transformer, power	V-5797	Transformer, power
V-4886-7	Reactor, R-F (L4, L31)	V-3668S	Washer, felt, for knobs	V-3668S	Washer, felt, for knobs
V-5794	Reactor, filter choke (L9)				
RC10AE680K	Resistor, 68 ohms K w. (R3, R4)				
RC30AE332K	Resistor, 3300 ohms 1 w. (R5, R6)				
RC10AE153K	Resistor, 15,000 ohms K w. (R7)				
RC30AE333K	Resistor, 33,000 ohms 1 w. (R8, R9)				
RC10AE152M	Resistor, 1500 ohms K w. (R10)				
RC10AE683M	Resistor, 68,000 ohms K w. (R11)				
RC10AE473M	Resistor, 47,000 ohms K w. (R12)				
RC10AE104K	Resistor, 100,000 ohms K w. (R13)				
RC20AE154K	Resistor, 150,000 ohms K w. (R14)				
RC10AE154M	Resistor, 150,000 ohms K w. (R15, R16, R30)				
RC30AE103K	Resistor, 10,000 ohms 1 w. (R17)				
RC10AE105M	Resistor, 1 megohm K w. (R18, R19)				
V-5982-1	Antenna Assembly, AM loop (H-190)	RCM20A101M	Capacitor, 100 mfd mica (C15, C16)	RCM20A101M	Capacitor, 100 mfd mica (C15, C16)
V-5875-1	Antenna Assembly, AM loop (H-191 and H-191A)	RCM20A151J	Capacitor, 150 mfd mica (C17, C18)	RCM20A151J	Capacitor, 150 mfd mica (C17, C18)
V-5986-1	Antenna Assembly, FM dipole (H-190)	V-5040-11	Capacitor, .005 mfd 600 v. (C19, C20, C21)	V-5040-11	Capacitor, .005 mfd 600 v. (C19, C20, C21)
V-5986-2	Antenna Assembly, FM dipole (H-191 and H-191A)	R5CC25Z7681M	Capacitor, 680 mfd ceramicon (C22)	R5CC25Z7681M	Capacitor, 680 mfd ceramicon (C22)
V-5812	Background, dial	V-5596	Capacitor, .005 mfd 450 v. (C23, C24, C25)	V-5596	Capacitor, .005 mfd 450 v. (C23, C24, C25)
V-5860-2	Cable Assembly, speaker (H-191 and H-191A)	RCM20A151M	Capacitor, 150 mfd mica (C26)	RCM20A151M	Capacitor, 150 mfd mica (C26)
V-4965-2	Cable, phono input (H-191 only)	R3CC21SL470K	Capacitor, 47 mfd ceramicon (C27, C28)	R3CC21SL470K	Capacitor, 47 mfd ceramicon (C27, C28)
RCP10W4103A	Capacitor, .01 mfd 400 v. (C1, C2, C3)	RCM20B220K	Capacitor, 22 mfd mica (C29)	RCM20B220K	Capacitor, 22 mfd mica (C29)
V-5040-13	Capacitor, .01 mfd 200 v. (C4)	R3CC20UR060G	Capacitor, 6 mfd ceramicon (C30)	R3CC20UR060G	Capacitor, 6 mfd ceramicon (C30)
RCP10W2503M	Capacitor, .05 mfd 200 v. (C5)	R5CC20ZV471M	Capacitor, 470 mfd ceramicon (C31)	R5CC20ZV471M	Capacitor, 470 mfd ceramicon (C31)
RCP10M6502A	Capacitor, .005 mfd 600 v. (C6, C8, C9, C10, C11)	RCM20A471M	Capacitor, 470 mfd mica (C32)	RCM20A471M	Capacitor, 470 mfd mica (C32)
RCM20A470M	Capacitor, 47 mfd mica (C12)	V-4634	Capacitor, dual line filter (C33, C34)	V-4634	Capacitor, dual line filter (C33, C34)
RCP10W4203A	Capacitor, .02 mfd 400 v. (C13)	V-5821	Capacitor, electrolytic 20-20 mfd 400 v. (C35, C36)	V-5821	Capacitor, electrolytic 20-20 mfd 400 v. (C35, C36)
RCP10W6102A	Capacitor, .001 mfd 600 v. (C14)	V-3236	Capacitor, electrolytic 20 mfd 25 v. (Cathode bypass - C37)	V-3236	Capacitor, electrolytic 20 mfd 25 v. (Cathode bypass - C37)
RCM20A101M	Capacitor, 100 mfd mica (C15, C16)	V-4885	Capacitor, electrolytic 4 mfd 450 v. (C38)	V-4885	Capacitor, electrolytic 4 mfd 450 v. (C38)
RCM20A151J	Capacitor, 150 mfd mica (C17, C18)	V-5985	Capacitor, electrolytic 10 mfd 350 v. (C39)	V-5985	Capacitor, electrolytic 10 mfd 350 v. (C39)
V-5040-11	Capacitor, .005 mfd 600 v. (C19, C20, C21)	V-4672	Capacitor, trimmer, AM oscillator (C40)	V-4672	Capacitor, trimmer, AM oscillator (C40)
R5CC25Z7681M	Capacitor, 680 mfd ceramicon (C22)	V-5802	Capacitor, variable AM antenna (C41)	V-5802	Capacitor, variable AM antenna (C41)
V-5596	Capacitor, .005 mfd 450 v. (C23, C24, C25)		FM antenna (C42)		FM antenna (C42)
RCM20A151M	Capacitor, 150 mfd mica (C26)		AM oscillator (C43)		AM oscillator (C43)
R3CC21SL470K	Capacitor, 47 mfd ceramicon (C27, C28)		FM oscillator (C44)		FM oscillator (C44)
RCM20B220K	Capacitor, 22 mfd mica (C29)		Trimmer FM antenna (C45)		Trimmer FM antenna (C45)
R3CC20UR060G	Capacitor, 6 mfd ceramicon (C30)		Trimmer AM antenna (C47)		Trimmer AM antenna (C47)
R5CC20ZV471M	Capacitor, 470 mfd ceramicon (C31)		Capacitor, .03 mfd 400 v. (C60)		Capacitor, .03 mfd 400 v. (C60)
RCM20A471M	Capacitor, 470 mfd mica (C32)				
V-4634	Capacitor, dual line filter (C33, C34)				
V-5821	Capacitor, electrolytic 20-20 mfd 400 v. (C35, C36)				
V-3236	Capacitor, electrolytic 20 mfd 25 v. (Cathode bypass - C37)				
V-4885	Capacitor, electrolytic 4 mfd 450 v. (C38)				
V-5985	Capacitor, electrolytic 10 mfd 350 v. (C39)				
V-4672	Capacitor, trimmer, AM oscillator (C40)				
V-5802	Capacitor, variable AM antenna (C41)				
	FM antenna (C42)				
	AM oscillator (C43)				
	FM oscillator (C44)				
	Trimmer FM antenna (C45)				
	Trimmer AM antenna (C47)				
	Capacitor, .03 mfd 400 v. (C60)				

MODELS H-202, H-204, WESTINGHOUSE ELECTRIC CORP.
 H-204A, CHASSIS
 V-2128-2

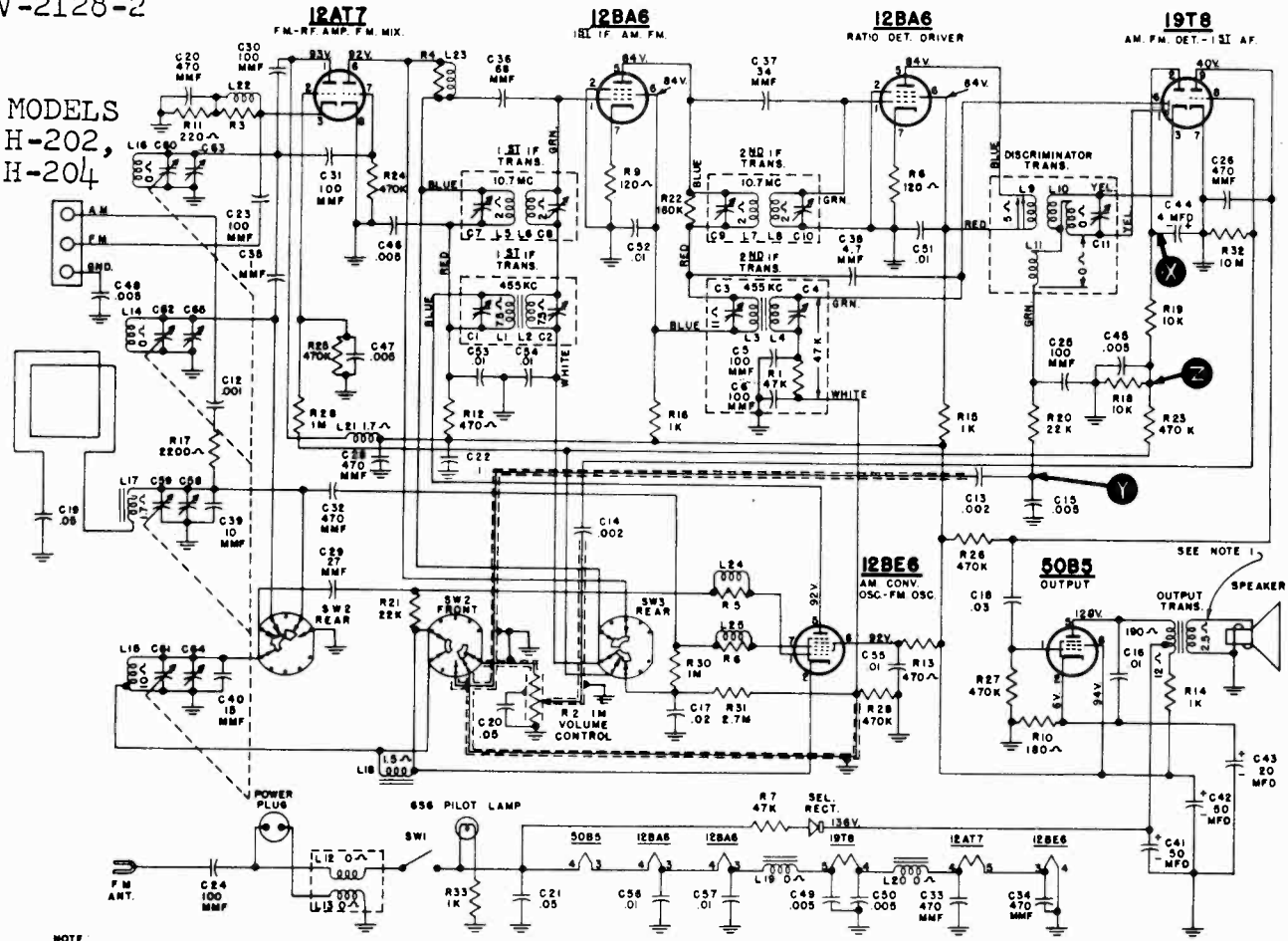

NOTE:
 1. VOICE COIL DISCONNECTED.
 2. SELECTOR SWITCH SW2 - SW3 SHOWN IN EXTREME COUNTER CLOCKWISE POSITION OR AM BAND. SECOND POSITION CLOCKWISE IS FM BAND.
 3. ALL VOLTAGES MEASURED FROM CHASSIS (GND) USING 20,000 OHM/VOLT METER - LINE VOLTAGE 117 V.A.C. VOLTAGES SHOULD BE AS SHOWN ± 20 PER CENT.
 CHASSIS NO. V-2128-2

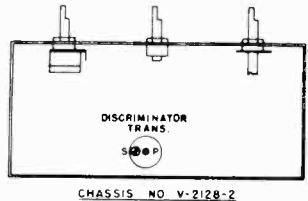
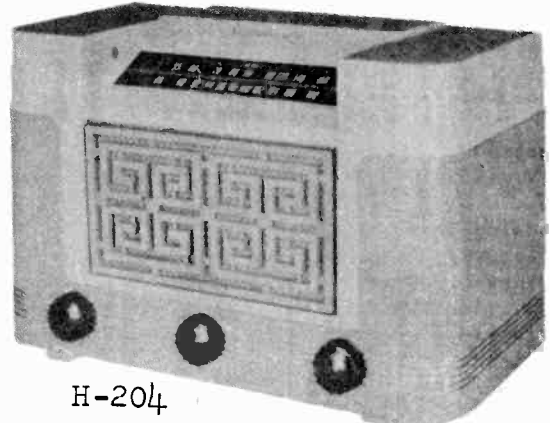
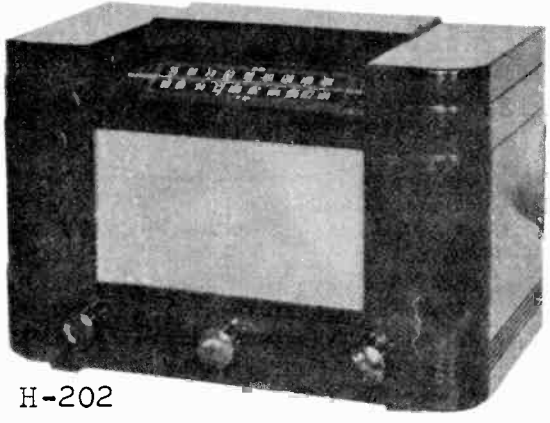

UNDER CHASSIS
 ADJUSTMENT

MODELS
 H-202,
 H-204,
 H-204A

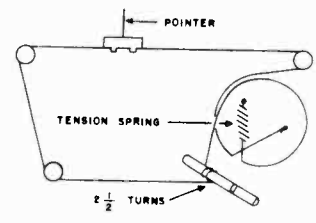

DIAL DRIVE

WESTINGHOUSE ELECTRIC CORP.

MODEL H-204A,
CHASSIS
V-2128-4

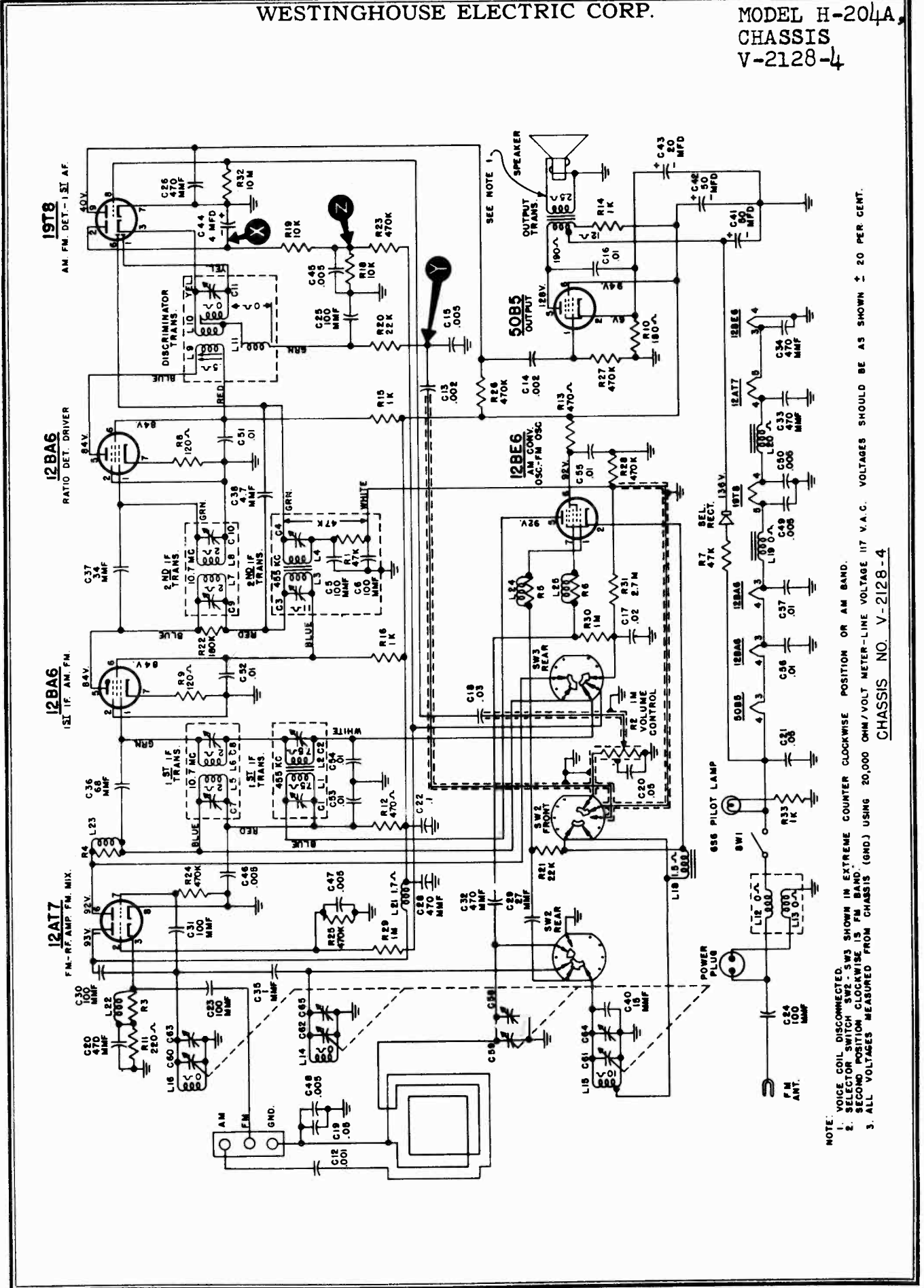

NOTE:
 1. VOICE COIL DISCONNECTED.
 2. SELECTOR SWITCH SW2 - SW3 SHOWN IN EXTREME COUNTER CLOCKWISE POSITION OR AM BAND.
 3. SECOND POSITION CLOCKWISE IS FM BAND.
 4. ALL VOLTAGES MEASURED FROM CHASSIS (GND) USING 20,000 OHM/VOLT METER-LINE VOLTAGE 117 V.A.C. VOLTAGES SHOULD BE AS SHOWN ± 20 PER CENT.

CHASSIS NO. V-2128-4

MODELS H-202, H-204, WESTINGHOUSE ELECTRIC CORP.
 H-204A, CHASSIS
 V-2128-2

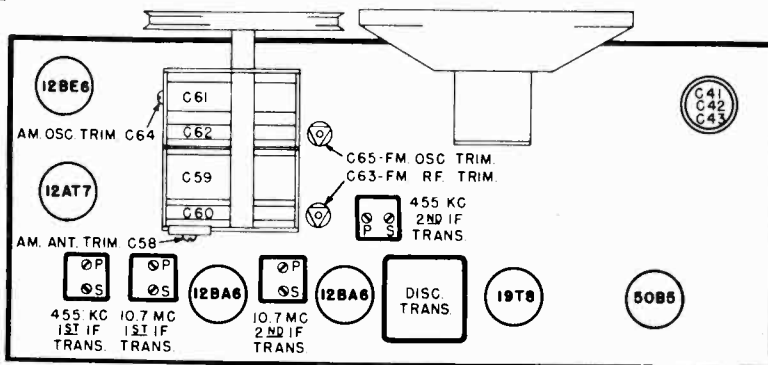

CHASSIS NO. V-2128-2

TOP VIEW

SPECIFICATIONS

FREQUENCY RANGES:

Standard Broadcast ... 540 to 1600 kc.
 Frequency Modulation ... 88 to 108 mc.

INTERMEDIATE FREQUENCIES:

Amplitude Modulation 455 kc.
 Frequency Modulation 10.7 mc.

TUBE COMPLEMENT:

- 1 12AT7 R-F Amp. and Mixer (FM)
- 1 12BE6 ... Converter (AM), Osc. (FM)
- 1 12BA6 I-F Amp.
- 1 12BA6 Ratio Det. Driver (FM)
- 1 19T8 Det., AVC, A-F Amp.
- 1 50B5 Output Amp.

PILOT LAMP: ... Westinghouse #6S6,
 120 volts, .05 amp.

POWER OUTPUT:

Undistorted 1 watt
 Maximum 2.1 watts

LOUDSPEAKER: 5" P.M.

OPERATING VOLTAGE:

105 to 120 volts 50 - 60 cycles
 A-C or 105 to 120 volts D-C.

POWER CONSUMPTION: 40 watts

Model H-204A is identical in external appearance with Model H-204. The similarity of these models extends also to the chassis, where the same chassis layout, adjustment points, and basic circuit exist. However, a low-impedance loop antenna is used in Model H-204, while the H-204A incorporates a high-impedance loop with a slightly different input circuit.

The service notes for Models H-202 and H-204, with the exception of the schematic diagram and a few of the items on the parts list, apply to the Model H-204A. The necessary parts information is given below,

With the exception of items that are equivalent to those listed below, all items that apply to the Model H-204, as listed in the H-202 and H-204 service notes, apply also to the Model H-204A.

The parts listed below apply only to Model H-204A.

Part No.	Description
V-6168-1	Cover Rivet Assembly, back (H-204A brown)
V-6168-2	Cover Rivet Assembly, back (H-204A ivory and green)
V-6061	Loop, antenna (H-204A)

WESTINGHOUSE ELECTRIC CORP.

MODELS H-202, H-204,
H-204A, CHASSIS
V-2128-2

CAUTION: One side of the power line is connected directly to the chassis in this model. Care must be exercised to avoid contacting the radio chassis and ground at the same time — **SERIOUS SHOCK MAY RESULT.** When making repairs or adjustments to the radio, it is recommended that the chassis be isolated from the power line by means of an isolation transformer.

ALIGNMENT BROADCAST BAND

Connect an output meter across the speaker voice coil.

While making the following adjustments, keep the volume control set for maximum output and the signal generator output attenuated to avoid AVC action.

Step	Connect Signal Generator to —	Signal Generator Frequency	Radio Dial Setting	Adjust
1	Set band switch to AM.			
2	Pin #1 of 12BA6 (1st I-F) tube through a 0.1 mfd capacitor	455 kc	minimum capacity	Sec. and pri. of 455 kc 2nd I-F trans. for max. output
3	Stator of tuning capacitor (C59) through a 0.1 mfd capacitor	455 kc	minimum capacity	Sec. and pri. of 455 kc 1st I-F 1st I-F trans. for max. output
4	Radiated signal (no actual connection)	1615 kc	minimum capacity	AM osc. trimmer (C64) for max. output
5	Radiated signal (no actual connection)	1400 kc	1400 kc	AM ant. trimmer (C58) for max. output

FM BAND

Do not align 10.7 mc. I-F circuits until 455 kc I-F adjustments have been completed.

1	Set band switch to FM.			
2	Connect a V.T.V.M. between point "X" and ground (See Fig. 4).			
3	Pin #1 of 12BA6 (Ratio det. driver) tube through a .002 mfd capacitor	10.7 mc	minimum capacity	Pri. of discriminator trans. for max. voltage
4	With the V.T.V.M. and signal generator connected as in Step 3, adjust the output of the signal generator until a reading of 2.5 volts is obtained on the V.T.V.M. Use this signal generator setting when performing Step 6.			
5	Connect the V.T.V.M. between points "Y" and "Z" (See Fig. 4).			
6	Same as Step 3.	10.7 mc	minimum capacity	Sec. of discriminator trans. for zero voltage. The voltage will change polarity as the trimmer is tuned through resonance — tune carefully for zero
7	Reconnect the V.T.V.M. between point "X" and ground.			
8	Same as Step 3.	10.7 mc	minimum capacity	Pri. of discriminator trans. for max. voltage
9	Pin #1 of 12BA6 (1st I-F) tube through a .002 mfd capacitor	10.7 mc	minimum capacity	Sec. and pri. of 10.7 mc 2nd I-F trans. for max. voltage
10	Pin #7 of 12AT7 tube through a .002 mfd capacitor	10.7 mc	minimum capacity	Sec. and pri. of 10.7 mc 1st I-F trans. for max. voltage
<i>NOTE: Do not attempt to peak the 2nd I-F transformer or discriminator transformer with the signal generator connected as in Step 10.</i>				
11	FM ant. terminals through a 300 ohm non-inductive resistor	108 mc	minimum capacity	FM osc. trimmer (C65) for max. voltage
12	Check calibration as explained below*.			
13	Same as Step 11.	105 mc	105 mc	FM R-F trimmer (C63) for max. voltage (rock in adjustment)
14	Check tracking as explained below**.			

*To check dial calibration, completely mesh the tuning capacitor plates and vary the signal generator frequency until the signal is maximum on the V.T.V.M. If at this setting, the generator frequency is 88 mc., no further oscillator adjustments are required. If the generator is higher in frequency than 88 mc., slightly compress the FM oscillator coil (L14); if the generator frequency is lower than 88 mc., slightly expand the FM oscillator coil (L14). Repeat Steps 11 and 12 until the receiver tunes to 108 mc. with the tuning capacitor fully open and 88 mc. with the tuning capacitor fully closed.

**Tune the receiver to a 90 mc. signal from the generator and adjust the FM R-F trimmer for maximum voltage. If the "peak" setting is the same at 90 mc. as it was at 105 mc., no further adjustment is necessary. If the trimmer capacitance must be increased for maximum voltage at 90 mc., slightly compress the FM R-F coil (L16); if the trimmer capacitance must be decreased for maximum voltage at 90 mc., slightly expand the FM R-F coil (L16). Re-adjust the FM R-F trimmer at 105 mc., and again check the tracking. Repeat this process until the tracking is correct.

MODELS H-202, H-204, WESTINGHOUSE ELECTRIC CORP.
H-204ACHASSIS
V-2128-2

Part No.	Description	Part No.	Description
V-5608	Background, dial	V-5560-2	Knob, AM-FM (H-204)
V-5528-1	Baffle and grille cloth assembly (H-202)	V-5558-1	Knob, tuning (H-202)
V-5527	Bushing, insulator, control	V-5558-2	Knob, tuning (H-204)
*V-1153-1	Cabinet (H-202 Ivory)	V-5559-1	Knob, volume (H-202)
*V-1153-2	Cabinet (H-202 Brown)	V-5559-2	Knob, volume (H-204)
*V-1153-3	Cabinet (H-204 Green)	No. 6S6	Lamp, pilot light
RCP10M6102A	Capacitor, .001 mfd 600 v. (C12)	*V-5638	Loop assembly, antenna
RCP10M6202M	Capacitor, .002 mfd 600 v. (C13, C14)	V-6119	Pointer
RCP10M6502A	Capacitor, .005 mfd 600 v. (C15)	V-6096-1	Pulley (metal)
RCP10M2103M	Capacitor, .01 mfd 200 v. (C16)	V-3166S	Pulley (wood)
RCP10M2203A	Capacitor, .02 mfd 200 v. (C17)	V-4886-1	Reactor, R-F (L18)
RCP10M2303M	Capacitor, .03 mfd 200 v. (C18)	V-4886-2	Reactor, R-F (L19, L20)
RCP10M2503A	Capacitor, .05 mfd 200 v. (C19, C20, C21)	V-4886-4	Reactor, R-F (L21)
RCP10M2104A	Capacitor, .1 mfd 200 v. (C22)	V-4886-5	Reactor, R-F (L22, R3)
RCM20A101K	Capacitor, mica 100 mmf (C23, C24)	V-4886-6	Reactor, R-F (L23, R4)
RCM20A101M	Capacitor, mica 100 mmf (C25)	V-4886-7	Reactor, R-F (L24, R5)
RCM20A471M	Capacitor, mica 470 mmf (C26, C27, C28)	V-4886-8	Reactor, R-F (L25, R6)
R2CC25HK270K	Capacitor, ceramicon 27 mmf (C29)	V-6070	Rectifier, selenium (100 milliamperes)
R2CC32CF101K	Capacitor, ceramicon 100 mmf (C30, C31)	V-6067-2	Resistor, glasohm 47 ohms (R7)
R5CC20ZY471M	Capacitor, ceramicon 470 mmf (C32)	RC20AE121K	Resistor, 120 ohms $\frac{1}{2}$ w. (R8, R9)
R5CC21ZY471M	Capacitor, ceramicon 470 mmf (C33, C34)	RC20AE181K	Resistor, 180 ohms $\frac{1}{2}$ w. (R10)
V-5658-1	Capacitor, 1 mmf (C35)	RC20AE221K	Resistor, 220 ohms $\frac{1}{2}$ w. (R11)
V-5658-4	Capacitor, 0.68 mmf (C36)	RC20AE471K	Resistor, 470 ohms $\frac{1}{2}$ w. (R12, R13)
V-5658-5	Capacitor, 0.34 mmf (C37)	RC40AE102K	Resistor, 1000 ohms 2 w. (R14, R33)
V-5658-6	Capacitor, 4.7 mmf (C38)	RC20AE102K	Resistor, 1000 ohms $\frac{1}{2}$ w. (R15, R16)
V-5658-7	Capacitor, 10 mmf (C39)	RC20AE222M	Resistor, 2200 ohms $\frac{1}{2}$ w. (R17)
V-5658-8	Capacitor, 15 mmf (C40)	RC20AE103J	Resistor, 10,000 ohms $\frac{1}{2}$ w. (R18, R19)
V-5493	Capacitor, dry electrolytic 50 mfd 150 v. (C41)	RC20AE223M	Resistor, 22,000 ohms $\frac{1}{2}$ w. (R20)
	50 mfd 150 v. (C42)	RC20AE223K	Resistor, 22,000 ohms $\frac{1}{2}$ w. (R21)
	20 mfd 25 v. (C43)	RC20AE184K	Resistor, 180,000 ohms $\frac{1}{2}$ w. (R22)
V-4637	Capacitor, electrolytic 4 mfd 50 v. (C44)	RC20AE474M	Resistor, 470,000 ohms $\frac{1}{2}$ w. (R23, R24, R25, R26, R27, R28)
V-5596	Capacitor, Hi-kaps 5000 mmf (C45, C46, C47, C48, C49, C50)	RC20AE105M	Resistor, 1 megohm $\frac{1}{2}$ w. (R29, R30)
V-5040-13	Capacitor, paper molded .01 mfd 200 v. (C51, C52, C53, C54, C55, C56, C57)	RC20AE275M	Resistor, 2.7 megohms $\frac{1}{2}$ w. (R31)
V-4992	Capacitor, trimmer (C58)	RC20AE106M	Resistor, 10 megohms $\frac{1}{2}$ w. (R32)
V-5494	Capacitor, variable 2-gang AM antenna (C59)	V-5601-1	Screw, #6-32 rosette head (H-202 brown, H-204 green)
	FM antenna (C60)	V-5601-2	Screw, #6-32 rosette head (H-202 ivory)
	AM oscillator (C61)	V-4292S	Socket, miniature molded (7 prong)
	FM oscillator (C62)	V-5673	Socket, miniature wafer (7 prong)
	Trimmer, FM antenna (C63)	V-5670	Socket, miniature wafer (7 prong)
	Trimmer, AM oscillator (C64)	V-6072-1	Socket, miniature wafer (9 prong)
	Trimmer, FM oscillator (C65)	V-4989	Socket, pilot light
V-5743	Coil, choke antenna (line) (L12, L13)	*V-5533	Speaker, 5" P.M.
V-5545	Coil, oscillator FM (L14)	V-3248S	Spring, dial drive
V-6078-1	Coil, oscillator AM (L15)	V-7332	Spring, knob
V-5546	Coil, R-F FM (L16)	V-5534	Switch, selector, (SW2, SW3)
V-5605	Coil, antenna loading AM (L17)	V-5723	Transformer, 1st I-F AM (C1, C2, L1, L2)
V-5517	Control, volume, 1 megohm (R2) and switch (SW1)	V-5539	Transformer, 2nd I-F AM (C3, C4, C5, C6, R1, L3, L4)
V-4304-19	Cord assembly, dial	V-5540	Transformer, 1st and 2nd I-F FM 1st (C7, C8, L5, L6) 2nd (C9, C10, L7, L8)
V-5522	Cord, power A-C	V-5538	Transformer, discriminator (C11, L9, L10, L11)
V-5610-1	Cover rivet assembly, back (H-202 brown, H-204 green)	V-5537	Transformer, output
V-5523	Dial	V-5606-1	Washer, felt
V-6092-1	Grille (H-204 green)		
V-5560-1	Knob, AM-FM (H-202)		

When ordering parts, specify model number of set in addition to part number and description of part.

WESTINGHOUSE ELECTRIC CORP.

MODELS H-203,
H-212

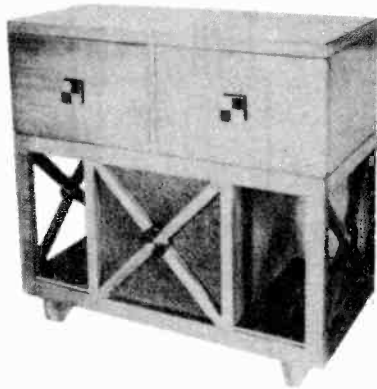

H-203



H-212

SPECIFICATIONS

FREQUENCY RANGES:

Amplitude Modulation 540 to 1600 kc.
Frequency Modulation 88 to 108 mc.

INTERMEDIATE FREQUENCIES:

Amplitude Modulation 455 kc.
Frequency Modulation 10.7 mc.

TUBE COMPLEMENT:

- 1 12AT7 R-F Amp. and Mixer (FM)
- 1 6BE6 H-F Osc. (AM/FM) and converter(AM)
- 1 6BA6 I-F Amp.
- 1 6BA6 I-F Driver (FM)
- 1 6AL5 Ratio Det. (FM)
- 1 6AV6 Det. & AVC (AM) and A-F Amp.
- 1 6V6GT Output Amp.
- 1 5Y3GT Rectifier

PILOT LAMPS:

2 Westinghouse No. 47 ... 6.3 v., 0.15 a.

POWER OUTPUT:

Undistorted 3.5 watts
Maximum 6 watts

LOUDSPEAKER:

H-203 10" P.M.
H-212 8" P.M.

OPERATING VOLTAGE:

..... 105 to 120 volts, 60 cycles A-C

POWER CONSUMPTION:

H-203 110 watts
H-212 85 watts

SERVICE NOTES

For information on the V-4944-2 record changer used with Model H-203, refer to the V-4944 Automatic Record Changer Service Notes. However, when ordering replacement parts, specify the items listed below rather than the corresponding parts as listed in the V-4944 Service Notes. The following parts are for the V-4944-2 changer only.

Loc.	Part No.	Description
9	V-7962	Pickup Cable with Connector (28")
13	V-7689	Cartridge, crystal (P-30)
15	V-7963	Nut, needle retaining (for P-30 cartridge)
(Last item on parts list)	V-7964	Needle, phonograph (for P-30 cartridge)

MODELS H-203,
H-212, CHASSIS
V-2137

WESTINGHOUSE ELECTRIC CORP.

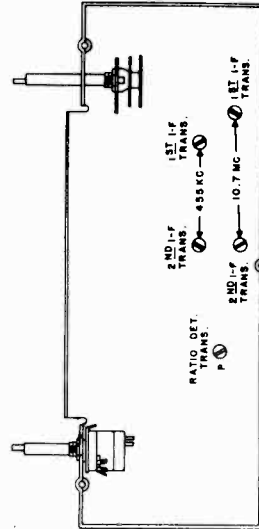
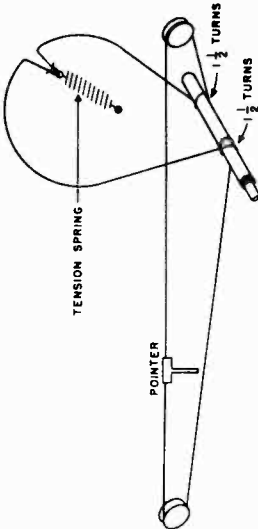
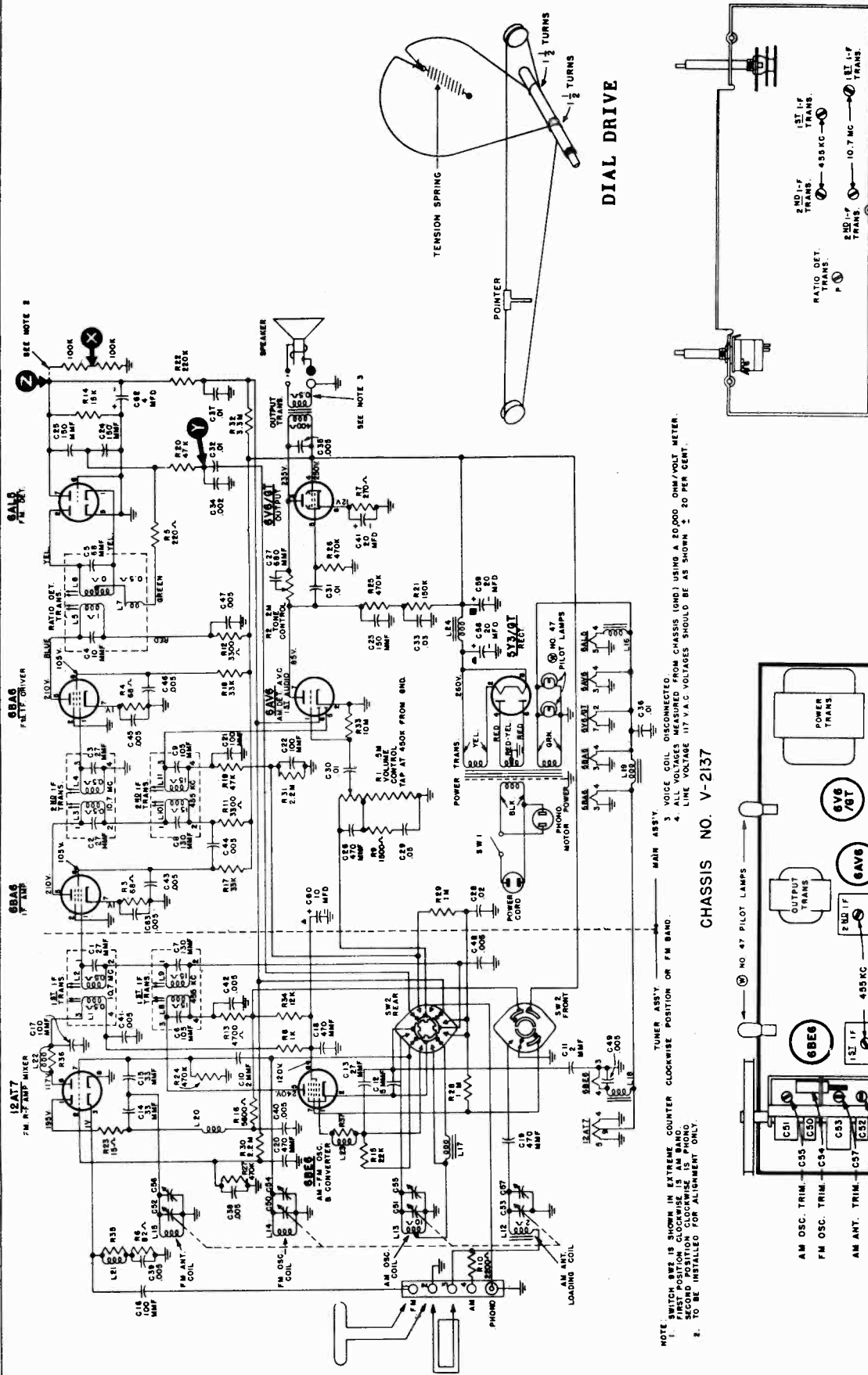

CHASSIS NO. V-2137
BOTTOM VIEW

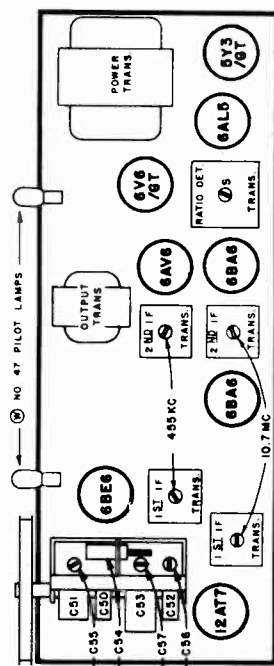

CHASSIS NO. V-2137
TOP VIEW

- NOTE SWITCH SW2 IS SHOWN IN EXTREME COUNTER CLOCKWISE POSITION ON FM BAND.
1. FIRST POSITION CLOCKWISE IS AM BAND.
 2. TO BE INSTALLED FOR ALIGNMENT ONLY.
 3. VOICE COIL DISCONNECTED.
 4. ALL VOLTAGES MEASURED FROM CHASSIS (GND) USING A 20,000 OHM/VOLT METER.
- LINE VOLTAGE 117V A.C. VOLTAGES SHOULD BE AS SHOWN ± 20 PER CENT.

WESTINGHOUSE ELECTRIC CORP. MODELS H-203, H-212,
CHASSIS V-2137

ALIGNMENT

BROADCAST BAND

Connect an output meter across the speaker voice coil.

While making the following adjustments, keep the volume control set for maximum output, the tone control set for maximum treble, and the signal generator output attenuated to avoid A.V.C. action.

Step	Connect Signal Generator to —	Signal Generator Frequency	Radio Dial Setting	Adjust
1	Set the band switch to AM.			
2	Stator of tuning capacitor (C51) through a 0.1 mfd capacitor	455 kc.	maximum capacity	455 kc. pri. and sec. of 1st and 2nd I-F trans. for max. output
<p><i>NOTE: If the I-F transformers are badly mis-aligned, it may be impossible to obtain sufficient output using the above system. In this event, it will be necessary to align each transformer separately. Start with the last I-F transformer and work forward, connecting the signal generator to the control grid of the tube preceding the transformer under alignment.</i></p>				
3	Radiated signal (no actual connection)	1600 kc.	1600 kc.	AM osc. trimmer (C55) for max. output
4	Radiated signal (no actual connection)	1400 kc.	tune to signal	AM ant. trimmer (C57) for max. output (rock-in adjustment)

FM BAND

Do not align the FM circuits until all AM adjustments have been completed.

Step	Connect Signal Generator to —	Signal Generator Frequency	Radio Dial Setting	Adjust
1	Set the band switch to FM.			
2	Connect two 100,000 ohm resistors (the resistances must be equal within 5 percent) between pin #7 of the 6AL5 tube and ground as shown on the schematic diagram.			
3	Connect a V.T.V.M. between points "X" and "Y" (see schematic diagram).			
4	Stator of FM osc. section (C50) on tuning capacitor through a .01 mfd mica capacitor	10.7 mc.	maximum capacity	Sec. of ratio det. trans. for zero (use medium strength signal)
5	Connect the V.T.V.M. between point "Z" and ground.			
6	Same as step 4	10.7 mc.	maximum capacity	Pri. of ratio det. trans. and pri. and sec. of 10.7 mc. 1st and 2nd I-F trans. for max.
<p><i>NOTE: The pri. of the ratio det. trans. peaks in two places. Use the peak with the slug farthest out.</i></p>				
7	Reconnect the V.T.V.M. between points "X" and "Y", and increase the signal strength 2 times.			
8	Same as step 4	10.7 mc.	maximum capacity	Recheck sec. of ratio det. trans. for zero voltage
9	Reconnect the V.T.V.M. between point "Z" and ground.			
10	Same as step 4	10.7 mc.	maximum capacity	Pri. of ratio det. trans. for maximum voltage
11	Remove the two 100,000 ohm resistors that were inserted in step 2.			
12	FM ant. terminal through a 300 ohm non-inductive resistor	105 mc.	105 mc.	FM osc. trimmer (C54) for maximum output
13	Same as step 12	105 mc.	105 mc.	FM ant. trimmer (C56) for maximum output

MODELS H-203, H-212, WESTINGHOUSE ELECTRIC CORP.
CHASSIS V-2137

PARTS LIST FOR MODELS H-203 AND H-212

When ordering parts, specify model number of set in addition to part number and description of part.

Part No.	Description	Part No.	Description
V-5982-2	Antenna Assembly, AM loop	V-4886-1	Reactor, R-F 14 microhenries (L16)
V-5986-3	Antenna Assembly, FM dipole(H-203)	V-4886-2	Reactor, R-F 1.1 microhenries (L17, L18, L19)
V-5986-4	Antenna Assembly, FM dipole(H-212)	V-4886-4	Reactor, R-F (L20)
V-6120	Background, dial	V-4886-10	Reactor, R-F (L21, R35)
V-5860-3	Cable Assembly, speaker	V-4886-6	Reactor, R-F (L22, R36)
R2CC30CK020D	Capacitor, 2 mmf (C10)	V-4886-7	Reactor, R-F (L23, R37)
R2CC30UK020D	Capacitor, 2 mmf (C11)	V-6161	Reactor, filter choke (L24)
R2CC30CK050D	Capacitor, 5 mmf (C12)	RC10AE680K	Resistor, 68 ohms $\frac{1}{2}$ w. (R3, R4)
R3CC30CK270K	Capacitor, 27 mmf (C13)	RC10AE221M	Resistor, 220 ohms $\frac{1}{2}$ w. (R5)
R3CC26CK330M	Capacitor, 33 mmf (C14, C15)	RC10AE820K	Resistor, 82 ohms $\frac{1}{2}$ w. (R6)
R3CC30SL101M	Capacitor, 100 mmf (C16)	RC30AE271K	Resistor, 270 ohms 1 w. (R7)
R3CC30SL101J	Capacitor, 100 mmf (C17)	RC10AE102K	Resistor, 1000 ohms $\frac{1}{2}$ w. (R8)
R5CC21ZY471M	Capacitor, 470 mmf (C18, C19, C20)	RC10AE152M	Resistor, 1500 ohms $\frac{1}{2}$ w. (R9)
RCM20A101M	Capacitor, 100 mmf (C21, C22)	RC10AE222K	Resistor, 2200 ohms, $\frac{1}{2}$ w. (R10) ..
RCM20A151M	Capacitor, 150 mmf (C23)	RC30AE332K	Resistor, 3300 ohms 1 w. (R11, R12)
RCM20A151J	Capacitor, 150 mmf (C24, C25)	RC10AE472K	Resistor, 4700 ohms $\frac{1}{2}$ w. (R13) ...
RCM20A471M	Capacitor, 470 mmf (C26)	RC10AE153K	Resistor, 15,000 ohms $\frac{1}{2}$ w. (R14) .
RCM20A681M	Capacitor, 680 mmf (C27)	RC10AE223K	Resistor, 22,000 ohms $\frac{1}{2}$ w. (R15) .
RCP10W2203A	Capacitor, .02 mfd 200 v. (C28) ..	RC30AE562K	Resistor, 5600 ohms 1 w. (R16) ...
RCP10W2503A	Capacitor, .05 mfd 200 v. (C29) ..	RC30AE333K	Resistor, 33,000 ohms 1 w. (R17, R18)
RCP10W4103A	Capacitor, .01 mfd 400 v. (C30, C31, C32)	RC10AE473M	Resistor, 47,000 ohms $\frac{1}{2}$ w. (R19, R20)
RCP10W4303A	Capacitor, .03 mfd 400 v. (C33) ..	RC10AE154M	Resistor, 150,000 ohms $\frac{1}{2}$ w. (R21)
RCP10W6202A	Capacitor, .002 mfd 600 v. (C34) ..	RC10AE224M	Resistor, 220,000 ohms $\frac{1}{2}$ w. (R22)
RCP10M6502A	Capacitor, .005 mfd 600 v. (C35) .	RC10AE150M	Resistor, 15 ohms $\frac{1}{2}$ w. (R23)
V-5040-13	Capacitor, molded paper .01 mfd 200 v. (C36, C37)	RC10AE474M	Resistor, 470,000 ohms $\frac{1}{2}$ w. (R24, R25, R26, R27)
V-5596	Capacitor, Hi-Kaps .005 mfd (C38, C39, C40, C41, C42, C43, C44, C45, C46, C47, C48, C49)	RC10AE105M	Resistor, 1.0 megohm $\frac{1}{2}$ w. (R28, R29)
V-6137	Capacitor, variable (C50, C51, C52, C53, C54, C55, C56, C57)	RC10AE225M	Resistor, 2.2 megohms $\frac{1}{2}$ w. (R30, R31)
V-6121	Capacitor, electrolytic	RC10AE335M	Resistor, 3.3 megohms $\frac{1}{2}$ w. (R32) .
	20 mfd 400 v. (C58)	RC10AE106M	Resistor, 10.0 megohms $\frac{1}{2}$ w. (R33)
	20 mfd 400 v. (C59)	RC41AE123K	Resistor, 12,000 ohms 2 w. (R34) .
	10 mfd 350 v. (C60)	V-6151-1	Rosette (H-203 mahogany)
	20 mfd 25 v. (C61)	V-6151-2	Rosette (H-203 blond)
V-4885	Capacitor, electrolytic 4 mfd 450 v. (C62)	V-6126-1	Shockmount
V-4898-1	Catch, bullet (H-203 mahogany) ..	V-6127	Sleeve, dial drive
V-4898-2	Catch, bullet (H-203 blond)	V-3353-3	Slide Mechanism, L.H. (H-203)
V-5637	Clip, tubular	V-3353-4	Slide Mechanism, R.H. (H-203)
V-6164	Coil, AM oscillator (L13)	V-6165-1	Socket, dial light, 5" leads
V-6157	Coil, antenna loading (L12)	V-6165-2	Socket, dial light, 7" leads
V-6139	Coil, FM antenna (L15)	V-5670	Socket, miniature wafer
V-6138	Coil, FM oscillator (L14)	V-5673	Socket, miniature wafer (unshielded)
V-6122	Control, volume - 0.5 megohm (R1), tone - 2.0 megohms (R2) and switch (SW1)	V-4195	Socket, molded octal tube
V-6123	Dial	V-5405	Socket, molded power
V-6155	Fastener	V-3246S	Socket, octal tube
V-5998-2	Grille Cloth, speaker (H-203 mahogany)	V-5571	Speaker, 10" P.M. (H-203)
V-6148-1	Grille Cloth, speaker (H-203 blond)	V-6251	Speaker, 8" P.M. (H-212)
V-6246-1	Grille Cloth Assembly (H-212) ...	V-3248S	Spring, dial drive
V-5066-5	Hinge, L.H. (H-203 mahogany)	V-4900-1	Strike, bullet catch (H-203 mahogany)
V-5066-3	Hinge, L.H. (H-203 blond)	V-4900-2	Strike, bullet catch (H-203 blonde)
V-5066-6	Hinge, R.H. (H-203 mahogany)	V-6140	Switch, selector
V-5066-4	Hinge, R.H. (H-203 blond)		Front wafer - SW2
V-6146-2	Knob, band (H-212 and H-203 mahogany)	V-6136	Rear wafer - SW2
V-6146-4	Knob, band (blond)	V-6130	Terminal Board, PHONO-ANT-GND
V-6147-2	Knob, rear (tuning)	V-6130	Transformer, AM 1st and 2nd I-F (455 kc.) (L8, L9, C6, C7, and L10, L11, C8, C9)
V-6146-1	Knob, OFF-ON-TONE (H-212 and H-203 mahogany)	V-5798	Transformer, audio output
V-6146-3	Knob, OFF-ON-TONE (blond)	V-6142	Transformer, FM 1st I-F (10.7 mc.) (L1, L2, C1)
V-6147-1	Knob, rear (volume)	V-6129	Transformer, FM 2nd I-F (10.7 mc.) (L3, L4, C2, C3)
No. 47	Lamp, pilot light	V-6131	Transformer, power
V-6160	Molding	V-6128	Transformer, ratio detector (L5, L6, L7, C4, C5)
V-4696	Nameplate, Westinghouse FM		
V-6154-1	Panel, control		
V-6125	Pointer		
V-6150-1	Pull, door (H-203 mahogany)		
V-6150-2	Pull, door (H-203 blond)		
V-3166S	Pulley, 7/16 dia.		

WESTINGHOUSE ELECTRIC CORP. MODELS H-210, H-211,
CHASSIS V-21144,
V-21144-1

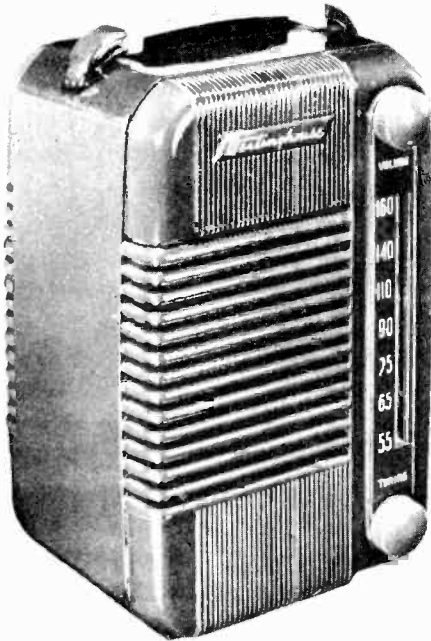

H-210

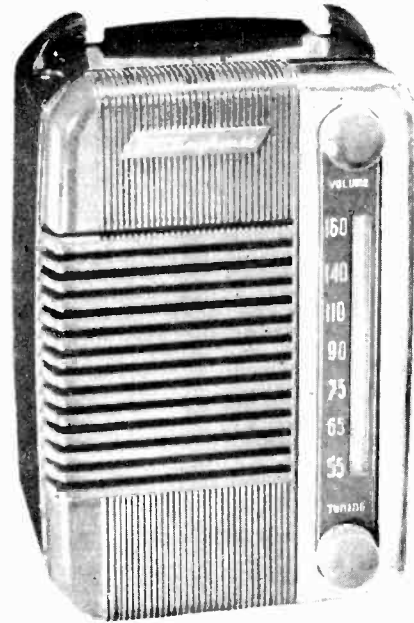

H-211

SPECIFICATIONS

FREQUENCY RANGE: 540 to 1600 kc.

INTERMEDIATE FREQUENCY: 455 kc.

TUBE COMPLEMENT:

- 1 12BE6 Converter
- 1 12BA6 I-F Amp.
- 1 12AT6 Det. and 1st A-F Amp.
- 1 50C5 Output Amp.
- 1 35W4 Rectifier

PILOT LAMP (H-211 only): Westinghouse No. 47

POWER OUTPUT:

- Undistorted 1 watt
- Maximum 1.5 watts

LOUDSPEAKER: 4" P.M.

OPERATING VOLTAGE: 105 to 125 volts 50 - 60 cycles A-C or D-C

POWER CONSUMPTION: 35 watts

MODELS H-210, H-211, WESTINGHOUSE ELECTRIC CORP.
 CHASSIS V-2144,
 V-2144-1

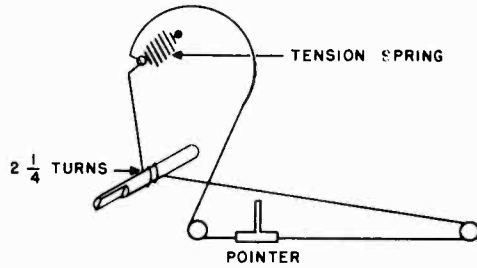
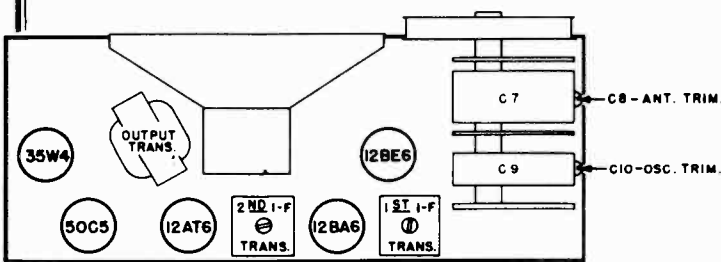
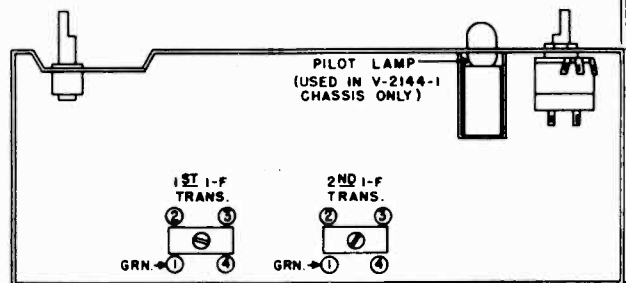

FIG. 1 — DIAL DRIVE



CHASSIS V-2144 and V-2144-1



CHASSIS V-2144 and V-2144-1

FIG. 2 — TOP VIEW

FIG. 3 — BOTTOM VIEW

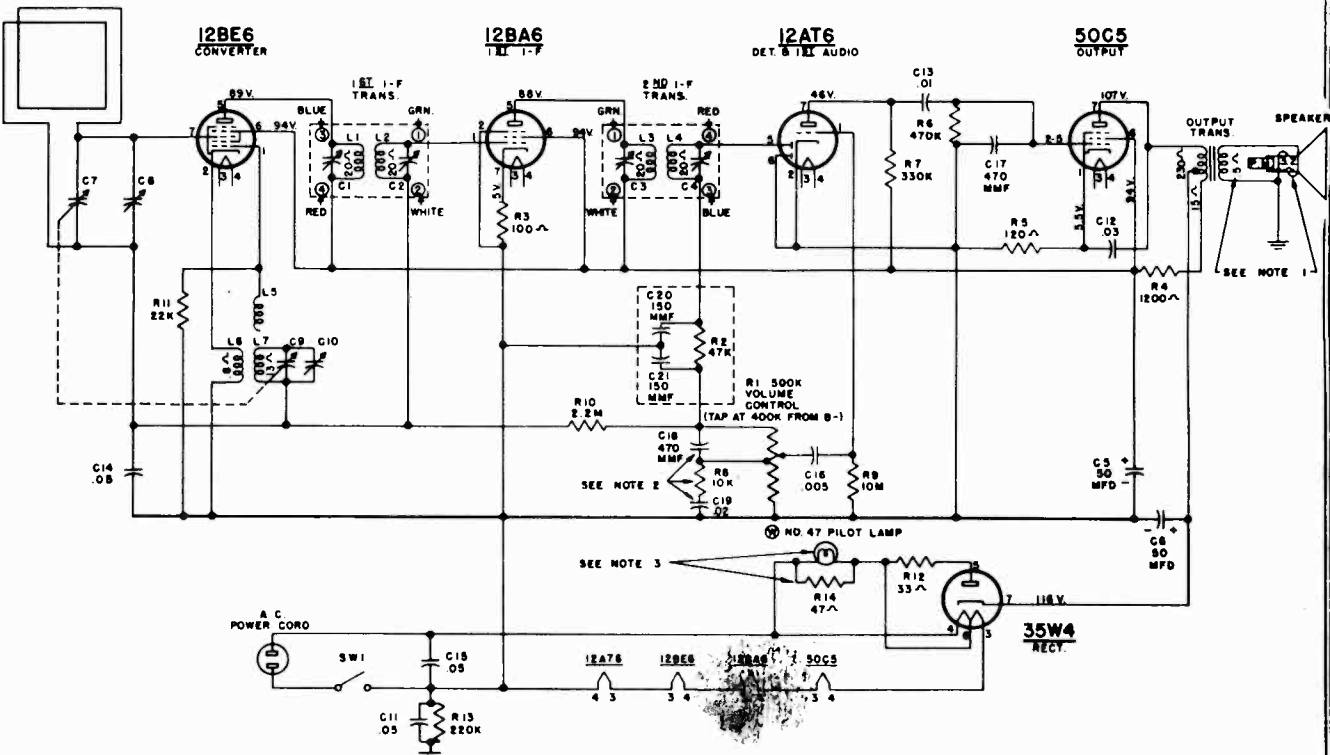

NOTE:
 1. VOICE COIL DISCONNECTED FOR RESISTANCE MEASUREMENT.
 2. C18, C19 AND R8 ARE NOT USED IN V-2144 CHASSIS (H-210).
 3. THE PILOT LAMP IS USED IN THE V-2144-1 CHASSIS (H-211) ONLY. R14 IS USED IN THE V-2144 CHASSIS (H-210) IN PLACE OF THE PILOT LAMP.

4. ALL VOLTAGES MEASURED FROM COMMON NEGATIVE LINE USING A 20,000 OHMS PER VOLT METER. LINE VOLTAGE 117 V.A.C. VOLTAGES SHOULD BE AS SHOWN ± 20 PER CENT.

WESTINGHOUSE ELECTRIC CORP. MODELS H-210, H-211,
CHASSIS V-211⁴⁴,
V-211⁴⁴-1

ALIGNMENT

It is recommended that the chassis be isolated from the power line by means of an isolation transformer.

Make certain that the dial pointer is correctly positioned on the dial cord.

While making the following adjustments, keep the volume control set for maximum output and the signal generator output attenuated to avoid AVC action.

Step	Connect Signal Generator to —	Signal Generator Frequency	Radio Dial Setting	Adjust
1.	Stator of R-F tuning capacitor (C7) through a 0.1 mfd capacitor	455 kc.	maximum capacity	Pri. and sec. of 1st and 2nd I-F transformers for max. output
<p><i>NOTE: If the I-F transformers are badly mis-aligned, it may be impossible to obtain sufficient output to use the above system. In this event, it will be necessary to align each transformer separately. Start with the last I-F transformer and work forward, connecting the signal generator to the control grid of the tube preceding the transformer under alignment.</i></p>				
2.	Radiated signal (no actual connection)	1615 kc.	minimum capacity	Osc. trimmer (C10) for max. output
3.	Radiated signal (no actual connection)	1400 kc.	1400 kc.	Ant. trimmer (C8) for max. output

PARTS LIST FOR MODELS H-210 AND H-211

When ordering parts, specify model number of set in addition to part number and description of part.

Part No.	Description	Part No.	Description
V-6188	Background Rivet Assembly, dial	V-6184-1	Knob (H-210)
V-1168-1	Cabinet (H-210 Maroon)	V-6184-2	Knob (H-211)
V-1168-2	Cabinet (H-211 Grey)	#47	Lamp, pilot (H-211)
V-6230	Capacitor, electrolytic	V-6186	Loop, antenna
	50 mfd 150 v. (C5)	V-6190	Pointer
	50 mfd 150 v. (C6)	RC10AE101J	Resistor, 100 ohms $\frac{1}{2}$ w. (R3)
V-6231	Capacitor, variable 2-gang ..	RC30AE122M	Resistor, 1200 ohms 1 w. (R4)
	Tuner, antenna (C7)	RC20AE121J	Resistor, 120 ohms $\frac{1}{2}$ w. (R5)
	Trimmer, antenna (C8)	RC10AE474M	Resistor, 470,000 ohms $\frac{1}{2}$ w. (R6)
	Tuner, oscillator (C9)	RC10AE334M	Resistor, 330,000 ohms $\frac{1}{2}$ w. (R7)
	Trimmer, oscillator (C10)	RC10AE103M	Resistor, 10,000 ohms $\frac{1}{2}$ w. (R8) (H-211)
V-5618-1	Capacitor, .05 resonant (C11)	RC10AE106M	Resistor, 10 megohms $\frac{1}{2}$ w. (R9)
RCP10W4303A	Capacitor, .03 mfd 400 v. (C12)	RC10AE225M	Resistor, 2.2 megohms $\frac{1}{2}$ w. (R10)
RCP10W4103A	Capacitor, .01 mfd 400 v. (C13)	RC10AE223M	Resistor, 22,000 ohms $\frac{1}{2}$ w. (R11)
RCP10W4503A	Capacitor, .05 mfd 400 v. (C14, C15)	RC20AE330M	Resistor, 33 ohms $\frac{1}{2}$ w. (R12)
RCP10W4502A	Capacitor, .005 mfd 400 v. (C16)	RC10AE224M	Resistor, 220,000 ohms $\frac{1}{2}$ w. (R13)
RCM20A471M	Capacitor, 470 mmf (C17, C18)	RC30AE470M	Resistor, 47 ohms 1 w. (R14) (H-210)
RCP10W4203A	Capacitor, .02 mfd 400 v. (C19)	V-5673	Socket, miniature wafer, unshielded (50C5, 35W4)
V-5426	Clip, I-F mounting	V-5852-1	Socket, miniature wafer (12AT6, 12BA6)
V-5684	Clip, tubular (Back cover clamp)	V-5852-3	Socket, miniature wafer (12BE6)
V-6182	Clip, spring (Back cover catch)	V-6193	Speaker, 4" P.M.
V-5851	Coil, oscillator (L5, L6, L7)	V-4057	Spring, dial drive
V-6198-1	Control, volume, 500 K (R1, SW1) (H-210)	V-6199-2	Transformer, 1st and 2nd I-F (C1, C2, L1, L2, and C3, C4, L3, L4)
V-6198-2	Control, volume, 500 K (R1, SW1) (H-211)	V-6233-1	Transformer, output
V-6242-1	Cover Plate, trim (H-211)		
V-6232-1	Filter, diode (C20, C21, R2) .		

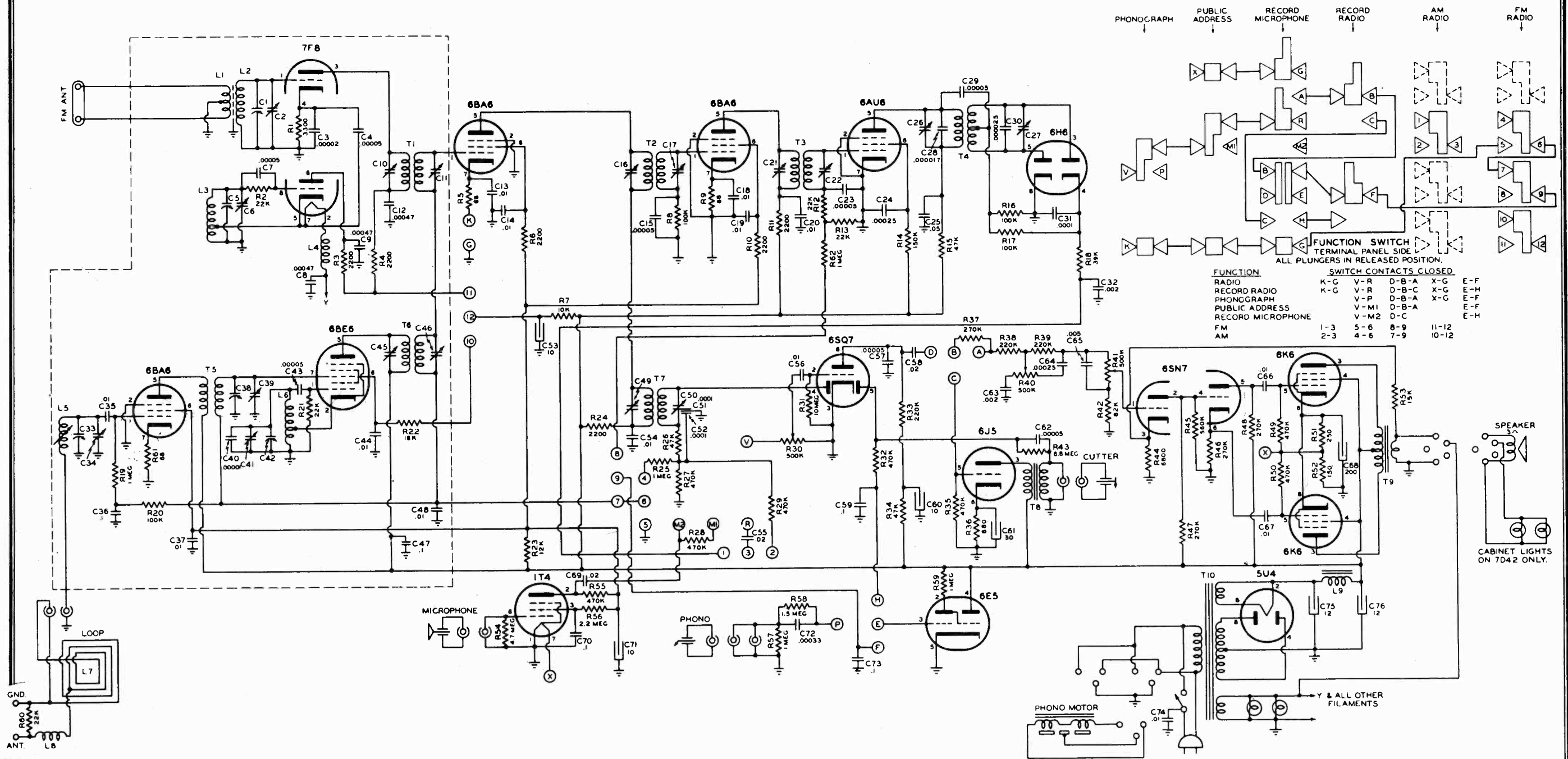

MODELS 7E40,
7E44

WILCOX-GAY CORP.

Models 7E40, 7E44
Schematic Diagram
(Serial No. 801,056 up)

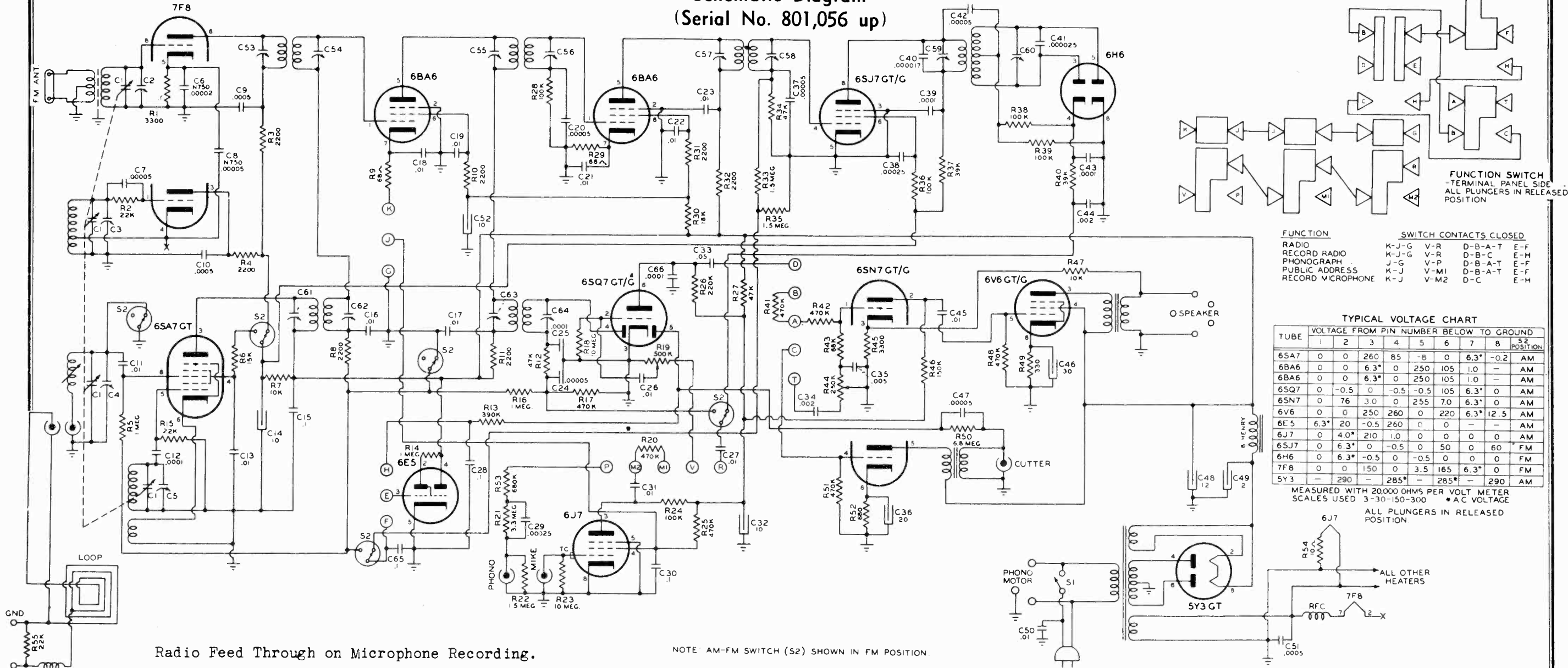

FUNCTION	SWITCH CONTACTS CLOSED			
RADIO	K-J-G	V-R	D-B-A-T	E-F
RECORD RADIO	K-J-G	V-R	D-B-C	E-F
PHONOGRAPH	J-G	V-P	D-B-A-T	E-F
PUBLIC ADDRESS	K-J	V-M1	D-B-A-T	E-F
RECORD MICROPHONE	K-J	V-M2	D-C	E-H

TYPICAL VOLTAGE CHART

TUBE	VOLTAGE FROM PIN NUMBER BELOW TO GROUND								S2 POSITION
	1	2	3	4	5	6	7	8	
6SA7	0	0	260	85	-8	0	6.3*	-0.2	AM
6BA6	0	0	6.3*	0	250	105	1.0	-	AM
6BA6	0	0	6.3*	0	250	105	1.0	-	AM
6S7	0	-0.5	0	-0.5	-0.5	105	6.3*	0	AM
6SN7	0	76	3.0	0	255	7.0	6.3*	0	AM
6V6	0	0	250	260	0	220	6.3*	12.5	AM
6E5	6.3*	20	-0.5	260	0	0	-	-	AM
6J7	0	4.0*	210	1.0	0	0	0	0	AM
6S7	0	6.3*	0	-0.5	0	50	0	60	FM
6H6	0	6.3*	-0.5	0	-0.5	0	0	0	FM
7F8	0	0	150	0	3.5	165	6.3*	0	FM
5Y3	-	290	-	285*	-	285*	-	290	AM

MEASURED WITH 20,000 OHMS PER VOLT METER
SCALES USED 3-30-150-300 * AC VOLTAGE

Radio Feed Through on Microphone Recording.

NOTE: AM-FM SWITCH (S2) SHOWN IN FM POSITION

In some localities where signal strength is great, difficulty has been encountered with the radio signal "leaking through" on Microphone Recording. This trouble is eliminated by removing the orange wire connecting pin No. 4 on the 6J7 tube socket to terminal J on the push-button switch.

All 7E40 and 7E44 models with serial numbers above 803,108 will have this lead removed.

On all chassis with serial number 804,045 and up, R53 in the phono circuit has been changed from 820 K to 470 K. This compensates for variance in values of the volume control and provides greater voltage to the audio section of the 6S9 phono amplifier tube.

If low phonograph gain is encountered on chassis with serial numbers below 804,045, R53 should be changed to 470 K to increase the gain.

WILCOX-GAY CORP.

MODELS 7E40,
7E44

A loading coil, can be substituted for the loop for bench alignment but the final adjustment of trimmer C-4 and L.F. antenna coil slug should be made with the chassis in cabinet. To make this loading coil, close wind 50 turns of #24 enamel wire on a 3/4" O.D. bakelite form. An antenna can be coupled to the ungrounded side of this coil through a .0001 mfd. condenser.

SIGNAL GENERATOR	DIAL	TRIMMER
FREQUENCY	SETTING	
1400 K.C.	1400 K.C.	Osc. (C-5)
1400 K.C.	1400 K.C.	Det. (C-4)
600 K.C.	600 K.C.	L.F. ANT.-AM

Note: Repeat procedure to obtain greatest accuracy in the adjustment of the trimmer condensers.

ALIGNMENT OF FREQUENCY MODULATION (FM) BAND.

An unmodulated signal generator with output at 10.7 MC and 100 MC is required for FM alignment. A vacuum tube voltmeter or a high resistance voltmeter, at least 20,000 OHMS per volt, is required to measure limiter grid voltage and discriminator output voltage.

FM alignment can be accomplished with an FM signal generator and oscilloscope. Instructions for this type of alignment are furnished by the manufacturers of FM signal generators.

I. F. SECTION

1. Connect 10.7 MC Signal Generator across ANT.FM section, (copper plates), of tuning condenser gang.
2. Connect VTVM or high resistance voltmeter across R-34 with positive terminal to ground.
3. Adjust trimmers C58, C57, C56, C55, C54 and C53 in order listed for maximum voltmeter reading.

Note: Reduce output from signal generator as alignment progresses so that the limiter grid voltage does not exceed 5 volts.

4. With signal generator connected as above, remove voltmeter from limiter grid and connect across discriminator load resistor, R39.
5. Adjust trimmer C-59 on Disc. Transformer for maximum voltmeter reading.
6. Connect voltmeter from 6H6 pin #4 to ground.
7. Adjust trimmer C-60 on Disc. Transformer for zero reading on voltmeter.

Note: When trimmer C-60 is adjusted correctly, slight detuning will give a positive voltage reading in one direction and a negative reading in the other.

R. F. SECTION

1. Disconnect FM antenna and connect signal generator with 150 ohm resistor in each lead to FM ANT terminals.
2. Connect voltmeter across R-34.
3. Set signal generator and radio dial pointer at 100 MC.
4. Adjust trimmer C-3 (OSC FM) to bring in signal.

Note: Two settings of this trimmer will give a response. The correct adjustment is the one for least capacity.

5. Adjust trimmer C-2 (ANT FM) for maximum voltmeter reading.

CORRECTION FOR EXCESSIVE AC HUM ON 7E MODELS

PART NO. NAME
 17-3026-A Antenna Coupling Coil Assembly
 59-2128 Cap Shield for metal 6J7 tube.
 147-1 Capristor .01 mfd. and 10 meg ohm res. Cap. 20-50 Res. 20%
 78-2053 Condenser, trimmer.
 77-2096 Condenser, variable, 2 gang.
 81-2096 Cutter Transformer
 56-2220 Dial Background
 20-2002 Dial Cord 54" long
 62-2134 Dial Light Socket Assembly
 56-2221 Dial Scale
 68-3007-A Discriminator Transformer Assembly FM
 27-2034-A Drive Drum Assembly
 18-2040 Electrolytic Capacitor 10-400V . . 20-25V
 18-2049 Electrolytic Capacitor 12-450V . . 30-25V
 9-2195 F.M. Transmission line.
 14-2101 Filter Choke
 68-3005-A I.F. Transformer 10.7 K.C.
 68-3001-C I.F. Transformer 456 K.C.
 68-3006-A I.F. Transformer Assembly AM 2nd
 68-3005-A I.F. Transformer Assembly FM 3rd
 68-3005-B I.F. Transformer Assembly FM 2nd
 59-2106-1 Loctal Tube Shield
 17-3015-A Loop Loading Coil Assembly
 62-2135 Magic eye socket and cable
 59-3002 Mike Socket Shield
 17-3028 Mixer Coil, F.M.
 81-2095 Output Transformer
 17-3023-A Osc. Coil Assembly A.M.
 17-3029 Osc. Coil, F.M.
 45-2003 Pilot Lamp
 39-2022-3 Pointer.
 20-2038 Power Cord
 80-2182 Power Transformer
 40-2043 Push Button.
 66-2173 Push Button Switch
 17-3025-A R.F. Choke Coil Assembly
 59-3020 R.F. Coil Shield
 66-3016 Switch
 19-2193 Tone Control
 97-3005 Tension Spring—Dial Cord
 19-2188-1 Volume Control

(Serial Nos. 800,000 to 801,055 Incl.)

Due to variance in tube characteristics, AC hum in some cases was objectionable on the first production run on 7E Models.

On all chassis with serial numbers above 801,055 the plate resistor (R46) of the audio section of the 6SN7 GT/G tube is connected to the junction of Resistor (R27) and Filter Capacitor (C32) instead of directly to the plate supply.

This change, shown below, takes care of tube variances and should be made, when necessary, in the field.

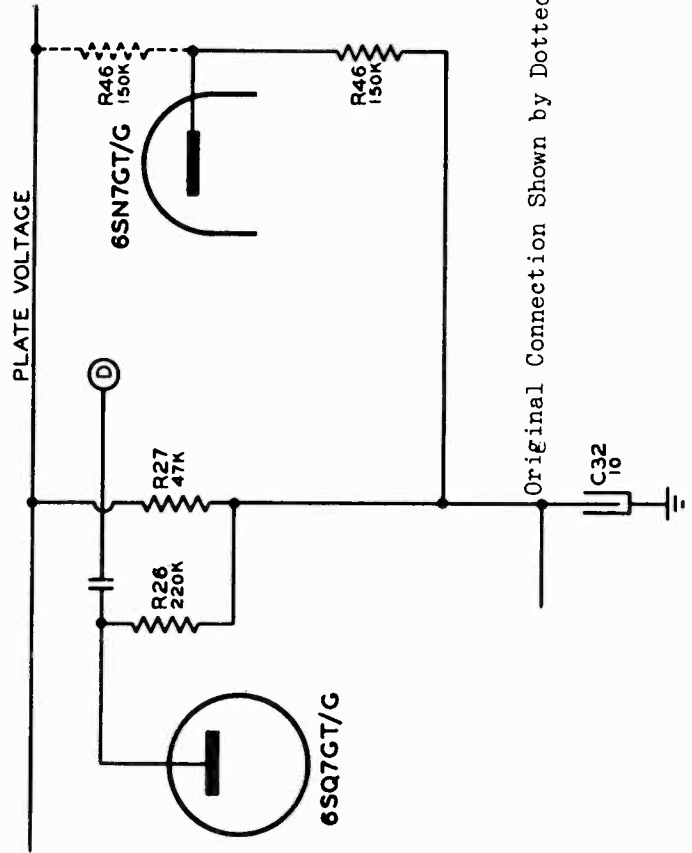

Original Connection Shown by Dotted Lines.

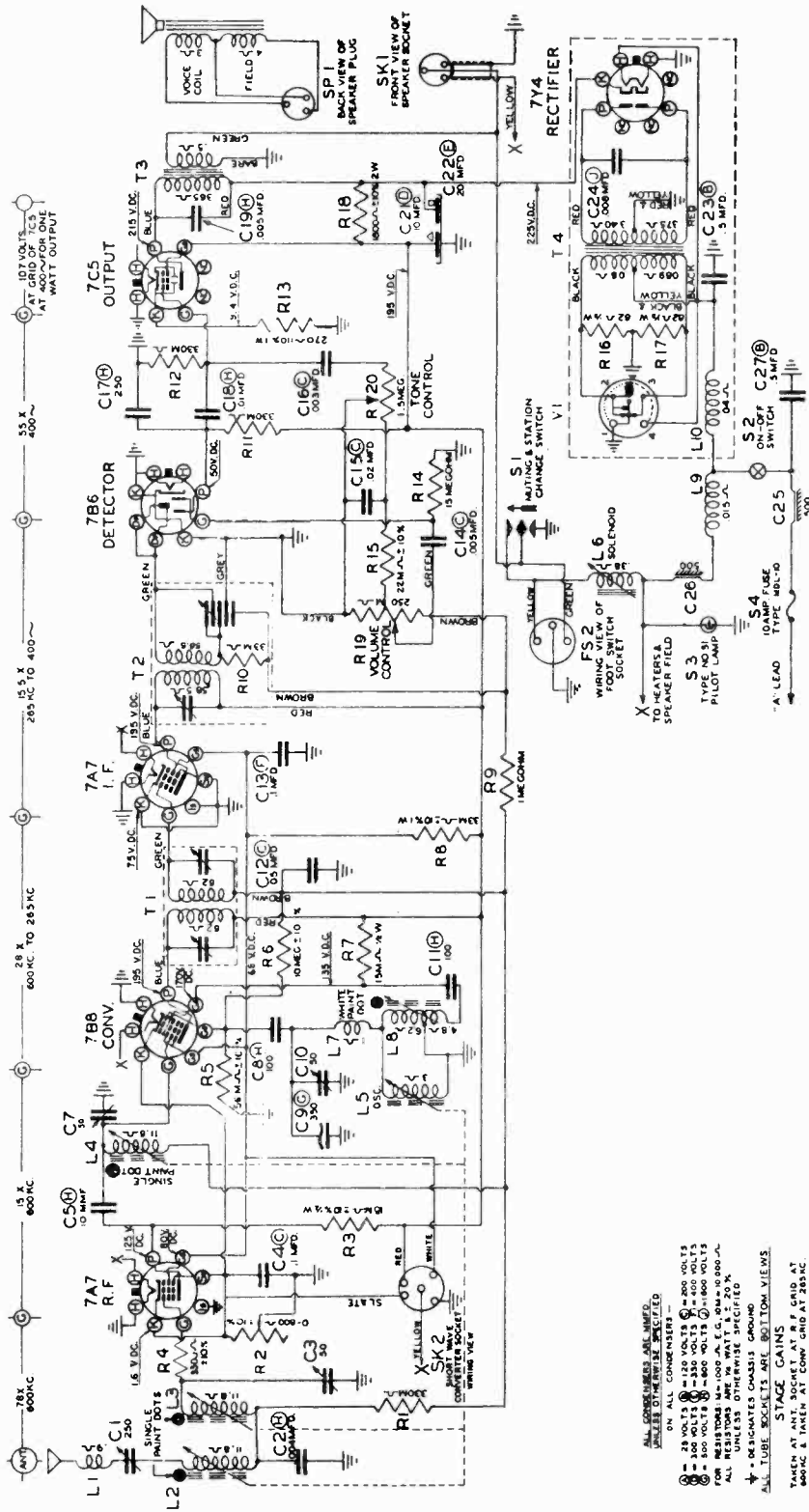

I. F. 265 KC.
TUNING RANGE 340KC. TO 1600 KC.

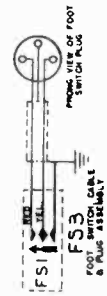

- ① - 25 VOLTS
- ② - 50 VOLTS
- ③ - 100 VOLTS
- ④ - 250 VOLTS
- ⑤ - 500 VOLTS
- ⑥ - 1000 VOLTS
- ⑦ - 1000 VOLTS
- ⑧ - 1000 VOLTS
- ⑨ - 1000 VOLTS
- ⑩ - 1000 VOLTS
- ⑪ - 1000 VOLTS
- ⑫ - 1000 VOLTS
- ⑬ - 1000 VOLTS
- ⑭ - 1000 VOLTS
- ⑮ - 1000 VOLTS
- ⑯ - 1000 VOLTS
- ⑰ - 1000 VOLTS
- ⑱ - 1000 VOLTS
- ⑲ - 1000 VOLTS
- ⑳ - 1000 VOLTS
- ㉑ - 1000 VOLTS
- ㉒ - 1000 VOLTS
- ㉓ - 1000 VOLTS
- ㉔ - 1000 VOLTS
- ㉕ - 1000 VOLTS
- ㉖ - 1000 VOLTS
- ㉗ - 1000 VOLTS
- ㉘ - 1000 VOLTS
- ㉙ - 1000 VOLTS
- ㉚ - 1000 VOLTS
- ㉛ - 1000 VOLTS
- ㉜ - 1000 VOLTS
- ㉝ - 1000 VOLTS
- ㉞ - 1000 VOLTS
- ㉟ - 1000 VOLTS
- ㊱ - 1000 VOLTS
- ㊲ - 1000 VOLTS
- ㊳ - 1000 VOLTS
- ㊴ - 1000 VOLTS
- ㊵ - 1000 VOLTS
- ㊶ - 1000 VOLTS
- ㊷ - 1000 VOLTS
- ㊸ - 1000 VOLTS
- ㊹ - 1000 VOLTS
- ㊺ - 1000 VOLTS
- ㊻ - 1000 VOLTS
- ㊼ - 1000 VOLTS
- ㊽ - 1000 VOLTS
- ㊾ - 1000 VOLTS
- ㊿ - 1000 VOLTS

MODEL 6MN788E,
Nash

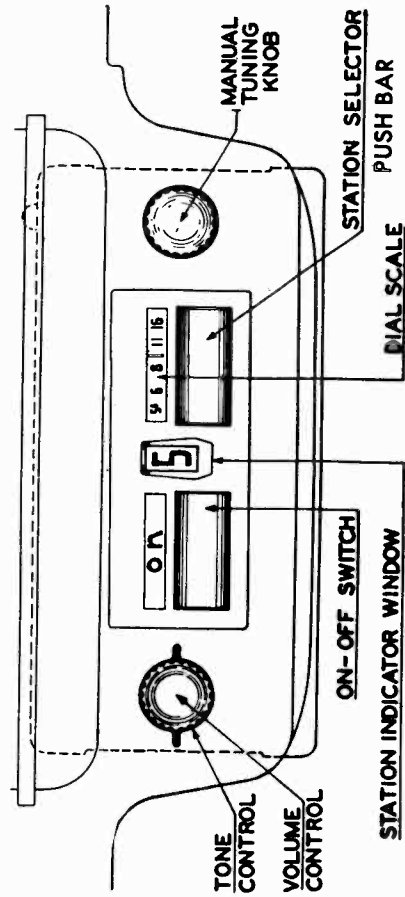
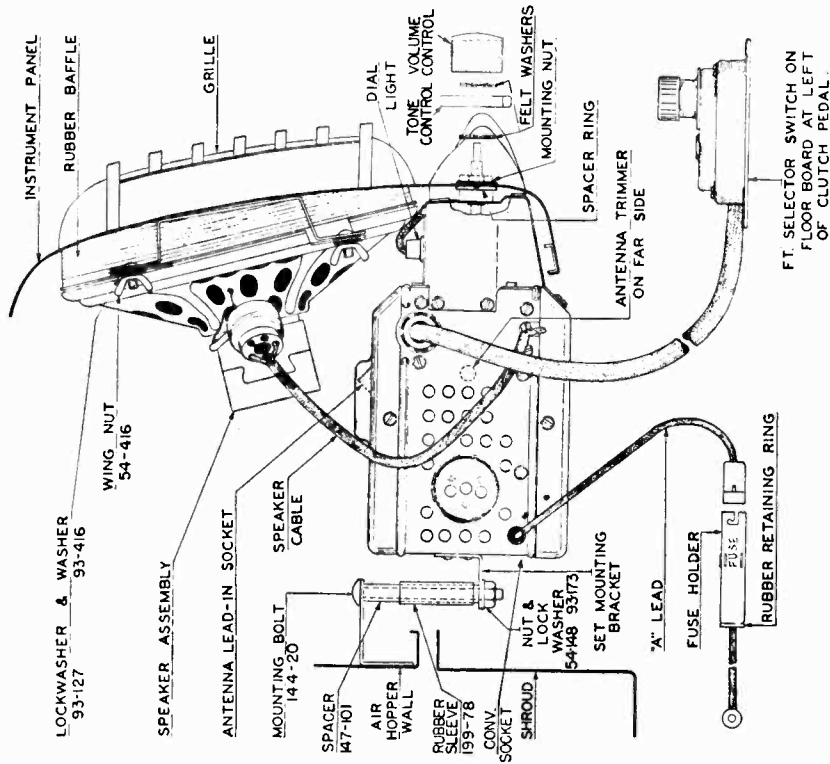

SETTING THE AUTOMATIC TUNER

Pressing the Push-Bar at the right below the dial repeatedly will cause the tuning mechanism to change through a cycle of six positions. Five of the automatic positions may be set for favorite local stations while the sixth position, at which "M" appears on the indicator drum, is used for selecting stations manually.

Allow the receiver to operate for at least fifteen minutes to bring the operating temperature up to normal before making the following automatic tuning settings.

Using "M" position as a reference point, the remaining five positions may be adjusted in succession to any desired dial setting. Setting these stations in sequence according to their frequencies beginning at the lowest frequency for number 1, and progressing through to the high frequency end of the dial for number 5 is the recommended practice to simplify the identification of each automatic tuned station.

1. Press station selector bar until number 1 appears in station indicator window.
2. Pull manual tuning knob outward to engage the automatic mechanism.
3. Select the station desired and tune to its frequency by turning tuning knob. Tune very carefully for clearest reception.
4. Press station selector bar, pull manual tuning knob outward, and tune in station desired for No. 2 position. Use same procedure for positions No. 3, 4 and 5.

NOTE: When "M" appears in the station indicator window, the manual tuning knob must be pulled outward and rotated to select the stations manually.

MODELS 6S62 $\frac{1}{2}$ CT,
6S643CT, Ch. 6B16CT

ZENITH RADIO CORP.

MODELS 6S643AT,
6S659AT, Ch. 6B16AT;
6S624BT, 6S643BT,
6S659BT, Ch. 6B16BT

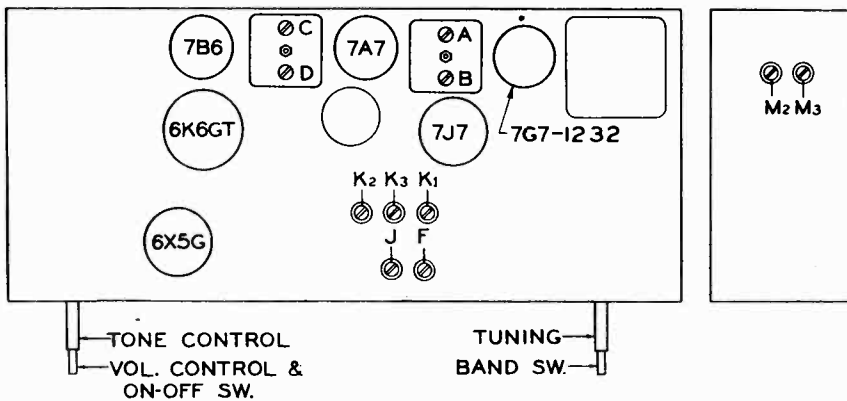
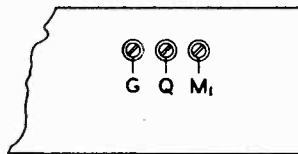
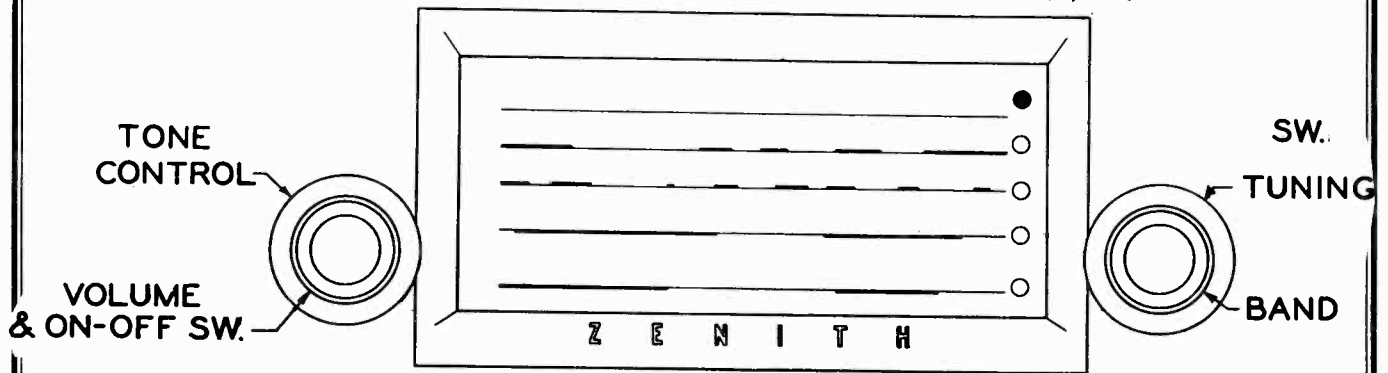

POWER

Under no circumstances should this receiver be connected to direct current (D.C.).

6B16AT — This chassis is designed to operate on 25 cycles alternating current (A.C.) and may be adjusted for use on 110-125-190-220 or 240 volts by means of the switch on top of the transformer.

6B16BT — This chassis is designed to operate on 50 to 100 cycle alternating current (A.C.) and may be adjusted for use on either 115 or 225 volts by means of the switch on the power transformer.

6B16CT — This chassis is designed to operate on 50 to 60 cycle alternating current (A.C.) and may be adjusted for use on either 95, 115 or 150 volts by means of the switch on the power transformer.

The total power consumption is 50 watts.

TUBES

The following tubes are used — (see Fig. 2):

- 7G7/1232 - 7J7 - 7A7 - 7B6 -
- 6K6GT - 6X5G

Operation	Connect test osc. to	Dummy Ant.	Input signal frequency	Band	Set Dial	Adjust Trim	Purpose
1	1st det. Gnd.	.1 mfd.	455 kc.	BC	600 kc.	ABCD	Align IF
2	Ant. Gnd.	200 mmf.	1400 kc.	BC	1400 kc.	F	Set osc. to scale
3	Ant. Gnd.	200 mmf.	1400 kc.	BC	1400 kc.	G	Align Ant.
4	Ant. Gnd.	200 mmf.	600 kc.	BC	Rock at 600 kc.	J	Set Padder
5	Ant. Gnd.	400 ohm	6.5 mc.	SW2	6.5 mc.	Q	Align SW2
6	Ant. Gnd.	400 ohm	18.0 mc.	SW1	18.0 mc.	K1	Set osc. to scale
7	Ant. Gnd.	400 ohm	18.0 mc.	SW1	18.0 mc.	M1	Align Ant.
8	Ant. Gnd.	400 ohm	17.8 mc.	19-16m	17.8 mc.	K3	Set osc. to scale
9	Ant. Gnd.	400 ohm	17.8 mc.	19-16m	17.8 mc.	M3	Align Ant.
10	Ant. Gnd.	400 ohm	11.8 mc.	25-31m	11.8 mc.	K2	Set osc. to scale
11	Ant. Gnd.	400 ohm	11.8 mc.	25-31m	11.8 mc.	M2	Align Ant.

ZENITH RADIO CORP.

MODEL 7H820,
CHASSIS 7E01

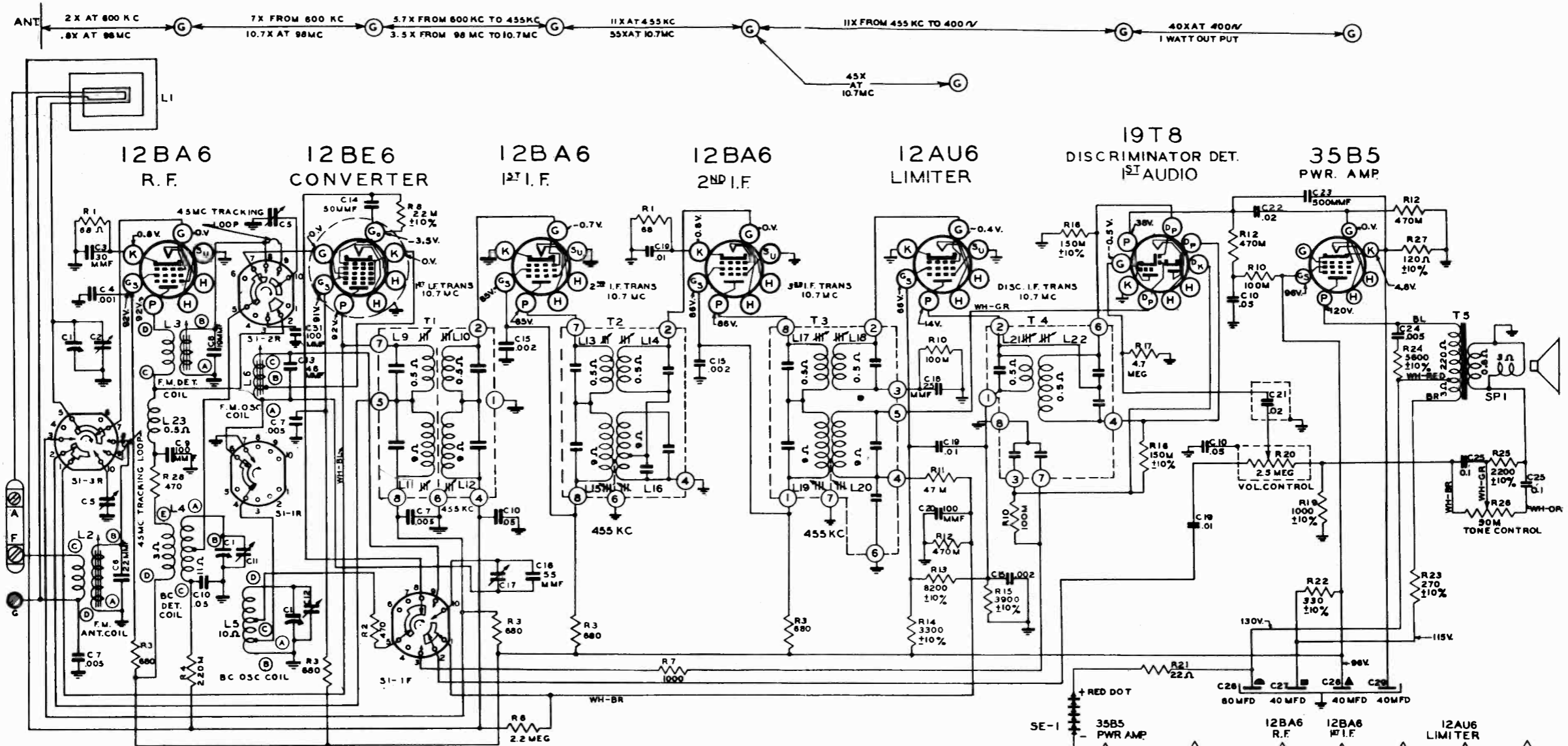

BAND SWITCH S1 SHOWN IN STANDARD BROADCAST POSITION
 BANDSWITCH POSITIONS
 1ST POS. - STD. BROADCAST
 2ND POS. - RM. 100 MC.
 3RD POS. - FM. 45 MC

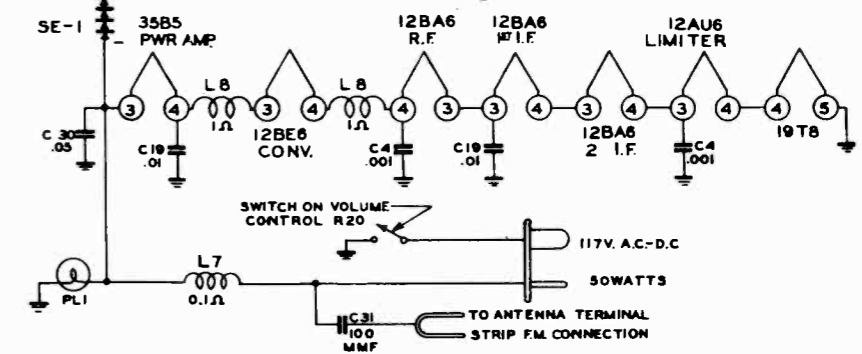
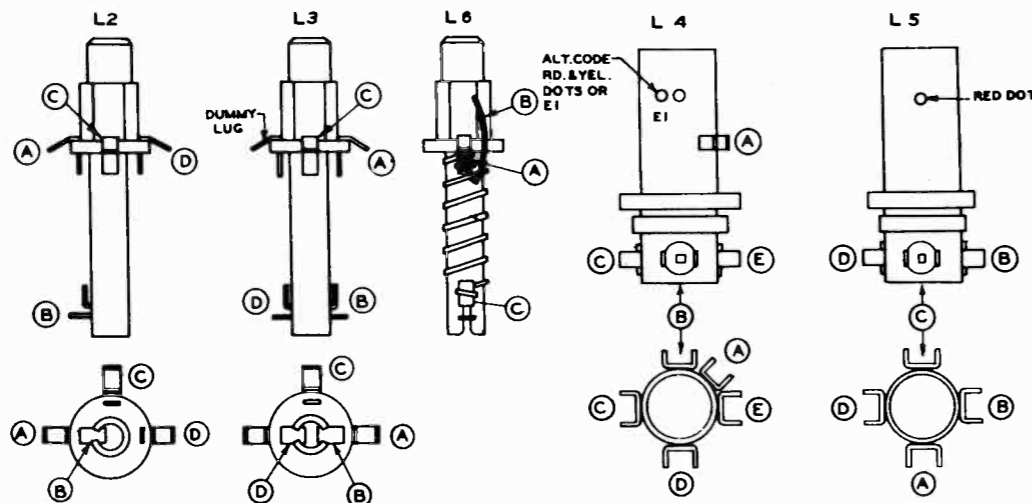

ALL VOLTAGE MEASURED FROM COMMON RETURN TO POINTS INDICATED WITH AN A.C., D.C. OR VACUUM TUBE VOLTMETER

ALL VOLTAGES ARE D.C. UNLESS OTHERWISE SPECIFIED

ALL RESISTORS ±20% TOLERANCE UNLESS OTHERWISE SPECIFIED

⊥ DENOTES CHASSIS

AMP. MOD. I.F. FREQUENCY 455 K.C.
 FREQ. MOD. I.F. FREQUENCY 10.7 M.C.

TUNING RANGES
 540-1620 K.C. STD. B.C.
 88-108 M.C. FM. 100
 42-48.5 M.C. FM. 45

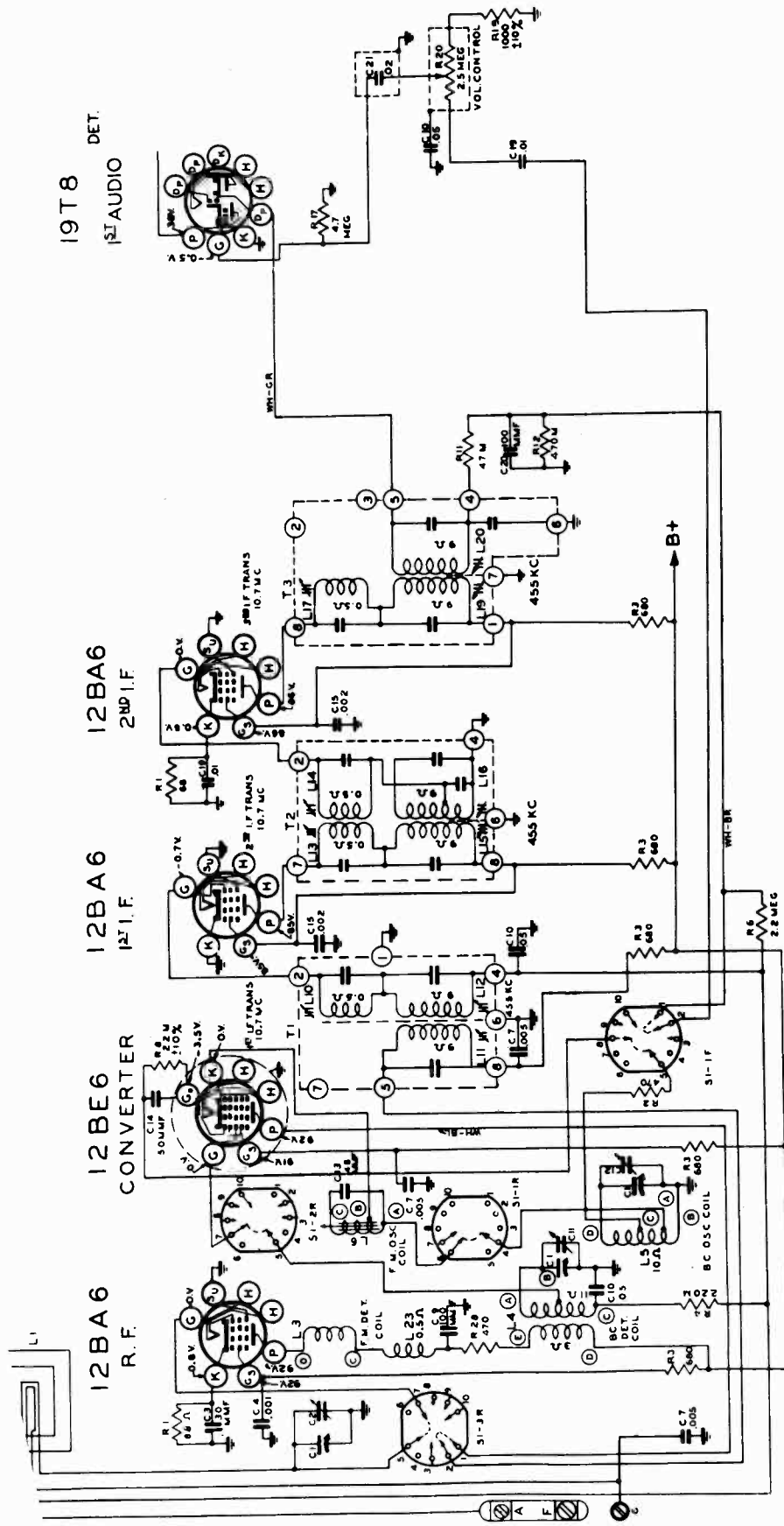

BAND-SWITCH SHOWN
AT 1ST POSITION.
BROADCAST BAND
540-1620 KC

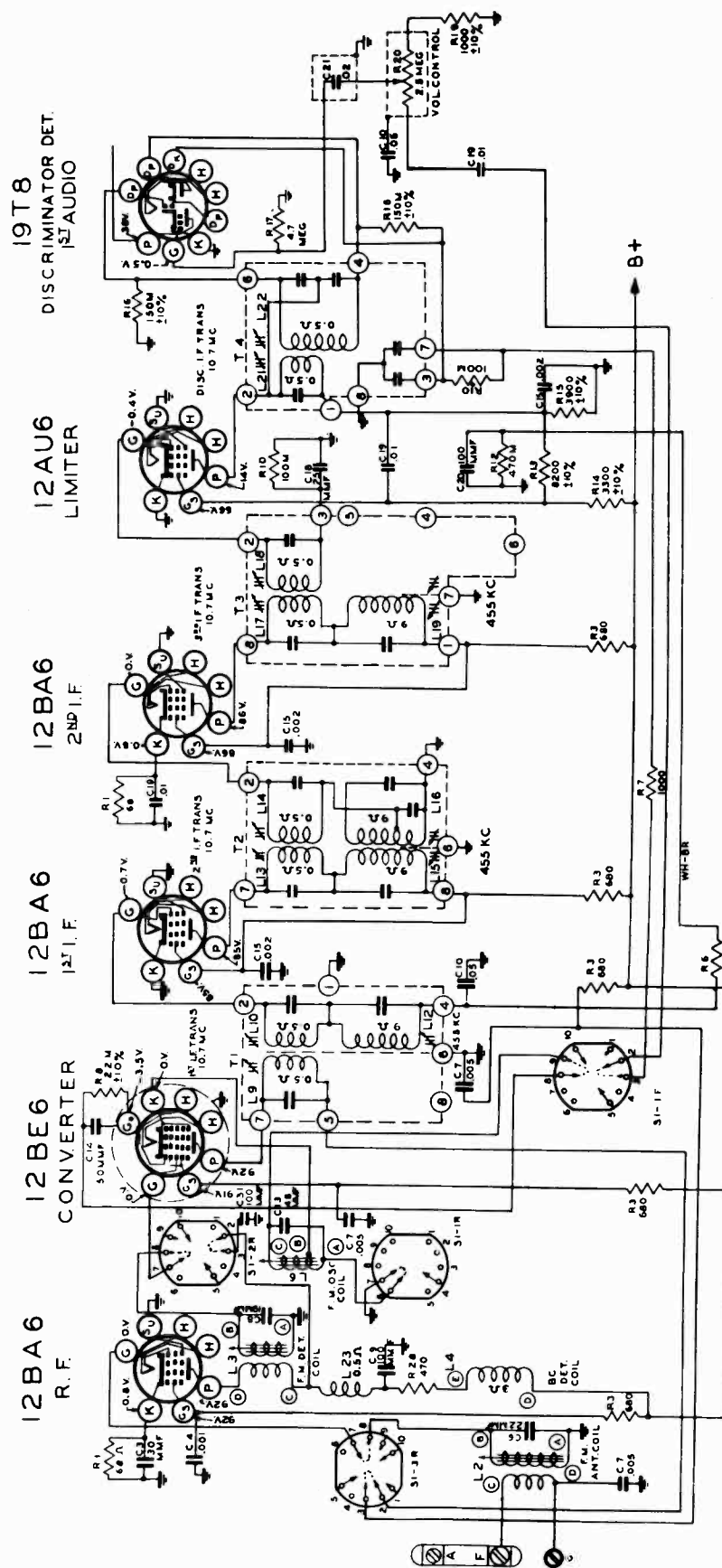

BAND-SWITCH SHOWN
AT 2ND POSITION CLOCKWISE
F M BAND
88-108 MC

CLARI - SKEMATIX

Registered Trademark

ZENITH RADIO CORP.

MODEL 7H820,
CHASSIS 7E01

19T8
DISCRIMINATOR DET.
1ST AUDIO

12AU6
LIMITER

12BA6
2ND I.F.

12BA6
1ST I.F.

12BE6
CONVERTER

12BA6
R.F.

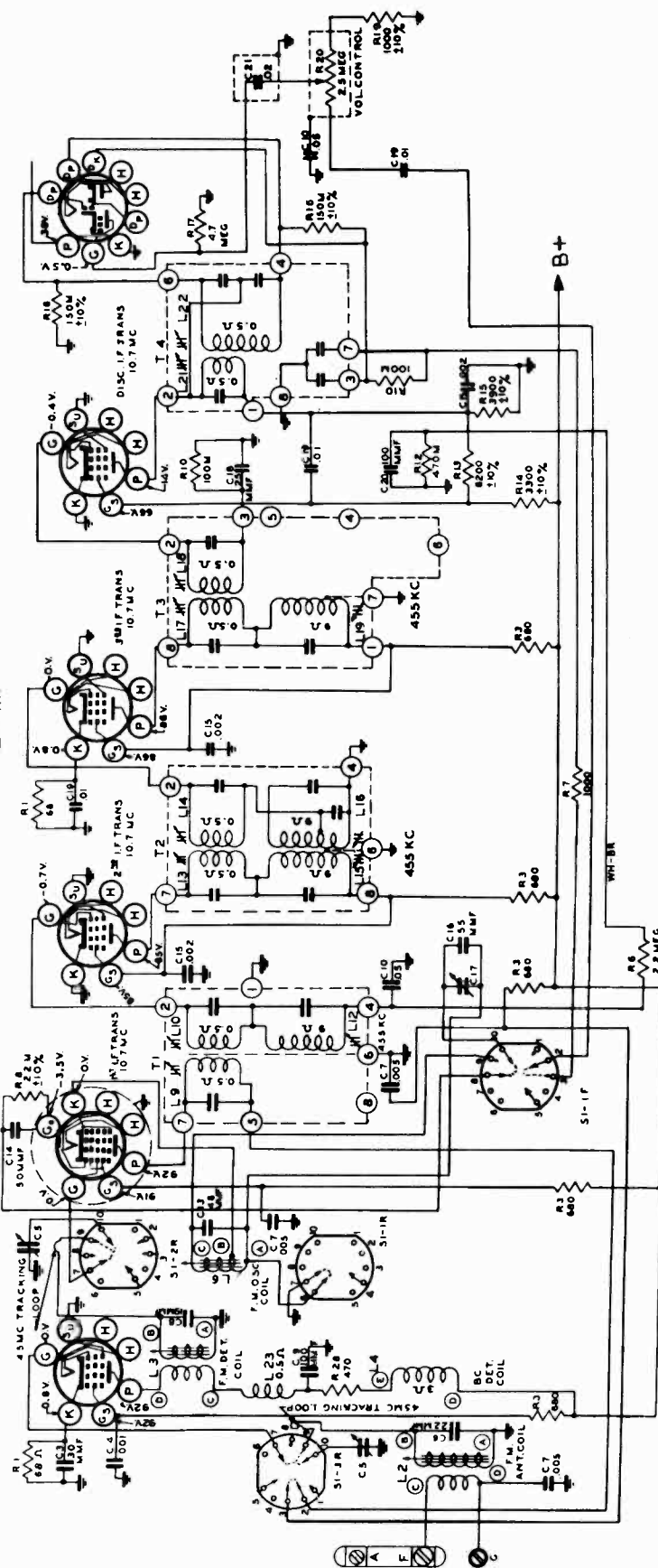

BAND-SWITCH SHOWN
AT 3RD POSITION CLOCKWISE .
F-M BAND
42-48.5 MC

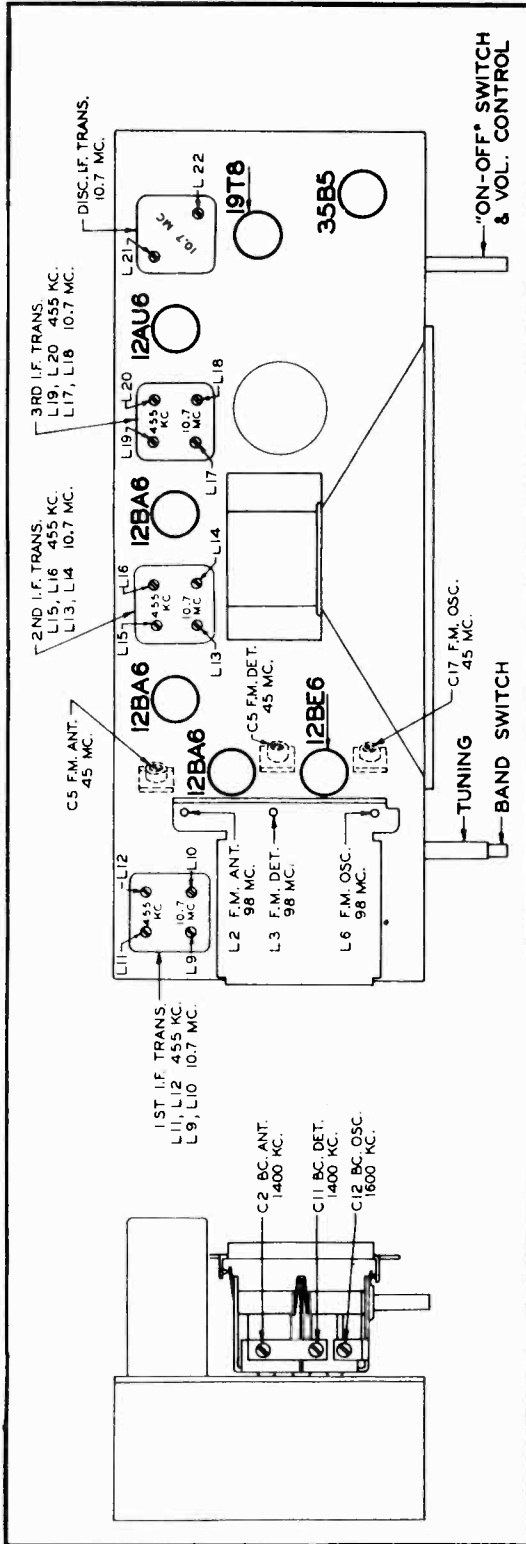

TUBE AND TRIMMER LOCATION

The 7E01 chassis incorporates a superheterodyne circuit with two stages of IF, and one stage of RF amplification on all bands. When adjustments are made on the 7E01 or any AC-DC chassis, a line isolation transformer (110 V input to 110 V output) is recommended in order to avoid a "hot" chassis. If an isolation transformer is not available, check the AC voltage between chassis and bench ground, and if there is any indication of voltage, reverse the plug before handling the set.

AM Alignment: The alignment of this chassis on the standard broadcast band is conventional. The alignment slugs in the IF transformers are threaded and screw into the coil forms. The slugs are slotted for a small size fiber screw driver. Do not press hard on the aligning tool or the threads in the coil forms will strip and adjustment will be impossible.

FM RF Alignment: The same coil slug arrangement which tunes the 100 MC FM band also tunes the 45 MC band. However, on 45 MC the band switch connects trimmer condensers in parallel and padding wires in series with the 100 MC coils. The tuning slugs are attached to threaded shafts and the slugs are varied in the field of the coils by turning the shafts clockwise or counter-clockwise. After adjustment the shafts must be secured with a drop of speaker cement.

FM IF Alignment: The same type of tuning slugs for aligning the AM IF Amplifier are used for the FM I.F.'s. Observe the same precautions when making adjustments.

FM Discriminator Alignment: When the secondary of the discriminator is aligned (operation 5) use sufficient signal input to get a good positive and negative indication before setting the slug for zero reading. A center zero indicating meter is recommended for this adjustment, but is not absolutely necessary. Reversing the leads of a non-zero center meter, or observing closely when the meter starts to go to the left (negative) of zero will give the same results.

The tone control is of the low impedance type in which a portion of the audio voltage is taken from the voice coil and fed back into the grid of the first audio. The voltage is fed back out of phase. R25, 26 and C25 determine the characteristic of the feedback voltage. A much greater variation of tone can be had by this system.

The filter circuits of chassis 7E01 incorporate new features. An examination of the schematic drawing will show the output transformer tapped slightly off center. This tap is the B+ connection from filter capacitor C26 off the selenium rectifier to the 35B5 plate. The lower connection of the output transformer feeds B+ to the rest of the tubes in the receiver. Current flowing through the upper windings of the output transformer to the 35B5 produces a magnetic field which is 180° out of phase with the magnetic field produced by current flowing in the opposite direction through the output transformer to the rest of the receiver, therefore, most of the AC hum is cancelled. Further reduction of hum is accomplished by filtering through resistors R22 and R23 capacitors C27 and C28.

This development in filtering systems allows a higher effective plate voltage on the 35B5 for increased power output.

NOTE: The output transformer must be replaced with an exact duplicate, Part No. 95-1035 be sure to add the speaker code letter to the transformer Part Number when ordering replacements.

ZENITH RADIO CORP.

MODEL 7H820,
CHASSIS 7E01

ALIGNMENT PROCEDURE

Operation	Connect Oscillator to	Dummy Antenna	Input Signal Frequency	Band	Set Dial To	Adj. Trimmers	Purpose
1	Pin 7 12BE6 Converter 2 turns loosely cpd. to wavemagnet	.05 Mfd.	455 Kc. Modulated	BC	600 Kc.	L-11, 12, 15, 16, 19 and 20	Align I. F. channel for maximum output.
2	2 turns loosely cpd. to wavemagnet	.05 Mfd.	1600 Kc. Modulated	BC	1600 Kc.	C12	Set oscillator to dial scale.
3	2 turns loosely cpd. cpd. to wavemagnet	.05 Mfd.	1400 Kc. Modulated	BC	1400 Kc.	C11 and C2	Align det. and ant. stages.
4 (a)	Pin 1 (grid) on 12AU6 limiter.	.05 Mfd.	10.7 Mc. Unmodulated	FM 45		L21 coil slug Primary discr.	Align primary of discriminator for maximum reading.
5 (b)	Pin 1 (grid) on 12AU6 limiter.	.05 Mfd.	10.7 Mc. Unmodulated	FM 45		L22 coil slug sec. of discr. L17 and L18 Prim. and Sec. of 3rd IF trans.	Adjust secondary of discriminat- or for zero reading.
6 (c)	Pin 1 (grid) on 12BA6 2nd IF.	.05 Mfd.	10.7 Mc. Unmodulated	FM 45		L13 and L14 Prim. and Sec. of 2nd IF transformer	Align 3rd IF transformer for maximum reading.
7 (c)	Pin 1 (grid) on 12BA6 1st IF.	.05 Mfd.	10.7 Mc. Unmodulated	FM 45		L9 and L10 Prim. and Sec. of 1st IF transformer	Align 2nd IF transformer for maximum reading.
8 (c)	Pin 7 (grid) on 12BE6 converter tube socket	.05 Mfd.	10.7 Mc. Unmodulated	FM 45		L6 Osc. Coil Slug L3 and L2 Det. and RF coil Slugs	Align 1st IF transformer for maximum reading.
9 (c) (d)		270 ohms	98 Mc. Unmodulated	FM 100	98 Mc.		Set Oscillator to dial scale.
10 (c) (d)	Antenna Post F (Re- move line ant.)	270 ohms	98 Mc. Unmodulated	FM 100	98 Mc.		Align det. and ant. stages to maximum reading.
11 (c)		270 ohms	45 Mc. Unmodulated	FM 45	45 Mc.	C17	Set oscillator to dial scale.
12 (c)		270 ohms	45 Mc. Unmodulated	FM 45	45 Mc.	C5 Det., C5 Ant.	Align detector and ant. stages for maximum reading.

IMPORTANT

Alignment of this chassis will in most cases be unnecessary unless an IF or RF transformer is replaced or the adjustments have been tampered with.

Correct alignment can only be made if the following procedure is followed:

A vacuum tube voltmeter with an isolation resistor of 2000,000 ohms in series with the hot lead will serve for FM adjustments. This lead should be shielded.

An AC output meter connected across the primary or secondary of the output transformer will be satisfactory for all AM adjustments. The signal generator output should be kept just high enough to get an indication on the meter.

(a) Vacuum Tube Voltmeter Lug 6 on discriminator transformer to chassis (half discriminator load).

(b) Vacuum Tube Voltmeter Lug 3 on discriminator transformer to chassis (full discriminator load).

(c) Vacuum Tube Voltmeter Lug 3 on 3rd IF transformer (Limiter Grid).

(d) Loosen Slugs by applying a hot iron to the cement.

ZENITH RADIO CORP.

MODEL 7H820,
CHASSIS 7E01

PART NO.	REF. NO.	DESCRIPTION	PART NO.	REF. NO.	DESCRIPTION
12-1407		Dial Light Socket Mounting Bracket.			
26-389		Louvre Dial			
46-538		Tuning Control Knob			
46-688		Tone Control Knob			
46-718		Band Switch Knob.			
54-211		Speed Nut (Dial Scale Mtg.)	22-162	C31	100 Mmfd. (or 22-1669)
57-1335		Tone Knob Escutcheon.	22-365	C20	100 Mmfd. (or 22-1701)
76-493		Tuning Shaft.	22-829	C10	.05 Mfd.
78-786		Dial Light Socket	22-830	C22	.02 Mfd.
80-69		Dial Cord Spring.	22-1017	C30	.05 Mfd.
80-209		Dial Cord Spring.	22-1138	C23	500 Mmfd. (or 22-1703)
80-444		Tuner Arm Tension Spring.	22-1220	C15	.002 Mfd.
80-580		Tuner Arm Stop Spring	22-1367	C14	50 Mmfd.
80-581		Tuner Arm Pressure Spring	22-1385	C19	.01 Mfd.
83-1504		Dial Light Shield	22-1418	C25	.1 Mfd.
93-475		Felt Washer	22-1506	C6	22 Mmfd. (Ceramic)
94-371		Pointer Pulley Bushing (S13944)	22-1507	C18	25 Mmfd. (Ceramic)
97-284		Dial Cord Guide Stud.	22-1661	C26, C27	Dry Electrolytic 80-40-40 Mfd. 150 V. X 40
100-97		Dial Light Bulb - 115 V. - 10 W.		C28, C29	Mfd. - 25 V
188-30		Retaining Ring (76-493)	22-1669	C9	100 Mmfd. (Ceramic)
188-102		Clamping Ring (46-538).	22-1676	C4	.001 Mfd. (Ceramic)
S-13944		Pointer Pulley and Bushing Assembly (59-205)	22-1677	C1	Three Gang Variable
S-13945		Cam, Pulley and Bushing Assembly.	22-1683	C21	.02 Mfd. (Shielded)
S-13981		Tone Control Mtg. Bracket and Lug Assem. (12-1404)	22-1685	C5	Single Section Trimmer
S-13982		Dial Cord and Eyelet Assembly (Short)	22-1686	C17	Single Section Trimmer
S-13983		Dial Cord and Eyelet Assembly (Long).	22-1688	C8	19 Mmfd. (Ceramic)
S-14129		Volume Control Knob Assembly (46-522-697)	22-1689	C13	48 Mmfd. (Ceramic)
S-14429		Tuner Arm Assembly.	22-1691	C16	55 Mmfd. (Silver on Ceramic)
		COILS AND CHOKES	22-1702	C24	.005 Mfd.
S-11157	L5	Broadcast Oscillator Coil Assembly.	22-1705	C2	30 Mmfd. (Ceramic)
S-12256	L7	A.C. Line Choke Coil Assembly	22-1706	C7	.005 Mfd. (Ceramic) (Disc Type)
S-12259	L6	F.M. Oscillator Coil Assembly			
S-13871	L3	F.M. Detector Coil Assembly	63-1202	R22	330 Ohm (Wirewound)
S-13970	T1	1st I.F. Transformer Assembly	63-1450	R21	22 Ohm (Wirewound)
S-13971	T2	2nd I.F. Transformer Assembly	63-1452	R23	270 Ohm (Wirewound)
S-13972	T3	3rd I.F. Transformer Assembly	63-1582	R26	50M Ohm Tone Control
S-13973	T4	Discriminator Transformer Assembly.	63-1584	R20	Volume Control and Switch
S-13974	L4	Broadcast Detector Coil Assembly.	63-1737	R1	68 Ohm (Insulated)
S-13997	L8	Filament Choke Coil Assembly.	63-1747	R27	120 Ohm (Insulated)
S-14126	L23	R.F. Choke Coil Assembly.	63-1772	R2	470 Ohm (Insulated)
S-14192	L2	F.M. Antenna Coil Assembly.	63-1779	R3	580 Ohm (Insulated)
93-125	#6	Internal Shakeproof Lockwasher #1206.	63-1765	R19	1M Ohm (Insulated)
93-126	#8	Internal Shakeproof Lockwasher #1208.	63-1786	R7	1000 Ohm (Insulated)
93-665		Fibre Washer	63-1799	R25	2200 Ohm (Insulated)
93-735		.012 x .093 x 11/64" Steel Washer - Cadmium.	63-1806	R14	3300 Ohm (Insulated)
93-889		Insulating Washer.	63-1810	R15	3900 Ohm (Insulated)
94-334		Speaker Mtg. Bushing	63-1871	R29	5600 Ohm (Insulated)
94-485		Fibre Bushing.	63-1824	R13	8200 Ohm (Insulated)
94-598		R.F. Plate Mtg. Bushing.	63-1841	R8	22M Ohm (Insulated)
95-1035		Output Transformer	63-1856	R11	47M Ohm (Insulated)
97-293		Insulating Stud (Chassis Mtg. Stud) (4 used)	63-1870	R10	100M Ohm (Insulated)
102-466		Dial Calibration Label	63-1876	R16	150M Ohm (Insulated)
110-130		Grille Cloth	63-1884	R4	220M Ohm (Insulated)
112-281	#10 x 3/4"	Oval Binding Hd. Self Tapping Screw Type Z - Stat. Bronze	63-1898	R12	470M Ohm (Insulated)
114-26	#8 x 1/4"	Hex Hd. Self Tapping Screw - Type Z - Cad.	63-1926	R6	2.2 Megohm (Insulated)
114-48	#6-32 x 1/4"	Hex Acorn Hd. M.S., Steel N.P. (9 used)	63-1940	R17	4.7 Megohm (Insulated)
114-78	#8 x 5/16"	Hex Hd. Slotted Self Tapping Screw (Wavemagnet Mtg.)			
114-92	#6 x 1-1/8"	Hex Hd. Slotted Self Tapping Screw Type Z - Cad.	12-1070		Wavemagnet Mounting Bracket.
114-157	#6 x 1/2"	Hex Hd. Self Tapping Screw - Stan-Tap. Cad	14-848		Model 820W - Plastic Cabinet (7H820W)
114-218	#10 x 7/8"	Slotted Washer Hd. Self Tapping Screw (Chassis Mtg.)	14-1020		Model 820 - Bakelite Cabinet (7H820)
114-291	#8-32 x 7/16"	Hex Hd. Slotted M. Screw - Steel, N.P	19-139		Cabinet Back Retaining Clip (4 used)
114-292	#6 x 5/8"	Hex Hd. Slotted Self Tapping Screw Stan-Tap. - Cad.	49-608		7/8" P. M. Speaker 208-608 and Voice Coil
125-17		Rubber Grommet (4 used) (49-608)	54-30		#8-32 x 5/16" x 7/64" Hex Nut - Steel N.P. (6 used)
125-62		Rubber Grommet (Used on R.F. Plate) (4 used)	54-139		#3/8-32 x 9/16" Nut - Type 9N-Steel-Cad. (2 used)
126-554		Miniature Tube Shield.	54-226		Speed Nut - Tinnerman #C518B-014-27 (3 used)
139-69		Speaker Baffle	57-1269		I.F. Transformer Terminal Plate.
149-39		Iron Core (Used on all I.F. and Discriminator Transf.)	58-168		Two Prong Plug
149-64		Tuning Core.	73-30		#6-32 x 1/4" Hex Hd. Set Screw - Cuppoint (2 used)
188-34		Retaining Ring	78-782		Socket - Miniature Tube (7 Contact) (2 used)
202-506		F.M. Instruction Book.	78-788		Socket - Miniature Tube (9 Contact)
202-553		Instruction Book	78-794		Socket - Miniature Tube (7 Contact) (3 used)
212-3		Selenium Rectifier (or 212-4).	78-795		Socket - Miniature Tube (7 Contact)
S-13977		Wavemagnet Assembly - Type 29D	83-1063		Threaded Insert (used on all I.F. Transformers)
S-14128		Cabinet Back, A.C. Plug and Cord Assembly (7H820)	83-1064		Threaded Insert (used on all I.F. and Discriminator Transformers)
S-14168		Bandswitch and Terminal Strip Assembly	83-1090		Insulating Strip (58-168)
S-14358		Wavemagnet Cable Assembly.	83-1479		Insulating Strip
S-14562		Cabinet Back, A.C. Plug and Cord Assembly (7H820W)	83-1480		Insulating Strip
			83-1503		Tone Arm Insulating Strip.
			85-417		Band Switch (use S-14168)
			93-2		.016 x .134 x 1/4" Brass Washer.
			93-94		Bakelite Shoulder Washer

OPERATING INSTRUCTIONS

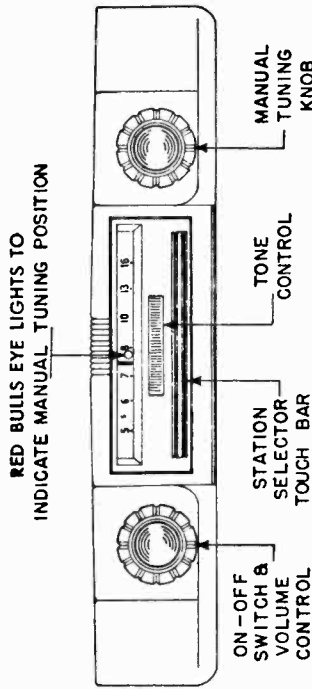

LINCOLN FIG. 1A

LINCOLN CONTINENTAL FIG. 1B

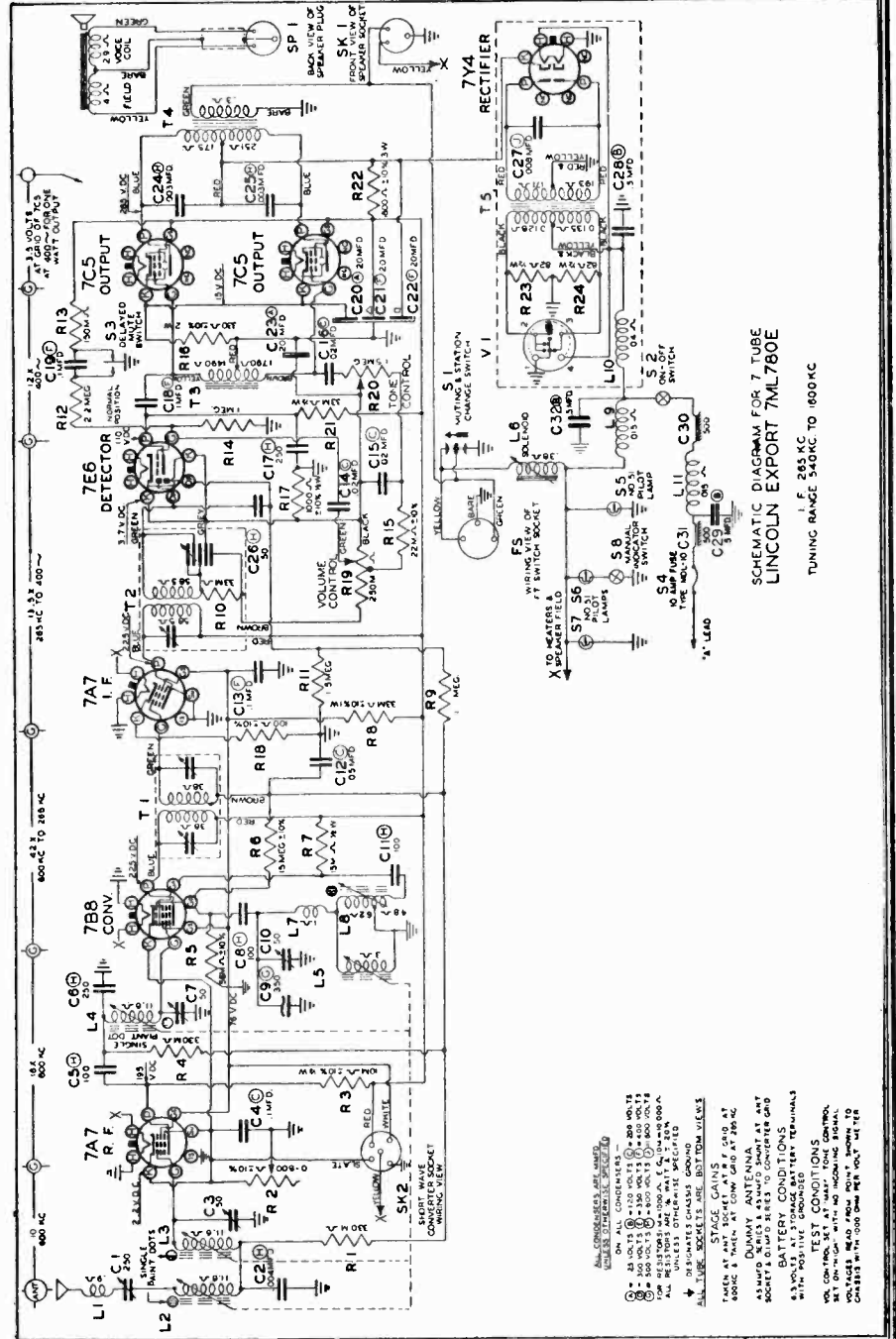

**SCHEMATIC DIAGRAM FOR 7 TUBE
LINCOLN EXPORT 7ML780E**

I.F. 263 KC
TUNING RANGE 540KC TO 1600 KC

ALL COMPONENTS ARE MARKED
UNLESS OTHERWISE SPECIFIED

① 250 VOLTS ② 100 VOLTS ③ 500 VOLTS
④ 500 VOLTS ⑤ 100 VOLTS ⑥ 500 VOLTS
⑦ 100 VOLTS ⑧ 500 VOLTS ⑨ 500 VOLTS
⑩ 100 VOLTS ⑪ 500 VOLTS ⑫ 500 VOLTS
⑬ 100 VOLTS ⑭ 500 VOLTS ⑮ 500 VOLTS
⑯ 100 VOLTS ⑰ 500 VOLTS ⑱ 500 VOLTS
⑲ 100 VOLTS ⑳ 500 VOLTS ㉑ 500 VOLTS
ALL UNLESS OTHERWISE SPECIFIED

↓ DESIGNATES CHASSIS GROUND

ALL TUBE SOCKETS ARE BOTTOM VIEW

TAKEN AT ANT SOCKET AT 2.5 V. 500 AT
500KC & TAKEN AT CONW GRID AT 250KC

DUMMY ANTENNA
SHOULD BE USED AT ANT
SOCKET & GRID REFS TO CONVERTER GRID

BATTERY CONDITIONS
BATTERY SHOULD BE VERY NEARLY FULL
WITH POSITIVE TERMINALS
TO CHASSIS

TEST CONDITIONS
W/ 500 VOLTS AT ANT SOCKET
W/ 500 VOLTS AT ANT SOCKET
VOLTAGES READ FROM POINT SHOWN TO
CHASSIS WITH 500 OHM RES. VOL. UTTER

MODEL 7ML780E,
Lincoln

ZENITH RADIO CORP.

Lincoln Receiver Installation

1—Remove the cardboard cover from the speaker hole in the center of the instrument panel. Do not discard the nuts. Remove the bezel from the instrument panel by loosening the nuts on the underside.

2—Remove the protective cover from the speaker. Install the speaker on the rear of the grille so the cable is toward the left. Use the nuts that held the instrument panel hole cover in place.

3—Hang the hook bolts "A" in the holes provided for them in the dash so that the hooks are turned away from the receiver.

4—Place the receiver in position and slip the threaded end of the hook bolts through the upper hanger brackets.

5—Apply lock washers "B" and wing nuts "C" to the hook bolts and tighten them sufficiently to hold the receiver in place while installing the lower support brackets "D." Fasten the tapped end of the brackets to the instrument panel, using spacer washers "F," lock washers "B", and oval head screws "E." Fasten the other end of the bracket to the lower angle bracket of the receiver. Tighten all screws and nuts so that the receiver is held firmly in place (Fig. 2).

6—Connect the "A" lead to the battery terminal of the circuit breaker on the firewall. (Fig. 3.)

7—Connect the speaker cable and the antenna lead-in cable to the receiver and turn the power on.

8—Place the escutcheon plate, furnished with the receiver, over the tuning and volume control shafts and fasten it in place with the two 8/32" flat head screws furnished in the installation kit.

9—Fit tuning and volume control knobs to their respective shafts.

NOTE: Tuning control knob is fastened to the shaft with a set screw. Shaft has a milled recess for the screw.

Lincoln Continental Receiver Installation

The Continental Radio installation is similar to the Lincoln installation with the exception of the speaker.

To install the Continental speaker, remove the speaker grille which is held in place by four nuts on the back of the instrument panel. Place the speaker in position through the front of instrument panel so the cable is to the left. Fasten securely with the four No. 10/32 machine screws and lock washers. Replace the grille and proceed with the installation of the receiver as instructed under Lincoln Receiver installation. Note position of bracket D in figure 2A.

Foot Control Switch Installation

1—Remove the floor mat around the clutch and brake pedals.

2—Drill a hole in each of the three extrusions in the floor, between the clutch and brake pedals, with a No. 27 drill. (Fig. 3.)

3—Fasten the foot control switch in place with the sheet metal screws furnished. Dress the cable so that the plug can be inserted into the foot switch cable receptacle at the left side of the receiver as shown in figure 2.

4—Cut a hole in the floor mat for the foot switch button. Install the foot switch eyelet (furnished in the installation kit) in the hole. Replace the floor mat. A piece of 1 1/8" pipe that has been sharpened on the inside of one end may be used to cut the hole.

ANTENNA. The new Lincoln antenna is especially designed to work satisfactorily with this receiver. The installation instructions are included with the antenna.

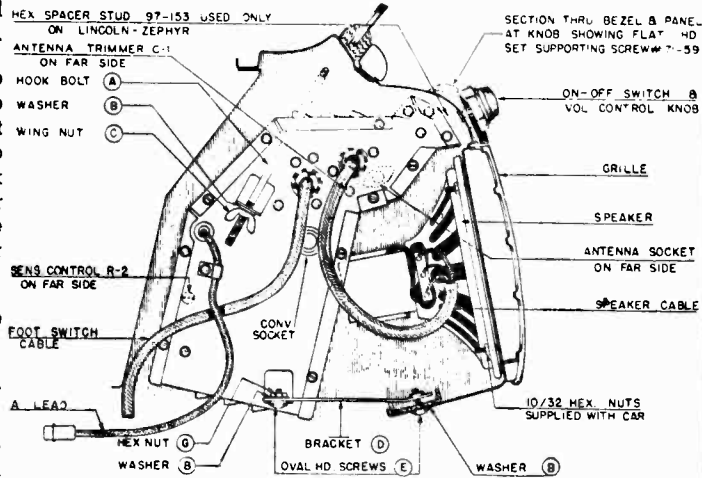

FIG. 2

IMPORTANT: 1200 K.C. ANTENNA ADJUSTMENT. After the receiver has operated for approximately 15 minutes, tune in a weak station near 1200 Kc. Adjust the antenna trimmer (C1, Fig. 2) for maximum signal.

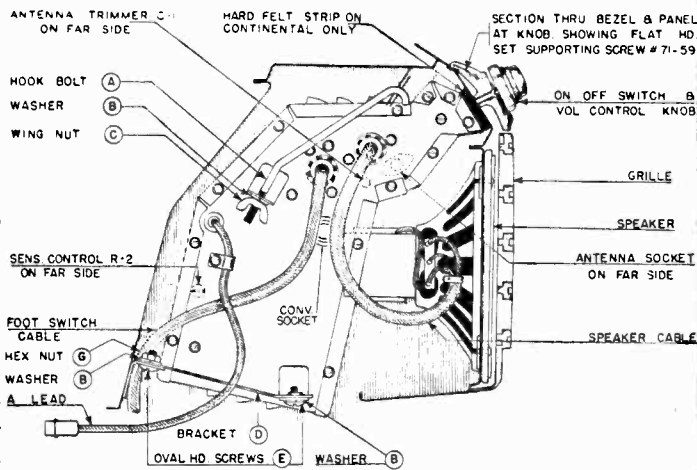

FIG. 2A

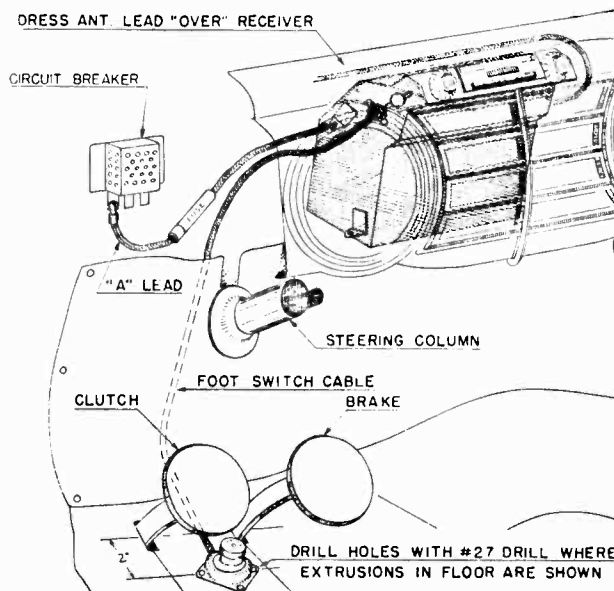

FIG. 3

Setting the Touch-Bar Tuning

Pressing the station selector touch-bar six times will cause the tuning mechanism to change through a cycle of six positions. Five of the Adjust-O-Matic positions may be set for favorite local stations. A red dot will appear in the tuning scale background when the Adjust-O-Matic is in the sixth position. This position may be used for selecting stations manually.

Using the manual (DIAL) position as a reference point, the remaining five positions may be adjusted in succession to any desired dial settings. Setting the stations in sequence according to their frequencies, beginning at the low frequency and progressing through to the high frequency end of the dial, is the recommended practice for simplifying the identification of each Adjust-O-Matic station.

Turn the receiver on and allow it to operate for at least fifteen minutes to bring the temperature up to normal before making the following Adjust-O-Matic settings.

1—Press station selector touch-bar (Figs. 1A and 1B) until red dot appears in dial scale background. Press the touch-bar once more to advance Adjust-O-Matic mechanism to No. 1 position.

2—Pull manual tuning knob outward to engage the Adjust-O-Matic mechanism.

3—Select the station desired and tune to its frequency by turning the tuning knob. Tune very carefully for clearest reception.

CAUTION: DO NOT ATTEMPT TO FORCE THE KNOB IN. The knob will automatically return to the "IN" position when the station selector touch bar or the foot switch is operated.

4—Press station selector bar, pull tuning knob outward, and tune in station desired for No. 2 position. Use same procedure for positions No. 3, 4 and 5. Note: When the red dot appears in the tuning scale background, the manual tuning knob must be pulled outward and rotated to select the stations manually.

Interference Elimination

IMPORTANT: Use the utmost care in the following operations to insure freedom from interference. Be sure that clean contacts are made when connecting condensers in the car. If necessary, clean away paint or dirt with emery paper to make good ground. Tighten all bolts and nuts securely.

1. Mount the voltage regulator condenser No. 22-1192 and the ground strap No. S-9343 on "ground" terminal of the voltage regulator. (Fig. 4.) Connect the lead of the condenser to the ARM. terminal of the voltage regulator. Connect the end of the ground strap to the lower, left hand voltage regulator mounting screw. (Fig. 4.)

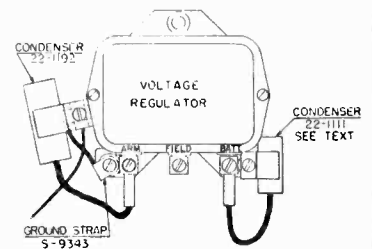

FIG. 4

2. Mount condenser No. 22-1111 under the lower right hand voltage regulator mounting bolt, and connect the lead to the BATT. terminal of the voltage regulator. (Fig. 4.)

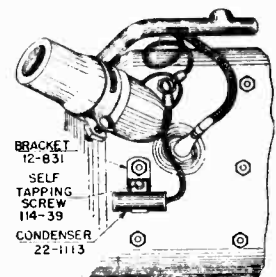

FIG. 5

3. Install the water temperature gauge condenser No. 22-1113 with its separate bracket (which fastens under one of the cylinder head nuts.) (Fig. 5.)

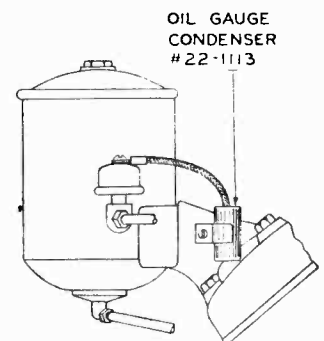

FIG. 6

4. Install the condenser No. 22-1113 on the oil gauge unit. (Fig. 6.)

5. Install the motor hood grounding spring. (Fig. 7.)

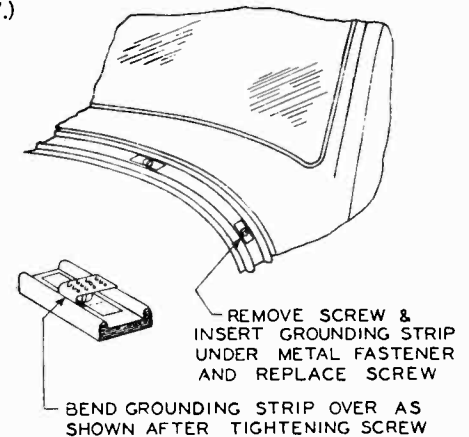
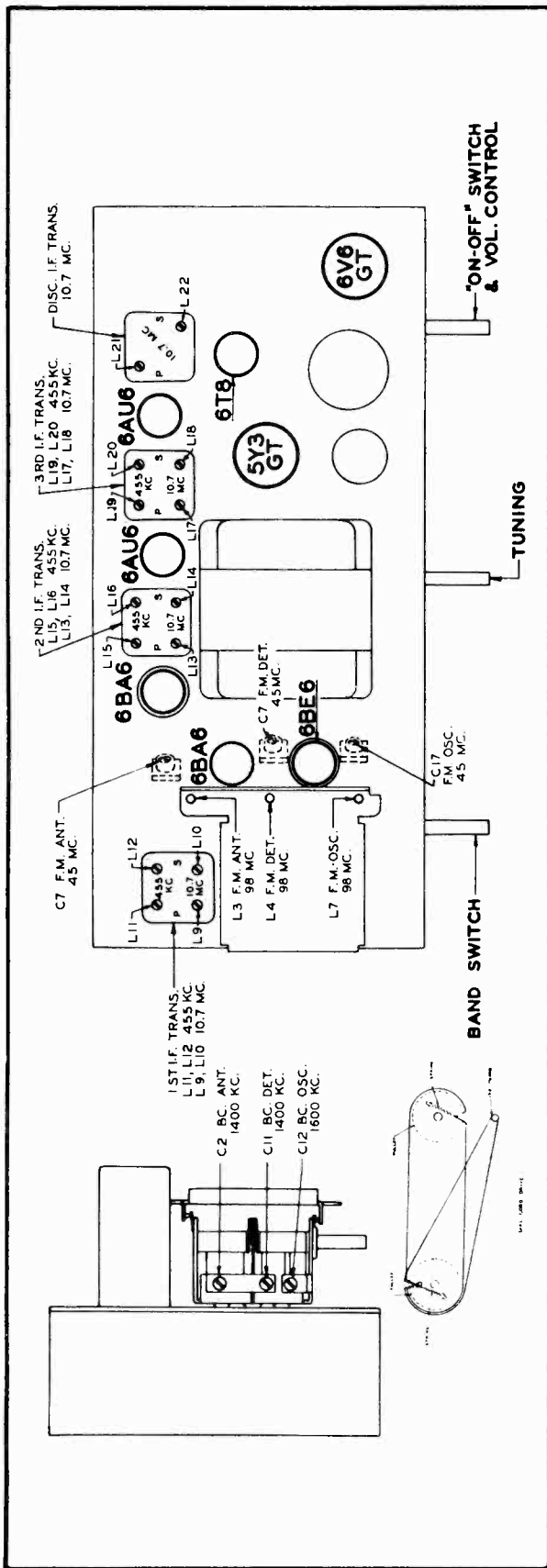

FIG. 7

MODELS 8H832, 8H861,
CHASSIS 8E20

ZENITH RADIO CORP.



TUBE, TRIMMER LOCATION AND DIAL CABLE DRAWING

The 8E20 chassis incorporates a superheterodyne circuit with two stages of IF, and one stage of RF amplification on all bands. The Radiorgan tone control is of the low impedance type in which a portion of the audio voltage is taken from the speaker voice coil and fed back out of phase into the grid of the first audio. The characteristic of the feedback voltage is determined by the setting of the Radiorgan buttons. To attenuate the high notes, more highs are fed back. To attenuate the low notes, more lows are fed back. For normal reproduction, both highs and lows are fed back and results in no overall change in tone.

AV Alignment: The alignment of this chassis on the standard broadcast band is conventional. The alignment slugs in the IF transformers are threaded and screw into the coil forms. The slugs are slotted for a small size fiber screw driver. Do not press hard on the aligning tool or the threads in the coil forms will strip and adjustment will be impossible.

FM RF Alignment: The same coil slug arrangement which tunes the 100 MC FM band also tunes the 45 MC band. However, on 45 MC the band switch connects trimmer condensers in parallel and padding wires in series with the 100 MC coils. The tuning slugs are attached to threaded shafts and the slugs are varied in the field of the coils by turning the shafts clockwise or counter-clockwise. After adjustment the shafts must be secured with a drop of speaker cement.

FM IF Alignment: Because of the wide band pass, it is desirable to use a FM signal generator and a cathode ray oscilloscope when aligning the FM IF channel. The instruction book for the Zenith Model 800 Signal Generator (Form Z8001) covers complete FM alignment procedure. If visual alignment equipment is unavailable, reasonably accurate alignment can be made by following the procedure outlined below.

FM Discriminator Alignment: When the secondary of the discriminator is aligned (operation 5) use sufficient signal input to get a good positive and negative indication before setting the slug for zero reading. A center zero indicating meter is recommended for this adjustment, but is not absolutely necessary. Reversing the leads of a non-zero center meter, or observing closely when the meter starts to go to the left (negative) of zero will give the same results.

NOTE: The output transformer must be replaced with an exact duplicate, Part No. 95-1096. Be sure to add the speaker code letter to the transformer Part Number when ordering replacements.

ZENITH RADIO CORP.

MODELS 8H832, 8H861,
CHASSIS 8E20

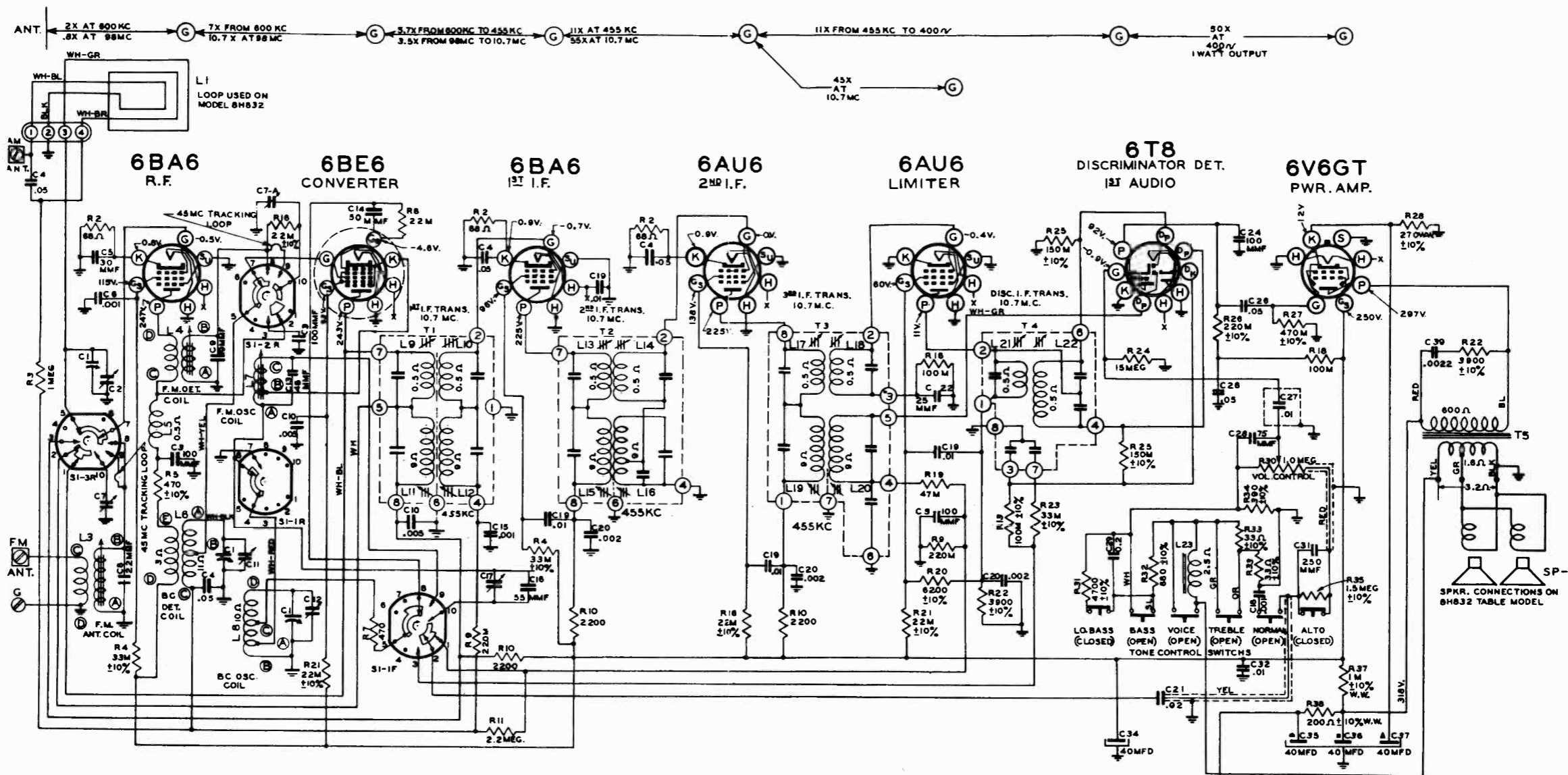

BAND SWITCH S1 SHOWN IN STANDARD BROADCAST POSITION
 1ST POS. - STD. BROADCAST
 2ND POS. - F.M. 100 MC.
 3RD POS. - F.M. 45 MC.

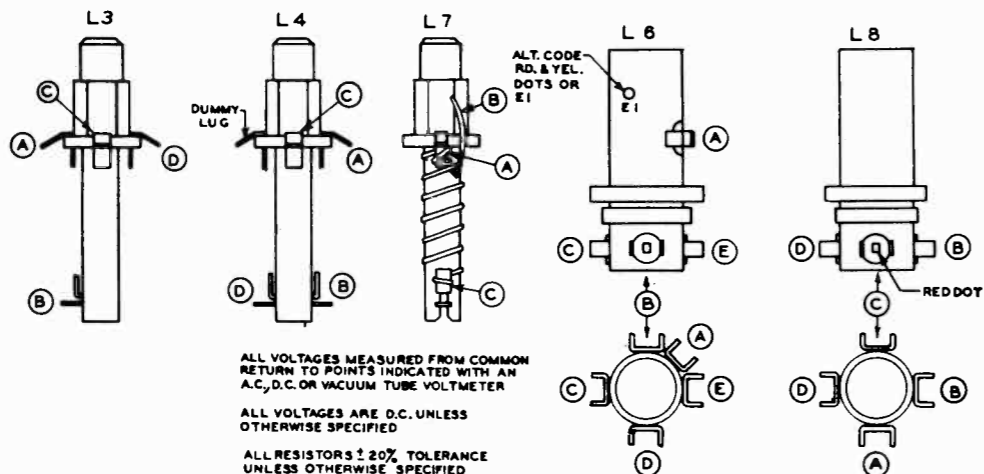

ALL VOLTAGES MEASURED FROM COMMON RETURN TO POINTS INDICATED WITH AN A.C., D.C. OR VACUUM TUBE VOLTMETER
 ALL VOLTAGES ARE D.C. UNLESS OTHERWISE SPECIFIED
 ALL RESISTORS ± 20% TOLERANCE UNLESS OTHERWISE SPECIFIED

⏏ DENOTES CHASSIS

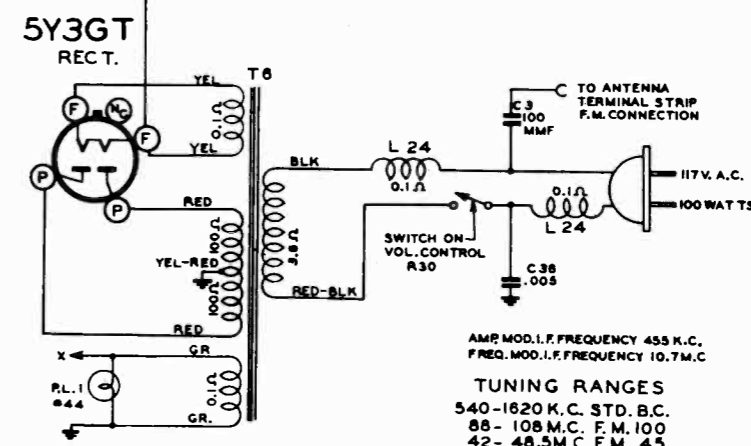

AMP. MOD. I.F. FREQUENCY 455 K.C.
 FREQ. MOD. I.F. FREQUENCY 10.7 M.C.
 TUNING RANGES
 540-1620 K.C. STD. B.C.
 88-108 M.C. F.M. 100
 42-48.5 M.C. F.M. 45

ALIGNMENT PROCEDURE

Operation	Connect Oscillator to	Dummy Antenna	Input Signal Frequency	Band	Set Dial To	Adj. Trimmers	Purpose
1	Pin 7 6BE6 Converter	.05 Mfd.	455 Kc. Modulated	BC	600 Kc.	L-11, 12, 15, 16, 19 and 20.	Align I. F. channel for maximum output
2	2 turns loosely cpd. to wavemagnet.		1600 Kc. Modulated	BC	1600 Kc.	C12	Set oscillator to dial scale.
3			1400 Kc. Modulated	BC	1400 Kc.	C11 and C2	Align det. and ant. stages.
4 (a)	Pin 1 (grid) on 6AUG Limiter	.05 Mfd.	10.7 Mc Unmodulated	FM		L21 coil slug Primary discr.	Align primary of discriminator for maximum reading.
5 (b)		.05 Mfd.	10.7 Mc Unmodulated	FM		L22 coil slug sec. of discr.	Adjust secondary of discriminator for zero reading.
6 (c)	Pin 1 (grid) on 6AUG 2nd IF.	.05 Mfd.	10.7 Mc. Unmodulated	FM		L17 and L18 Prim. and Sec. of 3rd IF trans.	Align 3rd IF transformer for maximum reading.
7 (c)	Pin 1 (grid) on 6BA6 1st IF.	.05 Mfd.	10.7 Mc Unmodulated	FM		L13 and L14 Prim. and Sec. of 2nd IF transformer	Align 2nd IF transformer for maximum reading.
8 (c)	Pin 7 (grid) on 6BE6 converter tube	.05 Mfd.	10.7 Mc. Unmodulated	FM		L9 and L10 Prim. and Sec. of 1st IF transformer	Align 1st IF transformer for maximum reading.
9 (c)(d)		270 ohms	98 Mc. Unmodulated	FM	98 Mc.	L7 Osc. Coil Slug	Set Oscillator to dial scale.
10 (c)(d)	FM Antenna Post (Remove line ant.)	270 ohms	98 Mc. Unmodulated	FM	98 Mc.	L4 and L3 Det. and RF coil Slugs	Align det. and ant. stages to maximum reading.
11 (c)		270 ohms	45 Mc. Unmodulated	FM	45 Mc.	C17	Set oscillator to dial scale.
12 (c)		270 ohms	45 Mc. Unmodulated	FM	45 Mc.	C7 Det., C7 Ant.	Align detector and ant. stages for maximum reading.

IMPORTANT

Alignment of this chassis will in most cases be unnecessary unless an IF or RF transformer is replaced or the adjustments have been tampered with.

Correct alignment can only be made if the following procedure is followed:

A vacuum tube voltmeter with an isolation resistor of 200,000 ohms in series with the hot lead will serve for FM adjustments. This lead should be shielded.

An AC output meter connected across the primary or secondary of the output transformer will be satisfactory for all AM adjustments.

The signal generator output should be kept just high enough to get an indication on the meter.

(a) Vacuum Tube Voltmeter Lug 6 on discriminator transformer to chassis (half discriminator load).

(b) Vacuum Tube Voltmeter Lug 3 on discriminator transformer to chassis (full discriminator load).

(c) Vacuum Tube Voltmeter Lug 3 on 3rd IF transformer (Limiter Grid).

(d) Loosen Slugs by applying a hot iron to the cement.

PART NO.	REF. NO.	DESCRIPTION
DIAL ASSEMBLY		
26-396		Dial Scale
59-209		Dial Pointer
76-498		Pointer Shaft
76-499		Tuning Control Shaft
78-797		Dial Light Socket
80-69		Dial Cord Tension Spring
80-209		Dial Cord Tension Spring
80-444		Tuner Arm Tension Spring
80-580		Tuner Arm Stop Spring
80-581		Tuner Arm Pressure Spring
93-721		Black Felt Dial Washer
100-36		Dial Light Bulb Mazda #44
149-64		Tuning Core & Spring
188-32		Retaining Ring (76-499)
S-14254		Pointer Pulley Assembly
S-14256		Pulley & Bushing Assembly
S-14268		Dial Cord & Eyelet Assembly (Short)
S-14269		Dial Cord & Eyelet Assembly (Long)
S-14270		Dial Scale & Strip Assembly (26-396)
S-14429		Tuner Arm Assembly
	PL-1	
COILS AND CHOKES		
S-11157	L8	Broadcast Oscillator Coil Assembly
S-12256	L24	A. C. Line Choke Coil Assembly
S-12259	L7	F. M. Oscillator Coil Assembly
S-13800	L23	Tone Choke Assembly
S-13871	L4	F. M. Detector Coil Assembly
S-13970	T1	1st. I. F. Transformer Assembly
S-13971	T2	2nd. I. F. Transformer Assembly
S-13972	T3	3rd. I. F. Transformer Assembly
S-13973	T4	Discriminator Transformer Assembly
S-13974	L6	Broadcast Detector Coil Assembly
S-14126	L5	R. F. Choke Coil Assembly
S-14192	L3	F. M. Antenna Coil Assembly
CONDENSERS		
22-171	C26	.05 MFD. 600 V.
22-196	C32	.01 MFD. 600 V.
22-348	C15	.001 MFD. 500 V.
22-365	C24	100 MMFD. (or 22-1670) 500 V.
22-829	C4	.05 MFD. 200 V.
22-830	C21	.02 MFD. 600 V.
22-1041	C38	.005 MFD. 400 V.
22-1136	C31	250 MMFD. (or 22-1745) 500 V.
22-1220	C20	.002 MFD. 600 V.
22-1256	C28	75 MMFD. (or 22-1746) 500 V.
22-1367	C14	50 MMFD. (Ceramic) 500 V.
22-1385	C19	.01 MFD. 200 V.
22-1506	C8	22 MMFD. (Ceramic) 500 V.
22-1507	C22	25 MMFD. (Ceramic) 500 V.
22-1531	C29	.2 MFD. 200 V.
22-1573	C34	40 MFD. Electrolytic 450 V.
22-1669	C3	100 MMFD. (Ceramic) 500 V.
22-1676	C6	.001 MFD. (Ceramic) 500 V.
22-1678	C1	Three Gang Variable
22-1695	C7	Single Section Trimmer
22-1686	C17	Single Section Trimmer
22-1688	C9	19 MMFD. (Ceramic) 500 V.
22-1689	C13	48 MMFD. (Ceramic) 500 V.
22-1691	C16	55 MMFD. (Silver on Ceramic)
22-1705	C5	30 MMFD. (Ceramic) 500 V.
22-1706	C10	.005 MMFD. (Ceramic) (Disc Type) 450 V.
22-1717	C18	.001 MFD. 200 V.
22-1718	C27	.01 MFD. (Shielded) 400 V.
22-1720	C35, 36, 37	Three Section Electrolytic 40 MFD. -25V x 40-40 MFD. 450 V.
22-1754	C39	.0022 MFD. 600 V.
RESISTORS		
63-957	R4	33M Ohm (Insulated) 1 W.
63-1369	R28	270 Ohm (Insulated) W. W. 1 W.
63-1566	R21	22M Ohm (Insulated) 2 W.
63-1588	R30	Volume Control & switch.
63-1589	R37, B8	Two Section Candohm.
63-1722	R33	33 Ohm (Insulated) 1 W.
63-1737	R2	68 Ohm (Insulated) 1 W.
63-1768	R34	390 Ohm (Insulated) 1 W.
63-1771	R5	470 Ohm (Insulated) 10% 1 W.
63-1772	R7	470 Ohm (Insulated) 20% 1 W.
63-1778	R32	680 Ohm (Insulated) 1 W.
63-1800	R10	2200 Ohm (Insulated) 1 W.

ZENITH RADIO CORP.

MODELS 8H832, 8H861,
CHASSIS 8E20

PART NO. REF. NO. DESCRIPTION

RESISTORS--Continued

63-1810	R22	3900 Ohm . (Insulated)	1/2 W
63-1813	R31	4700 Ohm . (Insulated)	1/2 W
63-1824	R20	8200 Ohm . (Insulated)	1/2 W
63-1841	R16	22K Ohm . (Insulated) 10%	1/2 W
63-1842	R8	22K Ohm . (Insulated) 20%	1/2 W
63-1848	R23	33K Ohm . (Insulated)	1/2 W
63-1856	R19	47K Ohm . (Insulated)	1/2 W
63-1869	R13	100K Ohm . (Insulated) 10%	1/2 W
63-1870	R18	100K Ohm . (Insulated) 20%	1/2 W
63-1876	R25	150K Ohm . (Insulated)	1/2 W
63-1883	R26	220K Ohm . (Insulated) 10%	1/2 W
63-1884	R9	220K Ohm . (Insulated) 20%	1/2 W
63-1897	R28	470K Ohm . (Insulated)	1/2 W
63-1912	R3	1 Megohm . (Insulated)	1/2 W
63-1918	R35	1.5 Megohm (Insulated)	1/2 W
63-1926	R11	2.2 Megohm (Insulated)	1/2 W
63-1961	R24	15 Megohm (Insulated)	1/2 W

MISCELLANEOUS

2-134		Cabinet Back	
11-104		Line Cord & Plug (7 ft.)	
46-697		Volume & Tuning Control Knob (2 used)	
46-718		Bandswitch Knob	
49-641	SP-1	5/4" P. M. Speaker (2 used)	
		208-641 Cone & Voice Coil	
54-30		#8-32 x 5/16" Hex Nut - Steel - N.P. (4 used)	
54-31		#10-32 x 3/8" x 1/8" Hex Nut (4 used on 95-1062)	
54-139		#3/8-32 x 9/16" Palnut-Cads (used on 63-1588)	
54-226		Speed Nut (3 used)	
54-262		Speed Nut	
57-1353		Diffusing Plate	
57-1386		Dial Escutcheon	
70-83		*6 x 1/2" Washer Hd. Wood Screw (8 used) (Cabt. Back Mtg.)	
72-58		*2 x 3/8" Phillips Flat Hd. Wood Screw (6 used) (Escutcheon Mtg.)	
78-250		Electrolytic Capacitor Socket	
78-782		Miniature Tube Socket (2 used)	
78-788		Miniature Tube Socket (9 Contact)	
78-793		Octal Tube Socket (2 used)	
78-794		Miniature Tube Socket (3 used) (7 Contact)	
85-424	S1	Bandswitch	
93-125		*6 Int. Lockwasher	
93-127		*10 Int. Lockwasher (4 used on 95-1062)	
93-392		3/32" x 33/64" x 1 Brown Felt Washer	
93-719		.031 x 3/16" x 7/16" Steel Washer	
95-1062		Pwr. Transformer	
95-1096		Output Transformer	
112-56		*6 x 1/4" Hex. Hd. Self Tapping Screw	
112-142		*8-32 x 1-1/8" Swedged Hd. M.S. (4 used)	
114-43		*10-32 x 3/8" Hex. Washer Hd. M.S.-Steel-N.P.	
114-128		*10 x 1-1/16" Hex. Washer Hd. Self Tapping Screw (4 used) (Chassis Mtg.)	
114-159		*6 x 1/4" Hex. Hd. Self Tapping Screw-Type A-Cad. Pl.	
114-270		*8 x 1/2" Hex. Hd. Slotted Self Tapping Screw	
114-292		*6 x 5/8" Hex. Hd. Slotted Self Tapping Screw	
125-62		Rubber Grommet (4 used)	
166-46		Rubber Bumper (4 used) (Rubber Feet)	
192-115		Dial Glass	
196-109		Dial Dust Gasket	
202-506		F. M. Instruction Book	
202-610		Instruction Book	
S-14647	L1	Wavemagnet Assembly Type 29E	
S-14648		Wavemagnet and Back Assembly	

RADIORGAN PARTS

57-1351		Radiorgan Escutcheon (L.H.)	
57-1352		Radiorgan Escutcheon (R.H.)	
76-444		Radiorgan Knob Retaining Shaft (2 Used)	
80-595		Radiorgan Mounting Spring (2 Used)	
S-13800		Tone Choke Assembly	
S-14255		Radiorgan Mounting Bracket Assembly (2 Used)	
S-14260		Radiorgan Strip and Contact Assembly (R.H.)	
S-14261		Radiorgan Strip and Contact Assembly (L.H.)	
S-14273		Radiorgan Knob and Eyelet Assembly (Lo-Bass)	
S-14274		Radiorgan Knob and Eyelet Assembly (Bass)	
S-14275		Radiorgan Knob and Eyelet Assembly (Voice)	
S-14276		Radiorgan Knob and Eyelet Assembly (Treble)	
S-14277		Radiorgan Knob and Eyelet Assembly (Alto)	
S-14278		Radiorgan Knob and Eyelet Assembly (Normal)	
S-14310		Radiorgan Escutcheon and Knob Assembly (L. H.) (Lo-Bass, Bass, Voice)	
S-14311		Radiorgan Escutcheon and Knob Assembly (R.H.) (Treble, Alto, Normal)	

MODELS 9H881, 9H882R,
9H885, 9H888R, CHASSIS
9E21

ZENITH RADIO CORP.

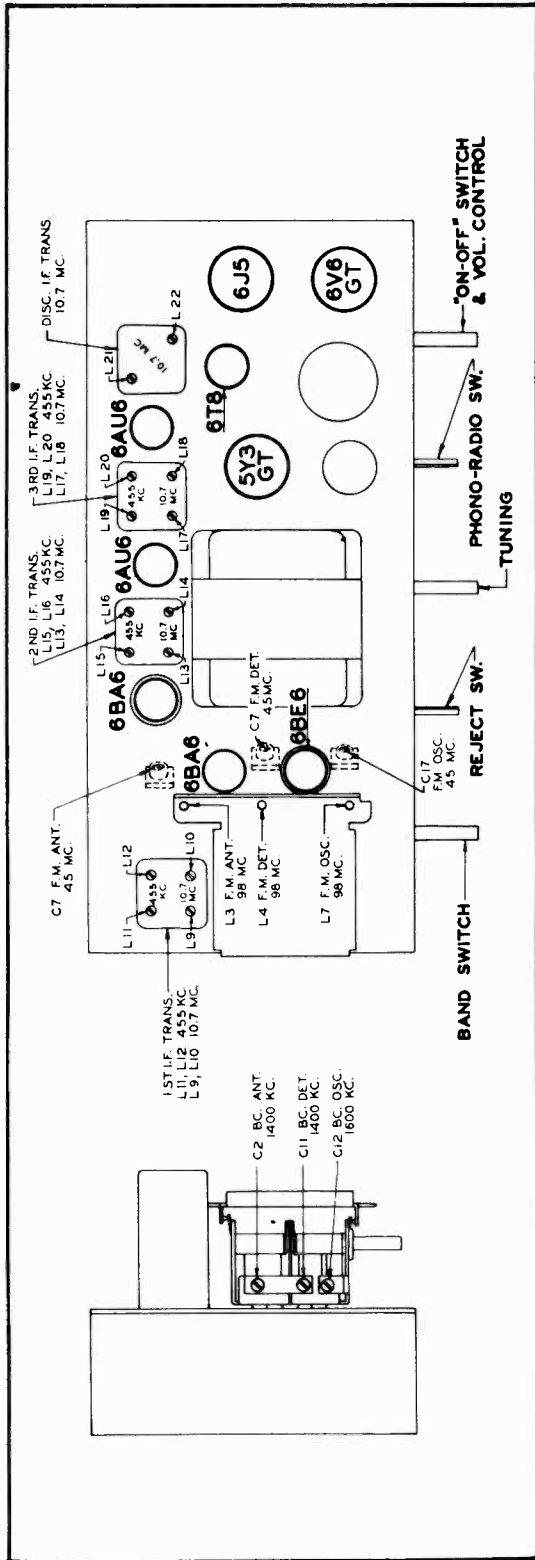

TUBE AND TRIMMER LOCATION

TO THE SERVICE MAN:

The 9E21 chassis incorporates a superheterodyne circuit with two stages of IF, and one stage of RF amplification on all bands. The Radiorgan tone control is of the low impedance type in which a portion of the audio voltage is taken from the speaker voice coil and fed back out of phase into the grid of the first audio. The characteristic of the feedback voltage is determined by the setting of the Radiorgan buttons. To attenuate the high notes, more highs are fed back. To attenuate the low notes, more lows are fed back. For normal reproduction, both highs and lows are fed back and results in no overall change in tone.

The 6BA6 1st IF tube is also the phono pre-amplifier. The output from the phono oscillator is fed to the grid of the 6BA6 through C21 and R14. The amplified output is taken from the screen grid and fed back through R12 and C20 into the volume control circuit and the grid of the 6T8 1st audio amplifier.

AM Alignment: The alignment of this chassis on the standard broadcast band is conventional. The alignment slugs in the IF transformers are threaded and screw into the coil forms. The slugs are slotted for a small size fiber screw driver. Do not press hard on the aligning tool or the threads in the coil forms will strip and adjustment will be impossible.

FM RF Alignment: The same coil slug arrangement which tunes the 100 MC FM band also tunes the 45 MC band. However, on 45 MC the band switch connects trimmer condensers in parallel and padding wires in series with the 100 MC coils. The tuning slugs are attached to threaded shafts and the slugs are varied in the field of the coils by turning the shafts clockwise or counter-clockwise. After adjustment the shafts must be secured with a drop of speaker cement.

FM IF Alignment: The same type of tuning slugs for aligning the AM IF Amplifier are used for the FM IF's. Observe the same precautions when making adjustments.

FM Discriminator Alignment: When the secondary of the discriminator is aligned (operation 5) use sufficient signal input to get a good positive and negative indication before setting the slug for zero reading. A center zero indicating meter is recommended for this adjustment, but is not absolutely necessary. Reversing the leads of a non-zero center meter, or observing closely when the meter starts to go to the left (negative) of zero will give the same results.

NOTE: The output transformer must be replaced with an exact duplicate, Part No.95-1063. Be sure to add the speaker code letter to the transformer Part Number when ordering replacements.

ZENITH RADIO CORP.

MODELS 9H881, 9H882R,
9H885, 9H888R, CHASSIS
9E21

ALIGNMENT PROCEDURE

Operation	Connect Oscillator to	Dummy Antenna	Input Signal Frequency	Band	Set Dial To	Adj. Trimmers	Purpose
1	Pin 7 6BE6 Converter	.05 Mfd.	455 Kc. Modulated	BC	600 Kc.	L-11, 12, 15, 16, 19 and 20.	Align I. F. channel for maximum output
2	2 turns loosely cpld. to wavemagnet.		1600 Kc. Modulated	BC	1600 Kc.	C12	Set oscillator to dial scale.
3			1400 Kc. Modulated	BC	1400 Kc.	C11 and C2	Align det. and ant. stages.
4 (a)	Pin 1 (grid) on 6AU6 Limiter	.05 Mfd.	10.7 Mc Unmodulated	FM		L21 coil slug	Align primary of discriminator for maximum reading.
5 (b)		.05 Mfd.	10.7 Mc Unmodulated	FM		Primary discr. L22 coil slug	Adjust secondary of discriminator or for zero reading.
6 (c)	Pin 1 (grid) on 6AU6 2nd IF.	.05 Mfd.	10.7 Mc. Unmodulated	FM		L17 and L18 Prim. and Sec. of 3rd IF trans.	Align 3rd IF transformer for maximum reading.
7 (c)	Pin 1 (grid) on 6BA6 1st IF.	.05 Mfd.	10.7 Mc Unmodulated	FM		L13 and L14 Prim. and Sec. of 2nd IF transformer	Align 2nd IF transformer for maximum reading.
8 (c)	Pin 7 (grid) on 6BE6 converter tube	.05 Mfd.	10.7 Mc. Unmodulated	FM		L9 and L10 Prim. and Sec. of 1st IF transformer	Align 1st IF transformer for maximum reading.
9 (c)(d)		270 ohms	98 Mc. Unmodulated	FM	98 Mc.	L7 Osc. Coil Slug	Set Oscillator to dial scale.
10 (c)(d)	FM Antenna Post (Re-move, line ant.)	270 ohms	98 Mc. Unmodulated	FM	98 Mc.	L4 and L3 Det. and RF coil Slugs	Align det. and ant. stages to maximum reading.
11 (c)		270 ohms	45 Mc. Unmodulated	FM	45 Mc.	C17	Set oscillator to dial scale.
12 (c)		270 ohms	45 Mc. Unmodulated	FM	45 Mc.	C7 Det., C7 Ant.	Align detector and ant. stages for maximum reading.

IMPORTANT

Alignment of this chassis will in most cases be unnecessary unless a IF or RF transformer is replaced or the adjustments have been tampered with.

Correct alignment can only be made if the following procedure is followed:

A vacuum tube voltmeter with an isolation resistor of 200,000 ohms in series with the hot lead will serve for FM adjustments. This lead should be shielded.

An AC output meter connected across the primary or secondary of the output transformer will be satisfactory for all AM adjustments.

The signal generator output should be kept just high enough to get an indication on the meter.

(a) Vacuum Tube Voltmeter Lug 6 on discriminator transformer to chassis (half discriminator load).

(b) Vacuum Tube Voltmeter Lug 3 on discriminator transformer to chassis (full discriminator load).

(c) Vacuum Tube Voltmeter Lug 3 on 3rd IF transformer (Limiter Grid).

(d) Loosen Slugs by applying a hot iron to the cement.

PART NUMBER	REF. NUMBER	DESCRIPTION	PARTS LIST	PART NUMBER	REF. NUMBER	DESCRIPTION
DIAL ASSEMBLY						
12-1434		Dial Light Mounting Bracket		63-1856	R19	47M ohm (Insulated) 1/2 W.
26-396		Dial Scale (use S-14270)		63-1869	R13	100M ohm (Insulated) 1/2 W.
59-209		Dial Pointer		63-1870	R18	100M ohm (Insulated) 1/2 W.
76-499		Tuning Control Shaft		63-1876	R25	150M ohm (Insulated) 1/2 W.
78-797		Dial Light Socket		63-1883	R26	220M ohm (Insulated) 1/2 W.
80-69		Dial Cord Tension Spring		63-1884	R9	220M ohm (Insulated) 1/2 W.
80-209		Dial Cord Tension Spring		63-1897	R27	470M ohm (Insulated) 1/2 W.
80-444		Tuner Arm Tension Spring		63-1911	R17	1 Megohm (Insulated) 1/2 W.
80-580		Tuner Arm Stop Spring		63-1912	R3	1 Megohm (Insulated) 1/2 W.
80-581		Tuner Arm Pressure Spring		63-1918	R35	15 Megohm (Insulated) 1/2 W.
100-36		Dial Light Bulb-Mazda 44		63-1926	R11	2.2 Megohm (Insulated) 1/2 W.
188-32		Retaining Ring (76-499)		63-1961	R24	15 Megohm (Insulated) 1/2 W.
196-109		Dial Dust Gasket		MISCELLANEOUS		
S14254		Pointer Pulley Assembly		11-106		Line Cord and Plug (9 ft. long) (or 11-101)
S14256		Cam Pulley and Bushing Assembly (Gang Cond)		54-226		Socket Nut-Tinnerman
S14268		Dial Cord & Eyelet Assembly (Short)		78-709		Socket-Octal Tube
S14269		Dial Cord & Eyelet Assembly (Long)		78-782		Socket-Miniature Tube (2 used)
S14270		Dial Scale and Strip Assembly (26-396)		78-788		Socket-Minial Miniature (9 contact)
S14429		Tuner Arm Assembly		78-791		Socket-Phono Cable (7 contact)
COILS AND CHOKES						
S11157	L8	Broadcast Oscillator Coil Assembly		78-794		Socket-Miniature Tube (7 contact)
S12256	L24	A.C. Line Choke Coil Assembly		85-421	S2	Phono-Radio Switch
S12259	L7	F.M. Oscillator Coil Assembly		85-422	S3	Phono-Reject Switch
S12603	L25	Phono Oscillator Coil Assembly		85-424	S1	Band Switch
S13800	L23	Tone Choke Assembly		94-295		Phono Switch Mounting Bushing
S13871	L4	F.M. Detector Coil Assembly		94-598		R.F. Plate Mounting Bushing (4 used)
S13970	T1	1st I.F. Transformer Assembly		95-1062	T6	Power Transformer
S13971	T2	2nd I.F. Transformer Assembly		95-1063	T5	Output Transformer
S13972	T3	3rd I.F. Transformer Assembly		125-17		Rubber Grommet (2 used (1 on 85-421) (1 on 85-422))
S13973	T4	Discriminator Transformer Assembly		125-62		Rubber Grommet (4 used)
S13974	L6	Broadcast Detector Coil Assembly		126-553		Miniature Tube Shield (Metal)
S14126	L5	R.F. Choke Coil Assembly		126-554		Miniature Tube Shield (Paper)
S14192	L3	F.M. Antenna Coil Assembly		126-569		Heat Shield
				149-64		Tuning Core and Spring (3 used)
CONDENSERS						
22-171	C26	.05MFD.		57-1351		Radiorgan Escutcheon (L.H.)
22-196	C32	.01MFD.	600V.	57-1352		Radiorgan Escutcheon (R.H.)
22-348	C15	.001MFD. (Mica)	500V.	76-444		Radiorgan Knob Retaining Shaft (2 used)
22-365	C24	100MMFD. (or 22-1670)	500V.	80-595		Radiorgan Mounting Spring (2 used)
22-829	C4	.05MFD.	200V.	114-159		#6x1/4 Hex. Hd. Self Tapping Screw (2 used)
22-830	C21	.02MFD.	600V.	S14255		Radiorgan Mounting Bracket Assembly (2 used)
22-1041	C42	.005MFD.	400V.	S14260		Radiorgan Strip and Contact Assembly (R.H.)
22-1136	C31	250MMFD. (or 22-1745)	500V.	S14261		Radiorgan Strip and Contact Assembly (L.H.)
22-1220	C20	.002MFD.	600V.	S14274		Radiorgan Knob and Eyelet Assembly (Bass)
22-1256	C28	75MMFD. (or 22-1746)	500V.	S14273		Radiorgan Knob and Eyelet Assembly (Lo-Bass)
22-1367	C14	50MMFD. (Ceramic)	500V.	S14275		Radiorgan Knob and Eyelet Assembly (Voice)
22-1385	C19	.01MFD.	200V.	S14276		Radiorgan Knob and Eyelet Assembly (Treble)
22-1418	C38	.1MFD.	200V.	S14277		Radiorgan Knob and Eyelet Assembly (Alto)
22-1489	C30	10MMFD. (Ceramic)	500V.	S14278		Radiorgan Knob and Eyelet Assembly (Normal)
22-1506	C8	22MMFD. (Ceramic)	500V.	S14310		Radiorgan Escutcheon & Knob Assembly (L.H.) (Lo-Bass-Voice)
22-1507	C22	25MMFD. (Ceramic)	500V.	S14311		Radiorgan Escutcheon and Knob Assembly (R.H.) (Treble-Alto-Normal)
22-1531	C29	.2MFD.	200V.	MODEL 9H881 CABINET PARTS		
22-1532	C40	50MMFD. (or 22-1674)	500V.	15-82		Plug Cap and Insulator (used on S14353)
22-1664	C39	50MMFD. (Ceramic)	500V.	19-123		Record Changer Mounting Clip (3 used)
22-1669	C3	100MMFD. (Ceramic)	500V.	27-81		Shaft Bearing Disc
22-1676	C6	.001MFD. (Ceramic)	500V.	36-39		Record Changer Frame Handle
22-1678	C1	Three Gang Variable		40-43		Cabinet Hinge (R.H.)
22-1685	C7	Single Section Trimmer		40-44		Cabinet Hinge (L.H.)
22-1686	C17	Single Section Trimmer		46-648		Door Pull (2 used)
22-1688	C9	19MMFD. (Ceramic)	500V.	46-697		Volume and Tuning Control Knob (2 used)
22-1689	C13	48MMFD. (Ceramic)	500V.	46-718		Band Switch Knob
22-1691	C16	55MMFD. (Silver on Ceramic)	500V.	46-726		Phono Switch Knob
22-1705	C5	30MMFD. (Ceramic)	500V.	49-624		12" P.M. Speaker
22-1706	C10	.005MFD. (Ceramic Disc Type)	450V.	57-1336		208-624 Cone and Voice Coil
22-1717	C18	.001MFD.	200V.	57-1353		Dial Escutcheon
22-1718	C27	.01MFD. (Shielded)	400V.	58-169		Diffusing Plate
22-1719	C33, C34	Two Section Electrolytic 15-40MFD	450V.	72-58		Seven Prong Plug (used on S-14353)
22-1720	C35, C36	Three Section Electrolytic 40MFD. -25V. x40-40MFD. -450.	450V.	78-798		#2 x 3/8 Phillips Flat Hd. Wood Screw-Steel Brass Plate (Esc. Mtg.)
22-1754	C43	.0022MFD.	600V.	80-463		Seven Contact Socket (used on S-14353)
RESISTORS						
63-957	R4	33M ohm (Insulated)	1 W.	83-1244		Record Changer Mounting Spring (4 used)
63-1065	R6	15M ohm (Insulated)	1 W.	93-392		Record Changer Trim Strip
63-1369	R28	270 ohm (Insulated-WW)	1 W.	112-489		3/32 x 33/64" Brown Felt Washer (3 used)
63-1565	R36	4700 ohm (Insulated)	1 W.	112-682		#8 x 1/2" Phillips R.H. Self Tapping Screw-cad (Handle Mtg. Screw)
63-1566	R21	22M ohm (Insulated)	2 W.			Record changer Mounting Screw (4 used)
63-1588	R30	Volume Control and Switch				
63-1589	R37, R38	Two Section Candohm (1000 ohm WW SW. 200 ohm WW 3W)	1/2 W.			
63-1722	R33	33 ohm (Insulated)	1/2 W.			
63-1737	R2	68 ohm (Insulated)	1/2 W.			
63-1768	R34	390 ohm (Insulated)	1/2 W.			
63-1771	R5	470 ohm (Insulated)	1/2 W.			
63-1772	R7	470 ohm (Insulated)	1/2 W.			
63-1778	R32	680 ohm (Insulated)	1/2 W.			
63-1779	R12	680 ohm (Insulated)	1/2 W.			
63-1800	R10	2200 ohm (Insulated)	1/2 W.			
63-1810	R22	3900 ohm (Insulated)	1/2 W.			
63-1813	R31	4700 ohm (Insulated)	1/2 W.			
63-1824	R20	8200 ohm (Insulated)	1/2 W.			
63-1827	R14	10M ohm (Insulated)	1/2 W.			
63-1841	R16	22M ohm (Insulated)	1/2 W.			
63-1842	R8	22M ohm (Insulated)	1/2 W.			
63-1848	R23	33M ohm (Insulated)	1/2 W.			

ZENITH RADIO CORP. MODELS 9H881, 9H882R, 9H885, 9H888R, CHASSIS 9E21

PART NUMBER	REF. NUMBER	DESCRIPTION	PART NUMBER	REF. NUMBER	DESCRIPTION
114-148		#10 x 7/8" Hex Washer Hd. Self-Tapping Screw (4 used) (Chassis Mtg.)	49-624		12" P.M. Speaker
114-233		#14 x 1-1/4" Slotted Hex Washer Hd. Self-Tapping Screw, Cad.	57-1336		208-624 Cone & Voice Coil
125-56		Rubber Grommer (4 used) (Spk. Mtg.)	57-1353		Dial Escutcheon
138-25		Metal Grille	58-169		Diffusing Plate
159-52		Plug Button (4 used)	70-96		Seven Prong Plug (7 used on S-14306)
165-13		Metal Glide (4 used)			#10 x 1-3/4" R.H.W.S. Steel N.P.
166-31		Rubber Bumper	72-58		(6 used)
188-91		Rubber Ring (2 used)	78-798		#2 x 3/8" Phillips Flat Hd. Wood Screw (Esc. Mtg.) (6 used)
192-115		Dial Glass	80-423		Seven Contact Socket (used on S-14306)
202-506		F. M. Instruction Book	80-463		Chassis Lift Spring (2 used)
202-566		Instruction Book			Record Changer Mounting Spring (4 used)
SI2864		Drive Wheel & Pin Assembly (2 used)	83-1244		Record Changer Trim Strip
SI4002		Intermixer Record Changer	93-392		3/32" x 33/64" x 1" Brown Felt Washer (3 used)
SI4195		Loading Coil Assembly (9H881, 9H885, 9H888)	112-558		#10-32 x 7/8 Flat Phillips Hd. M.S. Steel-Statuary Bronze (Pinch Pt.)
SI4305	L1	Low Impedance Loop Assembly (9H881, 9H885, 9H888)	112-611		Record Changer Mtg. Screw (3 used)
SI4352		Record Changer Mtg. Frame Assembly (complete)	112-682		Record Changer Mtg. Screw (1 used)
SI4353		Interconnecting Cable Assembly	114-257		#10 x 1-3/8" Hex Slotted Washer Hd. Sheet Metal Screw
MODEL 9H882R CABINET PARTS					
12-1183		Door Stop Bracket	125-49		Rubber Grommet (4 used)
15-64		Pin Plate Plug	125-56		Rubber Grommet (4 used) (49-624)
15-65		Plug Cap & Insulator (used on SI2591)	159-61		Plug Button-Statuary Bronze
15-82		Plug Cap & Insulator (used on SI4539)	165-9		Metal Glides
19-123		Record Changer Mounting Clip	192-115		Dial Glass
22-1240		Wavemagnet Trimmer Condenser	202-506		F. M. Instruction Book
22-1501		Electrolytic Capacitor, 150 Mfd. 60V.	202-566		Instruction Book (Radio & Phono)
36-39		Record Changer Frame Handle	S-10796		Lid Support Arm, Hinge Plate & Brkt. (R.H.)
40-54		Cabinet Hinge	S-10797		Lid Support Arm, Hinge Plate & Brkt. (L.H.)
46-697		Volume & Tuning Control Knob (2 used)	S-11429		Record Changer Mounting Frame Assembly
46-718		Band Switch Knob	S-12545		Phono Lift Spring & Bushing Assembly
46-726		Phono Switch Knob (2 used)	S-14002		Intermixer Record Changer Assembly
49-637		10" P.M. Speaker	S-14195		Loop Loading Coil Assembly
		208-637 Cone & Voice Coil	S-14305		Low Impedance Loop Assembly
52-188		Plug & Wire (used on SI4539)	S-14306		Interconnecting Cable Assembly (Phono.)
57-1336		Dial Escutcheon			Chassis Compartment Hinge Assembly (R.H.)
57-1353		Diffusing Plate	S-14433		Chassis Compartment Hinge Assembly (L.H.)
58-86		Two Prong Plug (used on SI2591)			
58-132		6 Prong Plug	S-14434		
58-169		7 Prong Plug (used on SI4539)			
70-126		#10 x 1-7/8" R.H. Wood Screw-Steel N.P.			
72-58		#2 x 3/8" Phillips Flat Hds. Wood Screw (Esc. Mtg.) (6 used)	15-82		Plug Cap & Insulator (used on S-14306)
78-555		Six Contact Socket (used on SI2591)	S-14306		Record Changer Mounting Clip (3 used)
78-798		Seven Contact Phono Socket (used on SI4539)	19-123		Knife Hinge (R.H.)
80-407		Motor Mounting Spring (8 used)	40-42		Knife Hinge (L.H.)
80-443		Cabinet Door Return Spring	40-65		Door Pull (2 used)
80-463		Record Changer Mtg. Spring (4 used)	46-648		Key Escutcheon
80-570		Shaft Tension Spring	46-659		Volume & Tuning Control Knob (2 used)
83-1244		Record Changer Trim Strip	46-697		Band Switch Knob
83-1431		Plastic Strip	46-718		Phono Switch Knob
85-351		Drive Out Control Switch (used on SI2591)	46-726		12" P.M. Speaker
			49-624		208-624 Cone & Voice Coil
85-382		S.P.D.T. Switch (used on SI2591)			Dial Escutcheon
93-168		Rubber Shoulder Washer (6 used)	57-1336		Diffusing Plate
93-392		Brown Felt Washer (3 used)	57-1353		Seven Prong Plug (used on SI4306)
93-540		Rubber Washer (4 used)	58-169		#10 x 1-3/4" R.H.W.S.-Steel N.P.
94-502		Motor Mounting Bushing	70-96		(6 used)
112-490		#8 x 5/8" Phillips R.H. Self Tapping Screw (Handle Mtg.)	72-58		#2-3/8" Phillips Flat Hds. Wood Screw
112-611		Record Changer Mtg. Screw (3 used)	78-798		Seven Contact Socket (used on SI4306)
112-682		Record Changer Mtg. Screw (1 used)			Chassis Lift Spring (2 used)
114-132		#10 x 1-5/8" Hex Washer Hd. Self-Tapping Screw (Chassis Mtg.)	80-423		Record Changer Mtg. Screw (4 used)
125-50		Rubber Grommet (2 used)	80-463		Record Changer Trim Strip
125-51		Rubber Grommet (8 used)	83-1244		3/32" x 33/64" x 1" Brown Felt Washer (3 used)
125-56		Rubber Grommet (4 used) (Spk. Mtg.)	93-392		#10-32 x 7/8 Flat Phillips Hd. M. Screw-Steel-Statuary-Bronze (Pinch Pt.)
143-44		Drive Out Coupling	112-558		Record Changer Mounting Screw (3 used)
165-12		Ball Bearing Caster (4 used)			Record Changer Mounting Screw (1 used)
192-115		Dial Glass			#10 x 1-3/8" Hex Slotted Washer Hd. Sheet Metal Screw
202-506		F. M. Instruction Book			Rubber Grommet
202-566		Instruction Book (Radio & Phono)	112-611		Rubber Grommet
S-12389	L2	Wavemagnet Loading Coil Assembly	112-682		Metal Grille
S-12411		Ball Bearing Shaft & Washer Assembly	114-257		Plug Button-Statuary Bronze
S-12412		Phono Drive Out Motor, Mtg. Brkt. & Cable Assembly			Metal Glides (4 used)
S-12591		Drive Out Switch, Plug & Cable Assembly	125-49		Dial Glass
S-14002		Intermixer Record Changer	125-56		F. M. Instruction Book
S-14445	L1	Wavemagnet Assembly-Type 30N	138-26		Instruction Book (Radio & Phono)
S-14538		Record Changer Mounting Frame Assembly	159-61		Lid Support Arm, Hinge Plate & Brkt. (R.H.)
S-14539		Interconnecting Cable Assembly	165-9		Lid Support Arm, Hinge Plate & Brkt. (L.H.)
S-12583		Phono Drive Out Motor & Plug (141-91) Induction Motor)	192-115		Record Changer Mtg. Frame Assembly
MODEL 9H885 CABINET PARTS					
15-82		Plug Cap & Insulator (used on S-14306)	S-11429		Phono Lift Spring & Bushing Assembly
19-123		Record Changer Mounting Clip (3 used)	S-12545		Intermixer Record Changer
40-42		Knife Hinge (R.H.)	S-14002		Loop Loading Coil Assembly
40-65		Knife Hinge (L.H.)	S-14195		Low Impedance Loop Assembly
46-662		Key Escutcheon (2 used)	S-14305		Interconnecting Cable Assembly (Phono.)
46-697		Volume & Tuning Knob (2 used)	S-14306		Chassis Compartment Hinge Assembly (R.H.)
46-718		Band Switch Knob			Chassis Compartment Hinge Assembly (L.H.)
46-725		Door Pull (2 used)	S-14433		
46-726		Phono Switch Knob (2 used)	S-14434		

CLARI-SKEMATIX

Registered Trademark

MODELS 9H881, 9H882R,
9H885, 9H888R, CHASSIS
9E21

ZENITH RADIO CORP.

6T8 DET.
13I AUDIO

6AU6
2ND I.F.

6BA6
1ST I.F.

6BE6
CONVERTER

6BA6
R.F.

PRIMARY FOR EXTERNAL A.M. ANTENNA
CONNECTION
USED ON
MODEL
9H885 ONLY

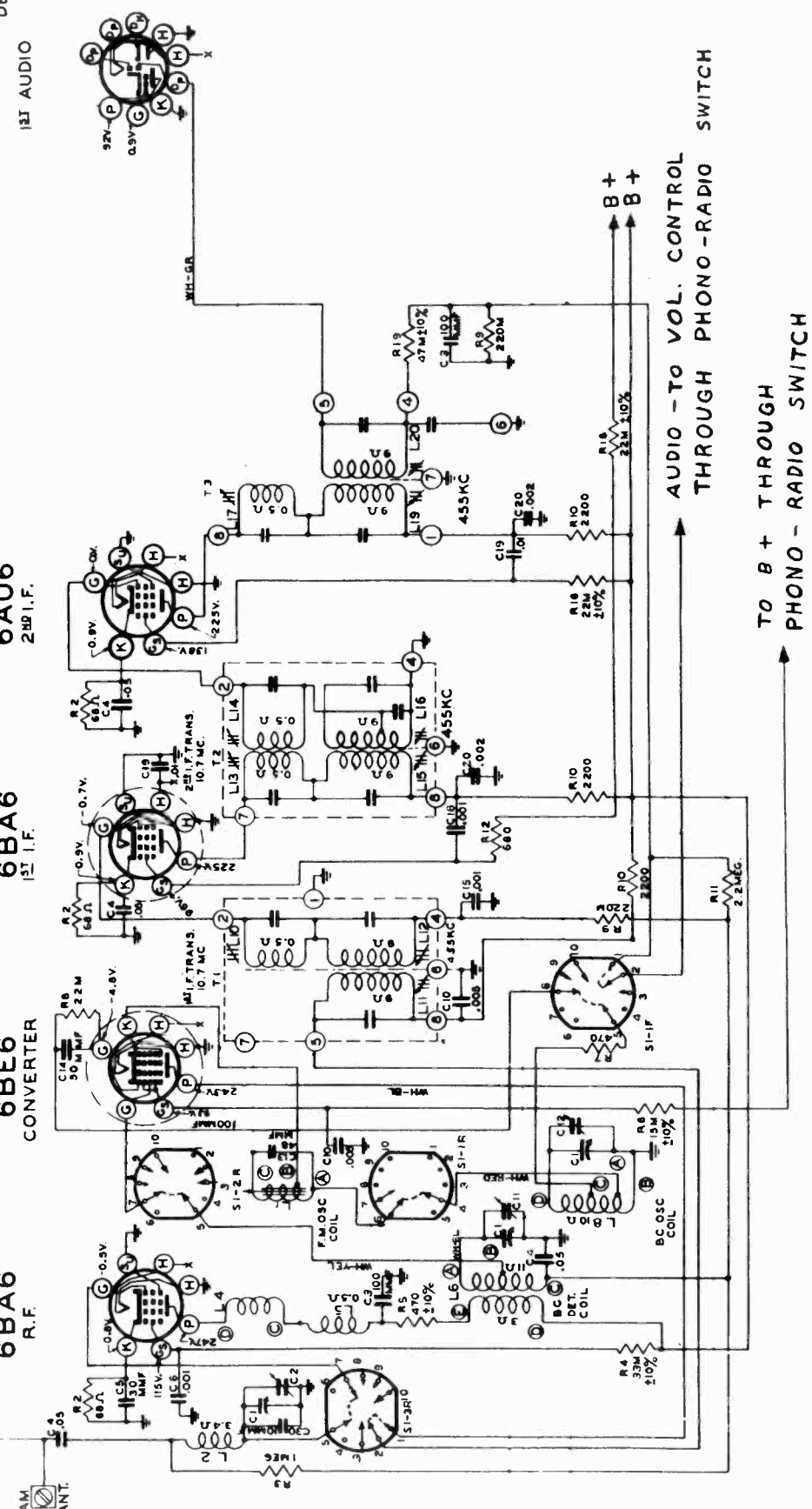

AUDIO - TO VOL. CONTROL
THROUGH PHONO - RADIO SWITCH
TO B+ THROUGH
PHONO - RADIO SWITCH

BAND - SWITCH SHOWN
AT 1ST POSITION.
BROADCAST BAND
540 - 1620 KC

CLARI - SKEMATIX

Registered Trademark

ZENITH RADIO CORP. MODELS 9H881, 9H882R, 9H885, 9H888R, CHASSIS 9E21

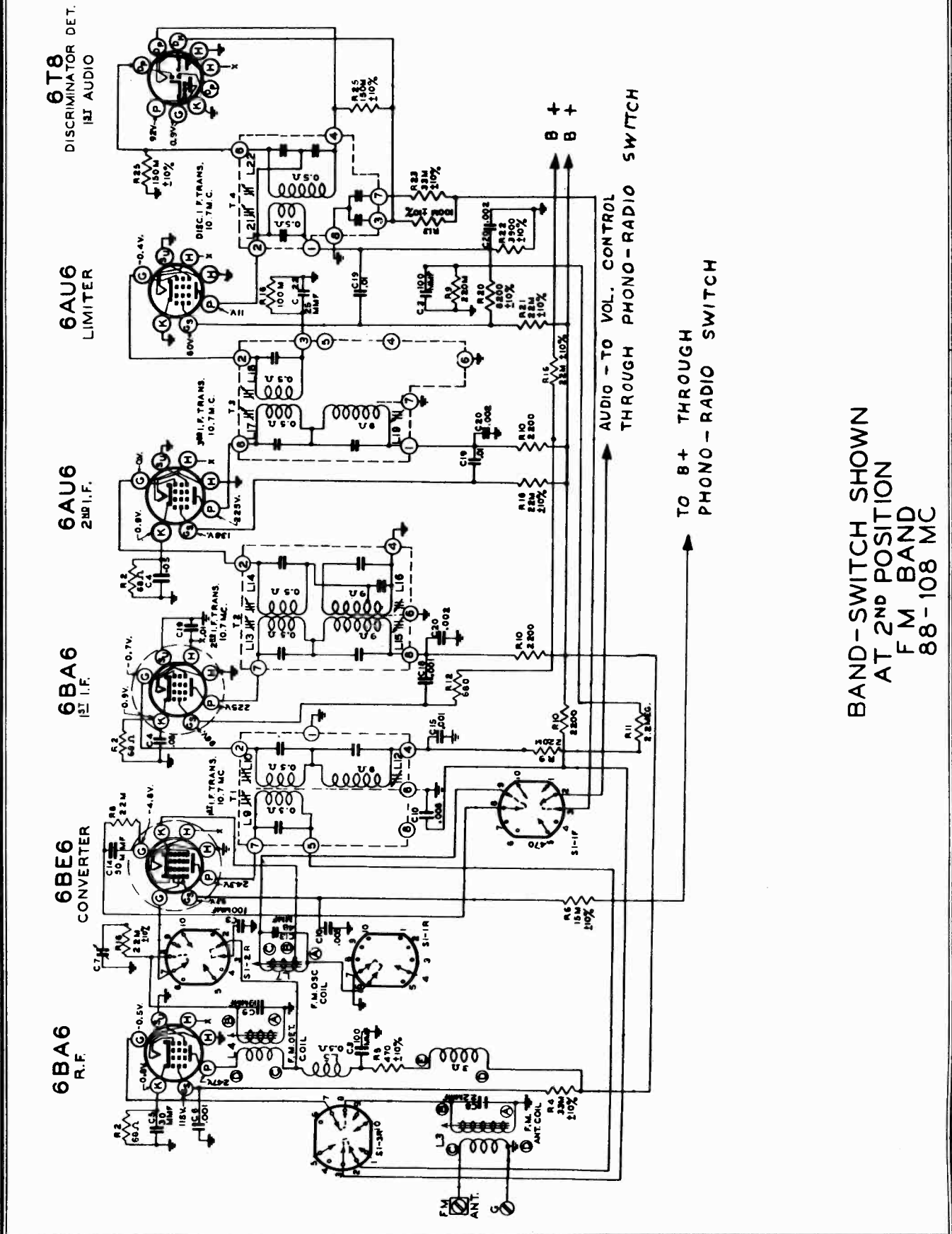

BAND-SWITCH SHOWN AT 2ND POSITION F.M. BAND 88-108 MC

CLARI - SKEMATIX

Registered Trademark

MODELS 9H881, 9H882R, 9H885, 9H888R ZENITH RADIO CORP.

CHASSIS 9E21

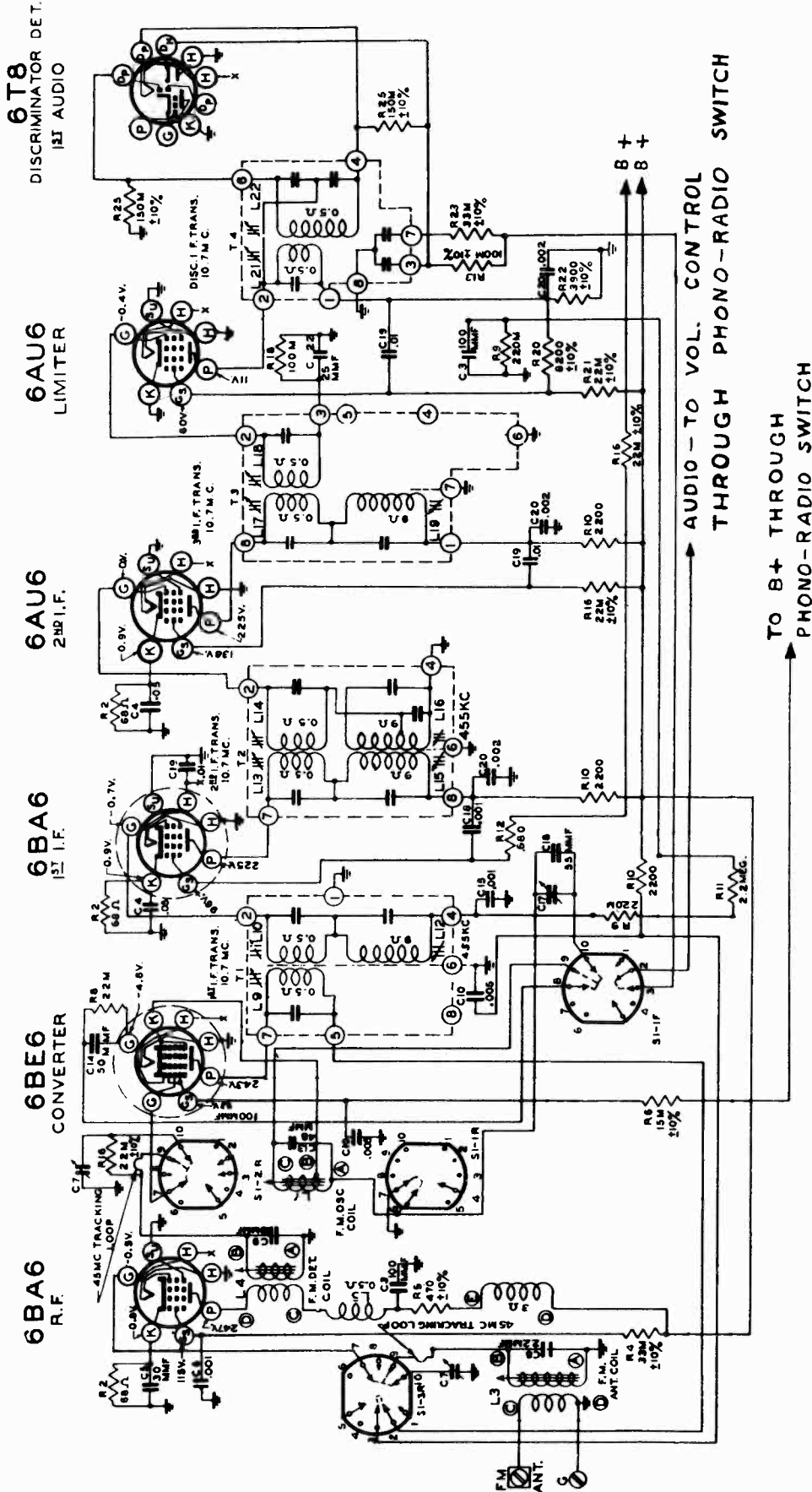

BAND-SWITCH SHOWN
AT 3RD POSITION
F M BAND
42 - 48.5 MC

ZENITH RADIO CORP.

MODELS 9H881, 9H882R, 9H885, 9H888R, CHASSIS 9E21

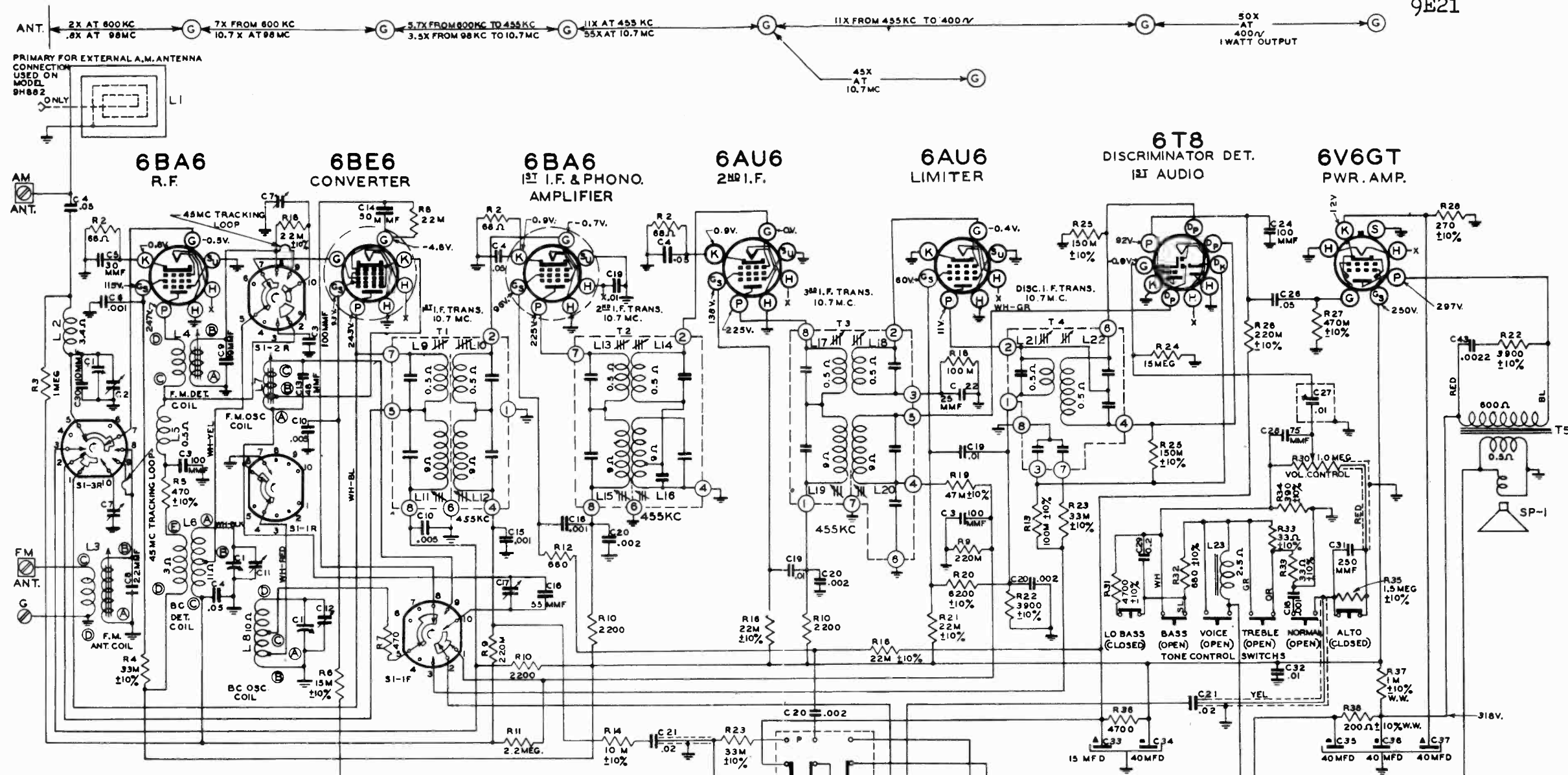

BAND SWITCH S1 SHOWN IN STANDARD BROADCAST POSITION
 1ST POS.-STD. BROADCAST
 2ND POS.-F.M. 100 MC.
 3RD POS.-F.M. 45 MC.

NOTE: ON MODEL 9H882 L2 RESISTANCE IS 1.8Ω AND C30 IS OMITTED

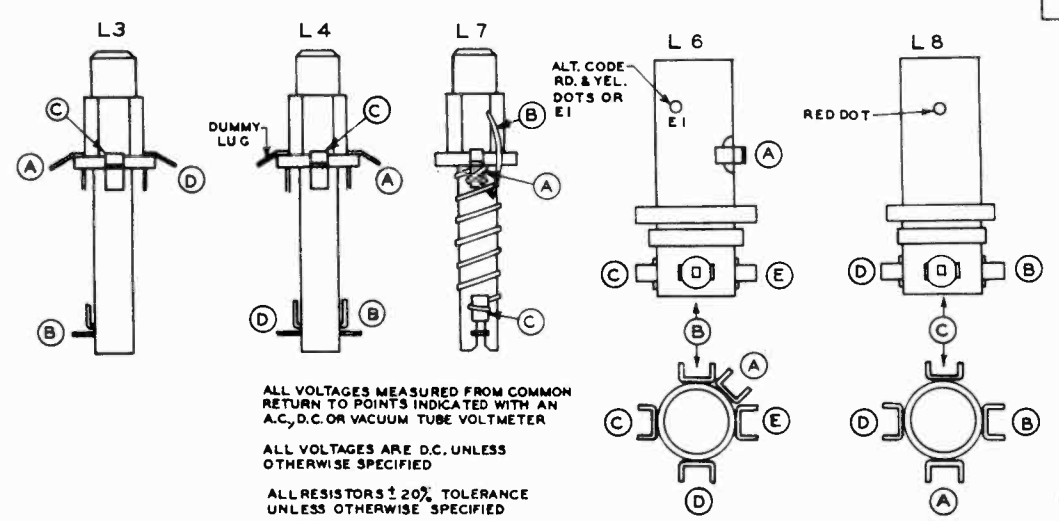

ALL VOLTAGES MEASURED FROM COMMON RETURN TO POINTS INDICATED WITH AN A.C., D.C. OR VACUUM TUBE VOLTMETER

ALL VOLTAGES ARE D.C. UNLESS OTHERWISE SPECIFIED

ALL RESISTORS ± 20% TOLERANCE UNLESS OTHERWISE SPECIFIED

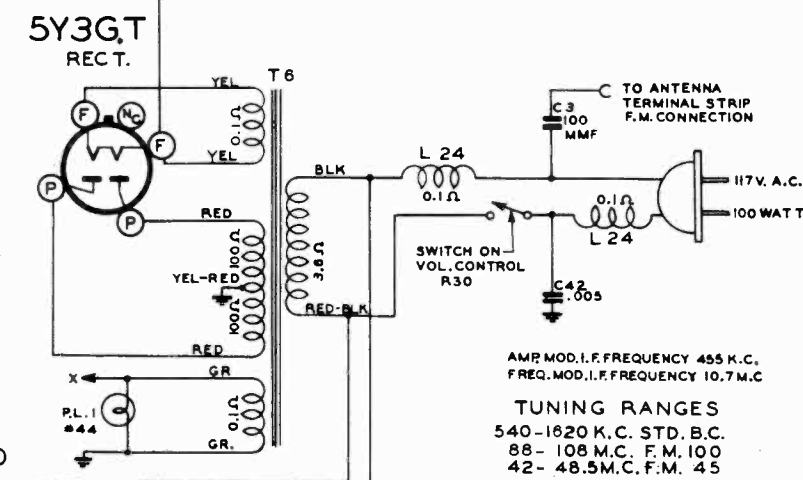
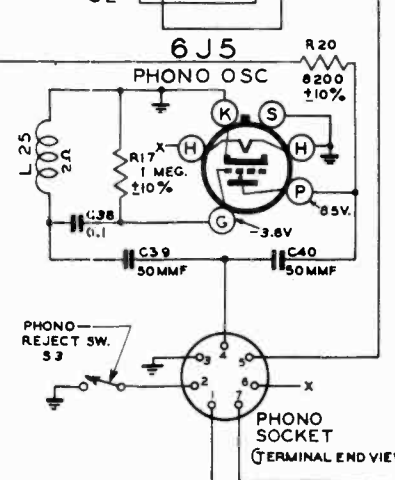

AMP. MOD. I.F. FREQUENCY 455 K.C.
 FREQ. MOD. I.F. FREQUENCY 10.7 M.C.

TUNING RANGES
 540-1620 K.C. STD. B.C.
 88-108 M.C. F.M. 100
 42-48.5 M.C. F.M. 45

⊥ DENOTES CHASSIS

MODELS 9H984, 9H984LP,
CHASSIS 9F22

ZENITH RADIO CORP.

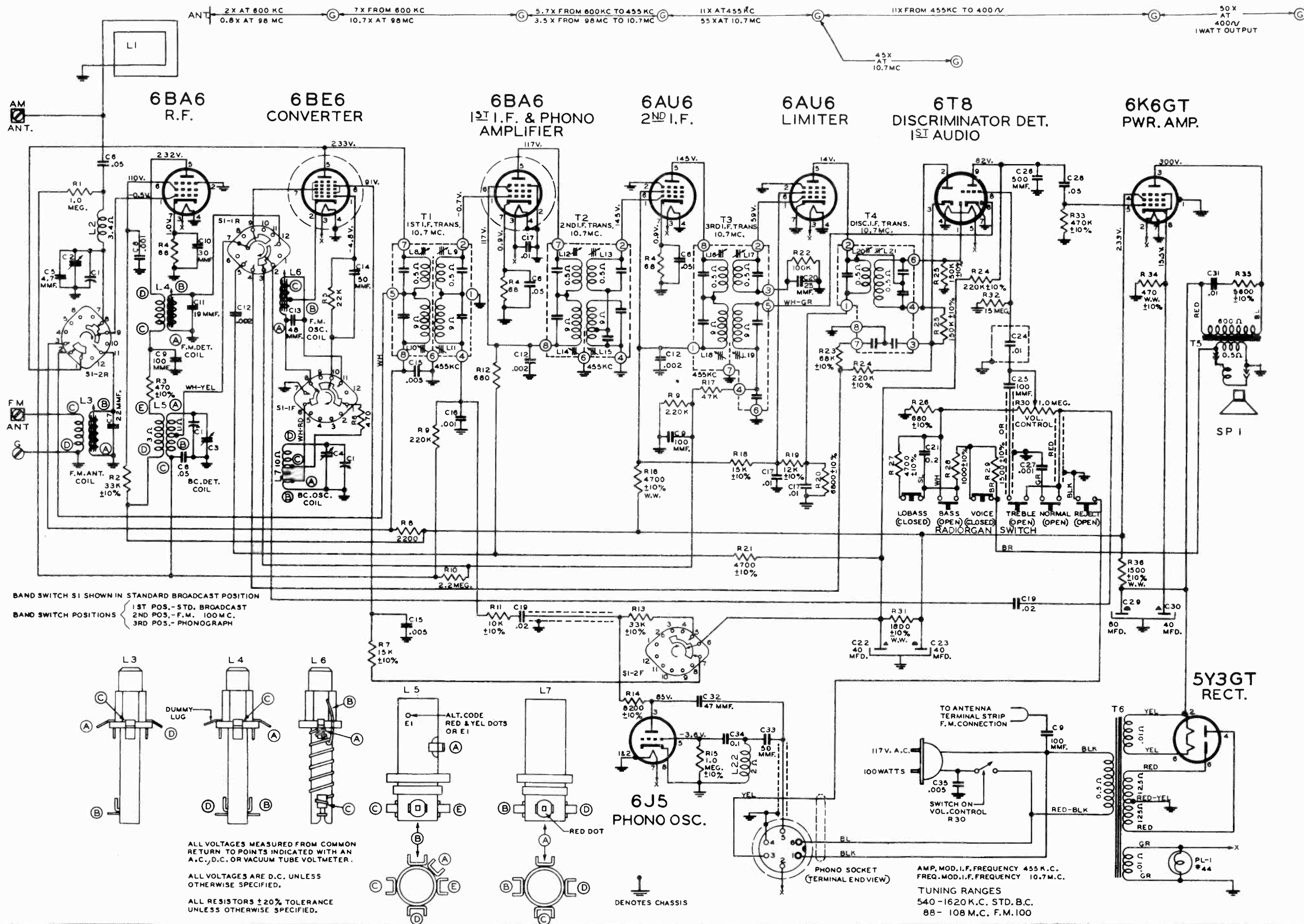

ZENITH RADIO CORP.

MODELS 9H984,
9H984LP, CHASSIS
9F22

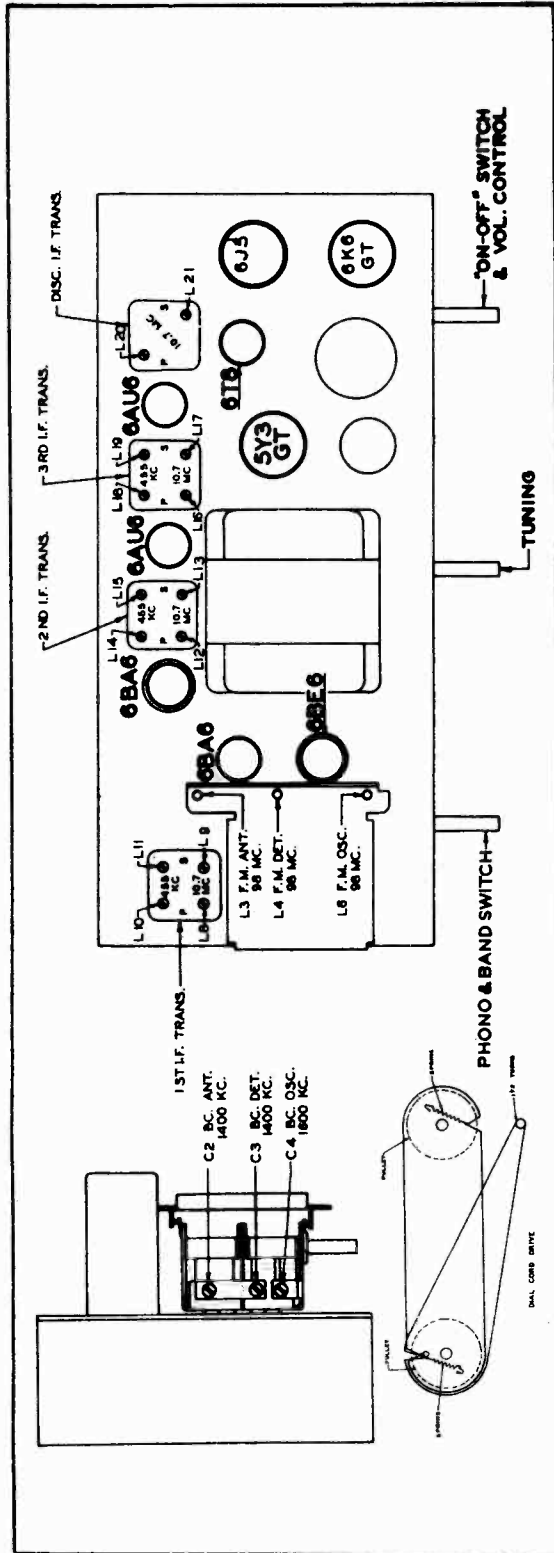

TUBE TRIMMER LOCATION AND DIAL CABLE DRAWING

The 9F22 chassis incorporates a superheterodyne circuit with two stages of IF, and one stage of RF amplification on all bands. The Radiorgan tone control is of the low impedance type in which a portion of the audio voltage is taken from the speaker voice coil and fed back out of phase into the grid of the first audio. The characteristic of the feedback voltage is determined by the setting of the Radiorgan buttons. To attenuate the high notes, more highs are fed back. To attenuate the low notes, more lows are fed back. For normal reproduction, both highs and lows are fed back and results in no overall change in tone.

The 6BA6 1st IF tube is also the phono pre-amplifier. The output from the phono oscillator is fed to the grid of the 6BA6 through C19 and R11. The amplified output is taken from the screen grid and fed back through R12, and C12 into the volume control circuit and the grid of the 6T8 1st audio amplifier.

AM Alignment: The alignment of this chassis on the standard broadcast band is conventional. The alignment slugs in the IF transformers are threaded and screw into the coil forms. The slugs are slotted for a small size fiber screw driver. Do not press hard on the aligning tool or the threads in the coil forms will strip and adjustment will be impossible.

FM RF Alignment: A coil slug arrangement tunes the 100 MC FM band. The tuning slugs are attached to threaded shafts and the slugs are varied in the field of the coils by turning the shafts clockwise or counter clockwise. After adjustment the shafts must be secured with a drop of speaker cement.

FM IF Alignment: The same type of tuning slugs for aligning the AM IF Amplifier are used for the FM IF's. Observe the same precautions when making adjustments.

FM Discriminator Alignment: When the secondary of the discriminator is aligned (operation 5) use sufficient signal input to get a good positive and negative indication before setting the slug for zero reading. A center zero indicating meter is recommended for this adjustment, but is not absolutely necessary. Reversing the leads of a non-zero center meter, or observing closely when the meter starts to go to the left (negative) of zero will give the same results.

NOTE: The output transformer must be replaced with an exact duplicate, Part No. 9S-1063. Be sure to add the speaker code letter to the transformer Part Number when ordering replacements.

FM IF Alignment: Because of the wide band pass, it is desirable to use a FM signal generator and a cathode ray oscilloscope when aligning the FM IF channel. The instruction book for the Zenith Model 8C0 Signal Generator (Form Z8001) covers complete FM alignment procedure. If visual alignment equipment is unavailable, reasonably accurate alignment can be made by following the procedure outlined below.

MODELS 9H984,
9H984LP, CHASSIS
9F22

ZENITH RADIO CORP.

ALIGNMENT PROCEDURE

Operation	Connect Oscillator to	Dummy Antenna	Input Signal Frequency	Band	Set Dial To	Adj. Trimmers	Purpose
1	Pin 7 6BE6 Converter	.05 Mfd.	455 Kc. Modulated	BC	600 Kc.	L-10, 11, 14, 15, 16, 18 and 19.	Align I. F. channel for maximum output.
2	2 turns loosely cpld. to wavemagnet.		1600 Kc. Modulated	BC	1600 Kc.	C4	Set oscillator to dial scale.
3			1400 Kc. Modulated	BC	1400 Kc.	C3 and C2	Align det. and ant. stages.
4 (a)	Pin 1 (grid) on 6AU6 Limiter	.05 Mfd.	10.7 Mc. Unmodulated	FM		L20 coil slug Primary discr.	Align primary of discriminator for maximum reading.
5 (b)		.05 Mfd.	10.7 Mc. Unmodulated	FM		L21 coil slug sec. of discr.	Adjust secondary of discriminator for zero reading.
6 (c)	Pin 1 (grid) on 6AU6 2nd IF.	.05 Mfd.	10.7 Mc. Unmodulated	FM		L16 and L17 Prim. and Sec. of 3rd IF trans.	Align 3rd IF transformer for maximum reading.
7 (c)	Pin 1 (grid) on 6BA6 1st IF.	.05 Mfd.	10.7 Mc. Unmodulated	FM		L12 and L13 Prim. and Sec. of 2nd IF transformer	Align 2nd IF transformer for maximum reading.
8 (c)	Pin 7 (grid) on 6BE6 converter tube	.05 Mfd.	10.7 Mc. Unmodulated	FM		L8 and L9 Prim. and Sec. of 1st IF transformer	Align 1st IF transformer for maximum reading.
9 (c)(d)	FM Antenna Post (Remove line ant.)	270 ohms	98 Mc. Unmodulated	FM	98 Mc.	L6 Osc. Coil Slug	Set Oscillator to dial scale.
10 (c)(c)		270 ohms	98 Mc. Unmodulated	FM	98 Mc.	L4 and L3 Det. and RF coil Slugs	Align det. and ant. stages to maximum reading.

IMPORTANT

Alignment of this chassis will in most cases be unnecessary unless an IF or RF transformer is replaced or the adjustments have been tampered with.

Correct alignment can only be made if the following procedure is followed:

A vacuum tube voltmeter with an isolation resistor of 200,000 ohms in series with the hot lead will serve for FM adjustments. This lead should be shielded.

An AC output meter connected across the primary or secondary of the output transformer will be satisfactory for all AM adjustments.

The signal generator output should be kept just high enough to get an indication on the meter.

(a) Vacuum Tube Voltmeter Lug 6 on discriminator transformer to chassis (half discriminator load).

(b) Vacuum Tube Voltmeter Lug 3 on discriminator transformer to chassis (full discriminator load).

(c) Vacuum Tube Voltmeter Lug 3 on 3rd IF transformer to chassis (full discriminator load).

(d) Loosen Slugs by applying a hot iron to the cement.

ZENITH RADIO CORP.

MODELS 9H984,
9H984LP, CHASSIS
9F22

PART NUMBER	REF. NUMBER	DESCRIPTION	PART NUMBER	REF. NUMBER	DESCRIPTION
DIAL ASSEMBLY			MISCELLANEOUS		
12-1434		Dial Light Mtg. Bracket.	11-108		Line Cord and Plug (9 ft. long)
26-410		Dial Scale use S 15394	54-226		Speed Nut - Tinnerman
59-209		Dial Pointer	57-1269		I.F. Trans. Terminal Plate
76-499		Tuning Control Shaft	78-709		Octal Tube Socket
78-797		Dial Light Socket	78-750		Six Contact Socket
80-69		Dial Cord Tension Spring	78-782		Miniature Tube Socket (2 used)
80-209		Dial Cord Tension Spring	78-788		Novel Miniature Socket
80-444		Tuner Arm Tension Spring	78-793		Octal Tube Socket (2 used)
80-581		Pressure Arm Tension Spring	78-794		Miniature Tube Socket (3 used)
93-721		Black Felt Washer (used on 59-209)	83-1545		Insulating Strip (4 used)
100-36	PL-1	Dial Light Bulb	85-442	S1	Band Switch
100-32		Retaining Ring	95-1063	T5	Output Transformer
S-14254		Pointer Pulley Assy (76-498)	95-1117	T6	Power Transformer
S-14256		Pulley & Bushing Assy.	125-26		Rubber Grommet (2 used) (mts. 78-709)
S-14260		Dial Cord & Eyelet Assy (short)	125-62		Rubber Grommet (4 used)
S-14269		Dial Cord & Eyelet Assy (long)	126-553		Metal Tube Shield
S-14429		Tuner Arm Assy	126-569		Heat Shield
S-15394		Dial Scale & Strip Assy. (26-410)	149-64		Tuning Core & Spring (3 used)
			S-15193		Phono Cable Assy. (or S-15467)
COILS & CHOKES			RADIORGAN ESC. ASSEMBLY		
S-11157	L7	B.C. Oscillator Coil Assy.	57-1351		Radiorgan Esc.
S-12254	L6	F.M. Oscillator Coil Assy.	57-1352		Radiorgan Esc.
S-12603	L22	Phono Oscillator Coil Assy.	76-444		Radiorgan Knob Retaining Shaft (2 used)
S-13871	L4	F.M. Detector Coil Assy.	80-595		Radiorgan Mtg. Spring (2 used)
S-13970	T1	1st I.F. Transformer Assy.	80-695		Knob Tension Spring
S-13971	T2	2nd I.F. Transformer Assy.	112-533		#6 x 1/4" Rd. Phill. Hd. S.T. Screw Type #25
S-13972	T3	3rd I.F. Transformer Assy.			CAD. (2 each used with S-15449 & S-15397)
S-13974	L5	B.C. Detector Coil Assy.	114-159		#6 x 1/4" Hex. Hd. S.T. Screw Type A CAD
S-14192	L3	F.M. Antenna Coil Assy.			(2 each used with S-15449 & S-15397)
S-14984	T4	Discriminator Trans. Assy.	S-14255		Radiorgan Mtg. Bracket Assy.
			S-14261		Radiorgan Strip & Contact Assy.
			S-14273		Radiorgan Knob & Eyelet Assy. (Lo-Bass)
			S-14274		Radiorgan Knob & Eyelet Assy. (Bass)
			S-14663		Radiorgan Knob & Eyelet Assy. (Voice)
			S-14276		Radiorgan Knob & Eyelet Assy. (Treble)
			S-14278		Radiorgan Knob & Eyelet Assy. (Normal)
			S-15397		Radiorgan Esc. & Knob Assy. (R.H.)
			S-15449		Radiorgan Esc. & Knob Assy. (L.H.)
CONDENSERS			TUBES		
22-171	C28	.05 Mfd.	600 V.		2 6BA6
22-340	C16	.001 Mfd.	500 V.		1 6BE6
22-365	C25	100 MMFD (or 22-1670)	500 V.		2 6AU6
22-929	C6	.05 Mfd.	200 V.		1 6TR
22-930	C19	.02 Mfd.	600 V.		1 6K6GT
22-854	C26	.0005 Mfd.	600 V.		1 6J5
22-1041	C35	.005 Mfd. (molded)	400 V.		1 5Y3GT
22-1220	C12	.002 Mfd.	600 V.		
22-1367	C14	50 MMFD (ceramic)	500 V.		
22-1385	C17	.01 Mfd.	200 V.		
22-1418	C34	.1 Mfd.	200 V.		
22-1506	C7	22 MMFD (ceramic)	500 V.		
22-1507	C20	25 MMFD (ceramic)	500 V.		
22-1516	C5	4.7 MMFD (molded)	500 V.		
22-1531	C21	.2 Mfd.	200 V.		
22-1532	C32	50 MMFD. (or 22-1674)	500 V.		
22-1627	C31	.01 Mfd. (or 22-1651)	600 V.		
22-1664	C33	50 MMFD (ceramic)	500 V.		
22-1669	C9	100 MMFD (ceramic)	500 V.		
22-1676	C8	.001 MMFD (ceramic)	500 V.		
22-1677	C1	Three gang variable.			
22-1688	C11	19 MMFD (ceramic)	500 V.		
22-1689	C13	48 MMFD (ceramic)	500 V.		
22-1705	C10	30 MMFD (ceramic)	500 V.		
22-1706	C15	.005 Mfd. (ceramic) (disc type)	450 V.		
22-1717	C27	.001 Mfd.	200 V.		
22-1718	C24	.01 Mfd. (shielded)	400 V.		
			40 Mfd.	350VA.	
22-1884	C22, 23	Two Sect. Electrolytic	40 Mfd.	450 V.	
22-1885	C29, 30	Two Sect. Electrolytic	40 Mfd.	25VX	
			80 Mfd.	450 V.	
RESISTORS			CABINET PARTS		
63-943	R21	4700 Ohm Insulated Resistor 10%	.1 W.	57-1353	Cabinet Back
63-957	R2	33K Ohm Insulated Resistor 10%	.1 W.	57-1469	Tone Arm Rest Bracket
63-1065	R7	15K Ohm Insulated Resistor 10%	.1 W.	70-83	Cable Clip
63-1222	R34	470 Ohm Insulated W. W. Resistor 10%	.1 W.	72-55	Cable Clip
63-1588	R30	Volume Control & Switch		72-58	Record Changer Mtg. Clip*(4 used)
63-1681	R36	Two Section Candohm			Loop Connector Clip (2 used)
63-1681	R31	1800 Ohm W.W. Zipohm 10%	.2 W.	80-678	Shaft Bearing Disc
63-1737	R4	68 Ohm Ins. Res. 20%	1/2 W.	83-1247	Record Changer Frame Handle
63-1771	R3	470 Ohm Ins. Res. 10%	1/2 W.	93-392	Tuning Control Knob (2 used)
63-1772	R6	470 Ohm Ins. Res. 20%	1/2 W.		Band Switch Knob
63-1778	R26	680 Ohm Ins. Res. 10%	1/2 W.	112-489	Band Switch Knob
63-1779	R12	680 Ohm Ins. Res. 20%	1/2 W.		Speaker 12" P.M.
63-1785	R28	1 K Ohm Ins. Res. 10%	1/2 W.	112-712	208-624 Cone & Voice Coil
63-1792	R29	1500 Ohm Ins. Res. 10%	1/2 W.	113-17	Diffusing Plate
63-1800	R8	2200 Ohm Ins. Res. 20%	1/2 W.		Dial Escutcheon
63-1813	R27	4700 Ohm Ins. Res. 10%	1/2 W.		6 x 1/2" Washer Hd. Wood Screw Steel Stat.Br
63-1817	R35	5600 Ohm Ins. Res. 10%	1/2 W.	114-78	(10 used to mount cab. back)
63-1820	R20	6800 Ohm Ins. Res. 10%	1/2 W.		#6 x 3/8" Phill. Fl.Hd. Wood Screw Steel N.P.
63-1824	R14	8200 Ohm Ins. Res. 10%	1/2 W.	114-148	(2 used with 27-81)
63-1827	R11	10K Ohm Ins. Res. 10%	1/2 W.		#2 x 3/8" Phill. Fl. Hd. Wood Screw Steel Brass
63-1831	R19	12K Ohm Ins. Res. 10%	1/2 W.	114-233	Pl. (6 used to mount 57-1469)
63-1834	R10	15K Ohm Ins. Res. 10%	1/2 W.		Record Changer Mtg. Spring (4 used)
63-1848	R5	22K Ohm Ins. Res. 20%	1/2 W.	159-52	Trim Strip
63-1848	R13	33K Ohm Ins. Res. 10%	1/2 W.	188-91	Brown Felt Washer - 3/32 x 33/64 x 1"
63-1856	R17	47K Ohm Ins. Res. 20%	1/2 W.	192-115	(used with 46-697 & 46-718)
63-1862	R23	68K Ohm Ins. Res. 10%	1/2 W.	196-109	#8 x 1/2" Phill. R.H.S.T. ShakeProof #25 Cad.
63-1870	R22	100K Ohm Ins. Res. 20%	1/2 W.	202-683	Pl. (Handle Mtg. Screw)
63-1876	R25	150K Ohm Ins. Res. 10%	1/2 W.	202-684	Record Changer Mtg. Screw (4 used)
63-1883	R24	220K Ohm Ins. Res. 10%	1/2 W.	202-685	6-32 x 1/4" R.H.M.S. Steel N.P. Lockwasher
63-1884	R9	220K Ohm Ins. Res. 20%	1/2 W.	S-12864	Attached (2 used to mount 12-1547 on L.P. only)
63-1897	R33	470K Ohm Ins. Res. 10%	1/2 W.	S-14004	#8 x 5/16 Hex. Hd. Slotted S.T. Type Z N.P.
63-1911	R15	1 Megohm Ins. Res. 10%	1/2 W.	S-14012	(used with 19-88)
63-1912	R1	1 Megohm Ins. Res. 20%	1/2 W.	S-14305	#10 x 7/8" Hex. Washer Hd. S.T. Type Z CAD.
63-1926	R10	2.2 Megohm Ins. Res. 20%	1/2 W.	S-15386	Pl. (4 used chassis stg.)
63-1961	R32	15 Megohm Ins. Res. 20%	1/2 W.	S-15395	#14 x 1-1/4" Slotted Hex. Washer Hd. S.T.
63-1998	R16	4700 Ohm W.W. Ins. Res. 10%	.2 W.	S-15396	Type Z CAD
				L2	Plug Button (4 used)
					Rubber Ring (2 used)
					Dial Glass
					Dial Glass Dust Gasket
					Radio Instruction Book
					Phono Instruction Book
					Phono Instruction Book (L.P. Only)
					Drive Wheel & Pin Assy.
					Non-Intermixer Record Changer (9H984L.P. only)
					Non-Intermixer Record Changer (9H984L.P. only)
					Low Impedance Loop
					Knob & Eyelet Assy (46-776)
					Record Changer Mtg. Frame Assy (complete)
					Loading Coil Assy.

CLARI-SKEMATIX

Registered Trademark

ZENITH RADIO CORP.

MODEL 14H789,
CHASSIS 13D22

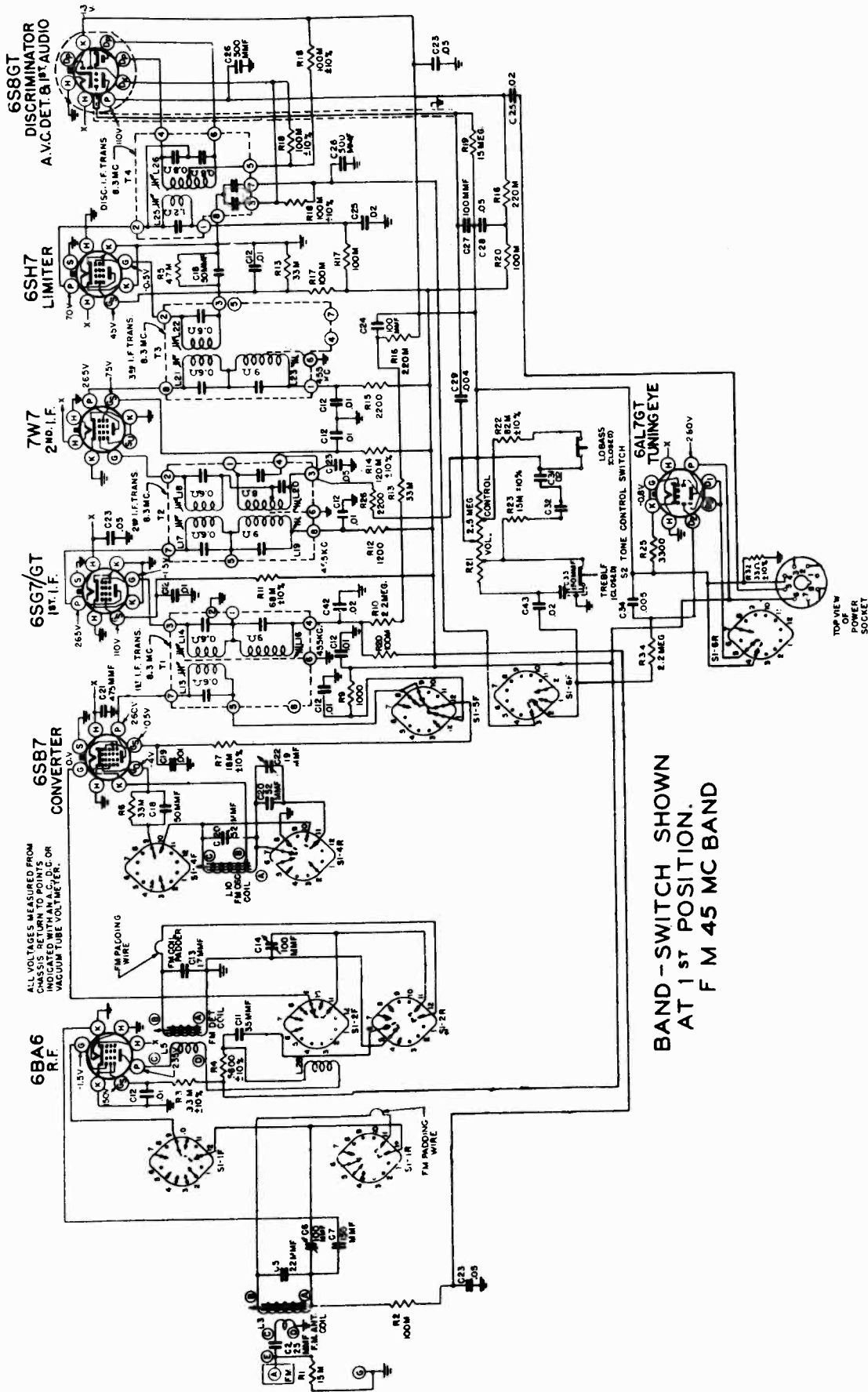

BAND - SWITCH SHOWN
AT 1ST POSITION.
F M 45 MC BAND

CLARI - SKEMATIX

Registered Trademark

ZENITH RADIO CORP.

PAGE 19-38 ZENITH

MODEL 14H789,
CHASSIS 13D22

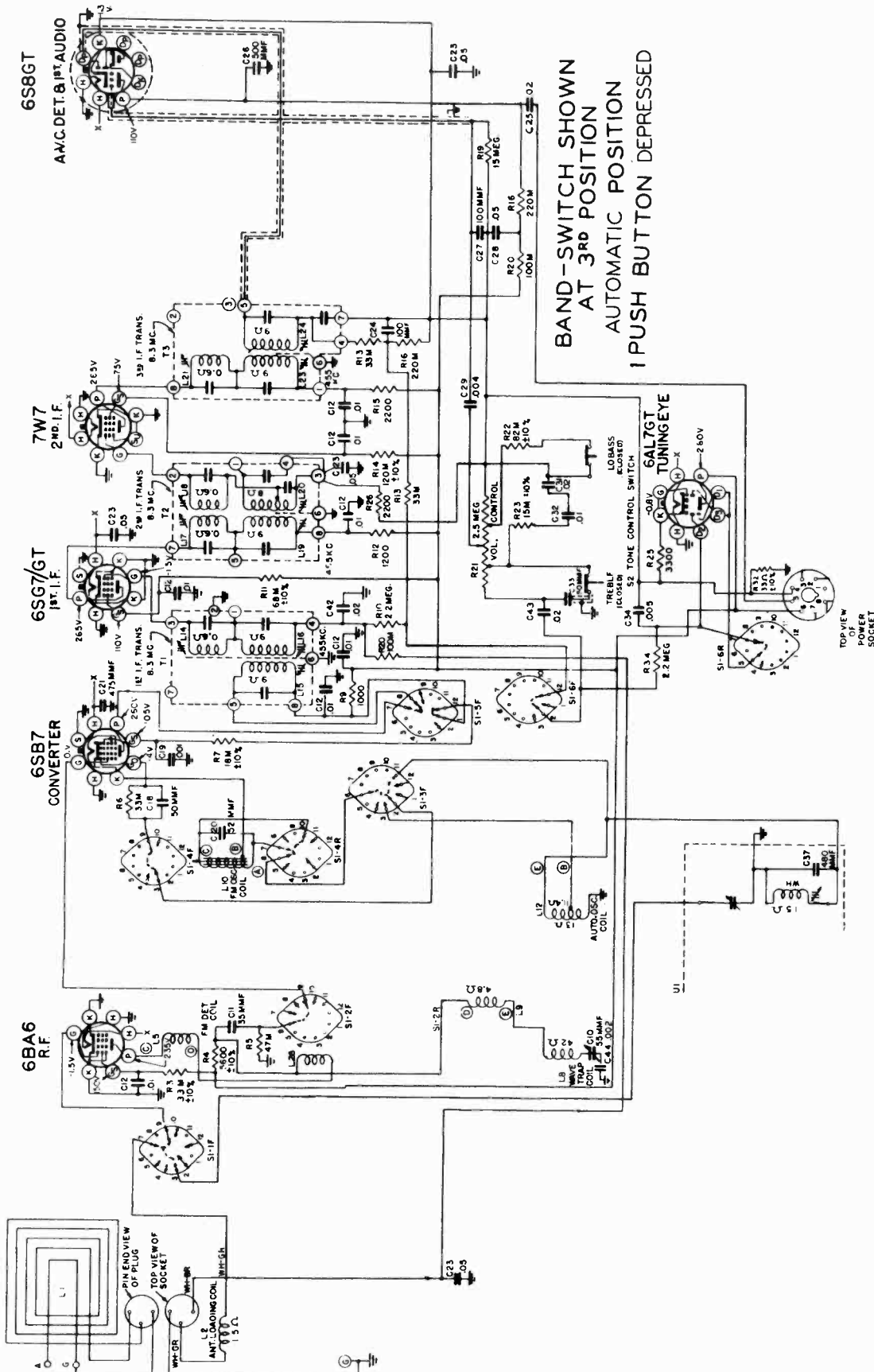

ZENITH RADIO CORP.

MODEL 14H789,
CHASSIS 13D22

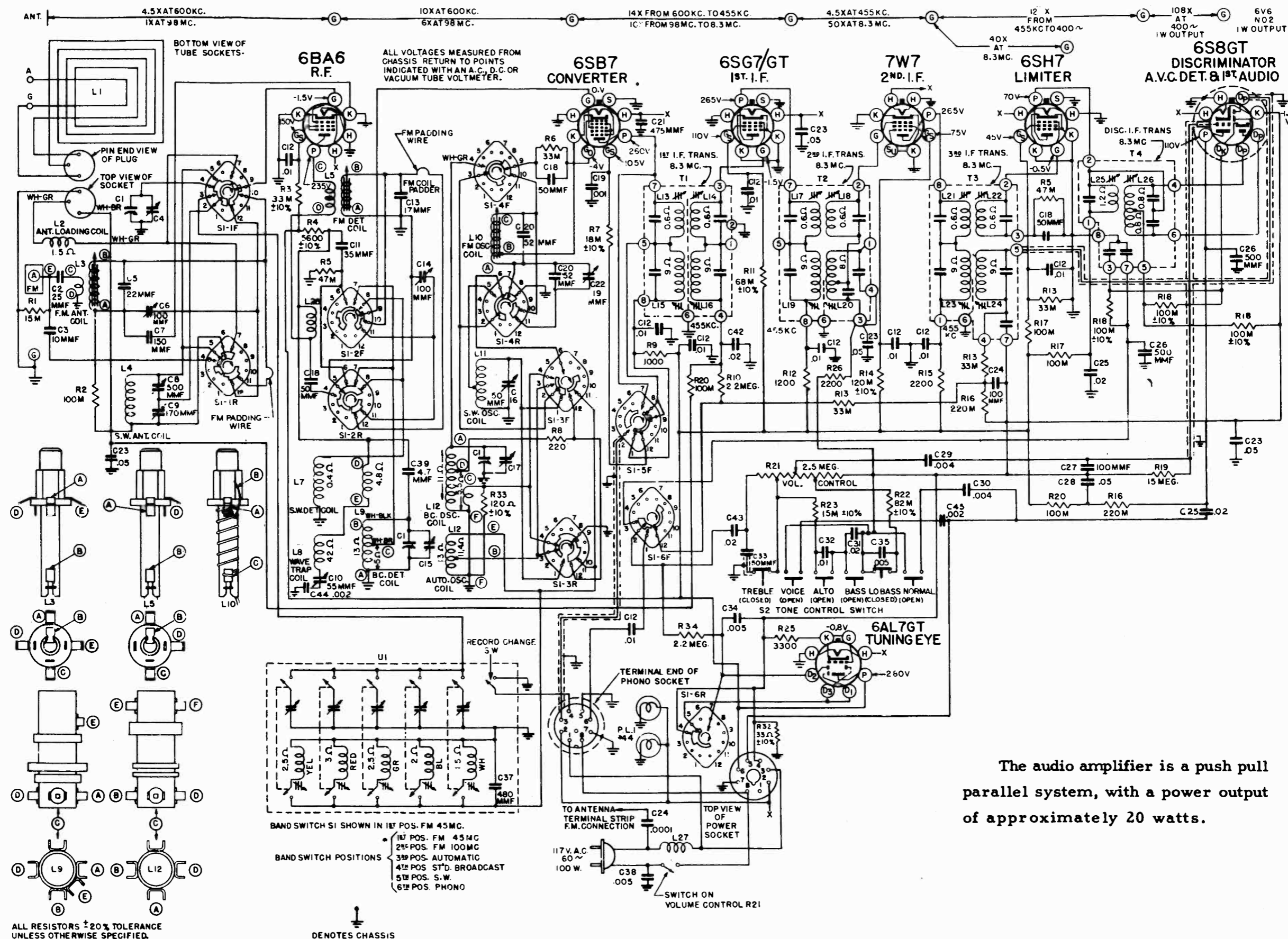

The audio amplifier is a push pull parallel system, with a power output of approximately 20 watts.

TO FIRST I.F. CONNECTIONS, THE
SAME AS IN AUTOMATIC POSITION

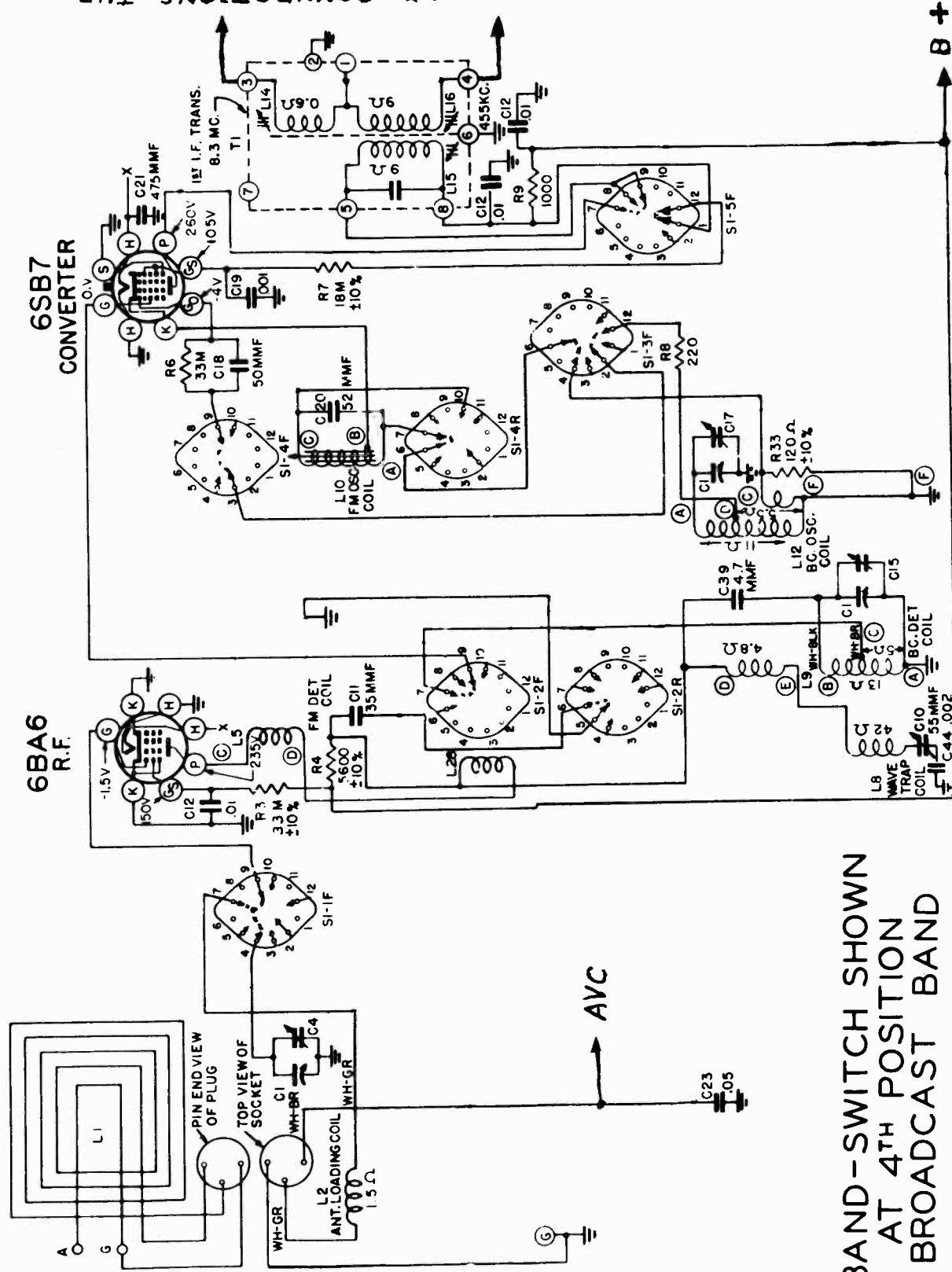

BAND-SWITCH SHOWN
AT 4TH POSITION
BROADCAST BAND

TO FIRST I.F. CONNECTIONS
SAME AS IN AUTOMATIC POSITION

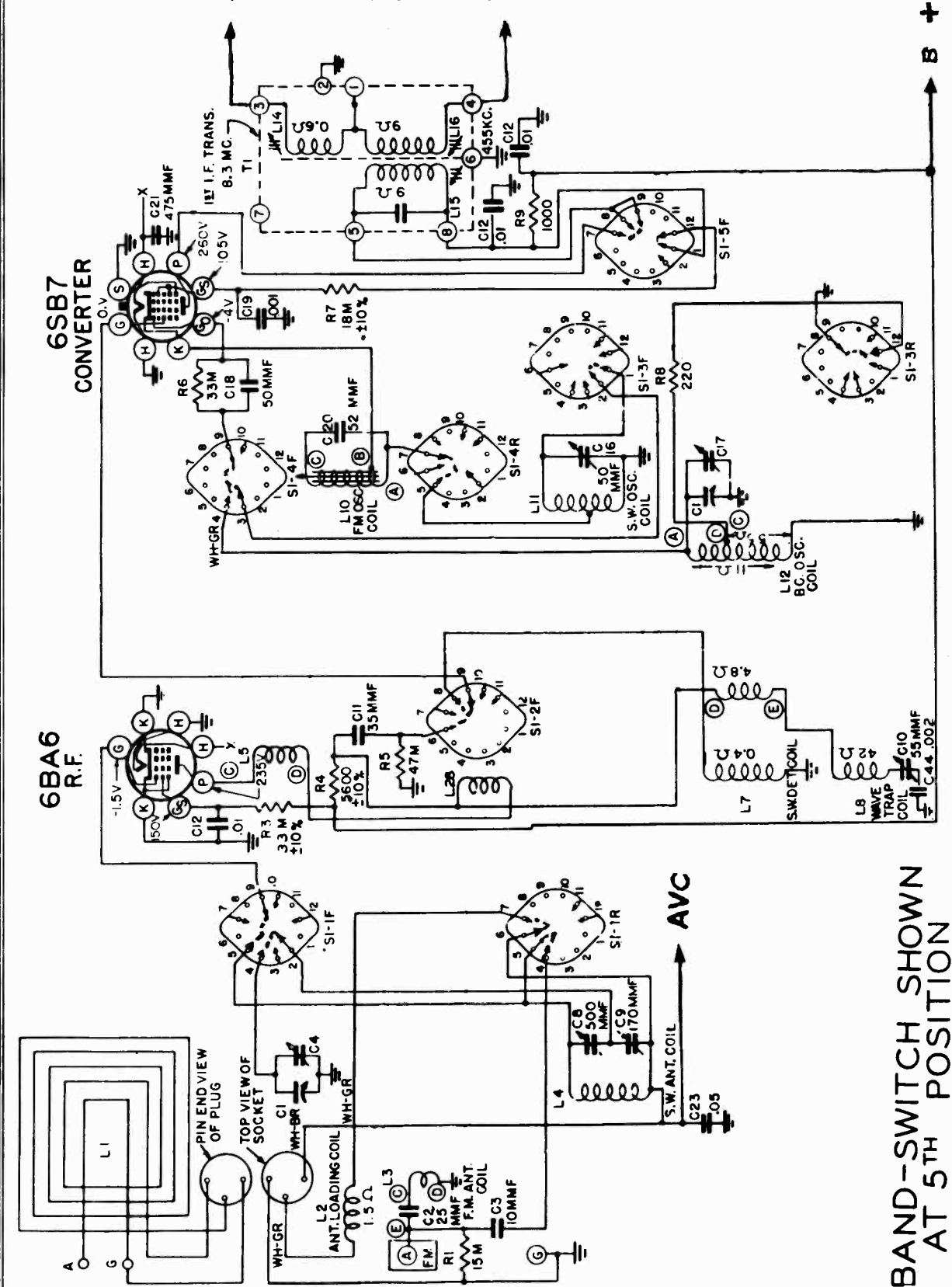

BAND-SWITCH SHOWN
AT 5TH POSITION
SHORT WAVE BAND

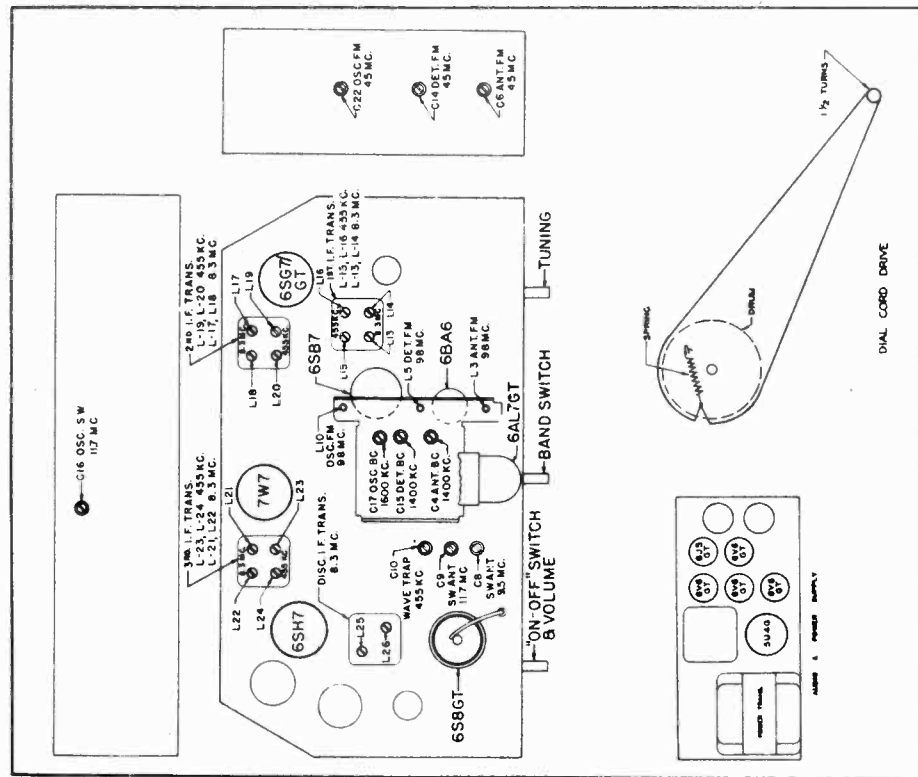

TUBE TRIMMER LOCATION AND DIAL CABLE DRAWING

The 11C21 chassis incorporate a superheterodyne circuit with two stages of IF, and one stage of RF amplification on all bands.

AM Alignment: The alignment of this chassis on the short wave and standard broadcast band is conventional. The alignment slugs in the IF transformers are threaded and screw into the coil forms. The slugs are slotted for a small size fiber screw driver. Do not press hard on the aligning tool (fiber screw driver) or the threads in the coil forms will strip and adjustment will be impossible.

FM RF Alignment: The same coil slug arrangement which tunes the 100 MC FM band also tunes the 45 MC band. However, on 45 MC the band switch connects trimmer condensers in parallel and padding wires in series with the 100 MC coils. The tuning slugs are attached to threaded shafts and the slugs are varied in the field of the coils by turning the shafts clockwise or counterclockwise. After adjustments the shafts must be secured with a drop of speaker cement.

FM IF Alignment: The same type of tuning slugs for aligning the AM IF Amplifier are used for the FM I.F. s. Observe the same precautions when making adjustments. The second 8.3 Mc IF stage is overcoupled. Overcoupling gives a wide band pass with good sensitivity. When an overcoupled stage is aligned with an unmodulated signal, the stage must be loaded. A 300 ohm carbon resistor soldered across the secondary of the second IF transformer provides a satisfactory load for this circuit. The resistor leads must be kept short to reduce the distributed capacity of the circuit.

When aligning a loaded stage, it will be found that considerable signal from the generator will be required, and that it will tune broadly. **THE LOAD RESISTOR MUST BE REMOVED AFTER ALIGNMENT.**

If the signal generator used does not have sufficient output to overcome the temporary loss caused by the load resistor, the load resistance may be increased or the signal fed into the preceding stage.

FM Discriminator Alignment: When the secondary of the discriminator is aligned (operation 9) use sufficient signal input to get a good positive and negative indication before setting the slug for zero reading. A center zero indicating meter is recommended for this adjustment, but is not absolutely necessary. Reversing the leads of a non-zero center meter, or observing closely when this meter starts to go to the left (negative) of zero will give the same results.

MODEL 14H789,
CHASSIS 13D22

ZENITH RADIO CORP.

ALIGNMENT PROCEDURE

Operation	Connect Oscillator to	Dummy Antenna	Input Signal Frequency	Band	Set Dial To	Adj. Trimmers	Purpose
1	Pin 8 on Converter Tube 6SB7 socket	.05 Mfd.	455 Kc. Modulated	BC	600 Kc.	L15, 16, 19, 20, 23 and 24	Align I.F. channel for maximum output
2	Pin 1 on R.F. tube 6AG5 socket	.05 Mfd.	455 Kc. Modulated	Aut.	Press any button on Auto.	C10	Adjust wavetrap to minimum
3	2 Turns loosely coupled to wavemaq.		1600 Kc. Modulated	BC	1600 Kc.	C17	Set oscillator to dial scale
4	2 Turns loosely coupled to wavemaq.		1400 Kc. Modulated	BC	1400 Kc.	C15 & C4	Align det. and ant. stages. Set oscillator to dial scale
5	Antenna Post (Re-move line ant.)	400 ohms	11.7 Mc. Modulated	SW	11.7 Mc.	C16	
6	Antenna Post (Re-move line ant.)	400 ohms	11.7 Mc. Modulated	SW	11.7 Mc.	C9	Align ant. stage
7	Antenna Post (Re-move line ant.)	400 ohms	9.7 Mc. Modulated	SW	9.7 Mc.	C8	Align ant. stage Repeat Oper. 6 for maximum output
8 (a)	Pin 4 grid on 6SH7 limiter socket	.05 Mfd.	8.3 Mc. Unmodulated	FM 45		L25 coil slug primary disc.	Align primary of discriminator for maximum reading
9 (b)	Pin 4 grid on 6SH7 limiter socket	.05 Mfd.	8.3 Mc. Unmodulated	FM 45		L26 coil slug sec. of disc.	Adjust secondary of disc. for zero reading
10 (c)	Pin 6 (grid) on 7W7 2nd IF tube socket	.05 Mfd.	8.3 Mc. Unmodulated	FM 45		L21 & L22 prim. & sec. of 3rd IF transformer	Align 3rd IF transformer for maximum reading
11 (c)	Pin 4 (grid) on 6SG7 1st IF tube socket	.05 Mfd.	8.3 Mc. Unmodulated	FM 45		L17 & L18 prim. & sec. of 2nd IF transformer	Align 2nd IF transformer for maximum reading
12 (c)	Pin 8 (grid) on 6SB7 converter tube socket	.05 Mfd.	8.3 Mc. Unmodulated	FM 45		L13 & L14 prim. & sec. of 1st IF transformer	Align 1st IF transformer for maximum reading
13 (c)	Antenna Post (Re-move line ant.)	270 ohms	98 Mc. Unmodulated	FM 100	98 Mc.	L10 Osc. coil Slug	Set oscillator to dial scale
14 (c)	Antenna Post (Re-move line ant.)	270 ohms	98 Mc. Unmodulated	FM 100	98 Mc.	L5 and L3 Det. and RF coil slugs	Align det. and ant. stage to maximum reading
15 (c)	Antenna Post (Re-move line ant.)	270 ohms	45 Mc. Unmodulated	FM 45	45 Mc.	C22	Set oscillator to dial scale
16 (c)	Antenna Post (Re-move line ant.)	270 ohms	45 Mc. Unmodulated	FM 45	45 Mc.	C14 and C6	Align detector and ant. stages for maximum reading

IMPORTANT: Alignment of this chassis will in most cases be unnecessary unless an IF or RF transformer is replaced or the adjustments have been tampered with.

A correct alignment can only be made if the following procedure is followed.

A vacuum tube voltmeter with an isolation resistor of 200,000 ohms in series with the hot lead will serve for FM adjustments. This lead must be shielded.

An ordinary AC output meter connected across the primary or secondary of the output transformer will be satisfactory for all AM adjustments.

The signal generator output should be kept just high enough to get an indication on the meter.

(a) Vacuum Tube Voltmeter pin 5 on discriminator transformer to chassis (half discriminator load.)

(b) Vacuum Tube Voltmeter pin 7 on discriminator transformer to chassis (full discriminator load.)

(c) Vacuum Tube Voltmeter 6SH7 limiter grid (pin 4 to chassis).

(d) 300 ohm 1/2 watt carbon resistor soldered across the secondary L18 (pin 2 and 3 of 2nd IF trans.). The leads to the resistor must be as short as possible and the resistor removed before operation L3 is started.

ZENITH RADIO CORP.

MODEL 14H789,
CHASSIS 13D22

PARTS LIST

PART NO.	REF. NO.	DESCRIPTION	PART NO.	REF. NO.	DESCRIPTION
DIAL ASSEMBLY					
59-159		DIAL POINTER	63-510	R7	18M OHM (INSULATED) . . . 2 W.
76-417		BAND SWITCH DRIVE SHAFT	63-579	R8	220 OHM 1/4 W.
76-418		TUNING CONTROL SHAFT	63-585	R26	2200 OHM 1/4 W.
78-585		DIAL LIGHT SOCKET AND WIRE ASSEMBLY	63-586	R25	3300 OHM 1/4 W.
78-586		DIAL LIGHT SOCKET AND WIRE ASSEMBLY	63-592	R13	33M OHM 1/4 W.
80-85		INDICATOR TENSION SPRING	63-593	R5	47M OHM 1/4 W.
80-402		DIAL CORD TENSION SPRING	63-595	R20	100M OHM 1/4 W.
80-445		TUNER ARM PRESSURE SPRING	63-600	R10	2.2 MEGOHM 1/4 W.
80-446		TUNER ARM TENSION SPRING	63-605	R9	1M OHM 1/2 W.
100-36		DIAL LIGHT BULB	63-607	R1	15M OHM 1/2 W.
188-32		RETAINING RING	63-620		33 OHM 1/4 W.
S-11330		DIAL CORD AND EYELET ASSEMBLY	63-626		120 OHM 1/4 W.
S-12242		IDLER BRACKET AND SHAFT ASSEMBLY	63-651	R22	82M OHM 1/4 W.
S-12243		BUSHING, GEAR AND INDICATOR ASSEMBLY	63-712	R6	33M OHM (INSULATED) . . . 1/4 W.
S-12245		GEAR AND BUSHING ASSEMBLY	63-715	R2	100M OHM (INSULATED) . . . 1/4 W.
S-12248		CAPACITOR PULLEY BUSHING AND CAM ASSEMBLY	63-752		180M OHM (INSULATED) . . . 1/4 W.
S-12266		IDLER WHEEL AND RUBBER RING ASSEMBLY	63-803	R15	2200 OHM 1/2 W.
S-12294		DIAL SCALE AND BRACING STRIP ASSEMBLY (26-338)	63-1166	R3	33M OHM 1/2 W.
S-12296		TUNER ARM ASSEMBLY	63-960	R11	68M OHM 1/2 W.
S-12297		RESONANCE INDICATOR SOCKET AND CABLE ASSEMBLY	63-976	R19	15 MEGOHM 1/4 W.
			63-1349	R21	VOLUME CONTROL AND SWITCH
			63-1446	R12	1200 OHM 1/2 W.
			63-1447	R14	120 OHM 1/2 W.
			63-1448	R4	5600 OHM 1/2 W.
COILS AND CHOKES					
S-11344	L12	OSCILLATOR COUPLER COIL ASSEM. (B.C. AND AUTOMATIC)	22-1128	C2	.02 MFD 600 V.
S-11591		WAVEMAGNET LOADING COIL ASSEM. (USED ON S-12356)	22-1134	C1	.002 MFD. 1000 V.
S-12249	T1	1ST I.F. TRANSFORMER ASSEMBLY	22-1515	C3, C4	TWO SECTION ELECTROLYTIC 15 MFD. - 30 MFD. . . . 450 V.
S-12250	T2	2ND I.F. TRANSFORMER ASSEMBLY	58-149	P1	MOULDED PLUG - 7 PRONG (POWER CABLE)
S-12251	T3	3RD I.F. TRANSFORMER ASSEMBLY	63-577	R5	100 OHM 1/4 W.
S-12252	T4	DISCRIMINATOR TRANSFORMER ASSEMBLY	63-648	R2	47M OHM 1/4 W.
S-12256	L27	A.C. LINE CHOKER COIL ASSEMBLY	63-776		330M OHM (INSULATED) . . . 1/4 W.
S-12281	L8	WAVE TRAP COIL ASSEMBLY	63-797		2200 OHM 1/2 W.
S-12282	L4	S.W. ANTENNA COIL ASSEMBLY	63-1551		CANOHM RESISTOR
S-12291	L7	S.W. DETECTOR COIL ASSEMBLY	63-1848	R8	33M OHM 1/2 W.
S-12292	L11	S.W. OSCILLATOR COIL ASSEMBLY	63-1880		180M OHM (INSULATED) . . . 1/2 W.
S-12293	L9	BROADCAST DETECTOR COIL ASSEMBLY	63-1883		220M OHM (INSULATED) . . . 1/2 W.
S-12301	L3	F.M. ANTENNA COIL ASSEMBLY	78-274		SOCKET - ELECTROLYTIC CAPACITOR (2 USED)
S-12302	L5	F.M. DETECTOR COIL ASSEMBLY	78-611		SOCKET - OCTAL TUBE (6 USED)
S-12303	L10	F.M. OSCILLATOR COIL ASSEMBLY	78-644	P.L.I.	SOCKET - SINGLE CONTACT
S-12529	L2	ANTENNA LOADING COIL ASSEMBLY	78-732	SO1	SOCKET - SPEAKER PLUG
			95-956	T1	POWER TRANSFORMER
			95-957	L1	FILTER CHOKE
			S-13489		INTERNAL CABLE ASSEMBLY
			S-13490		EXTERNAL CABLE ASSEMBLY
CONDENSERS					
22-162	C24	100 MMFD. 600 V.			
22-171	C28	.05 MFD 600 V.			
22-188		.02 MFD 400 V.			
22-196	C12	.01 MFD 600 V.	12-900		AUTOMATIC TUNING UNIT MTG. BRKT.
22-242	C36	750 MMFD. 500 V.	22-846		AUTOMATIC TUNING UNIT TRIMMER
22-289	C33	50 MMFD 600 V.	22-847		AUTOMATIC TUNING UNIT TRIMMER
22-319	C34	.005 MFD. 200 V.	22-848		AUTOMATIC TUNING UNIT TRIMMER
22-365	C27	100 MMFD. 600 V.	22-859		AUTOMATIC TUNING UNIT TRIMMER
22-448	C30	.004 MFD. 600 V.	22-868	C37	480 MMFD. SILVER MICA
22-829	C23	.05 MFD 200 V.	22-873		AUTOMATIC TUNING UNIT TRIMMER
22-830	C25	.02 MFD 600 V.	24-287		AUTOMATIC TUNING UNIT CARDBOARD COVER
22-912		.002 MFD. 600 V.	85-370		AUTOMATIC TUNING UNIT SWITCH
22-1041	C38	.005 MFD. 600 V.	112-223		ADJUSTING SCREW AND CORE (4 USED)
22-1126	C32	.01 MFD 400 V.	112-292		ADJUSTING SCREW AND CORE (1 USED)
22-1127	C31	.02 MFD 400 V.	S-6928		AUTOMATIC TUNING COIL (RED)
22-1135	C35	.005 MFD. 600 V.	S-6929		AUTOMATIC TUNING COIL (GREEN)
22-1138	C26	500 MMFD. 600 V.	S-7021		AUTOMATIC TUNING COIL (YELLOW)
22-1169	C19	.001 MFD. 600 V.	S-7859		AUTOMATIC TUNING COIL (BLUE)
22-1257		.005 MFD. 1000 V.	S-10100		AUTOMATIC TUNING COIL (WHITE)
22-1362	C29	.004 MFD. 600 V.	S-12331		AUTOMATIC TUNING UNIT COMPLETE
22-1363	C1	THREE GANG VARIABLE			
22-1367	C18	50 MMFD. (CERAMIC) . . . 500 V.			
22-1386		.02 MFD 200 V.			
22-1431		.001 MFD. 600 V.			
22-1493	C6	TRIMMER (F.M. ANT.)			
22-1494	C14	TRIMMER (F.M. DET.)			
22-1497	C-8-9-10	TRIMMER (S.W. ANTENNA AND WAVE TRAP)			
22-1502	C16	TRIMMER (S.W. Osc.)			
22-1503	C7	150 MMFD. 300 V.			
22-1504	C3	10 MMFD. (CERAMIC) . . . 500 V.			
22-1505	C13	17 MMFD. (CERAMIC) . . . 500 V.	46-674		AUTOMATIC STATION SELECTOR KNOB (5 USED)
22-1506	C5	22 MMFD. (CERAMIC) . . . 500 V.	46-681		PHONO REJECT KNOB
22-1507	C2	25 MMFD. (CERAMIC) . . . 500 V.	57-1293		AUTOMATIC PLASTIC ESCUTCHEON PLATE ONLY
22-1508	C11	35 MMFD. (CERAMIC) . . . 500 V.	76-342		AUTOMATIC KNOB RETAINING SHAFT
22-1509	C20	52 MMFD. (CERAMIC) . . . 500 V.	83-984		RUBBER STRIP
22-1514	C22	TRIMMER (F.M. Osc.)	83-1112		TRIM STRIP
63-260	R18	100M OHM 1/4 W.	S-12399		AUTOMATIC BRACKET AND LATCH ASSEMBLY
63-296	R16	220M OHM 1/4 W.	S-13671		AUTOMATIC TUNING KNOB AND ESCUTCHEON ASSEMBLY COMPLETE
63-380	R17	100M OHM 1 W.			
63-441		1 MEGOHM 1/4 W.			
63-503	R23	15M OHM (INSULATED) . . . 1/4 W.			
AUDIO POWER SUPPLY					
			22-1128	C2	.02 MFD 600 V.
			22-1134	C1	.002 MFD. 1000 V.
			22-1515	C3, C4	TWO SECTION ELECTROLYTIC 15 MFD. - 30 MFD. . . . 450 V.
			58-149	P1	MOULDED PLUG - 7 PRONG (POWER CABLE)
			63-577	R5	100 OHM 1/4 W.
			63-648	R2	47M OHM 1/4 W.
			63-776		330M OHM (INSULATED) . . . 1/4 W.
			63-797		2200 OHM 1/2 W.
			63-1551		CANOHM RESISTOR
			63-1848	R8	33M OHM 1/2 W.
			63-1880		180M OHM (INSULATED) . . . 1/2 W.
			63-1883		220M OHM (INSULATED) . . . 1/2 W.
			78-274		SOCKET - ELECTROLYTIC CAPACITOR (2 USED)
			78-611		SOCKET - OCTAL TUBE (6 USED)
			78-644	P.L.I.	SOCKET - SINGLE CONTACT
			78-732	SO1	SOCKET - SPEAKER PLUG
			95-956	T1	POWER TRANSFORMER
			95-957	L1	FILTER CHOKE
			S-13489		INTERNAL CABLE ASSEMBLY
			S-13490		EXTERNAL CABLE ASSEMBLY
AUTOMATIC TUNING UNIT					
			12-900		AUTOMATIC TUNING UNIT MTG. BRKT.
			22-846		AUTOMATIC TUNING UNIT TRIMMER
			22-847		AUTOMATIC TUNING UNIT TRIMMER
			22-848		AUTOMATIC TUNING UNIT TRIMMER
			22-859		AUTOMATIC TUNING UNIT TRIMMER
			22-868	C37	480 MMFD. SILVER MICA
			22-873		AUTOMATIC TUNING UNIT TRIMMER
			24-287		AUTOMATIC TUNING UNIT CARDBOARD COVER
			85-370		AUTOMATIC TUNING UNIT SWITCH
			112-223		ADJUSTING SCREW AND CORE (4 USED)
			112-292		ADJUSTING SCREW AND CORE (1 USED)
			S-6928		AUTOMATIC TUNING COIL (RED)
			S-6929		AUTOMATIC TUNING COIL (GREEN)
			S-7021		AUTOMATIC TUNING COIL (YELLOW)
			S-7859		AUTOMATIC TUNING COIL (BLUE)
			S-10100		AUTOMATIC TUNING COIL (WHITE)
			S-12331		AUTOMATIC TUNING UNIT COMPLETE
AUTOMATIC ESCUTCHEON PARTS					
			46-674		AUTOMATIC STATION SELECTOR KNOB (5 USED)
			46-681		PHONO REJECT KNOB
			57-1293		AUTOMATIC PLASTIC ESCUTCHEON PLATE ONLY
			76-342		AUTOMATIC KNOB RETAINING SHAFT
			83-984		RUBBER STRIP
			83-1112		TRIM STRIP
			S-12399		AUTOMATIC BRACKET AND LATCH ASSEMBLY
			S-13671		AUTOMATIC TUNING KNOB AND ESCUTCHEON ASSEMBLY COMPLETE
RESISTORS					

MODEL 14H789,
CHASSIS 13D22

ZENITH RADIO CORP.

PARTS LIST--Continued

PART NO.	REF. NO.	DESCRIPTION	PART NO.	REF. NO.	DESCRIPTION	
RADIOORGAN ESCUTCHEON PARTS						
57-1294		RADIOORGAN ESCUTCHEON PLATE ONLY	19-123		CABINET PARTS	
76-342		RADIOORGAN KNOB SHAFT	24-388			
83-1112		RADIOORGAN ESCUTCHEON TRIM STRIP	49-600	SP 1		
S-9606		RADIOORGAN STRIP AND CONTACT ASSEMBLY	57-1066			
S-12397		RADIOORGAN ESCUTCHEON BRACKET AND LATCH ASSEMBLY	57-1289			
S-13472		RADIOORGAN KNOB AND EYELET ASSEMBLY - NORMAL	69-193			
S-13475		RADIOORGAN KNOB AND EYELET ASSEMBLY - ALTO	78-761			
S-13476		RADIOORGAN KNOB AND EYELET ASSEMBLY - VOICE	80-423			
S-13667		RADIOORGAN ESCUTCHEON AND KNOB ASSEMBLY COMPLETE	80-463			
S-13668		RADIOORGAN KNOB AND EYELET ASSEMBLY - LO-BASS	83-1244			
S-13669		RADIOORGAN KNOB AND EYELET ASSEMBLY - BASS	90-367			
S-13670		RADIOORGAN KNOB AND EYELET ASSEMBLY - TREBLE	93-392			
MISCELLANEOUS						
11-87		LINE CORD AND PLUG	112-670			
27-87	C21	SILVER MICA DISC (475 MMF.)	112-671			
57-1054		SPARK PLATE	114-257			
58-133		NINE PRONG PLUG (USED ON S-13677)	171-7			
78-363		SOCKET - WAVEMAGNET PLUG	192-96			
78-376		SOCKET - OCTAL BASE TUBE (8 CONTACT)	202-506			
78-580		SOCKET - NINE CONTACT (PHONO)	202-512			
78-582		SOCKET - NINE CONTACT (2 USED ON S-13677)	202-514			
78-684		SOCKET - OCTAL BASE TUBE (MOULDED)	202-515			
78-685		SOCKET - MINIATURE TUBE	202-517			
80-451		TUBE RETAINING RING	S-12545			
125-49		CHASSIS MTG. RUBBER GROMMET	S-13058			
126-379		LOKAL TUBE SHIELD	S-13484			
149-54		F.M. IRON CORE AND SPRING (3 USED)	S-13672			
197-15		LIGHT DIFFUSING CUP	S-13673			
S-12356	S1	BAND SWITCH AND SHIELD ASSEMBLY (85-340)	S-13675			
S-12360		FILAMENT CABLE ASSEMBLY #1	S-13677			
S-12361		CABLE ASSEMBLY #2				

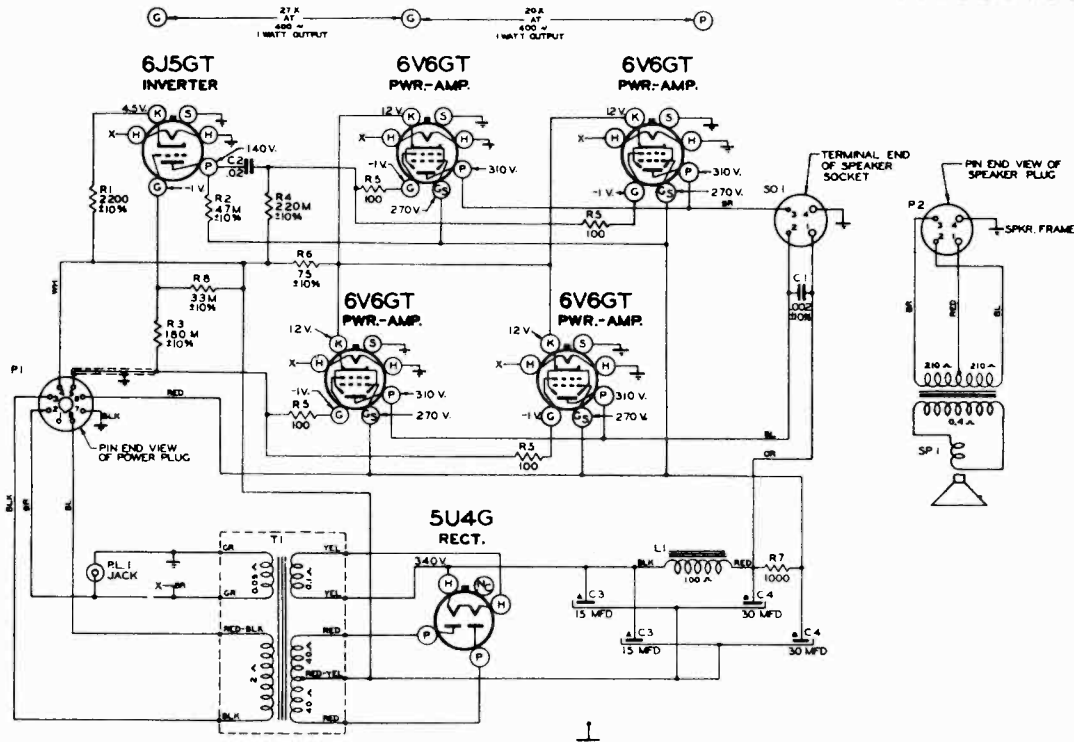

ALL RESISTORS 120% TOLERANCE UNLESS OTHERWISE SPECIFIED

⊥ DENOTES CHASSIS