

MAY, 1928

25 CENTS

# RADIO

(REG. U. S. PATENT OFF.)



*In This Issue*

ALL ABOUT THE ELECTRO-DYNAMIC SPEAKER



# New Dynamic Speakers

*Radio's first loud speaker—still the finest*

HERE is the original—the first type of loud speaker ever made. Created by Magnavox in 1911. The *only* type of speaker that has stood through every period of speaker development. Supreme in the beginning. Supreme today. Patented, controlled and made famous by Magnavox—and Magnavox has been made famous by it.

Over 400,000 Magnavox dynamic power units are now in use. The new models are widely acclaimed by press and public. They are used as built-in equipment by America's fine set makers—and the Magnavox principle is being adopted by speaker manufacturers under license agreements.



*Cordova Model (above)*

With dynamic 700 unit, 110 volt, 60 cycle AC. Combining rectifier and power amplifier. Takes place of last audio stage in set. Operates with one 381 or 281 tube and one 310 or 210 tube. Handsome walnut cabinet. *List \$175. Unit \$125.*

*New perfected models—to meet every power need—at new low prices*

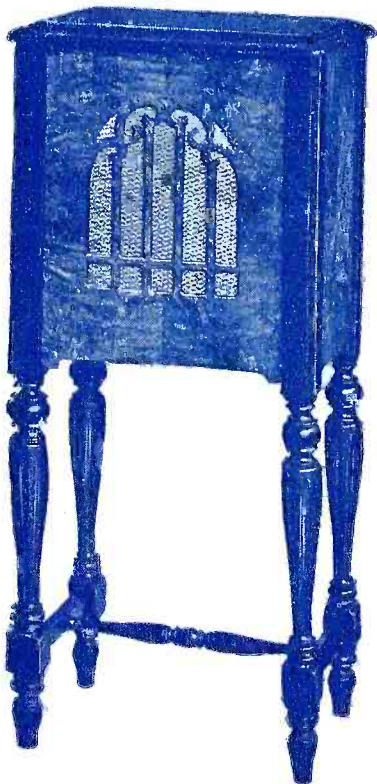

*Aristocrat Model (left)*

Beautiful butt burl walnut cabinet finished in two tones. It houses Dynamic 6, 7 or 80 unit. List prices:

*Aristocrat with Dynamic 6, \$70*

*Aristocrat with Dynamic 7, \$75*

*Aristocrat with Dynamic 80, \$85*

**Dynamic 80**  
*(right)*

110 volts AC. Has power transformer and dry rectifier. The most popular unit of the new line. Designed to operate with AC sets.

*Unit, list \$50.*

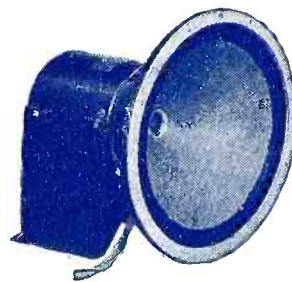
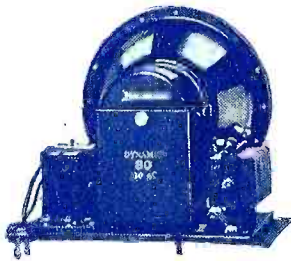

**Dynamic 6 (left)**  
6 volts DC. Field current consumption, 65 amperes. Operates from A battery.

*Unit list price \$35.*

**Dynamic 7**

110 to 220 volts D C. Field current consumption, 45 to 90 milliamperes. For use with power amplifiers using high voltage rectified alternating current—or with DC power supply. *Unit, list \$40.*

*Send for Dynamic power speaker bulletins, giving full information*  
**The Magnavox Company, Oakland, California**  
*Eastern Sales Office: — 1315 South Michigan Avenue, Chicago*

# MAGNAVOX

*Dynamic Power Speakers*



# HUNDREDS OF THOUSANDS ALL OVER AMERICA ARE USING CUSTOM-BUILT SETS

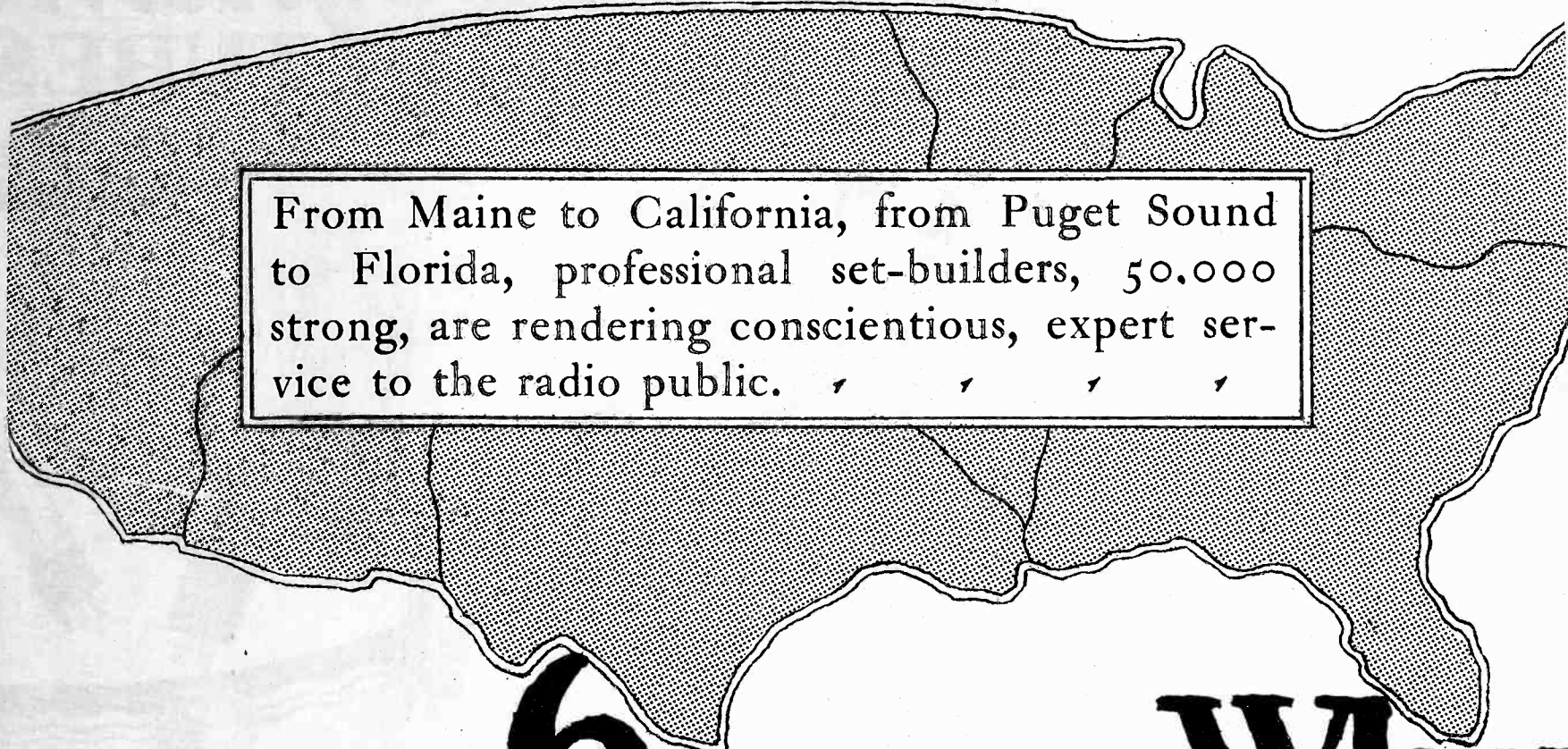

From Maine to California, from Puget Sound to Florida, professional set-builders, 50,000 strong, are rendering conscientious, expert service to the radio public. / / / /

## 6 REASONS Why

- 1 PERSONAL RESPONSIBILITY:** Your Professional Set-Builder is vitally interested in the successful operation of every set that he builds and sells. His reputation depends on the success of each installation. Naturally he spares no pains in his efforts to please you.
- 2 BETTER MATERIAL:** Cheap parts find no place in the receivers built by the Professional Set-Builder. He cannot afford to take chances on unreliable units that may fail at a critical moment. He has a wide choice of standard parts made by specialists and uses exactly the right part to obtain utmost efficiency.
- 3 QUALITY STANDARDS:** Every set must be exactly right before it leaves his workshop. He has not the high pressure of a production schedule. He can—and does—take the necessary time to make every receiver a perfect installation.
- 4 UP-TO-DATE:** As a rule the custom-built set is a year ahead of the factory-built product. Your Professional Set-Builder has no obsolete parts to work off, no expensive dies to discard, no large stock on hand to be sold somehow or other. Every advance in radio reception is immediately available to him.
- 5 LOCAL CONDITIONS MET:** The problems of radio reception differ tremendously in various localities. Your local Professional Set-Builder has made an actual test of conditions in your vicinity and will build exactly the set to meet your most rigid requirements at a minimum cost.
- 6 ECONOMY IN MAINTENANCE:** Once you have installed the custom-built set, the builder can keep it up to date for you from year to year at nominal cost by making an occasional change or improvement.

*Most Professional Set-Builders use Remler parts in their work. There is a substitute—at a lower price—for every Remler item but the Set-Builders know that there is no substitute for Remler design, accuracy and reliability.*

### REMLER

Division of

GRAY & DANIELSON MANUFACTURING COMPANY

260 First Street, San Francisco

Chicago

Eastern Warehouse, Elkhart, Indiana

New York

REMLER DIVISION, GRAY & DANIELSON MANUFACTURING CO.  
260 First Street, San Francisco, Calif.

Please place my name on your mailing list to receive:

- Future literature.  
 Bulletin Service for Professional Set-Builders.

Name..... Street..... City.....

Do you build and sell sets?.....



# RADIO

Established 1917

Published Monthly by the Pacific Radio Publishing Co.

ARTHUR H. HALLORAN,  
Editor

H. W. DICKOW,  
Business Manager

GERALD M. BEST,  
Technical Editor

A. I. RIVETT,  
Draughtsman

Entered as second-class matter at Post Office at  
San Francisco, Calif.

Copyright 1928 by the Pacific Radio Publishing Co.

Address all communications to

PACIFIC RADIO PUBLISHING COMPANY  
Pacific Building, San Francisco, California

Vol. X                      MAY, 1928                      No. 5

## CONTENTS

RADIOTORIAL COMMENT .....	9
RADIO—AVIATION'S SAFEGUARD.....	10
<i>By J. Garrick Eisenberg</i>	
RADIO 2XBK.....	13
THE ELECTRO-DYNAMIC SPEAKER.....	14
<i>By G. M. Best</i>	
SNAPPY RECEPTIONS ON LOW WAVES .....	17
<i>By Don C. Wallace</i>	
HOW IMPEDANCE RELATIONS AFFECT TONE QUALITY .....	19
<i>By Nelson P. Case</i>	
EXPERIMENTAL SHOP PRACTICE .....	20
<i>By Samuel G. McMeen</i>	
IMPROVED OPERATION OF THE 115 KILOCYCLE SUPER- HETERODYNE.....	21
<i>By G. M. Best</i>	
HOW TO MAKE THE TORU- SOLENOID .....	22
<i>By Harry R. Lubcke</i>	
A GOOD RECEIVER USING SHIELD-GRID TUBES.....	23
<i>By Francis Churchill</i>	
HOME-MADE DRUM DIALS.....	25
<i>By R. J. Robbins</i>	
SHORT-WAVE COILS.....	26
<i>By R. Wm. Tanner</i>	
PROTECTION OF METERS.....	26
<i>By B. F. McNamee</i>	
QUERIES AND REPLIES.....	27
THE COMMERCIAL BRASS- POUNDER.....	28
<i>By P. S. Lucas</i>	
WITH THE AMATEUR OPERATORS .....	30
RADIO KIT REVIEWS.....	31
A 10-METER RECEIVER .....	39
<i>By A. Binneweg, Jr.</i>	

### FORECAST FOR JUNE

"An Automatic Radio Receiver," by G. M. Best; "Practical Design of Band Pass Filters," by Arthur Hobart; "A Home-Made Photo-electric Cell," by John P. Arnold; "Weather Reports for Aviators," by S. R. Winters; "Harmonic Calibration," by E. A. Tubbs; "Vagaries of the Ether," by Wallace Kelk; "Voltage Dividers," by Howard Field, Jr.; "Scientific Set Design," by Richard F. Shea; "A Six-Tube Receiver with Shield-Grid Tubes," by Francis Churchill.

# Cunningham

## RADIO TUBES

### Take Notice

of the marked improvement in your radio reception when new Cunningham Radio Tubes are performing their special tasks in the various sockets of your radio.

Don't use old tubes with new ones — use new Cunningham Tubes throughout.

ψ ψ

**E. T. Cunningham, Inc.**  
New York Chicago San Francisco

## Use this Coupon and Save Money

The next six issues of "RADIO" will be outstanding, editorially. Plans have been completed for again publishing the annual show number in June. The July issue of "RADIO" will give you the first information on the new radio models as exhibited at the Radio Manufacturer's Association show in Chicago. Copies of last year's special show issue sold fast. The demand exceeded the supply. We urge you to subscribe now—today—at the special rate of one dollar for six months in order to protect yourself against missing the next six issues of "RADIO." Attach a dollar bill, check or money order to this coupon and mail now.

Name.....

Street and No.....

City and State.....

Tell them you saw it in RADIO



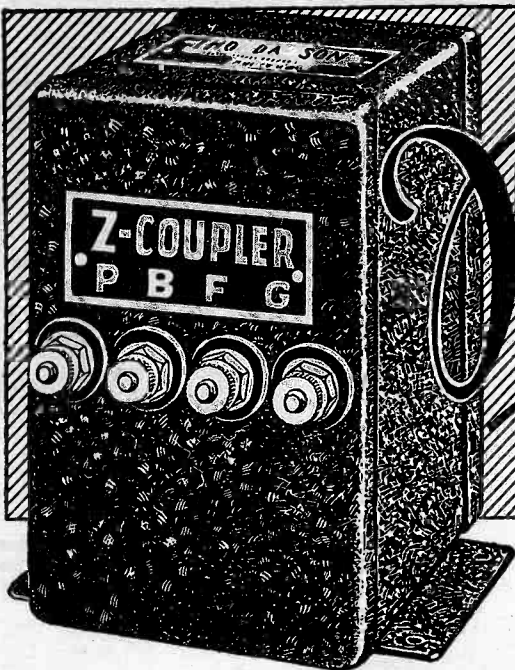

# new! SCREEN-GRID Audio Amplification

The Thordarson Z-Coupler, a special audio impedance coupler for use with screen grid tubes; price each, \$12.

Screen grid audio amplification, most revolutionary development in audio systems since the introduction of the power tube, is now an established fact.

The Thordarson Z-Coupler is a special audio coupling device designed for use with the screen grid tube UX-222.

With the remarkable amplification thus obtained a mere whisper from the detector is stepped up to a point that gives the power tube all it can handle in the way of signal voltage. In fact, one stage Z-Coupled audio has the amplification equivalent of two, or even three, stages of ordinary coupling. Signals barely audible before may now be heard at normal room volume.

In tone quality, too, the Z-Coupler is unexcelled. Despite the high amplification the tonal reproduction is as nearly perfect as any audio amplifier yet developed. Both high and low notes come through with the same volume increase. Even at 60 cycles the amplification is over 95% of maximum.

Regardless of the type of your receiver you can vastly improve its performance by including this new system of amplification. The Z-Coupler replaces the second audio transformer, with very few changes in the wiring. The screen grid tube is used in the first audio stage. No shielding is required.

## THORDARSON Z-COUPLER

THORDARSON ELECTRIC MANUFACTURING CO.

*Transformer Specialists Since 1895*

WORLD'S OLDEST AND LARGEST EXCLUSIVE TRANSFORMER MAKERS

*Huron and Kingsbury Streets - Chicago, Ill. U.S.A.*

*Write To-Day  
for Complete  
Information*

THORDARSON ELECTRIC MFG. CO.  
Huron and Kingsbury Sts., Chicago, Ill.  
Gentlemen:

Without obligation on my part, please send me complete information on screen grid audio amplifiers using your new Z-Coupler. (3578-G)

Name.....

Street and No.....

Town..... State.....



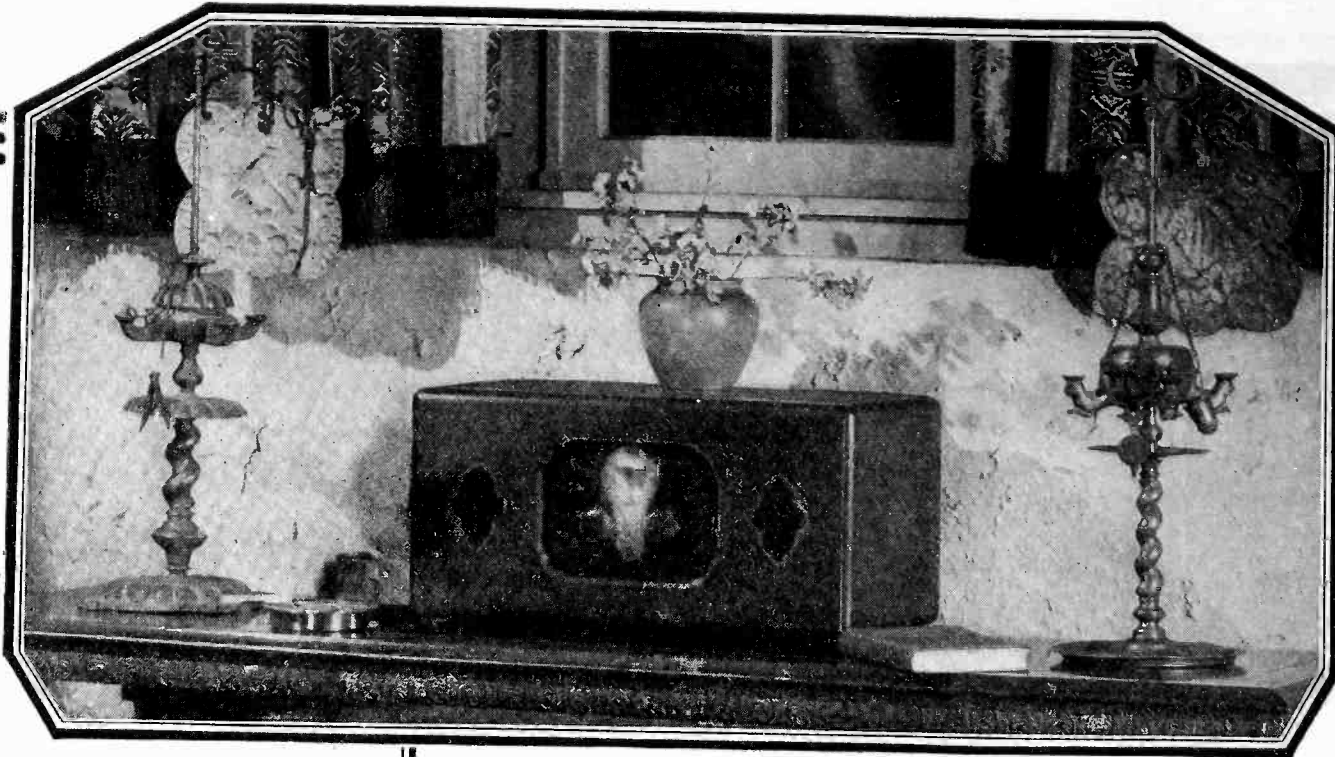

### What Others Say

Salt Lake City, Utah.  
Oct. 13, 1927.

My Bremer-Tully Receiver has given entire satisfaction and I am of the opinion that I have just a little better outfit than the other fellow.

It has been my experience to bring in stations within a radius of 2,000 miles. This is considered very good in this locality.

C. P.

Ft. Worth, Tex.  
Dec. 27, 1927.

I know nothing about radio other than to state that the Bremer-Tully which I purchased in 1925 is still the best I ever saw. I am using the same tubes that came with it, and getting results.

Livingston, Mont.  
Dec. 23, 1927.

Out here in Montana far away from broadcasting stations, we have to have a good radio to bring them in. Although I have heard many I never heard one that I could say I wanted until my friend brought me down to hear his Bremer-Tully. I now have one like it and have been able to get the best kind of reception every night and everybody says it is the best set they have ever heard.

J. V.

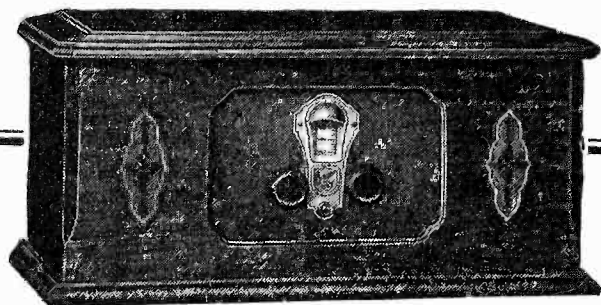

The 6-40 is furnished in two cabinet styles—Model "R" illustrated at the top of the page and Model "S" illustrated above. Both are of equal size.

# Bremer-Tully

## RADIO

SINCE the earliest days of commercial broadcasting every Bremer-Tully radio product has been a continued outstanding success.

Six years of progress—and a reputation second to none—Bremer-Tully start their seventh season with the finest receiver in its class, the new 6-40.

It is the culmination of these years of experience, the result of many months' intensive effort and development.

Simple, compact, self-contained, the 6-40 embodies all those features and refinements that are responsible for the traditionally fine Bremer-Tully quality—and at the amazingly low price of \$136.00.

A radio set that surpasses everything at anywhere near its price in musical reproduction—a set that excels in general performance as well.

See it, hear it, compare it—you will be convinced that here is the greatest radio value ever offered.

*The coupon will bring descriptive literature and name of our dealer in your community.*

## Bremer-Tully Mfg. Company

520-532 SO. CANAL ST., CHICAGO

Name.....

Address.....

City..... State.....



**New  
Different-  
Better** !

**The New Brielle B. A. Motor**  
will revolutionize the tone quality  
and volume of your  
speaker

**EXTREME VOLUME—**  
Capable of Carrying Full Power  
Output of 210 Push-Pull Amplifier  
*Unconditionally Guaranteed*

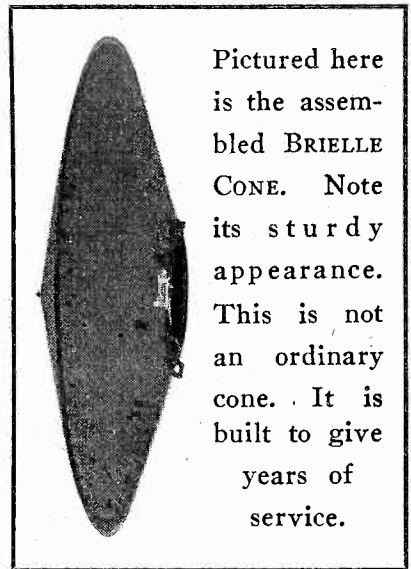

Pictured here is the assembled BRIELLE CONE. Note its sturdy appearance. This is not an ordinary cone. It is built to give years of service.

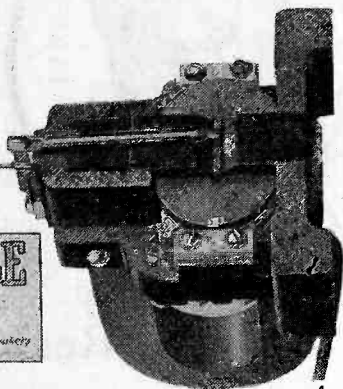

**BRIELLE**  
BALANCED ARMATURE  
MOTOR

**Reasons Why  
BRIELLE  
B-A Motor Excels**

1. Well designed, unusual mechanical features.
2. Sturdy.
3. Accessibility of parts.
4. Direct magnetic path.
5. Maximum action on armature due to broad pole face and armature of large effective surface.
6. Will handle output of existing Power Tubes direct through existing coils. No Output Transformer required.
7. Laminated Pole pieces provide maximum efficiency to the A. F. energy generated by coils. This feature of construction also eliminates eddy currents that might cause distortion.
8. Best magnetic material used. Magnetic strength will not decline with age.
9. For ordinary application, no polarizing needed.
10. Large size permanent magnet gives great sensitivity and volume throughout entire range.

Look at this unit. Operates on 45 to 800 volts. Requires no output transformer. Handles the output of existing Power Tubes direct through its own coils, without distortion. Notice the direct magnetic path—producing great sensitivity. Note the broad laminated pole face and large armature surface.

Experts say the New Brielle B. A. Motor is way in advance of ordinary design—sturdy, simple, yet unusually efficient.

**The BRIELLE Cone Kit**  
COMPLETE FOR 36", 30", 24" CONES

List of Parts

- BRIELLE Balanced Armature Motor
- Brass Motor Mounting
- Bronzed Aluminum Back Rings, Bolts, Nuts, etc.
- Two (2) Sheets Vibrotex, 38" x 38"
- Apex Discs
- Apex Nose-piece, consisting of three (3) parts
- Tube Special Cement

List Price **\$19.75**

**BRIELLE Motor Only**

List Price **\$14.50**

will bring you a Brielle B. A. Motor. This unit is all ready to be installed in your own cone speaker. Mail check or money order. We will pay the postage.

For \$5.25 additional, you can build your own Brielle Cone Speaker—with special Vibrotex Cone. Send for the Brielle Kit containing all the materials and complete directions for assembly. The Brielle Kit is specially designed for the new Brielle B. A. Motor. Cone may be obtained in 3 sizes, 24"—30"—36" for the same price.

Manufactured by G.R. PENN MANUFACTURING CO., 34 West 3rd St., New York, N. Y.

ORDER DIRECT FROM

Radio Dealers' Supply Service  
Wholesale Division of



1452 MARKET STREET San Francisco, California

OFFENBACH ELECTRIC COMPANY,  
1452 Market Street, San Francisco, Calif.

Please ship.....BRIELLE MOTORS.  
.....24"—30"—36" BRIELLE KITS.  
.....Literature and Discount Sheet.

Name .....

Street and No.....

City and State.....

Please send C.O.D. and give me my usual Dealer or Set Builder's Discount.

Tell them you saw it in RADIO



# Controls That Assure Satisfaction!



To the  
Set Builder or Owner  
To the  
Eliminator Builder  
To the  
Set Manufacturer

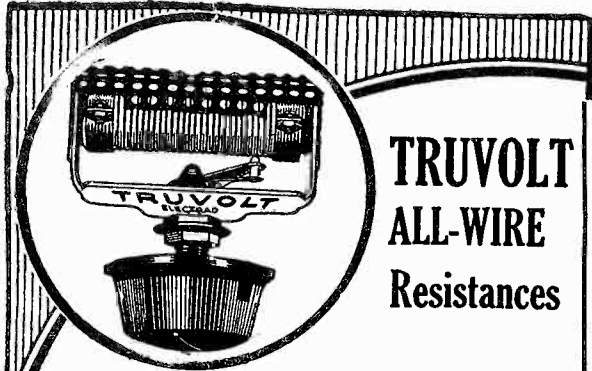

## TRUVOLT ALL-WIRE Resistances

Unique construction permits use of much larger resistance wire and keeps unit cool on the air-cooled engine principle. Gives accurate control of voltage, has far greater current-carrying capacity assuring long life.

In Truvolt Variable, the Contact arm slides smoothly over the turns of resistance wire, giving constant and delicate graduation of voltage through the complete range. An exclusive feature of Truvolt Fixed Resistances is that the contact taps can be moved and set at any point to afford fixed resistances of any values desired.

Twenty-two stock Types of Truvolts with resistances up to 50,000 ohms—all rated at 25 watts. A full line of fixed and tapped wire resistances.

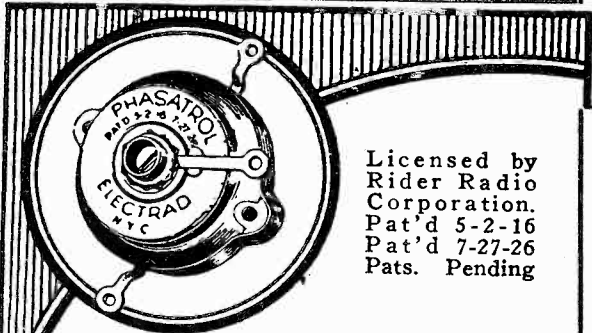

Licensed by  
Rider Radio  
Corporation.  
Pat'd 5-2-16  
Pat'd 7-27-26  
Pats. Pending

## PHASATROL

A True Balancing Device for  
Radio Frequency Amplifiers

Every fan who is building a set, or who now owns one, will want Phasatrol once he knows its efficiency in suppressing the squeals and noises of oscillation. Also checks distortion—clears up distance—and simplifies tuning. Very easy to install. Price \$2.75.

**Y**OU don't have to be a technical expert to know why you should choose Electrad Resistances for control of your eliminators or receiver. The "Electrad" name stands for the utmost quality, the most approved designs, superior accuracy and dependability in controls for all radio purposes. It is your assurance of fine performance and satisfaction.

That is why prominent radio engineers and circuit designers recommend Electrad Truvolts, Royalties, Phasatrols and Tonatrols for many of the best known eliminators and receivers.

Electrad Specializes in a  
Complete Line of Controls  
for all Radio Purposes.

Write for Free Installation  
Booklets and full information

Dept. 16-G, 175 Varick Street  
NEW YORK, N. Y.

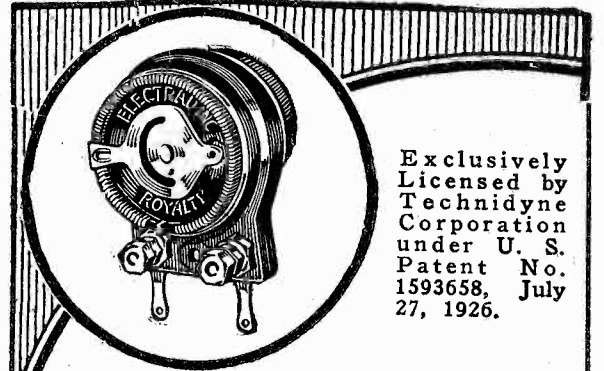

Exclusively  
Licensed by  
Technidyne  
Corporation  
under U. S.  
Patent No.  
1593658, July  
27, 1926.

## Royalty Variable High Resistances

Widely popular with builders of receivers and power units, due to their unusual accuracy and efficiency. Also free from harmful inductance and capacity effects, because only a minimum of metal and the finest of insulating materials are used in their design.

Same resistance always secured at same point. Whole resistance covered in one turn of knob. There is a Royalty for every purpose—11 types in all, designated A to L. Potentiometer type in all sizes \$2.00. All other types \$1.50.

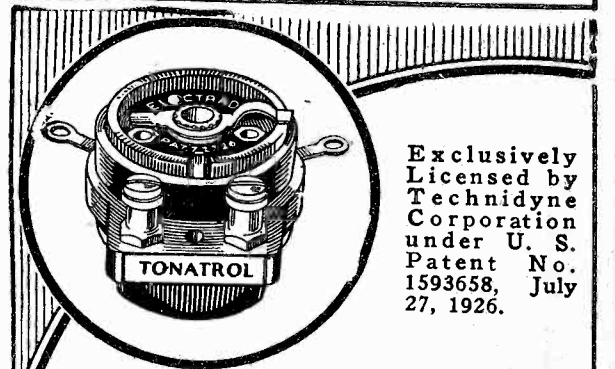

Exclusively  
Licensed by  
Technidyne  
Corporation  
under U. S.  
Patent No.  
1593658, July  
27, 1926.

## TONATROL

A True Tone and Volume Control

Volume through its complete range—from a mere whisper to full power—is at your finger tips with this superior control. An improvement for any receiver, and very simple to install. A full line of controls for battery and A. C. operated receivers. Prices \$1.50 to \$3.00.

# ELECTRAD Inc.

Pacific Coast Office, 905 Mission Street, San Francisco, Calif.



# RADIO

VOLUME X

MAY, 1928

No. 5

## Radiatorial Comment

The difference between a radio set which is made individually by a professional set-builder and those which are made

### *The Custom-Built Radio*

in quantity in a factory is the same as that between a tailor-made suit of clothes and one "off the pile." The professional set-builder loves his work as a hobby. He is always studying to find better ways of doing things. He is a practical man, well-equipped with tools and facilities for fine work. In its highest sense he is truly a professional man rather than a tradesman.

He takes a pride in his work. Every screw must fit, every joint must be tight, and the set must perform to his satisfaction before he will deliver it. He gives his personal attention to each individual detail. He works quietly and surely, without haste, for he has no manufacturing schedule to maintain. He is under little or no expense for advertising, salesmen, license fees, or overhead. He carries no stock of parts which must be used before he can adopt the newer and the better as they become available. When he makes a change in model, he has no expensive dies and machines to be scrapped; he is not hampered by having to protect dealers and jobbers against loss in the sale of out-of-date models.

All of these conditions, each of which is the exact opposite of what the factory meets in mass-production, are what give the master-craftsman his first advantage. Today he can make a set having ten kilocycle selectivity and reproducing the low notes of the drum with the same volume and fidelity as the high notes of the piccolo, whereas it may be six months before equivalent sets will be on regular sale in the stores. And six months from now he will be prepared to meet even more exacting requirements which will be met by the factories a year from now. Radio moves fast in these days and it takes the flexibility and adaptability of the professional to keep up with it.

Unquestionably, the man who actually makes a set is better qualified than any other to install it and keep it in working order. And having made it, he is able to bring it up-to-date at small expense as new ideas are developed. These are the main reasons for the success of thousands of set-builders.

Some of the big radio manufacturers are also making custom-built sets to order, just as is the local radio expert. Like a custom-built automobile or pair of shoes, such a set expresses the individuality and taste of the owner. It is something of which he rightly can be proud. So while the sales volume of the future will undoubtedly be greatest for those receivers which are made in the greatest quantity, it seems that there will always be a good market for the more exclusive models of custom-built sets.

An industry, like an individual, becomes a useful member of society when it attains consciousness of its moral duty to others. During its early struggle for existence neither an individual nor an industry can think of aught but itself.

### *The Broadcasters' Code of Ethics*

But as either grows in strength it begins to think of others in terms of its ideal behavior toward them. The fineness of these ideals is a measure of the real development of the industry or individual.

Consequently, great interest should be attached to the first code of ethics which has been recommended for adoption by the National Association of Broadcasters as printed in the latest number of their official publication. Do the broadcasters really realize their moral duty and responsibility? Are they ready to be admitted to the ranks of those who are working for human advancement? Their code of ethics answers affirmatively:

"1. To realize that radio enters into the daily lives of a greater number of people than any other man-created or man-directed activity since civilization began.

"2. To realize that no enterprise can long endure and prosper unless it renders a real service to humanity.

"3. To be conscious that the vast audience we reach is of mixed tendencies, prejudices, and beliefs, and to guard against any utterance or false note that might offend the sensibilities of any.

"4. To realize that radio goes as an intimate friend into the homes, and helps to mould the minds of little children as well as of grown-ups.

"5. To realize that the development of better cultural standards, better living, and better thinking is our principal mission.

"6. To realize that there is a greater gain in holding fast to an ideal than in the temporary advancement of any individual station."

This is not the code of the clothing merchant whose schoolboy son asked him what was meant by ethics and was told: "Ethics, ethics? Well, if a customer bought a five dollar hat and gave me two five-dollar bills by mistake, it would be ethics for me to decide whether to keep the extra five dollars myself, or to give half of it to my partner."

Nor is it the code of the deacon storekeeper who called to his assistant: "Have you sanded the sugar? Have you watered the milk? Have you put the chicory in the coffee? Yes? Then come up to prayers."

But it is a convincing statement of certain praiseworthy ideals, an assumption of due responsibility, displaying a spirit of toleration, recognizing a mission to be accomplished, and realizing that he profits most who serves best. It indicates that the broadcaster has "arrived." As compared with the pandering public press, or the filthy motivation of the movies, it is a code of honor which entitles its conformer to enter the most sacred and intimate precincts.





"The ideal radiator, suspended free in space"

## Radio--Aviation's Safeguard

By J. GARRICK EISENBERG

**I**N VIEW of the tragic consequences of the many inadequately prepared attempts to span the oceans by aeroplanes, it should hardly be necessary to stress the importance of the safeguards offered by radio equipment. A reliable radio transmitter capable of maintaining constant communication with its base, and having an adequate cruising margin to allow for emergencies, is the most important factor in the development of regular long distance commercial air services.

With the recent development of such long distance transmitters, many preconceived notions as to the functioning and restricted range of aircraft equipment have been discarded. Experience with standard aircraft radio, operating in the 600-1000 meter band, led us to expect that a transmitter of the requisite light weight and compactness placed a limit of a few hundred miles upon such communication.

But the results obtained with modern high frequency aircraft transmitters have considerably enlarged these possibilities, and have given vastly greater range at low powers. Furthermore the transmission characteristics are found to be relatively free from several disadvantages common to high frequency land stations.

A transmitter of this type was demonstrated with remarkable success by Captain William Erwin—the *Dallas Spirit*

—during his ill-fated search for the victims of the Dole race flight. The recording of the signals from this 33.2 meter set by thousands of listeners over a consistent radius in excess of 3,000 miles, proved the reliability of the transmitter beyond question of doubt, and demonstrated that for equivalent power, such transmitters are actually capable of covering the same range as do similar land stations. Further tests since have shown that the spectacular results obtained with this set were by no means freak transmissions, and may be duplicated at will by similar installations.

It is regrettable that the controversial claims of adherents of the standard aircraft transmitters which had long been tried and found wanting, still serve to confuse the issue of the proper choice of equipment. For instance, one authority on radio and aviation has recently stated that "the skip effect and fading, characteristic of waves much shorter than 80 meters, makes their use in aircraft communication of little value." This is the sort of ambiguous mis-statement which, contradicting established record, lends such an element of uncertainty to radio in the mind of the layman. Obviously the gentleman's knowledge of short wave transmission phenomena has been based upon observations of point-to-point land station characteristics. Upon such untenable premises he builds his assump-

tion that the successful long distance results obtained with high frequency aircraft installations are freaks.

I am somewhat diffident at taking issue with "Anonymous"—one never knows where the chips may fall. But I should like to point out that while data on aircraft transmissions is admittedly incomplete, certain facts have been established which show that these do not necessarily conform to the same expectations of earth propagated waves. This is particularly true of the skip distance effect. With high frequency aircraft transmitters, even at the lowest end of the wave band, no apparent skip is observable over varying distances, within what is normally the zone of silence for land stations of similar wavelength.

A. Hoyt Taylor, director the Naval Radio Laboratories, stressed this fact in his paper on skip effects, in August, 1926, *Proceedings of the Institute of Radio Engineers*. "If a station," he states, "is located on a sufficiently high elevation, the ground wave will account for a long distance before being absorbed. . . . It is always possible in such a way to cut out the initial skip distance. This has frequently been demonstrated in aircraft tests by this laboratory."

It is obvious that such a transmitter does not radiate a "ground wave" in the general sense of that term. It does, however, supply what is its equivalent. The



radiations from it may be assumed to take the form of a spherical wave, one portion of which travels along the Heaviside layer in the same manner as any ground propagated radiation; and the other portion of which is radiated

A patent reel, having a locking device which makes it impossible to race the wire out, is incorporated as part of the antenna circuit, and conveniently located for operation. On it is mounted the radiation ammeter—the only meter

necessary incidentally—by which the operator checks resonance, simply reeling in or out enough wire to make up his half wave radiator, when maximum current will be observed. A 50-watt transmitter of this type puts an average of 2 amperes into such an antenna at 33 meters.

A complete description of the apparatus in use aboard the *Dallas Spirit*, the prototype of several installations since placed in operation, was published in October, 1927, RADIO. For convenience the circuit diagram is reproduced here. These transmitters, designed by Ralph Heintz of San Francisco, embody the familiar tuned plate tuned grid circuit which has proven so rock steady for short-wave work. A particular feature of interest is its compactness; the set is only 13 x 10 x 5 in. overall—roughly the size of a bandbox receiver.

The specially developed wind-driven generator used with this installation is also of extremely small dimensions and has some unique features. It is of the magneto-generator type and requires no commutators or slip rings, the most vulnerable parts in ordinary machines. It is practically impossible to harm it—or the apparatus which it feeds—through overloads, for within a range of from one-half to twice the normal speed, its output is automatically held constant by the hysteric control of wattage, occasioned by any change in frequency. Thus, although its note may vary under different conditions of speed, the power radiated will not be affected. This permits further simplification of the transmitter. For once the laboratory adjustments have been made there is no further necessity for meters in any portion of the circuit other than the antenna proper. The two windings of this generator are identical and interchangeable, and supply both filament and plate voltage of the 50 watt tube through a suitable transformer. Its frequency at nor-

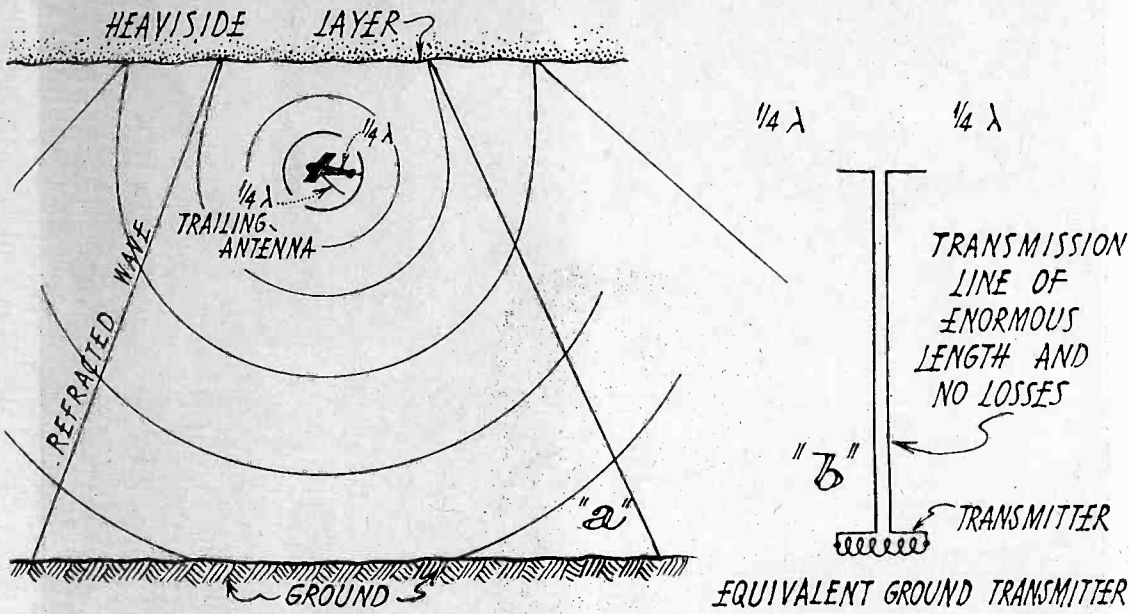

A Spherical Radiation from An Aircraft Antenna

downward. Since it encounters no absorbing medium in its spreading path to earth, this direct portion of the wave will be effective to the point of overlapping the zone beyond which the refracted wave returns to earth.

The high frequency aircraft transmitter attains closely to the ideal radiator, one suspended free in space. The plane itself is "tuned in" to form a section of a half wave Hertzian radiator, perhaps better known as a quarter wave doublet. The struts, fuselage ribs, and all metal portions are bonded together to form one quarter wave section. It is then only necessary to let down sufficient antenna to make up the other quarter wave of the doublet. As it is not important that this doublet be fed at its exact center, a larger or smaller ship simply means that the trailing length is slightly plus or minus a true quarter wave. An aircraft transmitter operating at 33 meters ordinarily calls for an antenna somewhat less than 30 feet in length. Such a radiator, at any height in excess of one quarter  $\lambda$  above the earth, corresponds then to the same characteristics of this well known doublet form, assuming an equivalent height and a transmission line of no losses, both conditions somewhat difficult of achievement in ground stations. Regardless of the direction of the plane or the angle of its trailing antenna to the earth, the usual directional effects of such antenna will not be encountered, due to the fact that the total relation of the radiating system to earth will then be changed only slightly.

The adjustment of such a radiating system is remarkably simple. The usual procedure is reversed: the transmitter is tuned and fixed at a definite wavelength in the laboratory. The antenna then is tuned to the transmitter, by letting out enough wire until resonance is achieved.

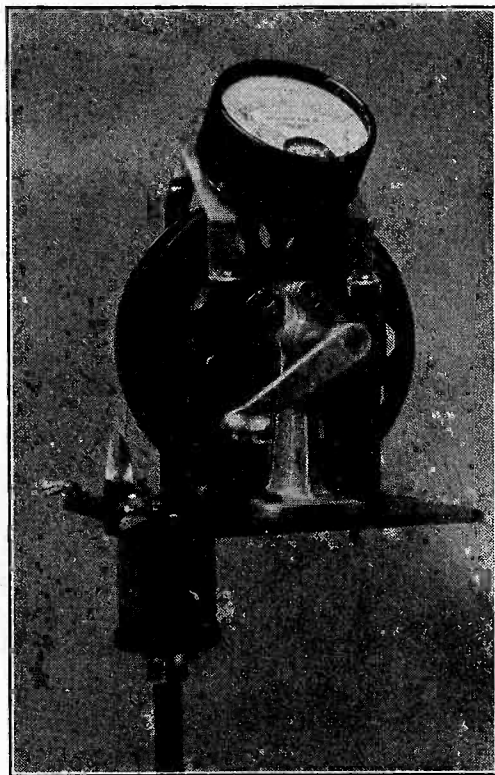

Dismounted Antenna Reel

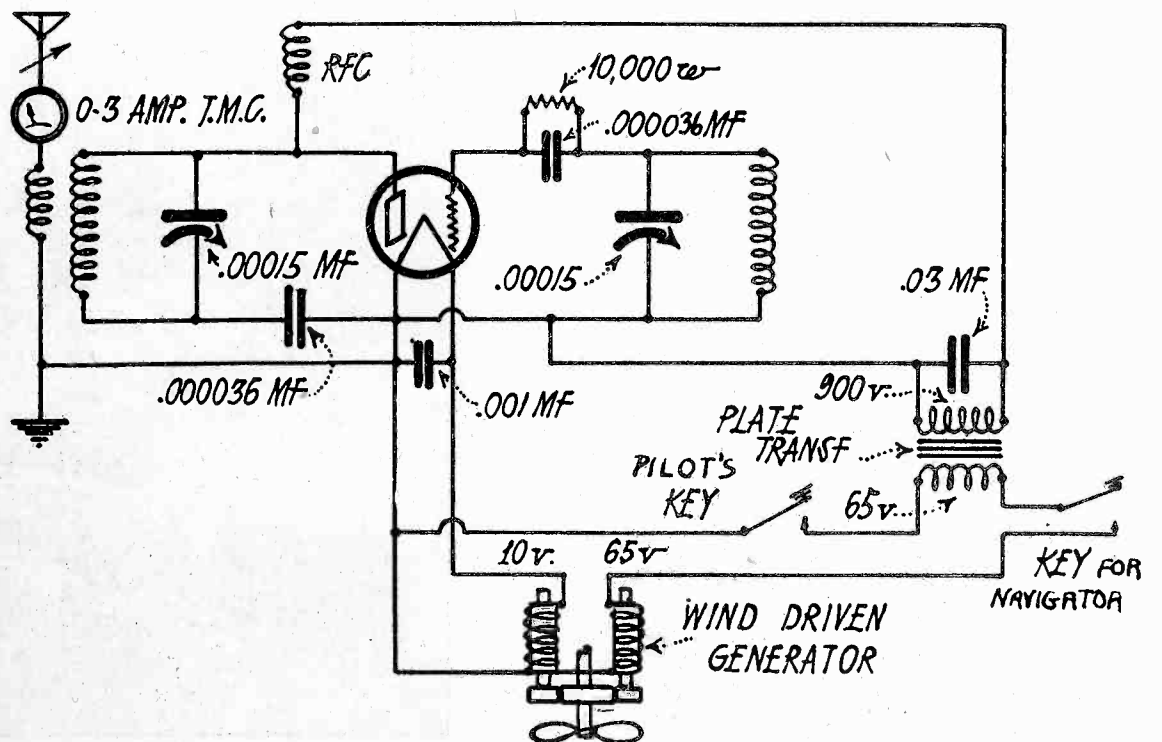

Circuit diagram of "Dallas Spirit" Transmitter



mal speed is 240 cycles, giving the signal an easily copied note.

The *Dallas Spirit* furnished a valuable comparative basis for distance range of such transmitters; during this brief but epic flight, which ended so disastrously, all records for radio transmission from aircraft were broken. For seven hours, from midafternoon until well after dark, and under varying conditions of speed and height, the plane was not only in constant communication with its San Francisco base, but throughout the United States its signals were logged by thousands of amateurs. At the *New York Times* receiving station solid copy was taken for news reporting, and the eastern papers carried a full account of the disaster within a very few minutes of the flashing of the SOS to the Pacific Coast stations. Not the least remarkable feature of this recording was that the major part of the 3,000 mile circuit was overland, yet no fading of signals was reported at any time. It has since been

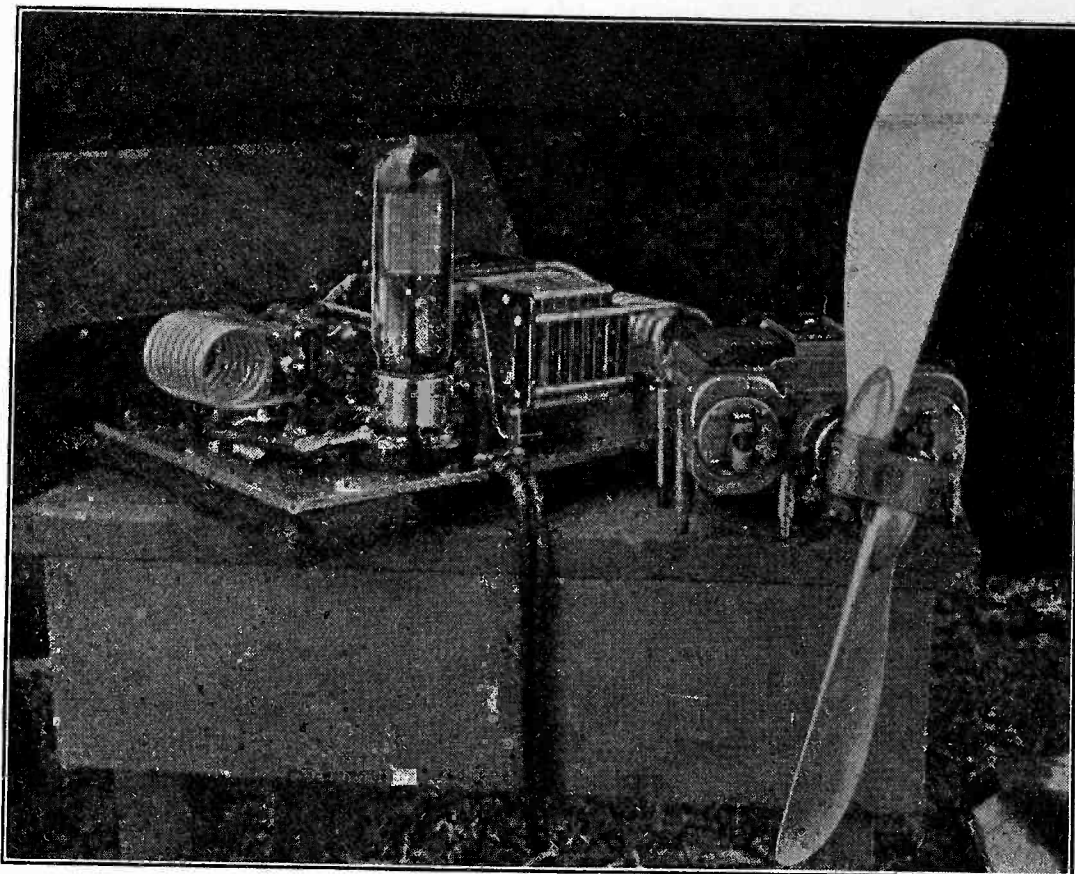

*Short Wave Transmitter on "Dallas Spirit"*

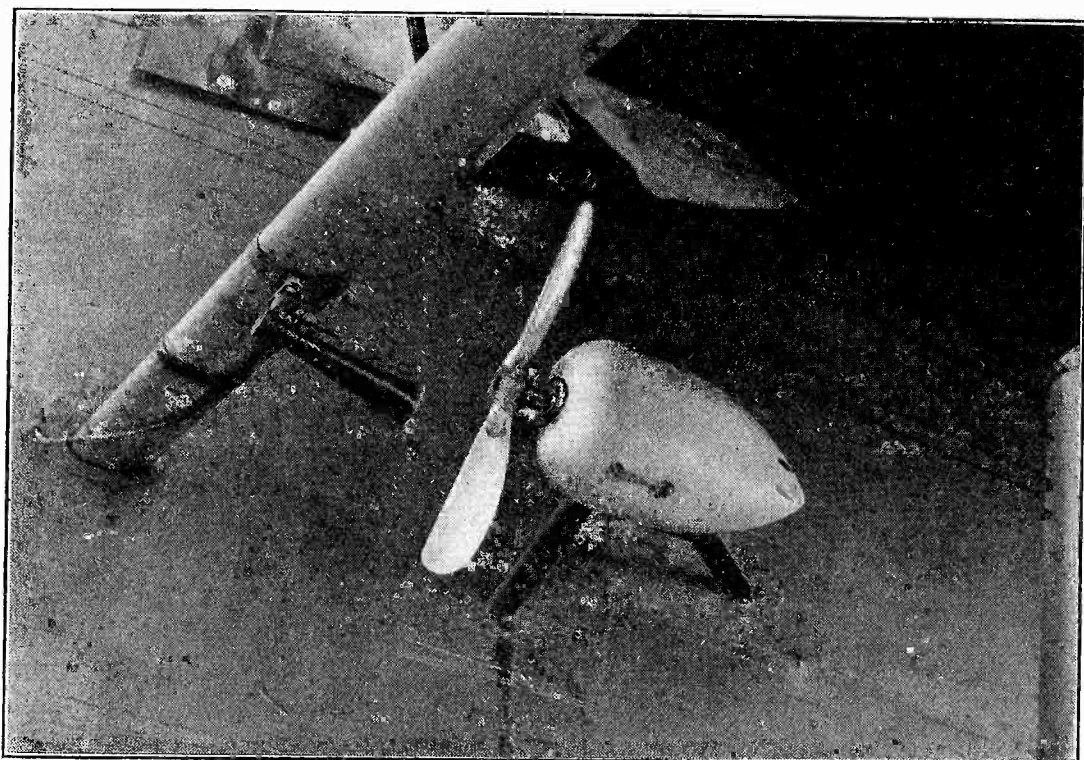

*Wind-driven Generator on "Southern Cross"*

determined that reception of the plane's signals was recorded at even more widely separated points. Amateurs in England and Italy, a steamer just leaving the Canal zone, and another nearing New Zealand picked up the call for assistance. No doubt there were many others, too, who did not report their reception. What a tragedy that the very nature of the disaster precluded any possibility of effecting a rescue.

Disregarding the recording of extreme distance reception during this flight, the consistent copying of signals on the East Coast with no apparent intervening skips affords sound proof of the reliability of such a transmitter in establishing continuous communication over a distance never approached heretofore by any installation of similar power.

This reliability has been verified by

the transmitter aboard the *Southern Cross*, the giant three-motored Fokker craft in which it is planned to fly from San Francisco to Australia. During two trial flights totaling some 97 hours, this 33.4 meter set—almost identical with the Erwin one—was in continuous operation. A strict log was kept at various points to determine the extent of skip distance and fading over this period. The results bear out previous observations in these respects. No skip was observable over the entire radius of the cruise (well within the theoretical silent zone for this wavelength) and while shadows encountered at some periods in her overland flight appeared to cause a sharp dip in signals at certain points, there was no time during these protracted tests when either the Los Angeles or San Francisco base could not be reached. The claims that high frequency

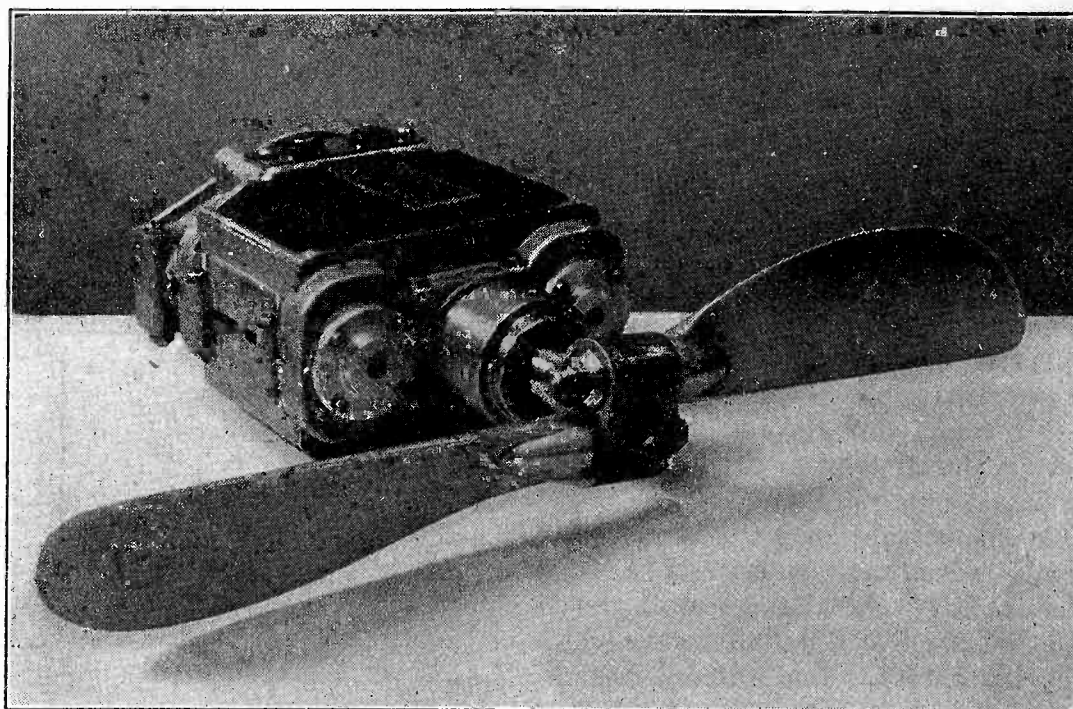

*Short Wave Generator and Impeller for Plane*



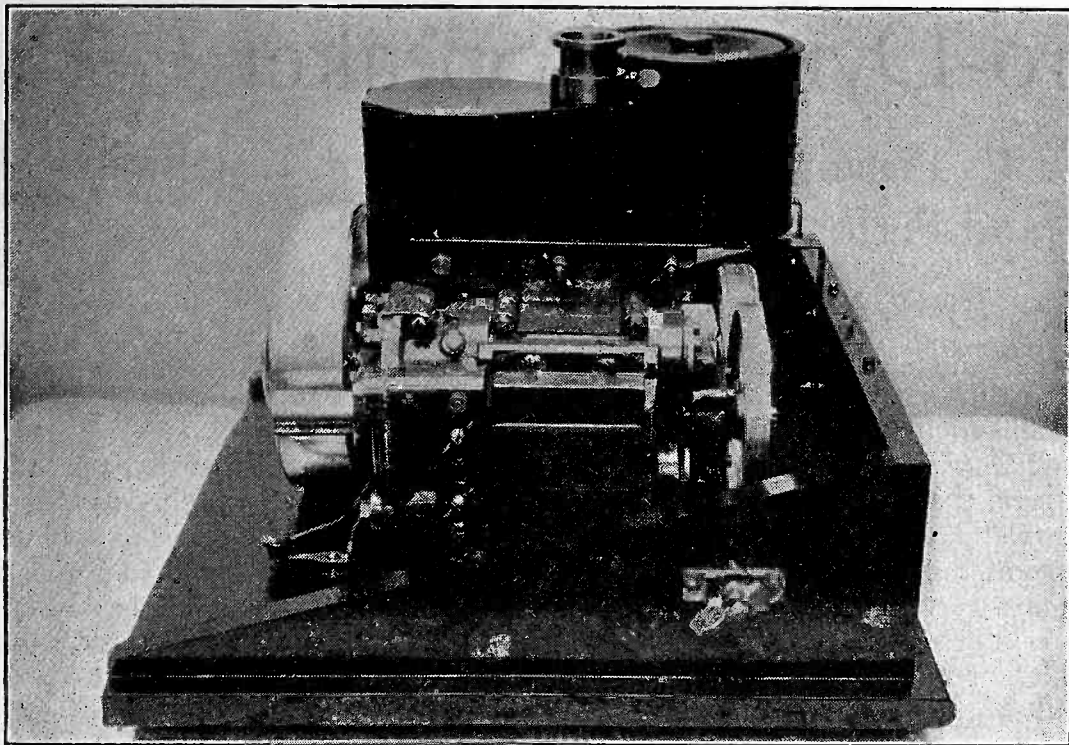

*Wilkins Generator dismantled for the Gas Engine Drive*

transmission from aircraft is erratic and unreliable are therefore definitely disproven in fact.

The claim often advanced that such installations require more critical adjustment than the longer wave type has also been disposed of. From the description of the transmitter adjustment it is obvious that this set is if anything, simpler to operate than the larger and more cumbersome type necessary for say, 600 meter operation.

The only remaining argument for 600 meter transmission is that in event of disaster an SOS on 600 meters would be immediately picked up by the nearest ship, with a consequent saving in time. This argument resolves itself into a question of continuous communication as against discontinuous communication; the possible loss of 5 or 10 minutes as against the possibility of being completely out of touch when the necessity for an SOS arises. The limited range of a 50 watt transmitter at this wavelength places sole reliance upon the possibility of being close enough to some vessel at the moment of emergency to summon assistance.

Against this we have the good probability of continuous contact at all times with the plane's base which a high frequency transmitter of this power affords.

These are not merely hypothetical conclusions either. Lloyd Bertaud's *Old Glory*, carrying such a long wave transmitter, was heard for several hours by the Naval Station at Portland, Maine, but they were unable to copy the signals due to heavy ship station interference on 600 meters. When she went down the only authentic position report available had been intercepted some two hours prior to her final gasped out "SOS . . . 500 miles east of Newfoundland." Hardly a specific location; it was more than a week before searching vessels located bits of wreckage from the plane. Contrast this with the *Dallas Spirit*, whose immediate position was known on shore at all times, and when disaster overtook her, was broadcast to all ships at sea by the powerful marine shore stations, and we see that the reasoning advanced for the favoring of the 600 meter wave is far from sound. Nor is the experience with *Old Glory* an isolated case. The Grayson plane, also carrying a 600

meter set, was unheard after passing out of sight of the coast, while in the Pacific Art Goebel's transmitter aboard the *Woolaroc* was only able to work an approximate 200 miles. No doubt all these sets were of competent design, but their inherent limitations at the longer wavelength definitely restricted their range to a small area.

Of equal importance is the fact that many of the participants in these flights were deterred from carrying radio by the comparative bulkiness and weight of the long-wave installation. It is definitely known that Jack Frost, whose *Golden Eagle* was fitted with every conceivable safety device, at the last moment removed the radio set because of these considerations. The same thing was done on the *Bellanca* plane after it was found that the elaborately designed transmitter weighed down the ship's tail.

There is no estimating what part such considerations played in contributing to the tragic loss of life attendant on these flights. I think there can be no question however that the high frequency transmission has proven itself to be the solution for aircraft communication of the future. In this connection it may be noted that during the recent flight of the Navy dirigible *Los Angeles* to Panama and return, a transmitter of this type kept the ship in touch with both ends of her circuit. The results being accomplished by the Wilkins' polar plane, whose signals have been heard at San Francisco and intermediate points while the expedition was based at Fairbanks, Alaska, also bear out this point. At this writing several aircraft companies operating commercial services are planning to install high frequency transmitters aboard their ships, and before many months additional proofs of the reliability of such equipment should be available.

## RADIO 2XBK

The radio equipment of the Stinson-Detroit monoplaner, which is making an American coast-to-coast and return tour, consists of a 100-watt phone and C. W. transmitter operating on 120 meters and five-tube r.f. receiver, which may be tuned to the 85-150 and 550-1100 meter wavelengths. Power is obtained from a 700 watt wind-driven generator.

The transmitter uses a UX-210 tube as a master oscillator, a 210 as a speech amplifier, a UX-211 as an output amplifier and a UX-211 as a modulator, all tubes being mounted on sponge rubber. It weighs 18 lbs. and is housed in an aluminum cabinet 16 x 12 x 8 in. It is operated from a separate control box, 6 x 12 x 8 in., weighing 8 lbs., placed in the rear of the passenger compartment. This box contains the antenna tuning variometer and various switches.

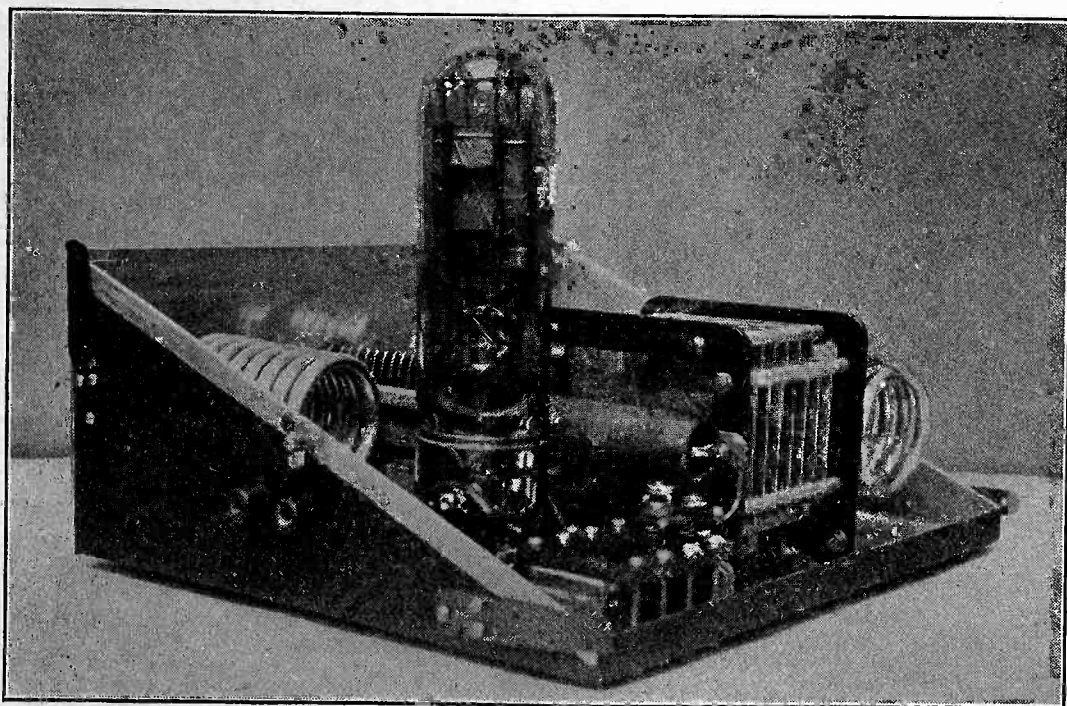

*The Wilkins Transmitter*



# The Electro-Dynamic Speaker

A Complete Explanation of Its Principles of Action, Design, Installation and Performance

By G. M. BEST

**T**HE action of the modern electro-dynamic speaker depends upon the movement of the surrounding air by a paper cone whose apex is attached to a moveable coil placed in the field of a strong electro-magnet. The coil carries the output from a radio receiver or other device producing variations in electrical current corresponding to variations in the sound which is to be reproduced. The reaction between the electro-magnetic fields of the moveable coil and the fixed electro-magnet moves the small coil which actuates the paper cone so that the frequency and amplitude of its movement corresponds to the tone and intensity of the sound which is heard.

The original Magnavox speaker, which first incorporated this principle as developed by Pridham and Jensen, used a metal diaphragm, instead of the paper cone, to move a column of air in a horn. But the cone, with its flexible supports, at the apex and front edge, has a greater freedom of movement, thus permitting the very low as well as high notes to be reproduced with unusual fidelity. Nor are any levers or springs necessary to restore its position, and incidentally introduce resonant effects, as are found in the usual magnetic type of speaker.

The general construction can easily be understood by referring to Fig. 1, which

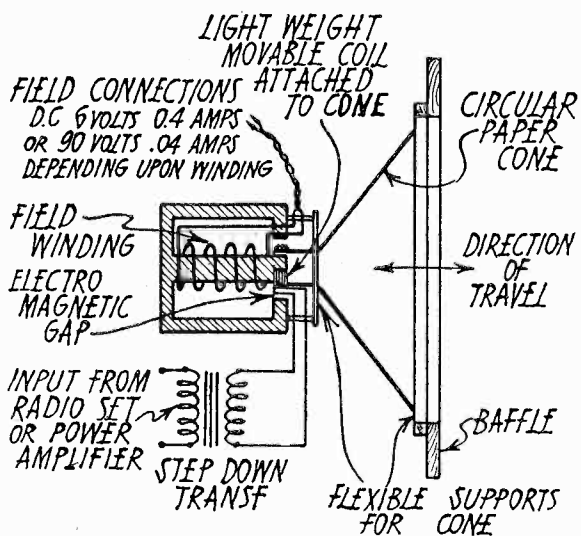

Fig. 1. Cross section of Electro-Dynamic Speaker

is a cross-sectional diagram of the unit. The electro-magnet consists of an iron core, on which is placed a field winding of such dimensions as to produce a certain number of magnetic lines of force per inch, in the air gap in which the moving coil is placed. Practical experience shows that from 1200 to 1400 ampere-turns are required for the field winding, so that if a current of 1 ampere

is passed through the field, it must have from 1200 to 1400 turns to produce the required flux density. If the current is  $\frac{1}{2}$  ampere, then the turns must be from 2400 to 2800, and so on in proportion as the current through the field is decreased. There are certain factors as to size of wire, resistance of the field winding, and the voltages available which enter into the design of the field, as will be mentioned later. An iron shell surrounds the coil and completes the magnetic path, this shell being so designed that it has a clearance of from 0.03 to 0.05 in. at the pole faces adjacent to the moving coil.

The moving coil is placed over the core of the magnet, so as to be in the center of the field, but not touching either the core or the shell at any point. This calls for great precision in manufacturing. While the tolerance allowed on one make of speaker is .0125 in. on each side of the moving coil, the actual clearance in practice is about .005 in. on each side.

It has been established that a field strength of not less than 10,000 lines per sq. cm. must be produced across the gap in which the moving coil is placed, and most factory-built speakers are designed for 12,000 lines per sq. cm. as a minimum. Where the air gap is approximately .15 in., a total of approximately 3000 ampere turns are required to produce the desired field strength. This total is composed of 175 ampere turns to take care of the flux density required for the iron, plus 2900 ampere turns to produce a field of like flux density across the .15-in. air gap. If the gap is cut to .075 in. the exciting current to produce the same flux across the gap can be cut in half. Disregarding the small amount of ampere turns needed to produce the proper flux in the iron, it is obvious that the ampere turns needed to produce a given flux density is directly proportional to the width of the gap. A rough formula for this work is given by multiply-

ing the gap width in cms. by 12,000, the required flux density.

For a given flux density, the width of the air gap varies roughly as the square of the required watts in the field coil, so that if 35 watts is required for a gap of .15 in., about 9 watts will be needed with a gap of .075 in., and about 2 watts for a gap of .038 in. In order to use as small an amount of energizing power as is possible, the air gap in most speakers is made very narrow, and the average power consumption of the field is about  $2\frac{1}{2}$  to 3 watts. Some of the newer models using rectified a.c. in the field run as high as 25 watts, permitting a larger air gap and greater tolerances in the manufacturing process.

The apex of the cone is held firmly in place by means of flexible supports, which are fastened to the shell of the field magnet, so that the travel of the cone follows a definite path, and yet it is free to move horizontally for at least  $\frac{1}{4}$  in. without hindrance from the supports. The method of suspension can be seen from the picture of the cone and the moving coil assembly of two different speakers in Fig. 2.

The three suspension strips used in one of the models are made of very thin and flexible metal, so that no resonant effect due to tension in the strips is introduced. The ends of the strips are fastened to the metal plate forming the end of the field coil shell. Their exact position is adjusted until the moving coil fits over the core of the magnet, with perfect clearance on all sides.

The other model illustrated has a suspension strip made of thin bakelite, with two points of support instead of three. The outer edge of the cone, in each of the models shown, is fastened to the metal supporting ring by means of a very thin ring of leather, which is cemented to the edge of the cone. The outer edge of the leather ring is supported between two resilient gaskets held

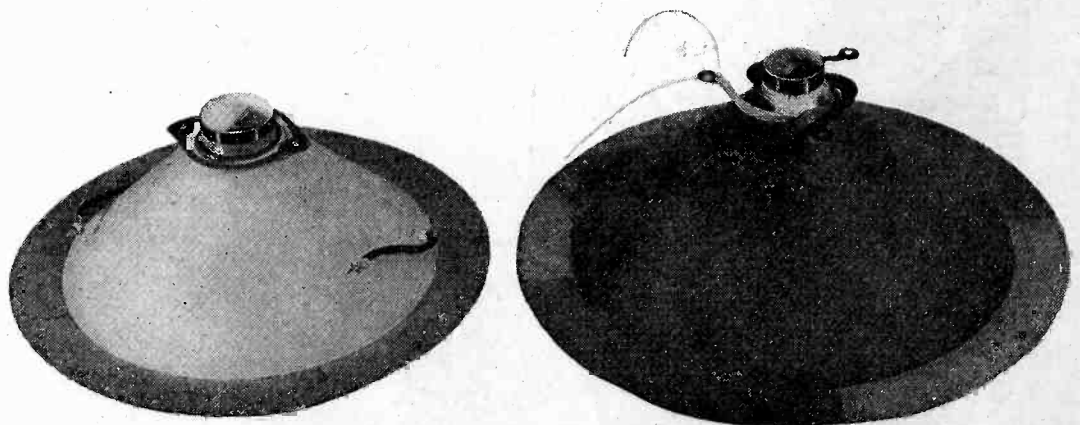

Fig. 2. Cone and Coil Assembly for Two Makes of Speakers



in a clamping ring. This allows the cone to move back and forth for  $\frac{1}{4}$  in. horizontally, as indicated by the arrows in Fig. 1.

The moving coil in practically all units now on the market is made by winding No. 32 or 34 enameled wire on a thin paper tube ranging in diameter from 1 to  $1\frac{1}{2}$  in. and usually about 1 in. long. One make of speaker has 120 turns of No. 32 enameled wire wound in four layers,  $\frac{1}{4}$  in. wide; each layer consisting of 30 turns, wound on a very thin paper form, the wire being made almost self-

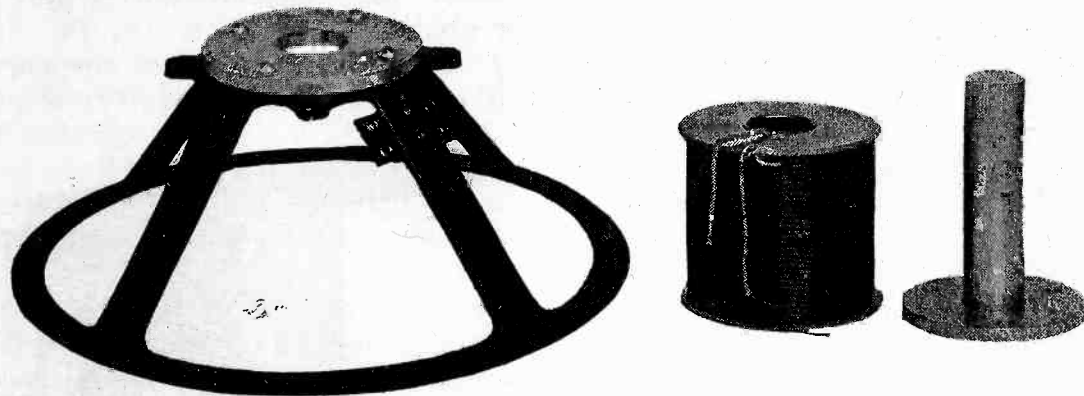

Fig. 3. Construction of Electro-Magnet

supporting by the use of a small amount of cellulose cement between each layer. It is extremely important that the moving coil be as light in weight as is possible, so that the inertia will be as small as is consistent with mechanical strength.

The a.c. impedance of this moving coil averages 8 ohms, the impedance curve showing about 5 ohms at 100 cycles, and 10 ohms at 6000 cycles, which is extremely low compared with the impedance of the average magnetic speaker of the permanent magnet type. As the inductance of the coil is very low, the speaker offers an almost pure resistance load to the power tube, resulting in a high power factor and an impedance which varies but slightly with frequency.

The construction of the electro-magnet is shown in Fig. 3, which is a picture of the field coil surrounding the iron core. For 6 volt excitation, the coil is wound with heavy enameled wire, from 18 to 19 gauge, with d.c. resistance of 15 ohms. Saturation of the core is reached at from .4 to 1 ampere, with 6 volts across the terminals. The stronger the field the greater the torque.

In assembling the speaker unit, the field coil is placed in the metal shell, the core being fastened to the end of the shell by means of a group of set-screws, or a bolt. An iron plate in which is set a copper spacing washer is placed over the front of the shell, completing the magnetic circuit, and holding the field coil in place. This plate can be seen attached to the metal ring which holds the edge of the cone in Fig. 3. The copper washer holds the field coil tightly against the shell, and being non-magnetic, does not affect the magnetic field.

Claims are made by some engineers that this copper ring screens the moving coil from the field winding, so that if the field is excited from rectified a.c. in

which there is a ripple, there will be no pulsations induced into the moving coil from this source.

The high resistance type of field for high voltage excitation, is generally wound with No. 30 or 32 enameled wire, with a total d.c. resistance of about 2500 ohms, and requiring 40 to 50 milliamperes at 90 to 100 volts d.c. supply. Both of these types of windings produce a field strength of about 12000 lines per sq. cm., and as there are from 8 to 9 sq. cms. of pole surface at the point where the moving coil is inserted in the

The inductance of either of the high resistance field windings mentioned above is high, averaging from 35 to 50 henrys with the exciting current flowing through the windings, so that the field coil can be used to replace one of the filter chokes in any *B* eliminator, where the total *B* current at least equals that of the current required by the field for proper excitation. If the total current drain is not sufficient to meet the requirements of the field, additional current can be drawn from the rectifier by shunting a variable high resistance across the filter output, as is shown in the diagram in Fig. 4.

A new development in the electro-dynamic speaker is shown in Fig. 5, it being designed to operate directly from the a.c. lighting mains, through the medium of a step-down transformer and rectifier, which supplies approximately 12 volts, 2 amperes, to the field windings. The transformer is located on the metal base-plate to the left of the speaker. On the right is a contact type rectifier, such as is used in battery chargers, which will operate over long periods of time without attention.

Due to the fact that the output of the rectifier is pulsating d.c., and even with the high inductance load into which it operates, there would be an objectionable a.c. hum were it not for a compensating winding of about 30 turns of No. 22 wire, which is placed on the core of the electro-magnet, and connected in series with the moving coil. The winding is just inside the shell supporting the field, over the core in a fixed position, and is poled so that it opposes the moving coil. Changes in flux density of the field due to the pulsating d.c. supply affect the position of the moving coil and cause an audible hum when the winding is not used. But with the winding in series with the moving coil, the hum is eliminated due to the fact that the a.c. voltage induced in the moving coil is opposite to that induced into the compensating winding, and the two neut-

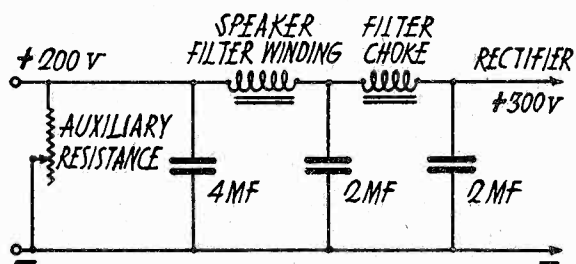

Fig. 4. Connection of Field Coil for Use as Filter Choke

field, the strength of the field can be well appreciated. One type of field which is in use in several electric phonograph and radio combinations is wound with No. 27 enameled wire, and is designed to carry 120 to 135 milliamperes at 100 volts, so that for economical operation, the field is used as the choke in the *B* supply filter circuit, which is also used to furnish *A* current to the extent of 60 milliamperes, for the 99 tube filaments in the receiver or phonograph amplifier, the filaments being in series.

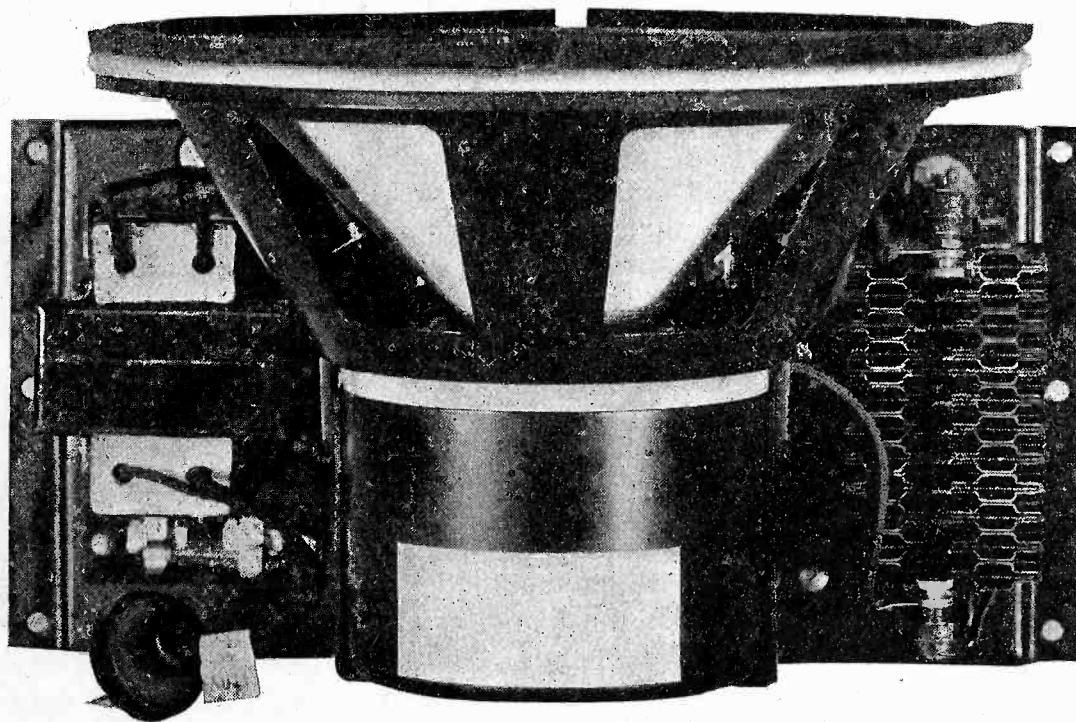

Fig. 5. A. C. Electro-Dynamic Speaker



ralize each other. For this reason, no filter is required with the rectifier unit, and the cost of operating the field from a.c. is greatly reduced. The presence of the compensating winding in series with the moving coil has no effect on the frequency range or response of the speaker, and adds to the impedance presented by the speaker to the radio set by only a small amount. If the speaker is not to be used with rectified a.c. supply, the presence of the compensating winding does no harm, and can be disregarded.

All speakers of the free edge cone type set up two distinct sound waves, one from the front and the other from the back of the cone. So that if the speaker is operated without proper provision to care for this phenomena, the two sets of waves will interfere and partially neutralize each other, especially at the low frequencies. Hence, the speaker must be mounted in a baffle plate, or baffle board, as it is often called, to prevent the two sets of waves from meeting.

This board must be so heavy that it will not vibrate at any of the frequencies reproduced by the speaker, and large enough to be effective at the lowest

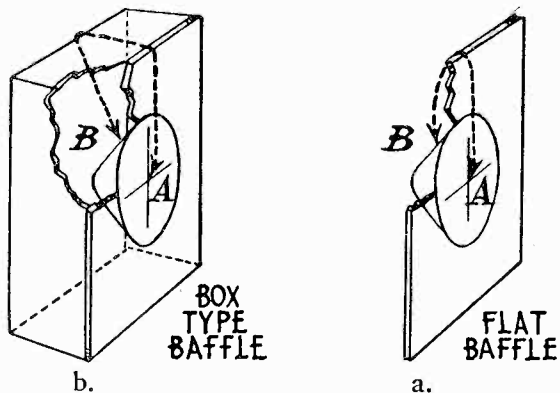

Fig. 6. (a) Path from front to back of Cone.  
(b) Path with Cabinet Baffle Plate

frequency which the speaker will emit at full value. The formula for computing the dimensions of the baffle for any given frequency is simple; the lowest frequency which the speaker will reproduce faithfully is one whose quarter wavelength is less than the distance from front to back of the cone, around the edge of the baffle. This can best be appreciated by reference to Fig. 6a, which shows the path to be measured, from *A* to *B*. The distance *A-B* is 32 in. for a 100 cycle note, 64 inches for a 50 cycle note, and 96 in. for a 35 cycle note, so that for the latter, the dimensions of the baffle, if made up of a square piece of wood, will be 8 ft. square.

Naturally, a baffle board 8x8 ft. would be inconvenient to install in the average home, so that there are two other methods of obtaining the same effect: the use of a cabinet, the walls as well as the front acting as a baffle, or the installation of the unit in the wall of the room. It is not necessary that the whole area of the baffle be flat, for the speaker may be mounted inside a cabinet, such as is shown in Fig. 6b, where the sides, top and bottom act as parts of the



Fig. 7. Wall Installation of Unit with Concealing Curtain

baffle. To figure the effective size of the baffle, the distance shown by the line *A-B* is measured, so that a cabinet having a front baffle plate 2 ft. square, with walls of about the same dimensions would have about 5 ft. of effective baffle, with a minimum of space occupied.

In using a cabinet type baffle, however, it is important that the back of the cabinet be equipped with numerous air vents, so as to permit free passage of the back wave from the cone. The ideal condition is to have the back of the cabinet entirely open, but commercial units of this type have a back with numerous screened holes, which also serve as ventilation for the amplifiers and rectifier equipment which may be housed in the cabinet. The air vents are also important in preventing resonant effects caused by the air column within the cabinet.

As a rule, the use of an open back will take care of this condition, but where even the opening of the back fails to

remove resonance, it can be reduced by padding the inside walls of the cabinet with felt. Several instances of bad cabinet resonance have been cured by placing a layer of  $\frac{1}{4}$  in. felt lining on the bottom, and one or more sides of the cabinet. If both sides, bottom and top of the cabinet are lined with felt, it may become so deadened to the high frequencies that an undesirable reduction in the high frequency output of the speaker may result. The best procedure is to place the felt on the bottom and one side of the interior of the cabinet, and note if the resonant effect has disappeared.

If the radio receiver does not amplify audio frequencies below 100 cycles, due

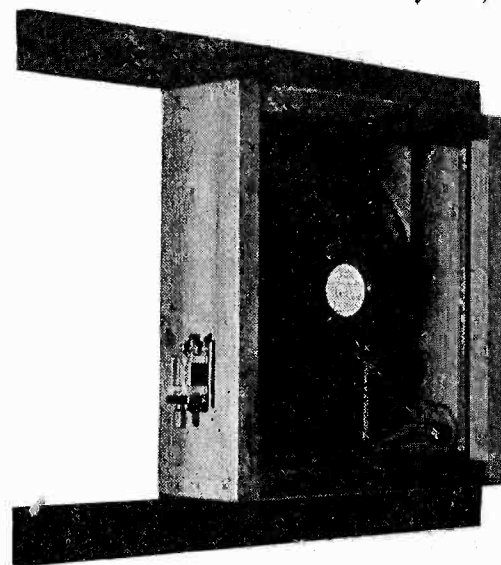
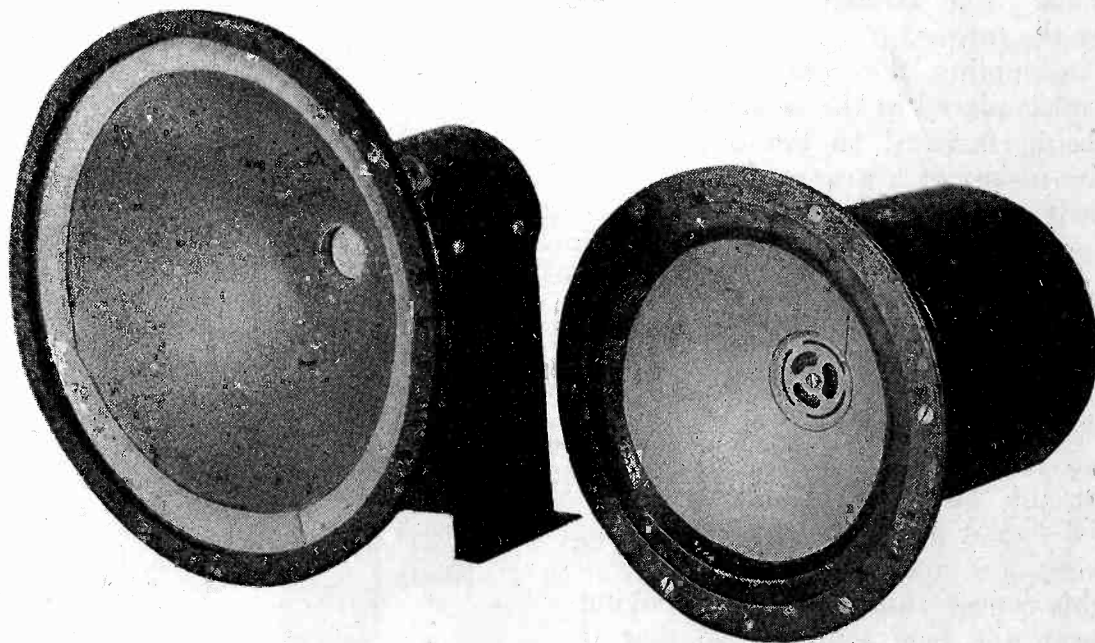

Fig. 8. Rear Construction of Wall Installation

to the characteristics of the amplifier equipment, it is useless to build a large baffle. But where the amplifier delivers good output at frequencies below 100 cycles, the placing of the speaker unit in the wall of the room where it is used is the ideal condition. By so doing, a practically infinite baffle is produced, as with the doors of the room closed, the sound waves from the back of the cone cannot interfere with those coming from the front, and with a high quality power amplifier, the resultant tone quality from the loud speaker is practically perfect.

This method requires the cutting of a hole in the wall of the room, and would

(Continued on Page 34)



Two Types of Electro-Dynamic Speakers



# Snappy Reception on Low Waves

By DON C. WALLACE

THE man who likes to build a set for the distant music and entertainment he can hear on the short waves with headphones should build a set such as this. Speaker volume on some foreign music and voice is had at times, but the man who wants to use a speaker exclusively should add two steps of audio, or equivalent. The shield grid tube is well worth while on short waves, giving greater volume, greater reliability and greater number of stations to be heard. Others seem to be under the impression that a shield grid stage of radio frequency adds another control.

While the picture of the set might indicate four controls, enough to scare out the average short wave enthusiast, this receiver is the most "single control" short wave set ever used. Only one dial has any bearing on the received wave length, and that is plainly marked "wave length." The radio frequency dial may be operated at will, but it has no bearing as to wave length, and within 20 or 30 degrees on the dial, has no relation to sensitivity or volume. If this dial is never used, and simply set in the middle of the scale, the receiver is far superior to any conceivable arrangement of "detector one step" or "detector two step" arrangement.

The tone dial (vernier) also has so little effect on the wavelength as to be

negligible in logging stations on the wavelength dial. The tone dial may be turned from side to side the full 100 degrees, and still a RAC signal from France or South America on 20 meters will not be lost. It is in reality a "Tone Corrector," and is a wonderful aid in speedy and accurate traffic handling since the d.c. notes can be "followed" with ease and mental abandon as they climb up the scale with each succeeding minute. As a strong example, the average crystal control receiver climbs ten degrees on this tone control, and if every amateur station in the world was crystal control, this dial would be just as necessary. With this easy method of tuning, the Chilean amateur sc1-AH was worked right on the dead beat of a powerful short wave US army station.

The Regeneration dial may be used, if desired. It slides into oscillation, thanks to the clarostat, over a space of 10 degrees. Turning this dial from side to side within the oscillation portion of the scale will not lose even a d.c. foreign station, so we can consider this dial as also unrelated to wavelength and also unrelated to necessary handling unless desired, as one setting is sufficient on the whole scale from 28 to 49 meters.

Thus one dial, and one dial only, enters into the picture when hunting stations. The stations come in easily and

smoothly, occupying a sizable portion of the dial, due to the vernier (6 to 1 ratio) used on this and on the other controls. The tuning scale is further spread by the use of straight line frequency condensers which enlarge the visible logging portion of the scale by 50 per cent. Personally, the writer dislikes a so-called one-dial receiver with a lot of knobs which may be turned to improve operation. Why not put honest-to-goodness scales on them in plain sight? Thus you can avoid the mental anguish of trying to guess at the place each knob should be set. The accompanying chart shows coil turns and coil spacing for all waves between 2 and 101 meters. Above that Aero coils are used. All coils below 101 meters are  $2\frac{1}{4}$  in. in diameter wound of spaced No. 20 SCC wire on a celluloid form.

The clarostat is slightly readjusted when switching to the 2 meter or 3 meter set of coils. Otherwise the same adjustment holds good, from 10 to 600 meters. This clarostat does more than place the proper detector voltage on the plate of the detector, it also makes the regeneration control slide in smoothly over a large portion of the dial.

The antenna midget is mounted inside the r.f. compartment, and is adjusted only when the coils are changed. It might just as well be set in the middle

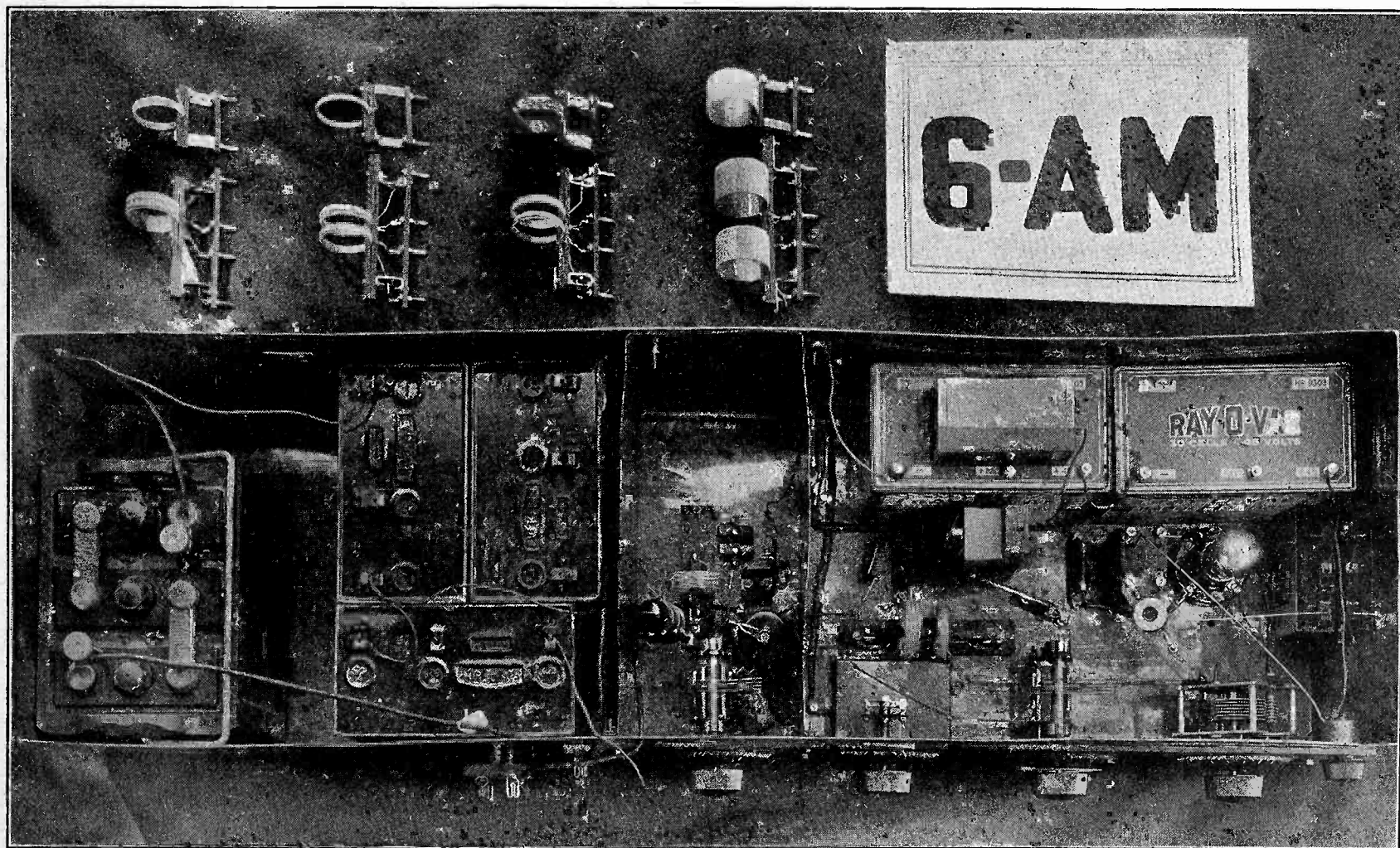

Receiver and Batteries in copper box. The controls for left and right are Antenna Switch, Battery Switch, R. F. Dial, Tone Dial, Wavelength Dial, Regeneration Dial, and Clarostat.







# How Impedance Relations Affect Tone Quality

A Simple Analysis of Their Effects in the Design and Performance of Transformer and Resistance Coupled Amplifiers, and of Loudspeakers

By NELSON P. CASE

**E**VEN with the excellent audio transformers and speakers which are now available, it is possible to get poor tone quality by ignoring proper relations between impedances. Much of the distortion which is heard from some sets using the very best parts can be avoided by providing proper impedance relations in the detector and audio frequency amplifier circuits.

Such audio distortion as might be introduced by the radio frequency amplifier is readily remedied by reducing the regeneration. Too much regeneration not only causes oscillatory squeals but sharpens the tuning to such an extent that the side bands are cut.

In a transformer coupled audio amplifier the impedance varies with the audio frequency, being relatively small for long frequencies and relatively great for high. With the general understanding of the fact that the impedance for the lowest frequency in the plate circuit of an amplifier tube should be at least as large as the tube's output impedance, it is amazing, for instance, to find *C* battery detection used with a transformer having a low impedance primary. The detector tube is also an amplifier. When worked at the lower bend of its characteristic curve its plate impedance is greater than that of the primary into which it feeds.

Plate impedance varies inversely with effective plate voltage, which is the algebraic sum of the actual plate voltage and the mu times the grid bias voltage. If the latter is negative and numerically nearly equal to the positive plate voltage, it is obvious that the plate impedance is very high.

The mathematical equation expressing the above facts is  $RP = K \div (EP + \mu EG)$  where  $RP$  is the plate impedance,  $K$  is a constant depending upon the type of tube,  $EP$  the plate voltage,  $\mu$  the amplification factor mu and  $EG$  the grid voltage. A 01-A tube with a mu of 8 has an impedance of 10,000 ohms when used as an amplifier with 90 volts plate and  $-4\frac{1}{2}$  volts grid. Substitution of these values in the equation gives 540,000 for  $K$ . When this tube is used as a detector with 45 volts plate and  $-4\frac{1}{2}$  grid its output impedance becomes 60,000 ohms, as found from the equation. To have an impedance of this value at 50 cycles the transformer primary would have to have an inductance of nearly 200 henries, which is found only in the open expensive transformers.

On the other hand, an A tube used as a detector with a grid condenser and leak of proper values may have an output impedance of 20,000 ohms. A transformer with a 100 henry primary has an impedance of 31,400 ohms at 50 cycles. It gives nearly as good amplification at 50 as at 1000 cycles.

Hugh-mu tubes, such as the -00A and -40 types, have a high output impedance and consequently do not give good reproduction of low notes if used as detectors with transformer coupled amplifiers.

For the best tone quality from two transformers having different turns ratios, that having the highest primary inductance should follow the tube with the highest output impedance, which is the detector tube. As the low ratio transformer generally has a greater primary inductance than a high ratio transformer, this means that the low ratio should come first. This changes the old practice of using the high ratio first in order to get greater amplification when only one stage is used.

If coupling inductances are used instead of transformers, they likewise should have a high inductance. By using an inductance of 350 henries it is possible to use high impedance tubes without losing the bass notes.

If the transformer or coupling inductance core is small or made of iron having a low permeability, the normal operating point will be too close to the point where the curve of flux versus plate current flattens out (See Fig. 1). The flux will not increase as much as it

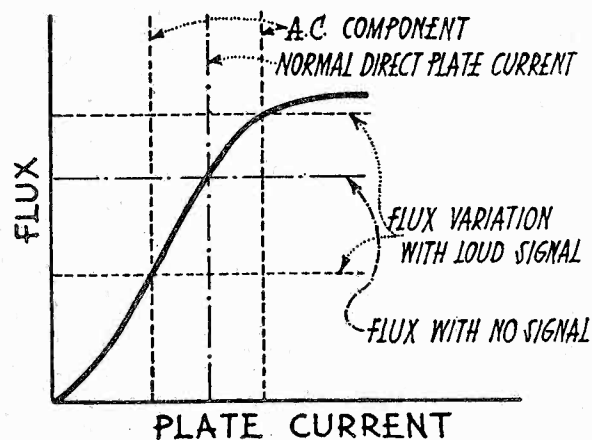

Fig. 1. Curve of Flux versus Plate Current

decreases when an alternating current of moderate magnitude is superimposed on the direct plate current, thus causing harmonics which were not in the original signal. Furthermore there is a contin-

uous change in the apparent inductance of the coil throughout the cycle, which also gives rise to a complicated system of unwanted harmonics, especially on the bass notes. If the core material is poor in quality, excessive hysteresis occurs, which not only wastes energy, but introduces distortion of somewhat similar character to that produced by too small a core, due principally to the change in the instantaneous values of inductance at different parts of the alternating current cycle.

The above-mentioned factors have been thoroughly understood and steps have been taken to make the cores of modern high grade transformers and inductances as nearly perfect as possible. To see the improvement in this regard, it is only necessary to compare a modern transformer with one built three or four years ago, and note the difference in size and weight.

While it is generally known that iron exhibits hysteresis, it is not usually realized that a vacuum tube will exhibit the same phenomenon under certain conditions. If the load in the plate circuit is reactive, the dynamic characteristic curve of the tube will be different, according to whether the grid voltage is increasing or decreasing, thus forming a sort of "hysteresis loop" in the dynamic characteristic. If this loop is very wide, it will result in considerable harmonic distortion. This loop has its minimum width when the phase angle of the load is either nearly zero or nearly 90 degrees.

The actual resistance of a transformer primary or of a coupling inductance is usually small compared to its reactance. But if the distributed capacity of the windings is sufficiently great, there will be a resonant point somewhere within the audible range. At the point of resonance, the effective resistance of the winding goes up tremendously, and the phase angle is changed from nearly 90 degrees to zero. At frequencies just below the resonant point, then, the hysteresis loop in the tube characteristic will be a maximum, with the consequent introduction of harmonics of these frequencies into the plate current.

This does not ordinarily produce as serious results as might be expected, however, because the frequency characteristic of the transformer or choke usually falls off quite rapidly after the

(Continued on Page 40)



# Experimental Shop Practice

By SAMUEL G. MCMEEEN

ONE of the greatest conveniences in an experimental shop devoted to radio and electrical work is a small stock of fluted reamers from  $\frac{1}{8}$  to  $\frac{1}{2}$  in. in size. The type known as solid hand reamers have a slight taper at the forward end and a squared shank at the rear for the engagement of a wrench such as that which comes with a set of taps and dies. For instance, a  $\frac{1}{4}$  in. rod which will not fit into a  $\frac{1}{4}$  in. hole which has been drilled in hardwood, will fit nicely after a  $\frac{1}{4}$  in. reamer has been run through the hole. Another shop trick which will accomplish the same purpose, however, is to rock the piece of wood back and forth as the drill is withdrawn part way from the hole. The drill is turning all the while and enlarges the hole enough to admit the rod.

Another tool meriting more use than it ordinarily receives is a screw-slotting cutter. These metal saws range from .006 to .182 in. in thickness and come in standard sizes of  $1\frac{3}{4}$ ,  $2\frac{1}{4}$  and  $2\frac{3}{4}$  in. diameter. They are hard-finished and cannot be sharpened by ordinary means. Many bits of cutting can be done to

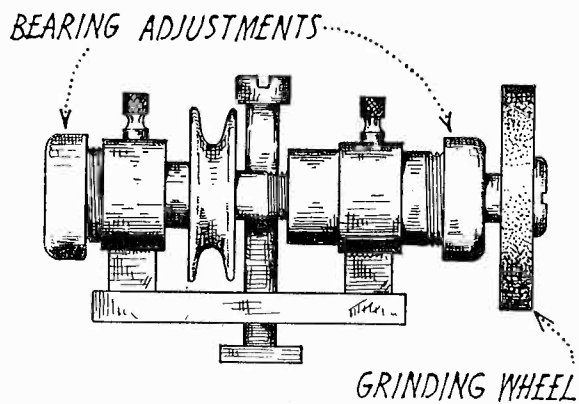

Fig. 1. Toolpost Grinder

advantage by clamping one of these cutters on a mandrel and by holding the work in or on the slide rest. While they have no set, they will work wood as well as metal.

A motor-driven grinder is the best tool for fashioning steel which must be hard, and therefore cannot be annealed so as to be softer than the tool when the finishing step is taken. A convenient form is shown in Fig. 1. Its large base assures a firm grip when it is attached to the slide rest with a square-headed screw. The motor should be mounted on the ceiling and the grooved grinder pulley driven by a round belt so as to allow a 7 in. shift of the slide rest. A grinding wheel  $3\frac{7}{8}$  in. in diameter run at 6000 r.p.m. will give the optimum peripheral speed of 6000 linear feet per minute.

As this speed is greater than can be secured from a 1750 r.p.m. motor and  $2\frac{1}{2}$  in. pulley it will be necessary to buy

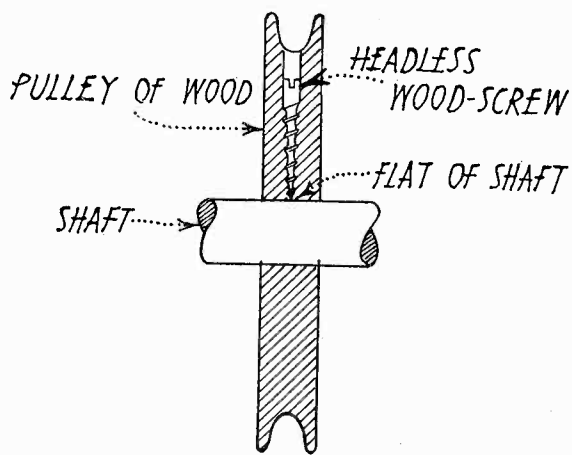

Fig. 2. Wood Pulley

or make a larger pulley. Fig. 2 shows how a simple turned wheel can be attached to the flattened shaft of a motor with a wood screw. Cut off the head of the screw, drill a radial hole in the pulley one size smaller than the screw, and slot the end where the head was cut off. Use a slender screw driver to set the screw home against the shaft.

The method or process used is the most important phase of shop practice. For tools and materials can be bought but methods or processes are the result of the worker's thought. A case in point is the method of making soft metal castings from type metal, white metal or brass, all of which are fusible in the flame of an acetylene blow pipe when the metal is contained in a graphite crucible.

Molds may be made of either sand or plaster. The making of sand molds is described in books on foundry practice. Plaster molds are made from two parts of plaster of paris and one part of powdered pumice mixed with water to the consistency of thick cream. The pumice stone gives porosity so that the steam from the partly damp mold may escape. The plaster must "part" properly, an art concerning which much can be learned by watching sand molders at work. The plaster is poured around the pattern, which is oiled and placed in proper position to receive the plaster. The molds should be thoroughly dry be-

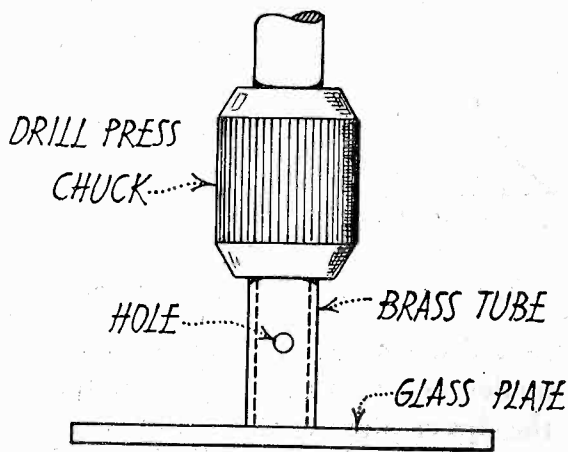

Fig. 3. Drilling a Hole in Glass

fore the hot metal is poured into them as otherwise the molten metal may blow out.

Type metal expands as it cools, being soft enough, just before expansion, to take the shape of the finest crevices and indentations of the mold.

Fig. 3 shows an abrasive method for quickly and neatly drilling holes in glass. A copper or brass tube with a hole in its side is set true in the check of a drill press or hand drill. The sheet of glass is placed on a flat board on the table or bench. While the tube is revolving, feed oil and emery through the hole in its side. The emery runs into the point of contact between the tube and the glass, imbeds itself in the soft metal, and grinds out a ring of glass.

Small holes can be drilled in glass with a flat drill, as shown in Fig. 4, if the contact of drill and glass is lubricated with a mixture of turpentine and gum camphor of about the consistency of light crank-case oil. Undue pressure should always be avoided when drilling glass.

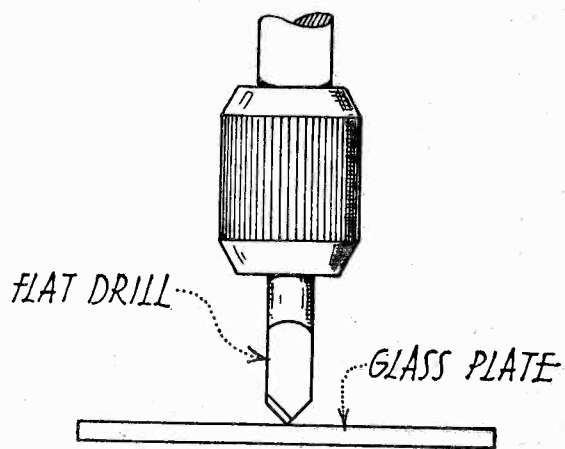

Fig. 4. Boring Glass with a Flat Drill

Brass can be plated with silver more easily than with nickel and has a better color and is more easily cleaned. The work to be plated should be buffed with tripoli and scrubbed with Dutch Cleanser before putting it, still wet, into the plating bath.

This solution is made by dissolving 100 grains of silver nitrate in as little distilled water as will serve; likewise dissolve 75 grains of potassium cyanide. Add the cyanide solution, drop by drop, to the silver solution until the precipitate begins to re-dissolve. Let the precipitate settle, throw away the surplus liquid, and dissolve the precipitate in the rest of the cyanide solution. Add enough distilled water to make a quart, and the plating bath is ready.

In the plating process a piece of pure silver, such as silver solder, is suspended in the solution and connected to the

(Continued on Page 45)



# Improved Operation of the 115 K. C. Super

By G. M. BEST

**D**IFFICULTIES experienced with the volume control of the 115 k.c. superheterodyne, in localities where powerful stations caused interference, has led to experiments which have resulted in an improved method which is shown in the schematic wiring diagram of Fig. 1. The original method used a 200,000 ohm variable resistor in the common *B* supply lead to the plate circuit of the two shielded grid r.f. amplifier tubes, so that the effective plate voltage for these tubes could be varied and their amplification controlled as a method of volume regulation. Where the set was near a powerful station, this resistance proved to be too small to cut the volume of the local stations to the proper value, and it was often necessary to either detune the r.f. dial, or adjust the 200 ohm potentiometer controlling the amplification of the intermediate amplifier tubes.

It was found that the substitution of a 500,000 ohm variable resistor for the smaller size helped matters considerably, but an even better method has now been developed. It consists of inserting a 500,000 ohm variable resistor in the 45 volt positive *B* lead supplying the four shield grids of the type 322 tubes, and also the *B* supply for the mixer tube. The 45 volt *B* lead to the detector tube is brought out separately, and is not controlled by the variable resistor, but all other tubes having 45 volt supply are in the volume control circuit. This method permits control of the amplification in the intermediate amplifier circuit at the same time that the gain of the tuned r.f. stages is controlled, so that for local stations, the gain of both amplifiers is cut to a small fraction of the possible maximum, and a minimum of shielded grid tube hiss is produced.

The full 135 volts positive *B* is applied to the plates of the four shielded grid tubes, and the variable resistor in the shield grids will be found to be as fine a control of volume as could be wished for. The variable resistor can be

mounted on the panel in the same position as the old control, the only changes necessary being in the wiring.

The diagram shown in Fig. 1 is similar to that reproduced in the March issue, except that no alternative connection for type 99 tubes is shown. This diagram is for type 322 tubes in the tuned r.f. and intermediate amplifier stages, and type A tubes in the mixer, oscillator, detector and first audio stages, with a power tube of whatever type is desired, in the power stage. A 1 ohm fixed resistor placed in the negative filament lead to the four type A tubes reduced the filament voltage to 5 volts, so that a minimum number of fixed resistors is required. Of course, individual 4-ohm resistances of the automatic control type can be used in the negative filament lead to each type A tube, if the additional expense is no objection. The four shielded grid tube filaments are controlled by the filament rheostat associated with the filament switch, with the voltmeter shunted across the filament circuit. The switch to cut out the intermediate amplifier and convert the set into a five-tube set is not shown in this diagram, but the connections can easily be made from the diagram shown in the March issue.

Where a type 112-A or 71-A power tube is operated from the same 135 volt *B* supply as that used for the shielded grid tubes, there have been instances of r.f. feedback, and instability in both the intermediate amplifier and the tuned r.f. amplifier. Where this occurs, a r.f. choke of 250 millihenries can be placed in the common *B* supply lead to the shielded grid tubes, as is shown in Fig. 1, and the *B* supply to the power tube will thus be protected so that no feedback will occur. This choke can be mounted on the end of the baseboard next to the battery cable terminal, as it does not take up much room.

Apparently there are many builders of this set who did not read the correction for the connections of the antenna

compensator which appeared in the March issue of RADIO. The connection of the wire leading from the terminal of the first r.f. coil socket, which is marked positive *F* on the socket, to the antenna compensator, should go to the lug on the stator nearest the front panel, and not to the lug at the rear of the stator, as was shown in the original pictorial diagram. The lug on the rear of the stator is used to connect the pig-tail lead from the rotor to the stator winding, completing the variometer circuit, and no external connection should be made to this lug.

In lining up the front end of the set, a handy method is to temporarily convert the set into a five tube receiver by removing the detector tube, and the input transformer to the intermediate amplifier; then connect a wire from the *P* terminal of the coil socket from which the input transformer was removed, to the *P* terminal of the first audio transformer. The intermediate amplifier tubes and the oscillator can be left in their sockets, so as not to disturb the filament regulation, and the three gang condenser can then be lined up with a modulated oscillator, if one is available, or from a local station.

A modulated oscillator is handy for this purpose, and if one is not on hand, it can be made up easily from an oscillator coupler such as is used in the original 45,000 cycle superheterodyne or some similar type, together with a variable condenser, a type A tube, and a 25 watt Mazda lamp. Connect the variable condenser across the grid coil of the os-

(Continued on Page 46)

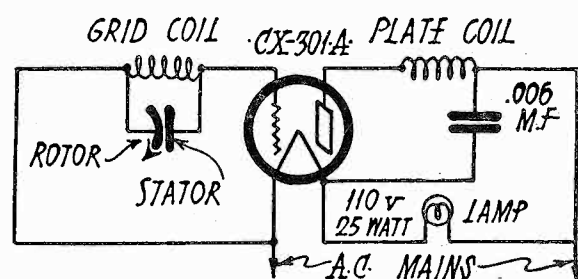

Fig. 2. Modulated Oscillator for lining up tuned R. F. Amplifier

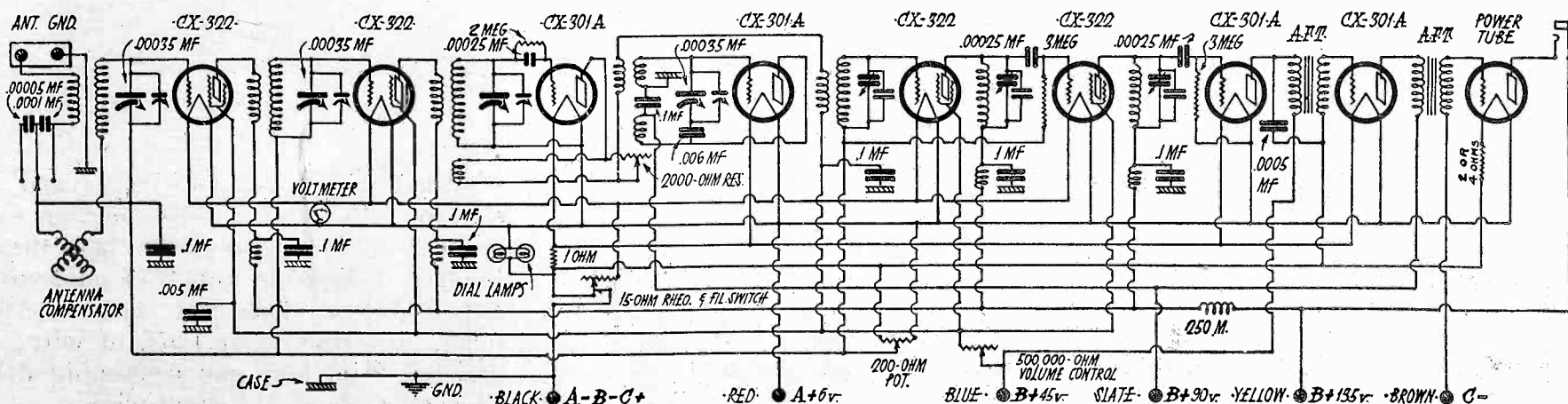

Fig. 1. Circuit of 115 K.C. Superheterodyne with improved Volume Control



# How to Make the Torusolenoid

Practical Directions for Constructing a Remarkable Coil and R. F. Transformer for Broadcast Reception

By HARRY R. LUBCKE

**T**HE torusolenoid is a new coil introduced by Dr. Ross Gunn of Yale University through the Proceedings of the Institute of Radio Engineers.

It admirably approaches the requisites of the perfect coil: (1) zero external field, (2) low distributed capacitance, (3) a high  $L/R$  ratio, (4) mechanical strength, and (5) moderate size. The ordinary solenoid falls on (1); and the toroid or doughnut coil on (2) and (3).

The torusolenoid consists essentially of two solenoids connected in parallel and bent into the circular form of a toroid. This closes their mutual magnetic fields. Since the connections come out at opposite ends of a diameter (Fig.

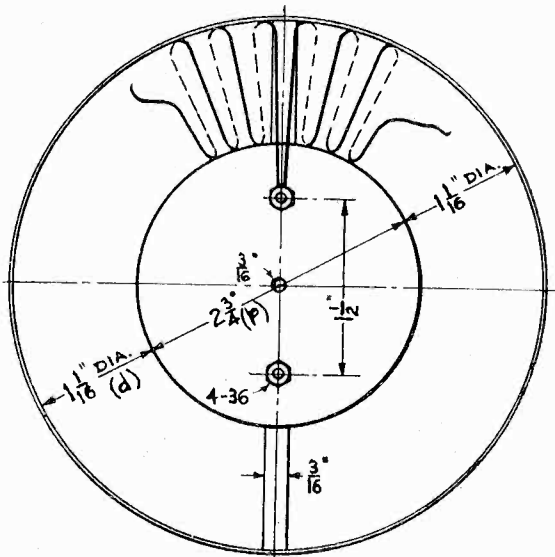

Fig. 1. Torusolenoid Dimensions, showing Start of Two Windings from the Same Binding Post.

1), the distributed capacitance is small. Further, since there are two coils in parallel, smaller wire can be used, resulting in a low ratio of high-frequency to d.c. resistance that materially aids the factor of merit of the coil and uses the wire to the best advantage.

So much to prove that the coil is good; now for some practical details. Using the torusolenoid formula and Maxwell's ratio for the most efficient proportions of a toroid, the writer has calculated the ideal dimensions for a coil covering the broadcast band. These are

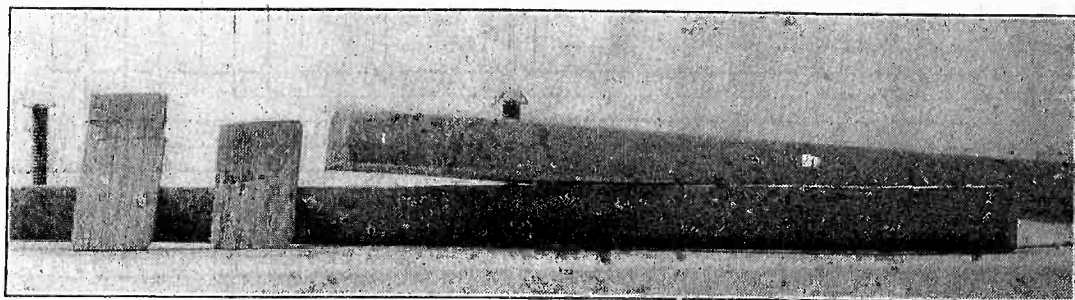

Fig. 2. Parts of Coil Form.

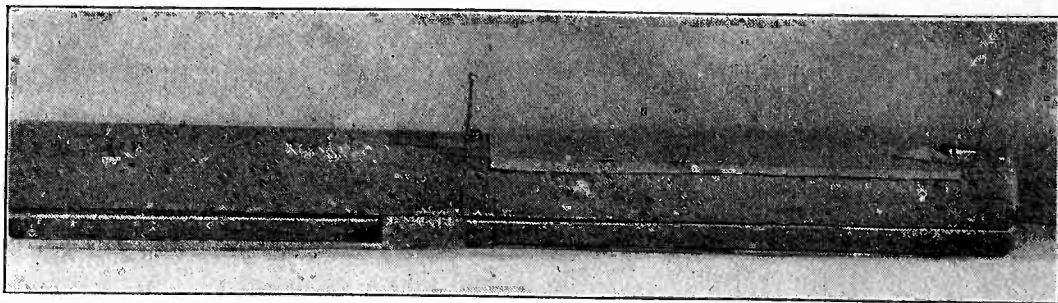

Fig. 3. Coil Form Ready for Winding

given in Fig. 1. The coil is wound with 516 turns of No. 29 single silk-covered wire, has an inductance of 168 microhenries, and is used with a .0005 mfd. variable condenser.

Even better than this, however, is a torusolenoid wound with litz wire, which causes the resistance to increase with frequency, instead of decrease, as with ordinary wire. This reduces the condition favorable to oscillation at low wavelengths and aids the uniform regeneration at all frequencies secured with the Loftin-White and other constant coupling systems. For this coil the cross-section diameter  $d$  of the winding is  $1\frac{3}{8}$  in., that of the bakelite center piece  $p$   $3\frac{3}{16}$  in., and a total of 436 turns of 20/38 litz are used.

The winding form is shown disassembled in Fig. 2. A piece of round dowel 9 in. long is drilled transversely with a No. 28 drill through two diameters spaced  $\frac{1}{2}$  in. and  $5\frac{3}{4}$  in. from one end, and threaded 8/32 for two 1 in. 8/32 screws used for holding the form together after it is split. Next the form is carefully cut in half longitudinally with a steel-back saw. Two flat wedges  $\frac{1}{32}$  in. thick are made as shown in Fig.

2 and placed near the screws to separate the halves the width of the sawcut as indicated in Fig. 3. The diameter of the dowel is 1 in. for the solid wire torusolenoid or  $1\frac{3}{8}$  in. for the litz; such stock can often be found in the form of broom handles, rollers, etc. Maple, used for the form shown in the pictures, threads nicely, but if taps are not available or the wood not suitable the screws can be provided with nuts and a No. 19 drill used. In any event the top half of the form is drilled No. 19 so that the screws will slip through it and thread into the other half.

The materials required for one coil are: one bakelite center piece, one brass mounting bracket, several strips of celluloid, two or four 4/36 screws  $\frac{1}{2}$  in. long with two nuts each, one 8/32 screw  $\frac{1}{4}$  in. long, DuPont household cement and the necessary wire. The center piece should be made of  $\frac{1}{4}$  in. or  $\frac{3}{16}$  in. material, being  $2\frac{3}{4}$  in. in diameter for solid wire or  $3\frac{3}{16}$  in. for litz. A "heavy" grade of celluloid, approximately  $\frac{1}{32}$  in. thick should be used. A strip 19 in. long will be required for the outside circumferential strip.

To wind a coil the form is assembled,

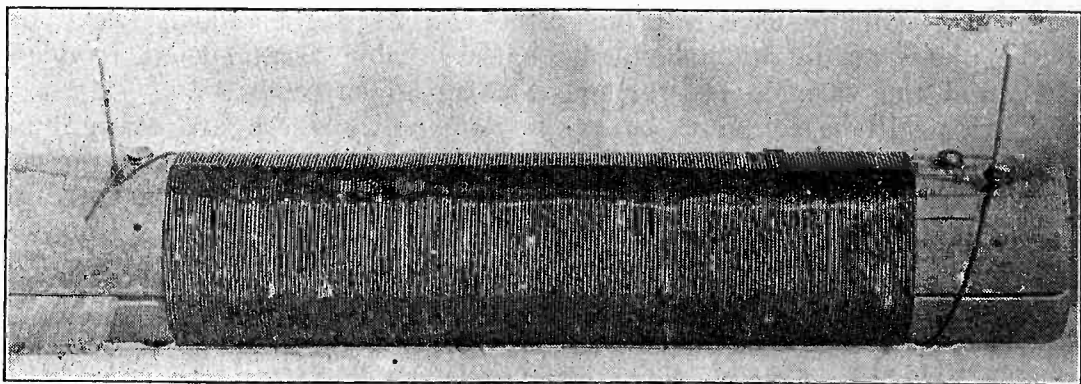

Fig. 4. Completed Coil.

provided with a strip of paper and a piece of celluloid  $\frac{1}{2}$  in. longer than the finished coil, and two pins to hold them in place as shown in Fig. 3. A solid wire coil is  $3\frac{3}{4}$  in. long and contains 258 turns, requiring about 1 oz. of wire; a litz coil 5 in. long and containing 218 turns takes about  $2\frac{1}{2}$  oz. of wire.

(Continued on Page 47)



# A Good Receiver Using Shield-Grid Tubes

Directions for Successfully Using Shield-Electrode Tubes as R. F. and A. F. Amplifiers in an Experimental Four-Tube Circuit

By FRANCIS CHURCHILL

THE shield-grid tube offers many opportunities for experiments and new adaptations of old circuits, of which the following is an example, which has given good results on both distant and local reception. It has a single drum control for tuning and has a volume control which regulates the amount of regeneration. Four tubes are used, two of the shield-grid or shielded-plate type, a detector and a power tube. The shield-electrode tubes give more nearly constant gain over the broadcast band than do three-element tubes.

The circuit consists essentially of one stage of r. f. amplification, a regenerative detector, a special audio stage and a

power stage. Special circuits are required to get the full amplification of which the shield-plate tube is capable when used as a radio frequency amplifier. It is necessary to use tuned impedance coupling or a r. f. transformer with a very large primary, that is, with nearly as many primary turns as secondary turns.

Any station carrier not on the resonant peak of these two circuits is greatly attenuated. The station to which this circuit is tuned will not be attenuated appreciably if the coils and condensers are of an efficient type. The capacity of  $C_4$  is about equal to the grid-to-plate

capacity of an ordinary tube and so has practically no effect on the tuning.

The selectivity obtained by using  $C_4$  instead of an extra tube may be illustrated by tuning the set to the 1000 k.c. band when an interfering station is on the 1020 k.c. band. The first tuned circuit will pass some of the 1020 k.c. band because its impedance to that band is not small enough to pass it to ground. The second circuit, tuned to 1000 k.c., offers another low impedance shunt to 1020 k.c. So very little of the 1020 k.c. is impressed on the grid of the r.f. amplifier tube. If  $C_4$  were another tube, its plate impedance would be in shunt to the second tuned circuit, making it tune

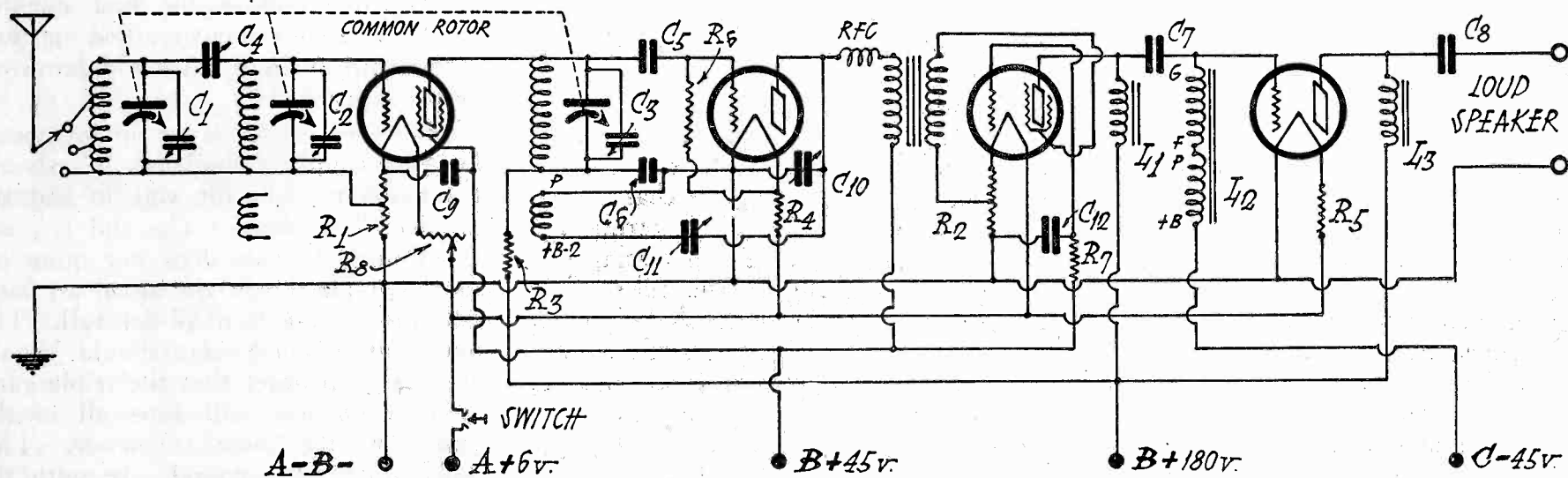

Fig. 1. Circuit Diagram of Four-Tube Receiver with Shield Grid Tubes in R. F. and First Audio Stages

$C_1, C_2, C_3$ —3 gang condenser .00035 per section.  
 $C_4$ —1.5 - 20 mmf. variocoupler.  
 $C_5$ —.00025 grid cond.  
 $C_6, C_7, C_8, C_{12}$ — $\frac{1}{2}$  mfd. bypass cond.

$C_9$ —2 mfd.  
 $C_{10}$ —.0002 mfd. max variocoupler.  
 $C_{11}$ —.001 mfd. max variocoupler.  
 $R_1, R_2$ —20 ohm fixed resistances.

$R_3$ —100,000 ohm resistor.  
 $R_4, R_5$ — $\frac{1}{4}$  and  $\frac{1}{2}$  amp. resistances.  
 $R_6$ —3 megohm. leak.  
 $R_7$ —5000 ohm resistor.

$R_8$ —30 ohm volume control rheostat and filament switch.  
 $L_1$ —225 henry choke.  
 $L_2$ —Primary and secondary of 3:1 audio transformer.  
 $L_3$ —30-henry choke.

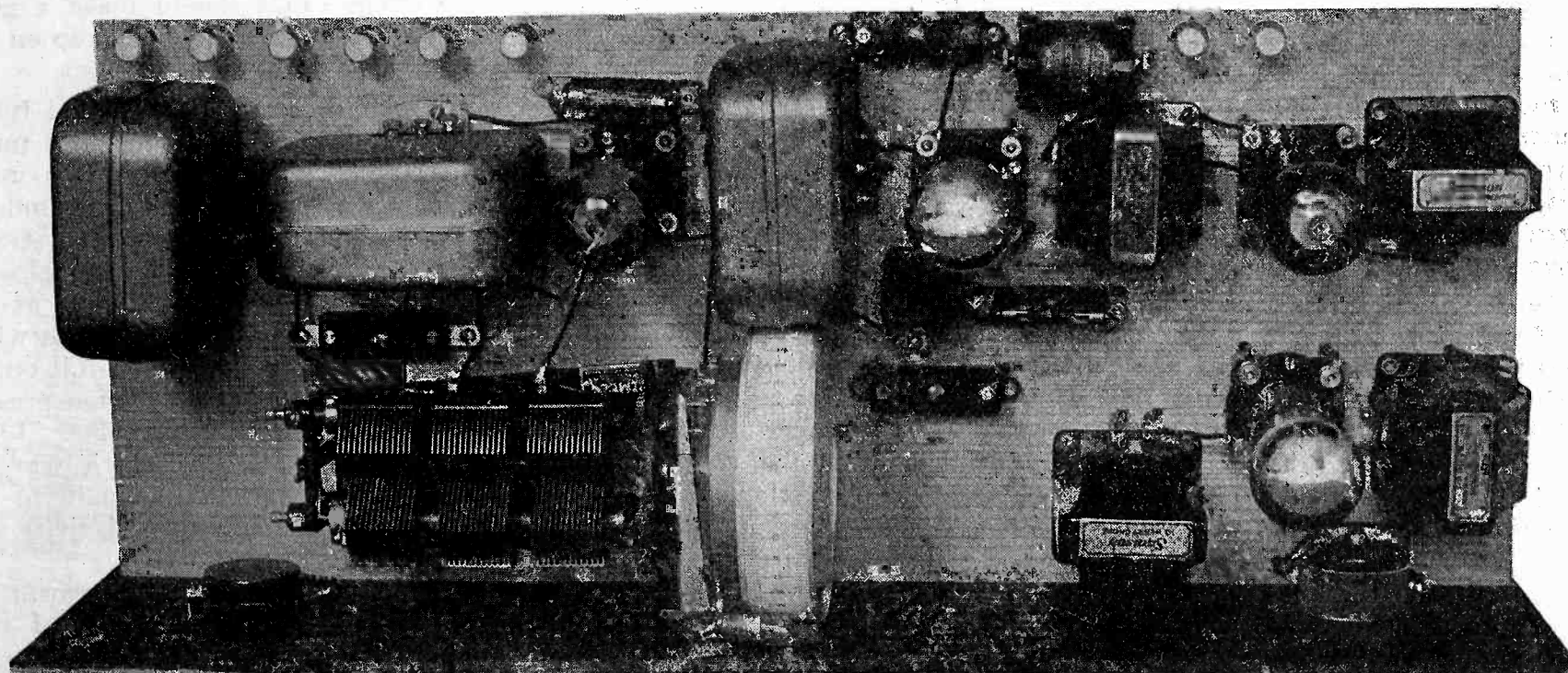

View of Completed Receiver



much more broadly than if only a grid circuit was in shunt to it. By having the special tuned circuits ahead of the amplifier tube instead of following it, the desired signal is amplified more in proportion.

In order that the relative amount of regeneration will be the same over the whole broadcast band, a special plate bypass condenser  $C_{10}$  is connected between the detector plate and filament. The impedance of this condenser is greatest at the upper end of the broadcast band so that its bypassing effect is smallest at this lowest frequency. The impedance of the feedback circuit of  $C_{11}$  and the "tickler" coil is more nearly constant in effect with the circuit constants used, so the regenerative effect is practically constant over the whole range.

The detector circuit is otherwise of the ordinary type, consisting of the usual grid condenser and grid leak, the latter being connected to the positive side of the filament. A r.f. choke is in series with the output plate circuit in order to confine the r.f. currents to the desired paths and to keep them out of the audio amplifier.

The audio amplifier uses a combination of high quality transformer and impedance coupling. The first audio tube is a shield-grid tube using the normal control grid as a space charge grid and the shield-grid as the audio control grid. This arrangement gives a high amplification constant with fairly low plate impedance so that the tube gives two or three times as much voltage amplification as an ordinary high mu tube. This means that the audio amplifier will give considerably more amplification than will the ordinary two-stage amplifier.

A little might be said here about the use of the shield-grid tube as a space charged grid tube. In the normal three element tube there is a large number of electrons emitted from the filament which haven't sufficient initial velocity to reach the plate. This "cloud" of electrons, heaviest near the filament, tends to repel other electrons nearer the filament and in effect makes the plate impedance of the tube relatively higher than would the negative charge on the grid. By placing a fourth element, another grid, near the filament and putting a positive potential on it, a large number of electrons are drawn towards it. Some of the electrons hit this space charge grid, but a large percentage pass through it towards the other grid and plate. This space charge grid tends to dispel the "cloud" of electrons around the filament by reason of its positive charge. If the inner grid in the shield-grid tube is used as a space charge grid, the tube will operate with an amplification constant of at least 60 with the "shield" grid as the regular or control grid. With about 20 volts or so positive bias on the inner grid, the plate impedance of the tube

#### PARTS USED

- 1 three gang condenser .00035 mfd. per section.
- 1 set of three shielded coils for use with .00035 tuning condensers.
- 4 sockets.
- 2 baseboard brackets.
- 1 baseboard  $\frac{1}{2}'' \times 9'' \times 2\frac{3}{2}''$ .
- 1 panel  $24 \times 7 \times \frac{3}{16}$ .
- 1 combination switch and 30 ohm rheostat.
- 2 20 ohm fixed resistances.
- 2 fixed filament resistances, 2 and 4 ohm.
- 1 2-mfd. condenser.
- 4  $\frac{1}{2}$  mfd. condensers.
- 1 .00025 mica condenser.
- 1 3 megohm grid leak.
- 1 100,000 ohm resistor.
- 1 5000 ohm resistor.
- 3 variocouplers, capacities of 20 mmf, 100 mmf and 1000 mmf max.
- 8 binding posts — aerial, —A, +A, —C, +45, +180, and 2 speaker posts.
- 3 grid leak mountings.
- 1 high quality transformer.
- 1 ordinary 3:1 transformer.
- 1 225 henry plate choke.
- 1 85 millihenry r.f. choke type.
- 1 roll of flexible hook-up wire.
- 2 shield-grid tubes.
- 1 special detector tube.
- 1 power tube.

drops from about 600,000 or 700,000 ohms to near 100,000 ohms, so that a very efficient audio amplifier tube results.

In the audio amplifier, the plate impedance  $L_1$  is a choke coil of about 225 henrys inductance, so it offers a high impedance even at low frequencies. The grid leak impedance  $L_2$  is the primary and secondary of a 3:1 transformer in series and has an inductance of several hundred henrys. The space charge grid has the effect of greatly lowering the plate impedance and so increasing the mutual conductance of the tube. The positive bias on this tube should be in the neighborhood of 20 volts. So a 5000 ohm resistance was cut in series with the 45 volt tap to reduce it to the proper value. A bypass condenser  $C_{12}$  of either  $\frac{1}{2}$  or 1 mfd., bypassed any audio frequency currents to ground or filament.

The last tube consists of a 171 power tube with a 30 henry choke and a 2 mfd. condenser for a loudspeaker filter. This choke and condenser are necessary, since a full 180 volts are used as plate supply for this tube in order to efficiently handle the power developed.

Automatic filament control resistances  $R_4$  and  $R_5$  are used to control the filaments of the detector and power tubes. The two shield-grid tubes have 20 ohm fixed resistances in series with the negative side of the filaments. These resistances reduce the 6 volt supply to the proper value for these tubes and also provide a grid bias of 1.5 volts by bringing the grid returns back to the center of these resistances. The volume control is an additional 30 ohm filament rheostat in the r.f. tube, which provides a very good control for this purpose. This rheostat has a filament switch combination so that when the volume control knob is at its lowest setting, the filaments of all the tubes are shut off.

The plate potential of the r.f. tube is reduced from 180 volts to about the correct value by means of a 100,000 ohm resistor  $R_3$ . This saves the use of a r.f. choke and also the use of a special 120

or 130 volt tap from a  $B$  eliminator or battery.

The picture of the set shows the actual layout of apparatus on the panel and baseboard. All of the bypass condensers and some of the resistances are mounted underneath the baseboard or sub-panel which is raised about an inch from the lower edge of the panel. Nearly all of the wiring is done underneath the sub-panel with the wires brought up through holes drilled for that purpose. Bus-wiring can hardly be used in a set using one shield-grid tube if efficiency is desired, and is absolutely out for two stages of r.f. unless shielded bus-wire is used.

The three gang condenser and drum dial are mounted on the panel so that the drum dial shows in the exact middle of the panel. The volume control and filament switch rheostat is mounted towards one end of the panel and the special three point switch furnished with the coils is mounted in a corresponding position at the other end of the panel. This switch connects the aerial to any one of three taps in the first shielded coil and is a convenient method approximating constant selectivity and gain over the broadcast band.

After the receiver is set up for operation, the coupling condenser  $C_4$  should be set about  $\frac{1}{3}$  of the way in and the "feedback" condensers  $C_{10}$  and  $C_{11}$  adjusted until the set does not quite oscillate any place over the broadcast band with the volume control on full. The compensating condensers should be adjusted also in order that the triple gang tuning condenser will tune all of the circuits to the same frequency. This combination will generally be with the detector section all of the way out, the middle section all of the way in, and the antenna section about two-thirds of the way in.

The connections to the "control" or inner grid should be made by means of a small piece of spring brass or bronze bent in the shape of an arc of about  $\frac{2}{3}$  of a circle. This should make a good connection to the little metal cap on the top of these shield-grid tubes.

To obtain selectivity, a special tuned circuit is used ahead of the first tuned grid circuit and the detector is made regenerative by utilizing the unused primary winding of the last r.f. transformer. This regeneration also helps on distant reception. The amount of regeneration is not very great except when the volume control is turned full on, in which case there is regeneration present in both r.f. and detector tubes. Only the coils are shielded, since it was desirable to have a slight amount of regeneration to increase the selectivity and also the gain.

The special circuit arrangement in front of the r.f. tube consists of two tuned circuits coupled together by means of a 5 or 10 mfd. condenser  $C_4$  in Fig. 1.



# Home-Made Drum Dials

By R. J. ROBBINS

THE writer has designed a drum dial which may be made at small expense, mostly from junk-box material. The dial may be made in either one of two styles: one with a single support panel for controlling one condenser or gang, the other with two support panels and capable of controlling two similar condensers.

are given in Fig. 3, which is also a side view of the double unit. The support panel is fastened to the main panel by means of flat-head 8/32 machine screws and a 4½ in. length of angle brass. Slots are cut to accommodate the dial and vernier drums as shown, clearance being cut at a sharp angle to the rear on top and bottom to allow sufficient forward

piece of ½ in. square brass stock to a size sufficiently large to insure a running fit. A single hole is then drilled in the exact center of one of the faces and tapped out for an 8/32 flat-head machine screw.

The assembly of the vernier is simple. First place shaft in bearing hole and on each end of shaft place an 8/32 hex nut,

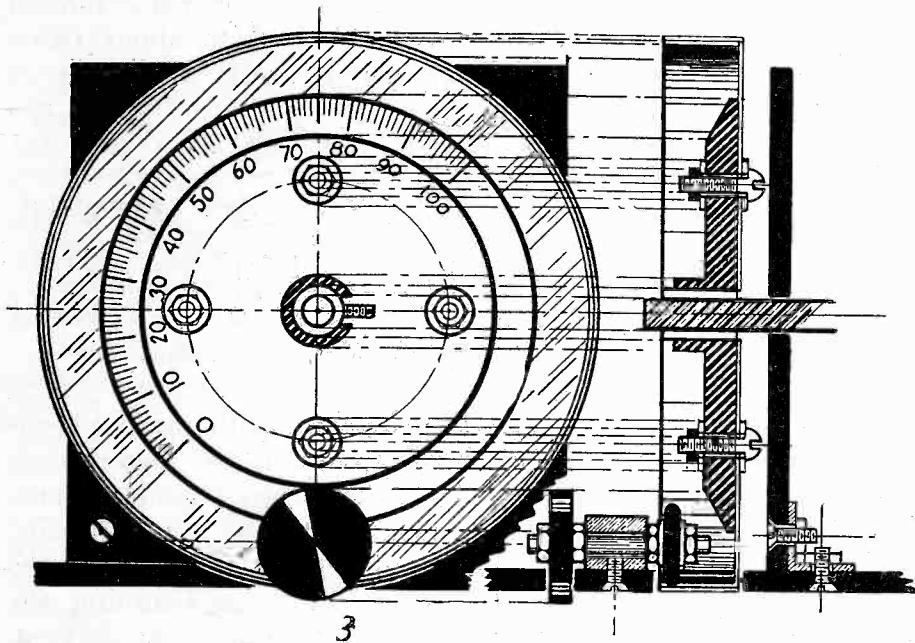

Fig. 1. Side and End Views of Single Drum Dial.

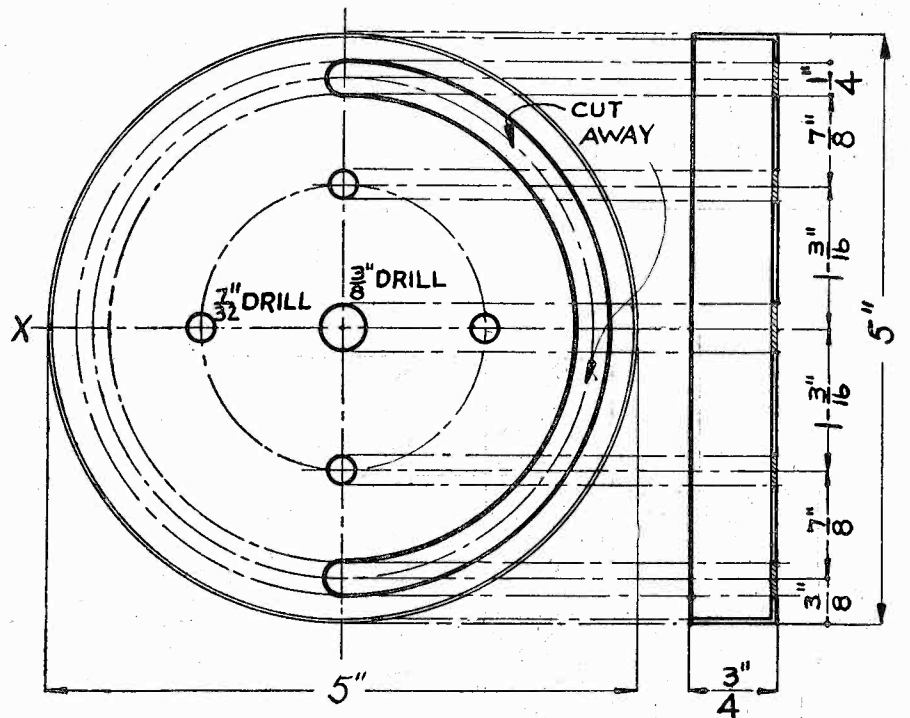

Fig. 2. Plan and Section of Cover Drilling for Bolt Holes.

Fig. 1 shows the single type. The drum is made from a coffee can cover, 5 in. in diameter. Inside of it is bolted, with four machine screws, an old style 4 in. dial which attaches the drum to the condenser shaft. The layout of bolt holes and dimensions for altering the can are shown in Fig. 2. The half-moon-shaped slot is necessary only for the double type of dial.

The dimensions of the support panel

placement of the two convex surfaces. When the dial is in position, the portion carrying the figures will come just flush with the front surface of panel, while the disc-shaped adjusting knob will protrude about 3/16 in.

The vernier is composed of a short length of 3/16 in. round brass rod which is to be threaded at both ends for a distance of about 5/8 in. A bearing is prepared by drilling a hole through a short

screwing same up until it is in loose contact with bearing. On the end which carries the rubber friction disc place next a 3/16 in. washer, a 3/4 in. rubber washer, another brass washer and finally another hex nut which tightens up the assembly. On the opposite end of shaft slip on the hard rubber disc which serves as a vernier knob.

This may be shaped on a lathe from a piece of old paneling or may be cut out roughly with a hack saw and shaped with a fine milled file. If of rubber, the edge can be sandpapered and then polished with chalk and oil. If of fiber or bakelite the polishing may be done with orange shellac and machine oil. An elastic rubber band around the edge of the disc will provide traction if the edge cannot be knurled.

The layout of aperture slots and mounting screws is shown in Fig. 4.

The scale is made from a piece of high-gloss bristol board of the same length and width as the edge of the drum. By the exercise of a little ingenuity and patience it can be divided into 100 equal divisions and marked every 10 divisions. It may be covered with a strip of transparent celluloid for protection and better appearance.

The double type unit is like the single type except that two 3 or 4 in. dials are used and the slot shown in Fig. 2 is

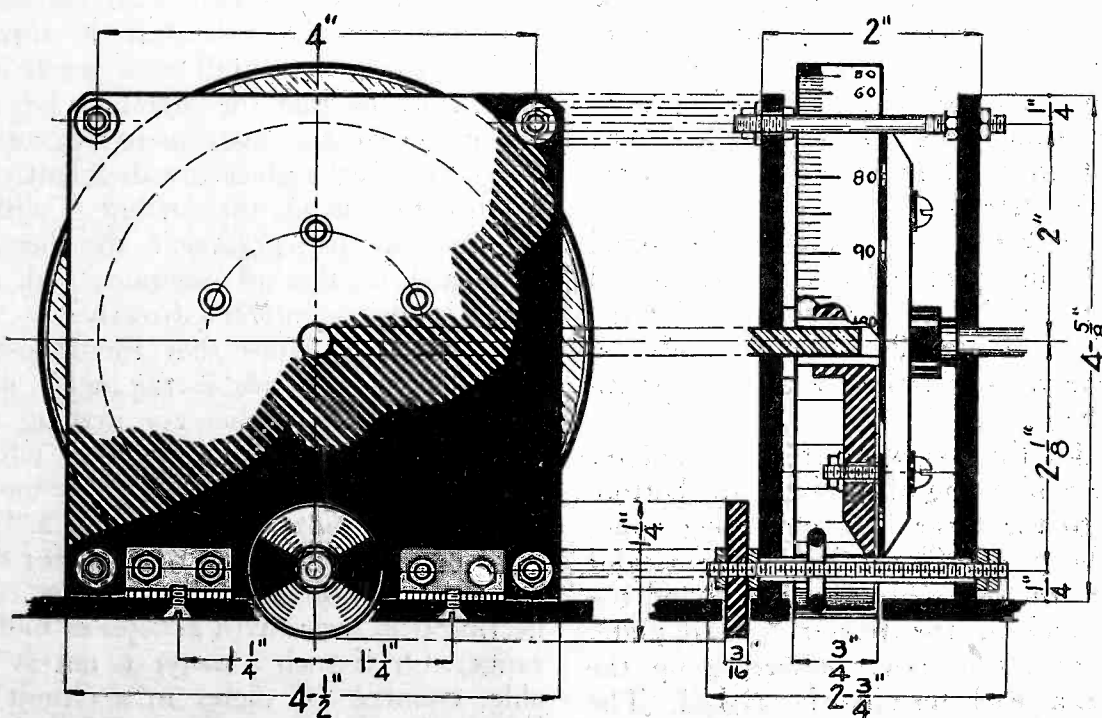

Fig. 3. Side and End Views of Double Drum Dial, with Support Panel Dimensions for Either Single or Double Drum Type.



necessary to admit the vernier shaft, which passes through the drum. The four bolt holes should be drilled in the two dials while they are temporarily clamped together by a small piece of  $\frac{1}{4}$  in. shafting in a vise. This shafting may also be used to keep the dials in alignment while the bolts are being tightened into place. The hole in the center of the coffee can cover should be large enough to clear the condenser shafts.

The two mounting panels shown in Fig. 3 should also be drilled simultaneously, the bearing holes for the vernier shaft being  $\frac{1}{4}$  in. in diameter so as to pass the  $\frac{1}{4}$  in. sleeves. The shaft is of  $\frac{3}{16}$  in. threaded stock, on one end of which the vernier disc is fastened tightly by means of two hex nuts. Next a spacer is slipped on, cut from  $\frac{1}{4}$  in. brass tub-

## Short Wave Coils

By R. WM. TANNER

SINCE writing "USES FOR BURNED-OUT TUBES" in February RADIO, I have found that, for short waves under 200 meters, the coils may be wound directly on the tube bases, resulting in a much neater and more compact plug-in coil. These small coils give greater distance and louder signals than on the 3 in. ones.

As the bases are only about  $1\frac{5}{16}$  in. in diameter, I had to wind the turns close together with No. 26 enamel wire for the 80 and 200 meter coils. The 20 and 40 meter coils were space wound with No. 20 enamel. The windings were all about  $1\frac{1}{16}$  in. long, making the length about the same as the di-

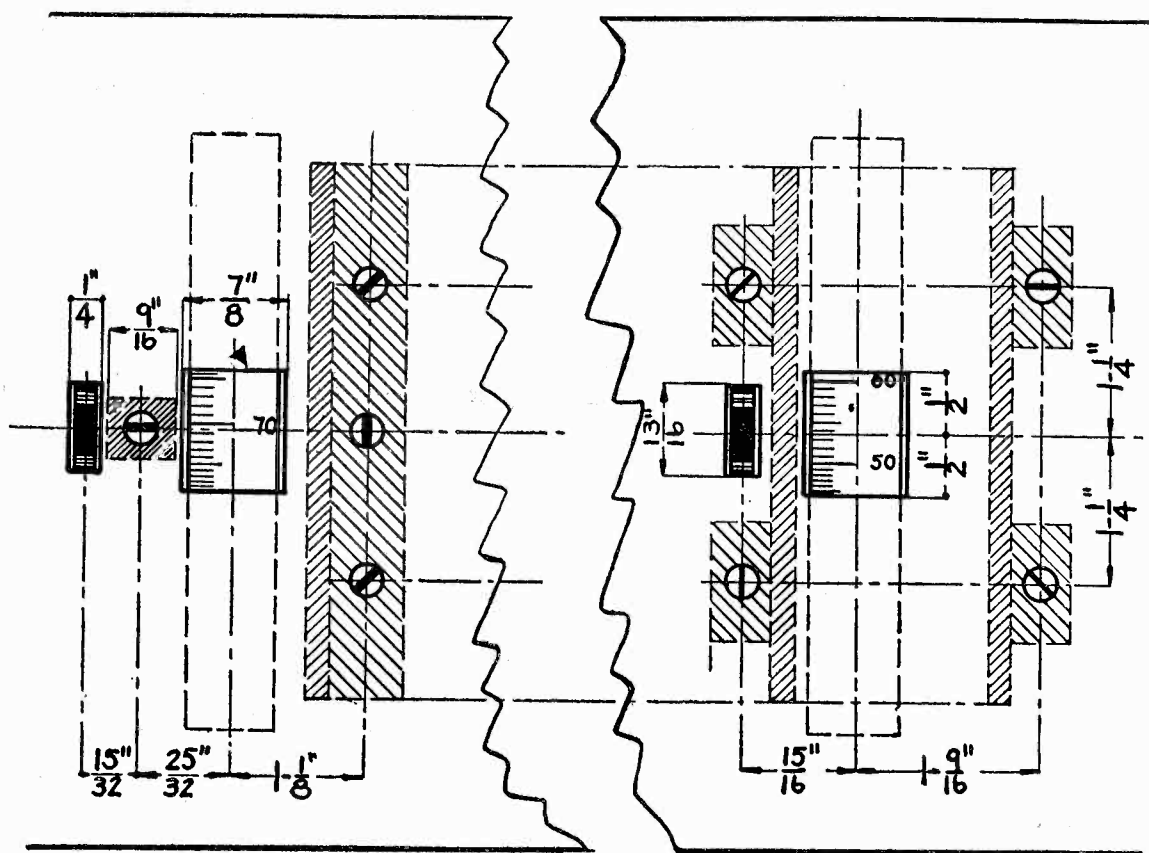

Fig. 4. Panel Layouts for Single and Double Types.

ing to a length of  $\frac{9}{16}$  in. If a rubber washer is to be used for the friction disc it will be well to put a plain brass washer on next, then the rubber washer, another brass washer, another piece of tubing  $1\frac{7}{16}$  in. long and finally two  $\frac{8}{32}$  hex nuts locked tightly to prevent the assembly from loosening. The last two nuts are not to be placed until the dial has been completely assembled. The two panels are accurately spaced apart at the rear by means of two  $\frac{3}{16}$  in. threaded tie rods with hex nuts as shown in Fig. 3. The unit is mounted with small angle pieces shown.

An ordinance prohibiting interference with radio reception during specified hours of the day and night has been passed by the city council of Wellington, Kansas, upon the request of Mayor W. P. White. The maximum penalty for violation is a fine of \$100 or thirty days in jail.

ameter. I think the reason for the efficiency of these coils is due to  $LD$  ratio and the small diameter, keeping the field of the winding from spreading all over the set.

The coils had  $7\frac{1}{2}$  turns for the 20 meter band,  $15\frac{1}{2}$  turns for 40 meters,  $32\frac{1}{2}$  turns for 80 meters and  $54\frac{1}{2}$  turns for 200 meters.

The tickler coils were scramble wound on a  $\frac{1}{2}$  in. form and had 6, 11, 18 and 24 turns of No. 26 enamel wire for the 20, 40, 80 and 200 meter bands respectively. The tickler was mounted inside the bases.

Solder the top wire of the secondary to the grid prong of the base, the bottom wire to the large filament prong opposite the grid. The inside of the tickler goes to the other filament prong and the other end of the tickler to the plate. This makes it easy connecting up the socket, as each terminal is marked. The pin on the side of the base should be pulled out.

## Protection of Meters

By B. F. McNAMEE

AS A MEANS for preventing the cause of that dejected feeling which occurs immediately following the accidental overloading and consequent demise of a good and faithful meter, the following arrangement has been found excellent. In most cases it is more satisfactory than a fuse of any sort. The margin between full scale current and the current which will damage a meter is often much too narrow for the fuse type of protection.

To protect the ordinary milliammeter, simply shunt it with a rheostat having a total resistance equal to about twice that of the meter itself, as shown in

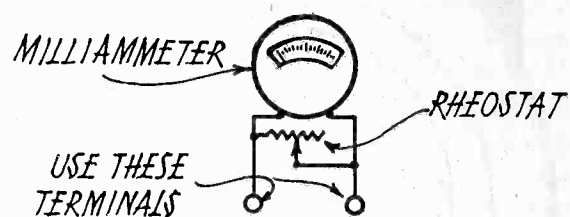

Fig. 1. Milliammeter Shunt

Fig. 1. This would usually mean a rheostat of about 2 ohms if the meter reads to 50 or 100 milliamperes, while 6 ohms would be about right for a 10 milliamperere scale, and 25 to 50 ohms on the very low scales. This is assuming the usual run of good-grade 3 or  $3\frac{1}{2}$  in. meters. Special instruments often have lower resistances, and therefore the shunting resistances should be correspondingly lower. The rheostat must have an open or "off" point, when the pointer is turned to the extreme right; that is, just beyond the highest resistance position. It must be a high-grade rheostat which makes firm, positive contact at all other points.

To use this arrangement, insert it in the circuit with the rheostat turned to the extreme right, or point of lowest resistance. If a shortcircuit exists, most of the current will pass through the resistance, and as the rheostat is turned slightly the pointer will soon reach full scale, showing that the current is beyond the range of the instrument; in other words, that's the place to call a halt. If, on the other hand, the current is within the range of the instrument, the rheostat is turned to the off position, and the meter reads the current directly.

It is also obvious that the rheostat, which acts as a shunt to the meter, may be used as a multiplier for making approximate readings of currents which are too large to be handled by the meter directly. A pointer and scale, or a dial, must be provided on the rheostat for this purpose. It can be calibrated by connecting it in series with a meter of higher range. Or if such a meter is not available, connect the meter in a circuit in which the current will give full scale

(Continued on Page 46)



# QUERIES and REPLIES



Questions of general interest are published in this department. Questions should be brief, typewritten, or in ink, written on one side of the paper, and should state whether the answer is to be published or personally acknowledged. Where personal answer is desired, a fee of 25c per question, including diagrams, should be sent. If questions require special work, or diagrams, particularly those of factory-built receivers, an extra charge will be made, and correspondents will be notified of the amount of this charge before answer is made.

Saw an article on using a 2 ampere Tungar charger for an "A" battery eliminator by placing 7½ volts of dry cells across the output. Would a 5 ampere charger be treated in the same way? Would also like to build a chemical "B" eliminator, without the use of transformers or other power apparatus—J. N., Lake Andes, S. D.

You could use the 5 ampere charger in the same manner, although operating the charger at a lighter load than that for which it was designed may burn out the filament of the Tungar bulb. When a 5 ampere charger is operated at 2 amperes, there will be a smaller load on the power transformer, and the voltage applied to the filament of the Tungar bulb will be higher, so that the filament current will be greater and the life of the filament will thereby be shortened. A circuit for a chemical B eliminator is shown in Fig. 1,

liquid only being used to fill the cells. Care should be taken to allow no dirt to enter. Wash and rinse the electrodes thoroughly in clean water, and place them in position in the jars so that at least ¾ in. of the electrode is immersed in the water.

It is important to note that before connecting the eliminator to the receiver, it is necessary to either disconnect the ground wire of the receiver, or insulate it from the ground by placing a .1 mfd. fixed condenser in series with the ground lead. With the usual ground connection a circuit would be formed through the eliminator from the 110 volt supply, and the house fuses would blow.

Would like a circuit for a two-stage audio amplifier to be used in connection with the Best 115 k.c. super, but using a push-pull power stage, with 71A tubes and 180 volts "B" supply.—T. P. D., Hartford, Conn.

a change will have to be made in the 1 ohm resistor which is placed in the negative A supply lead to the four tubes having a five-volt filament. This is because of the addition of an extra power tube, so that the resistor should be ¾ ohm. The grid return lead for the first audio stage goes directly to the negative A terminal, so as to obtain the voltage drop across the ¾ ohm resistance as C bias.

Please publish the data for constructing a set of short-wave coils, the secondary to be tuned with a .00015 mfd. condenser, and to cover bands of wavelength from 15 to 130 meters. Would prefer to have an antenna coil rather than couple the antenna to the grid through a small condenser.—D. W., San Jose, Calif.

The number of turns in the primary, secondary and tickler coils, for a set of three coils to cover the band from 15 to 130 meters is given in the table below:

Waveband	Primary	Secondary	Tickler
15-35	7	3	3
30-70	7	9	4
60-130	7	19	6

The primary may be wound with No. 26 or 27 cotton or enameled wire, on a 2¾ in. form and, if possible, it should be so mounted that it may be varied with respect to the secondary coil. The secondary is wound on a 3 in. tube, and should preferably be space wound, with No. 22 or 24 enameled wire. The tickler may be No. 28 or 30 silk or cotton-covered wire, wound on a 2¾ in. tube, and placed inside the secondary. It is assumed that the tickler condenser is .00025 mfd. and that it is placed in series with the tickler, between the latter and the filament of the detector tube.

Can a Western Electric 216-A tube be used in a short-wave transmitter? If so, what should the plate voltage be?—A. R., Lorain, Ohio.

The 216-A tube is usable at plate voltages up to 135, but should not be used at high

(Continued on Page 49)

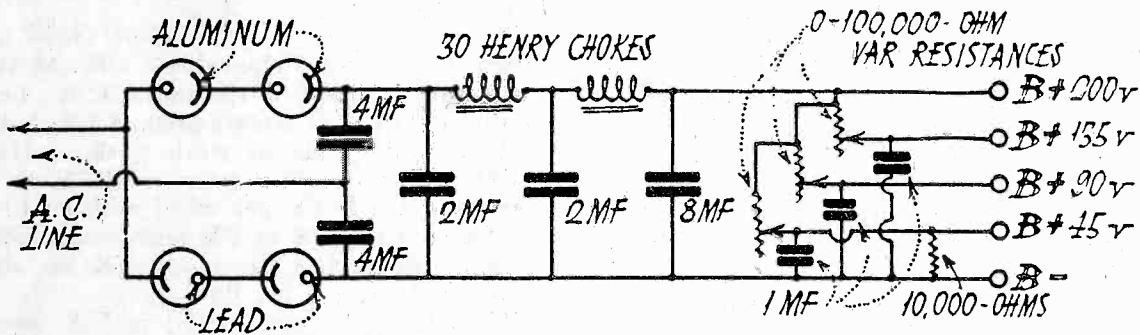

Fig. 1. Circuit for Electrolytic B Eliminator

it being known as the voltage doubling circuit, and was described in detail in July 1926 RADIO. A set of four rectifier jars are used, two being placed in series on each side of the 110-volt line. One cell may be used on each side, but the voltage output will be considerably lowered, and the efficiency less, as there will be large amounts of reverse current. The two 4 mfd. condensers placed in series across the filter input have a midtap which is connected to one side of the 110 volt a.c. line, and the other side of the a.c. circuit goes to the midtap of the rectifier. The materials necessary for the rectifier jars are: 4 small glass jars, 4 aluminum electrodes, 4 lead electrodes, 1 package Willard colloid filler, distilled water.

The aluminum and lead electrodes may be obtained from any Willard storage battery dealer, as they are standard replacement parts for their chargers. Common borax may be used instead of the colloid filler. The electrodes may be mounted on small bakelite strips, so that the aluminum electrode will be on one side of the jar, and the lead electrode on the other. The solution is prepared by dissolving the filler in a pint of distilled water, or, if borax is to be used, by dissolving as much borax as possible in distilled water, to make a saturated solution. The solution should be stirred thoroughly, then allowed to stand and settle, the clear upper

The audio frequency amplifier combination you request is shown in Fig. 2. A suggested arrangement of the amplifier would be to mount the first audio stage on the sub-panel of the receiving set, with a phone jack on the panel so that the power stage could be cut out, and the phones connected to the first audio output. The push-pull stage could then be placed on a separate mounting, located in the compartment with the B eliminator. As the circuit has been arranged as a modification of the diagram of the 115 k.c. super which appears elsewhere in this issue,

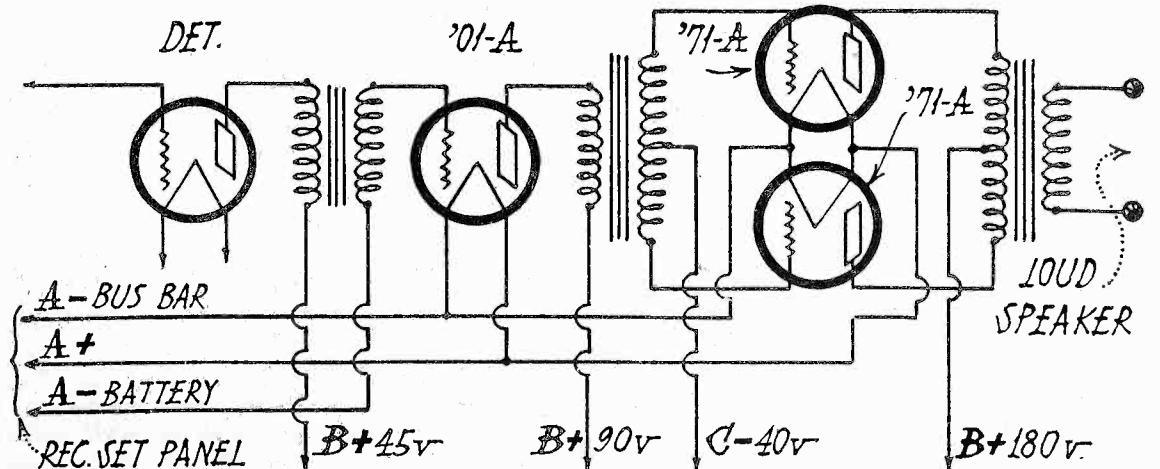
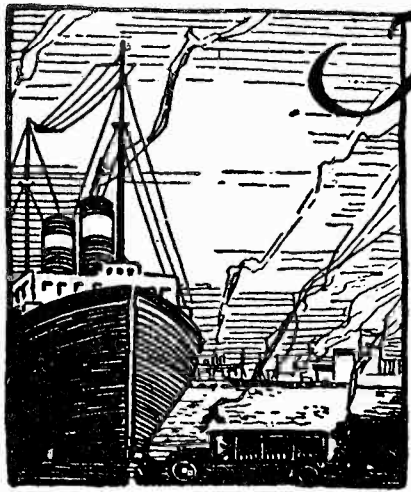

Fig. 2. Push-Pull Amplifier for 115 K. C. Superheterodyne





# The COMMERCIAL BRASSPOUNDER

A Department  
for the Operator  
at Sea and Ashore



Edited by P. S. LUCAS  
R. O. KOCH, Assistant



## VIS, MARINE TRANSMITTER AT SYDNEY, AUSTRALIA

By J. GARRICK EISENBERG

The marine transmitter of Sydney Radio is thirteen miles from the city at the Pennant Hills station of Amalgamated Wireless, which also houses the short wave and broadcast plants. In fact the marine unit, occupying a very small corner of the operating room and surrounded by the imposing broadcast frames and polished brass paneled short wave transmitters is apt to be passed over by the casual observer. The keying relay on the panel front of course attracts attention to it, when the transmitter is thrown into action by remote control from the receiver station.

It is a commonplace enough appearing panel as electrical equipment goes; the unit stands about 5 ft. by 3 ft. and is completely enclosed so that only the meters and the associated inductances—and to a trained ear the keying—tell one what its particular function at this radio central happens to be.

The antenna for the marine service is suspended from the single 700 ft. mast, from which radiate a multitude of antennae for the various services, and the coupling is provided by an r.f. lecher feed. Incidentally this method of antenna coupling is used invariably in Australia; in some cases the antenna is more than a thousand feet distant from the transmitter house, but no serious energy loss is encountered with even this length of lecher, one side of which is earthed, or as we say, grounded.

The transmitter itself does not differ much from standard practice. It is a self-exciting oscillator, putting about 1 k.w. into the antenna—it's rated somewhat higher, but for some reason they still stick to the English system of rating, according to plate circuit powers. The keying system is worthy of comment, however. Use is made of a holding negative bias to keep the tube blocked with key up; with key down a "bucking" battery places a slight positive potential on the grid, the tube then drawing normal plate current. It makes a smooth keying scheme as the filaments are always at constant potential; there are no keying thumps and as the bias batteries are of low voltage, no precautions are required to prevent arcing at key contacts even at 30 WPM. In fact the same principle is used for keying the beam circuits up to 300 WPM!

Another unusual stunt in use at this station is a chopper, which instead of interrupting the load, operates to short out and in consecutively a few turns of antenna inductance. As the voltage across these turns is low the circuit is smoothly cut in and out to give a note of about 900 cycles—dependent on speed and number of segments of chopper commutator—and a few meters broad. This scheme also has the advantage of maintaining the load constant—an idea we could make more use of in our own circuits.

That's about all there is to report except the favorable impression conveyed by the fine

construction jobs done on the various transmitters manufactured in Australia. This is particularly true of the S. W. sets. The jobs as mentioned are highly polished brass completely enclosed with heavy plate glass strips as supports. They've done a good bit on marine S. W. there—claim to work the Tahiti regularly in Vancouver Harbor on traffic! I think that installation—Tahiti—was the first marine S. W. of record; it went in sometime in 1925. What about it? Anyone know any different?

## MUNICIPAL RADIO STATION WMH

By C. G. BARANY, Manager

This will introduce to you and all fellow readers of the "Brasspounders" column, coast station WMH of Baltimore, Md., owned by the city of Baltimore, but radio controlled by the Radio Corporation of America. Continuous 24 hour service is kept with Postal, Western Union, and Bell telephone wires in office. Coast tax 10 cents per word, no minimum. Location: 2nd floor, Recreation Pier, foot Broadway, Baltimore, Md. Station has been open to PG service since April 14th, 1927. Visitors always welcome.

WMH sends daily at 10:30 a. m. (E.S.T.) on 715 meters ICW the following information furnished by the U. S. Weather Bureau: Winds, Sandy Hook to Hatteras; forecast for the Chesapeake Bay; and weather conditions report for the following important maritime points on the Atlantic Coast—Sandy Hook, Philadelphia, Atlantic City, Delaware Breakwater, Baltimore, Norfolk, Cape Henry, and Hatteras. Storm warnings follow when issued. Our traffic list concludes the QST.

The receiver used is the type IP501A made by Wireless Specialty Apparatus Co. Wavelength range 300 to 8000 meters. Detector and 2 step in same cabinet.

The transmitters used consist of two separate sets. One main and one auxiliary transmitter. The main set is the RCA's model ET3626B, 500/750 watt CW-ICW, using 8 UV211 tubes. Wavelengths: 600, 715, and 2290 meters. CW or ICW.

The auxiliary consists of a 200 watt, CW or ICW (chopper modulation) with but two wavelengths, 600 and 715. Both transmitters use the Coupled Hartley circuit. Our daylight range on ICW is about 175 miles, night 250; and on CW, daylight 275 miles, night 500. The auxiliary uses 4 UV211 tubes.

The radio staff of WMH are Mr. Wm. Q. Ranft, Mr. Wm. D. Kelly and Mr. Wm. H. Davis. Please note that all are "Bills" with the exception of myself.

## SOUTH AMERICAN DOPE

By R. MADDEN, S.S. Condor

Of the Pacific Coast countries, Peru has by far the most stations, and messages are handled through any of them with no relay charges. For instance, if I have a message for Lima, I can send it through the station at

Talara with no extra charge for the QSR. There are no telegraph lines in Peru and all messages are handled via radio. There are no LL charges for the following cities: Talara, Callao, Lima, El Encanto, Iquitos, Eten, Ilo, Leticia, Masisea, Pisco, Trujillo and Puerto Maldonado. For all other points the LL is 4c per word. The coast tax is 12c for messages in any language except Spanish and 6c for those in the native language.

Callao, OAA, is the only station supposed to keep constant watch, so messages for other stations should be in before 7 p.m. or wait until the next day. The best way to clear the hook is to wait for the stations to "CQ" before calling him, as he is probably taking a siesta outside and won't hear you anyway.

As far as I could find out, there are no WX or TX sent from Peruvian stations, but OAZ, Lima, sends PX every once in a while. He generally comes on a few minutes after WNU starts up with his PX and is but a few meters off the same wave. When near Lima, it is impossible to hear WNU after OAZ comes on.

There are two main stations in Chili: Arica, CCA, and Valparaiso, CCE. Most of the traffic is handled through CCA. There is also a station at Antofagasta, CCB, but he seldom condescends to work a ship. He is mainly used for point-to-point work. The Chilean coast tax is 12c per word with an LL of 2c. There is no WX or PX sent from Chilean stations, although CCE sends TX on about 2900 meters at 5 p. m., PST.

The above charges are all in U.S. money. If traffic is in English, it would be advisable to leave plenty of space between each word.

## SHORT WAVE PRESS SKEDS

By C. M. BENNETT, S.S. Melville Dollar

2UC, the New York Times station on 39 meters ICW sends PX at 1 a. m. EST. I have copied him r 7 during daylight on the west coast of Mexico. His press is by far the best going. He sends a full page of interesting news and only takes 35 to 40 minutes. NAA sends PX at 2 a. m. on 37.4 meters ICW. This is also e.s.t. 6 xi or kph sends wwaa px at 3.10 a. m. e.s.t. on 34 meters. He may be copied most anywhere. He also began to send his 8.10 p. m. wx bulletin on that wave.

As for time, NAA sends it at the usual time on 37.4 meters; WNBT station of the Elgin Watch Co. at 1 a. m. on about 32.4 meters and FL Eiffel Tower on 32 meters at 7.56 a. m. g.m.t. and p. m. He is easily heard over here QSA.

This station has an ordinary one step s.w. receiver. Signals are received well on a 30 ft. aerial to stack. This seems to work a lot better than the ship's aerial.

We have for transmitter a e.t. 3628 500-watt set which gets out pretty well and 106d tuner. I am always glad to QSR TRS and ETC, and am usually QSO either WIM, WSC, or WGV from west coast and also KPH for about 2000 miles south.

# TIME, PRESS AND WEATHER SCHEDULES

By L. O. DORAN

## ATLANTIC COAST AND/TO PANAMA CANAL WEATHER REPORTS

Major Weather Bulletins covering the Atlantic and Gulf Coasts are sent twice daily by NAA, Arlington. The night bulletin is transmitted simultaneously on long and short waves and the short wave signal can be copied anywhere on the run.

Weather Bulletins containing observations and forecasts are transmitted by a number of stations on the Caribbean and Mexican Gulf and are shown in the schedule list.

Local weather reports are shown in a separate schedule list. There are wide discrepancies (on the East coast) between the schedules actually transmitted and those listed in the various official publications.

NAA Major Bulletins are sent in the same manner as explained previously for NPG. The standard code is used for shore and ship observations. Pressure synopsis and forecasts for the Atlantic regions follow the code section of the bulletins. Only the Key Letters of interest to vessels are given here. See H.O. No. 205, page 103 and Supplements.

### Key Letters

#### NAA Bulletins

GV—Galveston	NF—Norfolk
P—Pensacola	WA—Washington
TA—Tampa	AC—Atlantic City
K—Key West	NY—New York
JA—Jacksonville	T—Nantucket
C—Charleston	E—Eastport, Me.
H—Hatteras	B—Bermuda

The Observation Bulletins transmitted by the stations listed below, contain only one code group which gives barometer and wind as explained previously.

NAR Bulletin	TI—Turks Island, Bahamas
H—Hatteras	
C—Charleston	NAW Bulletin
JA—Jacksonville	SJ—San Juan, P. R.
MI—Miami	ST—St. Thomas, Virgin Islands
K—Key West	BT—Basseterre, St. Kitts
P—Pensacola	RS—Roseau, Dominica
BW—Burwood, La.	BB—Bridgetown, Barbados
GV—Galveston	SD—San Domingo, S. D.
BV—Brownsville	PL—Puerto Plata, S. D.
KN—Kingston, Jamaica	LU—Castries, St. Lucia
TI—Turks Is., Bahamas	W—Willemstadt, Curacao
HA—Havana	PS—Port of Spain, Trinidad
GO—Guantanamo Bay	SM—St. Martins, D. W. I.
SI—Swan Island	
SJ—San Juan, P. R.	WPA Bulletin

UB Bulletin	BV—Brownsville
SI—Swan Island	CC—Corpus Christi
BZ—Belize, Honduras	GV—Galveston
BFD—Bluefields, Nicaragua	PA—Port Arthur
W—Willemstadt, Curacao	NO—New Orleans
SJ—San Juan, P. R.	MO—Mobile
PP—Port au Prince, Haiti	K—Key West
CFG—Cienfuegos, Cuba	
GUE—Guane, Cuba	
KN—Kingston, Jamaica	

Some of these reports are sent only during the hurricane season as shown in the Schedule List.

### TIME SIGNALS

Time signals are available as shown in the main schedule list. NBA and NSS are heard in the Caribbean and NAA's 37.4 meter signal can be heard anywhere on the run. North of Cuba NAA can be heard on 2677 meters although NSS signals are generally better. NAA

also has a 4909 meter wave used in time signals but it has very poor range. NAR also has rather poor range.

### PRESS

NBA press can be copied in the Caribbean and north of Cuba. WNU and WAX can be copied anywhere on the eastern run. WSA and WSH do not carry well through the summer QRN south of Hatteras. NSS on long wave can be copied anywhere north of the Canal but QRN will frequently kill NAA on 2677 south of Cuba. WII or WRQ are good north of the Canal.

As on the Pacific side of the Intercoastal run, the best press, with no static difficulties, is the 40.8 meter schedule of 2UO and the 37.4 meter transmission of NAA. North of Hatteras and inside the "skip-distance zone," the signals of 2UO may become weaker.

2UO press gives all the main news items, domestic and foreign, that are printed in the N. Y. Times and includes sports and baseball scores for the Major and Pacific Coast Leagues. On Saturday nights the League standings are sent.

### GENERAL NOTES

All Gulf and Atlantic Coast commercial stations call and transmit on 600 meters or will shift on request. WCC and WSH maintain 2100 meter watch and various Gulf and Caribbean stations of the T.R.T. have schedules for 2100 and 2400 meter work. They generally call CQ on these waves when ready for business.

### MAIN SCHEDULES—PANAMA CANAL TO ATLANTIC COAST

E.S.T.	CALL	WAVE	SENDS
12:15 AM	WII	13750	Tribune press (1)
1:00	2UO	40.8	N. Y. Times press
1:30	WSA	630	Press
2:00	NAA-NNS	17130-2677-37.4	Navy press, all waves
5:00	NBA	6518	Navy press, all waves
6:30	WAX	5551	Press to KUS
10:30	NAA	2677	Major Weather Bulletin
11:30	WNU	3331	Wea, tfc and press to KUS
11:45	WPA	925	Weather (2)
11:55	NAA-NSS	17130-2677	Time sigs, both waves
11:55	NAR	2929	Time sigs, both waves
12:30 PM	UB	4075	Weather (4)
12:55	NBA	6518	Time sigs
9:00	NAW	600	Weather (3). Repeats on 2541 mtrs.
9:55	NAA-NSS	17130-2677-37.4	Time sigs
10:00	NAR	5657	Weather
10:30	NAA	2677-37.4	Major Wea Bulletin
10:45	WSH	2850	Press
11:30	WNU	3331	Wea, tfc and press to KUS
11:45	UB	4075	Weather
(1) May be sent by WRQ on 13500			
(2) June 1 to November 30, inclusive.			
(3) July 1 to November 15, inclusive			
(4) Code observations sent only from June to November.			

### ATLANTIC AND GULF COASTS—LOCAL WEATHER SCHEDULES

E.S.T.	CALL	WAVE	SENDS
9:00 AM	WSC	650	Sandy Hook weather
5:00 PM			
8:00 AM	NAM	600	Cape Henry and Cape Hatteras weather
8:00 PM			
10:30 AM	NAO	600	Charleston weather. Coast forecast
6:00 PM			
11:00 AM	NEV	**1500	Savannah weather. Coast forecast
6:00 PM			
11:30 AM	NAQ	**1304	Miami weather. Coast forecast
6:00 PM			

10:00 PM WNU 3331 Burwood, Port Arthur and Galveston weather. Coast forecast

(\*\*Approximate wave length).

Many incorrect schedules are given for these and other stations in various official publications.

### U. S. WEATHER BUREAU BROADCASTS Forecast Division

Since February 1, 1928, the U. S. Weather Bureau has broadcast weather reports, forecasts, and warnings in International Morse Code, in accordance with the following schedule. The broadcasts are made directly from the Weather Bureau office in Washington, D. C., in co-operation with the Office of Communications of the Navy Department, by distant control connection with the Naval Radio Station (NAA) at Arlington, Va.

### SCHEDULES IN EASTERN STANDARD TIME

(75th Meridian Time)

(a) 8:15 a. m.—Current weather observations from stations in the United States, Canada, and Alaska. Broadcast simultaneously on frequencies of 4015, 8030 and 12,045 kilocycles. (74.7, 37.4 and 24.9 meters, respectively.)

(b) 10 a. m.—Bulletin containing weather reports, information, forecasts, and storm warnings for the benefit of marine and aviation interests. Broadcast simultaneously on frequencies of 112 and 16,060 kilocycles. (2677 and 18.6 meters, respectively.)

(c) 11 a. m.—Observation reports from selected United States and Canadian land stations, and Atlantic ship reports, for the benefit of European meteorological services. Broadcast on a frequency of 12,045 kilocycles. (24.9 meters.)

(d) 8:15 p. m.—Current weather observations from stations in the United States, Canada, and Alaska. Broadcast on a frequency of 4015 kilocycles. (74.7 meters.)

(e) 10 p. m.—Immediately following the time signals. Bulletin containing weather reports, information, forecasts, and storm warnings for the benefit of marine and aviation interests. Broadcast simultaneously on frequencies of 36 and 112 kilocycles. (8328 and 2677 meters, respectively.)

(f) 11 p. m.—Observation reports from selected United States, Canadian, and Alaskan stations, and Atlantic ship reports, for the benefit of European meteorological services. Broadcast on a frequency of 4015 kilocycles. (74.7 meters.)

The 8:15 a. m. (a) and 8:15 p. m. (d) broadcasts are made by the regular U. S. Weather Bureau word code, which can be easily translated by means of a code book (Weather Bureau Code, 1924, W. B. No. 814), copies of which may be procured from the Superintendent of Documents, Washington, D. C., at \$1.25. They consist of weather observations of current date taken, respectively, at 8 a. m. and 8 p. m. at about 200 stations in the United States, Canada and Alaska, and show sea-level barometric pressure, current temperature, wind direction, temperature (minimum in a. m. reports and maximum in p. m. reports), wind velocity, amount of precipitation, clouds (kind, direction, and rate of movement), and other data. These broadcasts are made for the benefit of Army, Navy, and commercial aviation fields, for business organizations, and as a general public service.

The 10 a. m. (b) and 10 p. m. (e) broadcasts are the regular marine and aviation bulletins heretofore broadcast at 10:30 a. m. and 10:30 p. m.

The 11 a. m. (c) and 11 p. m. (f) broadcasts are in the International Numeral Code and are primarily intended for the benefit of European meteorological services. It forms a

(Continued on Page 38)



# With the Amateur Operators

## 40-20 METER ANTENNA SYSTEM

By HUGO E. ANDERSON

Present day transmission on short waves requires a quick means of shifting from one waveband to another. The three wavebands most in use are the 80, 40, and 20 meter. At the author's station, after many antenna arrangements, the one most liked was an antenna made for 40 meter work with facilities for a quick change to the 20 meter band, using one-half of the antenna with voltage feed. This system I will describe; it can be easily adapted to the individual requirements of other stations.

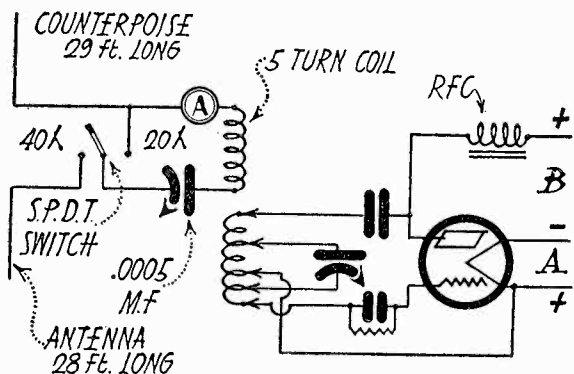

Antenna System

The accompanying diagram gives an idea of how the system operates. By throwing the S.P.D.T. switch to the left, the transmitter is ready for 40 meter operation, and by throwing the same switch to the right, 20 meter operation is in order. Of course, the tuning condensers and coil clips must be changed for different bands, but these can be jotted down on a piece of paper, once the best adjustment is found. At 9BKN it takes less than a minute to change from 40 to 20 meters or vice versa.

Current feed is used for 40 meter work and voltage feed for 20 meter operation, without a transmission line. For best operation, the transmitter should be located as near to the lead-in as is electrically and mechanically possible. About a foot from the lead-in is about the maximum distance for best results, otherwise the losses will be too high.

Resonance with the antenna can be shown in the usual manner with ammeter or flashlight; if a flashlight is used, it should be shunted with a S.P.S.T. switch after the final adjustment has been made.

The "top" of the Hertz antenna is made longer than the "bottom" so that when 20 meters is used, the "bottom" will not absorb any r.f. energy. This isn't a very important precaution, but still is worth while.

This antenna system has been in use at the author's station for some while and has proven satisfactory from every viewpoint. Any of the usual methods used for lightning protection can be used on this antenna system. But all told, it is an expensive layout which results when one follows the Underwriters' requirements on a transmitting aerial of any kind. A system of clips is used at 9BKN for grounding, and has been found to work well and to have low losses.

### CALLS HEARD

By John Mardesich, 7MX, 1419 So. G Street, Tacoma, Wash.

am1AB, eb4WW, eb4ZZ, ef8JF, ef8IX, enOJA, es1CO, na7ABE, na7AER, na7KK, na7OL, nj2PZ, nm9A, nm9B, nn1NIC, nq2CF, nq2AC, nr2FG, nrCTO, nx1XL, oa2CH, oa2DY, oa2JC, oa2MH, oa2MK, oa2NO, oa2RB, oa2RT, oa2SH, oa2WB, oa2WC, oa2XI, oa2YI, oa2YJ, oa3BD, oa3ES, oa3HR, oa3JK, oa3LS, oa3WM, oa3XK, oa4AW, oa4GO, oa4HW, oa4NW, oa5DX, oa5HG, oa5QP, oa3RJ, oa5XG, oa7CW, oa7DX, oa7HL, oc8XZ,

(Continued on Page 48)

## NU 6JU—6CZA

The amateur station of the San Mateo Junior College Radio Club, at San Mateo, Calif., has a location to be envied by most amateurs. The "shack" is a three-room house built on top of the three-story main building of the college. It consists of an operating room, a club room, and a generator room. The operating room is 10 by 12 feet with a 3 ft. bench running clear around three sides of the room. The transmitter is mounted on

The receivers are the conventional Schnell type. The main set seen on the left uses 201-A tubes and Aero coils. The small set uses UX-199 tubes and has dry A and B batteries mounted in it. Both receivers may be operated at once to cover one or more of the amateur bands. The receiving antenna is 150 ft. long.

In the line of additional equipment there is a Grebe 200 to 1500 meter set for use when the ops want some practice on commercial stuff, a Radiola super-het in the clubroom,

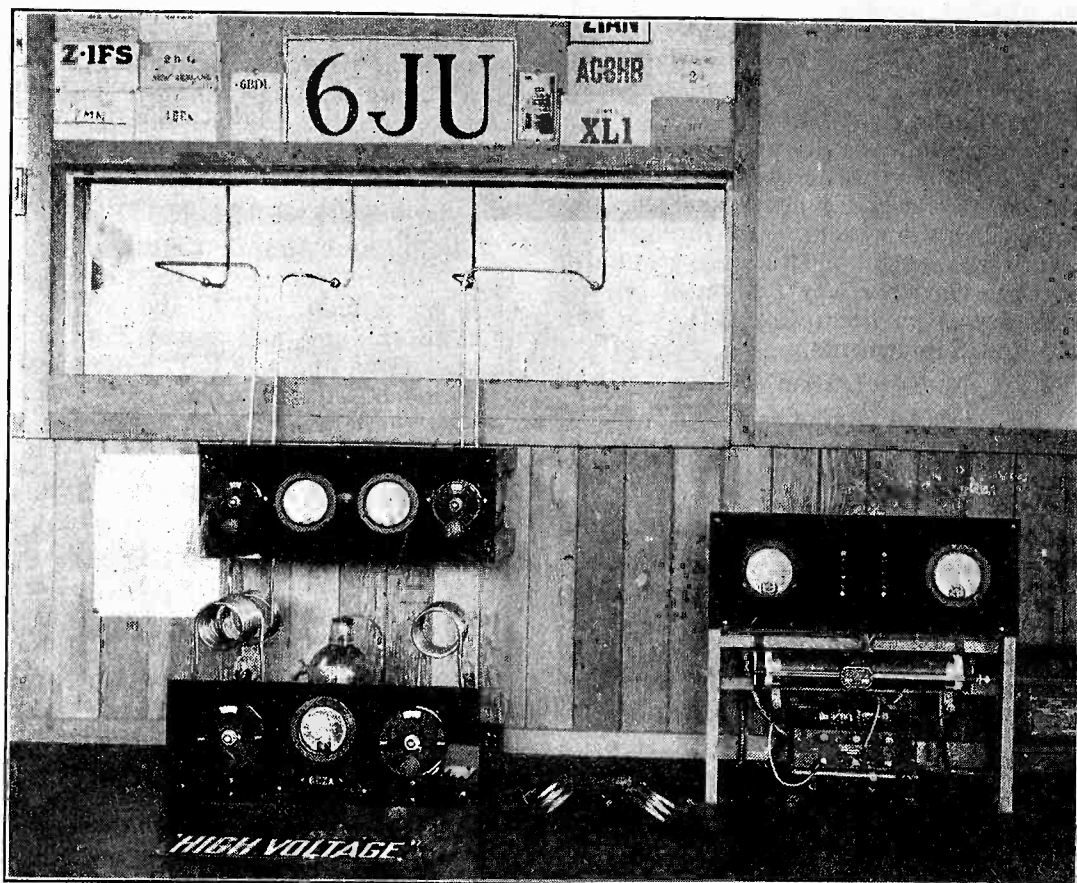

Short Wave Transmitter at 6JU

the left side, the short wave receivers in the center and a Grebe intermediate wave receiver on the right side.

The transmitter uses a UX 852 tube in the tuned grid and plate circuit. Plug-in coils allow a quick change from 40 to 20 meters. The antenna unit, which is mounted on the wall, consists of two 43 plate series condensers and two 0-2 T.C. ammeters. Coupling is varied by moving the oscillator unit on the table. Plate current is supplied by an Esco 200 watt 1200 volt machine which is placed in the back room and mounted on sponge rubber balls to minimize noise. A relay in the center tap of the filament transformer keys the outfit, and Remy battery cutouts control both motor generator and filament power from the receiving table, thus removing all a.c. wiring from around the receivers.

The antennas at 6JU—6CZA are ideal. The 40 meter antenna is 90 ft. high, being swung across the tennis court from a 40 ft. pole on the main building of the college to a 50 ft. pole on the laboratory building. The flat top is 128 ft. long and each feeder is 32 ft. long. The 20 meter antenna runs up to the 40 ft. pole with a top of 32 ft. and 16 ft. feeders. Feeders of both antennas are fastened above the plate glass lead-in window to large pyrex stand-off insulators. Copper tubing runs from the stand-off insulators through the window to the antenna panel where either antenna may be connected by clips and flexible leads.

and a General Radio 15 to 220 meter wavemeter.

Since last September when the station came on the air in its new location, two way communication has been held with all continents and twenty different countries.

Those responsible for building this station are Davey 6BRN, R. Fisher, McColough 6CHE, Bolton 6AGY, Emerson 6BRQ, and McAulay 6CLO, under the direction, and with the help of R. J. Hopkins, dean of the college.

### COMMISSION REGULATION OF AMATEUR RADIO

The Federal Radio Commission has adopted the following definition and regulation: "An amateur station is a station operated by a person interested in radio technique solely with a personal aim and without pecuniary interest. Amateur licenses will not be issued to stations of other classes."

In accordance with the channels designated for amateur use under the new International Radiotelegraph Convention, the Federal Radio Commission has opened for amateur use the new additional band between 30,000 and 28,000 kilocycles, or 9.99 and 10.71 meters.

The Federal Radio Commission has revised the list of radio telephone bands open for amateur operation to read as follows:

Kilocycles	Meters
64,000 to 56,000	or 4.69 to 5.35
3,550 to 3,500	or 84.5 to 85.7
2,000 to 1,715	or 150.0 to 175.0

# Radio Kit Reviews

## The Aero Radiophone Transmitter

This is a complete short-wave transmitter for either phone or C.W. which may be assembled from standard parts at a cost of about \$150, exclusive of tubes and microphone. It is designed for socket-power operation and is rated at  $7\frac{1}{2}$  watts at 550 volts.

The oscillator uses a type 210 tube in a tuned-grid tuned-plate circuit with series

feed. It is built in two decks, all r.f. current being confined to the upper and all a.f. circuits to the lower deck. On the upper panel are the controls for the tuning condensers and the antenna current and the plate current meters. On the lower panel are the plate current meter for the modulator tubes, the modulator *C* bias control, switch for changing from telephony to telegraphy, and necessary binding posts.

The circuit diagram in Fig. 1 shows both portions of the circuit. Good speech quality is assured by using two 210 tubes as modulators, though one may be used. The output of the microphone transformer is amplified by a 112 tube. A key click filter is connected across the key terminals.

Due to the use of Aero interchangeable coils the set may be tuned to any desired wave between 18 and 180 meters. This transmitter is now in operation at the Aero Products station, 9 DBM, Chicago, which has worked all U.S. districts on 40 meter code and 800 miles on phone.

The transmitter may also be constructed for C.W. operation only by omitting the parts required for phone transmission. In this form it is obtainable as a separate kit.

The kits include printed and engraved panels and all woodwork for the frame, if wanted. The complete instrument stands 16 in. high, 18 in. wide and  $10\frac{1}{4}$  in. deep. Actual size layout sheets and schematics for both decks are supplied with the panels together with printed instructions for assembly, testing and operation. Of course it should not be overlooked that the operator must be licensed by the government.

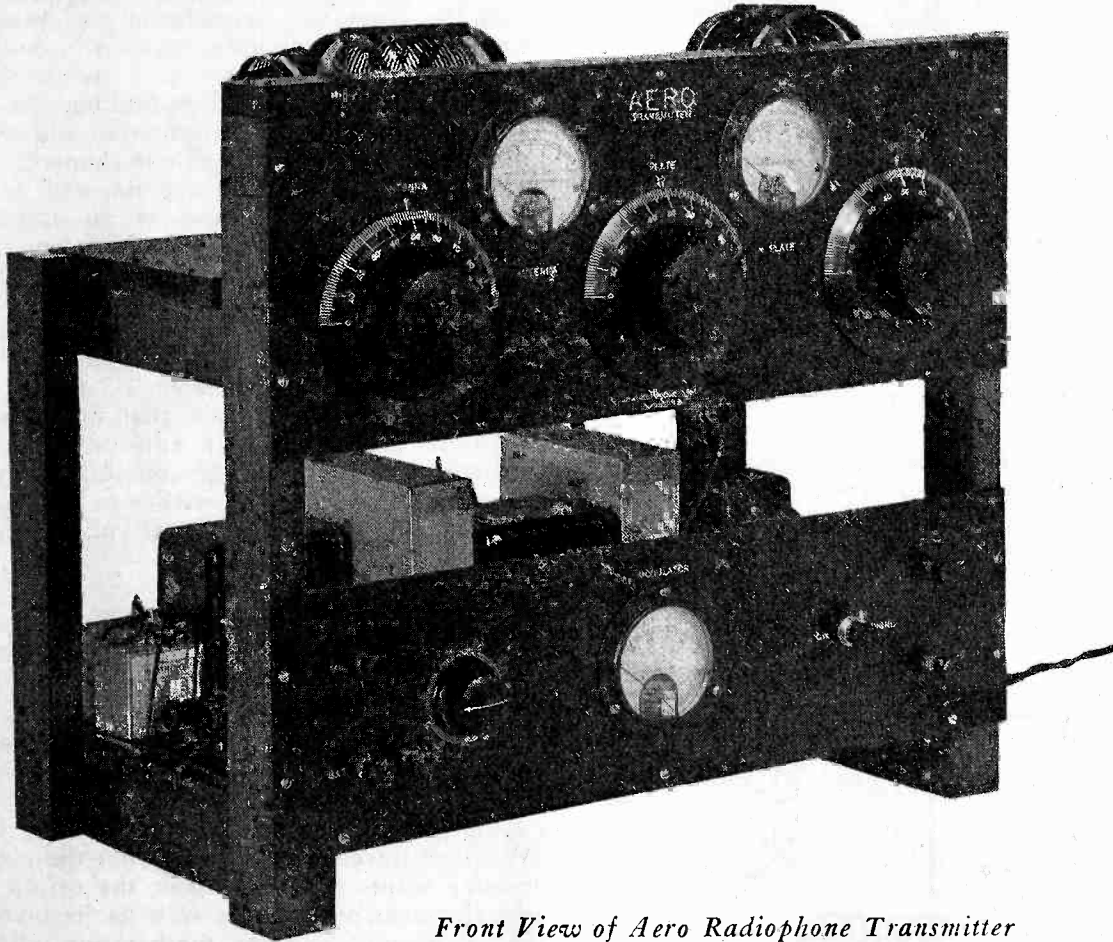

Front View of Aero Radiophone Transmitter

## Building a Cheap Dry Charger

An excellent *A* battery charger can be made by combining a Marathon contact rectifier with the transformer from a discarded full

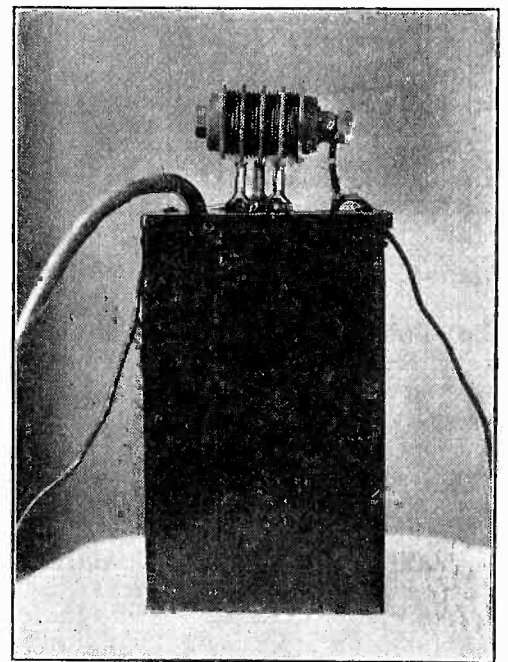

Completed Home-built Charger

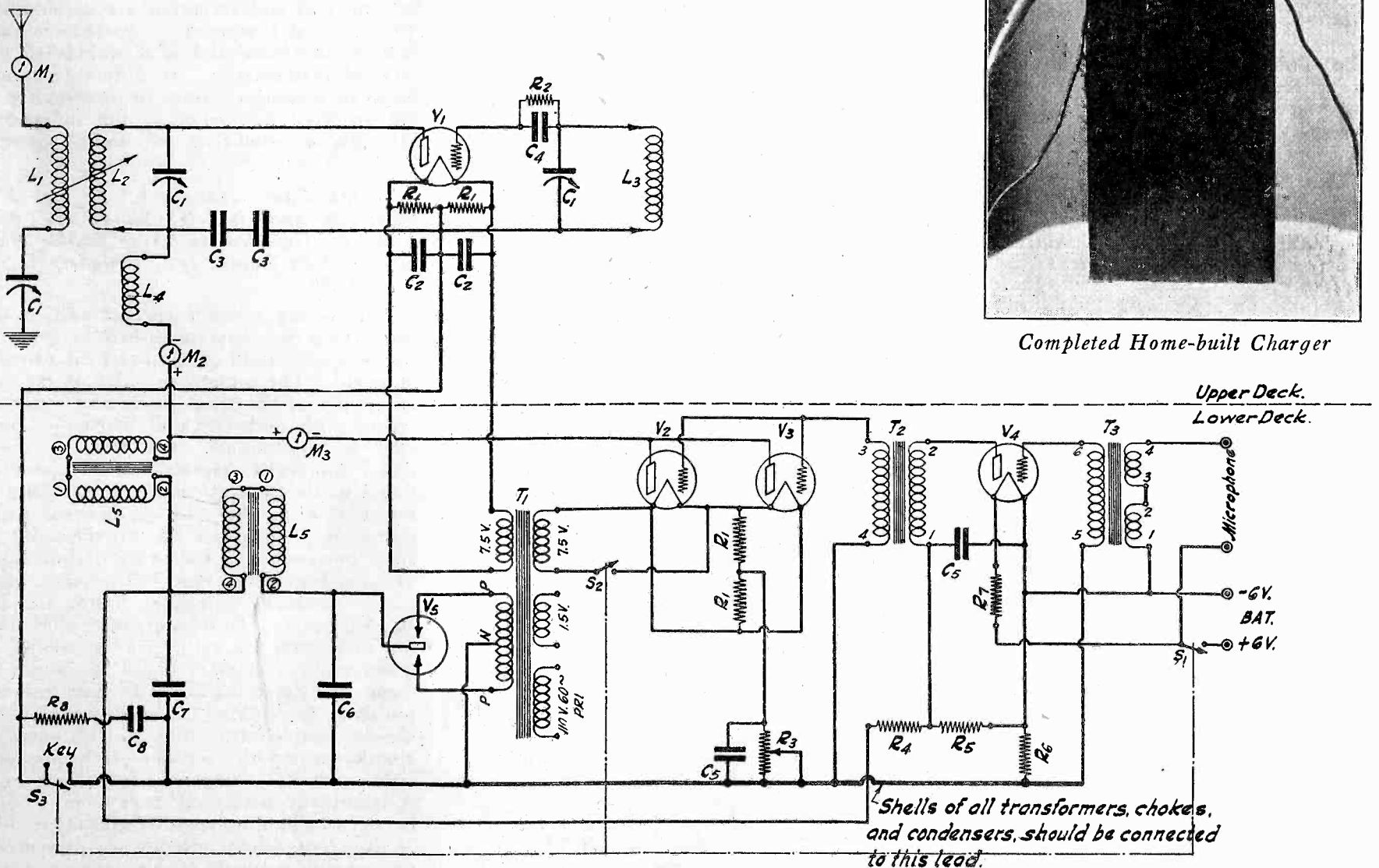

Fig. 1. Schematic Diagram of Aero Transmitter



wave charger of the wet type. While the battery is being charged no hum will be heard on an average five-tube set with this device. The picture shows such an outfit as built by the writer.

Upon dismantling a Balkite charger the transformer was found to be in a can about 2 x 4 x 7 in. The secondary had two coils, the outside leads of one coil protruding through the top, and of the other through the side. The latter were withdrawn so that they came out of the top of the compound with which the transformer is surrounded.

The two secondary coils were then connected in parallel, as found by test with a dry cell lamp or buzzer. A short piece of wire was connected and taped to each set of terminals.

A suitable mount for the rectifier clips was made with a 2 x 4 piece of scrap bakelite, drilled to pass the a.c. leads and the secondary leads as well as the bolts for the rectifier clips. Two small wooden pieces were bolted inside the top of the can flush with the upper edge through whose center a small bolt was fastened to anchor the bakelite with a nut.

The contact rectifier fitted into three clips and had an end connecting bolt. The positive lead from the battery was connected to the center clip and the negative lead to the end bolt. The two secondary leads were connected to the two remaining clips. After the a.c. leads were passed through the hole provided for them, the bakelite was fastened on top of the can. The rectifying element was fitted into the three clips, thus completing the assembly of a charger which gave 4 amperes at 6 volts.

The power transformer secondary has eight taps so that 6 volts may be delivered to as many as eight tubes. The lower voltage taps are used when fewer tubes are employed. The rectifier is of the dry type. In fact no liquid of any kind is used in any part of the device.

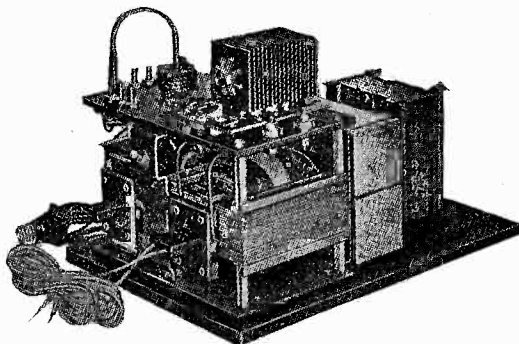

The Assembled Knapp Unit without Metal Cover

The filter consists of two heavy duty choke coils and two 1500 mfd. condensers, connected as shown in Fig. 1.

The kit is accompanied with complete text and drawings that show every detail of the assembly.

### NEW RADIO CATALOGS

Gray & Danielson Manufacturing Co. of San Francisco are distributing a set of service sheets for the information of professional set-builders. These contain descriptions of various kits which use Remler parts. Details have already been given for six circuits and more are in preparation.

### BOOK REVIEWS

"Radio Engineering Principles," by Lauer and Brown; 2nd edition, 300 pp., 6x9 in., published by McGraw-Hill Book Co., New York City, price \$3.50.

This book is avowedly devoted to the theory of radio, with but little description of specific apparatus. As the second edition of a text published nine years ago, it contains much new material having to do with the development of the art during this period. The authors, in their treatment of the subject, first derive the basic formulas for inductance, capacity and resistance in terms of the electron theory of matter. They then discuss the reactance, impedance and resonant conditions of oscillating circuits. Antenna systems and radiation are next described, including methods of direction finding. Damped and undamped wave transmission and reception are each the subject of one chapter. Four of the eleven chapters are devoted to the vacuum tube and its use as an amplifier, oscillator and detector. The final two chapters are concerned with radio telephony and miscellaneous applications. A complete understanding of the contents presupposes the equivalent of a two years' engineering college course. The treatment is concise and more easily understandable than most texts of a similar scope. It is an admirable text for a junior or senior college course and for an electrical engineer who wishes to become informed on the fundamental principles of modern radio.

"A Popular Guide to Radio," by B. Francis Dashiell; 286 pages, 5x8 in., published by Williams & Wilkens Co., Baltimore, Md., price \$3.50.

This book admirably fulfills the purpose indicated in its title and furnishes a good foundation for more advanced study. The author, through his connection with the U. S. Weather Bureau, has sensed what the general reader wants to know about the origin and development of radio as well as its underlying principles and the mechanisms whereby transmission and reception are accomplished. The general treatment is qualitative rather than quantitative and is distinguished by a lack of mathematics. It differs from other books of a similar nature in its complete and authoritative discussion of the influence of atmospheric conditions on radio operation.

"Lefax Radio Handbook," by Dr. J. H. Dellinger and W. H. Shirk, 180 pages, 3 3/4 x 7 in., loose leaf in 6-ring flexible binder, published by Lefax, Inc., Philadelphia, Pa., price \$3.50.

This is the seventh revised edition of a text which was first published in 1922 as a simple explanation of the practical principles of radio. The author, as chief of the radio laboratory of the U. S. Bureau of Standards, writes with authority and first-hand knowledge of the subject. The treatment is divided into seven chapters. Chapter One tells What Radio Does, its many uses on land and sea and in the air, the reasons for assignments of frequencies for broadcasting and other purposes, and the cause of interference between stations. Chapter Two explains the Fundamental Principles of Radio, including electric current, both alternating and direct, the production of radio waves, tuning and modulation. Chapter Three gives the Elements of Receiving and Transmitting Apparatus. It explains the uses of the antenna, the detector, electron tube and its parts, and circuits necessary for the transmission of radio waves. Chapter Four discusses the Assembly of Receiving Sets from a simple crystal to a multitube superheterodyne. Many of the most popular circuits are presented together with methods of supplying power for

(Continued on Page 49)

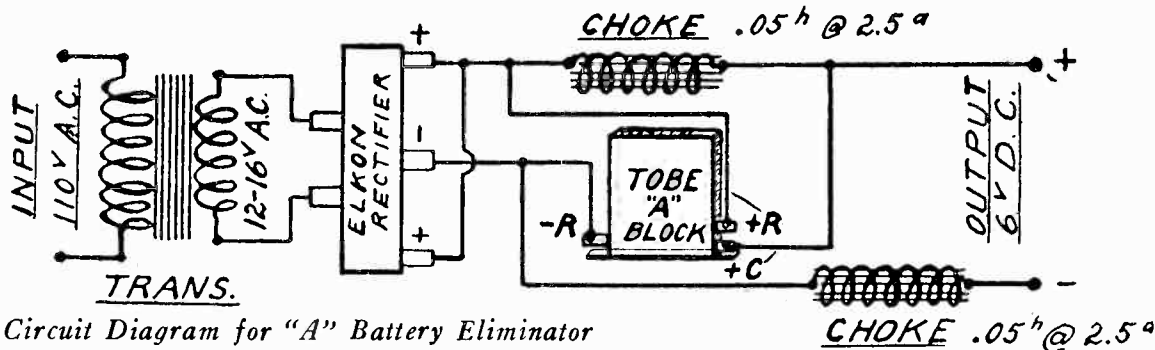

Circuit Diagram for "A" Battery Eliminator

The Tobe "A" block is an ultra-high capacity condenser intended for use in an "A" battery eliminator. When connected in a circuit as shown herewith it may be used with proper choke coils and a rectifier to deliver 2 amperes to the tube filaments in a radio receiver. Its capacity is about 5000 mfd.

### NOTES FROM THE RADIO MANUFACTURERS

The latest "CeCo" tube is the shielded-grid r.f. 22. Its operating characteristics are the same as similar tubes previously described in these columns.

### THE KNAPP "A" POWER KIT

This kit contains all the material necessary for the assembly of an A battery eliminator for use with 6-volt d.c. tubes. It consists essentially of a step-down transformer, a contact rectifier and a filter, together with base-plate, cover, and plug connections.

"What B eliminator shall I build?" is the subject of a 32-page booklet from Electrad, Inc., New York City. It contains circuit diagrams and lists of parts for nine different kits together with data on the resistance and current-carrying capacity of various "Truvolt" fixed and variable resistors.

The Powerizer is a self-contained device for converting battery operated receivers to a.c. operation with a.c. tubes, and at the same time providing a power amplifier stage using a type 210 tube. It consists of a B voltage supply unit, with rectifier, filter and voltage divider, a wiring harness with adapters so that the sockets in the receiver can be equipped with a.c. tubes throughout without changes in the wiring of the set, and a power amplifier stage, without output transformer. It is mounted in a fireproof metal case, with flexible connections to the receiver and the power circuit.

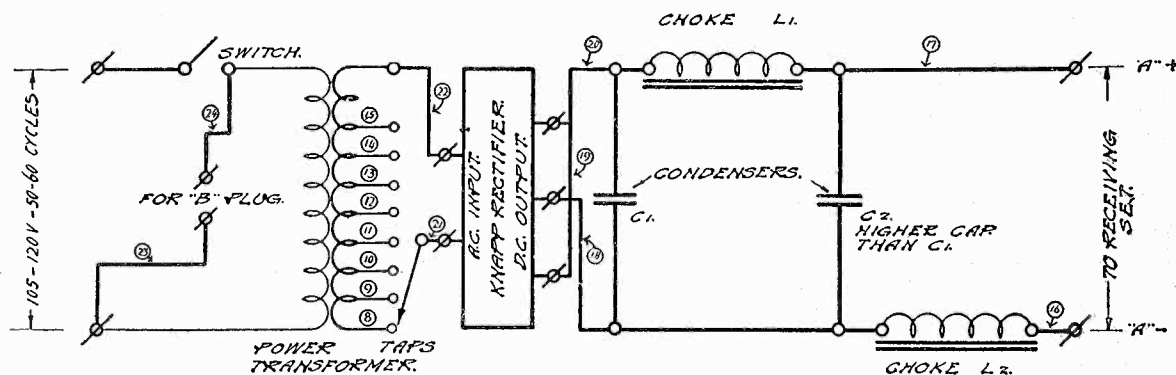

Fig. 1. Diagram of connections for Knapp "A" Power Kit

**ABSOLUTE TONE FIDELITY**

## No Substitute for Dynamic Cone Performance

NO MATTER what speaker you own... or how much you paid for it.. you will very soon agree with us that there can be no substitute for Dynamic Cone Performance.

New as a practical application of a proven principle..the Jensen Dynamic Speaker sets unsurpassed standards of tone reproduction.

From the deepest bass to the highest treble ..(20 to 6000 cycles) this speaker reflects the whole sound range without distortion and with lifelike fidelity. To hear the Jensen Speaker is to understand the Jensen claim

... "*The Finest in Radio*"

### JENSEN RADIO MFG. CO.

212 Ninth Street  
OAKLAND, CALIF.

35 East Wacker Drive  
CHICAGO, ILL.

Write for our two-color folder which completely describes and illustrates the various types of speakers.

# JENSEN

## DYNAMIC SPEAKER

*"The Finest in Radio"*



### Cabinet Models

- TYPE D-44 . . . \$65.00  
For 6 volts operation
- TYPE D-45 . . . \$67.50  
For 90 volts operation
- TYPE D-44 A.C. . \$75.00  
For 110 volts A.C. operation  
Height 14". Width 16".  
Depth 12".



### Jensen Dynamic Units

- TYPE D-4 . . . \$47.50  
For 6 volts operation
- TYPE D-5 . . . \$50.00  
For 90 volts operation
- TYPE D-4 A.C. . \$57.50  
For 110 volts A.C. operation  
Height 10¾". Width 10".  
Depth 8½".



### Console Model

- TYPE D-54 A.C. . \$90.00  
Height 34½". Width 14¼".  
Depth 11".



# electrify your set the easy practical Knapp way....

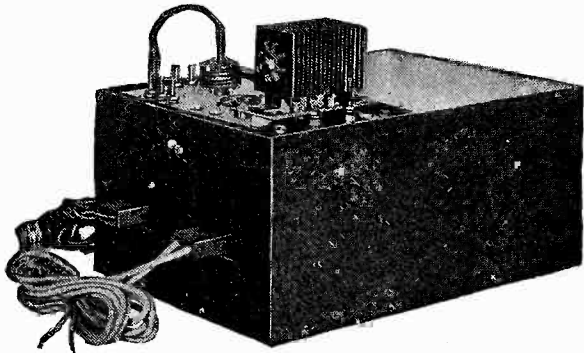

The Kit completely assembled with metal cover in place. Operates on 105-120 volts AC, 50 to 60 cycles.

## Knapp "A" POWER KIT

No expensive short lived AC Tubes, no troublesome re-wiring, no annoying hum. Increase instead of decrease the efficiency of your set, no waiting... the Knapp "A" Power gives you music *instantly* at the snap of a switch.

This absolutely dry "A" Power is not in any way a battery combination... not something to add to your battery... it is the most efficient "A" Battery Eliminator ever designed. It supplies unfailing "A" current to any set using 201-A or 6 volt tubes, regardless of number.

### Magic Silence

So silent is Knapp "A" Power, that you can place a pair of head phones directly across the output and not be able to detect a hum. This is made possible by the efficient Knapp filter system, consisting of 2 over sized chokes and 2 condensers of 1500 microfarads each. A new discovery makes these amazing capacities possible in the small space of 2x2x8 inches!

### Absolutely Dry

There is not a drop of moisture in this absolutely dry unit. The condensers are baked so that not a drop of moisture remains. The unique, fully patented, solid, full-wave rectifier is absolutely dry. No water... no acid... no alkali... no tubes... no electrolytic action. Nothing to get out of order. Nothing that needs attention.

### Assemble in Half an Hour

The Knapp "A" Power Kit is so easily assembled, that within half an hour after you receive it, you can have it in operation. The parts seem to fall in place, No drilling and very little soldering. Everything supplied, even to the screws, wire, drilled base-board and metal cover. It is so complete, that even a plug is supplied so that a "B" Eliminator may be operated from the same switch. We have never seen such simple instructions.

### Big Profits for Set Builders

Our president, Mr. David W. Knapp, is offering the set builders of America, for a limited time only, a money-saving, profit-making plan which is unique in the annals of radio. Send the coupon today, before it is too late.

Knapp Electric Corporation  
Port Chester, N. Y.

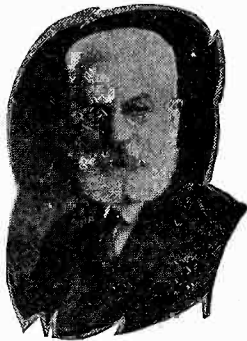

MR. DAVID W. KNAPP, Pres.  
Knapp Electric Corporation  
355 Fox Island Road,  
Port Chester, N. Y.

Send me complete information regarding the Knapp "A" Power Kit and your special discount to Set Builders.

Name.....

Address.....



## THE ELECTRO-DYNAMIC SPEAKER

(Continued from Page 16)

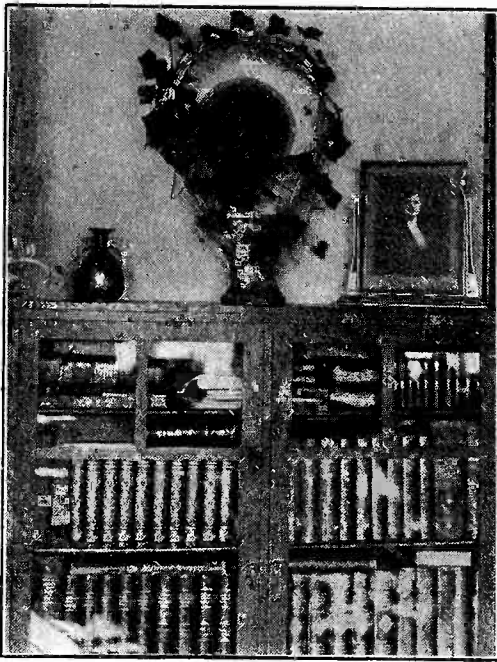

Concealed Wall Installation of Dynamic Speaker

hardly be advisable in an apartment or rented home. But for a permanent installation, it is ideal. Fig 7 shows a wall type installation, in which the back of the speaker is in a hallway leading to the cellar.

The appearance of the rear construction is shown in Fig. 8. A hole is cut

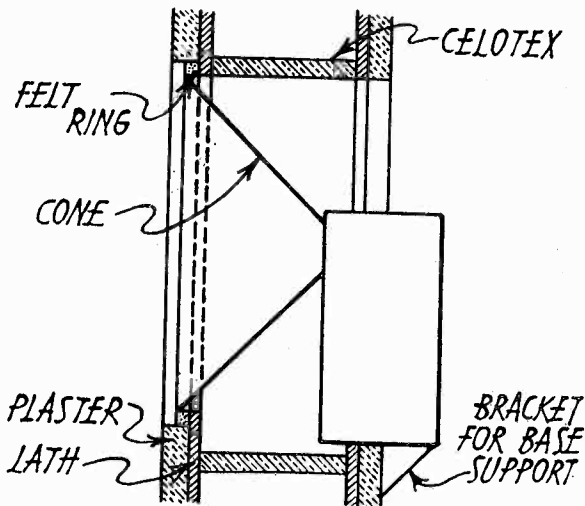

Fig. 9. Wall Installation of Cone

through the lath and plaster, at a point between two uprights, which can be located by tapping the wall and locating a spot where there is a hollow sound. This hole should be the exact diameter of the metal ring supporting the outer edge of the cone, so that for two standard types of unit, it will be a 10-in. hole in the plaster and a 9½-in. hole in the lath. Remove the felt ring from the front of the unit and glue it on the back, so that the felt will rest against the lath, as is shown in Fig. 9. Fill in the space between projecting laths with plaster, and cut out a strip of celotex or other composition material to close up the space above and below the unit, between the two sets of laths, to prevent plaster from falling down on the cone. A bracket placed on the rear wall to support the base of the unit completes the installation.

The front of the speaker can be camouflaged with a suitable piece of silk

## NATIONAL VELVET VERNIER DRUM DIAL TYPE F



NEW in design, but with the familiar NATIONAL Velvet-Vernier Tuning. Made to USE and to last. Full 360 degree motion.

Visible portion of dial inclined upward for easier reading.

Easily attached. Ask for Type F.— Price \$4. Type 28 Illuminator 50¢

Send for Bulletin 121-P

NATIONAL COMPANY INC.  
MALDEN, MASS. W. A. READY, PRESIDENT

## NATIONAL RADIO PRODUCTS

## Gerald Best's SUPER BLUE PRINTS

The complete working plans in full size for building the new incomparable Gerald Best 115 Kilocycle superheterodyne with full instructions for building.

\$1.00 Per set. Postpaid anywhere in the U. S. Send remittance by cash, check or money order. Stamps also accepted. "RADIO," Pacific Bldg., San Francisco, California.



Herman  
Schnitzel  
der Professor...  
University  
Cincinnati  
Oh ho ho

Herman Schnitzel, famed Pacific Coast radio announcer, has published a little booklet containing 26 short radio subjects, written in his comical dialect. These stories have made a hit among thousands of broadcast listeners who have enjoyed Schnitzel's lectures. You, too, will get many a hearty laugh if you read his "works." Send for Schnitzel's book, "Unt Comes It Now." Limited supply on hand.

50 CENTS  
POST  
PAID

"RADIO"  
Pacific Bldg.  
San Francisco  
California

# Reputation

**A**MONG those who know radio, the name "Browning-Drake" stands for a development in the radio art that has won friends everywhere.

Complete factory-built receivers, ranging in price from \$95 to \$260, are offered to meet any requirement for radio reception. For three years Browning-Drake Kits have been the most popular on the market. Now a new loud speaker, licensed under Whitmore, Air-Chrome, patents pending, which reaches nearly an octave lower than the average speaker, is being manufactured by Browning-Drake.

In a word, the reputation of Browning-Drake has been built and is being maintained by designing and manufacturing radio products that supply the demand for something better.

The Browning-Drake Corporation  
110 Brookline St., Cambridge, Mass.

**BROWNING-DRAKE  
RADIO**

## Practical— Radio Telegraphy

A new book, worthy of a place in any radio man's library. Written by Arthur R. Nilson, Director West Side Y.M.C.A. Radio Institute, New York and J. L. Hornung, Chief Instructor, West Side Y.M.C.A. Radio Institute, New York. A book expressly for radio students preparing to become radio operators. A fine general handbook for those having to use and care for modern radio transmitting and receiving equipment. Every commercial operator should have this very latest down-to-the-minute book. Wonderful help to those who contemplate taking commercial operator's examinations.

**380 PAGES**

Bound in cloth. 223 illustrations. Will be sent postpaid upon receipt of price to any part of the U. S. or Canada. Edition limited. Prompt action necessary. **\$3.00**

**PUBLISHERS OF "RADIO"**

433 Pacific Building San Francisco

drapery, such as is used in Fig. 7, or it can be arranged as shown in the picture of a vase or basket of flowers placed in front of the cone to conceal it. Heavy tapestry or other objects which might impair the passage of the sound should not be used.

If the rear of the speaker opens into a room or hall, the sound from the rear speaker may prove objectionable. So this should be taken into account when the location for the speaker is selected. If the back of the unit faces a room where its appearance would attract attention, it may be covered with cloth, and the connecting wires can be dropped down between the partitions, or a grill work of ornamental wood can be placed over the frame supporting the unit. It is important in placing the speaker in position to set it in the wall from the front, so that the felt ring will rest against the laths, and prevent vibration with resulting rattling noises.

Aside from the baffle, which is important enough, there is the practical consideration of the connection between the radio set and the speaker unit. All units now on the market are equipped with an output transformer, having a primary impedance designed to match that of the type 210 power tube, and also a fair match for the 71 or 112, with the secondary designed to match the impedance of the moving coil attached to the speaker cone. As the average a.c. impedance of this coil is 8 ohms, and the output impedance of the power tube is from 2000 to 4000 ohms, depending on the type, a step-down transformer having a turns ratio of at least 25 to 1 is required. It is not practical to connect the plate circuit of the power tube directly to the moving coil, due to the wide difference in impedance.

In England there are several types of electro-dynamic speakers with a high impedance moving coil, but none in the United States.

The ordinary output transformer designed to couple a power tube and an electro-magnetic speaker has a 2 to 1 ratio or less, and is unsuitable for use with an electro-dynamic unit. So all electro-dynamic units are equipped at the factory to prevent confusion and insure good operation. If the radio receiver is already equipped with an output transformer, it should be cut out of the circuit. While the speaker will undoubtedly work with the two output transformers in tandem, a large transition loss will occur, and probably not more than 75 per cent of the available power will reach the moving coil.

Where the receiver is equipped with impedance coupled output, with choke coil to bypass the plate current, and a fixed condenser for the a.c. output, the input of the step-down transformer in the unit can be connected directly to the output terminals of the receiver. However, if the bypass condenser is 1 mfd.



## Announcing DONGAN By-Pass and Filter Type Condensers

With the acquisition of the business and equipment of the Electrical Specialties Mfg. Co., Inc., Dongan now offers the manufacturers of radio receivers a line of fixed condensers comparable in quality and ingenuity of design to Dongan Transformers.

Mr. C. Ringwald, an authority on condenser design and construction, will direct the condenser division of the Dongan radio line.

Just as Dongan has pioneered in transformer development, so will the Dongan laboratories strive to maintain front rank in fixed condenser design.

Thus the radio industry is assured additional permanency in the approved parts field.

*Dongan will continue its policy as an exclusive source to set manufacturers.*

## —another Transformer Success

To meet the increased capacity of the new UX 250 power amplifier tube Dongan engineers have perfected two new Output Transformers. No. 1176 is Push Pull type, No. 1177 a straight power amplifier type.

## A Popular A C Transformer



No. 6521

This is one of the best-liked A C transformers on the market. It is designed to operate with 4 UX 226, 1 UY 227 and 1 UX 171 power amplifier tubes. Mounted substantially in crystallized lacquered case, equipped with lamp cord and plug outlet for "B" eliminator, also tap for control switch. \$5.75

## Set Manufacturers and Custom Set Builders

will be furnished with any desired information and engineering data on request

**DONGAN ELECTRIC MFG. CO.**

2991-3001 Franklin St., Detroit, Mich.

TRANSFORMERS of MERIT for FIFTEEN YEARS

Tell them you saw it in RADIO



# AEROVOX

## MORE POWER From YOUR Eliminator



**I**f your Raytheon eliminator will not hold its voltage when supplying one or two 171 or 371 tubes, you can probably bring it back to full voltage by the addition of an Aerovox Condenser as shown. Here is the circuit. The condenser is a 4 Mfd., Type 402.

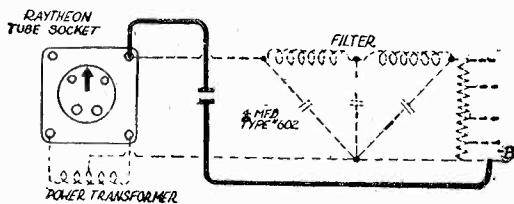

**AEROVOX**

Moulded Mica Condensers are individually calibrated before moulding. They are most accurate.

*The Aerovox "Research Worker" contains much useful and interesting information. A postcard will put your name on the mailing list.*

# AEROVOX

"Built Better"

70 Washington St., Brooklyn, N. Y.

Specified by G. M. Best for the 115 K. C. Super

or smaller, it will materially impair the low notes. It would be better to cut out the choke and condenser, and feed the plate current of the power tube through the output transformer primary. If the condenser is 2 mfd. or more, the effect on the low notes will probably not be appreciable, and will be offset by the improved operation of the output transformer due to no direct current flow through the primary winding.

For push-pull amplifiers, there are two methods available, as shown in Fig. 10. The secondary winding of the push-pull output transformer already in use, and probably designed for a 2000 ohm loud speaker, is abandoned in the upper diagram of Fig. 10 and the primary is used as a push-pull impedance shunted across the primary of the transformer in the base of the speaker unit. The shunt effect of the inductance of the output transformer center-tapped primary will rob the step-down transformer of some of the low frequencies, but it is an easy method of connecting an electro-dynamic speaker to a push-pull amplifier without the use of new apparatus.

Fig. 10 also shows a better way, which involves the elimination of the old push-pull output transformer in the amplifier, as well as the step-down transformer in the base of the speaker, and the substitution thereof of a new output transformer having a center-tapped primary, and low impedance secondary designed to match the impedance of the moving coil in the speaker unit. Transformers of this type are now available, and will give excellent results with a push-pull amplifier. Do not make the mistake of connecting this output transformer to the primary of the transformer already installed in the speaker, for the impedances will then be hopelessly mismatched, and only a feeble scratching sound will be produced.

Some of the units have a filter shunted across the primary of the output transformer, to correct humps in the characteristic curve at the high frequencies. This filter consists of a choke coil and condenser in series, and is designed to cut out frequencies above 5000 cycles, or to produce such a loss to those frequencies as to remove any objectionable shrillness due to vibration of the cone at the high frequencies. Recent improvements in this respect are the use of a ribbed cone, by which it is claimed that the vibration of the cone paper at the higher frequencies is eliminated, and a flatter frequency characteristic is thereby obtained.

Various "dopes" and patented mixtures which are alleged to "charge storage batteries, reduce internal resistance, remove sulphation, prevent freezing" have been found by the Better Business Bureau to be ineffective. The outstanding battery dope coming to the Bureau's attention during the past year was composed essentially of corn starch.

## COMING

The Great Annual Show  
Issue of "RADIO"

### THE JULY NUMBER

First showing of  
NEXT SEASON'S MODELS  
direct from the Manufacturers'  
Show in Chicago.

Out 10 days after the show closes  
**RESERVE YOUR COPY NOW!**

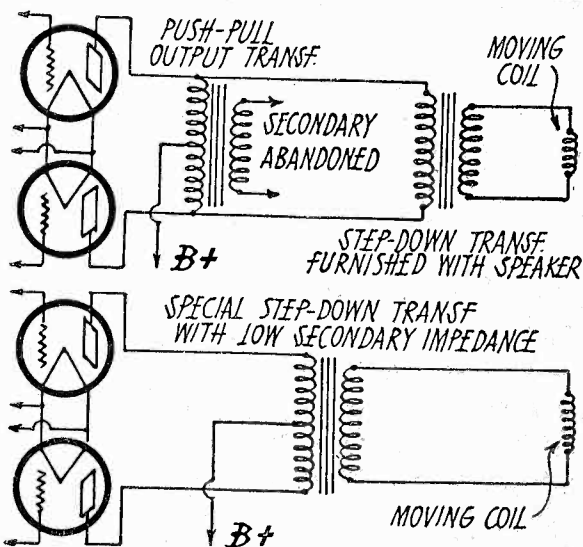

Fig. 10. Connection of Push-pull Amplifier to Unit

**Further  
PROOF  
of  
INFRADYNE  
Superiority**

"With my Infradyne, I am able to separate any station which is not closer than about 7 1/2 KC to some other station."

"From experience I can safely say that you have in the Infradyne the greatest set on the market."

"The first Infradyne I built, I still have in my home. I built that in November, 1926. You could not have that set for any money."

"Discriminating radio buyers are quick to realize the unequalled range and selectivity of the Infradyne."

"It has no peer of operation."

"For quietness of operation, sharp tuning and quality of reproduction the Infradyne is without a peer."

"The Infradyne set is giving me complete satisfaction."  
"The Infradyne sure is some radio. The tone is the best I ever heard."

"The thing that pleases me about the set is that I have all the selectivity of a good superheterodyne."

"My Remler Infradyne Receiver 1928 Model is just about the finest set the writer has ever listened to."

"My friends marvel at the volume and rave over the quality—you may well believe I am boosting Infradyne."

"So far have found no set either home built or factory-made that can compare with your Infradyne."

"In a noisy locality where there are high power stations and such the Infradyne will bring them in where other sets fail."

"No trouble cutting through stations that are as close as 3 to 5 miles, bringing them in with full strength."

"Very weak at Houston and other set that will bring in the Infradyne."

"The Infradyne is all that any man regardless of what he demands of his radio set could want."

"Have not found anything yet that excels the Infradyne for both local and long-distance reception."

"Any professional set-builder, who is capable and a worker, can make the Infradyne pay him good profits."

"This Infradyne is the tenth set which I have had in two years and it certainly tops them all."

"At four this morning I picked up Australia on the Infradyne."

"The Infradyne is the last radio we installed and it has the unqualified approval of our guests and ourselves."

"During the last two weeks I have had loud speaker reception on my Infradyne of JOAK, Japan; 3LO Melbourne, Australia; KGU Honolulu and all the principal stations in the United States."

"Have found in a given locality Infradyne would outstrip it had to compete."

"The Infradyne is the most powerful, and the greatest on the market."

"Infradyne) make of ra of handl"

REMLER DIVISION, GRAY & DANIELSON MANUFACTURING CO.  
260 First Street, San Francisco, Calif.

Please send me complete information about the Infradyne and folder describing all Remler Parts.

Name..... Street..... City.....

Do you build and sell sets?..... R-5-28



# CROSLLEY

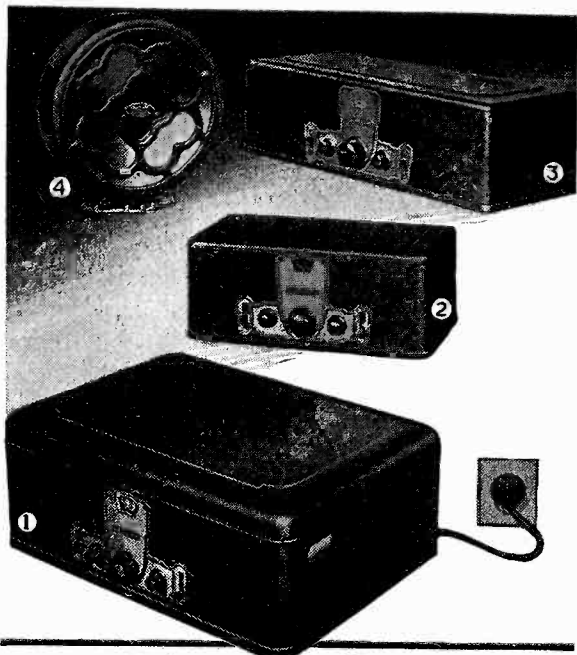

## NEUTRODYNE

THE radio Leadership of 1928! Compare these amazing radios! Check them with any set! Learn for yourself by comparison their amazing reception qualities. Genuine neutrodyne AC receivers!

1. Single Unit AC Jewelbox, \$95. Completely shielded and very selective.
2. Dry cell operated Bandbox Junior, \$35. Loud speaker volume—most economical.
3. Bandbox 601, \$55. Operates from batteries or power supply units. Splendid volume.
4. Double unit AC Bandbox, \$90. For console installation. Adaptable to any installation.
5. New Type-D Musicone, \$15. Loud speaker leadership in popular price field since 1925.

Write Dept. 19 for descriptive information.

### THE CROSLLEY RADIO CORPORATION

Powel Crosley, Jr., Pres. Cincinnati, O.

Licensed only for Radio Amateur, Experimental and Broadcast Reception.

Montana, Wyoming, Colorado, New Mexico and West, prices slightly higher.

## RADIO

# FREE RADIO BOOK!

40 pages chock-full of vital information for radio set builders. 14 new Aero circuits—receivers, transmitters, radiophones, short wave—fully described. Complete construction data, schematics, photos, etc. Exactly the book you've wanted. Write for FREE copy TODAY. Address AERO PRODUCTS, Inc., Dept. 103, 1772 Wilson Ave., Chicago, Ill.

**SEND FOR FREE**

From Chicago's Oldest Radio Jobbers. The Most Valuable Radio Catalog.

Write for your copy today—IT'S FREE!  
TELEPHONE MAINTENANCE CO.  
123-5 S. Wells St., Dept. 79, Chicago, Ill.

## SNAPPY RECEPTION ON LOW WAVES

(Continued from Page 18)

or less rare intervals. The reception of 80 meter amateurs is brought up many fold on the r.f. and the ever increasing popularity of this band justifies the proper equipment for good reception here.

This leaves a gap between 49 and 59 meters. This is appropriately filled in with what we call our "Broadcast Coil." This coil is the best for receiving US short wave broadcasts during the evening.

No ground is used on the receiver, as with a sizable antenna the ground adds more noise than signal. Incidentally, the power leak noises are of less intensity, as related to signal strength, than on the ordinary type of receiver.

The picture shows a rather unusual grid leak. It is 6 in. long, and is made up on special order by Arthur H. Lynch, Inc. The same metalized resistor element as used in the heavier elements is used. In this way a real 20 meg. resistor, capable of really handling the grid current from the UX210 used as a detector is secured. In addition the r.f. choking ability of a long resistor is much better than a short one. This type of resistor also keeps the tube from paralyzing while the transmitter is being used, whereas the usual type of short resistor requires a second or so to start the tube oscillating.

Receivers such as this make us feel enthusiastic about the possibilities of the future. Most certainly more amateur work can be done with this receiver on the new amateur assignments, than with the old receiver under the old assignments. The solidity of foreign radio phone stations, either when broadcasting or rebroadcasting their local programs, as well as the numerous amateur voice transmissions on twenty meters open up a field for the listener or the amateur, hitherto unapproached.

## WEATHER BROADCASTS

(Continued from Page 29)

part of the system of international exchange of weather information and, in a more extended form, replaces what is known as the "Angot" Bulletin, heretofore transmitted at 4:30 p. m. and midnight. The broadcasts are repeated from the radio station on the Eiffel Tower in Paris. They consist, respectively, of 8 a. m. and 8 p. m. observations of current date from 75 selected stations, and indicate the name of the station, barometric pressure in millibars, pressure change during preceding two hours, wind direction, state of weather, and temperature; also reports from ships in the western portion of the Atlantic Ocean. Information concerning the code used in these bulletins may be obtained upon application to the Weather Bureau at Washington, D. C.

GARD, the San Francisco Examiner, is sending out press on 42 meters, with a 500 cycle note. The press is sent QST at 1 a.m. and 1 p.m. daily, and seems to be carefully planned stuff of good news value. QSLs would be greatly appreciated.

## BRUNO PARTS OF THE BETTER KIND

Bruno "99" Tuning Coil

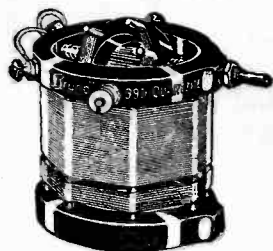

The Bruno "99" Tuner is matched for .0005 condensers. Tunes from 200-575 meters. The coil is wound on quartzite glass.

LIST \$5.50  
PRICE \$2.50

Bruno "99" R. F. Coil

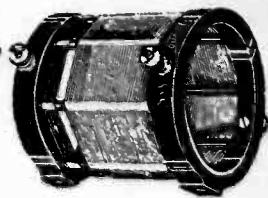

The Bruno "99" R. F. Coil is matched for .0005 condensers. Tunes from 200-575 meters. The coil is wound on quartzite glass.

LIST \$3.00  
PRICE \$1.50

Bruno R. F. Unitune

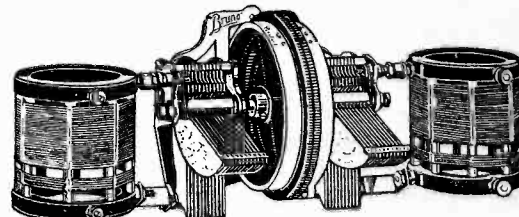

The Bruno Browning-Drake Unitune consists of two specially wound coils for the B-D Circuit, panel frame, plate and drum mounted.

LIST \$21.00 PRICE \$10.50

TK UNITUNE consists of 1 Bruno "99" Tuner and 1 Bruno "99" R. F. Coil mounted. LIST \$17.00 PRICE \$8.50

R. F. UNITUNE consists of 2 Bruno R. F. Coils mounted. LIST \$20.00 PRICE \$10.00

Mail Orders Promptly Filled

Send for Free Catalog

**B. C. L. Radio Service Co.,**  
INCORPORATED

218 Fulton Street New York City

## Quality Radio Products

INCLUDE

# Potter Condensers



Potter Manufacturing Co.  
No. Chicago, Ill.

Pacific Coast Offices  
905 MISSION STREET  
San Francisco California

## A 10-METER RECEIVER

By A. BINNEWEG, JR.

The amateur band at 10 meters is of considerable interest to experimenters, for it is known that in this vicinity the maximum DX will be done in daylight. A receiver to cover this band must be compact and have short leads. The circuit diagram is shown in Fig. 1. To operate at any of the other short-wave bands, merely insert the proper coils.

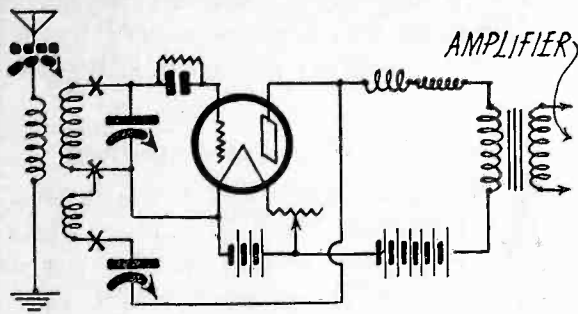
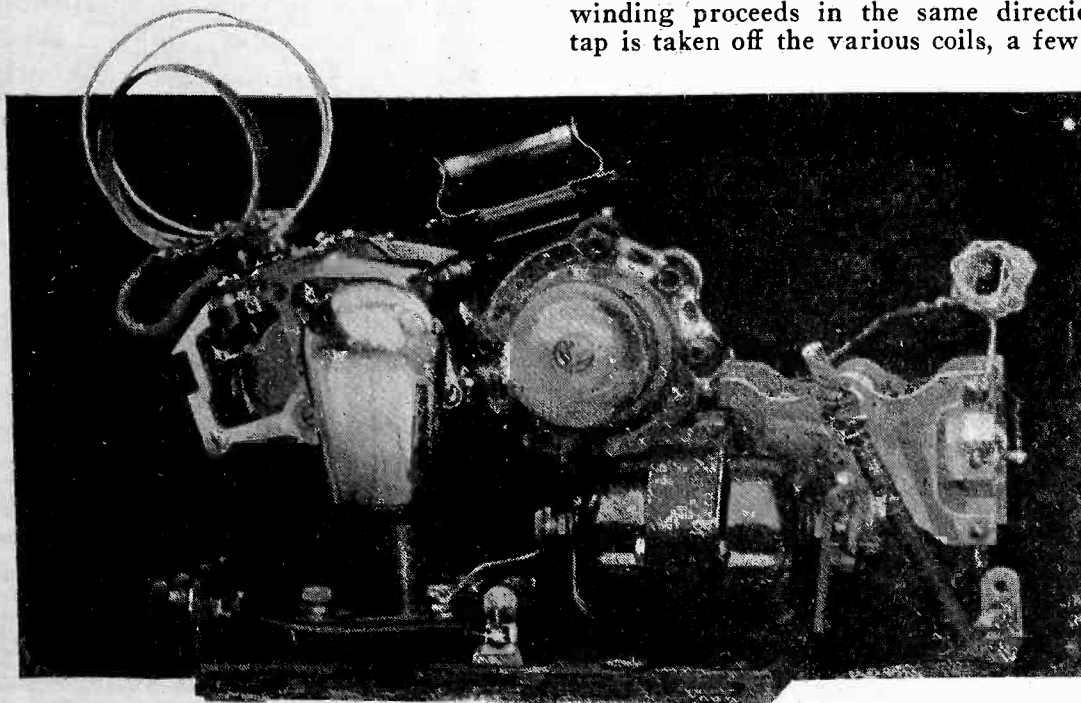

Fig. 1. Circuit of 10-Meter Receiver

The bakelite strip supporting the coil-jacks is mounted on the back of the tuning condenser, thus, in conjunction with the socket arrangement, giving the shortest possible leads so that reception at 10 meters is possible with an ordinary layout. At 10 meters a single 3 in. turn is used for both secondary and tickler, although the exact size will vary with the layout; the tuning-range with the 4-plate condenser, found to be a good size for general short-wave use, is about 8 to 11 meters. To cover all the short-wave bands, a single-layer space-wound receiver choke is used and results were better at 10 meters with a small basket-weave coil connected in series at the plate. With this arrangement, one can do without a short extension handle on the regeneration-control shaft if a vernier dial is used, thus removing the hand from the shaft in some types.

The tuning condenser in a Bremer-Tully cut down to 4 plates and the regeneration control is of the usual size. The plate choke consists of about 100 spaced turns on a 1-4 in. dowel. The binding-post strip fits over the screws on the transformer and is thereby held in place.

The tickler must be adjusted so that good regeneration is secured when this control is near a maximum setting, otherwise it will have some effect on the wave length, also. With proper adjustment, there is no wave-change to speak of, even at 10 meters. The tickler is mounted on the filament side of the secondary and the coupling is not adjusted



10-Meter Receiver

### PARTS FOR 10-METER RECEIVER

- 1 4-plate tuning condenser
- 1 .00007 mfd. moulded grid condenser
- 1 metalized 5 meg. leak
- 1 Variable filament resistance
- 4 jacks
- 3 G-R plugs for each coil
- 1 13-plate regeneration control
- 1 detector socket
- 1 amplifier socket
- 1 filament resistor
- 1 audio transformer high ratio
- 1 telephone jack and plug
- 5 binding posts
- 1 CX 300A or 112 detector tube
- 1 CX 301A amplifier

as a tapped coil is used for all-around convenience.

The detector tube-socket is supported between the two condensers and the leads hold it as well and are thus also short. It is extremely important to have short leads since the total inductance necessary is already very small and difficulty may be had with regeneration if there is not sufficient inductance to couple the tickler to, at 10 meters.

For the shorter waves, coils 2 in. in diameter are more convenient than the usual sizes; these are wound of No. 18 wire and the windings are conveniently supported by celluloid strips painted with collodion. Small coils allow somewhat closer placing of parts, which is necessary at 10 meters.

Loose coupling should be used so that antenna resonances will not give "dead-spots". Should these be troublesome, at any particular wave-band, an antenna series-condenser may be used to shift such out of the tuning range.

The primary coil is provided with a G-R plug and jack and can be rotated in same, to vary the coupling. Antenna and ground connections are made to the end of the coil strip by means of flexible leads. The antenna coil is of 10 turns and a flexible lead connects to the ground post, the jack and plug serving as one terminal. An ordinary long antenna is used for 10 meter reception, the coupling being made somewhat looser than usual.

The CX-112 tube is usually better as a regenerative detector for the shorter waves and requires somewhat less plate voltage for good results. A Bradleystat is used for filament-control and allows the selection of proper filament values for best regeneration control with any tube used. At higher waves the CX-300A works best.

The plug-in coil arrangement is simplified as shown in the illustration and diagram, only three plugs being necessary. The tickler and secondary are one coil; the correct direction for the tickler coil being so that the winding proceeds in the same direction; a tap is taken off the various coils, a few turns

from the end, this serving as the tickler. Most of the loss in coils is usually within the wire of the winding itself.

If desired, a stage of radio-frequency can be added ahead of the detector, the CX-322 having been found to give effective amplification as low as 3 meters.

The wave length for operation may be determined by lecher wires as described in October, 1927, *Radio*. The wires must be twice as long for 10 meter calibration, but when a point in this vicinity is once determined, one can obtain complete calibration by using harmonics from the 20 or 40 meter bands.

## BOOK REVIEWS

**Modern Radio Reception.** By CHARLES R. LEUTZ. 383 pages, 6 by 9 inches, published by C. R. Leutz, Inc., Long Island City, N. Y.

This is the third edition of a text which has been entirely revised and rewritten to conform with recent developments in broadcast receivers. The author is a pioneer radio experimenter who has been active in designing circuits. The treatment is non-technical and is presented under five heads: reception, laboratory apparatus, receivers, tube data, and standards and definitions.

The subjects treated under the head of reception are practical hints on aerial construction, suggestions for operation with a loop antenna, the use of tuning inductances and condensers, shielding, and the selection of resistance units for socket power devices.

The laboratory instruments whose basic principles and methods of operation are described include the audibility meter, direct reading capacity meter, high and low frequency oscillators, amplifiers, capacity bridge, vacuum tube bridge, string oscillographs, wavemeters, and battery chargers.

The receivers which are described by means of text, pictures and circuit diagrams are the Western Electric superheterodyne, Grebe Synchronphase Seven, Silver Ghost, Universal Transoceanic "Phantom," and others which have been designed by the author. There is also an extended discussion on short-wave reception and several types of loud speakers and phonograph pick-up units.

The chapter on tube data gives the characteristics and various applications of all types of vacuum tubes. It also contains information regarding r. f. chokes and the transmission unit.

As a whole, the book is an intelligent compilation of information that has been released by various manufacturers or published in different magazines. Its contents are such as would be collected in a good radio scrap-book. Its general usefulness would be greatly enhanced by an index to facilitate the finding of the facts that it contains.

The right fit for a screw to be driven into a hole in hardwood can be secured by scraping the thread of the screw lengthwise against a piece of beeswax and heating the screw with a match until the wax flows all over the thread. When cool it may be driven home with a screw driver with the greatest ease. A nail may likewise be driven home in the end of the handle of a hammer without splitting the wood, by first boring a hole and filling it with wax into which the nail is driven.





## High Resistance Voltmeter

(For the Set Owner)

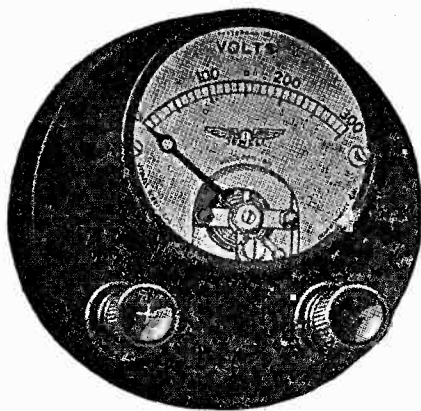

Pattern No. 139

In the adjustment of his B-eliminator voltages the set owner has been at a disadvantage because of the excessive cost of reliable testing instruments of sufficient sensitivity to give accurate results. This disadvantage has been recently eliminated by the introduction of the Jewell Pattern No. 139 high resistance voltmeter.

Although the price of this instrument is low, it is of the D'Arsonval or moving coil type with the movement swung between genuine sapphire jewels. The full scale value is 300 volts, the scale having 30 divisions. Movement parts are silvered and the scale is silver etched with black characters. The series resistance is wound with fine wire and accurately adjusted to give correct readings at all times. The instrument throughout is of the very highest grade of workmanship.

Dealers carry this instrument in stock, or a descriptive circular No. 1103 may be obtained by writing us direct. Ask for a copy.

**Jewell Electrical Instrument Co.**

1650 Walnut Street, Chicago

"28 Years Making Good Instruments"

# PRECISION!

Sangamo engineering of Audio Apparatus is followed up by precision production methods gained in nearly 30 years precision instrument manufacturing. In Sangamo Transformers and Impedances the set builder and manufacturer is thus assured of that precise matching of each unit to the designated tube so necessary for superior tone quality.

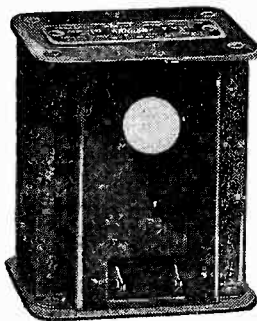

**The "Yellow Spot"**  
Designates the Sangamo Type "A" Audio Transformer used for cascade amplification. This transformer has the flattest curve (most uniform amplification at all audible frequencies) available in any transformer at the present time. Look for the transformer with the yellow spot.

**"Light Blue"**  
The Light Blue Spot identifies the Sangamo Input Transformer for push-pull amplification. Has high inductance primary to secure high amplification on low frequencies. Accurately divided secondary gives almost identical

frequency characteristic curve on each half. "Type B"—known by the light blue spot.

**"Dark Blue"**  
Output Transformer for push-pull amplifier having an impedance to match UX-210, CX-310, UX-112 and CX-112 tubes. Maximum transference of energy on low end of the musical scale.

**"Green"**  
Same as above except impedance matches UX-171 and CX-371 tubes.

**"Red"**  
The Red-Spot designates the Sangamo Type "E"

Output Impedance, keeps heavy D. C. "B" current from loudspeaker windings. Tap provided for matching impedance to UX-171 (CX-371) or UX-210 (CX-310) tubes, also UX-112 (CX-112).

**"Orange"**  
Used for impedance coupled amplification, auto-transformer coupled amplification, or as impedance in plate circuit of detector tube to prevent feed-back, oscillation or "motor-boating" in transformer coupled amplifier.  
Also makers of Sangamo Mica Condensers, moulded in Bakelite—made accurate and STAY accurate.

# SANGAMO

SANGAMO ELECTRIC COMPANY

Springfield, Illinois

## IMPEDANCE RELATIONS

(Continued from Page 19)

resonant point is reached, and the high frequency harmonics may not be passed by the transformer to any great extent. Under certain conditions, though, notably when a loud speaker that is very sensitive to high frequencies is used, this distortion produced by the looped characteristic is quite noticeable to the ear. It is very noticeable when a fairly large condenser is placed across a transformer secondary to give an artificially deep tone.

### Resistance Coupled Amplifiers

WE MAY also make use of our knowledge of impedance relations to determine the proper size of blocking condenser for inductance or resistance coupled amplifiers. We have the general condition that the reactance of this condenser at the lowest frequency to be amplified should be negligible compared to the input impedance of the succeeding tube. In practice, negligible can be interpreted as meaning not more than 5 per cent.

Obviously the grid leak is in shunt with the actual tube input impedance, which is of the order of half a megohm for an ordinary tube with proper negative grid bias. Other things being equal, the higher the grid leak resistance up to about one megohm, the smaller blocking condenser we can use for the same reproduction. If we assume that the input impedance of the tube with its associated grid leak is 400,000 ohms, then we want a blocking condenser whose reactance at 50 cycles is not over 20,000 ohms. The condenser which fulfills this condition is of .159 mfd. capacity. The standard size that is next above this figure is .25 mfd. and this is the size that would be used under the assumed conditions.

Suppose the grid leak is only 50,000 ohms, as was recommended for one early resistance-coupled amplifier. Then the reactance of our coupling condenser at 50 cycles should not be greater than 2,500 ohms, requiring a capacity of not less than  $1\frac{1}{4}$  mfd. This particular amplifier used a capacity of .006 mfd.

The set builder can always figure the proper values of inductance and capacity in various parts of the circuit by remembering that

$$L = \frac{X_L}{2\pi f} \quad \text{and} \quad C = \frac{1}{2\pi f X_C}$$

where  $L$  is inductance,  $X_L$  is inductive reactance,  $C$  is capacity in farads,  $X_C$  is capacitive reactance, and  $f$  is the frequency of the alternating current involved.

After we have decided on the size of the blocking condenser in designing a resistance coupled amplifier, we wish to find out what size of coupling resistor to use, and what the  $B$  voltage should be. Suppose we are going to use -01A

(Continued on Page 42)

# FIVE TYPE UX222 SCREEN GRID TUBES ARE USED IN THIS ULTRA-POWERFUL BROADCAST RECEIVER, INCREASING THE RADIO FREQUENCY AMPLIFICATION AND SENSITIVITY OVER 500 TIMES

Front Panel View  
**NEW ADMIRALTY MODEL**  
 with complete set of indicating meters. Panel size 9 x 36 x 1/4 inches. Weight 45 lbs.

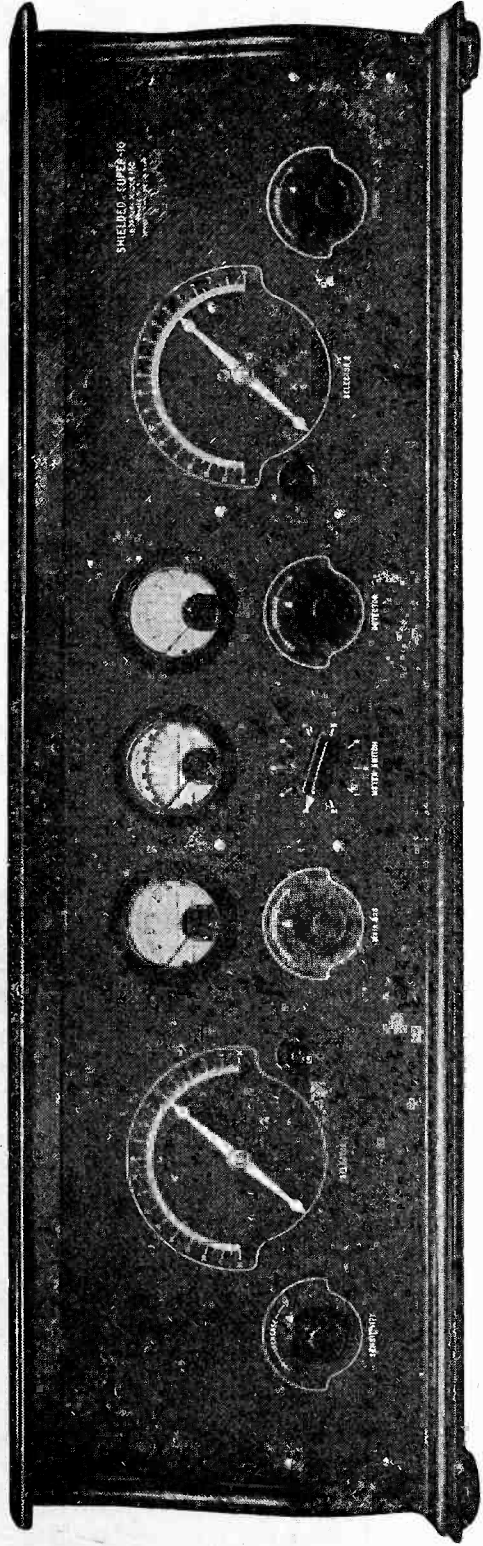

Licensed under Hogan Patent  
 No. 1,014,002

## The New Norden-Hauck

# SHIELDED SUPER-10

Highest Class Receiver in the World

The New NORDEN-HAUCK SHIELDED SUPER-10 is fundamentally different, being specially designed for crowded broadcast conditions. It is a long distance concert Receiver which marks radio's final arrival at the goal of the connoisseur of performance.

Far away stations are received like locals, using only a small loop or short piece of wire for the antenna. Distance possibilities seem unlimited with this new model. Usual background noises are conspicuously absent, and an extraordinary quality of reproduction is obtained with the improved audio amplifier in the Shielded Super-10.

Smashing power with complete fidelity makes previous standards of reception pale into insignificance. There is simply nothing like it. This great 10-tube Model is so far in advance of others that its absolute superiority is instantly apparent to anyone.

Standard Shielded Super-10—Front Panel view. This model is identical with the Admiralty model except for the indicating meters. However, it is equipped for the Weston Pin-jack Voltmeter.

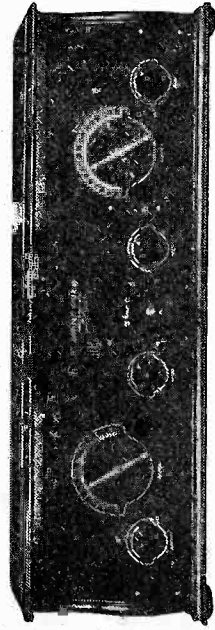

### Some Exclusive Features

1. Ten tubes. A combination of Screen Grid and Power Tubes arranged for maximum efficiency.
2. Totally shielded in accordance with latest research data. Various circuits are completely isolated.
3. Selectivity remarkable—Tunes completely through local broadcasters.
4. Either A. C. electric operation or batteries may be used as desired.
5. Simple to operate—only two main tuning controls.
6. An entirely new audio amplifier, with two power tubes handling the output.
7. Provision made for electric phonograph pickup.
8. A precision laboratory instrument. Material and workmanship conform to U. S. Navy Standards.
9. Moderately priced. Deferred terms of payment can be arranged if desired.
10. Beautiful new, and less expensive console cabinets are available.

This design and development of the Shielded Super-10 is a crowning achievement which has been made possible by the revolutionary "screen grid" tubes. It will be several years before any AC tube is developed that will even approach the efficiency of the "screen grid" tube as a radio frequency amplifier. This new tube raises the amplification factor thirty to forty times over that secured with the conventional 201-A tube.

Everyone can have this wonderful Receiving Set, for it is sold as a complete manufactured laboratory tested Receiver and also in a kit of parts for home construction, or for the professional set builder and dealer.

The full size genuine blue prints and instructions are so complete in every detail, that it is exceedingly easy for anyone to build the Shielded Super-10. Almost everything is done for you to simplify this work.

Learn more about this remarkable Receiver. Send for attractively illustrated literature on the new NORDEN-SHIELDED SUPER-10, which will be gladly sent to you without cost or obligation on your part.

Fill out and mail this coupon.

NORDEN-HAUCK, Inc., I. I. F.  
 Marine Bldg., Phila., Pa.  
 Gentlemen:

Without cost or obligation on my part kindly send me complete attractively illustrated literature on the new Norden-Hauck Shielded Super-10.

I enclose \$2.00 for which kindly send me immediately, Postpaid, complete constructional Blue Prints and operating instructions for the new Norden-Hauck Shielded Super-10.

NAME.....  
 ADDRESS.....

Builders of the Highest Class Radio Apparatus in the World

**NORDEN-HAUCK, Inc., Engineers**

Marine Bldg., Delaware Ave. and South Street, Philadelphia, Pa., U. S. A. Cables: "NORHAUCK"





**A NEW  
A.C. Portable Instrument**  
Three Ranges—150/8/4 Volts  
for Radio and General Testing  
**MODEL 528**

NOTE its small, compact shape—how convenient and light in weight! Contained in a red and black mottled bakelite case. Bold, legible figures on a silvered dial—no mistake in taking quick readings, and no question as to their accuracy.

In all features of electrical design and construction it is a truly high-class scientific instrument equally serviceable for laboratory experimental work as well as for home use in making a periodic check-up of your A. C. set. Inexpensive, too. Altogether, it is an outstanding Weston achievement.

It is designed with a high range for testing the A. C. supply voltage and with two low ranges for checking the voltage of the two kinds of A. C. tubes. The same instrument is also made as double range Voltmeters up to 600 volts—all resistance self-contained—and as single range Ammeters and Milliammeters.

**Electrical Characteristics**

Accuracy, guaranteed at 2%.

Open scales give readings down to 1/10 of full scale value.

Designed for continuous operation, with negligible heating, on any commercial frequency.

Responsive, and excellently damped.

Exceptionally high resistance in ohms per volt, and hence of very low current consumption.

**Weston Electrical Instrument Corporation**

600 Frelinghuysen Ave., Newark, N. J.

Pacific Coast Representatives:

GRAYBAR ELECTRIC COMPANY, Inc.  
84 Marion Street  
Seattle, Wash.

A. A. BARBERA  
Los Angeles, Calif.

REPAIR SERVICE LABORATORY  
682 Mission Street  
San Francisco, Calif.

J. H. SOUTHARD  
San Francisco, Calif.

**WESTON  
RADIO  
INSTRUMENTS**

(Continued from Page 40)

tubes which work well with 90 volts of *B* battery and  $4\frac{1}{2}$  volts *C*, under which conditions they have a plate impedance of around 10,000 ohms. If the coupling resistor has about half again as much resistance as the plate circuit of the tube, we shall get practically as much amplification as we would with a much higher resistance, and we can still keep the *B* voltage down to a reasonable figure. Under this condition, our coupling resistor would have a value of 15,000 ohms.

Since the plate circuit resistance of the tube is now only  $\frac{2}{5}$  of the total resistance in the plate circuit, only  $\frac{2}{5}$  of the *B* battery voltage will actually be applied to the plate of the tube; but we have already postulated that we wish 90 volts on the tube itself, so we must use 225 volts of *B* battery to get it.

It is apparent that this voltage is much higher than is customarily used on such an amplifier; this explains in large part the unsatisfactory performance of the average resistance coupled amplifier. A resistance coupled amplifier with proper *B* and *C* voltages in each stage to handle the load in that stage will give beautiful reproduction. The average commercial resistance amplifier is so poorly designed, however, that it gives much worse reproduction than even mediocre transformers, especially when loud signals are being received.

It might be said that there is no need of using such a high *C* battery voltage with a resistance coupled amplifier, but that is a fallacious idea, as this type of amplifier demands a negative grid at all times even more strongly than other types. A grid can go slightly positive in a transformer coupled amplifier, with no effect other than a moderate amount of distortion, but if a grid goes positive with a resistance or impedance coupled amplifier, it will pick up a great number of electrons which can only escape by leaking off through the grid leak. If it picks up enough electrons, the tube will cease to function altogether until the excess electrons have a chance to leak off. This is called "blocking," and produces all sorts of effects, from a sharp "thud, thud," to a peanut whistle, depending on the time constant of the grid condenser and leak.

**Loud Speaker Impedances**

HAVING disposed of the amplifier, we still have to examine the impedance relations between the power tube and the loud speaker. Up to this time we have been considering only voltage operated devices, i.e., the input circuits of vacuum tubes, but now we are going to deal with a power operated device, the loud speaker. It is well known that the maximum power will be delivered to the load when its impedance is equal to the impedance of the source. Since the sensitivity of even the best

(Continued on Page 44)

Tell them you saw it in RADIO

**What.  
Filament  
Control**

Good tube performance demands perfect filament control. AMPERITE alone gives it, automatically. Eliminates hand rheostats, guessing and tube damage. Simplifies wiring and panel design. Backed by 6 years of perfect service. There is no alternative. Insist on AMPERITE. \$1.10 mounted (in U. S. A.). All dealers sell it.

**RADIALL CO.**  
50 Franklin St. New York

**FREE**  
Write for "Amperite Book" of best circuits and latest construction data to Dept. 5



**AMPERITE**  
The "SELF-ADJUSTING" Rheostat

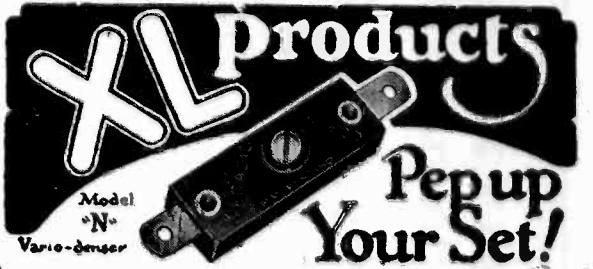

**VARIO DENSER**

Tune quickly—adjust accurately—eliminate distracting noises—get correct tube oscillation—with X-L VARIO DENSERS in your circuit. Designers of all latest and best circuits specify and endorse.

MODEL "N"—Micrometer adjustment easily made, assures exact oscillation control in all tuned radio frequency circuits, Neutrodyne, Roberts two tube, Browning-Drake, Silver's Knock-out. Capacity range 1.8 to 20 micro-microfarads.

Price ..... \$1.00

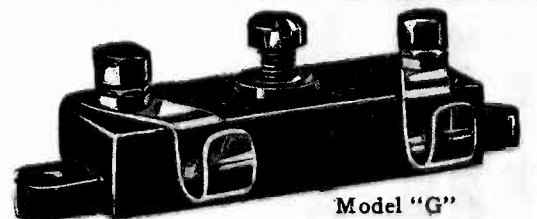

Model "G"

MODEL "G"—Obtains the proper grid capacity on Cockaday circuits, filter and intermediate frequency tuning in superheterodyne and positive grid bias in all sets.

Capacity range:  
Model G-1 .00002 to .0001 M. F. D.  
Model G-5 .0001 to .0005 M. F. D.  
Model G-10 .0003 to .001 M. F. D.

Price, each with grid clips ..... \$1.50

X-L PUSH POST—Push it down with your thumb, insert wire, remove pressure and wire is firmly held. Vibrations will not loosen. Releases instantly. A push post that excels in appearance, action, service and convenience.

Price each ..... 15c

X-L PUSH POST PANEL  
Seven push posts mounted on black insulating panel with permanent white markings. Soldering lugs, raising bushings and screws for mounting, etc., in box complete.

Price ..... \$1.50



X-L Push Post



X-L Push Post Panel

FREE—New, up-to-date book of wiring diagrams showing use of X-L units in the new LOFTIN-WHITE constant coupled radio frequency circuit, and in other popular hook-ups. Also the Goodwin Aperiodic Detector Circuit which adds a stage without adding tuning controls. Applicable to any set. WRITE TODAY!

**XL Radio Laboratories**

2428 Lincoln Ave. Chicago, Ill.

# POWERIZER

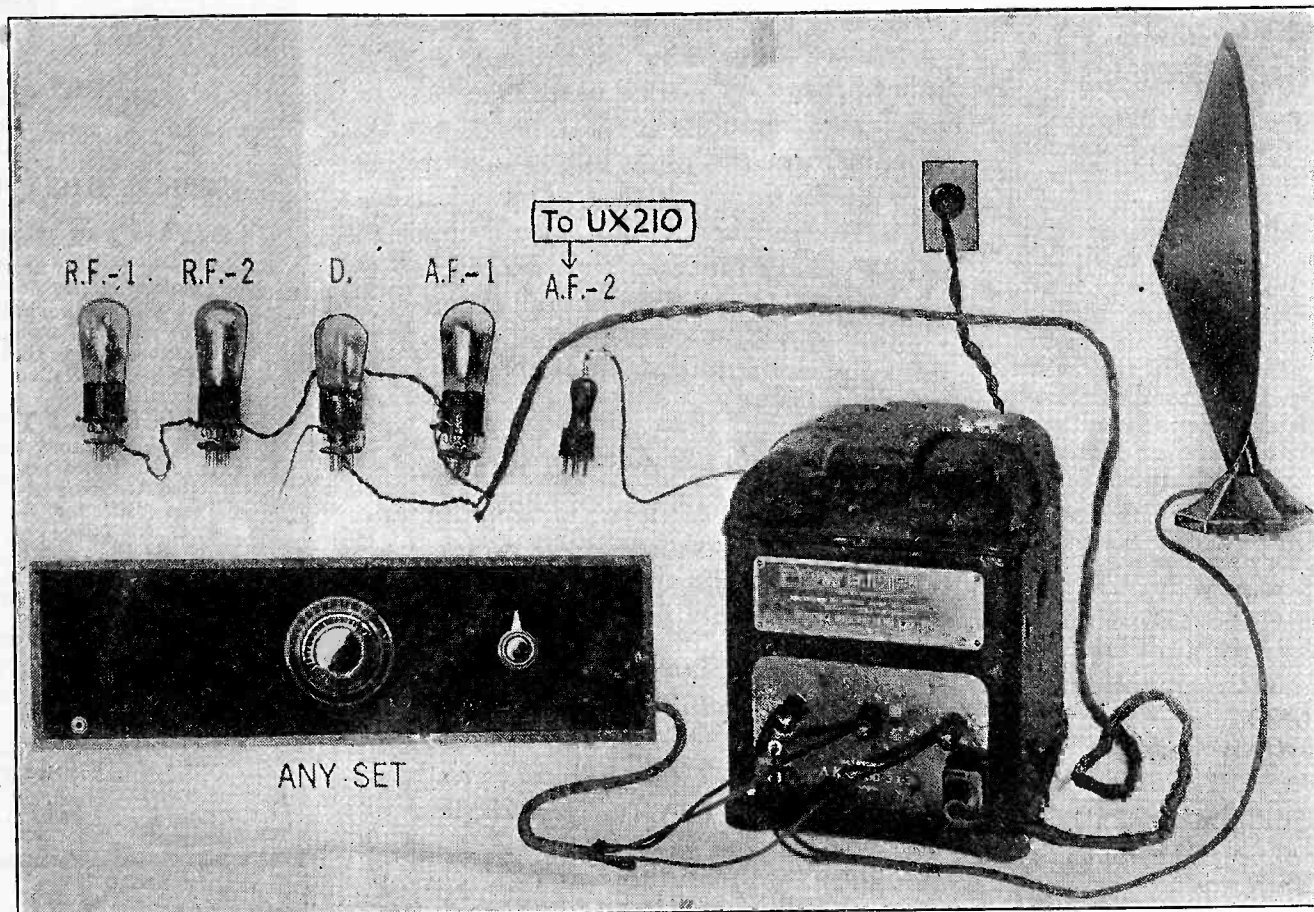

**POWERIZER** NOT ONLY MAKES EVERY RADIO SET AN A C ALL ELECTRIC, BUT ALSO MAKES EVERY SET A "DE LUXE" A C ALL ELECTRIC USING THE A C RADIOTRONS WITH POWER AMPLIFICATION (U X 210 OR C X 310).

**POWERIZER** EQUIPMENT IS NOW OPERATING SUCCESSFULLY ON THOUSANDS OF STANDARD SETS.

- |   |      |                               |
|---|------|-------------------------------|
| General Model for Tuned R.F., Neutrodyne, and most radio sets | \$60 | Tubes extra<br>(With Harness) |
| For Radiola Model 20  | \$59 | Tubes extra<br>(With Harness) |
| For Radiola 28 or 25 with A.C. Pack                           | \$84 | Tubes extra                   |

Write for Bulletin PR 1018 and 1019

Licensed by Radio Corporation of America and Associated Companies

**RADIO RECEPTOR CO.**

106 SEVENTH AVE.  
NEW YORK CITY

Tell them you saw it in RADIO





# AMERTRAN

## Push-Pull Power Stage for Dynamic Speakers

For best results, every dynamic type speaker should be preceded by a push-pull amplifier. This is particularly true because they reproduce frequencies as low as 30 cycles and the attendant hum from raw AC on the filaments of power tubes is greatly pronounced unless filtered out by a push-pull amplifier.

The AmerTran completely wired push-pull power stage has been specially designed for dynamic speakers. Consists of type 151 input and output transformers (200 for working out of 210 type tubes or type 362 for 171 type tubes). Both the 200 and the 362 have the secondary designed for connecting directly to the moving coil of the speakers. Completely wired with sockets and resistances. Also available for cone type speakers and for both 210 and 171 tubes.

Licensed under patents owned or controlled by RCA and may be bought with tubes.

Price complete (without tubes)

**\$36.00**

(slightly higher west of Rocky Mountains)

Write us for hook-up of this remarkable instrument.

**AMERICAN TRANSFORMER COMPANY**

Transformer Builders for more than 28 Years

130 Emmet Street, Newark, N. J.

(Continued from Page 42)

cone speakers falls off at the lower frequencies, we wish to match our speaker to the power tube so that the maximum power will be delivered to the speaker at the lowest frequency we wish to reproduce. Now at 50 cycles the average good cone will have an impedance of a little more than 1000 ohms. By looking up a table of tube characteristics we find that a couple of tubes of the -71 type in parallel will just about meet the requirements. If we wish to use only one power tube, or to use a tube of different output characteristics, it will be necessary to transform the plate impedance of the tube down to match that of the speaker. This transformer should have sufficient primary inductance so that its reactance at the lowest frequency is high compared to the plate impedance of the power tube. The turns ratio is determined by the equation

$$n = \sqrt{Z_s/Z_T}$$

where  $n$  is the turns ratio,  $Z_s$  the impedance of the speaker at 50 cycles, and  $Z_T$  the output impedance of the power tube.

It is only a question of time until some of the manufacturers realize that output transformers should be designed for the particular tube which is to feed them; in fact, several manufacturers have already placed on the market push-pull output transformers of different ratios for different tubes. In this connection, it is worthy of note that the output impedance of a pair of tubes connected push-pull is twice that of one tube alone; hence it is much more imperative to have a proper step-down transformer after an amplifier of this type than after an ordinary amplifier. It is to be regretted that certain makers have brought out "push-pull output impedances," hailing them as great improvements over output transformers, when in fact there is nothing except cheapness of manufacture in their favor.

Aside from the fact that a proper impedance match cannot be easily obtained between the power tube and the loud speaker, there is yet another serious disadvantage attending the use of a choke and condenser combination for feeding the loud speaker. At low frequencies the voltage drop across any reasonable value of coupling capacity is a very appreciable fraction of the total voltage available. At 50 cycles, the reactance of a 4 mfd. condenser, which is about as large as is ordinarily used, is in the neighborhood of 800 ohms. Thus, if we assume a loud speaker impedance of 1600 ohms at this frequency, which is probably too high, only two-thirds of the voltage in the plate circuit is actually applied to the speaker, resulting in a marked loss of the low frequencies.

In the preceding discussion, the reader will have noticed that 50 cycles has been

Tell them you saw it in RADIO



## A-C Adaptor Harness

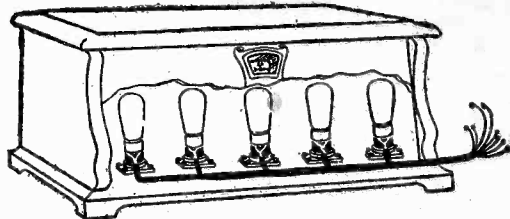

### Easiest and Quickest Way to A-C Tube Operation

No re-wiring. Can be used to convert all makes of receivers of six tubes or less. Connect the harness to any standard step-down transformer, insert the A-C tubes into the adaptors and the battery set is changed into a house current Receiver.

#### Made for All Types A-C Tubes

One with adaptors attached for R. C. A. Type A-C tubes and one without adaptors for Arcturus A-C cable tubes.

Type "R" for R. C. A. Tubes	Type "A" for Arcturus Tubes
\$8.50	\$6.00

If your dealer can't supply you order direct. Circular on request.

#### Cornish Wire Company

30 Church St., New York City

Use Braidite Hook-up Wire  
The braid slides back

25' Stranded Braidite...35c

25' Solid Braidite.....30c

Made in red, green, yellow,  
blue and black.



## Radio Convenience Outlets

Enjoy your radio programs in any room in the house. Put the batteries in any out-of-the-way place. Bring aerial and ground connections to most convenient point. These outlets fit any standard switch box. Full instructions with each outlet.

No. 135—For Loud Speaker.....\$1.00

No. 137—For Battery Connections.....2.50

No. 136—For Aerial and Ground.....1.00

Also furnished in two and three plate gang combinations.

#### With Bakelite Plates

Now furnished with a rich satin brown Bakelite plate, with beautiful markings to harmonize, at 25 cents extra. See illustration.

At Your Dealer's

**YAXLEY MFG. COMPANY**

Dept. A, 9 So. Clinton Street  
Chicago, Ill.

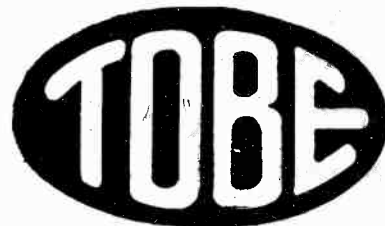

## Condensers B-Blocks Veritas Resistors

Essential, Trouble-Proof, Tested Components of all Modern A. C. Sets. Made especially for and universally specified for A. C. Circuits by Leading Radio Engineers.

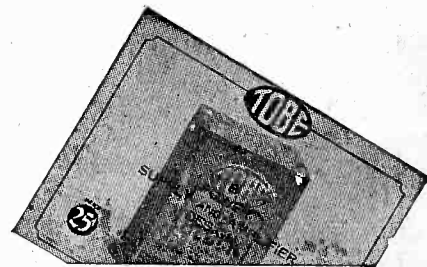

Send 25c for new Tobe Power Pamphlet "TOBE B-POWER SUPPLY and AMPLIFIER DESIGN."

Send for free information on the new TOBE A-Condenser.

**Tobe Deutschmann Company**  
Cambridge Mass.

arbitrarily taken as the lowest frequency to be transmitted, in spite of the fact that amplifiers can be built that will reproduce perfectly considerably lower frequencies than this. The reason for this limit is that the ordinary loud speaker will not reproduce these lower frequencies. Even to bring out 50 cycles at its full value it is necessary to place a 6 ft. baffle around a cone speaker of the free-edge type, and an exponential horn needs to be about 12 ft. long to accomplish the same results.

A table is appended, showing the output impedances of various types of tubes under typical grid and plate voltage conditions. For other conditions than those given, sufficient information is given to enable the reader to find the required impedance from the equation.

VACUUM TUBE IMPEDANCE TABLE

Type	Plate Voltage	Grid Voltage	Output Impedance	Mu
WD-11, WX-12 UV-199	90	-4.5	16,000	6.2
UX-199	90	-4.5	15,000	6.25
UX-120	135	-22.5	6,600	3.3
UX-201-A	90	-4.5	12,000	8.5
	135	-9.0	11,000	8.5
UX-112	90	-6.0	8,800	7.9
UX-112-A	135	-9.0	5,000	8.2
	157	-10.5	4,800	8.2
UX-171	135	-27.0	2,200	2.9
UX-171-A	180	-40.5	2,100	2.9
UX-210	250	-18.0	5,600	7.5
	425	-35.0	5,000	7.7
UX-222 (Sh. grid connection)	135	-1.5	850,000	300
UX-222 (Space change connection)	180	-1.5	150,000	60
UX-200-A	45		30,000	20
UX-226	90	-6.0	9,400	8.2
	135	-9.0	7,400	8.2
UY-227	45		10,000	8.0
UX-240	135	-1.5	150,000	30

### SHOP PRACTICE

(Continued from Page 20)

positive pole of the source of current. The work to be plated is likewise connected to the negative pole. The source of current may be either a low voltage d.c. generator or storage battery with a rheostat to hold the current small enough to cause no bubbles of hydrogen on the surface to be plated. The plated surface first appears bright and then ivory white. The work is then removed and burnished with a hand or rotary scratch brush of spring brass. This process of whitening and burnishing is repeated two or three times, depending upon the thickness of plating desired.

Before silver plating iron, pewter or any lead alloy the work must first be copper plated in a bath consisting of 14 drams acetate of copper, 14 drams carbonate of soda,  $\frac{3}{4}$  oz. bisulphite of soda, and  $1\frac{7}{8}$  oz. cyanide of potassium dissolved in a quart of water in the order named. The positive pole of the current source is connected to a piece of copper about the size of the object to be plated and the negative pole to the work. One plating and burnishing is sufficient.

With  
**Samson Units**  
you do not guess at results

as each tube is operated under the exact conditions specified by its manufacturer. All terminals are covered to prevent shock. Underwriter and AIEE Standards are met by a less than 20 deg. C. temperature rise after 24 hours continuous operation under full load. Fourteen types of units meet the needs of all sets from smallest to largest. Send 10c for Construction Bulletin on B Eliminators and Power Amplifiers.

**Samson Electric Co.**

Manufacturers  
Since 1882

MEMBER  
**RMA**

Main Offices at  
Canton, Mass.

## ANOTHER SPECIAL OFFER!

### UNI-RECTRON POWER AMPLIFIERS

Model AP-935



As the Uni-Rectron stands it is a super power amplifier, which can be used in connection with any radio set and loud speaker. Binding posts are provided for input to the Uni-Rectron and output to the speaker. Requires no batteries for its operation. It obtains its power from the 110 volt, 60 cycle alternating current lighting circuit of your house.

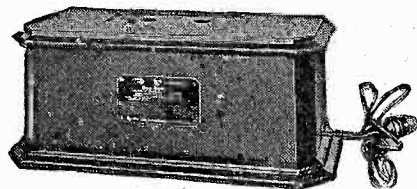

The UX-210 super power amplifying tube and the UX-216B or 281 rectifying tube are used with this amplifier, which cannot overload. From the faintest whisper to the loudest crash of sound—R. C. A. Uni-Rectron amplifies each note at its true value. High and low notes are all treated alike. The

volume and quality delivered will be a revelation. Also by removing the input and output transformers it can be used as a source of power for an oscillating or transmitting tube, furnishing power for all circuits, grid, plate and filament. Every one new and packed in original factory carton

List Price \$88.50

(Without tubes)

**Special at \$19.75**

each

AMERICAN SALES CO., 19-21 WARREN ST., NEW YORK CITY

## PHOTOELECTRIC CELLS — GLOW LAMPS TELEVISION APPARATUS

WRITE FOR BULLETIN E-3

PHOTON INSTRUMENT CORP., 574 Southern Blvd., New York City



# At Your Service wherever there is an ELECTRIC LIGHT SOCKET

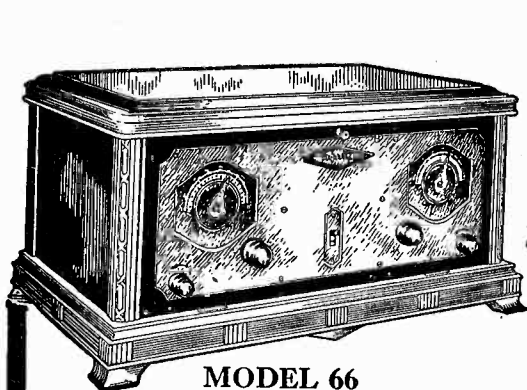

MODEL 66  
CONSOLETTA  
\$175

## Sleeper Electric Radio

Made in Both AC and DC Types

Think of the thrill, convenience and saving in having a marvelously toned and beautiful radio that does away with all batteries and operates right from your electric light socket—that's the Sleeper Electric—the radio you've waited for. It assures you simplicity of operation, a material saving in batteries and recharging costs and dependable service day after day and month after month. Buy yourself a Sleeper Electric Radio and enjoy life. Let us give you a free demonstration in your own home.

We invite correspondence from Western Dealers and Jobbers

**SLEEPER RADIO & MFG. CORP.**

GORDON C. SLEEPER, President  
LONG ISLAND CITY, N. Y.

# Sleeper

## THE 115 K. C. SUPER

(Continued from Page 21)

cillator coupler, and place the filament of the tube in series with the 25 watt lamp. Connect the positive *B* terminal of the oscillator coupler to the side of the lamp which is connected to the power circuit, as is shown in Fig. 2, and the grid return terminal to the *A* tube connection to the power circuit. The voltage drop across the Mazda lamp is the effective *B* voltage, and the tube will oscillate readily over the entire broadcast band, with a 60 cycle modulation which can be picked up in the headphones or loud speaker without difficulty.

The oscillator should be placed a few feet away from the antenna lead-in, and the oscillator condenser can be varied until the sound of the modulated output is heard in the superheterodyne. This makes the experimenter independent of local or distant stations when lining up a tuned r.f. amplifier, and no accurate calibration of the oscillator condenser dial is necessary, only approximate settings being necessary for the lining up process.

In running the plate leads of the shielded grid tubes from one compartment to another, do not run the wires through the same hole in the shield can base that is used for the *B* supply leads, or any of the other wiring of that particular stage. Make the plate leads as short and direct as possible, and use the hole through the shield through which the plate lead is run, exclusively for that lead.

## PROTECTION OF METERS

(Continued from Page 26)

deflection or nearly so, with the rheostat on the off point. Now turn the rheostat until the reading is reduced to one-tenth of its former value. This point on the rheostat is noted, and when at this position all readings of the meter are to be multiplied by ten.

A similar scheme for protecting volt-

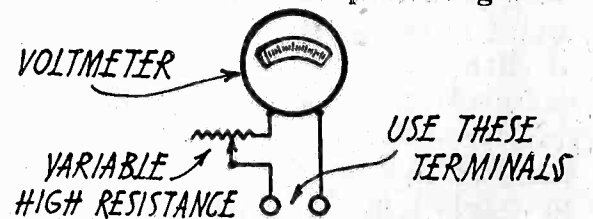
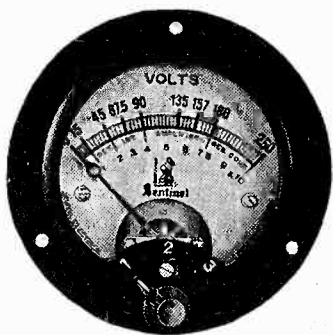

Fig. 2. Voltmeter Shunt

meters is shown in Fig. 2. The variable high resistance should be from five to ten times the resistance of the meter. In most cases a good value is obtained by multiplying the number of volts full scale deflection by fifty. The low resistance end should be a short circuit.

When connecting the meter to a circuit of uncertain voltage, start with high resistance end of the variable. As it is turned from this point, the reading will increase gradually. When the rheostat is at the point which shorts out the resistance, the reading of the voltmeter will be normal. This arrangement may also be calibrated as a multiplier, but for this purpose it is important to use one of the wire-wound type, as those which depend on carbon or graphite are apt to change in value.



## ANOTHER SPECIAL OFFER! JEWELL HIGH RESISTANCE VOLTMETER

0-250 VOLTS D. C. (3 Readings)

### A High Grade, Accurate, Reliable Instrument

Just what you want for checking the true operation of your "B" Eliminator or any source of plate voltage, which cannot be obtained from ordinary low resistance type meters.

Can be permanently placed in the set which will enable the user to apply desired plate voltage accurately to each circuit of his receiver. By means of the front switch three readings can be obtained without

disconnecting any wires, namely: the detector circuit, the radio frequency or intermediate circuit; and the maximum or output circuit including last audio tube.

Requires little current to operate due to its high internal resistance.

Flush Panel Mounting. Zero Adjuster.

List Price \$22.00 each

Special at \$4.75

New Jewell Meters Packed in Original Factory Cartons

AMERICAN SALES CO., 19-21 WARREN STREET, NEW YORK CITY

## THE TORUSOLENOID

(Continued from Page 22)

The celluloid strip is covered with a thin layer of cement for an inch or so and the wire wound on, covered for the next inch and the winding continued, progressing thus in increments since the cement dries quickly. After completing a coil and allowing 5 minutes for drying, the screws are loosened, wedges removed, and the coil slipped off. The piece of paper is removed from the coil, it being used to prevent the coil sticking to the form. The other coil is wound similarly—except that it is wound in the opposite direction. A finished coil on the form is shown in Fig. 7.

Two short celluloid strips  $\frac{3}{16}$  in. wide and approximately  $4\frac{1}{2}$  in. long are cut and cemented to the bakelite piece at the extremities of a diameter as shown

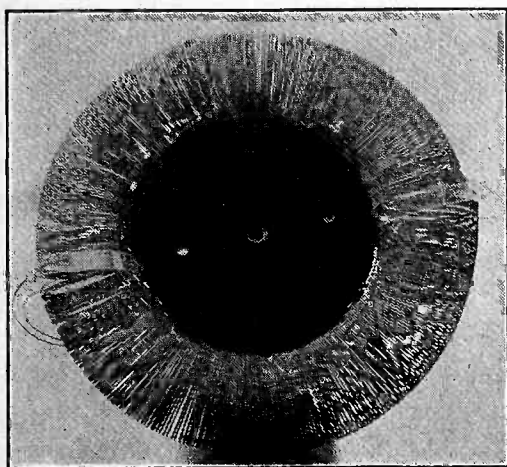

Fig. 5. Pair of Coils Cemented in Place.

in Fig. 5. Half the circumference of the piece is now given a layer of cement and one coil put in place. Using the celluloid strip of the coil as a backbone and placing it around the circumference of the piece, the coil is held in place for three minutes until the cement hardens. The second coil is similarly placed on the other side, making the four ends of the windings come at the short celluloid strips, where adjacent ends are connected and run to the nearby binding post.

Finally the short celluloid pieces and



Fig. 6. Rear View of Completed Torusolenoid.

the outer circumferential strip ( $\frac{3}{16}$  in. wide) are cemented to the windings, the



# JUST OUT!

## Radio's Greatest Publication

Contains all the latest  
radio information—  
New Circuits, Shielded  
Grid Tubes—Supers  
—and finest circuits of  
the spring season.

World's greatest list of  
broadcast stations, wave-  
lengths, etc. Photographs  
in rotogravure of leading  
radio personalities. Handy  
hints, and a wealth of radio  
data which every radio  
owner needs.

On Sale Everywhere

# 50c

Published by

CITIZENS' RADIO  
SERVICE BUREAU

508 South Dearborn Street  
CHICAGO, ILL.

Tell them you saw it in RADIO

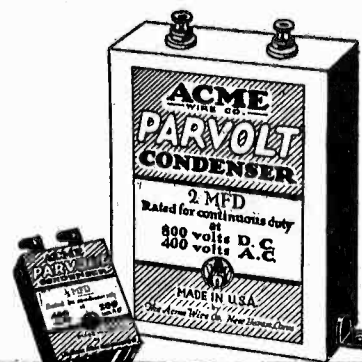

## Radio Experts Warn You —

Imperfect condensers, improperly rated condensers, non-uniform condensers—all break down sooner or later under the destructive action of voltage overloads. Blown condensers usually mean blown tubes, burned out transformers and chokes and even the destruction of speaker units.

Why take chances with ordinary condensers when ACME PARVOLTS give you positive protection?

These condensers are made only from highest grade insulation papers and special foils. Every detail of manufacture is under the constant supervision of experts who have devoted many years to the manufacture of condensers for heavy and continuous industrial duty. Every PARVOLT is tested to R.M.A. and N.E.M.A. standards, and can be relied upon for accuracy and continuous duty. Sold by leading jobbers and dealers. Made by THE ACME WIRE CO., New Haven, Conn., manufacturers of magnet and enameled wire, varnished insulations, coil windings, insulated tubing and radio cables.

## Play Safe with PARVOLTS

ACME PARVOLT FILTER CONDENSERS — In all required mfd. capacities for 200, 400, 600, 800, 1000 and 1500 Volt D.C. requirements. Supplied singly or in complete wired blocks for the important power supply units.

ACME PARVOLT BY-PASS CONDENSERS — Supplied in all required mfd. capacities and for all standard working voltages.

Made by the Manufacturers of  
ACME CELATSITE WIRE

FLEXIBLE and SOLID—For all types of radio wiring. High insulation value; non-inflammable; 10 colors.

ENAMELED AERIAL WIRE—Enameled copper wire, stranded or solid. Also Acme Lead-ins, Battery Cables, Indoor and Loop Aerial Wire.

ACME SPAGHETTI — A superior cambric tubing; 10 colors.

## Master the Code

Wireless or Morse—at home with the TELEPLEX Automatic Code Instructor. No better method for self-instruction exists. Quick—Easy—Thorough. Endorsed by U. S. Navy. The only instrument that Reproduces actual sending—messages, radiograms, etc. Any speed. Complete Course (6 tapes) FREE. Thirty times as many words as any other instrument. Avail yourself of the TELEPLEX for a quick mastery of the code. Write for booklet R. TELEPLEX CO., 76 Cortlandt Street, New York.

Phonograph  
Motor

TELEPLEX

## POWER UNIT

Save 75% of cost of Electro-Magnetic Power Unit. All parts factory-made—easily put together—A modern driving unit in knockdown form—complete only \$6.75. Send for circular or send us your order—GUARANTEED.

TUNBAR RADIO CO.

26 Cortlandt St., New York



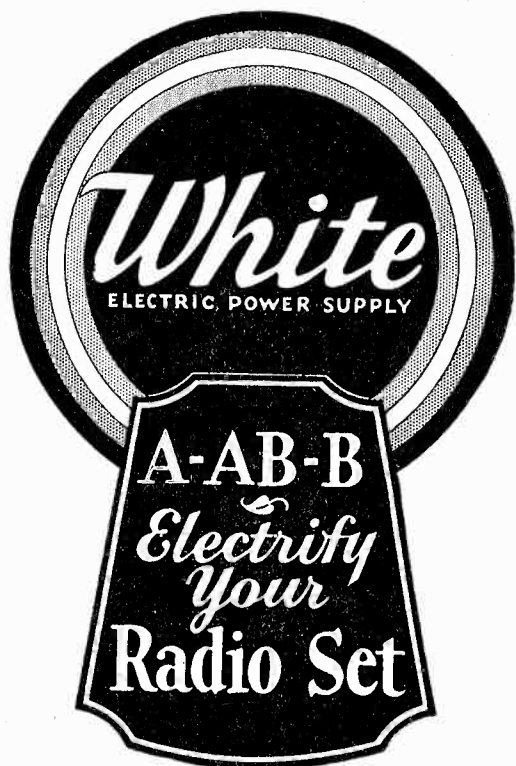

**“T**HERE is going to be a big re-adjustment in the Radio accessory industry in the next few months. Those Distributors, and Retailers, whose connections are sound from the point of engineering ability, manufacturing efficiency and finance will be fortunate.”

So we wrote in our trade paper advertising ninety days ago. And it has come.

In this period of re-adjustment White dealers (both Distributors and Retailers) have found themselves indeed fortunate. The technical and financial resources of this institution were ready. Our dealers got the benefit—immediately!

For months men in our research laboratories had been experimenting. Today our new AC unit is an established fact. We know it will do the work. We have proved it. And we are ready.

The phrase “White Electric Power Supply” means something whether it is supplied by A, AB, B, or AC units.

These things mean something to every Manufacturer, Distributor or Dealer who needs reliable electrical power supply units.

## JULIAN M. WHITE MFG. CO.

Makers of “A,” “B,” “AB” and “AC” units for  
Radio Power Supply.

SIoux CITY, IOWA

Factory Sales Agencies Company  
693 Mission Street  
SAN FRANCISCO, CALIFORNIA  
San Francisco Representatives

brass mounting strip (3½ in. long, ⅜ in. wide, 1/32 in. thick) put in place, and the torusolenoid is finished. Fig. 6 shows the finished product with the brass strip in place.

R.F. transformers are easily made of torusolenoid construction. Two “bundle wound” or concentrated coils of 50 turns each of No. 36 single silk-covered wire are wound and sandwiched in between the turns of the main coil near the filament (say the lower) end, and cemented in place. The 50 turns specified are for 01A and a.c. type tubes. The coils are wound in opposite directions on the regular winding form over a piece of paper, made rigid with a coat of cement and then slipped off. The ends are connected together so that the two wires from one binding post start around the coil in the same direction, which is the same direction as that of the half of the main coil in which it is placed. This gives the slot wound feature and the use of very small wire low mutual capacitance in accordance with the fundamental principles of efficient transformer design as expounded by Browning and Drake.

An r.f. transformer of this construction was substituted directly in place of an old solenoid type in an actual receiver. The sharper tuning and better performance obtained was very gratifying, an increase in regeneration of very considerable magnitude bespoke lower coil resistance at radio frequencies and proved experimentally the worth of the torusolenoid and the claims made for it.

The value of the closed field of the torusolenoid is not to be overlooked, when it is considered that it is less than that of the ordinary toroid, ordinarily spoken of as “closed,” since the equivalent geometrical shape of a toroid is that of a single turn of wire the circumference of which is the circumference of a single turn. The torusolenoid has no equivalent geometrical shape and if constructed absolutely symmetrically would have no external field. This fact makes the electromagnetic component of interstage coupling zero and, with careful wiring, that of the wiring and electrostatic component can be made negligible, making shielding unnecessary. Truly, this coil can be regarded as the greatest improvement in coil construction in the history of modern radio.

### CALLS HEARD

(Continued from Page 30)

ooBAM, op1CW, op1HR, oz1AN, oz1AO, oz1AP, oz1FB, oz1FE, oz1FJ, oz1FP, oz2AC, oz2AE, oz2AL, oz2AY, oz2GA, oz3AI, oz3AJ, oz3AP, oz3AR, oz3AU, oz3AZ, oz4AC, oz4AM, sb1AC, sb1AK, sb1AO, sb1AW, sb1BE, sb1BG, sb1CA, sb1IC, sb2AG, sb2AJ, sb2AX, sb2IG, sbSOF, sulOA, su2AK, sv1XC, WNP, ATC, VOQ, etc.  
SS Margaret Dollar, KDUV, E. O. Schwerdtfeger.

Operator, Docked at Cristobal, C. Z.

1add, 1cmf, 2ahi, 2bf, 2rs, 3ag, 3aim, 3aps, 3ec, 3ht, 4bl, 4cf, 4ge, 4rp, 4tk, 5acl, 5aqq, 5ayd, 5gr, 5pr, 5rg, 5rtn, 5we, 6ad, 6ard, 6ary, 6bil, 7adb, 7cke, 8alu, 8ank, 8avp, 8bti, 8cbf, 8hx, 8uy, 9aca, 9arn, 9au, 9aue, 9avv, 9baf, 9bca, 9bht, 9cv, 9dr, 9dkc, 9sk, nc-1ar, nc-3mp., AGJ, GLK, GLQ, FAMJ, IRI, PCP, PKX, XCF, XOM.

## RADIO ADS

### A CLASSIFIED ADVERTISING SECTION READ BY BETTER BUYERS

The rate per word is eight cents net. Remittance must accompany all advertisements. Include name and address when counting words.

Ads for the June Issue Must Reach Us by May Fifth

**FOR SALE** — 20-watt Transmitter complete, mounted on 24 x 24 in. panel with separate power and filament transformers, filters, radiation meter, milliammeter, filament voltmeter. Two R.C.A. oscillating transformers. Cost \$300.00. Will sell for \$150.00. EX 3. N. J. H. V. Houyoux, 4 School Plaza, Franklin, N. J.

**RADIOBUSTER**—A book of a dozen Alaskan radio stories by Volney G. Mathison. Bound in cloth. Acknowledged as the best radio fiction. Price, \$1.00 per copy. Postpaid anywhere. "RADIO," 433 Pacific Bldg., San Francisco.

**DO YOU GET TIRED** of buying "B" Batteries? A lifetime Edison will solve your troubles. Good, live, large size elements connected with pure nickel wire, electrically welded, 7c pair. All parts for sale. Sample cell and dope sheet, 10c. Paul Mills, Woodburn, Oregon.

**WESTERN ELECTRIC VT1 Tubes**, \$1.00; Aladdin tubes, UX201A, \$1.00; 112 or 171, \$2.00; Hallordson copper-shielded audio transformers, \$1.25. Write for list. Wm. Wagner, 819 DeKalb Ave., Brooklyn, New York.

Back issues of "RADIO," perfect condition. Early or late issues 65 cents postpaid. Speedy service. Money orders or 2c stamps. R. M. Harris, Star Box 5-A, Grimes, California.

**MEN**—Big pay working romantic South America. Fare, expenses paid. South American Service Bureau, 14,600 Alma, Detroit, Mich.

**BUMBLEBEE** amateur transmitter complete with motor generator ready to operate. 15 Watts. Beautiful walnut cabinet mounting with heavy iron angle bracket supports for coils. Exactly as pictured and described by Gerald Best in May 1927 issue of "Radio." Motor generator mounted on substantial base with quadruple belt drive. Absolutely in perfect condition. Never used. Cost more than \$200.00. Will sell for \$100.00 without tubes, f.o.b. San Francisco. All copper coils and mechanical work by Heintz and Kaufmann, built to our specifications. A real buy. D. B. McGown, 435 Pacific Building, San Francisco, Calif.

**BE THE LICENSED RADIO DOCTOR IN YOUR COMMUNITY.** \$7 to \$10 spare time evenings. Our co-operative plan procures all the work you want. Secure franchised territory now. Write for booklet. Co-operative Radio Doctors, Dept. P., 131 Essex St., Salem, Mass.

**BARGAIN**—1 Bristophon Model L Phonograph. Pickup, gold plated, never used. Cost \$45.00. Will sell for \$15.00. G. M. Best, 435 Pacific Bldg., San Francisco, Calif.

## BOOK REVIEWS

(Continued from Page 32)

a.c. operation. Chapter Five explains the Operation of Receiving Sets and Their Accessories, how to remedy receiving set troubles, the use of batteries and various types of battery chargers. Chapter Six presents a thorough discussion on Antennas, showing their use and construction and how to protect them against lightning discharges. The properties of the loop antenna and its application to direction finding are also given. Chapter Seven contains Data in the form of numerous tables, Underwriters' Rules, definitions of terms, formulas and characteristics of modern receiving and power tubes.

Because of its loose-leaf form and the monthly service of supplementary data sheets it may continually be kept up to date as the art progresses, thus making it a valuable addition to any radio library.

## QUERIES AND REPLIES

(Continued from Page 27)

plate voltages where tube life is a consideration. The plate current of this tube should not exceed 10 to 15 milliamperes, or the filament will soon wear out. The normal filament current is 1 ampere at 6 volts, and when used as an amplifier, with 135 volts plate, the C battery should be 9 volts.

# FROST-RADIO

## ANNOUNCEMENT

**A**T THE Radio Trade Show in Chicago the week of June 11 Frost-Radio will announce a new and improved line of Quality Parts. This new line will be well worth waiting for. Descriptive literature will be ready for release on or before the opening of the Show. Have us place your name on our list to receive this literature. Write us now about this, while the matter is fresh in mind.

**HERBERT H. FROST, Inc.**

New York City

ELKHART, IND.

Chicago, Ill.

## SHIP AERIAL

GENUINE SAWCA heavy duty 718 and 722 Silicon Bronze Ship Aerial, exactly as employed by ocean liners, ships, wireless and major broadcasting stations. Conductivity, pick-up energy and distance range greater than any other antenna wire available. Prices, per foot 722, two cents. 718 three cents, F.O.B. Brooklyn. Sample of either, 10 cents.

Ship Aerial Wire Co. of America

217 Wyckoff Avenue

Brooklyn, N. Y.

## NEW BOOKLET

On Audio Amplification, A. C. and D. C. Power Amplifiers, and Specially Developed Receivers—How to Get Better Tone, Volume and Power.

Newest circuits. 30 pages with diagrams and photographs.

Send 10c to cover mailing cost

**FERRANTI, Inc.**

130 West 42nd St., New York, N. Y.

## Send for Free Catalog

### Airplane Cloth Speaker

Also many bargains in all types of Cone Speakers, Units, complete parts to build all types of cone speakers. Also the latest parts of the new AIRPLANE Cone Speaker. Accessories.

ACCUSTI-CONE, 1 No. 7th St., Phila., Pa.

## WHAT'S WRONG WITH YOUR SUPER?

Jeems Super Trouble Shooter, most complete, accurate, sure-fire method of locating trouble in any superheterodyne. Chart comprises 16 symptoms, 130 possible causes; result of ten years' trouble finding on supers. By mail 50 cents.

**ROBERTS RADIO SERVICE**

508 So. Dearborn Street  
Chicago, Ill.



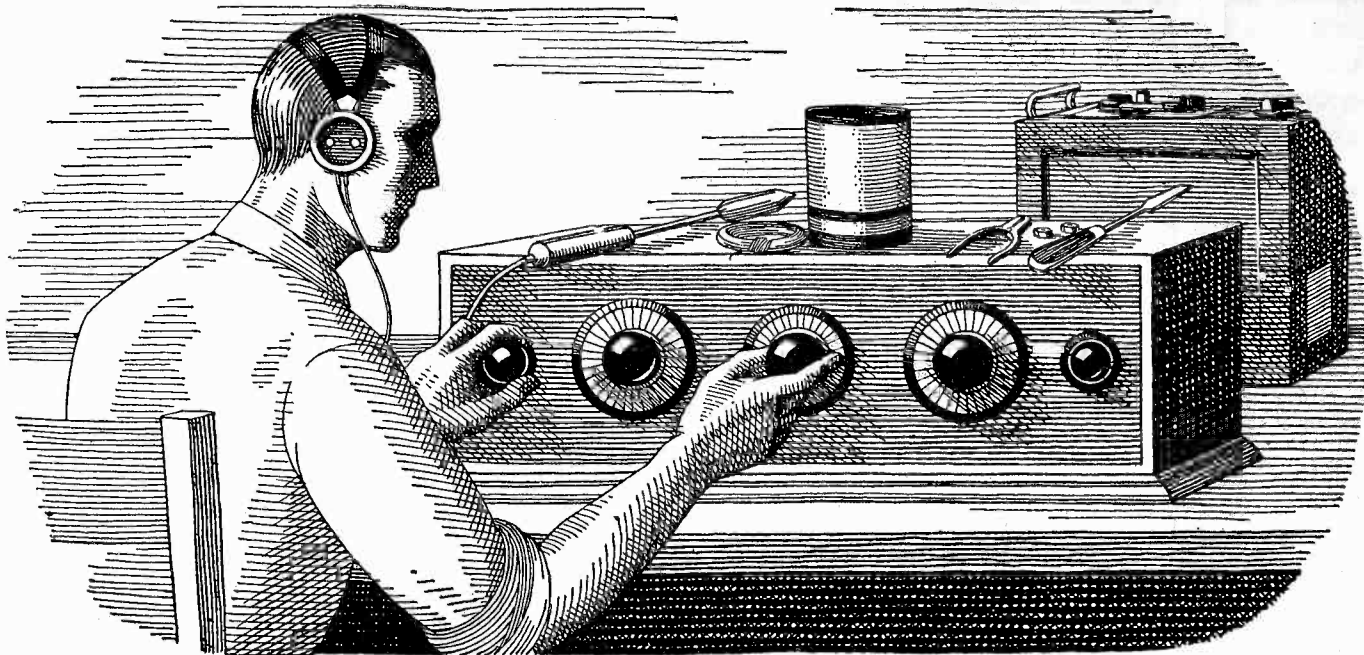

*If all the Radio sets I've "fooled" with in my time were piled on top of each other, they'd reach about halfway to Mars. The trouble with me was that I thought I knew so much about Radio that I really didn't know the first thing. I thought Radio was a plaything—that was all I could see in it for me.*

# I Thought Radio Was a Plaything

*But Now My Eyes Are Opened, And I'm Making Over \$100 a Week!*

\$50 a week! Man alive, just one year ago a salary that big would have been the height of my ambition.

Twelve months ago I was scrimping along on starvation wages, just barely making both ends meet. It was the same old story—a little job, a salary just as small as the job while I myself had been dragging along in the rut so long I couldn't see over the sides.

If you'd told me a year ago that in twelve months' time I would be making \$100 and more every week in the Radio business—whew! I know I'd have thought you were crazy. But that's the sort of money I'm pulling down right now—and in the future I expect even more. Why only today—

But I'm getting ahead of my story. I was hard up a year ago because I was kidding myself, that's all—not because I had to be. I could have been holding then the same sort of job I'm holding now, if I'd only been wise to myself. If you've fooled around with Radio, but never thought of it as a serious business, maybe you're in just the same boat I was. If so, you'll want to read how my eyes were opened for me.

When broadcasting first became the rage, several years ago, I first began my dabbling with the new art of Radio. I was "nuts" about the subject, like many thousands of other fellows all over the country. And no wonder! There's a fascination—something that grabs hold of a fellow—about twirling a little knob and suddenly listening to a voice speaking a thousand miles away. Twirling it a little more and listening to the mysterious dots and dashes of steamers far at sea. Even today I get a thrill from this strange force. In those days, many times I stayed up almost the whole night trying for DX. Many times I missed supper because I couldn't be dragged away from the latest circuit I was trying out.

I never seemed to get very far with it, though. I used to read the Radio magazines and occasionally a Radio book, but I never understood the subject very clearly, and lots of things I didn't see through at all.

So, up to a year ago, I was just a dabbler—I thought Radio was a plaything. I never realized what an enormous, fast growing industry Radio had come to be—employing thousands and thousands of trained men.

I usually stayed home in the evenings after work, because I didn't make enough money to go out very much. And generally during the evening I'd tinker a little with Radio—a set of my own or some friend's. I even made a little spare change this way, which helped a lot, but I didn't know enough to go very far with such work.

And as for the idea that a splendid Radio job might be mine, if I made a little effort to prepare for it—such an idea never entered my mind. When a friend suggested it to me one year ago, I laughed at him.

"You're kidding me," I said.

"I'm not," he replied. "Take a look at this ad."

He pointed to a page ad in a magazine, an advertisement I'd seen many times but just passed up without thinking, never dreaming it applied to me. This time I read the ad carefully. It told of many big opportunities for trained men to succeed in the great new Radio field. With the advertisement was a coupon offering a big free book full of information. I sent the coupon in, and in a few days received a handsome 64-page book, printed in two colors, telling all about the opportunities in the Radio field and how a man can prepare quickly and easily at home to take advantage of these opportunities. Well, it was a revelation to me. I read the book carefully, and when I finished it I made my decision.

What's happened in the twelve months since that day, as I've already told you, seems almost like a dream to me now. For ten of those twelve months, I've had a Radio business of my own. At first, of course, I started it as a little proposition on the side, under the guidance of the National Radio Institute, the outfit that gave me my Radio training. It wasn't long before I was getting so much to do in the Radio line that I quit my measly little clerical job, and devoted my full time to my Radio business.

Since that time I've gone right on up, always under the watchful guidance of my friends at the National Radio Institute. They would have given me just as much help, too, if I had wanted to follow some other line of Radio besides building my own retail business—such as broadcasting, manufacturing, experimenting, sea operating, or any one of the score of lines they prepare you for.

And to think that until that day I sent for their eye-opening book, I'd been wailing "I never had a chance!"

Now I'm making, as I told you before, over \$100 a week. And I know the future holds even more, for Radio is one of the most progressive, fastest-growing businesses in the world today. And it's work that I like—work a man can get interested in.

Here's a real tip. You may not be as bad off as I was. But think it over—are you satisfied? Are you making enough money, at work that you like? Would you sign a contract to stay where you are now for the next ten years—making the same money? If not, you'd better be doing something about it instead of drifting.

This new Radio game is a live-wire field of golden rewards. The work, in any of the 20 different lines of Radio, is fascinating, absorbing, well paid. The National Radio Institute—oldest and largest Radio home-study school in the world—will train you inexpensively in your own home to know Radio from A to Z and to increase your earnings in the Radio field.

Take another tip—no matter what your plans are, no matter how much or how little you know about Radio—clip the coupon below and look their free book over. It is filled with interesting facts, figures, and photos, and the information it will give you is worth a few minutes of anybody's time. You will place yourself under no obligation—the book is free, and is gladly sent to any one who wants to know about Radio. Just address J. E. Smith, President, National Radio Institute, Dept. 5-R, Washington, D. C.

J. E. SMITH, President,  
National Radio Institute,  
Dept. 5-R, Washington, D. C.

Dear Mr. Smith:

Please send me your 64-page free book, printed in two colors, giving all information about the opportunities in Radio and how I can learn quickly and easily at home to take advantage of them. I understand this request places me under no obligation, and that no salesman will call on me.

Name.....

Address.....

Town..... State.....

Occupation.....

# VOLUME AND QUALITY

has always been the demand in regard to audio units. The most recent contribution is the UX 250 (CX 350) power amplifier tube. This tube is capable of delivering to the speaker three times more undistorted energy than a UX 210. To realize the full possibility of this new tube it must be used with equipment especially designed for it. General Radio have developed a complete line of transformers and filters especially for this new power tube. Folders describing complete amplifier units and component apparatus will be sent on request.



*Type 565-A* TRANSFORMER

A transformer designed for half wave rectification when used with one UX 281 Rectifier tube or equivalent. Rated at 200 watts, Primary designed for 105--120 volt 56-60 cycle AC line. High voltage secondary of 600 volts. Two low voltage secondaries of 7.5 volts each for filament of rectifier and power amplifier tubes together with one secondary of 2.5 volts.

PRICE .....\$20.00

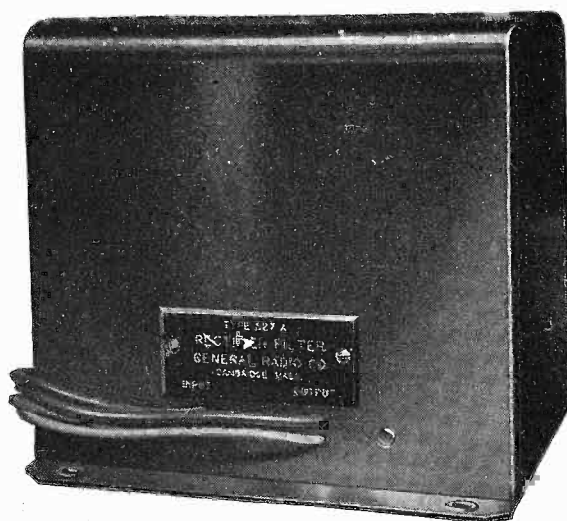

*Type 527-A* RECTIFIER FILTER

A complete filter unit mounted in the same style case as the Type 565-A transformer. This instrument consists of two heavy duty chokes of approximately 13 henries each having a current rating of 100 milliamperes and a condenser combination of 4-2-4 mf. The condensers are rated at 1000 volts while the direct current resistance of each choke coil is but 175 ohms.

PRICE .....\$25.00

# GENERAL RADIO

## QUALITY APPARATUS

Bulletin No. 929 describing complete line of quality apparatus will be sent on request

# GENERAL RADIO COMPANY

30 State St., Cambridge, Mass.

274 Brannan St., San Francisco, Calif.



# ABOX

## "A" BATTERY ELIMINATOR

### A. C. OPERATION— Without Change in Set Wiring or Tubes

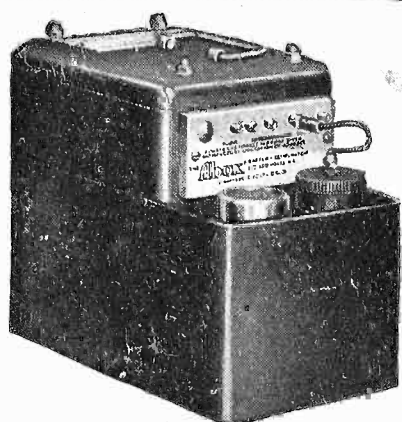

6-Volt Abox Eliminator

This model will operate any set using eight or less standard 6-volt tubes. Not necessary to change set wiring. Over 100,000 of this type in use.

\$ 32<sup>50</sup>

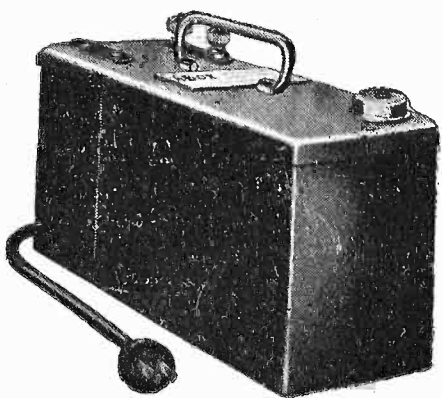

4-Volt Abox Eliminator

A new model for sets using 4-volt tubes. Fits Radiola battery compartment. Size 8<sup>3</sup>/<sub>4</sub> in. long, 4 in. wide, 6<sup>7</sup>/<sub>8</sub> in. high. Output—6 amperes, 4 volts D. C.

\$ 27<sup>50</sup>

All Prices Slightly Higher on West Coast

Changing to electric operation is a step toward convenience and dependability. By all means do it, but do not overlook the advantages of using the most sensitive tubes available.

A. C. operation using Abox is the most practical, economical and satisfactory method because it changes house current to the kind of power necessary to operate proven standard tubes.

Abox is a rectifier-filter combination adaptable to any receiver using eight 1/4 ampere tubes or less, or sixteen of the proposed new 1/8 ampere tubes. You make no changes in set wiring or tubes. Simply attach Abox and plug in. Reception is noticeably improved and consistently better. The convenience alone is worth the small investment.

Abox also makes available the many new special purpose tubes that improve radio operation and constitute the heart of practically all new custom-built circuits. A graphic comparison of the tubes possible to use with an Abox and the other A. C. type, is strikingly illustrated in the chart below, showing the superiority of Abox from every standpoint, where conversion is contemplated.

These tubes can be operated direct from the light socket with Abox:

UX 222	Screen Grid Amplifier	UV 199	Detector, Amplifier
UX 201B	1/8 Ampere Amplifier	UX 199	Detector, Amplifier
UX 112A	Power Amplifier	UX 200A	Supersensitive Detector
UX 120	Power Amplifier	UX 201A	Detector, Amplifier
UX 171A	Power Amplifier	UX 240	Voltage Amplifier

#### A. C. TYPES:

226 Amplifier

227 Detector

Use coupon for further information

# The Abox Company

215 North Michigan Avenue

Chicago, Illinois

THE ABOX COMPANY  
215 No. Michigan Avenue, Dept. 5, Chicago, Ill.

Please send me further information on how I can electrify my set with ABOX.

Name .....

Address .....

Check here if you are a dealer

Press of

THE JAMES H. BARRY COMPANY  
SAN FRANCISCO, U. S. A.