

JULY
1937

QUALITY POWER AMPLIFIERS

RADIO WORLD

REG. U.S. PAT. OFF.

A LUXURIOUS TUNER (See Page 8)

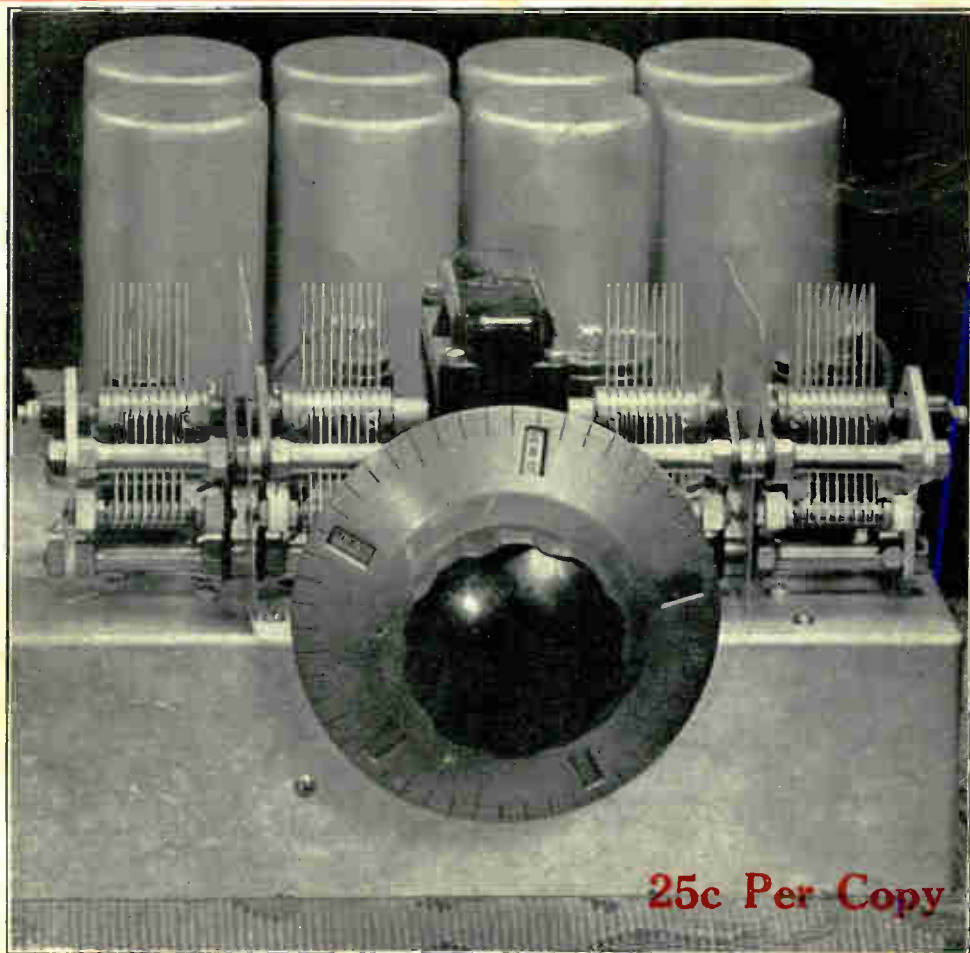

25c Per Copy

INTERNATIONAL ACCEPTANCE

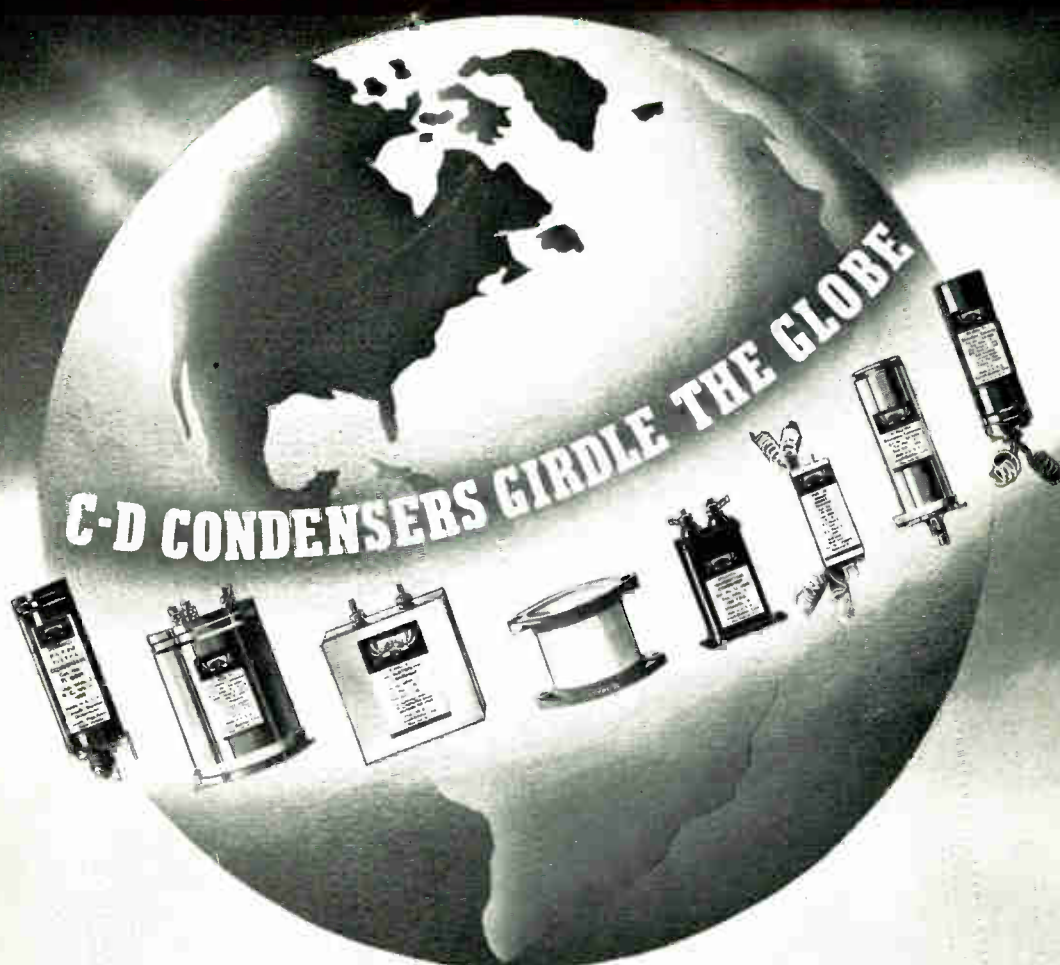

The broadcast engineer in far off China—the radio serviceman in Rangoon—the "Ham" in Iceland—the "Sparks" of a tramp steamer plying tropic seas—the Manufacturer of radio receivers in America—all know, approve, and use Cornell-Dubilier Condensers.

Because C-D Condensers are engineered and constructed to withstand the rigors of every conceivable degree of abuse—because they provide dependable service consistently—they are the internationally accepted standard by which condensers are judged. Look for the C-D trademark. It is truly a symbol of quality.

WORLD'S LARGEST EXCLUSIVE MANUFACTURERS OF CAPACITORS
MICA • PAPER • WET & DRY ELECTROLYTICS • DYKANOL

CORNELL-DUBILIER

C O R P O R A T I O N

SOUTH PLAINFIELD • NEW JERSEY

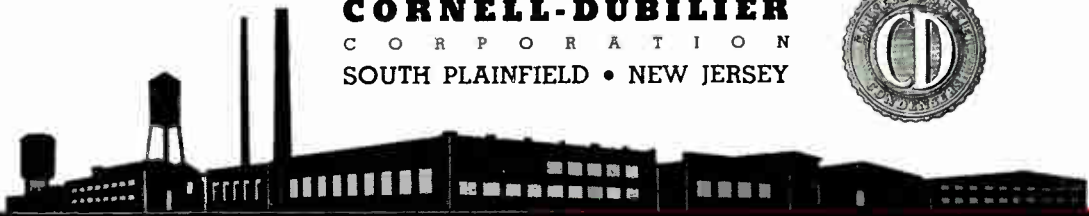

CORNELL-DUBILIER

I WILL TRAIN YOU AT HOME IN SPARE TIME FOR A GOOD RADIO JOB!



**J. E. Smith, President
National Radio Institute**
The man who has directed the home study training of more men for the Radio Industry than any other man in America.

**HERE'S
PROOF**



**Works for
State of
Illinois**

"If I had not taken your Course I would still be digging ditches. I just started to work for the State of Illinois, operating their 1,000 watt transmitter. If anyone wants to write me about your Course, I shall be glad to answer." R. S. LEWIS, 128 E. Ashe St., Springfield, Ill.

**Picked up
\$1800 White
Learning**



"I picked up \$1800 while studying and I call that easy money—the time I gave my Radio work did not interfere with my other business." OTIS DENTON, 14105 Lorain Avenue, Cleveland, Ohio.

FREE LESSON on Radio Servicing Tips

I'll prove that my training is practical, easy to understand—just what you need to make money in Radio. My sample lesson text, "Radio Receiver Troubles—their Cause and Remedy" covers a long list of Radio receiver troubles in A.C., D.C., battery, universal, auto, T. R. E., super-heterodyne, all-wave, and other types of sets. No obligation. Mail coupon.

FREE BOOK TELLS HOW MAIL COUPON

Do you want to make more money? Radio offers you many opportunities for well-paying spare time and full time jobs. And you don't have to give up your present job or leave home and spend a lot of money to become a Radio Expert.

Many Radio Experts Make \$30, \$50, \$75 a Week

Radio broadcasting stations employ engineers, operators, station managers and pay up to \$5,000 a year. Spare time Radio set servicing pays as much as \$200 to \$500 a year—full time jobs with Radio jobbers, manufacturers and dealers as much as \$30, \$50, \$75 a week. Many Radio Experts operate their own full time or part time Radio sales and service businesses. Radio manufacturers and jobbers employ testers, inspectors, foremen, engineers, servicemen, paying up to \$6,000 a year. Radio operators on ships get good pay and see the world besides. Automobile, police, aviation, commercial Radio, and loud speaker systems are newer fields offering good opportunities now and for the future. Television promises to open many good jobs soon. Men I have trained are holding good jobs in these branches of Radio. Read their statements. Mail the coupon.

There's a Real Future in Radio for Well Trained Men

Radio already gives good jobs to more than 300,000 people. And in 1936, Radio enjoyed one of its most prosperous years. More than \$500,000,000 worth of sets, tubes and parts were sold—an increase of more than 60% over 1935. Over a million Auto Radios were sold, a big increase over 1936. 24,000,000 homes now have one or more Radio sets, and more than 4,000,000 autos are Radio equipped. Every year millions of these sets go out of date and are replaced with newer models. More millions need servicing, new tubes, repairs, etc. A few hundred \$30, \$50, \$75 a week jobs have grown to thousands in 20 years. And Radio is still a new industry—growing fast!

**Many Make \$5, \$10, \$15 a Week Extra
in Spare Time While Learning**

Practically every neighborhood needs a good spare time serviceman. The day you enroll I start sending you Extra Money Job Sheets. They show you how to do Radio repair jobs that you can cash in on quickly. Throughout your training I send you plans that made good spare time money—\$200 to \$500 a year—for hundreds of fellows. My training is famous as "the Course that pays for itself."

I Give You Practical Experience

My Course is not all book training. I send you special Radio equipment and show you how to



conduct experiments and build circuits which illustrate important principles used in modern Radio receivers, broadcast stations and loud speaker installations. I show you how to build testing apparatus for use in spare time work from this equipment. Read about this 50-50 method of training—how it makes learning at home interesting, quick, fascinating, practical. Mail coupon.

Money Back Agreement Protects You
I am so sure that I can train you successfully that I agree in writing to refund every penny you pay me if you are not satisfied with my Lessons and Instruction Service when you finish. I'll send you a copy of this agreement with my Free Book.

**Find Out What Radio Offers You
Act Today.** Mail the coupon now for "Rich Rewards in Radio." It's free to any fellow over 16 years old. It describes Radio's spare time and full time opportunities and those coming in Television; tells about my training in Radio and Television; shows you actual letters from men I have trained, telling what they are doing and earning. Find out what Radio offers YOU! MAIL THE COUPON in an envelope, or paste it on a penny post card—NOW!

**J. E. SMITH, President, Dept. 7GM4
National Radio Institute, Washington, D. C.**

**MAIL
COUPON
NOW!**



**This FREE BOOK has Helped Hundreds
of Men to Make More Money**

**J. E. SMITH, President, Dept. 7GM4
National Radio Institute, Washington, D. C.**

Dear Mr. Smith: Without obligating me, send "Rich Rewards in Radio," which points out the spare time and full time opportunities in Radio and explains your 50-50 method of training men at home in spare time to become Radio Experts. (Please Write Plainly.)

NAME.....AGE.....
ADDRESS.....
CITY.....STATE.....

14 x 1

**The Tested WAY
to BETTER PAY**

Now—a high powered

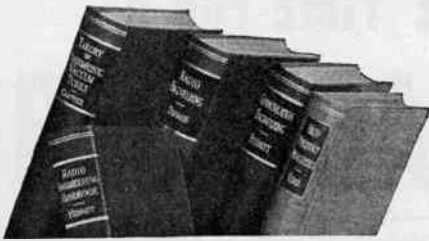

Radio Engineering Library

—especially selected by radio specialists of McGraw-Hill publications

—to give most complete, dependable coverage of facts needed by all whose fields are grounded on radio fundamentals

—available at a special price and terms.

These books cover circuit phenomena, tube theory, networks, measurements, and other subjects—give specialized treatment of all fields of practical design and application. They are books of recognized position in the literature—books you will refer to and be referred to often. If you are practical designer, researcher or engineer in any field based on radio, you want these books for the help they give in hundreds of problems throughout the whole field of radio engineering.

5 volumes, 2891 pages, 2000 illustrations

1. Everitt's COMMUNICATION ENGINEERING
2. Terman's RADIO ENGINEERING
3. Chaffee's THEORY OF THERMIONIC VACUUM TUBES
4. Hndd's HIGH-FREQUENCY MEASUREMENTS
5. Henney's RADIO ENGINEERING HANDBOOK

10 days' examination. Special price. Monthly payments \$26.00 worth of books cost you only \$23.50 under this offer. Add these standard works to your library now; pay small monthly installments, while you use the books.

SEND THIS ON-APPROVAL COUPON

McGraw-Hill Book Co., Inc.
330 W. 42nd St., New York, N. Y.

Send me Radio Engineering Library, 5 vols., for 10 days' examination on approval. In 10 days I will send \$23.50, plus few cents postage, and \$3.00 monthly till \$23.50 is paid, or return books postpaid. (We pay postage on orders accompanied by remittance of first installment.)

Name

Address

City and State

Position

Company R.W. 7-37



William Greer at the "Super-Pro" Controls

★ "A GRAND RECEIVER"

★ SAYS William Greer, chief engineer of WNEL. He adds, "Super-Pro" . . . only set able to use for re-broadcasting. . . . 'Super-Pro' not susceptible to the high noise level. . . . Found possible to receive United States stations with a field intensity of few micro-volts, and frequency separated from WNEL's by only a few kilocycles."

MAIL COUPON BELOW FOR "SUPER-PRO" DETAILS!

HAMMARLUND MFG. CO., Inc.
424-438 W. 33rd St., New York City
Please mail me new "Super-Pro" bulletin.

Name

Address

City..... State.....

RW-7



HAMMARLUND

AMATEURS! Get ALLIED's New Spring CATALOG!



Send for the new Spring 1937 ALLIED Radio Catalog! 156 pages packed with Everything in Radio at lowest prices; more than 10,000 exact duplicate and replacement parts; latest Amateur transmitters, receivers and transceivers; dozens of set-builders' kits; 53 new Knight Radios; test instruments; P. A.; books, tools, etc.—Radio's Complete Supply Guide!

ALLIED RADIO CORP. Dept. 16-G
833 W. Jackson Blvd., Chicago, Ill.

Send me your Free New 1937 ALLIED Catalog.

Name

Address

Free

RADIO WORLD AND POPULAR MECHANICS MAGAZINE
—Radio World is \$2.50 a year, and Popular Mechanics Magazine is \$2.50 a year. Popular Mechanics Magazine does not cut rates, but Radio World will send both publications to you for one year for \$3.75. RADIO WORLD, 145 West 45th Street, New York City.

MIDWEST..

FACTORY-TO-YOU

SAVES 50%

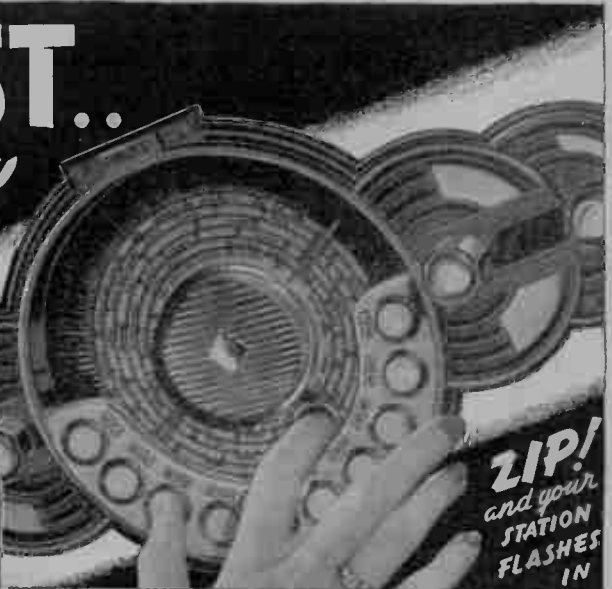
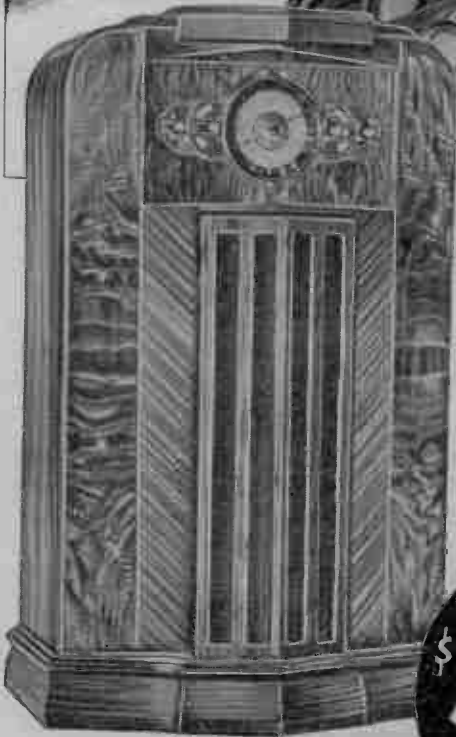

ZIP!
and your
STATION
FLASHES
IN

HALF the Cost... TWICE the Performance

14 TUBES FOR THE PRICE OF 8

This great new Midwest has caught the nation's fancy, because scores of marvelous new features like Dial-A-Matic Tuning*, Elektrik-Saver* (optional*) give magnificent world-wide reception and glorious crystal clear realism. America OK's Midwest radios because they out-perform ordinary sets on a point-for-point comparison. Not a cut-price set, but a more powerful super performing radio in a big, exquisitely designed cabinet

of matched walnut! You are triply protected with Foreign Reception Guarantee . . . One-Year Warranty and Money-Back Guarantee. Now, you can roam the world in a flash . . . switching instantly from American programs to police, amateur, commercial, airplane and ship broadcasts . . . to the most fascinating foreign programs. When you buy the Midwest factory-to-you way, you deal directly with the factory that makes radios — instead of paying extra profits to wholesalers, distributors, retailers, etc.

Only
\$39.95
AND UP
NEW LOW BASE PRICE*
FOR A WORLD-WIDE
MIDWEST

30 DAYS FREE TRIAL!

For seventeen years, Midwest engineers have pioneered many features and advantages which others quickly copied. The new 1937 Midwest is designed years in advance. It has everything! Not just two or three outstanding features, but scores of new developments...many of them exclusive. Send for the FREE 40-page book. See for yourself that Midwest offers today's greatest radio values. See why so many say: "Midwest sets the pace!"



Midwest engineers discussing new chassis

*Other Midwest radios complete with tubes and console, \$29.95 and up! (*Base price, less tubes and console.)*

Send for FREE 40-PAGE CATALOG!

Remember! Nothing of value is added to a radio just because it is handled many times. You have a year to pay . . . terms as low as 10c a day . . . you secure the privilege of 30 days FREE trial in your own home.

ZIP!... and Your Station Flashes In! Your radio enjoyment is doubled with Dial-A-Matic Tuning, the amazing new Midwest feature that makes this radio practically tune itself. Zip! . . . Zip! . . . Zip! . . . stations come in instantly, automatically, perfectly . . . as fast as you can push buttons.



PASTE COUPON ON I¢ POSTCARD...OR WRITE TODAY!

MIDWEST RADIO CORPORATION
Dept. R.W.7, Cincinnati, O.
Send me your new FREE catalog and complete details of your liberal 30-day FREE trial offer.
(Special offer and prices prevail only when dealing direct with factory by mail.)

Name.....
Address.....
Town..... State.....
User-Agents Make Easy Extra Money Check Here for details.

MIDWEST RADIO CORP.

DEPT. R.W.7 CINCINNATI, OHIO, U.S.A.
Established 1920 Cable Address MIRACO...All Codes

RADIO WORLD

Sixteenth Year

ROLAND BURKE HENNESSY
Editor

H. J. BERNARD
Managing Editor

HERBERT E. HAYDEN
Advertising Manager

Table of Contents for JULY, 1937

A Luxurious Tuner 8 By Garrison Formell <i>Self-Powered, Using National Co. Parts</i>	A World-Wide Trouble Solved .. 26 By Dudley E. Foster <i>External Cross-Modulation Analyzed</i>
Capacity-Leakage Rigs 11 By Richard F. Lonergan <i>Simple Measurements with 0-1 Milliammeter</i>	Laboratory Findings 30 <i>Blocking in Battery Sets</i> <i>Bigger Air Gap Improves Midgets</i> <i>Queer Oscillations Remedied</i> <i>Non-Locking Pentagrid Alignment</i> <i>Smaller Condenser Aids Tone</i>
Table of Subharmonic Frequencies 14	Right or Wrong? 32 <i>Six Propositions Put, and Answers Given</i>
The Surprise Amplifier 15 By Paul C. Burkholder <i>A Tone-Conscious Experimenter's Development</i>	Straightening Them Out 33 <i>Discussion of Attacks on Squeal Article</i>
High-Fidelity Audio 16 By T. J. P. <i>Experimenter Describes His Attainment</i>	Standards of A-C Voltages 34 By William C. Farrow <i>Second-Harmonic Generator Produces Them</i>
Tuner, Amplifier DeLuxe 19 By H. L. Smith <i>Unit Construction, Latest Developments</i>	Auto Receiver Design 37 By Jerome C. Smith <i>Growth of Car Set; Problems Posed</i>
Public Address Growing Fast .. 22 By M. N. Beitman <i>Opportunities Ripe for Money-Making</i>	Servicing — Past, Present and Future 49 By F. E. Wenger
33 Oscillator, 6 Volts on Plate .. 23 By R. K. Wheeler <i>Stability and Self-Modulation</i>	Instrument Needs of Servicemen 52 By Samuel C. Milbourne
Moisture Dangerous in Transformers 24 By Emil Buchwald <i>A Safeguarded Drying Method Outlined</i>	New Products 54
	Radio Construction University 56 <i>Answers to Questions on the Building and Servicing of Radio and Allied Devices</i>
	Ohm's Law Applied to D.C. 60 By Bradley Argus <i>How to Put Decimal Point in Right Place</i>

Vol. XXX, July, 1937. No. 4. Whole No. 706. RADIO WORLD, published monthly by Hennessy Radio Publications Corporation, 145 West 45th Street, New York, N. Y. Editorial and executive offices, 145 West 45th Street, New York, N. Y. Executives of RADIO WORLD: Roland Burke Hennessy, editor and business manager; H. J. Bernard, managing editor; Herbert E. Hayden, advertising manager. Officers of corporation: Roland Burke Hennessy, president-treasurer; Roland Burke Hennessy, Jr., vice-president, H. J. Bernard, secretary. Entered as second-class matter March, 1922, at the Post Office at New York, N. Y., under Act of March 3rd, 1879.

SUBSCRIPTION RATE

Price 25 cents per copy. Subscription \$2.50 per year (12 issues); \$1.25 per six months (6 issues); postpaid in United States and Possessions; \$3.00 per year, \$1.50 per six months, postpaid in all other countries. Remittance for foreign subscription should be by International money-order (postal or express) or draft against or discountable at New York bank.

RADIO WORLD is distributed by the American News Company and its Branches

7C 5-Tube Short Wave Receiver 8 $\frac{1}{4}$ to 625 Meters

Bigger and More Powerful Than Ever, a Giant in Performance

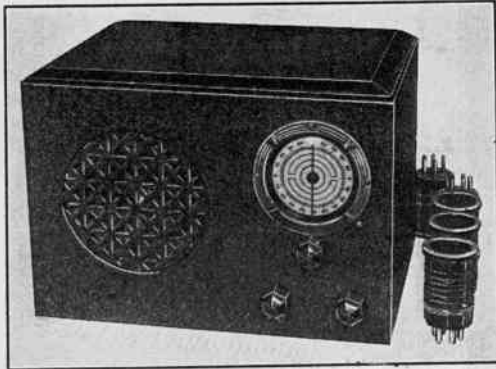

FULL 6 TUBE PERFORMANCE plus THE NEW K92A SERIES TUBE makes this an outstanding value. Equipped with a powerful 3 stage audio frequency amplifier.

Uses 6D6-6F7 (twin 2 in 1 tube)—76—K92A-12A7 (twin tube) tubes as R.F. amplifier, electron coupled screen grid regenerative detector, powerful 3 stage audio amplifier with pentode output stage, rectifier and complete built-in power supply. Operates entirely from 105 to 130 volt AC or DC light socket.

BAND SPREAD TUNING—smooth regeneration control—built-in high quality loudspeaker—automatic headphone jack—large, illuminated airplane type vernier dial—large low-loss inductances. Heavy, black shrivel finish metal chassis and cabinet. Must be seen to be appreciated. Satisfied owners report as high as 35 foreign countries on the loudspeaker with this model. You may do the same under fair conditions. ORDER YOURS TODAY! YOU WILL NOT REGRET IT!

EILEN 7C RECEIVER, wired, in cabinet, complete, READY TO USE, with speaker, 5 RCA tubes, 4 coils for 8 $\frac{1}{4}$ to 200 meters, and simple instructions **\$12.95**
2 Broadcast Band Coils, extra.....\$1.25

7C KIT, unwired, of necessary parts, 4 coils for 8 $\frac{1}{4}$ to 200 meters, and instructions, less cabinet. **\$7.25**
speaker, tubes\$1.23
Beautiful metal cabinet, extra.....\$1.23
5 matched RCA tubes.....\$1.15
Special loudspeaker\$1.45
(2) Broadcast band coils, 200-625 meters.....\$1.25
Labor for wiring and testing, extra.....\$1.50

SPECIAL: COMPLETE KIT, unwired, cabinet, 5 tubes, speaker, 4 coils for 8 $\frac{1}{4}$ to 200 meters, and simple instructions **\$11.45**
2 broadcast coils, extra.....\$1.25

AMATEURS: Model 7C-AB, same specifications as 7C except that has special tuning circuit and coils for spreading out the 20-40-80-160 M bands over 80% of dial. Also equipped with plate voltage cut-off switch. Same price as 7C. Model 6B or 6B-AB battery model of 7C. Operates from inexpensive dry batteries. Same price.

BS-5-6-TUBE BAND SWITCH RECEIVER—

FREE: New

10 to 600 Meters

1937 catalogue RW 7

of short wave receivers, transmitters, and 5 meter apparatus. Send stamp to cover mailing costs on YOUR copy.

JUST OFF THE PRESS!

BS-5 KIT, of necessary parts, including detailed instructions; less tubes, cabinet, unwired.....

\$10.95

A powerful, sensitive, and selective SW receiver covering the entire wave-length span of 10 to 600 meters in 5 steps. NO PLUG-IN COILS are used. Simply turn the wave-band selector switch and enjoy reception on any wavelength within this range.

Uses two 6D6, one 76, one 45, one K92A, and one 2Z5 tubes as RF amplifier, electron coupled screen grid regenerative detector, powerful 2 stage audio amplifier with pentode output stage, rectifier, and complete built-in power supply.

HUM-FREE—Hi-fidelity dynamic loudspeaker—illuminated, airplane type vernier dial—band spread tuning control—automatic headphone jack—extremely smooth acting controls—operates from your AC or DC house current—beautiful heavy, black shrivel finish chassis and cabinet.

DELIVERS GREAT LOUDSPEAKER VOLUME ON THE GREAT MAJORITY OF SHORT WAVE FOREIGN STATIONS UNDER FAIR CONDITIONS.

PRICE, complete, with 6 tubes, cabinet, wired, and instructions, ready to use **\$16.95**

Beam Power Tubes to Be Had

SPECIAL: Complete kit, cabinet, tubes and instructions, unwired.....

\$14.95

(If metal tubes are preferred to glass type, add \$1)

Prompt service, 20% deposit on C.O.D. orders

EILEN RADIO LABORATORIES, Dept. RW-7—136 Liberty St. NEW YORK, N. Y.

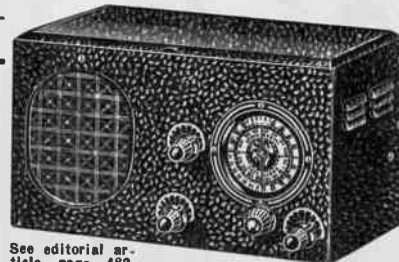

See editorial article page 482, Dec. issue S.W.C.

AMATEURS:

Model BS-5-AB has same specifications as BS-5 except that it has special bandspread circuit for 20-40-80-160 M bands and is equipped with plate voltage cut-off switch. Add \$1.00 to above price.

A Luxurious Tuner

**SELF-POWERED, COVERS
BROADCAST BAND IN TWO
SWITCH POSITIONS, AND IS
INTENDED TO FEED A SUPERB
POWER AMPLIFIER**

**By
Garrison Formell**

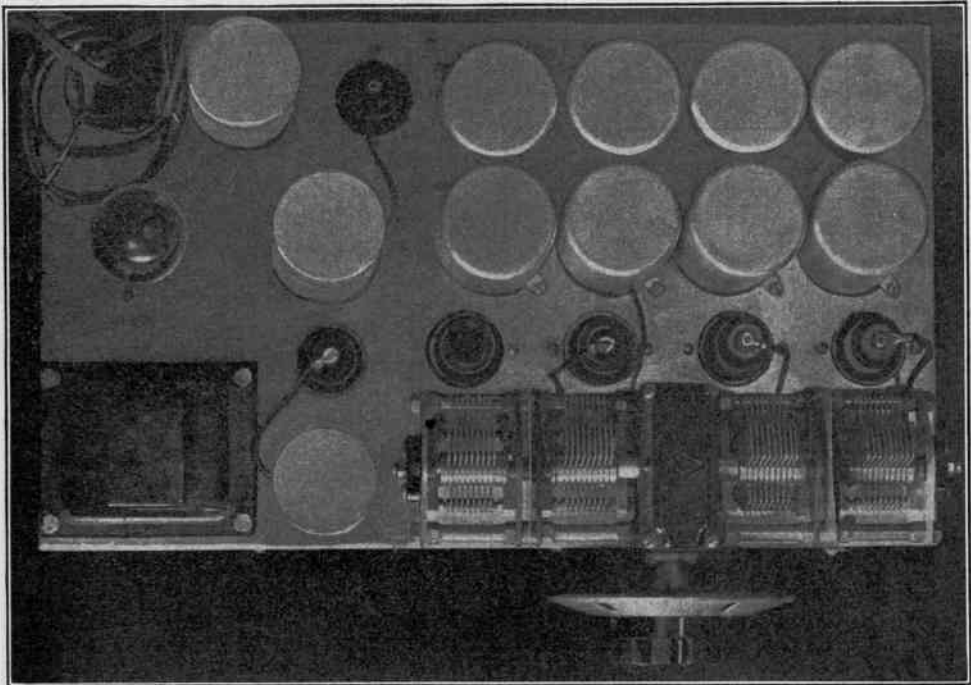

Top view of the nine-tube deluxe tuner, that uses the balanced detector circuit developed by Orval LaFrance. The intermediate-frequency coils are at left.

THE La France balanced detector was included in a luxurious tuner that covered the standard broadcast band in two jumps, had National Company's four-gang precision condenser, pre-loaded worm-drive dial mechanism, and air-core intermediate-frequency coils, was intended to be "delovely" and was.

The tuning mechanism is shown in the view on this page, with the radio-frequency coils in the background. One row represents one band, about 500-1,000 kc, and the other row the other band, about 1,000 to 2,000 kc. As the bands were selected by switching, the switch was run beneath the "straight eight" coils and terminated at the right-hand side of the chassis. While the shaft of the switch is not visible, its position may well be imagined from a glimpse of the top

view on this page. The cabinet arrangement was such that a lever, working in 30 degrees, threw the switch one way or the other. Another way of working such a distaff-side switch is to use a drum for turning it, with front panel extrusion of the rim.

Also the cabinet arrangement was such that the dial itself was at center. A book compartment at right took up the equalizing space.

TUNING INDICATOR USED

The top view reveals also the three i-f coils and eight of the nine tubes. One tube is partly hidden by the line cord, upper left, in the top view. The ninth tube, for tuning indicator, was on a commercial extension cable.

The balanced detector was included because

Padders Used as Grid Condensers for Economy

When two or more bands are to be covered by switching, and a Hartley is the local oscillator of a superheterodyne, an extra switch deck may be avoided by using the padding condensers as grid condensers.

The diagram relates to a 500-1,000 and 1,000-2,000 kc tuner. The proper padding condensers were .00035 mfd. for the lower frequency band, .00055 mfd. for the higher frequency band. In such an oscillator the grid leak has to be of low value. The 25,000 ohms shown were verified experimentally.

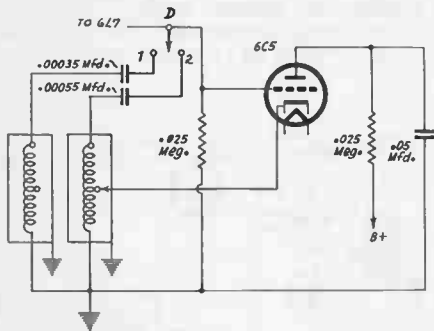

The circuit for making condensers serve two purposes.

National Company Parts Grace Superb Tuner

(Continued from preceding page)
complete diagram has a deck specially devoted to bringing the padding condensers into the oscillator circuit, but since the tuner was built that way a change has been made, just as a trial, and it worked out very well. The padding condensers were used as the grid condensers and a switch deck thus omitted. A note and diagram on this detail appear herewith. The tuning condenser is assumed from D to ground.

The voltages and other information are given in the diagram. The i.f. was 456 kc. The grid leak in the 6C5 local oscillator circuit, marked .25 on the diagram, should read .025 meg., i. e., a 25,000-ohm resistor is required. Higher values will not do, not with the circuit and coils used.

SUPERB PERFORMANCE

These coils are the same ones as used in one of National Company's receivers, but are not commercially obtainable. Any desiring data on inductances, coupling, padding and shielding, may obtain them by addressing the author, care of RADIO WORLD, 145 West 45th Street, N. Y. City.

The parts generally will be recognized as the precision products of National Company, Malden, Mass., and it must be agreed that they made a fetching layout. Their performance in this self-powered luxurious tuner was superb.

ENGINEERS, BEWARE!

REGARDING the May issue, which seems to have been mainly devoted to pasting the servicer in the eye, let me say that all those who contributed so nobly are sitting supinely on the far side of the fence, securely ensconced in various engineering (?) capacities and are thus enabled to throw mud in the servicer's eye. Only one seemed to have had previous servicing experience, and that was Rider.

All of them had a particular axe to grind in the form of equipment which they arbitrarily put on their "must" list to enable servicers to be able to do efficient work. Nearly everyone dusted off that prehistoric reference to the screwdriver mechanic and gave it a whirl. Maybe they were born completely equipped with tools and knowledge? None of them had to experiment; they knew it all the time!

WHAT THEY FORGET

To accomplish anything in the way of furthering any trade, the criticism must be constructive and must emanate from a dispassionate mind. Only one in the group even remotely reached these requirements. They forget so easily that many fool engineering stunts have reached the field where they had to be ironed out by others than "engineers." We are glutted with diagrams bearing mute testimony to airy fancies which had been allowed to come into

being, and which should never have left the engineers' heads.

One homely example will serve to illustrate my point. These dabblers who draw high pay have devised dozens of ways to bias a tube, each believing that though it had been done before another way, he had the *best* way. For that reason we have to know all the methods, all the weaknesses, of all too many power supplies, the ultimate result of which is only to confuse instead of to clarify the situation.

My shoulders are quite broad, but when it comes to taking it from these so-called engineering experts, telling another branch of the art how they should run their part of it, I can't take it lying down.

What these birds forget is that there is room for improvement all around; they have no more reached the golden peak than we have.

STILL WITH YOU, ED

I hope, Mr. Editor, that you are still with me at the end of this harangue, but if you get a chance, kick a few of the engineers in the slats for me when you see them next. Nothing personal in all this, but you alone are available as the relay station. I still like your magazine a lot in spite of the way the above might be open to misinterpretation.

EDWIN A. WOLF,
115 Church Street, West Roxbury, Mass.

Capacity-Leakage Rigs

Simple Measurements, Using 0-1 Milliammeter

By Richard F. Lonergan

THE three measurements made of condensers, particularly those of medium and high capacity, are capacity, leakage and power factor. There is no particular necessity that the capacity be accurately known, unless the condenser is in some very special circuit, such as a tuned filter. There is nothing critical about the leakage checkup, either, as the only requirement is that the leakage be not intolerably high. The power factor is not of any great moment, either, as that is really a measure of the behavior to radio frequencies, or economy of a-c motor

resistor in additionally, and bring out the terminals of this particular resistor to posts. The unknown capacity can be read on the basis of the current increase caused by inclusion of the condenser. Only a small part of the meter scale can be used.

If the meter is made less sensitive, by shunting, and the current is permitted to increase to 4 milliamperes, which may be read anywhere save close to full scale, then the capacities will be direct-reading, from 1 mfd. to 10 or 12 mfd., no more.

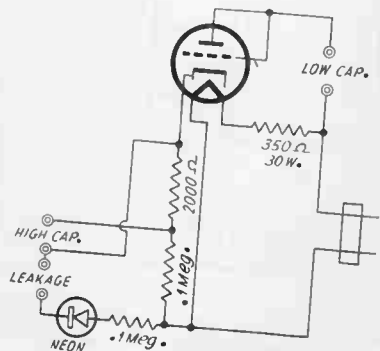
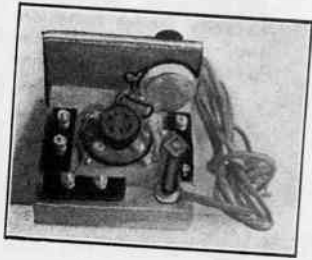

Triode used as rectifier, 0-1 milliammeter assumed in series with the cathode and the 2,000-ohm resistor. Low capacity, high capacity and leakage may be measured. The scheme works only on a.c. calibrations for one voltage or frequency, does not apply to other voltages or frequencies.

operation, and not to filtering commercial line frequencies.

You have three measurements, none of them seems to matter much. So what?

Nobody need argue that if an electrolytic condenser is marked 8 mfd. and turns out to be 10 mfd. that there will be much difference in the receiver performance. Nor even if the capacity was supposed to be 10 and proved to be 8 would the difference cause an effect worth mentioning. However, should 8 mfd. be specified and only 1 mfd. exist, that would be a great difference, and could account for much annoying and erratic circuit behavior. So some measure of capacity is advisable. It need not be very accurate, but it should be a fair enough reflection of the reality.

SIMPLE MEASURING SCHEME

One method of measuring the high capacities is to set up a rectifier circuit, using the line frequency of 60 cycles, insert a resistor to afford full-scaled deflection of a d-c series meter (say, 0-1 milliammeter), and then put a 2,000-ohm

The method applies to all types of condensers, including electrolytics, but it should be borne in mind this is a capacity test, and not a test of the condenser's quality, because the voltage at which the test is made is very low. One way out, with electrolytics, is to charge the condenser at its rated d-c voltage for 5 minutes, then discharge the condenser, and make the low-voltage capacity test just described, with the electrolytic's-positive toward the cathode.

CONDENSER AS A RESISTANCE

The triode diagram shows such an arrangement, with six binding posts used, and the layout is revealed in the photograph. Here both low and high capacities are considered. For the high-capacity test, just discussed, the low capacity terminals are shorted, and the effect across the 2,000 ohms is studied. As stated, this may be direct reading, if starting at 4 milliamperes, at 1 mfd. for each .1 milliampere change, up to a total change of 1.2 milliamperes, or up to 12 mfd.

(Continued on following page)

(Continued from preceding page)

However, medium capacities may be measured by the series method. This uses the ohmmeter principle, the condenser being treated as if it were a resistance. Then the effect of this equivalent resistance in reducing the current is a measure of the capacity. However, it is necessary, in following the diagram, to put a resistance of 10,000 ohms or more between plate and cathode, for this capacity measurement.

The question arises: How does a condenser, which is a capacity, turn out to be a resistor?

The condenser resists the flow of current. The smaller the capacity of the condenser, the greater the opposition to, hence reduction of, the current flow. That holds true for a particular frequency. If the capacity is fixed and the frequency is changed, the effect on current changes, too.

For a particular capacity condenser, the current flow is limited mostly by the property we have been discussing, whereby a condenser's

combination of all causes that contribute to the reduction of current is called the impedance, and what we do when we apply the ohmmeter method is to get a reading based on impedance and then ascribe all the retardation to the capacity reactance, which for practical purposes is satisfactory.

Now the low capacity measurements will cover quite a range, for around 115 volts from the a-c line. No capacity measurements can be made with this circuit from the d-c line. The minimum easily read on a 0-1 milliammeter would be .002 mfd. and the maximum would be around 10 mfd. It can be seen that the high capacity scale is practically duplicated, as it took care of 1-10 mfd. by the shunting method. But the medium capacities are well measured by the series or equivalent ohmmeter method, while the high capacities, especially electrolytics of large capacity, are better measured in a circuit wherein the capacity readings are practically independent of the d-c

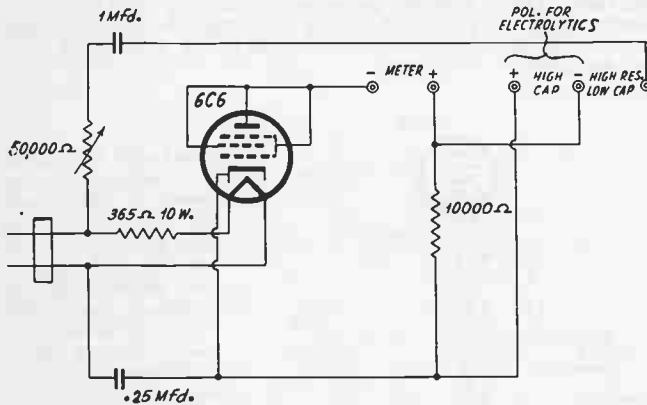

Impedance method of measuring capacity and inductance, applicable also to high resistance, 500 to 500,000 ohms. Besides two capacity ranges there are two resistance ranges, the lower being from less than one ohm to 500 ohms.

capacity has a different effect at different frequencies, or different capacities have different effects at the same frequency. This property is called the capacity reactance (symbol X_c) and is equal to 6.28 times the frequency in cycles times the capacity in farads, divided into the number one. The capacity reactance is stated in ohms, the same as resistance. The lower the frequency, the higher the reactance of any stated capacity, or the higher the capacity, the lower the reactance for a given frequency.

THERE ARE OTHER THINGS

But is the reactance the only thing about a condenser that reduces the current flow? No, there are two other elements that enter. One is the a-c resistance of the condenser and the other is the d-c resistance or leakage. The a-c resistance is the resistance that a condenser has to alternating current and is practically the same regardless of frequency, so is nonreactive. The leakage or d-c resistance becomes serious only in connection with electrolytic condensers, as paper and mica condensers, unless shorted, usually have high d-c resistance (low leakage).

However, the other factors besides reactances need not be considered in any approximating device, because likely to be small effect. The

leakage effect. Besides, the readings from 1 to 10 mfd. are pretty crowded on the series scale.

LEAKAGE TESTS

Leakage still has to be considered. The diagram on page 10 shows how, although a filter capacity should be included between cathode and the joint of the two .1 meg. resistors, to minimize the a-c through the neon lamp. Such lamps as ordinarily obtained have a limiting resistor built in, of around the prescribed value, so only one .1 meg. would be needed. Small neon lamps for test panels, relaxation, oscillators, etc., about as long as a dime's diameter, may be used, but these normally are without limiting resistor, hence require two .1 meg.

The neon lamp circuit is open, until closed by the condenser under test. This closure takes place with positive of condenser toward cathode, negative toward neon lamp. If the condenser is connected the wrong way—polarities opposite to those stated—the condenser may cause full lamp illumination, as the resistance is nearly zero with the 100 volts or so across the condenser in reversed polarity. Connected the right way, the condenser may be considered satisfactory if the flashes are no more than one per

second. If the condenser is to be used for filtering, this test is sufficient, but if it is to be used as a stopping condenser, from plate to grid, in a resistance or impedance-coupled amplifier, or otherwise, then the leakage resistance must be higher, at and the rule is, no more than one flash every four seconds, otherwise condenser is unsatisfactory for the purpose, though good for other uses.

Quite the other way 'round the rule for low-voltage electrolytics, say, to 35 volts rating, where the condenser would be considered O.K. at not more than two flashes, instead of limitation to only one flash, per second.

The voltage ratings now have to be considered. These are stated by the manufacturer. The limit in the circuit under discussion is a little above 110 volts, so no matter what the voltage rating, above that, the test is made only at maximum obtainable, which may be a fraction of what would be desired. Nevertheless, a condenser that shows up poorly at this voltage though rated for higher voltage will prove worse, not better, on at the higher voltage. Quality test for low-voltage condensers may be made between the extreme posts (topmost and bottommost).

ANOTHER CIRCUIT, USING 6C6

A circuit with a few more parts, and somewhat handier to work, is the one using the 6C6. In general, the same considerations already discussed are applicable. A 0-1 milliammeter is placed at two of the five posts, polarities of which are designated on the diagram. The 10,000-ohm load resistor is permanently present. This shunts the rectifier and is all right. The measurements possible are:

Medium Capacity.

High Capacity.

High Resistance.

Low Resistance.

High Inductance (Henries).

Medium capacity is of the .002-10 mfd. range, as before. The ohmmeter principle is used, and all the impedance is ascribed to the capacity reactance and calibrated as capacity.

High capacity may be measured by putting units of known quality and capacity across the 10,000 ohms, and calibrating.

One instance of direct reading was cited, in connection with the other diagram, but all else must be calibrated. The capacities and high resistances may be measured on capmeters and ohmmeters, measured units transferred to the unknown, and current values established, after full-scaling. Low resistances are computed more accurately than measured, if the meter resistance is known.

HENRIES AND LOW RESISTANCE

The high inductance values are based on the effect of inductance alone in diminishing the current. The d-c resistance of the coil is not taken into account, or other factors, but for the range considered these are negligible, say, above 10 henries. However, the inductance is one thing for an unloaded coil, another for a coil under load. The stopping condensers permit measurement of the coil right in the operating

transmitter or receiver. The high ohms scale is used, and for each 377 ohms one henry is allowed, therefore a scale from 5 to 1,000 henries is easily established.

Low resistance is measured by putting the unknown across the meter. If the unknown resistance reduces the meter reading from full scale to half scale, then as much current flows through the meter as through the unknown, hence the unknown must equal the meter resistance. If the unknown exceeds the meter resistance the current reduction will never read as much as 50 per cent. If the unknown is less than the meter resistance, the reading will be less than half scale, and a value as low as .03 ohm may be read for a meter of as high resistance as 50 ohms. The resistance of the winding of the coil in the meter is meant.

LOW RESISTANCE COMPUTATION

Since the values are computed, not measured, either even values of resistance may be selected, resulting in odd currents for reference, or even currents, with their normally odd resistance values.

Consider two readings of the meter. One is full scale and call it 1,000 (meaning 1,000 microamperes, equal one milliampere, for a meter of such sensitivity). The other reading is the one that obtains when the unknown is across the meter. The resistance of the meter, R_m , is known. A catalogue informs you, or the manufacturer will, if you specify model and serial numbers. The unknown resistance then is equal to the meter resistance divided by one less than the ratio of the two readings. One reading is imaginary—it is full scale and never taken.

The formula is

$$R_x = \frac{R_m}{(I_m \div I_o) - 1}$$

where R_x is the unknown resistance shunting the meter, I_m is the full-scale meter current, I_o the current read on the meter after R_x is put across the meter.

Weston Socket Layout Covers 400 Tube Types

A newly revised folder which classifies more than 400 makes and types of vacuum tubes according to their base connections has just been issued by the Weston. Seventy-three octal tubes and twenty-two of the 4, 5, 6, or 7-prong types have been added since the previous edition.

The tube base connection diagrams in the folder now show 85 different prong arrangements and base connections. This covers all tubes, old and new, likely to be encountered in radio servicing, and many other special designs used in sound equipment, public address systems, amateur radio and other electronic circuits.

The diagrams have been specially prepared to facilitate the Weston methods of selective analysis, which remain applicable to the latest tube and circuit developments as well as the older receivers. The leaflet is available to servicemen without charge by addressing Dept. RW, Weston Electrical Instrument Corp., Newark, N. J.

List of Submultiples of Station Frequencies for Harmonic Reference

<i>H</i>	<i>WMCA</i>	<i>WEAF</i>	<i>WOR</i>	<i>WJZ.</i>	<i>WNYC</i>	<i>WABC</i>	<i>WAAT</i>	<i>WHN</i>	<i>WLWL</i>	<i>WINS</i>	<i>WNEW</i>	<i>WHOM</i>	<i>WMBQ</i>
1	570	660	710	760	810	860	940	1010	1100	1180	1250	1450	1500
2	285	330	355	380	405	430	470	505	550	590	625	725	750
3	190	220	236.666	255	270	286.666	313.333	336.667	366.667	393.333	416.666	483.333	500
4	142.500	165	177.500	190	202.500	215	235	252.5	275	295	312.500	362.500	375
5	114	132	142	152	162	172	188	202	220	236	250	290	300
6	95	110	118.333	126.666	135	143.333	156.666	168.333	183.333	196.666	208.333	241.666	250
7	81.428	94.286	101.428	108.571	115.714	122.857	134.286	144.286	157.143	168.555	178.555	207.143	214.286
8	71.250	82.500	88.750	95	101.250	107.500	117.500	126.250	137.500	147.500	156.250	181.25	187.500
9	63.333	73.333	78.888	84.444	90	95.555	104.444	112.222	122.222	131.111	138.888	161.111	166.667
10	57	66	71	76	81	86	94	101	110	118	125	145	150
11	51.818	60	64.545	69.091	73.636	78.182	85.454	91.818	100	107.273	113.636	131.888	136.364
12	47.500	55	59.166	63.333	67.500	71.666	78.333	84.167	91.666	98.333	104.166	120.833	125
13	43.846	50.761	54.615	58.462	62.308	66.154	72.308	77.692	84.615	90.769	96.154	111.539	115.385
14	40.714	47.143	50.714	54.285	57.857	61.428	67.143	72.143	78.571	74.277	89.277	103.571	107.143
15	38	44	47.333	50.666	54	57.333	62.666	67.333	73.333	78.666	83.333	96.666	100
16	35.625	41.250	44.375	47.500	50.625	53.750	58.750	63.125	68.750	73.750	78.125	90.625	93.750
17	33.529	38.823	41.765	44.706	47.647	50.588	55.294	59.412	64.706	69.412	73.529	85.294	88.235
18	31.666	36.666	39.444	42.222	45	47.777	52.222	56.111	61.111	65.555	69.444	80.555	83.333
19	30	34.737	37.368	40	42.631	45.263	49.474	53.158	57.894	62.105	65.789	76.315	78.942
20	28.5	33	35.500	38	40.5	43	47	50.500	55	59	62.500	72.500	75

High-Fidelity Audio

Experimenter Describes Its Attainment

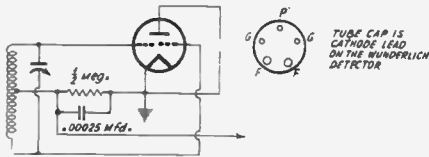

FIG. 1
Full-wave diode, using Wunderlich tube.

THE following are conclusions and experiences of an amateur experimenter.

A high-fidelity amplifier adopted by the writer will be analyzed from the detector right through to the speaker.

The author's firm selection is a full-wave diode detector. This detector was used because a really distortionless detector must conform to three specifications. It must be non-amplifying (diode); it must be a full-wave circuit; and it must be directly coupled to the grids of the following a. f. amplifier. Otherwise frequency, amplitude and phase distortion will appear in the audio signal to an appreciable degree.

The .5 meg. resistor in the detector circuit serves a double purpose. It is the load resistor for the diodes and also the blocking resistor for the grids of the paralleled drivers. The r-f condenser shunted across it is optional. The writer did not use one, so as to bring out all the brilliant "highs" of programs. Circuit capacities are high enough to do whatever bypassing is necessary and besides, since the detector is full-wave, there is no theoretical necessity for r-f filtration. The r-f component is supposed to be balanced out. However, any value of .00025 to .001 may be inserted to get a tone control effect to suit the acoustics of the receiver's cabinet and room or the operator's ear.

WHY 27'S WERE SELECTED

Next come the 27's in parallel, which serve as drivers for the 2A3's. Paralleled drivers were used for two reasons: The power output stage is not strictly Class A, but a Prime, as is the standard practice. Theoretically the grids of the power tubes will draw power from the drivers at higher signal voltages; secondly, most

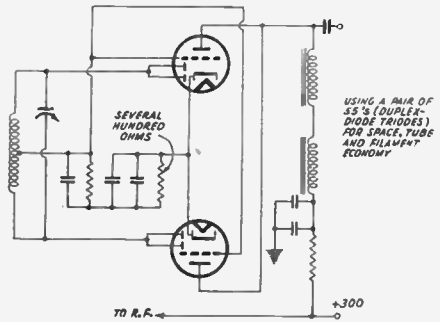

FIG. 2
Separate tubes as detectors. Here 55's are used for space economy.

experimenters recognize the fact that as plate currents of detector and audio tubes begin to drop off, the tone quality of the signal coming out of the speaker begins to get tinny and begins to lose the bass undertones. The paralleling of two drivers is merely an insurance against a weak plate current and a consequent decrease in audio quality.

A pair of 27's was used instead of some more modern tubes with a higher mu because as the gain of an audio tube goes up, so does the frequency (harmonic) distortion. In the author's amplifier, the insertion of a pair of 56's, while producing greater signal strength, caused a decrease in audio quality, particularly in the higher audio frequencies. The 56 has roughly only about 50% more gain than the 27. If the newer and higher-mu triodes are used, more distortion in the highs and a greater weakening of the bass will result. It is a question of gain versus quality, and since quality was the writer's goal, the 27's were used.

IMPEDANCE NETWORK VITAL

The costly impedance circuit between the drivers and the input push-pull transformer is almost a necessity. While outwardly superfluous, its results are so superior to direct coupling between tubes and transformer that the expense is more than justified. This arrangement was used for several reasons. The prin-

(Continued from preceding page)
into the front of my fireplace. The sounding board is backed up with three inches of mineral wool to cut out any resonance peaks, and rests on sponge rubber all around. The inside of the fireplace is lined with acoustic Celotex, with 4x12" opening at the top to permit an exit up the open flue.

I do not know the exact range of this ampli-

fier, but designed it to go to 20 cycles, and know that you can "feel" the bass drum and low notes on an organ. I tried a bass booster on this but took it off as undesirable. Even at low volume the bass is audible.

The high notes came through clearly, and all speech is more intelligible than on any amplifier I ever heard. There are no disagreeable, harsh peaks at any place.

principal reason is that there is less harmonic distortion because as the flux density in the magnetic core of a transformer increases, the eddy current and hysteresis losses increase and the harmonic content of the secondary current jumps up, particularly the third harmonic. By impedance coupling the tubes, the direct current is kept out of the primary winding, the transformer core is run at a lower flux density, and there is less frequency distortion. While the a-c component (signal) is swinging back and forth in the primary, the d-c component is flowing steadily in one direction only, causing unbalance distortion. This effect is much the same as if one of a pair of tubes in a push-pull circuit is drawing 10 ma more current than the other. Such unbalance works havoc with the signal. Of course, transformer design, such as air gaps, etc., tend to offset these adverse effects, but with much less success.

The two 250-henry chokes place a higher and more efficient load of about 500 henries (depending upon the current flowing through them) upon the 27's than any normal transformer could supply. This results in a flatter and wider frequency response. The use of chokes instead of a resistance assures a high plate current and ample driving power for the 2A3's.

CONDENSER CONSIDERATIONS

The value for the coupling (or blocking) condenser between the chokes and transformer is not critical. It may have any value from .5 to 4 mfd. The only important thing here is that it possesses a high voltage rating, at least 600 volts (working). Theoretically, the higher the capacity, the less capacitive reactance to low frequencies and so the better the bass. But the higher audio range may suffer because a cumbersome condenser may have appreciable inductive reactance at higher frequencies and so a happy medium must be arrived at. Only test equipment can determine that.

Only one stage of amplification was used because it is adequate to drive the 2A3's for home use. For every stage added so much more distortion is introduced.

Starting at the power tubes and working

back, the 2A3's are biased at about 60 volts or so. To drive them to the limit, the drivers must supply between 50 and 60 volts. The voltage amplification of the 27's in this circuit is about 7. To deliver the required signal about 8 volts must be impressed on their grids. Since the 27's are biased at about 9 volts without any signal on the diodes, and are biased higher as a signal hits the diodes. It is evident that the 27's will take the required 8 volts on the grid without being overloaded. The diodes, if necessary, can stand almost 100 volts apiece. So there is no earthly reason for using two a-f stages. True, if the drivers are pushed to the limit, their harmonic distortion will jump up, especially the second harmonic. But for home use there would be no call for such volume requirements, and besides the two stages would probably introduce more distortion than the single stage.

REASONS FOR BYPASSING

The elaborate bypassing is resorted to for two reasons. Insufficient bypassing may cause coupling between stages, which may result either in regeneration or degeneration, depending upon circuit constants, and this will result in oscillation, distortion or poor frequency response or all three, particularly at high volume levels. Even if there is no appreciable coupling, individual circuit frequency response will suffer, and poor bass and distorted highs will be the result.

The electrolytics are bypassed by paper condensers, because they have a poor power factor and have appreciable inductive reactance at higher audio frequencies (choke effect) and may not bypass these frequencies adequately.

The transformers on both sides of the 2A3's must be of the laboratory standard type, with a frequency response flat within 1 db. from 30 to 20,000 cycles. Otherwise all the fuss over a bit of distortion here and there is a waste of time, energy and expense. The finest engineered and designed audio system in the world automatically becomes mediocre if "back-eighty-nine" transformers are inserted into them. The input transformer is particularly important.

(Continued on following page)

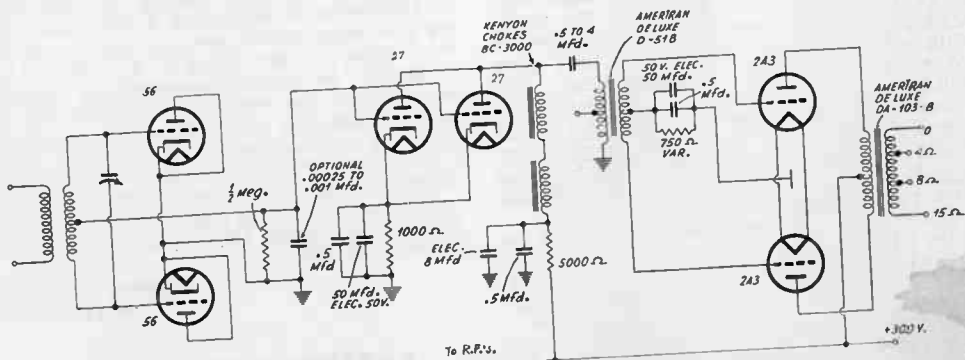

FIG. 3

The full-wave detector (left), feeding paralleled 27's, which drive the 2A3 output tubes.

(Continued from preceding page)

The 2A3's were used because of their very low voltage amplification and very high power amplification characteristics, the more Class A triode power walloping the speaker, the richer and more realistic the tone and the heavier the bass. This eliminates the necessity for phoney "tone controls" which muffle down the tone quality and give a boomy, barrel effect and introduce phase distortion in the high audio frequencies.

ADJUSTABLE BIAS RESISTOR

The 20-watt bias resistor on the 2A3's should be of the adjustable type, and after making certain that the two tubes draw equal currents, the constructor may follow a tip given by one of the authors in this magazine, and temporarily disconnect a filter condenser in the power pack and adjust the resistor (within reason) till the hum is strongest. The idea is that under these conditions the bass will come through full blast.

As with the transformers, so with the speaker, it must be of high quality if one expects high quality results. A \$3 speaker cannot be expected to handle a pair of 2A3's or deliver the tone quality as committed from the amplifier. An auditorium type, capable of handling 15 watts or more, with a frequency response fairly flat from 30 to 8,000 cycles, is advisable.

Several precautions must be made in using this amplifier. It is a very low gain circuit. One may have gain or quality, but scarcely both in an audio stage. Since the voltage gain is perhaps only about 30 for the whole amplifier, the r-f or i-f stages must have plenty of "hop" and must be stable. Besides that, to utilize the potentially wide range of the amplifier the h-f stages must pass a band at least 10 kc wide. Or, better still, some provision for varying the selectivity should be made, so that when dx-ing the selectivity can be made razor-edged and when enjoying standard broadcast it can be made broad as a house to get in all the highs.

LAYOUT OF PARTS

Another thing to keep in mind is the fact that the arrangement of circuit parts can affect its performance. Keep chokes and transformers away from each other and from the power transformer. Set them up at various positions with respect to each other so that their cores do not occupy the same relative positions. This will minimize coupling. By energizing one transformer with a couple of volts (A.C.) and connecting earphones to another, coupling between them will be detected as a weak hum and a good position can be found in this manner. Give yourself plenty of room.

One cannot get something for nothing in radio. If one seeks real quality in the audio section, then amplification and the pocketbook must be disregarded. One will get out only what one has put into the circuit and no more.

In Fig. 1 is shown the Wunderlich detector tube (with its two interwoven grids) in the detector circuit. While this tube is a bit more expensive than a 56 or a 27, its use is justified where space or filament current is at a

premium. It's cheaper than the two required tubes anyway. The cap is the cathode lead.

Fig. 2 represents economy, as the paralleled amplifier is provided also.

This is a circuit where a considerable saving in tubes, space and filament current is affected. The cathode resistor in the triode sections in all cases must be adjusted to such a value (with a milliammeter) so that the correct plate current flows for the plate voltage on the constructor's triode plates at normal volume conditions.

This must be done because all these circuits are diode-biased because of the direct coupling between the diodes and triode drivers. The negative rectified signal biases the grids of the triodes. The cathode resistor merely serves as a current-limiting device when no signal is hitting the diodes.

USE OF OTHER TUBES

If the constructor has a 6-volt filament supply and wishes to use the newer metal tubes, he may use the Duplex diode 6H6 as the detector; a pair of 6C5 triodes as the paralleled drivers; and a bank of 6F6's in push-pull parallel (the 6F6's to be connected up as triodes). The proper output transformer must be employed to match the plates of the 6F6's. This will be roughly 5,000 for 4 tubes in P.P. parallel.

Figs. 3 and 4 are admittedly theoretical and in the writer's opinion will not give as satisfactory results as the circuit with separate tubes.

In all the diode circuits, the value of the diode load resistor is shown as .5 meg. This is an arbitrary value. It is selected because sufficiently high to yield a linear characteristic.

—T. J. P.

THE SCOPE OF THE 'SCOPE

The cathode-ray oscilloscope is described quite properly as an instrument that can serve an almost unlimited number of purposes. Never have all its possibilities and ramifications been included within the covers of a single book, and probably never will be. While the vastness of its applications is staggering, I don't mind telling you many persons own an oscilloscope and don't know a single thing to do with the instrument! No, not one measurement, observation or study can they make, and it is not for want of sufficient instructions from manufacturers or explanations in the technical press. Probably the trouble has been that the explanations explained too much. The fact is the oscilloscope is used for very few purposes in servicing, say, three, but for those purposes its possession is vital.

CONDON HARLEY,
Cincinnati, O.

PARTNER IS BOUGHT OUT

Maxwell M. Hauben and Max Steir are the proprietors of Superior Instruments Co., having bought out the third partner, Edwin K. Butler.

Set Built on Unit Plan

Inverse Feedback Expansion and Other Refinements

By H. L. Smith

4740 North Woodburn Street, Milwaukee, Wis.

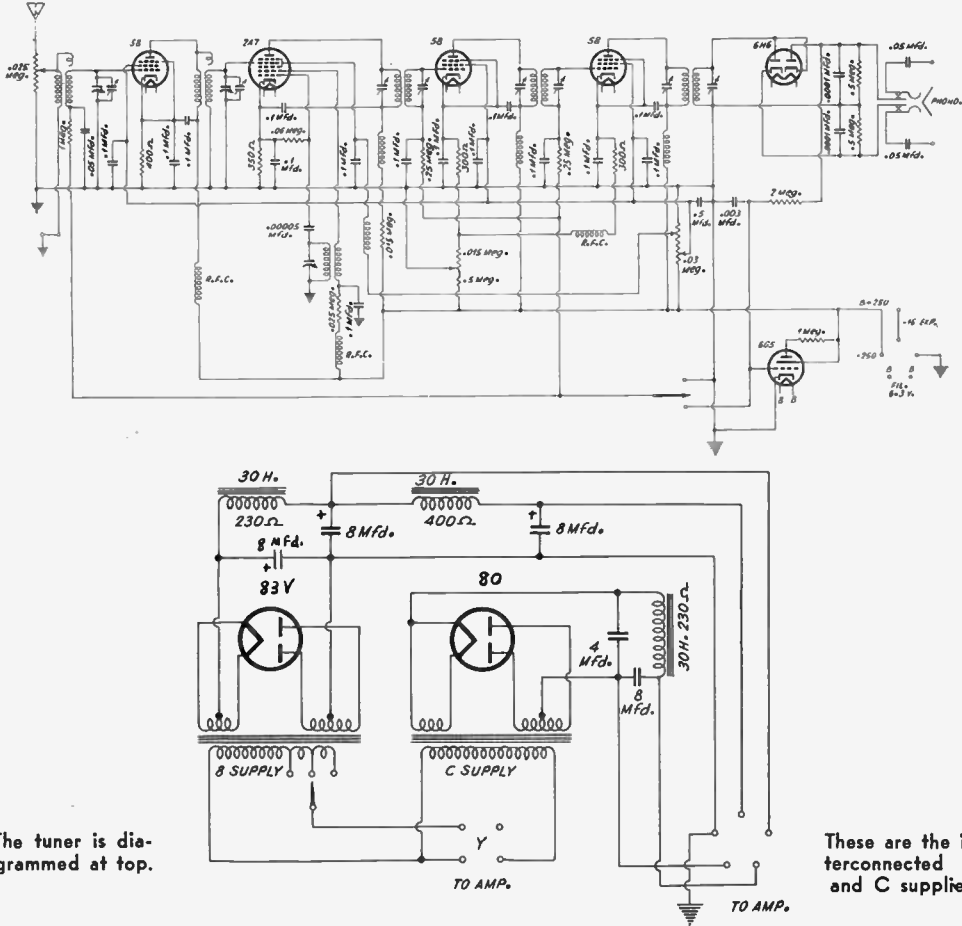

The tuner is diagrammed at top.

These are the interconnected B and C supplies.

I have been reading RADIO WORLD since it became a monthly, and at present it is the only radio magazine I buy regularly. I like it, as it gives more engineering data, and complete enough so the circuits can be built. I have been very much interested in the special circuits shown during the last few months and have tried out several of them.

I now have a superheterodyne using the inverse audio feedback as shown in the October 1936, issue; the balanced detector as shown in January issue, and the volume expander, in March. The results are very satisfactory.

My set was made in the unit plan so these changes could be quite readily made

The tuner is the standard circuit except for the balanced detector which follows along the lines shown in RADIO WORLD. The expander, however, was modified to suit the balanced detector circuit, that is, a push-pull circuit was used, with two 6L7 tubes, both grids controlled by the 6H6. As I had fixed bias in the amplifier, and plenty of plate current capacity, the expander was wired into the tuner. A home-made drum controller cuts the expander entirely out of the circuit, filaments also.

The results obtained have been quite satisfactory, as a full range of frequencies is obtained. The inverse feedback was added first.

(Continued on page 21)

At right, power supply and push-pull output used by T. J. P., author of preceding audio article, and below, driver and output of Mr. Smith's system.

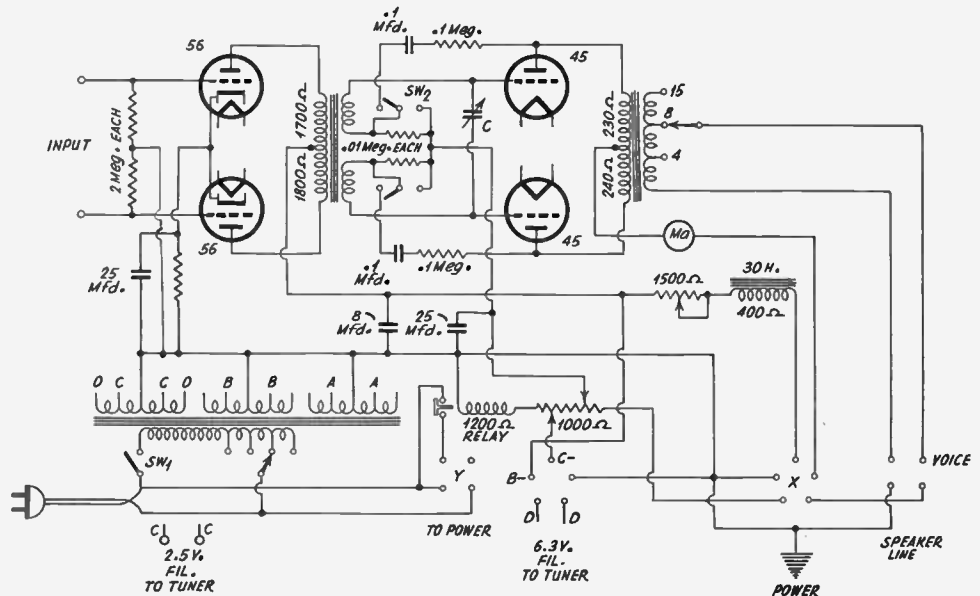
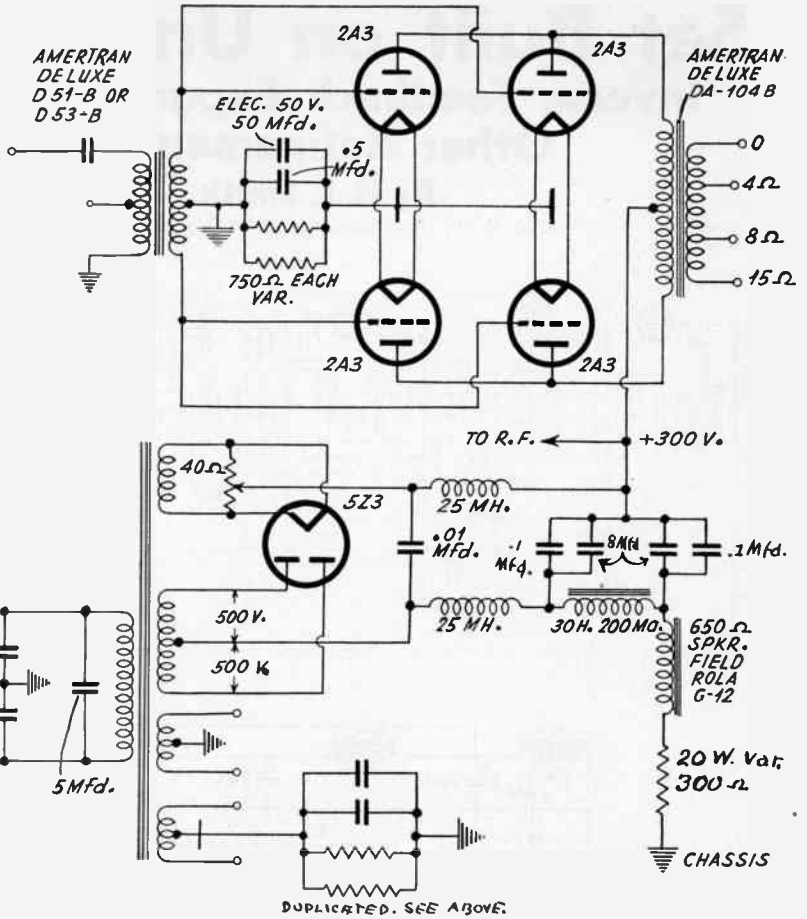

(Continued from page 19)

A noticeable increase in low-frequency response was obtained, and a desirable decrease in the harsh intermediate range. The very high frequencies were lacking, however. The detector was a single diode, and i-f channel tuned as broadly as possible by the stagger method. The next step, however, was the balanced detector, which brought out the high frequencies in great shape. This circuit of necessity cut out a single tube audio circuit feeding direct into the push-pull driver stage.

The addition of the expander was entirely

an experiment, and I was afraid of a reduction in quality, so went to the push-pull circuit. The quality seems to be about the same. However, the expansion seems to add brilliance to some programs. The expansion action is very pronounced and has to be toned down to obtain pleasing results. Results with a phonograph pick up are good. However, there is not quite enough amplification in the amplifier circuit. The two 6L7 tubes do not add much with the present bias of 16 volts minus. I think the expander is worth while, however. It can be cut out for ordinary broadcasts.

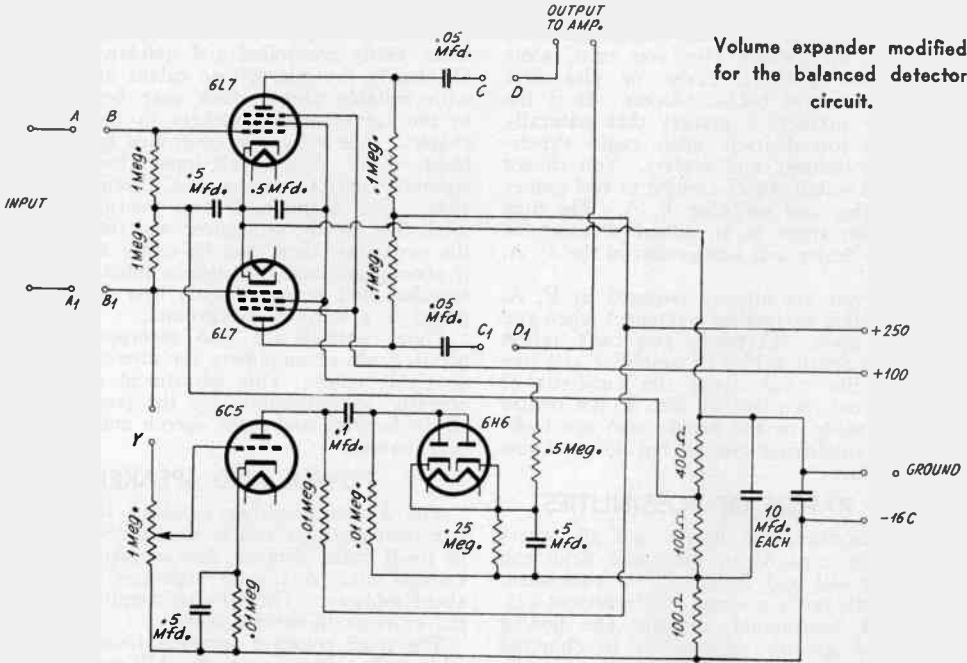

Home and Car Set Gadgets by Ghirardi

As an aid to the solution of service problems affecting home receivers or auto sets, Alfred A. Ghirardi has devised two gadgets, one for home, other for auto sets, but otherwise of the same construction. The price is 50c each or \$1 for both. They are merchandised through Radio & Technical Publishing



Company, Dept. RW, 45 Astor Place, N. Y. C.

For any of the eight common trouble symptoms (Hum, Weak, Noisy, Dead, Intermittent, Fading, Oscillation and Distortion) in either a home or autoradio receiver, these gadgets tell you what may be wrong in the power unit, receiver circuits proper, tubes, loudspeaker, antenna system, etc. They not only list the "remedy" for each trouble, but also tell you what test to make to "spot" it quickly.

Each gadget consists of a set of pocket-size

wear-resisting cards printed in two contrasting colors and eyletted together to cover all these troubles.

The former "home radio gadget," which sold for 25 cents, has been discontinued.

C-D Exhibition Popular At Two Trade Shows

At the National Radio Parts Trade Show, Hotel Stevens, Chicago, was an unusual array of radio capacitors. The Cornell-Dubilier Corporation had a complete display of condensers with voltage ratings from ten to a million volts. This exhibition of capacitors for every radio requirement was also a center of attraction at the recent I. R. E. show, held at the Hotel Pennsylvania, New York.

Why Public Address is Growing Fast

By **M. N. Beitman**

The Radolek Company

EVERY day new and more versatile applications for public address systems are found. In schools, churches, offices, factories, and almost everywhere else you turn, some task is made possible, easier or pleasanter through the use of public address. It is the new money market, a market that naturally turned and forced itself upon radio experimenters, servicemen, and dealers. You cannot sit back and watch others cashing in real money selling, renting and servicing P. A. The time is here when there is an actual demand for every radio dealer and serviceman in the P. A. field.

Perhaps you are already engaged in P. A. business, selling or renting equipment when you are called upon. Certainly you can't refuse to sell Mr. Smith a 15-watt amplifier and two speakers. But what about the hundreds of Smiths in your own locality who do not realize their own needs, or the people who are looking for an amplifying system, but do not know where to turn?

WIDE RANGE OF POSSIBILITIES

The servicemen, the dealer and all others commercially engaged in the radio field, can successfully sell and install P. A. equipment. Every church needs a sound reinforcement system. And hearing-aid systems are finding greater and greater applications in churches and theatres. Are the schools in your vicinity equipped with loudspeaker systems? Are the athletic events dry because they lack sound? And your ballrooms, clubs, taverns? What about call systems in factories, offices, garages? And mobile advertising, politics, talking signs, fairs—there must be hundreds of other applications that have suggested themselves to you.

Any standard amplifying system consists of three essential, distinct parts inter-connected by cables. These three parts are the microphone or other source of input, the amplifier proper, and the loudspeakers and associated baffles or projectors.

The source of input may be any type of microphone, an electric type phonograph, or a regular radio set. The microphone is used to change sound to corresponding electrical energy. At the present time, crystal and velocity type microphones are extensively used. These microphones have very good frequency response characteristics and faithfully change the acoustical sound energy to electrical impulses.

MUCH PROGRESS IN AMPLIFIERS

The microphone or other source of input is connected with shielded cables to the amplifier

unit. The amplifier design has been developed and advanced to a remarkable degree, the present-day amplifiers are compact, attractive units, easily controlled and quickly connected. Ordinarily the microphone cables are supplied with suitable plugs which may be connected to the corresponding sockets in the amplifier chassis. The volume is controlled by means of handy dials. Since each input channel has a separate control, mixing and blending is possible. For example, if two microphones are used, one for the announcer and the other for the orchestra, they may be easily mixed. Or if phonograph and microphone inputs are used, speeches and announcements may be superimposed on a musical background.

Tone controls are also incorporated in a better grade of amplifiers for attenuating bass or treble notes. This adjustment enables the operator to compensate for the poor acoustics of the location and make speech and music appear natural.

POWER AND SPEAKERS

The 5-watt amplifier is about the smallest size manufactured and is used for installations in small halls, window demonstrations, paging systems, etc. A 15-watt high-gain amplifier is about midway. The 60-watt amplifier is near the extreme in service work.

The most common speakers found in public address installations are the 12" dynamic cone types. These have field coils of correct resistance to obtain field excitation from the associated amplifier. Matching transformers are mounted directly on the speakers. Very little loss of power will result in the speaker connecting cable if the speakers are located within 100 feet of the amplifier.

There are only a few facts to be decided for any one installation. What kind of microphone to use, what size amplifier, and how many speakers? The four commonly used microphones employed at the present time are the carbon, crystal, velocity and velotron.

Each one of these types is best adaptable to some specific installation. A chart on page 36 gives the characteristics and applications of each kind.

PLACEMENT OF SPEAKERS

Standard amplifiers are available in sizes ranging from 5 to 60 watts. The selection of the size depends on the size of the location and the number of people to be served.

As few speakers as practical should be used. With small amplifiers use a single speaker,
(Continued on following page)

33 Oscillator, 6 Volts on Plate

Stability and Self-Modulation

By R. K. Wheeler

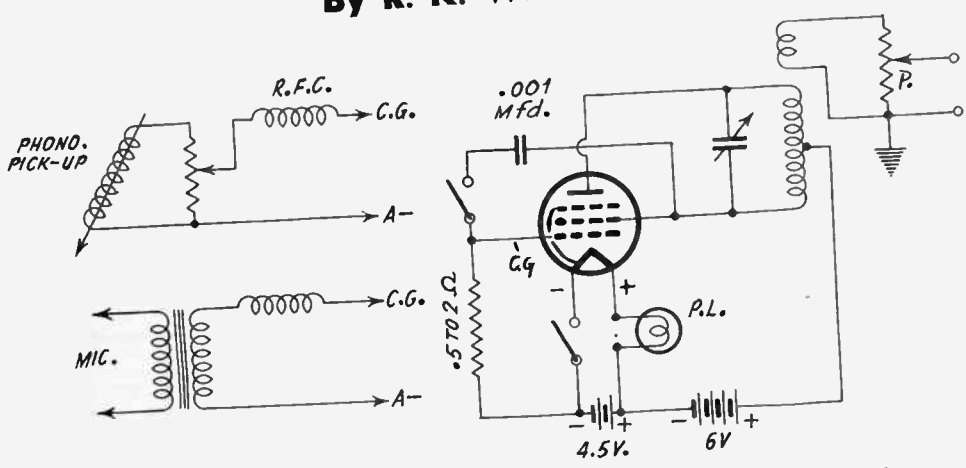

The 33 oscillator, with two insets, one for phonograph pick-up, other for microphone.

THE many varieties of multi-electrode tubes released during the past few years have offered many interesting opportunities to the experimenter and engineer. Practically every tube containing the requisite grid, or grids, and plate are tried out as oscillators, most of which offer little or no advantages over those already developed.

OSCILLATION COIL CENTER-TAPPED

The power pentode of the two-volt series, type 33, is a tube that does offer distinct advantages over other types of oscillators. Its principal advantages are:

1. Better than ordinary stability.
2. Operates on a plate supply as low as 6 volts.
3. Easily self-modulated, with good clean note.

4. Requires only a single center-tapped coil for a given band.
5. Requires no selection of tubes.

In this application the center-tapped coil is connected between screen and plate, B plus connected to the tap. A .001 condenser between control grid and screen provides self-modulation. The grid is returned to the negative filament through a resistor of .5 to 2 megohms.

When the 33 is used, bear in mind that the suppressor is connected to the negative side of the filament inside the tube and the tube socket should be wired accordingly.

The plate supply may consist of two small 3-volt flashlight batteries, which are very satisfactory in this service, as the modulated plate current is around 75 microamperes, the unmodulated plate current around 200 microamperes. As the filament current requirement

(Continued on following page)

(Continued from preceding page)
15- to 30-watt amplifier requires two large-sized dynamics, other larger sizes up to about 60 watts work out successfully with four speakers. Each amplifier usually has provisions for supplying field current to a limited number of speakers. Permanent magnet speakers require no field excitation.

The speakers should be placed close to the stage or any other place where the sound orig-

inates. A good installation should reinforce the program, but should not noticeably distort it. The location of the speakers, therefore, should be such that the majority of the listeners should hear simultaneously the original sound and the sound coming from the loudspeakers.

The installation and sale of public address equipment are relatively simple and every experimenter, radio serviceman and dealer should cash in on this growing market.

Moisture Is Dangerous In Transformers

A Safeguarded Drying Method Is Described

By Emil Buchwald

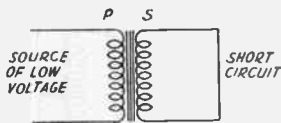

FIG. 1

Shorted secondary, with only 5 to 10 per cent of the normal voltage on primary.

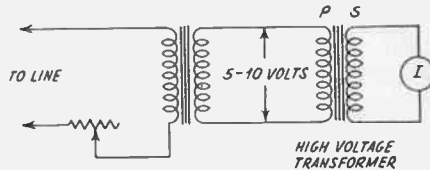

FIG. 2

The two-transformer method, with fine control of current. This method, with meter, avoids danger.

TRANSFORMERS that stand unused for a length of time in a damp place such as the average cellar absorb considerable moisture from the air. Coils that are impregnated with an insulating varnish and those that are immersed in an insulating compound are not affected of course, but the open type of coil with the conventional tape insulation is susceptible to moisture. With the passage of time, the insulation deteriorates, cracks and becomes more or less porous, paving the way for the entrance of moisture. The time element, the moisture content of the air and the quality of the insulation determine the depth of moisture penetration into the coils. If the device is not used for a considerable period, complete moisture permeation is likely, which will inevitably result in a breakdown of the transformer if used in this condition.

High-voltage transformers that have a high potential difference between layers of wire on the coils, or between the primary and secondary, are adversely affected by moisture. Primarily this means a lowered insulation resistance through which the current seeks a path. Once a path is established the current generates con-

siderable heat in the insulation, and a carbon formation results. This in turn works in a vicious circle, since carbon is a good conductor, so complete breakdown is inevitable.

THE TRANSFORMER LOSSES

On low-voltage devices, such as audio transformers, breakdown is not an immediate danger, but the leakage created is detrimental to efficient operation. Audio transformers are not entirely immune, however, as the leakage path to the core or between coils has an electrolytic action due to the direct current flowing in the windings. In time the gradual wasting away of copper will cause an open, which is not quite as demonstrative as a burn out, but has about the same effect on the pocketbook.

A number of schemes for drying come into one's mind, among them being the removal of the transformer to a warm spot for a few days, or placing it in a moderately warm oven for a few hours. Where it is impractical or inconvenient to remove the transformer for drying by

(Continued on following page)

(Continued from preceding page)

is .25 ampere it will be seen that flashlight cells can be used only for short occasional service. It is recommended that three cells, or a total of 4.5 volts be used, and a pilot light included in the filament circuit so that there remains little likelihood of the oscillator being left operating unnecessarily. The output is obtained from a few turns coupled to the plate side of the coil. Such an oscillator will function on fundamentals as high as 10 megacycles. Above that, harmonics may be used.

As practically all power pentodes are good strong oscillators, the 38 may also be used in

this service, and if desired the filament supply obtained from the power line through a suitable line cord.

A novel use for either oscillator, which also has some practical aspects, is as a small transmitter for phonograph records or voice, with suitable coupling to the control grid. As some r. f. is likely to be fed back to the control grid the use of a choke at this point is desirable.

The principal disadvantages of this tube have been mentioned: the .25 ampere required for the filament and the limitation of 10 megacycles as the highest fundamental. At increased plate voltage 10 mc may not be the h-f limit.

(Continued from preceding page)

applying heat externally, it may be dried very efficiently by electrical means, merely by taking advantage of the core and I²R losses.

A transformer, besides possessing the ability to change voltages from one level to another, has losses which are dissipated in the form of heat. These losses are three in number and consist of hysteresis, eddy currents and the copper loss, namely the I²R loss. The core loss does not offer much assistance for the purpose of drying, since comparatively small in a good transformer, and it would require considerable time before the core became warm enough for drying. The core loss is practically constant and varies but a fraction in a magnitude from no-load to full-load operation. The copper loss, on the other hand, varies as the square of the current, that is, if the current is doubled the power dissipation is four times as great.

POWER LOSS FOR DRYING

From these facts it can be seen that if a reasonable amount of current is allowed to flow through the coils, the resultant power loss may be used for drying purposes.

Connecting the transformer to the line and short-circuiting the secondary through a resistance will serve the purpose, but it has the disadvantage of high voltage circulating in a device that is in a damp condition. To avoid this, the secondary is thoroughly short-circuited with a piece of wire and a low voltage applied to the primary, 5 to 10 percent of the normal primary voltage. Fig. 1 will serve to illustrate the basic circuit.

By varying the primary voltage the degree of heat generated in the coils may be controlled very nicely. A 50 or 75-watt low-voltage transformer is necessary, a rheostat and an alternating current milliammeter reading up to 250 m.a. A little calculation is also necessary before attempting this scheme in order to limit the current in the secondary to avoid overheating.

As an example, suppose it is desired to dry a transformer having a capacity of 500 watts, a primary rating of 110 volts and a secondary voltage of 2,000. Since

$$I = \frac{W}{E}$$

it is found upon computation that the secondary current will be .25 ampere or 250 milliamperes, that is, at full load. This figure does not take into account the losses, and the actual current in the secondary at full load will be less than the calculated figure, unless the device is overloaded, and in that case the primary power input will be proportionally higher.

THE SAFEST WAY

The secondary of the transformer is now short-circuited through the milliammeter and a voltage of about five volts is applied to the primary, as in Fig. 2. The rheostat is now adjusted until the secondary current is about 200 milliamperes, a value which is well below the normal current and prevents excessive heating.

The resistance of the secondary in a trans-

former of this size runs about 300 ohms and since:

$$W = I^2 R$$

it will be seen that the power dissipated in the secondary is of the order of 12 watts, which furnishes enough heat for a slow drying.

With this current setting, the transformer is left to "cook" for about ten or twelve hours. It is advisable to watch the operation closely for the first hour or so and to note the warmth of the coils with the hand. If the heat appears to be excessive, the power dissipation is too high and the secondary current should be reduced accordingly by means of the rheostat in the primary of the low voltage transformer. Allowing the current to circulate for about twelve hours is about the length of time required for thorough drying. However, for larger transformers more time may be necessary.

WATCH THIS SEQUENCE!

One more point to be remembered is that if the high-voltage transformer contains other secondaries besides the high-voltage windings, proper allowance must be made when calculating the current rating of the high-voltage secondary. For instance, if the transformer has an additional secondary winding of ten volts rated at ten amperes, the power in watts which is 100, must be subtracted from the total wattage rating of the transformer. Hence the wattage rating of the high voltage secondary will be 400 watts instead of 500 and the maximum permissible current will be correspondingly lower.

A word of caution: Do not open the secondary before turning off the source of power to the primary.

Condenser Advance Made by Cornell-Dubilier

Etched foil dry electrolytic condensers, which are extremely compact, usually have power factors higher than those of equivalent plain foil types. Engineers in the development laboratories of Cornell-Dubilier Corporation announce that they have applied their hi-formation process to the manufacture of the KR and JR series, popular etched foil dry electrolytics, resulting in power factors on par with equivalent plain foil types.

"It is an achievement, and a contribution to the progress of the radio industry, when the mass of radio component can be reduced in size and weight, without altering its operating characteristics," said Sales Manager Leon Adelman, who predicted that the new development precipitates a trend toward etched foil dry electrolytics.

Servicing System Devised

Last December H. J. Bernard proposed that a definite system of servicing be established, at least applicable to the majority of cases. Up to that time there was no system. Since then Mr. Bernard has devised one.

World-wide Trouble

External Cross-Modulation Baffled Service Engineers Three Years

IN 1934 transmissions from the high-wave-length, high-powered station of Luxembourg, a principality neighboring Belgium, were heard on the standard broadcasting channels in Holland, and immediately it was suspected that a non-linear transmission medium existed. To be explicit, the ether was suspected, perhaps mostly because there was not the slightest factual background for the idea of a non-linear ether.

Two years later, in the United States, complaints began to be numerous that stations in the standard broadcast band were interfering with each other, not due to low selectivity in the receiver, for the sets were highly selective; not due to inter-channel interference, as the stations were usually 50 kc apart; and finally, after two years, it was found that the trouble was not even due to the receiver.

SOLUTIONS AT HOME

That recalled the "Luxembourg effect." There, too, the receivers were not at fault: the frequency of the Luxembourg station was so remote from the frequencies of the broadcasting stations that some factor other than selectivity had to be considered. Hence the convenient ether was invoked, and endowed with what it had not been known to possess. But now, with cases close to home, which we could investigate ourselves, the mystery of what took place, and why, could be solved in our own way.

Since the form of interference was experienced in several parts of the United States, and particularly in sections where there were high-powered stations, it was only natural that independent investigators should tackle it, and perhaps just as natural that they should come to the same conclusion. One of these investigators was Radio Corporation of America, acting through the technical forces of its license division. Another investigator was H. J. Bernard.

The article by Bernard, "Full Analysis of Super Squeals," in the April, 1937, issue of RADIO WORLD, published March 25th, said the trouble was due to "exterior cross-modulation," where some rectifying element had the effect of introducing the modulation of one carrier onto another carrier.

EVEN NAMES NEARLY ALIKE

In the April, 1937, issue of "RCA Review," a quarterly, Dudley E. Foster, of the RCA License Division Laboratory, reviews what RCA has done about it, in an article, "A New Form of Interference—External Crossmodulation."

Though both articles are in issues dated April, the RADIO WORLD issue was out by late March, while the RCA quarterly, also dated April,

was not out until more than a month later, or about the end of April. However, the RCA researches had been going on for more than a year. So it was just a coincidence that two agencies were investigating the same mystery, both came to the same conclusion, and even nearly selected the same name for the malady. "Exterior" crossmodulation, said Bernard; "external" crossmodulation, said RCA.

Following is Foster's discussion, from "RCA Review":

SOMEWHAT over a year ago reports began to be heard concerning a type of interference with broadcast reception which had never before been noticed. The interference occurred only in localities having high field strength from one or more local stations, and its new characteristics was that the program of the strong local station was heard when the receiver was tuned to one particular other station, but not to still others. The effect was not due to lack of selectivity because, when tuning the receiver, the local station could be tuned out and then would reappear when a certain other station was tuned in. Occasionally two local stations would be heard together on a frequency which was quite different from that of either one of them.

This type of interference also had other peculiarities. In the area in which it occurred, it would be found in one house whereas the house next door would be free from interference even when the same set was used. In those houses where it occurred, any make or model of receiver, including battery sets, experienced it. Still another puzzling factor was that the interference was not constant, being much more severe at some times than at others, and occasionally disappearing entirely for a period. In one case the interference was eliminated by opening the window through which the antenna lead-in passed, and in another case the interference was heard only when a certain bed-room light was turned on.

EXTERNAL AGENCY SUSPECTED

These characteristics led to the deduction that the interference was not caused in the radio receiver, but by some agency external to the receiver itself. This was further proven by laboratory experiments with two signal generators simulating the desired and interfering stations. In the laboratory inputs of three or four volts applied to the receiver did not cause interference, whereas, in the field at those locations having this type of interference, field strengths causing less than half a volt signal to be impressed on the receiver were present. Further-

more, decreasing the length of antenna did not eliminate the interference.

A survey was made to determine whether interference of this nature had been noticed in other parts of the country. Reports as a result of this survey showed it to be present in certain areas in or near the following cities: Cincinnati, Chicago, New York, San Francisco, Seattle and Washington.

Since by this time it was evident that the trouble was some form of cross-modulation, and since it was exterior to the receiver, this type of interference was designated "external cross-modulation."

A location was found where the cross-modulation existed consistently and a study was made

ductors near the receiving antenna and at some point along the conductor were impressed on a rectifier or non-linear circuit element.

The characteristic giving the output current of a rectifying element is commonly expressed as a series expansion in ascending powers of the applied voltage, the applied voltage in this case being the radio-frequency signals present on the power wiring or other conductor. The power-series representation of the rectifier characteristic discloses the new harmonic and combination frequencies which result from the rectification process. A simple laboratory test confirmed the observations. Two antennas were placed a few feet apart and to one of them a radio receiver was connected. An impedance

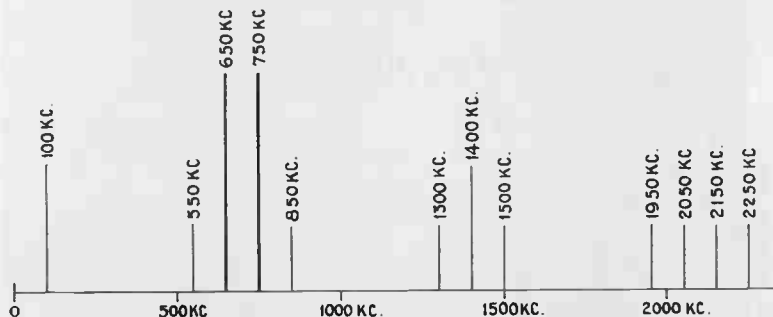

FIG. 1

Two strong, local stations are on 650 kc, called "a", and 750 kc. called "b." They produce ten new frequencies, five of which are in the standard broadcast band, and five outside that band. The two original and ten derived frequencies are above the horizontal line, which is graded in 500 kc steps.

to determine the fundamental cause and a remedy. In this location, a battery receiver with a short antenna exhibited cross-modulation inside the house, but when the receiver was a few feet outside the house, cross-modulation ceased. A trap circuit in the antenna was of no benefit, which was further proof that the difficulty was external to the receiver. It was observed that at this location, as well as at others where the effect was serious, that the house wiring was of the knob and tube type and the service mains from the distribution transformer were overhead. A filter near the receiver, consisting of two .1 mfd. condensers across the line with the center point grounded had only a slight effect on the interference, but an additional condenser across the line where it entered the house greatly decreased the cross-modulation. It was further found that by placing the antenna at a distance from the power lines and using a shielded lead-in, the external cross-modulation disappeared.

CLUE TO RECTIFICATION

This experience showed that the cross-modulation was due to rectification of radio frequencies in the power wiring, with resultant new, spurious frequencies being induced in the antenna or lead-in. Radio signals were picked up by the power wiring or other metallic con-

ductors near the other antenna and ground, and when a simple diode was connected across this impedance, cross-modulation of the signals in the first antenna occurred.

The question arises as to where the rectifier may exist in the field. Wherever there is a poor connection between any two metallic bodies, especially if oxidation is present, rectification can take place. The poor contact may be in the lighting lines, in piping, or even in the antenna itself. In one case the trouble was located at a point where a pipe passed through metal wall lathing. Bonding the pipe and lath together eliminated the interference. In another case two pipes were found to be touching and insertion of a block of wood between them cleared up the cross-modulation. When such a rectifier exists and one or more powerful signals are present, new frequencies are generated by the rectifier. Where only one powerful signal is present, the only new frequencies made by the rectifier are multiples of the fundamental, that is the second harmonic, third harmonic, etc. of the signal frequency.

CASE OF TWO STRONG LOCALS

Where two strong signals exist, a number of cross-modulation combinations take place. Let us call the frequency of one of the strong sta-

(Continued on following page)

(Continued from preceding page)
 tions a , and that of another b , then the rectifier generates the following frequencies:

$a + b$	$2a - b$
$a - b$	$2b + a$
$2a$	$2b - a$
$2b$	$3a$
$2a + b$	$3b$

An effect also takes place whereby the modulation of station with frequency a is heard on station b , and the modulation of station b is heard on a .

two stations would produce five new frequencies in the broadcast band and five new frequencies outside the broadcast band where one or both the stations together would be heard. It can be appreciated readily that a large amount of interference will be produced in this manner. The interference produced by station of frequency a on frequency b and vice versa has been found to be serious only when the rectifying action is particularly severe, because the modulation of the strong desired station usually masks the interfering modulation.

It may be seen also that there is a possibility of hum modulation being introduced when a

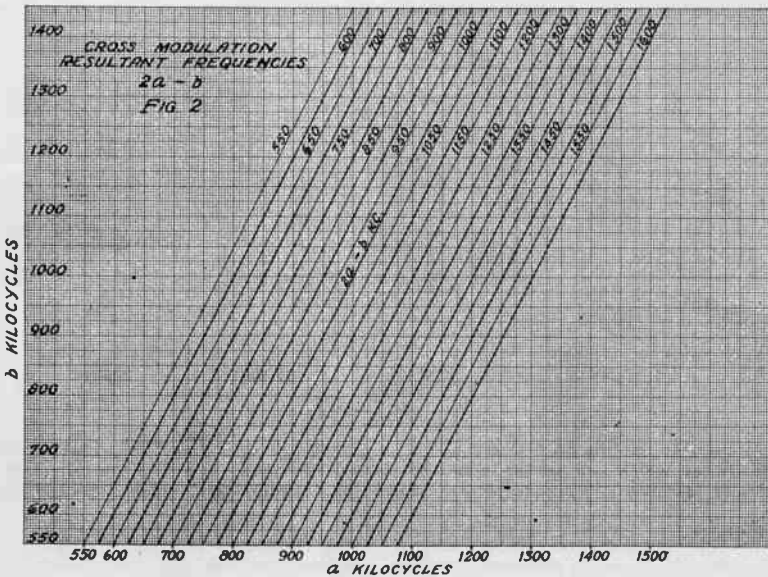

FIG. 2

The two station frequencies are a and b , and their mixtures cause trouble, practically twice frequency a , minus frequency b . Where the interference falls, in the standard broadcast band, for $2a - b$, is plotted on the slanting lines, 550, 1600 kc.

It should be noted that these spurious frequencies do not depend upon the presence of a second harmonic from either of the stations. If both stations are entirely free from harmonic radiation these same frequencies are generated if a rectifier is present.

Let us suppose that two stations are so located that in the region between them signal strengths of .1 volt per meter occur from both, and that one station is on 650 kc. and the other on 750 kc. Then the following table shows the frequencies produced:

$a = 650$ kc.	$2a + b = 2050$ kc.
$b = 750$ kc.	$2a - b = 550$ kc.
$a + b = 1400$ kc.	$2b + a = 2150$ kc.
$a - b = 100$ kc.	$2b - a = 850$ kc.
$2a = 1300$ kc.	$3a = 1950$ kc.
$2b = 1500$ kc.	$3b = 2250$ kc.

These same frequencies are shown diagrammatically in Fig. 1. In this example these

rectifying condition exists in the power wiring. In this case, one of the frequencies is that of the signal carrier and the other that of the lighting system, which is usually 60 cycles. The rectifying action then imposes a 60-cycle modulation on the carrier. Some instances of modulation hum in receivers at certain locations have been traced to this source. Hum of this type would be present in a battery receiver at the same location. The remedy is the same as for interference between stations, namely elimination of the rectifying condition or changed installation of the antenna to avoid pickup of resultant spurious frequencies.

Knowledge of the frequencies produced is helpful in determining whether a case of interference is due to external cross-modulation or not. Most of the combination frequencies are readily calculated when the frequencies of the two stations having high field strength are known. The combinations $2a - b$ and $2b - a$ are usually in the broadcast band and for that

reason are troublesome. Fig. 2 is a chart for reading the spurious frequency $2a - b$ for any value of a and b . By reversing the designation of a and b the chart can be used for finding $2b - a$ also.

In investigating a situation where interference exists, the first step should be to determine whether or not it is due to external cross-modulation by observing the frequencies at which interference exists. For example, with the two strong signals at 650 kc. and 750 kc., if the program from both is heard at 550 kc., 850 kc. and 1400 kc., it may be safely assumed that the trouble is due to external cross-modulation. If the interference is not due to external cross-modulation, shortening the antenna or installation of a wave trap tuned to the interfering signal, or both, will remedy the situation.

Cross-modulation may, of course, be produced in the radio-frequency or first-detector stage of the receiver if the tubes are not of the remote cut-off or variable- μ type or if the operating bias is, for any reason, incorrect.¹ Cross-modulation occurring in the receiver can be differentiated from that due to external causes by use of a short antenna, a wave trap tuned to the strongest interfering station, or by substituting another receiver. These expedients will eliminate, or greatly reduce, cross-modulation which takes place in the receiver, but will not affect external cross-modulation.

RECTIFIER LOCATION

As seen from some of the cases, the rectifying element may be in the power wiring, piping, or in the antenna itself. Therefore, the first step in eliminating the trouble should be to make sure that the antenna and ground connections to the receiver have secure, tight joints throughout, soldered joints in the antenna being preferable. If this does not cure the interference, the next step is to endeavor to find the rectifying element elsewhere. If the rectifier is in the power wiring, connection of two .1 mfd. condensers across the lighting lines, with the center point going as directly as possible to a good ground, should produce at least some decrease in the cross-modulation. In this connection it should be remembered that steam or gas piping, and in some cases water piping, may have joints which are electrical rectifiers, and in this event use of such piping as a ground for the receiver will intensify cross-modulation. The house should be examined for indications of pipes or electrical conduits which touch each other. If such points are found they should be separated by a block of wood or else bonded together securely.

If the source of rectification cannot be located, it still is usually possible to secure interference-free reception by the proper type of antenna installation. The location for an antenna which is free from cross-modulation can be readily found by the use of a portable battery receiver equipped with a short antenna. It will be found

that the cross-modulation occurs in the battery receiver when it is within the house, but disappears a few feet outside the house. By this exploration means, a location for the antenna is to be found where cross-modulation does not exist. The spurious frequencies will, however, be picked up on the lead-in unless it is thoroughly shielded. In some cases metallic braid shielding may not be good enough and concentric transmission line cable, which is now available in small sizes, must be used. Since the shielded cable is low in impedance, it is necessary to use matching transformers at the antenna and at the receiver to obtain maximum efficiency. If such transformers are used, they should be examined for possibility of poor connections which will cause rectification and resultant cross-modulation interference. It must be remembered also that the ground lead of the receiver is capable of picking up radio-frequency energy so that it should be as short and direct as possible. The receiver should be re-located to accomplish this if necessary.

SUMMARY

The steps involved in eliminating cross-modulation interference are:

- 1—Calculate the frequency combination values to make sure the interference is cross-modulation.
- 2—Examine antenna and ground for poor connections.
- 3—Try capacity filter across light lines.
- 4—Look for and eliminate rectifying contacts in piping or wiring.
- 5—Find antenna location free from cross-modulation and install antenna there with shielded lead-in to set.

By following this procedure it should be possible to clear up even stubborn cases of interference due to external cross-modulation.

The discovery of the source of the external cross-modulation phenomenon has led to proper analysis and elimination of many cases of interference which formerly were mysterious in origin and therefore difficult or impossible to remedy.

Stations 100 Miles Apart, Yet They Cause Clash

About three years ago an effect was noticed in Europe whereby the modulation of the Luxembourg station, which is a high-powered long-wave station, was noticed in Holland on the frequencies of stations in the broadcast band, and caused interference with those stations.² This phenomenon was called the "Luxembourg effect" and was ascribed to a possible non-linearity of the transmission medium.

Later this phenomenon of interference from the Luxembourg station was noticed in several other European countries. It is entirely possible that the effect was due to some non-linear element in the neighborhood of the receiving location and was therefore what we have called external cross-modulation, especially since the Luxembourg effect is the first phenomenon

(Continued on following page)

¹"Reduction of Distortion and Cross-Talk in Radio Receivers by Means of Variable- μ Tetrodes." Stuart Ballantine and H. A. Snow. *Proceedings of the Institute of Radio Engineers*, December 1930.

LABORATORY FINDINGS

Copyright 1937 by RCA Manufacturing Co., Inc.

Blocking Solved in Battery Sets

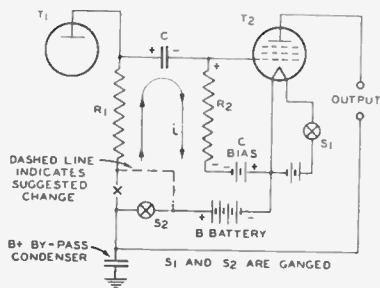

FIG. 1

On-Off switch connections for battery-operated receiver with resistance-coupled amplifier.

Many battery-operated receivers employ a dual off-on switch to control filament and B supply voltages simultaneously. Such receivers may block when this dual switch is opened and closed rapidly. The reason for the blocking can be seen from the a-f portion of a receiver circuit, shown in Fig. 1.

When the ganged switches (S_1 and S_2) have been closed for some time, the temperature of the filament is normal and the circuit is in operating condition. When S_1 and S_2 are opened, the temperature of the filament decreases and condenser C discharges almost immediately. Now, when S_1 and S_2 are closed before the temperature of the filament reaches a very low value, the charging current from the B battery through circuit R_1CR_2 , causes the grid of the tube to become positive by an amount equal to the voltage drop across R_2 , and the temperature of the filament starts to increase. Thus, due to the heating lag of the filament, it is possible for the grid to be highly positive while the temperature of the filament is

less than normal. The grid may emit secondary electrons under such conditions. This secondary-emission current flows in the same direction as the charging current (i); thus, the positive potential of the grid increases to a high value. The transconductance and, hence, the output of the tube is low under these conditions. Normal operation can be restored by turning the receiver off long enough for the filament to cool to a low temperature and then turning it on again.

Two methods may be used to eliminate this undesirable blocking. The lead to R_1 may be broken at x , Fig. 1, and R_1 connected directly to $B+$, as shown by the dashed line. With this connection, the B battery is connected to T_1 through R_1 at all times; hence, no charging current flows through C when S_2 is closed.

A second method of eliminating the trouble is to delay the closing of S_2 until the temperature of the filament is high enough to avoid secondary emission from the grid.

This secondary-emission effect is not peculiar to the output stage or to a particular tube type; it may occur in any resistance-coupled-amplifier stage.

Bigger Air Gap Improves Midgets

Measurements on a number of output transformers designed for a-c/d-c receivers indicate that an appreciable improvement in performance may be obtained by increasing the length of the air gap. The improvement obtained in one case is shown by the curves of Fig. 2. The proper load for the transformer was connected to the secondary; the total impedance across the primary terminals was measured at 420 cycles for different values of direct current through the primary with normal field current. The total impedance should have been approximately 2,000 ohms for a direct current of 50 milliamperes through the pri-

(Continued from preceding page)

which would indicate the possibility of a non-linear medium of propagation. Examples have been found in this country of external cross-modulation at distances from the interfering station of over 100 miles, which are similar to the observations of Luxembourg effect.

In general, when the interfering station is at such a distance, it has been found that the interfering station has high power and that there are high-tension lines extending in the direc-

tion where the interference was found, so that field intensity of the interfering signal was high at those points.

"Interaction of Radio Waves," by Balsh, van der Pol and J. van der Mark. Publications of N. V. Philips Gloeilampenfabrieken, Nos. 964 and 1036.

A. G. Butt, *Radio World*, April 28th, 1933.

B. D. H. Tellegen, *Nature*, June 10th, 1933.

Hochfrequenz Technik und Electro Akustik 46:181-186, 1935.

Onde Electrique 14 No. 168 80-808, 1935.

Wireless World, February 26th, 1937

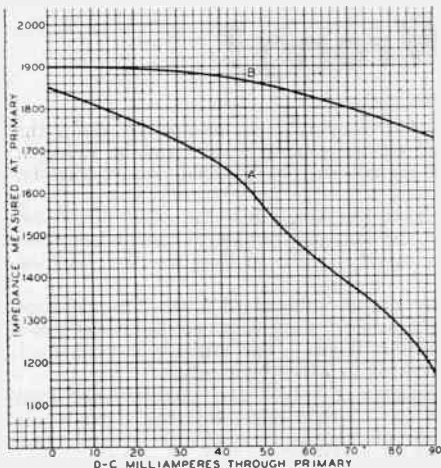

FIG. 2

A = Transformer as received. B = Transformer with air gap increased 0.003 inch and 5 turns removed from secondary.

mary; the measured value was found to be 1,560 ohms.

The variation in impedance with current is more important than the absolute value of the impedance. When the load impedance of a single-tube amplifier varies with current, the output is distorted; this distortion cannot be minimized by an adjustment of the bias or of the load impedance.

The impedance characteristic shown by curve A of Fig. 2 was corrected to that of curve B by an increase of 0.003 inch in the length of the air gap. A few turns were removed from the secondary in order to raise the impedance to a higher value. The important result, however, is the reduced change in impedance with current, because distortion is introduced by a load impedance which varies throughout the signal cycle.

Queer Oscillation Troubles Remedied

Difficulties due to oscillation in the output stage may be experienced when the transconductance of the output tube is high. In the case of the 25L6, 6L6, 6L6G, or 6V6G, it may be necessary to shunt the bias resistor with a small mica condenser (approximately 100 mmfd.) in order to prevent oscillation; the usual electrolytic bypass condenser is also used across the bias resistor when degeneration is not desired.

Another aid in suppressing oscillation is to ground the shell of each all-metal tube with a

short, heavy wire. When the impedance in series with the shell is appreciable, spurious oscillations at high frequencies may occur. This type of oscillation may be detected by an oscillograph or by measuring the screen current; the screen current will be appreciably higher than normal when the tube oscillates.

The following suggestions have been effective in suppressing oscillation in push-pull output stages using glass-type tubes. (1) Connect a 500-ohm resistor in series with the control grid of each output tube; each resistor should be mounted as close as possible to the grid terminal of the socket to which it connects. (2) Mount each plate bypass condenser as close as possible to the plate terminal of the socket to which it connects. The purpose of the suppressor resistor and the plate bypass condenser may not be served when they connect to a tube through comparatively long leads.

Alignment of Pentagrid Tubes to Avoid Locking

Difficulty is often experienced in lining up the oscillator and signal circuits of a pentagrid converter due to coupling between oscillator and signal sections of the tube. This difficulty is most noticeable at the high-frequency end of the high-frequency band. It has been found that a resistor of approximately 50 ohms connected in series with the signal grid (No. 4) and the tuned circuit reduces lining-up difficulties.

Smaller Stopping Condenser Aids Tone

When separate diodes are used for detection and a-v-c, and the i-f transformer is con-

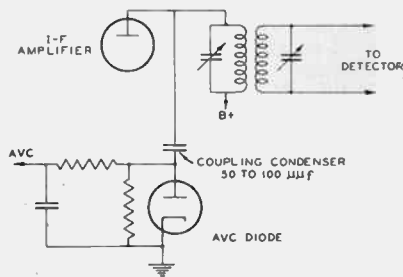

FIG. 3

Inter-diode connection for circuit having two diodes for detection and for avc.

nected through a condenser to the diode, it is desirable to employ a condenser of 50 to 100 mmfd. Values of coupling condensers greater than 100 mmfd. cause an appreciable decrease in output voltage at the higher audio frequencies.

The a-v-c diode loads the i-f transformer to which it connects (Fig. 3). Increasing the
(Continued on following page)

Right or Wrong?

Propositions

- 1 THE diode is the best type of rectifier, whether it draws current or not, i.e., loads the circuit or not, because the audio-frequency load on the circuit always can be made at least equal to the d-c load on the rectifier, hence signals can be handled distortionlessly, despite 100 per cent. modulation.
- 2 Extraneous noises usually come through the power line and affect the radio adversely, whereas the interference that arrives by way of the antenna, or due to the phenomenon of mixing of frequencies in superheterodynes, is relatively small, so that filtering the line cures most of the troubles.
- 3 The ether is an unknown quantity, representing the assignment of a word to describe something the existence of which we are in doubt, and yet something we discuss as if we were sure it existed, and to which we assign certain attributes. The ether is not assumed to be a liquid, a solid or a gas, and is in no way related to anaesthetic ether.
- 4 When tubes are connected in parallel the impedance is halved and therefore the load should be halved, compared to the load required for a single tube; whereas, if push-pull is used, as the tubes are effectively in series, the push-pull impedance is at least greater than the single impedance, and the impedance load should be doubled, or nearly so. Also, push-pull affords at least twice as much power output as does a single stage, at the same percentage distortion, and same voltage levels.
- 5 Audio amplifiers may oscillate at radio frequencies, also radio-frequency amplifiers may oscillate at audio frequencies, and the remedies in both instances are either to dampen the circuits to reduce the gain, or to remove the common impedance through which the feedback coupling is established, as by using filter networks, or condensers of lower impedance and choke coils of lower impedance.
- 6 The ground wave is the wave that travels close to, not through, the ground, and often reaches considerable distances, but it is the sky wave on which man depends for consistent distant reception, because it is transmitted toward the ionosphere, from which it is reflected back to earth at an angle, and thus traverses a great distance, with a gap of no-reception or poor-reception area, known as the skip distance.

Answers

- 1 Wrong. While the diode may be the best type of detector, the type most commonly used, which is splendid, nevertheless loads the circuit, and the audio-frequency load never can equal the d-c load, therefore full modulation capabilities are not enjoyed, and distortion above 80 per cent. modulation must be expected. The triode so connected that its characteristic is like that of a diode, since it does not load the circuit, permits quality reproduction of 100 per cent. modulated signals, as well as of signals of lower percentage modulation.
- 2 Wrong. Most extraneous noises come in through the antenna and few through the electric power line. Although line filtering will not cure nearly all the troubles, enough mischief is worked through the line to justify serious attention to that possible source of interference.
- 3 Right. Nobody knows what the ether is, or whether there is any such thing, for it is simply a name ascribed to the supposed medium through which radio waves pass. This medium is generic, it is fictitious, yet it is assigned attributes just as if it were a reality. For instance, it is said to possess linear properties for propagation, and experience has proven the existence of linearity, modified only by the Doppler effect, which accounts for apparent rather than real changes.
- 4 Right. Paralleling two resistances of equal value halves the resistance, and the same may be said of two equal tubes and their impedances. Push-pull is a series-connected circuit, and the resistance is doubled, although in practice loading less than this is usually recommended. The push-pull power increase is conservatively stated.
- 5 Right. The coupling through a common impedance is notorious in resistance-coupled audio amplifiers, and in high-gain audio amplifiers generally. Even at r.f. high gain makes for instability.
- 6 Right. The ground wave of American standard broadcasting band stations has been spotted in Europe, but the sky-wave effect is more pronounced at higher frequencies, hence much greater distance is penetrated on these short waves.

(Continued from preceding page)

value of the coupling condenser increases the loading; for a given value of coupling condenser, the loading increases with modulation frequency. A 50 to 100 mmfd. coupling condenser is suitable for most purposes. In one

instance, a decrease in the value of this condenser from 250 mmfd. to 50 mmfd. doubled the voltage output at 5,000 cycles. This change in output does not include the attenuation at 5,000 cycles due to the selectivity of the i-f transformer.

Standards of A-C Voltages Obtained from Second Harmonic Generator and Special Detector

By William C. Farrow

STANDARDS of frequency are easily obtainable, even zero frequency, for that is direct current. For instance, the Federal Government gives both radio-frequency and audio-frequency service, and all one need do is to tune in the transmissions. These are sent by the National Bureau of Standards from WWV, Beltsville, Md., near Washington, D. C., and are accurate to one part in 5,000,000. The new schedule is given berewith for those interested, especially as it now includes standard audio frequency.

But suppose you wanted a standard of voltage? Yes, suppose it was only direct-current voltage? Well, it would be possible to buy for ten dollars or so a cell that had the required accuracy, when kept at a specified temperature, etc., but the next problem would be to have an acceptable standard of alternating-current voltage. Now what would you propose? Did you ever hear tell of any such standard?

You can not take the house wiring line as a standard, because the voltage changes with load, nor can you accept any voltage derived from the line. It is clear, therefore, that you have to set up some voltage source of your own, and apply an authenticated technique whereby there will be possible the knowledge of what the output voltage is.

STANDARD A-C SOURCE

Just a little circumlocation is necessary to achieve this end. And when the end is at hand, one has a source of various voltages that may be used for calibration runs, and voltages much closer those normally found on a-c meters, where the accuracy is 5 per cent.

Let us see what this means. The accuracy refers to full-scale deflection only, so if the scale is 100 volts, it is permissible that the reading be off by 5 volts. But since the accuracy pertains only to full scale, the same departure of 5 volts is permissible all along the scale. Now, suppose we were measuring a voltage truly 10 volts, and it read 5 volts, an error of 100 per cent. This would be within the tolerance of the instrument.

Now, with the higher order of a-c accuracy, provided that the circuit is properly constituted and the meter itself has linear characteristics, as quite a few have—though some of the

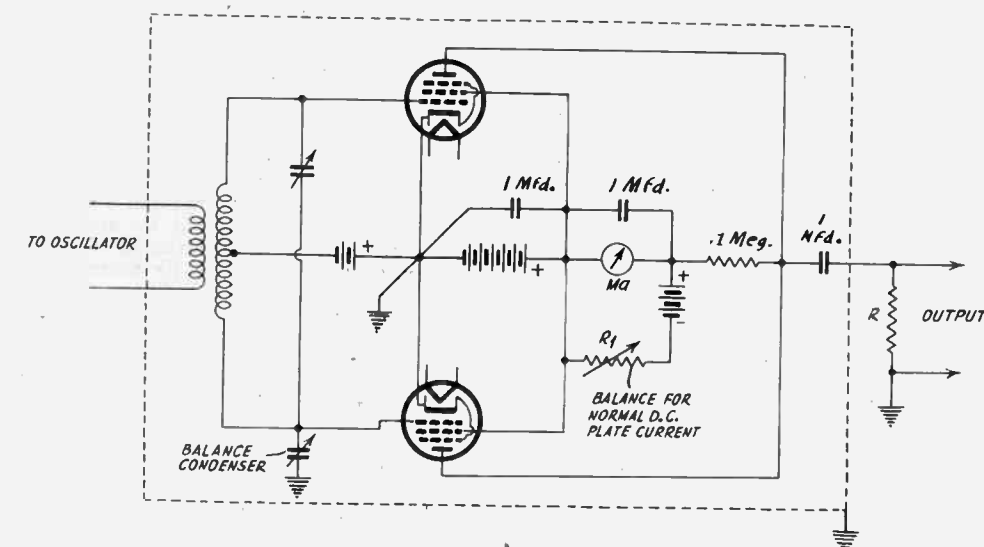

Since any signal generator will produce a second harmonic, the output of a generator at half the desired frequency is tuned in on the second harmonic by the special detector. The mathematical relationship is such that the change in d-c plate current is exactly a measure of the second-harmonic current of the generator. Hence known output voltages for second harmonics are established.

The instrument is made direct-reading by using a meter-bucking circuit.

cheaper kinds do not—we shall be able to do very much better than 5 per cent. accuracy, thus have a suitable standard.

The method is embodied in the second harmonic type signal generator, used in conjunction with a square-law detector of the full-wave type. The generator is tuned to half the frequency at which one desires to make the measurement, therefore the second harmonic of the generator is utilized. This bears the desired proportionality to the change in the plate current in the detector circuit.

The carrier wave is supplied by the signal generator, and it does not make any difference in the result whether the generator's wave is modulated or not. The grids of the full-wave, square-law detector receive the output of the signal generator as their input. Recall that half the frequency desired is generated, therefore the input to the detector is tuned to twice the generator frequency.

Now the plate circuit of the detector will be somewhat complex, but it will certainly contain a small quantity, of plate current due to

Standard U.S. Frequencies Begin Their New Schedule

The new schedule of WWV, from which the Government sends standard frequencies, now including audio, is as follows:

Each Tuesday and Friday, excepting holidays nationally observed:

10-11:30 a.m., EST, 5 mc

12-1:30 p.m., EST, 10 mc

2-3:30 p.m., EST, 20 mc

Each Wednesday, except holidays nationally observed, the same schedule as for Tuesday and Friday, and the same frequencies prevail, except that the carriers will be modulated with uninterrupted 1,000 kc note. The modulation will be 30 per cent. and the carrier power will be about 20 kw.

Further details of transmissions, how to use frequencies for checking, and other data are obtainable by addressing National Bureau of Standards, Washington, D. C.

the second harmonic of the generator frequency, and there will be present in the plate circuit the detected current, i.e., pulsating d.c. The fortunate circumstance previously referred to is that the peak amplitude of the second harmonic current is precisely equal to the rectified d-c current, so that when the rectified current is measured, the second-harmonic voltage is measured.

STARTING AT ZERO

The method of using this scheme is set forth by F. E. Terman in "Measurements in Radio Engineering" (McGraw-Hill), in concise form. The original development was due to Walter Van Brunt Roberts.

The output circuit is loaded with a resistor R of suitable value, say, 0.5 ohm or 1 ohm, so that for a given known current flowing there will be developed a known output voltage. For 1 ohm, for instance, at .5 milliamperes read on

(Continued on following page)

FOUR TYPES OF MICROPHONES COMPARED

Type	Characteristics	Frequency Response	D. B. Output	Applications
Carbon	High output. Needs re-packing often. Noticeable hiss present. Poor response.	45 to 5,000	-40	For use with amplifiers having low gain or where economy is important. Not popular any longer.
Crystal	Good frequency response, but not quite flat. May be moved about while in use. Very durable. In the medium price class.	40 to 9,000	-60	Good all around mike. Use a crystal mike for outdoor, mobile, portable installations.
Velocity	Best mike for permanent installations. Priced slightly higher than the crystal type, but has superior response curve.	30 to 12,000	-64	Directional qualities and good frequency response make this mike especially adaptable for indoor installations demanding the finest quality.
Velotron	A good microphone in the medium price class. Requires polarizing voltage. Suitable for general applications.	30 to 10,000	-50	For installations where microphone must be placed 200 ft. to 500 ft. away from amplifier.

Oscillator Provides Voltage Standards

(Continued from preceding page)
the meter, the voltage would be .005 volt, or 5 millivolts.

Ordinarily when a meter is inserted in the plate circuit there will be a steady reading due to the quiescent plate current. The needle will kick up, not down, for increased amplitude, but we desire to have the needle start at zero, because the whole scheme depends on the change in plate current, and for direct reading advantage it is necessary that the start or change be from zero.

INVERSE METER SHUNTING

The usual way of accomplishing this is to introduce a battery voltage of the opposite polarity to what exists in the meter, and thus cancel out the quiescent current. Naturally the resistor associated with the battery is variable, to permit the adjustment, and unless care is taken, the resistance will be so small that it serves as a ratable shunt for the meter, and the precision sought has been missed. That is, if we use a 0-500 microammeter, our predications are on that basis, and we should not let some shunting reduce the sensitivity of the meter, almost unknown to us, and therefore throw us off our guard. It is all right, indeed necessary to shunt the meter knowingly, for handling husky voltages, but not unknowingly.

Therefore the resistance for balancing out the normal d-c plate current is made several

hundred times greater than the meter resistance, and the battery voltage will be relatively high. The adjustment should be made from maximum resistance to less than maximum, so as to avoid putting the battery alone across the unprotected meter.

C_1 is a balancing condenser which, when adjusted properly, permits reduction of the oscillator frequency voltage across R to practically zero, for it will be recalled voltage of that frequency is not desired, but voltage at twice that frequency.

WORKS SATISFACTORILY

This direct-measurement method has proved very satisfactory and works on both high and low frequencies. Accuracy is much higher, as to known values of output voltage, than is found in most other types of instruments, although there are possibilities of error, as exist in practically all measurements we undertake. The particular source of error in this instance is due to the presence of voltages of frequencies other than the second harmonic. However, careful tuning, and use of a high Q circuit in the detector, plus signal generator with a good r-f wave form, and sine-wave modulation, if any modulation is present, help to get rid of the error sources, and leave the second-harmonic type signal generator, with special detector, as a very high-class shop standard of frequencies.

STRAIGHTENING THEM OUT

In his article in the April issue, analyzing squeals in superheterodynes, H. J. Bernard makes the point that cross-modulation may result from operating the first r-f tube, or some other intended amplifier tube, at more than the normal negative bias. He selects the first tube because, if that is the offender, the amplification of the offense is greatest.

What I do not understand is why the introduction of a more negative bias than the one representing the normal operating point should cause plate-bend detection. Suppose that a tube takes a normal negative bias of 3 volts, other voltages also normal, but that instead, a single change is made, e. g., the negative bias voltage is doubled. Now the operating point is at 6 volts negative grid.

My contention is that when the signal comes along, if it equals say one volt, it drives the grid upward by that one volt, and therefore the grid is operated at a negative effective voltage of $-6 + 1 = -5$ volts. The stronger the signal, the more it drives the grid toward a lower effective negative voltage. Therefore, if grossly excessive input signal voltages, as from test instruments, are ignored, then for operation at 3 volts, a signal of 3 volts could be put in, and within the prescribed limits, the stronger the signal, the nearer the tube is to its normal operating point. Am I right?—B. J.

If the tube is considered biased negatively by 6 volts, when 3 is the recommended value for normal operation, and if a battery voltage is introduced instead of a signal between grid and return, as this d-c input voltage is made more and more positive toward the grid, the effective grid bias is reduced, and if the d-c input is 3 volts, with positive toward grid, the negative bias otherwise obtained is bucked by the input voltage from the battery, the effective bias is $6 - 3 = 3$ volts, and the operation is steadily at this value. But when an alternating voltage is introduced there is absent the necessary requirement of a steady input voltage for fixed operating point at effectively 3 volts negative. Consider therefore the effect of the signal. The peak amplitude is, say, 3 volts positive. But that is only the peak. During the rest of the alternation the voltage is less than the peak, and finally it declines to zero. Twice in every cycle the input voltage is zero, because there are two alternations, positive and negative, to a cycle, and there is a zero voltage for each alternation. When the input signal voltage is zero it is the same as if there were no input, and the effective bias on the grid is the same as the steady bias, say, 6 volts in the example you cite. But the cycle is not complete. There is still the negative alternation. Just as in the example of the positive alternation there were instantaneous shifts in the operating point, so now with the negative alternation there are shifts of the same type, only

the polarity is different, negative this time, instead of positive. So instead of subtracting the signal voltage values from the operating bias value, since both signs are the same, the two are added, and the grid is driven more negative. How soon that instant of the negative alternation arrives when the grid is perhaps so highly negative that the plate current is cut off depends on various factors, including the type of tube used. But it can be seen that if plate-current cutoff is possible, plate-bend detection of the most effective kind is introduced.

* * *

There is one fault I have to find with the article by H. J. Bernard in your April issue, entitled "Full Analysis of Squeals in Supers." I have found by experiment that the squeal that is ascribed to the second harmonic of the intermediate frequency is not actually due to just that, but is found at a frequency somewhat different from, though reasonably close, to the i. f. For instance, the i-f channel is lined up, at 465 kc, using a signal generator on fundamental. Then the second harmonic of the signal generator, which must be the second harmonic of the i. f., since the i. f. is what the signal generator produced, is coupled at the antenna post, instead of a station. The interference should show up at $2 \times 465 \text{ kc} = 930 \text{ kc}$, but in fact appears at a frequency a little bit higher. That is, I tune the set to hear the beat, and when I pick up the generator's second harmonic, it is at a frequency on the accurately-calibrated receiver dial, a bit higher than 930 kc. So the i. f. second harmonic wanders.—O. H. H.

When you align an intermediate channel with a signal generator fundamental, at a particular frequency, that is the frequency to which the channel is aligned. That is one thing, separate and apart by itself, and was designated by the author as the intermediate amplifier frequency. When you set up a superheterodyne, the output of the mixer is the only intermediate frequency. This, too, is separate and apart by itself. It is a wave that is generated at a particular frequency. The intermediate amplifier is not a generator of a wave but a filter, something intended to pass the wave through, under conditions most favorable to amplification and also to damping of waves of any other frequencies. When the two are the same—that is, the generated intermediate frequency equals the amplifier frequency—the tracking is perfect. R. f. and oscillator are working together to produce just the intended intermediate frequency, the same frequency to which the amplifier is tuned. But if there is departure from perfect tracking, then the generated intermediate frequency and the frequency of the intermediate amplifier are different. The second harmonic of the very same generation used for aligning the i-f amplifier will not come in at a dial position equal to twice the frequency of the intermediate amplifier, but at a position equal to twice the generated intermediate frequency. Hence it is still the second harmonic of the intermediate frequency that causes the trouble.

Automobile Receiver Design

BY JEROME C. SMITH

Development Engineer, Automobile Receiver Section, RCA Manufacturing Co.

(Reprinted from *RCA Review*)

THE use of a mobile radio receiver is almost as old as radio itself. The necessity of making field strength measurements over wide areas within a reasonably short space of time possibly was one of the first reasons for operating a radio receiver in an automobile. Stories are told of accelerating the car to gain speed, then shutting off the motor and coasting while the measurements were taken. Somewhat later,

in the roof, the installation depending upon the amount of upholstery mutilation the car owner would allow. The car battery furnished the filament voltage, while the plate voltage was supplied by B batteries. These were placed in a water-proofed box which was mounted through a hole cut in the floor of the car. While the motor was in operation, the receiver could be used only on local stations, due to

FIG. 1

Eleven years ago this photograph was taken. A tuned-radio-frequency receiver with two tuning controls was rod-mounted to pierce the instrument panel, which had to be removed from the car to make the installation possible. That thing at upper right is the horn-type loudspeaker. The antenna was installed on the roof. Stations had to come in very strongly to override the ignition interference. There was no automatic volume control.



special installations were made for advertising purposes. One such combination used in 1922 consisted of a loop receiver with separate "A" battery for filament supply and a motor generator for "B" supply.

In 1926 a tuned radio-frequency receiver with two tuning controls, using a two-gang condenser on each control, was available to the public. Fig. 1 shows a receiver of this type installed in an automobile. The controls were mounted in the instrument panel, which was removed from the car to make the installation. The receiver was mounted on rods stretched between the dash and the instrument panel. The speaker was of the horn type, usually mounted on the header bar. The antenna was installed

in the roof, the installation depending upon the amount of upholstery mutilation the car owner would allow. The car battery furnished the filament voltage, while the plate voltage was supplied by B batteries. These were placed in a water-proofed box which was mounted through a hole cut in the floor of the car. While the motor was in operation, the receiver could be used only on local stations, due to

SUPPRESSORS INTRODUCED

Beginning in 1927, distributor and spark plug suppressors were used to reduce ignition interference, and a great deal of other work was done in this field over the next two years. This work involved both the automobile and the receiver and has continued from that day to this, progressing from complete shielding of all parts of the ignition system to the so-called suppressorless operation possible on many cars today, with no shielding of any sort.

Through the year 1929 the receivers were

(Continued on following page)

(Continued from preceding page)

generally so designed and mounted that no remote-control mechanism was used for tuning or volume adjustment. One such receiver, a battery-operated unit constructed by mass production methods, was mounted on rods directly behind the instrument panel. The tuning control and the volume control were concentric and direct connected, and were built into the instrument panel. A magnetic-type cone speaker mounted in a metal box was connected to the receiver by means of plug-in cables. The box was designed to mount in any convenient location, usually on the dash.

At about this time a.v.c. began to make its appearance in an important way, although its use was by no means universal until several years later. At this time also, the need for

saw the superheterodyne come into wide use. The use of a class B audio system in conjunction with a permanent magnet dynamic speaker was a feature of one receiver of this period. For the first time a fair output was available with reasonable battery drain, and in conjunction with the dash-mounted, permanent-magnet dynamic speaker the optimum in performance with low battery drains was approached.

The introduction of the six-volt indirectly heated cathode type tube in mid-summer of 1931 was a most important advance. While it had not been uncommon to find the 2.5 volt heater type tubes used, their power consumption was excessive for the generators and batteries of that day, and the six-volt tubes mark a major advance in automobile radio.

The advent of the six-volt tubes left the

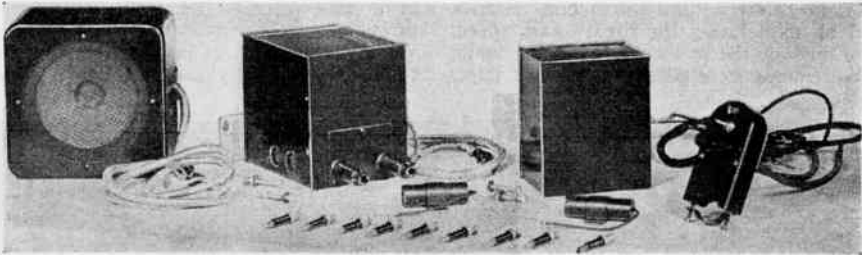

FIG. 2

Automobile Receiver—1932. Permanent magnet dynamic speaker, receiver unit, dynamotor unit, and steering column control, with typical accessories.

control mechanisms which would allow the receiver proper to be mounted more readily was manifest. Practically all receivers were installed in the field. The necessity of removing the instrument panel and drilling large holes was a major cost item and a great detriment to sales. Some work was done on electrical remote control systems similar to those available on home type receivers of that day, but these did not come into commercial use. Tension wire and torsional shaft drives made their appearance in 1930, and the latter type has since won almost complete acceptance on account of its simplicity. For several years the steering column control unit was very widely used except on custom-built factory installations, which were slowly growing in importance. The steering column control usually housed tuning and volume control knobs and a dial indicator, each knob actuating its appropriate unit in the receiver through a tension drive or a flexible shaft. These developments greatly simplified the installation problem and became a major factor in the increase of public acceptance of automobile radio. The flexible shaft control unit was also adapted for mounting under the instrument panel, and in custom installations, in the panel. In this form it dominates the present market, although in a current model discussed later in this paper the end of this dominance may perhaps be foreseen.

IMPORTANT TUBE ADVANCE

In 1930 tuned-radio-frequency receivers with battery B supply and filament type tubes were still almost universally used. The year 1931

B battery supply as the obvious weak spot in design, and the best engineering talent of a rapidly growing industry now attacked this problem. The limitations of the B batteries were many and obvious—high upkeep cost, excessive weight, and installation difficulties. Their installation was often more troublesome than that of all the other units of the receiver. Most serious of all they represented a major barrier to progress in respect to increased power output and stability of performance. There were motor generators and dynamotors, expensive, inefficient, noisy and mechanically cumbersome, available as substitutes. Nevertheless in 1932 the B batteries were discarded and the rotating machines substituted. Proper shielding and filtering were devised, and quite satisfactory operation resulted. Fig. 2 shows a receiver of this period. Receivers were often designed to use either batteries or generators, as the customers desired. The electrodynamic speaker came into practically universal use at this time, and for the first time, overall operation came within range of performance as we know it today.

RE-ENTER, THE VIBRATOR!

There had long been in use a piece of equipment almost as old as modern electricity—the vibrating reed rectifier. In another form, that of a simple interrupter or pole changer, it had been used to generate direct-current power. Engineers, working under the pressure of commercial need demonstrated what can be done in the way of developing and adapting old ideas.

This piece of apparatus soon became a cheap and efficient substitute for the rotating machine, and today the vibrator stands without a rival as the source of "B" power supply in automobile receivers. It is in use in two types, the synchronous and the non-synchronous. The former acts to convert six-volt d.c. to a.c. by impressing the battery voltage alternately across the halves of the transformer primary. The alternating voltage is then stepped up and rectified on contacts operated synchronously with the primary contacts. The non-synchronous type performs only the first function, while the second is performed by a tube rectifier having an indirectly heated cathode and designed to operate with the B potential between heater and cathode. The unit was usually either partially or completely shielded and was incorporated as an integral part of the receiver. This greatly simplified the installation problem, and 1933 and 1934 witnessed a tremendous growth in public acceptance of automobile radio.

In major items the 1934 receivers were much as are those of today. The greater part of

single or double unit receiver which mounts directly on the center line of the instrument panel (Fig. 4). It is supported at the rear by a hanger suspended from the rear hood saddle bolt. The usual control box and flexible shafts have been eliminated. The controls are built as an integral part of the receiver. The speaker opens through an ornamental grille in the instrument panel as shown in Fig. 5. This speaker location provides excellent sound distribution and clarity; in conjunction with the case and the electrical circuit design, adequate low frequency response is obtained as well. In the de luxe installation, the receiver is supplied with an auxiliary dash-mounted speaker. A suitable tap on this output transformer provides the correct impedance match. It is believed that this type of installation will become increasingly popular.

PROBLEMS OF HOME APPLY TO CAR SET

The designer of automobile radio has to face most of the problems of household radio, often

FIG. 3

A single-unit commercial type of receiver. The tuning and volume controls are at lower left and right. Besides the single unit there is the double unit, illustrated on following page. This is a 1937 model. Mounting is directly on the center line of the instrument panel.

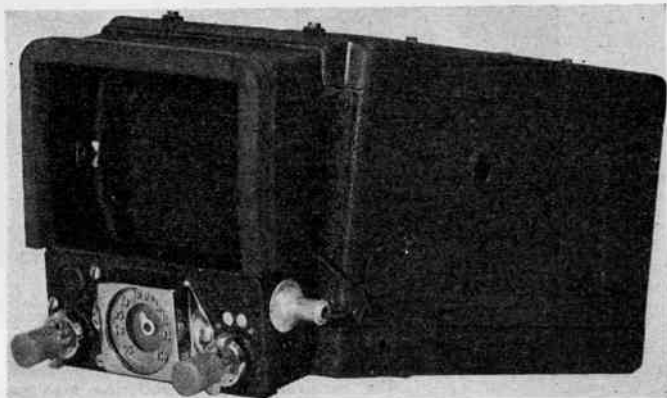

the engineers' work since 1934 has been in the refinement of circuit components and performance, the elimination of spark plug suppressors, the lowering of costs, and in the improvements and adaptations that have come through the closer coordination of the automobile and the radio engineers' efforts, particularly through their association in the design of custom installations. As the popularity of the automobile radio increased, its sales possibilities and engineering requirements became of increasing importance to the motor car manufacturer. Battery and generator capacities were increased. Provision was made for mounting the set without the necessity of drilling the dash of the car. Provision was made for speaker installation in the header, just above the windshield, and for custom control box installation. More care has been taken in the layout of the electrical system to avoid excessive ignition interference, although in many cases this is still far from satisfactory.

1937 CAR SETS "IN HIGH"

The receivers of 1937 mark a new high in radio performance. Of particular interest is a current model shown in Fig. 3. This is a

in an aggravated form, in addition to several others which do not concern the household radio designer. One of the most serious of these is the necessity for making the receiver as small as possible. This results in the crowding of major components in such a way that continual compromise must be made between size, accessibility, and performance. The components themselves must be made small, but not so small as to be costly or undependable, or to sacrifice performance. They must be so placed that the external connections, the battery lead, antenna connector, control box fittings, and possibly the tone control, squelch switch, or local-distance switch are readily accessible. The cover must be removable and the design such that tubes and vibrator can be easily serviced without removal of the receiver from the car. All these conditions must be met while insuring that the power supply and antenna circuits are not adjacent or electrically interwoven, that heat-generating units are not placed near the electrolytic capacitors, that the unit as a whole will perform at zero or 125° Fahrenheit, that water will not enter the unit if the cowl ventilator is left open, etc. ad infinitum.

(Continued on following page)

(Continued from preceding page)

It is only by constant detailed attention to layout requirements that electrical circuit trouble can be avoided. Every lead must be carefully considered with respect to its neighbors from the standpoint of regeneration, tweets, image response, vibrator interference, ignition interference, audio buzz and hum, strength and stability of alignment under shock and vibration, and last but not least, ease of manufacture.

This necessity for crowding of parts aggra-

been closely interwoven with the design of the components of the power supply system.

The design of the vibrator and power supply components for proper life and stability is a major problem. Fig. 5 shows the transformer primary wave-form of a synchronous vibrator. Its operation is briefly described as follows: Assume the vibrator in operation. At *A*, both primary and secondary are in contact and the instantaneous voltage is approximately equal to the battery voltage. At *B* the contacts open.

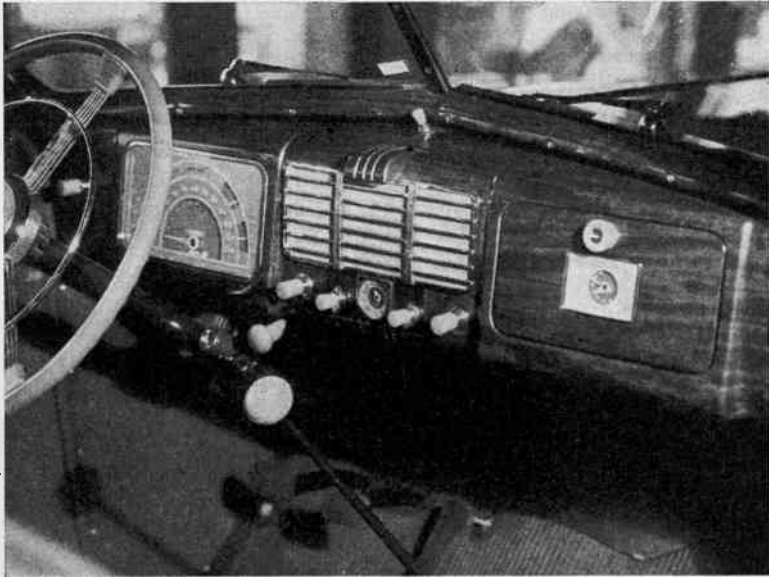

FIG. 4

The receiver as the installation man sees it.

vates many of the other special problems such as "vibrator interference." The vibrator power unit in performing its normal function generates random high-frequency voltage components, from which the high-gain radio circuits must be carefully shielded. All power leads must be filtered and so routed as to avoid excessive coupling to critical circuits. The power circuits must be brought into the receiver and controlled to keep the currents localized even within the metal of the chassis base. The radio and audio-frequency circuits must be grounded so as to avoid impedances in the chassis in common with those of the power supply currents. Unfortunately, "ground" is a very indeterminate word in automobile receivers.

CORRELATION NEEDED

In a performance check on a sample, care must be taken that interference has not been introduced into several circuits in such a way as to be self-neutralized. This neutralizing is relatively easy to do on a single sample, sometimes even accidentally, but is almost impossible to control in mass production. The general problem of vibrator interference has

The magnetizing current of the transformer tends to remain constant. It is supplied by the buffer capacitors on the secondary, whose voltage, referred to the primary, drops to point *C* in the process. At *C* the contacts close in the opposite polarity, sending a surge of current into the capacitor and almost instantly (depending on the circuit resistance and leakage inductance) raising its voltage to *D*, where leakage reactance resonance or contact chatter will produce irregularities until the energy is dissipated, or uniform contact obtained. The cycle is then repeated.

The problem in design lies in the proper correlation of the magnetizing current of the power transformer, the size of the buffer capacitors, and the frequency and time-efficiency of the vibrator, i.e. the percentage of the time that the vibrator contacts spend in the air-gap. These factors can be so balanced that points *C* and *D* coincide, producing a minimum of sparking at the contacts and, of course, a minimum of radio-frequency disturbance. For a number of reasons, however, this is not as desirable an adjustment as it would seem at first glance. Suppose that a unit is so adjusted, and is then

placed in a receiver in which the buffer capacitor is below the nominal value, and the magnetizing current of the transformer is above nominal. In this case, the voltage reaches point *E* before contact is made, placing a severe overload on the buffer capacitor units. As the vibrator contacts burn away the time interval between *B* and *E* is increased; the voltage at *E* increases, as does the sparking and contact burning. The cycle is obviously unstable and breakdown eventually takes place. With adjustment as at *F*, the buffer is too large, and unnecessary burning of the contacts takes place when the capacitor is shorted. Radio-frequency disturbances generated are very great though operation is entirely stable.

EFFECT OF SPARKING

With adjustment as at *C*, the sparking tends to decrease as wear occurs at the contacts, or as the magnetizing current increases, and the

of the transformers are kept reasonably low.

As we have noted, much of the early so-called vibrator trouble was due less to the vibrator design than to the lack of correlation of the design and adjustment of the vibrator on one hand, and the design of the associated transformer and buffer capacitors on the other. A contributing factor was a lack of knowledge of the variation in car battery voltage with the consequent effects on heating and on transformer saturation.

REGULATORS ON MANY NEW CARS

Fig. 6 shows the results of temperature and charging rates on the voltage of a typical fully-charged automobile battery. It will be noted particularly that at low though fairly common temperatures, the battery voltage rises sharply with only a few amperes of charging current. This results in a number of serious problems for the designer. Although a fully charged bat-

FIG. 5

Antennas and vibrators are two outstanding automobile set problems. Here we see a wave form of current in the primary of the vibrator transformer, for synchronous type vibrator. The operation is described in the text.

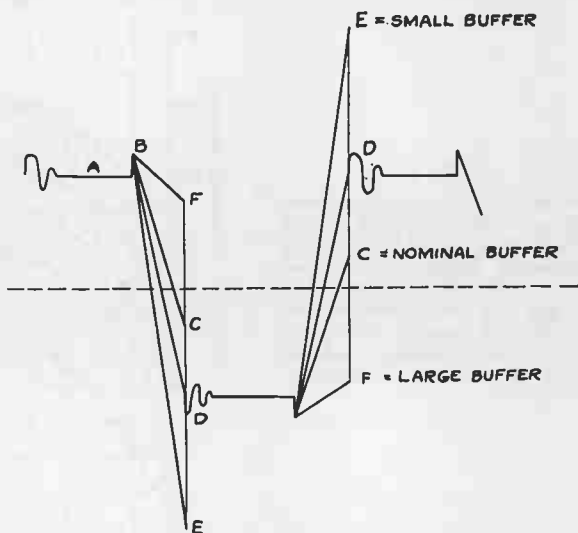

result is stable operation until point *D* is reached. Care must be taken that the vibrator transformer will not saturate at high battery voltages, that the buffer capacitors do not change capacity with life or at the temperatures reached in the receiver, and that the driving excitation of the vibrator is stable so that a relatively constant time-efficiency is attained. As previously mentioned, minimum sparking and vibrator interference are obtained with adjustment for operation at *D*, but much of the trouble with vibrators during their early use was due to the difficulty in maintaining such an adjustment during the life of the vibrator. The non-synchronous or tube-type vibrator has a similar problem during the tube warm-up period, and either buffer capacitor or rectifier tube may be broken down. After the tube functions, the peaks cannot exceed the normal operating voltage appreciably. The load currents of the transformer, both primary and secondary, are a minor problem, as they involve little storage of energy, provided the leakage reactances

of the transformers are kept reasonably low. As we have noted, much of the early so-called vibrator trouble was due less to the vibrator design than to the lack of correlation of the design and adjustment of the vibrator on one hand, and the design of the associated transformer and buffer capacitors on the other. A contributing factor was a lack of knowledge of the variation in car battery voltage with the consequent effects on heating and on transformer saturation.

Temperatures in the receiver must not be excessive at the higher voltages. Fortunately the battery voltage tends to decrease with increase in ambient temperature, so that heat runs may usually be satisfactorily made at 7.5 volts and 90 to 100° F. ambient. The vibrator should be designed to withstand the higher voltages and currents, and vibrator power circuits must

(Continued on following page)

(Continued from preceding page)
 remain stable. In general, factors involving life of components may be determined on a basis of a 7.5 volt battery, while breakdown must not occur at 9 to 9.5 volts. Fortunately the battery voltage situation is slowly improving. Many 1937 cars have voltage regulators which so reduce the charging rate that it is practically impossible for the potential to rise above 8 volts with the receiver in operation. It does not seem to be too much to hope that within a very few years automobile receivers can be designed to operate within as close voltage limits as are present household receivers.

SERIOUS ANTENNA PROBLEM

Probably the major recent problem of automobile radio has been the antenna and antenna

order as that of the roof antenna, but their effective height is usually somewhat less. Moreover, they are easily torn off in going over curbs or in rutted roads. They collect mud and ice, change capacity, and lose efficiency seriously in adverse weather. They are peculiarly susceptible to tire or wheel static interference.

RODS, WHIPS AND TOWEL RACKS

Various parts of the car have been insulated and used for antennas; steel insert tops, bumpers, rear trunk doors, and running boards. Of these, the latter type is probably the most satisfactory. With proper circuit design it offers performance comparable to that of the best roof type antenna. It, of course, requires careful engineering in order to incorporate it properly

FIG. 6

This shows the results of temperature and charging rates on the voltage of a typical fully-charged automobile battery. At low temperatures the battery voltage rises sharply, with only a few amperes of charging current. This results in a series of serious problems for the auto set designer.

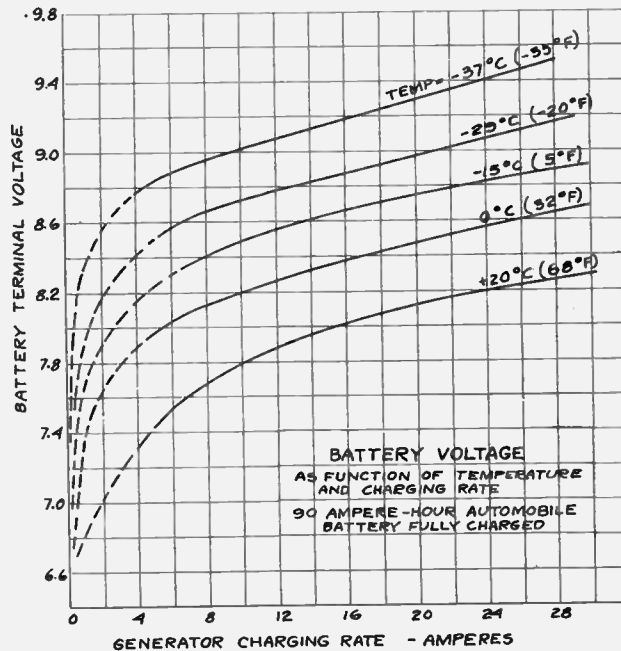

circuits. By its very nature it will probably never be said that it is solved—there is always another station in the background which could be received if the antenna were larger or the circuits better designed. Unfortunately, antenna progress has at times been retrograde. One of the oldest, simplest, and generally most satisfactory antennas yet devised, the netting placed under the cloth top, has been eliminated with the adoption of all-steel bodies. This roof antenna offered a fair effective height as automobile antennas go; and its output impedance (capacitive corresponding to the order of 175 micro-microfarads) was of a value relatively easy to incorporate into a circuit to good advantage. Its passing has caused the increased use of undercar antennas, consisting of metal straps, rods, wires, or plates fastened at a distance of two to four inches beneath one or both running boards. Their capacity is of the same

into the car design. It is thus available only on certain 1937 model automobiles.

A large variety of rod, whip, and overhead "towel rack" antennas are now coming into wide use. In general, these are of relatively great effective height, but of low capacity. Because of this capacity mismatch they are often not well adapted for use with receivers now commercially available. Their potentialities are very great, however. If the automobile body designers can be reconciled to their use, they may well be the antennas of the future. One popular 1937 car uses a rod-type antenna with the circuit properly designed to match. Performance at least comparable to the roof type is obtained even though the output capacity is but 12 mmfd. and the rod is only of the order of two feet in length. The "towel rack," or over-roof type, usually has a capacity of the order of 65 mmfd. It gives good performance when prop-

erly matched to the circuits, provided it is placed five inches or more above the car. The sale of this type of antenna to the general public is increasing rapidly. The whip antenna is quite similar in performance and probably the lowest in cost of any type. It can be quite readily connected to the receiver without necessarily requiring special transformers at the entrance to the lead-in cable as does the rod-type referred to above.

Because of the present state of change in antennas, the design of the antenna circuit is naturally a troublesome problem. In a receiver designed for general sale, the best compromise must be made for operation on the various types of antennas. In a custom-built receiver the antenna is usually specified by the car manufac-

tion of the electrons in the first tuned circuit of the receiver, and, in a properly designed automobile receiver, will predominate over all other noises generated in the receiver. The designer aims to arrange the circuits so that at any given low input from the specified antenna, this noise is made as small as possible. Thus, the true criterion of performance is not the ability to receive a signal, but rather to obtain it with as little "hiss" as possible. The "one microvolt" receiver has often been the goal of radio designers. Unfortunately, as we can readily observe, it has little fundamental significance, even assuming that the antenna capacity were specified, for it expresses nothing about the hiss to signal ratio* at the given output level.

A truer criterion, somewhat more cumber-

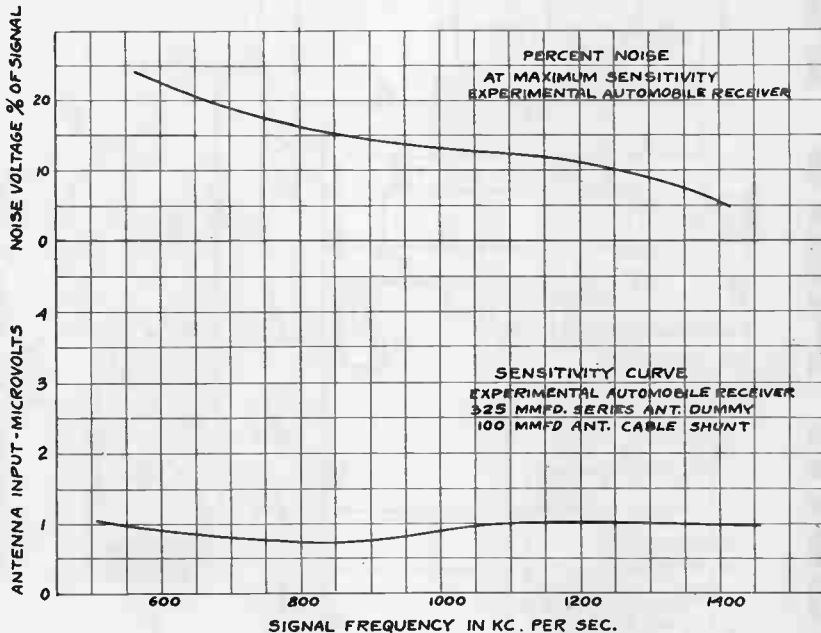

FIG. 7

Sensitivity and noise percentage curves of an experimental receiver.

turer, though it is often not the most desirable type electrically. In any case, given the antenna, the problem of the designer is to make use of available signals most efficiently. He is limited primarily by these factors: locally generated interference either external to the car, as street-car noise, or internal, as ignition noise, vibrator interference, and wheel static; secondly "natural" static; and in the absence of these, hiss in the form of thermal agitation voltage in the tuned grid circuit in the first amplifier stage.

THE REAL CRITERION

Let us assume that the installation is free from all of these except the thermal agitation effect. This is the "rushing noise" of which the customer complains when the receiver is made too sensitive. It is caused by the random

some to measure, is the input required to produce a specified hiss-to-signal ratio. A better figure of merit would be the hiss ratio at a standardized small carrier input or the standard of the Institute of Radio Engineers, the Equivalent Noise Side Band Input. These bases of comparison would apply only between receivers designed to operate from the same antenna. A satisfactory rating of hiss-to-signal behavior of receivers designed to operate from different antennas must express the performance of the antenna, together with its associated

(Continued on page 45)

*This quantity is determined by introducing a carrier of arbitrary modulation percentage, usually 30 per cent, through the proper dummy antenna. The modulation is removed and the residual noise voltage is measured and expressed as a percentage of the output when the carrier is modulated.

Typical Modern Auto Set Circuit

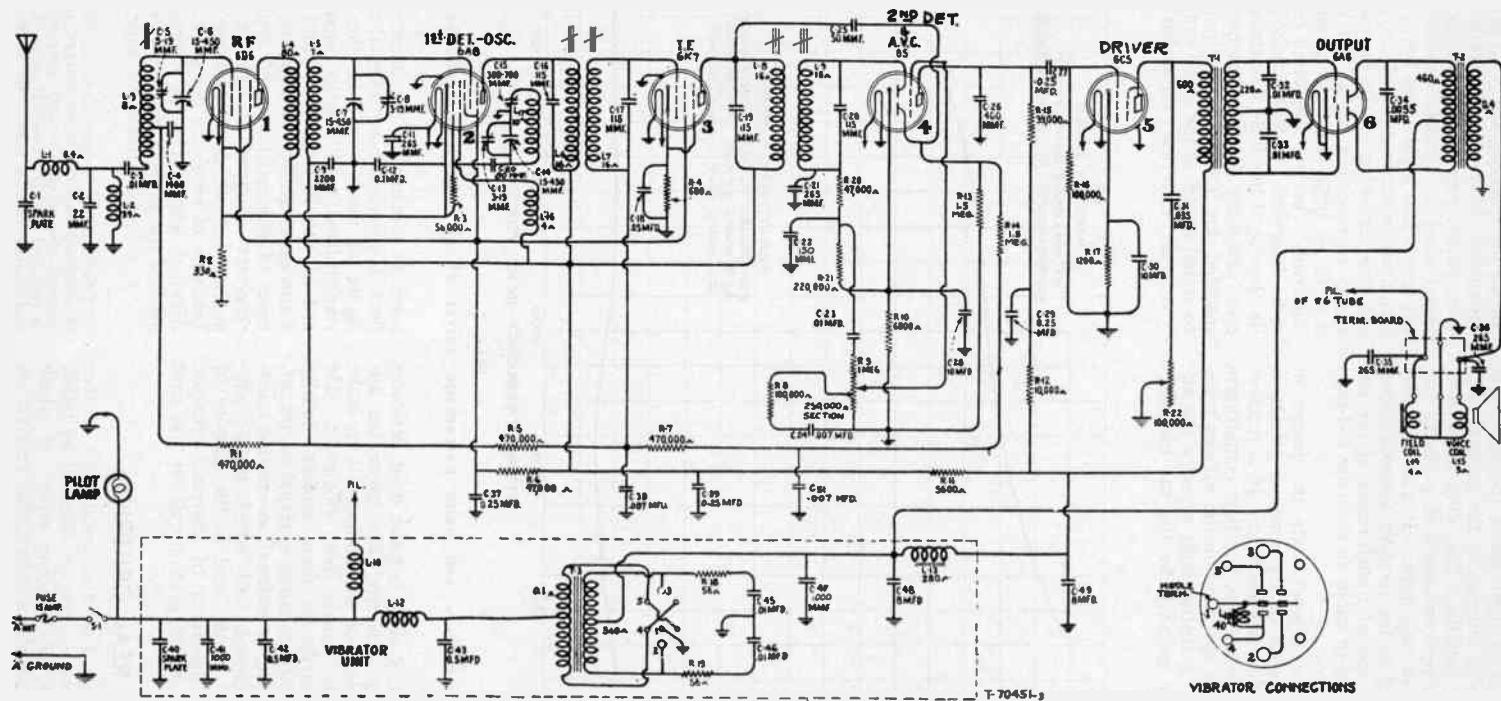

FIG. 8

Typical up-to-date auto receiver's circuit.

(Continued from page 43)

receiver. This could be done in terms of the field strength of a carrier of specified modulation depth which is necessary to produce hiss-to-signal ratio, or conversely, the hiss ratio at a given field strength. In general, sensitivity expressed as input for a standard audio power output† is not a problem. Even a four-tube circuit can be designed to give a greater value of sensitivity than can be used, hiss-to-signal ratio being the limiting factor.

For similar reasons, antenna gain is not an infallible measure of performance, even when comparisons are made with a given dummy an-

farads. The antenna gains, similarly measured, were in the same ratio. The former operated from a rod, the latter from a running board. Yet, they were very closely comparable in overall performance on low signal strength reception.

The acoustic problem is another consideration which has been of major importance and difficulty. It has had two phases, that of securing satisfactory bass note response, and of securing proper sound distribution. The former is of course due to lack of sufficient baffle area around the speaker, or of sufficient volume of air behind it. In practice, the header speaker gives good

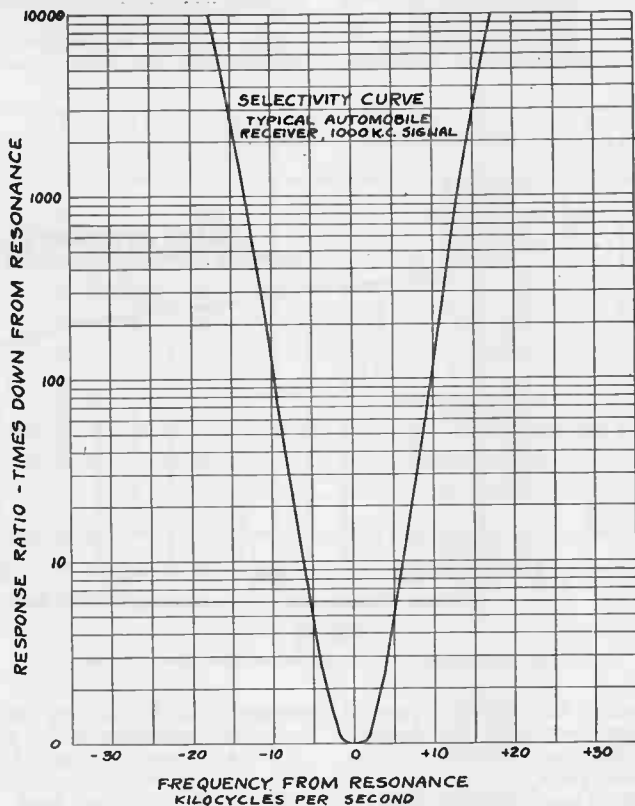

FIG. 9.

tenna. The gain may in one case be obtained by close coupling, in another by high secondary impedance with loose coupling. Identical gain would mean that the former is superior in regard to usable station-getting ability. The writer recalls two receiver designs of equal over-all performance. One had a sensitivity, measured through its 12 mmfd. dummy capacity, of approximately one-tenth that of the other, which, in turn, was measured through its dummy capacity of four hundred micro-micro-

distribution of sound throughout the car and excellent reproduction of voice, but very poor musical quality. The dash speakers, when carefully designed, give good musical quality, although low-frequency response is not under all conditions, all that may be desired. A type of dash installation which offers good low-frequency response, with freedom from objectionable resonance effects (barrel tone), was offered in the acoustic equalizer in 1936. The tendency at the high-frequency end of the audio spectrum is towards the reduction of the objectionable high frequency hiss components by cutting the audio-frequency range as much as possible. This is a natural consequence of the small signals available in most locations, and in the ab-

(Continued on following page)

†Because of the fact that the average output level of automobile receivers in normal operation is higher than that of receivers for home use, it is usual to use a greater value of standard audio output for performance measurements than has been usual for checks on home receivers. Generally the value of 1.0 watt is

(Continued from preceding page)

sence of satisfactory bass note response, has not been seriously detrimental, particularly in view of the fact that the customer's first move often is to adjust the tone control to the bass position.

A major barrier to advance in fidelity of tonal quality lies in the noises and rumbles of a car in motion. They have a striking masking effect upon the ear at both the extreme high and low frequencies. Fortunately the automobile industry is closing in on this problem. At 50 miles per hour the air-conditioned car of the future may be almost as quiet as one's living room.

Ignition noise is caused by the radio frequency pulses set up by the spark-generating equipment necessarily used to cause combustion to take place in the cylinders of the automobile

Very early in the development, it was noticed that material improvement in ignition noise could be obtained by carefully arranging the antenna lead-in with respect to the wires under the instrument panel, and especially with respect to the A lead of the receiver. Most early installations considered the proper placing of antenna and A lead as one of the regular procedures for reducing ignition noise. This was dependent upon introducing a small amount of out-of-phase ignition noise into the antenna circuit through coupling with the A lead. It is rather startling how completely a rather bad case of ignition noise can be cleaned up by properly balancing the feedback voltage. It is quite obvious that this system has many difficulties, such as the necessity of obtaining the balance with the driver (and sometimes the

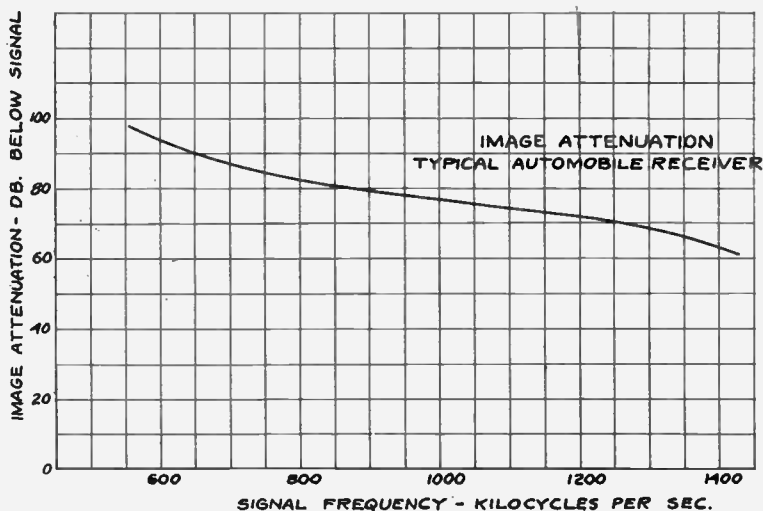

FIG. 10

Image attenuation of a typical automobile receiver.

engine. Fundamentally, the ignition system of a car has most of the components of a damped-wave transmitter. Therefore, from the automobile radio installation point of view, the hood of the car contains a small partially shielded transmitter, and unless special precautions are taken in making an automobile radio installation, the ignition noise will be the loudest and most persistent signal received. The obvious and fundamental method of attack is that of complete shielding of all parts of the ignition system. This method is now generally used in aircraft installations. While moderately successful in automobiles, it is very expensive, and often introduces difficulty with electrical leakage and consequent motor trouble. Often it is very inadequate because it fails to take care of chassis currents set up by the primary or because the location of coil and leads is such as to make complete shielding extremely impractical. The use of the resistance-type suppressor in the high-tension leads is a powerful weapon in the engineers' struggle with this problem, as it reduces the interference at its source.

passengers) in the car, and the great tendency to become unbalanced as the grounds and bonds of the car change with use. Moreover, in many cases it is impossible to obtain a balance at all points of the broadcast band.

A major step was accomplished when the automobile receiver was carefully shielded and the A supply lead sufficiently filtered that the receiver was entirely free from ignition noise with the antenna disconnected. By removing all the noise except that which was picked up directly upon the antenna, a marked improvement was made. On most cars in good condition, the spark-plug suppressors could be entirely removed and the one remaining distributor suppressor reduced until there was a very slight, if any, harmful effect on the starting and operation of the car.

The next step was to make improvements in the actual radiation from the ignition systems. The average modern car is fairly well shielded for radio frequencies extending well through the broadcast band, but at higher frequencies the shielding becomes more and more inadequate.

Another factor is the poor bonding or grounding of the motor and body to the frame of the car. Again the high frequencies are the most difficult to control because a bonding lead has a certain amount of inductance, and therefore

the type of motor design used. On this particular make of car, by properly by-passing the primary circuit at the coil and adding a small metallic cover to shield the distributor, all ignition noise is completely removed without the

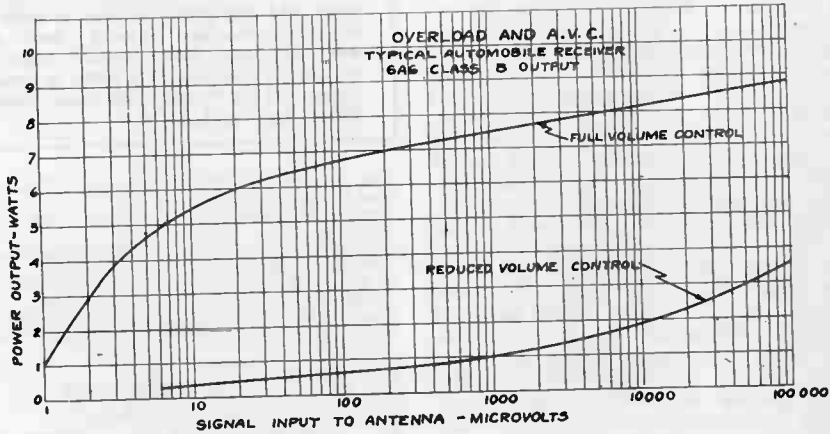

FIG. 11

Overload and automatic volume control curves of a modern automobile receiver.

there is a rise in the voltage between component parts (such as the motor to the frame and the frame to body) as the frequency increases.

addition of either spark-plug or distributor resistance. Thus, this problem of automobile radio performance, once a most serious one, is well on the way to solution.

When these facts were presented to the car manufacturers, most of them seriously attempted to reduce high-tension lead lengths and to keep low-tension wiring and connections for lighting

Fig. 8 shows the circuit diagram of a current model automobile receiver. Graphs of the major performance items of rather typical or experimental receivers are shown in Fig. 7 and Fig. 9 to Fig. 12.

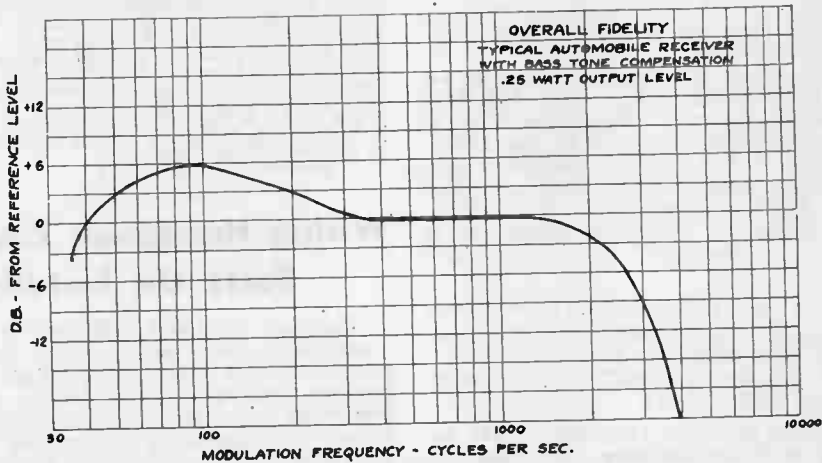

FIG. 12

Overall fidelity curve, typical automobile receiver incorporating bass compensation.

circuits well separated from the high-tension leads. Some ignition manufacturers operate the switch mechanically from the instrument panel to the coil. This removes primary coupling to the wires on the instrument panel, and also diminishes direct radiation to a roof antenna. Another manufacturer has completely shielded the spark-plugs as an indirect consequence of

Fig. 7 shows the noise percentage and sensitivity curves (taken at one watt output) of a developmental receiver designed to match an antenna capacity, including lead-in, of 425 nmfd. The design is open to criticism on the basis that the noise percentage (usable sensitivity) is not uniform over the broadcast band.

(Continued on following page)

(Continued from preceding page)

Fig. 9 shows the selectivity of a modern receiver using flat-topped (critically coupled) high-Q, magnetic-core, intermediate-frequency transformers. The stability of such a design is very good, and optimum performance is obtained without sacrifice of desired high-frequency response. With such a design, tuning is made easier for a given selectivity performance. Fig. 10 shows the image attenuation of a typical automobile receiver. Image rejection problems in automobile radio are not greatly different from those of home radio. Fig. 11 shows the overload and automatic volume control curves of a receiver incorporating a Class B 6A6 output system and delayed automatic volume control. This system offers exceptional output power. This automatic volume control is very good for signals above the delay point, but poor for signals below this level. The undelayed type of circuit is also widely used. It offers poorer performance on strong signals, although better on signals below the delay threshold. Fig. 12 shows the overall fidelity (voltage across the voice coil) of a receiver incorporating bass compensation. This circuit arrangement is commonly used on better grade receivers as a means of obtaining more satisfactory low-frequency response and partial aural compensation.

ACKNOWLEDGMENT

The writer wishes to acknowledge the aid of Messrs. A. A. Leonard, D. S. Bond, J. R. Gelzer, and other members of the Automobile Receiver Section of the RCA Manufacturing Company in the preparation of this paper.

SUPPLEMENTARY REFERENCES

- LLEWELLYN, F. B.: "A Study of Noise in Vacuum Tubes and Attached Circuits," *Proc. I.R.E.* Feb. 1930.
- FARNHAM, PAUL O: "Broadcast Receiver for Use in Automobiles," *Proc. I.R.E.* Feb. 1930.
- BALLANTINE, STUART: "Fluctuation Noise in Radio Receivers," *Proc. I.R.E.* Aug. 1930.
- LLEWELLYN, F. B.: "A Rapid Method of Estimating the Signal-to-Noise Ratio of a High Gain Receiver," *Proc. I.R.E.* March 1931.
- CURTIS, LESLIE, F.: "Electrical Interference in Motor Car Receivers," *Proc. I.R.E.* April 1932.

Reports of joint R.M.A.-S.A.E. Committees—
 "Automobile Radio Standards," *S.A.E. Journal* Nov. 1932, Page 26.
 "Car Antenna Problems," *S.A.E. Journal*, June 1933, Page 12.

Report of the Standards Committee of The Institute of Radio Engineers, 1933, Page 106.

NORRIS R. F.: "Automotive Quieting," *Journal Acoustical Society of America* 8 100 (1936).

TIME FOR NEW STANDARDS

Standards for automobile as well as for home receivers will be considered when the standardization committees of radio and electrical societies meet again. The last standards were dated 1931.

Literature Wanted

Readers whose names and addresses are printed herewith desire trade literature on parts and apparatus for use in radio construction. Readers desiring their names and addresses listed should send their request on postcard or in letter to Literature Editor, Radio World, 145 West Forty-fifth Street, New York, N. Y.

- Geo. T. Branski, 1505 S. 70th St., Milwaukee, Wis.
 Paul Grayson, Gastonia, N. C.
 Godfrey Deuchler, No. 5, Omaha, Neb., on metal locators.
 Robert Gold, Secretary of the Mt. Vernon Radio Club, 574 East Third St., Mt. Vernon, N. Y.
 M. Perez, G. E. Radio Service Station, 1162 State St., Bridgeport, Conn., on test instruments.
 George Batt, 623 Brookline Ave., Brookline, Mass.
 H. Delago, 6125 Broadway, New York City, N. Y., c/o Lotito.
 G. Hayslette, Covington, Va.
 Miss Edna R. Beasley, Ridgway, Colo.
 Mrs. Harry C. Cole, Penn Yan, N. Y.
 Eckert Baillo, Grand Saline, Texas.
 R. E. Hogarth, R. F. D. No. 1, Bellows Falls, Vt.
 Manuel F. Xavier, Puunene, Maui, Hawaii.
 A. B. Chismar, Streator, Ill.
 Wm. A. Thomas, 321 Caroline St., Neenah, Wis.
 M. G. Motsiff, 225 Fayette Blvd., Syracuse, N. Y.—Meters and other test equipment for radio servicing, and particularly building test equipment.
 David Friedman, 4702 12th Ave., Brooklyn, N. Y.
 Henry L. Grant, 1032 Wood St., Norfolk, Va.—on servicing, also set building and experimentations.
 Gordon Rosekilly, 4037 26th St., San Francisco, Calif.
 L. T. Moore, 4039 Washington Ave., Fresno, Calif.
 Norman Nelson, Clifford, N. D.
 James White, Official Radio Repair, 3522 W. 3rd St., Los Angeles, Calif.
 Stanley Schaafl, 4449 N. Damen Ave., Chicago, Ill.
 Lawrence Schafer, 320 Garfield St., McMechen, W. Va.
 Joseph Turek, Jr., 6828 Windsor Ave., Berwyn, Ill.
 Al Zeitzer, 2008 East 3rd St., Brooklyn, N. Y.
 Frank H. Perry, 139 Lily St., Paterson, N. J.
 Wm. F. Hockin, 3622 N. Camac St., Philadelphia, Pa.
 Glen Nye, 1592 Front St., San Diego, Calif.
 Henry Sargent, 108 Hopkins St., Brooklyn, N. Y.
 John Bricker, Mantua, Ohio.
 Sidney Multz, 90 West 27th St., New York, N. Y.
 J. L. Davis, Radio Sales & Service, Basin, Wyo.
 V. M. Moen, Tracy, Minn.
 T. C. Bracken, St. Albans, N. Y.

Wiring Handbook Gives Facts On Installation

"Handbook of Interior Wiring," for sales promotion in radio and electrical fields, has just been issued. Sponsored by Radio Manufacturers Association, the Artistic Lighting Equipment Association, the Edison Electric Institute, the Illuminating Engineering Society, the International Association of Electrical Inspectors, the National Electrical Contractors Association, the National Electrical Manufacturers Association, and the National Electrical Wholesalers Association, the handbook emphasizes proper provision for equipment and operation of radio receivers, including power outlets and also adequate antennas and antenna leads.

Single copies cost \$1.00, obtainable from the Industry Committee on Interior Wiring Design, Room 2650, 420 Lexington Avenue, New York City.

From the Crude Start to Date

By F. E. Wenger

Engineer, Triplett Electrical Instrument Co.

IN analyzing the advance of instrumentation it would be necessary to retrace our steps to the beginning of broadcasting and follow the advance of the radio service art from that period through to the present day.

At the beginning of broadcasting there was no profession known as radio service engineer or radio serviceman. There were only a relatively few manufacturers of completed radios and a number of manufacturers of parts and kits for the building of radios.

It was during this time that a number of us broke into the field. Some have made a great name for themselves by constant study and application to their work, while others have dropped by the wayside.

At the beginning, there being very few broadcasting stations and very few sets, the majority of these sets being home-built and very inefficient, the public who at that time owned radios were satisfied with the results only because of the newness of radio. When one of the sets went bad, the kit builder or the handy man of the community generally came in, tested the A batteries and the B batteries, saw if the tubes lighted, and substituted new tubes for the ones in the set to determine if the trouble was in the tubes.

FAR-SIGHTEDNESS EXHIBITED

At this early time of radio, there were no tube testers nor instruments known as set analyzers. It was necessary when attempting to repair the radio to study one or more of the several radio magazines, to have a knowledge of electricity and also a couple of inexpensive voltmeters.

Along about 1924 some of the more progressive and serious-minded young men who were interested in radio, saw the opportunity to make radio their lifetime profession. There were one or two set manufacturers at this time who also saw the possibility that this profession some day would have a sizable following. These manufacturers either employed their own technician or had consulting technicians who understood

the problems of radio at that time, and endeavored to bring out service equipment which was adequate for the servicing of radio sets at that time.

The first radio equipment comprised a tube checker, which was simply a milliammeter to be plugged into the set socket, the tube being removed from the set and placed in the tube checker, and the current drain read. Oscillator type, also grid shift, was then added to tube checkers so the approximate condition of the tube could be determined. Voltmeters were placed in cases, called set testers, and means were provided so the battery voltages could be tested at the tube sockets or the terminals of the batteries. Thus, the serviceman had to increase his education to interpret the meter readings, as when the voltages were taken at the tube socket, they were not always the true voltages due to the resistances which were in the circuits then in use.

It is distinctly recalled that the circuits were very simple, had extremely low resistance in comparison with the modern radio, and when one looks back, it all seems very simple indeed. However, it offered many problems which the better serviceman soon overcame and was ready for the next advance in radio, which was battery eliminators.

With the advent of battery eliminators, it was found that he no longer could rely upon his early inexpensive voltmeter, as it consumed too much current, and therefore the tester manufacturers supplied a high-resistance voltmeter as a part of the tester which enabled the relatively accurate measurement of voltages from power supplies.

PREMATURE WITH OSCILLATOR

Neutrodynes at this time were very popular and some means for neutralizing the set must be had. Therefore, the oscillator was designed, although it never became very popular because the serviceman did not want to learn all the possibilities and use of an oscillator. It was simply a case of the test instrument manufacturers being a number of years ahead of the serviceman, as oscillators did not find their greatest use until the advent of superheterodynes.

Shortly after the eliminators were added to radios came the A power pack, which offered no great problems of equipment, as the serviceman could use what they already had. Immediately after this came the first a-c radios, which offered innumerable problems and caused the redesign of test equipment. Up to this time there was little change in the design of test equipment, as it was a matter of simply progressing along, keeping pace with the industry and growing better with each succeeding year. It might be stated that the serviceman was also keeping pace with the industry and was learning new uses for his test equipment.

Screen-grid tubes followed upon the heels of the a-c radio and this offered no great service problem. However, the superheterodyne was made popular immediately after the advent of the screen grid tubes and the world became superheterodyne-conscious. This was a startling

(Continued on following page)



F. E. WENGER

(Continued from preceding page)

change, as it caused the serviceman to dig deeper into his book of knowledge so he could better understand the superheterodyne principle of reception, and therefore do a better job of servicing. Test equipment manufacturers kept pace and designed equipment so the servicemen could service the radio sets to the best advantage.

About this time the better test equipment manufacturer started to anticipate the design of radio and in doing this also anticipated the needs of the radio serviceman so when the new circuits were announced, the test equipment was ready then to take care of the new developments in circuits and parts.

This brings us more or less into the semi-modern development of test equipment. Considerable research was spent, and out of the research laboratories came the power output tube checker.

THE TUBE CHECKER

The history of the power output tube checker is interesting. Just a brief description will be given. In the early days of radio, test equipment engineers, as well as servicemen, noted that the best test of a radio tube was that of the tube in actual operation in the receiver. With this thought in mind test equipment designers asked, why not build a tube tester that works on the principle of a radio set? If the same thought had occurred ten years previously, it would have been very simple, as the tubes at that time were simple in construction. Tubes and parts became more complicated as to type, design, etc. However, the engineers attacked this problem and the first power output tester was evolved.

This power output tester provided for inserting a tube in a socket and means to provide the normal voltages, which the tube would receive in receiver operating conditions. This tube tester also had incorporated a radio-frequency audio-modulated oscillator. The oscillator signal was fed into the grid of the tube and resulted in change of the plate current. Also, the audio voltage was measured from the plate of the tube. This type of tester remained in the experimental laboratory for some time and was found to be the answer to the ideal tube tester. However, the cost was rather high and the operation rather clumsy. Further experiments showed that the same results could be achieved if the oscillator were dispensed with and 60-cycle a-c fed to the grid of the tube. This type of tester was then given the acid test and was further refined in the laboratory.

The outgrowth of this was the new Power Output Tube Tester whereby the pulsations of rectified 60-cycle current is used to drive the grid of the tube and the audio output voltage measured as before. This tester had been improved in the laboratory to simplify and bring the operation in line with other testers. The cost of manufacture was also brought to a minimum so every serviceman could afford this last word in tube testers.

Briefly speaking, the fundamental principle of a power output tube tester is provision of means for applying the proper voltages to the various elements of the tube under test and also

means for superimposing an a-c voltage on the d-c grid voltage of the grid of the tube and measuring the resultant amplification of the a-c or pulsating voltage in the output of the plate circuit. Those who are familiar with radio will immediately see that this is what takes place in the radio receiver, and a tube tester which gives this kind of a test will give the answer to the tube tester problems. Such a tester is the Triplett Model 1502.

For diode tubes this tester also provides means for measuring the emission of the diode or rectifying characteristics of the tube, which is the final answer for this type of service.

SET TESTERS HIGHLY IMPROVED

Today set testers are much improved over the earlier models. The voltage and milliampere ranges are much extended. It was found for the modern radio that while the set tester and the volt-ohm-milliammeter gave a reliable indication of the condition of a set, the inquiring engineer and progressive serviceman had so advanced in his technique that he wanted to know exactly what was taking place in each stage of the radio, as well as to measure the voltage drop across extremely high resistances. For this purpose the vacuum-tube voltmeter was designed. It will be described later on in this treatise as there is considerable tie-up with the modern servicing between the vacuum-tube voltmeter and the r-f oscillator as it is manufactured today.

Keeping in advance of such design, the test instrument manufacturers continued to improve their oscillators, covering greater frequencies and giving better shielding so the signal was always under the control of the operator, and so the operator could apply to the radio set being tested only that signal which is required.

Now begins a new phase in radio servicing, one which will be almost imperative to apply in the servicing of television sets, the use of the vacuum-tube voltmeter in conjunction with the r-f oscillator.

A vacuum-tube voltmeter is an instrument which is extremely sensitive and offers an infinitely high input impedance so there will be no voltage drop across any of the circuits being measured, due to the circuit upset of the vacuum tube voltmeter when measuring from various stages.

GAIN-PER-STAGE METHOD

We are primarily interested in what takes place in each stage of a radio. I do not believe it advisable to go into a lengthy description of the use of an oscillator, as every radio serviceman knows many of its uses. What is generally considered in the use of the oscillator is that it will furnish a reliable and predetermined signal of the frequency desired to the radio set either for alignment purposes or for purposes of studying the action of the different r-f stages. It is not the scope of this article to go into the phases of the alignment of various radios as this is covered in the many servicing instructions made available to every serviceman.

Substituting an oscillator for the broadcasting station signal gives a definite control over the signal entering the radio.

Provided with a definite means of controlling the signal from the oscillator, we use the vacuum-tube voltmeter conjunctively as a means of measuring the actual gain per stage of the radio set at any frequency desired. Thus by placing the vacuum-tube voltmeter across the output of the first r-f stage the actual output of this r-f stage can be measured. By placing the vacuum-tube voltmeter across the second r-f stage likewise, the gain of the two stages can be measured. By placing the vacuum-tube voltmeter across the output of the oscillator circuit of the radio set, the output voltage of the radio set oscillator is known. By placing the vacuum-tube voltmeter across the first i-f output, we again have the gain of this stage. So it follows that the vacuum-tube voltmeter when placed across any stage of the set, measures the a-c voltage of that stage or any gain between stages, of radio frequency or any other externally-applied frequency. By judicious placing of the oscillator with respect to any given stage, and by a corresponding measuring of the output voltage of the stage, or series of stages, one can readily analyze the receiver for its true amplifying conditions in respect to voltage input and output. Also, the vacuum-tube voltmeter may be used for the measurement of a-v-c voltages, as any other means of measuring this part of the radio circuit does not give the true value. The vacuum-tube voltmeter is the best method for aligning discriminator circuits for a-f-c. It is very easy to align these with a vacuum-tube voltmeter to a null indication. A vacuum-tube voltmeter may be used to measure any superimposed a-c hum on any d-c voltage or any other superimposed a-c voltage on any d-c voltage and many other uses.

CASE OF RAY TUBE

There has been considerable interest in the past few years in cathode-ray oscilloscopy, which has increased from year to year. The test manufacturers are today producing oscilloscopes with their associated equipment which are superior to those of the earlier days.

The oscilloscope, however, is not the final piece of equipment in the hands of the serviceman. It should be used only in conjunction with the pieces of equipment which up to this time have been found necessary in the service shop. The best and most reliable service a cathode-ray oscilloscope performs is that of giving the serviceman a visual picture of what takes place within the radio. However, those who desire to purchase this type of equipment must make up their minds that they have to spend considerable time and effort in studying and mastering the use of such equipment. It is very necessary that a good oscillator and wobulator should become an adjunct in the hands of the serviceman to get full use of his oscilloscope when analyzing r-f circuits. The writer's greatest complaint in the use of the oscilloscope in the past has been there has not been enough effort expended to learn its proper operation, and the serviceman fails to receive all the advantages which this type of equipment has to offer. In a number of instances, the oscilloscope may be substituted for other equipment. However, it



RADIO SERVICING SHORT-CUTS and Money Making Ideas

A completely new and different book tells how radios may be repaired quickly with the absolute minimum of test equipment. Proves that by an actual test 9 out of 10 radios can be fixed with simple tools and volt ohmmeter. The author, M. N. Beitman, for years in the servicing profession, realized and kept data on these facts. Page after page of practical information. Many real money-making ideas and hints applicable to all sets.

Principles of

PUBLIC ADDRESS SYSTEMS

The only practical handbook on P. A. Covers in detail everything about Sound, from various microphones to loudspeaker placement. Many examples and circuit diagrams.

MATHEMATICS OF RADIO SERVICING

Introduces and explains the use of arithmetic and elementary algebra in connection with problems found in radio servicing. Numerous examples taken from actual radio cases. Plainly written and easy to understand. Size: 8½ x 11 in.

PRICE 50c EACH

SUPREME PUBLICATIONS

3727 West 13th St., Chicago, Illinois

finds its best use in the study of wave form and in the alignment of i-f transformers, study of vibrators, rectifiers, etc.

For the average serviceman's test equipment an ohmmeter which is sufficient to measure the resistance of all resistors in the modern radio is advisable. Also, he should be equipped with a good condenser tester, such as Triplett 1241. This is most essential.

A WORD ABOUT FUTURE

Now a word for the future of radio servicing. In the writer's estimation radio servicing holds a great future only for those who wish diligently to apply themselves to their work to learn to use their test equipment in the most efficient manner, and who keep pace with the radio profession. Not only to keep pace, but devote at least one to two hours every day to the study of some particular problem with which he is constantly confronted. It is only by keeping abreast of his problems that the radio serviceman can continue to advance and hold forth in the field in which he is servicing. Without proper equipment the radio serviceman is lost. Without knowledge in the use of his equipment the radio serviceman cannot progress. The two go hand in hand. Placing them in their proper order, the writer concludes that knowledge and ability to apply this knowledge to his everyday problems are the essentials of success.

Instrument Needs Of Servicemen

By Samuel C. Milbourne

Service Engineer, Supreme Instruments
Corporation, Greenwood, Miss.

THE radio service industry continues to have "growing pains." Many such symptoms are reflected in the efforts of individuals and groups of servicemen to elevate the service industry to its rightful place and to educate the serviceman away from "tinkering" and toward a professional outlook.

There is an old saying, "A laborer is only as worthy as his tools."

This truism applies doubly to the serviceman. Compare, for an instant, the relative abilities of a "screwdriver mechanic" and a completely-equipped serviceman. The one works by "rule of thumb" and from the results obtained, he very often must be all thumbs. The second man, properly fitted to handle the job, accomplishes it rapidly, efficiently and economically with complete satisfaction to the customer.

What are the "tools" of a radio serviceman? Taken in a broad sense, they embrace all the interlacing factors entering into the man personally, his attitude toward his customers and his customers' attitude toward him. In a more limited sense, they embrace the man's education, experience, technical ability, sales ability, and the mechanical or electrical devices he uses to perform his duties.

WHEN EDUCATION JUST BEGINS

No serviceman can consider that his education is completed when he is graduated from a technical school or snaps closed the cover of his text book on the last lesson of a correspondence course. Decidedly, no! His education has just begun. He should spend at least a half-hour daily studying under some *previously planned* system. By this we mean that idle turning of the pages of current radio magazines should not constitute "study."

There are hundreds of good articles published yearly in these magazines, but they should be studied and digested, not superficially skimmed over.

A serviceman's education should include the ownership and understanding of an ever-increasing library of technical books. He should join at least one servicemen's organization. He should have a complete set of Service Manuals to enable him properly to service sets as well as a supplementary file of information on sets.

Experience, technical ability and sales ability are the children of "Time." No one can get them from a course of study. The experienced serviceman knows that a great deal of his technical ability is due to the type of instruments or "tools" he uses and this logically

brings us to the question, "What test instruments are necessary to Modern Servicemen?" Well, that depends on whether you intend to do a part-time or full-time job. It depends upon how much you desire to pay for your equipment. It also depends upon the amount of use to which you place these instruments, that is, whether they will earn money for you and pay for their "keep."

INSTRUMENTS TABULATED

However, we can give a list of testing instruments necessary to the proper operation of a modern service laboratory in the order of their importance:

- (1) Multimeter or analyzer
- (2) Tube checker
- (3) Signal generator
- (4) Cathode-ray oscilloscope
- (5) Resistor and capacitor decade box
- (6) Other specialized pieces of semi-laboratory equipment.

Many servicemen prefer to make only point-to-point tests, centering their probings on a-c and d-c voltages and resistances in the set. For this purpose, a Multimeter such as the Supreme Model 590 or Model 490 is ideal.

An even larger percentage of servicemen has consistently adhered to the Free Reference Point System of Analysis, which, in Supreme testers, allows the measurements of any voltage, current or resistance appearing in or between any two elements of a radio receiver's tube sockets. This is accomplished by means of an analyzer cable terminating in a plug which is inserted in the radio receiver socket under test (in place of the tube), the tube being inserted in the proper socket on the tester panel at which the other end of the cable terminates. Twin jacks are included in each cable circuit so that by measuring between any two twin jacks, potential or resistance may be ascertained. By inserting the test prods in both jacks of any one twin jack, the internal circuit across that twin jack is broken and any device such as a milliammeter may be introduced in series with that particular circuit for current measurements.

TUBE TESTERS AND COMBINATIONS

Turning our attention to tube testers, we should first state the difficulties besetting the design of a satisfactory tube tester. Such a tester should be designed to (1) reduce obsolescence probabilities to a minimum, (2) provide utmost flexibility, (3) test all tubes without adapters, (4) test all tubes at rated loads.

After a radio tube is placed in use, its service life will be limited by one of two factors: (1) loss of emission or (2) inter-element leakages. The "quality" test should be designed to indicate the extent of loss of emission of any tube, and the "leakage" test should be intended to reveal the presence of any objectionable inter-element leakages. Of course, the tube tester should contain an English-reading tube scale and some method of indicating the percentage of full-scale deflection for closer comparison between tube of similar types. It should have adjustment for variations in power supply, a

full sized neon lamp for tube leakages, separate tests of diodes, individual elements tests of all multi-element and multi-purpose tubes and separate plate tests of all full-wave rectifiers and detectors. One 8-hole socket should be used to test all octal tubes regardless of filament connections by means of a "floating" filament selector so that the filament can terminate at *any two elements!*

A tester such as this is pictured in Fig. 7.

Many times it is advantageous for the serviceman to combine in one unit, a tube tester and a multimeter. This is particularly helpful when making a preliminary check-up in the customers' home.

An exclusive Supreme development—Uni-construction—is incorporated in the Model 585, being the design of a number of component instruments into one compact unit. By utilizing "uni-construction" the serviceman has everything in one compact unit and actually pays less for it because of the saving in combining several units.

SIGNAL GENERATOR REQUIREMENTS

Next, let us consider signal generators. Modern signal generator design dictates that the signal generator's frequency range should include all frequencies from 125 kc to 60 mc. It should have a full-vision direct reading airplane type dial calibrated from 125 kc to 60 mc. At least the first five bands should be at fundamentals, covering frequencies which lie between 125 kc to 15 mc; and the remaining two bands should be harmonic relations of the fifth band. An electron-coupled oscillator circuit should be used, the generated frequency of which is practically independent of moderate variations in supply voltages. It should have a self-contained modulator stage which modulates the carrier 30% at 400 cycles.

The method used in coupling the modulator stage to the radio-frequency operating stage should reduce the total "wobble" in the carrier to a very minute percentage of the carrier frequency. It should be so arranged that the carrier may be externally modulated at any frequency from 20 to 10,000 cycles with a minimum of distortion. Attenuator should be of the ladder type, consisting of variable control and multipliers. The two controls should be graduated for use in gauging approximate microvolt output of generator. Provisions should be incorporated for obtaining either modulated or unmodulated r-f output and two pin jacks should make available the 400 cycle audio output of the modulator stage for audio test purposes where a sinusoidal wave is desired.

The signal generator should also be suitable for use with cathode-ray equipment for visual alignment procedure. It should have either an internal frequency modulator, modulating a grid in the radio-frequency generating stage tube, or should have some means of introducing external frequency modulation.

CATHODE RAY OSCILLOSCOPES

Two signal generators are shown. The first requires external frequency modulation, whereas the second includes a means of internal fre-

quency modulation as well as a 0 to 10,000 cycle audio beat frequency oscillator for audio measurements.

No serviceman can consider his shop to be up-to-date in equipment unless he possesses a cathode-ray oscilloscope. Every serviceman who possesses, at present, a good tube tester, analyzer or multimeter, and a signal generator which may be frequency modulated, should bend every effort toward the purchase of a cathode-ray oscilloscope.

There are four general classifications of cathode-ray tubes according to size. (1", 2", 3" and 5").

The 5" tube, while it produces a large picture, requires rather high operating potentials. Probably service oscilloscopes of the future may use five inch tubes, but the present trend is towards small tubes.

As soon as the 1" cathode-ray tube was announced, many manufacturers of radio testing equipment immediately offered oscilloscopes using this tube, without questioning whether the tube was actually suitable for service work. Our engineering department took the stand, after considerable research, that the 1" tube was not desirable from the viewpoint of service work. As a result, Supreme oscilloscopes incorporate a 2" tube which has a screen area actually four times larger than a 1" tube and a diameter two-thirds that of the 3" tube.

The Model 545 oscilloscope employs a 3" tube as does the Model 555 while a new frequency modulator unit (Model 529) is used in conjunction with the average signal generator and cathode-ray equipment for alignment purposes.

There are two models of the 2" oscilloscopes (Model 530 and 535). The portability of such compact units enables servicemen to take these instruments into the customers' homes and there they may be used as powerful sales helps in convincing the customers of their need for a complete visual alignment for their radio.

DECADE BOX

Just a word about the uses to which a serviceman can place a good capacity-resistor decade box. Such a unit can be used as a substitute for a resistor or capacitor which has become defective and the original value of which is unknown. By inserting the decade or capacitor box in the circuit and adjusting to proper circuit performance, the equivalent value of the unknown part can be directly read from the dials.

TEST EQUIPMENT—A GOOD INVESTMENT

In the foregoing article, we have attempted to bring you the story of good testing instruments.

They are yours to help you (1) speed up your work, (2) make it more accurate and (3) return profits to you.

Remember—it will not be long before television receiving sets will need servicing. New designs and new circuits in voice broadcasting are making it an increasingly difficult job for the "tinkerer" and the "screwdriver mechanic" to stay in the radio business.

Invest in test instruments. There is no better way to insure service profits for you.

NEW PRODUCTS

Hammarlund Announces Iron-Core Transformers

A new group of iron-core i-f transformers is announced by the Hammarlund Manufacturing Company, Inc., 424 West 33d St., New York City.

These new transformers provide extremely high gain per stage, together with extremely sharp selectivity. Specially developed, finely powdered high permeability magnesium alloy, rust proof and non-corrosive, is used for the core. This core affords a great increase in inductance, thus permitting a reduction in the number of winding turns and consequently greatly reducing eddy current losses.

These transformers may be used with all tubes normally present in i-f amplifiers. A single stage amplifier employing iron-core transformers will usually provide as great a sensitivity and selectivity as two stages employing ordinary type of transformers. An added advantage is that since one fewer i-f stage may be used, tube noises are greatly reduced.

Since the gain of these transformers is so high, special precautions must be taken when using them in two-stage amplifiers. Therefore, five types are being made for single-stage and two-stage amplifier types. Their overall size is only $4\frac{1}{8}$ inches high by $1\frac{3}{4}$ inches square. They are all tuned to 465 kc.

Details of the five types of these transformers are contained in the new Hammarlund catalog available free of charge. Address Dept. RW of the company at the above address.

C-D Offers Pocket Size Mica Capacity Chart

A convenient chart, of vest pocket size, illustrating the standard R.M.A. mica capacity color code, has been made available by the Cornell-Dubilier Corporation. The extreme compactness of the modern mica capacitor has necessitated the substitution of a color code for the usual numeral capacity identification. This chart, therefore, will be found of exceptional value by the serviceman, engineer and amateur. The chart is obtainable from jobbers at no charge.

TUBES LAST LONGER

Recent tests show that tube life is now longer than it ever was.

Radolek I-O Device Works Up to 5 Stations

The new selective Inter-Office Communication system marketed by The Radolek Co., 601 West Randolph Street, Chicago, Dept. RW, is said to be essential in every business, factory, large home, and institution. A push of the button permits instant, automatic, direct communication between any stations with excellent volume and clarity. The device coordinates the activities of any large business or other institution, eliminates extra steps and waste of time. It may be employed between offices and other rooms for instant selective two-way conversation, for paging individuals, for announcements, etc.

Up to five outlying stations may be used with the master unit. When the desired outlying station is selected on the selector of the master

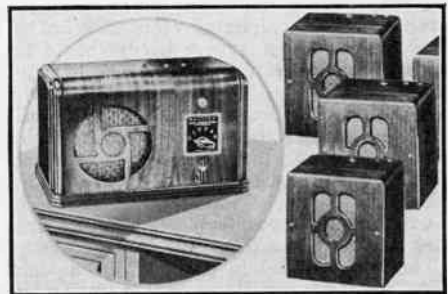

Views of the Radolek Master and Station Devices for Inter-Office Communication.

station, you merely push the button to talk and release to listen. Outlying stations calling to the master station must press a button until identified, after that both sides of the conversation are controlled at the master station.

A free illustrated booklet describing this and other communication systems is obtainable by addressing the company, Dept. RW, at the above address.

New Servicing Book

Supreme Publications announce a new radio publication, "Radio Servicing Short-Cuts and Money Making Ideas," priced at 50c. The book points out that many radio jobs can be successfully handled with simple tools and no test equipment. Proper testing procedure is explained. The author, M. N. Beitman, has been in the servicing profession for years and has kept careful data on important service shortcuts. There are money-making ideas.

Radolek's De Luxe Amplifier 60 Watts



A newly-developed giant amplifier has been recently placed on the market by the Radolek Company, 601 West Randolph St., Chicago, Ill. Using the new beam power tubes, the amplifier is capable of delivering 60 watts. The novel circuit uses the latest tubes for higher fidelity. Five inputs are provided, with volume controls for mixing and blending. There is also a master control and a variable tone control. The output meter shows the operating conditions at a glance. All connections are made by means of handy plug-in sockets, eliminating all possibilities of errors.

This is a quality amplifier, especially made for stadiums, race tracks and other large installations. It will easily cover an area of 65,000 square feet or serve 25,000 persons. Complete descriptive circular available free by addressing the company, Dept. RW.

Wholesale Radio Has New Ham—S. W. Catalogue

Western Electric transmitting tubes and apparatus for the amateur and experimenter are listed in Amateur and Short-Wave Catalog No. 66, just released by Wholesale Radio Service Company, Inc., of 100 Sixth Ave., New York City. This is as a result of their appointment as authorized sales agents by Graybar.

"This noteworthy addition to our already extensive representation of leading radio manufacturers, places Wholesale Radio's new Amateur Catalog in the position as the most complete short-wave buying guide available today," the publicity division of W.R.S. set forth.

A free copy may be obtained by personally visiting, phoning or writing any of their branches at 100 Sixth Avenue, New York City; 542 E. Fordham Road, Bronx, New York City; 90-08 166th Street, Jamaica, Long Island, N. Y. City; 901 W. Jackson Blvd., Chicago, Ill., 430 W. Peachtree Street, N.W., Atlanta, Ga., or 219 Central Avenue, Newark, N. J.



Ohmite Line Chokes Reduce Interference

A power line choke of unusual effectiveness is announced as a new product of the Ohmite Manufacturing Company, Dep't RW, 4835 Flournoy St., Chicago, Ill., makers of rheostats and resistors.

These chokes were primarily designed for use on amateur radio transmitters, to prevent the interference which they may cause to owners of radio receiving sets in their immediate neighborhood, insofar as such interference may be fed back out over power lines.

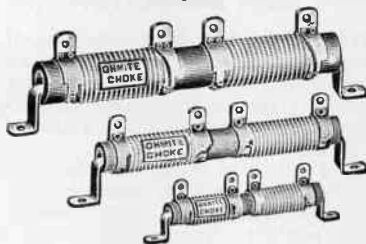

The physical units.

One of these chokes, however, is also specifically designed to be used on radio receivers, to prevent interference of radio frequency from coming into such sets over house lines and power lines, from sources nearby.

These power line chokes will not prevent interference of audio frequency and they are not recommended for that purpose. However, the choke mentioned in the above paragraph as being suitable for use on radio receivers will suppress the radio frequency component of many miscellaneous sources of noise coming into a radio receiver over the house line, in addition to preventing interference coming in over the line from recognized sources as *high-frequency* currents—such as radio transmitters, therapeutic machines, welding machines and similar apparatus.

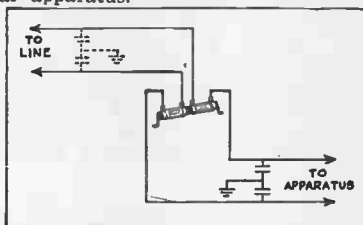

The electrical circuit.

The chokes must in all cases be used in connection with grounding condensers, as shown on the diagram, to form a filter. These bypass condensers are each 0.1 mfd. Their best location is determined by trial. Three sizes of these line chokes are now available, capable of handling currents of 5, 10 and 20 amperes, respectively. The smallest is designed to be also used on receivers. In devices where currents greater than 20 amperes are used special units are made up to order to fit the special requirements of each case.

(Continued from preceding page)
can have a sine-wave output, particularly easy in the case of the beat-note oscillator.

* * *

CAPACITY RELAY HOUSING

YOU published an article on the construction of a capacity relay, in the May issue. Will you please show the front panel and cabinet?—L. W. F.

The photograph of the housing and front panel is reproduced herewith.

* * *

FREQUENCY MODULATION

WILL you state what is the purpose of a frequency modulator in conjunction with a cathode-ray oscilloscope, and whether this modulator is the same as a wobbler?—W. D. C.

The frequency modulator is also called a wobbler and its purpose is to introduce a predetermined change of frequency in a radio-frequency generator, so that instead of generator output being of a single frequency it is of a band of frequencies. This band width may be fixed, say, at 30 kc, or is preferably variable,

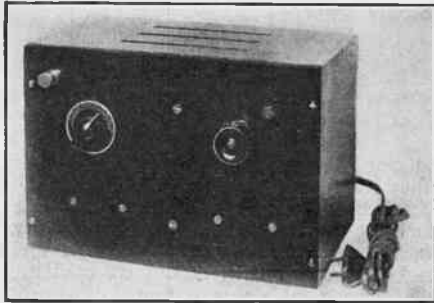

This is the outside view of the capacity relay.

say, from practically zero to 30 kc or more. Both methods are used in commercial equipment. Suppose that a superheterodyne has an intermediate amplifier at 455 kc and is supposed to be adjusted so that a band of frequencies 20 kc wide is passed, instead of the channel being made as sharp as possible (peaked). The quickest and most reliable way to align the channel would be to adjust it in the usual way for 455 kc, with the signal generator at this frequency, connect the wobbler to the r-f generator, and inject the new r-f oscillator output into the i-f channel, and the output of that channel (second detector) through a large stopping condenser (1 mfd., paper dielectric) to one set of plates of a cathode-ray tube. The sweep oscillator would be connected to the other set of plates (usually the pair creating horizontal movement). The r-f generator may have to be readjusted a little so that the resultant trace, or selectivity curve, has its crest neat half way between the skirts of the viewed selectivity curve. The frequency band width is adjusted to 20 kc on the wobbler, this being the total band to be viewed, half or 10 kc being from center to one extreme and

other half from center to other extreme. The condensers on the i-f coils are then readjusted, or the coupling, or both, depending on the type of coils and the set manufacturers' instructions, until a flat-topped trace appears.

* * *

SUPER-REGENERATION PROBLEM

IS it possible to introduce super-regeneration at low radio frequencies, if so, what is the limit?—L. D.

Usually super-regeneration is reserved for high radio frequencies, and is particularly effective at frequencies so high that ordinary regeneration fails, or produces negligible results. Thus we have many 5-meter super-regenerative receivers. However, the radio frequencies may be much lower, or wave lengths much higher. It is entirely practical to encompass the standard broadcast band with super-regeneration. The tuning is broad, you understand, but there is a great deal more pep than by utilizing normal regeneration. Just how low in the radio-frequency spectrum one may go has not been definitely established. Since super-regeneration introduces two frequencies of oscillation, one in the receiving range, the other much lower, one limit is due to the fact that the auxiliary frequency soon would be in the audio region and might be so objectionably loud as to drown out much of the intelligence desired to be received.

* * *

HIGH INDUCTANCE READINGS

IN the measurement of high inductances, suppose that a center-tapped winding is being measured, and that the reading between tap and one extreme is 85 henries (no external load), and about the same reading obtains between the center tap and the other extreme, is it correct to find that the total inductance across the two extremes reads greatly in excess of the sum of the other two readings?—I. R. C.

Yes. The inductance of the full winding is not twice that of half the winding. Purely theoretical considerations would call for the total inductance being four times that of half the number of turns. However, other factors enter, and in practice the full winding may be expected to read around five times the reading for half the winding, so a reading somewhere around 400 henries would not ordinarily be much amiss.

* * *

DETECTORS COMPARED

COMPARING the various type of quality detectors, do you think that the proponents of various special types of detectors make such a bad case against the diode, which has been recognized right along as the quality detector?—W. W.

No, we think they point out the diode virtues and limitations, and then discuss detectors that offer other contributions, and perhaps also other difficulties. The diode is very good, and most welcome. It does load the circuit, which may be serious in single-stage i-f amplifiers, but scarce-

ly can be called that in two-tube i-f amplifiers, where it may serve even as a stabilizing agency. It does fail to respond distortionlessly to deep modulation. But, in all, it is far better than the detectors it replaced, and it permits ready a.v.c. The diode in dual form, with connections reversed, has the tonal and other advantages of diodes generally, plus better sensitivity. This is known as the LaFrance circuit. It has the same general characteristics as a diode, with more sensitivity, but is subject to being temporarily paralyzed by an overstrong signal. The infinite impedance diode, which is a triode with the characteristics of a diode, does not load the circuit, as it presents a pure capacitative reactance at the input, will respond well to 100 per cent modulation, if resistors are properly chosen, but permits no ready a.v.c.

SOLDERING TO THE CHASSIS

IS it all right to solder to the chassis? This is a handy way to make common returns, if permissible.—L. S. B.

It is in general not good practice to solder to the chassis, but if only the broadcast band is being covered by the tuner, then it might be passable. First it is necessary to remove all trace of plating from the chassis; second, it is required that a goodly amount of solder flux be applied to the place where the joint is to be made; third, the iron has to be of the type that yields all-sufficient heat, 100 watts up. The final test is that after the joint has been made it should not be possible to disturb it by normal

pressure, nor to lift off the solder from the chassis in one operation with a chisel. Otherwise the intended joint is often very deceptive, being more of a high resistance than a conductance.

* * *

DIAL CALIBRATION

WILL you please give me some assistance in the calibration of a dial? Is it better to put a piece of stiff cardboard on the condenser shaft, and then mark down the settings for various frequencies, or would you prefer using the protractor directly.—L. M. C.

It is much betted to use the protractor directly. This may be an improvised rotary protractor, as illustrated, which is transparent, so that a fine black line on the cardboard held by bracket beneath the scale serves as indicator. When numerous well-distributed points are registered, a curve is drawn on cross-section paper, and frequencies in given separations are ascertained, e.g. bars 10 kc, or 50 kc apart, etc., depending on the band and also on the frequency ratio of tuning.

THERE YOU ARE, WHERE ARE WE?

YOUR magazine is always around the radio shack here but just as soon as we have a visitor he wants to "borrow yer RADIO WORLD"—so ya' see where I am for that issue.

H. J. WEIXLER,
RM3C, U.S.S. Barry (248),
San Diego, Calif

The protraction of frequencies and dial settings, so that a new scale could be made that would be direct-reading in frequencies, was accomplished by affixing the protractor to the condenser shaft. This necessitated piercing the protractor so that it is held by a metal disc behind it, which disc had a bushing for receiving the condenser shaft. The arrangement was direct drive. The indexing was accomplished below.

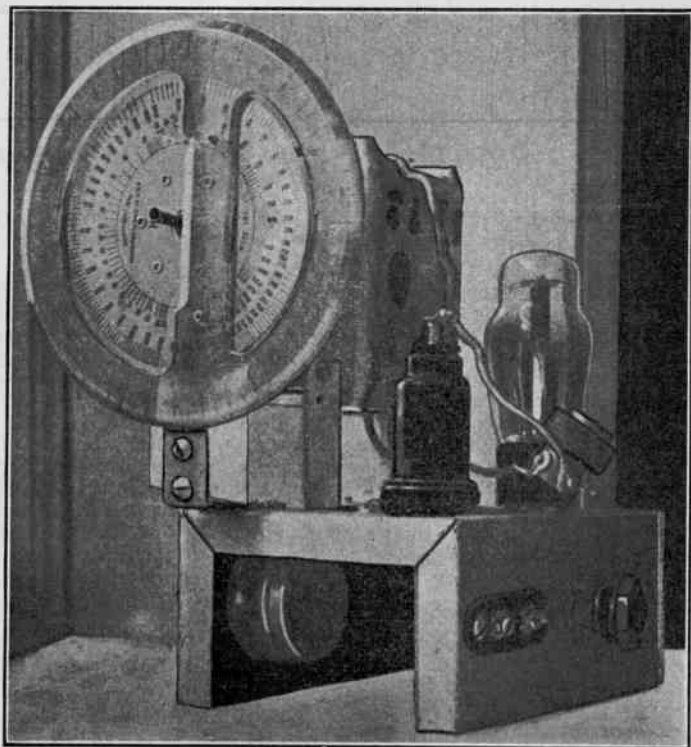

Ohm's Law Applied to D.C.

How to Put Decimal Point in Right Place

By Bradley Argus

AN exposition of Ohm's law was printed in last month's issue, so more examples will be given this month. The basis of Ohm's law is the relation of current (I), voltage (E) and resistance (R). The three forms of the same equation are:

$$I = \frac{E}{R} \quad (\text{also written } I = E \div R)$$

$$E = IR \quad (\text{same as } E = RI)$$

$$R = \frac{E}{I} \quad (\text{also written } R = E \div I).$$

Ohm's law is the most important equation and must be well understood by anyone intending

given in unit values (amperes, volts and ohms) our first example gives units of volts all right (3.5 volts), but the current is less than one ampere, and we must find out what to do about that. That is, "unit" means a whole number, with or without fraction additional, whereas we are now dealing with a fraction only. The fraction is expressed in decimal, i. e., in milliamperes, which we should remember are thousandths of an ampere. Since fractions must be expressed in terms of units, i. e., decimal parts of an ampere, volt or ohm, here we need only find where to put the decimal point ahead of the 26. If there are 1,000 milliamperes in an ampere, then one milliampere is one one-thousandth of an ampere, and so we write down tentatively the decimal expression for one one-

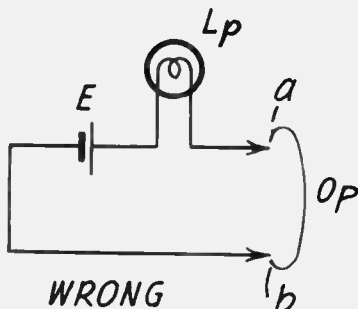
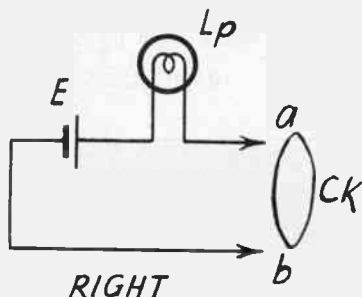

Lamp as continuity tester practically always requires a low-resistance circuit (CK) and is indelicate on an open (OP).

to service radio receivers and transmitters. It deals with the basic element, resistance, that arises in d-c considerations, and relates this element to current and voltage. The two other elements, and these arise in alternating-current considerations, are capacity and inductance.

Voltage and current are common to all three elements, therefore Ohm's law is the password to an understanding of d-c applications, and also it applies in only slightly changed form to a-c as well. For instance, in a-c applications impedance (Z) replaces resistance (R), the other factors unchanged, but only where the wave is of the pure or sine type.

EXAMPLES GIVEN

Since Ohm's law is so richly important, two examples will be given of each of the foregoing tabulated three forms of the equation.

The voltage is 3.5 volts, the current is 26 milliamperes. What is the resistance?

At once we find that, though the formula is

thousandth, which is .001. But since there are 26 milliamperes instead of just one, we replace the 1 with 26, putting the 6 where the 1 was, and get .026 ampere as the same current value as 26 milliamperes, though given in amperes, as required.

Now we have the two unknowns in proper form, the first (volts) as a gift, the second (milliamperes) as a conversion to decimal value of the fundamental unit (ampere). Remembering it is the resistance we are to find, we apply the formula and divide the voltage by the current.

$$R = \frac{3.5}{0.026} = \frac{350}{26} = 134.6 \text{ ohms}$$

SOLVING FOR VOLTAGE

The voltage is 336 volts, the current is 168 milliamperes, what is the resistance?

We now have

$$R = \frac{336}{.168} = \frac{336,000}{168} = 2,000 \text{ ohms}$$

The current is 3/5 ampere, the resistance is 72 ohms, what is the voltage?

The only new feature is that the current is expressed as a numerical fraction. This should be reduced to a decimal. Since one fifth equals two tenths, written .2, three fifths are .6, the way we write down the current in amperes. So

$$E = .6 \times 72 = 43.2 \text{ ohms}$$

The current is 2.4 amperes, the resistance is 5 ohms, what is the voltage?

$$E = 2.4 \times 5 = 12 \text{ volts}$$

The voltage is 16 volts, the current is 3.3 amperes. What is the resistance?

$$R = \frac{16}{3.3} = \frac{160}{33} = 4.848 \text{ ohms}$$

The voltage is 196 millivolts, the current is 49 microamperes. What is the resistance?

Here we find millivolts, which are thousandths of a volt, expressible for one millivolt as .001 volt, so 196 millivolts are .196 volt. Also current is in microamperes. One microampere being one one-millionths of an ampere, or .000001, then 49 microamperes would be written in amperes as .000049. Hence

$$R = \frac{.196}{.000049} = \frac{196,000}{49} = 4,000 \text{ ohms.}$$

We have therefore learned the three forms of Ohm's law, applied this knowledge to a total of six examples, two for each form, and learned to convert fractional or decimal parts of units so that the forms could be properly applied. The answers always are in amperes, volts and ohms, either as units, as we found in the six cases, or in decimal fractions of units. An example where the unknown is less than one follows:

The voltage is 1.28 volts and the current is 32 amperes. What is the resistance?

$$R = \frac{1.28}{32} = .04 \text{ ohm.}$$

Pure Resistance Is Hard to Find

Resistance is opposition offered to current flow, and when the opposition is great the resistance is high. But there are purposes where it is desired that the resistance shall be so high that it is almost impossible to attain such a high value, almost infinite. For instance, at radio frequencies, especially high ones (i.e., on short waves), every aspect of leakage is critically examined and all efforts are concentrated on keeping the leakage very low, or leakage resistance very high. In that direction various compounds have been experimented with, and some have been found to be so superior that their use is practically orthodox in well-engineered circuits.

It is therefore apparent that a resistance is

a conductor at all times, and the object in such a case as the one outlined is to have it do just as little conducting and as much resisting as possible. Since resistance and conductance are in opposite directions, one is said to be the reciprocal of the other, i.e., if R is the resistance and G is the conductance, then $G=1 \div R$ or $R=1 \div G$.

Resistance as such is non-reactive, i.e., has the same opposing effect at all frequencies. But then the resistance must be nothing but resistance. If there is capacity or inductance present in the resistor—and there nearly always is—there is some reactive effect certainly. Particularly capacity is present for carbon types, whereas both capacity and inductance exist for carbon types. That is, a pure resistance, like a good man, is hard to find.

Mallory Buys Out Electrad

P. R. Mallory & Co., Inc., Indianapolis, announce the purchase of the assets, good-will, trade-marks, patents and patent rights of Electrad, Inc., New York City. L. A. de Rosa, chief engineer, and other key employees of Electrad, Inc., will join the Mallory organization. Plant and offices will be moved to Indianapolis. Yaxley is a division of Mallory.

Wheel Static Cure



Spring coils inserted behind cap help cure wheel static by grounding contact.

PRINTED HANDSHAKES

READERS WONDERFUL, TOO

I THINK RADIO WORLD is a wonderful paper for service men.

G. T. GROVE,
No. Battleford, Sask., Canada
* * *

MUST MEAN FUNNY FORMULAS

TO me RADIO WORLD is the best radio magazine out. It covers all phases, but does so with a conciseness and touch of humor that appeal to me.

RICHARD B. STETSON,
No. 6-147 R St., N.E., Washington, D. C.
* * *

PLENTY OF SAME ADVICE LEFT

In my daily work RADIO WORLD is a mighty helpful and useful companion. To be without it is like being without an analyzer or voltmeter on the bench. I have not missed a single copy since you first suggested it to me.

JOSEPH LESMEISTER,
Lesmeister's Radio-Electric Service,
Harvey, North Dakota.
* * *

CAN STAND IT THESE DAYS

RADIO WORLD is most helpful to me in my business."

M. G. MOTSIFF
Motsiff Radio Service, 225 Fayette Blvd., Syracuse, N. Y.
* * *

NON-STOP, 1925 ON

I have taken your magazine for the last twelve years, and find it the best for the fan.

E. O. ERICSON
Room 409, City Hall, Duluth, Minn.
* * *

WORLD ANY WAY YOU TAKE IT

RADIO WORLD, to the serviceman, means a world of radio service.

FRANCIS J. CUSACK
1606 N. Lockwood Ave., Chicago, Ill.
* * *

REGULAR AS A CLOCK

I am a regular reader of your fine journal, and have made several fine sets from your published circuits.

C. E. C. HURST
17 Clock Block, Boaz Island, Bermuda
* * *

EVERY YEAR IN EVERY WAY

RADIO WORLD is going better each year. Keep the good work up.

EDWARD FISCHER
5988 Manton Ave., Chicago, Ill.

WE WEREN'T CONSIDERING CUT

Though your magazine continues to improve, I'm very glad to see the price remains the same.

LESLIE THIRLWALL
1205-15 Ave. West, Calgary, Canada
* * *

WE FURNISH DOPE FOR HIS PLUG

Have all copies of RADIO WORLD published since 1930 and have never missed an opportunity to "plug" for this deserving publication. Thank you for dependable dope.

SYD. W. PRALL
3825½ Avelon Boulevard, Los Angeles, Calif.
* * *

CERTAINLY! WE EAT UP PRAISE

May I take this opportunity to compliment RADIO WORLD on its long and successful career? H. J. Bernard and Capt. O'Rourke are about my speed.

PETER HENDERSON
The House Gymnasium, New House Office Bldg., Washington, D. C.

Lowell Thomas Versatile



Besides being one of the world's outstanding radio commentators, Lowell Thomas is also president of the Advertising Club of New York, editor of "The Commentator," monthly magazine that gives contributors much freedom, and is the author of true adventure and travel books. Biographies of noted men of adventure are right up his alley. He also possesses a remarkable personality.

Insuline Announces Large-Hole Punches

An improved type of self-aligning punch for making large holes in chassis for tube sockets, filter condensers, etc., has been brought out by the Insuline Corporation of America, 25 Park Place, New York, N. Y.

This new tool produces perfectly clean, round holes in a few seconds. Because of a spring-supported inner member, the cutting edges center themselves automatically when the head of the punch is struck by the hammer, and shearing is entirely impossible. No drilling of center hole is required. Hardened and tempered steel is used throughout, and hundreds of holes of uniform size can be made in succession.

Designed for amateurs, experimenters, servicemen, machinists and other workers in sheet metal, the new ICA punch is available in five sizes, to

make holes of the following diameters:

$\frac{3}{4}$, $\frac{7}{8}$, $1\frac{1}{16}$, $1\frac{1}{8}$ and $1\frac{1}{4}$ inches.

List prices run between \$3.50 and \$4.50.



Hickok Combines Tube Tester with Multimeter

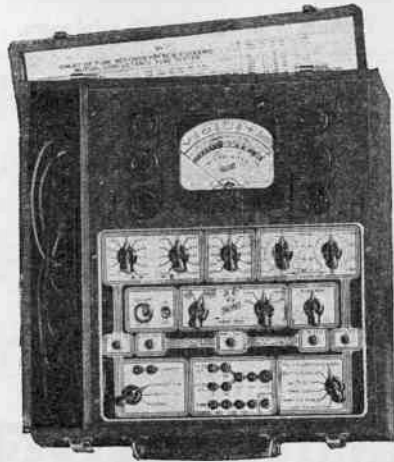

The new Hickok combination instrument.

Hickok announced its Model AC-51X, a combination tube tester measuring mutual conductance of all radio tubes.

The Model AC-51X not only tests all tubes but also indicates volts, ohms, milliamperes, output, microfarads, capacity leakage and decibels. As a tube tester it is dual reading. One scale is marked "poor" and "replace" while the other is graduated in micromhos of mutual conductance. In addition to the quantities listed above it also indicates the amount of hum in filter systems and checks the inductance of chokes with or without the d-c component of current. The voltmeter is accurate on all commercial and audio frequencies. The ohmmeter uses no batteries, but operates from the built-in power pack.

The meter is a Hickok-built D'Arsonval type, scale length more than four inches, with etched dial easily readable, owing to color grouping of ranges. The same scale is used for reading a-c and d-c volts, and it is uniform. No copper oxide rectifiers are used anywhere in the circuit. All rectification is accomplished by vacuum tube circuits.

The unit is contained in a compact case through careful arrangement of the component parts. The case is rubbed walnut, operating panel etched chromium finish. All necessary leads are furnished. Further particulars are obtainable from Dept. RW, The Hickok Electric Instrument Co., Cleveland, Ohio.

Flat Curve Dynamic Mike by Transducer

The original microphone was a dynamic type, constructed in keeping with sound engineering fundamentals. At that time, however, the dynamic mike was out of the question from a practical mass production standpoint, due to lack of certain basic materials which formed a vital part of its construction. Engineers turned to other methods and developed carbon, condenser, ribbon and velocity mikes. These types have been in wide use.

After months of experimentation in collaboration with acoustical and design engineers, Transducer Corporation produced a dynamic microphone which for functional reasons took the shape of a bullet, high sensitivity and unusual ruggedness. The uniform flat characteristics have been attained. The Transducer Corporation has headquarters in Rockefeller Center, N. Y. City. A complete line of microphones and inter-room communications systems is made. G. M. Giannini is president.

The Transducer factory, which had been located at 22 West Forty-Eighth Street, has moved to larger quarters at 455 West 45th Street. In charge of activities at the new address are F. L. Lester, production engineer, and Ben Eisenberg, test and design engineer. Design consultant is Richard W. Carlisle, former member of the staff of Westinghouse and RCA.

CHASSIS-CABINETS PANELS & CANS

STANDARD SIZES ON HAND
SPECIAL SIZES MADE TO ORDER

KORROL RADIO PRODUCTS CO.

232 Greenwich St. R.W.-7-37 New York City

CLASSIFIED ADVERTISEMENTS

7 cents a word. \$1.00 minimum.

AMATEUR RADIO. Commercial Radiotelephone and Radiotelegraph licenses, complete training. Resident and correspondence courses. Every graduate a licensed operator. **NEW YORK WIRELESS SCHOOL**, 1123 Broadway, New York.

FREE SAMPLE SNAPSHOTS. Send two negatives with this ad for samples new style embossed prints in individual photo album. Artists, Rockford, Illinois.

AMATEUR CARTOONISTS—WIN \$25.00. No drawing ability necessary to win. 26 prizes in all. Rush name on postcard for valuable tips on "How to Make Money With Simple Cartoons." Cash Prize Entire Blank and Rules. Send no money. Cartoonists' Exchange, Dept. C-1457, Pleasant Hill, Ohio.

HAVE YOU BACK NUMBERS of Radio World, for May, August, 1935, or June, October, 1936? If so, please communicate with Radio World, 145 West 45th St., New York, N. Y.

MAILING LISTS



GET OUR FREE
REFERENCE
BOOK and
MAILING
LIST CATALOG
FREE

Gives counts and prices on accurate guaranteed mailing lists of all classes of business enterprises in the U. S. Wholesalers—Retailers—Manufacturers by classification and state. Also hundreds of selections of individuals such as professional men, auto owners, income lists, etc.

Write today for your copy

R. L. POLK & CO.
Polk Bldg.—Detroit, Mich.
Branches in Principal Cities
World's Largest City Directory Publishers
Mailing List Compilers. Business Statistics. Producers of Direct Mail Advertising.

A COMBINATION OFFER! RADIO WORLD and "RADIO NEWS"

\$3.50

Canadian and Foreign, \$1.50 extra on this offer.

You can obtain the two leading radio technical magazines that cater to experimenters, service men and students, for one year each, at a saving of \$1.50. The regular mail subscription rate for **RADIO WORLD** for one year is \$2.50. Send in \$1.00 extra, get "Radio News" also for a year—a new issue each month for twelve months. Total 24 issues for \$3.50 and \$5.00 to foreign countries.

RADIO WORLD, 145 West 45th Street, N. Y. City

COIL WINDING; NO COMPUTATION!

SOLENOIDS for all radio frequencies, from the fringe of the ultra highs, to the fringe of audio, may be wound, using popular wire sizes and form diameters, with no computation, yet at 1% accuracy. This is made possible by a series of quick-answer charts constituting "The Inductance Authority," by Edward M. Shiepe, plus an 18 x 20" supplement.

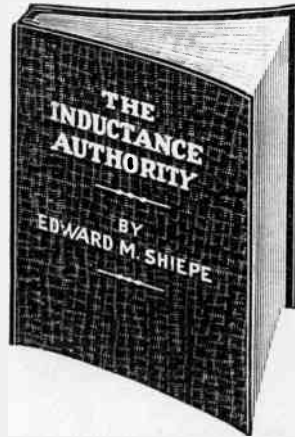

Winding solenoid coils for radio frequencies requires knowledge of the number of turns of any selected type of wire on any sensible diameter to attain an inductance suitable for the tuning condenser and lowest frequency. Hence, with capacity and frequency known, there are two unknowns: (1), the required inductance; (2), the number of turns to establish that inductance. The answers are obtained by consulting "The Inductance Authority," and the supplement. On the large supplement are

plotted the "curves of frequency, capacity and inductance in straight lines, so for a desired low frequency and known capacity the unknown inductance is solved by mere inspection. The number of turns for attainment of that inductance, for all popular tubing diameters and all generally used wire diameters and wire insulations, is read from the inductance-turns charts which are in the bound volume. Coil and set manufacturers, as well as home and shop experimenters, students and teachers freely use this book. The only book of its kind in the world.

Order Cat. INA (price includes bound volume and supplement) postpaid **\$2.00** anywhere on earth.....

Or send \$5.00 for a two-year subscription for **RADIO WORLD**, regular rate, and this valuable book and supplement will be sent **FREE** and postpaid anywhere on earth.

Order Cat. PR-IAC.

RADIO WORLD

145 West 45th Street

New York City

WHEN WRITING TO ADVERTISERS
PLEASE MENTION THAT YOU SAW THE
ADVERTISEMENT IN RADIO WORLD.



THE SUMMER AND EARLY FALL EDITION OF the 1937 Radolek Profit Guide is the most complete and up-to-date radio parts book ever published. Over 1000 new items . . . plus AN ADVANCE SHOWING OF 1938 RECEIVER MODELS. Radolek's new edition is the only absolutely NEW parts book in Radio! New repair parts, New test instruments, New auto radios, New home receivers, and New P.A. equipment. Contains over 12,000 parts . . . the most extensive listings of replacement condensers, resistors, volume controls, transformers, and auto radio parts and accessories ever assembled under one cover.

RADOLEK SERVICE IS FAST AND DEPENDABLE. There's no Sit-Down, Lay-Down, or Slow-Down at Radolek—our organization is geared-up to serve you best, to give you what you want when you want it and at the Right Prices. Send for this Big New Book TODAY—it's FREE.

R A D O L E K
 601 W. Randolph, Chicago, Dept. G-8.
 Send me the Radolek Radio Profit Guide FREE.
 Name
 Address
 Serviceman? Dealer? Experimenter?

WHEN WRITING TO ADVERTISERS PLEASE MENTION THAT YOU SAW THE ADVERTISEMENT IN RADIO WORLD.

TELEVISION

"TELEVISION WITH CATHODE RAYS," by Arthur H. Halloran. Farnsworth and Zworykin systems fully explained. The treatment is mathematical. It is a book for the well-grounded radio man who has vision, the man who wants to be among the first to cash in when the pictures go on the air commercially, but is not for novices. 100 pages or more of supplementary data. Price \$2.75 post-paid (including Supplements).

RADIO WORLD

145 West 45th Street, New York City, N. Y.

National Radio Products

Descriptive price list Bulletin No. 261

If you are without a copy of the new National General Catalog, write us and we will gladly send you one. Or better, visit your dealer. He will welcome the opportunity to give you a copy of this new catalog and to demonstrate the latest National products.

NATIONAL CO., INC., MALDEN, MASS.

SPECIAL 2-FOR-1 OFFER RADIO WORLD

THE HOW-TO-MAKE-IT MAGAZINE
In Its New Monthly Form

Radio World is \$2.50 a year (12 issues), 25c. per copy. Canada and foreign, \$3.00 yearly. Offers of Radio World and other worthwhile publications for one full year on each (NET):

- RADIO WORLD and SHORT-WAVE and TELEVISION, \$3.50.
- RADIO WORLD and POPULAR SCIENCE MONTHLY, \$3.50.
- RADIO WORLD and RADIO, (Los Angeles), \$3.50.
- RADIO WORLD and RADIO-CRAFT (12 issues), \$3.50.
- RADIO WORLD and RADIO INDEX (monthly, 10 issues), stations, programs, etc., \$3.50.
- RADIO WORLD and SERVICE (monthly), \$3.50.
- RADIO WORLD and EVERYDAY SCIENCE AND MECHANICS (monthly), \$3.50.
- RADIO WORLD and BOYS' LIFE (monthly, 12 issues), \$3.50.
- RADIO WORLD and TRUE STORY (monthly), \$3.00.
- RADIO WORLD and LIBERTY (weekly), \$3.00, U. S. only.

Select any one of these magazines and get for an entire year by sending in a year's subscription for RADIO WORLD at the regular price, \$2.50, plus a small additional amount, per quotations above. (Add \$1.50 for extra foreign or Canadian postage for both publications.)

Name
 Address
 City and State.....

- If renewing an existing or expiring subscription for RADIO WORLD, put cross in square.
- If renewing an existing or expiring subscription for other magazines, put cross in square.

Special Trial Offer for Radio World only: \$1.00 for 5 months. postpaid. Mail order with remittance to Radio World Office. NET.

RADIO WORLD, 145 W. 45th St., New York

Expertly Selected Radio Books

Best Calculated to Advance Your Knowledge and Expedite Your Operative Technique



Undisputed Leader of All Radio Service Books

Alfred A. Ghirardi's "Modern Radio Servicing" is the standard book in the field. It contains everything you need to know about radio servicing as it is practiced today by the most successful organizations in the country. All about test instruments, their theory, operation and construction, complete with circuit diagrams. All the latest test and repair methods and trouble-shooting short-cuts. All the most successful repair methods. Big sections on noise and interference "spotting" and elimination in broadcast and all-wave sets; on aligning receivers (including cathode-ray method); AVC and QAVC circuits; auto radio; sales and advertising; etc. More than 1,300 pages. 749 illustrations. Order Cat. MRS, postpaid, \$4.00.

Ghirardi's "Radio Field Service Data," new edition, has more than 400 pages of practical "bench data"—twice as much as the first edition. I.F. peaks for 5,226 superhets, including 1937 models. "Case Histories" for over 1,500 receivers, giving actual trouble symptoms and remedies for each one. Ignition system data, interference remedies, and electrical wiring diagrams for all cars. Latest data on glass and metal tubes. In all, more than 70 different charts, diagrams and tables arranged in handy form for quick reference. Now in loose-leaf form, it is easily kept up to date with the Supplements issued every January and June. Order Cat. RFS, postpaid, \$2.50 (includes supplements for one year).

Combination price of \$6 gives you both these indispensable servicing books, together with one year's supplements to the Data Book. Order Cat. COMRFS.

Other Top Selections

"THE INDUCTANCE AUTHORITY," by Edward M. Shiepe. Enables winding radio-frequency solenoids to 1% accuracy without computation. Order Cat. INA @ \$2.00, postpaid. Price includes 18x20" inductance-capacity-frequency chart as supplement.

"MEASUREMENTS IN RADIO ENGINEERING," by Frederick Emmons Terman, revealing the measurement equipment and technique, from the pen of a great authority. 400 pages, 6x9. 208 illustrations. Order Cat. TMRE, postpaid, \$4.00.

"PRACTICAL RADIO COMMUNICATION," by Arthur R. Nilson and J. L. Hornung, a complete instruction course and reference guide in radio station operation. Principles, systems, equipment, operation (including short and ultra waves). 754 pages, 6x9; 435 illustrations; flexible cover. Order NHPRC, postpaid, \$5.00.

The Handiest Handbook of All!

A handbook is handy when it "has what it takes." Is expertly referenced, and quickly provides authoritative solutions. This Keith Henney's "Radio Engineering Handbook" certainly does. It's a great book for engineer or experimenter. Really 24 reference books under one cover. 850 pages, 4 1/2 x 7. Fully illustrated. Flexible cover. Order Cat. HREH, postpaid, @ \$5.00. New edition.

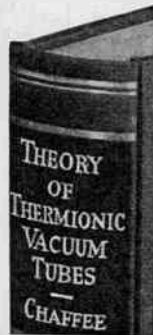

The Tube Authority

A fundamental treatise, comprehensive and authoritative. "Theory of Thermionic Vacuum Tubes," by E. Leon Chaffee, Professor of Physics, Harvard University, covers the field. A knowledge of algebra and some calculus are necessary for full appreciation of the contents. Treatment is mathematical. 653 pages, 6x9; 257 illustrations. Order Cat. CTTVT, postpaid, @ \$6.00.



Any or All of Above Books Sold on Five-Day Money-Back Guarantee!
BOOK DEPARTMENT, RADIO WORLD, 145 W. 45th ST., N. Y. C.

DeLuxe Superior GENEMETER

100 Kc to 100 Mc
With Variable Audio

\$14.40

Complete with
Four Tubes

FEATURES:

1. Direct reading in frequencies, 100 kc—22 mc, in five bands, all fundamentals, by front-panel switching. Ultra band by harmonics to 105 mc, also direct-reading.
2. Direct reading in frequencies, 25—10,000 cycles, in three bands, all fundamentals, by front-panel switching.
3. R.F. and A.F. outputs independently obtainable alone, or with A.F. (any frequency) modulating R.F.
4. Output meter for connection across primary of receivers' output transformer for peaking with modulation "on."
5. R.F. is subject to attenuation, and oscillation leakage is minimum.
6. Condenser and other leakages tested, to 100 megohms.
7. Main dial protracted on 7½" diameter, used full size, with precision pointer (no parallax), and 4-to-1 vernier planetary drive.
8. All services on 90-130 volts a.c. or d.c.

Shipping weight, 10 lbs.

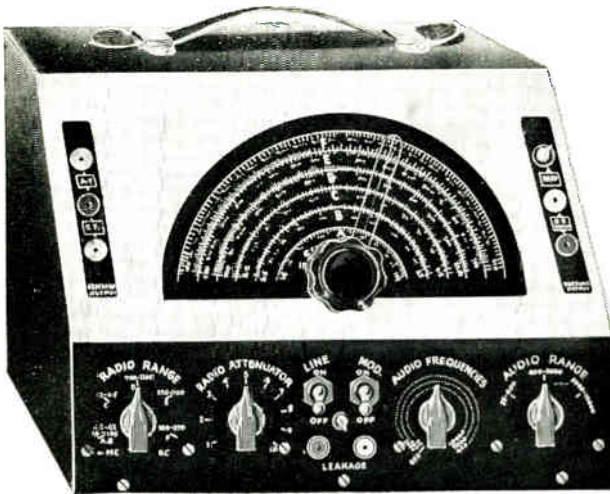

A Thing of Beauty and a Joy Forever Is Our New Genemeter, an All-Wave Signal Generator, with Variable Audio. Its Front Panel Slopes at the Pitch of a Cash Register. And Servicemen Equipped with Our New Instrument Will Ring the Bell Often and Every Time!

ALL the refinements that you would demand of a costly Signal Generator are embodied in our new GENEMETER. First in importance is accuracy. The GENEMETER has it—½% on intermediate and broadcast bands, 2% on short waves. Modulation must be present or absent by switching. It is. And, besides, the audio is variable. Direct reading in frequencies, it permits response measurements of amplifiers.

Beauty? The picture tells the story. Output meter? That is included, too. Even condenser and other leakage may be tested. All frequencies, radio and audio, are direct-reading. The large dial is 4-to-1 vernier, with costly planetary drive.

Outstanding is the word for GENEMETER.

The New ALLMETER

for Rapid, Accurate Measurements **\$10.40**

The ALLMETER is a multi-purpose meter, 1,000 ohms per volt, d'Arsonval movement, for measuring a.c. and d.c. volts, a.c. and d.c. currents, capacity, decibels, resistance and inductance.

Volts and milliamperes, 15-15-750.
Capacity, .01-50 mfd., including electrolytics.
Decibels, for total change of 42 db.
Resistance, .03-500 and 500-500,000 ohms.
Inductance, 5 to 1,000 henries.



The Allmeter, 21 instruments in one.

ORDER DIRECT FROM

SUPERIOR INSTRUMENTS CO.

136 Liberty St., New York, N. Y.
Dept. RW7

Send for our free Catalogue PV, in colors, describing our complete line.

Handy... and for 1000 Uses

SIZE
3 1/16" x 5 5/8" x 2 1/8"



**Pocket
Volt-Ohm-
Milliammeter**

● For laboratory, shop or field use. Handy Pocket size yet sturdy and precision built.

Model 666

Dealer Price **\$15.00**

A complete instrument for all servicing needs. Can be used for all A.C.-D.C. voltage, current and resistance analyses.

Leather Carrying Case, Model 669, supplied extra. Dealer Price... \$3.00.

Very attractive. Of black, heavy leather with finished edges and strap.

SEE YOUR JOBBER - WRITE FOR CATALOG

Remember Booth 79, Radio Parts Show, Hotel Stevens. Many new items in the Ever Enlarging Triplet Line will be Displayed

Model 666

- Uses Large 3" Sq. Triplett Instrument.
- A.C.-D.C. Voltage Scales Read: 10-50-250-500-1000 at 1000 ohms per volt.
- D.C. Milliampere Scale Reads: 1-10-50-250.
- Ohms Scales Read: Low 1/2-300; High, 250,000.
- Black Molded Case and Panel.
- Low Loss Selector Switch.
- Complete with Alligator Clips, Battery and Test Leads.

DEALER PRICE **\$15.00**

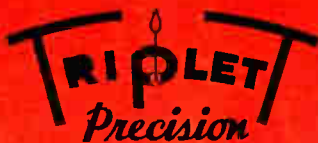

ELECTRICAL INSTRUMENTS

The Triplett Electrical Instrument Co.
277 Harmon Avenue, Bluffton, Ohio.

—Without obligation please send me more information on Model 666.

—I am also interested in.....

Name

Address

City State