

DEC. 30
1933



15¢
Per Copy

**STABILIZED
REGENERATIVE
DETECTOR AND
AMPLIFIER
CIRCUITS**

RADIO

REG. U.S. PAT. OFF.

WORLD

The First and Only National Radio Weekly
614th Consecutive Issue—Twelfth Year

5-TUBE A-C SHORT-WAVE SET

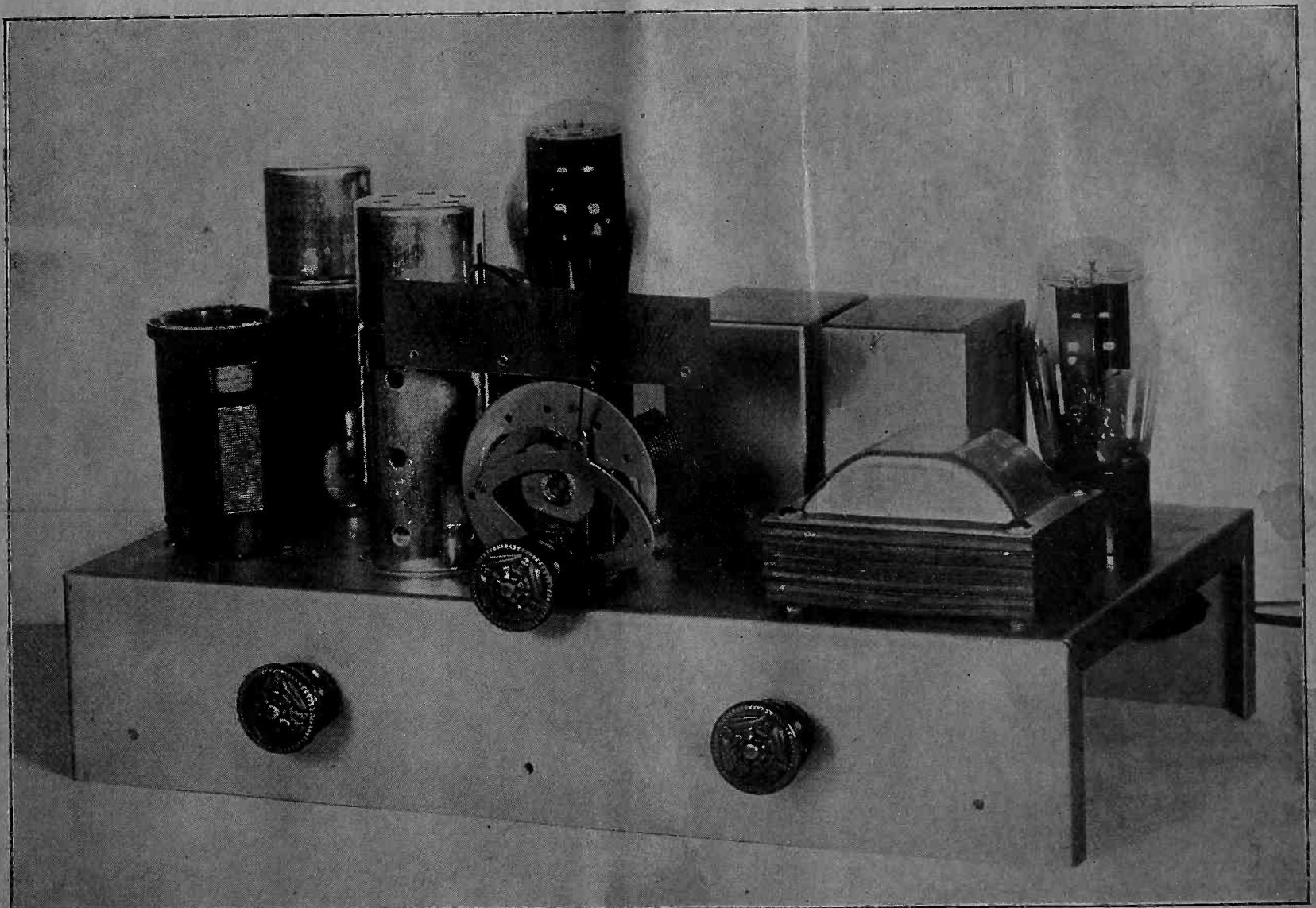

A complete, small, effective short-wave set. See page 12.

POWERTONE

FIVE TUBE A. C. SHORT WAVE RECEIVER

Described in this issue of Radio World—by Herman Cosman

THE most advanced model of the A.C. short-wave receiver line that can be built at a minimum cost.

Its completeness has been recognized to the extent that many amateurs all over the country have sets of similar nature in their stations.

Foreign short-wave stations can be logged on a loud speaker with very little effort. Regeneration is super-

sensitive, requiring a minimum of adjustment to step-up stations to a clear, distinct tone. The four coils included in the kit of parts having a tuning range of 15 to 200 meters. A regular broadcast, at a nominal extra charge, can tune stations up to 550 meters, with the same clarity of tone as the regular broadcast receivers.

Complete Kit of Parts as listed, less tubes. **\$16.50**

Wired and Tested.....\$4.00 Extra
Set of R.C.A. licensed tubes....\$3.75

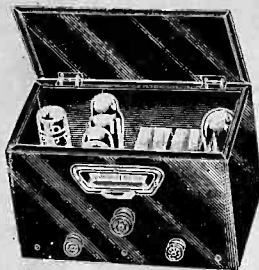

POWERTONE

Universal A.C.-D.C. Short-Wave Receiver

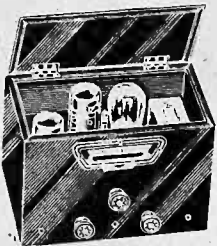

On the first trial, it received Melbourne, Australia—over 11,000 miles from New York City. Universal sets are rapidly gaining popularity due to their extreme simplicity in design, and universality.

Uses 1-43, 1-78 and the new 1-25Z5 tube. Ham marlund

parts add to its fine performance. Tunes from 15 to 200 meters.

Kit of parts, 4 coils, cabinet and instructions. **\$8.95**

Wired and Tested.....\$2.00 extra

TRY-MO RADIO CO., INC., Dept. RW, 85 Cortlandt St., New York

Branch: 179 Greenwich Street

Now Ready!

Handy Service-men's Manual

Regularly, **\$1.00**

Full of important information.

25c

BAIRD

Universal A.C.-D.C. Short-Wave Converter

Described in RADIO WORLD Nov. 4, 1933.

Will operate efficiently with any radio set on the market today.

Covers the short-wave band from 15 to 200 meters.

Housed in an attractive walnut cabinet. Complete kit of parts, instructions, 4 coils, less tubes.... **\$4.95**

Kit of tubes....\$1.25 Cabinet.....\$1.00
Wired and tested.....\$1.50 extra

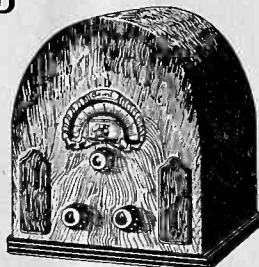

METAL-WORKING

LATHE

Precision equipment for the small shop. New designs and manufacturing processes make this amazing bargain possible. Complete metal-working lathe with compound slide-rest, combination face-plate and independent chuck and tail center: 8" swing; 24" length, 20 lbs. Send \$1.00. Balance plus postage C.O.D. Lathe for wood-turning alone, \$4. Attachments for milling, grinding, sanding, saw-table, etc., available at low prices. Order from ad at once and have a complete machine shop. American Machine & Tool Co., 200 Broadway, New York, Dept. R.8.



\$7.50
COMPLETE

WAFER SOCKETS

6/32 mounting holes, 1-11/16 inches apart; central socket hole recommended, 1 3/8 inches, although 1 1/4 inches may be used.

UX, with insulator.....10c
UY, with insulator.....10c
Six-pin, with insulator.....11c
Seven-pin, with insulator.....12c

HENNESSY RADIO PUBS. CORP.

145 WEST 45th STREET, N. Y. CITY

RCA INSTITUTES

Recognized Standard in Radio Instruction Since 1909

Technical Training Courses in Radio and

Associated Electronic Arts

RESIDENT SCHOOLS NEW YORK AND CHICAGO

Illustrated Catalog on Request

EXTENSION COURSES FOR HOME STUDY

under convenient "no obligation" plan.

RCA INSTITUTES, INC.

Dept. WR-1

75 VARICK STREET, NEW YORK

1154 MERCHANDISE MART, CHICAGO



175 KC TUNING UNIT FREE WITH SUBSCRIPTION

For use with 175 kc intermediate frequency. Unit includes four-gang condenser, three r-f coils, the proper oscillator inductance and 800-1,350 mmfd. padding condenser. Send \$12.00 for two-year subscription and order Cat. SUTU-175, which will be sent postpaid.

Radio World

145 West 45th Street

New York City

LAPEL MICROPHONE

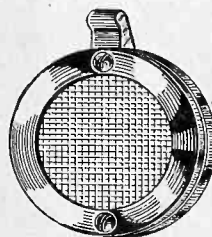

A single-button carbon-granule lapel microphone, impedance 200 ohms, requiring 4.5-volt excitation, of good frequency characteristics, and both handy and inconspicuous. Outside diameter, 1 1/2 inches. The case is chromium-plated brass. The excitation may be provided by introducing the microphone in a cathode circuit carrying around 20 to 25 milliamperes, or a 4.5-volt C biasing battery may be used. Net price, \$2.95.

RELIABLE RADIO COMPANY
145 West 45th Street, New York, N. Y.

Powertone Wallace Short Wave Receiver

The battery operated short-wave set which won the Hoover Cup for premier short-wave design and performance; well designed both electrically and mechanically. Built of the finest precision parts, each operating at maximum efficiency at all times; the Wallace has many features to recommend it to all interested in short-wave reception. Among these features are:

1. Band spread tuning for the crowded bands, controlled by a single panel switch.
2. Ultra Low-Loss coils wound with silver ribbon.
3. Each circuit individually controlled.
4. Highly efficient tuned antenna system.
5. Zero body capacity.
6. 15-200 meter tuning range.

The set is for earphone operation, using two 230 tubes, which require a 2-volt filament supply and 45-90 volts of "B" battery.

The receiver uses four plug-in coils whose tuning ranges are:

- | | |
|--------------------------|----------------------------|
| No. 1. coil—20-32 meters | No. 3. coil—75-150 meters |
| No. 2. coil—40-60 meters | No. 4. coil—150-200 meters |

Complete kit of parts, with one coil.....\$14.70

Each additional coil.....1.18

Wiring and testing (if desired) extra.....3.23

Guaranty Radio Goods Co., 145 W. 45th St., New York, N. Y.

Vol. III of RIDER'S MANUAL (A New Book)

Just out. John F. Rider's Vol. III Manual weighs nearly 11 lbs. and has 1,100 pages, all diagrams of commercial receivers, etc. (no text). Sets announced up to May 1st, 1933, are included—and complete information on every one, including resistance values. The volume is original and necessary and does not repeat data that are in Vols. I and II.

A Chronological Catalog and Index of all nationally-advertised radio receivers manufactured and sold in the United States between January, 1921 and January, 1933 are contained in Volume III. This list will be of tremendous aid in the identification of receivers for which the model number is not known.

Complete data include schematic wiring diagrams; chassis wiring diagrams; parts layouts; photographic views of chassis; socket layouts; voltage data; resistor values; condenser values; location of alignment and trimmer condensers; alignment and trimmer adjustment frequencies; intermediate-frequency amplifier peaks; alignment and intermediate-frequency adjustment instructions; color coding; transformer connections; point-to-point data; continuity test data; parts list with prices; special notes.

Complete tabulation of tube data showing electrical characteristics and constants for all of the tubes employed in radio receivers and amplifiers since 1921. Also a table of interchangeable types.

A complete table of I-F. peak frequencies as used in radio receivers. This list supplements the information of this type shown upon the diagram pages. Intermediate-frequency amplifier peak information is very important because quite a few of the manufacturers employ more than one figure in their year's production. A wrong guess on your part means trouble.

Order Cat. RM-3 @ \$7.50. Remit with order and we pay postage. Order C.O.D. and you pay postage.

Volume II—Order Cat. RM-2 @ \$6.50

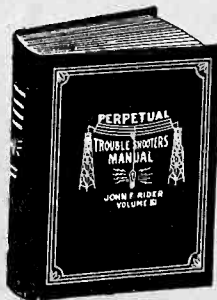

Volume III of Rider's Manual has a page sequence in accordance with Vols. I and II, and is not cumulative, or repetitive of the earlier volumes. However, it contains an index for all three volumes.

HENNESSY RADIO PUBLICATIONS CORP.
145 WEST 45th STREET, NEW YORK CITY

Quick-Action Classified Advertisements

7c a Word—\$1.00 Minimum

RADIO SERVICEMAN, JUNIOR PARTNER WANTED. Reliable. Car desirable. No investment. Legitimate proposition. State qualifications, equipment, etc. Box 30, Radio World.

MANUSCRIPTS, typed, paragraphed and corrected, 75c 1000 words. Sylvia Camos, 1107 Chouteau, St. Louis, Mo.

"MODERN ELECTRIC AND GAS REFRIGERATION," by A. D. Althouse and C. H. Turnquist. A timely book of practical and usable information on installation, service, repair of all types of automatic refrigerators. 275 pages, 175 illustrations, diagrams in six and eight colors. Price \$4.00. **RADIO WORLD,** 145 W. 45th St., New York City

"RADIO TROUBLE SHOOTING," Second Edition, by E. R. Haan. Contains the latest on A.C. receivers, dynamic speakers and television. A practical book for practical men. Contains a special chart showing all possible radio troubles and the way to detect them. Size 6 x 9 inches. 361 pages, 300 illustrations. Flexible binding. Price \$3.00. **RADIO WORLD,** 145 W. 45th St., New York City.

NEW RADIO AMATEURS HANDBOOK, 180,000 words, 207 illustrations, 218 pages (10th edition, issued 1933). Issued by the American Radio Relay League. Price, \$1.00 per copy. **Radio World,** 145 West 45th Street, New York, N. Y.

Introducing - - -

**NEW
1934**

DIAMOND of the AIR

**A-C OPERATED
SHORT-WAVE RECEIVERS**

12,500-Mile Reception

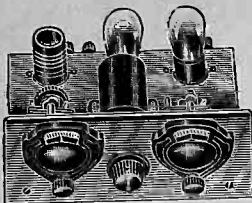

2-TUBE

Introducing the latest in short-wave receivers. The "Diamond of the Air" 2- and 3-tube battery receivers for many months have been acclaimed by owners to be the most remarkable short-wave receivers in their class. Now, for the first time, Reliable Radio Company introduces the 1934 A-C SHORT-WAVE "DIAMOND"—incorporating all the features of the battery-operated sets plus the convenience of a-c operation. The receivers have to be powered additionally and the power pack quotations will be found on this page.

IMPROVED RECEPTIVE QUALITIES

All 1934 features have been incorporated in the new "Diamond of the Air" a-c short-wave receiver and, besides, the popular battery-operated models have been improved in a new 1934 design. The lowest in price, yet these sets will log stations from all parts of the world regularly.

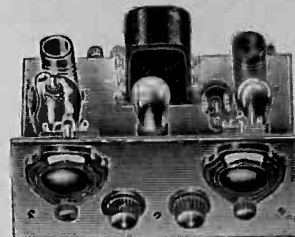

3-TUBE

The A-C "Diamond of the Air" Receivers

The a-c receivers have been developed for those who have the benefit of electric service. They use the latest type triple-grid tubes, resulting in more selective and sensitive reception.

The 2-tube model employs a 57 tube, resistance coupled to a 56 type output tube. For those desiring to use this receiver on batteries, simply replace the 57 type tube with a 77 and the 56 tube with a 37, for heater excitation from a 6-volt storage battery and use B batteries for plates. Loudspeaker reception on all local and many distant stations.

The 3-tube a-c receiver uses a 58 as an r-f amplifier, followed by a 57 detector and a 56 as an output tube. This receiver can be used on batteries by using 77, 78 and 37 tubes as detailed above. Capable of logging stations from all parts of the world.

Employs the Highest-Grade Materials

A receiver is only as good as the parts used in its construction. Only the finest parts are included. Hammarlund condensers, representing the finest, are used. The metal panel eliminates body capacity.

DIAMOND OF THE AIR

Battery-Operated Short-Wave Receivers

The battery-operated receivers employ the 2-volt low-current tubes, saving considerable expense to those living in districts where no a-c is available.

The two-tube model uses two 30 tubes. Especially designed for headphone reception, although loudspeaker reception may be obtained at ordinary room volume.

The 3-tube two-volt model employs one 34 and two 30 tubes. It will receive short-wave stations from all parts of the globe on a loudspeaker.

Electric Models

- Cat. No. 5025-D. Two-tube A-C kit, with blueprint. Shipping weight, 5 lbs. \$8.45
- Cat. No. 5026-D. Above, wired and tested. Shipping weight, 5 lbs. 9.45
- Cat. No. 5027-D. Complete set of tubes for above, either one 57 and one 56 for a-c operation or one 77 and one 37 for battery operation. Specify which. Shipping weight, 2 lbs. 1.45
- Cat. No. 5028-D. Three-tube a-c kit, with blueprint. Shipping weight, 7 lbs. 11.45

- Cat. No. 5029-D. Above, wired and tested. Shipping weight, 7 lbs. 13.45
- Cat. No. 5030-D. Complete set of tubes, either one 58, one 57 and one 56 for a-c operation or one 78, one 77 and one 37 for battery operation. Specify which. 2.45

Two-Volt Battery Models

- Cat. 5019-D. Two-tube kit, with blueprint, less accessories listed below. Shipping weight, 5 lbs. \$7.75
- Cat. No. 5029-D. Above, wired and tested, less accessories listed below. Shipping weight, 5 lbs. 8.75
- Cat. No. 5021-D. Complete accessories including two 230 tubes, one set of standard headphones, two No. 6 dry cells, two standard 45-volt B batteries. Shipping weight, 22 lbs. 4.50
- Cat. No. 5022-D. Three-tube kit, with blueprint, less accessories listed below. Shipping weight, 7 lbs. 9.95
- Cat. No. 5023-D. Above, wired and tested, less accessories listed below. Shipping weight, 7 lbs. 10.95
- Cat. No. 5024-D. Complete accessories, including two 30 tubes and one 34 tube, one set of standard headphones, two No. 6 dry cells, three standard 45-volt B batteries, one 6-inch magnetic speaker. Shipping weight, 32 lbs. 8.95

DIAMOND of the AIR

SHORT-WAVE

POWER PACK

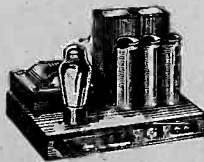

Supplies clear hum-free power regardless of circuit sensitivity. Especially designed for use with the "Diamond of the Air" Short-Wave receivers, but can be

used on any short-wave battery-operated receiver for B supply.

Contains a brute-force filter, employing two heavy-duty 30-henry chokes, specially-designed power transformer, and three electrolytic condensers. These factors assure pure d.c.

Will deliver 180 volts. Supply your own taps, 135, 90 and 45 volts. Supplies 2½ volts at 10 amperes for filament drain. All taps terminate at binding posts on the side of the pack. Employs an 80 rectifier. Will stand up to 75 ma. drain for B current.

All parts are mounted on a sturdy metal base finished in silver.

Cat. DAPP. Price, including 80 tube \$5.95

Shipping Weight, 20 Lbs.

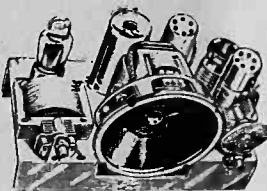

**Four-Tube
A-C
Short-Wave
Receiver
with Built-
In Speaker**

Will tune in short-wave stations from all parts of the world with ease. Uses four plug-in coils to cover the entire short-wave band from 15 to 200 meters. The built-in power supply is entirely free from hum or disturbing line noises. Uses an ultra-sensitive dynamic speaker which aids in tuning in the weaker signals.

- Cat. 4TK. Kit of Parts, less cabinet, less tubes \$11.50
- Cat. 4TW. Above, completely wired and tested \$13.75
- Cat. 4TCB. Cabinet only \$1.50 extra
- Cat. 4TTU. Complete set of licensed tubes \$2.50 extra

Reliable Radio Company

145 West 45th Street
NEW YORK CITY



For A-C and D-C Operation

Will work anywhere that 110 volt A-C or D-C is available. U. S. amateur reception is assured on loudspeaker by the use of a 43 power tube in the output.

With headphones the entire world is at your finger-tips. Chassis is completely encased in a beautiful crystal finished cabinet. Covers the short wave, band from 15-200 meters. Uses one 78, one 25Z5 and one 43 tube.

Price Kit \$8.95
Wired \$2.00 extra. Tubes \$3.25

FREE
HANDY SERVICEMEN'S
MANUAL
WITH EACH PURCHASE OF
A SHORT-WAVE RECEIVER



ALL SHIPMENTS MADE EXPRESS COLLECT UNLESS OTHERWISE DIRECTED BY PURCHASER

ROLAND BURKE HENNESSY
Editor

HERMAN BERNARD
Managing Editor

RADIO WORLD

REG. U.S. PAT. OFF.

The First and Only National Radio Weekly
TWELFTH YEAR

J. E. ANDERSON
Technical Editor

J. MURRAY BARRON
Advertising Manager

Vol. XXIV

DECEMBER 30th, 1933

No. 16. Whole No. 614

Published Weekly by Hennessy Radio Publications Corporation, 145 West 45th Street, New York, N. Y.

Editorial and Executive Offices: 145 West 45th Street, New York

Telephone: BR-yant 9-0558

OFFICERS: Roland Burke Hennessy, President and Treasurer; M. B. Hennessy, Vice-President; Herman Bernard, Secretary.

Entered as second-class matter March, 1922, at the Post Office at New York, N. Y., under Act of March 3, 1879. Title registered in U. S. Patent Office. Printed in the United States of America. We do not assume any responsibility for unsolicited manuscripts, photographs, drawings, etc., although we are careful with them.

Price, 15c per Copy; \$6.00 per Year by mail. \$1.00 extra per year in Foreign countries. Subscribers' change of address becomes effective two weeks after receipt of notice.

REGENERATION IMPROVED

FIRST FACTS EVER PUBLISHED ABOUT A STABILIZED
DETECTOR FEEDBACK CIRCUIT FOR AVOIDING
PLOP AND CHANGE OF FREQUENCY DUE
TO COUPLING AND RESISTANCE

By J. E. Anderson

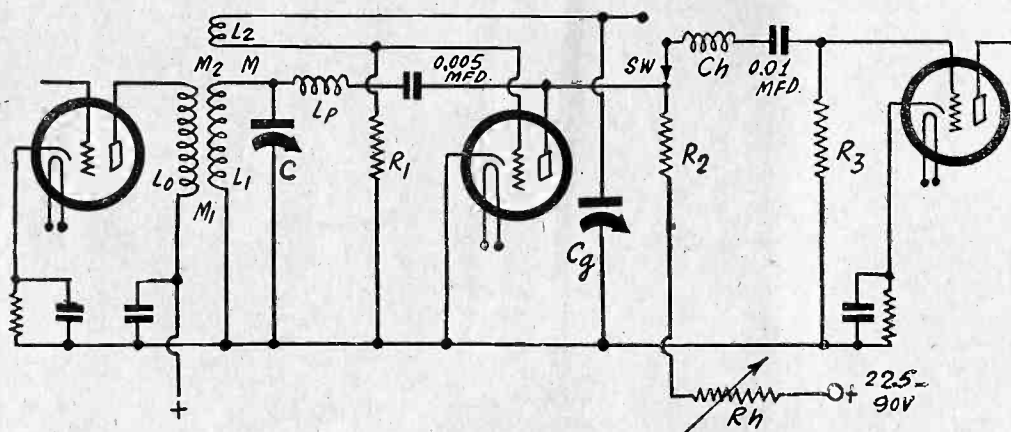

FIG. 1

The circuit of a stabilized regenerator in which the tuned circuit is in the plate. An optional connection as indicated by the one shown is preferable for frequency stability.

SEVERAL times we have discussed frequency-stabilized oscillators, but this subject does not seem to have a great deal of interest for the set builder. Frequency stability to a high order of accuracy is not required in receivers, at least not in broadcast receivers. There is one field, however, where the principles of stabilization can be used advantageously in building receivers, and that is the regenerative amplifier or detector.

Everybody who has done any work with

a regenerative receiver knows that at times it is very difficult to take full advantage of the regeneration because the circuit "spills over," while in other cases it is easy to advance the feedback to the point of oscillation and to gain enormously in sensitivity. The difference between the two cases lies in the degree of frequency stability of the regenerative circuits. If the circuit is stable as to frequency when it is an oscillator, the frequency of oscillation will be the same as the frequency to

which the circuit is tuned when it is an amplifier. If the oscillator is not stabilized, the frequency of the oscillator will change the instant oscillation begins, and the signal is no longer in tune. The cause of the change is the radical change that occurs in the plate and grid resistances of the tube as the circuit begins to oscillate. Retuning will not help because the regeneration must be decreased until oscillation stops, and then the grid and plate resistances assume their original values, and once more the circuit is out of tune with the signal frequency. When the circuit is stabilized as to frequency there is no change in the frequency of resonance as a result of changes in the grid and plate resistances.

Plate-Tuned Regenerator

But how can the principles of stabilization be applied to regenerative receivers? Let us illustrate with circuits. In Fig. 1 we have a regenerative hook-up in which the tickler is tuned. This circuit is suitable for both regenerative amplification and grid leak detection because there is a grid stopping condenser. L_0 is the regular primary connected in the plate circuit of the tube ahead of the regenerator, L_1 is the tickler, which is tuned with condenser C , L_2 is the grid coil, not tuned, L_p is a stabilizing coil in the plate circuit of the tube, and C_g is a stabilizing condenser in the grid circuit, which also serves as the stopping condenser. M_1 is the mutual inductance between the primary and the tickler, M_2 that between the primary and the grid coil, and M that between the tickler and the grid coil, and

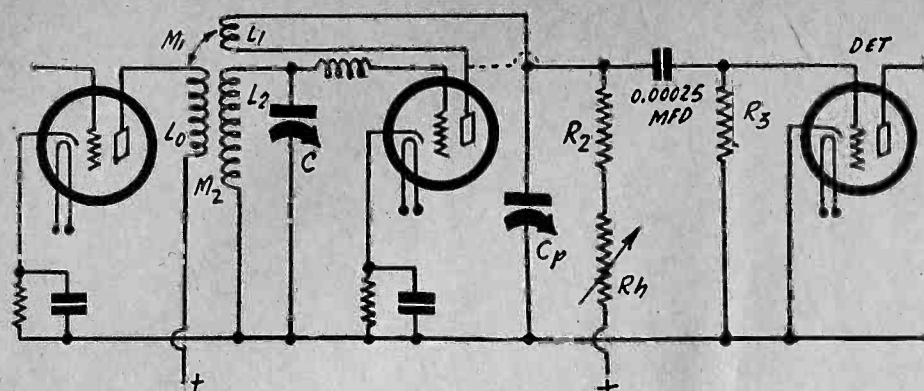

FIG. 2

In this stabilized regenerator the tuned circuit is placed on the grid side. An optional connection is shown by the dotted line, and that is preferable because the frequency stability is better.

it is that which is responsible for regeneration.

The value of L_p should be exactly the same as that of L_1 , but it must not be coupled in any way to the $L_0L_1L_2$ system. C_p should have such a value that it resonates with L_2 at the frequency to which the circuit is tuned. Particularly, it should be $C_p = L_1C/L_2$, so that if L_1 and L_2 are equal the two condensers should also be equal.

The Gain

A few words about the mutual inductances are in order. If L_0 is coupled to both L_1 and L_2 , will not the induced voltages buck each other so that greater response would result if one of them were zero? If that is the case, which one should be zero, M_1 or M_2 ? Investigation shows that they will not buck each other but that the voltages induced are in quadrature, or at right angles to each other. Thus we need not worry about the relative values of M_1 and M_2 . When the voltages are in quadrature their results on the output voltage of the tube combine in the same manner as the sides of a rectangle combine to make the diagonal. In other words, if A_1 is the amplification due to M_1 and A_2 is that due to M_2 , the combined effect, A , is given by $(A_1^2 + A_2^2)^{1/2}$. We can forget about these two mutual inductances, except in so far that they affect the selectivity and to total value of A . Both should be small, as usual, if the selectivity is to be high, and both should be large if the gain is to be high. As always we have to compromise. If the plate resistance of the first tube is high the mutual inductances can be higher than if the plate resistance is low.

The value of M is important, for if it is too high the circuit will regenerate too much and too easily, and if it is too low the circuit may not oscillate at all, especially on the lower frequencies. In this stabilized circuit oscillation will occur when M is extremely small, which is due to the fact that the feedback is always in phase. Yet if it is too small oscillation will fail, and in a practical case it is well to make it large enough to insure oscillation on the lowest frequency covered by L_1C and then introduce plate circuit resistance to stop oscillation on the higher frequencies—at all frequencies for that matter, for oscillation must not actually be permitted.

Tracking of Stabilizing Condenser

Since the value of C_p is critical it is well to arrange the circuit so that it will track with the tuning condenser. This is most easily done by making L_1 and L_2 equal, when C and C_g are also equal. They can then be two sections of the

same gang, provided the sections are equal. Thus there will be three equal coils in the circuit, namely, L_1 , L_2 , and L_p ; L_1 and L_2 being on the same form as L_0 , and L_p being on a separate form and placed so that there is no mutual between the two systems. The mutual might be eliminated either by shielding or by placement at right angles.

It is clear that condenser C_g cannot be used for controlling the regeneration, for its function is to tune the grid coil, and it serves only incidentally as grid stopping condenser. Regeneration must be controlled by varying the effective plate voltage on the tube. It is for this reason that the variable resistance R_2 is put in series with the plate return. There is also a fixed resistor R_2 in this circuit. Its function is to prevent a short of the output by the rheostat, and also to enable closer control of the regeneration. For a given value M , the largest value of R_2 should be used that will insure oscillation on the lowest signal frequency, for this resistance, in conjunction with R_h , serves as the load impedance on the tube for the detected signal. If R_2 is low there will be very little output. We have suggested that the applied plate voltage may range from 22.5 volts to 90 volts. There is really no reason why it should be limited to 90 volts for the higher the voltage, the higher the value of R_2 may be, and the greater will be the output. After R_2 and the voltage have been selected, for a given value of M , R_h should be chosen so that oscillation can be stopped with it on the highest signal frequency covered

by the L_2C circuit. Yet it should not be any larger than necessary because the smaller it is the better the control of the regeneration.

The feedback can also be varied by means of M , which used to be the preferred way of controlling regeneration. But this is mechanically more difficult than controlling by means of plate voltage and plate resistance, for it requires a means for rotating the reaction coil L_1 in respect to L_2 . Moreover, a change in the mutual will change the reactances in the circuit by introducing different stray capacities.

Filtering

There is a 0.005 condenser in series with L_p . This is a disturbing factor because it makes complete stability impossible, since its reactance is comparable with that of the coil L_p . Yet it cannot be made larger for then it would short circuit the audio output of the circuit. One method of avoiding this is to take the output from the condenser C_g and then making the plate condenser 1 mfd. or more. If we connect the input to the third tube to the high potential side of the grid condenser, as indicated by the switch, we sacrifice the audio amplification in the regenerative tube. Still, this may be preferable for we can easily make up for the loss by having higher gain in the rest of the audio amplifier.

The resistance shunt in the plate circuit, that is, R_2 and R_h , does not change the stability conditions, but only the conditions for oscillation. The radio frequency choke and the stopping condenser in the lead to the third tube do change the stability conditions slightly, but not enough to make any difference provided the choke has an inductance of the order of 10 millihenries at broadcast frequencies.

Tuned Grid Regenerator

The tuned grid regenerator can also be stabilized, but it is not at all suitable for combined amplification and detector because in this case there must be a coil in the grid circuit instead of a condenser. One arrangement is shown in Fig. 2. In this case C_p , the plate stabilizing condenser, should tune L_1 and its value should be $C_p = L_2C/L_1$. Again if L_1 and L_2 are equal the condensers are also equal and they may be ganged. L_2 in the grid lead should be equal to L_2 in the tuned circuit.

A possible connection of the detector is also shown. A condenser of 0.00025 mfd. is used for stopping condenser and a grid leak R_3 of about one megohm is used as usual. The arrangement is not very sensitive because the drop in C_p is not high and the input capacity of the detector tube cuts down the input.

(Continued on next page)

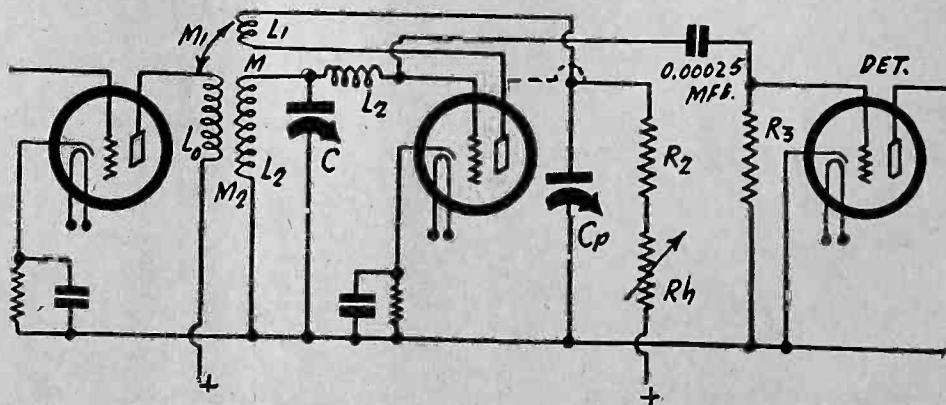

FIG. 3

Another arrangement of the tuned grid regenerator in which the input to the detector is taken from the grid. The connection shown by the dotted line is preferable.

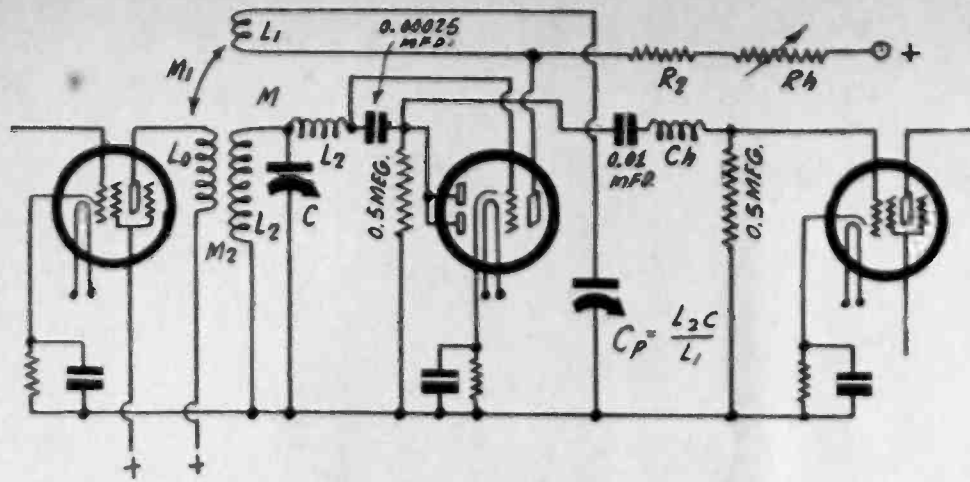

FIG. 4

In this tuned grid regenerator the triode of the 55 is used only for boosting the signal and the diode is used for detection in the usual way. Regeneration is controlled by R_h .

(Continued from preceding page)

In Fig. 3 is a different arrangement of the connections. In this circuit the input to the detector tube is taken from the grid of the regenerator. This arrangement is more effective. It will be even more effective if the input lead is connected to the top of the L_2C circuit than to the grid, but the difference is not great.

Infinite Grid Resistance

It should be observed that the regenerative tube functions as an amplifier and for that reason it may be given the usual amplifier bias. If no grid current flows, the coil L_2 in the grid lead is not needed for stabilization, but it is not possible to make it infinite if the detector following draws current, either through the grid or through the external resistance R_3 . Hence it is best to use the stabilizing grid coil in all instances.

In Fig. 2 it is also possible to connect the coupling resistor R_2 directly to the plate. If this is done the effect of the detector on the stabilizing condition will be less, and that may be the preferable connection. Of course, this may also be done in Fig. 3. The dotted lines show the optional connections.

Diode Detection with Stabilized Circuit

It is possible to combine the tuned grid regenerator with diode detection by arranging the circuit as shown in Fig. 4. The triode part of the tube is the controlled oscillator and it is fully stabilized. The diodes are connected together and then joined to the grid stabilizing coil through a condenser of 0.00025 mfd. Its main function is to stop the audio frequency component from shorting through the tuning system. It is not desirable from the point of view of frequency stability to put a condenser in shunt with the 0.5-megohm load resistance, but there is usually enough stray capacity to

insure detection. Ordinarily stray capacity is detrimental but in this case it is advantageous. If it were not for the stabilizing coil L_2 the tuning condenser and the 0.00025 mfd. stopping condenser would serve as bypass across the load resistance, but the coil acts as a choke, not to the signal frequency, for it is tuned to that, but to the harmonics of it.

Input to Audio Amplifier

The input voltage to the audio amplifier is derived directly from the two diode plates. Since there is a rather high radio frequency potential at this point, a choke Ch in the lead to the audio tube grid is used to eliminate it. A 0.01 mfd. stopping condenser is used in the lead so that the grid of the amplifier can be biased independently of the drop in the load resistance.

It is interesting to speculate as to what would happen if the amplifier were diode biased, which it would be if the 0.01 mfd. stopping condenser and the second 0.5 megohm grid leak were omitted. Before oscillation started there would be very little voltage drop in the diode load resistance and the bias on the audio tube would be determined only by the bias resistor used for that tube. But as oscillation started there would be a rapid increase in the drop in the load resistance and the bias on the audio amplifier would rise to the point where the plate current was completely cut off, for the oscillation intensity might well rise to such a point that the bias would become 100 volts. Of course, if the regeneration were increased gently there would be no such rise in the diode output.

There would be a certain advantage in having the audio amplifier choke up as oscillation begins, for it would automatically shut out noises that are associated with oscillation. While the circuit has been stabilized as to frequency, it does not prevent mistuning that would give rise to the usual heterodynes.

that crude device. There are now two methods of scanning that appear promising. One employs the reflecting lens-mirror wheel and the other employs the cathode ray oscillograph. The sponsors of both have demonstrated that these methods have real merit and that they give promise for the future.

Real improvement has been effected by increasing the number of scanning lines per frame. It will be recalled that when television was first started in this country, the number of lines used was as low as 24. This quickly proved useless. Then 45 lines per frame were tried, and that gave not much better results.

Sixty Lines Not Sufficient

Sixty lines per frame was the next step, and when that was used it was possible to recognize features of persons televised. But the results were far from good, and the public would not accept them. However, many experimenters continued to use sixty lines per frame because many of the problems connected with television could be solved just as easily with 60 lines as with a greater number.

From sixty lines per frame the experimenters went to 120 lines, then to 180, and finally to 240 lines. Each time the number of lines was stepped up the details of the received pictures became clearer and finer. At 240 lines per frame it is scarcely possible to tell whether a picture has been received by television or by photographic enlargement. At present several use 240-line scanning. Whether or not there will be an increase in the number of lines above this is impossible to say, but it is not likely because as the scanning lines increase the difficulties of transmission and reception multiply rapidly.

Just what is meant by a scanning line? Approximately the same as is meant by a line of type in a book. Take a page and count off 60 lines from top to bottom, with a length of each line approximately equal to the depth of the page. That page is then the frame. Each line is a scanning line.

Contents Noted

To get the content of the page we have to read, or scan, it line by line, from left to right in each line and from top to bottom on the frame, or page. To scan a picture the same thing has to be done, and similarly to reconstruct the picture. The picture, of course, is not made of letters, but of lights and shades, or black and white.

The scanning beam is a kind of luminous pencil with which the picture is painted. There is a dark area in the picture, and the pencil of light becomes dim or goes out completely. There is an area of high lights in the picture, and the pencil of light becomes bright. A picture could be reconstructed in the same way with a brush drawn across a sheet of paper in definite and equi-spaced lines. When the picture is to be dark, pressure is exerted on the brush and it leaves a heavy black. If the picture is to be light, pressure is released and the paper is darkened only little or it is left clean. If the gradations from black to white in each line are made fine enough and the depth of each line narrow enough by increasing the total number of lines per picture, the greater will be the detail, and that is the reason why the number of scanning lines in television is increased.

The difficulties that multiply as the number of lines is increased are mostly electrical. The problem is to transmit and receive a very wide band of frequencies with about the same intensity. In broadcast a band width of 10,000 cycles per second is allowed. In first-rate television transmission the band will have to be 1,000,000 cycles wide at least. Detail cannot be increased by increasing the number of lines per frame unless the transmission band is increased at the same time, and approximately as the square of the number of lines.

Television Improved as Several Use 240 Lines By Brunsten Brunn

PUBLIC interest in television has been dormant during the last two years, but not engineering interest, because in several laboratories television experiments have been conducted continuously by competent men, who have advanced the art to a point where it now gives real promise of having enter-

tainment possibilities. It is now possible to reproduce television images that compare favorably with home movies, and that is as much as we can hope for some time.

The advancement did not come as a result of improving the old familiar scanning disc. It came largely as a result of abandoning

The Decibel Rating

It is the Only True One for Differentiating Volume Levels

By Einar Andrews

WE OFTEN hear statements regarding relative volume strengths. One might say: "It increased the volume fully 50 per cent." Someone else may have as great a change as 100 per cent., or 200 per cent., or the volume might go up or down 50 per cent. Just what is meant by such statements? When is one output level 100 per cent. higher than another, or when is it 50 per cent. less?

Such statements concerning volume have little meaning. They may be true or false, and there is no way of proving or disproving their correctness until we know exactly what is meant. Certainly the ear, which is the sole instrument relied on in making these statements, is not sufficiently exact to enable anyone to pass judgment.

The best system devised for expressing relative values of volumes and that which is now used everywhere is the decibel system. It is a true percentage system, for it is based on logarithms of ratios. The decibel, or db, is defined by the relation $db = 20 \log_{10} (E1/E2)$, in which E1 and E2 are two voltages compared. When E1 and E2 have such values that twenty times the common logarithm of their ratio is unity, they differ by one db. This says nothing about the actual values of either one, for only their ratio is involved.

Care in Use

The above definition of the decibel is not strictly true and it has to be used with precautions. The true definition is $db = 10 \log_{10} (P1/P2)$, in which P1 and P2 are the two powers compared. The only time the other definition is true is when the voltages compared exist across the same impedance and the frequency is unchanged. Since it is customary to measure outputs across specified resistances and specified frequencies, the voltage definition can be used. It is also possible to define the decibel by $db = 20 \log_{10} (I1/I2)$, in which I1 and I2 are two currents. This is subject to the same limitations as the voltage definition, because it is only true when the currents flow in the same resistance and when the frequency remains unchanged. The true definition can also be expressed $db = 10 \log_{10} (E1I1/E2I2)$ since the power is the product of the current and the voltage. When the power is used the factor before the logarithm is 10 but when either current or voltage is used it is 20. The reason for this is that the power is proportional to the square of the current or of the voltage, and the logarithm of a square of a number is equal to twice the logarithm of that number.

Use of Decibel

The decibel is usually employed for expressing amplification and loss in amplifiers or for expressing the effect of detuning. Attenuators, that is, volume controls, are usually made so as to vary the output in steps of a certain number of decibels, for example, one decibel at each step. It is not exceedingly difficult to construct such a volume control, and we shall show how it can be done.

Suppose the volume is controlled in the grid circuit of an amplifier tube in which the grid is biased so that no grid current

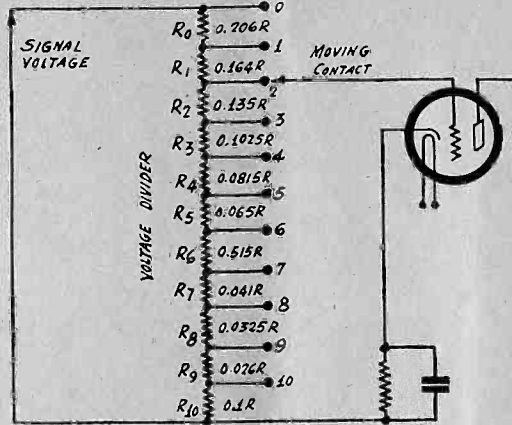

FIG. 1

This circuit shows the design and connection of a voltage divider that varies the output in 2 db steps from 2 db to 20 db. The value of R, which is the total resistance of the voltage divider, depends on impedance of the source of the signal.

flows. A potentiometer, or designating more properly, a voltage divider is connected across the output of the amplifier ahead and the grid of the second tube is connected to the slider. This is the usual method of connecting when the volume is controlled by means of a potentiometer in the grid circuit of an amplifier. We shall add nothing new but the design of the potentiometer and the location of the taps that will vary the volume in steps of one decibel, from zero to 10.

Computation

We shall base the design on a potentiometer having a total resistance of R ohms, to which we may assign any value.

The signal current flows through the whole resistance, so that the current is the same in every section. The reason we stipulated no grid current was to insure that the current should be the same in every section. Since the current is the same in every section, the voltage drops will be proportional to the resistances, and we can use resistance values in the formula for the number of decibels. That is, if the total resistance between the grid cap and ground is r, the ratio of the resistance in the grid circuit to the total is R/r and we have $n = 20 \log_{10} (R/r)$, where n give the number of decibels down at any given value of r.

For simplicity let us divide the resistance so that the output volume is varied in steps of 2 db from zero to 20 db. When $n = 20$, the logarithm of the resistance ratio is unity, and therefore the ratio itself is 10. Therefore $r = 0.1R$, which is the value of the lowest section of the resistance strip. When $n = 18$, the logarithm is 0.9, and the resistance ratio is 7.94, when $r = 0.126R$. It follows that the resistance between the second tap from ground and ground is 0.126R and that the second resistance, R_9 , is 0.026R. The next value of n is 16 db. Therefore

the resistance ratio is 15.85, and $R_8 = 0.325R$. By proceeding in the same manner we get the following values: $R_7 = 0.041R$, $R_6 = 0.0515R$, $R_5 = 0.065R$, $R_4 = 0.0815R$, $R_3 = 0.1025R$, $R_2 = 0.130R$, $R_1 = 0.164R$, and $R_0 = 0.206R$.

Obtaining Actual Values

The value of R in these expressions depends on where the voltage divider is to be used. It may be one ohm or a million. It will be noticed that the coefficients of R add up to unity, so that whatever R is made, that is the value of the total resistance of the voltage divider. A suitable value for a voltage divider that is to be used between a 27, a 56, a 37, or similar tube and an amplifier tube is 100,000 ohms. When that value is used the resistances of the various sections are obtained by shifting the decimal point five places. Thus we would start with a value of 10,000 ohms for R10 and end up with a value of 20,600 ohms for R0. R9 is the smallest resistance and would be 2,600 ohms.

If the total resistance is only 10,000 ohms, each section has a resistance only one-tenth as large. Higher values of R can also be used in certain cases, especially when the output resistance of the tube which is the source of the signal voltage has a high resistance. It might, for example, be 1,000,000 ohms when the tube is a 2B7 or a tube having an output resistance approximating one megohm. There are also cases where the total resistance would be much lower, say 1,000 or 100 ohms. This might be the case when the source of the signal is phonograph pick-up or a microphone. The solution of the voltage division problem indicated in Fig. 1 applies to all cases where the variation is to be in steps of 2 db from 2 db to 20 db.

TAXI RADIOS RETAINED

An order issued by Police Commissioner Bolan of New York City prohibiting radio operation in taxicabs that had sets installed was rescinded by him pending a test case to be brought by the taxi men. Also, on January 1st Bolan is to be succeeded by Maj.-Gen. John O'Ryan.

SUBSCRIBE NOW!

RADIO WORLD, 145 West 45th St., New York City. Enclosed please find my remittance for subscription for RADIO WORLD, one copy each week for specified period.

- \$10.00 for two years, 104 issues.
- \$6 for one year, 52 issues.
- \$3 for six months, 26 issues.
- \$1.50 for three months, 13 issues.
- \$1.00 extra per year for foreign postage.
- This is a renewal of an existing mail subscription (Check off if true)

Your name

Address

City

32-OHM METER

APPLIED TO A D-C INSTRUMENT WITH SPECIAL SHUNTING FOR 1 TO 1,000 -OHM MEASUREMENTS, BESIDES 1,000 TO 100,000 OHMS, 0-1, 0-10, 0-100 MA, 0-3, 0-10, 0-100 AND 0-1000 VOLTS

By Herman Bernard

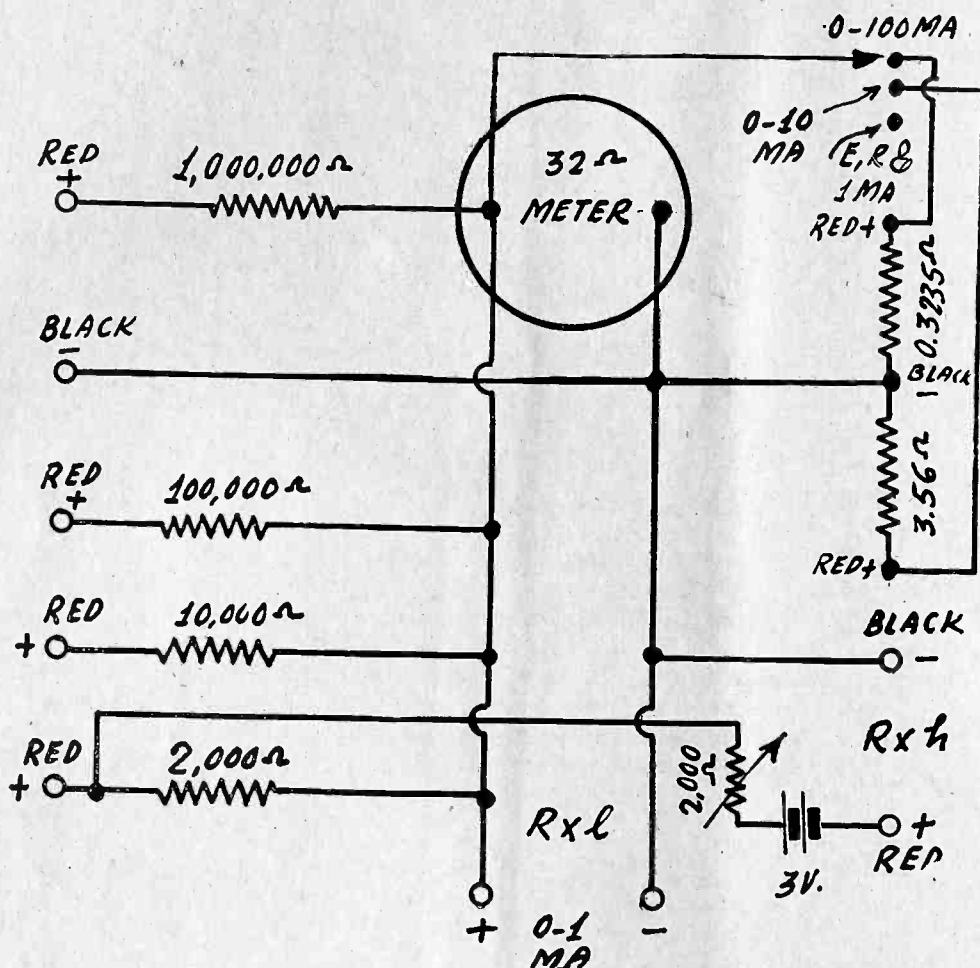

A current-voltage-resistance meter for d-c only. The ranges are 0-1, 0-10, 0-100 ma, 0-3, 0-10, 0-100 and 0-1,000 volts and 1-1,000 and 1,000 to 100,000 ohms. The data are for the Triplet meter, internal resistance 32 ohms.

A VOLT-CURRENT-OHMMETER, for d-c use, was described in the December 16th issue. A feature of the contrivance was the capability of measuring low resistances with only 1 milliamperes flowing, instead of the usual high current. From about 1 ohm to about 1,000 ohms can be measured by the special method, as well as high resistances, to 100,000 ohms, in the usual manner. The low-resistance method is to shunt the meter with the unknown when the terminals for high resistance measurements are shorted.

This week the data are given for the Triplet 321 meter, also 0-1 milliamperes, but having a meter resistance of 32 ohms. For voltage measurements and even for low current shunts of course the internal resistance of the meter is of small significance, since the normal range of good meters in the internal ohms is from 27 to 50 ohms. But for the low-resistance measurement the difference between a 27-ohm and a 32-ohm meter is a substantial

part of the reckoning. For instance, a resistance of 27 ohms as shunt would give half-scale deflection in the one instance and a resistance of 32 ohms would result in half-scale deflection in the other instance, a difference of 5 ohms, or roughly 20 per cent.

Rheostat Added

The circuit is a bit different this time, with five binding posts on either side of the meter, and two posts at lower front for access to the "raw" meter. The d-c voltages that may be read are 0-1,000, 0-100, 0-10 and 0-3 volts. The d-c currents are 0-1, 0-10 and 0-100 ma. A rheostat has been added to take up for the resistance of the 3-volt battery used for all resistance measurements.

The low-resistance measurements still are from 1 to 1,000 ohms and the high-resistance measurements from less than 1,000 ohms to more than 100,000 ohms.

For the benefit of those not familiar with the special shunting method for low-

resistance measurements the theory will be restated.

If one is to measure high resistances, first he shorts the terminals Rxh, and adjusts the 2,000-ohm variable resistor. Since the meter has a sensitivity of 1,000 ohms per volt, and there are 3 volts obtained from the battery, the limiting resistor should be 3,000 ohms, so that when the Rxh terminals are shorted the meter reads full-scale deflection. However, the battery increases in resistance with age and use, and this increase appears as a decrease in voltage, because the current through the resistance of the battery causes a voltage drop that bucks the battery voltage. Hence if the fixed portion of the limiting resistance is 2,000 ohms, and the variable is 2,000 ohms, battery resistance up to 1,000 ohms could be compensated, and that is all-sufficient, for if the battery resistance mounts to anything like that, then a new battery is the prescription.

Table of Resistance

Now, with Rxh terminals shorted and the adjustment of the 2,000-ohm variable made so that there is full-scale deflection, whereby the total resistance is 3,000 ohms for limitations, it is clear that if we shunt the meter itself, which we may do at the "raw" meter terminals, we will reduce the amount of current through the meter proportionate to the shunt resistance. Hence if we draw a curve we can read from that curve the value of the unknown shunt. Data for such a curve may be obtained from the following table:

I	Rxl	I	Rxl
0.025	0.82	0.6	47.15
0.05	1.683	0.8	123.00
0.1	3.56	0.85	171.00
0.15	5.64	0.9	254.00
0.2	7.975	0.95	515.00
0.5	32.00	0.975	891.00

How to Draw Curve

The Triplet meter has five main divisions and ten subdivisions for each main division, hence a total of 50 bars, representing 0.02 ma. per bar (20 microamperes). The figures in the foregoing table may be read under I for current as microamperes by moving the decimal point three places to the right, hence, 25, 50, 100, 150, 200 etc. microamperes, up to 975 microamperes. Full-scale deflection, 1 milliamperes, equals 1,000 microamperes.

A curve drawn from the foregoing should be on large logarithmic paper, preferably two-cycle logarithms, ten lines to the inch. Then the current values for even ohms may be obtained, and fine decimal values ignored.

The plain current values of 10 and 100 milliamperes are obtained by introducing shunts of 3.56 ohms and 0.3235 ohms respectively, and the December 16th issue contained data on making your own shunts. A switch is needed, and may be of the single-pole, triple-throw type, with one of the three positions used as "off," so that there will be no shunt of this type

Formula for Obtaining Unknown Low Resistances

For those who desire to make their own calculations for the value of the unknown low resistance, R_x , in terms of current for the circuit shown, or any similar circuit, with any similar meter, the formula is given herewith:

$$R_x = \frac{R_m (R_o + R_m)}{\frac{E}{I_m} - R_o}$$

where R_x is the unknown low resistance shunting the meter, R_m is the internal resistance of the meter, R_o is the limiting resistance (3,000 ohms in the special case), E is the battery voltage and I_m is the current through the meter alone.

The Completed Meter

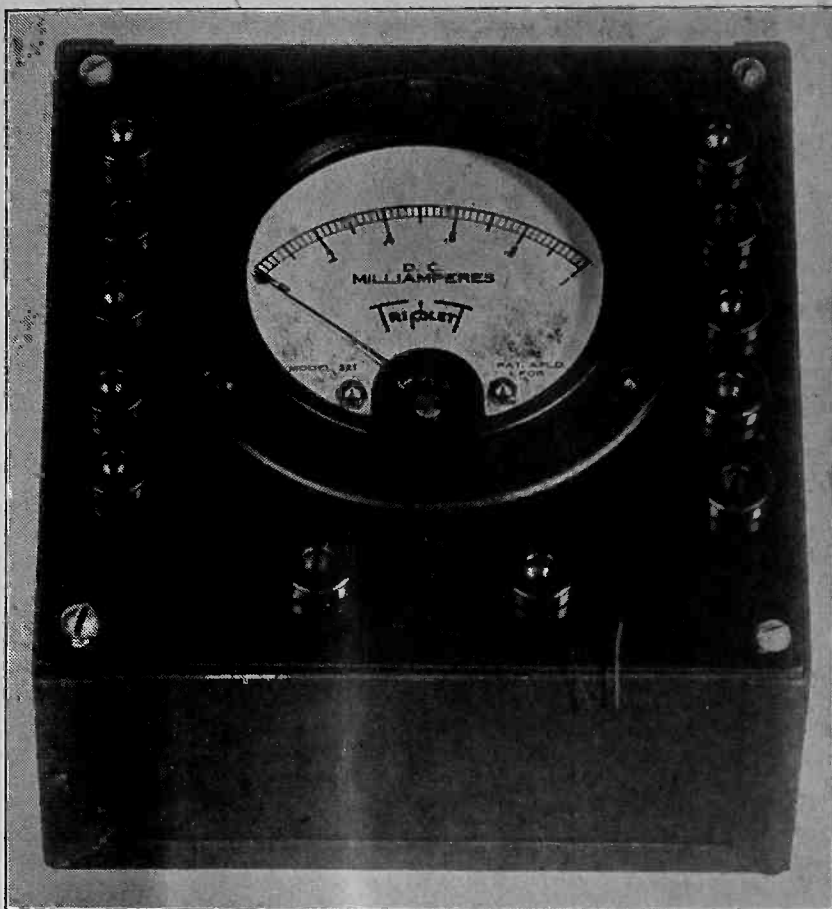

when the meter is to be used for any voltage or resistance measurement, or for 0-1 ma current measurement.

The diagram shows the meter positive in the position it will occupy when you look at the back of the meter, but the rest of the circuit is reversed, so that the voltage jack terminals are at left in the diagram, to coincide with the position in which they are found when one looks at the top of the meter panel (see photograph). So, too, the current and high-resistance posts are at right in the diagram because at right on the panel, although the reversal should be borne in mind as a detail.

Reason for 3-Volt Scale

The jack posts are red or black, red for positive, black for negative. For the voltages at left there are four red or positive jacks and one single common black minus. Therefore to read voltage, connect negative of line to the black second from top, and positive to any one of the three others, depending on the extent of the voltage to be read. As a safety measure always assume that the voltage to be read is 1,000 volts, then go down in steps, to 100 volts, 10 volts and finally 3 volts, if necessary.

The only reason for including the 3-volt scale is that the limiting resistor is available for that purpose. If full-scale is read as 1, then multiply the full-scale or integral readings by 3 to obtain the actual voltage. The correct adjustment is made by shorting R_x and turning the rheostat knob until deflection is actually full-scale. Then the short is opened and the two posts used, one second from left top, the other left bottom.

For the current shunts for 0-10 ma or 0-100 ma readings, the switch is turned to the proper position. Again, the off posi-

The two lower jacks are for access to the 0-1 milliammeter without shunts or multipliers. These terminals would be used only for measuring currents of 1 milliamperes or less, and for low resistance measurements. The high-resistance terminals at lower right would be shorted and the unknown put across the meter for the low resistance measurements. The sequence is from high voltage (left) and high current (right) to low values, top to bottom, for the side jacks. To avoid trouble, always assume the unknown voltage or current is the maximum, thus starting from the top and going down.

tion of the switch must be used when any voltage or resistance measurement is to be made, or if the "raw" meter is to be used as a 0-1 milliammeter.

Does Not Measure A-C

On the right-hand side there are three red jacks and two black ones. Black is the common minus. The upper red is for 0-100 ma, below it is the common minus black, below that the red for 0-10 milliamperes, while the black and red terminals for the high-resistance measurements,

R_x , are literally coded, but there is no external potential applied, so simply insert the unknown high resistance blindly between these two points. The unknown low resistances, as already stated, go across the meter when the high-resistance terminals are shorted and the 2,000-ohm rheostat adjusted to yield full-scale deflection of the meter.

No a-c measurements can be made with this device, but only the d-c voltages and currents stated, and the resistance values stated.

Noted Britons to Regale Us

H. G. Wells, George Bernard Shaw, Viscountess Rhondda, Winston Churchill, David Lloyd George and many other outstanding figures in the economic, literary and social life of Great Britain will be heard in new series of addresses over a National Broadcasting Company network on Tuesday afternoons, beginning January 9th.

Under the general title of "Whither Britain?" these prominent personages will give their opinions of the future of British culture and political progress. The unfettered expressions of individual viewpoints by eleven speakers will embrace eight subjects, and the opinions will be

summed up in the final broadcast by the Right Honorable Walter Elliot, well known Conservative M. P. from Glasgow, Scotland. The talks will be sent by short wave from London and will be rebroadcast in this country over an NBC-WEAF network each Tuesday to March 27th, from 3:30 to 4:00 p.m., E.S.T.

Wells and Shaw will express the viewpoints of the individual thinker, and Churchill and Lloyd George will represent different political schools of thought in the discussions. Viscountess Rhondda, British feminist movement leader, will set forth the opinion of women regarding the future of the Empire. Youth's visions

will be expressed by the Honorable Quintin McGarel Hogg, Fellow of All Souls College, Oxford, and Michael Roberts; Trade unions will speak through Ernest Bevin; Israel Sieff will be the representative of the industrialists; the scientists will be heard through Prof. Patrick Blackett; and religion's views will be stated by the Dean of Exeter.

This series follows a list of programs from London over an NBC network which recently was concluded and which brought to American listeners the opinions of British political party leaders on many controversial subjects of government policy.

FOUR TUNED CIRCUITS

FOUND ADVISABLE IN BROADCAST RECEIVER TO PREVENT HETERODYNE SQUEALS AND SPURIOUS RECEPTION DUE TO OSCILLATOR HARMONICS

By Edward L. Liebers

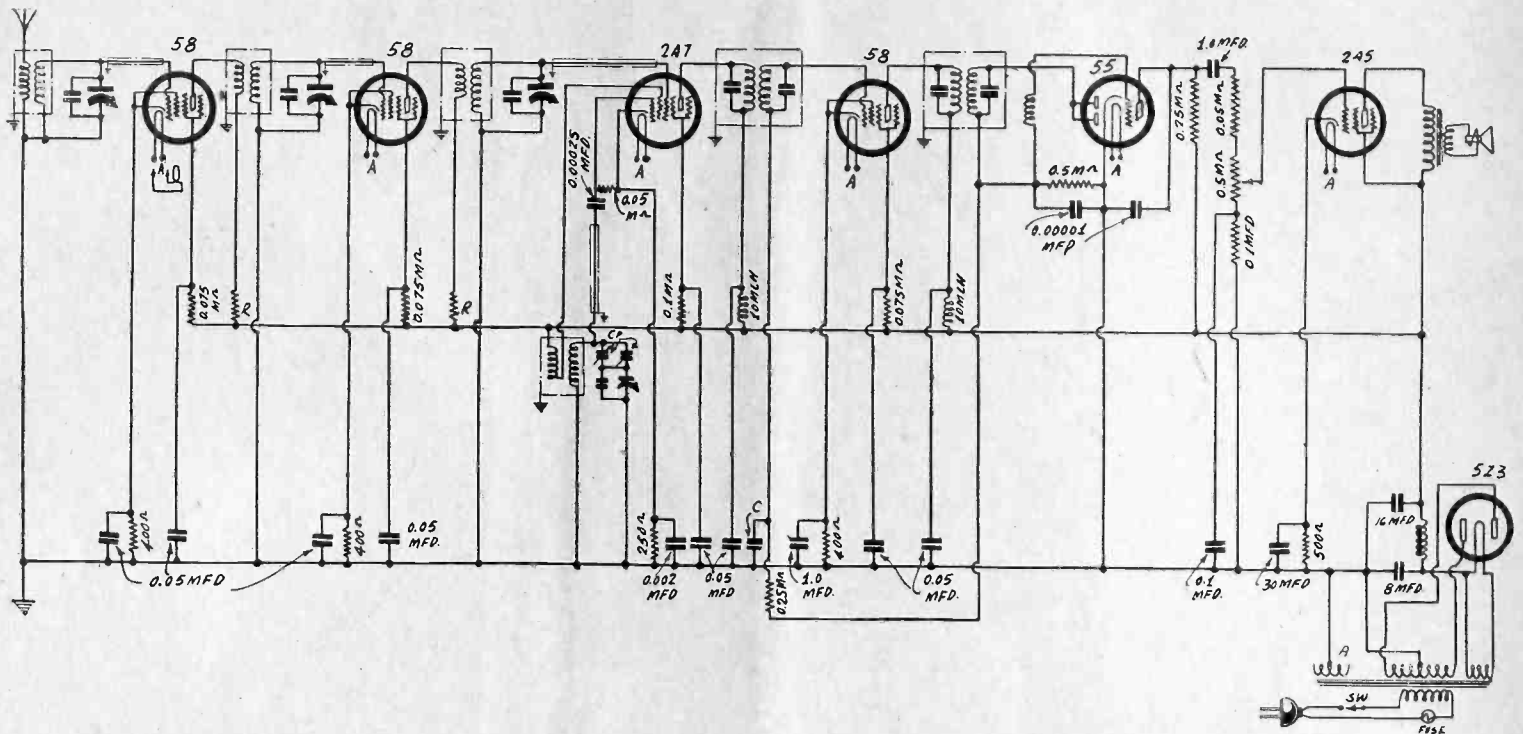

Four tuned circuits for the broadcast band have been found highly advisable, from months of experience with many circuits, if the usual full input from an outdoor antenna is to be used. If a small series condenser is included in the antenna circuit, the four stages would not be vital, three sufficing, but sensitivity would be reduced considerably.

THOSE who desire to build a broadcast superheterodyne almost always raise the question whether a three-gang or a four-gang condenser should be used, and whether the pentagrid converter tube is better than using two separate tubes.

The desirability of having four tuned circuits arises from the fact that strong locals, off-resonant frequencies, still deliver some voltage to the mixer tube, and as a result there would be heterodyne squeals, which the extra or fourth tuned circuit will greatly reduce or totally eliminate.

It has been the experience of practically all who build the four-tuned-circuit receivers that the heterodyne interference trouble is eliminated. Rather than use band-pass tuning, tubes should be included between circuits, so the front end would consist of two stages of tuned radio-frequency amplification, tuned input to modulator and tuned oscillator.

Harmonics Present

As for the use of the pentagrid tube, this simplifies the construction, reduces the stray coupling from oscillator, and makes the coupling practically independent of frequency in the broadcast band for the stray external coupling will be small in a well-designed chassis. If a grid-leak-condenser type oscillator is used, whether in a pentagrid converter tube or two separate oscillators, the harmonics are

rich, and it is possible sometimes to get a high-frequency station on a low-frequency setting of the receiver. Assume 465 kc i.f., receiver set to tune in 600 kc, the oscillator is generating 1065 kc, the second harmonic of which is 2,130. Therefore a signal sent out on 1,665 kc conceivably could come through, since that is the station carrier frequency lower than the oscillator by the amount 465 kc. The extra stage of tuning therefore tends to keep out this factitious reception.

To reduce the harmonic intensity generally, the oscillator should have a small feedback winding, just enough for oscillation at the high-frequency end. The usual recommendations of a higher mutual coupling than prevailed even with the run of previous tubes, to achieve highest practical conversion conductance, has no significance in the light of more serious efforts to limit harmonics, because there is no need in a seven-tube receiver like the one shown to press all gain to the utmost, since there is some to spare anyway, and that is one reason why less than the full audio amplitude is put into the last tube.

The two-stage r-f system in the tuner is open to the objection of squealing, but closed by the known means of getting rid of such oscillation. One precaution is to use shielded wire for the overhead grids of the two 58's and the control grid of the 2A7, grounding the sheath, but being sure not to use "skinny" shield wire, but the type of almost half-inch outside diam-

eter, to make the capacity between conductor and grounded shield negligible.

Series resistors may be used in the plate circuits. These are marked R. Their values will lie somewhere between 2,000 and 5,000 ohms, and the answer is supplied by actual test. After the receiver is completed and there is no trouble at the low-frequency end of tuning, but screams, squeals, catcalls and other irritating noises beginning, say, at 1,300 kc or so, to 1,600 kc, r-f oscillation is the cause, and the two series resistors are introduced, heightened in value until the last vestige of a squeal disappears at the highest frequency to which the circuit tunes.

The values of the resistors need not be equal, either, and if one resistor is made large enough the other may be omitted.

Such resistors also have the added effect of levelling the amplification, 2,000 ohms almost getting rid of the rising characteristic of the t-r-f section. Of course the intermediate and audio levels have practically flat amplification characteristics, in the sense now conveyed, and therefore a step is taken in the right direction.

Selectivity Considerations

The only precaution is in respect to selectivity, but that is taken care of automatically, because the resistance is made no higher than that required to suppress

oscillation at the highest receivable frequency, and that is the condition when selectivity is best, consistent with quiet reception. The effect of the resistors on the low-frequency end is not important.

The circuit may be built for 465 kc or 175 kc i. f., as preferred, or for some other i. f., using either padding or tracking. The padding method is shown, because the coils for such purposes are generally obtainable. For tracking, special oscillator coils of inductance specified by manufacturers are necessary.

The four-gang condenser may be of any capacity from 0.00035 mfd. to 0.00045 mfd., provided the minimum of the condenser does not exceed 25 mmfd., and it doesn't in the general run of condensers as made by DeJur-Amsco, General Instrument Company and the others. That is, the same coils may be used if the capacity is 0.00035 mfd. or higher, but the higher the capacity of the condenser the smaller the padding condenser should be in the oscillator circuit. However, the range of a 850-1,350 mmfd. padding condenser takes in the whole group.

Oscillation Aspects

So far the r-f section the regular coils may be used as obtainable commercially for 0.00035 mfd., whether they be of the type with special winding for antenna primary, or all coils alike, or whether the primaries for interstage are r-f chokes, with a single turn for coupling by capacity to the secondary. The oscillator coil should have an inductance of 126 microhenries for 465 kc, and 190 microhenries for 175 kc, but these coils are commercially obtainable, and are the same as used for separate-tube oscillator. If the tickler is quite large, it is permissible to remove turns, but not so many turns that oscillation stops.

Assuming a leak-condenser oscillator, although the same is probably true of any oscillator, the oscillation voltage has to be built up for the benefit of the low-frequency end, so as to keep the oscillator going, for the LC ratio is least favorable there. This condition required for supporting any oscillation whatever is also pretty close to the amount of oscillation that is so large that by slight increase the oscillation stops because the amplification is less than unity, plate resistance too high or load resistance too low.

Padding Capacities

Hence the tickler arrangement should be tested at the high-frequency end, to be sure there is oscillation where there is most danger of non-oscillation due rather to overdose than paucity. Then a mere check is made that oscillation prevails at the low-frequency end, as it practically always does if at present at the h-f end.

The padding capacities differ for the two frequencies stated. For 465 kc the capacity is nearly 450 mmfd., so a condenser of 350-450 mmfd. would be nearly all the way in, and possibly a condenser of 400-500 mmfd. would give a little better latitude. For 175 kc i. f. the padding condenser would be nearer 1,100 mmfd., so 830-1,350 mmfd. would be suitable. One reason for exceeding the intended range considerably is that the capacities of these condensers as commercially produced are not highly accurate. Once they are set, however, good results may be enjoyed.

The padding capacity may be improvised. As the approximate values are stated, something less may be comprised of fixed condensers in parallel (using mica types exclusively), then the variable may be air-core or compression mica type, and of small capacity, say, 25-100 mmfd. range. This would require the fixed capacities total not less than 75 mmfd. below the required final value.

Test by Sensitivity

There need be no doubt about the right setting, though the actual capacity is not

known, for after the receiver is built, with r-f lined up at 1,450 kc, and oscillator parallel trimmer set for that too. When the receiver is turned to bring in 600 kc or thereabouts, the setting of the series padding condenser is critical, especially for the higher intermediate frequencies, like 465 kc. When volume is tremendous the right point is reached. When it is slight the capacity may be off only a few per cent.

Cp therefore may be read as a single condenser of the right capacity range, or of teamed condensers as explained and as literally diagramed. R, with no value imprinted on the diagram, has been discussed, leaving only C. This condenser may be reduced in capacity if any tendency to i-f oscillation is present. Normally 0.05 mfd. would be used, but as low as 0.00025 mfd. may be substituted in the event of oscillation.

Series Resistor for B Voltage

If the overhead grids of the i-f amplifier have shielded wire connections, shield grounded, and voltages are as stated, there should be no oscillation.

If the B voltage from plate return of r-f or i-f tubes is higher than 250 volts it is advisable to insert a series resistor between the plate return of the 55 and the feed to the previous tubes, to reduce the voltage for these preceding tubes (but not for the 55) to 250 volts or less. A resistance around 1,000 ohms, 3 watts, is usually suitable, and even if the voltage drops to 200 volts the condition is satisfactory.

Theory of Operation

The theory of operation of the total circuit is as follows: The signal-carrier is subjected to tuning in two radio-frequency amplifying stages and also at the input to the modulator, accounting for three sections of the four-gang condenser. The oscillator is padded and tuned to frequencies always higher than the signal-carrier level by the amount of the intermediate frequency. Thus, if the carrier is 1,000 kc and the i. f. is 465 kc, the oscillator is tuned to 1,465 kc. Or, if the i. f. is 175 kc, the oscillator is tuned to 1,175 kc for the same carrier. Padding is accomplished for the high-frequency end, say, at 1,450 kc, by proper oscillator inductance and trimmer capacity, and at a low frequency, say, 600 kc, by adjusting the series padding condenser.

The oscillator and amplified and selected signal-carrier frequencies are mixed in the Pentagrid converter tube by electron coupling, since the cathode sleeve is common to both oscillator triode and modulator quad-rod. There are two predominating resultant frequencies, one of which is selected because the first intermediate transformer, and the i. f. channel as a whole, are tuned to that frequency, which is the difference between the higher oscillator and lower carrier-signal frequencies. The amplified new carrier, or intermediate wave, is put into the paralleled plates of the diode half-wave (full-voltage) detector. The load resistor for this detector is 0.5 meg. and it is bypassed by a small condenser to hold up the rectified voltage.

Some Automatic Volume Control

The grid return of the intermediate amplifier tube is made to the high-potential side of the diode load resistor, so that whatever rectified voltage appears is applied as extra bias to this i-f tube. In that way automatic volume control is introduced, and for signals even down to medium intensity, the control makes a substantial contribution. For instance, WGY, a notorious fading station in a particular location in New York City, was held to sufficient constancy by this method to eradicate any audibly discernible fading. But if the signal is very weak the rectified voltage is not sufficient to contribute this compensation, but that is true of automatic volume control in general, along lines of present usage.

Since there is direct current of a pulsating

nature in the 0.5-meg. load resistor of the diode, this may be put directly into the grid of the amplifier triode of the 55. This method is called diode-biasing, because the bias on the triode is exactly equal to the rectified component of the carrier. Also, diode biasing is more sensitive than the more formal biasing method with stopping condenser.

An r-f choke of 10 millihenries is put between the load resistor and the grid to stop radio-frequency currents from getting into the triode to be amplified in that tube and in a subsequent circuit that amplifies r. f. as well as a. f. The triode plate circuit bypass condenser augments the detouring of radio frequencies. Use of less than the full voltage input to the 2A5 serves two purposes: it gives some protection against overload and besides tends to correct for i-f oscillation, as the circuit to ground becomes a lower impedance path than the grid-to-ground circuit.

The speaker's output transformer transfers the audio to the voice coil circuit for actuation of the speaker diaphragm.

Constants Discussed

The power transformer supplies 2.5 volts for all heaters, 5 volts for the 5Z3 rectifier, and high voltage to the rectifier plates. Thus, with primary, only four windings are necessary, because the common 2.5-volt winding is acceptable on account of the power tube being of the heater type.

As for values of constants, those of any critical nature have been discussed. The bypass capacities need not be exactly as stated, and may be larger rather than smaller, except for C where oscillation is present. After the rectifier choke it is good practice to use 16 mfd. instead of the more usual 8 mfd., as hum is considerably reduced, and regulation improved. If the B voltage is not high enough, the 8 mfd. may be put at the end of the field choke, toward the power tube plate circuit, and the 16 mfd. next to the rectifier. Such low voltage might result if the power transformer itself delivered too low a B voltage or if the d-c resistance of the speaker field were much more than intended. A resistance value in excess of 2,500 ohms scarcely would be used, and more customary values would be 1,800 and 2,100 ohms.

The biasing resistors may be a hundred ohms or more than specified, except for the power tube and the 2A7, where the values should be as stated, or close thereto.

Voltage Values

As for voltages, the total B voltage, from the common B feed of the set to ground, may be 270 volts, in which case it would be advisable to use the series resistor previously mentioned, with a bypass condenser of 0.1 mfd. or so from the lower voltage to ground. If the total is 250 volts without that, then the 500-ohm biasing resistor of the 2A5 may be reduced to 400 ohms, and of course series B resistor omitted. The bias on the r-f and pentagrid tubes may be around 3 or 3.5 volts, with stated resistance values used, and the steady bias on the i-f tube the same, if the measurement is made at no signal input.

The screen resistors are high enough to effectuate bypassing of a substantial order by the condensers of 0.05 mfd., and for 250 volts will drop the screen voltage to approximately 90 volts. The 10 mh. r-f chokes do not reduce the plate voltage substantially, as they have a d-c resistance of around 75 ohms, equivalent to a reduction of 7.5 volts if the plate current is 10 ma.

The voltage across the detector load resistor of 0.5 meg. can not be read with current-drawing meters, but some idea of the functioning of the circuit may be attained by putting a 0-1 milliammeter in series with the load resistor, as between ground and the end of the load resistor shown going to ground. This would constitute the meter a 500-volt range instrument, and strongest locals might not develop much more than 10 volts or so, therefore the deflection will be small, but can be increased by halving the load resistor for any lining-up tests to be

(Continued on next page)

A FIVE-TUBE A-C SHORT-WAVE SET WITH 'PHONE PLUG AND SEPARATE SPEAKER

By *Herm...*
Try-Mo Ra...

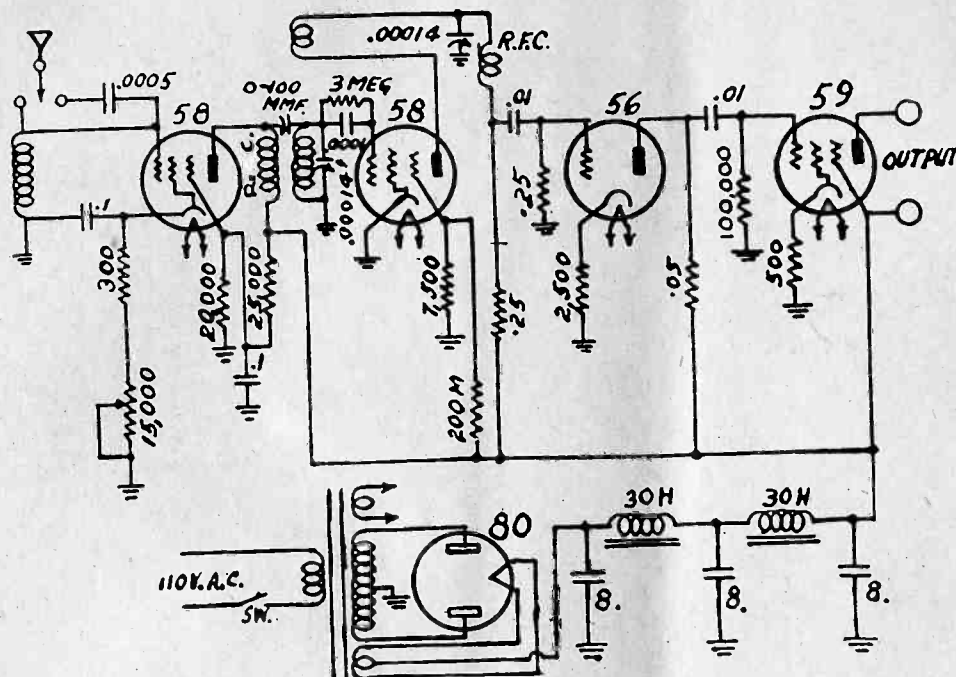

The five-tube short-wave set that enables foreign reception and with which either earphones or magnetic speaker are to be used. A jack takes care of the phones, while the speaker output posts are at rear of the chassis.

HERE we have a simple five-tube, a-c operated short wave receiver that makes itself heard whenever there is some chance of bringing in the distant stations, and the chance occurs very often with a receiver with as high gain as this one. Indeed, it occurs every day and for the greater part of every day. Of course, the high sensitivity of the receiver is largely due to the use of high gain tubes. For example, we have a 58 as radio frequency amplifier, and there is no better tube for that purpose, considering gain and stability. Then we have a similar tube as regenerative detector, and that tube is mighty fine for that purpose. It is somewhat critical as to regeneration for certain voltage combinations, but those combinations need not be selected, and they have not been in the present receiver.

The first audio amplifier is a 56. While this is not a high gain tube, it does boost the signal many times, and this is just so much extra gain in the circuit, for the amplification in the output pentode would be sufficient if the circuit were not to be outstanding for sensitivity.

Aperiodic Input

Aperiodic input is used as this is entirely non-critical and dependable at all times. However, there is a switch in the antenna lead by which the grid of the first tube may be picked up directly or through a small condenser. The coil between the grid and ground is a radio frequency choke which is effective at all frequencies covered by the coils furnished.

It will be noticed that a volume control is inserted in the cathode lead of the first 58. It is a 15,000-ohm variable resistor in series with the 300-ohm bias limiting resistor. Volume is controlled, therefore, by controlling the bias on the radio frequency amplifier. This by itself is not sufficient when the signals are very strong, but

there is another way of controlling the gain in the circuit is the regeneration control. This takes the form of a 140 mmfd. variable condenser connected between the tickler and ground. This condenser serves as the main volume control as well as the regeneration control because the volume change that can be effected by regeneration is very large. The tickler winding for each coil has been designed so that the 140 mmfd. variable condenser is sufficient to stop oscillation on the highest frequency and to insure oscillation on the lowest covered by that coil and the 140 mmfd. tuning condenser.

The coupling between the radio frequency amplifier and the regenerative detector is of the choke-capacity type. That is, the plate of the amplifier is fed

(Continued from preceding page)
made this way. Afterwards the higher resistance would be restored.

Nor can the voltage from plate of the 55 to ground or to B plus be read with much accuracy with usual meters, due to the small current, and readings of "50 volts" or so may be taken as satisfactory, though meaningless save as relative indication, that is, true indication of voltage does not prevail.

The drop in the primary of the output transformer will be around 25 volts, usually a little less.

Directions for lining up have been given repeatedly, so just a brief concluding sketch will be made of this procedure. With properly selected coils it is not necessary to rig up the receiver as a t-r-f set, but it may be constituted at once as a super, and 1,450 kc used for the high-frequency tie-down point. A test oscillator is preferable, though

LIST OF PARTS

Coils

- One set of four plug-in coils
- Two radio frequency chokes
- One 250 mh. radio frequency choke
- One electrostatically shielded power transformer
- Two 30-henry filter chokes

Condensers

- Two 140 mmfd. variable tuning condensers
- One 100 mmfd. tuning condenser
- One 0.0001 mfd. fixed mica condenser
- Two 0.01 mfd. fixed mica condensers
- Two 0.1 mfd. fixed condensers
- One 0.0005 mfd. fixed condenser
- Three 8 mfd. electrolytic condensers (50 volts)

Resistors

- One 15,000-ohm variable resistor with limit switch attached
- One 300-ohm resistor
- One 2,500-ohm resistor
- One 7,500-ohm resistor
- One 20,000-ohm resistor
- One 25,000-ohm resistor
- One 50,000-ohm resistor
- One 100,000-ohm resistor
- One 200,000-ohm resistor
- Two 250,000-ohm resistors
- One three-megohm grid leak
- One 500-ohm, 10-watt resistor

Other Requirements

- One black crackle finish shield can
- One drilled and punched metal base
- One slow motion vernier full-vision dial
- Two 58 sockets
- One 56 socket
- One 59 socket
- One 80 socket
- One coil socket
- Three tube shields
- One antenna-ground binding post strip
- One pair output binding posts
- One roll hookup wire
- One kit of assorted hardware
- One AC cable (cord and plug)
- Three knobs

A Seven-Tube Super

a station at or near this frequency may be used. With a test oscillator, connect its output to the antenna post, with aerial removed, and turn the test oscillator dial for generation of 1,450 kc, or a lower frequency yielding a harmonic which is 1,450 kc. The modulation of the test oscillator will be strong enough to enable you to get satisfactory deflection on the 0-1 milliammeter previously mentioned.

Have the trimmers half way out, then adjust the oscillator trimmer for maximum response, and adjust the r-f trimmers, one at a time, backwards, that is, modulation input first, second r-f next and first r-f last. The reason for the inverse order is that this is the order of greater apparent effect. Then "rock" the dial as the oscillator's trimmer is experimentally readjusted one way and another, in an endeavor to get bigger response. Select the oscillator trimmer

SHORT-WAVE RECEIVER

OUTPUT FOR MAGNETIC SPEAKER

Cosman
Corporation

through a radio frequency choke and the signal is passed to the tuned circuit through a small condenser, in this case variable and having a maximum capacity of 100 mmfd. This condenser offers another means for controlling volume, because the smaller it is the less the amplification, and vice versa. However, as the condenser is decreased the effectiveness of the regeneration also goes up, so that the condenser serves mainly as a means for controlling the selectivity. This in itself is a valuable feature.

Plug-in Coils Used

The plug-in coil system is used because so far that has given greatest all-around satisfaction. The coils employed are of fairly large diameter but fit into standard sockets, and they are ribbed so that the wire is for the most part in air. This is recognized as the best coil construction when low loss and high efficiency are of first importance. Besides this, the coil forms are of a low loss material, and that, of course, helps to make them efficient.

There are four coils in a complete set and they cover, with the 140 mmfd. tuning condenser, the frequency range from 1,500 to 20,000 kc, that is, from 200 to 15 meters.

Built-in Power Supply

The power supply is built into the receiver and its consists of a regular rectifier with filter. As a means of reducing the hum to a vanishing minimum, which is really essential in a regenerative short wave receiver, both the filament and the anode windings of the power transformer have been centertapped. For broadcast receivers the filament winding is seldom centertapped these days, but the positive output lead is taken from one side of the filament. With the lead connected to the center tap there is less hum. Besides this precaution against hum, there are two sections of low pass filter in the output, consisting of two 30-henry chokes in series

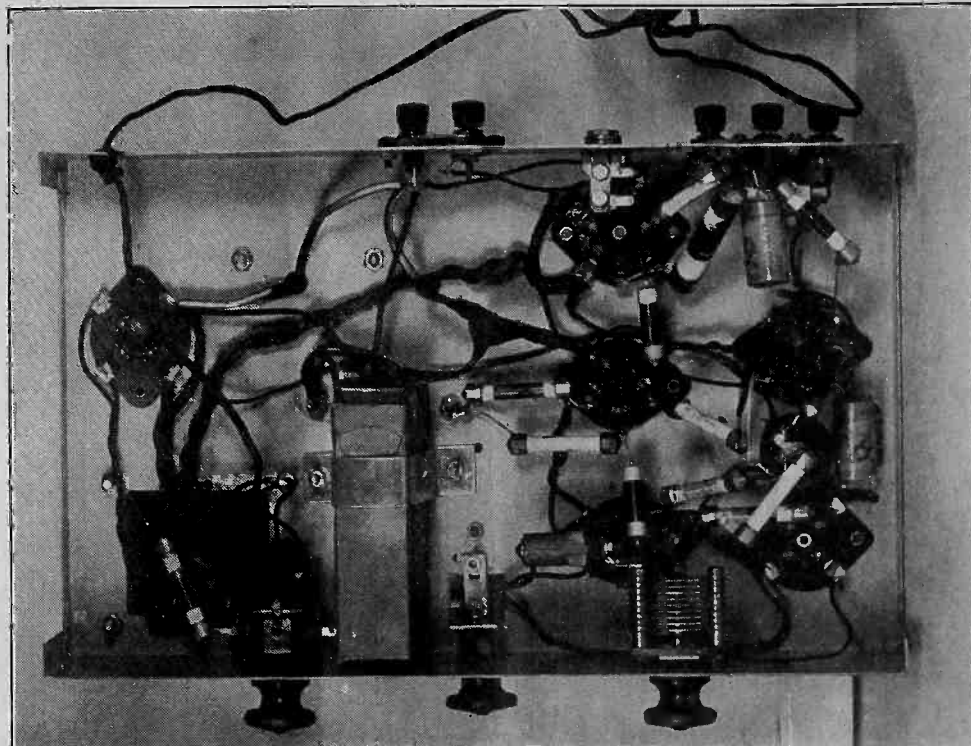

Bottom view of the wiring of Herman Cosman's receiver. Two 8 mfd. condensers in view are electrolytics in oblong blocks.

and three 8 mfd. condensers in shunt with the line.

Plate and Screen Supply

All the plate and screen leads are returned to the same point on the B supply without any common resistance or choke. There is no chance of back coupling, for the common impedance presented by the filter is entirely negligible. All the plates are returned directly to the high voltage, but the detector and the 56 audio amplifier have high resistances in series so that the effective voltages on their plates are low.

The screens of the first two tubes are

maintained at lower potentials by means of individual voltage dividers. Thus in the screen circuit of the first tube we have a 20,000-ohm resistor between the screen and ground and a 25,000-ohm resistor between the screen and the B supply. The screen, therefore, gets a little less than half as much voltage as the plate does. In the screen circuit of the detector we have a similar arrangement, but in this case the resistor between the screen and ground is only 7,500 ohms while that between the screen and the B supply is 200,000 ohms. In this case, then, the screen voltage is comparatively very low. It should be when a screen grid tube is used for detection.

Bias Voltages

As we have already pointed out, the first tube is biased first with a 300-ohm resistance in the cathode lead and a variable resistance in series with it, the variable resistance having a maximum value of 15,000 ohms. This combination of bias resistance is shunted by a condenser of 0.1 mfd.

The detector tube is not biased because the grid leak and stopping condenser method of detection is employed, and, of course, that type of detector is self biased. The grid stopping condenser is only 100 mmfd., quite large enough for short wave reception, and the grid leak is 3 megohms.

The 56 is biased by means of a 2,500-ohm resistor in the cathode lead. It is not by-passed for the circuit is more stable on the low audio frequencies if it is not. The power pentode is biased by means of a 500-ohm resistor in the cathode lead, and the by-pass condenser for this is also omitted in the interest of stability on the low audio frequencies.

of Consequence

ting that gives greatest needle deflection or most sound output. Then set the test oscillator at 600 kc, turn the receiver dial to about three-quarters the full displacement, near the maximum capacity of the condenser, and adjust the series padding condenser, turning it bit by bit, each time removing the screwdriver, until greatest deflection or sound volume results. Do not readjust the parallel trimmers after they have been set once, unless a large change has been made in the series capacity, when a new and final test may be made on the oscillator trimmer alone, at 1,450 kc.

The foregoing presupposes the intermediate channel is lined up first at the proper frequency, which is done by connecting test oscillator to the grid of the 58 i-f tube, tuning the grid circuit condenser (the one that does not give a B voltage reading to shield can of coil), and then adjusting the

plate condenser in this coil. Do not readjust the grid circuit after the plate has been tuned. Next put the test oscillator to the plate of the 2A7 quadrod, which is primary of the first i-f coil, and adjust grid circuit and then plate circuit condenser, not molesting the grid circuit after the plate circuit has been set. In some instances, if the test oscillation is rather strong, it may be put into the first i-f tube simply by wrapping a turn or two of wire from the test oscillator's output, around the glass of the tube.

The data given in this article are based on actual construction and reconstruction of circuits, and on many hours of experimenting and testing, and the circuit may be built with complete confidence that it will bring the desired results.

The selectivity is great enough to tune through a local for DX 10 kc off.

Radio University

A QUESTION and Answer Department. Only questions from Radio University members are answered. Such membership is obtained by sending subscription order direct to RADIO WORLD for one year (52 issues) at \$6 without any other premium.

RADIO WORLD, 145 WEST 45th STREET, NEW YORK, N. Y.

Shunts on A-C Meters

IS IT PRACTICAL to put shunts on a-c meters to extend their range just as the range of a d-c instrument is extended? If not, why does it not work?—W. E. R.

If the meter is non-reactive and if non-reactive shunts are used, it will work. It is difficult to get non-reactive shunts even if the instrument is non-reactive. An a-c meter using a hot wire or a thermocouple is practically non-reactive and for these shunts might be used. If the frequency of the alternating current to be measured is low there is no difficulty in making the shunts non-reactive.

* * *

Use of Oscillating C Supply

YOU HAVE DESCRIBED a C supply consisting of a high frequency oscillator and a rectifier, using a 55 for both functions. Will not the harmonics of the oscillation frequency interfere with the reception of radio signals when a device of this kind is employed? It seems to me that they would.—F. N. C.

If the frequency of the oscillator is too high there will be some interference. However, it would be possible to exclude the harmonics by thorough filtering. Moreover, it is not necessary to use such a high frequency that the harmonics in the tuning range of the receiver would be strong. If the frequency is placed just above the upper audio limit there should be no trouble.

* * *

Regeneration in Intermediate Amplifiers

HOW CAN REGENERATION be introduced into an intermediate frequency amplifier to make the gain higher? Is it practical to do it?—W. M.

One way of doing it is to connect a high resistance between the plate of one tube and the plate of the preceding. This can be done directly if the supply voltages on the two tubes are the same. If they are different there should be a condenser in series with the resistance. Regeneration in intermediate frequency amplifiers is not very successful because it makes the circuit very unstable, and besides, if the frequency is low, it makes the circuit entirely too selective. If the intermediate frequency is as high as 465 kc some advantage should be gained by regeneration. The method suggested does not adapt itself to a variable control because the resistance is put between high potential leads.

Calibration Mixup

HAVING BUILT a test oscillator, following a design shown by Herman Bernard, I get excellent results, except for calibration trouble. I used WOR, 710 kc, in calibrating and since the test oscillator is in the low-frequency (intermediate fundamental range, I find that the frequency actually generated at what should be 177.5 kc is instead only 165 kc, and of course the calibration is haywire throughout. I am sure I connected all the parts as they should be, but evidently ran into calibration trouble due to my scant knowledge of the use of harmonics.—E.M.S.H.

Yes, you ran into calibration trouble, but you can get out of it easily enough. You thought you were lining up the oscillator on the basis of its harmonics beating with WOR, 710 kc, whereas in point of fact you had your receiver tuned to WEA, 660 kc, and therefore the fundamental (i. e., 177.7 kc) you thought harmonic yielded a fourth harmonic to beat with 710 kc really yielded a fourth harmonic to beat with 660 kc, i. e., fundamental of test oscillator was 165 kc. If you will do the work over again, using either station, but being sure this time which is which, you will not have any further trouble.

* * *

Tuned Plate or Tuned Grid

FROM the viewpoint of harmonics, which is the better, the tuned plate or the tuned grid circuit? That is, will the harmonics be amplified more in the tuned plate than in the tuned grid, or vice versa? Please show these circuits in equivalent form.—W. H. U.

There should be no difference between these two circuits whether they are used in amplifiers or oscillators, for in each there is a mutual inductance and a condenser. The difference is just in the order in which they appear. Yet, if the amplification is carefully checked for both these circuits, it will be found that the tuned plate is slightly superior. This does not seem to agree with common experience for the tuned plate circuit is generally regarded as being much less selective than the tuned grid. Well, we must distinguish between the two when the secondary draws appreciable current and when it does not draw any. The plate tuned circuit is superior when the grid draws current, it may not be when the grid resistance is infinite, as it will be in a well designed radio frequency amplifier. Below are shown two couplers together with their equivalent circuits. It will be noticed in the equivalent circuits that in each there is a condenser and a mutual inductance shunt. In the tuned plate the condenser comes first, in the tuned grid the mutual comes first.

Radiation and Induction Fields

WHAT is the difference between the radiation and induction fields about an antenna? Or are they one and the same thing?—F. G. L.

The radiation field is due to energy radiated from the antenna and appears as radiation resistance. The induction field is due to energy which is thrown out but returns again. This adds nothing to the radiation resistance. The radiation field varies inversely as the distance from the antenna; the induction field, on the other hand, varies inversely as the square of the distance. Very close to the antenna the induction field is the stronger, but at a distance greater than about half a wavelength the radiation field is the stronger.

* * *

Sources of Noise in Car

WHAT are the main sources of electrical noise in a car? How should they be reduced?—W. B. J.

The spark plugs, the distributor, and the generator commutator are the principal sources of noise. Noise from the spark plugs is suppressed by inserting spark suppressors in series with the "hot" leads to the plugs, which are usually high resistances. Noise from the commutator and the distributor are usually suppressed with by-pass condensers. It is important that the commutator and the distributor points be kept clean, for only dirty contacts cause much sparking.

* * *

Best Insulators

WHAT ARE some of the very best electrical insulators, not from the point of view of high frequency losses but from the point of view of high electrical resistivity?—W. B.

Sulphur is one of the very best known insulators. Hard rubber is also very good, and that may be because it contains a high percentage of sulphur. Another good insulator is paraffine. In fact, there are many waxes, both vegetable and mineral, that are good. Mica is also a high grade insulator. But sulphur stands at the top of the list.

* * *

Construction of Voltage Multipliers

WHEN voltage multipliers are constructed for voltmeters why is not the internal resistance of the meter taken into account? When high accuracy is to be had, it seems to me, this resistance should be taken into account.—R. B.

The internal resistance of the meter is always taken into account. But it is a question of the accuracy of the meter aside from the multipliers. Suppose, for example, that the internal resistance is 50 ohms and that the meter is to be used for measuring 500 volts, assuming that the instrument has a full scale deflection of one milliampere. The total resistance in the circuit must be 500,000 ohms. Suppose no allowance is made for the 50 ohms in the meter. What is the error? It is 50 parts in 500,000, or one part in 10,000. The scale of the meter might be readable to one part in 200. Hence it would be impossible to tell the difference whether we had 500,000 ohms in the circuit or 500,050 ohms. The same applies to lower multipliers, but the lower the total resistance the more important it is to take the meter resistance into account. Suppose for illustration that the meter is to read 1 volt

(Continued on next page)

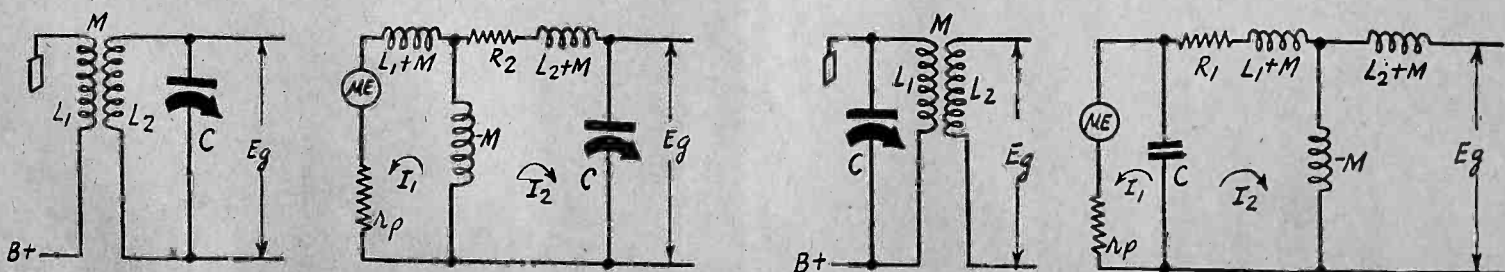

The tuned grid and the tuned plate circuits are closely similar whether they are used amplifiers or oscillators. Above are shown the two with their equivalent circuits. At left is the tuned grid and at right the tuned plate.

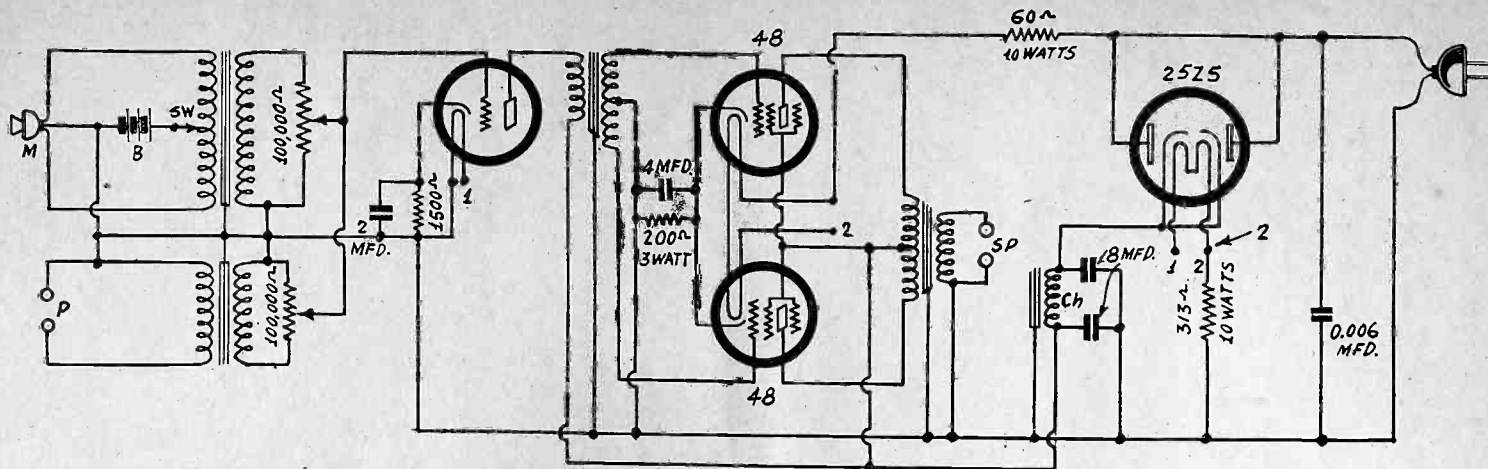

A public address system of 5 watts output

(Continued from preceding page)
at full scale. The total resistance now should be 1,000 ohms. If it is 1,050 ohms we commit an error of 5 per cent, and that is ten times more than the error in reading the scale. Therefore in this case we would make allowance for the 50 ohms in the meter. The more accurate the scale on the meter the closer must be the accuracy of the resistors.

Quality and Selectivity

WHAT is the relationship, if any, between the quality of output of a receiver and the selectivity? How would you connect a high impedance phone to the output of a power detector?—J. T. M.

The higher the selectivity the greater is the cut-off of the higher audio frequencies. Hence, if the receiver is too selective the receiver will have a "low pitch." Consonants in speech will not be distinct and therefore it will be difficult to understand a speaker. Music will lack brilliancy. Connect the high impedance phones in the plate circuit of the power detector tube and connect a by-pass condenser of about 0.001 mfd. from the plate to ground. The condenser is really not necessary but it helps detection a bit.

Resistance Wire for Instruments

I WISH to construct a number of resistors and am wondering what wire to use. I know that Manganin is used for resistance standards but could not some other and more common wire be used equally well?—G. D.

If the accuracy and constancy are not to be very great you can use Nichrome wire. That has the highest resistivity of all wires and therefore will require the shortest

length for a given size and resistance. That wire is easily obtainable.

Public Address System

PLEASE SHOW a universal type power amplifier, for radio, phonograph pickup and for microphone use. The first tube should be a 37 and should drive push-pull 48 tubes, with of course a 25Z5 rectifier.—J. K. S.

The circuit is depicted on this page. The transformer with the battery to be switched in and out is for the microphone connection. M, and the impedance of the primary should match that of the microphone. The details of the requirement for a particular microphone may be obtained from the manufacturer of that device. The phonograph pickup P would have a separate transformer. The diagram is for a public address system. For input from a radio set, a stopping condenser from detector-loaded plate to either secondary (for M or P) would suffice. The 315-ohm resistor is the shunt to take up the difference in current between the 48 heater (0.4 ampere) and the other heaters (0.3 ampere).

25-Cycle Receiver

WILL a 25-cycle receiver operate on the same voltage at 60 cycles? Why? Will a 60-cycle receiver operate on 25 cycles and the same voltage?—J. T. M.

A 25-cycle receiver will operate on 60 cycles if the voltages are the same because the primary impedance is high enough for the higher frequency if it is high enough for the lower. The output voltage will be slightly higher on the higher frequency but not so much higher that it is not safe. A 60-cycle receiver, on the other hand, will not work on 25 cycles because the primary inductance and the size of the core of the input transformer are too low.

Varying Oscillation Intensity

CAN you suggest a method of varying the oscillation intensity to compensate for the difference between the high and the low frequencies of an oscillator? The circuit oscillates more easily at the high frequencies but the current in the tuned circuit is stronger on the low. I want a method of compensating.—E. L.

The difference is due to the difference in the L-C ratio mainly. If the circuit is just barely oscillating the current in the tuned circuit is very large because it has to be in order that the grid voltage should be sufficiently high to maintain the oscillation. This suggests a possibility of making allowance for the difference. Suppose the grid leak is made a potentiometer and the grid is connected to the slider. As the slider is moved down toward ground the effective value of the amplification factor, as far as the tuned circuit is concerned, is reduced. If the slider is moved just to the point where oscillation ceases the current in the tuned circuit will be about the same regardless of the frequency. This is only a suggestion, not a statement of fact, but the suggestion is based on well-known facts.

Non-Reactive Resistors

IS IT necessary that multiplier and shunt resistances for d-c meters be wound non-inductively, or is it permissible to use ordinary spools of wire? What is the best method of making non-reactive resistances?—R. N. A.

No, it is not necessary that the shunts and multipliers for d-c meters be non-reactive, and they can be wound in spool form. This is nearly always done. The best method of winding non-reactive resistances is what is known as the Ayrton-Perry method. A wire is wound on a flat piece of hard rubber or bakelite with a space between turns equal to the thickness of the wire. Then another wire is wound on the same form in the opposite direction in the spaces left vacant when the first wire was put on. The two wires are then connected in parallel. The two wires will cross each other at every turn, but due to the fact that they are parallel the voltage between the two wires at any crossing will be zero. Hence there will be no loss from capacity. Since the two coils are wound in opposite direction the inductances of the two will neutralize each other. The fact that coils are flat will also reduce inductance. Resistances wound in this manner can be used even at radio frequencies but, of course, the higher the frequency the more will the small residual reactance affect the effective value of the resistance.

Regeneration Control by Resistance

WHY is it possible to vary the regeneration in a circuit by varying the resistance in the plate circuit of the tube?—L. W. C.
Regeneration and oscillation are due to the amplifying property of the tube, and the amplification depends on the mutual con-

Two for the price of One

Get EXTRA one-year subscription for any One of these magazines:

- POPULAR SCIENCE MONTHLY.
- RADIO-CRAFT (monthly, 12 issues).
- RADIO INDEX (monthly, 12 issues), stations, programs, etc.
- RADIO (monthly, 12 issues; for Amateurs and short-wave experimenters).
- EVERYDAY SCIENCE AND MECHANICS (monthly).
- RADIO LOG AND LORE. Bi-monthly; 5 issues. Full station lists, cross indexed; etc.
- AMERICAN BOY—YOUTH'S COMPANION (monthly, 12 issues; popular magazine).
- BOYS' LIFE (monthly, 12 issues; popular magazine).
- OPEN ROAD FOR BOYS (monthly, 12 issues).

Select any one of these magazines and get it free for an entire year by sending in a year's subscription for RADIO WORLD at the regular price, \$6.00. Cash in now on this opportunity to get RADIO WORLD WEEKLY, 52 weeks at the standard price for such subscription, plus a full year's subscription for any ONE of the other enumerated magazines FREE. Put a cross in the square next to the magazine of your choice, in the above list, fill out the coupon below, and mail \$6 check money order or stamps to RADIO WORLD, 145 West 45th Street, New York, N. Y. (Add \$1.50, making \$7.50 in all, for extra foreign or Canadian postage for both publications.)

Your Name.....

Your Street Address.....

City..... State.....

- If renewing an existing or expiring subscription for RADIO WORLD, please put a cross in square at beginning of this sentence.
- If renewing an existing or expiring subscription for other magazines, please put a cross in square at the beginning of this sentence.

RADIO WORLD, 145 West 45th Street, New York. (Just East of Broadway)

DOUBLE VALUE!

ductance of the tube, or of the tube and the plate circuit. By varying the effective voltage on the plate, or the total resistance in the plate circuit, the mutual conductance can be varied, and in that way the regeneration is controlled. The same effect can be obtained by varying the filament current, or rather the emission from the cathode. This is practical in filament type tubes, and for that reason filament control of regeneration was used regularly when battery tubes were common. When the tube is of the cathode type, this is not practical because of the sluggishness of the cathode in responding to changes in the filament current.

What Intermediate Frequency

MANY different intermediate frequencies have been used in broadcast and short-wave superheterodynes, but there seems to be no agreement as to which one is best. Is there any basis on which the frequency is selected, or is it just a matter of hit or miss?—S. H.

There are many facts to be considered in the selection of an intermediate frequency. First, the lower the frequency the more selective is the circuit in the intermediate channel and the greater will stable amplification be. Second, the frequency must not be too low for then it is not practical to secure sufficient selectivity in the radio frequency tuner to suppress the second beat frequency, or rather to suppress those radio frequencies which cause the second beat. It is for this reason that the intermediate frequency has been progressively increased. This increase was made practical by the introduction of new tubes which could be operated stably at the higher frequencies. Third, certain frequencies should be avoided in order to avoid harmonic interference. This, however, is very difficult to do. The 175 kc frequency was selected because the fourth harmonic was the first that fell in the broadcast band, or because it was that highest that could be used and still insure that the third harmonic was below the broadcast band. The highest frequency that can be used and insure that the second harmonic should fall below the broadcast band is 270 kc, and for that reason frequencies of about that value have been used. Now the common frequency is 456 kc. Its second harmonic 912 kc, which is in the broadcast band, but it does not coincide with any broadcast frequency. When the circuit is to be used for high frequency reception it is customary to use 465 kc or higher. Such a high value is used because it is necessary in order to have some radio frequency selectivity. The higher the signal frequency the higher should the intermediate frequency be, for it makes it easier to discriminate between channels on the high signal frequencies. It is not particularly desirable to have an intermediate frequency that falls in the broadcast band, for then it is difficult to exclude broadcast frequencies from the intermediate amplifier. Of course, this should be done by shielding but shielding is not always 100 per cent perfect.

Effective Height of Antenna

HOW CAN the effective height of an antenna be determined? Does the flat top portion add anything to the height or is only the leadin to be counted?—T. L. C.

The flat top portion of the antenna adds to the effective height but not nearly so much as the vertical portion. In fact, one yard of the horizontal portion is about equal to one foot of the vertical. This, of course, is not exact, but it can be used as an estimate. The only way to determine the effective height of the antenna is to measure it. This can be done by measuring the field strength of a given signal and then determine how much voltage the antenna picks up of the same signal. The voltage in the antenna is equal to the product of the effective height and the field strength. The field strength is most generally measured with a loop of known dimensions and number of turns. The effective height of the loop can be computed from the dimensions and the turns and the voltage it picks up can

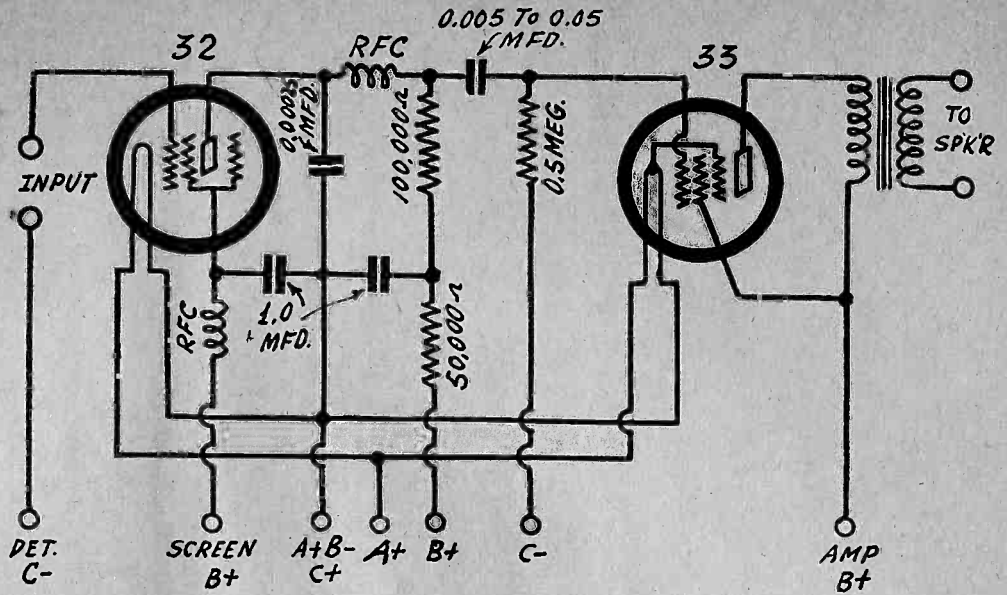

A small detector amplifier, using two-volt tubes, the 32 as detector and the 33 as output. The 32 is a screen grid tube, the 33 is a pentode.

be measured. Hence the field strength can be obtained and with this known the effective height of the vertical antenna can be computed after having measured the voltage it picks up from the same field.

Two-Volt Tube Circuit

JUST A SKETCH, please, of a detector-amplifier, two tubes, 2-volt type, with as much sensitivity as practical.—W. E. S.

The diagram is given herewith. RFC may be a choke of 10-millihenries inductance. Excellent quality can be obtained from this simple detector and single audio-stage circuit. The bias for the detector may be 3.5 volts negative, for 90 volts of B, whereas the 33 takes negative 13.5 volts for 135 volts of B. The screen voltage for the 32 may be 45 to 67.5 volts.

Ballast Resistors

I HAVE a receiver in which two 48s are in series with 6.3-volt, 0.3-ampere tubes. The shunt resistance that takes care of the difference in currents is 277 ohms and the

series ballast is 68 ohms. I want to add another 239 tube. What should the shunt resistance and the ballast resistance be in the new arrangement?—W. H. C.

The voltage drop across the shunt will be increased by 6.3 volts and since the current in it is 0.1 ampere, the resistance should be increased by 63 ohms, making the total 340 ohms. The drop in the ballast will be reduced by 6.3 volts, and since the current in this resistance is 0.4 ampere, the resistance should be decreased by 8 ohms, making the new resistance 60 ohms. There is no need of changing the wattage rating of the resistors provided that they were heavy enough in the first place.

Loss of Power in Grid Circuit

HOW much power is lost in the grid circuit of an amplifier operating at radio frequency? How much in an oscillator?—A. B. L.

If the tube is biased so that no grid current is drawn, the loss is zero. (Continued on next page)

Join Radio World's

UNIVERSITY CLUB

And Get Free Question and Answer Service for the Coming 52 Weeks.

THIS SERVICE FOR UNIVERSITY SUBSCRIBERS ONLY

Subscribe for RADIO WORLD for one year (52 numbers). Use the coupon below or write on a separate sheet of paper, if preferred. Your name will be entered on our subscription and University Club lists by special number and you will be apprised of the number. When sending questions, put this number on the outside of the forwarding envelope (not the enclosed return envelope) and also put it at the head of your query. If already a subscriber, send \$6 for renewal from close of present subscription and your name will be entered in Radio University.

NO OTHER PREMIUM GIVEN WITH THIS OFFER

[In sending in your queries to the University Department, please paragraph and number them. Write on one side of sheet only. Always give your University Club Number.]

RADIO WORLD, 145 West 45th Street, New York City.

Enclosed find \$6.00 for Radio World for one year (52 nos.) and also enter my name on the list of members of RADIO WORLD'S UNIVERSITY CLUB, which gives me free answers to radio queries for 52 ensuing weeks, and send me my number indicating membership.

Name

Street

City and State.....

The Review

Questions and Answers Based on Articles Printed in Last Week's Issue

Questions

1. What is the effect of the degree of coupling in the antenna circuit which is coupled to a tuned secondary?

2. Has a variable series antenna condenser an effect on tuning? On resistance?

3. Considering short-wave reception, may the inductance of a standard antenna be neglected? If so, why? If not, state values tending to prove that such neglect may not be practiced.

4. What determines the natural frequency of an antenna? Is there any type of antenna that does not have a natural frequency? If so, name it.

5. Is the expression "shortening the antenna," as applied to use of a series antenna condenser, a proper one? If so, why? If not, why not? State one outstanding difference between physical shortening and electrical shortening of the antenna.

6. Are loop antennas more efficient on short waves or on long waves? State two advantages of a loop and one disadvantage.

7. Give a method of dual control of regeneration and state a reason for resorting to this practice.

8. What is "tinning" a soldering iron? How is it done?

9. Should soldering paste be applied to a hot iron or to the joints to be soldered? What is the effect of soldering paste?

10. Should heavy pressure be applied to parts intended to be joined by soldering, so that the iron presses strongly against the parts? If so, why? If not, why not?

11. Should a hot iron be moved about the parts to be soldered, so as better to distribute the heat?

12. In a switch type short-wave set, state the reason for including a separate trimmer across each secondary.

13. If the local oscillator inductance is known, state a simple method of capacity measurement for determining padding values, etc.

14. State one reason why excellent two-way reception was enjoyed between land stations and the Settle-Fordney balloon expedition into the stratosphere.

15. State a method of using a potentiometer as an output control, retaining a grounded slider, and yet not introducing any shorting makeshift.

16. State a satisfactory substitute for a 300-ohm 30-watt resistor in a circuit drawing 0.3 ampere.

17. Does a small diameter necessarily mean a poor coil for short waves? What is the basis of judging what the diameter should be, or the length of the winding, if the diameter is pre-selected?

18. Which is the most sensitive output tube of the 6.3-volt series? State two difficulties concerning its use and a simple solution for one of the difficulties.

19. Is the triode of the 55 a good oscillator?

20. What is the object of a series plate resistor, unbypassed, in a radio-frequency or intermediate-frequency circuit?

Answers

1. The degree of coupling controls the amount of input and the degree of selectivity. The closer the coupling the less the selectivity and the greater the voltage communicated to the tuned secondary.

2. A variable antenna series condenser has a considerable tuning effect, depending much on the condenser's capacity in relation to the antenna's self-capacity. If the relationship is such that the effective capacity change is considerable, the resistance change is considerable. The smaller the series capacity the lower the radio-frequency resistance of the antenna circuit.

3. For short waves the inductance of the standard antenna must not be neglected, as it is 20 microhenries in the standard as adopted by the American Standards Association, and the primary of a short-wave antenna coil may have an inductance of only a few microhenries.

4. Every antenna has a natural period or frequency, determined by the self-capacity and the distributed inductance of the antenna. Hence there is no type of antenna that fails to have a natural frequency.

5. The expression, "shortening the antenna," used when a series condenser is introduced, is a proper one, as the antenna capacity is reduced, just as it is when the antenna is physically, rather than electrically, shortened. One outstanding difference between the two methods, physical and electrical, is that the physical method reduces the distributed inductance, whereas the series capacity method does not change that inductance at all.

6. Loops are more efficient on shorter waves. Two advantages are improved selectivity and directional sensitivity. A disadvantage is inconvenience.

7. A method of dual regeneration control is to have fixed tickler and a shunt feed variable condenser, and turn the condenser for main regeneration control, and have a variable series resistor to alter the plate voltage. The series resistor may be used as a vernier and thus the most sensitive point of operation, just below oscillation, may be more slowly and conveniently approached.

8. Tinning a soldering iron consists of heating it for a few minutes, cleaning the four squarish surfaces on the tip, if necessary, applying soldering paste, and then immersing the squarish surfaces of the tip in solder. When the solder brightly covers the surface it is proof the iron is clean. Also, the iron is most effective when clean.

9. When joints are to be soldered, paste should be applied to the parts that will constitute the joint, and should not be applied to the iron. The effect of soldering paste is to remove film and other impurities and thus prepare the parts for clean joining.

10. Heavy pressure should not be applied from the iron to the parts to be joined, because the joint is to result from heat, and not from mechanical force. Heavy pressure does not improve the heat, but may render the parts insecure at the moment of soldering.

11. The iron should not be moved at all, but should be kept still at the place where the soldering is to be done, for concentration of heat is desired, not distribution of heat.

12. A separate trimmer is used across each secondary in a switch-type short-wave set because any single trimmer capacity applies only to a particular coil, and for other coils the circuit capacity discrepancies that are to be ironed out may be considerably different. For instance, the distributed capacities of the other coils will be different, also the capacity due to wiring, since the other coils occupy other positions, and the leads will be longer or shorter.

13. If a local oscillator inductance is shown, and phones are put in the plate circuit, an antenna connection made loosely to the oscillator, beats will be established with broadcasting stations of known frequency. Thus tuning condenser's capacity may be calibrated, and the calibrated condenser used for determining unknown values.

14. Excellent results in radiophone with the stratosphere scientists were enjoyed because of the absence of ground reflections. This changed favorably the angle of reflection for the radio ceiling. Two-way talk, height about 11 miles, was had, with actual

output power of 1 watt from the balloon transmitter.

15. Use a transformer. Instead of grounding the secondary, put the total potentiometer resistance across it, ground the slider, and connect output from high side of the coil through a condenser.

16. A 40-watt electric lamp.

17. No. The preferred ratio is that the diameter (including wire thickness) be approximately 2.5 times the axial length of the winding. Thus a coil of half-inch diameter may be excellent.

18. The 48. The difficulties: (a) it does not heat at same rate as other tubes in this series, so requires a separate ballast resistor, for which there is no solution, simple or otherwise; (b) draws more current (0.4 ampere) than the other tubes of the series (0.3 ampere), but the simple solution is a shunting resistor across the other tubes in their entirety.

19. Yes. In fact, it is one of the readiest oscillators and tends to be a grid emitter of a high order.

20. Stopping oscillation.

PERSONS OF MOMENT

Robert Simmons, young American tenor featured with Jack Pearl and Al Goodman's orchestra on the Lucky Strike program, sings in German, French and Italian as well as English. "A good actor should be able to play all the parts, and a good singer should be able to sing in several languages," says Simmons.

* * *

Pick-ups in the San Francisco NBC studios: Meredith Willson, orchestra sup supervisor, always smiling, never is photographed save in serious mien . . . Johnny Toffoli is playing a new accordion designed by himself . . . Carlton E. Morse, author of "One Man's Family," is a native of Louisiana who was reared on an Oregon ranch.

* * *

Don't walk—run, is Graham McNamee's idea of things. The veteran NBC announcer is always in a hurry, excited and enthusiastic. His breathless eagerness is reflected in his voice, whether describing a sports event or serving as a foil for Ed Wynn.

* * *

John Seagle, youthful baritone and son of Oscar Seagle, himself a famous baritone in his day, was christened Jean. The French variant of John was bestowed on the younger Seagle when he was born in Paris in 1906. He changed it on coming to America to live because his boy friends kidded him about being a "Frenchie."

* * *

People always want to know if Senator Frankenstein Fishface of the Carefree Carnival ad-libs his tangled nouns and adjectives, or just reads them. . . . "No," he admits, "I have to write them all down in advance. I'm no good at ad-libbing so I just read the copy . . . but I DO get mixed up sometimes, I guess!"

* * *

Michael Raffetto, who plays Paul in One Man's Family, has a new job on his hands—that of literary guide for Billy Page, who is Jack in the same serial. Billy, who is a high school student, has lately become interested in the classics, and Mike is steering him through a course of reading that embraces everything from Jane Austen to Pierre Loti.

"DOUBLE ECHO" IN BYRD TALK IS EXPLAINED

A vocal echo that travelled 'round the world in a split second and other oddities of short-wave radio signals were described recently by O. H. Caldwell, former Federal Radio Commissioner, and now president of the Science Forum of the New York Electrical Society, in a talk over WABC and the Columbia network.

Illustrating the rapidity with which a radio signal travels, Caldwell told how he had heard his own voice come back in an echo a seventh of a second after he had uttered a syllable which had travelled the entire 25,000 miles around the earth. He explained that short-wave signals rebound from a reflecting layer about a hundred miles above the earth and thus are made to follow the earth's curvature rather than shoot off on a straight line into space. This is called the Kennelly-Heaviside layer, Caldwell said.

He opened his talk, titled "The Earth Shrinks," with the statement that radio engineers have figuratively caused the world to shrink, as far as sound is concerned, to the width of a city street.

Radio Wave's Lag Noticeable

"Even though radio speeds at 186,000 miles per second," Dr. Caldwell said, "the time it takes to go 25,000 miles is noticeable. My words came back to me as a sort of double echo of each syllable. Each syllable was prolonged a fraction of a second, very much as one notices the echo when talking in a hall 75 feet or so in length. In fact, the time taken for sound waves in air (which move at the slow speed of 1,000 feet a second) to travel 75 feet to an opposite wall and then echo back to the starting point, is the same as the time required for a radio wave to go clear around the world."

Caldwell told how radio signals sent from New York to Paris are picked up and also continued on around the world, eventually reaching Paris a second time and causing a slight slur in the original signal.

One of the reasons that short-wave radio signals are being received so clearly these days, Caldwell explained, is that there are so few sun spots and magnetic storms at present. Sun spots tend to break up the Kennelly-Heaviside layer, so the waves do not come back to earth with their usual force.

In line with the science of short-wave broadcasting Caldwell said the current experiments in transmitting programs on a regular schedule from the Byrd Antarctic Expedition's flagship, Jacob Ruppert, en route to Little America, were interesting because of several unorthodox features surrounding them.

Impressed by Byrd Stunt

"Radio men with whom I have talked," he asserted, "have all been impressed with the remarkable transmission obtained from the ship's antenna and one-kilowatt transmitter. This is all the more remarkable when it is realized that the ship's course was changed a day or two after she left the Panama Canal, so that instead of following the South American coast southward to the Antarctic, in connection with which provision had been made for a radio pick-up through Buenos Aires, Admiral Byrd decided to sail almost due

Studio Insights

Gene Arnold, heard in many NBC programs each week, went hunting over a weekend and left his brand new shotgun in the taxicab on the way to the station. So he borrowed one and got the legal limit of quail.

* * *

Charlie Howard, tenor, walks to his destination whenever possible.

* * *

Dick Teela, tenor who is heard in the new Climalene Carnival program, sang in more than 2,000 programs during his first year with NBC.

* * *

Cliff Soubier is a versatile sort of fellow. He plays the "heavy" roles (generally the villain) in "First Nighter," is an end man in the Sinclair Minstrels and spels nickel-plated words as the barker in the Sealed Power Side Show. Cliff got his start playing Little Eva in "Uncle Tom's Cabin" at the age of five.

* * *

Annette Hanshaw, radio Show Boat star, received an unusual request the other day. One of her fans asked her to send a description of what she was going to wear at her next broadcast, so she could create a more concrete picture of Annette as she stood before the microphone.

west across the Pacific for Wellington, New Zealand, so that Honolulu had to be substituted as the pick-up point for the broadcasts of the last three Saturday nights. And, amazingly enough, the resourcefulness of radio, as arranged by the tireless technical men of the Columbia network and RCA Communications, was able to follow Admiral Byrd all over the trackless wastes of the South Pacific and keep him in touch with American listeners."

Caldwell perceived in one of the recent broadcasts from Admiral Byrd's ship an example of the difference in the speed of short-wave radio signals and signals carried by wire. The signals from the ship came to New York in two channels—one a direct aerial route from Honolulu, the other a relay of the Honolulu signal from San Francisco to New York by wire. For a short period, he explained, the direct route from Honolulu to New York was substituted for the wire relay.

"During the transition of fading from one circuit to the other," said Caldwell, "listeners heard a curious double echo effect, as if Admiral Byrd were talking in an echoing hall. This double effect was entirely in the transmission circuits and was caused by the fact that Admiral Byrd's syllables over the radio reached New York and the network about a fifth of a second before the same syllables, coming by telephone wire, reached New York. Radio waves travel 186,000 miles per second through the open ether, while transmission over wires is somewhat slower. So listeners at the moment of transition heard both circuits, one a fifth of a second behind the other, and the double echo resulted."

Caldwell said the distance of the broadcast from the Byrd flagship was 9,600 miles by radio and that, when the expedition reaches Little America, although farther south, it will be nearer to New York in a radio line. When the transmitter is settled in that spot and a directional antenna is put into operation, he said, it is expected reception of the transmitter's signals in New York will be far better than it has been so far.

STATIONS COME TO TERMS WITH 3 NEWS GROUPS

The agreement between broadcasting stations and news-gathering organizations, prophesied in the December 16th issue in an article about the quarrel over news broadcasts, has been perfected. That advance article, by Robert Eichberg, set forth that the two factions were about to come to terms, in realization of the news-gatherers' property right in news.

The newspapers, as subscribers to news-gathering agencies like the Associated Press, the United Press and International News Service, feared that their circulation was suffering because of the extent to which spot news was broadcast, often at about the same time that the editions of the newspapers went on the street. Since in a large measure the source of this very news was deemed to be the complaining newspapers, the argument about unfairness was raised.

Chains Quit News Business

Of the ten points covered by the agreement, one provision calls for a newspaper committee to select bulletins that are to be sent out, and fix the time at which these broadcasts are to be made. In that way conflict with edition releases by the newspapers will be avoided. The bulletins are to be limited to thirty words, a condition previously in force, the reason being that only skeleton information is to be disseminated over the air, and to the newspapers is to be reserved the potentialities of that reading market that seeks the intimate details of the news.

The bulletins will be furnished to stations by news agencies co-operating with newspapers. Also it is expected that the general commentators on news, whose position is somewhat different, and not completely covered yet, will continue with their admonition to the listeners to "read your favorite newspaper for full details."

The Columbia Broadcasting System had been building up an extensive news-gathering agency, and had been seeking representation in press galleries of Federal and State capitals, while to a lesser degree the National Broadcasting System had been gathering news, but under the terms of the agreement both chains will cease these activities, and foot the bills to date for their own endeavors.

Favored Stoppage

Sports talks hereafter are to be of a "background" and "atmosphere" type, rather than spot news announcing details of leading events. The newspapers, who spend enormous amounts of money to gather news and disseminate it, directly and through the associations, and who to some extent print radio programs, felt that broadcasting of spot news of sporting events was decidedly unfair to their circulation, particularly of evening newspapers where afternoon results are in the final editions, which editions depend considerably for their sale on appeasing curiosity over such outcome.

The three previously mentioned news-gathering and news-disseminating agencies will supply the thirty-word bulletins.

Last Spring the long-standing hard feeling between news-gathering agencies, and broadcasting stations that send out news, became heightened and the newspaper publishers favored stoppage of broadcasts.

Station Sparks

By Alice Remsen

Changes in Programs

Although reports have been heard around Radio Row that Ethel Waters would be off the Amco show, the dusky chanteuse remains for another month, and maybe longer. As predicted in this column a couple of weeks ago, George Beatty will be missing unless the sponsors change their minds. It would be a shame not to have Beatty, as this writer thinks he did a fine job and provided some original humor to the gag-infested air-waves. It is rumored that George will beat it for Hollywood to screen his "Broken Arms Hotel"—which is a fine idea, too. . . . Have you heard that nice program on WOR, "Romance in Rhythm and Rhyme," Fridays at 10:45 a. m., with Joe Bier and Sylvia Cyde? Miss Cyde is youthful and her soprano voice possesses a decidedly refreshing charm, and her lyrics are understandable, which is more than can be said of a great many sopranos. Joe Bier has a mellow baritone which will blend well with Miss Cyde's voice when they become more used to each other. Joe's solo work is fine, and not only that, he writes the cute poetic continuity which makes the program a little different from the ordinary run of boy-and-girl efforts. A good commercial possibility.

FRANK PARKER QUILTS

And now I understand that Frank Parker is leaving the A. and P. Gypsies after a long association with that fine organization; the Gypsies will hereafter use guest artists each week. . . . Edith Murray, from musical comedy, is causing some talk with her rhythm singing on the WABC Jessel broadcasts. . . . A great many people will be sorry to hear that Crumit and Sanderson leave their Blackstone Cigar spot on Tuesday nights over WEA, on December 26th, and I suppose that just as many other folk will be glad to hear that Fred Allen will succeed them with a new series. Both acts have their own followers. . . . And as mentioned here before, Lum and Abner quit, with Fred Waring taking over the program spots. Lum and Abner finish up on December 29th and go to work for another sponsor. . . . Have you noticed the epidemic of cowboy shows on the air lately? On WABC we have "Cowboy Tom," "Bobby Benson," "Sunny Jim," "The Texas Rangers" and "The Crazy Buckaroos;" on NBC there are "Bar X Days and Nights" and "The Tom Mix Straight Shooters;" WOR, not to be outdone, has "Maverick Jim." . . . The new Buick series, with Robert Benchley, Howard Marsh and the Kostelanetz Orchestra, made its debut on Christmas Day. . . . The English Singers entertained via WABC and the Columbia network on Christmas Eve. . . . Kay Thompson and Her Rhythm Kings have been signed to appear on the weekly Crosby-Hayton programs from the Pacific Coast. Miss Thompson is a singing pianist. . . . The Vagabonds, Harold, Dean and Curt, of Station WSM, Nashville, Tennessee, recently made twenty records for Victor; the boys feature the "home type" of songs. . . .

MORE RANGE SONGS

There is a new trio on station WLS, Chicago, which is known as "The Prairie Farmer Station." This new trio features Mountain and Range songs, and is heard daily between six and seven a. m. Trio includes Jack Dunnigan, Trulan Wilder and Skyland Scotty. Jack plays a guitar and Scotty a five-stringed banjo. . . . The Chicago Herald and Examiner Station, KYW, is one of the many local stations broadcasting that hardy perennial transcription series, "Detectives Black and Blue" . . . There is a mysterious personality at WMCA known as "Don Apollo," who appears at his broadcasts hooded and disguised. Nobody at the studio has seen this person's face, and nobody knows who he is, at least according to the Press Department. He is supposed to be one of the greatest of operatic stars and the radio listeners are invited to tune in on WMCA each Tuesday evening at 8:30 p. m. and figure out for themselves whose personality hides behind the mask and whose

voice it is that comes over the air so sweetly. . . . Westell Gordon, who was featured for a number of years with the Capitol family, is the latest concert and radio star to be added to the staff of WMCA. Westell is featured on "The Ballad Hour" each Sunday night at 7:45 p. m., together with Billie Dauscha and Bob Haring's Orchestra. . . . In case you do not know it, Westell Gordon is not only a fine singer, but a talented cellist and composer also; some of his better known songs are "One Little Dream of You," "The Lantern of Love," "No One Knows" and "Far Away Bells." . . . WMCA is really to be congratulated upon its list of famous concert and opera stars now featured regularly over its air-waves. Mary Lewis, Redferne Hollingshead, Charles Hackett and Beniamino Riccio, are among them. . . .

TRY IT ON THE KIDS

The latest catch phrase around the studios of WHOM is "Ki fels a nagy resz farcasrel?"—which might be a good thing to try on your friends some time. It means "Who's Afraid of the Big Bad Wolf?" in Hungarian and its vogue was started by Margaret Hambek, the talented young Hungarian musician who broadcasts piano and violin solos and duos with her sister Gabrielle every Sunday afternoon at 2:15 p. m. . . . Did you know that a vocal echo travels around the world in a split second? And that short wave signals rebound from a reflecting layer one hundred miles above the earth and thus are made to follow the earth's curvature rather than shoot off on a straight line into space? And that short wave signals may be received more clearly when there are no sun spots or magnetic storms? All these pointers and many others of great interest were told by O. H. Caldwell, former Federal Radio Commissioner, and now the president of the Science Forum of the New York Electrical Society, in a talk over WABC and the Columbia network on a recent evening. I know a little bit more about radio since listening to Mr. Caldwell. . . .

62% FOR THE GOOD OLD SONGS

According to Bert Lahr, the radio public likes old gags the best. Mr. Lahr recently wasted a lot of his hard-earned money sending out questionnaires to twenty-five thousand listeners; their replies proved that sixty-two per cent prefer the moss-covered variety and only thirty-eight per cent require their risibilities tickled with a new bunch of laugh-getters. . . . Listeners on this side of the ocean have a chance to tune in on a British version of "Why does a chicken cross the road," and other old minstrel jokes when the BBC shortwaved its "Kentucky Minstrels" from London. I remember when I was a kid, my Dad used to take me to see the Moore & Burgess Minstrels up at Isling-

A THOUGHT FOR THE WEEK

*T*HERE probably always will be friction between daily papers and the news commentators attached to broadcasting stations. The papers feel that radio has taken away some of their circulation and advertising, while the stations are likely, though erroneously, to figure that news is news and common property. This makes no allowance for the fact that news as such becomes the property of those who gather it and send it out in special form for the eyes of the world. The property right in news was confirmed by the United States Supreme Court more than a decade ago.

ton, in North London. It wasn't funny to me then, but it would be now, to hear cockney voices impersonating Bones and Tambo. . . . Ozzie Nelson will remain at the Park Central until June. . . . Jack Martin, who takes care of Jack Lait's broadcast over WINS, while Jack is away, manages to get some fine radio stars to sing for him—and why not? He is a very nice young chap and gives the artist a good break in publicity—which after all is very necessary in these days of keen competition. . . . Billy White, the "platinum-voiced" tenor from Chicago, has joined Glen Gray and his Casa Loma Orchestra at the Essex House Colonades as vocalist; he was formerly featured with the Gus Arnheim, Ted Fiorito and Frank Westphal orchestras. . . . Jack Smart has returned to the March of Time cast. He is a very versatile chap and has done as many as five impersonations on one broadcast. . . .

WOOLLCOTT TO CHANGE

Alexander Woollcott's "Town Crier" program is on a new schedule, every Tuesday and Friday 9:15 p. m. . . . Marge, of "Myrt and Marge," is having her portrait painted by Samuel Malmberg. . . . Harry Stockwell, recently added to the "Easy Aces" cast, used to be radio editor of the Kansas City Journal-Post when Goodman Ace was dramatic critic of the same paper. . . . It's raining like the deuce, washing all the nice white snow away. Oh, well, guess I won't drown, so here goes for town!

STUDIO GOSSIP

Edward Davies, baritone heard on the Hoover Sentinels program each Sunday, has more than a professional interest in his sponsor's products. Long before he rose to the ranks of radio stars he spent two years selling Hoover products. With the commissions earned he paid his way through music school, became a radio star and now is back again with his old employers, but this time in a different capacity.

Gene Arnold can manipulate a typewriter, but he says he can't think while using one, so he writes all his programs in longhand; then has them typed.

Marcel Rodrigo, Spanish operatic baritone, called at Radio City the other day to have lunch with an NBC executive—and would be awfully hungry by this time if it hadn't been for Yvette Trinnette Bedard, a young secretary in the sales department. The executive, it seems, had been called away from his office unexpectedly, leaving word for Rodrigo to that effect. As Rodrigo speaks only Spanish and French, he continued to wait, and to grow hungrier and hungrier, until Miss Bedard, a young lady of French descent, came to his rescue and explained the situation.

The Landt Trio and White have a stooge named Minnie on their morning programs who is getting more fan mail than they are. Minnie's voice is simulated by one of the Landt Brothers, a little known fact, for the fan mail writers address Minnie personally.

TRADIOGRAMS

By J. Murray Barron

The General Electric Company announces that the General Laminated Products Corporation, 233 Spring Street, New York City, has been appointed exclusive distributor of Laminated Textolite fabricated and in sheet, rod and tubing, exclusive of gears and gear material.

* * *

J. M. Davis, formerly at the 61 Cortlandt Street store of Nussbaum's, is now in charge of servicing at the Forty-second Street-Sixth Avenue store in New York City. Those interested in short-wave work will find Mr. Davis an accommodating fellow and ready to aid the brother experimenter.

* * *

Although there are various short-wave clubs, leagues, etc., not overlooking the New York Chapter of the Short-Wave Club of Klondike, there is some talk of another short-wave club in New York City, which of course would include other points. It is the purpose of any club that counts, and the value it has for the members. If it's a fan club for the mutual good of the short-wave listeners throughout the world, fine and dandy. If it's just another scheme to get short-wave fan names and commercialize them, then it might turn out to be a racket. It's too bad that more fans cannot read between the lines, so to speak, and judge so many radio rackets for themselves. In this respect it's not always just the little fellow that works a racket. To the newcomers in short-wave radio and those who do not fully realize the extent to which the fans throughout the world are interested in short-wave reception, it might be surprising to learn of the extensive correspondence that many mail-order houses have with all points of the globe.

* * *

There are some inquiries from those interested in radio knowledge who, it seems, regret not being in a position to attend local radio schools and other technical courses. To those it might be surprising to learn of many prominent men in various industries who received their early training from correspondence schools. Today those living at remote points or whose business hours and obligations prevent them attending a resident school can quite easily acquire technical knowledge and practical experience at home. There are various booklets with full detailed information to be had, including a new one from the RCA Institute, at 75 Varick Street, New York City, or 1154 Merchandise Mart, Chicago, Ill.

* * *

From the downtown section of New York comes the good news that Thor's Radio Bargain Basement has in preparation a new short-wave receiver kit and will within a few weeks be ready to make deliveries. Bob Herzog has concentrated on designing a most efficient receiver, kits to sell at a minimum cost.

* * *

American Sales Company, a large New York mail order house, reports a considerable increase in business, and particularly a large demand for short-wave converters, sets and coils, as well as constantly-modulated test oscillators that cover the intermediate and broadcast frequencies and to work on a-c., or d-c. or batteries.

Beetle "Baker's Dozen"

Beetle, the haunter of Phil Baker, appears in so many places at the same time that Harry (Bottle) McNaughton ventures to say that he must be a "Baker's dozen."

Film Called Choice Subject for Television

Plans for the television of motion pictures, the use of which is said to have certain definite advantages over television presentations by "live" talent, were outlined today by Eugene W. Castle, of Castle Films, producers of business and educational films. According to Mr. Castle, recent advances in television indicate that this entertainment medium will be in general use within a few years, and material for television presentation must now be considered.

While television broadcasts to date have been built around programs given by "live" casts, experiments have been made which show that motion pictures can not only be satisfactorily televised, but have definite points of superiority. One of these is that the motion picture screen, as a flat surface, makes it easier for pictures to be picked up by television transmitters than would be possible if several characters were moving about a stage.

Pioneering in the field of producing motion pictures for television use, Castle Films is at present designing films so that they can be readily adapted for this purpose. According to Mr. Castle, films now in process of production can be revised for television presentation within twenty-four hours.

Discussing the future use of business motion pictures in television, Eugene W. Castle declared:

"Having built up a library of silent and sound films during the past nineteen years, it is easy to understand why Castle Films can adapt educational and business films for television use. All of these films have wide interest. We have learned that through showings to millions of people. Simple editing of these productions will make them suitable for the wider showing that television will make possible.

"During the past few years we have, as a matter of fact, had the inevitable advent of television in mind, and films have been designed with this possible use in view. We are merely awaiting the signal to go ahead. We are all ready here."

Literature Wanted

Readers desiring radio literature from manufacturers and jobbers should send a request for publication of their name and address. Address Literature Editor, RADIO WORLD, 145 West 45th Street, New York, N. Y.

John C. Mohn, 150 Jerome Place, Bloomfield, N. J.
Carl E. Bagford, Box 114, Spring Valley, Ohio.
A. W. Burnett, 111 S. Grand, Cherokee, Okla.
Joseph Iatarola, 1219 N. 23rd Ave., Melrose Park, Ill.

Rudy Zaunick, Star Route, Kane, Penna.
Kenneth H. Jones, 1711 Que Street, N. W., Washington, D. C.

Tom C. Brickham, 57 Bay St., Oshkosh, Wisc.
Norman Koe, 866 Jackson St., San Francisco, Calif.
Arthur L. Bohnert, 712 20th Ave., Seattle Wash.
Wendell Cihaneck, 1744 N. 18th St., Milwaukee, Wisc.

L. M. Seghers, 1628 Alvar St., New Orleans, La.
Jos. Belick, 65 Front St., Box 133, Coplay, Penna.
O. J. Marshick, 1519 Clark Ave., Detroit, Mich.
John O. Lee, Box 3, Lewistown, Ill.

C. M. Laudemberger, 511 Parsons St., Easton, Penna.
William A. Temple, 4713 88th St., Elmhurst, L. I., N. Y.

M. S. Meyer, Rohrer Electric Co., Inc., 1313 Main St., Niagara Falls, N. Y.

R. S. Hall, Box 36 H. S., Springfield, Mass.
W. H. M. Bartlett, c/o Hydro Electric System, 55 Princess St., Winnipeg, Man., Canada.

Charles J. Parkman, 86 Fuller St., Dorchester, Mass.

F. Hoekstra, Hoekstra's Radio Lab., 18 So. Marguerita Ave., Alhambra, Calif.
Carlton Slater, Quality Radio Repairing, Saginaw, Mich.

Elmer A. Noble, P. O. Box 642, Borger, Texas.
A. E. Gayton, 515 William St., London, Ont., Canada.

H. R. Carter, Box 27, Vermilion, Ohio.
Robert Kebernik, 1224 Oakdale Ave., Chicago, Ill.
Edward Anderson, 1930 Alhambra Blvd., Sacramento, Calif.

NBC Programs for Year Consisted of 67% Music

Music occupied more than two-thirds of the National Broadcasting Company's time on the air during 1933, said M. H. Aylesworth, president. The company's broadcasts through its two coast-to-coast networks of 86 stations totalled 330,540 station-hours for the year.

The remaining third of the network time was taken up with literature, lectures, reports of outstanding events, women's and children's programs, dramas, novelty broadcasts, physical training and religion. Figures given in the analysis are estimates for the year, based on actual tabulations of the first eleven months.

The Statistics

GENERAL STATISTICS

Number of Broadcasts.....	34,385
Microphone Appearances.....	396,316
Station Hours.....	330,540

PROGRAM ANALYSIS

Classification	Percent. of Total
Music	67.4
Literature, drama, talks, etc.....	17.9
Outstanding events, current news reports	3.1
Women's and children's programs	4.7
Novelty broadcasts.....	2.8
Physical training.....	2.3
Religion	1.8

100.0

Programs falling under any of the above classifications, with the exception of "novelty," may be educational in nature, either wholly or in part, and therefore a distinct analysis was made to obtain the educational percentage. It revealed that during 1933 education occupied 21.15 percent of all NBC's time on the air.

Under this classification, for example, were included the programs of the NBC Music Appreciation Hour series, conducted by Dr. Walter Damrosch, which is distinctly educational, although included under "music" in the program analysis.

International Broadcasts

Twenty-three foreign countries were heard over the two networks during the year. The total of "imported" programs for 1933, again basing the figure on an eleven month average, was 149, exclusive of Canadian ones, which are heard regularly.

England led the list, with 65, due partly to the fact that many broadcasts from London resulted from the World Monetary and Economic Conference last Spring. Germany was second, with 24, and France third, with 11. Countries heard over NBC networks a lesser number of times, were Argentina, Austria, Bermuda, Brazil, Cuba, Denmark, Hawaii, Holland, Hungary, India, Italy, Palestine, Poland, Russia, Spain, Sweden, Switzerland, Uruguay and Venezuela.

Voices from India, Palestine and Russia had never been heard on the American broadcast air before.

CORPORATION REPORTS

Zenith Radio Corporation—Profit for the six months ended Oct. 31st, 1933, after deduction of expenses, depreciation and other charges, but before Federal taxes, \$131,741. For the same period in 1932 there was a net loss of \$201,973. Profit for the quarter ended Oct. 31, 1933, \$123,405, after same deductions, against profit of \$8,336 before taxes in preceding quarter, and net loss of \$126,131 in quarter ended Oct. 31st, 1932.

Weston Electrical Instrument Corporation—A dividend of 50 cents a share declared on the class A stock. This marks resumption of payments for the first time since January 3d, 1933, when a quarterly dividend of 50 cents was paid.

NEW SERVICE EQUIPMENT



De Luxe Analyzer Plug, with new seven-pin base, with 5-ft. cable (not shown), two alternate grid connector caps and stud socket at bottom that connects to both grid caps. Eight-wire cable assures adaptability to future tube designs, including tubes with 7-pin bases and grid cap soon to be released to the public (2A7, 6B7, 2B7 and 6A7).

The eighth lead connects to the two grid caps and stud socket which is a latch lock. Standard adapters for the De Luxe Analyzer Plug are 7 top to 6 bottom, 7 top to 5 bottom and 7 top to 4 bottom, thus reducing to required number of pins and enabling testing of circuits using all popular tubes. Special adapters, as for UX-199, UV-199, etc., obtainable.

Cat. 907 WLC De Luxe Analyzer Plug, with 5-ft. 8-lead cable attached. Price \$3.23

Latch in Analyzer Plug base grips adapter studs so adapter is always pulled out with Analyzer Plug (adapter can't stick in set socket). Pressing latch lever at bottom of Analyzer plug releases adapter. Analyzer Plug is of smaller diameter than smallest tube and thus fits into tightest places. Made by Alden.

Analyzer Plug, 7 pin, with 8-lead 5-foot cable attached. (adapters extra). Cat. 907-WLC @.....\$3.23

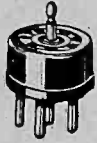

Cat. 976-DS New plug-in adapter, 7-hole top, 6-pin base, with locking stud that fits into 907-WLC latch. Price73
 Cat. 975-DS New plug-in adapter, 7-hole top, 5-pin base, with locking stud that fits into 907-WLC latch. Price73
 Cat. 974-DS New plug-in adapter, 7-hole top, 5-pin base, with locking stud that fits into 907-WLC latch. Price73

Above three adapters essential for 907-WLC to test UX, UY and 6-pin tubes, including such tubes with grid caps.

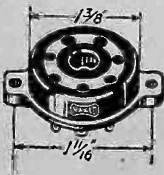

CAT. 456-E In the Analyzer end, use a 9-hole universal socket, that automatically takes UX, UY and six-pin tubes, with errorless connections. Price..... .35
 CAT. 437 E To accommodate 7-pin tubes, which will not fit into Cat. 456-E universal socket, use Cat. 437 E, a seven-pin companion socket, same size. Price 24

If instead of using two sockets, the universal Cat. 456-E and the Cat. 437, the universal alone may be used with an adapter that has six-pin bottom and 7-hole top to enable putting 7-pin tubes into the universal socket. A 6-inch lead with phone tip is eye-letted to the side. A pin Jack you put on Analyzer, connected to seventh lead of 907-WLC cable, picks up control grid of 7-pin tube through the eye-letted lead. Cat. 976-SL\$.73

MULTIPLE SWITCH

For switching to nine different positions, enabling current, voltage and other readings. Any one position opens a circuit and closes another. Thus the opener, by interruption, gives access to plate, cathode, etc., leads, for current readings, while the closer puts the current meter in the otherwise open circuit. Opener is disregarded for positions used for voltage measurements. Switch has detent for "snappy" action. Cat. 2N89-KP-9-B9\$ 2.65
 Double pole, nine throw switch. Cat. 2N89-KP-9\$2.18

Hennessy Radio Pubs. Corp.
 143 West 45th St., New York City

Beginner's Twin S. W. Receiver with Hammarlund Parts

Acclaimed by RADIO WORLD readers, who have purchased "TWIN," as the finest short wave set to learn the mysteries of short waves. A letter to N.Y. Sun, May 20th, from one of our customers, states that he received stations in England, Germany, Italy, Africa, Geneva and Spain.

Economical—Uses two 2-volt 230 low current tubes.
 KIT OF PARTS (blueprints, 4 coils, etc.)
 Wired, with 4 coils (15-200 meters).....\$7.95

RELIABLE RADIO CO., 145 W. 45th St., N. Y. City

Just the Dandy Meters You Want!

O-1 MILLIAMMETER

A O-1 milliammeter is the outstanding measuring instrument in radio work. We offer a precision instrument of highest type manufacture, with large, easily-readable scale, with five marked divisions of 0.2, 0.4, 0.6, 0.8 and 1.0, each subdivided into ten divisions, a total of 50 subdivisions over the scale, or 20 microamperes per subdivision. The diameter is 3/4 inches, the case is finished in dull black and has wide mounting flange, with three mounting holes, for which screws are supplied. The scale length is 2 3/4 inches, contrasty black on a permanent white disc. This is a moving coil type of instrument with highest grade magnets. Meter resistance is 32 ohms. The milliammeter and mounting screws are supplied only, as a premium with a two-year subscription for RADIO WORLD, 104 issues, one each week. By using multiplier resistors the instrument may be used as a voltmeter (1,000 ohms per volt), or, by using resistance shunts, as a less sensitive current meter. Remit \$12, order Cat. ZWMA, and meter and screws will be shipped prepaid.

Non-inductive multiplier resistors, wound on slotted ceramic spools, to convert the instrument into a voltmeter, are obtainable additionally on basis of outright purchase at following prices for resistance tolerance of only 1/2 per cent.:

Resistance of Multiplier	Full-Scale Deflection Voltage	Net Price (Prepaid)
1,000	1	\$ 0.92
10,000	10	.98
100,000	100	1.56
1,000,000	1,000	4.11

(Current shunts, 10 ma, 58c; 100 ma, 69c; 1,000 ma (1 amp.), \$1.26)

DIRECT-READING OHMMETER

Two Scales, 0-1,000 and 0-10,000 Ohms

A direct-reading ohmmeter with two scales, one reading 1,000 ohms at maximum, the other 10,000 ohms, either service accessible by throwing a snap switch to "Hi" or "Low," more than doubles the usefulness, compared to a single-scale instrument. This ohmmeter has a self-contained 4.5-volt battery and is provided with a zero resistance-reading adjuster. Two tipped flexible leads are furnished. The instrument is contained in a baked enamel case. Send \$10 for an 86-week subscription for RADIO WORLD, order Cat. DROM, and get this excellent instrument free, postpaid.

NINE JUNIOR METERS

There is no necessity of going without a meter that your work requires. From the list below you may select any one meter and obtain it free, postpaid, by sending \$1.50 for a 12-week subscription for RADIO WORLD (12 issues), or \$3.00 for a 26-week subscription and get two meters, or \$6 for a year's subscription (52 issues) and get four meters.

- 0-6 Voltmeter D.C.....No. 1326
 - 0-25 Milliamperes D.C....No. 1325
 - 0-50 Voltmeter D.C.....No. 1337
 - 0-50 Milliamperes D.C....No. 1350
 - 0-100 Milliamperes D.C....No. 1390
 - 6-Volt Charge Tester D.C., No. 1323
 - 0-300 Milliamperes D.C....No. 1399
 - 0-10 Amperes D.C.....No. 1338
 - 0-400 Milliamperes D.C....No. 1394
- (Ohmmeter and Junior Meters Sent Prepaid)

RADIO WORLD and RADIO NEWS } \$7.00

Get both of these magazines for one year for \$7.00, although the regular subscription price of RADIO WORLD alone is \$6.00 a year and that of "Radio News" alone is \$2.50 a year. Instead of paying \$8.50 you pay \$7 and you get 52 issues of RADIO WORLD (one a week) and 12 issues of "Radio News" (one a month). "Radio News" recently bought "Citizens Radio Call Book," and "Technical Review" and consolidated them with "Radio News." This offer at this combination price applies only to United States and possessions. Send \$7.00 and order Cat. PRE-RWRN. To Canadian and other Foreign subscribers the combination price offer is at \$8.50 for these two magazines. Order Cat. PRE-FOR-RWRN.

RADIO WORLD, 145 West 45th Street, New York City

BOTH FOR ONE FULL YEAR

RADIO WORLD and "RADIO NEWS"

\$7.00

Canadian and Foreign, \$1.50 extra.

You can obtain the two leading radio technical magazines that cater to experimenters, service men and students, the first national radio weekly and the leading monthly for one year each, at a saving of \$1.50. The regular mail subscription rate for Radio World for one year, a new and fascinating copy each week for 52 weeks, is \$6.00. Send in \$1.00 extra, get "Radio News" also for a year—a new issue each month for twelve months. Total 64 issues for \$7.00.

RADIO WORLD, 145 West 45th Street, New York, N. Y.

115 DIAGRAMS FREE

115 Circuit Diagrams of Commercial Receivers and lower supplies supplementing the diagrams in John F. Rider's "Trouble Shooter's Manual." These schematic diagrams of factory-made receivers, giving the manufacturer's name and model number on each diagram, include the MOST IMPORTANT SCREEN GRID RECEIVERS. The 115 diagrams, each in black and white, on sheets 1 1/2 x 11 inches, punched with three standard holes for loose-leaf binding, constitute a supplement that must be obtained by all possessors of "Trouble Shooter's Manual," to make the manual complete. Circuits include Bosch 54 D. C. screen grid; Balkite Model F. Crosley 20, 21, 23 screen grid; Eveready series 50 screen grid; Eria 124 A.C. screen grid; Fearless Electrostatic series; Philco 16 screen grid. Subscribe for Radio World for 8 months at the regular subscription rate of \$1.50, and have these diagrams delivered to you FREE! Present subscribers may take advantage of this offer. Please put a cross here to expedite extending your expiration date.

Radio World, 145 West 45th St., New York, N. Y.

Valuable Gifts with Subscriptions for RADIO WORLD

A NEW TEST OSCILLATOR

That Works A.C., D.C., or Batteries!

A NEW TEST oscillator, Model 30, has been produced by Herman Bernard, so that all the requirements for lining up broadcast receivers, both tuned radio frequency and superheterodyne types, will be fully and accurately met. This device may be connected to 90-120-v a.c., any commercial frequency, without regard to polarity of the plug, and will function perfectly. It may be used also on 90-120-volt d.c. line, but plug polarity must be observed. One of the plug prongs has a red spot, denoting the side to be connected to positive of the line. If you don't know the d.c. line polarity, you may connect either way, without danger. The oscillator will work on d.c. only when the connection is made the right way. Moreover, 90 volts of B battery may be used instead of either of the foregoing, simply by connecting two wires between the plug at the batteries, observing polarity. No separate filament excitation is required. The oscillator is modulated with a strong, low note under all circumstances. It uses a 30 tube.

THE dial of the Bernard Model 30 Test Oscillator is directly calibrated in kilocycles, so there is no awkward necessity of consulting a chart. The fundamental frequencies are 135 to 380 kc, so that nearly all commercial intermediate frequencies as used in present-day superheterodynes are read on the fundamental. The points for other intermediate frequencies, e.g., 400, 450, 456 and 465 kc, are registered on the dial also, two harmonics, with which the user need not concern himself, being the basis of these registrations. Besides, the broadcast band is taken care of by the fourth harmonic and the dial is calibrated for that band, also. The divisions on the dial for the fundamental band, 135 to 380 kc, are 1 kc apart from 135 to 140 kc, 2 kc apart for 140 to 180 kc and 5 kc apart for 180 to 380 kc. For the broadcast band, 10 kc apart from 550 to 800 kc, 20 kc apart from 800 to 1,500 kc. The test oscillator may be used also for short waves, by resorting to higher harmonics.

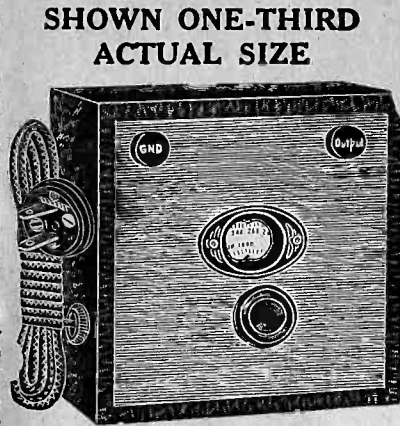

Over-All Size Is Only 5x5x3"! Dial Reads Frequencies Directly!

Send \$12 for 2-year subscription for RADIO WORLD and order Cat. BO-30 sent free, with tube (prepaid in United States and Canada). Another model, BO-30-S, same as above, except frequencies are ten times as high, hence instrument is for short-wave work only, is available on same basis.

THE ONLY BOOK OF ITS KIND IN THE WORLD. "The Inductance Authority"

By EDWARD M. SHIEPE, B.S., M.E.E.

Each turns chart for a given wire has a separate curve for each of the thirteen form diameters. The two other charts are the tri-relationship one and a frequency-ratio chart, which gives the frequency ratio of tuning with any inductance, when using any condenser the maximum and minimum capacities of which are known. The book contains all the necessary information to give the final word on coil construction to service men engaged in replacement work, home experimenters, short-wave enthusiasts, amateurs, engineers, teachers, students, etc. There are ten pages of textual discussion by Mr. Shiepe, graduate of the Massachusetts Institute of Technology and of the Polytechnic Institute of Brooklyn, in which the considerations for accuracy in attaining inductive values are set forth. These include original methods. The curves are for close-wound inductances, but the text includes information on correction factors for use of spaced winding, as well as for inclusion of the coils in shields. The book therefore covers the field fully and surpasses in its accuracy any and all mechanical aids to obtaining inductance values. The publisher considers this the most useful and practical book so far published in the radio field, in that it dispenses with the great amount of computation otherwise necessary for obtaining inductance values, and disposes of the problem with speed that sacrifices no accuracy. The book has a flexible colored cover, the page size is 9 x 12 inches and the legibility of all curves (black lines on white field) is excellent.

Send \$4.00 for 84-week subscription for RADIO WORLD and order Cat. PIA sent free, with supplement, postpaid in United States and Canada.

RADIO WORLD

145 West 45th Street New York, N. Y.

540-4,500 kc Tuning Units

The Tuning Units consist of a four-gang 0.00046 mfd. condenser, with trimmers on it, 3/8-inch diameter shaft, 1 1/2 inches long, mounting spades, condenser closing to the left; and a set of four shielded coils. The condenser is the same for tuned radio frequency sets or superheterodynes, but for superheterodynes a series padding condenser is supplied also. For t-r-f sets the four coils are alike. For supers three coils are alike and there is a different coil for the oscillator, with a selection for 175 kc, 456 kc or 465 kc intermediate frequency. For t-r-f construction, three stages of t-r-f and tuned detector input, four equal shielded coils, tapped for the police band and properly matched to the tuning condenser which is supplied also. Order Cat. TRFTU, which will be sent free, postpaid, on receipt of \$10.00 for 86-week subscription for RADIO WORLD (86 issues).

For superheterodyne construction, two stages of t-r-f, tuned oscillator and tuned input to modulator, three identical coils and an oscillator coil, with the proper padding condenser and the four-gang condenser, are supplied as noted below:
175 kc—For use with 175 kc intermediate frequency. Unit includes four-gang condenser, three r-f coils, the proper oscillator inductance and 800-1,350 mmfd. padding condenser. Send \$12.00 for two-year subscription and order Cat. SUTU-175, which will be sent postpaid.
456 kc—For use with 456 kc i.f. order Cat. SUTU-456. Padding condenser is 350-450 mmfd.
465 kc—For use with 465 kc order Cat. SUTU-465. Padding condenser is 350-450 mmfd.
Those desiring to use the short-wave feature will want a switch, which is sold outright and separately. This is a long switch that has sections very close to where the wiring would have to be, and thus insures short leads. The switch is Cat. 4GSW @ \$2.25 postpaid.

SOLDERING IRON

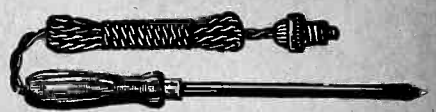

A reliable soldering iron of 40-watt capacity, suitable for radio work, and equipped with a long cable and a snappy plug. This iron may be used in either alternating current or direct current, 85 to 135 volts. It is a graceful iron and has stood up well, as we have been offering this iron for three years and have yet to receive a complaint about its value and dependability. Send \$2.00 for 16-week subscription for RADIO WORLD, order Cat. SO, and get this soldering iron free (postpaid). Please remit with order.

What Radio World Is

RADIO WORLD, now in its twelfth year, is a weekly periodical devoted to the scientific side of radio, and presenting accurately and promptly all the news of the latest developments and circuits in radio, for broadcast and short-wave frequencies. Receiver and test oscillator construction are featured in its varied aspects. Testing in all its branches is given authentic and extensive treatment. Not only how to build, but how to measure what you've built, are featured regularly, and all receiver and test oscillator construction includes coil-winding data, if the coils possibly can be wound at home or in the ordinary laboratory or shop. Articles by leading authorities are augmented by carefully checked station lists. A subscription for RADIO WORLD is one of the first requisites for the service man, home constructor, experimenter, student and teacher. Leading schools and laboratories subscribe for it and you will be in excellent company. Send in your subscription NOW.

PADDING CONDENSERS



Either capacity, 50c

A HIGH-CLASS padding condenser is required for a superheterodyne's oscillator, one that will hold its capacity setting and will not introduce losses in the circuit, for losses create frequency instability. The Hammarlund padding condensers are of single-condenser construction on Isolantite base, with set-screw easily accessible, and non-stripping thread. For 175 kc. intermediate frequency use the 850-1350 mmfd. model. For i.-f. from 460 to 365 kc., use the 350-450 mmfd.

0.0005 HAMMARLUND S. F. L. at 59c.

A sturdy, precision straight frequency line condenser, no end stops. The removable shaft protrudes front and rear and permits ganging with coupling device, also use of clockwise or anti-clockwise dials, or two either side of drum dial. Front panel and chassis-top mounting facilities. True straight line. This rugged condenser has Hammarlund's high quality workmanship and is suitable for precision work. It is a most excellent condenser for calibrated radio frequency test oscillators, any frequency region, 100 to 60,000 kc., short-wave converters and adapters and TRF or Superheterodyne broadcast receivers. Lowest loss construction, rigidity, Hammarlund's perfection throughout.

Order Cat. HOS @59c net
Reliable Radio Co., 143 West 45th Street, New York, N. Y.

COMPLETE TUBE CHARACTERISTICS WITH SOCKET CONNECTIONS

In Radio World dated Sept. 9, 1933. 15c a copy; or start your subscription with that issue. Radio World, 145 West 45th St., New York City.

Vest Pocket Size Flashlight for Radio Repair Work—FREE

Great for getting right down into your set!
Obtain one free with 3 months' subscription for Radio World at the regular rate of \$1.50. Send postpaid.
Sub. Dept.
RADIO WORLD
145 West 45th Street New York, N. Y.