

# HEATER TYPE PENTODE OUTPUT TUBE

# RADIO

REG. U.S. PAT. OFF.

# WORLD

The First and Only National Radio Weekly  
*Eleventh Year—534th Issue*

JUNE 18  
1932

15c  
per copy

Measuring Capacity

---

How to Insure  
Wave Band Coverage

---

Plane Over Los Angeles  
Picks up Television

## NO SQUEALING IN MULTI-STAGE RECEIVER

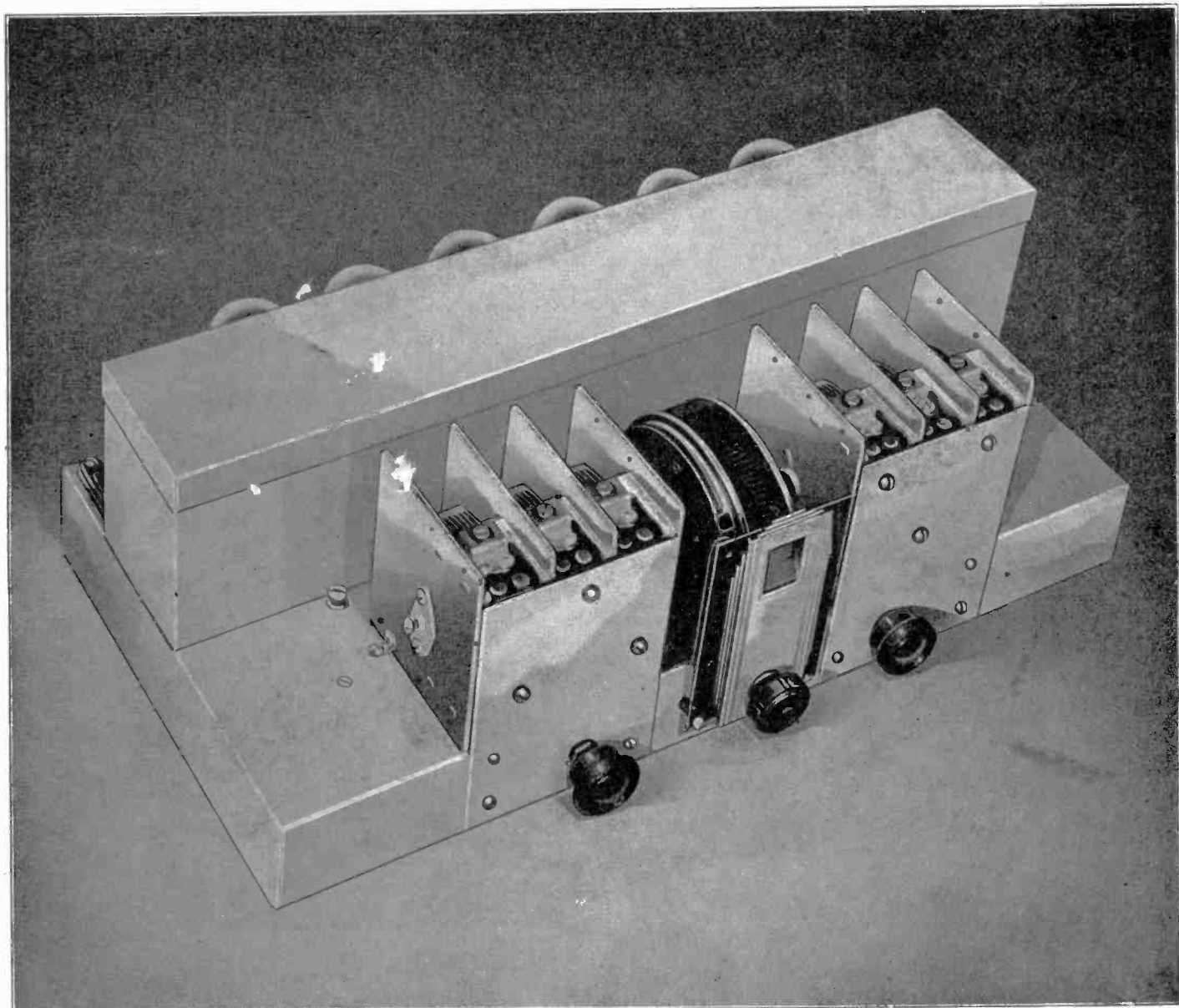

The new regeneration-proof receiver designed by Father Daley. See page 3.

## START RIGHT! Use These... Superb Condensers for Short Waves!

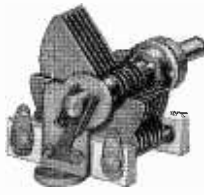

Single 0.00014 mfd. Hammarlund condenser; non-inductive pigtail; single hole panel mount and two-point base mount; Isolantite insulation; brass plates.

Single 0.00014 mfd. sent free with a 3-months subscription for Radio World (13 issues, \$1.50). Double 0.00014 mfd. sent free with a 6-months subscription (26 issues, \$3.00).

THE most popular capacity for short-wave use, and the one for which virtually all commercial short-wave coils are wound, is 0.00014 mfd. The Hammarlund condensers of this capacity, both single and double, are compact and efficient. They have Isolantite insulation and Hammarlund precision workmanship. See offer at lower left. Present subscribers may extend their subscriptions under this offer.

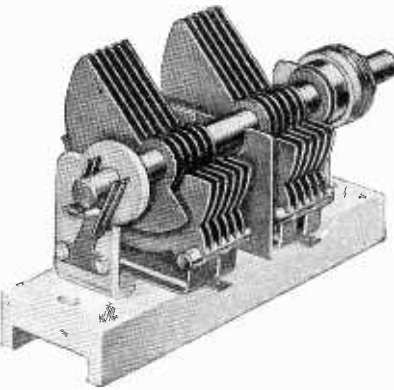

RADIO WORLD, 145 West 45th St., New York, N. Y.

## BINDER FREE For New Yearly Subscribers

This binder is made of fine brown Spanish fabricoid and will hold 52 issues of Radio World, Year 1931-32 stamped in gold on front cover. A very limited supply on hand. Sent free to new yearly subscribers who send \$6 direct to publication office before May 10, 1932. If already a subscriber, send \$6 and 52 issues will be added to present subscription. No other premium with this offer.

RADIO WORLD, 145 WEST 45th STREET, NEW YORK CITY

### FIXED CONDENSERS

Dubilier Micon fixed condensers, type 642, are available at following capacities and prices:

.0001 mfd. ....	10¢	.001 .....	12¢
.00025 mfd. ....	10¢	.002 .....	12¢
.00035 mfd. ....	12¢	.006 .....	12¢
.00025 with elips .....	15¢		

All are guaranteed electrically perfect and money back if not satisfied within five days.

GUARANTY RADIO GOODS CO.  
143 West 45th St. New York, N. Y.

### — SPECIALS —

Five-lead cable, 2 ft. long, with plug to fit a five-prong (UY) socket. The cable is connected at the factory so that following wires represent the respective prongs of the socket: Blue with white marker—G post of socket; Red—plate of socket; Green—cathode of socket; Yellow—heater adjoining cathode; Black with yellow marker—heater adjoining plate. ....Net 65c

GUARANTY RADIO GOODS CO.  
143 West 45th St. New York, N. Y.

## Your Choice of NINE Meters!

To do your radio work properly you need meters. Here is your opportunity to get them at no extra cost. See the list of nine meters below. Heretofore we have offered the choice of any one of these meters free with an 8-weeks' subscription for RADIO WORLD, at \$1, the regular price for such subscription. Now we extend this offer. For the first time you are permitted to obtain any one or more or all of these meters free, by sending in \$1 for 8-weeks' subscription, entitling you to one meter; \$2 for 16 weeks, entitling you to two meters; \$3 for 26 weeks, entitling you to 3 meters; \$6 for 52 weeks, entitling you to six meters. Return coupon with remittance, and check off desired meters in squares below.

RADIO WORLD, 145 West 45th Street, New York, N. Y.  
(Just East of Broadway)

Enclosed please find \$.....for.....weeks subscription for RADIO WORLD and please send as free premium the meters checked off below.

I am a subscriber. Extend my subscription. (Check off if true.)

- |                          |                                |         |
|--------------------------|--------------------------------|---------|
| <input type="checkbox"/> | 0-6 Voltmeter D.C. ....        | No. 326 |
| <input type="checkbox"/> | 0-50 Voltmeter D.C. ....       | No. 327 |
| <input type="checkbox"/> | 0-Volt Charge Tester D.C. .... | No. 23  |
| <input type="checkbox"/> | 0-10 Amperes B.C. ....         | No. 328 |
| <input type="checkbox"/> | 0-25 Milliamperes D.C. ....    | No. 325 |
| <input type="checkbox"/> | 0-50 Milliamperes D.C. ....    | No. 380 |
| <input type="checkbox"/> | 0-100 Milliamperes D.C. ....   | No. 390 |
| <input type="checkbox"/> | 0-300 Milliamperes D.C. ....   | No. 399 |
| <input type="checkbox"/> | 0-400 Milliamperes D.C. ....   | No. 394 |

NAME .....

ADDRESS .....

CITY..... STATE.....

## IMMEDIATE DELIVERY ON NEW TUBES!



Eveready-Raytheon  
4-Pillar Construction

46 Power amplifier, UY base, for Class A or Class B, due to optional connections. Net price.....\$0.90

56 High mu detector, UY base; an improvement over the '27. Net price .....\$0.75

57 Screen grid pentode with suppressor grid; detector and a-f amplifier. 6-pin base. Net price.....\$0.96

58 Super control (vari-mu) r-f pentode with suppressor grid. 6-pin base. Net price .....\$0.96

82 Mercury vapor rectifier for Class B amplifiers. Net price.....\$0.75

Type	List Price	Your Cost	Type	List Price	Your Cost
46.....	\$1.50	\$.90	200A.....	4.00	2.40
56.....	1.25	.75	240.....	3.00	1.80
57.....	1.60	.96	112A.....	1.50	.90
58.....	1.60	.96	222.....	3.00	1.80
82.....	1.25	.75	230.....	1.60	.96
227.....	1.00	.60	231.....	1.60	.96
224.....	1.60	.96	232.....	2.30	1.38
235.....	1.60	.96	233.....	2.75	1.65
226.....	.80	.48	234.....	2.75	1.65
171A.....	.90	.54	236.....	2.75	1.65
210.....	7.00	4.20	237.....	1.75	1.05
245.....	1.10	.66	238.....	2.75	1.65
247.....	1.55	.93	239.....	2.75	1.65
250.....	6.00	3.60	280.....	1.00	.60
v199.....	2.75	1.65	281.....	5.00	3.00
x199.....	2.50	1.50	BH.....	4.50	2.70
120.....	3.00	1.80	201A.....	7.50	4.50

GUARANTY RADIO GOODS CO.  
145 West 45th Street New York City

### LOOK AT YOUR WRAPPER

You will see by the date thereon when your subscription for Radio World expires. If the subscription is about to run out, please send us renewal so that you will not miss any copies. Subscription Department, RADIO WORLD, 145 West 45th St., N. Y. City.

## Volume No. 2 of Perpetual Trouble Shooter's Manual

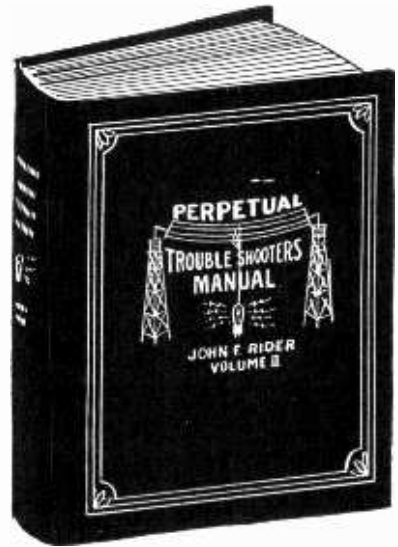

Having assembled 2,000 diagrams of commercial receivers, power amplifiers, converters, etc., in 1,200 pages of Volume No. 1 of his Perpetual Trouble Shooter's Manual, John F. Rider, noted radio engineer, has prepared Volume No. 2 on an even more detailed scale, covering all the latest receivers. Volume No. 2 does not duplicate diagrams in Volume No. 1 but contains only new, additional diagrams, and a new all-inclusive information on the circuits covered.

All Electrical Values Given for  
First Time

This new detailed, comprehensive information gives the resistance values from point to point in all circuits in Volume No. 2—such complete information as is unobtainable elsewhere. All condenser values are given. Chassis diagrams (pictorial), schematic diagrams and photographic views of receiver "insides" are included. Parts are identified on photographs. Intermediate frequencies are stated. Socket and tube identities are revealed, color codes given, continuities of sealed units disclosed. The information is painstakingly complete. Rider made personal trips virtually all over the country to obtain the information, and it's now yours.

Everyone who makes his living as a radio service man, salesman, laboratory man or in any other technical capacity, as well as all students and teachers of radio, should possess Volume No. 2.

Volume II and Volume I are loose-leaf editions of 8½ x 11" page size, flexible fabrikoid binding.

Volume No. 2—Perpetual Trouble Shooter's Manual, by John F. Rider. Shipping weight 6 lbs. Order Cat. RM-VI @ \$5.00  
Volume No. 1 (8 lbs.). Order Cat. RM-VO @ .....\$4.50

We pay postage in United States on receipt of purchase price with order. Canadian remittances must be in funds payable in New York.

We will send a copy of Volume No. 2 as it has just recently come off the press—on a 10-day money-back guarantee, on receipt of remittance. Volume No. 1 can be shipped at once. Same guarantee, same postage defrayal.

RADIO WORLD  
145 WEST 45th ST., NEW YORK, N. Y.

ROLAND BURKE HENNESSY  
Editor

HERMAN BERNARD  
Managing Editor

# RADIO WORLD

The First and Only National Radio Weekly  
ELEVENTH YEAR

J. E. ANDERSON  
Technical Editor

J. MURRAY BARRON  
Advertising Manager

Vol. XXI

JUNE 18th, 1932

No. 14. Whole No. 534

Published weekly by Hennessy Radio Publications Corporation, 145 West 45th Street, New York, N. Y.

Editorial and Executive Offices: 145 West 45th Street, New York

Telephone: BR-yant 9-0558

OFFICERS: Roland Burke Hennessy, President and Treasurer; M. B. Hennessy, Vice-President; Herman Bernard, Secretary.

Entered as second-class matter March, 1922, at the Post Office at New York, N. Y., under Act of March 3, 1879. Title registered in U. S. Patent Office. Printed in the United States of America. We do not assume any responsibility for unsolicited manuscripts, photographs, drawings, etc., although we are careful with them.

Price, 15c per Copy; \$6.00 per Year by mail. \$1.00 extra per year in foreign countries. Subscribers' change of address becomes effective two weeks after receipt of notice.

## The 4-Circuit Daley Set

### High Sensitivity and Selectivity for T-R-F

By Brunsten Brunn

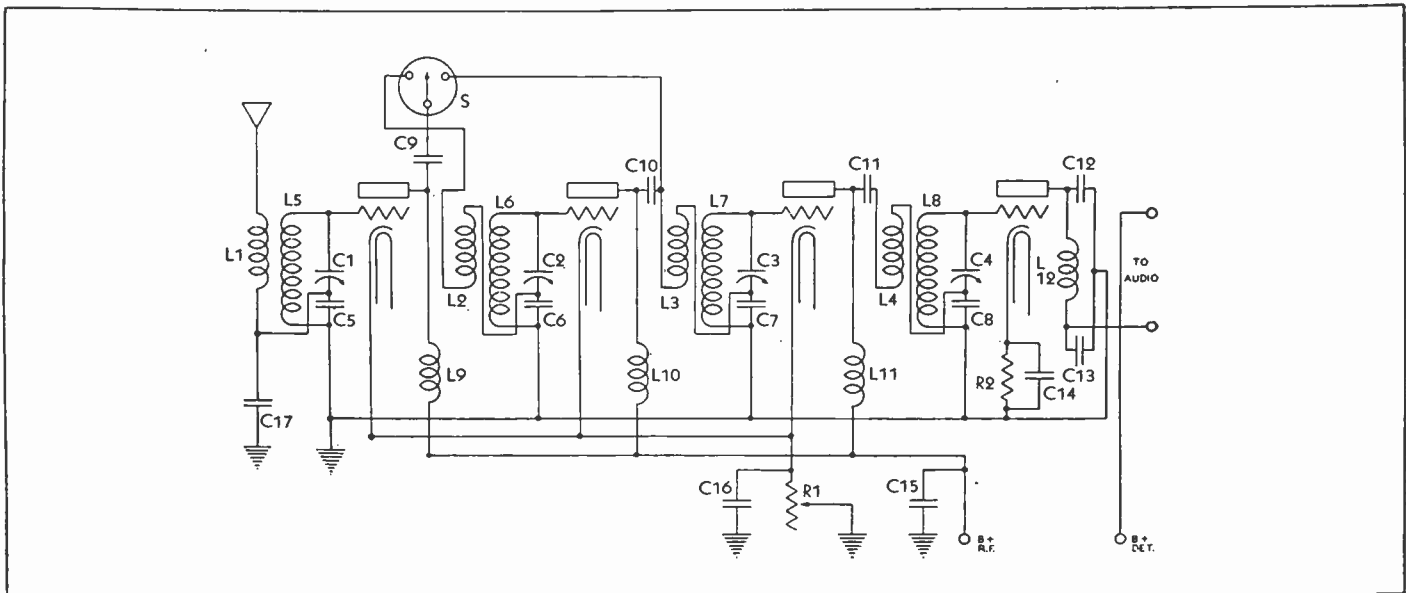

FIG. 1

The diagram of Rev. Daley's four-tube radio frequency amplifier and detector. The switch S is arranged to cut out one of the stages.

[Herewith are constructional details and performance curves on the four-circuit tuner model of the Daley circuit, the invention of the Rev. Joseph J. Daley, of Boston. The system of tuned radio frequency amplification, almost unlimited number of stages possible, prevents regeneration, by an equipotential method outlined theoretically in the May 28th issue. This week the four-tube model is discussed, while next week, June 25th issue, the curves and other data on the six-tube model (illustrated this week on front cover) will be printed.—EDITOR.]

PERFORMANCE of a high order is obtainable from the Daley circuit, the four-tube model of which has a sensitivity from  $1\frac{1}{4}$  to 2.15 microvolts per meter, unusual for a three-stage t-r-f and detector circuit, considering also the

fact of practically uniform sensitivity. In most other t-r-f systems the sensitivity falls off badly at the lower frequencies.

The proper design values of the parts in the four-tube circuit given in Fig. 1 are as follows: C1, C2, C3, and C4, variable tuning condensers of 350 mmfd.; C5, C6, C7, and C8, fixed condensers of 10,000 mmfd., that is, 0.01 mfd.; C9, C10, and C11, fixed condensers of 870 mmfd. each; C12 and C13, fixed condensers of 1,000 mmfd.; C14 and C15, fixed bypass condensers of 2 mfd. each; C16, a bypass condenser of 0.05 mfd.; C17, a bypass condenser of 0.005 mfd.; L1, L2, L3, and L4, primary inductances of 22.5 microhenries; L5, L6, L7, and L8, secondary inductances of 275 microhenries; L9, L10, L11, and L12, radio frequency chokes of 175 millihenries each; R1, r-f cathode re-

sistor of 400 ohms; R2, detector cathode resistor of 25,000 ohms; S, stage selector switch for cutting out one stage.

In Fig. 2 is shown a front and top view of the completed four-tube receiver. The four tubes, all of the heater triode type with a  $\mu$  of 30, are drawn up in a line at the back of the chassis. The special coils or coupling units are inclosed in shield box in front of the tubes. Inside this box there are partitions so that the coils pertaining to one stage are separated and completely shielded from each other.

In the front row are the four tuning condensers and the drum dial. As will be noticed there are two equal double tuning condensers of opposite shaft rotation driven by the drum. As two are on one  
(Continued on next page)

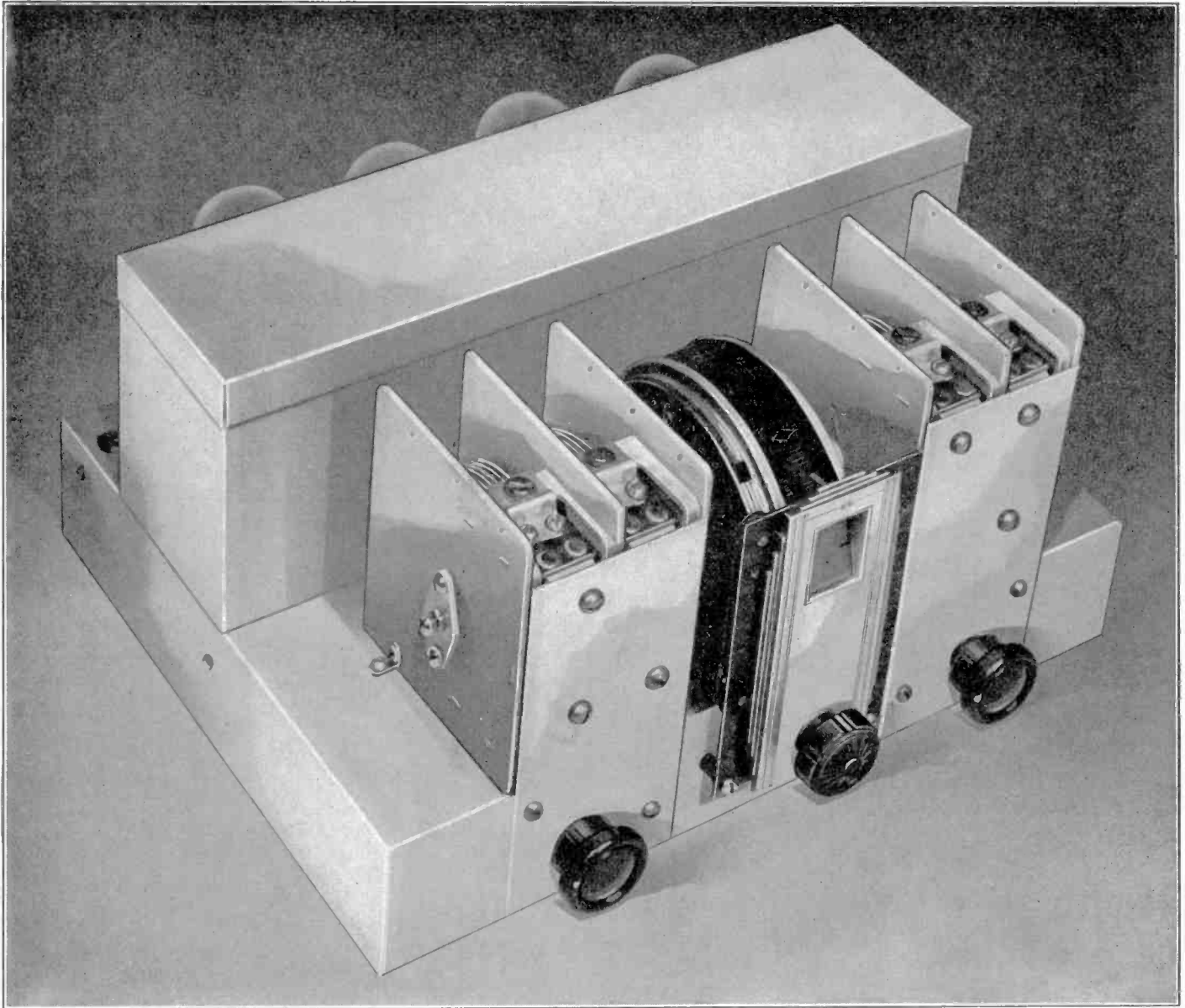

FIG. 2

This shows the construction of the Rev. Mr. Daley's four-tube receiver. The four tubes are at the rear, the coils in the metal box, and the tuning condensers and the dial in front.

(Continued from preceding page)

side of the drum and two on the other, one pair must be of the clockwise rotation type and the other pair of the counter-clockwise rotation. Metal shields are placed in front of the tuning condensers to eliminate body capacity. The separator and end plates of the sections extend some distance above the stators in order to eliminate capacity coupling between adjacent stators.

Of the three knobs on the front panel

the left-hand one is a stage selector switch, the middle is the drum tuning control, and the right is the volume control, that is, the control for the 25,000 ohm cathode resistor.

The sensitivity of the four tube set is shown in Fig. 3. The ordinates of this curve give the signal in terms of microvolts per meter required to put out a standard signal under test conditions specified by the Institute of Radio Engineers. The ordinates should be divided

by four to give the actual sensitivity in microvolts per meter. The greatest sensitivity occurs at 1,500 kc, where it has a value of 1.25 microvolts. At the 550 kc end of the range the sensitivity is approximately 2.15 microvolts per meter. This is a very small variation. The circuit is satisfactory not only from the viewpoint of uniformity of sensitivity but also from the point of view of absolute sensitivity.

In Fig. 4 are reproduced three reso-

**FIG. 3**  
The curve in this graph shows the sensitivity of the four-tube receiver outlined in Fig. 1. The sensitivity is practically uniform throughout the broadcast band.

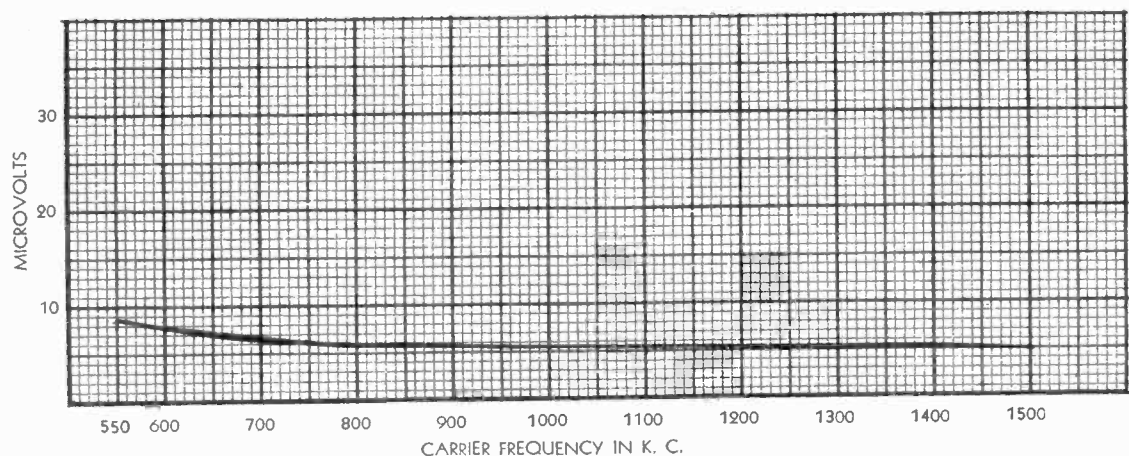



nance curves of the four-tuner circuit, taken at the standard test frequencies 600, 1,000, and 1,400 kc. The ordinates are field strength ratio and the abscissas kilocycles off resonance. On these curves we first notice a peculiarity of the receiver. The selectivity is greatest at 1,400 kc and least at 600 ks. In most circuits it is just the other way about. The selectivity curve at 1,000 kc crosses the other curves a number of times and it cannot be said to represent either a greater or less selectivity than the other curves. All the curves are very steep and if there is any criticism it must be that the circuit is too selective, a novel "fault" to find with t-r-f systems. The set certainly will separate stations.

**Circuit Theory**

The Research Products Corporation, 43 Tremont Street, Boston, is licensing set manufacturers to use the Daley system.

In the Daley circuit the mutual coupling between the primaries and the secondaries is phased so that it aids the capacity coupling, and the coil symbols in the diagrams have been drawn to indicate this fact. The vector impedance of a condenser at a two pi frequency  $\omega$  is  $-j/C\omega$ , where C is the capacity of the condenser in farads and the frequency ( $\omega$ ) is expressed in radians per second. The j indicates that the impedance is at right angles to the resistance factor. The mutual impedance between two coils is  $jM\omega$ , in which M is the mutual inductance is henries and  $\omega$  has the same significance as before, or the mutual impedance is  $-jM\omega$ . The sign is determined by the connections of the coils.

Now if the capacitive and mutual inductive couplings are to aid, the signs of the two impedances must be the same. Hence we must connect the coils so that the sign of the mutual impedance is negative. If we were to connect so that the mutual impedance had a positive sign, the inductive and capacitive couplings would buck each other, and if the values were such that at some frequencies they were equal, there would be no coupling whatsoever at that frequency.

**Same Sign**

This must be avoided. Since both the impedances have the same sign we need not consider either the sign or the vectorial factor j, but only the magnitudes of the two.

It is possible to compute what M and C should be in order to make the coupling the same at two different values, say at 600 and at 1,400 kc. Moreover, we can

**FIG. 4**

The three curves in this graph show the selectivity of Rev. Daley's four-tube radio frequency amplifier at three different test frequencies. A high selectivity is indicated at all frequencies.

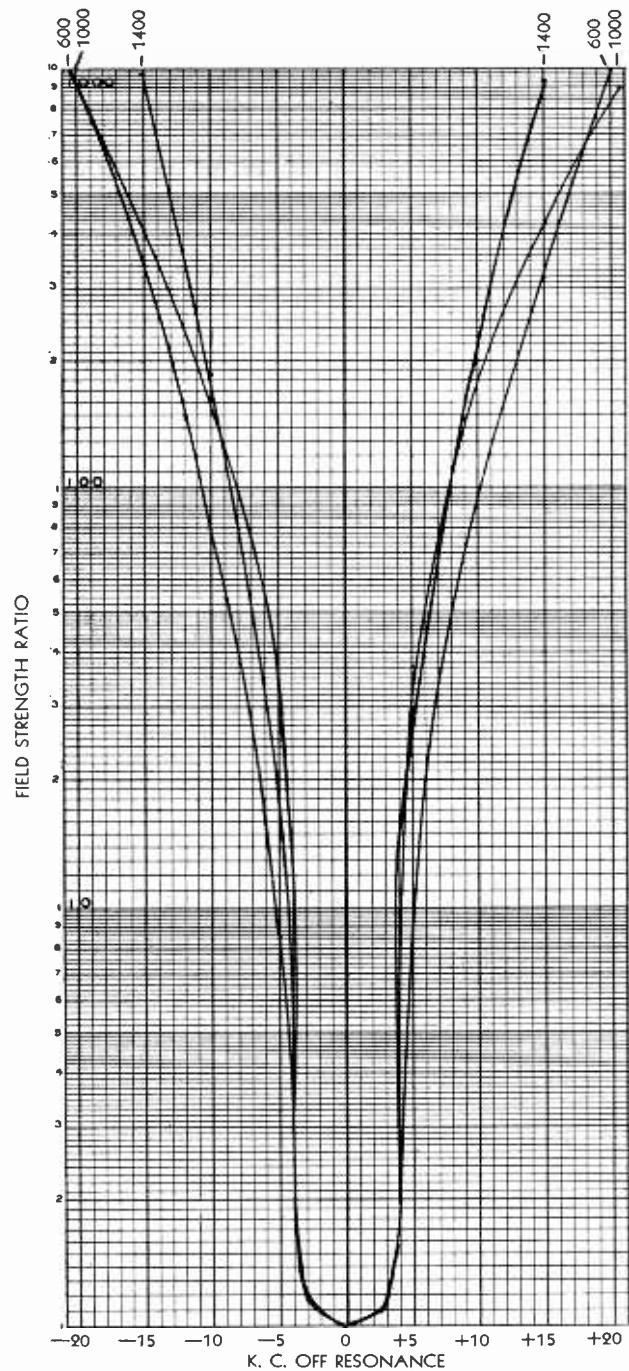

choose this impedance so that it is the same as it is in the middle of the band.

The point of the circuit invented by the Rev. Mr. Daley is constancy of coupling between stages as the frequency of resonance changes. This constancy is obtained by combining inductive and capacitive coupling in correct proportion and phase. At the high radio frequencies the inductive coupling predominates because then the mutual impedance is high and the capacity coupling impedance is very low. At the low radio frequencies the capacity coupling predominates because the capacity impedance is greater and the mutual impedance less.

The tubes used are special heater type triodes having an amplification constant of 30. This high amplification, properly made use of, and the lack of feedback account for the high sensitivity of the circuit. Of course, the use of three radio frequency amplifiers and four good tuners also accounts for the high gain.

**WSM's Aerial, Vertical Type, to Rise 878 Feet**

A new type vertical radiator antenna system is to be installed by WSM at Nashville, Tenn., 878 feet high, the tallest in the country. The vertical radiator is expected to bring even distribution of signal strength in all directions.

Installation of the slender shaft will not be completed until September 1st, according to Mr. Stono, but WSM will begin operations presently with high power—50,000 watts was recently granted the station by the Federal Radio Commission—on a standard antenna system.

Arrangements are being made throughout North America by engineers of the Federal Radio Commission and private units to make exhaustive tests of WSM's operation under both antenna systems.

The tower or vertical radiator is a radical departure from the usual antenna system. In the old systems, in use for the past decade, the antenna has been either of the flat-top or vertical quarter-wave type.

Two towers, from 125 to 300 feet high,

spaced from 200 to 600 feet apart, have been erected, with wires strung between them for the flat-top system, and a circular of "cage" arrangement of wires suspended vertically from a cable running between the two towers in the cage type system. Often the two systems were combined, with part flat-top and part vertical lead-in for the carrier.

WSM's vertical radiator will be mounted in a solid concrete block approaching in size a small house with an

insulator imbedded in the block. The mast itself will be only two feet square at the base.

Approval by the aeronautics division of the Department of Commerce had to be obtained by WSM before the Federal Radio Commission would grant permission for the erection of the vertical radiator.

An engineer of the Department of Commerce spent three days in Nashville going into all details of the structure and making a close study of location of the transmitter in relation to present and planned air routes.

The tower will conform to Department of Commerce regulations in regard to lighting and painting. Black, orange and white, in twenty-foot wide stripes, will be used in painting the tower, while lights will be spaced every hundred feet the entire length of the tower, with two lights at the top. In addition, an airplane beacon signal will be maintained atop the transmitter building.

**BUSINESS BRIEFS**

E. A. Wildermuth, long a distributor of Atwater Kent radios in Brooklyn, N. Y., has taken over the sole distribution of this line for Manhattan.

\* \* \*

Pilot Radio & Tube Corp., Lawrence, Mass., has issued a new booklet and catalog of parts for set builders and servicemen.

# CAPACITY EASILY MEASURED

## BA

By J. E.

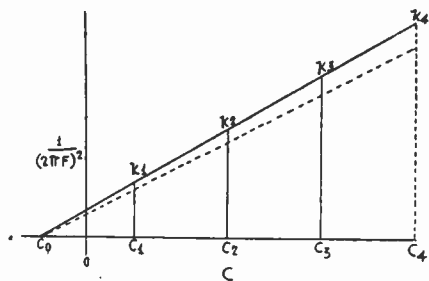

FIG. 1

This illustrates how the distributed capacity of a tuned circuit as well as the inductance of the coil may be obtained graphically. The inductance is the slope and the distributed capacity the 0-C<sub>0</sub> intercept

A QUICK method of measuring capacity is often desirable. If we have a calibrated oscillator and a coil of known inductance a very simple method can be worked out. The formula connecting frequency, capacity, and inductance is  $F=1/2\pi(LC)^{1/2}$ , in which F is the frequency in cycles per second, L the inductance in henries, and C the capacity in farads. If we want to determine capacity in terms of frequency and inductance we can rewrite this formula in this manner:  $C=1/4\pi^2LF^2$ , in which C, L and F still have the same significance. Now the reciprocal of 4 pi squared is 0.02533. Hence if we make the inductance equal to 253.3 microhenries we can write the formula  $C=(10/F)^2$ , in which C is measured in micromicrofarads and F is measured in megacycles per second. Thus if we have a coil of this particular inductance and put it in a circuit and find the frequency of resonance, we can get the capacity in micromicrofarads by dividing 10 by the number of megacycles and squaring the result.

### An Example

Let us illustrate with a few numerical examples. Suppose we have this particular coil and find that it resonates with a certain capacity at 1,000 kc, or 1 mc. What is the capacity of the condenser across the coil? Putting the known frequency in the formula we have  $(10/1)^2$  squared, or 100 mmfd. Again, suppose the circuit resonates at 500 kc. What is the capacity? In this case we have  $(10/0.5)^2$  squared, or 400 mmfd. Again, what capacity is needed to make the circuit resonate at 550 kc? We have  $(10/0.55)^2$  squared, or 330 mmfd.

We can use the same formula for determining the distributed capacity in the circuit of which this particular coil forms a part. Suppose there is no condenser across the coil except a certain distributed capacity. Let us assume that the frequency of resonance is 2.5 megacycles. What is the distributed capacity? We have  $C=(10/2.5)^2$  squared, or C=16 mmfd. This includes the distributed capacity of the coil itself, and if there is no other capacity across the coil, that is, if the coil is by itself, then it is the self cap-

acity of the coil. This should be determined first because in later measuring capacity of a condenser it should be subtracted from the result obtained.

Suppose the coil is connected to a tube. What is the distributed capacity due to the tube and what is that due to the coil? We first determine the capacity of the coil itself and then of the coil and the tube. Let us assume that the coil capacity has been determined to be 16 mmfd. Then suppose that the frequency of resonance of the coil and the distributed capacity is 1,600 kc. What is the capacity of the tube? The total capacity is  $(10/1.6)^2$  squared, or 39.1. Hence the capacity of the tube is 23.1 mmfd. By the same method we can determine the capacity of a small condenser first by measuring the capacity without this condenser and then with it and finding the difference.

### The Coil

The simple method depends on having a coil of exactly 253.3 microhenries. Let us determine a design for a coil of this inductance. In order to get a correct computed value let us use fine wire and a small diameter. Let the diameter of the form be one inch and let the wire be No. 32 enameled. This wire has a mean diameter of 0.008 inch so that it will wind 125 turns to the inch, and 119 turns will be required. Thus the length of the winding should be 0.952 inch. This assumes very close winding of the turns.

The coil must be used without a shield for shielding will reduce the effective inductance. If it is coupled to another coil the coupling should be loose for the presence of another coil will change both the effective inductance and the capacity. If loose coupling is used this effect is negligible. For resonance indication when the coil is not connected to a tube, a thermocouple meter is the best. However, if the coil is used as a wave trap and coupled loosely to the oscillating coil in the calibrated oscillator, the resonance point can be found by the double click method. This, of course, requires a headset for listening in somewhere on the calibrated oscillator. Or if the oscillator is being modulated and the signal generated is being received, the click, or the stopping of the signal, can be heard in that receiver. There are many ways of finding the resonance point, but the simplest in all cases is the best.

If the coil is used as a coupling coil between two tubes resonance can be found by the method of maximum output, either aural or visual. The coil might work into a grid biased detector, for example, when a milliammeter in the plate circuit of that detector will show resonance.

### Using the Coil as Oscillator

Visual indication is more accurate than any aural method with the exception of the zero beat method. But to use the zero beat method it is necessary to use the coil in an oscillator. This would be just as accurate if we could know the inductance in the oscillator, and that it is 253.3 microhenries. However, the inductance will not be quite the same in an oscillator as it will be in a simple resonant circuit. Hence it would be necessary to adjust the inductance in the circuit to have the desired inductance. The

error will be small, though, so that if accurate measurement of capacity is not necessary it will work all right using the computed coil.

It is also possible using a similar formula to measure inductances. All we have to do is to interchange the inductance and the capacity. If we use a fixed capacity of 253.3 mmfd. the formula becomes  $L=(10/F)^2$  in which L is given in microhenries and F in megacycles. We might get a fixed condenser of 253.3 mmfd., accurately adjusted, and then use it for determining the inductance. This, however, leaves the distributed capacity of the coil in question.

### Determining Inductance Experimentally

If a calibrated condenser is available the inductance of the coil can be checked experimentally with the aid of known frequencies. If we have a number of fixed condensers of accurately known values we need a calibrated oscillator but

## Heater Po

Two new heater type tubes have been announced by the Arcturus Radio Tube Company. Both are power pentodes and are intended to be used in the last stage of a receiver. One has a rated power output of 3.5 watts and the other a rated output of 1.2 watts.

The tables give their operating conditions and characteristics and their physi-

### AVERAGE CHARACTERISTICS OF

#### A heater type power pentode

Heater volts .....	6.3
Heater current, ampere .....	0.75
Plate voltage .....	250
Space charge grid volts .....	250
Control grid bias, volts .....	-16.5
Load resistance, ohms .....	7,000
Amplification factor .....	100
Plate resistance, ohms .....	33,300
Transconductance, micromhos ..	3,000
Plate current, milliamperes .....	33.5
Space charge grid current, milli-	
amperes .....	8.0
Undistorted power output, watts ..	3.5
Power sensitivity .....	0.160
Maximum overall length, inches ..	5 5/8
Maximum overall diameter, inches	2 3/16
Bulb, S-17	
Base, six-terminal	

## Brazil to

The Department of Commerce, at Washington, D. C., issued the following: "Considerable progress has been made towards the organization of a company in Rio de Janeiro which will have as its purpose the arrangement of facilities for rebroadcasting short wave programs on a wave length suitable for local reception. The projected organization will have a capital of 4,000 contos (about \$250,000), which amount is to be accumulated from

# D ON SIS OF KNOWN INDUCTANCE

Anderson

if we have a calibrated condenser we can use known broadcast frequencies. The method is illustrated in Fig. 1.

Find the frequency of resonance of the coil and four different values of the calibrated condenser or find four values of capacity for four known broadcast frequencies. For each frequency find the corresponding value of  $1/(2\pi F)^2$ . Enter this value against the corresponding value of capacity on cross section paper. Draw a straight line through all the points and produce the line until it cuts the horizontal axis at the left. It may be that due to inaccuracies all the points will not lie on one line but draw the curve so that as many as possible will lie on it, or so that they are off as little as possible. But make it straight and produce it until it cuts the axis. The four known values of capacity are indicated by C1, C2, C3, and C4. Any capacity is measured from 0 to the point in question.

### Finding the Inductance

As soon as the curve has been drawn,

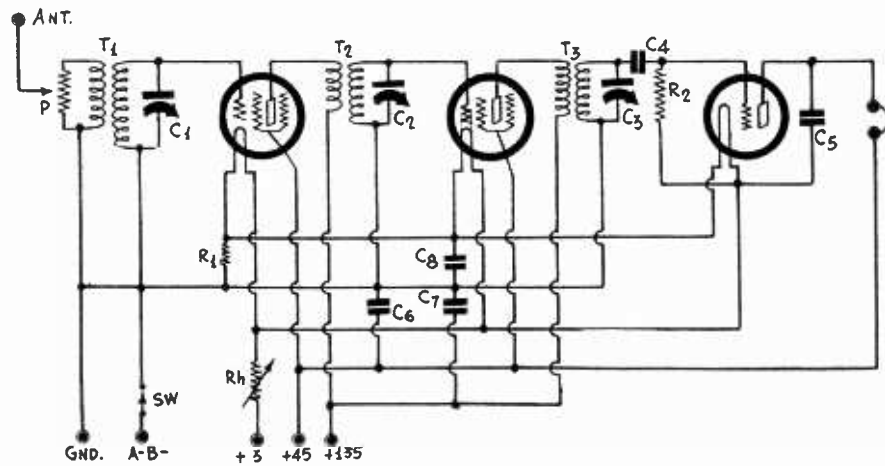

FIG. 2

A tuned radio frequency circuit with a three-gang condenser. The effective capacity across C3 is often greater than that across C1 or C2. It is due to the grid current and reflected capacity from the plate circuit.

## wer Tube

cal dimensions. They are tentative and may be changed in some particulars.

Both tubes require a six-terminal socket and the arrangement of the terminals is standard. Looking down on the socket with the large heater prongs toward the observer the terminals are: heater, cathode, control grid, space charge grid, plate and heater, proceeding in a clockwise direction around the socket.

### AVERAGE CHARACTERISTICS OF

#### A heater type power amplifier

Heater voltage, a-c or d-c.....	6.3
Heater current, ampere.....	0.75
Plate voltage.....	167.5
Space charge grid voltage.....	167.5
Control grid bias, volts.....	-12.5
Load resistance, ohms.....	12,000
Amplification factor.....	100
Plate resistance, ohms.....	44,500
Transconductance, micromhos.....	2,250
Plate current, milliamperes.....	14.5
Space charge grid current, milli-amperes.....	3.5
Undistorted power output, watts.....	1.2
Power sensitivity.....	0.125
Maximum overall length, ins....	4 11/16
Maximum overall diameter, ins..	1 13/18
Bulb, S-14	
Base, six-terminal	

not only the distributed capacity but also the inductance of the coil can be found. The distributed capacity is the distance between 0 and Co. The total capacity in the circuit at any setting of the condenser is the sum of Co and the capacity of the condenser. For example, at C4 the total capacity in the circuit is Co+C4. The total effective inductance in the circuit is the slope of the line, and this may be obtained by dividing the distance between the line and the axis at any point by the distance from that point to Co. If the distance from k4 to C4 is d4 and the distance from C4 to Co is D4, then the slope is d4/D4. Of course, the proper units must be used, the units used in plotting the curve.

The only reason for plotting the curve is to obtain the value of Co. It will be noted that the slope of the line is nothing but  $1/(2\pi F)^2(Co+C)$ . For any value of F the corresponding value of C is measured, or vice versa, and only Co is obtained by drawing the curve. But as soon as the curve has been drawn Co is known and the slope, which is  $L$ , can be computed. It is really necessary to take two observations, say those at C1 and C4. But the other two are valuable to indicate any errors in the two observations. There might be a large error in the observation at C1.

### Correcting the Inductance

If the computed slope, or inductance is not what is desired, say 253.3 microhenries, it can easily be corrected by removing or adding turns. A line with the proper slope can be drawn on the graph passing it through Co, for this point will not change appreciably by adding or subtracting a turn or two. The second point on this line we can select where we please. Suppose we choose C4. Then the total capacity in the circuit is (Co+C4). This we multiply by the desired inductance, or slope, namely, 253.3 microhenries. The resulting value gives the vertical distance from C4 to the point. If the inductance is to be increased the new point will lie above k4; if it is to be decreased it will lie below it.

When we have found this point we can draw the line with the proper slope, and we can change the inductance until the observed points fall on the new line. If the dotted line is the correct one, we have to decrease the inductance of the coil by removing turns or by pushing the end turns away from the main coil depending on the amount by which the inductance must be changed. To find out whether the inductance is correct after a change we do not have to take more than one observation, say at C4. We just find the frequency with the calibrated oscillator and compute the ordinate  $1/(2\pi F)^2$  and then see whether it falls on the new line.

We can also do it by computing the frequency from the known ordinate, set the oscillator at this frequency, and then adjust the coil until zero beat is obtained. We know the desired ordinate, for it is  $L(C+Co)$ . Hence by computation we know the frequency, and we can adjust the inductance until the oscillator containing this inductance gives the desired frequency.

It is useless to go through this work unless the capacities we use are accurately known and also unless the oscillator is accurately calibrated. It requires a precision condenser and an oscillator that has been calibrated carefully. If the condenser capacities are not accurately known it is just as well to compute the inductance and assume that its value is correct. The inductance given above is accurate enough for ordinary work on radio receivers.

### TRADE NOTES

Pacnet Electric Co., 91 Seventh Ave., New York City, is offering a combination home recorder and reproducing device. There is some illustrative literature.

Macy Electrical Products Co., 1453 Thirty-ninth Street, Brooklyn, N. Y., has some new literature on horns and units.

American Sales Company, 44 W. 18th Street, New York City, announces a new catalogue.

## Rebroadcast

contributions received from local radio importers and public utility companies serving Rio de Janeiro, Sao Paulo and other leading population centers of the country. Considering the inferior quality of the programs now being broadcasted by the country's seven stations, it can reasonably be expected that the realization of this plan will stimulate considerably the demand for American radio equipment and accessories.

# Full Band Coverage

## How to Rid Set of Missout Nuisance

By Brunsten Brunn

LACK OF band coverage in tuners is a common complaint from fans and a common trouble to engineers. Why does not a given tuning condenser cover the band in some circuits when the same condenser does it easily in another? Why will a given condenser not cover the band when a smaller condenser usually does it? We assume that the inductance coil has been wound correctly.

Troubles of this kind are always due to excessive distributed capacity. In order for a given condenser to cover a given band the ratio of the maximum to the minimum capacity should have a definite value determined by the square of the ratio of the highest to the lowest frequency in the band. For example, suppose we wish to cover the broadcast band with a certain condenser. The square of the ratio of the highest to the lowest broadcast frequency is 7.44, obtained by squaring 1.500/550. This ratio, that is, 7.44 to 1, should be the ratio of the maximum to the minimum capacity in the tuned circuit. If the ratio is less the tuner will fail to cover the band and will miss out either at the high or the low end, depending on the inductance. If the inductance is right for reaching the lowest frequency, the tuner will fail to reach the highest.

### Sources of Minimum Capacity

There are many sources of capacity which might contribute to the high minimum capacity. First, the grid circuit of the tube has some capacity. This might amount to about 10 mmfd. Second, the condenser itself has a minimum capacity, which might vary from 10 to 20 mmfd. Third, sometimes there is a trimmer condenser across the tuning condenser. This might have a minimum capacity of as high as 100 mmfd., but more frequently not more than of 20 mmfd. Fourth, there is also capacity between the coil and the shield, or the coil and other conductors of large surface near it. Its value depends on the size of the shield and the distance between the coil and the shield. This might contribute from 5 to 50 mmfd. Fifth, there is capacity between the primary and the secondary windings which sometimes adds as much as 50 mmfd. to the tuned winding. Sixth, sometimes capacity is reflected from the plate circuit to the tuner ahead, but this is small in screen grid type of tubes. Seventh, a resistance connected across a tuned circuit, whether that of a tube or an actual resistor, adds to the effective capacity. In this is included the resistance due to grid and plate current. Eighth, shielding around high potential leads sometimes adds a very large capacity. Shielded wire around grid leads are particularly vicious in this respect.

### Practical Examples

When the sum of the capacities from these effects is greater than the permissible minimum, lack of complete coverage results, and the greater the sum the more it falls short.

In one case an oscillator was supposed to cover the band from 950 to 1,900 kc with a tuning condenser of 350 mmfd. and a series condenser of 430 mmfd. The range was only from 950 to 1,300 kc. In this case a high minimum was responsible for the difficulty. The minimum should have been 48.4 mmfd., but it actu-

ally was 103 mmfd. The greater part of the excess was traced to the capacity between the tickler coil and the tuned winding. By increasing the thickness of the insulation between the two windings the minimum was decreased until the desired coverage was obtained. In another case the minimum was reduced by the required amount by putting in a stopping condenser and a grid leak in the oscillator, thereby preventing grid current and removing the effective resistance across the condenser.

### High Capacity Trimmers

Tuners made of 460 mmfd. condensers and proper coils to cover the broadcast band and containing 20 to 100 mmfd. trimmers failed to cover the band by about 200 kc at the high frequency end. However, when the trimmers were removed and larger coils were substituted, coils intended for 350 mmfd., the coverage was 500 to 1,550 kc. In this case the trouble was due entirely to the trimmer condensers. They had too high minimum capacity.

When the trimmer condensers are at fault they can often be omitted. But before they are removed the circuit should be tested for coverage with the trimmer condensers set wide open. It may be that the minimum is too high simply because the trimmers have been compressed too much. Open them up wide and then trim using as little capacity as possible. If the circuit still will not cover the band remove the trimmer, which must be opened most widely in order to trim, because the circuit in which that is connected has the greatest self capacity. When this has been done it may be possible to cover the band if the other trimmers are readjusted. This will not work, however, unless there is a wide divergence in the settings of the trimmers. If the circuit cannot be trimmed properly when this condenser has been removed, a certain trimmer capacity can be added by connecting one insulated wire to the stator and one to the rotor and twisting them together more or less. In fact, this method can be used on all of them provided the twisting is done with a non-conductive tool. Of course, smaller trimmer condensers can also be put on the tuning condensers.

### Capacity Between Windings

When the primary winding of an r-f transformer is wound over the tuned winding there is likely to be a high capacity between them which may be responsible for lack of coverage. The remedy in this case, as in the case of the oscillator, is to make the separation between the two windings thicker. The effect of this is readily realized when it is remembered that the capacity between two conductors is inversely proportional to the distance between them. Thus if the thickness of the insulation is doubled the capacity is cut in two. Another way of reducing the capacity between the windings is to use fine wire for the primary. This reduces the capacity because the capacity between two conductors is proportional to the area of the conducting surfaces facing each other. If the primary is of fine wire the effective area is reduced. Not only that, but the primary turns can be wound over a smaller portion of the secondary so that the mean distance be-

tween turns on the primary and secondary is reduced.

The capacity between the coil and the shield around it cannot be very large, because the distance between the turns and the shielding is large. The effect of the shield is mainly in reducing the effective inductance of the coil. This, however, might tend to cause the circuit to fall short of reaching the lower frequency limit of the broadcast band.

One great source of high minimum capacity is the use of shielded leads on the high potential side of the tuned circuits. It is not that the capacity is high because the potential is high but that the capacity is placed so that it is across the entire tuning coil and hence has a greater effect. While in some cases it is necessary to put shielding between the grid leads of different stages, this may be done so that the added capacity is entirely negligible. If the lead is run through a metal conduit of small diameter so that the high potential lead is close to the sleeve the capacity may be so high that band coverage will be impossible. And this is not the only disadvantage. The insulation between the two conductors will introduce high losses, and they will be higher because of the high potential.

### Experimental Trimming

It sometimes happens that the minimum capacity in one of the t-r-f circuits of a set is much higher than that in either of the others. The trimmer condenser can usually be left off that one. In that case there will be only two trimmers to adjust. To find out which one of the circuits has the high capacity connect a trimmer across each and trim at a high frequency. In one the trimmer condenser will be set at minimum when the others are set with a greater capacity. These trimmers may be of the midget variable type, say zero to 50 mmfd., or they may be regular compression type trimmers. If the trimmer across the circuit having the greatest minimum is removed it should be possible to trim the circuit with the other two, provided the minimum of the trimmers is not too high. This treatment of the circuit increases the chance of band coverage.

### Tube List Prices

Type	List Price	Type	List Price	Type	List Price
11	\$3.00	'31	1.60	56	1.25
12	3.00	'32	2.30	57	1.60
112-A	1.50	'33	2.75	58	1.60
220	3.00	'34	2.75	'80	1.00
'71-A	.90	'35	1.60	'81	5.00
UV-'99	2.75	'36	2.75	82	1.25
UX-'99	2.50	'37	1.75	'74	4.75
'200-A	4.00	'38	2.75	'76	6.50
'01-A	.75	'39	2.75	'86	6.50
'10	7.00	'40	3.00	'41	10.00
'22	3.00	'45	1.10	'68	7.50
'24-A	1.60	46	1.50	'64	2.00
'26	.80	47	1.55	'52	28.00
'27	1.00	'50	6.00	'65	15.00
'30	1.60			'66	7.50

### NEW AMPLIFIER

Baltimore Radio Corp., 725 Broadway, is featuring a new amplifier and has some descriptive literature; also a catalog of parts and general radio merchandise.



# Automatic Tone Control

## How New 58 Tube Accomplishes It

[The following data represent mainly verbatim information from RCA Radiotron Co., Inc., and E. T. Cunningham, Inc., the latter part, however, having been digested by us to avoid the mathematical treatment in the original. The two companies publish the full information in a confidential pamphlet, "Technical Discussion of the Application of the Type 58 Tube to the Control of Fidelity." The quotation and digest herewith are by special permission.—EDITOR.]

**I**N receiver design, one of the applications of the type 58 tube is fidelity control. This is made possible by means of an external connection for the suppressor of the 58. Heretofore such control has generally been accomplished by means of a variable electrical network shunted across the audio input or output transformer. The network usually consists of a condenser and resistor, the latter being varied manually to attenuate the higher audio frequencies. By this means, much of the tube hiss and high-frequency static noise which occur under conditions of maximum receiver sensitivity may be modified so as to improve reception from stations of low field strength.

It is realized that another potent reason for the inclusion in receivers of a manual fidelity control is the deference of the receiver manufacturer to the quite general acceptance and demand by the public for "soft" or slightly muffled reproduction of music. Much of this demand is due to an unconscious reaction by the public against the over-accentuation and distortion of higher frequencies occurring in older receiver designs.

### Improved Tone Enjoyed

Improved audio circuit design and the larger power output of modern receivers, together with the high quality of transmission available from many stations, provide improved tone. It is believed that the public will eventually be won by the realism which these improvements make possible.

With increasing public appreciation of good tone quality there will be less need, as regards local reception, for a fidelity control to produce "soft" music, but there will be a greater need to eliminate high-frequency noise and hiss from the reception of stations of low field strength. It seems desirable, therefore, to be able to alter automatically the response characteristic of the receiver so as to obtain high quality local reception or modified distant reception. For this purpose, a manual control instead of an automatic control, aside from the fact that it is an extra panel control, through improper use, might result in undue noise being received with distant station reception, or unnecessary attenuation of the higher frequencies with local reception.

Automatic fidelity control appears possible, without the use of physical resistances, by making use of the variation of tube plate resistance produced by a change of grid bias. This feature might be utilized in accomplishing control by connecting the plate and cathode of a tube across a tuned circuit so that a change in plate resistance ( $r_p$ ) will alter the selectivity curve and will suppress or admit sidebands.

### Characteristics of '24A and 58

Examination of the plate resistance-grid voltage curve of a '24A shows that, although  $r_p$  is in shunt with the tuned plate circuit of an amplifier,  $r_p$  increases

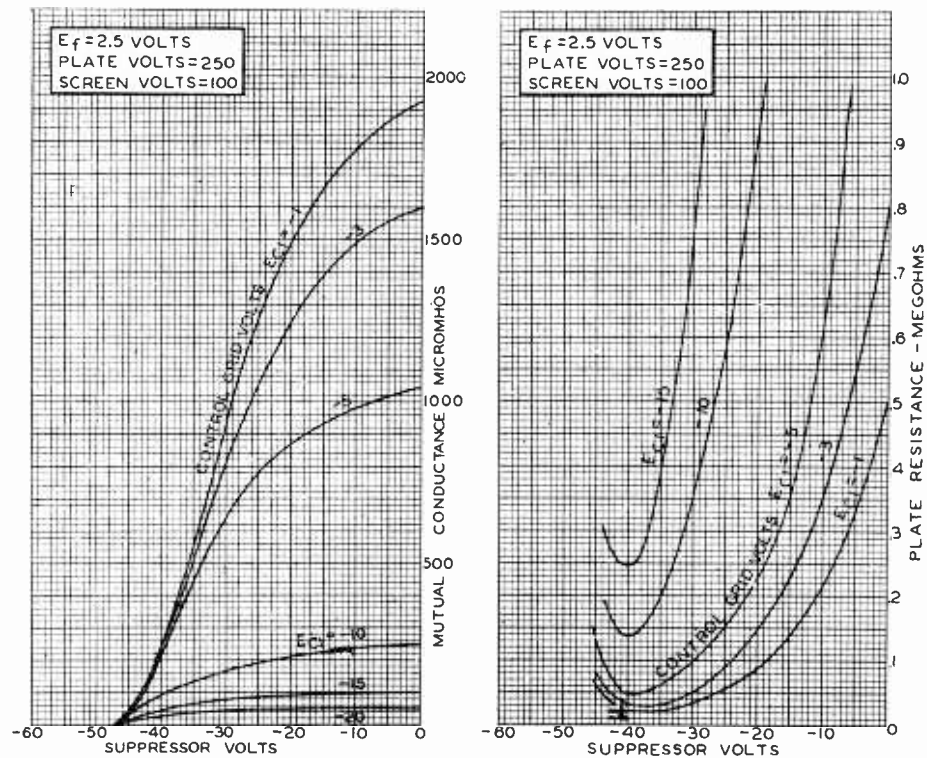

FIG. 1

Average characteristics of the RCA-58 tube. At left are curves showing the relation between the mutual conductance and suppressor grid volts for six different control grid voltages. At right are shown variation in plate resistance with suppressor volts.

with increase in grid voltage. Therefore,  $r_p$  is highest and provides maximum selectivity when the volume control bias is adjusted for local reception from a powerful station, while it is at a minimum when the volume control bias is adjusted for distant reception from a weak station. Since selectivity requirements, aside from fidelity considerations, are most severe when receiving distant stations, it is evident that the  $r_p$  change is opposite to the desired effect.

In contrast to results with the '24A, the plate resistance-suppressor voltage, curve (Figure 1) for the 58 shows, for fixed values of control grid voltages, decreasing  $r_p$  when the suppressor voltage is varied from 0 to -40 volts. This effect is in the right direction for selectivity and fidelity control and may be conveniently utilized for automatic control of these functions by connecting the suppressor to the a.v.c. resistor supplying variable control grid bias for the r-f and i-f tubes of a receiver.

Change of suppressor voltage from 0 to -40 volts for control grid voltage equal to -3 volts produces a 64 to 1 change in mutual conductance ( $g_m$ ) and, simultaneously, a change in  $r_p$  from 0.8 to 0.05 megohm.

[The foregoing is verbatim, the following is digested.]

### Tone Control

The suppressor grid provides a means not only for controlling the amplification over a wide range, but also for controlling the tone, as various degrees of attenuation of the higher audio frequencies can be obtained by varying the suppressor grid voltage. One point is noteworthy.

The attenuation of the high frequencies occurs when it is most needed, that is, when receiving stations of low field strength. The ordinary volume control which varies the grid bias works in the wrong direction in this respect, the high audio tones being stronger when receiving weak stations. This is because on receiving local strong stations the control bias is high and the plate resistance high, while on receiving weak stations the control bias is low and the plate resistance low.

### Range Attainable

The range of attainable attenuation may be increased or decreased by the choice of appropriate transformer impedances and coupling. As soon as transformer manufacturers have had time to analyze the requirements of the tube from this point of view, suitable transformers will be made available.

In receiver design, a desirable circuit arrangement might be to use the i-f stage immediately preceding the second detector for the fidelity control stage. The preceding stages may then be used to obtain the maximum selectivity desired for station discrimination when the plate resistance of the fidelity control stage is adjusted to an intermediate point in its variation range. With this adjustment, the overall selectivity will increase for low field strength stations and decrease somewhat for strong locals. The latter effect is permissible to some extent since selectivity requirements are not as stringent under these conditions. The most desirable adjustment is dependent upon the characteristics of preceding stages and is best determined by experiment.



# AND CURES; ING METHODS ARE POPULAR

Bernard

ground, and ground is used for the rest of the receiver as if it were B minus, although it is positive in respect to B minus, considering the rectifier, by the drop in the filter system. Also, the condenser next to B minus of the power transformer then has to be insulated from a metal chassis, since one side does not go to ground, and if a mid-section condenser is used with negative-leg choke, this condenser likewise must be insulated.

Several tests were made to determine whether the three-section filter choke, with 24 mfd. filter capacity, reduced hum more when 16 mfd. were at either end or 8 mfd. at each of the three points, and the separate eights did the trick most effectively.

The variations of uses of the condenser-resistor capacity combinations of the "100,000 series" previously discussed are very numerous, but the one object is phase shift. If the phases of the hum voltages are exactly opposite there is a complete cancellation, no matter what the amplitude.

The units may be tried, as series combinations in themselves, from plate of the power tube to grid of the first audio tube, or if a heavy-duty voltage divider is used, mere capacities of different sizes may be tried across only parts of the voltage divider. The values of these capacities will have to be obtained by experiment, but it can be said that they are of the order of 0.001 to 0.5 mfd. in general, and are not effective in all sets. When they are effective their effect is permanent.

The value of bypass condenser across the detector biasing resistor has a direct bearing on hum. In general it is true that the larger the condenser capacity the greater the practical amplification from the tube, that is, the higher the sensitivity. But it is not necessarily important to attain the very highest sensitivity. Something less than maximum can be tolerated as a contribution to hum removal.

## Actual Values Used

Therefore a compromise capacity is suggested. Actual values tried out that proved excellent were 20,000 ohms biasing resistor, 0.002 bypass condenser across it, in a circuit using a 224A as detector, with a relatively low screen voltage, and 180 volts applied in the plate circuit through 250,000 ohms. Only a power tube grid circuit filter was used, because there was only one stage of audio.

In all instances the connections of the output transformer, which joins the power tube or tubes to the speaker, should be tried both possible ways, as with single-sided circuits particularly there is often considerably less hum one way than the other. It may be necessary even to go against the directions of transformer manufacturers to follow this advice, but make the test yourself and use the less-hum method. There is no danger involved in the reversal.

The principal problem concerning hum has to do with the rectifier filtration, and with the phase shifting in the audio circuit (of which circuit the detector tube, since it handles audio frequencies, must be considered a part). If the choke coil is shorted, of course the hum will be large, as there will be no inductive assistance. The coil should be tested with a

resistance meter, or current put through the coil and a voltmeter reading taken across the coil to be sure that there is a potential difference between extremes. If the choke coil is the dynamic speaker's field coil a short would be indicated by very faint, tinny reception. The only remedy would be to have the manufacturer or a service man put in a new coil, if you can't get the coil and do the job yourself.

## Mechanical Hum

Another form of hum is really mechanical, not electrical, and is due to the vibration of the power transformer. Some of the laminations may be loose, or there may be a loose fitting of the case, whereby the loose part is set in motion when the transformer is put to use. If the laminations are loose, and the case can't be removed, hitting the side where the laminations are, using a strong hammer, only a few taps, often will jam the loose pieces tightly together. If the case itself is loosely fit, hammer a wedge into the loose part.

If the transformer has intended center taps on some windings, such as heater secondary and power tube filament secondary, assuming these are separate, the tap may be off center. Ignore the tap then and put a center-tapped resistor, 5 to 20 ohms, across the winding, and ground the center tap for the heaters, or for the power tube connect center to the positive side of the bias voltage, which in some instances also may be ground.

The two types of hum discussed have been (1) electrical, arising in the filter of the B supply exclusively, and (2) mechanical. A third type is tunable hum. This arises from a tendency of the receiver to oscillate when it should not, to ground hum due to the use of the same ground by the power company at an accidentally different potential than the one obtaining in your home, insufficient filtration in radio frequency circuits afflicted with cross-modulation or inter-modulation and too close proximity of the a-c line, rectifier tube or even B choke to the detector tube itself.

In some instances the tunable hum is heard only on a few stations, but it will be noticed that these few are the very loudest stations that you can receive. This is clearly a case of radio frequency tubes detecting, in other words, inter-modulation, and the hum is proportional to the sum of the amplitudes of the received wave and the exciting wave.

## Cure A-F Oscillator

If the receiver has a tendency to oscillate this should be cured at once. For instance, in t-r-f sets the negative permanent bias may be increased until there is no oscillation at the highest receivable frequency. The volume control may be in this circuit, and if so an oscillating receiver, may be tested by turning the control until oscillation ceases. This is a sure test that the oscillation caused the trouble, if cessation of oscillation eliminates the hum, and it is one of the easiest hum troubles to cure. Another method would be to remove some turns from the plate winding of the transformer connected in the first tube's output and second tube's input.

Ground current hum is prevalent in outlying districts, where the distance is considerable between the company's

transformer on a remote pole and the point where the current is utilized by the consumer. In such instances do not use an external ground on the set. Make the test to confirm the improvement, but if there is no improvement, restore the external ground. Whether or not externally grounded, the receiver and chassis still are grounded through the capacity of the windings of the power transformer to ground.

## R-F Filters

Insufficient filtration of the radio frequency B current is a relative term, since if the r-f tubes do not detect when they should not, then a certain amount of filtration already provided is sufficient, whereas if they do detect it is insufficient. Any one, however, may add a resistor-capacity filter. For usual t-r-f sets of a total of five or six tubes a resistor is placed between the intended B plus feed of the r-f tubes and the B plus terminals of the r-f coils, with a condenser from the coil terminals to ground. The values may be 2,000 ohms and 0.01 mfd. Or separate filters of this type may be used for each plate circuit, the B plus terminal of the coil going to one side of the resistor and to one side of the condenser, the other connections being resistor to B plus and condenser to ground. Then the resistor may be 5,000 ohms or so.

Remedies for mislocation of parts should be corrected at once by reassignment of positions. Grid leak and condenser detector particularly should be watched, as there is a strong static field about this combination, and it should be given plenty of "ventilation."

Push-pull normally is less hummy than single-sided output. Also the new heater type output tube, a pentode, made by some of the smaller tube manufacturers, is less productive of hum than the filament type tube, because of the independence of the tube circuit elements proper from the a-c that supplies the power for electron emission.

## Mismatched Impedances

One very unusual manifestation has to do with badly mismatched impedances in the power tube circuit. This usually consists of too low an impedance working out of a high impedance output tube, such as a transformer intended for the '45 being used in connection with a '47, and a speaker intended for the '45 being tied to a '47. In such cases there are continuous hum, despite absence of signal, and considerably augmented hum when a strong station is tuned in.

What the reason is may be open to speculation, but the fact is indisputable, and the mismatching was intentional. It is quite likely that since the effect of a mismatch is to make the output dissimilar from the input, instead of the output being a magnified pattern of the input, a form of detection takes place. Since any form of distortion is a form of detection this explanation seems to hold.

In the particular instance just cited the remedy applied was to remove the screen connection (K post of socket) from the high B voltage and connect it instead to the plate.

Thus the tube was changed from one with a high impedance characteristic (about 50,000 ohms) to one of low impedance (about 3,500 ohms).

# THE NEW TUBES IN A-C SETS

## 55 DE

By Michael

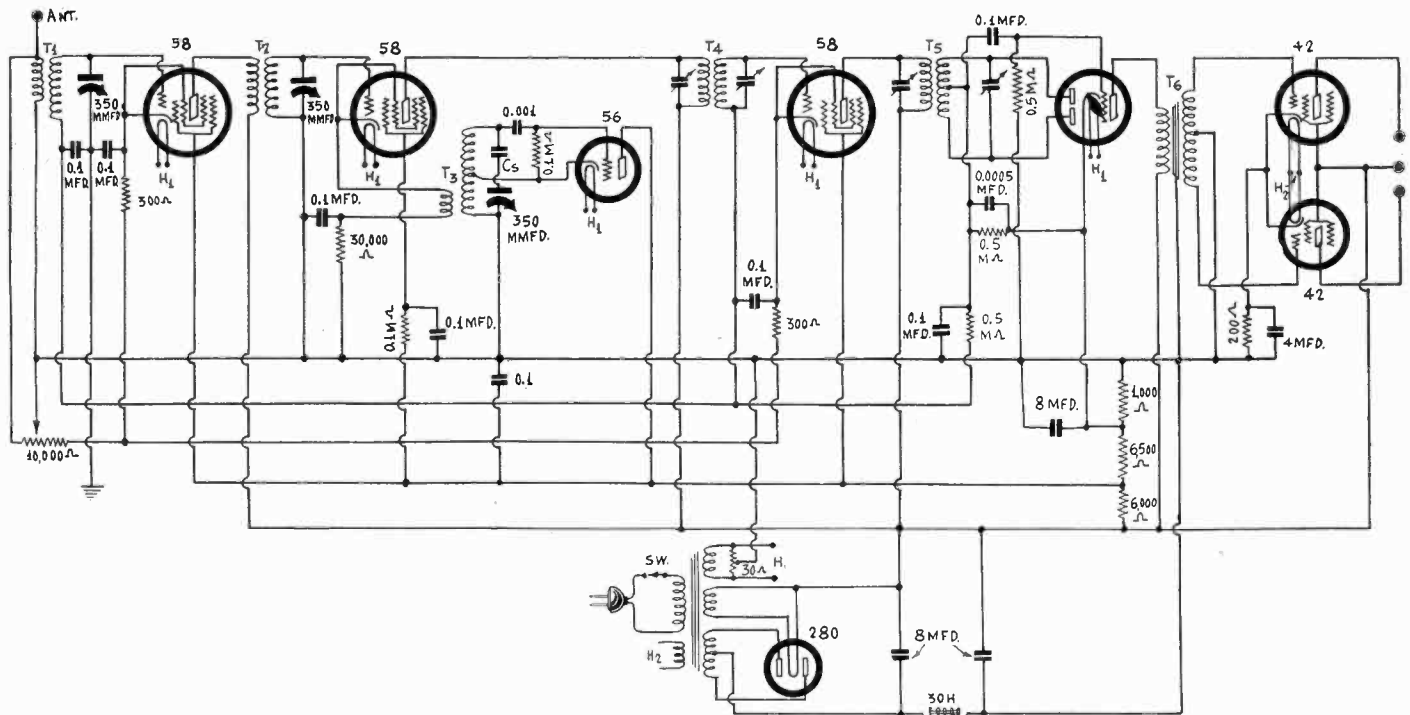

FIG. 1

An eight-tube superheterodyne employing the new amplifier and detector tubes. The duplex-diode triode is used for rectifier and first audio amplifier.

AS SOON AS the new tubes were announced radio fans began asking what changes would be necessary in old sets to adapt them to the new tubes. Of course, the answer to such questions depend entirely on what type of set is to be changed over. If it is only a question of installing the new tubes, very few changes are necessary. In the first place, most of the new tubes require 6-pin sockets. This applies to the 57 and 58. The 56 requires a 5-pin socket so if this is to be substituted for a 227, no change is necessary in this respect. The 46 requires a 5-pin socket, the same as the 247, so no change in socket is needed for this tube. The 42, which is also a new tube, requires a six-pin socket so if this is to be used a new socket is needed.

The main changes required pertain to the voltages, especially the screen and the plate voltages. All the new tubes require a maximum plate voltage of 250 volts and a screen voltage of 100 volts. Many of the old tubes have already been operated under these conditions so in some cases it will not be necessary even to make any changes in the voltages. It should be noted that the voltages specified are maximum, and it is not necessary to use the maximum in every instance.

### Coil Changes

The plate circuit characteristics of the new tubes are so nearly like those of the corresponding older tubes that it is not necessary to make any changes in the coils, nor in the coupling impedances in the audio amplifier. This is one question which seems to worry more people than any other, and it is the one question

about which there need be no worrying.

In the old tubes it has been customary to use a low screen voltage on the detectors and on audio tubes in resistance coupled circuits. This low voltage was necessary to overcome the effect of the electron emission from the plate when the effective plate voltage became equal to or less than the screen voltage. In the new tubes there is a suppressor grid which is supposed to overcome this effect and therefore it should not be necessary to lower the screen voltage, either by returning the screen to a low voltage on the voltage divider or by inserting a high resistance in the screen lead. However, a resistance may still be used.

Grid voltages required are approximately the same and if the tubes are self biased about the same values of resistance can be used. It is customary to use 300 ohms for a 224 and a 235, or a higher resistance when necessary to stop oscillation. The 57 and 58 require a resistance of about 270 ohms under the same conditions, so that a 300 ohm resistor would be all right. The 46, when used as a Class A amplifier requires a bias of 33 volts and at this current and recommended plate voltage the plate current is 22 milliamperes. Hence it requires a bias resistor of 1,500 ohms. This is the same as that required by a 245 tube but much higher than that required by a 247 tube, which is 400 ohms.

### A Typical Circuit

In order to have something definite to talk about let us refer to the circuit diagram in Fig. 1. This is an eight tube superheterodyne incorporating new tubes

in all sockets with the exception of that of the rectifier. The old reliable 280 is retained. In some respects the circuit is experimental in that it contains a diode full-wave rectifier-amplifier and a stage of push-pull with heater pentodes, the new 42.

The circuit is provided with an automatic volume control, the voltage drop in the load resistance on the diode being used for this purpose, and the controlled tubes are the first radio frequency amplifier and the intermediate frequency amplifier. These two amplifiers are 58 type tubes with the suppressor grid of each connected to the cathode. The suppressor grid, by the way, is the grid on the base which is physically adjacent to the cathode, though internally it is next to the plate.

### The Oscillator

The first detector is also a 58 because the manufacturers recommend the tube for this purpose. The suppressor grid of this also is connected to the cathode, a connection made on the socket. The bias resistor for this tube is marked 30,000 ohms on the diagram; but a value as high as 100,000 ohms may be used for the bias should be 10 volts and the current may be as low as 0.1 milliamperes. This resistor is not critical. With a bias of 10 volts the peak voltage impressed on the detector by the oscillator through the pick-up coil should be not more than 9 volts. Aside from that limitation it is not critical. If the oscillator voltage is more than 9 volts the detector is likely to overload.

There is a 100,000 ohm resistor in the

# IMPERS; DETECTOR-AMPLIFIER IN BOTH

J. O'Meara

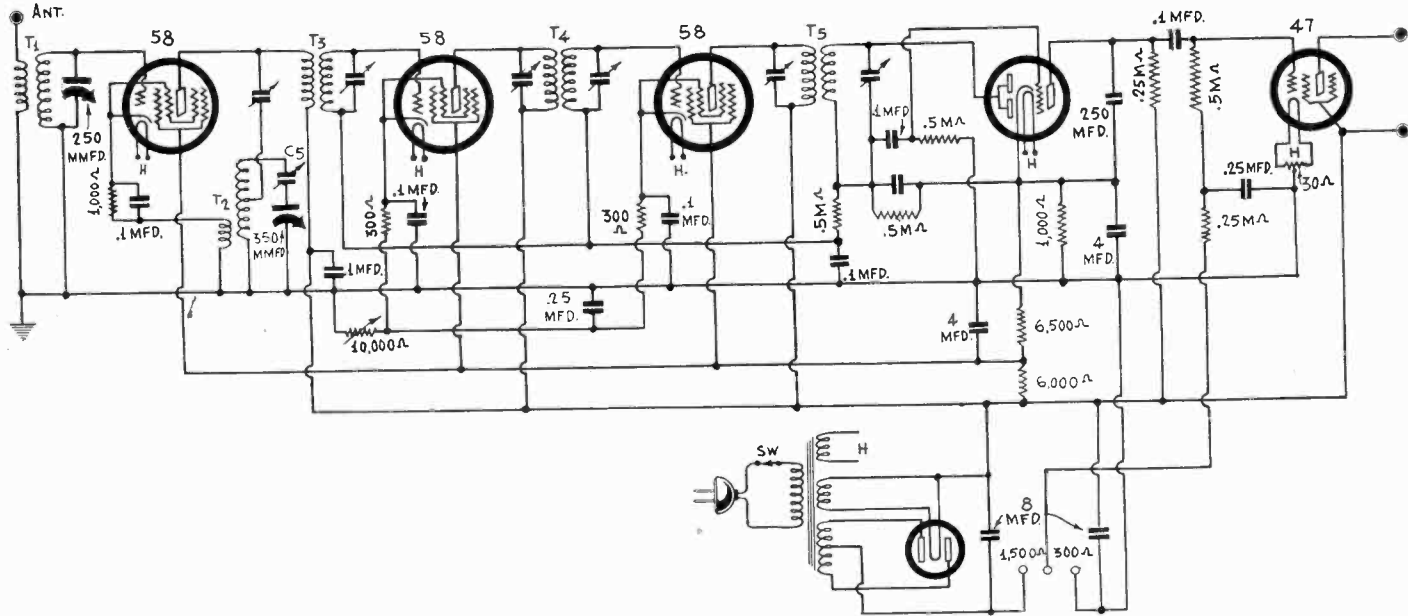

FIG. 2

A six-tube superheterodyne in which four of the new tubes are used. There are three 58s, one 55, one 47, and one 280. The first tube is both detector and oscillator. The fourth is both detector and amplifier.

screen circuit of the detector, shunted with a condenser of 0.1 mfd. As was pointed out above, it should not be necessary to use this resistor or condenser, but if used, it prevents overloading.

The oscillator is a typical Hartley circuit using a 56 type tube. Two windings only are used, the pick-up and the tuned, which is tapped at a point about 9/20 of the total number of turns from the ground side of the circuit. The tap should go to the cathode of the tube and should also pick up the low end of the 100,000 ohm grid leak. A lower value of leak should be used in case blocking occurs.

If the intermediate frequency is 175 kc, and the tuning condensers are 350 mmfd., then the tuned winding of T3 should contain 102 turns of No. 31 enameled wire on a one-inch form, with the tap placed at the 46th turn from the ground end. The tickler should contain 10 turns of the same size, or finer, wire, and it may be placed below the tuned winding. Or it may be placed over the ground end of the tuned winding provided that the two windings are separated with an insulator layer about 1/32 inch thick.

### The Detector

This oscillator coil assumes that the tuned windings of the r-f coils T1 and T2 contain 127 turns of No. 31 enameled wire on a one inch form. The primaries of these may contain 40 turns each of the same or finer wire, wound over the ground end of the secondary and separated from it by a layer of insulation. The coils are regular midget type coils encased in a shield measuring about 2.5 x 2.25 inches.

The detector used is a full-wave diode rectifier and triode amplifier known as the 55. It takes 2.5 volts on the filament, at

which voltage the current is one ampere. This tube contains three plates, two for the diode part and one for the triode. It also has a cathode and a control grid. In this circuit it is used first, as a full wave diode rectifier, second, as a triode amplifier feeding into a transformer load, and third, as an automatic volume control. The full details of this tube are given in another article in this issue.

As a full-wave rectifier the two plates connected to the secondary of T5 and the cathode come into play. Pulses of rectified current are sent through the half megohm load resistor connected between the cathode and the center of the secondary of T5. This current establishes a voltage drop across the resistor which becomes the detected signal. Carrier fluctuations are removed from it by the 500 mmfd. condenser across the resistor. Fluctuations occurring at an audio rate are not removed but are impressed as the signal on the control grid of the tube. This is done through a 0.1 mfd. stopping condenser and a half megohm grid leak.

The low end of this leak is connected to B minus, or ground. A bias of 20 volts on the grid of the tube is obtained by lifting the cathode by this amount, which is done by connecting the cathode to a point on the voltage divider 20 volts up from ground. An 8 mfd. condenser is connected across this resistor in order to prevent audio frequency feedback which would decrease the gain. The value of the resistance required depends on the current in the resistor. It is marked 1,000 ohms, which assumes that the total current in this resistor is 20 milliamperes. The tube current is 8 milliamperes and therefore the bleeder current is 12. The other resistors in the voltage divider have been determined on this basis and on the normal screen currents for the other tubes. The effective plate and screen

voltages are assumed to be 250 and 100 volts, respectively.

### The Automatic Control

The automatic control voltage is the drop in the load resistor on the full-wave detector. A half megohm resistor is connected from the negative end of this resistor and the grid returns of the controlled tubes. This resistor serves as a filter. In the drawing there is a 0.1 mfd. condenser from the center tap of the secondary of T5 to ground. This is in the wrong place and should be connected between the grid return end and ground. Where it is it will partly short-circuit the audio signal voltage on the triode part of the detector tube. It is really not needed because there is a condenser of the same capacity associated with the first r-f circuit which serves the purpose. This condenser is connected from the ground and the low side of the secondary of T1. There is no harm, though, in using 0.2 mfd. here.

The output stage is a regular push-pull amplifier coupled to the detector-amplifier with a push-pull input transformer. The push-pull tubes indicated are the 42 power pentodes. The two require a bias resistor of 200 ohms, and this resistor should be shunted with a 4 mfd. condenser.

The 42 as available requires a filament voltage of 6.3 volts and for that reason two filament windings are shown, H1 for 2.5 volts and H2 for 6.3 volts. Undoubtedly, the 42 will be available in 2.5 volts also. If there is a question of obtaining the necessary 6.3 volts for these tubes, a pair of 247 tubes can be substituted and the 2.5 volt winding used. The only change required would be the omission of the cathodes and connecting the positive end of the bias resistor to the center-tap of the filament. The center tap on H1 would then not be connected to ground.



# Radio University

**A QUESTION and Answer Department. Only questions from Radio University members are answered. Such membership is obtained by subscribing for RADIO WORLD for one year (52 issues) at \$6, without any other premium.**

RADIO WORLD, 145 WEST 45th STREET, NEW YORK, N. Y.

## Noise Elimination

WHY DOES a resistance across the secondary of an audio transformer remove some of the crackling and sparkling noises in a radio receiver?—G. H. A., Pittsburgh, Pa.

The noises are due to electrical shocks characterized by waves of steep wave fronts. These induce very high voltages in the secondary. If there is a resistance across the secondary the peaks of these voltages are reduced because current may flow in the resistance and in the secondary. Hence the high voltages are not impressed on the grid. The resistance across the secondary serves the same purpose as the r-f chokes in the anode leads of the 82 rectifier.

\* \* \*

## Connecting Phonograph to Receiver

WHERE WOULD be the best place to connect the phonograph pick-up to my five tube midget receiver? It contains only one stage of audio amplification and if I connect it in the grid circuit of the power tube I do not get sufficient volume, and if I connect it in the grid circuit I don't get anything.—A. M., Yonkers, N. Y.

There is only one place to connect it and that is in the grid circuit of the detector. If you do it right there will be plenty of amplification. You cannot connect it from the grid to ground for then the tuning coil will short circuit the pick-up unit. Neither can you connect it from the grid to ground if you remove the grid clip which is connected to the coil, for then the grid bias will not be right for amplification. Remove the grid clip and put another one in place of it, and this second clip should be connected to one side of the pick-up unit. The other side of the pick-up unit should be connected to a tap on the bias resistor. You can do this by making the grid bias resistor in two units, one of 20,000 ohms and the other of 10,000 ohms. Connect the 10,000 ohm resistor next to the cathode of the tube. If your bias resistance is higher than 30,000 ohms you can still make up the total with one 10,000 ohm unit and one other. Another way is to connect a 10,000 ohm resistor in parallel with the grid bias resistor when you want to use the phonograph. In this case one of the pick-up terminals can go to ground.

\* \* \*

## Intermittent Reception

MY RECEIVER works intermittently. At times the volume is fine but suddenly it dies out completely, only to come back after a while. On test everything seems to be all right. Can you suggest a possible cause of the trouble?—W. C. W., Jersey City, N. J.

Intermittent defects are very difficult to locate because they are all right when the circuit is tested. Often the trouble lies in a resistor which opens when it becomes heated. The set then dies and begins to cool. When the temperature has reached a certain value the defective joint closes and the set plays again for a while. About the only way to find the trouble is to substitute all parts which may cause the trouble, one at a time, until the defective one has been found. Another cause of intermittent reception lies in the

by-pass condensers. They break down and become shorted. The voltage falls on some element. The faults are self-healing too in some cases. When this is the cause it can usually be detected by measuring voltages. Incidentally, the defective contact may be in the heater circuit of the tubes. The break occurs after the temperature gets up to normal. Then the circuit gradually dies down while the cathode cools. This trouble works like a thermostat. Sometimes when a circuit is operating very near the oscillating point it might break into oscillation, when reception stops. The stopping may in turn remove the cause of the oscillation and the circuit will play again. In hunting troubles of this kind it is well to leave a voltmeter or a milliammeter in the circuit and to note what happens when the volume stops.

\* \* \*

## Varying Inductance

A SHORT WAVE coil is wound like a helical spring with heavy wire and with turns well separated. I wish to vary this inductance for tuning because the capacity I use is only the self capacity of the tube and the circuit. Will you suggest a means of doing so?—B. S., Newark, N. J.

Mount the coil so that you can stretch it and compress it along the axis. As you stretch it the inductance decreases and as you compress it the inductance increases. The range is not very great but you don't want a wide range in a high frequency circuit like that.

\* \* \*

## Speed of Radio Waves on Conductors

IN THE Lecher wire system it is assumed that the speed of the radio wave is the same as it is in free space provided that there is a negligible resistance in the wires. Now suppose that the wires be coiled up into very long solenoids and placed side by side. Would the speed of propagation be the same so that the wavelength could be measured in the same way?—G. W. F., Hoboken, N. J.

The wavelength could be measured in the same way but not the frequency because the speed along the two solenoids would not be the same as the speed of the radio wave in free space. The speed would be much smaller and the nodes would be much closer together. The speed would depend on the inductance and capacity per unit of length. The use of long solenoids in this manner would reduce the problem to that of the resonance wave coil.

\* \* \*

## High Pitch Squeal in Super

THERE IS a high pitch squeal in my superheterodyne which I have just built. It is practically the same at all settings of the tuning condensers so it cannot be a heterodyne. Will you kindly suggest a remedy?—T. E. L., New York, N. Y.

The squeal is undoubtedly due to blocking of the oscillator grid. The easiest way to stop this squeal, if it is due to blocking, is to lower the value of the grid leak in the oscillator. Another way is to put a resistance in series with the stopping condenser, either on the grid side

or on the tuning condenser side. Still another way is to reduce the plate voltage. And still another is to put in a grid bias resistor so that grid current will not flow, or so that it will flow only a small part of each cycle. Whichever remedy is applied should not be overdone because oscillation may stop entirely or the oscillation may become so weak that the set will be insensitive.

\* \* \*

## Construction of Colpitt's Oscillator

IS IT possible to construct a Colpitt's type oscillator with two equal tuning condensers in series so that both rotors are grounded? If so, please show a diagram?—R. B. N., Rye, New York.

It certainly is possible. For a diagram of the circuit see page 13, May 21st, 1932, issue of RADIO WORLD.

\* \* \*

## Close Tuning

IS THERE any way of arranging condensers in a tuner so that one of them will act as a very close adjuster, that is, so that after the main condenser has been adjusted approximately to the correct frequency the other can be used for tuning within a band of about 25,000 cycles, or even less? What I have in mind particularly is this: I have two oscillators, one of which is very steady and of fixed frequency. The other is similar but it is tunable. I want to get a beat between the two and I want this beat to cover the entire dial from zero to 25,000 cycles. I have tried a small condenser but it does not seem to work. Incidentally, the frequency of the fixed oscillator is 5,000 kc.—W. F. J., Columbus, Ohio.

Connect a very small condenser in series with a large variable condenser. Then connect the two, in series, across the main tuning condenser in the oscillator. The large variable condenser will then act as a means for very close adjustment. The smaller the small condenser is in comparison with the large variable, the closer the adjustment. As an illustration let us assume that the main tuning condenser is set at 100 mmfd., that the small fixed condenser is 10 mmfd., and that the large variable condenser is 500 mmfd. The total capacity of this combination when the large variable is fully meshed is 108.33 mmfd. When the large condenser is set at zero its capacity may be 20 mmfd. The capacity of the combination of the three condensers is 106.66 mmfd. Thus the capacity ratio is 1.0156 and the frequency ratio is about 1.0078. Thus at 5,000 kc you can vary the beat between zero and 39,000 cycles. If you make the small series condenser 1 mmfd. the range will be about 4,000 cycles.

\* \* \*

## Pick-up in Television

WHEN FLOOD-LIGHTING is used for transmitting television by the direct pick-up method does it make any difference what kind of light is used, or must the light be white like sun light? What will the effect be if only blue light is used, which is very effective in the photoelectric cells?—F. W. L., Binghamton, N. Y.

It depends much on what is transmitted. If only one color is used many things would appear black on the image which actually are bright in sun light. The effect would be just as unnatural as photographs taken with blue light. Suppose, for example, that blue light only is used. Any object not containing primarily blue would appear black or at most gray. A red object would certainly appear black, just as it does in most photographs. In order to show on the image there would have to be red light present, and the photocells would have to be responsive to red light. The image, of course, will not show red and blue but everything will be either bright or dark, but the reds in the object will not be black. They may be gray.

## WCFL ON 5 KW, FULL TIME, AS A NOVEL TEST

Washington

Its three-year fight for increased power and day-and-night operation was tentatively won by the American Federation of Labor when the Federal Radio Commission authorized WCFL, owned and operated by a subsidiary of the federation, to increase its power from 1,500 to 5,000 watts and utilize unlimited time experimentally, instead of only day time.

The station's frequency, 970 kc. is shared by KJR, Seattle, Wash., 5,000 watts, and this cleared channel is designated by the Commission as a cleared frequency, meaning only one high-powered station can operate on that frequency.

### Follows Court's Idea

However, in view of the court decision in the WGY case, when the Schenectady, N. Y., station was authorized to send simultaneously with its sister station, KGO, Oakland, Cal., the Board became convinced that it was worth while trying out WCFL and KJR, both on high power, with about half the geographical separation as in the other case.

WCFL will move its transmitter from Navy Pier, Chicago, to York Township, Ill., and install new equipment.

The vote in the Board was 4 to 1, Commissioner Lafount voting in the negative.

### No Interference at 1,500 Watts

The majority furnished the following information:

Although the stations have shared this frequency, WCFL's power has been but 1,500 watts, and the geographical separation between Chicago and Seattle has been sufficient to prevent interference. With the Chicago station operating with 5,000 watts, however, the separation may prove to be insufficient.

The Court of Appeals of the District of Columbia recently set a precedent in interpretation of cleared channel rulings when it ordered WGY, Schenectady, N. Y., to operate simultaneously full time with KGO, Oakland, Cal., on 790 kilocycles.

### In Public Interest

The court expressed the opinion that public interest would be better served with power stations operating on the same cleared frequency unlimited time as long as the stations are sufficiently separated geographically, so that interference will not result.

## WINS to Move

WINS will move its studios from atop the Hotel Lincoln to larger quarters at 114 East 58th Street. WINS will occupy a four-story structure to be known as the "WINS Building." The studios in the new location are far from completion but because of the rapid growth of the station's activities the management feels that it would be more satisfactory to move into unfinished quarters than to wait until such a time as the work will be entirely completed.

### MARINE RADIO FOR OIL TANKERS

The twenty-one ships of the Standard Oil Company of California are to be equipped with marine radio. The installation will be made by the Mackay Radio & Telegraph Co., a subsidiary of the International Telephone & Telegraph Co.

## 5 Cities of 100,000 Have No Station

Washington.

Five cities of more than 100,000 population have no broadcasting stations, although they receive service from stations in surrounding localities. These six cities are:

Duluth, Minn.  
Lowell, Cambridge and Lynn, Mass.  
Elizabeth, N. J.  
Duluth is in the Fourth Zone, the other cities in the First Zone.

## PATENT DENIED TO U. S. AGAIN

Philadelphia

The Circuit Court of Appeals upheld the decision of the District Court of Wilmington, Del., which decided that patents obtained by Percival D. Lowell and Francis W. Dunmore while they were employees of the Bureau of Standards, Department of Commerce, should not be decreed the property of the Federal Government. These patents were assigned by the inventors to Dubilier Condenser Corporation of America, which was sued by the government, which sought the conveyance decree.

The patents concerned principally the operation of a receiver from the alternating current electric light mains, particularly the power amplifier, although all three sections were involved—radio frequency amplifier, detector and power amplifier.

The court in its opinion said:

"We have carefully studied the record in this case, first, with the assistance of the very thorough briefs and, again, independently of the briefs. . . .

"It will be enough to say that, in accord with the learned trial judge, we find no evidence that would sustain a finding that Lowell and Dunmore were assigned by their superior to any research or development problems involving the inventions in controversy.

"Having given particular attention to dates, about which these questions revolve, we think the most that the evidence shows is that Lowell and Dunmore, after completing their inventions in substance, called them to the attention of their superior who, being greatly interested, permitted and encouraged them to pursue their work in the laboratory and perfect the inventions in detail. All this amounted to conduct after the event and is therefore not controlling.

"The decrees are affirmed."

In another case involving these patents—Dubilier vs. RCA—a district court held that the two Government employees did not invent anything but merely assembled into a working set the devices known to the prior art.

## New Zealand Woman Hears WRVA Direct

Mrs. Cora Judd, Tauranga, Bay of Plenty, New Zealand, using an Atwater Kent Model 60 eight-tube receiver, heard Pat Binford and the Old Timers in a program of Hill Billy music from WRVA, Richmond, Va. There was no fading.

The distance is approximately 10,000 miles one way and 14,000 miles the other. The station uses 5,000 watts and a frequency of 1110 kilocycles.

## AMATEUR AT 9½ SETS A RECORD; CALL IS W6FZA

A new claimant for the title of youngest licensed radio amateur is Alan T. Margo, of Porterville, Calif., 9½ years old. Alan passed his government radio operator's license examination and received his station license from the Federal Radio Commission.

Alan, who has just completed the fourth grade at school, is the proud owner of W6FZA. He has been interested in radio for a little more than a year and has built several sets during that time. He is able to receive the international Morse code at 15 words per minute at present, while the government licensing requirement is only ten words.

### Has 5-Watt Transmitter

His first transmitter, constructed from information supplied by the American Radio Relay League, the national amateur organization, is a single-tube affair of about five watts power. Alan plans soon to install a more elaborate rig, however, incorporating some recent developments in amateur equipment.

His father, Albert T. Margo, also was a youthful radio enthusiast, having built and operated an amateur spark transmitter under the call "NV" as a high-school boy, in 1910. He later had Signal Corps experience, and is now re-entering the amateur ranks with a new station of his own, as yet unlicensed.

### "Sons Know More Than Fathers"

Concerning the participation in amateur radio of young boys, Mr. Margo says:

"I believe that any boy of average intelligence and fair determination can pass the examinations, especially if he has some help from his father. The trouble is that most fathers do not know as much about radio as their sons."

Information concerning amateur radio can be obtained from the American Radio Relay League headquarters, at West Hartford, Conn.

## Court Won't Clarify Short-Wave Ruling

Washington.

The Federal Radio Commission, which applied to the District of Columbia Court of Appeals for clarification of an order issued by the court, or permission to reopen the case involving forty domestic short-wave commercial frequencies formerly held by the United Wireless Communications Company, has to accept the order as originally issued, without clarification and without permission to reconsider the cases. The court so ruled.

The communications company went into bankruptcy and the court ordered the frequencies be assigned by the Commission as it saw fit to Radio Corporation of America and the Mackay Radio and Telegraph Company, saying "the public is entitled to service," and these two companies have shown they can render it.

RCA had obtained a stay preventing the Commission from issuing licenses for any of the forty frequencies to any other company than the court indicated.

### FULL TIME FAVORED FOR KGGC

Washington.

An examiner of the Federal Radio Commission has recommended full time for KGGC, San Francisco, Calif., due to the Commission's denial of a license renewal to KFQU, Holy City, Calif.

# VISION SENT TO SOARING PLANE ON ULTRA WAVE

Los Angeles, Calif.

A motion picture was received for the first time by television aboard a plane roaring through the skies. The plane was more than a mile above the city.

This experiment was made possible by Harry R. Lubcke, director of television for the Don Lee Broadcasting System.

Using a new type cathode ray receiver embodying his own patents on scanning and synchronizing, for operation away from city electric light mains common to both transmitter and receiver, he sent the image of a motion picture actress and it was received aboard a speeding Western Air Express plane. The film was transmitted to the plane from W6XAO, at Seventh and Bixel Streets, Los Angeles.

On the receiving screen high up in the clouds in the darkened plane the image appeared. The screen was eight inches square, and the moving figure turned and acted exactly as it was reproduced from the strip of film being transmitted far below. The receiver was an electrically-operated cabinet model, intended for home use, with three knobs mounted in the familiar arrangement of the average home radio set.

## Used Ultra Frequency

In addition to the unusual characteristics of the receiver, the experiment was further advanced by use of the ultra-high frequency of 44,500 kilocycles, or  $6\frac{3}{4}$  meters, as a channel of transmission for the film. W6XAO, which is rated at 150 watts, operates on that newly-allocated television channel, transmitting an image of eighty lines at fifteen frames a second.

This ultra-high frequency has the decided advantage of providing a steady signal not subject to the usual "fading" and erratic behavior common to the commercial waves and other television channels now being generally exploited. This frequency is known as a quasi-optical channel.

"The waves emitted by the transmitter behave in a manner similar to light waves," said Lubcke, explaining this point after the experiment. "Thus the strongest signals were received when there was an unobstructed line of sight from transmitter to receiver."

As a result of the flight new data have become available to future television records. An air contour map showing W6XAO signal intensity over Los Angeles and surrounding territory was devised. It was found that a particularly strong beam of signal intensity was located at a northeasterly direction from the transmitting station.

## Unaffected by Shocks

The ruggedness and reliability of cathode ray type television receivers was ably demonstrated. The Lubcke receiver used in the tests withstood the shocks of take-offs and landings six times, without any effect on its operation whatsoever.

Lubcke is a graduate electrical engineer from the University of California. He superintended installation of W6XAO last December and has been continually engaged in pioneering research. The station operates on regular schedule daily, except Sundays, from 6:00 to 7:00 p.m., P. S. T., transmitting motion pictures and other images for experimental purposes.

He was assisted in the aeroplane experiment by Philip C. Tait, Frank M. Kennedy, J. Glenn Turner and Theodore Denton, all of the W6XAO television staff. Allen Barrie, veteran airmail flyer, piloted the plane.

# Forum

## Full of Joy

ALLOW ME to congratulate Mr. Rodman Markham on his splendid article, "Getting Rid of Noises," published in RADIO WORLD, May 21st issue. Every word of it was very interesting and a lot of helpful information will be obtained by the many service men who read your magazine. More information of this kind, I am sure, will be welcomed by your readers.

I would like also to thank you for the valuable tube information published in recent issues. In fact, there are so many things I would like to thank you for it would require a book to write them in.

I have been reading your magazine ever since you published the first diagram of the famous Diamond of the Air, by Herman Bernard, which reminds me of the song, "I Still Get a Thrill Thinking of You." Those were the good old radio days, believe me.

SYDNEY J. WRIGHT,  
506 West 179th Street, N. Y. City.

# DERBY SHOWN BY TELEVISION

London.

Using drums with mirrors at displaced angles, both at the transmitter and at the receiver, John Logie Baird, Scotch inventor working in London, treated a theatre audience of 4,000 to a 7x9-foot television showing of the Derby. It was England's first demonstration in a theatre of such large-size television, and at the end of the race the audience leaped to its feet and shouted its approval. Somebody cried "Author!", by force of habit, and a friend backstage pushed Mr. Baird forward.

The inventor seemed quite embarrassed, and words failed him, but he was able to bow stiffly. Afterward he told interviewers that the results were fairly good, considering the enormous technical problems involved in the transmission between Epsom Downs and London.

The audience fully enjoyed the showing, particularly as it could distinguish the progress of one horse from that of another, and in some instances even to identify the horses because of the stripes worn by the jockeys.

Large drums were used, with thirty mirrors around the circumference. A high degree of illumination was thus obtainable, and it was necessary for large-size projection. The pictures were about three times as large as those Mr. Baird usually shows in private demonstrations.

Direct pickup was used at the race-track. A special camera was devised for this work.

Natural sunlight illumination of the subjects was used, and the camera's projection on its ground glass scanned, the drum feeding photo-electric cells. The current impulses put out by the cells, equivalent to the light impulses received, were sent over a radio wave and picked up by a receiver in the theatre. The output of the receiver fed a series of neon lamps, which were scanned at the receiving point, and the result projected on the theatre screen.

## ROOSEVELT MEDAL TO MILLIKAN

The Roosevelt Memorial Association will award the Roosevelt medal for distinguished service in science to Dr. Robert A. Millikan for his researches in the field of electricity. Dr. Millikan is director Norman Bridge Laboratory, California Institute of Technology. He is a Nobel prize winner.

# CONVENTION ON AIR FOLLOWING 6-MONTH PLAN

Arrangements for broadcasting the national conventions in Chicago, the result of six months of conferences among political party leaders and officials and engineers of the National Broadcasting Company, are very complete.

The running story of the conventions will be handled by William Hard, political observer, and Graham McNamee, chief of the NBC announcing staff.

The NBC engineering staff moved into the Chicago Stadium six days before the opening of the Republican convention to complete the setting up of microphones and the installation of wire lines running to special positions. The convention opened June 14th.

## Parabolic Microphones Used

The parabolic microphones, placed on either side of the rostrum facing the delegates, make it possible to pick up for all networks operating from the stadium the voice of any one speaking from the floor, or the sound of any floor demonstrations. From the control room these "radio ears" may be aimed or focussed in any direction. They also are attached to a public address system so that all delegates may hear clearly anyone speaking from the floor.

Lowell Thomas, author, traveller and news broadcaster, went to Chicago to report the Republican and Democratic national conventions as the first feature of his new daily news summaries under the sponsorship of the Sun Oil Company.

## Quits "Digest" for Oil Company

Other important and interesting news events will be included as usual in Thomas' summaries, which will continue from New York following the adjournment of the Democratic convention. Thomas, who recently signed a long-time contract with his new sponsors, had been broadcasting his daily news talks over NBC networks since 1930 for the "Literary Digest."

Author of twenty books and a lecturer who has appeared in practically every English speaking city in the world, Thomas was widely celebrated as a reporter and traveler before he entered radio. He was born in a Colorado mining town, and while still in his early twenties led two expeditions into the Arctic. Since then his explorations have included extensive tours into Malaya, Upper Burma and Central Asia.

Thomas gave the world its first account of Colonel T. E. Lawrence, mystery man of Arabia, and toured India with the Prince of Wales. At the suggestion of President Wilson he was appointed to record the history of the World War, and he was one of the first correspondents to enter Germany after the armistice.

## WGN Signs Two Sponsors

Chicago.

The Gordon Baking Company and the Delatone Company have signed contracts for time on WGN. The baking company will sponsor the time signals three times a day, at 9 a.m., noon and 2 p.m. This contract is for six weeks. The Delatone Company has taken the period from 2 to 2:15 each Sunday afternoon with a program featuring Lawrence Salerno, Italian baritone, and Allan Grant, pianist.

# LEAGUE ASKS AUDIENCE RUN AIR CHANNELS

Chicago.

The American Radio Audience League has been formed, with headquarters at 59 East Madison Street, Chicago, to bring about a complete revolution of the United States system of radio. The object is to entrust "the financially valuable broadcast channels to competent agents representing the audience, rather than sellers of transmission."

Excessive advertising, lack of consistency of the service at any dial point, and grant of powers to unqualified persons to determine the content and character of radio programs are charged in a memorial addressed jointly to the Senate, the House and the Federal Radio Commission.

Harris K. Randall is executive director, Herbert Bebb, 29 South La Salle Street, Chicago, is treasurer, while there are twenty-three members, mostly educators located in Chicago and Evanston, on the provisional committee.

## Charges Free Monopolies

Randall in a circular letter to listeners says:

"Long ago I became convinced of the fact, now openly proclaimed by leading trade papers, that the average broadcast program carries altogether too high a percentage of station and sponsor "lineage," and that these impositions on the time and patience of the listener are restricting the wider use of radio receivers, the size of radio audiences, and the demand for new sets."

"Here are the facts as they affect both the audience and the radio trade:

"(1) While the price of receiving sets has fallen low, the broadcast advertising business (though similarly over-expanded) has waxed fat on its free monopolies of access to several billion dollars worth of receiving apparatus paid for by the public—an open door to most of America's purchasing power.

"(2) With the broadcast channels now apparently free from the 'private property' threat, the way seems open to make them public resources in fact as well as in theory—to conserve their tremendous value and use it to finance real uninterrupted public service on the air.

"(3) If that value were collected by the government as a tax, little if any of it would ever be expended for the broadcasting that the public wants to hear and the receiver industry needs.

## Wants Audience to Control Air

"(4) Both the collecting and the expending would therefore be better done by the most competent discoverable licensees, acting as local 'business agents for the radio audience.' Who should they be? Write your own ticket—but hardly anyone could be worse qualified for such responsibilities than men with 'over-expanded' transmitters on their hands which can be kept profitable only by a corresponding over-expansion of air advertising.

"Practically everybody else stands to gain by such a clean-up. Notice that it does not mean depriving jazz-lovers of their 'hot' music, nor advertisers of their audience, nor 'networks' of their outlets, nor broadcasters of their transmitting properties. What it does mean is giving everybody who has anything to sell a free field to sell it in: programs, recording, wire transmission, radio transmission, channel occupancy—the last-named item to be managed and marketed by licensed agents for its rightful owners (the audience)."

## Frances R. King Heads NBC-RKO Bureau

With the recent announcement of the appointment of Frances Rockefeller King to take charge of the coordinated Private Entertainment Bureau of NBC and RKO, George Engles, managing director of NBC Artists Service, also announced the following appointments to his staff:

William B. Murray, recently of the Judson Radio Program Corporation, in charge of booking popular talent for radio and personal appearances.

Marks Levine, of NBC Artists Service, in charge of booking classical talent for concert and operatic engagements for both radio and personal appearances.

Ernest Chappell, formerly of the staff of WHAM, NBC associated station at Rochester, N. Y., and more recently with Adams Broadcasting Service, to act as NBC Artists Service contact man between NBC program and sales departments.

Ernest Cutting, to act as contact man between NBC Artists Service and Radio-Keith-Orpheum Corporation.

Clifford Cairns, manager Artists and Repertoire Division RCA-Victor, and his assistant, Joseph Higgins, and their respective staffs, to join NBC Artists Service in charge of recordings and booking dance orchestras.

## HEARING HELD ON WJSV SALE

Washington

The reasons of the Columbia Broadcasting System for desiring to buy WJSV, Mount Vernon Hills, Va., situated near the estate of George Washington, were set forth before the Federal Radio Commission, which sat en bloc to hear the case.

The principal reason set forth was that the chain desires a Washington outlet that will not cause interference due to inability to mesh chain broadcasts. Mount Vernon Hills is just outside Alexandria, Va., which is across the Potomac from Washington, and CBS wants to feature more events of national importance emanating from the capital, tying in the station with its own chain, and utilizing a remote control line about fifteen miles long, from Washington to the transmitter.

WJSV operates on 1460 kc and uses 10,000 watts power. At present CBS is using WMAL as its Washington outlet, but cites instances of interference.

Col. Charles I. Stengle, representing the board of directors of WJSV, said that if the proposed purchase is sanctioned Washington will receive better service and programs.

Speaking for CBS, Harry Butcher said that if the application is granted a new studio and transmitter will be erected.

The actual transfer of ownership would be to the Old Dominion Broadcasting Company, wholly-owned subsidiary of CBS. Sam Pickard, vice-president of CBS, said CBS will be financially liable and vouched for the financial integrity of the Old Dominion company.

Andrew Ring, engineer for the Commission, pointed out that CBS would control 7.4 of the quota units in the United States, counting ownership and leases.

## CONFER ON AUTO RADIO

Efforts are being made to standardize automobile radio. Co-ordination is being effected between the Society of Automotive Engineers and the engineering division of Radio Manufacturers Association, Inc.

# NBC WOULD PAY \$600,000 FOR KPO IN 7 YEARS

Washington.

The price the National Broadcasting Company is to pay for KPO, San Francisco, is \$600,000, payable in five annual installments of \$100,000 and two annual payments of \$50,000 each, all without interest. This fact was brought out at a hearing before the Radio Federal Commission, sitting en bloc, on the question whether the proposed sale should be approved.

How much was to be paid had nothing to do with the Commission's problem, but rather the point considered was whether NBC has too great a hold on the Fifth Zone as it is, for in station quota units it has about four times as much as the Columbia Broadcasting System. A unit is a basis of rating adopted by the Commission which takes into consideration the service area.

## Board Engineer Speaks Up

Andrew W. Ring, an engineer of the Commission, gave the facts as follows: In the metropolitan area of San Francisco NBC has 10 units of the total 14.3 allotted to that district, while in the State of California NBC stations total 15.8 units out of a total of 38.84 assigned. He cited the NBC units as 42.8 for the Fifth Zone (comprising several States), while CBS had 10.55.

It was the first time the question of the comparative standing of the two big chains ever had been raised before the Commission in connection with station licenses. Nor was the question brought up or discussed at all by any representative of CBS, but only by the Commission engineer.

KPO went on the air in 1922 and has been losing money every year since then, due to the policy of the owners to admit only the highest types of sponsored programs, and to refuse to permit direct quotation of prices and other practices deemed unethical.

## Has 50,000-Watt Permit

Hale Bros. Stores, Inc., and the Chronicle Publishing Company are the joint owners. The station is licensed at 5,000 watts but has a construction permit for 50,000 watts. It started at 100 watts.

J. W. Laughlin, manager of the station, testified that NBC would decrease the deficit and further improve the service, as chain programs are very popular in the West.

Don E. Gilman, vice-president of NBC, explained that the station already is used as an NBC key station, for the gold network, but that programs will be improved because reduced deficits will enable spending more money for talent. He disclosed that when business conditions improve, NBC plans to run a dual wire line between the East and West Coasts, using KPO as Western outlet. Greater variety of programs, as well as better regularity of interchange, is expected as the result of the dual system.

## IGLOOS RADIO-EQUIPPED

Some of the 7,000 Eskimos in Arctic and sub-Arctic Canada have radio receivers in their igloos, and a few have sets on their auxiliary schooners at Aklavik, near the mouth of the Mackenzie River. There is no depression in eskimo-land.

## SCHOOL MANUAL UNDER WAY

A manual is to be issued by Radio Manufacturers Association, Inc., on radio and sound equipment in schools. The Office of Education, Department of Interior, suggested it.

A THOUGHT FOR THE WEEK

ALFRED E. SMITH has had a broadcasting studio installed in the Empire State Building at Fifth Avenue and 34th Street. Query: Will Mr. Chrysler enjoy his radio set as much as he once did?

# RADIO WORLD

The First and Only National Radio Weekly  
Eleventh Year

Owned and published by Hennessy Radio Publications Corporation, 145 West 45th Street, New York, N. Y. Roland Burke Hennessy, president and treasurer, 145 West 45th Street, New York, N. Y.; M. B. Hennessy, vice-president, 145 West 45th Street, New York, N. Y.; Herman Bernard, secretary, 145 West 45th Street, New York, N. Y. Roland Burke Hennessy, editor; Herman Bernard, managing editor and business manager; J. E. Anderson, technical editor; J. Murray Barron, advertising manager.

## The "Closed" Channels

TOO much concentration of the air privileges has been charged time and again, with the National Broadcasting Company a frequent target. This company is wholly owned by Radio Corporation of America.

Interest in this phase of the licensing problem has never been openly asserted by the Federal Radio Commission until now, when NBC seeks to buy out KPO, San Francisco, for \$600,000, a 5,000-watt station with a 50,000-watt construction permit. The Commission, at its hearing, has an engineer testify to the high percentages of quota units now to the credit of NBC, in the metropolitan section of San Francisco, in the State of California, and in the Fifth Radio Zone, with comparisons with the much smaller holdings or leases of the Columbia Broadcasting System.

Again, when CBS itself seeks to buy a station, WCJS, Mt. Vernon Hills, Va., the station's land taking in a little of the estate of George Washington, the quota units that would be held by CBS, compared to all the units allotted throughout the United States, are cited by the Commission's engineer. It is as if for the very purpose of giving recognition to the fact that concentrated holdings are growing, for obviously when independent stations sell out to chains, selling their very existence, their independence goes with it.

In radio broadcasting big business is growing bigger and little business is growing smaller, when one rates the situation on the basis of service area and type of programs, rather than by the mere rote of counting stations. The smaller ones grow less important merely because the larger ones grow better, though individually the smaller ones may not be degraded a bit.

However, the mere notation of the growing enormity of the enormous will not help the Commission or the public much. Radio has become so well established in home life that listening in is almost second nature, and it puts a severe strain on the stations to have to furnish highly acceptable programs day after day, even hour after hour. With such a close association as exists between life itself and radio at large, naturally the public becomes critical of what is transmitted. The less to listen to, the broader the mind. Now with so much on the air that the public wants, and indeed gets, entertainment is furnished that may run to \$40,000 or \$50,000 an hour over a single chain. How small stations are to furnish programs with a large, ramous orchestra, a guest conductor, a featured artist and some guest artists, all of whom get from hundreds to thousands of dollars for a performance, is impos-

## CELEBRITIES HONOR CELEBRITIES



More than a score of radio stars assembled to fete Pierre Brugnon, master of ceremonies of the "Evening in Paris" program, during the 182nd performance of that feature on Monday night last, over the WABC-Columbia network. The program was in the nature of a studio party and brought to the microphone distinguished guests. Among them were (l. to r. top) Lanny Ross, Stoopnagle and Budd, Kate Smith, Morton Downey, and (below) Singin' Sam, the Boswell Sisters and Norman Brokenshire. Seen in the center are Alice Remsen and Pierre Brugnon of the "Evening in Paris" cast.

sible to determine from any economic viewpoint.

In one sense, therefore, the critical public is itself voting for concentration of air privileges on large and powerful chains, while on the other hand it may be unambitiously opposing that as destructive of competition and against the American principle of open opportunities in natural resources. However, there is no such American principle. The plan of American business has been on the opposite scale. And there really isn't any competition when the local life and drum corps, nice boys but dull musicians, is on the air from a small station, while Walter Damrosch's symphony orchestra is on the air from a host of other stations.

Because such perplexities as these seem insoluble, torment the mind and offer no

surcease, we create such official bodies as the Federal Radio Commission, which is empowered to worry over them to the fullest.

## Perkins Sinks to 10-a-Day

Ray Perkins, National Broadcasting Company wit, had a tough time the day he finished his old Jergens program and started his new Barbasol program. He had a rehearsal for Barbasol, a rehearsal for Jergens, a performance for Barbasol, a performance for Jergens, four personal appearances at the Fordham Theatre, in the Bronx, New York City; a benefit at Scarsdale, N. Y., at 10 p. m., and a personal appearance at a Bronx high school, which made ten sessions in one day.



# STATION SPARKS

By Alice Remsen

## "The Mountaineer"

For Moonshine and Honeysuckle

WEAF, Sundays, 2:30 P.M.

The strength of a lion, the manner quite mild;

The guile of a serpent, the heart of a child;

The wisdom of ignorance, faith of a saint;  
Resistance to hardship without a complaint.

A preacher of kindness, though willing to fight.

A homely philosopher shedding the light,  
With great understanding of everyone's need;

A pattern to go by in word and in deed.

As clean as a birch tree, straight as a dart;

With good honest handclasp reaching the heart.

A man plain and simple, with eyes of a seer;

A son of the southland, a real mountaineer.

—A. R.

\* \* \*

And in the character of Clem Betts, as played by Louis Mason, in Lulu Vollmer's great southern epic, "Moonshine and Honeysuckle," we find a typical American mountaineer played with rare charm and understanding. Miss Vollmer thoroughly understands the nature of our people of the Carolina and Kentucky mountains. She has lived among them and written about them for years. "Moonshine and Honeysuckle" is a fine piece of writing, still interesting in spite of being on the air for over a year. Tune in and hear these mountain folk; you'll like them.

\* \* \*

## News of the Studios

WABC

To make things harder for harassed sponsors, who are frantically budgeting their advertising expenses, Columbia has increased its rates for time on the air to \$800.00 per hour for time after 6:00 P.M. This is an advance of \$150.00 an hour over the old rate. It seems to me that summer is a poor time to increase rates, especially under present financial conditions, when advertisers are cutting expenses to the bone. Granted that even with the new rates, WABC is the lowest priced high-power station in the New York area, nevertheless, boosting prices right now is not the way to attract new customers.

\* \* \*

The new Gem Safety Razor program may now be heard over WABC and a coast-to-coast Columbia network every Sunday evening from ten to ten-thirty. Ed Sullivan has charge of the program, so you may be sure of a worthwhile broadcast, with different guest stars each week and Jack Denny's internationally known orchestra furnishing the rhythms.

\* \* \*

Admirers of the versatile Irving Kaufman may now hear this clever baritone and mimic on Monday, Wednesday and Friday evenings at 8:00 P.M. He is featured on the Bath Club variety series, and on Friday mornings from 11:00 to 11:15 A.M. he may be heard as "The Singing Grocer" on the Bab-o Bright Spot series.

\* \* \*

NBC

And now Mary Roberts Rinehart's famous Tish stories are on the air. Tish,

Lizzie and Aggie, are old favorites of mine and I regret exceedingly that I shall be unable to listen in to all their humorous escapades, Monday nights being taken up for me by the "Evening in Paris" program. I can assure other listeners, however, of a rare treat if they tune in on the NBC-WJZ network Monday nights at 10:45 P.M.; as for me, I must be content with Tuesday and Wednesday evenings at the same time.

\* \* \*

Charlie Agnew and his singing orchestra replaces Herbie Kay's orchestra on the Yeast Foamers program, broadcast from the Chicago NBC studios, 2:30 P.M. each Sunday afternoon. Agnew, the young fellow who stepped into Paul Whiteman's shoes at the Edgewater Beach Hotel when Whiteman hit the vaudeville trail, has a singing-playing combination that is already well known to radio listeners through their broadcasts from the hotel. He started as a drummer, and has worked his way through the entire orchestra, playing any instrument. He worked with Vincent Lopez, Charles Strickland, Harry Yerkes and Del Lampe before he formed his own band.

\* \* \*

The NBC Artists Service Musicale, formerly heard on Wednesdays, has changed its schedule to Tuesday evenings at 9:00 P.M. J. Alden Edkins, baritone and Atwater-Kent prize winner in 1931, will be featured with Erno Rapee and a 35-piece orchestra in a series of four programs on the new schedule.

\* \* \*

WOR

The WOR press department has put its collective heads together in an effort to work out a novel feature for the summer months. Under the general title of "The Man in The Street" it hopes to present a vivid cross section in the thoughts and aspirations of the average man or woman. The program will be spotted three times a week, each program to run ten minutes. The newsboy, the street sweeper, the longshoreman, the captain of a tug-boat, the old lady who goes each day to the park with a bag of bread for the sparrows—all will find a place.

\* \* \*

An analysis of WOR programs in a total weekly broadcasting time of 117½ hours brings out the fact that jazz music has the best of it, with 36 hours and 40 minutes; other music, 22 hours, 20 minutes; informative matter, 18 hours, 20 minutes; culture owns 16 hours; education, 8 hours, 15 minutes; calisthenics, 7 hours, 30 minutes; topical news bulletins, debates, etc., 2 hours; time and weather announcements, 5 hours, 10 minutes; religion least of all, 1 hour and 15 minutes. Rather interesting and typical of the age—jazz on top, religion on the bottom.

\* \* \*

## Sidelights

EDDIE WALTERS, original ukulele hound, has written his first song, and is tempting fate by publishing it himself; 'tis a pretty thing, titled, "Since You Went Away, Sweetheart" . . . GEORGE SHACKLEY'S eggs (laid by hens, please) are popular at WOR—forty cents a dozen . . . EVERETT MITCHELL'S great-great-grandmother was a Penobscot Indian . . . BROWNING MUMMERY, of NBC's Merrie Men quartet, is an Australian . . . FRANK PARKER is an honest-to-goodness New Yorker; he was born on the lower East Side . . . Here are a few Pennsylvania-born NBC artists; JACK FULTON, Phillipsburg; ROBERT ARMSRUSTER, Philadelphia, and HOW-

ARD CLANEY, Pittsburgh . . . MORTON DOWNEY once sold phonographs for fifteen dollars a week . . . SINGIN' SAM'S first date on the air was in the Hoosier state and he advertised lawnmowers . . . JOE SANDERS was born in Thayer, Kansas . . . EDDIE DUCHIN shuts his eyes when playing hot choruses . . . JACQUES D'AVREY likes to ride horseback along the bride paths of Central Park . . . LOIS HAVRILLA has taken up horticulture . . . TED JEWETT was born in Japan . . . Jersey-born NBC artists include PHIL COOK, East Orange; ED THORGERSON, Elizabeth; JAMES WHALEN, Newark; CHARLES KENNY, West Orange, and JACK PARKER, Englewood . . . BEN ALLEY is Loew-vaudevilling . . . JOE SANTLEY would be a good bet for the air . . . BILL CARD will be radioman for Joe Morris upon his return from vacation-land.

\* \* \*

## ANSWERS TO CORRESPONDENTS

M. H. SCHONTZ, Palmyra, N. J. . . . Am running Ben Bernie's biography in this issue.

ALBERT MILLETT, London, England. . . . When you reach this side join our Short Wave Club. Glad you like the page.

\* \* \*

## Biographical Brevities

### ABOUT BEN BERNIE

Born in Brooklyn, right name Benjamin Ancel, the son of a blacksmith. His father decided he would be an engineer, his mother decided he would become a violin virtuoso and so Benjamin got a job demonstrating violins (\$4.98, case included) in a New York department store. Even in those early days, (the boy was seventeen), Ben was given to wisecracks. One day he was explaining to an amused group of onlookers that the life of a violinist was a very low one, but if anyone insisted on becoming a fiddler, one of those \$4.98 specials was as good, or as bad, as any other instrument.

Joe Schenck was among the amused spectators—so was Ben's boss—and so the erstwhile musical salesman took the try-out offered by Schenck for the Loew Circuit. His brand of humor clicked, and Benjamin Ancel became Ben Bernie of the team of Bernie and Klass, at \$35 per week.

Once during those early vaudeville days Ben aspired to the classics. He was attempting a violin solo in a small Kentucky town, when a native of the foothills turned the course of the Bernie career. Ben's music had failed to move the house. The native made several scathing remarks. Ben talked back; the crowd roared and demanded more—that made Ben know what they wanted—comedy, nothing else but. And so he teamed with Phil Baker.

Pay checks improved; then with the war the partnership dissolved. When the conflict was over, Ben was seized with an idea for a new type of dance band, with the conductor doing something besides beating the air with a baton. The result of the idea was big-time and headline vaudeville. Ben was booked into the Hotel Roosevelt Grill in New York for a month. Ben and his band stayed five years—then came London, Hollywood and Chicago, and present indications point to an epidemic of Bernie-i-tis sufficiently widespread to keep the Old Maestro going for many years. Vaudeville has him now, Columbia coast-to-coast network broadcasts him.

Golf, horses, contract bridge and hamburger sandwiches are the Bernie favorites. He's crazy about police dogs, sentimental about old friends, generous—a swell guy.

\* \* \*

(If you care to know something of your favorite artists, drop a card to the conductor of this page. Address her: Miss Alice Remsen, care Radio World, 145 W. 45th St., New York City.)

# BOARD DECREES SYNCHRONIZED WAVES FAILURE

Washington

Synchronization of high-powered stations, as exemplified by the matched crystal control of WEAJ-WTIC and of WJZ-WBAL, has failed, the Federal Radio Commission announced, after holding a hearing on the application of the stations for permission to continue the experiment beyond June 15th. Permission was denied.

WEAF, New York, has been synchronized for more than a year with WTIC, Hartford, and there have been conflicting reports as to the effectiveness of the experiment, the same being true of WJZ, New York, and WBAL, Baltimore, although interference was less, due to greater geographical separation. The New York stations are owned and operated by the National Broadcasting Company, while the tied-in stations have their independent frequency, which they used during hours of non-synchronization.

## Impairment, Says Board

With low-powered stations better results might be obtained, the Commission found, but with high-powered ones the disadvantages far outweighed the advantages. A statement by the Commission set forth:

"The experiments have resulted in impairment and reduction of a substantial portion of the good broadcast service otherwise received in the service areas.

"Synchronous operation of broadcast stations is in a preliminary stage," the decision pointed out, "and it appears that experiments seeking its successful conclusion could be conducted with advantage over lower-powered stations with more flexible installations, and so located as to result in a minimum of inconvenience to radio listeners."

Both WBAL and WTIC are clear-channel stations, the Board finds, saying that it does not appear that anything is gained by synchronizing stations that in themselves have an excellent service area in densely populated territory. Such stations, it is held, should not be used for synchronization experiments.

## No Solution in Sight

While the synchronization was not regarded by the stations themselves as perfect it was deemed to be sufficiently good to warrant further time and expense, and a plan was afoot to improve the transmitters and the synchronizing method so that the ideal would be more nearly approached.

"Even were the proposed equipment to function perfectly, serious and objectionable interference will still exist, since the solution of several of the causes for the interference arising from the synchronous operation of these stations has neither been found nor contemplated," said the Board.

Other stations were anxious to try a similar experiment. WBBM, Chicago, and KFAB, Lincoln, Nebr., were two of them. Besides, various other stations have had experience with synchronization, using different methods. Independent crystal control of the stations with a synchronizing Monitor between has been tried, also land wire synchronization, by sending a synchronizing frequency over the wire, as in the case of the WBZ-WBZA experiment.

It is expected that the WBBM-KFAB application will be denied.

## Regional Stations' End is Foreseen

Washington.

It is the opinion of Commissioner Harold A. Lafount, of the Federal Radio Commission, that there are too many local stations, and that the number is bound to be reduced, as well as the number of regional stations, until there are few regional stations left, except in the sparsely populated regions.

Power of 250 to 1,000 watts characterizes regional stations, of which there are 285 on six frequencies, whereas there is about the same number of local stations on four frequencies, the power of locals being less than 250 watts.

Small stations now sharing time will consolidate, the Commissioner believes.

## CHANGE IN PLAN OF RADIO CITY

Premier Mussolini's attention to detail was proved again recently when he studied the plans for Radio City, the great amusement and business center now erecting in midtown New York City.

A group of Italian business interests had favored taking occupancy of a nine-story building on the Fifth Avenue side, at Fifty-second Street. A delegation went to Rome to obtain the premier's approval. In this delegation were Hugh S. Robertson and Douglas S. Gibbs, representing John D. Rockefeller, Jr., who is financing the entire project through one of his corporations and Rinaldo Stroppa-Quaglia, representing the Italian business interests in New York. The delegation took with them a letter from Mr. Rockefeller to Il Duce explaining the whole project.

Premier Mussolini after studying the plan carefully expressed complete approval, and the delegation returned to New York for completion of the details of signing the lease.

The nine-story structure will be known as the Italian Building. It will be one of twin structures, the other to be known as the German building, leases for occupancy of which are now being signed.

A four-story arcade, fashioned after the arcades of Milan and Rome, will separate the twin buildings.

The twin buildings represent a change in plans, as originally a single large office building was to occupy this part of the 12-acre site. A tall office building will occupy the Fiftieth and Fifty-first Street frontage on Fifth Avenue.

Negotiations are still under way with the Metropolitan Opera Company for inclusion of the Opera House on this site, to replace the old building at Broadway and Thirty-ninth Street.

The entire development has been known as Radio City, but lately is being referred to as the Rockefeller Center, as the majority of the activities will not concern radio, although the tallest building, on the Sixth Avenue side, will be the RCA Building, in which RCA, the National Broadcasting Company, RKO and other similar undertakings will be housed.

The plans, except for the opera possibility, are now regarded as in final form.

## ONE-SIXTH FOR TAXES

H. B. Richmond, of General Radio Co., Cambridge, Mass., points out that about one-sixth of the revenue of business concerns and individuals is paid out in taxes, directly or indirectly.

# MONOPOLY SUIT GOES TO TRIAL OCTOBER 10th

Washington.

Warner Olney, Jr., special assistant to the Attorney-General, made a motion before Judge Niels in the U. S. District Court to have a trial date set for the government's monopoly case against Radio Corporation of America, General Electric Company, Westinghouse Electric & Manufacturing Company, and others. As a result the court fixed Monday, October 10th, when both sides will have to be ready to proceed.

The complaint has been filed and amended, and the answer has been put in.

The government charges the defendants with violation of the Clayton act in that by patent cross-licenses among themselves they have instituted a monopoly in restraint of trade, including the field of commercial communication by radio, set manufacturing and tube manufacturing.

## Question To Be Decided

The question to be decided is whether the acts of the defendants are a violation of the law, in view of the licensing by the defendants of others to engage in the branches of radio business in which it is claimed a monopoly was created, and in further view of their ownership of some 4,000 patents, the result of their own development work and of purchase.

The defendants have denied the charges and have pointed out their minority share of the business transacted in the radio field, including set-manufacturing and selling, tube manufacturing and selling, and broadcasting.

The case is considered of vast importance to the radio industry, including broadcasting, for set and tube licensees desire the patents held by one group, otherwise they would have to deal with an assortment of owners. Radio Manufacturers Association, Inc., recently took the stand that the court should administer the patents, to protect present licensees and safeguard against the issue of more licenses than the field will tolerate, even if legislation is required to insure such protection, and independent of the outcome of the case.

## Cites Official Incentive

The National Broadcasting Company, a wholly-owned subsidiary of RCA, recently escaped penalty when the Federal Radio Commission decided that the clause in prior contracts with set manufacturers, requiring the makers to equip their sets initially with only RCA tubes, did not invoke the penalty of the Radio law whereby reissue of station licenses would be denied to NBC. The eight stations concerned were among the most important ones in the country.

The defendants have denied the monopoly charge and have set forth their specific reasons in detail, including as a defense that a representative of the United States government suggested the formation of a group to maintain a strong commercial position by an American radio concern for domestic and foreign activities.

## VISION LICENSE DISFAVORED

Washington.

Denial of the application of the Shreveport Broadcasting Company, Shreveport, La., for a television transmitting license, was recommended to the Federal Radio Commission by one of its own examiners on the ground of failure to establish financial and technical equipment for such operation.

# OPEN EXPORTS TO FRANCE BY NEW COMPACT

Paris, France

The combined protests of American business men against the French restrictive quotas on American goods, the prompt action taken by the United States Department of State, the interceding by Ambassador Edge on behalf of his countrymen, plus the impending new administration of the French Government, have combined to bring about a lifting of the restrictions.

The situation in France was particularly distressing to American manufacturers, and the radio set, tube and accessory manufacturers deplored the severity of the restrictions against them, compared to much less stringent restrictions against other countries, such as Germany and Belgium.

## Amicable Arrangements Perfected

Importation of American radio goods, including tubes, had been progressing at a fast pace until the prohibitive decree was issued last January, it being found accidentally in the Journal Officiel after the decree had been in effect legally for several weeks. This method of bringing the facts to notice was another point of distress.

Very amicable arrangements have been perfected between Ambassador Edge and Premier Tardieu. It was learned that Premier Tardieu had consulted his prospective successor, Eduoard Herriot, due to the executory nature of the agreement, which in substance is a most-favored nation clause in favor of the United States. The effect of such an agreement is that the United States is to enjoy a position in respect to exports to France equal to that of the most favored nation in any other such agreements.

## Arthur Moss Led Fight

Many other products besides radio were at stake, the restrictions against them varying, and being based on previous importation figures but in a manner that has never been quite clear to the affected manufacturers.

Radio Manufacturers Association, Inc., made a protest to the State Department over the French radio quotas, acting through its foreign trade committee, of which Arthur Moss, president of Electrad, Inc., New York City, is chairman.

## Literature Wanted

Readers desiring radio literature from manufacturers and jobbers concerning standard parts and accessories, new products and new circuits, should send a request for publication of their name and address. Send request to Literature Editor, RADIO WORLD, 145 West 45th Street, New York, N. Y.

- Earl McClain, 832 South Broadway, New Philadelphia, Ohio.
- Robert J. Snyder, 300 W. Oley St., Reading, Pa.
- Henry Knoplick, Oak Ridge, N. J.
- D. V. Starosselsky, St. Thomas, Virgin Islands.
- Vernon Pickett, Pineville, Louisiana.
- Roger M. Stern, 27 W. 85th St., New York City.
- Pete J. Jarvis, Scarborough, W. Va.
- John Koteras, 1722 W. Congress St., Chicago, Ill.
- Eddie B. Tomberlin, Tomberlin-Ferrell Radio Shop, Greenville, Ala.
- Harry G. Wood, 116 Grota St., Houston, Texas.
- S. MacShay, 4423 Shaw St., Long Beach, Calif.
- Eugene Loeb, Medford, Wisc.
- Jesse P. Camp, Jr., 711 East Cambridge St., Greenwood, S. C.
- Kudrna Chevrolet Co., W. E. Kudrna, Bunnell, Fla.

## Pointed Opinion

**BOND GEDDES**, executive vice-president, Radio Manufacturers Association, Inc.:

"Some leading manufacturers state that their actual sales at the trade show this year were greater than during any previous trade show period. A hopeful if not optimistic opinion regarding future conditions seems prevalent. The national political conventions and campaigns are expected to stimulate sales. Radio is the one industry expected to benefit most and show an immediate upturn, possibly leading and aiding other industries toward improved business conditions."

# 20,049,450 HOMES WIRED

Washington

The most recent report on the number of homes wired for electricity shows that the steady increase is still going on. The number of homes so equipped is important to the radio industry, as nearly all of the wiring is for a-c, and the principal output of the set manufacturers thus has a wider market. Besides, the number of electrified homes is one index of general buying power. Other indexes are the population and the number of telephones.

The tabulation, as furnished by the Department of Commerce, follows:

State	Urban	Rural	Total
Alabama	112,140	37,714	149,854
Arizona	37,950	16,319	54,269
Arkansas	67,105	29,850	96,955
California	1,218,589	295,199	1,513,788
Connecticut	275,572	100,807	376,379
Colorado	127,764	42,145	169,909
Delaware	24,632	13,535	38,167
Dist. of Columbia	104,154		104,154
Florida	150,606	32,496	183,102
Georgia	122,705	40,662	163,367
Idaho	39,448	27,033	66,481
Illinois	1,392,061	208,718	1,600,779
Indiana	440,206	149,495	589,701
Iowa	241,415	156,776	398,191
Kansas	182,309	103,840	286,149
Kentucky	183,454	58,087	241,541
Louisiana	137,133	29,669	166,802
Maine	79,076	74,929	154,005
Maryland	201,017	74,919	275,936
Massachusetts	880,208	84,937	965,145
Michigan	750,370	182,612	932,982
Minnesota	291,245	82,425	373,670
Mississippi	47,379	25,593	72,972
Missouri	436,107	115,796	551,903
Montana	44,747	21,851	66,598
Nebraska	119,434	78,615	198,049
Nevada	8,223	5,041	13,264
New Hampshire	58,656	39,159	97,815
New Jersey	767,094	149,095	916,189
New Mexico	21,057	8,380	29,437
New York	2,648,140	351,644	2,999,784
North Carolina	138,347	75,373	213,720
North Dakota	22,954	25,241	48,195
Ohio	1,086,274	224,460	1,310,734
Oklahoma	164,803	57,934	222,737
Oregon	132,629	62,364	194,993
Pennsylvania	1,403,944	328,899	1,732,843
Rhode Island	146,510	16,279	162,789
South Carolina	55,767	28,997	84,764
South Dakota	30,013	33,099	63,112
Tennessee	166,231	38,452	204,683
Texas	435,565	110,335	545,900
Utah	62,963	31,499	94,462
Vermont	28,117	37,347	65,464
Virginia	158,523	60,199	218,722
Washington	235,891	105,092	340,983
West Virginia	98,710	50,934	149,644
Wisconsin	370,348	151,883	522,231
Wyoming	14,583	11,552	26,135
Grand total	15,962,168	4,087,282	20,049,450

## RMA LOSES 43 MEMBERS

Membership in Radio Manufacturers Association, Inc., is reported at 144, compared to 187 a year ago, a loss of 43 members.

# NATIONAL CO. OFFERS ULTRA WAVE DEVICES

National Company, 61 Sherman Street, Malden, Mass., has just published its Fall catalogue, a copy of which may be obtained by writing to James Millen, general manager, care of the company.

Among the new products are a full-vision dial with the famous National velvet vernier mechanism, in models for 180 degree rotation of the condenser, either direction, as well as for capacity increase by counter-clockwise motion for 270 degree condensers.

## New Thrill Box

The Thrill Box, the noteworthy short-wave receiver, has been retained as to circuit formation, but has been improved and includes two 58 tubes, for r-f and detector, 56 first audio and two 245's in push-pull for the output. The appearance is entirely changed and the new full-vision dial is used. Plug-in coils are available so that tuning from 9 to 850 meters obtains.

For aircraft, portable and other similar work the Thrill Box is obtainable with black bakelite flat type dial in three-tube form, either a-c or battery-operated, the push-pull stage being omitted.

An outstanding contribution is the ultra high frequency receiver, type HFR, 40 to 80 mc., requiring eight tubes (power supply extra), and the HFC model, six tubes (power supply extra), which covers 56-60 mc. over 80 divisions of the dial. Type HFR uses the true vernier National precision dial, type HFC the drum dial.

## Other New Parts

A high voltage shaft coupling, to unite condensers, is another new product. Besides, there is an assortment of dials for which National Company is famous, dial lever indicators, introduced last season; transmitting condensers of all capacities and types, including neutralizing condensers for amplifier, buffer and doubler stages, straight frequency line and other variable condensers for receivers, a frequency meter condenser; plug-in coil forms, coils and sockets of low-loss construction, either R-39 or Isolantite being used; radio frequency chokes, one of which is of 2.5 millihenries and is a new product; tube and coil shields, manuals of short waves, power units, the MB-32 radio frequency tuner, Velvetone power amplifier, also speaker amplifier, and the short-wave converter that made such a hit last season.

## Records Are Records and This One Counts

Aulis W. Aho, a Walpole, Mass., radio amateur, claims the world's record in distance-per-contact in the two-way communication indulged in by amateurs, reports the American Radio Relay League. He's been on the air only a short time with his station WIDGA and has contacted only two stations, one a scant half mile away from his home—the other VK2KX, an Australian on the other side of the globe! The average mileage, 5,500 miles, is a record that is expected to stand for a long, long time.

## WIDE-RANGE TRIMMERS

Electrical Insulation Corporation, 308 West Washington Street, Chicago, announces a trimmer condenser especially to meet the designs of all-wave receivers. The capacity ranges are 5-75 mmfd. and 300-900 mmfd.

# FRED WILLIAMS NEW PRESIDENT OF TRADE BODY

Fred D. Williams, of P. R. Mallory & Co., Inc., Indianapolis, Ind., was elected president of Radio Manufacturers Association, Inc. Other officers elected were: First vice president, Harry A. Beach, of the Stromberg Carlson Telephone Manufacturing Company, Rochester, N. Y.; second vice president, Meade Brunet, of the RCA Radiotron Co., Inc., Harrison, N. J.; third vice president, Leslie F. Muter, of the Muter Co., Chicago; and treasurer, E. N. Rauland, of the Rauland Corporation, Chicago.

Four new members of the board of directors to serve for three years were elected as follows:

W. S. Symington, president of the Colonial Radio Co., Buffalo; S. W. Muldowny, chairman of the board of the National Union Radio Corporation, New York City; C. B. Smith, president of the Stewart-Warner Corp., Chicago; and Franklin Hutchinson, president of Kolster Radio, Inc., Newark, N. J.

## Williams' Career

Born on a farm near Henry, Ill., Sept. 23, 1885, Mr. Williams, after being graduated from high school, immediately entered life as a salesman and has continued as such. He has been connected with the U. S. Rubber Co. in Chicago, the Johns-Mansville Co., in Chicago and Milwaukee; the L. H. Gilmer Co., of Philadelphia; the Music Master Co.; the Grigsby-Grunow Co., of Chicago; the Raytheon Mfg. Co., of Newton, Mass., the National Carbon Co., and on January 1st, 1932, became vice-president and general sales manager in charge of sales of all products of the Mallory Company which has long been a manufacturer of radio condensers as well as being prominent in the automotive field and in metallurgy. Subsidiaries include Elkon, Inc., Indianapolis, and Yaxley Mfg. Co., formerly of Chicago, manufacturers of radio parts.

## Dues to Be Reduced

Mr. Williams is the father of five children. He is a devotee of golf, horsemanship and other outdoor sports, and is one of the most widely known and popular men in the radio industry.

Reduction of RMA membership dues and expenses was voted at the first meeting of the new administration and the new board of directors, with President Williams presiding. The reduced dues are planned to be effective August 1st, with the beginning of the new fiscal year of the association. This was the first act of the new board of the new administration.

## Work on Budget

A special budget committee, composed of President Williams, E. N. Rauland and other directors, with the addition of A. S. Wells of Chicago, was authorized to make definite recommendations at the next board meeting, which will be held about the middle of July.

Bond Geddes was re-elected executive vice-president and also elected executive secretary following the resignation last April of Martin F. Flannagan of Chicago. Mr. Geddes will be in charge of both the Chicago and the New York RMA offices.

John W. Van Allen, of Buffalo, was

# Tradiograms

By J. Murray Barron

## A REAL MARKET

Although millions of electric radio receivers have been sold since 1927, some of which in the earlier days were not what would now be called a real job, there still seem to be some folk who fail fully to appreciate the volume of business there is for the replacement parts. When one adds to the natural replacements the faulty or poor receivers that require attention it should not be difficult to judge what a tremendous market there is.

From a careful canvass of the radio retail establishments of the larger cities of the country we find that in many cases forty per cent. of these stores are now handling and selling small and replacement parts. Of course in some of the communities the percentage does not run quite so high, nevertheless in most of the cities there is great indication of a large and increased demand for parts. Short wave sets, converters, public address systems, home recording apparatus, automobile and midget sets all have a part in bringing about a new interest in parts, so now perhaps one can better understand why the more progressive retail establishments are getting after this market.

With some of the merchants there is a feeling of more satisfactory business, fewer complaints from customers and generally more positive profits, or, as a well-known radio retailer said, "less headaches." Sales are generally final and relations between customer and store always pleasant.

In the smaller communities, where standard factory-made sets and equipment are sold at list or nearly so, the interest in custom-made radio equipment should be even greater, for parts can be bought at low prices.

\* \* \*

Eveready is making deliveries of the 46, 56, 57, 58 and 82 tubes.

\* \* \*

Eveready Raytheon Tube jobbers appointed recently by National Carbon Company, Inc., are San Antonio Music Company, of San Antonio, Tex.; Sabine Supply Company, of Orange, Tex.; Reichardt Abbott Company, of Brenham, Tex.; F. W. Heitman Company, of Houston, Tex.; Kansas City Distributing Corp., of Kansas City, Mo.; McPike Drug Company, of Kansas City, Mo.; and Grabe Electric Company, of Tucson, Ariz.

\* \* \*

Thomas A. White, chairman of the credit committee of Radio Manufacturers Association, Inc., said failures within the industry have been fewer and the amount of money involved less during the year ending May 31st, 1931, than during the preceding fiscal year. Statistics also show that the trend of failures in our industry has been more favorable than the general trend.

\* \* \*

The production activities of the Dubilier Condenser Corporation are now headed by Joseph F. Cook. He had been with RCA-Victor in Boston. For five years prior he was identified with the Wireless Specialty Apparatus Company. He is a graduate of Massachusetts Institute of Technology.

re-elected general counsel of the association and Frank D. Scott, of Washington, D. C., was re-elected legislative counsel.

Upon recommendation of the leading set and tube manufacturers the RMA directors decided not to indorse any public radio shows this year. RMA sponsorship for the New York and Chicago public show under private management had been sought but in view of general conditions it was decided to withhold indorsement.

# NEW TUBE LINE COST \$500,000 TO ENGINEER

In an 8-page two-color booklet for the trade, entitled "Creating a New Demand for Radio Receivers," RCA Radiotron Company, Inc., points out the advantages of the 46, 56, 57, 58 and 82 tubes, calling these the superphonic series, and stating that a sixth tube to be added is the 55 duplex-diode triode. This tube may be used as a full-wave diode detector or as a half-wave diode detector and automatic volume control, always with a stage of amplification, since the tube is both detector and amplifier. It is really two tubes in one.

Elmer T. Cunningham, president of the company, in a foreword says of the five tubes already released:

"These tubes are the result of one year's intensive effort and the expenditure of over \$500,000."

He cites the possibilities of improving the radio market by offering receivers embodying the new tubes and adds:

"With over 15,000,000 a-c receivers in American homes, with buyers hesitant and depressed, and competition among industries extremely severe, the radio industry must offer greater receiver values than ever if it is going to build sales volume. Values must not be based on low prices alone but on improved performance and results—values that will encourage and permit a trade-in market, the market that holds the greatest possibilities."

## Hammarlund Issues

### Short-Wave Booklet

The numerous high frequency developments created in the laboratories of the Hammarlund Manufacturing Company, and incorporated in their new Comet "Pro" receiver, are described in a recently published 16-page booklet.

Selection of correct intermediate frequencies, design of intermediate frequency and oscillator coils and condensers, special methods of balancing, band spread tuning systems, advantages of low-loss coil forms and sockets, are among the many topics discussed in detail. There are also pages of special laboratory curves on these subjects.

Incidentally, the booklet is also replete with data on successful short-wave tuning and requirements for installation.

Copies can be secured by addressing Lewis Winner, care of Hammarlund Mfg. Co., 424 West Thirty-third Street, N. Y. City.

## NEW INCORPORATIONS

Sylvan-Wellington, New York City, radio—Atty., I. Berman, 353 Canal St., New York City.  
Splitdorf Electrical Co. of New York, New York City—Atty., Bergman & Cole, 217 Broadway, New York City.  
Buyers Electric Co., New York City, electrical appliances—Atty., S. W. Sollfrey, 122 E. 42nd St., New York City.  
York Refrigerator Sales Co., Inc., Wilmington, Del., cooling devices—Atty., Corporation Fiscal Co., Wilmington, Del.  
State Refrigerator Sales Corp., Brooklyn, N. Y.—Atty., Cox & Arenson, 51 Chambers Street, New York, N. Y.  
Long Island Electrical Equipment, Queens, L. I., electrical refrigerators—Atty., Exco Lawyers Albany Service, 116 Nassau St., New York, N. Y.

### NAME CHANGE

Lee Hampton, Manhattan, to Frigid-Freezer Corporation.

**SUPERIORITY ON SHORT WAVES**



**ISOLANTITE COIL FORMS**

The watchword of short waves is "Results." The best results are obtained with plug-in coils. The best plug-in coil results are obtained with non-hygroscopic, low-loss coil forms. Hammarlund's Isolantite coil forms, 1 1/2" diameter, permit of an excellent "shape factor"—a better coil than with smaller diameters. These coil forms are obtainable with UX, UY or 6-pin bases.

Removable knob included.

Cat. HCF-4—(UX, four-pin base). Net price.....59c

Cat. HCF-5—(UY, five-pin base). Net price.....59c

Cat. HCF-6—(six-pin base). Net price.....59c

**ISOLANTITE SOCKETS**

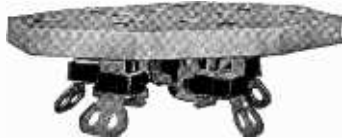

Having a superb coil form, one must have an equally efficient socket for coil form receptacle to produce uniformly superior results. Hammarlund's Isolantite socket may be mounted below or above chassis. Elevating bushings are provided.

Cat. HS-4—(UX, four-prong socket). Net price.....44c

Cat. HS-5—(UY, five-prong socket). Net price.....44c

Cat. HS-6—(six-prong socket). Net price.....44c

**Guaranty Radio Goods Co.**  
145 West 45th Street New York, N. Y.

**STATIONS BY FREQUENCIES**

Frequency list, broadcasting stations, call, owner, location, power, wavelength. United States, Canada, Cuba, Mexico and Newfoundland. In June 11th issue Radio World. Send 15c for a copy to Radio World, 145 West 45th Street, New York, N. Y.

**Quick-Action Classified Advertisements**

7c a Word — \$1.00 Minimum  
Cash With Order

**BACK NUMBERS OF ALL PERIODICALS**—Large selection. Radio News, Radio-Craft, etc. List free. Stuyvesant Book Shop, 31 Third Avenue, New York.

**LEARN TO FLY AT HOME!** Guaranteed Home-Study course in Aviation complete for \$1.00. Accurate—reliable—thorough! Special limited offer. Your money back if you want it. Rush \$1 to Edward Conley, Oronoco, Minn.

**"HANDBOOK OF REFRIGERATING ENGINEERING,"** by Woolrich—Of great use to everybody dealing in refrigerators. \$4. Book Dept., Radio World, 145 W. 45th St., N. Y. City.

**"THE CHEVROLET SIX CAR AND TRUCK"** (Construction—Operation—Repair) by Victor W. Pagé, author of "Modern Gasoline Automobile," "Ford Model A Car and AA Truck," etc., etc. 450 pages, price \$2.00. Radio World, 145 W. 45th St., N. Y. City.

**THE FORD MODEL—"A" Car and Model "AA" Truck**—Construction, Operation and Repair—Revised New Edition. Ford Car authority, Victor W. Page. 703 pages, 318 illustrations. Price \$2.50. Radio World, 145 W. 45th St., New York.

**TELEVISION STATIONS**—Complete list of operating television transmitters of the United States, with frequency, wavelength, power, owner, location, lines, frames, hours on the air and sound track schedules, in May 28th issue. Send 15c for a copy. Radio World, 145 West 45th Street, N. Y. City.

**EBY Ant.**—Ground twin binding post assemblies, 30c each. Guaranty Radio Goods Co., 143 W. 45th St., N. Y. C.

**RADIO WORLD and "RADIO NEWS"**

**BOTH FOR ONE YEAR \$7.00** Canadian and Foreign \$8.50

You can obtain the two leading radio technical magazines that cater to experimenters, service men and students, the first and only national radio weekly and the leading monthly for one year each at a saving of \$1.50. The regular mail subscription rate for Radio World for one year, a new and fascinating copy each week for 52 weeks is \$6.00. Send in \$1.00 extra, get "Radio News" also for a year—a new issue each month for twelve months. Total, 64 issues for \$7.00. RADIO WORLD, 145 West 45th Street, New York, N. Y.

**115 DIAGRAMS FREE!**

115 Circuit Diagrams of Commercial Receivers and Power Supplies supplementing the diagrams in John F. Bider's "Trouble Shooter's Manual." These schematic diagrams of factory-made receivers, giving the manufacturer's name and model number on each diagram, include the MOST IMPORTANT SCREEN GRID RECEIVERS. The 115 diagrams, each in black and white, on sheets 8 1/2 x 11 inches, punched with three standard holes for loose-leaf binding, constitute a supplement that must be obtained by all possessors of "Trouble Shooter's Manual," to make the manual complete. We guarantee no duplication of the diagrams that appear in the "Manual." Circuits include Bosch 54 D. C. screen grid; Balkite Model F, Crosley 20, 21, 23 screen grid; Eveready series 50 screen grid; Mrla 334 A. C. screen grid; Peerless Electrostatic series; Philco 76 screen grid. Subscribes for Radio World for 3 months at the regular subscription rate of \$1.50, and have these diagrams delivered to you FREE!

Present subscribers may take advantage of this offer. Please put a cross here  to expedite extending your expiration date.

Radio World, 145 West 45th St., New York, N. Y.

**360-Degree Condenser**



20 to 375 mmfd. capacity variation, effected over full 360 degrees, affords wide spread-out, better dial legibility. Great for test oscillators and all-wave tuning.

Price, \$3.00 net.

**DIRECT RADIO COMPANY**

145 WEST 45TH STREET  
NEW YORK, N. Y.

**SOLDERING IRON FREE!**



Works on 110-120 volts AC or DC, power, 50 watts. A serviceable iron, with copper tip, 5 ft. cable and male plug. Send \$1.50 for 13 weeks' subscription for Radio World and get these free! Please state if you are renewing existing subscription.

**RADIO WORLD**  
145 West 45th St. N. Y. City

**BLUEPRINTS OF STAR CIRCUITS**

**8-TUBE AUTO SET**

Sensitivity of 10 microvolts per meter characterizes the 8-tube auto receiver designed by J. E. Anderson, technical editor of Radio World, and therefore stations come in with only six feet of wire for aerial, and without ground. Most cars will afford greater aerial pickup, and besides the car chassis will be used as ground, so with this receiver you will get results. The blueprint for construction of this set covers all details, including directions for cars with negative A or positive A grounded. The circuit features are: (1) high sensitivity; (2), tunes through powerful locals and gets DX stations, 10 kc either side; (3), latest tubes, two 239 pentode r-f, two 236 screen grid, two 237 and two 238; push-pull pentodes, all of 6-volt automotive series; (4), remote tuning and volume control on steering post, plus automatic volume control due to low screen voltage on first detector; (5), running board aerial. The best car set we've published. This circuit was selected as the most highly prized after tests made on several and is an outstanding design by a recognized authority. Send for Blueprint 631, @ .....50c

**SHORT-WAVE CONVERTER**

If you want to build a short-wave converter that costs only a very few dollars, yet gives good results, furnishing all its own power from 110 volts a-c, and uses no plug-in coils, you can do so from Blueprint 630. Price.....25c

**5-TUBE AC, T-R-F**

Five-tube a-c receivers, using variable mu r-f, power detector, pentode output and 280 rectifier, are not all alike by any means. Forty circuits were carefully tested and one selected as far superior to the others. This prized circuit was the 627, and if you built it, you will always be glad you followed our authentic Blueprint, No. 627. This is the best 5-tube a-c t-r-f broadcast circuit we have ever published. Price .....25c

**A-C ALL-WAVE SET**

An all-wave set is admittedly what many persons want, and we have a circuit that gives excellent broadcast results, and is pretty good (not great) on short waves. No plug-in coils used. Cost of parts is low. Send for Blueprint, No. 628-B, @ .....25c. In preparation, an 8-tube broadcast super-heterodyne for 110v d-c. Write for particulars.

**RADIO WORLD, 145 West 45th Street, New York, N. Y.**

**Two for the price of One**

Get EXTRA one-year subscription for any One of these magazines:

- RADIO CALL BOOK MAGAZINE AND TECHNICAL REVIEW (monthly, 12 issues)
- Q.S.T. (monthly, 12 issues; official amateur organ).
- POPULAR SCIENCE MONTHLY
- RADIO-CRAFT (monthly, 12 issues).
- RADIO INDEX (monthly, 12 issues), stations, programs, etc.
- RADIO (monthly, 12 issues; exclusively trade magazine).
- MODERN RADIO (monthly).
- EVERYDAY SCIENCE AND MECHANICS (monthly).
- RADIO LOG AND LORE. Monthly. Full station lists, cross indexed, etc.
- AMERICAN BOY—YOUTH'S COMPANION (monthly, 12 issues; popular magazine).
- BOYS' LIFE (monthly, 12 issues; popular magazine).
- OPEN ROAD FOR BOYS (monthly, 12 issues).

Select any one of these magazines and get it free for an entire year by sending in a year's subscription for RADIO WORLD at the regular price, \$6.00. Cash in now on this opportunity to get RADIO WORLD WEEKLY, 52 weeks at the standard price for such subscription, plus a full year's subscription for any ONE of the other enumerated magazines FREE. Put a cross in the square next to the magazine of your choice, in the above list, fill out the coupon below, and mail \$6 check, money order or stamps to RADIO WORLD, 145 West 45th Street, New York, N. Y. (Add \$1.50, making \$7.50 in all, for extra foreign or Canadian postage for both publications.)

Your Name.....

Your Street Address .....

City ..... State..

- If renewing an existing or expiring subscription for RADIO WORLD, please put a cross in square at beginning of this sentence.
- If renewing an existing or expiring subscription for other magazine, please put a cross in square at the beginning of this sentence.

**RADIO WORLD, 145 West 45th Street, New York. (Just East of Broadway)**

**DOUBLE VALUE!**



# Coils That Exceed Your Requirements for Precision

Secondary Inductances Accurate to plus or minus 0.6 microhenry

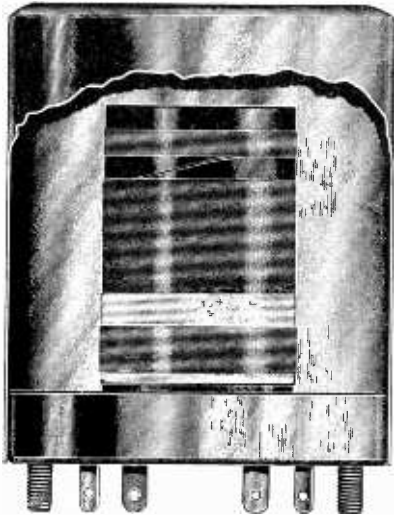

- CAT. NO. 1—Three matched shielded t-r-f transformers, for 0.00035 mfd., with 80-meter tap. \$1.35
- CAT. NO. 2—Three matched shielded t-r-f transformers, for 0.00040 mfd. (Scovill condenser), with 80-meter tap. \$1.35
- CAT. NO. 3—Three matched shielded t-r-f transformers, for 0.0005 mfd., with 80-meter tap. \$1.35

Three-deck long switch for above coils, \$2.50

## Tuned Radio Frequency Coils

THESE coils are for two stages of screen grid radio frequency amplification, using any type screen grid tubes, including the newest ones, and any type of detector tube. There are three coils to a set. Each coil is wound on a 1-inch diameter tubing and anchored to an aluminum shield base, to which base the shield proper makes a tight fit.

The bases have punched openings through which four lugs protrude, and also are provided with rigid 6/32 machine screws for mounting. These screws protrude downward and are 1 11/16 inches apart. The coils may be mounted on chassis cut for the wafer type tube socket, or may be mounted by means of threaded bushings, elevated half an inch from a chassis top, requiring no cutout chassis.

The shield has a small protected opening at top so the lead for the grid cap may be brought through. The opening is bevelled. This constitutes the protection against fraying the insulation of leadout wire to grid cap. The shield cover is 2 1/4 inches outside diameter and 2 1/2 inches high.

Inside the shield base are stamped designations as follows: P, B, G and ground symbol. These stampings are near openings through which the corresponding lugs protrude downward. Besides, there is a side lug, protruding outward near the bottom of the form. P and B are always the primary connections, P going to plate an B to B plus, except in the case of the coil used for antenna coupler, when P goes to aerial and B to ground. G is always the connection for grid cap of the r-f tubes, also grid cap of the detector if it is a screen grid tube, otherwise to G post of socket of the detector tube.

The side lug is the grid return connection, usually grounded in circuits. The stamped ground symbol is not the ground connection but represents a tap on the secondary for tuning to 80 meters. The broadcast band is covered in full with the entire secondary—G and side lug—while from 200 to 80 meters are covered when the ground symbol tap is picked up by condenser stator.

To accomplish 80-550 meter coverage, therefore, a three-deck switch, two positions for each deck, is required, and must be of the insulated type. The moving arms connect to condenser stators, and pick up either the full secondary or the tap, which is about one-quarter of the secondary, in number of turns. The full secondary is always in the grid circuit, wired as previously stated, but the tuned circuit is made to consist either of the full secondary of one-quarter of the secondary, by switching the condenser stator to either point.

The 80-meter tap does not have to be used, but is advantageous to those desiring to tune in television, amateurs, police calls, some relay broadcasting and other interesting transmissions in a band of frequencies replete with novelties for the usual broadcast listener.

High impedance primaries are used, the number of turns chosen so that the same coils may be used for antenna coupler and interstage couplers.

All coils are guaranteed to cover the wave band when condensers of the specified capacity are used. All coils are sold on a 5-day money-back guarantee. We pay the postage on all coil orders, on basis of remittance with order.

## Precision Coils for Double Detection Circuits

### Tuner-Mixer Coils

THE tuning coils for superheterodyne construction are for a stage of t-r-f, modulator and oscillator, with oscillator secondary inductance accurately chosen on the basis of specified capacity of padding condenser. These coils are for broadcast band coverage only.

The coils are of the same type of mechanical construction as the t-r-f coils. Since there is no secondary tap, the code for connecting the t-r-f coils of the superheterodyne combination is different: P and B, primary; G and ground symbol, secondary. P would go to plate or antenna, G to grid cap, while B and ground symbol are the returns.

The oscillator has a smaller inductance secondary, for padding, and moreover is a three-winding coil. The three windings are: pickup, secondary and tickler. The pickup winding consists of 10 turns, and is brought out to two side lugs. The polarity of its connections unusually is of no importance. The secondary is represented by G and ground symbol, G going to grid and ground symbol to grid return, usually ground. The tickler connections for oscillation require that the lug at B be connected not to B plus but to plate, hence the P lug goes to B plus. In any case, if no oscillation results, reverse the tickler connections.

### Tuning Coils for 175 kc Receivers

CAT. NO. 4—Three shielded coils, two for modulator and r-f and one for oscillator, for 0.00035 mfd. three-gang condenser. Oscillator coil has pickup winding. Intermediate frequency intended, 175 kc. Price includes padding condenser, 700-1000 mfd. \$1.80

CAT. NO. 5—Same as Cat. No. 4, except that this set is for 0.0005 mfd. \$1.80

CAT. NO. 6—Same as Cat. No. 4, except that this set is for the 0.00046 mfd. Scovill condenser. \$1.80

### Tuning Coils for 365-465 kc Receivers

CAT. NO. 7—Same as Cat. No. 4, except padding is for 365-465 kc and padding condenser is 350-450 mmfd. \$1.80

CAT. NO. 8—Same as Cat. No. 6, except padding is for 365-465 kc and padding condenser included is 350-450 mmfd. \$1.80

## Short-Wave Plug-in Coils



WOUND on 1.25 inch diameter finest bakelite forms, with flange for gripping, these short-wave plug-in coils afford high efficiency. Tube sockets serve as receptacles for these coils. The coverage with four coils is 13 to 200 meters with 0.00014 mfd. capacity. Also 0.00015 mfd. may be used without change. The coils may be used for any of the popular short-wave circuits.

CAT. SWA—Four plug-in coils, UX base, primary and secondary; primary may be used for feedback if condenser connects aerial to grid. \$1.35  
 CAT. SWB—Four plug-in coils, 6-pin base; primary, secondary, fixed tickler. \$1.70

UX wafer sockets or 6-pin wafer sockets, 11c. each

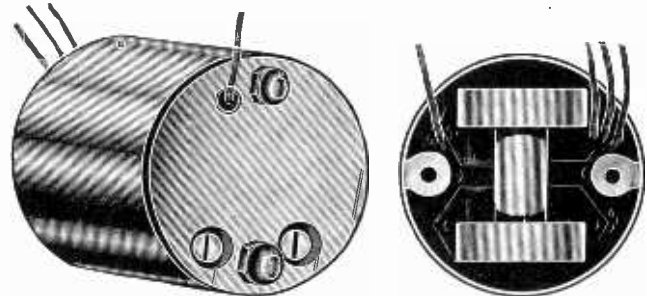

The intermediate frequency transformers are in an aluminum shield and consist of two loosely-coupled low r-f resistance honeycomb coils, with compression type Hammarlund condensers that hold their setting.

## Intermediate Transformers

THE intermediate transformers consist of two honeycomb coils, wound with low resistance wire, coils spaced 1 inch apart, and thus affording loose coupling, stability and high selectivity. The coil assembly is enclosed in an aluminum shield, with open bottom. The shields are 2 1/8 inches diameter, 2 inches high. At bottom are two small rigid brackets, tapped for 6/32 machine screws. The taps are 1 11/16 inches apart. Four outleads, 6 inches long, are wired to the coils. Their colors are green, black, yellow and red.

The primary consists of the yellow and red leads, yellow to plate, red to B plus. The secondary consists of the green and black leads. Green emerges through a protected small opening in the top of the shield and goes to grid cap of a screen grid tube. Black is the return for the secondary, usually to ground. Both primary and secondary are tuned, and thus the coils are for screen grid tubes exclusively, except the second detector may be any type tube. The condensers for tuning the coils are Hammarlund's compression type, on an Isolantite base. The set-screws for adjusting these condensers with a screw-driver are accessible from the top of the shield.

CAT. FF-175—Shielded intermediate frequency transformer, 175 kc. \$1.10

CAT. FF-450—Shielded intermediate frequency transformer, affording choice by condenser adjustment of frequencies from 365 to 450 kc. \$1.30

## Padding Condensers @ 45c Each

CAT. PC-710—For 175 kc intermediate. Put in series with oscillator tuning condenser. Capacity 700-1000 mmfd. Hammarlund, Isolantite base.  
 CAT. PC-3545—Same as above, except 350-450 mmfd. for 365-400 kc intermediate.

Prompt Service

**SCREEN GRID COIL CO.**  
 145 West 45th Street, N. Y. City

We Pay Postage