

# SHORT-WAVE AND TELEVISION NUMBER

FEB. 27  
1932

PRICE  
15c Per Copy

# RADIO

REG. U.S. PAT. OFF.

# WORLD

The First and Only National Radio Weekly  
**518th Consecutive Issue**  
TENTH YEAR

## TIME TABLE Of Short-Wave Transmissions

*How to Make  
Projection Disc  
for 10 x 12 Inch Image*

## DIRECTIONS FOR TUNING IN SHORT WAVES

# PRECISION TYPE ALL-WAVE SUPER

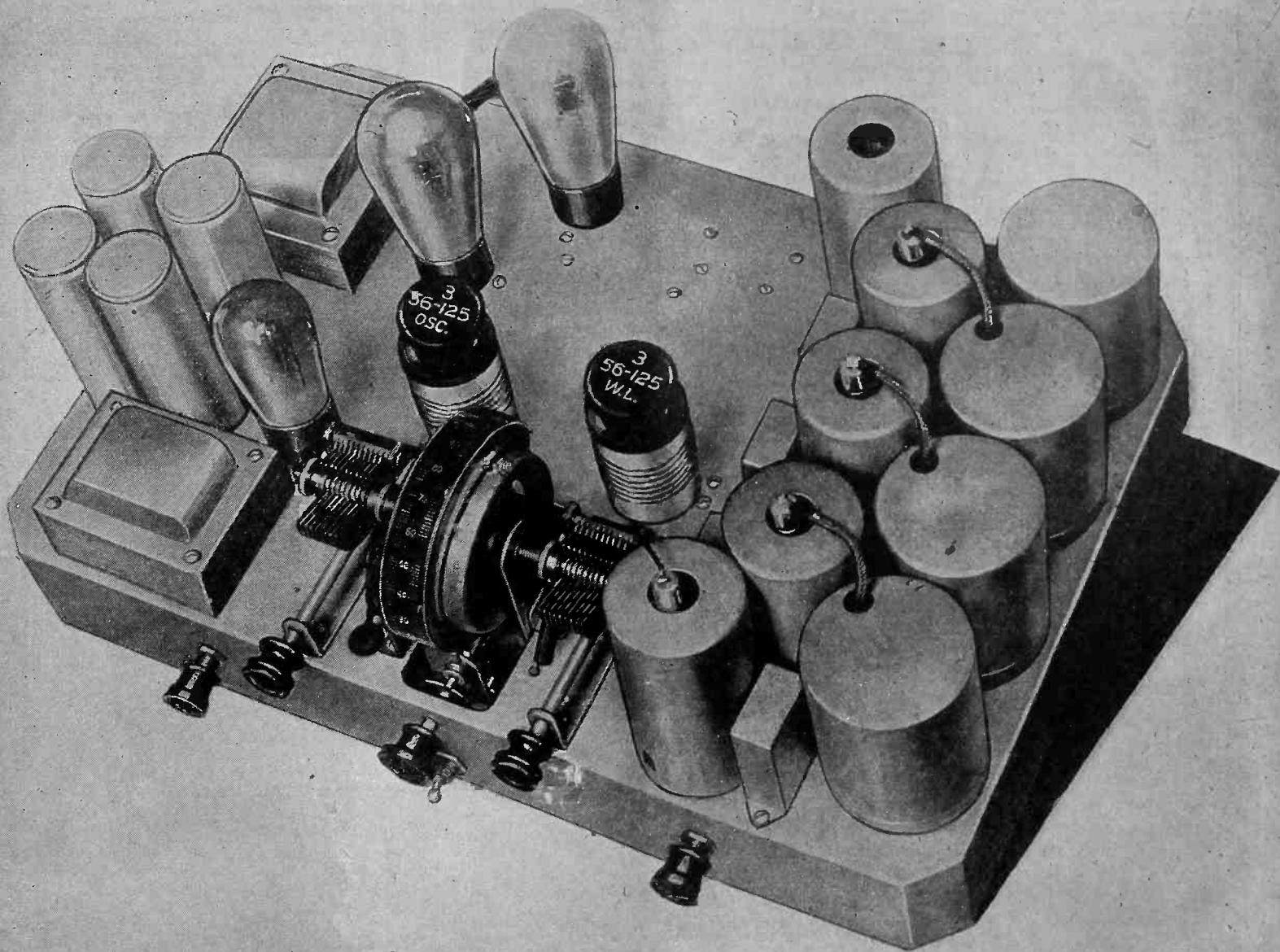

A carefully engineered product is the All-Wave Comet, 15 to 550 meters, with a separate local oscillator for resonance indication and interrupted continuous wave code. See pages 18 and 19.

25

# "NO COMPARISON POSSIBLE!"

## OTHERS SAY

So Writes an SW-45 Enthusiast

"What a kick this set has! Foreign stations so loud that you can hear the announcements three rooms away." . . . "I guarantee Rome, Italy on the loud speaker and the SW-45 has never failed me yet." . . . "Neatness, Precision, good results." . . . "45 continents and 23 countries received." . . . "Truly a masterpiece in the SW-45 field." (Names on request). So write a few admirers of the SW-45 THRILL-BOX, the outstanding short-wave receiver for serious every-day short-wave phone or broadcast reception, for code or experimental use.

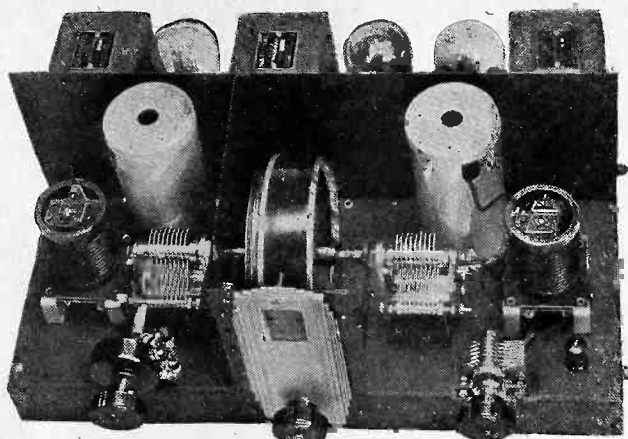

# NATIONAL

SW-45 THRILL-BOX



Write us today for our Shortwave Bulletin RW

NATIONAL CO., INC., 61 SHERMAN ST., MALDEN, MASS.

**HIGH-LIGHTS ON THE SW-5**  
Range 9-2000 meters. Extremely high signal to noise ratio. True single-knob tuning. Set and forget the antenna trimmer. Easy to log with NATIONAL projector Dial, type H, no parallax. Special 270° Type S.E. Tuning Condenser with insulated main-bearing and Constant-impedance pigtail makes gang-tuning possible on the short waves. Equipped with standard set of 4 pairs of R.F. Transformers covering range of 15 to 115 meters, wound on forms of genuine NATIONAL R-39. Uses the new UX-235 Variable-Mu tubes, giving improved sensitivity and less critical operation. Humless A.C. Power Supply with special filter section. R.F. Filter on Rectifier Tube, and Electrostatic shield. R.C.A. Licensed.

# FLASH NEWS! TELEVISION Has Arrived!

THE BIG BOOM IS NOW ON!

First National Television, Inc., (Training Division) of Kansas City will accept students for complete six and 12 weeks training at moderate cost. **DON'T DECIDE ON YOUR INSTRUCTION TILL YOU RECEIVE THIS FREE BOOK: "PRACTICAL TELEVISION."** A number of astonishing surprises in store for you.

Address:  
**FIRST NATIONAL TELEVISION, INC.**  
(Training Division)  
KANSAS CITY, KANSAS DEPT. 10

# New 360-Degree Condenser

A big improvement in radio technique—a new sensation—is our 360-degree condenser, affording 14-100 mmfd. over 0-180 degrees, and 100-370 mmfd., 180 to 360 degrees. Hence use the full 360 degrees for any tuning purpose, or the lesser capacity section for short waves, the entirety for broadcasts, without external switching or changing condensers. Requires 360 degree dial. Brass plates, cast aluminum frame, 3/4 inch shaft. Certificate of highest award from Radio World Laboratories.

Single Double Gang Triple Gang  
Cat. CS @ \$3.50 Cat. CD @ \$6.50 Cat. CT @ \$9.00  
National 360-degree VBC dial, 0-200 @ \$1.50

**EUGENE STROUD**  
1114 BAKER STREET  
BAKERSFIELD, CALIF.

# BLUEPRINTS OF PRIZED CIRCUITS

## 8-TUBE AUTO SET

Sensitivity of 10 microvolts per meter characterizes the 8-tube auto receiver designed by J. E. Anderson, technical editor of Radio World, and therefore stations come in with only six feet of wire for aerial, and without ground. Most cars will afford greater aerial pickup, and besides the car chassis will be used as ground, so with this receiver you will get results. The blueprint for construction of this set covers all details, including directions for cars with negative A or positive A grounded. The circuit features are: (1) high sensitivity; (2), tunes through powerful locals and gets DX stations, 10 kc either side; (3), latest tubes, two 239 pentode r-f, two 236 screen grid, two 237 and two 238; push-pull pentodes, all of 6-volt automotive series; (4), remote tuning and volume control on steering post, plus automatic volume control due to low screen voltage on first detector; (5), running board aerial. The best car set we've published. This circuit was selected as the most highly prized after tests made on several and is an outstanding design by a recognized authority. Send for Blueprint 631, @ .....50c

## SHORT-WAVE CONVERTER

If you want to build a short-wave converter that costs only a very few dollars, yet gives good results, furnishing all its own power from 110 volts a-c, and uses no plug-in coils, you can do so from Blueprint 630. Price.....25c

## 5-TUBE AC, T-R-F

Five-tube a-c receivers, using variable mu r-f, power detector, pentode output and 280 rectifier, are not all alike by any means. Forty circuits were carefully tested and one selected as far superior to the others. This prized circuit was the 627, and if you built it, you will always be glad you followed our authentic Blueprint, No. 627. This is the best 5-tube a-c t-r-f broadcast circuit we have ever published. Price .....25c

## A-C ALL-WAVE SET

An all-wave set is admittedly what many persons want, and we have a circuit that gives excellent broadcast results, and is pretty good (not great) on short waves. No plug-in coils used. Cost of parts is low. Send for Blueprint, No. 628-B, @ .....25c. In preparation, a 7-tube broadcast superheterodyne for a-c operation. Write for particulars.

RADIO WORLD, 145 West 45th Street, New York, N. Y.

# 115 DIAGRAMS FREE!

115 Circuit Diagrams of Commercial Receivers and Power Supplies supplementing the diagrams in John F. Rider's "Trouble Shooter's Manual." These schematic diagrams of factory-made receivers, giving the manufacturer's name and model number on each diagram, include the MOST IMPORTANT SCREEN GRID RECEIVERS.

The 115 diagrams, each in black and white, on sheets 8 1/2 x 11 inches, punched with three standard holes for loose-leaf binding, constitute a supplement that must be obtained by all possessors of "Trouble Shooter's Manual," to make the manual complete. We guarantee no duplication of the diagrams that appear in the "Manual." Circuits include Bosch 54 D. C. screen grid; Baklite Model F, Crosley 20, 21, 22 screen grid; Eveready series 50 screen grid; Wria 224 A. C. screen grid; Peerless Electrostatic series; Philco 76 screen grid.

Subscribe for Radio World for 8 months at the regular subscription rate of \$1.50, and have these diagrams delivered to you FREE!

Present subscribers may take advantage of this offer. Please put a cross here  to expedite extending your expiration date.

Radio World, 145 West 45th St., New York, N. Y.

"A B C OF TELEVISION" by Yates—A comprehensive book on the subject that is attracting attention of radioists and scientists all over the world. \$3.00, postpaid. Radio World, 145 West 45th St., N. Y. City.

# RADIO WORLD and "RADIO NEWS"

BOTH FOR ONE YEAR **\$7.00** Canadian and Foreign \$8.50

You can obtain the two leading radio technical magazines that cater to experimenters, service men and students, the first and only national radio weekly and the leading monthly for one year each, at a saving of \$1.50. The regular mail subscription rate for Radio World for one year, a new and fascinating copy each week for 52 weeks is \$6.00. Send in \$1.00 extra, get "Radio News" also for a year—a new issue each month for twelve months. Total, 64 issues for \$7.00. RADIO WORLD, 145 West 45th Street, New York, N. Y.

# Large Temple Dynamic

Dynamic speaker, AC 110 Volts, 50 to 60 cycles, housed in table cabinet made of walnut, with carved grille. Output transformer and dry rectifier built in, also a hum eliminating adjuster and a variable impedance matcher. Plugged AC cable and tipped speaker cords are attached to dynamic. Outside cabinet dimensions: Height 14", width 11, depth 7 1/2". Speaker diameter 9". Price, \$11.50 net.

Guaranty Radio Goods Company  
Dept. A, 143 W. 45th St., N. Y. C.

# LEARN TO INVENT

There is big money in inventions. Any one can learn to invent; and everyone should learn to. Every machine made is an invention; and besides, there are four other large classes of inventions. Do you know them? Complete easy course postpaid for 25c (coin). We want all kinds of inventions for market, whether patented or not. Many companies have offered cash for ideas not invented yet: \$5,000, \$10,000, \$20,000, \$50,000, etc. We will consider ANY new idea, whether we have been asked for it or not. Write us. American Patent Agency, 6420 S. Stewart Ave., Chicago

# THREE-IN-ONE TESTER FREE!

EVERYBODY who does any radio work whatsoever, whether for fun or for pay or for both, needs a continuity tester, so he can discover opens or shorts when testing.

A mere continuity tester is all right, but—

Often it is desired to determine the resistance value of a unit, to determine if it is correct, or to measure a low voltage, and then a continuity tester that is also a direct-reading ohmmeter and a DC voltmeter comes in triply handy.

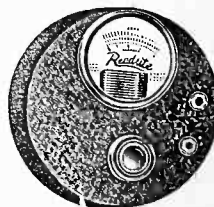

So here is the combination of all three:

A 0-4 1/2-volt DC voltmeter, a 0-10,000-ohm ohmmeter and a continuity tester. A rheostat is built in for correct zero resistance adjustment or maximum voltage adjustment. The unit contains a three-cell flashlight battery. Supplied with two 5-foot-long wire leads with tip plugs. Case is 4-inch diameter baked enamel. Weight, 1 lb. Sent free with an order for one year's subscription for RADIO WORLD (52 weeks) at the regular rate of \$6. Order Cat. PR-500.

Radio World, 145 W. 45th Street, New York, N. Y.

Enclosed please find \$6 for one year's subscription for Radio World (one copy a week, 52 issues). Send Cat. PR-500 as premium.

Name .....

Address .....

City..... State.....



ROLAND BURKE HENNESSY  
Editor

HERMAN BERNARD  
Managing Editor

# RADIO WORLD

TENTH YEAR

J. E. ANDERSON  
Technical Editor

J. MURRAY BARRON  
Advertising Manager

Vol. XX

FEBRUARY 27th, 1932

No. 24. Whole No. 518

Published weekly by Hennessy Radio Publications Corporation, 145 West 45th Street, New York, N. Y.

Editorial and Executive Offices: 145 West 45th Street, New York

OFFICERS: Roland Burke Hennessy, *President and Treasurer*; M. B. Hennessy, *Vice-President*; Herman Bernard, *Secretary*.

Entered as second-class matter March, 1922, at the Post Office at New York, N. Y., under Act of March 3, 1879. Title registered in U. S. Patent Office. Printed in the United States of America. We do not assume any responsibility for unsolicited manuscripts, photographs, drawings, etc., although we are careful with them.

Price, 15c per Copy; \$6.00 per Year by mail. \$1.00 extra per year in foreign countries. Subscribers' change of address becomes effective two weeks after receipt of notice.

## A Television Projector Lens Disc Affords 10 x 12" Screen Picture

By Ivan Bloch, E.E.

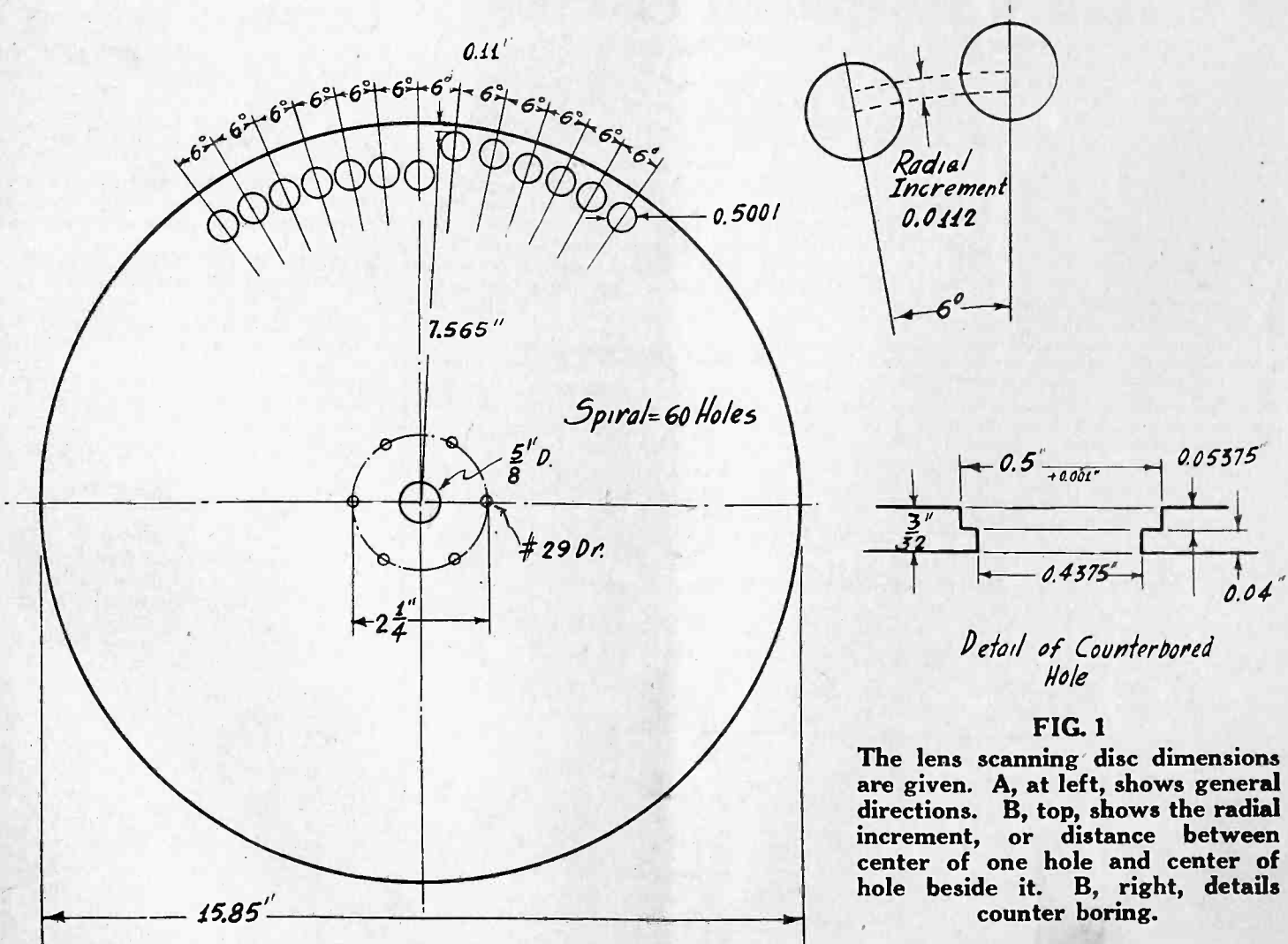

Detail of Counterbored Hole

FIG. 1

The lens scanning disc dimensions are given. A, at left, shows general directions. B, top, shows the radial increment, or distance between center of one hole and center of hole beside it. B, right, details counter boring.

[The projector and accessories for a fine 10 x 12 inch television image on a screen for home use, as described in the following article, have been carefully tested in practice by the author and designer, Ivan Bloch. He is a radio engineer specializing in television optics and has given demonstrations of images up to 3 x 3.5 feet with his tested apparatus, of the same nature as that described herewith. With lamps now available the 10 x 12 inch picture is preferable for home use. The reader is reminded that 10 x 12 inches constitutes a picture larger than the page on which these lines are printed which page is 9 x 12 inches.—EDITOR.]

CONTRARY to opinion, the construction of a television receiver producing a clear image 10 x 12 inches or larger is not beyond the skill of the experimenter, nor is it beyond his means.

The following details are not merely on paper, but have been incorporated in a machine which has been successfully demonstrated with a screen 3.5 x 3 feet, the image being brilliant and the detail excellent, when viewed at the correct distance.

It must be remembered by the televisionist that the heart of his  
(Continued on next page)

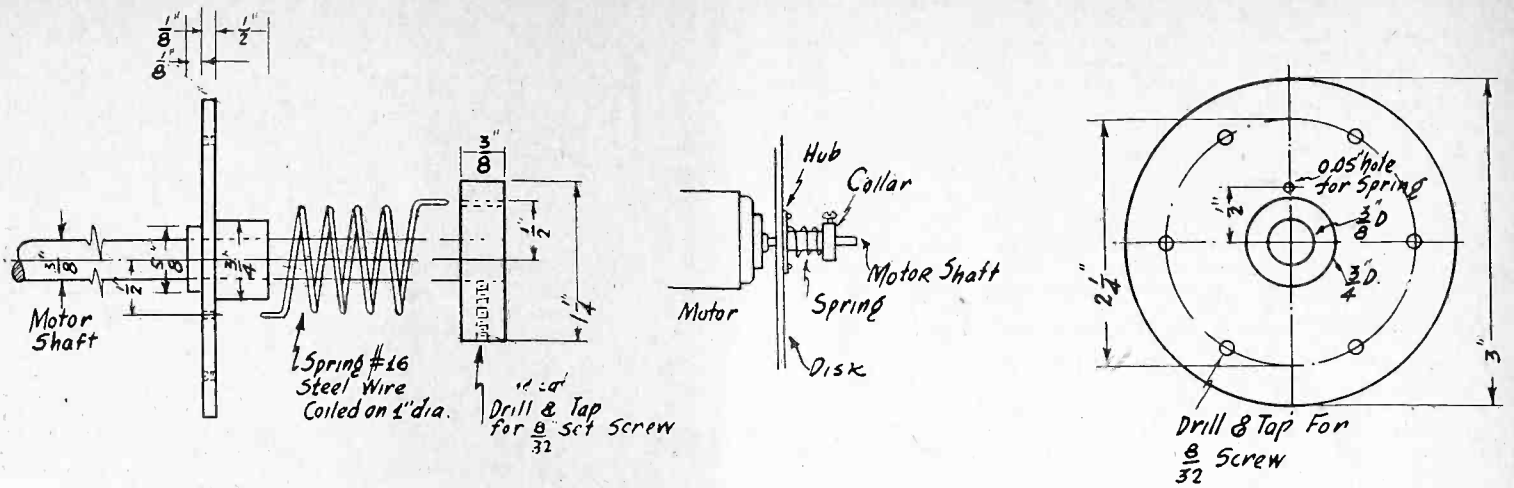

**FIG. 2**  
Synchronizing spring hub.

(Continued from preceding page)

apparatus in reality is his receiver of television signals and that if he is the possessor of a good set, in conjunction with the projector which will be described, he will receive excellent pictures, well worth looking at, and clearly visible by a roomful of persons, without eye strain.

Before proceeding, it is well to set down those factors which will influence the design and construction. The first two are obvious: least expense and smallest space. The whole projector, screen and receiver should be housed in a moderately sized cabinet, with the screen adjustable if desired. Hence, an image 10 x 12 inches will be the limit under these restrictions. For large images it is necessary to have a portable screen. The third factor is the neon crater lamp. Recent lamps have shown exceptionally good light intensities with a "0.020" anode screen aperture; thus, such a lamp will be used. Fourth factor: the driving motor should be self synchronizing. Either it should be synchronous for those locations where the receiver is located on the same power network as the transmitter, or it should be of variable speed with a synchronizing attachment such as a phonic wheel.

**Parts Required**

With these factors in mind, the following parts will be needed, the specifications for which will come under subsequent headings.

- (1)—One lens scanning disc with sixty holes for lenses.
- (2)—Sixty lenses, 1.75" focal length, 1/2" in diameter, either double convex or plano convex.
- (3)—One spring mounting-hub for the disc.
- (4)—One motor with supporting bracket (if synchronous), or with phonic wheel attachment if of variable speed. Also a vibration-absorbing rubber mat. Suitable starting condenser.
- (5)—One framing device for horizontal framing.
- (6)—One motor rotary snap switch.
- (7)—One neon crater lamp and socket.
- (8)—One lamp holder and focusing device.
- (9)—One screen in frame.
- (10)—One cabinet with screen support, with space for television receiver and, if desired, broadcast receiver, short-wave converter and loudspeaker.

It is strongly advisable that the lens disc be made with extreme care. Unless the experimenter is an excellent mechanic and has access to a good machine shop, it is worth while to have the disc made or purchase it ready made.

Those who have already perused articles about certain models of projector type receivers may wonder why the disc as shown in the illustrations herewith is larger than may seem to have been the practice. Without going into elaborate details as to the reasons for the perhaps peculiar dimensions, let it be said that the commercial designers have been guided more by the ease with which the discs could be manufactured than by sound optical facts. The question of correct screen-element overlap has been evaded, its relationship to spiral pitch obscured. The disc dimensioned below and in the illustration takes these and other effects into consideration.

**Specifications for Disc**

The material for the disc is duraluminum, 3/32 inch thick and the blank should be flat. The main dimensions are as follows:

Overall diameter .....	15.85 inch.
Radius at furthest hole.....	7.565 inch.
Radial increments .....	0.0112 inch.
Hub hole .....	3/8 inch.

Mounting screw-holes on 2 1/4" diameter circle, spaced 60°.

It is best to drill the hub and mounting holes first so as to have all other dimensions from the actual center of rotation. The holes for the lenses are first drilled with a 0.4375" drill, then counterbored with a square-faced reamer of 0.5001" diameter to a depth of 0.05375" as indicated in the illustrations.

After the disc is completely drilled and the surfaces gently polished with fine emery cloth, it should be thoroughly cleaned of grease and oil. Then both sides of the disc should be coated with a dull optical black paint to prevent reflection. This may be accomplished by dipping, painting or spraying.

When the paint is completely dry, each hole must be cleaned very carefully with a sharply pointed tool which can be made from an old screw driver filed down. Extreme care is necessary so as not to remove any metal from the shoulder and the sides of the holes.

**The Lenses**

From the image size and the anode screen aperture of the crater lamp the lenses are specified. As may be expected, the design of the scanning disc was also affected by the focal length  
(Continued on next page)

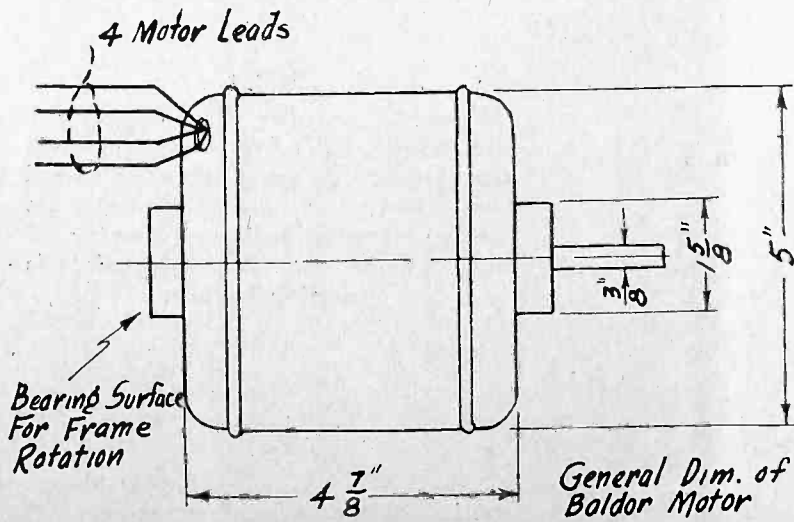

**FIG. 3**

General dimensions of the Baldor synchronous motor, at left, and of the motor mounting brackets, at right.

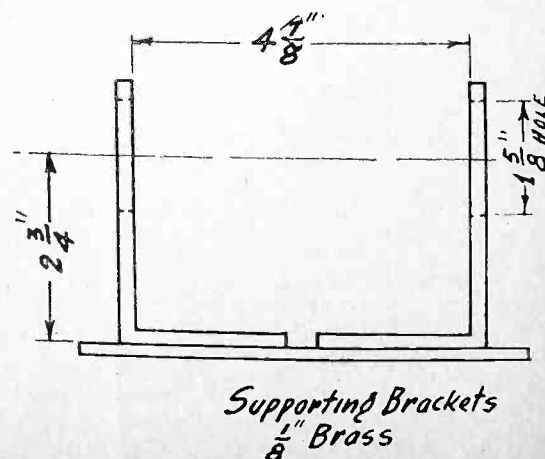

**FIG. 4**

(Continued from preceding page)

of the lenses. This is another point which others have passed over lightly. Such distortion is occasioned by angular lens distortion. Aberration is detrimental both to sharpness and detail of the image and lessens its brilliancy at the edges. The lenses selected, of 1.75 inch focal length, will allow the image to be projected in a minimum distance and yet reduce the above-mentioned distortion to such values as will not affect the results. The diameter of 1/2 inch allows plenty of light to go through the lens and allows for proper machining. These lenses can be obtained for about fifteen cents a piece and although this may seem a high price, if obtained from a reliable optical concern will reduce such possibilities as poor alignment between optical and geometrical centers, aberration, etc.

Several methods are available to the experimenter for the fastening of the lenses to the disc. The easiest, cheapest and most satisfactory method is cementing. However, it is best to use a cement such as the Capitol, which dries to brittle hardness. Some cements do not dry completely.

To cement the lenses, each hole is cleaned once more with wood alcohol. Proceeding one hole at a time, carefully coat the shoulder and hole with a bit of cement, then firmly press lens into place. Quite a bit of the cement will be squeezed over the lens surface, but this is not detrimental to the purpose, as the excess will be cleaned off. Each hole is thus treated until the whole disc is filled.

### Removal of Excess Cement

Using the same tool with which the paint was removed from the holes, the excess cement is very carefully scraped off when thoroughly dry. If a small amount still overlaps by about 1/50 of an inch, the lens can be sure to remain in place. One must remember that for a disc of 15 inches in diameter revolving at 1,200 revolutions per minute, the peripheral speed is more than 50 miles per hour, at which rate a flying lens can be quite damaging to life and property.

With a smooth and clean cloth, the disc and lenses can be thoroughly wiped, thus completing the construction of the scanning element.

The mounting hub obviously serves to fasten or hold the scanning disc to the motor shaft. However, it is necessary to add to its function. The disc is fairly heavy and to bring it to synchronous speed by means of the motor used would involve a large time element.

A simple expedient is resorted to, in which the potential energy of the disc is stored into a coiled helical spring and then released suddenly into kinetic energy.

Picture the disc attached to the hub, the hub capable of freely moving about the motor shaft. We then fasten one end of a helical spring to the hub and the other to the motor shaft by means of a collar. When the motor shaft begins to rotate, the spring will wind by virtue of the inertia of the disc. This then constitutes a direct connection between disc and motor shaft, and as soon as part of the disc's inertia is overcome, the spring will then release its stored energy, giving the disc a considerable spin, thus aiding it to reach synchronous speed. It is naturally necessary to have a spring so wound that upon starting the motor, it will wind. For this projector, a spring wound clockwise, looking from the front end, will accomplish its purpose. This is shown in an illustration. With the Baldor motor, the hub, spring and associated collars are furnished. Otherwise, it will be necessary to construct this hub, not a difficult job on a lathe. Dimensions are given, but they need not be adhered to rigorously.

### The Motor

The choice of two motor systems confronts the constructor. If he is located on the same alternating current power system as the transmitter, his problem is simplified a great deal. However, if he is not on the same synchronized network, it will be necessary to make certain provisions for self-synchronization.

If located on the synchronized network, a synchronous motor

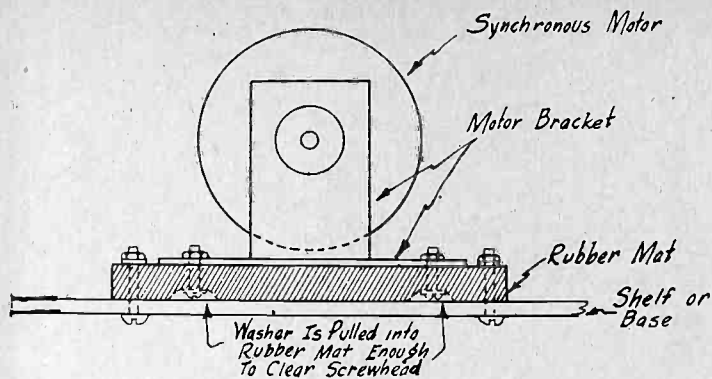

FIG. 5  
Vibration-absorbing method of mounting motor and supporting bracket.

to run at 1,200 RPM and of 1/20 HP is needed. The Baldor synchronous motor type C, frame M3CN, is recommended. This motor requires an auxiliary condenser of 3 mfd. capacity, 400 d-c volt rating, to be used as specified by the manufacturers. As previously mentioned, this motor is equipped with a suitable spring hub and, furthermore, is equipped with bearing surfaces for frame rotation. This latter point needs some elaboration.

Two situations may exist at a television receiver. The disc may be running synchronously, but its relative position may not be the same as at the transmitter. The image may therefore be out of frame horizontally as well as vertically. The vertical framing is accomplished by starting and stopping the motor rotation by means of the starting snap switch. The horizontal framing requires that the whole image be shifted horizontally until it is in frame.

### Frame Rotated About Own Axis

If it were possible to change the stator-rotor flux relationship in the ordinary motor, this would be simple. However, the same effect is accomplished by rotating the motor frame about its own axis. Thus, in order to do so, the frame must be supported at two points along its own axis and be allowed enough freedom of rotation so that a gearing or lever arrangement can be used to move the frame a small angular distance. This distance obviously need not be more than six degrees, as the picture frame limits are indicated by two radial lines separated by six degrees.

The Baldor motor when supported by a suitable bracket can be easily rotated. These supporting brackets can be made from brass and will have the general dimensions indicated in an illustration. In case some other motor is used, the frame legs must be removed and a supporting rig built. This naturally complicates matters, but the ingenuity of the constructor need not be taxed.

The other case under this heading, bearing on locations not on synchronized networks, obliges the use of a variable speed motor. The Baldor motor, type B, frame M2c, is recommended, although any good motor with a speed range of 1,750 RPM and 1/15 HP will do. The Baldor motor requires a 2 mfd. condenser at 400 volts d-c rating and also a starting rheostat as specified by the manufacturers. In order to synchronize, a phonic wheel attachment is used. The construction of such a phonic wheel is tedious, hence it is better to purchase it ready made. Kresge stores carry the phonic wheel and magnet assembly, also the necessary amplifier.

The purpose of the wheel is to make use of the 1,200 cycles picture frequency pulse, amplified to sufficiency and applied so that it will regulate the speed of the motor. The procedure is to run the motor to what seems to be its synchronous speed, which can be noticed by means of the image position, then close the synchronizer circuit, which will keep the image in frame.

(Continued on next page)

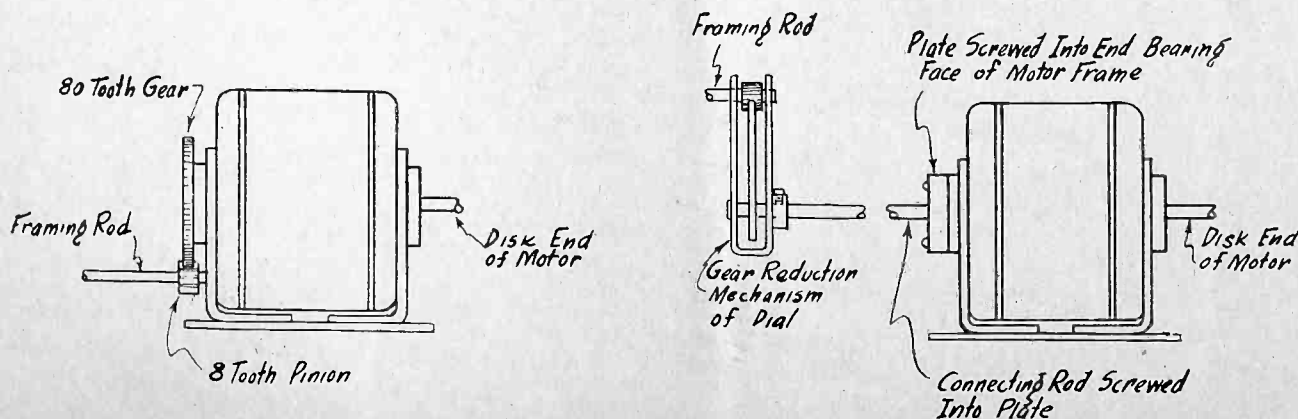

FIG. 6  
(A), left, (B), two at right, show horizontal framing methods.



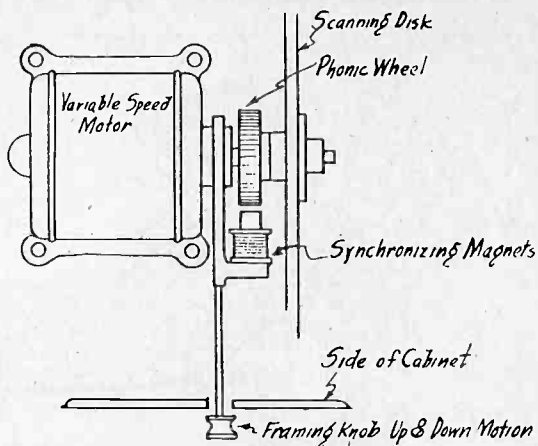

FIG. 7

General assembly of variable speed motor, synchronizing magnets and phonic wheel.

(Continued from preceding page)

An illustration indicates the position of the magnets, mounting, wheel, etc. The magnet mounting is so made that it is free to rotate about the motor frame collar. A small booklet entitled "The Romance of Television" and obtainable at the Kresge stores gives complete details of this synchronizing method.

**Mounted on Rubber Sheeting**

So as to minimize vibrational hum and noises, the motor and its supporting bracket should be mounted on a sheet of rubber 1/2 inch thick. Such sheets may be made from "kneeling pads" obtainable in chain stores. The method of fastening is shown.

In horizontal framing two cases are to be considered.

Where the motor frame is rotated, the problem resolves itself down to a simple gearing arrangement such as shown, or, if preferable, using a geared reduction dial mechanism. One must remember that since the picture frame swing is six degrees, only slight motions of the motor frame are necessary.

Hence, whatever motion is applied by turning the knob on the framing rod must be reduced before it reaches the motor frame. Generally, the total motor frame motion is not restricted to six degrees. However, as the leads from the motor would interfere with completely free motion, it is well to make some provisions to keep the rotation down to ninety or so degrees.

This may be done by screwing small stops on the motor frame. Another factor to take care of is that when the motor first starts there is a tendency for the frame to rotate, and if the brackets supporting it are very loose the rotation may be severe unless stops are placed. Hence it is advisable to put these stops in the correct position to prevent, first, the motor leads from being

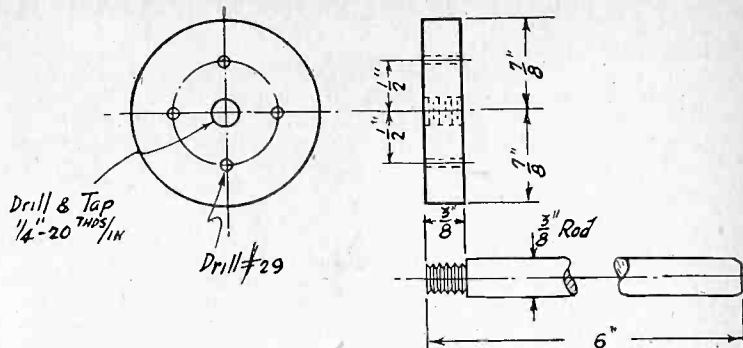

FIG. 8

The lamp support.

caught in the bracket, secondly, the frame from rotating when the motor is started.

**Case of Variable Speed Motor**

In the case of the variable speed motor, the synchronizing magnet assembly is rotated about the motor frame collar. This will exert a pull on the phonic wheel, the scanning disc and the motor shaft and twist them into frame position. By screwing a small rod into this magnet assembly, and allowing this rod to protrude through the side of the cabinet, the framing is accomplished with ease. This method can only be used with a variable speed motor.

To start and stop the motor in either case, a small rotary snap switch is used. With the variable speed motor, a starting rheostat is usually necessary and can be mounted on the front panel of the cabinet.

At the present time, neon crater lamps are not made in mass quantities and thus the distance from the socket base and the crater center will vary from lamp to lamp. It is necessary to provide adjustable means in every direction for proper focusing and crater alignment. The simplest and cheapest method makes use of the so-called physics clamp such as used in chemistry and physics laboratories. To support this clamp a small rod is used. Naturally, variations of this method can be suggested. As long as the lamp can be adjusted in any direction, any method is good. The one pictured is the simplest.

**The Screen**

The material for the screen should be chosen for the following characteristics: it should be translucent enough to let enough light through it, its surface should transmit this light in such a way that the observed image may be seen with equal intensity at angles up to thirty degrees from the normal. Ground glass

(Continued on next page)

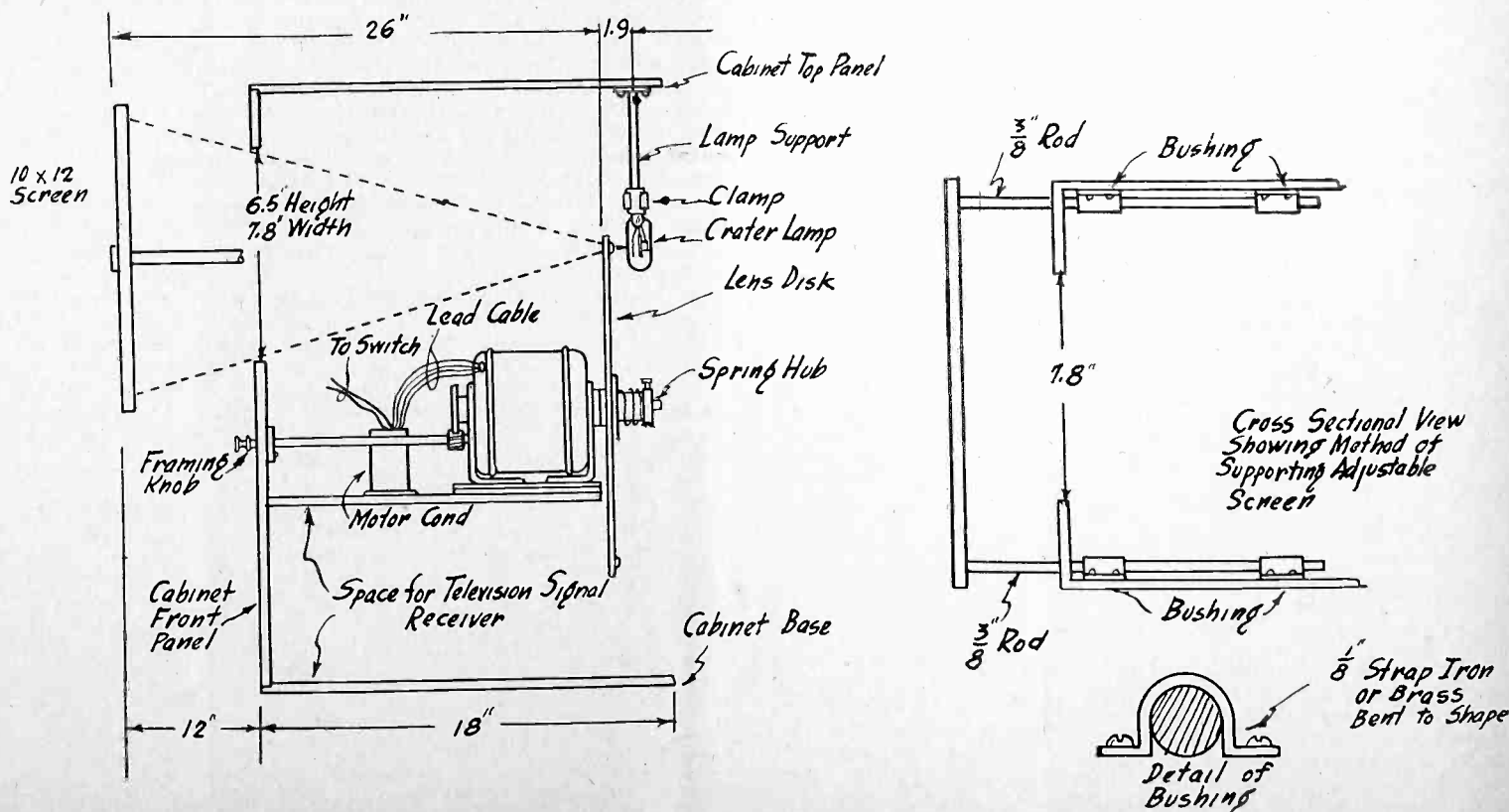
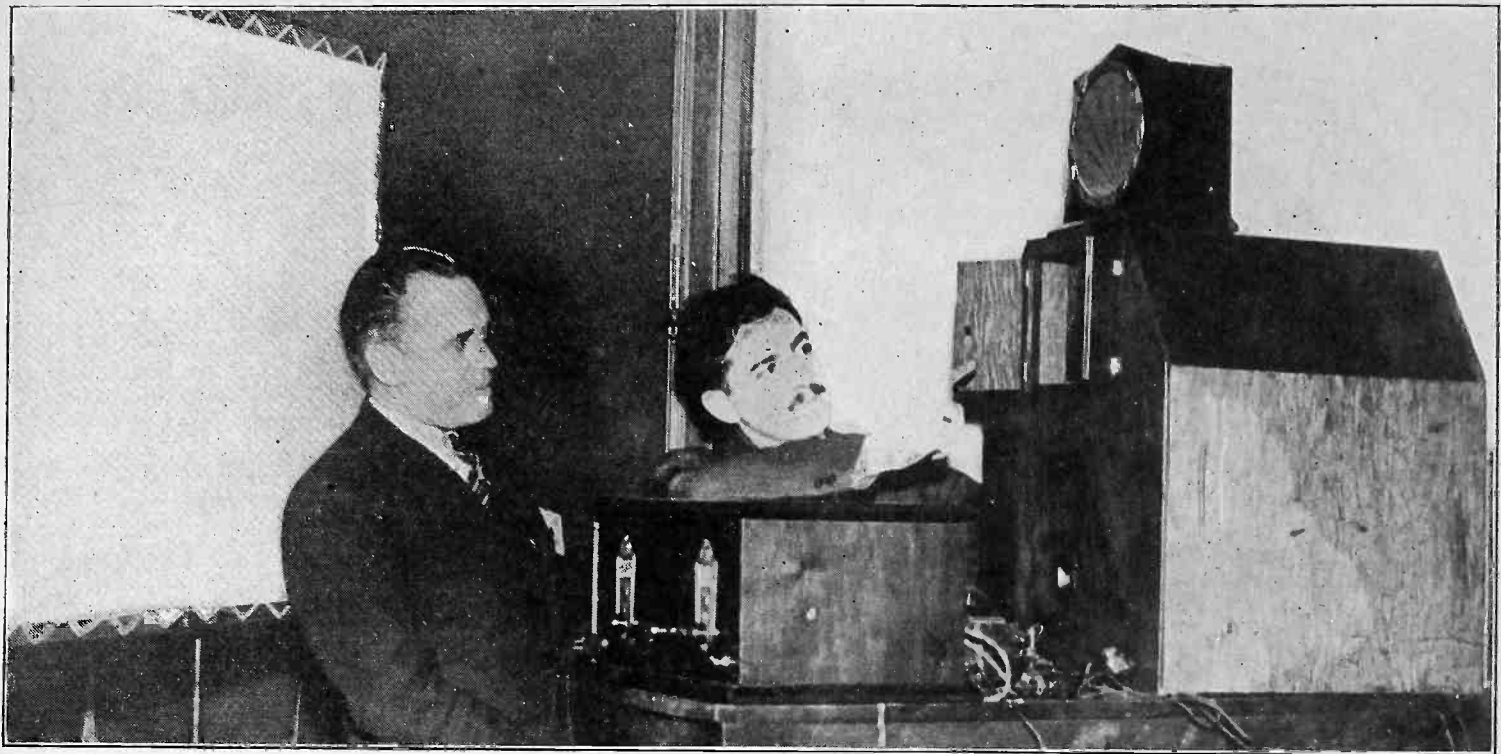

FIG. 9

General dimensions for cabinet.

# PROJECTED VISION DEMONSTRATED IN POLYTECHNIC INSTITUTE



Brooklyn Times Photo

The 3x3.5 foot screen used by Ivan Bloch is at left, while at right are the receiving, scanning and projection apparatus. At left is E. J. Squire, of Polytechnic Institute, Brooklyn, N. Y., to whom Mr. Bloch is showing the apparatus. A lens disc like the one Mr. Bloch describes in the accompanying article was used.

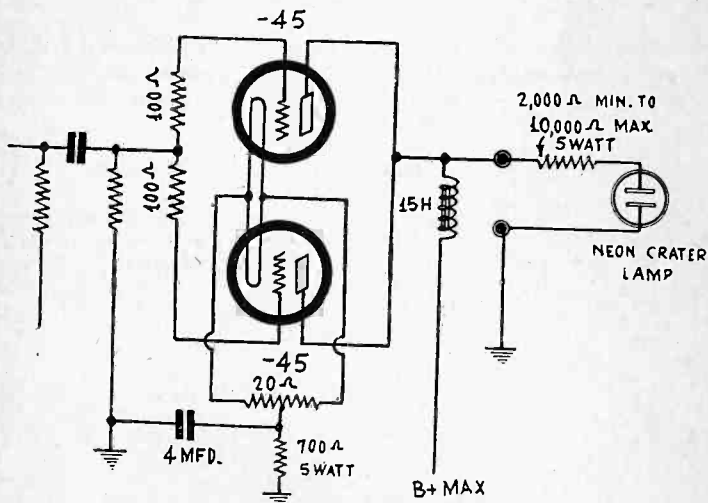

FIG. 10

One method of connecting a neon lamp to receiver output.

(Continued from preceding page)

has been used by nearly all experimenters and for its low cost, is recommended. However, for best results, the Translux screen material especially designed for television has not been excelled and if its cost is high, the features for which it is recommended overbalance this disadvantage. It is translucent, its angle of light distribution is correct, it cannot break, being of cloth-like material, and will not crack. It is much to be preferred over ground glass, or translucent sheet rubber which dries and cracks rapidly. Furthermore the material has been designed by projection engineers especially for television use, so that one may expect maximum efficiency from it.

A small frame is needed for the screen but its construction should require no description. For flexible material one must provide for stretching.

### The Cabinet

A few suggestions can be made about the cabinet, the design for which will vary with the individual. The projector may be mounted above the television signal receiver as shown. It also may be mounted quite separately or with a broadcast receiver, short-wave converter and loudspeaker. The later combination is especially attractive, but also is most elaborate. In the figure shown, the projector is mounted on a shelf placed above the television signal receiver. The whole cabinet is not much larger than an ordinary radio cabinet and with an adjustable screen can be made inconspicuous. The constructor's taste and in-

genuity will govern his design. The illustration offers a few suggestions. The motor may be seen mounted on brackets and rubber mat. The framing rod extends to the front panel. The motor condenser is screwed into the shelf in back of the motor. The lamp socket is screwed into the cabinet top. The method of mounting the screen is a simple one. This allows one to push or pull the screen to desired image size; naturally the lamp is to be adjusted for each screen position.

This design allows considerable variation in the constructor's methods. This will allow him to participate in the work, not only in the constructional sense, but in the design of his machine. There are certain parts, such as the disc, somewhat involved and therefore cannot well be made at home. But such parts as the lamp support or framing devices can be made in numerous ways.

The operation of the projector is extremely simple. The lamp is first focused and aligned to the screen—this is a simple matter. The television signal is tuned in by sound. The motor switch is then turned on as well as the neon crater lamp switch. The image will then appear on the screen, usually out of frame. The first step is to frame vertically by means of the stop and start switch. This only requires opening the motor circuit a few times, rapidly until the image is in frame vertically. The horizontal framing is accomplished by slowly turning the framing knob. The image will then be in frame and may need retuning.

It might be well to mention a few words about the output circuit of the television signal receiver. The impedance of the neon crater tubes is very low and its value may range from -200 ohms to + 200 ohms. In order to allow some sort of an impedance match, it is necessary to place a resistance in series with the lamp, so that no matter what its resistance may be, the combination of its resistance and the series resistance will always be large enough to constitute a load on the output stage. The series resistance also serves to reduce the current flow through the lamp. Certain lamps will take 25 milliamperes as operating value, while others will take more. It is to be recommended that the output stage be as shown for best results.

### TABLE OF CONTENTS

<i>Television</i>	
Lens Disc for Projected Television; Data on Accessories.....	Page 3
T-R-F Television Receiver.....	Page 8
Super-Regeneration for Ultra Waves.....	Page 10
Stroboscopic Synchronism.....	Page 11
Scanning.....	Page 12
Single Sideband Transmission.....	Page 14
Experiences at Columbia's Television Station.....	Page 15
Time Table of Television Stations.....	Page 30
Television Schools.....	Page 31
<i>Short Waves Generally</i>	
A New Pentode Power Method for Converters.....	Page 20
Battery-Operated Tuner.....	Page 22
Time Table of Short-Wave Stations.....	Page 24
How to Tune in Short Waves.....	Page 26
<i>Other Features</i>	
Portable Using New —34 Tubes.....	Page 25
Radio University (Questions and Answers).....	Page 27
News Events.....	Page 28

# Two Types of Television Receivers One a T-R-F Circuit, the

By Edwin

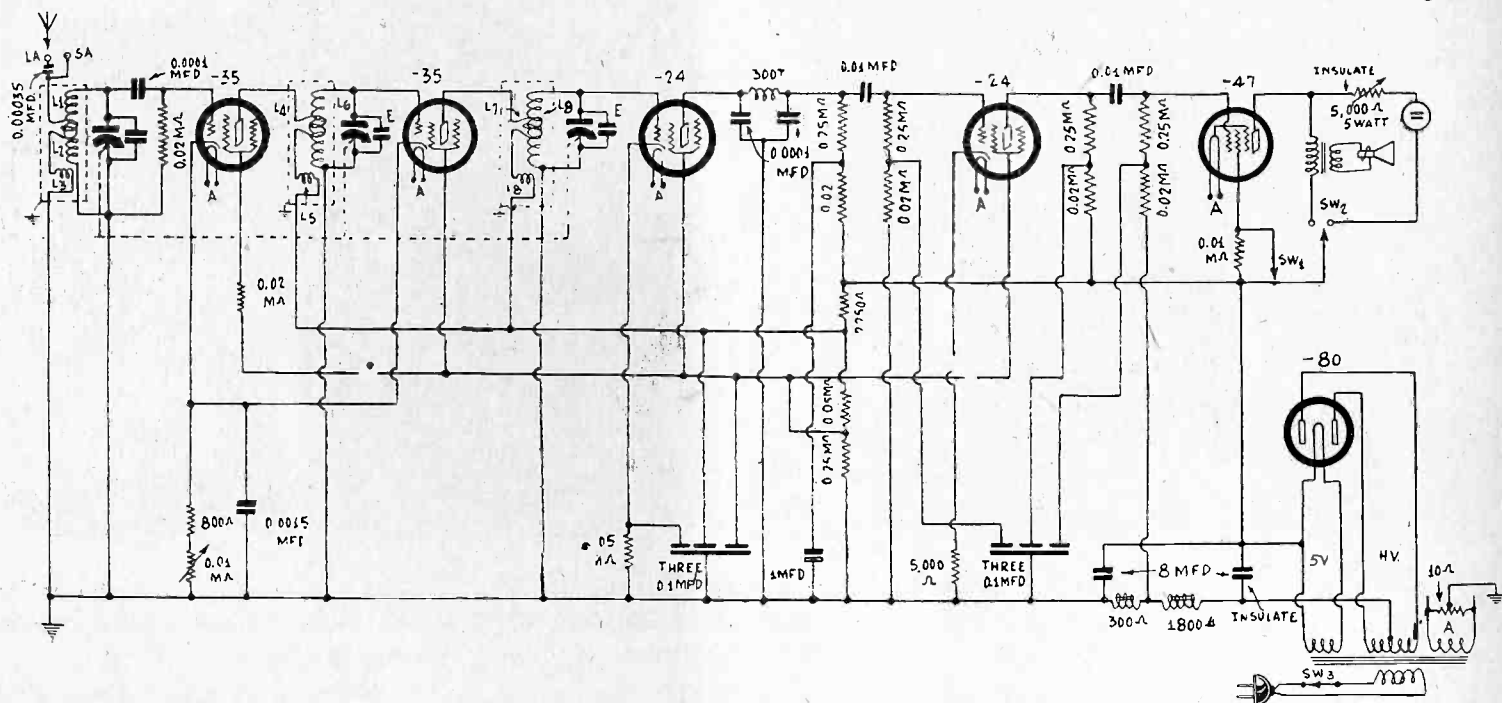

FIG. 1

Here is a television circuit of the tuned radio frequency type, using six tubes, with pentode output, and a switching arrangement to cut in neon lamp or speaker. The entire receiver may be put into a midget cabinet or console, except that the neon tube would be with the disc, and is not a part of the receiver proper.

A RECEIVER suitable for television is much like any other receiver, if of the tuned radio frequency type, except that the frequencies to be covered are different, and that broader tuning should prevail. The usual band covered by television receivers to-day is 80 to 200 meters, and this can be accomplished with a three-gang 0.00035 mfd. condenser, if the secondaries, on 1 inch diameter tubing, have 40 turns of No. 24 enamel wire. For stability reasons, and sufficient broadness of tuning as well as high sensitivity, it is well to use honeycomb coils as part of the antenna and plate loads, and have a few turns of wire, say, six, around the outside of the secondary for pickup. The honeycomb coils may consist of the small 200-turn type, placed inside the core of the form, at right angles, so there will be no coupling, since the few extra turns of primary around the secondary will afford sufficient transfer.

A volume control should be included, since it is possible to overload the detector, first audio and output tubes with a strong signal. Any who have tuned in television signals, including operators of short-wave converters, know how loud the buzz-saw sounds may be. Even stations a few hundred miles away may deliver a husky signal, as is the case in New York City of the television transmissions from Silver Springs, Md., not to mention some of the locals.

### Spillover Spoils Picture

The receiver should be fairly stable, but if it does regenerate a little the volume control will check that, and besides a small amount of regeneration has no deleterious effect on the picture's clearness. In fact, it is only when the tube spills over, flops into oscillation, that the patterns like a negative of repeated forked lightning and other designs, appear. These of course not only spoil the picture but obliterate it entirely.

Another fact, submerged from notice because of the obliteration of the image by spillover, is that detuning takes place, for when tubes oscillate the frequency is changed unless some provision for stabilizing the frequency is included.

### High Bias on Power Detector

The first r-f tube is the one likely to oscillate, if any tubes do that, so a grid leak and condenser are included, for minimizing the frequency distorting effect of any amount of regeneration below the point of actual oscillation. In fact, more regeneration can be used this way than without the inclusion of the leak-condenser combination. Sometimes a television fan will be goaded to build up the sensitivity this way as much as possible. While some distortion may appear, the resultant effect is a better picture, some-

times, because there was not enough "hop" to the radio-frequency amplifier otherwise.

Again for the reason of stability an unbypassed resistor of 0.02 meg. is shown in the screen leg of the first tube. Moreover, this resistor, and the relatively low value of resistance for grid leak, tend to broaden the tuning a little, the result being that sufficient sidebands are passed for a satisfactory image.

Coming to the detector, we find that the biasing resistor for this tube is 0.05 meg., a larger value than commonly recommended, but if the screen voltage is high the bias may be high, therefore actually around 8 volts negative bias will result, rather than the usual 5 volts. The current is less than 0.2 milliamper. It is therefore futile to try to read the voltage drop in the 0.05 meg. resistor with any save an electrostatic voltmeter, as any other meter would draw more current by far than would the "measured" circuit.

The detector plate circuit is filtered carefully, with a pi-filter consisting of a 300 turn honeycomb choke coil and two 0.0001 mfd. condensers. The capacities are 20-100 mmfd. equalizing condensers set at maximum. It is unwise to use large values of condensers in this position, because of the necessity of passing high audio frequencies of the modulation. The other part of the detector filter consists of the bypassed 0.02 meg. resistor between the true load resistor (0.25 meg.) and B plus maximum, for it can be seen that the full plate voltage, which may be from 230 to 250 volts, is applied. A condenser of 1 mfd. is connected between the juncture of these two resistors and ground, to prevent not only radio frequencies from getting into the power supply and thus becoming hum-modulated, but also for preventing hum from backing into the detector tube.

### Resistor-Capacity Filters

It is well known that hum troubles arise more pronouncedly in two-stage resistance-coupled amplifiers than in single-stage amplifiers, and therefore the detector filtration has to assist in meeting this exigency.

The same resistor-capacity filtration system is continued in the grid leg of the first audio tube and repeated in the plate and grid circuits of the first audio and output tubes. For any greater reduction in hum than results from the wiring of the circuit as shown, an extra condenser, of 0.25 mfd. to 1 mfd., may be placed across the 0.1 mfd. that bypasses the 0.02 meg. resistor in the lower part of the pentode grid circuit. However, it is hardly to be expected that any will complain there is much hum, for there is hardly any, the filtration being good in the rectifier circuit.

The dynamic speaker's field coil is used as B supply choke,



# What Give Results: Other a High-Intermediate Super Standard

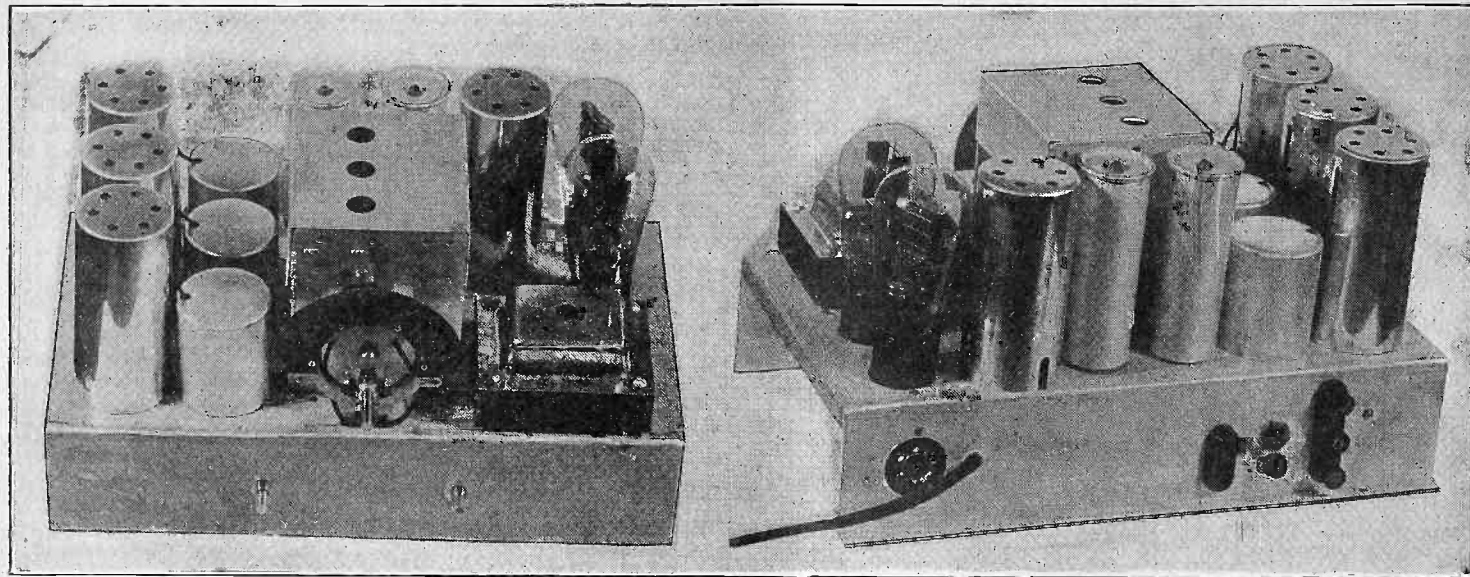

FIG. 2

The front view is shown at left and the rear view at right. The chassis size is 14x8x3 inches, and the assembly is compact and makes for simplicity of wiring. A speaker plug connects to the socket shown on the rear wall of the chassis.

FIG. 3

## LIST OF PARTS

### Coils

Three shielded radio frequency transformers as described (L1L2L3, L4L5L6, L7L8L9).

One 300 turn honeycomb coil.

(Note: field coil and output transformer are built into dynamic speaker specified later).

One power transformer for pentode tube and five heater tubes.

### Condensers

Three 20-100 mmfd. equalizing condensers, set at maximum for 0.0001 mfd. shown in Fig. 1.

One three-gang shielded 0.00035 mfd. condenser with equalizers (E) built in.

One 0.0015 mfd. fixed mica condenser.

One 0.00035 mfd. fixed condenser.

Two shielded blocks, three 0.1 mfd. in each block.

One 1 mfd. bypass condenser, 150 volts rating or higher.

Two 0.01 mfd. mica condensers.

Two 8 mfd. electrolytic condensers, one with two insulating washers and extra connecting lug.

### Resistors

Six 0.02 meg. (20,000 ohm) pigtail resistors.

One 800 ohm biasing pigtail biasing resistor.

One 0.01 meg. (10,000 ohm) rheostat or potentiometer with a-c switch attached.

Two 0.05 meg. (50,000 ohm) pigtail resistors.

One 0.025 meg. (25,000 ohm) pigtail resistor.

Four 0.25 meg. (250,000) pigtail resistors.

One 0.01 meg. (10,000 ohm) pigtail resistor.

One 0.005 meg. (5,000 ohm) pigtail resistor.

One 10 ohm center-tapped resistor.

One 0.005 meg. (5,000 ohm) 5 watt rheostat.

One 2,250 ohm 5 watt resistor.

### Other Requirements

One dynamic speaker, 7 inch cone; 1,800 ohm field coil, tapped at 300 ohms; output transformer built in; speaker plug and cable.

One 14x8x3 inch chassis, drilled, with six UY sockets and two UX sockets. (Speaker and neon sockets included.) Two insulators for neon lamp rheostat.

Four grid clips. Four tube shields and bases for shields.

One antenna-ground three-post assembly.

One vernier dial, lamp, scale, escutcheon.

One midget cabinet.

One single pole double throw switch (SW-2.) One single-pole single-throw switch (SW-1).

One twin jack assembly for television terminals, and two tinsel cord leads with speaker tip jacks.

with 16 mfd. of filter capacity, and part of this field coil (the 300 ohm section) is used for biasing the pentode.

The output is so circuited that either the neon lamp or the speaker is cut in. Many prefer to tune in by ear, and the speaker serves not only that purpose but also permits enjoyment of other than television reception—for instance, police calls and amateurs—within the frequency band covered.

### Fits in a Midget Cabinet

Besides, the whole arrangement is such that the receiver may be put in a midget cabinet or any console. Of course the television lamp would be behind the scanning disc, not in the set, so the television terminals, for which a phono jack is used, will receive tipped leads from the neon lamp.

The volume control has a switch attached for the a-c line. The other front panel control is the rheostat used as limiting resistor for the neon lamp, but this rheostat may be put on the motor frame, if preferred. It is customary with present-day lamps for non-projected vision to draw about 15 milliamperes, and the rheostat may be set until the correct amount of current flows, and also serves to prevent a negative impedance being presented to the plate circuit of the output tube, as the neon valve may "turn negative" on occasions if this precaution is not taken.

The pentode tube may heat up to a cherry red, the illumination running completely down to the stem of the tube, due to the high voltage on the screen, as compared to the effective voltage on the plate. In fact, the effective plate voltage may be only 50 volts with the neon lamp in circuit, while the screen would have 250 volts. Therefore a limiting resistor of 0.01 meg. is used when the lamp is in circuit, and may be shorted out for audible signal reception.

A switch is obtainable that serves the single-pole double-throw purpose of SW-2, to throw the output from lamp to speaker, and single-pole single-throw switch may be built into the other, so one operation would control both functions.

### The Layout of the Set

No bypass condenser is needed across the 5,000 ohm biasing resistor of the first audio tube, as the negative feedback produces a counter signal current that serves excellently as a hum reducer, with only slight sacrifice in audio amplification.

The circuit diagram, Fig. 1, has the coils designed L1, L2, L3, L4, L5, L6, L7, L8, L9, the data for winding which have been given. The coils should be shielded and the shields grounded which grounding results if a grounded metal panel is used. E represents equalizing condensers built into the main tuning condensers. The tubes are identified. All resistors may be of 1 watt rating, unless otherwise marked. These two exceptions are the 2,250 ohm 5 watt, to reduce the maximum B load to a lower voltage for tuner plates, and the 5,000 ohm 5 watt rheostat. Add the 10 ohm

(Continued on next page)

# The Super-Regenerator

## Use Favored for Ultra Frequencies

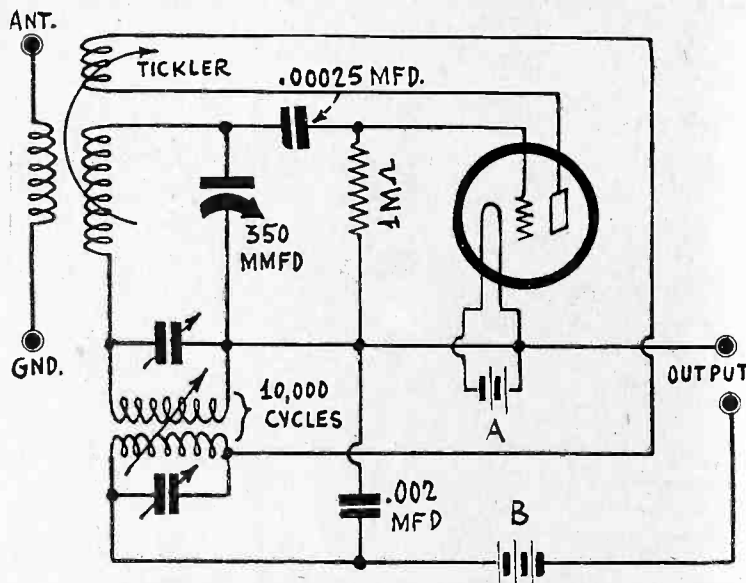

FIG. 1

The circuit diagram of a super-regenerative receiver using a single tube. The 10,000 cycle, doubly tuned circuit is used to stop periodically the oscillation at the high frequency. The coupling between the tickler and the tuned winding in each circuit should be variable to allow better control of the operation.

SHOULD present experiments prove that the television of the future will utilize the ultra short wave band (8 meters and less) it will mark the return of the super-regenerative circuit, contends Joseph D. R. Freed of the Freed Television and Radio Corporation.

Using the tubes generally available to the public at the present time," said he, "the super-regenerative receiver presents the greatest possibilities for ultra short wave television reception. Its simplicity, stability and enormous amplification make it ideal for picture reception.

### Variation Frequency Introduced

"The idea of regeneration in radio receivers was first presented by Armstrong in 1922 and at that time the circuit employing it enjoyed great popularity. Many variations of the circuit were built by manufacturers and amateurs. Due to diverse causes, the regenerative circuit did not survive the coming of house current

sets and until the invasion of the ultra high frequencies by experimenters it has been virtually a dead subject.

"There are several attributes of regenerative receivers that make a super-regeneration ideal for ultra-short wave work. It is a well-known fact that in a regenerative receiver the sensitivity increases rapidly with regeneration until oscillation occurs. The oscillation, of course, chokes the tube in such a manner that signals are not received.

"If it were possible to prevent choking up and still retain a considerable portion of the regeneration, the amplification would be enormous. In the ordinary receiver such an adjustment would be out of the question. This is especially so from the viewpoint of stability. However, in a super-regenerative circuit the regeneration, instead of being increased to a critical point where the tube is on the verge of oscillation, is momentarily increased beyond this point. Due to this momentary action, blocking and choking do not occur. This gain can be capitalized by introducing an alternating current source in the plate circuit of the detector. In other words, plate modulate the detector by an oscillator at a super-audible frequency.

"The frequency of the oscillator is characterized as the variation frequency and must be of such a value as not to interfere with the reception. As yet no definite value has been decided upon for the variation frequency. This must vary with the characteristics of the signals received.

### Favors Low Variation Frequency

"Experience has indicated that it is best to keep the variation frequency as low as possible, since the lower the variation frequency the more time there is for the current (proportional to amplification) to build up. The sensitivity is proportional to the ratio of the incoming frequency to the variation frequency, so it is only in the ultra high wave band that the super-regenerative circuit comes into its own.

"By using a separate tube to generate the variation frequency the receiver is simpler to operate, the usual irregularities being eliminated. The tuning of this specially designed receiver is truly as simple, since it is only necessary to employ a single tuned circuit. Its stability is remarkable for such tremendous amplification. None of the problems of the usual five-meter receiver is encountered. For instance, the critical adjustment of the feedback in the regenerative receiver is replaced in the super-regenerator by the variation frequency oscillator increasing and decreasing regeneration automatically.

### Some Difficulties Avoided

"The difficulties encountered in the adjustment of the frequency stability of the oscillator of the superheterodyne are not encountered in the super-regenerator, since the oscillator does not control the tuning and therefore a small variation in frequency is of little or no consequence."

It is not contended by Mr. Freed that the circuit is perfect but that it has shown such tremendous possibilities that Mr. Freed believes that it warrants serious consideration.

## The Tuned R-F Television Receiver

(Continued from preceding page)

center-tapped resistor, which is wirewound and of all-sufficient wattage in commercial production.

The front and rear views of the receiver, as built up by the author, are shown in Figs. 2 and 3. The tuning condenser is shielded, and the equalizers are accessible to a screwdriver. It is well to trim the circuit somewhere between 30 and 50 on the dial. The r-f and detector tubes are at left, Fig. 1, the detector at rear, and these tubes are shielded.

### First Audio Tube Requires Shield

It is also imperative to put a shield over the first audio tube, and this shield can be seen to the right of the electrolytic condensers at rear of the chassis. The pentode tube is at right near and the rectifier tube in front of it. The chassis is 14x8x3 inches and nicely accommodates the parts, the wiring being easy and direct. The volume control is at left, the rheostat for the neon tube at right. This rheostat must be insulated from the chassis, for which purpose two extended washers may be used, the washers attached to a 7/16 inch hole, one on the inside, the other on the outside of the chassis front, the collars of the washers facing each other. Then the rheostat may be tightened in place with safety. Also the 8 mfd. electrolytic condenser on the negative side must be insulated, and two washers are used for this purpose, as well as an extra connecting lug to establish contact with the otherwise insulated case of the condenser.

The rear view, Fig. 3, shows a socket at left, this socket being the speaker plug receptacle. The speaker has the dynamic field

coil built in, and there are three connections to this coil: two extremes of the 1,800 ohm winding, and the tap representing the pickup for the 300 ohm section. Connect the Rola speaker as follows: left rear terminal, end of field coil, to plate prong of the speaker socket; next terminal, tap, to G spring of this socket; next terminal, B minus end of field coil, to K terminal socket; pair of leads at right, representing primary of output transformer; interchangeable, one to the heater adjoining cathode and the other to heater adjoining plate. Then in the set connect the P of speaker socket to grounded chassis, G to grid return of pentode, K to B minus (yellow) lead of power transformer's high-voltage secondary, heater adjoining cathode to plate of pentode tube, heater adjoining plate to B plus maximum.

### Television Terminals

The television terminals are represented by the twin assembly, the switching is shown, with separate single-pole double-throw, and separate single-pole single-throw, for purposes already outlined, while the binding post assembly at right has marked posts for ground, long antenna (LA on Fig. 1) and short antenna (SA).

The construction of the receiver should be free from any difficulties as the circuit is a good one and is in general along the lines of six-tube television t-r-f receivers familiar to the "visionists."

Besides the receiver and its tubes, there are required a motor, disc and framing device and a neon lamp. The receiver is the amplifier-detector. The rest is the picture maker. Using a 1 foot disc, a picture about 1 inch in size is observed, but may be made to appear larger by putting a magnifying glass in front. The receiver serves excellently for projected television, and but to that end a lens disc is necessary. (Super next week.)



# Stroboscopic Synchronism

## Indication is Simply and Effectively Established

By H. Marshall Scolnick

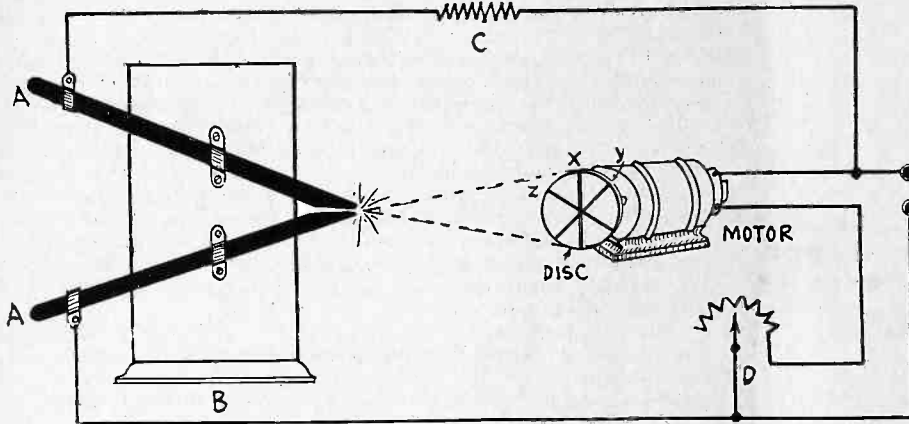

FIG. 1

Stroboscope using A-C operated arc light illumination AA, arc light carbons; B, arc light housing; C, ballast resistance; D, adjustable resistor.

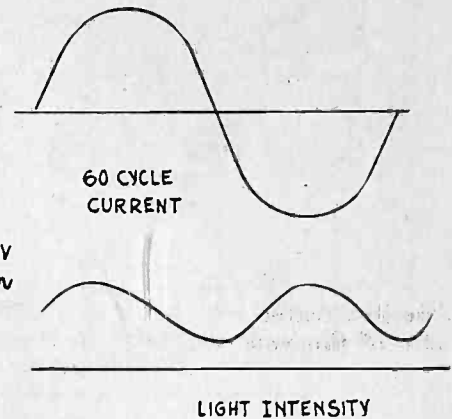

FIG. 2 (top)

FIG. 3 (bottom)

THE advent of television has brought before the public a new term, which is not generally understood, that is, the synchronizing of two machines and a means of indicating the same. While the methods described herein are old, still their application to television would necessarily be new.

Fig. 1 shows an arrangement of the connections of the apparatus necessary to show when a motor, at a given speed has reached synchronism.

A motor of which it is desired to determine the speed has mounted upon one end of the shaft a disc, the surface of which is divided up into a given number of segments. Usually the number of segments is equal to, or a multiple of, the number of poles of the motor. An arc light operating off the same line as the alternating current motor having a resistance of 15 to 20 ohms in series with it, throws its light upon the revolving disc.

### Sectors Appear Fixed

Let us assume we are working with a six pole motor and that six black sectors have been painted upon the disc. A six pole motor operating at synchronism on a sixty cycle current will run at exactly 1200 revolutions per minute. If the speed of the motor is exactly 1200 RPM then the sectors will appear fixed in space. If the speed increase to 1201 RPM then the sectors will appear to move so that they will make one complete revolution per minute in the direction of rotation of the motor. In a similar manner, if the speed is 1202 RPM the sectors will rotate in the direction of the rotation of the motor at a speed of two revolutions per minute. Conversely if the motor is operating at a speed of 1199 RPM, the sectors will appear to move in the reverse direction of the rotation of the motor at a speed of one revolution per minute. Thus by adjusting the motor speed control rheostat a point may be obtained where the sectors will appear to remain fixed in space; in other words, the motor will be then running at synchronous speed.

### Like Film in Movie Machine

The reason for obtaining this effect may be more easily understood by referring to Figs. 2 and 3. Fig. 2 indicates the general method of showing a 60 cycle current flowing through an arc or through a resistance. As the current flows in one direction increasing in magnitude, the light intensity given off by the arc increases in intensity. Then as the current drops off to zero, the light also falls off slightly. As the current reverses in direction and increases to a maximum, the light again increases until it has reached the maximum. Thus we have a pulsating intensity of light from the arc lamp which has a period of 120 cycles per second.

Let us consider Fig. 3 in conjunction with Fig. 1. Let us take the time when the light intensity is at point A on the curve. Fig. 3. Assume that at the same instant the sector marked x in Fig. 1 is vertical at the top of the disc. If then the time interval of the light intensive variation from the point A to B, in Fig. 3, is the same as the time interval required for the disc to travel 1/6 of a revolution, or in other words, until the sector Y has moved over

to the position marked X in Fig. 1, the sectors will appear to be stationary in space and plainly visible. The effect is very similar to that produced by the film travelling in front of a motion picture machine.

You can also see that if the speed of the motor is such that it has time to travel from the position Y to position Z, that we would again see the sectors outlined in a definite manner in space. Under these conditions, however, the motor would have to be travelling at a speed of 2400 RPM.

Going in the other way, if the speed of the motor were only 600, then in the interval of time from A to B in Fig. 3, would mean that the sector marked X would travel half the distance between Y and Z, Fig. 1, but on the next cycle of light intensity change, that is from B to C, at the point C, the sector X would be exactly over the sector Z and again we would receive an outline slightly dimmer than the one we did at the first change.

### Different Speeds Obtainable

With a 6 pole motor and 6 sectors on the disc we are able by means of an arc light to determine exactly the following speeds: 300, 600, 1200 and 2400 RPM.

If we should paint four sectors on the disc instead of six, then we would obtain the following speeds: 450, 900, 1800 and 3600 RPM.

A disc marked off into 12 sectors, or a combination of the two, would give us all the speeds that we have with the two discs mentioned before; that is, 300, 450, 600, 900, 1200, 1800, 2400 and 3600 RPM.

Until you are thoroughly familiar with the methods of handling the disc and observing the sectors it would be advisable only to use one combination, especially if you are working with only one certain speed, such as 1200 RPM. It is difficult to determine by visual observation alone when your motor is working at a speed of 900 RPM or lower, it is therefore advised that a speed indicator or tachometer be attached directly to the motor and to be operated in conjunction with the stroboscopic method described herein on the lower speeds.

### NEED FOR CALIBRATED OSCILLATOR

Any one who intends to work with superheterodynes should provide himself with a calibrated, modulated oscillator that not only covers the broadcast band but also the intermediate frequency band. The intermediate range should be from about 100 to 200 kc. or thereabouts. If it goes higher so much the better, but it is not necessary to go higher because harmonics can be used for aligning intermediate frequency amplifiers just as well as the fundamental. For example, if the lowest frequency is 100 kc, harmonics at least up to the sixth can be used, thus putting the useful range well into the broadcast range. Sub-harmonics are not useful for they do not exist except in reference to some other oscillator. Hence it is well to start the i-f oscillator at a low value. If it is expected that intermediate frequencies as low as 50 kc will be used, the oscillator should start at this frequency, or below.



SCAN

By J. E.

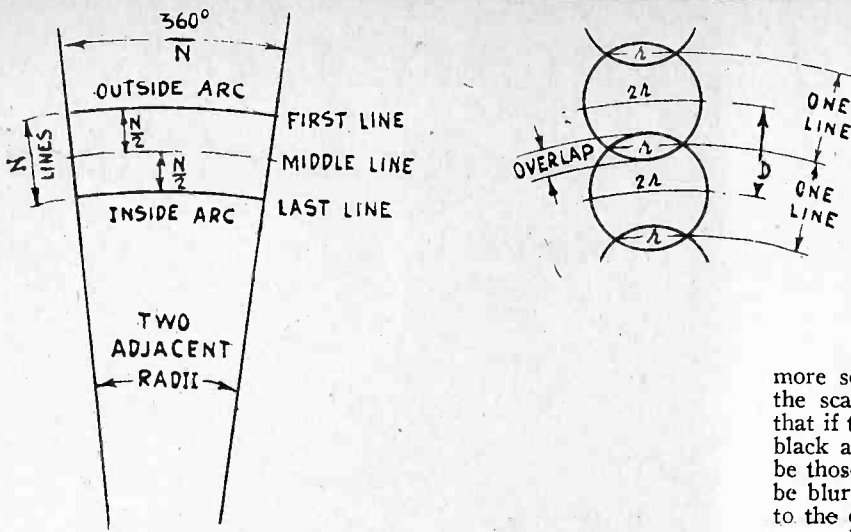

FIG. 1

This illustrates the method of obtaining the optimum ratio of the hole diameter to the radius of the disc for a 72:60 picture.

THERE is no means at this time of sending all the parts of a picture simultaneously by electrical means. The scene or picture must be broken up into tiny bits and then each bit sent separately. The sending of the various bits must be consecutive and in a definite order. At the receiving end these bits must be assembled in exactly the same order as they were sent, and this must be done synchronously with the sending.

To get a fair idea of the method of breaking up the picture, or of scanning it, as it is called, take a picture and rule equispaced lines across it. Then observe each line from left to right through a square aperture the side of which is equal to the width of one band or line. When one line has been scanned in this manner go to the next below and repeat, and so on until all the lines into which the picture was divided have been scanned. Then start at the upper left corner and go through it again. The picture is scanned just as a page in a book is read. If the picture is still, it is the same as if the same page were read over and over again, but if it is moving it is the same as starting a new page as soon as one is finished.

### Speed of Scanning

The speed of scanning differs in the various systems. Sometimes a picture is scanned completely once every 1/16th of a second; sometimes faster.

The number of lines into which the picture is divided also differs in different systems. There have been 20, 24, 48, 50, 60, 100, and more lines to a picture. As the art advances the number of lines always increases. At this time 60 lines is "standard" but that only means that most experimenters are now using 60 lines. Soon they will be using twice that number.

In systems using 60 lines, with a speed of one frame, or picture, per 1/16th second, each line is scanned in 1/960 part of a second. Thus the "reading" of the picture is extremely fast.

### Definition of Pictures

A large number of lines is necessary in order to get much detail in a picture. The definition of a picture scanned with 120 lines is twice as good as that of a picture scanned with 60 lines, and effectively it is even better than that.

It is customary to draw on the half tone process to estimate the effect of increasing the number of lines. A half tone is made up of a very large number of dots of various sizes. The larger the number of dots per square inch the clearer is the picture, provided the paper is fine enough to take the fine dots. A newspaper picture has 65 to the inch or 4,225 dots to the square inch. Finer half tones, as used in RADIO WORLD, may have 135 dots to the inch, and therefore 18,225 per square inch. The second is greatly superior in detail. Even finer "screens" are used, giving still finer detail, provided coated paper is used.

It is said that a television picture with sixty lines on a one inch square picture is equivalent to a half tone picture having sixty dots per inch, or 3,600 per square inch. This is only approximately true because a television picture is not sent in dots but rather in lines, or bands. The light beam tracing a line does not move jerkily, stopping sixty times in every line for a short interval, as it would have to do if the half tone analogy were to hold, but it moves continuously from one end of the line to the other, and then jumps suddenly to be beginning of the next line.

### Advantage of Continuous Motion

On the supposition that the picture is broken up into picture elements in the manner of the half tone, certain requirements of the electrical portion of the television system are imposed if the picture really is to be as good as the half tone. These requirements are much

more severe than those actually necessary because of the fact that the scanning in each line is continuous and not jerky. It is true that if the picture consisted of vertical black and white lines, with the black and white space equal, then the electrical requirements would be those demanded on the half tone principle. Such a picture would be blurred, the whites and the blacks changing gradually from one to the other, if the electrical system were not capable of carrying a very wide band of frequencies.

A picture line rarely consists of vertical strips of alternate black and white, but of gentle gradations. It does not require a very high grade electrical circuit to follow such gradations and even with a modest circuit it is possible to reproduce the lines, except in those rare instances where there are sharp contrasts, that is, where black changes into white, or white into black suddenly.

### Low Frequencies Required

Very often the low frequencies in the electrical equivalent of the picture are disregarded. They should not be. Indeed, it is just as important to reproduce frequencies below the audible limit as to reproduce those above the audible band. In one of the most elaborately worked out television circuits, the audio amplifier was designed to amplify effectively down to 10 cycles per second, because there was a strong frequency component of this value in the picture. This component was determined by the rate of picture repetition per second. As the speed of the scanning is increased the lowest required frequency will also be increased, but at present, with 15 frames per second, the amplifier should go down at least to 10 cycles per second. This is more important than that the amplification should hold up well at 20,000 cycles per second.

The so-called line in a television picture is not a line at all. It is a band of a certain width, which is determined by the size of the picture from top to bottom and the number of "lines" in the picture. Suppose the picture is four inches from top to bottom and that it is transmitted on a 60-line basis. Then the width of each "line" or band is 4/60 of an inch wide. The length of each line, from left to right, is equal to the width of the picture. This is not necessarily the same as the vertical dimension of the picture. Indeed, standard practice is to make the width of the picture longer than the vertical distance in the ratio of 72 to 60. Therefore, if the picture is 4 inches from top to bottom it is 4.66 inches from left to right.

### Production of Lines

The lines are produced in many different ways. In one method a flying spot of intense light scans the object to be transmitted. In this case only a tiny portion of the object is illuminated at a time. This statement is to be taken only in the relative sense, for the entire object may be so well illuminated that it is clearly seen, but the flying spot is so much more intense than the flood light that as far as the photo-electric cell is concerned everything is dark except the spot. This spot flies over the object in the order stated above, from left to right and from top to bottom, just as the eye moves in reading a book.

In the other method of scanning, the object is illuminated uniformly and this is scanned in the same manner, or a reduced image of the object is scanned. In this case the photo-electric cell "sees" only one spot at a time, as before, but it sees it because everything else is screen from the cell. The spot exposed moves in the manner stated.

The cross section of the beam of light between the scanner and the object is not the same in all instances. The ideal cross section would be a rectangle, longer in the vertical direction than in the direction of motion, and the vertical distance just equal to the width of a scanning band. It is not easy to obtain this ideal shape. Frequently the cross section is square, but it is more often round. The shape of the cross section is not really important in this stage of the art. It has been asserted that the best shape is that of an arrow, with the point forward. At this time about the same results are obtained with all shapes of cross section of the light beam.

### Overlap

In all cases it is attempted to scan so that there will be no streaks across the picture. If the spacing of the lines is not accurate there will be streaks, and they are often attributed to dirt on the scanning disc. Inaccurate spacing is more frequently the cause than dirt. Streaks would also result if the width of the scanning beam were wider than the true spacing determined by the size of the picture and the number of lines. However, if the cross section of the beam is circular, arrow-like, or diamond shaped, there should be some overlap if streaks are to be avoided.

# NING

## Anderson

If the cross section of the beam is circular the distance between the centers of adjacent bands and the radius of the beam should be connected by the relation  $D=2r\sin 60^\circ$ , or  $D=1.732r$ , in which  $D$  is the distance between lines, or the width of the band, and  $r$  is the radius of the cross section of the beam, if the streakiness is to be least.

If the cross section of the scanning beam is square, and if it moves with one corner forward in the middle of the band, then the distance  $D$  between centers of adjacent bands and the sides  $a$  of the square should be related by the equation  $D=0.707a$  for least streakiness. In both of these cases the assumption is that the bands are accurately spaced.

### Blurring and Size of Spot

The larger the spot or the cross section of the scanning beam, the more blurring of the picture there will be. One dimension is determined by the number of lines and the vertical size of the picture. After the line basis has been fixed the vertical dimension of the scanning beam has also been decided. But we are at liberty to choose the dimension in the direction of motion. The smaller this dimension the finer the detail will be. It was for this reason that we stated above that the ideal cross section of the scanning beam should be a rectangle shorter in the direction of motion than in the vertical direction. In this respect the ideal rectangle is a line having no dimension in the line of motion and a length equal to the spacing of the lines. Such a scanning beam would be capable of the greatest possible detail for a fixed distance between the lines. However, an aperture of this shape would not admit any light so that this ideal scanner is not possible. The nearest we can come to it is to make cross section rectangular with a finite width in the direction of motion.

The same problem arises in recording sound on film and reproducing from such a film. The scanning line here is made about one-eighth inch long and 0.001 inch in the direction of motion. Even with a slit so narrow it is not possible to bring out all the detail, that is, the high frequency sounds. It was not practical to make the slit any narrower, for optical as well as for sensitivity reasons, and therefore it was necessary to speed up the film.

Blurring in the sound film results in poor reproduction of the high frequencies. Blurring in a television picture results in actual blurring of the picture, but it is partly due to the elimination of the high frequencies.

### Explanation of Blurring

The cause of blurring is evident when we consider the mechanism of scanning. The scanning beam covers a definite area. Within this area the picture is not homogeneous, but different portions of it may have different values of light and shade. The photo-electric cell responds only to the mean value. That is, it blots out all detail within this area. This mean value of the picture varies continuously as the scanning spot moves across the picture and the result is a reproduction of the picture strip. Due to the fact that scanning spot moves continuously, less blurring is caused by the finite dimension of the spot in the direction of motion than is caused by the finite length of the spot in the vertical direction. Improvement must come by making the number of lines per picture larger, and hence the vertical dimension of the scanning spot smaller.

The shape of the cross section of the scanning beam is determined by the shape of the holes in the scanning disc. Circular holes will give circular cross section and rectangular holes will give rectangular cross section and so forth. The number of lines in the picture is determined by the number of holes in the spiral on the scanning disc. The vertical dimension of the picture is determined by the pitch of the spiral, or by the distance between the first and the last holes in the spiral. The length of a scanning line, or the horizontal width of the picture, is determined by the angular separation between adjacent holes on the disc.

### Avoiding Curvature of Lines

When a scanning disc is used no line is rectilinear but rather the arc of a circle. There is no objection to this curvature provided that it is exactly the same for both the transmitting and the receiving discs. If dissimilar discs are used the received picture will be distorted. This is true even if the same number of holes is used in both. Of course, if not the same number is used in both no reception is possible.

In order to avoid curvature discs are made comparatively large.

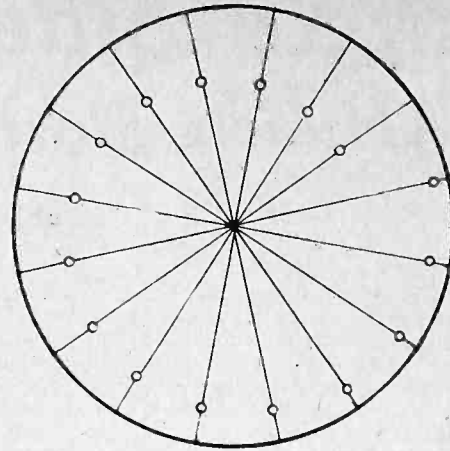

FIG. 2

This illustrates a 16-hole disc of one spiral. Separation between adjacent radii is 22.5 degrees. In this case  $D$  should equal  $0.01775r$ .

That is, the total picture area is a very small part of the total area of the disc.

There is another distorting effect when circular discs are used. The outside, or first, hole in the scanner will trace a line with less curvature than the holes nearer the center of the disc. If both discs are the same, proportionally, this does not matter as far as the reproduction of the picture is concerned.

### Dimensions of Disc and Pitch of Spiral

Suppose we wish to construct a disc with circular holes with the least streakiness, with a total of  $N$  holes in a single spiral, and a dimension ratio of 72 to 60. What should be the pitch of the spiral and the size of the holes? Since all the lines will not be of equal length, for the same angle, we shall consider the middle line as being 72 units. Lines nearer the periphery will be longer and those nearer the center will be shorter.

Since there are 360 degrees in the circle, the angular separation between any two adjacent holes will be  $360/N$  degrees. Let the outside, or first, line be  $R$  units from the center. Then the length of the arc will be  $2\pi R/N$  units long. The distance from the center to the inside line will be  $(N-1)D$  less than  $R$ , where  $D$  is the distance between two adjacent lines in the same units as  $R$ . Therefore the inside arc will be  $2\pi[R-(N-1)D]/N$ . Taking the mean between the inside and the outside arcs we get  $[2R-D(N-1)]\pi/N$ . This number should be to 72 as  $ND$  is to 60. If we set this proportion down as an equation and solve for  $D$ , we obtain the width of the line in terms of the outside radius and the number of lines. We get  $D=10R\pi/[6N^2+5\pi(N-1)]$ .

To construct the disc we first divide the circle into  $360/N$  equal angles. Then we place the first hole  $R$  units from the center on one of the radii. The next hole we place on the next radius a distance  $D$  nearer the center, the third on the third radius  $2D$  units nearer the center, and so on.

### Numerical Example

Suppose we wish to construct a 60-hole disc. Then  $N=60$  and  $360/N$  becomes 6 degrees. Therefore we draw 60 equi-spaced radii 6 degrees apart on the circles. We place the first hole at  $R$  from the center on one of them. If we substitute the value of  $N=60$  in the equation for  $D$  and simplify, we have  $D=R/717$ . We cannot proceed without knowing the actual value of  $R$ . Suppose it is 18 inches, that is, the disc is to be three feet in diameter, measuring only to the outside hole. Then in this case  $D$  equals 0.0251 inches. The size of the picture will be 1.81 inches wide and 1.501 inches deep.

Previously we gave the relationship that should exist for least streakiness in the case of circular holes. The relation was  $D=1.732r$ , in which  $r$  is the radius of the hole. Therefore the radius should be  $0.577D$ . We just found  $D$  for a 3-foot disc to be 0.0251 inches, and therefore the radius of the hole should be 0.01448 inch, or the diameter should be 0.029 inch. This should be the diameter of the drill or punch used in making the holes. This is less than  $1/32$  of an inch.

In the derivation of the formulas above we used the arc as the width of the picture rather than the actual distance. The arc is slightly longer than the chord, but the difference is so small that it can be neglected. Smaller or larger discs can be made in proportion.

The diameter  $d$  of the circular holes in the disc can be found directly in terms of  $N$  and  $R$  by the formula  $d=6.05R/(N^2+2.62N-2.62)$ . Suppose the value of  $N$  is 100 and the radius of the disc is 18 inches, the  $d=0.0106$  inch. In this case there would be 100 radii, 100 holes, and the radii would be spaced 3.6 degrees.



# Single Sideband for Vision

## W6XAH Gets More Detail Suppressing Carrier

By R. D. LeMert

Engineer in Charge

OUR station, W6XAH, Bakersfield, Calif., is somewhat different than the majority of stations operating in the visual field at this time, as it is the only one using single side band, suppressed carrier transmission. This system permits the transmission of more detail in the same channel width. We are using at the present time 96 lines in our picture with a ratio of 5 to 6. The scanning system consists of a disc using slots for scanning (motion pictures), with constant motion.

The horizontal scanning is done by the rotation of the scanning disc, which has its slots evenly spaced, and the vertical scanning by the downward motion of the film. The head amplifier utilizes two 224 screen grid tubes and one 171. This amplifier feeds the output into the main television amplifier, which consists of six stages of resistance coupled amplification, using three 227's, three 210's and a final stage of 545. This amplifier has practically a flat characteristic up to 80,000 cycles, from 80,000 to 92,160 cycles it is peaked in order to gain the maximum frequencies necessary in the transmission of 96 lines.

### Impression of Signal

From the main amplifier the energy is fed into the double push-pull modulator of the single side band equipment. In this equipment the signal (either voice or picture) is impressed on the grids of the modulators, out of phase, the special oscillator circuit supplying the carrier in phase.

The circuit is so arranged that the carrier is practically eliminated in the output circuit of the modulators, thus permitting only the two side bands to pass into the first filter. The upper sideband is discriminated against in the output circuit, thus assisting the first filter, which eliminates the upper sideband entirely. This sideband is again modulated and fed into a second filter.

The oscillator frequencies had to be carefully chosen in order that none of the harmonics would fall into the band covered by the visual broadcast range, as this would cause serious distortion.

From the single sideband apparatus which is enclosed in a screen cage in the transmission room, the output is fed to the main transmitter. The single sideband equipment consists of two stages of specially designed impedance amplification after the second filter, the last tube being 50 watts output. However, the amplification is low, in order to keep the frequency characteristic as flat as possible over the wide range which must be covered.

The transmitter proper consists of one 50-watt stage, and one 75 watt screen grid stage feeding four 250-watt tubes in parallel in the final stage.

It is interesting to note that no energy is radiated from the antenna system unless modulation is taking place.

### Sturdy Generators and Rectifiers

The generators and rectifier circuits must be designed to stand the sudden changes of load which take place during modulation and radiation. It is also quite interesting to note that only one-fourth of the input is required to obtain the same output as in other transmission work and equipment. The sideband transmitted in this case is slightly lower in amplitude than when both sidebands are trans-

mitted. By the use of this single sideband it is permissible to transmit the full 96 lines, giving a great deal more detail in the received image. In the 100 kc channel now allocated by the Federal Radio Commission it would not be possible to transmit a 96 line picture as this would require a channel width of 184 kc. By using the single sideband it only requires 92 kc and permits the transmission of a pilot frequency, which only requires approximately 30 cycles (to keep the receiver oscillator in synchronism), as the carrier in this case is re-supplied at the receiver. But it also permits the transmission of a voice channel (about 6 kc) in the same 100 kc channel.

It has been found that the service range of the station using single sideband suppressed carrier transmission is greatly increased, the noise level being also greatly decreased, as the carrier itself would have a tendency to be quite noisy. It is believed that the service range of W6XAH will cover the entire Pacific coast at night with 1,000 watts.

The antenna system consists of two wooden towers 150 feet high and spaced 150 feet apart. The antenna itself is a large single wire being fed by a specially constructed feed system.

### Buildings Described

The transmitter is housed in a building consisting of two rooms, each 24 feet wide by 48 feet long. One room houses the main transmitter and power control panels (consisting of three panels). On one side of the room, on the side, are the speech input racks, consisting of a Western Electric 8B rack and associated equipment. The transmitter also has incorporated a rectifier unit and a 5 kilowatt water-cooled 520M modulator tube. This is only used when using a carrier and modulating the four 250-watt tubes.

In the other room are the machine shop and testing equipment, the main television amplifier and projection machines. In a second building, located approximately 50 feet from this building, is the main studio. It contains the direct pick-up cameras and associated amplifiers, piano and microphones, studio fixtures and furniture. An underground line connects the equipment with the main transmission room. In all, the buildings and towers cover exactly half a city block.

It is hoped that the development work being carried on will be of real benefit to the art of television transmission. The entire equipment has been designed and built by the writer, who has been in the radio field nearly seventeen years, in which design he was assisted by Frank Schamblin, who has done the mechanical engineering. Mr. Schamblin has been associated in radio for the past ten years.

### Will Explore Ultra Waves Later

It is the intention of our company (the Pioneer Mercantile Co. of Bakersfield, Calif., and Taft, Calif.) to explore the higher frequency band as soon as the present work has been explored.

A number of very interesting patents have been developed and it is for this reason that some of the circuits can not be given out at this time.

## Use of Audio Matching Transformers

IN THE catalogues of transformer manufacturers there are many transformers of different characteristics listed. For example, there are tube-to-line, line-to-tube, and others that involve the line. What is meant by the line in such cases and where can the transformers be used advantageously? In some instances in radio articles I have seen the plate and grid circuits referred to as the line. Is there any relationship between this "line" and the line referred to in connection with the transformers? Please explain.—L. M. M., Forest Hills, N. Y.

The line referred to in connection with the transformers is not the same as the line referred to in connection with ordinary amplifier circuits. The line in respect to transformers refers to a pair of wires connecting different parts of a communication system located at considerable distances apart. It has been found that if voice or music is sent over a long line with high impedance terminal devices, such as ordinary transformers, there is a great loss or attenuation in the line and considerable frequency distortion, whereas if low impedance terminal devices are used there is little distortion and little attenuation. For this reason tube-to-line and line-to-tube transformers are used. A tube-to-line transformer is used between the output tube and one end of the line, and a line-to-tube transformer at the other end. The line side of either of these transformers has a comparatively low impedance, equal to the characteristic impedance of the line. That is, the tube and

the line are matched at one end by the tube-to-line transformer and the line and tube are matched at the other end by the line-to-tube transformer. Lines have characteristic impedances of 500 or 600 ohms, and consequently the secondary of a tube-to-line transformer has this impedance, looking from the line toward the tube, and a line-to-tube transformer has the same impedance, looking from the primary, or line side, toward the tube. A tube-to-line transformer should have an impedance equal to the optimum load impedance of the tube when looking from the primary toward the line. A line-to-tube transformer should have an exceedingly high impedance looking from the tube toward the line. Since the grid circuit of a tube ordinarily has so high impedance that it is difficult to make a matching transformer, it is customary to connect a certain high resistance across the secondary, or from grid to cathode, so that matching can be effected. A line-to-line transformer may be one of the one-to-one ratio, which is used between two lines of equal characteristic impedance, or it may have a ratio different from unity when it is to join two lines of different characteristic impedances. The characteristic impedance of a line is determined by the inductance per unit length and the capacity between the conductors per unit length. Lines are used between broadcast studios and transmitting stations and between various pick-up stations and the main studio. They are also used for connecting speakers and amplifiers placed considerable distances apart.



# "Best Station Seen"

## Columbia System's Experiences Narrated

By William A. Schudt, Jr.

Director Television, Columbia Broadcasting System

THEY would have you believe that television is just around the corner. Television is *not* just around the corner. Television is before your eyes.

Of course it is not a perfected, smooth-running, television but, nevertheless, recognizable visual broadcasting is an actual fact, and considering its limitations, has within a comparatively short time accomplished wonders.

Since the latter part of July, Columbia has been presenting the only continuous daily sight and sound television programs in the country. W2XAB on 2800 kilocycles, carries the sight while the sound is routed over W2XE, on 6120 kilocycles.

In presentation of these programs we have had to develop somewhat of a new technique. Our presentations have, to a certain degree, been developed along lines similar to those employed by the talking pictures companies.



The Television Ghost

### Keynote Is Action

Action is stressed in all productions. Of course it is not always possible to have action when you are limited to closeup projection most of the time. Some singers are good actors and make good television talent, while others—oh well!

During the program week we present from seventy-five to eighty complete programs, all of which carry sound synchronization. Many have been culled from the ranks of the regular Columbia Broadcasting System while a great many others are originations of our own. Sometimes our ideas of programs work out and are heralded as huge successes and then again they don't. When the latter occurs we at least create something humorous and if nothing else we amuse the television engineers.

Some of the outstanding successes which we have projected recently include:

Weekly broadcasting of football games by means of a scoreboard. Action on the board was synchronized with Ted Husing's descriptions. The board was black with white lines and the football white. Reports differed on this color combination. Some claimed that a reverse of contrasts would work out better but we have found that the black base made far better pictures on the outside. Others have various ideas but we're not at all sure of anything along these lines except that the subject makes interesting discussion at all times.

### Ghost Gets His Chance

The Television Ghost is a little less than a sensation. The first mystery character to peer out at you from the television studios, he plays the part of murderer risen from the grave. Made up entirely in white (as all ghosts should be made up) he is scanned against a black backdrop screen. Reception is 100%.

Puppet shows are both interesting to watch and excellent television material. We are booking a great many of these acts, since letters from lookers-in applaud them spiritedly.

Boxing has been so successful that we are presenting a three-round exhibition bout, featuring amateurs, every Tuesday evening. This is the most difficult show to produce and control. It is a fast moving feature with the focusing running the gamut of long and close-up projection. Reports from the outside have been highly favorable. One looker in Westchester thought our bouts were filmed and projected.

A wide variety of television experimental dramas has been projected. These are being developed. We shall shortly utilize scenery and props. A special dramatic department, headed by Eleanor Hiler, will begin functioning. The basic idea will be to develop some kind of interesting dramatic sketch for present facilities of television broadcasting.

### Credit to Engineers

Our caricaturists and pen sketchers are excellent television entertainment.



Puppet shows are popular with lookers. Dialogue, synchronized over W2XE, is supplied by human actors in the wings. Peter Williams, puppeteer, who designed his wooden actors especially for television, is shown.

Experiments with miniature musical comedies are being carried on every Thursday evening with assistance of Ned Wayburn Institute. Much, if not all, of our success in being reported the best television station on the air in the United States, if not in the world, is due to the excellent work on the part of our engineers, headed by Edgar Wallace. Harry Spears, Roy Briand, Bernard Sachs and Louis Weber are contributing much to the advancement of television apparatus.

Detail of CBS television pictures is repeatedly reported as best seen. Excerpts from DX letters follow:

**W. R. Mitchell, 514 N. 17th st., Manhattan, Kan.:** "W2XAB comes in very clear and strong, and I receive all the evening programs regularly."

**John Haller, Department of Chemistry, Middlebury College, Middlebury, Vermont:** "May I congratulate you on the excellent visual programs that I am receiving from your station W2XAB. Reception is very dependable and the signal strength is quite sufficient for good quality. In fact, of the six stations that I receive regularly yours gives the greatest detail."

**Burrey Television Service, 448 Lincoln Ave., Marion, Ohio:** "We received your television program tonight and it came through 100%. Pictures that you televised from 8:30 to 8:45 p.m. Woman with hat was best."

Others report reception in Montreal, Canada; Washington, D. C.; Baltimore, Md.; Waterbury, Conn.; Chicago, Ill.; Schenectady, N. Y.; Camden, N. J.; and from the entire local territory (radius of 50 miles of 485 Madison Avenue, New York City).

Do you think television is "just around the corner?"

## RADIO WORLD'S

### ADVERTISING RATES

	1 Inser.	4 consec. Inser. (ca.)	13 consec. Inser. (ca.)	26 consec. Inser. (ca.)	52 consec. Inser. (ca.)
1 page .....	\$150.00	10%	12½%	15%	20%
½ page .....	75.00	67.50	65.62	63.75	60.00
¼ page .....	50.00	45.00	43.75	42.50	40.00
⅓ page .....	37.50	33.75	32.81	31.87	30.00
⅔ page .....	25.00	22.50	21.87	21.25	20.00
1 inch .....	18.75	16.87	16.41	15.94	15.00
1 inch .....	5.00	4.50	4.37	4.25	4.00

Classified advertisements, 7 cents a word; \$1.00 minimum; must be paid in advance.

### Advertising Department

Radio World, 145 West 45th St., New York, N. Y.

## Battery Set 15 to 200 Meters

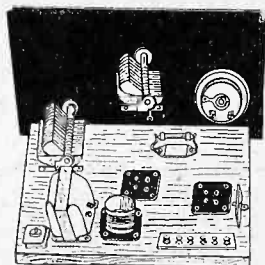

A SHORT-WAVE receiver, using two 230 (2-volt) tubes, requiring 3 volts filament battery source and 90 volts of B battery. The circuit is detector and one transformer coupled audio stage. This "detector and one step" has been standard for ten years. With this circuit reception the world over has been enjoyed and the elated users number into the teeming thousands. Ranges 15 to 200 meters, using five plug-in coils. Old-timers know this circuit well. Persons who have had no experience with short-waves will find this a most appropriate circuit for a thrilling beginning. The circuit can be wired in 1½ hours.

**PARTS REQUIRED:** 5 plug-in coils, \$1.50; Hammarlund 0.00014 mfd. tuning cond., \$1.20; Hammarlund 0.0002 tuning cond., \$1.35; three UX sockets, 30c; audio trans., 70c; 50,000 ohm leak, 10c; 300 turn honeycomb, 30c; 0.00025 mfd. clips, 15c; 200 ohm rheostat, 40c; 20-100 mmfd. equalizer, 20c; battery switch, 20c; 6 bind. posts, 30c; bind. post strip, 10c; vernier dial, 50c; two knobs, 10c; 7 x 10 bakelite panel, \$1.25; 7 x 10 baseboard, 25c.

Complete parts, with blueprint, less tubes, (Cat. SW-DAF), @ .....\$8.95  
Two 230 tubes @ total of.....\$1.92

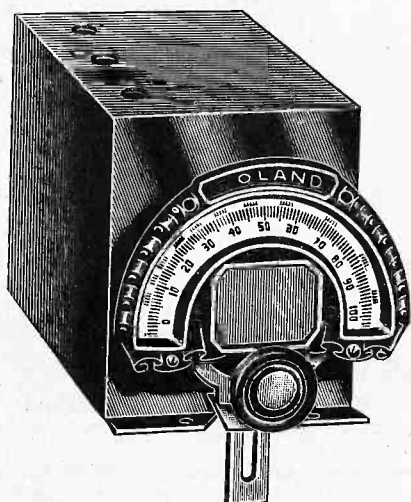

0.0005 mfd. Scovill tuning condenser, brass plates, shaft at both ends so condenser takes 0-100 or 100-0 dials and two can be used with drum dial; sectional shields built in, trimmers affixed; total enclosed in additional shield as illustrated. Access to trimmers with screwdriver. Side holes for bringing out leads to caps of screen grid tubes. Cat. SCSHC @.....\$2.95

Same as above, with ghost type dial (travelling light). Cat. SCSHC-DL @.....\$4.20

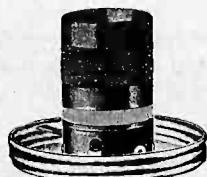

The Roland 80-550 meter coils have a side lug (shown at left) and four identified lugs at bottom. The side lug is for grid return. The ground symbol lug is the 80-meter tap. P and B go to antenna and ground or plate and B plus. For oscillation B goes to plate and P to B plus.

**TAPPED** coils are proving very popular, as they make for economy of room and also afford good results. The Roland coils are obtainable for broadcast coverage, 200 to 550 meters, with tap for going down to 80 meters, so television, airplane talks, amateur and other interesting transmission may be heard. An insulated three-deck two-tap long switch is needed for front panel band shifting. See illustration at right. These coils are wound on 1½ inch diameter and are attached at the factory to aluminum screw bases, with four identified lugs protruding at bottom and a fifth lug at side. An aluminum cover (not illustrated) screws over the base.

The primary is wound over the secondary, with insulating fabric between, and the inductance is kept exactly equal for all coils by keeping the axial length of the winding identical, as well as the number of turns. Therefore at top (what looks like a separate winding), a space is "spun," as well as at bottom, to insure such identical inductance.

For 80-550 meters, for use with 0.00035 mfd. three gang, order Cat. M-35-C (three coils, three shields at this price) @ .....\$2.45

For 0.0005 mfd. order Cat. M-05-C @ .....\$2.45

## 80-550 Meter Set, No. 627

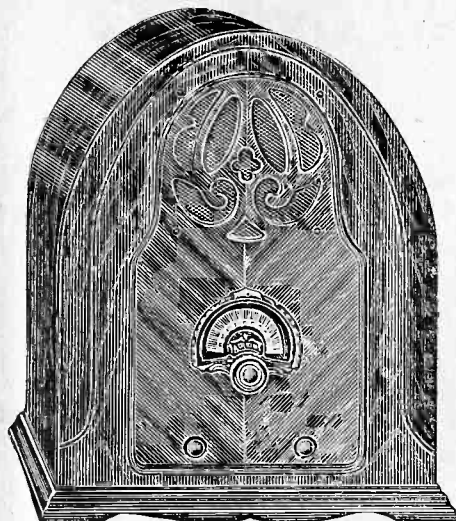

THE Roland 627 kit is for a five-tube tuned radio frequency circuit of extremely high sensitivity, covering 80 to 550 meters, using our 80-meter coils and condensers. The wave band is shifted by a long panel switch (see bottom at center of this page). Stations come in loud and clear. The kit includes everything, with full-scale blueprint (less tubes). The tubes used are two 235 (or 551), one 224, one 247 and one 280. The circuit is hum-free and is a most astonishing performer. Tone and selectivity are excellent. We now of no other 5-tube circuit that excels it.

Complete kit of parts, including Dorset cabinet as illustrated; blueprint, long switch, less tubes, (Cat. 627-K) @ .....\$23.50

Blueprint 627 alone, (Cat. BP-627) @.....\$ .25

Set of five tubes for this receiver, (Cat. 627-TUK) @ \$4.41

**TELEVISION KIT**, 80-100 meters, using two stages 235-r-f, 224 power detector, 224 first a-f, 247 output, 280 rectifier. R-f coils have right-angle honeycomb chokes with 4-turn pickup windings. Designed by Edwin Standard. Stanton cabinet incl. Order Cat. TK @ .....\$18.95

## ROLA DYNAMIC SPEAKERS

Series F, Rola dynamic speakers for single pentode output, with 1,800 ohm field coil tapped at 300 ohms. Field coil may be used as B supply choke, with 300 ohm section for 247 bias, if field is put in negative rectifier leg. Output transformer built in. 7" cone. Cat. RO-18 @ .....\$4.50

Same as above, except that cone diameter is 10.5 inches. Cat. RO-18-10 @ .....\$5.85

Same as above, except that cone diameter is 12 inches. Cat. RO-18-12 @ .....\$6.95

Rola dynamic 6-inch cone for automobile sets, 6 volt field to be connected to car's storage battery. Speaker fits on fireboard under the instrument board. Shielded cable is supplied with each speaker. Cat. RO-AU @.....\$4.95

We can supply Rola dynamic speakers for other output tubes and for push-pull. State requirements and we shall quote prices.

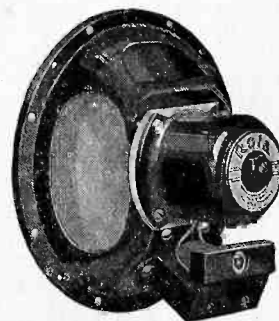

## 15-200

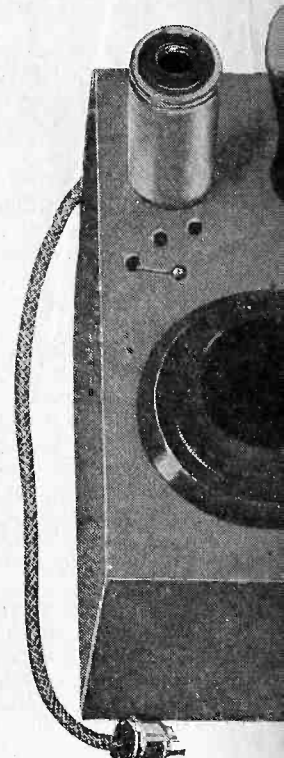

A SHORT-WAVE circuit, using only a few parts costing only a few dollars in power, provides great results. It should not be assumed that a receiver of this rate. Of all the kits for sale, this has never been returned, not ornamental; the cabinet is extra. If you are thinking of buying this one, for despite the fact that it is a converter. There are many other converters (both modulator and heater tubes) are used; (less tubes) @ .....\$23.50

Blueprint alone (Cat. BP-627) @ .....\$ .25

Three 237 tubes cost.....\$4.41

## INTERMEDIATE

FOR short-wave frequency modulation. Our 1,600 ohm selectivity shield built in, a Shield is Cat. FF-18. Doubly tuned pass filter and second diameter, 5 Cat. FF-17. Same as

## SHORT

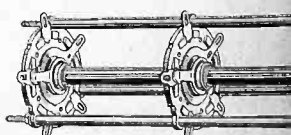

For building short-wave short-wave and all-wave sets, switches are needed, so the coils to switch and condenser short. All the switches we use are insulated shaft, so switch is of a metal panel. The switch on panel nor can knob slip off.

## LONG SWITCHES

Three decks, four different each deck. Cat. LSW-4-3 @ .....\$2.95

Three decks, two different positions on each deck (used in 627 circuit). Cat. LSW-2-3 @ .....\$2.65

## BROADCAST COILS WITH 80-METER TAP

## EVEREADY-RAYTHEON 4-PILLAR TUBES

240 @ \$1.80	236 @ \$1.65
112A @ .90	237 @ 1.05
222 @ 2.70	238 @ 1.65
230 @ .96	239 @ 2.05
231 @ .96	280 @ .60
232 @ 1.30	281 @ 3.00
233 @ 1.65	Neon @ 4.50
234 @ 1.65	245 @ .66
227 @ .60	250 @ 3.60
224 @ .96	U-99 @ 1.50
235 @ .96	V-99 @ 1.68
247 @ .93	120 @ 1.80
226 @ .48	201A @ .45
171A @ .54	202A @ 2.40
	210 @ 4.20

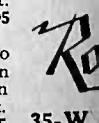



# Meter Converter



... that works on any set can be built of and yet this converter supplies its own sensitivity and requires no plug-in coils. At the low price that performance is seconds converter that we have supplied, not one. The parts supplied are substantial though included in the price, but the tubes are investing in a converter you should choose price, it ranks in performance with costly separate tuning controls for greatest sensibility being tuned. Three 237 (6 volt) cost 0.1c per hour. Order Cat. NCV-630 @ ..... \$7.60 @ ..... \$2.25 @ ..... \$3.15

# FREQUENCY TRANSFORMERS

Superheterodyne work 1,600 kc. is the popular intermediate frequency you can tune to below 9 meters without interlocking of oscillator circuits, due to the high intermediate frequency. These transformers have large diameter wire, loose coupling for stability, and Hammarlund's new superheterodyne condensers on a screwdriver. Both plate and grid circuits are tuned. Diameter, 2 1/2 inches high. For variable mu tubes. Order Cat. FT-400 @ ..... \$1.65  
 Frequency transformer, 1 to 1 ratio, 175 kilocycles. Band 20-100 mfd. equalizers across primary. Aluminum shield (must be grounded), 2 1/4 inches high, removable bottom. For variable mu tubes. Order Cat. FT-400 @ ..... \$1.50  
 Above, for 400 kc. Order Cat. FT-400 @ ..... \$1.50

# WAVE SWITCHES

## SHORT SWITCHES

Switches of special precision, positive contact, non-shorting, are needed for testers, analyzers and radio coil purposes. These rotary selector switches are suitable for moving the stator connections of tuning condensers to taps or to separate coils. Single knob actuates multiple circuits.

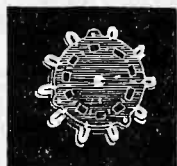

Three decks, four different positions for each deck. (Cat. 4-3-SW) @ ..... \$2.28

## SUPER CONDENSERS

Fixed padding condenser, 0.00076 mfd. for 0.00035 mfd., tuning, when i-f is 175 kc. Cat. PC-76 @ ..... \$3.36

Coupling condenser, oscillator grid to modulator grid, 0.6 mmfd., no pickup winding needed. Cat. C-6T @ ..... \$2.28

**Radio Co**

St. Brooklyn, N. Y. Williamsburg 5-0443

# Anderson's Auto Set, No. 631

In an automobile set what you need and must have is SENSITIVITY. You read about high-powered home receivers having a sensitivity of 10 microvolts per meter. Here is an 8-tube auto set, chassis 7 x 11 1/2 x 2 1/4 inches, that has just such sensitivity. It brings in DX through 50,000 watt locals 10 kc. removed. Did you ever hear of that before in an auto set? Volume is high, without distortion. Push-pull pentode output. This circuit was designed and engineered by J. E. Anderson and is by far the best auto set we've ever heard. Variable mu, pentode r-f tubes.

Complete kit of parts, including remote tuning control, running board aerial, speaker, battery box, everything but tubes which are: two 236, two 237, two 238 and two 239 (automotive 6-volt series). Order Cat. JE-631 @ ..... \$50.00  
 Set of tubes for car receiver (Cat. 630-TUK), @ ..... \$11.80

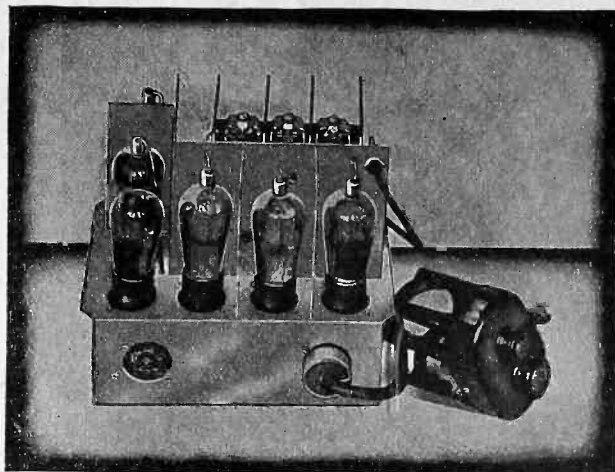

# 15-200 Meter Set



YOU can build a midget short wave set that will give you the acme of performance—six tubes, including variable mu radiic frequency amplification, screen grid power detection, and THREE STAGES OF REGENERATED AUDIO AMPLIFICATION. Then you can bring in short waves with a wallop. This set enables band shifting from the front panel without any further effort than turning a single knob. It is equipped also with on-and-off switch and volume control (one unit) and a rotary band selector switch of the anti-capacity and non-shorting, insulated type. You know from your experience with short waves that you need plenty of audio amplification, and here you have it—two stages of screen grid audio and 247 pentode output! The audio amplifier is of the highest quality and is perfectly suitable for television. The Stanton cabinet (illustrated) is one of exquisite beauty, being a two-tone walnut effect, with decorative grille for a 7 inch dynamic speaker. All parts are of the highest class, including Rola full dynamic speaker (7 inch cone). Build this set and know real short wave reception. All parts and schematic (not blueprint) diagram are supplied at this price, excepting tubes. Order Cat. R-S @ ..... \$24.25

Tubes used: three 235, one 224, one 247 and one 880 @ ..... \$5.37

# Precision Parts

- 800 TURN HONEYCOMB coil, total diameter 1 1/4 inches; will tune to 175 kc. with 0.0001 mfd. (or 20-100 mmfd equalizer). Cat. HC-800 @ ..... \$0.50
- 300 TURN HONEYCOMB coil, same style, tunes to 400 kc. with 0.0001 mfd. Also may be used without condenser as antenna input coil, screen and plate choking, or two used inductively coupled for evening the amplification of t-r-f sets, in untuned stage feeding detector. Cat. HC-300 (each) @ ..... \$0.43
- 50 TURN HONEYCOMB coil, 1/4 millihenry, for all short wave purposes. Cat. HC-50 @ ..... \$0.25
- 1 WATT PIGTAIL RESISTORS, all resistance values. Mention Cat. PGTB and state resistance in ohms thereafter. Prices ..... \$0.15
- 5 WATT 2,250 OHM resistor to drop maximum B to B plus 180 volts for plates of r-f tubes in any t-r-f set. Cat. 5-W-2 @ ..... \$0.45
- POTENTIOMETERS: 400 ohms at 27c; 5,000 ohms @ 95c; 25,000 ohms @ \$1.25; 50,000 ohms @ \$1.25; 100,000 ohms @ \$1.25; 500,000 ohms @ \$1.25.
- POTENTIOMETER with a-c switch attached, 10,000 ohms, for variable mu grid bias as volume control. Cat. POT-5-SW @ ..... \$1.55
- WALNUT FINISH ROLAND, DORSET OR STANTON CABINET for midget sets, cut for 7-inch cone. Cat. MDCB @ ..... \$4.90
- TWO GANG 0.00035 MFD, straight frequency line condenser, brass plates; long 1/4 inch shaft; nicked frame. Shielded. Cat. DJA-35 @ ..... \$1.95
- KELFORD 30 henry choke; stands up to 100 ma; in black shield case. Cat. KEL-30 @ ..... \$1.75
- KELFORD 15 henry B supply choke; 60 ma; unshielded. Cat. KEL-15 @ ..... \$0.85
- 2.5 VOLT center tapped fil. trans., 8 amperes (will stand up to five heater tubes, when voltage is 2.25 v). Cat. FLT @ ..... \$1.62
- HAMMARLUND 0.0002 mfd. variable condenser, junior midline; rotation is within 2-inch diameter; for short waves. Cat. H-20 @ ..... \$1.35
- HAMMARLUND 60 mmfd. manual trimming condenser. Cat. H-60 @ ..... \$0.79
- HAMMARLUND 20-100 MMFD. EQUALIZERS: adjusting screw works in a threaded brass stud, so excess force cannot damage the unit. Cat. 3-EQ-100 (price is for three) ..... \$0.60
- CHASSIS for midget, fits in Roland cabinet; chassis is 13 1/2 inches wide, 7 1/2 inches front to back; flaps front and back 3 inches high; drilled for sockets and speaker plug and for volume control and switch at front. Cat. 5-TCH @ ..... \$1.75
- CHASSIS for 6 tube midget. Cat. 6-TCH @ ..... \$1.75
- TWO GANG 0.00035 MFD, straight frequency line condenser, brass plates; long 1/4 inch shaft; nicked frame. Cat. DJA-35 @ ..... \$1.95
- THREE 0.1 MFD. condensers in one shield case; black lead is common; three red leads go interchangeably to destination; mounting screw built in. Cat. 31 @ ..... \$0.57
- MIDGET POWER TRANSFORMER, for five-tube set, to handle three heater tubes, one 247 and one 280. Cat. MPT-5 @ ..... \$3.15
- MIDGET POWER TRANSFORMER for six-tube set, to handle four heater tubes, one 247 and one 280. Cat. MPT-6 @ ..... \$3.55
- 8 MFD. WET ELECTROLYTIC condenser, for inverted mounting; washer and extra lug provides insulation from chassis for circuits with B choke in negative leg. Cat. LCT-8 @ ..... \$0.62

# BLUEPRINTS

Our authentic blueprints, made by our own expert draughting department, and checked by the engineering staff, show circuits that are of surpassing performance. In some instances the results of building more than 1,000 sets are embodied in the blueprints, while there are only verified data in any of them. All are full scale.

- NO. 631—J. E. Anderson's sensational 8-tube auto set that has 10 microvolts-per-meter sensitivity. In our estimation the best car set there is. Order BP-631 @ ..... \$50
- NO. 630—Three tube a-c operated short-wave converter. (Cat. BP-630) @ ..... \$25
- NO. 629—Six tube auto set, t-r-f. (Cat. BP-629) @ ..... \$25
- NO. 628B—Six tube a-c receiver, 15-550 meters, switch controlled. (Cat. BP-628B) @ ..... \$25
- NO. 627—Five tube vari-mu, pentode a-c set, 80-550 meters. (Cat. BP-627) @ ..... \$25



# 15 to 500 Meters with Efficiency Beat Oscillator Used for

By Lewis

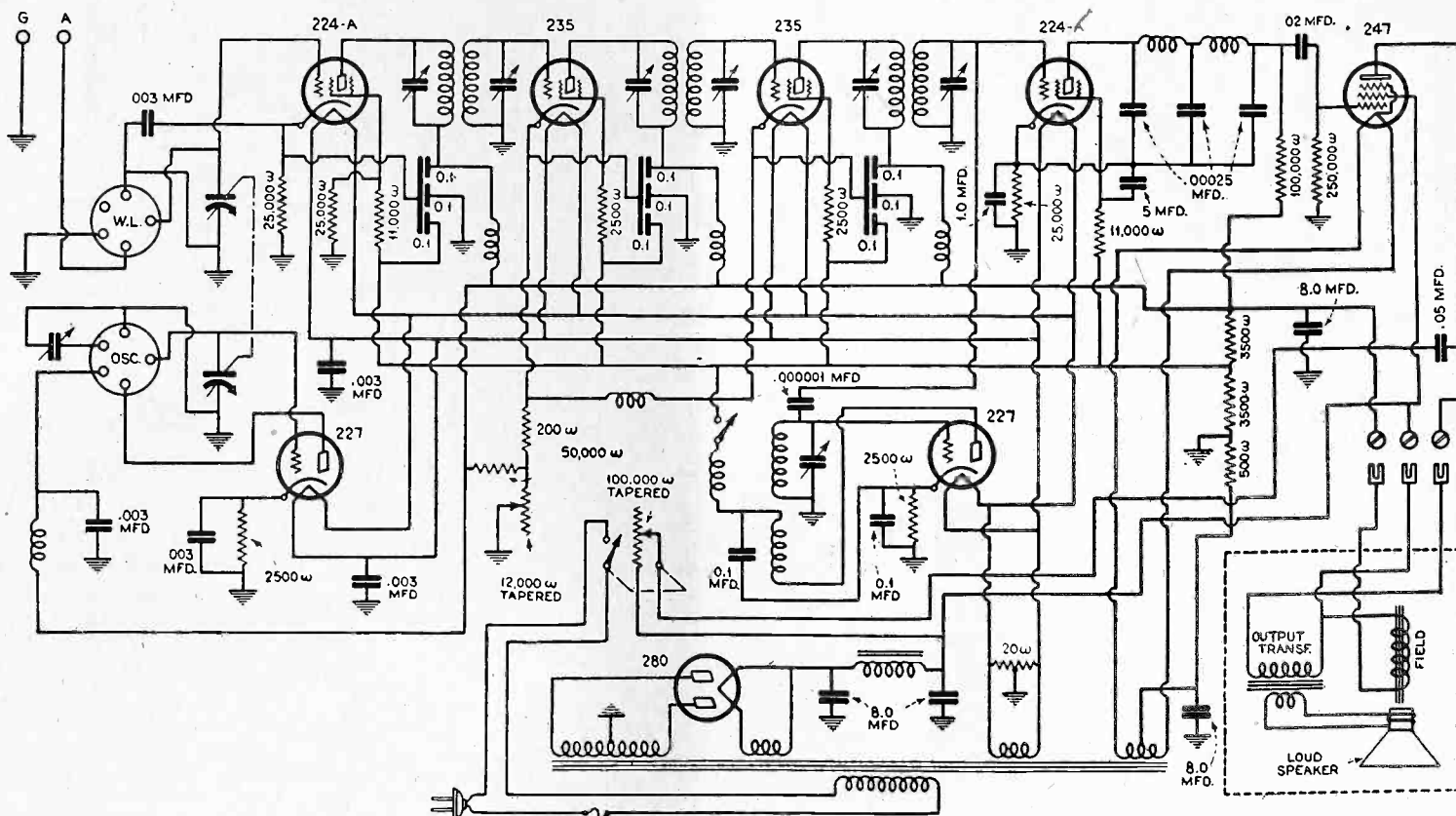

The complete circuit diagram of the "Comet" all-wave superheterodyne. An oscillator station finder is a unique feature.

THE OLD pastime of DX hunting has lost none of its fascination that it held in the early days of radio broadcasting. There is no one interested in radio, not even a veteran radio engineer, who does not get a thrill out of hearing a station a few thousand miles away. The only difference between the situation now and ten years ago is that expected distances have been increased. Then a thousand miles was considered DX but now it requires at least 2,500 miles before it will be so classed. The thrill now experienced when a station 2,500 miles away comes in clearly is mild compared with what it was a decade ago, but when a signal comes in clearly from a station twice that distance the adult radio enthusiast feels like a child who has seen Santa Claus. Short waves are the most prolific producers of thrills in radio at this time, for they are readily brought in from remote places. Yet these signals are no strangers in the homes of those who possess up-to-date radio receivers provided with short wave features. The foreign short-wave stations are always welcome for they never come in except at the beck and call of the host. The satisfying part of a modern sensitive receiver is that the short waves seldom decline an invitation to come.

### An All-Wave Super

One receiver which promises to give many radio enthusiasts the thrills of DX reception is the Hammarlund "Comet," an eight-tube, all-wave custom-built superheterodyne that brings in stations from 550 kc. to about 20,000 kc, that is, from 546 to 15 meters. This covers everything in radio that has any public interest at this time. Not only is the set equipped for receiving voice modulated signals but also for receiving code, an oscillator being used to bring out the code as a musical tone.

The eight tubes are two 227 oscillators, two 224 detectors, two 235 intermediate frequency amplifiers, one 247 pentode output tube, and one 280 rectifier tube.

The second oscillator is an unusual feature in broadcast sets, though it is used frequently in receivers designed for code recep-

tion. It is used in this set not only as an aid in picking up interrupted continuous waves but also as an aid in locating voice and music modulated waves.

When the oscillator is started it generates a certain frequency differing from the intermediate frequency by an audible amount. As the receiver is tuned, the intermediate frequency generated by beats between the signal and the first local oscillator will vary, and this will produce the familiar heterodyne. When the beat tone is loudest the circuit is in tune with the incoming signal. If desired the frequency of the second oscillator can be adjusted so that it is exactly equal to the intermediate frequency of the i-f transformers. In that case the circuit is in tune with the signal at zero beat.

### A Tone Control

For code reception the second oscillator is allowed to continue and the tuner is set so that the tone of the signal has a pleasant and clearly audible frequency. When signals are modulated with voice or music, or any other modulation not of the interrupted continuous wave type, the second oscillator is stopped as soon as the signal has been located. This is done by means of a switch located on the panel.

A tone control is built into the receiver. It consists of a 0.05 mfd. condenser in series with a 100,000 ohm variable resistance, the two being connected between the plate of the 247 power tube and B plus. Thus the control is effectively in shunt with the primary of the output transformer, and the greatest suppression of the high audio frequencies is obtained when no resistance is used in series with the 0.05 mfd. condenser.

This feature of the receiver is valuable when there is a great deal of noise in the signal, for a large part of the noise, being on very high audio frequencies, can be materially reduced.

Precise tuning is facilitated by supplementary mechanical verniers, one for each tuning condenser, located near the main tuning knob. A projection type scale is used on the main con-

# Throughout; Resonance Indicator and Code

W. Martin

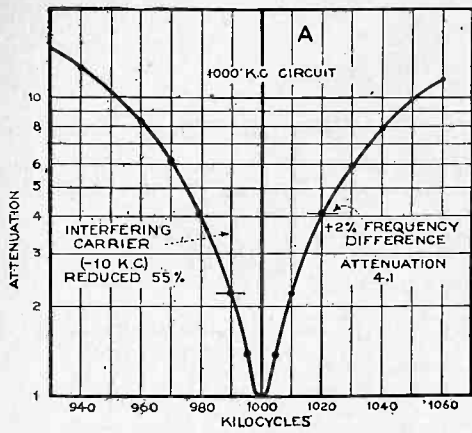

FIG. 1A

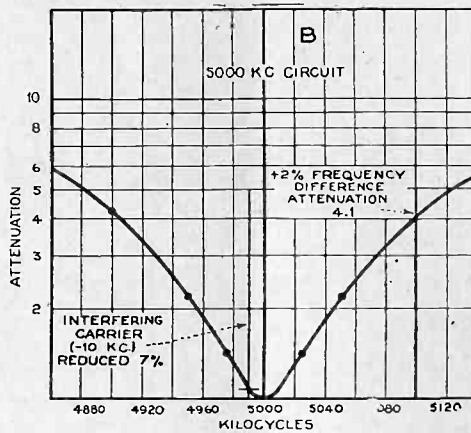

FIG. 1B

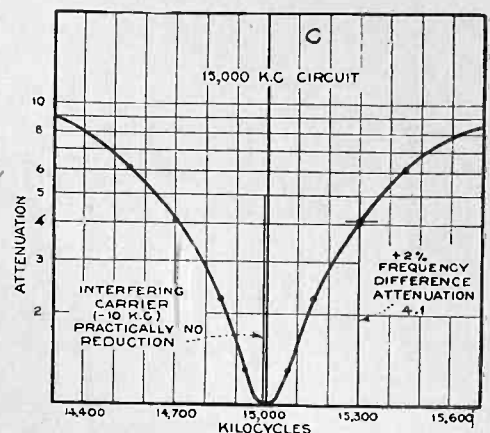

FIG. 1C

trol, affording magnification of the scale and making readings easier in cases where stations come in very close together.

### Plug-in Coils Used

In order to avoid complexity, plug-in coils are used to cover the different frequency bands. This method also permits the use of short leads and the highest efficiency for each coil. The plug-in coils are wound on special Isolantite forms because of the very low losses in this material. Another advantage of this material is that the surface is non-skid so that the coil turns will stay in position. Hence there is no change in inductance in the coils, an important feature in connection with the calibration of the tuners. There are five sets of coils, two coils in a set. The ranges of these coils are: 15—30, 28.5—62.5, 58.8—130, 120—273, and 240—550 meters. Thus they cover the entire range from 15 to 550 meters with plenty, yet not excessive, overlap of adjacent ranges.

A special feature is an Oriental burl walnut cabinet designed for the set. In the lid of this cabinet are pockets for holding the coils not used in the sockets. Any one who has had to do with plug-in coils will appreciate this feature. Changing coils is like changing records on a phonograph where the records are catalogued with each record placed in its own niche.

### Discussion of Circuit

The superheterodyne has been called the "king" of radio receivers, chiefly because its circuit simplifies the problem of obtaining uniform radio frequency amplification of almost any desired amount and at the same time a high order of selectivity which is also substantially uniform over a wide band of signal frequencies. In the early days, the first of these advantages was the most important, because radio frequency amplification at signal frequencies of 500 k.c. was practically unknown and almost impossible with the tubes and equipment available at that time. But since the advent of screen grid tubes, gang condensers, and elaborate shielding, r-f amplification at frequencies within the broadcast band is easily accomplished. Therefore, the outstanding advantage of the superheterodyne at present is in the matter of selectivity.

While this advantage is good at the comparatively low frequencies of the broadcast band, at the high frequencies involved in short-wave reception is truly remarkable. This follows from the fact that the ability of a tuned circuit (or series of tuned circuits) to discriminate between a desired signal and an interfering signal depends entirely on the percentage difference between their two frequencies, not the actual difference in kilocycles. However, the international frequency allocation is not based on a percentage difference but rather on a specific number of kilocycles, usually ten, even at frequencies as high as 20,000 kc (15 meters). It can be shown that a series of tuned circuits possessing good discrimination between two signals on adjacent channels (say 1,000 kc and 990 kc) must be of very high quality, as the percentage difference is only 1%. Assuming it to be possible to build a series of circuits of the same efficiency to operate, say, in the 10,000 to 20,000 kc band, it would be practically impossible to separate two stations operating at 15,000 kc and 14,990 kc since the percentage difference is but 1/5 of 1%.

### Why Super Is Selective

This principle is clearly illustrated in Fig. 1. Curves A, B, and C represent the tuning characteristics of single tuned circuits resonant at 1,000 kc, 5,000 and 15,000 kc respectively.

The power factor of all three circuits is 0.01 (Q=100), which is reasonably good for radio circuits. Since the power factors of all the circuits are identical, the selectivity of each must also be

the same. This is shown by the amount of attenuation for frequencies 2% greater than the resonant frequency, which is 4.1 in all three cases. However, the reduction of an interfering carrier 10 kc below the resonant frequency is far from uniform and is substantially zero in the 15,000 kc circuit. This is in sharp contrast with the reduction of 77% shown on Curve "A" of Fig. 2.

With the super heterodyne principle this difficulty disappears. By means of the local heterodyne oscillator, the 1,000 kc signal (which we shall assume to be the one desired) is changed to 465 kc. At the same time the undesired 990 kc signal is changed to 455 kc and both signals are impressed on the intermediate amplifier. The intermediate amplifier then has the task of amplifying the 465 kc signal (for which it is tuned) and reducing (or rejecting altogether) the 455 kc interference. This is comparatively easy as the percentage difference here is 10/465 or over 2% (as was the case with the 1,000 kc and 990 kc signals), which corresponds to a gain in selectivity of over 30 times, as the original percentage difference between the two signals was only 1/15 of 1%.

An important point must be considered here, however. This gain in selectivity as outlined above is only realized if the tuned circuits constituting the intermediate amplifier have low loss characteristics comparable to the good tuning circuits used at broadcast signal frequencies in high grade receivers. If the intermediate coils are, for example, only one-fourth as efficient (for reason of economy), the gain in selectivity due to the shifting of the frequency is proportionately reduced. This in the case of the 15,000 kc signal the gain in selectivity would be only 7½ times and in the case of the 1,000 kc signal there would result an actual loss of 50% in selectivity instead of a gain of 2 times.

Fig. 2 illustrates very clearly the result of increased resistance in the intermediate coils. Curve "A" is the tuning characteristic of a single intermediate coil as used in the "Comet." Curve "B" is that of a coil of the same inductance having four times as much resistance. The loss of selectivity due to the higher power factor is considerable.

For this reason the intermediate coils used in the "Comet" are wound with special "Litz" wire, resulting in a power factor of 0.01 (Q of 100). Six of these coils are used, two in each transformer, in the tuned plate-tuned grid hook-up. This provides six sharply tuned low-loss circuits in the intermediate amplifier. While this arrangement affords extreme selectivity, the double-tuned critically-coupled circuits result in a steep-sided response curve with a rounded top, thus minimizing side band cutting. All the above factors together account for the remarkable selectivity of the "Comet" at both broadcast and short waves.

### Tuning Curves

Fig. 3 shows the actual tuning characteristics of a complete i-f transformer using two of the Litz-wound coils, each having a power factor of 0.01. While no overall selectivity curves are available at this time, a fairly accurate idea of same is given by Fig. 4, which is a calculated curve of the selectivity of the complete intermediate amplifier, based on the actual characteristics of one transformer as shown in Fig. 3.

Although it is obvious that a lower intermediate frequency would afford even greater selectivity by reason of a further increase in the percentage frequency difference, there is another consideration which makes a high intermediate frequency desirable. All superheterodyne receivers are subject to an "image" interference, which, stated briefly, means an undesired signal whose frequency difference from the desired signal is exactly equal to twice the intermediate frequency used in the receiver. It naturally follows that a high intermediate frequency lessens interference from this source.

(Continued next week)

# Powering a Converter From a Pen Imposing

By Herman

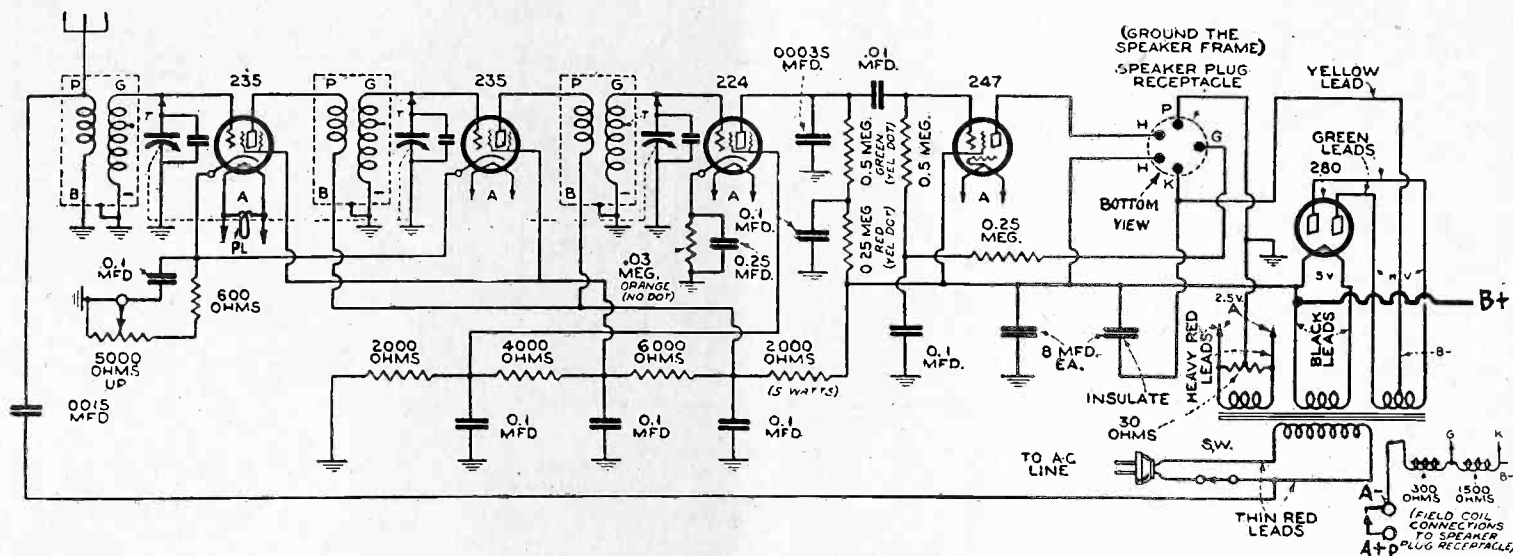

FIG. 1

The 627 circuit, showing the connections to be made in the set to derive all power for working a short-wave converter. The 0.0015 mfd. fixed condenser from a-c line to aerial is a makeshift antenna for broadcast reception in case no outdoor aerial is handy, but for working the set with a converter this connection must be removed and a good outdoor aerial should be used.

POWER for a short-wave converter may be derived from a five-tube a-c pentode receiver, such as the one covered by Blueprint No. 627, if the 2-volt tubes are used for the mixer. The filament voltage is derived from the total B current being passed through series connected filaments.

Since the pentode biasing section of the dynamic field coil has a resistance of 300 ohms, and the drop across it is 18 volts, the current is 60 milliamperes, which is just right for the two-volt tubes. The only other required voltages are for the plates of the converter tubes and for biasing the oscillator. The plate voltage is taken from the maximum B feed, and dropped to suitable value through an 0.02 meg. (20,000 ohm) resistor, while the bias is afforded by proper connection of grid return of the oscillator, using the 2 volts dropped in the modulator filament circuit.

## One Method of Connecting

Now, the two sources of external power, the B current of the receiver and the maximum B voltage, may be taken off in any of these places, all however resulting in the same connections.

For passing the receiver current through the filaments of the mixer tubes it is necessary to break the choke lead to ground and interpose the filaments there. This may be done by unsoldering the connection to the speaker plug, at the P lead of the cable, as plate spring of the speaker socket is grounded, and likewise B plus may be picked up, but without a break, for it is one of the heater springs, usually heater next to cathode of the speaker socket. This socket, be it remembered, does not take a tube, but the speaker plug, and the references to plate and heater have nothing to do with any tube elements.

Instead of working at the speaker plug, however, it is practical to obtain the outlets at the speaker itself. The 1,800 ohm dynamic field has a tap of 300 ohms. One side of the 300 ohms goes to ground, the tap goes to pentode grid return, the extreme of the 1,500 ohm section goes to B minus of the power transformer. These facts are verified on the diagram, Fig. 1.

## Operating on the Speaker

Two screws hold a plate on the speaker rear, and these screws may be loosened for removal of the plate. The screws themselves do not have to be removed. The leads are, left to right, with the terminal strip before you and the two screws toward the bottom: extreme left (red), ground; second from left (yellow), 300 ohm tap to pentode grid return; third from left (green), end of the 1,500 ohm tap, to B minus of the power transformer. At right are two terminals, representing the primary of the power tube's output transformer, but which is which in a given set cannot be foretold,

since these leads are interchangeable. A voltmeter will disclose B plus, as distinguished from plate, as there is a higher voltage at B plus (about 30 volts higher), or, if you have no voltmeter, you can recognize the plate connection because it will give mushy results, whereas B plus itself will give fine results. The two leads referred to are blue and black respectively.

The red lead is therefore unsoldered from the lug and a wire run out. The connections for the filament are made between the lug on the speaker terminal strip, where the red lead was, and the red lead. B plus is then picked up, without snipping any lead, as previously explained. Be careful to connect to the converter so that the speaker lug, where red lead was, goes to minus of modulator tube (upper part of Fig. 2) and the positive side of the oscillator filament goes to the red lead.

## The Preferred Method

The two methods just discussed do not require any change in the receiver itself, but the preferable method is the one that does require such a change, as indicated in Fig. 1.

Since it is easy to turn the chassis upside down and examine it, you can tell which spring of an unidentified speaker plug socket goes to ground by the very fact of its connection to chassis. In the 627, as stated, this is the plate spring. All that is necessary is to disconnect this, putting the filaments of the two 230 tubes in series between the socket spring and chassis. For this purpose only one binding post is absolutely necessary, and that is one connecting to P (or other post, if circumstances require), of the speaker receptacle. The other connection is the chassis itself and may be picked up at the ground binding post. However, most persons will prefer to put in two binding posts, and of course an on-off switch is put across the posts.

It has been stated that the current is 60 milliamperes, but that is the value at no signal. When signals are being received, if the intensity is not great, the current will be just a little more than 60 milliamperes, and even on loud passages of a carrier of merely average intensity the rise in current will be only momentarily.

However, it is possible that even on short waves some steadily loud signals may be brought in, for instance television, and therefore the B current will increase and the rise will be for the duration of reception of that signal.

## Safety Factor

So the advisability arises of putting limiting resistors across the filaments, so that there will be no more than about 60 milliamperes flowing through the filaments if the B current for the receiver rises to 70 milliamperes, and these limiting resistors also take into



# pentode Receiver, Virtually No Extra Drain on Set

Bernard

FIG. 2

A short-wave converter that derives its operating power from a broadcast receiver drawing about 60 milliamperes, as is the case with the 627 diagrammed at left. The 400-ohm limiting resistors take care of surges. Two 230 tubes are used in the mixer, and the required filament current for these tubes is 60 ma. so only negligible added drain is placed on the receiver, equal to the converter's plate current.

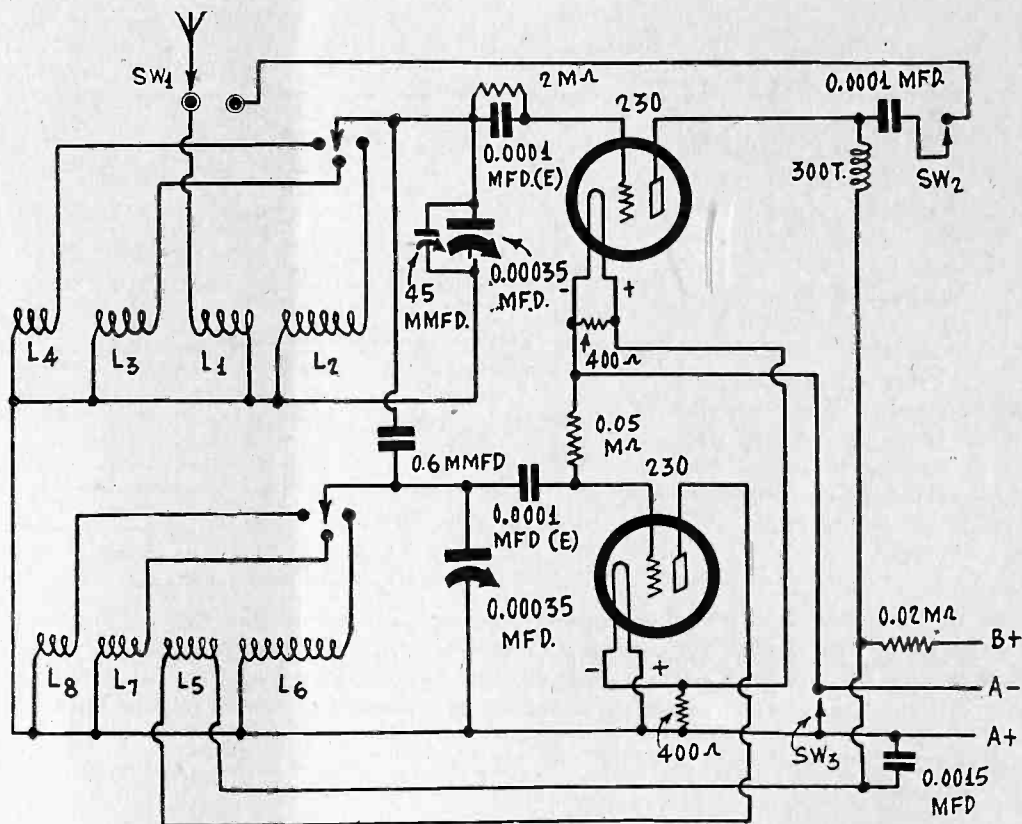

account the plate current of one mixer tube flowing through the filament of the other mixer tube. The limiting resistors are of the wire-wound type, because the current is larger than ordinary pigtail resistors will withstand.

Examination of the under side of the chassis has the further advantage of disclosing by mere observation which speaker receptable spring is actually B plus, and this is brought out to a binding post. So the three voltage access posts are established.

Now, as for the converter itself, it consists of the two tubes, modulator and oscillator, with a single switch of two decks, three positions on each deck, for wave band shifting. The other switches are the filament switch already discussed, and the antenna and output

switches. The antenna switch moves the antenna connection from converter to set. The output switch removes the modulator plate load from parallel connection with the primary of the set's antenna coupler, for if the plate circuit load were not thus removed the input to the receiver proper, for broadcast reception, would be somewhat diminished.

The directions will be given for winding two forms on the basis of tuning with a 0.00035 mfd. two-gang condenser, and the  
(Continued on next page)

## LIST OF PARTS

### Coils

- One set of coils for modulator and oscillator as described.
- One 300-turn honeycomb r-f transformer, inductance about 1.3 millihenries.

### Condensers

- One two-gang 0.00035 mfd. straight frequency line condenser.
- One 45 mmfd. manual trimming condenser.
- One 0.6 mmfd. fixed condenser.
- Three 0.0001 mfd. fixed condensers (20-100 mmfd. equalizers set at maximum).
- One 0.0015 mfd. mica fixed condenser.

### Resistors

- One 5 to 7 meg. resistor for oscillator grid leak.
- Two 400 ohm wire-wound resistors.
- One 0.02 meg. (20,000 ohm) pigtail resistor.

### Other Requirements

- One rotary selector switch, two decks, three connections on each deck, besides connection for moving arm or index; shaft must be insulated.
- One single pole double throw switch (SW-1) and two single pole single throw switches (SW-2 and SW-3), or one switch to combine the three functions.
- Five binding posts; antenna, output, filament (two) and B plus.
- One vernier dial.
- One front panel, one chassis with two UX sockets, and one cabinet.

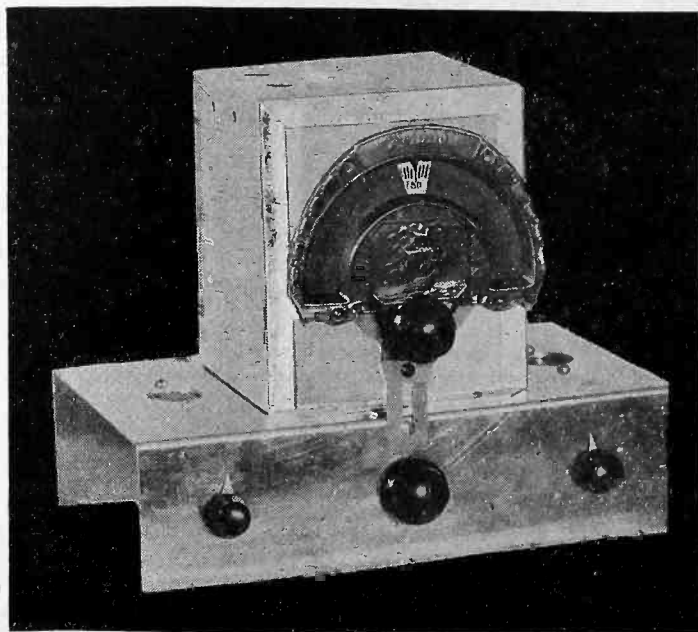

FIG. 3

A shielded two-gang 0.00035 mfd. straight frequency line condenser is at center, behind the "ghost" dial, for the converter that obtains its power from the pentode tube socket.

# Battery-Operated "Detector and 200-24 Meter Results Go

By Jack

**FIG. 1**  
For enjoyment of good results on short waves a battery-operated circuit may be used, consisting of two two-volt tubes. Regeneration is controlled by a variable condenser. Plug-in coils are used. The results from 24 to 200 meters are good, and from 24 to 15 meters are fair.

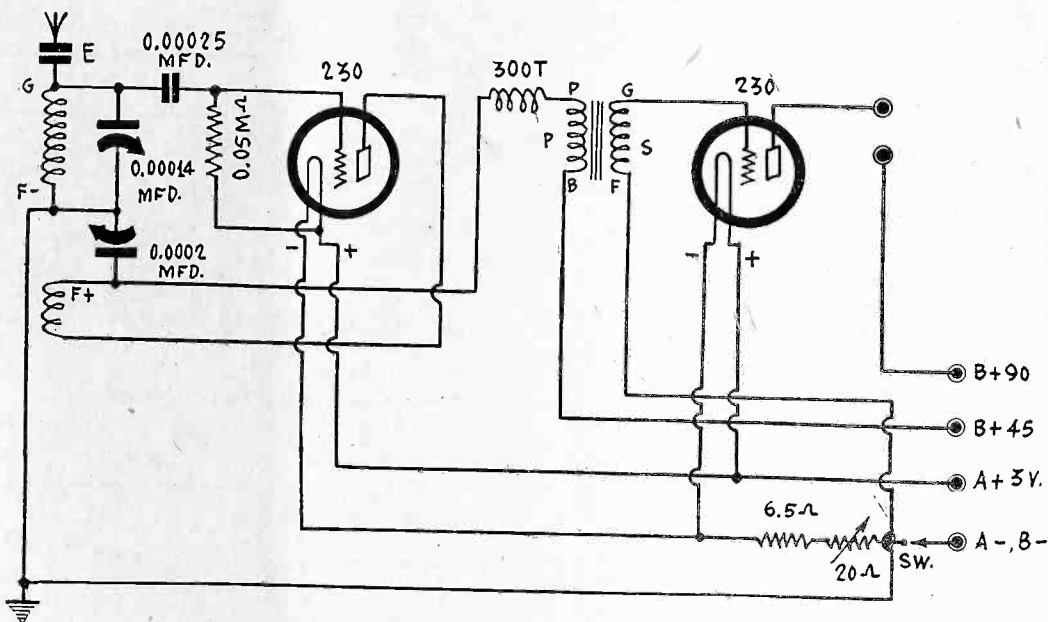

It should not be supposed that anything elaborate is necessary for the satisfactory reception of short waves. So modest a device as detector and one stage of audio amplification will do very nicely, and has moreover the advantage of long test in the school of experience. Many of the old-timers in short waves still used the "detector and one step," with earphones, of course, and get a great deal of enjoyment.

For simplicity and inexpensiveness of original cost the set should be battery-operated, and therefore two of the general purpose tubes of the 2-volt series are used. These tubes serve well as detector and amplifier. For detection, if a grid leak and condenser are used, the return is to positive, and since condenser with coil terminal tied to it is grounded at A minus, it is handy to put the grid condenser in series and the leak is parallel, as in Fig. 1. Then the positive grid return is readily established despite the difference, in d-c potential between coil return and grid return.

The diagram is shown in Fig. 1, with the layout illustrated in Fig. 2. Since an insulated front panel is used in conjunction with a baseboard, the leak may be put across the condenser, if desired, and the grid coil returned to plus instead of to minus.

## Reason for Leak Valve

The reason for selecting such a relatively low value of leak is that it has been found that on the very high frequencies the

grid may block, causing a steady squeal to be heard, if the leak value is too high. In fact, too high a leak value is purposely introduced in some types of oscillators for the very purpose of introducing this high note as modulation. Moreover, the pitch can be varied by using different values of grid leak.

The circuit at hand is not strictly speaking an oscillator, but a regenerator. The terms *oscillation* and *regeneration* have come to mean specifically different things. Oscillation is the condition of electrical instability that causes the tube to send off waves of its own generation, while regeneration is feedback of a value short of the amount necessary to produce such radiation. It should be remembered, however, that the waves being received are oscillating all the time, but the distinction between regeneration and oscillation, in the common meaning, is based on whether the tube itself is oscillating or merely acquiring greater sensitivity by feedback.

## Avoids Squawk on Spillover

Hence the directions concerning the low value of resistor, while applying strictly to oscillators, nevertheless encompass to an extent all regenerative systems, because on occasion it is almost impossible to avoid a spillover, especially in tuning in foreign stations, and there would be considerable squawking or steady squealing while the circuit was oscillating, due to the insufficient leakage from grid to its return.

Moreover, there will be grid current flowing under nearly all conditions of operation, and the leak tends to maintain the frequency stability of the circuit despite flow of grid current, because the d-c voltage is partly stabilized. When grid current flows the drop in the leak becomes greater, and as the developed voltage is of a bucking nature, the grid is maintained less positive.

## LIST OF PARTS

- One set of four tube base coils, as described (fifth coil may be tried experimentally, as stated.)
- One 0.0014 mfd. junior midline tuning condenser.
- One 0.0002 mfd. junior midline tuning condenser.
- Three UX sockets (one used as coil receptacle).
- One 3½-to-1 audio transformer.
- One 300-turn honeycomb choke coil.
- One 0.05 meg. (50,000 ohm) grid leak.
- One 0.00025 mfd. grid condenser with clips (leak may be used across clips and circuit changed as outlined, if desired.)
- One 6.5 ohm filament resistor.
- One 20-ohm rheostat.
- One 20-100 mmfd. equalizer, used at nearly full capacity for antenna series condenser.
- Six binding posts.
- One A battery switch.
- One binding post strip.
- One vernier dial.
- Two knobs.
- One 7x10 inch front panel.
- One 7x10 inch baseboard.

## Short-Wave

(Continued from preceding page)

use of an intermediate frequency somewhere around 600 kc. There are two pieces of tubing used, 2 inches in diameter, about 27½ inches long. On one is wound the modulator coil system, on the other the oscillator coil system. The modulator windings consist of 10 turns of No. 18 enamel wire for L1, leave a tiny speck of space, say, 1/64 inch and wind 40 turns of No. 28 enamel wire for L2, on one side of the primary, L1. On the other side of the primary, leaving 1/16 inch space, wind 15 turns of No. 18 enamel for L3, and, leaving 1/8 inch space, next wind 7 turns of No. 18 enamel, for L4.

The oscillator windings are: 20 turns of any fine insulated wire for tickler, L5; small separation, say 1/64 inch, 30 turns of No. 28 enamel wire for L6; leave 1/16 inch space, wind 13 turns of No. 18 enamel for L7; leaving 1/16 inch space, wind 7 turns of No. 18 enamel for L8.



# One Step" for Short Waves; od, Those from 24-15 Meters Fair Tully

It is all right to try higher values of grid leak, especially as the sensitivity will be a little greater. But if you find the uncanny modulation present you know the remedy—lower leak value.

## Aerial Coupling

The coupling between grid and aerial is made through a small condenser, marked E on the diagram, and consisting of a 20-100 mmfd. equalizing, adjusted to nearly maximum capacity (plates screwed nearly all the way down). Such a small capacity is necessary for several reasons, including principally that anything much higher would introduce too much of the antenna resistance into the tuned circuit and stop oscillation at around 50 meters, and a considerably higher value of capacity also would cut down the wavelength span for any given tuning condenser and coil, because of the antenna capacity being in parallel with the tuning condenser.

An average capacity for an aerial may be considered to be 0.0002 mfd., so with E used at 86 mmfd. the resultant capacity is 60 mmfd. The tuning condenser of 0.00014 mfd. has a minimum of 5 mmfd., the tuning coil, tube, wiring, etc., about 15 mmfd., so the total is 80 mmfd. minimum, and the maximum for a 0.00014 mfd. condenser therefore would be 0.000220 mfd. The capacity ratio is therefore 8-22, or nearly 1-to-3, giving a frequency ratio of about 1.7-to-1. Thus with four plug-in coils the total frequency ratio is the cube of 1.7, or a little more than 8. Hence, starting from 200 meters, the circuit, with four coils, would tune to about 25 meters (actually a little lower in wavelength).

## Information on Coils

The coils are wound on tube base diameters, which are approximately  $1\frac{1}{4}$  inches, and the data are as follows:

Grid Coil	Plate Coil	Range
60 turns of No. 32 enamel	32 turns of No. 32 enamel	200 to 118 meters
33 turns of No. 24 enamel	15 turns of No. 32 enamel	118 to 69 meters
20 turns of No. 18 enamel	10 turns of No. 32 enamel	69 to 40 meters
12 turns of No. 18 enamel	12 turns of No. 32 enamel	40 to 24 meters

While results below 24 meters will not be accompanied by very great sensitivity, nevertheless the coil data that may be used are:

7 turns of No. 18 enamel	7 turns of No. 28 enamel	24 to 15 meters
--------------------------	--------------------------	-----------------

The ranges are approximate, because of the lack of knowledge of what the antenna capacity actually is, but the alteration will not be much, due to the low value of the series condenser compared to the antenna capacity. Also, the coil data provide for some overlap, not indicated in the tabulation, so that when you have tuned to the highest frequency of one coil, the next coil's lowest frequency actually will be lower than the highest frequency of the immediately antecedent coil.

It has been found that wire smaller than No. 18 should not be used on the secondary of the coils beyond the second one, and particularly is this true of the smallest coil (7 turns) and

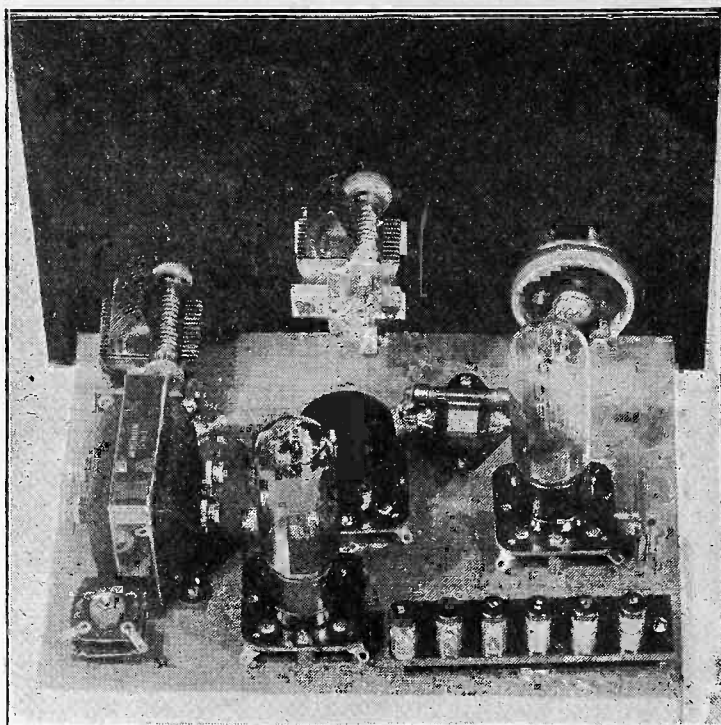

FIG. 2

The parts for the "detector and one step" are laid out as shown. The A battery switch would not be necessary, since the rheostat may be opened to open the A circuit, but the switch permits leaving the rheostat at a predetermined setting.

the next smallest (12 turns), for regeneration may stop, due to the high resistance of the wire used for winding. Actual instances of stoppage of regeneration at around 27 meters were cured by using larger wire, and of course the same condition held true for the lower waves. However, larger than No. 18 wire was not found to be necessary, as regeneration was attained at around 16 meters, using the smallest coil, but, as stated, not with much attendant sensitivity. However, with the four principal coils, tuning from 24 to 200 meters, results were excellent.

An advantage of the plug-in coil system, whatever the drawbacks as to inconvenience, is that the tickler windings can be apportioned correctly. It will be noted that the ratio of tickler turns to grid turns increases as the frequency increases. The separation between windings, however, remains the same, about  $1/16$  inch. The windings must be put on in the same direction. Then the facing or inside terminals of the two coils would go respectively to ground and B plus. This method permits regeneration. If the coils are wound in opposite directions, and the same connections made, or in the same direction with opposite potentials facing, then the feedback is negative and no regeneration can take place.

Regeneration is controlled by a variable condenser about half again as large in capacity as the tuning condenser, as the larger capacity is necessary for control over the various ranges. It will be noted that the rotors of both condensers are grounded, and that is a great help in getting rid of body capacity, which in the present set-up will not be present on waves down to 24 meters, but may show up on waves below that. The regeneration condenser also acts as an r-f bypass condenser for the output of the detector, and thus a high impedance is presented to audio frequencies by the a-f transformer primary and a low one to radio frequencies by the condenser and plate coil. This is the condition necessary for good detection.

The audio transformer may have any ratio, around 1-to-3 $\frac{1}{2}$ , primary to secondary, being satisfactory. The output tube has phones connected in the plate circuit. An optional condenser of 0.00025 mfd. to 0.001 mfd. may be connected across the phones, and bypass condensers of 0.0015 mfd. up, without limit, connected from B plus 90 and B plus 45 to A minus, B minus. These three condenser are not shown, as the circuit worked satisfactorily without them.

## Converter Layout

Certain polarities are required for the oscillator coil only. In the case of the other coil there is little difference. If the oscillator windings are all in the same direction, then the polarities are as shown in Fig. 2. That is, from extreme terminal of the smallest coil to the extreme terminal of the largest coil the connections are: ground, grid tap on switch, ground, grid tap on switch, plate, B plus, ground and grid tap on switch.

The coils may be mounted perpendicularly under a chassis, centers 3 inches apart. The coils should be so placed or wound that the terminals are brought out on what will be facing sides when the coils are mounted. The switch fits nicely in front of the coils, while an aluminum partition is run perpendicularly from the under side of the chassis, to reduce the coupling between coils. Usually no receptions will result unless extra coupling is provided, and to that end a fixed condenser is put from stator to stator of the tuning condensers. This fixed capacity is only 0.6 mmfd.

# Short-Wave Time-Table

The following time table of stations includes all the principal ones from 14.01 to 21.28 meters, the world over, and represents the first such time table ever published. The complete table, up to about 125 meters, all the principal stations of the world, is in preparation. If interested in the Complete Short-Wave Time-Table write to Short-Wave Editor, RADIO WORLD, 145 West 45th Street, New York, N. Y.

(Copyright 1932)

Abbreviations: GMT=Greenwich mean time; EST=Eastern Standard Time; CST=Central Standard Time; MST=Mountain Standard Time; PST=Pacific Standard Time; m=wavelength in meters; kc=frequency in kilocycles.

<p><b>GMT EST CST MST PST</b> 17-18 12 m.-1 p.m. 11-12 a.m. 10-11 a.m. 9-10 a.m. (No call) Pontoise, France, to 12:30 p.m. 19.68 m., 15,244 kc. I2RO, Rome, Italy, irregular. 25.40 m., 11,811 kc. PCJ, Eindhoven, Holland (Weds.). 31.28 m., 9,590 kc. W9XAA (WCFL), Chicago, Ill. (daily &amp; Sun.). 25.34 m., 11,839 kc, or on 49.34 m., 6,080 kc; 16.873 m., 1-7,780 kc.</p> <p><b>GMT EST CST MST PST</b> 18-19 1-2 p.m. 12-1 p.m. 11-12 a.m. 10-11 a.m. (No call) Pontoise, France (daily and Sun.), starts 1:30. 25.20 m., 11,905 kc. PJC, Eindhoven, Holland (Weds.). 31.28 m., 9,590 kc.</p> <p><b>GMT EST CST MST PST</b> 19-20 2-3 p.m. 1-2 p.m. 12-1 p.m. 11-12 a.m. W8XK (KDKA), Pittsburgh, Pa. (Wed. &amp; Sat.) 19.70 m., 15,228 kc. (No call) Pontoise, France (daily &amp; Sun.). 25.20 m., 11,905 kc. PCJ, Eindhoven, Holland. (Weds.). 31.28 m., 9,590 kc.</p> <p>W2XAD (WGY), Schenectady, N. Y. (Sun.). 19.56 m., 15,337 kc. G2NM, Sonning-on-Thames, Eng. (Sun.). 20.95 m., 14,320 kc. W8XK (KDKA), Pittsburgh, Pa. (daily &amp; Sun.). 25.25 m., 11,881 kc. I2RO, Rome Italy, irregular. 25.40 m., 11,811 kc. Starts 2:30. G5SW, Chelmsford, Eng. (daily except Sat. &amp; Sun.). 25.53 m., 11,751 kc. VK2ME, Sydney, Australia. 31.28 m., 9,590 kc.</p> <p><b>GMT EST CST MST PST</b> 20-21 3-4 p.m. 2-3 p.m. 1-2 p.m. 12-1 p.m. W2XAD (WGY), Schenectady, N. Y. (Sun.). 19.56 m., 15,337 kc. W8XK (KDKA), Pittsburgh, Pa. (Wed. &amp; Sat.) 19.70 m., 15,228 kc. (No call) Pontoise, France (daily &amp; Sun., to 3:30). 25.20 m., 11,905 kc. W8XK (KDKA), Pittsburgh, Pa. (daily &amp; Sun.). 25.25 m., 11,881 kc. I2RO, Rome, Italy, irregular. 25.40 m., 11,811 kc. XDA, Mexico City, Mexico (daily &amp; Sun.). 25.50 m., 11,765 kc. G5SW, Chelmsford, Eng. (daily except Sat. &amp; Sun.). 25.53 m., 11,751 kc. VK2ME, Sydney, Australia. 31.28 m., 9,590 kc.</p> <p><b>GMT EST CST MST PST</b> 21-22 4-5 p.m. 3-4 p.m. 2-3 p.m. 1-2 p.m. W2XAD (WGY), Schenectady, N. Y. (daily &amp; Sun.). 19.56 m., 15,337 kc. W8XK (KDKA), Pittsburgh, Pa. (Wed. &amp; Sat.). 19.70 m., 15,228 kc. W8XK (KDKA), Pittsburgh, Pa. (daily &amp; Sun.). 25.25 m., 11,881 kc. I2RO, Rome, Italy, irregular. 25.40 m., 11,811 kc. G5SW, Chelmsford, Eng. (daily except Sat. &amp; Sun.). 25.53 m., 11,751 kc. (No call) Pontoise, France (daily &amp; Sun.). 25.63 m., 11,705 m.</p>	<p><b>GMT EST CST MST PST</b> 22-23 5-6 p.m. 4-5 p.m. 3-4 p.m. 2-3 p.m. W2XAD (WGY), Schenectady, N. Y. (daily &amp; Sun.). 19.6 m., 15,337 kc. W8XK (KDKA), Pittsburgh, Pa. (daily &amp; Sun.). 25.25 m., 11,881 kc. G5SW, Chelmsford, Eng. (daily except Sat. &amp; Sun.). 25.53 m., 11,751 kc. (No call) Pontoise, France (daily &amp; Sun.). 25.63 m., 11,705 m. PCJ, Eindhoven, Holland (Fri.). 31.28 m., 9,590 kc.</p> <p><b>GMT EST CST MST PST</b> 23-24 6-7 p.m. 5-6 p.m. 4-5 p.m. 3-4 p.m. W9XAA (WCFL), Chicago, Ill. (daily &amp; Sun.). 16.873 m., 17,780 kc. W2XAD (WGY), Schenectady, N. Y. (daily &amp; Sun.). 19.56 m., 15,337 kc. W8XK (KDKA), Pittsburgh, Pa. (daily &amp; Sun.). 25.25 m., 11,881 kc. W9XAA (WCFL), Chicago, Ill. (daily &amp; Sun.). 25.34 m., 11,839 kc. G5SW, Chelmsford, Eng. (daily except Sat. &amp; Sun.). 25.52 m., 11,751 kc. PCJ, Eindhoven, Holland (Fri.). 31.28 m., 9,590 kc. W9XAA (WCFL), Chicago, Ill. (daily &amp; Sun.). 49.34 m., 6,080 kc (when not using 25.34 m. or 16.873 m. at this time).</p> <p><b>GMT EST CST MST PST</b> 0-1 7-8 p.m. 6-7 p.m. 5-6 p.m. 4-5 p.m. W9XAA (WCFL), Chicago, Ill. (daily &amp; Sun.). 16.873 m., 17,780 kc (or 49.34 m. or 25.34). W8XK (KDKA), Pittsburgh, Pa. (daily &amp; Sun.). 25.25 m., 11,881 kc. W9XAA (WCFL), Chicago, Ill. (daily &amp; Sun.). 25.34 m., 11,839 kc. G5SW, Chelmsford, Eng. (daily except Sat. &amp; Sun.). 25.53 m., 11,751 kc. T-14, Heredia, Costa Rica (until 8:30) (Mon. &amp; Weds.). 29.30 m., 10,239 kc. PCJ, Eindhoven, Holland (Fri.). 31.28 m., 9,590 kc. W9XAA (WCFL), Chicago, Ill. (daily &amp; Sun.). 49.34 m., 6,080 kc (or 25.34 or 16.873 m.).</p> <p><b>GMT EST CST MST PST</b> 1-2 8-9 p.m. 7-8 p.m. 6-7 p.m. 5-6 p.m. W9XAA (WCFL), Chicago, Ill. (daily &amp; Sun.). 16.873 m., 17,780 kc, when not on 25.34 m., or 49.34 m. at this time. W8XK (KDKA), Pittsburgh, Pa. (daily &amp; Sun.). 25.25 m., 11,881 kc. W9XAA (WCFL), Chicago, Ill. (daily &amp; Sun.). 25.34 m., 11,839 kc. W9XAA (WCFL), Chicago, Ill. (daily &amp; Sun.). 49.34 m., 6,080 kc, when not on 25.34 m. or 16.873 m. at this time. EAQ, Madrid, Spain (8:15 to 8:30 only). 30.40 m., 9,870 kc. PCJ, Eindhoven, Holland (Fri. &amp; Sat.). 31.28 m., 9,590 kc.</p> <p><b>GMT EST CST MST PST</b> 2-3 9-10 p.m. 8-9 p.m. 7-8 p.m. 6-7 p.m. W8XK (KDKA), Pittsburgh, Pa. (daily &amp; Sun.). 25.25 m., 11,881 kc. T-14, Heredia, Costa Rica (Thurs. &amp; Sat.). 29.30 m., 10,239 kc. PCJ, Eindhoven, Holland (Sat.), 31.28 m., 9,590 kc.</p>	<p><b>GMT EST CST MST PST</b> 3-4 10-11 p.m. 9-10 p.m. 8-9 p.m. 7-8 p.m. PCJ, Eindhoven, Holland (Sat.). 31.28 m., 9,590 kc.</p> <p><b>GMT EST CST MST PST</b> 4-5 11-12 p.m. 10-11 p.m. 9-10 p.m. 8-9 p.m. PCJ, Eindhoven, Holland (Sat.). 31.28 m., 9,590 kc.</p> <p><b>GMT EST CST MST PST</b> 5-6 12 p.m.-1 a.m. 11-12 p.m. 10-11 p.m. 9-10 p.m. VK2ME, Sydney, Australia (Sun.). 31.28 m., 9,590 kc. PCJ, Eindhoven, Holland (Sun.). 31.28 m., 9,590 kc.</p> <p><b>GMT EST CST MST PST</b> 6-7 1-2 a.m. 12-1 a.m. 11-12 p.m. 10-11 p.m. VK2ME, Sydney, Australia (Sun.). 31.28 m., 9,590 kc.</p> <p><b>GMT EST CST MST PST</b> 7-8 2-3 a.m. 1-2 a.m. 12-1 a.m. 11-12 a.m. G2NM, Sonning-on-Thames, Eng. (Sat.). 20.95 m., 14,320 kc.</p> <p><b>GMT EST CST MST PST</b> 8-9 3-4 a.m. 2-3 a.m. 1-2 a.m. 12-1 a.m. None</p> <p><b>GMT EST CST MST PST</b> 9-10 4-5 a.m. 3-4 a.m. 2-3 a.m. 1-2 a.m. VK2ME, Sydney, Australia. 31.28 m., 9,590 kc.</p> <p><b>GMT EST CST MST PST</b> 10-11 5-6 a.m. 4-5 a.m. 3-4 a.m. 2-3 a.m. VK2ME, Sydney, Australia. 31.28 m., 9,590 kc.</p> <p><b>GMT EST CST MST PST</b> 11-12 6-7 a.m. 5-6 a.m. 4-5 a.m. 3-4 a.m. CMS, Camaguey, Cuba. 25.05 m., 11,976 kc. VK2ME, Sydney, Australia. 31.28 m., 9,590 kc.</p> <p><b>GMT EST CST MST PST</b> 12-13 7-8 a.m. 6-7 a.m. 5-6 a.m. 4-5 a.m. (No call) Rabat, Morocco, Africa (starts 7:30) (Sun.). 23.38 m., 12,831 kc. CMS, Camaguey, Cuba. 25.05 m., 11,976 kc. G5SW, Chelmsford, Eng. (starts 7:30) (daily except Sat. &amp; Sun.). 25.53 m., 11,751 kc. VK2ME, Sydney, Australia. 31.28 m., 9,590 kc.</p> <p><b>GMT EST CST MST PST</b> 13-14 8-9 a.m. 7-8 a.m. 6-7 a.m. 5-6 a.m. (No call) Rabat, Morocco, Africa (Sun.). 23.38 m., 12,831 kc. G5SW, Chelmsford, Eng. (until 8:30) (daily except Sat. &amp; Sun.). 25.53 m., 11,751 kc. VK2ME, Sydney, Australia (to 8:30). 31.28 m., 9,590 kc.</p> <p><b>GMT EST CST MST PST</b> 14-15 9-10 a.m. 8-9 a.m. 7-8 a.m. 6-7 a.m. (No call) Pontoise, France (from 9:30). 19.68 m., 15,244 kc. PCJ, Eindhoven, Holland (Weds.), 31.28 m., 9,590 kc.</p> <p><b>GMT EST CST MST PST</b> 15-16 10-11 a.m. 9-10 a.m. 8-9 a.m. 7-8 a.m. (No call) Pontoise, France. (19.68 m., 15,244 kc. PCJ, Eindhoven, Holland (Weds.). 31.28 m., 9,590 kc.</p> <p><b>GMT EST CST MST PST</b> 16-17 11 a.m.-12 m. 10-11 a.m. 9-10 a.m. 8-9 a.m. (No call) Pontoise, France. (19.68 m., 15,244 kc. I2RO, Rome, Italy, irregular. 25.40 m., 11,811 kc. PCJ, Eindhoven, Holland (Weds.). 31.28 m., 9,590 kc.</p>
---	---	--

### Literature Wanted

Readers desiring radio literature from manufacturers and jobbers concerning standard parts and accessories, new products and new circuits, should send a request for publication of their name and address. Send request to Literature Editor, RADIO WORLD, 145 West 45th Street, New York, N. Y.

- Albert G. Beyer, 4317 Cherry Lane, St. Louis, Mo.
- Maxson Weide, 1411 Quinientos St., Santa Barbara, Calif.
- Raben C. Schenk, 433 Locust St., Mt. Vernon, Ind.
- Chester L. Price, Radio Service, 110 Heartt Ave., Cohoes, N. Y.
- Albert E. Gerth, 321 E. 10th St., Mt. Vernon, Ind.
- S. S. Jacobs, 420 N. Main, Minot, No. Dak.
- Louis G. Maxwell, 229 1/2 Capitol St., Charleston, W. Va.
- Edward Moennig, 2814 Bowser Ave., Ft. Wayne, Ind.
- H. A. Wenzel (for ultra short-wave and telev.), 1016 Chestnut St., Quincy, Ill.

- Roy E. Crossman, 216 So. Cox Ave., Joplin, Mo.
- F. P. Barron, Georgetown, Miss.
- Alfred Thomas, Laredo, Mo.
- J. Warren Donahue, 1326 Oak St., Los Angeles, Calif.
- J. B. Whiddy, 870 First St., Macon, Ga.
- M. G. Waddell, 2600 22nd Ave., San Francisco, Calif.
- Phillip Ward, c/o Ernest Whitaker's Drug Store, Jacksonville, Tex.
- W. E. Donohue, 665 W. Hancock, Detroit, Mich.
- K. Tripp, 8540 Chalfont, Detroit, Mich.
- Roy F. Lieser, Concordia, Missouri.
- L. T. Hill, Jr., 501 West 6th St., Chattanooga, Tenn.
- Chas. Blust, Kent, Ill.
- Homer Lareen, 3225 N. Linder Ave., Chicago, Ill.
- Kenneth Laurnders, P. O. Box 816, Nassau, N. P., Bahamas, B.W.I.
- Frank Robertson, 216 Forth Ave., North, Great Falls, Mont.
- Leland Cray, Springfield, Ore.
- H. Osborne, Gen. Delivery, Calgary, Alta., Canada.
- Lloyd A. Miller, 1332 W. 83rd St., Cleveland, Ohio.
- John H. Baker, c/o E. E. Clarkson & Co., Burlington, Vermont.
- Rudolph Weise, R.F.D. No. 2, Cardington, Ohio.
- H. A. Garrett, Trumann, Ark.

### New Incorporations

- Television Equipment Co., New York, N. Y. - Attys., Moffat & Sanford, 342 Madison Avenue, New York, N. Y.
- Stone-Warfield Co., Wilmington, Del., radio, radio accessories - Filed by the company.
- Manhattan Radio Corp., Brooklyn, N. Y. - Atty., E. Stempel, 545 Fifth Ave., New York, N. Y.
- Duo-Ice Equipment Corp., New York, N. Y., refrigerators - Attys., Deutsch & Trier, Corona, L. I.
- Garfunkel, Inc., Jersey City, N. J., electrical motors and supplies - Atty., Saul N. Emser, Jersey City, N. J.
- Endwell Manufacturing Co., New York City, operate electrical, chemical and other laboratories - Attys., Corporation Trust Co., Wilmington, Del.
- Knuckles Electric Shop, Inc., Asbury Park, N. J., electricians - Atty., Lillian Broder Levington, Asbury Park, N. J.

#### ASSIGNMENTS

Yorkville Radio Company, Inc., 149 East 86th St., New York, N. Y., radios and accessories, to Harold J. Craft, 480 Lexington Ave., New York, N. Y.



# R-F Pentodes in a Portable

## Sensitivity Greatly Increased with New 34 Tubes

By Charles J. Endicott

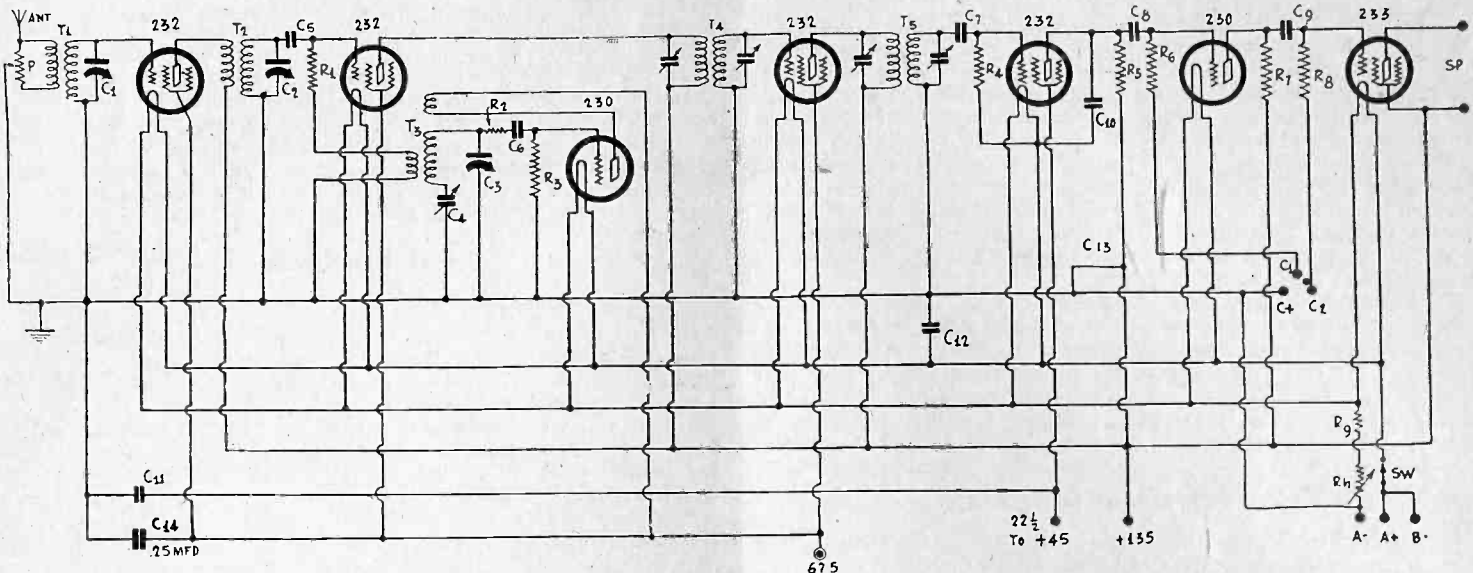

FIG. 1

In this seven tube portable superheterodyne the new 234 2-volt r-f pentodes can be used effectively in the first and the fourth sockets, that is, in the two high frequency amplifiers.

LAST week, February 20th issue, we described a seven--tube superheterodyne utilizing the 2-volt tubes. Since that was written a new 2-volt variable mu tube, to be known as the 234, has been announced. The characteristics of this new tube were also given in last week's issue. From the table, which appears on page 16 of that issue, it will be found that the tube is especially recommended for portable sets, when the screen and plate voltages are 67.5 volts.

The new tube can be put into the portable receiver because it takes the same filament current and voltage as the 232 which it replaces. In only two places will it be advantageous to make the substitution, in the first socket and in the fourth. The 232 should be retained as first and second detectors and the 230 should be retained as oscillator and first audio frequency amplifier.

### Using R-F Pentodes

In the drawing of the portable superheterodyne the screen voltage on the two tubes which are to be replaced by 234s is 45 volts. This voltage should be increased to 67.5 volts. This voltage can also be used on the oscillator plate, but on the two detector screens the voltage should not be increased. If any change is to be made on these it should be downward, especially on the second detector. Therefore to adapt the circuit to the new tubes the voltage on the lead now marked 45 volts should be increased to 67.5 volts and the two screen leads from the two detectors should be taken off this line and connected to a place on the battery where the voltage is 45 or 22.5 volts.

It is not necessary to change the grid voltage for the new tube requires the same grid bias as the 232 tube. However, since a grid battery is used, and since it is provided with taps at every cell, it is all right to try different bias values if greater sensitivity is obtained that way. But the bias should not be made less than 1.5 volts.

### Low Plate Voltage Recommended

In the table of characteristics it is especially recommended that 67.5 volts be used on the plates of the new tubes when they are employed in portable receivers. This applies mainly to cases when no higher voltage is available. But if a loudspeaker and a 233 power tube are to be used, very little output will be obtained with 67.5 volts are used on the elements of the power pentode. The voltage on the plate and screen of this tube should be 135 volts. In as much as this voltage is in the set there is no reason why as low a voltage as 67.5 volts should be used on the 234 r-f pentodes. Use the highest voltage available and then make the screen voltage 67.5 volts.

If a power pentode is not used in the set at all, then there is a point in using only 67.5 volts on the plates of the r-f pentodes, for then this could well be the highest voltage in the

circuit. No plate or screen of any set would then get more than 67.5 volts. In such cases the last tube should be a 230 all purpose tube. This will naturally change the grid bias on the output tube, and "C1" and "C2" would be joined together and given the voltage suitable for the 230 tube. This would be considerably less than when the plate voltage on the 230 tube is 135 volts. It would not be necessary to use a 15-volt grid battery. One of 4.5 volts would be enough.

In case the last tube is a 230, as suggested above, it is necessary to change the ballast resistance R9. The total filament current would be 0.42 amperes and therefore the resistance of R9 and the rheostat together should be 2.38 ohms. R9, therefore, might be 2 ohms and the rheostat might be raised to 10 or 15 ohms.

Even for a portable set it is not recommended that the voltage be less than 135 volts, nor that the 233 power pentode be omitted. This power tube is good and has a comparatively high undistorted output.

One of the best volume controls when the r-f and i-f amplifiers are variable mu pentodes is one that changes the bias on the grids. However, a battery operated circuit is not suitable for taking advantage of this unless a separate filament battery is used for the tube or tubes so controlled. This is not very convenient and therefore it is just as well to retain the volume control indicated in the drawing, that is, the potentiometer across the primary of the r-f input transformer.

### Advantage of High Plate Voltage

The advantage of using 135 volts on the plates of the 234 tubes is clear when we refer to the table of characteristics of this new pentode. When both the screen and the plate voltages are 67.5 volts, the mutual conductance is only 560 and the amplification constant only 224. When the plate voltage is raised to 90 volts, leaving the screen voltage at 67.5 volts, these values are 580 and 290 respectively. When the voltage on the plate is 135 volts, the screen voltage remaining at 67.5 volts, the values are 600 and 360, respectively. Thus the amplification for a given load impedance rises rapidly as the plate voltage is increased and a much higher sensitivity can be expected with the higher plate voltage.

By looking in the lines for plate and screen current we note that there is no change in the drain on the plate battery. When the two voltages are 67.5 volts the sum of the screen and the plate currents is 3.8 milliamperes and when the plate voltage is 135 and the screen voltage is 67.5 volts, the sum of the plate and the screen currents is still 3.8 milliamperes. The plate current increases a little but the screen current decreases by the same amount. Hence by using a higher plate voltage we gain much in sensitivity without shortening the life of the tubes.

The new tube is a pentode, not an ordinary screen grid tube. The fifth element is not represented by an external lead but is connected to the filament as it is in the 247 power pentode, as well as on all other pentodes now on the market.

# Expert Tuning Advice

## Methodical Procedure Brings in Short Waves

By James Millen

General Manager, National Co., Malden, Mass.

**T**UNING a short-wave set is entirely different than tuning a regular broadcast receiver. A great many details make up this difference, as high frequencies or short waves have characteristics entirely unlike the long waves. Receivers, too, are made somewhat different, inasmuch as the wave bands covered must be compensated for by different coils. All in all, it is simply a matter of the operator learning how to tune his set. A good receiver, even the widely accepted Thrill Box, does not solve the question of results on short waves, for the operator must learn something about short waves and their peculiarities also. Once this is mastered, it is just as simple to get distant stations under ordinary circumstances as to get local stations.

The first thing a new user of the Thrill Box should do is to log as many local stations as possible and mark down their dial settings. Stations do not appear on every part of the dial, so the local stations will act as frequency guides to distant stations. The operator should also find just what each dial on his set does when tuned, and what effect the dial has on the stations once they are tuned in. Locating the spots where stations are heard the best is a good idea.

### Time Important for Results

In "fishing" for stations the listener should time his reception, or tune on certain wavelengths at certain times of the day.

From 14 to 20 meters all tuning should be done from daybreak till 3 p.m. local time.

From 20 to 33 meters stations to the East of the listener will be heard best from about 11 a.m. till 10 p.m. Stations to the West of the listener in this band should be heard best from midnight till about two hours after daybreak, when they will fade out.

From 33 to 70 meters distant stations can be heard only after darkness falls.

Very little in the way of distance can be heard above 70 meters, although the ships, police, fire, coast guard and aircraft stations are all heard above that wavelength.

Short wave stations have a habit of changing in volume from time to time, these changes being affected mostly by the amount of daylight between the stations and the listener.

### Summer Best for "European Trips"

For example, European stations are always best for American listeners during the Summer months. In reverse, South Americans are best during the Winter months.

Each year we hear from hundreds of listeners arguing that Winter months are best for distant reception and others that Summer

months are best. It depends mostly on the habits of the listener and his location. By habits we mean the stations he generally tunes for. There is not the least doubt that European stations are best during the Summer months and stations like G5SW, I2RO, PCJ, Zeesen and OXY are best during these months.

Differences in time is one thing which is hard for short wave fans to understand. Listening at 7 p.m., EST to "Big Ben" striking midnight brings this mind, but still listeners who fail to hear this station at 8 p.m. wonder why not.

### Breakfast Stations

Almost all stations broadcast at times to conform with activities in their part of the world. Europeans, with the exception of PCJ, which broadcasts special programs for American and Australian listeners at times, close down as early as 6 p.m. South Americans are heard from then on till midnight, EST.

Stations in Siam, Japan and that part of the world get busy while New Yorkers are thinking about breakfast. And people in Japan are getting ready to go to bed. It is therefore quite natural that listeners should tune for European stations in the afternoons providing they live in the United States and tune for stations in the Antipodes, in the early mornings. Always keep a good station list on hand.

### Eleven "Don'ts"

A few pointers for new listeners are:

**Don't** expect to find stations on all parts of the dials. Short-wave stations are widely separated except in a very few places.

**Don't** expect stations to tune broadly. Most distant stations tune very sharp.

**Don't** expect to hear the world the first day you tune. It requires some knowledge of tuning to get excellent results.

**Don't** expect to hear a station simply because it is on the air. Many things govern short-wave reception.

**Don't** get discouraged. If reception is poor one day, it may be fine the next.

**Don't** skim over the dials. Tune slowly.

**Don't** pass up any weak signals. Often a weak program can be brought out plainly by a careful tuning.

**Don't** tune for stations when they are not on the air. Use a good station list.

**Don't** tune haphazardly. Learn where stations should be found on the dials of your particular receiver.

**Don't** tune above 33 meters for distant stations in daylight.

**Don't** tune below 25 meters for distant stations after dark.

## W6XAO Reports No Fading, No Static

The transmitter of W6XAO, Don Lee, Inc., 1076 West Seventh Street, Los Angeles, Calif., operates on the ultra-high frequency of 44,500 kc., which corresponds to a wavelength of 6¾ meters and is on the air daily except Sunday, 6 to 7 p.m.

Eighty lines are used in an image repeated fifteen times per second.

A new electrical scanning system is used employing cathode-ray tubes, and a cathode-ray receiver is best suited to receive the image.

A single spiral disk of 80 holes revolving at a speed of 900 hpm. may be used, however.

An ultra-high frequency receiver is required to pick up the signals. Such a receiver is not available commercially, but can be built by a well-informed radio amateur.

An 80-hole disc is not available commercially, but can be similarly built.

None of the standard television receivers available commercially can be used to receive the broadcasts. W6XAO uses the newest band of television waves and the newest type of scanning; as a consequence commercial receivers are not yet available. Other television receivers will not pick up the signal because they do not tune to a high enough frequency and do not have enough holes in the disc or drum.

The ultra-high frequency or quasi-optical waves employed behave somewhat like light, traveling in nearly straight lines. The strongest signal is received when a direct and unobstructed line of sight exists between transmitter and receiver. At a distance of forty miles or more the curvature of the earth makes this impossible. Thus, the maximum range of such a transmitter does not exceed forty miles. Within this area the waves are free from fading and static interference.

## Short-Wave Club

Here is a list of new members. Almost every week such a list is published. There are no repetitions. Any rader may join by sending in his name to Short-Wave Club, RADIO WORLD, 145 West 45th Street, New York, N. Y.

Roy E. Crossman, 216 So. Cox Ave., Joplin, Missouri.  
Ray A. Smith, 1132 North 11th St., Terre Haute, Ind.  
J. Lindholm, 1957 2nd Ave., New York, N. Y.  
Clifford Huddleson, 3409 Union St., Eureka, Calif.

Wm. R. Hendricks, Box 296, Williamson, West Va.  
Rudolph E. Blomstrom, 101 Norfolk St., Cranston, R. I.  
L. Gancher, 121 W. 17th St., New York, N. Y.  
Floyd E. Eddington, 101 So. Salina St., Santa Barbara, Calif.  
E. S. Jefferson, Bellhaven, N. Carolina.  
Mark Chestnutwood, 2438 Freemansburg Ave., Easton, Penna.  
T. R. Dobrydnio, 3 Shawmut Ave., Holyoke, Mass.  
James W. Kenyon, 381 Pecks Road, Pittsfield, Mass.  
C. Biddle Atlee, 114 Elm Ave., Riverton, N. J.  
John Jasinski, 337 Lake Ave., Manchester, N. H.  
Odell Stitt, Box 84, Hawthorn, Fla.  
Chester L. Price, 110 Heartt Ave., Cohoes, N. Y.  
M. L. Cassidy, R. 78, Greendale Ave., Needham, Mass.  
Richard Diem, 32 Nelson St., Rochester, N. Y.



**A Question and Answer Department conducted by Radio World's Technical Staff. Only Questions sent in by University Club Members are answered. Answers printed herewith have been mailed to University Members.**

# Radio University

To obtain a membership in Radio World's University Club for one year, send \$6 for one year's subscription (52 issues of Radio World) and you will get a University number. Put this number at top of letter (not envelope) containing questions. Address, Radio World, 145 West 45th Street, New York, N. Y.

Annual subscriptions are accepted at \$6 for 52 numbers, with the privilege of obtaining answers to radio questions for the period of the subscription, but not if any other premium is obtained with the subscription.

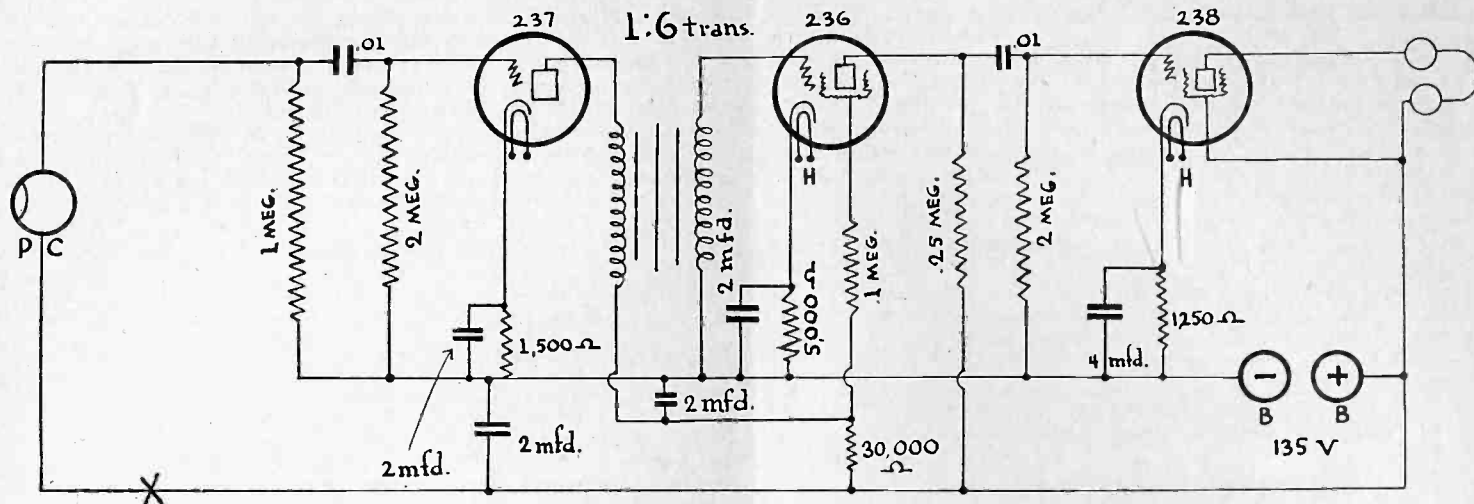

Fig. 992

**A three tube circuit adapted to the amplification of signals from a phototube together with the connections for the light sensitive tube.**

### Detuning by Volume Control

MANY volume controls are quite satisfactory as far as the control of volume is concerned, but they detune the circuit considerably. This effect is so great in some instances, especially in superheterodynes and at the high frequency end, that several stations may be completely tuned in and out by merely turning the volume control. Can you suggest a remedy or a volume control which is not subject to this effect?—B. W., St. Joseph, Mo.

If the change in the tuning is so great when turning the volume control, it can only mean that you have an unstabilized oscillator and that the regulation of the plate voltage is very poor. There are oscillators which are relatively stable in respect to frequency, and one of them should be used. Isolating the tube elements from the resonant circuit as far as possible is an effective way. One way is to use a grid leak and stopping condenser in the oscillator grid circuit and also a resistance in the grid lead, say between the stopping condenser and the high voltage side of the oscillator circuit. Another is to connect the grid lead to a tap on the tuned coil well down from the high voltage side. Grid bias on the oscillator helps but not as much as the grid leak and stopping condenser, or as the tap connection. Several of these methods may be combined, and usually are. A high order of stability is not required and the above precautions are sufficient. Since the main change in the circuit as the volume control is turned is in the effective plate voltage on the oscillator, it is well to provide good regulation of the voltage. This may be done by using a lower resistance voltage divider and a larger bleeder circuit. High resistances in series with plate leads should be avoided. The plate returns should be made directly to the voltage divider. Changes in the constants of the r-f circuits are not so important, but good regulation will help here too.

\* \* \*

### Suggestions About Padding Oscillators

WHEN I first started to build my superheterodyne it was my understanding that the tracking problem was very simple if the right coils and padding condensers were available. Now I have specified parts in every respect but still I have not been able to effect tracking. At the high frequency end there is no difficulty at all but at the low frequency end I can only bring in one station at the time by adjusting the series condenser. What is the trouble?—F. W. R., Newark, N. J.

There are many things which may be at fault. First, you may have too much minimum capacity. You can reduce this by using the grid leak and stopping condenser in the grid circuit of the oscillator, also putting a 10,000 ohm resistance between the stopping condenser and the tuned circuit. Then you must be sure that the

oscillator inductance has the right value. To adjust the inductance set the series condenser at approximately the right value and the tuner at the highest broadcast frequency you can tune in. Then adjust the inductance by adding or removing turns until this frequency comes in loudest. It may not be possible to do this without adjusting the trimmer on the oscillator condenser, but change the inductance so that it will require as little change as possible in the trimmer to bring in the station. Having fixed the inductance, adjust the trimmer until the station is loudest and leave it set. Now go to the other end of the dial, setting it where a long wave broadcast station should come in. Then adjust the series condenser until this station comes in loudest. The padding will not work if the minimum capacity in the oscillator condenser is too large, for then so many turns will have to be removed in order to bring in the high frequency station that there will not be enough inductance to bring in the low frequency station.

\* \* \*

### Power Loss in Choke Coil

PLEASE explain how the power loss in choke coil can be figured when the voltage across it, the resistance, and the inductance are known. Also, explain how it may be figured when the current is known.—S. G., Brooklyn, N. Y.

If the d-c resistance and the d-c current are known the power loss is determined just as if the choke were a pure resistance. That is, the power loss is equal to the current squared multiplied by the resistance. If the d-c voltage drop is known as well as the current, the power loss is the product of the voltage and the current. If the voltage across the coil and the resistance are known, then the power loss is the square of the voltage divided by the resistance. The inductance of the choke enters only when alternating current is involved, in which case the frequency of the current must also be taken into account.

\* \* \*

### Amplifier for Phototube Input

WILL you kindly publish the diagram of a three tube amplifier suitable for use with a photoelectric cell. I plan to use earphones for reception but I would prefer an output tube large enough to operate a speaker. Please show all values of parts and name the photoelectric cell that is most suitable.—E. S., St. George, N. Y.

Fig. 992 is such an amplifier using one 237, one 236, and one 238 tubes. It would be preferable to substitute a 239 tube for the 236, as this will amplify more. A small photoelectric cell of the soft, or gaseous type should be used, as this is more sensitive than the high vacuum tube. If your light source contains much red, or all red, it would be best to use a caesium type cell, for this is red-sensitive.

### A THOUGHT FOR THE WEEK

**S**OMEbody in television is suing somebody else in television for \$25,000,000. Who says radio and television are not progressing! The days are here when men are men and a million a mere handful of loose change. And what a time for corporation lawyers and patent experts—heaven bless their innocent, playful little hearts.

# RADIO WORLD

The First and Only National Radio Weekly  
Tenth Year

Owned and published by Hennessy Radio Publications Corporation, 145 West 45th Street, New York, N. Y. Roland Burke Hennessy, president and treasurer, 145 West 45th Street, New York, N. Y.; M. B. Hennessy, vice-president, 145 West 45th Street, New York, N. Y.; Herman Bernard, secretary, 145 West 45th Street, New York, N. Y. Roland Burke Hennessy, editor; Herman Bernard, managing editor and business manager; J. E. Anderson, technical editor; J. Murray Barron, advertising manager.

## Tradiograms

By J. Murray Barron

Precise Radio Mfg. Co. announces removal to 10 Lafayette Avenue, Brooklyn, N. Y.

\* \* \*

Blair Radio Labs. are now in production on an antenna filter coupler. With this unit it is possible to connect up 50 to 100 radio sets without loss of volume. Servicemen and others can receive free information.

\* \* \*

Jewell Radio Co., 56 Vesey Street, has opened a new store at 110 Chambers Street, New York City. Power equipment, special parts and "ham" supplies will be stocked.

\* \* \*

Globe Television Co., Inc., has leased quarters in the Starrett-Lehigh Terminal Building, New York City, for an experimental laboratory and receiving station.

\* \* \*

Television Exhibitions, Inc., 11 Broadway, New York City, has recently been formed. Eric Palmer, the president, is a pioneer in radio.

\* \* \*

A very interesting public television demonstration was given at Gimbel's department store in New York City. The large attendance required special officers to hold the crowd in line. A Baird televisor and equipment were used.

\* \* \*

P. L. Laboratories, 1460 Huron Street, Toledo, Ohio, have put on the market a simple low-wave converter that will bring in police signals and other short-wave signals when used in conjunction with any radio broadcast receiver. By an ingenious arrangement the device takes all the required power from the receiver and no external source is needed. It may be connected for operation in a few minutes.

\* \* \*

Duovac Radio Tube Corp., 360 Furman Street, Brooklyn, N. Y., manufacturer of the Flasher Neon Tube, also makes a crater tube for television and is prepared to keep abreast of the increasing demand.

## Bloch Shows 3-Foot Image

The Polytechnic Institute of Brooklyn, N. Y., recently demonstrated the possibilities of television as an educational adjunct. Using receiving apparatus recently developed by Ivan Bloch, graduate of the college, and by the co-operation of the Columbia Broadcasting System, a physics lecture was successfully televised and transmitted to a group of 100 physics teachers of the metropolitan area, gathered in the main Physics Lecture Hall at the Institute.

Prof. E. P. Slack of the Institute delivered a complete lecture, with actual demonstration on some acoustic problems. The lecturer was televised at the Columbia Broadcasting studio, W2XAB, while his voice was carried simultaneously over short waves by W2XE. The image of Prof. Slack was plainly seen by the group in the lecture room. The voice was amplified through suitable amplifiers and correlated the movements of the lecturer.

Coincidentally, Prof. John Dewey, noted philosopher, professor at Columbia University, had expressed the thought that

some day television would be an excellent method to broadcast a lecture by an eminent research worker and would thus allow a great multitude to watch the master at work. It was therefore considered that Prof. Dewey's prophecy was fulfilled.

A few days after the demonstration, the annual "open house" of the Institute was held. Two television demonstrations were given. One demonstration was by a commercial concern while the other was by Mr. Bloch, who this time used a screen 3.5 x 3 feet. The illumination of the screen was the subject of much discussion, for its extreme brilliancy. This development was made possible by the use of a new neon crater lamp and by the flexible qualities of the apparatus designed by Mr. Bloch. The demonstration was marred by excessive interference from the multitude of electrical machinery in motion in other parts of the building, including a high voltage and high frequency generator. However, more than 5000 persons watched the demonstration and listened to notes of explanation.

## Monopoly Trial of RCA Group to Go on Despite Patent Pool

Washington.

The Radio Corporation of America and its associates will be tried under the anti-trust laws on grounds of their intercorporate relationship and other charges, regardless of whether they release their patents through an open pool, according to the testimony of John Lord O'Brien, assistant to the attorney general and head of the anti-trust division of the Department of Justice. He testified before the House Appropriations Committee.

The corporations associated with Radio Corporation of America in the action are the General Electric Co., the Westinghouse Electric and Manufacturing Co., the American Telephone and Telegraph Co., and the General Motors Corporation.

The Government complains of the intercorporate relationship of the companies and their contracts among themselves, as well as of their patent holdings, and on the first points there is no prospect of agreement between the Government and the defendants, Mr. O'Brien testified. If an open patent pool could be agreed on, according to Mr. O'Brien, it would eliminate one important and expensive part of the trial. The points must be adjudicated.

"The case has perhaps the widest scope of any anti-trust case ever instituted," according to Mr. O'Brien. "It is an extraordinarily complicated case, not only because of the intercorporate relationship of the parties and various agreements between them and also with outsiders, but because of the cross-licensing of patents."

### TELEVISION PARTS LISTED

Dienelt & Eisenhardt, Inc., 1304 N. Howard St., Philadelphia, Pa., have issued a booklet on television parts. It is very complete and should be of real interest to experimenters and set builders.

## Copyright Lasting Indefinitely Held Menace by Stations

Washington.

Louis Caldwell, formerly counsel to the Federal Radio Commission, told the House Committee on Patents that the "automatic" copyright has many "pitfalls for the innocent infringer," and could be "almost perpetual." Mr. Caldwell represented the National Association of Broadcasters.

"If the floodgates are completely opened with automatic copyright in the sense in which it is in force in Europe," he said, "together with a copyright term consisting of the life of the author, plus 50 years, so that no one can tell when the term ends, there will in reality be almost perpetual copyright."

"The man who has no control over what music is played and who cannot possibly protect himself against infringement, no matter what precautions are taken, should not be held liable under sound copyright legislation," he said.

"The broadcasters agree," he added, "that copyright should originally vest in the author or composer who creates the work and who should have the right to assign to whomever he chooses. Authors or composers should have the right to assign divisible portions of their copyright; in other words, there should be divisibility of copyright with good title to the several assignees. All this the broadcasters agree to, subject to proper safeguard by way of notice and registration."

### VISIONETTE KIT

A. G. Heller, chief engineer of The Insuline Corporation, 23 Park Place, New York City, announces the visionette is furnished complete in kit form. There is also a television receiver of sufficient power to operate practically any type of flat plate or crater lamp. To the man who likes to assemble his own apparatus there is some free literature.

**IMPORTANT NOTICE TO CANADIAN SUBSCRIBERS — RADIO WORLD will accept new subscriptions at the present rates of \$6 a year (52 issues); \$3 for six months; \$1.50 for three months; (net, without premium). Present Canadian subscribers may renew at these rates beyond expiration dates of their current subscriptions. Orders and remittance should be mailed not later than April 15th, 1932. Subscription Dept., Radio World, 145 W. 45th St., New York, N. Y.**



# STATION SPARKS

By Alice Remsen

## Evening in Paris

FOR PIERRE BRUGNON

(WABC; Every Monday, 9:30 p.m.)

Oh, have you seen my boulevards beside the River Seine?  
My gaily lighted boulevards beneath a slanting rain!  
I think of them at sunset and my heart is full of pain,  
I wonder if I'll ever see my boulevards again.

The gay cocottes now trip along with perfect savoir faire,  
Venders with their fragrant flowers perfuming all the air;  
The merry cafe chantants and the music halls so gay,  
With so much love and laughter all inviting one to stay.

Oh, some may love my boulevards when snow is in the air,  
And some may love them when the sun is shining out so fair;  
But if I had my choice to see them only once again,  
I'd rather see my boulevards beneath a slanting rain.

Oh, have you seen my boulevards beside the River Seine?  
My haunting, flaunting boulevards beneath a slanting rain!  
I think of them at sunset and my heart is full of pain,  
I wonder if I'll ever see my boulevards again.

—A.R.

Pierre Brugnon, the popular master of ceremonies on the Bourgeois program, Evening in Paris, heard over WABC every Monday evening at 9:30, is celebrating his second anniversary with that delightful program on the evening of February 29th. He will be guest of honor and do the whole program with Andre Baruch as a foil. Monsieur Brugnon has created a radio following for himself and deservedly so, for he makes a charming master of ceremonies. His Gallic accent and songs are most appropriate for the French atmosphere needed to surround the Bourgeois products. The orchestra, under the fine leadership of Max Smolen, will continue to do its part toward making Evening in Paris one of the finest programs of its type on the air.

\* \* \*

The Columbia Broadcasting System has signed one of radio's most versatile entertainers, Little Jack Little, to appear over its network exclusively. He will be heard in his own piano and song recitals every morning except Sunday at 9:00 o'clock, E.S.T. For several years Little Jack Little, who gained initial prominence on the air over Station WLW of Cincinnati, has been one of the outstanding personalities of radio. He is not only a vocalist and pianist, but a composer of popular songs also, being the creator of "I Promise You," "Let a Little Pleasure Interfere With Business" and other numbers.

\* \* \*

One of Paul Whiteman's Radio Finds, during his nation-wide search for new radio talent, is Billy Wallace, a professional lightweight boxer of Cleveland; which reminds me that another professional boxer made the radio grade some time ago and is still broadcasting with a fine tenor voice. I am referring to Tommy Weir, heard over WAAT, Jersey City, three times weekly.

\* \* \*

Listened to a very delightful program on Sunday, February 14th—the initial broadcast of the Yardley period. The talent consists of the London String Quartet, Beatrice Herford and Katherine Bacon. An unnamed soprano sang the theme song in a very sweet manner. "The Londoners," as the string group is known, will alternate with Mischa Levitski, young American pianist; Miss Herford will be heard each week. Do not miss this very

entertaining fifteen minutes. WJZ, every Sunday at 2:00 p.m. E.S.T.

\* \* \*

If you are fond of poetry listen in to Charles Barrenpohl's poetry-musical over WCDA, Saturdays at 9:30 p.m. The musical portion of these recitals is entrusted to the able F. Dudley Kinsey, concert pianist.

\* \* \*

Admirers of Elsie Janis may now hear her every Wednesday and Friday at 7:45 p.m. E.S.T. over an NBC-WJZ network, under the sponsorship of the Standard Oil Co. of New Jersey. Miss Janis has replaced Bob Ripley, of "Believe It or Not" fame, who has gone on a long cruise around the world to gather more strange data. Mr. Ripley cables one strange fact for each broadcast and Miss Janis relays it to the radio audience. For her own part Miss Janis gives her famous impersonations, tells stories and indulges in humorous dialogue with her pianist, Jack King.

\* \* \*

Jerry Macy and Ed Smalle are having a great time on Tuesdays, Wednesdays and Thursdays. They are heard over WOR as The Tea-Timers at 9:30 p.m. and on Sunday nights, 7:15, over WEF as the Rexall Boys. That isn't all; almost every day in the week they're recording straight records and electrical transcriptions; Ed makes special arrangements and Jerry writes special lyrics. During their spare time they eat and sleep.

\* \* \*

## Sidelights

SHIRLEY BELL plays Little Orphan Annie . . . MARY AND BOB of True Story fame are not married . . . CHARLES FINAN AND PAUL WIN-KOPP play Snoop and Peep . . . GENE CARROLL, of Gene and Glenn, created and plays the roles of Jake and Lena . . . GLENN ROWELL, the second member of this comedy team, plays the piano and sings those appealing solos. They're on the air from WTAM, Cleveland . . . FRANK SINGISER, NBC announcer, is studying philosophy at Columbia University . . . And now PETER DIXON avers he writes his scripts in what was once the coal bin of his Long Island home. Peter, Peter! is that where you get those artistic nose smudges? ED WHITNEY can imitate every barnyard

creature . . . AILEEN CLARKE, NBC singer, is a whirlwind checker player . . . GENE MULHOLLAND, of NBC Press Relations, has gone to Texas . . . GLADYS RICE learned Spanish in order to present a special program for the General Motors . . . BILL BASSO, the Balladist, has a swell voice . . . LOUIS DEAN went to school in Valley Head, Alabama . . . BILL WIRGES has a new song of his own. It is published by Luz Brothers, and is titled "The Kiss I Stole From You" . . . LEN JOY is fond of shooting out candles in Sixth Avenue penny arcades . . . ANN LEAF enjoys playing Debussy, particularly the "Golliwogs Cake Walk" . . . and so DAVE ROSS has also turned songwriter. With Marty Quinto he has written one called "Thank You, Until Tomorrow Night" . . . CARLETON BOXHILL, tenor of the Bath Club quartet, once drove a taxi . . . JOHN FOGARTY, NBC tenor, tells of a sign he saw on a garage in Utah. It read, "We repair automobiles and fix Fords" . . . WALTER DAMROSCH has a complete file of Punch, beginning with the first issue in 1841 . . . ELIZABETH TODD, of the NBC continuity department, writes the scripts of Margie the Stenog. Marcella Shields and Helene Handin are featured in the cast . . . AL-FRED SHIRLEY was in the insurance business in England before becoming an actor.

\* \* \*

## Biographical Brevities

### About Frank Black

Frank Black was born in Philadelphia. At six he began to take music lessons. At ten he made his debut in a recital. He had secretly started his public career a year before—when he sneaked away from home evenings to play piano in a local movie nickelodeon for ten dollars. One night as Frank turned to bow to the audience, he bowed right into his father's hands. His premature movie career ended right there and he joined the St. Clements choir as a soprano soloist. The greatest excitement at that work was singing at weddings and funerals.

When he grew older Frank studied organ in Philadelphia and commuted to New York week-ends to study piano under Rafael Joseffy, Hungarian-American pianist and noted interpreter of Brahms. He remained one of Joseffy's favorite pupils until the latter's death, when Frank was seventeen years old. His varied experience with piano, organ, voice and violin gave Frank Black a well-rounded knowledge of music, which formed the foundation of his later success; but his family looked askance at a musical career, so the boy continued his chemistry studies through Haverford College and received his degree in that subject. On one vacation he went to Harrisburg seeking work with the State Department of Chemistry. Someone offered him a job as hotel pianist and he took it because he could make more money. That settled the question of his future; from then onwards he never looked back.

He has conducted and played for many noted artists as well as for his own orchestral recordings. In 1916 he directed a musical comedy at the Century Theatre, New York. He returned to Philadelphia as assistant to Erno Rapee at the Fox Theatre for about a year, then joined a music publishing firm to make popular arrangements of the classics.

When radio was in its infancy, Black made the acquaintance of Gustave Haenschen, another director who had prepared for a musical career by taking an engineering course at college. They worked together and later formed a partnership.

For a long time Black had worked on the idea of "orchestrating music for voices." No vocal group had interpreted

(Continued on next page)

# Time Table of Television Transmitters

[The following data were obtained by procuring a list of television licenses from the Federal Radio Commission and writing to the licensees for information. Blanks denote failure to respond or lack of fixed schedule. Non-operating stations are not included except three as noted, deemed about to go on the air. Call, power, owner, location, scanning data and schedule are given.]

(Copyright 1932)

Call	Watts	Owner	Lines	Frames	Schedule
<b>1,600-1,700 KC</b>					
W1XAV	1,000	Shortwave and Television Laboratories, Inc.....Boston, Mass.	60	20	2 to 4 p.m., 8 to 10 p.m. daily except Sunday
W2XR	1,000	Radio Pictures, Inc.....Long Island City	60	20	4 to 10 p.m. daily except Sun. and holidays. Sound W2XAR, 1,550 kc, daily 8 to 9 p.m.
<b>2,000-2,100 KC</b>					
W3XK	5,000	Jenkins Laboratories.....Wheaton, Md.	60	20	{ 3 to 5 p.m., 6 to 9 p.m., daily; 5 to 9 p.m., Sunday; voice over WINS; 1,180 kc. } { 9 to 10 p.m., daily. }
W2XCR (WINS)	5,000	Jenkins Television Corp.....New York City	60	20	
W2XAP (WMAL, Wash'ton, D. C.)	250	Jenkins Television Corp.....Portable	..	..	
W2XCD	5,000	De Forest Radio Co.....Passaic, N. J.	60	20	
W9XAO (WIBO, Chicago)	500	Western Television Corp.....Chicago, Ill.	..	..	
W6XAH	1,000	Pioneer Mercantile Co.....Bakersfield, Cal.	..	..	..
<b>2,100-2,200 KC</b>					
W3XAK	5,000	National Broadcasting Co.....Portable	..	..	Usually 20 No fixed schedule. 3:30 to 4:30 p.m., Friday. Uses 2,150 kc. 12:35-8 p.m., Mon. to Fri. incl.; 12 m. to 6:45 p.m., Sat.; none Sun. Uses 2,150 kc.
W2XBS	5,000	National Broadcasting Co.....New York City	..	..	
W3KAD (WGY)	500	RCA Victor Co.....Camden, N. J.	..	..	
W2XCW	20,000	General Electric Co.....Schenectady, N. Y.	Vary	..	
W3XAV (KDKA)	20,000	Westinghouse E. & M. Co.....Pittsburgh, Pa.	60	20	
W6XS (KHJ, Los Angeles)	500	Don Lee Broadcasting System.....Gardena, Cal.	..	..	
W9XAP (WMAQ)	2,500	National Broadcasting Co.....Chicago	45	15	
..	..	..	..	..	
<b>2,750-2,850 KC</b>					
W9XAA (WCFL, Chicago)	500	Chicago Federation of Labor.....Chicago	..	..	Not operating yet No fixed schedule at present; uses 2,800 kc. { 2 to 6 p.m., 7 to 11 p.m., both daily. Uses 2,800 kc. Sound on W2XE, 6,120 kc. }
W9XG (WBAA, Lafayette, Ind.)	1,500	Purdue University.....W. Lafayette, Ind.	60 to 100	20	
W2XAB (WABC, New York City; sound over W2XE)	500	Atlantic Broadcasting Corp.....New York City	60	20	
W3XE	1,500	Philadelphia Storage Bat. Co.....Philadelphia	..	..	
<b>43,000-46,000, 48,500-50,300 AND 60,000-80,000 KC</b>					
W10XG (C. P.)	500	De Forest Radio Co.....Portable	..	..	{ 4 to 6 p.m. except Sat. and Sun. Uses 43,500 kc. }
W9XD (WTMJ, Milwaukee)	500	The Milwaukee Journal.....Milwaukee, Wis.	45	15	
W3XAD	2,000	RCA Victor Co., Inc.....Camden, N. J.	..	..	{ Usually morning, also 2 to 3 p.m., 5 to 6 p.m.; 7:30 to 10 p.m. Try W2XK, 61,000 kc. }
W2XBT	750	National Broadcasting Co.....Portable	..	..	
W1XG	30	Shortwave & Television Co.....Portable	..	..	
W2XF	5,000	National Broadcasting Co.....New York City	..	..	
W2XDS	2,000	Jenkins Television Co.....Portable	..	..	
..	..	..	..	..	
W6XAO	150	Don Lee Broadcasting System.....Los Angeles, Cal.	80	15	{ 6 to 7 p.m., except Sun. and holidays—using 44,500 kc. }
W3XK	1,000	Jenkins Laboratories.....Silver Springs, Md.	..	..	
W3XE	1,500	Philadelphia Storage Bat. Co.....Philadelphia	..	..	

## STATION SPARKS

(Continued from preceding page)

his unusual work successfully until one day in 1925 he heard a male quartet sing in a recording studio. Their harmony was of such quality that Black believed he had at last found the group for his purpose. He enlisted their aid and revolutionized singing of this type. Needless to say, the male quartet is known internationally as The Revelers, well known on National Broadcasting Company programs. Black has been associated with them ever since, making their arrangements and accompanying them at the piano, until quite recently, when the personnel and management were changed.

Frank Black is responsible for many musical innovations familiar to radio audiences. He made symphonic arrangements of simple Tin-Pan Alley tunes, and by reversing the process, simplified the classics for popular consumption. He also wrote lyrical settings for well-known piano and orchestral pieces, chief of them being Rachmaninoff's "Prelude in C Sharp Minor," which he calls "Bells at Eventide," and the "Prelude in G Minor" which he has named "Sea Tales." These are considered by critics as outstanding achievements in their line and have won the approval of Rachmaninoff.

Black is an even six feet tall, weighs 150 pounds, is crowned with straight, thick black hair, streaked with gray, has unusually intelligent, bright brown eyes, long slender, beautifully kept hands, and a rather pallid complexion. He is a con-

servative dresser and usually wears a derby, even when directing.

His hobbies include collecting rare music and bronze pieces, automobile driving and reading. His pet aversion is listening to people who talk music but know nothing about it.

\* \* \*

### SUNDRY SUGGESTION FOR WEEK COMMENCING SUNDAY, FEBRUARY 28

Sun., Feb. 28: Footlight Echoes...WOR 10:30 p.m.  
 Mon., Feb. 29: Evening in Paris...WABC 9:30 p.m.  
 Tues., March 1:  
 David Guion's Orchestra.....WJZ 10:15 p.m.  
 Wed., March 2: Big Time.....WEAF 8:00 p.m.  
 Thurs., March 3: Golden Blasoms  
 Maria Cardinale.....WJZ 8:30 p.m.  
 Friday, March 4: Singin' Sam...WABC 8:15 p.m.  
 Sat., March 5: Little Symphony...WOR 8:00 p.m.

## Pointed Opinions

J. CLARKE COIT, President, U. S. Radio & Television Corporation: "Radio has stepped out of the class of seasonal merchandise and can be made to sell in every month of the year. Radio receivers have been developed to a point where every service condition and virtually every price consideration can be met. Virtually every influence that has limited the year-around enjoyment of radio has been removed during the past two or three years. Summer has been regarded as a poor period for radio reception, but this objection is no longer valid."

## PATENT ANSWERS

IS THERE any limit to the number of claims permitted in one patent?—R. F. E., Newport, Rhode Island.

No. But recently the Patent Office has put in effect a rule that for every claim originally filed in a case or finally issued in the patent over twenty, an additional filing fee, or final fee of \$1.00 must be paid. If the applicant, through his attorney, files a needlessly large number of claims which do not patentably distinguish from one another the Examiner may reject the case on the ground of "multiplicity." Patents have issued with as many as 389 claims, although the average, week in and week out, is between 6 and 7 claims. It is interesting to note that the average number of claims in patents taken out through the office of inferior attorneys is considerably below the average for all patents above, and that the average of patents issued to the patent attorneys for large corporations is considerably above. For instance, one man served one large corporation nearly six years, averaging throughout the period twenty-five claims per patent on a large number of cases of all kinds, both simple and complicated. A large number of claims does not always mean greater protection to the inventor, but it often does.

### CARTER IN NEW MOVE

The laboratories of A. J. Carter, at 2657 Farwell Ave., Chicago, are busy nowadays. Television and remote control are in line. Some things of real interest will be announced shortly.



# Television Instruction

## First National Television Inc. Kansas City, Kansas

First National Television, Inc., (training division), for some time has been offering an exclusive course in television receiving, servicing, construction and transmitting. A preparatory course in radio is given and is outlined especially for the man just starting in radio. It covers the field of radio receiving, servicing and sales, as well as radio transmitters. Those who desire to enter broadcasting work in radio will be given actual practice and experience in operating of radio transmitters. On completion of this course the student is ready to take the government examination, should he desire a limited broadcast license.

The advanced or television training is outlined for those with sufficient knowledge of radio, as gained from business or other sources. This is a double purpose course, one purpose serving those who desire to get into the various money-making branches of television, such as parts or complete receivers, servicing and sales, etc., a course for firm owners, their superintendents, foremen or department heads. A second purpose serves those who desire to qualify for maintenance and operation of a television transmitting station in conjunction with a radio broadcasting station. This branch is very flexible in that a student may specialize along branches of his preference with a view to the use he desires to make of his television training, be it construction, repairing, sales, service or manufacturing of parts.

The super course or general course in a combination of the two above described courses offered at a tuition discount and covers 12 weeks' training, and is outlined for the man just entering the field of radio-television. It is complete in every detail from start to finish, and takes the student up to his final objective—whether or not it be any or many of the numerous commercial branches, or simply to qualify as an operator of a television broadcast station.

G. L. (Jerry) Taylor, formerly an engineer attached to the Federal Radio Commission, is chief of the technical staff and is in charge of instruction, as well as experimental and development work which the corporation is doing at this time. Others on the technical staff are Meyer Eisenberg, a licensed operator of a Kansas City broadcasting station; H. C. Austin, who has contributed a number of published articles on television science, and C. Bradner Brown, who recently was elected to Sigma Xi for his television development work. All of the corporation engineers devote a part of their time each day to the training division.

Extensive laboratory equipment is maintained for the experimental work carried on and complete pickup apparatus for taking television pictures is available for student training, as well as the model studio and 500 watt transmitter designed for television transmitting.

SID NOEL, President.

\* \* \*

## WCFL Radio Study Club 3325 Lincoln Avenue, Chicago

Television unquestionably is the magic word responsible for the unusual interest in the WCFL Radio and Television Course, a series of concise home-study lessons supplied free of cost by WCFL, Chicago. The course was started about two years ago as a good-will project of Organized Labor, owners of WCFL, and to date more than 100,000 requests for the lessons have been filled.

One lesson details WCFL's pioneer television experiments and summarizes other

achievements in picture broadcasting, as well as presenting the general theory of television. Schematics and instructions for building and operating a television receiver are given. Television is presented as a wonderful achievement but as yet a study for experimenters and an opportunity for inventive genius, rather than as a satisfactory means of family entertainment, such as is now the reception of aural broadcasts. This frank statement apparently stimulates rather than deters student interest, since the television lesson seems more attractive than any other part of the course.

Because of the antipathy of labor unions for any dissemination of technical information outside the apprentice system, WCFL recently has been compelled to discontinue its unique educational project. However, the course is being re-written and will be republished under other auspices. In the meantime copies of the original lessons are available on request, although no publicity effort is being given to the offer.

PAUL STEPHENS, President.

\* \* \*

## National Radio Institute Washington, D. C.

All students of the National Radio Institute have the privilege of selecting as part of their training, a course in television, after they have completed their fundamental training. Men who are qualified by previous training or experience to undertake this course without N. R. I. fundamental training, are also given the right to subscribe for it. Their television course covers these subjects: Photocells and glow lamps, short-wave reception and transmission, decibels, Audio amplification, design of power amplifiers, typical broadcast transmitters, essentials of television, optics, theory of light, geometric optics, applied optics, television quality requirements, synchronization and framing, facsimile transmission and tel-photo, mechanical television systems, electronic television systems, a television transmitter and studio, how to build radiovisors, how to build radiovisor receivers.

E. L. DEGENER,  
Advertising Manager.

\* \* \*

## Capital Radio Engineering Institute Washington, D. C.

We have recently added instruction in television. All of our courses are home study courses. We have both advanced and complete courses in practical television engineering. Our advanced course is arranged primarily for men who have had not less than two years of active commercial radio experience. Our complete course consists of the advanced course, preceded by an introductory course which has been prepared with the idea of giving the less experienced radioman a general foundation to start the more advanced work.

Our television course is written with the idea that a man must first be a radio engineer before he can be a television engineer. We give thorough training in the essential mathematics, alternating current theory and practice, vacuum tubes and their associated circuits, before we touch television.

In the specific study of television we teach the principles and latest practice. We take up in detail the photocell, photocell circuits, amplifiers, scanning, synchronization, glow lamps, cathode ray systems, optical systems and theory, television receivers and transmitters, present systems.

Our television and radio courses are separate. However, the student can get the combined courses, without the duplication of material common to both courses, for a

slightly greater cost than that of a single course.

E. H. RIETZKE, President.

\* \* \*

## Radio Institute of Canada

310 Yonge Street, Toronto, Canada

At present we do not give a separate course for television because we do not consider that television has reached a stage which would warrant such a procedure. We include television in our regular course and have installed Baird and Jenkins apparatus for instructional purposes.

As Toronto has no visual broadcasting station, reception here is very difficult, if not impossible. However if any of the Toronto stations start visual broadcasting it would be of great assistance to us and we would then add considerably to our equipment.

We are watching television very closely and as soon as it is necessary we will of course start a special course. We feel, however, that before studying television a student should have a first-class knowledge of radio, otherwise he is bound to be working in the dark on many of the problems involved.

J. C. WILSON, President,  
Radio College of Canada, Limited.

\* \* \*

## West Side Y.M.C.A.

5 West Sixty-third Street, N. Y. City

The West Side Y. M. C. A. schools pioneers in the field of radio, conducting courses in radio operating and radio mechanics, have within the past few months started a course in television for training men in this fast developing and fascinating field.

The object of the course is to teach thoroughly the operating technique and some of the problems involved in the field of television. A few of the subjects covered are: scanning, synchronizing, optics and light, photo electricity, vacuum tubes, amplifiers, receivers, glow lamps and cathode ray systems.

The entrance requirements necessitate a basic knowledge of radio.

The course is under the instruction of Garrett V. Dulenbach, an experienced radio engineer.

Instruction is given evenings only, the class meeting Monday and Thursday from 7:30 to 9:30. The course covers a period of ten weeks.

## Delft Radio Co.

A Pacific coast firm devoting its entire plant to the manufacture of short-wave receivers and parts only is Delft Radio Co., 624-RW Fairbanks Ave., Oakland, Calif. It manufactures short-wave and ultra-short-wave receivers and apparatus only. Kits of parts and also complete sets are sold direct to fans. The latest circuits are used in one-tube, two-tube, three-tube and four-tube receivers, using screen-grid and pentode tubes. Transmitting sets, short-wave wavemeters, special amateur-band wavemeters (also a special wavemeter for superheterodyne receivers and converters) and coil winding sets are also manufactured. A two-tube pentode portable set which is very light in weight, small and compact, gives headset volume. Special "boosters" which can be connected ahead of any short-wave receiver, adapter or converter, to increase distance are made. This firm also manufactures radio equipment for locating buried deposits of gold or other ore, by electrical means. Ultra-short-wave and television equipment, code-practice sets of special design and sets of plug-in coils are also handled. A catalogue describes all lines manufactured as well as all necessary parts for short-wave constructional work. When writing mention RADIO WORLD.

**Special Announcement!**  
**Servicemen and Amateurs**

Can now buy direct, at wholesale prices: Public Address Systems, Transmitters for every purpose, "Ham" and commercial equipment. Write for listing of new development of transmitting and associated apparatus.

**BLAIR RADIO LABS.**  
23-25 Park Place New York, N. Y.

**GET THEM!**

Some Television Articles That Have Appeared in Radio World

- WANTED: TELEVISION VALVE. By Meyer H. Eisenberg—June 28, 1930.
  - TELEVISION TECHNIQUE. By Arthur Braddock—August 2, 1930.
  - FUN IN TELEVISION NOW. By Brainard Foote—Nov. 29, 1930.
  - NEON LAMP FOR TELEVISION AND STROBOSCOPE. By J. E. Anderson—Dec. 6, 1930.
  - WHERE TELEVISION STANDS TODAY. Brainard Foote—March 7, 1931.
  - POWER AMPLIFIER FOR TELEVISION BROADCASTS AND PHONOGRAPH. By Feodor Rofpatkin—March 14, 1931.
  - TELEVISION ON THE MICRO-RAY—May 16, 1931.
  - GOOD IMAGES CALLED VITAL TO TELEVISION—May 23, 1931.
  - TELEVISION DIFFERENCES. Einar Andrews—June 6, 1931.
- 15c per copy. Any 7 copies for \$1.00. Radio World, 145 W. 45th St., New York City.

**SOLDERING IRON FREE!**



Works on 110-120 volts, AC or DC; power, 50 watts. A serviceable iron, with copper tip, 5 ft. cable and male plug. Send \$1.50 for 13 weeks' subscription for Radio World and get these free! Please state if you are renewing existing subscription.

**RADIO WORLD**  
145 West 45th St. N. Y. City

**SHORT-WAVE NUMBERS OF RADIO WORLD.** Copies of Radio World from Nov. 8, 1930 to Jan. 3, 1931, covering the various short-wave angles sent on receipt of \$1.00. Radio World, 145 W. 45th St., N. Y. City.

**BINDER FREE For Yearly Subscribers**

This binder is made of fine brown Spanish fabricoid and will hold 52 issues of Radio World. Year 1931-32 stamped in gold on front cover. A very limited supply on hand. Sent free to new yearly subscribers who send \$6 before March 1, 1932. If already a subscriber, send \$6 and 52 issues will be added to present subscription. No other premium with this offer.

**RADIO WORLD, 145 WEST 45th STREET, NEW YORK CITY**

**Two for the price of One**

Get a FREE one-year subscription for any ONE of these magazines:

- RADIO CALL BOOK MAGAZINE AND TECHNICAL REVIEW (monthly, 12 issues)
- Q.S.T. (monthly, 12 issues; official amateur organ).
- POPULAR MECHANICS AND SCIENCE AND INVENTION (combined) (monthly, 12 issues).
- POPULAR SCIENCE MONTHLY
- RADIO INDEX (monthly, 12 issues), stations, programs, etc.
- RADIO (monthly, 12 issues; exclusively trade magazine).
- MODERN RADIO (monthly).
- EVERYDAY SCIENCE AND MECHANICS (monthly).
- RADIO LOG AND LORE. Monthly. Full station lists, cross indexed, etc.
- AMERICAN BOY—YOUTH'S COMPANION (monthly, 12 issues; popular magazine).
- BOYS' LIFE (monthly, 12 issues; popular magazine).

Select any one of these magazines and get it FREE for an entire year by sending in a year's subscription for RADIO WORLD at the regular price, \$6.00. Cash in now on this opportunity to get RADIO WORLD WEEKLY, 52 weeks at the standard price for such subscription, plus a full year's subscription for any ONE of the other enumerated magazines FREE! Put a cross in the square next to the magazine of your choice, in the above list, fill out the coupon below, and mail \$6 check, money order or stamps to RADIO WORLD, 145 West 45th Street, New York, N. Y. (Add \$2.00, making \$8.00 in all, for extra foreign or Canadian postage for both publications).

Your Name.....  
Your Street Address.....  
City.....State.....

**DOUBLE VALUE!**

- If renewing an existing or expiring subscription for RADIO WORLD, please put a cross in square at beginning of this sentence.
- If renewing an existing or expiring subscription for other magazine, please put a cross in square at the beginning of this sentence.

**RADIO WORLD, 145 West 45th Street, New York. (Just East of Broadway)**

**LENS-SCANNING DISC**

60-Hex Lens and 22" Aluminum Disc with Recessed holes. Easily Assembled, \$34.95. 14" Dia. \$31.95. 60-Hole Precision Punched Disc, 18" \$5.50. 24" Dia. \$6.50.

Write for Free Catalogue of Parts

**Hartman Laboratories**

1310 N. Howard St. Philadelphia, Pa.

**1,000 PAGES!  
2,000 DIAGRAMS!  
IN RIDER'S NEW  
7-POUND MANUAL**

**JOHN F. RIDER'S PERPETUAL TROUBLE SHOOTER'S MANUAL** is the book you need if you want to do profitable servicing.

This loose leaf volume contains every bit of radio service information of all popular commercial broadcast receivers manufactured since 1920 and includes the latest diagrams. In addition to the wiring diagrams of the receivers the Manual contains chassis layouts, color coding, electrical values, chassis wiring diagrams, and the wiring of units sealed in cans. It also contains a course in Trouble Shooting, the use of set analyzers, data upon Superheterodynes, automatic volume control, etc. Page size is 8 1/2 x 11, bound, 1,000 pages, index and advertisements on additional pages. Order CAT. RM-31 and remit \$4.50. We will then pay postage. Shipping weight 8 pounds. Ten day money back guarantee.

**RADIO WORLD**  
145 WEST 45th ST NEW YORK CITY

**GOOD RADIO BOOKS**

"EXPERIMENTAL RADIO ENGINEERING," by Prof. John H. Morecroft, of the Department of Electrical Engineering, Columbia University. A companion book to the author's "Principles of Radio Communication," but in itself a text on practical radio measurements. Cloth bound, 345 pages, 6 x 9, 250 figures.....\$3.50

"FOUNDATIONS OF RADIO," by Rudolph L. Duncan. A treatise for the beginner, setting forth clearly and carefully the electrical phenomena associated with radio. Just the book to give you a firm grip on the subject.....\$2.50

"THE RADIO HANDBOOK," by James A. Moyer and John F. Wostrel, both of the Massachusetts Department of Education. Meets the need for a complete digest of authoritative radio data, both theoretical and practical. Flexible binding, 886 pages, 650 illustrations.....\$5.00

Remit with order. We pay transportation.  
**RADIO WORLD, 145 W. 45th St., New York, N. Y.**

**SERVICEMEN! Resistor Replacement Manual FREE**

with purchase of 10 LYNCH Metallized Resistors, or \$1 cash More Than 200 Circuits

**LYNCH Resistors** 1, 2, 3 WATTS  
Write for Manual, new Reduced Price Catalog and RMA Color Code Card  
**LYNCH MFG. CO., INC., 1775 WR B'WAY, New York**

**POLICE LOW-WAVE CONVERTER**



Simple to attach to any Radio; enables you to tune in on local POLICE and short-wave broadcasting and get such thrilling—exciting—and often sensational items as headquarters puts on the air for RADIO-POLICE squads. Sent postpaid for \$3.00; no stamps; or send 10c in stamps for C.O.D. order; pay postman balance of \$2.90. LIVE AGENTS WANTED. Write us.

**P. L. LABORATORY**  
1460 Huron St., Dept. 40, Toledo, Ohio

**Quick-Action Classified Advertisements**

7c a Word — \$1.00 Minimum  
Cash With Order

**SHORT WAVE CONVERTER BLUEPRINTS.** Four (4) A.C. and Battery models, including a three tube A.C. self-powered converter for TRF and Superhet sets, 25c (coin). Super Engineering Lab., 1313 40th St., Brooklyn, N. Y.

"AMATEUR MOVIE CRAFT," by James R. Cameron. A book dealing with the making and showing of 16 m/m pictures and equipment necessary for same. Paper cover, \$1.00; Cloth, \$1.50. Radio World, 145 W. 45th St., New York, N. Y.

"THE CHEVROLET SIX CAR AND TRUCK" (Construction—Operation—Repair) by Victor W. Page, author of "Modern Gasoline Automobile," "Ford Model A Car and AA Truck," etc., etc. 450 pages, price \$2.00. Radio World, 145 W. 45th St., N. Y. City.

"1932 OFFICIAL RADIO SERVICE MANUAL," by Gernsback. Complete Directory of all 1931-1932 Radio Receivers. Full Radio Service Guide. Leatheroid binding, \$4.00. Radio World, 145 W. 45th St., New York, N. Y.

**THE FORD MODEL—"A" Car and Model "AA" Truck**—Construction, Operation and Repair—Revised New Edition. Ford Car authority, Victor W. Page. 703 pages, 318 illustrations. Price \$2.50. Radio World, 145 W. 45th St., New York.

**RF CHOKES VOLUME CONTROL TYPE**

Where a receiver is to be built to incorporate automatic volume control, the shielded choke, consisting of two closely coupled separate windings, may be used. Connect one winding (yellow leads) from detector plate, to the audio input. Connect the two other leads (red and black) as follows: Black to the slider of a potentiometer (400 ohms up, without limit), red to the joined grid and plate leads of a 227 tube used as automatic volume control. Connect cathode of that tube to ground (B minus), and the grid returns of coils in controlled tube or tubes to arm of the potentiometer. Put 1 mfd. from arm to ground. Order: Cat. DW-SHCH (maximum current rating, 25 ma) @.....67c

**DIRECT RADIO COMPANY**  
143 West 45th Street New York City

**SUBSCRIBE NOW!**

RADIO WORLD, 145 West 45th St., New York City. Enclosed please find my remittance for subscription for RADIO WORLD, one copy each week for specified period.

- \$10.00 for two years, 104 issues.
- \$6 for one year, 52 issues.
- \$3 for six months, 26 issues.
- \$1.50 for three months, 13 issues.
- \$1.00 extra per year for foreign postage.
- This is a renewal of an existing mail subscription (Check off if true)

Your name.....  
Address.....  
City.....