

MARCH 7  
1931

# RADIO

Price 15¢  
Per Copy

REG. U.S. PAT. OFF.

# WORLD

How to Build  
a Volt-Ammeter

The First and Only National Radio Weekly  
467th Consecutive Issue—NINTH YEAR

Lining up Coils  
and Condensers

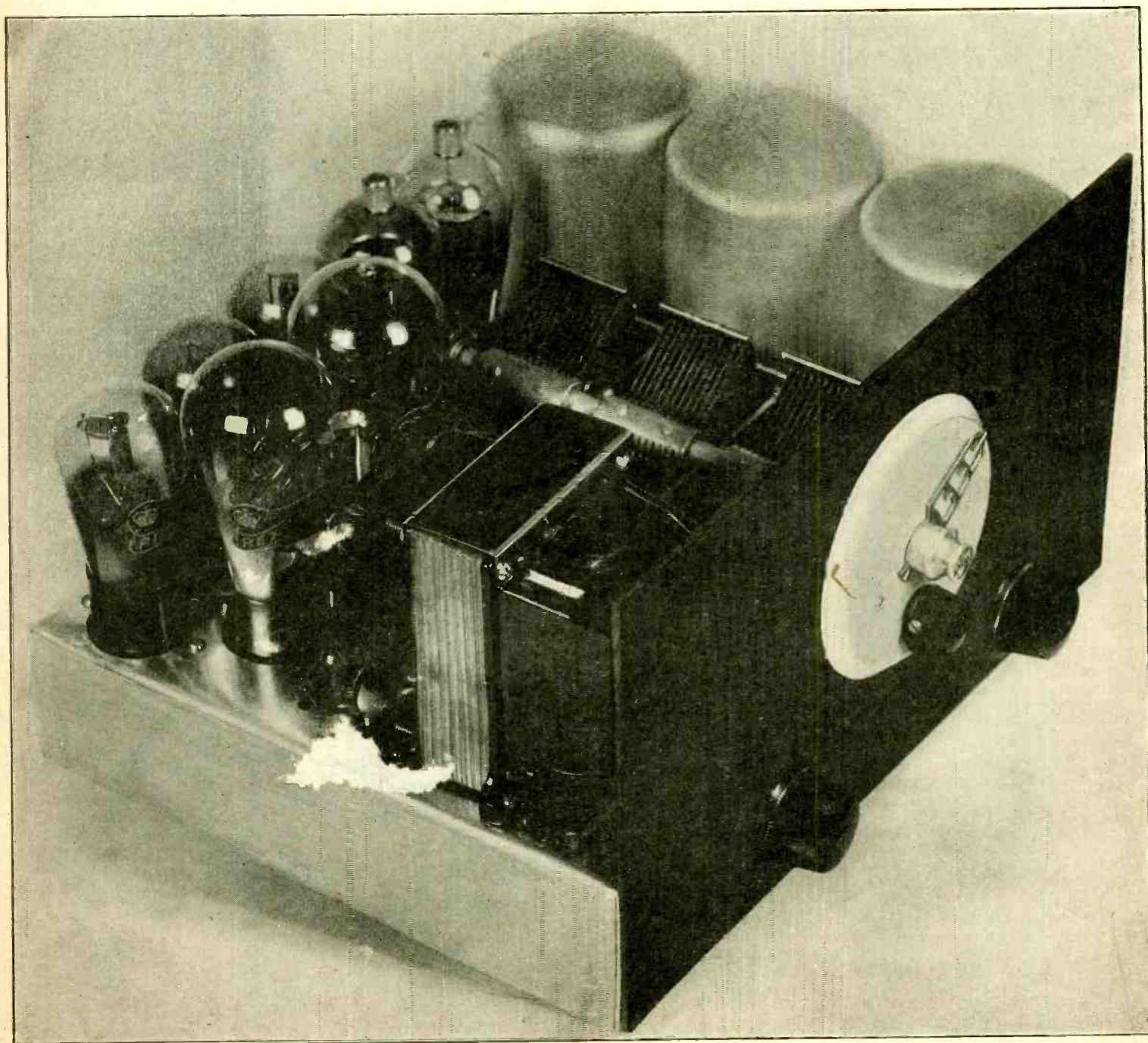

A 7-tube complete AC receiver, using a 7 x 12" front panel, is one of the Diamond Midgets described on pages 3, 4, 5, 6, 7, 8, 9 and 10

# 115 DIAGRAMS FREE!

115 Circuit Diagrams of Commercial Receivers and Power Supplies supplementing the diagrams in John F. Rider's "Trouble Shooter's Manual." These schematic diagrams of factory-made receivers, giving the manufacturer's name and model number on each diagram, include the MOST IMPORTANT SCREEN GRID RECEIVERS.

The 115 diagrams, each in black and white, on sheets 8 1/2 x 11 inches, punched with three standard holes for loose-leaf binding, constitute a supplement that must be obtained by all possessors of "Trouble Shooter's Manual," to make the manual complete. We guarantee no duplication of the diagrams that appear in the "Manual." Circuits include Bosch 54 D. C. screen grid; Balkite Model F, Crosley 20, 21, 22 screen grid; Eveready series 50 screen grid; Eris 224 A. C. screen grid; Peerless Electrostatic series; Philco 76 screen grid.

Subscribe for Radio World for 16 weeks at the regular subscription rate of \$2.00, and have these diagrams delivered to you FREE!

Present subscribers may take advantage of this offer. Please put a cross here  to expedite extending your expiration date.

Radio World, 145 West 45th St., N. Y. C.

## SUBSCRIBE NOW!

RADIO WORLD, 145 West 45th St., New York City. Enclosed please find my remittance for subscription for RADIO WORLD one copy each week for specified period:

- \$10.00 for two years, 104 issues.
- \$6 for one year, 52 issues.
- \$3 for six months, 26 issues.
- \$1.50 for three months, 13 issues.
- This is a renewal of an existing mail subscription (Check off if true).

Your name .....

Address .....

City .....

### Do You Tune or Simply Fish for Short Wave Stations?

INTERNATIONAL SHORT WAVE RADIO NEWS will bring you up-to-date schedules of Short Wave Stations throughout the World for 12 months for only \$1.00, single copy, 10 cents. In addition INTERNATIONAL SHORT WAVE RADIO NEWS will bring you all the important "dope" of happenings in Short Wave Radio everywhere.

Order Your Copies Today

INTERNATIONAL  
SHORT WAVE RADIO NEWS  
Box 22, Boston, 30,  
Jamaica Plain Station Massachusetts

### DEALERS and SERVICE MEN! STANDARDIZE ON



for Permanent Replacement—Accurate—Guaranteed  
Write for descriptive catalogue "W"  
LYNCH MFG. CO., INC., 1775 Broadway, New York



### BIG 3 FT. TELESCOPE

Five Sections, Brassbound, Powerful Lenses, 10-Mile range. Special Eye-Piece for looking at the sun, included FREE. Can be used as a Microscope. Guaranteed. Big value. Postpaid \$1.75. C.O.D. 15c extra.  
BENNER & CO., T-67, TRENTON, N. J.

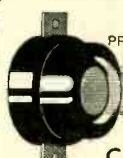

CICO CELL  
PRACTICAL PHOTO-SENSITIVE CELL OF MERIT  
SMALL—UNBREAKABLE—POSITIVE  
A SWITCH THAT IS OPERATED  
BY A BEAM OF LIGHT.  
SUITABLE FOR COUNTING, SORTING,  
TRAFFIC CONTROL, ALARMS & ETC.  
PRICE \$ 5.50 - POSTPAID  
CLARK INSTRUMENT CO.  
119 N. 4th ST., CAMDEN, N. J.

*Radite AERVOX Farador Webster de Forest*

**EXTRA** **EXTRA**

**American SALES COMPANY**  
19-21 Warren Street, New York City

Radio and Electric Wholesale Bargain Bulletin

Experimenters! Servicemen!  
**!! NOW READY !!**  
New Wholesale Catalog  
No. 66 full of real low prices on: Condensers, Transformers, Speakers, and other numerous items including replacement parts.

**GET COPY NOW**

*Graybar KOLSTER SPECTROPHOTOMETER Western Electric POWERIZER FLECHTHEIM JEWELL*

**American Sales Company**  
W-44 West 18th St., N. Y. C.

## RADIO MAP OF NORTH AMERICA

22 x 22 inches, printed in two colors, bound in cover.

Shows every city from Balboa to Edmonton which has a broadcasting station.

Indexed by states, provinces and cities with key for instant location on map.

Call letters, power and frequency given for each station.

**Accurate; up-to-date**

Scale in miles gives distances between any two cities. Time zones correctly marked.

*Just what you have been wanting.*

**25 cents**

**THE RADEX PRESS**  
1368 E. 6th St. Cleveland, Ohio

## AMER-TRAN AUDIOS

First stage, de luxe (illustrated), primary, in detector circuit, has 200 henrys inductance at 1 ma; turns ratio, 1-to-5. Cat. DL-1, list price, \$8.00 net \$4.70.

Push-pull input transformer, turns ratio, 1-to-2 1/2; single primary; two separate windings for secondary; Cat. 151, list price, \$12; net, \$7.05.

[Remit with order and we pay transportation.]

**GUARANTY RADIO GOODS CO.**  
143 West 45th Street, New York, N. Y.

# The New Jiffy Tester

## Chromium-Plated Case and Accurate Meters

**A** NEW and improved Jiffy Tester, improved in both performance and appearance, is Model JT-N. The meters are of the moving iron type. Tested on precise batteries, they show errors not exceeding 2%. As for appearance, the case is first copper plated, then nickel plated, then chromium plated, giving a lustrous, permanent, non-peeling non-rusting finish. It is the same finish found on hardware in fine automobiles. The handle and lock strap are genuine leather.

Jiffy Tester, Model JT-N, consists of three double-reading meters, with cable plug, 4-prong adapter, test cords and screen grid cable, enabling simultaneous reading of plate voltage, plate current and filament or heater voltage (DC or AC), when plugged into the socket of any set. The ranges are filament, heater or other AC or DC; 0-10 v, 0-140 v; plate current; 0-20, 0-100 ma; plate voltage; 0-50, 0-300 v. It makes all tests former models made. Each meter is also independently accessible for each range. The entire device is built in a chromium-plated case with chromium-plated slip-cover. Instruction sheet will be found inside. Order Cat. JT-N.

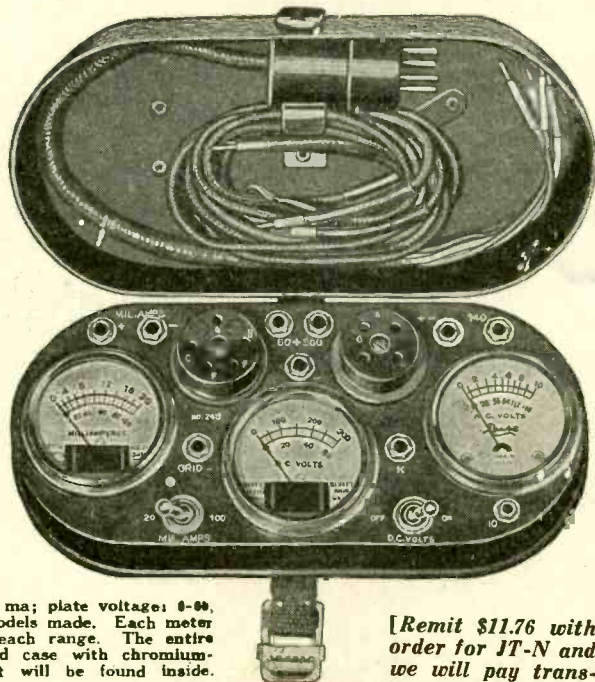

[Remit \$11.76 with order for JT-N and we will pay transportation.]

**GUARANTY RADIO GOODS CO.**  
143 WEST 45th STREET (Just East of Broadway) NEW YORK, N. Y.



Vol. XVIII. No. 25 Whole No. 267  
 March 7th, 1931  
 [Entered as second-class matter, March 1922, at the Post Office at New York, N. Y., under act of March, 1879]  
 15c per Copy, \$6.00 per Year

NINTH YEAR  
 Technical Accuracy Second to None  
 Latest Circuits and News

A Weekly Paper published by Hennessy Radio Publications Corporation, from Publication Office, 145 West 45th Street, New York, N. Y.  
 (Just East of Broadway)  
 Telephone, BRyant 9-0558 and 9-0559

RADIO WORLD, owned and published by Hennessy Radio Publications Corporation, 145 West 45th Street, New York, N. Y. Roland Burke Hennessy, president and treasurer, 145 West 45th Street, New York, N. Y.; M. B. Hennessy, vice-president, 145 West 45th Street, New York, N. Y.; Herman Bernard, secretary, 145 West 45th Street, New York, N. Y.; Roland Burke Hennessy, editor; Herman Bernard, business manager and managing editor; J. E. Anderson, technical editor.

# The Diamond Midgets

By Herman Bernard

**FIG. 1**  
 The Diamond HS Tuner, so-called because it has heater supply built in. The first tube is preceded by a filter tuner that prevents cross modulation. Switches may be built into the coils to permit short-wave reception.

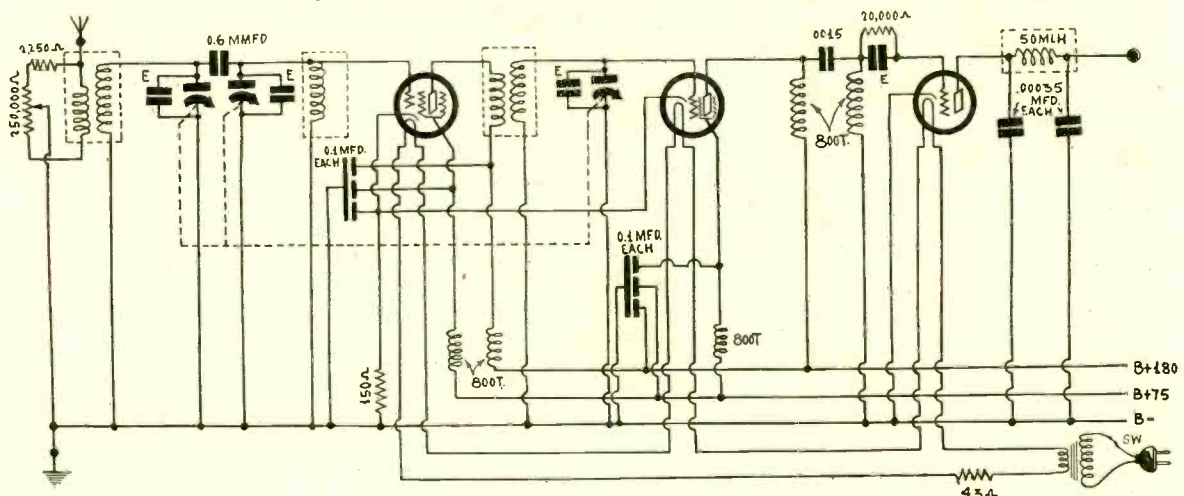

[Herewith is a mighty interesting article, describing Diamond tuners and receivers, all embodying the same radio frequency circuit with pre-selector tuning. Compactness marks all models and puts them in the midget class, in size only, not in performance. The speaker is to be used externally. The circuits are:

- (1)—A tuner for AC operation, without B supply.
- (2)—A tuner for AC operation with B supply.
- (3)—A complete AC receiver.
- (4)—A tuner for battery operation.
- (5)—A complete battery-operated receiver.

The variety therefore meets every one's individual requirement, no matter if the builder's home is wired for electricity or not, or whether he has an audio power amplifier or not. Besides, the battery models are brought up to the performance level of the AC models, except in the case of the receiver's maximum undistorted power output.—EDITOR.]

## THE DIAMOND HS TUNER

THE use of the screen grid tube as a radio frequency amplifier has become virtually standard practice, but the requirement for providing adequate selectivity ahead of the first tube becomes more and more emphatically realized as experiments with the use of this tube are carried on.

Up-to-date receivers generally include a doubly-tuned circuit to take care of this necessity, and in that way the antenna input may be at a relatively high level without causing cross modulation. The strong local station that would cause interference even at frequencies considerably removed from its own frequency is thereby tuned out successfully, and the first tube is not subject to detection by shock excitation.

A good way to utilize three tuned circuits is to have two of them ahead of the first tube, and the next one an interstage coupler. Then you have a good radio frequency channel, although one subject to

(Continued on next page)

## LIST OF PARTS

### Coils

- One shielded antenna coupler for .0005 mfd. (15-75)
- One shielded tuned impedance RF coupler for .0005 mfd. (75)
- One shielded interstage screen grid coupler for .0005 mfd. (25-75)
- Five 800-turn duo-lateral wound RF choke coils.
- One copper shielded 50 mH radio frequency choke coil (SH-RFC)
- One filament transformer for series heaters (FTSH)

### Condensers

- One 0.6 mmfd. Hammarlund fixed condenser (FC-6)
- Four 100 mmfd. Hammarlund equalizers (EQ-100)
- One three-gang Scovill .0005 mfd. tuning condenser, brass plates (SC-3G)
- Two blocks, three 0.1 mfd. condensers in each block (SUP-31)
- One .0015 mfd. fixed condenser (MICON-15)
- Two .00035 mfd. fixed condensers (MICON-35)

### Resistors

- One 4.3 ohm fixed resistor, 2 ampere rating (CL-43)
- One Electrad 150 ohm flexible biasing resistor (EL-150)
- One 2,250 ohm fixed resistor (FR-225)
- One 250,000 ohm potentiometer (POT-250)
- One .02 meg. pigtail resistor, 20,000 ohms (PGT-02)

### Other Parts

- One 9 1/4 x 8 x 3 inch metal subpanel, with socket holes drilled (37-3ASP)
- Two UY (YSO) and one UX socket (XSO)
- Two knobs (KB)
- Three binding posts, for antenna, ground and output (BPA, BPG, BPO)
- One AC shaft type switch (STSW)
- One REL Vernier dial (REL)
- One 25-ft. roll of slide-back hookup wire (HW)
- One AC cable (CAL)
- One male plug (MP)
- One 7x12 inch drilled front panel (black or walnut bakelite)

# Tuner and Complete Rec

## Signal Selector With and Without B Supply,

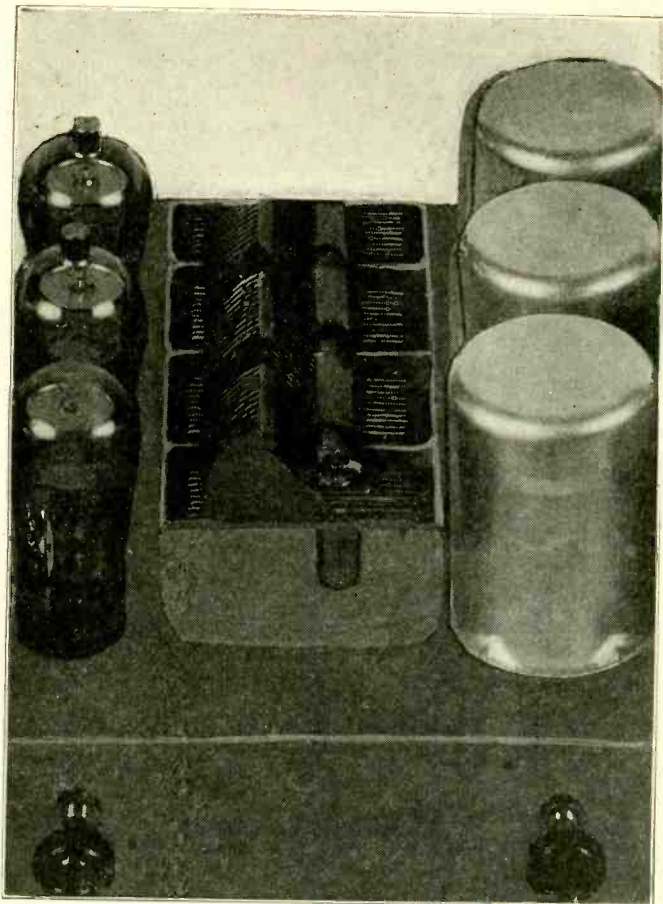

FIG. 2

View of the tuners. Both the HS and HB Models have the same appearance.

(Continued from preceding page)

the familiar effect of amplifying more greatly at the higher radio frequencies.

### Uniform Radio Frequency Amplifier

There are several ways of meeting this situation. One is by use of a combination of inductive and capacitive coupling, because then each type of coupling works in the opposite direction, the inductive predominating at the higher radio frequencies and the capacitive at the lower radio frequencies. Another, and the one adopted in the present instance, is to use a pair of radio frequency choke coils to couple to the detector. Thus a second stage of radio frequency amplification is introduced, and it is one broadly peaked at around 600 meters, provided the chokes have the proper inductance. This may be obtained from 800 turns of No. 38 silk enamel wire, wound on any convenient diameter, it being preferable, however, to use the duolateral (honeycomb) type of winding, for then the distributed capacity may be less than 1 mmfd.

It can be seen, therefore, that the extra stage provides much greater amplification in the region where the rest of the tuner provides much less amplification, so the total overall result is to achieve relatively uniform amplification over the broadcast band of wavelengths.

### A Wholesome Process

Another advantage relates to squealing. Since the amplification is not disproportionately high at the upper frequency end, the tuner does not have to be damped to suppress oscillation, since the very excess of amplification at the high frequencies, that causes squealing only in this region, is absent. Amplification has been taken away from the higher radio frequencies, and given to the lower ones, but this is a wholesome process. Other methods usually result in the purposeful reduction of amplification at the higher frequencies, to stop squealing, with inevitable and unintentional reduction also at the lower frequencies, where, above everything else, the amplification should be increased. In one instance there exists what may be termed waste, while in the other what is taken from an overfed body is given to an undernourished one.

So many have had the experience of building a tuner that was adequate at the higher radio frequencies, but suffered severely in

volume at the lower radio frequencies, that they should experiment along the lines of more nearly equal amplification throughout the broadcast band. If the experiments are made along the lines suggested here, excellent success should result.

The necessity for introducing some method of building up the broadcast band. If the experiments are made along the lines suggested at the higher ones, is heightened by the fact that shielding is used with coils in nearly all present-day circuits. The principal reason for using shielding is to prevent stray inductive coupling between stages, to confine the coupling to the intended media.

### Shields Alone Do Not Solve Problem

For the same reason of close confinement of the current paths, radio frequency choke coils are used in screen leads and plate leads, bypassed by suitable capacity condensers, say 0.1 mfd. But if the load is itself a choke coil, no extra choke need be introduced, for the load is virtually all that any additional adjunct would be.

Shielding introduces a loss, in effect due to the increased resistance, which cuts down the amplification most at the higher radio frequencies. This situation would seem to be gratifying. However, while reduction is greatest where needed most, it is also present (though proportionately less) at the lower frequencies. The point is, again, that we desire the amplification at the lower frequencies to be greatly improved, not curtailed. So the use of shielding alone does not solve the problem.

To enable good response at these slighted lower radio frequencies, the antenna input should be adequate. This requires a tuning system ahead of the first tube that will provide the required selectivity, despite the generous proportions of the input. It has been found that cross modulation can be prevented by reducing the degree of coupling between antenna and set, as by the introduction of a series condenser in the antenna circuit, say, .0005 or .00035 mfd. fixed capacity. This reduces the volume at all frequencies, so it would then become necessary to introduce a corrective, for instance, regeneration.

### Broadcast Band in Full, Some Short Waves Optional

However, without resorting to regeneration, which is a method of obtaining greater sensitivity that hardly appeals to the family, the amplification may be maintained substantially uniform throughout the dial scale, with adequate selectivity, by utilizing the circuit of the Diamond HS Tuner, Fig. 1. All the precautions deemed desirable, as already outlined, have been incorporated, including doubly tuned input, screen and plate filtration where required, stage of levelling amplification, and even a volume control in the preferred position, with minimum setting not totally removing the signal, due to the permanent inclusion of 2,250 ohms.

Besides these features there are a heater supply from a special transformer (heaters being in series), and inductances tapped to permit reception of short waves simply by pulling out three switches. The short-wave range is about 30 to 115 meters, while the broadcast range will depend slightly on the trimmer capacity setting, but will exceed the broadcast band a little, at all hazards. Normally the curve is from 196 to 551 meters.

Some special features of the circuit are particularly interesting. The filter tuner ahead of the first tube consists of a radio frequency transformer, with secondary tuned by one of the gang condenser sections, with a single coil, tuned by another section, coupled to the previous secondary by a capacity that on the face of it looks suspiciously small. That capacity is only 0.6 mmfd. Expressed in microfarads it is .000006 mfd. It is a special condenser, tiny in size as in capacity, and is made by the Hammarlund Manufacturing Company.

### Why .000006 Mfd. Is Large Enough

The reason for using so small a capacity is, of course, that it is large enough for the purpose. The potentials at the plates of this condenser are "hot," and the slight capacity has a relatively large effect. The coupling between the two tuned circuits is almost as strong as is that between the antenna winding and its associated secondary. Besides, use of a much larger capacity would be prohibitive, because destructive of tuning synchronism. A large condenser here would have the effect of increasing greatly the coupling between the two circuits, thus tending to unite the two inductances in parallel (with the net result a reduction), while tending to combine the tuning capacities in parallel (with net result an increase). There would be a severe diversity, tuning would be broad and the circuit very insensitive. With the small capacity quite the opposite is true. Sharp tuning is present, sensitivity and selectivity are high.

This tiny capacity may be viewed from another interesting angle. Considering the alternating current flowing through the condenser, and the voltage across the condenser, when the voltage on one side is in phase with the current, the voltage on the other side is out of phase with the current. Were this capacity high, the phase displacement would be small. The higher the capacity, the smaller the phase difference. So, with the "mere speck of capacity" used as diagrammed, and with a phase displacement of the voltages at

# Receiver for AC Operation

## also 7-Tube Speaker Set Equal to AC

the respective plates being substantial in respect to the current flowing through the condenser, a point is gained in favor of stability. There is less likelihood of running into squealing trouble, because in the circuit where the squeals are most likely to be predominant (the first radio frequency amplifier, in the grid circuit of which this tuning arrangement is connected), there is this phase dislocation that acts as a neutralizing agent.

The bias for the first and second radio frequency amplifiers is obtained through a common resistor of 150 ohms, affording a negative bias of 1.5 volts, when a total of 10 milliamperes flows through it. This current is the combined screen and plate currents of two tubes and flows when the plate voltage is 180 volts, the screen voltage 75 volts and the biasing resistor as prescribed.

### Leak-Condenser Power Detection

The detector is of the leak-condenser type, yet it is a power detector. This new form of detection was developed by Prof. Frederick E. Terman, of Leland Stanford, Jr., University. High plate voltage and low values of grid leak and condenser are required. The value cited for the grid leak in Fig. 1 is 20,000 ohms (.02 meg), while the condenser, E, is a Hammarlund equalizer of 100 mmfd. maximum capacity, used at full setting, screw turned all the way down. E represents these equalizers elsewhere in the diagram, too.

The output of the detector is filtered through a 50 mlh. radio frequency choke coil, with a .00035 mfd. condenser from each side of this coil to ground. The two condensers complete the filtration,

supplementing the action of the choke coil, which is in a copper shield. This tuner requires that the B voltages be supplied externally, and also that, for speaker operation, an audio power amplifier be used. This amplifier should consist at least of two transformer stages, or one resistance stage and one transformer stage, push-pull or otherwise, or three resistance-coupled stages, to provide the desired volume on far-distant stations. The gain under these circumstances may be more than 300 in the audio channel, which is in line with modern practice.

It should be observed that since the heaters are in series, no tube will be heated unless all three tubes are heated. The current taken from the secondary of the filament transformer is 1.75 amperes, since current is the same in series connection, when the voltage is increased to make up the difference. So the voltage from one side of the filament transformer secondary to the far side of the limiting resistor of 4.3 ohms is  $3 \times 2.5$  volts, or 7.5 volts.

As for connections, antenna and ground are brought to the respective binding posts, while the only other post is for the output of the detector. The B voltage for the detector will be supplied automatically from the power amplifier, since the tuner output would go, for instance, to an audio transformer primary or to one side of a resistor, or audio choke coil, the other side of which is connected to B plus in the amplifier. However, if this B voltage in the amplifier is 45 volts or so, intended for conventional leak-condenser detection, increase the voltage to 90 to 180 volts.

This model of the Diamond tuner is called HS, because only the heater supply is built in. Another model contains B supply as well.

**FIG. 3**  
A completely AC operated device is the Diamond HB Tuner, with heater and B supplies built in. Note the special 227 rectifier, the invention of J. E. Anderson and Herman Bernard. This tuner may be used for earphone reception or for feeding an audio power amplifier that does not furnish external voltage.

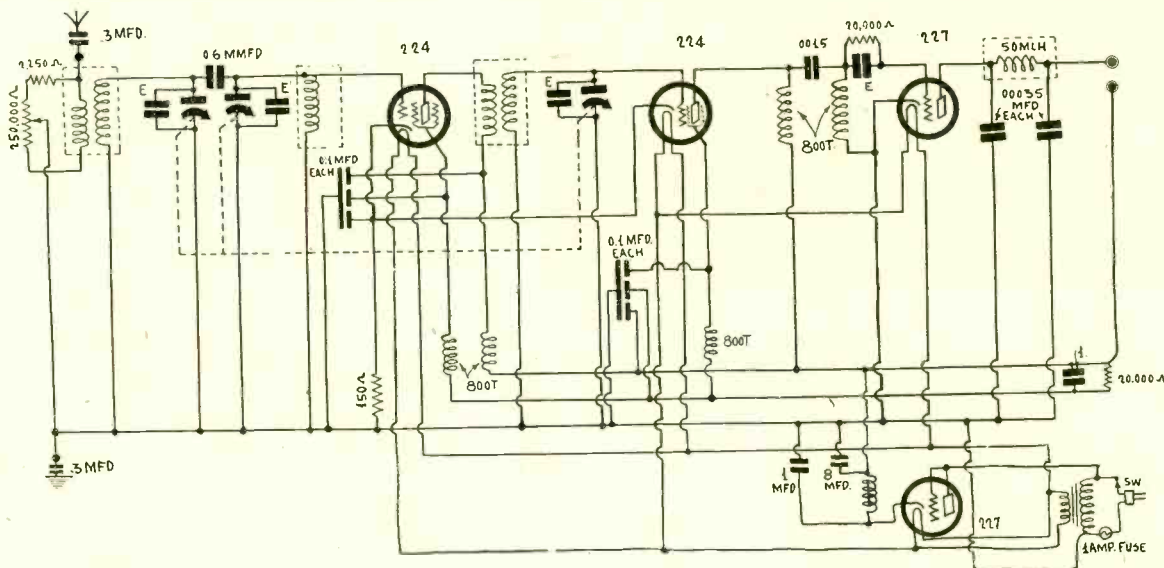

### THE DIAMOND HB TUNER

**M**ANY radioists possess an audio power amplifier that has everything in it required for its own purpose, but which is not intended to supply any voltage externally. An example of such power amplifiers are the Series 80 line made by American

Transformer Company. Almost any load may be put on a power amplifier when external voltages are accessible, so the voltages actually applied to the power amplifier itself—heater, filament, bias, plate and screen voltages—will be lower, the larger the external drain.

To the possessors of power amplifiers thus independently constituted a tuner that is completely self-operated is attractive. So the same circuit shown in Fig. 1 is presented in the totally-operative  
(Continued on next page)

### LIST OF PARTS

#### Coils

- One shielded antenna coupler for .0005 mfd. (15-75)
- One shielded tuned impedance RF coupler for .0005 mfd. (75)
- One shielded interstage screen grid coupler for .0005 mfd. (25-75)
- Five 800-turn duo-lateral wound RF choke coils.
- One copper shielded 50 mlh radio frequency choke coil (SH-RFC)
- One filament transformer for parallel heaters (SUP-FT)
- One 30 henry choke (K-30)

#### Condensers

- Two 1 mfd. condensers (POL-1)
- One 8 mfd. electrolytic (C-8)
- One 0.6 mmfd. Hammarlund fixed condenser (FC-6)
- Four 100 mmfd. Hammarlund equalizers (EQ-100)
- One three-gang Scovill .0005 mfd. tuning condenser, brass plates (SC-3G)
- Four blocks, three 0.1 mfd. condensers in each block (SUP-31)
- One .0015 mfd. fixed condenser (MICON-15)
- Two .00035 mfd. fixed condensers (MICON-35)

#### Resistors

- One 4.3 ohm fixed resistor, 2 ampere rating (CL-43)
- One Electrad 150 ohm flexible biasing resistor (EL-150)
- One 2,250 ohm fixed resistor (FR-225)
- One 250,000 ohm potentiometer (POT-250)
- Two .02 meg. pigtail resistor, 20,000 ohms (PGT-02)

#### Other Parts

- One 9 1/2 x 9 1/2 x 3 inch metal subpanel, with socket holes drilled (DHPT-SP)
- Four UY sockets (YSO)
- Two knobs (KB)
- Four binding posts (for antenna, ground and output)
- One AC shaft type switch (STSW)
- One REL Vernier dial (REL)
- One 25-ft. roll of slide-back hookup wire (HW)
- One AC cable (CAL)
- One male plug (MP)

# Parts and Layout of Di

Operation Singularly Free from Hum,

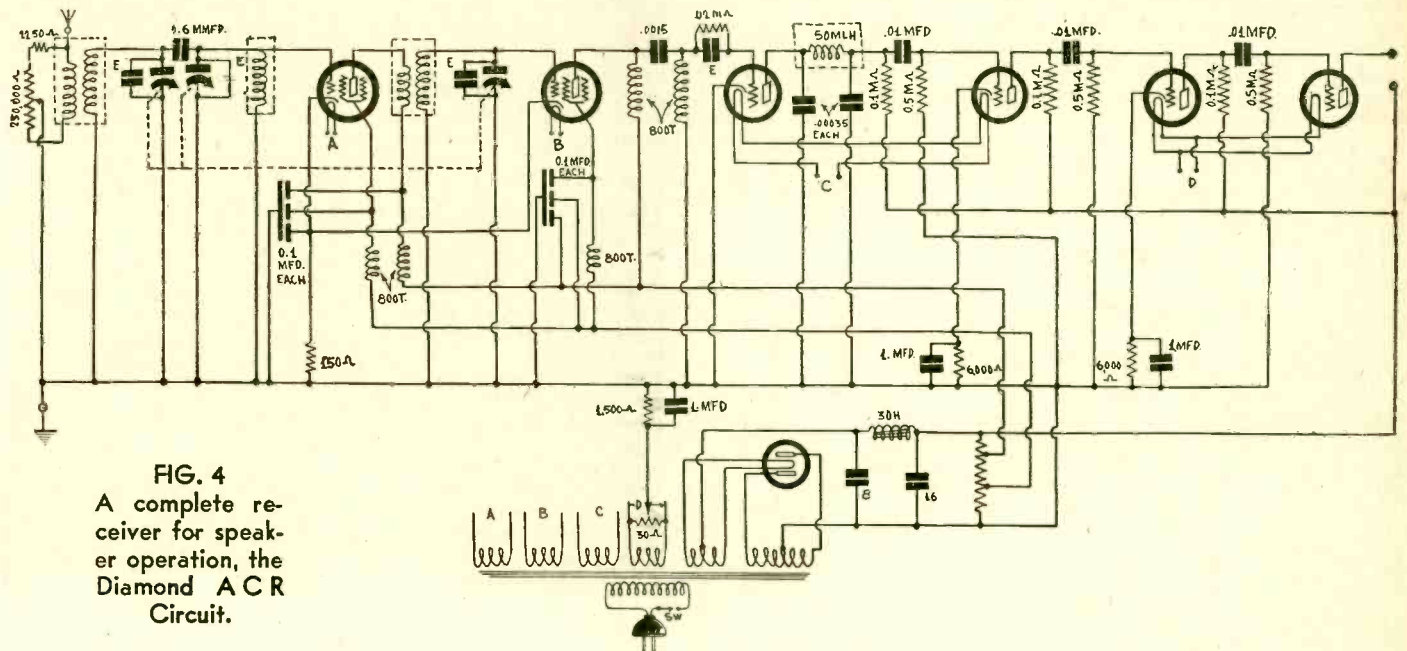

FIG. 4  
A complete receiver for speaker operation, the Diamond ACR Circuit.

(Continued from preceding page)  
form, known as the Diamond HB Tuner, because it contains both the heater and B supply.

There is certainly nothing complicated by the B supply. It consists simply of a 227 rectifier, with the alternating current taken directly from the line, and introduced between the united plate-grid (negative plate) and the cathode of the rectifier (positive

plate). In all instances the cathode is positive with the 227 used as rectifier.

The total B current drawn by the tuner and associated equipment is only 12.5 milliamperes, and this is well within the working limits of the 227 tube used as a rectifier. In fact, up to 20 milliamperes have been drawn from this same rectifier, with good results, the only difference being that a slight hum was present when the current taken was so high.

## LIST OF PARTS

### Coils

- One shielded antenna coupler for .0005 mfd. (15-75)
- One shielded tuned impedance RF coupler for .0005 mfd. (75)
- One shielded interstage screen grid coupler for .0005 mfd. (25-75)
- Five 800-turn duo-lateral wound RF choke coils
- One copper shielded 50 mlh radio frequency choke coil (SH-RFC)
- One power transformer (K-245)
- One 30-henry B supply choke coil (K-30H)

### Condensers

- Three 1 mfd. condensers (POL-1)
- One 0.6 mmfd. Hammarlund fixed condenser (FC-6)
- Four 100 mmfd. Hammarlund equalizers (EQ-100)
- One three-gang Scovill .0005 mfd. tuning condenser, brass plates (SC-3G)
- Two blocks, three 0.1 mfd. condensers in each block (SUP-31)
- One .0015 mfd. fixed condenser (MICON-15)
- Two .00035 mfd. fixed condensers (MICON-35)
- Three 8 mfd. electrolytics (C8)

### Resistors

- One 1,500 ohm 5 watt resistor (R-1500)
- One Electrad 150 ohm flexible biasing resistor (EL-150)
- Two 6,000 ohm 5 watt resistors (R-6000)
- Three 0.1 meg. pigtail resistors (PGT-110)
- Three 0.5 meg. pigtail resistors (PGT-510)
- One 2,250 ohm fixed resistor (FR-225)
- One 250,000 ohm potentiometer (POT-250)
- One .02 meg. pigtail resistor, 20,000 ohms (PGT-02)
- One voltage divider, 50 watt, 15,000 ohms minimum (VD)

### Other Parts

- One 9½x12x3 inch metal subpanel, with three socket holes drilled (37-3ASP)
- Two UY (YSO) and one UX socket (XSO)
- Two knobs (KB)
- Four binding posts for antenna, ground and output (BPA, BPG, BPO)
- One AC shaft type switch (STSW)
- One REL Vernier dial (REL)
- One 25-ft. roll of slide-back hookup wire (HW)
- One AC cable (CAL)
- One male plug (MP)
- One 7x12 inch bakelite panel, black or walnut (DFP)

## Current and Voltage

When the current is 12.5 milliamperes the DC voltage is 92.4. This is because the current drawn is small. You can get direct current equal to the peak value of the alternating current if you do not draw any current from the rectifier. The peak value of AC is 1.41 times the root mean square value, so 110 volts AC, as rated in considering the line voltage, may have a peak value of 155.1 volts. The voltage drop in the rectifier is zero when no direct current is drawn, so with no current the DC value may be 155.1 volts also. However, rectifiers do not serve any purpose until current is drawn, and when it is drawn the resistance of the tube becomes effective. It so happens, then, that the root mean square value of AC input to this rectifier is 16% above the resultant DC value for use with the tuner, when 12.5 milliamperes flow.

## Current Rises

The current is not steady at first, naturally enough. When the switch is turned on, no current flows because all tubes are of the heater type, and the heaters being cold, do not emit electrons. As the heaters begin to warm up, current starts to flow. At first, the flow starts to rise from zero to 5 ma. or so, and will rise perhaps to 20 milliamperes temporarily, due principally to the high capacity condenser charging up, but the current will subside quickly to a normal value, around 12.5 ma. It is not essential that the steady value of current be just that. It may be more or less, due to difference in line voltage. If the current is a little less there is nothing to worry about, but if it goes beyond 18 ma. the tuner may hum just a little. Otherwise it is singularly free from hum, due in part to the action of the primary of the filament transformer serving as a B supply choke coil, but principally to the large capacity condenser.

[This completes the text on the two AC Diamond tuners, one without B supply built in (Model HST), the other with B supply (HBT). The diagram of the remaining AC circuit, the complete receiver (Model ACR) is published on this page, and the text concerning it will be found on the next page. It is recommended that a careful study be made of these three circuits, if one is interested in AC models, and that suitable choice be made accordingly. On page 8 will be found the beginning of the discussion of the battery models using 2 volt tubes throughout. These are the tuner (Model BTU) and the complete receiver (Model DBR). The design of the battery circuits is such as to bring their performance up to that of the AC models. Location requirements will largely determine the choice from among this assortment of five models, constituting a comprehensive array for the satisfaction of virtually all personal requirements.—EDITOR.]

# iamond Midget Receiver

as 24 mfd. of Filter Capacity is Used

## The Diamond ACR Circuit

ON a chassis 12 inches wide by 9½ inches front to back, with elevation flap 3 inches high, these being overall dimensions, the complete AC receiver is built. This has a 245 power supply, with transformer windings that provide heater and filament voltages and currents, and adequate plate voltages as well, to energize the receiver.

### Rectifier Current

The power transformer is a small one, in physical size, but it has enough core and large enough diameter wire on the windings to stand the strain. The total plate current is not large for a B supply of this sort, however, so even a modest power transformer would fit the requirements. The total plate current drawn by the set is less than 50 milliamperes, while the only other current from the rectifier is that taken by the voltage divider itself, and will depend on the resistance of the divider. The maximum output voltage is 300 volts at 70 milliamperes, slightly less at higher drain, slightly more at lower drain. The bleeder current can be determined approximately, by disregarding the regulation of the rectifier (that causes voltage to change with current drain) and figuring on 300 volts. Divide the voltage in volts by the resistance in ohms. Thus, if the voltage divider has a resistance of 20,000 ohms, the bleeder current would be 15 milliamperes, and the total current from the rectifier (plate current plus bleeder current) would be 15 ma plus 50 ma, or 65 ma.

### Excellent Filtration Established

In a receiver that has a good audio amplifier it is most important to provide adequate filtration. In the present instance this is established to a point beyond which it is of little value to go, since there is less than the allowable 5 per cent. hum component. In fact, it is nearer 2 per cent., which means that even those most critical about eradicating hum will be perfectly satisfied.

Another point in the same direction is the fact that no coils are used in audio coupling. These might set up a field that would couple with that of some other coil, including the power transformer, and introduce hum. These remarks have no reference to radio frequency coils, as the frequency difference is so great there would be no modulation by 60-cycle pickup even if the coils were not shielded, but of course shields are used.

The condenser next to the rectifier has a capacity of 8 mfd. and is of the electrolytic type, since this affords high capacity in compact and enduring form. A great wave of popularity has set in for electrolytic condensers, since they have been brought to a point of fine performance. The need for high capacity has been appreciated all along, but when paper condensers were the vogue the cost of high capacity at high voltage rating became prohibitive. Now we think nothing of using 8 mfd. next to the rectifier, because the electrolytic condenser costs less than a paper condenser of 2 mfd. of the same voltage rating.

### Reservoir Capacity

And, at the end of the filter section, two 8 mfd. electrolytic condensers are used in parallel, to constitute 16 mfd. Thus abundant reservoir capacity is provided where it is needed most. The condenser at this position stores up electricity and supplies it to the set when strong low notes call for a heavy delivery of current. Part of this current is taken instantaneously from the rectifier circuit itself, but most of it from the storage tank at the end of the filter, that is, the 16 mfd. capacity.

The B supply choke coil need have only an untapped winding, since if the capacity is large enough at the two ends, as it is in this circuit, the filtration will be excellent, and no midtap or similar device need be used. In fact, it sometimes happens, due to an unexpected twist in phase relationships, that the use of a condenser from some intermediate tap of a B choke will increase the hum, rather than decrease it. Here, however, we have no such possibility, due to resort to large capacity with adequate inductance choke to solve the problem. Chokes having a commercial value of 30 henries are quite sufficient.

### Audio Channel Stable

The stability of the audio amplifier is assured, both by the adequacy of the filtration capacity and the values of the isolating condensers (.01 mfd.) and grid leaks (0.5 meg.). It is quite permissible, however, to try larger values of grid leaks, so long as you do not introduce audio oscillation. This subject will be found discussed more fully under the consideration of the battery-operated complete receiver.

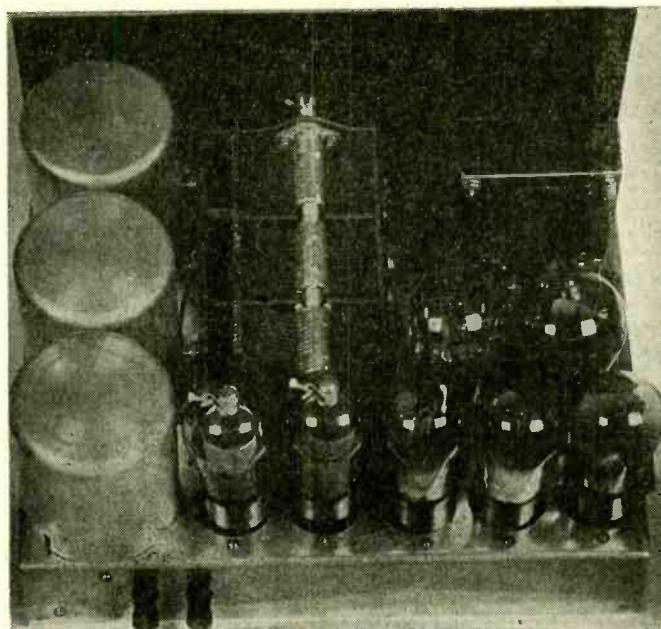

Fig. 5  
View of the completed AC receiver.

The top plan of the complete AC receiver is shown in Fig. 6, conforming to the photographic view. The dimensions for the socket holes are given. It is assumed that wafer type sockets will be used, and the chassis is punched for this purpose. The fit will be a close one for the tubes, but there is enough room to accommodate them, especially if you see to it that they are put into the socket straight.

The elevation of the chassis top is 3 inches over all. This is determined by the elevation of the B supply choke used in the AC models, as this choke goes under the tuning condenser. As the same chassis is used for the battery model receiver, the same 3 inch height prevails.

Regarding this height, in respect to the front panel, it is obvious that 3 inches plus the elevation of the screen grid tubes will total a little more than 7 inches, so the tubes will be higher than the top of the front panel. This is all right, for if a cabinet is used (and one may be obtained commercially, if desired), there will be a stringpiece across the front, almost 1 inch high, and the cabinet lid therefore comes down at a height of 8 inches from the bottom of the front panel. This is true of nearly all cabinets, by the way. Moreover, no problem presents itself in console installations, either, as then there is a great deal of room to spare.

[The battery models are described on pages immediately following.]

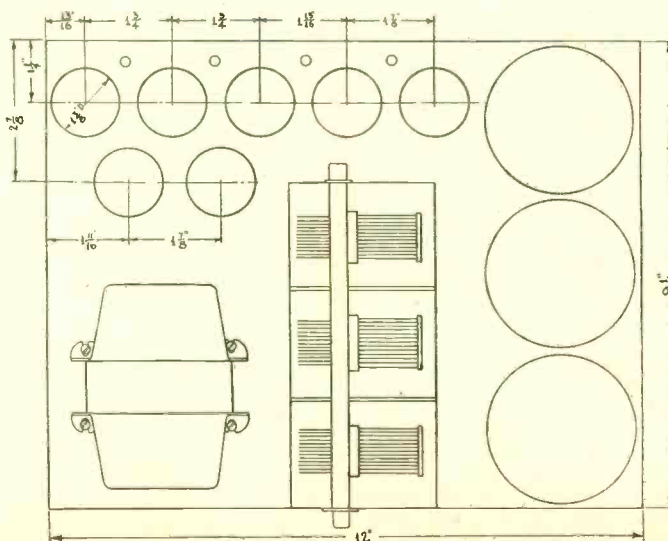

Fig. 6  
Dimensions of top of subpanel, with location of parts.

# Compact Diamonds

## New 2-Volt Tubes Used in Tuner

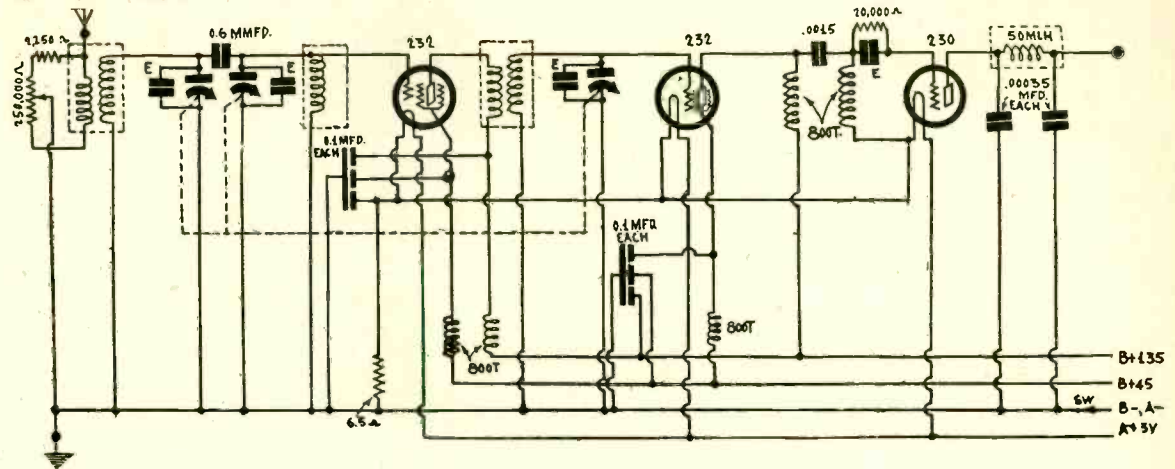

Fig. 7  
This tuner Model BTU, is for battery operation of filaments and plates.

### THE 2-V DIAMOND TUNER, MODEL BTU

**B**OTH the tuner and the complete receiver are presented for battery operation, using the 2-volt tubes, of which the 232 is the screen grid tube, the 230 the general purpose tube (each of these drawing .06 ampere filament current at 2 volts), while the power tube is the 231 (drawing .12 ampere at 2 volts). In the instance of the tuner we are concerned only with the 232 and 230 tubes.

The tuner RF circuit is the same for battery operation as is the AC model, and the performance of both is on a par, only such changes having been introduced as were required by the difference in the type of tubes and the voltages.

The input circuit to the first tube is the same, embodying the pre-selector, while the filament resistor of 6.5 ohms also is the biasing resistor for the two radio frequency amplifiers. The 6.5 ohm filament resistor, through which the total current is .192 ma, drops almost 1.3 volts. This current is due to the addition of the filament currents of the three tubes, equalling .18

amperes and the plate current of these tubes, equalling .12 ampere.

### Two No. 6 Cells for "A" Supply

The voltage on the filaments, when the source is 3 volts, therefore is 1.7 volts, instead of the rated 2 volts, but it has been found that such is a safe operating point, and avoids all danger of putting too much voltage on the filament, if the simple precaution is taken to use a 3-volt source. This may consist simply of two No. 6 dry cells connected in series. This constitutes the A battery, since a battery is composed of two or more cells.

Since the negative bias is equal to the voltage drop in the filament resistor, this bias is 1.3 volts, which is sufficient, even though the usually recommended bias is 3 volts. While the plate current is increased by the use of the smaller bias, so is the volume. Moreover, the 1.3 volt bias is ample for quality purposes, as neither of the radio frequency amplifiers will be called upon to handle a signal voltage so large as to require more than 1.3 volt bias.

The detector bias is actually slightly negative, although it appears from the diagram to be zero bias, due to grid return to negative filament. All biases for battery operation are reckoned from the negative filament. However, a peculiarity of tube operation is that when the apparent zero bias return is applied, the grid is slightly negative because of grid current flow.

### More Output at Higher Voltage

The leak-condenser power detector in this instance, as in the previous examples, requires a higher plate voltage than normally used for leak-condenser detection, so the positive voltage application (not shown, as it might be in an additional audio channel you may use), should be made 90 or 135 volts. At the higher voltage you will get more out of the detector.

Of course, the tuner may be used solely for earphone reception, in which instance one side of the phones would go to the plate output post and the other side of the phones to B plus 135 volts.

Since wired connections are required from batteries to the tuner, it is advisable to have a UY socket in the tuner chassis into which a five-prong plug fits. This plug is cabled. Only four leads need be used for battery purposes of the five available, or the antenna may be connected to the cable for utilization of the fifth lead. It is well to adhere to a given system of connecting the different colored leads of the cable. In respect to the five-prong (UY) socket used for receiving the cable plug, the leads with recommended connections, are:

Cable Color	Connects to	Tuner Use
Blue with white marker	Grid	Aerial
Red	Plate	B+135
Green	Cathode	B+45
Yellow	Heater nearer plate	A+
Black with yellow marker	Heater nearer cathode	B-, A-

### Battery Connection Outlined

The method of connecting the batteries is as follows:  
Two No. 6 dry cells, 1½ volts each, are connected with center of one (positive) to the binding post on rim of the other (negative). Thus on the battery so constituted there remain a positive post (center) and a negative post (outside) not yet used. These two are the polarities of the 3-volt battery, comprised of two dry cells in series.

Three 45-volt B batteries are required, and may be of the

### LIST OF PARTS

#### Coils

- One shielded antenna coupler for .0005 mfd. (15-75)
- One shielded tuned impedance RF coupler for .0005 mfd. (75)
- One shielded interstage screen grid coupler for .0005 mfd. (25-75)
- Five 800-turn duo-lateral wound RF choke coils
- One copper shielded 50 mlh radio frequency choke coil (SH-RFC)

#### Condensers

- One 0.6 mmfd. Hammarlund fixed condenser (FC-6)
- Four 100 mmfd. Hammarlund equalizers (EQ-100)
- One three-gang Scovill .0005 mfd. tuning condenser, brass plates (SC-3G)
- Two blocks, three 0.1 mfd. condensers in each block (SUP-31)
- One .0015 mfd. fixed condenser (MICON-15)
- Two .00035 mfd. fixed condensers (MICON-35)

#### Resistors

- One 6.5 ohm fixed resistor (CL-65)
- One 2,250 ohm fixed resistor (FR-225)
- One 250,000 ohm potentiometer (POT-250)
- One .02 meg. pigtail resistor, 20,000 ohms (PGT-02)

#### Other Parts

- One 9½x9½x3 inch metal subpanel, with socket holes drilled (BTU-SP)
- One bakelite front panel, black or walnut (DFP)
- Three UX (XSO) and one UY (YSO) sockets
- Two knobs (KB)
- Three binding posts (for antenna, ground and output)
- One shaft type switch (STSW)
- One REL Vernier dial (REL)
- One 25-ft. roll of slide-back hookup wire (HW)
- One 5-lead cable and plug (CPL)



# for Battery Operation

## and Complete Receiver for Results

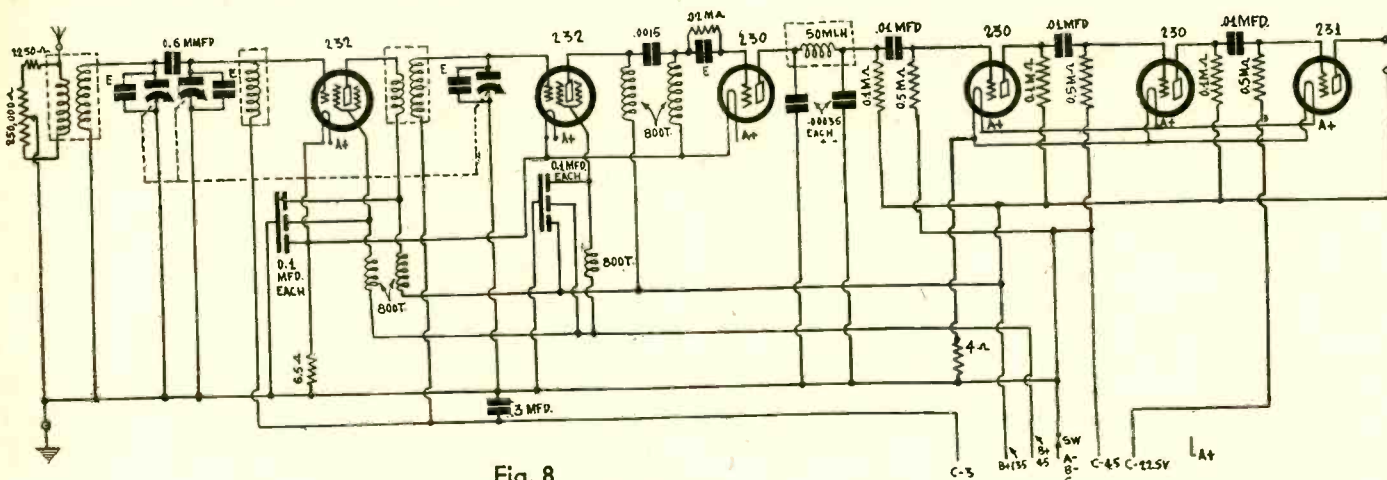

Fig. 8  
The battery receiver, Model DBR.

heavy-duty type, in which case they should last about a year, with average use. These batteries also are connected in series, positive of one to negative of the other in two instances, leaving again a negative and a positive unconnected. The posts on these batteries are marked as to voltage. Starting from minus, to terminals of each battery, you would obtain 0, 45, and then by addition, 90 and 135 volts. Connect the negative of the B battery block to negative of the A battery combination. Ground may be connected to this same point at the batteries to avoid requiring a separate ground lead for the tuner. A minus goes to one side of the 6.5 ohm resistor, the other side of which resistor goes to the negative filaments of all three tubes. The positive of the A battery goes to the positive filament of all three tubes. The 45-volt post of the first B battery in the series goes to the screens of the two radio frequency tubes, while positive post of the third B battery goes to the plate returns of the two radio frequency tubes, and, in case earphones are to be used, to one side of the earphones as well, other side of earphones goes to the radio frequency choke coil leading from the detector plate.

### Battery Receiver, Model DBR

THE complete receiver for battery operation is diagrammed in Fig. 8 and shows the same tuner as previously described for battery operation, with three stages of resistance-coupled audio. The audio tubes are two 230's and 231 output tube.

In the radio frequency channel the negative bias on the two amplifiers has been increased, so that it becomes 4.3 volts, due to the 3 volts obtained from the C battery and the 1.3 volts arising from the voltage drop in the 6.5 ohm filament resistor. This larger bias is due to the desire to keep the plate current down as low as possible, since this is a complete receiver, and the audio amplification is quite sufficient to make the resultant volume all it should be. A condenser of 0.3 mfd., consisting of three paralleled 0.1 mfd. in one case (reds connected together) bypasses the C voltage in the tuned circuit.

The total plate current of the receiver will be around 20 milliamperes, usually a little less, which is a very low drain, and makes it possible to get almost a year's use out of heavy-duty B batteries, at the average number of listening hours.

#### Four Cells in Series-Parallel

The total filament current is .42 ampere, so that four No. 6 dry cells may be used, connected in series parallel. That connection requires that two cells be joined in series (positive of one to negative of another) and that two more cells be connected likewise. The corresponding remaining posts are connected together, that is, negative to negative and positive to positive. The reason is that since the current drain is higher. The parallel addition of series-connected cells doubles the drain that the battery thus constituted will stand, consistent with long life. It is all right to draw up to .25 ampere from one such cell, or from any number of such cells in series, while the parallel addition does not increase the voltage but does increase the current capacity.

The audio channel has stability, due to the choice of resistance and capacity values. The condensers for isolating the positive voltage of the preceding plate from the negative voltage of the succeeding grid, sometimes mistakenly called coupling

condensers but in reality stopping condensers, are .01 mfd. each. The grid leaks are 0.5 meg. each.

#### Optional Increase in Leak Values

The volume is adequate for speaker operation, even on distant stations, but the values of grid leaks chosen are such that in no instance will motorboating result, so long as the B batteries are not exhausted. However, the extreme precaution taken to insure stability necessarily reduces the amplification a little, and since the audio amplifier is stable with values as shown, it is suggested that all builders experiment with larger values of grid leaks in the first and second audio stages especially.

The first place to make the experiment is in the first audio stage, because here the grid leak is in parallel with the detector plate resistor. It is well to present a substantial impedance to the detector output, and a value of 2 meg. may be tried in the first audio grid circuit. Usually this brings about a volume increase. If stability is still present, the grid leak in the next stage may be of higher value. Even the leak in the last stage may be increased in value. The point to remember is that there is no limit to the possible increase, except that arising

(Continued on next page)

### LIST OF PARTS

#### Coils

- One shielded antenna coupler for .0005 mfd. (15-75)
- One shielded tuned impedance RF coupler for .0005 mfd. (75)
- One shielded interstage screen grid coupler for .0005 mfd. (25-75)
- Five 800-turn duo-lateral wound RF choke coils
- One copper shielded 50 mlh radio frequency choke coil (SH-RFC)

#### Condensers

- One 0.6 mmfd. Hammarlund fixed condenser (FC-6)
- Four 100 mmfd. Hammarlund equalizers (EQ-100)
- One three-gang Scovill .0005 mfd. tuning condenser, brass plates (SC-3G)
- Three blocks, three 0.1 mfd. condensers in each block (SUP-31)
- One .0015 mfd. fixed condenser (MICON-15)
- Two .00035 mfd. fixed condensers (MICON-35)
- Three 0.1 meg. pigtail resistors (PGT-110)
- Three 0.5 meg. pigtail resistors (PGT-510)

#### Resistors

- One 6.5 resistor (CL-65)
- One Electrad 150 ohm flexible biasing resistor (EL-150)
- One 2,250 ohm fixed resistor (FR-225)
- One 250,000 ohm potentiometer (POT-250)
- One .02 meg. pigtail resistor, 20,000 ohms (PGT-02)
- One 4 ohm resistor (CL-4)

#### Other Parts

- One 9 1/2 x 12 x 3 inch metal subpanel, with three socket holes drilled (DBR-SP)
- Six UX (X50) and one UY (YSO) sockets
- Two knobs (KB)
- Four binding posts (for antenna, ground and output)
- One shaft type switch (STSW)
- One REL Vernier dial (REL)
- One 25-ft. roll of slide-back hookup wire (HW)
- One 5-lead battery cable with male plug (CPL)
- One 7x12 inch front panel, black or walnut (DFP)

# A 6-Tube Battery Set

New 2-volt Tubes in Diamond Midget Draw Only 20-ma. Plate Current

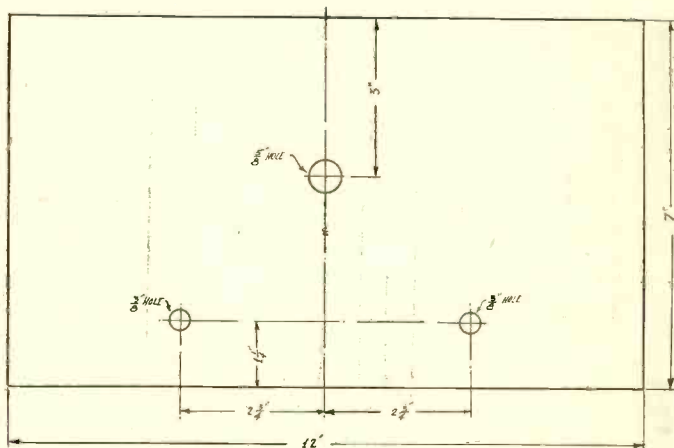

Fig. 9

The same front panel dimensions from center line apply to all models.

(Continued from preceding page)

from instability, and that as soon as you run into audio oscillation trouble, which may be a put-put sound or a whistle, reduce the grid leak values to the largest possible, consistent with stability.

## Regeneration at Audio Frequencies

While it is true that larger values of grid leaks usually are recommended, than those designated in the diagram, it should be remembered that resistance-coupled audio amplifiers have a tendency to regenerate strongly at the low audio frequencies, and to regenerate somewhat throughout the entire audio scale. So there need be no hesitancy about using a smaller value of grid leak in the interest of stability, since regeneration steps in to assist, and the response over the audio scale is fairly uniform.

The plate resistors should not be much greater than 0.1 meg., for if they were, then the capacity effect would be high. For instance, 0.25 meg. would cause serious attenuation of the high audio frequency response, due to the bypassing effect of the

resultant high capacity, which shows up, by a tube phenomenon, as the input capacity of the tube.

No output device is shown. It is perfectly safe to connect a magnetic speaker directly in the plate circuit of the last tube, as 8 milliamperes are trivial in this respect. If you have a dynamic speaker it has an output transformer built in, so again there is no need for concern.

An excellent speaker to use with this circuit is the Farrand 10-G, which is an inductor dynamic. The two tipped cords should be connected directly in the plate circuit. Reverse these connections to see which gives the greater volume. If there is a third lead from this speaker, with no tip, ignore this lead for the purposes of the present receiver.

## Use of a Baffle

All speakers require some kind of baffle for good reproduction. A magnetic speaker may be contained in a cabinet, and if so the cabinet acts as a baffle, although hardly with perfect acoustical results. A baffle is any stiff surface placed in front of the speaker, with cutout to permit radiation from the speaker forward. The object of a baffle is to act as an auxiliary diaphragm of the speaker and to reduce the radiation from front toward the back of the speaker, which back-coupling results in some distortion, since the speaker radiates from the rear as well, as the sound waves become united out of phase. The baffle should be as large as circumstances permit, and may be of wood or any of the popular special materials. The general objective is to obtain a baffle that has no strong resonant characteristics, so materials are used that are called "acoustically dead."

There are seven socket holes on the chassis, but only six tubes. One of the sockets is used for receiving a 5-lead cable that has a UY plug at one end. Thus this extra socket is used as a cable connector. Suggested connections follow:

Cable Color	Connects to	Receiver Use
Blue with white marker	Grid	C-22½
Red	Plate	B+135
Green	Cathode	B+45
Yellow	Heater nearer plate	A+
Black with yellow marker	Heater nearer cathode	A-, B-, C+

The bias voltage for the RF and first and second AF amplifier tubes is taken from a C battery that is placed just outside the set, to avoid long leads. The 3-volt tap of a 4½ volt C battery goes to the RF grid returns, the 4½-volt tap to the audio tubes mentioned.

## How to Wind Coils for Midget Diamonds

CONSIDERING the circuits from left to right in each instance, the coil data would be:

For antenna coupler: Use 1¼-inch diameter bakelite, 3¼ inches long. Cut a slot near one end, using a buzz saw, or, if you have access to a lathe, use a sharp chisel edge to gouge out a little of the bakelite in a straight circumference. In this groove wind 15 turns of No. 28 enamel wire. This is the primary. Leave ⅛ inch separation, and if you have a threading machine, set it so that it will wind 75 turns and take up all except ½ inch of the remaining space. Use No. 28 enamel wire. If you have no access to a threading machine, you may be able to procure threaded bakelite, or, lacking this, may wind the 75 turns by hand closely, in the usual manner. The object of using space winding, however, is to make possible a much finer matching of inductances of the secondaries of the three coils, and to keep the distributed capacities low, due to wider separation, i.e., greater distance between "plates" hence wider dielectric medium, where each turn is a "plate."

### Short-Wave Tap

This secondary winding may be tapped at the 20th turn from the primary, if it is desired to incorporate a switching arrangement to permit short-wave reception. The switch may be built into the shield at top, and need not be insulated therefrom, since in the three instances where it will apply the return is made to grounded B minus, and the shield must be grounded.

This first coil is known as 15-75 because of the number of turns.

The tuned impedance coil is of the same as the other except that primary is omitted. 75 turns are wound with No. 28 enamel wire, preferably space wound, but wound without spacing if

you can not obtain or make the threaded form. The tap at the 20th turn again is optional.

The second coil is known as 75 because it has only one winding, of 75 turns.

The third coil is wound the same as the first coil, except that the primary has 25 turns, instead of 15 turns, and has No. 36 primary wire, instead of No. 28. The reason for using finer wire is simply to utilize the same size groove as formerly, but if you have only the one size wire, i.e., No. 28 enamel, you may use that also on the primary. The higher resistance of the finer wire should not be considered a drawback, as it is in a plate circuit that has a resistance thousands of times greater than that of the winding.

All secondaries have No. 28 enamel wire.

### Shield Size Important

If the short-wave feature is used, the switch should be connected so that when it is closed it will short out all except 20 turns of the tuned winding. This will enable full coverage of the 30-100 meter range, where most of the interesting short-wave programs within reach are to be found.

The shield used with the coil is important. It should be aluminum or copper. As copper is more expensive and difficult to obtain for radio home construction, aluminum will be chosen. The diameter should be at least 3 inches and the height should be at least 3¼ inches.

A base is desirable for receiving and holding the bakelite form and for receiving the shield, but these may be dispensed with if you provide your own means for anchoring coil form and shield rigidly.

The coils must be centered in the shields.

# Set Is a Toy Robot

By Herbert E. Hayden

Photographs by the Author

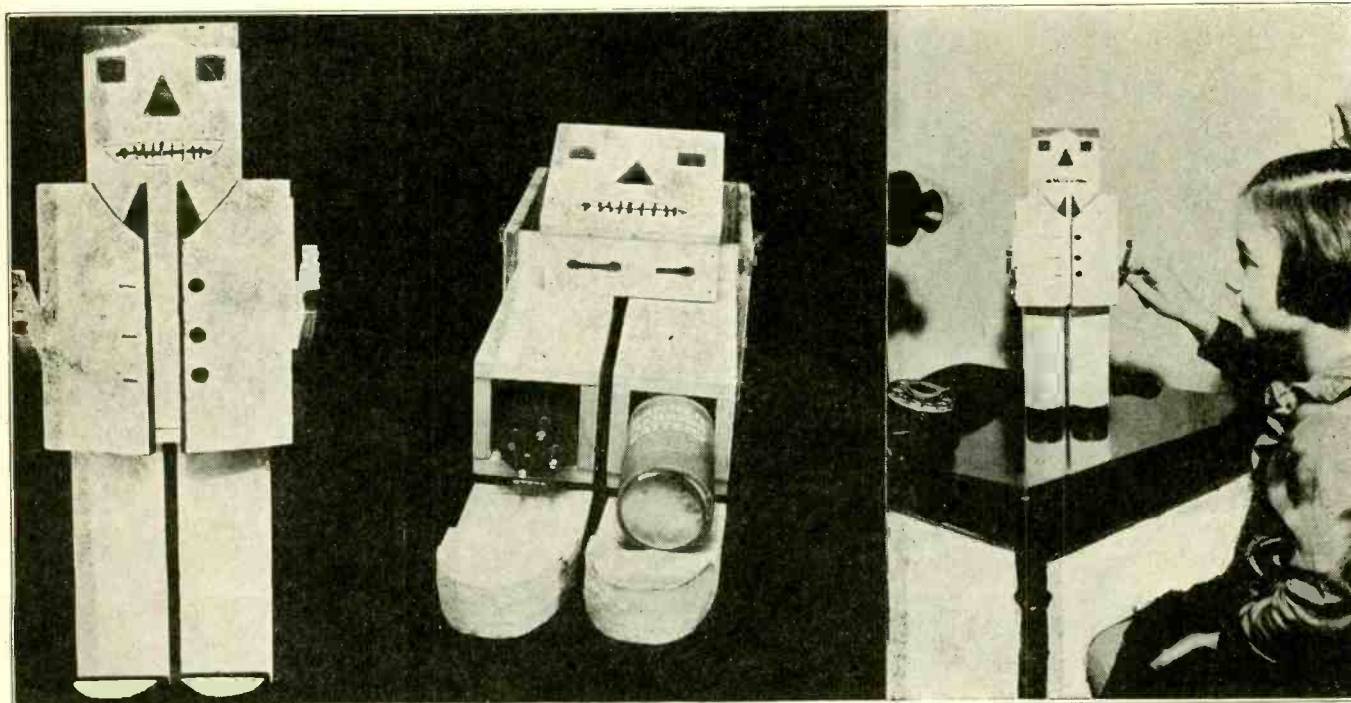

Fig. 1

Photographic views of a radio robot, a tiny one tube regenerative receiver. Left, the assembled robot; middle, prone position of the robot, feet first, showing how the tube and the filament battery are disposed in the legs; right, a little girl operating the robot.

THERE is quite a flair these days for building robots, or mechanical men, to amuse the builders and a few other adults. The more these robots do, the more they are admired by their builders. They sing and talk, shake hands, and even walk. In fact, they do about everything but think. If these machines, housed in something resembling a human being, amuse adults, why not build them for children? Surely they will be amused by their antics, even as the adults.

Readers, meet Tommy Radiovox, as lusty a robot as was ever built, and a distant relative of Mr. Televox, who has achieved fame for shaking hands, making speeches, and turning on and off electric lights, as well as for a few other accomplishments. Tommy Radiovox is the pride of his builder and the delight of the builder's little daughter, for he sings in any voice from basso profundo to lyric soprano, talks with the wisdom of a college professor and the abandon of a politician, plays every known musical instrument with the skill of the master or the uncertainty of the tyro. He is versatility personified, or maybe it is robotized.

He not only has something up his sleeve but he has also something up each of his trouser legs. One leg conceals a 3-volt battery and the other a vacuum tube. Just how he conceals these parts is illustrated in the middle of Fig. 1, which shows him lying in a prone position, feet first, with his sabots, or wooden shoes, turned forward on their hinges. Every proper robot must have hinges instead of joints.

The question may arise as to how connections are made to the tube. Well, the leads are soldered directly on the tips of the prongs.

At the left in Fig. 1 the robot is all dressed up and ready to go. But it won't go without a B battery to supply the power. This is contained in the torso, which consists of a box 4.5 x 5 x 3 inches, width, height and depth respectively, and the battery consists of two 22.5 volt units which fit into this box without any extra room to spare. Three-ply veneer is the material of the box as well as of the rest of the body.

The tuning system is concealed in the coat and vest. In each side is a variometer, one for tuning the antenna circuit and the other for regeneration. The stator of each variometer is in the vest and the rotor in the coat. To tune it is only necessary to open or close one side of the coat and to vary the volume it is only necessary to operate similarly with the other. Fig. 2 is a diagram of the simple circuit.

The forms for the variometers are made of quarter-inch veneer measuring 1.5 inches wide and 4.5 inches long and each contains 20 turns of No. 32 enameled wire. There are four of these, two

for each variometer. The only parts not specified in the drawing are the grid condenser and the grid leak. These have the usual values of .00025 mfd. and 2 megohms. The twenty-ohm resistance in the filament circuit is the resistance part of a rheostat

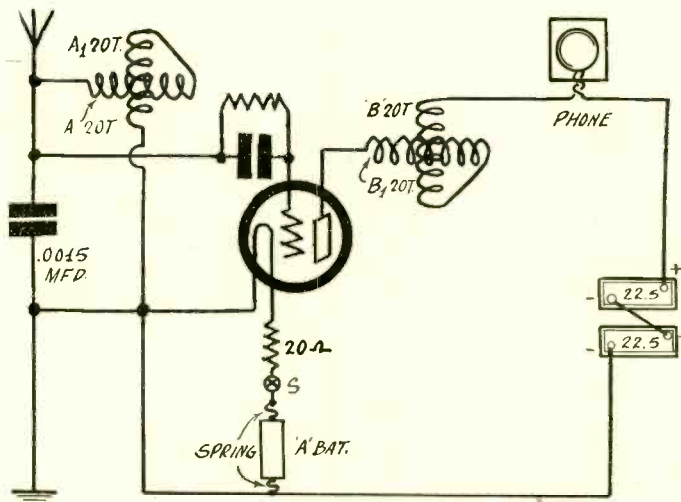

Fig. 2

The circuit diagram of the receiver built into the robot.

of this value, but only five-sixths of the total is actually in the circuit, that is, 16.7 ohms.

The left arm of the robot controls the filament switch S. The right arm is used for no special purpose.

The headset unit, which is used in place of a loudspeaker, is mounted in the head, which consists of a box 3 inches square and 1.75 inches deep. The head is detachable from the torso and may be removed and placed against the ear for listening to weak signals.

Provision for the antenna and ground leads are made on the right side of the torso and on the left side for the headset.

# TELEVISION ON REGULAR NIGHT SCHEDULE NOW

De Forest Radio Corporation, Passaic, N. J., has announced a daily schedule of television transmission to be continued indefinitely. The program each day begins at 9 p.m., Eastern Standard Time, and continues one hour and a half. Officials of the company assert that there are now 10,000 television-equipped radio receivers, and the regular program is intended to serve the owners of these sets.

The transmission consists of radio movie-talkies, the pictures being broadcast on 149 meters (2,050 kilocycles) from W2XD and the sound accompaniment on 187 meters (1,600 kc) from W2XCR. Any one with a short-wave receiver or converter will be able to receive the sound accompaniment, but only those who have the regular scanning devices will be able to look in on the visual portion of the transmission.

## Will Include Direct Pickup

According to officials of the De Forest company, recent advances in the art of television have made this regular schedule distinctly feasible. The programs will contain both "talkies" and direct pickup, the first hour of each period being devoted to "talkies" and the rest to direct pickup.

During the first week the programs contained mostly adventure and travel films as judged by the titles of the features: "People Who Live in the Desert," "Over the Bounding Main," "Hunting Grizzlies in Alaska," "Ride 'Em, Cowboy," "Anchors Aweigh," "How Salmon Are Caught," "The Man at the Throttle" and "Lumbering in British Columbia." These features are interspersed by musical selections, boxing bouts and various educational matters, such as lessons in the fundamentals of television and vacuum tubes.

## Resistance Audio Favored

The television is broadcast on the 48-line basis and 900 revolutions per minute of the scanning device. Fans who have scanners and motors of this nature will be able to pick up the pictures provided they also have an additional radio receiver capable of receiving signals on 2,050 kilocycles or about 149 meters.

In order to get clear images, the detector of this short-wave receiver should be followed by a resistance coupled audio amplifier capable of responding equally to all audio frequencies from about 20 to 10,000 cycles per second, or to a still wider band.

## Like the Early Days

The first programs were of about the same nature as the programs in the early days of sound broadcasting, about ten years ago, and the first body of listeners numbered approximately the same. Indeed, the first "lookers" will in many instances be the same individuals who first ventured to provide themselves with crystal sets for listening to the early sound broadcasts.

It is expected that the regular programs will stir up considerable interest in television and that the "lookers in" will rapidly increase in number.

# Where Televisio

By Brain

**T**HE greatly increased demand for information and equipment for radio television receiving at home shows the absorbing interest in television that exists among experimenters today. Also, the general public is discussing the subject hopefully.

This has in no small degree come about because of the rapid growth in the use of short-wave receiving sets. You, too, if you have ever operated a short-wave set or a short-wave adapter or converter for your regular set, have tuned in those queer, shrill whirring sounds of television broadcasts which probably mystified you.

And if you had the patience to listen to these sounds for a while you have heard a "snap" as a switch was connected and have perhaps heard a voice announce:

"This is Radio Television Station W3XK of Washington, D. C., broadcasting a television program." Such announcements are given frequently for the benefit of short-wave listeners who may happen to be tuned in.

## More Stations on Air

About two dozen television broadcasting stations are in operation today, principally in the eastern and central parts of the United States. These stations transmit regular programs in some cases and experimental broadcasts in others.

In a few instances the voice or music part of the program is sent out on a different wavelength, so that you are able to hear as well as see what is going on! This, of course, is the logical ultimate development of vision and audio modulation.

A number of factors combine to make television enjoyment far more practical and dependable than heretofore. The increased use of short-wave receiving sets is a very great aid, and very highly developed short-wave sets or "kits" of parts may be purchased. While these sets are primarily designed for broadcast voice or music reception, or for amateur phone and code communication, they are readily made into tuning units for the television experimenter.

## 60-Cycle Steadiness

Another important factor is the great stabilization of the ordinary 110 volt, 60-cycle house current supply. This has been brought about mainly by the widespread use of electric clocks, which require absolute regularity of the current supply frequency.

The most difficult part of television reception is that of maintaining the motor of the receiving set at exactly the same speed as that of the transmitter motor. This is called synchronism. Formerly a large amount of manual adjusting of the speed rheostat or control was necessary.

With the steady frequencies offered by power lines today, much less trouble is encountered from changing motor speeds. Where you are on the same power system as your television station, you can very easily maintain perfect synchronism.

C. Francis Jenkins is one of the leading proponents of television. His company and associated companies are not only broadcasting television programs, but are manufacturing television equipment.

Numerous other companies are going into the television business, too, so that the television enthusiast finds no lack of equipment to satisfy his experimental inclinations.

## Blurb Experts Are on the Job

The probability of television being very widely utilized in the near future is emphasized by the investigations now being made by several of the leading advertising agencies into the possibilities of television as a new radio advertising medium. Advertising will undoubtedly aid television's progress as it has that of regular radio broadcasting.

It is idle to claim that television is near perfection. The pictures that you are able to see are only a few inches square, but it's seeing by radio nevertheless. Do you remember the early days of radio broadcasting when no commercially built sets could be purchased? In those days radio enthusiasts bought parts and constructed their own receiving sets.

# Questions on Tele

**I**N my television outfit I have trouble with pictures that are much too bright and the pictures are not very detailed.—S. F.

Probably you use too high a voltage on the television tube. Use a variable resistance in series with it to reduce it.

\* \* \*

**I**HAVE a great deal of trouble due to dark streaks across the images, except on very strong stations. How can I eliminate this trouble?—E.F.J.

Perhaps your scanning disc is not accurately made, or it may have dirt in the holes.

\* \* \*

**I**S any special drill necessary to bore the holes for a scanning disc? How are the holes laid out?—P.S.L.

Do not attempt to construct your own scanning disc unless you are an extremely expert mechanic. Even very slight variations would spoil the picture. Buy the disc from a reliable manufacturer or dealer and be sure of results.

\* \* \*

**C**AN a three-spiral scanning disc be used for receiving television signals that have been transmitted with a single-spiral scanning disc if the total number of holes in the two scanners is the same?—O. W. C.

These scanning discs are not interchangeable because the single-spiral disc scans the picture from top to bottom in one sweep while the three-spiral disc scans in three zones. The picture produced with a three-spiral disc would be unrecognizable.

# Television Stands Today

By Gard Foote

A similar condition has just about arrived with regard to television. As a hobby for home entertainment and experimenting, there are few scientific pursuits that can be followed by almost anyone equal in fun to television. The equipment is simple and inexpensive. For the listener who is using short-wave sets already, or a short-wave adapter or converter, it's a simple step to television. For the boy, no hobby is superior to television for its absorbing interest and educational value.

### Set Differences

While a short-wave receiving set of the conventional form may be made suitable for tuning in the television stations, an amplifier using transformers, such as you find with broadcast sets, does not amplify the various frequencies uniformly enough for television.

Accordingly, a special resistance-coupled amplifier is used. As this type of amplifier also operates well for ordinary voice or music broadcasting, the general custom for adjusting the set is to use an ordinary loudspeaker or earphones while the television station is being tuned in and adjusted to maximum clearness and volume. Then a switch is moved to disconnect the loudspeaker and to connect the television lamp.

The lamp glows or blinks in accordance with the television impulses and the light from the lamp shines through tiny holes in a disc revolving in front of it, so that the flashes of light pass through at the exact required place. The numerous light flashes form themselves into the picture you see. A magnifying lens is often used to enlarge the size of the picture.

### Station Details

Almost all television stations in this country will be found on wavelengths between 100 and 150 meters (3,000 to 2,000 kilocycles). The scanning disc generally used has 48 or 60 holes, although some stations will be found using discs with 24 and 45 holes. In order to receive properly, your own set must have a scanning disc corresponding to that of the television station. Can change discs without much trouble.

Don't be afraid of television! It's not too complicated for you! Find out about it! It's a new and thrilling field for anyone.

### LIST OF TELEVISION STATIONS

Station	Location	Owners	Power	Disc
W2XCD	Passaic, N. J.	DeForest Radio Co.	5 KW	48
W2XR	L. I. City	Radio Pictures, Inc.	500 W	48
W9XAO	Chicago	Western Television Corp.	500 W	45
W8XAV	Pittsburgh	Westinghouse Elec. & Mfg. Co.	20 KW	60
W2XCR	New York	Jenkins Television Corp.	5 KW	48
W1XAV	Boston	Short Wave & Television Lab.	500 W	48
W9XAP	Chicago	Chicago Daily News	1 KW	45
W3XK	Wheaton, Md.	Jenkins Laboratories	5 KW	48
W2XBS	New York	National Broadcasting Co.	5 KW	60
W3XAD	Camden, N. J.	RCA-Victor Co.	500 W	60
The above stations operate on regular daily schedules with television broadcast programs. Following are a few experimental stations whose programs are not on a regular schedule:				
W9XR	Downer's Grove, Ill.	Great Lakes Broadcasting Co.	5 KW	24
W9XG	W. Lafayette, Ind.	Purdue University	1½ KW	..
W2XCW	Schenectady, N. Y.	General Electric Co.	20 KW	..
W2XBO	L. I. City	United Research Corp.	500 W	..
W9XAA	Chicago, Ill.	Chicago Federation of Labor	1 KW	48
W2XAP	(Portable)	Jenkins Television Corp.	250	48
W3XAK	Bound Brook, N. J.	National Broadcasting Co.	5 KW	60
W2XBU	Beacon, N. Y.	Harold E. Smith	100	48

## Television Answered

**W**HAT effect does the tuning of the set have on the television results? For instance, would an extra selective set be better for reception?—M.N.C.

No, it would not be as good, because it would reduce the amplification of higher frequencies. Television stations are generally not subject to serious interference, and over-sharp tuning is not required.

\* \* \*

**I**S it possible to use a short-wave adapter for getting television programs? The regular set could be used in that case.

No, because the set's audio amplifier uses transformers, which do not amplify the various frequencies uniformly enough. In ordinary voice or music the frequencies do not go much above 5,000 cycles. In television, frequencies up to 15,000 are necessary for only fair detail, and up to 30,000 for accurate detail. A special audio amplifier with resistance coupling is used, with a power tube such as the 210 or 250.

\* \* \*

**I**S television transmitted regularly from more than one station on the 900 revolutions per minute speed?—F.C.

Television programs are transmitted more or less regularly from a number of stations throughout the country. Most of them use the 900 revolution speed and the 48 line system, but there are also many other speeds and lines per frame.

## STRICTER LOGS NOW REQUIRED FROM STATIONS

Washington.

A new order of the Federal Radio Commission has just gone into effect, making stricter the requirements of log-keeping by broadcasting stations.

The order is No. 106 and the full text follows:

All broadcasting stations shall be required to maintain two logs after 1931, as follows:

1. Program Log: This log shall contain—

(a) An entry of all stations and call announcements and the time made.

(b) An entry describing each program broadcast with the time beginning and ending. If phonograph records or electrical transcriptions are used, that fact shall be noted together with the announcement made thereof.

2. Operating Log: This log shall contain—

(a) An entry of the time the station's carrier wave goes on the air and the time the station's carrier wave is stopped.

(b) An entry of the time the program begins and ends.

(c) An entry of every interruption of the carrier wave, its cause and duration.

(d) An entry of each of the following shall be made every 30 minutes: (1) Operating constants on last radio stage (total plate current and plate voltage); antenna current. (2) Frequency check. (3) Temperature of crystal chamber (if used).

These logs shall be kept by the person or persons competent to do so having actual knowledge or information of the facts herein required, who shall sign the log when coming on duty and again when going off duty. The logs herein required shall be open to inspection at all reasonable times by Government radio inspectors and other persons authorized to do so by the Federal Radio Commission.

## Unemployed Win Big Money in Test

Peter Copeland, young architect of Newark, New Jersey, unemployed, captured the first prize of \$5,000 in the Westinghouse Radio \$10,000 Idea Contest for the improvement of radio cabinets.

Lucy K. Wilkes, a young housewife of New York, was awarded the second prize of \$2,000.

Charles Preston Bassett, a young interior decorator of Pittsburgh, Pa., unemployed, received the third prize of \$1,000. There were forty-five other cash prizes awarded ranging from \$200 down to \$25.

### WORTH THINKING OVER

**T**HE astrologers are having their fling over the air. The disgusting thing about this is that they try to give the impression they are scientists. Mr. Webster refers to astrology as "the pseudo science." We wonder if one of these days some of the weak sisters among the bookers of air attractions will offer clairvoyants and fortune tellers as "talent." That would be a good way to convey the air, if that be the object of certain addled program purveyors.

# How to Line Up Tuning

By J. E.

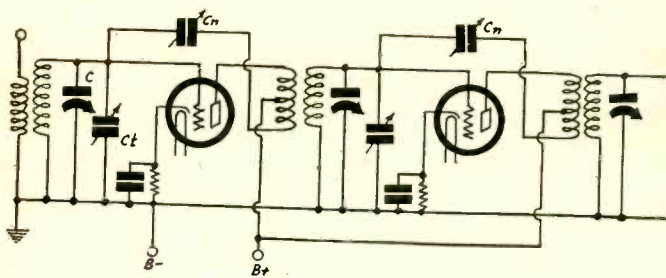

Fig. 1

Two stages of a neutrodyne type receiver with ganged condensers.  $C_n$  are neutralizing condensers and  $C_t$  trimmer condensers. The settings of the neutralizing and the trimmers are dependent on each other.

**I**N neutrodyne type of receivers in which the tuning condensers are ganged and have trimmers, the adjustments of the trimmer and the neutralizing condensers are mutually dependent. For example, if the setting of a neutralizing condenser is changed it becomes necessary to change the corresponding trimmer condenser also. This dependence makes it difficult to effect both adjustments in a multi-tube receiver. If the circuit is neutralized so that oscillation is stopped chances are that it is not selective because of trimmer condensers are not correctly set, and if the trimmers are set correctly chances are that the circuit will oscillate at the low wave end of the dial, and sometimes at the high end.

Trimming of a circuit alone is not the easiest thing to do because in most cases it is not only the distributed capacities in the tuned circuits which differ but also the rates of change of the tuning capacities and the effective values of the inductances. The fact that two tuning coils contain the same number of turns on primaries and secondaries and the fact that they are as nearly alike as possible do not assure equality of the effective values of inductance. The coils must also be in exactly similar settings. Shields and other conducting material in the fields of coils change the inductances by amounts depending on the distribution of the conductors with respect to the coils.

## Making the Adjustments

The first thing to do is to adjust the neutralizing condensers so that the circuit will not oscillate at the low wavelength end of the dial. This adjustment should be followed by an adjustment of the trimmer condensers until the signal at some selected low wave is as strong as possible. But this adjustment may start the circuit oscillating because the neutralization may not have been complete. Therefore the neutralizing condensers should be readjusted until the oscillation stops, this to be followed by another adjustment of the trimmer condensers. These adjustments are preliminary.

For the final adjustment select a weak station near the zero end of the dial and tune and trim the circuit accurately. Listen in with a pair of headphones. Open the heater circuit of the first tube in the circuit without making any other changes whatsoever. Now adjust the first neutralizing condenser until the sound in the telephone is zero or as weak as possible. This done, restore the heater circuit of the first tube and open up that of the second. Then adjust the second neutralizing condenser until the sound in the telephone is minimum or zero. Continue in this way until all the circuits have been neutralized. Before making the adjustment on any neutralizing condenser wait until the tube in question has cooled off to the point where it does not amplify at all.

## What Not to Expect

It is too much to expect that these adjustments should effect complete neutralization all over the dial. It will not. But it is not necessary that it should, for the only object of the neutralization is to stop oscillation. If the neutralization is less than complete the circuit will not only be more sensitive but also more selective. But if the adjustment is less than required there will be oscillation at some setting of the tuner and the receiver will not be much good.

In some cases it is not possible to set the trimmer condensers

so that the tuned circuits will be lined up throughout the range because the rates of change of capacity are not the same for all the sections in the gang condenser. As a matter of fact, this difficulty is quite common. The trouble is not that the condenser plates are unlike, for they have been cut with the same die out of the same stock. The trouble enters when the rotors are put on the common shaft. The spacing is not the same for all. If the rotors are attached to the shaft by means of set screws, which is nearly always the case, this difficulty can be remedied very quickly, for it is only necessary to loosen the screws and shift the rotor in one direction or the other along the shaft. The rotor plates should be centered between the stator plates, and the correct position for any rotor can be determined by inspection. This setting is best done when the plates are fully enmeshed.

## When to Adjust Rotors

The adjustment of the condensers should really be done before they are put into the receivers, but it may be done afterward provided the gang is not boxed in a case that cannot be opened up. Unfortunately, this is the case in many commercial receivers.

When the adjustment of the rotors is made before the gang is put into the receiver the sections may be put in a wavetrap circuit, one after the other. The same tuning coil is then used for all the sections. The trap may be put in the antenna circuit ahead of a receiver and a calibration curve, or simply a log, taken of each condenser. As many stations as practicable are tuned in with the receiver throughout the dial and the trap is tuned to each and the setting of the dial noted. The frequency of the stations tuned in may be set in one column and the dial settings for each of the sections in the gang in other columns. If the readings in any row for all the condensers are the same there is no need of resetting the rotors for the sections are then equal throughout. If, however, there is a systematic deviation for one of the sections, that section should be reset until the readings for this are the same as for the others. Slight deviations should be expected because some are due to errors in setting the trap circuits and others are due to irregularities in the condenser sections which cannot be remedied.

A calibrated oscillator, if modulated, can be substituted for the broadcast stations in case they are not convenient.

## Change of Capacity and Inductance

If all the sections in the gang condenser give the same readings for the same frequencies when they are connected, in turn, to the same inductance, any differences that develop later when they are connected in the circuit must be due to either changed minimum capacity or to changed inductances. If they are due to changed distributed capacity only, they may be removed by adjusting the trimmer condensers, because the added capacity is fixed in value. This is particularly true if the sections of the condensers are shielded both when they are in the trap circuit and when in the receiver. If there is no shielding small differences may develop due to the presence of conductors, such as coil shielding and metal panels. These are variable but so small that they may be disregarded. However, it is well to shield the tuning condensers for this reason.

If the differences are large when the gang is put in the receiver and cannot be compensated for by the trimmer condensers, the inductances across which they are connected must be unequal. To check them for equality they may in turn be connected across the same condenser in the gang and a set of

## New Screen Grid Tu

**T**HE production of a new screen grid tube specifically designed for use in automobiles and DC districts was announced by Dr. Ralph E. Myers, vice-president in charge of engineering, National Union Radio Corporation. This tube, designated as the NY 64, draws 0.4 ampere at 6.3 volts on the heater.

"The practice among manufacturers of automobile sets has been to employ type 224 tubes with the heaters in series," said Dr. Myers. "This method of operation from direct current has been undesirable because the rather heavy current (1.75 amperes). We were guided by experience in the manufacture of

# Condensers and Coils

Anderson

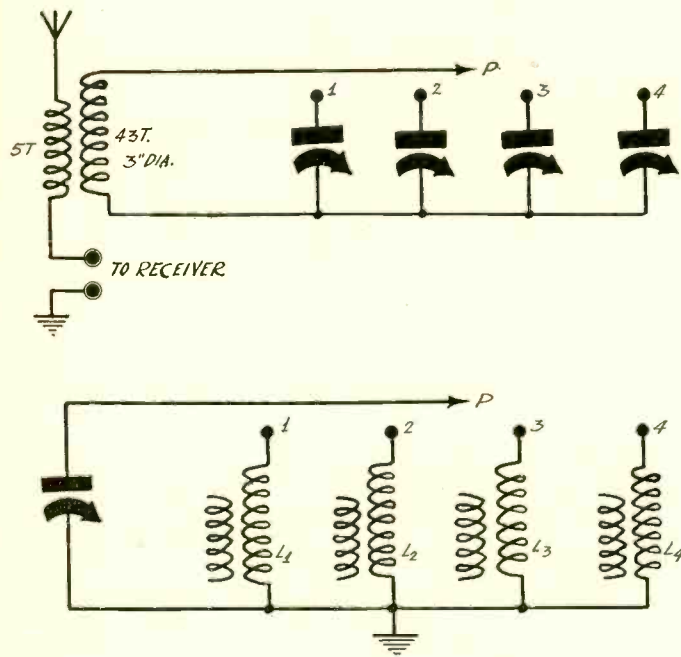

Fig. 2 Upper

Trap circuit arrangement suggested for testing the equality of the sections of a gang condenser.

Fig. 3 Lower

This circuit may be used for testing the equality of the coils in a receiver under test.

curves, or a log, take just as it was taken for the several sections and the single coil. If there are any inequalities in the coils they will show up by different dial settings. The data thus obtained will show whether the turns on a given coil should be increased or decreased.

When taking data on the coils against the same condenser, they should be taken with the shields on, if shields are to be used on the coils, or without shields if no shields are to be used. That is, the data on the coils should be taken with the coils in the position in which they are to be used.

If more capacity is needed to tune in a given frequency with one coil than with another, the coil requiring more capacity is too small and more turns should be taken. On the other hand, if less capacity is required to tune in a given frequency, the coil is too large and turns should be removed. While this adjustment is being done it is well to note the effect of removing the shields from the coils, or the effect of moving the shield up or down over the coil. The effect of putting a shield over a coil should have the same effect as removing turns, that is, lowering the inductance. Of course, this will show up by requiring more capacity for a given frequency.

It may be well to summarize the methods of testing the condensers and the coils for equality. The several sections in a gang are used in a wave trap, one after the other, with the same coil each time, and the coils are tested in the same way across the same condenser. After having got a set of data for each condenser across the same coil note whether the readings are

the same for all the condensers for the same frequencies. Do likewise for all the coils with the same condenser.

It is admitted that all this is tedious work, but if it is done in this orderly fashion satisfactory results will be obtained in a much shorter time than if the adjustments are made in a desultory manner.

If the data on the condensers show a systematic divergence it may be well to adjust the trimmers on the condensers in an effort to effect equality. While this adjustment of the trimmers before the condensers are in the receiver has no significance in respect to the equality of the condensers in the final circuit, it will show if the systematic divergence is due to differences in zero capacity of the condensers. If it is possible to remove the divergences by the trimmers before the condenser are put into the final circuit it is also possible to do it in the final adjustment. It may save tampering with the setting of the rotors.

When adjusting the trimmers this way set the dial at the mean value indicated in the data table for some particular frequency and then without touching the main tuning control tune by means of the trimmers. A new set of data should then show equal readings throughout if the divergences before were due to unequal distributed capacity. If the divergences still persist the rate of change of the capacities is not the same for all the condensers and an adjustment of one of the rotors may help. It should be noted that the percentage rate of change of the capacity of any condenser depends on the magnitude of the zero setting capacity and it is for this reason that changing the trimmers may help to line up the condensers without the necessity of adjusting the position of the rotors.

## Test Connections

In Fig. 2 is shown the connection of the trap circuit for testing the equality of the condensers in a four-section gang. The primary of the common coil is connected in the antenna circuit directly over the input to the broadcast receiver. A suitable coil is one wound with 43 turns of No. 24 D.C.C. on a 3-inch diameter, the primary having five turns on the same form and about half inch from the secondary. By means of the flexible lead terminating in P, each of the condensers is connected in the trap in turn and a calibration curve, or log, made for each.

Fig. 3 illustrates the arrangement of the single condenser, which may be one of the gang in Fig 2, and four coils in a receiver. The secondary windings to be tested in position are numbered from (1) to (4) and the flexible lead terminating in P is used to pick up one at a time. Again a tuning curve, or log, is made for each coil. When the test condenser is put across a coil there should be no other condenser across it, except the inevitable distributed capacity.

It is best that the condenser in Fig 3 is an independent and external one. In that case the condenser across a coil may be disconnected and the test condenser substituted. The circuit under test may then be used for tuning in signals, the test circuit then being a dual control receiver, one control for the three condensers of the gang not disconnected and the other for the test condenser. This introduces an error because of possible inequalities of the tuned circuits, but on the average this error is negligible.

If it is desired to avoid even this error the circuits formed in Fig. 3 may be used as trap circuits just as in Fig 2, but this requires an auxiliary receiver for detecting the signals and finding the resonance points. It is much more convenient to use the receiver under test as suggested in the preceding paragraph.

## Wavelength and Frequency

What is the difference between wavelength in meters and frequency in kilocycles?

Radio waves travel, like water waves, a certain distance apart. A 400-meter wave measures exactly 400 meters (about 1,310 feet) from the "peak" of one wave to the peak of the next one. All radio waves travel at the same speed—about 186,000 miles (300,000,000 meters) per second. The frequency means the number of waves per second. The number of waves passing by in one second is determined by the speed, which is the same for all radio waves, 300 million meters per second. Accordingly, to find the frequency of a 400-meter wave, divide 400 into 300,000,000 and you'll find the frequency is 750,000 cycles, or 750 kilocycles (750 kc.). The frequency term is the better one to use. It is more convenient generally, and all radio calculations must be made on the frequency basis. Modern sets use the kilocycle designations, whereas older sets use meters. Hence, programs in newspapers show both.

## be for DC and Autos

automobile headlight lamps, showing that the best filament voltage design point is 6.3 volts, this figure supposedly representing the average voltage of the battery.

The advantages of this tube in DC district sets are evident when it is realized that to build a screen grid DC set it has been necessary to burn type 224 tubes in series with the result that such sets consume about 200 watts, only about one-quarter of this power being used to any good purpose, the remaining being dissipated in heat. A set using the new NY 64 consumes only 50 watts."

# Variable Mu Tube Operation

By Sidney E. Finkelstein

**A**S SOON as a problem arises in radio, engineers set out to find the solution, and they usually succeed in doing so without much delay. The long parade of tubes is a result of this solution of problems. Every tube turned out has been designed to meet a specific problem. At first we had only one tube, which was used for both amplification and detection. Soon it was found that a more sensitive detector could be produced by making a change in the tube, so we got the special detector. Then as the number of tubes in receivers was increased the problem of filament supply became acute, and we got the low-current tubes. Tubes were made for both home receivers and portable, and the difference was mainly one of filament current requirements.

But even these improvements did not suffice when receivers were built requiring tubes by the half dozen and dozen. AC current tubes were turned out to meet the problem. And then hum became a serious obstacle to the enjoyment of radio programs, and the engineers solved it by making heater type tubes, first only to be used as detector but later for amplification as well. The design of rectifier tubes kept pace with the amplifier tube development as a means of getting cheap, convenient, dependable and steady plate supply to replace the unsatisfactory B batteries and storage batteries.

## Advent of Power Tubes

When loudspeakers came into use they brought with them the problem of getting undistorted output in large quantity. No power tubes worthy of the name existed and frequency distortion by overloading assumed first importance as the "weakest link." The engineers turned out larger and larger power tubes until we got the 250 tube. It was soon realized that this was too large to be of rational use and it was further realized that its filament requirements were not in line with those of other tubes which had been developed. Hence we got the 245 power tube, which seems to meet all requirements at this time. Now we not only have this power tube to choose, but we have one for every series of amplifier tubes so that no matter what the receiver requirements we have a consistent set of tubes for our purpose.

The problem of oscillation in receivers was met by the introduction of screen grid tubes, the 222 in the 3.3 volt series, the 232 in the 2 volt series, and the 224 in the 2.5 volt, AC series. We can now get a high degree of amplification in any type of receiver without instability. With the aid of screen grid tubes we can get just as much amplification as we can reasonably use, for we can dip away below the noise level even when this level is the lowest, and this without neutralization, the use of lossers and similar devices.

## Cross Modulation

One of the most baffling problems has been cross modulation, or cross talk between two stations of different frequency when the tuner is adjusted to only one of them. This trouble has been recognized for a long time and the cause of it has been thoroughly understood, but it was not until the use of screen grid tubes that it became serious. In receivers having many screen grid tubes the trouble is most annoying, and it is the graver the greater the amplification. The cause of cross modulation is detection in the radio frequency amplifiers, especially in the first.

The reason cross modulation is greater in screen grid tube receivers is that these are good detectors when the grid bias is a little too high, or when the screen voltage is low, that is, when the voltages are so adjusted that the amplification is less than the possible maximum. Now screen grid tube receivers are usually made extremely sensitive in order to pick up weak distant stations. Hence when they are used for receiving local stations it is necessary to cut down the sensitivity, and this in most instances is done either by increasing the grid bias or by decreasing the screen voltage. Either way the tubes are converted to detectors and if there are two stations operating in the reception range of the receiver while thus adjusted, the signals will mix so that when the circuit is tuned to either it will also bring in the other. The tuners after the cross modulation has taken place are of no help to cut out the interfering signal because it is carried through just as any other modulation. There are only two ways in which cross modulation can be prevented. One is to tune the circuit so sharply and completely ahead of the first tube that only one carrier is impressed on that tube. The other is to operate the tube amplifiers so that if there are two or more carriers impressed on the first tube only one can get through the circuit.

## Relative Values

Both of these things are relative. It is impossible to tune the circuit so completely that only one carrier will be impressed on the first grid. The interfering signal may be relatively extremely weak, yet when mixed with the stronger and desired signal the resulting cross talk may be quite strong. Likewise, it is not possible to operate any tube as a pure amplifier because no matter at what combination of grid, screen and plate voltages it is operated, there will always be some detection. But when the tubes are operated far below the maximum amplifying efficiency they are very good detectors. Hence the cross modulation is strong.

When automatic volume controls are used in receivers the amplification is reduced by increasing the control grid bias and therefore by converting the tubes to detectors. The same thing is done automatically that is done manually when the grid bias is varied for controlling the gain. Hence the condition for severe cross modulation is brought about on all strong stations, whether it is done automatically or manually.

## Variable Mu Tube

This problem was so serious that it was natural that engineers should undertake to solve it, and the answer is the variable mu tube manufactured by the makers of Majestic radio receivers and tubes. This tube has an amplification factor which decreases with the increase in control grid bias and does not become an effective detector at the same time. At low bias it is just as good an amplifier as any ordinary screen grid tube of the —24 type, but at high bias it assumes the nature of a power tube with very low amplification factor. Because of this characteristic the gain may be cut down on strong signals either manually or automatically without increasing cross modulation. Receivers with this tube in the radio frequency stages have already appeared and their sensitivity range is enormous. There is no appreciable cross talk even on the strongest local stations.

# FREE AID TO A NEW JOB!

SITUATIONS WANTED AND HELP WANTED ADVERTISEMENTS WITHOUT COST!

Address: Industrial Dept., RADIO WORLD, 145 W. 45th St., N. Y. C.

## SITUATIONS WANTED

**GRADUATE NATIONAL RADIO INSTITUTE.** experience with public address systems, short wave radio, and general servicing. Age, 20 years. Locate anywhere. B. H. Love, Valley Center, Kansas.

**RADIO REPAIR AND SERVICE MAN.** Age, 19 years. High school graduate. Course in Radio and Television Institute, Chicago. Would consider radio position of any kind anywhere in U. S. Willing to start at reasonable salary, with chance of promotion. Lloyd B. Phillips, R. F. D. No. 2, New Bethlehem, Pa.

**NATIONAL RADIO INSTITUTE GRADUATE,** two years' High School; age 20; experience in radio servicing, selling, building, and repairing. Fred J. Kellish, 452 Court St., Elizabeth, N. J.

**GOOD SERVICE MAN,** age 23, colored. 8 years' radio practice. Knows theory, power amplifiers, and laboratory apparatus. Will consider any radio work. P. Donald Carr, 6523 Evans Ave., Chicago, Ill.

**RADIO GRADUATE OF THE I. C. SCHOOLS,** with technical training both in servicing and construction, wishes steady job in store or factory. Francisco Bou, Jr., 4448 Elizabeth St., Philadelphia, Penn.

**RADIO SERVICE MAN** would like to make connection with store or factory or take care of radio service work for store on contract basis. 5 years' experience, 3 years outside. Reference, National Radio Institute, Washington, D. C. Louis Schudde, 155 Meserole St., Brooklyn, N. Y.

**MEMBER OF INSTITUTE RADIO ENGINEERS,** 30 years of age. Many years varied experience as asst.-Chief Engineer, Development, Technical, and Apparatus and Research Engineer with reliable firms. For past two years member of technical staff of Engineering Dept. of Arcturus Radio Tube Co. Business and personal references of the highest order. Gilbert Emerson Maul, 651 Lincoln Ave., Mountain Station, Essex County, N. J. Phone: Nassau 4-6845M.

**INVENTIVELY INCLINED,** and have diploma from Radio Training Association of America; would like to get in touch with radio factory with high-class laboratory. Former student in Electrical & Mechanical College of University of Kentucky. P. B. Kehoe, 2100 Lee Street, Fort Myers, Florida.



# A Volt-Ammeter

By Einar Andrews

**M**ANY who have 0-10 milliammeters have expressed a desire to convert them to multi-range voltammeter. That is, they wish to use them for measuring voltage as well as current and to have available several ranges for each use. How can it be done?

To convert this instrument to a voltmeter is a simple matter. It is only necessary to connect the proper resistances in series with the instrument and then to read the scale according to the resistance connected in series. A 0-10 milliammeter will become a 100 ohms per volt instrument when used as a voltmeter, and the proper resistance for each range is 100 ohms for every volt in the range. For example, if the range is to be 0-10 volts, the resistance in series should be 1,000 ohms. This is the total resistance and should include the resistance of the coil. If the meter is to have a range of 50 volts the proper resistance is 5,000 ohms, and if it is to have a range of 500 volts the resistance should be 50,000 ohms.

### Suitable Voltage Ranges

Since the instrument is a 0-10 milliammeter the scale will be divided into ten major divisions and possibly subdivisions of these. Therefore the voltage ranges selected should be multiples of 10, the most convenient being 10, 100 and 1,000 volts. However, ranges like 50, 200 and 500 volts are also convenient. As a rule it is not desirable to provide a range as high as 1,000 because such voltages require special care in the insulation. Perhaps the highest range that should be used is 500 volts. It is very seldom that higher voltages are met in radio receivers. Ranges of 0-10, 0-100, and 0-500 volts are suggested. These will require series resistances of 1,000, 10,000 and 50,000 ohms, respectively all of which can be obtained in wirewound form at reasonable prices.

The Weston Model 301 0-10 milliammeter has an internal resistance of 8.5 ohms, which is 0.85 percent of the resistance required for the 0-10 volt range. This is less than the accuracy of either the scale or the resistance. Hence it is not necessary to allow for it on this range. There is still less reason for making allowance for it in the higher resistances. It is well, however to compare the improvised voltmeter with one that is known to be correct before the readings are relied on.

### Sensitivity

The sensitivity of this voltmeter is not nearly as good as one that is made with a 0-1 milliammeter, but it is greater than that of many standard voltmeters. The current requirement of the meter should always be kept in mind when using it where there is a high resistance in series with the circuit, for example, in the plate circuits of resistance coupled amplifiers. It cannot be used at all in such circuits, because the voltage indication will be only one half, or less, of the actual voltage. But it can be used for measuring the voltage of batteries of all kinds and the voltage of B battery eliminators in which the voltage divider resistance is small.

### Use as Current Meter

Extending the current range of the meter is not quite so simple as converting it to a voltmeter, because when extending the current range the internal resistance becomes of prime importance. If we take the instrument which has an internal resistance of 8.5 ohms we must put shunts across the terminals such that the current through the meter is a known fraction of the total current measured. For example, if the range of the meter is to be 0-100 milliamperes the shunt resistance must be 8.5/9 ohm. This will insure that one-tenth of the total current flows through the meter and nine-tenths through the shunt. Since at full scale the current through the meter is 10 milliamperes 90 milliamperes will flow through the shunt and therefore the total current is 100 milliamperes at full scale.

If we want the total current to be one ampere at full scale the shunt must be such that 990 milliamperes flow through the shunt and 10 through the meter, which requires that the shunt be 8.5/99 ohm, or about .08585 ohm.

The difficulty here is that the shunt resistance required is extremely small and therefore not easy to obtain. The adjustment of the resistance must be made with extreme accuracy. To obtain an accurate resistance of such small value it is necessary to use heavy resistance wire so that it will take a piece of appreciable length to give the required resistance.

### Avoiding Low Resistance

There is a way of avoiding the necessity of using such low resistance shunts. A comparatively high resistance may be con-

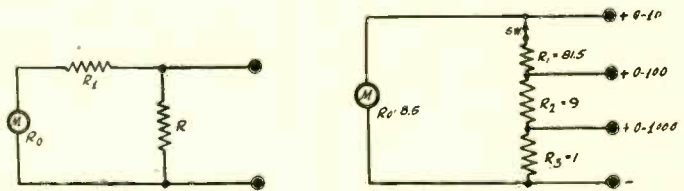

Fig. 1 (Above) Circuit showing how a series resistance may be used in conjunction with a shunt to avoid small shunts when extending the range of a milliammeter.

Fig. 2 (right upper) Circuit showing how a tapped shunt may be used for a multi-range current meter when applying the series resistance shown in Fig. 1.

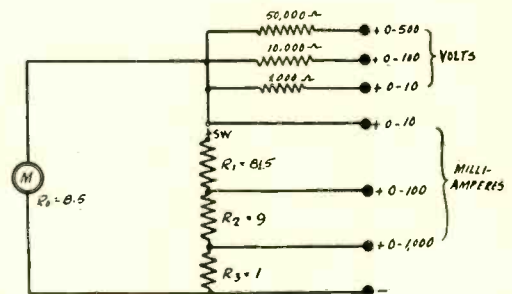

Fig. 3 (lower) The complete circuit of a multi-range volt-ammeter with three ranges for each function.

Values are based on Model 301, 0-10 milliammeter Weston instrument and the ranges indicated.

nected in series with the meter and then a low resistance in shunt with the combination. This is illustrated in Fig. 1. \$R\_0\$ is the internal resistance of the meter and \$R\_1\$ a higher resistance in series with it. \$R\$ is the shunt resistance across these two. Suppose we make \$R\$ equal to 10 ohms when \$R\_0\$ is 8.5 ohms. How large should \$R\_1\$ be in order to make the current divide in the ratio of 10 milliamperes through the meter and 990 through the shunt? The voltage drop across the shunt is equal to that across \$R\_0\$ and \$R\_1\$. Hence we have  $990R = (R_1 + 8.5)10$ , with which we get  $R_1 = 981.5$  ohms. We can also make \$R\$ equal one ohm, when \$R\_1\$ turns out to be 90.5 ohms.

This series-shunt idea can be applied practically as illustrated in Fig. 2. When the range is to be 0-10 the highest plus terminal is used and the switch \$Sw\$ is opened to remove all shunts. When the range is to be 0-100 or 0-1,000 milliamperes the switch is closed. For 0-100 the second plus terminal from the top is used thus throwing in a series resistance \$R\_1\$ and a shunt \$R\_2\$ plus \$R\_3\$. We can arbitrarily make the sum of \$R\_2\$ and \$R\_3\$ 10 ohms, when \$R\_1\$ should be 81.5 ohms.

It now remains to divide \$R\_2\$ and \$R\_3\$ so that when the first plus terminal from the bottom is used the range will be 0-1 ampere. \$R\_2\$ is now a part of the series resistance and \$R\_3\$ is the shunt. We have the equations  $(8.5 + 81.5 + R_2)10 = 990R_3$  and  $R_2 + R_3 = 10$  from which to determine the values of \$R\_2\$ and \$R\_3\$. We get  $R_2 = 9$  and  $R_3 = 1$ .

### The Voltammeter

A voltammeter is simply a combination voltmeter and ammeter, that is, a meter with which either voltage or current can be measured. The combination just worked out is shown in Fig. 3. Only one point not previously taken up need be emphasized. When the meter is used as a voltmeter the switch \$Sw\$ must be open so that no shunt current can flow.

As a voltmeter this instrument has three ranges, 0-10, 0-100, and 0-500 volts, with a sensitivity of 100 ohms per volt. As a current meter it has also three ranges, 0-10 and 0-100 milliamperes and 0-1 ampere. All the resistance involved with the exception of \$R\_1\$ are easily obtainable, and that can be made from the proper length of resistance wire.

### How to Learn Code

There are many good ways to learn the code. Several commercial systems teach the code by phonograph records, by special mechanical transmitting outfits that are rented to learners, etc. A good way is to join a local radio club. Many of them conduct code classes. A buzzer, telegraph key and battery will make up a simple outfit for you to learn the formation of the characters at home.

**A Question and Answer Department conducted by Radio World's Technical Staff. Only Questions sent in by University Club Members are answered. Those not answered in these columns are answered by mail.**

# Radio University

Annual subscriptions are accepted at \$6 for \$2 numbers, with the privilege of obtaining answers to radio questions for the period of the subscription, but not if any other premium is obtained with the subscription.

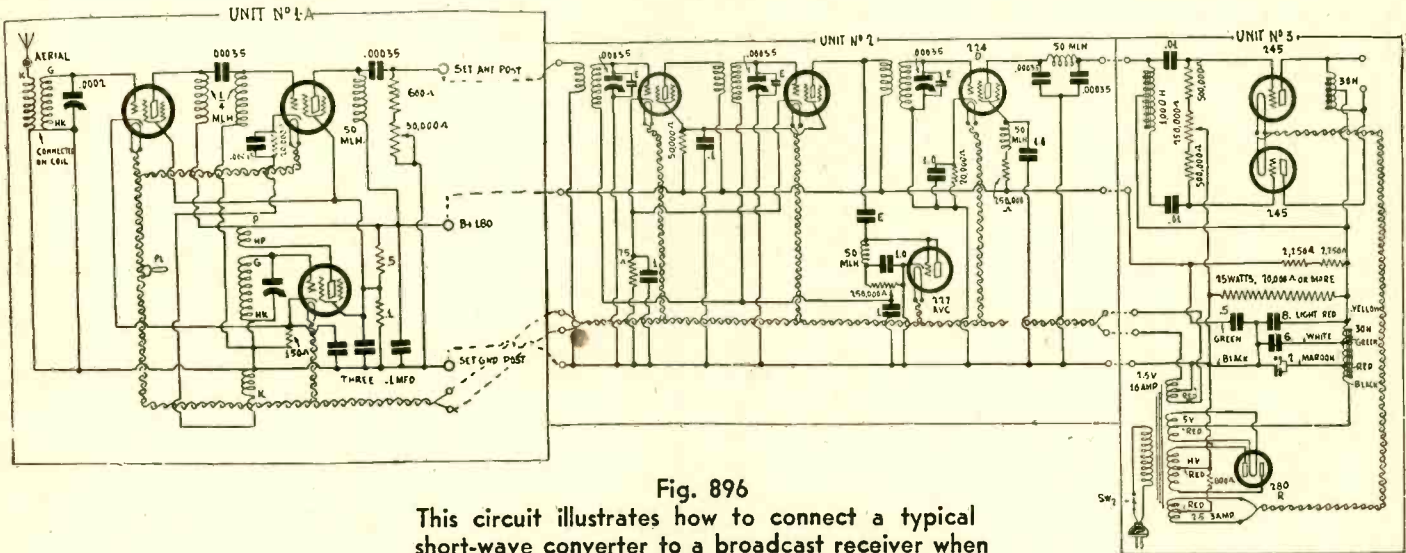

**Fig. 896**  
This circuit illustrates how to connect a typical short-wave converter to a broadcast receiver when heater and plate voltages are taken from the set. Five connections are made.

### Connection of Short-wave Converter

**W**ILL you kindly publish a diagram showing how to connect the 1A short-wave converter to a receiver? I have one of these but I am afraid that I have not connected it correctly. My receiver is home-made and has a tuned circuit ahead of the first tube with a rather large primary in the antenna circuit.—F.R.A.

Fig. 896 shows how the 1A converter is connected. This shows the way when the heater current for the converter tubes is taken from the receiver. If you have a separate heater transformer for the converter connect the two lower dotted lines to the 2.5 volt winding of this transformer.

\* \* \*

### Ganging Oscillator in Superheterodyne

**W**ILL you kindly give the values of the condensers necessary in the oscillator of an all-wave superheterodyne to make the circuit tune exactly at two settings of the oscillator dial that is, so that the sensitivity of the circuit would be as sensitive at these settings as if the RF and oscillator condensers were tuned separately?—B.N.W.

It is not possible to fix the condensers in an all-wave set to achieve this. Moreover, it is not possible to fix them so even in the broadcast band unless the intermediate frequency is known. Besides, there are several other factors that must be known before an attempt can be made to line up the condensers.

\* \* \*

### Coupling in Band Pass Filters

**W**HICH is the better coupler in a band pass filter, a small inductance coil or a condenser? Which will give the better quality? If we wish to make the coupling equal what should the inductance and the capacity be?—M.C.D.

One is just as good as the other, except that when a condenser is used the mounting problem is simpler. The coupler has very little to do with the quality of the output of a receiver. If we wish to make the coupling the same in the two cases we have to make the impedance of the coil equal to the impedance of the condenser. Since the impedance depends on the frequency we can only make them equal at one frequency. If we select this frequency at 1,000 kc a condenser of .04 mfd. is equivalent to a coil of .833 microhenry.

\* \* \*

### Push-Pull Tubes With Series Filament

**I**S THERE any way in which the filaments of tubes in push-pull can be connected in series, for battery type tubes, and still give each tube the same grid bias with respect to its own filament? If so, please show how?—L. W.W.

There are several ways in which this can be done. If the low potential ends of the two parts of the secondary winding are brought out separately, as they are in one well known transformer, each can be connected to the required grid bias. If the

secondary of the input transformer is only center-tapped, the tap may be ignored and two equal grid leaks connected from the grids and separately run to the proper grid voltage. Other ways could be contrived but these two are quite sufficient for filament type tubes. In the case of heater tubes the problem does not arise because the cathodes may be connected together whether the heaters are in parallel or in series.

\* \* \*

### Estimating Amplification

**C**AN the amplification to be expected from a tube be estimated from a curve giving the relationship between the grid voltage and the plate current? If not, what curve should be used for this work?—S.C.

No, the amplification cannot be estimated from the grid voltage plate current curve of the tube alone. However, if the tube is used in a resistance coupled amplifier and the curve gives the relationship between the grid voltage and the plate current through the load resistance, then the amplification can be estimated. Multiply the current change by the load resistance and then divide by the grid voltage change which produced the current change. The result is the amplification that can be expected on low frequencies. For example, suppose the plate current through a 100,000 ohm resistor changes from 1 milliampere to .25 milliampere as the grid voltage changes from .5 volt to 2.5 volts, then the amplification is 37.5. The grid voltage change is 2 volts and the plate current change is .75 milliampere. Another way of estimating the amplification is to use a family of plate voltage, plate current curves on the tube alone for a large number of grid voltages and then draw a load line across the curve corresponding to the load resistance. From this the change in the plate voltage and the corresponding change in the grid voltage can be obtained, and the ratio is the amplification.

\* \* \*

### Plug-in Preferred

**W**HICH is the better way to cover the short-wave band, with tapped coils or with plug-in coils? Also, which is better, to use small tuning condensers covering a narrow band with each coil or larger condensers covering a wide band?—F.W.C.

It is better to use plug-in coils because then it is possible to avoid taps and their complications, because with plug-in coils all the windings may be made to fit the particular band covered by a given coil, and because with plug-in coils it is easy to change the coils to cover different bands. If there is a good vernier dial attached to the condenser there is no serious objection to the use of a large capacity, but it is preferable to use a rather small one because the sensitivity is greater when the capacity is small and the inductance comparatively large and also because the stations are spread out on the dial more, making it easier to find the stations.

**A Wheatstone Bridge**

**I**S it possible for a fan to construct a Wheatstone bridge for measuring resistance that would be any good? Will you suggest how?—E.S.

The simplest is the so-called slide wire bridge. It requires only one standard resistor and a resistance wire about one meter long, or half a meter. For balance indicator a milliammeter of 0-1 range can be used, but preferably a DC galvanometer, which has a zero center, should be employed. The more sensitive this meter the more accurately can the balance point be obtained. The unknown resistance is determined in terms of the standard resistance and the ratio of the lengths of the resistance wire between the two ends and the balance point.

\*\*\*

**IF for Superheterodyne**

**I**S 250 kc a good intermediate frequency for a superheterodyne? It seems to me that it should be good for both broadcast and short-wave signals. If this frequency is all right, could a 100 trimmer condenser be used for tuning the intermediate frequency coils?—B.C.

Yes, 250 kc is all right and a 100 mmfd. trimmer condenser can be used for tuning the coils. The required inductance in the tuned circuit is 4.05 millihenries.

\*\*\*

**Radio Frequency Choke Values**

**W**HEN a radio frequency choke is used in the plate circuit of the detector, what should the inductance value be?

Should the same inductance be used in radio frequency sets and in superheterodynes, or does it have anything to do with the frequency? If there is any rule by which the value is determined will you kindly give it?—K. C. L.

It depends on the frequency and should be different in TRF sets and superheterodynes. The value also depends on whether or not there is a by-pass condenser on the audio side of the choke and on the type of load on the detector tube. The choke should offer a high impedance to the carrier frequency and a negligible impedance to the audio frequencies. If there is a condenser on each side of the choke the trap circuit so formed should be tuned to the intermediate frequency in a superheterodyne and to a frequency of about 450,000 cycles in the case of TRF broadcast receivers. The natural frequency of the circuit is obtained by considering the two by-pass condensers in series with each other and with the coil. Thus if each condenser has a capacity of .00025 mfd. the effective capacity is .000125 mfd. Therefore if the circuit is to be tuned at 450 kc the inductance of the choke should be one millihenry. The choke may be considerably larger without offering appreciable impedance even at the highest audio frequency. For that reason chokes as high as 85 millihenries are often used. In modern sets, however, the tendency is to use much smaller values. In the case of a superheterodyne having an intermediate frequency of 175 kc, the two condensers may be of .0005 mfd. and the choke coil 3.31 millihenries. To be effective this tuned trap should be tuned exactly to the intermediate frequency. If not, it is better to use a much larger choke coil.

\*\*\*

**Calibrating a Voltmeter**

**I**HAVE a voltmeter which I have made with a 0-1 milliammeter and series resistances. I don't know whether the voltage indications are correct or not. Please suggest a simple way in which I could calibrate the instrument, or check its readings.—V.M.C.

Get another voltmeter which you know is good and connect them across the same voltage at the same time. They should read the same if both are correct. If the improvised meter reads high or low you can get the correction factor necessary. This factor will be the same at every point on the scale so that if you get it at one voltage you have it for all. If, for example, the reading is low by 5 per cent, increase each reading by the same percentage, and if it is high by the same percentage, decrease each reading by the same percentage. It might be better to readjust the series resistance so that the readings are correct.

\*\*\*

**High Note Suppression**

**I**N many commercial super heterodynes a small by-pass condenser is connected across the secondary of the push-pull input transformer, or from grid to grid of the two push-pull tubes. What is the purpose of this condenser?—S.G.H.

The effect of this condenser is to lower the amplification on the high audio notes to some extent, and the purpose is to take some of the high pitch noises out of the signal. Sometimes the object is to reduce undesired noise and at other times to create a "mellow" output.

\*\*\*

**Intermediate Coil**

**I**HAVE a number of coils wound with 150 turns of No. 36 enameled wire on a diameter of one inch, which I desire to use in an intermediate amplifier of the tuned impedance type. If this is possible will you please give the capacity that should be connected across each coil to make the intermediate frequency 175 kc?—W.H.J.

You will need a capacity of .00193 mfd. Since this is not

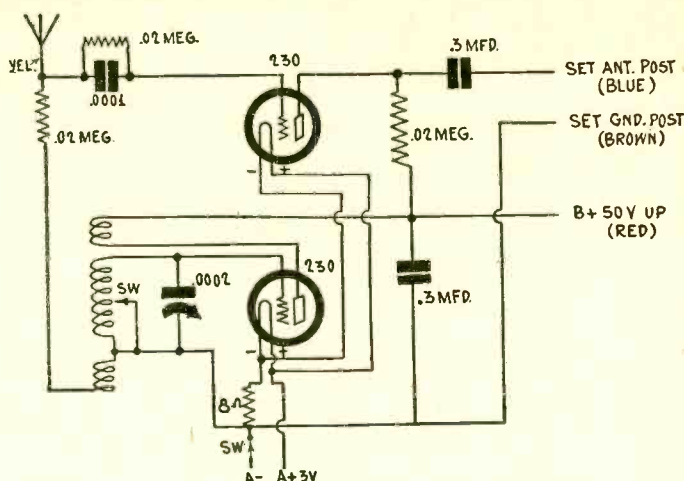

Fig. 897

This is the diagram of a simple, short-wave converter employing two 230 tubes.

obtainable in a unit it will either have to be built up or else a .002 mfd. condenser will have to be used. If the IF must be 175 kc, turns may be removed from the coils to compensate.

\*\*\*

**Simple Converter**

**I**AM looking for a simple short-wave converter using not more than two tubes and with only one coil for the oscillator. I wish to use battery tubes. Please publish a diagram.—F. X. McN.

You will find the diagram you ask for in Fig. 897. This is designed for 230 type tubes and a filament voltage source of 3 volts, that is, two dry cells connected in series.

\*\*\*

**What Makes Amplifiers Motorboat**

**W**HAT makes audio frequency amplifiers motorboat? I have built many resistance coupled amplifiers and almost without exception they have motorboated. If I knew what causes the trouble perhaps I could stop it without ruining the quality of the circuit. If the cause cannot be stated briefly, could you suggest a book in which there is a complete discussion?—W.A.F.

The cause of motorboating is the common impedance of the B battery or other B supply. Any device that will reduce the impedance of the B supply will help in reducing the oscillation. Also, any device that will reduce the relative value of the common impedance and the impedances in the plate circuits will help. If the oscillation has a very low frequency, say less than 20 per second, it can be stopped by reducing the stopping condensers and the grid leaks. The best way to reduce the common impedance is to connect large condensers across B supply. Another good way is to put a high resistance or a choke in the lead to each plate and then by-pass this impedance to ground with a rather large condenser, say 1 mfd. or larger. A discussion of the causes and remedies for motorboating is contained in "Audio Power Amplifiers" by Anderson and Bernard.

\*\*\*

**Summer Reception in South**

**D**OWN here in the tropics we do not have the choice of radio programs that you have up in the North and we have to depend on distant stations for our entertainment. In the winter regular broadcast receivers of the superheterodyne type are all right but in the summer static is too severe. In the spring we have to resort to short-wave receivers for they bring in distant stations without much interference from static. I note that you have emphasized short-wave converters, and I am wondering whether they could be used down here in conjunction with our broadcast receivers in the summer. If they can be they would be a blessing to many people here.—J. S.

The short-wave converters can be used anywhere in conjunction with broadcast receivers for reception during the static season, and already many persons are using them in the Caribbean region. Most reports from these users are highly favorable.

\*\*\*

**Overloading in Interstage Tubes**

**A**T certain times there is a sound in my receiver indicating overloading, but a milliammeter placed in the plate circuit of the power tube does not show any flicker, and therefore I am sure that the noise is not due to overloading. Is there any other cause for a noise of this type?—R.R.

Just because there is no overloading in the power tube you cannot logically assume that there is no overloading. The tube just ahead of the power tube may be overloaded, or any tube in the audio amplifier, including the detector. It makes no difference where the overloading takes place, the effect on the output is the same. Chances are that the bias on one of the tubes is not properly adjusted.

# REPORT BACKS 50 KW TO 8 OF 20 APPLICANTS

Washington.

Of twenty stations competing for eight channels to which the Federal Radio Commission is prepared to assign the maximum power of 50,000 watts power, the following were recommended by Chief Examiner Ellis A. Yost:

WJZ, New York City, now 30,000 watts.  
WCAU, Philadelphia, now 10,000 watts.  
WSB, Atlanta, Ga., now 5,000 watts.  
WCCO, Minneapolis, Minn., now 7,500 watts.  
WSM, Nashville, Tenn., now 5,000 watts.  
WGN, Chicago, now 25,000 watts.  
KPO, San Francisco, now 4,000 watts.  
KOA, Denver, Col., now 12,500 watts.

Of the remaining twelve applicants, one is using 25,000 watts (WBBM, Chicago), and he recommends that eleven others be elevated to the 25,000-watt rating.

## 25,000 Watts for Others

There are forty cleared channels. The Commission permits 50,000 watts on twenty of these, as there are five radio zones, there are eight cleared channels to each zone. However, the Commission permits only half of the cleared channels in any one zone to use more than 25,000 watts, so no zone will have more than four 50,000-watt stations.

The stations recommended for 25,000 watts, instead of the requested 50,000, are:

First Zone—WOR, Newark, N. J.; WHAM, Rochester, N. Y.; WBZ, Springfield, Mass.

Second Zone—WHAS, Louisville, Ky.

Third Zone—KVOO, Tulsa, Okla.; WBT, Charlotte, N. C., and WAPI, Birmingham, Ala.

Fourth Zone—WMAQ, Chicago; WHO-WOC, Davenport and Des Moines, Ia.; WBBM, Chicago (status quo).

Fifth Zone—KGO, San Francisco, and KSL, Salt Lake City.

The list of 50,000-watt stations would be as follows if the recommendations are adopted, the list adding the recommended stations to the existing ones, or noting power increase:

### First Zone

WTIC, Hartford, Conn.  
WEAF, New York, N. Y.  
WABC (C. P.), New York, N. Y.  
WJZ, New York, N. J.

### Second Zone

WCAU, Philadelphia, Pa.  
KDKA, Pittsburgh, Pa.  
WLW, Cincinnati, Ohio.  
WTAM, Cleveland, Ohio.

### Third Zone

WBAP, Fort Worth, Tex., and WFAA, Dallas, Tex., share time.  
WOAI, San Antonio, Tex.  
WSB, Atlanta, Ga.  
WSM, Nashville, Tenn.

### Fourth Zone

WENR and WLS, Chicago, Ill., share time.  
WGN, Chicago, Ill.  
KMOX, St. Louis, Mo.  
WCCO, Minneapolis, Minn.

### Fifth Zone

KFI (C. P.), Los Angeles, Calif.  
KNX (C. P.), Hollywood, Calif.  
KPO, San Francisco, Calif.  
KOA, Denver, Colo.

# Forum

I HAVE built two or three new sets recently, two of them superheterodynes published in your paper. These sets worked very well. Down here we need sets that are sensitive and can reach out and get the stations.

Would you kindly publish a circuit of a superheterodyne set consisting of seven or eight tubes of the new 2-volt battery type? About 75 or 80 per cent of the sets used here are battery-operated. I believe such circuits would be a benefit to many of the rural people and farmers who have no electric current and must have battery-operated sets.

Our radio reception down here this Winter has been very good. Generally beginning in March we have static, sometimes so bad that we cannot get even the Havana stations only 90 miles away. We then have to resort to the short waves. I have a 3-tube converter made from one of the circuits you published. With this converter I have no difficulty in getting most of the short-wave stations in the United States. Two or three times I have had G5SW in London.

HERMAN C. ARHEIT,  
San Pedro, Isle of Pines, Cuba.

I WANT to compliment you on your magazine in that it is lively and up-to-date, full of interesting circuits and news of the latest developments.

The converters designed by Herman Bernard are what you claim. That they are sensitive there is no doubt and that they work is a fact.

Now these pessimists who complain that all they receive is code should exercise patience. These converters, when coupled correctly to a broadcast receiver, should do exactly as you claim, providing the converter is wired correctly.

The most important part is that there is not much hand capacity, if any.

Also, most of the persons complaining of these converters do not fully read your account of what these converters can do under operating conditions.

Concerning the RC-30 converter in the February 7th issue, I built this, too. This converter, coupled up to a Crosley 5-50 battery-operated set, brought in Chicago, New York, Canada, and Honduras, all on the loudspeaker.

S. KANZIUS,  
R. F. D. 20, Langeloth, Pa.

## Literature Wanted

Readers desiring radio literature from manufacturers and jobbers concerning standard parts and accessories, new products and new circuits, should send a request for publication of their name and address. Send request to Literature Editor, RADIO WORLD, 145 West 45th Street, New York, N. Y.

Grover Reil, 41 Colby St., Phillipsburg, N. J.  
Bernard E. Charter, P. O. Box 278, Milford, Conn.

John H. Burke, 88 Pearl St., Chelsea, Mass.  
H. T. Hoffman, Q300Q2QQ Q.E. 79th St., Chicago, Ill.

R. F. Lambert, 1524 Clairmont Ave., Detroit, Mich.

Ernest Eckstrand, R. R. No. 2, Berwick, Pa.

Art A. Johnson Garage, Rockford, Ill.

Henry M. Whitehead, 39 McKinley St., Rochester, N. Y.

A. E. Christ, 3rd Floor, Wear Ever Building, New Kensington, Pa.

H. L. Bumbaugh, 215 S. New Hampshire Ave., Los Angeles, Calif.

W. H. Henning, 238 N. Jackson Ave., No. Plainfield, N. J.

Chas. LaBelle, 134 Osceola St., Laurium, Mich.

I. L. Treat, Gen'l. Delivery, Westerly, R. I.

Geo. G. Meyer, D.D.S., 2002 Noble St., Swissvale, Pa.

Eugene Smaltz, 607 Jefferson Ave. Toledo, Ohio

H. Oren Willis, 108 E. Morgan St., Cleves, Ohio.

A. Scott Aimers, Jr., 1107 E. 2nd St., Brooklyn, N. Y.

A. M. Rowe, Grain Valley, Mo.

# TRADE-IN PRICE CALLED DODGE

The Boston Better Business Bureau issued the following:

Recently a practice has developed in radio advertising which seems to be a serious abuse tending to break down public confidence and sound radio advertising. It is the offering of fictitious or false valuations on trade-ins of old radios, phonographs, or any article of furniture, regardless of condition, toward the purchase of radios at cut prices.

When any "old radio, phonograph, or article of furniture, regardless of condition," may be traded for any amount up to \$50, depending upon the radio purchased, it is apparent that the valuation placed upon such article traded in is purely fictitious.

There seems to be an attempt to create the impression that list prices are not actually cut, or that the reduced prices are obtainable only by means of having something to trade in. This investigation revealed that the so-called valuations on trade-ins were fictitious and that it was apparently an attempt to disguise price reductions.

The Better Business Bureau believes that fictitious valuations on trade-ins should be discontinued, and requests the cooperation of advertisers. At the same time, the Bureau is requesting the National Better Business Bureau to take up the subject directly with the radio manufacturers.

The Bureau suggests that if there is a price reduction it should be advertised as such, with no attempt to disguise it with fictitious valuations on valueless trade-ins.

The Boston Bureau investigated several radio advertisements which quoted prices for advertised radio "less tubes" and found that the advertised radios would not be sold "less tubes" at the advertised prices, but customers would have to pay the complete price (including tubes) which was not quoted in the advertising.

The Bureau recommends that if a set is advertised at a price "less tubes," or "tubes extra," the set should be sold "less tubes" if desired by the customer.

If a set will not be sold "less tubes" the "less tubes" price should not be quoted but the complete price should be quoted.

## New Corporations

Seedman-Sandford Corp., wireless apparatus—Atty. D. L. Sprung, 295 Madison Ave., New York, N. Y.

Advance Radio Corp., Paterson, radio receivers—Atty. W. A. Harrison, Fairlawn, N. J.

M. A. Leese Radio Corp., Wilmington, Del., broadcasting—Corp. Trust Co.

Central Radio Corporation, Newark, N. J., deal in radios—Atty. Silber & Silber, Newark, N. J.

Minute-Men Radio Service Corp.—Atty. C. Bonowitz, 67 West 44th St., New York, N. Y.

Radio Artists Recording Service—Atty. W. Strelsin, 167 East 86th St., New York, N. Y.

Pacnet Film Laboratories, motion talking pictures exchanges—Atty. B. H. Noden, 91 7th Ave., New York, N. Y.

Talking Pictures Programs, install talking pictures—Atty. Dills & Towsley, 100 East 42nd St., New York, N. Y.

Savil Radio Engineering Corp., radio apparatus—Atty. E. F. Vilkomerson, 2 Lafayette St., New York, N. Y.

Rayner Broadcasting Corp., Wilmington, Del.—Colonial Charter Co.

## A THOUGHT FOR THE WEEK

THE READER suggests that Congress enact a law making it illegal for any broadcasting station to permit the sending out of programs in which any religion is attacked. The penalty proposed, naturally enough, is the cancellation of an offender's license. That sounds reasonable enough. How about another of those referendums that some of our statesmen so glibly talk about and so rarely put over?

# U. S. WILL SEEK MEANS TO END FADING EFFECT

Washington. More intensive study of fading, and of the general radio transmission and reception characteristics, will be undertaken by the Bureau of Standards under legislation passed by the Senate and the House.

Authorizing \$147,000 for the two new experimental stations to be operated by the Bureau under the supervision of Dr. J. H. Dellinger, Chief of the Radio Section, a bill was passed by the Senate. The measure was passed by the House at the last session.

## Enlarged Frequency Service

With the additional facilities the Bureau's work should be materially expanded in combating the ailments of radio, and in elimination of interference both as respects broadcasting and communications, Dr. Dellinger explained orally in connection with the legislation.

The present standard frequency service of the Bureau, broadcast on regular schedule, and by which all licensed users of the ether may check their frequency stability so as to avoid "wobbling," would be extended so as ultimately to provide a 24-hour continuous service, Dr. Dellinger explained.

The work for which the additional facilities are needed, he explained, includes the study of the variations which radio waves undergo in transit between the transmitter and the receiver, the transmission of standard radio frequencies, and transmission of special signals as an auxiliary to the Bureau's development work on uses of radio in aviation, and for other experimental purposes.

The reasons for the work, continued the Director, can be readily understood when it is realized that radio "has already reached such widespread use that space is crowded with it."

## Scope of Study

Transmitting and receiving equipment has been brought to a high degree of perfection. Additional uses and more satisfactory service for these uses already established "seem to depend largely on attaining more precise control of frequencies and more complete knowledge of the way in which radio waves are transmitted through space and of their characteristics as received," he declared, according to "The United States Daily," adding that the projects for which the two proposed stations would serve are intended to meet these needs.

"The studies most urgently needed on received radio waves have to do with fading, one of the most serious limitations on broadcasting; changes in direction, of great importance in navigation of ships and aircraft; and the behavior of short waves (high frequencies)," he added.

## A SCIENTIFIC SHRUG

**H**ERR EINSTEIN, whose relativity problem has helped to silver the domes of many a professor and high-brow student, was asked the other day if he thought radio was anywhere near its final development as a science. The learned gentleman shrugged his shoulders—which reply is suggested for use by the aforesaid query-answering professors who are growing old before their time.

# Distance Lure Is Rife Again

Interest in the reception of distant stations again is high, and this fact has been confirmed by a survey made by the United States Department of Commerce. It is found that builders, and purchasers of commercial sets, inquire about the distance-getting ability, and that manufacturers of kits and sets make a point to tell the public that their sets are excellent for distance.

For a few years the word distance almost had disappeared from the advertising, particularly as manufacturers could not tell just what a set would do in a certain locality. It might bring in lots of DX in one place and little in another.

## Outdo Predecessors

However, an outstanding point in regard to the receivers marketed today is that they are far more sensitive than their predecessors. Therefore the question of difference in performance in different localities is not so important, since even when conditions are untoward, due for instance, to part-absorption of a wave prior to its striking the particular antenna, the extreme sensitivity of the latest receivers is able to cope with the situation.

Better results are obtained in poor locations with the up-to-date sets than were obtained in good locations with the former models.

In the short-wave field particularly are the charms of distance alluring, as great distances may be covered.

## Bring in Europe

It is nothing unusual for the possessor of a short-wave set or converter to tune in Europe directly, and indeed the principal attraction of short-wave devices for most of the users is that they can "bring in Europe while there's company in the house."

Part of the burden of making distance receivable rests with the stations, and thus with the administrative bodies, for instance, in the United States, with the Federal Radio Commission.

## JACKS FOR EXTRA SPEAKER

Silver-Marshall provides a pair of extension speaker jacks on the new Compact and Cadet superheterodyne. The jacks enable operation of an extra speaker, or two speakers, in distant rooms.

# STATIONS TO BE IN EGYPT OASES

Egypt is planning desert radio, said William J. Avery, export manager of the Atwater Kent Manufacturing Company, who just returned from a 15,000-mile trip through Northern Africa and across Europe.

"The principal source of radio programs in Egypt is the new broadcasting station in Rome, one of the most powerful in the world, with a power of 50 kilowatts but capable of being stepped up to 100 kilowatts," he said. "This station was fabricated from materials brought over from the United States."

"Interest in radio programs has increased decidedly in Egypt and in Algeria since the opening of the new Italian station. The fine musical programs particularly are appreciated."

"The Egyptian government itself has become interested in radio and plans to modernize the desert by erecting three high-powered transmitting stations. King Fuad has taken the proposal in hand personally and under plans already formulated three large oases have been chosen as the sites for the stations. Supplemental services will be had through six mobile stations located at strategic centers in Egypt and the Lybian desert. American radio engineers will supervise the proposed work."

# Third of NBC Programs Were Sponsored

Only one-third of the programs heard over networks of the National Broadcasting Company during 1930 were sponsored by advertisers. That, approximately, was the ratio during the last three months of that year.

All the remaining programs of that period were designed and produced by NBC and its associated stations on a sustaining basis.

A statistical chart of those months shows that dramatic programs and special events, as well as educational and religious features, occupied distinct niches in the program plan as a whole. Of these divisions, the educational programs predominated, by occupying a total of 8.6 per cent. of the broadcasting time, or sixty to seventy hours per month.

**Important Issue Coming!**

**9th Anniversary Number**

**O F RADIO WORLD**

**Dated March 28. Published March 25. LAST form closes March 17. Increased distribution. Increased value. Increased sales for advertisers.**

	1 Inser.	4 consec. Inser. (each) 10%	13 consec. Inser. 12½%	26 consec. Inser. 15%	52 consec. Inser. 20%
1 page	\$150.00	\$135.00	\$131.25	\$127.50	\$120.00
½ page	75.00	67.50	65.62	63.75	60.00
¼ page	50.00	45.00	43.75	42.50	40.00
1/8 page	37.50	33.75	32.81	31.87	30.00
1/16 page	25.00	22.50	21.87	21.25	20.00
1 inch	18.75	16.87	16.41	15.94	15.00
1 inch	5.00	4.50	4.37	4.25	4.00

Classified advertisements, 7 cents a word; \$1.00 minimum; must be paid in advance.

Radio World, 145 West 45th St., New York, N. Y.

Advertising Department

# THIS MONTH'S SPECIALS!

ALL merchandise listed is BRAND NEW and is shipped in the original, factory sealed cartons and carries the same guarantee of ABSOLUTE SATISFACTION! Due to the demand for this seasonable merchandise actually exceeding the available supply, ACT IMMEDIATELY! In most

instances, our SALE PRICES ARE LOWER THAN THE ACTUAL MANUFACTURER'S COST! Join the ever swelling ranks of our 100 per cent SATISFIED CUSTOMERS. ORDER DIRECT FROM THIS PAGE TODAY. NEW LOW PRICES.

### Dry Electrolytic Condensers

Mount in any position! Guaranteed never to blow out! Remarkably compact and very inexpensive, permitting generous use of filtering systems. The greater the mfd. capacity employed, the less A.C. hum remains. 500 volt peak rating. Ideal for all 171A - 245 power packs—use two of each capacity desired for 250 power packs (1,000 volt peak thereby assured).



No.	Mfd.	Diameter	Length	YOUR PRICE
1801	1	3/4 in.	2 3/4 in.	\$0.28
1802	2	1 in.	2 3/4 in.	.45
1804	4	1 1/2 in.	2 3/4 in.	.85
1808	8	1 3/4 in.	4 1/2 in.	1.25
1816	16	3 in.	4 1/2 in.	2.12
1824	24	3 in.	4 1/2 in.	2.75
1832	32	3 in.	4 1/2 in.	3.33

### R.C.A. Double Filter Chokes

This heavy-duty, extremely strong, double filter choke can be used for all types of filter circuits, experimental work, power amplifiers, receivers, eliminators, power packs, converted sets, etc. Known as R. C. A. replacement part for all Radiola models, particularly Nos. 33, 17 and 18. Each choke D.C. resistance, 500 ohms. Connected in parallel, these double filter chokes have a rating of 15 Henries at 100 Mills; connected in series, 60 Henries at 80 Mills. Fully shielded in heavy metal case with special insulating compound. Size 5 1/4 x 3 3/4 x 2 1/2. Shipping weight 6 lbs. List Price \$10.05.



No. 8336—YOUR SPECIAL PRICE... **95c**

### Earl Power Transformer

Make money revamping the old battery set. This power transformer used in Earl Model 22 receiver supplies "A," "B," and "C" potentials for: two '27's (or screen - grid '24's), three '26's, two '71A's and one '80 rectifier; total current output of high-voltage winding at maximum output (about 200 volts) is 80 ma. High-voltage secondary, filament winding for '27's, and for '71A's are center-tapped. May be used in any number of combinations. Suitable resistors, a couple of 4-mf. filter condensers, two 30-henry chokes and by-pass condensers complete fine power pack. Size 3 1/2 x 3 x 2 3/4 inches. 16 long leads and full wiring directions. Shipping weight 5 lbs. List Price \$7.50.

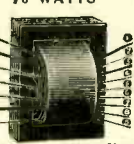

No. 1410—YOUR SPECIAL PRICE **\$1.75**

### Utah Dynamic A.C. Power Speaker—Model 33A

110-volt, 60-cycle A.C. light socket supply for field excitation with Westinghouse dry rectifier. 9 in. high, 9 1/2 in. wide, 7 1/2 in. deep. Speaker cones packed in wooden crate. Weight 19 lbs. It is one of the most powerful as well as best reproducers in the market. 9-inch cone. List Price \$50.00.



No. 1506—YOUR SPECIAL PRICE **\$7.50**

### Cavalier Model 159 Console With Peerless Speaker

This beautiful and distinctive cabinet is sold with the built-in Peerless Speaker. It is designed to provide a maximum cabinet at a minimum price. Veneers of Figured Walnut with attractive carvings and unusual turnings. Set compartment, 21 1/4 in. wide x 10 1/2 in. deep x 8 in. high. Height, 38 in. Shipping weight 65 lbs. Packed in original crate. Complete with Speaker.

No. 159—YOUR SPECIAL PRICE **\$9.95**

### Thordarson Standard Replacement Power Transformer

This transformer may be used in building up inexpensive chassis; or for replacement in such standard combinations as three '24's, two '27's, two '71A's or two '45's, and an '80 rectifier. Suitable for the home-built rack-and-panel public address amplifier, or cabinet-type phonograph power amplifier. Just the foundation unit for an audio amplifier to be used as a standard of comparison. Well designed. Connections are made to soldering lugs on the two end plates. Dimensions: 3 1/4 x 3 1/2 x 4 inches. For 110-120 volts, 50-60 cycles. Shipping weight 5 1/4 lbs. List Price, \$12.50.

No. 1405—YOUR PRICE... **\$2.55**

### Kolster Speaker Chassis

May be connected directly in the plate circuit of type '12A tubes; or to higher-power tubes through an output device. In push-pull circuits, speaker may be connected from plate to plate. "9-inch cone" type. Paper-rattle is prevented by a flannel damper; bass notes are well reproduced due to the "free-edge" effect. Its small dimensions make it eligible for use in home-constructed midget sets.

Comes with 6 ft. cord. Dimensions: 10 x 5 1/2 x 9 1/2 inches. Shipping weight 6 1/2 lbs. List Price, \$18.00.

No. 1500—YOUR PRICE... **\$2.85**

### Short-Wave Converter

Build a short-wave converter at lowest price on record, but with which excellent results are obtainable nevertheless. The voltage for the three 227 tubes used may be obtained from an external filament transformer or from a secondary winding of 2 1/2 volts in a power pack. Wavelength from 30 to 110 meters. No plug-in coils; coil switch is used to cover wave band. Single dial tuning, no grunting, no body capacity, no squeals. Leak-condenser modulation. Converter consisting of all parts (less filament transformer) including cabinet, panel, diagram and 4-page instruction sheet (less tubes).

No. 1619—YOUR PRICE... **\$4.85**

No. 1615—6-Volt Battery Model, same price.

### "250" A.C. Power Transformer

This power transformer supplies currents for five 15-volt Arcturus tubes drawing 5 Ma. and 1/2 amp. on filaments; one 2.5 V. tube; two '50's, and two '81's. Two '27 or '24 (if suitable resistance is used) and 750 volts. Full wave "B" and "C." A line ballast resistor, such as the Amperite, in conjunction with the special 85-volt primary, will maintain even voltage over 105 to 125 volts. Entirely shielded in metal. 4 1/4 x 4 1/4 x 6 1/2 inches high. Weight 15 lbs. For 110-120 volts, 50-60 cycles. List Price, \$20.00.

No. 1412—YOUR PRICE... **\$3.75**

### 2.5 Volt Filament Transformer

60 WATTS Has 2 center-tapped windings. Both deliver 2.5 volts. One winding gives 3 amperes; the other, 11 amperes. Pistal leads. Heavy iron case, beautifully finished in brown crackle. 110 to 120 volts, 50 to 60 cycles. Dimensions: 3 1/4 x 5 x 4 1/2 inches. Shipping weight 9 lbs. List Price, \$6.00.

No. 1414—YOUR PRICE... **\$3.45**

### Shielded "A" Transformer

Modernize storage battery receivers by replacing '01A's with '26's and '27's heated by this filament transformer. Supplies 1.5, 2.5, and 5 volts; 2.5-volt winding center-tapped. Heats three '26's, two '27's, and two '12A's or '71A's. 3x3x4 inches. For 110-120 volts, 50-60 cycles.

Weight 3 1/2 lbs. List Price, \$4.50.

No. 1400—YOUR PRICE... **\$1.75**

### A.K. 37 Filter Choke Condenser

Contains two filter chokes, a speaker output choke, two high-voltage filter condensers, a detector by-pass condenser, and an R.F.-A.F. by-pass condenser, each connecting lead being identified by colors. To make up efficient power pack for a receiver using a type '71A output tube you need only a rectifier tube socket, a voltage divider, a power transformer, and this filter block. 3 1/4 x 4 1/2 x 5 inches. Shipping weight 6 lbs. List Price, \$7.50.

No. 1800-283—YOUR PRICE... **\$4.95**

### 6 MONTHS GUARANTEED NEONTRON TUBES

Sold on a 6 MONTHS FREE REPLACEMENT GUARANTEE BASIS, PROVIDING TUBE LIGHTS! All tubes are carefully meter-tested before shipment, and carefully packed. Do not confuse these HIGH QUALITY tubes with any other "low priced" tubes—our low prices are possible because we do a VOLUME business!

Choice of	Choice of	Choice of	Choice of
226	112A	245	222
227	200-A-199UX	280	210
171A	199UV-120	171	250
201A	224		281

63c each      70c each      80c each      \$1.60 each

## FREE

RADIO SERVICE TREATISE

AND RADIO BARGAIN CATALOG

FOR RADIO SERVICE MEN—RADIO TECHNICIANS—RADIO DEALERS

RADIO TRADING CO.

25 WEST BROADWAY  
NEW YORK CITY

We have just issued our new "RADIO SERVICE TREATISE." It's red hot all the way through. 52 new hookups and circuit diagrams. 110 illustrations.

Partial contents: Modernizing old radio sets. How to convert battery to power sets. Selection of tubes. The detector tube. The power tube. Changes in grid or "C" bias circuits. Push pull amplifiers. Replacing audio transformers. Phono. attachments. How to choose power transformers. Voltage dividers. Wattage of power transformers. Selecting and installing replacement parts in radio sets. Filter condensers. Repairing "B" eliminators. ALL BRAND NEW DOPE—NOT A REPRINT. Chuck full of REAL radio information all the way through. Even the catalog section has dozens of hookups—never found anywhere before.

WRITE TODAY. Enclose 2 cents for postage. Treatise sent by return mail.

### The SONOLA 1931 A.C. Model Midget Receiver

This Midget Receiver will outperform many of its larger brothers. Uses 5 tubes: 3 screen grid, 245 power tube, 280 rectifier. Rola dynamic. Large capacity filter. Perfectly shielded. Selectivity obtained by use of three tuned stages. High amplification is assured by screen grid RF, screen grid power detector and '45 output. Rola Dynamic gives wonderful reproduction. So small you can put it anywhere you like. There may be cheaper midgets on the market. We are fully aware of this. That's exactly why you should have a SONOLA. There is NO GRIEF with this high grade set. For 50 to 60 cycle, 110 volts. Dimensions: 14 x 9 x 18 inches high. Shipping weight 30 lbs. List Price, \$59.50.

No. 2500—Your Price (less tubes) **\$29.85**

### Genuine Magnavox Microphone

Do Your Own Home Phonograph Recording. Made by the world-famous Magnavox Co. While originally made to strap on the head, it is easy to screw a handle onto one of the side brackets. The side brackets are covered with soft rubber and place the microphone at the best speaking distance from the mouth. Comes with 6 feet of cord. The biggest mike bargain in America! Complete with straps and buckle to fit around head. Brand new, in original factory packing. Shipping weight 1 lb. List Price, \$10.75.

No. 1610—YOUR SPECIAL PRICE **\$1.55**

### "RTC" High-Voltage "Puncture Proof" Filter Condenser Units

We guarantee these condensers unconditionally. They are ideal for general replacement purposes and can be installed in any new power-pack. All condensers are furnished with 8-inch lengths of tinned "push-back" wire.

600 VOLTS			800 VOLTS		
Cat. No.	Mfd.	Your Price	Cat. No.	Mfd.	Your Price
1702	1/2	\$0.25	1706	1	\$0.45
1703	1	.30	1707	2	.75
1704	2	.40	1708	4	1.10
1705	4	.60			

WE ARE A WHOLESALE HOUSE AND CANNOT ACCEPT ORDERS FOR LESS THAN \$3.00. If C. O. D. shipment is desired, please remit 20% remittance, which must accompany all orders. If full cash accompanies order, deduct 2% discount. Send money order—certified check—U. S. stamps.

**Radio Trading Co.**  
**25 R West Broadway**  
**New York, N. Y.**

ORDER FROM THIS PAGE. You will find special prices from time to time in this magazine. Get our big FREE catalog for the greatest Radio Bargains. Should you wish goods shipped by parcel post, be sure to include sufficient extra remittance for same. Any excess will be refunded.

## Multi-Tap Voltage Divider

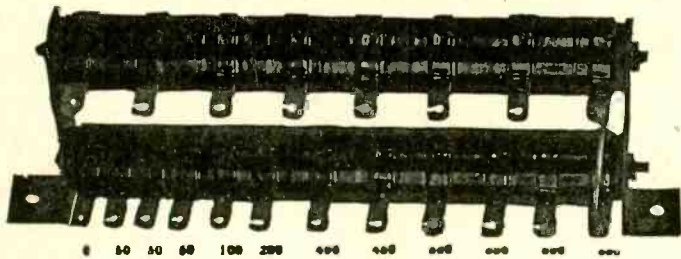

The resistance values between the twenty taps of the new Multi-Tap Voltage Divider are given above. The total is 17,100 ohms and affords nineteen different voltages.

The Multi-Tap Voltage Divider is useful in all circuits, including push-pull and single-sided ones, in which the current rating of 100 milliamperes is not seriously exceeded and the maximum voltage is not more than 400 volts. Higher voltages may be used at lesser drain. Conservative rating, 40 watts.

### GUARANTY RADIO GOODS CO.

143 W. 45TH ST., NEW YORK, N. Y.

The expertness of design and construction will be appreciated by those whose knowledge teaches them to appreciate parts finely made. When the Multi-Tap Voltage Divider is placed across the filtered output of a B supply which serves a receiver, the voltages are in proportion to the current flowing through the various resistances. By making connection of grid returns to ground, the lower voltages may be used for negative bias by connecting filament center, or in 2T and 2T<sub>2</sub> tubes, cathode to a higher voltage. If push-pull is used, the current in the biasing section is almost doubled, so the midline of the power tubes' filament winding would go to a lug about half way down on the lower bank.

Order Cat. MTVD.  
list price \$2.95  
\$2.50  
ret price..

## The 1-A Unit

THE de luxe model all-wave converter tunes from 15 to 600 meters, using two tuned circuits, with a Hammarlund condenser in each, and a total of five plug-in coils of the tube base type. This model, the 1-A Unit, consists of a beautifully finished bakelite front panel and sub-panel, with National modernistic dial.



Three screen grid tubes are used. Filament transformer is built-in, while AC switch is on the front panel.

The assembly is totally rigid and self-supporting, requiring no cabinet.

This model is of the very finest type, and gives you the advantage of triple screen grid in a de luxe assembly. Consistent direct reception of Europe is reported by users of the 1-A.

All parts, including filament transformer and five tube base coils, but not tubes, order Cat. 1-A, @..... \$19.87

Wired model, Cat. 1-AW, @..... \$22.87

Precision 3" diameter plug-in coils can be supplied instead of the tube base type. These coils are wound on 97% air dielectric. Nine coils are supplied, to tune from 10 to 600 meters. These coils fit 5-prong tube sockets used as coil sockets. Order Cat. K-9 @ \$12.00

If precision coils are desired with kits or wired models of 1-A Unit, order Cat. 1-A-K or Cat. 1-A-WK @ .....\$8.25 extra

### Polo Engineering Laboratories

125 WEST 45TH STREET, NEW YORK, N. Y.

Telephone: BRyant 9-8093

## FOUR-GANG .00035 MFD. WITH TRIMMERS BUILT IN !

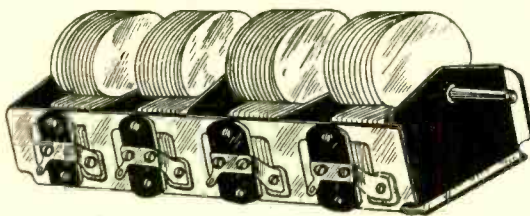

This condenser, each of four sections .00035 mfd. has aluminum plates that are removable and adjustable, on a 1/4" diameter steel shaft that is removable. It is sturdy and is suitable for popular four-circuit screen grid tuners. Trimming condensers are built in. The condenser may be mounted on its bottom or side. Total overall length, including shaft, 1 1/2". Overall width, 4". The frame is steel. Order Cat. 4-G @.....

\$3.95

(Between 46th and 47th Streets)

RELIABLE RADIO COMPANY

145 W. 45th St., N. Y. C.

SEND FOR FREE RADIO CATALOG LOWEST PRICES!

COAST TO COAST RADIO CORPORATION

HEADQUARTERS ALL RADIO REPLACEMENT PARTS

142 W. LIBERTY ST., NEW YORK

## PARTS FOR BERNARD'S DIAMOND MIDGETS

3-tube AC tuner, less B supply, complete parts as specified by Herman Bernard. Pre-selector tuning, space-wound shielded coils, aluminum chassis drilled for socket holes. High sensitivity. No cross-modulation. Adequate selectivity. All parts (less tubes, less front panel) order Cat. DHST @ \$17.28

AC tuner, with B supply built in, using 227 as rectifier; two 224 RF tubes, 227 detector. Same circuit as DHST, except that special rectifier circuit is added, so that tuner may be worked with audio power amplifier that provides no external voltage. All parts (less tubes, less front panel) order \$21.82

Complete AC receiver, with the same tuner as the others, but with three-stage audio, with 245 output. All parts fit on a 12" wide x 9 1/2" front-to-back chassis, with elevating flap 3" high. Filtration perfect (24 mfd. used). Requires two 224, three 227, one 245, one 230. All parts (less tubes, less front panel) order \$31.09

Battery-operated tuner, using two 232 RF and one 231 tube (new 2-volt type), affording same sensitivity and selectivity as either model AC tuner. Just the thing for those whose homes have no electricity. Supplied with cable connector plug for extreme convenience in connecting batteries. All parts (less tubes, less front panel) order \$16.94

The complete battery-operated receiver, six tubes (two 232, three 230, one 231). All parts (less tubes, less front panel) order \$23.91

Note: All models use same front panel. Supplied in bakelite, 7 x 12 inches, drilled for REL dial, volume control and switch, to coincide with chassis. Order Cat. DFP-Black or DFP-Walnut @ \$1.62

GUARANTY RADIO GOODS COMPANY, 143 WEST 45th STREET, NEW YORK, N. Y. (Just East of Broadway)

# Quick Action Classified Ads

## Radio World's Speedy Medium for Enterprise and Sales

7 cents a word—\$1.00 minimum—Cash with Order

**FILAMENT TRANSFORMERS**—1 1/2, 2 1/2, 5/110 v. \$1.00. Build your own. Laminations and core, 85c. Transformers for Power Packs. Write for Prices. Transformers made. P. P. Extra. A. Apfelbaum, 2711 Girard Ave., Phila., Penna.

**RESISTANCES, CONDENSERS, TRANSFORMERS, CHOKE-COILS,** etc. Write for sensational low price list. Bronx Wholesale Radio Company, 7 West Tremont Avenue, New York.

**H.F.L. MASTERTONE.** List \$195. Sell \$85. World's finest radio. W. J. Reed, Aurora, Ill.

**HORN UNIT, \$1.95**—This is the Fidelity Unit and has stood the test of time. Guaranty Radio Goods Co., 143 W. 45th St., New York

**"HANDBOOK OF REFRIGERATING ENGINEERING,** by Woolrich.—Of great use to everybody dealing in refrigerators. \$4. Book Dept., Radio World, 145 W. 45th St., N. Y. City.

**SHORT-WAVE NUMBERS OF RADIO WORLD.** Copies of Radio World from Nov. 8, 1930 to Jan. 3, 1931, covering the various short-wave angles, sent on receipt of \$1.00. Radio World, 145 W. 45th St., N. Y. City.

**CONSTRUCTIONAL DATA**—30 henry choke 50c; laminations in stock. Radio Power, 1028 Forest Road, Schenectady, N. Y.

**DRILL PRESS STAND** for the work bench. Blueprint showing how to build it, \$1.00. Inquire about complete kit of parts. Super Engineering Laboratories, 1313 - 40th St., Brooklyn, N. Y.

**PRINTING: 1000 BUSINESS CARDS \$2.75 POSTPAID.** Other printing reasonable. Samples free. Miller, (RW), Printer, Narberth, Pa.

**"FORD MODEL 'A' CAR."** Its Construction, Operation and Repair, By Victor W. Page, M.E. 545 Pages, 251 Specially Made Engravings. \$2. postpaid. Radio World, 145 W. 45th St., N. Y. City.

**BARGAINS** in first-class, highest grade merchandise. B-B-L phonograph pick-up, theatre type, suitable for home with vol. control, \$6.57; phono-link pick-up with vol. control and adapter, \$3.32; steel cabinet for HB Compact, \$3.00; four-gang .00035 mfd. with trimmers built in, \$1.95; .00025 mfd. Dubilier grid condenser with clips 18c. P. Cohen, Room 1214, at 143 West 45th Street, N. Y. City.

**SCOTT WORLD RECORD SUPERHET,** Demon-strator, with radiotrons, \$29.50. Jaeger, 607 West 138th St., New York City.

**FILAMENT TRANSFORMERS**—1 1/2, 2 1/2, 5 volt, \$1.00; 2 1/2 volt, 5 1/2 amp., \$1.10; 7 1/2 volt, 3 amp., \$1.25. C. T. secondaries, primary 110 volt. Write L. Waterman, 2140 Kirby West, Detroit, Mich.

**SOUND PICTURES TROUBLE SHOOTER'S MANUAL,** by Cameron and Rider, an authority on this new science and art. Price \$7.50. Book Dept., Radio World, 145 W. 45th St., N. Y. City.

**RADIO WORLD AND RADIO NEWS.** Both for one year, \$7.00. Radio World, 145 W. 45th St., N. Y. City

**"MATHEMATICS OF RADIO."**—A great help to everybody interested in radio. \$2 postpaid. Radio World, 145 W. 45th St., N. Y. City

**"A B C OF TELEVISION"** by Yates—A comprehensive book on the subject that is attracting attention of radioists and scientists all over the world. \$3.00, postpaid. Radio World, 145 West 45th St., N. Y. City.

# SHORT WAVES with a Converter!

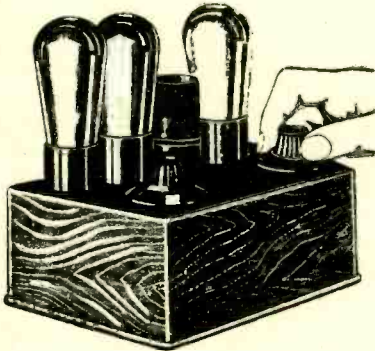

The Model PR-3FS Short-Wave Converter that is, in fact, an all-wave converter, as it enables also the reception of broadcast frequencies. The range is 25 to 600 meters, so you are sure to cover the television band, too.

**W**ITH high-gain radio frequency amplifiers characterizing experimenters' broadcast receivers today, and audio amplification remarkably faithful, it is convenient, economical and easy to tune in short waves and television with a converter. In that way you use your entire broadcast receiver just as it is, and besides the television band, tune in other short waves. The range is 25 to 600 meters, when the broadcast set is worked at a high frequency, around 1,500 kc.

The converter illustrated is model PR-3FS and has a filament transformer built in. There are only four external connections to make, and one of these is to a positive B voltage, 50 to 180 volts, taken from the receiver. If you have a screen grid set you may take this voltage from the screen of a radio frequency tube, by looping the bared end of the B plus lead and slipping the screen prong of the tube through the loop before reinserting the tube in the set.

The converter uses three 227 tubes and plug-in coils of the tube base type. There is an AC switch built in, but there is only one tuning dial (at right). The condenser is the new Hammarlund Junior Midline of .0002 mfd. capacity.

This short-wave converter has proved highly satisfactory, developing great sensitivity and enabling the penetration of great distances. There are no body capacity, no squealing, no squawking and no tricky tuning.

By all means provide yourself with the complete parts for this dandy converter, as specified by Herman Bernard, the designer.

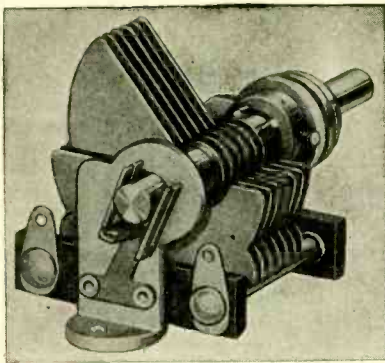

The new Hammarlund Junior Midline Short-Wave Condenser, capacity .0002 mfd. The rotor plates turn in a diameter of only 2 inches, while the total frame depth is only 1 5/8 inches. So this is an extremely compact condenser, made by one of the foremost condenser manufacturers in the world. It is our Model No. PR-H-20, made specially for us.

**T**HE newest condenser to come from the laboratories of the Hammarlund Manufacturing Co. is the Junior Midline, made especially for us, and designed for highest grade short-wave performance. The capacity is .0002 mfd. and the midline tuning characteristic prevails. Single hole panel mount, in a 3/8-inch hole (with option of sub-panel mounting by built-in brackets); end stop provision at both extremes; rigid plate assembly and the fine workmanship of Hammarlund mark this compact condenser. The overall depth of the frame is 1 5/8 inches, while the rotor plates turn in a diameter of only two inches. This condenser, our Model PR-H-20, is a superb product, in line with the modern vogue of compact parts.



**P**RECISION short-wave plug-in coils, three coils to a kit, not counting as a coil the movable tickler. Used with .0002 mfd. for tuning, this kit of coils affords coverage of from 15 to 160 meters. These coils are wound on 97% air dielectric and are precision, de luxe products. A receptacle base, on which the adjustable tickler is mounted, is supplied with each coil kit. This kit is our Model No. PR-AK-1 and represents the pinnacle of short-wave plug-in coil achievement. It is for short-wave receiver circuits.



## EXTRA-SPECIAL FREE OFFERS OF SUBSCRIPTION PREMIUMS!

RADIO WORLD, now in its *ninth* year, is the first and only national radio weekly, and publishes the latest, up-to-the-second news of circuits, both of kit types and of 1931 commercial receivers, as well as news of happenings in the broadcasting field. Lists of broadcast and short-wave stations, including television stations, are published regularly. You get your information weekly—which means quickly—and you get it accurately, so be sure to become or remain a subscriber for RADIO WORLD. We are able to offer now premiums especially attractive to short-wave experimenters, and ask you to make your choice from the parts offered on this page. When ordering, please use coupon.

The regular subscription rates are: \$6 for one year, 52 issues, one each week; \$3 for 6 months, (26 weeks); \$1.50 for three months, (13 weeks); \$1 for 8 weeks; 15c per single copy.

**RADIO WORLD.**  
145 West 45th St., New York, N. Y.  
Enclosed please find:

\$12.00 for two years' subscription (104 issues) for RADIO WORLD at the regular rate. Please send as a premium all parts to build the Short-Wave Converter, including filament transformer and 5 1/2 x 7-inch cabinet, but not including tubes. This is your Model PR-3FS.

\$6.00 for one year's subscription (52 issues) for RADIO WORLD. Please send the Short-Wave Coil Kit as a premium, your model PR-AK-1, consisting of three plug-in coils and base receptacle.

\$3.00 for six months' subscription (26 issues). Please send the Hammarlund Condenser, PR-H-20.

Name .....

Address .....

City..... State.....

**NEW DRAKE'S ENCYCLOPEDIA**  
1,650 Alphabetical Headings from A-battery to Zero Beat; 1,025 Illustrations, 920 Pages, 240 Combinations for Receiver Layouts. Price, \$6.00. Radio World, 145 W. 45th St., N. Y. C

**"A" BATTERY SWITCH**

A push-pull switch for battery-operated sets. Made by Benjamin Firm, sure contact, extremely long life. Special price, only .....13c

**GUARANTY RADIO GOODS CO.,**  
143 West 45th St., New York, N. Y.

**ERLA-DYNAMIC CHASSIS, WESTINGHOUSE RECTIFIER.** Sensitive and efficient dynamic speaker chassis. List price, \$25; our net price, \$9.95. Guaranty Radio Goods Co., 143 W. 45th St., New York.