

JAN. 10  
1931

NEW DOUBLE PUSH-PULL AF

15 Cents  
Per Copy

RADIO

REG. U.S. PAT. OFF.

WORLD

The First and Only National Radio Weekly

459th Consecutive Issue—NINTH YEAR

TRIPLE SCREEN GRID, TWO TUNED CIRCUITED CONVERTER

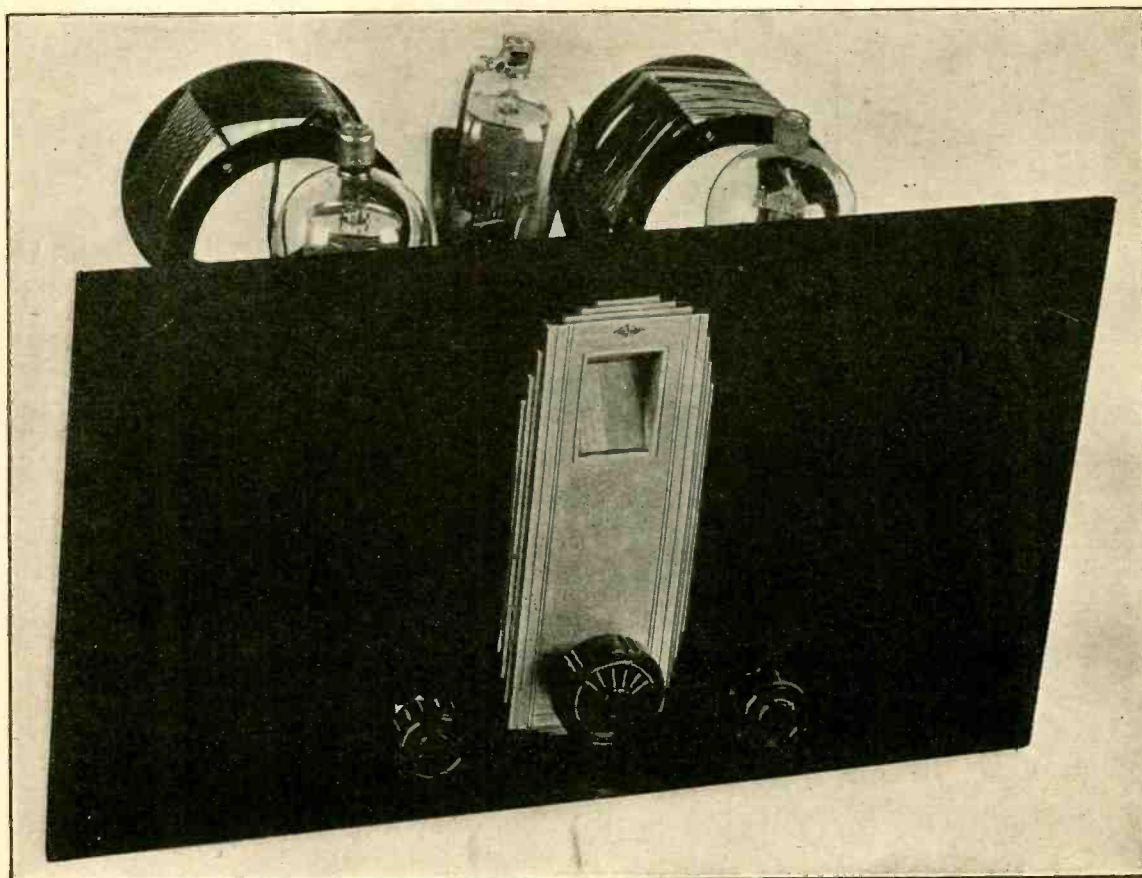

Three screen grid tubes, two tuned circuits, and a total of only four plug-in coils for 15 to 600 meters. See pages 14 and 15.

RADIO WORLD, Published by Hennessy Radio Publications Corporation. Roland Burke Hennessy, editor; Herman Bernard, managing editor and business manager, all of 145 West 45th Street, New York, N. Y.

A WIDE CHOICE OF PARTS

UNSHIELDED BROADCAST COILS ON 3" DIAMETER BAKELITE

- (Cat. SGT-5)—Three circuit tuned for .0005 mfd. condenser, for use where the untuned high impedance primary is in the plate circuit of a screen grid tube. The tuned secondary may be connected to any type tube. \$ .90
(Cat. SGT-2)—Same as above, only for .00035 mfd. condenser .90
(Cat. 5-HT)—Special three-circuit tuner for .0005 mfd. tuned primary in plate circuit of a screen grid tube; untuned secondary .95
(Cat. 3-HT)—Same as Cat. 5-HT, except that it is for .00035 mfd. tuning .95
(Cat. T-5)—Standard 3-circuit tuner for .0005 mfd., where primary is for any type of tube other than plate circuit of screen grid tube. .80
(Cat. T-3)—Same as T-5, except for .00035 mfd. condenser instead of .0005 .80
(Cat. 2-R5)—Radio frequency transformer for .0005 mfd. condenser where high impedance untuned primary is in plate circuit of a screen grid tube, and secondary is tuned by .0005 mfd. .60
(Cat. 2-R3)—Same as 2-R5, except that it is for .00035 mfd. tuning .60
(Cat. 5-TP)—Radio frequency transformer for use where primary is tuned and placed in plate circuit of screen grid tube, while secondary is not tuned. For .0005 mfd. .55
(Cat. 3-TP)—Same as Cat. 5-TP, except that it is for .00035 mfd. tuning .55
(Cat. RF-5)—Radio frequency transformer for .0005 mfd. tuning where untuned primary is in plate circuit of any type tube except screen grid. Usual also as antenna coupler. .55
(Cat. RF-3)—Same as Cat. RF-5, except that it is for .00035 mfd. tuning. .55

RADIO FREQUENCY CHOKES

- (Cat. 50-MLH)—A radio frequency choke coil for filtration in broadcast use, as in screen or plate leads, particularly detector plate, or in the output (plate circuit) of a short-wave converter. Mounting bracket supplied. Not shielded. .47
(Cat. QML)—A radio frequency choke for short-wave work only. Inductance, 1/4 millihenry. Wound on 3/4" diameter bakelite rod, with connecting lugs at end, and mounting bracket. .47
FILTER AND BY-PASS CONDENSERS
(Cat. HV-1)—Compact 1 mfd. filter condenser, for use in filter section of any B supply intended to work 245 tubes, single or push-pull, and rest of tubes in receiver. \$1.50
(Cat. HV-2)—Compact 2 mfd. condenser for 245 B supply. 2.50
(Cat. AVX-8)—Compact 8 mfd. Aerovox dry electrolytic condenser with mounting bracket, for 245 B supply. 1.47
(Cat. LV-1)—1 mfd. low-voltage condenser for bypassing, 200 v. DC rating. .50
(Cat. LV-2)—2 mfd. low-voltage condenser for bypassing, 200 v. DC rating. 1.00
(Cat. LV-4)—4 mfd. low-voltage condenser for bypassing, 200 v. DC rating. 2.00
(Cat. SUP-31)—Three 0.1 mfd. condensers in one compact case, 200 v. DC rating. .57

KNOBS AND DIALS

- (Cat. KNB-2)—3-inch diameter moulded bakelite black knob, no pointer; 3/4" shaft. .18
(Cat. KNB-13)—1/2" diameter moulded bakelite black knob, no pointer; 3/4" shaft. .18
(Cat. KNW-15)—1 1/4" diameter moulded bakelite walnut knob, with pointer; 3/4" shaft. .18
(Cat. MCD)—Marco vernier dial; moulded bakelite; black; pilot light window. .60
(Cat. NAT-H)—National velvet vernier drum dial, type H, with modernistic escutcheon, color wheel (rainbow feature). 8.13
(Cat. NAT-G)—National velvet vernier flat type dial, for use when tuning condenser shaft is at right angles to the front panel; modernistic dial; single color projection. 2.05
(Cat. NAT-VBD)—National velvet vernier black moulded bakelite circular dial, variable ratio lever, 6-1 to 20-1; reads 0-100-0; with dial light and bracket. 1.70

BLUEPRINTS

- (Cat. BP-3A)—Blueprint of three-tube Supertone short-wave converter, using 227 tubes; filament transformer external; coil winding data, list of parts, schematic diagram included. .25
(Cat. BP-DLC)—Blueprint of DeLux short wave converter, using two National VBD dials, two Hammarlund SFL .0005, precision plug-in coils. .25
(Cat. BP-33)—Blueprint of the HB-33, seven-tube screen-grid battery set, using 222a for RF, push-pull 171A output. .25
(Cat. BP-44)—Blueprint of the HB-44, eight-tube AC screen-grid set, 245 push-pull output; screen-grid power detector. .25
(Cat. BP-SGD-4)—Blueprint of 4-tube battery Diamond of the Air, one stage RF 222, regenerative detector, two transformer audio. .25
(Cat. BP-PPBD)—Blueprint of 5-tube battery Diamond. Extra tube due to push-pull output, either 112A or 171A. .25
(Cat. BP-DBX)—Blueprint of 4-tube Diamond, for AC operation; screen-grid RF; 222B supply, as 190-volt B eliminator is to be used. .25
(Cat. BP-UNB)—Blueprint of 4-tube Universal, with 222 BF; battery operation. .25
(Cat. BP-LIB)—Blueprint library of AC hookups. .25

GUARANTY RADIO GOODS CO.

143 West 45th Street, New York, N. Y. Enclosed please find... for which please ship at once the following:

- SGT-5 @ 90c
SGT-3 @ 90c
5-HT @ 95c
3-HT @ 85c
T-5 @ 80c
2-R5 @ 60c
2-R3 @ 60c
5-TP @ 55c
8-TP @ 55c
RF-5 @ 55c
RF-3 @ 55c
50-MLH @ 47c
QML @ 47c
HV-1 @ 1.50
HV-2 @ 2.50
AVX-8 @ 1.50
LV-1 @ 50c
LV-2 @ 1.00
LV-4 @ 2.00
SUP-31 @ 2.00
KNB-2 @ 18c
KNB-15 @ 16c
KNW-15 @ 18c
MCD @ 60c
NAT-H @ 3.13
NAT-G @ 2.05
NAT-VBD @ 1.70
BP-3A @ 25c
BP-DLC @ 25c
BP-33 @ 25c
BP-44 @ 25c
BP-SGD4 @ 25c
BP-PPBD @ 25c
BP-DBX @ 25c
BP-UNB @ 25c
BP-LIB @ 25c
Mail Items C. O. D.

Name
Address
City State

Multi-Tap Voltage Divider

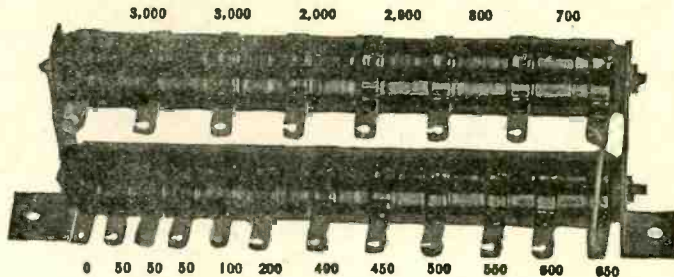

The resistance values between the twenty taps of the new Multi-Tap Voltage Divider are given above. The total is 17,100 ohms and affords nineteen different voltages.

The Multi-Tap Voltage Divider is useful in all circuits, including push-pull and single-sided ones, in which the current rating of 100 milliamperes is not seriously exceeded and the maximum voltage is not more than 400 volts. Higher voltages may be used at lesser drain. Conservative rating, 40 watts.

GUARANTY RADIO GOODS CO.

143 W. 45TH ST., NEW YORK, N. Y.

The expertness of design and construction will be appreciated by those whose knowledge teaches them to appreciate parts finely made.

When the Multi-Tap Voltage Divider is placed across the filtered output of a B supply which serves a receiver, the voltages are in proportion to the current flowing through the various resistances. By making connection of grid returns to ground, the lower voltages may be used for negative bias by connecting filament center, or in 227 and 224 tubes, cathode to a higher voltage.

If push-pull is used, the current in the biasing section is almost doubled, so the midtan of the power tubes' filament winding would go to a lug about half way down on the lower bank.

Order Cat. MTVD. list price \$3.25 \$6.50 net price..

FOUR-GANG .00035 MFD. WITH TRIMMERS BUILT IN!

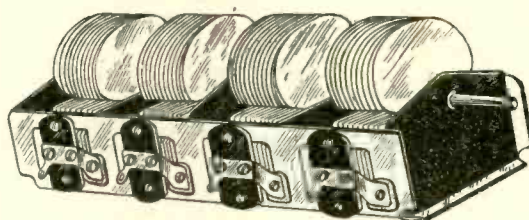

This condenser, each of four sections .00035 mfd., has aluminum plates that are removable and adjustable, also a 1/4" diameter steel shaft that is removable. It is sturdy and is suitable for popular four-circuit screen grid tuners. Trimming condensers are built in. The condenser may be mounted on its bottom or side. Total overall length, including shaft, 1 1/2". Overall width, 4". The frame is steel order Cat. 4-G @ \$3.95 (Between 46th and 47th Streets)

RELIABLE RADIO COMPANY 145 W. 45th St., N. Y. C.

RADIO WORLD and "RADIO NEWS"

BOTH FOR ONE YEAR @ \$7.00

You can obtain the two leading radio technical magazines that cater to experimenters, service men and students, the first and only national radio weekly and the leading monthly, for one year each, at a saving of \$1.50. The regular mail subscription rate for Radio World for one year, a new and fascinating copy each week for 52 weeks, is \$6.00. Send in \$1.00 extra, get "Radio News" also for a year—a new issue each month for twelve months. Total, 64 issues for \$7.00. RADIO WORLD, 145 West 45th Street, New York, N. Y.

HAMMARLUND SFL

Hammarlund's precision .0005 mfd. condenser, with removable shaft; single hole panel mount. Lowest loss construction; rigidity; Hammarlund's perfection throughout. Order Cat. HAM-SFL @ \$3.00 net price. Guaranty Radio Goods Co., 143 W. 45th St., New York.

"RADIO TROUBLE SHOOTING," E. R. Haan. 328 pages, 300 illustrations, \$3. Guaranty Radio Goods Co., 143 W. 45th St., New York.

TUNER ASSEMBLIES

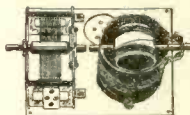

A tuning condenser with coil to match, mounted on an aluminum base that has socket built in. The condenser shaft goes in a dial (not furnished). The tuned circuit includes a fixed and a movable winding (rotor coil) in series. The moving coil is used as a trimmer, set once and left thus, so two separate dials are made to read alike, or gang tuning is made practical. No equalizing condensers needed. Do not couple the adjoining shafts.

For antenna circuit, input to 226, 201A, UX199, 240, 230, 232 and 222, or any other tube fitting four-prong UX socket, or for interstage coupling for 226, 201A, 199, 240 or 230, but NOT interstage for 232 or 222, order cat. BT-L-DC @ \$1.25
For interstage coupling for 232 and 222, order cat. BT-R-DC @ \$1.25
For antenna circuit as RF input to 224 or 227, or for 227 interstage coupling, (five-prong UY socket furnished) order cat. BT-L-AC @ \$1.25
For interstage coupling for 224 (5-prong UY socket furnished, order cat. BT-R-AC @ \$1.25

SCREEN GRID COIL CO.

143 West 45th Street, New York, N. Y. (Just East of Broadway)

HAYDEN'S DANDY MIDGET!

All parts, complete, as specified by Herbert E. Hayden, including cabinet (less tubes) \$22.46

Guaranty Radio Goods Co. 143 West 45th Street New York, N. Y.

CIRCUIT DIAGRAMS

115 Circuit Diagrams of Latest Commercial Receivers and Power Supplies, by John F. Rider. Each in black and white on separate sheets 8 1/2 x 11. Send \$3.00 to RADIO WORLD for 6 months' subscription and get this FREE.

FIDELITY HORN UNIT—Stands up to 450 volts without filtering. Can be used in the portable without horn attached. Price, \$2.25. Guaranty Radio Goods Co., 143 W. 45th St., New York.

SUBSCRIBE NOW!

RADIO WORLD, 145 West 45th St., New York City. Enclosed please find my remittance for subscription for RADIO WORLD. one copy each week for specified period:

- \$10.00 for two years, 104 issues.
\$6 for one year, 52 issues.
\$3 for six months, 26 issues.
\$1.50 for three months, 13 issues.
This is a renewal of an existing mail subscription (Check off if true).

Your name
Address
City

# POLO Short-Wave Converter Series

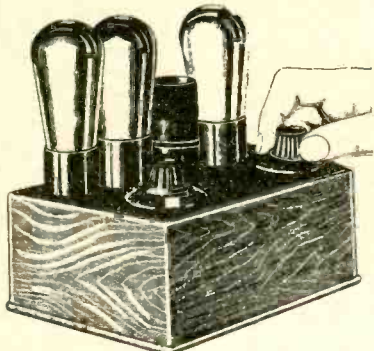

**E**FFICIENT AC all-wave converter, 15 to 600 meters with total of only two plug-in coils. Filament transformer built in. Three 27 tubes used. One tuned circuit. Hammarlund condenser. Equipped with AC switch. Works with any broadcast receiver, either TRF or Superheterodyne. No molestation of receiver. No grunting, body capacity or squeals. All parts (less tubes, but including 5 x 6 1/2" cabinet). Order at 3FS @ \$9.58



tubes) @ \$19.87

### SHORT WAVES FOR \$4.87

Lowest price ever for parts for a short-wave converter, Supertone Cat. SUP-3A, exactly as specified by Herman Bernard. (less tubes.) Single control, no squealing. It does work fine. Instruction sheet and pictorial diagram. External filament transformer required.

### Polo Precision — Power Equipment

#### POWER TRANSFORMERS

50-60 cycles, 105-120 v. primary; 2 1/2 v. 12 amps, ct., 5 v. 3 a., high voltage, 300 DC @ 80 ma. Choke built-in. Used in Herman's double push-pull. Black case. Cat. M @ \$9.50  
 50-60 cycle 105-120 v. primary; secondaries, 2 1/2 v. 16 amps.; 2 1/2 v. 3 amps.; 5 v. 2 amps.; high voltage to afford 300 v. DC @ 100 ma.; all secondaries center tapped. Cat. 245-PT @ \$9.56

#### B SUPPLY CHOKE

100 ma. rating; 30 henrys; DC resistance 200 ohms; tabbed at 40 and 100 ohms; suitable for "choke input" filter system; black to rectifier filament; red, not used; green, first filter condenser; yellow, final filter condenser. Suitable as center-tapped impedance, using black and yellow for extremes, green as center. Cat. 245-CH @ \$4.25

#### FILAMENT TRANSFORMER

For short-wave converters; 2 1/2 v. 8 amps. (thick leads). Cat. SW-FLT @ \$2.50  
 For complete sets; 2 1/2 v. 12 amps; 2 1/2 v. 3 amps.; both secondaries center-tapped. Cat. SP-FLT @ \$4.25

#### HERMAN'S DOUBLE PUSH-PULL

All parts as specified by H. B. Herman...\$23.69

### Polo Engineering Laboratories

Exclusive Distributors

125 West 45th Street, New York, N. Y.

In the November 8th issue of RADIO WORLD there began a remarkable series of articles dealing with the construction of short-wave converters that really do work, and that work well. Besides, the cost of parts is low. One model, 30 to 110 meters, no plug-in coils, may be built of parts costing less than \$5, for battery operation, or for AC with extra filament transformer external, while another model, 10-200 meters, two plug-in coils, using somewhat superior parts, filament transformer built-in, can be made up by you for less than \$10. Surely these are prices within the reach of all.

Low price and high achievement go hand in hand in these designs by Herman Bernard.

The series ran in the November 8th, 15th, 22nd and 29th, and December 6th, 13th, and 20th issues. Send \$1 and we will forward these seven issues and a blueprint of the AC \$5 model.

RADIO WORLD, 145 West 45th Street, New York, N. Y.

Enclosed please find \$1.00 for which send me the November 8th, 15th, 22nd and 29th, and Dec. 6th, 13th and 20th issues, containing the series of articles on short-wave converters of extremely low price, and a blueprint of the AC \$5 model.

Name .....

Address .....

City ..... State .....

**ANSONIA GOTHIC SPEAKER—\$3.95**  
 Magnetic speaker in genuine beautiful walnut cabinet. Order Cat. AN-G at \$3.95. Guaranty Radio Goods Co., 143 W. 45th St., New York.

### Subscribers! Important!

Note subscription expiration date on wrapper containing your copy of RADIO WORLD. If nearing expiration date, please send in renewal so that you will not miss any copies. Subscription Dept., RADIO WORLD, 145 W. 45th St., New York City.

### Erla Dynamic Chassis, Westinghouse Rectifier

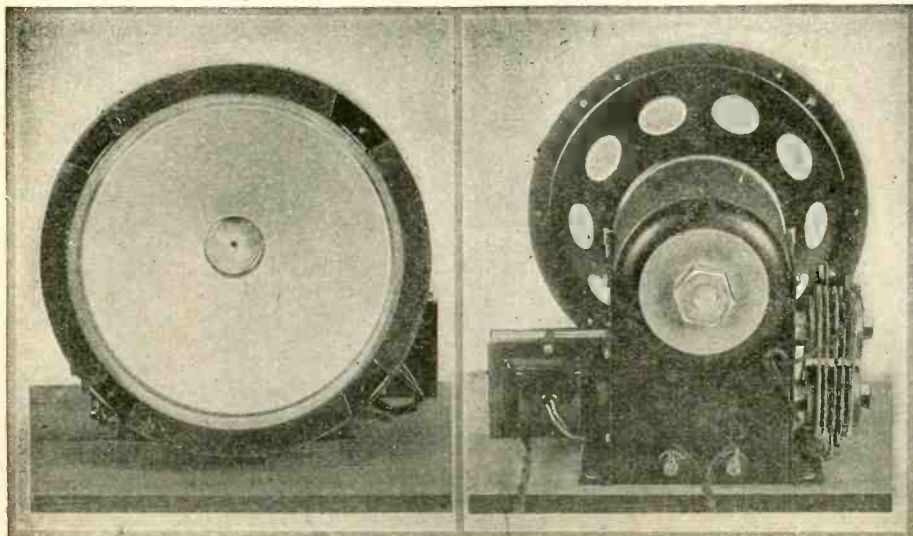

One of the most sensitive and most faithful dynamic speaker chassis, the Erla, has a 9-inch outside diameter cone, with built-in Westinghouse Rectox dry metallic rectifier, output transformer and mounting board. Equipped with 10-ft. A.C. cable and plug, to go into house socket, 110 v. 50-60 cycle, and two 10-ft. tipped leads for connection to set. Will stand up to output of 250 tubes in push-pull, but will work well on any set, battery-operated or A.C. Order Cat. ER-D-AC. List price \$25.00; net price 6v. DC model, to be energized by your 6-volt storage battery. Order Cat. ER-6-v. @ \$10.50

GUARANTY RADIO GOODS CO., 143 West 45th St., New York, N. Y.

### When in Doubt Lead TRUMPS!

—and, likewise, play safe and use

### ELECTRAD

#### Resistors & Voltage Controls

They solve many radio problems. They are thoroughly reliable, they give amazing service, and they are correctly priced.

Circular of Electrad Products on Request. Address Dept. RW-1-10

175 Varick St., New York, N.Y.

### ELECTRAD

INC.

### DEALERS and SERVICE MEN! STANDARDIZE ON



For Permanent Replacement—Accurate—Guaranteed

Write for descriptive catalogue "W"

LYNCH MFG. CO., INC., 1775 Broadway, New York

### Experimental Model

4-tube screen-grid set, battery operated requiring outdoor antenna. Ideal where economical operation is desired, sensitive and selective, but not in a cabinet.

Price, \$20.50

GUARANTY RADIO COMPANY

143 West 45th Street, New York City



### Your Choice of NINE Meters!

To do your radio work properly you need meters. Here is your opportunity to get them at no extra cost. See the list of nine meters below. Heretofore we have offered the choice of any one of these meters free with an 8-weeks subscription for RADIO WORLD, at \$1, the regular price for such subscription. Now we extend this offer. For the first time you are permitted to obtain any one or more or all of these meters free, by sending in \$1 for 8-weeks' subscription, entitling you to one meter; \$2 for 16 weeks, entitling you to two meters; \$3 for 26 weeks, entitling you to three meters; \$4 for 35 weeks, entitling you to four meters; \$5 for 44 weeks, entitling you to 5 meters; \$6 for 52 weeks, entitling you to six meters. Return this offer with remittance, and check off desired meters in squares below.

RADIO WORLD, 145 West 45th Street, New York, N. Y. (Just East of Broadway)

Enclosed please find \$..... for..... weeks subscription for RADIO WORLD and please send as free premium the meters checked off below.

I am a subscriber. Extend my subscription. (Check off if true.)

- 0-6 Voltmeter D.C. .... No. 326
- 0-50 Voltmeter D.C. .... No. 337
- 6-Volt Charge Tester D.C. .... No. 23
- 0-10 Amperes D.C. .... No. 338
- 0-25 Milliamperes D.C. .... No. 325
- 0-50 Milliamperes D.C. .... No. 350
- 0-100 Milliamperes D.C. .... No. 390
- 0-300 Milliamperes D.C. .... No. 399
- 0-400 Milliamperes D.C. .... No. 394

NAME .....

ADDRESS .....

CITY..... STATE.....

# Save Money on Tubes!

## Get a Guarantee Just the Same!

**Q**UANTITY tubes at enormously reduced prices enable you to save money and obtain full satisfaction. Any tube will be replaced on request within thirty days of its sale!

These tubes are made by a manufacturer of national reputation and are not "distress merchandise." No tube is shipped until it is carefully checked on a Readrite No. 9 Radio Test Kit.

Type	List Price	Your Cost	Type	List Price	Your Cost	Type	List Price	Your Cost
<input type="checkbox"/> 201A	\$1.25	49c	<input type="checkbox"/> WD-12	\$3.00	59c	<input type="checkbox"/> 245	\$2.00	59c
<input type="checkbox"/> 226	1.75	49c	<input type="checkbox"/> 200A	4.00	59c	<input type="checkbox"/> 280	1.90	59c
<input type="checkbox"/> 199-UX	2.50	59c	<input type="checkbox"/> 171A	2.25	59c	<input type="checkbox"/> 224	3.30	59c
<input type="checkbox"/> 199-UV	2.75	59c	<input type="checkbox"/> 171AC	2.25	59c	<input type="checkbox"/> 222	4.50	95c
<input type="checkbox"/> 120	3.00	59c	<input type="checkbox"/> 112A	2.25	59c	<input type="checkbox"/> 281	7.25	95c
<input type="checkbox"/> WD-11	3.00	59c	<input type="checkbox"/> 227	2.20	59c	<input type="checkbox"/> 210	9.00	95c

250, List \$11.00, your cost, 95c.

[Remit with order for tubes and we pay postage]

### DIRECT RADIO CO.

143 West 45th St., New York, N. Y.

## SHIELDED LEAD-IN WIRE

No. 18 solid wire, surrounded by a solid rubber insulation covering, and above that a covering of braided copper mesh wire, which braid is to be grounded, to prevent stray pick-up.

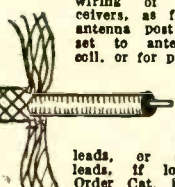

Also used to advantage in the wiring of receivers, as from antenna post of set to antenna coil, or for plate leads, or any leads, if long.

This wire is exceptionally good for antenna lead-in, to avoid pick-up of man-made static, such as from electrical machines.

Order Cat. SE. LW. List 9c, net, 5c per ft.

143 West 45th St., New York, N. Y.  
**GUARANTY RADIO GOODS CO.**

### BRACH RELAY ONLY 99c

Connect relay's cable plug to 105-125 volt AC line, etc., etc. Then turning on your set turns on B eliminator and turns off charger. Turning off set turns on charger and turns off B eliminator. Guaranty Radio Goods Co., 143 West 45th St., New York.

## Fixed Condensers

Dublier Micon fixed condensers, type 642, are available at following capacities and prices:

.0001 mfd.	10c	.008	20c
.00025 mfd.	10c	.00025 with clips	20c
.0003 mfd.	10c	All are guaranteed	
.00035 mfd.	12c	electrically perfect and	
.001	12c	money back if not	
.0015	12c	satisfied within five	
.002	18c	days.	

Order Cat. MICON .0001 etc. at prices stated.

**GUARANTY RADIO GOODS CO.**  
143 West 45th St., New York, N. Y.

## Ansonia Gothic Speaker - - \$3.95

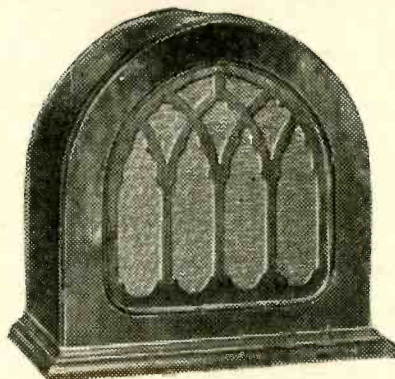

Magnetic speaker in genuine, beautiful walnut cabinet. Order Cat. AN-G at \$3.95.

Square Model (same unit and cone) Cat. AN-S at \$3.67

**Guaranty Radio Goods Co.**  
143 West 45th St., New York, N. Y.

### SOLDERING IRON FREE!

A serviceable iron, with copper tip, 5 ft. cable and male plug. Send \$1.50 for 13 weeks' subscription for RADIO WORLD and get this free! Please state if subscription is a renewal. RADIO WORLD, 145 W. 45th St., New York.

## Parts for the Best Circuits

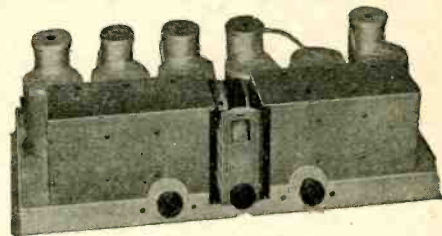

**NEW NATIONAL DE LUXE MB-30 SCREEN GRID TUNER**—This is one of the most sensitive tuners ever developed, averaging 1 microvolt per meter, and at some frequencies attaining 1/4 microvolt per meter. Its selectivity is most remarkable, and without material sideband cutting, due to use of Vreeland band pass filter and pre-selector circuits. Six tuned circuits, perfectly aligned and tested with laboratory equipment that cost more than \$1,000. The circuit, which is for AC only, uses four 224 and one 227 tubes and requires a power amplifier that will power the heaters as well. All parts mounted on chassis, ready for wiring. Steel chassis, 2 1/2 x 10 x 1 1/2". Order Cat. MB-30-P, list price \$85 less tubes; net price \$48.97. **WIRED MODEL**, Cat. MB-30-W, list price \$95 less tubes; net price \$54.88.

**MB-29-A TUNER**, a smaller version of the MB-30, using four instead of six tuned circuits, but including also the pre-selector and band pass filter circuits. Uses three 224 and one 227. Aluminum chassis 1 5/8 x 10 x 1 1/4". Order Cat. MB-29-AP, list price \$69.50 less tubes; net price \$40.88. **WIRED MODEL**, Cat. MB-29-AW, list price \$79.50, less tubes; net price \$48.74.

**NATIONAL VELVETONE Push-Pull Power Amplifier**, using one 227, two 245's and one 280; two stages of transformer coupling, with output transformer; heater voltage for five extra tubes; plate voltage for tuner. A matched unit for the MB-30 or MB-29-A. Phonograph jack built in. Velvetone comes completely wired. Licensed by RCA. Order Cat. PPPA, list price \$97.50, less tubes; net price \$57.33.

## HI-Q 31

**HAMMARLUND HI-Q-31**—The latest development in custom-set building, a 9-tube circuit, using a 8-stage band-pass filter pre-selector, three stages of 224 RF, 224 power detector, 227 first audio, two 245's for push-pull output, and a voltage regulator tube. Chassis is 2 3/4 x 12 1/2". Order Cat. AC-31-B, list price of complete parts, \$159.80, less tubes; net price \$81.00.

**WIRED MODEL HI-Q-31**—Order Cat. AC-31-BW, list price, \$184.80, less tubes; net price \$111.05.

**HI-Q AC TUNER WITH POWER SUPPLY** (less audio)—Order Cat. AC-31-TPS, list price \$148.55, less tubes; net price \$82.78.

**HI-Q-AC TUNER ONLY** (for use with external power supply)—Order Cat. AC-31-T, list price, \$107.20, less tubes; net price \$61.09.

**HI-Q-31 FOR BATTERY OPERATION**—Order Cat. BAT-31-B, list price, \$119.55, less tubes; net price \$68.14.

**HI-Q-31 TUNER FOR BATTERY OPERATION** (less audio)—Order Cat. BAT-31-T, list price \$102.95, less tubes; net price \$58.69.

## Short Waves

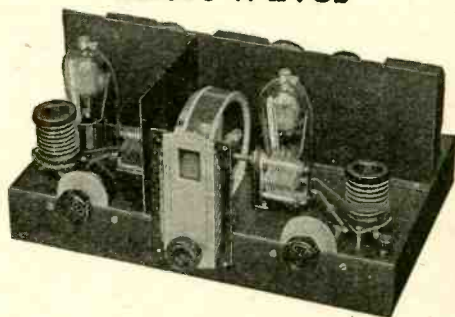

**NATIONAL 5-TUBE THRILL BOX**—A remarkably sensitive short-wave outfit, noted for reception of foreign stations. Uses 224 RF, 224 detector, 227 first audio, 227 push-pull second audio. A separate A and B supply is required. See below. Standard set of four pairs of coils included (21.2 to 2.61 megacycles). Humless operation, even on earphones. Single tuning control. No grunting, no backlash, no hand capacity. Order Cat. AC-SW-5, list price, less tubes, less B supply, \$79.50; net price \$46.74.

**NATIONAL SW POWER UNIT**—Furnishes heater voltage and B voltage for the AC Thrill Box. Uses 250 rectifier. Comes in wired form only. Licensed under RCA patents. Order Cat. 5880, list price, less tube, \$34.50; net price \$20.28.

**BATTERY MODEL THRILL BOX**—This uses the new 2-volt tubes; two 232 screen grid, three 230 and one 231, in same general circuit. Order Cat. DC-SW-5, list price \$75; net price \$44.10.

**WIRED MODEL AC THRILL BOX**—Order Cat. AC-SW-5-W. List price, \$89.50, less tubes, less power unit; net price \$52.82.

**WIRED MODEL BATTERY THRILL BOX**—Order Cat. DC-SW-5-W. List price, \$85, less tubes; net price \$49.98.

**Guaranty Radio Goods Co.**

143 West 45th Street,  
New York, N. Y.

## FILL OUT AND MAIL NOW

SUBSCRIPTION BLANK

# RADIO WORLD

RADIO WORLD

145 West 45th Street, New York City

Please send me RADIO WORLD for ..... months, for which

SUBSCRIPTION RATES:

Single Copy	.....\$ .15
Three Months	..... 1.50
Six Months	..... 3.00
One Year, 52 Issues	..... 6.00

Add \$1.00 a Year for Foreign Postage; 50c for Canadian Postage.

If this is a renewal, put cross in square at left.

please find enclosed



Vol. XVIII, No. 17 Whole No. 459  
 January 10th, 1931  
 [Entered as second-class matter, March, 1922, at the Post Office at New York, N. Y., under act of March, 1879]  
 15c per Copy, \$6.00 per Year

**NINTH YEAR**  
 Technical Accuracy Second to None  
 Latest Circuits and News

A Weekly Paper published by Hennessy Radio Publications Corporation, from Publication Office, 145 West 45th Street, New York, N. Y.  
 (Just East of Broadway)  
 Telephone, BRyant 9-0558 and 9-0559

RADIO WORLD, owned and published by Hennessy Radio Publications Corporation, 145 West 45th Street, New York, N. Y. Roland Burke Hennessy, president and treasurer, 145 West 45th Street, New York, N. Y.; M. B. Hennessy, vice-president, 145 West 45th Street, New York, N. Y.; Herman Bernard, Secretary, 145 West 45th Street, New York, N. Y.; Roland Burke Hennessy, editor; Herman Bernard, business manager and managing editor; J. E. Anderson, technical editor

# Double Push-Pull AF In A New Form

By Henry B. Herman

**D**DOUBLE push-pull amplification is most readily and economically accomplished by the use of a center-tapped high inductance choke coil followed by resistance coupling, so that finest quality is achieved in an audio power amplifier using parts costing less than \$25.

The higher the inductance of the choke coil, half of which is directly in the plate leg of the detector tube, the better. For this reason an enormous inductance was chosen—1,000 henrys, with a DC resistance of about 15,000 ohms. While this DC resistance is large for any choke coil, it is small compared with the resistance of the plate circuit in which it is connected, therefore no compensation is necessary for inequality of load on the two sections, in only one of which DC flows.

### The Push-Pull Action

Novelty attaches to this method of using a choke coil. It is assumed the detector is a 224 tube, since that imposes the highest inductance requirement one will encounter in ordinary practice. Assume a voltage drop across the upper section, with the current flowing from the B plus junction to the plate at any selected instance. Due to the series-connected windings being on the same core, the instant when the signal voltage is positive in the upper leg it is negative in the lower leg, and vice versa. The signal current, which alternates, is assumed to be flowing from B plus to plate. An equal signal current, but opposite in phase, will be flowing from the plate of the lower tube to B plus, at the same instant. If arrows were drawn they would seem to be pointing in the same direction, but of course the direction is in fact opposite, for in one instance the current is flowing toward the center tap and in the other instance away from that tap.

Thus is established the push-pull relationship. To achieve this practically, some form of inductance is necessary. Often a push-pull input transformer is used for coupling detector to the first audio stage, for double push-pull purposes, whereupon the next stage would have also a push-pull transformer, or push-pull resistance coupling.

The reason for requiring some sort of coil is that only a coil has a magnetic field, and to achieve push-pull, with its equal but opposite voltages and currents at any given instant, a magnetic field is essential. Simple resistors won't do, because both plates are effectively grounded. If the detector is a 227 a standard 30-henry center-tapped choke is all right.

### Difficulties with Other Systems

Some experimental forms of push-pull, with straight resistance coupling, have been discussed from time to time, but none of them has proven wholly successful. It is necessary to change the phase. An extra tube could be pressed into service to accomplish this, or resistances back-coupled, with dissimilar values used in an attempt to equalize the input to a push-pull stage, but the equalization is a tender job, and few would succeed with it.

While the high-inductance choke coil is suggested, and there is a commercial one available, there is no reason why you may not use the secondary of push-pull transformer for which you have no other particular use. It may be a cheap transformer, and still results will be very good, since there is no coupling transformer action that would require highest type and per-

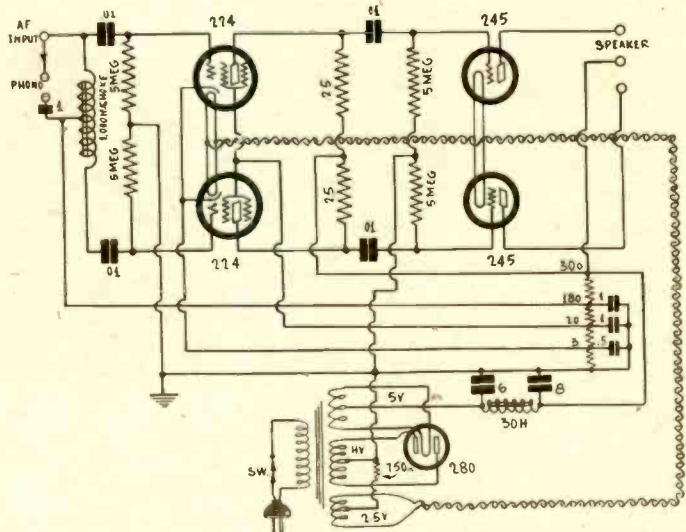

Fig. 1

A new method of introducing the push-pull relationship by means of a center-tapped choke coil is used in this double push-pull audio power amplifier.

meability of the core, and the direct current will be less than 1 milliampere, hence no burden on the inductance. Whenever heavy direct current flows in a metal-core inductance the inductance falls sharply.

The advantages of double push pull are well appreciated. They are the same in principle as for single-push-pull, to which  
 (Continued on next page)

### LIST OF PARTS

- One Polo type M power transformer with choke built in.
- One Polo 1,000-henry center-tapped choke, type Z.
- Four 0.01 mfd. mica fixed condensers.
- Four 5.0 meg. grid leaks with pigtailed.
- Two 0.25 meg. plate resistors with pigtailed.
- One Multi-Tap Voltage Divider (17,100 ohms, 20 different voltages.)
- One Condenser bank, 6.0, 8.0, 1.0, 1.0 and 0.5 mfd.
- One Phono twin assembly.
- One Speaker twin assembly.
- One 1.0 mfd. bypass condenser.
- One 750-ohm, 25-watt resistor.
- Three binding posts, with bakelite terminal strip.
- One bakelite socket strip, with three UX and two UY sockets.
- One steel cabinet with removable top and bottom.
- Twisted hair for 2½ volts AC output.
- Hardware and hookup wire.

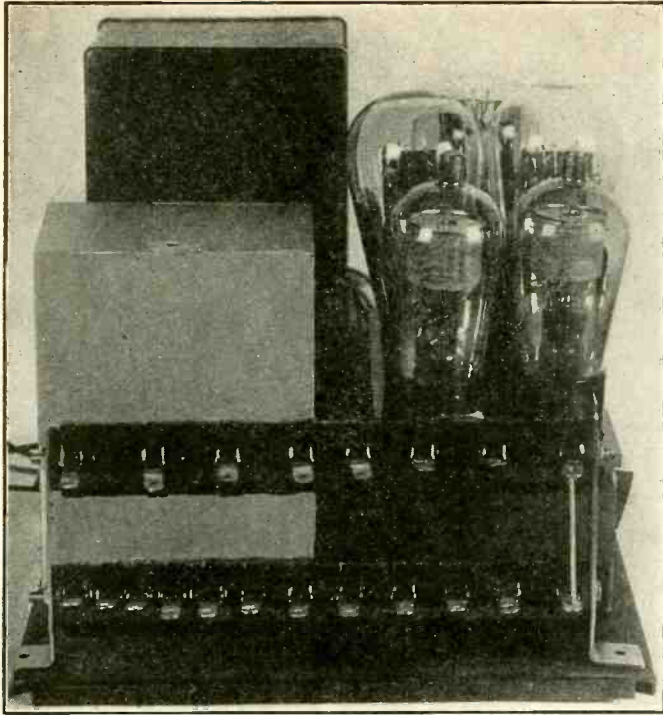

Fig. 2

View of some of the parts mounted on the bottom piece of the steel cabinet, showing bracket extended that is to be "toed in."

(Continued from preceding page)

nearly everybody is committed. The signal is purer, the maximum load that can be handled without distortion is greater, the stability is enhanced and the hum is much less.

#### 2½-volt Consolidation

Despite the facility for ridding the circuit of hum by the push-pull method, high capacity is used for filtration, particularly as it is quite probable that B voltage to run a tuner will be taken from the power amplifier.

Also, the heaters of the tuner may be served by the power amplifier, up to five heater tubes in addition to the four tubes of both types used in the amplifier. It will be seen that the same 2½-volt winding is used for the 245s as for the heater type tubes, which is all right.

This double utility of the 2½-volt winding also makes for compactness. The new Polo power transformer therefore has room inside for the choke coil as well, built on separate core. All four windings of the power transformer (primary, 2½ volts AC, 5 volts AC and high voltage AC) as well as a choke coil of 30 henries, are inside a steel case finished in crinkle black.

There is room on the socket strip for the large inductance choke coil, the Polo type Z, and also for the miscellaneous parts, not including the condenser bank, power transformer and voltage divider, for which room is provided separately.

#### Placement Avoids Difficulties

The placement of parts is such as to avoid troubles otherwise hard to conquer. The condenser bank is far enough removed from the voltage divider and the 280 tube to avoid overheating which would affect the special wax compound in which the capacities are sealed. All condensers, except the .01 mfd. and one 1.0 mfd., are in this bank, which is provided with mounting feet, as are the power transformer and the voltage divider. In fact, the divider has special brackets already attached, and the one of these brackets is to be removed and turned about, so that the angle points toward the opposite end of the divider. This is necessary to prevent the bracket from extending beyond the steel base which is one of the component parts of the cabinet.

These component parts are: (1), the four-sided piece, 11½ inches wide, 8½ inches high x 9 inches front to back, outside dimensions. (2), the top cover, which slides over the outside; and (3) the bottom cover, on which the power transformer, condenser block, voltage divider and socket strip are to be mounted, and which bottom piece fits inside the main housing and is tapped for 6/32 machine screws, so that securing the bottom piece to the main part of the cabinet is easy.

#### Vent Holes Are Provided

Symmetrical ventilating holes already are drilled in the cabinet pieces, but holes for mounting some of the apparatus will have to be drilled by the builder. This is not obstructive, since an ordinary hand drill will make the necessary holes, without becoming too dull for further use.

The detector voltage is provided in the power amplifier, and it is assumed that negative bias detection is used, or so-called

power detection. While a 224 detector is suggested, it is not imperative, as the system will work with a 227 detector, although the volume will not be so great.

Those desiring to incorporate screen grid detection in a tuner not already provided therewith may do so, by putting a positive bias of around 16 to 20 volts on the connection now used for control grid, but which will be the screen grid, and by bringing the connection from the juncture of tuning condenser and radio frequency transformer secondary, to a flexible lead, with grid clip thereon, for connection to the cap of the tube. The biasing resistor, usually around 20,000 ohms, would have to be increased, in most instances, because the plate current is less and the 224 takes a lower bias than does the 227. An easy solution is to put a resistor in series with the present one. If the one now used is 20,000 ohms, use 20,000 ohms more. The total should be around 40,000 to 50,000 ohms. The bypass condenser across the detector biasing resistor should include the total resistance.

#### Output and Speaker

The detector circuit is not diagrammed, as it is not a part of the audio power amplifier, except the plate circuit, and it is not practical to cover all the possibilities without a long series of diagrams. The directions given, however, may be applied to the tuner, as it is assumed that any one possessing a tuner will be sufficiently familiar with its circuit and constants to effectuate the recommended change.

It is true, also, that detection will result without enlargement of the biasing resistor, but it is preferable to move the bias up higher than could result under those circumstances.

The output shown has three leads, and the list of parts call for a twin output assembly for the speaker. The reason is that the two plate leads go to the tipped leads of the speaker, while the maximum positive voltage is supplied to a center-tap on the speaker coil, this simply being a lead of insulated wire. The speaker in mind for this particular power amplifier was the Farrand 12-G, which has a lug thereon representing the center of the speaker magnet coil. This lug is to be connected to the maximum voltage.

Where other types of speakers are to be used, if one is fortunate enough to have a reproducer with a push-pull primary on the output transformer, the connection would be the same as for the 12-G Farrand inductor dynamic. For the general run of speakers, however, a center-tapped choke coil would have to be used, with extremes to plates of the 245s, and center to B plus maximum. The speaker's tipped cords, again, go to the plates. There is no room in the power amplifier for this output choke, which may have a total inductance of 30 to 50 henries, so if the choke is required, place it in the speaker cabinet, or, if a console is used, anywhere near the speaker.

The maximum applied voltage is not the same in all instances. It so happens in this circuit that it is higher for the plate circuits of the screen grid tubes than for the plate circuits of the 245s, due to the distribution of the total 300 volts DC to include bias. Since the 245 tubes take 50 volts negative bias, the applied plate voltage is the total B voltage (300) less the bias voltage (50), or 250 volts. The total is therefore apportioned by connection of the reference point, to filament center of the 2½-volt winding, to a voltage 50 volts above ground potential.

With the screen grid tubes, however, the bias voltage is only 3 volts, so the applied plate voltage is the maximum (300) minus the bias (3), or 297 volts, or 47 volts higher than in the case of the 245s. The screen grid tubes are well able to stand this voltage, particularly as the current is very small, less than 1 milliampere, due in part to the high value of plate resistor, 250,000 ohms. This resistance value may be used safely, in respect to tone quality, because while the high resistor results in high gain, it does so without serious effect on the high frequencies, because the inter-electrode capacity is small. With 227 tubes this would not be true, for the load resistor then should be 100,000 ohms or less. The gain would be smaller with 227 tubes, and it is strongly recommended that the screen grid tubes be used.

#### 20 Voltages from Divider

Whatever voltages are desired or needed may be obtained from the voltage divider. Even the power tube bias could be obtained therefrom, but it was deemed preferable to use a separate resistor because of the balancing effect of the signal current therein. Where the plate current of only the push-pull output tubes flows through the biasing resistor, as is true in this instance, no bypass condenser is needed, and, indeed, it would be objectionable, since the signal current through this resistor is neutralized by the push-pull action, and there is no sense in attempting to remove this valuable stabilizing agency.

Although only a two-stage amplifier, this circuit is one where the first stage is high gain, and requires one principal precaution. There should be no objectionable feedback, but if any is encountered, an easy solution is to use lower values of equal resistances in the grid circuit of either the first or second stage. At 1 meg. no trouble will crop up, but the low-note amplification will not be quite so strong. At 2 meg. there should be no trouble, and no serious effect on low notes. Only when 5 meg. is used in all four position in the grid circuits is there likelihood that there will be a little instability. The 5 meg. values are indicated on the diagram because it is well to use them, if possible, but if any trouble arises you know what to do. Stability, once achieved, will be permanent.

# A TRF Short-Wave Set

By Lester Chadwick

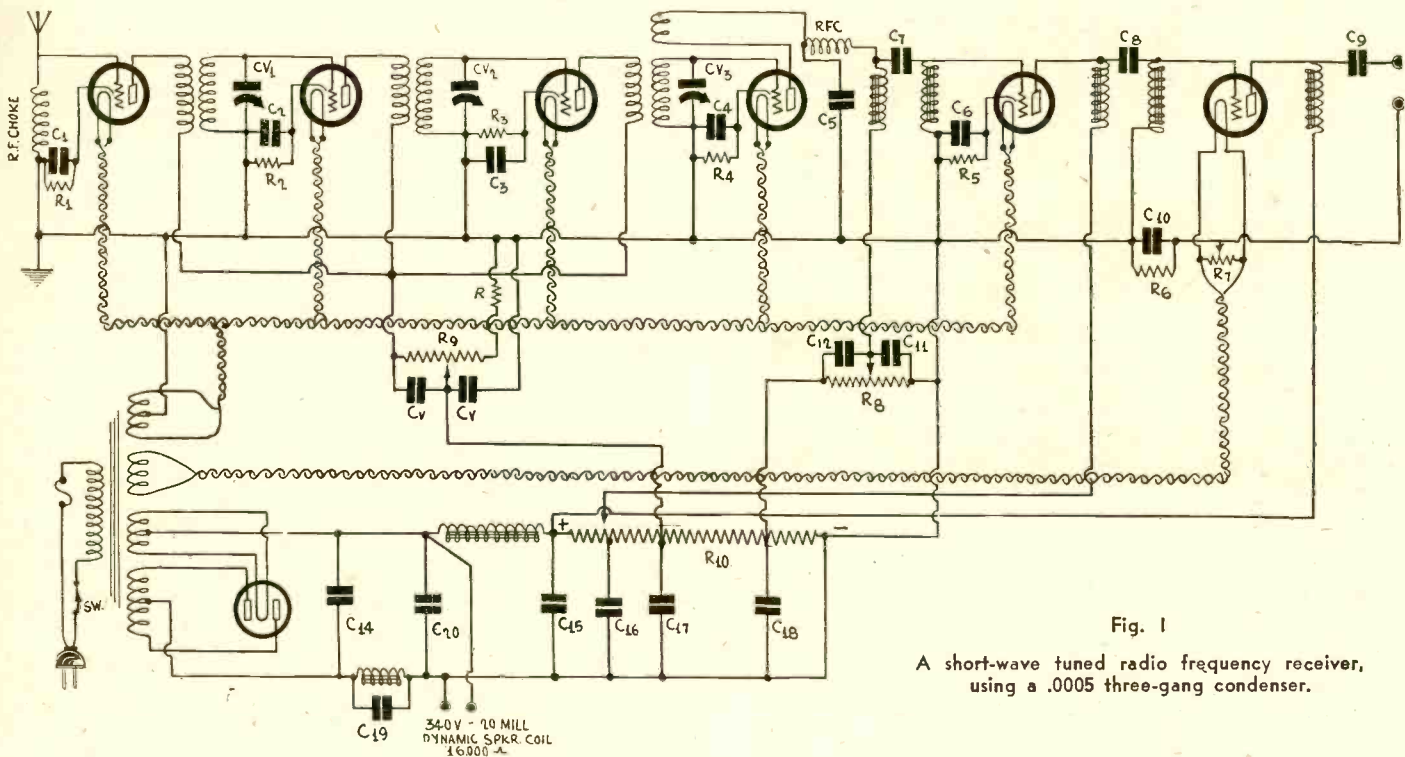

Fig. 1

A short-wave tuned radio frequency receiver, using a .0005 three-gang condenser.

THE short-wave set diagrammed in Fig. 1 is provided with a self-contained power pack. The output is rendered free of hum by means of a series hum trap. The effect of the trap is reinforced by the inclusion of a high impedance dynamic speaker field winding connected across the input to B choke. The DC resistance of such a field coil may range from 10,000 ohms to 16,000 ohms. The operative voltage will be between 300 and 320 volts. The resultant current at this voltage will range between 20 and 30 millamperes. The average field coil with which the pot magnet is energized (for sizes commonly used), is wound either with No. 35 or No. 34 plain enamel. The tabulated resistance of No. 35 is 3,352 ohms per pound, while that of No. 34 is 2,118 ohms per pound.

The coils are random wound, however, this resulting in the finished resistance being slightly higher than the tabulated values.

Between three to three and a half pounds of wire are required, and your present AC dry rectifier-operated speaker coil could be rewound with comparative ease with a breast drill clamped in a portable vise. The job might take a little time but it is worth while.

Fine copper wire is subject to a rather rapid change of resistance with change in temperature. This change in resistance may be as much as 250 ohms for the case of three and a half pounds of No. 34 enamel, after the wire has been operating on a 300-volt circuit for one and a half hours.

The change in resistance has no effect on the inductance value, so long as there are no turns of the field coil shorted. The divider load imposed by five 227s and one 245 is not excessive, hence no special mode of connection need be made to insure stability of the voltage supplied to the plates.

### Multi-Tap Divider Used

A standard multi-tap voltage divider of 17,100 ohms, providing twenty taps, is used, giving the fullest latitude of adjustment in this regard. The largest change of distributed voltage occurs when adjustment of the plate voltage of the three radio frequency input tubes is made. With a volume control of the type shown to the right, the rather large change of plate load current would result in a change of distributed voltage of the divider system, which in turn would react unfavorably elsewhere in the set, hence we put a 30,000 ohm potentiometer, R9, in the circuit in series with a fixed resistor, R, of 7,000 to 10,000 ohms.

Regarding the power pack, there is a choice of two assembly arrangements that will work out all right, but the better one will depend on the general arrangement of units that the fan has in mind. The writer's plan is to place the power pack parts in a steel case. The connections are made to the set by a cable so bypassed that signal pickup from this source is impossible. The parts that compose the power pack are shown diagrammat-

ically at the lower left of Fig. 1, and these parts are separately listed on the table of parts herewith. They are to be assembled to the base of the steel cabinet.

The second choice of power pack arrangement is that of enclosing the power transformer in the steel case that is used to furnish the plate voltages, and mount a separate heater transformer at a convenient point on the set chassis. This method applies where you have a power transformer without heater winding.

### LIST OF PARTS

The tuner.

- Six short-wave coils (Two sets, three to a set).
- Three plug-in coil sockets (One with tickler mounted).
- Two short-wave chokes ( $\frac{1}{4}$  mlh).
- Five five-prong tube sockets.
- One four-prong tube socket.
- One 30-ohm potentiometer, R7.
- Three .01 mfd grid bias condensers, C1, C3, C5.
- Three 300-ohm flexible resistors, R1, R2, R4.
- One 20,000-ohm grid bias resistor with pigtail, R1.
- One 5,000-ohm grid bias resistor, R5.
- One 5,000-ohm grid bias resistor, R5, with mounting.
- Eight 1.0 mfd by-pass condensers, C4, C7, C8, C10, C11, C12, CV and CV.
- One 2 mfd by-pass condensers, C9.
- Two feet of  $\frac{1}{4}$ -inch square bare copper wire, for common return ground lead.
- One .00025 mfd bypass condenser, C5.
- One 1,500-ohm grid bias resistor, R6.
- One three-gang .0005 mfd variable condenser, CV1, CV2, CV3.
- Twelve binding posts.
- Five 227 tubes.
- One 245 tube.
- Two 30,000-ohm potentiometers, one with AC switch. R8 and R9.
- One 10,000-ohm fixed resistor, R.

The Power Pack.

- One Polo 245 power transformer, 2 $\frac{1}{2}$  volts, 16 amperes, 2 $\frac{1}{2}$  volts, 3 amperes, 340 volts, 80 mills DC rectified output.
- One Polo tuned choke.
- C-19 is between 1 and 1 $\frac{1}{2}$  mfd.
- One condenser block, C14 to C18 (6, 8, 1, 1, 0.5 mfd).
- One twenty-tap voltage divider, 17,100-ohms, R10.
- One AC switch.
- One two ampere fuse and holder.
- One pound of flux core solder.
- One dozen 3 $\frac{3}{4}$ -inch x 6/32 brass machine screws and nuts.
- One dozen 1 $\frac{1}{2}$ -inch x 6/32 brass machine screws and nuts.
- One 280 tube.

# The 232 as Amplifier

By J. E.

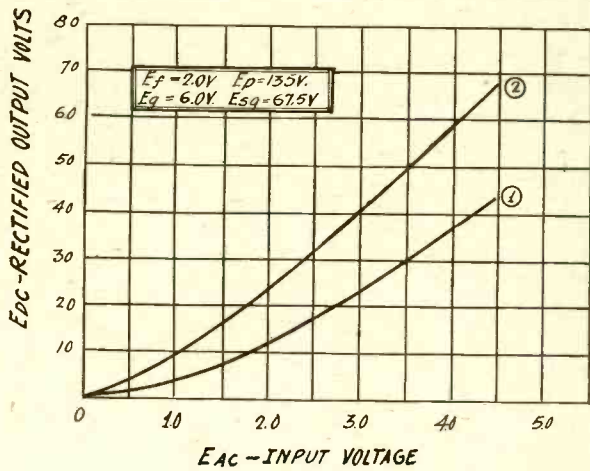

Fig. 1  
Two curves showing the relationship between the rectified output voltage and the AC input voltage for the 232 screen grid tube when it is used as power detector. (1) is for a load resistance of 75,000 and (2) for 200,000 ohms.

**D**ETECTION and amplification by means of screen grid tubes in resistance coupled circuits are rapidly becoming more popular because it has been found that a high undistorted output can be obtained at low circuit cost. The majority of commercial receivers of the latest designs now utilize screen grid tubes both as detectors, and as amplifiers in conjunction with resistance coupling.

However, there is a tendency to use the screen grid tube as a high voltage detector so that no audio frequency amplification other than the power stage is necessary. In such cases the required voltage amplification is obtained in the radio frequency amplifier. That is, the tube that is omitted from the audio frequency amplifier is put in the radio frequency amplifier. This, of course, is in the interest of quality, since there is virtually no distortion in the radio frequency amplifier, while there would inevitably be some in the audio.

### The 232 as Power Detector

Fig. 1 gives two curves which show the relationship between the rectified output voltage of a 232 screen grid tube for different values of AC input voltages on the grid. The various voltages applied to the elements are given on the graph. Curve (1) is for a load resistance of 75,000 ohms and curve (2) for a load resistance of 200,000 ohms. In both cases there is a resistance of 100,000 ohms in the screen circuit.

It will be noted that the maximum DC output voltage, when the effective AC input voltage is 4.5 volts, is about 67 volts when the load resistance is 200,000 ohms. Since this represents twice the amplitude of the input voltage to the next tube the peak value of the input to the next tube will be about 33 volts, which is more than required to overload a 231 power tube, for this tube requires a grid bias, hence allows a maximum peak signal input of 22.5 volts.

Even when the load resistance on the tube is only 75,000 ohms, the maximum output voltage is 42 volts, which is about sufficient to load up a 231 power tube with an effective AC input voltage of 4.5 volts.

It is important to use a 100,000 ohm resistor in the screen circuit because if it is not used the curves will be entirely different and the distortion will be much greater, that is, unless the applied screen voltage is considerably smaller than that specified on the graph.

### Variation of Output with Load

Fig. 2 gives six curves showing the relationship between the rectified output voltage and the load resistance for different effective AC input voltages. It will be noticed that in each case there is one value of resistance which gives the greatest output, and that this resistance is higher the lower the effective AC input voltage. There are two groups of curves (1), (2), and (3), for no resistance in the screen circuit, and (4), (5), and (6) for a screen circuit resistance of 100,000 ohms. In each case the maximum output is greater when there is a resistance in the screen circuit, and the adjustment is less critical.

The reason for the wide difference between the two cases is that when there is no resistance in the screen circuit the screen voltage becomes equal to or greater than the effective value of the plate voltage. If the applied screen voltage were lower to start with, the two sets of curves would be more nearly equal.

As will be noticed on the operating specifications, the applied screen voltage is 67.5 volts. If this were reduced to 20 volts or less, it would not be necessary to use the 100,000 ohm resistance

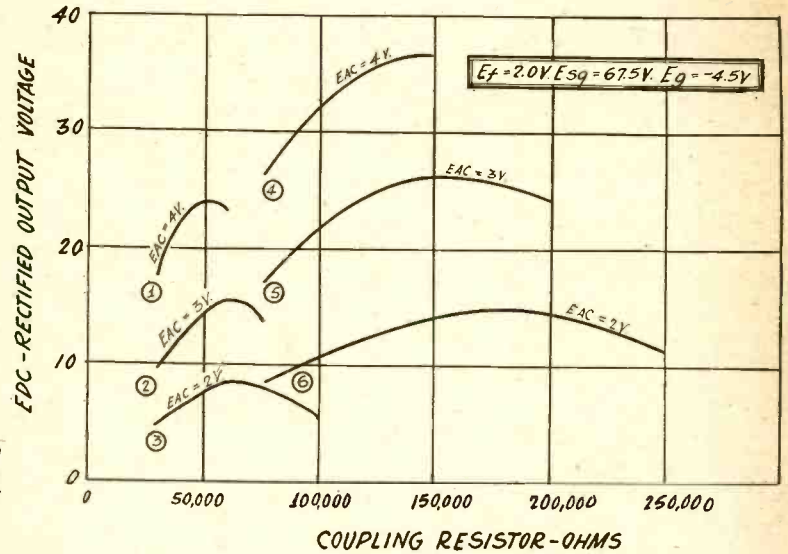

Fig. 2  
These curves show the relationship between the rectified output voltage of a 232 power detector and the load resistance. The three curves at the left are for no screen resistance and the curves at right for a resistance of 100,000 ohms.

in the screen circuit. It will also be noticed that the operating grid bias is minus 4.5 volts. If this were somewhat greater there would be a different set of curves and the maximum output would not occur at the same value of load resistance.

### Effect of Grid Bias Resistor

It is not usually realized that the plate current is different when the grid bias is obtained from a battery and a bias resistor, but this is a fact that should be taken into account when a circuit is designed. The reason that the current is different is clear. When the bias is obtained from a battery it remains constant for all values of plate voltage, but when it is obtained from a bias resistor it varies directly as the plate current. For example, when the plate current is high the bias is high, and when the plate current is very low the bias is also very low. This tends to check the variation in the plate current as the plate voltage varies. The effect on the signal voltage is similar, so that a self-biased tube appears to have a lower amplification constant than one in which the bias is independent of the plate current. Analysis will show that the bias resistor reduces the effective amplification.

In Fig. 3 are shown two plate current, plate voltage curves, for self bias and the other for battery bias. The slope of the one for self bias and the other for battery bias. The slope of the and plate load resistances.

The effect of the bias resistor on the signal can be reduced considerably by putting a condenser across the resistor. This will help to maintain the grid bias at a constant value, and the stabilization is more nearly complete the larger the by-pass condenser. The condenser acts as a filter or storage tank. When the signal current is high, the charge on the condenser is drawn on, and the voltage on the condenser does not change much. As the current is reduced, the condenser charges up again, and the voltage across the condenser once more remains practically constant. The nearly constant bias, therefore, is the voltage across the condenser.

### Self-bias Filament Resistor

When the bias is obtained from a drop in a resistor in the filament circuit, there is little change in the effective bias because the change in the current due to changes in the signal is negligibly small. The filament current remains constant and the variable plate current which flows through the filament in addition is negligibly small in comparison with the constant filament current.

Plate current, plate voltage curves for the 232 tube are given in Fig. 4 for three different screen voltages. These screen voltages are the actual potentials on the screen, measured with respect to the negative end of the filament, and the plate voltages are the actual plate potentials measured with respect to the negative end of the filament. That is, the voltages are the applied voltages diminished by the voltage drop in the screen and plate load resistances.

It is the region to the left, where the curves drop, that must



# and Power Detector

Anderson

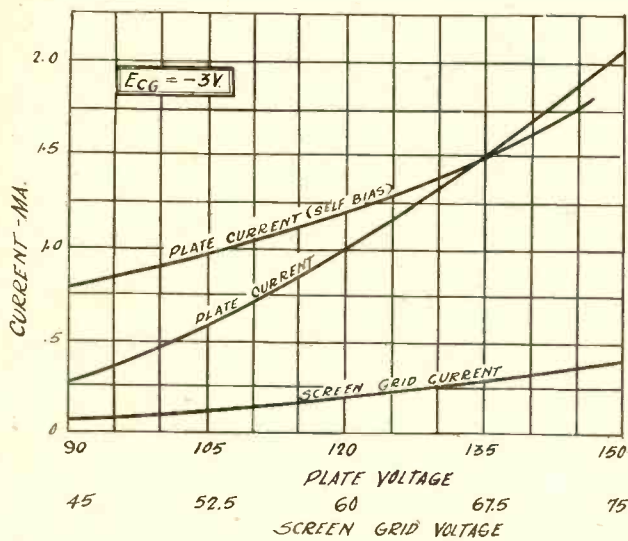

Fig. 3

Curves showing the difference in the plate current of a 232 tube when it is biased by a battery and a resistance in the plate circuit.

be avoided if the tube is to amplify without distortion. This can be done by increasing the applied plate voltage to such a value that even after the voltage drop in the plate load resistance has been subtracted, the effective value of the plate voltage is still high enough to put the operating point well to the left of the irregular part of the curves. It may also be done by putting a resistance in the screen circuit so that the irregular portion is shifted to the left, or by lowering the applied screen voltage to a third or a fourth of the new value indicated on the graph. These conditions for distortionless amplification are reiterated because they are of first importance, and unless they are observed neither proper detection nor distortionless amplification can be obtained from the tube.

### Simple Detector-Amplifier

In Fig. 5 is the diagram of a simple detector-amplifier in which the 232 tube is used as power detector and feeds directly by means of a resistance coupler the grid circuit of a 231 power stage. All the necessary voltages, resistance values, and by-pass condensers are shown on the drawing. A voltmeter is indicated across the filament circuit and a rheostat in series with the positive line to the filament battery. The rheostat should be adjusted until the meter reads exactly 2 volts. The value of the rheostat depends on the voltage across the "A" terminals. If the battery voltage is 2 volts, a 10 ohm rheostat is sufficient and in most instances it will have to be set at minimum. If the battery voltage is 6 volts, that is, if a storage battery is used, the rheostat should be set at 21 ohms and it should have a maximum value of about 30 ohms. This assumes that the tubes in the radio frequency amplifier are on another

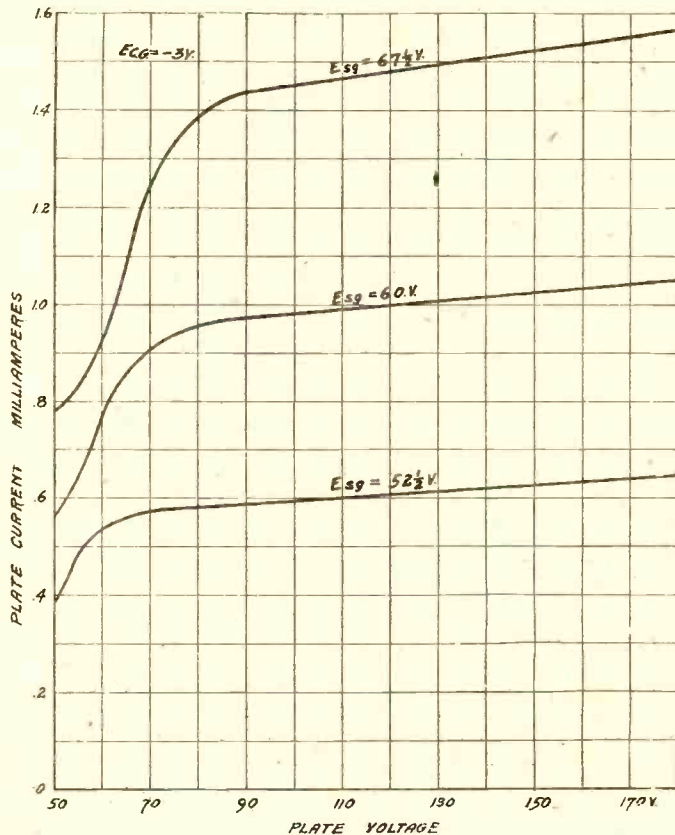

Fig. 4

Plate current, plate voltage curves for a 232 tube for three different screen voltages.

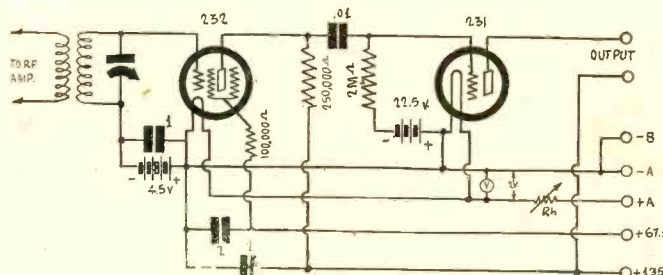

Fig. 5

A simple detector-amplifier circuit in which the 232 tube is used as power detector feeding a 231 power tube through a resistance coupler.

rheostat. If these tubes are also on the same rheostat, the resistance value would depend on the number of tubes, as well as on the voltage of the filament battery.

## FREE AID TO A NEW JOB!

SITUATIONS WANTED AND HELP WANTED ADVERTISEMENTS WITHOUT COST!

Address: Industrial Dept., RADIO WORLD, 145 W. 45th St., N. Y. C.

### SITUATIONS WANTED

**27 YEARS OF AGE, TECHNICAL GRADUATE** '23, experienced in radio work both in laboratory and in field, also in location department of large power company; speak, read and write Spanish; desire to locate in experimental work or in field; would consider location with some firm having branches in Spanish speaking locality. Good references on request. Address: Fairview, McKinley, Isle of Pines, Cuba.

**YOUNG MAN WISHES CONNECTION** with a Radio Research Laboratory which is interested in the reduction of received static only. Write S. Stella, 958 Hoe Ave., Bronx, New York City.

**RADIO SERVICE**—A married man with a family; have had nine years experience in building and servicing sets; also a recent graduate of R.C.A. Institute. Have and use an up-to-date set analyzer and tube checker. Am willing to locate any place. Address 20 Royce Ave., Middletown, New York. Beryl A. Wallace.

**A REGISTERED RADIO TECHNICIAN** wishes position either store or factory. Anywhere in United States. Have three years' experience. Fred Kelly, 1909 4th Ave., North, Minneapolis, Minn.

**FIRST-CLASS RADIO TECHNICIAN.**—Young man. Have had seven years' experience in service work and custom set building. Public address and sound equipment a specialty. Willing to go anywhere. William Wallace, Box 431, Wallaceburg, Ont., Can.

**RADIO SERVICE MAN,** 35 years old, desires position in southwest. Been actively engaged in radio in all forms since its beginning. Just recently disposed of own shop. Would like to get in the sound engineering game. Address, D. W. Pickett, 917 No. Washington St., Kokomo, Indiana.

# A Converter for N

By Einar

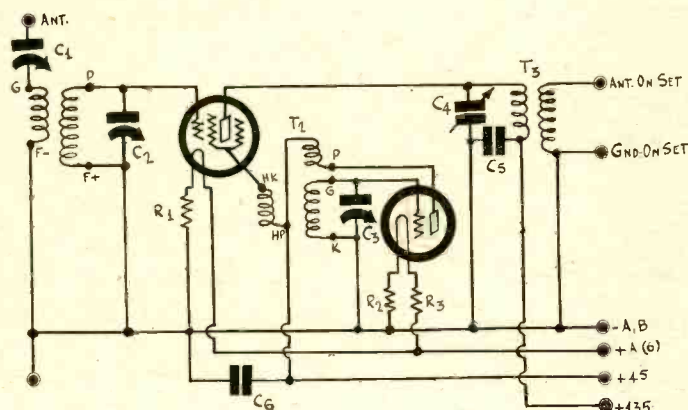

**Fig. 1**  
The circuit diagram of a two-tube short-wave converter in which the 232 screen grid tube is used as modulator and the 230 as oscillator.

**T**HOSE who live out in the country a long way from electric power line are in a fortunate position in respect to reception of short-wave signals from remote point, for they are relatively free from the most annoying aspect of short-wave reception, noises in the power line. They should be able to get clear signals from foreign countries almost any day or night when static is not filling the air, and if they operate on waves below 50 meters they should be able to get clear signals all the time, for on these short waves static is not serious even in the home of static, the tropics.

No doubt there are just as many of the battery set owners who are interested in short-wave reception as of electric set owners, and judging by the expressed interest, that includes everybody.

For those who have battery operated receiver sensitive enough to get most broadcast stations within a 1,000 mile radius can hook up a short-wave converter to operate in conjunction with it at a very small cost, and they will have a sensitive short-wave receiver of the superheterodyne type.

## Short-wave Converter

In Fig. 1 is a simple diagram of a two-tube short-wave converter utilizing one 232 screen grid tube and one 230 general purpose tube. The screen grid tube is used as modulator and the 230 as oscillator. There are three tuned circuits in the hook-up. The first is tuned to the desired short-wave signal, the second to the signal that has a higher or a lower frequency by an amount depending on the setting of the broadcast receiver tuner, and the third is tuned to the same frequency as the broadcast receiver.

The first of these tuners is not critical at all, but may be made so when desired. The second, the oscillator tuner, is quite critical and may be regarded as the only tuner in the circuit, for the first may well be regarded as a mere tuning control. The third tuner is not tampered with once it has been tuned to the frequency to which the broadcast receiver is adjusted.

In the antenna circuit we have a condenser C1, a midget used to sharpen up the tuning of the input tuner. In most instances this condenser may be set at maximum. The first tuner is the secondary of T1 and condenser C2. For strong stations, and when there is no interference requiring sharp tuning in the antenna circuit, C2 may be set at minimum, while the stations are tuned in with the oscillator condenser C3.

## Oscillator System

The oscillator consists of the coil T2, which has three windings, the tuning condenser C3, and the 230 tube. The oscillations are impressed on the modulator tube by way of the screen circuit of the modulator tube, a method which is effective when the voltages on the elements are adjusted properly. In this circuit the voltage in the plate circuit of the modulator tube is 135 volts, that in the screen circuit 45 volts, and that on the control grid about 4 volts, which is obtained from the drop in R1. It is assumed that the filament battery voltage is 6 volts and that the 4 volt excess is dropped in the negative leg of the 232 tube filament.

The plate circuit of the modulator tube is tuned to the intermediate frequency for three reasons. First, because the screen

grid tube requires a high impedance load to work effectively; second, because a by-pass condenser is necessary to make it work effectively as a detector; and third, because it is desirable to couple the modulator most effectively to the broadcast receiver at one frequency only. The output is tuned by means of condenser C4, which may consist of a fixed condenser shunted by a small variable trimmer or a large variable condenser.

## Sharpening the Set

When the primary of T3 is tuned with C4 to the frequency to which the broadcast receiver is tuned, there is very little signal pick-up in the broadcast range, except at the frequency to which the output circuit and the broadcast receiver are tuned, and it is always possible to select a frequency at which there is no interference.

Although the oscillator will tune very sharply, especially if the broadcast receiver is selective at the frequency stated, there may be a certain amount of interference due to cross talk and image interference. The only way to reduce this, if it should occur, is to tune sharply ahead of the modulator, that is, by means of C2 and C1. When the signal has been located on the oscillator, with C1 set at maximum and C2 at minimum, it may be tuned in by adjusting C2. The signal may be made louder by tuning C2, but it may be that the selectivity on this tuner is not as great as it should be. In that case condenser C1 should be opened up and C2 retuned. It may be found that it is necessary to set C1 at minimum before C2 becomes sharp.

## The Coil Set

It is also possible that the signal is loudest when C2 is set at minimum and that it disappears entirely when the condenser is closed up. If that is the case a smaller coil is needed in the T1 position.

To cover the short-wave band at least six coils are needed,

# Right or

## Questions

(1)—A 224 detector tube working into a resistance load of the order of half megohm will deliver an output voltage high enough to load up a 245 power tube when the grid bias on the power tube is 50 volts.

(2)—When two condensers are connected in series the capacity of the two is smaller than that of the smaller of the two so connected.

(3)—When two inductance coils are connected in parallel and placed far apart the inductance of the two is smaller than that of the smaller of the two coils.

(4)—When two condensers are connected in parallel the capacity of the two is equal to the sum of the two capacities.

(5)—When two inductance coils are connected in series and placed far apart, the inductance of the two is equal to the sum of the two inductances.

(6)—There is no advantage in putting fuses in the primary of a power transformer because before the fuses have time to melt the tube filaments blow out.

(7)—There is no use in amplifying the low notes because the loudspeaker will not reproduce them anyway.

(8)—In a resistance coupled amplifier with three-element tubes the high frequencies are not amplified nearly as much as the low because of the high effective input capacity to the tube that is followed by a resistance coupler.

(9)—The high frequency suppression in a resistance coupled amplifier is greater the higher the load resistance and also the higher the amplification.

(10)—When a screen grid tube is used in a resistance coupled amplifier there is comparatively little suppression of the higher frequencies because the plate to control grid capacity is negligibly small, and it is this capacity that is directly responsible for the suppression.

## Answers

(1)—Right. Detected voltages over 100 volts may be obtained from a screen grid tube operating as a power detector and the signal required to load up a 245 tube is 100 volts, 50 volts in each direction. To get this voltage from a screen grid detector it is necessary to have a much higher voltage in the plate cir-

# ew 2-Volt Tubes

Andrews

three for T1 and three for T2. This assumes that C2 and C3 are 150 mmfd. condensers. While it is possible to cover the short-wave band with fewer coils if the tuning condensers are made larger, louder signals are obtained when the condensers are small and the coils comparatively large. Of course, plug-in coils should be used.

## Coil Turn Errata

T1 is wound on a form that plugs into a UX socket and T2 on a form that fits a UY socket. There are such forms available which have diameters of 1.25 inches. The tuned windings on T1 and T2 may be the same when the tuning condensers C2 and C3 have the same values. Using No. 24 double cotton covered wire, the smallest winding should have 5 turns, the next 9 turns, and the largest 17 turns. The corresponding primary windings on T1 should have 2, 4, and 7 turns, and the corresponding tickler windings on the oscillator coil T2 should have 3, 7, and 15 turns. The tickler windings are not critical and it is better to have too many than too few turns.

The pick-up winding on T2 is not critical either. However, if too many turns are used the modulator might overload seriously. It has been found by experiment that the pick-up winding on the smallest coil, that is, on the 5 turn coil, that a single turn is satisfactory. Three turns for the middle oscillator coil and 5 for the largest also have proved satisfactory.

## Coil Terminal Connections

The connections of the terminals of these coils on the forms are indicated on the drawing. Thus the antenna terminal goes to the G prong, the ground terminal to the F minus prong, the grid terminal to the P prong and the ground on the secondary to the F plug. Thus the live terminals are connected in the reverse order, which is done to shorten leads, and the two low potential prongs are connected together, either in the coil

## LIST OF PARTS

- C1—One 100 mmfd. midget condenser  
 C2, C3—Two 150 mmfd. tuning condensers with dials  
 C4—One .0005 mfd. variable condenser  
 C5, C6—Two one mfd. condensers  
 T1—One set of three short-wave coils as described  
 T2—One set of short-wave oscillator coils as described  
 T3—One RF tuning coil with primary wound for .0005 mfd.  
 R1—One 67-ohm ballast resistor  
 R2, R3—Two 33-ohm ballast resistors  
 Two UX sockets, one for antenna coil and the other for oscillator tube  
 Two UY sockets, one for modulator tube and the other for oscillator coil

itself or externally. It is better to make the connection externally, for then it is possible to use the coil as an interstage coupler without any changes.

The terminals of the oscillator coil are made as indicated on T2. Hk represents that heater prong on the UY base that is nearer the K prong and Hp that prong which is nearer the plate prong. Note that two coil terminals are made to the Hp, the low potential ends of the tickler and the pick-up coils. The fact that the same voltage is used on the plate of the oscillator as on the screen grid of the modulator, makes it possible to use a five-prong form for a six-terminal coil system.

## Intermediate Coil

The intermediate coil T3 may be an ordinary radio frequency transformer wound for a screen grid tube, with the large winding in the primary and the smaller in the secondary. However, there should be little difference in the number of turns on these two windings. With such a coil the tuning condenser should either be a .00035 or a .0005 mfd., depending on the number of turns on the primary.

Resistance R1 should have a value of 67 ohms and R3 and R4 each 33 ohms. Condensers C5 and C6 should be 1 mfd. condensers. Such large values are desirable in order to insure oscillation at all settings of the oscillator.

## Wrong?

cuit, for the output voltage can never be as great as the applied voltage.

(2)—Right. The capacity of the combination is obtained by multiplying the two capacities together and then dividing the product by the sum of the two. The number thus obtained is always less than the smaller of the two entering the combination.

(3)—Right. Two inductances connected in parallel combine in exactly the same manner as two capacities in series, provided that the two coils are far enough away from each other that the mutual inductance may be neglected.

(4)—Right. They add together because the combination can hold as much electricity, for a given voltage across them, when they are tied together as when they are apart.

(5)—Right. If there is no mutual inductance between the two coils when they are connected in series, the inductance of the two is just equal to the sum of the two inductances.

(6)—Wrong. Even if the statement were true in respect to the blowing out of the filaments, there would still be an advantage in using fuses because they would protect the installation in case of a short-circuit.

(7)—Wrong. Reproduction by a speaker is relative. There is no frequency in the audible range which is not reproduced to some extent. If the speaker reproduces the low notes weakly there is all the more reason why the audio amplifier should amplify these notes so as to compensate for the deficiency of the speaker.

(8)—Right. The suppression is due to reverse feed-back through the plate to grid capacity and this is greater the higher the amplification. The effect may be interpreted as due to an increase in the grid to filament capacity of the tube.

(9)—Right. The effective input capacity is greater the greater the amplification constant of the tube, the greater the load resistance, the greater the capacity between the plate and the grid, and the higher the frequency involved.

(10)—Right. The plate to control grid capacity in a screen grid tube is of the order of 0.02 mmfd., while that of a high mu three-element tube is of the order of 6 mmfd., a ratio of 300 to one. The other factors affecting the high frequency amplification are not in the same ratio but favor the screen grid tube so that the high note suppression in a screen grid tube circuit is not nearly as high as that in a circuit using three element tubes.

## Condition of Battery Affected by Freezing

WHERE storage batteries for car or radio service are at all exposed to temperature conditions outdoors or in cold rooms or basement, be sure that they are maintained fully charged, or nearly so, during the winter time.

A fully-charged battery freezes at minus 80 degrees Fahrenheit! This is low enough for safety anywhere, but consider a fully-discharged battery. The liquid will freeze at 25 degrees. Even a partly run-down battery will freeze at temperatures above zero. So, watch the "specific gravity" of your battery by testing it with a hydrometer, and if the car battery or radio battery falls below 1.200, have it charged at once.

Where the radio battery is kept in the cellar, it should be on a high shelf, well off the floor so as to avoid dampness. Keep the battery clean. Wash it off well with a hose once in a while. With sandpaper clean the terminals, especially the positive pole, which so easily becomes coated with greenish substances. After replacing the connecting wires, cover each terminal with a thick coat of auto grease to retard further acid corrosion.

Be careful to keep sufficient liquid in the battery to cover the plates. Use distilled water only. Faucet water will ruin a battery in a short time, because of the minerals it contains. Rain water is ideal for a battery, as is clean melted snow. In collecting rainwater, wait until the rain has been falling heavily for an hour or so, to clear dust from the air. Snow may be used, if collected 2 or 3 inches above the ground, for the same reason as in the case of rain. Collect a gallon or two of rain-water or melted snow for your battery and keep it tightly corked for use the year round. Add water, every month, and test each cell with the hydrometer (before adding water) often enough to make sure the battery is kept in a charged condition.

How to Use Precision De Luxe  
 Plug in Coils in an All-Wave  
 Converter! See next week's issue, dated  
 January 17th.

# The 1931 Colonial

**FIG. 1** is a diagram of Colonial Model 32 DC receiver, with four 224 screen grid tubes, one 227 detector, and two 245 power tubes. The heaters and the filaments of all the tubes are connected in series, a resistance R11 being connected in shunt with the filaments of the 245 tubes to allow for the difference in current requirements of the heaters and the 245 fila-

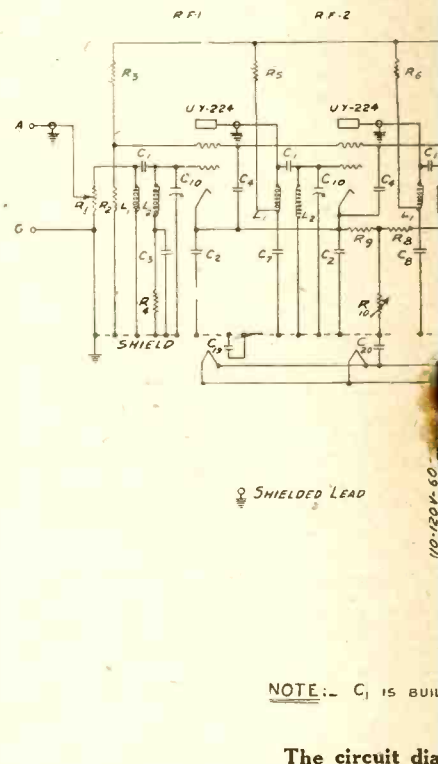
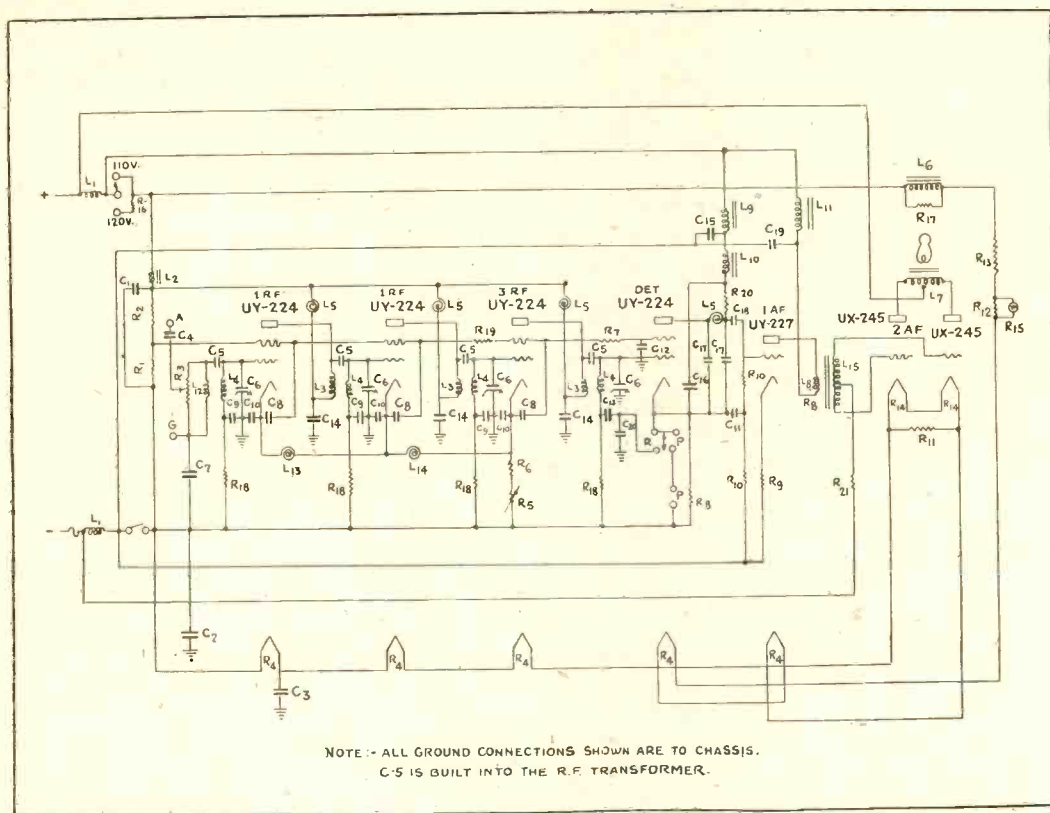

ments. The total current in the series is 1.75 amperes, and since the 245 tubes require only 1.5 amperes, resistance R11 must carry 0.25 ampere. Since the voltage across this resistance is 5 volts, the value of R11 is 20 ohms.

The series connection of the filaments of the two 245 tubes makes the grid bias on these tubes different by the amount of drop in one of them, that is, by 2.5 volts. This is not a serious difference when the total bias is so high as it is for the 245 tubes. Bias for the other amplifier tubes is obtained by suitably returning the grids to the heater line.

### Thorough Filtration

Note the thoroughness of the filtering in the stages of both the RF and AF amplifiers. In each plate circuit there is a choke coil in series with the coupling impedance, and each choke is shunted to ground with a condenser. In the radio frequency stages these chokes are marked L5 and the corresponding by-pass condensers C14. In the plate circuit of the detector the choke is marked L10 and the corresponding condenser C16. There is a second choke L9 in this line and a second by-pass condenser C15. In series with the plate circuit of the first AF amplifier is a choke L11 and this is by-passed by a condenser C19. There is no choke in series with the B supply to the power tubes because they are in push-pull and the hum is balanced out. There are two coils, both marked L1, which carry the plate current of all the tubes except the power tubes and thus filter the supply. The lower of these coils also carries the plate current of the power tubes. An additional coil L2 is used to filter the plate and screen supply of the first three tubes.

### Volume Control

There are two volume controls in the circuit. The first is the high resistance potentiometer R3 across the antenna coil L12. The antenna is connected to the slider of this potentiometer through a small condenser C4. The other volume control is the variable resistance R5, which varies the bias on the first three tubes, since it is in the common cathode lead of these tubes.

Provision for a phonograph pick-up unit is made in the cathode lead of the detector tube.

The field coil L6 for the dynamic speaker is connected in series with the heaters and the filaments. Thus it is not necessary to draw any extra current from the line for this purpose.

### Colonial Model 32 AC

The AC model is similar to the DC model in so far as the circuit exclusive of the power supply is concerned. However, instead of using individual chokes for filters in the plate circuits, resistances are used. There are five of these filter resis-

**Fig. 1**  
The circuit diagram of Colonial Model 32 DC Receiver.

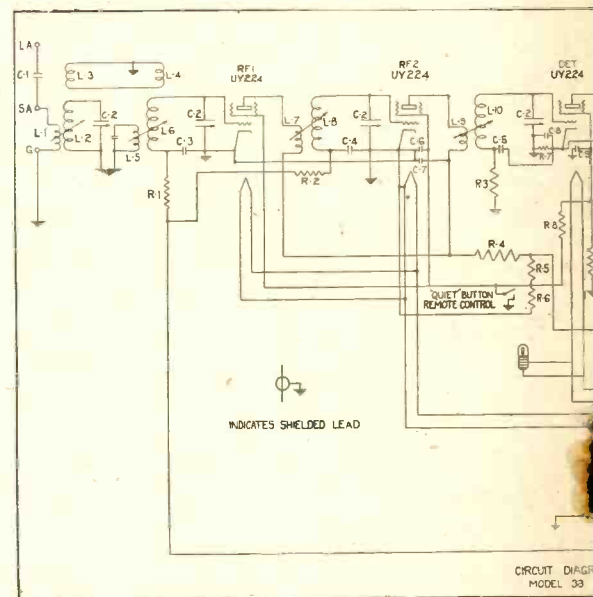

**Fig. 3**  
The diagram of Colonial Model 33 DC. This is a six filament receiver.

tors, R5, R6, R7, R15, and R16. R15 is also the plate coupling resistance in the plate circuit of the detector and R16 the feed for the plate of the first audio frequency amplifier.

The volume control in this receiver is also the same as that in the DC model. R1 is the antenna potentiometer for varying the input to the circuit and R10 is a variable grid bias resistor for the first three tubes in the circuit.

Provision is also made for a phonograph pick-up in the grid circuit of the detector. A single pole, double throw switch changes from radio to phonograph or in the opposite direction. The pick-up unit may be connected permanently to the terminals marked P. When the switch is thrown to the phonograph position the unit is connected in parallel with the bias resistor R14 and when it is thrown to the radio position the full value of this resistance is in the circuit. Thus the bias on the tube is automatically changed to suit the function of the tube, that is, as amplifier or detector.

The volume control for the pick-up is supposed to be built into that unit, as is the case in most instances, but there is a switch provided for changing the volume in case it is necessary.

This s  
audio  
and th  
The  
of the  
switch  
protoc  
In t  
noises  
denser  
line.  
up by  
conder  
circuit  
conder  
circuit  
The  
betwe  
the en  
The

# al Receivers

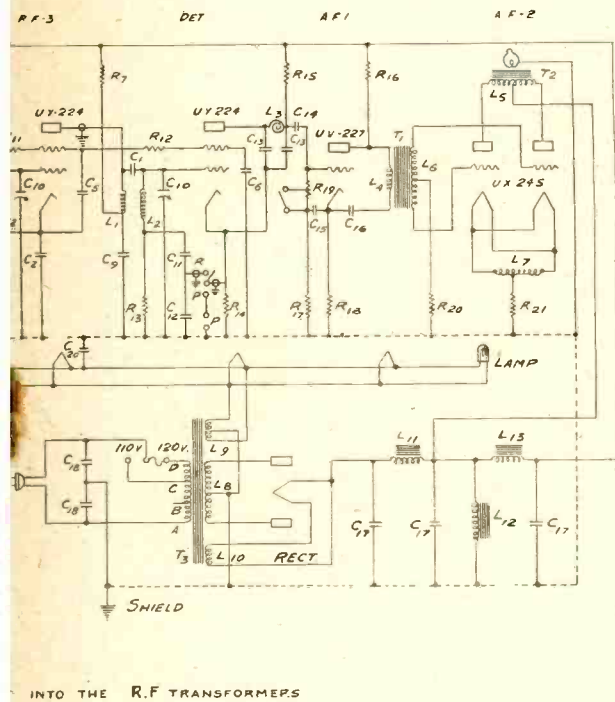
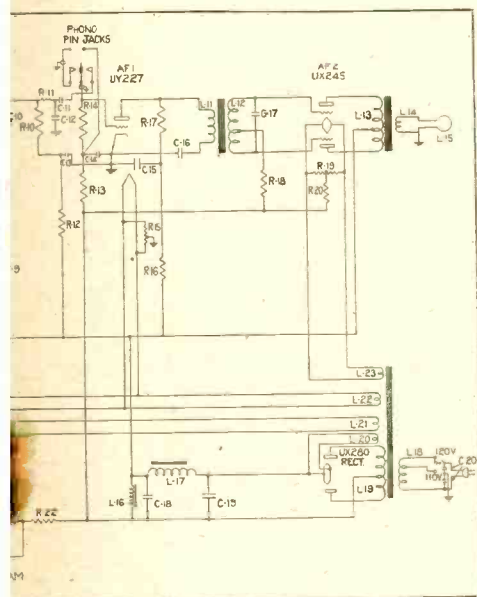

Fig. 2  
Diagram of Colonial Model 32 AC.



-tube receiver in which the heaters and  
d in series.

switch is across a portion of the grid leak in the first amplifier. When it is closed part of the leak is shorted and amplification is reduced. The power input arrangement is noteworthy. The primary transformer is tapped for either 110 or 120 volts. To change from one to the other it is only necessary to move the line fuse from one position to another. In the primary there is also a noise filter to prevent line noise from entering the set. This filter consists of two condensers C18 connected in series with each other and across the line. The junction of the two is grounded. Thus noises picked up on either side of the line are shunted to ground. Small capacitors C20 are also connected from one side of the heater winding to ground. Since the center of this circuit is also grounded, capacitors C20 are connected across one-half of the 2.5 volt speaker field L12 is connected across the B supply line between the two filter chokes L11 and L13. Since this is across the full line voltage it is a high resistance field winding. The plate current of the power tubes flows only through the

first choke L11, while the plate and screen currents of the other tubes flow through both. All the plates and screens are returned to the same point but the screen voltage is dropped to the required value in resistance R3, and R2 is the bleeder which helps to determine the screen voltage. Indeed, the screen voltage is equal to the drop in this resistance, neglecting the small grid bias on the screen grid tubes.

Fig. 3 is the circuit diagram of Colonial Model 33 DC receiver. It makes use of three screen grid tubes of the 224 type, two as radio frequency amplifiers and one as detector, one 227 type as first audio frequency amplifier and two 245 tubes as power amplifiers in a push-pull circuit. All the heaters and filaments are connected in series as in the preceding DC model. The field

Fig. 3 (below)  
The diagram of Colonial  
Model 33 DC Receiver.

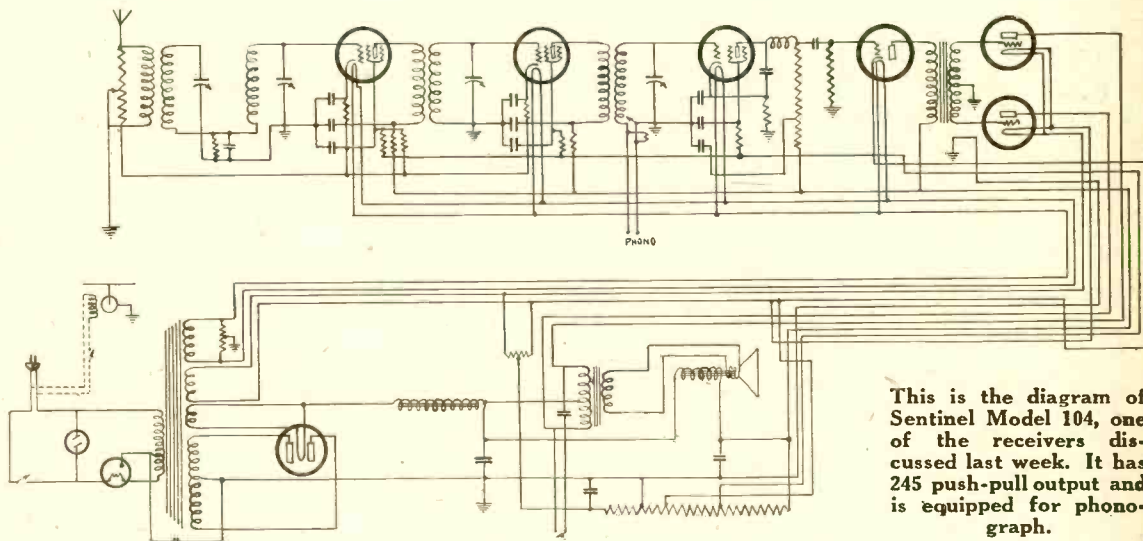
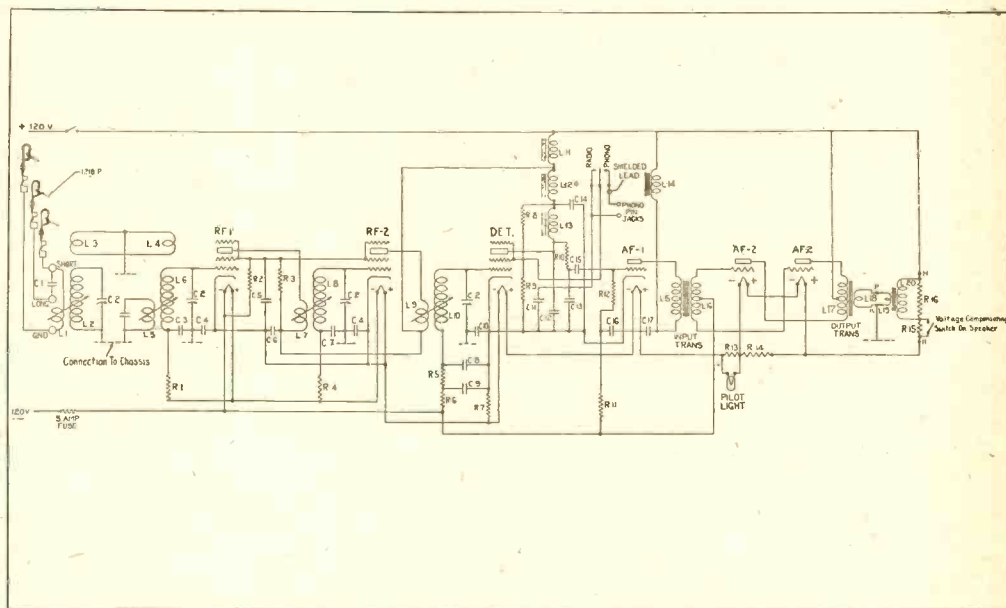

This is the diagram of  
Sentinel Model 104, one  
of the receivers discussed  
last week. It has  
245 push-pull output and  
is equipped for phono-  
graph.

winding of the dynamic speaker is also on this series, a resistance R16 being connected across the field to pass the current not needed for the field.

The phonograph pick-up unit is connected in the screen circuit of the detector tube, which is a unique position for it.

The B supply and filter arrangement is the same as in Model 32 DC, most of the filtering being in the detector supply.

Model 33 AC is like Model 33 DC except that the power supply is different. There are three 2.5 volt filament windings, one serving the radio frequency amplifiers, another serving the detector and the first audio frequency amplifier, and a third serving the two 245 tubes in the power stage. The center of the winding serving the detector is grounded by means of a center-tapped resistance R15 and the winding serving the power tubes is similarly balanced by means of a resistance R19. The other winding is grounded on one side rather than in the center.

An interesting feature is that where by-passing is done in the plate circuits the connection is always made to the cathode rather than to ground. Thus in the second RF tube the by-pass condensers are connected from the screen and the plate return to the cathode of that tube. In the detector plate circuit condenser C10 which by-passes the radio frequency component goes to the cathode directly and likewise condensers C15 and C16 in the plate circuit of the first audio frequency tube are connected to the cathode. Thus the signal currents are always led back to the source by the shortest route. This minimizes feedback through the common elements in the supply circuit. The fact that the cathodes are also grounded does not alter the desirable effects of the by-passing.

# Coil Data For An A

By Herman

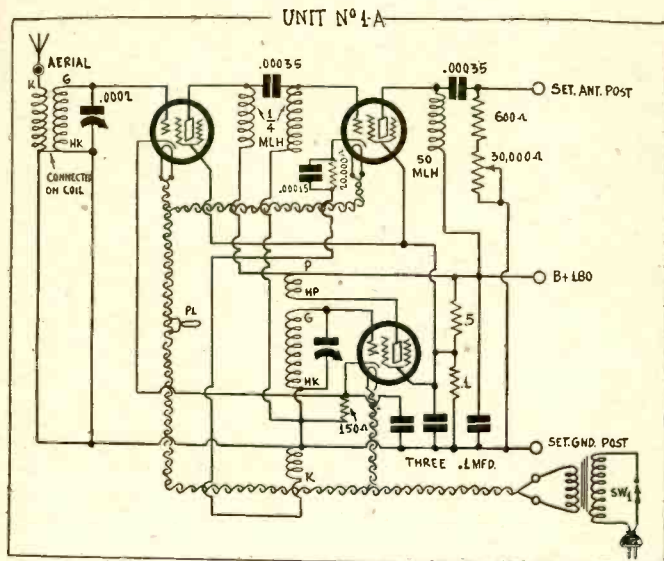

Fig. 1

The triple screen grid all-wave converter, using two tuned circuits. This may be worked with any type broadcast receiver. A total of only four plug-in coils is used.

**T**HE tuning curve of the all-wave converter diagrammed in Fig. 1 is such that, with an intermediate frequency of 1,500 kc, the lowest broadcast frequency comes in at 89 on the oscillator dial and the highest broadcast frequency at 42, using the larger of the two plug-in coils intended for the oscillator circuit. The principal tuning is done by virtue of the oscillator action, and it is the oscillator condenser alone that is actuated by the National dial. The other condenser, across the modulator grid circuit, while it is effective enough to tune out a weak signal, or to bring in a few different broadcast frequencies without moving the oscillator setting if the signals are very loud, is after all a secondary consideration in the tuning.

That the oscillator functions to make possible reception of the broadcast band of frequencies over 47 divisions of the dial is due simply to the fact that the oscillator frequency is higher than the station carrier frequency by the amount of the intermediate frequency, so the rate of frequency change is more rapid, since higher frequencies are involved.

### Intermediate Frequency Compensation

The 1,500 kc intermediate frequency is cited, as it is assumed that users will prefer a high intermediate frequency, provided the broadcast set is sensitive in that region, but if such sensitivity is not present there, a lower intermediate frequency may be used. For this reason it is advisable to have some blank space at the lower frequency region of oscillator tuning, if a 1,500 kc intermediate is used, for as the intermediate frequency is lowered, the dial settings are numerically higher, for the same broadcast stations.

If it is decided to set the receiver dial with condenser plates fully enmeshed, which would give the lowest intermediate frequency, then if the lowest frequency broadcast stations don't come in, because the oscillator dial will not tune so low, a small fixed condenser may be placed across the oscillator condenser. A suitable capacity would be the Hammarlund equalizer, 20-100 mmfd. The set-screw should be turned until the lowest frequency station does come in, and the setting need not be disturbed thereafter. Of course, the highest broadcast frequency will come in, even if .0001 mfd., the maximum of the equalizer, is across the oscillator tuning condenser, which itself is a .0002 mfd. Hammarlund variable, a midget model with midline tuning characteristic.

### Wide Turning Range Afforded

The oscillator coil, indeed, may be wound so that the broadcast band will be covered when the lowest intermediate frequency is used, with high dial setting for the lowest wave. Then, when it is desired to tune to higher frequencies, instead of using the same intermediate frequency as previously, the receiver dial may be turned to the opposite extreme, and 1,500 kc or a little higher frequency used, rather than 540 kc or thereabouts. In that way, without changing the oscillator coil at all, you can tune in the broadcast band of wavelengths at the lowest intermediate frequency the receiver affords, and simply by changing the intermediate frequency by 1,000 kc or so, rise right into the short-wave band, and begin tuning at

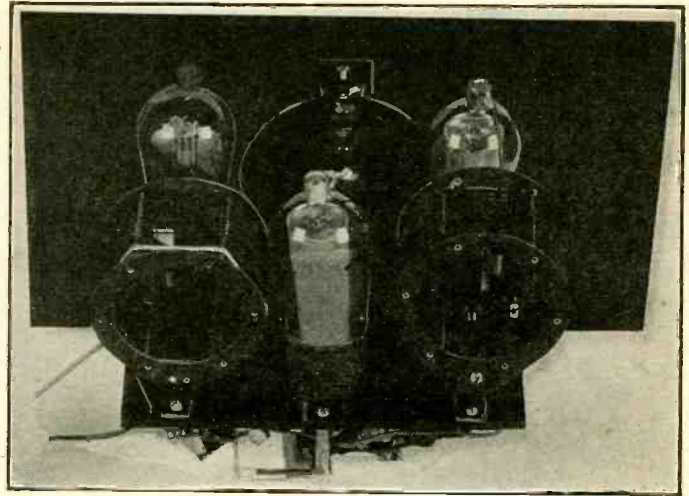

Fig. 2

Rear view of the converter. Either tube base type coils, or the illustrated precision air-wound coils may be used.

1,500 kc or so, at the setting of the oscillator dial that previously brought in 550 kc.

The tuning range is narrow for the broadcast modulator coil, being restricted the 1,500-500 kc band. With a .0002 mfd. or .00025 mfd. tuning condenser, about all that one can cover without changing coils, is the broadcast band. It is a simple example of tuned radio frequency, using a transformer and a variable condenser, where the transformer happens to be of the plug-in type, and the condenser one of relatively small maximum capacity for the purpose, although large enough to insure wave band coverage.

### How Coil Connections Are Made

Assuming the use of coil forms of the tube base type, with diameters that vary from  $1\frac{1}{4}$  to  $1\frac{1}{2}$  inches, the number of turns of No. 28 enamel wire to put on the oscillator secondary in any such instance, for an intermediate frequency of around 540 kc, or the lowest to which your set will tune, is 23. This is the winding across which the oscillator tuning condenser is connected. The pickup winding is in reality a continuation of the other, and the number of turns may be any number, from 1 to 8 or so, depending on the degree of coupling desired. The largest winding will afford most volume and least selectivity. So the coil may consist of 31 turns, tapped at the eighth.

The tickler winding need have only enough turns of the same kind of wire to insure oscillation. If coupling is tight, say,  $\frac{1}{8}$ -inch separation between windings, the tickler may consist of 12 to 15 turns.

The winding terminals are brought out to prongs of the coil forms, and these prongs fit into a five-prong tube socket (UY type). The method of bringing out the leads for Fig. 1 was as follows, winding from bottom up: Antenna coil, cathode prong (K) to aerial; heater adjoining cathode (HK) to ground and grid prong (G) to grid. By this method ground is nearer to grid than is antenna, in a physical examination of the winding, and the antenna might be assumed to be grounded, pickup being prevented. If the number of antenna primary turns were very small this might be relatively true, but with a generous primary here, the effect is one of mutual induction, and the coupling is wholly adequate. The antenna primary therefore may consist of 20 turns and the tuned winding, 112 turns, using No. 28 enamel wire. These are equivalent to 132 turns tapped at the 15th.

### Disposition of Turns

The oscillator coil, from bottom up, has pickup winding at bottom, grid winding next, plate winding at top. The secondary has cathode prong (K) connected to the cathode circuit of the modulator tube, as diagrammed in Fig. 1; heater adjoining cathode (HK) connected to ground; grid prong (G) connected to grid; heater adjoining plate (HP) to B plus, and plate prong (P) to plate, if the windings are in the same direction. If the oscillator plate winding and grid winding are put on in opposite directions, then HP goes to plate and P prong to B plus, as marked in Fig. 1. It is immaterial which method is used, but imperative that it must be one method when the windings are in the same direction, and the other when they are in opposite directions, otherwise the oscillator will not be what its name

# II-Wave Converter

Bernard

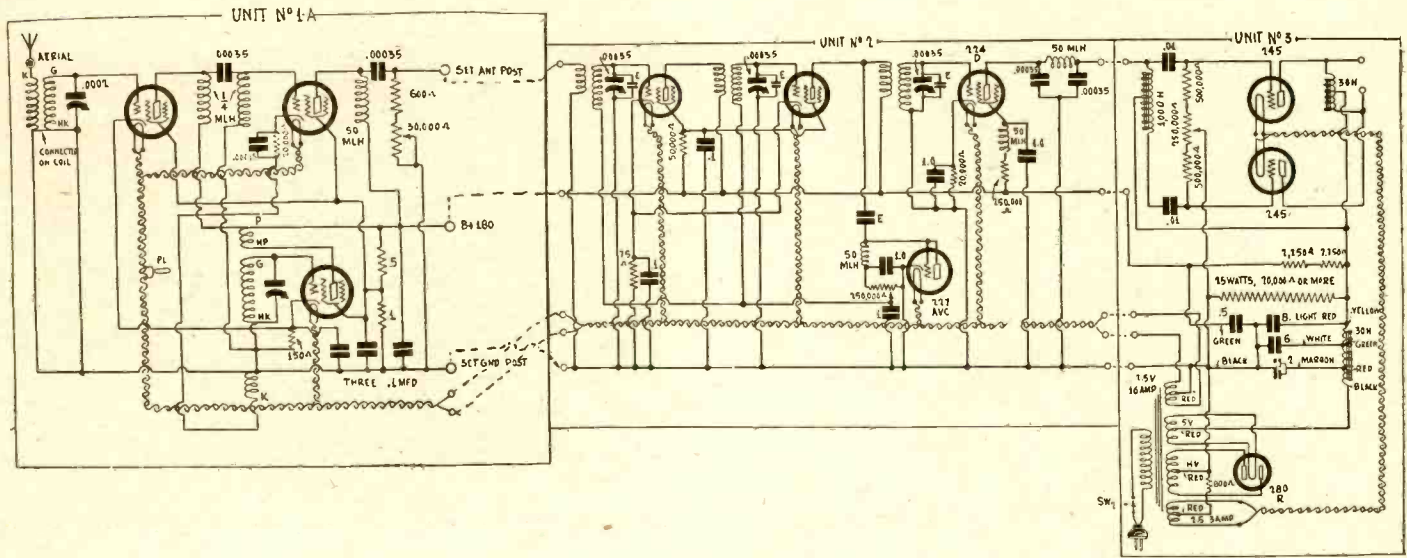

Fig. 3

The all-wave converter of Fig. 1 adapted to a complete AC Superheterodyne with automatic volume control, besides a manual volume control.

implies. For instance, it would be wrong to have both windings in the same direction and to connect as lettered in Figs. 1 and 3.

The above data refer to tuning in broadcast wavelengths at a low intermediate frequency, but as even use of the highest broadcast frequency will displace the required frequency of oscillation by only 1,000 kc or so, and the oscillator condenser covers a wide frequency band, the same oscillator coil will enable reception of broadcast frequencies through the set's intermediate channel, no matter to what frequency that intermediate is tuned. The dial readings will be displaced somewhat. The higher than broadcast frequencies will be tuned in at lower numerical dial settings, as outlined previously, when a 47-division span covered the broadcast band.

It can be seen that while the oscillator condenser has a wide range, and the modulator condenser for broadcast frequency reception has a relatively narrow one, so the modulator coil would have to be changed before the oscillator coil, for higher than broadcast frequencies.

The next pair of coils, using the same kind of wire, may consist of 13 turns for the oscillator secondary, 6-turn pickup winding, and 15-turn plate winding, the separation between secondary and tickler being 1/8-inch. For the modulator the antenna winding consist of 20 turns, with the tuned secondary of 13 turns, hence a coil of 33 turns is used, tapped at the 20th turn. The two inductances for the secondaries are alike, since with shortest waves being tuned in, the intermediate frequency, even if 1,500 kc, is only a small percentage of the original carrier frequencies, and dial differences are small. The small oscillator coil, for instance brings in WENR at 83 1/2. The frequency is 6,020 kc (48.83 meters). The short-wave call, by the way, is W9XF, and the station is operated by the Great Lakes Broadcasting Company, Chicago. The highest wave that can be brought in with the smaller oscillator coil is about 55 meters, or lowest frequency of 5,500 kc. The highest frequency one can tune in under these circumstances is 20,000 kc, or 15 meters.

As you know the intermediate frequency, you know the oscillator range. It is the original carrier range plus the oscillator frequency, or 21,500 kc to 7,000 kc. The only confusing point is that some strong stations may come in at two settings, one representing the lower frequency of oscillation, but the higher one is to be preferred, as greater sensitivity results. The lower one may be used, however, if necessary to get rid of interference. The fact that the modulator circuit is tuned gets rid of most interference due to image reception. Image interference is caused by the oscillator setting required for bringing in the desired station also being the alternative setting that brings in an undesired station differing from the desired one by twice the intermediate frequency.

From the foregoing it can be realized that to bring in higher than broadcast frequencies, although the oscillator coil need not be immediately substituted for the smaller one, the modulator circuit must have a smaller coil. There is a small gap, not covered by the modulator coil directions, due to this very disparity, unless avoided, as may be done readily.

The solution lies in working three coils in the modulator to team up with only two coils in the oscillator. This would require five coils, but the winding directions make the oscillator

coils interchangeable in the modulator circuit, though the opposite situation does not obtain.

Here is the procedure:

- (1)—For broadcast wavelengths, use the larger modulator coil and the larger oscillator coil.
- (2)—For the first short-wave band (1,500 kc up), remove the oscillator coil, put it in the modulator coil socket, and place the smaller oscillator coil in the oscillator circuit.
- (3)—For the highest frequency band, put the smaller modulator coil, previously not used, in the modulator position, and leave the smaller oscillator coil where it is.

Instead of tube base type coils, one may use de luxe precision coils, space wound on air dielectric, with the wire insulation touching only thin bakelite ribs. Data will be given later.

The circuit, as diagrammed in Fig. 1, consists of a screen grid radio frequency amplifier, with tuned input, untuned coupling from the RF stage to the screen grid modulator, and a tuned screen grid oscillator coupled to the modulator. The choke coils in the plate and grid circuits of the RF and modulator are special ones, that safeguard against dead spots on the dial (of which there will be none). The inductance of these chokes is 1/4 mlh, and their distributed capacity is extremely low, of the order of 1 mmfd.

The model has a filament transformer built in, while the volume control may have an AC switch attached, to restrict the panel knobs to three: one for the dial, one for the modulator condenser and one for the switch-volume control.

The same mixer circuit may be used with a complete Superheterodyne, as shown in Fig. 3. This is the same circuit as was presented last week, except that the RF stage has been added ahead of the modulator, to conform to Fig. 1, and plug-in coils are used instead of a switching device. Automatic volume control is included.

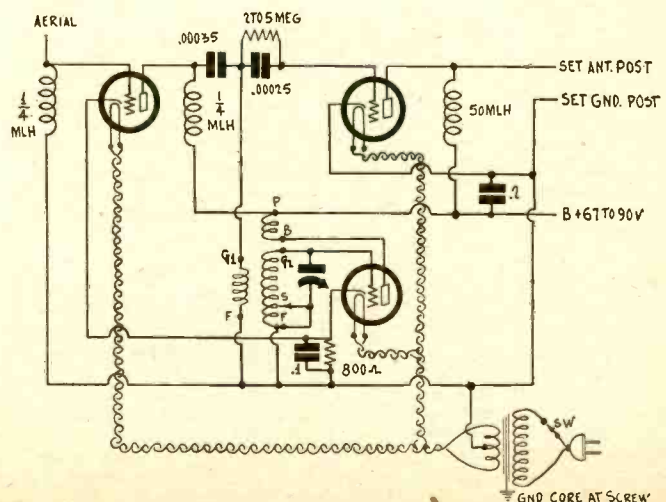

The original circuit from which Figs. 1 and 3 were derived.

# Series and Parallel

By Brainard Foote

**Y**OU often see or hear the words "series" and "parallel" used in connection with the method employed in joining together various units in a radio receiving set.

Let's consider a tube. A tube has a filament, the element composed of fine wire which becomes hot when current from the storage battery or the power transformer is passed through it. Each tube has its own filament.

In the simplest battery type radio set, all tubes are the same and the filaments are connected in parallel. This means that the corresponding ends of the filaments of all the tubes are connected together and also to one terminal of the battery. The other ends of the tube filaments are connected together, too, and to the other terminal of the battery, so that parallel connection is seen to increase the drain.

Thus the current from the battery flows to and through all the tubes simultaneously. The result is the same as if you had first connected the filament contacts of one tube to the battery terminals, and then had done the same with all the other tubes. Since each tube requires a certain amount of current, the total current drawn is the sum of the amounts taken by the individual tubes. If we have a 5-tube set, with 201A tubes drawing one-quarter ampere apiece, the total current taken would be  $1\frac{1}{4}$  amperes. (Consideration of the rheostat is omitted for simplicity.)

Sometimes tube filaments are connected in series, that is, end to end. Where the house supply is direct current instead of the more common alternating current, series connection frequently obtains. Then the tube circuit is like this: One end of the filament of the first tube is connected to the power line. The other end of this filament goes to one end of the filament of the next tube, and so on, with the remaining end of the filament of the final tube being connected to the other terminal of the power supply line. You can then trace a continuous path through all the tubes, one at a time.

## Condenser Situation

The amount of current needed for any number of identical tubes is therefore the same as that drawn by a single tube, but the voltage (or pressure) necessary to force the same current through a series of tubes must be as many times greater than the voltage for one tube as the total number of tubes. Five 201A tubes in series would draw one-quarter ampere, but the voltage would have to be 25 volts. Any excess voltage at the source is dropped in a separate resistance.

As a general rule condensers for radio sets are designed in advance with the correct capacity for the particular location in the set. However, the home builder or experimenter often wants a capacity, not a standard size, or he would like to use whatever condensers he has on hand. Either may be done by combining the condensers in series or in parallel to obtain the correct value.

In parallel connections of condensers the corresponding

terminals are merely joined together, and the effect is that of a single condenser of larger size, equal in capacity to the sum of the capacities of the individual units. As many condensers as desired may be used. If we have condensers of 1 mfd., 2 mfd. and one-half mfd., the total in parallel is  $3\frac{1}{2}$  mfd.

In series connections of condensers the resulting capacity is less than that of either of the condensers so connected, according to a mathematical law known as the "reciprocal of the sum of the reciprocals." A common use of a series condenser is in a radio antenna circuit, giving a lower capacity and therefore creating the effect of a smaller aerial. If Y and Z are the series

capacities, the resultant, X, is

$$X = \frac{1}{\frac{1}{Y} + \frac{1}{Z}}$$

## Dry Cell Examples

Dry cells used in battery sets illustrate series and parallel connections nicely. Dry cells are used to light the filaments of dry cell type radio sets. With tubes like the 199, three dry cells in series are required. The voltage is then tripled (each cell is  $1\frac{1}{2}$  volts; total is therefore  $4\frac{1}{2}$  volts). The current capacity of the cell remains the same as that of one cell, however. For other tubes, such as the WD11, only  $1\frac{1}{2}$  volts are required, but one cell does not have enough current capacity to light all the tubes of the set. Therefore a number of dry cells, any number desired, is connected in parallel, that is, with their positive terminals joined together, and their negative terminals joined together. This acts as a single dry cell, still of  $1\frac{1}{2}$  volts, but of greater current capacity.

The storage battery, used in radio and car, itself is composed of three separate cells. Each cell gives 2 volts, and 3 of them are placed in a carrying box or case, and connected together to provide 6 volts.

The scanning disc is a vital element in present-day television broadcasting and reception. Its action is extremely interesting.

The disc is made of metal, as a rule, and is thin and rigid, a foot or more in diameter. There is a spirally located series of tiny holes drilled through the disc, and the disc is rotated by an electric motor which must be maintained at exactly the same speed as the corresponding motor at the broadcasting station.

The holes are placed a certain distance apart horizontally, that is, in the direction of rotation, and also a certain distance apart vertically, that is, toward the center of the disc. The horizontal distance between the holes determines the width of the picture, usually about  $1\frac{1}{4}$  inches. The holes are spaced apart vertically a distance equal to the diameter of the hole (usually very slightly less).

# How Television Systems Are Worked

## Disc Between Screen and Lamp

In back of the disc we have a neon tube, which blinks bright and dim in accordance with the impulses from the transmitting station. In front of the disc we have a small ground glass screen on which we view the images. The disc passes between, so that no light from the neon tube may reach the screen except through a hole in the disc. And only one hole at a time can be between the bulb and screen. The top hole traces its path along the top of the screen, and during this brief passage, the neon tube may brighten and dim a number of times, making flashes of light at different places along the path of this hole.

Next comes the second hole, starting its quick trip across the picture just as the first hole leaves at the other side. Again the neon tube flashes up and off, sending further shots of light. Each hole in succession traces its path, each path slightly lower down than its predecessor, until all the holes have passed and "swept" the picture complete.

## Persistence of Vision

Your eye retains the image of each flash of light some time after it has gone. This is known as persistence of vision. The whole process occurs a number of times every second, perhaps ten times or more. The eye does not realize that the light flashes which compose themselves together really came only one at a time in a series of flashes. The eye sees the complete picture.

If there are only twenty-four holes in the disc, the picture is less detailed, but the neon tube does not have to respond so fast. When wider bands are allowed for television purposes, larger and better pictures may be transmitted.

Naturally, the accuracy of speed control is highly important, for the picture would break up into a meaningless jumble of distorted light and dark spots should the disc get out of synchronism with that in the television broadcasting station.

Hence the best drive for the disc is a synchronous motor, with mechanical braking device as second choice.

## New Frequency Standard

Washington.

The Department of Commerce has recently released for publication some interesting details regarding the extraordinary care that is exercised to devise frequency tests for the checking up on the accuracy of the frequencies of the broadcast spectrum which we now use nationally. This information is given by a representative of the Radio Section of the Bureau of Standards, and the gist of it is that chaos would be the result if the broadcasting stations of the Nation were not kept in their assigned places. This much most of us are aware of but of the means

resorted to, to attain this degree of maintained precision we do not know much about. The present communications channels are now so crowded that if the frequency assignment is not strictly adhered to the resulting interference would defy description. The degree of accuracy that must be maintained these days requires that the transmitter be capable of being compared with a frequency meter of accuracy that a few years ago would have been thought only requisite in a laboratory. So it is clear that the modern laboratory standards must be extraordinarily accurate, and it is a fact that the degree of accuracy now attained compares with the order of spectroscopic precision, which are considered the final standards of measurement reference, the ne plus ultra of physical measurement.



# Some Tips on a Super

By John C. Williams

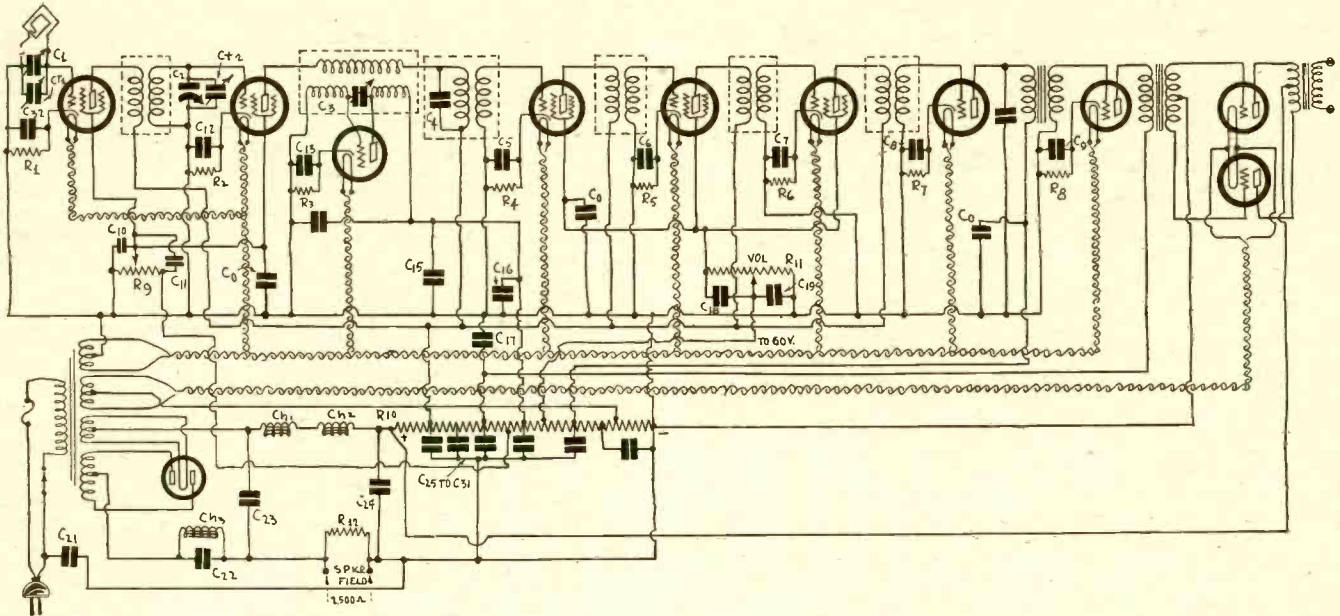

Fig. 1

Circuit diagram used for illustrating pointers on Superheterodyne construction.

**T**HERE are two kinds of input to Superheterodynes, one adapted to an external antenna and ground, the other a loop. The prevailing cabinet styles, that permit the enclosure of the set and the speaker are in most cases large enough to house a loop antenna, whose turns may be stretched on insulating supports, as was the practice with commercial sets. But a loop has directional qualities, which though not of value where the field density is high, are decidedly useful when distant signals are to be brought in. On this account a movable loop would be preferable to a fixed loop.

### IF Transformers Designed for S. G. Tubes

The fan may choose whichever system he prefers, and it is easy to guess that the preference will be a regular aerial-ground system. All the 1931 commercial Superheterodynes use that. Loops of all kinds have gone out of style in home installations. The input stage tube, a 224, is biased as a radio frequency amplifier, and in series with the plate circuit of this tube is a high impedance primary as is customary with the screen grid amplifier, this primary being coupled loosely to the tuned secondary. The second tuned stage that is that of the modulator, likewise a 224. The plate of this and of the first tube may be supplied from the 80-volt tap on the voltage divider, and the screen's applied voltage controlled by the potentiometer R.

### Choke Cores Grounded

The third tube from the right is a 227, which is the oscillator, the frequency of which is controlled by the shunted variable condenser C. The return lead of the grid coil goes to common ground, and in series with the cathode are a 300-ohm flexible biasing resistor and a .01 mfd fixed condenser. The potentiometer resistor that is marked VOL (R<sub>11</sub>) is arranged so that the screen voltage is supplied to the slider, the screens connect to the left-hand end of the potentiometer, the right hand end going to common return. This arrangement helps to keep the distributed voltage value along the divider from fluctuating too much. In case two similar ratio audio transformers are used it must be remembered that the primaries must be connected in opposing phase. The plate voltage lead from the divider goes to plate terminal of one transformer, and to B plus terminal of the other one. The B plus terminal of the first one, and the plate terminal of the last ones goes to the plates of the 245s.

### Assembly Test Useful

An additional tip is to ground the cores of the several chokes and transformers. This usually tends to allay noises due to induction, the effect obtained being due to the formation of a condenser to ground. The usual plan followed by those who build up their sets from parts is to make a series of tests during the construction of the set, thus checking the functions of the separate parts of

the receiver as far as possible. This plan is all right if you know what to expect of the partly assembled set.

### Cable for Connection

No two fans will wire a given set in precisely the same manner, though they will make the same connections. As the Superheterodyne layout is rather long, no matter how it is assembled, it becomes necessary to keep the heater leads as far away as possible from the RF leads, and in addition they are to be twisted. The power unit used with the set is connected to the set with short leads. If the fan has a separate B voltage supply in mind, and intends to mount the heater transformer integral with the set, and keep the high current density leads short, the power pack will have to be connected to the set by means of a cable made of eight wires. If on the other hand the power transformer is in the pack assembly, twelve wires will have to be used, two will carry the total 227 heater current, the filaments of the 2-2455 being supplied by a separate pair. The 227 heater supply pair will have to be equivalent in conductivity to No. 9 B & S. The 245 filament supply pair should be similarly equivalent to No. 16 B & S. Thus with this arrangement four additional lead wires are used. Attention is directed to the apparent liberal use of by-pass condensers, which are essential in this design, at the points depicted.

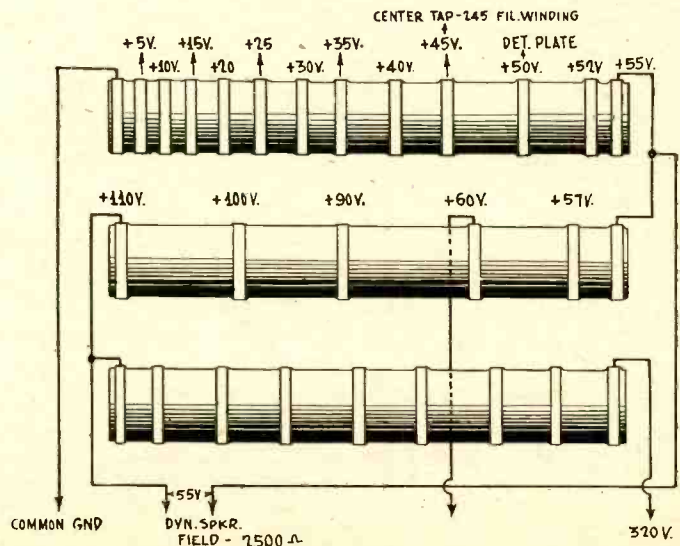

Fig. 2

Voltage divider connections and layout for the tuned choke type plate supply that powers eight 227s and two 245s.

# Radio University

A Question and Answer Department conducted by Radio World's Technical Staff. Only Questions sent in by University Club Members are answered. Those not answered in these columns are answered by mail.

Annual subscriptions are accepted at \$6 for 52 numbers, with the privilege of obtaining answers to radio questions for the period of the subscription, but not if any other premium is obtained with the subscription.

## Power Screen Grid Detector

**I**S it possible to get enough output from a 224 screen grid tube, operated as a detector, to load up a 245 power tube when a high resistance coupler is used between the tubes?—W. H. J.

It is quite possible. It is only necessary to have sufficient voltage in the plate circuit of the detector tube and the required control grid bias. A plate resistance of 250,000 ohms, a grid bias on the detector of about 10 volts, a grid leak ahead of the power tube of about one megohm, and an applied plate voltage of about 300 volts on the detector are suitable values.

## Advantages of High Intermediate

**W**HAT are the principal advantages of a high intermediate frequency in a superheterodyne receiver? When supers first came out frequencies of 30,000 and 45,000 cycles were used in the intermediate frequency amplifier and the reason given for using such low frequencies was that the amplification was higher. Does this reason still hold good?—B. L. F.

The main advantage of a high intermediate frequency in a superheterodyne is the possibility of eliminating image interference by a simple tuner in the RF circuit. Suppose, for example, that the intermediate frequency is 500 kc. Interference might result from a station differing from the desired station frequency by twice the intermediate frequency, or 1,000 kc. It does not require much of a tuner to differentiate sharply between two stations differing by 1,000 kc. But suppose the intermediate frequency is only 30 kc. The interfering station, or stations, would then be 60 kc away. It requires a very sharp tuner to suppress one completely when the other is tuned in. If the suppression is not very great, there will be image interference. There is practically no difference in respect to amplification. Just about as great amplification per stage, with stability, can be obtained with a high intermediate frequency as with a low one. One of the disadvantages of a high intermediate frequency is that the selectivity in the intermediate will not be so high as when a low one is used. But if a broadcast receiver of the TRF type can be made selective enough, one of the superheterodyne type can be made so more easily.

## An All-Wave Super

**I**AM planning to build an all-wave superheterodyne with a set of plug-in coils covering the range from 550 kc to 30,000 kc. I wish to use an intermediate frequency of 400 or 500 kc. Now I can cover the tuning range with a large tuning condenser in each circuit and a small number of coils in a set, or with a small condenser and a large number of coils in a set. Which is the better arrangement and why?—L. B. F.

Since you are to use plug-in coils it is just as well that you use small tuning condensers and many coils in the set. The tuning will be less critical, a fact which you will appreciate when you tune in the very high frequency signals. A tuning condenser as small as 125 mmfd. will work satisfactorily.

## Tuned Shunt in B Supply

**I**WISH to try a tuned circuit across the output of my B supply to reduce hum. If I use a 2 mfd. condenser, what should the inductance of the coil be to tune the circuit to the hum, the line frequency being 60 cycles?—W. H. S.

You need 0.88 henry. To make the tune shunt effective, not only adjust the coil accurately but also wind it with heavy wire so that the DC resistance is as low as possible.

## Low Frequency Oscillator

**I**S it possible by means of vacuum tubes and associated circuits containing no iron to build an oscillator which will generate a frequency less than one cycle per second? If so, will you kindly explain how it may be done?—W. A. J.

The simplest way of getting an oscillator generating a frequency of this order, with or without iron, is to set up two radio frequency oscillators and adjust their frequencies until they differ by the desired amount. The best frequency can be made almost as low as desired. It is only necessary to couple the two oscillators very loosely to insure that they do not interlock before

the best frequency has been lowered to the desired value. Since the frequencies of the two oscillators will change with changes in temperature and changes in voltages, the best frequency will not be very steady unless extreme precautions are taken to keep the oscillators constant. If the beat frequency must be kept constant, it may be necessary to control the frequencies of the beating oscillators by means of crystals, and to keep the crystals under constant temperatures besides.

\* \* \*

## Removal of Resonance Peaks

**I**S there any way in which resonance peaks in a loudspeaker can be removed so as to improve the response? It is very unpleasant to listen to a speaker when certain notes come out many times stronger than they should be and persist longer than they should. Will an exponential horn or a large baffle board help in any way?—P. C.

Any load on the vibrating member of the loudspeaker will help to remove resonance peaks if these peaks originate in the speaker. A long exponential horn or a large baffle board forms a good load and in this respect helps. It may also be possible to locate the cause of the resonance and remove it. If the trouble is due to box resonance filling the cavity with cotton or some such substance will help to break it up. If the resonance is in one of the vibrating members an application of rubber tape at a suitable point might break it up. If the trouble is in the electrical circuit, little can be expected from treatment of the speaker, and putting a load like an exponential horn or a baffle board might make it worse. Any band resonance in the electric circuit is usually due to regeneration in the audio amplifier as a result of feed-back through the B supply, and this can be overcome by the usual remedies for motor-boating. If the resonance is at a high audio frequency, a tuned shunt across the B supply terminals should stop the trouble, if the shunt is tuned to the frequency at which the disturbance takes place.

\* \* \*

## Beat Oscillator with Single Crystal

**I**S it possible to set up a beat frequency oscillator controlled by a single crystal, that is, is it possible to make a crystal oscillator at two different frequencies differing by an audible frequency? I am asking this because I have heard it said that it can be done but I fail to see how it could be possible.—J. C. M.

This has been done by scientists at the Bureau of Standards.

\* \* \*

## Estimating the Intermediate Frequency

**I**S there any way that I can estimate the intermediate frequency of my superheterodyne? The frequency is supposed to be 90 kc.—B. F. L.

You can measure it against broadcast stations by calibrating the oscillator dial. First connect a headset in series with the plate circuit of the first detector, so that you can hear the squeals when you turn the oscillator dial. Then calibrate your oscillator against broadcast stations. Set the modulator dial where a given station, say one of 600 kc. normally comes in. Turn the oscillator dial until you hear a loud squeal. Note the setting of the dial where the zero beat occurs. Put this down against 600 kc. Repeat for many stations over the entire scale, the more the better. Having found a list of dial settings on the oscillator against frequencies, plot a curve. When this curve is complete restore the receiver to its original condition. Now tune in any station in the middle of the band and note the oscillator setting where it comes in. Then tune in the same station on the other setting of the oscillator and note the setting. Look up the frequencies of these settings on the curve, subtract one from the other and divide by 2, and the result is the intermediate frequency. The more accurate the calibration and the subsequent reading the more accurate is its value.

\* \* \*

## AC Clocks

**C**AN I connect an electric clock with my house circuit? We have 60 cycles, 110 volts in the house.—N. O.

Call up your power company to inquire whether their generators are governed in accordance with Washington time. If not, the electric clock would be incorrect.

## NEW BOOKS

"The Manual of Short Wave Radio," compiled by Zeh Bouck, is a collection of articles on short-wave reception by such well-known authorities as Bouck, James Millen, Edward W. Wilby, Robert S. Kruse, Fred H. Schnell, L. W. Hatry, Howard Allan Chinn, Thomas A. Marshall, Volney Hurd, Manson E. Wood, and John B. Brennan.

There are seventeen articles on the construction of different kinds of short-wave receivers, converters and adapters. Besides these there is a list of Characteristic Letters of International Amateur Calls, International Frequency and Wavelength Allocations, International Commercial Call Letter Allocations, Time Conversion Table for the entire world, The International Morse Code, and Call List of International S-W Stations. The book is published by National Company, Malden, Mass.

# Forum

## He Tunes Screens and Likes It

HERE is a circuit I've never seen anywhere else. It is a six-circuit tuner, using only three tubes. The novelty consists of tuning the screen circuits. I know this is unorthodox, but I tried it and it works. My opinion is that it works well. There are theoretical reasons why tuning the screens shouldn't do much good, in fact, may decrease amplification and selectivity. These reasons include the fact a high impedance is placed in the

No. 36 enameled wire on an old resistor with the resistance removed.

The first station I picked up was W3XAL, at Bound Brook, N. J., to which I am now listening at 10 p.m. During daylight I have picked up a station in Winnipeg, also WENR (6,020 kc) at Chicago.

I read RADIO WORLD regular now and appreciate the dope published in it. Have read it at odd times, starting 'way back in the old days of the Superdyne, which was a go-getter also.

Am an old-timer at the game, serving R.C.A. three years in capacity of operator, and also two years with U. S. exclusively with Signal Corps and Air Service on portable tube transmitters and receivers.

FRANK ACKERMAN,  
Box 363, Colfax, Calif.

## Literature Wanted

Readers desiring radio literature from manufacturers and jobbers concerning standard parts and accessories, new products and new circuits, should send a request for publication of their name and address. Send request to Literature Editor, RADIO WORLD, 145 West 45th Street, New York, N. Y.

- Albert Eckfeld, Jr., 1005 Second St., Portsmouth, Ohio.
- J. F. Ballitch, R. D. No. 4, Mansfield, Ohio.
- C. M. Laudenberger, 511 Parsons St., Easton, Pa.
- Louis Vernier, 600 S. Mill St., Louisville, Ohio.
- Raymond L. Walker, 967 Chestnut St., Union, N. J.
- Roy E. Crossman, Set Builder, 216 So. Cox Ave., Joplin, Mo.
- W. A. Smuth, 842 Hathaway St., Cincinnati, Ohio.
- Ezra J. Cranker, 137 N. Main St., Gloversville, N. Y.
- L. H. Adams, 201 Cimmaron, La Junta, Colo.
- D. C. McCall, 94 Waddell St., N. E., Atlanta, Ga.
- C. A. Swinney, 23 Providence Rd., Charlotte, N. C.
- R. W. Bebb, Scranton, Pa.
- Albert Miller, Jr., 2419 Lockbourne Rd., Columbus, Ohio.
- Iver Paulsen, 32 Hawthorne St., Woburn, Mass.
- John Howe, 3913 W. 23rd St., Cleveland, Ohio.
- Albert Driver, 199 Collette St., New Bedford, Mass.
- T. E. Edwards, c/o G.S.K.S.A.L. Ry. Co., Portsmouth, Va.
- J. E. Mills, 339 Carriere Ave., Norwood Grove, N. Winnipeg, Man., Canada.
- D. M. Bedenbaugh, 1111 Carr Ave., Memphis, Tenn.
- George Downs, 146 Dunning Ave., San Antonio, Tex.
- H. R. Williamson, 101 Tenn. Ave., Knoxville, Tenn.
- James Browning, Belt, Mont.
- L. P. McBrayer, 700 State Ave., Cincinnati, Ohio.
- Coffman Brothers, Swoope, Virginia.
- K. J. Linnane, 685-63rd St., Oakland, Calif.
- J. M. Lovret, 612 N. Florence St., El Paso, Tex.
- Clarence J. Chelell, 920 Kansas City St., Rapid City, So. Dak.
- Ira Armatrou, 89 Toland St., London, Ohio.
- R. P. Wilson, Radio Service, 3228 Rokeby St., Chicago, Ill.
- Roy Swan, Hannacroix, N. Y.
- Claude N. Beasley, 278 Main St., Suffield, Conn.
- Guy C. Chadwick, 401 Grand Ave., Cumberland, Md.
- R. E. Davison, Harvard, Nebr.
- O. F. Wrightsman, Holmesville, Nebr.
- J. M. McCoy, R. No. 1, Box 610, Seffner, Fla.

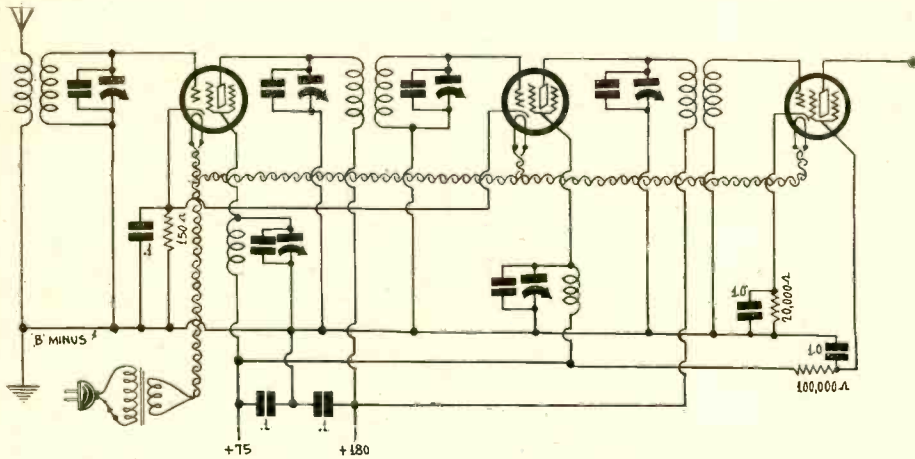

Tuning the screen circuits, a method theoretically considered taboo, proved a good method in practice, reports Edwin Stannard, who sent in the circuit diagram as published herewith.

screen circuit and may kill the purpose of the tube. But listen to this:

When I tuned those screens I got more stations, got them louder and with better selectivity than when I did not tune them.

I would be interested in hearing from readers who try this stunt.

EDWIN STANNARD,  
100 Old Amboy Road,  
Eltingville, Staten Island, N. Y.

## Good Results from Crystal

ALINE to tell you of an experiment with a crystal, of the old cat whisker type, in series with the antenna. Solder a short lead to the top of crystal, another to bottom, connect one to antenna lead in, other to antenna post on set. That is all there is to it.

I notice that the selectivity is greatly improved. One evening between 7 and 9 p.m. I got three stations in Canada, two in Cuba, one in Mexico and KFI. I got KFI every evening before 9 p.m., with crystal, then took off the crystal, tried for a week and never received KFI a single time. I put the crystal back and picked up KFI the first evening. When my set was new and the tubes were new I had to wait until about midnight to get KFI. Now the set and tubes are fourteen months old.

I notice a great improvement over the whole range. I pick out Cuban and Canadian stations without interference.

I am wondering if some one who owns a quartz crystal will try it in the same manner and see what results can be had.

W. C. COOMBE,  
1318 Hoefgen St.,  
Indianapolis, Ind.

## Cross-Continent with Converter

FOR some time I planned to build a converter to use with my broadcast receiver. Just finished it today and boy does it work, and how! The circuit used is Fig. 7, page 9, in the December 13th issue of RADIO WORLD.

The 1/4 mlh chokes were 100 turns of

The circuit used by Frank Ackerman, and with which he got excellent results, is that of a battery-operated converter, with three 230 tubes, filaments in series. The method of grid returns takes care of the biases. A 6-volt storage battery is recommended.

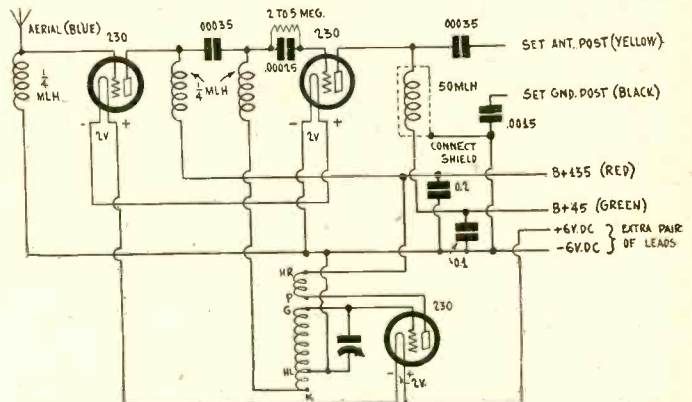

## THE AIR SHAFT

A RECENT survey of listeners called for answers to numerous radio questions. One was: "Are you tired of listening to the radio?" About one per cent answered yes. The percentage of persons tired of living is also about one per cent.

LOWELL THOMAS, the radio voice of "The Literary Digest," in signing off says "so long." Recently he did it in what he assured listeners was Chinese. It's O.K. with us in any language, so long as it isn't farewell.

## A THOUGHT FOR THE WEEK

WHO is America's most popular broadcaster? There's a query that leads to all kinds of interesting conjectures, for, after all, it's the listeners-in who should decide the matter. RADIO WORLD might, if given sufficient encouragement, throw open its pages and give the American public an opportunity to go on record in the matter. If you are interested, drop a line to this paper and let us know what you think of the idea.

## NEW CORPORATIONS

- National Radio Advertising—Atty. E. K. Hessberg, 11 W. 42nd St., New York, N. Y.
- Warsaw Electric and Radio Corp.—Atty. R. L. Stein, 225 East 19th St., New York, N. Y.
- National Recording Corp. of America, talking motion pictures—Atty. A. Goodman, 1,140 Broadway, New York, N. Y.
- Columbia Radio Corp.—Atty. J. E. Wilner, Chicago, Ill.
- Bell Radio—Atty. I. Eherman, 270 Broadway, New York, N. Y.
- Paramount Automatic Radio Co.—Atty. S. H. Lagusker, 1,472 Broadway, New York, N. Y.
- Universal Talking Pictures Amplification, Inc., Philadelphia, Pa.—Corporation Guarantee and Trust Co.
- Sunrise Radio Service, radio accessories—Atty. S. Levine, 277 Broadway, New York, N. Y.
- WDKO, radio broadcasting, Albany, N. Y.—Atty. Hun, Parker & Reilly, Albany, N. Y.
- Royal Recording Studios, radio broadcasting—Atty. B. Bag, 150 Nassau St., New York, N. Y.
- Dale Distributing Co., radio—Atty. J. Weil, 36 West 44th St., New York, N. Y.
- Mart Electric Radio Service—Atty. Selzer & Fischman, Spring Valley, N. Y.
- Milliss Radio Shop—Atty. L. L. Levine, Richmond Hill, N. Y.

Band-Pass Filter Diamond of the Air, for AC Operation. See next week's issue, dated January 17.

# MEXICO ADDS TO ETHER JAM; PARLEY LOOMS

Washington.

The Federal Radio Commission has been reasonably successful in its efforts at reducing broadcasting station interference within the borders of the United States, but now it has a new problem on its hands, says L. D. Batson, a radio specialist of the Department of Commerce. He calls attention to the recent licensing of sixteen new stations by Mexico, which, reception reports show, are causing no little interference with American stations. Also, at least two Canadian stations are said to be causing interference, due to frequency trespassing.

Records of the Radio Division of the Department of Commerce show that Mexico has thirty-five stations on the air, nine of which have 1,000 watts or more. Seven of the nine stations operate on frequencies assigned to United States stations. XEW, of Mexico City, operates with 5,000 watts, which is shortly to be increased to 50,000 watts, and XED, of Reynosa, Rio Grande Valley, operates with 10,000 watts. Both use frequencies assigned to Canada, XEW using 780 kc and XED 960 kc. The 960 kc frequency is supposed to be Canada's cleared channel.

#### Cases Cited

XEW, on 780 kc, is using the frequency assigned to CKY, of Winnipeg, which operates with 5,000 watts. This 780 kc channel is also reserved for six regional stations of the United States of low power. XED, on 960 kc, uses the frequency assignment of CJBC and CFRB of Toronto, Canada, and produces interference with the programs of comparatively low powered stations not far removed from this frequency.

It is declared that the granting of higher power to XEW will be ruinous to local reception of American stations by listeners located within the service area of both, to say nothing of the lower powered stations not far removed from this frequency assignment.

#### Conference in Prospect

The Federal Radio Commission has received reports by letter of the interference that the Mexican stations are producing from broadcasting listeners. The resulting checkup by the Commission's engineers and Mr. Batson corroborate the assertions.

Possibility of another North American broadcasting conference has been discussed by American radio officials with the Department of State. Under the existing "gentleman's agreement," Canada has exclusive use of six of the 96 broadcasting channels available and shares a dozen with the United States. Mexico is not a party to this agreement.

## Beam for Aircraft Guidance Worked Out

Washington.

The Department of Commerce announced that the successful transmission of beam signals for aircraft guidance over a distance of 125 miles is the achievement of a new type radio beacon, the location of which is not yet public.

## State Tax on Sets Again Challenged

Columbia, S. C.

Four resident petitioners of the State of South Carolina seek an injunction to compel the State to show cause why it should not be enjoined from further attempt to levy and collect a tax on receiving sets.

The South Carolina Tax Commission and the Assistant Attorney General, represented respectively by John Fraser Lyon and Cordie Page, appeared for the State. The attorney for the petitioners (George L. Buist) claims that the tax constitutes interference with interstate commerce, and amounts to regulation of radio communication by the State Government.

Federal Radio Commissioner Harold A. Lafount had expressed a decidedly negative opinion when his reaction was sought on the advisability of instituting a tax on radio receiving sets. The petitioners are: WBT, of Charlotte; Hugh A. Ray, a private set owner; The Louis D. Rubin Electrical Co., and a retail radio dealer. The tax is adjusted in accordance with the value of the set, as follows: fifty cents for sets costing less than \$50, \$1 for sets between \$50 and \$200, \$2 for sets between \$200 and \$500, and \$2.50 for sets costing more than \$500.

## SYNCHRONIZED AERIALS TRIED

Washington.

The Federal Radio Commission, represented by Commissioner Harold A. Lafount, points to impending improvements expected to revise present broadcasting standards.

Particular attention is focussed on the perfection of the synchronization of broadcasting plants, now in the advanced experimental stage. It has been the fear that with the advent of synchronization that the operation of a number of stations of high power on a single frequency would spell the climax of the small broadcaster, but Commissioner Lafount points out that there will be no monopoly of wavelengths permitted. Synchronization will call into being an old ally in a new form, called a booster station. The duty of such a station will be to maintain the signal level at a satisfactory value, at the synchronization frequency, to insure uniform coverage of the country, and to stimulate response to radio business and advertising.

One of the many technical improvements being worked on is the design of the transmitting antenna which has been found to affect the accuracy of synchronization. This will partake of the nature of synchronous aerials. The use of the ground wave is being developed. Experiments with the sky wave tend to show that it is more susceptible to elemental interference, such as atmospheric discharges.

Another problem now being worked on is a master frequency available to the broadcasting stations of the nation, as a means of checkup of their synchronization frequency. This service is under contemplation by the American Telephone and Telegraph Company, which plans to transmit the standardization frequency by wire to subscribing stations.

## Blanket O. K. for Super Power Halted

Washington.

The recently proposed plan submitted to the Federal Radio Commission whereby the whole present quota of cleared channel stations was to receive en masse the privilege of using the present maximum output power of 50,000 watts has been returned to Chief Examiner Ellis A. Yost, with instructions to submit a new report compiled on a different basis.

A resolution adopted by the Commission at the suggestion of its Vice Chairman, Eugene C. Sykes, instructs the Chief Examiner to report the number of the total of twenty stations that applied for the eight remaining assignments for the use of maximum power and make out a separate report for each of them.

This does not mean that the project is shelved, but that the Commission members desire to make a detailed examination of the material of the report to ascertain which stations should be allowed the maximum output power.

It will be recalled that under the Commission's existing order to date, only twenty of the forty cleared channels may be used by 50,000 watt stations, or only four channels in each of the five zones in which the Nation is at present divided. But with twelve of this total now pre-assigned (some of them being in actual use), there are eight places for which twenty applicants are bidding

## Government Is Best Customer of Stations

Washington.

According to a recent survey the best customer of the broadcasting business during 1930 was The United States Government. The Government has used about 1,000 hours for the exposition of Federal activities, this time being divided between the networks of the National Broadcasting Company and the Columbia Broadcasting System.

A total of 328 Government officials has spoken over the networks, every department being represented. In addition to the above, foreign diplomats of 45 nations have been heard on the Conclave of Nations programs, heard via the Columbia network. President Hoover has established a new record by addressing the radio audience, via the National Broadcasting network, 27 times over a period of 22 months, equalling in that time the record of former President Coolidge over a seven-year period.

## 25 KW for KFAB, But No Full Time

Washington.

The Federal Radio Commission, through its chief examiner, Ellis A. Yost, has recommended that the application of KFAB, Lincoln, Neb., for full time operation on 770 kc., which it now uses for the equivalent of three days a week, be denied. The station's request for permission to increase its power from 5,000 watts to 25,000 watts was granted.

Allowing full-time would increase the present over-quota time assignment of Nebraska and the Fourth Radio Zone, hence the denial, Mr. Yost said. It was pointed out that public interest would not be served by this station taking the time now assigned to WBBM, Chicago.

The granting of the application for increased power will not cause undue interference to other stations, according to the Commission.

# SHORT-WAVE SPECIALTIES

## EXTRA-SPECIAL FREE OFFERS OF SUBSCRIPTION PREMIUMS!

RADIO WORLD, now in its ninth year, is the first and only national radio weekly, and publishes the latest, up-to-the-second news of circuits, both of kit types and of 1931 commercial receivers, as well as news of happenings in the broadcasting field. Lists of broadcast and short-wave stations are published regularly. You get your information weekly—which means quickly—and you get it accurately, so be sure to become or remain a subscriber for RADIO WORLD. We are able to offer now specially attractive premiums, and ask you to make your choice from the well-chosen variety of parts offered on this page and on the opposite page. When ordering, please use coupon.

The regular subscription rates are: \$6 for one year, 52 issues, one each week; \$3 for 6 months, (26 weeks); \$1.50 for three months, (13 weeks); \$1 for 8 weeks; 15c per single copy.

### TUBE-BASE TYPE COILS

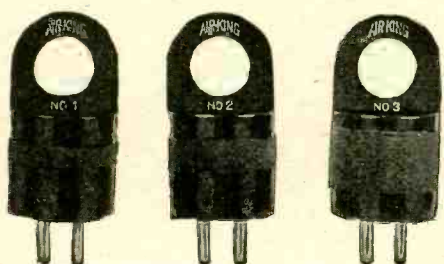

Three finger-handle type plug-in coils, wound on tube-base diameter, although of greater height than a tube base, for short wave plug-in service, where a 4-prong (UX) tube socket is used as coil receptacle. There are two separate windings, tightly coupled. The coil socket connections are: plate prong to plate, filament plus to phones; grid prong to grid and ant.; filament minus to stator of a feedback condenser. The tuning condenser (stator to grid prong, rotor to filament plus prong) may be .00015 or more for 15 to 110 meters; the feedback condenser .00025 mfd. B voltage is supplied through phones or audio transformer primary. Order PR-TBC free (less coil socket) with 6 mos. (26 weeks) subscription @ \$3.00

### PRECISION PLUG-IN COILS

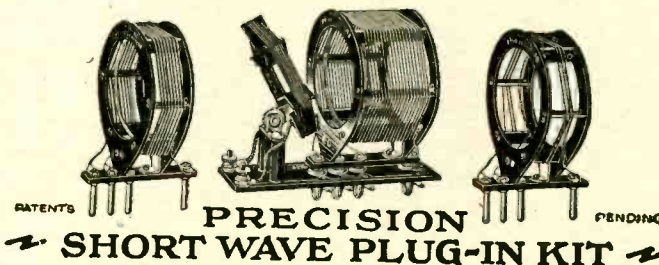

The finest short-wave coils, of de luxe construction, wound on ribs, affording 97% air dielectric, and available for various capacities of condensers, as listed below. All precision short-wave coils are provided with receptacle bases and apply to standard circuits.

For .0001 or .00015 mfd. tuning; three plug-in coils with receptacle base as illustrated, with adjustable primary built onto receptacle, 15 to 150 meters. Order PR-AK-1, free with one year's subscription @ \$6.00.

For .00025 or .0002 mfd. tuning; only two coils are required, for 15 to 150 meters. Order PR-AK-2, and get two coils, receptacle and adjustable coil (third inductance) built in. Free with nine months' subscription (39 weeks), at regular rate, \$4.50.

Note—We can supply .00015 mfd. (PR-H-15) or .0002 mfd. (PR-H-20) Hammarlund short-wave midline condenser, swings inside 2-inch diameter, with three months (13 weeks) additional subscription @ regular \$3 rate.

### "DIAMOND" PAIR IN STANDARD AND DE LUXE TYPES

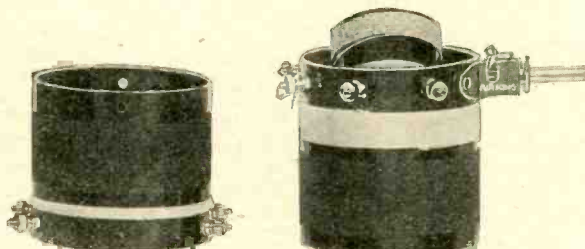

The Diamond of the Air is a popular circuit using an antenna coil and a three-circuit tuner. For this circuit the standard Diamond pair of coils consists of two, wound on 3" diameters, except for rotor on smaller form. The standard pair may be obtained for .0005 or .00035 mfd. tuning. Tickler coil has single hole panel mount. For .0005 mfd. order PR-SDP-5, with blueprint, free with a six-month subscription (26 weeks) @ \$3.00. For .00035 mfd. order PR-SDP-35, free with 6-month subscription @ \$3.00.

These coils will give extreme satisfaction and are excellent for the Diamond of the Air, being specified by Herman Bernard, the designer of the circuit.



De luxe Diamond pair, with large primaries center-tapped. For the Diamond use center tap and one extreme of the primary for antenna circuit, RF coil (at right); use full primary on tickler (lowest winding at left). The de luxe pair have silver-plated wire, for loss-reduction, wound on moulded bakelite, with threading, so coils are space-wound to reduce distributed capacity. Three-circuit coil is single-hole panel mount. Additional holes for optional base mounting on both, using brackets (not supplied.) For .0005 mfd. only. (None for .00035 mfd.) Order PR-GWN free with a year's subscription (52 issues) @ \$6.00.

### GET THE COMPLETE DATA ON SHORT-WAVE CONVERTERS

Short-wave converters are all the rage. They enable you to tune in short waves on a broadcast receiver of any kind. A serial article by Herman Bernard, on this topic, discussing several models, with full-size picture diagrams, was published in the November 8th, 15th, 22nd, 29th, December 6th, 13th and 20th issues. Send \$2 for 17 weeks' subscription and get these seven issues free. Order PR-SWCS.

### PARTS FOR A SHORT-WAVE CONVERTER

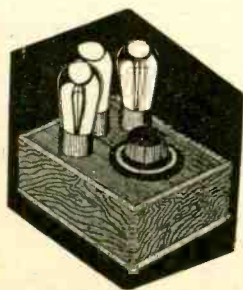

No matter what type of broadcast receiver you have, you can get short waves by using a short-wave converter built of parts we can supply. The panel is only 5 x 6 1/2 inches. There is only one tuning control. No squeals, howls or body capacity. Two models are available, one for A.C., the other for battery operation. The battery model uses three 227 tubes with heaters in series. Full details supplied with order.

All parts for A.C. model (less filament transformer, less three 227 tubes), order PR-SUP-3A, free with a year's subscription @ \$6.

All parts for the battery model (less three 227 tubes), free with a year's subscription for Radio World @ \$6.00. Order PR-SUP-3B.

A third model (of different appearance than illustrated) enables filament transformer to be built in. All parts, including filament transformer; two wound plug-in coils, 15-200 meters. Hammarlund condenser, (less tubes), order PR-SUP-3FS free with two-year subscription @ \$12.

### PLEASE USE THIS COUPON!

RADIO WORLD,  
145 West 45th Street, New York, N. Y.

I hereby take advantage of your extra-special premium offers and subscribe for RADIO WORLD for the number of weeks specified in the list below. Please send indicated premium. My remittance of \$ ..... is enclosed. RW-1-10

- |  |  |
|--|--|
| <input type="checkbox"/> PR-TBC (26 wks.) \$3.00 | <input type="checkbox"/> PR-SDP-35 (26 wks.) \$3.00  |
| <input type="checkbox"/> PR-AK-1 (52 wks.) 6.00  | <input type="checkbox"/> PR-GWN (52 wks.) 6.00       |
| <input type="checkbox"/> PR-AK-2 (39 wks.) 4.50  | <input type="checkbox"/> PR-SWCS (17 wks.) 2.00      |
| <input type="checkbox"/> PR-H-15 (13 wks.) 1.50  | <input type="checkbox"/> PR-SUP-3A (52 wks.) 6.00    |
| <input type="checkbox"/> PR-H-20 (13 wks.) 1.50  | <input type="checkbox"/> PR-SUP-3B (52 wks.) 6.00    |
| <input type="checkbox"/> PR-SDP-5 (26 wks.) 3.00 | <input type="checkbox"/> PR-SUP-3FS (104 wks.) 12.00 |

Name .....

Address .....

City ..... State .....

Please put cross here if renewing an existing subscription.

# A Complete Line of Radio Books!

SERVICE MANUAL

RAMSAY

HAAN

RADIO MANUAL

ANDERSON and BERNARD

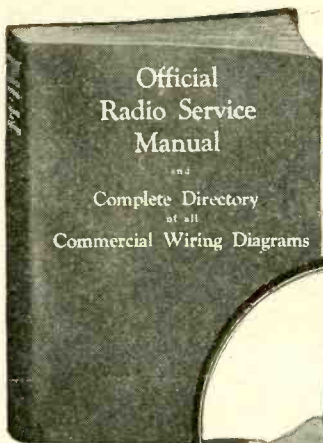

"Official Service Manual," by Gerstbach and Fitch, 1,000 illustrations; diagrams of commercial receivers and power amplifiers; 352 pages; includes course on servicing. Weight, 3 1/2 lbs. Complete 5-page index. Flexible leatherette cover, loose-leaf binding. Order Cat. ORSM @ \$3.50



The index to the commercial wiring diagrams takes up five pages alone. The index is an alphabetical array of the manufacturers' names, with model names and numbers stated.

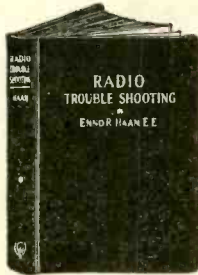

"Radio Trouble Shooting," by E. R. Haan, passes over theory, tells what to do to cure troubles. 300 illustrations, flexible binding 361 pages 6x9". Order Cat. HAAN... @ \$3.00

"Experimental Radio by E. R. Ramsey, Ph.D., Prof. Physics, Indiana University. 255 pages, 168 illustrations. Cloth cover. Order Cat. REX... @ \$2.75

"Fundamentals of Radio," by Ramsey. 374 pages, 402 illustrations. Order Cat. RFM @ \$3.50



The new edition of "The Radio Manual" answers questions about the principles, methods, or apparatus of radio transmitting and receiving. A complete course in radio operation in a single volume. 20 big chapters include: Elementary Electricity and Magnetism; Motors and Generators; Storage Batteries and Charging Circuits; The Vacuum Tube; Circuits Employed in Vacuum Tube Transmitters; Modulating Systems and 100% Modulation; Wave-meters; Piezo-Electric Oscillators; Wave Traps. Nearly 900 pages, 369 illustrations; flexible fabricoid cover. Order Cat. MAN @ \$6.00

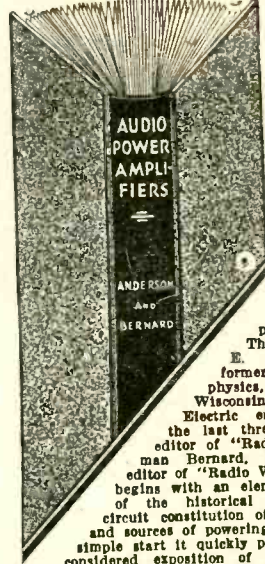

An understanding of audio amplifiers of all types, and of the use of tubes in audio channels, is a prerequisite today, when audio amplification is to the fore in radio, in public address systems and in the talkies.

"Audio Power Amplifiers" is the first and only book on the important subject. The authors are J. E. Anderson, M.A., former instructor in physics, University of Wisconsin, former Western Electric engineer, and for the last three years technical editor of "Radio World"; Herman Bernard, I.L.B., managing editor of "Radio World." The book begins with an elementary exposition of the historical development and circuit constitution of audio amplifiers and sources of powering them. From this simple start it quickly proceeds to a well-considered exposition of circuit laws, including Ohm's laws and Kirchhoff's laws. The determination of resistance values to produce required voltages is carefully expounded. All types of power amplifiers are used as examples: AC, DC, battery operated and composite. But the book treats of AC power amplifiers most generously, due to the superior importance of such power amplifiers commercially. Tube characteristic tables and curves profusely included. Cloth cover, 193 pages. Order Cat. APAM @ \$3.50

## BOOKS BY JOHN F. RIDER

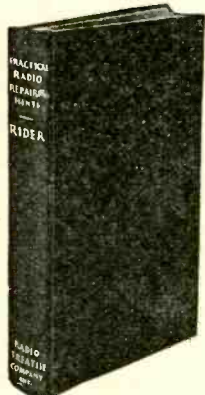

Two new books by Rider are: (1)—"Practical Radio Repairing Hints," a handbook for the radio worker. Replete with facts and figures, hints and tricks. No Theory. No Formulae. In it you will find explanations of the modern radio systems, automatic volume control circuits, new forms of voltage distribution in automobile radio sets, public address systems, etc. Order Cat. PRRH @ \$2.00

(2)—"Practical Testing Systems," the first complete collection of accurate and practical testing circuits of interest to the service man, professional builder and experimenter. Among the many testing systems described in this book are tube testers, capacity measuring systems, signal generators, radio frequency oscillators, audio oscillators, vacuum tube voltmeters, resistance testers, continuity testers, etc. Material for the man who wants a simple test unit or desires a laboratory arrangement. Order Cat. PTS @ \$1.00

Other books by Rider are: "Trouble Shooter's Manual," the first comprehensive volume devoted exclusively to the topic. It is not only a treatise for service men, telling them how to overcome their most serious problems, and diagramming the solutions, but it is a course in how to become a service man. It gives details of servicing and includes more than 100 actual factory-drawn diagrams of commercial receivers. 240 pages, 8 x 11", 200 illustrations. Order Cat. TSM @ \$3.50



"Supplement No. 1," containing 115 diagrams of commercial receivers, supplementing the diagrams in "Trouble Shooter's Manual," but not duplicating any. These 115 diagrams are supplied loose. They are a necessary adjunct to those in "Trouble Shooter's Manual." Order Cat. SUPP-1 @ \$1.20

"Mathematics of Radio," by Rider, 128 pages, 8 1/2 x 11", 119 illustrations, bridges the gap between the novice and the college professor. It gives a theoretical background so necessary for a proper understanding of radio and audio circuits and their servicing. Formulas for capacity, inductance, impedance, resistance, etc., are explained. Flexible cover. Order Cat. MOR @ \$2.00

## TWO MASTERPIECES BY PROF. MORECROFT

"Principles of Radio Communication," by Prof. John H. Morecroft, second edition. Prof. Morecroft, of the Electrical Engineering Department of Columbia University and past president of the Institute of Radio Engineers, is a noted authority. Prior electrical and mathematical knowledge required. 1,001 pages and 831 illustrations. Cloth-bound. Order Cat. M-PRIN @ \$7.50

"Elements of Radio Communication," written in plain language, requiring little foundation knowledge of radio, is another fine Morecroft book. The book is a complete course on the elements of radio, containing much material never before published. 226 pages, 170 illustrations and a complete index. Cloth bound. This is one book you must have in your library. Order Cat. M-ELEM @ \$3.00

## THREE BOOKS BY MOYER AND WOSTREL

The need for an up-to-date book on radio tubes that answers all the important questions has been filed by James A. Moyer, Director of University Extension, and John F. Wostrel, instructor in radio engineering, Division of University Extension, Massachusetts Department of Education. This book is a complete discussion of tube principles, functions and uses. The essential principles underlying the operation of vacuum tubes are explained in as simple, non-technical a manner as is consistent with accuracy. The book covers the construction, action, reactivation testing and use of vacuum tubes as well as specifications for vacuum tubes and applications for distant control of industrial processes and precision measurements. 297 pages, cloth bound. Order Cat. MWT @ \$2.50

"Practical Radio," including the testing of radio receiving sets. 378 pages, 223 illustrations. Cloth bound. Order Cat. MWP @ \$2.50

"Practical Radio Construction and Repairing," 319 pages, a companion volume to the above. New edition. Order Cat. MWC @ \$2.50

## FOOTHOLD ON RADIO

In simple English that any one can understand, the technical side of radio is presented by Anderson and Bernard in their book, "Foothold on Radio." Any one who can read English can understand this book. It is intended for the sheer novice. The treatment is non-mathematical. The origin of the broadcast wave, its radiation, reception, amplification are set forth in clear language. Side bands are explained simply. The types of receiving circuits are illustrated, described and contrasted. A chapter is devoted to loudspeakers, explaining the different kinds and the principles of their operation. Performance is compared. Audio coupling is fully explained, also the action of the vacuum tube, with a special analysis of plate current and its behavior. Those who have been thirsting for a book that readily reveals the marvels of the radio science will appreciate this little volume. Paper cover 80 pages, fully illustrated. Order Cat. For @ \$1.00

## "A B C OF TELEVISION"

"A B C of Television, or, Seeing by Radio," by Raymond Francis Yates, editor of "Television," formerly editor of "Popular Radio." 210 pages (5 1/2 x 8 1/2"). 100 illustrations. Cloth bound. This book is not a dull, technical treatise. Rather, it is a popular, easily understood and practical book containing descriptions of television systems, and also detailed information concerning many fascinating television experiments that may easily be conducted with modest equipment. It is not a book for engineering "high-brows" nor is it a superficial treatise written merely to entertain and amaze the novice. It is an intensely practical volume written for those who wish to do things. It stresses the "how" of the art as well as the "why." In its essence, it is an academic treatise brought down to the level of the lay mind. Engaging in its simplicity, penetrating and wide in its scope, it stands as the first popular American book devoted to television and telephotography. The book contains two hundred fifty pages profusely illustrated. The reading matter is arranged in simple stepping stones dealing with the problems of scanning, amplification of light modulated signals, photo-electric cells and neon lamps. The book has been written especially for those who wish to build and use television receivers and transmitters for entertainment and research purposes. It is written for amateurs and experimenters who crave action and results rather than high-sounding theory. Order Cat. TEL @ \$3.00

"Drake's Encyclopedia," new edition, 2 1/2" thick, weighs 3 1/2 lbs., 920 pages, 1,025 illustrations. Order Cat. DBA @ \$6.00

"Principles of Radio," by Keith Henny, M.A., former director, laboratory, Radio Broadcast. 477 pages, 305 illustrations. Order Cat. PRK @ \$3.50

"Radio Telegraphy and Telephony," by Rudolph L. Duncanson and Charles E. Drew, of Radio Institute of America. Order Cat. RTT @ \$7.50

Radio World, 145 West 45th Street, New York, N. Y.

Enclosed please find \$..... for which please send at once, postpaid, books indicated by my crosses

<input type="checkbox"/> Cat. ORSM @ 3.50	<input type="checkbox"/> Cat. PRRH @ 2.00
<input type="checkbox"/> Cat. HAAN @ 3.00	<input type="checkbox"/> Cat. PTS @ 1.0
<input type="checkbox"/> Cat. REX @ 2.75	<input type="checkbox"/> Cat. TSM @ 3.5
<input type="checkbox"/> Cat. RFM @ 3.50	<input type="checkbox"/> Cat. SUP-1 @ 1.20
<input type="checkbox"/> Cat. MAN @ 6.00	<input type="checkbox"/> Cat. MOR @ 2.00
<input type="checkbox"/> Cat. APAM @ 3.50	<input type="checkbox"/> Cat. M-PRIN @ 7.5
<input type="checkbox"/> Cat. FOR @ 1.00	<input type="checkbox"/> Cat. M-ELEM @ 3.0
<input type="checkbox"/> Cat. ABSS @ 1.50	<input type="checkbox"/> Cat. MWT @ 2.5
<input type="checkbox"/> Cat. TEL @ 3.00	<input type="checkbox"/> Cat. MWP @ 2.50
<input type="checkbox"/> Cat. DRB @ 6.00	<input type="checkbox"/> Cat. MWC @ 2.50
<input type="checkbox"/> Cat. PRK @ 3.50	<input type="checkbox"/> Cat. RTT @ 7.50

Name .....

Address .....

City ..... State .....

Check here if C. O. D. is desired.

### Remit with Order for Books and We Pay Postage

**Orders - Inquiries**

60 pages  
Send for FREE COPY  
Can be Secured by MAIL

**POLK'S REFERENCE BOOK and Mailing List Catalog**

Gives counts and prices on over 8,000 different lines of business. No matter what your business. In this book you will find the number of your prospective customers listed.  
Valuable information is also given as to how you can use the mails to secure orders and inquiries for your products or services.

Write for Your FREE Copy  
**R. L. POLK & CO., Detroit, Mich.**  
Largest City Directory Publishers in the World  
Mailing List Compilers—Business Statistics  
Producers of Direct Mail Advertising

# The New Jiffy Tester

## Chromium-Plated Case and Accurate Meters

A NEW and improved Jiffy Tester, improved in both performance and appearance, is Model JT-N. The meters are of the moving iron type. Tested on precise batteries, they show errors not exceeding 2%. As for appearance, the case is first copper plated, then nickel plated, then chromium plated, giving a lustrous, permanent, non-peeling non-rusting finish. It is the same finish found on hardware in fine automobiles. The handle and lock strap are genuine leather.

Jiffy Tester, Model JT-N, consists of three double-reading meters, with cable plug, 4-prong adapter, test cords and screen grid cable, enabling simultaneous reading of plate voltage, plate current and filament or heater voltage (DC or AC), when plugged into the socket of any set. The ranges are filament, heater or other AC or DC: 0-10 v., 0-140 v.; plate current: 0-20, 0-100 ma; plate voltage: 0-60, 0-300 v. It makes all tests former models made. Each meter is also independently accessible for each range. The entire device is built in a chromium-plated case with chromium-plated slip-cover. Instruction sheet will be found inside. Order Cat. JT-N.

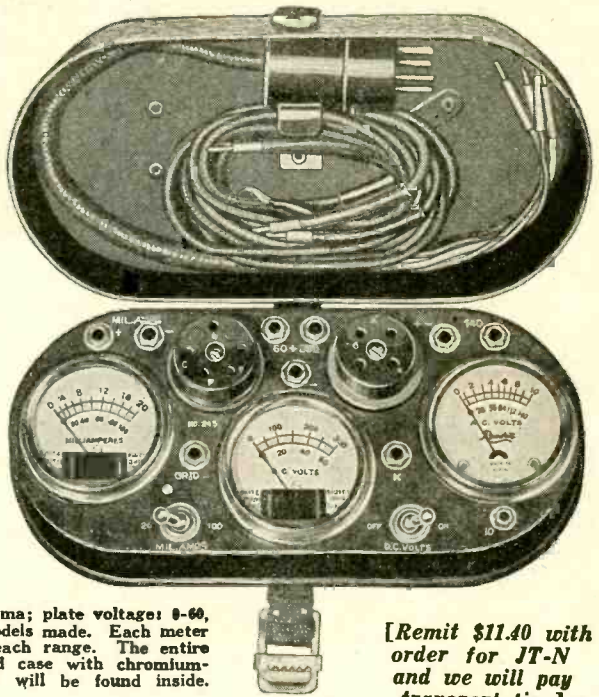

[Remit \$11.40 with order for JT-N and we will pay transportation]

## RADIO MAP OF NORTH AMERICA

22 x 22 inches, printed in two colors, bound in cover.

Shows every city from Balboa to Edmonton which has a broadcasting station.

Indexed by states, provinces and cities with key for instant location on map.

Call letters, power and frequency given for each station.

**Accurate; up-to-date**

Scale in miles gives distances between any two cities. Time zones correctly marked.

Just what you have been wanting.

**25 cents**

**THE RADEX PRESS**

1368 E. 6th St. Cleveland, Ohio

## GUARANTY RADIO GOODS CO.

143 WEST 45th STREET (Just East of Broadway) NEW YORK, N. Y.

### Horn Unit \$1.95



Fidelity Unit, Cat. FDU,

or otherwise. The casing is full nickel finish, highest Polish.

This unit can be used in a portable without any horn attached and will give loud reproduction.

Order Cat. FDU with 50-inch typed cord; weight, 2 1/2 lbs.; size, 2 1/4-inch diameter, 2 3/4-inch height. (This is the large size). Price..... \$1.95

**GUARANTY RADIO GOODS CO.**

143 West 45th Street, New York City

### BRACH RELAY

**ONLY 99c**

List price, \$4.50

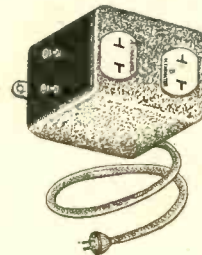

Connect relay's cable plug to 105-125 volt AC line. Connect B eliminator cable plug to relay socket so marked; connect trickle or other charger's plug to relay socket so marked; connect one side of A battery to binding post, other side to A set. Then turning on your set turns on B eliminator and set turns off charger, turning off set turns on charger and turns off B eliminator.

**GUARANTY RADIO GOODS CO.**

143 West 45th Street  
New York City—Just E. of B'way

# Quick Action Classified Ads

## Radio World's Speedy Medium for Enterprise and Sales

7 cents a word—\$1.00 minimum—Cash with Order

**FLORIDA FRUIT BOX** containing 45 oranges, 12 grapefruit, 20 tangerines, 100 kumquats, jar fruit preserves. Express prepaid anywhere, \$3.00, Florida Fruit Growers Packing Company, P. O. Box 282, Tampa, Fla.

**SMALL MOTOR GEN.** 3 phase, 220 to 7 1/2 volts D.C. Like new, \$75. R. Campbell, 365 Edgewood Ave., New Haven, Conn.

**CHOICE FLORIDA ORANGES, GRAPEFRUIT AND TANGERINES.** Full standard bushel, straight or assorted, \$1.75 with order, express charges collect. Medium grade oranges \$1.25. Mrs. Helen Thomas, Box 110, Thonotosassa, Florida.

"**MATHEMATICS OF RADIO.**"—A great help to everybody interested in radio. \$2 postpaid Radio World, 145 W. 45th St., N. Y. City.

**BARGAINS** in first-class, highest grade merchandise. B-B-L phonograph pick-up, theatre type, suitable for home with vol. control \$6.57; phono-link pick-up with vol. control and adapter, \$3.32; steel cabinet for HB Compact, \$3.00; four-gang .00035 mfd. with trimmers built in, \$1.95; .00025 mfd. Dubilier grid condenser with clips 18c. P. Cohen, Room 1214, at 143 West 45th Street, N. Y. City.

**EXPERT CONSTRUCTIONAL DATA** — Power transformers 245 and 250, .50 each. Cores supplied. Radio Power, 1028 Forest Road, Schenectady, N. Y.

**IMPORTED NOVELTY OF MYSTERY.** Fascinating and amusing, sample 15c, Ray-Hud Co. Box 471, West Tulsa, Okla., Dept. R.

"**A B C OF TELEVISION**" by Yates—A comprehensive book on the subject that is attracting attention of radioists and scientists all over the world. \$3.00, postpaid. Radio World, 145 West 45th St., N. Y. City.

**POWER UNIT CONSTRUCTION**—The book that enables you to wind your transformers, chokes, and figure correct size resistors for the voltage control, and other valuable information. Price .50. Shipped C. O. D. Ralph B. Davis & Co., Prestonsburg, Ky.

**SILVER MARSHALL 712 TUNER** with tubes \$25.00, complete. J. D. Avery, 245 Federal St., Greenfield, Mass.

**OUR CONVERTER** makes your radio public address system. Bay Laboratories, Box 1183, San Francisco, Calif.

**RADIO COURSES**, sets, books, bargains. Stephen Plavetich, 1597 East 47th St., Cleveland, Ohio.

**HORN UNIT, \$2.25**—This is the Fidelity Unit and has stood the test of time. Guaranty Radio Goods Co., 143 W. 45th St., New York.

**BUY NOW**  
While Prices Are Lowest!

Now all the fans who build their own sets or service men who are making replacements are using the dry electrolytic condenser. It affords high, lasting capacity in compact form. The lug at top represents the anode and goes to the positive side (B+ or C+), while the aluminum case is to go to the negative side, usually ground. The capacity of the condenser is 8 mfd. The condenser, a product of Aerovox, is admirably suited for use in filter circuits, for use on rectified AC or pulsating DC. The condenser must not be used on raw AC. Maximum peak voltage, 500 volts DC. Normal operating voltage, 400 volts DC. Dry, self-healing, high capacity, low leakage, unaffected by moisture. Size, 1-5/16" diam. x 4 1/2" overall. Mounts in any position. Brackets supplied. Order Cat. AV-8 @ \$1.42

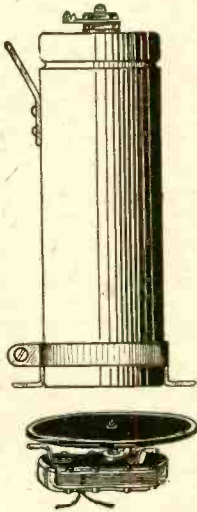

An outstanding example of the readily popular midget receiver, not very much larger than any good speaker, yet it contains a very sensitive, efficient and powerful AC radio set, AC power pack and a speaker that would do justice reproducing the output of the most elaborate AC receiver! Startling statements, yes, but they are undeniable facts! Imagine, not even as large as most battery operated portable sets, and lighter in weight! The set will duplicate in performance (considering selectivity, sensitivity and volume) that of its much larger and more costly brother! One dial tuning control, also switch and volume control knob (not illustrated.) Uses six tubes: three 224, one 227, one 245 and one 280. Perfect reproduction! Combined weight of entire set, speaker and tubes less than 20 lbs.! Entirely self-contained! 3 gang tuning condenser. Uses power tubes and push-pull electro-dynamic speaker! Durably built in handsome walnut case. For 110-120 volts, 50-60 cycle AC. Complete set, with the six tubes, cabinet, speaker—nothing else to buy! Order Cat. MDST @ .....\$39.95

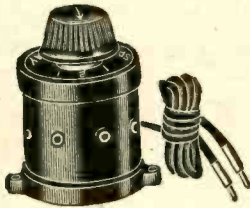
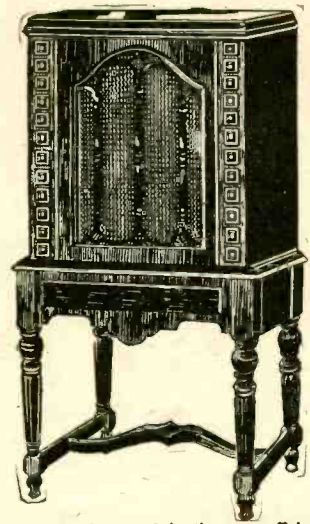

New Speakerelay for connecting two speakers to it and playing either one (position No. 1, left); or the other (position No. 1, right); or both at once (position No. 2); by turning the knob. Built into an attractive black moulded bakelite case, with 18-inch connecting cords to go to the output posts of the receiver or amplifier. The speakers' cords are connected to the relay by plugging into built-in jacks. This device can be used also for switching from "phonograph pickup" to "radio." Order Cat. 121 @ .....\$1.10

Synchronous motor for 60-cycle lines, 105 to 125 volts, with turntable, producing 80 turntable revolutions per minute. Takes up to 21-inch records. Sturdy and compact, this motor is only 1 1/4 inches thick. Not affected by line voltage fluctuations. The compactness permits installation in consoles or any other available space. Made by Allen-Hough, makers of the Phono-link pickup. Shipping weight, 7 lbs. Order Cat. SYN-M (with turntable) @ .....\$4.25

**PHONOGRAPH PICK-UP \$3.32**

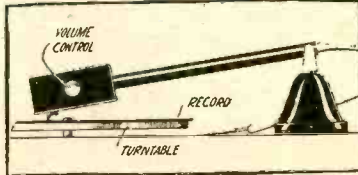

The famous Phono-link, made by Allen-Hough, enables playing phonograph records electrically, on your set. Volume control is built in. Adapter, free with each order, enables immediate connection to your set. Instruction sheet enclosed. Order Cat. PHL @ \$3.32.

Positively the last word in the most efficient and powerful reproducer made! As a fitting companion, it is housed in a truly exquisite deep two-tone walnut console, of rare beauty and craftsmanship! To properly baffle the ultra-powerful Peerless chassis, a chamber 15" deep, 17 1/2" wide and 18" high houses same. Front baffle of 3/4" thickness! Size of opening, 10 inches. Ideal for use with the most powerful public address amplifier. NO RATTLING, NO DISTORTION—JUST PERFECT REPRODUCTION! For that matter it is equally suited with ordinary sets, employing the average type of audio amplification systems. Order Cat. SSC @ .....\$24.88 [If cabinet only is desired (less speaker) order Cat. SCO @ .....\$13.44]



Bernard nippers. Drop-forged steel. Handiest tool for radio workers as wire-cutter, insulation stripper, and as screw-cutting. It will easily nip off protruding brass or iron screw ends up to 5/8" with easy hand pressure. A rugged, reliable and renowned instrument. Order Cat. BNP @ .....\$1.27



Here is the best buy of the year: A 15" diameter 110 volt D.C. dynamic chassis, with two field coil resistances, 800 ohms AND 4,000 ohms. Contains push-pull output transformer. Designed for use with any super-power amplifier—for auditorium reproduction. Shipping weight, 25 lbs. Order Cat. 1100 @ .....\$16.95

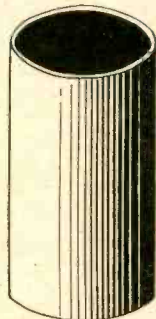

Natural bakelite tubing, made by Spaulding, in two diameters, 1 1/2 inches and 2 inches, outside diameters. One will fit inside the other even after wire is wound on the smaller diameter. Length Diam. Price 1 1/2" 1 1/2" \$0.08 2" 2" .12 36" 2" .40 The 1 1/2" length, 1 1/2" diameter, can be used for winding a primary, and be inserted.

**Temple Dynamic \$15.34**  
Beautiful Carved Wood Grille Front

This is one of the finest dynamic speakers ever made, and is highly recommended by us. AC switch is provided. A knob is built in for adjusting the speaker impedance to that of your set. An output transformer and dry rectifier are built in. Connect plugged AC cable to 110 volts AC, 50 to 60 cycles and connect tipped cords to speaker post of receiver. This remarkable speaker The Temple 10 chassis in the fascinatingly decorative walnut cabinet, with carved grille ornament, as illustrated; both front and back finished. (Cabinet not sold separately.) Order Cat. TEM @ .....\$15.34

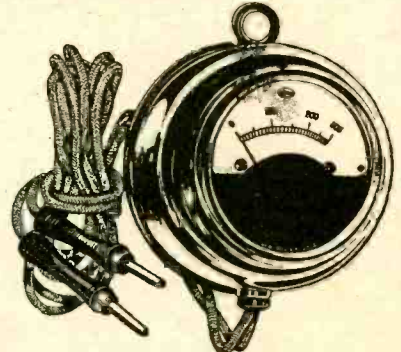

0-600 volts, high resistance; AC and DC (same meter reads both types). DC readings accurate to 2%, also AC readings 2% at 50-60 cycles, but accuracy is less on AC at substantially different frequencies. Order Cat. F-600 @ .....\$4.95 0-300 volts, high resistance. Accuracy, 2%. Case is full nickel finish. Long connecting cords have especially ornamental tip holders. Meter should be read in perpendicular position. Order Cat. F-308 @ .....\$2.59 0-500 volts, same as above in appearance, but the range is greater. Order Cat. F-500 @ .....\$3.75

**Special "Buy-Now" Bargain Coupon!**  
GUARANTY RADIO GOODS CO., 148 West 45th Street, New York, N. Y. (Just East of Broadway)

- Please ship at once the following:
- |   |   |   |
|---|---|---|
| <input type="checkbox"/> Cat. AV-8 @ ...\$1.42  | <input type="checkbox"/> Cat. SCO @ ...\$13.44  | <input type="checkbox"/> Cat. 1021 @ ...\$11.95 |
| <input type="checkbox"/> Cat. MDST @ ...\$39.95 | <input type="checkbox"/> Cat. 1100 @ ...\$16.95 | <input type="checkbox"/> Cat. 1022 @ ...\$9.95  |
| <input type="checkbox"/> Cat. 121 @ ...\$1.10   | <input type="checkbox"/> Cat. 719 @ ...\$14.95  | <input type="checkbox"/> Cat. 1023 @ ...\$7.95  |
| <input type="checkbox"/> Cat. SYN-M @ ...\$4.25 | <input type="checkbox"/> Cat. 720 @ ...\$15.95  | <input type="checkbox"/> Cat. 1024 @ ...\$7.95  |
| <input type="checkbox"/> Cat. PHL @ ...\$3.32   | <input type="checkbox"/> Cat. 721 @ ...\$9.95   | <input type="checkbox"/> Cat. BNP @ ...\$1.27   |
| <input type="checkbox"/> Cat. SSC @ ...\$24.88  | <input type="checkbox"/> Cat. 1020 @ ...\$9.95  | <input type="checkbox"/> Cat. TEM @ ...\$15.34  |
- METERS**
- |   |   |   |
|---|---|---|
| <input type="checkbox"/> Cat. F-600 @ ...\$4.95 | <input type="checkbox"/> Cat. F-300 @ ...\$2.95 | <input type="checkbox"/> Cat. F-500 @ ...\$3.75 |
|---|---|---|
- EXTRA-SPECIAL SPECIALS!**
- |   |   |   |
|---|---|---|
| <input type="checkbox"/> Cat. SPEC-1 @ \$9.90 | <input type="checkbox"/> Cat. SPEC-4 @ \$0.25 | <input type="checkbox"/> Cat. SPEC-7 @ \$0.11 |
| <input type="checkbox"/> Cat. SPEC-2 @ .87    | <input type="checkbox"/> Cat. SPEC-5 @ .18    | <input type="checkbox"/> Cat. SPEC-8 @ 7.50   |
| <input type="checkbox"/> Cat. SPEC-3 @ 1.22   | <input type="checkbox"/> Cat. SPEC-6 @ .11    |   |

Name .....  
Address .....  
City ..... State .....

(Above prices are on basis of remittance with order, but if C. O. D. is desired, if you enclose 1/4 of total amount, shipment will be made C.O.D. for balance.)

**EXTRA-SPECIAL SPECIALS!**

- (Cat. SPEC-1)—Erla DC dynamic chassis, 9-inch cone, for operation from 6-volt storage battery. Connect speaker-tipped cords to output of set, and connect twisted pair to 6-volt storage battery. Draws 1/2 amp. from battery. Price.....\$9.00
- (Cat. SPEC-2)—Wave trap, for cutting out interference. Connect aerial to one side of the trap, other side to antenna post of receiver from which aerial was removed, and tune out interfering stations. A great selectivity booster. Price......87
- (Cat. SPEC-3)—Rider's Supplement No. 1, containing diagrams supplemental to those in Rider's "Trouble Shooting Manual, and an invaluable addition, for completeness, to any who possess Rider's manual. Price..... 1.22
- (Cat. SPEC-4)—AC blueprint library, consisting of a book containing AC circuits for home construction, with actual blueprints therein. List of parts, coil-winding data, etc. Also encyclopedic information on radio. Price..... .25
- (Cat. SPEC-5)—Dubilier .01 mfd. fixed mica condenser..... .16
- (Cat. SPEC-6)—Dubilier .06025 mfd. mica fixed condenser, with clips for grid leak mounting..... .11
- (Cat. SPEC-7)—.0001 mfd. Dubilier fixed condenser, for connection in series with aerial to improve selectivity..... .11
- (Cat. SPEC-8)—Power transformer with two chokes built in for B filtration. Primary, 105-125 volts, 50-60 cycles; secondaries, all center-tapped with red leads, are for high voltage for 280 to work 245 tubes, single or push-pull, and rest of tubes in set up to 100 mba; 300 volts DC output; 2 1/2 volts 2 amps. for 245s, single or push-pull; 2 1/2 volts 14 amperes, for 227s and 224s, up to 8 of these; 5 volts for filament of 280. All, including chokes, in one cadmium plated steel case. Leads identified. Chokes are 30 henries each..... 7.50