

FEB. 28  
1931

15 Cents  
Per Copy

# RADIO

REG. U.S. PAT. OFF.

# WORLD

The First and Only National Radio Weekly  
466th Consecutive Issue—NINTH YEAR

**Tuned Output  
for Short-Wave  
Converters**

**How a Receiver  
Works, from  
Aerial to Speaker**

## Uses of New Variable Mu Tube

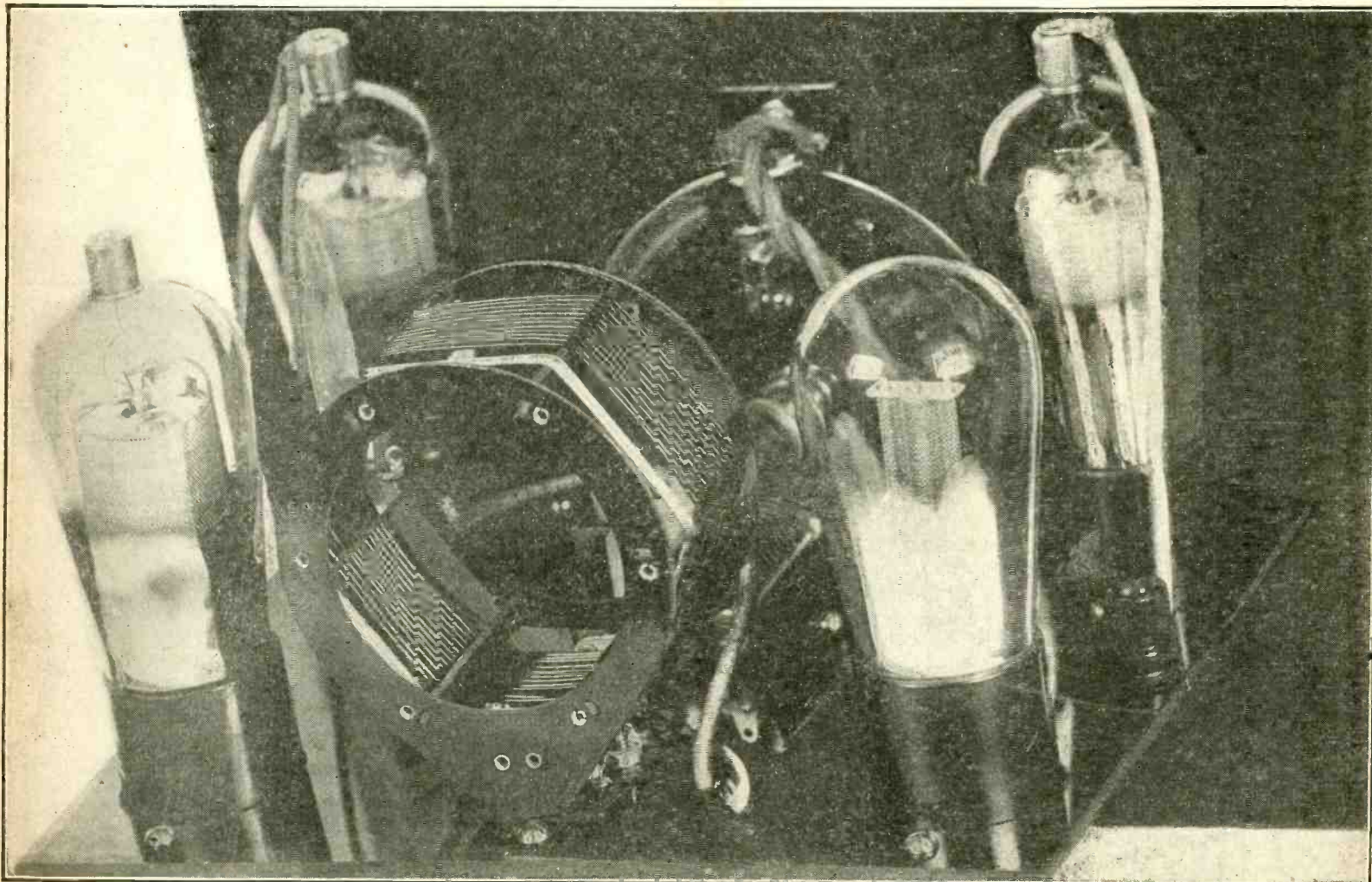

The Variable Mu Tube May Be Used in Converters. See Tube Data, Page 3

**Common  
Coupling in  
B Batteries**

**What You  
Should Expect  
from Tubes**

**Marconi's Data  
on Vatican's  
New Station**

**The 1-A Unit**

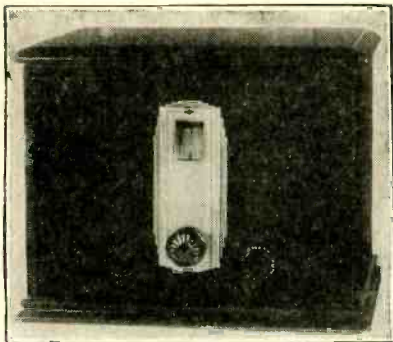

**T**HE de luxe model all-wave converter tunes from 15 to 600 meters, using two tuned circuits, with a Hammarlund condenser in each, and a total of five plug-in coils of the tube base type. This model, the 1-A Unit, consists of a beautifully finished bakelite front panel and sub-panel, with National modernistic dial.

Three screen grid tubes are used. Filament assembly is totally rigid and self-supporting, requiring no cabinet.

This model is of the very finest type, and gives you the advantage of triple screen grid in a de luxe assembly. Consistent direct reception of Europe is reported by users of the 1-A.

All parts, including filament transformer and five tube base coils, but not tubes, order Cat. 1-A, @.....\$19.87  
Wired model, Cat. 1-AW, @.....\$22.87

Precision 3" diameter plug-in coils can be supplied instead of the tube base type. These coils are wound on 97% air dielectric. Nine coils are supplied, to tune from 10 to 600 meters. These coils fit 5-prong tube sockets used as coil sockets. Order Cat. K-9 @ \$12.00

If precision coils are desired with kits or wired models of 1-A Unit, order Cat. 1-A-K or Cat. 1-A-WK @ .....\$8.25 extra

**RC-27 Converter**

**E**XTRÊMELY high sensitivity is achieved in the very latest short-wave converter, Cat. RC-27, using two 227 tubes and one tuned circuit, with the new Hammarlund Junior midline condenser, covering 30-135 meters without plug-in coils. A coil switch changes the wave band. Used with any fairly good receiver, this AC model converter penetrates uncanny distance, as users report direct reception of European transmitters.

All parts, exactly as specified by Herman Bernard (less tubes), order Cat. RC-27 @ .....\$10.00  
Wired model (less tubes), order Cat. RC-27-W @ .....\$12.00

**Polio Engineering Laboratories**

125 WEST 45TH STREET,  
NEW YORK, N. Y.

Telephone: BRyant 9-8093

Our Entire Line on Exhibition at Our Office

**Orders - Inquiries**

60 pages  
Send for FREE COPY  
Can be Secured by MAIL

**POLK'S REFERENCE BOOK and Mailing List Catalog**

Gives counts and prices on over 8,000 different lines of business. No matter what your business, in this book you will find the number of your prospective customers listed.  
Valuable information is also given as to how you can use the mails to secure orders and inquiries for your products or services.

Write for Your FREE Copy  
R. L. POLK & CO., Detroit, Mich.  
Largest City Directory Publishers in the World  
Mailing List Compilers—Business Statistics  
Producers of Direct Mail Advertising

**RADIO MAP OF NORTH AMERICA**

22 x 22 inches, printed in two colors, bound in cover.

Shows every city from Balboa to Edmonton which has a broadcasting station.

Indexed by states, provinces and cities with key for instant location on map.

Call letters, power and frequency given for each station.

**Accurate; up-to-date**

Scale in miles gives distances between any two cities. Time zones correctly marked.

Just what you have been wanting.

**25 cents**

**THE RADEX PRESS**

1368 E. 6th St. Cleveland, Ohio

**ERLA-DYNAMIC CHASSIS, WEST-INGHOUSE RECTIFIER.** Sensitive and efficient dynamic speaker chassis. List price, \$25; our net price, \$9.95. Guaranty Radio Goods Co., 143 W. 45th St., New York.

**CICO CELL**  
PRACTICAL PHOTO-SENSITIVE CELL OF MERT  
SMALL—UNBREAKABLE—POSITIVE  
A SWITCH THAT IS OPERATED  
BY A BEAM OF LIGHT.  
SUITABLE FOR COUNTING, SORTING,  
TRAFFIC CONTROL, ALARMS & ETC.  
PRICE \$5.50—POSTPAID  
**CLARK INSTRUMENT CO.**  
119 N. 4th ST., CAMDEN, N. J.

**DEALERS and SERVICE MEN!**  
STANDARDIZE ON  
**LYNCH METALLIZED RESISTORS**  
For Permanent Replacement—Accurate—Guaranteed  
Write for descriptive catalogue "W"  
**LYNCH MFG. CO., INC., 1775 Broadway, New York**

**"A" BATTERY SWITCH**  
A push-pull switch for battery-operated sets. Made by Benjamin Firm, sure contact, extremely long life. Special price, only .....13c  
**GUARANTY RADIO GOODS CO.**  
143 West 45th St., New York, N. Y.

**RADIO WORLD and "RADIO NEWS"**

**BOTH FOR ONE YEAR @ \$7.00**

You can obtain the two leading radio technical magazines that cater to experimenters, service men and students, the first and only national radio weekly and the leading monthly, for one year each, at a saving of \$1.50. The regular mail subscription rate for Radio World for one year, a new and fascinating copy each week for 52 weeks, is \$6.00. Send in \$1.00 extra, get "Radio News" also for a year—a new issue each month for twelve months. Total, 64 issues for \$7.00.  
**RADIO WORLD, 143 West 45th Street, New York, N. Y.**

**The New Jiffy Tester**  
Chromium-Plated Case and Accurate Meters

**A** NEW and improved Jiffy Tester, improved in both performance and appearance, is Model JT-N. The meters are of the moving iron type. Tested on precise batteries, they show errors not exceeding 2%. As for appearance, the case is first copper plated, then nickel plated, then chromium plated, giving a lustrous, permanent, non-peeling non-rusting finish. It is the same finish found on hardware in fine automobiles. The handle and lock strap are genuine leather.

Jiffy Tester, Model JT-N, consists of three double-reading meters, with cable plug, 4-prong adapter, test cords and screen grid cable, enabling simultaneous reading of plate voltage, plate current and filament or heater voltage (DC or AC), when plugged into the socket of any set. The ranges are filament, heater or other AC or DC: 0-10 v, 0-140 v; plate current: 0-25, 0-100 ma; plate voltage: 0-60, 0-300 v. It makes all tests former models made. Each meter is also independently accessible for each range. The entire device is built in a chromium-plated case with chromium-plated slip-cover. Instruction sheet will be found inside. Order Cat. JT-N.

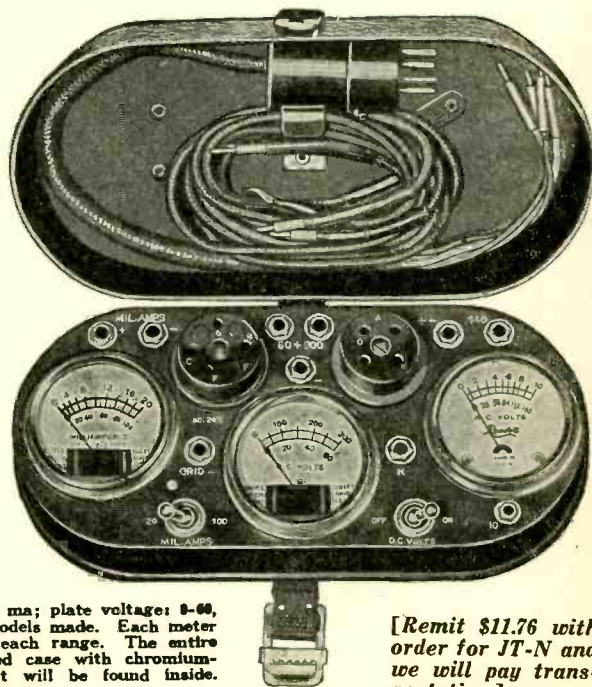

[Order \$11.76 with remit for JT-N and we will pay transportation.]

**GUARANTY RADIO GOODS CO.**

143 WEST 45th STREET (Just East of Broadway) NEW YORK, N. Y.

**FIDELITY HORN UNIT**—Stands up to 450 volts without filtering. Can be used in the portable without horn attached. Price, \$1.95. Guaranty Radio Goods Co., 143 W. 45th St., New York.

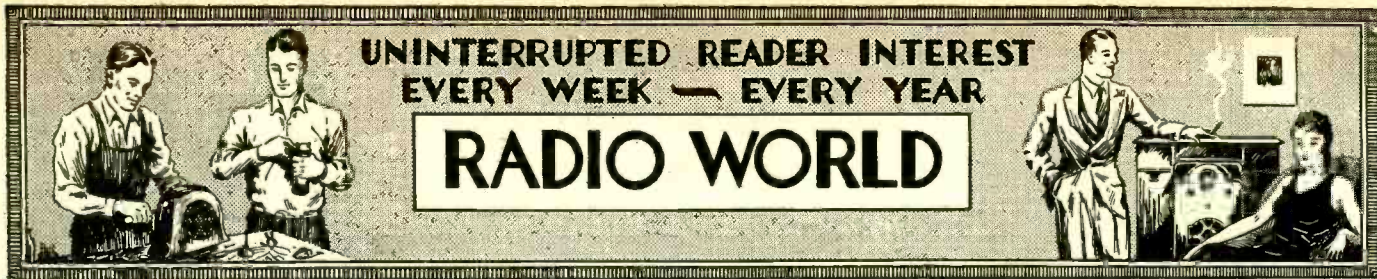

Vol. XVIII, No. 24 Whole No. 466  
 February 28th, 1931  
 [Entered as second-class matter, March  
 1922, at the Post Office at New York,  
 N. Y., under act of March, 1879]  
 15c per Copy, \$6.00 per Year

**NINTH YEAR**  
 Technical Accuracy Second to None  
 Latest Circuits and News

A Weekly Paper published by Hennessy  
 Radio Publications Corporation, from  
 Publication Office, 145 West 45th Street,  
 New York, N. Y.  
 (Just East of Broadway)  
 Telephone, BRyant 9-0558 and 9-0559

RADIO WORLD, owned and published by Hennessy Radio Publications Corporation, 145 West 45th Street, New York, N. Y. Roland Burke Hennessy, president and treasurer, 145 West 45th Street, New York, N. Y.; M. B. Hennessy, vice-president, 145 West 45th Street, New York, N. Y.; Herman Bernard, secretary, 145 West 45th Street, New York, N. Y.; Roland Burke Hennessy, editor; Herman Bernard, business manager and managing editor; J. E. Anderson, technical editor.

# The Variable Mu Tube

By J. E. Anderson

CROSS modulation in radio receivers has been recognized as a defect for many years. When it first came to be recognized it was referred to as "riding through" because of its peculiarity that the signals from one station rode through the tuner on the carrier wave of another station to which the receiver was tuned. It was not a case of lack of selectivity, because when the receiver was detuned just a little both signals disappeared.

The cause of the trouble was that the radio frequency amplifiers in the receiver acted as detectors, or modulators, instead of amplifiers only. The guilty tube in most instances was the first, although other tubes may have contributed to the trouble. The remedy for this condition was principally tuning the receiver very sharply before the first tube so that only one signal was impressed on the grid of that tube. However, when there is a strong local station and a weak station is desired, it is usually not possible to tune the receiver so sharply as to completely suppress the strong station and, therefore, cross modulation occurs.

## Too High Grid Bias

Since the detecting efficiency of a tube depends on the grid bias the degree of cross modulation depends on the grid bias also and in such a way that the higher the bias the greater the trouble up to the point where the plate current is cut off. That is, greatest cross modulation occurs where the tube detects most efficiently.

Cross modulation was not a serious trouble until screen grid tubes came to be used in receivers. These tubes are not only efficient amplifiers but also excellent grid bias detectors, and the grid bias difference between the two types of operation is very small, due to the high amplification factor of the tube. Hence a slight maladjustment of the grid bias will convert the tube from an amplifier to a detector, or to a cross modulator.

The degree of cross modulation also depends on the signal level in the radio frequency amplifiers. If the signal level is kept down to the lowest possible value in all the tubes, consistent with a given output, the cross modulation will also be kept down to the lowest possible level, other factors remaining constant. For this reason, the volume control should be put ahead of the first tube so that only enough signal voltage to produce the desired output will be impressed on the first tube. It is an error of design to put it after the first tube, or after any other tube, because then the damage will have occurred before the signal gets to the volume control.

## Volume Control in Screen Grid Circuit

When screen grid tubes are used in amplifiers it is customary to control the volume by either varying the screen voltage or the grid bias voltage. Sometimes it is also controlled by varying the plate voltage. Any one of these methods of controlling the volume is wrong from the point of view of cross modulation because all increase the detecting efficiency when the control is adjusted so as to decrease the amplification.

When an automatic volume control is incorporated in a receiver, and there is one in nearly every modern receiver, the amplification is decreased on strong signals by increasing the bias, and strong cross modulation should be expected whenever the signal is strong at the antenna because in order to cut down the amplification sufficiently it is necessary to increase the bias to the point where the tubes automatically controlled become detectors. It is for this reason that cross modulation is a serious defect in most up-to-date receivers. This, of course, is

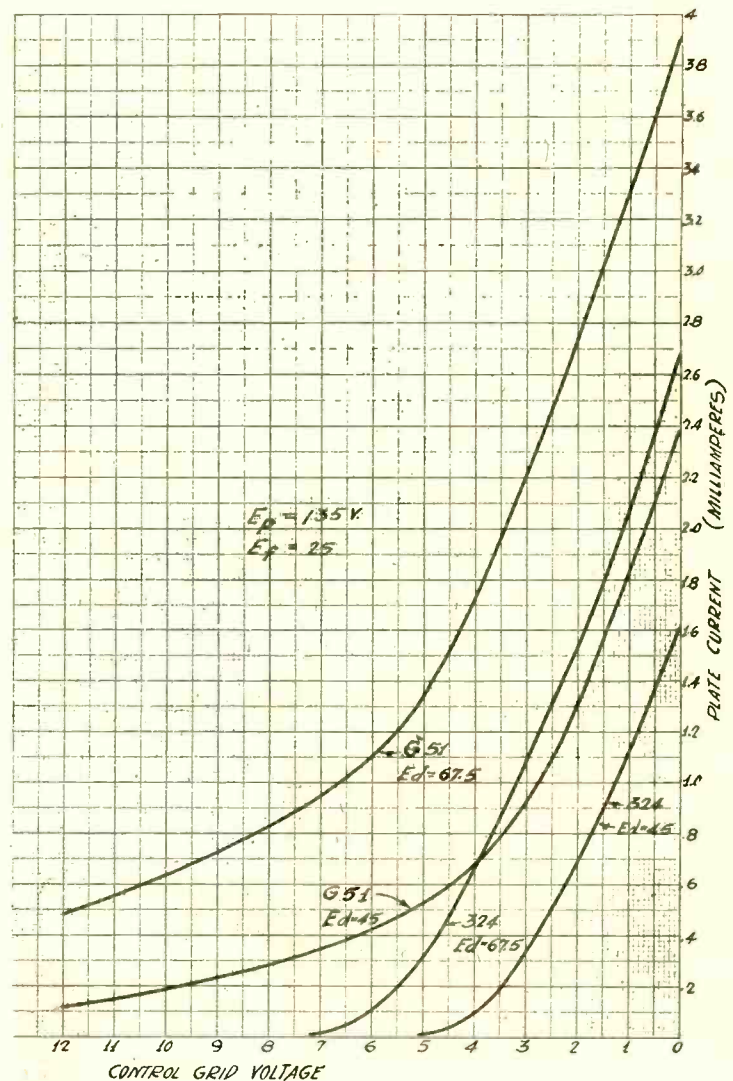

Keuffel & Esser  
 Fig. 1  
 Curves of a 324 screen grid tube and a variable mu screen grid tube for one plate voltage and two different screen voltages. The curves for the variable mu tube do not approach zero current as rapidly as those for the 324 tube.

not limited to screen grid tubes, but the trouble is more serious in them.

## Curves Illustrated

The production of cross modulation in screen grid tubes is well illustrated by grid voltage, plate current curves taken on such tubes. Two such curves taken on -24 type tubes are given  
 (Continued on next page)

# New Screen Grid Tube

Valve Developed By Ballantine Ampli

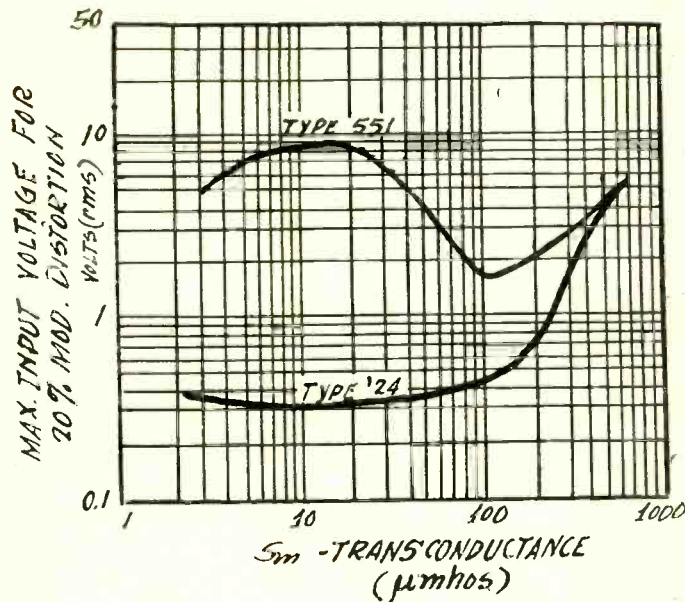

Fig. 2

Curves showing the comparative performances of the -24 and the G51 tubes.

(Continued from preceding page)

in Fig. 1. The screen and plate voltages at which these curves were taken are specified on the graphs. The proper operating point for amplification is when the bias is 1.5 volts negative. At this point the distortion for moderately strong signals is negligible.

In order to reduce the amplification by means of an increase of the grid bias it is necessary to make the bias 3 volts or more, depending on the value of the plate and screen voltages, and as soon as the bias is high enough to cut down the amplification the tube is operating in the detecting range and the distortion is great. Distortion is equivalent to cross modulation as soon as the tubes are exposed to more than one signal carrier. On the curve for  $E_d$  equals 45 volts the bias would have to be made about 4 volts before there would be a great decrease in the amplification, and this is the point where the detecting efficiency is greatest. On the curve for  $E_d$  equals 67.5 volts the bias would have to be made about 6 volts negative before there would be much decrease in the amplification, and this point, too, coincides with that of greatest detecting efficiency. Cross modulation is inevitable unless the interfering signal is kept away from the grid of the first tube, and the grids of the succeeding tubes. It is doubtful, even if a dual tuner is put ahead of the first tube, that cross modulation could be avoided in many instances.

## The Dilemma

If we are to have automatic volume controls, and they seem necessary in modern sets, we cannot put the control ahead of the first tube since it must operate on a tube. Hence we are faced with the cross modulation problem as soon as we decide on the use of an automatic volume control. This difficulty has long been recognized and it is one of the reasons why a local-distant switch has been put in most receivers. This switch is an attempt to relieve the automatic volume control of much of the work and so to decrease cross modulation. By means of it the great signal variations from station to station can be taken up by a manual control placed in the antenna circuit, the proper place. The automatic feature is then left to control the signal variations from any one station due to fading and similar phenomena which cannot be handled by a manual device. But when fading is severe, as it often is, the demands on the automatic volume control are enough to bring out cross modulation, so the local-distant switch is only a partial remedy.

When an automatic volume control is used it should be made to control those radio frequency amplifier tubes which follow as many tuners as possible so that the interfering signals are as completely suppressed as possible before the automatic control. It is seldom that the first tube is automatically controlled for this reason, and quite often it is only the tube ahead of the detector that is so controlled. That is as it should be. When there are three or four tuners ahead of the automatically con-

trolled tube, or tubes, and when there is a local-distant switch, the trouble from cross modulation is greatly diminished. Still it is not completely eliminated as is evidenced by the fact that there are many complaints from users of up-to-date sets.

## Variable Mu Tube

What is needed when automatic volume control is used is a tube with a variable amplification factor, variable with the grid bias. For example, if the tube is such that the amplification factor of the tube decreases as the grid bias increases, the curvature which causes cross modulation is reduced and so is the cross modulation itself. The tube, in effect, would then change its character from one of very high mu when the signal is weak to one of very low mu when the signal is strong. Such a tube would obviate the necessity of using a local-distant switch and to a large extent the necessity of insuring that a large number of sharp tuners precede the tubes automatically controlled.

But is such a tube possible? It is not only possible but it is an actuality. It is on the market.

The amplification factor of a tube depends on the geometrical structure of the tube, especially that of the grid in respect to the plate. It has been found possible to arrange the structure of the grid so that the effective portion of it varies with the operating bias. Stuart Ballantine, of the Radio Frequency Laboratories, Boonton, N. J., has developed the theory and the structure of such a tube and it has been manufactured by the makers of Majestic receivers and tubes. The code name for the tube is G51. It looks like an AC screen grid tube and it acts like one as long as the grid bias is low but when the bias is high it acts like a different tube.

## Curves for G51 Tube

In Fig. 1 are two curves taken on the G51 tube under the same screen and plate voltage conditions as the two curves for the 324 tube reproduced in that figure. It will be noticed that for grid bias voltages less than about 3.5 volts the G51 and the 324 are practically alike as far as the amplification constants are concerned, for the corresponding curves are parallel and the slopes are the same. For higher grid bias voltages the characteristics of the two tubes diverge greatly. The curves for the 324 drop to zero quickly whereas those for the G51 flatten out and approach zero much more slowly, indicating that the amplification factor has changed to a lower value. The

# Right or

## Questions

- (1)—Power detection by the grid leak and condenser method is not possible because the detector tube chokes up so that on strong signals no output is obtained.
- (2)—By using a tube as a diode it is possible to employ the same tube for both automatic volume control tube and detector.
- (3)—If the automatic volume control tube and its associated circuit are such as to follow the carrier frequency accurately the feedback is not DC but AC and results in reducing the sensitivity of the receiver.
- (4)—The higher the plate current that is drawn by a receiver the poorer is the filtration of the current from the B supply.
- (5)—An electro-static shield is one that prevents transfer of energy from one circuit to another by capacity coupling.
- (6)—A higher selectivity can be obtained with variable condensers than with fixed condensers.
- (7)—If the audio frequency amplifier is designed so that there is no frequency distortion between the detector and the output of the last tube, high class quality is assured.
- (8)—If the output of a receiver as delivered into a pure resistance equal to twice the internal resistance of the power tube is measured and it is found that the amplification is practically uniform over the entire audible scale, the quality of the music heard will be truly represented by the data.

## Answers

- (1)—Wrong. To obtain power detection, that is, high signal detection, it is only necessary to reduce the grid leak resistance. It is true, however, that as much output voltage cannot be obtained with grid leak detection as with grid bias detection. This is offset by the fact that grid leak detection is more sensitive.
- (2)—Right. When the tube is used as a diode the cathode may be grounded and then the plate, or grid, is negative with respect to the cathode by an amount depending on the carrier

# Reduces Cross Modulation

## fies Even at Very High Negative Bias

change, of course, is gradual.

It is clear that if the tubes in the radio frequency amplifier are like the G51 there will not be nearly as much cross modulation as the grid bias increases as if the tubes are of the -24 type. Consider the two curves for Ed equals 45 volts, for example. Suppose the signal is such that the automatic volume control forces the grid bias on the controlled tubes to 4.5 volts. The ordinary screen grid tube then operates as a detector while the variable mu tube still operates as an amplifier, although not as effectively as if the bias were lower.

If the signal forces the bias still more negative, say to five volts, the distortion in the -24 type tube is great, due to detection, but the other tube still remains an amplifier of somewhat less efficiency.

The G51 tube will continue to operate as an amplifier without much distortion long after the -24 type tube has ceased to function either as an amplifier or as a detector.

### Decrease of Mutual Conductance

From the data contained in Fig. 1 we cannot determine the amplification of either tube but we can determine the mutual conductance, since this is the slope of a curve at any selected place. At zero bias the upper curve for the G51 tube the plate current is 3.91 milliamperes and at 1 volt it is 3.3 milliamperes. Thus a change of one volt in the bias changes the plate current by .61 milliamperes, and therefore the mutual conductance at 0.5 volt bias is 610 micromhos. At 4.5 volts we get a slope of 380 micromhos, and at 9 volts a slope of 100 micromhos.

The corresponding slopes of the lower G51 curve are 550, 160, and 50 micromhos. The mutual conductance at 0.5 for the -24 tube, taken on the upper curve, is 620 micromhos and at 4.5 volts 360 micromhos. For 9 volts the mutual conductance is zero since there is no change in the plate current with changes in the grid bias, for the current is zero in this region. On the lower curve for the -24 tube the slope is 480 micromhos at 0.5 volt and at 4.5 volts it is about 90 micromhos. Beyond this value the current is zero. For the variable mu tube the mutual conductance does not drop to zero as rapidly as it does for the regular screen grid tube and this is largely due to the fact that the amplification factor for the G51 decreases as the bias increases.

The curves for the G51 tube are higher than the curves for the -24 tube. This indicates that the internal plate resistance for the G51 tube is lower than that for the -24. At zero bias

the ratio of the applied plate voltage to the plate current is 34,500 for the G51 and 50,400 ohms for the -24, in each case taking the curve for the higher screen voltage. At the same bias for the 45 volt screen voltage the two ratios are 56,750 ohms and 83,800 ohms.

### Suggested Use of New Tubes

Receivers have already been designed for the new tubes and in these receivers they are used in all the radio frequency stages. They are employed in superheterodynes as well as in radio frequency amplifier sets.

Just because these tubes will amplify without much cross modulation, there is no reason why other precautions against this nuisance should be abandoned. For example, if one of these tubes is put in the first stage of a radio frequency amplifier, and that is the proper place for it if only one of the type is to be used in a receiver, this tube should be operated as an amplifier with a fixed bias, say in the neighborhood of 1.5 volts. The modulation will be small there and the amplification will be high. Preceding this tube there should be one or more sharp tuners, and shielding should be employed to prevent signal pickup by the coils after the first tube.

The automatic volume control might operate on the grids of the two tubes immediately preceding the detector, and these tubes should be of the G51 type in order to put a check on the amplification without undue distortion of the waveform on high signal voltages.

### Number of Controlled Tubes

In many receivers incorporating an automatic volume control this is made to operate on only one tube, which is usually sufficient because the change is so rapid near the cut-off of the -24 type tube characteristic. When the new tubes are used, the automatic control feature should operate on two or more tubes to produce the same quantitative effect, since the change in each tube is not so rapid. If the automatic control operates on two or more tubes, the change per tube need not be so great and therefore the distortion will be considerably less, since the amount of distortion depends on the swing.

As seen from the curves, the amplification obtainable with the G51 is about the same as that with -24, provided that the grid bias is in the neighborhood of 1.5 volts. Thus, if a G51 is substituted for a -24 in an amplifier circuit there should be practically no change in volume, and if there should be a change it indicates that the bias is greater than it should be. If the same grid bias resistor is used for both tubes, the bias on the G51 will be greater than that for the -24, due to the difference in the plate current.

The curve shows a plate current of 1.8 milliamperes at 1.5 volts for the -24, Ed equals 67.5 volts, and if a grid bias resistor is to be used to establish this voltage it will have to be 833 ohms. For the G51 tube the corresponding current is 3.02 milliamperes, so that if the same bias resistor is used the bias will be less than  $3.02 \times 833$  volts. It is less than this because as the grid voltage increases the plate current decreases. Equilibrium will be established at about 2.2 volts. At this point the amplification is somewhat less than at 1.5 volts.

### Requires No Circuit Changes

No circuit changes are necessary when changing over from -24 type screen grid tubes to G51 tubes for both have the same base, the same arrangement of the terminals, the same heater voltage and current, and the same plate, screen and plate voltages. While the curves in Fig. 1 are for a plate voltage of 135 volts, the normal rated plate voltage is 180 volts and the corresponding screen voltage is 75 volts, just as for the -24 type tube. Curves for the higher voltages are of the same relative shape as those given except that the current for a given grid bias is higher.

It is claimed that cross talk due to modulation is reduced in the ratio of 500 to one by the new tube. If this be true in practice there should be no more trouble from cross modulation no matter how severe are the conditions. Even if the reduction were only in the ratio of 25 to one there would be a great improvement well worth the installation of a new set of tubes in the receiver subject to annoying cross talk.

Those who are interested in a complete discussion of the variable mu tube and the theoretical benefits derived from its use, will find a paper by the inventor of the tube, Stuart Ballantine, in the December, 1930, issue of the Proceedings of the Institute of Radio Engineers. Many comparative curves between the new tube and the -24 type tube are given in this paper. There are also illustrations of various geometric structures which will yield the variable mu type of tube.

## Wrong?

voltage that is impressed. The rectified voltage drop across a resistance can be used as input voltage to the audio amplifier and at the same time it can be used as bias on the radio frequency tubes. Indeed, it is possible to do away with the grid bias resistor on the first audio amplifier, for the bias for this tube may be taken from the detector also.

(3)—Right. The automatic volume control circuit is such as to feed back a voltage which is directly proportional to the signal and reverse in phase. If the carrier is not removed from this feedback the effect is the same as if a tickler were reversed.

(4)—Right. There are two reasons for this. In the first place the heavier the current the lower the inductance of the choke and hence the poorer the filtration. In the second place, a condenser of given capacity discharges more rapidly when the plate current is heavy, for during part of the cycle the current for the plates comes from the condensers rather than from the rectifier tube.

(5)—Wrong. There is no electro-static shield and none is ever needed. Static electricity cannot induce any troublesome voltage in another circuit. The term electro-static shield is nothing but a misnomer for an electric shield.

(6)—Wrong. The fixity or variability of a condenser has nothing to do with the selectivity of the circuit of which it forms a part. This does not mean that a fixed condenser with poor dielectric makes as selective circuit as a variable air condenser connected in the same position. When there are many tuned circuits in tandem the combined selectivity may be less with fixed condensers than with variable but this would be due to lack of tuning the circuits to the same frequency.

(7)—Wrong. The quality may be spoiled before the signal gets to the detector, for example, when it passes through an excessively selective tuner. It may also be spoiled after it passes the power tube, and even after it has left the loudspeaker.

(8)—Wrong. The loudspeaker will change the quality so that the characteristic of the receiver as a whole will not be the same as when the load is a pure resistance.

# What Happens in a

By Henry

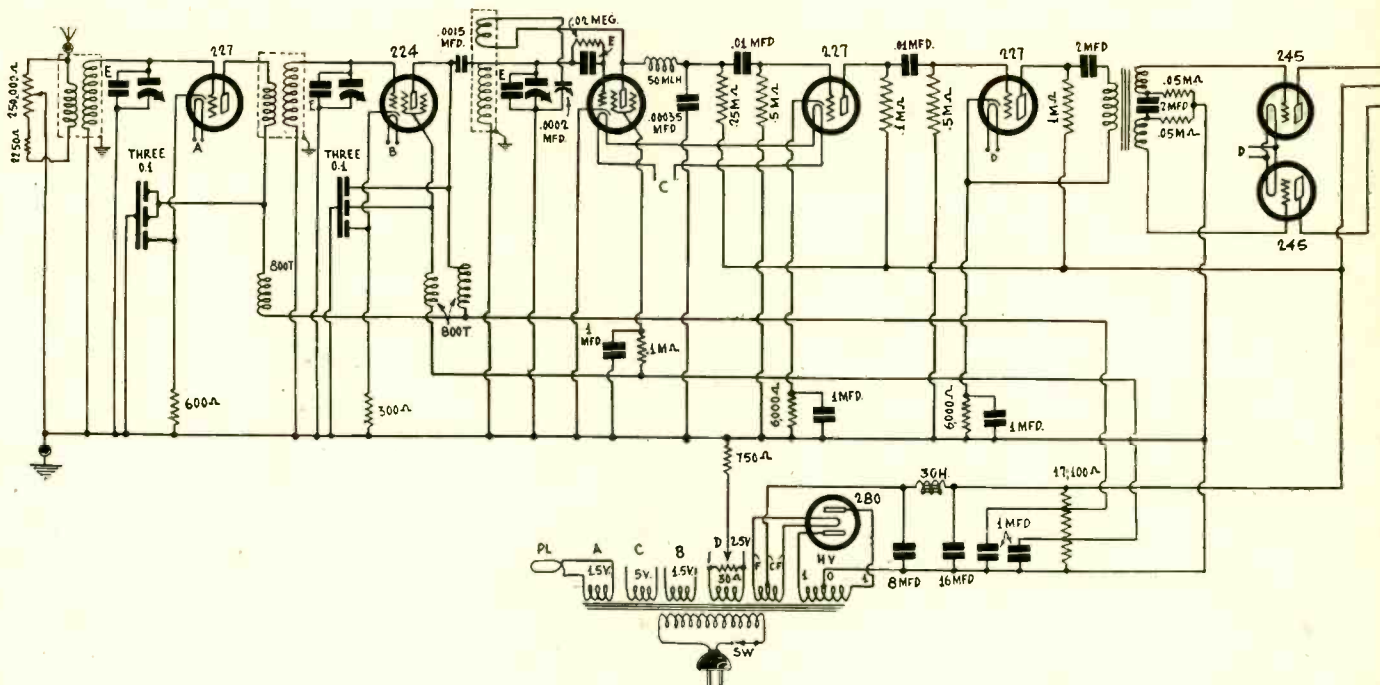

An excellent receiver, one that brings in far-distant stations with plenty of volume, is diagrammed herewith. This circuit is used as the basis of explaining the functioning of a receiver.

**L**ET us examine what happens in a receiver. Antenna, ground and speaker are connected, tubes inserted in sockets, and the set turned "on."

A voltage develops across the antenna-ground coil. This is due to the fact that the aerial-ground system is like a condenser, where the aerial is one plate, the ground the other. But besides being a condenser, or a discharging-storage tank for handling radio waves, it is also an instrumentality for picking them up. Indeed, the pickup qualities are those most persons have in mind first. As the wave alternates between antenna and ground, at the frequency determined by the carrier, the aerial is enabled to impart that frequency to whatever load is placed between it and ground. It imparts all radio frequencies, some more pronouncedly than others, nevertheless with fair uniformity.

## Tuning the Input

The load on the antenna-ground circuit is a coil across which are two resistors which for the discussion may be considered as one. So it is easy to comprehend that all radio frequencies that are in the ether at this point with any magnitude to deserve consideration are present in the antenna winding, which is the smaller of two closely coupled windings of a coil system. The small winding is called the primary, the large winding the secondary.

We see that a tuning condenser is across the secondary, so the input to the first tube is tuned. Moreover, the adjustable feature of the resistor across the antenna winding permits the utilization of various degrees of the voltage drop in the resistor, for transfer on to the rest of the chain, so volume is controlled or selected, as well as radio frequency, prior to any amplification.

A volume control in this position, where gradations start from zero resistance and increase to a specified maximum, which maximum may be anything from 10,000 ohms up, makes the signal disappear, on average volume stations, at about the midway setting of the volume control. The purpose of inserting a series resistor is to establish a substantial minimum volume setting and increase the useful range of the volume control.

## How Bias Results

The condenser with the arrow at bottom, used for tuning the secondary, is a variable condenser, and the arrow designates the movable or rotor plates. The stator plates, that do not move, go to grid. E represents a small adjustable condenser, set once and left at a certain capacity. When the receiver is built, these small condensers E are adjusted. Their function is to compensate for capacity inequalities, and make the capacity in each circuit equal for any given setting. They are called compensators or trimmers, and their presence is due to the use of several capacities on one shaft, in gang formation, or other

mechanical method of making one motion adjust the frequency or response of several circuits.

By mutual induction the energy is imparted by primary to secondary through the air between the windings, so that input is made to the grid circuit of the first tube. This input circuit is from grid to cathode, really, but the tuning condenser is returned to ground because in that way body capacity is avoided in tuning, while the secondary coil is returned to ground to afford a negative bias on the first tube equal to the voltage drop in the biasing resistor.

The first tube is a 227, and has three essential elements. One is the grid, made of mesh wire, and interposed between the solid metal plate and the small metal internal cap called the cathode. The plate receives a positive potential in respect to the cathode, which should be regarded as zero potential, the so-called datum or starting point, while the grid in virtually all circuits nowadays is maintained negative.

In Fig. 1 the application of a positive potential to the plate causes plate current to flow when the heater has sufficiently heated the cathode to make the cathode emit electrons, small particles of electricity. The direction of plate current flow is from plate to B minus, in this instance also ground. Therefore, as the grid is between the plate and the cathode, the plate current in general flows through the grid. How much plate current shall flow may be determined by the negative bias voltage applied to the grid, since the more negative this bias voltage, assuming a constant and steady plate voltage, the less plate current will flow.

## Voltage Measured or Computed

It will be realized, therefore, that as the plate voltage is constant, indeed, as the voltage from B plus to ground is a constant total, but is simply differently apportioned, that the vacuum tube has the characteristic of a variable resistance, the variation depending on the voltages applied. Since less current will flow when the grid is more negative, there has been an increase in resistance somewhere. The plate resistance has gone up.

The plate current, whatever its value, flowing through the tube to cathode, then goes through the biasing resistor to grounded B minus. Since ground is the extreme negative point, and there is a voltage difference between cathode and ground, due to the voltage drop in the biasing resistor, the cathode must be positive, and the grid, due to return to ground, negative. This negative bias may be measured in volts with a precision voltmeter, or may be computed in volts by Ohm's law, if one knows the resistance and the current. The voltage is current in amperes multiplied by the resistance. If the current is 10 milliamperes (.01 ampere), since the resistor is 600 ohms, the voltage drop across the resistor, or bias voltage, is  $.01 \times 600$  or 6 volts.

So far we have completed the circuit "looking into" the first

# Functioning Receiver

B. Herman

tube, except for some bypass capacities. The only capacity that need be considered right now is the one from cathode to ground, or across the biasing resistor. Since the plate current flows through this resistor, and this current is changing at a frequency equal to the frequency of the carrier, it is of the same effect as a radio frequency current for all the practical purposes of passing it through a resistor. It is known as pulsating direct current. The opposition offered by 600 ohms to radio frequency is high, and the biasing resistor alone would constitute a serious damper on the intensity of the signal, were not the radio frequency, in which we are not interested for biasing purposes, bypassed around the resistor, or, substantially, removed from the bias circuit. The bypass condenser does that, detouring the radio frequency by the condenser path, while the direct current must flow through the resistor, because a condenser does not pass direct current.

The condenser used happened to be a capacity of 0.1 mfd., one section of a block of three condensers of equal capacity, two of which are joined together for another purpose. When such a three-in-one block is used, there will be four leads: one, usually black, which represents the common side of the three capacities; then the three others, usually red, representing the individual other sides of these capacities. To constitute 0.2 mfd., for instance, two reds would be connected together, for this is a parallel connection, and parallel capacities add up. It makes no difference whatever which two reds are selected. The remaining capacity would be a single 0.1 mfd. condenser, and that is what is used across the 600 ohm biasing resistor.

## Distributed Capacity

The output of the first radio frequency tube is taken from the plate circuit. Here again a radio frequency transformer is used, as in the antenna circuit, but the primary is in the plate circuit, and it has about the same number of turns than the antenna winding. If a screen grid tube were used the number of primary turns in the plate circuit would be about doubled, because the plate of a screen grid tube is better served by a high impedance load.

The coil marked 800-T interrupts the primary on its way to B plus. This represents an 800-turn duolateral-wound radio frequency choke coil (honeycomb coil). The placing of turns of wire next to each other on the winding form causes the capacity existing between turns to add, the result being this total distributed capacity between the two extreme terminals of the coils is rather large, but if the duolateral method of winding is used, where the coil is built "outward" instead of "upward," these capacities between respective turns are in series, and the greater the number of turns, the less the distributed capacity. As 800 turns constitute a considerable number, and as needed high inductance is obtained, the result is achieved without developing more than a trivial distributed capacity.

In some positions the total capacity should be very small, in others it is not nearly large enough, so a condenser is used for providing such added large capacity. However, the same coil is suitable in any instance, as the condenser would be used anyway, if needed. The point here is that low distributed capacity is present, but high capacity is needed, and the coil is chosen for its high inductance and compactness, and the extra capacity supplied.

## Use of Choke Coil

The purpose of the coil in this position is to choke the radio frequency currents, that is, prevent them from straying to the B supply and to other courses where there would result undesirable coupling between tubes and wires. The bypass capacity from the choke coil to ground directs the radio frequency currents to ground that might even escape through the choke coil, as the choking effect is not complete without the condenser. The choking is called filtering, and the object of filtration, in the final sense, is to establish stability, so the set will not squeal at radio frequencies, even though the amplification is built up to large proportions. The squealing tendency of a set is proportional to the amplification.

On the point of stray coupling and squealing it is well to mention that shields are put over the radio frequency transformers or tuning coils, so that these vices will not be present. Tin should not be used for shielding radio frequency circuits, as the loss introduced is tremendous. Aluminum is the most popular metal for such shielding, although copper is superior. However, copper costs more, due principally to extra labor and machinery charges involved, otherwise copper would be used. Moreover, the shield should not hug the coil closely, but there should be some distance between the coil and the shield wall, and preferably the tuned winding should be centered in the available space. A shield is not truly a shield unless and until

it is grounded, so the ground symbols on the shields remind you to attend to this necessity.

## Prevents Cross-Modulation

The biasing of the second radio frequency stage is along the same lines as that of the first. The biasing resistor is only 300 ohms, as about 5 milliamperes of plate-screen current will flow, so the bias will be 1.5 volts, which is the recommended value for the screen grid tube when the plate voltage is 180 volts and the screen voltage is 75 volts.

The first radio frequency amplifier was a 227 tube, so only the plate current had to be considered. However, the plate current of the 227 tube is about twice as great as the plate-screen current of the 224. The reason for using a 227 in the first stage, rather than a screen grid tube, was to prevent cross-modulation, that is, the signals of a strong local being heard when some other station, local or distant, is tuned in, though the frequency separating them may be considerable.

The filtration of the screen lead of the second radio frequency tube is along the same lines as that for the plate circuit of that tube, with the extra advantage that the condenser tends to maintain the screen at a steady (ground) potential. This refers to the radio frequency voltage.

The next tube is the detector. A radio frequency choke coil is the plate load of the preceding tube. A condenser is used for isolating the divergent voltages on preceding plate and succeeding grid. The tuned winding in the detector grid circuit is substantially in parallel with the plate load of the preceding tube.

## Detection Takes Place

The .0015 mfd. condenser may be considered in series with the tuned circuit, so the plate load would be in parallel with that series circuit. To view it somewhat differently, but to the same ultimate effect, the condenser may be considered in series with the plate load coil, and the tuned winding in parallel with that series circuit.

The radio frequency voltage developed across the plate load is therefore the input to the detector tube, since the tuned circuit, by its parallel connection to the other, receives this voltage.

Up to the grid leak only radio frequencies are involved, but thereafter there is what is variously termed rectification, detection and demodulation, which consists simply of removing the carrier and leaving only the audio frequencies. This the detector tube does by suppression, but the radio frequencies are not fully filtered out, even up to the plate of the detector tube, therefore radio frequency may be fed back from plate to the grid of that tube by some intentional method, such as the one shown, called capacity feedback. The .0002 mfd. variable condenser controls this feedback, and you have regeneration, which improves sensitivity and selectivity.

## Detector Filtration

It will be noted that the plate is connected to the feedback coil which is in inductive relationship to the grid winding, but that from the plate, in the direction of the audio channel, a 50 millihenry radio frequency choke coil is connected, with a .00035 mfd. condenser from its "far" end to ground. This condenser completes the filtration of radio frequencies, leaving only audio frequencies for the audio channel. Were this filtration other than good, radio frequencies would be amplified as well as audio frequencies, in the intended audio channel, at least up to and including the second audio tube, because resistance coupling is effective on radio frequency amplification, too.

The detector tube is a screen grid tube, with a plate load of 250,000 ohms (0.25 meg.), a grid leak of 500,000 ohms (0.5 meg.) being used in the next circuit. The screen of the detector may be returned through a high resistance to the 180-volt line, because 300 volts are applied to the plate, or may be returned through a lower value resistance, e.g., 0.1 meg., to a lower voltage, in this instance the screen voltage for the radio frequency tubes.

## Leak-Condenser Power Detection

The detector is of the power type, even though grid leak and condenser are used, with return to grounded cathode. The small values of grid leak and grid condenser account for the high input voltage which this type of detector will stand without overload, so that greater sensitivity may be enjoyed and yet quality reception be present. The condenser used as grid condenser is a 100 mmfd. equalizer, E, set at maximum capacity.

In the audio channel the plate and grid loads for the first and second tubes are resistors, with isolating condensers of

(Continued on next page)

# Coil Winding Data

## For Sensitive TRF Set—Audio and B Supply Analyzed

(Continued from preceding page)

.01 mfd. capacity. These condensers sometimes are called coupling condensers, although, as explained, their true purpose is not to couple but rather to isolate, that is, keep the diverse direct current voltages apart, the highly positive plate and the negative grid.

Coming to the last audio stage, this is arranged in push-pull. The output of the second audio tube is through a capacity-inductance series circuit in parallel with a resistor. The inductance, here the primary of a push-pull input transformer, may be placed directly in the plate circuit of the tube, omitting the 0.1 meg. resistor and 2 mfd. condenser, but under such circumstances about 10 milliamperes would flow in the primary, and immediately the primary inductance would be very low, while with little direct current flowing through it, say, 1 milliampere, the inductance is high. In the diagrammed circuit no direct current flows through the primary.

It has been explained that this use of a condenser is for isolating direct current voltages. The condenser offers no obstruction to the signal voltage, which is audio frequency, that is, actually alternating.

### Amertran Connections

The secondary of the push-pull transformer consists of two separate windings, if an Amertran 151 is used. The two 50,000-ohm resistors and 2 mfd. condensers serve stability purposes. If the push-pull transformer has no such provision for connecting in these three parts, then the center tap would be connected simply to ground.

The output is not defined. There are two leads going from the respective plates, while the high voltage from the B supply is between them. Here one may connect a center-tapped choke coil, of the audio frequency type, that is, with silicon steel, alloy or similar core, in which case any speaker may be connected to the plates alone, and no direct current will flow in the speaker windings. Or, an output transformer with center-tapped primary, such as is present in some special dynamic speakers, may be used. Another option is to select the Farrand 10-G speaker, an inductor dynamic, which has a center-tapped magnet coil, so that no output device is needed, the center tap going to B plus, and the two tipped cords to the plates.

Below we see the rectifier. The alternating current is received by the primary of the power transformer. A high-voltage secondary feeds the plates of the 280 rectifier. The center tap of this winding goes to ground, which thus becomes B minus. The rectification is of the full-wave type, that is, both alternations of a cycle are utilized.

### Rectifier Filament Always Positive

The rectifier filament is positive in respect to the plates and the center-tap of the high voltage winding. Rectification takes place because of the vacuum tube's property of passing current in only one direction. Therefore the maximum B voltage is taken from the filament, here the center tap C, while a B supply choke coil of 30 henries, with suitable filter capacities (electrolytic condensers), smoothes out the remaining ripple, to enable hum-free reproduction. Across the output is a re-

sistor, with taps on it to afford a variety of voltages. This resistor, because of this function of distributing the voltage available, is called a voltage divider.

We have thus traced the action in the radio frequency amplifier, detector and B supply, competing a brief discussion of how the receiver and its adjuncts work.

Some may be interested in what kind of a performance such a receiver yields. It is highly satisfactory. The only serious trouble from a similar circuit was cross-modulation, and so the 227 tube was substituted for a screen grid tube in the first radio frequency stage, because it will stand a heavier signal input, afford a higher bias and better practical selectivity. In general, cross-modulation is a question of inadequate selectivity. Another remedy would be to omit the first tube in Fig. 1, and use two tuned circuits, in pre-selector fashion, which also would remove the cross-modulation trouble.

### Variable Mu Tube Appears

However, the 227 was used, and it worked out as a satisfactory solution. It will be recalled that cross-modulation was not mentioned before the screen grid tube appeared, so a remedy ought to suggest itself.

However, at present there is a special variable mu screen grid tube purposely designed to cut down cross-modulation severely, virtually making it disappear, as well as reducing background noises and cross-talk. Cross-modulation may arise from a powerful local although you are bringing in loudly a station 100 kc removed, while cross-talk is interference between stations of either strong or weak field strength on adjoining or otherwise closely related channels.

The circuit, as diagrammed, may oscillate at first, but the screen voltage on the second radio frequency tube should be adjusted until this trouble disappears. Also, the number of turns on the primary of the 227 should be small.

Those anxious to know what the winding data are may follow these directions for .0005 mfd. tuning:

On a 1 $\frac{3}{4}$ -inch diameter bakelite tubing, about 3 inches high, wind all three tuned inductances alike, consisting of 75 turns of No. 28 enamel wire. The primary in the antenna circuit consists of 12 turns, as does that in the plate circuit of the following 227 tube. The plate coil in the detector circuit has 20 turns. These primaries and feedback coil may be wound of No. 24 or 26 wire, silk or enamel covered, and spaced  $\frac{1}{8}$  inch from the secondary. Preferably wind both windings in the same direction. This is important only in the detector circuit, however, so that the directions to connect the adjoining terminals of grid and plate windings to ground and stator of feedback condenser, will produce regeneration. At any rate, if regeneration fails, reverse these connections, that is, put the plate to the terminal that formerly went to the stator of the feedback condenser, the connection that formerly went to the plate now going to the stator of the feedback condenser.

When the circuit is properly wired and voltaged, plenty of distance will be received, great volume being present even on far-distant stations, while there will not be even a trace of radio frequency oscillation ahead of the detector, and no cross-modulation.

## Hold Screen Grid DC Voltages Constant!

### Avoiding Cross Modulation

WHAT is the best method of avoiding cross modulation in receivers utilizing screen grid tubes in the radio frequency amplifier? Is it better to control the volume by varying the grid bias or the screen voltage? Or is neither good?—P. C. H.

The best way to avoid cross modulation is to prevent overloading of the screen grid tubes. Tampering with the grid, screen, and plate voltages just makes the trouble worse. The circuit should be designed so that the signal voltage in every tube is just as low as is consistent with the desired output, and this should be achieved without reducing any of the steady voltages on the elements. A logical place in which to put the volume control is in the antenna circuit, or ahead of the first tube. A potentiometer in the antenna circuit or one across the first tuned circuit and in the grid circuit of the first tube is very good from this point of view. It is relatively easy to avoid

cross modulation. It is impossible to get rid of it after it has occurred. That applies to all forms of wave form distortion, and cross modulation is due to nothing else. Tuning sharply ahead of the first tube so that the interfering carrier is practically completely suppressed is also effective in preventing the trouble.

\* \* \*

### Ultra-Short Waves and Heaviside Layer

IT IS my understanding that short waves of the order of 10 meters and less will not travel around the earth like somewhat longer waves. If this is true, why do they not?—W. H. J. Ultra-short waves are not reflected by the Heaviside layer but pass through into the space beyond. Therefore they are not returned to earth at great distances away from the transmitter as the longer waves are. At least this is the explanation given and there is much evidence tending to prove that the explanation is correct.



# Scale Gives Resistance

## How 0-1 ma is Calibrated

THE calibration of an ohmmeter can be done with a pencil and a piece of paper without a single experiment. It is simply a matter of calculating the current that will flow through a circuit when the voltage and the resistance in it are known. Suppose we have a 0-1 milliammeter which we wish to use as an ohmmeter, and further that we wish to use a 1.5 volt cell as the source of current.

In order to protect the milliammeter it is necessary to put a resistance of 1,500 ohms in series. This value is chosen because when this alone is in the circuit the current will be just one milliampere and the reading will be exactly full scale. If we add more resistance the reading will be less and the amount of added resistance is determined by the deviation of the needle of the meter from the full-scale position. When the resistance scale is placed on the meter zero for resistance coincides with full scale for current.

### Calibration Formula

The formula from which the calibration curve, or scale, is constructed is  $I = 1.5 / (1,500 + R_x)$ , where the current is expressed in amperes. To construct the calibration curve we first calculate I for a selected number of resistances, that is, values of  $R_x$ , and then we set the values of  $R_x$  opposite the corresponding value of I. This we may do directly on the scale of the milliammeter or on a scale detached from the meter. In this case the current is read on the meter and then the resistance is read on the detached scale opposite the current.

Let us apply the formula in a few cases. Let  $R_x$  first be 100 ohms. The total resistance in the circuit is then 1,600 ohms and the current is 1.5/1.6 milliamperes, or .9375 ma. Now let it be 500 ohms. We get .75 milliampere now. When  $R_x$  is 1,000 ohms we get .6 milliampere. When  $R_x$  is 2,000 ohms we get .4286. We can calculate just as many points as we choose.

It is not easy to put the resistance scale on the meter scale for it requires opening the meter, removing the scale, and inking in the resistance values at the proper places. Also, the meter scale is rather short and for that reason it is difficult to locate the resistance values accurately. A much better way is to construct a detached scale, which may be linear.

For this purpose a strip of cross-section paper may be employed, or simply a piece of white cardboard laid off accurately on a decimal basis. For example, the scale may be 10 inches long. One end of this scale would be marked zero for current and infinity for resistance. The other end of the scale would be marked 1 milliampere for current and zero for resistance. The inches should be divided into tenths of inches. There will then be 100 divisions on the current scale. That will be more than on the current scale on the meter.

### Cross-Section Paper Best

In case an inch scale divided into tenths of inches cannot be obtained it is all right to make the scale 12.5 inches long, divided into ten parts each 10/8 long. Or if a shorter scale is preferred, a metric scale can be used. This is already divided into tenths and hundredths. The scale might be either 10 centimeters long or 20 cm long. In case the scale is made 20 cm long each tenth part would contain 20 millimeters and the whole scale would contain 200 divisions.

The best way to get a scale is to use cross-section paper. This may be obtained either in metric or English units and the inch scales on this paper are nearly always divided into tenths of inches. Fig. 1 shows a current-resistance scale made on cross-section paper in which the inches have been divided into tenths.

In case the current reading should fall between two adjacent lines on the resistance scale it is necessary to interpolate or estimate the true resistance. For example, suppose the current reading is .7 milliamperes. It is clear that this indicates a resistance somewhat less than 650 ohms, or by about 1/5 of the difference between 600 and 650 ohms. Hence we estimate the resistance to be 640 ohms. Computation shows that the resistance is actually 643 ohms.

If it is desired to compute the resistance from the current value it may be done by the following formula:  $R_x = 1,500(1 - I) / I$ , in which I is measured in milliamperes. Let us apply this formula to a current value where the resistance values on the scale are far apart, say at .4 milliamperes. The scale indicates that the resistance is somewhere between 2,000 and 2,500 ohms. The value of I in this case is .4 and on substituting this in the formula we get 2,250 ohms. Again, suppose the current reading is .355 milliampere. Substituting this in the formula we get 2,725 ohms.

### Using Higher Voltage

The resistance scale is very crowded at the high resistance values and therefore it is difficult to get accurate readings there. If the instrument is to be used primarily for measuring high resistances it is better to use a higher voltage. This, however, requires a higher protecting resistance. For example, if the voltage used in 3 volts, the protecting resistance must be 3,000 ohms. In general, the protecting resistance must be multiplied by the same factor as the voltage. That is, if the voltage is multiplied by N the 1,500 ohm resistance must also be multiplied by N. Thus if the voltage to be used is 22.5 volts, the protecting resistance must be  $15 \times 1,500$  ohms since 22.5 is 15 times greater than 1.5 volts.

When a higher voltage is used in the ohmmeter the indicated resistance must be multiplied by the same factor as the voltage. For example, if the indicated resistance is 600 ohms when the battery used has a voltage of 22.5 volts, the actual resistance is 9,000 ohms.

Between zero and 1,000 ohms graduations are made for every 50 ohms but the numbers are only given for every 100 ohms. Between 1,000 and 1,500 ohms graduations are given for every 100 ohms but the numbers are omitted to avoid crowding the scale. Between 2,000 and 5,000 ohm graduations are given for every 500 ohms, with each graduation marked. Between 6,000 and 10,000 ohms graduations are marked every 1,000 ohms, and between 20,000 and 50,000 ohms graduations are made for every 10,000 ohms. Above 50,000 ohms there is only one resistance marked, 100,000 ohms. To go higher would be entirely meaningless.

The scale in Fig. 1 can be used with any 0-1 milliammeter provided that 1,500 ohms are connected in series with it and a 1.5 volt cell is used to actuate the circuit.

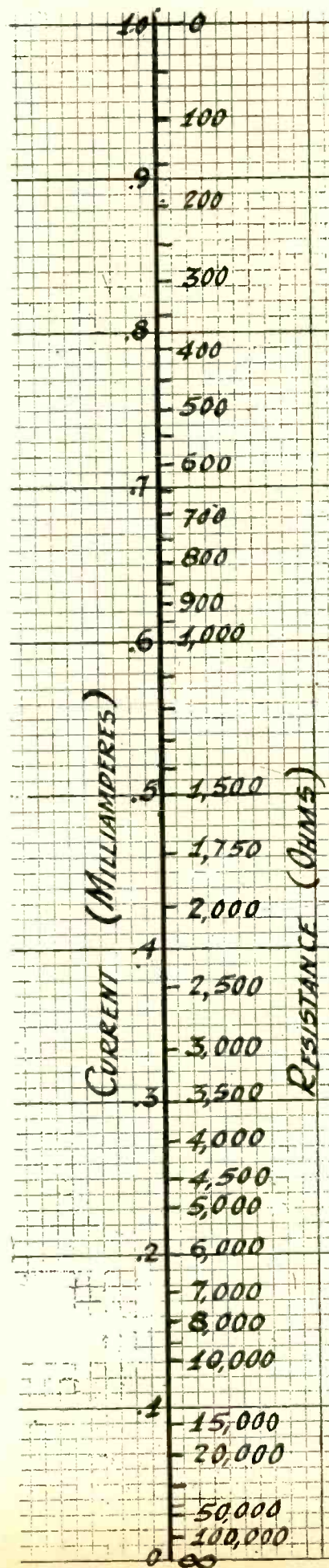

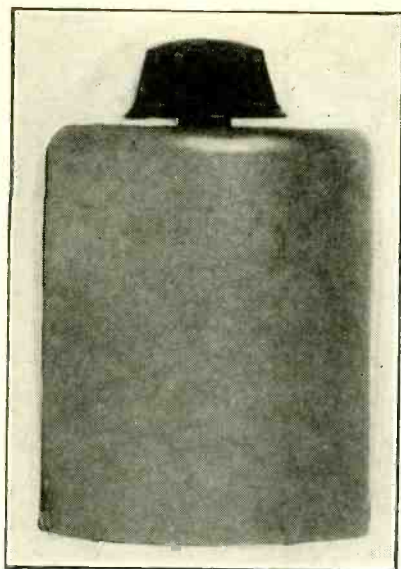
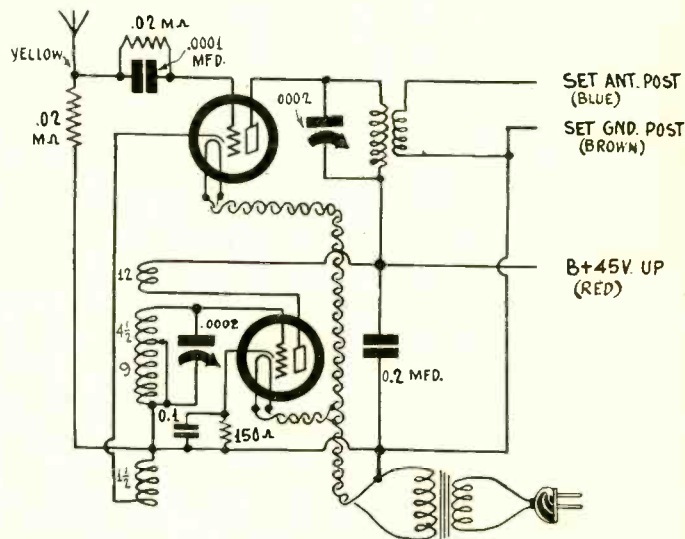

Fig. 1  
Appearance of the output device.

# Converter Output

By John C. Williams

Fig. 2  
How the converter output is tuned by the shielded coupler



THE observations of some fans, particularly those in metropolitan districts, are to the effect that when one tunes in the short-wave signals, it is not uncommon to hear signals of some regular broadcasting station. These signals come in frequently with the intensity of the short-wave signals, and if the station announcer does not explain the origin of the signals the user may think that the converter is working unusually well.

The latter part of this statement is not any reflection on either the converter or the designer but is due to the choice of an intermediate frequency on which there is a broadcasting station. Converter design has moved so fast since the inception of its popularity that it is a cause of wonder that those in charge of development of the circuits have brought them to such a high plane of performance. Undue complication has to be avoided, and cost kept within reason. Complicated short-wave circuits don't work consistently, anyway, so this means that a lot of ideas are conceived, tried, and of the total considered, a small fraction is retained.

In connection with the above it is a fact that the designers of short-wave circuits have been trying to find some way of diminishing the pickup of broadcast stations directly, and a step in this direction has been taken.

## Broadcasts Come In Directly

Let us suppose that the operator of a short-wave converter lives at some point remote from regular broadcasting stations, and the sensitivity of the converter attached to his receiver is such that he receives the short-wave signals very well on a variety of intermediate frequencies. Now further suppose that he can move easily in the direction of an area where the broadcasting stations are concentrated. Then there will be places on the set dial where the signals of the broadcast stations are heard as interference, and if the converter is disconnected and the set is operated as a regular receiver, the broadcast's signals may be brought in strongly.

It is wrong to suppose dual reception is due to harmonics. Instead, it is due to closeness to powerful stations or use of a very sensitive receiver. A remedy is to use a setting of the receiver dial beyond the broadcast band, either above 1,500 kc or below 550 kc.

If possible, use the higher frequency as coils for all-wave converters in particular are wound on that basis. So the converter, with an intermediate frequency of 1,600 kc or thereabouts, tunes in 600 to 150 meters on one oscillator coil. If, instead, an intermediate frequency of 550 kc is used, the converter responds to a higher frequency, with the same coil. The broadcast band covers 950 kc, so the same coil in the oscillator socket now will tune from about 1,450 kc up, that is, virtually misses out on the broadcast band and removes the all-wave feature, unless a new oscillator coil with larger number of secondary turns is used.

## Advantage of Tuned Output

By tuning the converter output to the intermediate frequency, direct reception of broadcast waves may be reduced considerably.

Some proof of this statement was afforded the writer when he constructed such a short-wave converter, with the result that hardly any broadcast stations interfered at any frequency, yet the short-wave signal came in just as expected. The apparatus with which these results were obtained was cumbersome, and therefore not an assembly that would grace the home,

to say the least, nevertheless it was the basis of a short-wave converter that received short waves and virtually nothing else. The experiments with this apparatus pointed the way to practical means whereby the reception of short-wave signals might be freed of broadcast signals to a large extent, and the cost of this means at the same time was kept within bounds.

The possessor of a sensitive broadcast receiver stands the best chance of picking up distant short-wave signals, as invariably these receivers are capable of resonating to at least 1500 kilocycles, and some will reach even higher frequencies, perhaps up to 1750 kilocycles. But the receiver may be far more sensitive at some lower frequency, hence a tuned output serves as a filter and enables practical use of these other frequencies. We provide a means whereby it may be possible to realize the most important advantage of the expensive set. This will be done with a shielded coil unit. This coil is assembled in an aluminum shield. The variable condenser that tunes the coil is one of high quality, with unusually high leakage resistance at the short-wave frequencies, and its operation at a lower order frequency means that the losses are virtually nil.

The tuned winding with 80 turns of No. 28 enamel wire on 1 3/4 inch diameter. The primary is a three-section coil, separated 1/8 inch, and consists of thirty turns tapped at the 10th and 20th turns, using No. 28 wire.

## How Response Frequency Shifts

The frequency of response will depend on the capacity of condenser used. The Hammarlund .0002 mid. junior midline fits into the space and will permit filtering the output from 1,700 kc to 850 kc.

The method is simple. The tuned circuit is placed in the plate circuit of the modulator tube. The condenser is insulated from the shield, so no short results when the shield is grounded, as it should be. The small winding is really the secondary, and is connected to a three-tap switch, so ten, twenty or thirty turns may be used for coupling to the receiver. It is another case of matching impedances. One side of the small secondary (extreme terminal) goes to ground, the switch arm to receiver antenna post. Try the taps, one at a time, to see which works best. Also decide on some intermediate frequency that brings best results from your receiver. Keep the lead short to the antenna post of the set.

The writer has found it advisable to conduct some observations of a relatively simple character to determine the extent of the influence of the change of physical dimensions of the coils. As often happens, the fan who reads a technical article relative to the subject of short-wave reception casts about to see whether he can find the wherewithal to copy the circuit. Experiments have shown that the substitution of tube base type coil winding forms, while possible, yields no superior result.

The important coil dimension is apparently the 1 3/4 inch diameter. It will be realized that the dimensions do depend to some extent on the size and thickness of the shield, which in this case is of aluminum, and about 1/32nd inch thick, about 3 1/4 inch diameter. The substitution of a larger coil, without—at the same time increasing the size of the shield, also invites possible trouble.

The additional experiments that the writer conducted, with the aid of a standard 1,500 kilocycle transmission, have shown the feasibility of constructing a short-wave superheterodyne and using as the intermediate amplifier the coupling transformer outlined herewith.

# The 227 Tube as Rectifier

## Simple Circuit Invented to Solve Low-Current Problem

[A short-wave converter with B supply built in, along the lines laid down in the following article, will be published in the March 14th issue. It will be a triple-screen grid converter. With the 227 rectifier the tubes total four. Plug-in precision coils will be used. The rectifier method is the invention of J. E. Anderson and Herman Bernard. The converter will be known as the DX-4.—EDITOR.]

GETTING the plate voltage for a short-wave converter from the receiver seems to be a problem that is difficult to solve in some instances. Many reported failures of converters have been due to nothing else than lack of proper voltage. Often the positive lead is located all right but then no return is provided, and no converter will work unless the plate circuits are completed.

There is only one logical solution of this problem, that is to build the B supply into the converter. When this is done only two signal lead connections need be made, one the antenna on the converter and the other the output lead which goes to the vacated antenna post on the set. Of course, there is also a power connection to be made to some convenient outlet. But that is all.

Building a B supply into the converter adds to the cost, but there is no reason for employing an expensive B supply. The converter tubes need not draw much current and neither is the required voltage high. Hence the rectifier tube may be a 227 connected as a half-wave rectifier. It is not even necessary to use a power transformer other than the filament transformer for the tubes. The high voltage for the plate of the rectifier tube may be taken from the line by utilizing the primary winding of the filament transformer.

### Simple Rectifier

The circuit of a simple rectifier is given in Fig. 1. The plate and the grid of the rectifier tube are connected together to form the anode, which is connected to one side of the primary of the filament transformer. The cathode of the tube is connected to a resistance, the other side of which goes to the remaining AC lead. C1 is a fifth condenser. When the current in the primary is in the direction indicated by the arrows, the anode is positive in respect to the cathode and space current flows around the circuit. The cathode is positive with respect to the lower side of the primary of the transformer. Thus if the plate returns of the tubes in the converter are connected to the cathode of the rectifier tube and the other end of resistance R is connected to ground in the converter a circuit is established.

When the alternating current in the primary of the transformer flows in the direction opposite to that indicated by the arrows, the anode is negative with respect to the cathode and no current flows around the circuit. During this half-cycle the rectifier is inactive. However, condenser C2, which should have a large value, charges up during the active half cycle and discharges during the inactive half, so that current flows all the time in the external circuit, that is, through R and the plate circuits of the tubes connected across it.

It has been found that no hum results provided that condenser C2 is 8 mfd, provided the current drawn is under 10 milliamperes. If the condenser is omitted there is considerable hum because there is then no storage facility for the charge.

At first it might appear that no current at all could flow, but no doubt disappears when it is realized that the primary is really an autotransformer with a one-to-one ratio of turns. The discharge of condenser C2 takes place mostly through the primary winding so that this acts as a filter choke.

With a rectifier like this the extra cost of the converter is small, for the only additional parts needed is a socket and a tube, a couple of filter condensers C1 and C2, and a voltage divider R.

Not much current can be drawn from this B supply because the emission of the 227 is quite limited. At the most, the current that can be drawn safely is around 15 milliamperes, while for hum suppression the limit should be 10 milliamperes. There is no good reason for drawing 15 ma, for an efficient, three-tube converter can be designed which will only require between 5 and 10 milliamperes. This the 227 tube will deliver for a year or more of service four hours a day.

### Protection of Line

A low-current fuse is put in each side of the line to protect the wiring against possible short-circuit, even if by mistake the "high" side of the converter power source is connected to the ground lead of the receiver. It may happen that one side of the line is grounded and if the plug should be inserted so that the other side also is grounded through the converter or through the set, a dead short would occur. If a couple of 3-ampere fuses are put in the line there can be no danger, except to one of the fuses. It would be even better to use smaller fuses, say

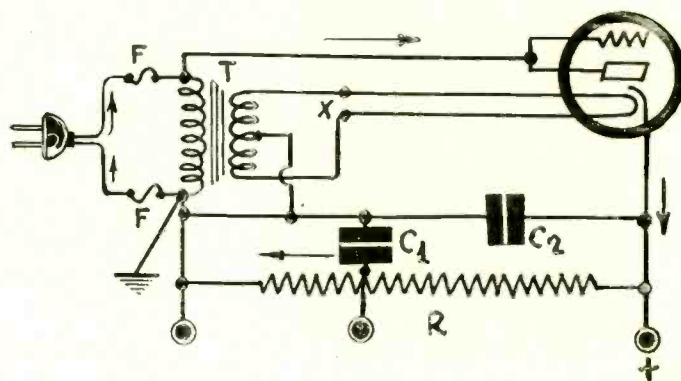

FIG. 1

The diagram of a simple B supply suitable for a short-wave converter.

half-ampere, which can be obtained in both automobile supply and radio stores.

It is true that the converter will be alive with 110 volts when this B supply is used, but precautions can be taken against possible trouble from this fact. For example, a small condenser may be put in the antenna lead of the converter and another may be connected in the ground lead that connects with the receiver with which the converter is used. These condensers can be built into the converter so that they will always be ready for service. Of course there is no need to tolerate the danger at all. Simply do not connect the converter to ground of the receiver.

The effective voltage across the primary of the transformer will normally be 110 volts, although it may vary from 100 to 120 volts. The peak value of this voltage, assuming good wave form of the AC wave in the supply circuit, will be 1.414 times the effective value. That is, the peak voltage may be as high as 156 volts for a 110 volt effective value. This will be the peak voltage at the output of the rectifier on open circuit. While current is taken from the circuit the rectified and filtered voltage will be considerably less than this, the amount of lowering depending on the current drawn. With the current required by about three tubes and the voltage divider a rectified voltage of 90 volts can be expected.

Converters incorporating screen grid tubes require at least two different voltages. Hence a tap is put at a suitable point on the voltage divider and a condenser of about 1 mfd. is connected from the tap to B minus. The tap should be placed approximately in the center of the resistance. R may be 20,000 ohms or more. Another method is to use bypassed seven resistors in the screen leads to the B voltage.

### The Filament Supply

The secondary of the filament transformer not only serves the rectifier tube but also the tubes in the rest of the converter, the heater terminals of these tubes being connected to the two points marked X. The midtap of the 2.5 volt winding is connected to ground, but if there is no centertap the connection may be omitted.

## Replacement of Audio Transformers

When an audio transformer in your set breaks down, it is not always possible to obtain the same style to replace it. Service men provide themselves with replacement transformers, which are made with fairly long connecting leads, rather than with fixed soldering terminals. In this way it is possible to make a quick installation without much trouble, regardless of the manner in which the original transformer was connected.

However, it is just as well to be watchful of such replacements. There are all sorts of audio transformers, and cheap replacement transformers are not usually of especially high quality. Better pay the difference to purchase a good make of transformer, and a little more for the extra time your repairman may take to make the necessary connections. Tone quality depends upon the transformers!

# The New Fada Model 43

## Equalized Radio Frequency Amplification

THE Fada Model 43 is a six-tube receiver incorporating three 224 type screen grid tubes, one 227 audio amplifier, and two 245 power amplifiers. There is also a 280 type rectifier in the B supply.

There are four tuned circuits in the receiver, two of which are ahead of the first tube. The volume control is also put ahead of the first tube, actually in the antenna circuit. This is the correct position if cross modulation and other distortion are to be prevented.

It will be observed that coupling in the radio frequency amplifier is part inductive and part capacitive. The coupling between the antenna coil and the first tuned circuit is all capacitive since one side of the primary is not connected to anything. There are similar loose-end couplers in the two interstage transformers. The object of this type of coupling is to equalize the amplification over the entire broadcast band.

### The Detector

A screen grid tube in grid bias connection is used for detection. The bias resistor is 50,000 ohms and this is shunted by a one microfarad condenser. A special voltage divider is provided for the screen of this tube and the resistances are proportioned so that the screen voltage is approximately 20 volts.

A low pass filter consisting of two .00025 mfd. condensers and a radio frequency choke is connected in the plate circuit of the detector to segregate the carrier and audio frequencies. Note that the common sides of the two condensers in the filter are connected to the cathode of the tube rather than to the ground. Thus by-passing is done direct to the source of electrons.

Careful design has been done to prevent distortion from feedback or possible oscillation at audio frequency. The coupling resistor in the detector plate circuit is 250,000 ohms, but this is in series with a 125,000-ohm resistor used for filtering. A one microfarad condenser is connected from the junction of the two resistors to ground. This arrangement quite effectively prevents feedback. The grid circuit following is treated in the same manner, the grid leak being 500,000 ohms and the filter resistor 125,000 ohms, also by-passed by a condenser of 0.1 mfd. A stopping condenser of 0.01 mfd. joins the tops of the plate and grid resistances.

It is clear from the design of this coupler between the detector and the first audio tube that low notes as well as the high are transmitted and there is no danger of oscillation on the low notes. That is, there is no danger of motorboating.

### Push-Pull Amplification

Since a screen grid tube does not work efficiently into a push-pull transformer it is necessary to interpose a 227 tube in the

(Continued at top of last column)

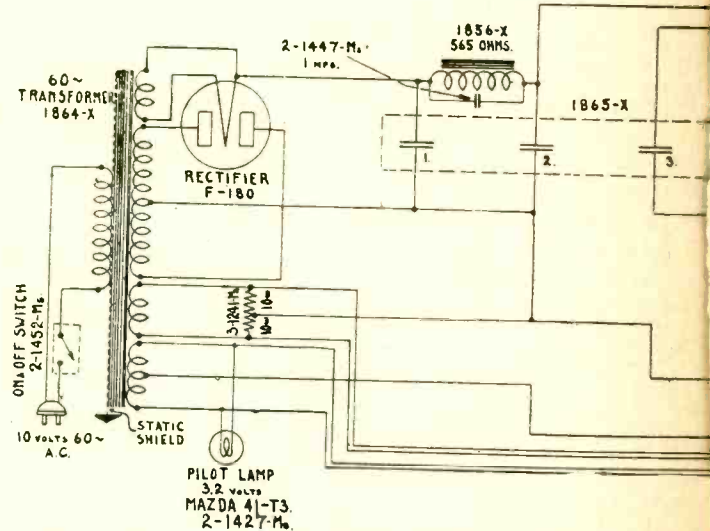
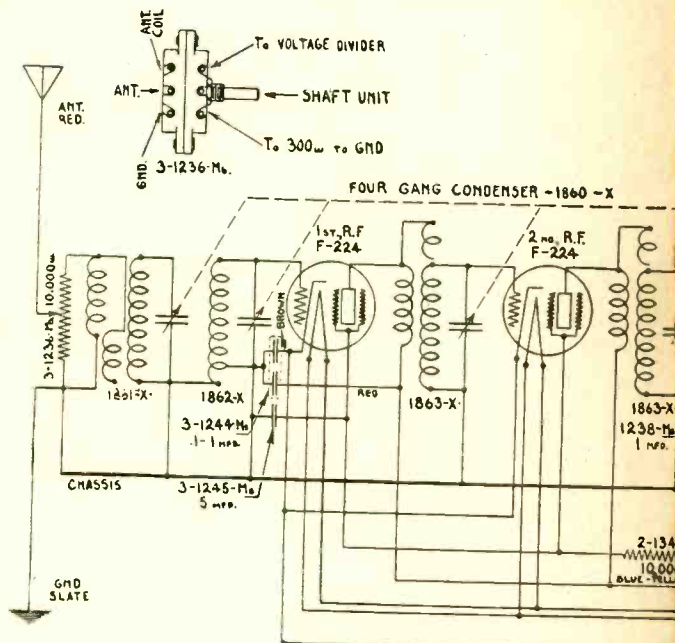

**Important Issue Coming!**  
**9th Anniversary Number**

## RADIO WORLD

Dated March 28. Published March 25. LAST form closes March 17. Increased distribution. Increased value. Increased sales for advertisers.

	1 Inset	4 consec. Inset. (each) 10%	13 consec. Inset. 12 1/2%	26 consec. Inset. 15%	52 consec. Inset. 20%
1 page	\$150.00	\$135.00	\$131.25	\$127.50	\$120.00
1/2 page	75.00	67.50	65.62	63.75	60.00
1/4 page	50.00	45.00	43.75	42.50	40.00
1/8 page	37.50	33.75	32.81	31.87	30.00
1/16 page	25.00	22.50	21.87	21.25	20.00
1/32 page	18.75	16.87	16.41	15.94	15.00
1 inch	5.00	4.50	4.37	4.25	4.00

Classified advertisements, 7 cents a word; \$1.00 minimum; must be paid in advance.

### Advertising Department

Radio World, 145 West 45th St., New York, N. Y.

The volume control in the Fada 43 is a double-acting most up-to-date practice. A band pass effect frequency amplifiers. Inductive-capacity coupling is push-pull 245 output.

## Resistance AF U

UNDISTORTED amplification over an enormous frequency range is one of the outstanding problems in radio television. While the ear may be fooled into accepting as perfect an amplification curve which plots like the profile of the Rocky Mountains, the eye immediately detects uneven amplification in its pictorial interpretation. Thus the best transformer coupling will not do except for crude silhouettes. The most advanced form or resistance-coupled amplification is essential for fine half-tone pictures, with a flat frequency response curve up to and beyond 50,000 cycles.

Notable progress has been scored in television amplifiers, both at the transmitting and receiving ends. Aside from the proper selection of resistance and capacity values, as well as other circuit considerations, the resistors themselves have received critical consideration.

# Model 43 Receiver

Achieved by Inductive-Capacitive Coupling

(Continued from column 1)  
 audio amplifier, and this feeds into the primary of the push-pull input transformer. This feeds a standard 245 tube push-pull stage which in turn delivers its output to a dynamic loudspeaker.

### Tuned Choke

The field of the speaker is the second filter choke in the B supply. The first is of the tuned type, that is, a condenser is connected across it and adjusted so that a resonant circuit is formed at the second harmonic of the line frequency. Since the tuning condenser across the coil is 0.1 mfd. and the frequency at which resonance must occur is 120 cycles, the effective inductance of the first choke must be 17.6 henries.

The shunt condensers in the filter are comparatively small, the first two being only 2 mfd. each. These are ample when one of the filter chokes is tuned. The other condensers, across portions of the voltage divider, are only one microfarad each. The filtering is so thorough that no hum is heard even when the set is tuned in on a strong unmodulated carrier.

### Resistor Values

The volume control is double acting, one part being in the antenna circuit for controlling the input and the other in the cathode return circuits of the first two tubes for controlling the bias on these tubes. The voltage divider controlling this bias has a value of 3,000 ohms and is connected as a portion of the voltage divider. It is that portion of the voltage divider to which the arrow marked "shaft unit" points. Below this is a 300 ohm resistor. On the other side of the grounded point on the voltage divider the bias resistors for the power tubes are located.

### Complete Shielding

All the radio frequency circuits are completely shielded, and the shielding is double where necessary to insure complete

freedom from back-door interference caused by powerful local stations close to the receiver location. This type of interference usually is the result of shielding so that the signal from the local stations is not forced to go through the tuner in the receiver, but may enter after the tuner, or after part of the tuner. With thorough shielding no signal can get in except by way of the antenna, and when it gets in at this point it has to go through all the tuners.

The chassis has been built so as to eliminate vibrations as a result of exposure of the tubes and other parts to the sound from the loudspeaker, not only as the sounds are transmitted through the air but also as transmitted mechanically in the chassis structure. There is no tendency for the plates of the tuning condenser to vibrate when subjected to the vibrations from the speaker and hence there is no microphonic howl. In many receivers the condenser plates vibrate when exposed to sound vibrations and the result is a continuous howl. The noise usually occurs when the volume is turned up, but frequently it occurs even when the volume is very weak. Rigidity of the assembly is one method of preventing the development of the howl.

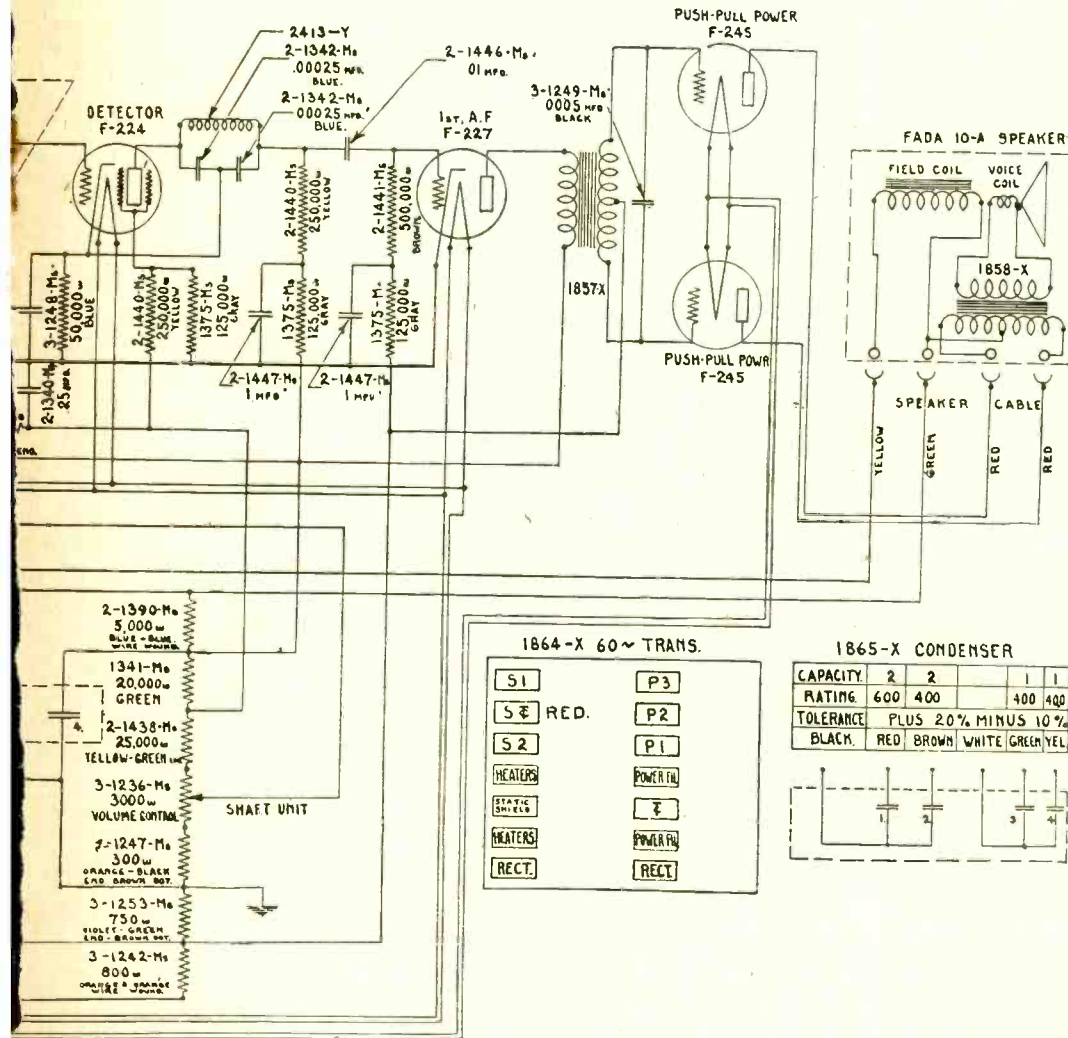

potentiometer, partly governing the amplitude of the input, in line with the reveals in the doubly tuned input to the first of the two screen grid radio frequency stages. The audio is one stage resistance coupled, with

## Used for Television

The slightest imperfection in resistors, according to Jesse Marsten, chief engineer of International Resistance Company, gives rise to serious pictorial defects. Noisy resistors are detected by blotches in the pictures, similar to those caused by severe static. Uncertain resistance values result in upsetting the delicate gradation of half-tone pictures and breaking up the finer detail of silhouette pictures. Due to the exceptionally high amplification at the pick-up end as well as at the receiving end, the resistors are severely tested in television work.

The high resistance values required make the wire-wound type too costly. The standard resistor employed in television work is the heavy-duty or powerohm type of metallized resistor, the positive conduction and perfect contacts of which insure noiseless operation together with freedom from moisture due to the special ceramic enclosure.

# Coupling in B Batteries

By Brainard Foote

**T**HE fact that radio sets employ a number of radio tubes, all of which utilize the very same set of B batteries, gives us the key to certain difficulties often encountered.

The B batteries energize the plate circuits of the set. In early days, every extra amplifying tube in the radio set meant an entirely new set of batteries. Later methods, however, made it possible to use a common B battery.

Then if we trace the path of each tube circuit we discover that the paths all come together and run together momentarily through the B battery.

Now, if this common path happened to be a length of heavy copper wire, trouble might not arise from the fact that all the circuits used this same portion of the circuit. When the common path happens to be a battery, however, conditions are different. The battery is composed of a number of small dry cells of the same in construction, though much smaller in size, than the cells in the dry batteries used for ringing doorbells.

The cells have a slight amount of resistance, because of the chemical material, and since the cells are all connected end to end, in series, the total resistance of a battery may become appreciable in amount.

## Coupling May Produce Oscillation

Picture a fluctuation in the amount of current drawn by one of the plate circuits, say, in the first tube in your set. This fluctuation causes a slight change in the voltage, because of the battery resistance, and this change effects the other plate circuits common at that point. The variations are therefore amplified and may affect the reproduction of music in many different ways.

The tubes in the radio frequency amplifier may be caused to oscillate at radio frequencies because of this coupling of the circuits together in the battery resistance. Oscillation is evidenced by whistling when the set is tuned for the broadcasting stations. The whistles are beats between the oscillation and

the carriers. General instability of the set is another effect. In the audio frequency amplifier portion of the set, howling or motorboating may result, since these, too, are oscillations, only at audio frequencies.

When the batteries are new the internal resistance is very small, so that no trouble is encountered as a rule at this stage. Gradually, as the batteries age, the resistance increases and trouble begins.

Since it is only variations in current that cause the trouble, and not the steady direct current delivered by the batteries, it is clear that we can prevent the trouble if we can keep these variations out of the battery.

## Bypass Condensers Are a Solution

This can be done. Usually, a fixed condenser connected across the troublesome voltage, to the B minus, will serve to reduce the common coupling sufficiently. The condenser should have a large capacity, at least 4 mfd. In some extreme instances 18 mfd. or more will be needed. The rated voltage of the condenser should be above that of the battery voltage across which the condenser is connected.

The condensers draw no current, so there is no harm in having them permanently connected in the circuit.

In extreme cases, a radio specialist may advise the installation of an audio choke coil.

The condensers advised will generally improve reception very materially, in addition to remedying any tendency toward howling, squealing or other fault due to common coupling, and they will further enable you to use your B batteries longer than formerly. Frequently the only real trouble with worn B batteries is in their high internal resistance, and with condensers connected to by-pass this, results will continue to be good for considerably longer periods.

A B battery is useful as long as it renders satisfactory service.

## How Electrolytic Capacity Arises

**E**LECTROLYTIC condensers are very popular and are useful for certain purposes. They provide a large electrical capacity with a minimum of space and cost. In addition, they automatically repair themselves in event of puncture due to excessive voltage.

Here are the details of construction: There is a metal container, which is employed as the negative terminal of the condenser. In the center there is an aluminum plate, which is corrugated so as to enlarge greatly its surface area. The aluminum plate is the positive terminal. The electrolyte may be a liquid solution of borax or other special material, or may be a paste. In one instance the condenser is called "wet" and in the other "dry."

In theory, the liquid is supposed to react chemically with the aluminum, forming an extremely thin coating of gas all

over the aluminum plate. In this way, the aluminum becomes one terminal of the condenser, and the liquid in the cell the other real terminal. The separating medium or dielectric is only the extremely thin layer of the gas between the liquid and the aluminum. Because of the thinness of this gas layer, the electrical capacity is far greater than with condensers which are separated by paper sheets or other insulating substances. It is important that the aluminum be connected to the plus terminal of the circuit.

The electrolytic condenser is principally serviceable for low voltages, but for higher voltages the great capacity available can be utilized by connecting several of these condensers in series. Condensers that serve for up to 500 volts DC are considered "low voltage." Electrolytic condensers can be used on DC only.

## New Portable Microphone Equipment

**R**ADIO microphone equipment for outside or remote programs, as sensitive and efficient as anything that is to be found in the studio, has been developed by the engineers of WGY, Schenectady, N. Y., and is now in use on all programs originating outside the studio. An important feature of the equipment, from the viewpoint of the operator, is its portability and weight.

Long after the condenser microphone was adopted for studio use broadcasting stations continued to use the carbon microphone for outside jobs because of the rough treatment to which the pick-up device was subjected in handling, and not infrequently by the table-pounding speaker.

WGY has long used the condenser microphone on outside jobs but only recently a complete amplifying and microphone equipment has been condensed to three containers and with a total weight of 120 pounds, each container a little larger than a suit-case. The

remote control program, therefore, is today brought to a par with the program originating in the studio.

Two of the boxes are made of wood, one to contain three microphones, dry batteries and spare tubes, while the other contains cable, tripods for the microphone and dry-batteries. The third element is the control board with five positions for microphones. In other words the board is made to take care of a five-microphone pick-up. The control board contains the amplifier and mixers for each microphone. At this board the operator checks the quality, controls the volume and cuts microphones in or out as the program requires. The wooden boxes may be used as a table for the control board. The microphones are so made that they may be easily handled by operator and announcer. Should occasion arise where it is necessary for the announcer to carry a microphone to speaker in a crowd this may be done very easily providing a sufficiently long lead is attached.

### TEST OF B ELIMINATOR

**I**N testing a B eliminator, should I do it with the set on or with it turned off?—C. L.

Preferably with the set turned on. But the voltmeter used, unless of the high resistance type, will read much less than the voltage obtained when the meter is disconnected. If there is a perceptible drop in the volume when the voltmeter is connected, you may feel fairly sure that the reading is wrong. The current drawn by the meter itself is responsible for this effect.

### VALUABLE LEAK FOR CRITICAL DETECTOR

**P**LEASE advise the value of an adjustable grid leak?—W. V. McC.

Is sometimes valuable with a "soft" tube like the 200A to obtain the most sensitive point. Will also help to obtain maximum volume from faint stations. A strong station requires a lower resistance leak to enable excess electrical charges to leak away from the grid rapidly. With a faint station, a higher resistance can be used and somewhat more volume can be obtained.

# Are Headphones Selfish?

## Individual Listening is Held an Enduring Advantage

**I**N dealing with the progress of the broadcasting art, we invariably mention the transition from the headphone or "selfish" stage of reception to the loudspeaker or "unselfish" stage. We are to assume, no doubt, that headphone or individual enjoyment of radio programs is decidedly a thing of the past, never to return again. Even our latest short-wave receivers, reducing what has heretofore been an experiment to a positive form of entertainment, replace the headphones with a powerful loudspeaker, so that the entire household and even a good portion of the neighborhood may hear (willingly or otherwise) the programs from many lands.

Perhaps we have been a trifle hasty in branding headphones as selfish reception, a thing of the past. Perhaps we are foregoing many of the pleasures and advantages of which modern radio is capable, particularly with the remarkable variety of simultaneous programs, in standing by the usual loudspeaker radio set at all times and in all places.

### Tastes Differ in Home

There are few homes indeed where the radio entertainment tastes of the entire household are absolutely standardized. There are divergent tastes for young and old, male and female, practical and esthetic. The variety of simultaneous entertainment provided by broadcasters remains to be matched by a variety of reception facilities at the home end, so that each member of the family may enjoy his or her individual tastes without the autocratic imposition of a common program by the loudspeaker receiver. Individual reception, of course, means headphone reception, not only in confining a selected program to the given listener without disturbing others, but also in order that the given listener may be shut off from the rest of the household for a fuller enjoyment of the presentation.

Then there is the hospital, with its many admonitions to be silent. The standard loudspeaker set is decidedly out of place

here. Nevertheless, the patient may find no end of mental comfort in having an individual radio set, with headphones, which will not disturb other patients in the least.

### Serves the Traveler

The traveler who is a confirmed radio addict may want to have his radio features wherever he goes. Here again there is need for the individual radio set in highly portable form and requiring a minimum of installation.

The boy or girl at school or college may find much use for an individual radio set, not only for entertainment purposes but even more along the lines of sound enlightenment. The usual radio set, whether it be of the console, midget or table categories, may prove unsuitable in the dormitory.

On vacation, there is need for the individual radio set. Particularly is this true of the business man who desires to keep in touch with the market quotations, with important business talks, and other features of such importance that they cannot be left behind even during the vacation.

### Use in Business

Finally, the business or professional man may find it essential to listen in on important broadcast features during office hours. The radio broadcasting service of late has assumed an importance approaching that of the stock quotation ticker. A standard radio set in an office is just about as welcome as that proverbial bull in the china shop.

And so we come to the urgent need for individual radio reception—a return, but in modernized form, to the headphone idea whereby the radio listener may shut himself off from his surroundings, enjoying his own selected program without imposing it upon others.

## Science Can Now Predict Fading

**I**T is possible to predict some time in advance those short periods of time when radio reception "fades," according to Robert M. Morris, development engineer for the National Broadcasting Company. However, no device or method has been discovered to prevent these recurring seasons when listeners are unable to hear distinctly their favorite programs.

Reception in the daytime always is more certain than it is at night, Morris declared. A transmitter radiates signals in all directions, he explained, but only the horizontal waves are picked up by the receiving sets. Those signals which are sent vertical or at an angle into the air are absorbed or neutralized by an ionization process which is caused by the action of the sun, according to the theory which is accepted generally by engineers.

### Effect of Layer

Absence of the sun's rays causes a "ceiling" to form through which these radio signals rarely pass. This ceiling is called the Kennelly-Heavyside Layer, in honor of the engineers who first advanced this theory.

It is believed that radio signals which would be absorbed in the daytime, at night are reflected by this Kennelly-Heavyside Layer and are bent back toward the earth to interfere with the horizontal waves and thus cause fading.

While the reflection of radio waves causes listeners to programs from nearby transmitters some irritation, it permits the

broadcast of programs from abroad. Since radio signals travel in a straight line, it would be impossible to pick up the radiations of a transmitter on the other side of the globe unless these waves were reflected. Experience has revealed that short waves are deflected by the ceiling more perfectly than longer waves.

### Affected by Earth's Field

Engineers surmise, although they cannot explain the phenomena, that the strength of the earth's magnetic field determines the "toughness" of the ceiling. In the winter, when the magnetic field is the more powerful, the ceiling is more difficult to pierce and the reflection of radio signals is more pronounced.

Experience in observing the action of the earth's magnetic field has taught engineers to forecast the strength of it. The force of this magnetic attraction can be plotted in advance and the periods of the fading of radio reception can be predicted with accuracy.

"We have found that the hour of greatest interference is in the early evening," Morris said. "We have had a number of complaints from listeners that stations not connected with NBC were trying to ruin the Amos 'n' Andy program by interference, since fading was more noticeable then than during any other program. But it happens that that is the time when this reflection is the greatest."

## Why Voltmeters Lose Accuracy

**T**HE lower-priced multi-range voltmeters frequently become inaccurate in time, so far as their higher reading scales are concerned. This is due to the altered value of the multiplier resistances. Until recently, when precision wire-wound resistors became generally available, some instrument makers made use of composition resistors which changed their resistance value over a period of time.

The accuracy of a multi-range voltmeter may best be checked by direct comparison with a precision voltmeter or any other one of known accuracy. If there is a marked discrepancy in the voltage readings, several readings may be taken at different voltages, and an approximate correction factor worked out for offsetting the inaccuracy of the meter reading. Thus the useful life of the meter may be extended.

The original resistance value or values for the multiplier may

be ascertained by writing to the instrument manufacturer, and a precision wire-wound resistor substituted for each resistor of the multiplier. The multiplier resistances are usually contained inside the instrument case of the multi-range voltmeter, except where an external multiplier is used.

With the recent introduction of the precision wire-wound resistor, an accuracy of better than 1% is obtained in commercial units available at reasonable cost. Such resistors maintain their original resistance values throughout life and are therefore ideal for voltmeter multiplier.

When substituted for resistors formerly employed, they maintain the series resistance values throughout the life of the meter. Many meters which would otherwise be discarded because of inaccurate readings may now be restored to practical use.

# Tube Troubles Dissected

## Valves Wear Out Slowly But Must Be Replaced

**A**LMOST everyone has heard a friend or neighbor boast about the length of time he's had his radio tubes. "And they're still working fine," he confides proudly. "But I don't know what's the matter with that set. It seems to get poorer all the time."

Every service man knows that the trouble is probably due to the radio tubes. They are still physically intact, they still light, but there's just one thing the matter with them—they're worn out.

Is this the fault of the tube? Should it wear out? Isn't it just another case of a poor deal from the manufacturer? So the layman is likely to ask. But an engineer knows better.

"Do you expect your spark plugs to last the life of your car?" he will counter.

According to research engineers of the RCA Radiotron Company tube failures may be divided into two classes.

The first class, and one which is of minor importance for this discussion, is the case where the tubes actually become inoperative and the set performance shows either a marked and sudden change in characteristics, or else complete silence. This type of failure is automatic announcement to the customer that new tubes are required.

The second class of failure is undoubtedly the more common and, due to the character of the failure, is frequently not perceived by the user until complete failure of the tube results. Here failure extends over many months of service, and is not noticeable until brought to the user's attention by odious comparison of his set with others, or by chance remarks of visitors in his home.

### Radio Tubes Similar to Spark Plugs

Analogies can be found in almost any line of product which the customer purchases. The slow, imperceptible reduction from the original new-product performance, passes unperceived by the customer until his attention is forcibly directed to the matter. Take spark plugs as an example. The reduction in efficiency from day to day is so slight that the average driver does not notice the fact. After some thousands of miles of use, however, a very noticeable improvement in car service is obtained if a new set of spark plugs is installed.

A very important reason for a new vacuum tube giving satisfactory performance is because a copious supply of electrons is available. These electrons are supplied by the cathode or filament of the tube and are projected from the filament or cathode when heat is applied to the filament or heater. Present day vacuum tubes almost universally employ coated filaments or the coated cathode construction. The active material which produces the electrons is coated on the filament, but during the life of the tube is gradually used up and becomes less active. Finally, a point is reached where there is insufficient emission to give any results. Long before this point is reached, however, performance of the set is reduced to a point of really unsatisfactory quality. The reason that the filament does not fail

altogether is because the coating method of the present day is so efficient that the filaments operate at comparatively low temperature.

### Effects of Loss of Electron Emission

This loss of electron emission may cause impaired set performance in a number of ways. For example, in the case of rectifier tubes the loss of emission means that the rectifier voltage supplied by the tube is reduced to a point which reduces the sensitivity of the set, introduces distortion in the output, and limits the volume at which the set can be operated.

In the case of output tubes, the maximum obtainable volume is reduced. If this reduction in volume is carried to an extreme, the set develops an extremely harsh and rasping quality.

In the case of the detector and audio stages, somewhat similar effect in quality is obtained as the tubes wear out.

In the radio frequency stages, a loss of sensitivity and corresponding loss of volume results.

### Age Reduces Quality

Since the supply of electrons from the filament must be adequate to supply at least twice the normal plate current, as tubes wear out, their quality is greatly reduced. If this condition is not met, the tube is over-loaded on strong signals and the quality of the set response is impaired.

If tubes are operated to the point where the emission is very much reduced, the faults in reproduction generally are obvious. This may take the form of noisiness or a pronounced hum.

One bad tube will impair the performance of the set. But if the other tubes are old, the original volume and tone quality cannot be restored by replacing that one tube alone. The only satisfactory remedy is to renew all tubes at once, and then every year thereafter.

## Eight Reasons for Renewal of Tubes

The following are eight reasons for installing new tubes:

- (1)—Increased sensitivity.
- (2)—Increased volume.
- (3)—Tone quality—freedom from distortion.
- (4)—Minimum hum.
- (5)—Poor tubes impair performance of the good.
- (6)—Insurance of uninterrupted service.
- (7)—Take advantage of latest developments and improvements in radio tube design manufacture.
- (8)—Better radio reception.

## Reactivation Confined to One Style Filament

**T**HERE are two general types of radio tubes now in use, the oxide coated filament tubes and the thorium-impregnated filament tubes. The thoriated type is the only one that may be reactivated. The process of reactivation is a method for releasing some of the hidden element thorium from the interior of the filament of the tube.

The thorium is an element that is impregnated into the tungsten metal of the tube filament in manufacture. The thorium gradually comes to the surface and greatly multiplies the number of electrons given off from the heated filament, so that a much lower temperature is possible. When the thorium is boiled away the electron emission decreases until the tube goes dead.

By reactivating the tube, through a process of forcing additional thorium to the filament surface, it again becomes sensitive for some time. The method used is to light the tube at a voltage much higher than customary, without plate voltage. In general, the tube is taken out of the set and inserted in the reactivator (also called rejuvenator) in a socket to which no B voltage is connected. The standard tubes that may be reactivated are: 199, 120, 201A, 200A, 240, 210 and 216B. Some popular tubes which cannot be reactivated are: 250, 280, 281, 227, 220, 171A, 112A, WD11, and WX12.

Frequently where your tubes are fairly good, a simple method for greatly improving the sensitivity, is to disconnect the B supply entirely, and to turn on the tubes in the set as brightly as possible and keep them burning 2 to 4 hours.

Where tubes are especially bad, the reactivation usually consists of two steps. The first step is flashing, in which the tubes

are lighted for about 10 to 15 seconds at voltages averaging 12 to 16. The second step is cooking, in which the tubes are lighted for about one-half minute at voltages slightly higher than normal. All this is done without any connection to the grid or plate elements of the tube.

Reactivators are inexpensive as they may be operated by alternating or direct current.

### WINDING SHORT-WAVE COILS

**W**HICH is preferable for short wave coils, enamelled wire or cotton-covered wire?—C. Z.

Either may be used. If enamelled wire is employed, the wire for the smallest coil may be wound with an extra wire between the turns, that is later removed, in order to have the turns of wire spaced apart. With cotton-covered wire, especially where it is double-covered, the thickness of the cotton provides the spacing. Spacing the wires is helpful because it reduces the capacity effect between the wires. This factor is not important for broadcast purposes or the higher brackets of the short waves.

### WALL-MOUNTED SPEAKERS

**I**S it true that less volume is obtained with a wall-mounted loudspeaker?—M. N. T.

That depends on the method used in mounting. If you cut a hole in a wall and placed a dynamic unit against it, you would get the sound from the front part of the speaker only, thus cutting the volume in half.



**A Question and Answer Department conducted by Radio World's Technical Staff. Only Questions sent in by University Club Members are answered. Those not answered in these columns are answered by mail.**

# Radio University

Annual subscriptions are accepted at \$6 for 52 numbers, with the privilege of obtaining answers to radio questions for the period of the subscription, but not if any other premium is obtained with the subscription.

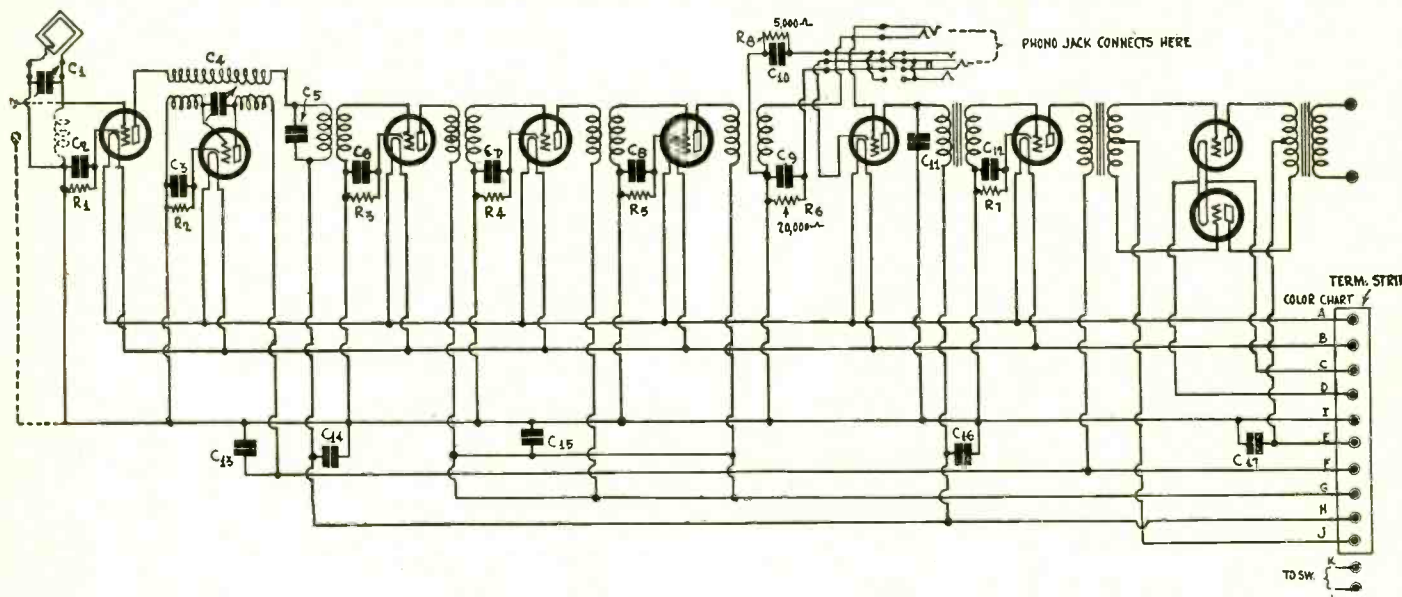

FIG. 894

Circuit showing how to convert a Victoreen superheterodyne to AC operation. All the voltage terminals, including those for the filaments, are brought to a terminal strip.

**I** HAVE a Victoreen superheterodyne which I wish to convert to AC operation. Will you kindly publish a diagram of it showing the necessary changes?—L. W. C.  
 Fig. 894 shows a diagram of a converted Victoreen. The heater and filament terminals have been brought to a terminal strip to which the leads of filament transformer windings may be connected.

\* \* \*

### Correction of Ohmmeter Readings

**I** HAVE an ohmmeter designed for use with a 1.5 volt dry cell. I realize that when the battery gets old that the voltage drops and that the readings are not correct. Is there any way of overcoming or compensating for this error without replacing the battery?—B. W. C.

It is not the voltage of the battery that drops but the voltage across the output terminals when a current is taken from the cell. There is a distinction between these two statements, and in the difference lies the answer to your question. The drop of voltage is due to the internal resistance of the cell, and this resistance is in the circuit in series with the resistance to be measured and the zero setting resistance used to protect the meter. When the cell is fresh the ohmmeter reads zero when the terminals for the unknown resistance are short-circuited, but when the cell is old a definite resistance is indicated. This indicated resistance is the resistance of the battery. First take a reading with the unknown resistance shorted and then take another when the short is removed. The difference between these two indicated resistances is the resistance of the unknown. There is an error even in this, however, for the resistance of the cell may vary, increasing with the current. Since the current will be less when the unknown resistance is in the circuit, the internal resistance will be lower, and therefore the correction may be overdone. However, a more nearly correct value will be obtained by applying the correction than not. Hence it is worth while to correct for the zero error.

\* \* \*

### Dry Cells for Bias

**I** N MY receiver the bias for the tubes is supplied by dry cells. When I measure the voltage of these cells I scarcely get any reading at all, showing the cells are practically dead. Yet the receiver operates well with these old batteries in the circuit. If I remove them and make the bias zero the results are very bad. Will you kindly explain why this is?—W. H. J.

The trouble is that the grid battery is exhausted and not dead. The electromotive force of each cell is practically the same as it was when the cell was new but the internal resistance is so high that when you draw current to operate voltmeter most of the voltage drop occurs in the cell. This means that the resistance of the cell is much larger than the resistance of the meter. In fact, the resistance of the meter is negligible in com-

parison. When the cells are in the grid circuit no current is drawn and the bias is about the same as it was when the cells were fresh. That the electromotive force of a cell does not drop as it becomes exhausted can be proved by measuring its voltage by a vacuum tube voltmeter. Even if a 1,000 ohms per volt voltmeter does not give any appreciable indication, the vacuum tube voltmeter will give close to 1.5 volts per cell.

\* \* \*

### Winding Data for Coils

**I** HAVE a gang of .0005 mfd. condensers which I wish to use in a tuner covering the broadcast band and I want to use 1.5 inch tubing. How many turns should I use and what size wire do you recommend?—B. L. F.

Use 60 turns of No. 30 enameled wire without space winding. For the antenna winding 15 turns should be enough and for the primary to be connected to the plate circuit of a screen grid tube 30 turns.

\* \* \*

### Ganging Super Oscillator to RF Circuits

**W** ILL you kindly discuss the necessary conditions for successful ganging of the oscillator condenser to the radio frequency tuning condensers in a superheterodyne? Can it be done when all the condensers are the same in capacity and type of plates?—J. E. D.

If the intermediate frequency is not too high it is possible to obtain approximate alignment of the condensers without specially cut plates for the oscillator, but when the intermediate frequency is high it is difficult to achieve it. It is done in commercial receivers having an intermediate frequency of 175 kc. It is necessary to alter the rate of change of the oscillator capacity with respect to that of the other condensers, and in practice this is done by making the zero setting capacity comparatively high for the oscillator and also by putting a condenser in series with the oscillator condenser. If we have three adjustable condensers, one the main tuning condenser, another connected in series with this, and the third connected across the two, it is possible to adjust the circuit so that the oscillator and the RF tuners will be lined up exactly at two points, which may be chosen at will. If these are chosen at 600 and 1,400 kc the deviation at other points will not be great.

\* \* \*

### Resistor Across Coupling Capacitor

**W** HAT is the purpose of the resistor across the coupling condenser in band pass filters used in many commercial receivers? The coupling condenser usually has a capacity of .04 mfd. and the resistance across it is 500 ohms. Does the resistance change the effective value of the capacity to any appreciable extent?—B. F.

Usually the only purpose of the resistance across the coupling  
 (Continued on next page)

# Radio University

A Question and Answer Department conducted by Radio World's Technical Staff. Only Questions sent in by University Club Members are answered. Those not answered in these columns are answered by mail.

Annual subscriptions are accepted at \$6 for 52 numbers, with the privilege of obtaining answers to radio questions for the period of the subscription, but not if any other premium is obtained with the subscription.

(Continued from preceding page)

condenser is to insure a grid return of the tube following the filter. When there is a secondary winding on the second coil in the filter and this secondary is connected in the grid circuit and is returned to ground, there is no need of the resistor. It affects the effective capacity to a small extent. If the capacity of the condenser is .04 mfd. and the resistance is 500 ohms, the effective capacity of the combination at 1,000 kc is increased by 2.5 mmfd., which is entirely negligible. If the resistance across the condenser is larger the difference is still smaller.

### Interference in Converter Reception

I HAVE a short-wave converter that is very sensitive but it is subject to interference from broadcast stations. No matter what intermediate frequency I use broadcast stations come in and the converter acts as a booster. When I remove the antenna from the converter no broadcast signals come in, and no short-wave signals of course, but when I put on the antenna, both short and broadcast waves come in. It is not possible to tune out the broadcast signals with the converter tuner. Can you suggest anyway of overcoming this difficulty?—S. J.

Apparently the converter itself does not act as an antenna but as a booster, just as you say. Hence it is a question of preventing the converter circuit from transmitting the broadcast waves. The first thing to do is to make the broadcast receiver selective at the frequency you use for intermediate. Most receivers are not at all selective at the 1,500 kc end of the scale because the trimming has been done higher up. You might retrim the circuit at the short-wave end and then use an intermediate frequency around 1,500 kc. Select one at which there is no strong station operating. If this cannot be done trim the circuit at 550 kc and use that frequency, provided that there is no local station on that. Undoubtedly the circuit has been trimmed at some frequency in the middle of the band and if you cannot find a clear frequency at the ends select one near the center where the trimming has been done. It is nearly always possible to get a clear frequency. Considerable improvement can be effected by tuning to the short-wave carrier frequency and making the coupling between the antenna and the tuned coil very loose.

### One Meter Television

IN YOUR February 7th issue you have a news item in which Senator C. C. Dill predicts television on one meter waves. What advantages would these short waves have over those now used for television? Is there any likelihood that there will be extensive developments along this line in the near future?—D. E. C.

At this time there is the advantage of plenty of room. Tele-

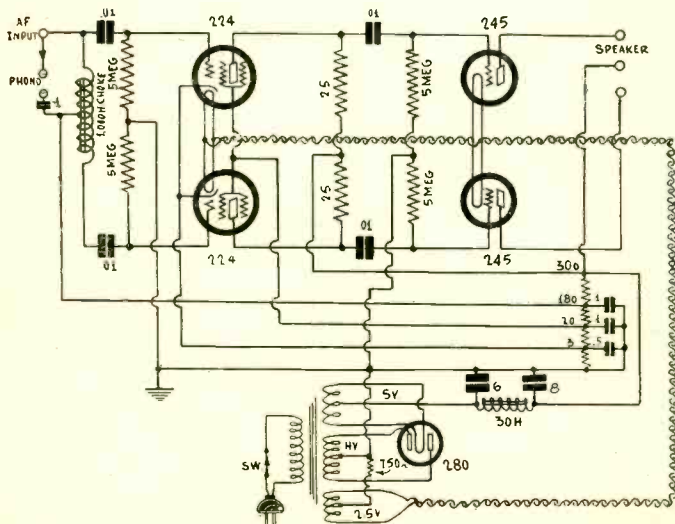

FIG. 895

The circuit of a two-stage push-pull amplifier using 224s and 245s. It may be coupled to a 224 grid bias detector, the centertapped choke making this possible.

vision channels as wide as 1,000 kc could be accommodated, and these would afford television of high quality, that is, of much detail. But as soon as the art has been developed to the point where these short waves can be used for television they can also be used for other communication and there will be a scramble for assignments. Hence as soon as the art is ready for television in this frequency range the chief advantage will be lost. If, however, satisfactory television service can be established around one meter, channels might be reserved. These short waves do not travel so well as those between 10 and 200 meters so that they would be used for local service, and that seems to be the only present application of television.

I AM desirous of building a push-pull amplifier utilizing two 224 tubes and two 245s with resistance coupling between.

The coupling between the detector and the first stage should be a centertapped choke with stopping condensers and grid leaks. If you have a diagram of this type will you kindly publish it? Will the secondary of a push-pull input transformer do for the centertapped choke or is it necessary to get a special choke coil?—F. C.

You will find the diagram you ask for in Fig. 895. The input transformers will be all right. You simply ignore the primary winding.

### Oscillator Bias

IN THE circuit diagram of the RC-27 converter the oscillator has a 150 ohm bias resistor when the tube is a 227. The regular bias resistance for this tube is 2,000 ohms. Why do you use such a low bias resistor and does not the plate current become excessive?—A. L.

You will notice that the plate voltage on this tube is only 45 volts. Often no bias is used at all when the plate voltage is no higher. The 150 ohm resistor gives a low bias to the tube but it is quite sufficient. The value is not critical.

### Three-Tube Converter

IN THE February 7th issue you published a diagram of a three-tube converter utilizing one stage of intermediate. Is this circuit practical?—O. B. F.

Surely it is practical. It is especially suitable for receivers in which there is not a great deal of radio frequency amplification.

### Noise Level and DX Reception

IS THE noise level the same at all times and in all places? Also, is it the same for all circuits, or does some of the noise originate in the set?—V. B. Y.

The noise level varies all the time in any one place and it also varies from place to place. Some of the noise is natural and some man-made. It is not the same for all receivers for some are noisier than others, and as a rule, the larger the number of tubes the higher the noise level.

### Wired Radio

WHAT is the meaning of wired radio? There have been many references to it but I have never seen any explanation of it. Will you kindly give a brief explanation of it?—E. S.

Wired radio is the name given carrier current telephony on wires. It was invented by General Squier, formerly Chief Signal Officer of the U. S. Army, while he still held that office. One company organized to exploit the invention, calls it wired radio while the old established communication companies call it carrier current telephony. It is also applied to telegraphy. The scheme consists of modulating high frequency currents which are sent by wire just as radio waves are sent through the air. If we should connect a transmitting station and a receiving station by wire we would have wired radio. There is no radiation in wired radio and hence it cannot logically be called radio.

### Obtaining B Voltage for Converter

IS THERE not a simple way of obtaining plate voltage for the tubes in a converter without using a B battery or entering the receiver to get it? I have in mind a built-in B supply with a rectifier. It must be inexpensive.—S. W. G.

Yes, there is a simple way and you will see many circuits incorporating the scheme in the near future. In fact, one circuit was published in the February 21st issue. You may have seen it.

### Ground Removed Aided Sensitivity

OUR ground wire became accidentally disconnected and I noticed that many of the stations, especially on the shorter waves, came in much stronger. Yet there was a disturbing hum present. What causes this peculiar effect? Is there any way to keep the improvement and get rid of the hum?—L. V.

When you disconnect the ground wire, the ground contact, so far as the radio waves are concerned, takes place by means of the small capacity existing between the secondary and primary coils of the power transformer to the electric wiring system, which is grounded. The effect is the same as that of a series condenser between the aerial post of the set and the aerial. An actual ground is needed with most sets to insure absence of hum. Try the series condenser, or else a shorter aerial.

# MARCONI TELLS TECHNIQUE OF VATICAN PLANT

By GUGLIELMO MARCONI

The Vatican transmitter, in its main features, follows the design of the Marconi short-wave high-speed beam transmitters which are used in the British Imperial beam stations. The complete transmitter consists of four main panels, and is designed for telephony and high-speed telegraphy on wavelengths of 19.84 or 50.26 meters.

The first of the four panels is the main magnifier unit for both waves. The second panel contains the intermediate magnifiers and the Marconi Franklin tube master drive unit for the shorter wavelength. The third panel comprises the intermediate magnifier units and master drive unit for the longer wave-length, while the fourth panel is a combined modulator for telephony and absorber driving unit for high speed telegraphy.

## Rating on Telegraphy and Telephony

On telephony, the transmitter is rated to deliver from eight to ten kilowatts of unmodulated carrier wave energy to the aerial feeder system, the output depending on the wavelength used. The normal degree of modulation is eighty per cent. The rating on continuous wave telegraphy is thirteen to fifteen kilowatts to the aerial feeder.

Two transmitting aeriels of the Marconi uniform type are provided, one aerial for each wavelength. This type of aerial has been recently developed by the Marconi Company and is an improved type of vertical short-wave aerial. Both aeriels are suspended and insulated from a triatic slung between two self-supporting lattice steel towers sixty-one meters in height, placed ninety meters apart.

The energy from the transmitting building is conveyed to the two aeriels by two separate concentric copper tube feeders similar to those used in the British Imperial beam stations. The transmitting building itself is situated in a part of the grounds in the Vatican which is surrounded by a Roman wall, forty-five feet high, while the masts are placed outside this wall. In order not to destroy the amenities of the Vatican gardens, a tunnel forty-three metres long, passing under the Roman wall, has been constructed to accommodate the aerial feeders.

## Permits World Broadcast

A special receiver, partly made of standard parts of the normal telephone and high-speed Marconi receiver and telephone terminal four wire-two wire equipment, will secure good telephone and telegraph duplex communication between Vatican City and any part of the world. This receiver is situated in one of the rooms of the transmitting station, and utilizes the vertical antenna situated at a distance of only a few yards from the sending antenna. This receiving antenna is suspended to the same triatic which carries the sending aerial and its length is adjustable from the receiving room.

The new wireless station, which may be considered to represent the latest word in short-wave technique, not only provides the Vatican City with a radio telegraph and telephone link with distant parts of the earth, but also enables the voice of His Holiness, the Pope, to be broadcast throughout the world.

## Address by Pope Heard World Over

The first radio broadcast by a Pope of the Holy See took place at the Vatican plant designed, installed and donated by Guglielmo Marconi, when Pope Pius XI recently literally spoke to the world.

The Vatican station, HVJ, used the 19.84-meter wavelength, at a power of 10 kw. His Holiness' utterance was picked up on the short wave by stations the world over and relayed to millions of listeners on regular broadcast waves. In the United States the National Broadcasting Company sent the talk over its chain, while the Columbia Broadcasting System rendered the same service to its member stations. More than 160 stations in the United States transmitted the program.

The National Broadcasting Company obtained from Marconi the technical data on the Vatican station, published herewith.

# KING OF ARABIA TURNS TO RADIO

Radio sets are to be fitted on lorries in Arabia so that King Ibn Saud may be able to keep in constant touch with his palaces in his two capitals, Mecca and Riyadh, during journeys into the desert, according to a statement just issued by the Department of Commerce. In addition, facilities are being provided for radio communication between the palaces in the two capital cities, which are 400 miles apart, it is declared in the statement, which follows in full text:

The modernization of Arabia in the field of communications has reached a new stage with the signing of a contract between the King of Hedjaz and the Nejd and the Marconi Company for fifteen of the newest type radio stations, according to British information received in the Commerce Department.

In addition to fixed stations in towns, four sets fitted on lorries are to be supplied as general mobile telegraph stations, and to enable the King to keep in constant touch with his two capitals, Mecca and Riyadh, during his journeys into the desert.

In Mecca a 6-kilowatt telephone and telegraph transmitter (type "U") and receiver (R. G. 19) will be installed within the Holy City by a Mohammedan engineer. Similar stations are to be erected at Riyadh, the capital of Nejd, about 400 miles from Mecca, so that King Ibn Saud, who has palaces in both towns, will be able to talk from one to the other by means of special microphones.

The stations in the smaller towns, according to "The United States Daily," will be of the type XMC2 of 500 watts. As they will be worked by Arab operators, the controls will be adjusted to fixed wave lengths and interlocked, so that by merely moving a handle into the position of "transit" or "receive" the operator will automatically switch on the set at the correct wave length for the service required.

## COWAN A PILOT EXECUTIVE

Wayne W. Cowan has been placed in charge of the set department of the Pilot Radio & Tube Corporation, of Lawrence, Mass. Mr. Cowan formerly was with the Edison, Splitdorf and Kolster companies.

# SPONSOR USES 35 STATIONS, COVERS NATION

The R. J. Reynolds Tobacco Company added nineteen powerful broadcasting stations to the already extensive network of the Camel Pleasure Hour to complete a transcontinental hook-up. The Camel Pleasure Hour will be heard in every section of the country.

## List of New Additions

The new stations that hear the Camel Pleasure Hour every Wednesday night from 11:15 to 12:15 E. S. T. are as follows: WTMJ, Milwaukee; WEBC, Duluth-Superior; WHAS, Louisville; WSM, Nashville; WMC, Memphis; WSB, Atlanta; WAPI, Birmingham; WJDX, Jackson; KTHS, Hot Springs; WBAP, Ft. Worth; WKY, Oklahoma City; KOA, Denver; KGO, San Francisco; KECA, Los Angeles; KGW, Portland; KOMO, Seattle; KHQ, Spokane; KFSD, San Diego; KTAR, Phoenix.

With the addition of the above extensive chain, the Camel Pleasure Hour will have a total hook-up of 35 stations.

## The 9:30 P.M. List

This will mean that every Wednesday night there will be two separate broadcasts of the Camel program. The first from 9:30 to 10:30 E. S. T. will continue as before from WJZ and the following associated stations: WBZA, Boston; WBZ, Springfield; WHAM, Rochester; KDKA, Pittsburgh; WJR, Detroit; WLW, Cincinnati; KYW, Chicago; KWK, St. Louis; WREN, Kansas City; WSJS, Winston-Salem; WRVA, Richmond; WJAX, Jacksonville; WIOD, Miami; WFLA, Tampa; WGAR, Cleveland.

## RCA Holds \$750,000 in German Company

Berlin, Germany.

The latest news item of interest from Germany is the news that the ownership of the Nauen Radio station has passed to possession of the German Ministry of Communications.

The former owner was the Trans-radio Corporation, whose principal stockholders are the Telefunken Gelleschaft. The Siemens Gelleschaft, The Electrical Trust, and in addition the Radio Corporation of America, which it is said holds about \$750,000 worth of its shares.

## Predicts Sending 40 Messages at One Time

London.

At a recent demonstration to the press of the Stenode Radiostat by Dr. James Robinson it was predicted that forty simultaneous messages soon would be sent over a single line and that entire letters would be sent by cable because of the cheapness of telegraphy. At present six channels per line is regarded as the maximum by the older methods.

At the demonstration simultaneous working on three channels was seen. The messages were sent over 240 miles of land line from London to Bristol, thence back to London, where they were recorded on paper tape. The frequency separation was only one-half as great as that in any other multiplex system.

## EUROPE TIRING OF TAX, LOOKS TO SPONSORING

Washington.

Selectivity is a primary requisite in radio sets designed for use in Europe, according to Lawrence D. Batson in an analysis of world markets for radio equipment which the Commerce Department has just released.

In the United States, Mr. Batson points out, the system of chain broadcasting whereby identical programs are broadcast by large stations in various parts of the country makes this attribute of lesser importance. In Europe, on the other hand, there is little or no chain broadcasting; the large broadcasting stations enjoy absolutely clear channels and the radio fan is able to choose his entertainment from a wide field of programs coming from many different countries.

More than 24,000,000 radio sets, representing a value of approximately \$1,500,000,000, are in use throughout the world today, Mr. Batson's report reveals. Forty-five per cent of the world total, or 10,500,000 sets, with a value of \$676,000,000, are in the United States. The total investment in broadcasting stations throughout the world is estimated in the neighborhood of \$29,000,000, of which one-half is represented by stations in this country.

### Difference in Crystal Sets

Socket-power sets account for 52 per cent of the total number in use in North America, for about one-half of the sets in Europe, and one-quarter of those in South America. Crystal sets are fewest in North and South America, representing 1 and 2 per cent respectively, and highest in Russia and Turkey where the ratio is around 20 per cent.

In the majority of countries outside of the United States and Canada the cost of broadcasting is paid by a system of license fees levied on the radio sets in use. These fees range from as low as 39 cents in France to as high as \$44 per set in Turkey. The average license fee, however, runs between \$3 and \$4.

As there are approximately 11,000,000 radio sets in Europe, it is apparent that the amount paid yearly by radio fans in that area is between \$40,000,000 and \$45,000,000. According to Mr. Batson there is a definite trend in some foreign countries toward adopting the American system of a sponsored program. Most foreign countries, however, prefer to retain the license fee system, having a prejudice against mixing advertising with radio entertainment.

### American Sets Deemed Best

Referring to the type of foreign broadcasting programs, the report shows that a sort of "universal" program has been adopted similar to that used in the United States, consisting of music, addresses, and informative talks. Even sports and news events are now put on the air by foreign stations, although not to the extent prevailing in this country.

American radios, according to Mr. Batson, are generally regarded as superior to the great majority of foreign makes. In European manufacturing countries, his report shows, most of the sets in use are of domestic origin. After the United States, England and Germany have made the greatest advance in radio development and each has built up a substantial export trade in radio sets and equipment.

## Jazz is Taboo on Davey Hour

The Davey hour holds to its policy to use no jazz numbers. More than half way through its second season, this feature has broadcast 588 selections without using jazz. "The popularity of the Davey hour seems to indicate that jazz isn't essential, no matter what anyone may say to the contrary," remarked an official of the Davey Company, tree experts.

All of the Davey musical numbers are melodious, and nearly all oldtime and appeal to memories.

## W2XAF POINTS WAVE TO ANDES

Signals of W2XAF, the 31.48 meter transmitter of WGY at Schenectady, N. Y., are directed to Venezuela at 11 p. m. e.s.t. every Saturday, to a group of men making up the Syracuse University Andean Expedition. A special receiving set made up by the General Electric Radio section will enable the explorers to hear messages from members of their families and friends at home.

The directive antenna, developed by Dr. E. F. W. Alexanderson for the broadcasts to the Byrd expedition in Antarctica, has been reset so that the electromagnetic waves will be most strongly directed to South America. There is every reason to expect that the signals of W2XAF will be received clearly and with good volume.

The Syracuse University Andean Expedition is headed by Dr. Parke H. Struthers and is engaged in gathering scientific data on hitherto unexplored regions of the Andes Mountains.

W2XAF has been heard in practically every country in the world and has been rebroadcast frequently in Europe, South Africa, South America and Australia. It is today one of the best-known intercontinental station and its engineers regard it as an "unofficial ambassador of the United States."

In providing special service to isolated explorers of the Andean Expedition W2XAF is filling again the role of friend of explorers. In 1926 the facilities of W2XAF were offered to both Byrd and Amundsen North Pole expeditions prior to their flights from Kings Bay, Spitzbergen. Daily time-signals were transmitted to Francis Gow-Smith to assist him in map-making while he was in the interior of South America.

Donald MacMillan has acknowledged indebtedness to W2XAF for programs and information, received while he was on his Arctic trips. The expedition of the University of Iowa into northern Canada, also received personal messages from W2XAF. The fortnightly programs, of messages and entertainment, carried on over a period of one year, proved of great value in upholding the morale of the Byrd Expedition personnel, according to Admiral Richard E. Byrd.

### U. S. IS LARGEST EXPORTER

The United States today is the world's largest exporter of radios and during the last three years has made striking gains in this field. Foreign sales rose from something more than \$9,000,000 in 1927 to \$12,000,000 in 1928, while the export figure for 1929 was more than \$23,000,000. Figures for the first ten months show total sales of radios and equipment in foreign market had a value of \$17,800,000.

## HOOVER HAILED AS THE "IDEAL" RADIO TALKER

Washington.

Two obstacles of broadcasting's early days, microphone fright and the possibility of speakers running under or over their allotted time, are fast disappearing among government officials in Washington, according to Frank M. Russell, vice-president of the National Broadcasting Company, located here.

"The year 1930 showed a distinct improvement," Russell said. "Cabinet members, senators, representatives and other government officials are not awed when they face the microphone. Frequent radio appearances have made these officials feel perfectly at home in the studio.

"The task of getting speakers off the air on time is becoming easier. In 1930, there was only one instance where a speaker exceeded the allotted time, a greater number running short of the period."

Russell pointed out that in 1930 there were 328 government officials who spoke over NBC networks from Washington and added:

"President Hoover is radio's ideal speaker. He is never late. His addresses run the specified time, almost to the minute. His voice never varies. While most of his speeches are made on platforms before large audiences, he never forgets the microphone. He faces it at all times, never turning to one side or the other, as most speakers do. President Hoover's voice, from the viewpoint of radio engineers, is easier to handle than the voices of most speakers."

## McCardell's New Book Big Seller in 3 Days

The first book of modern fiction to make the all-pervading and mighty radio its basic background, for that very reason and because it was given a mention in a book talk over the air, was established as a big seller in three days.

The book in question is the laughable dramatic novel, "My Uncle Oswald," by Roy L. McCardell. It was published on Feb. 5 and on Feb. 8 thousands of booksellers in the United States had sold out all copies on hand and had reordered.

"My Uncle Oswald" is the sequel to the riotous "My Aunt Angie," a smashing success of last year, by the same author.

"My Uncle Oswald" is a radio and newspaper romance, and the radio for the first time in fiction is given full consideration and its power and influence in business and entertainment regarded in their proper light.

It cannot be said that "My Uncle Oswald" seriously considers radio in the generally accepted sense of the term. And yet it is most thoroughly considered in this book as a factor of our modern life that is far more dominating and influential than the newspapers. In fact, it would appear that the author's opinion is that radio is usurping the functions of newspapers and periodicals.

Of course, being a humorous philosopher, Roy L. McCardell pokes gorgeous fun at the radio and the ultra-sentimentality of many of its programs—but, for all that, he marks its prestige, power and popularity, and "My Uncle Oswald" tells convincing truths that might well be heeded by the magnates of radio.

## NEW MACHINES GIVE REALISTIC SOUND EFFECTS

"Auditory realism" is the goal toward which the studio sound effects men are striving these days. By this phrase the thunder makers mean that the sound-effect machines they have constructed in their workshops shall reproduce accurately and realistically the noises incident to a dramatic broadcast program.

The latest development in the National Broadcasting Company's sound effects is in process of completion and consists of an electrically operated device, housed in a wooden box three feet by three feet by five feet, which is expected to accurately reproduce noises associated with railroad train operation.

N. Ray Kelly, sound technician, is responsible for the novelty. Kelly spent hours recording train noises in the Sunnyside (Long Island) yards of the Pennsylvania Railroad, in New York City. He listened to clanking driving rods, escaping steam, all the chug-chugs, puff-puffs, grinding brakes, shrieking whistles, clickety-clicks of wheels over rail ends and other racket.

### One-Man Job

Recently he completed his blue prints and the NBC workshops are now engaged in putting the intricate apparatus into working condition. The new device will probably be heard on the air shortly. It is a distinct improvement over present methods of reproducing train operation. The Great Northern Railroad programs, heard from NBC studios in Chicago, are featured by a miniature railroad operated by four men. Kelly's device will be controlled at one end of the box by one man.

NBC engineers make use of a wide variety of articles to give the radio audience carefully adjusted sounds.

For example, the crumpling of stiff white paper in front of a microphone sounds like a roaring, crackling fire; running the fingers across a comb's teeth will, with proper pressure, sound like the mournful notes of a tree toad; animals are heard crashing through the underbrush when a sound engineer squeezes the straws of a house wife's broom, and the swish of steady rain is "produced" when excelsior is rubbed against the closed end of a microphone, while a torrential downpour is effected by pouring salt on wax paper held before the "mike."

### Man Taps Head, Dog's Tail "Wags"

The audible creaking of a porch swing, as reproduced by the microphone, calls for the gentle rocking of a rusty swivel chair; the sound of a dog wagging his tail is simulated by a man tapping his head before the microphone with a padded stick; rifle and pistol shots, which would ruin expensive studio equipment, are reproduced for radio listeners when engineers smack a padded board with a flat stick, while heavy artillery calls for the use of tympani, because of the long reverberating sound.

Thunder rumbles, roars and booms from the "thunder drum" which, in the NBC laboratory, is a four foot frame covered with heavy parchment. A pull on the string, running through the sheepskin covered bottom of a bucket, will sound like a roaring lion.

Specially designed whistles imitate the trills of birds, but unusual care is exer-

## Home Television

### Due "This Year"

"Inauguration of commercial radio-television will take place this year," said D. E. Replogle, of the Jenkins Television Corporation.

The company's three television stations, W2XCR, W2XCD and W3XK, are going to operate on the same frequency, sharing time. Collectively, they will be on the air from morning until night. Each station is to have a voice channel, for the essential sound accompaniment to the radio pictures. The assigned frequency is 2000-2100 kilocycles.

## RCA TO APPEAL TUBE DEFEAT

Philadelphia.

"Clause Nine," as written in contracts with set manufacturers, compelling them to use only RCA tubes for "initial equipment," constituted a monopoly, the Federal Circuit Court of Appeals held, affirming the decision of the lower court.

Defeated in this appeal, R.C.A., Westinghouse Electric & Mfg. Co., the A. T. & T. and several subsidiaries, all defendants, will seek means to bring the case before the United States Supreme Court.

The De Forest Radio Company led the independent tube manufacturers that pressed the case as plaintiffs. The independents asserted that "Clause Nine" froze them out of the tube market for "initial equipment," since R.C.A. licensed the manufacturers of sets, and refused to issue licenses under any other terms.

This the plaintiffs contended was monopolistic in violation of the Clayton anti-trust law, to which two courts have agreed, on the merits.

The Radio Corporation of America made the following statement:

"We shall apply as promptly as possible to the Supreme Court of the United States for a writ of certiorari. The clause to which the litigation was directed, as a matter of fact, has not been in force since July, 1928. Nevertheless, the case raises important and novel questions as to the rights of an owner of patents in the granting of licenses. These questions have not yet been passed upon by the Supreme Court."

The independents have since been licensed by RCA as tube manufacturers and prior thereto the clause under dispute was eradicated from contracts, as R.C.A. agreed that as a matter of policy its inclusion was undesirable. However, the questions at stake have to do with the independents' claims to damages.

cised in manipulating these as an extra "peep" would spoil many a program.

Airplane motors are heard by use of electrically whirled leather strips that beat against drum heads at varying speeds, ranging from the slow, uncertain sputter of warming motors to the splinting, high-pitched drone of the take-off. The sound of a threshing machine is simulated by a combination of intricate machinery and a baby's rattle.

The NBC sound laboratories even have a "garage." This consists of a wooden board two feet square to which are attached many automobile horns, even including a "garage" siren for hair-raising fire scenes.

## 4,000 BESIEGE STORE TO PEEP AT TELEVISION

Boston.

That the public is ready to accept television if properly presented seems to have been proved by interest displayed in a public demonstration in one of the department stores here. It is estimated that 4,000 persons crowded around the television, eager to catch a glimpse of the pictures and to hear the accompanying voices.

The system used by the Short Wave and Television Laboratories, sponsors of the demonstration, is of the 48-line type, but differs from other systems in the scanning mechanism. Instead of using the circular disc with the 48 holes in a spiral, this system uses what may be called a spider on the rim of which is a flexible steel strip containing the scanning holes.

### Rectangular Tracing

The scanning disc traces slightly curved lines across the field and results in a somewhat distorted field of view while this method traces straight line and results in a rectangular field.

Accurately placed square-cut holes are punched in the scanning strip, assuring uniformity of illumination and lack of undesired "structure" of the field of view. The strip system also adapts itself readily to the use of different scanning detail when desired. For example, when it is desired to use 60-line scanning it is only necessary to remove the scanning strip having 48 holes and substituting one having 60 holes.

The pictures were received on a short-wave, resistance-coupled set capable of amplifying the detail of the picture.

### Offers Kit at \$90

A television set kit was offered by the store at \$90.

The signals received by the sets in the store were transmitted by W1XAV, operated by Short-Wave and Television Laboratory on 140 meters and 500 watts. Since there was no sound channel the sound accompaniment was provided by a special wire line between the transmitter and the store.

## Literature Wanted

Readers desiring radio literature from manufacturers and jobbers concerning standard parts and accessories, new products and new circuits, should send a request for publication of their name and address. Send request to Literature Editor, RADIO WORLD, 145 West 45th Street, New York, N. Y.

Vincent A. Millett, 808 Armstrong Ave., St. Paul, Minn.

G. M. Sandberg, 517-55th St., Brooklyn, N. Y.

Reed Barton, 1718 Ridge Ave., Coraopolis, Pa.

Budd Radio Service, Hobbs, New Mex.

Harold A. Neiswanger, 402 "A" St., Keokuk, Iowa.

Fred Stafford, 106 E. Cherry St., Sevierville, Tenn.

Philip Deckebach, 1413 Edgewood Drive, Royal Oak, Mich.

Otta T. Hageh, 203 S. Page St., Stoughton, Wis.

John P. Ripton, 1547 Sherbourne Dr., Los Angeles, Calif.

M. J. Geer, Box 453, Sabetha, Kans.

George W. Pope, 836 Lorimer St., Brooklyn, N. Y.

M. L. Gaston, 3825-5th St., Des Moines, Iowa.

A. M. Rowe, Grain Valley, Mo.

Dr. F. Russell, East Hampton, N. Y.

Michael Ert, of Milwaukee, Wis., Chairman of the Board of the National Federation of Radio Associations, representing some 20,000 radio tradesmen throughout the United States, commented on the business situation as follows: "The entrance of the midget or lower price set in the radio field has created an additional consumer market, in that many owners of console type receivers are now purchasing midgets to use as their second set. It is expected that the many new owners of midget radios, unable at the present time to afford the purchase of a larger set, will become so thoroughly sold on the necessity and advantages of owning a radio set that they will be potential prospects for a larger or console type sale. The desire to own a radio of higher quality and workmanship will be created which will greatly stimulate our business. It is my observation, through a recent trip in the various centers of the United States, that business conditions are decidedly on the upward trend and I look forward to the radio industry to participate in this improvement within the next sixty days. The future of radio looks very bright."

Charles Gilbert, executive vice-president of the Pilot Radio & Tube Corporation, previously located in New York, has moved to Lawrence, Mass., where the general offices and factories of the company are located. Harold T. Porter has been appointed general sales manager in charge of the United States and Canada. Robert I. Lewis has been appointed zone manager of the Metropolitan New York district, 525 Broadway, New York. Robert Hertzberg, formerly connected with the New York office, has moved to Lawrence.

Cut-price "bargains" in radio receiving sets, due to distress merchandise of a few manufacturers, are vanishing rapidly, according to a survey of the radio industry made at a conference here of the officers and directors of the Radio Manufacturers' Association, the national industry organization. Distress merchandise, confined to a very few radio manufacturers, is being disposed of rapidly and will be liquidated soon, it was the consensus of the industry leaders. Fewer failures among radio manufacturers last year than in 1929 were reported by RMA officers. During 1930 there were officially reported twenty-two failures of radio manufacturers involving \$4,300,000, and credit extension granted involving \$400,000. This compares with twenty-five failures involving over \$12,000,000, and credit extensions to three concerns involving a little over \$4,000,000 in 1929.

Beginning March 1, all the works and offices of the Westinghouse Electric and Manufacturing Company will omit Saturday operations, except as involved in maintaining adequate service with customers and others with whom the company does business, President F. A. Merrick announced. Mr. Merrick emphasizes that this arrangement is solely an emergency measure and that normal arrangements will be reinstated with the advent of normal times.

A new line of Amertran Sound System Panels has just been announced by the American Transformer Company, 178 Emmet Street, Newark, N. J. These panels are made for fourteen different applications and may be assembled in various combinations on standard mounting racks to make up complete sound systems for every conceivable requirement. The panels have been designed to permit extreme flexibility. In all cases the apparatus is mounted on solid aluminum panels of standard (19") width but vary-

# TRADIOGRAMS

ing in height  $1\frac{3}{4}$ " multiples, the edges being notched to facilitate assembly in the most convenient position on standard mounting racks. Dust covers are provided on the rear to protect apparatus and for the safety of the operator. Knock-out boxes for BX wiring are also included on all dust covers to comply with Fire Underwriters' regulations. A comprehensive twenty-one page booklet entitled "The Amertran Sound System" has just been prepared and a copy will be sent free of charge to any interested person, provided his request is written on business stationary.

The Flexible Cord Group of the National Electrical Manufacturers Association, 420 Lexington Avenue, N. Y. City, has just issued the first NEMA standard color card for flexible cord. The cards are 3-1/8 and 6-1/8 inches in size and are durably made. They cost 20 cents each.

A series of midget type tuning condensers ranging in capacity from 19 mmfd. to 322 mmfd., having the midline characteristic, has been developed by the Hammarlund Manufacturing Company, 424 West 33rd Street, New York City, for manufacturer's use. A series of straight line capacity models also has been produced.

The smallest condenser is  $2\frac{3}{4}$  inches long and the largest, 4 inches long. All midline types are 2 inches wide with plates fully extended. The capacity type is only  $1\frac{1}{2}$  inches wide.

Solid bright-dipped brass plates are used in all models. All plates are well spaced and soldered, the stator being soldered to brass slotted bars and rotor to a slotted brass shaft.

There are also end stops so that neither rotor nor stator plates can be damaged by jamming. A set screw is provided for locking plates in any position permanently.

No screws or nuts are used anywhere in the construction of this condenser, soldered eyelets being employed.

The models are made in both clockwise and anticlockwise fashion, and for base or one hole panel mounting. The shaft is  $\frac{1}{4}$  inch diameter.

The condensers are made in the following capacities: 19.2 mmfd; 34.2 mmfd; 49.2 mmfd; 78.6 mmfd; 93.6 mmfd; 100.2 mmfd; 138 mmfd; 198.6 mmfd; 242.4 mmfd; 294 mmfd; and 322 mmfd.

A triad marine radio, combining a broadcast receiver, position finder and compass in one apparatus, was recently developed by the Pioneer Instrument Company, New York City, a division of the Bendix Aviation Corporation, and was shown for the first time at the motor boat show at Grand Central Palace in New York City.

A new battery set, designed to operate an average of three hours daily for one year without recharging or replacing batteries, is announced by the General Motors Radio Corporation, Dayton, Ohio. It has been named the Pioneer. This set was brought out particularly to meet a rapidly growing demand from the rural sections, where lack of power lines bars the use of an AC set. Using the two-volt tubes and battery to coincide, the set if operated on an average of three hours a day, is built to operate over a period of approximately a year, giving the same standard of performance on the farm as is enjoyed with the AC receiver in the city homes.

F. A. Merrick, president of the Westinghouse Electric and Manufacturing Company, announces the appointment of Herbert A. May as assistant to the president. Mr. May will make his headquarters in the Grant Building, Pittsburgh, where the offices of the Westinghouse Central Sales District are located.

Fada announced a new model, 43. This is a portable and can be used wherever AC is available. It is adapted for Summer camp or cottage as well as for use in towns and cities. Approximate weight is thirty-five pounds.

The Zenith Radio Corporation of Chicago announces that shipments in fair volume are being made of the new Zenette line of table model receivers. For sixteen years this manufacturer has specialized in the high price field with the Zenith radio set.

The Philadelphia Storage Battery Company, makers of Philco radios, named Edward Davis, formerly president and one of the founders of the company, to be chairman of the board of directors, and James M. Skinner, vice-president and general manager, president. Two new officers are George E. Deming, executive vice-president, and Walter E. Holland, vice-president in charge of engineering. Deming was formerly works manager and Holland was chief engineer.

Control of the set from any part of the room or house is now possible with the new Westinghouse radio receivers, WR-6 and WR-7.

Frank Andrea, president of Fada, said his February production will be nearly double that of January. Except for a short inventory taking period in December, the wheels of the plant, in Long Island City, N. Y., have not stopped running since production started last Spring on the present line.

At the annual meeting of the Simplex Radio Company Sandusky, Ohio, H. C. Maibohm, president, reported an increase of 240% in net earnings for 1930 over 1929, the company's best previous year. He said:

"Approximately three times as many radio sets were sold as in 1929 and the company attributes its highly successful year almost entirely to its foresight early in the season in sensing a public demand for the now popular priced midget types and concentrating its major production activities on an excellently engineered and substantially built small radio in three cabinet types."

## NEW BOOKS

Radio, Its Future. Edited by Martin Codel. Harper & Brothers. New York. 327 pp. \$4.

"Radio and Its Future," is a new book off the press of Harper and Brothers. This work treats of the various branches of the American radio art and industry. The author has enlisted the services of several contemporary authorities. The result of this collaboration is a crystallization of the aims and hopes of the industry, depicting the progress that has taken place in the past few years, and prophesying what is reasonably expected to materialize in the next decade.

The book opens with a description of the beginnings of American broadcasting. Production of commercial receivers and phases of broadcasting are discussed, and among the reviews is one by E. H. Colpitts, of the American Telephone & Telegraph Co., on radio telephony.

(1)—Write in the frequencies.  
 (2)—Write in the call letters.  
 (3)—Hub takes 1/4-inch shaft.  
 (4)—Knob operates vernier for hair-splitting adjustment. 20 to 1

**88c**

**ULTRA-VERNIER  
 TUNING CONTROL**

The dial, shown full size (4-inch diameter), has a beautiful dull silver finish.

Order Cat. REL @ 88c

(Clockwise dial [illustrated] will be sent unless otherwise ordered)

RELIABLE RADIO CO., 143 West 45th Street, New York, N. Y.

**SOLDERING IRON  
 FREE!**



Works on 110-120 volts, AC or DC; power, 50 watts. A serviceable iron, with copper tip, 5 ft. cable and male plug. Send \$1.50 for 13 weeks' subscription for Radio World and get these free! Please state if you are renewing existing subscription.

RADIO WORLD

145 West 45th St.

N. Y. City

**Three 0.1 mfd. in One Case**

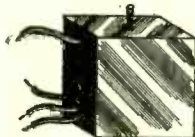

Three Supertone non-inductive fixed condensers of 0.1 mfd. each, (250 v.) in steel case, provided with a 6/32 mounting screw built in. The black lead is common to the three condensers, the three red leads are the other sides of the respective capacitances. Size, 1 1/2" square by 3/8" wide. Order Cat. SUP-31, list price, \$1.00; net price, 57c.

GUARANTY RADIO GOODS CO.

143 West 45th St., New York, N. Y.

**Short-Wave  
 Converter Series**

In the November 8th issue of RADIO WORLD there began a remarkable series of articles dealing with the construction of short-wave converters that really do work, and that work well. Besides, the cost of parts is low. One model, 30 to 110 meters, no plug-in coils, may be built of parts costing less than \$5, for battery operation, or for AC with extra filament transformer external, while another model, 10-200 meters, two plug-in coils, using somewhat superior parts, filament transformer built-in, can be made up by you for less than \$10. Surely these are prices within the reach of all.

Low price and high achievement go hand in hand in these designs by Herman Bernard.

The series ran in the November 8th, 15th, 22nd and 29th, and December 6th, 13th, and 20th issues. Send \$1 and we will forward these seven issues and a blueprint of the AC \$5 model. Or send \$3.00 for 6 months' subscription and these copies and blue print will be sent FREE.

RADIO WORLD, 145 West 45th Street, New York, N. Y.

Enclosed please find \$1.00 for which send me the November 8th, 15th, 22nd and 29th, and Dec. 6th, 13th and 20th issues, containing the series of articles on short-wave converters of extremely low price, and a blueprint of the AC \$5 model.

Name .....

Address .....

City ..... State .....

**Subscribers! Important!**

Note subscription expiration date on wrapper containing your copy of RADIO WORLD. If nearing expiration date, please send in renewal so that you will not miss any copies. Subscription Dept., RADIO WORLD, 145 W. 45th St., New York City.

**Quick Action Classified Ads**

Radio World's Speedy Medium for Enterprise and Sales

7 cents a word—\$1.00 minimum—Cash with Order

SCOTT WORLD RECORD SUPERHET, Demonstrator, with Radiotrons, \$29.50. Jaeger, 607 West 138th St., New York City.

RESISTANCES, CONDENSERS, TRANSFORMERS, CHOKE-COILS, etc. Write for sensational low price list. Bronx Wholesale Radio Company, 7 West Tremont Avenue, New York.

DRILL PRESS STAND for the work bench. Blueprint showing how to build it, \$1.00. Inquire about complete kit of parts. Super Engineering Laboratories, 1313 - 40th St., Brooklyn, N. Y.

PRINTING: 1000 BUSINESS CARDS \$2.75 POSTPAID. Other printing reasonable. Samples free. Miller, (RW), Printer, Narberth, Pa.

SOUND PICTURES TROUBLE SHOOTER'S MANUAL, by Cameron and Rider, an authority on this new science and art. Price \$7.50. Book Dept., Radio World, 145 W. 45th St., N. Y. City.

BARGAINS in first-class, highest grade merchandise. B-B-L phonograph pick-up, theatre type, suitable for home with vol. control, \$6.57; phono-link pick-up with vol. control and adapter, \$3.32; steel cabinet for HB Compact, \$3.00; four-gang .00035 mfd. with trimmers built in, \$1.95; .00025 mfd. Dubilier grid condenser with clips 18c. P. Cohen, Room 1214, at 143 West 45th Street. N. Y. City.

HORN UNIT, \$1.95—This is the Fidelity Unit and has stood the test of time. Guaranty Radio Goods Co., 143 W. 45th St., New York.

H.F.L. MASTERTONE. List \$195. Sell \$85. World's finest radio. W. J. Reed, Aurora, Ill.

"MATHEMATICS OF RADIO."—A great help to everybody interested in radio. \$2 postpaid. Radio World, 145 W. 45th St., N. Y. City.

SHORT-WAVE NUMBERS OF RADIO WORLD. Copies of Radio World from Nov. 8, 1930 to Jan. 3, 1931, covering the various short-wave angles, sent on receipt of \$1.00. Radio World, 145 W. 45th St., N. Y. City.

FILAMENT TRANSFORMERS—1 1/2, 2 1/2, 5 volt, \$1.00; 2 1/2 volt, 5 1/2 amp., \$1.10; 7 1/2 volt, 3 amp., \$1.25. C. T. secondaries, primary 110 volt. Write L. Waterman, 2140 Kirby West, Detroit, Mich.

CONSTRUCTIONAL DATA—30 henry choke 50c; laminations in stock. Radio Power, 1028 Forest Road, Schenectady, N. Y.

"FORD MODEL 'A' CAR." Its Construction, Operation and Repair, By Victor W. Page, M.E. 545 Pages, 251 Specially Made Engravings. \$2. postpaid. Radio World, 145 W. 45th St., N. Y. City.

"A B C OF TELEVISION" by Yates—A comprehensive book on the subject that is attracting attention of radioists and scientists all over the world. \$3.00, postpaid. Radio World, 145 West 45th St., N. Y. City.

RADIO WORLD AND RADIO NEWS. Both for one year, \$7.00. Radio World, 145 W. 45th St., N. Y. City.

# SHORT-WAVE SPECIALTIES

## EXTRA-SPECIAL FREE OFFERS OF SUBSCRIPTION PREMIUMS!

RADIO WORLD, now in its ninth year, is the first and only national radio weekly, and publishes the latest, up-to-the-second news of circuits, both of kit types and of 1931 commercial receivers, as well as news of happenings in the broadcasting field. Lists of broadcast and short-wave stations are published regularly. You get your information weekly—which means quickly—and you get it accurately, so be sure to become or remain a subscriber for RADIO WORLD. We are able to offer now specially attractive premiums, and ask you to make your choice from the well-chosen variety of parts offered on this page and on the opposite page. When ordering, please use coupon.

The regular subscription rates are: \$6 for one year, 52 issues, one each week; \$3 for 6 months, (26 weeks); \$1.50 for three months, (13 weeks); \$1 for 8 weeks; 15c per single copy.

### TUBE-BASE TYPE COILS

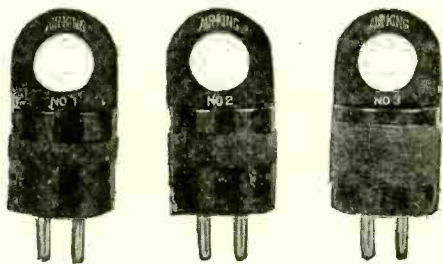

Three finger-handle type plug-in coils, wound on tube-base diameter, although of greater height than a tube base, for short wave plug-in service, where a 4-prong (UX) tube socket is used as coil receptacle. There are two separate windings, tightly coupled. The coil socket connections are: plate prong to plate, filament plus to phones; grid prong to grid and ant.; filament minus to stator of a feedback condenser. The tuning condenser (stator to grid prong, rotor to filament plus prong) may be .00015 or more for 15 to 110 meters; the feedback condenser .00025 mfd. B voltage is supplied through phones or audio transformer primary. Order PR-TBC free (less coil socket) with 6 mos. (26 weeks) subscription @ \$3.00

### PRECISION PLUG-IN COILS

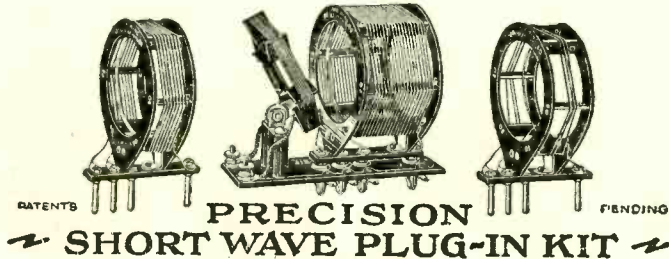

The finest short-wave coils, of de luxe construction, wound on ribs, affording 97% air dielectric, and available for various capacities of condensers, as listed below. All precision short-wave coils are provided with receptacle bases and apply to standard circuits.

For .0001 or .00015 mfd. tuning; three plug-in coils with receptacle base as illustrated, with adjustable primary built onto receptacle, 15 to 150 meters. Order PR-AK-1, free with one year's subscription @ \$6.00.

For .00025 or .0002 mfd. tuning; only two coils are required, for 15 to 150 meters. Order PR-AK-2, and get two coils, receptacle and adjustable coil (third inductance) built in. Free with nine months' subscription (39 weeks), at regular rate, \$4.50.

Note—We can supply .00015 mfd. (PR-H-15) or .0002 mfd. (PR-H-20) Hammarlund short-wave midline condenser, swinus inside 2-inch diameter, with three months (13 weeks) additional subscription @ regular \$3 rate.

### "DIAMOND" PAIR IN STANDARD AND DE LUXE TYPES

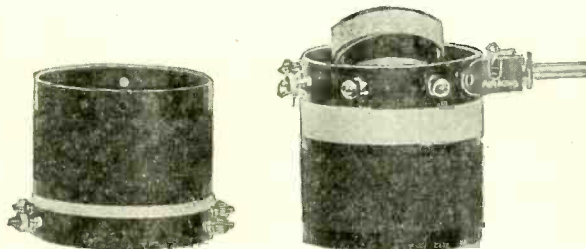

The Diamond of the Air is a popular circuit using an antenna coil and a three-circuit tuner. For this circuit the standard Diamond pair of coils consists of two, wound on 3" diameters, except for rotor on smaller form. The standard pair may be obtained for .0005 or .00035 mfd. tuning. Ticker coil has single hole panel mount. For .0005 mfd. order PR-SDP-5, with blueprint, free with a six-month subscription (26 weeks) @ \$3.00. For .00035 mfd. order PR-SDP-35, free with 6-month subscription @ \$3.00.

These coils will give extreme satisfaction and are excellent for the Diamond of the Air, being specified by Herman Bernard, the designer of the circuit.



De luxe Diamond pair, with large primaries center-tapped. For the Diamond use center tap and one extreme of the primary for antenna circuit, RF coil (at right); use full primary on tickler (lowest winding at left). The de luxe pair have silver-plated wire, for loss-reduction, wound on moulded bakelite, with threading, so coils are space-wound to reduce distributed capacity. Three-circuit coil is single-hole panel mount. Additional holes for optional base mounting on both, using brackets (not supplied.) For .0005 mfd. only. (None for .00035 mfd.) Order PR-OWN free with a year's subscription (52 issues) @ \$6.00.

### GET THE COMPLETE DATA ON SHORT-WAVE CONVERTERS

Short-wave converters are all the rage. They enable you to tune in short waves on a broadcast receiver of any kind. A serial article by Herman Bernard, on this topic, discussing several models, with full-size picture diagrams, was published in the November 8th, 15th, 22nd, 29th, December 6th, 13th and 20th issues. Send \$2 for 17 weeks' subscription and get these seven issues free. Order PR-SWCS.

### PLEASE USE THIS COUPON!

RADIO WORLD,  
145 West 45th Street, New York, N. Y.

I hereby take advantage of your extra-special premium offers and subscribe for RADIO WORLD for the number of weeks specified in the list below. Please send indicated premium. My remittance of \$ ..... is enclosed. RW-1-10

- |  |  |
|--|--|
| <input type="checkbox"/> PR-TBC (26 wks.) \$3.00 | <input type="checkbox"/> PR-SDP-35 (26 wks.) \$3.00  |
| <input type="checkbox"/> PR-AK-1 (52 wks.) 6.00  | <input type="checkbox"/> PR-GWN (52 wks.) 6.00       |
| <input type="checkbox"/> PR-AK-2 (39 wks.) 4.50  | <input type="checkbox"/> PR-SWCS (17 wks.) 2.00      |
| <input type="checkbox"/> PR-H-15 (13 wks.) 1.50  | <input type="checkbox"/> PR-SUP-3A (52 wks.) 6.00    |
| <input type="checkbox"/> PR-H-20 (13 wks.) 1.50  | <input type="checkbox"/> PR-SUP-3B (52 wks.) 6.00    |
| <input type="checkbox"/> PR-SDP-5 (26 wks.) 3.00 | <input type="checkbox"/> PR-SUP-3FS (104 wks.) 12.00 |

Name .....

Address .....

City ..... State .....

Please put cross here if renewing an existing subscription.

### PARTS FOR A SHORT-WAVE CONVERTER

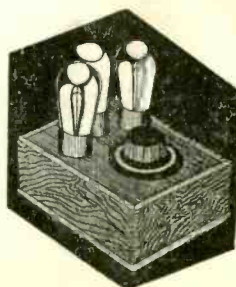

No matter what type of broadcast receiver you have, you can get short waves by using a short-wave converter built of parts we can supply. The panel is only 5 x 6 1/2 inches. There is only one tuning control. No squeals, howls or body capacity. Two models are available, one for A.C., the other for battery operation. The battery model uses three 227 tubes with heaters in series. Full details supplied with order.

All parts for A.C. model (less filament transformer, less three 227 tubes), order PR-SUP-3A, free with a year's subscription @ \$6.

All parts for the battery model (less three 227 tubes), free with a year's subscription for Radio World @ \$6.00. Order PR-SUP-3B.

A third model (of different appearance than illustrated) enables filament transformer to be built in. All parts, including filament transformer; two wound plus-in coils, 15-200 meters. Hammarlund condenser, (less tubes), order PR-SUP-3FS free with two-year subscription @ \$12.