

SEPT. 13th

1930

HOW TO MEASURE MU OF A TUBE

PRICE
15 CENTS
PER COPY

RADIO

REG. U.S. PAT. OFF.

WORLD

The First and Only National Radio Weekly
442nd Consecutive Issue—NINTH YEAR

A 6-TUBE ALL-WAVE AC RECEIVER

RESONANCE AND BEATS IN SOUND PHYSICS

HOME SOUND RECORDING IS NEW RAGE!

(See Article on Pages 3 and 4)



RADIO WORLD, Published by Hennessy Radio Publications Corporation; Roland Burke Hennessy, editor; Herman Bernard, managing editor and business manager, all of 145 West 45th Street, New York, N. Y.

Horn Unit \$2.25



The Fidelity unit is pre-eminent for horn-type speakers such as exponential horns. The faintest word from a "whispering tenor" or the tumultuous shout of the crowd or highest crescendo of the band is brought out clearly, distinctly. Stands up to 450 volts without filtering. Works right out of your set's power tube, or tubes, requiring no extra voltage source. Standard size nozzle and thread. Works great from AC set, battery set or any other set, push-pull or otherwise. The casing is full nickel finish, highest polish.

This unit can be used in a portable without any horn attached and will give loud reproduction. Order Cat. FDU, with 50-inch tipped cord; weight, 2 1/4 lbs.; size, 2 3/4-inch diameter, 2 3/4-inch height. (This is the large size). Price \$2.25

GUARANTY RADIO GOODS CO.
143 West 45th Street, New York City

NEW NATIONAL THRILL BOX

Cat. ACSW5, National complete parts for 5-tube AC Short Wave Thrill Box; list price, \$79.50, net price, \$45.35
Cat. DCSW5, National complete parts for 5-tube battery operated short-wave Thrill Box; list price, \$75; net price, \$42.75
Wired by Jackson Laboratories, \$5.70 extra. Add letter "W" to catalogue symbols.
AC model uses two UY224, three UY227, with provision for pentode in RF stage if preferred. Cat. ACSW5 does not include power supply. Use National A and B power unit, 2.5 v. AC, 180 plate volts, Cat. 5880-AB; list, \$34.50; net \$19.66. One 280 tube required. Order 280. Key tube @ \$1.13 net

Guaranty Radio Goods Co.
143 West 45th Street
New York, N. Y.
(Just East of Broadway)

RADIO WORLD and "RADIO NEWS"

BOTH FOR ONE YEAR @ **\$7.00**

You can obtain the two leading radio technical magazines that cater to experimenters, service men and students, the first and only national radio weekly and the leading monthly, for one year each, at a saving of \$1.50. The regular mail subscription rate for Radio World for one year, a new and fascinating copy each week for 52 weeks, is \$6.00. Send in \$1.00 extra, get "Radio News" also for a year—a new issue each month for twelve months. Total, 64 issues for \$7.00
 If renewing Radio World subscription, put cross in square at beginning of this sentence.
 If renewing Radio News subscription, put cross in square at beginning of this sentence.
RADIO WORLD, 145 West 45th Street, New York, N. Y.

MB-30 Price Hi-Q 30 Price

OPEN-SHORT-OK TESTER PRICE

Write or wire!

Guaranty Radio Goods Co.
143 West 45th St.
New York City

RADIO WORLD'S BOOK SERVICE has been found of great value not only by radio fans, constructors, etc., but also by radio and other technical schools throughout the country. See the radio books advertisement in this issue.

RADIO AND OTHER TECHNICAL BOOKS

At a Glance

RADIO and TELEGRAPHY

- "Audio Power Amplifiers," by Anderson and Bernard\$3.50
- "Foothold on Radio," by Anderson and Bernard 1.00
- "The Superheterodyne," by Anderson and Bernard 1.50
- "Treatise on Testing Units," by Rider..... 1.00
- "Trouble Shooter's Manual," by Rider..... 3.50
- "115 Latest Commercial Set Diagrams," by Rider 2.50
- "Mathematics of Radio," by Rider..... 2.00
- "Drake's Radio Cyclopeda," by Manly..... 6.00
- "The Electric Word," by Shubert..... 2.50
- "Elements of Radio Communication," by Morecroft 3.00
- "Experimental Radio," by Ramsey..... 2.75
- "Fundamentals of Radio," by Ramsey..... 3.50
- "Practical Radio," by Moyer and Wostrel... 2.50
- "Practical Radio Construction and Repairing," by Moyer and Wostrel..... 2.50
- "Principles of Radio," by Henney..... 3.50
- "Principles of Radio Communication," by Morecroft 7.50
- "Radio Blueprint Library"—AC Hook-ups.... 35
- "The Radio Manual," by Sterling..... 6.00
- "Radio Receiving for Beginners," by Snodgrass and Camp..... 1.00
- "Radio Receiving Tubes," by Moyer and Wostrel 2.50
- "Radio Telegraphy and Telephony," by Duncan 7.50
- "Radio Trouble Shooting," by Haan..... 3.00
- "Storage Batteries," by Morse..... 2.00
- "Storage Batteries Simplified," by Page..... 2.00
- "Telegraphy Self-Taught," by Theodore A. Edison 1.25
- "The Thermionic Vacuum Tube," by Van der Bijl 5.00

TELEVISION

- "A B C of Television," by Yates..... 3.00

AVIATION

- "A B C of Aviation," by Maj. Page..... 1.00
- "Aerial Navigation and Meteorology," by Capt. Yancy 4.00
- "Aviation from the Ground Up," by Manly.. 3.50
- "Everybody's Aviation Guide," by Maj. Page. 4.00
- "Modern Aircraft," by Maj. Page..... 5.00
- "Modern Aviation Engines," by Maj. Page... 9.00

AUTOMOBILES

- "Auto and Radio Battery Care and Repair," by Manly 2.00
- "Automotive Repair," by Wright..... 3.75
- "Dyke's Automobile and Gasoline Engine Encyclopedia," by A. L. Dyke..... 6.00
- "Dyke's Carburetor Book," by A. L. Dyke.. 2.00
- "Ford Model 'A' Car"—Its Construction, Operation and Repair—by Maj. Page..... 2.00
- "Modern Gasoline Automobile," by Page..... 5.00
- "The Motor Cycle Handbook," by Manly..... 1.50

ELECTRICAL

- "Absolute Measurements in Electricity and Magnetism," by Gray..... 14.50
- "Alternating Currents and AC Machinery," by D. C. and J. P. Jackson..... 6.00
- "Arithmetic of Electricity," by Sloane..... 1.50
- "Electrician's Handy Book," by Sloane..... 4.00
- "Essentials of Electricity," by Timbie..... 1.75
- "House Wiring," by Poppe..... 1.00
- "Industrial Electricity," by Timbie..... 3.50
- "Principles of Transmission in Telephony," by M. P. Weinbach..... 4.00
- "Rudiments of Electrical Engineering," by Kemp 2.00
- "Standard Electrical Dictionary," by Sloane... 5.00

BOOK DEPARTMENT

RADIO WORLD

145 West 45th Street
New York, N. Y.
(Just East of Broadway)

Trouble-Finding Dial FREE!

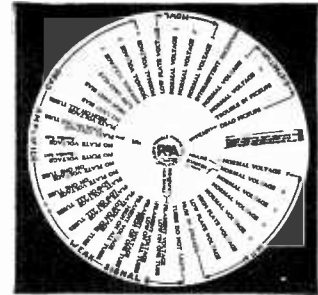

Here is an 8" diameter dial that you slide around to shoot trouble in an audio circuit or B supply or power amplifier. Trouble is divided into five groups: distortion, howl, dead amplifier, weak signals and hum. By sliding the dial to one of fifty different positions the cause of the trouble is read in the slotted opening. Invented by John F. Rider. Send 50 cents for four weeks subscription for Radio World and get a Trouble-Finding Dial free with instructions on back. If extending an existing subscription please so state.

RADIO WORLD

145 West 45th Street, New York, N. Y.

Official Parts for Popular Circuits

Universal Short-Wave Converter, using three 227 tubes; five de luxe precision short-wave air dielectric coils, condensers, chokes, 7"x14" panel, cabinet, etc. Cat. UN-SWC @.....\$24.73

GUARANTY RADIO GOODS CO.
143 West 45th Street
New York City

ERLA-DYNAMIC CHASSIS, WEST-INGHOUSE RECTIFIER. Sensitive and efficient dynamic speaker chassis. List price, \$25; our net price, \$12.50. Guaranty Radio Goods Co., 143 W. 45th St., New York. For 110 v. AC. Also, 6-v. DC., storage battery type, \$9.25.

Subscribers! Important!

Note subscription expiration date on wrapper containing your copy of RADIO WORLD. If nearing expiration date, please send in renewal so that you will not miss any copies. Subscription Dept., RADIO WORLD, 145 W. 45th St., New York City.

1930 ISSUES OF RADIO WORLD TO COMPLETE YOUR FILES

If you missed any copies of RADIO WORLD while away on vacation this Summer, you can procure these through our Circulation Department at 15c a copy, or any 7 issues for \$1.00.

RADIO WORLD

145 W. 45th St. New York City

SUBSCRIBE NOW!

RADIO WORLD, 145 West 45th St., New York City. Enclosed please find my remittance for subscription for RADIO WORLD, one copy each week for specified period:

- \$6 for one year, 52 issues.
- \$3 for six months, 26 issues.
- \$1.50 for three months, 13 issues.
- This is a renewal of an existing mail subscription (Check off if true).

Your name

Address

City



Vol. XVII, No. 26 Whole No. 442
 September 13th, 1930
 15c per Copy, \$6.00 per Year
 [Entered as second-class matter, March, 1922, at the Post Office at New York, N. Y., under act of March, 1879.]

NINTH YEAR
Latest Circuits and News
Technical Accuracy Second to None

A Weekly Paper published by Hennessy Radio Publications Corporation, from Publication Office, 145 West 45th Street, New York, N. Y.
 (Just East of Broadway)
 Telephone, BRyant 0558 and 0559

RADIO WORLD, owned and published by Hennessy Radio Publications Corporation, 145 West 45th Street, New York, N. Y. Roland Burke Hennessy, president and treasurer, 145 West 45th Street, New York, N. Y.; M. B. Hennessy, vice-president, 145 West 45th Street, New York, N. Y.; Herman Bernard, secretary, 145 West 45th Street, New York, N. Y.; Roland Burke Hennessy, editor; Herman Bernard, business manager and managing editor; J. E. Anderson, technical editor

Home Sound Recording

By Alliston Adams

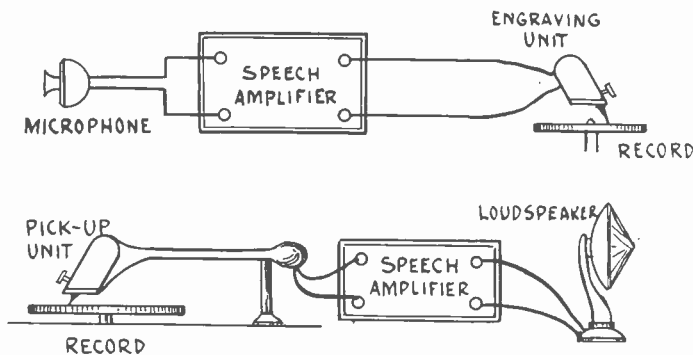

FIG. 1

FUNCTIONAL DIAGRAMS OF THE PARTS IN THE HOME PHONOGRAPH RECORDING DEVICE. ABOVE IS THE RECORDING ARRANGEMENT AND BELOW THE PLAY-BACK ARRANGEMENT.

WHAT parents would not like to have a record of the words spoken by their first born from the first almost intelligible gurgle to the college valedictory address? What parents would not like to have such a record of each of their offspring? What individual would not like to hear himself or herself on the phonograph? What radio fan would not like to have a means of recording certain choice programs that the radio set brings in? What detective would not like to record the evidence that he needs to convict a criminal, or that he needs to establish a claim to alimony for one of his clients?

Many attempts have been made to supply the public with the means to satisfy these desires, but few have been successful. Some have been too cumbersome and difficult to operate. Others have been defective from the quality point of view, and still others have been too expensive and not suitable for home use.

One of the difficulties met with in these sound recording devices is the means of forcing the needle to describe the proper spiral on the record. Pre-grooved records have been used for this purpose but they led to complexities since they required two turn-tables, one for the pre-grooved but otherwise blank record and the other for the blank disk to be made into a record, and these had to be coupled together mechanically so that the recording needle moved over the uncut disk in a spiral determined by the groove in the other disk.

A Simple Device

This Fall there will be put on the market at least one sound recorder which is simple and inexpensive yet which satisfies the condition of good recorded quality. The complete equipment includes a microphone, a speech amplifier, a recording or engraving unit, a motor, a turn-table, and a mechanical gear for moving the engraving unit in the proper spiral. The entire recording device is as simple to operate as the playing of a phonograph, and records made which may be played back as soon as the engraving unit has made a trip across the blank record. To play it back it is not necessary to stop the motor

or to remove the record, only to remove the recording unit and replace it with an ordinary electric pickup unit, to connect the loudspeaker to the output of the speech amplifier in place of the recording unit, and to connect the pick-up unit in place of the microphone.

Fig. 1 shows the arrangement components both for recording and for playing back. The upper portion of the picture is for recording and the lower for playing the record.

If a regular phonograph record be placed on the turn-table first and then a small blank disk is placed in the center, it is possible to transfer a portion of the regular record to the blank. The pick-up unit is put on the large record and then connected to the input of the speech amplifier. The output of the amplifier is then led to the engraving unit, which is placed on the blank. As the motor is started the transfer process is begun. If the loudspeaker is also connected to the output of the speech amplifier the playing is audible but the transfer goes on whether it is audible or not.

Simultaneous Playing and Recording

If the microphone is also connected to the input of the speech amplifier it is possible to superimpose other sounds on the recording. For example, a man may sing a song the tune of which is being transferred from one record to another. Of course, to do this it is necessary that he hear what is being recorded, and this he may do by listening in with a headset. When the loudspeaker is being operated near the microphone there is danger of feedback sufficient to cause howling. During a demonstration of this device a loudspeaker was actually used, the microphone and the loudspeaker being separated about 15 feet. There was at times a very high pitched howl due to feedback when the microphone was exposed to the direct sound waves from the loudspeaker, but the howl stopped when the performer stood between the microphone and the loudspeaker.

The recording device has unlimited possibilities of entertainment and usefulness. Fond parents will want to record the first words of their children, cute sayings of somewhat older children, and recitations and musical efforts of the older children. The parents themselves will want to record their own voices so that they can hear themselves as others hear them. It offers possibilities in the entertainment of visitors for the recording of conversation and the like.

Making copies of standard phonograph records before these records have been worn is another possibility that may be profitable as well as entertaining. Every once in a while a choice radio program is scheduled, and the recording device offers a ready means for preserving at least part of the program. For example, there is an important boxing match being broadcast. The announcer speaks rapidly and excitedly. It is difficult to catch every word and remember it. Arguments as to just what has been said often arise in such cases. But if the voice of the announcer is recorded the record may be played back as soon as the match is over and the argument thus settled.

Detective Work

A detective may seek evidence in an important case. He himself cannot be present to hear what is being said at some conference of those involved, but he can often conceal a microphone leading to a recording instrument. Every word said at the conference will be recorded and can be reproduced in court
(Continued on next page)

Home Made Records

(Continued from preceding page)

if necessary. The principals cannot deny that something or other was said when the phonograph reproduces the conversation exactly as it occurred.

Another possibility is in the keeping of minutes of a business conference where verbal contracts are being entered into, or where directors meet to decide on important policies of a corporation.

Still another practical application of the recording device is to dictation. An executive can address his letters to the microphone in the absence of his stenographer and then turn over the records to the typist, or he can even send the records to the addressee.

Quality of Recordings

One ordinarily expects the quality of the reproduction from home recorders to be only mediocre at best. But on hearing the play-backs of records produced by this device one is pleasantly surprised, for the quality is excellent. For example, one hears the speaker address the microphone and in a few minutes when the record is played back one hears the loudspeaker repeat word for word what the speaker had just said, and it is almost impossible to tell the difference between the original and reproduction. Again, one hears the reproduction from a standard record which is being transferred, and in a few minutes the loudspeaker reproduces it from the new record without any noticeable deterioration of the quality. It is only when the transfer process has repeated many times that there is an appreciable change in the quality.

Naturally, the quality that results depends on the microphone that is used, on the quality of the speech amplifier, on the loudspeaker. The quality of reproduction cannot be better than that of these components. But there are first class microphones that can be obtained at reasonable prices, and some of the speech amplifiers and loudspeakers now used in up-to-date radio receivers are of excellent quality.

Type of Disks Used

The sound is recorded on aluminum disks which may be obtained for a very small price, and records may be put on both sides of these disks. In size these disks may vary from a few inches to about 12 inches, depending on the duration of the sound to be recorded. After a record has been made it may be played 50 times before there is any noticeable deterioration in the quality due to wear.

A special hard alloy engraving needle is used for cutting the soft metal. No other needle than that supplied with the device is suitable. For playing the record a special wood needle is used. It is necessary to use wood because a harder substance would rapidly wear the record. A new wood needle should be used for each playing of a full size record, or the old needle should be sharpened for every such playing.

Mechanical Features of Device

The recording mechanism and the turn-table are driven by an electric motor of the usual type, at a rate of 79 revolutions per minute. Extremely constant speed is maintained, which is necessary if variation in pitch is to be avoided.

Attached to the top of the shaft of the motor is a worm which engages with a sector on a horizontal member and turns this member at an appropriate rate. The peripheral end of the horizontal member is lodged in a vertical fixture attached to the table under which the motor is mounted, and turns freely in this fixture. The horizontal member contains a long worm or screw on which the engraving unit rides. The pitch of this screw and the pitch of the worm on the spindle are such that the engraving unit moves across the record at a rate of approxi-

mately 0.02 inch per revolution, which is the standard pitch of the spiral in phonograph records. The engraving unit can be placed at any point of the horizontal screw for starting the engraving.

With the recording and reproducing equipment, which is known as the Presto, a standard Amertran power amplifier is used, and this comprises two stages of push-pull with 245 tubes in the last stage. This has a greater undistorted output than is necessary to operate the engraving unit.

The same amplifier is used both for recording and playing back. A simple switching arrangement is used for making the necessary circuit changes when changing from one mode of operation to the other. More sound power is needed for the engraving unit than for the loudspeaker, and to compensate for the difference a standard commercial fader is employed. A single knob controls it. Of course, it is possible to use any of the well known volume controls to adjust the output of the amplifier to suit the engraving or the loudspeaker units.

Depth of Engraving

It is clear that the greater the output of the amplifier to the engraving unit the deeper will be the modulation on the record, or the greater will be the amplitude of the record groove. There is danger of getting the amplitude too great so that the engraving needle will cut into the territory properly belonging to adjacent grooves. A little experimenting will soon teach the operator how great the output should be to give as deep modulation as is possible without cutting through. There will be no danger of cutting through except on the very lowest audio frequencies. The experienced operator can tell by feeling the vibration of the engraving needle whether or not the amplitude is correct.

The deeper the modulation the louder will be the output of the amplifier when a record is played back. But for any given depth of modulation the output can be varied to suit requirements by adjusting either the input to the amplifier or the amplification.

So simple is the device and its operation that a novice need not spoil more than one small record blank before he becomes proficient in handling the outfit. This is because the volume controls associated with the amplifier permit considerable latitude in modulation depth. It is well to remember that no good results can be obtained unless the needles used in both recording and playing are sharp. But with this requirement every phonograph user is already familiar.

Perhaps the most interesting feature about this recorder is that its cost comes well within the financial limitations of the great majority of radio fans. It may be had in kit form for less than the cost of a medium priced radio receiver. This does not include the amplifier and the loudspeaker but does include the microphone, the driving motor, the recording and reproducing units, and needles and record blanks sufficient to give the purchaser a good start at this fascinating sport. Since most people now have good speech amplifiers in their radio receivers, as well as good dynamic speakers, there is no need of getting this new equipment in order to enjoy the pleasures of recording, unless they prefer to get still better equipment.

Proof of Snoring

Have you ever heard yourself snore? Oh, you don't snore! But your wife says that you do, and she is undoubtedly right, for everybody snores. If you doubt your wife's assertion, why not put it to a test by having her record the sounds you make while asleep. There is no better proof, making a record of the snoring and playing it while you are awake. If you lose, which you are sure to do, you might get your revenge by recording her discordant breathing during her sleep.

Automatic Television Synchronization

SYNCHRONIZATION, or the keeping of the receiving scanning disc in exact step with the transmitter scanning disc, has been one of the most difficult problems associated with television. However, it is gradually being solved by comparatively simple means, and only simple schemes will afford a solution. When the transmitter and the receiver are both on the same AC power system, it is only necessary to use synchronous motors for driving the two discs to keep them at exactly the same speed. The phasing and framing, which are also necessary for satisfactory reception of television, can be accomplished without much difficulty.

When the two discs are on different power systems synchronization is impossible, and then other means must be resorted to.

One method developed by the engineers of the Jenkins Television Corporation, Jersey City, N. J., appears to offer a satisfactory solution to the problem. In this method two motors are used for driving the receiving scanning disc, one an induc-

tion motor which supplies most of the motive power required to keep the disc spinning, and the other special synchronous motor of very small power used only to aid or retard the main motor as the speed may require.

Synchronizing Motor

The Jenkins television transmission is carried on with 48 lines per frame and 15 frames per second. In such transmission there is a strong component frequency of 15×48 , or 720 cycles per second. This frequency is selected by means of a filter at the receiving end and amplified by an extra amplifier, after which it is used to feed the special synchronous motor designed to operate on this frequency. This motor is in the nature of a phonic wheel, comprising a toothed wheel of iron attached to the shaft of the scanning disc and a field electromagnet energized by the 720-cycle energy provided by the extra amplifier tube.

(Continued on page 10)

All Waves on Six Tubes

By Herman Bernard

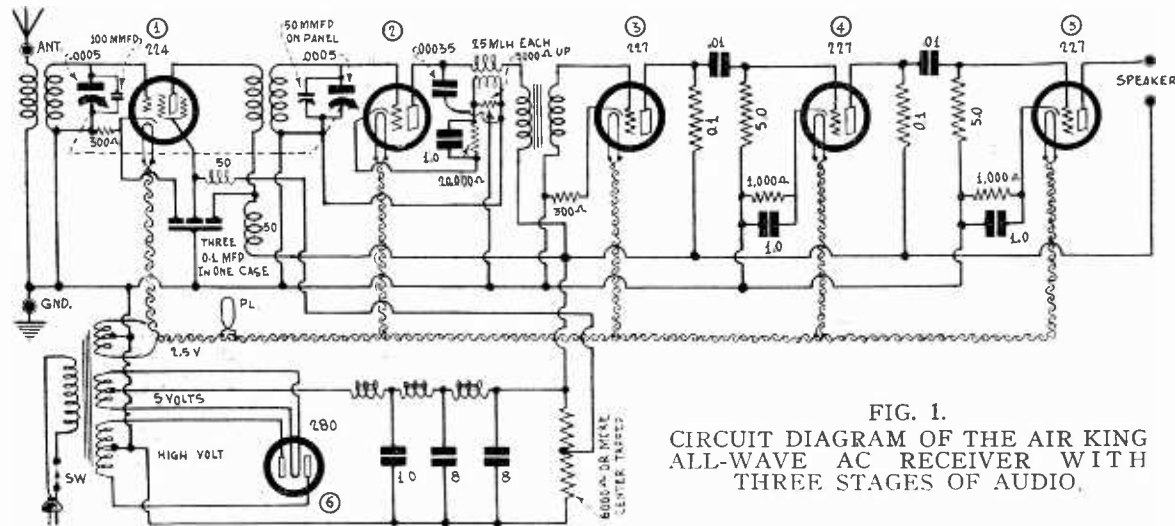

FIG. 1.
CIRCUIT DIAGRAM OF THE AIR KING
ALL-WAVE AC RECEIVER WITH
THREE STAGES OF AUDIO.

"IS it any good?"

That question was asked by a man who was among the first to see photographs of the new Air King All-Wave Receiver.

He was impressed with the appearance.

The choice of parts proved that quality apparatus had been used. The tuning condensers were Hammarlund's .0005 mfd. straight frequency line. The coils were of the 97 per cent. air dielectric type, made by Air King Products Company. The power transformer and special choke were the products of the Polo Engineering Laboratories. The electrolytic condensers of 8 mfd. each, two being used in the filter, were Aerovox's new contribution to the world's line of parts. The dial was National Company's modernistic drum, with color wheel. The chassis was steel, first copper plated, then nickel plated, then chromium plated, leaving a highly polished, rich finish like that on the new Polo apparatus that it matches and permanently peelproof and rust-proof.

Fair Question Fairly Answered

Yet the question asked was fair enough. In the early days of broadcasting the dependability of receivers was always something you had better investigate although today good performance is the rule. Short-wave reception is in about the same stage of development as was broadcasting six years ago, and some short-wave receivers leave much to the imagination.

It so happens that the Air King All-Wave AC Receiver is really an all-wave receiver, because an extra pair of coils, one coil for each of the two tuned circuits, permits covering the entire broadcast band of wavelengths. So two criteria must be applied.

The circuit is good indeed, and so is the performance, on short waves. On broadcast waves the receiver is satisfactory, but not a world-beater, since for broadcast in congested areas two tuned circuits may not afford all the desired selectivity. However, on short waves the selectivity is all that you need, and the tuning operation is relatively easy.

In the August 30th issue the circuit was shown with only two stages of resistance-coupling. Now the circuit has the extra stage of audio, introduced so that volume would be still greater.

No Motorboating

The problem to solve was to use the extra stage of audio and still prevent feedback. The usual result of such feedback would be motorboating. But the solution was found in the arrangement of the filter section, by use of a so-called choke input, with no condenser across the rectifier, and then, in succession in each leg of the series choke, 1.0 mfd., 8.0 mfd. and 8.0 mfd., respectively.

The choke's total DC resistance is 200 ohms; its total inductance 30 henries. The section between the rectifier and the 1.0 mfd. paper condenser has 40 ohms DC resistance, that between the 1.0 mfd. and the first 8.0 mfd. 60 ohms, and the final section 100 ohms.

This proportion also filters out the hum with entire satisfaction. On some signals modulation hum will result, but this is easily checked by retarding the volume control a little. No device in the filter section would avoid modulation hum, and since a slight turn of the volume control knob provides the solution, there is no real problem, only a fact to call frankly to the builder's or operator's attention.

The choke system is one that should prove highly popular this year, because quite a few circuit designers have selected

the "choke input" as standard. The main object of omitting a condenser from the first take-off of the rectifier's positive lead (here the center-tap of the 5-volt winding) is to lengthen the life of the 280 rectifier. The high starting current, a tax on the tube, is avoided by the choke input.

"Will It Get Europe?"

The circuit arrangement is a standard one, with a stage of tuned radio frequency amplification, a volume control in the cathode lead of the detector tube, three stages of audio, and a 280 rectifier. The inclusion of the rectifier and filter right on the same small chassis represents an accomplishment, and the placement of the plug-in coils' two receptacles at rear permits console installation, with easy access to the receptacles to change inductances. The tuning range of the short-wave coils, of which there are two pairs, is 15 to 120 meters, while the broadcast pair tune from 197 to 550 meters. The total number of coils is six, or three pairs.

It has been said that the short-wave circuit works very well, indeed. The next question is likely to be: "Will it get Europe?"

(Continued on next page)

LIST OF PARTS

- Three pairs of Air King precision plug-in coils, two pairs for short waves, one pair for broadcasts.
- Two Hammarlund .0005 mfd. straight frequency line variable condensers.
- One Hammarlund 100 mmfd. equalizer.
- One 50 mmfd. variable condenser (trimmer).
- Three 0.1 mfd. bypass condensers in one case.
- Three 1.0 mfd. bypass condensers, 200 volts DC.
- One 1.0 mfd. high voltage condenser (500 volts AC, continuous working voltage).
- One .00035 mfd. fixed condenser.
- One double RF choke, two windings, each 25 millihenries, inductively coupled.
- Two 8.0 mfd. Aerovox electrolytic condensers.
- Two 50 millihenry RF chokes.
- Two .01 mfd. mica dielectric condensers.
- Two 0.1 meg. plate resistors.
- Two 5.0 meg. grid resistors.
- One audio transformer.
- One potentiometer, 5,000 ohms total, or more.
- Two 300-ohm flexible resistors.
- One 20,000-ohm cartridge resistor with mounting.
- Two 1,000-ohm wire-wound resistors.
- One Polo power transformer, Cat. AW-27. Primary: 110 v., 50-60 cycles; secondaries: 2½ volts, 10 amperes; 5 volts, 2 amperes; 440 volts AC; all secondaries center-tapped.
- One 30-henry choke, 200 ohms DC resistance, tapped at 40 and 100 ohms (four leads).
- One voltage divider, 6,000 ohms or more, center tapped (20 watts).
- One AC toggle switch.
- One National modernistic drum dial, type H, with 2½-v. pilot lamp and bracket.
- One 7x15-inch plated metal subpanel, 2½ inch high.
- Five UY (five-prong) and one UX (four-prong) sockets.
- Four binding posts: antenna, ground, two speaker.
- One 224, four 227 and one 280 tubes.

Mechanical Analogies

By Manning

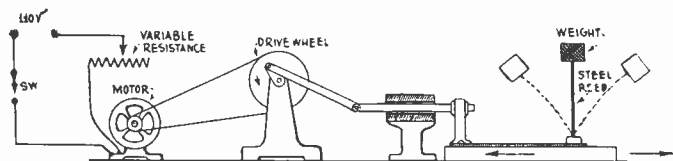

FIG. 1
THE SIMPLEST APPARATUS WITH WHICH TO SHOW MECHANICAL RESONANCE.

THE reader of today is gradually growing used to having things thrust at him, whether the data are related to physical, financial, sporting facts or events. And likewise also, regardless of his or her receptive capacity, is the radio novice treated by the progress of modern enterprise.

And there are those who do seem content merely to glean the high spots of interest without looking for underlying fact or theory, while the rest who ponder a little think some of these things are worth looking into and perhaps productive of useful information.

To be a novice, or to admit that you are one, need not place you in an embarrassing position at all. On the other hand, some learned men are novices in fields other than the sphere of their special knowledge.

An understanding, if not an appreciation, of the contributory conditions incidental to the creation of a condition of matter in motion (called resonance) in mechanics, makes the further understanding of electrical resonance as used in radio circuits much easier. Hence, the novice may well investigate the mechanical resonance features. The best apparatus layout that could be conceived is presented herewith.

Equipment Used

It consists principally of a stout oak board 3 feet long and 6 inches wide on which are mounted, from left to right, with due regard to their use and disposition physically: Terminal block and switch, 60-ohm variable 300-watt resistor, 1/12th H.P. motor, mounted drive wheel with offset crank, horizontal guide-rod and bearing moving platform (engaged by guide slots) on which is mounted a stout steel reed (heavy clock-spring) 1/2"x3/2"x6", the attached loading consisting of a piece of lead, a 1-inch cube, and attached by means of a "grub" screw, the steel reed passing through the center of the block, the screw pinching it. A small sewing machine belt passing over the drive wheel and motor pulley is also necessary.

With the apparatus now all ready to work, we cut in all the variable resistance and close the switch.

The motor turns slowly and the moving platform begins to oscillate back and forth, but as we study the motion of the reed we see that the clamped block's distance of horizontal motion is practically the same as that of the horizontal platform, and also the block arrives at the extremity of its trip at about the same time as the moving platform does.

But if now the motor's speed be slightly increased, we find the motion of the lead block is not quite the same, but the block appears to be gradually developing a motional relationship relative to the moving platform whereby as the speed is still further increased, the block tends to come to rest. In fact, a rate of platform oscillation will be found at which the lead block will hardly move at all, and if the steel reed was ideally elastic, and consumed no energy at all, the point could be found where the block would be absolutely still. This is not resonance.

Gradually Increasing Speed

A gradually increasing speed is what is required to bring about the condition of resonance which we are primarily interested in. So the platform oscillation speed is increased slowly, and it is observed that the relative motional direction of the block and platform have undergone a change. When the platform has reached the end of its trip to the left, the block has just started to move to the right, but before it can get over far enough to the right, the platform returns from its trip to left and reaches the right hand extremity ahead of the block. Because the center of support is now at the right-hand side of the center of gravity of the block, the block starts to move to the left, but never gets there because the above cycle of events is again repeated. This is partial resonance.

But a further increase in platform oscillation speed soon changes the above relative motions and we now find that the platform reaches the end of its left-hand trip only shortly after the block completes its right-hand trip, and if the speed is now increased just enough the block's amplitude of vibration sud-

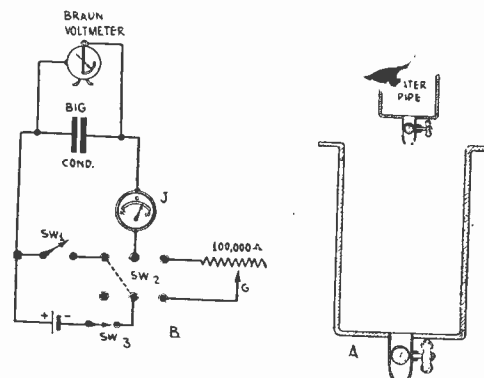

FIG. 2
A—WATER-PIPE ANALOG OF "CONDENSER CHARGE."
B—CIRCUIT FOR CONDENSER-DISCHARGE EFFECTS.

denly will reach a maximum of motion exactly opposite in phase to that of the moving platform. This is full resonance.

Increasing the platform oscillation speed will merely cause the vibrational amplitude of the block to decrease again, because the platform support center of gravity of the reed will reach left before the block does, resulting in some opposition to its completing its trip.

Thus it is seen in mechanical systems under a resonant vibrating condition that the supplied distorting energy always tends to lag with respect to the amplitude and phase of the secondary force, due initially to such distortion. This truth will be self-evident when any mechanical vibrating system is investigated.

Like an Electrical Condenser

Another related system is depicted in drawing A of Fig. 2. A large water pipe, fitted with a valve which is controllable, is arranged to empty water into an open-at-one-end cylindrical vessel also equipped with an adjustable dump valve. For any one adjustment of the dump valve it is apparent that there is only one rate of flow that will exactly fill the cylindrical vessel. But this time-rate of filling is also analogous to a resonance effect

Television Synchronized

(Concluded from page 4)

If the output of the 720-cycle amplifier were great enough it would not be necessary to use the induction motor but it is not practical to provide a tube capable of driving the disc unaided. Hence the induction motor is used to supply the greater part of the motive power and the 720-cycle motor is used only to accelerate the disc when it tends to run slow and to retard it when it tends to run fast. It requires just a little bit of energy to exercise this control function.

Since the 720-cycle frequency is determined by the rate of speed of the transmitting disc, if the receiving disc is controlled by it the two discs will run exactly at the same speed, once they have been brought in approximate synchronism by the induction motor control. If for any reason the transmitting disc changes speed slowly and by small amounts, as it is likely to do, the 720-cycle frequency deviates slightly from that value, but it makes the receiving disc spin at the proper speed at all times.

Principle of Phonic Wheel

The principle of the phonic wheel is very simple. First there is a toothed iron wheel rotor. This spins between the poles of an electro-magnet, which is energized once every period of the driving current. As the electromagnet is energized, the two teeth nearest the two poles are attracted toward the poles, but as the teeth are opposite the poles the energizing current has gone to zero so that there is no longer an attraction. The wheel continues to spin by virtue of its moment of inertia and by the time the next pair of teeth approach the poles there is another pulse of current causing attraction. The rotor must be started and brought to approximate synchronism or the pulses will not maintain the motion in one direction but will only cause the wheel to oscillate. It could spin in either direction but the starting determines in which direction it will rotate.

In the Jenkins device the induction motor starts the disc and the synchronizer motor. If the induction motor runs too fast the pulses in the electromagnet will arrive at such a time that

of Electrical Devices

Manwaring

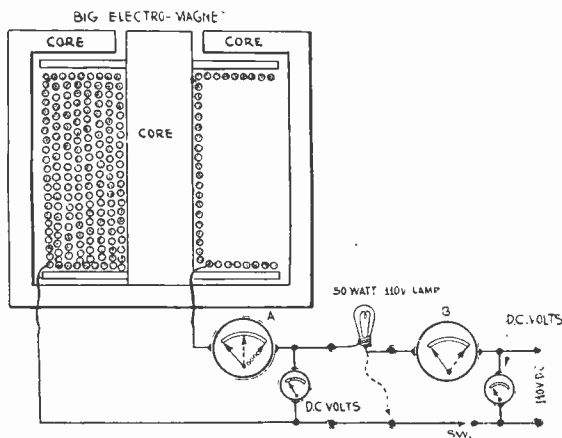

FIG. 3

CIRCUIT AND APPARATUS FOR EXAMINING BIG SELF-INDUCTION EFFECTS.

and, further, it is a good example of variable resonance, because the time rate of filling is controlled by the degree of opening of the dump valve. If the valve is closed, the vessel fills in a minimum of time, and when open the reverse occurs (within reasonable limits).

Here the electrical counterpart is a condenser. The water pipe and valve represent the charging source and its available quantity of current, while the large cylindrical vessel represents an adjustable condenser with time-rate of discharge helping in a limited way to vary the rate of charge, and by so doing correlate it to the supply rate.

Fig. 3 illustrates the circuit of a rather large electromagnet, and some associated apparatus. This system, purely for demonstration purposes, has a lot of self-induction (electrical inertia) and is somewhat related to Fig. 1, which treats of the observed motional effects of a heavy block of lead.

The circuit consists of the large magnet, which is in series with a central zero ammeter A, and is shunted by a high-resistance voltmeter (DC volts) and from here the terminal wires go to two terminals (heavy dots) situated to the left of the

with Phonic Wheel

the attraction on the teeth is backward so that there is a slight retardation. If, on the other hand, the induction motor runs too slowly, the pulses arrive ahead of time so that the attraction helps the induction motor. If the speed is just right the synchronizing motor has practically nothing to do, except to remain on the alert for any changes in speed, whether that change be due to the motor driving the transmitter disc or the motor driving receiver disc.

Manual Synchronization

When the receiver scanning disc is first brought into synchronism a manual control is employed, and its use is facilitated by the appearance of the non-synchronized image, or field where the image is to appear. Before the disc is synchronized bright parallel lines appear throughout the field. If the inductor motor and the disc are running too fast, these lines will slope in one direction; if the speed is too slow, the lines will slope in the opposite direction. When synchronism is approached the lines are horizontal and at the same time seem to disappear. In their place a living image develops.

The manual control consists of two parts, one that retards the speed and another that accelerates it. Besides these manual controls there is framing control by means of which the image may be shifted from one side to the other. The adjustment of the synchronizer is no more difficult than the tuning in of a radio receiver and adjusting the volume.

Talking Images

The images as transmitted from the Jenkins station are accompanied at times with voice and music. The face of the actor before the televisor appears in the apparatus, his lips move, and his voice is heard on a loudspeaker in perfect synchronism. The realism is astounding.

The actual size of the image is, of course, very small, say one inch each way. The apparent size is life size, and this increase in size is due to a magnifying lens placed between the actual image on neon lamp plate and the observer.

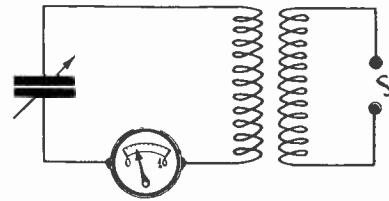

FIG. 4

CAPACITY AND INDUCTANCE IN SERIES FORM A "RESONANT" CIRCUIT WHEN PROPERLY COMBINED.

50-watt lamp. The other two dots are terminals that go to ammeter B, and SW. The right hand voltmeter is merely a line voltage indicator.

With the dotted line circuit not connected to anything (as shown), and with 110 volts DC ready we close SW.

Current Lags in Inductive Circuits

The DC voltmeter between the lamp and the magnet immediately indicates the applied line voltage, but ammeter A is deflecting and showing a slowly increasing current, a fact to which the lamp bears visible testimony. At the end of nearly a second, the lamp is glowing brightly and the full line deflection of the ammeter shows that at last the final full load current is flowing.

This basic sequence of effects, a universal property of all electrical systems that contain inductance, gives rise to the following statement:

In circuits containing inductance the current lags behind the voltage.

Circuits that contain a large amount of inductance can do more work than those that do not, regardless of what other properties they may possess.

In order to show this, we should have another magnet of low inductance, relatively speaking, but we may have to depend upon a word-picture instead of a drawing to show this.

The proposition now is to charge the magnet with the lamp in series as we did previously, but immediately after the load current has reached its full value, we are to simultaneously open the switch SW and touch the dotted line arrow to the terminal at which it is pointing. If the transfer is made quickly enough, the lamp filament will burn out, and the circled line deflection arrow of ammeter A shows a discharge current just twice as big as the original load (charge) current. If a smaller magnet had been used which required the same charge current, the discharge effect, as noted above, would have been much less.

This property of an electrical circuit containing inductance, that is manifested by its ability to store energy is one other property of electrical circuits identified with the phenomenon of electrical resonance.

A somewhat similar effect may be shown in the case of a large condenser, as in drawing B of Fig. 2.

The apparatus necessary consists of a low range Braun voltmeter which shunts the big condenser, and tracing a circuit around the system from the condenser we go through a milliammeter J to the moving arm terminal of a 2 pole double throw switch. The other condenser lead goes to B+ and B- connects to SW3. The other connections are indicated and the object of the set up is the electrical confirmation of what was previously said about the water analog.

With SW2 thrown to the left and SW3 closed the deflection of J will indicate the current that is called the "charging current,"—the voltmeter will indicate a steady value when the deflection of J is zero.

This deflection of the Braun Voltmeter will be finally identical with that of the source of supply.

Let us now open SW3 and notice that the deflection of the Braun Voltmeter is unchanged.

Next we close SW1 and the Braun Voltmeter needle returns to zero and the meter J shows a reverse deflection of amount equal to that of the original charging current.

It is now seen that if inductance effect (that tends to prolong the time of discharge rate), and capacity effect (that tends to keep charge and discharge rate nearly constant) are both made co-existent in an electrical circuit the result will be that once started the oscillatory current would continue indefinitely.

Actually this is not so, however, because of the effect of resistance, which like friction we always have with us.

Fig. 4 shows such a circuit and in practice the meter shown is omitted, except in cases where it is desired to measure the oscillatory current, and even then its use interposes some additional resistance.

Resonance and Beat Not

By John C.

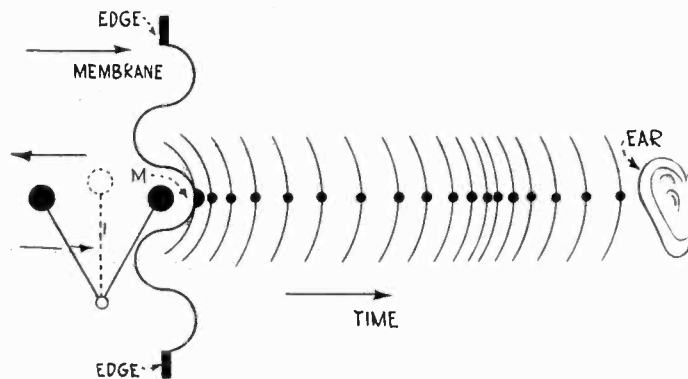

FIG. 1
SOUND WAVES ARE SET UP IN AIR BY VIBRATING BODIES.

FIG. 1 shows a steel sheet in violent vibration, being driven by a felt-covered hammer.

The steel sheet is clamped firmly at its outer edges, as shown, and a series of dots drawn along a central axis perpendicular to the plane of the vibrating sheet are in some way being made to travel over to the ear of an individual not very far distant.

Why do the sound waves travel? Why are they formed? And what are they, anyway?

Imagine that no air exists between the diaphragm shown and the ear. Would you expect to hear anything? Certainly not, because sound is carried by air, and if the air is removed, you simply do not hear anything at all, no matter *how violently* the diaphragm is struck!

Sound is not a tangible or material thing. It is merely one of the manifestations of nature that our ears, and to a limited extent our bodies sense.

What Sound Is

Sound is nothing more than an extremely rapid vibration of air particles that are in contact with the sides of the diaphragm. As the big metal disk wiggles to and fro it hits the air particles next to it in much the same manner as Babe Ruth bats a ball, only the air particle pulses that reach your ear in the form of sound are the only ones that reach "home plate." All the others go far, far over the bleachers never to return again.

The air particles next to the metal disk, when struck, naturally move away but in doing so they strike up against their neighbors who in turn repeat the first process. This sort of-pass-it-along scheme finally results in some air particles striking your ear drum and making it wiggle at the same frequency as the big metal disk is vibrating, though at very much reduced amplitude.

Thus sound waves are formed because the disk sends out an air compression. This air compressional pulse travels away from its starting point for the same reason that the baseball did, namely, it has inertia and since motion has been imparted to it, it has momentum and hence the power to do work when its motion is checked.

How Sound Waves Are Formed

Fig. 2 shows the line of dots of Fig. 1 and a wavy line below them.

This wavy line is seen on close inspection to be in some way related to the distribution of the dots, and it is seen that the peak of the wavy line above the central axis is labelled maximum pressure, while below the line the peaks that point downward are minimum pressure points.

It is apparent that if in a large sample of air, made up of millions of tiny dot-particles, the distribution was uniform, that we would say that there was no disturbance or no wind or, in brief, no change of pressure at all, hence no motion of air particles.

The same reasoning is true, then, of the situation in Fig. 2. Where the air particles are closest together the pressure is highest and where they are farthest apart it is lowest.

Therefore the big metal diaphragm of Fig. 1 is in reality the cause of the peculiar distribution of dots in Fig. 2.

These alternate close and wide dot groupings are called respectively compressions and rarefactions and these are propagated away from every sound-vibrating body at a rate that

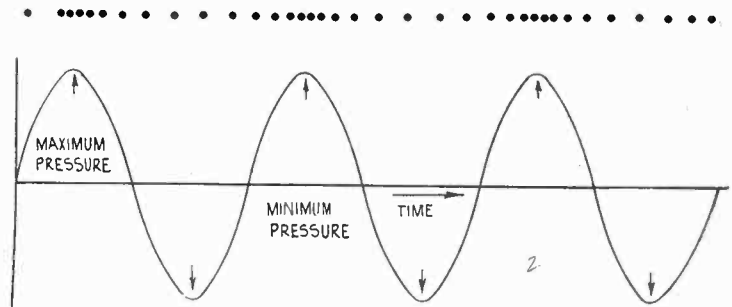

FIG. 2
SOUND WAVE RECORDS MAKE GRAPHS LIKE THIS. THE LOUDER THE SOUND, THE BIGGER THE WAVE.

corresponds to the frequency of vibration, and with a degree of mechanical force that depends upon the amplitude of the vibrator.

Changes Noted

Thus it is seen that the curved line of Fig. 2 starts to increase (at the left) as the dots get closer together and is a maximum when they appear to touch, dipping down as they grow farther apart and reaching a downward peak when they are farthest apart and, as the line moves upward again the dots close in again—starting the cycle all over again.

Insofar as the human reaction to sound is involved, excluding the secondary influences (likes and dislikes, emotional interpretations, etc.) the primary influence of sound is mechanical, strange as that may seem, and involves the varying atmospheric pressures acting on the ear drum, causing it to execute inward and outward excursions at a rate of displacement that tends to correspond with the frequency of the sound pressure—rarefaction wave, and with linear displacement depending upon the effective magnitude of the change from pressure to rarefaction.

But the story does not end here because, as even novices know, some ears can hear certain notes very much better than other notes, while the uniform effect of sounds do not produce uniform aural response.

The first case, of hearing some notes better than others, represents the manifestation of sound resonance, or audible selectivity, comparable to the varying degrees of electrical wave frequency selectivity, while the second case, of dissimilar response to uniform sound, represents in a broader sense the influence of uniform sound resistance, in varying degrees from uniformly low acoustic resistance values to very high resistance values. An example of the condition is that a relatively deaf person requires perhaps much greater sound pressure applied to the ear drum, even to hear a little. See Fig. 3 in respect to sound selectivity.

Fig 3 shows what appears to be a hollow semispherical cross-section that is evidently open at each side. In reality it is a hollow sheet brass cavity. The smaller of the two open

A New Method of

A process of recording sound on moving picture film has just been announced by G. K. Spoor, formerly owner of the Biograph Company.

Mr. Spoor is also a co-inventor of the stereoscopic camera, a device that makes possible the illusion of depth in a picture.

The new recording process is the result of experiments in progress since before March, 1929.

The new sound recording process involves some direct mechanical processes intended to result in unprecedented production economies. It involves the making of a master record, which is carved on a plain film at the same time that the negative picture is being taken on the emulsified film. Thus when the positive copies are made, the sound track is merely engraved on the edge of the positive film by an engraving machine that uses the previously made master record. This quick method results in avoiding the lengthy transcription processes of the

Resonance in Sound Propagation

Williams

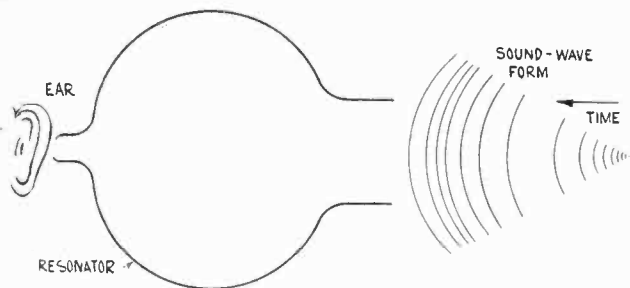

FIG. 3
APPLICATION OF A HELMHOLTZ RESONATOR.

ends is so sized and shaped that it fits the entrance of the aural canal, while the other more open end is turned in the direction whence sound waves are shown coming. The hollow globular affair is a form of a Helmholtz resonator, named after an early German physicist.

What Sound Resonance Is

The simplest way of explaining the use of this cavity is to create an easily understood analogy. Flower-pots are usually open at both ends. Suppose we hold one under a running tap, and with the water running slowly (low frequency sound wave) see how long it takes to fill the pot with water. We find that at this rate it will never fill at all, so increase the rate of water-flow (increase the applied sound frequency) and the pot fills up to about a quarter of its capacity. So turn on more water and finally find a rate of flow that completely fills the pot before a relatively large amount is lost. A sound pressure frequency that permits the largest number of complete sound waves to occupy the length of the given enclosure in a given time, as they pass through hit to the ear located outside, is thus represented.

It should be just as easy to vision the idea of the natural period of a cavity as being directly due to the time rate of re-filling with a substance as it is to realize that even the flower-pot has a similar time rate of filling that depends mainly upon its capacity for holding a substance under standard conditions.

The resonator shown is one that can be completely filled and emptied of all air at the rate of 256 times in each second, a very rapid rate of events no doubt, but if a sound-pressure wave be directed at the large end of this resonator, and enough pressure is supplied at the same time, the desired results will be obtained. But even then, should there be insufficient air to do all this, an ear placed as shown will detect a greatly magnified tendency for this rate of pressure change to be passed through the device, as compared to all other sound-pressure frequencies that may be applied to it.

A conch shell that you hold to your ear at the seashore is a good example of a Helmholtz resonator.

The name given to the tendency to respond to a certain pressure rate change is "resonance" and is a universal phenomenon in nature. It is not to be confused with reflections, echoes or

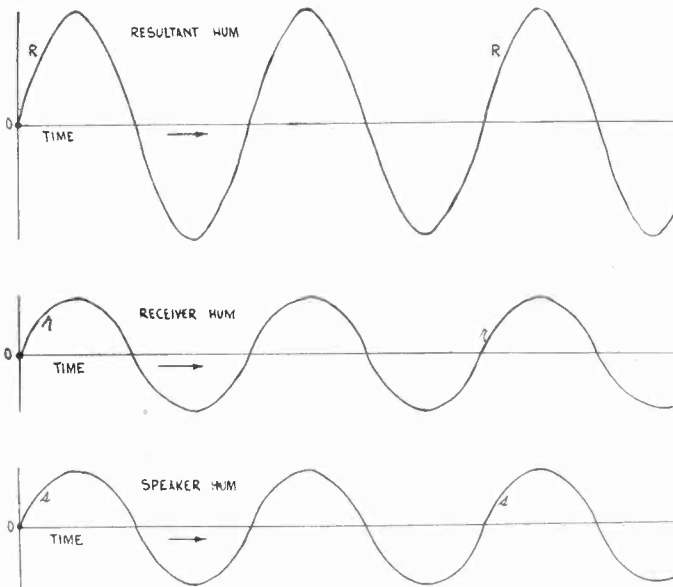

FIG. 4
EFFECT OF TWO SOUNDS OF SIMILAR FREQUENCY AND AMPLITUDE. (LOUDNESS)

refractions (bendings) of the sound-pressure propagation path from its originally imparted direction of motion.

The Marvelous Ear

The material of which a resonator is made, just so long as it is stiff, does not influence the rate of filling, called the periodicity. The material does not affect the fundamental of the resonator except to alter the tone quality, or response to overtones.

The ear is truly a most marvelous creation, consisting as it does of a compact and complete sound-sensitive and sound-selective apparatus, although not free from imperfections.

Fig. 4 represents two sound-pressure graphs not unlike Fig. 2 that were obtained in the same way. The big graph at the top is the result of the combined effects of the two lower ones.

The large sound-wave graph's increased height and general contour may be checked roughly by the novice.

Merely draw a line at exactly right angles to the three time axis shown, so that it completely overlaps the peaks of all the curved lines. Then take the vertical distance of each of the small curves to the point where each intersects the vertical line or lines you draw, and the sum of these distances will be found to equal the distance to the intersection made by the line of the larger graph.

In the case where two sounds of the same frequency and intensity cause no sound to be heard, a graph of this condition would show that the two wave forms reached equal compressions and rarefactions at the same time. But if the wave forms don't exactly cancel, that is, where one is slightly faster than the other, the result is a sound wave of intermittent pulsating quality and the phenomenon is called a beat.

Inspection will show that the frequency is entirely independent of the amplitude, and that the large curved line has just as many humps and hollows as have the two smaller lines, and it would make no difference how small these wave forms were, just as long as they had similar periodicity. Their resultant (what you hear) would always be represented by a curved line with an amplitude twice as great as that of either of the two waves that compose it.

Musical Instruments Source of Sound Graphs

With the aid of an ordinary reading-glass you can show that the wavy traces on a phonograph record correspond in general contour to the preceding drawings, although these traces vary considerably in relative amplitude, whereas the drawings are more or less of simple sine wave shape.

Violin, oboes and large pipe organs are sources of nearly sine-wave (simple) tones, while brass, wind instruments provide curve that are rich in harmonics. The resultant shape of the sound-pressure output graph of any of these latter instruments would be a continuously wavy line like that of Figs. 2 and 4, but the line itself would be very irregular indeed.

Talkie Recording

present light track and photoelectric cell and amplifier systems by means of which it is declared a sound record passes through five separate stages before it is ready for copy.

The voices of the persons recording are transcribed onto the film directly, without the barrel roll effect that robs the degree of naturalness.

There are at present around 30,000 feet of sound track film supplied to cutting rooms of each Coastal studio daily. This film costs about 10 cents per foot or a total of \$3,000. The new process makes it possible to convert 30,000 feet of sound track film into a usable product at a cost of about \$40 worth of celluloid.

A further striking example is the following: All light-track films require laboratory work for production development, while the new sound films can be heard directly after recording, no laboratory work being necessary.

The Latest Screen-

By J. E.

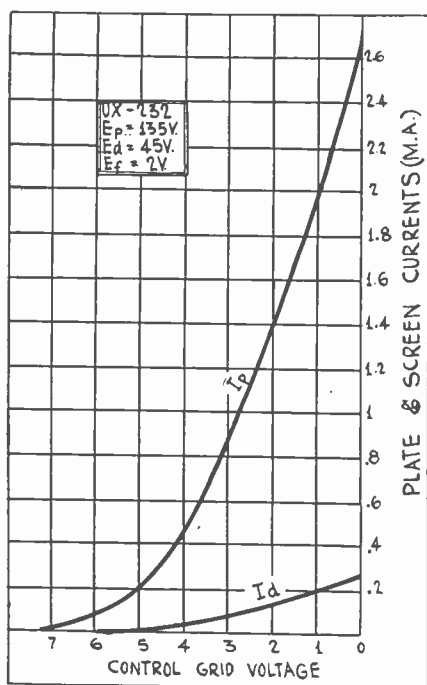

FIG. 58

GRID VOLTAGE, PLATE CURRENT AND SCREEN CURRENT CURVES FOR THE 232 SCREEN GRID TUBE WITH 45 VOLTS ON THE SCREEN AND 135 VOLTS ON THE PLATE.

[This is the sixth weekly instalment of "Modern Radio Tubes." The first instalment appeared in the August 9th issue. Subsequent instalments have dealt with three-element battery operated tubes. Next week additional information will be given on the 232, while the 222 and the 224 screen grid tubes will be discussed also.—EDITOR.]

232

THE 232 is a four-element, or screen grid, tube and is designed to be used as radio frequency amplifier in circuits in which the 230 general purpose tube and the 231 power tube are used. While it is primarily a radio frequency amplifier, it can also be used as detector, Superheterodyne modulator, and audio frequency amplifier, provided that the load impedances and the voltages on the elements are suitably chosen.

CHARACTERISTICS OF THE 232

Filament voltage	2.0
Filament current, amperes.....	.06
Plate voltage, maximum.....	135.
Control grid voltage.....	-3.
Screen grid voltage, maximum.....	45.
Plate current, milliamperes.....	1.5
Screen current, milliamperes.....	0.5 or less
Plate resistance, megohms.....	0.8
Amplification factor	440.
Mutual conductance, micromhos.....	550.
Effective grid-plate capacity, mmfd., maximum	0.02
Base	Standard UX

In appearance the 232 tube is like the 222 screen grid tube, the control grid being brought out at the top of the glass bulb and the screen grid being brought out at the regular grid prong in the base. The size of the 232 is also the same as that of the 222 and is therefore considerably larger than the size of either the 230 or the 231.

Curves

Fig. 58 gives the relationship between the control grid voltage and the plate and screen currents as obtained with one of these tubes under the operating conditions stated, namely, 135 volts in the plate circuit, 45 volts in the screen circuit, and 2 volts across the filament. The plate current I_p begins when the control grid voltage is 7.5 volts and rises rapidly as the bias decreases, reaching 2.7 milliamperes when the bias is zero. The

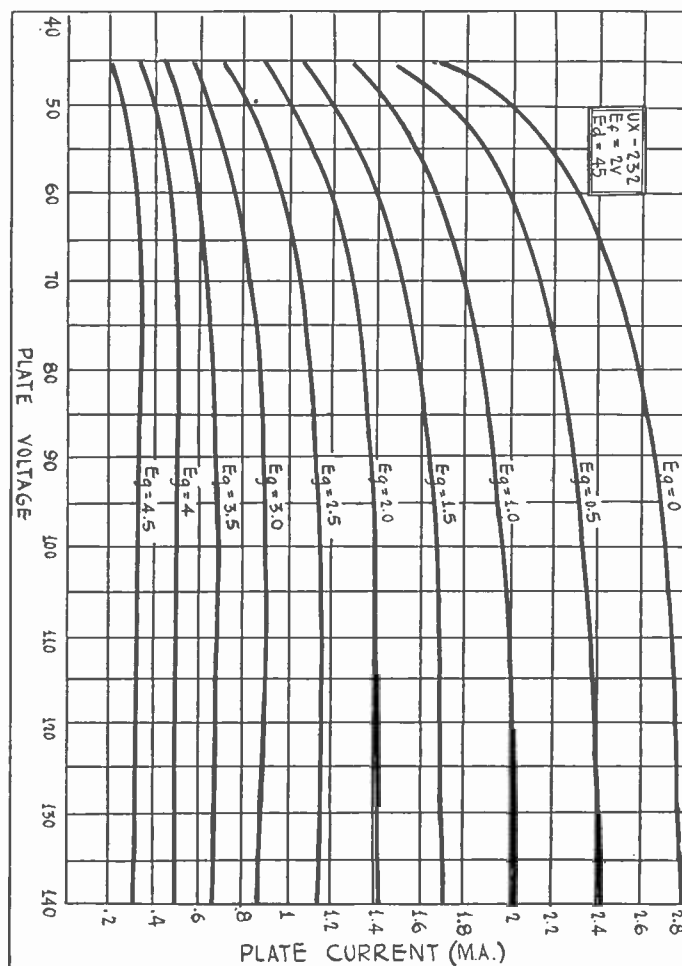

FIG. 59

A FAMILY OF PLATE VOLTAGE, PLATE CURRENT CURVES FOR THE 232 SCREEN GRID TUBE WITH 45 VOLTS ON THE SCREEN.

slope of this curve, which is the mutual conductance, varies, since the curve is not a straight line. At a bias of 1.5 volts the slope is 590 micromhos, at 2 volts it is 550 micromhos, and at 3 volts it is 500 micromhos. The rated value, as given in the above table, is 550 micromhos.

The screen current I_d is approximately one-tenth as great as the plate current. At zero bias it is 0.28 milliamperes and it reduces to zero at about 6 volts. As the plate voltage decreases, the screen voltage being kept constant, the plate current for any given bias decreases and at the same time the screen current increases. For example, when both the screen and the plate voltages are 45 volts, the plate current is 1.63 and the screen current is 1.05 milliamperes. These values were obtained on the same tube with the same filament, voltage as the data from which the curve in Fig. 58 was plotted.

Use of Tube as Detector

The plate current curve in Fig. 58 shows that when the tube is used as a grid bias detector the bias should be approximately 6 volts. The curve, however, does not show what signal amplitude may be applied without distortion, for when the tube is working into a resistance of high value the curve will not rise uniformly as the bias is decreased. Other curves showing the effective output voltage across the load resistance for different grid bias voltages will be given later. These curves will also show the voltage gain when the operating bias is adjusted for amplification.

In Fig. 59 is a family of plate voltage, plate current curves for the 232 tube when the screen voltage is maintained at 45 volts. These curves are for a particular tube of the type and do not represent the average. The customary load lines are not drawn across the curves because it is rather difficult to make good use of them for a screen grid tube. However, if a load line for 100,000 ohms is drawn through the point represented by 135 volts on the plate and 2 volts on the control grid, it is found that a grid bias change of about 0.056 volt produces a change

Grid Tube, the 232

Anderson

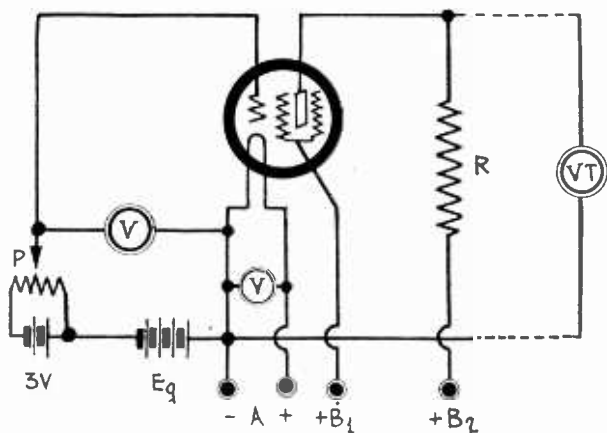

FIG. 60

A SIMPLE CIRCUIT, SHOWING THE CONNECTIONS FOR TAKING GRID VOLTAGE, PLATE OUTPUT VOLTAGE CURVES WITH A VACUUM TUBE VOLTMETER.

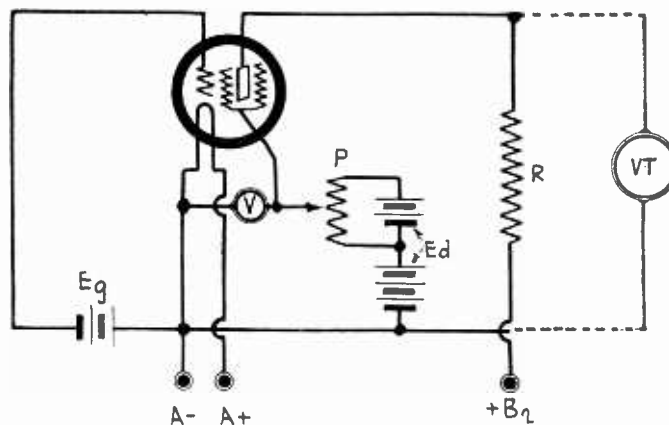

FIG. 63

A SIMPLE CIRCUIT, SHOWING THE CONNECTIONS FOR TAKING SCREEN GRID VOLTAGE, PLATE OUTPUT VOLTAGE CURVES WITH A VACUUM TUBE VOLTMETER.

in the effective plate voltage of 10 volts. This indicates a voltage amplification of nearly 180 times.

The curves in Fig. 59 are useful in estimating the plate current when the control grid bias and the effective plate voltage are known, or for estimating the effective plate voltage when the control grid bias and the plate current are known. They may also be used for estimating the grid bias when the effective plate voltage and the plate current are known. Of course, the curves apply only when the screen voltage is 45 volts and when the filament voltage is 2 volts. Again it is emphasized that the curves are for a particular tube, so that some variation may be expected.

Voltage Amplification

When the screen grid tube is used as an audio frequency amplifier it should be used with resistance coupling with a load resistance of not less than 100,000 ohms. When it is so used, the customary values of control grid bias, screen voltage and plate voltage cannot be used, because the characteristic curves between plate voltage and control grid voltage are entirely different from the corresponding curves when there is no load in the plate circuit. If the plate and screen voltages are those recommended for radio frequency amplification, the grid bias must be increased. If the grid and plate voltages are those recommended for radio frequency amplification, the screen grid voltage must be reduced considerably if the circuit is to yield distortionless amplification. And if the grid bias and screen voltages are those recommended, the applied plate voltage must be increased greatly.

We can illustrate two of these statements with the aid of the curves in Fig. 59. Suppose the load impedance is 250,000 ohms and the voltage in the plate circuit is 135 volts. The load line is drawn through the point on the voltage axis at 135 volts and the point 0.36 milliampere on the 45-volt ordinate. If we take 0.06 milliampere as the minimum current, we find that the load line crosses the 0.06 milliampere abscissa at 120 volts. We cannot permit the effective plate voltage to become less than 50 volts, for if we do we enter the region of excessive curvature at the left. Hence, we have to adjust the grid bias so that the effective voltage on the plate is 85 volts, the mean between 50 and 120 volts. At this plate voltage the load line indicates a current of 0.2 milliampere. From Fig. 58 we find that this current is given when the bias is exactly 5 volts. Hence, that should be the bias. Fig. 58 shows that at this bias the tube is a good detector, but it is also a fair amplifier. But there will be a good deal of distortion. The indicated amplification is only 37.

Increasing Plate Voltage

Now, if we are to use the recommended grid bias of 3 volts and a load resistance of 250,000 ohms, we have to boost the applied plate voltage so that the effective voltage on the plate is 135 volts. The steady plate current will be 0.88 milliampere, so that the voltage drop in the load resistance will be 220 volts. Hence, we have to apply a voltage of 355 volts. The load line will pass through 0.88 ma. and 135 volts and 1.22 ma. and 45 volts. To avoid considerable curvature at the left, we have to limit the effective plate voltage to about 60 volts, where the grid bias is 2 volts. The signal amplitude that may be impressed is therefore one volt, and this grid voltage change produces a change

in the plate voltage of 75.5 volts. Thus the amplification is 75.5, at least on the positive half of the signal cycle. The curves do not extend far enough toward the right to tell what happens to the negative half of the cycle. It is of little interest because it is not practical to apply voltages as high as 355 volts on the plate. It is preferable to make the screen grid tube operative by lowering the screen voltage.

Grid Voltage, Plate Voltage Curves

The most useful curves for a screen grid tube when it is used in a resistance coupled circuit are those that give the relation between the voltage on the control grid and the corresponding voltage between the plate and the filament or cathode. Such curves give directly the voltage amplification, the optimum grid bias and the output voltage.

The best way of taking such curves is by means of a circuit such as is suggested in Fig. 60. The voltmeter connected between the control grid and the filament indicates the applied grid bias and the meter across the filament indicates the filament voltage. This voltage should be kept at 2 volts with the aid of a rheostat in the positive filament lead. The rheostat is not shown. R is the load resistance and VT indicates a vacuum tube voltmeter which should be adjusted so that it draws no current.

The grid voltage is supplied by an adjustable battery E_g . A 400-ohm voltage divider P is connected across two cells of this battery and the slider is connected to the grid and the grid voltmeter. By means of this voltage divider the applied bias can be adjusted accurately to any convenient values. A reading of the plate output voltage should be taken for every half volt on the grid, beginning with zero and increasing it until the plate output voltage is equal to the applied plate voltage. This should be repeated for different values of screen grid voltage and for several voltages in the plate circuit.

Sample curves will be published as soon as they are available.

Another interesting and useful set of curves is one giving the relationship between the screen voltage and the plate output voltage for some fixed grid bias and a fixed applied plate voltage. Since the screen grid tube is frequently used as a modulator by impressing the signal voltage on the control grid and the local oscillation voltage on the screen, such curves should be taken for that control grid bias which makes the tube most efficient as a detector.

The arrangement for taking such curves is shown in Fig. 63, in which E_g represents the fixed control grid bias, E_d the adjustable screen voltage, which is measured by means of V, and R represents the plate load on the tube. P is the same 400-ohm voltage divider as was used in Fig. 60, and VT is the same or a similar vacuum tube voltmeter.

Sample curves will be published as soon as they are available.

Vacuum Tube Voltmeter

The circuit of a vacuum tube voltmeter suitable for measuring the effective plate voltage in circuits of Figs. 60 and 63 is shown in Fig. 66. The tube in this circuit should preferably be a 171A or some other tube having a high mutual conductance. The plate voltage on this tube may have any convenient value

(Continued on next page)

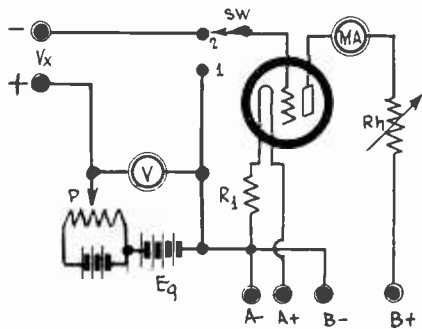

FIG. 66

THE CIRCUIT OF A VACUUM TUBE VOLTMETER, UTILIZING PLATE AND BALANCING BATTERIES. THIS CIRCUIT IS SUITABLE FOR TAKING MEASUREMENTS ON THE TUBES IN FIGS. 60 AND 63.

(Continued from preceding page)

and the milliammeter MA should have a range about 0.5 milliamperes. The high resistance rheostat Rh is used simply to adjust the plate current until the needle of the milliammeter points to one of the scale divisions. It makes little difference what current is selected, for it is used only as a null-point or reference point. To establish this point the grid switch is thrown to position (1), which makes the bias on the tube equal to the drop in ballast resistor R1, and Rh is adjusted until the meter MA reads the desired value.

The unknown voltage is applied across the terminals marked Vx, with the polarity indicated. The unknown voltage will make the grid of the vacuum tube voltmeter negative, and this negative voltage is balanced by means of battery Eg and the voltage divider P. The grid switch is thrown on point (2) and Eg adjusted until the plate current is returned to the reference point. When that has been done, the unknown voltage is read on voltmeter V across Eg.

It is necessary to use DC on the filament of the vacuum tube voltmeter and also to use the drop in R1 as a permanent bias in order to insure that the grid will take no current when the balance of voltages has been effected.

The value of Rh depends on the plate voltage applied to the tube and also on the range of the meter MA. It is suggested that it be 50,000 ohms and that the plate voltage be adjusted so that the reading on the milliammeter has approximately the desired reading. Rh can then be used to bring the reading to exactly the desired point. R1 can be an ordinary filament ballast resistor for a 171A tube, if that tube be used.

Range of Voltmeter

The range of the voltmeter V and the voltage of Eg depends entirely on the range of voltage to be applied across the Vx terminals. They should at least be equal to the applied plate voltage on the tube the output voltage of which is to be measured.

It is imperative that there be no connection between the filament batteries serving the vacuum tube voltmeter and the tube under measurement, for if there is there will be a disastrous short-circuit.

Fig. 67 shows the circuit of a slightly different vacuum tube voltmeter in which the plate voltage and the balancing voltage may be applied by a B battery eliminator. This has the advantage that no batteries are needed either for the vacuum tube voltmeter plate or for balancing. R in this case is the regular voltage divider on the B supply and may have a total resistance of 10,000 to 20,000 ohms. It should be tapped so that one end of the voltage divider P may be put on points lower than the maximum. This makes closer adjustment possible. P should have a total resistance of about 10,000 ohms, and Rh should have a value of about 50,000 ohms.

Note carefully the polarity of the unknown voltage terminals. It is the reverse of that in Fig. 66. The method of use of this vacuum tube voltmeter is exactly the same as that of Fig. 66, but the null-point should be checked each time a reading is taken, for it will shift whenever the slider of P is moved. First find an approximate balance, then establish the null-point, and then readjust P for an accurate reading. If the second adjustment of P is considerable, it may be necessary to re-establish the null-point. The need for this can be checked by throwing the grid switch from (2) to (1). If the current changes as indicated by the needle's deviation from the null-point, a readjustment is necessary.

Use Is Simple

This appears more complex than it really is, for it takes only a moment to check and readjust the null-point.

In case the voltmeter V is one of the 1,000 ohms per volt type, R may be omitted and P, a 30,000-ohm voltage divider, may take its place.

The total output voltage of the B supply should be equal to or exceed the voltage to be measured, for no higher voltage can be measured directly. However, if the voltage to be measured exceeds the maximum voltage of the B supply, it is still possible to measure the unknown by inserting an auxiliary battery at the terminals marked Va, with the polarity indicated. When no battery is inserted here, the terminals should be short-cir-

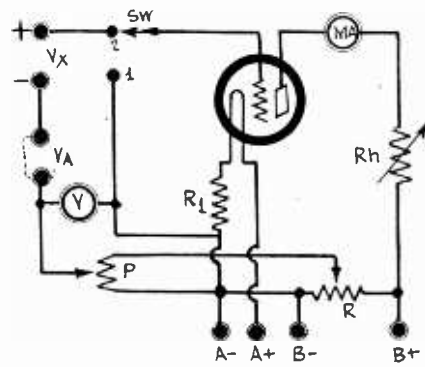

FIG. 67

THE CIRCUIT OF A VACUUM TUBE VOLTMETER, UTILIZING A B SUPPLY UNIT FOR THE PLATE AND BALANCING VOLTAGES. THIS ALSO IS SUITABLE FOR USE WITH THE TUBES IN FIGS. 60 AND 63.

cuted as indicated by the dotted line. If the voltmeter V has sufficient range, it may be connected so that it also measures the voltage of Va. If not, the voltage of Va should be added to the reading of the voltmeter whenever it is necessary to use the auxiliary battery.

A vacuum tube voltmeter of the type shown in Figs. 66 and 67 may be used for measuring any DC voltage whatsoever within the range of voltmeter used, and it is especially suitable for measuring DC voltages wherever it is essential that the measuring instrument take no current from the circuit under measurement. For example, it may be used for measuring the drop in a plate resistor or grid leak resistance, where any current-drawing instrument would give spurious readings. It may also be used for measuring the drop in grid bias resistors and in the sections of a voltage divider, as well as the actual voltage on a grid where there is a high resistance in the grid circuit. The use of the instrument for taking output voltage curves is a case of measuring actual plate voltages when there is a high resistance in the plate circuit.

It is possible to arrive at the correct voltage on the plate of a tube by measuring the direct current in the plate circuit with a sensitive milliammeter or microammeter, multiplying this current by the resistance in the external load of the tube, and then subtracting this product from the applied plate voltage. This method, however, offers many disadvantages. First, the resistance in the load circuit must be measured accurately, and this resistance must include that of the voltage source. Second, it requires a great deal of computation. Third, it requires a sensitive, delicate, and expensive current meter.

(Continued next week)

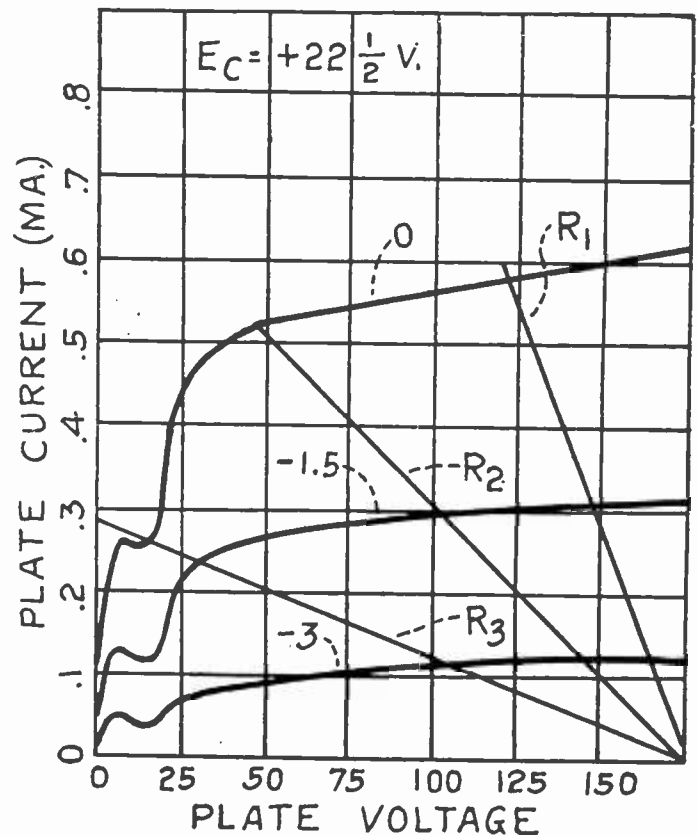

FIG. 68

THESE CURVES SHOW THE VARIATION IN THE PLATE CURRENT IN THE 222 SCREEN GRID TUBE WHEN THE SCREEN VOLTAGE IS 22½ VOLTS AND FOR THREE DIFFERENT CONTROL GRID VOLTAGES IS INDICATED.

A Question and Answer Department conducted by Radio World's Technical Staff. Only Questions sent in by University Club Members are answered. The reply is mailed to the member. Join now!

RADIO UNIVERSITY

Annual subscriptions are accepted at \$6 for 52 numbers, with the privilege of obtaining answers to radio questions for the period of the subscription, but not if any other premium is obtained with the subscription.

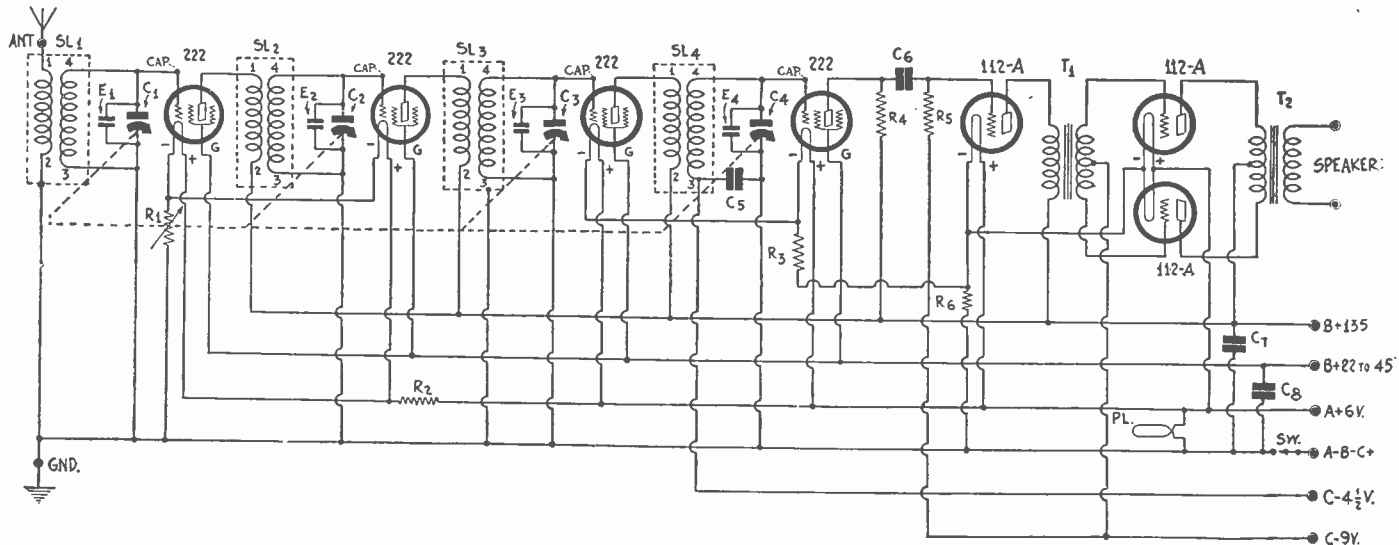

FIG. 846

A RECEIVER UTILIZING FOUR SCREEN GRID TUBES AND THREE 112A TUBES WITH PUSH-PULL OUTPUT.

Modulation by Screen Grid Tubes

YOU HAVE PUBLISHED many circuits in which the 224 screen grid tube was used as a modulator in which one frequency was impressed on the control grid and the other on the screen grid. How is it possible to mix the two in this manner and to obtain a current or voltage of a frequency equal to the difference between the two impressed frequencies? In other words, how does the output of the tube depend on the screen voltage? I have never seen any curves giving the relation between the plate current and the screen voltage for fixed values of the control voltage.—W. A. F.

So far no such curves have been published but we know that the higher the screen voltage the greater the screen current and the more of the total current goes to the screen. Hence less goes to the plate. But this statement does not hold true for all voltages on the three electrical elements of the tube. To get good modulation efficiency it is necessary to adjust the voltages properly. In an early issue of RADIO WORLD curves showing the relation between the plate current, or plate output voltage, and the screen voltage will be published. Look for them in the articles on "Modern Radio Tubes."

Estimation of Output Power

WILL YOU KINDLY give a method for estimating the output power of a tube such as a 245?—C. D. A.

The best way is to take a family of plate voltage, plate current curves of the tube and draw a load line for a resistance equal to twice the internal resistance of the tube. When this line crosses the curve of zero bias note the effective plate voltage and the plate current. Also note where the line crosses the minimum current line, which for the 245 tube may be taken at 2 milliamperes. Note the effective plate voltage at this intersection. Find the difference between the two effective plate voltages and also the difference between the two currents. Multiply them together and divide by 8. In the absence of a family of curves put a resistance in the plate circuit equal to twice the internal resistance of the tube and take a reading of the plate current when the bias is zero and another when the bias is equal to twice the value of the operating bias. Take the difference between these two current readings. Take the square of this difference. Multiply by the load resistance and divide by eight. The results is the power in milliwatts if the resistance was expressed in ohms and the current in milliamperes.

High Resistance Voltmeter

WHAT SHOULD the resistance per volt of a voltmeter be if it is to give correct readings of the voltages on a B supply?—L. B.

The resistance should be infinite. If the resistance is finite there will always be some error in the reading. The only practical meter having an infinite resistance is a vacuum tube voltmeter. However, a meter having a resistance of 1,000 ohms per volt will give sufficiently accurate readings in most instances. Occasionally the current drawn from the supply is so small that the current required to operate even a meter of 1,000 ohms per volt will result in inaccurate readings. One case where a 1,000-ohms-per-volt instrument does not give accurate readings is in the measurement of the effective

voltage on the plate of a tube in a resistance coupled amplifier. The reading will be entirely wrong because the voltage drop in the coupling resistor will be greater than the drop in the meter itself.

* * *

Effectiveness of By-Pass Condenser

WHAT IS THE effective resistance of a 250,000 ohm resistor at 10,000 cycles when a .00025 mfd. condenser is connected across it? I have reference to the by-pass condenser and the load resistor in the plate circuit of the detector in a resistance coupled amplifier.—S. G. A.

The effective resistance is 15,200 ohms. The effective reactance of the combination is nearly 60,000 ohms, while the impedance at 10,000 cycles is 61,700 ohms. It is clear that the condenser causes a considerable frequency distortion since at very low frequencies the load is 250,000 ohms and at 10,000 cycles it is only about 60,000 ohms. If the effective value of the internal tube resistance is 100,000 ohms, which is a reasonable assumption, the output voltage at very low frequencies will be 1.9 times as great as at 10,000 cycles. That difference is equivalent to 2.3 decibels.

* * *

Always Use Sharp Needle

IS IT A FACT that if the phonograph needle is too blunt it will not follow the high-frequency modulation of the record so that the high notes will not be reproduced even if the pick-up unit and the amplifier system are capable of handling these notes?—D. B. H.

It is a fact. It may well be that the wavelength of the modulation on the record is so short that the radius of the needle point is of comparable dimensions. In that case the needle would not follow the curve but would ride over ridges and hollows. A similar effect is present in film reproduction of sound, but in this case it is the width of the scanning slit that determines the effectiveness of the pick-up.

* * *

Power Loss in Condenser

IS THERE NOT a considerable power loss in the stopping condenser between the plate and the loudspeaker when the output filter is used for separating the DC and the AC?—H. B. S.

The power loss is very small even if the condenser is relatively poor. Practically all the power taken from the circuit is utilized in the speaker. However, on the low notes the condenser lowers the power delivered to the speaker although it does not itself absorb any appreciable portion of it. It simply retards the current from flowing. Power lost should not be confused with power drawn from the supply.

* * *

Grid Bias Resistor for Battery Circuits

IN AC RECEIVERS it is customary to provide the grid bias by means of resistors, while in DC receivers batteries are used almost exclusively. Would it not be practical to use bias resistors for DC circuits also?—J. B.

If the same bias resistor can be used for all the tubes, it is practical but not otherwise, unless separate filament batteries or separate B batteries are used for all the tubes. These provisions do not sound as if the scheme is practical.

Heats by Induction.

WHAT IS THE principle of the instrument now used in medicine for inducing artificial fever in the treatment of diseases? How is the heat in the body developed?—E. R. B.
The principle is based on the induction of high frequency currents in the tissues of the body, or in the body fluids such as the blood and the lymphatic fluid. The means for doing it are varied. In one method the patient is placed between the plates of the oscillator condenser. In another the short waves are focused by means of a parabolic mirror and the patient placed at the focal point. It is safest to leave experimentation along this line to physicians.

How to Measure Grid Bias Voltage.

YOU HAVE STATED many times that the correct grid bias to use on any tube is determined by the voltage in the plate circuit rather than on the effective voltage on the plate, and that the same bias is required whether the voltage is applied through a transformer of low resistance or a resistor of high value. What is the justification for this statement?—S. E. E.

The bias at which the plate current is just reduced to zero is determined by the ratio of the voltage in the plate circuit to the amplification constant of the tube. When there is no plate current, there is no drop in the load impedance and consequently the voltage in the plate circuit is also the effective voltage on the plate. But that is only true when the plate current is zero. The bias to use is largely determined by the grid voltage that just reduces the plate current to zero. That the bias should be the same in the two cases can easily be verified by taking a grid voltage, plate current curves for both types of load on the tube and then plotting the two on such current scales that the curves when plotted on the same sheet coincide at zero bias. We have just found that they coincide at the point where the plate current is just zero, provided the applied plate circuit voltage is the same in the two cases. It will be found that the two curves practically coincide at every grid bias. The only difference is that the resistance-coupled curve will be slightly less curved. It has been asserted time and again that resistance coupling gives a curve that is nearly straight and therefore that this type of amplification will produce less amplitude distortion. Plotting the two curves as suggested above will show that the difference is not as great as it has been commonly assumed. There is a slight advantage in favor of resistance coupling, but only a slight one. This, of course, has nothing to do with frequency distortion, for in this respect the resistance-coupled circuit is superior. The grid bias should be the same for the two types of coupling because the plate current reduces to zero at the same bias and the curves have the same shape relatively.

Coupling Headphones to Speaker.

I WISH TO ARRANGE a circuit so that I can listen in with a headset on the first audio amplifier without in any way interfering with the operation of the loudspeaker. Is it possible? If so, please suggest a simple way.—N. C. Y.

One very simple way is to couple the first and the second audio amplifiers by means of an impedance coupler, using for the impedance the secondary of an audio transformer. The primary winding can then be used for feeding the headphones. Run the primary

Join

Radio World's

UNIVERSITY CLUB

And Get Free Question and Answer Service for the Coming 52 Weeks. This Service for University Subscribers Only

Subscribe for RADIO WORLD for one year (52 numbers) Use the coupon below. Your name will be entered on our subscription and University Club lists by special number. When sending questions, put this number on the outside of the forwarding envelope (not the enclosed return envelope) and also put it at the head of your queries. If already a subscriber, send \$6 for renewal from close of present subscription and your name will be entered in Radio University.

NO OTHER PREMIUM GIVEN WITH THIS OFFER

[In sending in your queries to the University Department please paragraph and number them. Write on one side of sheet only. Always give your University Club Number.]

RADIO WORLD, 145 West 45th Street, New York City. Enclosed find \$6.00 for RADIO WORLD for one year (52 nos.) and also enter my name on the list of members of RADIO WORLD'S UNIVERSITY CLUB, which gives me free answers to radio queries for 52 ensuing weeks, and send me my number indicating membership.

Name
Street
City and State

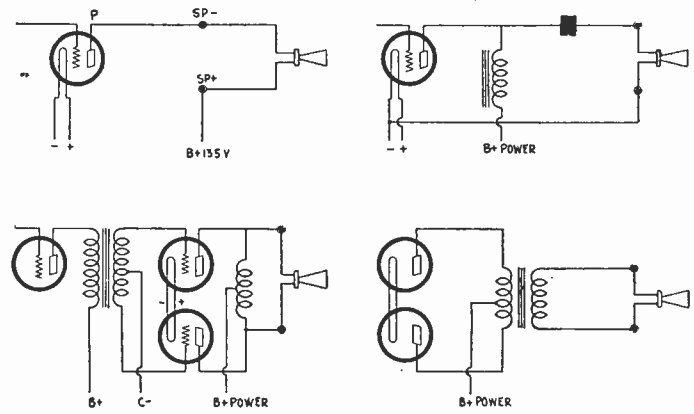

FIG. 847
FOUR DIFFERENT TYPES OF OUTPUT CIRCUITS, TWO FOR SINGLE TUBE AMPLIFIERS AND TWO FOR PUSH-PULL

winding terminals to a phone jack and plug in the headset whenever it is desired to listen in with it.

Making a High Resistance Voltmeter

PLEASE EXPLAIN how a milliammeter can be used for making a voltmeter. Is it not a fact that a milliammeter always indicates current? If it does, how can it also indicate voltage?—C. O. R.

It is true that a milliammeter always indicates current and it is also true that if the resistance is constant the current is directly proportional to the voltage across the resistance. This proportionality is used in measuring voltage by means of current. By Ohm's law the voltage drop V equals RI , where R is the resistance in ohms and I the current in amperes. If the resistance is fixed the voltage is directly proportional to the current and it is only necessary to calibrate the milliammeter scale in terms of volts instead of in milliamperes. Suppose, for example, that we have a milliammeter that covers the range 0-1 milliamperes. If we connect a 100,000 ohm resistance in series with this meter and then connect the meter and the resistance across a voltage source of 100 volts, the current through the resistance, and through the meter is $100/100,000$, or 1 milliamperes. Therefore, when the meter deflection is full-scale, the voltage across the resistance is 100 volts. We can mark the scale 100 volts instead of 1 milliamperes, that is, provided we don't change the resistance in series with the meter. If we divide the scale in 100 equal divisions each division represents one volt. Hence any voltage between zero and 100 can be measured. If we want a different voltage range, say 0-10 volts, we connect a resistance of 10,000 ohms in series with the meter, and then each division on the scale would represent 0-1 volt. This voltmeter would have a sensitivity of 1,000 ohms per volt. If a milliammeter of 0-5 milliamperes range were used the sensitivity would be 200 ohms per volt. And if a 0-100 microammeter would be used as indicator the sensitivity would be 10,000 ohms per volt. This would be a high grade instrument, provided that the resistors used in series with the meter were high class. The meter is no better than the accuracy of the series resistances.

Dielectric Strength

WHAT IS meant by the dielectric strength of an insulating material, such as bakelite, glass, quartz, and hard rubber?—N. V. E.

The dielectric strength of an insulating material is the voltage required to puncture unit thickness of the material. That varies with many different factors, and when it is given the conditions are also stated. For example, when the dielectric strength of air is given it is usually stated that the electrodes are spherical and that the radius of the spherical surfaces have a specified value. Air breaks down more quickly if the electrodes are sharp-pointed.

A Battery-Operated Circuit With Screen Grid Tubes

IF YOU HAVE diagram of a battery-operated receiver using 222 screen grid tubes and push-pull output, I would appreciate it if you would publish it. Please give the values of the filament resistors.—W. A. R.

A circuit like that you request is given in Fig. 846. The output stage uses two 112A tubes and the stage preceding one of the same type. All the other tubes are 222 screen grid tubes. R1 may be a 20-ohm rheostat, R2 10 ohms, R3 15 ohms, and R6 one ohm.

Output Circuits

HOW SHOULD the speaker be returned in a battery-operated amplifier when the choke and condenser output type of filter is used? If mid-tapped choke coil is used in the output is it necessary to use two stopping condensers, or is one sufficient, in a push-pull amplifier?—D. A. G.

Fig. 847 shows three output circuits, two for single power tubes and two for push-pull, all using battery operated tubes. The upper right figure shows the correct return of the speaker when choke and condenser are used. The lower left figure shows a way of coupling the speaker to a push-pull output tube when a center-tapped choke coil is available. No stopping condenser is used and none is needed.

Headquarters for Outstanding Books—FREE!

"AUDIO POWER AMPLIFIERS"—Anderson and Bernard



"Audio Power Amplifiers" is the first and only book on this important subject. The authors are:

J. E. Anderson, M.A., former instructor in physics, University of Wisconsin, former Western Electric engineer, and for the last three years technical editor of "Radio World."

Herman Bernard, LL.B., managing editor of "Radio World."

The book begins with an elementary exposition of the historical development and circuit constitution of audio amplifiers and sources of powering them. From this simple start it quickly proceeds to a well-considered exposition of circuit laws, including Ohm's laws and Kirchhoff's laws. The determination of resistance values to produce required voltages is carefully expounded. All types of power amplifiers are used as examples: AC, DC, battery operated and composite. But the book treats of AC power amplifiers most generously, due to the superior importance of such power amplifiers commercially.

CHAPTER I. (page 1) General Principles, analyzes the four types of power amplifiers, AC, DC, battery-operated and composite, illustrates them in functional blocks and schematic diagrams.—CHAPTER II. (page 20) Circuit Laws, expounds and applies Ohm's laws and those known as Kirchhoff's laws.—CHAPTER III. (page 35) Principles of Rectification, expounds the vacuum tube, both filament and gaseous types, electrolytic and contact rectifiers, full-wave and half-wave rectification, current flow and voltage derivation. Regulation curves for the 280 tube are given.—CHAPTER IV. (page 62) Practical Voltage Adjustments, gives the experimental use of the theoretical knowledge previously imparted. Determination of resistance values is carefully revealed.—CHAPTER V. (page 72) Methods of Obtaining Grid Bias.—CHAPTER VI. (page 90) Principles of Push-Pull Amplifier.—CHAPTER VII. (page 98) Oscillation in Audio Amplifiers, motorboating and oscillation at higher audio frequencies.—CHAPTER VIII. (page 118) Characteristics of Tubes, tells how to run curves on tubes, how to build and how to use a vacuum tube voltmeter, discusses hum in tubes with AC on the filament or heaters and presents families of curves, plate voltage-plate current, for 240, 250, 201A, 12A, 171A, and 250 with load lines. Also, plate voltage-plate current characteristics of 220, 200A, 201A, 112A, 171A, 222, 240, 226, 227, 224, 245, 210, 250, full data on everything. There is a composite table (II) of characteristics of Rectifier and Voltage Regulator Tubes, and individual tables, giving grid voltage, plate current characteristics over full useful voltage ranges for the 220, 201A, 112A, 171A, 222, 240, 227, 245 and 224.—CHAPTER IX. (page 151) Reproduction of Recordings, states practical methods and shows circuits for best connections.—CHAPTER X. (page 161) Power Detection.—CHAPTER XI. (page 121) Practical Power Amplifier, gives AC circuits and shows the design of a sound reproduction system for theatres. A page is devoted to power amplifier symbols.—CHAPTER XII. (page 183) Measurements and Testing, discloses methods of qualitative and quantitative analysis of power amplifier performance. Order Cat. APAM.

"Radio Manual"—Sterling



The new edition of "The Radio Manual" answers questions about the principles, methods, or apparatus of radio transmitting and receiving. A complete course in radio operation in a single volume. 20 big chapters cover: Elementary Electricity and Magnetism; Motors and Generators; Storage Batteries and Charging Circuits; The Vacuum Tube; Circuits Employed in Vacuum Tube Transmitters; Modulating Systems and 100% Modulation; Wave-meters; Piezo-Electric Oscillators; Wave Traps; Marine Vacuum Tube Transmitters; Radio Broadcasting Equipment; Arc Transmitters; Spark Transmitters; Commercial Radio Receivers; Marconi Auto-Alarm; Radio Beacons; Aircraft Radio Equipment; Practical Television and Radiomovies; Eliminating Radio Interference; Radio Laws and Regulations; Handling and Abstracting Traffic.

The author, G. E. Sterling, is Radio Inspector and Examining Officer, Radio Division, U. S. Dept. of Commerce. Edited by Robert S. Kruse, Nearly 800 Pages, 369 illustrations; flexible fabric cover. Order Cat. MAN.

"FOOTHOLD ON RADIO"

Bernard in their book, "Foothold on Radio." Any one who can understand this book. It is intended for the sheer novice. The treatment is non-mathematical. The origin of the broadcast wave, its radiation, reception, amplification and rectification are set forth in clear language. Side bands are explained simply. The types of receiving circuits are illustrated, described and contrasted. A chapter is devoted to loudspeakers, explaining the different kinds and the principles of their operation. Performance is compared. Audio coupling is fully explained, also the action of the vacuum tube, with a special analysis of plate current and its behavior. Those who have been thirsting for a book that readily reveals the marvels of the radio science will appreciate this little volume. Paper cover 60 pages, fully illustrated. Published May, 1930. Order Cat. FOR.

"Principles"—Morecroft

The outstanding book by Prof. John H. Morecroft is "Principles of Radio Communication," of which the new second edition is now ready. Prof. Morecroft, of the Electrical Engineering Department of Columbia University and past president of the Institute of Radio Engineers, is a noted authority. Set builders, experimenters, distributors, dealers, salesmen and teachers, students and operators, all find Morecroft their standby, and now the new second edition awaits you. 1,001 pages and 831 illustrations in this cloth-bound volume. Order Cat. M-PRIN.

"THE SUPERHETERODYNE"

heterodyne method of receiving. It explains the function of the oscillator, the modulator, the pre-modulator selector, and the intermediate frequency amplifier. It explains the cause of repeat points and gives methods for avoiding them or minimizing their effect. It expounds the relative advantages and disadvantages of high and low intermediate frequencies, and shows the effect of selectivity on the quality.

It illustrates various forms of oscillators and tells of the advantages of each. Different types of modulators and pick-up systems are explained and their advantages stated. Different methods of coupling in the intermediate frequency amplifier are shown.

Image interference is discussed in detail and methods given by which it may be reduced. A special method of ganging the oscillator to the radio frequency condensers is explained, a method which allows either the high or the low oscillator setting to be selected by means of a variometer in the oscillator circuit. One section is given over to coil design for the radio frequency tuners, the oscillator, and the intermediate frequency filter.

Audio amplifiers suitable for superheterodynes are also described. These include transformer, resistance, and push-pull amplifiers both for AC and DC.

While the book is primarily intended to expound the principles of the Superheterodyne, the practical phase has not been neglected. Detailed descriptions of AC and DC superheterodynes, designed in conformity with best practice and sound applications of the principles, have been included in the book. These descriptions are well illustrated. Order Cat. ABSH.

115 LATEST COMMERCIAL SET DIAGRAMS—Rider

Schematic diagrams of 115 latest commercial receivers, including screen grid, collated by John F. Rider, into Supplement No. 1, each diagram on a separate sheet 8 1/2 x 11 inches. Needed by every service man. "Trouble Shooter's Manual," by Rider, contains 200 diagrams, but the present 115 are additional and up to date. No duplication.

41S, 42S, 82S, 60S 61S, 62S; Sonora 7P, A30, A32, A34, A36, A40, A44; Kennedy 80, 10, 20; Stewart-Warner 900 A.C., 950 battery, 950 A.C., 950 D.C., Model B; Radiola 44, 47, 66; Majestic 90, 9P6 power unit, 9P3 power unit; Stromberg-Carlson 841, 842, 846; Edison R1, R2, C2 (50 and 25 cycles), R5 and C4, C1; American Bosch 54 D.C.; Victor B32 and BE45; Grebe SK4 A.C. (early model), SK4 A.C. (late model), SK4 D.C., 428; Traveler A.C. power pack; Eria 224 A.C. screen grid; Silver-Marshall 30B, 30C, 30D, 30E; Eveready 1, 2, and 3, Series 30, Series 40, Series 50; Steinite 40, 50 and 102, 50 power unit; All American Mohawk 98 (60 cycle), 90 (25 cycle), 90 (60 cycle), 70, 73 and 75; Gulbranson Model C (early model), Model C (late model); Bremer-Tully 7-70 and 7-71, 81, 82; Earl 21, 22, 31, 32, 41, 42; Philco 65, 76, 87, 95 screen grid; Peerless Electrostatic series, screen grid; Fada 20, 20Z, 22 battery, 25, 25Z, 25Z, M250Z, Electric units, 35, 35Z, 75, 77; Brunswick 5 NC8 Radio Chassis Schematic, NC8 Audio Chassis Schematic, NC8 and 3 NC8, Audio Chassis Schematic, 5 NC8 cabinet wiring, 3 NC8 Radio Chassis Schematic, 3 NC8 cabinet wiring, S14, S21, S31, S32 screen grid Radio Chassis Schematic, (25 cycle), S14, S21, S31, S32, S33, S34, S35, S36, S37, S38, S39, S40, S41, S42, S43, S44, S45, S46, S47, S48, S49, S50, S51, S52, S53, S54, S55, S56, S57, S58, S59, S60, S61, S62, S63, S64, S65, S66, S67, S68, S69, S70, S71, S72, S73, S74, S75, S76, S77, S78, S79, S80, S81, S82, S83, S84, S85, S86, S87, S88, S89, S90, S91, S92, S93, S94, S95, S96, S97, S98, S99, S100, S101, S102, S103, S104, S105, S106, S107, S108, S109, S110, S111, S112, S113, S114, S115, S116, S117, S118, S119, S120, S121, S122, S123, S124, S125, S126, S127, S128, S129, S130, S131, S132, S133, S134, S135, S136, S137, S138, S139, S140, S141, S142, S143, S144, S145, S146, S147, S148, S149, S150, S151, S152, S153, S154, S155, S156, S157, S158, S159, S160, S161, S162, S163, S164, S165, S166, S167, S168, S169, S170, S171, S172, S173, S174, S175, S176, S177, S178, S179, S180, S181, S182, S183, S184, S185, S186, S187, S188, S189, S190, S191, S192, S193, S194, S195, S196, S197, S198, S199, S200, S201, S202, S203, S204, S205, S206, S207, S208, S209, S210, S211, S212, S213, S214, S215, S216, S217, S218, S219, S220, S221, S222, S223, S224, S225, S226, S227, S228, S229, S230, S231, S232, S233, S234, S235, S236, S237, S238, S239, S240, S241, S242, S243, S244, S245, S246, S247, S248, S249, S250, S251, S252, S253, S254, S255, S256, S257, S258, S259, S260, S261, S262, S263, S264, S265, S266, S267, S268, S269, S270, S271, S272, S273, S274, S275, S276, S277, S278, S279, S280, S281, S282, S283, S284, S285, S286, S287, S288, S289, S290, S291, S292, S293, S294, S295, S296, S297, S298, S299, S300, S301, S302, S303, S304, S305, S306, S307, S308, S309, S310, S311, S312, S313, S314, S315, S316, S317, S318, S319, S320, S321, S322, S323, S324, S325, S326, S327, S328, S329, S330, S331, S332, S333, S334, S335, S336, S337, S338, S339, S340, S341, S342, S343, S344, S345, S346, S347, S348, S349, S350, S351, S352, S353, S354, S355, S356, S357, S358, S359, S360, S361, S362, S363, S364, S365, S366, S367, S368, S369, S370, S371, S372, S373, S374, S375, S376, S377, S378, S379, S380, S381, S382, S383, S384, S385, S386, S387, S388, S389, S390, S391, S392, S393, S394, S395, S396, S397, S398, S399, S400, S401, S402, S403, S404, S405, S406, S407, S408, S409, S410, S411, S412, S413, S414, S415, S416, S417, S418, S419, S420, S421, S422, S423, S424, S425, S426, S427, S428, S429, S430, S431, S432, S433, S434, S435, S436, S437, S438, S439, S440, S441, S442, S443, S444, S445, S446, S447, S448, S449, S450, S451, S452, S453, S454, S455, S456, S457, S458, S459, S460, S461, S462, S463, S464, S465, S466, S467, S468, S469, S470, S471, S472, S473, S474, S475, S476, S477, S478, S479, S480, S481, S482, S483, S484, S485, S486, S487, S488, S489, S490, S491, S492, S493, S494, S495, S496, S497, S498, S499, S500, S501, S502, S503, S504, S505, S506, S507, S508, S509, S510, S511, S512, S513, S514, S515, S516, S517, S518, S519, S520, S521, S522, S523, S524, S525, S526, S527, S528, S529, S530, S531, S532, S533, S534, S535, S536, S537, S538, S539, S540, S541, S542, S543, S544, S545, S546, S547, S548, S549, S550, S551, S552, S553, S554, S555, S556, S557, S558, S559, S560, S561, S562, S563, S564, S565, S566, S567, S568, S569, S570, S571, S572, S573, S574, S575, S576, S577, S578, S579, S580, S581, S582, S583, S584, S585, S586, S587, S588, S589, S590, S591, S592, S593, S594, S595, S596, S597, S598, S599, S600, S601, S602, S603, S604, S605, S606, S607, S608, S609, S610, S611, S612, S613, S614, S615, S616, S617, S618, S619, S620, S621, S622, S623, S624, S625, S626, S627, S628, S629, S630, S631, S632, S633, S634, S635, S636, S637, S638, S639, S640, S641, S642, S643, S644, S645, S646, S647, S648, S649, S650, S651, S652, S653, S654, S655, S656, S657, S658, S659, S660, S661, S662, S663, S664, S665, S666, S667, S668, S669, S670, S671, S672, S673, S674, S675, S676, S677, S678, S679, S680, S681, S682, S683, S684, S685, S686, S687, S688, S689, S690, S691, S692, S693, S694, S695, S696, S697, S698, S699, S700, S701, S702, S703, S704, S705, S706, S707, S708, S709, S710, S711, S712, S713, S714, S715, S716, S717, S718, S719, S720, S721, S722, S723, S724, S725, S726, S727, S728, S729, S730, S731, S732, S733, S734, S735, S736, S737, S738, S739, S740, S741, S742, S743, S744, S745, S746, S747, S748, S749, S750, S751, S752, S753, S754, S755, S756, S757, S758, S759, S760, S761, S762, S763, S764, S765, S766, S767, S768, S769, S770, S771, S772, S773, S774, S775, S776, S777, S778, S779, S780, S781, S782, S783, S784, S785, S786, S787, S788, S789, S790, S791, S792, S793, S794, S795, S796, S797, S798, S799, S800, S801, S802, S803, S804, S805, S806, S807, S808, S809, S810, S811, S812, S813, S814, S815, S816, S817, S818, S819, S820, S821, S822, S823, S824, S825, S826, S827, S828, S829, S830, S831, S832, S833, S834, S835, S836, S837, S838, S839, S840, S841, S842, S843, S844, S845, S846, S847, S848, S849, S850, S851, S852, S853, S854, S855, S856, S857, S858, S859, S860, S861, S862, S863, S864, S865, S866, S867, S868, S869, S870, S871, S872, S873, S874, S875, S876, S877, S878, S879, S880, S881, S882, S883, S884, S885, S886, S887, S888, S889, S890, S891, S892, S893, S894, S895, S896, S897, S898, S899, S900, S901, S902, S903, S904, S905, S906, S907, S908, S909, S910, S911, S912, S913, S914, S915, S916, S917, S918, S919, S920, S921, S922, S923, S924, S925, S926, S927, S928, S929, S930, S931, S932, S933, S934, S935, S936, S937, S938, S939, S940, S941, S942, S943, S944, S945, S946, S947, S948, S949, S950, S951, S952, S953, S954, S955, S956, S957, S958, S959, S960, S961, S962, S963, S964, S965, S966, S967, S968, S969, S970, S971, S972, S973, S974, S975, S976, S977, S978, S979, S980, S981, S982, S983, S984, S985, S986, S987, S988, S989, S990, S991, S992, S993, S994, S995, S996, S997, S998, S999, S1000, S1001, S1002, S1003, S1004, S1005, S1006, S1007, S1008, S1009, S1010, S1011, S1012, S1013, S1014, S1015, S1016, S1017, S1018, S1019, S1020, S1021, S1022, S1023, S1024, S1025, S1026, S1027, S1028, S1029, S1030, S1031, S1032, S1033, S1034, S1035, S1036, S1037, S1038, S1039, S1040, S1041, S1042, S1043, S1044, S1045, S1046, S1047, S1048, S1049, S1050, S1051, S1052, S1053, S1054, S1055, S1056, S1057, S1058, S1059, S1060, S1061, S1062, S1063, S1064, S1065, S1066, S1067, S1068, S1069, S1070, S1071, S1072, S1073, S1074, S1075, S1076, S1077, S1078, S1079, S1080, S1081, S1082, S1083, S1084, S1085, S1086, S1087, S1088, S1089, S1090, S1091, S1092, S1093, S1094, S1095, S1096, S1097, S1098, S1099, S1100, S1101, S1102, S1103, S1104, S1105, S1106, S1107, S1108, S1109, S1110, S1111, S1112, S1113, S1114, S1115, S1116, S1117, S1118, S1119, S1120, S1121, S1122, S1123, S1124, S1125, S1126, S1127, S1128, S1129, S1130, S1131, S1132, S1133, S1134, S1135, S1136, S1137, S1138, S1139, S1140, S1141, S1142, S1143, S1144, S1145, S1146, S1147, S1148, S1149, S1150, S1151, S1152, S1153, S1154, S1155, S1156, S1157, S1158, S1159, S1160, S1161, S1162, S1163, S1164, S1165, S1166, S1167, S1168, S1169, S1170, S1171, S1172, S1173, S1174, S1175, S1176, S1177, S1178, S1179, S1180, S1181, S1182, S1183, S1184, S1185, S1186, S1187, S1188, S1189, S1190, S1191, S1192, S1193, S1194, S1195, S1196, S1197, S1198, S1199, S1200, S1201, S1202, S1203, S1204, S1205, S1206, S1207, S1208, S1209, S1210, S1211, S1212, S1213, S1214, S1215, S1216, S1217, S1218, S1219, S1220, S1221, S1222, S1223, S1224, S1225, S1226, S1227, S1228, S1229, S1230, S1231, S1232, S1233, S1234, S1235, S1236, S1237, S1238, S1239, S1240, S1241, S1242, S1243, S1244, S1245, S1246, S1247, S1248, S1249, S1250, S1251, S1252, S1253, S1254, S1255, S1256, S1257, S1258, S1259, S1260, S1261, S1262, S1263, S1264, S1265, S1266, S1267, S1268, S1269, S1270, S1271, S1272, S1273, S1274, S1275, S1276, S1277, S1278, S1279, S1280, S1281, S1282, S1283, S1284, S1285, S1286, S1287, S1288, S1289, S1290, S1291, S1292, S1293, S1294, S1295, S1296, S1297, S1298, S1299, S1300, S1301, S1302, S1303, S1304, S1305, S1306, S1307, S1308, S1309, S1310, S1311, S1312, S1313, S1314, S1315, S1316, S1317, S1318, S1319, S1320, S1321, S1322, S1323, S1324, S1325, S1326, S1327, S1328, S1329, S1330, S1331, S1332, S1333, S1334, S1335, S1336, S1337, S1338, S1339, S1340, S1341, S1342, S1343, S1344, S1345, S1346, S1347, S1348, S1349, S1350, S1351, S1352, S1353, S1354, S1355, S1356, S1357, S1358, S1359, S1360, S1361, S1362, S1363, S1364, S1365, S1366, S1367, S1368, S1369, S1370, S1371, S1372, S1373, S1374, S1375, S1376, S1377, S1378, S1379, S1380, S1381, S1382, S1383, S1384, S1385, S1386, S1387, S1388, S1389, S1390, S1391, S1392, S1393, S1394, S1395, S1396, S1397, S1398, S1399, S1400, S1401, S1402, S1403, S1404, S1405, S1406, S1407, S1408, S1409, S1410, S1411, S1412, S1413, S1414, S1415, S1416, S1417, S1418, S1419, S1420, S1421, S1422, S1423, S1424, S1425, S1426, S1427, S1428, S1429, S1430, S1431, S1432, S1433, S1434, S1435, S1436, S1437, S1438, S1439, S1440, S1441, S1442, S1443, S1444, S1445, S1446, S1447, S1448, S1449, S1450, S1451, S1452, S1453, S1454, S1455, S1456, S1457, S1458, S1459, S1460, S1461, S1462, S1463, S1464, S1465, S1466, S1467, S1468, S1469, S1470, S1471, S1472, S1473, S1474, S1475, S1476, S1477, S1478, S1479, S1480, S1481, S1482, S1483, S1484, S1485, S1486, S1487, S1488, S1489, S1490, S1491, S1492, S1493, S1494, S1495, S1496, S1497, S1498, S1499, S1500, S1501, S1502, S1503, S1504, S1505, S1506, S1507, S1508, S1509, S1510, S1511, S1512, S1513, S1514, S1515, S1516, S1517, S1518, S1519, S1520, S1521, S1522, S1523, S1524, S1525, S1526, S1527, S1528, S1529, S1530, S1531, S1532, S1533, S1534, S1535, S1536, S1537, S1538, S1539, S1540, S1541, S1542, S1543, S1544, S1545, S1546, S1547, S1548, S1549, S1550, S1551, S1552, S1553, S1554, S1555, S1556, S1557, S1558, S1559, S1560, S1561, S1562, S1563, S1564, S1565, S1566, S1567, S1568, S1569, S1570, S1571, S1572, S1573, S1574, S1575, S1576, S1577, S1578, S1579, S1580, S1581, S1582, S1583, S1584, S1585, S1586, S1587, S1588, S1589, S1590, S1591, S1592, S1593, S1594, S1595, S1596, S1597, S1598, S1599, S1600, S1601, S1602, S1603, S1604, S1605, S1606, S1607, S1608, S1609, S1610, S1611, S1612, S1613, S1614, S1615, S1616, S1617, S1618, S1619, S1620, S1621, S1622, S1623, S1624, S1625, S1626, S1627, S1628, S1629, S1630, S1631, S1632, S1633, S1634, S1635, S1636, S1637, S1638, S1639, S1640, S1641, S1642, S1643, S1644, S1645, S1646, S1647, S1648, S1649, S1650, S1651, S1652, S1653, S1654, S1655, S1656, S1657, S1658, S1659, S1660, S1661, S1662, S1663, S1664, S1665, S1666, S1667, S1668, S1669, S1670, S1671, S1672, S1673, S1674, S1675, S1676, S1677, S1678, S1679, S1680, S1681, S1682, S1683, S1684, S1685, S1686, S1687, S1688, S1689, S1690, S1691, S1692, S1693, S1694, S1695, S1696, S1697, S1698, S1699, S1700, S1701, S1702, S1703, S1704, S1705, S1706, S1707, S1708, S17

The Expert's Log

RADEX, published monthly, contains an accurate, official list of all broadcasting stations in North America, indexed five ways:

- By dial numbers
- By frequencies
- By wave lengths
- By call letters
- By states and cities.

With **RADEX** you can tell:

- The frequency set is tuned to for any setting of dials.
- Where to set your dials for any station in America.
- What program you are hearing without announcement.
- Hour-by-hour programs of all chain features.

At newsstands, radio stores or Kresge's or by mail postpaid 25c.

Trial subscription, \$1.00 for next five issues.

Complete list of world stations in September number.

RADEX PRESS

1368 E. 6th St. Cleveland, Ohio

A Pure Gold ELECTRAD Resistor?

We'd Make One If It Would **PERFORM BETTER**

All **ELECTRAD** products are built to highest performance standards. **ELECTRAD** has used sterling silver where necessary. . . Monel metal where it's best. . . we would use gold, if it takes gold to do the job. That is why **ELECTRAD** Resistors and voltage Controls are first when radio experts talk quality.

Write Dept. R.W.-913 for descriptive circulars.

175 Varick St., New York, N.Y. **ELECTRAD**

Songwriters Service Co.

6719 Hollywood Boulevard, Dept. R. W. Hollywood, California

Talking Pictures offer new opportunities. Your songs personally submitted to Picture Studios, revised for publication by Hit Writers. Words, Music, Arranging, everything pertaining to songs.



KEY TUBES

Quality First

The following constitute the thirteen most popular tubes used in radio today. Despite the severely low prices the Key tubes are firsts of the very first quality. The tubes are manufactured under licenses granted by the RCA and its affiliated companies.

All prices are net and represent extreme discount already deducted.

GUARANTY RADIO GOODS CO.,
143 West 45th St., N. Y. City. (Just East of Broadway)
Enclosed please find \$..... for which ship at once tubes marked below:

- 224 AC screen grid\$1.43
- 245 AC power tube\$1.10
- 226 AC amplifier\$.68
- 227 AC det.-amp.\$.85
- 222 battery 6G\$1.88
- 112A power tube\$.78
- 171A power tube\$.78
- 201A battery tube\$.53
- 240 hi mu tube\$1.80
- 250 power tube\$.95
- 210 power tube\$3.25
- 280 AC rectifier\$1.00
- 281 AC rectifier\$2.85

Name

Address

City..... State.....

Put cross here if C. O. D. shipment is desired. Canadian remittance must be by postal or express money order.

DOUBLE RANGE POTENTIOMETER; made by Centralab, designed for volume control. In dust-proof bakelite case. Price, \$1.05. Guaranty Radio Goods Co., 143 W. 45th St., New York.

"SECONDS"

TUBES that fall a trifle below the most exacting laboratory specifications may be obtained at prices that seem incredible. They are called "seconds" and they are "seconds," but they are not "thirds." Note the prices. Remit with order.

- | | |
|----------------|-----------------|
| 201A50c | 22470c |
| UV19970c | 24575c |
| UX19970c | 28075c |
| 200A70c | 28185c |
| 24070c | 21090c |
| 22770c | 250\$1.00 |

DIRECT RADIO CO.

Room 504

1562 Broadway, N. Y. City
(Between 46th and 47th Streets)

MAIL ORDERS FILLED

"MATHEMATICS OF RADIO."—A great help to everybody interested in radio. \$2 postpaid. Radio World, 145 W. 45th St., N. Y. City.

Two for the price of One

Get a **FREE** one-year subscription for any **ONE** of these magazines:

- CITIZENS RADIO CALL BOOK AND SCIENTIFIC DIGEST** (quarterly, four issues).
- RADIO** (monthly, 12 issues; exclusively trade magazine).
- RADIO ENGINEERING** (monthly, 12 issues; technical and trade magazine).
- RADIO INDEX** ((monthly, 12 issues) Stations, programs, etc.
- SCIENCE & INVENTION** (monthly, 12 issues; scientific magazine, with some radio technical articles).
- AMERICAN BOY—YOUTH'S COMPANION** (monthly, 12 issues; popular magazine).
- BOYS' LIFE** (monthly, 12 issues; popular magazine).

Select any one of these magazines and get it **FREE** for an entire year by sending in a year's subscription for **RADIO WORLD** at the regular price, \$6.00. Cash in now on this opportunity to get **RADIO WORLD WEEKLY**, 52 weeks, at the standard price for such subscription, plus a full year's subscription for any **ONE** of the other enumerated magazines **FREE!** Put a cross in the square next to the magazine of your choice, in the above list, fill out the coupon below, and mail \$6 check, money order or stamps to **RADIO WORLD**, 145 West 45th Street, New York, N. Y. (Just East of Broadway).

Your Name

Your Street Address

City..... State.....

- If renewing an existing or expiring subscription for **RADIO WORLD**, please put a cross in square at beginning of this sentence.
- If renewing an existing or expiring subscription for other magazine, please put a cross in square at the beginning of this sentence.

RADIO WORLD, 145 West 45th Street, New York, N. Y. (Just East of Broadway)

DOUBLE VALUE!

Quick Action Classified Ads

Radio World's Speedy Medium for Enterprise and Sales

7 cents a word — 10 words minimum — Cash with Order

TESTED TUBES—201A, .43; 226, 227, 171A, 224, 245, 280, .48. Unshielded 85 milliamper filter chokes, .49. Waterman Radio, 2140 Kirby West, Detroit, Mich.

COLOSSAL BARGAIN—A 4-tube AC 105-120 Volt, 50-60 cycle, custom made receiver, in table model cabinet, with Mayolian B eliminator, A battery, Westinghouse trickle charger, C bias batteries, Relay switch, 5 tubes (includes Raytheon rectifier). One dial finger tuning, 171 output. Operates dynamic. Humless, sturdy performer. Can be heard by appointment. Will install free in residence if in or around New York City. A. Bashein, 1116-56 Street, Brooklyn, N. Y.

ELECTRAD LOFTIN-WHITE DIRECT-COUPLED AMPLIFIER NEVER USED \$17.50. USED FRESHMAN PORTABLE 210 POWER AMPLIFIER \$10.00, WITH TUBES \$13.75. REAL BARGAINS. H. DE LANEY, 35 REMY AVE., MANSFIELD, OHIO.

LOFTIN-WHITE AMPLIFIER \$30—Wired and Tested. Robert Murphy, 1108 Ridgewood Drive, Fort Wayne, Indiana.

400 **QUESTIONS** Radio Course \$2.00. Stephen Plavetich, 1597 East 47th Street, Cleveland, Ohio.

MODEL AEROPLANES
"CITY OF CHICAGO" WORLD'S DURATION PLANE—30" Plan 20c. Model Aviator, Dept. RW, 601 Washington, Chicago.

BARGAINS in first-class, highest grade merchandise. B-B-L phonograph pick-up, theatre type, suitable for home, with vol. control, \$6.57; phono-link pick-up with vol. control and adapter, \$3.50; steel cabinet for HB Compact, \$3.00; four-gang .00035 mfd. with trimmers built in, \$1.95; .00025 mfd. Dubilier grid condenser with clips, 18c. P. Cohen, Room 1214, at 143 West 45th Street, N. Y. City

High-Gain Shielded Coils

A SHIELDED radio frequency transformer for use as antenna coupler or as interstage coupler, for screen grid circuits. The coil is wound on a 1 1/2-inch diameter bakelite form with No. 28 enamel wire, primary on the outside, separated from the secondary by an insulating wrapper 42/10,000-inch thick. This moisture-proof insulation is so shaped that it completely insulates the primary from the secondary, preventing short-circuit. The coil form is mounted on a wooden base, which base has the removable shield bottom fastened to it. The drawn aluminum shield fits snugly over the wooden base, and coils remain always erect and amply spaced from the shield wall in all directions. The shielded coils are suitable for baseboard or metal chassis mounting. The four leads emerge through an insulated hole in the shield bottom.

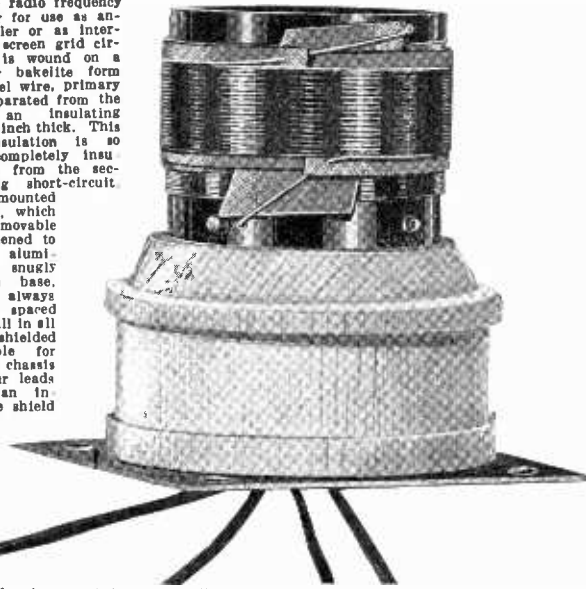

The coil comes already mounted on a shellacked wooden base, which is fastened at the factory to the shield bottom. Series A coil is illustrated.



The external appearance of the shield, with four 6/32 machine screws and nuts, which are supplied with each coil assembly.

Precisely Matched for Gang Tuning

O NE primary lead-out wire from the coil, for antenna or plate connection, has a braided tinned alloy covering over the insulation. This alloy braid shields the lead against stray pick-up when the braid alone is soldered to a ground connection. The outleads are 6 inches long and are color identified. The wire terminals of the windings themselves, and the outleads, are soldered to copper rivets. Each coil comes completely assembled inside the shield, which is 2 1/4 inches square at bottom (size of shield bottom) and 3 1/2 inches high. High impedance primaries of 40 turns are used. Secondaries have 80 turns for .00035 mfd. and 70 turns for .0005 mfd.

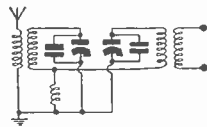

BP-6 is the coil at bottom.

EXTREME accuracy in winding and spacing is essential for coils used in gang tuning. These coils are specially suited for gang condensers, because the inductances of all are identical for the stated size condenser. The coils are matched by a radio frequency oscillator. The color scheme is as follows: shielded wire outlead is for antenna or plate; red is for ground or B plus. (These options are due to use of the same coil for antenna coupling or interstage coupling.) Blue is for grid and yellow is for grid return. For .00035 mfd. the Cat. No. is A-40-80-S. For .0005 mfd. the Cat. No. is A-40-70-S. Where a band pass filter circuit is used the small coupling coil to unite circuits is Cat. BP-6. The connection is illustrated berewith.

Junior Model Inductances

The Series B coils have the same inductance and the same shields as the Series A coils, but the primary, instead of being wound over the secondary, with special insulation between, is wound adjoining the secondary, on the form, with 1/4-inch separation, resulting in looser coupling. No wooden base is provided, as the bakelite coil form is longer, and is fastened to the shield bottom piece by means of two brackets. No outleads. Wire terminals are not soldered. Order Cat. B-SH-3 for .00035 mfd. and Cat. B-SH-5 for .0005 mfd.

Coils for Six-Circuit Tuner

Series C coils for use with six tuned circuits, as in Herman Bernard's six-circuit tuner, are wound the same as type A shielded coils, but the shields are a little larger (3 1/16-inch diameter, 3 3/4 inches high), and there are no shield bottoms, as a metal chassis must be used with such highly sensitive circuits. Fasten the brackets to the shield and then, from underneath the chassis, fasten the other arm of the two brackets to the chassis. Order Cat. C-6-CT-5 for .0005 mfd. and Cat. C-6-CT-5 for .00035 mfd. Five needed for Bernard's circuit. If band pass filter coupling coil is desired order Cat. BP-6 extra.

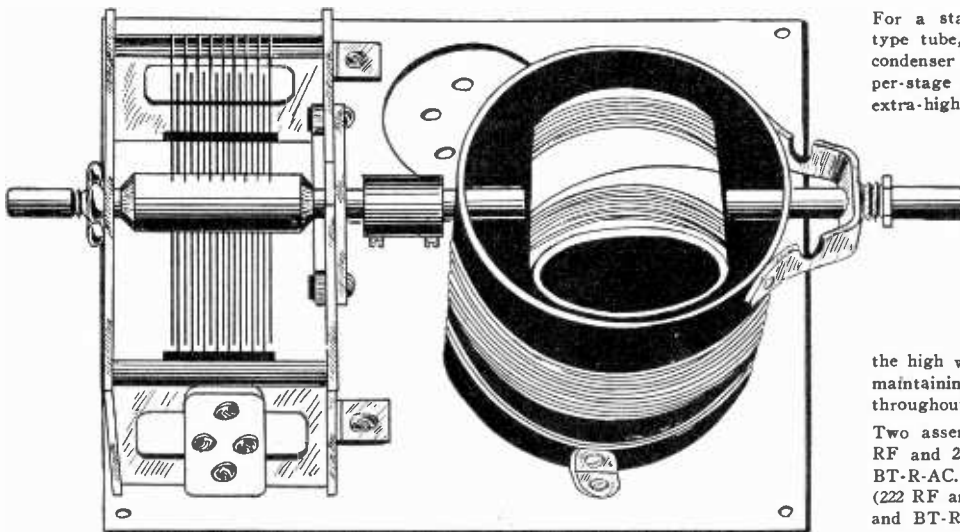

For a stage of screen grid RF, either for battery type tube, 222, or AC, 224, followed by a grid-leak-condenser detector, no shielding is needed, and higher per-stage amplification is attainable and useful. This extra-high per-stage gain, not practical where more than one RF stage is used, is easily obtained by using dynamic tuners. Two assemblies are needed. These are furnished with condensers erected on a socketed aluminum base. Each coil has its tuned winding divided into a fixed and a moving segment. The moving coil, actuated by the condenser shaft itself, acts as a vario-meter, which bucks the fixed winding at the low wavelengths and aids it at the high wavelengths, thus being self-neutralizing and maintaining an even degree of extra-high amplification throughout the broadcast scale.

Two assemblies are needed. For AC operation (224 RF and 224 or 227 detector), use Cat. BT-L-AC and BT-R-AC. For battery or A eliminator operation (222 RF and any tube as detector), use Cat. BT-L-DC and BT-R-DC.

BT-L for the antenna stage and BT-R for the detector input. BT-L consists of a small primary, with suitable secondary for the .00035 mfd. condenser supplied. BT-B has two effective coils: the tuned combination winding in the RF plate circuit, the inside fixed winding in the detector grid circuit. The moving coils must be "matched." This is done as follows: Turn the condensers until plates are fully emmeshed, and have the moving coils parallel with the fixed winding. Tune in the highest wavelength station receivable—above 450 meters surely. Now turn the moving coils half way round and retune to bring in the station. The setting that represents the use of lesser capacity of the condenser to bring in that station is the correct one. If gang tuning is used, put a 20-100 mmfd equalizing condenser across the secondary in the antenna circuit and adjust the equalizer for a low wavelength (300 meters or less).

Screen Grid Coil Co., 143 West 45th Street, New York (Just East of Broadway):

- Enclosed please find \$..... (Canadian must be express or P. O. Money Order), for which send me prepaid the following:
- A-40-80-S, each \$2.25
 - Matched set, 4 A-40-80-S, \$1 matching 10.00
 - A-40-70-S, each 2.25
 - Matched set of four A-40-70-S..... 10.00
 - BT-L-AC and BT-R-AC, assembled, with condenser, link, socket and base, per pair..... 6.00
 - BT-L-DC and BT-R-DC assembled, with condenser, link, socket, base, per pair..... 6.00
 - C-6-CT-5, .0005 mfd. shielded coil for six-circuit tuner.....each \$2.25
 - C-6-CT-3, .00035 mfd. shielded coil for six-circuit tuner.....each \$2.25
 - BP-625
 - EQ-100, equalizer of 20-100 mfd. capacity, made by Hammarlund..... .35
- (Note: All coils come with shields, except BP-6 and BT-L.)

NAME..... ADDRESS.....
 CITY..... STATE.....
 If ordering C.O.D. put cross here. Post office fee will be added to prices quoted.

Balkite Push-Pull Receiver

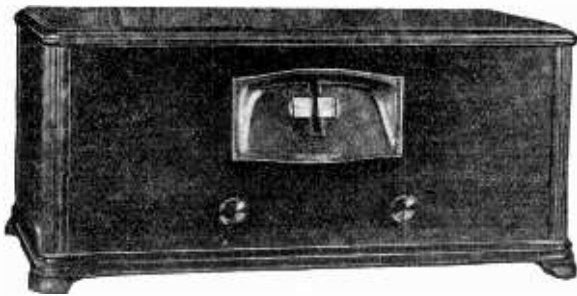

The Balkite A-5 Neutrodyne, one of the most sensitive commercial receivers ever developed; 8 tubes, including 280 rectifier. Wholly AC operated, 105-120 v. 50-60 cycles; in a table model cabinet, genuine walnut, made by Berkey & Gay.

Three stages of tuned RF, neutralized, so there's no squealing; easy tuning; operation on short piece of wire indoors perfectly satisfactory; no repeat tuning points; no hum; phonograph pickup jack built in; excellent tone quality; good selectivity. Two posts are accessible for connecting the field coil of a DC dynamic speaker.

The parts of which this receiver is made are all ace-high and the wiring is done with extreme expertness, by Gillilan. The power supply is exceptionally fine, the set being worked at 50% less than the rated capacity of the power transformer and chokes, assuring long life. There is no hum, as filtration is remarkably good.

The illuminated drum dial, at center, reads 0-100 at left, and at right has a blank space in which to write call letters. The little knob at left is the volume control, and the one at right is the AC switch. Each RF stage is filtered and bypassed individually, and the RF coils, tuning condenser and power transformer are separately and totally shielded. The lead from antenna binding post to antenna winding of the first coil is of shielded wire that is grounded. Also, the receiver as a whole is totally shielded, with metal chassis and metal under-cover, so there is no stray pickup. Complete with walnut magnetic speaker and tubes.....

\$56.57

Silver-Plated Coils



Wound with non-insulated wire plated with genuine silver, on grooved forms, these coils afford high efficiency because of the low resistance that silver has to radio frequencies. The grooves in the moulded bakelite forms insure accurate space winding, thus reducing the distributed capacity, and keep the number of turns and separation constant. Hence the secondary reactances are identical and ideal for gang tuning.

The radio frequency transformer may be perpendicularly or horizontally mounted, and has braced holes for that purpose. It has a center-tapped primary, so that it may be used as antenna coil with half or all the primary in circuit, or as interstage coupler, with all the primary on a screen grid plate circuit, or half the primary for any other type tubes, including pentodes. The three-circuit tuner has a center-tapped primary, also. This tuner is of the single hole panel mount, but may be mounted on a chassis, if preferred, by using the braced holes. Pair consists of RF transformer and three-circuit tuner, both for .0005 mfd. only. Order Cat., G-RF-3CT. List price \$5.00; net price.....

\$2.48

Shielded Lead-in Wire

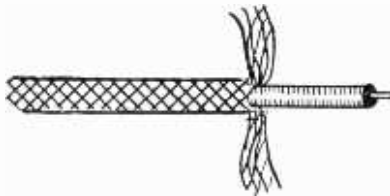

No 18 solid wire, surrounded by a solid rubber insulation covering, and above that a covering of braided copper mesh wire, which braid is to be grounded, to prevent stray pick-up. This wire is exceptionally good for antenna lead-in, to avoid pick-up of man-made static, such as from electrical machines. Also used to advantage in the wiring of receivers, as from antenna post of set to antenna coil, or for plate leads, or any leads, if long. This method of wiring a set improves selectivity and reduces hum. This wire is now appearing on the general market for the first time although long used in the best grade of commercial receivers. Order Cat. SH-LW. List price 9c per ft.; net price per foot

5c

New Multi-Tap Voltage Divider

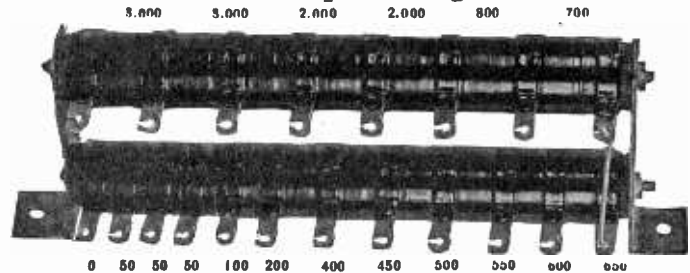

The resistance values between the twenty taps of the new Multi-Tap Voltage Divider are given above. The total is 17,100 ohms and affords nineteen different voltages.

The Multi-Tap Voltage Divider is useful in all circuits, including push-pull and single-ended ones, in which the current rating of 100 milliamperes is not seriously exceeded and the maximum voltage is not more than 400 volts. Higher voltages may be used at lesser drain.

The expertness of design and construction will be appreciated by those whose knowledge teaches them to appreciate parts finely made.

When the Multi-Tap Voltage Divider is placed across the filtered output of a B supply which serves a receiver, the voltages are in proportion to the current flowing through the various resistances. By making connection of grid returns to ground, the lower voltages may be used for negative bias by connecting filament center, or, in 227 and 224 tubes, cathode to a higher voltage.

If push-pull is used, the current in the biasing section is almost doubled, so the midtap of the power tube filament winding would go to a lug about half way down on the lower bank.

\$3.90

Order Cat. MTVD, list price \$6.50, net price.....

R-245 Set and Tube Tester

With the R-245 Tube and Set Tester you plug the cable into a vacated socket of a receiver, putting the removed tube in the tester, and using the receiver's power for making these tests: Plate current, on 0-20 or 0-100 ma. scale, changed by throwing a built-in switch; 0-80, 0-300 v. DC, changed by moving one of the tipped cables to another jack; filament or heater voltage (AC or DC), up to 10 volts, or any other AC voltage source, measured independently, up to 140 volts, including AC line voltage. Also screen grid voltage and screen grid current may be read by following connections specified in the new 8-page instruction sheet.

Each meter may be used independently. The two test leads, one red, the other black with tip jack terminals, enable quick connections to meters for independent use.

With this outfit you can shoot trouble in receivers and test circuits using the following tubes: 301A, 200A, UX198, UX120, 210, 171, 171A, 112, 112A, 245, 224, 222, 226, 227, and pentodes.

When the R-245 is plugged into the vacated socket of a set and the removed tube is placed in the proper socket of the Tester, the receiver's power supplies all the voltages and currents. You see the vital tests made right before your eyes, all three meters registering immediately, all three reading at the same time.

Here are some of the questions answered by the Tester when plugged into the receiver:

What is the filament or heater voltage (no matter if DC or AC)? What is the plate voltage at the plate itself? What is the plate current drawn by the tube? Is the tube in good condition or does it require replacement? What is the grid bias voltage? What is the cathode voltage? What is the screen grid voltage? Besides, when meters are used independently, you can answer these questions: What is the screen grid current? What is the line voltage (no matter if AC or DC)? Is the circuit continuous or is it open? What is the total plate current drawn in the receiver? What are the respective B voltages at the B batteries or voltage divider?

Order Cat. R-245. List price, \$20; net price..... **\$11.40**

Fixed Condensers



Dubilier Micon fixed condensers, type #42, are available at following capacities and prices:

.0001 mfd.	10c	.006	20c
.00025 mfd.	10c	.00025 with clips.	20c
.0003 mfd.	10c	.001	10c
.00035 mfd.	15c	.0015	17c
.001	17c	.002	18c
.0015	17c		
.002	18c		

Order Cat. MICON .0001 etc. at prices stated.

High-Voltage Meters



0-300 v., 200 ohms per volt. Cat. F-300 @ \$2.59
0-500 v., 233 o.p.v. Cat. F-600 @..... 3.73
0-600 v., AC and DC (same meter reads both); 100 ohms p.v. Order Cat. M-600 @ 4.98

Double Drum Dial

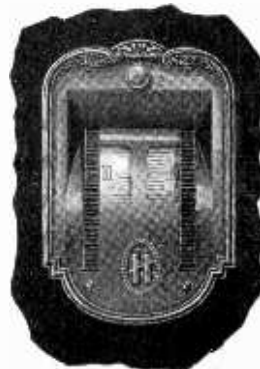

Hammarlund double drum dial, each section individually tunable. Order Cat. H-DDD. List price \$6.00; net **\$3.00** price

Shielded RF Choke

Excellent in detector plate circuit or in B-plus RF leads of radio frequency tubes to purify signals.

An efficient radio frequency choke in a shielded case, inductance, 50 millihenries. Useful for all RF chokes.

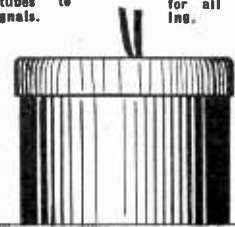

In some instances one outlead is connected to case, so use this lead for B-plus or for ground, otherwise ground the case additionally. Order Cat. SH-RFC. List price, \$1.00; net price

Guaranty Radio Goods Co., 143 West 45th St., New York, N. Y. (Just East of Broadway)

Enclosed please find \$..... (Canadian must be express or post office money order, for which please ship:

- Balkite comp. \$56.57 Ft. of SH-LW M-600 @..... \$4.95
- MTVD @... 3.90 @.....5c p. f. F-300 @..... \$2.59
- G-RF-3CT @ 2.48 H-DDD @... \$3.00 F-500 @..... 3.73
- R-245 @..... 11.40 SH-RFC @... 50c MICON..... @

Your Name

Address

City..... State.....

Accurate Tuning Condensers and Accessories

EQUALIZER

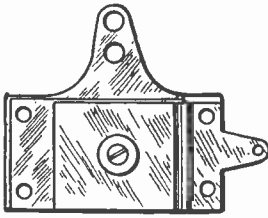

CAT. EQ-100 AT 35c

The most precise and rugged equalizing condenser made, with 20 mmfd. minimum and 100 mmfd. maximum, for equalizing the capacity where gang condensers are used that are not provided with built-in trimmers. Turning the screw alters the position of the moving plate, hence the capacity. Cross-section reveals special threaded brass bushing into which screw turns, hence you can not strip the thread. Useful in all circuits where trimming capacity of 100 mmfd. or less is specified.

SINGLE .00035

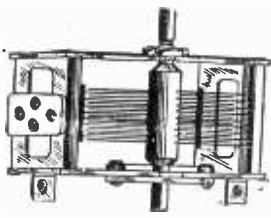

CAT. KH-3 AT 85c

A single .00035 mfd. condenser with nonremovable shaft, having shaft extension front and back, hence useful for ganging with drum dial or any other dial. Shaft is 1/4 inch diameter, and its length may be extended 3/4 inch by use of Cat. XS-4. Brackets built in enable direct sub-panel mounting, or may be piled off easily. Front panel mounting is practical by removing two small screws and replacing with two 3/84 screws 3/4 inch long. Condenser made by Scovill Mfg. Co.

THREE-GANG SCOVILL .0005 MFD.

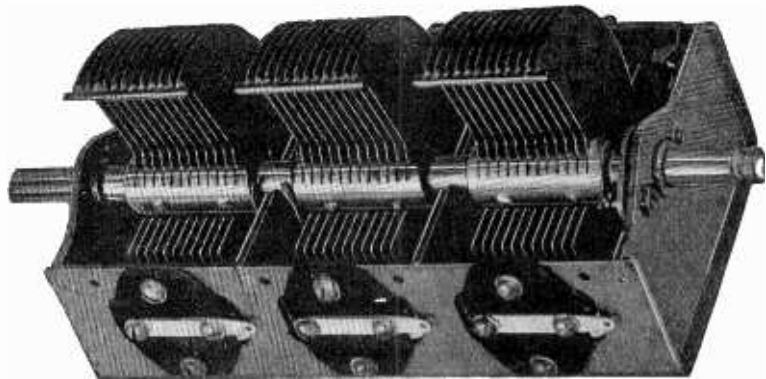

One of the most, strongest and best gang condensers ever made is this three-gang unit, each section of full .0005 mfd. capacity, with a modified straight frequency line characteristic. The net weight of this condenser is 3 3/4 lbs. Cat. SC-3G-5 at \$4.80.

HERE is a three-gang condenser of most superior design and workmanship, with an accuracy of at least 99% per cent. at any setting — rugged beyond anything you've ever seen. Solid brass plates perfectly aligned and protected to the fullest extent against any displacement except the rotation for tuning. It has both side and bottom mounting facilities. Shaft is 3/8 inch diameter and extends at front and back, so two of these three-gangs may be used with a single drum dial for single tuning control. For use of this condenser with any dial of 1/4 inch diameter bore, use Cat. XS-8, one for each three-gang. Tension adjusters shown at right, either side of shaft.

SALIENT FEATURES OF THE CONDENSER

- (1)—Three equal sections of .0005 mfd. capacity each.
- (2)—Modified straight line frequency shape of plates, so-called midline.
- (3)—Sturdy steel frame with rigid steel shields between adjacent sections. These shields minimize electric coupling between sections.
- (4)—The frame and the rotor are electrically connected at the two bearings and again with two sturdy springs, thus insuring positive, low resistance contact at all times.
- (5)—Both the rotor and the stator plates are accurately spaced and the rotor plates are accurately centered between stator plates.
- (6)—Two spring stoppers prevent jarring when the plates are brought into full mesh.
- (7)—The rotor turns as desired, the tension being adjustable by set-screw at end.
- (8)—The shaft is of steel and is 3/8 inch in diameter.
- (9)—Each set of stator plates is mounted with two screws at each side of insulators, which in turn are mounted with two screws to the frame. Thus the stator plates cannot turn sideways with respect to the rotor plates. This insures permanence of capacity and prevents any possible short circuit.
- (10)—Each stator section is provided with two soldering lugs so that connection can be made to either side.
- (11)—The thick brass plates and the generous proportions of the frame insure low resistance.
- (12)—Provision made for independent attachment of a trimmer to each section.
- (13)—The steel frame is sprayed to match the brass plates.
- (14)—The condenser, made by America's largest condenser manufacturer, is one of the best and sturdiest ever made, assuredly a precise instrument.

RIGID AND FLEXIBLE LINKS



CAT. RL-3 AT 12c

The rigid link, Cat. RL-3, has two set-screws, one to engage each shaft, and is particularly serviceable where a grounded metal chassis is used, as the returns then need no insulation.



CAT. FL-4 at 30c

Flexible insulated coupler for uniting coil or condenser shafts of 1/4 inch diameter. Provides option of insulated circuits.

For coupling two 1/4 inch diameter shafts either coil shaft and condenser shaft, or two condenser shafts, a coupling link is used. This may be of the rigid type, all metal, where the link-end units are not to be insulated.

EXTENSION SHAFTS, TWO SIZES



CAT. XS-4 AT 10c

Here is a handy aid to salvaging condensers and coils that have 1/4" diameter shafts not long enough for your purpose. Fits on 1/4" shaft and provides 3/4" extension, still at 1/4". Hence both the extension shaft and the bore or opening are 1/4" diameter. Order Cat. XS-4.

For condensers with 3/8" diameter shaft, to accommodate to dials that take 1/4" shaft, order Cat. XS-8 at 15c.

.00035 TWO-GANG

A two-gang condenser, like the single type, KHS-3, but consisting of two sections on one frame, is Cat. KHD-3, also made by Scovill. The same mounting facilities are provided. There is a shield between the respective sections. The tuning characteristic is modified straight frequency line. Order Cat. KHD-3 at \$1.70.

DRUM DIAL

CAT DD-0-100 @ \$1.50

A suitable drum dial of direct drive type is obtainable for 1/4" shafts or 3/8" shafts, and with 0-100 scales. An escutcheon is furnished with each dial.



FOUR-GANG .00035 MFD. WITH TRIMMERS BUILT IN

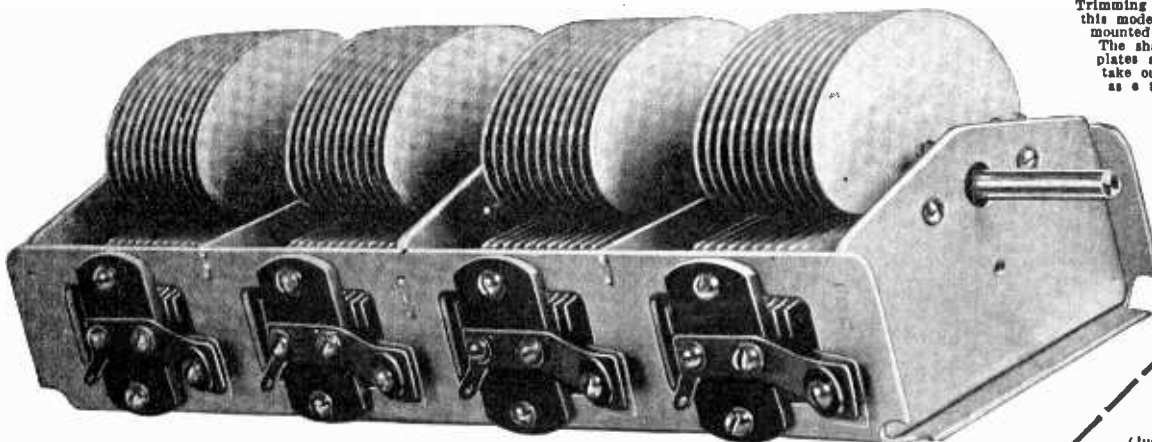

Four-gang .00035 mfd. with trimmers built in. Shaft and rotor blades removable. Steel frame and shaft aluminum plates. Adjustable tension at rear. Overall length, 11 inches. Weight, 3 1/2 lbs. Cat. SPL-4G-3 \$3.95.

SHORT WAVES

Tuning condensers for short waves, especially suitable for mixer circuits and short-wave adapters. These condensers are .00015 mfd. (150 micro-microfarads) in capacity. They are suitable for use with any plug-in coils. Order Cat. SW-S-150 @ \$1.50. To provide regeneration from plate to grid return, for circuits calling for this, use .00025 mfd. Order Cat. SW-S-250 @ \$1.50.

A four-gang condenser of good, sturdy construction and reliable performance fits into the most popular tuning requirement of the day. It serves its purpose well with the most popular screen grid designs, which call for four tuned stages, including the detector input. Ordinarily a good condenser of this type costs, at the best discount you can contrive to get, about twice as much as is charged for the one illustrated and even then the trimming condensers are not included. The question then arises, has quality been sacrificed to meet a price? As a reply, read the twenty-six points of advantage. The first consideration was to build quality into the condenser. The accuracy is 99%.

Trimming condensers are built into this model. The condenser may be mounted on bottom or on side. The shaft is removable, also the plates are removable, so you can take out one section and operate as a three-gang.

GUARANTY
RADIO GOODS CO.,
143 West 45th St.,
N. Y. C. Ity
(Just East of Broadway.)

Enclosed find \$.....for
which ship designated parts:

Street Address.....
City..... State.....

the following merchandise as advertised:

- | | |
|---|--|
| <input type="checkbox"/> Cat. XS-4 @ 10c | <input type="checkbox"/> Cat. EQ-100 @ 35c |
| <input type="checkbox"/> Cat. KH-3 @ 85c | <input type="checkbox"/> Cat. SC-3 G-5 @ \$4.80 |
| <input type="checkbox"/> Cat. XS-8 @ 15c | <input type="checkbox"/> Cat. SPL-4 G-3 @ \$3.95 |
| <input type="checkbox"/> Cat. KHD-3 @ \$1.70 | <input type="checkbox"/> Cat. FL-4 @ 30c |
| <input type="checkbox"/> Cat. RL-3 @ 12c | <input type="checkbox"/> Cat. SW-S-150 |
| <input type="checkbox"/> Cat. DD-0-100 @ \$1.50 | <input type="checkbox"/> Cat. SW-S-250 |

ALL PRICES ARE NET.

New Polo Power Transformers and Chokes

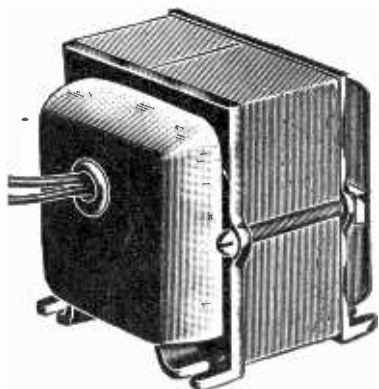

Shielded single choke, 200 ohms D.C. resistance, non-saturable at 100 milliamperes, with two black outleads, each 6 inches long. For filtration of B supplies. Inductance, 30 henrys. Cat. SH-S-CH, price.....\$5.00

The shielded single choke will pass 100 ma. One will suffice if the current is 100 ma. or less, for filtration of B supplies, provided the capacity at the filter output is 8 mfd. or more. Use two such shielded chokes if less than 8 mfd. is used at the filter output. Also, the shielded single choke may be used as in the power tube circuit for an output filter. In this connection use at least 2 mfd. for the capacity section of the filtered speaker output. Order Cat. SH-S-CH @.....\$5.00

The shielded double choke may be used for filtration where the B current is 60 ma. or less, with relatively small filter capacities, no less than 4 mfd at the output, however. This choke consists of one winding, center-tapped. Its use is especially recommended for 11A, 11A, 245 or 210 push-pull output. Connect the black leads (extremes of windings) to plates of the push-pull tubes, red center tap to B plus, and the speaker may be connected directly to plates without any direct current, but only signal current, flowing through the speaker. This system is applicable only to push-pull. Order Cat. SH-D-CH @.....\$6.00

In the same type of case a 20-volt secondary filament transformer, for 110 volts, 50-133 cycle, may be obtained for use in conjunction with dry rectifiers, such as Kuprox, Westinghouse, Benwood-Linze and Elkton. In dynamic speakers or A battery eliminators. Not made for 25 or 40 cycles. Order Cat. SH-F-20 @.....\$2.50

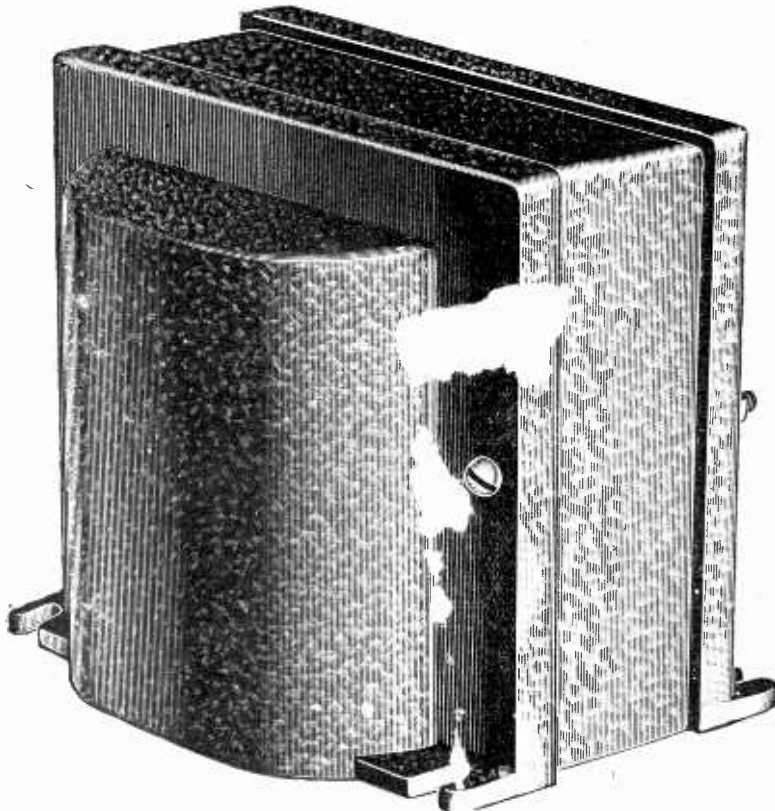

245 Power Transformer for use with 280 rectifier, to deliver 300 volts D.C. at 100 milliamperes, slightly higher voltage at lower drain, and supply filament volt. Cat. 245-PT price.....\$8.50

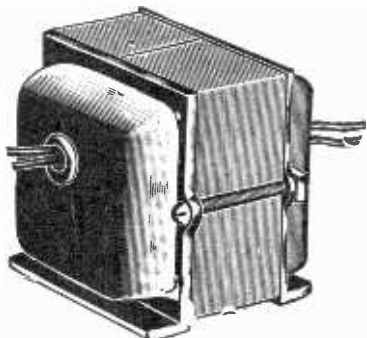

Twenty-volt filament transformer, 110 v. 50-133 cycle input, for use in conjunction with dry rectifiers. It will pass 2.25 amperes.

In a different type case, square, of cadmium plated steel with four mounting screws built in, size 4 1/2 inches wide by 3 1/2 inches high by 4 inches front to back, a 50-60 cycle filament transformer is obtainable with the same windings as the 245 power transformer, except that the high voltage secondary is omitted. Order Cat. 245-FIL @.....\$4.50 For 40 cycles order Cat. 245-FIL-40 @.....7.00 For 25 cycles order Cat. 245-FIL-25 @.....6.50 [Any of the above three in the same case as the 245 power transformer, @ \$1.00 extra. Add PTC after the Cat. number.]

A single choke, unshielded, 65 ma rating, 30 henrys inductance, for B filtration or single output filter of speaker, is our Cat. US-S-CH @.....\$1.25

The Polo 245 power transformer is expertly designed and constructed, wire, silicon grade A steel core and air gap large enough to stand the full rated load. The primary is for 110v A.C., 50-60 cycles, tapped for 82.5 volts in case a voltage regulator, such as a Clorostat or Amperite, is used. The black primary lead is common. If no voltage regulator is used, connect black lead to one side of the A.C. line, green lead to the other side of the line, and ignore red lead, except to tape the end. For use with a voltage regulator (82.5-volt primary) use red lead and ignore the green except to tape the end. The secondaries are: high voltage for 280 plates, with red center tap to ground; 2.5 volts, 3 amperes, red center tap to C plus, for 245 output, single or pushpull; 5 volts, 2 amperes, red center tap, as positive B lead, for filament of 280 tube; 2.5 volts, 16 amperes, red center tap to ground, for 224, 227 and pentode tubes, up to nine heater type tubes. Hence there are five windings.

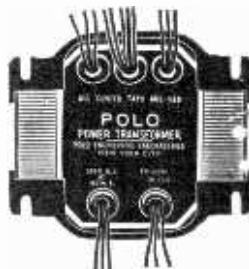

Bottom view of the 245 power transformer. All leads are plainly marked on the nameplate, including the top row.

A special filament transformer, 110 v., 50-60 cycles, with two secondaries, one of 2.5 v., 3 amp. for 245s, single or push-pull, other 2.5 v., 12 amperes for 224, 227, etc., both secondaries center-tapped. Shielded case, 6 ft. AC cable, with plug. Order Cat. F-2.5-D @.....\$3.75

The conservative rating of the Polo 245 power transformer insures superb results even at maximum rated draw, working up to twelve tubes, including rectifier, without saturation, or overheating due to any other cause. This ability to stand the gaff requires adequate size wire, core and air gap, all of which are carefully provided. At less than maximum draw the voltages will be slightly greater, including the filament voltages, hence the 16 ampere winding will give 2.25 volts at maximum draw, which is an entirely satisfactory operating voltage, increasing to 2.5 volts maximum at fewer than a total of nine RF, detector and preliminary audio tubes are used.

The avoidance of excessive heat aids in the efficient operation of the transformer and in the maintenance of good regulation, but excessive heat increases the resistance of the windings.

The transformer is equipped with four slotted mounting feet and a nameplate with all leads identified. It is one of the very finest instruments on the radio market.

Highest Capacity of Filament Secondary

SPECIAL pains were taken in the design and manufacture of the Polo 245 power transformer to meet the needs of experimenters. For instance, excellent regulation was provided to effect minimum change of voltage with given change in current used. Also, the 2.5 volt winding for RF, detector and preliminary audio tubes, was specially designed for high current, to stand 16 amperes, the highest capacity of any 245 power transformer on the market. Hence you have the option of using nine heater type tubes. The shielded case is crinkle brown finished steel, and the assembly is perfectly tight, preventing mechanical vibration.

The power transformer weighs 1 1/2 lbs., is 7 inches high, 4 1/2 inches wide, and 4 1/2" front to back overall.

Elevating washers may be used at the mounting feet to clear the outleads, or holes may be drilled in a chassis to pass these leads, and the transformer mounted flush.

Advice in Use of Chokes and Condensers in Filter

With the 245 power transformer either one or two single chokes should be used, or a shielded double choke, depending on the current drain and the capacity of filter condenser used. Where the capacity at the output is 8 mfd. or more for a drain of 65 to 100 ma., a single choke will suffice (Cat. SH-S-CH), but where smaller output capacity than 8 mfd. is used on such drain, two such chokes should be used in series. Next to the rectifier in a filter circuit, use a 2 mfd., 550 A.C. working voltage rating condenser (D.C. rating, 1,000 v.).

If the drain is to be 100 ma. or more, the 2 mfd. choke, Cat. SH-D-CH, may be used for filtration, instead of two single chokes. The 2 mfd. choke may be obtained for 25 cycles or 40 cycles on special order, as these are not stocked regularly, and remittance must accompany order. The same guaranty attaches to them as to all other Polo apparatus—money back if not satisfied after trial of five days. In these the primary and secondary voltages and taps are the same, only the case is deeper (front to back) because of larger core and wire for lower frequency. For 40 cycles order Cat. 245-PT-40.....@ \$9.50 For 25 cycles order Cat. 245-PT-25.....@ \$12.50 [Note: The filter for 40 cycles should consist of two shielded single chokes, Cat. SH-S-CH, with 2 mfd. next to the rectifier and 4 mfd. minimum at the joint of the two chokes and at the end of the filter. For 25 cycles the same holds true, except that the output capacity at end of chokes should be 8 mfd. minimum.]

We Make Special Transformers to Order

Polo Engineering Laboratories, 143 West 45th St., New York, N. Y.

- Enclosed please find \$_____ for which ship at once:
- | | |
|---|--|
| <input type="checkbox"/> Cat. 245-PT @...\$8.50 | <input type="checkbox"/> Cat. 245-FIL @...\$4.50 |
| <input type="checkbox"/> Cat. 245-PT-40 @ 9.50 | <input type="checkbox"/> Cat. 245-FIL-40 @ 7.00 |
| <input type="checkbox"/> Cat. 245-PT-25 @ 12.00 | <input type="checkbox"/> Cat. 245-FIL-25 @ 6.50 |
| <input type="checkbox"/> Cat. SH-S-CH @ 5.00 | <input type="checkbox"/> Cat. SH-F-20 @ 2.50 |
| <input type="checkbox"/> Cat. SH-D-CH @ 6.00 | <input type="checkbox"/> Cat. UN-S-CH @ 1.25 |
| <input type="checkbox"/> F-2.5-D @.....3.75 | |

Note: Canadian remittance must be by post office or express money order.

If C.O.D. shipment is desired, put cross here. No C.O.D. on 25 and 40 cycle apparatus. For these full remittance must accompany order. The 25 and 40 cycle apparatus bears the 50-60-cycle label, but you will get actually what you order.

Name.....
Address.....
City..... State.....